



RADIO AND TELEVISION

# Service News

A PUBLICATION OF THE RCA ELECTRON TUBE DIVISION

DECEMBER

1957

Vol. 22, No. 5



Photo courtesy of the Toledo Blade

Authorized Dealer of RCA Electron Tubes, skilled television and radio service technician, homemaker, and mother of six, Mrs. Vito Chiaverni of Toledo, Ohio, leads an active life by anybody's standards. (See story which is featured on page 2 of this issue.)

# It's a ServiceMAN'S World —Or Is It?



Owner of the ABC Repair Shop, Mrs. Vito Chiaverni is shown here receiving her copy of the RCA Color Television Pict-O-Guide from Duane Owen, parts salesman for Main Line Distributors, RCA tube distributor in Toledo. Jack F. Leahy (left), RCA Electron Tube Division salesman, and Edmund Walkowski, manager of Main Line's parts department, are noticeably happy to be on hand for the special presentation.

As is always the case, you mustn't forget that women can get in the act, too—and with skill, training, perseverance, and experience can display a technical performance of which their male service-dealer associates indeed can be proud.

For instance, take Annette Barbara Chiaverni (Mrs. Vito Chiaverni to those in the know). Owner of the ABC Repair Shop in Toledo, Ohio, and an Authorized Dealer of RCA Electron Tubes, she leads a double life as homemaker and TV-radio servicewoman. Her shop is open from nine to nine, and it's quite a busy 12 hours for this talented mother of six.

According to a copyrighted story by Jeanne Ernsberger in the *Toledo Blade*, before Mrs. Chiaverni turns the store key on weekday mornings, she first sees to it that Mary, Judy, David, Rita, and Gail are ready and off to school. Jascha, the one pre-schooler in the brood, is left to guard the home front, with the help of a competent babysitter. Then Mrs. Chiaverni goes to her shop to check the day's schedules, returns

home for three or four hours to take care of daily house routines, then off to the shop again to busy herself with wires, parts, tools, and tubes (RCA, of course).

Servicing TV and radio receivers is fun, says the ABC Repair Shop owner. When she and the two servicemen in her employ are not out on house calls, they spend their time playing the "game" of fixing broken-down sets. This "game" comes in mighty handy in building their knowledge of TV repair. It saves them time and effort when they're analyzing TV-receiver troubles in the setowner's home. And it also

helps them develop quite a knack for properly diagnosing a set's ailments over the telephone.

Are men surprised to find a woman servicing a radio or TV receiver? Some are—but their sales-resistance soon fades away when they realize the competence with which Mrs. Chiaverni performs her repair work.

By the way, RADIO AND TELEVISION SERVICE NEWS readers who are also members of the fairer sex should be interested in noting that Mrs. Chiaverni is as enthusiastic in her work at home as she is on the job. After store-closing, she prepares food for the freezer. On Sundays—her day of rest?—she makes many of her children's clothes. And, during the summer, she cans over 1,000 quarts of fruits and vegetables. She also finds some spare time to crochet and knit. Quite a gal, huh?

Mrs. Chiaverni's career has been a varied one. Before becoming interested in electronics, she was a beauty contest winner, a model, a beauty parlor operator, a barber, and a book-binder. She opened her ABC Repair Shop in 1952, taking private lessons in radio-TV servicing to learn the trade. Her actual course took a little more than a year but, since then, she's continued to study on her own. You never can learn enough about this growing business, you know.

## RCA Issues All-New, 216-Page 1958 Edition of Popular Reference Book

The all-new, pocket-sized 1958 edition of the popular RCA Reference Book is off the press and in your local RCA distributor's hands. You'll surely want to ask him for your copy—for it contains 216 pages of up-to-date information on RCA electron tubes, test equipment, batteries, transistors, and semiconductor diodes.

Tailor-made for ready reference by electronics service technicians, as well as design engineers and purchasing agents, the revised edition includes a

"Quick Selection Guide" of RCA cathode-ray tubes, power tubes, phototubes, special tubes, and semiconductor devices for communications and industry, plus 50 pages of receiving tube characteristics, with base and envelope diagrams. Picture tube characteristics and socket diagrams occupy 13 pages.

The new RCA Reference Book features "Interchangeability Directories" for tubes, transistors, and batteries. It also contains a daily reminder calendar.

**RADIO AND TELEVISION**

**RCA**

*Service News*

A PUBLICATION OF THE RCA ELECTRON TUBE DIVISION

RCA RADIO & TELEVISION SERVICE NEWS is published in the interest of dealers and service technicians. It is written to assist them in providing better service, and to foster the growth of their business by supplying them with information on the latest trouble-shooting and sales promotion techniques, sales and service aids, together with invaluable data on RCA tubes, transistors, batteries, parts, and test equipment.

RCA RADIO & TELEVISION SERVICE NEWS is a bi-monthly publication of the RCA Electron Tube Division, Harrison, New Jersey.

© 1957  
Radio Corporation of America

Harvey Slovik  
Editor  
Robert Leedy  
Technical Editor

DECEMBER  
1957  
Vol. 22, No. 5

## AN UNUSUAL COLOR TV PROBLEM

by M. B. Knight

Advanced Development  
RCA Electron Tube Division

I recently had an experience that may be a "first" in color-TV servicing. During a heavy thunderstorm, lightning struck a vent pipe on my roof, causing relatively minor damage to the roof and attic. Because my color-TV set was in the far corner of the house and its antenna lead-in was properly

protected by a lightning arrester, I suspected no damage. The next day, any traces of doubt were removed; my daughter was happily watching "Howdy Doody."

When I turned on the set that evening, however, I found the white uniformity disturbed on the left side; left-center was green, top and bottom were purple. I realized that something was magnetized because I had recently seen a dramatic purity change in a

# Now Available: Special Accessories for Use With RCA's Portable WT-110A Automatic Electron-Tube Tester for Service Technicians

The last issue of RADIO AND TELEVISION SERVICE NEWS alerted you on the commercial availability of the RCA WT-110A Automatic Electron-Tube Tester that comes supplied with a set of 239 pre-punched cards for 7-pin and 9-pin miniature, octal-type, and lock-in type receiving tubes. Now the editors are pleased to report that your local RCA distributor can also provide you with reasonably priced packages of accessory cards for testing popular receiving-tube types for TV and radio receivers other than those covered by the initial card file.

Each of the 13 new Accessory Punched-Card packages listed below utilizes an accessory type designation with a WG prefix, to facilitate your ordering. These packages contain 24 pre-punched and printed cards for the indicated tube types. Because some tube types require two cards for complete testing in the WT-110A, the number of types listed under the various WG-package numbers will differ.

\* \* \*

The following packages are currently available:

- **WG-310A** (1R5, 1T4, 1U4, 1U5, 1V2, 3BN6, 3V4, 5Y3-GT, 6BA8-A, 6SA7-GT, 6SJ7-GT, 6SK7-GT, 6SQ7-GT, 12SA7-GT, 12SK7-GT, 12SQ7-GT, 25CD6-G, 35Z5-G, 50C5, 50L6-GT)

- **WG-311A** (1L6, 1S5, 2CY5, 3A3, 5AS4-A, 5BT8, 5R4-G, 5V6-GT, 6AS7-G, 6BZ8, 6H6, 12AJ6, 12AY7, 12CN5, 12J8, 25C5, 35Y4, 50A5, 50B5, 117Z3)

- **WG-312A** (3BU8, 3S4, 5AV8, 5B8, 6AZ8, 6BN8, 6CL8, 6CR6, 6F6, 6J4, 10C8, 12AC6, 12BK5, 12SG7, 12SJ7, 12SL7-GT, 25Z6-GT)

- **WG-313A** (1L4, 3Q4, 3Q5-GT, 5AU4, 5BE8, 6AQ6, 6AS6, 6CE5, 6DQ5, 6K7-GT, 6N7-GT, 6SC7, 6SH7, 7A8, 12D4, 14B6, 17AX4-GT, 17H3, 18A5, 25CA5, 80)

- **WG-314A** (1N5-GT, 3A5, 3DK6, 4BN6, 4BU8, 6DN6, 6SF5-GT, 6SR7, 7B7, 7C6, 7C7, 7F8, 8AU8, 8CM7,

- 8CN7, 12CT8, 25F5, 35Z4-GT)

- **WG-315A** (1A7-GT, 1AH4, 1AJ5, 1V6, 3A2, 5Z3, 6A8, 6BJ7, 6BJ8, 6C5, 6DC6, 6F5, 7AK7, 9U8-A, 12AD7, 14A7, 19BG6-GA, 25CU6, 26A6, 35B5)

- **WG-316A** (1H5-G, 1LH4, 1LN5, (Continued on next page)

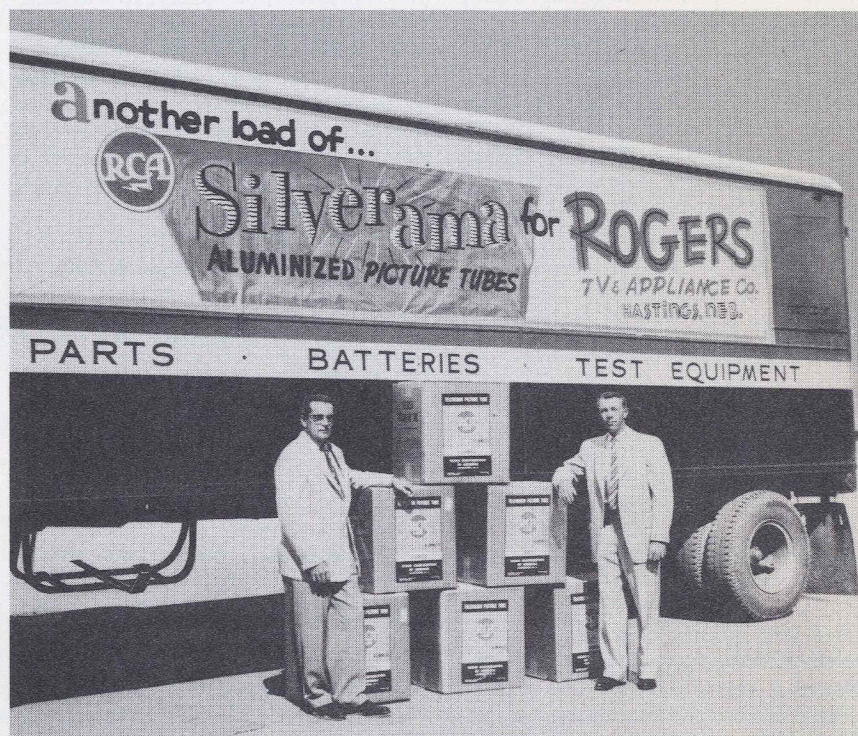

**TO BE BIG, YOU HAVE TO THINK AND ACT BIG!** This could very well be the philosophy behind the way the Rogers TV and Appliance Company conducts its business. There aren't many service-dealer operations in this country which can boast that they buy television picture tubes by the truckload. Yet this is exactly what that Hastings, Nebr., firm did just recently. On hand to welcome the arrival of a truckload of RCA Silverama Super-Aluminized Picture Tubes were Roger Hill (shown at left), owner of the Rogers TV and Appliance Company, and Keith Watson, salesman for the Electronics Parts Division of the Sidles Company of Omaha, Rogers' RCA tube distributor.

laboratory color tube caused by a stud welder used in the installation of air-conditioning ducts. It had been necessary to demagnetize both the tube and the metal racks in the laboratory to cure that problem. I just hoped I wouldn't have to "degauss" all the plumbing in the house.

Fortunately, I didn't. Using the tools at hand to improvise on the recommended procedure for demagnetizing the color picture tube (Ed. note: See RCA Application Note AN-163, "Demagnetizing the RCA-21AXP22 Color Kinescope"), I merely removed the top

of the cabinet and made a few passes around the tube with my trusty "demagnetizer"—and the uniform white field was restored.

For such demagnetizing operations, as well as for fixing tools that have been too close to speaker magnets or PM focus magnets, I use an old RCA-202D1 focus coil. This coil is less effective than those recommended for use on the color picture tube, but it proved adequate for this minor "degaussing" job since it was possible for me to go beyond the usual procedure of working only from outside the cabinet.

For construction of such a "demagnetizer," the metal shell is removed from the 202D1 focus coil, and an ac plug is attached to the leads. The coil does not overheat when a supply voltage of 110 volts ac is used, and it produces a strong enough field to demagnetize most things as long as it is moved away from the parts before the plug is removed (lest it work as an effective magnetizer, too).

\* \* \*

Just remember this tip the next time your house (or your customer's) is struck by lightning.

## Special Accessories

(Continued from preceding page)

3BE6, 4BC5, 5CM8, 6AJ4, 6AJ5, 6AK4, 6AN4, 6BV8, 7Y4, 12H6, 12J5-GT, 14Q7, 19X8, 26A7-GT, 45, 117Z6-GT)

● **WG-317A** (1AD4, 1LA6, 3A4, 5AW4, 5Y4-GT, 6A7, 6AM4, 6AX8, 6BA7, 6BC7, 6L7, 6Q7, 7A7, 7AG7, 12A6, 12R5, 19C8, 25AV5-GT, 35A5, 50Y6-GT, 50Y7-GT)

● **WG-318A** (1S4, 3AF4-A, 3BA6, 5Z4, 6AR5, 6BW4, 6K8, 7A6, 7B6, 7B8, 7V7, 9CL8, 12BA7, 12K7-GT, 12SH7, 17AV5-GA, 25DQ6, 25Z5, 28D7, 35Z3, 50X6)

● **WG-319A** (2A3, 4CY5, 6AD4, 6B4-G, 6B8, 6SB7-Y, 6SF7, 6SS7, 7A4, 7B5, 7H7, 7Q7, 7Z4, 12AW6, 12CS6, 12SC7, 14AF7, 14R7, 42, 75)

● **WG-320A** (1A5-GT, 1AG4, 1LB4, 1LC6, 6AN6, 6BC4, 6C6, 6D6, 6S8-GT, 7X7, 12SF5, 12SF7, 12SW7, 12SY7, 14F7, 41, 117L7/M7-GT, 117N7-GT)

● **WG-321A** (1A3, 3LF4, 5A6, 5T4, 5V3, 6AN5, 6BA5, 6BF7, 6CM8, 6F8-G, 7AF7, 7B4, 8BH8, 12A8-GT, 12AS5, 12Q7-GT, 17C5, 19J6, 25W6-GT, 78, 84)

● **WG-322A** (1LD5, 1LE3, 1-V, 2B3, 3CE5, 4BX8, 5AZ4, 5BQ7-A, 6AR6, 6BL4, 7A5, 8BN8, 8SN7-GTB, 12AL8, 12C8, 14C7, 26C6, 26D6, 76)

Perhaps you prefer to prepare your own punched cards for tube types of your own choosing. If so, ask your RCA distributor for an RCA WG-325A Accessory Unpunched-Card package and an RCA WG-326A Accessory Card Punch. By punching your own cards, you can save some money. At the same time, your testing of new tube types will not be held up by your waiting for each new pre-punched card package to become available. You can test a new tube type by following the card-punching information to be published by RCA in **RADIO AND TELEVISION SERVICE NEWS**.

For complete instructions on the preparation of punched cards, refer to

RCA's "Test Card Data" Bulletin (ICE-174). One copy is packaged with each WT-110A Automatic Electron Tube Tester.

In addition to the 13 Accessory Punched Card packages, the Unpunched-Card package, and the special, heavy-duty Accessory Card Punch, your RCA distributor also can provide you with RCA's WG-337A, WG-338A, and WG-339A accessory socket adapters for use with the WT-110A, as follows:

● **RCA WG-337A Tube Socket Adapter Set**—four adapters for testing tubes with *small 4-pin bases, small 5-pin bases, small 6-pin bases, and small and medium 7-pin bases* in RCA WT-110A Automatic Electron-Tube Tester.

● **RCA WG-338A Tube Socket Adapter**—for testing *7-lead in-line sub-miniature tubes* in RCA WT-110A Automatic Electron-Tube Tester.

● **RCA WG-339A Tube Socket Adapter**—for testing *8-lead circular sub-miniature tubes* in RCA WT-110A Automatic Electron-Tube Tester.

### PART 3 OF A SERIES OF SPECIALLY PREPARED ARTICLES

# Electronics Servicing is Big Business

by R. B. Sampson

Manager, Market Research  
RCA Electron Tube Division

Are you getting your share of the service industry's electron tube sales volume?

In 1956, the tube manufacturers sold 167 million entertainment- and industrial-type receiving tubes and 5.3 million television picture tubes in the renewal market. This year we have forecasted (and we expect it to materialize) 180 million entertainment- and industrial-type receiving tubes and 6.1 million TV picture tubes. Compare the 1957 figures with three years ago and you will note the tremendous expansion that has taken place in a relatively short period of time. In 1954, only 115 million entertainment- and industrial-type receiving tubes and 3.8 million picture tubes were sold.

The end of the rise is not in sight. We estimate that next year the electronics maintenance market will consume 190 million entertainment- and industrial-type receiving tubes and 6.5 million picture tubes. The largest percentage of this volume, by a wide margin, will pass through the service-dealer industry in which you earn your livelihood. Why? Because the tremendous number of sets (television receivers, radios, etc.) in use today re-

quire the maintenance and service which you provide.

I believe that most of the service technicians who read this column are getting their share of this tube sales volume; but the continuous expansion in the industry and the increased competitive activity make it necessary for you to be constantly alert to the potential business in your own community—and particularly in your own neighborhood.

That latter statement leads to another point: the possibility that the concentration of sets within a particular neighborhood or section of a city will no longer require you to cover a large range of territory. In other words, look to your own backyard for business. Promote it, develop it, and thus cut down the cost of operating over a wide expanse of territory. I do not need to dwell on this subject at length because you are already well aware of the costs incurred in serving the fringe areas of your territory.

How do you promote business in a specific area? The answers are known to you—but often they are not put into practice. In brief, here are just some of the approaches to the problem:

One is direct mail. You have many opportunities to avail yourself of this media. It is a time-honored practice that will work as well for you as it does for your neighborhood automobile

dealers, service stations, grocery stores, etc.

Do you have an up-to-date customer file and mailing list? Again, these areas are elementary, but they are often completely and wholly neglected. The hard copy of your customer repair order is one of the most important documents in your business, if not *the* most important. File it, maintain it in proper order, and use it for customer follow-up at regular intervals, as well as for other pertinent purposes.

Are you in the classified telephone directory? I am sure the answer is "yes" in the majority of cases; but I know there are exceptions. It, too, is a valuable source of new business and you cannot afford to overlook it.

What about the appearance of your store? You will stimulate business by using your store window as a showroom, being sure it is well lighted and dressed regularly with interesting displays that include an illuminated sign and professionally-done placards. Inside your store, feature attractive merchandising units, shelf strips, signs, and other display materials to spark impulse purchases. Most of all remember that a neat-looking store interior, window, and storefront is of the utmost importance. Neatness makes a good impression on present and potential customers. It develops and retains customer confidence and goodwill.

# Sync and Sweep Selection in CRO Applications

by Rhys Samuel

Commercial Engineering  
RCA Electron Tube Division

Cathode-ray oscilloscopes are widely used by service technicians in signal tracing, response-curve observation, and voltage, current, and distortion measurements of all types. Because these applications utilize both sine waves and a variety of complex pulses, the trend in 'scope design is toward increased bandwidth and improved amplification characteristics. In addition, special provisions are made in the horizontal-amplifier and sweep-synchronization circuits to permit stable, fast lock-in and display of different waveshapes.

These special provisions are often a source of confusion because their purposes and functions are not clearly understood. Each sync and sweep position on the selector switches has a specific purpose which, when properly understood by the technician using the equipment, can be an excellent advantage. Improper use of these facilities often can result in an erroneous evaluation of the displayed waveshape.

Some or all of the special sync and sweep features described here are incorporated in most service-type 'scopes, although various models may differ somewhat in internal circuitry and in the labeling and placement of controls.

## Principles of CRO Operation

Figure 1 shows the main sections of a 'scope in block-diagram form. The vertical amplifier amplifies the incoming signal for vertical display and, in most service 'scopes, is the high-gain wide-bandpass section of the instrument. The horizontal amplifier, which usually has lower gain and narrower bandpass characteristics, has the primary function of providing a horizontal sweep or time base along which the incoming waveshape is displayed. The types of horizontal sweep necessary, i.e., a linear sawtooth or a sinusoidal sweep, depend upon the type of incoming signal. In TV-alignment applications which utilize an FM (sweep) signal, for example, it is usually necessary to employ a sinusoidal horizontal sweep signal. Observation of most other types of waveshapes requires use of a sawtooth horizontal sweep. The 'scope should be able to provide both types of time-base sweep.

To obtain stationary lock-in on the incoming signal, it is necessary to lock the sweep of the horizontal oscillator at a submultiple of the vertical-signal

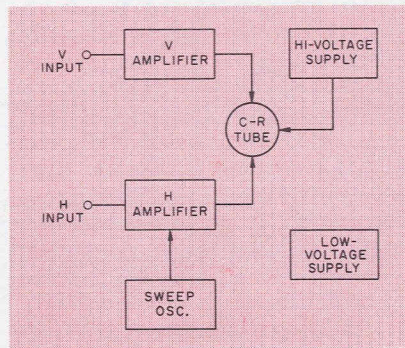

Figure 1. Block diagram of CRO.

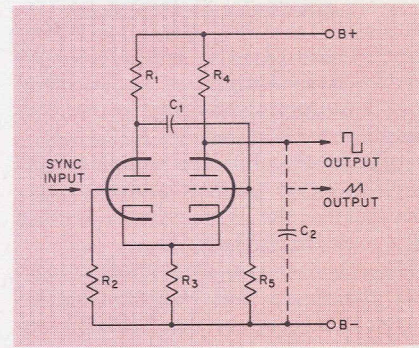

Figure 2. Basic cathode-coupled multivibrator.

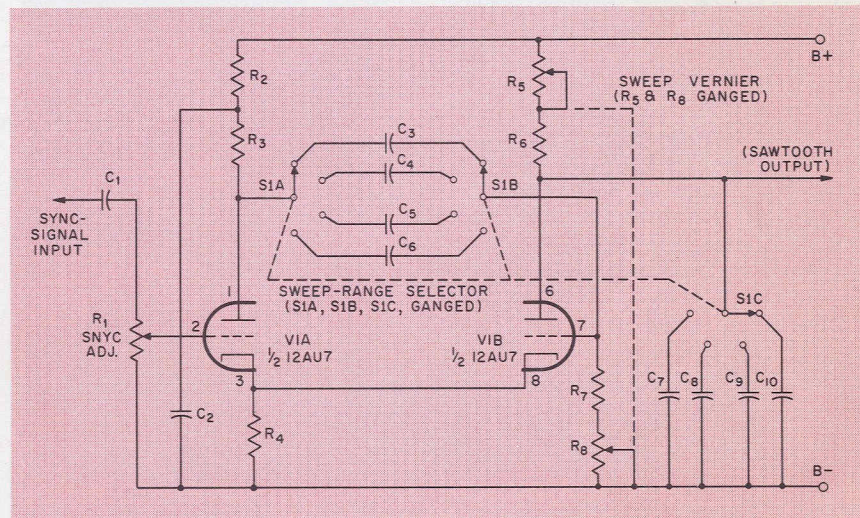

Figure 3. Simplified diagram of oscilloscope sweep oscillator.

frequency so that the horizontal amplifier provides a sweep signal at a stable, repetitive rate. Therefore, the horizontal-sweep signal must be synchronized with the incoming signal. Because of various types of waveshape, polarity, and frequency of incoming signals, it is necessary to provide the operator with a choice of synchronizing methods.

## The Sweep Oscillator

General-purpose, service-type 'scopes incorporate sweep oscillators which operate over a range from a few cps up to approximately 30 Kc. The most popular type of oscillator circuit is the Potter-type, free-running, cathode-coupled multivibrator shown in simplified form in Figure 2.  $C_1$ ,  $R_4$ , and  $R_5$  are the principal frequency-determining components. The normal output from this oscillator is a square wave. Addition of the capacitor  $C_2$  changes the output from a square wave to a sawtooth.

The circuit shown in Figure 3 is an adaptation of the circuit in Figure 2 which is used in the general-purpose service oscilloscope, RCA WO-88A. The WO-88A provides a sawtooth

horizontal sweep from approximately 15 cps to 30 Kc in four ranges. Capacitors  $C_3$ ,  $C_4$ ,  $C_5$ , and  $C_6$  provide rough frequency adjustment; ganged potentiometers  $R_5$  and  $R_8$  provide precise adjustment. As the frequency-determining capacitor is switched, the output-shaping capacitor is also changed by switch  $S_{1C}$  to preserve the sawtooth waveshape at all output frequencies.

This type of oscillator is characteristically unstable in frequency in its free-running state. The oscillator, therefore, should be synchronized with either the incoming signal or another signal. Synchronization is accomplished by feeding a signal to the grid of tube  $V_{1A}$  through coupling capacitor  $C_1$ . The voltage level of the injected sync signal is controlled by potentiometer  $R_1$ , which is a front-panel control. The multivibrator can be synchronized by either a positive-going pulse or a sinusoidal ac signal.

## Types of Synchronizing Signals

An obvious method of synchronizing horizontal sweep is to utilize part of the input signal itself; this system is

(Continued on next page)

# Sync and Sweep Selection In CRO Applications

(Continued from preceding page)

employed in all oscilloscopes. A sample of the vertical signal is tapped off at an appropriate point in the vertical-amplifier section and fed to the sweep oscillator. Because the sample signal may be either positive-going or negative-going, the sync-selector switch has positions for both.

Figure 4 shows, in simplified fashion, the sweep and synchronizing arrangement used in the WO-88A. In this instrument, the vertical-amplifier section contains two direct-coupled push-pull stages. With the input signal shown, the signal sample tapped off at point "A" will be positive-going; the signal at point "B" is negative-going. A choice of "+" or "-" internal sync is provided because the polarity of the input signals determines the polarity at points "A" and "B," and a positive-going pulse is required to sync the oscillator properly. The front-panel switching provision makes it simple for the service technician to select the positive-going waveshape.

In TV-servicing applications requiring observation of the composite signal, it is often possible to obtain better lock-in by the application of external sync signal from the horizontal section of the TV receiver to the EXT SYNC terminal. The composite signal, containing sync pulses and video information, is taken from the video amplifier and fed to the V-input terminal. This method of synchronizing is helpful when circuit troubles affect the sync

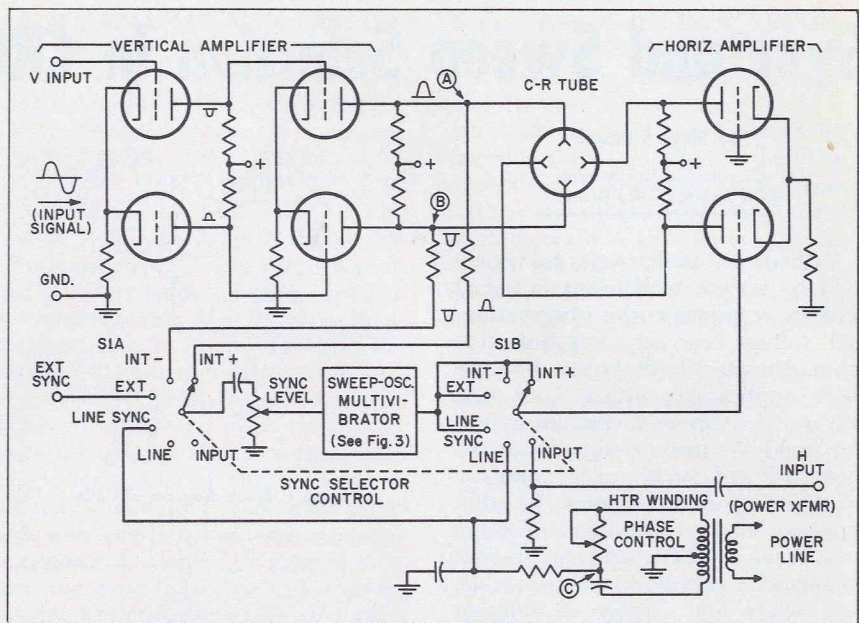

Figure 4. RCA WO-88A sync-selector system.

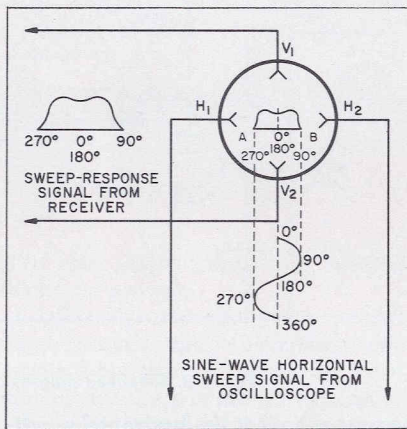

Figure 5. Sine-wave-driven sweep signal oscilloscope display.

or when the signal contains above-average noise.

In the "Line Sync" position of the switch, a sample sinusoidal voltage is taken from the 6.3-volt heater winding on the power transformer at point "C" and fed directly to the sweep oscillator. This synchronizing voltage is at the line frequency (usually 60 cps). Because line-frequency signals are used in many TV and industrial applications, such as the vertical-deflection and synchronizing circuits in a TV receiver, this position can also be used to lock in on low-frequency signals which are multiples of the line frequency, although the number of displayed waveshapes will increase with the signal frequency.

The "Line" and "Input" positions on switch section S<sub>1A</sub> are not utilized; the output from the oscillator is disconnected from the horizontal amplifier in these positions by switch section S<sub>1B</sub>. B+ voltage is also removed from the oscillator to prevent crosstalk in the horizontal amplifier. In the "Line" position, the sinusoidal signal tapped from point "C" is fed directly into the input circuit of the horizontal amplifier, which amplifies the signal for application to the horizontal-deflecting electrodes.

The necessity for using a sinusoidal sweep can be seen in Figure 5. Most FM and TV-receiver alignment applications utilize a swept-oscillator signal which is varied in a 60-cps sinusoidal fashion. To provide a linear display for the sweep trace, it is necessary that the horizontal-deflecting voltage change at the same rate as the sweep signal from the generator. Because the generator sweep oscillator is swept by a 60-cps sine-wave signal, a 60-cps sine wave

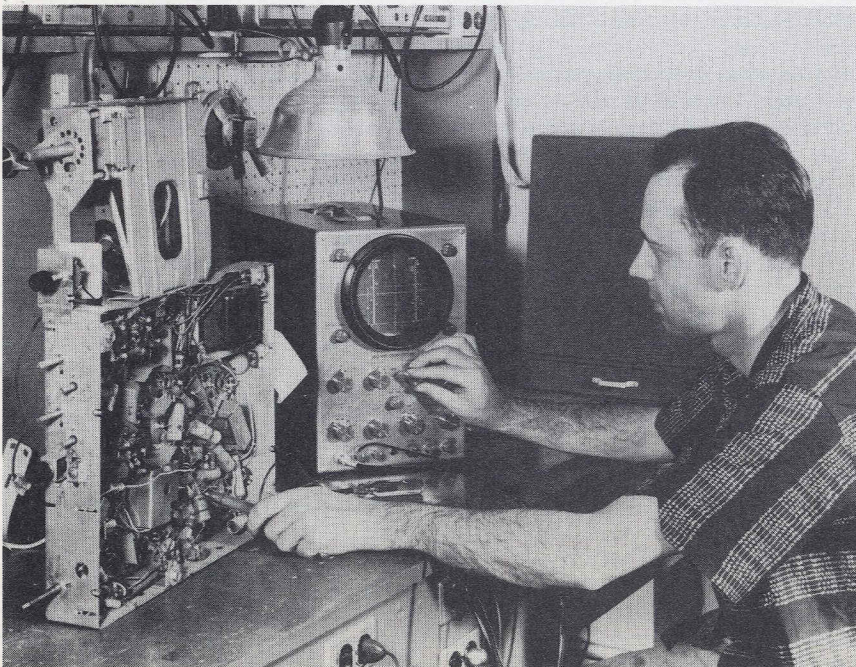

Rhys Samuel is shown investigating sync and sweep techniques.

must be applied to the horizontal-deflecting electrodes of the 'scope, as shown in Figure 5. When the sine-wave voltage is applied to the horizontal-deflecting electrodes of the cathode-ray tube, the beam sweeps from left to right (shown as A and B) on the tube. Correct adjustment of the Phase Control in the 'scope causes the forward sweep of the horizontal-deflecting voltage to coincide exactly with the start of the forward sweep of the signal taken from the receiver. These two starting points are shown as zero-degree points in the illustration. Because the swept-response signal is applied to the vertical-deflecting electrodes, the beam is deflected vertically at the same time that it is deflected horizontally. On the coincident forward sweeps, therefore, the beam follows the curved-trace path from A to B on the tube. It is evident that a sawtooth sweep signal cannot faithfully reproduce a sine-wave-driven sweep signal.

Sweep oscillators which employ a saturable reactor for modulation utilize a sawtooth driving waveform and, therefore, require use of a sawtooth time-base.

The "Input" position, which is used to feed an external signal directly to the horizontal amplifier, can also be utilized in sweep-alignment work. Many sweep generators are equipped with binding posts which provide a sample of the internal driving-motor voltage. In generators which utilize reactance modulators for driving the internal oscillator, the sweep frequency may be adjustable over a wide range or fixed at 400 cps. At frequencies other than 60 cps, the driving signal for the 'scope may be taken directly from the generator. In these cases, it is necessary to employ a phase control at the sweep generator.

#### Prefixed 'V' and 'H' Positions

Service technicians will find that many TV service 'scopes are equipped with pre-fixed "V" and "H" sync positions to permit instantaneous lock-in on the vertical and horizontal sync and scanning frequencies. In the RCA-WO-91A and other similar 'scopes, the "V" position is factory-set at 30 cps; the horizontal position is set at 7875 cps. These positions will lock-in two complete waveshapes on the 'scope screen. The prefixed positions utilize two internal screw-driver-adjusted potentiometers connected in the frequency-determining sections of the sweep oscillator.

#### Operating Tips and Precautions

The first recommendation for service technicians using any 'scope is to read the instruction manual and learn the functions of all of the controls. Once

the functions of the different sync and sweep provisions are clearly understood, trouble-shooting can be done considerably faster.

Some of the most common operating difficulties encountered by TV-servicing personnel are (1) a running waveshape moving from left to right or from right to left; (2) a jumping waveform; and (3) a distorted waveform. A running waveshape indicates that the sweep oscillator is not set to the correct submultiple of the vertical frequency or that insufficient injection voltage is being applied to the sweep oscillator. This symptom requires readjustment of the sweep-frequency control or reset-

ting of the sync-level adjustment. If sync injection voltage is insufficient, the sweep oscillator cannot be locked to a stable running frequency. The correct procedure for setting this control is as follows: with the sync-adjustment control at minimum setting, (1) set the sweep-range and sweep-vernier controls to give the desired number of waveshapes moving slowly to the left; (2) turn the sync-adjustment control clockwise until solid lock-in is obtained.

This procedure will help prevent the third type of difficulty: waveshape distortion caused by overdriving the sweep oscillator.



Al Thompson (third from left in the back row), RCA sales representative, appears here with the members of the Luzerne County Television and Radio Servicemen's Association who qualified for special certificates after attending Shelborne Electronics' classes in color-TV servicing.

## Color-TV 'School' Graduates Organized Group

From northeastern Pennsylvania comes news of the first *organized group* of service technicians to complete the color-TV servicing course formulated by RCA Institutes, Inc., one of the foremost television and electronics schools in the United States, and made available through the RCA Electron Tube Division.

In a special "graduation" ceremony, 24 members of the Luzerne County Television and Radio Servicemen's Association recently received certificates attesting to the fact that they passed the 10-month color-television course en masse.

The "school" sessions—held two evenings a week—were established by Shelborne Electronics, Inc., RCA tube distributor in Wilkes-Barre, Pa. Classes were conducted by Michael Boyson, chairman of the Research Division of the Luzerne County servicemen's association.

At the commencement exercises, Al Thompson, RCA sales representative

and guest speaker for the special occasion, presented the certificates to: Ted Petrikonis, Joseph Sincavage, Al Spunar, Michael Boyson, Daniel Grant, George Gracely, Charles Andrews, Frank Chabala, Charles McKechnie, George Haines, Albert S. Ridila, Nicholas Souchik, Austin Renville, Paul Granick, John Hannibal, Ralph Miller, Thomas Finn, Sam Harrison, Joseph Toole, Raymond Labatch, Alfred E. Novenski, Adam J. Deets, Stanley G. Wright, and Edward Martin.

With Mr. Boyson as chairman, the committee in charge of arrangements consisted of the following Luzerne County Television and Radio Servicemen's Association executive officers and color course "graduates": Mr. Deets, president; Mr. Labatch, treasurer of the Research Division; Mr. Spunar, vice-president of the association and secretary of the Research Division; and Mr. Hannibal, member of the board of directors of the Research Division.

# RCA SUPPORTS SERVICE DEALERS WITH DYNAMIC NEW "PROFIT BUILDERS!"



Here are your "Tubes Tested By Experts" promotion aids... interest-arousing leaflets to mail or hand out... eye-catching easel-card... traffic-stopping 30" x 40" display... 3-color streamer... illuminated sign... ad mat!

**Close-to-a-hundred different sales-exciting displays, advertising, mailing, and promotional materials—for all-year use—draw customers, create good will, build prestige and sales.**

It takes more than a "meter" to service radio and TV. It takes an expert—like you—with special training, experience, and solid knowledge of how to use all the tools of the trade. And RCA continues to support the "experts" with sales-promoting materials that tell everyone there is only one "short-cut" to saving money in radio-and-TV repairs—that's by coming to you first with their tube and repair problems.

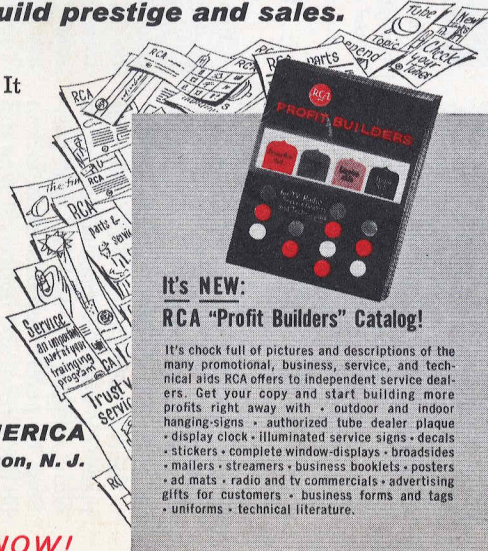

## It's NEW: RCA "Profit Builders" Catalog!

It's chock full of pictures and descriptions of the many promotional, business, service, and technical aids RCA offers to independent service dealers. Get your copy with • outdoor and indoor hanging signs • authorized tube dealer plaque • display clock • illuminated service signs • decals • stickers • complete window-displays • broadsides • mailers • streamers • business booklets • posters • ad mats • radio and tv commercials • advertising gifts for customers • business forms and tags • uniforms • technical literature.



**RADIO CORPORATION OF AMERICA**  
Electron Tube Division  
Harrison, N. J.

Contact Your RCA Tube Distributor...NOW!



RCA  
Electron Tube Division  
Harrison, N. J.

Compliments of Your  
Local RCA Distributor

Headquarters for:

# RCA

Tubes  
Batteries  
Electronic Components  
Test Equipment  
Technical Publications

Devices and arrangements shown or described herein may use patents of RCA or others. Information contained herein is furnished without responsibility by RCA for its use and without prejudice to RCA's patent rights.



Form 3547 Requested

POSTAGE