



RADIO SERVICE NEWS

VOLUME XIII, No. 5

EDITORIAL OFFICES, RCA, HARRISON, NEW JERSEY

September-October, 1948

HERE IT IS—YOUR BIG ALL-TELEVISION RADIO SERVICE NEWS

**RSN Answers Big Demand for
the Latest in TV Information**

Here's an extra special issue of **RADIO SERVICE NEWS**, devoted to the latest and most authoritative TV information available. It's an issue every serviceman will want to file for future reference.

In order to devote as much space as possible to this tremendous field, most of the regular departments of RSN have been omitted.

Table of Contents

New TV-FM-AM Test Equipment,
by Arthur Liebscher page 1

Television Receiving Antennas.
A John Rider Article page 2

Television Service (Part 3).
By John R. Meagher page 3

(Each article is completely self-contained.)

Chart of Television Channels and
Relative Frequencies page 5

(Keep this handy and see at a glance the frequency you need.)

Frequency Modulation Channels
Numbers vs Frequencies page 5

Television Tube Complement Data
Sheet pages 6-7.

(A reprint of the original copy, full sized for easy reference.)

Overload Protection for the Horizontal
Deflection Circuit page 8.

(How to protect your set from burning up.)

Another of those original Jack Lally
Cartoons page 8

(Exclusive with RSN.)

How The Image Orthicon Works.
page 11

(Excerpts from the 2P23 Image Orthicon
Bulletin.)

The RCA Television Picture Magnifiers page 11

(The Already Popular 10-inch plus the brand new 7-inch model.)

RADIO SERVICE NEWS is glad to be able to bring you their contribution to the banner year of Television. Following its policy of the best service news possible, as fast as possible, RSN will continue to keep you abreast of, or ahead of the times through its pages of authoritative information—every issue a Television Issue.

For the best in television components and tubes—it's RCA. For the best in Television Data—it's RCA **RADIO SERVICE NEWS**.

FOR THE MODERN SERVICE SHOP

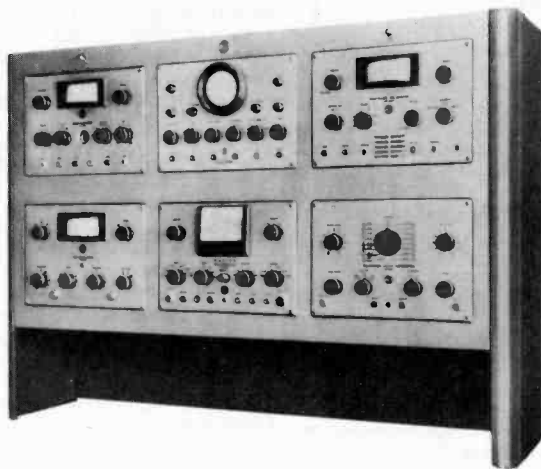

Fig. 1. Two-shelf rack assembly of TV/FM/AM test units affords easy access to all facilities. Left to right (lower row); test oscillator, television sweep generator; (upper row); audio oscillator, oscilloscope, television calibrator.

NEW TV/FM/AM TEST EQUIPMENT

By **ARTHUR LIEBSCHER**

Merchandise Group, RCA Tube Department

This article first appeared in the July 1948 issue of **RADIO NEWS**, and is reprinted herewith by their permission.

The expansion of the radio industry to include FM and television receivers is having a marked effect on servicing activities and requirements. Television receivers, particularly, being more complex than AM receivers, necessitate the use of additional and more elaborate test facilities than those needed for servicing AM receivers.

Recognizing the inevitability of these new servicing requirements, RCA engineers have developed a group of new test instruments and an assembly rack to provide service technicians with equipment suitable for servicing all classes of receivers efficiently.

Customers expect their sets to be serviced in accordance with original design specifications. In the case of television receivers, particularly, a service technician must have, and know how to most effectively use, new test equipment that is capable of measuring the performance of the better receivers.

It is important that technicians duplicate the intermediate-frequency and video response curves recommended by receiver manufac-

turers, because these matters are as important to good sound and good picture reproduction as are all the efforts of broadcasters in obtaining high-quality signals. The measurement of peak-to-peak voltages of various waveforms, and of small capacitance values, will become common practice.

In anticipating and analyzing the problems encountered in television and frequency-modulation servicing, RCA engineers decided that complete servicing efficiency required test equipment designed to measure current and voltage, including peak-to-peak values; resistance, capacitance, and frequency, over wide ranges; to provide signals, both variable and fixed, up to and including television channel 13, and to incorporate crystal-controlled frequencies for calibrating purposes.

They also decided that problems of minimizing the effects of circuit intercoupling, and the requirements of optimum flexibility and portability called for the use of a number of separate units, each designed for a specific application.

(Continued on Page 9)

TWO RCA TELEVISION INSTRUCTION BOOKS FOR THE SERVICEMAN

**The Latest in TV Receiver
Servicing—Welcome Additions
To Every Servicing Library**

Two RCA publications, recently announced, provide a wealth of data for the modern serviceman. One is authored by one of the outstanding Television authorities of the day—John R. Meagher, an already well known name to **RADIO SERVICE NEWS** readers. The other publication is one of RCA's Service Data series, the first on TV receivers.

Meagher's newest work, which bears the title "Television Trouble Shooting and Alignment", is a 40-page, paper bound book, 8½ x 11 inches in size. The text is based on the series of lectures delivered by the author to the "Town Meeting of Radio Technicians", in Philadelphia, Pennsylvania earlier this year. The outstanding coverage given TV servicing is unequalled in the field. "Television Trouble Shooting and Alignment", by John R. Meagher, is available through your local RCA distributor—price \$1.00.

The second publication, "RCA Television Service Data", gives a complete coverage of servicing on two of the more popular models of RCA TV receivers. Alignment procedures, schematics, parts lists, wiring diagrams, and chassis layouts are provided for the RCA 630TS and RCA 648PTK. RCA Television Service Data, form number TV-1003, is also available through RCA distributors. The price—\$1.50.

FIRST RESULTS ON THE SAFETY CONTEST

The first trio of ISOTAP winners in the "Shock-of-the-Month Club" have been selected. Because this is an all-television issue of **RADIO SERVICE NEWS**, publication of the first set of winning letters has been postponed to the next issue.

Meanwhile, the second contest is in full swing so get your letters in today. The full details on this contest appeared on page 1 of the July-August **RADIO SERVICE NEWS**. Briefly—there's an RCA Isotap Transformer for each of the writers of the three best letters selected for each issue, plus an RCA Battery VoltOhmyst for the best letter of them all by the end of the year.

WJA

SOME NOTES ON TELEVISION RECEIVING ANTENNAS

Reprinted from "Successful Servicing", a John Rider publication.

If there is one factor that makes for a good television installation, it is in the receiving antenna. Its importance cannot be emphasized sufficiently. It is impossible in the space available to enter into all the various factors that are involved in a television antenna installation; only a relatively few can be considered here, but they should be of assistance to men who are doing television work now or who will be in the near future.

One of the most important things to bear in mind is that an antenna for the reception of television signals should be as high above the ground as it is possible to have it. Due to the nature of the high-frequency signals, the distance they can travel is determined by line-of-sight paths, which are indicated by AB and CD in Fig. 1. Assume that the transmitting antenna is at a height above the ground and the receiving antenna is at a height B. Signals radiating from A will be received at B as each is far enough above the ground so the line-of-sight path is tangent to the earth at X. If the height of the transmitting antenna were increased to C, the length of the path will also be increased so that it is tangent to the earth at Y and the signals can be received at an antenna D of the same height as B but at a greater distance.

The distance or horizon range from the transmitting antenna to X or Y can be found from the formula, Distance = 1.23 \sqrt{h} , where the distance is measured in miles; h, the antenna height above the ground, in feet; and 1.23 is a constant which takes into account the curvature of the earth. Assume that the transmitting antenna is 1000 feet above the ground; substitute this for h in the above formula and we have Distance = 1.23 $\sqrt{1000}$ = 1.23 x 31.62 = 38.9 miles

Now if the receiver installation is within this horizon range of the transmitter, the antenna should be as high as possible in order to avoid

local obstructions, but its height is not of paramount importance as it is when the antenna is beyond the range, as B or D in Fig. 1. In this case, the height above ground of both antennas must be taken into consideration and the following formula is used.

$$H, \text{ height of receiving antenna} = \left(\frac{\text{Distance}}{1.23} - \sqrt{h} \right)^2$$

Assume that you wish to know how far above ground a receiving antenna should be installed at a location, say 50 miles from the transmitter with an antenna height of 1000 feet, as in the above example. Substitute 50 for the distance and 1000 for h in the above equation. Thus we have

$$H = \left(\frac{50}{1.23} - \sqrt{1000} \right)^2 = (40.6 - 31.6)^2$$

$$H = (9)^2 = 81 \text{ feet}$$

You will find that this height H increases quite rapidly with an increase in the line-of-sight distance; for example, at 55 miles, a receiving antenna would have to be 171 feet above ground with a 1000-foot transmitting antenna, and at 60 miles, H would be 294 feet above ground.

It should be clear from the foregoing that if you perform similar calculations, you should know accurately the line-of-sight distance of the location where the receiving antenna is to be installed, because just a few miles means such a great difference in the height.

Multiple Receiver Connections

It may happen that you will want to have more than one television receiver connected to a single antenna; this might easily occur if the installation is to be in an apartment house, a store, a dealer's display room, etc. This can be done if the relative signal strength of the signals is sufficient in the locality. It is necessary to know this, because the number of sets which can be connected to one antenna is limited by the signal strength available, the maximum being four for two televi-

sion receivers, the available signal voltage is cut 2 to 1; for three sets, it is cut 3 to 1, and for four sets, 4 to 1.

Two methods of connections are shown in Figs. 2 and 3, the former being that employed with receivers with a balanced input and the latter with unbalanced-input sets. It goes without saying that in order for the signal to be a maximum at the receiver input, the impedance match between the antenna, the lead, and the input should be as nearly perfect as possible. In Fig. 2 (A), a folded dipole is indicated (this has a 300-ohm impedance) and it is connected to the resistors and switches by a twin lead with the same impedance. In Fig. 3 (A) a half-wave dipole is indicated, this having an impedance of 75 ohms and a coaxial line of the same impedance being employed.

You will note that in Fig. 2 there are two double pole-double throw switches connected in parallel through series resistors to the twin-lead line from the antenna. The number of receivers connected to the antenna determine the value of these series resistors; for two receivers, the value is 150 ohms; for three receivers, 300 ohms; and for four receivers, 450 ohms. It is important to use carbon and not wire-wound resistors, as the latter may unbalance the system. Of course, the dummy load in each case remains 300 ohms, thus matching the input of the set and providing a balance in the event the set is removed from the system.

With receivers having an unbalanced input of 75 ohms, single pole-double throw switches are used with series resistors connected to the center lead of the coaxial line from the antenna. Here again the value of these series resistors changes with

the number of sets connected in the system. In the case of two sets in the system, the value of each series resistor is 75 ohms; if three sets are used, the value becomes 150 ohms; and when four receivers are used, the value becomes 225 ohms. Carbon resistors must be used here also. In the event that a set is disconnected, then the switch in that circuit is thrown to the dummy load.

The equivalent circuits of each of these methods of connection are shown in Figs. 2 and 3 (B). In the former, the two 150-ohm resistors in series with the 300 ohms of either the set input or the dummy load, give two parallel circuits of 600 ohms each. Hence, the impedance of the combination is 300 ohms, providing the proper match for the twin-lead line. In the event that three sets are connected to the same folded dipole, the 150-ohm series resistors are changed to 300 ohms each, making each parallel branch circuit 900 ohms. The total resistance of three 900-ohm circuits in parallel is again 300 ohms, providing the required impedance match for the line.

The same reasoning can be applied to Fig. 3 (B). Here but one resistor is needed in series with the 75-ohm unbalanced input of the receiver to provide the impedance match. The total resistance of each series circuit is 225 ohms and the total resistance of the three parallel circuits is 75 ohms. If four 75-ohm receivers are to be connected to the one dipole, the series resistances are changed from 150 to 225 ohms, the total resistance of each series circuit being 300 ohms. Therefore, the total resistance of four 300-ohm parallel circuits would again be 75 ohms, giving the correct match.

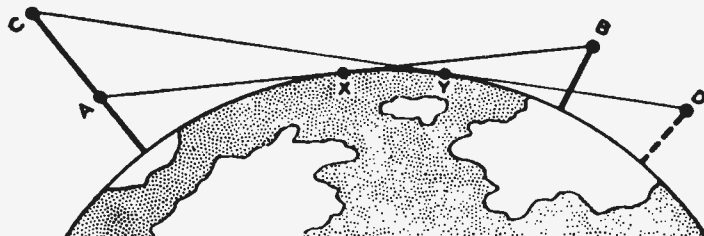
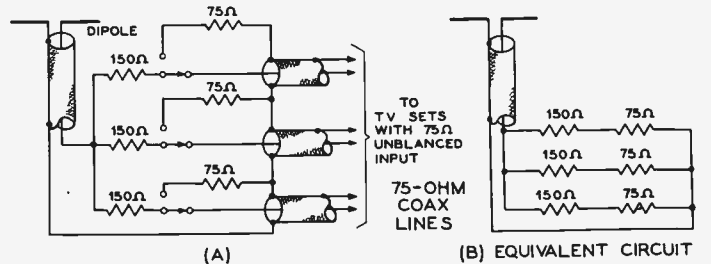
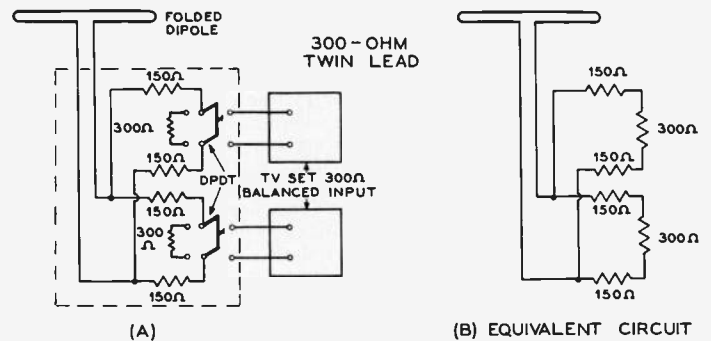

Figure 1.



Figures 2 and 3.



RCA SERVICE

SUPPLEMENT

RADIO SERVICE NEWS

September-October, 1948

RCA RADIO SERVICE NEWS

Page 3

TELEVISION SERVICE

By JOHN R. MEAGHER

Television Specialist, RCA Renewal Sales

A high percentage of television service calls, possibly 80%, are due to troubles that can be located and corrected without requiring a great amount of technical knowledge, providing the technician has been adequately informed of the common troubles and their symptoms and remedies in the particular model of TV receiver.

PART 3

The other 20% of service jobs require capable and resourceful technicians with thorough understanding of basic television principles and considerable practical experience. Serious technicians realize this fact and are continually striving for clearer understanding of basic principles.

In this series of articles, we will cover many essential television principles in the process of showing how to diagnose troubles. Two essential principles are included in the present article.

We recommend that readers purchase a copy of the author's booklet "Television Trouble-Shooting and Alignment" which has recently been published by the RCA Service Co., Inc., Camden, N. J. This booklet shows how to localize troubles, describes the requirements for TV alignment equipment, and gives illustrated step-by-step alignment

instructions for two popular makes of TV receivers. (40 pages, 49 illustrations, price \$1.00).

To check the over-all (rf, if, video) frequency and phase response of a television receiver, we would ordinarily need three pieces of laboratory equipment—

1. A square-wave video signal generator.
2. A high-frequency oscillator, amplitude modulated by the video generator.
3. A wide-band cathode-ray oscilloscope.

When a test pattern is available, however, the over-all frequency and phase response of the television set can be checked quickly and conveniently by observation and analysis of the test pattern on the kinescope.

1. The wedges in the test pattern take the place of the square-wave video signal generator.
2. The TV station provides the rf.

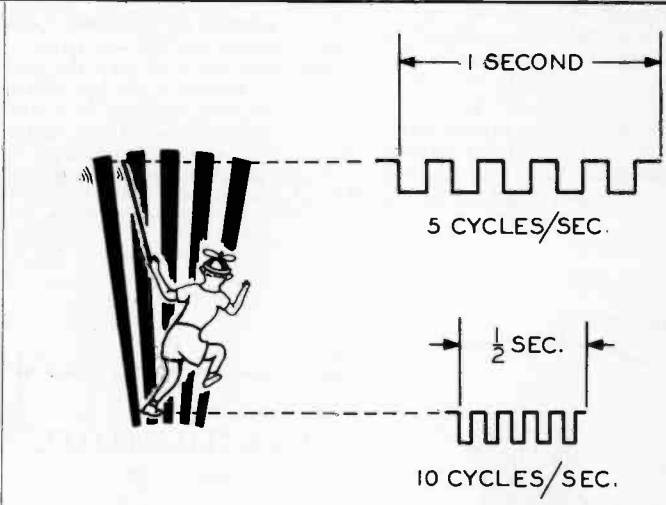

FIGURE 2—ANALOGY TO VERTICAL WEDGE IN TEST PATTERN

signal, which is amplitude-modulated by the square-wave video signals of the wedges.

3. The kinescope takes the place of the wide-band oscilloscope.

Figure 1 shows both of these setups. The test pattern and the kinescope provide a very convenient and useful testing system for everyday TV service. But we must furnish the initiative, the persistence, and the time to learn how to use them.

Wedges are Video Signals

It is important to understand that the wedges in the transmitted test patterns are much more than a collection of black and white lines. They actually represent video signals ranging from about 30,000 to 4,000,000 cycles-per-second.

These video signals are generated in the camera tube and are used to amplitude-modulate the station's carrier. The transmitted video signals are square-wave at the lower frequencies, and essentially sine-wave at the higher frequencies.

The following simple analogy may help in understanding how the wedges are utilized at the transmitter in producing this wide range of video signals: When a boy runs a stick across a picket fence, he generates a noise, or an audible signal. The frequency of the signal depends on the speed of the stick and the number of pickets in a given distance.

Suppose the boy had a V-shaped trellis with 5 pickets, as shown in Figure 2. As he draws the stick across the pickets, the motion at the

tip of the stick resembles a series of square waves. If the stick is drawn across at the top in one second, it traces 5 square waves in one second, or a frequency of 5 cycles-per-second.

If the stick is drawn at the same speed across the bottom of the trellis, which is half the width of the top, it traces 5 square waves in 1/2 second. This is a rate of 10 cycles-per-second, double the previous frequency.

In an analogous manner, as shown in Figure 3, the camera tube at the TV transmitter produces an electrical square-wave signal as the electron beam in the camera tube is drawn across the image of the vertical wedge. But in this case the frequency is very high because the beam crosses the wedge in a few millionths of a second.

In this particular example, there are 10 black and 10 white lines in the wedge, equivalent to 10 cycles. (For simplicity, there is assumed to be a white line at the right-hand side of the wedge.)

At the top of the wedge, the beam crosses the 10 cycles in 5 millionths of a second, or 5 microseconds: In one microsecond, the beam crosses 2 cycles. This is equivalent to a rate of 2 million cycles-per-second, or 2 Mc.

At the bottom of the wedge, which in this example is half the width of the top, the beam crosses the 10 cycles in 1/2 the time, or in 2.5 microseconds: In one microsecond, the beam crosses 4 cycles. This is

(Continued on Page 4)

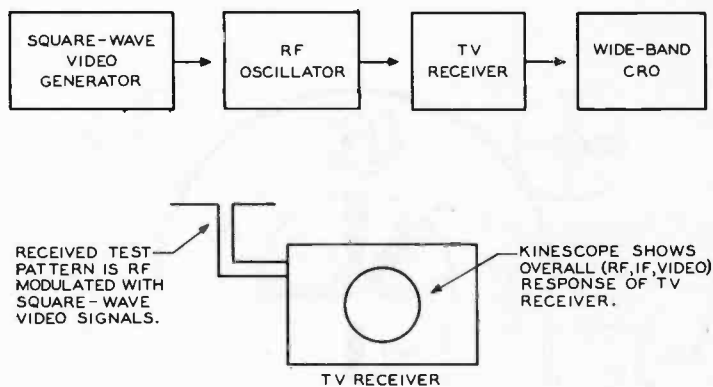

FIGURE 1—COMPARISON OF TWO METHODS OF CHECKING TV RESPONSE

TELEVISION SERVICE

(Continued from Page 3)

equivalent to a rate of 4 million cycles in one second, or 4 Mc.

When the beam scans across other points along the wedge, the generated frequency is between 2 and 4 Mc.

The horizontal wedge can be analyzed in the same manner, but for our purpose it is sufficient to know that in test patterns where the center line of the horizontal wedge is about 1/4 the length of a horizontal scanning line, it represents a half-cycle of a 30-kc square wave. In the RCA Indian-head pattern the horizontal lines (at bottom center) represent half-cycles of

scanning line and immediately visualize how the signal voltage must be changing to produce the changes in brightness that we see along the particular scanning line.

The following paragraphs briefly cover this subject:

The intensity of the electron beam in the kinescope, and consequently the brightness of the spot, depends on the voltage at any instant between the grid and cathode of the kinescope.

If we connect an electronic voltmeter between the grid and cathode of the kinescope, and vary the grid voltage, by means of the brightness control, we can observe how the brightness of the spot or raster changes as the grid voltage is changed. An arbitrary example of this relation is listed below:

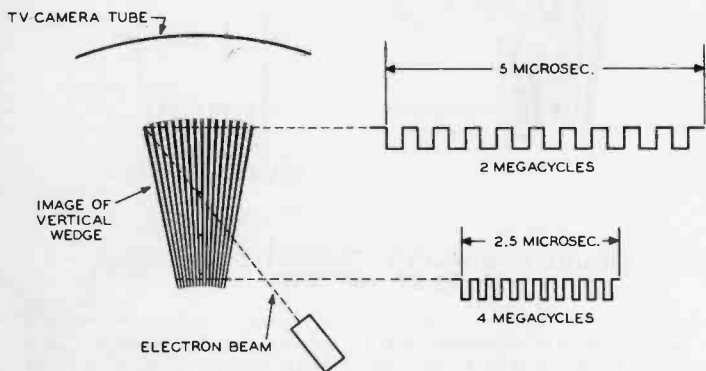

FIGURE 3—VERTICAL WEDGE IS USED IN PROVIDING SQUARE-WAVE VIDEO SIGNALS OF A WIDE FREQUENCY RANGE.

square-wave signals ranging from about 19 kc. to 0.6 Mc.

Signal-Wave Form vs Brightness

Electrical signals are changes in voltage during a period of time. Such signals are shown in books and on the screens of cathode-ray oscilloscopes as "waveshapes" or "waveforms".

In radio, if we want to see the wave-form of audio-frequency signals, we must use an oscilloscope.

In television we have a tremendous advantage because, without using an oscilloscope, we actually see each of the thousands of video signals that form the complete test pattern or picture. We see these signals not as waveforms, but as changes in brightness along each scanning line on the kinescope: We see signals that last for as little as one-tenth of one-millionth of a second; we see other signals that remain unchanged for as long as 53 millionths of a second.

To take advantage of this graphic display of the picture signals, we must understand the relation between the changes in brightness and the waveform of the signal that produces these changes: We must learn to look at any section of a

Kinescope grid voltage	Brightness of spot or raster
0 v.	Bright (—white—)
—10 v.	Light grey
—20 v.	Medium grey
—30 v.	Dark grey
—40 v.	Black

(For simplicity, we are using a reference of zero volts for white.)

Assume that the receiver in this example is tuned to a TV station, and the brightness and contrast controls are correctly adjusted:

When the electron beam in the TV camera is scanning a white portion of the picture, the rf output of the transmitter is zero (for practical purposes). This results in zero signal voltage at the kinescope grid, which, as shown in the table above, is the condition that makes the spot bright, producing "white" on the kinescope.

When the camera is scanning a black portion of the picture, the rf voltage output of the transmitter is maximum (for picture signals). This produces maximum negative signal voltage at the kinescope grid, or —40 volts in the above example. This is the condition that extinguishes the spot, producing "black" on the kinescope.

When the camera is scanning a

grey portion of the picture, the rf voltage output of the transmitter is some percentage of the black signal output. This produces the same percentage of the maximum negative signal voltage at the kinescope grid, and results in the same shade of grey on the kinescope.

We are not particularly interested in the actual values of signal voltage at the kinescope grid, because it is preferable to think in terms of percentage, or relative signal voltage, as listed below:

Spot Brightness	Relative Signal Voltage
Black	100%
Dark Grey	75%
Medium Grey	50%
Light Grey	25%
Bright (—white—)	0

(For simplicity in this discussion, we are omitting reference to the sync pulses, which are 33% higher in voltage than the black signal level.)

It should be pointed out that the "blackness" of black portions on the kinescope depends on how much

direct or stray light from lamps and windows is illuminating the front of the kinescope. In a pitch-dark room, the black portions of the picture are quite black, but in a bright room, the black portions of the picture can not be darker than the front of the kinescope appears when the TV set is turned off. This may seem like an obvious fact, but it is frequently overlooked. In visualizing the waveform of the signal, it is desirable to have the kinescope screen reasonably well shaded so that the blacks will be black.

Figure 4 shows how the signal voltage changes along one scanning line in the NBC test pattern. We have shown the background of this pattern as a medium grey, but the printed illustration may appear as a lighter or darker grey.

Figure 5 shows how the signal voltage changes along one scanning line in the RCA Indian-head pattern.

For practice, we recommend that the reader sketch out the changes in signal voltage across other lines in those test patterns. There is no better way to become acquainted with this subject.



FIGURE 4—WAVEFORM OF SIGNAL VOLTAGE ALONG ONE LINE OF WNBT TEST PATTERN.

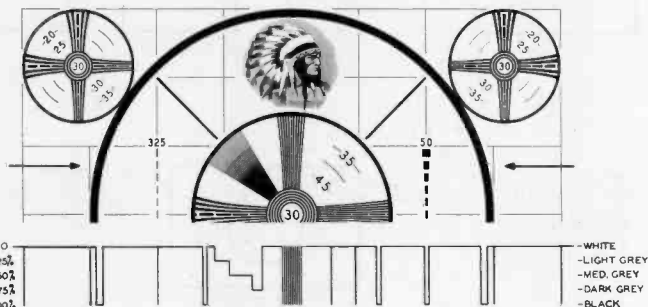

FIGURE 5—WAVEFORM OF SIGNAL VOLTAGE ALONG ONE LINE IN RCA INDIAN-HEAD TEST PATTERN

TELEVISION TUBE COMPLEMENT
DATA SHEET

Mfgr.	RCA VICTOR							PHILCO		GENERAL ELECTRIC			EMERSON	BELMONT	HALLI-CRAFTERS	MOTOROLA		CROSLLEY	ADMIRAL		
Model	621 TS	630 TS&TCS 8T530	641 TV	648 PTK	721 TV	730 TV	741 PCS	48-1000	48-2500	801	802 803	901			T54	VK-101	VT-71	307TA 9-408	30A14 15&16		
Picture Tube Size	7"	10"	10"	5" Proj.	10"	10"	5" Proj.	10"	4" Proj.	10"	10"	5" Proj.	10"	7"	7"	10"	7"	10"	10"		
Tot. Tubes Used	21	30	41	48	21	30	41	26	29	24	26	43	28	22	23	29	16	30	29		
No. of Miniatures	10	15	22	23	12	17	16	9	10	1	3	4	10	11	5	11	8	15	16		
6AG5	3	4	4	4	3	3	4	6	6			1	3		2	5	4	4	3		
6AH6															2						
6AK5											2			2							
6AL5	1	3	5	4	2	3	3	2	3				1	2	1	1	1	3	3		
6AT6	1	1	1	2	1	1	2											1			
6AU6	1	2	3	4	1	2	2			1	1	1	2	2		2	2	2	5		
6BA6	1	2	5	5	1	2	2						1	2		2		2	1		
6BE6			1	1		2					2										
6C4															2						
6J6	3	3	3	3	3	3	3	1	1				3			1		3	4		
12AT7																	1				
12AU7					1	1															
No. of Metal	1	4	6	8		2	8				8	8	14	1		8	7	1	4	1	
6AC7		1	1	1			1				4	4	4				1		1		
6AG7													1				1				
6H6	1			1			1			1	1	2	1		2	1					
6J5		1	2	4			4									2		1			
6SA7											1										
6SC7												1	1								
6SG7											1	1	2								
6SH7		1	1	1			1								6	1		1			
6SJ7																				1	
6SK7		1	1	1			1									1		1			
6SQ7			1			2											1				
6SV7											1	1	3								
No. of Glass	9	10	12	16	8	10	16	18	18	14	14	24	16	10	9	10	6	10	11		
1B3GT/8016	1	1	1	3	1	1	3	1	3	1	1	4	1	1	1	1	1	1	1		
5U4G	1	2	3	4	1	1	4	2	2	1	1	2	0	1		2		2	1		
5V4G	1	1	1	1	1	1	1						1			1		1	1		
5Y3GT						1				1	1								1		
6AL7GT												1									
6A07GT											1	1	1								
6AS7G				1			1	1	1	1	1	1									
6BG6G	1	1	1	2	1	1	2	1	1	1	1	2	1			1		1	1		
6F6G			2	2			2														
6K6GT	1	4	3	2	1	2	2	1					2	2				4	2		
6L6G												1									
6S8GT													1			1					
6SL7GT								2	2	2	2	4		1			1				
6SN7GT	4	1	1		3	3				3	3	3	5	4			1	1	2		
6V6GT				1			1		1	2	2	4	0	1		3			1		
6X5GT																1					
6X6G																				1	
7AD7									1												
7B4								1	1												
7B5								2	2												
7B6								1	1												
7C5								1													
7F8								1	1	1	1	1									
7W7								2	2												
12SN7GT																5		2			
25L6GT																1		2			
25Z6GT													5			1					
Cathode-Ray	1	1	1	1	1	1	1	1	1	1	1	1	1	1	1	1	1	1	1		
5TP4				1			1					1									
7DP4	1														1						
7JP4														1	1		1				
10BP4		1	1		1	1		1		1	1		1			1		1	1		
TP400A									1												

OVERLOAD PROTECTION FOR THE HORIZONTAL DEFLECTION CIRCUIT

PROTECT YOUR TV RECEIVER WITH THIS SIMPLE PRECAUTION

Television receivers using magnetic-deflection circuits occasionally require replacement of a burned-out horizontal-deflection transformer due to a short circuit in the horizontal deflection circuit.

A typical magnetic-deflection circuit is shown in Fig. 1, from which it is seen that short-circuit failure of the 6BG6-G tube can cause excessive current flow through the deflection transformer T. Such failure may result from a slow air leak, or

from an internal short between plate and cathode of the 6BG6-G.

It is recommended, consequently, that a fuse F be placed in series with the primary of transformer T, as indicated in Fig. 1. The current-carrying capacity of the fuse should be about twice the rated dc plate current of the 6BG6-G in the given circuit. This margin gives an adequate safety factor against high line voltage and against commercial tolerances of circuit components and tubes.

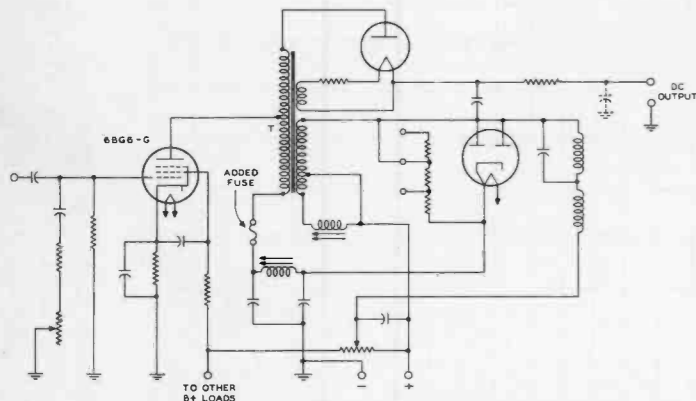
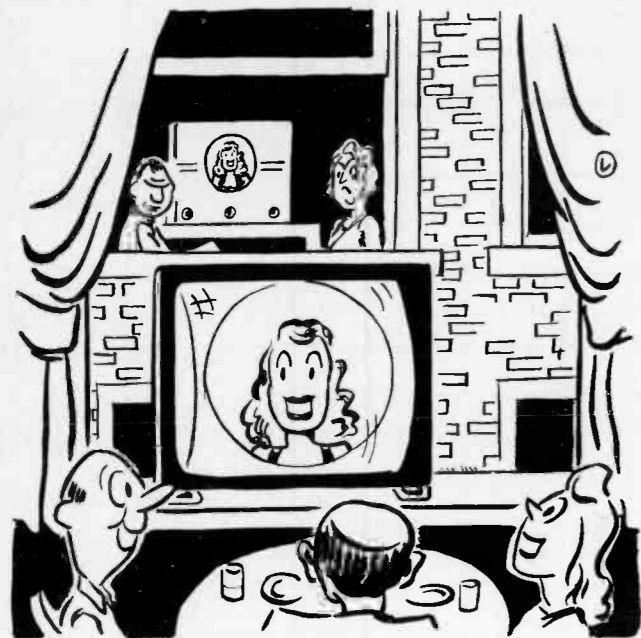

FIG. 1 - TYPICAL HORIZONTAL-DEFLECTION CIRCUIT AND PULSE-OPERATED HIGH VOLTAGE SUPPLY

Figure 1.



TELEVISION PICTURE MAGNIFIERS GIVE LARGE, CLEAR PICTURES

Liquid-filled plastic lenses, designed and manufactured by RCA, are the choice of thousands of TV receiver owners. Placed in front of TV screen, the image is greatly enlarged, yet at no sacrifice of clarity and brilliance.

There are two models of the popular RCA Television Picture Magnifier. The one above is for use with 10-inch kinescopes, giving a resultant picture equal in size to that usually obtained from a 15-inch tube. This model, identified as the 203P2, sells for a suggested list price of \$36.95, complete with a universal mounting bracket.

The other model lens, more recently introduced, is the 205P1 for use with 7 inch kinescopes. The pic-

ture thus obtained is equal in size to 10 or 12 inch tube pictures, greatly increasing the utility of the 7-inch tube. This model also complete with mounting as illustrated below, sells at a suggested list price of \$24.95.

Your customer will want one of these lenses when he sees it in use. Why not demonstrate both sizes of these RCA TV Picture Magnifiers in your window or showroom and profit by the added business.



FREQUENCY CHANNELS FOR FM AND TELEVISION BROADCAST*

FREQUENCY RANGE Mc	TELEVISION CHANNEL NO.	CARRIER FREQUENCIES Mc	FREQUENCY RANGE Mc	TELEVISION CHANNEL NO.	CARRIER FREQUENCIES Mc	FM CHANNEL NO.	CARRIER FREQUENCY Mc
54-60	2	← VIDEO:55.25	174-180	7	← VIDEO:175.25	201	← 88.1
		← AUDIO:59.75			← AUDIO:179.75		
60-66	3	← VIDEO:61.25	180-186	8	← VIDEO:181.25	220	← 91.9
		← AUDIO:65.75			← AUDIO:185.75		
66-72	4	← VIDEO:67.25	186-192	9	← VIDEO:187.25	221	← 92.1
		← AUDIO:71.75			← VIDEO:193.25		
76-82	5	← VIDEO:77.25	192-198	10	← VIDEO:199.25	250	← 97.9
		← AUDIO:81.75			← VIDEO:203.75		
82-88	6	← VIDEO:83.25	198-204	11	← VIDEO:205.25	275	← 102.9
		← AUDIO:87.75			← VIDEO:209.75		
204-210	12	← VIDEO:211.25	204-210	12	← VIDEO:211.25	300	← 107.9
		← AUDIO:215.75			← VIDEO:215.75		
210-216	13	← VIDEO:215.75	210-216	13	← VIDEO:215.75		
		← AUDIO:215.75					

NOTE:
FREQUENCY RANGE 44-50Mc,
FORMERLY TELEVISION CHANNEL
NO.1, WAS REASSIGNED TO
MOBILE SERVICES IN MAY, 1948.

NOTES:
FM CHANNELS 201-220 INCLUSIVE ARE ASSIGNED TO EDUCATIONAL SERVICES.
FM CHANNELS 221-300 INCLUSIVE ARE ASSIGNED TO COMMERCIAL BROADCAST SERVICES.
FM CARRIER FREQUENCIES HAVE A UNIFORM SEPARATION OF 0.2 Mc.

* BASED ON FCC RELEASE OF APRIL 13



Fig. 2. (Left) Instant channel selection is a feature of this television sweep generator. (Center) Television calibrator for the precision alignment of wideband amplifiers. (Right) The vacuum tube voltmeter is practically a universal test instrument applicable to all types of radio and electronic servicing.

NEW TEST EQUIPMENT

(Continued from Page 1)

The decision to utilize separate units made it practical to design them to a common size, suitable either for assembly at the work bench or for carrying them individually to the job if the occasion demanded.

It also makes possible the construction of a rack for the work bench in which the units can be located to suit the individual requirements of the service technician and to provide extensive testing facilities, all within easy arm's reach. Fig. 1 illustrates the arrangement of the units in the RCA WS-16A. In this arrangement, all of the equipment can easily be reached by the technician whether he is sitting on a bench stool or standing at the job.

Because of the importance of making it as easy as possible to take readings on the VoltOhmyst electronic meter WV-95A, it is suggested that this instrument be located in the center of the bottom row. This brings the scale of the VoltOhmyst into direct line-of-sight. For a similar reason, it is desirable to locate the WO-55A oscilloscope in the center of the second row.

Two instruments, namely the WA-54A audio oscillator and the WR-67A test oscillator, can be grouped together on either side of the rack. In addition to their usual use in servicing AM receivers, these instruments are important in signal-tracing FM- and television-video circuits.

The two final instruments of those described in this article are companion units designed for the alignment of both television and FM receivers. The television sweep generator WR-59A is conveniently placed below the television calibrator WR-39A.

Combination Advantages

In considering the individual functions of each instrument mentioned, it is also logical to think of the added advantage of their combined facilities. In television servicing, dual uses for the six instruments are practical. For example, the audio oscillator is handy for signal tracing by the signal-injection method, in video as well as in audio circuits.

The test oscillator, particularly designed for high-speed servicing of AM radios, can, with its signal-injection probe and step attenuator, do an equally fast job of signal-tracing-picture-if and FM-if trouble. Picture-if stages can be traced with a signal from the test oscillator by viewing horizontal modulation bars on the picture tube, or by ingenious trick of capacitance-coupling the output of the picture detector to the television set's audio input and listening to the audio component of the interfering signal. (See Fig. 5.)

Grouping instruments makes it easy to use the vacuum-tube voltmeter for calibrating the scope, thus obtaining quick peak-to-peak voltage reading of any waveform visible on the cathode-ray tube. When these instruments are used in combination, the peak-to-peak voltage of the saw-

tooth waveform of television deflection circuits can be measured on the oscilloscope at the same time that the associated dc voltage is measured on the VoltOhmyst meter.

Separate housing of the television calibrator and the television sweep generator serves to eliminate troublesome problems of leakage and inter-coupling. In applying signals from either or both units to a television receiver, complete control of the independent signals is possible. Since sweep and marker frequencies can heterodyne only in the detector of the set being aligned, little or nothing would be gained by trying to mix the signals in one or the other of the instruments.

In passing, one important fact becomes obvious, and that is that problems of troubleshooting should be solved with signal tracing and voltage indications, including observation of deflection and synchronizing waveforms, before time is spent on alignment procedures. Analogous to this is the application of a prime coat of paint and its drying before a finish coat is applied.

New Features Throughout

Starting with new streamline styling and taking advantage of developments of modern plastics for meter cases and bezels, all six instruments shown in the test rack of Fig. 1 have been designed with many things in common. As mentioned before, the units are uniform in size and are therefore interchangeable in the rack. This feature provides a further advantage in that any of the six

instruments can fit into the RCA WG-274 standard-size luggage-type carrying case. This case also has space for test leads and a few tools.

All six instruments have standard binding-jacks for unshielded test leads, and employ standard microphone connectors for shielded leads. With few exceptions, this makes interchange of test leads practical and convenient, and helps solve the problem of what to do with inactive leads. Fig. 1 shows all instruments less leads, the proper appearance when the bench is not in use.

Since test leads have a habit of getting in each other's way, it is good practice to work with as few as are needed for any one job, and to store the rest where they can be conveniently located, and in a manner that keeps them ready for instant use. For their proper care and maximum life, test leads are best stored in a straight hanging position along a wall or beside a storage cabinet. (See Fig. 4.)

While on the subject of connectors, it should be noted that the binding jacks can be used with either a removable binding post RCA Stock No. 47062, or a locking-pin plug, RCA Stock No. 47089. The binding posts are essential in high-current or low-capacitance measurements. Having a straight shank, the binding post can also be used as a pin plug if desired.

A safety factor is provided in the locking-pin plug, in that a single turn will prevent the test lead from

(Continued on Page 10)

Fig. 3. (Left) The oscilloscope is a useful tool in visual alignment procedures and for observing waveforms. (Center) The r.f. test oscillator is a basic AM servicing instrument. (Right) The audio oscillator is valuable in the service shop and may be used to locate performance difficulties in video amplifiers.



NEW TEST EQUIPMENT

(Continued from Page 9)

pulling out of its panel connection. This is rather important when it is necessary to depend on a good ground connection during high-voltage measurements.

Television Sweep Generator

The television sweep generator shown in Fig. 2 incorporates many new design features. While it employs the usual heterodyne system for the video and all if sweeps, only the fundamental of a single frequency-modulated oscillator is used on any of the rf channels. This method avoids rf coupling between the desired sweep and any other signals present in the equipment.

The channel selector provides for choice of any one of the pre-tuned 13 channel positions for choice of if or video sweep voltages. Although a sweep-width control is a part of the equipment, the maximum sweep is pre-set to approximately 30% override for each channel requirement. In becoming accustomed to the sweep-width control, it will be noticed that the normal action is the reverse of that of a scope gain control. In other words, increasing the sweep width makes more of the over-all curve visible, while decreasing the sweep width enlarges a portion of the curve.

The 60-cycle sine-wave sweep rate will produce two identical images on the scope screen and so it is necessary to have a phase control to position these two images so that they coincide. When blanking is chosen, however, one of the images is blanked out and the return trace appears as a base line. This line provides a convenient means for measuring the amplitude of various parts of the remaining trace. With the help of the graph screen on the scope it becomes an easy matter, for example, to locate the 70-per-cent point on an if or rf curve.

Television Calibrator

The television calibrator illustrated in Fig. 2 produces cw signals which show as heterodyne markers on the scope screen when both its signal and the sweep signal are applied to a television receiver for curve observation. The marker indicates the definite frequency of any one point on a curve. In the adjustment of receiver rf oscillators and trap circuits or in the alignment of stagger-tuned if strips, the calibrator can be used as a signal generator with inherent crystal-controlled accuracy.

The television calibrator itself contains a tunable oscillator which produces a dial-indicated signal from 19 Mc to 110 Mc and from 170 Mc to 240 Mc. An internal crystal-controlled oscillator is used to check the accuracy of the dial. Heterodyning signals are detected and amplified within the instrument and reproduced audibly by a small built-in speaker. Applying the crystal-controlled oscillator harmonics in this way facilitates checking and accurately resetting the dial to any 2.5-Mc point within its range.

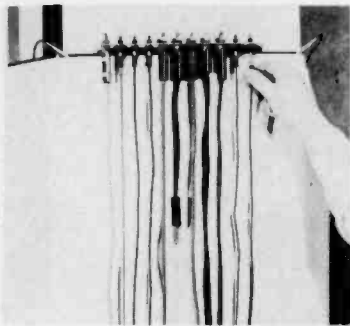

Figure 4. A popular gadget for the busy test shop, this plug-in rack can be easily constructed from standard jacks and connectors.

A second crystal can be switched in to add its 0.25-Mc signal frequency by modulating the 2.5-Mc oscillator. This in turn makes it possible to divide the 2.5-Mc harmonic points on the dial into 0.25-Mc calibrations. Once a 2.5 Mc point is established, it is easy to count the added 0.25-Mc in-between steps and thus arrive at a precise calibration for television receiver requirements.

Having such facilities available, plus the signal from one television station, makes a truly scientific alignment job a reality, for with crystal accuracy and properly reproduced curves, a receiver can be adjusted for maximum dependable service on all 13 television channels.

Vacuum Tube Voltmeter

The new vacuum-tube voltmeter seen in Fig. 2, designated commercially as the "RCA Master Volt-Ohmyst VTVM" is quite a universal testing instrument in itself. As normally found on electronic meters, dc ranges up to 1000 volts, resistance ranges up to 1000 megohms, and ac ranges flat to 20 kc and reading to 1000 volts, are provided with increased sensitivity. For rf voltages, an accessory crystal probe can be

used to read RMS values to 100 Mc, or an accessory diode probe will read RMS voltages to 150 Mc, or values proportional to peak-to-peak voltages of complex waves. This makes the instrument useful for checking vhf oscillator voltages and peak values of deflection voltages regardless of waveform.

Six capacitance ranges enable the meter to indicate directly on one scale, any value between 5 microfarads and 1000 microfarads. With this new feature, tuning capacitors, rf- and if-bypass capacitors, audio-, video-, power-supply, and deflection-circuit capacitors can all be accurately tested.

Oscilloscope

The oscilloscope shown in Fig. 3, besides taking its rightful place in the test rack, is small and light enough to carry to the job when the job can't come to the bench. This instrument has the new feature of calibrated vertical deflection which enables direct reading of peak-to-peak voltages regardless of waveform. A removable graph screen, once calibrated on a 10-division basis, reads voltages throughout the deflection range.

When the sweep selector is set to "line" position, a small sine-wave voltage at power-line frequency is applied to the horizontal amplifier. This feature provides a time-base deflection for sweep alignment, since it eliminates the need for connecting the sweep generator to the scope. Both instruments can be synchronized to the power line and thus to each other.

While wide-band response is essential for the observation of synchronizing and blanking-pulse shapes, it is well to point out here that a scope, such as described, having a response of ± 10 per cent to 40 kc is ample for all sweep-alignment work on television or FM



This new portable carrying case is custom built to hold any one of the RCA matched TV/FM/AM test instruments. The case (WG-274) resembles a piece of smart business luggage and is especially designed for transporting the RCA test equipment to the job. The dimensions are approximately 16 inches long by 11 inches high by 9 inches deep.

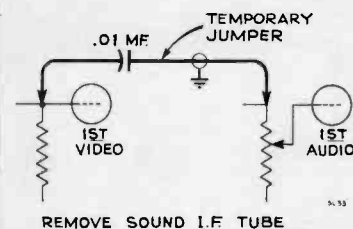

Figure 5. Here is an ingenious dodge in checking picture-rf stages. When the output of the picture detector is capacitance-coupled to the audio output of a television set, the operator can listen to interference on the picture channel. Frequently the nature of the interference can be immediately identified.

sets. The sweep curve observed is not rf, but is derived from the frequency-modulated rf or if signal by detection, and so it is actually well within the audio range. When it is desired to check a video curve, an additional detector such as the RCA WG-263 crystal probe is required to demodulate the video sweep.

Test Oscillator

The test oscillator illustrated in Fig. 3 can be considered an old friend, since most users are familiar with its basic function of providing a tunable cw signal from 100 kc. to 30 Mc. Troubleshooting if circuits in FM and TV sets now adds to its usefulness. Due to vastly improved rf waveshape, harmonic content of the test oscillator is considerably lower than heretofore, so no claims are made for second-harmonic signals above the fundamental maximum of 30 Mc. Supplying higher-frequency signals is a job that belongs to the television calibrator.

Audio Oscillator

With the audio oscillator seen in Fig. 3, video signal tracing can be accomplished in the same manner as audio signal tracing, for only one frequency is needed at a time to run down normal failures in video circuits. After a video circuit has been repaired, it can be tested for characteristic response with the television sweep generator and oscilloscope, but as the low-frequency end of the curve is difficult to interpret, it is often advantageous to refer to audio oscillator signals for low-frequency determinations.

The audio oscillator can also be used advantageously to produce bar-like patterns on the screen of a television picture tube, and thus furnish a means of testing television receiver sweep circuits for linearity.

BACK TALK

In the last issue of RADIO SERVICE NEWS, the article describing the RCA Isotap Transformer gave a suggested list price of \$8.95. The correct price, which should have been quoted, is \$8.95 suggested user price. Sorry if this oversight has caused anyone an inconvenience.

HOW THE IMAGE ORTHICON WORKS

The 2P23 image orthicon is one of the most universally used television camera tubes. Its performance no doubt has been somewhat of a mystery to many readers, and for that reason the following excerpt from the data bulletin of the RCA 2P23 is reproduced.

The 2P23 has three sections—image section, a scanning section, and a multiplier section, as shown in Fig. 1.

Image Section

The image section contains a semi-transparent photocathode on the inside of the face plate, a grid to provide an electrostatic accelerating field, and a target which consists of a thin glass disc with a fine mesh screen very closely spaced to it on the photocathode side. Focusing is accomplished by means of a magnetic field produced by an external coil, and by varying the photocathode voltage.

Light from the scene being televised is picked up by an optical lens system and focused on the photocathode which emits electrons from each illuminated area in proportion to the intensity of the light striking the area. The streams of electrons are focused on the target by the magnetic and accelerating fields.

On striking the target, the electrons cause secondary electrons to be emitted by the glass. The secondaries thus emitted are collected by the adjacent mesh screen which is held at a definite potential of about one volt. Therefore, the potential of the glass disc is limited for all values of light and stable operation is achieved. Emission of the secondaries leaves on the photocathode side of the glass a pattern of positive charges which corresponds with the pattern of light from the scene being televised. The charges set up a corresponding potential pattern on the opposite or scanned side of the glass.

Scanning Section

The opposite side of the glass is scanned by a low-velocity electron beam produced by the electron gun in the scanning section. This gun contains a thermionic cathode, a control grid (grid No. 1), and an accelerating grid (grid No. 2). The beam is focused at the target by the magnetic field of an external focusing coil and the electrostatic field of grid No. 4.

Grid No. 5 serves to adjust the shape of the decelerating field between grid No. 4 and the target in order to obtain uniform landing of electrons over the entire target area. The electrons stop their forward motion at the surface of the glass and are turned back and focused into a five-stage signal multiplier, except when they approach the glass. When this condition occurs, they are deposited from the scanning beam in quantities sufficient to neutralize the potential pattern on the glass. Such deposition leaves the glass with a negative charge on the scanned side and a positive charge on the photocathode side. These charges will neutralize each other by conductivity through the glass in less than the time of one frame.

Alignment of the beam from the gun is accomplished by a transverse magnetic field produced by an external coil located at the gun end of the focusing coil.

Deflection of the beam is accomplished by transverse magnetic fields produced by external deflecting coils.

The electrons turned back at the target form the return beam which has been amplitude modulated by absorption of electrons at the target in accord with the charge pattern whose more positive areas correspond to the highlights of the televised scene.

Multiplier Section

The return beam is directed to the first dynode of a five-stage electrostatically focused multiplier. This utilizes the phenomenon of secondary emission to amplify signals composed of electron beams. The electrons in the beam impinging on the first dynode surface produce many other electrons, the number depending on the energy of the impinging electrons. These secondary electrons are then directed to the second dynode and knock out more new electrons. Grid No. 3 facilitates a more complete collection by dynode No. 2 of the secondaries from dynode No. 1. The multiplying process is repeated in each suc-

THE NEW RCA STACKED ARRAY FOR TV

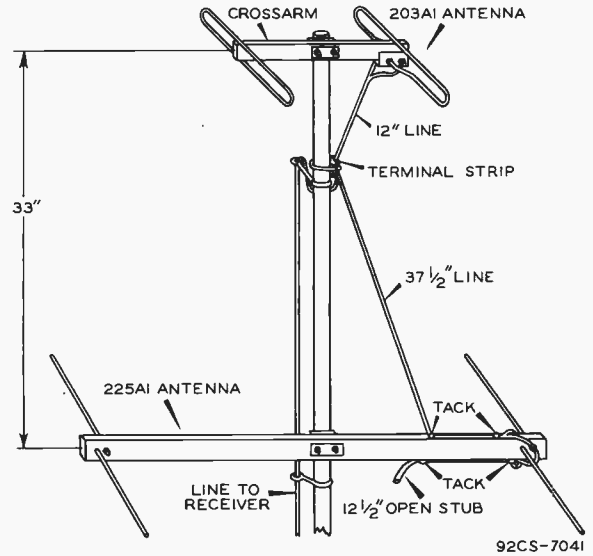

Shown above is the new RCA 203A1 television antenna and reflector mounted above the standard RCA 225A1 antenna. This array provides a high gain twelve channel receiving system for television signals.

RCA 203A1 TELEVISION ANTENNA FOR HIGH GAIN ON CHANNELS 7-13

The RCA-203A1 is a "high-frequency" antenna utilizing a folded dipole for both the receptor and reflector. It may be mounted on the same mast with the RCA-225A1 or other similar television antennas to provide a high-gain, 12-channel receiving system. This combination requires only one transmission line and when used with television receivers having a 300-ohm input impedance requires no external transformers or matching stubs.

The 203A1 may be mounted either above or below the RCA-225A1 antenna. For mechanical stability, especially in high winds, the 203A1 should preferably be mounted above the large antenna. Installation is then made as outlined on the instruction sheet.

In cases where the array is to be used for increasing the signal on the high channels, and no reflections are present, each antenna should be oriented toward the station desired. The lines should be connected in phase at the junction (i.e.—the left-hand element of one antenna tied to the left-hand element of the other), if the orientation is not more than 45 degrees apart. If the orientation is greater than this, the connections should be tried both ways to determine the better condition.

In cases where reflections are encountered, mount both antennas on the mast, as above, but connect the transmission line to only one antenna at a time. By rotating the mast, determine the best orientation for each antenna separately, using a station having a suitable frequency. When the antennas are properly oriented, tighten them on the mast so that they will both point in the proper direction when the mast is in place. Then connect the antennas together as described above. If any increase in reflections is noticed, try reversing the connections of the transmission line at the terminal strip. This should be done for both the in-phase and the out-of-phase connection of the antennas to determine the better condition.

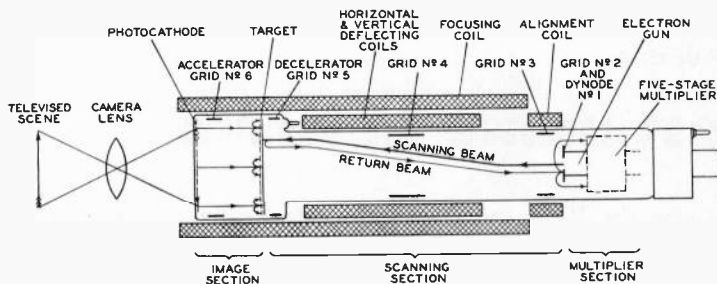

Figure 1.

cessive stage, with an ever-increasing stream of electrons until those emitted from dynode No. 5 are collected by the anode and constitute the current utilized in the output circuit.

The multiplier section amplifies the modulated beam about 500 times. The multiplication so obtained increases the signal-to-noise ratio of the tube and also permits the use of an amplifier with fewer stages. The gain of the multiplier is sufficiently high so that the limiting noise in the use of the tube is the

random noise of the electron beam multiplied by the multiplier stages. This noise is larger than the input noise of the video amplifier.

It can be seen that when the beam moves from a less positive portion on the target to a more positive portion, the signal output voltage across the load resistor (R3 in Fig. 2) changes in the positive direction. Hence, highlights in the scene produce an output signal voltage of positive polarity across the load resistor. As a result, the grid of the first video-amplifier stage swings in the positive direction.

POSTMASTER: If undeliverable for any reason, notify sender, stating reason, on Form 3547, postage for which is guaranteed.

From

TO:

WM. DANDRETA & COMPANY
129 REGENT AVENUE
PROVIDENCE, R. I.
Tel. UNION 2800

RADIO SERVICE NEWS

RCA Radio Service News is published by the RCA Tube Department in the interest of radio servicemen and dealers everywhere. It is distributed free of charge to members of the radio-service fraternity through the courtesy of RCA and its tube, battery, test equipment and parts distributors.



*Push RCA Tubes, Batteries, Parts and Test Equipment
—and watch your business grow!*

Radio's greatest line . . . backed by the greatest name in radio

● RCA and *only* RCA, brings you this preferred line of related products for greater sales volume throughout the year.

You benefit by handling RCA Tubes, Batteries, Test Equipment, Parts and Accessories . . . because you can concentrate your requirements with *one* dependable source of supply . . .

because the RCA monogram on *any* product gives it immediate customer acceptance.

What's more, you'll save time and give greater customer satisfaction using the outstanding new line of laboratory-engineered RCA Test Equipment in your service shop.

See your RCA Distributor today for full details.