

# Amateur Radio

Volume 81  
Number 10  
October 2013  
Price: \$8 Incl GST

[www.wia.org.au](http://www.wia.org.au)



Electromagnetic radiation safety  
Build a modern HV supply  
Australian Fox Hunt Championship



## HB 160 m transmitter

ISSN 0002-6859

10



**The radio... YAESU**

HF/50MHz 100W Transceiver

# FT DX 1200

This medium-price HF Transceiver Excels on all fronts. The High Frequency Design Technology it has inherited, ensures "Best in Class Performance".  
The Outstanding Operability is Perfect for the DX Scene.



Superior triple conversion receiver, and optimum gain distribution at each IF stage will eliminate out of band unwanted signals.

The 1st IF frequency is set at 40 MHz and is protected by selectable 3 kHz, 6 kHz and 15 kHz roofing filters, which effectively attenuate interfering signals.

Similar to the high end series Yaesu transceivers, it uses the 32-bit high speed floating point DSP, TMS320C6727B by Texas Instruments, for its IF DSP. The acclaimed superior Yaesu DSP algorithm is highly effective in weak signal processing and enhancement.

The Full Color, 4.3 inch TFT display on the left side of the front panel, has a wide viewing angle and provides excellent visibility. It beautifully displays the various functions unique to this high class HF transceiver.

An optional built-in FFT-UNIT supports advanced functionality, including the AF-FFT Scope, RTTY/PSK31 Encode/Decode, CW Decode and CW Auto Zero-in.

**YAESU**  
The radio

**YAESU Authorized Dealer in Australia and New Zealand**

**Andrews Communications Systems**  
Shop 8, 41-51 Bathurst Street,  
Greystanes NSW 2145  
URL : [www.andrewscom.com.au](http://www.andrewscom.com.au)  
Tel: +61-2-9636-9060

**Strictly HAM Pty. Ltd.**  
14 Church Street,  
Bayswater Vic. 3153  
URL : [www.strictlyham.com.au](http://www.strictlyham.com.au)  
Tel: +61-3-9729-7656

**GEOPLEX DISTRIBUTION LTD**  
Level 1, 60 Cook Street,  
Auckland 1010, New Zealand  
Tel: +64-21-434342

**YAESU Authorized Service Center in Australia and New Zealand**

**Andrews Communications Systems**  
Shop 8, 41-51 Bathurst Street, Greystanes NSW 2145  
Tel: +61-2-9636-9060. Fax: +61-2-9688-1995  
E-mail: [radioandrews@hotmail.com](mailto:radioandrews@hotmail.com)

**JNB Electronics Pty Ltd**  
St Kilda Rd Towers, Suite 1138, 1 Queens Rd, Melbourne, VIC 3004  
Tel: +61-3-9465-9399, Fax: +61-3-8682-8748  
E-mail: [yaesu@jnb.com.au](mailto:yaesu@jnb.com.au)



The Full Color 4.3 inch TFT display



Spectrum-Scope (Full Screen display)





# Amateur Radio

The Journal of the Wireless Institute of Australia

Volume 81  
Number 10  
October 2013  
ISSN 0002-6859

## Editorial

**Editor**  
Peter Freeman VK3PF  
editor@wia.org.au

**Technical Editor**  
Peter Gibson VK3AZL

**Publications committee**  
Peter Hartfield VK3PH  
Don Jackson VK3DBB  
Evan Jarman VK3ANI  
Bill Roper VK3BR  
Ewen Templeton VK3OW  
Ernie Walls VK3FM

**All circulation matters**  
nationaloffice@wia.org.au

**How to submit material**  
**Secretary**  
AR Publications Committee  
PO Box 2042  
BAYSWATER VIC 3153  
or armag@wia.org.au

**Letters to Editor**  
Editor AR Magazine  
PO Box 273  
Churchill Vic 3842  
or editor@wia.org.au

**Hamads**  
'Hamads'  
PO Box 2042  
BAYSWATER VIC 3153  
hamads@wia.org.au

**Advertising**  
All enquiries to  
Advertising Manager  
AR Publications Committee  
PO Box 2042  
BAYSWATER VIC 3153  
or admanager@wia.org.au

**Registered Office**  
Unit 20 11-13 Havelock Road  
BAYSWATER VIC 3153  
Australia  
Phone: 03 9729 0400  
Fax: 03 9729 7325

**Production Deadlines**  
All articles, columns, hamads and  
advertising booking by **first day of  
previous month.**

The contents of Amateur Radio are Copyright  
Wireless Institute of Australia © 2013

## General

<b>WIA Traveller's Badge</b>	<b>11</b>
<b>VK0JJJ at Mawson Station, Mac Robertson Land, Antarctica</b>	<b>12</b>
Craig Hayhow VK0JJJ	
<b>A sea rescue - amateur radio emergency communications</b>	<b>15</b>
Gary Gibson VK8BN	
<b>Australian Foxhunting Championships 2013</b>	<b>27</b>
Greg Williams VK3VT/VK3FOX	
<b>Epilogue to the High Power Trial: electromagnetic radiation safety and your station</b>	<b>41</b>
Roger Harrison VK2ZRH	
<b>WIA Comment - November 2010</b>	<b>45</b>
Michael Owen VK3KI (SK)	

## Technical

<b>A 160 metre homebrew AM transmitter project</b>	<b>6</b>
Noel Ferguson VK3FI	
<b>A high voltage power supply</b>	<b>17</b>
Date Hughes VK1DSH	

## Columns

ALARA	60
AMSAT	35
Contests	49, 59
DX - News & Views	57
Editorial	2
Hamads	62
Over to You	47, 48, 52
Silent Key	32, 52
SOTA	38
Spotlight On SWLing	49
VHF/UHF - An Expanding World	55
WIA Comment	3
WIA News	4
VK1 News	30
VK2 News	31, 39
VK3 News	32, 33
VK6 News	53
VK7 News	51



*This month's cover*  
The main photo shows the VK7RML repeater site on Mt Lloyd, quite a remote location. See the VK7 News column for an update on this repeater. Photo by Hayden Honeywood VK7HA. Inset photo shows some of the internals of the homebrew 160 m AM transmitter built by Noel Ferguson VK3FI. Photo by Noel Ferguson VK3FI.

## Contributions to Amateur Radio



Amateur Radio is a forum for WIA members' amateur radio experiments, experiences, opinions and news. Manuscripts with drawings and/or photos are welcome and will be considered for publication. Articles attached to email are especially welcome. The

WIA cannot be responsible for loss or damage to any material. Information on house style is available from the Editor.

### Back Issues

Back issues are available directly from the WIA National Office (until stocks are exhausted), at \$8.00 each (including postage within Australia) to members.

### Photostat copies

If back issues are unavailable, photocopies of articles are available to members at \$2.50 each (plus an additional \$2 for each additional issue in which the article appears).

### Disclaimer

The opinions expressed in this publication do not necessarily reflect the official view of the WIA and the WIA cannot be held responsible for incorrect information published.

## Amateur Radio Service

A radiocommunication service for the purpose of self-training, intercommunication and technical investigation carried out by amateurs; that is, by duly authorised persons interested in radio technique solely with a personal aim and without pecuniary interest.

### Wireless Institute of Australia

The world's oldest

National Radio Society, founded 1910.

Representing

*The Australian Amateur Radio Service*

*Member of the International Amateur Radio Union*

#### Registered Office of the WIA

Andersson House

Unit 20, 11-13 Havelock Road

Bayswater, Victoria, 3153

Tel: (03) 9729 0400 Fax (03) 9729 7325

email: [nationaloffice@wia.org.au](mailto:nationaloffice@wia.org.au)

<http://www.wia.org.au>

All mail to

**PO Box 2042 BAYSWATER VIC 3153**

Business hours: 10am – 4pm weekdays

#### National Office staff

*Manager* Mal Brooks VK3FDL  
*Examination Officer* Dianne Ashton VK3FDZ

#### Board of Directors

*President* Phil Wait VK2ASD  
*Vice-President* Chris Platt VK5CP  
*Directors* Bob Bristow VK6POP  
Robert Broomhead VK3DN  
Roger Harrison VK2ZRH  
Ewan McLeod VK4ERM  
Fred Swainston VK3DAC  
*Secretary* David Williams VK3RU  
*Treasurer* John Longayroux VK3PZ

#### Coordinators

*AMSAT* Paul Paradigm VK2TXT  
*ARDF* Jack Bramham VK3WWW  
*Australian ARIGS* Tony Hutchison VK5ZAI  
*Awards* Chris Platt VK5CP  
*Clubs* Ted Thrift VK2ARA  
*Contests* Craig Edwards VK3PDX  
*John Moyle Field Day* Denis Johnstone VK4AE  
*Editor 'AR'* Peter Freeman VK3PF  
*EMC/EMR* Gilbert Hughes VK1GH  
*Standards* Gilbert Hughes VK1GH  
David Wardlaw VK3ADW  
John Bishop VK2ZDI  
John Martin VK3KM  
*NTAC* Peter Wolfenden VK3RV  
*Historian* Peter Wolfenden VK3RV  
*IARU Region 3 Liaison* Chris Platt VK5CP  
*Monitoring Service* Peter Young VK3MV

#### ITU Conference & Study Group

David Wardlaw VK3ADW  
Brett Dawson VK2CBD  
Dale Hughes VK1DSH

#### OSL Curator

*Repeater* National Office  
Peter Mill VK3ZPP  
Richard Cerveny VK2AAH  
*Webpage* Robert Broomhead VK3DN

#### Emergency Communications Group

*Coordinator* Phil Wait VK2ASD  
*Members* Ewan McLeod VK4ERM  
Peter Young VK3MV



## Editorial

Peter Freeman VK3PF

### Fact or Fiction (perhaps Friction)?

I have received one interesting Letter to the Editor (or Over to you, if you prefer) recently.

The OTY item was about the story by Steve Mahony VK5AIM published in the September issue. Readers may recall that I noted that the story was in fact fiction, interlaced with some factual possibilities.

I do not plan to publish the entire OTY item, but most of it is presented here:

*"I am always excited when I receive the latest edition of the WIA journal and proceed almost immediately to flick through as to find any interesting articles.*

*I then tend to read an article of interest in blocks rather than all at once so I can absorb the dialog.*

*I was really pleased to read an article on locating a lost child using amateur radio techniques with APRS attached to a dog.*

*I was relaying this feat of achievement to my wife who also thought that the amateur fraternity has again been very helpful in the event of the rescue and the what must have been frantic parents of the child with the cooperation between the authority's and the amateur operators.*

*Until I got to the end of the article where it said it was **fiction!**"*

The writer then presents his opinion that *Amateur Radio* should publish facts only, not fiction.

I fully acknowledge that everyone has the right to hold and express their opinion. If we had the space, I may even have published the writer's entire contribution.

As Editor, I considered that Steve's article had merit and was worthy of publication. After all, we do mainly publish factual material, but does it hurt to occasionally publish an article which others may find interesting, even if all is not factual? I received no adverse comments from Ernie VK3FM (Secretary of Publications Committee) when I sent the article through for our normal processing and registration on

our tracking system. Similarly, there were no adverse comments from those who undertake the proof reading of the magazine.

In my opinion, such occasional items do have a place in this publication, provided that fiction is identified as such.

I do not intend to cause friction with this informal policy. Of course, readers are welcome to let the Publications Committee know their own thoughts on this question (or any other for that matter) – simply email [armag@wia.org.au](mailto:armag@wia.org.au)

### High power trial decision

In this issue, we have included an update on the ACMA decision to not extend the "High power trial". It seems that the decision has caused some considerable friction in parts of the Australian amateur community, some in the form of OTY items.

I thank Roger Harrison VK2ZRH for preparing the article which explains the current situation.

It seems that many amateurs may not be aware of the details contained in the Apparatus Licence LCD with which we must comply, in addition to complying with the Amateur LCD.

I suspect that we will be publishing some additional articles covering the topic of electromagnetic radiation safety and compliance in coming issues. I know that several clubs have recently, or are planning to, have presentations on this topic. It is an issue of which we must all be aware and we must be able to demonstrate that our amateur station and antennas meet the compliance requirements. Perhaps all of us, if we have not yet done so, should investigate the issues further? There are links to the relevant information available on the WIA website, plus please read the VK2ZRH article in this issue.

Until next month,

Cheers,

Peter VK3PF





## WIA comment

Phil Wait VK2ASD

### One Year On

I can't believe it's now one year since I received that fateful phone call telling me that Michael Owen, VK3KI, had suddenly passed away. My initial reaction can only be described as shock, and a feeling of despair for Michael's family with whom he was obviously very close.

Shortly after came the creeping realisation that I, as WIA Vice-President, was in the hot seat. In fact, I had shortly before told Michael that my work commitments were increasing and after 10 years as a Director it might be time for somebody else to have a go.

Michael, being his usual persuasive self, told me there was absolutely nothing to worry about: "Vice Presidents don't have to do anything much anyway, and I'm not planning on going anywhere". Thanks mate!

So, one year later, I thought it might be useful to recap where we are now, so members can decide what sort of job we have made of it since Michael's passing.

Inevitably, a new leader brings some new directions and a different management style. Early-on it became obvious that nobody could devote the amount of time to the WIA that Michael did, so micro-management definitely was out of the question. Very quickly the Board decided to introduce a system of functional committees comprising the many volunteers who perform the many functional activities of the WIA. That committee system is now mostly up and running, with some committees such as Radio Activities (QSLs, contests, awards etc.), Spectrum (ACMA liaison, technical, repeaters and beacons etc.), and

Publications and Marketing (print media, the website and marketing etc.) being very active. More needs to be done, especially in the area of co-ordination.

One thing I find very encouraging is the number of people who have recently offered their services to the WIA, and also the number of people who stood for election as a WIA Director this year. That is indeed a sign of a vibrant organisation.

One facet of amateur radio that Michael was particularly passionate about is the international work, both through the IARU (of which he was Region 3 Chair) and also the WIA's work with the Australian delegation to the ITU and the Asia-Pacific Telecommunity (the APT). Dale Hughes VK1DSH is very ably continuing that work as Chair of the ITU Working Party which is considering the possibility of a new amateur service frequency allocation at 5 MHz.

Towards the end of Michael's term it was obvious that the WIA needed to cut costs in order to avoid a membership fee increase during a time of economic uncertainty. Membership fee increases are inevitable, but the Board's intent is to explore all avenues of cost savings in the first instance. To this end we introduced the MEMNET cloud-based membership management system (which has saved one part-time staff position) and the Go-to-Meeting teleconference system (which has greatly reduced Directors' travel expenses while allowing monthly on-line Board meetings). Further savings are being made in other

areas, such as the hold-over of the Club Grant Scheme for this year.

Naturally, not everything goes to plan, and this was the case with the Higher Power Trial. The WIA is quite disappointed about the ACMA decision not to proceed with a 1 kW peak power limit for Australian advanced radio amateurs, which would bring them in line with many other Western nations. But putting aside some obvious concerns about the conduct of the trial, we do accept the reality that we need to promote a greater degree of EMR awareness amongst amateur licensees.

The next year is going to be very much about further strengthening the WIA committee system, continuing the international work, and promoting EMR awareness and compliance in preparation for another go at the higher power limit.

So, would Michael be pleased? Maybe – lawyers are never 100% happy with anything, but I'm sure he would think we haven't done too badly.

**Phil Wait VK2ASD**

*President, WIA*

*PS. Dale Hughes VK1DSH has asked for as many written comments as possible about the potential benefits to amateur radio from a new 5 MHz frequency allocation. Please send your comments to the WIA as soon as possible, and let's not have a repeat of the situation with the higher power trial when only a very small number of responses were received.*



## WIA announces new publicity drive

The activity of amateur radio is mostly unknown to the general public who are often surprised it actually survives in this internet, mobile phone and digital age. The possibilities for young people through amateur radio are enormous for the tech savvy among them who want to explore and learn.

The older generation may have a stereotypical view remembered by having a neighbour in his shack or from a portrayal in a movie scene. British comedian Tony Hancock and his famous Half Hour, "The Radio Ham?", continues to repeat the old but is far removed from modern amateur radio.

Most other activities seek to be part of the community, so they are better understood and recognised. So should amateur radio, particularly since it is now easily accessed and enjoyed.

The Wireless Institute of Australia (WIA) considers promotion of the hobby to be very worthwhile with plenty of discussion on the topic by the WIA Directors. The WIA has announced the PR4AmateurRadio Expo, to be held on April 11-13, 2014, which will concentrate the publicity effort and harness the involvement of its affiliates.

Now is the time for all to start and think how to be involved with the PR4AmateurRadio Expo. Those taking part need to commit up to 12 hours on that weekend. More detail will be available in due course.

## Further good promotion for amateur radio

Looking for a media hook to leverage some publicity for amateur radio has been effectively used by the revived Armidale and District Amateur Radio Club, located half-way between Sydney and Brisbane.

In the Armidale Express newspaper it honours the hard work done by Roger Chubb VK2FGE in trying to get the club going again. He sadly became a silent key in May. President Rick Rodgers VK4HF saw a few people at the funeral and they decided to get the club going and dedicate it to Roger Chubb.

Three months later the WIA affiliated Northern Tablelands of New South Wales club has installed its VK2RAD VHF and UHF repeaters to keep the area in contact locally and the further afield Echolink. The repeaters provide a useful link for travellers using the New England Highway from Guyra to Uralla. Rick VK4HF and his team have some bigger plans including a possible digital television facility and classes with its two WIA assessors.

## 4th APT (Asia Pacific Telecommunity) Workshop on Disaster Management & Communications

Chairman of IARU Region 3 Mr Gopal Madhavan VU2GMN, along with Ramon Anquilan DU1UGZ of PARA (Philippines Amateur Radio Association) attended and delivered a presentation to the 4th APT (Asia Pacific Telecommunity) Workshop on Disaster Management & Communications in Pasay City, Philippines on 23-25 July.

Many questions were asked of the presenters and informed responses provided.

The APT appreciated the high quality of the presentation on Amateur Radio Emergency Communications and acknowledged the presentation was very well received by the delegates and added good value to the content of the workshop.

APT further requested the continued support and expertise of the amateur radio community, through the IARU R3 in future APT work programmes.

The Workshop was sponsored by the Department of Science and Technology and the presence of the IARU was specially mentioned during the opening ceremony. The ITU were also present at the Conference.

There were a variety of presentations covering topics such as forecasting impending disasters, warning systems using SMS to mobiles etc.

IARU Region 3 appreciated the opportunity to contribute to the further understanding of the wider community, the role that amateur radio can play in providing communications during major disruptions to citizens, in times of disasters.

## New frequencies for wireless microphones

Radio clubs are advised that a large number of wireless radio microphones currently operating under a Class Licence using frequencies between the analogue TV broadcasting channels (520-820 MHz), will soon become illegal as the analogue TV frequencies are phased out this year.

An estimated 150,000 wireless radio microphones in use by churches, schools, entertainment venues, fitness instructors, tourism operators and community groups will be affected.

Now is the time for radio clubs and others to check their equipment because 694 MHz to 820 MHz will be withdrawn to provide the so-called "digital dividend" of spectrum made possible with an end of analogue TV in Australia.

Those radio clubs who own wireless microphones used for presentations are encouraged by the WIA to check the operating frequency of their equipment to ensure it remains compliant with the upcoming frequency re-allocation.

For more information check with your supplier or the ACMA website.



# The Ultimate in Portable Antenna



Dipoles, Slopers, Vees, Verticals or 'you name it' are just some of the antenna configurations possible with **Buddipole** components.

#### A Buddistick contains the following:

- 2 x 280 mm Anodized aluminium arms
- 1 x Stainless steel telescopic whip
- 1 x Multiband loading coil and coil clips
- 1 x 9.5 m radial wire on line winder
- 1 Mounting plate with SO239 adapter
- 1 x Compartmentalized portfolio bag
- 1 x Operating manual

#### The Buddistick deluxe kit also includes:

- 1 x Vertical antenna clamp
- 1 x Additional stainless steel whip

#### A basic Buddipole kit contains the following:

- 1 x VersaTee center section
- 2 x Stainless steel telescopic whips
- 2 x 560 mm Anodized aluminium arms
- 2 x Multiband loading coils and coil clips
- 1 x 7.6 m coaxial feed line with choke balun
- 1 x Black thermoplastic carrying case
- 1 x Operating manual

#### The Buddipole deluxe kit also includes:

- 1 x Portable 2.4 m mast and base tripod
- 1 x Rotating arm kit- change configurations
- 3 x Extra coil clips
- 1 x Additional telescopic whip
- 1 x Antenna system bag – padded nylon with shoulder strap
- 10 page modeling report

#### Accessories

Long (5.48 m) telescopic mast, Low band coils and extended whips, Shock cord whips and Shock cord masts, Light weight mini coils, Knurled whip protection sleeves, Switchable 1:1 2:1 4:1 baluns, Capacity hats.

**All Buddipole components are available for purchase as individual parts.**



Supplied by



tts systems

Phone 03 59774808

Fax 03 59774801

Email [info@ttssystems.com.au](mailto:info@ttssystems.com.au)

Visit us on: [www.ttssystems.com.au](http://www.ttssystems.com.au)

# A 160 metre homebrew AM transmitter project

Noel Ferguson VK3FI - vk3fi@wia.org.au

This project came from a challenge made by the then Sunraysia Radio Group's President, Garry VK3KYF. Garry's idea was along the lines, 'Let's build an AM 160 metre transmitter using valves'. The idea was to try and stimulate club interest in homebrew and also the 160 metre band.

Having been 'trapped into this project', I then managed to add a couple of extra thoughts. Great idea for a project KYF, but let's try and use what we have in our junk box, and along the way hopefully we will revise some basic theory.

I also have an old Kingsley AR7 gathering dust that I hope to use when and if we get a 160 AM net operational in the Mildura area. So the project was up and running.

I should say that these notes are not intended to be a step by step construction article, but rather a series of comments on how we have gone about the project using 'on hand' components where possible. Notes will cover thoughts on circuits, construction, setting up, testing and actual on air results.

So where do we start on such a project? I was particularly keen to use good old plate and screen modulation having visited clamp and screen modulation in the past, and from that experience I also knew some of the advantages and, I might say more to the point, many of the problems when using those methods of generating AM.

Fishing around in my junk box, well, storeroom, I came across an old Pye AM base station. Possibly from a taxi or similar system and I think it operated somewhere in the 70 MHz range. The chassis was covered in dust and grime and it had a couple of wasp's nests attached, but the power and

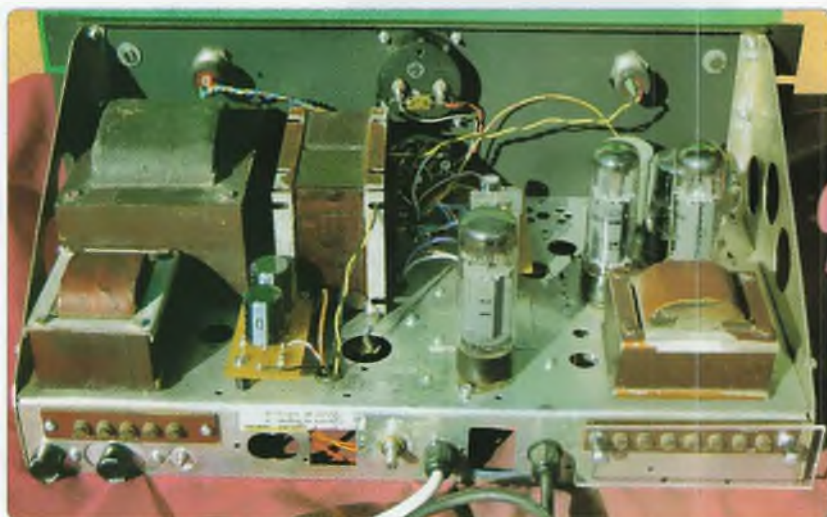

Photo 1: The power supply and modulator chassis from the inside.

modulation transformers looked like they would clean up and be ideal for the job. From memory I think that Vinten and maybe other companies produced similar units.

I was unable to turn up any Pye AM base circuits on the internet, but I did find a couple of photographs and comments on what I believed to be the same model. From that information, and inspection of the transmitter it appeared to have used a pair of 6V6 valves in the modulator, and something like an 832 in the RF output stage. On that basis I felt that the transformers would be more than capable of running the twenty to twenty five watts carrier output power that I was aiming for.

The original transmitter also had a separate filament transformer, with two windings, and a rather hefty filter choke and the modulation transformer. All very useful.

Inspection of the under chassis wiring indicated that the main HT was dropped by wire wound resistors to feed the low level



Photo 2: The power supply and modulator chassis showing the front view.



stages. I wasn't keen on that idea and so the main power transformer was set up on the bench to check the open circuit voltage and then design a new power supply circuit. For those who have only worked with semiconductors, and I should add those of us who are showing a 'few turns on the coil', remember that with 240 volts AC floating about, and the secondary voltage on transformers that may be up to a thousand volts plus, safety first.

And another trap, if you are dismantling older equipment a couple of minutes checking and making notes on the 'as wired' connections might well save a lot of time later.

In my case I simply cut all the wiring, stripped the transformers off the chassis, only to find that the power and filament transformers had double primary windings with multiple taps. Not difficult to sort out using the multimeter, but it could have been a disaster if I had connected the 240 volt mains across the 110 volt winding.

The power transformer had a centre tapped secondary winding, with a measured open circuit voltage of 550 either side of centre. Obviously a bridge rectifier across the full winding was out of the question, so a full wave rectifier with centre tapped transmitter switching would have to be used.

Now, the first of three concessions to modern technology in this project was the use of silicon diode rectifiers. Why? To save space and, more importantly, for the constant voltage drop across those devices. And that would also leave the second winding on the filament transformer available, but more on that shortly. A few quick calculations showed that at least two 1N4007 diodes would be required in each leg. Remember PIV? Equalizing resistors together with capacitors would also be installed across each diode as per normal practice.

A HT mock up using choke input and a single filter capacitor into a 2800  $\Omega$  load resulted in an output voltage of 465 V DC. And where to find a test load? Two forty watt, 240 volt globes operating in series calculates out to approximately 2800  $\Omega$ .

The use of silicon diodes in the power supply introduces the problem of a surge current when switching to transmit. So a surge control circuit using a wire wound resistor and capacitor combination, with relay switching to step the voltage to about 370 V then to full voltage in about half a second on transmit was incorporated. Contacts on that relay were also available for receiver switching.

My requirement was for both local PTT (microphone) and remote control (with audio line input), so a 12 volt PTT supply was needed. That control power supply and the AR7 speaker were fitted into a separate panel in the rack cabinet.

If you intend to later use a linear amplifier, a sequence control system should also be considered.

I've made mention of not being enthused about dropping the main HT through resistors to supply the

## Electronics Enthusiasts ONE-STOP-SHOP

**Jaycar**  
Electronics  
Better. More Technical.

### 10MHz Handheld Pocket Oscilloscope

A complete portable oscilloscope! Aside from standard scope features, it has nifty tools for measurement of RMS speaker power, display hold function, and memory storage for 2 signals. Housed in a durable rubber surround with backlit LCD display and inbuilt Ni-MH battery. See our website or in-store for full specifications.

Quote **AMATEUR RADIO OFFER** "AA-0036" to get \$20 discount!

- CRO probe and USB charge cable supplied
- 10MHz, rechargeable
- Size: 114(H) x 74(W) x 29(D)mm

QC-1914 Was \$249

Note: PCB not included

\$229

SAVE \$20



### Cable Tester

Simply plug the cable under test and turn the rotary switch. The LEDs gives an instant go/no-go status of each conductor path in the cable. With bullet-proof all-metal construction, it's ideally suited to harsh environments. Suitable for any technician working with cables.

- Requires 1 x 9V battery
- Size: 190(L) x 98(W) x 35(H)mm

AA-0405

\$49.95



### Mini Tap & Die Set

This 31 piece set is for the ultra small screws found in electronics. Consists of 9 metric screw cutting dies and 18 equivalent taps in the same sizes but with a taper and a plug version of the tap. Supplied in a see-through plastic case.

- Size: 83(W) x 153(L) x 12(D)mm

TD-2443

\$59.95

NEW 2013



### 22 Piece Long Bit Screwdriver Set

Tackle a wide range of fastening scenarios using our compact screwdriver set comprised of a selection of popular slotted, Phillips, Star and TRI bits. Packed away neatly inside a handy storage case. See website for contents.

- Size: 105(W) x 145(H) x 30(D)mm

TD-2114

\$29.95

### 4 Tray Tool/Storage Case

Each compartment has a 233 x 122 x 32mm 13 compartment storage box for small items with dividers that can be removed to accommodate larger things. All the hinges and catches are the durable pintle type and the top tray has a generous 265 x 160 x 65 space for ancillary items.

- Size: 270(W) x 260(H) x 150(D)mm

HB-6302

\$16.95



Prices valid until 31st October 2013

Phone Orders 1800 022 888  
[www.jaycar.com.au](http://www.jaycar.com.au)

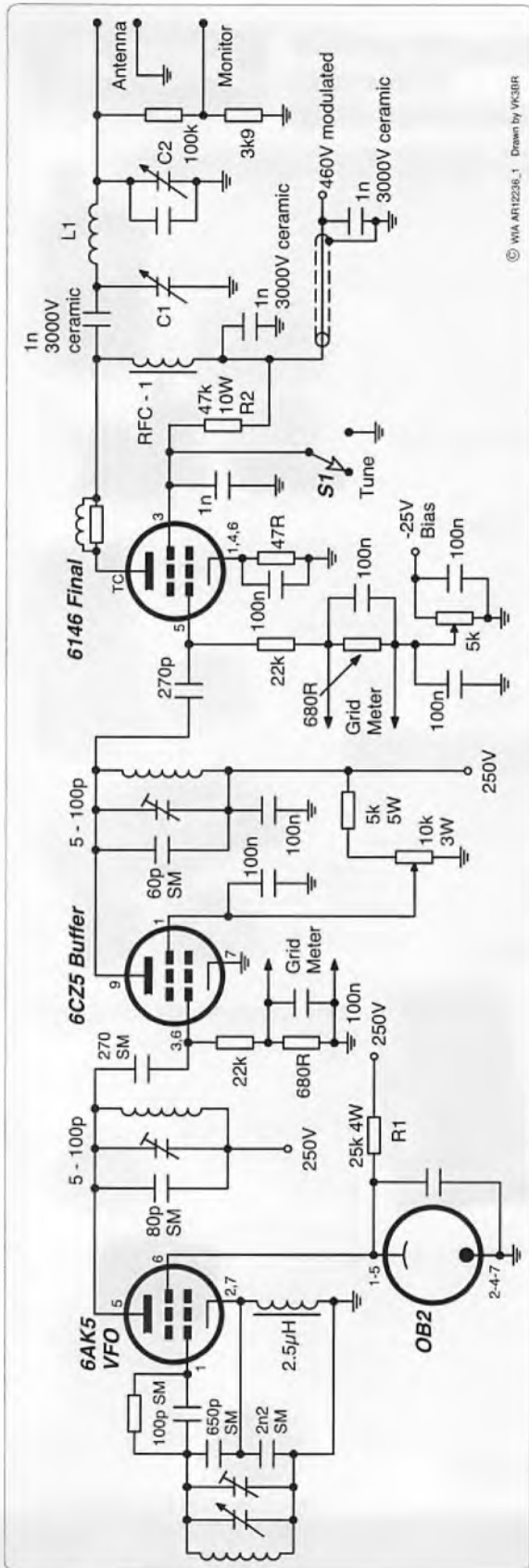

Figure 1: The circuit diagram.

low level stages so I thought why not use a series regulator circuit with the advantage of a set regulated voltage for the low level stages. I had recently wrecked an old modulation monitor, and the power supply used a fairly standard series regulator circuit. The circuit was borrowed but as the original tube was damaged I substituted an 'on hand' 6CA7.

A mock-up on the bench resulted in a very stable output of 250 volts, with the adjustment potentiometer almost centred.

This is where the spare filament winding was used, as the series regulator circuit required the filament supply to be above earth.

Now decision time! What tubes to use in the modulator? Looking through my collection I found a few 6V6 tubes. However a quick test showed they were very low in emission, in fact not even good enough for the audio output in the AR7. Again 6CA7 were finally decided upon as they were generally available and would be OK with the power supply voltage. Some consideration was given to modulator output impedance and matching to the final RF output stage as the available modulation transformer secondary did not have taps. The final thought was that the DC input to the RF final could be adjusted if necessary to trim the matching. The overall line up of the modulator was conventional, 6CA7 output, 6SN7 phase splitter with a 12AX7 as preamp, driver. Some modifications may be done in the preamp stage when time permits as its common for the first triode of a 12AX7 used as a preamp to drive the second stage into clipping if the levels are not carefully set up. Another future addition to the modulator would be negative feedback.

A good old 807 was the preference for the RF final, but just wasn't practical as the plan was to use a standard 4U rack cabinet, so finally a 6146 was chosen. Driver tubes were a problem with nothing much in my collection. KYF suggested several vertical TV output tubes and I decided to try the 6CZ5, because it had the lowest filament power requirements.

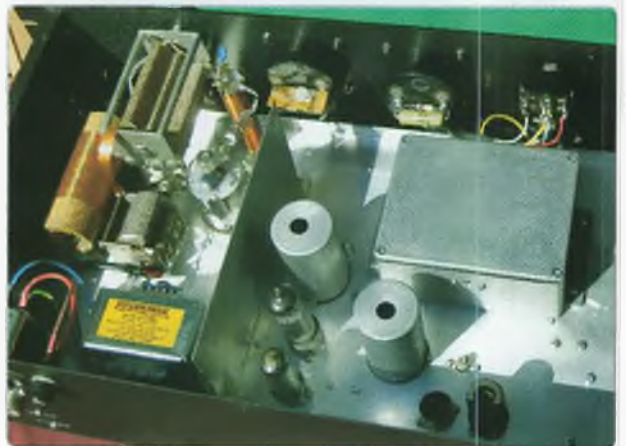

Photo 3: A view of the various components of the RF chassis.



So the RF line up consists of a Colpitts VFO (6AK5), buffer (6CZ5), and the 6146 final, with Pi coupling output. Stability of the three stages was obtained by the combination of capacity coupling and next stage grid resistor providing damping across tuned circuits. The result was 100% stability.

Having decided on the valve line up it had become obvious that the complete transmitter, power supply and modulator would not fit on the original chassis. So the metal work would consist of the original base station chassis for the power supplies and modulator with a rack cabinet to house the RF deck.

Just enough terminations on the rear of the original chassis and a Jones plug/socket for the RF deck made interconnection easy and effective. The only extra was to fit a Perspex cover over the otherwise open connections on the modulator and power supply.

There were plenty of mounting holes on the old chassis for both



Photo 4: The RF chassis front panel.

valve sockets and transformers. But it was a bit of a culture shock after using PCB for years to go back to 'point to point' wiring. However the second concession to modern technology was the use of homebrew PCBs to mount power supply diodes, electrolytics and relays. This approach certainly saved space and made construction easier.

So to the Pi-coupler components. Well, there are

a couple of ways to go about obtaining values – for example all the formulas are available in handbooks such as the ARRL, RSGB and the like. But this time around I decided to go a different direction to find the values. I had previously constructed a noise bridge, as per Lou Destefano's VK3AQZ kit. So why not use the bridge, set at 50  $\Omega$ , zero reactance – connected at the output of the

# TET-EMTRON

Kits!  
Kits!  
Kits!



- Everything you need to make a complete balun in either hanging, beam or portable styles. Excludes Glue and solder
- 1:1, 4:1 and higher ratios. Balun or UnUn
- All the standard high quality TET parts you expect including stainless hardware, gold pin and Bakelite connectors.
- Can be tailored to your needs.
- Full instructions, or use your own design.
- Different ferrites available for different frequencies up to 60 MHz
- Separate parts also available.

**TET-Emtron**  
47 Ocean Drive,  
PORT DENISON,  
W.A 6525  
08 9927 1872  
See our wide range of new parts and  
products at:-  
[www.tetemtron.com.au](http://www.tetemtron.com.au)



**More and more Kits coming  
every month!!!**

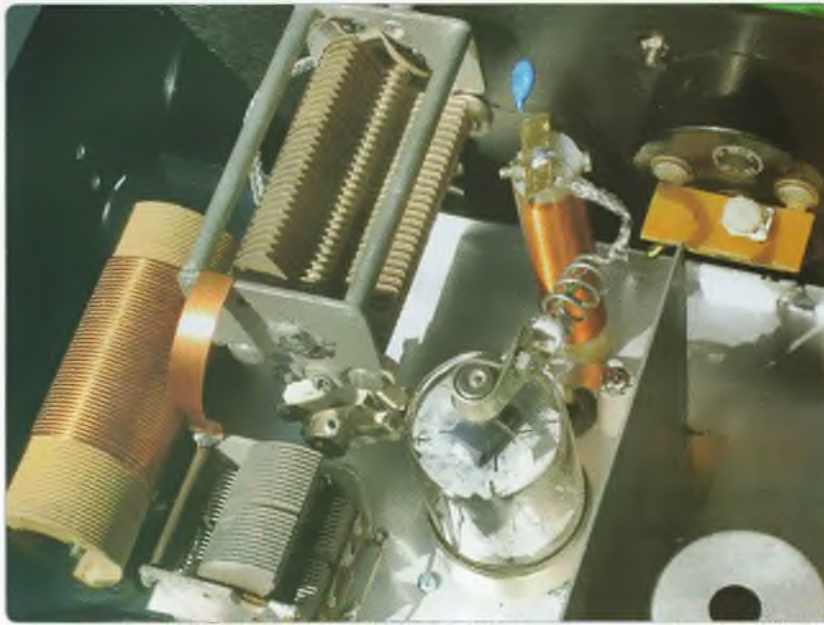

Photo 5: A close up view of the RF chassis.

Pi-coupler, and a resistor equal to the expected plate impedance across the input and then adjust the coupler components for a match? A bench hook-up and a few minutes fiddling, and hooray, a perfect match as indicated on the noise bridge. While this approach does not take Q into account, a nice sharp (unloaded) plate dip and the efficiency of the final will later tell the story.

Now to the RF final stage high tension choke. I dug out what I thought would be a suitable former, and wound on approximately 67 mm length of 0.3 mm diameter ECW. And then out with the 'old' GDO for a couple of basic tests.

First test was to check if the choke had any undesirable resonance in or near 160. All was OK with the inductor both open circuit and shorted.

Next was an estimation of the inductive reactance. Easy if you have an inductance meter, but it may also be done the old way, again using the GDO, find the resonant frequency with a known capacitor, then calculate the inductance and then inductive reactance at 160 metres. Remember formulas for

resonant frequency and inductive reactance?

It can be seen that the aim is to end up with an inductive reactance several times the plate impedance and without any resonance in or near the operating frequency. Photo 5 shows the final RF output stage. Note the third concession being new capacitors.

Now to the grid drive requirements for the final amplifier. Class C theory requires that the RF output tube be biased to one and a half times cut-off. Checks of the various handbooks and circuits suggested that a grid voltage of some minus eighty volts was required for the 6146 at the intended operating voltages. Given the selected grid resistor and a safety voltage of negative twenty five, all that equated to a grid current of three milliamps.

So far, so good! But the next requirement was metering. The old Pye base station was fitted with a usable scaled meter and suitable switching and could be re-arranged to monitor the various power supply voltages. Calculation of the meter multipliers is easy enough if you know the moving coil

meter characteristics, but don't be tempted to try and measure the meter resistance with an analogue ohmmeter. Current through the probes on low ohms range can be several hundred milliamps. Again it's back to basics, set up the selected meter on the bench with a battery and a potentiometer in series (or a very low voltage power supply) and adjust the pot for full scale meter reading. Then connect a second pot in parallel across the meter and adjust so the meter reading drops to half scale. The meter resistance will then equal the resistance of the parallel pot. Of course if you have a digital multimeter the resistance may be safely measured directly.

And a multimeter, on a suitable range, in series with the meter under test will show the FSD current if it's not known.

Knowing the meter characteristics, it's now easy using ohms law to calculate the multiplier values. In my case I set up the meter and switching combination for a FSD of 500 volts (main HT), 250 volts (regulated HT), and minus 25 volts for fixed bias checking. Dedicated meters were fitted on the RF deck for final grid and anode current measurement.

And the final plate current metering required a different approach as I didn't want to have high voltage on the actual front panel meter. A low value, carefully bypassed resistor was inserted into the cathode of the final and the voltage drop used to indicate plate (and screen) current. Meter circuits may be pre calibrated on the bench, again using a combination of a low voltage supply and a pot - in series with a standard multimeter.

So it's finally on to 'air tests'. Audio quality on the microphone was reasonable but not brilliant, mainly due to the old CB type hand microphone used. But results with 'line in' from the main shack mixer were more than acceptable - maybe the only critical comment being a small amount of hum, measured at 1 % - and easily fixed with



some additional power supply filter capacitors.

Now to the on-air report. With about 25 watts of carrier into a full size 160 metre inverted vee VK3KYF reported reasonable reception on a portable transistor radio.

While no real field strength tests were done, that report indicated good ground wave signal covering most of the Sunraysia (Mildura) district as the KYF QTH is located approximately ten kilometres west of Mildura and my QTH is about seven kilometres east. And that was despite the less than desirable antenna for ground wave working. That is, a vertical would be expected to have better ground wave coverage than the inverted V on 160 metres.

While 'out of town' contacts have not been chased, a brief but effective first contact was had with VK5ACY who at the time was operating out of Mannum in VK5.

Overall, a satisfying project is up and running. But now it's on to the next project, a Class E transmitter. And I look forward to comparing the construction and on air performance of the two transmitters.

### Transmitter circuit notes

#### Pi-coupler components

L1 tank coil	35 mm diameter ceramic former. 1.2 mm ECW, 50 mm winding length.
RFC final choke former	Plastic rod, approximately 17 mm diameter. 0.3 mm ECW close wound, 67 mm length.
C1 plate tune	230 pF wide spaced.
C2 loading	570 pF (two gang cap) and 750 pF 500 V SM in parallel.
Note: Capacity shown for C1 and C2, transmitter tuned and loaded to 25 watts output.	
R1 voltage regulator dropping resistor	4 x 100 one watt resistors.
R2 6146 screen dropping resistor	10 x 4.7 kΩ one watt resistors.



## WIA Traveller's Badge



WIA members who are fond of travelling and wish to be recognised by fellow amateur radio operators in Australia and abroad, now have a handsome badge in the green and gold of Australia, produced by the WIA, which will provide that recognition.

Its familiar shape of a diamond incorporating antenna and earth symbols will be recognised by fellow amateurs around the world.

We are grateful to Geoff VK4MGB for initiating its production. He had thought that while travelling he must have been, at times, in company with fellow amateurs, but, like ships passing in the night, there was no recognition of the common interest.

Geoff contacted the WIA in February 2011 requesting that such a badge be produced and subsequent to that, at the May 2011 Conference in Darwin, it was agreed to organise for the badge to be designed and produced. Eventually, a competition was held to design a badge, and the accompanying photo shows the badge that evolved from that competition.

Congratulations to Murray de Plater VK1MDP for submitting the winning design.

The badge can be ordered from the WIA office or via the WIA website at [www.wia.org.au/members/bookshop/about/](http://www.wia.org.au/members/bookshop/about/) under the "Merchandise" heading. The price is \$10 plus postage and packaging.



# VK0JJJ at Mawson Station, Mac Robertson Land, Antarctica

Craig Hayhow VK0JJJ

I arrived at Mawson on 5 February, 2013 as an expeditioner on the 66th Australian National Antarctic Research Expedition (ANARE). Since my arrival I have been extremely busy in my spare time erecting antennas and pulling cables before the weather gets too bad.

I will be wintering at Mawson Station for approximately twelve months, then returning to Australia around February, 2014. My usual call is VK6JJJ and my QTH is Perth.

I am active on all bands from 160 m to 6 m and operating modes include SSB, phone, CW, digital modes, satellite and six metre EME.

My first priority when I got to Mawson was to locate all my personal belongings and radio equipment.



Photo 1: The VK0JJJ QSL card.



Lucky it was all there and undamaged. Then I turned my focus to installing a six metre propagation beacon to monitor any openings. Unfortunately it was just too late in the season for any activity so I will have to wait till next summer for the chance of a rare contact back to VK.

I installed the beacon on the highest point at Mawson and it's using two M2HO

loops with an EIRP of 280 watts, the frequency is 50.300 MHz and the call sign is VK0RTM. The transceiver is forced air cooled for long life and I can tell you, installing the antennas up the tower with a -15°C temperature and 40 knot wind was hard work.

My next priority was to find a suitable operating location and an antenna for HF operation. I decided to set up my equipment in the old transmitter building, circa 1960s. Unfortunately this building is one of the furthest from the accommodation building but it was convenient in many other ways. The building was freezing cold and I had to seal up all the windows and add a couple of heaters to melt all the ice out of the walls to make it cosy and habitable as a radio shack. Within days there were icicles all around the building as the ice slowly melted out.

Once I got all my equipment set up in the shack, I then had to

Photo 2: The six metre beacon antenna.



manufacture all the interconnection cables and then the earthing between all the equipment. An internet cable, antenna switches and finally a power supply were all added. As my transceiver is a Flex 5000A, I also had to install a PC with many different software applications that also had to be set up to talk to each other, so many late nights were spent in the new radio shack sorting things out.

Next was the HF antenna. I tried a sloping terminated triangle in various directions until I decided on the fixed position which just happens to be 58 degrees. This antenna is 19 metres high with the long sides 100 metres in length and the short side 80 metres. It is installed over rock only about five metres above sea level, and which is now covered in ice. The antenna is fed with 50 ohm cable to a balun at the base of the tower and then 600 ohm feeder to the antenna. I feed it with a kW and it really puts out a good signal. The noise floor sits around -40 dB here, so when conditions are good I can hear portable stations on the other side of the world with ease.

This antenna will actually load up well from 160 metres to 10 metres but I only use it for 40



Photo 3: The Mawson shack.

metres to 10 metres. Now that I had a good antenna, I took my attention to an old 34 metre vertical that used to be a conical monopole in another life. I installed about 14 ground radials including a large surface area sea water connection. This antenna was intended primarily for use on 160 metres, but also for 80 and 40 as well. I organised a couple of 160 metre skeds into VK4 and ZL without any luck but caused pile

ups in Europe, so I figured it was radiating well.

Finally I had to get a six metre antenna up and ready for a possible rare contact into VK or ZS late in the year. This posed quite a problem as I had to be able to remove or lower the antenna while not in use as a blizzard would destroy the antenna within hours, left to the elements (No pun intended). I brought with me a M2 6M5XHP and a portable mast with the idea to quickly raise the mast and antenna as required and leave it securely down when not in use. Unfortunately the mast I bought online was junk and not acceptable for this environment so I had to come up with a new idea.

I ended up placing a six metre length of heavy wall steel pipe into a 200 litre (44 gallon) drum strategically placed in the lee of the radio shack for wind protection. In the drum I placed very large rocks, followed by smaller rocks, then gravel and finally water that froze and bonded it all together and glued the drum to the ground. The mast has a rope and pulley which I can use to raise and lower the antenna within seconds and the antenna uses an arm strong rotator with a rope at either end for anchoring

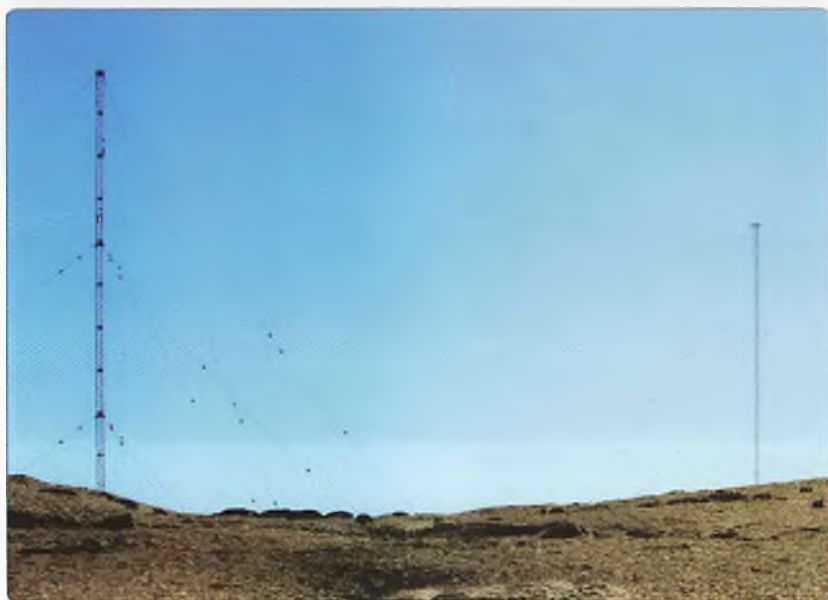

Photo 4: The triangle and mono.



Photo 5: The moon bounce antenna.

into the ice to keep it in position in anything less than 40 knot wind.

The system works very well and I installed a pre amp onto the antenna boom and then got to work building a home brew six metre 500 watt linear amplifier. Once complete, I let the EME big guns know I was ready to try and by my third ever attempt at EME I had the following three calls in the log – G8BCG, SM7FJE and SM7AED, so I figured it was radiating well. Last weekend I replaced the RG213 feed line with LDF550 so I expect much improved results.

To get this far has taken me three months and much hard work and frozen fingers but I can now sit back in comfort and enjoy the pile ups and the excitement of an EME contact. I really enjoy giving people a real surprise when I answer their CQ and they discover where I'm located. It is also very enjoyable to spend a Sunday holed up in

the shack when outside there is a raging 200 km/h blizzard shaking the building.

I do enjoy the more difficult bands and giving out rare contacts

such as 160 metres and EME and also I enjoy 10 metres and activating the WARC bands. Twenty metres is my favourite band but it seems too easy from here. It has been a fantastic opportunity for me to be able to operate amateur radio here in Antarctica but I also see it as a great opportunity to give something back to the hobby that has given me so much enjoyment over the years.

If you see me on the Logger or hear me in a pile up give me a call. I try to make myself available for skeds where possible but just remember I am here to work and at the moment the sea has frozen for hundreds of kilometres and the daily temperature is around -20°C. We are down to about six hours of sunlight a day and we are experiencing raging 200 km/h blizzards regularly which makes it a challenge just getting to the shack at times.

For further details including information on my QSL manager please look up my QRZ.com page. 73 from Craig VK0JJJ.



Photo 6: Mawson Station, Antarctica.

Attend

**Rosebud RadioFest 2013 (SPARC)**

**24 November**



# A sea rescue - amateur radio emergency communications

Gary Gibson VK8BN

In July 2012 Mike Hall VK8MH took part in the Sail Timor Leste boat rally on board his highly modified Triton 24 Colleen, along with his crew, brothers Gary and Geoff and his daughter Kylee.

Mike arranged for skeds on 40 metres at 0730 and 1600 daily for the duration of the voyage, which he estimated would be about a month. Conditions were good with signals usually strength 9 or more into Darwin. The radio on board was a Barrett 950 marine radio with several amateur frequencies programmed.

Mike also carried on board a Spot Tracker, a great little device that sends signals via satellite giving his GPS position about every 10 minutes, via a web interface, and those interested in his progress were able to keep track of Colleen's progress in real time.

On 16th July, several days out of Darwin on the 0730 sked Mike reported all was well with moderate to rough seas and nothing of any great interest to report. At about 1100 Darwin time I noticed that Colleen's progress had come to a halt and from the position reports from the Spot Tracker they appeared to be drifting in a north easterly direction. As the day wore on it was obvious that Colleen was not making much progress but I would be able to find out what the situation was at 1600.

The 1600 sked revealed that in the rough seas two stainless steel bolts that connect the steering to the rudder stock had sheared leaving Colleen with no steering. Mike asked me to contact the rally committee and see if there were any other vessels in the vicinity that may be able to help.



Photo 1: Colleen, shown here safely back at anchor in Darwin.

I could not find any phone information for the rally organizers so I rang the Darwin Sailing Club and at the same time I sent this email:

To: [mail@sailtimorleste.org](mailto:mail@sailtimorleste.org)

Subject: Colleen In trouble

Mike Hall on Colleen is in contact with me via HF radio and has reported loss of steering in rough seas.

He would be able to restore steering but requires 2 x 3 1/2" bolts and the means to drill two 3/8 holes in 1/4 inch stainless plate. Mike asked if it would be possible to contact other boats in the area that could possibly supply the items above. Colleen's position at 16:00 was -9 degrees 41 minutes south, 128 degrees 42minutes east.

Regards Gary Gibson

I received this reply:

From: [mail@sailtimorleste.org](mailto:mail@sailtimorleste.org)

Sent: Monday, July 16, 2012 4:32 PM

To: Gary

Subject: Re: Colleen In trouble  
Gary

We have received Colleen's message and advised:

1. RCC in Canberra
2. The comms support vessel in the fleet that is running the HF sched.

We are waiting to hear back from him, and based on this feedback, will then start contacting yachts in the fleet by sat phone.

Regards

XXXX



Photo 2: Showing the slightly bent rail on Colleen after the rescue package 'collided' with it.

A few minutes later I received a phone call from the Rescue Coordination Centre (RCC) in Canberra. I was advised that if I could deliver the equipment required to the Darwin Airport quickly, a RCC Dornier aircraft was ready and waiting to deliver the equipment to Colleen, however I would have to hurry as the drop needed to occur before last light.

As luck has it I live only about five minutes from the airport and the local Bunning's hardware shop is also adjacent to the airport.

I made a hasty phone call to one of Mike's family and arranged for him to meet me at the airport with a

charged battery drill, while I dashed to Bunning's and bought the bolts and drill bit.

We met the Dornier crew and handed over the equipment.

We were also lucky enough to have another amateur in the fleet, another Mike VK2HSR.

He sent this message at 0959 GMT.

*Subject: Colleen Air Drop Successful*

*Date: Mon, 16 Jul 2012 09:59:00 -0000*

*From: VK2HSR@XXXXXX*

*To: mail@sailtimorleste.org*

*Hi guys,*

*I just spoke with Colleen on HF after monitoring the Dornier on ch 16 during their adventures. Colleen advises the package landed ON THE DECK! That's gotta run well in the press. The drop was carried out pretty much at last light.*

*Colleen is unpacking the materials and will get to work on repairing their steering.*

*I broadcast a message to the fleet on VHF so everyone knows Colleen's status.*

*Cheers,*

*Mike.*

The crew of Colleen was able to make the repair and successfully completed their voyage to Dili in Timor Leste and spent the following few weeks cruising to Kupang and back to Darwin.

The RCC Dornier crew is the real hero in this story, to drop a container from an aircraft at 130 knots to the deck of a small vessel is very impressive.

The package was attached to about 50 metres of rope with a small parachute on the end. The package was supposed to go over the boat leaving the rope across the deck for Colleen's crew to retrieve.

The package actually hit the side rail and landed on the deck.

Mike has a slightly bent rail that he intends to leave bent as a memento; he's not complaining.

I should point out that while amateur radio played a great role in this event the rally organizers also had regular HF skeds and Colleen would have been able to arrange for assistance using the rally official channels. In this particular emergency without amateur radio and willing friends the airdrop would not have been possible until the following day. With Colleen being tossed about and not under way some of Mike's crew were already suffering from sea sickness; another night would have had to have been endured before any possible rescue could be effected.

All in all this is a good news story for ham radio and I am sure Mike will arrange for amateur skeds on his next voyage.



## Erratum Winter VHF/UHF Field Day Results

For some reason VK5ZT Tim Dixon got credit for second place for Section F: Rover Station in the Winter Field Day results on page 61 of September 2013 AR.

On this year's event, David VK5KK was designated rover. He gave up his nice sheltered winter operating spot in the Adelaide Hills and drove 800 km through wind, rain, hail, more wind, 4WDing in mud (fun) and still got beaten by those VK2s! The very next day he flew out to Friedrichshafen!

Second place should be David Minchin VK5KK as per the Winter 2013 results from WIA website.



# A high voltage power supply

Dale Hughes VK1DSH

I was recently given a number of transmitting valves by a local amateur who is very enthusiastic about valves and that reignited my interest in building a valve power amplifier for use on the two metre band. I already had a collection of bits and pieces acquired during many hours lurking around scrap metal yards, field days, disposals and electronics shops, so it was time to put them to use! It's likely that anyone wanting to build a similar power supply will have to adapt the general design to whatever parts they have available, so this article is really about ideas rather than detailed construction. Getting in before the editor does... high voltage power supplies can be lethal devices so great care is required in the construction and testing of such circuits.

Why write an article about power supplies? There is plenty of information available in the standard amateur reference books and on the web (References 1, 2 and 3). My original view was that the power supply is a relatively boring part of the system, just something to be built to make the amplifier work and it is usually straight forward to design and build. I gathered quite a lot of information about HV power supply design and came to the conclusion that there are many issues and subtleties that make power supplies quite interesting, especially the control and protection aspects. Many of the existing designs use elaborate circuits consisting of individual timers, amplifiers and comparators to sequence and monitor the operation of the power supply and they would appear to work very well. However, looking at the various designs I thought that it was an ideal application for a microcontroller as that could simplify the circuits and allow a more flexible approach to the problem. This article

is the result of that work; building the power supply turned into a fascinating design challenge in its own right and very far from boring.

The specifications of the design are:

- High voltage output of 2 kV DC at up to 250 mA for the amplifier plate circuit, depending on the available transformer.
- A regulated 350 V DC supply for the screen grid circuit that can source or sink 50 mA.
- A -130 V DC output for grid bias.
- A sequenced start to prevent application of plate and screen grid voltages until the valve cathode is at its operating temperature.
- Comprehensive protection against low plate voltage output, plate over current; low or high screen grid voltage and screen overcurrent; failure of the grid bias supply; over-temperature. The plate and screen voltages are removed within a few milliseconds from when an abnormal situation is detected.
- Remote monitoring via a TOSLINK optical fibre link: plate voltage and current, screen grid voltage and current, grid bias voltage and heat-sink temperature can all be monitored on a host computer. If any of the power supply parameters exceed their pre-set limit, the supply shuts down immediately and sends a message via the TOSLINK interface.

A significant part of this project was the software design and implementation. In previous projects using microcontrollers, the programming had all been done in assembler code as that allowed very good control of the system hardware; however it was time to do something different so I looked around at various options that might

reduce the effort required to write the code. I looked at the increasingly popular Arduino devices as they have a well-developed programming language and development environment; I also looked at AVR GCC C compiler that works with the AVR studio development system, but neither of those solutions was quite what I was looking for. Then I came across BASCOM-AVR (Reference 4) which is a development environment that allows you to write the code in a version of BASIC and this seemed ideal for what I wanted. The evaluation version worked very well (and is probably sufficient for this project) so I purchased a complete version and have been very happy with the results. BASCOM-AVR produces executable code for the ATmega16 processor that works quickly and reliably, and the finished product is much simpler to understand, modify and maintain than any assembler code I have ever written! Perhaps the main advantage of this approach is that many of the operational parameters of the power supply can be set by changing a few constants in the BASIC source code. It is no longer necessary to adjust trim-pots to change timer values, or voltage and current limits as it can all be done in software without exposing yourself to any high voltages.

The following pages provide a detailed description of the various circuits and components of the system. I hope you find it as interesting as I did!

## Circuit and module description

Figure 1 is a simplified overall schematic of the power supply and it shows the various components and modules that make up the system. Each of the modules is described in detail in the following sections.





The main rectifier and filter circuitry is built on two single sided circuit boards, Figures 2 and 3, which are mounted between two Perspex plates; this prevents accidental contact and also provides a tunnel for the cooling air from one of the fans. The input to the rectifier module has a 10 ohm fusible resistor in each leg of the input which acts as a final overload protection should the other protection measures fail. Standard 1N5408 diodes shunted

with voltage equalisation resistors are used as the diodes have a reasonable surge capability, are inexpensive and readily available. The filter board holds the electrolytic capacitors and shunt resistors which equalise the voltage across each of the capacitors in the string and also act as bleeder resistors to quickly discharge the capacitors when the power is turned off. A 47 ohm wire-wound resistor in the output provides some current limiting if a short occurs on the HT

line. The current supplied by the main filter/rectifier is measured via a one ohm resistor in the earthed side of the HT supply and the voltage developed across this resistor is measured by the control board. A pair of diodes provides over-voltage protection when HT faults occur. As the voltage developed across the resistor is negative with respect to earth, it is inverted by an amplifier (U84A) with a gain of -1 on the controller PCB. The output voltage is monitored via a voltage divider

Figure 2: High voltage rectifier circuit board.

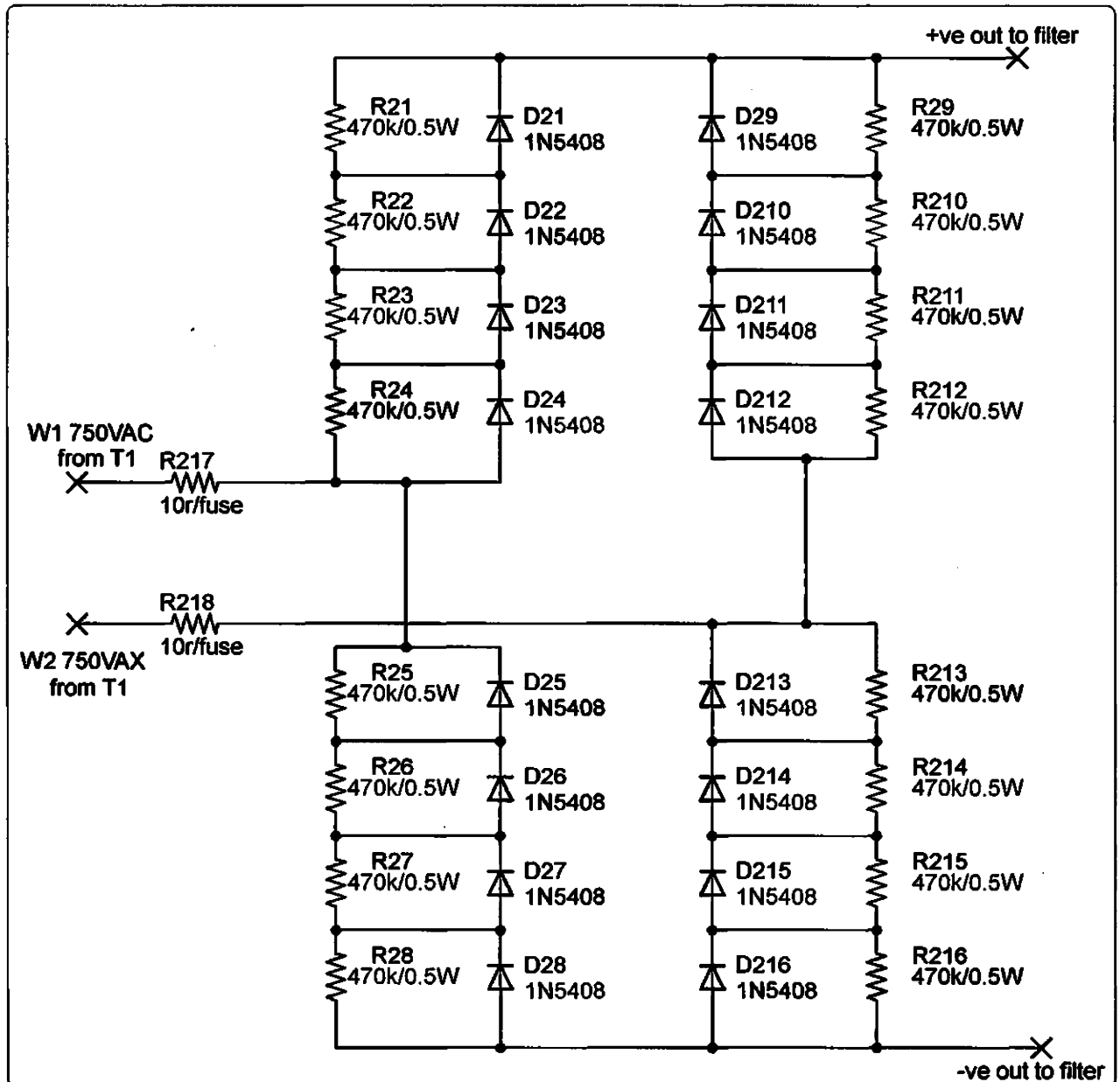

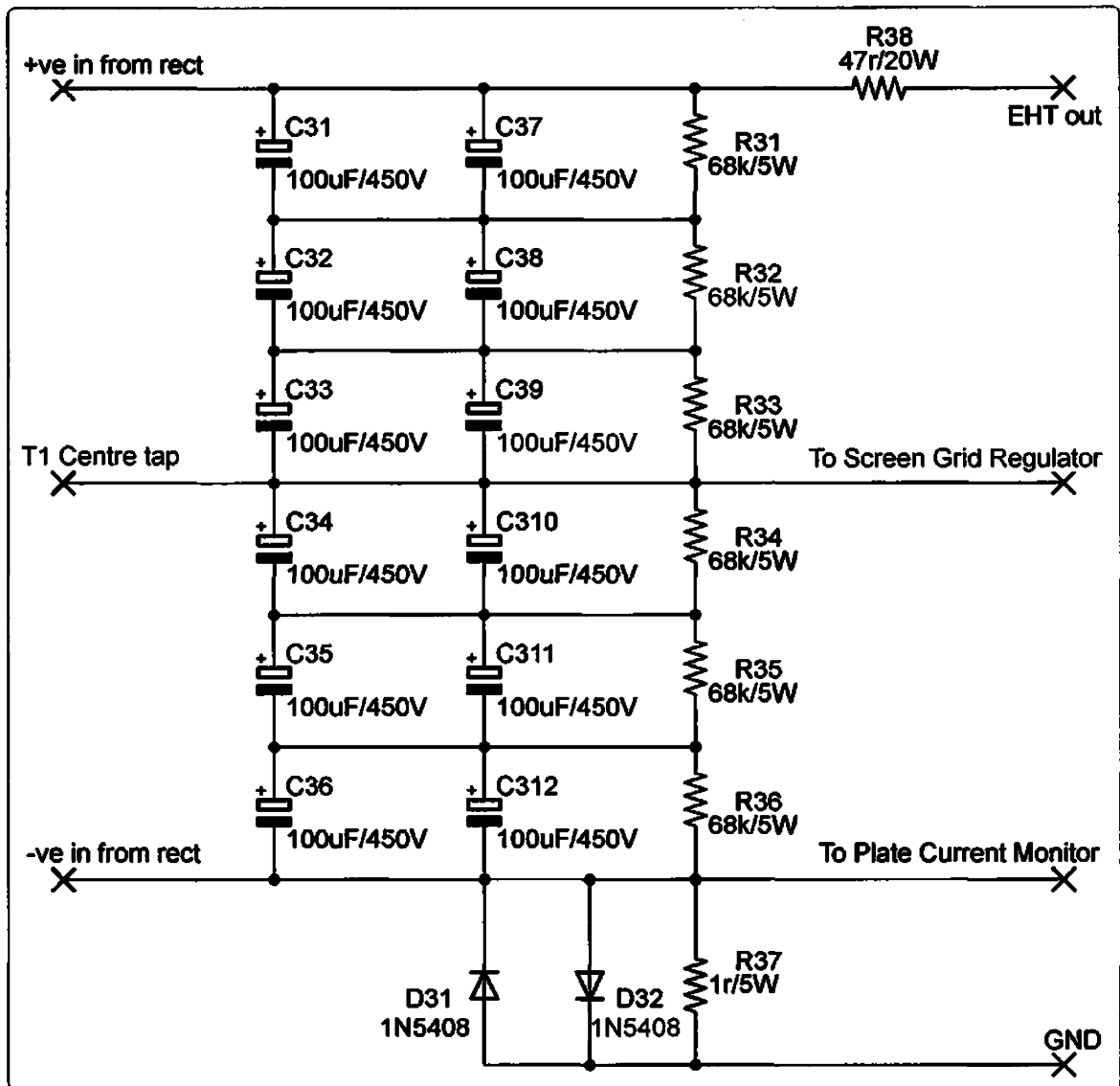

Figure 3: High voltage filter circuit board.

consisting of a number of high-voltage rated 1 M ohm resistors which also drives a 0 to 1 mA panel meter. The panel meter is not really necessary but it provides a useful reminder that HT may be present at the power supply output. A Zener diode and capacitor across the 3 k ohm monitor resistor protect the controller board from voltage surges. Power for the screen grid regulator is derived from the centre-tap of transformer T1, the voltage at this point is approximately 1 kV.

Much of the modern literature on tetrode amplifiers, for example, 4CX250 etc. indicates that the

screen grid voltage needs to be well regulated and that the associated screen grid supply needs to be able to source and sink current. Previously, screen grid regulators were based on gas discharge tubes or strings of Zener diodes, but more modern designs use an active device (FET, valve etc) as a shunt regulator. As high-voltage FETs are readily available and inexpensive this was the approach taken here and this design was derived from reference 1. This version, refer Figure 4, is powered from the +12 V DC supply directly rather than from the unregulated screen supply

via dropping resistor as in the original design. The FET is a 600 V 20 A device which is protected by a number of 250 V transient protection diodes ('Transils'). The 10 k ohm 100 W resistor and regulator FET are mounted on the same heatsink which is fan cooled; its temperature is monitored by a LM335 temperature sensor. If the heatsink temperature rises above 60 degrees Celsius the supply is shut down, but during normal operation the temperature sits at around 35 C. Note that as the regulator is of the shunt configuration, its power dissipation reduces when screen



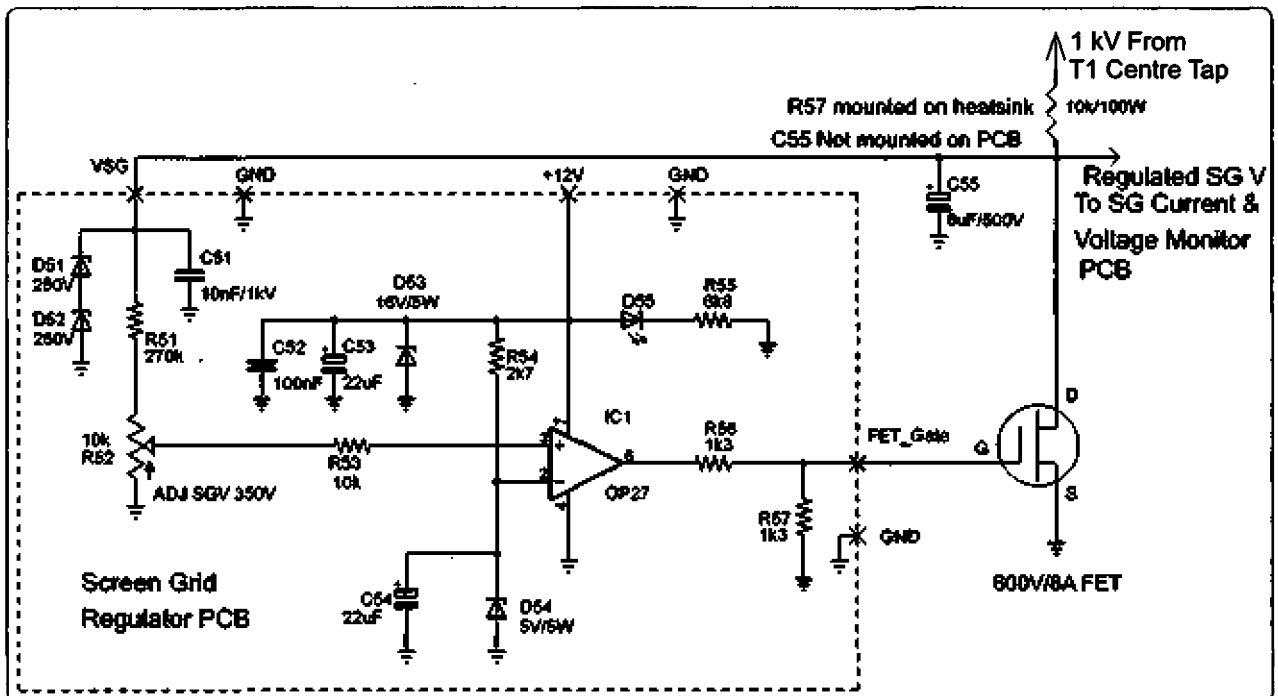

Figure 4: Screen grid regulator. The regulator FET and 10 k/100 W resistor are mounted on a heatsink which is monitored by an LM335 temperature sensor.

grid current is consumed by the amplifier tube. The circuit works very well and holds the screen grid supply to within approximately +/- 100 mV over the full range of load current. The screen grid current limits are set in software to be +/- 50 mA.

The screen grid voltage and current is monitored by a separate circuit, refer Figure 5, which provides suitable measurement voltages for the control board. The screen grid voltage is monitored by a conventional voltage divider and buffer amplifier, however monitoring the current was a bit more challenging. There are two complications: (1) the current can flow either way into the shunt regulator transistor, (2) the current shunt (R61 through R64) is floating at 350 V above earth. The solution was to use an amplifier that is powered by an isolated power supply and use an analogue signal isolator. The screen grid current passes through a one ohm resistor and the voltage across the resistor is amplified by an AD623 instrumentation amplifier

(U61) which develops an output of 10 mV/mA. This output voltage is fed to an ISO122 analogue isolator (U62) which has an isolation voltage rating of 1500 V and a gain of one. The earth referenced output voltage is then monitored by the control board. Power to the AD623 and the high voltage side of the ISO122 is provided by a small DC-DC converter (U65) which has an isolation voltage rating of 1 kV. As the analogue-to-digital converter on the control board can only accept input voltages in the range 0 to 5.12 V DC, the input to the ISO122 is level shifted by 2.560 V so that 0 mA screen grid current corresponds to an output voltage of 2.560 V. The overall transfer function of the amplifier is 10 mV/mA centred on 2.560 V, thus if the screen grid current is +50 mA, the voltage is  $2.56 + 0.50 = 3.06$  V. Although the 2.560 V reference can be trimmed by an on-board potentiometer it does drift slightly due to temperature changes, so the control board is programmed to measure the offset voltage before the screen grid voltage is applied

and the measured offset voltage is then used to correct the calculated screen grid current. Therefore any drift in the system is automatically corrected.

The low voltage DC and grid-bias supplies, refer Figure 6, are fairly conventional and are powered from transformer T2 (ex-equipment) which had a useful range of taps; however it's more than likely that other constructors will need to use two transformers. The grid-bias supply generates approximately -130 V DC and the voltage is monitored by an inverting amplifier which converts the negative input voltage to a positive output. As the OP27 device (U42) is configured as an inverting amplifier, its input is a virtual earth so the current flowing into the virtual earth from the -130 V supply is determined by the 470 k and 30 k resistors and this is converted to a positive output voltage at the OP27 output. For an input range of 0 to -200 VDC the output is 0 to 4 VDC which is monitored by the control board. The input to the OP27 amplifier is

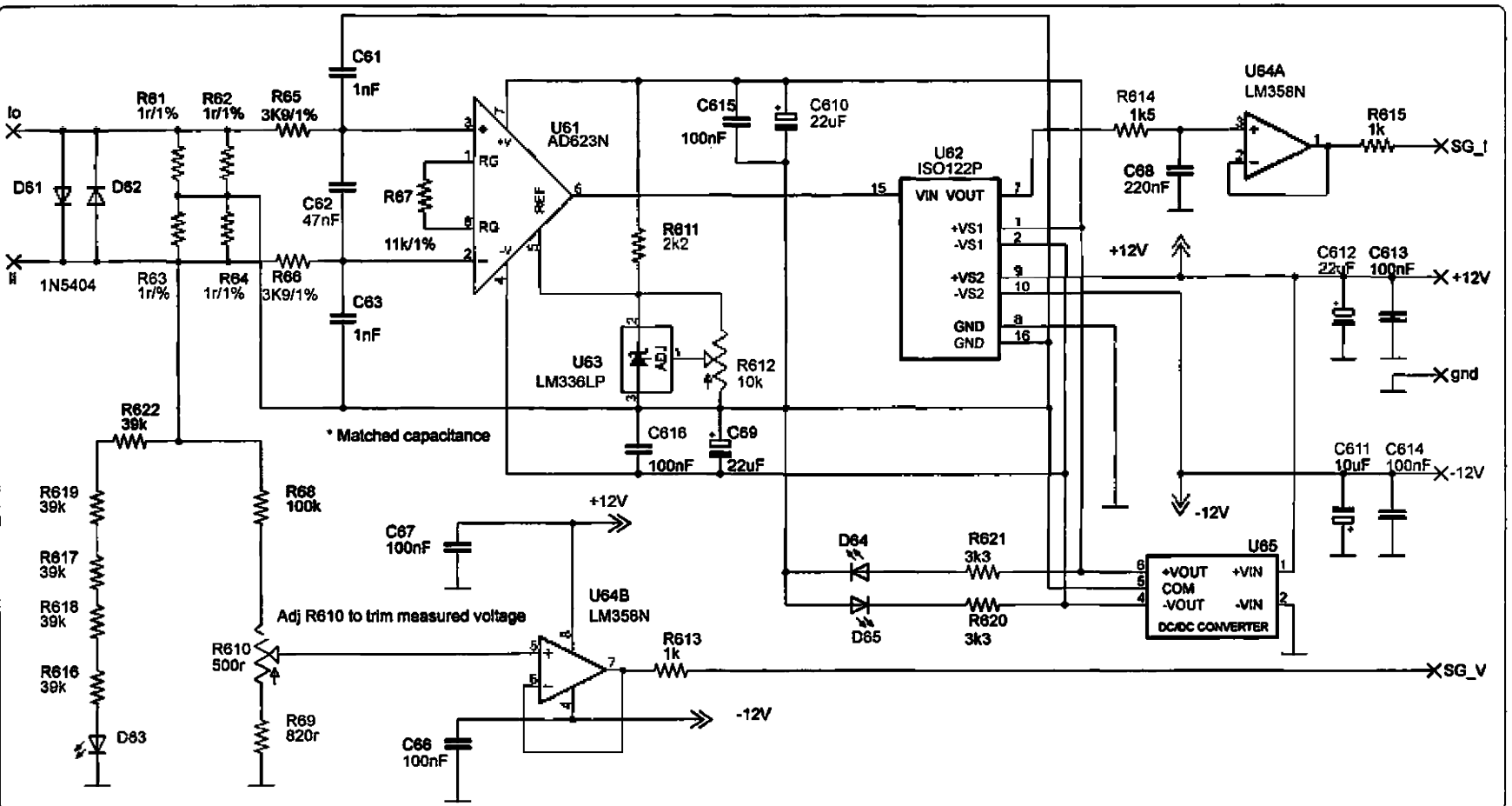

protected against transients by a 12 V 5 W Zener diode and capacitor. A number of Light Emitting Diodes are fitted as indicators to aid fault finding. The board also provides an (approximately) 24 VDC supply for relays and interlocking functions.

The control board, referred to in figure 7, is the most complex part of the power supply, mostly due to the extensive overvoltage and overcurrent protection. This protection is required so that the controller is not damaged by faults in the various high voltage circuits. All of the analogue inputs are protected by input resistors and diodes that will limit the applied voltage and currents to safe levels. Digital inputs are protected by optical-isolators and digital outputs drive relays via a Darlington driver chip (U87). As a further measure of protection the control board is mounted in a separate enclosure within the power supply box and all signals to and from the controller are passed through feed-through capacitors.

The system has been tested by applying direct short circuits to the grid-bias, screen grid and (inadvertently...) the 2 kV output. The controller performed correctly and safely shut down the power supply and no damage was done to any part of the supply. To ensure

**Figure 5:** Screen grid current and voltage monitor. R610 is adjusted so that the microcontroller reports the correct screen grid voltage. R 612 should be adjusted so that the SG\_J output = 2.560 V when no current is flowing through the current sense resistors R61, R62, R63 and R64.



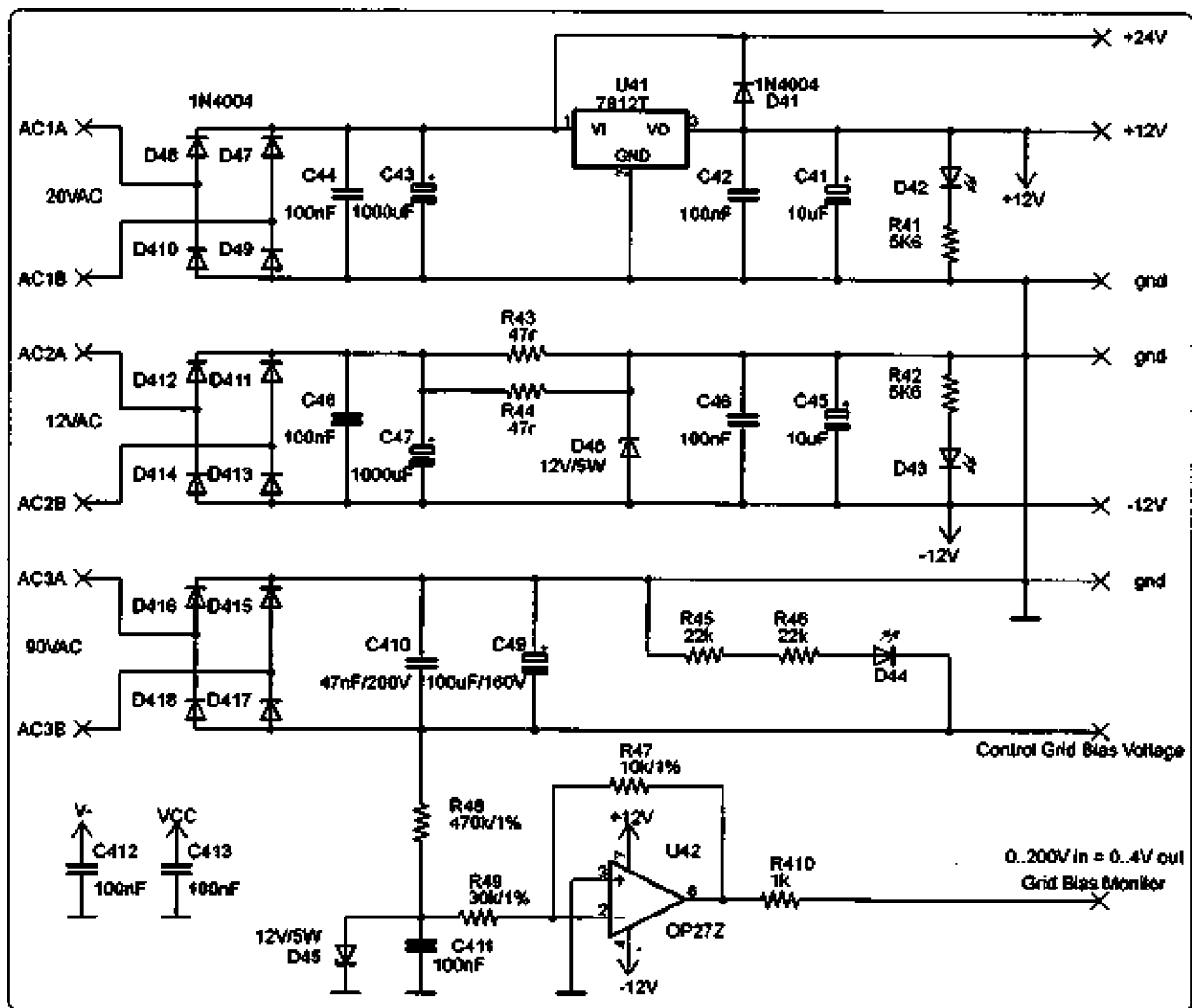

Figure 6: Control and grid bias supply circuit board.

measurement accuracy of the power supply operating conditions, the reference voltage for the microcontroller Analogue-to-Digital-Converter is developed by a REF02 voltage reference circuit (U86) and its output can be set precisely to 5.120 V by the adjustment potentiometer (R827). This then means that the 10 bit ADC has a resolution of 5 mV per bit which is adequate for the measurement tasks in the power supply. As some of the op-amps require a negative voltage for correct operation, a -5 V supply is generated on-board by a charge-pump voltage converter chip (U82). Serial data for transmission to the host PC is from the TXD port of the

microcontroller through connector K82. The control board has a number of inputs and outputs which are not currently used in this project; they were included for possible future use.

Rather than providing extensive metering facilities for monitoring circuit operation (except for the HT output) the measurements are sent as serial strings to a host PC through an optical fibre link, refer Figure 8. The fibre link has the significant advantage that it provides full Galvanic isolation between the power supply and host PC, so any faults cannot cause hardware damage to the PC. Inexpensive TOSLINK modules from

Jaycar were used. Serial data to the TOSLINK transmitter module is sent from the controller which is then received by the TOSLINK receiver which feeds the received serial data to serial-to-USB converter (Reference 5); the received data can be displayed using a terminal emulator or purpose written software.

### Software

The software which controls the unit deserves some comment as it shows the simplicity of the BASIC code which controls the system. Extract 1 is the section of the source code that executes whenever the power supply is providing HT to the load. The lines that

Figure 7: Main control board.

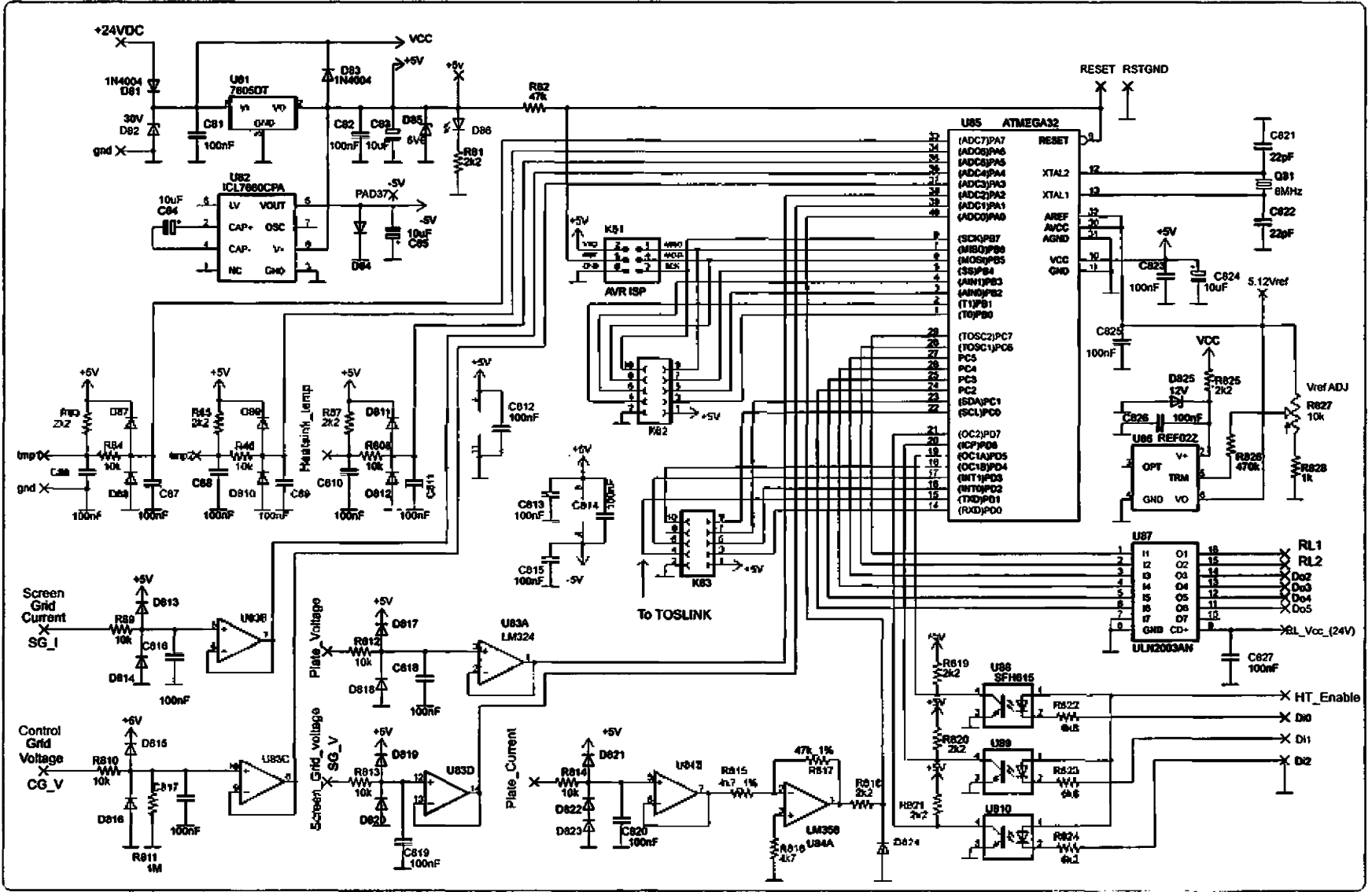





## Adjustments

There are a number of adjustments that need to be made for correct operation of the power supply control system:

- R827 on the controller board should be adjusted so that the 5.12 Vref test point reads 5.120 V. This is important as all measurements are referenced to this value and any error here will affect all measurements.
- R52 on the screen grid regulator board should be adjusted so that the regulated screen grid supply is equal to 350 V.
- R612 on the screen grid monitor board should be adjusted so that the SG\_I output reads 2.560 V when no screen grid current is flowing. This is best done with no screen grid voltage applied as the potentiometer is floating at 350 V above earth when voltage is applied.
- R610 on the screen grid monitor board should be adjusted so that the SG\_V output read 3.500 V when the screen grid voltage equals 350 V DC. R610 is not floating, but care is still required when working in this part of the circuit.

If 1% tolerance components are used where shown on the schematics, all measurements should be reasonably accurate.

## Components and construction

Somewhat surprisingly, most of the components for the power supply are readily available. All of the semiconductors, high voltage and general components were purchased from various suppliers: Element14 (formerly Farnell), RS components, Rockby Electronics and Jaycar. The junk box yielded transformers T1 & T2, feed-through capacitors, the main enclosure, multi-pole and HV connectors and meters – for these components intending constructors will have to make use of what they can locate.

The circuit boards that carry high voltages have been designed to have the appropriate creepage and clearance distances for the applied voltages, so ensure that any HV cabling also has appropriate insulation and that there is sufficient clearance between HV conductors. I used solid core RG59 coaxial cable for the HT wiring as it has suitably thick insulation.

The power supply was built into a rack mountable enclosure which formerly held some nucleonic instrumentation. The enclosure is well screened and solidly built and helps make a professional looking power supply. Virtually all of the various circuits are built onto printed circuit boards and the PCB design files (EAGLECAD format) are available to interested persons. The BASIC source code for the controller is also available upon request.

## Conclusion

A relatively complex high voltage power supply has been presented, but that complexity provides great flexibility, good performance and operational convenience. Learning about HV power supply design, safety consideration and construction techniques was very interesting and provided much food for thought.

Thanks should go to VK1SV for the valves and his enthusiasm which prompted this project.

## References

1. The Power Supply Handbook. J. Fielding, ZS5JF, RSGB and ARRL 2006.
2. The tetrode boards; <http://www.ifwtech.co.uk/g3sek/boards/tetrode/tetrode-1.htm>
3. Power and Protection for Modern Tetrodes. Ian White, G3SEK. QEX October 1997
4. BASCOM-AVR is produced by MCS Electronics, see <http://www.mcselec.com/> Their Australian distributor is Dontronics; <http://www.dontronics.com>
5. Breakout Board for FT232RL USB to Serial: <http://littlebirdelectronics.com/products/breakout-board-for-ft232rl-usb-to-serial>

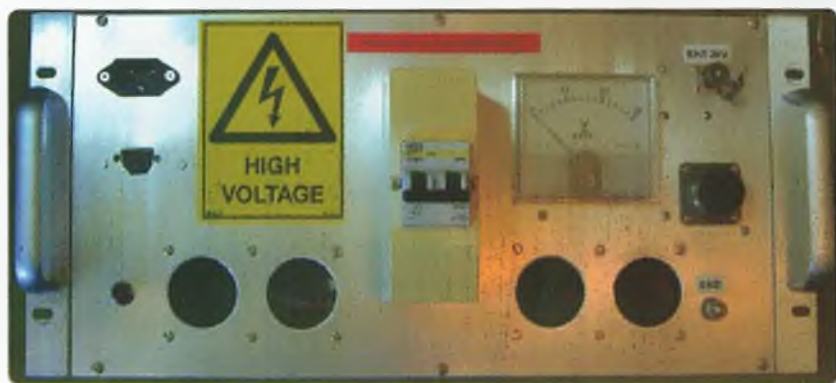

Figure 9: A front view of the completed power supply. A standard IEC type mains connector is used for the 240 V AC input. The 2 kV output connector is a high voltage type BNC connector and the multi-pole connector has the other control and supply circuits for the attached amplifier. Ventilation holes provide sufficient air flow for the internal cooling fans. A six mm bolt provides an earth point so that the power supply can be securely connected to the station earth.

## Erratum

In the September issue, on page 41, we listed a SK notice for "John Pile VK3APO". This material was reproduced as supplied and it was noticed after publication that the callsign was incorrect. It should read "John Pile VK3ZPO". Our apologies to Peter Mill VK3APO and his friends.



# Australian Foxhunting Championships 2013

Greg Williams VK3VT/VK3FOX

*Editor's note: Greg has been licensed since 1966 and has been involved in foxhunting since 1975. Teams in which he has been involved have won the trophy at Mount Gambier eight times. He enjoys many aspects of amateur radio, including home brewing, DXing, contesting, training new amateurs as well as fox hunting and ARDF.*

For the last 49 years the South East Radio Group (SERG) in Mount Gambier has been running a convention on the Queen's Birthday Weekend. For as long as I can remember, foxhunts have been part of this event. In 1989 the SERG were asked to run the Australian Foxhunt Championships as part of their convention and they took up the challenge with relish.

I have attended many of these conventions over the years as a member of several different teams and this year joined with Doug VK3JDO, Mark VK3MD and Kristian (not yet callsigned!) under



Photo 1: Hounds at the start of the first event.

the callsign VK3FOX (a callsign I could not resist!). We had practiced at the Victorian Championships and discovered some equipment problems which were repaired and so we were on our way.

A number of teams headed over from Victoria including VK3FVXN,

VK3FAST, VK3OW, VK3TXO, VK3BLN and VK3FOX. There was the venerable Bevan VK5TV from Adelaide along with VK5KB, VK5QI, VK5ZT and VK5KJ. Bevan has not missed a convention for 43 years and just loves his foxhunting.

For those of you that are not sure what a foxhunt amateur radio style is; it involves the 'Fox' hiding a transmitter somewhere and then 'Hounds', using some form of direction finding gear, try to locate the fox as quickly as possible. These are vehicle based hunts with the rules requiring that all the equipment to be used by the team must be in or on the vehicle at the start of the hunt. It is usual to have four team members, the driver – who does just that, the beam swinger – operates the equipment and turns the antenna, if required, and two navigators who can argue over the best route to follow. Some teams vary this by having two independent systems with two beam swingers, others do without the extra navigator. The minimum requirement is two as the driver does need to just drive.

Photo 2: Team VK3BLI plotting tactics.





The Australian Championships use transmitters on the following bands: 3.5 MHz, 28 MHz, 52 MHz, 144 MHz, 432 MHz and 1296 MHz. It has become somewhat traditional at Mount Gambier for the fox to hide in one of the numerous pine plantations in the area. This makes for very interesting hunting as many hounds have discovered that pine trees make very good RF reflectors or re-radiators. GPS tracking devices were fitted to each hound vehicle this year to make sure that the speed limits and other requirements were adhered to and for later analysis and finger pointing.

The weekend kicks off on Saturday morning at 1100 local with a 'Sniffer Hunt' - this requires the participants to locate 10 low power 144 MHz fox transmitters within a defined area as quickly as possible; all on foot carrying a three element beam and a small sniffer receiver. The transmitters are all on different frequencies so you have to keep scanning the frequencies as you make your way around the area. You cannot hear all the transmitters from any one spot. At each fox you collect a ticket that has the fox number and your position in finding that fox. I walk around for this event and am amazed at the speed of some of the other competitors. Bryan VK3YNG from the VK3FAST team won this event, with Kristian from the VK3FOX team second and Adam from VK3BLN third. This was Kristian's first attempt at this style of



Photo 3: Team VK3FVXN front seat gear.

event and I guess you can now see why he was part of our team - he can run!

Second event for the day was on 439.025 MHz and started after lunch. This was likened to tracing an EPIRB with a very short duration transmission, which had caused many difficulties last year. In the end the fox was kind and there was plenty of signal. The hounds headed out from the start towards the west and then suddenly the signal became confused; this was plum in the middle of a pine plantation for us and so we stayed confused for some time; other teams realised that the direction had changed

and were now following the fox in a completely different direction. Eventually we realised our error and set off some distance behind the pack. It turns out the fox was attached to a balloon and several hounds detected this and were quickly on

the track after it. The hunt was won by VK3TXO, with VK5TV second and VK3BLN third. For those that may be interested you can follow the track of the fox and the hounds at <http://www.youtube.com/watch?v=lJnpUvikUac>

Event 3 was a multi-leg hunt where you have to find one fox, then immediately start hunting another, often on a different band. This hunt was on 146.525 MHz on the first leg, 439.025 MHz on the second leg and 146.550 on the last leg. In Melbourne there are regular monthly fox hunts on two metres and 70 cm so all the Melbourne teams are reasonably proficient on these frequencies. Thus there was a tight pack of hounds closing on the first fox. If you missed one turn or pulled up too early your placing could change from first to fifth in a blink of an eye!! Some teams had to take that short break and change antennas for the next leg while others have two or more antennas mounted at the start. When the results were tallied VK3FOX won with VK3FVXN second and VK3TXO third.

Saturday evening dinner has had a number of traditions over the years. When I first started attending

Photo 4: Team VK3FVXN gear on the roof of the team vehicle.



in the 1980s there was a BBQ put on by the SERG at the showground. For a short time there was a formal convention dinner which the hounds had to leave early to participate in the night hunt. Then there was the smorgasbord at a local restaurant, however in recent years a number of the Melbourne teams have got together at one of the motels for a bring-your-own share meal. This was very enjoyable with Josh VK3XJM going the extra mile with home brew, cider, and ginger beer on tap! Many thanks to everyone who contributed to the meal, it was great. During dinner we noted the absence of the VK3BLN team. It appeared they had a major problem with their automatic antenna rotating system, brought about by contact with something in a pine forest. They were trying to effect repairs while we were enjoying dinner.

After such a feast we all headed out east from Mount Gambier to the sale yards which is the start location for the Wayne Kilpatrick Memorial Night 'Multi-Leg' Foxhunt. This is named after VK5ZX who passed away a couple of years ago and was a stalwart of the SERG; he was the main organiser of the fox hunts for a number of years and all the hounds liked and respected him. This hunt is probably the most hotly contested of the weekend and every hound wants to do well. There are five legs - 146.525 FM, 439.025 FM, 146.550 FM, 52.100 FM and 28.450 USB. As the start time arrived team VK3BLN was nowhere to be seen and so we assumed they had withdrawn. The first leg was a progression with all the teams in line heading towards the fox. A few different turns in the forest and the intermittent nature of the transmissions spread the field a bit but soon we were all on the way towards the second leg. We found this reasonably quickly and headed towards the third leg. Up close we were having problems and had to rely on Kristian on foot with the sniffer to locate the lair; then we were off on the 52.1 MHz leg. There

was another team also hunting this fox and they were just a bit ahead of us in the pine forest. We stopped to wait for the next transmission and found we were stopped almost beside the fox. What a thrill! We were first on the fourth leg with just 28.450 MHz to go. We changed antennas and started trying to find directions but, nothing! As you can imagine this can be very frustrating to find a leg fox first then have to wait for the next fox to start transmitting - meaning everyone is catching up and you have no idea where to go! After a while we called on the liaison repeater and the fox told us he has problems. After a while more we get the sad news that the problems are terminal and there will be no 28.450 MHz leg. All the teams waiting for that transmitter to come on were sure they could have found it first. I know Andrew VK5KET, the fox for this leg, was bitterly disappointed in having to cancel it, as evidently the foxes look forward to this event just as much as the hounds do!

As each leg of the hunt is scored separately, and the points tallied to determine the winner, the first person to find the last leg is not necessarily the winner and in this case the hunt was won by VK3FVXN, with VK3FOX second and VK3OW third. The North East Radio Group (The NERGs) from Melbourne had identified some time ago that the 'First team home' was something very special in this 'Infamous night hunt' and so a NERG sponsored perpetual trophy is presented to the first team home, thus this went to VK3FOX. We later discovered that team VK3BLN did in fact get repairs completed and although missing the first leg did find the other three; well done to them and many thanks to the young lad that donated his bike frame for spare parts - not sure he was aware of it though!

Sunday was chilly but fine and all the hounds were out at 0900 for a second sniffer hunt, still with ten transmitters but in a different area.

This was won by Gary VK3TXO, with Darian VK3FAST second and Bryan VK3YNG third, however, as Bryan and Darian are in the same team, team points were awarded to VK3TXO, VK3FAST and VK3FOX in third, with Kristian once again doing his bit for the team.

Event 6 was another triple legged event with transmitters on 146.525 MHz, 439.000 MHz and 146.000 MHz. After a bit of messing around we found the first two legs but hearing the third leg was problematical. We thought we could hear something but it just faded away and even after some hints from the fox decided that we would call it quits. As the event was running overtime the transmitters were turned off before all teams were in. VK3FVXN seemed to have no problems here and were first in with VK3FAST second, third was VK3BLN.

Lunch at the hall was devoured by the hounds with the willing catering staff kept very busy feeding the pack.

Event 8, *yes it may not look right but Event 7 on the program is the homebrew competition and this is not part of the foxhunt championships.* This is a multi-band multi-leg affair with transmitters on 146.525 MHz, 3.585 MHz and 52.100 MHz. After finding the first leg we encountered an S9 noise on 80 metres and could not hear the fox at all. Gary VK3TXO took off in a hurry and we assumed he had signal so it was follow the leader for us. Eventually we found the source of the noise - the laptop DC to DC power supply that we have been using for years had suddenly developed a problem. Turns out the VK3TXO team, and us, were not going in the right direction after all! Finally we found the 80 metre fox and were off after the six metre one. We were never really sure exactly where he was but we were very close and just could not close those last few hundred metres. Winner of this event was VK3FVXN with VK3FAST second and VK3TXO third.



The final event was the 1296 MHz hunt and this is usually just around near the crater next to the blue lake but this year the fox led the hounds on a long chase out to 'The Bluff'. For us a lack of certainty with the gear and a wrong decision meant we never saw this fox but those that did quickly found it, with VK3FAST winning followed by VK3BLN and VK5KB.

All that was left was result announcements and presentations. The 2013 Australian Foxhunt Champions are the VK3FAST team and congratulations go to Steve VK3YLE, Bryan VK3YNG, Darian VK3FAST and Matthew VK3FEMH.

On behalf of all the hounds that took part in this event I would like to thank the SERG for the excellent organisation and running of these championships. I know they spend many hours planning and plotting to make the hunts difficult and interesting and we as hounds really appreciate their efforts. Teams would not keep returning every year without this planning and organisation. Once again thank you to all the foxes, the catering team and the other club members who



Photo 5: Greg VK3FOX with certificate and prize.

made the event so enjoyable for the participants. The foxes came from SERG, Naracoorte Radio Club and some AREG representatives.

The 2014 Australian Foxhunting Championships are planned for the Queen's Birthday weekend in June 2014 at Mount Gambier. For those that would like to participate

I suggest that you concentrate on two metres and 70 cm as these are involved in most events and are run as the first part of the event so you can participate and then withdraw after those bands have been hunted (should you choose).



## VK1 news

Nic Smelt VK1NS

It's spring! And while most Canberrans' minds turn to Floriade and vitamin D, CRARC's turns to WICEN. The last quarter of the year is a busy time for WICEN ACT. Four significant events are supported through this time with a strong transport theme: horse endurance, mountain biking and car rallying. These events represent a huge body of work from the coordinators, volunteers and the club.

CRARC has also been anticipating the arrival of spring from more pressing practical reasons. With the spring thaw coming on, CRARC will be able to

access the Mount Ginini repeater site again soon; the territory government closes the access roads during winter! For the past few months the receiver of the Mount Ginini two metre repeater has been in an extremely degraded state, to the point of effectively being 'deaf'. The Mount Ginini two metre repeater VK1RGI, with an output on 146.950 MHz, has been the perennial workhorse of the ACT region's repeater suite. With a significant HASL it is workable from most areas in and around the ACT region. We hope to have the repeater operational again soon.

SOTA continues to attract a strong following in VK1. This is shown by the recent simultaneous activation of several summits around the Canberra region to celebrate six months of SOTA in the ACT.

CRARC is continuing its strong commitment to education with a successful Foundation course being run in July producing another six successful Foundation licensees and still another Foundation course being held in September.





## VK2news

Tim Mills VK2ZTM  
e vk2ztm@wia.org.au

The Oxley Region ARC held their AGM in early August with some changes in their office bearers. President is again Henry VK2ZHE with Treasurer Keith VK2FKJA continuing. There is a new Vice President Larry VK2CLL and Secretary David VK2FRAB. New on the committee are Paul VK2PPP and Alex VK2HBF with Charles VK2KCE returning. Retiring from the committee were Bruce VK2HOT, Arthur VK2ATM and Bill VK2ZCV.

The following ORARC members were awarded Life Membership, Allan VK2OA and Jim VK2FJKD. There are also two Clubman of the Year being Larry VK2CLL and Henry VK2ZHE. The ORARC has moved their Friday evening training into an Advanced licence course. Their Christmas meeting will be held on Saturday 7th December at the Settlement Point picnic area.

Jeff Pages VK2BYY is putting pen to paper or should that be fingers to the keyboard with another novel in his 'barefoot times' series. Jeff said recently that he had created enough for the next book in the series which he hopes will be finished next year with a release in 2015. Check out [www.barefoottimes.net](http://www.barefoottimes.net) for his previous productions.

WICEN NSW held their AGM last month. This month major events

include the Memory Walk in the Illawarra on the 13th, the Barrington Tops SAREX aircraft search and the Hawkesbury Canoe Classic. Westlakes ARC held their annual field day last month. Summerland ARC held their SARCFEST in August which was opened by federal member Janelle Saffin. Last month they held a meeting to elect Trustees for the club. Blue Mountains ARC have scheduled Foundation courses on the second weekend of the even months which will be the 12th and 13th this month. The Manly Warringah RS have developed a new contest based on the use of portable flagpoles as antenna masts. They had the first contest last month. Check out [www.mwrs.org.au](http://www.mwrs.org.au). A recently formed group in Sydney is the Sydney Amateur Radio Group. Their web site is [www.meetup.com/Sydney-Amateur-Radio-Group](http://www.meetup.com/Sydney-Amateur-Radio-Group) and their publicity officer is Peter VK2GPH on 0411 473 696.

The Central Coast ARC have advised next year's Wyong field day will held on Sunday 23rd February rain or shine at the Wyong Race Course. Their AGM was held mid-August with only minor position changes as the club entered their 57th year. They have meetings every Saturday with an important lecture scheduled for October 26th when

Karen VK2AKB will present 'EMR Awareness'.

Waverley ARS has a Foundation weekend scheduled for the 9th and 10th November. Details at [education@vk2bv.org](mailto:education@vk2bv.org) The Armidale and District ARC has reactivated a two metre repeater with plans for one on 70 cm. An amateur from the region was keen to get the former club back in action but unfortunately Roger Chubb VK2GFE became a Silent Key last May. Other amateurs in the district rallied to his ideals and now there are over 26 involved. The repeater has been located at a local FM broadcast site with antennas sharing the transmission tower. Rick VK4HF/2 heads the new team.

ARNSW final Foundation weekend for the year will be 16th and 17th November with assessments for all licence grades on Sunday the 17th. Bookings at [education@arnsw.org.au](mailto:education@arnsw.org.au) The final Trash and Treasure for the year is on Sunday 24th November. A mini field day for ARNSW members is planned for Sunday 10th November 2013 to be held at the VK2WI site. ARNSW is looking at introducing a Grant Scheme to operate within VK2 next year.

Check out the latest news on VK2WI Sunday at 10 am and 7.30 pm.

73 - Tim VK2ZTM.



## Plan NOW for JOTA/JOTI 2013!

Contact your local Scout or Guide group.

The **56th Jamboree On The Air** will take place on 19 and 20 October 2013.

This year's theme is: **Let's Share!**



Rod Green VK3AYQ

## Commemorative Dinner

In August we celebrated the fiftieth year of our society. A dinner was held for members, partners and friends at the Geelong RSL Club. The dinner was preceded with finger food and drinks, and allowed attendees time to catch up with friends. This was followed by a two course dinner, fruit platter, and tea or coffee. Each person was given a commemorative enamel badge which had been specially made to mark the occasion. The badge showed the society logo and underneath the words '50th ANNIVERSARY 1963-2013.'

The guest speaker was Fred Swainston VK3DAC. His topic was on the re-invention of amateur radio. Fred outlined how the hobby of amateur radio had re-invented itself in the past. Examples were the no code or 'Z call' licence, the Novice licence, and the Foundation licence. With each change to the licensing system there had been some who opposed the changes, but all were embraced by the majority. As a result of these changes, the hobby of amateur radio in Australia has seen an increase in licensed amateurs at a time when other countries have suffered a decrease in numbers.

Throughout his talk Fred also included information on his own life, hobbies and travels. As one member mentioned, this made the talk more interesting for member's partners. Our club historian gave a brief history of the society. This included names of people past and present who had made a significant contribution to our society over the last 50 years. Due to the generosity of Jaycar, we had a power supply to be given as a door prize on the night. This was won by Keith Vriens VK3AFI.

## VK3ANR50

For a period of one week the society used the call VK3ANR50. The society station was manned each day and hundreds of contacts were made during the week. One of our newer foundation licensees, Aaron Brown VK3FAHB, took advantage of this time and gained experience operating our club station under the guidance of club members. All stations contacted will be sent a QSL card which has been especially designed to reflect our 50 year celebrations.



Aaron VK3FAHB operating VK3ANR50.

## Silent Key

### Doug Tamblyn VK5GA

It is with great sadness that we report the passing on Saturday, 18 May 2013 of our foundation member Doug Tamblyn VK5GA.

Doug was not only at the forefront of the founding of the Riverland Radio Club but at the club's inaugural meeting in 1986 he was elected Secretary/Treasurer – a position he occupied until his passing.

Always a thorough gentleman, Doug was enthusiastic in his secretarial

duties and became well known for his support and encouragement of club members and club activities. Just as well-known was the battered and well used case that Doug diligently bought to each meeting and which contained the Club's historical records, secretarial paraphernalia and other assorted items of mysterious origin. The case will be treasured by the Club and will continue to be treated with the same care and attention that Doug

always bestowed upon it.

Doug leaves a large legacy and will be remembered with fondness by the Club for his cheerfulness, humour, integrity and friendship. Doug was in every sense the epitome of 'a good bloke'.

Our sympathy and condolences go to Doug's wife Bev and his family.

Contributed by the Riverland Radio Club Inc., Renmark, SA.





## The GARC training facilities

Whilst the GARC is renowned for its technical excellence the same can also be said regarding its Training Programme. For those interested in acquiring a Foundation licence, the Training Administrator for the GARC is Jenni VK3FJEN who may be contacted through the web site [www.vk3atl.org](http://www.vk3atl.org) for information regarding courses.

Pertinent factors relating to the GARC Training Programme

- There are no pre conditions imposed on applicants, they simply have to express a desire to acquire a Foundation amateur radio licence
- Those participating in the programme have come mainly from the Greater Geelong area but also as far afield as Melton South, Werribee and Wyndham Vale; some with referrals from the WIA.
- The trainees, both male and female, come from a diverse range of ages and occupational backgrounds, not necessarily with any direct connection to the world of electronics.
- There is no requirement for trainees to formally join the GARC as a pre requisite for training, but we do encourage, where ever practical, an enduring relationship; so they can participate in club activities such as Field Days and derive the benefits of accessing first rate technical support on all aspects of the hobby.
- The GARC makes no charge for its Training and Assessment services.

- The only costs to the participants are for the WIA Foundation Manual and those charges from the WIA/ACMA for the formal examination assessment and the granting of a licence, where appropriate; all of which can be found on their website. These costs are regularly updated on the GARC web site at [www.vk3atl.org/education](http://www.vk3atl.org/education)
- The GARC course comprises a 12 week programme of 45 minutes every Friday evening, starting at 7.00 pm at the club house; each session covering one chapter of the WIA Foundation Manual
- The programme covers both the theoretical and practical operational requirements for acquiring a Foundation licence. During this 'hands on' experience, considerable effort is put into making sure that when they come on the air, they are not only competent operators, but also sound confident.
- The GARC has implemented some self-directed learning activities for both adults and children, to support the tutorial and homework requirements of the program.
- The Trainers and Assessors all have the necessary Working With Children Approval and are endorsed by the WIA.
- A white board has existed for many years and an overhead data projector was installed at the beginning of the Foundation licence training to assist in all training.

- The GARC is currently working on a protocol to assist in implementing training for Foundation licensees and Standard licensees in upgrading to the next level.

The club trainers include Chas VK3PY, Ken VK3NW and Lou VK3ALB, supported by Lee VK3PK. The club assessors are Rex VK3ARG, Ken VK3NW, Craig VK3CRG and Andre VK3AVZ.

At a recent examination, two trainees George and Matthew acquired their 'F' call licences, (George VK3FADQ and Matthew VK3FADV) and Andrew, now VK3ARR, acquired his Advanced licence. Students Moya, Peter, Adrian and Rob sat their Foundation assessment on the 24<sup>th</sup> of August. The next scheduled examination is in November.

From an historical stand point when the Foundation licence was first being mooted for Australia, two lecturers in electronics at the Gordon TAFE, Lee VK3PK and Chas VK3PY put together a proposed **Foundation Syllabus**, in order to put Foundation licence training in place at the GARC at the earliest opportunity and have candidates ready at its inception. The proposed syllabus was a best guess of what would be a reasonable standard. It was based on a simplified, then current Novice standard and somewhat aligned with input from the UK's OFCOM Foundation licence syllabus, which had already been running for two years, so it would be close to CEPT standards. This was subsequently submitted to the WIA for comment

and was discussed within the WIA Foundation Licence Committee of which Lee VK3PK was a member. Subsequently the WIA's document was a major input to the ACMA.

Once the syllabus was in place and approved by the ACMA, the WIA produced the excellent and very comprehensive Foundation Manual on which our current training programme is now based. One of the first F call licences in Australia, through the GARC training programme, was issued to Garry VK3FWGR, in 2006.



Photo 1: Lee VK3PK and Ken VK3NW at a Friday evening training session.



A **2014 Callbook** makes a great Christmas present.



**Ballarat Amateur Radio Group Inc. (BARG)**

# HAMVENTION

**Sunday 20 October 2013**

**At the Ballarat Greyhound Racing Club's Function Room,  
Rubicon Street, Redan**

## **DISPLAY & SALES**

Traders \$6.00 per person, Trade Tables \$10.00 each

## **GENERAL ADMISSION \$6.00**

**STRICTLY 10 AM START**  
(Under 15 Years Free)

**Food & Drink will be available on the premises**

Enquiries & Bookings to: Tom Wood 0408 396 992 Email: [hamvention2013@barg.org.au](mailto:hamvention2013@barg.org.au)





# AMSAT

David Giles VK5DQG

✉ vk5dgg@amsat.org

It has been a while since I have done an update of what is up there for you to enjoy.

## Review of operational OSCARs

Here is an updated review of the operational OSCARs and other satellites using amateur satellite service bands. The names of the satellites are given as OSCAR number, full name and (NASA catalogue number). Modes are represented by frequency bands:

### AO-7 AMSAT OSCAR 7 (7530)

**Launched:** 15/11/1974

**Status:** Operational only when it is in sunlight. It may be in any mode. During non-eclipse periods as it is currently, AO-7 will alternate between modes V/H and U/V every 24 hours. Beacons are not always on and may not give accurate values.

**Mode:** V/H (old mode 'A'), linear, non-inverting.

**Uplink:** 145.850-145.950 MHz, Downlink: 29.400-29.500 MHz

**Beacon:** 29.502 MHz CW. Occasionally the 435.106 MHz CW or RTTY beacon may be on.

**Mode:** U/V (old mode 'B'), linear, inverting.

**Uplink:** 432.125-432.175 MHz, Downlink: 145.975-145.925 MHz

**Beacon:** 145.972 MHz CW at 10 or 20 wpm

### UO-11 UOSAT-2 (14781)

**Launched:** 1/3/1984

**Status:** Intermittent. UO-11's 145.826 MHz beacon will only work when in full sunlight. You may hear its distinctive signal while monitoring the frequency for other satellites such as ISS and NO-44.

**Beacon:** 145.826 MHz FM 1k2 AFSK  
<http://www.g3cww.co.uk/oscar11.htm>

### LO-19 LUSAT (20442)

**Launched:** 22/1/1990

**Status:** Semi-operational. LUSAT recently came back to life but is only transmitting random dits, dahs, and extended carrier

H=10 m, V=2 m, U=70 cm, L=23 cm, in order of uplink/downlink.

Use SSB and CW on the linear transponders. Most linear transponders are 'inverting' types and use LSB for the uplink and USB on the downlink. For AO-7 mode V/H use USB for both links. Most of the activity is in the middle of the passband. If manually adjusting for Doppler then the most compensation should be done with the highest band in use. Foundation licensees are permitted to transmit

bursts. It is operational only when in sunlight.

**Beacon:** 437.125 MHz CW

### IO-26 ITAMSAT (22826)

**Launched:** 26/9/1993

**Status:** Semi-operational. It doesn't sound healthy when it is on and the carrier frequency has dropped another 4 kHz or so. It is still in MBL mode with the occasional telemetry packet sent.

**Beacon:** 435.786 MHz 1k2 BPSK.

### FO-29 FUJI-OSCAR 29 JAS-2 (24278)

**Launched:** 17/8/1996

**Status:** Semi-operational as linear transponder. Most activity is around 435.850 MHz. The BBS and digtalker operation have not been used since 2003. FO-29 has started an eclipse period that will last for the next two years. Best to use during daylight passes.

**Mode:** V/U linear, inverting.

**Uplink:** 145.900-146.000 MHz, Downlink: 435.900-435.800 MHz

**Beacon:** 435.795 MHz CW telemetry.  
<http://www.ne.jp/asahi/hamradio/je9pel/index.htm>  
<http://tinyurl.com/FO29Blog>

### NO-44 PCSAT (26931)

**Launched:** 30/9/2001

**Status:** Operational only in full sunlight. One solar panel and the batteries are not functioning.

to any of the satellites in the 10 m, 2 m and 70 cm bands as well as receive all the satellites. Foundation licensees are not permitted to use 23 cm uplinks (for example, CO-65).

Telemetry decoding programs for several satellites are available from Mike Rupprecht's website at <http://www.dk3wn.info/software.shtml> Reports of selected satellites heard by amateurs during the past six days can be found at <http://oscar.dcar.org> (especially useful for AO-7).

**Mode:** V/V 1k2 AFSK packet digipeater

**Uplink:** 145.827 MHz, Downlink 145.827 MHz  
<http://pcsat.aprs.org>

### SO-50 SAUDISAT-1C (27607)

**Launched:** 20/12/2002

**Status:** Operational. SO-50 has a sensitive receiver and a transmit power of only 250 mW.

**Mode:** V/U FM voice with 67 Hz CTCSS tone

**Uplink:** 145.850 MHz, Downlink 436.795 MHz (but may switch to 436.790 MHz).

To switch the transmitter on you need to send a few seconds of 74.4 Hz CTCSS tone.

The order of operation is thus (allow for Doppler as necessary):

- 1) Transmit on 145.850 MHz with a tone of 74.4 Hz to arm the 10 minute timer on board the spacecraft.
- 2) Now transmit on 145.850 MHz FM voice using a 67 Hz CTCSS tone to access the transponder.
- 3) Sending the 74.4 Hz tone again within the 10 minute window will reset the timer.

### VO-52 HAMSAT (28850)

**Launched:** 5/5/2005

**Status:** Operational. VO-52 has two linear transponders that use nearly the same passbands. The Dutch transponder has been in use since March 2012. Its beacon is very strong and an 'image' can be heard in the transponder downlink. Most activity is around



145.900 MHz. AMSAT-India have requested that FM is not used through either transponder.

**Mode:** U/V linear inverting.

**Indian transponder:**

**Uplink:** 435.220-435.280 MHz, Downlink 145.930-145.870 MHz

**Beacon:** 145.936 MHz continuous carrier

**Dutch transponder:**

**Uplink:** 435.225-435.275 MHz, Downlink 145.925-145.875 MHz (up to +/-5 kHz variation)

**Beacon:** 145.862 MHz CW 12 wpm preset message

<http://www.amsatindia.org>

The following are mainly Cubesats.

Reception reports are often well received and can result in a QSL card for your efforts. See websites for details.

### CO-55 CUTE-1 (27844)

**Launched:** 30/6/2003

**Status:** semi-operational. From the first cubesat launch CO-55's transmission is now mostly carrier with slight CW modulation.

**Beacon:** 436.8375 MHz CW telemetry  
[http://lss.mes.titech.ac.jp/ssp/cubesat/index\\_e.html](http://lss.mes.titech.ac.jp/ssp/cubesat/index_e.html)

### CO-57 Xi-IV (27848)

**Launched:** 30/6/2003

**Status:** Operational. Also from the first cubesat launch, CO-57 continues to send CW telemetry. It has an on-board camera. Pictures of the Earth can be found on the website below.

**Beacon:** 436.8475 MHz CW telemetry  
<http://www.space.t.u-tokyo.ac.jp/gsen/satinfo.html#xi4>

### CO-58 Xi-V (28895)

**Launched:** 27/10/2005

**Status:** Operational. CO-58 has an on-board camera. Pictures of the Earth can be found on the website below.

**Beacon:** 437.465 MHz CW telemetry  
<http://www.space.t.u-tokyo.ac.jp/gsen/satinfo.html#xi5>

### DO-64 Delfi-C3 (32789)

**Launched:** 28/4/2008

**Status:** Semi-operational. The linear transponder has failed. The control team switched DO-64 back to science mode on 29/1/2009. Often by the time it has reached VK/ZL the transmitter has stopped, so it will be heard here occasionally. If they change it to basic mode then the telemetry will be heard over VK/ZL on most passes. The telemetry can be demodulated and decoded using software from the Delfi website.

**Beacon:** 145.870 MHz (primary) or 145.930 MHz (secondary) 1k2 BPSK telemetry  
<http://www.delfic3.nl/index.php>

### CO-65 CUTE-1.7+APDII (32785)

**Launched:** 28/4/2008

**Status:** Operational. The CW beacon is on continuously. The mode L/U APRS digipeater has been activated during weekends using 9k6 GMSK modulation. Unproto via JQ1YTC.

**Mode:** L/U 9k6 GMSK

**Uplink:** 1267.602 MHz, Downlink 437.475 MHz

**Beacon:** 437.275 MHz CW telemetry.

[http://lss.mes.titech.ac.jp/ssp/cute1.7/index\\_e.html](http://lss.mes.titech.ac.jp/ssp/cute1.7/index_e.html)

### CO-66 SEEDS II (32791)

**Launched:** 28/4/2008

**Status:** Operational. CO-66 is a cubesat that transmits CW telemetry, packet telemetry and a pre-recorded message of voice and SSTV. Sometimes all three can be heard during a pass over VK/ZL as it changes modes. At 450 mW output, CO-66 has one of the strongest signals of any cubesat. Most passes I've heard have been the CW beacon.

**Beacon:** 437.385 MHz CW telemetry, 1k2 AFSK packet and FM Digital/SSTV

[http://cubesat.aero.cst.nihon-u.ac.jp/english/main\\_e.html](http://cubesat.aero.cst.nihon-u.ac.jp/english/main_e.html)

### HO-68 XW-1 CAMSAT (36122)

**Launched:** 15/12/2009

**Status:** Semi-operational. A faulty antenna relay is stopping use of the transponders but the beacon is operating continuously.

**Beacon:** 435.790 MHz CW telemetry

### MO-72 MaSat-1 (38081)

**Launched:** 13/2/2012

**Status:** Operational. MO-72 was built by the Budapest University in Hungary. Its mission is student design of various subsystems. It has taken some stunning photos of the southern hemisphere. Telemetry decoding software is available on the website. MO-72 is very popular among the amateurs who want to try working with satellite telemetry.

**Downlink:** 437.345 MHz CW and GFSK

<http://cubesat.bme.hu/en/>

### RS-series satellites

#### RS-15 RADIO ROSTO (23439)

**Launched:** 26/12/1994

**Status:** intermittent. The beacon only comes on when satellite is in full sunlight, and is not on every pass.

**Beacon:** 29.352 MHz on/off carrier

## Other satellites using amateur frequencies

### ISS (25544)

**Launched:** 20/11/1998

**Status:** Operational. The International Space Station has an amateur radio station that operates in many modes. Ultimately it depends on the manned crew's activities. Voice, digital, and SSTV modes are used. A new digital TV transmitter has been flown to the ISS with 13 cm downlinks.

**Mode:** U/V crossband FM repeater.

**Uplink:** 437.800 MHz FM, Downlink 145.800 MHz

**Mode:** V/V Digital / APRS 1k2 AFSK FM

**Uplink:** 145.825 MHz, Downlink: 145.825 MHz

**Mode:** V/V FM Voice, SSTV

**Uplink:** (Region 1) 145.200 MHz, (Region 2/3) 144.490 MHz, Downlink: 145.800 MHz

<http://www.issfanclub.com/>

<http://www.rac.ca/ariss/>

### AAUSat-II (32788)

**Launched:** 28/4/2008

**Status:** Operational. From the Aalborg University in Denmark, AAUSat-II's mission is measuring radiation. AAUSat-II is sending packets during daylight passes only.

**Beacon:** 437.432 1k2 MSK

<http://www.space.aau.dk/aausatii/eng/>

### STARS (33498)

**Launched:** 23/1/2009

**Status:** Semi-operational. STARS is two satellites tethered together. Both 'Mother' and 'Daughter' have CW and 1k2 AFSK packet telemetry on 70 cm but now only 'Mother' is operational.

**Beacon:** Mother 437.485 MHz, FM 1k2 AFSK, 437.305 MHz CW telemetry

<http://stars1.eng.kagawa-u.ac.jp/english/index.html>

### PRISM (33493)

**Launched:** 23/1/2009

**Status:** Operational. Following from the success of CO-57 and CO-58, the University of Tokyo built PRISM to carry a larger camera with a telephoto lens. The packet downlink is only available over the command stations in Japan, though the CW beacon is on worldwide. PRISM also has a messaging system, details on the website.

**Mode:** -/U 1k2 AFSK or 9k6 GMSK

**Downlink and CW beacon:** 437.425 MHz

<http://www.space.t.u-tokyo.ac.jp/prism/en/main.html>

### KKS-1 (33499)

**Launched:** 23/1/2009

**Status:** Operational. KKS-1 transmits a series of messages on its CW beacon though its batteries have deteriorated and it may stop part way through a message. Or it may just repeat the same message throughout the pass.

**Beacon:** 437.385 MHz CW message

### SWISSCUBE (35932)

**Launched:** 23/9/2009

**Status:** Operational. Transmits CW telemetry with frames every 30 seconds. Decoding software is available at their website. SWISSCUBE's mission has ended and will now be under control of two amateur stations in Europe.

**Beacon:** 437.505 MHz CW telemetry

<http://swisscube.epfl.ch>

### ITUpSAT (35935)

**Launched:** 23/9/2009

**Status:** Operational. This Turkish cubesat transmits a frame of CW every three minutes giving its name and callsign.

**Beacon:** 437.325 MHz CW message

### Tisat-1 (36799)

**Launched:** 12/7/2010

**Status:** Operational. Tisat-1 is the first Swiss student-built satellite. Its mission is to test various materials exposed to atomic oxygen at low Earth orbit.

**Downlink:** 145.980 MHz FM FSK, CW

**Beacon:** 437.305 MHz CW at varying speeds.

<http://www.spacelab.dti.supsi.ch/tiSat1MS.php>

### SRMSAT (37841)

**Launched:** 12/10/2011

**Status:** Operational. SRMSAT is a 10 kg nanosatellite built by SRM University in India. Its mission is to monitor greenhouse gasses.

**Downlink:** 437.425 MHz CW telemetry

<http://srmsat.in>

### HRBE and MCUBED (37855)

**Launched:** 28/10/2011

**Status:** Operational. The Hiscock Radiation Belt Explorer (formally known as E1P; Explorer one prime) is a cubesat developed at the University of Montana. Its mission is to measure the lower Van Allen radiation belt similar to the original

Explorer One. HRBE has a strong signal and should be easy to decode. It is joined to M-CUBED from the University of Michigan. M-CUBED's mission is to photograph the earth but has been unsuccessful so far. The satellites didn't separate after launch.

**MCUBED Downlink:** 437.480 MHz 9k6 FSK

**HRBE Downlink:** 437.501 MHz 1200 baud AFSK (use SSB not FM)

<http://ssel.montana.edu/e1p/>

<http://www.pe0sat.vgnet.nl/satellite/cube-nano-picosats/e1p/>

<http://www.umcubed.org/>

### Xatcobeo-1 (38082)

**Launched:** 13/2/2012

Xatcobeo is a cubesat from the university of Vigo in Spain and is demonstrating a software defined radio and measuring ionising radiation.

**Downlink:** 437.365 MHz CW (use FM to receive, 75 seconds between frames), 1k2 FFSK

<http://www.xatcobeo.com/cms/>

## AMSAT-VK

AMSAT Co-ordinator  
Paul Paradigm VK2TXT  
email: [coordinator@amsat-vk.org](mailto:coordinator@amsat-vk.org)

Group Moderator  
Judy Williams VK2TJU  
email: [secretary@amsat-vk.org](mailto:secretary@amsat-vk.org)

Website:  
[www.amsat-vk.org](http://www.amsat-vk.org)

Group site:  
[group.amsat-vk.org](http://group.amsat-vk.org)

#### In New South Wales

VK2RBM Blue Mountains repeater on 147.050 MHz

#### In Queensland

VK4RIL Laidley repeater on 147.700 MHz  
VK4RRC Redcliffe 146.925 MHz IRLP node 6404, EchoLink node 44666

#### In South Australia

VK5TRM, Loxton on 147.175 MHz  
VK5RSC, Mt Terrible on 439.825 MHz IRLP node 6278,  
EchoLink node 399996

#### In Tasmania

VK7RTV Gawler 6 metre repeater 53.775 MHz IRLP node 6124  
VK7RTV Gawler 2 metre repeater 146.775 MHz IRLP node 6616

#### In the Northern Territory

VK8MA Katherine 146.700 MHz FM

Operators may join the net via the above repeaters or by connecting to EchoLink on either the AMSAT or VK3JED conferences. Past experience has shown that the VK3JED server offers clearer audio. The net is also available via IRLP reflector number 9558. We are keen to have the net carried by other EchoLink or IRLP enabled repeaters and links in order to improve coverage. If you are interested in carrying our net on your system, please contact Paul via email. Frequencies and nodes can change without much notice. Details are put on the AMSAT-VK group site.

### Become involved

Amateur satellite operating is one of the most interesting and rewarding modes in our hobby. The birds are relatively easy to access and require very little hardware investment to get started. You can gain access to the FM 'repeaters in the sky' with just a dual band handheld operating on 2 m and 70 cm. These easy-to-use and popular FM satellites will give hams national communications and handheld access into New Zealand at various times through the day and night. Currently only SO-50 is available.

Should you wish to join AMSAT-VK, details are available on the web site or sign-up at our group site as above. Membership is free and you will be made very welcome.



### About AMSAT-VK

AMSAT-VK is a group of Australian amateur radio operators who share a common interest in building, launching and communicating with each other through non-commercial amateur radio satellites. Many of our members also have an interest in other space based communications, including listening to and communicating with the International Space Station, Earth-Moon-Earth (EME), monitoring weather (WX) satellites and other spacecraft. AMSAT-VK is the primary point of contact for those interested in becoming involved in amateur radio satellite operations. If you are interested in learning more about satellite operations or just wish to become a member of AMSAT-Australia, please see our website.

### AMSAT-VK monthly net Australian National Satellite net

The net takes place on the 2nd Tuesday of each month at 8.30 pm eastern time, that is 0930 Z or 1030 Z depending on daylight saving. Check-in starts 10 minutes prior to the start time. The AMSAT-VK net has been running for many years with the aim of allowing amateur radio operators who are operating or have an interest in working in the satellite mode, to make contact with others in order to share their experiences and to catch up on pertinent news. The format also facilitates other aspects like making 'skeds' and for a general 'off-bird' chat. In addition to the EchoLink conference, the net will also be available via RF on the following repeaters and links.



### **HORYU-II (39340)**

**Launched:** 21/5/2012

**Status:** Operational. Horyu-II will investigate high voltage generation issues with solar panels. The CW beacon is on worldwide, the 1k2 packet downlink is used over Japan.

**Downlink:** 437.345 MHz 20 WPM CW telemetry and 1k2 AFSK

[http://kitsat.ele.kyutech.ac.jp/index\\_e\\_new.html](http://kitsat.ele.kyutech.ac.jp/index_e_new.html)

### **AAUSat-3 (39087)**

**Launched:** 25/2/2013

**Status:** Operational. The third satellite from Aalborg University in Denmark, AAUSat-3's mission is a software defined radio capable of receiving shipping beacons in the north Atlantic. It has a beacon that transmits every 30 seconds. Nine bursts of data then the next is CW at 30 wpm.

**Beacon:** 437.425 MHz

<http://www.space.aau.dk/aausat3/>

### **STRaND-1 (39090)**

**Launched:** 25/2/2013

**Status:** Operational. From SSTL, Strand-1 is a 3U size cubesat based around a Google Nexus One smartphone. It will demonstrate a water-alcohol propulsion system.

**Beacon:** 437.568 MHz 9k6

<http://www.sstl.co.uk/Missions/STRaND-1-Launched-2013>

### **CUBEBUG (39153)**

**Launched:** 26/4/2013

**Status:** Operational. From Argentina, Cubebug is a demonstration satellite using open source hardware and software. Perhaps its greatest claim to fame is that it had a rare collision in space and has successfully been recovered.

**Beacon:** 437.4384 MHz 1k2 or 9k6 packet

<http://1.cubebug.org/>

### **ESTCube-1 (39161)**

**Launched:** 7/5/2013

**Status:** Operational. The first Estonian satellite has an electric solar wind sail.

**Beacon:** 437.250 MHz 18 WPM CW every 3-4 minutes

<http://www.estcube.eu/en/radio-details>

### **Final pass**

That's the lot heard during August. If all goes to plan in the next few months we will see the launch of UKube-1, FUNCube-1 and Delfi-n3Xt; all with mode U/v linear transponders (among other bits).



## **SOTA**

*Allen Harvie VK3HRA*

It has been a wet and windy couple of weeks but with the end of winter we are expecting the weather to improve. Whilst there have been quite a few drenched activations in the last couple of weeks, the enthusiasm has not declined in fact the increase of 40 m activity is being seen by many non SOTA players as positive. Whilst a bit hard to quantify, SOTA has to be contributing to the health of not just the amateurs involved but to the hobby generally.

The highlight of this month was VK1 celebrating 6 months on Sunday 11<sup>th</sup> August. The weather started foggy but after that evaporated there was a fairly calm sunny winter's day. Not content to wait for VK2 to be launched, Ed VK2JI, Rod VK2LAX and Jim VK2LC joined Andrew VK1DA, Ian VK1DI, Glen VK1FB, Matt VK1MA, Andrew VK1MBE, Mark VK1MDC, Andrew VK1NAM and Al VK1RX qualifying 9 VK1 summits.

There were with more S2S contacts than you could poke a stick at and on completion of the

morning's activations, the majority of VK1 activators reappeared at a cafe back in Canberra and enjoyed a late lunch whilst having a good chinwag. By all reports a great day was had by all.

Looking forward, the much anticipated launch of VK2 (New South Wales) and VK4 (Queensland) both on September 1st will only add to the activity. This will bring nearly 1500 additional summits and a yet unknown number of new activators and chasers. If the increase of activity as additional associations are launched are any indication, 40 m will not be big enough for all the activity. Other bands have to be addressed to cover the distances involved.

VK4 launches with over 400 summits and Dave Clodd VK4OZY as Association Manager. VK2 launches with over nearly 1100 summits and Andrew Davis VK1DA/VK2UH as Association Manager. There are far too many involved to mention here and not wanting to miss people, congratulations goes out to all involved with bringing

more SOTA fun to us, your efforts are appreciated.

Plans are already being formulated for a big launch.

So as the available regions and experience increases combined with improving weather, expect more adventurous activations.

Three new sloths in the one day is a good indication of how healthy the SOTA project is here in VK. The three new Shack Sloths, including one claiming the title of first for VK2 are Andrew VK2UH, Tony VK3CAT and Ian VK3TCX; with three new activators, Terry VK3UP, Colin VK5HCF and Glen VK1FB.

### **100 Point Activators:**

Ian VK5CZ  
Al VK1RX  
Paul VK5PAS

### **100 Point Chasers:**

Mike VK3XL,  
Phil VK3BHR  
Brian VK5FMID

Expect greater activity from down under.

73 Allen VK3HRA





# VK2news **Amateur Radio Central West Group**

*John Martin VK2EJM - Group Secretary*

In March 2012 a small gathering of licenced amateur radio operators and friends, in Orange NSW, tired of politics and paper shuffling, decided to form a new group dedicated to promotion of and participation in radio communications and electronics in a convivial atmosphere with minimal formalities. The group Intention was to offer training and instruction to school students and others in basic electronics and radio operation, including preparation for the Foundation Licence examination for those wishing to enjoy the amateur radio service as a licenced operator.

After several informal meetings the basic profile of the new group was decided and the process of establishing the group began.

From these meagre beginnings the 'Amateur Radio Central West Group' was inaugurated at a meeting convened on 15th April 2012. The Group has not sought Incorporation and has no intention to do so in the foreseeable future.

Over the following months Group rules were drawn up and formally adopted. Office bearers were elected and monthly meetings scheduled. As the Group has no permanent meeting place, meetings

will be held at various members homes until a permanent meeting place is available. The Central West is a large area across which members are scattered entailing considerable travel distances to attend meetings. Thus after 12 months meetings were rescheduled for every second month.

Since that time the Group has gone from strength to strength and although small in numbers the concerted effort of members has successfully applied for a Group callsign VK2ACW, repeater callsign VK2RCW and WIA affiliation. The repeater is now fully operational

*Photo 1: Group President Les VK2SON at the microphone in the 2012 RD contest.*





Photo 2: ARCWG members who attended the inaugural meeting.

on 147.200/147.800 MHz and a linked UHF repeater is under consideration. Office bearers have been elected and a bank account organised and administered by the Group Treasurer.

Group membership is by invitation only but expressions of interest are welcome and contact can be made by joining the HF net Wednesday evenings at 2000 EST

on 3.653 MHz; by e-mail to [arcwg@hotmail.com.au](mailto:arcwg@hotmail.com.au) or by post to the Secretary ARCWG, PO Box 8542, Orange 2800, NSW.

Group activities include field day events, contests, social outings and fund raising events in addition to training classes and equipment building projects (for example, link repeaters and antennas for both specific purposes and

experimental). Modes in use include CW, SSB, FM, digital and weak signal experiments (EME).

The Group participated in the 2012 VK/ZL and Remembrance Day Contests with VK2ACW operating portable, multi-operator single station and, in the RD contest gained second place, in the Multi-operators single station section, with 751 points. Our team in the 2013 VK/ZL contest was frustrated by appalling atmospheric conditions and abandoned the operation after a few hours.

The ARCWG webpage is accessible and, listed under Affiliated Clubs on the WIA website provides details of the Group, the office bearers, events, nets, contact details and more.

The ARCWG looks forward to friendly interaction and cooperation with clubs throughout our region. Membership is growing and the inquiries and expressions of interest being received heralds a healthy future for the Group.



## ADELAIDE HILLS AMATEUR RADIO SOCIETY INC

# Annual Hamfest

Sunday 3 November 2013

Goodwood Community Centre, Rosa St Goodwood

Buyers access from 9.30 am, Sellers set up from 7.30 am

Refreshments available. Door prizes.

Commercial traders in attendance.

Email [vk5bar@ahars.com.au](mailto:vk5bar@ahars.com.au) with enquiries and table bookings. More info at [www.ahars.com.au](http://www.ahars.com.au)



# Epilogue to the High Power Trial: electromagnetic radiation safety and your station

Roger Harrison VK2ZRH<sup>1</sup>

Understandably, many amateurs have expressed disappointment with the ACMA's decision to not make the necessary regulatory arrangements to allow Advanced Licensees to run powers up to 1 kW following the ending of the High Power Trial.

Some amateurs were surprised, some were not surprised.

The WIA Board has received a number of emails and letters from members; some members also emailed the Editor, and several have been published along with this article. There has also been lengthy discussions on-air and on the internet, particularly on the VKLogger Forums.

Debate is all to the good and reflects vigorous engagement with the issues related to the use of powers both up to and above that currently permitted.

Criticism of the ACMA's decision aside, the upshot is that we will *all* have to do some "homework" on our responsibilities concerning the electromagnetic emissions regulations and gain the necessary knowledge to assess our stations' current compliance, and likely compliance when making future plans.

## Background

Announced by the WIA on the website on 22 December 2011, and the weekly broadcast on 25 December 2011, the trial began on 1 March 2012 and ended on 31 August 2013.

The ACMA made regulatory arrangements so that Advanced licensees could apply for authorization to use transmitter output powers up to 1 kW peak envelope power (PEP) from one or more nominated fixed locations, with the following conditions applied:



Image reproduced with thanks from Wikimedia Commons.

- higher power could only be used on amateur primary service bands from 80 m to 10 m;
- stations had to comply with the limits on human exposure to electromagnetic radiation specified in the ARPANSA standard<sup>2</sup>;
- applicants were not required to demonstrate compliance with the ARPANSA standard at the time they applied;
- at any time during the trial, the ACMA could require a licensee to demonstrate compliance with the standard;
- RF interference was not to be caused to other devices – including, but not limited to, domestic consumer devices; and
- interested licensees could apply by completing form R057 and paying a once-off fee of \$49.

## History

Over 1997–98, the Australian Communications Authority (ACA – predecessor of the ACMA) introduced a general regulation for all apparatus-licensed transmitters, the *Radiocommunications Licence Conditions (Apparatus Licence) Determination* (it first appeared in an Advisory Note on my 1998 licence).

In 2000, the ACA required amateurs to assess their stations' compliance with electromagnetic radiation (EMR) exposure limits, publishing *Human Exposure to EMR: Assessment of Amateur Radio Stations for Compliance with ACA Requirements*. This was subsequently updated in 2002 and 2005<sup>3</sup>.

In 2003, the ACMA instigated regulatory reform of Amateur licensing, creating three licence

grades in 2004 with attendant PEP power limits: Foundation licence – 10 W, Standard licence – 100 W, and Advanced – 400 W. Meanwhile, the ACMA gazetted the *Radiocommunications Licence Conditions (Apparatus Licence) Determination 2003* (the “Apparatus Licence LCD”), with a commencement date of 1 March 2003. This LCD details the conditions applying to all apparatus-licensed transmitter installations (including broadcast, maritime, outback, scientific and amateur, etc) for compliance with electromagnetic emissions (EME) limits, based on the ARPANSA standard.

On 23 May 2003, the ACMA wrote to all apparatus licensees to inform them of the conditions imposed relating to electromagnetic radiation (EMR) health exposure requirements set out in the new Apparatus Licence LCD, and enclosing an “EMR Question and Answer Sheet” that explained the Compliance Level 1 and Compliance Level 2 categories, which was also posted to its website. The ACMA has maintained and updated information on the EME/EMR requirements for apparatus licensees on its website over the past decade.

Following creation of the National WIA in 2004, the Institute pursued regular liaison with the ACMA as the new peak body representing Australian radio amateurs. The question of a higher power limit for Advanced Licensees was among the wide variety of issues pursued by the WIA with the ACMA over the years between 2004 and 2010, although introduction of the Foundation Licence and other issues relating to the new Amateur licensing regime were foremost over the first few years. The WIA learned that sections within the ACMA were opposed to higher power on the grounds of interference and EME risks.

On 15 October 2010, then WIA President Michael Owen VK3KI (SK) wrote to the ACMA concerning a

higher power limit, advocating a change to the existing ACMA policy and regulations, proposing a basis for a new policy as follows:

- a) Advanced licensees could apply for a variation to their licence conditions;
- b) a power limit of up to 1 kW PEP, or 500 W mean; and
- c) applicants to demonstrate compliance with the ARPANSA EME standard.

In November 2010, the salient content of this letter formed the content of Michael’s *WIA Comment* column in AR magazine and the President’s blog on the WIA website, which has also been published here for your reference.

The higher power issue was pursued at further ACMA meetings, culminating in a meeting on 19 December 2011, followed by a letter of 21 December 2011 in which the ACMA proposed a trial commencing on 1 March 2012, to be reviewed after 12 months. The letter set out the principles and parameters of the proposed trial, which were detailed on the HF High Power Trial page on the WIA website (at: <http://www.wia.org.au/licenses/licensing/hfhighpowertrial/>).

On 22 February 2012, further details relating to the trial were announced on the WIA website and on the broadcast of 26 February 2012. This foreshadowed the start of the trial on 1 March. The WIA announcement pointed out that the Board

*“... thought it very important to point out to every amateur considering obtaining a higher power permit that this is a trial, and if problems do emerge, this could affect whether Australian amateurs will continue to be able*

*to use the higher power, if they wish. In particular, if interference is caused to others, the WIA advises that the amateur must immediately do whatever it takes to stop the interference, and must resolve the problem without resort to the ACMA.”*

Clearly, both the ACMA and the WIA advised that continuation of the regulations permitting higher power would not necessarily be automatic.

At the time the High Power Trial was announced, the ACMA issued an information paper, *Human exposure to radiofrequency electromagnetic energy Information for licensees, December 2012*<sup>4</sup>, and published a short article in its online “engage” newsletter. The ACMA also had EME self-assessment guidance information and a software application online, targeting all apparatus licensees.

The ACMA carried out a ‘desk audit’ to assess the trial over 1 March to late July 2013, writing to 90 participants and carrying out some three station inspections in conjunction with the audit.

### **The ACMA’s Decision**

On 5 August 2013, the WIA’s Spectrum Committee met with the ACMA in Melbourne and Sydney via video conference. The high power trial was discussed at length, the ACMA explaining its decision to not put in place the regulatory arrangements to enable Advanced licensees to operate on powers up to 1 kW. Other matters were also discussed, but the High Power Trial was the key topic. The WIA asked for the issue to be re-visited at a future time and the ACMA indicated it would be willing to do so in one year.

The ACMA subsequently wrote to the WIA, detailing reasons for

. . . we will all have to do some “homework” on our responsibilities concerning the electromagnetic emissions regulations . . .



the decision, and published a statement on its website in mid-August<sup>2</sup>, setting out those reasons, as follows:

*"As an evidenced-based regulator, the ACMA collected data from a number of areas in order to reach an informed decision on whether permanent regulatory arrangements should be put in place for the use of Higher Power. The specific areas covered were:*

- The demand for Higher Power reflected by the number of applications the ACMA received.
- A submission provided by the Wireless Institute of Australia including benefits derived from the use of Higher Power.
- A desk-based audit of trial participants' knowledge of, and compliance with, electromagnetic energy (EME) requirements specified in the Radiocommunications Licence Conditions (Apparatus Licence Determination 2003 (Apparatus Licence LCD).
- The results of site visits undertaken in conjunction with the desk-based audit.
- Relevant complaints of interference of which the ACMA was made aware during the trial.
- The impact the trial had on other services that operate in the high frequency bands.
- An examination of other countries' arrangements concerning the use of Higher Power.

After taking into consideration all the data obtained as part of the assessment process, the ACMA is of the view that the arrangements put in place for the trial should not continue. The ACMA has reached this conclusion for a number of reasons:

1. The number of Advanced Licensees that applied to use Higher Power was not substantial. As at 20 May 2013, 297 Advanced Licensees had applied for the Higher Power authorisation out of a

Clearly, both the ACMA and the WIA advised that continuation of the regulations permitting higher power would not necessarily be automatic.

total number of 10,690. This demonstrates that the vast majority of Advanced Licensees did not seek the Higher Power authorisation. Of the 297 that did obtain the authorisation, the ACMA was advised by some participants that took part in the desk-based audit that they had not used Higher Power. Therefore, the figure of 297 applicants is not an accurate reflection of the number of Advanced Licensees that actually used Higher Power.

2. The Wireless Institute of Australia's submission to the ACMA contains a limited number of contributions from trial participants. The contributions indicate that the benefits of Higher Power use were confined to those respondents and do not demonstrate broader benefits to the wider community. The limited number of contributions is also indicative of limited active engagement from trial participants.
3. Some Advanced Licensees' knowledge and awareness of the requirements of the Apparatus Licence LCD did not meet ACMA expectations. This is borne out by the results of the desk-based audit. There were 90 Advanced Licensees that took part in the desk-based audit. Of those 90, 17 were unable to demonstrate their compliance with the Apparatus Licence LCD. The reasons for this varied; some did not respond to the ACMA's request for information made in accordance with Apparatus Licence LCD, whilst others incorrectly assessed

the compliance level of their station. This was an important consideration given that the use of Higher Power was taking place within the wider community and the Apparatus Licence LCD sets out, among other things, the EME requirements for the operation of transmitters.

4. The ACMA is aware that *some* countries permit the use of transmitter power levels greater than in Australia. Whilst the ACMA did have regard to permissible power levels in other countries, these countries are likely to have different and unique regulatory arrangements and policy considerations. The ACMA, as an evidence-based regulator, must base its decision on the data collected during the assessment process and the requirements of the domestic legislative environment."

### The WIA Board's Position

The Board has conveyed its disappointment to the ACMA and has offered rebuttals to key issues outlined in the four reasons above.

In the lead-up to the trial, the WIA informed the ACMA that it estimated some 400-450 might be interested in the trial. The Board believes that the ACMA's view that 297 trial participants out of 10,690 Advanced licensees was "not substantial" is a specious comparison. Apart from the fact that the figure of 10,690 includes beacons, repeaters, expired and surrendered licences, and amateurs holding multiple licences – there were 9949 individual licensees at the end of August 2013, according

to the ACMA database – the number of individual licensees doesn't represent the "whole target audience" (the target market, if you like).

As neither the ACMA, nor the WIA, wrote to all the Advanced licensees to advise them of the trial, they were not all directly advised and could not possibly have been engaged. The WIA publicized the trial through its usual channels over some months – the weekly broadcast, the website and *AR* magazine.

Many amateurs maintain their licences, even though they're inactive. Most are active when first licensed and then go through periods of inactivity, returning to more consistent on-air activity later in life. At any one time, there is a considerable cohort simply maintaining their licence. Hence, only a comparatively small number of Advanced licensees had the opportunity to learn of the trial. The vast majority did not apply because they simply would not have known about it. On the WIA's estimate of the available target audience (400-450), the percentage participation was very high, from 66% at minimum to 74% at maximum.

As the trial had a defined period with no certainty as to the outcome, this appears to have deterred some otherwise interested amateurs who did not wish risking an investment in higher powered equipment for a trial with an uncertain outcome, while others were simply happy to observe "from the sidelines". Some may have simply been unable to afford higher power equipment, while still others may have been constrained in the erection of suitable antenna systems.

The WIA Board also believes that the ACMA's dismissal of the WIA's submission, conveying the results of the Institute's request for comments on the trial, to be unwarranted.

The submission was developed from responses to the request for comments publicized via the WIA broadcast and website in early 2013. The limited number of responses is indicative of the limited publicity period. The WIA had no idea of the number of trial participants, or their callsigns, and so was unable to write to participants in order to conduct a more effective survey. The Board took the view that the ACMA did not articulate its expectations and thus those who responded to the survey, and also the Board, could not address those expectations in the submission. "Second guessing" is the business of fortune tellers.

However, from discussion with ACMA representatives during the trial assessment period, it became apparent that a limited number of Advanced Licensees participating in the desk audit had apparently misunderstood, or misinterpreted, the requirements set out in the EME/EMR regulations. At the time, the WIA pointed out that the regulations and the supporting guidelines were lacking in clarity, coverage and accessibility. The ACMA agreed.

Regarding the issue that 17 of the 90 audited trial participants ". . . were unable to demonstrate their compliance with the Apparatus Licence LCD", for a variety of reasons, the Board has conveyed to the ACMA that, as this is a limited number in the broader context of the trial, it is the Institute's view there was no proper foundation to take that percentage (~19%) and

extrapolate it across either the 297 trial participants, or the whole cohort of Advanced Licensees (be it 9949 or 10,690).

The WIA also criticized the ACMA's research into the permissible amateur licence power limits in other countries, conveying the Board's belief that it was too limited in scope. The Institute pointed out that Japan, the USA and many European countries, all having higher population densities than Australia, permit amateur power levels ranging from 750 W to 2000 W, yet have government EME/EMR regulatory standards in place with human exposure levels not dissimilar to Australia's standard.

The WIA notes that the ACMA wrote to all 90 participants involved in the desk audit, advising them of the compliance outcome, and that the ACMA invited all 17 trial participants who incorrectly assessed the compliance level of their stations to provide new records to demonstrate compliance with the current EME/EMR requirements. The WIA is not aware of the outcome of the latter, at this stage.

### Where to From Here?

As the Spectrum Committee intends to revisit the issue of higher permitted power levels with the ACMA, scheduled to happen in the second half of 2014, the Institute now needs to prepare and implement plans over the coming year, to promote widespread awareness of the electromagnetic energy compliance requirements for amateur stations.

Electromagnetic radiation compliance is not just a technical issue, it is also a political issue among sectors of the community, as you may be aware, and as licensed amateurs we need to be mindful of that. As the regulator, the ACMA is responsible for notifying licensees of the requirements and pursuing compliance with the EME/EMR regulations.

Now is not the time to pursue 'who did what, why did it "go wrong", and who's to blame?' It will not contribute to achieving the

A lot of work will be required to plan and implement an awareness and knowledge-building campaign before the WIA can return to the ACMA with a new submission . . .



ultimate goal of achieving suitable regulations that permit the use of higher power across all the Australian amateur band allocations.

The Institute is aware that there isn't universal interest in operating with higher power than currently permitted. However, for some amateurs, it is the *availability* of higher power under their licence that is important as it affords the *opportunity* to experiment and learn about the technology, its applications and the advantages that may be obtained. After all, experimentation and self-training are at the very heart of the ITU definition of amateur radio.

The issue of compliance with the current EME/EMR regulations is not confined to the use of higher power than the 400 watts already permitted, it also applies to lower powers and differs in different sectors of the RF spectrum.

The WIA is set to work with the ACMA to update and improve the EME/EMR documentation so that the language is clarified and more accessible, and the coverage is broadened.

Already, the WIA has worked with the ACMA and Doug McArthur

VK3UM to update Doug's EMR Calculator application<sup>6</sup>, a very useful and comprehensive self-assessment tool.

A lot of work will be required to plan and implement an awareness and knowledge-building campaign before the WIA can return to the ACMA with a new submission requesting updated regulations on higher permitted power for Advanced Licensees. This has to be a collective project, to have any chance of succeeding, and the WIA encourages any and every interested amateur, and amateur radio clubs and societies, to take a close interest and participate when requested. Watch this space.

#### Endnotes

1. Roger is a director of the WIA and a member of the Spectrum Committee. He participated in liaison meetings with the ACMA this year concerning the High Power Trial and the subsequent updating of the VK3UM EMR Calculator.
2. This is the *Radiation Protection Standard for Maximum Exposure Levels to Radiofrequency Fields – 3 kHz to 300 GHz*, published

- by the Australian Radiation Protection and Nuclear Safety Agency (ARPANSA).
3. On the ACMA website at: [www.acma.gov.au/~media/Radiocommunications%20Licencing%20and%20Telecommunications%20Deployment/Information/pdf/Human%20exposure%20to%20EMR%20Assessment%20of%20Amateur%20Radio%20Stations%20for%20Compliance%20with%20ACMA%20Requirements.pdf](http://www.acma.gov.au/~media/Radiocommunications%20Licencing%20and%20Telecommunications%20Deployment/Information/pdf/Human%20exposure%20to%20EMR%20Assessment%20of%20Amateur%20Radio%20Stations%20for%20Compliance%20with%20ACMA%20Requirements.pdf)
4. On the ACMA website at: [www.wia.org.au/licenses/licensing/rfpowermeasurement/documents/EMR%20Assessment%20Guide%20for%20Amateur\\_radio.pdf](http://www.wia.org.au/licenses/licensing/rfpowermeasurement/documents/EMR%20Assessment%20Guide%20for%20Amateur_radio.pdf)
5. ACMA statement on its assessment of the trial: [www.acma.gov.au/Industry/Spectrum/Acquire-a-licence/Apparatus-licences/trial-of-higher-transmitter-output-power-for-licensees-i-acma](http://www.acma.gov.au/Industry/Spectrum/Acquire-a-licence/Apparatus-licences/trial-of-higher-transmitter-output-power-for-licensees-i-acma)
6. Available to download on the WIA website at: [www.wia.org.au/members/technical/emr/](http://www.wia.org.au/members/technical/emr/)



## WIA Comment - November 2010

### Permitted Power Levels

The WIA Board has considered the many representations that have been made about the permitted power levels for amateur transmitters, and has decided to again raise the issue, in the context of applications to vary the conditions of a licence. I set out, slightly edited, the substance of my letter to the Australian Communications and Media Authority on the issue.

"The issue of the permitted power levels for amateur transmitters has been raised many times with the WIA by many members, and has been the subject of previous

correspondence. This letter again addresses this issue.

The (then) ACA's Outcomes of the Review of Amateur Service Regulation, May 2004, (the Outcomes), Appendix A, specified Permitted Power as 10 W PEP all permitted modes for Foundation licensees, 100 W PEP for all permitted modes for Standard licensees and 400 W PEP all modes for Advanced licensees. By a letter of May 2005 advising that the introduction of the Outcomes would be delayed, Mr. Alan Jordan also advised:

"I also advise that the proposal to specify transmitter output power

only in terms of Peak Envelope Power (pX) will now not go ahead. This change is due to concerns about the potential for increased human exposure to electromagnetic radiation and increased interference resulting from what would be an effective increase in transmitter power output for some emission modes".

The WIA responded to that letter by a letter dated 12 January 2006, seeking a reconsideration of the ACMA position. The position of the Authority in refusing the WIA's request was set out in a letter from Mr. Jordan to the WIA dated 2 May 2006. The Authority has adopted

a policy to allow higher power for earth-moon-earth experiments above 50 MHz for Advanced licensees. That policy is set out on the ACMA website.

The WIA does not suggest any change to that policy in respect of earth-moon-earth experiments. However, many amateurs have continued to express concern in respect of the ACMA policy in relation to amateur power limits outside that policy. The WIA believes that these concerns are justified, and now proposes a solution that meets the concerns of the ACMA. We believe that the reasons for change are valid.

One matter that is raised by many is the power limits permitted by other administrations, particularly the United Kingdom and New Zealand. The Table below gives a summary of power limits permitted in a number of countries. While the Table covers only 13 countries it does provide a broad indication of the positions taken by countries with significant amateur radio activity. The Table covers the general position at HF and 2 meters with number of countries having special conditions, such as for VLF and 6 meters.

There are variations as to whether the power is measured "at the transmitter" or "at the antenna". The UK has adopted the "at the antenna" measurement and NZ "at the transmitter". Higher power limits are sought for a number of reasons. One is to overcome the increasing global electro-magnetic noise pollution on all HF bands from consumer and commercial devices.

A factor influencing many is that the lower power limits imposed by Australia detrimentally affect their ability to provide emergency HF communications with countries in the region suffering natural disasters and to participate in radio sports. There are an increasing number of contests throughout the year, and Australian amateurs wishing to participate must do so at a disadvantage to those competing

Country	Power limit for highest licence level
Belgium	1000 watts
Canada	2250 watts PEP or 750 watts carrier
France	750 watts PEP all modes on HF 120 watts PEP all modes on 2 meters
Germany	750 watts PEP all modes
Holland	400 watts PEP all modes
Japan	1000 watts HF, 50 watts 2 meters
Oman	150 watts
New Zealand	500 watts PEP all modes
South Africa	400 watts PEP all modes
Spain	HF 800 watts PEP, 200 watts carrier 2 meters, 200 watts PEP, 50 watts carrier
UK	400 watts PEP all modes
USA	1500 watts PEP all modes
Former Yugoslavian Countries	2000 watts

*Permitted maximum transmit power levels in selected countries, 2010.*

from other countries. Recognising the previously expressed concerns of the ACMA the WIA proposes that the ACMA adopt a policy that allows Advanced licensees to apply for a variation of their licence to permit higher power from a fixed location. This would enable assessment on a case by case basis, and allow better management of interference issues.

The WIA suggests that the following should form the basis of such a policy:

- As in the case of applications for higher power for EME experiments, the applicant must satisfy the ACMA that the proposed signal levels from the station comply with the radiofrequency emission limits stipulated in the ARPANSA standard Radiation Protection Standard for Maximum Exposure Levels to Radiofrequency Fields - 3 kHz to 300 GHz.
- Higher power should be available on all HF bands where the amateur service is primary (and the band 7100 to 7200 kHz).
- Power limits up to 1,000 watts PEP or 500 watts mean should be allowed.
- This policy should be applicable only to Advanced licensees.

May we ask that the ACMA clarify one matter?

It is noted that within the "Key Documents" for the Amateur Service, there is a lack of clarity in respect to how transmitter power should be measured and what the test parameters should be? As a starting point the WIA suggests that the methods contained in Sections 5.43, 5.44, 5.45, and 5.46 of the former Amateur Operator's Handbook (Revised December 1978) may be a starting point. We ask that the ACMA specify the preferred methodology for measuring transmitter RF power for the following emissions, namely SSB, AM, pulse and digital emission modes (FSK, PSK, MFSK and MPSK) which could be classified under either peak power or mean power methods.

With those changes the WIA submits that the ACMA would be adopting a policy that provides a realistic response to the many requests for a review of the earlier decision, but addresses the concerns of interference and electromagnetic radiation exposure."

I hope you agree with what is expressed in the letter.

**Michael Owen VK3KI (SK)**  
[www.wia.org.au/joinwia/wia/presidentsblog/](http://www.wia.org.au/joinwia/wia/presidentsblog/)





# Over to you

## High power trial

Dear Peter,

Like many fellow amateurs, I have been somewhat taken aback by the ACMA's decision not to move forward towards more permanent arrangements in authorising the use of higher amateur transmitter output power with the conclusion of the recent 'high power trial period' granted to applicants recently. To do so would have merely brought Australian amateurs in line with many other countries.

I accept Phil Wait's statement (WIA website) that "radio amateurs are not being singled out here.....compliance ....applies to all apparatus licensees....." Also credible is the statement by the ACMA that - "Through auditing, it was demonstrated that some participants' knowledge and awareness of the requirements of the Radiocommunications Licence Conditions (Apparatus Licence) Determination 2003 did not meet expectations". With the full onus being upon each amateur to 'self-access' regarding many aspects of the quite complex area of 'electromagnetic radiation' it's not at all surprising that many have not applied themselves as diligently as required the licencing conditions. The ACMA audit, it seems, bears out that some have been happy to partake of the privileges without realising, or caring, to meet their responsibilities towards licencing conditions.

I get all that!

There are, however, quite a number of things I 'don't get'!

Surely our fellow operators in other countries are no more astute at applying themselves to meet complex 'world-standard' EMC requirements than we Australians? Indeed, as stated in a letter originating from the ACMA "The ACMA examined arrangements overseas which demonstrated that there is no uniform approach when it comes to the use of Higher Power"

How is it that spectrum regulators' of other countries see fit to allow **their** amateur citizens be entrusted with 'high power'? Considerably higher power, actually!

Do they not also require their amateurs to 'self-access' accurately? Are we to assume our fellow overseas amateurs are smarter?

Personally, despite Phil's point of "radio amateurs are not being singled out", I'm feeling somewhat discriminated against as fellow amateurs in other countries **do not** seem to be under the same level of scrutiny as what we in Australia are required to face!

The introduction of the high power trial felt like a positive and encouraging 'carrot' being offered by our communications authority. I personally hoped it would usher in a more realistic era whereby amateurs would more freely admit to the use of the power levels they had been using for eons; levels more representative of the hobbies history if we are honest.

The notion that amateurs have religiously adhered to '400 watts' as per licencing conditions is pure fantasy that only somewhat naive bureaucrats' could think is the case!

After seeing the relaxing of requirements such as Morse code, multi-choice theory exams, the introduction of Foundation licence grades and the like, an experienced broadcast technician and fellow amateur once told me, "What incentives have ever been offered by the spectrum administrators to 'Advanced' level licensees". To continue: "We have diligently applied ourselves over the years to 'growing in the knowledge and application of radio technique' (the basis of our licence) - and they've made it almost impossible for me to gain a bit of extra power for my moon-bounce activities"

One would have thought it only a natural progression of good policy making that the ACMA not *seemingly* go out of their way to make it so difficult for amateurs to use higher power. I believe the ACMA's present 'stick approach' only encourages a feeling of the amateur radio hobby being administered by heavy bureaucrat - out of touch hands, thereby encouraging disrespect leading to **willing** breaches of licencing conditions. The authorities would do well to reflect upon the fact that many amateurs have entered the **regulated** hobby of amateur radio via 'Citizens Band' ranks where the poor attitudes of 'getting away with what you could' presided.

With such a 'demonstrable background' (as the bureaucrats may choose to put it) - do they really think the words of the LCD would put a halt to any such mentality?

Surely it be far better that they **encourage** where possible 'individual ownership of responsibilities' towards operating amateur stations to required standards, rather than foster a 'we'll just see if can get away with it' mentality as **will** continue as it has in the past.

The ACMA also stated that "Benefit from the trial was confined to a few Higher Power users, and there was no demonstration of benefit to the wider community"

I would have thought "benefit to the wider community" very hard to measure? Amateurs have a proven history of being of great 'benefit to the wider community' in times of disaster - 'Cyclone Tracey' and the like. I'm quite sure many a powerful linear amplifier was dragged into use to establish **reliable** communication with Darwin after the 1974 disaster where all 'official' communications means had failed for a period of time?

There will be those that consider 'we no longer need to practice HF technique anymore in this twenty-first century now that we have satellites, the internet and highly organised emergency services. However, it only takes a quick read of July 2013 'Amateur Radio' magazine (page 12) to see how modern digital communication links can quickly totally and catastrophically fail. Should we ever experience a 'Carrington' level solar event (a massive solar flare of the 1800's that caused an equally massive geomagnetic storm with its extreme earth induced currents) - destroying a large amount of world communication and power infrastructure - we would soon see if H.F. is so very, very redundant. If I were head of 'Defence' I would find it comforting to think there were 'duly licenced private citizens' (amateurs) - with at least *some* established level of communications proficiency come such events.

Lastly, perhaps this high power trial *policy reversal* decision by the ACMA is a wake-up call to all those who 'knock' the 'Wireless Institute' and its relevance.

I'm personally convinced there will be more and more of the sort of bureaucratic encroachment into the hobby recently displayed by the ACMA considering the world-wide 'over concern' by the general public in regard to 'electromagnetic radiation levels' - borne in the main *out of scientific ignorance* in my opinion. The resulting political pressure brought upon governments and communications authorities like the ACMA will continue to see more 'stick' emerging from bureaucratically driven departments' of the like, world-wide.

The old adage 'united we stand, divided we fall' appears apt when it comes to whether we bother with membership of 'WIA' or not. At least 'united' (substantial WIA membership) - we can become *at least part of the* 'political' discourse; as individuals we are powerless. I'm hoping the WIA will continue to negotiate with the ACMA on this matter.

Regards,

Aubrey McKibben VK3QD

## Over to you

### High power trial

Dear Editor,

I was one of the 297 participants in the Higher Power Trial conducted by the ACMA. At the time that my application was approved, I was quite confident that my station would conform to the ARPANSA EMR exposure limits. The only question to be resolved was whether the increased power resulted in unintended interference in the wider community.

Correspondence dated 24 July 2013 from ACMA's Compliance Operations Section notified me that an audit of my self assessment has been recorded as a pass. Up to this point, my station had successfully jumped two hurdles, namely that my modeling placed EMR at compliance level 1, and that no reports of interference had been attributed to my on air activities. Given that the potential for interference is real, and has historically been a barrier to running higher power in Australia, all seemed to be running smoothly. In particular, as only one instance – to my knowledge – of interference by one participant was both notified and resolved, there was cause for optimism that the trial had been a success.

Monday 5 August 2013 was not a good day. That was when the WIA was informed by ACMA that the higher power arrangements would not be made

permanent. What could have possibly gone so awry for ACMA to take this position?

Perusing the initial media release from ACMA dated 22 February 2012; this is part of what was stated ..... "ACMA believes a trial is appropriate to assess the impact of the higher power authorisation, including potential interference issues. After evaluating the success of the trial, the ACMA will consider whether more permanent regulatory arrangements are warranted. ....". This seemed rather uncomplicated – something akin to releasing a party balloon and seeing where it lands.

Quite clearly, the evaluation of the trial gave a very wide meaning to the words "...assess the impact...". Reading through the assessment of the trial was almost like writing the selection criteria for a job vacancy after all applicants had been interviewed. ACMA took into account that only 297 applications were made from 10,690 Advanced Licensees, inferring that the low demand was a criterion for not making the arrangements permanent. Applying this logic further, should all applications for an EME high power authorisation be denied on the basis of substantially fewer requests? Could the application fee for participation in the trial have deterred potential applicants from applying?

Another issue was that "...Some Advanced Licensees" knowledge and awareness of the requirements of the Apparatus Licence LCD did not meet ACMA expectations. ....". 90 desk audits were completed and the "some" refers to 17 amateurs who for one reason or another, either did not supply requested information, or incorrectly assessed the compliance level of their station. It appears that the remaining amateurs who correctly assessed their station have been hard done by. In all fairness, you cannot give every student a failing grade just because "some" have not achieved the class standard. There does seem to have been a real lack of natural justice here.

All is not lost however, as there is an agreement between ACMA and the WIA to revisit this matter, and in particular, to address concerns that amateurs generally need to be more aware of the EMR compliance requirements. This is not an onerous task, and it is not peculiar to our hobby. The same obligations fall on all radio users. It is up to all of us, working in conjunction with the only organisation that represents and promotes our interests - the WIA - to ensure the trial arrangements ultimately proceed to permanency.

Chris Bourke VK4YE

## Over to you

### High power trial

Dear Sir,

I see from the ACMA press release referring to the 1 kW "trial" that the ACMA believed that not all Amateurs intending to run 1 kW had taken part. This is not surprising - amateurs were never asked to do that.

I will certainly use 1 kW when it becomes available, but the reason I did not take part in the trial results from over 40 years of experience with politics and bureaucracy.

There could have been many different reactions from ACMA in response to the New Zealand decision. They chose a trial. However, there were no quantitative parameters for success or failure stated

from the start. This told me very clearly that the point of the trial was to delay, and hopefully find an excuse to deny, the request for higher power.

I was simply not prepared to waste my time and money on the charade of a trial.

The WIA must now demand the trial surveys and re-analyse the results. I am certain they will not support the capricious decision of the ACMA to deny Amateurs the use of 1 kW.

What will be found is that a number of Amateurs made mistakes in their audits. However, they will be found to be mainly administrative errors with little technical relevance to the issue of RF exposure. It will also show that the majority carried out

the surveys properly and had no problem in running 1 kW.

In any case if radio amateurs are doing their RF exposure tests inadequately then it is up to the ACMA to provide reliable guidance. The problem such as it is claimed to be will be just as relevant at 100 watts (on a small block of land) as at 1 kW (on a large block).

The WIA should pursue this through Freedom of Information, Ombudsman and Ministerial questions. Can we also identify the individual officers making these decisions. I, for one, am tired of people hiding behind the anonymity of a Government Department!

Martin Luther VK7GN





## Spotlight on SWLing

Robin Harwood VK7RH

e vk7rh@wia.org.au

August here in northern Tasmania has been one of the wettest on record. We have had over 190 mm of precipitation and one of my friends wondered when St. Swithins Day was celebrated. Yes it is usually celebrated in mid-July and although it has been very wet here, it has not been consistent. Whilst it has been wet here the opposite has been true for England over the same period. Dry and hot. It certainly looks as if the story of St Swithins Day is based on folk lore and not on meteorological fact.

Listening this winter season has been rather disappointing because of the departure of so many stations and services that utilise shortwave. Around June 21st we usually get signals coming in from Europe around 0200 UTC on the 49 metre broadcasting allocation. Alas they

have now gone. There were only a few very weak and warbly carriers that usually turned out to be nearby electronic devices. The higher frequencies were better. However I note that signals now seem to come from due north, usually from China. There was a strong signal with Radio China International yet checking online databases, it was originating from Albania. Apparently Beijing has upgraded their existing senders in Albania and also erected senders within the PRC close to the borders of Afghanistan, Iran and Kazakhstan.

As I have previously mentioned, the Chinese seem to now be the dominant shortwave broadcaster after the demise of many international broadcasters. When I first started out, it was Radio Moscow which was easy to hear.

They used to simultaneously transmit on many channels as they had a huge network of senders that stretched out the wide expanses of the USSR as well as utilising senders in so-called 'friendly' nations. Radio Moscow commenced in 1929 and will be finishing broadcasting on the 31st of December this year. This is hardly surprising as they have been steadily reducing their output in the past five years. The organisation will continue uploading podcasts. I am somewhat reluctant to go to any Russian websites because they seem to be infected with malware. Although Russian external broadcasting may be finishing, there are still plenty of utility and amateur stations to be heard.



## Spring VHF-UHF Field Day 2013

John Martin VK3KM - Contest Manager

### Operating periods

Stations entering the 8 hour sections may operate for more than 8 hours, and nominate which 8 hour period they wish to claim for scoring purposes.

### Entering more than one section

If a portable station operates for more than 8 hours, it may enter both the 24 hour and 8 hour sections.

If the winner of a 24 hour portable section has also entered the corresponding 8 hour section, his log will be excluded from the 8 hour section.

### Dates: Saturday and Sunday 23 and 24 November 2013

Duration in all call areas other than VK6: 0100 UTC Saturday to 0100 UTC Sunday.

Duration in VK6 only: 0400 UTC Saturday to 0400 UTC Sunday.

### Sections

- A: Portable station, single operator, 24 hours.
- B: Portable station, single operator, 8 hours.
- C: Portable station, multiple operator, 24 hours.
- D: Portable station, multiple operator, 8 hours.
- E: Home station, 24 hours.
- F: Rover station, 24 hours.

If a portable or rover station spends part of the contest period operating from his home station, he may also enter the home station section.

### Rover stations

The Rover section is for all portable or mobile stations that operate from more than two locator squares or

change locator squares more than twice.

### Two operators

If two operators set up a joint station with shared equipment, they may choose to enter Section A, B or F as separate stations under their own callsigns, or Section C, D or F under a single callsign. If they enter as separate stations, they may not claim contacts with each other.

### Multi-operator stations

Portable stations with more than two operators must enter Section C or D. Operators of stations in Section C or D may not make contest exchanges using callsigns other than the club or group callsign.

### General Rules

One callsign per station. Operation may be from any location. A station is portable only if all of its equipment is transported to a place which is not the normal location of any amateur station. Portable stations may change location during the Field Day provided the station is dismantled and reassembled each time it moves. You may work stations within your own locator square. Repeater, satellite, EME or crossband contacts are not permitted. Contacts using digital modes with computer decoding of the received signal are not permitted. Contacts made using modulated light are permitted, but they will be totalled separately and will not contribute to the final all-band score.

Except for CW, no contest operation is allowed below 50.150 MHz. Recognised DX calling frequencies must not be used for contest activity. Suggested procedure for SSB stations is to call on .150 or higher on each band, and QSY up to make the contest exchange.

### Contest Exchange

RS (or RST) reports, a serial number, and your four digit Maidenhead locator. Six digit locators may be exchanged but are not compulsory.

Band	Locators Activated (10 points each)	+	Locators Worked (10 points each)	+	QSOs	x	Multiplier	=	Band Total	
6 m	10	+	40	+	40	x	1	=	90	
2 m	10	+	40	+	30	x	3	=	240	
70 cm	10	+	40	+	20	x	5	=	350	
etc.										
Overall Total									=	680

The Maidenhead locator is optional if it has already been exchanged in a previous contact during the Field Day and neither station has moved since then.

### Repeat Contacts

Stations may be worked again on each band after three hours. If either station is moved to a new location in a different locator square, repeat contacts may be made immediately. If the station moves back into the previous locator square, the three hour limit still applies to stations worked from that square.

### Logs

Logs should cover the entire operating period and include the following for each contact: UTC time; frequency; station worked; serial numbers and locator numbers exchanged.

### Scoring

For each band, score 10 points for each 4 digit locator square in which your station operates, plus 10 points for each locator square worked, plus 1 point per contact. Multiply the total by the band multiplier as follows:

6 m	2 m	70 cm	23 cm	Higher
x 1	x 3	x 5	x 8	x 10

Then total the scores for all bands.

### Cover Sheet

The cover sheet should contain the names and callsigns of all

operators; postal address; station location and Maidenhead locator; the section(s) entered; the scoring table; and a signed declaration that the contest manager's decision will be accepted as final.

Please use the following format for your scoring table (shown on above table). In this example the operator has activated (operated from) one locator and worked four locators on each band

A blank cover sheet, with scoring table, is available on the Field Day page of the WIA web site.

### Entries

Electronic logs are preferred. Acceptable log formats include: ASCII text, RTF, DOC, DOCX, XLS, XLSX, MDB, PDF, or any Open Document format. Please email electronic logs to [vhfuhf@wia.org.au](mailto:vhfuhf@wia.org.au). Paper logs may be posted to the Manager, VHF-UHF Field Day, PO Box 2042, Bayswater Vic 3153. Logs must be received by Monday, 9 December 2013. Early logs would be appreciated.

**FIELD DAY WEB SITE** – <http://www.wia.org.au/members/contests/vhfuhf/>

This site includes the rules for the next Field Day, rules and results of all past VHF-UHF Field Days, cover sheets and scoring tables, and other information.



# WIA 2014 Callbook

Available in October





## VK7news

Justin Giles-Clark VK7TW

[vk7tw@wia.org.au](mailto:vk7tw@wia.org.au)

[groups.yahoo.com/group/vk7regionalnews/](http://groups.yahoo.com/group/vk7regionalnews/)

Congratulations to Rex VK7MO for setting VK2, VK4 and Digital EME records recently. Rex VK7MO and David VK3HZ set the 10 GHz VK2 record over a distance of 725.3 km. Rex and Doug VK4OE set the 10 GHz VK4 record over a distance of 196 km. Not one to stand still, Rex went on to set the 10 GHz Digital EME record with G3WDG over a distance of 17437.0 km. On ya Rex!

### EMCOMM Recollections

In the VK7 Regional News we recently ran an article on the history of the Mt Read repeater VK7RWC, by Dale VK7NDH. This sparked some interesting recollections of an early search and rescue on the rugged west Coast. WICEN's Roger VK7ARN worked on the west Coast and recalls that he was in one of the search parties in January 1987 searching for lost school children.

Roger recalls that it was near the old Dundas township and he was leading one of the search teams with an SES back pack radio operator and commented that communications were less than adequate. To give an idea of the rugged terrain and thick vegetation the radio operator had visual on the helicopter that was hovering only about 850 metres above and about 100 metres off the hillside but still had to talk the helicopter in as the pilot could not locate the ground party in the thick vegetation. This event was one of the leading reasons for the creation of the West Coast Radio Group who went on to put VK7RWC on Mt Read.

### Repeater and beacon news

The following news comes from Hayden VK7HA from the Southern Tasmanian Repeater Association.



The VK7RML repeater site on Mt Lloyd, at 933 metres – near New Norfolk in the Derwent Valley. Photo courtesy of VK7HA.

There is now a new 70 cm repeater VK7RML on Mt. Lloyd near New Norfolk providing coverage for the Derwent Valley and south west. Frequencies are 439.950 MHz output and 434.950 MHz input with a CTCSS tone of 91.5 Hz. This is permanently linked to VK7RCH (Grey Mountain) and VK7RAA (Mt Barrow). There is also an APRS digipeater now located on Mt Lloyd.

Of interest to the north and north west of VK7 would be that the VK3RXX beacons in Camberwell, QF22nd are now GPS locked. At 10 watts each on 1296.530 MHz and 2403.530 MHz, and on 10368.530 MHz at two watts and

all are horizontal polarisation. Signal reports to Alan VK3XPB.

### North west news

Rick VK7RI has been running shed nights over the last few months that has seen RT85 six metre conversion nights, other radio related activities and social gatherings. Recently there have been some video nights of DXpeditions to Scarborough Reef, Heard Island and South Georgia. Stay tuned to the VK7 Regional News for what's coming up in future shed nights.

### Northern Tasmania Amateur Radio Club

Who is Hearth Vader? No it's not a new Star Wars character; it's the new fireplace in the NTARC clubrooms! Regular working bees at the clubrooms have seen many improvements made including a new fireplace which was rapidly pressed into service over winter. A big thank you goes to Ian VK7IH for the donation of the fireplace and John VK7XX for the additional flue.

The NTARC August meeting saw a presentation from Lalla Mackenzie and Dylan Parrant on the NBN

project. The presentation was well received with special appreciation made of the remote telemedicine possibilities of the NBN into the future. Thanks to Lalla and Dylan for a great presentation. By all accounts the social dinner night held at the Queens Head Inn, Perth was a great success as well. 28 members and partners attended.

### Radio and Electronics Association of Southern Tasmania

REAST's annual Show and Tell night was another great success. Thanks to Tony VK7VKT for this information. There were many members who brought along items of interest. We had everything from audio amplifiers, a homebrewed two meter portable radio complete with the case made from an aluminium press of a vinyl record, home brew test gear, computer cassette tape drive, remote control PC interface, kit radios, power supply units and much more. Thanks also to Tony VK7VKT for running the social nights during August whilst the

## Silent Key

Colin Perger VK3KWM

Colin Perger would be known to many VK7s as 'the original' VK7KW. He died peacefully on August 13, age 72.

Colin moved to Tasmania in the 1960s, having married his Tasmanian wife Doreen. His earlier career had been in military radio communications. His first Tasmanian job was with Nichols Radio in Launceston, during which time Trevor VK7TB had some influence that resulted in Col's first call sign VK7ZCP.

His employment soon changed to radio maintenance at Launceston airport where he worked with VK7PF, VK7ZRF and VK7ZEC and upgraded to the call sign VK7KW. During this time he became President of Northern Zone, WIA, Tasmanian Division, now known as the NTARC. He was also elected to the Tasmanian Divisional Council.

Col made an important contribution to the building of the two metre FM repeater in the airport facilities on Mt Barrow. During this time he took leave-of-absence to 'overwinter' at Casey Base Antarctica. Many would remember the regular skeds with VK0KW.

Col later worked for a time with VK7JG at AWA then in his own marine communications business. On retirement he and Doreen moved to Col's native Victoria where he became heavily involved with the Eastern and Mountain District Radio Club. His last call sign was VK3KWM.

Vale Col.

Contributed by Joe VK7JG and Yvonne VK7FYMX.

author was in VK5, DATV and club station VK7OTC proudly participated for the third time in the ATV QSO Party held over the

weekend of 30/31 August and a big thank you to Peter VK3BFG for organising and performing the master control function.

## Over to you

We have recently been allocated two new bands, 136 kHz and 472 kHz.

The activity in these two new bands has been sporadic and the uptake by amateurs has been very low. This is in part because of the lack of commercial equipment, which is understandable. There is also a general misconception that efficient aerials for the two lowest bands will not fit in the typical suburban block. While this is true, experiments done with very small aerials show that while the efficiency achieved is indeed very low, the propagation characteristics on both bands make up for it, at least to a degree.

CW contacts covering hundreds of kilometres are challenging but possible for the well prepared, restricted aerial, operators. Slow speed digital modes do even better, even for the QRP operators. In fact, while SSB or other voice modes are generally very inefficient and there are bandwidth restrictions that would

prevent amateurs from using them, traditional Morse code, which scares some amateurs away, is certainly not the only mode used in the new bands.

Regarding the lack of commercial equipment, my view is that the lower bands are very forgiving in the construction techniques and require only the most modest test equipment, a DMM and an old CRO is all that is needed. I would argue that LF and MF are the ideal bands for those who would like to have a go at making their own radio equipment. It is also important to note that, in general, no expensive and exotic parts are needed, at least for the lower power constructions. There are many simple designs published around the world, including designs by Drew VK3XU and Dale VK1DSH published in AR.

In conclusion, please consider using the new bands. Speaking from my experience, my

involvement in LF and MF has been the most rewarding experience in amateur radio so far. I have learnt a lot, and this knowledge is certainly transferable to other aspects of our hobby.

Search the net and you will discover many ideas for equipment, aerial construction, operating techniques, and organised groups (such as the Australian 630 metre Yahoo group), full of people willing to assist you in your first steps in these very exciting new bands.

I will end this short letter with a suggestion to all contest managers. Please consider including the new bands in the contests you are managing. Give extra points for contacts on these bands, to reflect the challenges involved and to encourage amateurs to use them.

73. Dimitris Tsifakis VK1SV.



Keith Bainbridge VK6RK

e vk6rk@wia.org.au

This month we have a good selection of reports from around the State, so I'll start off with the **NCRG and Hamfest 2013**.

We had some fears and doubts about Hamfest this year as numbers in the hobby seem to be declining but our concerns were unfounded. Just over 300 passed through the doors and spent some money! We had reports on how good the beef rolls were, how many caught up with friends they hadn't seen for years and one report from a local that the radio he had sold several years ago at Hamfest had been seen being sold again a few years ago and was sold once again this year, true recycling!

We would like to thank Icom Australia for their continued support and the caps and other promotional items they sent over. The raffle was well supported again with the first prize of an Icom IC-718 jointly provided by Timberden Plant Hire and

the NCRG. Other prizes were donated by VK4ICE Comms, Tet Emtron and VK6APK, thank you all. Thanks also to all those who took tables to promote their groups, for instance the VHF Group, WARG, Hills Group, Peel Group, Bunbury radio club, Scouts and the many traders, especially Fritz VK6UZ, ten tables this year!

Also, a big thank you to all NCRG members for their hard work organizing and grafting on the day. The hall is booked again for the first Sunday in August 2014, see you all there I hope.

Other NCRG news is that one of our members Tim VK6EI is into RC Helicopters and brought along a hexacopter to show us. For those unfamiliar with these devices have a Google, they are amazing. He had a GoPro camera attached to the beast and flew it up several hundred feet above the clubhouse. I've attached one picture of many that he took of the club from up there,

a very different perspective on the antennas and towers.

The NCRG will repeat last year's event and host a car boot sale on Sunday November 3rd at 9 am. It will be at the NPSARC, Whiteman Park, off Gngangara Road and there will be a BBQ on the day. So put it in your calendars and let us know if you want a space reserved. More details to follow closer to the day but just letting you all know.

## News from the Peel Amateur Radio Group Inc (PARG)

On Saturday July 20th PARG members got together for the 2013 inaugural Saturday session/club practical day at the Mandurah Scout hall on Anstruther Road. Members enjoyed some valuable airtime using the clubs mobile communications unit for some great overseas contacts on 20 metres. Recently joined amateur Stevie VK6SMK enjoyed some club fellowship

Top of the 40 metre tower at the NPSARC.

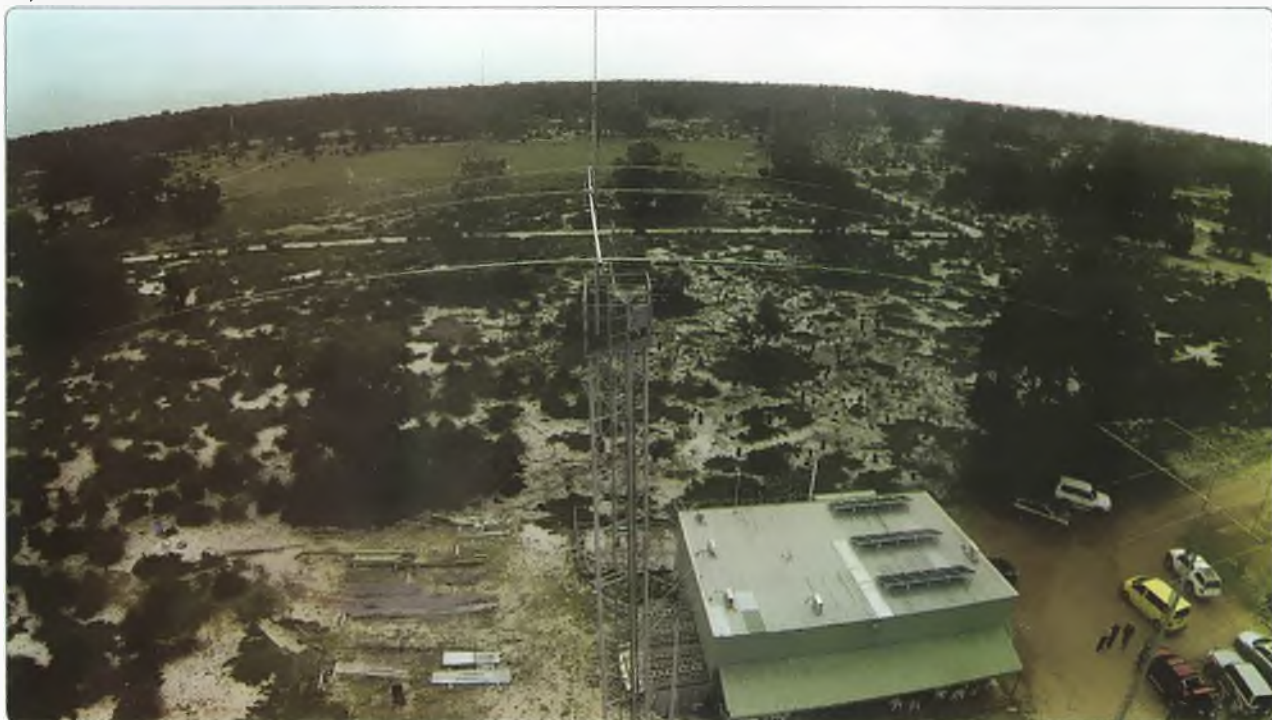

and the chance to test recently purchased radio gear on the clubs HF antennas.

Some much needed maintenance was done on the groups HF Loop Skywire antenna in preparation for JOTA. Matching problems were not fully sorted with this loop, so at Lance VK6LR's suggestion members will return with a variety of baluns at a later date to get the antenna right, primarily for 40 and 80 metres.

Hamfest on August 4th was a very successful outing for PARG members. With an excellent group turnout we earned some very useful funds from the sale of donated radio gear. With regret I couldn't attend myself as once again I was already booked for instructing Scouts in techniques of Car Racing.

Well done to NCRG once again for hosting this great get together. PARG members will get together again for the second Saturday club session at the Mandurah Scout hall on August 31st at 1130 local.

Paul Gardner VK6LL, President - Peel Amateur Radio Group Inc.

Thanks Paul.

## News from the Hills Amateur Radio Group

HARG took part in the ILLW and RD Contest on Saturday 17th August by setting up at Woodman Point. A large metal fence and the nearby water served as a counterpoise to the squid pole antenna with an automatic tuner at the base. The Club's Annual General Meeting was held on Saturday 31st August and the committee members for the next year are President: Martin VK6ZMS, Vice President: Rob VK6UFO, Secretary: Christie VK6XCJ, Treasurer: Cliff VK6LZ. Committee members are Miles VK6MAB, Heath VK6TWO (Technical Officer) and Bill VK6WJ (Publicity Officer). At this meeting we also welcomed four new members - Bob VK6ZGN, Mal VK6LC, Craig VK6VCK and Anthony VK6US. Thanks for joining HARG and we hope to see you all on a regular basis from now on. On the 28th to 30th September a number of HARG members spent the

long weekend on an "RF Campout" at the Bald Hill Camp Ground near Toodyay. Various antennas were put through their paces and a pleasant weekend was had by all. At our next General Meeting on Saturday 26th October, Heath VK6TWO will be giving a talk on Android Apps for Ham Radio and showing off a Wireless Bluetooth VNA/Antenna Analyser controllable remotely by Android and Windows. This meeting was originally scheduled to be a talk on Satellite Communication but recent interest in Android Apps by several members led to the change. At our social/practical meeting on Saturday 9th November Rob VK6LD will give us a talk on Fox Hunting techniques. Cheers and 73 from Bill VK6WJ for HARG.

Now a report from WARG on their recent activity day.

## WARG equipment test day

On Sunday 23rd of June 2013, WARG held an equipment test and tune up day at the Peter Hughes Scout communication centre in East Cannington.

For a gold coin donation amateur operators could get their equipment tested on sophisticated radio test equipment, not normally found in the shacks of radio amateurs.

Anthony VK6AXB and Ray VK6ZRW performed the tests on equipment and recorded results on a test report to see whether equipment was to specification.

Some surprising results were obtained and some suspected faults were verified during the day.

Thanks to Heath VK6TWO for that update.

The Scouts have been busy, here's a report from Bob VK6POP:

*Recently the Scout Communications team travelled to Dwellingup to set up radio communications for a Scout event. Some 700 Scouts participated in an overnight hike on a course around the outskirts of the town.*

*The Scouts reported into seven control bases, and there they took part in an activity, and were scored*

*on how well they worked as a team to complete the activity. The bases also reported back to the administration centre, by radio, when the Scout patrols arrived, when they moved on, which direction they were heading, and how they scored on the activity.*

*To facilitate this communication, our team set up a repeater on a high point, and provided the bases and administration with radios.*

*The Scout Communications team recently acquired some commercial UHF licences to enable the operation of fixed location repeaters at the Manjedal Scout Activity Centre, and two portable repeaters for statewide operation.*

*Several Scout events every year benefit from effective communications both for operational and safety reasons. To this end, the Scout communications team has accumulated the equipment to make this possible.*

*Back to Dwellingup. The communications team set up a base camp near the repeater, and stayed on deck all night in case of problems with the equipment. Like all good amateurs do, we put up an antenna, a G5RV, and switched on a transceiver. Using EchoLink, we made contact with a Scout and guide camp in Suffolk, England, with Peter GB8LS running the radio shack. After having an EchoLink QSO with a few kids, we arranged to talk on 20 metres. We agreed on a frequency, and there they were. Peter was using the Suffolk Scouts and Guides callsign, GB4SSG. Conditions were a bit noisy, however we did make contact and hold a brief QSO.*

Thanks Bob.

Finally there was good turnout for the RD Contest in VK6 this year and it looks as though some certificates for both individual and group activities will be winging their way west soon, well done to you all, more when the results are known!

I've received many pictures this month, so I'll try and include the ones I can't use this month for next time.

73 de Keith VK6RK.







# VHF/UHF - An Expanding World

David Smith VK3HZ  
✉ vk3hz@wia.org.au

As could be predicted in the depths of winter, August has been a very quiet month for VHF/UHF propagation. So, there's really nothing to report in that regard.

There is on-going activity in the digital area, with a number of people running WSPR beacons so it's worth describing again. WSPR was created by Joe K1JT (of WSJT fame). More information can be found on his web site at: <http://physics.princeton.edu/pulsar/K1JT/wspr.html>

To quote from the WSPR User Manual:

*WSPR (pronounced 'whisper') stands for 'Weak Signal Propagation Reporter.' The WSPR software is designed for probing potential radio propagation paths using low-power beacon-like transmissions. WSPR signals convey a callsign, Maidenhead grid locator, and power level using a compressed data format with strong forward error correction and narrow-band 4-FSK modulation. The protocol is effective at signal-to-noise ratios as low as -28 dB in a 2500 Hz bandwidth. Receiving stations with internet access may automatically upload reception reports to a central database. The WSPRnet web site provides a simple user interface for querying the database, a mapping facility, and many other features.*

While WSPR was originally designed for HF use, it certainly works well for monitoring paths on two metres. On that band in VK, the nominal WSPR frequency is 144.489 MHz.

Storing the spots in a database means that, in the longer term, some interesting analysis of propagation trends over certain paths may be possible. However, for the data to be useful and comparable from day to day, it's important that the station

setup - in particular the antenna - be constant. While it's interesting to beam in different directions to see how far the signal goes, the beam heading is not stored in the database, so there's no knowing for a given report if the antenna was pointing north, south, east or west. Therefore, to produce useful results, it's better to run either an omnidirectional antenna or, if there's a particular path of interest (for example, the Bight) use a fixed Yagi. While five watts of WSPR into an omnidirectional antenna doesn't sound like much, it is roughly equivalent to 100 watts of SSB into a modest Yagi.

More information on WSPR activities in Australia can be found on the VK Logger in the Forums under Digital Modes.

## VK3RXX 1296 MHz, 2.4 GHz and 10 GHz beacons

Alan VK3XPD reports the following: *Both the 1296.530 and 2403.530 MHz VK3RXX beacons are now back on air, GPS-locked, both running 10 watts. Antennas are Alford Slots, now a little higher at about 10 metres so hopefully they will get out a bit better. The 10 GHz beacon on 10368.530 MHz is also still running with two watts into a Waveguide Slot at 10 metres.*

*All signal reports to Alan at [alandevlin@bigpond.com](mailto:alandevlin@bigpond.com) will be gratefully received and acknowledged.*

Please send any Weak Signal reports to David VK3HZ at [vk3hz@wia.org.au](mailto:vk3hz@wia.org.au)

## Meteor Scatter by Kevin VK4UH

As we have touched on in this column over recent months, the number of meteors providing us



## Digital DX Modes

Rex Moncur  
VK7MO

with useful 'radio' returns is neither constant over a 24 hour day nor across the seasons of the year. Although 'random' meteor activity can occur at any time of the day or night and during all months of the year, there are distinct peaks for radio returns occurring just before dawn, with a corresponding trough during the afternoon and evening, and during the summer months in each hemisphere, with a corresponding period of low activity during the winter. Visible meteor trails are seen in the night sky only because those occurring in the daytime are masked by ambient light.

Superimposed on this cyclical pattern of random meteor activity are periods of often markedly increased rates of meteors observations. These meteor 'showers,' or at least their visual effects, have been observed since the earliest times and were recognised as returning at the same time each year. Unlike 'random' meteors, those seen in showers appear to be originating from the same point or 'radiant' in the sky. Meteor showers are therefore very predictable and are named according to the star constellation from where they appear to originate. To make optimum use of meteor showers for VHF communications requires a knowledge of the peak predicted dates and the radiant (source constellation) of the shower

being above the horizon at both ends of the path. Maximum activity during meteor showers may not correspond to the normal pre-dawn peak from randoms.

Much of what is written about amateur VHF meteor scatter relates to activity in the northern hemisphere. Some of the most intense meteor scatter propagation reported across Europe and North America occur from showers whose radiants are below our horizon and therefore do not support VHF propagation across VK and ZL.

I am grateful for the advice and assistance from Arie VK3AMZ in the preparation of the following Meteor Shower Calendar specifically intended for our region.

Meteor shower name	Date of shower peak
Lyrids	22nd April
Eta Aquarids	5/6th May
Southern Delta Aquarids	28/29th July
Orionids	21st October
Leonids	17/18th November
Geminids	13/14th December

Both the Geminids and Eta Aquarids are very intense, so much so that meteor scatter two way contacts have been successful on 432 MHz using FSK441 and SSB.

Without a major shower occurring during August, meteor scatter activity has reflected the slow rise from the winter trough of random MS propagation. Complete QSOs using MS on 144 MHz, FSK441 and JTMS modes, during the Saturday and Sunday activity periods have been reported on the VHF Logger between VK's 1, 2, 3, 4 and 5 and across ZL. Contacts across the Tasman between ZL and the southerly call areas have also been occurring. In general across this month, reported meteor return rates have been low with the majority of pings being weak. Typical conditions for this time of year. I had some personal success having completed for the first time with Rex VK7MO in Hobart on 21st August. At 1798 km this is my furthest QRB and a new grid and

call area for me on MS. The QSO took 40 minutes to complete. Roll on summer and the next meteor shower, the Orionids, in October.

Please send any Digital DX Modes reports to Rex VK7MO at [rmoncur@bigpond.net.au](mailto:rmoncur@bigpond.net.au)



## The Magic Band – 6 m DX

John McRae  
VK5PO

August has been another reasonably quiet month. The band has been open into JA from mostly the northern tropics region. VK6OX/p made a contact with JI1CUL on 21st August from grid-square PG08MM.

VK8MS worked Fred KH7Y in Hawaii on the 24th of August.

Brian VK4EK and Lloyd VK4FP worked into JA at various times during August, and Wayne VK4WTN heard several JA beacons on the 19th, and snared a contact with BA4SII! On the 29th and 30th, Wayne heard various JA beacons again. Signals were reasonably weak by all accounts. Let us all hope for a 'burst' of solar activity soon, so that some exotic DX is worked from VK, particularly from the southern part of our continent.

Darrell VK2BLS reports on meteor scatter propagation:

*My August operating continued with morning digital modes MS contacts on 50.230 with Wayne VK4WTN. Most days we try 50.2 SSB and point south, looking for Frank VK7DX. John VK4ZJB can usually be heard working Frank. Oly VK3XDX worked Scott VK4CZ on occasions with fast CW on MS.*

*The August MS bursts and burns have generally been fast and short. Working MS can be a bit like fishing, by patiently monitoring 50.200 and VK7RAE with Spectran running. This brilliant software helps show when the MS bursts and A/E are starting,*

*then calling on 50.200 can result in many two way contacts, although short and sweet, but on some mornings there is very little activity.*

And from Steve Gregory VK3OT/ ZAZ:

*VK4ZJB and myself, VK3ZAZ are about to log 50 years on 50 MHz. We Lost 50-52 in 1964 and still do not have it all back of sorts. Both of us have six metre DXCC obtained two cycles ago after 20 years of trying. I have recently completed 105 countries on six metre CW which also took 20 years.*

*Many other VK stations from the era of initial 'ZED' calls will also be reaching the 50 year milestone on six metres. Let's hear from you guys! Maybe we can start a '50 on 50' club.*

*Some highlights are: VK3 to EU over two cycles, 25 countries contacted and much common ground created.*

*Handing out 10 different countries on the six metre band and making first 50 MHz QSOs for many stations, including into VK.*

*Repeat Florida QSOs during this cycle along with VK5PO who pipped me for longest terrestrial distance so far (recorded) in the world this sun spot cycle.*

*Holder of many VK six metre records over four cycles, 33 years.*

*Mexico and USA worked over 33 years and four cycles 21-24.*

*W6 from YJ8 in 1979 which ARRL recorded as a US First.*

*Worked all seven continents in 1993, along with VK3LK and VK5NC (Antarctica is unofficial number seven).*

I reckon Gary VK5ZK and Brian (now VK5BC) have clocked up 50 on 50 too. Of course there are many others. I would really like to hear from anyone about their exploits on six metres over 50 years. I bet there are some more great stories just waiting to be told to us all.

Please submit reports, logs or other information you may consider useful to John VK5PO at [vk5po@wia.org.au](mailto:vk5po@wia.org.au)







# DX-News & Views

Chris Chapman VK3QB and Luke Steele VK3HU  
e vk3qb@wia.org.au

## August on the bands

As the days finally start to lengthen, so too has propagation started improving. The higher bands are still not doing much, but that should pick up through spring. 160 m has seen some weak openings to USA our evenings, but that should soon be better. 80 m remains fairly consistent, with some nice signals across the Pacific. Steady performers, 40 and 30 m have been good. The long path to Europe is good on 20 m late afternoons, with some openings to Africa about the same time, also long path. Signals are starting to appear again late at night on the 20 and 17 m bands, mostly Europe on the short path. Keep a watch on 15, 12 and 10 m, as these bands should also fire up.

The Vatican station HV0A was on air early in the month, with some very good CW operators. This one is only on air occasionally, with little notice, so keep an eye on the DX Cluster.

A nice surprise was Zorro JH1AJT's operation as XZ1Z in Myanmar. Zorro was in the new capitol Nay Pyi Taw, on a Foundation for Global Children mission. He expects to be back in Myanmar in October/November. ARRL DXCC Desk has already approved XZ1Z for DXCC credit.

Fernando TZ6BB shows up almost daily, and is good copy on 20 m long path in the late afternoon, both on CW and SSB. Bob, 3B9FR has been on daily around 0230 on 20 m CW. Palestine was also on air, with Peri E44PM doing another great solo operation. Venezuelan IOTA expedition YW5X was very

## Some Upcoming DX Operations

The following table summarises some of the DX activations that may be of interest to VK operators.

Date	Call	QSL via	Information
24 Sep – 16 Nov	5X1NH	G3RWF	Uganda. Nick G3RWF.
27 Sep – 11 Oct	3D2GC/p 3D2DD/p	Home call	Rotuma (OC-060). LZ1GC as 3D2GC and 3D2DD, HF, CW, SSB.
1 – 3 Oct	H7H	LotW	Nicaragua. Spanish team of six. 160 – 6 m, CW, SSB, RTTY.
1 – 11 Oct	CY0P	VE1RGB	Sable I. (NA-063). VE1RGB, WA4DAN, A15P. 160 – 10 m, CW, SSB, RTTY.
2 – 5 Oct	9N2YY	LotW	Nepal. OH2YY, 20 – 10 m SSB.
2 – 14 Oct	TX5D	LotW	Austral I, Raivavae (OC-114). KZ1W, N7QT. 80 – 10 m, CW, SSB, RTTY, PSK.
3 – 17 Oct	TO2TT	OQRS	Mayotte (AF-027). Team of seven ops, 160 – 6 m.
6 – 10 Oct	A52YY	LotW	Bhutan. OH2YY. 20 – 10 m SSB.
7 – 18 Oct	K9W	LotW	Wake I (OC-053). 160 – 6 m, CW, SSB, RTTY.
8 – 20 Oct	XR0ZR	LotW	Juan Fernandez, Robinson Crusoe I (SA-005). Eight ops, 160 – 6 m, CW, SSB, RTTY.

active from Orchila Island. Magdi ST2M has been on air from Khartoum, Sudan.

There is a lot of DX to look forward to from October onwards. Enjoy the chase!

5X1NH, **Uganda**. Nick G3RWF is working pro bono again from the University of the Mountains of the Moon in Fort Portal, Western Uganda, and occasionally from Kampala. He prefers CW, but also uses SSB and digital modes. QSL via home call, direct with \$2 or 1 IRC, or LotW.

3D2GC/p, **Rotuma I**. See website: <http://3d2gc.com/>

H7H, **Nicaragua**. See website: <http://nicaragua2013.com/>

CY0P, **Sable I**. QSL manager is Gary VE1RGB. See website: <http://www.cy0dpedition.com/>

9N2YY, **Nepal**. Pekka OH2YY will be on air from Nepal, most likely in the evenings on 20 – 10 m SSB. Callsign 9N2YY has been requested and will be confirmed upon arrival.

TX5D, **Austral I**. Grant KZ1W and Rob N7QT will be operating from Raivavae, on the north side of the island, very close to the Pacific Ocean. They plan to upload logs to ClubLog. QSL via LotW, eQSL, bureau or direct.

TO2TT, **Mayotte**. See website: <http://www.i2ysb.com/joomla5/>  
A52YY, **Bhutan**. After his visit to Nepal, Pekka OH2YY will be

in Bhutan. Activity will most likely be evenings, on 20 – 10 m SSB. Callsign A52YY has been requested and will be confirmed upon arrival.

**K9W, Wake I.** Operating dates announced: 7 – 18 October. Make the most of this operation, in our own 'backyard'. It is ranked 14th Most Wanted on ClubLog. The DXpedition is dedicated to preserving the memory of 'The Forgotten 98' a group of civilian contractors who lost their lives on Wake Island on 7 October 1943 during World War II. See the website for all information: <http://www.wake2013.org/>

**XR0ZR, Juan Fernandez.** Operators Fabrizio IW3SQY, Franco IZ8GCE, Josep EA3AKY, Art WA7NB, Les SP3DOI, Paolo IV3DSH, Ron PA3EWP and Hans DL6JGN will be on air with four stations on Robinson Crusoe I. This one hasn't had much activity

for a while, and is now ranked No. 33 on the ClubLog Most Wanted list. See website: <http://www.juanfernandez2013.com/>

**TN2MS, Congo.** Dutch operators Arie PA3A, Marian PD1AEG, Ad PA8AD and Angelina PA8AN will be working aboard the hospital ship **Africa Mercy** from 6 – 11 October. They will then operate the DXpedition from the afternoon of the 12th till the morning of the 24th October. The aim of the DXpedition is to raise awareness of the Mercy Ships, and all donations and surplus funds will go to the Mercy Ships charity project. See website: <http://www.tn2ms.nl/>

**C82DX, Mozambique.** A large group of fourteen operators from Japan, USA, Canada and South Africa will be on air from Xai Xai. The focus will be on the low bands, but during the day they will be operating all HF bands and 6 m. See website: <http://c82dx.com>

**D44TXT, Cape Verde.** Husband and wife DXpeditioners Lot DJ7ZG and Babs DL7AFS will be on air from Santiago I on 80 – 6 m, SSB, RTTY and PSK31. QSL via DL7AFS.

As well as the above, the CQ Worldwide SSB Contest will be on over the last weekend in October. The CQ WW Contests are great hunting grounds for some choice DX. As usual, look out for contest stations before and after the contest.

Special thanks to the authors of The Daily DX, 425 DX News, DX World, NG3K's Announced DX Operations, and QRZ.DX for information appearing in this month's column. Interested readers can obtain a free two week trial of The Daily DX from [www.dailydx.com/trial.htm](http://www.dailydx.com/trial.htm)



## Visit our **Bookshop**

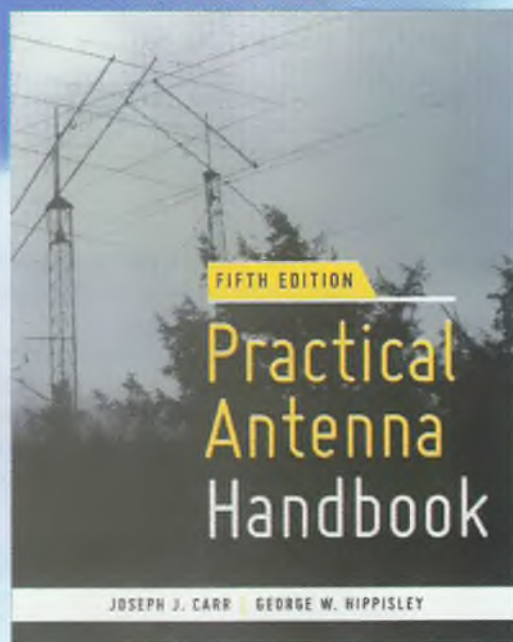

**Members: \$55.00 \* Retail: \$65.00 \***

*\*Plus Postage & Packaging*

## Practical Antenna Handbook

Reorganized to flow logically from broad physical principles to specific antenna design and construction techniques, the book begins by covering the fundamentals.

Then the half-wave dipole is discussed both as an excellent antenna in its own right and as a conceptual tool for predicting the performance of other designs. Transmission line impedance matching techniques—and a companion Smith chart tutorial—lead into "must have" accessories for tuning, monitoring, and troubleshooting antenna system performance.

Other tools, such as antenna modeling software and network analyzer add-ons for PCs and Macs, are addressed, and concluding chapters offer fresh insights into support structures and installation techniques.

Antenna topics covered include:

- Dipoles and inverted-Vs
- Quads, delta, and NVIS loops
- Wire arrays (bobtail curtain, half-square, rhombic)
- Verticals and shunt-fed towers
- Rotatable Yagi beams
- MF/HF receiving antennas (flag, pennant, K9AY, Beverage)
- Mobile and portable antennas
- VHF/UHF/microwave antennas

...and many more!

**Order your copy today!** Visit our online bookshop for details. <http://www.wia.org.au/members/bookshop/about/>



# Contests

James Fleming VK4TJF  
e leartez@bigpond.com

The premier contest this month is the Oceania DX Contest. Every year that I work the contest on CW I always enjoy a nice pile up. There are many operators all around the world waiting to work me. It feels like I have a bigger station and that I'm especially in demand. A large part of this must be that the contest has been getting more and more attention from the international amateur radio community and it has become rather popular. I do happen to get a lot of European stations, particularly Russians, so this contest really tests my ability to work large pile ups, and work weak signals. Perhaps it's so popular because it is a fun and easy contest. The results come out in a timely manner and the certificates are downloadable as a PDF file.

The Oceania DX Contest is divided in to phone and CW. Phone is the first weekend in October, and that happens to fall on the 5th and 6th of October this year. The CW contest is on the 2nd weekend in October, the 12th and 13th of this year. Times for both are from 0800 UTC Saturday to 0800 UTC Sunday. The rules of the game here are to make as many contacts as possible both inside and outside of the Oceania region, if you are in the region; everyone else only gets points for contacts with stations within the Oceania region. High power is up to 1500 watts and low power 100 watts. QSO alerting assistance is allowed along with remote operation. Entry categories are single operator high and low power, and multi-operator single, two, or multi transmitter. The exchange is RST and a sequential

## Contest Calendar for October - December 2013

October	5th - 6th	0800 UTC	24 hours	Oceania DX contest	SSB
	12th - 13th	0800 UTC	24 hours	Oceania DX contest	CW
	19th - 20th	0000 UTC	48 hours	JARTS WW RTTY contest	RTTY
	26th - 27th	0000 UTC	48 hours	CQ WW DX contest	SSB
November	2nd - 3rd	1200 UTC	24 hours	Ukrainian DX contest	CW / SSB
	9th - 10th	0000 UTC	48 hours	WAE DX contest	RTTY
	9th - 10th	0700 UTC	30 hours	Japan International DX contest	SSB
	17th	0000 UTC	24 hours	EPC PSK63 QSO party	PSK63
	23th - 24th	0100 UTC	24 hours	Spring VHF/UHF Field Day	CW / SSB / FM
	23rd - 24th	0000 UTC	48 hours	CQ WW DX contest	CW
December	6th - 8th	2200 UTC	42 hours	ARRL 160 metre contest	CW
	14th - 15th	0000 UTC	48 hours	ARRL 10 metre contest	CW / SSB
	21st	0000 UTC	24 hours	OK DX RTTY contest	RTTY
	28th - 29th	0000 UTC	24 hours	RAC Winter contest	CW / SSB

serial number starting at 001. If a station does not give a serial number and a contact is made, no problem, just list them as 001, however I don't think this will be much of a problem. The multiplier is the number of valid prefixes worked. The contact points per band are broken down as follows. 20 points on the 160 m band, 10 points on 80 m, 5 points on 40 m, 1 point on 20 m, 2 points on 15 m, and 3 points on 10 m. Well that's it in a nut shell, pretty basic if you ask me. The easiest way to work the contest is using the VKCL software and let the program give you your score and submit your log electronically via email.

Now if you have not got enough contesting out of your blood by the end of October there is another good contest for you, the CW WW DX contest SSB, and this one offers some nice things for those who do things the classic way without computers and for those that like to QRP. So without further

ado the goal is to work as many other amateurs in other zones and countries. Bands are 1.8, 3.5, 7, 14, 21, and 28. Exchange is the RS plus the CQ zone number. You get 3 points for working a station on a different continent, and 1 point for contact with countries on the same continent. The multipliers are the different zones and countries. You can do single operator high-power 1500 watts, low power 100 watts, or QRP 5 watts, assisted or Rookie or classic. Rookie if you have been licensed less than 3 years before the start of the contest. And classic you can only use one radio, no QSO alerting assistance, only operate 24 of the 48 hours, and if you take a break it has to be for at least an hour. There is also multi-operator one, two, or multi transmitter. The dates are October 26-27 starting at 0000 UTC Saturday to 2359 UTC Sunday. So have a great contesting month and have a listen to all the signals on the band.

Participate

**Spring VHF/UHF Field Day** 23-24 November

# ALARA

Margaret Blight VK3FMAB – Publicity Officer

With the helpful assistance of some radio friends, I finally have an antenna erected at my new home and my radio is back in operation. I now have a Diamond X-200 for use with my Yaesu FT-2800 two metre radio. My main radio is a Yaesu FT-450 which now operates HF from a trapped inverted vee for 40 and 80 metres.

For the past few months we have been having an addition built which now houses my rig and is also the proposed area for my other hobbies. With any number of tradesmen arriving each day and with an accumulation of dust throughout the entire building, it has not been a good time before now to proceed with the project. I am very grateful to everyone who has been involved and realise anew, just how much being part of the radio community can lead to having friends who are willing to support others in their hobby.

It has been interesting to learn in earlier articles how other women operators have become involved in radio. Unni LA6RHA from Norway is this month's guest contributor. What a fascinating life she has been leading, especially since being introduced to radio. Unni also explains the origin of SYLRA which is the Scandinavian equivalent of ALARA.

## ALARA contest

The 33rd ALARA contest was held over the weekend of 24-25 August, 2013. All licensed operators were invited to attend. There were an encouraging number of ALARA members participating and everyone seemed to be having an enjoyable time. There were rumours of some sore wrists being experienced as a result of long sessions on the radio, but that is part of the fun to be had during a contest.



Photo 1: The Diamond X-200 mounted on the mast.

## Foundation course for YLs

On 14-15th September a Foundation course especially designed for YLs was held in Melbourne. There will be more details outlined in the next edition as they come to hand. It will be interesting to have an overview of the results of the course and feedback from the participants so an assessment can be made regarding any particular benefits from such a course. This is likely to have an impact on the fashioning of any future YL Foundation courses.

## Profile – Unni LA6RHA

Reprinted with permission from ALARA News.

I remember seeing a photo of

a wireless operator and read about him when I was young. I decided there and then to become a wireless operator aboard a ship. When I called the seaman school, they told me that I was born

four days too late to get into the school. Being a woman you were not permitted to come into the school before being 19. They told me to apply the year after, but at that time I had met my ex-husband and radio was out of my mind.

Many years later, we moved to an apartment building where I still live. One day some strange sounds came out of the loudspeakers for my tape and CD player. I began to listen and a voice said 'CQ CQ...' I wondered what that was for a long time and one day while sitting on the phone I heard the same 'CQ CQ' but this time through the phone.

My ex said 'I think it is our new neighbours.' I was in the process



Photo 2: Steve VK3SIR, John VK3DQ and Lino VK3EI.





Photo 3: Unni LA6RHA.

of getting my pilot's licence at that time and included in the theoretical part was radio, so I thought I would ask my neighbour. Up I went and found John LA0EM was subsequently was great in putting ferrites around my equipment.

Every morning and evening (for four hours all together) over two months, I practised CW. I studied so hard and so much that when my alarm clock went off in the mornings I shouted 'Hi' as in didididit didit... hi. When I got my result back I had one little fault in my whole test and I was very proud, but gosh what hard work it had been. All thanks to my neighbour John LA0EM.

My first years as a ham were exciting. I bought myself a 10 metre rig with a mobile antenna. Put it amongst the flowers on my balcony and worked 27 countries on around 10 watts, from LA in the west to almost China in the east, from Frantz Josef Land in the north to Morocco in the south. I participated in field days and helped out in marathon and other running events.

After taking my Private Pilot's Licence radio part in English and the amateur radio licence, I went into the Norwegian National Guard. In the Signal Corps I found my right place. Never a problem when I was leading the platoon on our exercises. After taking further time in the National Guard to become an

officer, I went on courses covering both their radio and crypto areas and, being both a radio amateur and a pilot with navigation skills, it really made it easy for me and my platoon.

When travelling, I always tried to obtain a licence. I wrote to the radio club BY1PK in Beijing and got permission to operate from their club station while visiting China. I went on two metres from the UK, Northern Ireland and Ireland. I also had my two metre with me on Sardegna Island in Italy and in Corsica, as well as on a visit to South Africa after being permitted to operate.

Ruth LA6ZH (SK) introduced me to International YL meetings and my first was in 1996 in Berlin. I had a presentation at Svalbard and was coming home when Ruth, Turid and I heard that the next YL meeting location was uncertain, so we offered to have it in 1998 on Svalbard. JW0YL. After two years I was also permitted to operate from Jan Mayen as JX6RHA. After Berlin I went to Vietnam and thanks to Mr Ai, who I met in Berlin, I got my own call 3W6JD. On Svalbard in 1997 Turid and I went on a seal vessel around the whole of Svalbard through the ice and to Kvitya (White Island) in the north of the archipelago. No radio amateurs (YL or OM) had ever transmitted

amateur radio from this island; we were the first to operate from there. Thanks to my stubbornness in bringing with me my favourite radio and antenna we activated radio every place we stopped. Some places I even had to have a rifle ready in case a polar bear appeared. When a YL expedition to Falkland Islands was announced, I at once sent off an email to say I was interested and in January of 2009 I flew over with YLs from UK, Italy, Greece the Netherlands. The expedition was a success and we made 25,000 QSOs.

My favourite rig which has followed me almost up to the North Pole is a Ten Tec Scout 55 with band modules. I used this on Jan Mayen as my portable sitting outside as the coax from the dipole was too short to sit inside. Fully dressed and with an emergency radio and a knife to protect me if polar bears appeared! The last one had appeared seven years prior to my visit. The Ten Tec Scout was with me around the whole of Svalbard and on Kvitya above 80 degrees as we made 19 contacts with nine countries (even Japan).

Before travelling to Sicily in 2002, Ingrid LA8FOA and I talked about a Norwegian YL organization. I was aware that Turid LA9THA had tried to organise one before and there was not much response. So we discussed the possibility of the Scandinavian YLs forming an organization. So while in Sicily for the International YL meeting, the Swedish, Danish, Finnish and Norwegian YLs had a talk together and decided to try founding a Scandinavian YL organization. Inger OZ7AGR knew two YLs in Iceland so she agreed to contact them. Though as with all good ideas, it appears the process takes time. So it was the following year before the YLs from Denmark, Copenhagen and Iceland were invited to meet at Inger and Bjarne's house in Norway and, after a long meeting, SYLRA was founded in 2003.



# Hamads

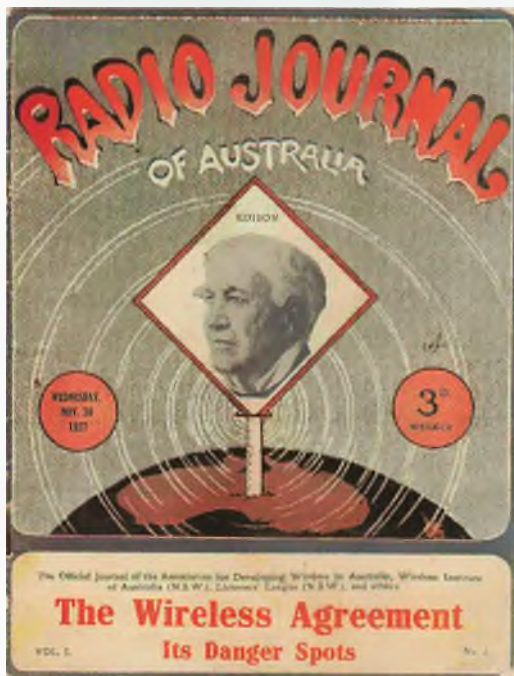

## WANTED – NATIONAL

### Copies of Radio Journal of Australia magazine

The WIA Archive is seeking copies of the Radio Journal of Australia for copying and/or adding to the WIA Archive's shelves.

Little is known about this magazine. The WIA holds one copy only. Volume 1, Number 2 published on 30th November 1927 which contains 64 pages. The magazine claims to be the Official Organ of the Association for Developing Wireless in Australia, the Listeners' League (N.S.W.) and of importance to us, the Wireless Institute of Australia (N.S.W.).

The magazine contains articles of general radio interest, a comprehensive weekly radio guide for stations in N.S.W., S.A. Qld. and Vic. and some notes from the WIA, NSW Division. It was published in Sydney, presumably commencing on 23rd November 1927.

It is of interest to note that the magazine's Editor was George A. Taylor, the person responsible for calling the first meeting of Sydney wireless experimenters in March 1910 from which the WIA grew. Taylor was never known to be a member of the WIA, rather he returned to his interests in aviation and defence. Later he went on to form the Association for Developing Wireless in Australia, an organisation predominately representing those involved in commercial broadcasting.

There is little doubt that Australia had a colourful and heady start to those early days of radio communication and broadcasting - in all of its forms and magazines such as this provide a glimpse of that exciting pioneering time past!

Please contact WIA Historian, Peter VK3RV via email [vk3rv@wia.org.au](mailto:vk3rv@wia.org.au) or c/o the National Office in Bayswater if you can help us locate copies of this magazine.

## FOR SALE – VIC

HP-141T spectrum analyzer (1250 MHz plug-in) S/N 1615A 14456, complete with

HP-8444A 0.5-1300 MHz tracking generator, S/N 2325A 06429. In good working condition. I can supply pictures via email if required. \$800.00 OBO. Pick-up ONLY.

Please contact Glenn VK3PE at [vk3pe@bigpond.com](mailto:vk3pe@bigpond.com)

## WANTED – VIC

1.8250 MHz crystal for the VK3 160 m AM net. Prefer HC49 size if possible.

Please contact Glenn VK3PE at [vk3pe@bigpond.com](mailto:vk3pe@bigpond.com)

Relay for Alinco two metre linear amplifier, model ELH-230E.

Battery valve type 3A5 twin triode.

True carbon resistors, 470  $\Omega$  and 1000  $\Omega$ .

Any information, including a circuit diagram, for a Ramsey electronic frequency counter, model CT-50.

Word processor, Citizen model CMB-10WP, working or not, but with the LCD screen complete and undamaged.

Phone Brewster QTHR on **03 9527 2661** after 6 pm - if no answer please leave a message and return phone number.

## WANTED – NSW

Central Electronics 100 V or 200 V (yes, even more of a long shot!) transmitter. Preferably in operating condition, but as long as unit is complete, that would be great. I am looking for Central Electronics gear in general.

Contact Steve Beveridge VK2LW on **0412 194 513** or email on [steve.b@internode.on.net](mailto:steve.b@internode.on.net)

Beam antennas, for the two metre and 70 cm bands.

Please contact Malcolm VK2BMS on [vk2bms@bigpond.com](mailto:vk2bms@bigpond.com) or phone **02 9958 1114**.

## FOR SALE – QLD

MFJ-1026 Noise Cancelling Signal Enhancer. The unit is in mint condition, fully serviceable, has had very little use and is not modified. See the MFJ catalogue for a full description. \$100.

Contact Rod VK4RA QTHR email [rod@opticalfibre.com.au](mailto:rod@opticalfibre.com.au) or mobile **0409 141 140**.

## FOR SALE – SA

The VK5JST Aerial Analyser (AR May 2006). Over 10,000 built, and still available from the Adelaide Hills Amateur Radio Society. For full details see [www.ahars.com.au](http://www.ahars.com.au)

# WIA 2014 Callbook

Available in October







## Contributions to Amateur Radio

AR is a forum for WIA members' amateur radio experiments, experiences, opinions and news.

Your contribution and feedback is welcomed.

Guidelines for contributors can be found in the AR section of the WIA website, at <http://www.wia.org.au/members/armag/contributing/>

Email the Editor:  
[editor@wia.org.au](mailto:editor@wia.org.au)

## About Hamads

- Submit by email (**MUCH PREFERRED**) or if written and mailed please print carefully and clearly, use upper AND lower case.
- Deceased estates Hamads will be published in full, even if some items are not radio equipment.
- WIA policy recommends that the serial number of all equipment for sale should be included.
- QTHR means the address is correct in the current WIA Call Book.
- Ordinary Hamads from those who are deemed to be in general electronics retail and wholesale distributive trades should be certified as referring only to private articles not being re-sold for merchandising purposes.
- Commercial advertising on these pages Contact [admanager@wia.org.au](mailto:admanager@wia.org.au)
- Copy to be received by the deadlines on page 1 of each issue of Amateur Radio.
- Separate forms for For Sale and Wanted items. Include name, address STD telephone number and WIA membership number.

**'Hamads'**  
PO Box 2042  
BAYSWATER VIC 3153  
[hamads@wia.org.au](mailto:hamads@wia.org.au)

## AMIDON FERROMAGNETIC CORES



tts systems

Phone 03 5977 4808. Fax 03 5977 4801  
[info@ttsystems.com.au](mailto:info@ttsystems.com.au)

## VKHAM.COM

AUSTRALIAN AMATEUR RADIO  
Hundreds of pages and links  
related to Amateur Radio  
and radio in general

### HOME OF

- VK Classifieds
- VK Auctions
- VKs on the Internet

Repeater Maps, Software, Prefix Maps and more...

## RM Products Italy

are now available in Australia after the  
appointment of

Hamak Electrical Industries Pty Ltd

as distributor for RM products  
Visit the Hamak website at

**[Hamak.com.au](http://Hamak.com.au)**

for

**Linear amplifiers,  
Power supplies  
and accessories**



## JACKSON BROS

[www.jacksonbrothers.com.au](http://www.jacksonbrothers.com.au)

Highest quality products made by UK craftsmen  
Variable and trimmer  
capacitors, reduction drives,  
dials, ceramic standoffs



## CATALOGUES, PRICE LISTS AVAILABLE HAMMOND ENCLOSURES

HAMMOND  
MANUFACTURING. Large range of quality electronic  
enclosures for the discerning Radio Amateur.  
Diecast, extruded aluminium and plastic enclosures  
and instrument cases. As seen in many APRL projects.



Cookson CHARLES I COOKSON  
Controls PTY LTD

11-13 Port Rd Queenstown SA 5014  
Tel: (08) 8240 3200 Fax: (08) 8240 3233  
[sales@jacksonbrothers.com.au](mailto:sales@jacksonbrothers.com.au)  
[ccookson@hammfg.com](mailto:ccookson@hammfg.com)  
ALL MAJOR CREDIT CARDS ACCEPTED  
SOLE AGENTS AUSTRALIA AND NEW ZEALAND



## Suppliers of Aluminium Tube

1/4 to 1 1/8 inch drawn  
28 mm to 68 mm telescopic  
**NBS Tilt Over Masts meet new  
NSW and 9 Australian standards**

Antenna height from 3 m to 12 m  
for easy adjustments and tuning  
**Antenna Parts and Accessories**

Phone 0402 930 581  
[brian@nbsantennas.com.au](mailto:brian@nbsantennas.com.au)

## Studying for the Standard or the Advanced Licence?



Here are 4  
books that  
will get you  
there.

TAKE A LOOK AT  
[www.gscott.com.au](http://www.gscott.com.au)

for more information  
and order form.

PO Box 385, Albury NSW 2640

## ADVERTISERS INDEX

Cookson (Jackson Bros)	63
Hamak Electrical Industries	63
Icom	BC
Jaycar	7
NBS Antennas	63
TET-Emtron	9
TTS	5, 63
Yaesu	IFC

## TRADE PRACTICES ACT

It is impossible for us to ensure that the advertisements submitted for publication comply with the Trade Practices Act 1974. Therefore, advertisers will appreciate the absolute need for themselves to ensure that the provisions of the Act are strictly complied with.

## VICTORIAN CONSUMER AFFAIRS ACT

Advertisements with only a PO Box number address cannot be accepted without the addition of the business address of the box-holder or seller of the goods.

# Directory

## National Office

Unit 20, 11-13 Havelock Road  
PO Box 2042 BAYSWATER VIC 3153

Contact 10 am to 4 pm weekdays  
Phone **03 9729 0400** Fax **03 9729 7325**  
nationaloffice@wia.org.au  
http://www.wia.org.au



## The Amateur Service

... a radio communications service for the purpose of self training, intercommunication and technical investigation carried out by amateurs, that is, by duly authorised persons interested in radio technique with a personal aim and without any pecuniary interest.

56 ITU Radio Regulations

## Advisory Committees

### New South Wales/ACT Advisory Committee

Email: vk2advisory@wia.org.au

- \* John Bishop VK2BK
- Dominic Dahi VK2YDD
- \* Timothy Mills VK2ZTM / VK2UJ
- Gilbert Hughes VK1GH

### Victorian Advisory Committee

Email: vk3advisory@wia.org.au

- \* Bob Tait VK3XP
- Luke Steele VK3HJ
- Noel Ferguson VK3FGN
- Chris Chapman VK3QB

### Queensland Advisory Committee

Email: vk4advisory@wia.org.au

- Don Wilschefski VK4BY
- Kevin Johnston VK4UH
- \* Michael Charteris VK4QS
- Alan Shannon VK4SN

### South Australian Advisory Committee

Email: vk5advisory@wia.org.au

- \* David Clegg VK5KC
- \* Peter Reichelt VK5APR
- Ben Broadbent VK5BE
- Trevor Quick VK5ATQ

### Western Australian Advisory Committee

Email: vk6advisory@wia.org.au

- \* Heath Walder VK6TWO
- \* Craig Lamb VK6FLAM

### Tasmanian Advisory Committee

Email: vk7advisory@wia.org.au

- Clayton Reading VK7ZGR
- \* Justin Giles-Clark VK7TW
- Peter Rumble VK7IY

### Northern Territory Advisory Committee

Email: vk8advisory@wia.org.au

- \* Peter Blackadder VK8HPB
- Garry Woods VK8GW
- \* Alan Baker VK8AB
- Mark Sellers VK8MS

\*Denotes Committee Chairman

\*Denotes nominated by the WIA Board ("Nominated Member")

## WIA Gift Certificate - Membership

Why not encourage your friends to become members of the **Wireless Institute of Australia** by giving them a **Become a WIA Member** Gift Certificate.



**Available for purchase in Full, Concession, Student and Family membership grades. \*\***

\*\* Note: To redeem a **Become a WIA Member** Gift Certificate, it will need to be accompanied by a completed and signed *WIA membership application form*.

[www.wia.org.au/members/bookshop/gift\\_certificates/](http://www.wia.org.au/members/bookshop/gift_certificates/)



# WIA **2014** Callbook

**Available** in October



Wireless Institute of Australia

## 2014 Callbook

Visit our  
online  
bookshop  
for details.

Includes **Searchable CD** containing:  
The complete 2014 Australian Callbook  
Amateur Radio Magazine 2012 editions,  
Repeater and Beacon Listings  
Vision Impaired Version

[www.wia.org.au/members/bookshop/about/](http://www.wia.org.au/members/bookshop/about/)

 ICOM

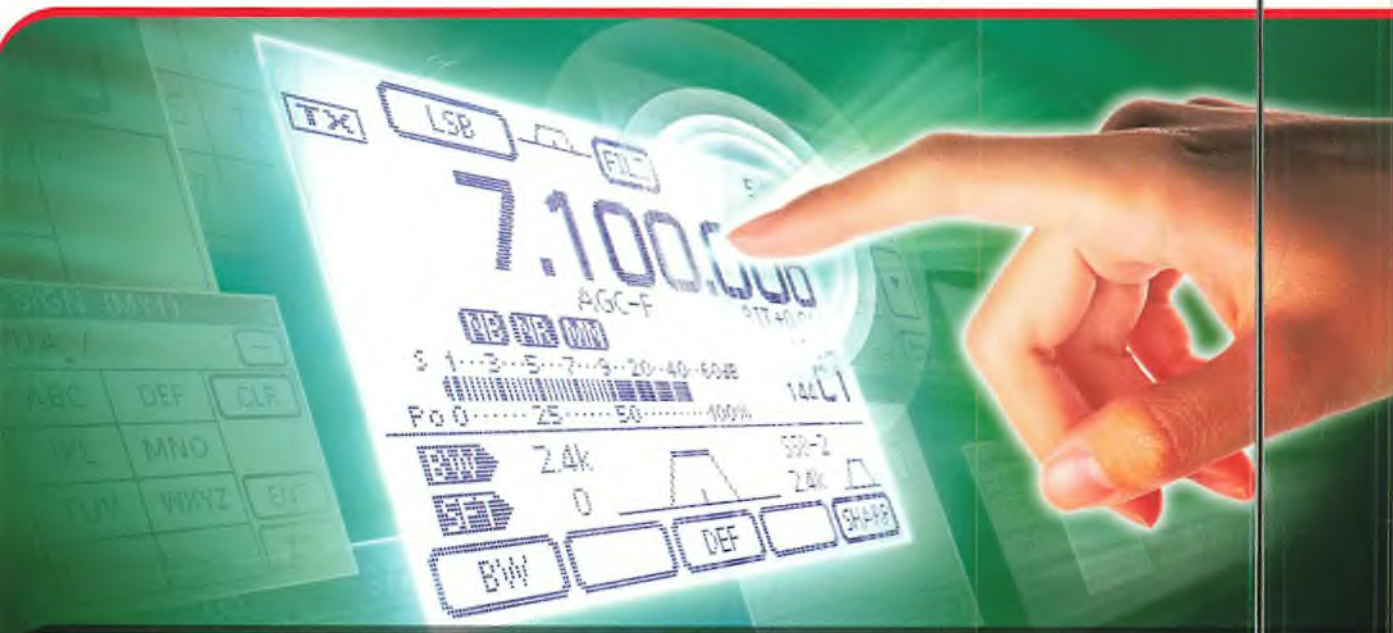

# A touch of class

## IC-7100

Introducing the new IC-7100 multi-mode amateur transceiver.

Featuring an intuitive remote head touch screen display, D-STAR DV mode communication and intelligent auto-tuning operation with the optional AH-740 antenna.

## D-STAR



## AH-740

HF Antenna



To find out more about our latest products,  
call Icom on 03 9549 7500 or visit [www.icom.net.au](http://www.icom.net.au)