

# Amateur Radio

Volume 81  
Number 12  
December 2013  
Price: \$9.70 incl GST  
[www.wia.org.au](http://www.wia.org.au)



## Want to try a **new** band? **Build a transverter**

### Antenna ideas:

- An 80 m special
- An EFHW for QRP/p

### Antenna "tuners"

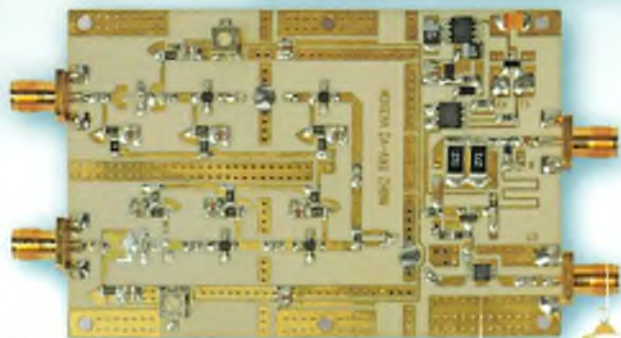
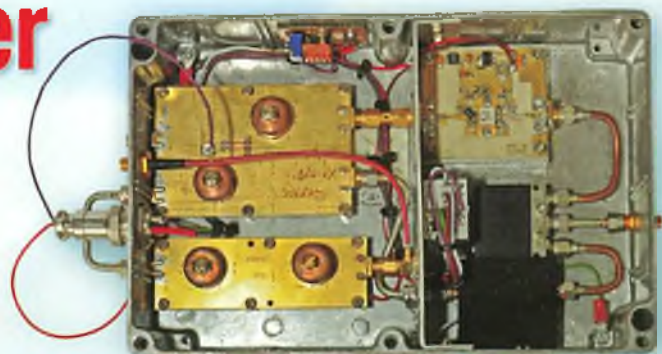
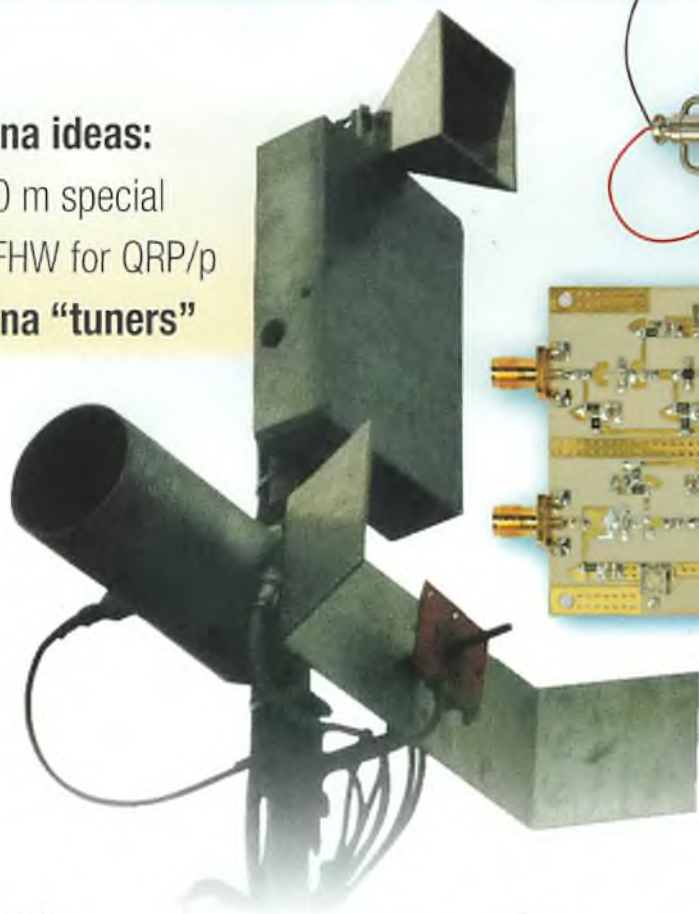

*Season's Greetings*

ISSN 0002-6859

12



700021685062

**The radio... YAESU**

HF/50MHz 100W Transceiver

# FT DX 1200

This medium-price HF Transceiver Excels on all fronts. The High Frequency Design Technology it has inherited, ensures "Best in Class Performance".  
The Outstanding Operability is Perfect for the DX Scene.



Superior triple conversion receiver, and optimum gain distribution at each IF stage will eliminate out of band unwanted signals.

The 1st IF frequency is set at 40 MHz and is protected by selectable 3 kHz, 6 kHz and 15 kHz roofing filters, which effectively attenuate interfering signals.

Similar to the high end series Yaesu transceivers, it uses the 32-bit high speed floating point DSP, TMS320C6727B by Texas Instruments, for its IF DSP. The acclaimed superior Yaesu DSP algorithm is highly effective in weak signal processing and enhancement.

The Full Color, 4.3 inch TFT display on the left side of the front panel, has a wide viewing angle and provides excellent visibility. It beautifully displays the various functions unique to this high class HF transceiver.

An optional built-in FFT-UNIT supports advanced functionality, including the AF-FFT Scope, RTTY/PSK31 Encode/Decode, CW Decode and CW Auto Zero-in.

**YAESU**  
The radio

YAESU Authorized Dealer in Australia and New Zealand

**Andrews Communications Systems**  
Shop 8, 41-51 Bathurst Street,  
Greystanes NSW 2145  
URL : [www.andrewscom.com.au](http://www.andrewscom.com.au)  
Tel: +61-2-9636-9060

**Strictly HAM Pty. Ltd.**  
14 Church Street,  
Bayswater Vic. 3153  
URL : [www.strictlyham.com.au](http://www.strictlyham.com.au)  
Tel: +61-3-9729-7656

**GEOPLEX DISTRIBUTION LTD**  
Level 1, 60 Cook Street,  
Auckland 1010, New Zealand  
Tel: +64-21-434342

YAESU Authorized Service Center in Australia and New Zealand

**Andrews Communications Systems**  
Shop 8, 41-51 Bathurst Street, Greystanes NSW 2145  
Tel: +61-2-9636-9060, Fax: +61-2-9688-1995  
E-mail: [radioandrews@hotmail.com](mailto:radioandrews@hotmail.com)

**JNB Electronics Pty Ltd**  
St Kilda Rd Towers, Suite 1138, 1 Queens Rd, Melbourne, VIC 3004  
Tel: +61-3-9465-9399, Fax: +61-3-8662-8748  
E-mail: [yaesu@jnb.com.au](mailto:yaesu@jnb.com.au)



The Full Color 4.3 inch TFT display



Spectrum-Scope (Full Screen display)





# Amateur Radio

The Journal of the Wireless Institute of Australia

Volume 81  
Number 12  
December 2013  
ISSN 0002-6659

## Editorial

### Editor

Peter Freeman VK3PF  
editor@wia.org.au

### Technical Editor

Peter Gibson VK3AZL

### Publications committee

Peter Harfield VK3PH  
Don Jackson VK3DBB  
Evan Jarman VK3ANI  
Bill Roper VK3BR  
Ewen Templeton VK3OW  
Ernie Walls VK3FM

### All circulation matters

nationaloffice@wia.org.au

### How to submit material

Secretary  
AR Publications Committee  
PO Box 2042  
BAYSWATER VIC 3153  
or armag@wia.org.au

### Letters to Editor

Editor AR Magazine  
PO Box 273  
Churchill Vic 3842  
or editor@wia.org.au

### Hamads

'Hamads'  
PO Box 2042  
BAYSWATER VIC 3153  
hamads@wia.org.au

### Advertising

All enquiries to  
Advertising Manager  
AR Publications Committee  
PO Box 2042  
BAYSWATER VIC 3153  
or admanager@wia.org.au

### Registered Office

Unit 20 11-13 Havelock Road  
BAYSWATER VIC 3153  
Australia  
Phone: 03 9729 0400  
Fax: 03 9729 7325

### Production Deadlines

All articles, columns, hamads and advertising booking by **first day of previous month.**

The contents of Amateur Radio are Copyright Wireless Institute of Australia © 2013

## Technical

Transverter systems 6  
Graham Byrnes VK3XDK

Review of Videomate U620F DVB/SDR (Software Defined Radio) 13  
John Titmuss VK4JWT

A triband end-fed wire antenna for QRP portable 17  
Peter Parker VK3YE

Antenna tuners 22  
Kevin Parsons VK2JS



### This month's cover

Our cover this month shows a mast-mounted 10 GHz transverter and horn antenna – an excellent means of minimising feedline loss. The upper right photo shows inside a complete microwave transverter. The lower right image shows a completed transverter board ready for testing and final assembly into complete function unit. See the article on page 6. Photos by Graham Byrnes VK3XDK.

## General

Pair ranked analysis 20  
Dr Hank Prunckun VK5XB

'Play time' on 80 metres: A high performance antenna system for the VK/ZL Trans-Tasman contest, 2013 26  
Jim McNabb VK3AMN and Michael Romanov VK3CMV

One hundred wonderful years 30  
Ron S Goodhew VK4EMF

Gridsquare Standings at 18 October 2013 38  
Guy Fletcher VK2KU

## Columns

ALARA	33
AMSAT	36
Contests	46, 47, 48
DX - News & Views	41
Editorial	2, 5
Hamads	62
Over to You	29, 64
SOTA News	49
Spotlight On SWLing	16
VHF/UHF – An Expanding World	43
WIA Comment	3, 5
WIA News	4
VK2 News	54, 55
VK3 News	51, 52
VK4 News	59
VK5 News	42
VK6 News	57
VK7 News	60

## Contributions to Amateur Radio



Amateur Radio is a forum for WIA members' amateur radio experiments, experiences, opinions and news. Manuscripts with drawings and/or photos are welcome and will be considered for publication. Articles attached to email are especially welcome. The WIA cannot be responsible for loss or damage to any material. Information on house style is available from the Editor.

### Back Issues

Back issues are available directly from the WIA National Office (until stocks are exhausted), at \$6.00 each (including postage within Australia) to members.

### Photostat copies

If back issues are unavailable, photocopies of articles are available to members at \$2.50 each (plus an additional \$2 for each additional issue in which the article appears).

### Disclaimer

The opinions expressed in this publication do not necessarily reflect the official view of the WIA and the WIA cannot be held responsible for incorrect information published.

## Amateur Radio Service

A radiocommunication service for the purpose of self-training, intercommunication and technical investigation carried out by amateurs; that is, by duly authorised persons interested in radio technique solely with a personal aim and without pecuniary interest.

### Wireless Institute of Australia

The world's oldest

National Radio Society, founded 1910.

Representing

*The Australian Amateur Radio Service*

*Member of the International Amateur Radio Union*

#### Registered Office of the WIA

Andersson House

Unit 20, 11-13 Havelock Road

Bayswater, Victoria, 3153

Tel: (03) 9729 0400 Fax (03) 9729 7325

email: [nationaloffice@wia.org.au](mailto:nationaloffice@wia.org.au)

<http://www.wia.org.au>

All mail to

**PO Box 2042 BAYSWATER VIC 3153**

Business hours: 10am – 4pm weekdays

#### National Office staff

*Manager* Mal Brooks VK3FDSL  
*Examination Officer* Dianne Ashton VK3FDIZ

#### Board of Directors

*President* Phil Wait VK2ASD  
*Vice-President* Chris Platt VK5CP  
*Directors* Bob Bristow VK6POP  
Robert Broomhead VK3DN  
Roger Harrison VK2ZRH  
Ewan McLeod VK4ERM  
Fred Swainston VK3DAC  
*Secretary* David Williams VK3RU  
*Treasurer* John Longayroux VK3PZ

#### Coordinators

*AMSAT* Paul Paradigm VK2TXT  
*ARDF* Jack Bramham VK3WWW  
*Australian ARIS* Tony Hutchison VK5ZAI  
*Awards* Chris Platt VK5CP  
*Clubs* Ted Thrift VK2ARA  
*Contests* Craig Edwards VK8PDX  
*John Moyle Field Day* Denis Johnstone VK4AE  
*Editor 'AR'* Peter Freeman VK3PF  
*EMC/EMR* Gilbert Hughes VK1GH  
*Standards* Gilbert Hughes VK1GH  
David Wardlaw VK3ADW  
John Bishop VK2ZOI  
John Martin VK3KM  
*NTAC* Peter Wollenden VK3RV  
*IARU Region 3 Liaison* Chris Platt VK5CP  
*Monitoring Service* Peter Young VK3MV  
*ITU Conference & Study Group*  
David Wardlaw VK3ADW  
Brett Dawson VK2CBD  
Dale Hughes VK1DSH  
*QSL Curator* National Office  
*Repeater* Peter Mill VK3ZPP  
Richard Cerveny VK2AAH  
*Webpage* Robert Broomhead VK3DN  
*Emergency Communications Group*  
*Coordinator* Phil Wait VK2ASD  
*Members* Ewan McLeod VK4ERM  
Peter Young VK3MV



## Editorial

Peter Freeman VK3PF

### Communication

Basically, our hobby is all about communication. Despite what some might think, communication is fundamentally a two way process. One aspect is delivering information from one source to one or many recipients. The second aspect is the reception of that information by the recipient/s. Acknowledgement of the receipt of the information may not be critical in some areas. For example, companies pay for their advertising to be transmitted via commercial radio and television. We can choose to take notice of the messages or not – some may even grab the remote control and channel surf as soon as a commercial break comes on whilst watching television. So the message may or may not be received by all intended recipients. However, in many (most?) aspects of our hobby, reception is usually required – the contact is not complete unless callsigns, reports and the reports have been acknowledgement by both parties.

A fundamental aspect of our hobby therefore is to listen. We listen for our report from the station with whom we are communicating.

So it can be interesting to listen to the behaviour of some of our peers.

I was recently listening on HF and experienced the dog piles generated by DXpedition stations located at relatively rare locations.

It seemed that everyone wanted to work the new station NOW, even though the station would be on air 24/7 for at least a week. One could hear the DX station struggling to pull a callsign out of the dog pile and asking all others to stand by so that one amateur could complete a

contact with the DX. What did you hear if you listened on the frequency where the DX was listening – a slightly less loud dog pile! It seemed that everyone simply ignored the request/instructions from the DX.

The DX would ask the Japanese stations to please stand by and attempt to work a different region of the globe for a few minutes. Result on the listening frequency for the DX? You guessed it – calls from all over the globe, including Japan, making it very difficult for the DX to work the targeted region. Mind you, it was not just the JA stations at fault. At one stage I heard many very loud (some even distorted) VK stations calling when the DX asked for ZL stations only.

Why is it that so many people have little patience and cannot simply listen to the DX station's instructions? Have they all forgotten about the Amateur's Code? It is clear that many have not read and understood the DX Code of Conduct (see <http://www.dx-code.org/>).

Mind you, sometimes the DX was his own worst enemy: Not able to find a callsign from the targeted area, he would often then answer a JA station and complete a contact. Then again ask the JAs to standby whilst he listened for stateside stations..... Such behaviour would, in my humble opinion, only encourage the JAs to continue calling!

I had a brief email exchange with a couple of local amateurs about the situation, simply to voice my opinions. I am expecting that we may have an article in coming

Continued on page 5





## WIA comment

Phil Wait VK2ASD

### On Reflection (High SWR)

The end of the year is always a good time to take stock of things: where we are and the most important priorities for the New Year.

For the WIA, 2013 has largely been a year of consolidation – the introduction of the MEMNET membership management system, the continuing development of the new WIA committee system, the ongoing advocacy with the ACMA, the IARU and the ITU, the examination and assessment of new radio amateurs along with those upgrading to Standard and Advanced licences, continuing the improvements to *AR* magazine, reducing the processing time for new repeater licences, and improving day-to-day support for individual members and affiliated clubs, etc., etc.

Also, together with the ACMA, we have completed an update of the regulation exam syllabus, and the EMR awareness campaign is now well under way in preparation for a revisit of the 1 kW Higher Power Licence issue.

So, what's planned for 2014?

The WIA Board has identified three broad areas worthy of special attention in 2014 – improving the social/community relevance and accessibility of amateur radio, bedding down the new WIA Volunteers Committees and turning around the finances.

The first two items are a continuation of activities begun in 2013. As you may have noticed, the WIA is promoting amateur radio to the public through such actions as the "PR4 Amateur Radio initiative" and mounting displays at the recent 'Maker' exhibitions in Melbourne and Sydney. Amateur

radio has a lot to offer this new breed of DIY constructors, newly-termed 'Makers', especially in relation to technologies such as wireless telemetry, wireless-linked applications and digital signalling. Clearly, reviewing the privileges of the Foundation licence in relation to permitted digital modes is necessary to make amateur radio attractive to this group as well as other potential amateurs with an interest in 'things digital'. The WIA Board plans to further pursue such avenues in future to promote the hobby.

However, by far the greatest challenge facing the WIA right now is financial, with another loss projected for this year. Although the introduction of the MEMNET system saved one part-time staff member, and the postponing of the Club Grants Scheme this year also saved a further \$6000, increasing costs are certainly taking their toll on the finances of the WIA. Compounded with a reduction in magazine advertising revenue and a fall-off in merchandise and bookshop sales (a product of changing advertising spending policies and the economic times), the projected loss for this year is expected to be around \$25,000. While the WIA has sufficient reserves to cover the loss, it would not be prudent to allow the situation to persist.

Fortunately, this year's flow of new members and fewer non-renewals provides some saving grace, as membership remains strong. The simple answer to the financial issues would be to jack-up membership fees, including some buffer for future years to cover the shortfall. But, as many clubs in the

community have found, increasing our membership fees could easily become counter-productive. The other obvious remedy is to cut costs by targeting ALL areas of expenditure, but the elephant in our financial room is always going to be the costs associated with printing and distributing *Amateur Radio* magazine, currently running at about \$100,000 per year (printing and distribution alone – not composition and layout).

The WIA is not alone in this – most other member organisations supporting their own magazines are turning to digital publication and distribution, and this is clearly an option for the WIA, possibly with a printed *AR* magazine yearbook of construction projects and popular articles.

Basically, if the WIA is going to turn around its finances, the choice is clearly between an increase in membership fees, (either incrementally over several years, or in one hit), or a change in the way *AR* magazine is published and distributed to members. There are other areas of possible savings, but they are minor and incremental at best and most would adversely affect services to members and affiliated clubs. Mind you, it has been estimated that electricity costs for the national office will fall by \$73 next year with the abolition of the carbon tax! Every little helps.

Before the WIA Board can make any decisions about which way to go (cost-cutting versus increased membership fees, or a mix of both), we need to know your opinions. We intend to produce a survey

Continued on page 5

## A foray into the do-it-yourself world

On display at the Eurisko exhibition in early November in Melbourne was the hands-on aspect of amateur radio. The well-presented WIA stand was designed to showcase amateur radio to a select audience and hopefully link up with those who can see an application for their interests.

The paying visitors attracted to the Eurisko exhibition were mainly of a younger age group interested in making, crafting and do-it-yourself activities. There were many stands including those with basic soldering, 3D printing, chemistry, computers, electronics, robotics, rocketry, and self-help learning groups. A few also held workshops during the two-day event.

Fitting right in was the WIA stand that had working displays of amateur television, homebrew equipment design and construction, a video display of various aspects of amateur radio plus information on how to become a radio amateur. New to them was amateur radio's ability to handle telemetry for experiments, and that some of us are already into balloon launches and other practical experimentation.

Spending a lot of time at the WIA stand was Dr Zoz Brooks, a special guest at the exhibition from Fab Lab Adelaide and co-host of the internationally telecast Discovery Channel's Time Warp show, devoted to high speed imaging of natural and scientific phenomena.

The Adelaide-based engineer, artist, robot expert, hacker and teacher spent well over an hour with those from the WIA to learn all he could about amateur radio and like many visitors thought about what modern amateur radio offers their interests and how to become a radio amateur.

The WIA hopes that collaboration with other do-it-yourself interest groups can be achieved.

Tapping into a near-perfect audience, with targeted messages delivered by individuals with a high degree of interpersonal skills, the stand effectively showed off what Amateur Radio has to offer. Participation in the Eurisko Melbourne exhibition is in line with a recent WIA email survey of radio clubs on the broad topic of how best to promote modern amateur radio.

A YouTube presentation by Peter VK3YE is available at: <http://www.youtube.com/watch?v=PoPqwpOKgRY>

## What will be amateur radio in the future?

Are you happy with the way things are now, without giving deep thought how, over the years, amateur radio has truly evolved?

First we had wireless experimenters dabbling in the scientific oddity of spark-gap telegraphy, then came valves, amplitude modulation, radio broadcasting and shortwaves opening up the world, satellites and more. A lot has happened, not to mention television, the Internet and the use of a plethora of digital modes and weak signal working.

Do visionaries that look to the next five, 10 or 20 years still exist? A declining number of newcomers can pose a real threat to amateur radio, and it could happen in Australia. An unknowing community has rarely heard of amateur radio, or thinks we're old fashioned, bypassed by computer and information technology, and does not provide new challenges.

Think about how best you can promote amateur radio – sure we need to reflect on the past, but we also need to emphasise the now and the future. The WIA through its clubs and individuals has the PR4AmateurRadio Expo in April. Details about it can be read now on [www.wia.org.au](http://www.wia.org.au) and visiting the "What's On" section.



## WIA Traveller's Badge



**New stocks of this very popular item have just arrived!**

**The first batch sold out in just a few days, so get your order in quickly.**

The badge can be ordered from the WIA office or via the WIA website at [www.wia.org.au/members/bookshop/about/](http://www.wia.org.au/members/bookshop/about/) under the "Merchandise" heading.

The price is \$10 plus postage and packaging.



## Editorial

Continued from page 2

months about how to maximize your chances of success in working that DX station.

I have also heard similar behaviour locally within VK when on a SOTA summit. The SOTA Activator is the DX and calls for QRP stations only, or calling via call areas. Often one hears base stations still running

full power calling back or out of turn. They were simply too impatient to make the contact to wait for their call area to be called.

We are moving into the festive season. Can I suggest that all operators think a little more carefully and consider others before hitting the PTT button?

May you and your families all have a safe and enjoyable festive season, and a safe and prosperous New Year.

Cheers,  
Peter VK3PF



## WIA comment

Continued from page 3

asking you to rate your preferences to various options proposed in the survey, and also asking you to rate the various services the WIA offers.

So, it looks like an interesting year coming up. I have said many times that, for such a small organisation, the WIA is exceptionally complex, with many highly specialist functions, from magazine publication to high-level governmental advocacy. The WIA can only continue to be effective

because of the goodwill and generosity of its many volunteers, the dedication of its staff, and the loyalty of our members. For that, I thank you all very much.

Have a safe and happy Christmas and see you all in the New Year.

### PS

Please do make sure you have registered for MEMNET. Go to [www.wia.org.au](http://www.wia.org.au) click on 'For Members',

then click on 'Log into MEMNET', and register... it's very simple.

If you have already registered for MEMNET but have not received a confirmation Email we may not have your correct Email address. Please email [memnet@wia.org.au](mailto:memnet@wia.org.au) with your email address, name and membership number.

If you are changing your Email address, please remember to update your information in MEMNET.



## The Wireless Institute of Australia ACN 004 920 745

### Election of Directors - Call for Nominations

Pursuant to clause 14.1 (c) of the Constitution the WIA Board has determined that the election of directors shall be conducted by postal ballot.

Three directors retire at the conclusion of the next Annual General Meeting which will be held on the Sunshine Coast, Qld., on the 17th May 2014, namely Philip John Wait, Christopher Brian Platt and Robert Stanley Bristow. Each is eligible for re-election and Philip John Wait, Christopher Brian Platt and Robert Stanley Bristow have offered themselves for re-election to three of the three vacancies.

**Nominations are called for from others also seeking election as a director of the WIA.**

A director must be a voting member of the WIA and must hold an Australian amateur radio licence.

Any person wishing to nominate as a candidate for election as director of the WIA must deliver or cause to be delivered to the Returning Officer by not later than 31 January 2014:

A statement signed by the candidate signifying his or her willingness to be a candidate for election as a director together with;

the full name, age, occupation and callsign of the candidate, and such other biographical details or other information as the candidate wishes to accompany the ballot papers, but in all not exceeding 250 words.

Delivery to the Returning Officer may be made by hand when the WIA national office is open at:

Unit 20  
11-13 Havelock Road  
Bayswater  
Victoria 3153

or by mail to:  
PO Box 2042  
Bayswater  
Victoria 3153

**Nominations received by facsimile or by electronic means cannot be accepted.**

**Geoffrey Atkinson VK3AFA**  
Returning Officer

# Transverter systems

Graham Byrnes VK3XDK

## Overview

Transverter systems offer a simple and effective way to convert frequencies up or down to suit bands or frequencies that would not typically be available to our transceivers. Transverters in some cases can even be used to improve performance on frequencies or bands that the transceiver is capable of operating.

Note: Most transverters are designed for both transmit and receive, but can be used as receiver or transmitter only.

## Beginner's notes

RF construction is not easy and gets increasingly difficult as the frequencies get higher. Although many designs look incredibly simple, this is usually not the case.

Even experienced 'microwavers' have problems at times!

With the high bands especially, careful and neat construction, quality interconnects, RF relays (rated for the appropriate frequency, isolation and power levels) and closely following PCB layouts and instruction are some of the more important keys to success.

## Theory of operation

For simplicity I will use the 2.4 GHz (2403 MHz) band as an example; this is a good band for those getting started in 'Microwaves' due to the availability of surplus 'WiFi' amplifiers and antennas. It also has greater tolerance to construction imperfections than higher bands.



Photo 1: 10 GHz transverter (box with horn antenna) mounted 'remotely' on pole.

## TX

433.150 MHz (from the IF transceiver) and 1970.000 MHz (from the Local Oscillator) is 'mixed' together then filtered (on the transverter board) leaving 2403.150 MHz to be amplified and sent out to the antenna.

$$1970 \text{ MHz} + 433.150 \text{ MHz} = 2403.150 \text{ MHz}$$

Figure 1: Basic system.

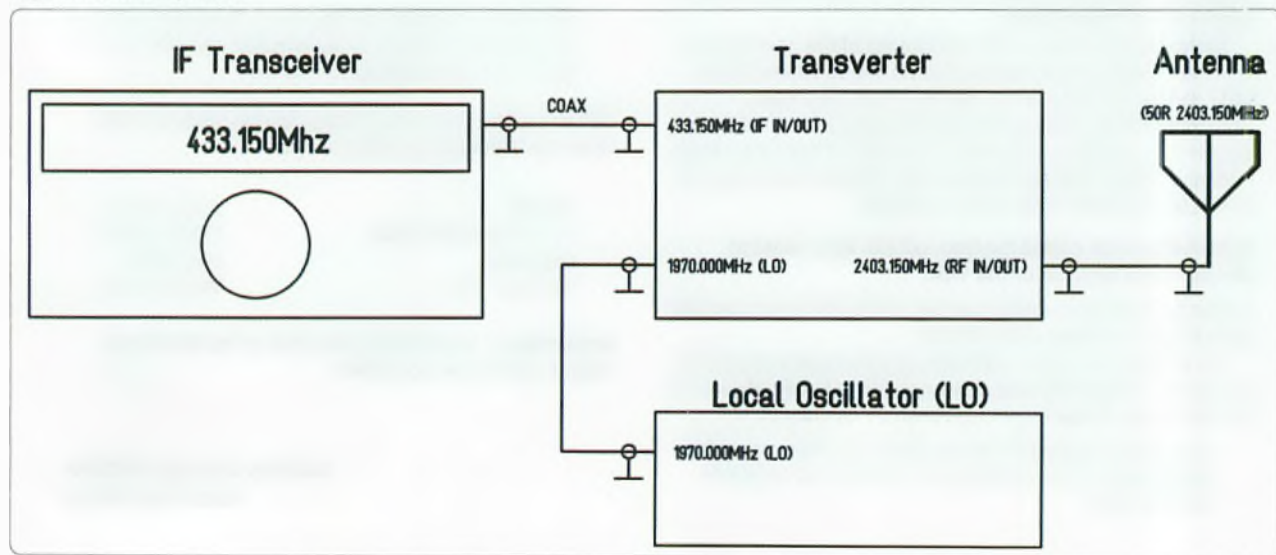



## RX

2403.150 MHz (from the antenna) is amplified then 'mixed' with 1970.000 MHz (from the Local Oscillator) by the transverter, leaving 433.150 MHz to be sent to the IF transceiver.

$$2403.150 \text{ MHz} - 1970.000 \text{ MHz} = 433.150 \text{ MHz}$$

These are both examples of 'low-side injection', which is typical of most transverters. There is a possibility of 'high-side injection' but is not used often due to the fact that the IF tuning ends up being back to front and the LO requirements are higher.

TX example:  $2836.300 \text{ MHz (LO)} - 433.150 \text{ MHz (IF)} = 2403.150 \text{ MHz (RF)}$

RX example:  $2836.300 \text{ MHz (LO)} - 2403.150 \text{ MHz (RF)} = 433.150 \text{ MHz (IF)}$

In both cases different IF frequencies are possible by changing the LO frequency but there are often limitations due to the transverter's mixer and filtering.

Note: Transverters are normally 'linear' and can usually handle all-modes (SSB, AM/FM, digital).

## The complete system

Figure 1 shows a very simplified system; in reality there is a lot more to consider.

## IF requirements

### IF power levels

Not only does the IF transceiver need to be able to both receive and transmit on the required (IF) frequency, it also needs to be able to deliver the correct level of IF power during TX.

Typical transverters can only handle up to around 10 dBm (10 mW) on their IF input, any more than this can damage the unit's mixer. Of course 10 mW is much lower than the minimum output settings on most transceivers so some power attenuation is usually needed.

Note: Attenuation left in during RX will decrease receiver sensitivity; the attenuator is normally bypassed while receiving.

Some transverters have on-board attenuation (often adjustable) to decrease the IF level to suit the transverter's mixer, this can greatly simplify the IF interface but levels still have to be considered as on-board attenuators can normally only handle a couple of watts.

### IF switching

Some transverters have an IF input and an IF output, this is typical for a dual mixer (split IF/LO) system.

This being the case, the IF line from the transceiver will need to be switched to the appropriate IF port on the transverter. This is normally done with RF relays, PIN diode/transistor switching or possibly even a standard relay at lower IF frequencies.

In some systems a small time delay is required, this will be covered later in Control Lines/Sequencing.

Electronics  
Enthusiasts

Jaycar  
Electronics

ONE-STOP-SHOP

Better. More Technical.

### World Band AM/FM/SW/LW/AIR PLL Radio with SSB

Ideal for the novice ham radio licensee, packed with features including:

- Single-sideband modulation (SSB)
- Auto tuning with 500 presets
- RF gain control
- Local/world time
- Large backlit LCD
- Local/DX antenna switch

\$179

AR-1945



### Screw Mount LED Magnifier Lamp

High quality magnifier with 90 super bright LEDs and metal handle for quick repositioning. A must for your work bench or table.

- 120mm, 3 x magnification lens
- Metal frame construction
- 2m long cord
- Mains powered
- Total extended length 900mm

\$119

### USB Mini Inspection Camera

Water resistant inspection camera with a massive 7m flexible cable.

- Camera 10mm diameter
- Lit with 4 x white LED's
- Hook, magnet and 45° mirror attachments included
- Resolution 640 x 480

QC-3374

Also available in 1.5m Flexible Cable QC-3373 \$39.95

NEW 2013



\$59.95

### Cable/Wiring Kit with Gas Soldering Iron

Kit contains Pro gas soldering iron with tips, solder & desolder braid. Wire strippers, cutters and shears. Heatshrink and splices. See website for full contents.

TS-1114

\$99.00



### 30 Piece Electronic Tool Kit

An excellent tool kit for electronic or computer repairs with all the essentials - cutters, pliers, screwdrivers (Phillips head, slotted, Posidriver), nut drivers etc. See website for full contents.

TO-2107

\$29.95



### Light Duty Hook-up Wire Pack

Quality tinned hook-up wire on plastic spools. 8 colours - buy one roll of each.

- 8 colours, 25m roll each

WH-3009

\$34.95



Prices valid until 31st December 2013

Phone Orders 1800 022 888  
[www.jaycar.com.au](http://www.jaycar.com.au)

## LO (Local Oscillator)

### Levels

For mixers to operate correctly, they need to be fed with an appropriate level of constant RF power at the correct frequency, this is the job of the LO (Local Oscillator).

Common mixers are as follows:

Level 7 (7 dBm), these typically require an LO level of 4 to 10 dBm (3 to 10 mW)

Level 10 (10 dBm), these typically require an LO level of 5 to 13 dBm (3.5 to 20 mW)

Level 13 (13 dBm), these typically require an LO level of 7 to 16 dBm (5 to 40 mW)

Variations such as singly balanced, double balanced, harmonic etc. are available but will not be covered in this document.

So for instance, if our transverter's mixer is a 'level 10' we need to make sure that our LO is supplying between 5 to 13 dBm (3.5 to 20 mW) to its LO port. Losses (including interconnects) need to be taken into account.

Mixer performance drops rapidly if the levels are not correct.

### Stability

LO stability, both long term and short term is also a critical factor.

For the microwave bands, to generate an LO at 1970.000 MHz, for example, we often need to 'multiply' a lower frequency. Due to this multiplication process, a low frequency offset (or error) will be multiplied many times putting us (in some cases) a long way from where we mean to be in the spectrum!

For example,

$$10.000 \text{ MHz (correct)} \times 197 = 1970.000 \text{ MHz}$$

$$10.001 \text{ MHz (error)} \times 197 = 1970.197 \text{ MHz (197 kHz error)}$$

For this reason, a good 'oven' oscillator (OCXO) or GPS locked oscillator/PLL is often used to generate the initial (or direct) LO frequency.

### GPS

A very popular and versatile system that uses signals sent from the satellite Global Positioning System to 'discipline' (correct) an oscillator's frequency.

Typically a 10 MHz oscillator is compared to a signal from

the GPS network. Any error is quickly corrected within the 'GPS Reference' circuit leaving us with an extremely stable and accurate 10 MHz signal which can then be multiplied to a higher frequency or used as a reference signal in a PLL system.

GPS Reference systems can be built from parts or purchased on the surplus market, but be careful to get one that has a 10 MHz output.

### PLL

PLL systems are perhaps the easiest way to generate LO frequencies.

They can be used in conjunction with a multiplier or some can produce an LO frequency directly (taking out the multiplication process)

PLL systems can often take advantage of a GPS locked 10 MHz reference for excellent stability.

**Note:** PLL systems can have higher 'phase noise' than an equivalent crystal/multiplier chain *but* the system is usually a lot easier to implement.

### Multipliers

As mentioned earlier, LO signals are often too high to generate directly. A multiplier (or multiplying chain) is normally used if this is the case.

The multiplier needs a signal of the correct level and frequency (often referred to as the 'sub LO'). The 'sub LO' signal drives the input stages of the multiplier into 'saturation' creating 'harmonics' (multiples of the original input signal). The correct multiple is then filtered and amplified to suit the following stage which could be the transverter mixer or another stage of multiplication.

**Note:** For a multiplier to work correctly, the input level (sub LO) has to be just right. If the level is too low adequate harmonics may not be produced. Too high can cause unwanted harmonics and a dirty signal.

Figure 2: A typical relay buffer.

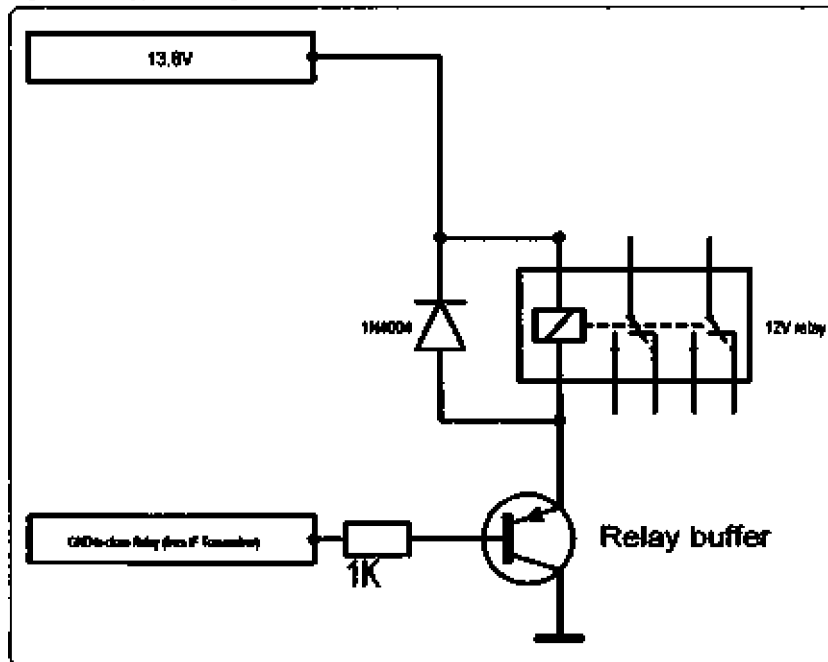



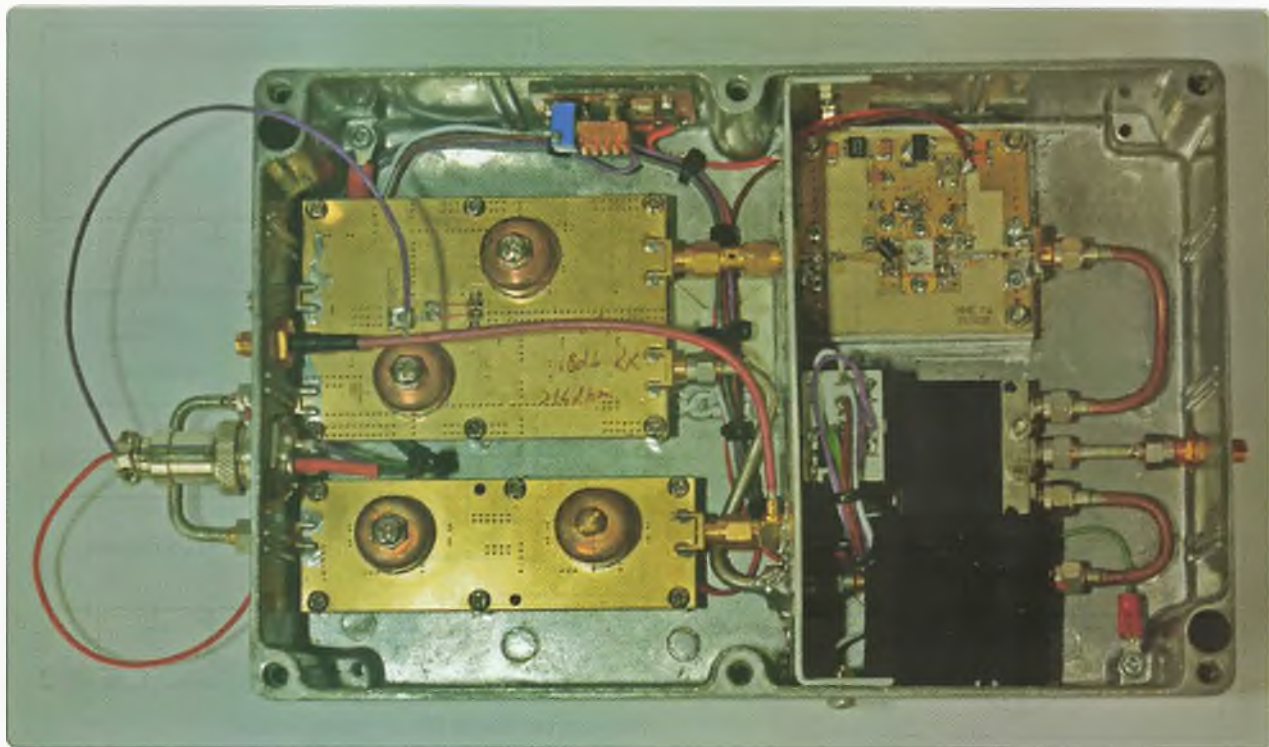

Photo 2: A view inside a microwave transverter destined for mast-head mounting. The modules are (clockwise from bottom left): the LO multiplier/buffer board (the LO itself would be located in the shack), the transverter board, a Tx power amplifier, the antenna changeover relay and a low noise amplifier for Rx.

# TET-EMTRON

**Kits!**  
**Kits!**  
**Kits!**

**TET-Emtron**  
47 Ocean Drive,  
**PORT DENISON.**  
W.A 6525  
08 9927 1872  
See our wide range of new parts and  
products at:-  
[www.tetemtron.com.au](http://www.tetemtron.com.au)



- Everything you need to make a complete balun in either hanging, beam or portable styles. Excludes Glue and solder
- 1:1, 4:1 and higher ratios. Balun or UnUn
- All the standard high quality TET parts you expect including stainless hardware, gold pin and Bakelite connectors.
- Can be tailored to your needs.
- Full instructions, or use your own design.
- Different ferrites available for different frequencies up to 60 MHz
- Separate parts also available.



**More and more Kits coming every month!!!**

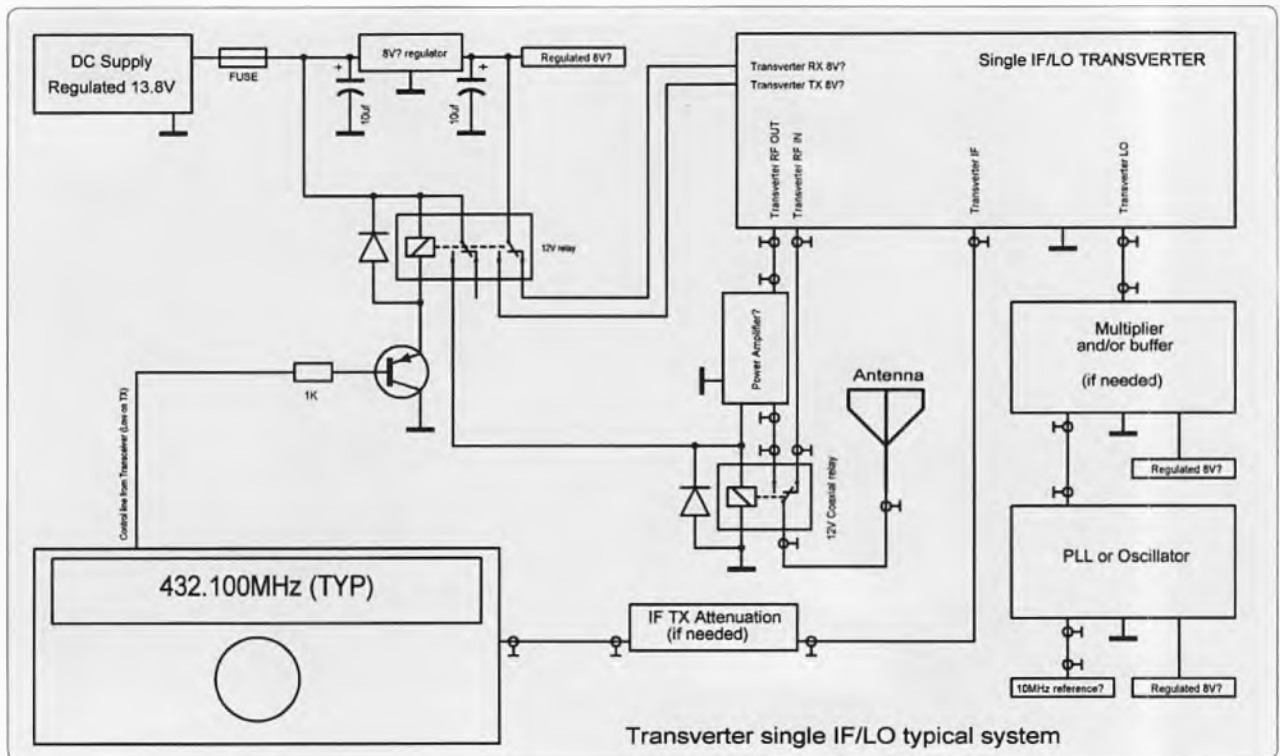

Figure 3a: A typical complete system.

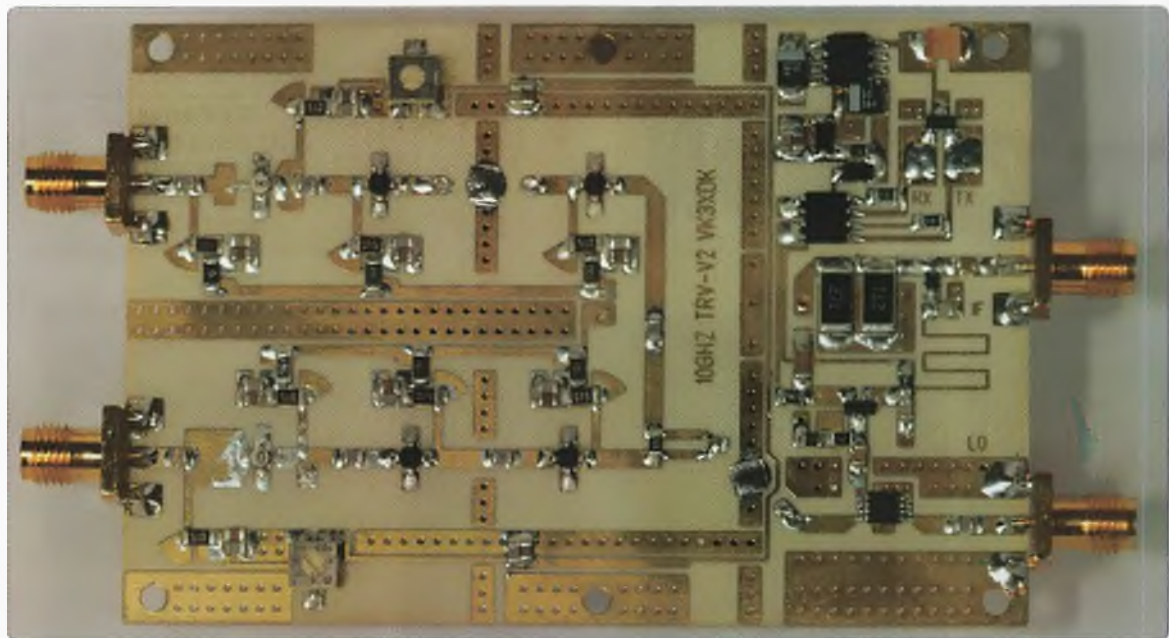

Photo 3: A detailed view of the main transverter board for 10 GHz. Filtering in this case is achieved by the use of "pipe cap" filters soldered on the other side of the pcb (see Photo 2).

### Control Lines/Sequencing

Coaxial relays, amplifiers and the transverter itself need to be switched to suit the TX or RX cycle, this is normally taken care of by the 'sequencer'. Sequencers

are normally controlled by the IF transceiver through their accessories in/out connection. Most transceivers have this connection but we need to set it up correctly and take note of its characteristics.

Some of the important considerations are:

- It's ability to 'sink' or 'source'. Most accessory connectors can only handle a limited amount of power; we often need to use a



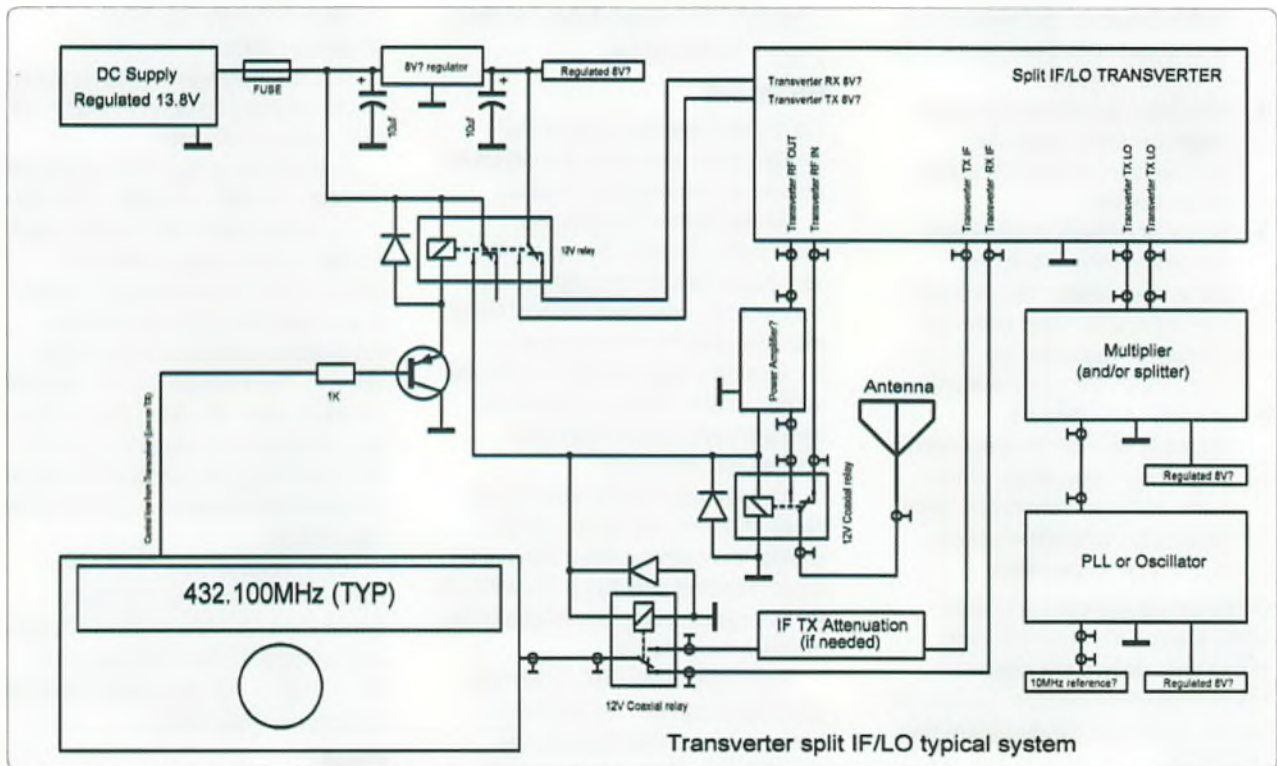

Figure 3b: Another typical complete system.



tts systems

**YouKits**

New Products coming soon

[www.ttssystems.com.au](http://www.ttssystems.com.au)

Phone: 03 5977 4808 Email: [info@ttssystems.com.au](mailto:info@ttssystems.com.au)

Your Australian reseller for:

**AVAILABLE NOW**

Hard Drawn Copper Wire, Insulators, Dipole Centres  
 Open Wire Transmission Line, Spreaders, Kevlar Guy Line  
 Spiderbeam Fibreglass Poles, Baluns and Switches



BUDDIPOLE



ELECTRONICS



...America's Best!



Meanwell power supplies  
 Diamond products  
 Daiwa products  
 Technical books  
 Amidon products  
 Custom cables made to order



Merry Christmas

buffer between the transceiver and sequencer. See Figure 3 for a simple example.

- Whether the connection goes 'high' or 'Low' when the transceiver is in the TX state, (most go low).
- Some accessory connection on some transceivers are band dependent. We choose the connection that suits our chosen IF (typically the 70 cm connection for a 432 MHz IF).
- A delay can often be incorporated by the transceiver (usually a menu item). This is very useful; a higher time delay gives our transverter system more time to get ready.

A typical sequencer can be as simple as a DC relay but often small time delays are needed in the sequence to prevent signals (or power) going to places before they are ready.

A relay for example may take a few milliseconds to close; if a power amplifier was to transmit into an open circuit it could be damaged. Similarly, if supply is enabled to a power amplifier before its bias is established we are sure to see smoke with most microwave devices.

The inherent time delay in relays can also be used to our advantage in a sequencing system, often a complex system is not needed.

Note: Relays can be used in

'cascade' for longer delays or delay steps in a sequence.

### RF in/out

This is the business end of the system and most (all?) are designed around an impedance of 50 Ω.

At the higher frequencies, losses can quickly add up so it is very important to use high quality connectors, coax and coaxial relays that are rated for the frequency. If an amplifier (high power) is included in the system, these components become even more important. Losses turn into heat!

Lead (coax) lengths also should be as short as possible to reduce losses. It is common for a transverter to be mounted directly on the antenna for this reason (a big advantage of the 'transverter system').

Input and output RF is normally switched through a coaxial relay to the antenna. Sequencing was mentioned earlier and is especially important if high power is being used.

### The dB/dBm system

Normally on the higher bands we talk about dB and dBm (as opposed to watts).

It is a very handy system and makes design and 'getting a system together' a lot easier if it is understood. It is also the units used by most microwave test equipment.

Basically, -10 dBm = 0.1 mW into 50 Ω.  
0 dBm = 1 mW into 50 Ω.

10 dBm = 10 mW into 50 Ω.  
20 dBm = 100 mW into 50 Ω.

A 3 dB increase is around about 2 x the power (10 dBm + 3 dB = 13 dBm, around 20 mW).

A 10 dB increase is 10 x the power (10 dBm + 10 dB = 20 dBm, 100 mW).

Another prefix that is often seen is 'dBc' which means decibels below carrier and frequently arises when specifications are relating to spurious emissions (unwanted signals). For example a 'LO rejection of better than -40 dBc' means that the unwanted LO signal is over 40 dB lower than the wanted RF signal (a reasonable figure for a microwave transverter).

Or in relation to a 2403 MHz power amplifier, '2nd harmonic better than -30 dBc @ 10 W' means that without further filtering, a 10 W - 30 dB = 10 mW signal could be radiated at 4806 MHz!

### Final

So there we have a brief look at transverter systems. There are numerous 'ready to go' commercial units available and an even larger number of 'sub modules', 'kits' and 'home brew' circuits for frequencies from 136 kHz to over 47 GHz! And there are many avid 'microwavers' in VK, some of whom are at the forefront of the higher spectrum and are usually more than happy to help out the beginner. The internet, particularly 'Forums', are also great places to seek information and advice.



## Plan ahead

**John Moyle Field Day**

**15 - 16 March**

**PR4 Amateur Radio Expo**

**11 -13 April**

**WIA Annual Conference Sunshine Coast**

**17 - 18 May**



# Review of Videomate U620F DVB/SDR (Software Defined Radio)

John Titmuss VK4JWT

The Videomate U620F from Compro Technology is an RLT2832 based digital TV receiver.

With the help of some very smart software, it can be turned into a fully optioned communications receiver/spectrum analyser, covering the frequencies from 51.4 MHz to well over 1.7 GHz. This is a quick start-up and review.

The U620F comes in a brightly coloured box, complete with antenna and installation CD.

First things first - do not run the installation CD, as we will need to run a special driver to perform the magic. This is one of the better built units I have seen, made in Taiwan, not China; it has a very nice black gloss case, and feels well built.

Firstly, unpack the receiver, and plug it into a spare USB port. Do not load any drivers. When you plug your U620F in for the first time, Windows may request a driver or automatically install a driver from Microsoft - this is OK as it will be replaced in the next few steps using Zadig. Don't install the software on the CD that comes with the device.

## Zadig

Note that you will need to run Zadig for every USB port you use the U620F in as Windows seems



Photo 1: The Videomate U620F. Photo courtesy COMPRO Technology.

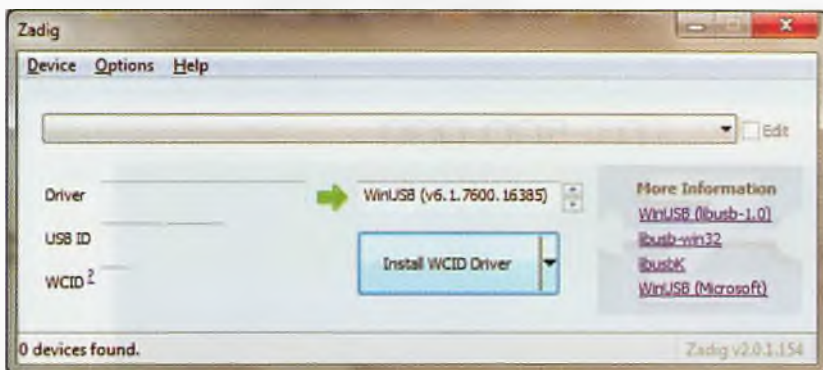

Figure 1: The initial screen displayed when loading the Zadig drivers.

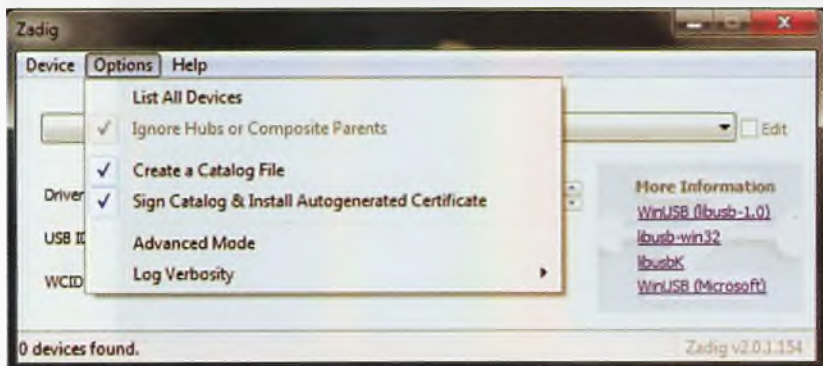

Figure 2: Step 2: Select "List All Devices" under Options.

to only apply this driver to the port in question at the time.

- Download the latest version of [Zadig](#). You will need to use [7zip](#) to extract it from the .7z file.
- Run the Zadig.exe file and you should see the following with an empty list. Refer Figure 1.
- Click on Options and select 'List All Devices'.
- Choose the one that says 'VMU6XX'.
- In the box to the right of the green arrow make sure 'WinUSB' is chosen - not libusb or libusbk. The big button underneath will say 'Replace Driver' or 'install Driver'. Refer Figure 3.

Once the WinUSB driver is installed you are ready to run SDRSHARP with the RTL-SDR/USB input device.

## SDR#

- Download the latest version of SDR SHARP and SDR SHARP RTLSDR Plugins from here:

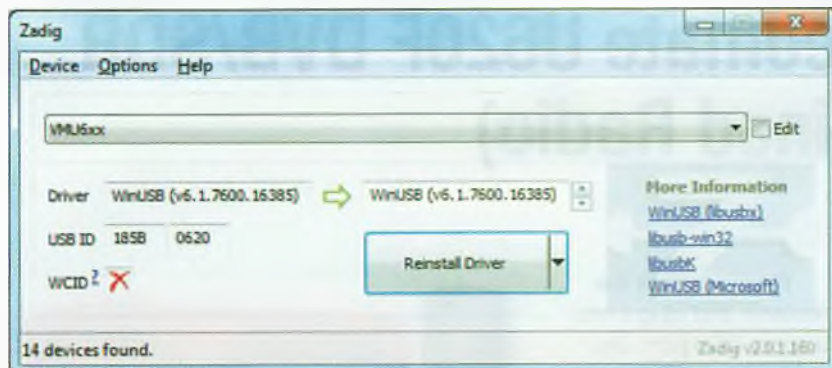

Figure 3: Screen shot of the final step prior to initialisation of driver installation.

- <http://sdrsharp.com/index.php/downloads>
  - Unzip all files into one directory SDR SHARP, then copy the config file from its own directory into the main directory.
  - Run SDR SHARP and you should see the following screen – refer Figure 4.
1. Set Radio to WFM (Wideband FM)
  2. Set the centre frequency to (101,500,000) - this is the FM radio band.
  3. Set the button next to the stop button to 'RTLSDR / USB'

4. Click on the configure button and set the device to Compro U620F and sampling rate to 2048 Msps
5. Click on Play.

You should now see an orange waterfall display in the bottom half and a dancing blue spectrum in the top half. By clicking and dragging on the blue spectrum you can conveniently change the frequency. In the example below I have dragged the spectrum and centred on an FM station. All going well you should

Frequency	12 dB SINAD reading	Microvolts
53-426 MHz	-118.4 dBm	0.26
436-483 MHz	-117.2 dBm	0.31
493-550 MHz	-115.4 dBm	0.38
803-910 MHz	-118 dBm	0.28

hear the audio coming out of the PC speaker.

## RF Testing

I have performed a 12 dB SINAD test on the unit with a 3 kHz deviation input signal, and the receiver set to narrow band FM 12.5 kHz bandwidth. The results are very good, on par with a modern communications receiver. I measured some spot frequencies within the bands shown on the table below.

## Features

If you click on the configure button, you can set the sampling rate, which will change the spectrum bandwidth on the screen. You can also use the RF gain control manually if you untick the tuner AGC. I generally leave the tuner AGC ticked, and have the RF gain adjust automatically.

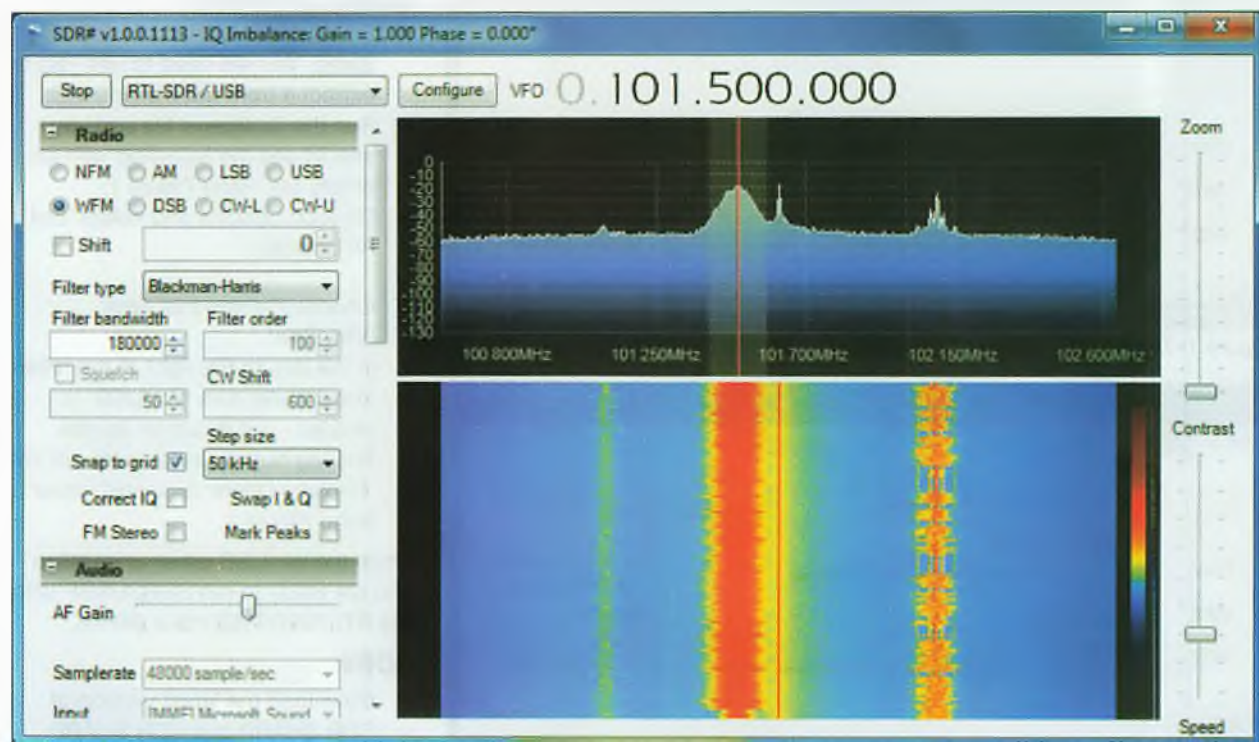

Figure 4: The SDR# application up and running for the first time.



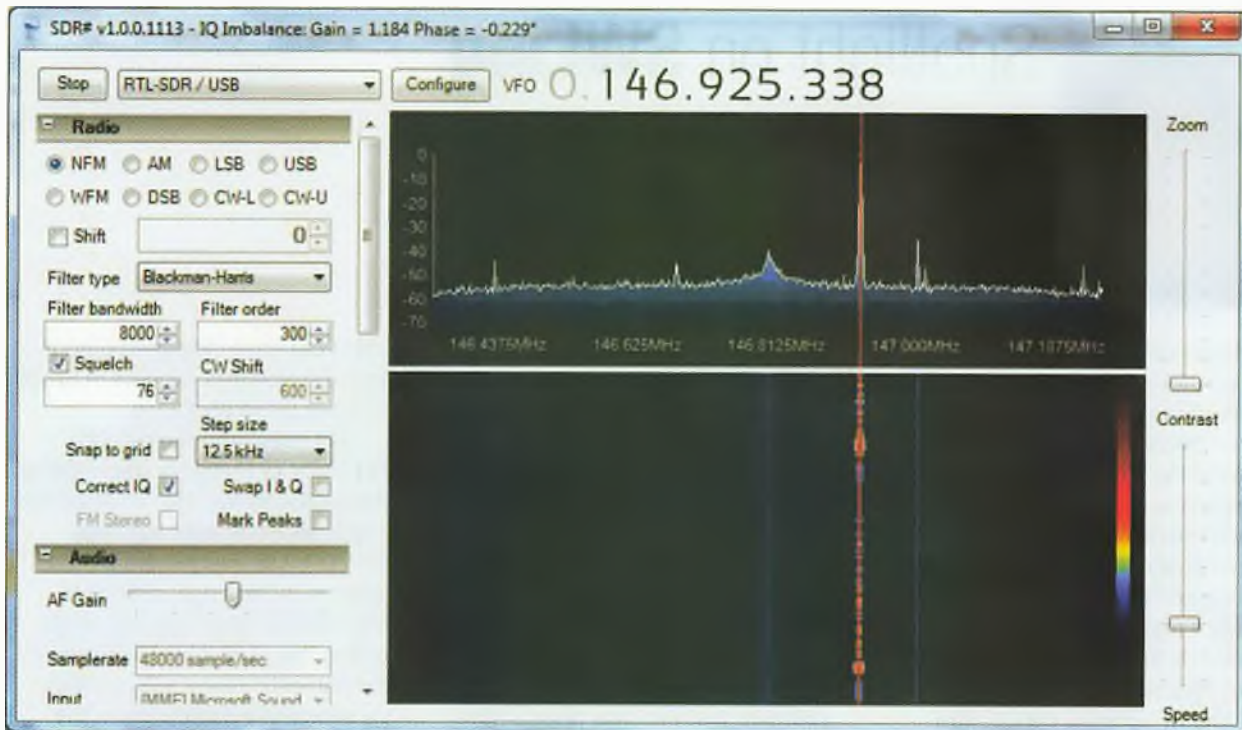

Figure 5: The SDR# application with the receiver tuned to a two metre repeater on 146.925 MHz narrowband FM.

You can also use the frequency correction box, which corrects any discrepancy in the actual received frequency. Just tune to a known frequency, and move the frequency correction PPM up or down to get it spot on. Next are the mode buttons for AM, FM SSB and so on. The filter bandwidths are all automatically set or you can manually set them. Tick the correct IQ button to get rid of any image frequencies on the spectrum. The squelch can also be adjusted and ticked for FMN operation. Another handy feature is the mark peaks setting, which will draw a small circle on all peaks, just like a real spectrum analyser.

Audio gain is adjusted with the audio slider control, and a tick box filters the audio with DSP, and gets rid of noise from the audio signal. Tick the use AGC box as well as the use hang box. In the

FFT display menu, you can view just the spectrum analyser, or just the waterfall, or both. I generally leave it on both, and set the resolution to 65535, this is the best compromise between processing power required, and resolution of the spectrum trace.

There is also a frequency manager, so you can store all your favourite frequencies, as well as a recording menu, where you can record the whole baseband, and play it back later, and actually tune around in it, or you can record just the audio output.

Below - refer Figure 5 - is a screen capture of the receiver tuned to a two metre repeater on 146.925 MHz narrowband FM. You could record the whole band as seen below, or you could record just the audio coming from this one frequency.

## Conclusion

The Compro U620F is definitely worth the money. For around \$25.00 you are getting a very useful tool, which is capable of capturing a 3.2 MHz slice of radio spectrum, tuneable between 51.4 MHz and 1.7 GHz. As an SDR, the PC software can implement a wide range of demodulation and filtering modes. The SDR is not a substitute for a \$50,000 commercial spectrum analyser, but it does give a technician who may not have a spectrum analyser on hand a visual indication of the spectrum, and audio demodulation of the channel being monitored.

## Reference for further information

<http://www.comprousa.com/en/product/u620f/u620f.html>



## Contribute

Articles and high quality photographs for *Amateur Radio* and *Callbook*.

See <http://www.wia.org.au/members/armag/contributing/>



## Spotlight on SWLing

Robin Harwood VK7RH  
e vk7rh@wia.org.au

2013 is rapidly drawing to a close. As predicted, we have reached the peak of the current sunspot cycle and it will slowly go downhill. It has not been as spectacular as in previous cycles and it really did not reach the peak of the last cycle. In fact it seemed to stretch out beyond the usual 11 year cycle. What also made it notable was the rapid decline in shortwave broadcasting and utility services.

The HF amateur bands have also declined, compared to how congested they were only half a decade ago. In the final weekend of October, there was a CME, which seriously affected propagation, but you would not know because the annual CQ Worldwide contest was in full swing. Bands that I thought were moribund certainly burst into frenzied activity. Monitoring from the excellent University of Twente software designed radio (SDR) at Enschede, Holland, I could only marvel at the 28 MHz band springing into life. Many signals seemed to emanate from the former Soviet Union and this led me to tune down to see if the reported taxi activity was present just a megahertz down. Indeed it was, being a mixture of AM and narrow band FM. Many taxis are said to also be present on

28 MHz but they must have been overwhelmed by the sheer size of ham activity that weekend.

I have also heard that there are licensed broadcasts emanating from Roman Catholic parishes in both Ireland and Ulster between 27 and 28 MHz, mainly on Sunday mornings. These are primarily for home bound parishioners unable to attend Mass. These signals are also utilising narrow band FM. I am informed that the local priests have been stunned to receive reports from across Europe and North America, although the senders are supposed to be less than 12 watts.

Poland exited shortwave on the 27th of September, plus the relay station of Spanish Foreign Radio in Costa Rica. Programming continues from Greece on 9420 but is apparently now in government hands, after expelling striking workers with their own source of programming. Music now seems to be a mixture of jazz and European pop styles. I do miss the ethnic Greek style. As mentioned previously, Spanish Foreign Radio (REE) has made some tough decisions brought on by the on-going budget woes on the Iberian Peninsula. They have closed Costa Rica and also ended relays via

China but have increased output from the Noblejas senders in Spain to cover these decisions.

As I have reported recently, The Voice of Russia is also quitting shortwave on the 31st of December. It was only a decade ago that the VOR was everywhere but has become increasingly difficult to find recently. Now they are finally pulling the plug. It is still unclear if the domestic relays will continue via shortwave particularly in the Russian Far East.

I have finally managed to hear Brazil on shortwave. I confess that it was not direct but using the above mentioned SDR via the web. It was on 11764.8 kHz. Apparently Brazilian stations are notorious for being off-frequency. This station was in Porto Alegre in the south of that nation and programming consisted of sermons from a Pentecostal movement. Brazil has always been an extremely hard catch for me on HF. There was a solitary contact over 35 years ago but I do not recall hearing him yet he apparently heard me.

I do hope that you have a safe and restful Christmas/New Year period and that the bands will open for you. I wonder what will happen in 2014?

## MEMNET



Have you registered for MEMNET yet?

Go to [www.wia.org.au](http://www.wia.org.au) click on 'For Members', then click on 'Log into MEMNET', and register... it's very simple.

If you have already registered for MEMNET but have not received a confirmation Email we may not have your correct email address.

Please email [memnet@wia.org.au](mailto:memnet@wia.org.au) with your email address, name and membership number.

If you are changing your email address, please remember to update your information in MEMNET.



# A triband end-fed wire antenna for QRP portable

Peter Parker VK3YE

End-fed half wave wire antennas have many advantages for lightweight portable use. These include the absence of bulky coax feedline, their need for just one high support and modest ground or counterpoise requirements.

On their own, such wires present a poor (high impedance) load to the transceiver. An antenna coupler or transformer between the two is required for efficient performance. The common L-match allows the one wire to cover several bands but needs adjustment with each change.

A fixed ratio transformer can be used instead if 'set and forget' operating is important. It steps the radio's 50 ohm impedance to the 4000 ohms (approximately) demanded of the half wavelength wire. A trimmer capacitor can be added for minor tweaking.

This article describes a transformer and end-fed antenna suitable for HF QRP portable use.

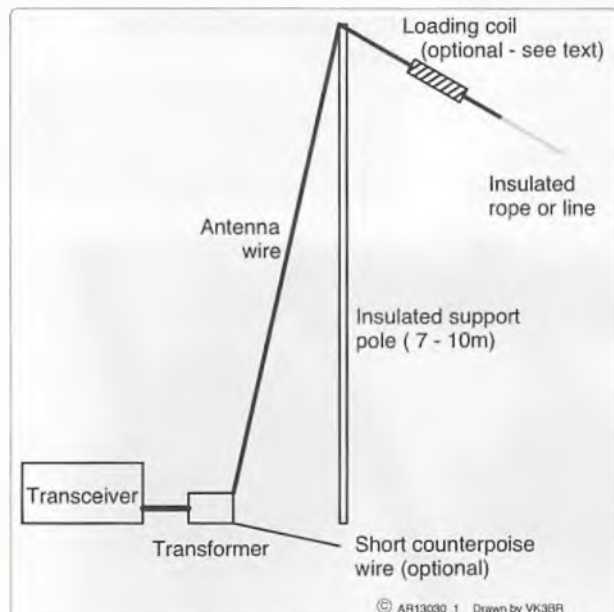

Figure 1: Typical end-fed antenna installation.



Photo 1: Inside the transformer unit.

Operation on any band is possible with the appropriate length wire. I'll also describe a compact loaded version for half wave operation on 40 and 20 metres plus 10 metres as a full wave.

## Transformer

Changing the radio's 50 ohm impedance to the antenna's 4000 ohms (approximately) requires an impedance step up of 80 times. A ferrite transformer can accomplish this. Just like a power transformer there are two windings, each with a different number of turns. The winding with fewer turns

## OUTbacker

www.outbacker.biz

The OB8 Classic, the go-anywhere mobile antenna - the unquestioned, all season, all climate, all terrain, HF mobile champion. This 1.8 metre tall antenna, (990mm when packed) covers 80-75-40-30-20-17-15-12-10m, no antenna tuning or base matching device is needed. When combined with OUTBACKER's, (TCCOSB) heavy duty, spring base, the OB8 makes a very rugged and professional installation, which will last for years. Maximum power:- 300 Watts.

The shorter COVERT series are similar in construction and have the same bands but are lighter and more suited for portable mounting to vehicle body panels ie: Guards and Boots. As with this Stealth antenna all Outbacker HF antenna are coated with the latest, strongest the most technology advanced thermal setting plastics.

Grow to our website for more antenna models and mounting accessories

OB8 STEALTH TCCOSB TCCM130

40 years on and still the same owners and still Australian made.

**TC** TERRY CLINCH COMMUNICATIONS  
Ph 0414532070 Fx 0894575372  
terry@outbacker.biz

goes to the low voltage/high current/low impedance side (the transceiver), while the longer winding (high voltage/low current/high impedance) goes to the antenna.

The impedance transformation depends on the square of the ratio between the number of turns on each winding. In other words a transformer with 3 turns on one side and 6 turns on the other will have a turns ratio of 2, or an impedance step-up of 4 times.

A half wavelength end-fed wire needs a higher step-up due to its high impedance. We do the calculation in reverse, taking the square root of our 80 times step up. The nearest whole number to this is 9, which becomes the turns ratio. As the transformer here has a 3 turn primary winding, the secondary needs 27 turns to achieve the 1:9 ratio.

### Construction

Key parts required are a FT-50-43 ferrite toroid, trimmer capacitor, SO-239 or BNC antenna socket, binding post, small plastic box and enamelled copper wire. See Figure 2 and Photo 2.

The 13 mm toroid used does not heat with five watts but is not recommended for use with much more. The trimmer is a compression type from a salvaged transmitter with a maximum capacitance of about 400 pF. While intended to be 'set and forget', there are times when screwdriver adjustment is desirable.

Obtain some thin enamelled copper wire approximately 0.5 mm in diameter, such as from old power transformers, for the toroid. Cut lengths of 80 cm and 15 cm. Twist these together with the ends of both wires aligning at the start (Figure 2). This can either be done by hand or in the chuck of a hand drill. Stop when there are approximately two twists per centimetre.

Take the twisted start end and feed onto the ferrite with turns looping through the hole. Once you've reached three turns untwist the end of the shorter wire from the

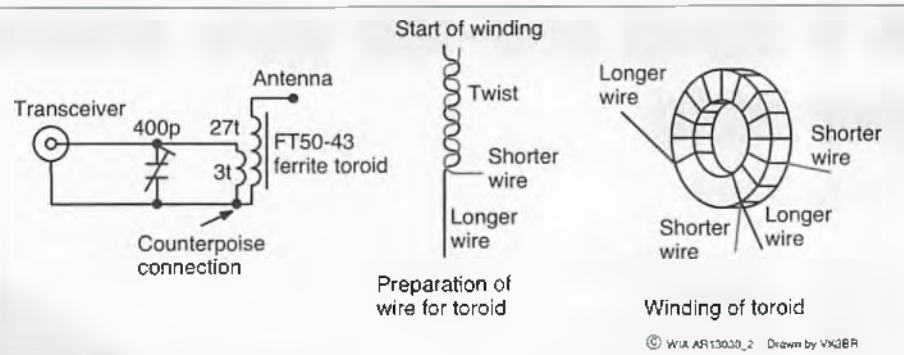

Figure 2: Diagram of transformer unit.

longer. Keep winding the longer wire through the hole to make a total of 27 turns. This should be pulled firmly and spread over about  $\frac{3}{4}$  of the toroid's circumference.

Check the toroid to ensure that the overlapping twisted wires pass only three times through the hole. Trim excess wire to form ends about 3 or 4 centimetres long and use a knife to strip around 5 mm of enamel off each wire. The start of the short and long windings are then twisted and soldered together.

The result will be a transformer as per Figure 2. The free end of the 3 turn winding goes to the transceiver side while the free end of the 27 turn winding goes to the antenna side. The common connection goes to the outer braid of the coax to the transceiver (and a short counterpoise if desired).

If you cannot obtain the compression trimmer specified, substitute a standard plastic transistor radio tuning capacitor with both gangs shorted (often the

outer two terminals labelled 'A' and 'O'). This provides a maximum of 220 pF. If insufficient a 220 pF parallel fixed capacitor could be switched in.

The adjustment of this control is coarser and less critical than the L-match often used with end-fed wire antennas. For greater robustness you can probably get away with not fitting the normally supplied knob and just adjust the stub with your fingers.

Connections to the transformer box are a matter for personal taste. I used a BNC for the transmitter end and a binding post for the antenna end. The latter must accept bare wire if you need to be able to thread the main radiating element through the eye of a squid pole.

### A simple end-fed wire antenna

Erect 20 metres of wire using a tree or pole for support similar to Figure One. Connect the transformer unit to it and the transceiver via a short



Photo 2: Triband loaded end-fed antenna.



coax lead. The SWR should be acceptably low on 7 MHz. Adjust the trimmer capacitor and/or the wire length slightly if required. Good performance for contacts up to about 3000 km should be achieved.

This length may also give low SWR on 14, 21 and 28 MHz as it is an even multiple of a half wave. Tweaking the trimmer may however be necessary on each band. This arrangement is small, light and versatile but DX performance will vary if the antenna's radiation pattern and angles are unfavourable.

Try other lengths. 10 metres of wire will work effectively as a half wave on 14 MHz and can be more easily supported vertically by a tree or squid pole. It should also work on 28 MHz. Lengths of 6, 7.5, 8.5 or 15 metres may also be worth trying for 12, 15, 17 and 30 metres. The result should be an effective lightweight DX antenna.

### A triband loaded wire antenna

A progression from the simple wire is a loaded antenna. This takes longer to construct but is shorter. It is also easier to erect more of it vertically. This is useful where low radiation angles are desired, especially if operating over water.

As shown in Figure 3 (C), the basic antenna is a half wavelength on 14 MHz a little over 10 metres long. It is largely vertical when used with a 9 metre squid pole and should radiate a fairly low angle of radiation suitable for DX.

A loading coil and tail (approximately 2 m long) allows 7 MHz coverage, this time as a shortened half wave. The top can be tied off to a nearby fence (via an insulated support rope) to form an inverted-L. This provides a mix of radiation angles useful for the short and medium distances typically worked on this band. The result is an antenna that operates on two popular HF bands without switching. As a bonus 28 MHz operation is also possible, with the

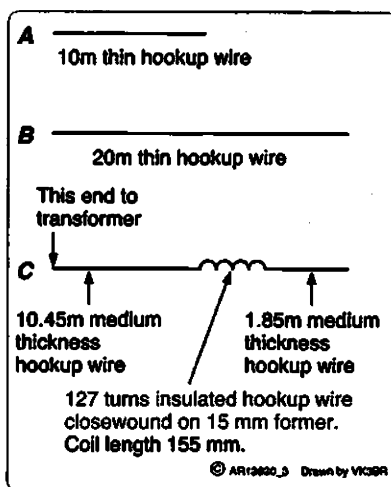

Figure 3: Antenna options.

lower section used as a full wave.

Use medium thickness hook-up or split up speaker cable for adequate support of the loading coil. Solder a firm fitting banana plug to the end of each. Suggested dimensions are given but some 'cut and try' will be required. However once done you will have a compact antenna suitable for three popular bands.

Photo 3 shows the loading coil. This has 127 turns of thin insulated hook-up wire close-wound on a 15 mm diameter plastic tube which in the prototype came from a feather duster. Plastic conduit should also be suitable as a former. Experiment with different coil lengths, anchoring with tape, and then once optimum make small holes at each end of the coil to anchor the wire. Add end-caps and banana sockets to make the coil detachable for easier packing. It has a measured inductance of 29  $\mu$ H.

An antenna analyser is desirable but not necessary. The SWR on 14 MHz is checked and the lower section is adjusted until it is satisfactorily low midband. It is then tested on 7 MHz. As its bandwidth is narrower there it should be possible to discern a peak in receive noise as the receiver is tuned between approximately 5 and 9 MHz.

There will be interaction between the lower wire length,

the coil length and the upper wire length. But it should be possible to arrive at a combination of lengths that provides a low SWR on 40, 20 and 10 metres at one setting of the capacitor in the transformer box.

### Results and conclusion

Both unloaded and loaded end-fed half wave wire antennas have given good results when operating QRP portable.

Morning QRP SSB contacts have been made to Europe (on 40 metres) and North America (on 20 metres) from Port Phillip Bay. An excursion to RF-quiet French Island provided 28 contacts in 7 hours of operating. Contacts were about evenly split between 40 and 20 metres, CW and SSB and DX and VK.

End-feds' small size and light weight make them excellent choices for casual QRP or SOTA style activity. Several versions, including the loaded type described here, can be seen tested on the author's YouTube channel. Adaption for higher power use has not been attempted but should be possible with a larger toroid, wire and capacitor.

### References and further reading

The transformer unit and the loaded version of this antenna were inspired by the following:

- <http://pages.suddenlink.net/wa5bdu/efhw.htm>
- <http://pa-11019.blogspot.com.au/2012/04/149-transformer-for-endfed-antennas-35.html>
- <http://www.hamradio.me/antennas/lnr-precision-ef-102040mkii-examination.html>
- <http://pa3hho.wordpress.com/antennes/multiary-band-end-fed-english/>
- <http://www.hyendfedantenna.nl/joomla/blog/17-multi-band-hyendfed.html>
- <http://www.parelectronics.com/end-fedz.php>



# Pair ranked analysis

*Dr Hank Prunckun VK5XB*

It was the end of a scorching hot day and I was pleased to be about to finish a long drive from Leigh Creek to Marree in the far north of South Australia. Earlier that day my wife and I had carried out some repairs to a solar-operated VHF repeater on one of the mountains outside of Leigh Creek. It was a rough drive up and back down a mountain track as parts had been washed away by the winter rains.

So I was looking forward to a 'cold one' as I turned our 4WD into the last vacant car park in front of the Marree hotel - seemed it was a popular place to be on a hot day. After ordering, my wife and I took up a position at the curved bar and I allowed the amber liquid to coat my throat. As I sipped, I could overhear two young blokes opposite us at the bar debating which UHF-CB radio was the 'best' for four-wheel driving in the bush. From appearances, they looked like it was their first venture beyond the inner suburbs.

'No you're wrong,' one of them said, 'it has a 3.5 mm jack at the back for extension speakers so that has to be better.'

The other bloke replied, 'Yes, but the screen on it is a bit too small for my liking.'

And so the conversation went with them comparing this feature with that and this model transceiver with some other model. They were getting nowhere despite their best efforts to inject a bit of lubrication into the thinking process by way of a few ales. Their quest for the best transceiver was grinding to a slow halt.

I asked my wife if she'd excuse me - I said this would only take me five minutes. She looked at me with a doubtful expression that only a wife could muster. But then, we had worked together all day repairing



*Figure 1: The pair ranked analysis beer coaster tally sheet.*

the repeater, so perhaps she was glad to have a break from my chatter about leaky capacitors and diodes with incorrect values...

I carried my beer over to the two blokes and introduced myself. I explained that I couldn't help but overhear their discussion and offered to assist them arrive at an answer. I told them that I could solve their problem in less than five minutes.

They laughed and told me that they were at the bar last night tossing around their thoughts and had been at it again that evening for a few hours—they were no closer to deciding. Roy, the bigger of the two with his RM Williams boots and hat that looked like he just bought a few days ago, said 'If you can solve this, the beers are on me. Your time starts now,' and he laid his watch on the bar.

Oh boy, I thought. I had to come good with my promise - to them as well as my wife - so I flipped over a spare drink coaster laying on the bar and took out a pencil. I asked them for the names of the radios they were interested in - there were four. I wrote the names on the coaster in a column down the left.

Tapping my pencil on the drink coaster I said, 'The first problem you have is that you have been trying to compare various transceivers using different criteria - rear speaker jacks, illuminated display screens, fix channels or programmable, and so on.'

They both nodded and Aldo, a tall skinny bloke with one of those trendy close-cut beards, said, 'Yep, that's true,' and elbowed Roy in the ribs. 'See I told you,' he added.

'The second issue that has stopped you from arriving at a conclusion,' I explained, 'is that you have given each feature on these different radios equal importance, when the features do not have the same importance.'

They regarded me with the suspicion afforded a fortune-teller. Then in unison they took a long slow pull of their ales. But reflecting on my advice, I could see that they were starting to realise where their faulty reasoning had taken them - nowhere.

'And the third reason you weren't able to decide,' I emphasised, 'is because you were not comparing each radio against every other radio - this is essential.'

'Okay,' blurted out Roy, 'so how do we do it? The clock's ticking.' His face had a smirk to suggest his disbelief that I'd be able to sort out the issue.

By this time, the bartender had positioned himself in front of us and was pretending to clean a few glasses, but he had overheard the conversation and was interested in the answer too - which UHF CB was the best for 4WDing? There were a few others starting to mill around at the back of us. One of them, a grey-haired bloke with ill-fitting dentures, said, 'I'd like to know too - I have that turbo diesel/caravan combo



out front and I want to get a good two-way radio for it - I don't want any rubbish.'

'Alright, alright,' I exclaimed, 'here's the answer, but you need to make a few decisions first. Be honest and answer straight away.'

They agreed.

I asked, 'If you had to buy one of these radios, which one would it be, radio A or radio B?' (For the purposes of this article, I have substituted letters for the brand names of the radios).

'Roy started to explain something about radio A, but I cut him off, 'No, just tell me - A or B. It's as simple as that - if I had these two radios here right now and you had to buy one, which one would it be?'

Together they both said, 'Radio B.'

So I placed a 'tick' mark to the right of radio B to indicate the start of a tally.

'Okay, now if you had to buy one, which would it be, radio A or radio C?'

They agreed on radio C this time.

I continued through all the remaining combinations - A or D, then B or C, B or D, and finally C or D.

Having compared each radio against every other radio, I presented the tally that I had recorded on the back of the drink coaster to the now sizable collection of outback personalities who had gathered around us.

A re-creation of those results is shown in Figure 1. This figure

highlights that radio D was the favourite choice with a tally of three 'ticks.' This was followed by radio B with two, and then radio C with one. Radio A had no ticks against it.

Returning the smirk Roy gave me a few minutes before, I said, 'Pretty clear which radio is best for you two blokes,' and pointed to the watch sitting on the bar - I had a minute to spare.

Roy's jaw was sagging as he stared at the results. Less than five minutes and he now knew which transceiver he needed to buy for his 4WD.

Aldo rubbed his manicured beard and asked, 'Hey, do you reckon that that method would work for a longer list of radios.'

'Sure,' I explained, 'in fact with a longer list, the more pronounced the difference between them tends to be.'

'Give me one of those drink coasters,' demanded the grey-haired bloke. As he adjusted his dentures, he stated, 'I'm going to my list now. When I hit Adelaide I'm going to get my radio installed.'

I smiled at him and also to the group of happy wanderers who had collected around us. Turning to the bartender I raised my empty glass and said, 'Roy's buying; I'll have a Cooper's Sparkling Ale.'

Pair ranked analysis is a simple but effective method for helping people make decisions. In a world where we often have numerous choices, it is difficult to decide on just one - whatever that may be - a new radio transceiver, an antenna

system, a holiday destination, a choice of different cruise liners, a school to send the kids to, which car or house to buy, and so forth.

The pair ranked analysis forces you to make a decision about each and every combination on the basis of a holistic comparison; that is, you compare one item with another in its entirety. It prevents you engaging in the microanalysis that Roy and Aldo did. That's a road to nowhere.

Some may find the forced comparisons a bit unsettling because it is a structured way of thinking. But if you use it a few times you'll see the clarity it delivers for decisions that had multiple choices. It is ideally suited for amateur radio operators who face decisions about what equipment to buy for their radio shack. Until I came across this method, I bought and sold a dozen radios because I used the dishevelled reasoning process that Roy and Aldo used. I commend it to anyone with a number of options to weigh-up. Try it when you go to buy your next piece of gear for the radio shack.

Having helped solve the UHF CB radio issue for those who gathered at the pub that evening, I returned to my wife, who was waiting patiently at the other end of the bar. I think she was surprised that it only took the five minutes I had said. We ordered a counter meal and had an enjoyable evening watching the last rays of the sun set over the old rail yard across the road - the world was right.

AR

*The WIA office will be closed from 4:00pm Friday, 20th December @ will  
reopen 10:00am, Monday, 13th January, 2014.*

*Further details are available at our website [www.wia.org.au](http://www.wia.org.au)*

*The Wireless Institute of Australia extends to all  
radio amateurs very best wishes for the festive season.*



# Antenna tuners

Kevin Parsons VK2JS

For the new operator setting up, there are books and articles on antennas without number, but few say much of practical use for the shack end of the system; how exactly to connect the rig to the antenna. This article offers some thoughts on assembling antenna tuning units which purists may call antenna coupling units, antenna system tuning units and the like. Indeed, of the useful devices one can actually make, an ATU must be at the top of the list. A well-made home-brew tuner has lifetime potential and will work at least as well as commercial items. Some scrounging is necessary, but it can be done.

Before getting to nuts and bolts, it is recognized that many hams have no need for tuners; such as DX operators with rotary beams or with real estate to accommodate a multiplicity of wire antennas. Oddly there are others opposed to the use of antenna tuners on some kind of principle... only proper thing is resonant aerials ... reflected power is not radiated - returns to overheat the final amplifier... much of which is hardly creditable, to put it kindly.

The fact is many hams live on suburban blocks on which aerial farms, or anything like them, are out of the question; they may be limited, for one reason or another, to a single aerial wire somewhat shorter than an 80 metre dipole. So for them, of course, an ATU is the essential device. In this fairly common situation, it is hard to improve on getting as much wire in the air as practicable, as high as possible, centre-fed with open-wire line to a choke-balun on the outside of the building. From there a short length of coax through the wall to a good tuner will produce a straightforward all-band aerial with almost

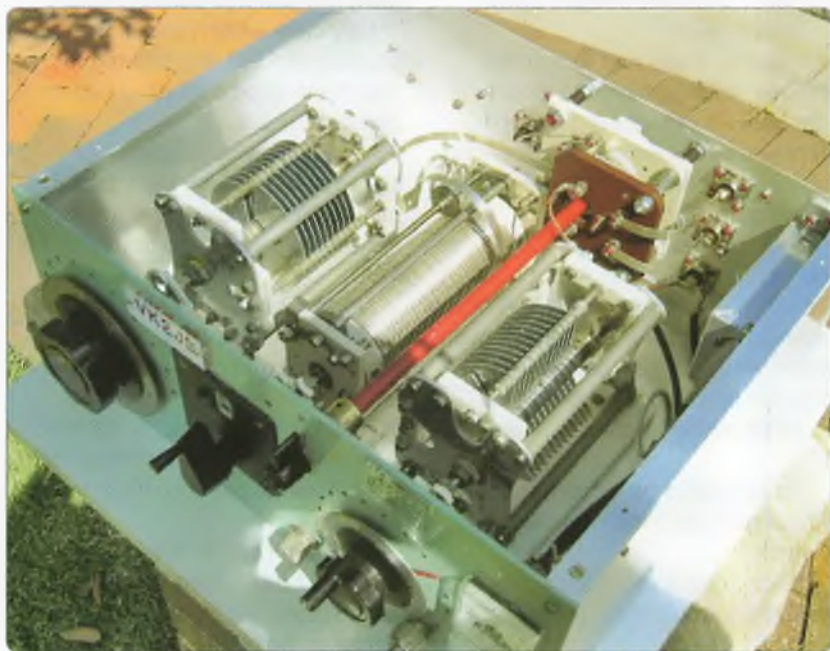

Photo 1: The T-tuner made by the author circa 1982.

nothing to go wrong. The design is simple, but does allow an operator access to any frequency in the 3.5 to 28 MHz bands, and often to good effect.

For example, the writer is constrained by his building block to a length of wire of 30.5 metres; longer than a half-wave on the 40-metre band and more so on higher-frequency bands. It tunes up easily on all, retaining the full length of wire in service, and works well on 80 metres where it is about twenty-five percent short.

As a general point, matching any aerial system by repetitive raising and lowering, pruning, soldering on and measuring can be hit and miss. Much easier, often with a better result, is to have the tuner produce a near perfect 50  $\Omega$  resistive match with very little system loss.

In making an ATU, there are a few practicalities. One that, for other than QRP operation, a tuner should

be housed in a metal box to contain the RF that would otherwise get into everything; also coaxial output is generally the most useful. Of the circuit configurations, the view is that band-changing by lifting the lid to fiddle with crocodile clips at various tapping points takes time, and is not much fun. So for practical every-day use, it really comes down, in the writer's opinion, to two classes of tuner; T-matches or Z-matches.

The Z-match has quite a bit going for it, the single-coil or the original two-coil assembly. One must acquire a respectable split-stator capacitor of about 250 pF per section (not easy) plus a 500 pF, or thereabouts, capacitor such as an old BC tuning condenser. The coils are not too difficult to make and the completed device uses only two controls on the panel. Variants involving switchable taps on the inductors etc. make it more



complex, and not so simple to build. All Z-matches have the virtue of being able to feed balanced lines, coax or single wires. On the other hand, they may struggle to match some impedances, especially at 28 MHz. By and large, though, it is a good tuner made in the thousands. From experience, the Lloyd Butler single-coil Z-match described in *AR* works well.

But for the author's money, nothing beats a T-match for its inherent flexibility and ability to match almost anything. Also once set up for various frequencies, and the settings logged, it can be quickly re-tuned to some other frequency. No crocodile-clips.

It has to be said that some hams have shied away from T-matches because, as they point out, they have the characteristics of a high-pass filter and therefore do nothing to suppress any harmonic output from the rig. On the other hand, they will say a pi-coupler has the opposite characteristics, uses the same components, and is therefore preferred. A pi-coupler is indeed a good device and does use much the same components, but will have a significantly reduced matching range than it would if built as a T. The manufacturers of serious

antenna tuners nearly always opt for the T-configuration. While the high-pass, low-pass argument might have substance if we were making a harmonic suppressor, we need to remember why we are making it.

So if we can put the harmonic business behind, we are faced with a few T-match variants. We could consider the ARRL Ultimate Transmatch (split-stator input capacitor), SPC tuner (series/parallel output capacitors) or the simple T-match (two capacitors and a coil). The Ultimate Transmatch's split-stator input is said to provide, in effect, a variable tapping point on the coil. But so what, given we are going to connect up and down the coil anyway? The writer has a learned friend with whom there has been a little debate on this point. The SPC attempts to get around the high-pass filter objection, if it is of concern, by ensuring some capacitance in parallel at all times. As they all work well, and it is doubted the operator will find any practical difference, one can make hunting for capacitors significantly easier by going for the plain T-match.

A coil and two variable capacitors with adequate plate spacing are needed. When meshed,

about two millimetres and up is OK for most power levels and the maximum capacitance should be at least 250 pF. A low minimum helps at the high-frequency end of the spectrum. If the end-plates are ceramic or composition rather than aluminium it should be possible to bolt the units directly to the floor of the cabinet; if metal, they will need to be insulated from ground, which is not difficult. Also, as the capacitors are floating, an insulated coupling between the control shafts and each capacitor spindle is necessary.

Moving to the coil, there are two main options for obtaining a variable inductance as needed; a fixed coil with permanent taps selected by a switch, or a roller-inductor. Both have pluses and minuses. The tapped coil can be home-made at very little cost, with the tapping points identified on the panel by labelled switch positions. A downside is that on several bands, especially the higher frequencies, a connecting point between taps can make the difference between a perfect match and something not so good. Also a typical ceramic rotary switch with up to eleven contacts (if all are needed) will result in a birds-nest of wires between coil and

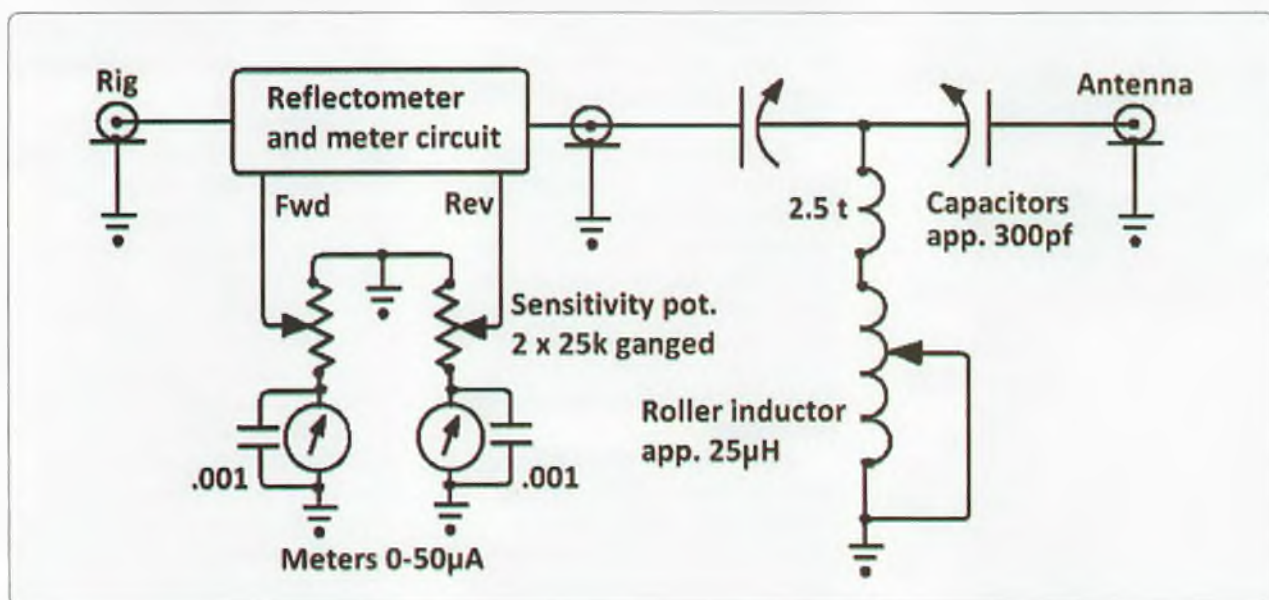

Diagram 1: Reflectometer and meter circuit.

switch. Messy, but OK. It may not be easy to find a switch which will stand up to demands.

A roller-inductor is really the way to go. A hand-cranked silver-plated coil, on a ceramic former, with a jockey-wheel engaging the turns as they rotate has just about everything, with practically nothing to go wrong. It has, perhaps, one disadvantage; to know from the front panel how many turns are in circuit when changing frequency. It needs a turns-counter of some kind, logging from zero to about 25 turns. Of huge value, if it can be found, is a two or three-digit counter mechanism with crank-handle. Otherwise something can be fabricated; think about hobby-shop gears etc.

It has been said that a turns-counter is not essential since the reverse-current meter will tell when the device is tuned. And so it will, but when a net-controller says something like "80 metres is not looking too good, let's all QSY to 40" one could be dragging the chain without a visible setting point for quick change to the new frequency.

Before going further it is about time we drew the circuit of the tuner, with no prize for originality. If wished, some switching at the output can be added for selecting various antennas, dummy load, or to by-pass the ATU completely. Make sure they are good switches, and mount them on or near the back panel using insulated extension shafts (6 mm knitting needles can be useful).

About connecting the roller-inductor, some designers leave the bottom end of the coil floating on the score that the unused turns would otherwise be shorted producing high circulating currents and resultant losses. Though the Q of the coil will be lowered, grounding the earthy end turns out to be not a problem in practice, and preferable to the auto-transformer effect which, if left open-ended, will generate very high RF voltages.

There is also the matter of



Photo 2: The more recent of the author's tuners, circa 2008.

maintaining a useful form-factor in the inductor when requiring only a single turn or less to obtain a match on 28 MHz. If the roller inductor to be used happens to be manufactured with the first two or three turns at a wider spacing than the rest of the coil, it can be used as is. If, however, all turns are equally spaced, it is good practice to make a small coil of two or three turns with heavy wire, about two centimetres long and three centimetres diameter and to solder it, self-supporting, as shown in the circuit diagram. Make its axis roughly at right angles to the roller coil.

Apart from the turns-counter, try to find two 6:1 or thereabouts planetary reduction drives for the capacitor shafts. They used to be sold locally; alas no more, but can still be ordered from the US of A. They make an incredible difference to the ease of adjustment and the mechanical stability of the settings once made.

Next, if we are going to homebrew the reflectometer, we need to think about meters. Do we need one meter or two, and do we need to measure absolute forward and reflected power? One meter

switched is OK, but two meters are nice because we can see the forward meter bouncing around with modulation while the reverse meter stays, as it should, more or less on the stop. Metering the actual SWR and power on the ATU itself is often not all that important as an internal reflectometer in most rigs these days will display both. The reverse-power meter on the ATU is the all-important indicator of accurate tuning, and shows immediately if something is going wrong. 50 or 100  $\mu$ A meter movements are about right, but may need to be bridged to reduce sensitivity.

A reflectometer can be made from readily obtainable components and there are many, though minor, circuit variants. Because of its sensitivity to frequency, avoid the strip line arrangement in which a pick-up conductor is run parallel to the main input conductor. The forward/reverse bridge, based on a winding on a small toroid slipped over a few centimetres of coax in which the braid is earthed at one end only to form a Faraday shield works well and is not too frequency conscious. Because tune-up power should be no more than a few watts, a sensitivity pot (ganged, if using



two meters) is needed to keep the meters on scale when the power is turned up.

In the actual building of the ATU, it is not necessary to buy an expensive cabinet. Work out exactly the size of the panels needed and find your friendly aluminium sheet-metal fabricator. For a few dollars he will cut with great accuracy what is needed to make the front, back, sides and top of the box. It will be good to cut the front panel from about 3 mm sheet, the base and back panel about 2 mm, and 1 mm for the sides and top. Use strips of 10 x 10 mm hardware-shop aluminium angle to assemble the sheets.

It looks better to have the front panel about 5 mm wider on each side than the rest of the box. It also helps enormously to invert the lower fixing angles so as to have the floor of the cabinet about 10 mm above the operating table to accommodate the heads etc. of the fixing devices. When finished with cutting holes for meters, drive shafts, sensitivity pots and the like on the front panel clean it up with wet-and-dry paper followed by a coat of etch primer and a few spray-coats of automotive enamel.

In laying out the components it may be tempting to mirror the circuit diagram; coil between the two capacitors. This is OK, but not the best arrangement; it is better to locate the two capacitors side by side and then the coil, or the other way round. Interconnecting lead-lengths will be reduced. Also if you have capacitors that require to be insulated from the base, you can assemble them as a unit before installing in the box. A visit to a kitchen shop, or some hardware shops, will locate a polythene cutting board from which to make a single insulated base for the two capacitors.

Two photographs show the workings of a couple of tuners

made by the writer (apologies for the backgrounds). The first is a T-tuner made in about 1982 and modified from time to time, as can be seen. It was a good device and saw service for many years, but note the layout of capacitors and coil, and the long, albeit silver-plated, leads. This one had also various by-pass, dummy-load and other switching facilities (mostly never used). The second tuner (with a few recycled parts) was made four or five years ago with a much superior layout. Disregarding the by-pass etc. switching of the first photo, the inter-component wiring is greatly simplified. The two variable capacitors were pre-assembled on a polythene block.

Some hams may wish to bring ladder-line right into the shack to the tuner, so a word or two on organising balanced-output connections on the rear panel. Logic may suggest that use of, say, 450 ohm line calls for a step-up impedance-transforming device at this point. But there is no good reason to do this. The complex impedance of the antenna transformed by the length of transmission line down to the shack could be, depending on the variables, anywhere from a few tens of ohms to several hundreds; which is the reason for making the ATU in the first place. For a random length of both antenna wire and transmission line, a 1:1 balun is as logical a starting point as anything else.

Be aware, also, of placing bifilar or trifilar windings directly onto iron-powder or ferrite cores. The efficiency of such baluns using can drop alarmingly if the impedance to be matched is too far removed from the characteristic impedance of the windings on the core. The very use of these devices in the situation we are talking about can seriously reduce the matching range of the tuner itself. They should best

be avoided. On the other hand, a choke-balun using coax and ferrites does not have the same problem; it is of no significance that RF energy flows internally through a metre or so of coiled coax rather than through a straight run. Very significant, though, is that the coil will raise the outer skin of the coax braid to an impedance well above ground at the feeder connection point – forming in effect an impedance-tolerant wideband 1:1 balun.

But in the writer's view, as said near the beginning, it is usually more manageable to locate the choke-balun outside the shack at the end of a few metres of good coax at a place where the open-wire feeder naturally falls, or to where it can be run. No matter what the SWR, the loss at HF in a short run of RG213 will not be measurable. PVC sewerage or drainage fittings make excellent waterproof housings for chokes etc.

Finally, it has to be admitted that antenna tuners are not at the cutting edge of technology, but they are real wireless, and somehow embody the essence of traditional ham radio. Great projects and, for most, a must-have item in the shack. It is hoped the above may be of some little use, and that the faint noises in the background are not about sucking eggs.

73.

*(Editor's note: Many amateurs would argue that the above discussion is not about "antenna tuners", rather it is about "antenna matching units". I have no wish to start any discussion on this topic! But do remember, all that the "tuner" is doing is to provide a better impedance match to the transmitter. It does not change the actual antenna impedance or the antenna behaviour. Peter VK3PF.)*



Don't forget

Don't forget to register for MEMNET.

# 'Play time' on 80 metres: A high performance antenna system for the VK/ZL Trans-Tasman contest, 2013

Jim McNabb VK3AMN and Michael Romanov VK3CMV

Following the Sherbrooke Community Radio Club's (SCRC) Trans-Tasman result in 2012, members embarked on a serious study of antenna articles<sup>1</sup> and the classic textbooks, ranging from the recent, superb publication 'ON4UN's Low Band Dxing'<sup>2</sup>, through to old QST<sup>3</sup> articles from the 1930-50s, and also the 'More Wire Antenna Classics Handbook, Volume 2 (ARRL)<sup>4</sup>, all with the aim of building a better antenna for this year's contest.

The ultimate goal was to combine a high performance antenna system with a superior contest grade transceiver, an Icom IC-7600 and to, hopefully, improve our own contest operating

procedures to a very high level.

Members looked closely at the 2012 contest results and the antenna system and transceivers that were used last year. Then, they decided what they would like to achieve in 2013. The primary goal was the construction of a high gain, low radiation angle and *omnidirectional* antenna on 80 metres. Notice the emphasis on 'omnidirectional'. The club wanted to achieve substantial signal gain, preferably from all compass directions. Again, it's the old amateur saying, 'If you can't hear them, you can't work them'.

The major secondary goal was that the antenna system had to be affordable on a low budget,

without any engineering expertise or specialized tools. Our antenna had to hear and transmit much better than a simple dipole or inverted vee, preferably in all directions at once; and not cost the earth to build.

The question to be answered was, does such an antenna system exist, or has it ever existed?

Our clubs answer is; if it did not, it is most certainly well on the way now! Members have read, rag chewed and now, finally, they have constructed and are in the process of fine-tuning a high gain wire array, which practically anyone can afford to build.

With conventional antenna theory, gain is normally achieved in the one direction, at the expense

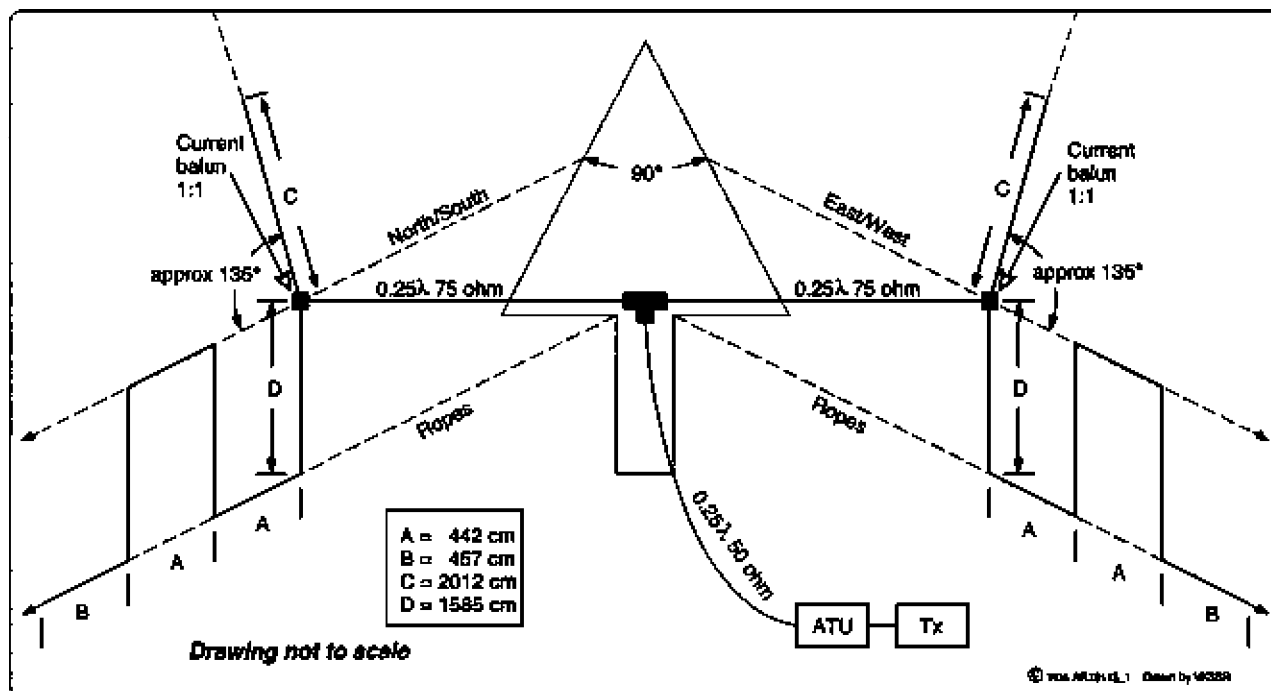

Figure 1: The schematic of the planned 80 metre antenna.





Photo 1: The KE4UP antenna.

of signal loss in other directions. Such designs use combinations of a driven element along with directors and/or a reflector. The disadvantage is the need to be able to rotate the array, which is very difficult on 80 metres. Other systems achieve gain by using multiple verticals and a phasing/switching harness. This is more achievable on 80, but lower gain; large verticals are needed and are not really affordable on a tight budget. Other systems use separate receive and transmit antennas. Again, this is achievable, but often complex and more expensive to construct.

The antenna system built for this year's contest by the club is not the club's original design, but has been an evolution of the excellent design by KE4UYP'.

This antenna combines dual horizontal/vertical polarization with top fed, linear loaded, phased vertical element sections. The antenna is a  $\frac{3}{4}$  wavelength long,

on one side, with a quarter wave horizontal counterpoise on the opposite side. Several club members run this design as their home 80-metre antenna with very good results. The radiation pattern is bi-directional in an elongated figure eight pattern with a quoted 5.9 dBi gain.

SCRC members built two identical antennas and then co-phased them, locating them physically a half wavelength

apart at the feed points. The antennas were aligned with their axis running at ninety degrees to each other, giving an elongated four-leaf clover radiation pattern, with close to 360-degree coverage. Each antenna was fed with a 1:1 current balun via a quarter wave

of 75  $\Omega$  coax into a T connector and from the T connector to the transmitter with a quarter wavelength of 50  $\Omega$  coax, resulting in a theoretical gain of 8.9 dBi.

Note the  $\frac{1}{4}$  wavelength of 75  $\Omega$  coax (adjusted for velocity factor of the type of coax) with a quarter wavelength of 50  $\Omega$  coax, (again with velocity factor adjustment for the type of coax) equalling a total one-half wavelength of coax on 80 metres. This combination makes the high current points occur at the baluns on the antenna feed points and at the back of the transceiver, giving no impedance mismatch.

We should clearly point out at this time; these trials were carried out at our 'Kurth Kiln' location in a relatively small clearing. There is extremely dense forest very close around the site. It is, literally, physically impossible to walk around in this forest with a field strength meter on a pole, in order to achieve accurate polar plot patterns. That's a club project for another day and another larger, much clearer, test location.

Our first trial with this driven phased array, commenced in February this year. Initial results left 'El Presidente' slack jawed, completely speechless, with shaking head, a miracle achievement in itself.



Photo 2: Kurth Kiln.

Simply stated, this array provides the best antenna performance ever experienced on 80 metres by any club member. After receiving a 30 dB+ signal report from Scott VK7NWT in Sisters Beach, Tasmania, the transmitter output power was progressively wound back from 100 watts down to the minimum transceiver output of two watts, with a 5/7 report being received. A 5/9+ report was also received from a portable VK4 station, located on Cape York in far North Queensland. Very strong reports were also received from Nelson in New Zealand. At the end of the initial trial weekend, we all went home patting ourselves on the back and smiling from ear to ear. Big mistake!

Our second trial session was in the week commencing 3rd May, with the Harry Angel Sprint event on the 4th and ending with the 2013 Trans Tasman Contest on the 11th. Results prior to the competition had us doing some major head scratching, and back to some serious reading of the books again!

The set up was slightly different this time and physical distance between the two legs of the array was less. This created some major headaches that were not resolved to our satisfaction prior to the Trans Tasman. Our array did not resonate well and we suspect that the physical spacing between the two legs is critical to performance. The system was rechecked but the issues with the phasing system remained. For the competition we ended up running two 50 Ω resonant feed lines and switching between the two antennas, giving the coverage required at the flick of a switch.

Our notes from trialling this array is as follows: The dimensions of each side of the array must be identical. This is absolutely critical. A small mismatch in length creates major matching problems, as we found out the hard way, during our initial adjustments. A YouKits FG-01 handheld SWR analyser was used



Photo 3: VK3AMN with a last minute tune up.

to independently adjust each half of the array, to exact resonance on 3.6 MHz prior to the array assembly. An effective operating bandwidth of 110 kHz was achieved.

The same 'identical' note applies to the length of the quarter wave phasing harness. Near enough is not good enough with these measurements, they must be absolutely identical in both physical length and velocity factor of the coaxial cable used in the phasing harness. The principle applies again, for construction of the two 1:1 current baluns. Also, when adjusting the antenna or antennas to resonance, don't adjust the  $\frac{3}{4}$  wave driven side, adjust the length of the counterpoise only.

Now for some real world results! Our on air competition results, using this array, to date, are as follows:

The club's hand written log (ouch!) submitted for the Harry Angel Sprint Contest records 70 contacts in 106 minutes, official 4th place. The log submitted for the VK/ZL Trans-Tasman records 266 contacts in six hours, with contacts into all Australian states with the exception of VK8. Most ZL regions were repeatedly logged. The DXpedition on Norfolk Island (VK9NT) was also worked on several occasions during the evening, as were a number of VK6 stations.

Future club development plans for this array include better sorting

out of the phasing system, including possible use of open wire feed line to reduce the hanging weight and also the feed line losses, plus scaling back of this system for use on 40 and 20 metres where fitting on a suburban block becomes entirely possible.

So, how much did this high performance array cost?

1. The 500 metre drum of insulated five strand copper wire that we obtained from a scrap merchant's yard cost \$50. About 80 metres was used for each half of the antenna, leaving about two thirds of the drum for other projects. Cost was about \$16.
2. Second hand plexiglass, with the pieces again purchased from a scrap merchant's yard, were used for building the fourteen, hand cut, corner and end insulators, cost \$5.
3. Two homemade 1 to 1 current baluns were constructed, each costing \$19.50; the parts were obtained from eBay. Cost \$39.
4. A T-piece coaxial connector was purchased for \$2.50, from a hamfest.

The total for the materials used in building the entire array came to \$62.50. For the costing of this antenna system we did not include the cost of the coax feed line and support ropes. It was assumed the majority of amateur operators would



have an existing supply of coax to some extent and some suitable ropes. Not a bad result for an expenditure of \$62.50.

With a theoretical gain of 8.9 dBi, a better value for money, a high gain 80-metre antenna system, will be difficult to find. If you do, please tell us about it. We may well try it.

SCRC members are preparing an article detailing the building of the insulators and the baluns used

in this array for submission to *AR* and possible inclusion in a future issue in the 'Foundation licence' section.

Our sincere thanks go to Icom Australia for providing the club with the Icom IC-7600 for use prior to and during the competitions. Members are writing a 'User Impressions' article, to be submitted to *AR*, again for possible future publication.

## References

1. KE4UYP's Antennas: <http://ke4uyp.tripod.com/index-22.html>
2. ON4UN's Low Band DXing: ISBN 978-0-87259-856-0
3. Solving Feeder Problems Graphically, page 25, *QST*, September, 1946
4. More Wire Antenna Classics, Volume 2, *ARRL* - ISBN 0-87259-770-9



## Over to you

### High Power Trial

Further to the excellent article by Roger Harrison VK2ZRH in *AR* October 2013, and letters from VK3QD, VK4YE and VK7GN regarding ACMA's decision to not permit Advanced Licensees to run power outputs up to 1 kW. All writers make very good points and Roger's article puts the now concluded trial and ACMA's decision into perspective.

There are a range of questions and issues ACMA's decision raises, and these include: How do the nine countries listed in Roger's article (and this list is not complete) that permit power levels above 400 W manage when in Australia we demonstrably cannot? Is their RF different from ours? Are their regulations different from ours, and if so why? The population density, therefore by implication the density of electronic consumer, commercial and industrial appliances and equipment in most northern hemisphere countries is higher than in Australia. The propensity for RFI, logically, has to be greater than in a country like Australia.

Continental USA, for instance, has a land mass about the same size as Australia, but has more than 10 times our population, therefore greater population density. In the US power levels up to 1.5 kW PEP are permitted. Does the US have an EMI/RFI problem we don't know about, and if so how is it managed? How are EME and EMR limits regulated, managed and dealt with in the countries that permit higher power levels than permitted in Australia? Do those administrations care less about their citizens than our governments do about us here in Australia?

I expect however there is an unspoken reason, in official circles at least, behind this decision apart from any scientific justifications, and this is ACMA staff levels. In the 'good old days' the Post Master General's Department (PMG) had radio inspectors (RIs) strategically located around Australia to deal with all and any radio related issues in their district, including TVI, BCI, RFI, EMI. Such is not the case today. It is my understanding that the RI staff numbers within ACMA are a shadow of what they were decades ago, and those relatively few that are employed are not strategically dispersed around the country like they once were, but are in fact located in some, not all, capital cities.

I respectfully suggest that herein lays the reason for a significant part of the decision ACMA has recently made in regard to this issue. I suspect it struggles to deal with its current work load, let alone create more work for its already stretched investigative resources by allowing radio amateurs to use significantly higher power levels than is currently permitted. I expect this is not the fault of the field staff or their immediate managers. I do however suspect that beyond the lower levels of ACMA it is difficult to mount a case for more staff in this part of the organisation.

It has to be recognised that ACMA is an Australian Government agency staffed by public servants, and like many parts of the public service is staffed often by generalists without significant or any technical knowledge. The electromagnetic spectrum is invisible, taken for granted by most that benefit from it, and only care about it when their radio, television

or mobile telephone ceases to operate correctly. I expect ACMA field staff have tremendous difficulty trying to justify their own positions, let alone new ones to service the ever increasing population and proliferation of RF and electromagnetic emitting devices. The bottom line is, I feel, there is insufficient technically qualified ACMA field staff to go around and I have empathy with the few that are currently employed.

In closing, let me support Aubrey's (VK3QD) point about those amateurs that 'knock' the WIA and won't join. The WIA is the only thing that stands between government officialdom, the ever increasing demand for spectrum from commercial interests, and our hobby. Many within our ranks have significant sums of money, not to mention time, invested in amateur radio. Governments don't like dealing with individuals or disparate groups when making policy decision. Instead preferring to deal with collectives such as industry associations and recreational bodies. The WIA and the various state/territory bodies that represent our great hobby are such organisations. Individuals that think they can go it alone and represent themselves when difficulties arise are totally ignorant of how governments operate. Understandably it is, in the main, only those of us that have worked for, or been able to closely interface with government administrations that can likely appreciate this last point.

73

Bruce R Kendall VK3WL/9V1WL



# One hundred wonderful years

Ron S Goodhew VK4EMF

The years between 1890 and 1920 saw a huge advancement in the knowledge of a new science, 'wireless'. All over the world men were conducting experiments, ever trying to extend the range of their transmissions. On 12th December, 1901 Marconi succeeded in sending the first signal across the Atlantic Ocean, followed by the first commercial link in October, 1907. The first wireless message between Wales and Sydney was received on 22nd September, 1918.

Control of the airwaves was a topic which caused much argument in Australia. Wireless originally came under the mantle of the Navy and they fought hard and long to retain that control, endeavouring to stop private [amateur] experimentation. In October, 1905 the Australian Government passed the 'Wireless Telegraphy Act'. Control of wireless was passed to the Postmaster General. This Act permitted private persons to apply and later pay for a permit to build and *receive only*; a law so unpopular and difficult to police that it was relaxed in the 1920s.

'During 1910 three experimenters came into prominence in Queensland. In Brisbane, David James Garland obtained permission to conduct tests before official call-signs were issued. The permit was a six-page, near foolscap size document, outlining in detail the equipment to be used and the regulations pertaining to it, dated and signed by the licensee in the presence of an agent of the Postmaster General. After much testing he managed to send a spark transmission a distance of thirty miles and is recognized as the State's *FIRST* private wireless experimenter. He never returned to on-air amateur activity after WW1'. Refer Reference 1.



M.J.G. Brims · 1888-1982

*Photo 1: Marcus JG Brims XQA. Photo used with the permission of the Brims family.*

The little country town of Mareeba, some 1600 kilometres north of Brisbane, was a busy, dusty, important railway junction town. Here lived two talented young men, Andrew Couper Jnr and Marcus John Gordon Brims, both keen wireless experimenters.

Andrew Couper Jnr was born in Mareeba on 10th July, 1893 the son

of Andy Couper of Couper's Vulcan Foundry. I believe from discussions with old-timers of the town that he was active as a wireless experimenter from approximately 1909. Archived letters show that he was experimenting at Chillagoe in 1910 whilst working as a shift electrician at the Chillagoe Smelting Works. Andy was first issued with



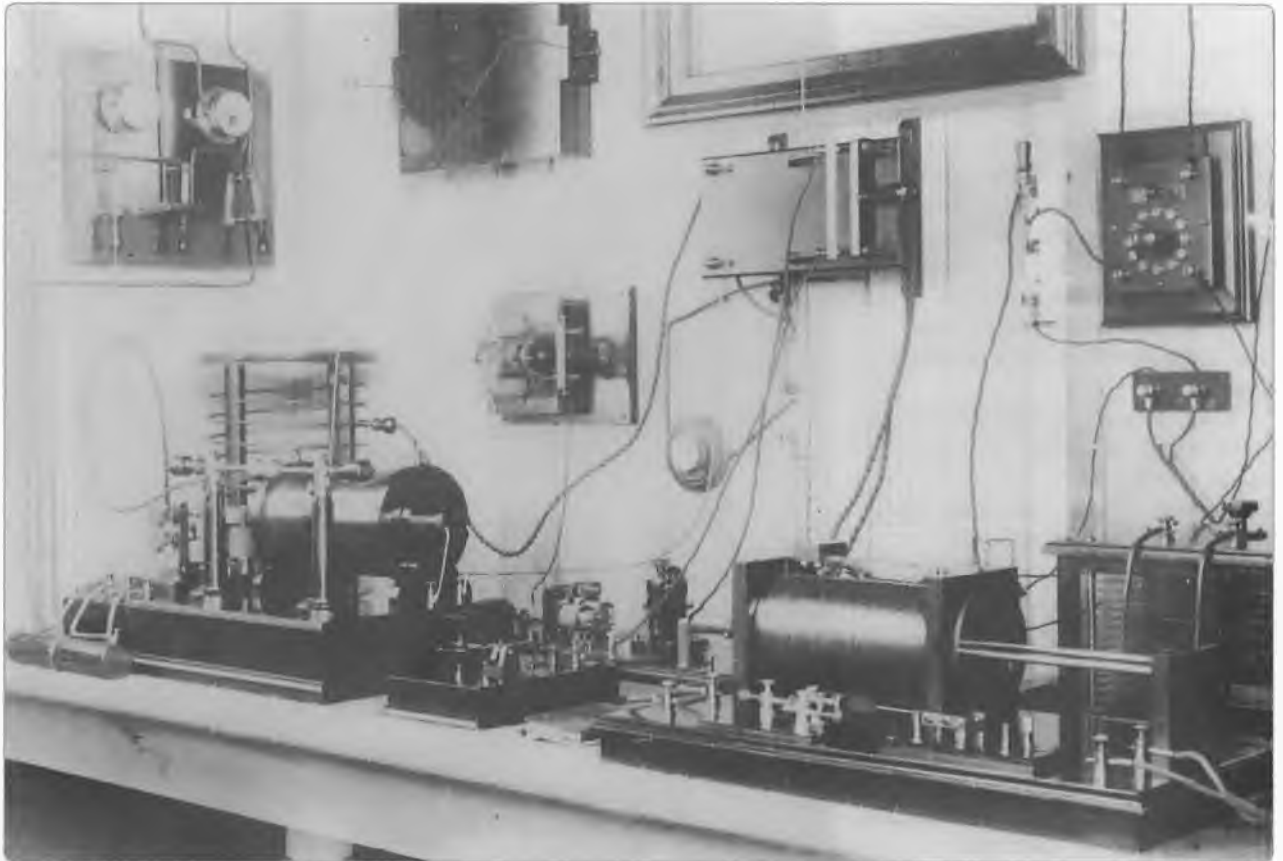

Photo 2: Marcus Brims XQA station circa 1914. Photo used with the permission of the Brims family.

the call-sign XQM, which changed to OA4BW and, finally, to VK4BW. He was an active amateur right until he passed away on 7th July, 1958. Andy is best remembered for his part in restoring communications with the south during the 1927 cyclone. All communications had been cut and after official pleas for help, Andy managed to establish a link with Leighton Gibson OA4AN, and for a period of some five days passed thousands of words of official traffic. Both men were publicly praised.

Marcus JG Brims was born in Ingham in 1888. The family moved to Mareeba where they operated a sash and door making factory. Whilst still in their teens, Marcus and one of his brothers were responsible for the building of some of the town's principal buildings, namely the Anglican Church, the Masonic Lodge, the Oddfellows Lodge, and the Queensland

National Bank. Like Andy Couper, I believe Marcus was experimenting with wireless as early as 1910. The first documented evidence of his experiments is a copy of his application for an experimental permit dated 24th July, 1913. The application required him to name the person or persons with whom he wished to communicate, the distance between stations, the power and type of equipment to be used. His permit was granted on 7th February, 1914, his call-sign XQA, *the first official experimental call-sign in Queensland*. Marcus listed Andrew Couper Jnr as the person with whom he wished to communicate, over a distance of 16 km. His permitted wavelength was 160 metres and his maximum power was 76 watts. Andrew received his call-sign XQM on the same day.

It would appear that Marcus Brims moved to Brisbane almost as soon as his permit had been

issued, as a letter from the Postmaster General's Department dated 6th August, 1914 was addressed to Mr. M.JG Brims, Cnr Vulture and Edgar Street, East Brisbane. This letter revoked the permit issued in February of that year and required that all wireless telegraphy equipment must be dismantled, packed up, sealed and forwarded to the Postmaster General's Department within twenty four hours. World War 1 had been declared!

A Hobby and Trades Exhibition was held in Mareeba circa 1914 and a local newspaper reported as follows: 'One of the principal attractions in the hall is the complete set of wireless telegraph instruments, the work of Mr Marcus Brims. This young Queenslander has completed his work in a masterful manner and this is the first wireless seen in Mareeba. The quality of the work is something to

be admired and the young master-worker has shown much originality in his work. The various stands for the instruments are made from silky oak, pencil cedar, bean tree and other timbers of this district. The instruments were all constructed by Marcus Brims and the work is equal to that of those whose profession is the building of these delicate instruments. It is pleasing to note that such talent is existent in North Queensland'.

Marcus never reassembled his spark station after WW1 although he did re-apply for his licence on 7th February, 1922. Marcus devoted his considerable talents to the family sawmilling business, to the development and manufacture of plywood and to the construction of aeroplanes. He retired from the family business in 1982, handing over the reins to his son John. He suffered a heart attack and died in Brisbane in July, 1982.

My first contact with the Brims family was back in 2000. John Brims kindly sent me copies of photographs of his father's station. I put them aside and did nothing further until our WIA Centenary Year 2010 when I felt that some of this history should be written down. I approached Mr Brims with the suggestion that maybe it was time for the spark station to come home to Mareeba. Months of discussion took place and a number of people were involved. The wonderful Brims family agreed that not only could this valuable part of our heritage go on permanent display at the Mareeba Heritage Museum but made a sizable financial contribution to allow the project to proceed. Further major financial assistance was made by the Tablelands Regional Council, assisted by a number of other local business and individual people and the Tableland Radio and Electronics Club Inc.

The Tableland Radio and Electronics Club applied for and



Photo 3: The XQA station at Mareeba Heritage Museum. Photo by Ron Goodhew VK4EMF.

obtained the call-sign VK4XQA in memory of Marcus Brims. This call-sign is used for special events, field days and the like. It is the club's intention to host a special award to commemorate the 100 years of licensed amateur radio in Queensland and this celebration will run from 14th February, 2014 until 6th August, 2014, the exact

life-time of the original spark station XQA. Details of this award will be available on the club's website at [www.treclub.org.au](http://www.treclub.org.au)

#### Reference

1. 'Halcyon Days', Alan Shawsmith VK4SS. Material used with permission of the author.



**Season's Greetings from the WIA.** Office re-opens 13 January 2014.



The SYLRA 10th anniversary conference was held on August 22-25 in Roskilde, Denmark. Christine VK5CTY was part of a group of Australian YLs and OMs and she has penned a memo of her experience. There is also a report from Roskilde itself from Rosel Zenker DL3KWR and an edited version is included below.

## SYLRA Meet in Denmark by Christine VK5CTY

ALARA was well represented in Roskilde, which is located just outside Copenhagen, where most of the SYLRA Meet was held. There were seven of us from Australia and two from New Zealand. Plus a number of sponsored members as well.

I travelled with Tina VK5TMC and Robert VH5ZHW accompanied by Jenny VK5FJAY and her OM Kevin VK5AKZ via the UK and France. Dot VK2DB and her OM John VK2ZOI had undertaken a tour of other parts of Scandinavia beforehand and planned to travel to Russia after the Meet in Denmark. Sharon ZL3AE and Glenn ZL3GL had come straight from New Zealand and were also going to do their touring at the completion of the Meet.

On arrival the first few hours were spent saying 'hello' to all those we hadn't seen since May, last year or even earlier. Somehow it doesn't matter how recently or how long ago you last met, it is like meeting best friends, every time.

Inger OZ7AGR and Bjarne OZ2UV have a large group of family members and many local friends who helped them to organise the catering for a marvellous barbecue at their home. These are the things that help an international activity go smoothly. On behalf of the visitors I extend my thanks.



Photo 1: Dot VK2DB, OM John VK2ZOI, Tina VK5TMC, OM Robert VK5ZHW, Jenny VK5FJAY, OM Kevin VK5AKZ and Christine VK5CTY.

We had a very interesting talk given to us by Kenneth OZ1IKY about his DXpedition to Clipperton Island in the Pacific Ocean. This was followed by a tour of the local area with a very good historical guide.

The Cathedral is particularly interesting because it was built in the Middle Ages; it was a Catholic church initially but after the Reformation, decorations such as statues were removed. The removal of the original stained glass windows and their replacement by clear glass windows made it a very different building indeed. All the kings and queens of Denmark are buried in this church despite the fact that it is not in the centre of Copenhagen. Well worth a visit.

We had some free time to go exploring in the city centre, which is a pedestrian only mall, before going to the Viking Museum which

happened to have on that weekend an open area where they were demonstrating all sorts of craft and handyman activities typical of those earlier days; there were enough activities to interest us all.

If you have an opportunity to go to an International YL Meet anywhere in the world, I would encourage you to try to get there. It is really a memorable experience.

## SYLRA meeting in Roskilde – an edited version taken from the SYLRA website

SYLRA (Scandinavian Young Ladies Radio Amateurs) was founded in 2003 by 10 YLs from the five Nordic countries. On 22 to 25 August 2013 the 6th SYLRA meeting was held in Roskilde, Denmark's former capital. Forty one YLs and 20 accompanying OMs from 16 countries participated.

The meeting took place in the historical Prindsen Hotel near the cathedral. After checking in on Thursday we took a bus to Solrød beach for a barbecue at Inger OZ7AGR and OM Bjarne OZ2UV. There was a celebratory champagne reception on arrival attended by Solrød's Mayor Niels Horup. Arne, the OM of Anita SM6FXW played the Danish National Anthem on his trumpet. After the obligatory group photograph was taken, the barbecue could begin. Inger and Bjarne's whole family had been involved in the preparations and now looked after the welfare of the guests. Henry OZ3FD, with his electric guitar provided for musical entertainment and a happy mood.

On Friday the program began with a presentation of the TX5K Pacific DXpedition to Clipperton Island. Kenneth OZ1IKY, gave us vivid impressions of this remote coral atoll, the adventurous

character of this expedition and of the magnificent radio activities. Then while the YLs were holding their meeting, the OMs visited the Radio Museum in Ringsted. The extensive exhibition shows typical exhibits from all areas of consumer electronics including homemade and amateur radio equipment. This wide range is systematized and compiled attractively.

At the meeting, after a welcome by YL's Chairwoman Inger we were given information from the SYLRA boards. The boards consist of the five Nordic contacts who mainly communicate via email and make personal contact only before the start of a meeting. The Chairwoman for the next two years will now be Vala TF3VD. The webmaster of [www.sylra](http://www.sylra) is still Anna TF3VB. Both offered to host the next meeting of SYLRA in 2015 and the 2014 International YL Meeting in Iceland. In their presentations, they

presented the planned sightseeing agenda.

There was time before the gala dinner for a city stroll. OM Palle OZ1RH from the club station OZ9EDR had set up a remote station. The IC-7100 transceiver, the amplifier and the antennas were 30 km away, near Ringsted. The Shack however was set up in the hotel, where both a control unit which included a touchscreen display and the internet were located. The club callsign OZ6SYL saw Rosel DL3KWR first on the air with CW on Thursday. Joana DJ5YL, Linda G0AJJ and Marita OH5KIZ activated the station on SSB.

The gala evening was held in the beautiful historic hotel. In the hall of the hotel a small band played, comprised of four thirteen year old girls playing keyboard, electric guitar, drums and vocals. They harvested enthusiastic applause for their first concert in front of an

# Wyong Field Day

Proudly presented by **CENTRAL COAST AMATEUR RADIO CLUB inc.**

**23<sup>rd</sup> February 2014**

**Gates open 6.30am – Traders & Exhibitors open 9am**

**Free shuttle bus from Wyong Station**

**The Wyong Field Day will be on Rain Hall or Shine!**

**Lucky gate prizes, Raffle, Lectures, Flea Market and so much more!**

**See you at the largest Amateur Radio gathering in the Southern Hemisphere!**

**Under 17's admitted free**

**For more information - <http://www.ccarc.org.au/wp/>**



international audience. An excellent dinner followed the entertainment. Later gifts and games were distributed to the guests at each table.

On Saturday there was an extensive sightseeing program. It started with a tour in the Cathedral (built between 1170 and 1280), which was the first and largest brick Gothic church in the Baltic region. In the Cathedral, a UNESCO World Heritage Site since 1995, the Danish kings and queens were crowned and buried. The grave chapels with tombs from nine centuries impressively show the transformation of Sepulchral Culture. After a stroll through the market, the Roskilde Viking Ship Museum was visited. The heart of the museum is the five Viking ships that were excavated in 1962 in Roskilde Fjord in Skuldelev.

Based on the salvaged and restored wrecks, one can study the shipbuilding and craftsmanship of the Vikings. In the museum harbour are 39 reconstructed or restored vehicles that are actively used for sailing. You can witness the most spectacular sailing on the basis of a film in large format. The replica longship (30 m) 2 Skuldelev sailed in the summer of 2007 as the 'Sea Stallion of Glendalough', with 62 crew members, to the Irish capital Dublin then Scotland in the summer of 2008 and southern England to return to Roskilde. Thus was the dream of 'how to sail like the Vikings' became a reality.

The weekend was also the 'Fire, Water and Vikings' festival at the Museum. Music bands played and we could get to know the Vikings technologies: the production of charcoal and ropes, the forging of iron, wood processing and the original replica of Viking boats. Boat race and sailing trips were organized. The fjord with its many

islands and islets, the picturesque silhouette of the Roskilde Cathedral, and above all a clear blue sky – was very impressive. Since the Prindsen hotel had offered us a special menu for dinner, no one thought to eat out. The menu was excellent and tasted just as decorative as they are done for gala evenings, which spoke highly of the excellent cuisine on offer. So we were all together and had nice conversations to round off the evening.

After breakfast on Sunday it was time to say farewell. We have again caught up with old friends and met new ones. YLs parted, having experienced many wonderful impressions, hopeful of meeting again in two years. Tusind TAK to Inger and Bjarne and to their family and friends who have organized this meeting so well.

#### VK5 news

Jeanne VK5JQ has been keeping the VK5 YLs informed with details of her marvellous Outback travel exploits. She and Keith have travelled from Adelaide to Alice Springs and on to Broome with

many interesting stops along the way including Halls Creek and the Bungle Bungles. Then on east to Derby, managing a fascinating flight over the Mitchell Plateau and Falls. It appears they are having a great experience and she is managing to pass on details when stopping at a location such as Wyndham where she is able to connect to the internet. We are all very envious.

#### VK3 news

Social get-togethers are a way of keeping in touch with other YLs and OMs. For example, a meal at a local hotel.

The Men are looking for an alternate title to 'Hand Bag Carriers' and are trying out a new slogan. Time will tell if it is successful.

Arrangements have been made for the ALARA Christmas lunch which will be held in Bendigo. Plans are also underway to organise celebrations for ALARA's 40th birthday in 2015.

Every best wish for Christmas and the New Year.



Photo 2: Charlie VK3VZZ, Cheryl VK3FCYL, Susan VK3UMM, Margaret VK3FMAB, John VK3DQ, Steven VK3SIR, VK3VIP's Mother Elsie, Jean VK3VIP, Donna VK3FRET and Peter VK3ADO.

#### Plan ahead

WIA AGM and Conference, Sunshine Coast, Qld., 17/18 May 2014



# AMSAT

David Giles VK5DG

• vk5dg@amsat.org

Last month's column dealt with the launch of the most satellites ever with amateur radio on board. Hopefully all went well and we now have plenty of different ones to play with. This time I would like to expand the horizons a little bit further.

## AMSAT awards

Some of the AMSAT organisations around the world have their own award program. AMSAT-NA has various awards ranging from one contact via satellite to 100 countries. Unless you have spent time on the HEOs (AO-10, AO-13 and AO-40) it is unlikely you will be able to earn the bigger awards. But the South Africa AMSAT Satellite Communication Achievement Award should be within reach as it only needs confirmed contacts (card only) with 25 different stations using LEO satellites. They also have an award for 1000 QSOs (logbook extract) on any satellites [1].

The Japan Amateur Radio League sponsors their satellite award. You need ten confirmed contacts using any of the Fuji satellites – FO-12, FO-20 and FO-29. They have updated their requirements and you can use eQSL and PayPal [2].

## Worked All States

AMSAT-VK has its own award. I recently received mine so I thought I would share the details. The award comes in three variations with all of them requiring a contact with each state and territory (VK1 to VK8). You also need either:

- 1) a contact with VK9 or VK0, or
- 2) a contact with ZL and another country, or

- 3) a confirmed contact with an astronaut/cosmonaut

If you have the above then contact Judy VK2TJU by email ([secretary@amsat-vk.org](mailto:secretary@amsat-vk.org)) and she will help you through the rest of the process. I got mine with contacts made mainly during the AO-40 days for VK9 and KL7 (as my other country). Photos of both sides of the QSL cards were sent and the award was on the shack wall soon after.

## Very short wave listening

I have mentioned in my six-monthly satellite reports that some satellite builders like to know that other people are showing some interest in their birds. A good example is CO-66 SEEDS. The Nihon University issue four cards, depending on which mode your report is based (CW, packet, Digi-talker or SSTV). [3]. So far I have cards for LO-19, FO-29, CO-55, CO-57, CO-58, CO-65, CO-66 (CW and SSTV), AO-71, KKS-1, and CP-6. Probably the pick is from CP-6 as it is signed by all those who worked on it.

## Juno

There have been occasions when large organisations such as JPL or NASA have asked amateurs to participate in experiments. Recently we were asked to 'Say Hi to Juno'. Juno is the first solar powered spacecraft to go to Jupiter and will spend a year in orbit searching for clues as to the origins of Jupiter and hence the solar system. They hope to answer such questions as whether there is a solid core, how much water is in the atmosphere and what powers the great red spot. In October Juno had a flyby past the Earth to give it enough speed to overcome the Sun's gravity and get

to Jupiter by mid-2016. Thanks to the law of conservation of energy, Juno gained plenty of speed at the expense of Earth slowing down a tiny bit using the technique known as gravity assist. Jupiter with its moon Io creates huge amounts of broadband noise in the HF spectrum. You can listen to Jupiter using any HF receiver between 14 and 38 MHz (17 m, 15 m and 12 m amateur bands work well). This is something you may like to try at the low end of the solar cycle. On board the Juno spacecraft are four wideband receivers (50 Hz to 45 MHz) collectively known as the Waves instrument. NASA asked amateurs to send HI in slow CW to Juno during the flyby on 10 m, coordinated on a special website [4]. I was up at 6 am for the second half of the flyby as that was when it was above my horizon. Did Juno hear us? I don't know yet as results haven't been published. The only news since was that Juno experienced a hiccup and went into safe mode for 25 minutes during the flyby. This didn't affect Juno's trajectory or the other experiments. While some have joked that the amateurs were running their amplifiers a bit too much and tripped a circuit breaker the most likely cause is that as Juno was in eclipse an under voltage trigger was set too high which caused an alarm. One quip was that by receiving the amateurs Juno was looking for intelligent life on Earth [5, 6].

## Interplanetary craft

Something a bit different from bouncing signals off the moon is listening to signals from the moon (or other planets). Back in 2008 I was able to listen to the carrier



from Japan's Kaguya spacecraft in lunar orbit. It transmitted on 2263 MHz so I was able to use the MDS downconverter and 'BBQ grill' dish that worked with AO-40 and AO-51 on 2.4 GHz. While decoding the signals was not possible I was able to track the signal using a soundcard and waterfall display. From it I could tell some features of its orbit from the Doppler shift. My downconverter wasn't stable enough to make any serious measurements but it was easy to tell when it was about to disappear and re-appear from behind the moon. Some amateurs build equipment

to listen to other space probes on X-Band (8.4 GHz). One site that lists frequencies and examples of equipment is <http://www.uhf-satcom.com>

### A final final Pass

When I first took on writing this column I thought I'd do it for five years. Now I feel it is time for a change. I would like to thank all those who have given me ideas, praise and criticism over the past (nearly) five years. I would also like to thank you for reading this column. See you on the birds.

### References

- [1] [http://ww2.amsat.org/?page\\_id=1107](http://ww2.amsat.org/?page_id=1107)
- [2] [http://www.jarl.or.jp/English/4\\_Library/A-4-2\\_Awards/](http://www.jarl.or.jp/English/4_Library/A-4-2_Awards/)
- [3] [http://sat.aero.cst.nihon-u.ac.jp/g/english/cardform\\_e.html](http://sat.aero.cst.nihon-u.ac.jp/g/english/cardform_e.html)
- [4] <http://www.jpl.nasa.gov/hijuno/>
- [5] <http://www.radiosky.com/rjcentral.html>
- [6] <http://www.planetary.org/blogs/emily-lakdawalla/2013/10161651-juno-in-safe-mode-again-but-okay.html>



## AMSAT-VK

AMSAT Co-ordinator  
Paul Paradigm VK2TXT  
email: [coordinator@amsat-vk.org](mailto:coordinator@amsat-vk.org)

Group Moderator  
Judy Williams VK2TJU  
email: [secretary@amsat-vk.org](mailto:secretary@amsat-vk.org)

Website:  
[www.amsat-vk.org](http://www.amsat-vk.org)

Group site:  
[group.amsat-vk.org](http://group.amsat-vk.org)



### About AMSAT-VK

AMSAT-VK is a group of Australian amateur radio operators who share a common interest in building, launching and communicating with each other through non-commercial amateur radio satellites. Many of our members also have an interest in other space based communications, including listening to and communicating with the International Space Station, Earth-Moon-Earth (EME), monitoring weather (WX) satellites and other spacecraft. AMSAT-VK is the primary point of contact for those interested in becoming involved in amateur radio satellite operations. If you are interested in learning more about satellite operations or just wish to become a member of AMSAT-Australia, please see our website.

### AMSAT-VK monthly net

#### Australian National Satellite net

The net takes place on the 2nd Tuesday of each month at 8.30 pm eastern time, that is 0930 Z or 1030 Z depending on daylight saving. Check-in starts 10 minutes prior to the start time. The AMSAT-VK net has been running for many years with the aim of allowing amateur radio operators who are operating or have an interest in working in the satellite mode, to make contact with others in order to share their experiences and to catch up on pertinent news. The format also facilitates other aspects like making 'skeds' and for a general 'off-bird' chat. In addition to the EchoLink conference, the net will also be available via RF on the following repeaters and links.

#### In New South Wales

VK2RBM Blue Mountains repeater on 147.050 MHz

#### In Queensland

VK4RIL Laidley repeater on 147.700 MHz  
VK4RRC Redcliffe 146.925 MHz IRLP node 6404, EchoLink node 44666

#### In South Australia

VK5TAM, Loxton on 147.175 MHz  
VK5RSC, Mt Terrible on 439.825 MHz IRLP node 6278, EchoLink node 399996

#### In Tasmania

VK7RTV Gawler 6 metre repeater 53.775 MHz IRLP node 6124  
VK7RTV Gawler 2 metre repeater 146.775 MHz IRLP node 6616

#### In the Northern Territory

VK8MA Katherine 146.700 MHz FM

Operators may join the net via the above repeaters or by connecting to EchoLink on either the AMSAT or VK3JED conferences. Past experience has shown that the VK3JED server offers clearer audio. The net is also available via IRLP reflector number 9558. We are keen to have the net carried by other EchoLink or IRLP enabled repeaters and links in order to improve coverage. If you are interested in carrying our net on your system, please contact Paul via email. Frequencies and nodes can change without much notice. Details are put on the AMSAT-VK group site.

### Become involved

Amateur satellite operating is one of the most interesting and rewarding modes in our hobby. The birds are relatively easy to access and require very little hardware investment to get started. You can gain access to the FM 'repeaters in the sky' with just a dual band handheld operating on 2 m and 70 cm. These easy-to-use and popular FM satellites will give hams national communications and handheld access into New Zealand at various times through the day and night. Currently only SO-50 is available.

Should you wish to join AMSAT-VK, details are available on the web site or sign-up at our group site as above. Membership is free and you will be made very welcome.



# WIA 2014 Callbook

Available now

# Gridsquare Standings at 18 October 2013

Guy Fletcher VK2KU

144 MHz	Terrestrial	
VK2FLR	Mike	120
VK3NX	Charlie	107
VK2KU	Guy	102
VK3HZ	David	93
VK3PF	Peter	90
VK2ZT	Steve	87 SSB
VK5AKK	Phil	85 SSB
VK3PY	Chas	82 SSB
VK2DVZ	Ross	79 SSB
VK2ZAB	Gordon	78 SSB
VK3BDL	Mike	76 SSB
VK2AMS	Mark	71
VK3BJM	Barry	70 SSB
VK3QM	David	69 SSB
VK7MO	Rex	67
VK3AKK	Ken	64 SSB
VK2TK	John	62
VK3WRE	Ralph	60 SSB
VK3PF	Peter	56 SSB
VK3KH	Michael	55 SSB
VK3HY	Gavin	54
VK2MER	Kirk	52 SSB
VK3ZLS	Les	51 SSB
VK4CDI	Phil	51
VK4CDI	Phil	47 SSB
VK7MO	Rex	47 SSB
VK7MO	Rex	46 Digi
ZL3TY	Bob	46
VK3EJ	Gordon	40 SSB
VK3PF	Peter	40 Digi
VK3UH	Ken	40
VK2TG	Bob	39 SSB
VK2TK	John	35 SSB
VK3ZUX	Denis	33 SSB
VK3DXE	Alan	32
VK1DA/p	Andrew	31
VK3DXE	Alan	31 SSB
VK1WJ	Waldis	29
VK4KSY	David	28 SSB
VK2TK	John	27 Digi
VK1WJ	Waldis	25 Digi
VK3KH	Michael	25 Digi
VK4CDI	Phil	25 Digi
VK3TLW	Mark	24
VK4EME	Allan	23
VK3ALB/p	GARC Team	22 SSB
VK6KZ	Wally	20

VK2ZT	Steve	19 Digi
VK4EME	Allan	19 SSB
VK3AL	Alan	18 SSB
VK6KZ/p	Wally	16
ZL3TY	Bob	15 Digi
VK2DVZ	Ross	14 Digi
VK2AMS	Mark	13 Digi
VK4EME	Allan	13 Digi
VK5APN	Wayne	13
VK4AE	Denis	9 SSB
ZL1UJG	Kevin	8 Digi
VK1WJ	Waldis	7 SSB
VK5APN	Wayne	7 Digi
VK5APN	Wayne	7 SSB
ZL3TY	Bob	7 CW
VK1WJ	Waldis	5 CW
VK3DXE	Alan	5 Digi
VK4KSY	David	5 Digi
ZL1UJG	Kevin	5 SSB
VK3DXE	Alan	4 CW
VK3QM	David	1 Digi

144 MHz	EME	
VK2KU	Guy	483
VK2KU	Guy	469 Digi
ZL3TY	Bob	424
VK3AXH	Ian	343 Digi
VK4CDI	Phil	308 Digi
VK5APN	Wayne	253
VK5APN	Wayne	248 Digi
VK7MO	Rex	157 Digi
VK2DVZ	Ross	120 Digi
VK2FLR	Mike	120
VK3KH	Michael	61 Digi
VK2KU	Guy	44 CW
VK3BJM	Barry	36 Digi
VK2ZT	Steve	28 Digi
VK3HZ	David	19
VK5APN	Wayne	17 CW
VK3DXE	Alan	16 Digi
VK3NX	Charlie	5 CW
VK4EME	Allan	5 Digi
VK3AXH	Ian	3 CW
VK2DVZ	Ross	2 CW
VK3AXH	Ian	1 SSB

432 MHz	Terrestrial	
VK2ZAB	Gordon	57 SSB
VK3PY	Chas	53 SSB
VK3QM	David	52 SSB
VK3NX	Charlie	50 SSB
VK3HZ	David	42
VK3ZLS	Les	40 SSB
VK3BJM	Barry	39 SSB
VK5AKK	Phil	39 SSB
VK2KU	Guy	38
VK2DVZ	Ross	35 SSB
VK2ZT	Steve	35 SSB
VK3BDL	Mike	35 SSB
VK3AKK	Ken	34 SSB
VK3WRE	Ralph	34 SSB
VK3PF	Peter	32
VK3PF	Peter	30 SSB
VK1DA/p	Andrew	24
VK3KH	Michael	22 SSB
VK7MO	Rex	21
VK2AMS	Mark	19
VK7MO	Rex	19 SSB
VK2TK	John	18
VK3ALB/p	GARC Team	18 SSB
VK2TK	John	17 SSB
VK4CDI	Phil	17
VK4CDI	Phil	17 SSB
VK3HY	Gavin	15
VK3TLW	Mark	15
VK3ZUX	Denis	15 SSB
VK2MER	Kirk	13 SSB
VK6KZ	Wally	13
VK2TG	Bob	11 SSB
VK3AL	Alan	10 SSB
VK3UH	Ken	8
VK4CDI	Phil	8 Digi
VK6KZ/p	Wally	8
ZL3TY	Bob	8
VK3KH	Michael	7 Digi
VK4AE	Denis	7 SSB
VK7MO	Rex	7 Digi
VK2DVZ	Ross	6 Digi
VK4EME	Allan	6 SSB
VK1WJ	Waldis	5 SSB
VK2ZT	Steve	4 Digi
VK3PF	Peter	4 Digi
VK3PY	Chas	4 Digi



VK3QM	David	4 Digi
VK2AMS	Mark	3 Digi
VK3DXE	Alan	3 SSB
VK2TK	John	1 Digi

432 MHz	EME	
VK4EME	Allan	80
VK4EME	Allan	75 Digi
VK4CDI	Phil	54
VK4CDI	Phil	54 Digi
VK4EME	Allan	12 CW
VK7MO	Rex	10
VK7MO	Rex	9 Digi
VK3NX	Charlie	5 CW
VK3AXH	Ian	4 Digi
VK3HZ	David	4
VK3KH	Michael	3 Digi
VK3NX	Charlie	3 Digi
VK2ZT	Steve	2 Digi
ZL3TY	Bob	2 Digi
VK4CDI	Phil	1 CW

1296 MHz	Terrestrial	
VK3PY	Chas	42 SSB
VK3QM	David	42 SSB
VK3NX	Charlie	40 SSB
VK2ZAB	Gordon	29 SSB
VK3AKK	Ken	28 SSB
VK2DVZ	Ross	27 SSB
VK3ZLS	Les	26 SSB
VK5AKK	Phil	26 SSB
VK2KU	Guy	25
VK3BJM	Barry	22 SSB
VK3PF	Peter	22
VK3BDL	Mike	21 SSB
VK3WRE	Ralph	21 SSB
VK3PF	Peter	20 SSB
VK3HZ	David	19
VK3KWA	John	19
VK3KH	Michael	17 SSB
VK3ALB/p	GARC Team	16 SSB
VK2ZT	Steve	14 SSB
VK7MO	Rex	12 SSB
VK1DA/p	Andrew	10
VK2TK	John	10 SSB
VK2AMS	Mark	9
VK3HY	Gavin	8
VK3TLW	Mark	8
VK3AL	Alan	7 SSB
VK3UH	Ken	7
VK2MER	Kirk	6 SSB
VK3ZUX	Denis	5 SSB

VK4CDI	Phil	5
VK4CDI	Phil	5 SSB
VK6KZ/p	Wally	5
VK3KH	Michael	4 Digi
VK6KZ	Wally	4
VK2TG	Bob	3 SSB
VK4AE	Denis	3 SSB
VK4EME	Allan	3 SSB
VK7MO	Rex	3 Digi
VK2DVZ	Ross	2 Digi
VK3PF	Peter	2 Digi
VK3QM	David	2 Digi
VK4CDI	Phil	2 Digi
VK2ZT	Steve	1 Digi
ZL3TY	Bob	1 SSB

1296 MHz	EME	
VK4CDI	Phil	101
VK4CDI	Phil	84 Digi
VK3NX	Charlie	66 CW
VK7MO	Rex	41
VK4CDI	Phil	36 CW
VK7MO	Rex	36 Digi
VK2AMS	Mark	34 Digi
VK2DVZ	Ross	33 Digi
VK3AXH	Ian	14 Digi
VK3NX	Charlie	4 SSB
VK4CDI	Phil	4 SSB
VK2MER	Kirk	3 Digi
VK2AMS	Mark	1 SSB
VK2DVZ	Ross	1 SSB

2.4 GHz	Terrestrial	
VK3NX	Charlie	28 SSB
VK3PY	Chas	28 SSB
VK3QM	David	28 SSB
VK3AKK	Ken	25 SSB
VK3WRE	Ralph	12 SSB
VK3ALB/p	GARC Team	7 SSB
VK3BJM	Barry	7 SSB
VK3PF	Peter	7 SSB
VK3KH	Michael	6 SSB
VK3HZ	David	5
VK6KZ	Wally	4
VK3KH	Michael	3 Digi
VK3ZUX	Denis	3 SSB
VK1DA/p	Andrew	2
VK2AMS	Mark	2
VK3PF	Peter	2 Digi
VK2DVZ	Ross	1 SSB
VK3TLW	Mark	1
VK4EME	Allan	1 SSB

2.4 GHz	EME	
VK3NX	Charlie	44 CW
VK7MO	Rex	14
VK7MO	Rex	10 Digi
VK3NX	Charlie	8 SSB

3.4 GHz	Terrestrial	
VK3NX	Charlie	26 SSB
VK3QM	David	26 SSB
VK3AKK	Ken	22 SSB
VK3PY	Chas	22 SSB
VK3WRE	Ralph	8 SSB
VK3PF	Peter	6 SSB
VK6KZ	Wally	4
VK2AMS	Mark	3
VK4CDI	Phil	3 SSB
VK2AMS	Mark	1 Digi
VK2EM	Bruce	1 SSB

3.4 GHz	EME	
VK3NX	Charlie	29 CW
VK4CDI	Phil	8 CW
VK3NX	Charlie	3 SSB
VK3NX	Charlie	1 Digi

5.7 GHz	Terrestrial	
VK3NX	Charlie	25 SSB
VK3QM	David	25 SSB
VK3AKK	Ken	23 SSB
VK3PY	Chas	23 SSB
VK3WRE	Ralph	9 SSB
VK3PF	Peter	7 SSB
VK3ALB/p	GARC Team	6 SSB
VK6KZ	Wally	4
VK2AMS	Mark	2
VK3BJM	Barry	2 SSB
VK3PF	Peter	2 Digi
VK3ZUX	Denis	1 SSB

5.7 GHz	EME	
VK3NX	Charlie	37 CW
VK3NX	Charlie	4 SSB
VK3NX	Charlie	1 Digi

10 GHz	Terrestrial	
VK3HZ	David	74
VK3HZ	David	36 SSB
VK3NX	Charlie	31 SSB
VK3PY	Chas	28 SSB
VK3QM	David	28 SSB
VK3AKK	Ken	26 SSB
VK3PF	Peter	13 SSB
VK3WRE	Ralph	12 SSB

VK3HY	Gavin	9
VK3ALB/p	GARC Team	7 SSB
VK7MO	Rex	7
VK7MO	Rex	6 SSB
VK6KZ	Wally	5
VK2AMS	Mark	3
VK2EM	Bruce	3 SSB
VK3KH	Michael	3 SSB
VK3KH	Michael	3 Digi
VK3TLW	Mark	3
VK1DA/p	Andrew	2
VK3BJM	Barry	2 SSB
VK3UH	Ken	2
VK3ZUX	Denis	2 SSB
VK7MO	Rex	2 Digi
VK3NX	Charlie	1 Digi

10 GHz	EME	
VK3NX	Charlie	32
VK3NX	Charlie	27 CW
VK3NX	Charlie	5 Digi
VK7MO	Rex	5 Digi
VK3NX	Charlie	1 SSB

24 GHz	Terrestrial	
VK3HZ	David	19
VK3HZ	David	10 SSB
VK3QM	David	6 SSB
VK3AKK	Ken	5 SSB
VK3NX	Charlie	5 SSB
VK7MO	Rex	3 SSB
VK6KZ	Wally	2
VK3WRE	Ralph	1 SSB

24 GHz	EME	
VK7MO	Rex	2 Digi

47 GHz	Terrestrial	
VK3AKK	Ken	4 SSB
VK3NX	Charlie	4 SSB
VK3QM	David	4 SSB

76 GHz	Terrestrial	
VK3KH	Michael	1 SSB

122 GHz	Terrestrial	
VK3KH	Michael	1 SSB

474 THz		
VK3WRE	Ralph	3 AM
VK3HZ	David	2
VK7MO	Rex	2
VK7MO	Rex	2 Digi
VK7TW	Justin	2
VK7TW	Justin	1 Digi

Additions, updates and requests for the guidelines to Guy VK2KU.

The guidelines (and the latest League Table) are also available on the VK VHF DX Site at <http://vhfdx.radiocorner.net> - click on Gridsquares.

Next update of this table will close on or about 14 February 2014.

Stations who do not confirm their status for more than 12 months may be dropped from the table.



## InnoVAntennas

Performance through Innovation

Presenting our new 4 band single feed Yagi™ for 20/15/10/6!

FOR MORE DETAILS OR TO ORDER:  
[www.innovantennas.com](http://www.innovantennas.com)  
 CALL US: + 44 2033 84 0072  
 eMail: [info@innovantennas.com](mailto:info@innovantennas.com)

### New Multi-Bander!

- Wind Rating 200 kph!
- Power rated to 2 kW plus!
- Just 3.7 m long and 25 kilos!
- Introductory price: \$1399.00!
- Superior gain and bandwidth!
- 4 band single feed Yagi™ for 20/15/10/6!
- Longest element 11.5 m (8.9 m for compact version)

4 band single feed Yagi™ for 20/15/10/6 - available now from [www.innovantennas.com](http://www.innovantennas.com)  
 Visit us for more information and other InnoVAntenna™ products





# DX-News & Views

Chris Chapman VK3QB and Luke Steele VK3HU  
 e vk3qb@wia.org.au

## October and November on the bands

Conditions picked up significantly in October, with some nice openings on the higher bands. The sun burst into life late in the month, with a week of high solar activity, including several M-class and some X-class flares. Solar indices had not been this high in ten years. We may be experiencing the second solar peak that some predicted. November continued on with the good conditions.

Some of the calls worked included: TX5D/TX5RV (Austral I), CY0P, TO2TT (Mayotte), 9N2YY, A52YY, H7H (Nicaragua), FW5JJ, CP/DF7NX, HV5PUL, C82DX, E51NOU, SU9AF, Z21DXI, TN2MS, K9W (Wake I), 5J0R (San Andres I), XR0YY, 8R1A, T33A, multiple ZD8 and D44, W8A/N8A (American Samoa), 3DA0ET, Z81X, VU7AG, S21ZBB/S21ZBC, XR0ZR, and then some more!

The CQ WW SSB contest went well, with excellent 10 m band conditions reported, and all bands were generally good. A big surprise in the contest was the unexpected appearance of 7O2A. Dmitry RA9USU operated from Socotra Island, which counts for Yemen. He was only on air for the duration of the contest, immediately after which he packed up and headed home.

FW5JJ is Jean-Jacques TK5JJ, who will be in Wallis and Futuna I for the next two years. He first appeared on air in October. Jean-Jacques is using 100 watts and a G5RV, but should soon have an amplifier and a Spiderbeam. QSL via F5RXL, bureau, direct or OQRS.

With the number of DXpeditions on air in November, there was some

## Some Upcoming DX Operations

The following table summarises some of the DX activations that may be of interest to VK operators.

Date	Call	QSL via	Information
20 Nov – 3 Dec	TY1	ON6DX direct	Benin. ON6DX, 40 – 6 m, SSB, CW, RTTY.
20 Nov – 10 Dec	VU7AG	LoTW	Lakshadweep, Agatti I (AS-011). Nine ops, 160 – 10 m, CW, SSB, RTTY.
28 Nov – 3 Dec	T32TM	K8NA	East Kiribati, Kiritimati I (OC-024). NL8F, HF, SSB.
29 Nov – 7 Dec	6V7D	DL7VOA	Senegal. DL7VOA, 40 – 10 m, CW, possibly SSB.
1 – 8 Dec	ZF2OK	N00K	Grand Cayman I (NA-016). N00K, 20, 17, 15, 10 m, mainly RTTY.
4 – 11 Dec	T32RC	OQRS	East Kiribati, Kiritimati I (OC-024). Team, 160 – 10 m, CW, SSB, RTTY.
7 – 17 Dec	E6RQ	VK4FI	Niue, Alofi I (OC-040). VK4WR, VK4FI, HF.
8 – 14 Dec	6W	AA1AC	Senegal, La Somone. AA1AC operating as 6W/AA1AC
21 Dec – 10 Jan	H40FN	DK9FN	Temotu Province, Nendo I (OC-100). DK9FN, 160 – 10 m, mainly CW, and some SSB.
3 – 21 Jan	6W7SK	LoTW	Senegal. F6BLP, 160 – 10 m.
13 – 19 Jan	TO3JA	EB7DX	Martinique (NA-107). JA3ARJ and JA1CJA.
24 Jan – 12 Feb	FT5ZM	N200	Amsterdam I (AF-002). Team, 160 – 10 m, CW, SSB, RTTY.
26 Jan – 28 Feb	XT2AW	M0OXO	Burkina Faso, Ouagadougou. DF2WO, CW, SSB, holiday style.

overlap, and confusion. DXpedition callsigns were incorrectly spotted, and some worked one DXpedition, when they thought it was another. Always verify for yourself just who it is you worked, before you enter them in your log. Do not rely on the sometimes incorrect information posted on the DX cluster network.

Enjoy the good conditions while they last. It's looking like a good summer for DX.

TY1, Benin. Wim ON6DX will be in Benin with his wife. He will be

using vertical antennas for 40 and 30 m, and a Hex Beam from 20 – 6 m. For more information see <http://dxpedition.be/Benin.html>

VU7AG, Lakshadweep. Nine operators will be active for 14 days from Agatti I. They will be active on HF using CW, SSB and RTTY. There is a possibility they may be active with the callsign VU7KA, which will be a demonstration station, showing ham radio to local officials on Kavaratti Island. QSL also OK via OQRS and W4VKU. For more

information see <http://www.vu7ag.info/>

**T32TM, East Kiribati.** Tim NL8F will be operating solo from Kiritimati I, on HF, SSB. He will then take part in the Russian Robinson Club activity.

**6V7D, Senegal.** Rob DL7VOA will be operating 'holiday style' from a beach near Toubab Dialaw, on 40 – 10 m, on CW and possibly SSB. He'll be using 100 watts, vertical dipoles, and groundplanes. QSL bureau or direct to DL7VOA. Note that this callsign has been reissued, having been previously used by a Russian DXpedition in 2011.

**ZF2OK, Cayman I.** Curt N00K will be operating 'holiday style', mainly RTTY, on 20, 17, 15 and 10 m.

**T32RC, East Kiribati.** A team celebrating the twentieth anniversary of the Russian Robinson Club will be active from Kiritimati (Christmas) Island. For more information see <http://www.t32-2013.com/>

**E6RQ, Niue.** Alan VK4WR and Graeme VK4FI will be on Alofi, operating HF bands. QSL via VK4FI direct.

**6W/AA1AC, Senegal.** Mark AA1AC will be operating from Le Calao, Sonome. QSL direct or bureau to his home callsign.

**H40FN, Temotu.** Siegfried DK9FN will be on air again from Lata Village, Nendo I in the Temotu Province. Siegfried prefers CW, but may operate some SSB. For more information see <http://www.qrz.com/db/H40FN>

**6W7SK, Senegal.** Francis F6BLP will return to Senegal to operate 160 – 10 m. Francis prefers CW. For more information see <http://www.f6blp.org/>

**TO3JA, Martinique.** Operators JA3ARJ and JA1CJA have requested the callsign TO3JA for the January DXpedition to Martinique.

**FT5ZM, Amsterdam I.** A team of around fourteen operators will be activating this Top Ten Most Wanted

entity in late January. The last big activation was in 1998. The island is in the southern Indian Ocean, so should be reasonably accessible in VK. The DXpedition team have a nine day sea voyage from Fremantle aboard the MV Braveheart. This means a very large budget, so please show your appreciation for the DXpedition with a donation. For more information see <http://www.amsterdamdx.org/>

**XT2AW, Burkina Faso.** Harald DF2WO will be operating 'holiday style' from Ougagadougou, using CW and SSB. He is there for a month, so hopefully will have some time to work VK. For more information see <http://www.qrz.com/db/XT2AW>

Special thanks to the authors of The Daily DX, 425 DX News, DX World, NG3K's Announced DX Operations, and QRZ.DX for information appearing in this month's column. Interested readers can obtain a free two week trial of The Daily DX from [www.dailydx.com/trial.htm](http://www.dailydx.com/trial.htm)

## VK5news Adelaide Hills Amateur Radio Society

Christine Taylor VK5CTY

Two members conducted this meeting, Barry VK5BW and Dennis VK5HH.

Barry explained the purpose and activities of Bletchley Park during World War 2. Barry (and several other members of AHARS) had visited Bletchley Park in England in the last few months. All found it to be interesting to hear about the way in which messages between German Army, Air Force and Naval units were decoded, there, at Bletchley Park. As a consequence of their success in decoding these messages many lives were saved.

The main focus was a complex machine, the Enigma coding machine. The Enigma machine used several sequential steps to encode each message with the intention that only someone who knew the

details of each step would be able to read the message. Fortunately for the lives of many service personnel, the clever people at Bletchley Park were able to unravel the codes.

To explain message coding and how it works Dennis demonstrated on the board the simple codes many of us probably used as children and how these were made more and more complex over the years, resulting in the Enigma machine. To complete the demonstration Barry had found, on the internet, an Enigma simulator. The website explained the way the machines were made and how they were used and allows us, if we like, to send and read a message sent by an enigma machine.

It all made for a very interesting evening.

The Club has recently had displays at three country shows. Interest was high in all cases and felt to be worthwhile in spreading the word on our hobby.

AHARS continues to hold their social and lecture Saturday mornings alternately each week, at the Shack at Blackwood. We have also held several demonstration stations at the local Agricultural Shows, and to participate in JOTA up at the shack.

Some members are also running Summits of the Air stations from time to time; watch the website for details of these events so you can make contact with them.

Best wishes to everyone for Christmas and New Year from the AHARS committee.





# VHF/UHF - An Expanding World

David Smith VK3HZ  
e vk3hz@wia.org.au

## Weak Signal

The afternoon of October 23rd brought another opening from mid-northern VK across to ZL. At 0410Z, Adrian VK4OX worked Nick ZL1IU on 2 m at 5x1. Signals then dropped away, but at 0645Z, they were able to again work, but on CW with a 519 report. At 0700Z, Ross VK2DVZ worked Nick at 5x6. Adrian again worked Nick, this time with 5x6 reports. They QSY'ed to 70 cm and succeeded with a CW contact with a 519 report. At 0740Z, Ross again worked Nick on 2 m (5x4) and then worked via SSB on 70 cm (4x1). Adrian then worked Harry ZL2ADU exchanging 5x3 and 5x5 reports over a distance of almost 2400 km. Conditions then dropped away and no further contacts were made.

## VK4 5.7 GHz Shootout

The Redcliffe & Districts Radio Club recently held a 5.7 GHz shootout day. The weather gods were shining down upon them on the day, and a number of hopefuls lined up their systems, hoping to receive the weak signal source planted on the other side of the field.

Doug VK4OE was the winner on the day and was spotted later proudly wearing his 'Best 5.7 GHz Ears' Award.

## VK3 144.150 net

The weather is warming up, and more people are visiting their shacks of an evening. As a result, the VK3 '150' net (144.150 MHz at 2030 local each Wednesday evening) was well attended recently. Run by Michael VK3KH (to the west) and Rob VK3MQ (east), 12 stations participated including David VK3NDG, Ian VK3AXH,



Photo 1: The starters in the Redcliffe 5.7 GHz shootout day.

Craig VK3KG, Ian VK3YCCQ, John VK3ACA, David VK3HZ, Peter VK3ATC, Frank VK3UBU, Russ VK3ART and Mike VK3XL. Various

interesting discussions were had. So, if you want to burn the cobwebs out of the radios prior to the busy season, come up on the '150' net.

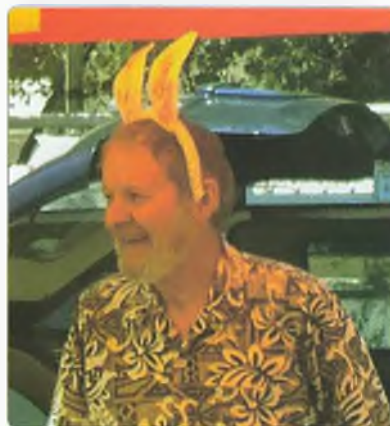

Photo 2: Doug VK4OE, wearing his 'Best 5.7 GHz Ears' award.

## Yet another source of local interference

I've recently rebuilt my 24 GHz system with a larger dish and more power, and made some minor adjustments to the 10 GHz system. My normal test for receive performance is to set the systems up in the front yard (north) with the Boonton microwatt meter connected to the IF output and measure the level of sun noise received as I swing the dish past the sun. (I also use the opportunity to align the optical sight I use for pointing the dish - carefully).

This time, the 24 GHz system showed a very worthwhile improvement in sun noise – more than the increase in dish size would give – indicating that dish efficiency had also improved with the new feed. However, when I went to measure the 10 GHz system, I couldn't get a stable noise reading. The background noise level was varying all over the place, by more than 10 dB at times. Sun noise measurement was completely out of the question. All sorts of theories went through my mind – something taking off, a loose/bad connector ... Nothing I did seemed to settle it down until I put my hand right over the feed horn whereupon the noise dropped to a low, steady level. So, it seemed like a very unstable signal at 10 GHz was being received. I swung the dish around, and the level peaked in the direction of ... the recently installed 'Smart' meter.

Searching on the web, I discovered that the 'Smart' meters communicate via a mesh network in the 915 to 928 MHz ISM band, with a proposal to move higher up the 900 MHz spectrum at some stage. The meters not only transmit their own data, but also relay data from other nearby meters. 10368 MHz divided by 11 is 942.5 MHz – relatively close given that my sun noise measurement is fairly broadband.

Next step is to drag the spectrum analyser down into the front yard and measure the crud coming from the 'Smart' meter. If there's that much at 10 GHz, I'll be interested to see what's coming out at the lower harmonics.

I notice that I now also have a regular 'tick' on 2 m – somewhat like the interference from an electric fence. However, there'd be no electric fences anywhere near this inner suburban location. I suspect this is another 'benefit' of the 'Smart' meter.

Please send any Weak Signal reports to David VK3HZ at [vk3hz@wia.org.au](mailto:vk3hz@wia.org.au)



## Digital DX Modes

Rex Mancur  
VK7MO

### Meteor Scatter by Kevin VK4UH

1 October brought the much anticipated Orionid meteor shower. This annual event usually marks the end of the winter doldrums of meteor activity. The Orionid shower, which often produces some of the best meteor scatter propagation opportunities of the year, occurs as the Earth's orbit around the Sun takes it through streams of debris remaining from Halley's Comet.

As has been described before, unlike 'random' meteor activity, meteor showers occur at exactly the same time each year, that is, at the same points in the Earth's orbit, and are therefore highly predictable. The Orionid shower was expected to peak around October 22nd however this particular shower is recognised as being very broad, reflecting the size of the Halley's debris cloud, typically producing meteors across many days. On 15th October Spaceweather.com reported 'Two bright Orionid Fireballs being seen in the sky over the USA' indicating an early start this year.

It is worth remembering that the usual pre-dawn peak expected from 'random' meteor activity may not apply for operation during meteor showers. The determinant is the presence of the star constellation (the radiant in the sky from where the shower 'appears' to be coming from) being above the horizon at both ends of the path. The ideal timing for MS activity during this shower was when Orion was low over the horizon thus providing the best conditions for long paths. A catch for new players is that these ideal conditions will occur at different times from

those advertised on the web for MS activity in USA and northern hemisphere.

In his posting on the VKLogger, Peter VK5PJ in Adelaide provided a link to the very useful 'VIRGO – Meteor Sky View' application for predicting both the position and activity of meteor showers. I have reproduced the link here: <http://www.d11dbc.net/Meteorscatter/>

The programme is JAVA based and does require a fairly recent version to run properly.

In Peter's words 'Virgo shows the position of the shower relative to your location. Do not forget to put your call sign and grid locator into the boxes on the left hand side, and then press the GO button.'

In the event unfortunately, from this location in VK4 at least, the results this year were disappointing. Although the number of observed meteor returns was certainly enhanced in both duration and frequency, compared to recent months, expectations were not realised. During the Saturday morning activity session on 18 October I observed several hyperdense 'burns' lasting the entire 30 second receive period from Arie VK3AMZ but nothing from ZL. Several factors may have contributed to the poor results this year. The optimum times for Orionid activity occurred outside of the regular activity sessions with few stations on-air particularly from the southern states. I suspect that the Ballarat convention that weekend also stole a few of the usual participants from VK3. The lack of daylight saving in VK4 made the optimum operating times 'very early' up here. Better luck next year. The next significant showers expected include the Leonids 17/18 November and the Geminids 13/14 December.

Information has been requested about VK/ZL meteor scatter activity on six metres.

There are a number of stations regularly active on this band including Darrell VK2BLS



(Wollongong), Wayne VK4WTN (Hervey Bay) and Phil VK4FIL (recently relocated to Adelaide). Activity is on 50.230 MHz FSK441 with 30 second periods and time wise coinciding with the 2 m activity periods each weekend from 2000 UTC. Period selection corresponds to 2 m. Darrell operates concurrently on both 2 m and 6 m which is easy to do since transmit and receive periods coincide of course. In fact MS is much easier on 6 m than 2 m. Theoretically, since the wavelength on 6 m is roughly three times that on 2 m the duration of returns should be  $3^2$  (3 to power 2) = 9 times longer. The amplitude of the signals should be  $3^3$  (3 to power 3) = 27 times or approximately 15 dB louder. Consequently a meteor producing a good 3 second burn on 2 m would last almost 30 seconds on 6 m and an un-decodable 100 ms ping on 2 m would be expected to coincide with an easily decodable one second ping on 6 m. There is additional information to be found on the VK Logger in the 6 m section regarding MS activity on this band. My thanks to Darrel VK2BLS for his advice.

I am always happy to receive reports, questions or enquiries about meteor scatter in general or the digital modes used. I can be reached at [vk4uh@wia.org.au](mailto:vk4uh@wia.org.au)

Please send any Digital DX Modes reports to Rex VK7MO at [rmoncur@bigpond.net.au](mailto:rmoncur@bigpond.net.au)



## The Magic Band – 6 m DX

John McRae  
VK5PO

October started out relatively quiet, with the SFI hovering around the 110 mark. On the 25th, several X-class flares were prevalent, being the first X-Class flares for quite some time. There have been three

X-Class flares, and as of writing, there is an earth bound CME event, and the SFI has risen to 167. The CME event should add to the SFI in a few days. This hopefully brings with it, some good DX possibilities on the MAGIC band.

The band has been open into JA from mostly the northern tropics region again, but it became obvious that the south west region of WA got some great conditions. Western Australia's long time 6 metre 'stalwart' Graham, VK6RO/VK6SIX writes:

*On October 21, we saw the longest and strongest six metre opening from Japan to Perth since April 1985. Signals started building at 0432Z with the last signal heard at 0811Z.*

*I actually used my 1/2 wave 50 MHz vertical at about 10 metres, and 100 watts for all of the contacts made. The Japanese stations were a genuine 59 plus 10 db on the vertical at times!*

*This vertical is my 'scanning' antenna and connected to the rig which scans memories non stop during normal days and nights. A grand total of 36 JA stations worked, and I heard one HL station.*

*The various BY-TV offsets around 49.750 MHz and the UAO 'warbler' were also up to S9.*

*It was fantastic to make contact again with a few stations I have not worked for many years.*

*Steve VK6IR, who is about two km from me worked many more than I did.*

*After 13 years Perth had another opening to the Middle East area on October 25th.*

*The last two openings to the Middle East occurred in April 1992 to 9K2 (Kuwait) and in November 2002 to JY (Jordan). At around 1050Z Dave A92IO heard 'bits and pieces' of VK6IR, Steve's CW. But no contact was made at that time. At 1150Z a few Perth stations worked A92HK on SSB, he was 5x5 on my radio. Again at 1256Z some Perth stations worked A92IO on CW, Dave being 559 into my suburban QTH.*

*VK6IR made it finally with A92IO also. It was possibly open from*

around 1100 to 1300Z.

*Country # 58 for me after 35 years of Magic Band operating.*

Steve VK6IR a 'newcomer' to the Magic band adds his activity: *I have a FT-2000 with an Acom amplifier and was running about 400 watts into my five element LFA yagi at 10 metres.*

*On 21 October I called CQ on 50.110 at 0444Z, immediately answered by JA3EGE with a 59 +10db signal. What a surprise!*

*Six metres stayed open till 0849Z - just over four hours, but I think VK6AKT worked a few more after this time. The log book was well utilised, with a total of 141 JA stations (mostly SSB, 17 on CW, 2 on JT65) and six South Korean stations. The strongest signal received was a huge +40db.*

*I could have worked more, but had a look around a few times for BY or other stations but nothing was heard.*

On the 19th, Paul VK4MA, along with Scott VK4CZ, along with Brian VK4DDC and George VK4AMG made it into the west coast of the USA. Conditions at 0134Z saw the four VK4 stations make two way CW contacts with Todd W6TOD, who has his QTH in the Mojave Desert in California. Lots of deep QSB noted with low S9 signals to contend with. Paul had a stronger signal, and made his contact around 0150Z.

Arno VK4JAO, from Toowoomba, made some brisk contacts into Japan and writes: *My modest station consists of a 'vintage' Trio Kenwood TS-600, THPHL-66 linear at 50 watts output, and a home brew five element HB9CV.*

*On the 21st October around 0300Z, I heard some weak CW signals around 50.110 MHz.*

*Some other things to do, I returned at 0400Z to the shack...six metres was open into JAI JA8CAR, JH8LLE, JA1NAQ, JH1PIA, JH1WHS, JM1IGS were contacted, with signals around the 5x5 mark.*

Signals faded down, and the band closed about 0430Z.

And here is an interesting few paragraphs from Joe VK7JG: Just reading your six metre notes in the latest AR magazine. Thanks for your work.

Unfortunately I did not obtain my amateur license till 1965 so have a couple of years before obtaining the 50 years on six metres. I was operational on 6 and 2 the day I obtained my callsign having built equipment prior to obtaining my licence.

Living in VK7 has the problem of Bass Strait and the extra distance to the northern hemisphere but I have enjoyed my time on the air and at one time or another have held every VHF distance record for VK7 on 6,

2, 70 and 1296 MHz.

I never mastered CW having the 'ZED' call for the first 12 years of operation so nearly all of my contacts have been on SSB and in the early days, AM.

From memory I have worked about 40 countries terrestrially - I still use a paper log so would take a little time to check. Since operating six metre EME have clocked up 37 initials - five in the USA, and the rest in Europe - so I have a few more countries here.

I must sit down one day and put them on a computer logging program.

Have been away for most of the past three months. Did another Simpson Desert crossing in August, then a month in VK4 babysitting

granddaughter, just returned from three weeks in Cambodia /Laos/ Vietnam, was home two days then went to Flinders Island for a week.

Looking forward to getting back into some six metre EME. Unfortunately I have severe power-line QRM on my moonrise so obtaining contacts is very difficult. My next move is to install elevation once I get some work around the house finalised.

Another station in VK7 with 50 years on 50 would be VK7PD.

Please submit reports, logs or other info you may consider useful to John VK5PO at vk5po@wia.org.au

## Contests

James Fleming VK4TJF

Well the year is just about over and all that is left is this month of December.

The contest for this month is the ARRL 10 metre contest running as it does for 48 hours on the second full weekend of December, starting at 0000 UTC on Saturday, 8 December until 2359 UTC on Sunday, 9 December. That is around 1000 am here in VK4 on a Monday.

However you can only operate up to a total of 36 hours. Off times must be at least 30 minutes in duration, plenty of time to enjoy a quick BBQ snack. There are multiple modes - you can do phone, CW or mixed and high, low and QRP power. You can also team up with other amateurs and run a multi-operator station. DX stations give their RST and serial number and stations from W/VE give RST and province or state abbreviation. Mexican stations give their RST and state. Scoring is two points for phone and four points for CW. Multipliers are many, being each US state, Canadian province, Mexican state, ITU region and DXCC country.

### Contest Calendar for December 2013 - February 2014

December	6th - 8th	2200 UTC	42 hours	ARRL 160 metre contest	CW
	8th	0000 UTC	24 hours	Ten-metre contest	RTTY
	14th - 15th	0000 UTC	48 hours	ARRL 10 metre contest	CW / SSB
	21st	0000 UTC	24 hours	OK DX RTTY contest	RTTY
	21st - 22nd	1400 UTC	24 hours	Croatian CW contest	CW
	28th - 29th	0000 UTC	24 hours	RAC Winter contest	CW / SSB
January	1st - 31st	0000 UTC	Month	Ross Hull Memorial VHF-UHF	ALL
	4th - 5th	1800 UTC	30 hours	ARRL RTTY Roundup	RTTY
	11th - 12th	0100 UTC	24 hours	Summer VHF/UHF Field Day	SSB / CW / FM
	18th - 19th	1200 UTC	24 hours	Hungarian DX contest	CW / SSB
	25th - 26th	0600 UTC	36 hours	REF contest	CW
	25th - 26th	1200 UTC	24 hours	BARTG RTTY Sprint contest	RTTY
February	1st - 2nd	1800 UTC	24 hours	Mexico RTTY International contest	RTTY
	8th - 9th	0000 UTC	48 hours	CQ WW RTTY WPX contest	RTTY
	15th - 16th	0000 UTC	48 hours	ARRL International DX contest	CW
	22nd - 23rd	0600 UTC	36 hours	REF contest	SSB
	22nd - 23rd	1300 UTC	24 hours	UBA (Belgian) DX contest	CW

An easy way to log the contest is to use the VKCL logging program and sending in your log electronically, via email.

So that is the contest in a nut shell. It may help some people to get Monday morning off work to make more contacts to North America. It may also help to know that during this time of year trans-equatorial propagation signals from Japan and New Zealand are

common. Band conditions as of late have been very good and remain promising with high sun spot activity. I hope to hear everyone active in the 10 metre contest.

I wish everyone a Merry Christmas and a Happy New Year! And hope that this year has brought everyone lots of fun contesting. I for one am looking forward to next year. Cheers.



# ALARA - 33rd ALARA contest results

Lesley R Smit VK5LOL - ALARA Contest Manager

What a wonderful contest! Much more participation this year and generally better conditions, except to ZL. Congratulations to all but special congratulations to Jean VK3VIP, our President, who won the contest overall, to Leonie VK2FHRK our top Foundation licensee member, to Lyn VK4SWE for her sterling effort on CW, to Shirley VK5YL for her EchoLink performance and our two non-ALARA members Sally VK2FBND and Suzanne VE7IM, who participated in the contest. They will be rewarded with one year's membership to ALARA.

The OMs in NSW really worked hard for top spot. It was a bit of a toss-up between Hilary VK2IUW, Derrick VK2DEK and Gerald VK2HBG but Hilary won the Top VK OM spot by using a bit of CW and EchoLink. Congratulations Hilary! My thanks go to all the YLs and OMs who participated.

Details of our contest each year can be found on the ALARA website and access to the preferred logging program can be found by googling 'VKCL'.

Look forward to another good contest next year.

Jean	VK3VIP	1227	Top overall, Top Phone, Top VK3 ALARA member
Catherine	VK4GH	1088	Top VK4 ALARA member
Leonie	VK2FHRK	912	Top Foundation Licensee
Pam	VK4ON	774	
Pat	VK3OZ	629	
Jenny	VK3WQ	339	
Hilary	VK2IUW	338	Top VK OM, Top VK2 OM
Derrick	VK2DEK	300	
Gerald	VK2HBG	279	
Lyn	VK4SWE	256	Top YL CW (CW score - 240)
Shirley	VK5YL	229	Top VK5 ALARA member Top YL EchoLink (77 points)
Rosanne	VK7NAW	174	Top VK7 ALARA member
Yern	VK2KJJ	130	(CW score - 50)
Sally	VK2FBND	108	Top scoring VK non-ALARA member
John	VK3FMPB	101	Top VK3 OM
Bill	ZL3VZ	100	Top ZL OM
Susan	VK3UMM	99	
James	VK2ZMC	60	
Malcolm	VK2FITH	45	
Lesley	VK5LOL/4	43	Check Log
Suzanne	VE7IM	39	Top DX YL (non-ALARA member)
Patrick	VK5MPJ	35	Top VK5 OM
Elizabeth	VE7YL	34	Top Canadian ALARA member
Robert	VK2RL	34	
Mark	VK4MON	30	Top VK4 OM
Bambi	VK4PYL	25	
Celia	ZL1ALK	15	
Margaret	VE7TJF	10	
Dean	VK5FAIR	5	

Table 1: 33rd ALARA contest results

## Over to you

### Lip sync

Peter,

I have been using my stereo amp for surround sound with my TV for quite a long time and lip sync between sound and vision was spot on.

But more recently, I don't know what has happened but lip sync is out by quite a few milliseconds so I have had to resort

to using only the TV's speakers which are quite inferior to those previously used.

The programs are coming in to me via the internet from Telstra.

Can any reader / WIA member throw some light on my problem?

73, Scotty VK2KE

### Solution found

Further to my recent letter to you re lip sync on TV being a problem here with the surround sound amp: the solution I have found is to take a feed from the TV's optical output port straight to the amp and now lip sync is perfect.

Other readers may be interested in the cure.

73 Scotty VK2KE

# Summer VHF-UHF Field Day 2014

Contest Manager: John Martin V<sub>k</sub>3KM

## Dates: Saturday and Sunday 11 and 12 January 2014

Duration in all call areas other than VK6: 0100 UTC Saturday to 0100 UTC Sunday.

Duration in VK6 only: 0400 UTC Saturday to 0400 UTC Sunday.

## Sections

- A: Portable station, single operator, 24 hours.
- B: Portable station, single operator, 8 hours.
- C: Portable station, multiple operator, 24 hours.
- D: Portable station, multiple operator, 8 hours.
- E: Home station, 24 hours.
- F: Rover station, 24 hours.

## Operating periods

Stations entering the 8 hour sections may operate for more than 8 hours, and nominate which 8 hour period they wish to claim for scoring purposes.

## Entering more than one section

If a portable station operates for more than 8 hours, it may enter both the 24 hour and 8 hour sections. If the winner of a 24 hour portable section has also entered the corresponding 8 hour section, his log will be excluded from the 8 hour section.

If a portable or rover station spends part of the contest period operating from his home station, he may also enter the home station section.

## Rover stations

The Rover section is for all portable or mobile stations that operate from more than two locator squares or change locator squares more than twice.

## Two operators

If two operators set up a joint station with shared equipment, they

may choose to enter Section A, B or F as separate stations under their own call signs, or Section C, D or F under a single call sign. If they enter as separate stations, they may not claim contacts with each other.

## Multi-operator stations

Portable stations with more than two operators must enter Section C or D. Operators of stations in Section C or D may not make contest exchanges using call signs other than the club or group call sign.

## General Rules

One call sign per station. Operation may be from any location. A station is portable only if all of its equipment is transported to a place which is not the normal location of any amateur station. Portable stations may change location during the Field Day provided the station is dismantled and reassembled each time it moves. You may work stations within your own locator square. Repeater, satellite, EME or crossband contacts are not permitted. Contacts using digital modes with computer decoding of the received signal are not permitted. Contacts made using modulated light are permitted, but they will be totalled separately and will not contribute to the final all-band score.

Except for CW, no contest operation is allowed below 50.150 MHz. Recognised DX calling frequencies must not be used for contest activity. Suggested procedure for SSB stations is to call on 150 or higher on each band, and QSY up to make the contest exchange.

## Contest Exchange

RS (or RST) reports, a serial number, and your four digit Maidenhead

locator. Six digit locators may be exchanged but are not compulsory. The Maidenhead locator is optional if it has already been exchanged in a previous contact during the Field Day and neither station has moved since then.

## Repeat Contacts

Stations may be worked again on each band after three hours. If either station is moved to a new location in a different locator square, repeat contacts may be made immediately. If the station moves back into the previous locator square, the three hour limit still applies to stations worked from that square.

## Logs

Logs should cover the entire operating period and include the following for each contact: UTC time; frequency; station worked; serial numbers and locator numbers exchanged.

## Scoring

For each band, score 10 points for each 4 digit locator square in which your station operates, plus 10 points for each locator square worked, plus 1 point per contact. Multiply the total by the band multiplier as follows:

6 m	2 m	70 cm	23 cm	Higher
x 1	x 3	x 5	x 8	x 10

Then total the scores for all bands.

## Cover Sheet

The cover sheet should contain the names and call signs of all operators; postal address; station location and Maidenhead locator; the section(s) entered; the scoring table; and a signed declaration that the contest manager's decision will be accepted as final.

Please use the following format for your scoring table, showing on next page.



Band	Locators Activated (10 points each)	+	Locators Worked (10 points each)	+	QSOs (1 point each)	x	Multiplier	=	Band Total
6 m	10	+	40	+	40	x	1	=	90
2 m	10	+	40	+	30	x	3	=	240
70 cm	10	+	40	+	20	x	5	=	350
etc.									
Overall Total								=	680

In this example the operator has activated (operated from) one locator and worked four locators on each band:

A blank cover sheet, with scoring table, is available on the Field Day page of the WIA web site.

### Entries

Electronic logs are preferred. Acceptable log formats include:

ASCII text, RTF, DOC, DOCX, XLS, XLSX, MDB, PDF, or any Open Document format. Please email electronic logs to [vhfuhf@wia.org.au](mailto:vhfuhf@wia.org.au). Paper logs may be posted to the Manager, VHF-UHF Field Day, PO Box 2042, Bayswater Vic 3153. Logs must be received by Monday, 27 January 2014. Early logs would be appreciated.

### FIELD DAY WEB SITE

<http://www.wia.org.au/members/contests/vhfuhf/>

This site includes the rules for the next Field Day, rules and results of all past VHF-UHF Field Days, cover sheets and scoring tables, and other information.



## SOTA News

*Allen Harvie VK3HRA and Bernard Petherbridge VK3AMB*

### HF antenna choice

In this edition, we will look at the types of antenna that are being most frequently used for SOTA activations in Australia.

We all know that the antenna plays a most important role in this hobby and SOTA brings additional considerations related to the portable nature of the activity. As you will be carrying the antenna, the size and weight are factors not normally considered in a typical portable operation. The view that 'the more wire in the air the better' is correct but beams are out of the question for HF activations so we will consider the basic wire dipole and when activators are measuring the weight of their antenna in 'grams' you know that they are getting serious.

The half wave dipole has a strong following due to ease of use and an antenna cut to resonant frequency requires no tuner or ground wires, plus they are easy to carry and setup. There are several variations on the basic half-wave dipole that offer distinct advantages and disadvantages for consideration.

#### Linked Half Wave Dipole (LHWD) (Photo 1)

The linked dipole is the clear favourite with SOTA activators pursuing multi-band activations.

#### Doublet (Photo 2)

An excellent and robust performer for local and DX contacts.



Photo 1.



Photo 2.

### Off-Centre Fed Antenna

Another multi-band antenna that requires a Balun but not a tuner.

### End Fed Half Wave (EFHW) (Photo 3)

Multi band antenna requiring a tuner and single support.

### LHWD (Linked Half Wave Dipole).

In order to bring multi-band capabilities to the humble dipole without the requirement for a tuner all that is required is to cut your wire to the appropriate lengths and add links. The 12/20/40 designs appear to support the bands of choice in VK. The links typically utilise alligator clips, RCA plugs or Anderson PowerPoles. More information is available at: <http://vk3zpf.com/link-dipole>

The doublet is also of great interest to SOTA. A doublet is a dipole feed with balanced line. They are typically constructed using speaker cable or TV ribbon. The Doublet offers vertical and horizontal radiation, multiband abilities and is robust in nature. This is a case of the 'more wire the better' principal. A balanced tuner or 4:1 balun and tuner is required here.

An OCF cut for 40 m can be used on 40/20/10 m without a tuner to meet the multi-band and weight criteria. A 4:1 balun is required. The balun weight may be a consideration. Some are deploying 20/40 m linked dipoles as LHWD where one leg is open and the other closed to reproduce this behaviour.

The EFHW (End Fed Half Wave) is a variation of the much more common half wavelength dipole fed from one end and requiring a matching device and (optional) counterpoise. It provides multiband abilities and has the advantage of being easy to set-up due to needing only a single point of support, which could be a convenient tree. The matching devices are easy to make and deploy. They are an ideal SOTA antenna combining speed of setup and low weight with an efficient design. More information available at: <http://vk1nam.wordpress.com/efhw-antenna/>

Whilst linked dipoles and end fed antennas are versatile for multi-band work they are not where I would suggest starting. Tuning a multi-band linked dipole, whilst a simple task, can be quite time consuming. Time that could be better spent walking up hills :) Initial activations should concentrate on a single band. A dipole cut to calling frequency will provide excellent capabilities and eliminates the need for purchasing and carrying tuners.

For a fast, easy, minimal effort intro to SOTA activation, I'd suggest a 1/2 wave no balun 40 m dipole.

Simply cut two pieces of wire about 10.7 metres long, trim to achieve resonance, connected to a length of coax. About 30 minutes work and you're on the air.

You may consider the purchase of commercially made centre and end insulators with coax connectors and baluns built-in. Whilst this is certainly a lot less work, being creative and adapting to what is at hand is the nature of amateur radio.



Photo 3.

Suitable wire winders can also be purchased or home built. A 1:1 balun can enhance performance though you don't strictly need a balun. In fact not having a balun makes addressing issues on site easier due to clearer connectivity configurations. See Photo 4.



Photo 4.

Be sure all connections are secure, both mechanically and electrically. Ensure that joints are properly soldered and use weatherproofing. Remember to provide some type of strain relief at the centre insulator for your "dangling" feed line. Not only can the feed line present a strong downward tug, but is prone to adding to the mechanical stress on the connections in harsh weather.



A good strain relief system is to wrap the feed cable once around the centre insulator and secure it with tie-wraps. Another option is to use a short length of double-sided Velcro® material to attach the coax to your mast (if you use one) about 1 to 2 m below the feed point. The same length of Velcro® can be used to hold together your wound up coil of coax cable.

Always cut your antenna lengths a bit long. This will allow you to "fine tune" the antenna by trimming. You will quickly learn that "trimming" is

a LOT easier than "adding to" and if you have access to an antenna analyser then the tuning process will be much faster again.

Another aspect to consider is the impact of continually winding and un-winding the antenna and coax with respect to the stresses placed upon joints. A few activations have been completed with bare wires poked into RF connectors, so remember also to check your gear before heading off to a summit.

When on-site, it is likely that the position of available supports will

dictate the antenna orientation. In VK3 a dipole setup to point north will provide coverage into VK2 and VK5.

Watch the mass of products and get up the closest summit and on the air.

The UK has over 800 Activators, the US around 500. In VK we have about 80 Activators at the time of writing... We have some catching up to do... Get out there and give it a go!



## VK3 news Amateur Radio Victoria

Jim Linton VK3PC

e [arv@amateurradio.com.au](mailto:arv@amateurradio.com.au)

w [www.amateurradio.com.au](http://www.amateurradio.com.au)

### Season's greetings and HNY

We have reached the final month of what has been a momentous year for us all.

On behalf of the President, Barry Robinson VK3PV, Treasurer/Secretary, Ross Pittard VK3CE, Peter Mill VK3APO, Terry Murphy VK3UP, Tony Hambling VK3VTH, Peter Cossins VK3BFG, Keith Proctor VK3FT and Jim Linton VK3PC, all the best for the festive season and have a Happy New Year.

Notices of Motion for the Annual General Meeting must be signed by at least three members. Both must be in the hands of the Secretary not less than 90 days before the Annual General Meeting, held on Tuesday 13 May, at 40g Victory Boulevard, Ashburton.

The Council term is ending and 2014-17 nominations are now open on the prescribed form available from the Secretary. Each candidate must agree to serve, be financial and have the nomination signed by two financial members.

Hardworking volunteers run the office which will close at 1 pm on 17 December and reopen on 4 February, 2014. Only urgent matters will be handled during the closure

while a stocktake will occur and reports prepared.

### Events saw a busy year

On November 15-17 we held, for a third year in a row, the very successful activation of National Parks, under the guidance of Award Manager, Tony Hambling VK3VTH.

It was held under the Keith Roget Memorial National Parks Award, but a report is yet to be completed. However judging on proposed portable stations on the Master List there was plenty of interest by those activating parks and many working them.

One of our regular activities is the International Lighthouse & Lightship Weekend at the Time Ball Tower at Point Gellibrand Heritage Coastal Park, which has been activated for the 10th consecutive year. This was yet another great event with 22 individual lighthouses out of an overall total of about 90 contacts on the weekend of August 17-18. Events Coordinator Terry Murphy VK3UP and Ian Downie VK3LA set up at the Time Ball Tower.

The Gellibrand Coastal Park location was visited by David Scott VK3FMPW, Mark Flanders VK3FMGF, Barry Robinson VK3PV,

Johnno Karr VK3FMPB, Jeff Swaby VK3HJA and Jim Linton VK3PC.

The weekend of August 30-31 had the World Digital ATV QSO Party organised and anchored through the VK3RTV digital repeater by Peter Cossins VK3BFG. It was a huge success with about 30 televising their set-ups in Australia and the USA, and exchanging messages of goodwill.

Many reports have already appeared in print and on video. The event that combines ATV and Skype originated in 2011 as a Centenary of Amateur Radio Victoria activity. Peter VK3BFG is now planning its fourth year in 2014.

### Promotion is needed

The state-wide organisation Amateur Radio Victoria is looking at the WIA initiative of the PR4AmateurRadio Expo to be held in April 2014.

Promotion is something we have done since 1911 and the proposed Expo is starting to look very promising. Although yet to be fully discussed by the Council, the idea behind having a public outreach activity to showcase amateur radio is something we need to consider.





# VK3news Geelong Amateur Radio Club

Tony Collis VK3JGC

## First two way CW contact on the new 630 metre band

On 1st January, 2013 the new 630 metre band covering 472 to 479 kHz became available to amateurs in Australia holding an Advanced licence. The ACMA limited conditions of the band use to a radiated power of not more than five watts EIRP with a maximum bandwidth of 2.1 kHz. One of the first to operate on the new band was GARC member Donald VK3IT.



Photo 1: Donald VK3IT.

The transmitter used by Donald was in fact a Wavetech audio oscillator. The output of which was fed through a Morse key into a MOSFET audio power amplifier that had been modified to improve its wide band response by removing some roll off components. The voltage gain of the amplifier was well down but it had current gain on the new band. Donald's first contact was using CW on 474 kHz.

The transmit antenna at VK3IT was a 'T' about 27 metres high with a 17 metre long single wire top load wire. The antenna was fed against an extensive radial earth mat. The antenna tuning and matching was



Photo 2: The VK3IT 630 metre coupling coil.

done with a single coil with a few turns of insulated wire coupled into it from the transmission line. The coil is about 62 years old having been originally the output tank coil in the 3CS Colac AWA transmitter. The antenna was tuned by selecting the number of turns that gave the highest antenna current.

The SWR meter indicated about four watts forward power to the antenna tuner. The antenna current was approximately one ampere. The radiation resistance of the antenna was about one  $\Omega$  therefore the radiated power was around one watt. The maximum permitted power is not specified but the maximum radiated field is specified at five watts EIRP which corresponds to about three watts radiated from a vertically polarised

antenna. In practice the efficiency of a suburban antenna will likely be only a few per cent, therefore a 100 watt transmitter may be appropriate.

The receiver used was a Ten Tec 'Omni VII' transceiver that receives

satisfactorily to below 400 kHz. The receive antenna used was a random wire. The actual first contact, just after midnight we believe, was with Drew VK3XU on CW working Grant VK3HP, on SSB. After that contact finished Drew and Donald established a two way CW contact. Signals were 579 both ways. It is believed that Drew and Donald were each radiating approximately one watt. Drew used a home brew transmitter of 100 watts into a 12 metre high inverted L antenna with about two amps of antenna current fed against earth.

The benefit of the propagation on this band is that it is long distance stable day or night ground wave propagation independent of the ionosphere and several stations have now been heard actively utilising it.



Photo 3: The VK3IT 630 metre transmitter.





Photo 4: The Point Lonsdale Lighthouse.

For future operation on the 630 metre band Donald plans to build a dedicated CW transmitter. The use of AM is compromised in quality by the current bandwidth limitation of 2.1 kHz. At some point it is hoped that someone will produce a digital codec to give good quality voice capability.

Coincidentally Drew and Donald also worked on the 30 metre band on the first morning that band became available some 31 years ago. The included photos and quite a bit of information were kindly supplied by Donald VK3IT.

### The Lighthouse weekend (ILLW) at Point Lonsdale 2013

Once again the GARC set up its antenna's close by the Point Lonsdale Lighthouse on the Saturday morning ready for the weekend activities, where they utilised VK3ATL, the club call sign.



Photo 5: The assembled GARC ILLW team at the Point Lonsdale lighthouse.

This year, during Saturday morning Les Irving-Dusting, the officer in charge of the lighthouse fog horn, was presented with a fully restored Vaughan/Weston LM6 HF transceiver, with the old AM marine channels fitted (TX disabled, of course) for the Queenscliff Maritime Museum. The LM6 was first given to the GARC, restored and then

passed on to the Museum as an example of marine radio technology in the 50s and 60s.

This Australian made (Sydney) LM6 AM transceiver was used by all types of marine craft, fishing and pleasure craft as well as RFDS and CFA during that period. Photos and information were kindly supplied by Calvin VK3ZPK.



Photo 6: The Vaughan/Weston LM6 AM transceiver.

## Participate

1-31 January 2014

11-12 January 2014

**Ross Hull Memorial VHF/UHF Contest**

**Summer VHF/UHF Field Day**



## VK2news

Tim Mills VK2ZTM  
e vk2ztm@wia.org.au

### Season's Greetings

This month we start with some news from the **Illawarra Amateur Radio Society (IARS)**, submitted by Rob VK2MT – Publicity Officer IARS.

Meeting attendance normally seems to go down when a club calls an AGM, whatever the purpose of the club! However, the recent AGM held by the IARS broke that tradition, with both a large number attending, along with many nominations for, and acceptance of, the committee positions.

With the previous committee members thanked, Returning Officer John VK2BHO set about finding takers for the Executive positions and Committee. Rob VK2XIC was elected President, with Phil VK2EMD Secretary and John VK2EJL as Treasurer. Additionally, two Vice Presidents were elected, Rob VK2MT who had been caretaker President for the past 10 months, along with Daniel VK2FDSD.

The Committee nominations were many, with six positions eventually being filled, they being Fred VK2FEDC, Bob VK2NRB, Iain VK2FDAB, Shane VK2HCO, Michael VK2MLD and Peter VK2NRL. Library, Website, Canteen and Repeater Sub-Committees were then also easily filled. It was very pleasing to see such a great interest in the running of the Club, with many ideas being floated to both increase Membership and also raise the profile of Amateur Radio in the area.

The next **Foundation course** from ARNSW will be on 18/19th January, 2014 with assessments on Sunday, 19th January. The



Photo 1: The IARS committee members for 2013/14 are: Back Row - Fred VK2FEDC, John VK2EJL, Phil VK2EMD, Rob VK2XIC, Iain VK2FDAB and Rob VK2MT. Front Row - John VK2AAL, Bob VK2NRB, Shane VK2HCO, Daniel VK2FDSD and Michael VK2MLD.

first Trash and Treasure will be on Sunday 26th January, 2014. The 2014 AGM will be on Saturday 3rd May, 2014. The Monday evening upgrade course will commence on 3rd March, 2014. VK2WI will have morning only broadcasts on December 29th and January 5th and 12th. The evening news will resume on the 19th. ARNSW is also wishing to establish a gardening group for the Dural site. Work is being undertaken to get the library working and is seeking help from members to form a working team.

The **Hunter Radio Group** celebrated their 90th anniversary last October. It started as the Newcastle and District Radio Society on 13th October, 1922 in the suburb of Hamilton. There were 70 enthusiasts in attendance under the chairmanship of Lionel Swain. In the 1950s they became the Hunter Branch of the NSW Division and then the Hunter Radio Group in the 1980's.

The **Oxley Region ARC** will have their Xmas party on Saturday 7th December at Settlement Point. On Sunday 8th the Oxley club will be manning the sausage tent at the local Bunnings. Such activity is a good way of fund raising. Westlakes ARC meet every Saturday from 11 am, have the monthly general meeting on the first Saturday and have recommenced exam assessments.

**WICEN NSW** has had a busy time with involvement in the annual search for lost aircraft VH-MDX and the Hawkesbury Canoe Classic in October.

The **Central Coast ARC** operate ATV from their Kariong site each week on the high end of 70 cm. They have readjusted some antennas to provide a signal into Woy Woy. They have recently commissioned a 23 cm voice repeater on 1273.4 MHz on the standard 20 MHz offset. No tone is required. The club is open



on Saturday from 10.30 am and Friday from 7.30 pm. Chris VK2YY conducts assessments, enquiries welcome at [vk2yychris@gmail.com](mailto:vk2yychris@gmail.com) For contact with the club go to [ccarc.org.au](http://ccarc.org.au) Remember the annual Wyong Field Day on Sunday 23rd February, 2014, rain, hail or shine.

**Waverley ARS** has a project day on the first Saturday afternoon with a working bee on Tuesday but check first via VK2ROT and if you require exams inquire via [education@vk2bv.org](mailto:education@vk2bv.org)

**Fishers Ghost ARC** cover south west Sydney with meetings on the last Wednesday night of the month. Contact via [www.fgarc.net](http://www.fgarc.net)

**St. George ARS** operated their 19th JOTA from Kurnell with over 1000 scouts and guides attending the two stations, that were operating on battery power.

The **Illawarra ARS** meet on the second Tuesday at 7.30 pm in the Coniston Community Hall in Bridge Street, Coniston. It is next door to the Bridge Theatre on one side,

with the Coniston Railway station on the other.

Several clubs continue to produce a downloadable newsletter like Westlakes each month with a 24 page edition. HADARC has QUA with six pages monthly and Oxley Region each odd numbered month with 12 pages. Remember that some clubs will not be having a January meeting and all clubs are asked to advise VK2WI News at [news@amsw.org.au](mailto:news@amsw.org.au) of their meeting arrangements for the next couple of months. 73. Tim VK2ZTM.



## VK4news QTC

Mike Charteris VK4QS  
e [mikevk4qs@gmail.com](mailto:mikevk4qs@gmail.com)

Well my friends welcome to the December issue of VK4news - QTC.

This month we have a wealth of news from many clubs, and it makes for interesting reading as to what they have been up to in recent times. I trust you will enjoy it and perhaps draw on the successes of other clubs with a view to improving your own over the next trip round the sun. Please consider asking for a volunteer from your club to write up a paragraph or so each month next year to email to me for the 'News'. I look forward to hearing from you. My email address is [mikevk4qs@gmail.com](mailto:mikevk4qs@gmail.com) I am also on QRZ.com, so all the best for now and happy days.

### News from the Bundaberg Amateur Radio Club Inc

The Bundaberg club has been busy; we may not have written much about our year but it's been a big one. We all know that natural disasters are a constant battle and while bushfires will be prominent in people's minds, for us it's been the recovery and rebuilding after

devastating January 2013 floods.

During the floods our WICEN group set up an emergency communications station in a community cut off when a tornado took out the power poles and then the flood washed away the bridge approaches. They were isolated, without power and that meant no landlines, mobiles or internet. The station managed human needs and welfare traffic for residents of five rural villages and stranded travellers and we have some great tales to tell but this wasn't what we decided to focus on.

We know we did good work and that our training and our strong repeater network came to the fore empowering our communities. The Disaster Management authorities know what we did and we're a glowing example of self-help for them but we knew there was still more work to be done.

There has been a noticeable shift in government and agency advertising encouraging people to take responsibility, make an emergency kit, have food and water on hand and so on and with this in mind we've been working with other communities to help them to 'help themselves.' We've previously trained six members of the Hervey Bay club and donated equipment to

them to establish their own WICEN group and now it was time to look to our neighbours to the north.

We did a presentation to community groups on the Baffle Creek and explained the concept of Emergency Amateur Radio; we demonstrated our new Emergency Cases but also showed them the older equipment which can be purchased cheaply. From those tentative contacts people came forward and sought training with the Club for their 'F' calls and we're proud to say that we have the seeds of WICEN groups in the Baffle Creek township and also the Winfield/Colonial Cove side of the waterway. Our testing has shown that all three of the Bundaberg club repeaters can be accessed using moderate power and very basic antennas so we're pleased with the degree of redundancy this offers them. As each contact was made they saw their isolation fade away and knowing that trained and resourceful members were listening on the 'other side' has given them a great boost.

What's next? Well we've gathered some old equipment, thanks to donations from club members and we're building some VHF/UHF cradles which are easy to

relocate as needed. We'll put these cradles into these townships as a way of kick-starting their community communications group.

So that's what Bundaberg Amateur Radio Club has been up too; we've always led the way in WICEN training although our fame might cause us grief as the Gladstone Disaster Management group are asking how far north we'd be prepared to go for demonstration and training... so it looks like we may have some road trips in our future. Anyone seeking information about our activities can check the [www.wicen-bundaberg.org.au](http://www.wicen-bundaberg.org.au) webpages.

### **News from Redcliffe & District Radio Club**

The Redcliffe & District Radio Club participated in the 2013 JOTA activities at the Murrenbong Scout Campsite, Kurwongbah, about 25 km north east of Brisbane CBD. Using the call sign VK4SMB, we were active on both 20 and 40 metres HF as well as EchoLink on nodes 44666 and 888046 and IRLP on nodes 6404 and 6403 as well as D-STAR reflector 3C. Other activities included kit building and fox hunting, which saw the scouts enjoying themselves running through the bush searching for the fox. Numbers were down on previous years, and we are now looking at some fresh ideas for next year.

**Redcliffe Tech Talks:** Every third Monday at the clubhouse. We have recently been privileged to enjoy two cracking talks, firstly from Doug VK4OE, on microwave operating and equipment. Most recently a talk was given by Richard VK4XRL on the history of amateur television in south east Queensland. Most of our tech talks are broadcast live on SEQATV groups ATV repeater VK4RMG, on 446.5 MHz DVB-T, and captured to YouTube Channels. Links to the videos are on the club website [www.redclifferadioclub.org.au](http://www.redclifferadioclub.org.au)

The interference observed on our Mount Glorious Repeater, VK4RBN, has been reduced by way of the installation of a stub on the receive

port to attenuate the nearby air band transmitter, as well as the squelch being increased. Unfortunately this may result in decreased sensitivity, and perhaps the tall will be missing for a while. EchoLink and IRLP are available via this repeater, but remember to use a star in front of the EchoLink node number. The club's six metre repeater is getting closer to being on air, and perhaps as this goes to print it will be operational on the following frequencies of 53.625 MHz, input 52.625 MHz.

Our Wednesday crowd has been helping out with the communications checks conducted by the Sunshine Coast Amateur Radio Club, with thanks to Noel VK4NL, Ken VK4FKEN and Roger VK4ZLQ. Our radio room was activated for a communications check as part of the Sunshine Coast regional council's Local Disaster Management Group plan. We plan to extend the checks to Moreton Bay Regional Council, thus increasing our EMMCOM participation, previously known as WICEN.

Finally, I wish to report that our inaugural RED-Fest was a fantastic success. We counted 80 paying customers through the gates, and saw 15 tables sold to vendors on the day. Commercial attendance was great with RF Solutions representing many manufacturers such as Bengali, Icom, and Ultra Beam. Also in attendance was Dave Tavener with VK4ICE Communications. Some wonderful raffle prizes were accepted by the lucky attendees. We are planning to do it all again next year with the addition of an Espresso coffee machine as well as bacon and egg burgers on the menu.

Cheers for now from Peter VK4EA, President, Redcliffe & District Radio Club.

### **News from RADAR, Rockhampton**

RADAR Club took part in the recent JOTA/JOTI weekend when it attended both Seonee Park and Shannon Park in Rockhampton.

Jim VK4JYM organised both JOTA and JOTI for the Boy Scouts, while Len VK4WAL and Clive VK4ACC organised JOTA for the Central Area Guides. This saw some 60 boys at Seonee Park and 36 girls at the Guides hut in Shannon Park in Rockhampton. Len installed his squid pole with HF and Clive ran the VHF/UHF side of things. The girl Guides reported that they had the best JOTA ever due to the fun that they had on the radio. Jim's XYL had the girls learning Morse code, and guess what, they really enjoyed it. We also conducted a fox hunt with a difference, with one of the Guides operating a handheld for a game of radio hide and seek, they had a ball.

### **News from The City of Brisbane Radio Club**

Ron VK4CRO reports that the club is off to the south west of Gatton for the VHF/UHF Field Day.

The members will be operational on six metres, two metres, 70 cm, 1296 MHz, 2.4 GHz and 10 GHz, so look out for them on the day and give them a shout. The club has also in recent times been active from Ron's Shed, using the club call sign VK4WIE, for the ARRL contest. The club's next operation will be at 'The Shed' on December 4th, which will see a BBQ and participation in a 48 hour contest.

### **News from the Caboolture Amateur Radio Club**

Peter VK4QC reports that the club has had a very good year indeed with the financial assistance of various 'grants'. This could indeed also be good news for other struggling radio clubs out there, and here is a bit of a rundown of how the Caboolture Club went. By way of the Gambling Community Benefit Grant, the club received the requested sum of \$13,834.82. This saw us achieve a new Kenwood TS-590 HF transceiver, a six KVA generator and a three KVA generator, two air conditioning units, two 12 volt deep cycle batteries, a 200 watt solar panel, two Diawa 35 ampere PSU's, six folding tables and 32 stackable chairs. Now this should not be seen as a brag list by any



stretch, merely a very good example of the money that is available for clubs. If your club could do with an injection of funds for all those worthy projects that would make your club a much better community organization, then perhaps your Executive could look into it.

The club has recently joined the Local Disaster Management Group, and thereby received a Motorola GM388 transceiver donated by the Sunshine Coast Amateur Radio Club. We are now participating in monthly radio checks with SARC and Coast Guard on marine VHF channels. This could eventually include SES and other organizations.

During the course of the past year the CRC successfully mentored five new amateurs to achieve their Foundation licence, which was conducted at the Redcliffe & District Radio Club. And it was all hands on deck for the recent JOTA which saw local Scouts visit the clubhouse for a day on air with many contacts being made on both the 20 and 40 metre bands. Thanks must go to Fred VK4DY for guiding the scouts through many a successful contact on the day. All up it has been a

pretty busy and successful year at the Caboolture Club. Don't forget you can pop by on our 80 metre net on Friday nights on 3.610 from 7.30 pm.

### News from the Brisbane Amateur Radio Club

Club President, Kevin VK4ZR, reports that BARC have been very busy lately with a program of fitting front panels to some Tait radios with a view to converting them to 70 cm. This process has involved most of the club members and seen a hive of activity at the clubhouse. Kevin was kind enough to give a talk to the club members on his experiments with the Tait radios. He spoke on the difference between the various models, and demonstrated his homebrew electret microphone for the transceiver.

By all accounts the membership is increasing, with many looking to undertake the Foundation licence course.

Les VK4SO has been very busy indeed conducting at least five radio exams lately, and all with good results. The club undertook JOTA at the clubhouse/Scout Den on October 19th last. Many thanks to Bill VK4TWS for setting up his slow

scan equipment, both analogue and digital, to demonstrate to any Scouts who dropped by on the day. He also brought along his HF transceiver to use on the club's three element tri-band antenna. It was a success with lots of contacts made with other Scout groups over the course of the day. The scouts and younger members of the clubs really enjoyed the day.

And finally don't forget if you would like to join the BARC members on air, their HF net frequency and time is as follows, 28.450 MHz +/- on Monday night from 8.00 pm Queensland time.

Well that's it for the year 2013 my friends. I would like to take this opportunity to wish you all a safe and happy Festive Season with your loved ones. I would also like to heartily thank all those clubs and individuals who have contributed to VK4news QTC since I have taken the helm. I would especially like to thank Ernie VK3FM for his patience and guidance in assisting me with undertaking this new role. I look forward to working with you in 2014 to promote your radio club.

Cheers from Mike Charteris  
VK4QS.



## VK6news

Keith Bainbridge VK6RK

vk6rk@wia.org.au

Welcome to the Xmas and New Year edition of VK6news.

I'd like to take this opportunity to wish all amateurs, their families and friends the very best Season's Greetings. I hope you all have a wonderful, relaxing and above all safe time over the festive period.

To business!

First off the rank today is **PARG**, the Peel Amateur Radio Group, from Paul VK6LL.

The Peel Amateur Radio Group (PARG) did JOTA/JOTI in Mandurah on Saturday 19th October. Since 1994, PARG has been running a JOTA/JOTI station in the Mandurah

and Rockingham area in Western Australia, presenting amateur radio in all its forms to the Scouting and Guide community. The event was once again co-ordinated by Paul VK6LL, on behalf of the WA Scout Communications Team.

This year we set up our mobile communications unit and 12 metre mast at the Mandurah Scout Hall where we operated on 20 metres. We also set-up a VHF radio which was linked via simplex to the EchoLink node of Martin VK6MJ, situated at his QTH, a couple of clicks up the road. The Scout Hall has a large open area where

computers were set-up, thanks to Scout Leader Matthew from the Rockingham Scout Group. The computers were each linked into the Scouting IRC network and made it possible to talk via the net to Scouts around the planet. Rex VK6SN and Clive VK6TN operated several Morse keys.

Many Peel district Scouts and Guides came through on the day. We had a total of 50 youth and adults, enjoying QSOs on HF with stations in VK3 and VK2, the latter QSO (with VK2LE) lasting more than three hours, thanks to Greg VK2GSB and Ken VK2BBQ.

Memorable QSOs included a seven year old Cub Scout, Olivia, who was thrilled to spend 20 minutes talking to Scouts in VK2.

For many visitors, this was their first exposure to amateur radio and several look to be hooked for life. 73 from Paul Gardner VK6LL.

Thank you Paul, it sounds as though a fun time was had by all.

Next we hear from Heath VK6TWO on SOTA activity in VK6.

Assessment and cataloguing of the VK6 summits is well under way in VK6. 2014 should see many VK6ers activating for the first time, and liven up VK-wide activators/ chasers and S2S (summit to summit) contacts.

Given the typical distances and time zones across VK, many SOTA stations will be inclined to use the less common bands such as 30 m/17 m/15 m/12 m for east-west contacts. Details will be announced on the WAHAMS Google group, and on NewsWest broadcasts shortly.

Thanks Heath, I'm glad SOTA is at last taking off in WA, I have many G friends who enjoy it immensely.

Now our monthly dose of news from the Hills, HARG have been busy again.

The October General Meeting at HARG saw a talk by Heath VK6TWO on using Android devices for amateur radio. The demonstration covered various sized and priced Android devices, as well as some of the many apps specifically for amateur radio. These included apps for Tx/Rx of CW/RTTY/SSTV/PSK, APRS, satellites, HF Propagation, EchoLink, SOTA and many more. More detailed demonstrations included Bluetooth remote rig control, and a remote Bluetooth antenna analyser (VNA). Follow-up information can be found on the HARG website [harg.org.au](http://harg.org.au)

At the November Social Meeting Rob VK6LD gave us a talk on Fox Hunting techniques and equipment and at the November General Meeting Heath VK6TWO covered Summits on The Air (SOTA). In

particular we had a demonstration of a typical SOTA hilltop set-up, other popular setups, and many of the SOTA activation guidelines.

Our December Christmas Barbecue will be held on Saturday 14th December at 1.00 pm at the club rooms, at the corner of Sanderson and Brady Roads, Lesmurdie. All are welcome and if anyone wants to call by our shack on the day they are welcome to use our special event callsign V16WA100 to celebrate 100 years of amateur radio in Western Australia.

Merry Christmas and a Happy New Year to everyone from HARG.

I'd like to personally congratulate all those from VK6 who took part in the RD Contest this year and made VK6 the winning state once again, and no, it never gets monotonous being the winner!

On the subject of winning the NCRG recently received the pictured certificate for winning, again, the CQ WPX contest for multi single operation in Australia and second overall in Oceania; we have to beat those Hawaiians one day! This contest and CQWW SSB are always targeted by the club and almost always result in a win in our class. A massive effort was made in CQWW SSB at the end of October and looking at the score of almost 6 million points it's to be hoped the club has won that one yet again. Major upgrades to the station are in progress at present, including a stack of three six element beams on 15 metres, which should be a pile up breaker!



The regular 'Business' meeting of the NCRG on 22nd October saw a visit from David Cutter G3UNA. David was a member of the T32C DXpedition to East Kiribati Island, IOTA OC-024 in September/October 2011.

David, a member of the Five Star DXers Association, who was holidaying in Perth at the time, offered to do a video presentation to members at our normal meeting night and was warmly welcomed.

The DXpedition lasted some four weeks during which time they broke several world records including at total of 213,169 QSOs of which 103,216 were in CW mode. David outlined the huge amount of organization involved in planning such an event, especially when the equipment container didn't get there and expedition members had to improvise with their own and borrowed gear! It was a most entertaining presentation and David left a DVD of the whole event for members to watch.

Thanks David, hope to 'CUAGN.'

The club also held a Car Boot sale on Sunday 3rd November which is in three days' time as I write this! With the temperature forecast to be 36 degrees I hope I didn't cook! More on the outcome of the sale at a later date.

The NCRG will be having our usual Xmas party at the Brook Tavern in Ellenbrook, just down the road from the clubhouse; it's always a good feed (and drink).

Well that's it for this month.

Again, I hope you all have a great festive season and that we see you and your group's contributions next year!

73.

Keith VK6RK.

The VK6NC certificate for 7<sup>th</sup> place VK in the CQ WPX SSB Multi-Single division in 2013.



Richard Nixon VK4FRIK

Hi everyone, the CQARA has recently had a couple of very busy months. There is a lot going on at the moment.

We have finally finished our 439.900 repeater out at Bouldacombe. It is in its final spot approximately 230 metres above sea level. Thanks to our regular Weasel Park HQ Wednesday workers, Jack VK4JRC, Ray VK4HOT, Graham VK4NFZ, Shaun VK4NSP, Mick VK4NHX, Merv VK4DV and Frank VK4FLR who has been in charge of the Sun and all things powered from it. *(Can you turn down the Sun a little please Frank)*. We have been testing our EchoLink Node (9003) with a lot of success and receiving good feedback from users. We are also testing a six metre simplex repeater on 52.125 MHz at the moment with various levels of success. We are looking at the possibility of a two metre repeater in the near future that could be linked with one or more of the local repeaters.

On the 5th of September, the CQARA held another Sunday social



Photo 1: The Weasel Park HQ crew, from left – Shaun VK4NSP, Bob VK4HRC, Ray VK4HOT, Frank VK4FLR, Brian VK4MBG, Merv VK4DV, Graham VK4NFZ, Adon *(no callsign - yet!)* with Jack VK4JRC behind the camera.

day down at Yeppoon. We had a great roll up of members and their families. We had more than 30 people turn up which was fantastic. It was organized at fairly short notice, and it was amazing to see so many people turn up and enjoy themselves. Thanks again to all those who had a hand in organizing a great relaxing day.

On the weekend of the 5th of October, one of our club members put out a call for the possibility of members getting involved in the Oceania DX Contest. A credit to several of the members, it was organised for several members to attend our Weasel Park HQ to spend the night competing in the contest. Four members turned up to compete with approximately 110 contacts made on and off throughout the night.

Every Friday around 9.00 am we have a gathering of any available club members at the retirement village (Village Life2) of one of our members, Les VK4QI. Tea and coffee is supplied for a small donation, and it is bring your own biscuits or the like – a great opportunity for a catch up.

Every weekday morning around 7.30 am, we have a group gather on 7.095 to have a bit of a chin wag. Depending on conditions, we normally get between five and 10 people who regularly call in.

We are glad to report that several of our members managed to attend the ILLW weekend in August of this

year. A great weekend was had by all. A lot of crab was eaten during this weekend. It was held at the Sea Hill Lighthouse on Curtis Island near Gladstone. AU0060. Five members Jack VK4JRC, Ray VK4HOT, Graham VK4NFZ, Jason VK4FJGS and myself Richard VK4FRIK attended and a great weekend was had.

Recently we have had a number of out of town amateurs ask about becoming a part of our club, which we are very excited about. We are now looking at updating our website – [www.cqara.org.au](http://www.cqara.org.au) to include a membership form that can be printed off and sent to our post box or emailed back to us. We are also looking at adding some banking information so that those who wish to pay by way of electronic transfer will be able to be accommodated.

Please check out our webpage which is being updated constantly for new videos, pictures and club information. All our contact details are there as well. I hope to speak to you on the air soon.

73 Richard VK4FRIK.



Photo 2: The CQARA 70 cm repeater mast and antenna at Bouldacombe, near Rockhampton. Output is 30 watts. EchoLink Node 9003.



Photo 3: Inside the fully insulated shed are the 'internals' of the CQARA 70 cm repeater. The solar panels produce 400 watts to power the site.





## VK7news

Justin Giles-Clark VK7TW

e vk7tw@wia.org.au

w groups.yahoo.com/group/vk7regionalnews/

### Sewing Circle Net - Frequency Change

Have you gone to 3.59 MHz at 5 pm each night and wondered where the Sewing Circle was? Well during daylight savings the Sewing Circle Net is trialling 7.105 MHz LSB ± QRM if 3.59 proves to be unusable. See you there!

### Equine endurance events

In recent years there has been a rise in the use of radio equipment for equine endurance events throughout VK7. In the last few months of the year there are no less than four for which WICEN and VK7 clubs members have provided safety checkpoints.

The Burnie Equine Endurance Riders (BEER) ride was held at Sassafras on Saturday 5 October and contained 80, 40 and 20 km rides. Three checkpoints and a base station were operated by a crew of six Cradle Coast ARC members.

The competitors and organisers were grateful of the service that was delivered seamlessly and thanks to David VK7DC for the information.

The WICEN Tasmania (South) crew with Geoff VK7GW helped out with the Portland Endurance Riders 80, 40 and 20 km events at Pyengana on 19 October. The base station was set up in the Pyengana Community Hall and radio checks performed the day before. The weather on the day was perfect! Only two horses were vetted out and one rider lost the track. Organizers were notified and the rider and horse were located shortly after and floated out. Thanks to Cedric VK7CL for this information.

### Repeater and beacon news

Rick VK7RI let me know that a new transmitting antenna has been installed on the VK7RMD two metre repeater at Mt Duncan which is located in the Dial Range

behind Penguin in north west VK7. The coverage and performance in comparison with the existing antenna has certainly improved. Thanks to VK7DB, VK7VHF and VK7RI.

### Flinders Island Amateur Radio Club

Thanks to Peter VK7PD for the following report. A dinner meeting of the FIARC was held on 18 October at the Furneaux Tavern with six members present including two guests and four apologies and was presided over by Kerry VK7FKEK. The aim of FIARC is to promote amateur radio in the region, particularly through IOTA and providing practical support for those members who are permanent residents of the island. Many participants are also members of NTARC.

As an example, repairs to VK7KPB's G5RV antenna were high on the action points of the meeting along with a two metre antenna for VK7FKEK. Flinders Island is a popular IOTA location using the club's call sign VK7FLI and VK7AN reported a number of IOTA contacts during the visit.

### Cradle Coast Amateur Radio Club

CCARC members VK7DB, VK7NWT, VK7FLSB, VK7FKEV, VK7DC and VK7RI were involved in providing JOTA/JOTI for Joeys, Cubs and Scouts in Burnie. Contacts were made on HF, EchoLink, local repeaters and via Scout Link. About 30 kids from across the Hellyer district went through the station during the day. Thanks to all involved.



Photo 1: A competitor in the Portland Endurance Riders event – the smile says it all! Photo courtesy of Jessica Sweeney.



There have been some committee changes within CCARC resulting in the following committee composition: President – Rick Polden VK7RI, Vice President – Eric Edwards VK7EK, Treasurer – Dick Whatley VK7LDK, Secretary – Dick Van Beek VK7DIK and Committee Person – Dave Cleland VK7DC. The club and committee would like to thank David VK7EX for his service and contribution to the club.

### North West Tasmanian Amateur Television Group

Tony VK7AX lets us know that his Packet - JNOS Gateway and BBS is up and going and provision has been made for users of the system to have their own email address, whereby personal packet mail and email can be picked up or delivered externally by use of the POP3 and an SMTP server. If interested then contact Tony at email [vk7ax@vk7ax.id.au](mailto:vk7ax@vk7ax.id.au)

NWTATVG operators Ross VK7WP, Graham VK7NGA, Stephen VK7LA and Tony VK7AX set up at Paton Park Ulverstone to operate JOTA station VK7SDL. Operation was on HF, six metre and two metre repeaters and VOIP modes. Thanks to all involved for another

successful JOTA operation.

### Northern Tasmania Amateur Radio Club

Congratulation to Andrew VK7AAB on receiving his advanced licence, welcome to the bands and we look forward to hearing you on air! The NTARC October meeting was a BBQ social event held in the freshly painted and carpeted new clubrooms in Archer St, Rocherlea in Launceston and had over 30 people attend. Thanks to Don VK7DON for the painting and Frank VK7BC for the donation of carpet for the training room.

NTARC operated JOTA from the clubrooms using HF, VHF, UHF and EchoLink. Tony VK7YBG brought along his Yaesu FT-897 mounted in a Korean War vintage Dodge M37 military truck and Lewis VK7FLPL provided a display of vintage CW keys. Peter VK7KPC also had running on his laptop a display of live APRS linked to Google Street View. Over the weekend of JOTA there were 39 Joeys, Cubs, Scouts and Guides, 19 leaders and eight parents go through the club rooms. Thanks to Kevin VK7HKN, Steve VK7BI, Idris VK7ZIR, Peter VK7KPC,

Tony VK7YBG, Bill VK7MX, Yvonne VK7FYM, Ann VK7FYBG, Andre VK7ZAB, new member Bernie and Kay, XYL of VK7KPC. The event also saw the first use of the club's callsign VK7TAZ on the club station. Thanks to all involved.

### Radio and Electronics Association of Southern Tasmania

REAST's October event was a visit to Tasmanian lightning and surge protection company Novaris. This company is run by Phil Tompson VK7SS who gave a great presentation on the fundamentals of lightning protection and what can be done to reduce the damage that a strike can cause. The average lightning strike current is 30,000 amps flowing for around 10 microseconds of the strike. This creates some significant high frequency effects and means that the inductance in the conductors conducting the current can be very significant and this was demonstrated by Phil.

Phil and Bob Reid VK7RF then gave a demonstration on measuring Electro Magnetic Radiation (EMR) which the company undertakes periodically. The demonstration showed the energy exposure level radiated by an amateur handheld and the level decreasing quickly with distance. Phil then gave the group a tour of the manufacturing facility and the high voltage surge generator. Phil demonstrated the power of the magnetic field created by 20,000 amps momentarily through a coil with an aluminium can in the coil. The can was cut in half in an instant! Thanks to Phil, Bob and Phil's XYL for a great presentation and supper.



Photo 2: Phil Tompson VK7SS, Managing Director – Novaris. Photo courtesy of VK7TW.

# Hamads

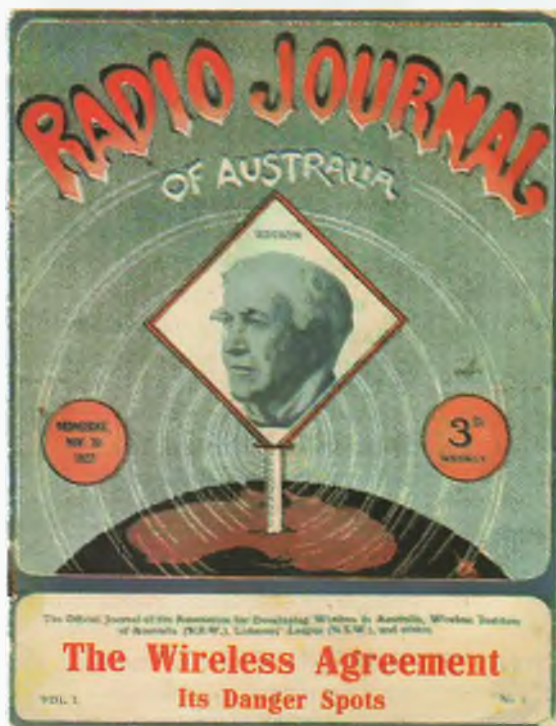

## WANTED – NATIONAL

Copies of Radio Journal of Australia magazine

The WIA Archive is seeking copies of the Radio Journal of Australia for copying and/or adding to the WIA Archive's shelves.

Little is known about this magazine. The WIA holds one copy only. Volume 1, Number 2 published on 30th November 1927 which contains 64 pages. The magazine claims to be the Official Organ of the Association for Developing Wireless in Australia, the Listeners' League (N.S.W.) and of importance to us, the Wireless Institute of Australia (N.S.W.).

The magazine contains articles of general radio interest, a comprehensive weekly radio guide for stations in N.S.W., S.A. Qld. and Vic. and some notes from the WIA, NSW Division. It was published in Sydney, presumably commencing on 23rd November 1927.

It is of interest to note that the magazine's Editor was George A. Taylor, the person responsible for calling the first meeting of Sydney wireless experimenters in March 1910 from

which the WIA grew. Taylor was never known to be a member of the WIA, rather he returned to his interests in aviation and defence. Later he went on to form the Association for Developing Wireless in Australia, an organisation predominately representing those involved in commercial broadcasting.

There is little doubt that Australia had a colourful and heady start to those early days of radio communication and broadcasting - in all of its forms and magazines such as this provide a glimpse of that exciting pioneering time past!

Please contact WIA Historian, Peter VK3RV via email [vk3rv@wia.org.au](mailto:vk3rv@wia.org.au) or c/o the National Office

in Bayswater if you can help us locate copies of this magazine.

## FOR SALE – VIC

Diamond X200 two metre/70 cm ground plane antenna, as new, been in storage for last three years, \$150.

HyGain 80 metre resonator, cheap way to get on 80, \$40.

Rak two metre 5/8 mobile whip, \$20.

Inversion health table for back strengthening, brand new, never used, 150kg rating, \$70.

Contact Stan Korczynski VK3BNJ 03 9743 6708 anytime.

Magnum 1012 five watt 12/10 m AM/SSB/FM HH transceiver, with repeater offset capability. Includes 10 x 1700 mAh NiMH batteries, hardly used. \$150.00.

Wouxun KGUVDIP top of the range 2 m/70 cm five watt transceiver, \$95.00.

GME TX670 40 channel UHF 477 MHz transceiver, last year's Xmas present but never used. Two watt output. \$80.00.

Contact Stan VK3BNJ, on 03 9743 6708.

Three mast sections, each being three metres in length. These are commercially made, hot dipped galvanised. They are of triangular (300 mm) construction that includes steps and brackets for attaching guy wires, as well as three sets of HTS guy wires.

A bottom hinged base that can be used for lowering the mast using a gin pole. Note that this base is not galvanised. \$300 the lot, and buyer collects.

Contact Eric Christer VK3EAC on [echrister@bigpond.com](mailto:echrister@bigpond.com) or text 04 2474 4563.

## FREE – VIC

First in first served. Back copies of *Amateur Radio*, including most issues from 2001 to 2011 inclusive. Free.

Contact Laurie VK3BV on [shirlau@netbay.com.au](mailto:shirlau@netbay.com.au) for replies.

## WANTED – NSW

Antenna tower. I am looking for an antenna tower at least 15 metres in height that is not used and currently unwanted and is in need of a new home. Reasonable offers considered under \$1,000.

If interested please send photos by email to me at [ibutcher59@optusnet.com.au](mailto:ibutcher59@optusnet.com.au) Thank-you, John VK2HA.

## FOR SALE – SA

The VK5JST Aerial Analyser (AR May 2006). Over 10,000 built, and still available from the Adelaide Hills Amateur Radio Society. For full details see [www.ahars.com.au](http://www.ahars.com.au)

## WANTED – SA

An R-25/ARC-5 or CBY-46104 'Command' series receiver covering 1.5 MHz (Mc/s) to 3 MHz (Mc/s) or parts such as the RF coil pack, 705 kHz IF transformers, BFO coil, calibrated dial etc to suit this model, please.

Contact Andy VK5AAQ QTHR or email [vk5aaq@wia.org.au](mailto:vk5aaq@wia.org.au)





## Contributions to Amateur Radio

AR is a forum for WIA members' amateur radio experiments, experiences, opinions and news.

Your contribution and feedback is welcomed.

Guidelines for contributors can be found in the AR section of the WIA website, at <http://www.wia.org.au/members/armag/contributing/>

Email the Editor:  
[editor@wia.org.au](mailto:editor@wia.org.au)

## About Hamads

- Submit by email (MUCH PREFERRED) or if written and mailed please print carefully and clearly, use upper AND lower case.
- Deceased estates Hamads will be published in full, even if some items are not radio equipment.
- WIA policy recommends that the serial number of all equipment for sale should be included.
- QTHR means the address is correct in the current WIA Call Book.
- Ordinary Hamads from those who are deemed to be in general electronics retail and wholesale distributive trades should be certified as referring only to private articles not being re-sold for merchandising purposes.
- Commercial advertising on these pages Contact [admanager@wia.org.au](mailto:admanager@wia.org.au)
- Copy to be received by the deadlines on page 1 of each issue of Amateur Radio.
- Separate forms for For Sale and Wanted items. Include name, address STD telephone number and WIA membership number.

'Hamads'  
PO Box 2042  
BAYSWATER VIC 3153  
[hamads@wia.org.au](mailto:hamads@wia.org.au)

## AMIDON FERROMAGNETIC CORES



tts systems

Phone 03 5977 4808. Fax 03 5977 4801  
[info@ttssystem.com.au](mailto:info@ttssystem.com.au)

## VKHAM.COM

AUSTRALIAN AMATEUR RADIO  
Hundreds of pages and links  
related to Amateur Radio  
and radio in general

- HOME OF
- VK Classifieds
  - VK Auctions
  - VKs on the Internet

Repeater Maps, Software, Prefix Maps and more...

## RM Products Italy

are now available in Australia after the appointment of

Hamak Electrical Industries Pty Ltd

as distributor for RM products  
Visit the Hamak website at

**[Hamak.com.au](http://Hamak.com.au)**  
for

**Linear amplifiers,  
Power supplies  
and accessories**



## JACKSON BROS

[www.jacksonbrothers.com.au](http://www.jacksonbrothers.com.au)

Highest quality products made by UK craftsmen  
Variable and trimmer  
capacitors, reduction drives,  
dials, ceramic standoffs



CATALOGUES, PRICE LISTS AVAILABLE

## HAMMOND ENCLOSURES



HAMMOND MANUFACTURING... Large range of quality electronic enclosures for the discerning Radio Amateur.  
Diecast, extruded aluminium and plastic enclosures and instrument cases. As seen in many AFRL projects.



Cookson Controls CHARLES I COOKSON PTY LTD

11-13 Port Rd Queenstown SA 5014  
Tel: (08) 8240 3200 Fax: (08) 8240 3233  
[sales@jacksonbrothers.com.au](mailto:sales@jacksonbrothers.com.au)  
[ccoakson@hammfg.com](mailto:ccoakson@hammfg.com)  
ALL MAJOR CREDIT CARDS ACCEPTED  
SOLE AGENTS AUSTRALIA AND NEW ZEALAND



## Suppliers of Aluminium Tube

1/4 to 1 1/8 inch drawn  
28 mm to 68 mm telescopic  
NBS Tilt Over Masts meet new  
NSW and 9 Australian standards

Antenna height from 3 m to 12 m  
for easy adjustments and tuning  
Antenna Parts and Accessories

Phone 0402 930 581  
[brian@nbsantennas.com.au](mailto:brian@nbsantennas.com.au)

## Studying for the Standard or the Advanced Licence?



Here are 4  
books that  
will get you  
there.

TAKE A LOOK AT  
[www.gscott.com.au](http://www.gscott.com.au)

for more information  
and order form.

PO Box 385, Albury NSW 2640

## ADVERTISERS INDEX

Cookson (Jackson Bros)	63
Hamak Electrical Industries	63
Icom	BC
InnoVAntennas	40
Jaycar	7
NBS Antennas	13
Outbacker	17
TET-Emtron	9
TTS	11, 63
Yaesu	IFC

## TRADE PRACTICES ACT

It is impossible for us to ensure that the advertisements submitted for publication comply with the Trade Practices Act 1974. Therefore, advertisers will appreciate the absolute need for themselves to ensure that the provisions of the Act are strictly complied with.

## VICTORIAN CONSUMER AFFAIRS ACT

Advertisements with only a PO Box number address cannot be accepted without the addition of the business address of the box-holder or seller of the goods.

# Directory

## National Office

Unit 20, 11-13 Havelock Road  
PO Box 2042 BAYSWATER VIC 3153

Contact 10 am to 4 pm weekdays  
Phone **03 9729 0400** Fax **03 9729 7325**  
nationaloffice@wia.org.au  
http://www.wia.org.au



## The Amateur Service

... a radio communications service for the purpose of self training, intercommunication and technical investigation carried out by amateurs, that is, by duly authorised persons interested in radio technique with a personal aim and without any pecuniary interest.

56 ITU Radio Regulations

## Advisory Committees

### New South Wales/ACT Advisory Committee

Email: vk2advisory@wia.org.au

- \* John Bishop VK2BK
- Dominic Dahl VK2YDD
- \* Timothy Mills VK2ZTM / VK2UJ
- Gilbert Hughes VK1GH

### Victorian Advisory Committee

Email: vk3advisory@wia.org.au

- \* Bob Tait VK3XP
- Luke Steele VK3HJ
- Noel Ferguson VK3FGN
- Chris Chapman VK3QB

### Queensland Advisory Committee

Email: vk4advisory@wia.org.au

- Don Wilschefski VK4BY
- Kevin Johnston VK4UH
- \* Michael Charteris VK4QS
- Alan Shannon VK4SN

### South Australian Advisory Committee

Email: vk5advisory@wia.org.au

- \* David Clegg VK5KC
- \* Peter Reichelt VK5APR
- Ben Broadbent VK5BB
- Trevor Quick VK5ATQ

### Western Australian Advisory Committee

Email: vk6advisory@wia.org.au

- \* Heath Walder VK6TWO
- \* Craig Lamb VK6FLAM

### Tasmanian Advisory Committee

Email: vk7advisory@wia.org.au

- Clayton Reading VK7ZOR
- \* Justin Giles-Clark VK7TW
- Peter Rumble VK7IY

### Northern Territory Advisory Committee

Email: vk8advisory@wia.org.au

- \* Peter Blackadder VK8HPB
- Garry Woods VK8GW
- \* Alan Baker VK8AB
- Mark Sellers VK8MS

\*Denotes Committee Chairman

\*Denotes nominated by the WIA Board  
("Nominated Member")

## Over to you

### Windows 64 bit woes

In recent years many of our Australian amateurs have been buying computers with 64 bit versions of Windows. This is a very different operating system internally and it brings with it some problems when you try to run 32 bit programs. Observed problems include files being saved in places other than the programmer intended resulting in a file being hard to find and appearing lost, program locking or generally unstable operation. Occasionally a program will just fail to run. What makes it especially frustrating for all of us is that one Windows 64 bit machine may run a program satisfactorily while another has problems. For example my RD Logger works fine on my 64 bit Win 7 laptop but will misplace files on some users' machines. Doug VK3UM has had a report of Win 64 bit problems with his EMR Calculator but others find it runs

fine. This makes it very difficult for us as programmers, and for you as users.

Most amateur software is produced for the 32 bit market. Software writers in the amateur world are often amateurs in the field of computing too. We have limited budgets to spend on the compilers that convert our source code into a program a computer can understand. Many of you may not be aware that 64 bit compilers can cost thousands of dollars whereas a quality 32 bit compiler may still cost hundreds of dollars. Most of us give our programs away as something we do for our fellow amateurs so we need to justify our expenses in a household budget.

So what can you do about it? Firstly you need to know what version of Windows you are using. This can be done by opening Control Panel and then System. A screen will show your Windows Version.

If you use a 64 bit machine, and if you think the program may be 32 bit, consider running the program in 32 bit compatibility mode. To do this, right click on the desktop shortcut for the program. Click on Properties, then on the Compatibility Tab. Next tick the box 'Run in compatibility mode' and select the Windows XP Service Pack 3. Click Apply and Close. A 32 bit program will now probably behave itself on your 64 bit platform. I say 'probably' because as much as we might wish otherwise in the computing world nothing is certain.

On my part, future programs will detect if you are running 64 bit Windows and put a warning on screen. The warning will disappear once compatibility mode is set. As programmers we appreciate friendly feedback and we do our best to make our software useful to you.

John Drew VK5DJ



# WIA **2014** Callbook

**Available now**



Wireless Institute of Australia

## 2014 Callbook



Includes **Searchable CD** containing:  
The complete 2014 Australian Callbook  
Amateur Radio Magazine 2012 editions,  
Repeater and Beacon Listings  
Vision Impaired Version



**Order  
early for  
Christmas!**

[www.wia.org.au/members/bookshop/about/](http://www.wia.org.au/members/bookshop/about/)

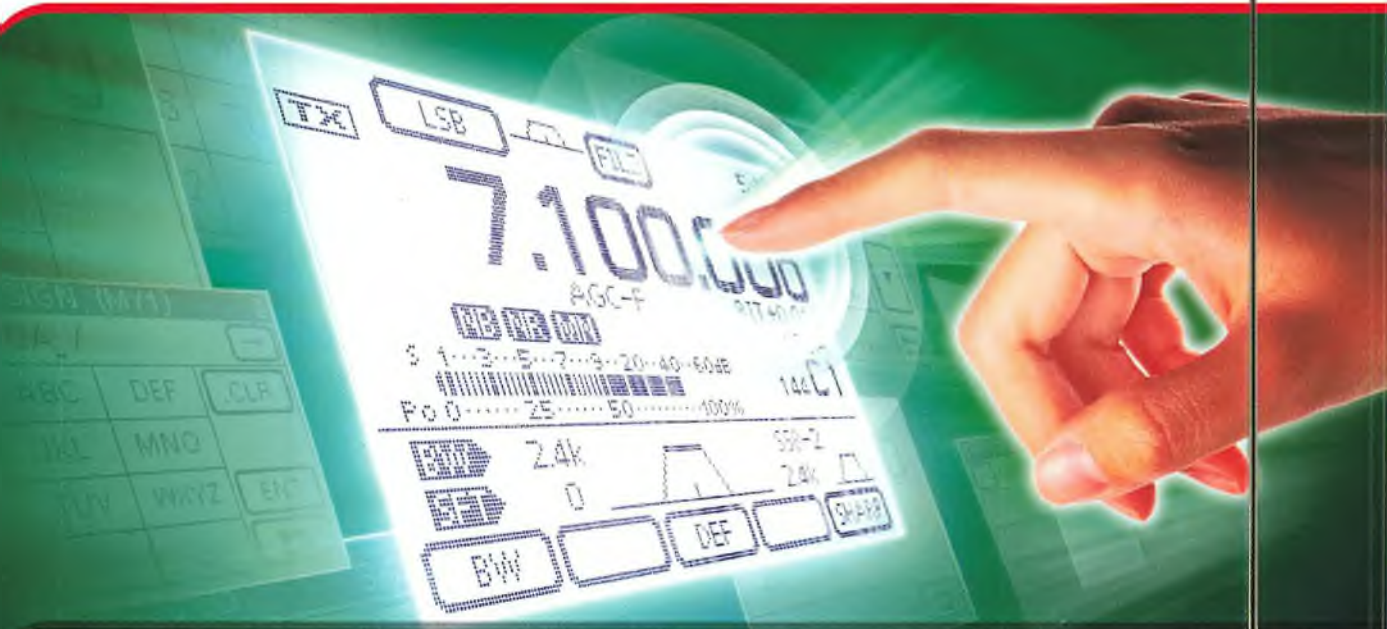

# A touch of class

## IC-7100

Introducing the new IC-7100 multi-mode amateur transceiver.

Featuring an intuitive remote head touch screen display, D-STAR DV mode communication and intelligent auto-tuning operation with the optional AH-740 antenna.



## AH-740

HF Antenna

## D-STAR

To find out more about our latest products,  
call Icom on 03 9549 7500 or visit [www.icom.net.au](http://www.icom.net.au)