

# Amateur Radio

Volume 83  
Number 7  
July 2015  
Price: \$9.70 incl GST  
[www.wia.org.au](http://www.wia.org.au)



## A loop antenna in action

Compact and effective



- ▶ The Peryton story
- ▶ Arduino antenna rotator
- ▶ Snow VK3MR: POW

ISSN 0002-6859



770002 685062



# FT2DR

144/430 MHz DUAL BAND DIGITAL TRANSCEIVER

## Advanced C4FM Technology Opens up New Vistas for Amateur Radio

- C4FM Digital with FM Friendly AMS
- Advanced Touch Panel Operation
- Huge 43.2 × 43.2mm Full-dot Matrix Display
- Snapshot Image Display
- Simultaneous C4FM/C4FM standby
- New Digital Features



**C4FM**  
DIGITAL CLEAR VOICE  
Clear and Crisp Voice Technology

**AMS**  
Automatic Mode Select

**WIRES-X**

**YAESU**  
The radio

### YAESU Authorized Dealer

Andrews Communications Systems  
Shop 8, 41-51 Bathurst Street, Greystanes NSW 2145  
URL : [www.andrewscom.com.au](http://www.andrewscom.com.au)  
Tel: +61-2-9636-9060

### YAESU Authorized Service Center

Andrews Communications Systems  
Shop 8, 41-51 Bathurst Street, Greystanes NSW 2145  
Tel: +61-2-9636-9060, Fax: +61-2-9686-1995  
E-mail: [radioandrews@hotmail.com](mailto:radioandrews@hotmail.com)

Strictly HAM Pty. Ltd.  
Shop 12B Church Street Bayswater Vic. 3153  
URL : [www.strictlyham.com.au](http://www.strictlyham.com.au)  
Tel: +61-3-9729-7656

JNB Electronics Pty Ltd  
347 Settlement Rd, Thomastown Victoria 3074  
Tel: +61-3-9465-9399, Fax: +61-3-8682-6746  
E-mail: [yaesu@jnb.com.au](mailto:yaesu@jnb.com.au)





# Amateur Radio

The Journal of the Wireless Institute of Australia

Volume 83  
Number 7  
July 2015  
ISSN 0002-6859

## Editorial

### Editor

Peter Freeman VK3PF  
editor@wia.org.au

### Technical Editor

Peter Gibson VK3AZL

### Publications Committee

Peter Hartfield VK3PH  
Evan Jarman VK3ANI  
Ewen Templeton VK3OW  
Kaye Wright VK3FKDW

### All circulation matters

nationaloffice@wia.org.au

### How to submit material

Secretary  
AR Publications Committee  
PO Box 2042  
BAYSWATER VIC 3153  
or armag@wia.org.au

### Letters to Editor

Editor AR Magazine  
PO Box 273  
Churchill Vic 3842  
or editor@wia.org.au

### Hamads

'Hamads'  
PO Box 2042  
BAYSWATER VIC 3153  
hamads@wia.org.au

### Advertising

All enquiries to  
Advertising Manager  
AR Publications Committee  
PO Box 2042  
BAYSWATER VIC 3153  
or admanager@wia.org.au

### Registered Office

Unit 20 11-13 Havelock Road  
BAYSWATER VIC 3153  
Australia  
Phone: 03 9729 0400  
Fax: 03 9729 7325

### Production Deadlines

All articles, columns, hamads and advertising booking by **first day of previous month**.

The contents of Amateur Radio are Copyright  
Wireless Institute of Australia © 2015

## Technical

**Perytons: A case of UHF-SHF interference** 6

Peter Ellis VK1PE

**Arduino based antenna rotator controller** 10

Dale Hughes VK1DSH

**Mount Duncan Repeater VK7RMD site upgrade** 23

David Cleland VK7DC



### This month's cover

Lee VK6TY operating 10 watts portable south of Wagin on the regular afternoon 40 metre sked with Brian VK6LO in Gidgegannup and trying a new magnetic loop made by Geoff VK6YR with excellent copy both ways despite an approaching thunder storm. Photo courtesy of Geoff Griffiths VK6YR.

## General

**"Snow" Campbell VK3MR, International DXer, Prisoner Of War** 16

Peter Wolfenden VK3RV

**Jamboree of the Air 2014 at the Rochedale Scout Den and BARC** 18

Les Neilson VK4FAEB

**SOTA on Black Mountain** 19

Monique Faulkner VK6FMON

**Results John Moyle Memorial Field Day 2015** 33

Denis Johnstone VK4AE/VK3ZUX

**Results from the Easter Urunga Radio Convention 2015** 57

Ken Golden VK2DGT

## Columns

ALARA	44
Contests	31
DX Talk	28
Editorial	2
Hamads	62
Silent Key	53, 56
SOTA News	21
Spotlight On SWLING	30
VHF/UHF – An Expanding World	39
WIA Comment	3, 5
WIA News	4, 5
VK2 News	46
VK3 News	47, 49, 51
VK5 News	43
VK6 News	59
VK7 News	54

## Contributions to Amateur Radio



Amateur Radio is a forum for WIA members' amateur radio experiments, experiences, opinions and news. Manuscripts with drawings and/or photos are welcome and will be considered for publication. Articles attached to email are especially welcome. The

WIA cannot be responsible for loss or damage to any material. Information on house style is available from the Editor.

### Back issues

Back issues are available directly from the WIA National Office (until stocks are exhausted), at \$8.00 each (including postage within Australia) to members.

### Photostat copies

If back issues are unavailable, photocopies of articles are available to members at \$2.50 each (plus an additional \$2 for each additional issue in which the article appears).

### Disclaimer

The opinions expressed in this publication do not necessarily reflect the official view of the WIA and the WIA cannot be held responsible for incorrect information published.

## Amateur Radio Service

A radiocommunication service for the purpose of self-training, intercommunication and technical investigations carried out by amateurs; that is, by duly authorised persons interested in radio technique solely with a personal aim and without pecuniary interest.

### Wireless Institute of Australia

ABN 56 004 920 745

The world's oldest  
National Radio Society, founded 1910.

Representing

*The Australian Amateur Radio Service*

*Member of the International Amateur Radio Union*

#### Registered Office of the WIA

Andersson House

Unit 20, 11 Havelock Road

Bayswater, Victoria, 3153

Tel: (03) 9729 0400 Fax (03) 9729 7325

email: [nationaloffice@wia.org.au](mailto:nationaloffice@wia.org.au)

<http://www.wia.org.au>

All mail to

**PO Box 2042 BAYSWATER VIC 3153**

Business hours: 10am - 4pm weekdays

#### National Office staff

Manager Mal Brooks VK3FDL  
Examination Officer Dianne Ashton VK3FOIZ

#### Board of Directors

President Phil Wait VK2ASD  
Vice-President Fred Swainston VK3DAC  
Directors Robert Broomhead VK3DN  
Rowan Dollar VK2ELF  
Roger Harrison VK2ZRH  
Ewan McLeod VK4ERM  
Chris Platt VK5CP  
Secretary David Williams VK3RU  
Treasurer John Longayroux VK3PZ

#### Coordinators

AMSAT Paul Paradigm VK2TXT  
ARDF Jack Bramham VK3WWW  
Australian ARISS Tony Hutchison VK5ZAI  
Awards Chris Platt VK5CP  
Clubs Ted Thrift VK2ARA  
Contests Craig Edwards VK8PDX  
John Moyla Field Day Denis Johnstone VK4AE  
Editor 'AR' Peter Freeman VK3PF  
EMC/EMR Gilbert Hughes VK1GH  
Standards Gilbert Hughes VK1GH  
David Wardlaw VK3ADW  
John Bishop VK2ZDI  
NTAC John Martin VK3KM  
Historian Peter Wollenden VK3RV  
IARU Region 3 Liaison Chris Platt VK5CP  
Monitoring Service Peter Young VK3MV

#### ITU Conference & Study Group

David Wardlaw VK3ADW  
Brett Dawson VK2CBD  
Dale Hughes VK1DSH  
QSL Curator National Office  
Repeater Peter Mill VK3ZPP  
Webpage Robert Broomhead VK3DN

#### Emergency Communications Group

Coordinator Phil Wait VK2ASD  
Members Ewan McLeod VK4ERM  
Peter Young VK3MV



## Editorial

Peter Freeman VK3PF

### Winter has arrived

In the southern states, winter has clearly arrived. As this piece is being prepared, we have a slow moving high pressure system moving across Victoria. The first days of the high brought sunny skies and mild (for winter) temperatures for the afternoon, but very cold mornings. Looking out the window, I see blanket low cloud, with low air temperature. In a couple of days, we expect to see a cold front work its way across, hopefully bringing some more snow to the higher peaks. Many skiers would have been happy, as the main snow resorts in Victoria actually had sufficient snow to run lifts on the season opening weekend - Queen's Birthday weekend.

The teaching semester is winding up for me, but that brings examination scripts to be marked. Once those tasks are completed, it will be time to finalise arrangements for the second semester courses. In the middle of the break that the students will enjoy, I shall be busy. In addition, the local club has its annual GippsTech Conference to run. Several club members, including myself, are busy with the final arrangements and starting to process registrations.

It looks as if we will have an interesting program of presentations and anticipate a good number of attendees, which should result in lots of interesting discussions, especially during the tea/coffee and meal breaks.

On the radio front, things have been fairly quiet for me: a little SOTA and Parks chasing when I get the opportunity. Weekend and after-hours activity will depend on other tasks at hand. During the

week, I may occasionally make a dash to the car from the office to make a SOTA contact, if I am working on a task that can tolerate a brief interruption. I really must start looking for an iambic paddle suitable to use in the car: at present I do make some CW contacts from the car, simply using the Up/Down buttons on the microphone as the dit/dah buttons. My CW skills are slowly improving, but I really should spend more time practicing. One recent CW contact made me happy - a CW QSO with a station in Arizona, giving me my first US SOTA contact.

I am hoping to see some more snow on the ground so that I can pull out my cross-country skis and get some exercise, combined with some SOTA activations during the bonus point season. In several states, the winter attracts a seasonal bonus, increasing the summit points for the Activator only. The logic behind the bonus is the weather conditions combined with more difficult access. As a result, the Activator gains additional points for activations of summits above 1200 m. We simply need some more snow to fall and some nice weather on some weekends free of other commitments, and I will be able (I hope) to get that exercise by skiing to some summits to then play radio!

As noted in the President's Comment this month, new draft band plans have been released for comment. The published deadline for comments is in mid-June, but I am sure that the team will also consider any comments that arrive in the week or two after the nominal closing date. If you have any thoughts, you had best make them quickly.

Until next month,  
Cheers,  
Peter VK3PF





# WIA comment

Phil Wait VK2ASD

## Postcard from Dallas

This has been quite a month, and I'm struggling to know exactly where to begin, but since I'm sitting in Dallas Airport with a few hours to spare, I'll start at the beginning.

The WIA's 2015 AGM and Open Forum in Canberra highlighted several areas of strategic importance that will occupy the WIA Board's attention over the next year.

The Friday afternoon prior to the AGM was devoted to finding a way forward to the many difficult issues surrounding the 2 metre and 70 cm bandplans. Happily, consensus was achieved at the meeting (no, it wasn't a 'done deal') and over the next few days, John VK3KM, Peter VK3APO and Grant VK5GR refined the few outstanding issues and finalised the draft plans. When this magazine hits your mailbox, the new draft 2 m and 70 cm bandplans would have been published in the Hot Issues section of the WIA website for comment. Importantly, the revised bandplans do not force any existing users to change frequency, but they do make some very fundamental and wide-ranging alterations to improve our band usage and efficiency and we are keen to hear from any special interest groups or repeater licensees who believe they are adversely affected.

After going through the necessary corporate matters in the formal AGM, which this time took about 20 minutes (thankfully, our AGMs are short affairs), we moved on to the Open Forum. This is where the rubber hits the road in WIA affairs and where members present are encouraged to air their views on subjects close to their heart. Initially, we heard a presentation from Dale Hughes VK1DSH about the IARU and his work at the ITU (Dale is chair of ITU

Working Party 5, which is attempting to achieve a 5 MHz allocation for amateur radio within the ITU rules), and then we heard from Peter Young VK3PV about the impending changes to Australian Radiocommunications legislation and how it could affect amateur radio – more on that later.

Then, members were encouraged to ask questions of the Board and to air their views. A number of issues were discussed, but the biggest take-away opinion was that the WIA could improve and broaden how it communicates with members and the wider community. Although not a real surprise to the Board, it is something of a perennial issue – the more we do, the more people want! Constrained by resources, available time and to some extent cost, I am nevertheless amazed at the volume and frequency of WIA news produced and delivered via this magazine, the weekly broadcasts and the website, especially when compared against other societies having greater resources. That said, I recognise that it's a constant battle getting the message out, especially to those members who may not listen to WIA broadcasts, carefully read this magazine or spend little time online, but we do need to find or make more avenues and opportunities to tell members what is going on, and extend that effort to the community.

In our defence, some readers may recall that two recent President's Comments asked for suggestions about how we can improve the interface between the WIA and the affiliated clubs. Well, we only received two comments from individual members and none from the clubs themselves, so we won't ask that one again. However, the WIA Board has taken notice, and with the help of Jim VK3PC, by the time this edition hits your mailbox, you should have noticed some early improvements.

Additionally, over the past year we have introduced a "Hot Issues" section on the WIA website home page where members can follow the most important current issues, and a summary of monthly WIA Board meetings is now published on the WIA website (in the "About the WIA" section) and emailed to members who have registered on MEMNET. These notes are also being emailed to the Presidents and Secretaries of all affiliated clubs.

During the Saturday night annual dinner, Mark Loney, Executive Manager, Operations and Services Branch at the ACMA, discussed the changes occurring within the ACMA and some of the possible outcomes from the Spectrum Review. At the time of writing this President's Comment, the Department of Communications has only just released their recommendations in the Spectrum Review Report into spectrum management, which will now go to Government for their approval or modification. This is a very fast-moving area, and I will again refer readers to the Hot Issues section on the WIA website for the latest up-to-date information. The WIA has been working very positively with the ACMA over the last few years and, more recently the Department of Communications, in the lead-up to the release of the Spectrum Review Report. Although the recommended changes are far-reaching, advocating as they do a complete re-write of the radiocommunications legislation and spectrum management practices, they have not come as a surprise to us because we've paid close attention to what's happening and participated in the public consultation. In fact, if things work out as we anticipate, the outcomes for amateur radio and for the WIA promise to be quite beneficial.

I've been trying to get to the Dayton Hamvention in the USA for about 10 years, but the WIA's

Continued on page 5

## WIA visits the NZART AGM

The close relationship between the Wireless Institute of Australia (WIA) and the New Zealand Association of Radio Transmitters (NZART) includes an alternate visit to each other's annual general meeting. This year it was the WIA's turn to send representatives to Hamilton, New Zealand. They were the WIA Vice President, Fred Swainston VK3DAC and Director Rowan Dollar VK2OE.

Held on the Queen's Birthday long-weekend (May 29 to June 1), there were various presentations. Rowan VK2OE attended forums on Amateur Digital Mobile Radio, an update on the KiwiSAT project, and strategies to encourage new entrants into amateur radio.

Fred VK3DAC addressed the conference on the Australian experience of 10 years of Foundation licence, the changes including more portable activity, the remake of the Licence Condition Determinations, the Spectrum Review and the ANZAC 100 Commemoration. There was an obvious strong relationship between emergency services and the amateur radio community in New Zealand. The Amateur Radio Emergency Communications Forum held its own AGM at the venue. A report to the WIA Board included a range of mutual issues as a result of them being discussed during the weekend.

The WIA representatives were invited to the NZART Council Meeting AGM weekend. Led by the newly elected NZART President, Stuart Watchman ZL2TW, it further considered the role of office staff, development strategies for the website, and the future of amateur radio. The WIA and NZART representatives discussed regional and global matters – with the IARU Region 3 triennial conference to be held in Bali Indonesia in September, and the World Communications Conference, in Geneva, Switzerland early November.

## The ANZAC Centenary Award

This limited issue operating Award is available to commemorate the

ANZAC Centenary. The rules for any radio amateur or SWL to qualify have been slightly modified to make them clearer to understand, and a little easier to obtain.

The rules still need 10 qualifying contacts to be logged, but have been loosened up to make the ANZAC Centenary Award even more popular. The 10 contacts can be any ANZAC-suffixed callsign or combination of them. However one contact only allowed for each of VK100ANZAC or the VI state or territory callsign event listed on the WIA website.

Your award application may also include contacts with TC100-prefix stations in Turkey, the OP0PPY stations Belgium, the special callsigns such as VI4AE2, ZL100ANZAC and others that are relevant, so long as each contact logged was from a unique callsign activation.

Check out the full rules and claiming requirements on the WIA website, which also lists all individual events in the ANZAC 100 program.

## Dick Smith gets Queens Birthday honour

Philanthropist, businessman, aviator and activist, Dick Smith VK2DIK is now a Companion of the Order of Australia, the highest honour, for his eminent service to the community. He joined the more than 700 Australians who were recognised for their achievements in the Queen's Birthday honours.

The 71-year-old began working in a factory, set up a small car radio installation business and eventually created a multi-million dollar retailer, Dick Smith Electronics, which he has sold. Dick has supported a range of humanitarian, social welfare and conservation organisations, medical research and the arts. Describing the new honour, he describes himself as being lucky to have the resources that enabled him to assist people. Among his other awards he was made an Officer of the Order of Australia in 1999, and was Australian of the Year in 1986.

Dick Smith VK2DIK was Patron of the Wireless Institute of Australia's 100th Anniversary, including being the major speaker at the annual general meeting in Canberra 2010. The next day he hosted a BBQ at his recreated aero-club property near Gundaroo, New South Wales.

## Another VK balloon circumnavigates the earth

The party-type foil balloon PS-46 from Australia has shown that going around the southern hemisphere is no fluke – although it does need some perseverance. A very excited but humble Andy Nguyen VK3YT, who launched the balloon carrying an amateur radio payload, said: *"I express a big thank you to everyone assisting with its tracking across the continents."*

The solar power helium balloons in his series use a 25 mW transmitter with WSPR, JT9 and sometimes Olivia signals on the 30 m and 20 m bands. That enables tracking through stations who report on its altitude, speed, direction and battery condition. He explained that PS-46 flight left Australia at 0700 (AEST) on May 25, making its epic flight in just over 12 days. Andy VK3YT said: *"This time it was in the right position (before arriving in Western Australia) for the jet stream to push it over land."*

The balloon did an s-shape over the Pacific to South America, traversed the South Atlantic to Namibia, tracked above South Africa, crossed the Indian Ocean to Cape Le Grand near Esperance West Australia, and completed the world trip on Thursday, June 4. After reaching Australia the balloon tracked inland from South Australia (VK5), just touched New South Wales at Cameron's Corner (three state border point) and then to Queensland making the circulation complete.

Earlier balloon PS-41 launched by Andy VK3YT was the first to circle the earth. On its second time around it visited the Antarctic region, but disappeared in the Southern Ocean around April 21.



## Remembering the ANZAC spirit

The WIA ANZAC 100 program continues with a host of events. If you would like to activate an ANZAC callsign, then please make contact with Fred Swainston VK3DAC via email to [trainsafe@silvertrain.com.au](mailto:trainsafe@silvertrain.com.au)

The callsign VK100ANZAC will do a great job on the HF bands in the hands of DXer Tommy Horozakis VK2IR and others who will be on air from June 4-10.

From June 5, and for nine days, the Yarra Valley Amateur Radio Group commemorates a major event in WWII that we call D-Day, by using VI3ANZAC. Landing at Normandy was the largest seaborne invasion in history, regained occupied Western Europe, led to the liberation of France and contributed to an Allied war victory.

For a more recent involvement in a theatre of conflict, on Saturday June 6, VI5ANZAC at the Elizabeth RSL will commemorate the 50th

Anniversary of Australian Forces at Vung Tau, Vietnam, landed by the Royal Australian Navy. The Elizabeth Amateur Radio Club will be on both the 40 m and 80 m bands for this occasion for Vietnam War Veterans and the service community.

A bit later, the Adelaide Hills Amateur Radio Society led by Paul Simmonds VK5PAS activates VK100WIA for 48 hours on June 17-18. This event commemorates the '75th Anniversary of RAAF Secret Mission' - when an amphibious Walrus aircraft took off from near Plymouth in England. It had an Australian pilot and navigator, and the other two British crew members, one on the wireless and the other an intelligence officer. Their mission was to rescue Madam Yvonne de Gaulle and her three children; the family of General Charles de Gaulle the leader of the Free French forces. On reaching London he asked that his family be rescued from advancing troops. However, Madam de Gaulle had fled

on board the last boat to England. The secret mission came to an abrupt end with a crash and fire that took all four crew, two from the 10 Squadron RAAF, the first RAAF members to die in action. The locals buried them in the town cemetery. The War Graves Commission later put headstones on the graves. Townspeople continue to remember them on All Souls' Day and other times of remembrance.

## Reciprocal Licence Review

As changes occur to overseas amateur radio qualifications, a review of reciprocal licences is required. This review has commenced and new tables will be available on the website and in the next edition of the *Callbook*. The review process involved ACMA and is not expected to impede reciprocal licence applications however there may be some changes to outcomes. These changes are expected to be minor.

## WIA comment

Continued from page 3

AGM date has always clashed. This year was different, so I took the opportunity and cashed in some points and headed off to Dayton, Ohio. Dayton is anything but a tourist destination, but if you ever get the chance, don't hesitate - go! There was a healthy contingent of VKs there, judging from the pins placed on a world map at the ARRL stand, and I was joined by Co-Director Chris Platt VK5CP. Dayton is an amazing collection of people and amateur radio suppliers, with just about everything you can imagine to do with amateur radio, from the latest software defined radios to a healthy collection of "boat anchors". The flea market itself takes almost a day to walk around and there was even a 180 foot tower on display. I bought a Heil microphone, some rig remote control equipment, and a 150TH valve (sorry, vacuum tube) for the mantelpiece.

The sign in the street leading into Hara Arena, which houses the

Hamvention, was reassuring - "Per Ohio law, concealed weapons are prohibited on these premises for this event" - and the front-page item in today's newspaper here in Dallas was a debate on whether university students should be allowed to carry their handguns into classes for self-protection, rather than leave them in their car. *Only in America!*

Several other societies were represented at Dayton, including the RSGB (UK), the DARC (Germany), the RAC (Canada), the Qatar Amateur Radio Society, AMSAT, ARISS, and of course the IARU. The ARRL contingent was very impressive, with all the major ARRL activities represented, and I spent quite a bit of time talking to their various leaders. It's both impressive and envy-making to see what can be achieved with about 100 paid staff! Although their level of activity is way beyond the resources of the WIA, I believe there may be opportunities for us to

leverage off some of their initiatives, especially in promoting a modern image of amateur radio to youth.

Before coming to Dallas, I spent a couple of days in Chicago, my favourite US city, with very late nights at Blue Chicago - a must-visit blues bar on Chicago's north side - and a visit to the museums of science and technology and broadcasting, plus a few days in Austin Texas, now my second favourite US city. I'm about to board the A380 for the 16-hour non-stop flight back to Sydney, and back to work. Drat, it's all too short!

*PS. Don't forget to register your support on the WIA website for Norfolk Island for next year's AGM and Open Forum venue. As I write (end of May) we have over 100 people who have indicated they would attend, which is encouraging, but more would be better; we want to spread the excitement around!*

# Perytons: A case of UHF-SHF interference

Peter Ellis VK1PE



Photo 1: Parkes Observatory. Photo by Ian Sutton, courtesy of Wikipedia.

*Peter Ellis VK1PE tells how scientists using the Parkes radio telescope have found and explained an unusual electromagnetic phenomenon (perytos) that amateurs may also hear.*

In January 2015, scientists associated with the Parkes Observatory (1) announced results confirming the existence of a rare cosmic event that had first been discovered in Parkes data.

The central-west NSW town of Parkes hosts the 64-metre Parkes radio telescope, one of the telescopes comprising CSIRO's Australia Telescope National Facility.

## **Brief but powerful signals**

When amateurs think of gain in a transmission, we tend to want to find an antenna with a narrow beam, high gain, good front-to-back ratio, low side lobes, etc. This is precisely the situation for radio astronomers.

Obligingly, many radio astronomy sources such as pulsars have identifiable directionality in their emissions, as they spin. Yet, listening to a source brings in another consideration. What if the emitter is inherently broadband and unfocussed? Or, what if the transmission is 'instantaneous' and does not repeat?

Such was the situation encountered by Prof. Duncan R Lorimer (a "fast radio burst" (FRB), and this has become known as the "Lorimer Burst" of 2007), written up as "A bright millisecond radio burst of extragalactic origin" (2) discovered by researchers when they examined Parkes records over years of listening.

The issue became a scientific curiosity when Parkes data showed up more, similar bursts, but other receiver sites could not duplicate the data. Finally, in 2013, a similar, extragalactic signal was found in data from the Arecibo Observatory



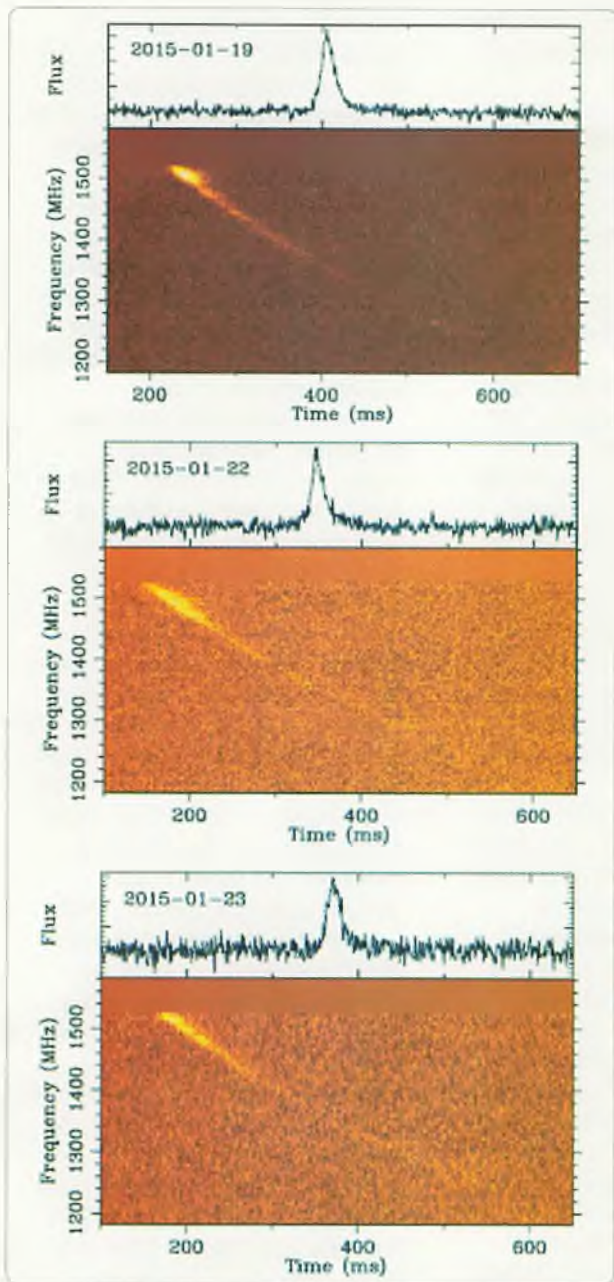

Figure 1: The time-frequency structure of the three January Perytons.



Photo 2: Emily Petroff has fixed The Dish's bug.

radio-telescope in Puerto Rico, and the repeatability issue was dispelled.

Then, in early 2015, CSIRO reported (3) that Emily Petroff, a PhD candidate from Melbourne's Swinburne University of Technology,

working at Parkes, had seen a burst occur in real time, and was able to alert other observers at twelve

Electronics  
Enthusiasts

Jaycar  
Electronics  
Better. More Technical

## ONE-STOP-SHOP

### Anti-Static Protection Lotion

Ideal for soldering or working on ESD sensitive components. This non-greasy lotion protects your hands and body parts from dirt, grease, hazardous chemicals and harsh contaminants. Perfect for mechanical and electrical jobs.

59ml Squeeze Bottle NA-1200 \$12.95  
472ml Pump Bottle NA-1202 \$34.95



FROM  
\$12.95  
NEW

### 35-Piece Electronic Tool Kit

A multi-purpose precision screwdriver tool set consisting of 30 bits, two cutters, two pliers and a flexible shaft adaptor for those tricky to reach screws. Ideal for electronic DIY and hobbyists  
TD-2117



\$34.95  
NEW

### Battery/Bulb/Fuse Tester

Tests AAA, AA, C, D (1.5V) & 9V batteries and displays their power levels. Also includes a handy compartment to store spare fuses, bulbs and button cells.  
QP-2252



\$13.95

### Cat III Autoranging Digital Multimeter

- True RMS for accurate readings
- AC/DC voltages up to 600V
- AC/DC current; up to 10A
- Temperature, resistance, capacitance and more

QM-1551



\$59.95

### 60W Lead-Free Soldering Station

An excellent mains powered soldering station suited to both lead-free and ordinary leaded soldering. Microprocessor controlled for precision jobs.

• Temp range 160°C to 480°C  
TS-1390



\$149

### Variable Laboratory Autotransformer (Variac)

Encased in heavy-duty steel housing, this unit enables the AC input to a mains powered appliance to be easily varied from 0 to full line voltage (or greater).

• Rated power handling: 500VA (fused)  
• Output Voltage: 0 to 260VAC @50Hz  
MP-3080



\$229

Prices valid until 31st July 2015

To order call 1800 022 888 or visit  
[www.jaycar.com.au](http://www.jaycar.com.au)

telescopes around the world; however, no optical, infrared, ultraviolet or X-ray indications were seen, which ruled out certain obvious candidate causes.

The signals were from cosmic distances. The radio signal was 'smeared out' in frequency from travelling through the electron cloud in space, pointing to the burst starting up to 5.5 billion light-years away, well beyond our galaxy, and lasted mere milliseconds. Estimates of the power in those instantaneous signals put it at the electromagnetic output of the Sun in a day.

### Spurious signals

However, these data searches also turned up spurious signals, also brief and powerful, but of a different type much closer to Parkes that have, until now, defied explanation. These have been called "Perytons", after the *Peryton*, a mythological hybrid animal combining the physical features of a stag and a bird. These radio pulses are not what they appear: supposedly coming from outside of our galaxy but they are actually local (Earth or nearby) interference.

A paper (5) in 2010 by Dr Sarah Burke-Spolaor et al. describing these signals came to my attention while I was looking into the discovery of the new galactic signals. It describes how, "*The data were archival pulsar surveys taken over the years 1998 to 2003 with the 20 cm [1.5 GHz] multi-beam receiver installed at Parkes Telescope.*" They detected "... 16 pulses with two striking features that distinguish them from all others in the data..." and led them to a terrestrial origin rather than cosmic.

Realistically, that's a lot of data, a lot of looking (analysis), and not a lot of finding anything.

In the course of following up with Dr Sarah Burke-Spolaor, and co-author Professor Ron Ekers of CSIRO, I suggested that amateurs may already be gathering data that would assist in characterising these spurious signals, or might be

persuaded to do so. *I proposed that amateurs might be interested in an "intruder hunt".*

### Known knowns, etc.

See Figure 1. The signals sweep from around 1550+ MHz to around 1250 MHz and lower in about 400 ms. Quite obviously, amateurs listening and recording in the 23 cm band (1240-1300 MHz) may detect these signals.

By examination, these signals are falling at a rate of approx. 100 MHz/50 ms (2 MHz/ms) in the 23 cm band and maybe 1.5 times that rate (if there) in the 13 cm band. Such interference would surely be of interest to amateurs.

A "known unknown" comes from a visual examination of the signal diagrams in Figure 1; that the signals may begin at up to twice that frequency and therefore be detectable on 13 cm (2300 / 2400-2450 MHz).

The Astropulse (4) SETI@home project is using Arecibo data sets to listen for similar signals. Wideband pulses would be "chirped" by passage through the interstellar medium; that is, high frequencies would arrive earlier and lower frequencies would arrive later. Thus, for pulses with wideband frequency content, dispersion hints at a signal's extra-terrestrial origin. Astropulse searches for pulses with dispersion measures ranging from 50 parsec/cm<sup>-3</sup> to 800 pc/cm<sup>-3</sup> (chirp rates of 7000 Hz to 400 Hz per microsecond), allowing detection of sources almost anywhere within the Milky Way.

Timing is everything. I had done some simple geometry using Sarah's Peryton data, and did not discover a common horizon direction. I drafted an article suggesting that amateurs should scour any recorded UHF-SHF signals and listen out for Perytons. I sent a copy of the draft to Sarah and Ron in early April 2015, and had a quick turn-around from Ron with another article attached, "*Identifying the source of Perytons at the Parkes*

*radio telescope*" (6), that was to be published the next day, 10 April 2015. Lead author is Emily Petroff, who had caught the fast radio burst red-handed. She has also caught the RF interference.

The scientists had observed a cluster of Perytons in late January 2015. The telescope had an RFI monitor installed late in 2014, and there was a correlation between new observed Perytons and the RFI monitor data on 2.4 GHz.

Two local sources were then discovered; two microwave ovens, one at the Parkes Visitor Centre, and another in the staff accommodation. Both were about 17 years old, and this hints at gradual magnetron breakdown.

Emily Petroff's paper analyses the time of day for Perytons versus fast radio bursts and, sure enough, FRBs occur randomly while Perytons are during times when people might be expected to use the microwaves. Also, finding the source has meant that Perytons can be accurately measured and shown to be demonstrably different from FRBs.

However, this did not answer all the questions. For instance, why does the telescope not hear perytons every day? We all know there are two ways to stop a microwave oven; letting the time run out, and the operator opening the door before the timer runs to zero.

That's it! The occasional, slight 'leakage', as the door opens and the older magnetron is powering down, can cause chirping at a wide range of frequencies from the fundamental at 2.4 GHz (13 cm) and its half at around the astronomically important observing frequency 23 cm. But, they were also only heard in the telescope receiver when the azimuth and elevation allowed a clear line of sight to the receiver horns. The Dish itself hid other Perytons from the receivers.

For radio astronomers everywhere, proving that FRBs are extra-terrestrial will be easier as a result, as will locating local interference.



And, amateurs, if you are on 13 or 23 cm and are being driven mad by a chirp, check the microwave ovens at home and in houses nearby.

Peter Ellis VK1PE

## References

1. <http://www.parkes.atnf.csiro.au/>
2. Duncan Lorimer (West Virginia University, USA), Matthew Bailes (Swinburne University), Maura McLaughlin (West Virginia University, USA), David Narkevic (West Virginia University, USA) and Fronefield Crawford (Franklin & Marshall College, USA); A bright millisecond radio burst of extragalactic origin; <http://www.atnf.csiro.au/news/newsletter/oct07/MSburst.htm>; arXiv:0709.4301
3. Cosmic radio burst caught red-handed, CSIRO; <http://www.csiro.au/en/News/News-releases/2015/Cosmic-radio-burst-caught-red-handed>
4. [http://setiathome.berkeley.edu/astropulse\\_faq.php](http://setiathome.berkeley.edu/astropulse_faq.php)
5. Sarah Burke-Spolaor, Matthew Bailes, Ronald Ekers, Jean-Pierre Macquart, Fronefield Crawford III (2010). "Radio Bursts with Extragalactic Spectral Characteristics Show Terrestrial Origins". arXiv:1009.5382
6. E. Petroff et al. "Identifying the source of perytons at the Parkes radio telescope". arXiv:1504.02165

## Contribute



Articles and high quality photographs for *Amateur Radio* and *Callbook*.

See <http://www.wia.org.au/members/armag/contributing/>

# TET-EMTRON

Kits!

Kits!

Kits!

## New Hanging Dipole Kits!!!



Make your own dipole centre using the new kit. All the parts are there including insulators in some kits. Just bring your own wire

- Gold pin connector
- Glue lined heatsink.
- Tinned solder tabs.
- Stainless hardware.

Perfect for club project days.

- All the standard high quality TET parts you expect including stainless hardware.
- Full instructions.
- A range of ferrites
- Parts also available separately.
- Club discounts apply

TET-Emtron  
47 Ocean Drive,  
PORT DENISON,  
W.A 6525  
08 9927 1872  
See our wide range of new parts and products at:-  
[www.tetemtron.com.au](http://www.tetemtron.com.au)

## Balun Kits!



More and more Kits coming every month!!!

# Arduino based antenna rotator controller

Dale Hughes VK1DSH

Over the years I have acquired a number of second hand antenna rotators; all operate on 24 to 30 VAC and the drive motor is a small split-phase synchronous motor. The required phase difference for the motor windings is generated by passing the Alternating Current through a capacitor and the direction of rotation is set by the relative phase difference of the AC through the two motor windings. Figure 1 shows the general idea.

In some rotators, the pointing direction can be determined from measurements made by a potentiometer which is mechanically coupled to the rotator output shaft. The angular position of the potentiometer is then displayed on a panel meter. Others units have a small synchronous motor in the control unit which tracks and display the pointing direction on a scale.

I wanted to build an azimuth-elevation control system to move an antenna so that it could point to a specified position in space and the ability to know and display the pointing direction was important. Two rotators were used in the final system:

- For the azimuth direction a small elevation rotator without a position indicating potentiometer.
- For elevation movement a KR500 elevation rotator with a potentiometer for position indication.

As I wanted the antenna position to be controlled from a PC, a suitable control system was required and this project is the result. The controller accepts position commands from the host PC via a USB-serial

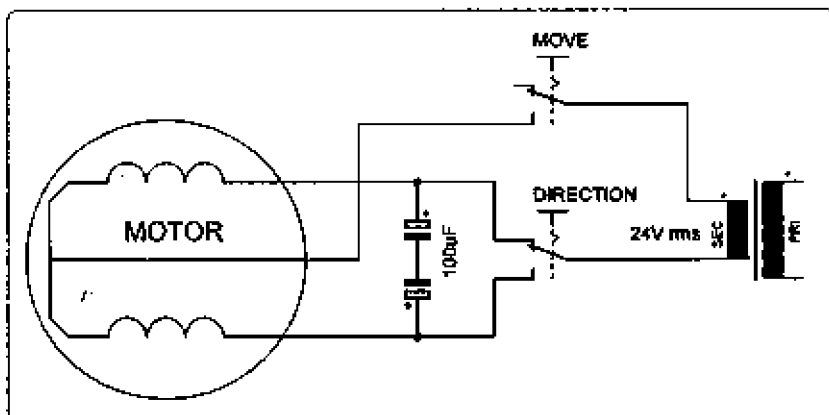

Figure 1: Schematic of a typical rotator motor control system. The direction is determined by the relative phase of the alternating current through the motor windings and this is controlled by which of the direction switches are operated. The value of the two capacitors is between 100  $\mu$ F and 220  $\mu$ F in the rotator systems that have been inspected. Note that both direction switches should not be simultaneously operated and they are normally mechanically or electrically interlocked.

connection and moves the rotator motors to the required position. The pointing direction of the antenna is displayed on a Liquid Crystal Display in the control box. The control unit also provides facilities for manual operation of azimuth and elevation axes, calibration and hardware protection through both 'hard' and 'soft' movement limits. Figures 2 and 3 show the control unit.

The rotator control system is based on the readily available Arduino<sup>1</sup> range of open source microcontrollers and the unit I used was the 'Eleven' unit from Freetronics<sup>2</sup> which is fully compatible with the Arduino 'Uno' device. The LCD-keyboard<sup>3</sup> unit (known as a 'shield') is also from Freetronics and this unit interfaces directly and simply with the microcontroller PCB. The Arduino software development environment is freely available from the Arduino

website; it is easy to install and use. The Arduino language is based on the 'C' language and has a number of useful simplifications, so it is easy to learn and use which makes it ideal for many amateur radio applications.

Despite the low cost and apparent simplicity of the Arduino hardware and software, it is capable of complex control tasks and can be easily interfaced to a wide range of external hardware. In this project the microcontroller unit controls the motors via a number of solid state relays and limit switches in addition to the LCD and keyboard.

As the rotator motors are synchronous motors their position can be controlled by the number of cycles of AC that are applied. The microcontroller counts the number of cycles applied to the motors by an interrupt generated from the 50 Hz mains supply that powers the two





# Check our transceivers, receivers, antenna tuners & pre-amp kits



## Ten Tec Rebel 506 Open Source QRP CW Transceiver

ChipKIT UNO32 32 bit, 80 MHz processor with 128 k of flash memory.  
DDS Based VFO for no drift operation  
100% Open Source hardware and software  
Covers 20 and 40 metre bands  
Hardware hooks for user added features



## Ten Tec Argonaut VI 539 QRP Transceiver

Convenient compact size  
10 W QRP  
CW and SSB filters included  
Model 702 Hand Microphone  
• *Call for new low price*



## Ten Tec Eagle 599AT 100 W Transceiver

Built-in Auto Tuner  
CW and SSB filters included  
Model 320 Noise Blanker  
Model 702 Hand Microphone  
• *Call for new low price*



## Ten Tec Omni VII 588AT 100 W Transceiver

• Built-in Auto Tuner  
CW and SSB filters included  
IP Port for network connection  
Model 707 Regal Microphone  
• *Call for new low price*



### The Model 1253 9 band regenerative shortwave receiver kit

The classic "first radio kit" is back better than ever! Ten Tec have combined the very same audio output circuit of TEN-TEC transceivers with a modern FET design for classic regenerative SWL receiving plus one-button electronic band switching.



### The Model 1215 full featured antenna tuner kit

Designed for transceivers from QRP through 200 watts. A wide matching range combined with an integral wattmeter and SWR bridge provides all the necessary capabilities to ensure efficient operation with minimal RF losses due to impedance mismatches between the feed line and radio.



### Model 1001 Broadband RF Pre-Amp kit

Broadband, un-tuned RF preamp. 50 ohm input, 50 ohm output. Excellent noise figure, gain and frequency coverage at a BUDGET PRICE. Up to 18.5 dB gain at 100 MHz, 17 dB gain typical at 500 MHz. Supply voltage: 8-14 VDC.



The first Morse keys were released for sale in 1905 and today VIBROPLEX celebrates their 109th year in business - the oldest name in amateur radio. A complete line of CW keys, dust covers, connecting cables and other accessories are available.



Auto Tuners designed specifically for the ham radio market. Tuners custom designed to integrate directly with common transceivers such as Alinco, Kenwood, Yaesu and Icom.

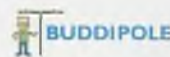

Probably the most flexible and popular portable antenna system ever designed.



High performance Amateur and Commercial grade auto and manual antenna couplers.



A supplier of ham transceiver and accessory kits from China. Most kits are available fully assembled.

Supplied by



tts systems

Phone 03 59774808 Fax 03 59774801 Email [info@ttsystems.com.au](mailto:info@ttsystems.com.au)

Visit us on [www.ttsystems.com.au](http://www.ttsystems.com.au)



Figure 2: Outside view of the control unit.

motors. It was found for the two motors used in this project that the transfer function was 0.1 degree/cycle for the azimuth motor and 0.05 degree/cycle for the elevation motor. These factors are easily determined by measuring the time it takes for each motor to move through a given angle. The control software includes a calibration function to more accurately refine the transfer function if required, or if the rotators used have significantly different characteristics to the default values.

Figure 3: Inside view of the control unit. The Freertronics 'Eleven' microcontroller and display/keyboard on the left-hand side. The solid-state relay interface board, USB connection and power transformers are on the right-hand side. (Note the comments in the main text about the axis control switches.)

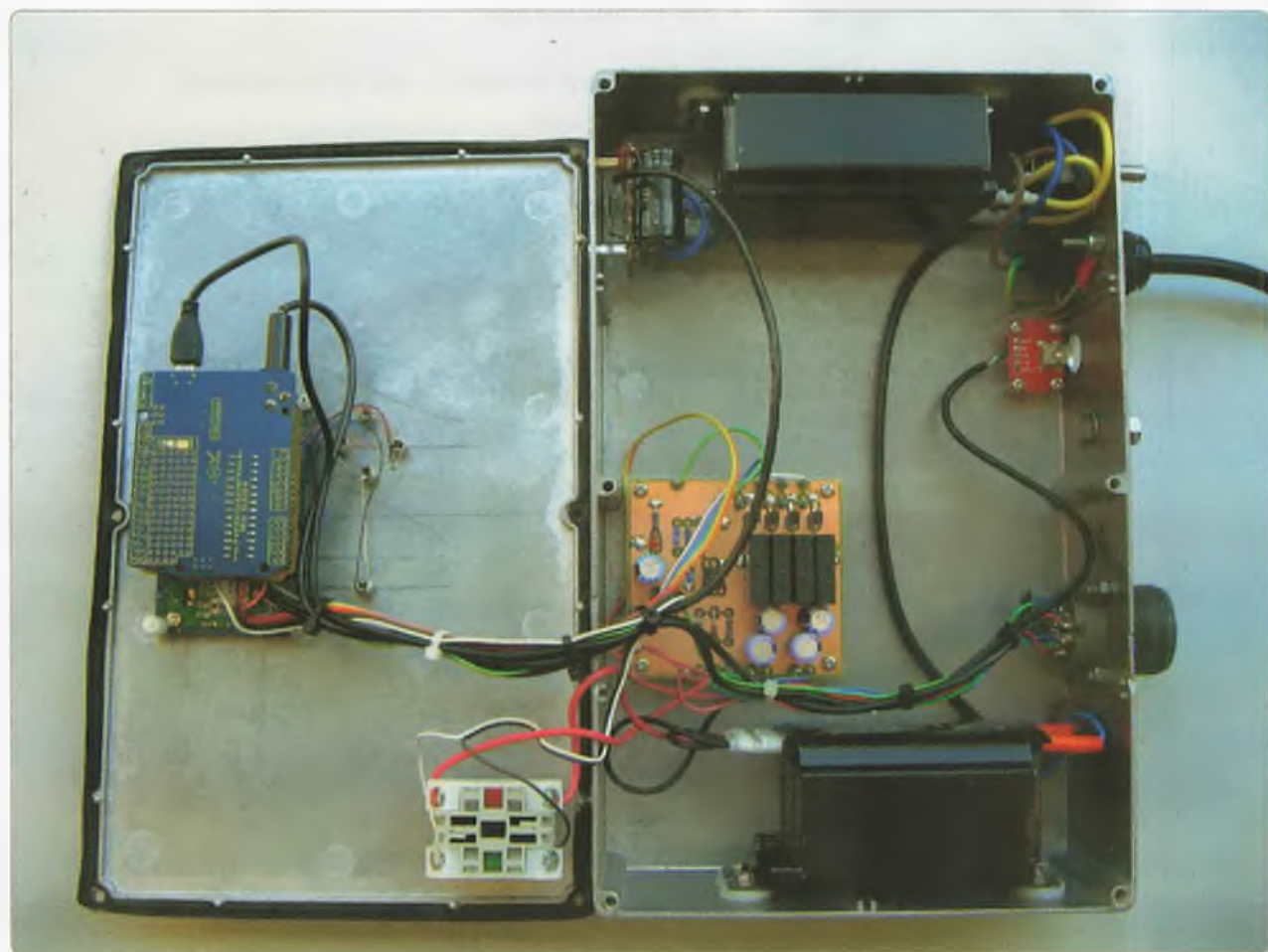



## Circuit Description

The overall schematic diagram is shown in figure 4; power to the control unit and rotator motors is provided by two transformers; TR1 provides power for the rotator motors and TR2 provides power for the control system and interface electronics. Regulator U1 provides +5 VDC for the opto-couplers and other interface circuitry. The Arduino controller is powered by an unregulated supply of approximately 9 VDC as it has its own on-board voltage regulator. The LCD shield is powered by the Arduino board.

The 50 Hz interrupt signal is generated by opto-coupler U2 and transistor Q1 which produce a square wave with sharp edges. This signal generates a hardware interrupt for the microcontroller hardware which is used for motor position control.

Control of power to the two motors is via four small solid state zero-crossing relays which directly energise one of the two windings in each motor, the other winding being energized through the phase shift capacitor. The relays are Jaycar SY-4088 devices and while these relays are rated for 50 - 240 VAC operation they appear to work equally well at 24 VAC.

Two limit switches for the azimuth motor are mounted on a plate underneath the azimuth motor (see figure 5). The switches are sealed sub-miniature microswitches (RS part number 472-8320) which are actuated by a pointer which moves around as the motor rotates. While not strictly necessary, direction bearings are marked on the plate and the pointing direction directly read directly from scale. This is useful for testing and calibration. When a particular limit switch is actuated, further movement in that direction is prevented by the software. The motors and limit switches are connected to the control unit by multicore cable of sufficient current carrying capacity.

Movement of the motor can be stopped at anytime by pressing the emergency stop switch which disconnects power to both motors and signals the Arduino processor that an emergency stop has occurred. The emergency stop switch is a Jaycar SP-0786 unit.

The display, operator switches and motor limit switches connect directly to the Arduino processor board and require little comment except that the manual control buttons originally supplied on the LCD module are quite small, so they were removed and replaced with larger and more robust switches mounted on the front panel of the box. The LCD shield uses a clever circuit to multiplex five buttons onto a single microprocessor input which simplifies wiring.

The elevation rotator is fitted with a position indicating potentiometer; however this is used only for calibration and limit sensing. Position determination for both motors is achieved by counting the number of cycles applied to the motors; the initial position of the motors being set by moving them to a known reference

## Contest time is Kuhne time

High Quality Made in Germany

### Equipment for winners

Discover all parts you need for a successful contest time in our Online-Shop.



High frequency range, low noise figure and high gain are just some outstanding features from our popular DB6NT products.

See it yourself!

www.shop.kuhne-electronic.de

Kuhne electronic GmbH

Schulstr. 3 | Telefon: +49 (0) 9233 / 800040

0-90180 Burg | E-Mail: info@kuhne-electronic.de

**KUHNE electronic**  
MICROWAVE COMPONENTS

Solutions for the wireless world

position. The software allows both motors to operate simultaneously which means that positioning time is reasonably quick.

## Connection a host PC

Connection to the host computer for remote control is via the inbuilt USB-serial link on the Arduino processor. Once the appropriate driver software is loaded on the PC, the serial connection appears as a standard COM port and commands can be sent to move the motors. The software accepts a character string that is the same as might be sent to a Yaesu GS-232B controller. For example, if the rotator is to be moved to an azimuth angle of 32 degrees and an elevation of 46 degrees the string is W032 046. The string is always 8 characters long and azimuth range is 0 to 360 degrees and the elevation range is 0 to 180 degrees.

## In Use

Prior to first use the motor transfer functions must be determined so that the control software knows how many cycles of AC are required to move through a given angle. The elevation axis calibration function built into the Arduino software drives the azimuth motor to the limits of travel (as set by the position of

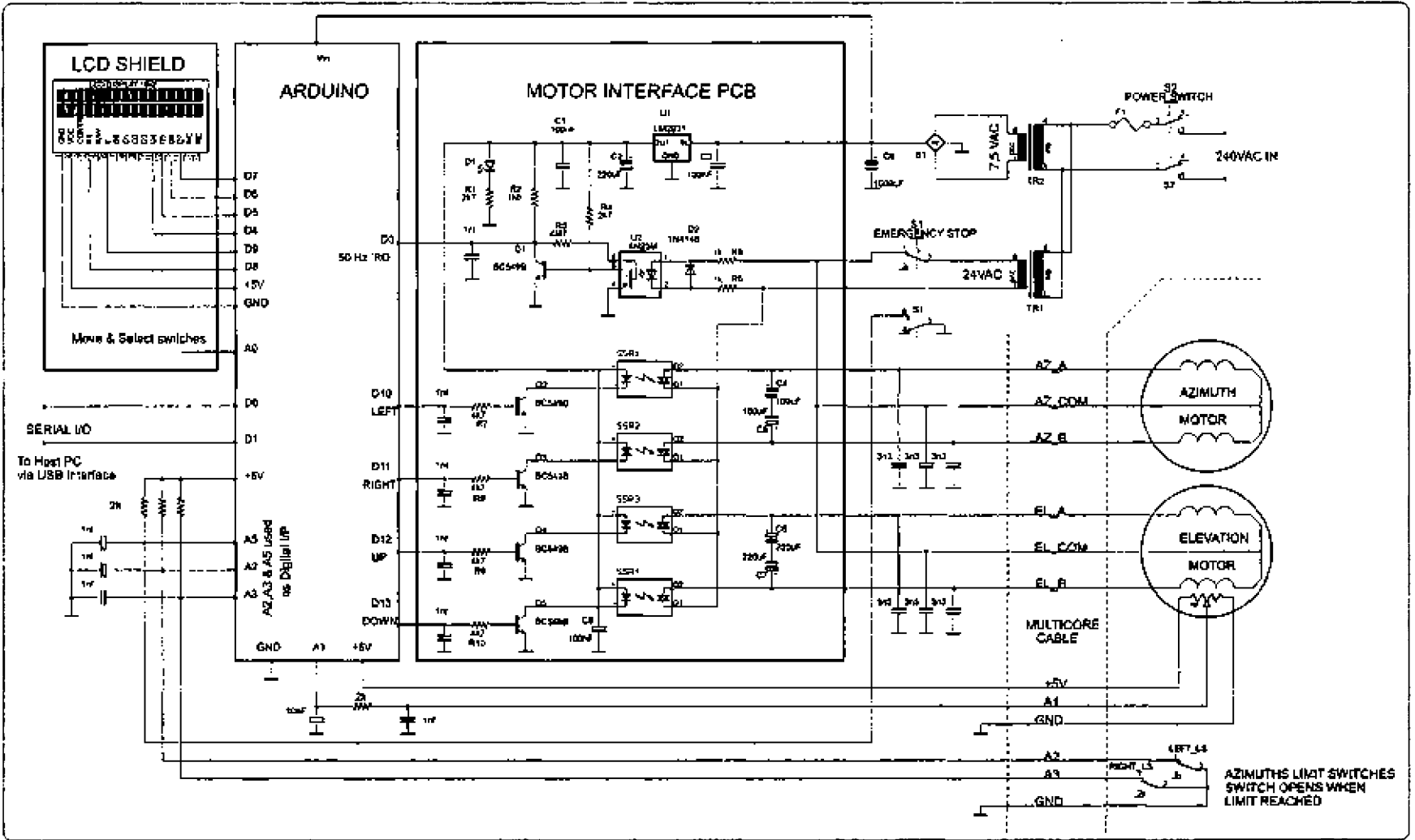

Figure 4: Block schematic diagram of the control unit.



the microswitches) while counting the number of cycles. When the movement is complete the user is prompted to enter the angular position of the limit switches (in degrees) and a transfer function is then calculated and saved to permanent memory. (The default azimuth values are +/- 175 degrees.) Calibration of the elevation axis is done by driving the elevation motor to a known start position e.g. zero degrees and then to another elevation angle e.g. 90 degrees. The user is then prompted to enter the calibration angles and an elevation transfer function is then calculated. The first reference position is also measured using the inbuilt position potentiometer and the resistance value is then used as an indicator for the elevation reference position.

The calibration of both movement axes only needs to be performed once prior to first use as the transfer functions are stored for later use.

In normal use the azimuth and elevation motors are driven to their reference positions when the system is started up and all positions are then relative to the reference positions. The control system works reliably and achieves a pointing accuracy of approximately +/- 2 degrees. The mechanical inertia of the antennas supported by the rotators potentially affects the overall positioning accuracy, but for most amateur applications the system is sufficiently accurate.

### Conclusion

The design of an Arduino base antenna rotator control system has

been presented and the system is being successfully used for amateur satellite communications via popular and readily available satellite tracking software.

A PCB design file for the motor interface circuit board and the Arduino source code are available from the author.

### Endnotes

1. <http://www.arduino.cc/>
2. <http://www.freetronics.com/collections/arduino/products/eleven>
3. <http://www.freetronics.com/collections/display/products/lcd-keypad-shield>

Figure 5: The complete azimuth-elevation rotator system showing the bearing plate and limit switch cover.

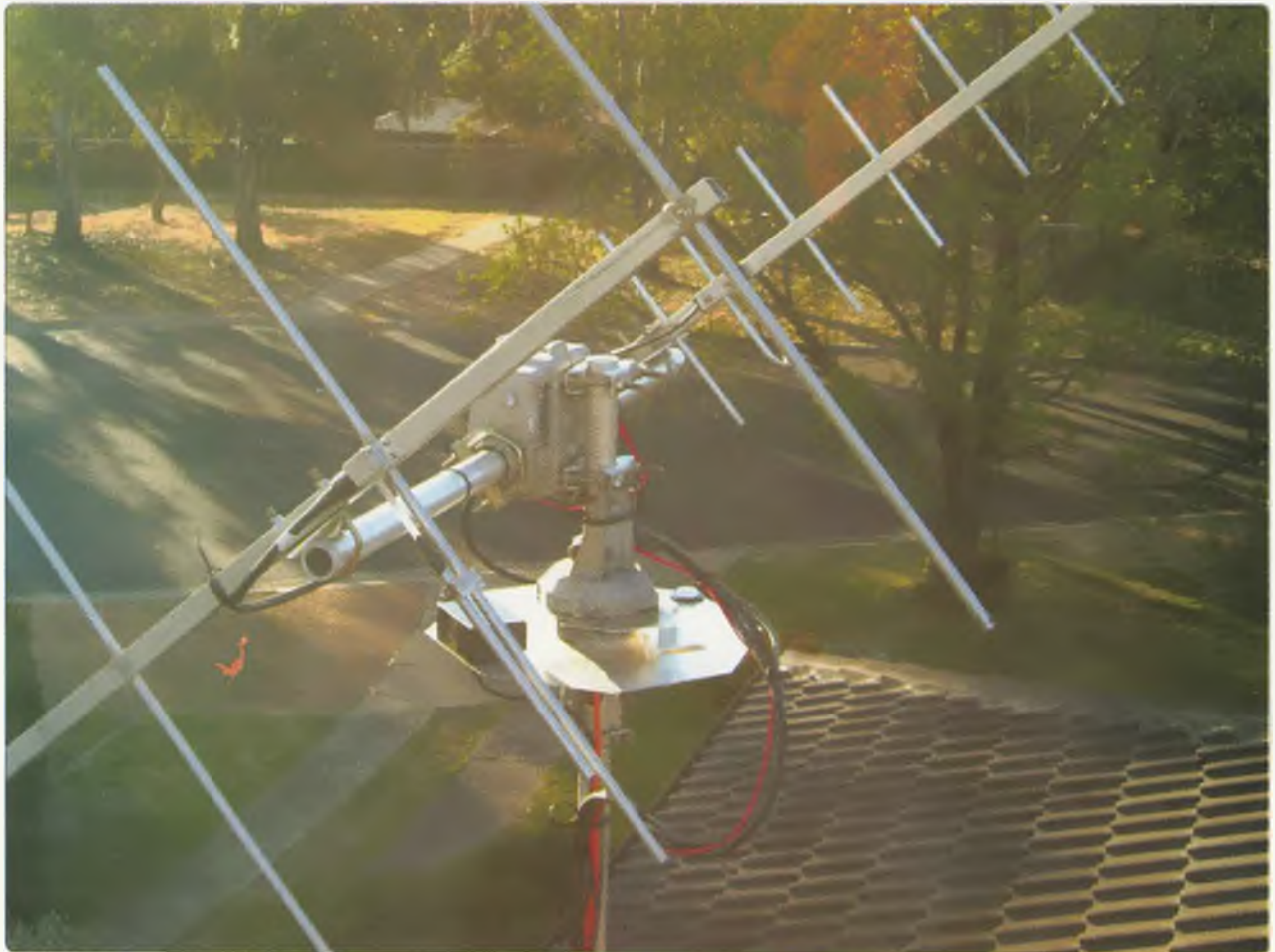

# "Snow" Campbell VK3MR, International DXer, Prisoner Of War

Peter Wolfenden VK3RV

Mervyn Richmond Campbell (SK) was born in March 1909. Known to almost everyone as "Snow", he was first listed as VK3MR according to the 1933 call sign listings. It did not take long for the "bug to really bite" Snow and he became a keen CW DXer with a world-wide reputation. In the early stages of WWII he enlisted in the RAAF at his home town of Coburg and was given service number 9190. His training took place at various RAAF establishments in NSW and Victoria including Point Cook where the Wireless Reserve met. Snow knew most of the local Reserve members and it is suggested that this was a factor in his joining the RAAF. He disembarked from Sydney in 1941 with the Number Three Squadron of the RAAF. After serving in Egypt and with the RAF in Palestine, he then went back to Egypt where he was captured by the Germans in 1941. Snow was held in a POW camp in Italy and finished up in the notorious Stalag 8B POW camp (1, 6).

At the RAOTC December 1976 Dinner, Snow related a number of his experiences in those POW camps including the story of his amateur radio club in Italy.

In Snow's own words:

.... "So it was mentioned that the fundamentals of radio [would be discussed] in the Mess Hall, we had a Mess Hall but never used it as such as we had nothing to eat! The first lesson, 600 people came to this course - I think I've done something for amateur radio didn't I? They were all just wearing shorts, no boots or socks, just shorts, all brown and burnt and hungry and they sat there and of course, I had to raise my voice for 600 people, you could well imagine - and I had my hair shaved off and had a pair of



Photo 1: VK3MR QSL card from 1932.

shorts, that was the general dress in those days. I was trying to convince them that there was something in amateur radio. After a few lectures it fell off, we expected that, and in the end there were about 200 real keen followers..... To further add interest to it [amateur radio course], we formed a short-wave listeners club. Now we didn't have any radio, we had a secretary, we struck a badge which I will show you, we had it on the notice-board and we used to get together and discuss what we can hear on radio, how we hear it and where we hear it and the best wavelengths and they were as keen as you fellows! This chap Shaw from South Africa in hut 7 was the secretary and questions were directed to him and we had a marvellous time and as we left I just grabbed that - there it is, that's our emblem or badge for the POW club in Italy!"(2)

Radio components were hard to find in Italy, but this was not the case in Germany.

... "When we went to Germany, there radio was fairly well established. In Germany there was plenty of equipment "laying around", in Italy there was no equipment laying around, but in Germany you could pick bits of equipment from the

tip and make a transmitter out of it. So we built receivers, the first one I built was the old crystal set with pan-cake coils for tuning and galena for crystals, the boys worked in various mines and quarries and there was plenty of galena - the usual system

in circuit and we used to hear the drum stations, it used to go boom, boom, boom, you probably heard it out here and after these signs they would give the news in English and all the nationalities in Europe. So I built this up (and built quite a few of them) and got more enterprising and I built a two valve set - a detector and one [amplifier]..... But to get this equipment, it was interesting. Various working parties went out - only the Army boys, so we [] swapped identities with the Army boys and I went out with the working party into a big depot where the all the telephone equipment from Warsaw had been stored - it had been pinched from Warsaw and stacked in here. So this was the chance of getting it as I went there on the pretence of working. I looked in the door of the big shed and there were meters - a marvellous array of equipment - beautiful - it was a ham's dream..... So I had all this equipment. I asked the carpenters to build a box, I had about 5 or 6 meters - you name it amps, milliamps, volts, anything you like - oh, a beautiful set-up. We used to dig a hole to bury it - to hide it of course, well anyhow we built the detector and audio, but we had to



get a condenser made and it was made out of aluminium plates, I gave the boys the shape I wanted, they had nail files and scissors. Out of the dixies [food container/dish], they shaped the plates, fixed and moving and the insulators were made out of tooth brush handles and spindles out of some bolts and each one made a separate part – they'd just walk around with a bit of aluminium, shaping it as so on, or a bit of tooth brush handle and in the end we got a proper condenser and a good one too! I wound the coils, I just used a tuned grid and a plate reaction, never mind a condenser, just bring the coil a bit closer, no audio and put up an aerial and lo and behold, it worked very well.

The first test of course, all the doubting Thomases- "it wouldn't work, it couldn't work" – the first test showed indication that there wouldn't have been any kick in it and there were quite a few gurus about it, I recalled "reverse reaction", I just reversed it and whew, up they come – the usual story! I had a 200 volt transformer and an ordinary vacuum tube rectifier, I could get all those things there – there was no trouble at all and of course we had aerials up and we used to get the London stations and all the European stations. The pathetic thing was that a lot of prisoners there were from Dunkirk, Englishmen and when they could hear Big Ben signing, they were in tears hearing it – they hadn't heard it for so long – they used to cluster around."

Photo 3: VK3MR QSL card from 1986.

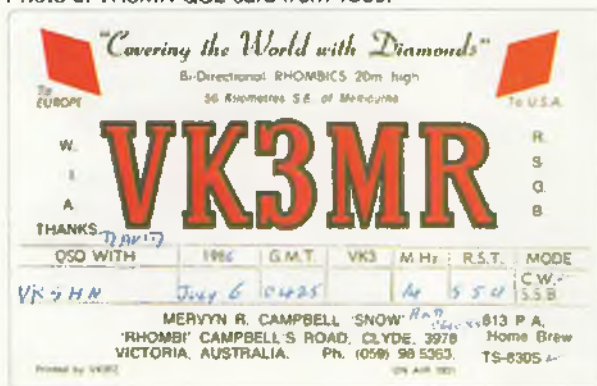

But having the radio was only part of the necessities – a suitable aerial was of utmost importance, but probably the hardest thing to hide. Snow picks up his story:

"..... the Germans used to search quite thoroughly for aerials and radios and all under the eaves, there were very thin wires and attached to crystal sets, so we used to just to pull their legs a bit, they would have a wire along the eaves, in the wash room, up the chimney, around the chimney, down to the other room then down into the ground. They'd be climbing through the ceiling looking all over the place and they'd finally come down to it, it went into the ground, they dug it away and found a box... "Nix radio here" and of course they'd usually jump up in the air about that one!

Well then, the other one was, I had a fine wire from the hut across to a tree and they came looking for these aerials, under the eaves and they were looking around and two stupid birds were sitting on this wire, and the others said: "shoo, shoo", and other language to make them go away. But they [the birds] didn't understand it – they just sat there between the hut and the tree, they were swinging like this, you know. But the Germans, it didn't worry them, two birds up in the air – that's the normal thing for birds to

be up in the air so they didn't worry about that! They didn't worry at all! We got away with that too!"

In conclusion, Snow said: "Anyhow that was radio and there was plenty of it there and during the march – we marched right across Germany,



Photo 2: WW2 Nominal Roll: Certificate for Mervyn Richmond Campbell.

we left without any radio but by scrounging in churches and other public buildings we picked up coils, wire and crystals and headphones and on this march we built another one which was most valuable to us. Well that's about all I can say about the radio side, there are many other sides, but that's the radio one."(3)

Amateur Radio for April 1945 reports on a WIA Prisoners of War Fund and mentions that parcels and books had been forwarded to Snow (4).

Then in the May 1945 issue, a report that all had been waiting for: Friends of M.R. (Snow) Campbell VK3MR will be delighted to learn that his people have received a cable stating that he is safe in London. We hope to see him home in the very near future (5).

## References

1. Mervyn Richmond Campbell records, Australian War Museum – <https://www.awm.gov.au/people/roll-search/all/>
2. Recording of RAOTC Dinner 1976 featuring Snow Campbell as guest speaker WIA CD11
3. Sounds of Amateur Radio Volume 2, WIA CD, 2010 (Available from WIA Book Shop)
4. Amateur Radio Magazine April 1945, page 6
5. Amateur Radio Magazine May 1945, page 9
6. VK3MR - Some Wartime Exploits, OTN, Journal of the RAOTC, February 1992, P10

Other articles about Snow Campbell appear in OTN for November 1996.

# Jamboree of the Air 2014 at the Rochedale Scout Den and BARC

*Les Neilson VK4FAEB*

The Brisbane Amateur Radio Club hosted an afternoon of radio services for the Rochedale Scout Den to experience the Jamboree of the Air 2014.

Our club meets in the Rochedale Scout Den and the Rochedale Scout Master being a member and the holder of a Foundation licence made it a very convenient process for everyone to participate and benefit.

On Saturday afternoon from 3 pm and until 8 pm, the Scouts would be able to experience the use of our amateur stations setup by our members.

Thirteen of our club members arrived with extra equipment to help make it a successful project for the exercise which was under the control of Standard or Advanced operators for the duration of the exercise.

Norm VK4ANB, Doug VK4DMB, Les VK4SO, Gordon VK4OU, Jim VK4HJK, Robert VK4HBD, Ray VK4HRP and Kevin VK4ZR supervised the operations.

At 2 pm we started to set up a number of stations.

Some shade was provided by the erection of a large tent provided by the Scout Group so that anyone operating the station had a nice shady spot to use. Help in was provided by Keith VK4FVKM, Greg VK4FPGM, Les VK4FAEB, Kyle VK4FKGF and Gary VK4FGZA.

Kyle VK4FKGF arrived with his newly bought transceiver and a Buddipole, and we set it up in the middle of the grounds. It was pre-tuned to 14.190 MHz according to the instructions that came with the antenna kit. The tuning was checked using a MFJ antenna analyser and found to be tuned to 13.5 MHz. After some readjustments and readings with the MFJ it was tuned to 14.190 MHz and the pole was anchored in place for use in the Jamboree of the Air.

Robert VK4HPD brought along a

two metre vertical which involved a rope over a branch in a tree to allow the vertical to be raised a number of metres off the ground. Robert brought along a two metre handheld transceiver and it was used to make contact with other 2 metre stations to allow the Scouts to make contact with other groups.

Gary VK4FGZA arrived with some gear as well. He had two HF Transceivers, an antenna tuning unit and a multiband horizontal dipole.

The dipole had to be raised off the ground and connected between two trees. Gary had an idea of using a fishing rod with a nylon line and sinker to get a rope over a high branch in one of the large trees on the ground. After quite a number of attempts, he settled for a much lower branch.

A second tree was selected and a rope was attached to a claw hammer which was thrown up and managed to pass over a suitable branch and some attempts were quite concerning as the President's car was parked near the tree.

Gary tried to see what could be heard on 40 metres but with poor results. The MFJ was put to use and the antenna was tuned to 7.8 MHz, so 15 metres and another transceiver was used. This time he had success and a number of Scouts then got to enjoy making many contacts via Gary's setup.

The main radio equipment set up in the Club's console consisted of a HF transceiver a Yaesu FT-897 which had an antenna tuner attached.

This was connected to the three element tri-band Yagi mounted on the club's triangular mast. The rotator worked well and the Yagi was pointed south. 15 metres was selected and other Scout groups were heard so the Rochedale Scout group made some interesting contacts with Keith VK4FVKM providing assistance in

getting the Scouts to say something interesting, e.g. not just one word answers.

The Club had an Icom IC-706MKIIG set up in the console and it was switched to 2 metres and connected to a 2 metre vertical mounted on the building. Erik VK4FAEC was asked to control the use of this transceiver and did a marvellous job of coaxing the Scouts to have some meaningful contacts with other groups. He had to make sure the second operators kept the microphone held correctly so that the PTT was operated correctly.

The day proved quite a success with contacts made all around Australia with other Scout Groups. A station in Slovenia made contact with our setup, so Kyle was quite surprised as to how well his portable station was performing.

It was a very successful afternoon activity with more the twenty Scouts throughout the day taking part in amateur radio communications. Some were reluctant to say more than a few words at first, and throughout the day became more adventurous having longer conversations with the other Scouts.

The Scout Group put on a barbeque around 6 pm to provide some refreshments to the Scouts and the BARC Members who controlled the five stations.

It was after 9 pm before the gear was packed up and the venue returned to normal before the evening closed on a great day out for the Scouts and BARC.

*Editor's note: You should be well underway with your planning now for the 2015 JOTA event. Most Scout and Guide groups plan their activities at least one and often two School Terms ahead.*



# SOTA on Black Mountain

*Monique Faulkner VK6FMON*

After a great day of presentations and QSOs at the WIA AGM and Annual Conference, on Sunday we thought we would couple some Canberra sightseeing with a SOTA activation. We ventured up to Black Mountain, and lo and behold, the summit already had gear in the process of being set up, and about to be activated.

Fortunately for us, Andrew VK1NAM was playing host to a couple of interstate SOTA enthusiasts, Paul VK5PAS and John VK5BJE and offered up his SOTA station consisting of a Yaesu FT-817 and a multiband linked dipole held aloft on a 'squid pole'. After many

*Photo 1: Host Andrew VK1NAM, Paul VK5PAS, John VK5BJE, Heath VK3TWO/VK6TWO, and Monique VK6FMON.*



*Photo 2: John VK5BJE and Paul VK5PAS.*





Photo 3: Host Andrew VK1NAM, Paul VK5PAS, John VK5BJE, Heath VK3TWO/VK6TWO.

SOTA contacts, and several photos later, the crew insisted that Heath VK3TWO/VK6TWO join in with the activation and exchange some points.

Activations included 40 m and 6 m for all four of us operating the SOTA station.

At the conclusion of the activation, we all ventured up the

tower to the Café to enjoy the views (and scope out other Summits) that the Canberra region had to offer.

A special thanks to Andrew for his hospitality and use of his SOTA gear.

Monique VK6FMON

## Visit our **Bookshop** **Radio Projects for the Amateur Volume 4**



120 pages of projects, hints and tips from Drew Diamond, a regular contributor to *Amateur Radio* magazine.

- Build - Receivers, Transmitters, Antennas, Test Equipment, Power Supplies.
- Hints and Tips for the home constructor.
- Projects include simple superhet receivers for 160, 80 and 40 metre bands, CW transmitters for the LF and HF bands. Build a 200 W dummy load with power meter.
- Projects feature B/W photos of the finished item, plus schematic diagrams and parts layouts.

If you're into "home brew" this book will be an excellent addition to your library.

Members: \$20.00 \* Retail: \$25.00 \*  
\*Plus Postage & Packaging

**Order your copy today!** Visit our online bookshop for details. <http://www.wia.org.au/members/bookshop/about/>



# SOTA News

Allen Harvie VK3HRA & Bernard Petherbridge VK3AV

Matt VK1MA has become the latest VK Super Shack Sloth joining Tony VK3CAT, Peter VK3FPSR, Gerard VK2IO and Peter VK3PF: 10,000+ Chaser points is quite an achievement.

## WIA AGM

Earlier in May, at the WIA Annual General Meeting, Parks and SOTA players received President's Commendations.

Paul Simmonds VK5PAS received a President's Commendation for outstanding achievement in the World-Wide Flora and Fauna amateur radio program, nationally and internationally, drawing attention to the importance of protecting nature, flora and fauna. See <http://www.wffaustralia.com/>

Allen Harvie VK3HRA received a President's Commendation for development of the "parksnpeaks" website, an online portal, providing

a major contribution to VK amateurs engaging in working from National and State parks, Summits on the Air, the World Wide Flora & Fauna program, and QRP activities. See <http://parksnpeaks.org/>

Joe Gonzales VK3YSP and Julie Gonzales VK3FOWL received the Al Shawsmith Award for 2014 for the article "The International Museums Weekend at the Melbourne Museum" published in the September 2014 issue of *Amateur Radio*. Joe and Julie are Parks and SOTA regulars.

Several visitors to Canberra (VK1) for the WIA AGM were keen enough to activate multiple local summits with the help of Andrew VK1NAM and Andrew VK1DA. Summits activated included Mt Ginini, Mt Coree, Mt Stromlo, Black Mt and Mt Ainslie. Peter VK3PF also activated Boboyan Range and Livingston Hill while travelling to and from Canberra. Other operators

heard making SOTA contacts from VK1 summits were Marc VK3OHM, Onno VK6FLAB, Alan VK4SN, Paul VK5PAS and John VK5BJE.

## AM Day - Andrew VK1DA/2UH

While the timing did suggest an April fool's day prank, it actually did happen and a few keen activators made 20+ contacts on various bands including 2 m, 6 m, 10 m and 40 m. It has to be pointed out the intent of the day was to make AM contacts not just Andrew contacts.

Contacts we know of include: Gerard VK2IO made 19 AM contacts on 40 m

Andrew VK1NAM made 26 on various bands: 40 m, 10 m, 6 m and 2 m

Andrew VK1DA made 21 on 40 m, 10 m, 6 m and 2 m

Adan VK1FJAW made 8 on 10 m and 2 m

VK5FO between the vertical elements on Mt Gawler VK5/SE-013. Note the damage to the site from the fires that went through in early 2015.



Andrew VK3ARR made 4 AM contacts on 40 m.

The sound of AM was nostalgic but it was subject to selective fading that was absent on SSB and also not all operators had their radios adjusted to produce the right balance of carrier and modulation, which was "interesting". After using AM for this activation my view was "thank goodness for SSB".

### SOTA 6/10 m challenge

This year's SOTA Challenge promotes contacts on 6 m and 10 m. Both bands are very quiet in VK with SOTA activators clinging to 40 and 20 m, however this challenge has created a bit more than the usual level of interest in these bands. To help kick off the challenge in VK1, several activations on 17th May by VK1NAM, VK1FJAW and VK1DA provided contacts with US chasers at good signal strengths on 10 m. In the process Adan VK1FJAW worked his first ever DX contacts, with four contacts into the US on 10 m using his FT-817 at 5 watts. Congratulations to Adan – even better to do it from a SOTA summit.

### Additional Nature Reserves qualifying for WWFF

May saw 33 Nature Reserves in VK1 added to the VKFF WWFF Parks list. This greatly increases the WWFF opportunities, as VK1 previously only had a single National Park, Namadgi NP, listed.

There are 7 SOTA summits in the new ACT Parks. See Table above.

The VK1 additions are on top of the 57 South Australian Conservation Parks, 26 Victorian State and 7 Victorian Coastal parks that WWFF coordinator VK5PAS Paul added mid-March.

### VK5FO – 2-element 20 m vertical

Keen to take advantage of new parks and increase DX opportunities, Activators are taking antennas beyond the typical dipole or EFHW. A recent example is the 2-element 20 m vertical deployed

Black Mountain NR	VKFF-834	Black Mountain	VK1/AC-042
Isaacs Ridge NR	VKFF-845	Isaacs Ridge	VK1/AC-041
Mount Ainslie NR	VKFF-850	Mount Ainslie	VK1/AC-040
Mount Majura NR	VKFF-851	Mount Majura	VK1/AC-034
Mount Taylor NR	VKFF-854	Mount Taylor	VK1/AC-037
Rob Roy NR	VKFF-861	Mount Rob Roy	VK1/AC-031
Tuggeranong Hill NR	VKFF-863	Tuggeranong Hill	VK1/AC-038

by Bob VK5FO. Bob's recent activation of Mt Gawler VK5/SE-013 was an unmitigated success with 45 contacts on 20 m with 36 of them being EU DX in 30 - 40 minutes. Using a KX3 at 10 W the key was a 2-element vertical antenna array. Yes, two elements on a summit really is a lot better than a dipole.

For more information: <http://vk5fo.com/>

### VK Summits and Parks Conference

The date and venue has now been confirmed for this event.

**Where:** Wagga Wagga Amateur Radio Club

**When:** 24th and 25th October 2015.

The weekend will start at midday on the Saturday at the clubrooms. Topics include Logging Software, Antennas beyond the dipole and mapping.

A dinner will be hosted on Saturday night at a venue to be advised.

Sunday will involve activations of local SOTA summits and WWFF parks.

About 20+ people have shown their interest in attending. Contact Allen – [arharvie@gmail.com](mailto:arharvie@gmail.com) for more details.

### Winter is coming

Whilst extra care must be taken, rewards await the brave who venture out in the bonus period. It is worth clarifying the timings for the application of the Bonus Points:

- VK1 and VK3: have an additional 3 points for summits  $\geq$  1200 m asl between 15th June and 14th October;
- VK2: additional 3 points for  $\geq$  1200 m (Summits with points of 8 and 10)

Period 15th June to 14th October for CT, SC, SM, ST, SW  
Period 1st July to 31 August for CW, HU, MN, NT, NW;

- VK7: additional 3 points for  $\geq$  1200 m between 15th June to 14th October.

Readers should note that some of the northern and central regions in VK6 have a Summer bonus points period due to the high temperatures (and also high humidity) – check the Association Reference Manual for the details.

### Summits

Some recent discussions with amateurs interested in activating has highlighted the need for the Activator to check the Summit Database via the internet rather than mobile applications only for additional details that have been uploaded by previous Activators or Association Managers.

Some summits are in locations that prohibit access such as water catchments and others on private property. Attempting to log the former will see the points deleted and in the latter case permission from the owner is always required. The key objective is to avoid bringing SOTA into disrepute (refer the General Rules).

The other benefit obtained from looking at the web site is the additional information that might relate to access paths, suitable set-up locations, additional mapping or links to Activator blogs related to the summit. A good example is VK3/VC-014 Mt Disappointment.

Until next month...have fun out there.

Allen VK3HRA & Bernard VK3AV



# Mount Duncan Repeater VK7RMD site upgrade

David Cleland VK7DC

The Cradle Coast Amateur Radio Club maintains three repeater sites on the North West coast of Tasmania. The main site is Mt Duncan, at around 650 metres above sea level.

Access is via a steep and rugged walking track entailing a 30 to 60 minute climb (depending on your fitness) over some rugged terrain.

The unpowered site has been in use for over 30 years and the original mast was a rusting 10 metre telescopic pole that was secured using guy wires tied to nearby rocks.

The existing site solar panels were secured to the pole and it was not possible to lower the pole for maintenance. The only access to



Photo 1: Tower base.

the antennas was by climbing the pole, which was at the end of its working life. It was now unsafe to

climb for any antenna servicing and it was a liability to the safety of the general bush walking public.

Photo 2: Tower ready to lift.



A decision was made 18 months beforehand by club members to upgrade the site and replace the mast with a galvanized tower.

From that point in time the new tower was designed, constructed and galvanized.

Due to the difficult access, the tower would have to either be carried up in pieces and assembled on site, or it could be lifted up by helicopter. The club had recently lifted up a new set of 830 Ah batteries by helicopter, so this seemed a logical option. The helicopter is capable of lifting 1.4 tonnes, so the tower would not be a problem.



Photo 3: Chopper arrives.

It was decided that the lift would entail two loads, one carrying the new shed sheet metal, solar panel and shed frames, new 2 m cavities and the solar panels. The second lift would be the tower itself, complete with antennas and HeliAx ready to connect.

The site has two small peaks about 40 metres apart and at a similar elevation. The bit of ground in between is a no-man's land, rugged and not so flat.

Beforehand some major works had to be undertaken. The new tower site had to be levelled out

on the rock surface. To mount the tower it was required to carry up a very heavy portable rock drill to bore the holes in the conglomerate rock at the peak. The drill was a petrol-driven device powered by a two stroke engine and was used to bore bolt holes about a metre deep for the tower and shorter holes for the new solar panels and site shed.

Photo 4: Shed panels ready to go.







*Photo 5: Dangling Tower.*

*Photo 6: The tower almost in position.*



Saturday 11 April 2015 was the planned date for installation. On the day prior to the installation all equipment was delivered to a farming property at the lift-off base at Purton's Flats, which is located 2 kilometres south east from Mt Duncan.

The tower was set up on a steel frame and all the antennas were mounted on the tower ready for lifting the next morning.

The new site antennas consist of 4 folded dipoles for 70 cm, 2 folded dipoles for 2 m, and a single folded dipole for 6 m. The Heliax feed lines were also attached to the antennas and run down to the base of the tower and coiled up.

On the next morning all was in readiness and good weather conditions allowed the planned tower upgrade of Mt Duncan to eventuate.

The day of the airlift started with the advance party heading up to the Mt Duncan summit very early in the morning to decommission existing equipment for the changeover.

The airlift began with the helicopter arriving at 9 am for the start from Purton's flats. The shed, frames and solar panels were first lifted up to the new site.

The old box containing the batteries was then airlifted from the old site to the new location, a distance of around 40 metres over extremely rugged terrain.

The helicopter then returned to the lift base where the tower was attached and promptly hoisted up to the top of Mt Duncan. It was a magnificent sight to see the tower flying away, dangling at the end of the 40 metre lift rope. At the Mt Duncan end, the new tower was lowered directly onto the new mounting bolts. It was then secured while being held steady by the helicopter.

Once the tower was secured, the pilot released the tower, leaving some lucky person to climb the tower to retrieve the lifting strops from the top of the tower. This would have been a nerve racking job given the steep drop off to the side of the tower.

In the few minutes after being transported from the other peak, the battery case had been promptly relieved of its batteries. Once the tower was released, the helicopter was able to pick up the vacated battery box which was filled with some other redundant items and then it was all flown back to the lift base.

Overall, the transport operation was completed in around 30 minutes of flying time on site, leaving the ground crew to tidy up. The mountain team had the rest of the day to assemble and mount the shed, mount the solar panels, install the batteries in the shed, complete the wiring changes, and re-install and test the radios.

With the new panels put in operation, battery charging currents of over 65 amps were observed. This should well and truly overcome the long periods of low battery charge during the cloudy winter months.

Since the installation and after periods of bad weather and high repeater usage overnight, the top current has been only around 20-30amps with the batteries boosting



*Photo 7: Tower guided in.*

and then going into float charge around 10 am.

The panels are 4 x 250 W 24 volt units and are hooked into a series parallel arrangement.

They are capable of providing around 80 volts open circuit, and 17 amps @ around 60 V. The solar regulator is a Midnight Classic which is a switch mode converter type, transforming down to 14 volts.

The decision to use 1 kW of panels was based on the

requirements unique to Tasmania, long spells of cloudy, wet winter days. The ability to get a large recharge on an isolated sunny day and even to get some charge on the cloudiest of days to minimize the loss of overall battery charge level was part of the selection parameters.

The large capacity of the batteries dictates that a high charge rate is required to maximize battery life. The previous panels were only





Photo 8: Antenna mounted and solar panels.

the 2 m and 70 cm coverage, and are probably providing the best coverage in the state.

Since being installed, a recent tropospheric enhancement event has seen coverage out to Ballarat on 6 m, 2 m and 70 cm, with 20+ signal reports on all bands.

At the previous club meeting, Dion VK7DB had presented the predicted radiation patterns on the big screen after he had modelled and optimised the antenna locations on the tower using computer

software. It appears that the theory is supported by the results.

The radios are all Unilab repeaters which have been modified for low idle current consumption and appear to be working extremely well.

Frequencies are 53.800 MHz 146.625 MHz and 438.600 MHz with the UHF repeater requiring tone input, accepting either 141.3 Hz or 91.5 Hz.

The club would like to thank all those who attended on the day to make this happen, including those that travelled from faraway Launceston and Hobart. Also thanks go to those in the lead up period over the last 18 months, with the construction evenings, building the tower, shed and solar panel frames.

Also deserving of a mention is the carrying up the petrol driven rock drill and boring mounting holes in the conglomerate rock for the tower, shed and solar panel frame.

Special thanks go to Dion VK7DB whose tireless persistence and efforts have driven this project to completion, not to mention the countless climbing trips he has made to the top of the mountain to make the necessary preparations.

There are some videos of the lift which can be found by searching for **vk7rmd** on YouTube and a search of **vk7db** reveals an overview from a quadcopter flyover prior to installation.

## References

1. Cradle Coast Amateur Radio Club Inc. (CCARC) web site: <http://www.my-x15.net/ccarc>
2. Web page link <http://my-x15.net/ccarc/TOWERLIFT.html>

capable of about 10 amps at best.

All antennas on the site are now fed with Heliac, reducing losses to a minimum. With the new tower and antennas installed, the early local signal reports have shown significant improvements in both

## WIA Traveller's Badge



### An ideal Gift for Hams

The badge can be ordered from the WIA office or via the WIA website at [www.wia.org.au/members/bookshop/about/](http://www.wia.org.au/members/bookshop/about/) under the "Merchandise" heading.

The price is \$10 plus postage and packaging.



Nick Hacko VK2DX

e vk2dx@wia.org.au

The propagational mid-season period on HF is that exciting time of the year when high bands can yield some amazing openings. This year was no exception and the active chasers were rewarded with some 'pipe-line' openings to Africa. From the mid March to early April, stations from West, Central and Southern Africa were booming in, especially on 15 m and 10 m bands. The beauty of the 'pipe-line' opening is that strange phenomenon where a distant station has no real propagation to any part of the world, other than VK! We can hear that DX station really loud, and since no one else is calling, he can hear us even at the QRP level.

This was surely the case with S01WS who's endless CQs on 15 m band via long path were only answered by VK2 and VK3s. Another loud one was ZS9M from Pretoria with a killer signal on 10 m. At the same time, many of us worked Baldur, DJ6SI and Jan, DJ8NK from Togo, who were active as 5V7BD and 5V7JH and an easy catch on 12 m.

The 17 m band was in particularly amazing shape. It would take no more than a few calls to generate a pileup of always keen Europeans. This band is open almost 24 hours per day to *somewhere* – so it should be monitored as often as possible. If you turn your antenna to Europe via long path, you can easily hear your echo (your signal travelling all around the globe) which is often a sign that you are heard well over South/Central America as well as West Africa. Try it – it is fun.

## IOTA ACTIVATIONS

**T88TI, T88GI, T88XX.** Tobi Island OC-296 is the latest addition to IOTA programme. Tobi is an island in the Palauan state of Hatohebei.

Population is in steady decline from about 80 in 1962 to around 7 inhabitants at the last count. Most of them live on the island's west side and speak Tobian. The total land area is less than 1 square kilometre and the highest point is just 6 metres above sea level. From March 11 to 13, Tobi Island was on air thanks to three seasoned IOTA activators: Nando IT9YRI, Claudio I1SNW and Mike K9AJ who sailed 2 days to reach their destination. They made many chasers happy, and they were an easy catch for us.

## INDONESIA

A firework of activations from various islands! YF1AR/4 was on Enggano Island, OC-204, YB4IR/7 operated from Karimata, OC-269 and YB3MM/p visited Gili Getting Island, OC-237.

Our Indonesian friends are keen island activators who operate on both phone and CW. Despite the low power and simple vertical antennas they are often an easy catch for us on 15 m and 20 m. To their credit, once they setup their operating site on an island, they invite and encourage local amateurs to join them on the air, using their own call signs. Our YB friends hop islands using very irregular commercial transport and are often required to cancel or change plans on short notice. When you hear such IOTA activation on air, do give them a call and keep in mind how hard our Indonesian friends work to give you a new one. Respect!

## BRAZIL

The one that got away: DXpedition to PQ0T Trindade Island, Brazil. April 2-7. Trindade and Martim Vaz is an archipelago located about 1,200 kilometres from the main land, in the Southern Atlantic Ocean. The archipelago has a total area of 10

km<sup>2</sup> and a population of 32 – all of them Brazilian Navy personnel. The archipelago consists of five islands and several rocks. The team of five Brazilian operators spent 4 days on the island under strict supervision of the Navy.

We all knew that this one is going to be tough for VK but nevertheless, we hoped for a miracle: a killer signal on an empty band, their Yagi pointed in our direction and those two magical words: "VK ONLY".

The reality was harsh: not a trace of PQ0T signal on any band which was really a result of low power setup and simple antennas. The time difference was also working against us.

## SOUTH AUSTRALIA

**VK5CE/p** St Peter Island, South Australia OC-220

It has been many years since the last operation from St Peter Island. Craig operated from March 29 to April 1 in a typical one-man and a generator style.

What a show! In just four days Craig logged 4,194 QSOs under extremely difficult conditions. I managed to secure an exclusive interview with Craig just in time for the deadline for DX Talk:

*Craig - what made you go to St Peter Island and how long it took you to plan/prepare the operation?*

I decided to go there because this IOTA had not been activated for 10 years. Even though 27.7% of IOTA chasers worked and confirmed this island, the fact that 10 years had passed meant that I knew a four day DXpedition would keep me busy with lots of people wanting this one. I also wanted to do this because it is my 'local' VK5 IOTA. After activating another VK5 island OC-261 two years ago (which also



hadn't been activated 10 years ago prior), I want to make sure they are activated for the hunters. I'll also be looking to activate OC-228 in VK5 which hasn't had a proper IOTA DXpedition for 11 years.

This DXpedition didn't take long to equip because I have all of the DXpedition equipment ready to go. I was able to find a boat and captain quite quickly but the permission from the South Australian Government's Department of Parks took 4 months of regular negotiation between offices in Ceduna and Adelaide. Rules for accessing this island changed dramatically in October 2014 and so it was a lot of hard work to get final approval.

*Apart from landing permit, what was the most challenging aspect of the operation?*

The most challenging part of this DXpedition was that it was an uninhabited island and I had to bring every conceivable part of life support with me and I was responsible for every aspect of life support and DX operation. The extreme heat at the very beginning of the DXpedition meant that I had to endure 42.5C in the tent for two days and deal with just 4-5 hours' sleep per night.

*What was your greatest fear?*

The greatest fear was that this island had a dense population of Black Tiger Snakes which are venomous and the captain said he has seen them living right on the beach.

*And the highlight?*

Being able to work 1000 QSOs per day; to work QRP stations in Europe; people running modest 50 W dipole stations in the UK and mobile stations in the USA. I figured that anyone who needed OC-220 now has it.

*What have you learned from this activation?*

This DXpedition reminded me to always give 10 m band a try before 15 m. The openings to North

America on 10 m in the mornings were great from east to west coast and the openings in the late afternoon/early evening to Europe were fantastic.

*Where do you go next?*

There are 10 VK IOTAs on my radar to visit over the upcoming years. It's a bit hard to say which one will be next because I have fishing lines in the water, some have taken the bait and so it just depends on which fish I reel in first!

*Thank you Craig for sharing your excitement with AR readers- we wish you calm seas on the next one and looking forward working you soon from another Australian Island.*

### **Your feedback**

More on Marion Island, ZS8

*"I always read the DX column first, no matter what the magazine, as this is where my amateur radio heart lies. I am not a great, or even particularly good DXer but I certainly can get enthusiastic at times.*

*The story in your April column concerning David VK3EW and his ZS8 Marion Island CW QSO was marvellous, although the story line is, very possibly, only something a committed DXer would fully understand and appreciate.*

*Now anyone who has played DX for some time has at least one story that they will recall forever, and mine concerned, yes, ZS8 Marion Island. But not in either the phone or CW modes, but rather a digital mode, to wit JT65*

*For some obscure reason I love JT65, and often scroll around the sub-bands looking for a new entity on the mode or even just a new station to work. And so I was on 5 February, 2014, at 0723 UTC, on the 15 metre band. Nothing was showing on the waterfall, so I tried a few CQ calls, hoping for a response but not particularly confident.*

*Then, after one such call, a station responded – ZS8Z Marion Island, operator David whose home call is ZS1BCE.*

*Now, over very many years of DXing I had grown accustomed to the old but very valid statement- WFWL (Work first, worry later), so I did just that. I made a good QSO and immediately rushed to the internet to confirm the call, and everything else about it, was indeed kosher. It was, and my Marion Island JT65 QSO gave me two new ones, a first ZS8 on 15 metres, and a new entity worked on digital.*

*The card came along in due course as did LOTW confirmation. Again, only a true DX lover could appreciate the happiness this whole episode created in the VK3FM household – half of it, anyway!"*  
Ernie Walls VK3FM

### **DXOP Spratly Island**

Not less than six countries make the possession claims on Spratly: China, Philippines, Malaysia, Vietnam, Brunei and Taiwan.

From amateur radio perspective and for the sake of DXCC credit all contacts with Spratly count as one single entity. However, in reality, an activation of Spratly is often seen as a political or even military statement. And this is precisely the case of DXOP activation which took place from April 16-20. An all-Philippine team landed on the Pagasa, the second largest Spratly Island. Pagasa is under control of Philippines since 1968. The team needed not to worry about transport and supplies – all the logistic was courtesy of Philippine's Navy. DXOP website proudly includes number of photos of Offshore Combat Force Philippine Fleet, including heavily armed personnel. Propaganda or not, we, the amateurs, would not be too picky- while DXOP was fairly weak in VK2, quite a few managed to work them on high bands.

At the time of this report, the total QSO number was not known but judging by the band activity and preliminary numbers published online, it will be around 6,000.

Spratly is not a particularly difficult one for us, but certainly is from both Americas.

## TX5P Clipperton Island

Without much fanfare, Alan F6BFH appeared on the air on 20 m CW. Alan and his XYL Daniele are part of scientific expedition to Clipperton with duties which include research, communication and support. A simple setup consisting of a 100 W radio with a dipole is all

he's got on his disposal. But as we say, an excellent CW operator is worth 30 dBs so getting in his log was not that difficult. The trick is (as always!) to be on the right frequency at the right time, before the TX5P is spotted on the cluster. 14.045 MHz is Alan's favourite frequency so call him 5-10 up. I am probably the only

person on the planet who missed 2013 TX5K mega DXpedition so getting Clipperton as an ATNO number 308 (all-time-new-one) was such a thrill.

Unfortunately this is all we had time for, so until next month—  
Good hunting and CU on the air!  
Nick Hacko VK2DX



## Spotlight on SWLing

Robin L. Harwood VK7RH

• vk7rh@wia.org.au

Winter has certainly hit here with a vengeance and it has hit me hard. Only a few weeks ago, I had a grommet placed in my right ear to relieve a fluid build-up. I thought initially it had succeeded but it seems to have slipped back to its former state, which has left me very frustrated and quite grumpy. To be fair, there has been some slight improvement but some further tweaking of my hearing aids is next. To add to my woes, I developed a nasty head cold that could have also contributed to the ongoing hassles. I miss being able to fully hear what is happening on shortwave.

Just in case you missed it, a second was deleted at 23:59:60 UTC on June 30<sup>th</sup>. Apparently the only complaint received was from on-line commodity traders who rely on currency and stock market fluctuations in milliseconds. This

apparently did not cause problems the last time it was done a few years ago.

### Emergency in Nepal

Nepal was badly hit by a series of earthquakes at the end of April and mid-May. Domestic telecommunications was severely disrupted and several emergency amateur radio nets quickly were established to provide health and welfare traffic for the Red Cross and other agencies. Special transmissions were also initiated by international broadcasters via shortwave. The BBC World Service had programming in Nepali as well as All-India Radio. The evangelical station KTWR on Guam also had programming in both Nepali and Bhutanese. There is quite a number of Bhutanese here in Launceston and quite naturally they were concerned for their relatives and

areas. The local community FM station has a weekly program for the Nepalese and Bhutanese community here.

As I am writing this column, I am listening to very fast CW operators who are involved in the WPX contest. Signals are coming in so well, especially on 14 MHz. It brings back so many memories of the time I used to rattle it out on the key. I really must trundle out to the local club station, VK7TAZ, and plug in a key. Some of you may remember Col VK2ASF and Roy VK2DO rattle it out around 3570 in the mid 70s and they did not use a bug either. Sadly I never got to meet Col as I was away at a family funeral the day he called to my QTH.

Well that is all for now. Don't forget you can reach me at vk7rh@wia.org.au

73 de Robin VK7RH

### Plan Ahead

**Remembrance Day Contest**

15 - 16 August

**ALARA Contest**

29 - 30 August





# Contests

James Fleming VK4TJF/K8UP

e vk4tjf@wia.org.au

## IARU HF Contest

This month in contesting the main event will be the IARU HF Championships contest. It will begin the second weekend of July the 11-12<sup>th</sup> for a 24 hour period from 1200 UTC Saturday to 1200 UTC Sunday.

The main object is to contact as many operators as possible on all bands especially the IARU member society HQ stations. As usual you can do either single or multi operator.

One can do phone, CW or mixed mode, high low or QRP power if you're a single operator.

As a multi operator you are restricted to single transmitter mixed mode only. Low power is classified as 150 watts, QRP 5 watts and High power would be 400 watts for us in Australia. Contest exchange is signal report and ITU Zone except for IARU member society HQ stations that give out signal report and official IARU member society abbreviation.

ITU zones in Australia are 55, 58, or 59. I live in sunny QLD so mine is

## Contest Calendar for July 2015 - September 2015

Month	Date	Starts at	Spans	Name	Mode
July	4th - 5th	1100 UTC	24 hours	DL-DX RTTY contest	RTTY
	11th - 12th	1200 UTC	24 hours	IARU HF World Championship	CW/SSB
	18th - 19th	1200 UTC	24 hours	DMC RTTY contest	RTTY
	25th - 26th	1200 UTC	24 hours	RSGB IOTA contest	CW/SSB
August	1st	0000 UTC	24 hours	TARA Grid Dip Shindig contest	RTTY/PSK63
	1st - 2nd	0001 UTC	48 hours	10-10 International Summer contest	SSB
	8th - 9th	0000 UTC	48 hours	Worked All Europe contest	CW
	15th - 16th	0300 UTC	24 hours	Remembrance Day contest	CW/Phone/RTTY/Mixed
	29th - 30th	0400 UTC	20 hours	ALARA contest (10 hours each day)	CW/SSB
September	5th - 6th	0000 UTC	48 hours	All Asian DX contest	SSB
	12th - 13th	0000 UTC	48 hours	Worked All Europe DX contest	SSB
	19th - 20th	1200 UTC	24 hours	Scandinavian Activity contest	CW
	26th - 27th	0000 UTC	48 hours	CQ WW DX contest	RTTY

55, if you live in Western Australia you are 58 and South Australia would be 59. For a nice map of the ITU zones see <http://www4.plala.or.jp/nomrax/ITU/>

The point breakdown is as follows:

Contacts within your own ITU zone, as well as QSOs with any IARU-member society HQ station

or IARU official (counting as the special multiplier), count one point each

Contacts with a station in the same ITU zone, but on a different continent count one point.

Contacts within your continent (but different ITU zone) count three points.

The logo for the IARU HF World Championship 2015.



Contacts with a different continent and IARU zone count five points. Multipliers are the ITU zones and the IARU member society HQ stations worked on each band (not mode).

Please send logs to [IARUHF@iaru.org](mailto:IARUHF@iaru.org) in Cabrillo format. As usual the VKCL logging program does all the work for you and makes life easy.

This is a fun contest that you should be able to increase your DXCC count while at the same time hitting up some of the IARU societies.

As a plus I have always received a QSL card from the IARU member societies. If you work 70 out of the possible 75 IARU zones, the Radio Society of Great Britain (RSGB) has a nice award for you, the worked ITU zones award at <http://rs.gb.org/main/operating/amateur-radio-awards/rsgb-hf-awards/worked-itu-zones/> Also you can get your

IARU Region 1, 2, or 3 award. So there is lots of fun to be had during this contest and one for the DXer, QSL card chaser and Award hunter. This is why this contest appeals to me; I'm all of these three things. So get into the spirit of DX in July and have a go at the contest. Or just contact some of the HQ stations and/or give out a few zones, I'm sure that Aussie zones will be in much demand - you might even get a pile up.

### **Ted Powell (VK2AU) Memorial DX Challenge**

The Fisher's Ghost Amateur Radio Club wishes to announce a new contest which will commence on 1 July 2015. They have been running a trial of this contest in-house since October 2014 with great results. They advise that the contest has proved to be fun, challenging and rewarding for the DX chaser.

The contest was developed

in memory of their friend and fellow Club member Ted Powell VK2AU (SK), who passed away in April 2014. Ted's passion was working rare DX and at the time of his passing, Ted had worked 301 entities and confirmed 300 by QSL cards.

The objective of this contest is to work the most wanted DXCC entity during an award period. The winner will be the station who works the most wanted DXCC entity based on its ranking in Club Log's "Most Wanted" list current at the start of the particular award period. There are also awards for 2nd and 3rd place. There are four award periods per year, each running for three months.

For more information, contest rules and entry submission details, see the contest website: <http://www.vk2au.org>

73 de James Fleming



Make more use of that multi-mode, multiband transceiver that includes 6 m, 2 m and 70 cm! Learn more about what can be worked on VHF, UHF and microwaves through a two-day immersion experience by attending the annual **GippsTech conference**



GippsTech has a reputation as a premier amateur radio technical conference. It focusses primarily on techniques applicable in the VHF, UHF and microwave bands, especially for weak-signal contacts.

It is almost that time again: GippsTech 2015 will be happening on the weekend of the 11th and 12th of July, at Federation University Australia Gippsland Campus in Churchill, Victoria, about 170 km east of Melbourne. Come for one day or the weekend.

A Partner's Tour will be conducted provided we have sufficient interest, together with an informal social

gathering for dinner on Friday and a Conference Dinner on Saturday.

Those of you who have more experience and have information to share with others are invited to submit titles of presentations to the Conference Chair Peter VK3PF as soon as possible.

We look forward to seeing you at GippsTech in early July.

Details and registration available on the EZARC website: <http://www.vk3bez.org/>



# Results John Moyle Memorial Field Day 2015

Denis Johnstone VK4AE/VK3ZUX

Contest Manager, JMMFD 2015

## 24 Hour Portable Operation – Multiple Operator

Call Sign	Operators	Mode	Band	Score	Contacts	Place /Award
VK3ER	Multi	All	All	8,457	1,121	1P
VK2WG	Multi	All	All	3,233	531	2P
VK3YVG	Multi	All	All	1,303	242	3P
VK4BAR	Multi	All	All	432	194	4P
VK4IZ	Multi	All	HF	700	331	1P
VK4CHB	Multi	All	HF	90	42	2P
VK3ANR	Multi	Phone	All	1,723	296	1P
VK2TG	Multi	Phone	All	949	391	2P
VK3CMZ	Multi	Phone	All	811	304	3P
VK6AHR	Multi	Phone	All	664	294	4P
VK6ARG	Multi	Phone	All	652	199	5P
VK6WI	Multi	Phone	All	443	210	6P
VK4WIT	Multi	Phone	All	351	136	7P
VK3KQ	Multi	Phone	VHF	3,677	285	1P
VK5WA	Multi	Phone	HF	2,282	1,141	1P
VK4OD	Multi	Phone	HF	1,282	644	2P
VK1MT	Multi	Phone	HF	692	347	3P
VK3CNE	Multi	Phone	HF	592	296	4P
VK5BDK	Multi	Phone	HF	590	295	5P
VK2ACH	Multi	Phone	HF	530	265	6P
VK4WID	Multi	Phone	HF	480	240	7P
VK3ATL	Multi	Phone	HF	336	168	8P

## Six Hour Portable Operation – Multiple Operator



Call Sign	Operators	Mode	Band	Score	Contacts	Place /Award
VK2BV	Multi	All	HF	342	177	1P
VK4GYM	Multi	All	HF	78	37	2P
VK5SR	Multi	Phone	All	396	187	1P
VK3BML	Multi	Phone	All	134	35	2P
VK6NAK	Multi	Phone	All	40	18	3P
VK3APC	Multi	Phone	VHF	350	43	1P
VK2SF	Multi	Phone	HF	576	288	1P
VK4BRC	Multi	Phone	HF	260	130	2P
VK2LE	Multi	Phone	HF	210	105	3P
VK2A0J	Multi	Phone	HF	202	101	4P
VK2BOR	Multi	Phone	HF	180	90	5P
VK2EWC	Multi	Phone	HF	174	87	6P
VK3III	Multi	Phone	HF	32	16	7P

## Comments on John Moyle Memorial National Field Day 2015

This year's entries came from every Australian mainland call areas with several from Tasmania but only one from New Zealand. The total number of eligible logs submitted was 184. This was a slight increase (2.8%) from the 179 logs received last year. Well done to all who took part and took the effort to submit a log. This year

## 24 Hour Portable Operation – Single Operator

Call Sign	Operators	Mode	Band	Score	Contacts	Place /Award
VK1DA	Single	All	All	3,636	224	1P
VK2ID	Single	All	All	147	62	2P
VK5KBJ	Single	Phone	All	1,510	232	1P
VK2FAAD	Single	Phone	All	1,158	100	2P
VK50Q	Single	Phone	All	844	144	3P
VK3PCW	Single	Phone	All	541	203	4P
VK3MRG	Single	Phone	All	342	35	5P
VK6ZK0	Single	Phone	All	81	53	6P
VK3ND	Single	Phone	All	58	9	7P
VK5TE	Single	Phone	VHF	1,846	231	1P
VK5KK	Single	Phone	VHF	1,742	213	2P
VK2IUB	Single	Phone	VHF	1,617	101	3P
VK2NH	Single	Phone	VHF	325	20	4P
VK2BBQ	Single	Phone	HF	700	350	1P
VK5RN	Single	Phone	HF	624	312	2P
VK8GM	Single	Phone	HF	594	298	3P
VK7JGD	Single	Phone	HF	302	151	4P
VK5MH	Single	Phone	HF	206	103	5P
VK3ADD	Single	Phone	HF	106	53	6P
VK2AWJ	Single	Phone	HF	80	40	7P
VK4MON	Single	Phone	HF	64	32	8P
VK2BJT	Single	CW	HF	104	26	1P
VK1WJ	Single	CW	HF	88	23	2P
VK3IT	Single	CW	HF	36	11	3P

 Certificate Awarded  
 President's Cup  
 Participation Certificate

6 YLs and XYLs entered a log– Well done! Many more were listed as taking part with a club station.

I have included in the results, all of the logs that I received and if any are missing, they are completely lost. I can only offer my apologies to anyone so affected. If your log is missing, it did not get it to me, despite my most careful procedures and cross checking.

Based upon submitted logs, there were some 21,405 contacts, (a 10.1% decrease from 2014) accumulating some 73,796 points claimed, (a 0.6% decrease from 2015). This was successful contesting for an Australian field day contest resulting from 184 logs being received. More than 1,230 Australian individual call signs were again logged during the contest.

Unfortunately, the numbers of stations who went to the considerable trouble of going out and setting up as a portable station and then not submitting a log as an entry, are still a disappointment. Some multiple operator stations got very big scores this perhaps simply reflects the great and varied planning and implementation efforts required to assemble and operate a multi operator station.

## Six Hour Portable Operation – Single Operator

Call Sign	Operators	Mode	Band	Score	Contacts	Place /Award
VK3PI	Single	All	All	422	80	1*
VK3YE	Single	All	HF	212	99	1*
VK1AI	Single	All	HF	175	85	2*
VK5RX	Single	Phone	All	1,314	123	1*
VK4ADC	Single	Phone	All	298	117	2*
VK6ZN	Single	Phone	All	282	61	3*
VK2XIC	Single	Phone	All	36	8	4*
VK5ZT	Single	Phone	VHF	1,451	83	1*
VK3VMC	Single	Phone	VHF	313	24	2*
VK3FIX	Single	Phone	VHF	271	23	3*
VK3MQ	Single	Phone	VHF	112	12	4*
VK6FMLB	Single	Phone	VHF	50	11	5*
VK5PAS	Single	Phone	HF	476	238	1*
VK3YSP	Single	Phone	HF	444	222	2*
VK3VTH	Single	Phone	HF	284	142	3*
VK2GZ	Single	Phone	HF	216	108	4*
VK3FOWL	Single	Phone	HF	212	106	5*
VK2MT	Single	Phone	HF	202	101	6*
VK4FFAB	Single	Phone	HF	200	100	7*
VK5RR	Single	Phone	HF	178	89	8*
VK5FO	Single	Phone	HF	168	84	9*
VK2ZB	Single	Phone	HF	126	63	10*
VK3ANL	Single	Phone	HF	122	62	11*
VK5KLV	Single	Phone	HF	86	43	12*
ZL3VZ	Single	Phone	HF	80	40	13*
VK4JRO	Single	Phone	HF	72	36	14*
VK3FALA	Single	Phone	HF	66	33	15*
VK6LCK	Single	Phone	HF	62	31	16*
VK4BH	Single	Phone	HF	58	29	17*
VK5FJEN	Single	Phone	HF	54	27	18*
VK5KPR	Single	Phone	HF	42	21	19*
VK5ZAT	Single	Phone	HF	40	20	20*
VK6VAX	Single	Phone	HF	8	4	21*
VK2DNZ	Single	CW	HF	64	16	1*
VK4JAZ	Single	CW	HF	12	3	2*

Activity was carried out on all bands permitted under the rules. There was a slight decrease in activity on HF, and there was less activity on the higher HF frequencies as would be expected by the decreasing sunspot cycle. This sunspot cycle is starting to decrease from top at the moment and conditions on some bands did not appear to change much. Activity on 40 m showed little change. The other lower bands seemed to be wiped out by the heavy QRM and general lack of activity.

In the higher UHF and Microwave bands there was an increase in activity; since it obviously follows a weather cycle, rather than the solar cycle? The weather in VK/3/5/6 was very good, so plenty of increased activity and with very wet conditions with some severe thunder storms in VK2/4 so activity there was greatly reduced.

The scoring in the VHF range was about the same as for last year, though the scoring as a ratio of contacts per station is substantially lower than for 2014. The absence of many club stations, because of the miserable

## Home Station – 24 Hour (Part 1)

Call Sign	Operators	Mode	Band	Score	Contacts	Award
VK3MEG	Home	All	All	454	231	1*
VK3MV	Home	All	All	54	20	2
VK3CG	Home	Phone	All	802	242	1*
VK5DT	Home	Phone	All	574	262	2*
VK3UX	Home	Phone	All	490	158	3
VK2ACD	Home	Phone	All	485	207	4
VK5DF	Home	Phone	All	437	216	5
VK4VDV	Home	Phone	All	388	200	6
VK2CZ	Home	Phone	All	374	187	7
VK5FDEC	Home	Phone	All	322	154	8/3
VK3AV	Home	Phone	All	298	134	9
VK3PH	Home	Phone	All	149	32	10
VK3FMHY	Home	Phone	All	145	68	11/3
VK3GC	Home	Phone	All	108	26	12
VK2ASY	Home	Phone	All	103	55	13
VK3NCC	Home	Phone	All	69	36	14
VK3TZ	Home	Phone	All	57	19	15
VK5DN	Home	Phone	All	55	35	16
VK2FCJZ	Home	Phone	All	53	30	17/3
VK1ATP	Home	Phone	All	50	37	18
VK6BDD	Home	Phone	All	46	16	19
VK6BMW	Home	Phone	All	27	13	20
VK6XL	Home	Phone	All	9	6	21
VK2UW	Home	All	HF	565	303	1*
VK2NP	Home	All	HF	284	163	2
VK2KTT	Home	All	HF	101	60	3
VK3DIP	Home	Phone	VHF	657	76	1*
VK1KW	Home	Phone	VHF	632	96	2
VK2WDD	Home	Phone	VHF	436	58	3
VK2AGC	Home	Phone	VHF	394	47	4
VK3VL	Home	Phone	VHF	364	30	5
VK3WT	Home	Phone	VHF	266	55	6
VK3FCIM	Home	Phone	VHF	139	92	7/3
VK3PZ	Home	Phone	VHF	71	20	8
VK3CEK	Home	Phone	VHF	80	15	9/3
VK3PHD	Home	Phone	VHF	20	5	10/3
VK5LJ	Home	CW	HF	112	23	1*

weather in some parts of VK certainly reduced activity, with many portable stations making such comments.

The other major change noticed this year was the increase in both Portable and Home Station operation as seen by the submitted logs. Clearly the new rule requiring all stations who contacted any station more than 5 times to submit a log has made a positive impact. There were however reports of stations, who when contacted later by a portable station, simply refusing the contact for then they would have to submit a log. This type of activity was most unsporting and not in line with the spirit of the contest. This activity appeared to make a very significant decrease in the number of contacts made and points earned per station. This was the real downside of the 5 contact rule.

The '5 Contact Rule' was devised to facilitate the checking and verifying of submitted logs. It was not devised to irritate and anger people who chose,



## Home Station – 24 Hour (Part 2)

Call Sign	Operators	Mode	Band	Score	Contacts	Award
VK3S(M)	Home	Phone	HF	692	478	
VK4DMC	Home	Phone	HF	285	226	2/
VK2DN	Home	Phone	HF	249	160	3
VK5UV	Home	Phone	HF	211	128	4
VK4KY	Home	Phone	HF	187	121	5
VK2ZCM	Home	Phone	HF	167	114	6
VK4IAA	Home	Phone	HF	160	99	7
VK3DF	Home	Phone	HF	156	88	8
VK2WRU	Home	Phone	HF	153	89	9
VK2BO	Home	Phone	HF	132	80	10
VK5FD	Home	Phone	HF	117	70	11
VK4ATH	Home	Phone	HF	104	63	12
VK2UVP	Home	Phone	HF	101	61	13
VK3KR	Home	Phone	HF	94	53	14
VK2EJW	Home	Phone	HF	78	52	15
VK4FPDG	Home	Phone	HF	70	42	16 /\$
VK2LEE	Home	Phone	HF	67	40	17
VK2VE	Home	Phone	HF	66	43	18
VK5NDP	Home	Phone	HF	65	36	19
VK2WJ	Home	Phone	HF	60	34	20
VK3WMM	Home	Phone	HF	50	30	21
VK7ZGK	Home	Phone	HF	39	24	22
VK4PO	Home	Phone	HF	32	20	23
VK6YTS	Home	Phone	HF	24	14	24
VK6LO	Home	Phone	HF	15	8	25
VK2GHD	Home	Phone	HF	10	6	26
VK6TU	Home	Phone	HF	6	3	27
VK4TAW	SWL		HF		78	17

 Certificate Awarded  
 Participation Certificate

for whatever reason, not to submit a log, but it was designed to encourage those who in the past did not see the need to submit their log – 'as they were not

## Home Station – 6 Hour

Call Sign	Operators	Mode	Band	Score	Contacts	Award
VK6KTV	Home	Phone	All	245	113	17
VK5HP	Home	Phone	All	154	65	2
VK3OHM	Home	Phone	All	114	55	3
VK5DK	Home	Phone	VHF	217	15	1/5
VK3SOT	Home	Phone	VHF	68	17	2
VK2PR	Home	Phone	HF	426	309	17
VK3FOSO	Home	Phone	HF	132	80	2/\$
VK2HFS	Home	Phone	HF	94	60	3
VK2KDP	Home	Phone	HF	63	42	4
VK5YK	Home	Phone	HF	56	35	5
VK2MTK	Home	Phone	HF	50	30	6
VK1HVE	Home	Phone	HF	39	24	7/\$
VK3ZAP	Home	Phone	HF	39	27	8
VK5AV	Home	Phone	HF	33	21	9
VK4MN	Home	Phone	HF	28	17	10
VK3FSWB	Home	Phone	HF	22	12	11/\$
VK2RH	Home	Phone	HF	19	10	12
VK8HPB	Home	Phone	HF	16	11	13
VK2AVR	Home	Phone	HF	10	5	14
VK6PA	Home	Phone	HF	10	6	15
VK2DCR	Home	Phone	HF	4	3	16
VK2AGA	Home	All	HF	216	112	17
VK4SN	Home	All	HF	48	23	2
VK2PN	Home	CW	HF	8	2	17
VK5BAR	Home	All	All	57	28	17

going to win anything'. Submitting their log is really is to help others as well as themselves.

The participation across the various call areas was patchy. There was an increase in Portable stations in most areas with only VK1 & VK4 showing a decrease. Home Station logs were greatly increased from last year in most call areas with the exception of VK4.

Band	S/UHF		VHF		HF	
	Points	Contacts	Points	Contacts	Points	Contacts
47 GHz	32 (0)	8 (0)				
24 GHz	91 (0)	19 (0)				
10 GHz	640 (247)	66 (28)				
5.7 GHz	574 (232)	63 (13)				
3.4 GHz	1,100 (402)	103 (37)				
2.4 GHz	1,016 (430)	116 (36)				
23 cm	4,066 (3,367)	399 (312)				
70 cm	9,412 (8,259)	957 (823)				
2 m			19,170 (17,125)	1,787 (1,754)		
6 m			4,907 (6,133)	529 (605)		
10 m					132 (1,601)	72 (758)
15 m					1,292 (1,373)	664 (696)
20 m					7,154 (6,637)	3,760 (3,285)
40 m					22,922 (24,433)	12,221 (13,386)
80 m					1,217 (3,730)	627 (1,970)
160 m					28 (194)	14 (96)
<b>Total</b>	<b>16,931 (12,946)</b>	<b>1,731 (1,249)</b>	<b>24,077 (23,258)</b>	<b>2,316 (2,359)</b>	<b>32,788 (37,968)</b>	<b>17,358 (20,191)</b>

Call Area	Portable		Home		Total	
VK1	4	5	3	1	7	6
VK2	21	21	28	24	49	45
VK3	25	21	26	24	51	45
VK4	14	16	9	17	23	32
VK5	18	15	13	14	31	30
VK6	9	8	8	9	17	17
VK7	1	0	2	1	3	1
VK8	1	0	0	1	1	1
P2	0	0	0	0	0	0
ZL	1	2	1	0	2	2
<b>Total</b>	<b>94</b>	<b>88</b>	<b>90</b>	<b>91</b>	<b>184</b>	<b>179</b>
	2015	2014	2015	2014	2015	2014

All of the portable stations that went to the effort to send in a log will get a certificate. The WIA believes that those who make the effort to set up and operate a portable station should be acknowledged. In line with previous years, the Foundation licence logs who did not achieve a placing were instead awarded a Participation Certificate for encouragement.

There were seventeen Foundation licenced operators who submitted a log. (Two from VK2, eight from VK3, two were from VK4, two from VK5 and two from VK6.) There were many more foundation call stations operating than these, who were logged during the contest, but they chose not to submit a log. All logs submitted by foundation operators were awarded a certificate. Logs from club stations did also show that a few 'F' Calls that also took part as part of the club station effort, well done.

#### Comparison between 2015 and Earlier Years

Year	Logs	Contacts	Points
2015	184	21,405	73,796
2014	179	23,799	74,172
2013	111	18,047	61,213
2012	140	22,173	88,270
2011	129	20,857	71,736
2010	122	23,573	80,087
2009	124	20,773	71,041
2008	104	17,258	98,940
2007	76	12,535	64,028
2006	78	10,865	61,387
2005	67	8,423	44,080
2004	66	8,602	49,855

This year, the rules again stated that EXCEL is the preferred submission format. A sample linked EXCEL logging report was prepared and was available on the WIA Contest website. (Contact me at vk4ae@wia.org.au if you would like a copy of my linked spreadsheet in EXCEL for next year.) Other suitable file submission formats are WORD, or \*.TXT output file from VKCL (VK Contest Log). PDF format is not acceptable as are JPG and TIFF.

The logs submitted in an electronic form this year, were usually fully readable, but a few stations had to resubmit their log in an acceptable format. I thank them for their cooperation.

There were still only 97% of logs submitted electronically this year, again up from last year. This has been due largely to the excellent work by Mike Subocz VK3AVV and his worthy program VKCL (VK Contest Log). Those that submitted a log in the VKCL export format were as usual very easy to work with. Those that simply forwarded the text output file of VKCL were also rather simpler to work with than any form of posted paper log or a log completed by hand.

Paper logs may also be used. A small log from an individual operator is, and will remain, completely acceptable. Large paper logs can require a very considerable manual work on the part the contest manager, to input the data into the contest database and are no longer

permitted. It is so much better to forward the computer files used to print the paper log, as part of an e-mail, for the data can then be easily extracted and used for checking purposes.

**A note for all HF Stations: All HF contacts are valid HF scoring contacts, whether they are from VK ZL or P2 stations or stations from overseas.**

Overseas stations cannot submit a log to the contest, but can exchange numbers with stations participating in the Field Day Contest. They are to be scored as a Portable station contact.

#### Comments Regarding this Year's Contest

##### 1. The comparative difference in score and scoring between HF and VHF/UHF contacts.

In fact within the John Moyle Contest, the rules allow for some 60 possible alternative categories as shown below. Each category is actually completely independent from every other category and so there are in fact 60 parallel contests. In this way it is completely different from any other contest presently in Australia. This year only 32 of the different categories were contested. See table on next page.

For this reason it is not possible to have overall winner in this contest, as scores from any category, especially between different bands and different modes are not directly comparable. Only scores within the same category are correctly comparable. To reduce the number of certificates awarded to Home Stations – the contest is a Field Day after all – only 1 certificate for every 10 logs received in each category will be awarded again this year.

The award of the President's Cup is a further parallel contest. It is awarded to the highest score from a Club Station, affiliated with the WIA, in any category. This year again it was awarded to VK3ER.



**Table of Existing categories**

Operators		Modes				Bands		
	Time							
Multi	24	Phone	CW	Digital	All	HF	VHF	All
Multi	6	Phone	CW	Digital	All	HF	VHF	All
Single	24	Phone	CW	Digital	All	HF	VHF	All
Single	6	Phone	CW	Digital	All	HF	VHF	All
Home	24	Phone	CW	Digital	All	HF	VHF	All
Home	6	Phone	CW	Digital	All	HF	VHF	All

**2. The number of logs submitted to the contest is again up on previous years**

The number of logs entered in this year's contest is significantly increased compared to the last few years of the contest. The number individual stations taking part in the contest and the number of their contacts seems about the same as for last few years, it is just that the number of logs submitted in 2013 was well down compared to 2012 and this reversed the trend seen over the last 10 years where the number of stations has continued to steadily rise. This drop has been reversed by the introduction of the 5 Contact rule. This has also greatly increased the percentage of verified contacts during the contest, making the contest manager's task a little easier.

**In 2015 a total of 184 logs were submitted from 94 portable stations and 90 home stations.**

**In 2014 a total of 179 logs were submitted from 88 portable stations and 91 home stations.**

**In 2013 a total of 111 logs were submitted from 67 portable stations and 44 home stations.**

**In 2012 a total of 140 logs were submitted from 77 portable stations and 63 home stations.**

**In 2011 a total of 129 logs were submitted from 83 portable stations and 46 home stations.**

**In 2010 a total of 122 logs were submitted from 73 portable stations and 49 home stations.**

**In 2009 a total of 124 logs were submitted from 63 portable stations and 61 home stations.**

In 2008 a total of 104 logs were submitted from 59 portable stations and 45 home stations.

In 2007 a total of 76 logs were submitted from 48 portable stations and 18 home stations.

**3. The issue of scoring for CW contacts.**

The number of All Mode contacts was significantly higher than in the recent past. A good sign!

While CW is no longer a precondition for obtaining an Amateur licence, it is a skill that is still widely distributed among existing operators and a skill that should be nurtured among the newer licence holders.

The rules were adjusted in the past to allow doubling the score for a contact on CW. For HF this was simple. However, for VHF contacts where there is a significant score already for the distance involved, the rules were amended for scoring VHF contacts on CW.

However, the use of computer generated/decoded CW is prevalent and it is felt that hand generated code that is decoded by ear alone should qualify as true CW.

Any computer method is simply just another digital mode and so should not score the same as hand CW, but only the same as any of the many other digital modes.

**4. The number of people who submitted logs claiming 'All Modes' and only logging contacts using SSB or FM.**

The Modes allowed in the rules are PHONE (SSB or FM), Morse (CW) (Manual) and DIGITAL (Computer) Mode.

The PHONE (Voice) only Modes are SSB, DSB, FM, PM or AM. That is the modulation is an audio signal derived in the first instance from a microphone.

The alternative is hand CW Mode, which is one where the operator simply turns the carrier on and off according to the Morse code. Digital CW by a computer is not acceptable.

DIGITAL mode is one which uses a computer to control the transmitter and to decode the information to allow the operator to complete the contact.

ALL MODE, is any combination of the above modes.

**5. Club Stations**

Club Stations were well operated and made some very big scores as a result of their combined efforts. Well done!!

The absence of a significant number of some 15 to 20 club Stations was noted for this year. Some of the missing clubs had their club call sign used and probably achieved significant scores, but the club chose not take the time to submit a log. This is a sad reflection upon the efforts made by some, not being fully supported by other members of their club.

**6. Low Power Contest**

A suggestion was made by a few stations that a QRP category could be allowed. The suggestion was that only a station that can be carried in a backpack should be allowed for the operation of the station. There were only five logs entered indicating that all operation was on low power. They are acknowledged on their certificate. It is still not thought to be necessary to create another category just yet (see above) but interest is still growing and may soon require a rule change.

It is interesting to note, the scores produced by some of the Foundation licensees that submitted a log, does indicate that plenty of contacts were made on the restricted lower power permitted by their LCD.

## 7. The Future

Now it is over to you. There are always ways to improve anything, but scrapping something because it does not suit you is not possible. But if benefits are shown to be available, further changes can be made to the contest to better serve the amateur community. But changes to force the majority to follow what suits a small minority is definitely not a good idea.

If you have any contribution to these topics, the Rules for this

contest are available at the WIA web site at <http://www.wia.org.au/members/contests/johnmoyle/> which already contains my contact information and please feel free to contact me with your submission for further consideration.

Well done to all of those stations that participated in the contest and well done those who bothered to submit a log. It is hoped that the number of logs to be submitted next year will continue this year's increased log numbers.

I wish to thank those who did send in photographs of their equipment set-up and personnel involved for inclusion in the AR magazine. These have been submitted to AR along with this report, so please give Peter Freeman via e-mail at [editor@wia.org.au](mailto:editor@wia.org.au) anything else you have for later use for the magazine.

AR



# GGREC HAMFEST

## Saturday 18<sup>th</sup> July 2015

**Gippsland Gate Radio & Electronics Club** invites you to our annual Hamfest at the CRANBOURNE PUBLIC HALL, located on the corner of Clarendon and High St. Melway 133 K4. See our web page at [ggrec.org.au/hamfest.html](http://ggrec.org.au/hamfest.html)



### 40 tables of new and used Electrical, Electronic and Amateur Radio equipment.

- Everything is under cover.
- Tea and Coffee available during the event.
- A selection of hot & cold food will be available.
- Great Door Prizes will be drawn at approx 1:00 pm.
- Doors open to sellers at about 8.30 am & buyers at 10 am.
- Buyers can gain entry for \$6.00.
- Sellers will pay \$22.00 per table, which includes entry.

Anyone wishing to reserve a table position should contact the Club soon, as tables go quickly.

Email to [hamfest@ggrec.org.au](mailto:hamfest@ggrec.org.au)





# VHF/UHF - An Expanding World

David Smith VK3HZ  
e vk3hz@wia.org.au

## Weak Signal

As has been said before, good propagation conditions are not just a summer "thing". Openings can happen at most times throughout the year. It's just that many people are not looking for them.

May 24/25 was just such an occasion. A slow-moving high-pressure cell passed across the south of the country producing good conditions. A number of good contacts were had from VK1 to VK5 and VK2 to VK7. Peter VK5PJ was reporting that the VK7RAE beacons were coming through over an extended period with the 23 cm beacon peaking to 529 at 2100Z on the morning of Sunday May 24.

Ian VK3AXH in Ballarat reported: *My first contact on Sunday morning was with Robin VK5TN on 2 m at well over S9. Shortly after I had a look at VK5 and VK7 beacons and was surprised to hear Adelaide's VK5VF at S9 on 2 m.*

*I tuned up to 144.200 and heard VK5PJ in contact with VK1KW and when they finished I called Peter VK5PJ and we changed to 144.180 where his 2 m signal was pinning my S meter. This was the strongest signal I've ever received from Peter on 2 m. We changed to 70 cm where his signal was S9 and then 23 cm and very solid at 5x5 being the strongest 23 cm signal I can recall between us on that band.*

*Peter VK5PJ when on 2 m played signals being received from the new GPS locked Ballarat beacons VK3RMB on both 70 cm and 23 cm with the 23 cm signal at S3.*

## Beacon Upgrades

Many may be aware that Alan VK3XPD has been encouraging the GPS-Locking of beacons by generously offering, in conjunction with the WIA, to co-fund a grant amount for anyone who upgrades their beacon to be frequency-locked. The offer expired at the end of May and, thanks to his initiative, 15 beacons are now operating with GPS-locking with another two to be operational very shortly.

A number of upgraded beacons have been announced in the last month. The first of these are the VK3RMB Beacons at Green Hill near Ballarat on 432.536 MHz and 1296.536 MHz. The site is slightly shielded in the Melbourne direction, but is quite good from southwest around to northeast. So, it should be a useful propagation indicator to the west to Adelaide, Mt Gambier and Western Australia. Ian VK3AXH would welcome signal reports.

The second are the VK5VF beacons on Mt Lofty near Adelaide. Mark VK5AVQ advises that there are now three of the beacons GPS-locked on 50.320 MHz, 144.450 MHz and 432.450 MHz. Again, signal reports are most welcome.

Still in South Australia, Iain VK5ZD reports that the VK5RLZ beacons located in the water tower on Kettering Road, Elizabeth South are on-air and GPS-locked. The beacons are nominally on xxx.452 MHz, but there are some minor variations due to PLL limitations. There are beacons on 23 cm (1296.45200486 MHz), 13 cm (2403.45205479MHz), 9 cm (3400.452 MHz) and 6 cm (5760.452

MHz). A 10 GHz beacon will be on in the near future.

Not too far way in Mildura, Peter VK3JUG reports that the VK3RRU beacon on 144.438 MHz is back on-air and GPS-locked. The beacon consists of an RF Innovations expaging transmitter running 35 watts, locked to a PicoSync 10 MHz GPS Reference and keyed by an Arduino. The antenna is a horizontal folded dipole.

Rob VK3BRS and the GGREC crew have been working on the VK3RLP beacons near Frankston. The two beacons on 1296.542 MHz (10 watts) and 2403.542 MHz (5 watts) are now GPS-locked. The antennas are Alford slots and one of the next jobs is to build a radome to protect them from the elements.

Alan VK3XPD also reports that a team in VK6 are working towards the completion of their GPS-locked Beacons. The two VK6RST Beacons in Albany on 144.564 MHz and 432.564 MHz and the VK6REP Beacon in Esperance on 144.568 MHz are all being worked on.

Finally, Dale VK4RMC reports that a new beacon is running in Far North Queensland. VK4RHT on 144.446 MHz (not stabilised) is in the Hann Tableland and is transmitting 10 watts into a vertically-polarised antenna.

For the latest information on these beacons, including current operational status, refer to the VK Logger Beacons page. As mentioned in one of the reports, some of these beacons are not exactly on frequency despite being GPS-locked. This is due to a limitation on divider length in the

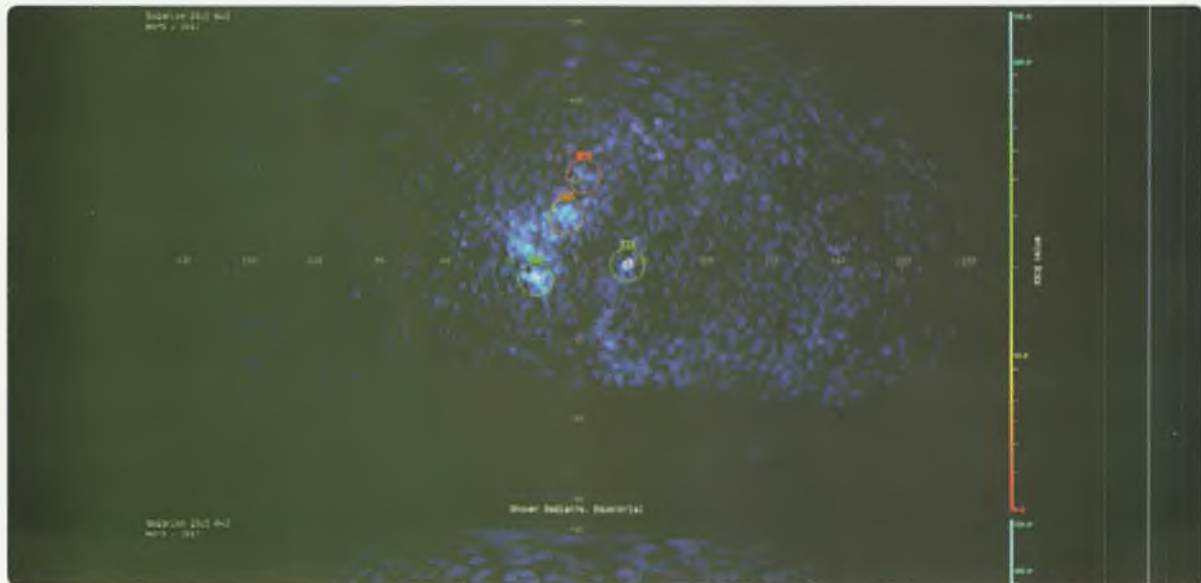

Figure 1: Image from the Canadian Meteor Radar on 5th May 2015. The bright pink spot at the centre of the image being the radiant of the ETA shower.

PLL chips being used. The exact frequency may be found on the VK Logger page.

### WIA Technical Excellence Award

Congratulations to Rex VK7MO and Derek VK6DZ who were honoured with an award at the recent WIA AGM. From the WIA web site:

*The Board introduced a new award this year, known as the Technical Excellence Award, granted where some technical excellence is demonstrated in any special technical aspect of amateur radio.*

*The very first Technical Excellence Award – for 2014 – was granted to Rex Moncur VK7MO and Derek Zeck VK6DZ, for outstanding achievement in establishing a new World DX Record for 10 GHz, exploiting tropospheric refraction across the Great Australian Bight to make contact over a distance of 2732 km.*

Please send any Weak Signal reports to David VK3HZ at vk3hz@wia.org.au



### Digital DX Modes

Rex Moncur  
VK7MO

#### Up-date on WSJT-X

I reported on the incorporation of JT4 into WSJT-X last month. Since then a group of us has been testing the program on 10 GHz EME and getting good results. Nevertheless, some bugs have been identified and a number of "nice to have" requests have been submitted to Joe K1JT.

The major bugs are:

1. DX station's grid locator changes from 6 to 4 characters when double left clicking decoded message (containing calls + locator) to transfer report to TX boxes, causing jumps in Doppler correction.
2. Problems with FT-817 CAT control causes an error.
3. Double left clicking decoded message triggers TX3 (R report), so if you have received calls and locator message you need manually to click TX2.

It is expected that these bugs and some enhancements will be added by the time you read this report and you should see an updated version of WSJT-X on K1JT's web site.

In addition Joe has been working on adding an improved version of WSPR to WSJT-X. Future plans call for all slow modes, JT9, JT65, JT4 and WSPR to be brought within WSJT-X which will be the ongoing development platform. There will be no further development of WSJT10 or WSPR as separate programs.

Please send any Digital DX Modes reports to Rex VK7MO at rmoncur@bigpond.net.au

### Meteor Scatter

Dr Kevin Johnston VK4UH

May 2015 brought the Eta Aquariids (ETA) Meteor Shower.

This shower, expected every year on or around the 6th May, occurs as the earth passes through clouds of debris remaining from the passage of Halley's Comet through our solar system. The Eta Aquariids is classified as a Class 1 Major Meteor Shower with a predicted Zenith Hourly Rate (ZHR) of 70/



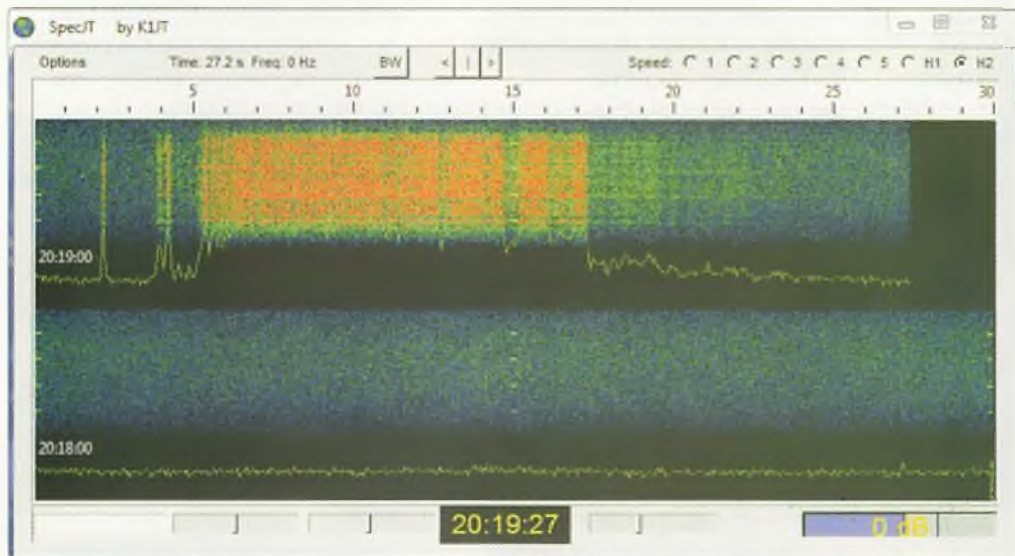

Figure 2: A typical burn received from VK3AMZ on 144 MHz lasting over 20 seconds. From the ETA meteor shower May 2015.

hour and hence one of the best likely events in the Meteor Scatter calendar for the year.

As discussed in previous columns the ZHR gives an index of the likely prevalence of visual meteor trails seen by the naked eye. If we assume that each visual meteor trail is likely to be associated with a hyper-dense burn, with strong signals extending for several seconds on 144 MHz and perhaps tens of seconds on 50 MHz, then at 70/hour we should expect a major

burn every one or two transmission periods, way beyond the normal return rate for random meteor pings. (A ZHR of 120/hr or higher would likely be associated with signals being received across almost every receive period.) Eta by the way is the brightest star in the constellation of Aquarius and is the radiant where the shower "appears" to originate. This year the actual ETA ZHR, as estimated by the Canadian Meteor radar system, did not even reach half of that predicted value. Meteor

I found conditions significantly enhanced and despite being a mid-week morning completed contacts with VK3AMZ (QF22fe), VK5PJ (PM95mk), VK3HY (QF22pd) on 144 MHz and with VK5PJ and VK3HY again on 50 MHz.

Using these long burns I was also able to complete an MS contact with Gavin VK3HY on SSB – a personal first.

A number of reports were received from other MS operators around the states:

Arie VK3AMZ near Geelong reported: "The ETA shower was interesting, but not as active as previous years, obviously celestial mechanics coupled with density variations in the meteor stream will create differences from year to year. It was predicted to peak on 5th and 6th May, reviewing meteor activity over this period I noted that the best day was 7th May. The shower produced at times, some

Figure 3: 50 MHz burn extending across at least three transmission periods from ETA Shower May 2015. This trace contained decodes from both VK5PJ and VK3HY.

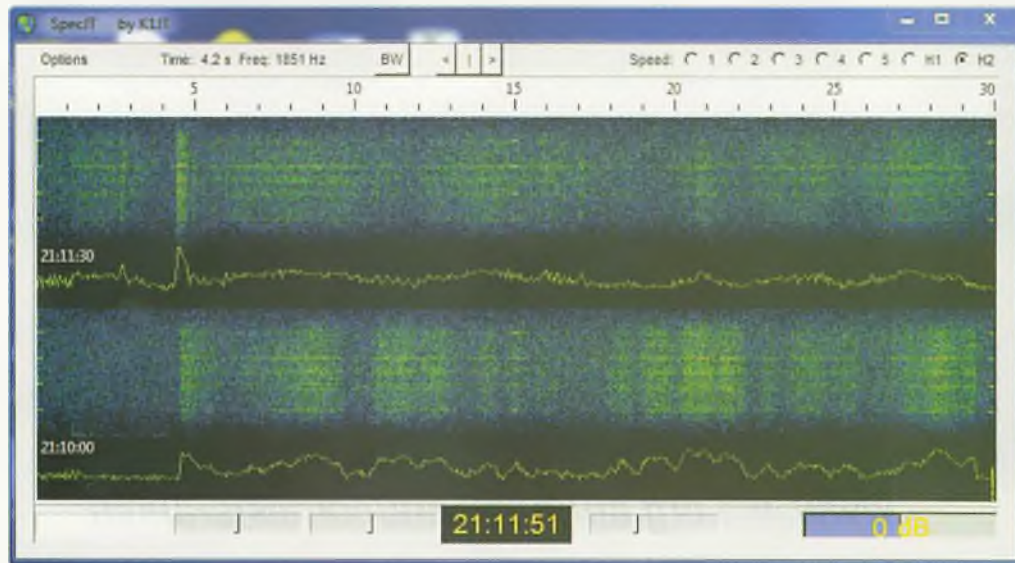

pretty spectacular meteor pings both in strength and duration but at the same time very inconsistent. Conditions were such that substantial pings were relatively infrequent, but when they did appear it was well worth the wait. I noted on several occasions pings exceeding 30 seconds with signal strengths greater than 20 dB S/N as indicated on the FSK441 panel. I don't think that the pings were consistent enough for success on 70 cm. Stations worked on two metres over several days of operation were the usual group from SE QLD and Northern NSW: VK4JMC, VK4NE, VK4UH, VK4KSY, VK4CZ, VK4LHD, VK4NWH, VK4MIL, VK4CRO, VK2XN, VK2AMS, VK2MAX, and VK1WJ (contact with Waldis is traditionally difficult to make due to the short distance between us). Besides FSK441 QSOs, I also worked Adrian VK4OX and Wayne VK2XN on SSB meteor scatter on numerous occasions."

Gavin VK3HY South of Melbourne reported: "I wasn't in the shack as often as one should be when trying to make the most of the ETA Aquarids meteor shower. However, some good results were obtained on both 50 MHz and 144 MHz.

1st May - FSK441 contacts were completed VK4CZ (50MHz) VK2AMS VK2XN (both 144 MHz).

2nd May - Worked VK4OX and VK2XN on SSB during a very long burn at 0147. FSK441 contacts

were completed VK4CZ (50 MHz) VK4JMC VK2AMS VK4KSY VK2XN & VK4CDI (all 144 MHz).

4th May - Worked VK4OX twice at 0110 and 0154 on 144 MHz SSB

5th May - FSK441 contacts were completed VK4UH (50 MHz) VK4UH & VK4NE (both 144 MHz) and also worked VK4UH on 50 MHz SSB with signals up to S9.

7th May - Worked VK4OX on 144 MHz with S9 signals both ways at 0142.

I suspect I probably missed the peak of the shower but one can't always be everywhere at once! It was good to note Steve VK3MEG at Melton taking an interest in the meteor scatter activity. I believe Steve heard VK4OX on SSB a few times."

Peter VK5PJ in the Barossa also reported some great burns on 2 and 6 m during the shower.

Nick VK4NE South of Brisbane reported: "I had some luck on Sunday the 4<sup>th</sup> May at 2130 GMT VK5PJ Peter with report from him 5/9 and my report back of 5/7 but I didn't see many station making the contact today the 5/May 2049 and 2058 GMT I did work VK5PJ again with exchange both way of 5/9 report also at the same time VK4MJF made the trip with exchange of 5/4 not sure if Peter was 5/4 but John was rapt on the contact."

After my 6 m SSB MS contact with VK3HY, I received an email from Frank VK7DX who had also heard me. Frank offered some very

useful information, for which I am very grateful, regarding the protocol for SSB exchanges, which I have reproduced as follows:

"In regard to 6m SSB via MS the usual operating frequency is 50.200 rather than 50.230 for FSK441.

When a station is heard you reply with, "signal report/name of op/your callsign"

e.g. if you hear me you would say: "56/Frank/vk4uh"

When I receive you I would send, "qsl/Kevin/vk7dx"

Most contacts are done on a single ping/burn so you have to be quick."

Conditions during the remainder of May were typical for the time of the year with a slow decline in meteor propagation as we head towards the Winter Minimum. One small compensation - as sunrise gets progressively later as we approach winter, is that the normal weekend MS activity sessions are starting to overlap with the pre-dawn peak in meteor returns even for stations in VK4.

The next major meteor showers for the diary are the Delta Aquarids around 31st July, a Class 1 Major shower but with a predicted ZHR of only 16/hr: generally not a big event, and then the Perseids around 13th August with a predicted ZHR of up to 100/hr.

Please send any reports, questions or enquiries about Meteor Scatter in general or the digital modes used to Kevin VK4UH at vk4uh@wia.org.au

## WIA Contest Website



To keep up to date with all of the major Australian contests, including rules and results, at the WIA Contest Website at:

**[www.wia.org.au/members/contests/about](http://www.wia.org.au/members/contests/about)**



Christine Taylor VK5CTY

We had a very interesting lecture for the May meeting about the participation in the National Parks Award we are sponsoring. It seems many amateurs like the excuse to visit a National park or a Conservation park where they can make contacts with their portable equipment while enjoying a day in the open air.

If you go to the AHARS website you can listen to Paul VK5PAS talk about this award and also find a list of National Parks (NP) and Conservation Parks (CP) in South Australia, both of which may be activated for the award. The award is open to all amateurs and to SWLs, so listen out.

At the last meeting on 21<sup>st</sup> May, Paul was recognised by the Committee of the WWFF, and a certificate was issued to him by Lars PHONO the Chairman of the WWFF Committee for Paul's efforts in setting up the Australian end of this award. The award was presented to him on behalf of the WWFF committee by the Club President Barry VK5BW.

AHARS was well represented at the WIA AGM in Canberra with 12 members attending. It was an interesting meeting with a thought provoking talk from Mark Loney of the ACMA. He outlined some of the changes that are being considered as ACMA moves closer to the "User Pays" system and away from the administration pattern. This may mean that the WIA will have to take on some of the administration that is currently done by ACMA.

For amateurs it is the possible changes to our license conditions that are of the most concern, especially if you are a home-brew expert. We may not be allowed to use other than commercial equipment at some time in the future, but we will need to see



Barry VK5BW (L) presents the Certificate of Recognition from the WWFF Committee to Paul VK5PAS (R). The certificate states: "World Wide Flora and Fauna. Certificate of Excellence is awarded to Mr Paul Simmons in recognition of your valuable contributions to WWFF through your efforts in VKFF. WWFF Committee."

the full document to see what lies ahead.

There will be more on this issue and future issues as the situation unfolds. As the WIA has a membership percentage of only about 30% of amateurs I would like to urge every amateur to think about how much more power the WIA would have if it represented us all.

**PLEASE THINK SERIOUSLY ABOUT JOINING THE WIA.**

It will be to your benefit.

Also it would be wise to keep an eye on any announcements by ACMA and comments from the WIA. Some of the changes will be certain to affect us as amateurs.

Activities at the "Shack" continue to be of a technical nature. Within our club we have many experts who are keen to share their knowledge with us. The Club has now purchased a new SDR radio, an ANAN 100D for use by members, and introduces the latest technology to our members, particularly to

those younger members coming up through our ranks.

As the month of May has five Saturdays there will be a breakfast on Saturday 30th, and an auction of equipment with a sausage sizzle lunch available for a gold coin donation to follow. Watch for the fifth Saturdays, they are a great social occasion and often an

opportunity to grab a bargain.

Next month, for all members and visitors our regular meeting on 18<sup>th</sup> June 2015 will be held at the Aviation Museum, 66 Lipson Street Port Adelaide. Gather at the doors by 7.00 pm. Tea and coffee will be there to finish the evening. The cockpit of the F-111 will be open as well as the workshops where the restoration is done. It should be a good night.

The mid-year dinner will be at Auchendarroch in Mount Barker on Sunday 21<sup>st</sup> June 2015. It is a historic building, now also part of a movie theatre complex, and well worth a visit.

Please let Barry VK5BW know if you would like to attend [vk5bw@wia.org.au](mailto:vk5bw@wia.org.au) so he has an idea of the numbers. We will be informed of the menus and which room in the mansion we will be occupying, at a later date.



# ALARA

Christine Taylor VK5CTY – Publicity Officer

## ALARA'S 40<sup>th</sup> BIRTHDAY – A Special Event

A Luncheon celebrating ALARA's 40th Birthday is being held on Saturday July 25th 2015 at the Novotel Hotel in Glen Waverley. Guest speakers, a 3-course meal, on site accommodation, a cake and many YLs to catch up with and a bus trip on Sunday are awaiting those who attend. Late acceptances must contact Jean VK3VIP immediately on [jeanfisher@optusnet.com.au](mailto:jeanfisher@optusnet.com.au)

Information for this event can be found on the ALARA website.

## ALARA notes from the WIA AGM

There were five ALARA members at the AGM: Dianne VK3FDIZ, Jenny VK3WQ, Jeanne VK5JQ, Jenny

VK3MDR and Christine VK5CTY.

There were a number of other YLs, XYLs for members, who have been at previous AGMs. It was pleasant to meet all of them.

The YLs who chose to go on the alternative tour of Canberra were accommodated on the regular Hop-on-hop-off bus. This can be highly recommended as it gives everyone the option to see just what he or she chooses to see. The bus returns to each of the regular stops once an hour so you meet up with friends each time you hop on the bus.

My preference, that day, was Questacon, the Science Centre. Although this is set up largely for children, it is so full of information and presents it in such an interesting fashion people of all ages can enjoy it.

Later I joined others to tour the old Parliament House. This was an eye-opener, too. We know that today our politicians have private offices and large personal staffs. When the "New" Parliament House was opened in 1927, the members of each party all worked and lived in one large room. Only the Prime Minister and Leader of the Opposition had separate, private rooms.

There was one telephone in the room. This sat on a desk where everyone could hear at least one side of the conversation. Large tables at one end provided the members with a place to work and private lockers were available for their papers.

For myself I was interested to know that my great aunt, who was

Photo 1: ALARA members at the WIA AGM in Canberra.







Photo 2: The group at the lunch gathering in Sunshine.

a Hansard stenographer, sat right beside either the Prime Minister or the Leader of the Opposition. There were two stenographers right in the midst of all the action, so they could record everything accurately and so that there were two records for confirmation. I had expected that my aunt would have been rather less conspicuous, although for them to be so close does make sense.

At the end of the AGM, Dianne VK3FDIZ was given a presentation recognising her upcoming retirement. She will be hard to replace.

But probably the most exciting thing to come out of the AGM was the announcement of the location of the AGM for 2016. It is proposed that it be held on Norfolk Island. At

the meeting there were around 80 hands raised to indicate that they would probably be there next year. No doubt there will be many more when delegates go back to their home clubs.

### **ALARA Lunch -23<sup>rd</sup> May 2015**

*From Margaret Blight VK3FMAB*

We were fortunate to have a lovely sunny day for our ALARA lunch in Sunshine. The chill of autumn has been upon us in recent weeks. There was a great turnout with 20 people in all. 13 ALARA members plus 6 OMs took the journey to Melbourne's Western Suburbs on the day.

The meeting place was The Granary Cafe which provided a comfortable environment and

everyone enjoyed their meal and the resultant conversations. It was a pleasure to welcome two new ALARA members Susan VK3FSUZ and Susan VK3FZZY to their first lunch and hope to see them at future occasions.

Members present were Jean VK3VIP her mother Elsie, Margaret VK3FMAB, Pam VJ3NK, Jenny VK3WQ, Judy VK3FJAG, Susan VK3FZZY, Susan VK3FSUZ, Cheryl VK3FCYL, Naree, Pat VK3OZ, Donna VK3FRET, Kaye VK3FKDW.

Many thanks to Kaye VK3FKDW, a near Sunshine local, for arranging the event.

33  
Christine Taylor VK5CTY

Don't forget

**Don't forget to register for MEMNET.**



## VK2 news

Tim Mills VK2ZTM  
e vk2ztm@wia.org.au

This month [July] at ARNSW there will be the regular bi-monthly Foundation course weekend on Saturday 18th and Sunday 19th. There will be assessments for all grades on the Sunday. Bookings are required for these sessions by an email to [education@arnsw.org.au](mailto:education@arnsw.org.au). There is a limit on the number who can be handled over the weekend, hence the need for bookings. However, with most of these events there are a few who book but don't show and don't advise. The Education Team is looking at ways to reduce the no shows. The bi-monthly Trash & Treasure is set down for the following Sunday - the 26th. The Library team reported at the end of May that they think they have all the magazines - some 15,000 - logged into the computer. Now they will have to start on the books. Some new shelving has been obtained and installed. There is more to be installed later in the year.

ARNSW having had their AGM in early May had the existing committee members again nominate for this year. Everybody was happy with their portfolios so this year the President role remains with Mathew VK2YAP who also looks after VK2WI Engineering and Broadcasts. Al VK2KAM is Senior Vice President and Treasurer. Peter VK2VG is Junior Vice President and Education Assessments. Tim VK2ZTM is Secretary and Dural Property Officer. Paul VK2APA is Course Supervisor. Mark VK2XOF handles Trash & Treasure, Deceased Estates and VK2WI Engineering. John VK2LJ heads up the Library Team. Bob VK2CAN has Membership and Welfare and Ken VK2BBQ covers Public Relations.

The 2015 ARNSW Development Fund grants for this year will be going to three clubs. Details had not been released as these notes were prepared. There have been some adjustments and additions with antennas at the VK2WI site. Two groups of multi band VHF / UHF verticals and HF dipoles have been installed on the Centenary Building for both the Library and Classroom to assist with the practical assessments. A similar set have been added to the VK2WI building for a future general station. The VK2RSY 2 metre and 70 cm beacons have been changed back to the original crossed dipoles until the new antennas can be mounted on a higher support. The new metal roof distorted the pattern of the experimental square loop antennas which had been installed. The VK2RSY 6 metre beacon operates on a wire dipole which previously looked north and south. With some tree work about to be undertaken it was moved to new support trees with the main lobe now looking east and west.

The Waverley ARS will be having this year's annual auction on Saturday 4th July at their Rose Bay club rooms. Go to their web site for details. A mid-morning start. They had their AGM in May with no change in office bearers. Also in May the Hornsby & District ARC had their AGM with no changes in the principal office bearers. For this year Secretary Bob VK2ZRM is calling on members to provide a range of short talks for the HADARC monthly meetings. The Hunter Radio Group will have their Ladies Day lunch on Saturday 11th July at a new venue in Cardiff. Check details via the Monday evening VK2AWX news session.

WICEN NSW now has over 150 members and will be assisting the BWRS Nav Shield exercise over the

weekend of 4th and 5th July. The postal address for WICEN NSW Inc has been changed to PO Box 6151, Dural Delivery Centres, NSW 2158. The former address was with the Regents Park post office which is being closed. In April, the former Omega tower in Eastern Victoria as reported in WIA National news, was felled for safety reasons! In Sydney the large microwave tower in the Eastern Suburbs near Bondi Junction has had its top removed and now is a shadow of its former self with only a ring of vertical antennas and cell phone panels. This was part of the former Telstra coastal microwave network through the Central Coast to Newcastle.

The bi-annual SMPTE trade event for the entertainment industry will be in Moore Park Sydney on 14th to 17th July. Jeff Pages VK2BYY who writes novels in his spare time has another in the Barefoot Services in the proof reading stage. It will be published in the next few weeks.

ARNSW with its bi-monthly Trash & Treasure service accepts both donations and Deceased Estates for resale. Major equipment on offer is listed on the ARNSW web site: [www.arnsw.org.au](http://www.arnsw.org.au) Check here for the details. Those interested in applying should carefully read the associated notes and email [disposals@answ.org.au](mailto:disposals@answ.org.au) Note that this is the only contact method for this service as telephone calls have to be retrieved from the message bank which introduces a delay as they have to be forwarded to the section. There are occasions where other family members have the problem of to do with your equipment should anything happen to you. Make them aware of the contact details - if in Sydney - for ARNSW or the local Amateur Radio club in your area.

73 - Tim VK2ZTM





Jim Linton VK3PC

e arv@amateurradio.com.au

w www.amateurradio.com.au

## Foundation licence 10 years on

After existing as a stepping stone to the hobby, the Foundation licence has attracted many people into amateur radio. It has given a taste of the hobby, including to those who tried the former Novice licence with its Morse code test.

There can be no doubt that this new entry point with a healthy upgrade level, has seen growth in its early years stemming the steady decline in the hobby. It was what we voted for at the time of the Australian Communications Authority (ACA) "Big Review" in 2004.

The ACA advised radio amateurs of the options being considered and invited them to participate in that review. Overwhelmingly its introduction had support and some say well overdue.

The "Big Review" was truly an opportunity to consider changes to amateur radio and simplification of its regulations and administration.

Many things happened as a result of the Amateur Service Regulation Review of 2004, and 10 years later, now is the time to look what worked in the past, and how it can be improved on for the future.

Before the Foundation licence the bands were quite different, but new blood, and a refreshing but occasionally different approach, saw revived activity generally. Along with it came the arrival of new technologies and a change in modern amateur radio of today.

Let us recognise and praise those who have used the Foundation licence to explore what the qualification has to offer in terms of them learning more by doing.

These are the quiet achievers, either looking for DX on the HF bands, chasing or going portable,

exploring alternative power sources, a few are on Morse code or gone back to study for an upgrade.

Two of these people who have achieved a lot in recent years are Amanda Bauer VK3FQSO and Julie VK3FOWL.

Amanda VK3FQSO has become the first Foundation licence holder to get a Keith Roget Memorial National Parks Award (KRMNPA) Merit Award for working all 45 National Parks.

Her quest began in November 2013 contacting Joe Gonzales VK3YSP during the famous road trips with his wife Julie VK3FOWL at the Greater Otway National Park.

Amanda VK3FQSO, in the last contact to top off 45, was with Mick

VK3PMG in the Wyperfeld National Park on May 17. She used a solar powered Alinco DX-SR8 transceiver on its super-low setting of 500 mW into a dipole.

A message from that achievement is that the KRMNPA is available to anyone, including Foundation licence holders, and we hope to hear from many more.

That brings me to Julie VK3FOWL, who readily shares her knowledge to publicise the hobby including at school libraries, and outdoor events like the International Museum Weekend and the International Lighthouse and Lightship Weekend.

Julie believes that the great story about amateur radio needs to be told, and the enthusiasm being shown by Julie and others is amazing.

## Participation certificate for KRMNPA

The Keith Roget Memorial National Parks Award activity period is November 15 to 19. In this its 5<sup>th</sup> year, a free participation certificate is being made available.

It will go to those who register with the Award Manager Tony Hambling VK3VTH and have not obtained a KRMNPA award certificate. To qualify you need to operate within a VK3 National Park and make five contacts. The aim is



Tim VK5AV proudly shows his KRMNPA Merit Award Plaque.

to encourage interest in operating portable.

The KRMNPA activity period in 2014 had 34 National Parks on air. With the participation certificate who knows how many will be activated this year. You can also still work those in National Parks from your own home, and the activity period is ideal to get your tally started or increased.

Please read the Award Rules and other material on the website. All inquiries to Tony VK3VTH at vk3vth@amateurradio.com

Mentioned above is the Merit Award to Amanda VK3FQSO. Two others have also recently received them, including Andrew Davis VK1DA and Tim Hann VK5AV, adding to the rapidly growing list of recipients.

Andrew VK1DA made his first contact with Wayne VK3WAM/P who was activating Terrick Terrick National Park in September 2011 and finished with #45 on May 3, with Paul VK5PAS/3 who was at Murray-Sunset National Park.

Well done to Tim VK5AV who has submitted an eligible log for the KRMNPA chasers Merit Award. His first KRMNPA contact was with Amateur Radio Victoria's Centenary station VK100ARV during the first KRMNPA activation weekend in November 2011.

Since then, Tim VK5AV has been adding the balance of stations slowly but surely, culminating in the final contact #45 with VK3VTH/P in Greater Bendigo National Park on April 17.

## Classes in August

The next class and assessment weekend for the Foundation licence will be on August 22 and 23, with enrolments now open.

These popular quality courses are held at the conveniently located and equipped office of 40G Victory Boulevard, Ashburton.

To enrol or obtain the Foundation licence manual study and operational practice guide book, contact Barry Robinson VK3PV on 0428 516 001 or [foundation@amateurradio.com.au](mailto:foundation@amateurradio.com.au)

The study and operational practice guide book for the Foundation licence is available online as a mail order for \$26 from the Amateur Radio Victoria on-line shop with its website.

## AMSAT-VK



AMSAT Co-ordinator  
Paul Paradigm VK2TXT  
email: [coordinator@amsat-vk.org](mailto:coordinator@amsat-vk.org)

Group Moderator  
Judy Williams VK2TJU  
email: [secretary@amsat-vk.org](mailto:secretary@amsat-vk.org)

Website:  
[www.amsat-vk.org](http://www.amsat-vk.org)

Group site:  
[group.amsat-vk.org](http://group.amsat-vk.org)

**In New South Wales**  
VK2RBM Blue Mountains repeater on 147.050 MHz

**In Queensland**  
VK4RIL Laidley repeater on 147.700 MHz  
VK4RRC Redcliffe 146.925 MHz IRLP node 6404, EchoLink node 44666

**In South Australia**  
VK5TRM, Loxton on 147.175 MHz  
VK5RSC, Mt Terrible on 439.825 MHz IRLP node 6278,  
EchoLink node: 399996

**In Tasmania**  
VK7RTV Gawler 6 metre repeater 53.775 MHz IRLP node 6124  
VK7RTV Gawler 2 metre repeater 146.775 MHz IRLP node 6616

**In the Northern Territory**  
VK8MA Katherine 146.700 MHz FM

Operators may join the net via the above repeaters or by connecting to EchoLink on either the AMSAT or VK3JED conferences. Past experience has shown that the VK3JED server offers clearer audio. The net is also available via IRLP reflector number 9558. We are keen to have the net carried by other EchoLink or IRLP enabled repeaters and links in order to improve coverage. If you are interested in carrying our net on your system, please contact Paul via email. Frequencies and nodes can change without much notice. Details are put on the AMSAT-VK group site.

### About AMSAT-VK

AMSAT-VK is a group of Australian amateur radio operators who share a common interest in building, launching and communicating with each other through non-commercial amateur radio satellites. Many of our members also have an interest in other space based communications, including listening to and communicating with the International Space Station, Earth-Moon-Earth (EME), monitoring weather (WX) satellites and other spacecraft.

AMSAT-VK is the primary point of contact for those interested in becoming involved in amateur radio satellite operations. If you are interested in learning more about satellite operations or just wish to become a member of AMSAT-Australia, please see our website.

### AMSAT-VK monthly net Australian National Satellite net

The net takes place on the 2nd Tuesday of each month at 8.30 pm eastern time, that is 0930 Z or 1030 Z depending on daylight saving. Check-in starts 10 minutes prior to the start time. The AMSAT-VK net has been running for many years with the aim of allowing amateur radio operators who are operating or have an interest in working in the satellite mode, to make contact with others in order to share their experiences and to catch up on pertinent news. The format also facilitates other aspects like making 'skeds' and for a general 'off-bird' chat. In addition to the EchoLink conference, the net will also be available via RF on the following repeaters and links.

### Become involved

Amateur satellite operating is one of the most interesting and rewarding modes in our hobby. The birds are relatively easy to access and require very little hardware investment to get started. You can gain access to the FM 'repeaters in the sky' with just a dual band handheld operating on 2 m and 70 cm. These easy-to-use and popular FM satellites will give hams national communications and handheld access into New Zealand at various times through the day and night. Currently only SO-50 is available.

Should you wish to join AMSAT-VK, details are available on the web site or sign-up at our group site as above. Membership is free and you will be made very welcome.

## Participate

# ALARA 40th Birthday Celebration Lunch

## 25 July





## VK3news Geelong Amateur Radio Club

Tony Collis VK3JGC

### ANZAC Communications Exhibition

The Geelong Amateur Radio Club Inc. was successful in obtaining a Department of Veterans Affairs' grant, under the ANZAC Community Grants Program; the Club believes it is the only Amateur Radio Club to receive such a grant.

Stemming from this the GARC will be hosting an interactive exhibition of military communications and navigational equipment at Osborne House, Geelong, during July, entitled **"From Morse to the Magnetron."** The exhibition will be of Military Communications, Signalling and Navigation technology from World War One to the Vietnam era, displaying the chronological

development of military communications from semaphore, pigeons, Aldis lamps and mule pack wireless sets to Satcom pack sets. The collection also includes A Spy and Coast-Watch section as well as some Australian designed and built equipment. A reminder of when Australia had an electronics industry!

The Geelong region itself has been, historically, at the forefront in the development of Wireless Telegraphy, including the First Ship to Shore transmission in the southern Hemisphere when Henry Jervoy sent a message to the Duke and Duchess of York and Cornwall, when they arrived to open the first Federal Parliament in May 1901 and also the first transmission

from Australia's mainland from The Ponds near Queenscliff to Devonport in July 1906.

Prior to this, early last year, the GARC successfully applied for and acquired, a special event call sign; then facilitated a national and international radio network in conjunction with the "First Shot" of WW1, as part of the ANZAC Centennial Commemorations.

The venue for the exhibition, **which is free to the public**, is at Osborne House, Swinburne Street, North Geelong. This location has a strong historical link with the Services, being the first Australian Naval College, the first Submarine Flotilla Headquarters, and a respite home for Nurses returned from serving in India in WW1.

Photo 1: Installation of the mast.





Photo 2: Bolting the mast to the mounting base.

This exhibition has been tirelessly project managed by Barry VK3SY in conjunction with Calvin VK3ZPK.

The Exhibition will be open each Thursday to Sunday commencing July 2nd to 30th from 10 am to 4 pm.

### The Marconi Hut Mast

For several years now the Geelong Amateur Radio Club has worked in partnership with the **Queenscliff Maritime Museum** to celebrate, annually, the first Marconi radio CW transmission from Point Lonsdale to Tasmania on the 12<sup>th</sup> of July 1906.

To commemorate this, a replica of the original Marconi Hut was designed by a team from the GARC, led by Calvin VK3ZPK and built by apprentices from the Gordon TAFE, with materials supplied by Mitre 10 Hardware, for the 100 year

anniversary, in 2006.

The Hut was eventually moved to its present position in the **Queenscliff Maritime Museum** grounds. In succeeding years antennas were erected and subsequently removed after the **Marconi day** exercise. It was felt that a permanent antenna arrangement was required and so a new Club project was commissioned to erect a permanent mast at the Museum next to the **Marconi Hut**, equipped with HF, VHF and UHF antennas.

Videos of the first phase of this project can be viewed via YouTube by entering "Marconi Hut" into the search bar which will bring up the hole boring and subsequent concrete pouring into the purpose built frame. The second phase of the GARC's installation of the permanent mast and antenna

system was recently completed by the project Manager Calvin VK3ZPK and the GARC's *Wednesday Crew*.

The top of the mast contains a weather proofed "Flower Pot" vertical for 2 m and 70 cm, as built by the Club from a design by VK2ZOI, and two stainless steel halyards are located at the top one to hoist the HF multi-band dipole and the other a flag.

The final phase will be to draw the coax cables into the hut and terminate them ready for use by the GARC on Marconi Day, as well as other contest occasions during the year. This project is being implemented with the full approval and cooperation of the Maritime Museum.

73

Tony Collis VK3JGC

Help us

**Contribute to the Weekly WIA News Broadcast. See our website for details.**  
[www.wia.org.au/members/broadcast/contribute/](http://www.wia.org.au/members/broadcast/contribute/)





## VK3news MDRC

Kaye Wright VK3FKDW



Photo 1: Operator Gerard VK3GER, Logger Denis VK3BGS, Observer Ian VK3IFM.



Photo 2: View of Memorial and RSL Mentone.

MDRC was able to secure the use of the **VK100ANZAC** call for the week of 2nd to 8th May 2015. The venue was the Mentone Memorial Gardens adjacent to the Mentone RSL supplemented by operation from the home stations of Lee VK3GK, Graeme VK3GL and Ron VK3AFW.

We were fortunate with the weather for the three days in the gardens, Saturday through to Monday. The Club Gazebo was set up with tables and chairs on a paved area in the gardens adjacent to the flag poles and Wreath Stele.

The power was obtained from a council owned outlet a few metres away. An Off Centre Fed Dipole with a modified feeder arrangement provided operation on 40 m through

to 10 m with the Club's TS-2000. A 7 m squid pole supported the centre of the dipole with one end being secured to the top of a light pole and the other to a fence.

On the Saturday Ian VK3IFM (our honourable President) and Ian VK3XI along with Ron VK3AFW collected the necessary equipment from the Club rooms and proceeded to the memorial Gardens where they were met by Gerard VK3GER. Initially it took 45 minutes to set up but by the third day set-up time was down to just over 20 minutes.

The station operated continuously from 10 am to 4 pm on the three days.

Because the Club members responded to the call it was easy to rotate operators and log keepers.

Nearly 300 contacts were made covering all VK states, ZL and some US, JA and European stations in the log.

ANZAC biscuits provided by Gerard and coffee kept the operators awake and on their toes.

A computer logging program, VKCL, was used. This is very easy to use for operations like this. Ian provided the computer. This program also has the right set-up for recording and scoring all Australian Contests.

No operation of this size can succeed with-out help from support people. Brenda and Kaye assisted with chauffeuring duties and Ken offered moral support and CHOCOLATE.

This event was a great success, mainly because it was supported by 12 members. Each one was presented with a certificate of appreciation.

MDRC President Ian VK3IFM was approached by District Joey Scout leader Murray Taylor VK3MJT to support the **Jamboree of the Trail** (JOTT) on 17th May 2015 and provide three stations on a walking trail along Gardner Creek Bike Track.

The walk started at Darling Station and continued to a turnaround point at Burke Rd South Wetlands, some three km away. The walk then returned to Darling station. Three operators supported the event, Fred VK3JM, Gerard VK3GER and Ian VK3IFM.

We used 2 m simplex and had good communications over the distance.

*Photo 4: JOTT Start and Finish of trail.*



The teams were of varying sizes made up from Regional Scout Groups with on average about fifteen Scouts and adults in each team. There were 19 teams of walkers. Our task was to radio times when teams arrived and left the two checkpoints on the track and

returned to the Start. The mission was accomplished without difficulty.

As usual the Hamfest was held on the Saturday before Mother's Day. Unfortunately, the WIA has taken to having their AGM on the



*Photo 3: Feedpoint at dipole.*

same weekend, meaning some familiar faces were missing. This year door sales were up and the cool weather produced a run on the hot BBQ food and tea and coffee but few cold drinks were sold.

The Cuppa and Chatter room was full most of the day – an excellent innovation.

Kaye VK3FKDW and Denis VK3BGS manned the ticket desk and Brian VK3MCD collected the table charge from the traders. This year we had an excellent book stand by Peter VK3FPRS, who is a keen SOTA chaser. Icom were busy fielding questions and most other traders did rather better than petrol money.

The editor was sorely tempted to buy an old piece of Yaesu gear but fortunately someone else nabbed it early on. Corrie, Noel VK3BMU and Tony VK3CAT ran the BBQ with their usual flair. The weather was a bit cool but not wet so that probably helped get a good turnout.

As usual, eyeball QSOs with friends seen face to face only at Hamfests featured highly on most attendees agendas.

Thanks to Graeme VK3GL, Cohen VK3HCL, Lee VK3GK, Ian VK3IFM, Ian VK3XI and Gerard VK3GER for the "heavy lifting".

*Photo 5: Bargain Hunters at the Hamfest.*



## Silent Key

Harley Benjamin Kerr VK3CHK



Harley was a long-time member of MDRC and he especially enjoyed the Tuesday Coffee meetings. He was a man of many skills who rose through the ranks to a senior position in the Gas and Fuel Corp of Victoria. He was often called upon to exercise his machine shop skills for other Club members and his chemical knowledge.

Harley came to the fore when he made marmalade of show quality and brandied cumquats that were heavenly.

Harley was part of a group who chatted every week afternoon on 2 m on their way home in their cars. This net eventually became more home based as members retired. It was known as Harley's (drive time) net and continues today. His sagacity and friendliness are sorely missed by his friends at MDRC.

## Silent Key

Rolphe Thomas Fox



After attending Mentone Grammar, Rolphe joined the RAAF as a young man and spent his time after training as a RADAR operator at various coastal RADAR stations.

Rolphe enjoyed a joke and could be relied upon to tell one at most Tuesday Coffee meetings. If he didn't have a joke, he would have a funny quip to make. This was a skill honed in his job as a sales representative for Hecla. In the 1950s through to at

least the 1980s, no salesman worth his salt would try to sell anything until he had made the client laugh.

Even when his battle with cancer was becoming more burdensome he was cheerful.

His cheeky grin and quick wit are missed by his friends at the Club.

## Silent Key

Arthur Brodie David Evans VK3VQ



Arthur passed away on Tuesday 3rd March 2015 aged 97. He had recently moved into Vasey RSL Community Care. Until then he had lived independently at home.

Arthur was licenced as VK3QF in 1937 at 20 years of age and proceeded to work the world using 25 watts of CW and a Windom antenna. A year later he became a Certified Practising Accountant.

He joined the WIA RAAF Wireless Re-serve and was called up almost immediately hostilities commenced in 1939. Within a fairly short time Flight Lieutenant Evans was in charge of a wireless unit which included the normal communications function and an Interceptors section. The story of the latter has been recorded in the book *The Eavesdroppers* by Jack Bleakly. Some of Arthur's exploits have been recorded in OTN magazine, for example in the March 1996 and September 1999 issues. Arthur's deployment included a lot of time around Papua New Guinea often setting up new stations as the allies moved forward.

Arthur's interceptor group was of course proficient at KANA: the Japanese version of Morse code and all received messages were written down and passed to the intelligence unit.

On one occasion one operator said to Arthur, something is up; we are all seeing a change from recruits operating the stations to professional operators. So well did Arthur's men know the individual operators sending, they knew when someone else used the key: New well-trained men had joined the outposts. This information was passed directly to the intelligence office and was the first alert General Mc Arthur had that a Japanese offensive was building.

Arthur returned to the family business Evan Evans making canvas goods and also flags and banners. Ivor Evans, Arthur's father, was co-winner of the design of Australia's Flag. Arthur was a stalwart of the canvas trade.

Arthur was an avid player of squash, hockey, tennis and golf. He was a train enthusiast and loved to travel.



## VK7news

Justin Giles-Clark VK7TW

✉ vk7tw@wia.org.au

🌐 groups.yahoo.com/group/vk7regionalnews/

### Award News

Congratulations to Rex VK7MO and Derek VK6DZ who were awarded the inaugural WIA Technical Excellence Award. This award is granted where some technical excellence is demonstrated in any special technical aspect of amateur radio. The award was for outstanding achievement in establishing a new World DX Record for 10 GHz, exploiting tropospheric refraction across the Great Australian Bight to make contact over a distance of 2732 km. Congratulations to Rex and Derek.

### VK7 Broadcast Year

The WIA AGM signals the start of a new broadcast year for the WIA National News and the VK7 Regional News Broadcasts. Considering there are only about 500 amateur radio operators licenced in VK7, the broadcast statistics tell a healthy story of VK7 involvement in the National and Local broadcasts for the last year.

The following are the total check-ins for each state in order of magnitude:

- VK2 = 8131
- VK6 = 8109
- VK4 = 7271
- VK5 = 5758
- VK7 = 4503**
- VK3 = 2978
- VK8 = 1066
- VK1 = 890

The 4503 callbacks are made from the three main repeaters in VK7: VK7RAD/RHT, VK7RAA and VK7RMD with 2566. HF rebroadcasts on 80, 40, 20 & 10 making up 1247 callbacks and other repeaters, ATV, Streaming and VOIP broadcasts make up the remaining

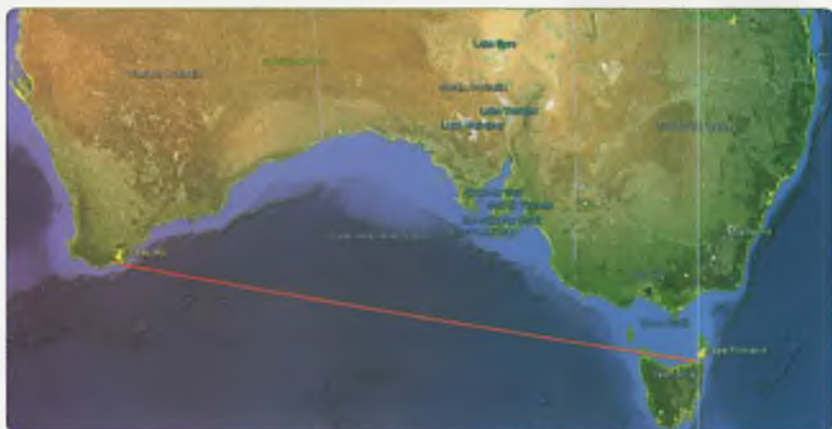

Photo 1: VK7MO – VK6DZ - 10 GHz Terrestrial World Record Path – 2732 km. (Google Earth Map with markup by VK7MO)

690. Thanks to all involved who made this a success throughout the year.

### Northern Tasmanian Amateur Radio Club

From 31 May to the 2 June 2015, NTARC activated VK100ANZAC. This started on Sunday at the Harry Murray Memorial Gardens in Evandale between 10 am and

3 pm with a highlight being an on air contact between Evandale and the Deloraine home of the Great Niece of Harry Murray - Mrs Anne Batilbasi. There was also great commercial media coverage of this event. The station then moved to the NTARC clubrooms at Rocherlea and operated and made many contacts around the world for the next two days using the callsign

Photo 2: Local members of Parliament, Dignitaries, NTARC members and the public take in the VK100ANZAC activation in Evandale, Tasmania.





VK100ANZAC. The clubrooms are well equipped with log fire (Hearth Vader), showers, amenities, kitchen and the all-important coffee machine...HIHI. The Tuesday night saw a BBQ put on by NTARC which was a big hit.

NTARC's May meeting was a fascinating presentation by Trevor Briggs VK7TB entitled "Some electrical fundamentals explained and displayed on a Network Analyser". By all accounts this was a very interesting talk demonstrating electrical theory in practice through the display on the computer connected vector network analyser. Trevor included inductive and capacitive reactance, impedance, resistance and resonance. These computer-connected VNAs are becoming much cheaper and accessible and they bring the theory to life. Trevor has been invited back for a follow-up presentation, thanks Trevor.

Congratulations to Peter Sulzberger and George Phillips, who both successfully passed their Foundation licence assessments in May. Mid May also saw NTARC providing communications and RFID tracking for the Lebrinna Equine Endurance Event. This was a 40 and 80 km ride and thanks to the following helpers: Norm VK7KTN, xyl Lorraine, Idris VK7ZIR, Andre VK7ZAB, Alvin, VK7ADQ, Ken VK7KKV, Stuart VK7FEAT, Bernie VK7BR, Yvonne VK7FYM, Wayne and xyl Meg.

### North West Tasmania Amateur Radio Interest Group

For those interested in the VK7AX Broadcasts transmitted via ATV and Video Streams – there has been a change to the URL for access to the stream. Tony VK7AX has gone back to using the British Amateur Television Club service at [www.batc.tv](http://www.batc.tv) go to the "Members Stream" then to VK7AX, alternatively, you



Photo 3: Simon VK1FAAS and his Foundation call SOTA experiences. (Photo courtesy of Justin VK7TW)

can go to [www.batc.tv/streams/731](http://www.batc.tv/streams/731) which will take you direct to the VK7AX Video Stream. A reminder that the WIA National News and VK7 Regional News are also transmitted via this medium with caption or video slide show as the accompanying video.

### Radio and Electronics Association of Southern Tasmania

Congratulations to Ross Hutchison (soon to be VK7ZR) who passed his Advanced licence requirements in the last month. REAST's May presentation was given by Dr Steve Hindley who is a GP in Hobart and was a fascinating talk about men's health. Dr Steve took us on an interesting journey that reflected upon many aspects of Men's health and many aspects of what is right and not so right with our health system. One that struck a chord with the author was "heart attack poker" where the high scoring cards were matched with the factor contributing to the risk of heart attack – a full-house is definitely not a hand you want! Thanks to Dr Steve and the presentation was video recorded for the DATV library.

REAST's June presentation was given by Simon Pearce VK1FAAS who was touring VK7 along with his XYL and we were privileged to have him give us his "SOTA from a Foundation licence perspective" presentation that he gave at the recent WIA AGM in VK1. Simon took the audience on a journey about SOTA and why it fits so well with the Foundation licence. Simon has great enthusiasm for the hobby and SOTA and this certainly showed. Thanks for giving the presentation Simon and apologies about the weather!

Our DATV Experimenter's nights over the past month included – touring the HMAS Canberra, trials and tribulations of LED automotive globes replacement, moon bows or lunar rainbows with actual pictures, linking Morse code practice sets, SOTA activation of The Needles in SW VK7, Cisco layer 2/3 switches and Sydney's Vivid festival pictures and videos (thanks Ben VK7BEN). Our videos included Noel VK3FI - Swan Hill and Lake Boga videos, UK - TX Factor, science and history videos compliments of the Interweb.

## Silent Key

Alan Ruthven VK7ZAR

It is with shock that I inform you of the sudden death of Alan Douglas Ruthven VK7ZAR – “The tsar”. Alan died on Monday May 4, 2015 aged 68 years.

Alan is known to so many and has been involved in amateur radio and the Wireless Institute for many years. In fact Richard VK7RO showed a January 1979 Amateur Radio magazine with a young Alan on the cover running the auction at the 1978 Tasmanian Amateur Radio Convention at Hobart College. Richard remembers one of Alan's favourite sayings when selling equipment – “Working

when last used”. Joe VK7JG reminds us that Alan was involved with the original construction and installation of the 6 m VK7RST beacon and Repeater 2 on Mt Wellington in the early years and has kept the VK7RST 6 and 2 m beacons up and going. Alan is survived by wife Elizabeth, daughters Jane and Mary and partners and grandchildren and his father Ronald.

Our deepest sympathy is sent to all his family and friends.

Vale Alan  
(Justin VK7TW)

## Silent Key

Klaus-Peter Effenberg  
VK7LED

It is with regret that we also inform you of the passing of Klaus VK7LED on Tuesday 5th May 2015.

Klaus recently studied and passed his amateur radio assessment back in August 2013.

He was regularly heard on the air-waves and always called into the broadcast call backs.

Our deepest sympathy is sent to all his family and friends.

Vale Klaus.  
(Justin VK7TW)

## Silent Key

Les Poole VK2APE/VK2LP

It is with sadness that I report the death of Les, affectionately known locally as “Ape”, or “The Ape Man”. For the last 10 years Les was Treasurer of NSW WICEN Hunter, and for the last seven he was RCO.

As a WICEN member, Les had been involved in emergency communications following the Newcastle earthquake in 1989, the ISDE motor bike event in the early nineties, and countless horse endurance rides since then all over NSW. The Shahzada group knew him well; always accompanied by his wife Heather, he used to make the

annual pilgrimage to St Albans and they would camp in their caravan for the entire week near the tennis sheds.

For about 10 years Les with his Yaesu FT-7B and his large stuffed “ape” suitably dressed in Cub Scout uniform was a vital part of JOTA for the 1st Byattunga Group at Morisset.

Several years ago, a photo appeared in AR of Les with his daughter VK2FGAI and granddaughter VK2FEMM – three generations of amateurs!

As well as amateur radio, Les has been

a keen sailor and a motor cycle rider; he was a member of the Ulysses – (Glow Old Disgracefully) motorcycle club. Most certainly he packed much activity into his 74 years.

Les, you will be sadly missed by the WICEN and the amateur fraternity, as well as by wife Heather, and the children and grandchildren.

Vale Les VK2APE, rest in peace.

Dan VK2GG, Secretary, NSW WICEN Hunter.



## Morse Code for Radio Amateurs

By Roger Cooke G3LDI

50% larger than its predecessor, the 11th edition of RSGB's Morse Code for Radio Amateurs is essential for anyone looking to expand their horizons by adding Morse code to their skills. It has everything you need to get started in the fascinating hobby, to using computers and increasing your speed.

A CD containing nearly an hour of audio recordings of Morse code, audio files which can be run on a PC soundcard or downloaded to a personal MP3 player and Morse Software for learning Morse code and Morse contesting is included.

48 pages. 11th edition. © 2013.

Published by Radio Society of Great Britain

\* Plus postage and packaging

Member Price: \$25.00\* Retail Price: \$33.00\*



# Results from the Easter Urunga Radio Convention 2015

Ken Golden VK2DGT



Photo 1: Night O-R Fox Hunt 6tx.

Photo 2: Tabatha and June Austin.

The Urunga Convention was a successful event despite rain – it didn't stop the Fox Hunters, although one got bogged (the fox was not there). All hunts were very popular, especially the Night OR Hunt 6 transmitters.

The Saturday night Dinner was well attended and enjoyed by all.

This year the Convention was dedicated to Arnold Austin VK2ADA who passed away after a long illness. He was President for many years and he and his wife June were loyal supporters of URC. He was sadly missed by the Fox Hunting community, renowned for his "kilowatt handshake" (a man's handshake).





Photo 3: Brett Austin presenting Arnold Austin Memorial Trophy to Jeff Pages.



Photo 4: Ken VK2DGT presenting Brian Starke memorial Trophy to Chris Williams.

The Arnold Austin Memorial Trophy was presented by Brett Austin (his son).

A thank you to all Sponsors and supporters.

We hope to see you all next year.

Ken Golden VK2DGT President

## Results Urunga Radio Convention 2015

### Saturday

3.5 MHz Hunt Mobile: No result...

146 MHz Pedestrian multi tx:

1st Cameron Williams

2nd Ken VK2DGT

146 MHz Mobile multi tx:

1st Craig VK2ZCM

2nd Allan VK2EFM

Talk In Mobile Hunt 2 m:

1st Jeff Pages VK2BYY

2nd Craig Martin VK2ZCM

Night Hunt Fox O-R:

1st Kevin VK2KD

2nd Allan VK2EFM

### Sunday

40 m Fun Event:

1st Jeff VK2BYY,

2nd Rodney VK2TI

146 MHz Mobile multi tx:

1st Chris Williams VK2YMW

2nd Jeff VK2BYY

146 MHz Pedestrian Multi tx:

1st Chris VK2YMW

2nd Rodney Carl Winkler VK2TI.

Talk in Pedestrian 2 m:

1st Rodney VK2TI

2nd Tabatha.



Photo 5: Ken bogged.



Photo 6: Len Christensen VK2BLZ Fox Master.





## VK6news

Keith Bainbridge  
✉ vk6rk@wia.org.au

I think I was right when I said last month that my contributors had gone into hibernation: There has been very little input this month so Secretaries, Publicity Officers, please dig a bit deeper for August's contributions.

**WARG** have some news so over to Anthony VK6AXB, with the following update from the West Australian Repeater Group.

WARG's Annual General Meeting took place on 4<sup>th</sup> May, resulting in changes to our Committee, including a new President, Vice President, Secretary and Technical Officer.

Several members of the previous committee had done three-year stints, and WARG's constitution requires office holders to stand down after three consecutive years in a position, to encourage other members to have a go.

Congratulations to Ray VK6ZRW, who was elected unopposed as WARG's new President. Previous President Anthony VK6AXB is now WARG's Secretary. Barry VK6SP has the Vice-President's job, and Bob VK6ZGN takes over from VK6ZRW as WARG's Technical Officer.

John VK6JAH continues as WARG's Treasurer and Membership officer (still working twice as hard as the rest of us).

We welcome Chris VK6FCBG as a member of WARG Committee, along with continuing members Steve VK6VHZ and Trevor VK6MS. Duncan VK6GHZ and Rob VK6LD also put their hands up for Committee roles.

The meeting noted the contributions of Cliff VK6LZ and Peter VK6PM who stepped down

from Committee duties, and also thanked Ron VK6HRB and XYL Dot for their many years of work managing the WARG cable and antenna shop. The contribution of WARG site managers and other members who volunteer their time to keep our repeaters running was also recognised.

The meeting also thanked Ian VK6LCT and Kylea VK6XYL for their kind donation of a Yaesu DR-1X Fusion repeater transceiver to WARG. Work is under way to get this unit on the air at the VK6RFM site near Fremantle.

The new Committee is to be congratulated for putting their hands up and taking on the tasks. They are already getting on with the job, having met on 27 May to progress a number of outstanding site work matters.

For those who want to find out more about WARG or get involved, WARG's technical and general net takes place on Sundays at 10:30 local on VK6RLM, 146.750. Our website is [www.warg.org.au](http://www.warg.org.au)

WARG meetings take place on the first Monday of the month, or the second if the first is a public holiday. Upcoming meetings include Monday July 6 and Monday August 3. Meeting venue is the Peter Hughes Scout Communications Centre, on the corner of Gibbs St and Welshpool Rd, East Cannington. Visitors are welcome, and for anyone wishing to become a WARG member, the cost is still a very reasonable \$25 per year.

Thanks Anthony, best of luck to the new committee.

Now to the southwest with the ever reliable Norm and his update

from the **Bunbury Radio Club**

The Club's May meeting was held in Harvey at the QTH of Nic VK6NA. Nic's QTH is high up on the Darling Escarpment with wonderful views of the Indian Ocean and rural valleys in the hinterland. Nic's place is also home to the "Bunbury" repeaters VK6RBY (2 metre and 70 cm). Because of their elevated position, the repeaters have excellent coverage. Soon, hopefully, we plan to put up a taller tower that should increase their respective ranges even further.

Our meeting was very well attended, with 14 members attending. Following the business session we were treated to a visit to the repeater site and a tour of Nic's ham shack. The shack is well equipped with a number of premium transceivers and ancillary equipment. It is interesting to note that even with some top of the range gear, Nic still enjoys using his more vintage radios. To complement the shack Nic has an aerial farm that most of us can only dream of.

A program of technical activities is close to completion, with topics such as fox hunting, ham radio software, QSLing, the art of DXing, some club contests and awards. The plan is for this to be finalised for the new financial year. The program will be designed to involve our more remote members who cannot easily attend meetings.

Brian VK6TGQ is working on the concept of an "experimenters net". The purpose of the net is to have fun while learning about a new piece of equipment or operating mode. It may be on HF so that more distant members can be involved.



Photo 1: The Bunbury Radio Club repeater site.



Photo 2: Many hands, etc. The large Yagi being carried into position.

Some proposed areas of interest include testing and tuning antennas, testing vintage radio, the various elements of packet radio, Slow Scan television, digital voice modes, internet usage, SDRs, Raspberry Pi, to name a few.

During April we ran a number of licence assessments in Bunbury. Five Foundation, two Standard and one Advanced applicants sat for their licences. Of these four passed. Currently we have another four potential applications awaiting the next lot of assessments. No date for these has been set yet.

The new Club rooms at the QTH of Richard, VK6VRO, are nearing completion. The tiling, painting and electrical work is completed and carpet is about to be laid. The plan is to be in the new room in time for our annual meeting in July.

Ian VK6MIB has been tasked with running a local award activity, entitled "Worked All Bunbury Dummies". Don't ask.

Our next meeting is on 13 June at 1400 at the QTH of Richard VK6VRO. All visitors are welcome. For further details contact our secretary Brian VK6TGQ on 0403 975 953 or [vk6brc@wia.org.au](mailto:vk6brc@wia.org.au)

Thanks Norm, things are certainly progressing in the South West.

The **NCRG** have been busy over the past few weeks and I've included a few pictures from the working bee's that have taken place.

We decided that we could get better performance from our antennas and towers if we had a shuffle around, so the 20 m long Yagi was removed from its tower and put in place of the 15 m Yagi. Then the 15 m Yagi was extended to a very long boom and will be installed in the next week or so. Finally the six metre beam was given a birthday and its tower made ready to accept the three element Steplr beam.

Are you still with me?

Good, while all this was going on Zeljko VK6VY was treating us to



his famous "Zone 29" Burgers for lunch. These have to be seen and tasted to be believed.

We have recently acquired two seven element wide spaced Yagis on 18.5 m booms for 10 m and 15 m and are trying to work these into our setup, so as usual, antenna work seems to take preference over all other projects. James VK6FJA has been busy with SSTV on the club 2 m repeater, with shack pictures being broadcast every few hours. He has great plans for more SSTV to be broadcast on the VK6RNC repeater so keep an eye/ear open on 146.625.

Recently many members have pitched in and helped remove all the radio equipment, antennas, towers, shelving etc. from the remote shack of Mirek VK6DXI SK, which involved Darby VK6FONC borrowing a HiAB truck and a trip to just outside Toodyay. It was a cold and wet day and all who helped remove the station out there were much relieved to get back home to dry out and warm up, not typical Perth weather that day unfortunately.

It was good to be able to help out Mirek's family and four members of the VKCC (the VK Contest Club) assisted by two other local amateurs, have managed to dispose of most of the estate.

As previously published, the NCRG was to assist with the upcoming Heard Island DXpedition, leaving from Fremantle in November this year. They have run into difficulties with the Russian ship that was to take them there and the result is they will no longer be sailing from Fremantle, but will be returning here at the end of the much reduced in numbers DXpedition on the good ship Braveheart, more on their website <http://vk0ek.org>

Finally this month a **Hamfest 2015** reminder.



Photo 3: One of the famous "Zone 29" hamburgers.

You should receive your copy of the August AR magazine well before the event this year.

As previously mentioned, Hamfest is one week later, the 9<sup>th</sup> August at 9 am at the Cyril Jackson Rec Centre, Fisher Rd, Ashfield (Bassendean) 6054.

All the usual attractions, the Big Raffle, excellent food, good company and a chance to catch up with those amateurs you speak to regularly but meet once a year!

For those of you who want to book a table, it's still \$5 admission for everyone and the tables are free, but you need to book.

Approximately 50 tables were taken last year, so get in early.

We have approached several associated hobbies/ interests this year and have asked them to put on

a display, hopefully this will happen. We are still in negotiations to put this in place as I write.

Table bookings to me please [vk6rk@wia.org.au](mailto:vk6rk@wia.org.au) or 0488 228 088.

This year the NCRG will have a sale table of NEW equipment, not our usual junk.

We are hoping to have Squid Poles, antennas, and associated radio accessories in an attempt to fill the gap created by not having a local radio shop from which to buy.

So we hope to see you all on the day, sellers from 7.30 am, buyers from 9 am.

That's all folks, please ask your publicity officers to contact me with updates on your clubs activities for the next edition of VK6 Notes.

73 de Keith VK6RK

Participate

International Lighthouse Lightship Weekend

15 - 16 August

## Assessors, Awards and President's Commendations at the 2015 AGM & Conference



1. Philip Adams VK3JNI, Assessor 10 years.
2. Craig Cook VK3KG, Assessor 10 years.
3. John Eyles VK2YW, Assessor 10 years.
4. Peter Freeman VK3PF, Assessor 10 years.
5. Amanda Hawes VK1WX, Assessor 10 years.
6. Alan Jenner VK4KZ, Assessor 10 years.
7. Jim Linton VK3PC, Assessor 10 years.
8. Chris Platt VK5CP, Assessor 10 years.
9. Trevor Quick VK5ATQ, Assessor 10 years.
10. Steve Tregear VK3TSR, Assessor 10 years.
11. Eric van de Weyer VK2VE, Assessor 10 years.
12. Peter Watts VK5PX, Assessor 10 years.
13. Robert Broomhead VK3DN, Assessor 10 years.
14. Dale Hughes VK1DSH, Amateur Radio Technical Award
15. Paul Simmonds VK5PAS, President's Commendation.
16. Peter Wolfenden VK3RV, President's Commendation.
17. Grahame O'Brien VK2FA, Assessor 10 years.

## Hamads

### WANTED - NSW

I am looking for a cheap FT-101E suitable for restoration or repair.

Anything considered. Thanks.

QTHR and [vk2cao@wia.org.au](mailto:vk2cao@wia.org.au) for contact. Noel Pakihi VK2CAO.

### FOR SALE - VIC

FT-747GX transceiver with FM board fitted. Desk Mike and Hand Held Mike. Manuals for the above. AT11MP auto antenna tuner with manual. Bencher low pass filter. Bencher antenna baluns. Lafayette TE48 GDO, TRIO noise bridge. MFJ TNCR Packet radio, model MFJ-1247. Alinco 2 m FM transceiver with manual. Osker SWR-200 meter.

VK Powermaster PSU. Low noise dummy load. 80 m mobile antenna. 2 coils coax cable. Other odds and ends. All items are in excellent condition and working OK. A complete station. Will not separate \$1000.00 the lot. Contact Norm EX VK3JAL anytime on 0354563122 or [bell122@westnet.com.au](mailto:bell122@westnet.com.au)





## Contributions to *Amateur Radio*

AR is a forum for WIA members' amateur radio experiments, experiences, opinions and news.

Your contribution and feedback is welcomed.

Guidelines for contributors can be found in the AR section of the WIA website, at <http://www.wia.org.au/members/armag/contributing/>

Email the Editor:  
[editor@wia.org.au](mailto:editor@wia.org.au)

### About Hamads

- Submit by email (**MUCH PREFERRED**) or if written and mailed please print carefully and clearly, use upper AND lower case.
- Deceased estates Hamads will be published in full, even if some items are not radio equipment.
- WIA policy recommends that the serial number of all equipment for sale should be included.
- OTHR means the address is correct in the current WIA Call Book.
- Ordinary Hamads from those who are deemed to be in general electronics retail and wholesale distributive trades should be certified as referring only to private articles not being re-sold for merchandising purposes.
- Commercial advertising on these pages Contact [admanager@wia.org.au](mailto:admanager@wia.org.au)
- Copy to be received by the deadlines on page 1 of each issue of Amateur Radio.
- Separate forms for For Sale and Wanted items. Include name, address STD telephone number and WIA membership number.

### 'Hamads'

PO Box 2042  
BAYSWATER VIC 3153  
[hamads@wia.org.au](mailto:hamads@wia.org.au)

## AMIDON FERROMAGNETIC CORES



tts systems

Phone 03 5977 4808. Fax 03 5977 4801  
[info@ttssystem.com.au](mailto:info@ttssystem.com.au)



11- 13 Port Road, Queenstown, SA 5014

### Quality Products for the Radio Amateur

**JACKSON BROS** variable and trimmer capacitors, reduction drives and ceramic stand-offs

**HAMMOND** transformers, enclosures and chassis's

**DSE HIBOX** large plastic waterproof enclosures

**ANDELI GROUP** indicator lights, relays and switches.

Pay by credit card, EFT or PayPal

**CALL (08) 8304 2000**

[sales@cooksoncontrols.com.au](mailto:sales@cooksoncontrols.com.au)  
[www.cooksoncontrols.com.au](http://www.cooksoncontrols.com.au)

### Studying for the Standard or the Advanced Licence?



Here are 4 books that will get you there.

TAKE A LOOK AT  
[www.gscott.com.au](http://www.gscott.com.au)

for more information and order form.  
635 Edmonson Avenue  
Albury NSW 2640

### "Hey, Old Timer..."

If you have been licensed for more than 25 years you are invited to join the



## Radio Amateurs Old Timers Club Australia

Or if you have been licensed for less than 25 but more than ten years, you are invited to become an Associate Member of the RAOTC.

In either case a \$5.00 joining fee plus \$18.00 for one year or \$32.00 for two years gets you two interesting OTN Journals a year plus good fellowship.

Write to **RAOTC**  
PO Box 107, Mentone  
VIC 3194

Ian Godsil 03 8707 1177

or Bill VK3BR on 03 9584 9512,  
email [raotc@raotc.org.au](mailto:raotc@raotc.org.au)  
for an application form.

### TRADE PRACTICES ACT

It is impossible for us to ensure that the advertisements submitted for publication comply with the Trade Practices Act 1974. Therefore, advertisers will appreciate the absolute need for themselves to ensure that the provisions of the Act are strictly complied with.

### VICTORIAN CONSUMER AFFAIRS ACT

Advertisements with only a PO Box number address cannot be accepted without the addition of the business address of the box-holder or seller of the goods.

### ADVERTISERS INDEX

Cookson Controls	63
Icom	BC
Jaycar	7
Kuhne electronic	13
TET-Emtron	9
TTS Systems	11, 63
Yaesu	IFC

# WIA Functional Committees

The WIA is a membership organisation with a very wide range of complex functions and member services. Core functions and services are administrative in nature (general administrative functions, membership services, examination and call sign management, financial etc...) and are performed by salaried staff.

Volunteers perform a diverse range of highly specialist functions (ACMA liaison, Frequency Co-ordination, Standards liaison, Interference issues, technical support and training and assessment etc.). These volunteers provide the majority of member services, however they have been loosely organised and often overstretched.

The new committee system attempts to structure the WIA's non-core activities into 10 broad functional areas, each comprising a team of volunteers under the direction of the WIA Board. This structure is intended to spread the workload on our volunteers, improve communications between members and the WIA Board, improve services to members, and encourage more people to become involved in the WIA.

## WIA Committee Charters

### Spectrum Committee

(Regulatory, ACMA, ITU, IARU, Repeaters & Beacons, Standards, Interference & EME, Monitoring Service)

Geoff VK3AFA, Phil VK2ASD (Director), Peter VK3MV, Roger VK2ZRH (Director), Brian VK3MI, Dale VK1DSH, Peter VK3APO, Richard VK2AAH, Gilbert VK1GH, Rob VK1KRM, Noel VK3NH, Doug VK3UM

- Perform all ITU and IARU liaison activities.
- Liaise with, and act as the 1st point of contact for, the ACMA.
- Advise the Board, and enact Board policy in relation to all radio communications regulatory issues and the LCD.
- Represent the WIA to State and Local Government
- Represent the WIA to Standards Australia
- Provide specialist technical advice and coordinate repeater and beacon licence applications and frequency allocation.
- Develop responses to significant and prolonged harmful interference issues affecting amateur radio operations.
- Provide an information resource for EMC/EMR issues.
- Administer the IARU Monitoring Service in Australia
- Provide a technical resource to other committees and the WIA Office.

### Technical Advisory sub-Committee (Tech support, Band plans etc.)

John VK3KM, Doug VK3UM, Rex VK7MO, Paul VK5BX, Walter VK6KZ, Barry VK2AAB, Bill VK4XZ, Peter VK3PF, Paul VK2TXT, Peter VK1NPW, John VK1ET, Peter VK3BFG, Eddie VK6ZSE, Peter VK3APO

### Administrative Committee

John VK3PZ (Treasurer), Greg VK2SM (Assistant Treasurer), David VK3RU (Secretary), Mal VK3FDSL (Office Manager), Phil VK2ASD (President), Chris VK5CP (Vice President)

- Responsible for the efficient and correct operation of the WIA office.
- Responsible for staffing and workplace safety.
- Provide a specialist administrative resource to the WIA office as required.
- Manage contractual agreements.
- Manage business relationships.
- Ensure compliance with the ACMA Business Rules
- Prepare yearly budgets
- Prepare quarterly financial reports for the Board
- Prepare independently reviewed YE financial reports and balance sheets for circulation to the membership prior to each Annual General Meeting.
- Manage insurances and to be responsible for currency of insurance policies.
- Maintain a complaints register.
- Ensure complaints are handled in accordance with WIA policy and any contractual agreements.

### Communications, Marketing, Publications and AGM Committee

Robert VK3DN (Director), Phil VK2ASD (Director), Jim VK3PC, Graham VK4BB (Broadcast), Roger VK2ZRH (Director) Publications sub-Committee (AR Magazine, Callbook etc): Peter VK3PF (Editor AR), Peter VK3PH (Editor Callbook), John VK3PZ (Treasurer), Ernie VK3FM, Peter VK3AZL, Evan VK3ANI, Ewan VK3OW, Bill VK3BR

- Communicate with members and the public:
- Communicate with the membership.
- Publicise WIA activities and initiatives.
- Develop strategies and resources for the promotion of Amateur radio to the public.
- Develop strategies and resources for the promotion of WIA membership to the Amateur community.
- Supervise and/or perform promotional activities.
- Co-ordinate the yearly AGM activities

### Education Committee

Fred VK3DAC (Director), Owen VK2AEJ, Ron VK2DQ, Mal VK3FDSL (Office Manager)

- In association with the WIA's RTO and affiliated clubs offering training services, develop and administer the WIA's training and assessment systems.
- In association with the Spectrum Strategy Committee, develop and maintain the various licence syllabi and associated question banks.
- In association with the Community Support Committee and the RTO, develop and maintain the Emergency Communications Operator scheme.
- Ensure the confidentiality and security of all personal information, question banks and examination papers.

### Radio Activities Committee

Chris VK5CP (Director), Geoff VK3TL

### Contests sub-Committee

Alan VK4SN, Denis VK4AE/3ZUX, John VK3KM, Tony VK3TZ, Kevin VK4UH, Colin VK5DK, James Fleming VK4TJF

### Awards sub-Committee

Bob VK3SX, Marc VK3OHM, Laurie VK7ZE, Alan VK2CA, Alek VK6APK, David VK3EW, Paul VK5PAS, ARDF sub-Committee: Jack VK3WWW, ARISS sub-Committee: Tony VK5ZA

- All activities associated with actual radio operation, such as: contests, awards, distance records, QSL services, ARISS, AMSAT, ARDF etc.

### QSL Card sub-Committee

Geoff VK3TL, Alex VK2ZM, John VK1CJ, Max VK3WT, June VK4SJ, Stephan VK5RZ, Alek VK6APK, John VK7RT, Craig VK8AS

### Historical and Archive Committee

Peter VK3RV, WIA Historian, (Leader), Drew VK3XU, Linda VK7QP, Martin VK7GN, Ian VK3IFM, Will VK6UJ, David VK3ADW, Jennifer VK3WQ/VK5ANW, Roger VK2ZRH (Director)

- Develop, maintain and preserve the WIA's historical and archive collection
- Encourage access to the collection by WIA members and those seeking historical material for publication.

### IT Services

Robert VK3DN (Director), Tim VK3KTB

- Provide an IT resource to other committees and the WIA Board.
- Be responsible for the off-site data back-up of all IT systems information.
- To update and maintain the WIA website as required.
- Advise the Administrative / Financial committee in relation to the MEMNET Cloud Service contract.

### Community Service Committee

Fred VK3DAC (Director), Greg VK2SM (Assistant Treasurer), Ewan VK4ERM (Director), Paul VK5PH

- Develop, promote and co-ordinate all WIA community support activities

### New Initiatives

Phil VK2ASD (Director), Robert VK3DN (Director), Roger VK2ZRH (Director), David VK3RU (Company Secretary)

- Think-tank ideas and initiatives to advance amateur radio and WIA membership.
- On approval by the Board, run proof of concept trials.

### Affiliated Clubs Committee

Ted VK2ARA, Mal VK3FDSL (Office Manager), John VK3PZ (Treasurer), Phil VK2ASD (Director)

- Manage all arrangements between the WIA and WIA Affiliated Clubs
- In cooperation with the Administrative / Financial committee, manage the Club Insurance Scheme
- Encourage stronger relationships and communications flow between the WIA and WIA Affiliated Clubs
- Encourage increasing WIA membership ratios in Affiliated Clubs
- Manage the Club Grants Scheme
- Identify and bring regional Affiliated Club issues to the attention of the WIA Board.



# WIA Annual Conference Canberra 8-10 May 2015



Part of the attentive crowd at the Conference Dinner.



Dianne VK3FDIZ receiving her certificate and gift from President Phil VK2ASD.



Part of the display of home-brew equipment built by members of the CRARC.



Roger VK2ZRH in an animated discussion with Peter VK3MV at the Friday gathering.



During the Conference session, Mai VK3FDSL (L) and Dianne VK3FDIZ (R) described the intricacies of the Assessment system processing at the WIA office.



Paul VK5PAS, John VK5BJE and Jenny VK3WQ at the Friday evening gathering.



Andrew VK1NAM (standing) and Simon VK1FAAS discussed SOTA activities with an emphasis on the Foundation licensee.



Mark Loney from the ACMA spoke about his experiences in Mongolia for the ITU and on upcoming changes in our regulatory environment.

# ICOM

**SIMPLICITY  
AND  
MOBILITY**



## IC-2730A

Introducing the new IC-2730A VHF/UHF dual band transceiver.

Featuring an easy-to-see white backlit LCD, optional Bluetooth and 50W of output on VHF and UHF, this amateur transceiver will take your communications to the next level.

To find out more about Icom's Amateur products email [sales@icom.net.au](mailto:sales@icom.net.au)

[WWW.ICOM.NET.AU](http://WWW.ICOM.NET.AU)