

# Amateur Radio

Volume 85  
Number 9  
September 2017  
Price: \$9.70 incl GST  
[www.wia.org.au](http://www.wia.org.au)



## Build the Plastic Fantastic

A magnetic loop for less than \$60

- ▶ Review of the LD-5 QRP multimode transceiver
- ▶ "Oh Danny boy": setting up & using JT65
- ▶ Prepare now for JOTA/JOTI

ISSN 0002-6859



09

17700021685062

**YAESU**  
The radio

# The Perfect Choice

## Sophisticated Dual Band Digital Transceiver

Built to Commercial Grade Specifications



《Actual Size》

**C4FM/FM 144/430MHz DUAL BAND  
5W DIGITAL TRANSCEIVER**

# FT-70DR

**C4FM**  
Clear and Crisp Voice Technology

**AMS**  
Automatic Mode Select

Advanced C4FM Digital

System Fusion Compatible

Combines FM and Digital Communications  
with AMS (Automatic Mode Select)

Coordinated Group Operation  
with Digital Group ID

700 mW of Loud, Clear Voice, Audio Output

5 Watts of Reliable RF Power  
from a Compact Handheld Unit

Wide Band Receive Coverage 108 - 579.995 MHz

Rugged Construction  
Meets IP54 (Dust & Water protection)

Large Multi-Color Operating Mode Indicator

Huge 1,105 Channel Memory

**YAESU**  
The radio

**YAESU Authorized Dealer**

**Andrews Communications Systems**  
Shop 8, 41-51 Bathurst Street, Greystanes NSW 2145  
Tel: +61-2-9636-9060  
URL: [www.andrewscom.com.au](http://www.andrewscom.com.au)

**YAESU Authorized Service Center**

**Andrews Communications Systems**  
Shop 8, 41-51 Bathurst Street, Greystanes NSW 2145  
Tel: +61-2-9636-9060, Fax: +61-2-9688-1995  
E-mail: [radioandrews@hotmail.com](mailto:radioandrews@hotmail.com)

**Strictly HAM Pty. Ltd.**

Shop 12B Church Street Bayswater Vic. 3153  
Tel: +61-3-9729-7656  
URL: [www.strictlyham.com.au](http://www.strictlyham.com.au)

**VK Radio Repairs**

347 Settlement Rd, Thomastown Victoria 3074  
Tel: +61-3-9465-9399, Fax: +61-3-8682-8748  
E-mail: [yaesu@vkradio.com.au](mailto:yaesu@vkradio.com.au)





# Amateur Radio

The Journal of the Wireless Institute of Australia

Volume 85

Number 9

September 2017

ISSN 0002-6859

## Editorial

### Editor

Peter Freeman VK3PF  
editor@wia.org.au

### Technical Editor

Peter Gibson VK3AZL

### Publications Committee

Peter Hartfield VK3PH  
John Morrissey VK3ZRK  
Ewen Templeton VK3OW  
Kaye Wright VK3FKDW (Secretary)  
WIA Office Bruce Deefholts VK3FBLD

### All circulation matters

nationaloffice@wia.org.au

### How to submit material

Secretary  
AR Publications Committee  
PO Box 2042  
BAYSWATER VIC 3153  
or armag@wia.org.au

### Letters to Editor

Editor AR Magazine  
PO Box 273  
Churchill Vic 3842  
or editor@wia.org.au

### Hamads

'Hamads'  
PO Box 2042  
BAYSWATER VIC 3153  
hamads@wia.org.au

### Advertising

All enquiries to  
Advertising Manager  
AR Publications Committee  
PO Box 2042  
BAYSWATER VIC 3153  
or admanager@wia.org.au

### Registered Office

Unit 20 11-13 Havelock Road  
BAYSWATER VIC 3153  
Australia  
Phone: 03 9729 0400  
Fax: 03 9729 7325

### Production Deadlines

All articles, columns, hamads and advertising booking by **first day of previous month.**

The contents of Amateur Radio are Copyright  
Wireless Institute of Australia © 2017

## Technical

Tech Review: LD-5 HF Ham Radio QRP Transceiver 6

James Hannibal KH2SR

The Plastic Fantastic: a Magnetic Loop costing around \$54 for 40 metres 14

Jim Tregellas VK5JST

Oh Danny boy, the pipes are calling 20

Joseph Kasser VK5WU



*This month's cover:*

*The Plastic Fantastic – a magnetic loop antenna for 40 m that you can build at low cost, using metallised plastic tubing designed for flammable gas delivery. See the story commencing on page 14. Photo by Jim Tregellas VK5JST.*

## General

Norfolk Island, South West Pacific: an autobiography 11

John G Anderson VK9JA

IARU Liaison Report #4 25

Jim Linton VK3PC

Jamboree on the Air and Jamboree on the Internet 26

Brett Nicholas VK2BNN

GippsTech 2017 Review: art, science, technology and tomfoolery 31

Roger Harrison VK2ZRH

GippsTech 2017: An organiser's view 37

Peter Freeman VK3PF

## Columns

ALARA 62

Board Comment 3, 5

Contests 28

WIA Awards 51

DX Talk 49

Editorial 2, 5

Hamads 13

Silent Key 35

SOTA & Parks 40

VHF/UHF – An Expanding World 42

WIA News 4, 30

VK2 News 52

VK3 News 39, 58

VK4 News 18, 61

VK5 News 59

VK6 News 55

VK7 News 53

## Contributions to Amateur Radio



Amateur Radio is a forum for WIA members' amateur radio experiments, experiences, opinions and news. Manuscripts with drawings and/or photos are welcome and will be considered for publication. Articles attached to email are especially welcome. The

WIA cannot be responsible for loss or damage to any material. Information on house style is available from the Editor.

### Back Issues

Back issues are available directly from the WIA National Office (until stocks are exhausted), at \$8.00 each (including postage within Australia) to members.

### Photostat copies

If back issues are unavailable, photocopies of articles are available to members at \$2.50 each (plus an additional \$2 for each additional issue in which the article appears).

### Disclaimer

The opinions expressed in this publication do not necessarily reflect the official view of the WIA and the WIA cannot be held responsible for incorrect information published.

## Amateur Radio Service

A radiocommunication service for the purpose of self-training, intercommunication and technical investigation carried out by amateurs; that is, by duly authorised persons interested in radio technique solely with a personal aim and without pecuniary interest.

### Wireless Institute of Australia

ABN 56 004 920 745

The world's oldest  
National Radio Society, founded 1910.

Representing

*The Australian Amateur Radio Service*

*Member of the International Amateur Radio Union*

#### Registered Office of the WIA

Andersson House

Unit 20, 11 Havelock Road  
Bayswater, Victoria, 3153

Tel: (03) 9729 0400 Fax (03) 9729 7325

email: [nationaloffice@wia.org.au](mailto:nationaloffice@wia.org.au)

<http://www.wia.org.au>

All mail to

**PO Box 2042 BAYSWATER VIC 3153**

Business hours: 10am – 4pm weekdays

### National Office

*Executive Administrator* Bruce Deetholls VK3FBLD

### Board of Directors

*President* Justin Giles-Clarke VK7TW

*Vice-President* David Ford VK5WP

*Directors* Marcus Berglund VK5WTF

Brian Clarke VK2GCE

Peter Clew VK8ZZ

Gregory Kelly VK2GPK

Philip Wait VK2ASD

*Secretary* Jim Linton VK3PC

*Treasurer* Vacant

### Coordinators

*AMSAT* Paul Paradigm VK2TXT

*ARDF* Jack Bramham VK3WWW

*Australian ARISS* Shane Lynd VK4KHZ

*Awards* TBA

*Clubs* Ted Thrift VK2ARA

*Contests* Craig Edwards VK8PDX

*John Moyle Field Day* Denis Johnstone VK4AE

*Editor 'AR'* Peter Freeman VK3PF

*EMC/EMR* Gilbert Hughes VK1GH

*Standards* Phil Wait VK2ASD

Ron Cook VK3AFW

Noel Higgins VK3NH

John Martin VK3KM

*NTAC* Peter Wolfenden VK3RV

*Historian* Jim Linton VK3PC

*IARU Region 3 Liaison* Peter Young VK3MV

*Monitoring Service*

*ITU Conference & Study Group*

Brett Dawson VK2CBD

Dale Hughes VK1DSH

*QSL Curator* National Office

*Repeater* Peter Mill VK3ZPP

Andrew Chapman VK4QF

*Webpage* Robert Broomhead VK3DN



## Editorial

Peter Freeman VK3PF

### Innovation and change

We continue to see advances in technology all around us, be it in matters affecting our hobby directly or in our broader lives and society. Unfortunately, some of the resulting changes may cause us grief...

For some amateurs, change never comes fast enough. I received an *Over to You* contribution only a few weeks after the WIA Annual General Meeting. The writer was expecting that significant changes in the direction being followed by the organisation would have already been implemented! He made personal attacks on at least one individual involved in the WIA organisation. As a result, his "contribution" was rejected. His expectations as articulated were unreasonable of themselves, but when combined with unwarranted personal attacks, he was clearly in breach of the draft WIA policy on the publication of contentious comment.

Speaking of the draft WIA policy on the publication of contentious comment, many may not be aware of its existence. The draft policy was developed by the outgoing Board earlier this year. Publications Committee had the opportunity to make comment on the draft. I understand that the new Board has approved the policy, subject to endorsement by Publications Committee (PubCom). We do not formally meet again until late September, when I would anticipate that the policy will be endorsed by the Committee. The policy should be added to the WIA website shortly after PubCom notifies the Board of our endorsement. The policy spells out what can and cannot be included in material submitted for

publication in this magazine and largely codifies current editorial practice.

The new Board is releasing more information about how it intends to operate, together with outlines of some of the issues being considered. Clearly, finances are important and you will see reference to the costs of producing and distributing this magazine. The Board is also seeking feedback from you, so please spend the time to visit the WIA website and complete the survey. Having looked at both the short and long surveys; I would recommend completing the longer survey instrument, as it may tease out some more information which the Board may find useful.

In the past few weeks, something in the local environment at home has changed which has resulted in a steady strength 5 or higher noise level on the 40 m band. I have not yet thoroughly investigated, but nothing has changed that is under my control. I anticipate that it is something radiating noise in the local neighbourhood. I guess that it is time to organise a small directional loop antenna and to searching for the noise source!

Combine the new higher noise level with the mediocre propagation, and you can imagine that it has made chasing SOTA and Parks stations much more difficult! Fortunately, the weather is slowly improving and the days are lengthening. I guess that there is a message in all of this – time to consider getting out into the great outdoors more often!

Continued on page 5





## Board comment

*Justin Giles-Clark VK7TW*

### Moving forward

It has been a full couple of months with many changes starting to happen across the WIA. By the time this comment goes to print, the various submissions to the ACMA on Spectrum Reform would have been finalised and submitted and we will be keeping members informed of progress and discussions with the ACMA.

Engagement with members and the broader amateur community on what you would like to see from your National representative body has commenced and in the words of Director David Ford VK4MZ we are embarking on a major strategic analysis and planning exercise. This includes the first stage of discovery, understanding and keeping the business running. The next stage is building capability and readying the organisation for change – more on this little later. The third stage is developing a roadmap for success and sharing that vision and strategy and the last stage is implementation and achievement of goals set.

In the discovery phase we are listening and gathering as many ideas, opportunities and opinions as we can from members, amateurs, industry, government/regulator, educational institutions and the general public to capture as much information as we can to inform the strategic analysis and planning exercise. Associated with this stage is ensuring that the organisation continues to deliver the services that existing members expect to the level they expect it. This is a definite balancing act between operating in an increasingly financially tight environment and rising member expectation levels in an organisation

predominately run by volunteers.

Then stage two – building capability – part of this exercise is bringing new volunteers into the organisation and empowering existing volunteers through the operational committees to take responsibility and control of their specialist areas. Through this process committees contribute and gain an understanding and capability of how to improve the broad range of WIA services for members.

There has been some confusion about the difference between operational committees and Board advisory committees. A Board advisory committee is an extension of the Board and has delegated authority from the Board and these advisory committees are led by a Board member and include at least two Board members. These advisory committees are only about the effective running of the Board and to assist the Board to meet its fiduciary obligations. There are currently two advisory committees – Strategy Advisory Committee and the Audit and Risk Advisory Committee. We are currently calling for volunteer non-Board members of these two advisory committees. Volunteers on the Board advisory committees must be truly independent and cannot have other volunteer roles within the WIA to avoid any perception, real or perceived, of conflict of interest.

In relation to Operational committees, the Board has clearly articulated that it is and will be extracting itself from these committees to allow them to better function. The Strategy

Advisory Committee deliberations will include the strategic analysis, testing, alignment, definition and strengthening of the operational committee structure. As this structure becomes clear many vacancies will be advertised and filled and this is even more opportunity for members to become involved in the running of their National organisation and build its capability. Without volunteers, we cannot move forward. Keep an eye and ear on the website, WIA facebook page, volunteer.com.au and broadcast for these volunteer advertisements.

The other part of stage two is readying the organisation for change and as you may have heard on the broadcast, the Board has analysed the financial position and has expressed some concern about the long-term financial trajectory of the WIA. At this point in time the revenue from memberships, publications and other sources does not equal or exceed expenses. This doesn't mean we are insolvent, far from it. However, if we do not remedy the situation then we may be in a more serious situation in about five years' time.

The Board is looking at a range of options of cost saving including our major expense which is this magazine. Don't worry, the Board is not going to make any sudden decisions as we have heard the feedback from members loud and clear about the magazine. However, we as organisation need to seriously consider some changes and members will be asked through

*Continued on page 5*

## WIA trial exams undergo further development

The WIA trial theory assessments available online since May this year require a simple registration process, and the feedback has been that they exceeded the expectations of those who have used the exams. Organised by WIA Trainer Fred Swainston VK4FE/VK3DAC and following feedback and comments, these trial exams will be converted to tutorials and left online.

The trial theory papers at the Foundation, Standard and Advanced level are similar to those used in the actual multi-choice exams. These were a 'proof-of-concept' exercise and a move closer by the WIA towards enabling WIA Nominated Assessors to use online exams for candidates needing a remote assessment.

Fred VK4FE / VK3DAC says a test of their use in remote assessments has been greatly helped by the feedback received. Quite a few requests were made to provide some additional material and answers to these trial examinations. Two Standard licence trial papers are being converted to tutorials where the answers are provided. Next to come will be the Regulations trial papers.

To access the trials you need the latest version of the flash player, and log on to the Silvertrain website [www.silvertrain.com.au](http://www.silvertrain.com.au) and clicking on the Amateur Radio tab.

## You have the power to make a difference!

Over the years, as Amateur Radio operators we have seen changes in the make-up of how we source our equipment, how we engage with each other, and the technologies that we integrate with our activities in Amateur Radio. As the Amateur Radio landscape changes, the WIA is working to ensure that its products and services remain

relevant.

The WIA today (6 August) releases the first in a series of consultations that are structured to better understand the market in which the WIA operates. The first consultation is provided by way of a survey that is written to better understand what brought you to the hobby and what keeps you in the hobby.

The survey is presented in two formats, a long and a short. The long version of the survey, which should take about ten minutes to complete, explores what brought you to the hobby, what keeps you in the hobby, and how you may, or may not engage with specific WIA products. The shorter version of the survey simply attempts to understand what brought you to the hobby, and what keeps you in the hobby.

The short survey (2-8 minutes) is available via: <https://www.surveymonkey.com/r/WIA1a>

The long survey (10-30 minutes) is available via: <https://www.surveymonkey.com/r/WIA1>

Please take the time to complete either survey and encourage other people to also share their opinions. The surveys are open to anyone that has an interest in Amateur Radio.

As we look forward to revitalising the WIA's product set, the WIA thanks you for taking the time to complete either survey and helping to build a better organisation by letting your voice and experiences be heard. Your story is important.

## WIA lodges strong response to the draft radiocommunications legislation

Arguing for no reduction in current conditions enjoyed by amateur licensees, coupled with advocacy for less burdensome administrative arrangements and ongoing engagement with

regulatory processes, are strong themes running through the Wireless Institute of Australia's (WIA) submission on the draft radiocommunications legislation.

The Radiocommunications Bill 2017, released publically in late May, followed with a raft of supporting papers and fact sheets, has set the scene for a new era in spectrum management in Australia, intended to simplify the regulatory framework and support new and innovative technologies and services.

The Department of Communications and the Arts sought stakeholder feedback, with a closing date for submissions of 30 June 2017, which was later extended to 30 July in response to requests from the industry. The Department gave the WIA an extension to 4 August.

Emailed on the morning of the due date, the more than 3000-word submission provides comment on most parts of the 21-part Bill. A three-page attachment with the submission explains about amateur radio, its role in the community context, and the benefits to society. Although one of the Government's prime objectives for the new act was simplification to remove unnecessary burdens on spectrum users, the WIA submission points out that the number of pages in the draft Bill compared to the current Act suggests that this simplification was not achieved.

Overall, the WIA expressed the view that the Bill appears to meet all the existing challenges to spectrum management. Noting that the amateur service in Australia has formally existed since 1912, following passing of the original Wireless Telegraphy Act, the WIA does not want to see any reduction of amateurs' existing conditions.

Continued on page 30



## Editorial

Continued from page 2

On a positive note, we are seeing a rapid uptake of the new FT8 digital mode (Franke-Taylor, 8-FSK modulation) recently released. The mode uses only 15 second periods but requires reasonable time synchronisation of the PC clock for reliable operation. I have listened briefly on air to some of the frequencies nominated and have found many are well off

the correct time synchronisation and those stations therefore do not decode correctly. Others are reporting many stations using the narrow nominated channels, making it difficult to make a contact. The FT8 mode can be found in a beta release of WSJT-X, version 1.8.0-rc1. By time you read this Editorial, the mode may well have moved into a full release version of the WSJT-X

software.

Once we have this edition of the magazine completed, I must improve the digital interface arrangements at home and explore the mode. I may even consider trying it out in the field at some stage in the near future.

Until next month,  
Cheers,  
Peter VK3PF

## Board comment

Continued from page 3

the Strategy Advisory Committee surveys for input into what their preferred options would be. The first of these surveys will explore the products and services mix that members and amateurs would like to see from the WIA.

Of course the other major improvement would be a 10-15% (~500) increase in membership taking us from 4200 to 4700 members or 28% to 31% of the amateur population in Australia. So, I encourage all WIA members to reach out to another non-WIA amateur, invite and convince them to become a member of the organisation that advocates, represents, educates, trains, assesses and supports amateur radio in Australia. We really need all amateurs to support the WIA at this time to enable us to provide and improve those services that amateurs and members are looking for.

You will hear more about the struggle that the Board is having with keeping the WIA viable throughout this strategic analysis exercise.

Stage three is where the Board

brings together all the above and shares the vision and strategy or the roadmap for success. This is where all the discovery, survey analysis, exploration, scenario analysis, projections, feedback and discussions are brought together into a coherent and structured plan for the future. This roadmap, vision and strategy is then validated with the membership to confirm that it represents what members and amateurs have told us and want from their National body.

Stage four is the implementation stage where all the preceding preparation and planning has resulted in a strong and capable organisation that is eager to realise its potential and position itself for the future of amateur radio in Australia for the next 3-5 years. This process is an opportunity for all amateurs to be involved in shaping your hobby for the future and we encourage you to become involved in making this hobby a strong, healthy and attractive option for all age groups in to the future.

On another important matter I remind all amateurs about is the Australian Band Plan which is

available on the WIA website at: <http://www.wia.org.au/members/bandplans/data/>. The Band Plans are constantly being updated to reflect changing needs and international alignments and it pays to refresh your knowledge as things may have changed. The Band Plan is an agreement that divides the RF spectrum into different bands or segments for different uses. It follows the same pattern as international and national band planning and aims to make the best use of the available spectrum and avoiding clashes by setting aside different band segments for each amateur radio activity and reduces interference to each other.

Finally a reminder that the WIA Facebook page is now live at: <https://www.facebook.com/wiavk/> and this provides another important communications and media channel along with the WIA website, regular RF broadcasts and recruitment opportunities on <https://www.volunteer.com.au/>

Justin Giles-Clark VK7TW on behalf of the WIA Board.

### Plan Ahead



# JOTA/JOTI | 20-22 October

# Tech Review: LD-5 HF Ham Radio QRP Transceiver

James Hannibal KH2SR



Photo 1: The LD-5 transceiver.

The LD-5 made in USA, by LNR Precision Inc. is an amazing little QRP 5 band SSB/CW Amateur Radio transceiver that's small and light enough to fit in just about any backpack, thus making this one of the most portable SSB multi-band HF rigs currently on the market. Not only is the LD-5 small in size at 4.724" L X 3.937" W x 1.957" H (120 x 100.5 x 49.7 mm (L, W, H)), it is also very lightweight, weighing in at only 1.19 pounds (540 g) (without microphone, antenna, or battery).

The LD-5 covers the following HF ham radio bands: 40 m, 30 m, 20 m, 17 m, & 15 m. One of the features of the LD-5 I have really enjoyed is how each of the five bands has its own independent dual VFO. This really comes in handy when switching back and forth between bands/frequencies and really sped up operations for me compared to other QRP rigs I have

used. I found the receiver to be exceptionally sensitive and able to pick up the weakest of signals.

There are a few features that you typically wouldn't find on most QRP

HF rigs that the LD-5 has, such as CW/SSB VOX, noise blanker, notch filter, noise reduction, PRF/ATT (Pre Amp/Attenuator) and even speech compression. Based on my testing, I found all of these features extremely effective at improving my ability to hear and be heard by other hams. I am convinced that several of the contacts I made would have been impossible if I didn't utilize the various filtering, noise reduction, and speech compression capabilities that are built into this amazing little radio. As far as I know, the LD-5 is the only 5-band QRP SSB HF ham radio with all these features that is sold new for under \$600 (USD).

The LD-5 is capable of much more than just SSB and CW. It is also capable of various digital modes such as PSK, RTTY, SSTV, and even HF APRS when used with the proper TNC/modem and computer with sound card. The menu system contains nearly two dozen settings that allow you to

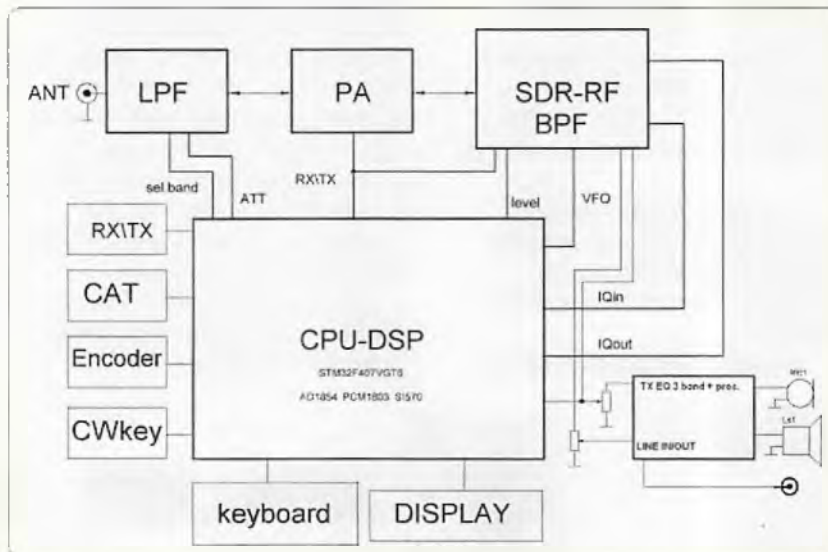

Figure 1: The block diagram of the LD-5 transceiver.



custom tailor the LD-5 to suite your specific needs and preferences. Luckily, there are also 13 buttons and two knobs on the LD-5 that allow you to manipulate many features without diving into the menu system. The tuning knob also has a really good sturdy feel and smooth movement while tuning. I especially enjoyed the bright and high contrast display with its power saving auto off feature for the backlight.

You might not realize it when looking at it but the LD-5 is actually an SDR (Software Defined Radio) with a software platform that was created exclusively for the LD-5. It uses only one Kenwood driver for CAT system fast connectivity. See Figure 1 for the block diagram that LNR shared with me which illustrates how this system works. When I asked LNR for more details on this being an SDR, they quickly gave me the following very detailed response:

*"It combines a powerful low internal noise schematic of a DSP and a special differential algorithm is applied for IQ processing of the channels with phase suppression of the unwanted side-band channel. Balancing ADC and DAC gives additional noise floor reduction and the receiver can handle interfering signals that are 100 dB stronger than the desired signal at a frequency separation of 10 kHz, and is about 130 dB stronger at 50 kHz separation. As the receiver and transmitter are using the same DSP channel, there is no gap between the receiver performance and the transmitter performance. So, there is a clean neighborhood on the bands. At the development stage, our intentions were motivated by the TX sideband noise of existing SDR manufacturers, so our aim was, to fully equalize our transmitter to have noise performance that is compatible with the best modern receivers, or even better. After an arduous year of development, we think we achieved it."*

A nice assortment of input and output ports allows you to widely customize the way you use the LD-5. These include jacks for: line in/out, phone out (headphones/speaker), mic in, key (CW straight key or iambic paddles), PTT out, BNC antenna connector, 12 volt DC power input, and even a USB/CAT port. The built-in USB port is another stand out feature on the LD-5. Not only will the USB port allow you to update the radios firmware, it will also allow you to interface the LD-5 radio with your computer, which allows you to use Mac/PC ham radio software programs such as N1MM, MIXW, Fldigi, and more.

During my field testing of the LD-5, I brought it along on a road trip up and down the California, Oregon, and Washington coastline. When stopped long enough, I would set up the EFT-MTR 40 m /30 m /20 m 65' (19.8 m) QRP End Fed antenna made by LNR. On one occasion, I was fortunate enough to stay on the second floor of a bed and breakfast situated on a hill. This allowed me to drape the 65' EFT-MTR End Fed antenna out the window and down the roofline in somewhat of a sloper configuration, which worked quite well with the LD-5.

# Jaycar Electronics

## STEREO AMPLIFIER WALL PLATE WITH BLUETOOTH® AA-0519

Replace that bulky amplifier powering your ceiling speakers with this clever wallplate. There is power and AUX connections on both sides of the plate, and Bluetooth technology to stream music from your Smartphone. Includes 12V mains adaptor.

- 2 x 15WRMS (40) Class-D amplifier



NEW 2017

Bluetooth

\$99

## SMA ADAPTORS

SMA PLUG TO FME PLUG

PA-0518 \$5.95

SMA PLUG TO SMA PLUG - R/A

PA-0831 \$6.95

SMA SOCKET TO SMA SOCKET - R/A

PA-0832 \$6.95

SMA SOCKET TO REVERSE SMA SOCKET

PA-0630 \$6.95



NEW 2017

FROM \$5.95

## POCKET WORLD BAND RADIO WITH SSB AR 1780

Covers most popular frequencies. Single Side Band (SSB) for Ham Radio, Morse Code and HF CB Radio. Also includes Long Wave and Air Band!

- FM/MW/SW/LW/ AIR Bands
- 650mm telescopic antenna

NEW 2017

\$129



EARN A POINT FOR EVERY DOLLAR SPENT AT ANY JAYCAR COMPANY STORE & BE REWARDED WITH A \$25 JAYCOINS GIFT CARD ONCE YOU REACH 500 POINTS!

\*Conditions apply. See website for T&Cs



SIGN-UP IN-STORE OR ONLINE TODAY BY VISITING:  
[www.jaycar.com.au/nerdperks](http://www.jaycar.com.au/nerdperks)

Valid until 23 September, 2017.

To order phone 1800 022 888 or visit [www.jaycar.com.au](http://www.jaycar.com.au)



Photo 2: The transceiver, SLA battery and end fed antenna make a compact combination.

During shorter stops at various beaches and state parks along the coast, I set up the LD-5 with my "Wonder Wand" and "Miracle Whip" antennas, which sets up in seconds, packs up small enough for most backpacks, and doesn't require any masts, ropes, tripods, clamps or long wire. Both are all band 52" (15.85 m) vertical telescopic whip antennas with a built-in dial for tuning to each band. These antennas work fairly well with the LD-5 and I have been able to make contact with amateurs that were within a couple of hundred miles away while using them.

During another trip, I used the same 65' End Fed EFT-MTR from LNR in a sloper configuration with a 22' (6.7 m) collapsible fiberglass mast while camping on a beach near Santa Cruz, CA. With that particular setup, I made SSB contacts on 20 m and 40 m at 573 miles (922 km) into Oregon, 676 miles (1088 km) into Washington State, 202 miles (325 km) into Nevada, 657 miles (1057 km) into Idaho, and 860 miles (1384 km) into Montana. With each of these contacts, I was only using 4 Watts of RF power output.

A couple of my longer distance

SSB contacts using the LD-5 included several different contacts that were 1,352 miles (2175 km) away in Kansas on 20 metres while using only 5 watts. My longest distance contact with the LD-5 so far was a 2,349 mile (3780 km) contact on the 15 metre band made to New York, again with only 5 watts of output power. The antenna I utilized to make these contacts is

my Carolina Windom 40 off centre fed dipole, which is up around 30 something feet (9 m) off the ground in an inverted V configuration.

The LD-5 is known for being able to make much longer range contacts than I have made with it so far. For example, my contact at LNR Precision Inc. informed me that while conducting a demo of the LD-5 at the Huntsville, AL Hamfest this year, a customer made contact with a fellow ham operator located on Rodrigues Island in the Indian Ocean while using a simple 20 metre end fed antenna oriented vertically which is made by LNR. That's an impressive 10,330 miles (16621 km)! Not too shabby for a 5 watt radio that can fit inside a kid's lunch box.

As far as the performance of the included microphone is concerned, I think it works great. It produces clean and clear audio without any noticeable over modulation, even when talking quite loud into it. A small speaker is built into the right side panel of the radio. The speaker produces decently clean audio but is a little on the weak side when it comes to audio volume output, especially when there are background noises such as road



Photo 3: a view of the transceiver from the left hand side.



noise, wind, or waves breaking on a nearby beach. If you are in a nice quiet spot, the speaker works great, but if there is any background noise, I recommend using headphones or an external amplified speaker.

Even though the included mic works great, in my opinion, it's not the best fit for this radio. Considering this radio is designed to be compact for portable use such as backpacking, I find it odd to include a microphone that takes up nearly the same amount of space as the radio itself when packed. Luckily, the included mic can be unplugged and replaced with whatever kind of mic you prefer to use. I plan on modifying a MFJ-285 mini HT speaker microphone to work with the LD-5. These little inexpensive HT mic's are roughly one quarter the size of the included mic and might be better suited for QRP backpackers with limited room in their packs.

A power plug and cable with



Photo 4: The transceiver removed from its main case.

bare ends is also included for you to connect to the battery or power supply of your choice. The LD-5 is designed to be powered from 10.5 volts to 15 volts DC. I happened

to have two fairly compact 12 volt batteries on hand. One is a SLA (Sealed Lead Acid); the other is a LiPo (Lithium Polymer). The LD-5 worked flawlessly with both types of

# TET-EMTRON

Ring Mark at 0455 463 452  
See our wide range of new parts and products at:-  
[www.tetemtron.com.au](http://www.tetemtron.com.au)  
P.O. Box 811 DONGARA, WA. 6525



New 7 MHz Traps.



Lightning Arrestors.



New Ununs



Balun Kits.



1.63 mm Hard Drawn Copper Wire.

batteries. If you plan on carrying this radio around in a backpack, I highly recommend going with a small 12 V lithium battery since they are around one third the mass when compared to an SLA battery of comparable power capacity. You might also want to consider a small lightweight folding solar panel so you can keep your battery topped off when operating from the great outdoors.

I was fortunate enough to have a spare small waterproof foam padded hard case that is not much bigger than the LD-5. There was just enough room in the case to also cram in a lithium battery, power cable, mini straight key, headphones, counterpoise, small logbook, mini pencil, and a printout of the ARRL band plan for good measure. This allowed me to pack the LD-5 into a backpack and hit

the trail without worrying about it getting banged up against my other gear. Protective cases such as this are in my opinion a necessity and can be easily found in a wide variety of local and online stores.

One of the really nice finishing touches on the LD-5 isn't high tech at all. It's the little fold out legs that allow you to conveniently prop up the radio at a much more comfortable viewing angle. So many QRP radios and kits out there just don't come with a stand/foot and it can really impede your ability to use the radio. To me, this simple feature is the icing on the cake for this radio, making it a real pleasure to use.

I have used several different portable HF QRP rigs now and even built a few myself. Out of all of them, the LD-5 from LNR is by

far my favourite. I found its ability to filter noise and pick out those weak signals very impressive. It has tons of great features, quick to setup, easy to operate, reliable, and just plain fun. Its compact size and lightweight construction make it an ideal radio for portable operations such as camping or backpacking. I can tell that LNR takes great pride in their work based on the build quality of their products as well as their staff's willingness to happily help you out with any questions or problems you might possibly encounter. I highly recommend this radio for anyone who is interested in operating portable QRP in the great outdoors without breaking the bank.

Made in USA Price: US\$575.

For more info, please visit:  
[www.lnrprecision.com](http://www.lnrprecision.com)



## AMSAT-VK

AMSAT Co-ordinator  
Paul Paradigm VK2TXX  
email: [coordinator@amsat-vk.org](mailto:coordinator@amsat-vk.org)

Group Moderator  
Judy Williams VK2TJU  
email: [secretary@amsat-vk.org](mailto:secretary@amsat-vk.org)

Website:  
[www.amsat-vk.org](http://www.amsat-vk.org)

Group site:  
[group.amsat-vk.org](http://group.amsat-vk.org)



### About AMSAT-VK

AMSAT-VK is a group of Australian amateur radio operators who share a common interest in building, launching and communicating with each other through non-commercial amateur radio satellites. Many of our members also have an interest in other space based communications, including listening to and communicating with the International Space Station, Earth-Moon-Earth (EME), monitoring weather (WX) satellites and other spacecraft.

AMSAT-VK is the primary point of contact for those interested in becoming involved in amateur radio satellite operations. If you are interested in learning more about satellite operations or just wish to become a member of AMSAT-Australia, please see our website.

### AMSAT-VK monthly net Australian National Satellite net

The Australian National Satellite Net is held on the second Tuesday of the month (except January) at 8.30 pm eastern, that's either 9.30 or 10.30Z depending on daylight saving. Please note we will be taking check-ins from 8.20pm-ish. Check-in starts 10 minutes prior to the start time. The AMSAT-VK net has been running for many years with the aim of allowing amateur radio operators who are operating or have an interest in working in the satellite mode, to make contact with others in order to share their experiences and to catch up on pertinent news. The format also facilitates other aspects like making "skeds" and for a general "off-bird" chat. Operators may join the net via EchoLink by connecting to either the "AMSAT" or "VK3JED" conferences. Past experience has shown that the VK3JED server

offers clearer audio. The net is also available via IRLP reflector numbers 9558. In addition to the EchoLink conference, the net will also be available via RF on the following repeaters and links.

**In New South Wales**  
VK2RBM Blue Mountains repeater on 147.050 MHz

**In Queensland**  
VK4RRC Redcliffe 146.925 MHz -ve offset IRLP node 6404 EchoLink 44666

**In South Australia**  
VK5TRM, Loxton on 147.175 MHz  
VK5RSC, Mt Terrible on 439.825 MHz IRLP node 6278.  
EchoLink node 399996

**In Tasmania**  
VK7RTV 2 m. Repeater Stowport 146.775 MHz. IRLP 6616

**In the Northern Territory**  
VK9MA, Katherine on 146.750, CTCSS 91.5, IRLP Node 6800

Operators may join the net via the above repeaters or by connecting to EchoLink on either the AMSAT or VK3JED conferences. Past experience has shown that the VK3JED server offers clearer audio. The net is also available via IRLP reflector number 9558. We are keen to have the net carried by other EchoLink or IRLP enabled repeaters and links in order to improve coverage. If you are interested in carrying our net on your system, please contact Paul via email. Frequencies and nodes can change without much notice. Details are put on the AMSAT-VK group site.

### Become involved

Amateur satellite operating is one of the most interesting and rewarding modes in our hobby. The birds are relatively easy to access and require very little hardware investment to get started. You can gain access to the FM repeaters in the sky with just a dual band handheld operating on 2 m and 70 cm. These easy-to-use and popular FM satellites will give hams national communications and handheld access into New Zealand at various times through the day and night. Currently only 50-50 is available.

Should you wish to join AMSAT-VK, details are available on the web site or sign-up at our group site as above. Membership is free and you will be made very welcome.

### Help us



Contribute to the Weekly WIA News Broadcast.  
See our website for details.

[www.wia.org.au/members/broadcast/contribute/](http://www.wia.org.au/members/broadcast/contribute/)



# Norfolk Island, South West Pacific: an autobiography

John G Anderson VK9JA



Photo: L2R: John Anderson VK9JA enjoying the plum and Nick Gee. (Photo courtesy of Allen VK7AN.)

## Foreword

*John G Anderson has lived on Norfolk Island from 1946 until the present; his activities have included serving as:*

- Meteorologist
- Curator of his own museum
- Board member of National Parks for 20 years
- Botanical gardens organizer
- Film maker
- Author
- Flora and Fauna Board member

When I arrived on Norfolk Island in 1946, there was an assortment of radio communications and navigation aids in different locations around the Island from the Second World War, when up to 230 aircraft were passing through the Island in one month to the Islands further north.

Owen King, in charge of the equipment for the New Zealand Air Force, was granted the first amateur licence, VK9ANF, on the Island and, in an emergency situation, to help some yachts in one of the first Trans-Tasman Yacht Races in 1945.

The Island had the best of receivers and powerful transmitters and importantly *HF Direction Finding (DF) equipment* etc. I was impressed, as a boy, with the equipment in the receiving station and the glowing dial of the RCA AR88 and the 'musical tone' of Morse code coming out of the speakers.

I trained as a Commercial Radio Operator at the Marconi School of Wireless in Sydney operated by AWA in the mid-1950s along with other courses they had. There were

many opportunities in those days to work in shipping, aviation or broadcasting.

The first ship had a Spark Transmitter and, keen to express my new skill, started contacting VIS (coastal Station) before the ship was out of the Sydney Heads, to send the departure message. The noisy radiation from the transmitter covering a wide spectrum in the shipping band (usually between 400 and 500 kHz) must have nearly blown up their receivers. I was told in no uncertain terms to get well down the coast before transmitting again.

Following time at sea, I became a radio technician with the Department of Civil Aviation (DCA). This involved one of my other interests, aviation.

Eventually I returned to Norfolk and set up my own business, *Hibiscus Radio Service*, and became the Sony dealer in the heydays when Norfolk Island was a tax free and duty free haven. I even sold Yaesu gear, mainly to New Zealanders and all imported direct from Japan.

I had no problem getting an amateur license and had a TH6 antenna above the shop for a number of years. I would have a weekly QSO with Pitcairn Island, both Islands sharing the descendants of the Bounty mutineers. Tom Christian was my main contact, although there were four or five others - probably the highest proportion of amateurs anywhere else in the World.

One amateur contact that took place from the shop seems to have impressed Sony in Japan and also one of their engineers, so it was written up on the *Sony International Newsletter*. I used a Yaesu FT-200 transmitter and Sony's CRF230 as receiver.

*'Mr T Huoshima (KA1BNW) of the Radio Engineering Section, Sony Corporation, Tokyo, and the original designer of Sony's World Zone 23 band radio, CRF 230, successfully exchanged long distance messages on 14.240 SSB between Japan and Norfolk Island (Mr Anderson VK9JA) in the South Pacific on November 17th, 1970.'*

One of the early amateurs on Norfolk Island after Owen King was Ray Hoare VK9RH, and started SSB transmission in the 50s.

In the early 90s, the Norfolk Island stamp issue featured the five amateurs operating on the Island at that time.

The Island had no public telephone communications with the outside world until the 1970s. Amateur radio often proved helpful in the isolated situations, particularly to help in emergencies and times of personal distress.

Over the years I have endeavoured, where possible, to save and display some of the WWII

equipment. In the hall we have the first Distance Measuring Equipment (DME) designed and manufactured in Australia by AWA.

The British COL Radar with a bedstead type antenna with 42 dipoles was installed on the top of Mt Bates in 1943. It had a radiation focus as narrow as 5°- 10°.

In April 1946, the edition of *'Radio & Hobbies'* magazine reported the radar receiver picking up the sun's radiation on the 150-200 Meg band area at sunrise and sunset. This led to the development of Radio Astronomy and these scientists visited Norfolk Island to celebrate the discovery in recent years and is now known as the *'Norfolk Effect'*.

The only remains of the radar is the rotator and it would be good if such organizations as WIA could encourage governments in the restoration and presentation of what is left.

In 1976, I joined an *Amateur Radio Maritime Net* (Tony's net ZL1ATE) for yachts focusing on the Pacific; at any one time there were a few hundred and one of the main routes was from North America down through Marquesas Tahiti, Cooks, Tonga and Fiji, then to New Zealand for the Cyclone season and then up to New Caledonia and Vanuatu, next season and further on.

A considerable number were licensed amateurs - considered an ideal communication addition on long oceanic voyages.

I would draw up a weather chart from five figure groups, Morse code transmission and other sources of information, which I had done as a hobby before joining the net. Yacht reports were added to the information, resulting in an instant analysis in some instances.

In 1982/83 summer season, a strong El-Nino developed with the Southern Oscillation Index (SOI) dropping to a very low level. This was an unusual or unknown event in those days. The result was six tropical cyclones forming in the

Tahiti area and some of the amateur yachts were able to be kept up with the latest developments.

As time went on, advances in computers with long range weather modelling developed, which helped yachts deciding in the best time to leave on a particular voyage. Climatology was often discussed.

The net was an ideal medium to invite amateur yachts to join what became known as *Pacific Wildlife Watch*. I would distribute information on *seabird, whale, dolphins, turtles, dugongs, etc.* Amateur radio was an ideal way of discussing the observations, including the identification and collating data.

A number of amateur yachts scattered in strategic locations, as an example, could track seabird Shearwater migration across parts of the Pacific and I would endeavour to coordinate the radio reports.

Similarly whales could be tracked - and spectacular sightings were made, and birthing locations reported - usually in remote lagoon locations. Seabird population counts were done on coral Cays.

Radio Australia interviewed about *'Pacific Wildlife Watch & Amateur Radio's role'*; it was broadcast around the world, with some of the highlights being:

- Several amateur yachts protesting and reporting from Mururoa Atoll and observed humpback whales entering the lagoon, when the bomb was about to be set off.
- A 3 week voyage from New Zealand to Tahiti as an example, observing wildlife - a stimulating pastime and something to talk about it on amateur radio.
- Tongan waters - amateur yacht reported seven Humpback whales leaping out of the water, sitting on their tails in a circle around the yacht!
- A amateur yacht that had been in the Pacific for 50 years, including US Navy WWII, watching turtles on Huon Reef, North New Caledonia; he said it





Photo 3: The new antenna is on the right of the building and compliments the original mast that supports the 70 cm repeater antenna.

hoisted into the air and tied off. With the ends of the Windom attached to ropes through the pulleys, they were stretched between the two trees and tied to the trunks of the trees. This now gives the Windom some good height and the Balun is located close to the Shack with a RG58 cable running over to the shack and entering the building. Next to do is to fit with a suitable plug and then test the antenna performance.

Future work includes some minor branch culling which would be in order so we can use the counter weights to compensate for tree movements instead of just tying it off with some slack in the line.

### Cable Tester Project

Les VK4SO has recently constructed a simple, effective and yet easy and adaptable project that can test cable continuity on the core and shield plus it can display any shorts in



Photo 4: Les VK4FAEB's Cable Test Project set up with various connectors.

the cable as well.

Les had installed SO239, N and BNC connectors in parallel but we can add more connectors to suit your wishes to test all types of cables that you might use.

The default use is to connect both ends to the tester using left and right connectors (different ones can be used if they have dissimilar connectors) and switching it on.

Two LEDs show inner and outer cable continuity and a central lamp indicates a short.

An optional use as a cable chaser is to connect one end of the cable to the tester and then locating the other end wherever it is and shorting it out to indicate you have the right cable or not.

Have a great Day.

Les Neilson VK4FAEB  
BARC President

# Oh Danny boy, the pipes are calling

Joseph Kasser VK5WU

I've often heard a very loud lonely piper playing some changing tones on 7.076 MHz and 14.076 MHz and briefly wondered what they were and then tuned away looking for RTTY and PSK contacts. Well, a few weeks ago, I finally found out what the haunting tones meant and made some contacts using a brand new (to me) digital mode of communications that was something completely different to my previous way of working other stations.

During my talk to the Adelaide Hills Amateur Radio Club in March on "fishing for DX" [1], I mentioned that I'd been reading about WSJT software for weak signal contacts and that was something I was going to try when I got around to it. A few days after the talk, Andrew VK5CV sent me some Internet links including the WSJT-X web site [2]. So after taking a while to get around to it I accessed the link, downloaded version 1.7.0 of the software and fired it up on my laptop running Windows 7. After entering my callsign and Grid Locator, it settled down. I clicked on the CQ button and heard the sound of the pipes coming from the laptop speaker. That solved the problem of what type of modulation the pipes represented. They were JT65. Two problems solved; I now knew what the lonely piper was transmitting and I was ready to try it on the air.

## Setting up the station for JT65

A brief scan of the documentation showed that the 40 m and 20 m JT65 frequencies were 7.076 MHz and 14.076 MHz. So the paperwork confirmed that the lonely piper was transmitting JT65 signals. All I had to do was interface my trusty IC-7000 to the laptop and I could become a piper myself. That became problem number 1. The simple solution, thinking like an engineer, was to connect an audio cable between the radio phones socket and the

audio input socket on the laptop [1]. Wireless and handleless! However, I didn't like that solution because I wanted to hear the audio as I was receiving it; my backup was to make sure that there really was a signal on the band.

I noted that the data connector on the IC-7000 rear panel was the same type of connector as the PS/2 keyboard connector on the back of my desk PC. Since I had a non-working keyboard in my junk box, I went online and looked up the connections on the PS/2 keyboard. Sure enough there were enough wires in the cable to do the job. I disassembled the keyboard and pulled out the cable which had colour coded wires and plugged into the keyboard PCB on an in-line connector. I traced the coloured wires to each pin and matched them to the IC-7000 pins and had a plan. I connected the radio audio output and ground wires in the cable to a short audio cable. I was ready to receive on the air signals.

I connected the laptop to the radio using the cable, tuned to 7.076 MHz and heard the lonely piper. I saw signals in the waterfall display so the interface cable was working, but nothing was being displayed on the data window. After waiting for about 30 seconds the piper stopped transmitting and there was silence. A few seconds later another weaker piper started playing his pipes. He played for a while and I noted the green horizontal bar growing at the base of the screen, the software switched from 'monitoring' to 'decode' but still no data. Then the lonely piper came on again. The sequence repeated but no decoded signals. It was time to read the manual. Sure enough, there it was in the small print; JT65 used USB on all frequencies and the IC-7000 had defaulted to LSB on 40 m. That gave rise to problem number 2; how to switch modes from LSB to USB on

40 m? It had been years since I did that.

Pushing the mode button gave me CW, FM, RTTY and LSB but no USB. Then I experienced a reverse 'senior moment' and with an "Aha" I held the mode button down and LSB changed to USB. I was hearing the pipes but nothing was still being displayed in either data window until suddenly the pipes were silent and the software switched from 'monitoring' to 'decode' and within moments a burst of signals showed up in the data window. Wow, it was working! Even after 50 years or so of practical engineering I am always amazed when something actually works for the first time.

As I was looking though the information in the window, another set of pipes began to play and this time there was more than one piper. Again there was no decoded data and 45 seconds later the pipes went silent. The software switched from 'monitoring' to 'decode' and within moments another burst of signals showed up. The counter display counted to 60 seconds and the original piper began to play again. He must have been so loud that he drowned out the other pipers on frequency. The pattern continued; it was a dance and the master or controlling piper was the clock. Stations took part in the dance in two groups; the first set transmitting on odd minutes and the second set on the even minutes. There was a 15 second interval between the sets. That explained why I had often only heard the lonely piper calling without a response; I had never stayed on frequency long enough to hear a full transmission or, when I did hear him stop piping, I had never hung around for the full 15 seconds.

## Dancing to the tune

How to join in the dance became problem number 3. The following day I dug out my RIGblaster sound



card interface that I last used 10 years ago at G3ZCZ and scratched my head. An out-of-the-box solution presented itself a moment later: put the RIGblaster back into the junk box and use acoustic coupling. I remembered that in the 1970s we used to dial up mainframe computers over the landline telephone and used an acoustic coupler to couple the telephone handset to the telephone. I didn't have an acoustic coupler so I used an alternative acoustic approach; the same one I had used to try out PSK31 more than 10 years ago.

Monitoring 14.076 MHz, I saw a strong station calling CQ, clicked on the call sign and enabled the transmitter. When the tones came out of the laptop speaker, I put the mike next to the speaker and pushed on the PTT switch. The transmitter turned on and I was on the air. I quickly adjusted the output level down and held the PTT switch for the full 45 seconds. I hoped the pipes were playing, "VK4NJR VK5WY PF95".

When the tones stopped, I released the PTT switch. After 15 seconds, the pipes began to play and the suspense began to grow. Was he coming back to me or not? The decode button lit up and sure enough I saw that the reply was to me, in royal purple, the line of text read: "VK5WU VK4NJR -10". Contact had been made. I transmitted the next lines of the QSO exchange using the same acoustic method and logged my first JT65 QSO. I was lucky that the local cricket had stopped his nightly CQing QRM but think the proximity of the speaker and mike would have overridden him anyhow. About 20 minutes later I exchanged reports with IZ0MIO who gave me a report of -22. This was a weak signal but he heard me. I had made my first two JT65 QSOs and was now a fully-fledged piper. This success led to problem number 4. The Armstrong acoustic coupler interface worked but I needed something more permanent to make QSOs.

I looked at the IC-7000 and the RIGblaster documentation. I could use the received audio connection out of the IC-7000 data port and couple the PTT and transmit audio between the radio and the computer via the RIGblaster. It was simple enough. All I had to do was set the jumpers inside the RIGblaster, connect the boxes and it should work. Right? Wrong! The laptop didn't have a RS232 serial port and the RIGblaster didn't have a USB port. This led to problem number 5. Delving once more into the junk box, I dug out a green cable USB-RS232 interface and plugged the cable into the laptop. The install driver software ran for a while and couldn't find any drivers. I went to my hard drive archive and found a few USB Serial port drivers and none of them worked. I eventually found a CD with the drivers and installed them. WSJT-X then agreed that it was communicating to the serial port. I set the RIGblaster jumpers for the Icom transmit audio connections and used DTR on the serial port for transmitter control.

In the same way as I wanted to hear the radio audio, I also wanted to use the laptop speaker for regular sound and would not inadvertently transmit Windows system sounds on the air. Another foray through the junk box



<http://ncrg.info/WP/2017/07/hamfest-2017-update/>

## NCRG HAMFEST WA WEEKEND

**Sept 30**

NCRG Club Rooms, Neil Penfold State  
Amateur Radio Centre, Whiteman Park

**Oct 1**

Cyril Jackson Community Hall, Fisher  
Street, Ashfield WA

Raffle First Prize is a

**Flex-6400**

sponsored by  
Future Systems &  
FlexRadio Systems



Proudly Sponsored by:

- FlexRadio Systems  
- Future Systems  
- DX Engineering  
- TET-Emtron

**Saturday Program;**

- Tech presentation and club open day  
- Gala dinner, The Henley Brook  
9810 West Swan Rd, Henley Brook, WA 6055

**Sunday Program:**

- Swap meet  
- Best mobile installation competition  
- Homebrew competition  
- Retail vendors present  
- Raffle

For tables and presentation reservations,  
Contact Us  
[hamfest@ncrg.org.au](mailto:hamfest@ncrg.org.au)  
Northern Corridor Radio Group

produced a USB generic sound card module. I plugged it into the laptop, set it to sample at 48,000 Hz and tried to use it for the JT65 audio, but the receiving side put a lot of vertical lines on the waterfall display. So I compromised. I set up the sound so that the transmit audio went through the USB soundcard and the receive audio went to the audio input socket on the laptop. I was all set for two-way communications, or so I thought.

I replied to a CQ but the transmitter did not turn on. I heard my pipes [ii] but nobody on frequency did because I was not transmitting them. Re-opening the RIGblaster, I checked the jumper RS232 connections and they were correct. I could also fire up the transmitter using the PTT connections on the data port but it seemed that the RIGblaster was not connecting the RS232 control signal. Since the RIGblaster and radio had VOX options, I enabled them and was able to transmit. I was on the air. However, when I reduced the transmitter audio level to the radio, the transmitter kept dropping out. VOX was not good enough; while I could and did make a few contacts that way; I really needed that PTT to work so I could reduce the power and keep the radio cool. I could have done transmit control manually with a footswitch on the floor or a hand switch on the desk but I had a computer; it should be doing that job. Figuring out why it was not doing that function was problem number 6.

During the troubleshooting with the RIGblaster opened up, I noted that the RS232 LEDs in the RIGblaster did not light up when the software enabled the transmitter. So it seemed that either the RIGblaster was faulty or the DTR control signal was not reaching the RIGblaster. I dug out my RS232 interface troubleshooting tool, last used about 20 years ago. It is a PC board with dual colour LEDs on the RS232 lines and has a connector at each end so it can be placed in series with a RS232 connection. I used it in the 1970s and 1980s to test the serial interface between PCs and TNCs for

packet and other digital modes when I was writing LanLink [3].

When I inserted the RS232 interface tester on the interface, the LEDs lit up green and did not change state when the software enabled the transmitter. It seemed that the green cable USB-RS232 converter was not controlling the DTR connection. In addition there didn't seem to be a way to adjust the driver. Luckily for me, I had another similar interface cable in the junk box. I replaced the green converter cable but the laptop could not find the drivers for the new interface cable. A quick internet search identified probable drivers which were downloaded and installed and seemed to work. WSJT-X was happy and the LEDs on the Interface were now red. Something had changed.

When I pushed the 'tune' button on the screen the DTR signal LED lit up on the RS232 interface tester and the radio began to transmit. I shut it down by pushing the button one more. It finally worked as it should, or did it? I now needed more USB connectors than the laptop had. The laptop had 3 but I needed 4: one for the mouse, one for the USB serial port and the last one for the external fan. As luck would have it, the Adelaide Hills Amateur Radio Club had a timely bring and buy sale where I was able to pick up a Dick Smith USB 2.0 expander for a song. I connected

it in-circuit making sure that the fan connected directly to the laptop since I wasn't sure how much power the USB expander could handle and the system worked and is stable.

So much for the process of setting up the station to take part in the dance!

The configuration is shown in Figure 1.

The coil of RG62 is an old length of Arc Net cable I use to prevent RF currents on the coax to the antenna from entering the shack. As long as the ATU can match the antenna and it has no noticeable signal loss at HF, it is a convenient place to store the cable. I saved the coil many years ago when upgrading from Arc Net to Ethernet because one day I might need a length of RG-62 to match an antenna to the feed coax.

## Operating JT65

From an *Operational* perspective [4], the JT65 dance seems to be designed for people who like to contact other stations but can't or don't like to talk to them. For example, people who do not have a common language, or people like me: I would rather be doing something technical in hardware or software than waste time chatting away to other stations. The timing protocol used in JT65 was originally designed for moon-bounce or Earth-Moon-Earth (EME) QSOs by K1JT. It synchronizes transmissions

Figure 1: System configuration at VK5WU.

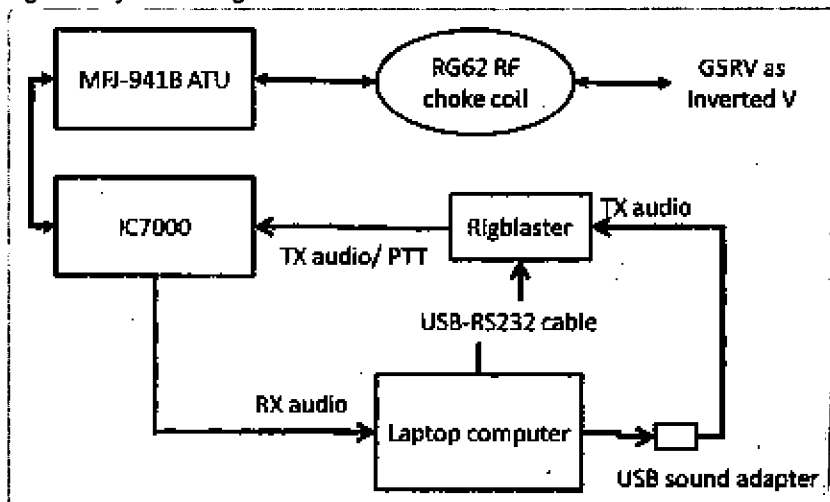



to minimize stations transmitting at the same time and not hearing each other. It does this by synchronizing to UTC and allows stations to transmit on odd or even minutes.

### Hence the dance.

In each minute, the JT65 stations transmit for 45 seconds and there is a 15 second time-out to decode the transmissions and allow for stations slightly out of synchronization. When sending a CQ, you can decide if you want to be odd or even. Select the one that fits your personality. When responding to a CQ, the software will take care of the synchronization. A basic QSO will take four to six minutes if there is no interference or fading.

A typical WSJT-X software display is the one I saw on 22 April 2017 shown in Figure 2. The screen has two signal windows (Band Activity and Rx Frequency) and a number of controls and displays. The Band Activity window displays all the signals decoded in the passband and information about the signals. So:

- *UTC* is the time the signal was heard to the closest minute.
- *dB*, according to the documentation, dB contains the signal report as a signal-to-noise (S/N) ratio in dB, using a standard reference noise bandwidth of 2500 Hz. Signals become visible on the waterfall at around a S/N ratio of -26 dB and audible (to someone with very good hearing) at around -15 dB. Thresholds for decodability are around -24 dB.
- *DT* is the signal's time offset in seconds relative to the computer clock. Since the difference between the stations heard and my computer time in Figure 2 is about 3.5 seconds, I am out of step with the other dancers.
- *Frequency* is the offset from the nominal frequency in the passband. I have copied up to 10 QSOs at a time in the passband.
- # shows that the signal was JT65.

- Message is the message sent by the station. The messages tend to be in a standard format that matches the control buttons on the software display. These messages are CQ, grid square, report in dB and 73.

The basic generic QSO format most stations seem to use is shown in Figure 2. Stations exchange Grid Square locations, reports and 73. There is provision for short up to 13 character custom messages and some stations do send custom messages.

I heard ZL3ACU calling CQ and called him as shown in Figure 2. The reply at 0958 is displayed in the Band Activity window. I was receiving him at -14 dB but he was sending me -11. I sent him his report at 0959 as displayed in the Rx Frequency window. I had to try twice before receiving the non-standard end of QSO message at 1002. I then terminated my end of the QSO by sending a 73 message. The whole QSO took five minutes.

Note the buttons on the software are lined up so that the operator just has to move the mouse down a button for each over. The software can be set up to remind the operator to log the contact when it transmits the final '73'. The log is a basic comma-delimited text file.

### Back to the story

I went to dance on Saturday evening but could not take part: I could hear the dancers but could not decode a single signal. I heard the pipes, the radio was set to USB but nothing was being decoded. I was even able to transmit into my Black Hole Antenna [iii]. So problem number 7 was to figure out why. I uninstalled the program and reinstalled it but was still unable to decode any signals. I noticed that I was out of step with the other dancers because I was transmitting about eight seconds later than the rest and after an hour or so of fiddling with the program and trying to set the time in the Windows 7 operating system [iv], I gave up and decided to sleep on it. On Sunday morning however, I was able to decode stations and was back in step. The laptop clock must have reset via the internet connection which was not working on Saturday evening. The documentation states that the built-in Windows facility for time synchronization is usually not adequate. It recommends the program *Meinberg NTP*. So a week or so after starting to use the software I downloaded the *Meinberg NTP* program from its web site but when I tried to install it I was notified that it did not work in my version of Windows 7. So I tried the alternative *Dimension 4* from Thinking Man Software which worked.

Figure 2: Typical WSJT-X screen display of a QSO.

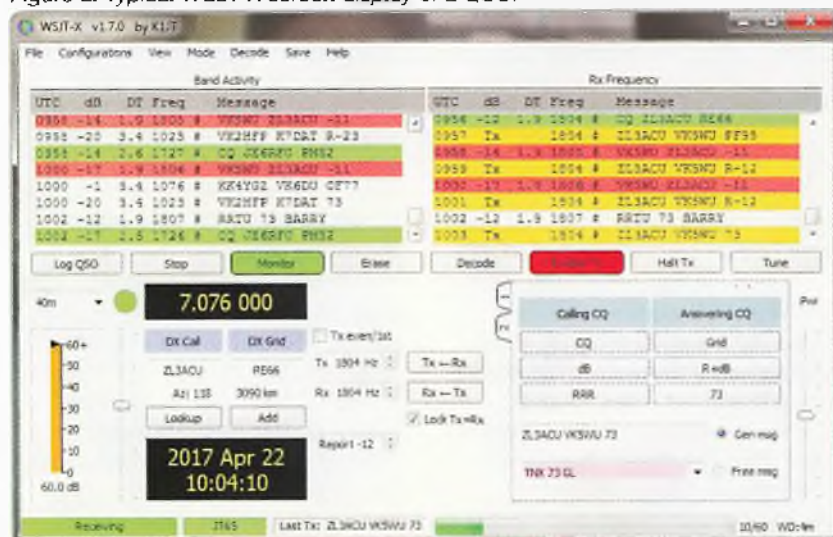

As the days passed, I realised that I was not listening to a lonely piper; there were a number of pipers all playing in tune at the same time more or less. Sometimes one piper masked the others and at other times I could hear a few pipers in the passband.

As I began to make contacts, I found that I was getting strong signal reports from VK3 and VK4 but the DX was much weaker. I attribute this to the antenna I am using. It is a G5RV in an inverted V configuration, the apex is at about 8 metres and the ends are bent to fit the garden which tends to produce mostly high angle radiation. I found that most of the time my responses to weak station CQ calls were not heard; the calling station would reply to someone stronger. This mirrored my experience with CW and SSB. One evening I worked every weak station that I called, wow! I looked for an explanation and noticed that while moving some stuff around I had left a powerful magnet in the loop of RG-62 Arc Net cable I use as a RF choke (See Figure 1). Had I invented a magnetic signal enhancer? How could that magnet make my signal more readable at the other end of the contact?

After some reflection, the most likely answer is that the magnet was not having any effect. What was probably happening was there was a lack of QRM at the other end of the link and I was the only station responding to the call. I sort of confirmed that hypothesis the following evening when I saw a DX station calling CQ. I called him but he came back to someone else as usual. Over the next hour he worked a few stations and then there were no responses to his CQ calls. At that point I called him and we had a QSO.

During the day, when there were no CW or SSB signals or beacons on the 20 m and 40 m bands there were usually a few weak JT65 signals fading in and out. I saw weak DX stations in contact or calling stations that I could not detect. There were stations from Japan, the Pacific islands, the USA, South and Central

America, Europe and Africa. In fact I could decode signals from most parts of the world at some time during the day or early evening local time. There also seem to be a lot of stations operating portable in grid locators RR73, TU73 and even a few in GL73 [v]. I could detect and decode signals and sometimes make a QSO when I could not hear any tones in the passband.

Talking about the passband, I have to adjust my output levels as I shift up and down the passband. The IC-7000 seems to have a shaped passband for transmitted audio. If I go down to low frequencies, there is no output from the radio which was somewhat disconcerting the first time it happened. Each time it happens my first thought is that the long duty cycle has damaged the transceiver even though I have modified the IC-7000 so that the fan runs continuously. But then I look at the frequency offset and see that I am in the lower end of the passband. One time I saw a DX CQ at an offset frequency of 433 Hz. I double clicked on the call and replied to the CQ. When I looked at the IC-7000 there was no signal being transmitted. I tuned down from 14.076 MHz to 14.075.5 MHz and when the second CQ call appeared called the station. The offset changed to 933 Hz and I was transmitting. I still didn't work him, but at least I was transmitting a signal.

I found the QSO timing a little confusing. I'd see a station calling CQ and call him. Nothing would happen for a few seconds then my transmitter would turn on at the start of the minute. I'd transmit for 45 seconds, then there would be a delay and the other station would transmit at the start of the next minute with a further 15 second delay. So after initiating the calling sequence, there'd be a two-minute wait to find out if contact had been made. I'm not the type of person who can sit and watch the screen for two minutes. So I'd do something else, read the manual, build a project or surf the Internet. This led to missed calls because I'd be engrossed in what I was doing and would miss the turnover time.

Sometimes I'd come back to the program and have to work out which time slot I was in and if I should be sending or receiving or which part of the message I should send in my next over. It would be nice if the software could go through the standard QSO sequence automatically once contact has been established. Sometimes I'd call someone and he'd respond to someone else. If I didn't catch that, my station would start to call him again and I'd hurriedly have to click on the 'Haft Tx' button. It would be nice if the software would recognize that the CQ had been responded to by someone else and disable my transmitter. These changes should be easy to make as the software already can detect various character strings in the messages and react or change the colours of the lines accordingly. The software changes colours for different messages as shown in Figure 1, for example:

- A CQ call.
- A CQ call from someone new.
- A CQ call from someone in a DXCC country that has not been worked before.
- A message containing your call sign.

The colours changes are very handy and help with managing a QSO especially when the software displays 10 different transmissions in the passband.

One evening when the Wi-Fi was not reaching the shack other stations were between 2.9 and 3.7 seconds with respect to my laptop clock. Since I did not want to get too far out of step with respect to the other dancers, I opened up the Windows adjust time window in the first part of the minute and set the seconds to 45. As the WSJC clock got to 45 seconds I waited a count of two seconds and clicked the button to set the time. The next and subsequent decoded messages showed that the time offset with other stations had changed and ranged from about 0.2 to -0.5 seconds. It would be nice if the software could do this automatically once the offset difference got to a predefined limit. A few evenings later I found out why



I had received the Dick Smith USB adapter for a song when it stopped working. Not having another one in my junk box, I decided to do without the fan since winter is coming and reconnected the cables to the three sockets on the laptop.

### Lessons learned

This has been an interesting project and has opened up new possibilities for making contacts when the band appears to be dead. The lessons learned include:

1. The solution to one problem gives rise to another problem.
2. Keep old test equipment if you have the space as you never know when you will need them again.
3. Make sure there is a DTR control signal in a USB-RS232 converter cable before you buy one if you plan to use that interface.
4. Examine the situation from a number of perspectives before making a decision.

5. If you don't call a station you will not make a contact. If you do call you might make a contact depending on your radiated power and other stations replying to the call.

### In conclusion

Danny boy, the pipes are calling; how about downloading the WSJT software and listening to the tune. Use the simple acoustic method to decode the signals to see where they are coming from [vi]. Then, who knows you may even be tempted to join in the dance.

### References

1. Taylor, Christine VK5CTY, VK5news Adelaide Hills Amateur Radio Society, May 2017
2. <http://physics.princeton.edu/pulsar/K1JT/> last accessed 21 May 2017
3. <http://therightrequirement.com/sfar/LLwindows.htm> last accessed 21 May 2017

4. Kasser, J.E., *Holistic Thinking: Creating innovative solutions to complex problems*, Createspace, 2013

### Notes

- i. The simpler solution which I thought of in the middle of the story was to place the headset mike in front of the radio speaker and use acoustic coupling.
- ii. I turned on the monitor function in the IC-7000 so I could hear the tones to make sure they were not being noticeably distorted.
- iii. A shielded dummy load.
- iv. There was no internet connection so the system clock could not be set via the internet.
- v. Can you work out what that means?
- vi. Put the laptop or PC mike next to the radio speaker. I do not recommend this as a permanent connection, but it will suffice to get started in receiving signals.



# IARU Liaison Report #4

Jim Linton VK3PC  
e [iaru@wia.org.au](mailto:iaru@wia.org.au)

### How the IARU is funded

Funding of the International Amateur Radio Union (IARU) is from more than 160 national radio societies through a levy taken from the membership subscriptions of their transmitting members.

The Wireless Institute of Australia (WIA) paid about \$3,500 in 2017 which is \$1 per head to the IARU but also has other expenses including attending the three-yearly IARU Region 3 Conferences.

The WIA is in Region 3 which covers Asia and the Pacific. The others are Region 1 with Europe, Africa and the Middle East and parts of Asia and Region 2 with North, South and Central America. The 17th IARU Region 3 Conference is due to be in Seoul, Korea late in 2018.

The IARU Administrative Council (AC) consists of the IARU President, Vice-President, Secretary and two representatives from each of the IARU regional organisations. Attending to international responsibilities, it meets annually at the IARU regional conferences.

The IARU works hard protecting the interests of the amateur service and amateur satellite service in the lead up to and at the International Telecommunications Union (ITU) World Radiocommunications Conference. The next is to be held in 2019.

### IARU Region 3 Michael Owen Plaque Winner

The IARU Region 3 highest scoring single operator at the IARU HF Championship was Hajime Hazuki

JR2GRX, who earns the prestigious Wireless Institute of Australia (WIA) plaque.

The WIA created the plaque for the Region 3 top single operator who uses any mode or bands in the contest, in memory of Michael Owen who served both the IARU and the WIA over many years.

The WIA Board of Directors is pleased to announce the fourth Michael Owen Plaque winner as Hajime JR2GRX, and arranged for the trophy to be inscribed.

The plaque for 'Outstanding Individual Achievement in 2016' will be presented at the JARL Ham Fair in Tokyo 2-3 September, by IARU Region 3 Director Peter Young VK3MV.

# Jamboree on the Air and Jamboree on the Internet

Brett Nicholas VK2BNN



Photo 1: Three Scouts operating under supervision at the 2016 JOTA event.



Australian Scouts and Guides invite you to become involved in the 60<sup>th</sup> Jamboree On The Air (JOTA) and the 21<sup>st</sup> Jamboree On The Internet (JOTI) in 2017. Sixty years ago, Les Mitchell G3BHK (SK), seeing the success of the Ninth World Scout Jamboree in Sutton Park England in 1957, launched the first Jamboree on the Air. JOTA-JOTI is now the largest Scouting and Guiding event in the world with over 1 million Scouts and Girl Guides of all ages in 150+ countries participating. JOTA-JOTI is held on the third full weekend of October each year. This year it will be held the 20, 21<sup>st</sup> and 22 October 2017.

JOTA-JOTI is about enabling young people to contact other young people and share their experience. It is great way for



the Amateur Radio community to support Australia's young people.

### Why get involved?

As an Amateur, why get involved? JOTA-JOTI provides a fantastic opportunity to show off our great hobby. To survive in the future we need to grow our ranks. Our radio spectrum has become a valued commodity and if we do not make good use of our allocated spectrum we will lose it.

There is also a more altruistic motive. The world is changing at a rapid technological rate. There is a lot of focus on Science, Technology, Engineering and Maths (STEM) education. It is vital that we start preparing our youth for the coming challenges. JOTA-JOTI provides a great opportunity to ignite that spark that may just lead to a career in STEM. Many of our current technologists, engineers and scientists got their start in amateur radio, often introduced via Scouting and Girl Guiding.

We encourage amateurs to get our youth members involved in the set up and operation. Take the time to explain things without the jargon, acronyms or assumed knowledge.

### How to get involved?

What types of operation are possible? It may be as simple as setting up a radio and antenna at the local Scout/Guide hall on the Saturday afternoon or a large weekend camp with many groups coming and going. Our district camps are at our local primary school. Any amateur mode of operation can be used and published international Scouting frequencies are available. Larger stations may have many different modes in use. EchoLink and D-STAR offer easy on-demand contacts. Satellite contacts and balloon launches are bound to capture imaginations or there is always the magic of a HF contact to a DX location.

### What Checks do I need?

Scouts Australia and Girl Guides Australia take child safety extremely seriously. It is important that you find out early what checks you need to complete to participate. To find out the specifics in your locality contact your local Scout or Girl Guide Group or the JOTA-JOTI coordinator in your state Branch

of Scouts Australia or Girl Guides Australia. They will be able to advise you of the relevant process in your locality. Allow plenty of time to have your application processed.

### Okay, I am interested, what do I do now?

If you have existing connections with your local Scout or Girl Guide Group this is a great place to start. If you are a club or individual that has an annual JOTA-JOTI involvement your preparations should be well under way. If this is all new or you are having trouble getting in contact with the local Scout or Girl Guide group then contact the Scouts Australia JOTA-JOTI Branch Coordinator in your state or the Girl Guides Australia JOTA-JOTI coordinator. They are there to help and will be able to assist you to contact the right people.

Contacts for Scouts Australia Branches can be found on [www.scouts.com.au](http://www.scouts.com.au)

Brett Nicholas VK2BNN  
National Coordinator JOTA/JOTI  
Scouts Australia

*Photo 2: Modern transceiver displays can sometimes be a little small, even for young eyes!*





# Contests

Trent Sampson VK4TS  
e vk4ts@wia.org.au

## Contest priorities for September 2017

Contest	Date (UTC)	Rules	Difficulty	Software	Modes
All Asian SSB	Sept 2 and 3	<a href="http://www.wia.org.au/members/contests/rd">http://www.wia.org.au/members/contests/rd</a> <a href="https://www.jarl.org/English/4_Library/A-4-3_Contests/2017AA_rule.htm#contest/">https://www.jarl.org/English/4_Library/A-4-3_Contests/2017AA_rule.htm#contest/</a>	Easy N1MM TR4W	VKCL	SSB
Worked All Europe	Sept 9 and 10	<a href="http://www.darc.de/dar-club/referat/referat-conteste/worked-all-europe-dx-contest/en/">http://www.darc.de/dar-club/referat/referat-conteste/worked-all-europe-dx-contest/en/</a>	Challenging	TR4W N1MM	SSB
CQ WW RTTY	Sept 23 and 24	Cqwwrtty.com	Fun and challenging	WriteLog N1MM	RTTY

## September

We always use September as our preparation month checking the systems and doing a few bursts in minor Contests to get everything in order for October which is one of the real big months on the Australian Contesting Calendar.

The CQWW RTTY being roughly one month before the CQWW SSB gives you a good chance to gauge propagation for the SSB event.

Make sure you have the interfaces sorted and ready to rumble as it is a good fun event.

## Contester Tip of the Month

Money spent on an antenna has the highest return in performance. Every dollar spent on antenna's is worth \$10 in the shack. These old chestnuts are so true when you assess the difference: For example a 10 dB gain antenna over a dipole will not only enhance transmit effective power but will increase receive capability.

When spending money on an antenna, look at the test gear - something that will greatly increase your understanding of how antenna's work.

Antenna analysers are so handy these days; no shack should be without one. Take the time to learn what all the numbers do and the effective use of the units - Far



Photo 1: Portable Contest at Mt Stirling - TH3 on 8 m pneumatic mast.

beyond simple SWR measurements - analysers can measure Coaxial cable loss, measure Stubs to reduce interference, check tuning of tuners - the lists goes on and on.

Most common are the MFJ 259 Series and many are following the eBay traders with Chinese digital units. The very fancy units available through Melbourne outlet Strictly Ham are worthy of perusal: <http://www.strictlyham.com.au/browse-by-type/antenna-analyzer>

## Contester of the Month September 2017

**Tony Burt VK3TZ**

Tony entered his first contest QSOs as a Novice in 1984, running 15 watts into a 4-element homebrew quad. I heard people handing out these numbers and I thought I can do that. I made about 150 QSOs in a few hours but never sent in a log - I had no idea. I just made QSOs. I have attended Dayton twice, the Contest University in 2017, visited Tim K3LR's super-station and met many





Photo 2: Tony VK3TZ, Tim K3LR, Teri K8MNJ and Clive GM3POI.

incredibly talented and dedicated contesters at the DX dinners and after parties. I also had the pleasure to guest operate at VK4KW a few times, which was fantastic, as well as operate SOSB from YJ8TZ. I have managed a few top 10 finishes world-wide in some popular categories but have never managed an all-out win. Perhaps one day.

#### **What is your favourite Contest?**

I like the CQ WPX phone best. I can operate the full 36 hours and still get enough sleep to remain sane. I have also had the most success with this contest especially in the Tri-bander/Wires category. At one stage I held about 8 or the top 10 scores in this contest category in VK. For sheer DXing challenge, the CQ WW is surely the one. For a good score, your station has to be capable on all HF bands plus 160 m and you cannot simply have a good score and ignore the low bands. I also love both of the Oceania DX Contests as they comprise some of the few times when all the beams point towards VK.

#### **What is your favourite Rig?**

My trusty FT-1000MP has been serving me well for almost two decades now. I love the ability to listen on two bands at once or be running on one VFO and looking for other QSOs search and pounce on the other VFO. However, it is getting long in the tooth now and I am keen to try an IC-7800 or IC-7850, having used one recently. I found it intuitive

and well rounded.

#### **What is your favourite contest band and why?**

10 m. I just love it when 10 m is open. Some of my favourite contest QSOs were made using unusual paths on 10 m. Working PY backscatter off Hawaii (I presume) and working over Europeans I could not hear into the Caribbean at 2 am Long Path was such a blast. Long path into North Africa and Western Europe in our mornings is also great and you just cannot go past the speed of a W pile-up on 10 m.

#### **What is your preferred Contesting Software?**

N1MM. I have also used Writelog and do find the inbuilt CW auto decoder rather handy, although I haven't used it in years. For about 15 years, I did use my own software based on DBASE IV and I still miss the predictive score algorithm I wrote to enhance motivation to keep plugging away. But N1MM and N1MM+ is a standout currently. Lee VK3GK and I had the pleasure of meeting the man himself during a lunch break at Dayton in 2015. That was a blast.

#### **What is your preferred Mic and Key?**

I use a modified headset with a Heil HC-4 insert. I do like to have a second headset with ear-pads that put pressure at a different place on the ears and head. 40 hours of headset pressure on one spot can

cause discomfort, especially as I need glasses nowadays. My key is a homebrew one given to me by Ray VK3RD in return for a favour. I use a Jaycar footswitch as I find the Heil versions require far too much pressure to activate which causes fatigue.

#### **What is your "not so secret" "weapon"?**

I don't think I have a secret weapon. The key is time in the chair; I learned that from Martin VK5GN. The other one would have to be setting minor goals. Some of the records and high scores seem unachievable. So setting small goals for each hour, hit 100 QSOs in the next hour, get to 300 multipliers, get to 500,000 points or to 1000 QSOs, etc. You keep setting new goals after you pass the previous ones. It works wonder to keep the motivation up when the eyes are heavy and mind is wandering in a sleep deprived haze. Drink cold water and try to use sugar snacks sparingly.

#### **What is your best tip to a newbie contester?**

Don't be afraid of the pile-up. Cherish it, they don't seem to last that long nowadays with the crowd jumping from spot to spot. When the pile-up gets too thick, put in attenuation and turn-off the pre-amplifier. The weaker ones will disappear below the noise floor and you will be left with fewer callers in the mix. It is then easier to pick out a stronger one and work them down that way. When the pile-up thins out, decrease the attenuation accordingly.

#### **What are your aspirations in contesting?**

I'd love to participate in a WRTC but my CW skills are simply not good enough for that currently. I am happy to operate with friends now in a Multi station environment as I don't think I have the persistence to want to do another 48 hour contest non-stop. I'd love to regain some of my low power records in the CQ WW phone for VK, especially an all band effort.



Photo 3: Tony VK3TZ, Clive GM3POI and Frank W3LPL.

### What would you like to improve in either your skills and/or station?

Well, I simply need to move out of the city. It is not possible to effectively compete from my QTH anymore. The days of trying my butt off to get a score close to Martin (VK5GN) are long gone, as the constant S9 hash from all manner of rubbish electronics has made it impossible. So I have been toying with finding land close enough to access easily and far enough away

to have a reasonable noise floor. I remember heading up to Lake Mountain for the CQ WPX SSB and having to constantly check the antennas. The noise floor was so low I thought they were disconnected!

### Who is VK3TZ?

I got my Novice licence at the age of 15 after studying with the EMDRC course in 1980. I had been on CB until it descended into chaos. I have been on the Oceania DX Contest Committee since its

inception around 2000/2001. I am a tertiary qualified communications engineer and I contract in systems engineering for major defence, telecommunications and the aerospace sectors having spent 10 years in the RAAF. I also am the owner and founder of Rippletch Electronics having built more baluns, verticals and wire antennas than I care to remember. Creating a new products and getting people on air with a better signal is great fun.

### Contest Terms

**M2:** (Multi Two) Multiple operators  
Two Transmitters

**MM:** (Multi Multi) Multiple Operators  
Multiple Transmitters

**Lockout:** A device that stops multiple transmitters keying at once outside contest rules

VK4TS Trent is the admin of VK Contest Club (VKCC) web ([www.vkcc.com](http://www.vkcc.com)) and Facebook pages and has been an active contester since the 1970s.

Emails can be sent to [vk4ts@wia.org.au](mailto:vk4ts@wia.org.au)

## WIA news

Continued from page 4

That said, the WIA added that it also wishes to work with any future regulatory bodies in developing subordinate regulations – such as licence conditions documents – to ensure that the basic principles of the amateur and amateur satellite services are addressed in a sensible manner, adding that, as technologies move forward, the rules that affect development must be fit for purpose.

The Department of Communications and the Arts now has its work cut out to analyse the responses from all stakeholders. The Minister advised in May, with the release of the Bill, that the Government intends to present a further Exposure Draft to stakeholders for comment before finalising the legislation

for introduction to Parliament. This subsequent Exposure Draft will be informed by stakeholder feedback from the consultation just concluded.

The submission was prepared by the WIA Spectrum Strategy Committee. It can be downloaded from the WIA website.

### Move over JT65 for a new kid on the block

The digital mode FT8 although still in Beta testing has caught on, luring many using the popular JT65 weak signal mode. The WSJT-X 1.8.0 beta software has the FT8 mode described as fast with an entire QSO taking about a minute, which is four times faster than JT65.

Developed by Steven K9AN and Joe K1JT – the name FT8 stands

for its creators Franke and Taylor and 8-Frequency Shift Keying modulation. Using a 15-second transmit and receive sequences it provides 50 per cent or better decoding probability down to -20 dB. Like JT65 it requires accurate time synchronisation.

An auto-sequencing option can also respond automatically to a CQ call decoded reply. It appears to be an excellent mode for HF DXing and multi-hop sporadic-E propagation on 6 metres where deep fading may make fast and reliable QSO completion desirable. Some are comparing FT8 use to that of JT65, and believe more are on-air trying the new one.



# GippsTech 2017 Review: art, science, technology and tomfoolery

Roger Harrison VK2ZRH



Photo 1: Part of the audience on Saturday morning as the lecture program began.

Staged over a weekend in July each year, the Gippsland Technology Conference (hence, GippsTech) offers a series of presentations over all-day Saturday and the Sunday morning, by amateurs for amateurs. Like solar cycles, sporadic-E seasons, and Billy Connelly comedy shows – every GippsTech is different!

Held over the weekend of 1 and 2 July, this year, it is the 11th one I have attended. That doesn't count "GippsTech Special Edition", held in May 2009 as part of the WIA Annual General Meeting and Conference. GippsTech 2017 marks its 20-year milestone. An astonishing thing!

The 2017 program was characteristically eclectic! Presentation topics ranged from 10 GHz moonbounce (EME) with small aperture homebrew horns (so much for large, unwieldy dishes of popular imagination), through development in digital transmission modes, re-purposing ex-commercial microwave equipment, remote station operation (or operating your home station when you're not at

home), pratfalls and planning when getting on 10 GHz, efficiency of mesh-covered dishes, technicalities of propagation beacons, down to a travelogue of northern hemisphere moonbouncers' homes (all "you wish" shacks!).

Apart from family, my four interests in life are art, science, technology and tomfoolery. GippsTech 2017 provided an opportunity to indulge all four. The conference generally satisfies the latter three. But, this year, my wife and I indulged our mutual interest in art by extending our stay by a day and attending the *Van Gogh and the Seasons* exhibition at the National Gallery of Victoria on the Monday.

## The sky's the limit

As you'd expect, GippsTech provides a golden opportunity for show-and-tell about EME, and advancing the art and science of moonbounce. Saturday opened with **EME on Small Aperture Horns**, presented by microwave EME stalwart Rex Moncur VK7MO, co-authored with pioneer moonbouncer

Charles Suckling G3WDG. Rex gave a comprehensive rundown on his experiments and adventures with making and using small aperture horns for 10 GHz EME. The horns he used successfully are equivalent to using a 13 cm (or 5 inch) dish. Say what? This reminded me of that old joke about an electronics manufacturer that was so successful at miniaturising the hardware it made that the company had to move into smaller premises.

Fabricated from aluminium sheet, bent up and seam-welded, Rex demonstrated that it's possible to have workable digital contacts via moonbounce with a horn less than a metre long, provided the other station is reasonably well-equipped (i.e. not necessarily a "super" station). Rex suggests that such small horns are ideal for 10 GHz moonbounce SWLing! Rex's presentation was a brilliant exposition of curiosity-driven investigation, planning, experimentation and execution that advances the 'state of the art'.

Joe and Julie Gonzales, VK3YSP and VK3FOWL respectively, gave a presentation on the design and home construction of their *Mini Satellite Antenna Rotator* for tracking the popular amateur satellites that have 2 m/70 cm transponders. Joe and Julie's motivation for this project was to demonstrate amateur radio satellite operation to primary school students.

While handheld antennas are usable, having the advantage of simplicity, this project makes satellite tracking a whole lot more convenient. It uses modest-cost, commercial-off-the-shelf assemblies in a simple mechanical design to enable pointing of a small VHF/UHF beam to any point in the sky. Better yet, it's smart! While the unit is controlled by an Arduino SBC, the smart bit is an electronic sensor module to resolve the antenna's absolute azimuth and elevation. This simplifies setup enormously. A variety of freely available software can be used to drive the unit. See [www.sarcnet.org/files/rotator/rotator.pdf](http://www.sarcnet.org/files/rotator/rotator.pdf)

### Signs of the future

Software is at the heart of so many things in amateur radio now. The closer the software gets to the antenna, the better, so say the enthusiasts. A presentation from Glenn English VK1XX epitomises, in a small but significant way, where software defined radio is taking us. **The New VK1 Triple-mode 2m Beacon – Best of 3 Worlds**, took us through the features and benefits afforded by a software defined beacon (SDB) capable of multiple, simultaneous, independent transmissions of different modes, with a 'cluster' of carrier frequencies separated by small, programmable offsets (say, 125 Hz). Read that again. Crikey! The waveforms for each transmission mode are completely defined in a programming language.

With 'automatic' reporting of beacon reception becoming

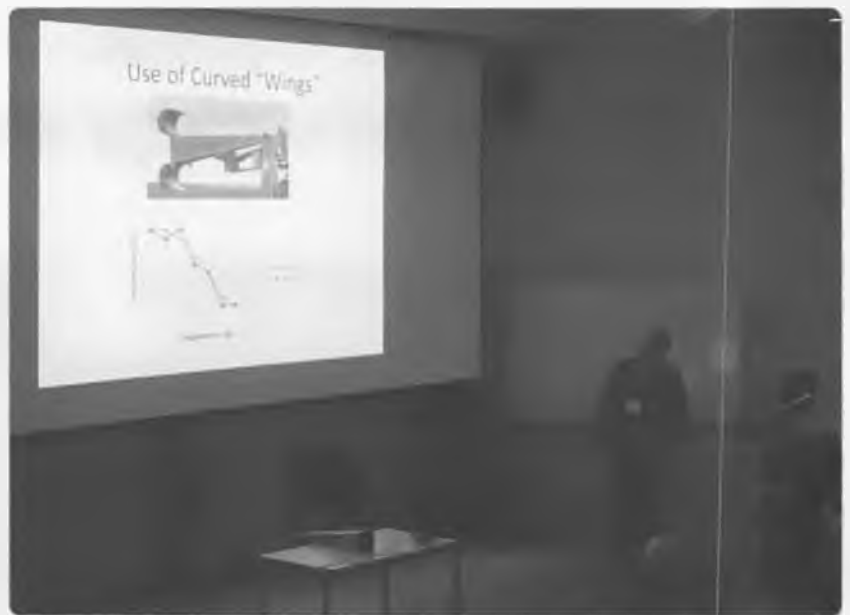

Photo 2: Rex VK7MO discussing options to improve the performance of small aperture horn antennas on 10 GHz.

widespread (WSPR – weak signal propagation reporter being a prime example), the concurrent transmissions enable monitoring the performance of different modes simultaneously, or selectively. Each mode can be transmitted at different power levels, as required. To satisfy legacy users, frequency-shift keyed (FSK) CW can be included, providing backwards compatibility. For monitoring meteor scatter, FSK144 is an ideal contender (part of Joe Taylor K1JT's set of digital modes in his weak signal software suite of WSJT) in a beacon application.

There's no necessity for a beacon to have different modes and powers to be 'cycled through' present periods so that users have to wait for the one of interest. No time is lost checking the different modes, says Glenn. Multiple beacons from one software generator are sent through the same amplifier chain, filter, transmission line and antenna. It means that one site and transmitter can provide propagation indications to multiple types of users, serving differing interests. The software could be loaded to a field programmable gate array (FPGA) – one chip.

Glenn proposes developing a 2 m beacon for VK1 in the manner described, providing FSK CW on the allocated frequency of 144.410 MHz running 1 watt, plus (for example) FSK441 on 144.407 MHz at 10 watts, and WSPR on 144.411 MHz at 1 watt. A slow Morse practice beacon could be added at 144.412 MHz at 100 mW output (all that'd be needed for local coverage), which could also carry the WIA News text edition in Morse. I suspect that last proposition is Glenn's wry sense of humour coming through.

It's no exaggeration to say that WSJT has transformed many aspects of amateur radio over the past two decades. With Joe's digital modes designed to reveal signals that cannot be heard by ear, and deal with "difficult" propagation conditions, it's no surprise that enthusiasts are using JT65 on 20 metres to get their DXCC. Development of WSJT digital modes continues apace. Reprising experiments carried out with earlier digital modes, Rex Moncur VK7MO gave a presentation on **Performance of QRA Compared to JT4**, of keen interest to moonbounce enthusiasts, stalwarts and neophytes alike.

Both are designed for making



QSOs under extremely weak-signal conditions. JT4 uses the same message structure and encoding as employed in the widely-used JT65. The newer QRA64 mode's internal code was designed by Nico Palermo IV3NWV and implemented in WSJT-X by Joe K1JT. Operationally, it is similar to JT65, but does not use a callsign database to 'recognise' noisy signals. Instead, it makes use of "already known" information gained as a QSO progresses, thus gaining additional sensitivity. Rex demonstrated how well the two modes perform under different practical circumstances. Always informative. Time and ongoing development will determine the digital mode user community's take-up and application to weak signal communications.

### **Antenna perennials**

Antennas – all types, configurations, construction, innovation and deployment are perennial subjects for amateurs. I'm not telling you anything new, here. Just reminding you that the topic is never exhausted. An online discussion in the weeks before GippsTech about the effect of adding mesh to a grid-pack antenna prompted Andy Sayers VK3ES to do some research using an electromagnetic simulator and put together a wonderfully informative presentation on **Efficiency of Mesh-covered Dishes**.

A grid-pack is, after all, a truncated sector of a parabolic dish. They can be secured cheaply second hand, ex-commercial service. Various models are also available new from electronics retailers and some IT stores. They're a popular choice for use on the 13 cm band as they're used in Wi-Fi network links and suchlike on 2.4 GHz. I have one. And this topic has been on my mind, as I've pondered replacing the feed with a triple-band one. The online discussion ranged across aspects of improving the reflector's efficiency on the chosen

band by adding hardware store mesh (brass, stainless steel), as well as for use on higher bands (9 cm, 6 cm). Using his CST 3D simulator software ([www.cst.com](http://www.cst.com)), Andy did a thorough job exploring the effects of different types of mesh in various situations, highlighting circumstances where use of mesh was worthwhile as well as those where it was marginal. Along the way, he sank a few myths. Well done!

Glenn English VK1XX followed-up on a presentation he gave at GippsTech 2016 titled "Near Effects of Ground and Your Field Day Setup" with a graphic presentation on **Near-antenna Fresnel Zone Clearance** (look up Fresnel zone on Wikipedia). Whether at home, or on a mountain top for a field day, you need to take care of your first Fresnel zone to get the best from your beam antenna installation. The upshot, Glenn demonstrated, particularly with field day antenna installation, is to strive for higher heights (shades of Dr Seuss) so that the first Fresnel zone gets clear of the ground in front – and that point is closer than you think.

### **Technology topics**

For adherents of V-U-HF and microwave weak-signal working, beacons are a bread-and-butter tool. Justin Giles-Clark VK7TW, with his newly-minted 'WIA President' badge, gave a presentation on **a GPS-locked Multi-beacons Controller Using the ZLPLL**. The ZLPLL is a compact, self-contained PC board designed for use as a local oscillator for VHF, UHF and microwave projects (see <https://zi2bk.com/projects/zlpll/>). Based on the Analog Devices ADF4351 PLL chip, the ZLPLL's chief features include operation on frequencies from 31 MHz to 4.4 GHz, 1 kHz or better frequency resolution, an internal OCXO or VCXO reference, and the facility to accept an external reference to 100 MHz. Add a GPSDO and a new world of applications opens up.

Justin explored the issues of re-purposing a ZLLPLL board to provide GPS-locked carriers for beacons across the VHF, UHF and microwave bands. Upgrades to salient VK7 beacons should stand Tassie locals in good stead for completing more contacts with stations on the big island to their north.

Promotion and use of weak-signal digital modes has been Rex VK7MO's forté for two decades or more. Especially for portable gigs. Rex has conducted personal expeditions to many rare grid squares across Australia, to make terrestrial and EME contacts. As with stand-up comedy, timing is everything. Rex and Larry Howler VK7WLH (not present at GippsTech, unfortunately) put together a presentation on the subject of **Timing for Portable Digital Operation With a \$20 USB GPS Receiver**. When using some digital modes, if the timing of your Tx and Rx sequences are not right it can be a pain in the peninsular. This cheap USB GPS receiver helps solve the problem. Another fine example of re-purposing technology to suit amateur applications.

Tim Dixon VK5ZT is an indefatigable experimenter and operator, particularly on the microwave bands. Utter "field day" and you won't see him for dust as he heads for the hills. It is unsurprising that, when the 3.5 GHz ex-link transceiver panels came on the market from the Geelong Amateur radio Club (GARC) a few years back, Tim secured a bunch to convert for use on 3.4 GHz. Tim regaled the GippsTech 2016 audience with his firmware modifications to these panel transceivers. While the conversion plan for these panels published by GARC uses 70 cm as the IF, Tim's portable microwave rigs all use a 2 m IF. Hence, Tim regaled this year's audience with **Building the two metre version of the Geelong 3.4 GHz Panel**. While that title sounds a bit 'dry', Tim's



Photo 3: Justin VK7TW discussing the improvements made to his 10 GHz transverter system.

presentations are always lively, practical, fast-paced and funny. A cracker!

The seemingly tireless Joe and Julie Gonzales (VK3YSP and VK3FOWL), having demonstrated their Mini Satellite Antenna Rotator, also served up a trio of projects that they confessed were built on their kitchen table! Having a cup of tea with Joe and Julie at home must be an interesting experience. Their **Remote Radio Control Server** presentation described how they set about operating a home transceiver away from home, without needing lots of money and a rack full of firmware, just modest-cost off-the-shelf modules and free software. Likewise, their **ARDF telemetry** talk informed the audience of their system for adding a fillip to the outdoor DFing they use to engage

school students. Finally, **APRS on HF** described a system they put together from off-the-shelf modules for use with portable HF rigs (attractive to school students!). See: [www.sarcnet.org/projects.html](http://www.sarcnet.org/projects.html)

### The other side

Each year, there are talks that add another dimension to GippsTech, while remaining in-keeping with the over-arching amateur radio theme.

So it was with **The International Governance of the Amateur Service – The Role of the IARU**, presented by Peter Young VK3MV, who is the WIA's Regulatory Counsel and a director of the IARU Region 3 Association. His talk answers the thorny Monty Pythonesque question of "what has the IARU ever done for us?", among other things. The IARU is a non-government organisation recognised

by the Geneva-based International Telecommunications Union (ITU) that determines global radio regulations and frequency allocations through regular World Radio Conferences. The IARU is 'our voice in Geneva'. Over the years, the IARU has secured ("for us") new allocations (30, 17 and 12 metres; 2200 m; 630 m; and recently, 60 m), and elimination of the Morse code requirement for HF access.

Justin VK7TW amused the audience with **My uniquely GippsTech 10 GHz adventure**, setting out the pitfalls he encountered and pratfalls experienced in pursuing compilation of station for the 3 cm band. The best laid plans of mice and men often go astray, said poet Robert Burns. And it's still true.

Chris Skeer VK5MC, aka "the man with the dirty great dish", presented a travelogue of his and his wife's journey to the 2016 EME Conference in Venice, via North America and Western Europe. **Long Path to the EME Conference Venice 2016** was a glorified "shack crawl", if you like, taking in many of the northern hemisphere's best-known moonbouncers' QTHs. All those "you wish" shacks!

I gave a short presentation titled **Challenging times for Australian Amateur Radio – Change coming from all directions**, outlining threats and opportunities arising from the Australian Government's Spectrum Reform program, mounting demand for spectrum (a global phenomenon) and pent-up demand for change in amateur licence conditions.

Photo 4: Lots of social interaction occurred at the Conference Dinner on Saturday evening.





## Epilogue

Organised by the Eastern Zone Amateur Radio Club (EZARC - VK3BEZ), GippsTech runs like a well-oiled machine. Facilities at the University campus in Churchill provide the venue every year.

There's a good reason why GippsTech rightly claims to be "the premier technical conference in VK". It's well organised, well run, attracts interesting presenters who cover wide-ranging topics, and draws an eclectic crowd of practitioners, enthusiasts, dabblers and fanatics, all eager to learn, discuss, critique and be entertained. While GippsTech's primary focus is "on techniques applicable in the VHF, UHF and microwave bands, especially for weak-signal contacts", the Conference's scope has broadened in recent years to include presentations on some of the newer frontiers in amateur radio.

GippsTech is brain food for the thinking amateur (as I've said before). It comes with a side serve of social events - the Friday night get-together at a local pub in Morwell, the Saturday night dinner in the Morwell Club, and the on-

campus lunchtimes and coffee breaks. And there's the partners' tours of the region.

Did I mention tomfoolery? The VK4 gang has made "a thing" of hiring a mini-bus for the GippsTech weekend to ferry them from Melbourne - GippsTech and return. Last year, the gang 'souvenired' one of the GippsTech roadside direction signs. This year, they returned it. David VK2JDS (23 cm EME) and Justin VK2CU (a GippsTech virgin) indulged in some techno-tomfoolery on Saturday night having BPSK audio QSOs across the dinner table using apps on their cellphones.

I have to give special thanks to Brian Young VK3BBB, EZARC member, who graciously ferried my wife and I between the Coal Valley Motor Inn and the university campus over the weekend. In addition, after all the years of attending GippsTech, we got to tour the nearby Loy Yang power station and its brown coal 'super pit' on the Sunday after lunch, thanks to Brian's hospitality. We also toured a variety of other local sites while waiting to pick up our baggage in the afternoon.

After that sight-seeing, Val and I caught the train from Morwell destined for Melbourne's Southern Cross Station. However, at Warragul, the train was held up by failed signalling on the line ahead. Soon however, V-Line organised buses to take passengers to stations up the line. As Val is wheelchair-bound, V-Line organised a wheelchair accessible taxi to take us to Melbourne. The Warragul stationmaster gave me a taxi e-card. A local taxi, driven by a wonderful owner-driver lady, picked us up. On the outskirts of Melbourne, the freeway traffic slowed to a stop-start crawl. There was an accident on the freeway in an inner-east suburb, after which travel returned to freeway speed limits. Our taxi driver delivered us to our CBD hotel opposite Southern Cross Station. The fare came to \$264. Thank you V-Line.

Our tour of the NGV's **Van Gogh and the Seasons** exhibition on Monday 3 June was glorious, and a fitting conclusion to a weekend of art, science, technology and tomfoolery.

*Photographs courtesy Michael Binz VK3ALZ.*

## Silent Key

Alan Booth VK4EAB

Edgar Alan Booth VK4EAB, known to his friends as Alan, was born in Richmond, Victoria on 19 August 1923. His first two to three years were spent with the sound of Morse code at his father's radio shop at Bridge Rd in Melbourne.

When Alan turned 18 in 1941, he was drafted into the RAAF and sent to 100 Sqn on the Beaufort Torpedo Bombers. Alan did courses on aircraft electricals, wireless mechanics and then as a wireless operator.

Alan was interested in radio all his life and made many friends all around the world. Later he did his electrical trade but it wasn't until he moved to Kybong (south of Gympie in South East Queensland) and met with some of the local radio amateurs that he decided to get his amateur licence. Alan's eyesight was starting to fail, so he made a date with the radio inspector who



later visited Alan's farm at Kybong and conducted the examination. Alan said he did the 10 words a minute and his marks in the radio theory were pretty good; he then obtained his full licence.

Alan was a valued life member of the Gympie Communications & Electronics Group and was also a former member of the Gympie Amateur Radio Club. In his

later years, Alan resided at the St Patricks Nursing home in Gympie but that never stopped Alan from being active on the air. With the help of Bob VK4MR and Roger VK4BNQ, Alan was active on both HF and 2 metre IRLP talking to people just up the road or on the other side of the globe. Alan was a true gentleman and always had a happy outlook on life; he will be sorely missed by his radio friends & family. Alan passed away peacefully on the 6th July 2017, aged 93.

Regards,

Neil Turner VK4NHT

Secretary - Gympie Communications and Electronics Group Inc.



*Photo 1: L to R: Cheryl (Doug's daughter), Peter VK3PF GippsTech Chair, Tim VK5ZT, inaugural VK3UM Award winner, and Peter McArthur after the presentation of the VK3UM. Peter VK3PF is holding the large perpetual trophy whilst Tim has his certificate.*

GippsTech now hosts two annual awards. The **VK3UM Award**, in memory of GippsTech stalwart, and world-renowned "amateurs' amateur", Doug McArthur, is a perpetual trophy awarded annually to the person recognised by his peers for the best presentation at the GippsTech Conference. The inaugural VK3UM Award was presented to Tim Dixon VK5ZT by Doug's son, Peter.

Doug was a WIA member from 1956, serving at different times on various WIA committees. He was noted for his contributions to the radiocommunications industry, and highly regarded internationally for his EME work, and the EME and EMR software that he developed and maintained and made freely available to others. Doug contributed many informative articles for *Amateur Radio* magazine and overseas journals. He was a major contributor to GippsTech and freely shared his knowledge locally through AR club events, and internationally.

The **Microwave Enthusiasts Award**, conceived, funded and promoted by Alan Devlin VK3XPD, and first presented at GippsTech 2016 to Doug Friend VK4OE,



*Photo 2: Rex VK7MO receiving the VK3XPD Microwave Enthusiast Award from Kevin VK4KJ.*



this year went to Rex Moncur VK7MO. It was presented by Kevin Johnson VK4UH as Alan VK3XPD was swanning around Europe on a microwave DXpedition in advance of the Friedrichshafen hamfest in Germany in mid-July (as you do). This Award recognizes a "worthy" VK amateur for their technical achievements through building and operating RF gear for use in our microwave and millimetre-wave bands, for their talent and enthusiasm, or their mentoring activities. Or all of those things. See: [www.rfresale.com/ME.html](http://www.rfresale.com/ME.html)

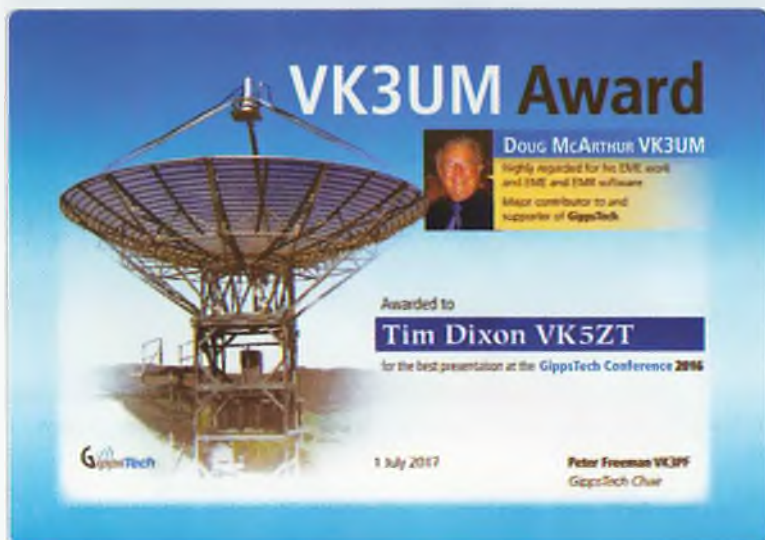

Figure 1: The handsome VK3UM Award certificate. The stylish trophy is kept by EZARC.

## GippsTech 2017: An organiser's view

Peter Freeman VK3PF

The organisation of an event such as GippsTech takes time and some coordination. Most of all, it requires willing hands immediately prior to the event and over the event itself. Of course, following the event there will be tasks that need to be completed. Most of the team are regular contributing members of the organising club, Eastern Zone Amateur Radio Club Inc. (EZARC).

Planning started immediately after the 2016 event: The Ham Radio event at Friedrichshafen had announced that the 2017 event would be later in the year than in previous years and would fall on the same weekend as that traditionally used to hold the GippsTech event. EZARC decided to hold the 2017 event two weeks earlier than usual, thus making it possible for amateurs to attend both events.

Bookings of the rooms at Churchill were made in early August and were finally confirmed in late January 2017.

In early February, approaches to other venues were made and bookings confirmed. The catering firm that provides the spit roast lunch on Saturday was booked.

The author collated the Proceedings volume for the 2016 event and organised for it to be printed prior to the 2017 event. Proceedings sales are an important income stream for the Club, plus they have the benefit of sharing in a more permanent manner the information presented during the Conference.

### Raffle

The 2017 event would be the twentieth annual GippsTech conference, so we decided that some significant raffle prizes would be in order. The Club ordered a Lime SDR via the Crowd Sourcing page.

We also made an approach to Icom Australia seeking possible support, a request which was successful. Icom Australia supplied an Icom IC-7300 transceiver at

a significantly discounted price, together with two discount vouchers for the purchase of Icom transceivers and some miscellaneous small prizes.

Tim VK5ZT donated a 3.4 GHz transverter, all ready to go with a 2 m IF transceiver.

Through the efforts of Alan Devlin VK3XPD, Joe Kraft DL8HCZ/CT1HZE supplied two editions of DUBUS Technik compendium.

Pages of Cobram/Radiobooks provided a \$50 book voucher.

Several small prizes were sourced by committee members.

A significant change for the raffle was the requirement to print formal tickets due to the prize values.

The Club decided to sell tickets at \$5 each. We hoped that we at least cover the cost of the prizes that we had purchased. In the end, it was a success. We made a profit of about \$800 on the raffle.

The IC-7300 was won by Bob Campbell VK4XV, who was very



Photo 1: Some of the raffle prizes on display during the breaks between lecture sessions.

happy. The Lime SDR was won by Ralph VK3WRE.

### Genesis of the VK3UM Award

In mid-February, the Club was approached via Gavin VK3HY with a suggestion of a perpetual award in Doug VK3UM's name. The idea had arisen many months earlier but was now forming into a firm idea, with the suggestion that the award to be associated with GippsTech.

Doug VK3UM had been one of the presenters at the very first GippsTech event in 1998 and has presented in most years since. Doug became a Silent Key in February 2016. He had always been a strong supporter of the GippsTech Conference.

The EZARC Committee discussed the suggestion and proposed to the family that the award be made for the "best presentation" made at the previous year's conference. The family agreed. The definition of "best presentation" was deliberately poorly defined, with the decision to be made by a small group of key organisers with input from Gavin VK3HY and Peter VK3MV. The family would have a trophy designed and made whilst the Club undertook to design a certificate for each winner.

The inaugural winner was

Tim VK5ZT for his entertaining presentation of his modifications to the 3.4 GHz panel transceivers to make a transverter. His presentation included a significant amount of technical information.

### Social events

As mentioned by Roger VK2ZRH in his review, social events form an important part of the weekend. Special thanks must go to Kevin VK3HKK and Damien VK3CT who acted as driver on Saturday and Sunday, respectively, for the Partners' Tour. The Club considers the tour as an integral component of the weekend, as those that participate always reflect on how they enjoy the tour of local attractions.

We always try to arrange an itinerary which will meet the desires of the participants and which also introduces them to some new venues each year.

### Sunday microwave activity

After lunch on Sunday, a number of amateurs participate in some

microwave activities. Some venture further afield, but others are willing to simply check their equipment across shorter distances. The sunny weather this year resulted in several amateurs checking out 10 GHz systems. All were able to depart with the confidence that their systems did actually work.

### Conclusion

EZARC offers thanks to all that assisted in making the event successful: Club members who simply helped out when asked, those on the organising committee and those that volunteered for more onerous tasks. The event only works because of the collective efforts of all involved. Special thanks to those that volunteer to present, as without them, there can be no talks! Consider giving a presentation about your local project next year.

Speaking of which, when will the 2018 event be held. The Club will announce the dates as soon as we can confirm venue bookings, but expect some time in early July.



Photo 2: Dave VK2JDS (front) and Lindsay VK2AMV operating 10 GHz SSB in the car park at the University.





# VK3news Geelong Amateur Radio Club

Tony Collis VK3JGC

## The GARC going Solar

At a GARC planning session recently, the viability of the GARC was discussed in terms of our incomes and expenditures, particularly in the light of a substantial planned rise in the price of electricity in 2017.

It seems that younger members do not seem to be attracted to either Amateur Radio and/or to joining clubs. This may mean, in the future, raising membership fees of a decreasing membership to cover the increasing expenditures, just one of which is the electric power bill.

Lee VK3PK, who has had many years' experience of grid connected Solar Power, suggested that it may be a good investment to put some of our resources into a solar system especially with the Victorian Government guaranteeing a better minimum feed-in tariff.

Lee and Ian, independently, collected the various information required to put together spreadsheets and do some modelling regarding the size of solar systems and the Return On Investment (ROI). This modelling included the unique opportunity where little power is actually consumed during the day time when the majority of solar power is generated. Systems from 2 to 6 kW were considered.

The outcome of this study was presented to the club in a technical talk and discussion by Lee. The optimum size of a system turned out to be a 5 kW system, with an effective return on investment of approximately 18% pa giving a payback period of 5.5 years and an expected lifetime of 15-20 years.



Photo: Lee VK3PK and Ian VK3ZIB.

In effect, we expect that our net electric bill will go from \$1400 pa, the current equivalent of 28 club member annual subscriptions, to \$0 for some time to come!

When a proposal of motion was circulated that the GARC should invest in a 4.8 kW solar system, a *Very Generous GARC Member* came forward with an offer to wholly cover the whole cost of the installation. Indeed an enduring gift to the GARC. The system has been ordered and will be installed at the start of Spring 2017.

## The Ray Cowling Trust

Calvin VK3ZPK produced a *Trust Document*, presenting it to the club in order to get agreement on its inception, in appreciation of the generosity of Raymond Cowling VK3ACL in financially assisting the Geelong Amateur Radio Club at various times over several years. The club members unanimously agreed to its implementation.

Ray has encouraged and enabled the Club continuously in the promotion of the Amateur Radio hobby.

The Trust will be managed by the Committee of the Geelong Amateur Radio Club with the financial oversight provided by the Club Treasurer. The intended beneficiaries of this Trust will be those persons desirous of becoming a licensed Amateur Radio operator who need some form of assistance albeit financial or the loan of equipment held by the Trust; the latter to be returned to the Trust after an agreed period.

For any person to be a beneficiary they must be a member of the GARC.

The Trustees (The Committee) will decide on the suitability of the needs of any potential beneficiary at a special meeting and then any recommendation arrived at will be put to a vote at a general or special meeting of the club.

The total financial benefits provided by the club to the beneficiaries will be limited to an agreed total annual amount and that there will be no requirement for repayment by the Recipients.



# SOTA & Parks

Allen Harvie VK3ARH

With winter settling in, the primary activity has been concentrating with Parks instead of from the Peaks. There were 134 distinct sites activated evenly split between SOTA and WWFF. This is not to say SOTA has been neglected; just that the operating environment for Parks is conducive to winter operations.

Gerard VK2JNG has taken to WWFF activations with gusto. He completed 18 separate sites for the month of July alone. Below is Gerard's setup demonstrating the elaborate setup and comfortable operating positions possible during park activations.

Bucking the trend was David VK3IL who kept up his usual winter summit grab chasing high points in Alpine: <http://vk3il.net/2017/07/>

Andrew VK1AD has been out making 23 cm activations from the Peaks around VK1. He has started a new 23 cm SOTA blog dedicated to reporting on 23 cm 1296 MHz activations: <https://vk1sotaon23cm.wordpress.com/>

John VA7JBE (from Canada) has been cruising around VK and ZL for the last four weeks. After living in the desert on the Arabian Peninsula with no licence, he was keen to get some skiing and SOTA. His CS-40 monoband 40 m SSB transceiver needed a transistor swapped out, so local amateurs helped with access to test equipment and loaning a VHF/UHF handheld. John joined local amateurs to activate sites within VK and ZL and details available: <https://summitsandradios.wordpress.com/>

Glenn VK3YY and myself Allen VK3ARH took advantage of the mild weather to activate Talbot Peak VK3/VT-010. This summit is a winter favourite due to being on the AAWT so having well defined clear access. Our previous attempt with Peter VK3ZPF two years ago was met with bad weather and was

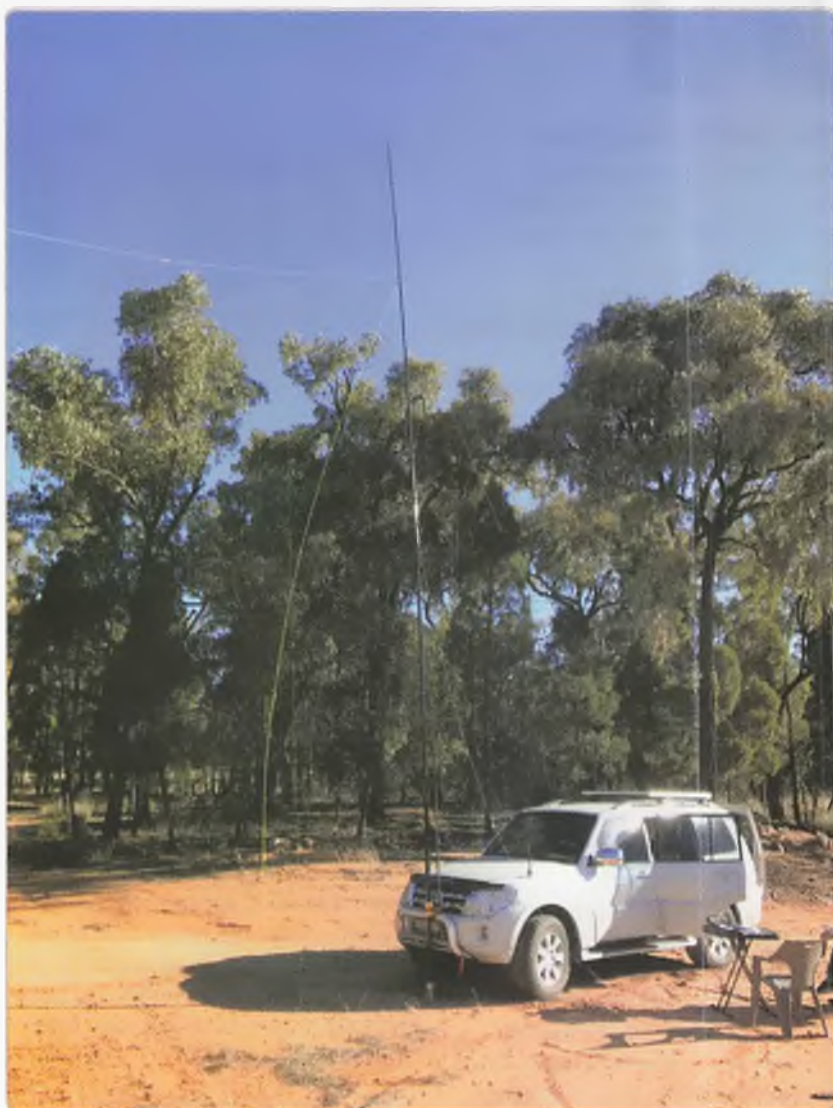

VK2JNG operating set up in a Park.

aborted. This expedition proceeded as planned including the expected midday snow reminding us it was time to head down.

<https://vk3hra.wordpress.com/2017/07/10/08072017-vk3vt-010/>

<https://vk3yy.wordpress.com/>

## New Parks and Data

The 2016 Collaborative Australian Protected Areas Database

(CAPAD2016) has been released. This data provides both spatial and textual information about government, Indigenous and privately protected areas for Australia, in both the marine and terrestrial environments. State, Territory and the large NGO conservation agencies supply data current for 30 June 2016.

The release caused a flurry of activity with Paul VK5PAS cross



checking the current list of all VKFF and SANPCPA sites with the CAPAD data to ensure the list is accurate and identify opportunities for new additions.

Paul has spent several weeks checking maps, searching on the internet and liaising with some of the WWFF activator die-hards, to come up with an accurate list of new sites. Please be patient if your local site is not recognised immediately as this is quite a big job dealing with discrepancies between what appears in the CAPAD list to what is showing on the various state authorities' websites as well as the misalignment between the official and local views.

There is a limit of 500 new references annually and Paul VK5PAS was already confirmed for this year:

- VK1 received two new Nature Reserves,
- VK2 received a new National park, 13 new Regional Parks and three State Conservation Areas,
- VK3 received a new coastal and four additional Regional Parks,
- VK5 only received two new parks but ahead of VK4 with 0,
- VK6 received thirty Nature Reserves and an additional National Park; this will be the final lot of parks for VK6 unless new Parks are gazetted,
- VK7 was the big winner with 52 State Reserves added to the list. All State Reserves in VK7 have now been added.

With an additional 150 Nature Reserves being verified to be added to the VK2 WWFF list before the year is out.

Please note that logs for references prior to the validation date are not valid for VKFF and will not be uploaded into LogSearch. Best to verify a parks status before heading out from -<http://www.wwffaustralia.com/qualifying-australian-parks.html>

For more information about WWFF upcoming operations, see: <http://wwff.co/agenda> or <https://parksnpeaks.org/viewWWFF.php>

And for more information on the World Wide Flora Fauna (WWFF) program, please have a look at: <http://www.wwffaustralia.com/>

### ParksnPeaks

With the release of the CAPAD 2016 data, a major update has occurred to the ParksNPeaks database to ensure aligned with WWFF updates. This has taken a couple of weeks to complete and now includes updated park data, SOTA peak alignment and GPS files.

Marc VK3OHM has verified and updated the park boundary files hosted on the site. There is now 96% coverage. The last 4% will take a while, but we're working on it. Download the files for the state of interest and load into Google Maps. The terrestrial parks are shown in blue and marine parks are shown in pink. Hover the mouse to see the boundary of the park, and click for details. Park boundary and other

local data is available from: <http://parksnpeaks.org/ParksnPeaksFiles.php>

As the site is maintained by humans, there are a handful of known and a larger group of unknown errors, so if you see any, let me know at [support@parksnpeaks.org](mailto:support@parksnpeaks.org)

### Upcoming Stuff

**Friday November 10 - Monday November 13 is the annual KRMNPA activation weekend.**

In 2016 we managed the record result of 41 VK3 National Parks "On the Air". This year, given the greater interest in parks, we should be able to get all 45 on over the weekend.

Contact Tony VK3XV on [vk3vth@wia.org.au](mailto:vk3vth@wia.org.au) to be added to the Activations list. Remember all 45 VK3 National Parks are also eligible for the VKFF Award!

**Saturday 25 - Sunday 26 November 2017 is the annual VKFF Activation Weekend.**

If you do intend to activate a park that weekend, please drop Paul VK5PAS an email at [vk5pas@wia.org.au](mailto:vk5pas@wia.org.au) with your intentions, so you can be placed into the activator spreadsheet.

And, with careful planning, you may also be eligible for the Shires Award and SOTA activities. Only three months to go, so now is the time to book that weekend away! Camping, Glamping or just a day trip!  
73, 44  
Allen VK3ARH.



## Wireless Men & Women at War

Young men and women who behind the scenes, were able to successfully use their developed skills in such a way as to make a difference – sometimes a big difference brought about largely by their interest in private radio communications. Read more...

Visit the WIA Bookshop at: [www.wia.org.au/members/bookshop/page\\_data.php?id=258](http://www.wia.org.au/members/bookshop/page_data.php?id=258)



# VHF/UHF - An Expanding World

David K Minchin VK5KK



Photo 1: The new beacon transmitters for VK2RSF. Photo by Rod VK2TWR.

moon. The installation is situated just east of the Chablis wine region (JN27si) in central France. The radar is on 143.050 MHz using an electronically steerable antenna that covers south (85 to 275 degrees azimuth) and up to 45 degrees elevation. The ERP allegedly runs into the megawatts so it doesn't exactly have to be looking at the moon for reflected signals to be heard! Ian VK3AXH reports ...  
*"Although I didn't attend this year's GippsTech, I did hear about a presentation given by Jim VK3ZYC regarding a French Radar known as "GRAVES*

## Introduction

This month's column has details on the new VK2RSF 144 MHz beacon as well as reports on the Graves Radar from Ian VK3AXH and Joe VK7JG. The EU mmWave DXpedition report follows on from last month as well as Kevin VK4UH's regular Meteor Scatter Column. Leigh VK2KRR is away this month, the WSPR report will return next month.

## New VK2RSF Beacon at Mt. Emerald

Rod VK2TWR reports ...  
*"A new 2 m beacon, broadcasting as VK2RSF has just been installed on Mt. Emerald in Southern NSW. This beacon replaces an older beacon which has been working for many years at this hostile location. The new beacon was built by Joe VK7JG and Rex VK7MO. It is a very reliable, GPS locked, commercial quality transceiver, which should provide many years of trouble-free performance. There are plans to*

*upgrade the beacon site by installing a Nally Radio Tower to get the antennas for this beacon as well as the existing 70 cm beacon to an optimum height."*

Joe VK7JG has provided a photo (Photo 3) and the following details on the beacon ...

*"The photo shows the replacement GPS locked VK2RSF beacon on 144.414 MHz. In the future, you won't have to go looking for it as it used to be up to 600 Hz high when cold! It is based on a Unilab KL150 PA using a ZLPLL as the exciter."*

## EME Report - Graves 143.050 MHz Radar

Jim VK3ZYC did a very interesting and popular presentation at GippsTech this year on the Graves Radar reception via the



Photo 2: An overview of the site and antennas at VK2RSF. Photo by Rod VK2TWR.





Photo 3: Inside the new VK2RSF 144.415 MHz Beacon. Photo by Joe VK7JG.

RADAR" which is primarily used as a space surveillance system. Articles have been written in DUBUS in 2007 and in many other publications explaining how it can be used as a VHF beacon, Meteor Scatter observations and Aircraft enhancement studies."

"Although I have been active for 13 years with VHF EME this is the first time I've heard about it and have subsequently been taking some measurements over time. Along with some other VK3 stations including VK3AUU and VK3RRR this signal has been received at varying

strengths dependent on the position of the moon at the time, degradation factors and the type of antenna being used. The RADAR's frequency is 143.050 MHz."

"Having now read quite a bit about this RADAR it seems that a signal can be readily detected by amateurs that have a small horizontally polarised 2 metre Yagi. Using the WSJT mode's waterfall in JT65B or JT-X and tuning your radio to 143.049 USB you should be able to see a 1 kHz trace of the radar signal. The radar is in Grid Square JN27si. By using moon location

software such as "Moonsked" with this grid square in the call.txt file together with your own callsign and grid locator suitable times and direction of the moon from your QTH is available to give the best opportunity to see the signal."

"Those endeavouring to attempt this should make sure the moon is no higher than 6 degrees above your horizon to obtain the best results. I'm aware that David VK3AUU using a pair of long Yagis has received signals at -12 dB and Richard VK3RRR -10 dB also using a pair of Yagis. When the moon is at elevation of 6 degrees or lower considerable ground gain can be achieved. My results so far have shown that signals fluctuate from day to day with my best result being -2 dB. My worst result so far has been around -17dB."

Joe VK7JG also report on his Graves Radar experiment's ... "Initially, when I looked for the Graves Radar I saw nothing but then I realised that 143.050 MHz is the carrier frequency and that I needed to tune to 143.049 MHz to hear a 1 kHz tone. While listening on 17/7/2017, signals were around -22 dB and I could just hear it in the speaker. When the moon was at 10 degrees elevation, signals were -17 dB at which point you can hear the CW tone quite distinctively. At first, I thought the keying was a little soft

Photo 4: Graves Radar signal received by VK3AXH using 4x18-el long Yagis.

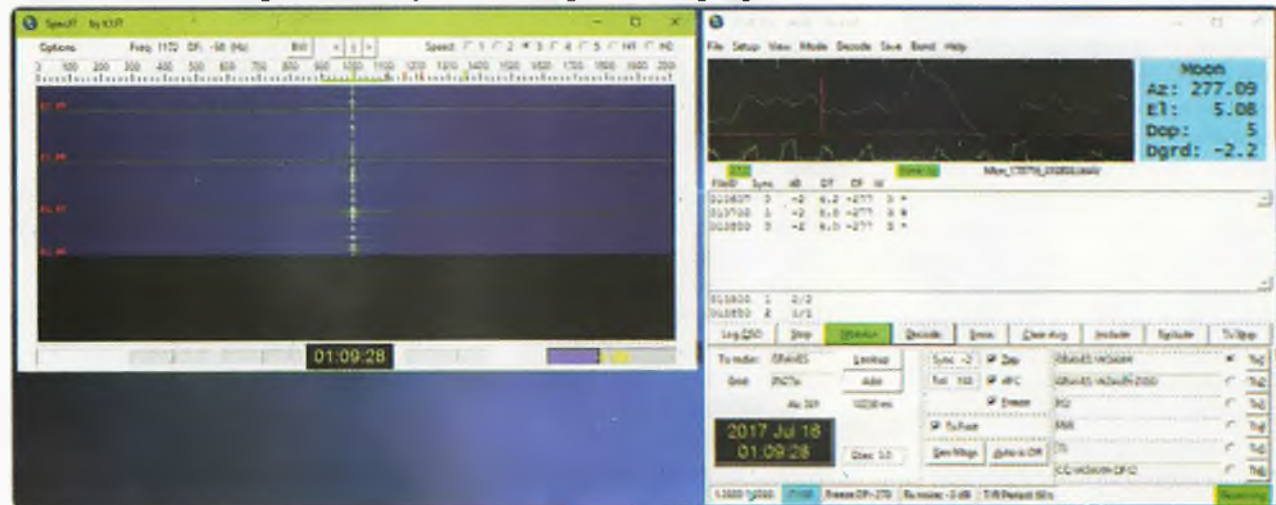

*but today Ian VK3AXH sent me an audio file that is exactly the same as what I was hearing. Next, I will do a polar plot of my aerial using the radar signal when conditions improve. Another 3 dB aerial gain would help!"*

## **2017 EU mmWave DXpedition**

As reported on the go last month, four Australians (VK3XPD, VK5KK, VK5ZD and VK5ZT) travelled to Europe for the third "Microwave DXpedition". The DXpedition was split into two parts; the "Southern Europe" part was on 8/9 July 2017 and Northern Europe from 13/7/2017 to 22/7/2017 with a break for the Friedrichshafen "Ham Radio" Fair from 14 to 16 July.

On previous trips, the group has travelled with enough equipment for one basic "QRP" setup on all bands from 1.2 GHz to 122 GHz. This time the focus was limited to 10, 24, 47, 76 and 122 GHz but with more power and enough equipment to assemble two separate portable stations on most bands. This translated to around 25 kg of equipment per person including tripods and dishes.

Travelling on aircraft with the best equipment you can manage to work significant distances is "complex" in the current security climate and necessary customs inspections. Documentation is important should you be challenged at customs. Copies of your licence attached to equipment referring to the CEPT agreement is important as well as a rehearsed "professional" summary of what you are doing and where you are going should you be asked. Batteries of any type are "Verboten" in check-in luggage and must be carried in carry-on luggage. Batteries must be under 100 Wh; those that aren't in a commercial looking or safely packed will get confiscated. Luckily all have reported that they and everything transported survived the round trip to Europe despite open bag inspections, curious X-Ray machine

operators and 60 GHz mmWave radar body scans!

Also, travelling between EU countries is now slower with the increase in border security. For example, travelling back into Germany from Austria now takes an hour or more as anything bigger than a hatchback and/or vehicles not registered in Western EU usually get a full search.

The Southern Europe part of the DXpedition focused on operation between Italy and Slovenia. David I/VK5KK was at Dia de Ablo (JN44ap) on 8/7/2017 and Monte Penice (JN44ps) on 9/7/2017. Alan I/VK3XPD at Comerlati (JN55no) on 9/7/2017 only. Wolfgang S5/OE4WOG and crew were at Mt Slavnik (JN65xm) in Slovenia on both 8 and 9 July.

On Saturday only David VK5KK and Wolfgang OE4WOG were active. The distance (475 km) proved too great for Troposcatter on 10 GHz between us and there was no rain scatter (RS) about. VK5KK was located on a look out near a 400-year-old church; despite being ringed by several bigger hills I did manage to work four local home stations on 10 GHz out to about 120 km.

On the Sunday (9/7/2017), I/VK5KK moved to Monte Penice (1460 m ASL, JN44ps). 10 GHz was worked to I/VK3XPD (175 km) on 10 GHz but S5/OE3WOG still was too far away (375 km) to work directly on 10 GHz! We now had some good rain scatter approaching from the west so both VK5KK and OE4WOG had several 10 GHz RS contacts to Germany and southern Italy on 10 GHz. The longest RS contact was I/VK5KK to Nino DL3IAS (JN49ej) 518 km. There was a lot of local 10 GHz activity in Northern Italy on the day with I/VK5KK working 10 stations as well as IW2BNA (JN45on) and I1KFH (JN45fg) on 24 GHz from their home stations. Distance around 90 km.

A test was also done with F6DRO (JN03TJ) south of Toulouse 630 km away with lots of short bursts of Aircraft enhancement (AE)

over a 10-minute period. AE on 10 GHz in Europe is almost point and click! The commercial flight density is insane over Europe, just look at [www.flightradar24.com](http://www.flightradar24.com) to see what I mean!

The Northern Europe part of the DXpedition started the following Thursday (13/7/2017) with short (4 km) range field tests on 10 - 122 GHz from DL/VK5KK and DL/VK5ZD located NE of Lindau and OE4WOG located just inside of Austria at the Berggasthof Stadler (JN47vn). This hotel is at 1000 metres ASL has a panoramic view to the West and has become a convenient mmWave operating spot with easy access to refreshments! The main aim was to check everything was working before attempting greater distances. Signals on 10, 24, 47 and 76 GHz were very strong as expected. OE1TGW was also worked on 10 and 47 GHz over the same path. The focus then shifted to 122 GHz with signals being heard straight away despite the path touching the tops of a few trees. It would seem that all the trees have grown a bit in the last few years! We moved to another site just inside Austria near a tiny church we had used two years prior on 122 GHz and barely scrapped in QSOs to OE5VRL. This time both VK5ZD and VK5KK worked OE4WOG with 59++ signals over a 3.8 km path so clearly our equipment was much better than the inefficient mixer arrangement used last time!

Later that day we travelled to another spot further to the south west and work OE4WOG on 122 GHz over 7 km with 59+ signals. Dew point was around 14 - 15 C, not exactly ideal for 122 GHz but we now had a good benchmark to work with for increasing the distance.

The next activity day was on Sunday (16/7/2017) with VK5KK and VK5ZD travelling to Switzerland to activate Mt Santis (JN47qf - 2500m ASL). Whilst Mt Santis was only 45km LOS from where we were staying the three stage trip took nearly 2.5 hours. First you must





Photo 5: HB9/VK5ZD and HB9/VK5KK portable at Mt Santis.

cross Lake Konstanz by car ferry, then drive 55 km on a mixture of motorway and mountain roads then load everything into a cable car for an almost vertical 1200 metre ascent to the top! OE4WOG and VK3XP were located at the Stadler again with Tim VK5ZT roving close by in Germany on 10 and 47 GHz. We had also arranged several skeds on 10, 24 and 47 GHz with attendees heading home from the Friedrichshafen Ham Radio Fair.

When we first arrived, we were in complete cloud so it took a little time to work out where we needed to point! Luckily the cloud base started to break up after midday. HB9/VK5KK and HB9/VK5ZD worked 8 stations on 10 GHz on Troposcatter (no RS) out to 240 km, 4 on 24 GHz, 6 on 47 GHz, and 3 on 76 GHz (59+ 48 km). The most notable contact was perhaps 175 km on 47 GHz SSB to DF9IC (JN48er) portable near Stuttgart despite Henning running only 20 mW SSB! We also worked Thomas DC7YS on 47 GHz over the same path running 800 mW on CW only. Of note, QSB was heavily influenced by the transit of heavy cloud at both ends of the path on 24 and 47GHz; on 10 GHz there was little or no difference.

Whilst we were on the mountain we experienced a fair amount of QRM from the TV transmitters, microwave links, etc. There was no area we could find that was

completely clear of interference. Our FT817s suffered a fair amount of IF interference on 400 MHz, the only way it could be eliminated was to unplug the CW key, speaker and microphone! After a bit of DFing and tuning we found the main source was broad band noise from the SSPA on the HB9SIX 50 MHz beacon. Later whilst talking to the duty RF technician, we found out that the beacon ran around 500 watts and its antenna was inside the Radome about 10 metres behind us!

Monday (17/7/2017) DL/VK5KK travelled to the SW corner of Germany to the ski resort at Feldberg (JN47au – 1493 m ASL). Tim HB9/VK5ZT went to Mt Santis with 47 GHz but unfortunately the mountain was completely clouded in so no contact was had. OE4WOG, OE1TGW and VK5ZT were at the Berggasthof 136 km away; contacts were had with both on 10, 24 and 47 GHz (59+) with both stations. Being a week day, there was less activity so only six stations were worked on 10 GHz out to 260 km. Again, the Rainscatter gods hadn't helped us! Later in the day, Henning DF9IC went portable to the same location (JN48er) as the day previous. This time the distance was only 98 km. Contacts were had on 10, 24 and 47 GHz OK but only one way on 76 GHz. Time ran out to complete a 76 GHz QSO as I had to pack up in time to catch the last cable car down the summit!

Tuesday (18/7/2017) was a planned "travel" day but now we had significant storm systems heading in from the West so OE4WOG elected to activate Liechtenstein HB0 on 10 GHz RS. Very few people have worked HB0 on 10 GHz, HB0/VK5ZT was very popular on 10 GHz on his trip there in 2015! Wolfgang worked a dozen stations to give them a new country on 10 GHz.

Meantime OE/VK5KK (now at Innsbruck) decided to have a go at RS from Hafelekarspitze (JN57qh), a 2300 metre mountain only a few km from the city. It's another 3-stage trip, one cog train then two different cable cars. This time only 10 GHz equipment as the mountain is surrounded by even higher mountains! RS was now evident to the West and to the East with several contacts to DL and HB9 as well as some Troposcatter to the North. The visit was cut short when the western cell arrived with lightning now striking the hills all around. We had to wait an hour at the summit station as cable cars don't run during storms, when we did leave we only got about 30 metres down when there was a flash and the car stopped! It took about 10 minutes for the "manual descent" system to be engaged; we then descended to the next station at 1700 metres where we waited another hour!

Wednesday (19/7/2017) OE/VK5ZD and OE/VK5KK activated Zugspitze (JN57lk - 2960 metres ASL) on the German/Austrian border. OE4WOG travelled several hours to the junction of the Austrian, German and Czech Republic borders (JN68vs) near Dressell, 260km away. Several other stations were out portable in DL with 10, 24, 47 and 76 GHz as well as some home stations towards Munich. Within 30 minutes of setting up we had heavy rain and ice so we had to pack everything up again! Once the weather cleared we worked a number of stations on 10 GHz as well as DJ8VY (110 km) and

DL6GCK (160 km) on 10, 24 and 47 GHz. OE4WOG was only worked one way on 24 and 47 GHz with the difference in power levels. 260 km proved to be a bit too far for 20 mW given the relatively high humidity with the approaching storms. By mid-afternoon, RS contacts on 10 GHz were now good to central and western DL/HB9. This day we had a lot of tourists about including at least half a dozen hams who had been to Friedrichshafen and one doing a SOTA activation!

Friday (21/7/2017) OE/VK5ZD and OE/VK5KK travelled up the cog train to Schafbergspitze (JN67rs - 1783 metres ASL). There is a Gasthof (Guest House) at the top so we stayed for two nights on the mountain. Last year when we activated the mountain we only had one day of good weather. This time we had two clear days with most thunderstorms passing through to the North. Wolfgang OE4WOG and Hans OE2JOM set up equipment on Gaisberg (JN67nt - 1225 metres ASL), near Salzburg. The mountain selected was only 24 km away so we could attempt to extend our 122 GHz distance. VK5ZD and VK5KK quickly ran through 10, 24, 47 and 76 GHz working OE4WOG and OE2JOM with 59++ signals. OE/VK3XPD was also visiting the site and gave us a QSO on 76 GHz using OE2JOM's equipment.

Now for 122 GHz. Wolfgang OE4WOG set up his system using a Tripler running about 0.5 mW CW on 122250.120 MHz into a 400 mm CNC machined aluminium dish. One end of the current 122 GHz world record! After a bit of antenna tweaking both VK5ZD and VK5KK copied this signal QSBing from 51 to 58! Wolfgang then swapped to his SSB mixer that runs much less power (about 20  $\mu$ W) but was still audible. OE/VK5KK then returned a signal using his SSB mixer and a CW contact was had with OE4WOG, 519 both ways. The distance is over four times the VK record! Later Iain VK5ZD ran his Tripler beacon with



Photo 6: OE/VK5KK 76 GHz and 122 GHz on the balcony!

OE4WOG and OE2JOM so they could compare and experiment with both their systems. Of note, as the humidity increased and visibility dropped over the path signals dropped 10 - 12 dB. Water vapour clearly kills 122 GHz at a rate of 3 to 4 dB per km. After these tests we now have a good idea of how our 122 GHz mixers work. Performance is very close to reciprocal with the OE equipment now but we still need to improve the accuracy of our antennas.

That night we conducted some light wave tests with Tim DL/VK5ZT portable about 60 km North towards the Czech Republic border. The light was plainly visible to the eye once it was aimed but holding the tripod steady proved to be a problem. As there was an approaching thunderstorm, Tim had to pack up before this could be sorted. It became a different light show after that with VK5ZD photographing the spectacular lightning show from the mountain! The next day Tim set up again; there was some cloud cover but as it was quite bright, we worked Tim on 47 GHz first so we could get an idea where he was located. Tim had now sorted out the tripod so when he turned the light on we could clearly see the light once it was aimed, despite it being daytime. Of note, Tim completed a light wave QSO with a German amateur a few days prior to this. We look forward to more experiments in

this area!

On Saturday (22/7/2017) we set up for Day 2 on Schafberg. The storms that passed the night before now provided RS to the East. VK5ZD and VK5KK ended up working five countries on 10 GHz including some new ones for us OK (Czech Republic), HA (Hungary) and OM (Slovakia). Other stations worked included Michael DB6NT from his home QTH via Tropo (320 km away) and later Wolfgang OE4WOG via RS from his home QTH garden! Signals were 59+ on RS so we ended up working him on FM noise free apart from the slight crackle of the RS. There is a YouTube video of the OE4WOG FM QSO, just Google "VK5KK Rainscatter" to find it.

On 23/7/2017 we all packed up and headed back to Munich. The 2017 trip was an interesting and diverse trip with a few lessons learnt as always. Foremost the impact of humidity is now the limiting factor for our mmWave operations. Best described as a "Wall of water" especially on 76 GHz once you get over 90 - 100km. On 122 GHz that is more like 20 km! Most of the mmWave records are set during the colder months when the dew point is low or negative, so any improvement now will require winter clothing! The other one is using CW. I must admit I was rusty to start with but improved as the days went by as most 10 GHz RS contacts are on



CW. Also the only way to get any greater distances on 122 GHz will be using Triplers on CW! Note to self... More CW practice!

## Vale Gordon McDonald VK3EJ/VK2ZAB

This column records the passing of Gordon McDonald VK3EJ/VK2ZAB (formerly VK5ZAB). Gordon passed away on 30 July 2017, aged 88 after a short illness. As many will know, Gordon was a staunch VHF operator for nearly 60 years in VK2, VK3, VK5 and VK6. His engagement in the hobby and encouragement for others to become active and improve was second to none. His ability to express an opinion in a manner that promoted "self-propelled discussion" was perhaps his trademark. One of a kind, the VHF and above community will be poorer for his absence. Vale Gordon.

### In closing

Feel free to drop me a line if you have something to report. Contributions regarding club projects or proposed activities are always welcome. Just email me at [david@vk5kk.com](mailto:david@vk5kk.com) and I'll include in the column.

73

David VK5KK.

## Meteor Scatter Report

Dr Kevin Johnston VK4UH

For the first time in twelve months there is something positive to report about Meteor Shower activity. To date, over the last year, all of the major meteor showers predicted have been "underwhelming" and "disappointing" at best. Most observers within VK have advised that results have been indistinguishable from normal background levels even during the peaks of showers.

The UTC weekend of 28-29 July and over several days either side of that peak however, brought spectacular enhancement of meteor returns over North-South paths. The

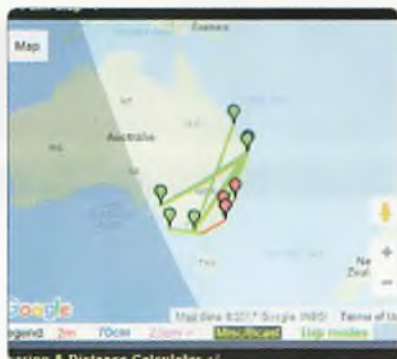

Photo 1: 2 m Meteor Scatter completions 28.7.17 during SDA Meteor Shower (VK-logger).

enhancement for meteor scatter activity resulted from the effects of the Southern Delta Aquarids (SDA) shower. SDA is an unusual shower in that it is a Southern Hemisphere event only and therefore attracts almost no mention from MS operators across Europe or USA. SDA is a major meteor shower but with a typical ZHR of only 16 meteors/hour, which places it well down the pecking order for annual showers. SDA is also unusual in that the parent body (originating comet) is unsure.

Meteor returns during the shower, on both 2 m and 6 m were loud, frequent and prolonged. Many "burns" were recorded on both

bands, extending from 1 to over 100 seconds, with many at over 15 dB above noise. Video clips have been posted on the VK-ZL Meteor Scatter Facebook page, showing live reception of such burns and are really worth a look if you missed the shower. I would recommend registration at this Facebook page, which is a private and secure ham-only group, even for those operators who might normally not participate in social media.

From this location in QG62 MSK144 MS contacts were completed on Saturday 28 July (UTC) with VK3ZL (QF22fe) and VK1MT (QF44nm) on 144 MHz and VK2ZIW (QF56hg), VK3ZL (QF22fe), and VK5PJ (PF59mk) on 50 MHz, across the dawn period. The following morning 29 July (UTC) completions were again made with VK1MT (QF44nm) and VK3ZL (QF22fe) on 144 MHz and later with VK2BLS (QF55kk), VK2EMA (QF37qs), VK5PJ (PF95mk) VK2ZMT (QF57ua), VK2FAD (QF56ss) and VK3ZL (QF22fe) on 6 m.

Pings were also audible from many of the 2 m and 6 m beacons from Far North Queensland, through VK1, 2, 3, 5 and 7.

For most operators, the only

Photo 2: Virgo Meteor Radar 28.7.17.

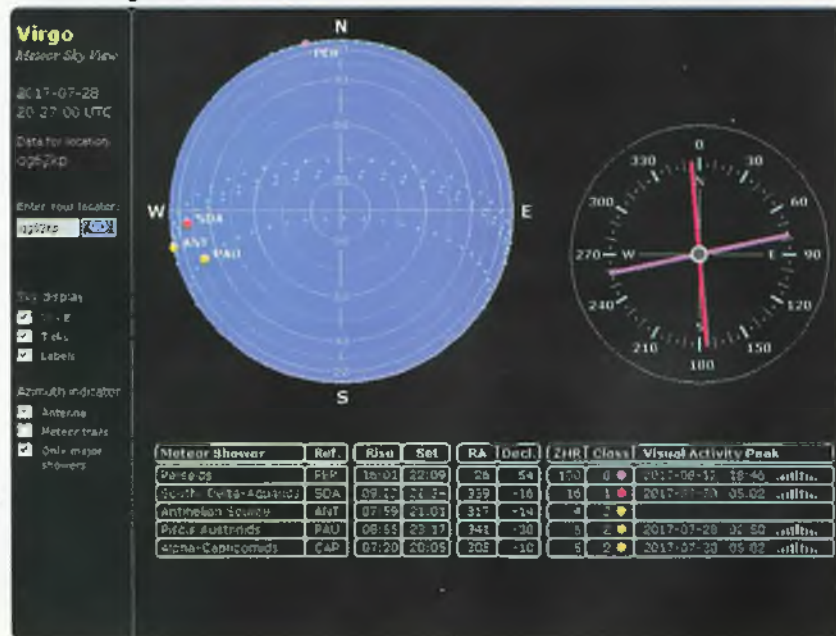

limitation was the low numbers of stations on-air during the enhanced propagation – particularly a drought from the southern states. Currently there are no stations in VK7 regularly joining the activity nets and only two in VK5 and VK3.

By contrast, we regularly have 10 or more stations operating from VK4.

During the same weekend activity period the Perseid Meteor Shower, which is not expected to peak until mid-August, was also evident on the Canadian Meteor radar system.

Regrettably, although this is a much more “productive” shower for MS stations in the Northern Hemisphere, with a predicted ZHR of 100 meteors/hour, it remains too far north to be of much benefit to most VK stations. Although the Perseid radiant appears well above the horizon for stations in Queensland, it is not generally visible for the southern states. Further, being so far north even for VK4s, the Perseid shower supports west-east paths and there are just no stations out there. We did look very carefully for any evidence of enhancement of the VK4-ZL path and for pings from the ZL or FK8 beacons but nothing was apparent.

At the time of writing it would seem that the “crowd-move” from FSK441 to the new FEC MSK144 mode has been complete in VK. I have not seen a single station operating FSK441 mode, during the weekend activity periods for several months now. Discussion

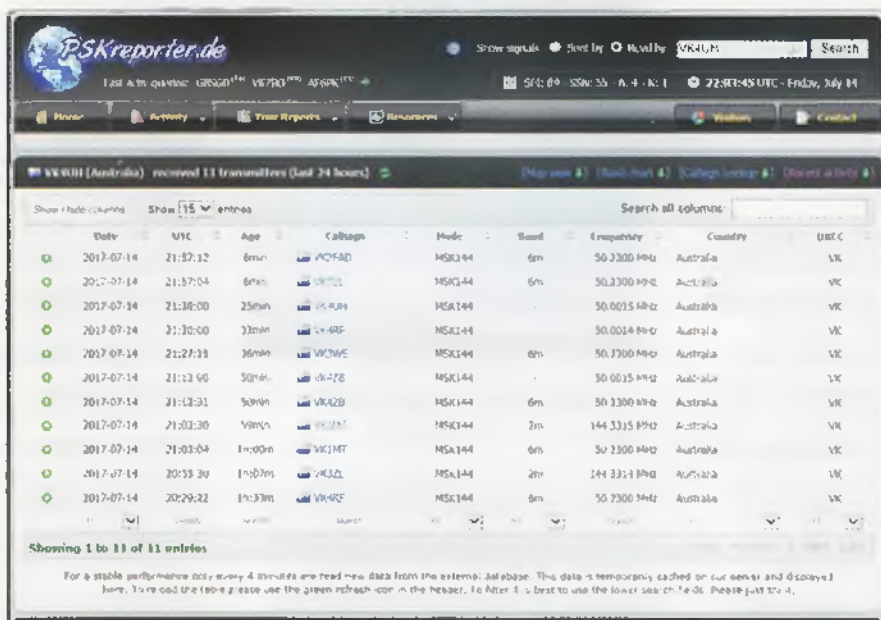

Photo 3: PSK reporter network page.

is still appearing on the Meteor Scatter VK-ZL FB page, with some operators lamenting the loss of the ability to be conducting QSOs with several stations concurrently. Clearly however most operators have concluded that this drawback is overshadowed by the improvement in reliable decoding particularly for short pings. A trial protocol was proposed to allow QSOs to be run with two stations concurrently in MSK144 mode. This was posted on the FB page for comment but to date no one has thought it worth trying. It is highly probable that MSK144 mode will not be the end of the evolutionary line for digital meteor communications, but for the present it would appear to be the standard.

Finally this month, I would like to draw attention to the value of the PSK-reporter network.

As its name suggests, this is an internet based reporting system initially established to allow automatic reporting of PSK digital activity on HF bands. All but the earliest versions of WSJT had the facility of automatic posting of all decoded digital signals to this service. To clarify however, it is not

just for PSK mode and it is not just for HF. The current system records all current digital modes including FSK441, MSK144, JT65, JT9 and even the new HF mode FT8 and this therefore includes MS activity. The auto-report facility is present in all current versions of WSJT WSJT-x and MSHV;

you just have to tick the appropriate box in the configuration pull down menus in each platform. If this is done and your computer has an internet connection then all stations you work or even just hear will be posted. This works in Rx mode only and many stations around the world leave their stations run 24/7 on receive as propagation observers. If you now connect to the PSK-reporter site it is possible to see live maps of current propagation paths around the world. You can select to see all the stations that had decoded your signals or to see all the stations that you have received. For example, after just 10 minutes of calling on JT65 on 20 m, during which time I had worked 2 stations only, it was clear from PSK-reporter that I was actually heard by over 75 stations across 5 continents. I currently leave my system Rx-only on 144.230 MHz on MSK144 mode for long periods. Try transmitting and see if you are getting through.

Contributions for this column are as always welcome. Please e-mail to [vk4uh@wia.or.au](mailto:vk4uh@wia.or.au)

Kevin Johnston VK4UH  
Brisbane





## DXTalk

Luke Steele VK3HJ

Solar and geomagnetic conditions remained mostly very quiet, but on 9 July, a Jupiter-sized sunspot group AR2665 produced an M-Class flare resulting in a shortwave blackout over East Asia and Australia.

A new digital mode designated "FT8" is a new mode offered in a beta release of WSJT-X allowing contacts to be completed in a quarter of the time that JT65 and JT9 needs. This mode uses 8 tones spaced by 6.25 Hz, occupying a bandwidth of 50 Hz. Transmit-receive cycles are 15 seconds, and an entire FT8 exchange can be completed in about a minute. FT8 has proven popular on HF and 6 m, offering sensitivity down to -20 dB. Correspondents all refer to the popularity of this new digital mode.

Your author was away for most of July, so here is some news from VK3JLS and VK5GR:

John VK3JLS reports: "Conditions have been woeful, although 5-9 signals have been heard from OTHR! Like Cliff VK9VKL (Christmas Island), I've been working low power FT8, but the only DX I've managed to get in the log over the past two weeks have been T2, XE, FT3, 5W1, LZ, NP3, FK1 and let's not forget VK9VKL. Hardly worth writing about (apologies to Cliff), other than that FT8 is really growing in popularity. Just looking right now, there is more FT8 activity across all bands than JT65 and JT9 combined."

And here is Grant VK5GR's report for July: "It has been a rather lacklustre month propagation-wise, which is having more than its fair share of impact on activity, however it isn't completely dead. The bands are

*still open, just not for as long or as regular. The lack of activity is being compounded by the inconsistency of the propagation. Openings are missed because there is no one on the other end to work! We should all be encouraged to get out to the shack and call CQ at least once a day - just to show everyone else that it does still work. A useful tool in this, incidentally, is the reverse beacon network ([www.reversebeacon.net](http://www.reversebeacon.net)) which can give you an indication of where it is open to, when you start calling. It can also be helpful in attracting the attention of those on the other end of the circuit!*

The month started out with contacts to TX5EG portable on OC-067 Huahine Island in the South Pacific using 40 m CW (this is their second stop on their three month Pacific IOTA odyssey - next look out for them on Marquesas Island OC-027 from July 29th).

Early in the month, 20 m Long Path South America also provided some spectacular propagation, yielding an ATNO for me with a contact to Bolivia (CP6CL) using JT65, beaming north from VK5 on 20 m in the morning. (I checked the short path and couldn't hear them so it wasn't coming in off the back of the beam either. Chile (CE4SFG) was also reached via the same path the following day and a few days later Argentina (LU4AA/F) was worked the same way during the IARU contest on CW.

Next up was the V6J DXpedition to Mokil Island in Micronesia (OC-226) worked on both CW and JT65. That same day saw RTTY contacts to the Island of Man (GD4SKA is back in town) on 20 m and a contact

with Balearic Islands (EA6AJ) on 20m PSK31 (during the late evening via Europe Short Path). More IOTA action was available too with the activation of Vanuatu (OC-035 group) by Geoff ZL3GA who ran as YJ0GA (OQRS now available for Geoff's activation).

The other bright spark I saw was the fun I had playing Headquarter Station bingo during the IARU Contest weekend. I saw more HQ stations running and calling CQ on the bands than anyone else at times. As I have finally started chasing my DXCC on SSB as well as Digimodes and CW it was a chance to catch up on a lot of new (to me) entities. In particular, 15 m opened to Europe from Adelaide on the Sunday afternoon allowing me to work SN0HQ, HA0HQ, 8N4HQ, LY0HQ, UN1HQ, OE0HQ, OL7HQ, YE0HQ, YR0HQ and DA0HQ. The moral of that story is - the solar minimum might be here but don't give up on the higher bands!

The other notable ones have been the IOTAs activated by the Russians - R24RRC on AS-114 Baydukov Island (worked 20/30 m), RI0C Iony Island AS-069 (worked 40 m) and RI10N EU-066 Ovsyannikov Island up near the Arctic circle. Of course there was also Andy VK5MAV's effort as VK9MAV OC-267 Marion Reef and VK9MAV/4 OC-140 from the Whitsundays at the end of June - his story is a fantastic read and his never give up attitude is what makes a truly dedicated IOTA expeditioner! (See <https://dx-world.net/the-vk9mav-story/>). We also had another expedition to Palau with T88GA operating from Koror Island OC-009 in the latter part of this month.

Finally, the talk of the month was the introduction of the new FT8 mode in the first general beta release of WSJT v1.8.0. This mode has really driven activity since it burst onto the scene in the last few weeks and has provided some noteworthy contacts too! FT3YL from the French Antarctic Base at Dumont D'Urville was worked using FT8 on 20 m and the activity from Europe and North America on 40/30/20 m has been fantastic to see. If you need Uzbekistan keep an eye out on 40 m JT65 also as several UK8 stations (UK8AEA and UK8LCK) have been seen and worked there in recent times.

Coming up, there are several expeditions planned by VK amateurs in our hemisphere to look out for too! First up will be yours truly operating as E6AG from Niue (IOTA OC-040) on 40-6 m from Sept 14 - 25 (see e6ag.net for details), then there is the VK DX Group's expeditions to Christmas Island (VK9XI) Oct 2 - 10 and Cocos Island (VK9CI) Oct 10 - 17 planned to coincide with the Oceania DX contests (more information from christmascocos2017.vkdxg.com). From the 12 - 16 of November we will also have Craig VK5CE operating from North Island (IOTA OC-198), part of the Sir Edward Pellew island group in the Gulf of Carpentaria as VK5CE/8. This is a very rare IOTA and one not to be missed. So look and for these intrepid VK's getting out there over the next few months!

Many thanks for John and Grant for their contributions.

Cliff VK9VKL on **Christmas Island**, a very new operator, whose first contact was with XX9D Macao on 25 February, has recently qualified DXCC!

Doc VK5BUG reports random daytime success on 30 m, working

the following prefixes in the June/July period: UA3, S58, SM0, OM5, ON4, LY5, IK4, G4, EA3, DK4, F6, FK8, GM3, OH2, OK1, SP3, UT3, VE1, ZL2 and TX5. All this with a modest station of FT-990 to a homebrew 23 foot (7 m) ground plane on the metal shed roof and a homebrew Cootie key.

### Upcoming DX

DXpedition activity scheduled for August includes the following.

**E6AG Niue** (OC-040), 14 - 25 September. Grant VK5GR will be holidaying with his family, with some radio time. Planned operation is on 40 - 6 m, maybe 80 m, mainly digital with some SSB, 500 watts. QSL via LotW, or via M0OXO OQRS, Club Log, eQSL or VK5GR via bureau. For more information see website. <http://e6ag.net/>

**HD8M Galapagos**, 14 - 21 September. WB2REM, VK2BXE, KG0YL, N1MWJ and G8OFJ will be operating from Isabela Island (SA-004) on 160 - 6 m. QSL via WB2REM

**A25 Botswana**, 15 - 25 September. RM0F as A25BI, R2AD as A25SP, and RC5A as A25BE will be operating from Kasane on 160 - 6 m on CW and SSB. QSL via home call direct or bureau, A25BI and A25BE via LotW.

**5T5OK Mauritania**, 16 - 28 September. With OK1BOA, OK1CRM, OK6DJ, OK1FCJ, OK1GK, OK2ZA, OK2ZI, 5T0JL and 5T2AI on 160 - 6 m, SSB, CW and RTTY. They will be using 100 watts only, with beams and vertical antennas. QSL via LotW, or via OK6DJ. For more information see website. <http://www.cdxp.cz/>

**FP St Pierre & Miquelon** (NA-032), 17 - 23 September. With M0WUT, M0BLF, DK2AB, G3ZAY, DH5FS and

G7VJR operating as FP/home call on all bands, all modes. QSL via home calls.

### Other news

#### RI1FJ Franz Josef Land

Evgenij UA4RX will be operating as RI1FJ from the Ernst Krenkel Observatory on Heiss Island, (EU-019) for the next year. QSL direct to UA2FM or LotW.

#### Baker Island

The Dateline DX Association, who most recently conducted the K4M Midway DXpedition in 2009, has announced that it has been selected by the Pacific Islands Refuges & Monuments Office of the US Fish and Wildlife Service to conduct a DXpedition to Baker Island National Wildlife Refuge (KH1). A vessel needs to be selected and approved before dates of activation and other information can be announced. Baker and Howlands Islands (KH1) last saw a major activation in 2002, and is currently #4 on the Most Wanted List.

#### Bouvet Island

The 3Y0Z Team is extremely grateful to the Northern California DX Foundation for their \$100,000 contribution for their upcoming DXpedition. This is the largest ever grant from the NCDXF, and reflects the high quality of the team, the high cost of activating such a remote location and the importance of this activation to the DXing community around the world.

Please email me with any DX related news for inclusion in this column. I am particularly interested in hearing about DX worked or heard in other states.

[vk3hj@wia.org.au](mailto:vk3hj@wia.org.au)  
73 and good DX,  
Luke VK3HJ.

Wanted

Articles and high quality photographs  
for *Amateur Radio* and *Callbook*.

See <http://www.wia.org.au/members/armag/contributing/>





# WIA Awards

Bob Robinson VK3SX

Below are listed all New awards issued in July 2017, plus all updates to DXCC awards.  
Go to <http://www.wia.org.au/members/wiadxawards/about/> to use the online award system.

## New awards

### 2017 AGM

#	Call	Name	Category
26	VK5GR	Grant Willis	General Award
27	VK4AAC	Robert Janoska	Gold Award
28	VK4AAC	Robert Janoska	General Award

### Antarctic

#	Call	Name	Mode
97	VK3OHM	Marc Hillman	Open

### DXCC Multi-band (1)

#	Call	Name	Mode	Band	Count
170	HA8TI	Janos Kakuk	Open	20m	242
171	HA8TI	Janos Kakuk	Phone	20m	127
172	HA8TI	Janos Kakuk	CW	20m	216
173	HA8TI	Janos Kakuk	Digital	20m	102
174	VK5GR	Grant Willis	Digital	20m	109
175	VK3JLS	John Seamons	Digital	20m	103

### DXCC Multi-band (3)

#	Call	Name	Mode	Band	Count
105	HA8TI	Janos Kakuk	Open	40-20-15m	630
106	HA8TI	Janos Kakuk	CW	40-20-15m	566

### DXCC Multi-band (5)

#	Call	Name	Mode	Band	Count
74	HA8TI	Janos Kakuk	Open	40-30-20-17-15m	903
75	HA8TI	Janos Kakuk	CW	40-30-20-15-10m	803

### DXCC Multi-band (7)

#	Call	Name	Mode	Band	Count
37	HA8TI	Janos Kakuk	Open	40-30-20-17-15-12-10m	1141

### DXCC Multi-mode (CW)

#	Call	Name	Count
251	HA8TI	Janos Kakuk	290

### DXCC Multi-mode (Digital)

#	Call	Name	Count
68	HA8TI	Janos Kakuk	143

### DXCC Multi-mode (Open)

#	Call	Name	Count
453	HA8TI	Janos Kakuk	298

### DXCC Multi-mode (Phone)

#	Call	Name	Count
618	HA8TI	Janos Kakuk	201

### Grid Square

#	Call	Name	Mode	Band
296	HA8TI	Janos Kakuk	Open	HF
297	HA8TI	Janos Kakuk	Phone	HF
298	HA8TI	Janos Kakuk	CW	HF
299	HA8TI	Janos Kakuk	Digital	HF

### Worked All VK Call Areas HF

#	Call	Name	Mode
2373	HA8TI	Janos Kakuk	Open
2374	VK6BMW	Richard Grocott	Open

## DXCC updates

### DXCC Multi-band (1)

#	Call	Name	Mode	Band	Count
54	VK3EW	David McAulay	Digital	20m	186
89	VK3OHM	Marc Hillman	Digital	20m	125
130	VK5DG	David Giles	Digital	30m	101
162	VK3AWG	Christopher Bellmont	Digital	20m	120
1	VK3OHM	Marc Hillman	Open	20m	201
20	VK3SX	Bob Robinson	Open	20m	321
76	VK3JLS	John Seamons	Open	20m	205
108	VK3AWG	Christopher Bellmont	Open	20m	186
165	VK5GR	Grant Willis	Open	20m	114
21	VK3SX	Bob Robinson	Phone	20m	321
35	VK3MEG	Steven Barr	Phone	20m	204
107	VK3AWG	Christopher Bellmont	Phone	20m	133
169	VK3JLS	John Seamons	Phone	20m	193

### DXCC Multi-band (3)

#	Call	Name	Mode	Band	Count
66	VK3EW	David McAulay	Digital	30-20-15m	478
30	VK3SX	Bob Robinson	Open	20-15-10m	682
69	VK3MEG	Steven Barr	Open	20-15-10m	526
31	VK3SX	Bob Robinson	Phone	20-15-10m	675
68	VK3MEG	Steven Barr	Phone	20-15-10m	494

### DXCC Multi-band (5)

#	Call	Name	Mode	Band	Count
47	VK3SX	Bob Robinson	Open	40-20-17-15-10m	942
52	VK3SX	Bob Robinson	Phone	40-20-17-15-10m	922

### DXCC Multi-band (7)

#	Call	Name	Mode	Band	Count
14	VK7CW	Steven Salvia	CW	40-30-20-17-15-12-10m	1471
15	VK7CW	Steven Salvia	Open	40-30-20-17-15-12-10m	1563

### DXCC Multi-mode (CW)

#	Call	Name	Count
223	VK6WX	Wesley Beck	181
243	VK3WE	Rhett Donnan	115

### DXCC Multi-mode (Digital)

#	Call	Name	Count
25	VK3OHM	Marc Hillman	150
47	VK3AWG	Christopher Belmont	144
59	VK4BRT	Benjamin Beresford	118
66	VK3JLS	John Seamons	115

### DXCC Multi-mode (Open)

#	Call	Name	Count
394	VK3JLS	John Seamons	230
397	VK3AWG	Christopher Belmont	226
413	VK3WE	Rhett Donnan	150
421	VK4BRT	Benjamin Beresford	149

### DXCC Multi-mode (Phone)

#	Call	Name	Count
587	VK3JLS	John Seamons	220
602	VK3AWG	Christopher Belmont	172
614	VK4BRT	Benjamin Beresford	117



## VK2news

Tim Mills VK2ZTM  
 e vk2ztm@wia.org.au

Welcome to spring now that another winter is behind us – in most places. With the lead time of at least a month with these columns giving mention of future events is always difficult. Mention has been made previously that the Manly Warringah R S were to have their annual Flag Pole contest this month. Well - plans change and it has been replaced by a Post Code contest. Their web site will carry the details of the one day event on the 16th.

Last month in VK2 there have been several AGM's which included Oxley Region, Central Coast, Illawarra and WICEN. Activity wise there has been the annual Remembrance Day Contest and

the Lighthouse and Light Ship weekends.

This month it's a little less busy with WICEN providing communication support on 15 to 17 September for the annual SAREX for light aircraft VH-MDX which went missing in the Barrington Tops over three decades ago. WICEN has the Trek for Timor on 7 and 8 October with the Hawkesbury Canoe Classic towards the end of October.

ARNSW will have a regular Foundation course and assessment weekend on 16 and 17 September. Any inquiries or bookings by email to [education@arnsw.org.au](mailto:education@arnsw.org.au) The bi-monthly Trash & Treasure at the VK2WI Dural site on Sunday 24. Before each T&T, a listing on the ARNSW home page of major items on offer is made. The instructions include no phone calls

are accepted - so use only the email address [disposals@arnsw.org.au](mailto:disposals@arnsw.org.au) The Disposal personal have no access to the ARNSW phones and any inquiry to the office phone will add days of delay as calls have to be retrieved from the answering machine and relayed on.

The VK2WI Sunday News sessions are now streamed for those who have reception difficulties. Go to [arnsw.org.au/](http://arnsw.org.au/) audio for the 1000 or 1930 sessions. The logging indicated many are using the service. You can also go to the Manly Warringah web site SDR where 1845, 3595, 7146 and 14170 are available. Some call backs have recently being taken on the Mt. Bindo VK2RDX 6650 and the Newcastle VK2RNC 6975. Any reports can be email to [callbacks@arnsw.org.au](mailto:callbacks@arnsw.org.au)

73  
 Tim VK2ZTM.

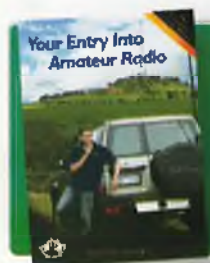

## New Foundation Manual is available now

Visit our Bookshop:

[http://www.wia.org.au/members/bookshop/page\\_data.php?id=113](http://www.wia.org.au/members/bookshop/page_data.php?id=113)





# VK7news

Justin Giles-Clark VK7TW

e vk7tw@wia.org.au

w <https://groups.yahoo.com/neo/groups/vk7regionalnews/info>

## North West Tas. Radio & TV Group (NWTR&TVG)

Congratulations to Tanya Michalek VK7FTBM who recently passed her Foundation licence assessment. We welcome Tanya to the airwaves.

## Northern Tasmanian Amateur Radio Club (NTARC)

NTARC reports they now have four Yaesu DR-1X repeaters and have taken advantage of generous 50% club rebate being offered by Yaesu. These repeaters are dual band and bi-mode with both analogue FM and Fusion C4FM and are progressively being installed. The NTARC June meeting was a BBQ ably cooked by Idris VK7ZIR, André VK7ZAB and Alvin VK7ADQ at the Rocherlea clubrooms which was enjoyed by all attending.

## ALARA VK7 News

Linda VK7QP let the author know that the ALARA (Australian Ladies Amateur Radio Association) Hobart members are regularly meeting for coffee and a chat each month and the invite is open to any women interested. ALARA's aim is to encourage women's interest and active participation in amateur radio. Any women wishing to join ALARA and/or come along to the coffee gathering can contact Linda. Email: vk7@alara.org.au

## Radio and Electronics Association of Southern Tasmania (REAST)

Congratulations and welcome to Dani VK7FREQ and Simon VK7FIRT on recently acquiring their Foundation call signs.



Photo 1: Scott Bragg VK7LXX, REAST Secretary, and Barry McCann, Tasmanian Maritime Radio, signing the long term lease. (Photo courtesy of Ben VK7BEN.)

The REAST July presentation was given by Ben VK7BEN on Lo-Ra (Long Range) and Low Power Wireless Networks. These networks are springing up to support the IoT or Internet of Things. Ben took the audience through the Lo-Ra platform and the radio chips and modulation techniques used. Ben then went into the practical application of IoT networks, which was mainly based around sensor devices but other applications are being developed all the time especially in agriculture. Scott VK7LXX and Murray VK7ZMS were then able to provide a uniquely Tasmanian example of Lo-Ra and the Sig-Fox devices



Photo 2: Martin VK7MA with soldering iron hot during the transverter conversion. (Photo courtesy of Ben VK7BEN.)

that members could get hands on with. Thanks to Ben, Scott and Murray.

The 23 cm QSO Party happens every Sunday morning in Southern Tasmania after the broadcast. There is an average of five or six stations and the Dolerite Organ Pipes on Mt Wellington provide a great passive reflector at 23 cm! We have also had a rover/net controller in Murray VK7ZMS who has been setting up at Mt Rumney and Lauderdale to try different operating locations.

REAST and Tasmanian Maritime radio has signed a long term lease for the historic and heritage-listed Marine Wireless Station for ten years with an additional ten year option. The signing of the lease ensures that members will be able to enjoy the clubrooms that have been the home of the WIA Tasmanian Division and then REAST for over 25 years. A huge thank you to Barry



Photo 3: Heads down and soldering irons at forty paces during the 3.4 GHz Transverter Conversions! (Photo courtesy of Ben VK7BEN.)

McCann, who has been instrumental in negotiating and securing the lease with the Hobart City Council, and ensuring that the interests of REAST members were maintained.

The Wednesday night Experimenter's Night has been in full swing with RaspberryPi Home Theatre systems, GippsTech 10 GHz Microwave Adventures and GPS locking microwave stations. Leading

up to the Remembrance Day contest, the experimenter's group has been undertaking the conversion of four 3.4 GHz panel transverters compliments of Joe Gelston VK7JG. A huge thank you to Joe, who donated four panels to REAST for conversion.

We had an enthusiastic team forming the conversion production line. All four panels checked out and the shields were removed along with the filter and hard-line. The control PCBs were populated and ready for installation along with the MiniKits RF changeover relays. The Surface Mount Device work was a challenge for "not-so-young" eyes but with assistance from additional lights and magnifiers, the SMD devices were soldered in place. After two nights and a Saturday session we had four panels up and going and ready for the RD Contest.



## SUNFEST

Doors Open at 09:00 hrs Saturday 9 September 2017

(Sellers from 07:00 hrs) at

**Woombye School of Arts**  
Blackall Street, Woombye (UBD Map 66 F12)

The Sunshine Coast Amateur Radio Club's annual HAMFEST is an event for Amateur Radio Operators, CB Radio users, Radio and Electronics enthusiasts, Computer bits and pieces.

New gear as well as pre-loved bits of everything on sale.

Egg & Bacon Roll, Pies, Tea & Coffee etc available.

Reservations for table space Contact:

Warwick Marshallsea VK4NW: mobile 0403 071 797 Email: [sunfest@vk4wis.org](mailto:sunfest@vk4wis.org)

Tables \$20 each (includes 2 persons) **Entry fee \$5** (includes free raffle tickets)



## Northern Corridor Radio Group (NCRG)

The main focus for NCRG this month has been preparation for the Hamfest Weekend (29 September to 1 October). The weekend will commence with a networking and open evening at NCRG on the Friday evening, followed by a Tech Day, again at the NCRG club rooms where we will be running two parallel sets of presentations covering a variety of subjects including SDR technology and operations, DMR, Radio Mobile Coverage analysis software and Trent Sampson is also make the trip over to present "Contest University". In addition, Gerald Youngblood – founder and President of FlexRadio, will present at the tech day via a 2-way video conference. This presentation will be one of the highlights of the tech day and will give attendees a unique insight into the most successful SDR enterprise in the Amateur sector. This will be followed by a Gala dinner jointly hosted by NCRG and NewsWest and will be aimed at being a VK6 event rather than just NCRG. There will be awards given and individual clubs are also invited to use the event to publicly acknowledge special contributions from its own members. On the Sunday, we will run our swap meet in a similar format to previous years but with some additional activities including a competition for the best mobile radio installation. There will be a raffle held with first prize being a Flex 6400, as well as many other prizes donated by vendors such as Future Systems, FlexRadio, TET Emtron and DX Engineering to name a few. The only way to buy tickets for the raffle will be to be at the Hamfest Swap Meet on the Sunday.

In other news, we are nearing completion of the new extension,

the 4-square 80 m array continues to be built and we hope to have it completed in time for the CQWW contest. Our 10 m Yagi was redesigned and rebuilt as a 5-element wide-spaced Yagi. Our 40 m Yagi is currently in need of repair but prior to making this repair, we are building a Gin Pole to allow the antenna to be lowered without use of a crane. Our 40 m tower is a square structure with a 1.2m face and a working platform at the top. Hopefully this month, the 15 m Yagi will be dropped and strengthened. We are also beginning to think about ways of improving the 160 m vertical through either the addition of more radials or elevating the ground radials.

Quite a few of our members are at Friedrichshafen for the famous Ham Radio show and, from all accounts, had a ball over the weekend. In addition, all our travellers extended the trip to catch up with family and friends in Italy, the Netherlands and the UK including catching up with our UK based club members.

More on this in next month's edition.

## Hills Amateur Radio Group (HARG)

HARG held its AGM on 29 July. More on who were elected next month.

The G5RV at the club was off air (along with the Morse tutor that uses the G5RV). Thanks to the efforts of Martin, Christie and Ian, the G5RV is back in the air and the Morse tutor will again be chipping away as normal. Reports are always appreciated. Listen for it on 3.685 MHz between 06:30 and 08:30 and again between 18:30 and 20:30 local each day.

This year's International Lighthouse and Lightship Weekend

is on August 19 and 20. HARG will be setup on the North Mole again this year so please call past and say g'day.

HARG has two officially set meeting days each month on the second and last Saturdays. We have access to the shack on most other Saturdays in the month as well. The last Saturday of the month contains the general meeting with all other occasions left open for social & practical activities. Even the Saturday with the general meeting is a social event. Doors officially open at 1:00 pm but you'll usually find someone there a little earlier. We usually kick off with a sausage sizzle. Visitors are always welcome. Get some more information at our website [www.harg.org.au](http://www.harg.org.au)

## Bunbury Radio Club

Due to poor attendance, our Annual General Meeting to be held in July was deferred to the August date. At the time of writing this article, the AGM had not yet been held, so we will have to leave you holding your breath in anticipation.

Our next regular meeting will be held on Saturday, 9 September 2017 from 2:00 pm. at 21 Halsey Street, Bunbury. Following the business meeting, Nick VK6FSEA will give a talk on Foundation licence matters.

Amateur licence assessments and upgrades are still scheduled for Sunday 17 September. The assessments will be held at the Busselton Masonic hall in West Street. On the preceding day (Saturday 16) we will be conducting a crash revision activity for those thinking of upgrading to the Standard licence. Anyone interested in sitting for a licence, or upgrading, please contact Norm VK6GOM on 0438 878 582.



Photo 1: PARG - Test setup of mast.

### The Peel Amateur Radio Group

PARG have had a very busy 2017 so far. The remainder of the year will keep us going flat out with projects, assessments and general club business. This year is our 35th anniversary and to celebrate, we will be holding our first Members only Club Contest. The date chosen is Saturday August 5 2017 and is the weekend before the RD contest. Our Birthday Bash will provide an opportunity for members to get their station equipment optimised for working the RD.

We are currently moving our Repeater to the new SES headquarters and looking at updating our Mobile Comms trailer. On Sunday 23 July, we spent several hours trialling the assembly of our new repeater mast. This was no light task; putting it all together on the roof untested as far as assembly goes could be foolhardy, so we put it all together on the ground and stood it up. Just as well we did. There were one or two small imperfections in the manufacturing process that left a prominent bump of weld inside one of the tubes. Had we not found that and corrected it we would have been up the proverbial creek at assembly time on the roof. Unfortunately,

the weather was against us when it came to finalise the antenna installation. Wet slippery roof and high wind conditions did not allow us to work safely; at the very least we are now fully prepared for the final installation. Weather permitting, we should be finished with the repeater relocation by mid-August. We will then be looking for some signal reports from far fields.

In September, we will be preparing for the NCRG Annual Hamfest in October. We will be attending as usual with a few items from a deceased estate as well as other collectables. Once the Hamfest is over, preparations will start for JOTA/JOTI on 21 October. PARG will again be assisting the Rockingham Scout Group. This year we will have four Foundation Licensee Scouts who will run the event with us assisting. Hopefully this will attract a few younger Scouts to the Amateur Radio world.

By this time the upgrade to our comms trailer should be well under way. Our trailer will be modified to be more operator friendly with new layout and mast for ease of setup. On September 2, we are holding a Sausage Sizzle at Bunnings Mandurah; this will help with much needed funds for our trailer.

PARG assessors have qualified

16 new amateurs in the 2016/2017 year. Most of the candidates are now club members. We are hoping to have several more assessors in the future. With the membership increasing slowly we are becoming more involved with contests and field activities.

On 4 February 2018, PARG will be holding what has now become an Annual Swap Meet. The date is to be released officially in AR fairly soon.

### Radio Amateurs Old Timers Club of Australia

Hello everyone, this is Clive VK6CSW with a few words about the RAOTC, the Radio Amateurs Old Timers Club of Australia. The Club was formed in the 1980s by a group of VK3 amateurs, modelled on the very active Radio Amateurs Old Timers Association in the United Kingdom with whom we still maintain close contact and is open to all suitably qualified persons throughout Australia. At present the club has over 500 members throughout the country.

The objectives of the RAOTC are to maintain the interest and original pioneer spirit of amateur radio, honour the history and heritage of our hobby and encourage good fellowship amongst all radio amateurs.

But what is a radio old timer? It has nothing to do with age but is defined solely by the length of time you have held, or been qualified to hold, an amateur radio licence. To be a full member of the RAOTC you must have held these qualifications for at least 25 years, but you can become an Associate member after 10 years. This now opens the door to Foundation licensees who obtained their licence when the scheme first started in October 2006. The only difference between Full and Associate membership is





Photo 2: New WARG meeting venue.

that only Full members have voting rights and can hold office within the Club.

As most amateurs will know, on the first Monday of each month except January, the club broadcasts a bulletin giving the latest club news plus other items of interest, which may range from tales of very early wireless discoveries and personal reminiscences to the latest advances in science. Details are promulgated via the National and local WIA broadcasts on the Sunday prior to the Monday transmission.

Each March and September, every member receives by post a high quality, 60 page, A4 size magazine entitled OTN or Old Timer News, containing a huge range of articles covering a wide variety of topics, all contributed by club members. A CD containing all back issues is also available.

Here in Perth, informal lunchtime meetings are held on the second Tuesday of each month, except for January, at the Bayswater Hotel in Bayswater where members can enjoy an inexpensive smorgasbord as well as chewing the fat.

In September, the Club holds an Australia wide on-air party where RAOTC members try to make as

many contacts as possible with other club members.

Are you interested in becoming an RAOTC member? Fees are very modest and, as will all things, the club is what you make it but at least 500 amateurs throughout Australia find it worthwhile to belong. To find out more, visit the club website at [www.raotc.org.au](http://www.raotc.org.au) where you will find all the information you need together with a downloadable application form. Take a few minutes to have a look.

73 from Clive VK6CSW

### West Australian Repeater Group

The VK6RRR repeater has now been moved. It has a new callsign and frequency. It is now VK6RLM with an input frequency of 431.525 MHz and an output of 438.525 MHz. The signal strength for the internet connection isn't

the best. We will make another visit soon to replace the omni antenna with a Yagi facing the mobile cell. The coverage is already greatly improved.

WARG has always hosted the VK HF beacon forming a part of the NCDXF beacon network and this month received a new beacon from NCDXF and is now on air. The new system includes a later model transceiver, new controller and GPS antenna and a new power supply.

WARG meets on the first Monday evening of each month at 1st Pelican Point Sea Scouts Group, 12 Australia Il Drive, Crawley WA 6009. New members are always welcome. Doors open at 19:00, meetings commence 19:30. Come along and enjoy a cuppa with us!

### F-Troop Weekly net

Since June 2011 we've been running a weekly net for New and Returning Amateurs who want to get on air and become part of the community. Held for an hour every Saturday morning, from 0:00 UTC, the net - called "F-troop" - is linked up via Allstar Link, EchoLink and IRLP, and has participation from amateurs across Australia and with regular visits from around the globe.

If you'd like to join in, say hello and ask questions about Amateur Radio, you're welcome any time.

The website is at <http://ftroop.vk6.net/> where you'll find details on how to join and how it works.



Photo 3: WARG NCDXF Beacon.

Jim Linton VK3PC

e [arv@amateurradio.com.au](mailto:arv@amateurradio.com.au)

w [www.amateurradio.com.au](http://www.amateurradio.com.au)

## Mt Macedon UHF repeater gets DMR

On a rather cold and windy winter's day, the VK3RMM UHF facility serving a large area of central Victoria was upgraded with a donated new Multi-Mode FM/DMR repeater.

The new repeater comes from Peter Brennan VK3TE, who assisted Amateur Radio Victoria volunteers install and commission it. Thank you for the generous donation.

Users of the FM analogue mode provided by VK3RMM can program the CTCSS 91.5 Hz tone in and out and not to hear the digital signal when the repeater is running in digital mode. The operating frequency remains 439.825 MHz.

In DMR mode, timeslot 1 is for local traffic and timeslot 2 for talk-group connections. These changes only effect the operation of the 70 cm analogue repeater.

There are no changes to the DSTAR repeater on 70 cm or the VK3RMM 2 metre repeater 147.250 MHz.

## Education licence classes

This month will see both a Foundation licence course with assessments and a Standard licence Bridging Course.

These will be at the centrally located Amateur Radio Victoria offices: 40g Victory Boulevard, Ashburton.

The entry level Foundation licence is the most popular way of getting into Amateur Radio and the next session is on 9-10 September 2017.

All attending are to read the study and operational practice guide book 'Your Entry Into Amateur Radio' available for \$35 from our shop <https://shop.amateurradio.com.au/>

The Standard licence Bridging Course is held on six Wednesday evenings, September 6, 13, 20, 27, October 4, 11 with Saturday 14 for revision and assessments on Sunday 15.

A prerequisite for those enrolling in this special course is to have a Foundation licence. An expert trainer covers the theory needed for the Standard licence with self-study between course sessions. To enrol, please act quickly by contacting Barry Robinson VK3PV Education manager or 0428 516 001.

## Challenges galore if you look

The wonderful hobby of Amateur Radio is full of challenges even for those who have been with it for many years.

Some move on from their normal practice of rag-chewing or phone operation and try out things such as wallpaper collecting, portable operation, entering a contest or trying a new mode.

For example, two VK3 DXers who have worked every country decided some time back to compete against themselves with DX on the so-called WARC bands.

One also went to the microwave bands and the other added the country challenge of the 80 metre DX window.

There are many facets to modern Amateur Radio including

making the transition from analogue to digital modes.

The new digital mode FT8 has taken off with many trying it out against the popular JT65 weak signal mode.

Beside this new one, there's a plethora of other digital text based modes; suggest PSK31 can be a good starting point for keyboard communication.

For those interested in sending images Digital SSTV looks interesting. Maybe computers and keyboards are little interest.

Perhaps digital voices is more attractive to you; then look up FreeDV the HF narrow-band digital voice mode and see what it offers.

There is also D-STAR, DMR and P25 to try through a number of repeaters. Communicating through orbiting satellites both phone and digital is another area of interest.

Read up on the possibilities and see them via YouTube videos. Learn more and perhaps give them a go yourself.

## KRMNPA gang getting ready

The Keith Roget Memorial National Park Award activity period November 10-13 is calling for intended activations. Hopefully all 45 Victorian National Parks will be on air this year. To read the rules or make a registration visit the Award section of our website.

More news about the event in this column next month.

## WIA Contest Website



To keep up to date with all of the major Australian contests, including rules and results, at the WIA Contest Website at: [www.wia.org.au/members/contests/about](http://www.wia.org.au/members/contests/about)





Christine Taylor VK5CTY

## Monthly Meeting

Barry VK5BW gave us a talk this month about transmission lines, the do's and don'ts and the pluses and minuses of various types available. He illustrated the talk with a very good selection of coaxial cables. These ranged from a cable about 1.5 mm in diameter to Heliax which was about 50 mm in diameter.

The purpose of a transmission line is to carry energy directly from one device to another as efficiently as possible with the least energy loss or mismatch. To achieve these criteria, the most important property of a coaxial cable is that the dielectric surrounding the central wire or tube has a consistent thickness and density all the way and the inner conductor is precisely located in the centre of the outer conductor (usually) braid. Any



Photo 1: Smaller size transmission lines.

variation in these parameters will lead to impedance variations and increased losses in the cable.

Therefore the most important DO is to use the best cable you can afford, DON'T penny pinch, buy the best available.

Mostly transmission lines carry energy from a transmitter to an aerial. The impedance of the cable can be calculated and depends

on the diameter of the inner wire, the type of the dielectric, and the quality and tightness of the outer braid. It is a logarithmic function so can vary widely because of a small change in one of the components of the equation.

Flat cables like the 300 ohm ribbon we had on all our early TVs, or a ladder line (commercial or home-made) are also effective transmission lines for a TX to an aerial and the use of a matching device will help to

match the impedances and reduce losses.

The higher the energy being transmitted, the thicker the cable needed. Another point that has to be taken into consideration is the sharpness any bends in the cable; the thicker the cable the larger the bends must be because sharp bends can make the central wire be misplaced from the centre of the cable. Barry showed us photos of the inside of some of the transmission rooms of such stations as Radio Australia!

Also demonstrated was a coaxial cable designed to leak RF, achieved by grinding holes in the ribs of the outer conductor on both sides and is known as Radiax or more commonly called 'leaky coax'. This is used in tunnels, mines, buildings and sub basements where getting RF energy into is very difficult, it will work both ways, allowing a repeater set up on one end of it transmit and receive signals from difficult places.

It was a very interesting and useful talk.

Photo 2: Two types of insulation found in larger sized coaxial cables.





Photo 3: Some samples of RG-59 and RG-213 coaxial cable.

### The mid-year Dinner

Apart from the good company and the good food, the biggest talking point of the afternoon was the décor of the room we were using at the Uraidla Hotel in the Adelaide Hills.

In the centre, upside-down was a Hills Hoist complete with peg bucket! The outer wires were used to suspend the lights etc. These lights were interesting of themselves as they didn't match each other but were all vintage fittings as were the fireplaces; all a very clever use of items otherwise thrown away.

Unfortunately there were half a dozen people who had not told Barry they would not be present. This is an unnecessary expense to the club but apart from this, they missed out on a great meal!

### The visit to the Fab Lab

22 members of AHARS visited the Fab Lab one Saturday morning and thoroughly enjoyed themselves. This facility has many unusual devices that

are available for the public to use at a small cost. One of these is a laser cutter (\$70,000 worth!) and Graham VK5ZFZ showed that it could be used to cut metals and plastics but that care must be exercised. It is extremely dangerous to look at any laser light and many materials give off toxic fumes when cut so the cutting is done inside a fume cupboard.

The manager of the Fab Lab demonstrated the use of a 3D printer by extruding plastic. Again, safety was emphasised as well as the use to which these devices can be put. There are a large number of

3D printers in the lab.

A third group had a resource talk by Trevor VK5NIX that showed some of the 200 printer projects available for amateurs. The AHARS members present were able to take the software away with them on the USB sticks available or on their laptops which they had been encouraged to bring with them. A number of other uses to which 3D printers have been put on TV and in films were shown to make it a fun morning.

The Fab Lab runs regular classes to learn about laser cutting and 3D printing and for those who have attended these classes, the Lab is open for a couple of sessions a week. The cost for classes and use of the facilities is quite nominal.

The whole visit was proclaimed to be brilliant!

### The Shack

Regular meetings at the shack are still continuing with examinations and special classes on some Saturdays. Such a class in September will be about the use of Arduino software.

This month the Shack security gets a boost, with the installation of a security fence around the entrance area. This should keep away the undesirables that want to create havoc, vandalise and trash everything in sight; this also allows us to mount our security cameras without having them damaged. All

photos will be going to the local police for them to deal with.

### AHARS and WICEN

David VK5LSB was talking at the mid-year dinner about some of the recent activities of WICEN in VK5 that I suspect many of us did not know about. Over the years, WICEN has acquired a great deal of equipment through

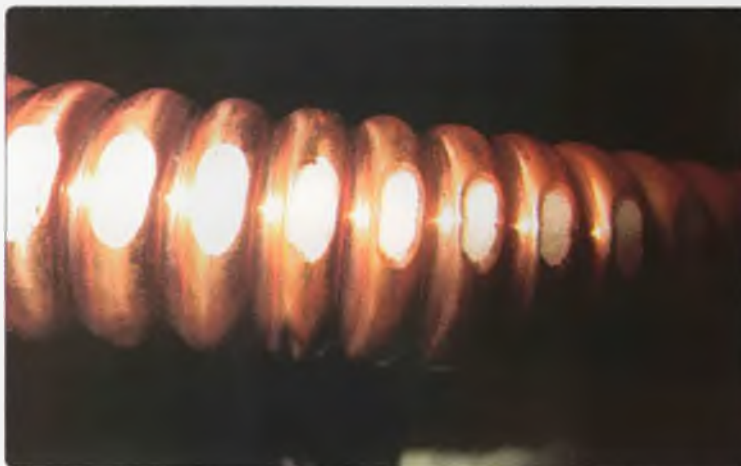

Photo 4: Radiax™ coaxial cable.





need as the number of events for which they have provided communications has increased.

The group now has a number of mobile repeaters, both on amateur and commercial frequencies that they can hire to activity groups. Very often the equipment is offered with operators to the delight of the hirers!

Recently they participated in a 24-hour Horse Endurance Trial, bike time and endurance trials and various fund-raising walks and runs. The most useful members are those who have battery backups for their mobile radios and even for their NBN systems!

Read more about it all in the latest Newsletter or on our website.

Photo 5: Hills Chandelier.



## VK4news Caboolture Radio Club

John Arnfield VK4JR

The Caboolture Radio Club is going from strength to strength.

On Saturday 17 June 2017 we had a visit from David Ford VK4MZ, the new Vice-President of the WIA. He addressed the gathered Club Members at our monthly General Meeting and fielded a number of questions during the meeting. He told us this was the first Club to be visited by a member of the Board from the WIA since the elections and he gave us a real insight into the way ahead that the new Board intends to operate.

He was asked about why the ACMA knocked back the increase in power levels for Advanced Licence holders when New Zealand had increased to 1 kW and also did not charge licence fees for Amateurs. He outlined the push to increase power levels, band segments and the introduction of digital modes for Foundation licence holders.

He was also asked why, when two letter call signs are at a premium and when they become available there has to be a ballot for the call sign, that a few VK4 Amateurs are holding three or four two letter call signs. He advised that he would look into the matter as "it was not in the spirit of Amateur

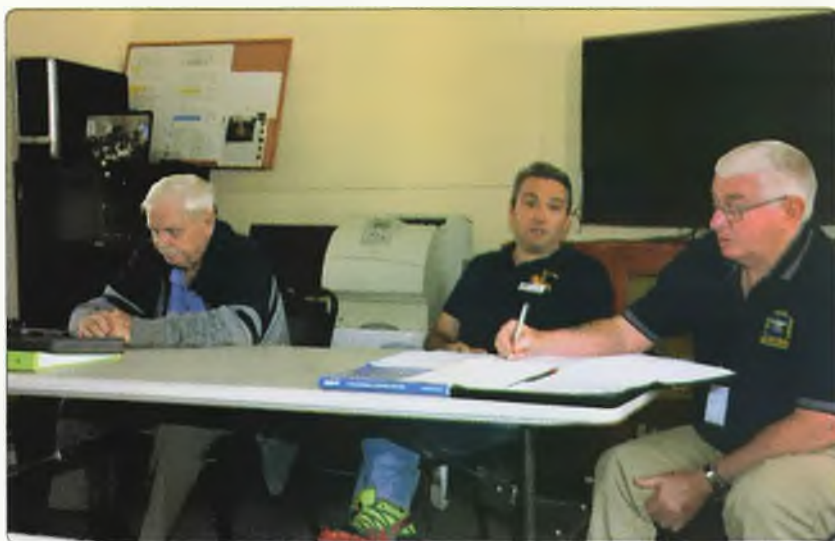

Photo: Brian VK4FBAD Club Treasurer, David VK4MZ (WIA Vice-President, WIA) and John VK4JR Club Secretary during David's visit.

Radio", in his opinion, for this to occur.

David is a great ambassador for the WIA and everyone in attendance appreciated the time David had taken to visit the Club and answer questions. We look forward to a great working relationship with David and the new Board.

One of our members, Roger VK4YB (or Yogi as he is known), has just set a world record on 630 metres. This will be confirmed

shortly.

We have put in an application to the Gaming Commission Grant Group for a grant to go completely "off line" by installing a solar system with battery back-up. If successful we can really reduce our reliance on the power distribution system.

73

John VK4JR  
Hon. Secretary  
Caboolture Radio Club Inc.





# ALARA

Diane Main VK4DI

Whilst doing some research recently, I found this amazing information written by Ashley Hennefer, published on this website <https://www.themarysue.com/female-ham-radio-operators/> It makes for interesting reading. I have reproduced some of the story.

## YL 33: The first female ham radio operators and their awesome legacy

Historically, literacy - in its many forms - has given the marginalized a way to speak and participate in a system that previously prevented them from doing so. And while the printing press revolutionized the way writing was exchanged and shared with the world, the invention of radio as entertainment, emergency and communication technology had a similar effect on oral storytelling. From this, ham radio, also known as amateur radio, was born as a subset of commercial radio. The appeal of communicating independently to others across the globe struck a chord with many people in the early 20th century - including women looking for ways to participate in war efforts and connect with other women around the world.

Although enthusiasm for ham radio as the medium of choice for hobbyists, veterans, and emergency responders hasn't waned much over the last fifty or so years, the hobby is making a strong resurgence as aspiring makers acknowledge radio's contribution to the movement. Many hams consider amateur radio to be the original maker skill, requiring knowledge of electricity, geography and communication.

And it's one of many mediums that gave women the chance to have a global voice - and they took it.

## Calm the ham

Female amateurs are called "YLS" which is short for "Young Lady" regardless of the operator's age. While that seems simultaneously antiquated, cute and patronizing, keep in mind that the amateur radio subset of men is referred to as "OMs" or "Old Man." The largest organization for YL ham operators in the world is the Young Ladies' Radio League, Inc. (YLRL), founded in 1939, which exists to encourage and assist YLs throughout the world to become licensed amateur radio operators.

Although amateur and commercial radio was heavily male-dominated, the response to the influx of women operators was—and still is—largely positive. In "The Feminine Wireless Amateur," a 1916 article in *The Electrical Experimenter*, the writer says:

*"JUST because a man, Signor Guglielmo Marconi by name, invented commercial wireless telegraphy does not mean for a moment that the fair sex cannot master its mysteries. [...]*

*Women seem to progress excellently in the engineering branches. Primarily, this is so because her brain is quick of action and moreover she usually will be found to have extremely well-balanced ideas as to proportions, so essential in designing. A wonderful imagination coupled to a number of other worthy faculties help to make a really fine combination, so that we find a steadily growing number of women architects, mechanical and electrical experts, radio operators, civil engineers, ad lib. What we need is more of them in the higher positions, where the square root and binomial theorem are everyday quantities."*

That's quite a positive - and

progressive - perspective on women in science and engineering - especially for 1919. A 1931 article in the *New York Times* also remarked on this trend, saying that:

*"The list of women obtaining licenses as amateur radio operators is increasing rapidly, the Department of Commerce said today, although there were only eight registered women commercial operators in the country. [...] There are eighty-six women amateurs, compared with about 18,000 men operators."*

This number has changed drastically since the 1930s. And while there are now thousands of women worldwide with call signs, several notable women during the early 20th century set the stage for the new generations of girls finding a voice on the airwaves.

## Clara Reger

It's impossible to talk about notable female hams without acknowledging the work of Clara Reger, who received her call sign in 1933 at age thirty-five. Reger had a long career as an operator and managed disaster communications after WWII. Known for her exceptional Morse code skills, Reger spent much of her life teaching others how to become operators. She also received the Edison Award for teaching a fourteen-year-old boy without arms to send Morse code with his feet.

But Reger is also known for her signature salutation, which she created especially for women communicating with other women - the salutation '33,' which meant love sealed with friendship. Reger knew that to hear another girl's voice on the other end was rare and special. What a gift, to find kinship with women, through the radio, across the ocean, across the globe!

YL 33 is considered sacred by female hams and there's



a poem dedicated to Reger's accomplishments and passion for radio communications. You can read it in full on the ALARA website, but here's a passage:

There's no real definition  
But its meaning is known well.  
It's how a YL says good evening  
To another friend YL.

Although these are just a few of the many women who used radio as their medium of choice, their stories as operators are fascinating and inspiring. These women are united in their mutual passion for exploration, technology and adventure and that still holds true today for many female ham operators.

### News from VK7

Congratulations to Tanya Michalek who was successful at passing her assessment for a Foundation licence recently in Burnie. Tanya who also lives in Burnie, has applied for the call VK7FTBM and plans to get on air as soon as the call is confirmed. So, when you hear Tanya on the air waves, please give her the traditional YL welcome to amateur radio.

Also, congratulations to Dani VK7FREQ on recently acquiring her Foundation license and newly issued callsign following her assessment a few weeks back! We're looking forward to hearing her on the air. Dani was part of the



*Photo 1: Dani: This shot is taken as I am making my first HF contact, during an ALARA event (VI4ALARA) while trying to get a photo for ALARA... I couldn't have planned it better if I tried!*

group who attended the REAST/ALARA lunch in June 2016. So now we have just about everyone who attended the lunch licensed and ready to operate. Perhaps it is time for another lunch to get some more ladies on the air? (*What a great result!*)

Linda VK7QP is now able to use the remote set up to access the bands. Martin VK7GN has been busy installing this over the past year. It has been a long and painful process, finding what network will work and setting up IP addresses. Over this period Linda was using a Kenwood TS-590 to operate at the shack. The radio and linear amplifier were taken up for each visit and needed to be connected up. Through this set up Linda was able to work a number of parks for the World Wide Flora and Fauna award. She is now the proud owner of two

certificates; an international certificate for contact with 44 parks and a VK Diamond Award for contact with 50 VKFF areas.

Congratulations Linda!

### Winners are Grinners

Dot VK2DB won one of the beautiful quilts at the CLARA (Canadian Ladies Amateur Radio Association) 50th Birthday Bash and had to re-arrange her luggage to get it home.

Dot says the Bash was extremely well planned even down to the weather.

She had so fun Meeting up with so many of the girls I've met at other meets or met on radio. Once it started on Tuesday it was all over so quickly. The day at the air museum and air traffic control was very interesting for all of us.

### ANZA Net

Lyn VK4SWE is net controller for the ANZA DX Net on 14.183 from 05.15 UTC on Mondays. Lyn has turned the Monday net into a real YL day. Shirley VK5YL, June VK4SJ and Diane VK4DI (operating as VI4ALARA) currently call in regularly to work some DX. Lyn would love to have more ALARA members call in to the net.

Diane VK4DI  
ALARA Publicity Officer



*Photo 2: Dot VK3DB and Suzanne VE7IM wrapped in their quilts that they won at the CLARA 50<sup>th</sup> Birthday Celebrations in Winnipeg.*



## Contributions to *Amateur Radio*

AR is a forum for WIA members' amateur radio experiments, experiences, opinions and news.

Your contribution and feedback is welcomed.

Guidelines for contributors can be found in the AR section of the WIA website, at <http://www.wia.org.au/members/armag/contributing/>

Email the Editor:  
[editor@wia.org.au](mailto:editor@wia.org.au)

### About Hamads

- Submit by email (**MUCH PREFERRED**) or if written and mailed please print carefully and clearly, use upper AND lower case.
- Deceased estates Hamads will be published in full, even if some items are not radio equipment.
- WIA policy recommends that the serial number of all equipment for sale should be included.
- OTHR means the address is correct in the current WIA Call Book.
- Ordinary Hamads from those who are deemed to be in general electronics retail and wholesale distributive trades should be certified as referring only to private articles not being re-sold for merchandising purposes.
- Commercial advertising on these pages Contact [admanager@wia.org.au](mailto:admanager@wia.org.au)
- Copy to be received by the deadlines on page 1 of each issue of Amateur Radio.
- Separate forms for For Sale and Wanted items. Include name, address STD telephone number and WIA membership number.

#### 'Hamads'

PO Box 2042  
BAYSWATER VIC 3153  
[hamads@wia.org.au](mailto:hamads@wia.org.au)

## AMIDON FERROMAGNETIC CORES



tts systems

Phone 03 5977 4808. Fax 03 5977 4801  
[info@ttssystems.com.au](mailto:info@ttssystems.com.au)



11- 13 Port Road, Queenstown, SA 5014

### Quality Products for the Radio Amateur

**JACKSON BROS** variable and trimmer capacitors, reduction drives and ceramic stand-offs

**HAMMOND** transformers, enclosures and chassis's

**DSE HIBOX** large plastic waterproof enclosures

**ANDELI GROUP** indicator lights, relays and switches.

Pay by credit card, EFT or PayPal

**CALL (08) 8304 2000**

[sales@cooksoncontrols.com.au](mailto:sales@cooksoncontrols.com.au)  
[www.cooksoncontrols.com.au](http://www.cooksoncontrols.com.au)

### Studying for the Standard or the Advanced Licence?



Here are 4 books that will get you there.

TAKE A LOOK AT [www.gscott.com.au](http://www.gscott.com.au)

for more information and order form.  
635 Edmonson Avenue  
Albury NSW 2640



## Have you held an amateur licence for 10 years or more?

If so, then you are invited to  
join the

### RAOTC

A \$5 joining fee, plus \$18 for one year or \$32 for two years, gets you two interesting 64 page **OTN Journals** each year, **PLUS** good fellowship, and a regular broadcast of news and events.

More information and a membership application are available from our web site at [www.raotc.org.au](http://www.raotc.org.au) or write to:-

PO Box 107, Mentone VIC 3194, or  
email:- [raotc@raotc.org.au](mailto:raotc@raotc.org.au) or  
call Secretary: Ian Godsil VK3JS  
on 0466 286 003.

#### TRADE PRACTICES ACT

It is unprovable for us to ensure that the advertisements submitted for publication comply with the Trade Practices Act 1974. Therefore, advertisers will appreciate the absolute need for themselves to ensure that the provisions of the Act are strictly complied with.

#### VICTORIAN CONSUMER AFFAIRS ACT

Advertisements with only a PO Box number address cannot be accepted without the addition of the business address of the box-holder or seller of the goods.

### ADVERTISERS INDEX

Cookson Controls	64
Future Systems	13, Inside Back Cover
Ham Radio House	15
Icom	Back Cover
Jaycar	7
TET-Emtron	9
Amidon	64
Yaesu	Inside Front Cover





FUTURE  
SYSTEMS

# Beautifully Simple

*Remote so easy it's practically magic*

 **FlexRadio Systems®**  
Software Defined Radios

Buy a FlexRadio and get started  
with SmartLink™ today



SmartSDR for iOS now available for iPad on the App Store

futuresystems.com.au | sales@futuresystems.com.au | +61 8 6336 9610



# IC-7610 RF Direct Sampling Evolution



## Coming Soon

### Introducing the IC-7610 SDR HF/50MHz All Mode Transceiver

Building on the success of the IC-7300, the IC-7610 features RMDR (Reciprocal Mixing Dynamic Range) of 110dB (at 2kHz), independent dual receivers, DIGI-SEL Preselectors on both Main and Sub Bands and a High Speed, High-Resolution Real-Time Spectrum Scope. All these features are easily controlled through the large 7 inch colour TFT LCD Touch Screen Interface.

To find out more about Icom's products email [sales@icom.net.au](mailto:sales@icom.net.au)

[WWW.ICOM.NET.AU](http://WWW.ICOM.NET.AU)