

Amateur Radio

Volume 86
Number 1
January/February 2018
Price: \$9.70 incl GST
www.wia.org.au



More portable operation

Mills on the air

Ferries Contest

- ▶ The ZS6BKW antenna
- ▶ Diplexer revisited

ISSN 0002-6859

01



70002685062

The radio... **YAESU**

Wide-Coverage Transceivers

HF through VHF/UHF in One Radio



↳ Specified performance: Amateur bands only

A Superb All-around Transceiver with a built-in real-time spectrum scope and superior basic operation

HF/50/144/430MHz 100W All Mode Transceiver

FT-991A

Operating Modes: CW/SSB/AM/FM/C4FM

- Covers all-modes SSB/CW/AM/FM and C4FM digital
- Built in Real-Time Spectrum Scope with Multi-Color Waterfall Display
- 100 Watts (2 Meter & 70 Centimeter: 50 Watts) of Solid Performance
- 1F DSP for Superb Interference Rejection
- 3.5-inch TFT Full-Color Touch Panel Display
- Advanced Support for C4FM Digital



* Desktop Microphone & External Speaker (Optional)



The Smallest HF/VHF/UHF Mobile Transceiver Provides base station performance from a compact package

HF/50/144/430MHz 100W All Mode Transceiver

FT-857D

Operating Modes: CW/SSB/AM/FM * C4FM digital mode is not supported

- Ultra-Compact Package (W155 x H52 x D233mm)
- The 4 Pole Rfnoing Filter (MCF) and 11 Band Pass Filter RF stages
- Large Radio Tuning Dial and Outstanding Ergonomics



The Ultimate Backpack Multi-Mode Portable Transceiver

HF/50/144/430MHz 5W All Mode Transceiver

FT-817ND

Operating Modes: CW/SSB/AM/FM * C4FM digital mode is not supported

- Incredibly Small Size (W135 x H38 x D165mm) and Light Weight
- Ni-MH Battery Pack and Battery Charger Included
- AA Alkaline Battery Operation

YAESU
The radio

YAESU Authorized Dealer

Andrews Communications Systems
Shop 8, 41-51 Bathurst Street, Greystanes NSW 2145
Tel: +61-2-9636-9060
URL: www.andrewscom.com.au

YAESU Authorized Service Center

Andrews Communications Systems
Shop 8, 41-51 Bathurst Street, Greystanes NSW 2145
Tel: +61-2-9636-9060, Fax: +61-2-9688-1995
E-mail: radioandrews@hotmail.com

Strictly HAM Pty. Ltd.

Shop 12B Church Street Bayswater Vic. 3153
Tel: +61-3-9729-7656
URL: www.strictlyham.com.au

VK Radio Repairs

347 Settlement Rd, Thomastown Victoria 3074
Tel: +61-3-9465-9399, Fax: +61-3-8682-8748
E-mail: yaesu@vkradio.com.au



Amateur Radio

Volume 86
Number 1
January/February 2018
ISSN 0002-6859

The Journal of the Wireless Institute of Australia

Editorial

Editor

Peter Freeman VK3PF
editor@wia.org.au

Technical Editor

Peter Gibson VK3AZL

Publications Committee

Peter Hartfield VK3PH
John Morrissey VK3ZRX
Ewen Templeton VK3OW
Jim Tregellas VK5JST
Kaye Wright VK3FKDW (Secretary)
WIA Office Bruce Deefhoets VK3FBLD

All circulation matters

nationaloffice@wia.org.au

How to submit material

Secretary
AR Publications Committee
PO Box 2042
BAYSWATER VIC 3153
or armag@wia.org.au

Letters to Editor

Editor AR Magazine
PO Box 273
Churchill Vic 3842
or editor@wia.org.au

Hamads

'Hamads'
PO Box 2042
BAYSWATER VIC 3153
hamads@wia.org.au

Advertising

All enquiries to
Advertising Manager
AR Publications Committee
PO Box 2042
BAYSWATER VIC 3153
or admanager@wia.org.au

Registered Office

Unit 20 11-13 Havelock Road
BAYSWATER VIC 3153
Australia
Phone: 03 9729 0400
Fax: 03 9729 7325

Production Deadlines

All articles, columns, hamads and advertising booking by **first day of previous month**.

The contents of Amateur Radio are Copyright
Wireless Institute of Australia © 2017

General

**Amateur Radio magazine:
a new beginning** 6

Jim Linton VK3PC

**The CQ World Wide Contest for
non-contesters** 8

Michael J Charteris VK4QS/VK4XQM

Truk (Chuuk) DX trip 12

Kevin Kelly VK3HKK

Sydney Harbour Ferry Contest 25

Laurie Gordon VK2GZ

Australia celebrates its Mills 32

Tony Falla VK3KKP

TAC Notes 36

John Martin VK3KM

Should we close the QSL Bureaus? 54

John Seamons VK3JLS

**Historical changes 60 years ago
shape today** 56

Jim Linton VK3PC

**Four Australian Ground Stations
provide HAMTV Chain for ARIS
S contact** 57

Francesco De Paolis IK0WGF



Contributions to Amateur Radio



Amateur Radio is a forum for WA members' amateur radio experiments, experiences, opinions and news. Manuscripts with drawings and/or photos are welcome and will be considered for publication. Articles attached to email are especially welcome. The WA cannot be responsible for loss or damage to any material. Information on house style is available from the Editor.

Technical

2 m homebrew duplexer 14

Albert (Bert) Gnaccarini, VK3TU

**The ZS6BKW antenna – build a
superior alternative to the G5RV** 19

Chris Meagher VK2ACD

New digital mode for LF/MF 58

Murray Greenman ZL1BPU

**An alternative and affordable
antenna elevator type mast** 59

Dale Anderson VK4NBX

Columns

Board Comment 3, 5

Contests 37, 40

DX Talk 35

Editorial 2, 5

Hamads 63

Over to You 24, 58

Silent Key 39, 42, 55, 56

SOTA & Parks 43

VHF/UHF -- An Expanding World 27

WIA News 4, 18

VK2 News 45

VK3 News 48

VK5 News 46

VK6 News 49

VK7 News 51

This month's cover:

Our cover shows members of the Central Goldfields Amateur Radio Group operating their portable station set up as part of the Mills On The Air event: Mick VK3GGG on the microphone with Tony VK3AJW looking on. Photo by Craig Terry VK3KLI. See the story on page 32.

Back Issues

Back issues are available directly from the WA National Office (until stocks are exhausted), at \$8.00 each (including postage within Australia) to members.

Photostat copies

If back issues are unavailable, photocopies of articles are available to members at \$2.50 each (plus an additional \$2 for each additional issue in which the article appears).

Disclaimer

The opinions expressed in this publication do not necessarily reflect the official view of the WIA and the WIA cannot be held responsible for incorrect information published.

Amateur Radio Service

A radiocommunication service for the purpose of self-training, intercommunication and technical investigation carried out by amateurs; that is, by duly authorised persons interested in radio technique solely with a personal aim and without pecuniary interest.

Wireless Institute of Australia

ABN 56 004 920 745

The world's oldest

National Radio Society, founded 1910.

Representing

The Australian Amateur Radio Service

Member of the International Amateur Radio Union

Registered Office of the WIA

Andersson House

Unit 20, 11 Havelock Road

Bayswater, Victoria, 3153

Tel: (03) 9729 0400 Fax (03) 9729 7325

email: nationaloffice@wia.org.au

<http://www.wia.org.au>

All mail to

PO Box 2042 BAYSWATER VIC 3153

Business hours: 10am – 4pm weekdays

National Office

Executive Administrator Bruce Deetholts VK3FBLD

Board of Directors

President Justin Giles-Clarke VK7TTW

Vice-President David Ford VK5WP

Directors Marcus Berglund VK5WTF

Brian Clarke VK2GCE

Peter Clea VK8ZZ

Gregory Kelly VK2GPK

Phillip Walt VK2ASD

Secretary Jim Linton VK3PC

Treasurer Vacant

Coordinators

AMSAT Paul Paradigm VK2TXT

ARDF Jack Bramham VK3WWW

Australian ARISS Shane Lynd VK4KHZ

Awards TBA

Clubs Ted Thrift VK2ARA

Contests Craig Edwards VK8PDY

John Moyle Field Day Denis Johnstone VK4AE

Editor 'AR' Peter Freeman VK3PF

EMC/EMR Gilbert Hughes VK1GH

Standards Phil Wait VK2ASD

Ron Cook VK3AFW

Noel Higgins VK3NH

NTAC John Marlin VK3KM

Historian Peter Wolfenden VK3RV

IARU Region 3 Liaison Jim Linton VK3PC

Monitoring Service Peter Young VK3MV

ITU Conference & Study Group

Brett Dawson VK2CBD

Dale Hughes VK1DSH

QSL Curator National Office

Repeater Peter Mill VK3ZPP

Andrew Chapman VK40F

Webpage Robert Broomhead VK3DN



Editorial

Peter Freeman VK3PF

A new era begins

As readers will be aware, the WIA Board decided in September 2017 to reduce the number of issues of this magazine from 11 per year to 6 per year, with the magazine being published bimonthly.

As the Board has outlined, the magazine is the largest single expense for the Institute. If one could clearly identify and aggregate costs into a single line item, one would suspect that the costs of running the office would likely be approaching the costs associated with this magazine. Offsetting the magazine production costs will be the income from advertisers and the relatively small number of copies sold via newsstands each month.

In January and February 2017, the Publications Committee (PubCom) prepared a discussion paper for the Board on mechanisms which might result in significant savings in relation to the magazine. Several options were outlined together with factors that may arise with each option. At the time, the incumbent Board decided to defer any decision until after the Annual General Meeting. The new Board had many issues to consider following the Annual General Meeting, so it took some time until a decision was reached. In the end, the Board decided to adopt the PubCom recommendation – a reduction in the number of issues published each year. Our sister society in New Zealand NZART took the same approach to reduce costs several years ago.

Some information published regarding the costs of producing and distributing *Amateur Radio* magazine has not been correct. Yes,

costs have been rising since 2011, but not to the extent some have claimed. In fact, it is anticipated that the final cost for 2017 will be less than the costs in 2009, when costs peaked and decisions were taken to reduce costs. In 2010, we changed magazine layout and changed some suppliers of services.

I am sure that we will see further changes in the magazine as the year develops and PubCom discusses ideas with the Board and the Strategy Advisory Committee.

Some radio activations

I spent a couple of weeks in late December making sure that I achieve a good "radio fix". A couple of days were spent travelling around Gippsland activating Parks, including one VKFF reference that had not yet been activated. I then headed northwards towards Wodonga via a somewhat circuitous route which allowed me to activate two more VKFF references which had not been previously activated.

After arrival in Wodonga, I had a mixture of some time with family and getting out and activating Parks and SOTA summits.

All of this culminated with New Year's Day, when I activated Mount Stanley on either side of the UTC day and year "rollover". The SOTA scoring system allows an Activator to score the points for a summit only once per year, based on the UTC clock. So our New Year's Day allows an Activator to claim the points twice for only a single approach to a summit, with UTC rollover occurring at 11:00 local time

Continued on page 5



Board comment

Justin Giles-Clark VK7TW

Focus on the Future

Welcome to 2018

The Australian Communications and Media Authority (ACMA) gives all stakeholders an opportunity to input into their spectrum management work program. This is done as part of their Five Year Spectrum Outlook (5YSO) prioritisation program.

The Wireless Institute of Australia (WIA) as the representative body of amateur radio in Australia takes these opportunities seriously. The WIA compiles information from the various consultations it undertook throughout the year and there were five in 2017. This enables the WIA Spectrum Strategy Committee to formulate an evidence-based view that represents the amateur community in Australia. This view is used to influence the priorities within the ACMA's Spectrum Management Program.

One principle the WIA is fighting for is to preserve the opportunities for citizens to explore communications technologies and techniques on allocated Amateur Service frequency bands throughout the spectrum. This goes to the heart of the ITU definition of the Amateur Service and the objects of the Radiocommunications Act 1992: Preserving the ability to experiment with, or adapt, existing and emerging technologies and applications for the purpose of self-training, intercommunication and technical investigations.

This principle leads to the WIA's pushing to increase the frequency assignments to the amateur service, especially where they align with amateur allocations in other nations. This also supports harmonisation of frequency allocations with other

IARU regions and world-wide. This provides greater opportunity for experimentation and maximises the opportunities for radio amateurs to explore, experiment, learn and communicate.

Spectrum especially UHF and microwave frequencies is under constant threat from a broad range of industries. The WIA fights to maintain the current frequency allocations: however, the WIA also needs to be realistic and be prepared to negotiate and facilitate solutions with the ACMA. The 3.6 GHz band is currently under review and the WIA accepts there will likely be some reassigned to new broadband and entertainment services.

In summary the WIA's input to the ACMA 5YSO prioritisation program includes:

- Harmonisation and extension of 1.8 - 2.0 MHz
- Harmonisation and extension of 3.8 - 4.0 MHz
- New secondary allocation at 5.3 MHz – WIA pushing for response and action
- Primary allocation in the 50-52 MHz band
- Secondary allocation in the 70 MHz band
- Allocation in the 803-804 MHz band for LIPD class licence for STEM educational programs
- Seeking retention of amateur access to 3.575 - 3.600 GHz outside of the specific geographic areas where future licensed services are deployed.

The Board has received some inquiries about the Licence Conditions Determination (LCD) submission following the three consultation surveys in June 2017.

The WIA will be submitting to the ACMA the LCD submission around the same time as the 5YSO submission.

The first survey results clearly show that future amateur radio licencing must not be less than what is embodied in the current apparatus licencing. Amateurs overwhelmingly want to see reduced regulation and greater self-determination. In relation to permitted power levels – it must be reviewed in a sensible, pragmatic way for all licence levels taking into account personal safety and electromagnetic emissions.

The second survey results clearly show the need for digital models for Foundation licensees and access to more bands for Foundation licensees. Overwhelming support for more power for Foundation licensees and ability to use non-commercially manufactured transceivers especially, in this world of digital experimentation and readily available kits. A high level of support was received for a review of Foundation call signs. Support for Standard licensees' access to more bands and higher power levels. Support for a relaxation of permitted bandwidths to reduce prescription across all licence levels. For advanced licensees there was support for harmonisation and extension in 160 m and 80 m, new allocation at 5.3 MHz, primary status in 50-52 MHz, secondary allocation in 70-70.5 MHz and secondary allocation in 918-925 MHz ISM band. There was overwhelming support for a

Continued on page 5

Australian presented with Yasme Foundation Award

These prestigious awards, which began in 2008, recognise individuals and groups who have made a significant contribution to Amateur Radio. The Yasme Foundation, a not-for-profit corporation supporting scientific and educational projects related to Amateur Radio, has given five Excellence Awards this year.

One went to Dale Hughes VK1DSH, acknowledging his international work at the World Radiocommunication Conference in November 2015. The award is for excellent chairman work in both the Amateur Working Group in ITU-R Working Party 5A, and a Sub-Working Group that addressed the allocation of a worldwide 60-metre Amateur Radio band. A humble Dale VK1DSH told the WIA and IARU he was surprised at receiving the Yasme Excellence Award, which consists of a cash grant and an individually engraved crystal globe. He has attributed the successful outcome to a team effort resulting from a great deal of work by individual delegates, amateur societies, the IARU and supportive national administrations.

The IARU team went to the World Radiocommunication Conference in November 2015, not at all confident about getting the allocation. It was not until a lot of negotiation and the Sixth Plenary that a new secondary allocation of 5351.5-5366.5 kHz was passed. Although now widely available, the ITU allocation did not come into effect until January 2017, when national administrations must formally revise their rules to permit amateur operation.

Some countries including Australia are yet to release the 60-metre band allocation. Information on it can be read on the WIA website 'Current WIA Hot Issues' at: <http://www.wia.org.au/>

[newsevents/hotissues/current/index.php](http://www.wia.org.au/newsevents/hotissues/current/index.php)

The other Yasme Foundation Excellence Awards went to:

- Dayton Amateur Radio Association for its Hamvention.
- Paul Verhage KD4STH and Bill Brown WB8ELK for leadership and continued technical innovation in Amateur Radio high-altitude ballooning.
- Nathaniel Frissell W2NAF and Magda Moses KM4EGE who created the Ham Radio Science Citizen Investigation that sponsored the Solar Eclipse QSO Party.
- The WSJT Development Team that has produced digital weak-signal mode software
- Supporting Grant also went to Gary Pearce, KN4AQ for the HamRadioNow and YouTube videos.

The Yasme Excellence Award consists of a cash grant and an individually engraved crystal globe.

WIA committees reinvigorated and explained

The Wireless Institute of Australia (WIA) relies on the work of its various specialist committees to deliver services, and to consider requests or changes in their areas. The WIA board has taken a number of steps towards restructuring the committees, and has found that some no longer exist while there is a need for some new ones. These steps included consultation that lead to introduction of the Volunteer Charter, a two-year tenure for new leaders, and the advertising of any vacancy.

Each committee was asked to explain how it operates, its structure and membership, and future planning. There was also an expectation they would report their activity frequently. Publicising the committees and encouraging broader participation of suitable

qualified people in them is part of the reform process. For any committee vacancy, or a need for additional resources, a public interview process including the applicant's curriculum vitae has been introduced. This addresses any concern that membership is closed or filled internally by the committee itself.

It has also been highlighted that committees can be misunderstood. The long established WIA Technical Advisory Committee is prime example. The TAC is not so much a committee as an umbrella for a group of jobs and the people who do them. In other words it's a pool of experts in various technical aspects of Amateur Radio that can be drawn upon when needed to lead discussion on particular areas. The TAC technical panel consists of advisors in VHF-UHF, microwaves, EME, satellites, repeaters, beacons, band plans, packet, APRS, ATV, D-Star, and digital DX modes. Its regular clerical jobs are repeater and beacon data bases, VHF-UHF distances records, and technical data compilation for WIA Callbook. The TAC does not meet behind closed doors, but consults and explores various issues as they arise using its panel of expertise.

Currently it is looking at a clash between the new digital FT8 mode on 6-metres, as well as the IARU project harmonising band planning worldwide. Each proposal for change is publicised and any input is welcome. The WIA committees appreciate all views, and work collaboratively to achieve the best outcome for all.

New digital mode puts beacon off air

A clash has occurred on 6-metres in Australia with the popular FT8

Continued on page 11

Board comment Continued from page 3

relaxation of permitted bandwidths and an increase in power to 1000 W where the operator can demonstrate compliance. The second survey finished with a question about balancing future conditions that satisfy the regulations with upgrade incentives making upgrading more attractive. Respondents were overwhelmingly in favour of this balance.

The third survey sought to address outstanding issues with licence conditions. The first question asked about clarifying the interference, station identification, retransmission and operation of repeaters and there was overwhelming support for clarification especially on

the operation of repeaters. The second area was the use of internet connected repeaters systems by Foundation licensees and there was over whelming support for clarification and simplification. There was also overwhelming support for clear visibility of the licensees' Electromagnetic Emission compliance responsibility. The last question asked in this survey sought to review callsign patterns, the use of prefixes and suffixes to determine if they are still fit-for-purpose and there was good support demonstrated.

There were over 1100 respondents to the surveys across all licence levels and across all VK call areas. I thank all who

took part in the surveys. By the time this Board comment goes to print the LCD submission will be with the ACMA for consideration and further discussion. The WIA will be pushing to expedite the implementation of the LCD recommendations: however, the WIA is aware the ACMA's current focus is on implementing the new Radiocommunications Act. Amateurs need to remember that our licence conditions and callsign assignment is different to all other spectrum users and what we pay for our privileges is low compared to other users. Stay tuned!

Justin Giles-Clark VK7TW on behalf of the WIA Board.

Editorial Continued from page 2

in VK3. It became somewhat hectic with activity, attempting to work other Activators on summits for the chaser and Summit to Summit points.

Well after local midday, I shut down the radio and headed off to find some lunch and then found a route to two additional summits which I had not previously

activated. It is always a small achievement when one activates a summit for the first time, increased slightly by the fact that by activating these summits I achieved two new "Completes" – summits which I had previously chased and now activated.

But all radio fun trips come to an end, and so I had to return home

to complete the tasks associated with completion of this issue of the magazine, plus a long list of domestic chores...

I trust that all have a safe and prosperous year.

Until the next issue,

Cheers,

Peter VK3PF



MEMNET

The Wireless Institute of Australia

[Register](#) [Login](#)

Have you registered for **MEMNET** yet?

Go to www.wia.org.au click on '**For Members**', then click on '**Log into MEMNET**', and register... it's very simple.

If you have already registered for MEMNET but have not received a confirmation Email we may not have your correct email address.

Please email memnet@wia.org.au with your email address, name and membership number.

If you are changing your email address, please *remember to update* your information in **MEMNET**.

Amateur Radio magazine: a new beginning

Jim Linton VK3PC

The final monthly edition has been printed and in 2018 it is to come out bi-monthly. Later there will be reflection on that necessary change and the opportunities to refocus it.

Before the magazine was born, the monthly *Sea, Land, and Air* magazine began in March 1918.

A year later it claimed to be the 'journal of the Wireless Institute of New South Wales', later expanded to Victoria and South Australia. Ultimately the title was changed to 'The Wireless Institutes of Australia and New Zealand'.

In his article *'The History of the*

WIA Journal', Colin MacKinnon VK2DYM (1) covers this claim that appears legitimate, and was replaced by another called *Radio* that continued as the official journal until October 1923.

In addition, some magazines were published by the WIA State Divisions and so were the official organ of the respective State.

How it began

It was in October 1933 that the very first edition of *Amateur Radio* was published (2). The magazine came out monthly, recorded the outbreak

of WWII in September 1939 in the October edition that reminded all that transmitting had ceased.

Many on its publications committee had already been called for war duty but wanted to keep the magazine going through contact with members.

The magazine continued for a few months but war conditions meant a drop in readership and advertising, leaving it at about 12 pages (2). These were hand duplicated magazines.

The aim was to keep up the interest with it having a cheaper



Photo 1: First edition Amateur Radio magazine.

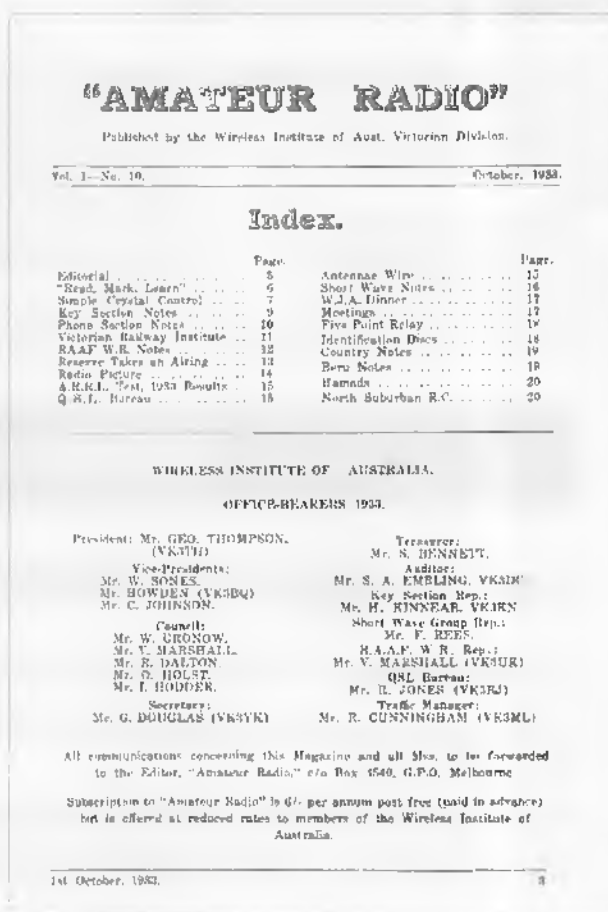

Photo 2: Content page of the first edition.

magazine with its first edition in March 1941 running until September 1945. It then returned to normal quality with the October edition.

The WIA reported on the post-war resumption of the hobby and its negotiations with authorities.

The next major phase was when *Amateur Radio* magazine and other historical WIA matters like the membership database run by the Victorian Division went to a new company, WIA Federal, in 1972.

The magazine evolution saw it adopt modern production and printing techniques. It moved from handwritten manuscripts or typewritten words that had to be converted to print, to digital files on disk, then through to email attachments.

Other changes saw it go from layout sheets being pasted up to desktop publishing so the actual words submitted did not have to be retyped. When it became viable the black and white publication slowly moved to a two-colour then four-colour process.

It faced commercial competition in 1995 with *Amateur Radio Action* and in 1999 *Radio and Communications* appeared to fill a gap left by the demise of *Amateur Radio Action* and another from that stable called *CB Action*. But that publication was short lived.

Now the reality change

Since 1933 *Amateur Radio* had sought to be a record of history and will continue in that role. A greater use of the internet for some items could result. I'm sure that the Editor will be looking out for a new breed of authors to achieve change.

Amateur Radio is the highest single expense of the Institute.

Going bi-monthly will not only naturally cut the costs but can result in new thinking about how to best use the printed magazine to position it as the official journal of the Wireless Institute of Australia.

To have appeal to the changing readership the contents will naturally change but that may take months to fully achieve.

As *Amateur Radio* enters the next phase; the readership, contributors, advertisers and those steering the course of this publication, have their own part to play in its future.

- (1) The History of the WIA Journal, Colin MacKinnon VK2DYM, *Amateur Radio*, January 1991.
- (2) Golden Jubilee, Jim Linton VK3PC, *Amateur Radio*, October 1983.



\$129



POCKET WORLD BAND RADIO

WITH SSB AR-1780

Covers most popular frequencies. Single Side Band (SSB) for Ham radio, morse code, long wave, and air band. 1000 memory presets.

- Requires 4 x AA batteries
- 150(W) x 95(H) x 30(D)mm

SHORTWAVE PASSIVE REEL ANTENNA AR-1947

Features two clips that attach to the telescopic rod antenna on the radio to boost reception.

- 7m maximum cable length



\$19⁹⁵

INLINE RCD CIRCUIT BREAKER OP-2002

Protect against electrocution and equipment damage.

- 10A, 240VAC.
- Built-in RCD safety switch
- IP65 rated enclosure



\$34⁹⁵

DUAL OUTPUT LABORATORY POWER SUPPLY MP-3087

Two outputs can be operated independently, connected in parallel, or series for multiple output currents and voltages. Large backlit display.

- 2 x 0 - 32VDC output voltage
- 2 x 0 - 3A output current
- 185(H) x 260(W) x 40(D)mm



\$399

EARN A POINT FOR EVERY DOLLAR SPENT AT ANY JAYCAR COMPANY. POINTS OR EQUIVALENTS WITH A \$25 JAYCAR'S GIFT CARD ONCE YOU REACH 500 POINTS!

Conditions apply. See website for T&Cs



SIGN-UP IN-STORE OR ONLINE TODAY BY VISITING:
www.jaycar.com.au/nerdperks

Valid until 23 February, 2018.

To order phone 1800 022 888 or visit www.jaycar.com.au



Don't forget to register
for MEMNET.

The CQ World Wide Contest for non-contesters

Michael J Charteris VK4QS/VK4XQM



“What’s in it for me, the average radio amateur?”

Monday, 30 October 2017, the clock has just passed 00:00 UTC and the CQ World Wide Contest has concluded just as sharply as it began two days before. Now the bands are eerily silent despite the propagation as all who participated begin the task of scoring and evaluation of this once a year event. For many of the Amateur Radio fraternity throughout the world, “Contests” generally are a right royal pain in the neck and considered as lost weekends. It sees the bands enveloped by thousands of determined operators seeking contacts worldwide with other people just as keen, if not as mad as themselves. For some it does not get any worse with the bands being full of foreign signals that somehow interfere with their version of the hobby. A full weekend of garbled “Duck-talk” cacophony

that fills the bands like some plague of swarming locusts from earlier biblical times.

But before I undertake too harsh a judgement on contests and those that pursue them, let’s consider who some of these people actually are. Many have made the effort to save their pennies for a year if not more to travel to exotic locations and activate seldom heard DX entities. Now this is not only for their benefit alone but for all those who seek to work them, perhaps for the very first time. Then there are the other operators who are a little more financially well-heeled than most of us. They have by contrast dedicated a lifetime into perfecting of their stations for the sole purpose of DXing. Investments of many tens of thousands of dollars have gone into establishing so called “contest stations” for the original form of Social Media; that is, Amateur Radio. These radio

megastructures seek to somehow defy the “Propagation Gods” as Big Guns of the airwaves with the goal of being heard despite any adverse conditions nature can throw at them.

So where does that leave the rest of us who are caught in the crossfire with a comparatively standard station setup at our various QTHs across the world? We, who are the many playing the game in other ways with different goals across a broad field of options within the hobby. We may be neither classed as “Contesters” nor described as diehard amateur radio operators. But rather we are both the audience and the appreciation for the efforts of those listed in the above paragraph. Now whether you hold a Foundation License with just 10 Watts PEP and utilize a ubiquitous G5RV, or you are an Advanced license holder with the option of 400 Watts PEP, you are all needed entities from a world zone point of view. So regardless of how you feel, do not underestimate the importance of your role in all of this. For if it was not for us of the many, the Contesters themselves would only hear the megaDXers working each other while the rest of us turned our backs and delivered them the bands full of silence.

But ironically, how else are we of the average tribe to hear and potentially contact rare DX from exotic locations across the vastness of the globe, if not by way of such opportunities that such contests provide. So the question remains “What’s in it for me?”, the so called “Non-Contester” when it comes to the CQ World Wide Contest? Well the answer my friends is plenty, but it all depends on how you look at

it. From this point forward I can but only offer you my own approach to this particular radio contest only.

I hope that you may take away a few good points and maybe slightly alter your views on such events that are a constant in our wonderful worldwide interactive hobby. Using the CQ World Wide Contest, where the world is broken up into 40 Zones, I decided a few years ago to set myself some goals based on the fact that I would never win any part of the contest. Once you adopt this outlook, then any contacts you make are a bonus towards your DXing goals generally. I chose to utilize this weekend of RF hysteria to challenge myself and my station and to assess where improvements could be made with the following goals as a guide.

- 1) To work as many Zones as possible out of the 40 up for grabs, propagation pending.
- 2) To only work one or possibly two stations from each zone if they became available.
- 3) To work many exotic DX from within a zone, even if it overrules Goal No 2.
- 4) To increase my overall country count worldwide for DXCC across the 40 zones.
- 5) To QSL those exotic DX stations that would QSL, after a confirming email reply.
- 6) To plot and understand how good or bad my antennas worked to certain areas.



TET-EMTRON

Ring Mark at 0455 463 452
See our wide range of new parts and products at:-
www.tetemtron.com.au

Come and see us at our stand at the Werribee and Wyong field days, and check out the great range of products:



- Baluns and Un-uns.
- Balun Kits.
- Lightning Arrestors.
- 6 metre passive Kits.
- Home Brew Parts.
- Verticals.
- Beam Parts.
- Connectors.



If you want something bought over, please don't hesitate to call and ask.

WAZ: 16 European Russia ITU: 29

UD4FD

Alexandr Sidoruk



- 7) To learn to "LISTEN" more and talk less, thus waiting for the right moment to strike.
- 8) To try new antennas and assess their DX qualities compared to my current ones.

The best place I believe to start is perhaps with my own quite basic station of just a transceiver with power output of 200 watts into a $5/8 \lambda$ Vertical for 20 m plus an Antenna Tuner. Now at 12.5 m long with a coil at the base and radials, plus three 10 m top hat wires, this particular antenna, the $5/8 \lambda$ Vertical offers a good many gifts for those willing to build one as an all band DX Vertical. So what do you get for your money I hear you ask? Well for one, it has not cost you an arm and a leg in the form of a tower, rotator and a Yagi. Yes, you do not have all the benefits of such a wonderful Beam set up but there is always two ways to skin a cat. Upon building a $5/8 \lambda$ Vertical you will have invariably applied both physics and science to achieve a take-off angle in the order of 16 degrees and some 3 dB of gain and reduced reception of high angle radiation. Now that 3 dB equates to a two times multiplication of the power which sees my 200 Watts input effectively become 400 Watts.

By comparison, a $1/4$ wave vertical for 20 m at five metres in

length will have a main radiation lobe in the order of 60 degrees and an effective mean take off angle of 30 degrees to the horizon. Now compare this to a $5/8 \lambda$ vertical for 20 m at 12.5 m long which in comparison will have a main radiation lobe of just 30 degrees and a mean take off angle of approx. 15 degrees and you can see everything has been halved. The gain factor and the lower angle of radiation of the signal to the horizon now work to your advantage for DX by a power factor of two. Another way of looking at it is to imagine it as a torch beam of light whereby the $1/4$ wave is fairly broad at 60 degrees but it is then sharply refocussed to be just 15 degrees by way of the $5/8 \lambda$ wavelength. You can now see how the intensity of the radiated light increases dramatically in the dark. This same antenna with a 40 turn base coil and three 10 m long top hat radials will work very well across 160 m through to 10 m, with an antenna tuner of course. So invariably you have managed to kill a few birds with one stone and you have also put all your eggs in one basket for better or for worse.

We all know of course that there are many factors that we have no control over, regardless of our towers and linear amps or basic verticals, dipoles, loops and

a few hundred Watts, if not just 10 watts. If the weather gods chuck a tantrum and next minute the Sun vomits a CME, its curtains for us all. Then as the Sunspot Cycle declines ever rapidly, we must endure fewer occasions of 59 plus signals across the globe from DX stations.

Conversely what you will find during such contests is that Radio Amateurs are indeed prepared to listen more intently and to dig your signal out of the noise to work you for your Zone and points. Whereas normally you might scream till you are blue in the face, now it seems that even at a signal strength of one and readability 3 to 5, that there is a contact made after a few attempts and everyone is happy. Many will also tell you of times past and perhaps more recently when with just a few Watts they worked across the planet for a 59 report that amazed everyone. This of course is one of the great joys of unpredictable propagation that is visited upon our stations from time to time. And then when it seems that across the world that the bands are dead, they magically come to life when a contest takes over the airwaves electrifying the ionosphere. So do not underestimate the capabilities of your station when it comes to the power of propagation. For even the mega stations suffer the fate of the many if the Gods dictate I and small so called QRP ones can often roar like lions when conditions are favourable.

I can tell you for a fact that I am not one for calling CQ Contest infinitum ad nauseam for two days. But rather, I like to work up and down the band for the best contacts at the time as propagation presents them. Then by the time I get to the end of the band and go back, the condition have changed slightly and a few more new stations have emerged from the ether. This of course is based on the spare time I have in between everything else going on over the course of the weekend. Thus I am not a slave to the contest itself, but rather enjoy it

at my own pace as time permits each day.

Some of the highlights for me in the 2017 CQ WW Contest are the following. A contact with D4Z way out on Cape Verde in Zone 35, a distance of 18,911 km, which I have proudly achieved for the past three years. I also enjoyed working ZF9CW in the Cayman Islands being Zone 8 at 14,454 km as a first. A definite standout were my contacts with KL7RA, being the North Pole Contest group in Zone 1 at a distance of 10,919 km and VE3EJ in Grassie, Ontario at 14,913 km. On a more local front but less often heard were contacts with P29LL Port Moresby in Zone 28, HS5SRH Thailand in Zone 26, A31MM Tonga in Zone 32, AH0K Tinian Island in Zone 27, another first, and B1Z China in Zone 24 to name but a few. Then there was station 4S7AYG in Sri Lanka which I worked. This was actually run by a group of Ukrainian DXpeditioners, who upon making contact requested I list them on the Cluster. I then listed on DX Summit and it is exactly the example I voiced before. These guys would have saved up for many months to come all the way out to nice hot Sri Lanka to provide us all with the opportunity to add this DX Entity to our logbooks. I later contacted them again on air as well as by email to confirm that I had listed them on DX Summit and they kindly responded with a lovely email reply.

In total for the time spent across the weekend, I managed to work 50 DX stations for a total of 26 zones out of the 40, of which Africa was not heard at this QTH. Interestingly despite signals from Oman and the UAE at S9, at my QTH, they could not hear me. Once you have made your contacts for the weekend, pop along to GOOGLE and type in "How far is it from (Your QTH) to the Location of the DX station" as listed on QRZ.com.

It makes for interesting analysis to also have a 40 Zone amateur radio map of the world as well as plotting your frequency, times and antenna used for the contact. We often seem to forget that every time we key the microphone or the CW Key, that we are undertaking an experiment with the Ionosphere and a myriad of factors in nature.



FUTURE SYSTEMS

futuresystems.com.au

SHOP ONLINE
WITH US TODAY

ANZ Dealer for
FlexRadio Systems



FlexRadio Systems®
Ultra-Defined Radios

New Models Now
Available for
Pre-Order

Stocking your favorite amateur radio
antennas and accessories from brands such as;

- FlexRadio Systems
- Hustler
- Benelec
- Codan
- Comet
- Dooren Electronic Solutions

DVMEGA Raspberry
Pi Dual Band Radio &
More Available Now!



Contact Us Today

(08) 6336 9610
futuresystems.com.au
retail@futuresystems.com.au

2/36 Irvine Dr, Malaga WA 6090

Future Systems (Aust.) Pty Ltd
ABN: 70 082 123 126

Thus, in the end my friends, it's up to you what you decide as regards this event, whether to embrace it or experiment during the next CQ WW Contest with your station. My best effort so far has been to work 30 of the 40 zones in one weekend and that's with just a 5/8 λ vertical for 20 m and 200 Watts as described.

So in the end, what's in it for you, the Radio Amateur who avoids, dislikes and fails to understand the driving force behind "Contesters"? Well there is plenty to be gained by undertaking to be part of the program, on your own terms and setting a few goals to be achieved along the way. For one,

the assessment of your current antennas across the globe, along with how well your radio performs under very crowded or noisy conditions. How about your skills as an Amateur Radio Operator by way of listening and replying?

Try a couple of the eight golden rules I listed above and see how you get on. There is of course the greater and more fundamental achievement of working another human being in an exotic land on the other side of the world from the comfort of your own back yard.

Somehow for me, even after being licensed for 33 years, the magic of amateur radio still permeates my soul. The sense

of achievement of rolling your own antennas and participating first-hand in the achievement of a contact across the globe still gives me a buzz. Far more indeed than email, Face-Book and other forms of socially transmitted 1s & 0s that have sought to render our hobby as old hat and Neanderthal.

Anyway, maybe I will hear you next year during the CQ World Wide Contest. In the meantime, I hope you have enjoyed reading about another man's view of the world and his Radio hobby.

Cheers and best 73 from Mike
Charteris VK4QS



Truk (Chuuk) DX trip

Kevin Kelly VK3HKK

Truk Lagoon in Micronesia is famous for its World War Two Japanese shipwrecks and a favoured destination for scuba divers. I've been there a number of times for diving and decided that on my next visit I'd bring an amateur rig and try for some contacts. The first step was obtaining a licence to operate which was surprisingly easy and quick. I downloaded a form from the Chuuk government website, emailed it off and received the licence in a couple of days with the call sign V63HKK.

The next item was a suitable rig. Because diving gear is somewhat heavy, there wasn't a lot of spare capacity in my luggage allowance so a Yaesu FT-817 was the only unit that really fitted the bill. I built a nine-to-one unun from instructions off the web. An LDG Z100 Plus antenna tuner, 10 metres of 2 mm cable, 20 metres of coax and some builders twine completed the equipment list. An amplifier small enough to take wasn't available unfortunately.

There were plenty of palm trees



Photo 1: The antenna.

to string the antenna from, although the taller ones were too high to reach with a 20 mm nut on the end of the builders twine and I had to settle for a height of about 7 metres. The antenna tuner runs on its own 9 volt battery but to power the FT-817

I had to rely on the batteries I used in my dive torches.

So with everything set up I tuned in to 14.200 MHz and put out some calls. After calling CQ for about 10 minutes with no result, I tuned up and down the band in search of a



Photo 2: The rig.

strong signal. I was able to make a few contacts with stations who were using beams but with only 5 watts at my end, the beams had to be pointed pretty much straight at me.

Truk Lagoon is a much undeveloped country with little industry, no television or even radio broadcast stations, so the airwaves are remarkably unpolluted and I was able to hear stations from all over on 20 and 40 metres. With a more powerful unit it would have

been possible to make dozens of contacts. As it was, I made contact with three stations on 20 metres, Brett VK2WWW in NSW, Ben JA2FDX and Shima JJ1BKB both in Japan.

All in all a fun addition to the diving trip, and I'd be very interested to hear from any other amateurs who have either been to Truk or made contacts there.

Kevin VK3HKK



Photo 3: The shack.

HAM RADIO HOUSE

The Boatanchor shop!

www.hamradiohouse.com

Email: hamradiohouse@tpg.com.au

Phone: Stephen - VK2ASC - 0414-392653

Valves for Drake, Swan, Hallicrafters, Hammarlund, Racal, Heathkit, military etc - many types incl CV series - just ask - examples below.....

0B2	\$9.00	G-807 rus	\$17.00
0A2	\$9.00	6J56C	\$75.00
8BN8	\$9.00	More avail incl sweep tubes.	
6EW6	\$9.00		
6EV7	\$9.00		
6DC6	\$14.00		
6CA4	\$25.00		
6BZ6	\$10.00		
6BV8	\$12.00		
6BN8	\$15.00		
6BE6	\$8.50		
6AP4	\$9.00		

HV Capacitors
available

40uH Inductors



\$30.00 each

Transmitting Valves

6145B NOS	\$48.00
6145BPENT	
A	\$35.00

"TENATESTA" Antenna Tester 100KHz-150MHz

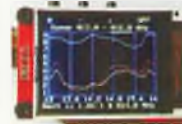

\$95 + P&P
Accessory cables + adaptors from \$3.50

Yaesu FT7- \$350
Swan 250 6M-\$500
Swan 117CP5- \$150
Swan 500C- \$500
Drake T4XB - \$500
Drake R4B - \$450
Drake T4XC - \$545
ICOM 701 - in orig box - \$465
Astatic D104 - \$90
Hallicrafters SR500 - \$650

New Foundation Manual



Available now!

http://www.wia.org.au/members/bookshop/page_data.php?id=113

Plan ahead

HARGfest

22 April 2018

2 m homebrew duplexer

Albert (Bert) Gnaccarini, VK3TU

The original design for this duplexer has been around for over 40 years now, having first seen publication in QST magazine in July 1972. The design has been replicated by repeater operators the world over and while it is still one of the simplest and most economical ways of home-brewing a VHF duplexer, there are a number of improvements that can be readily implemented to improve its overall performance and serviceability.

Like many others, the Geelong Amateur Radio Club built one of these duplexers for our VK3RGL 2 m repeater in the late 70s and it provided many, many years of reliable service. A recent upgrade of the Club's repeater site included replacement of the W1GAN duplexer with a Telewave 1486 duplexer that provided a significant improvement in performance albeit at almost four times the spatial requirements! The upgrade also provided us with an opportunity to revisit the W1GAN design with a view to refurbishing it for redeployment to another project.

Mechanical considerations

One of the problems experienced with the original execution of this duplexer design is that the builders did not provide adequate mechanical support of the tuning rod lock-nut.

The original design showed a bushing from underside of the lock-nut to the top flange of the cavity. The intention for the bushing was to transfer the load from the lock nut to the top flange of the cavity. Unfortunately, when our duplexer was built, this spacer was omitted and the lock-nut loaded the top of the diecast box

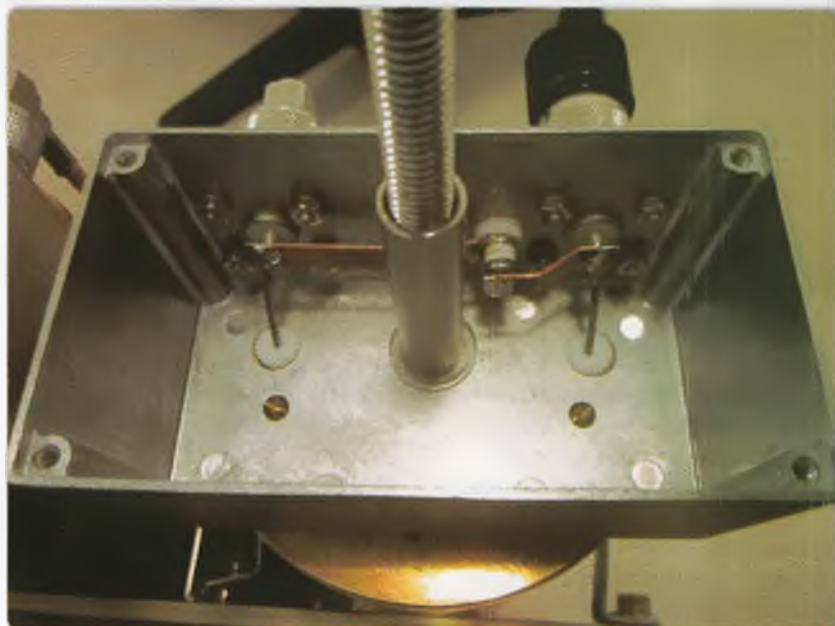

Photo 1: Low-side notch cavity showing location of Johanson 5202 trimmer capacitor on PTFE insulated bushing.

when it was tightened down. The mechanical stress on the box lid flexed it sufficiently to introduce some variance when the nut was tightened which made the cavities difficult to align precisely. Suitable spacers were made using thick-walled stainless steel tubing. The load from the lock-nut is now transferred directly onto the top of the flange as originally intended making the cavities much more stable mechanically.

The original W1GAN design did not provide any guidance for mounting the duplexer. The actual physical disposition was left to the imagination of the builder and our installation was basically a wooden rack which sat on the floor. In retrospect, it was considered that rigid mounting of the cavities with adequate mechanical support would contribute greatly to the long-term

stability and viability of the duplexer.

Suitable mounting straps that clamped the cavities onto rigid frame members were fabricated to replicate designs that are used on modern commercially made duplexers. This also offered the opportunity to design a mounting system that would permit rack mounting inside a cabinet where the duplexer would remain out of harm's way and would provide adequate support for any interconnect cabling.

Connectors

One of the limitations of the original design was the use of BNC connectors. The BNC connector has limitations which stem from its physical design. Principal amongst these is the fact that the connectors rely on a spring bayonet action to locate and seal properly. The

mechanical properties of these connectors can be compromised over time and reduce their effectiveness as oxidation and wear accumulate.

Corrosion is also likely to increase the potential for noise and intermodulation products in high-RF environments such as are likely to occur on congested group communications sites.

A better option is to use N series connectors which provide a much more stable platform. The positive threaded body allows for a much firmer and more stable mechanical action and the internal rubber seal provides for at least some protection against assault from air-borne moisture likely to be encountered on remote sites.

It is important to note that the connector internals form part of the RF path and will consequently contribute some amount of phase rotation as the signal propagates along that path. The path length of the male/female BNC connector combination is different to the N series and will therefore need to be taken into account when calculating the length of the interconnect cables.

An additional correction was applied to compensate for the use of 90 degree connectors as was the case on this rebuild. The choice of 90 degree connectors was made for three reasons. Firstly, they're more compact and allow for tighter packaging of the final product. Secondly, the overall signal path length can be easily measured centre to centre. Thirdly, they're easily re-usable if one has a ready supply of the requisite crimp barrels and that greatly facilitates the building of interconnect cables as some trial and error may be necessary.

Interconnect cables

There is nothing wrong with the original RG-55 cable used in the design as it is adequate for the task. Our build used RG-214 with bolt-on BNC connectors which were a bit awkward as the loops were a tight bend and inconveniently, protruded beyond the sides of the duplexer. The availability of modern mechanically equivalent cable types that are compatible with many commonly available N series connectors has opened up the list of possibilities significantly.

One of the more readily available types of cable is RG-142. Its loss characteristics at 2 m are not significantly different to RG-55 or RG-223 or not enough to matter in any case, and suppliers of compatible N series connectors are plentiful. RG-142 was chosen for this project simply for these reasons.

One consideration when changing the coax cables is that it WILL be necessary to correct for the velocity factor of the cable. RG-55 and RG-223 use a polyethylene dielectric (VF = 0.659) while RG-142 employs PTFE (Teflon) as the dielectric (VF = 0.694). In this case, it was simply a matter of scaling the dimensions proportionally taking into account the ratio between the original and the new velocity factors and applying the correction to the cable lengths. A correction for the N series connector path was also included in the calculation. All of these factors need to be taken into account for the specific circumstances of a rebuild.

Shunt trimmer capacitors

Another shortcoming of the original design was the rather inadequate mounting of the trimmer capacitors. While the original air-spaced capacitors were probably fine, it was considered that the mechanical arrangement for supporting them on the original design could be significantly improved with some care. The ready availability of high grade porcelain piston trimmers offers a much improved tuning characteristic than the 180 degrees of the air-spaced trimmers however and the Johanson 5202 trimmer capacitors were an obvious choice for this application.

A stable trimmer capacitor with a relatively low value at minimum is essential for correct tuning. A suitable way of rigidly mounting the trimmer capacitors that was stable and maintained good earth isolation was devised using spacers made of PTFE rod. The Johanson 5202 trimmer capacitors have a range of

Photo 2: High-side notch cavity showing location of inductor and Johanson 5202 trimmer capacitor on PTFE insulated bushing.

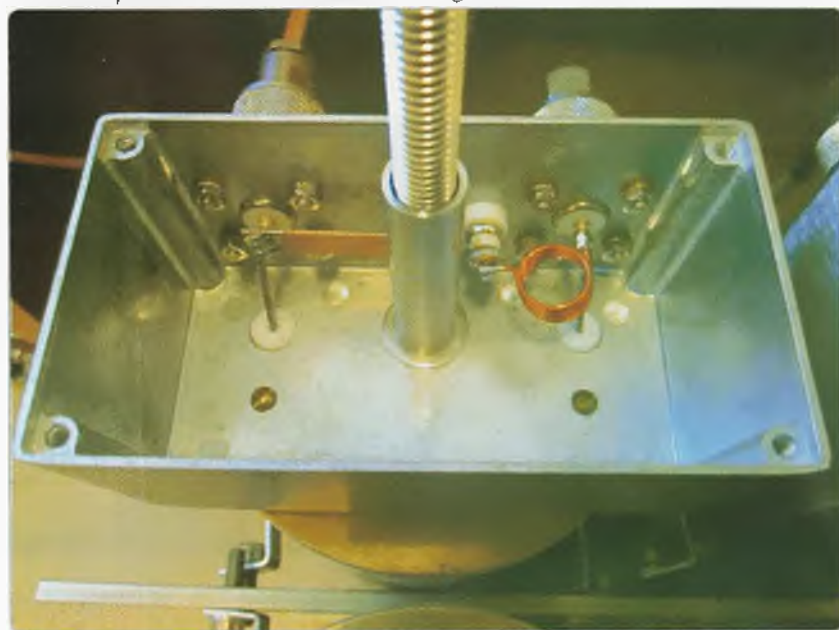



Photo 3: The refurbished W1GAN duplexer nearing completion showing 19" rack-mount frame and lugs.

0.8 to 10 pF which proved adequate however the range can be modified simply by connecting a low value ATC porcelain capacitor in parallel if required.

Shunt inductors

The original design did not allow very much latitude for changing the values of the shunt inductances which made the high-side notches difficult to align. The inductors used are essentially a straight piece of wire between the input and output

connectors. There is little or no scope for adjustment. Aligning the rejection notches precisely with all three cavities in circuit is always likely to involve some compromise in the pass frequency of one or more of these cavities with the inevitable consequence that the VSWR will suffer.

A simple remedy is to introduce a series LC shunt using a trimmer capacitor with a little more inductance than is actually required and making the notches adjustable

(with due acknowledgement to Jaques Audet VE2AZX for this idea). Four turns of 14 gauge enamelled wire, close spaced on a half inch former in series with the same Johanson 5202 capacitors used on the low-notch cavities was sufficient for the notches to tune comfortably but it may pay to experiment in specific cases if the tuning range doesn't meet your needs.

Internal strapping

It is important to keep the inductance of the links that connect the shunt Ls and Cs as low as possible. The original design used copper strap and there is no reason to change this approach. Solid copper straps are mechanically stable, easy to achieve and provide a strong method of mounting the necessary components.

Tuning and setting up

It helps if you have access to a Vector Network Analyser (VNA) or at least a trustworthy spectrum analyser with a tracking generator.

The tuning procedure is exactly as described in the original article. Cavity bandpass is adjusted on each individual cavity first. The respective individual high side/low side anti-resonance components are installed and the notches adjusted for a precise 600 kHz split from the pass frequency next.

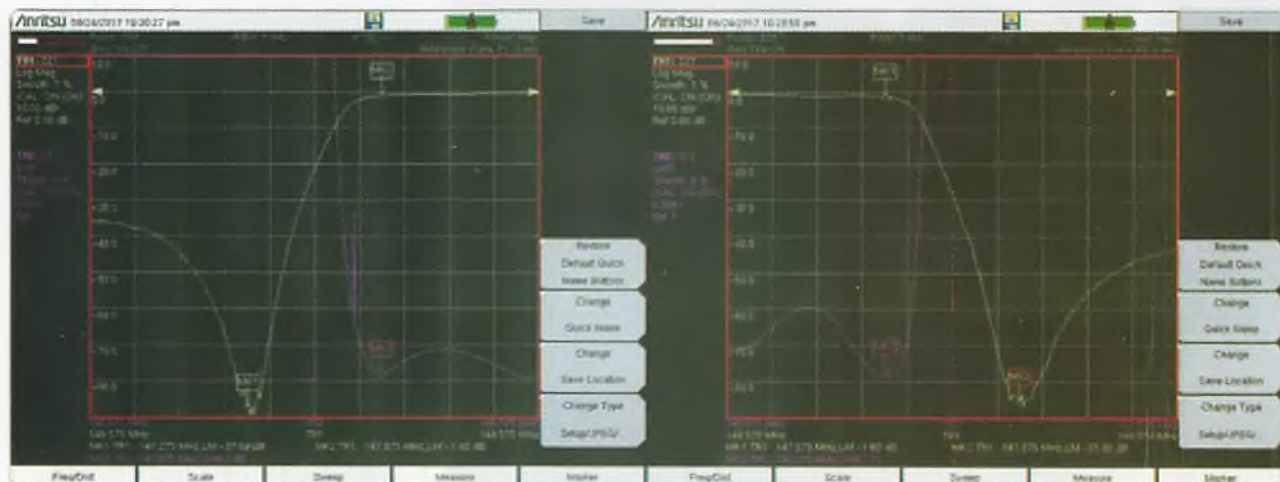

Photos 4a & 4b: VNA screen grabs showing RX and TX bandpass insertion loss, some IL was sacrificed in lieu of improved VSWR on the TX band-pass.

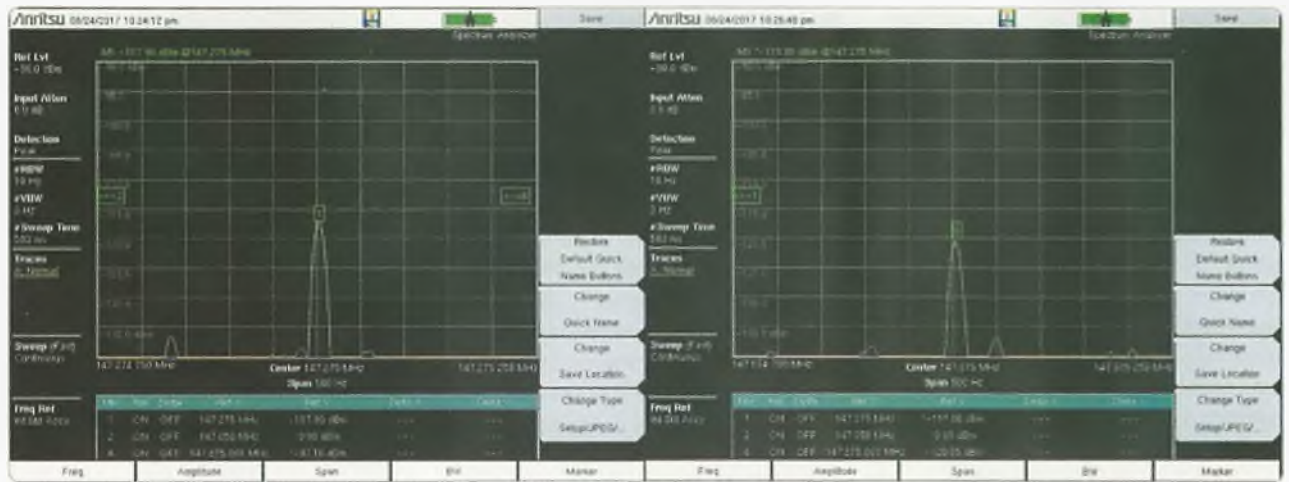

Photo 5a & 5b: Spectrum analyser screen grabs showing measured levels at each rejection notch for a +5 dBm input signal.

Then the whole thing is assembled with the coupling cables and checked again with any final 'fine' adjustments completed at this stage.

One point worth noting is that ANY mechanical stress applied to the cavities will detune them to some extent. Final adjustment should only ever be completed once the duplexer is *in situ* at its final location and all fasteners are firmly tightened down.

Performance

The new set-up in this case was for the VK3ROW 2 m repeater with a transmit frequency of 147.275 MHz and a receive frequency of 147.875 MHz. It is important to note that there was nothing wrong with the duplexer before it was refurbished. It was working and doing so reliably and meeting all the original design specifications. The only reason it was refurbished was to allow for an update in design philosophy, permit rack-mounting and hopefully extend its life for another 30 years!

Nothing else in the original design was changed. The internals were still nice and shiny after 30+ years of service and required very little in the way of cleaning. All original dimensions were retained save for some of the excess length being cut from the tuning rods. We were never likely to run the thing at 120 MHz anyway so it was not



Photo 6: The completed duplexer in its final installation ready for deployment.

necessary for it to tune that low! The BNC connectors were replaced with flanged N series connectors and the linking cables remade with RG-142 Teflon cable.

Pass-band insertion loss

Very little retuning was necessary for either the tuning rods or the notch trimmers once the individual cavities were aligned and the duplexer was assembled. Some slight adjustment was made for the high-pass set of cavities to improve the input VSWR. As can be seen from Photo 4, the insertion loss for the completed rebuild was 1.40 dB down the RX side and 1.60 dB on the TX side.

Rejection notches

The VNA was noise limited at the reject notch frequencies and these were measured individually using a +5 dBm signal source from a stable signal generator and a spectrum analyser. This technique allows the span and bandwidth to be reduced much more than with the VNA thus reducing the low signal noise and producing a much more stable pattern to tune out the notches with.

The signal generator was set up at the desired reject frequency in each case and the output signal level calibrated to the spectrum analyser for +5 dBm for each measurement. The spectrum analyser was

connected on the antenna port and the signal source applied to each of the RX and TX ports in turn with the opposing port terminated into a 50 Ω load. The resulting screen grabs in Photo 5 show levels of -120.86 dBm at 147.875 MHz and -117.90 dBm at 147.275 MHz respectively for a +5 dBm input level.

Acknowledgements

John Bilodeau W1GAN for the original design.

The Repeater Builder, <http://www.repeater-builder.com>

Jaques Audet VE2AZX, *Theory and Testing of Duplexers* (an excellent article on duplexers).

WIA news Continued from page 16

digital mode, introduced in June 2017 nominating 50.313 MHz as a worldwide operating frequency, already occupied by a propagation beacon. The Barossa Valley beacon VK5RBV has been switched off to avoid interfering with stations running FT8. Mind you, VK5RBV has been operating for many years on 50.315 MHz, but the developers of FT8 have nominated 50.313 MHz as its operating frequency.

The WIA Technical Advisory Committee is carefully looking at the matter and welcomes input as it looks for a new beacon frequency. The obvious choice would appear to be the band segment beginning at 50.400 MHz. This segment has already been adopted by IARU Region I as its new exclusive beacon segment, and it is logical for us to follow the same path.

This may be a forerunner of similar clashes as more new digital modes come into use in the same part of the band. FT8 is also

becoming popular on 2 metres, and may be ideally suited on a group of spot frequencies recommended for modes of different bandwidths. The narrow band channel on 144.320 MHz is the logical one for FT8 in the WIA band plan, but it's noted that 144.313 MHz has also been used for FT8.

The new digital mode of HF at weak signal levels lower power levels and almost any antenna is enabling lots of contacts, but the trend on 6m seems to be to use it on high power levels.

FT8 in its description has been designed for sporadic E propagation where signals may be weak and fading, openings may be short in duration, enabling fast completion of reliable QSOs.

Antarctic milestone being celebrated

Seventy years ago this month a group of 14 men set up on Heard Island in the Southern Ocean about

4,000 kilometres south-west of mainland Australia, and begun the first of the Australian National Antarctic Research Expeditions (ANARE). Arthur Campbell-Drury VK3ACD/Heard (SK) was at Atlas Cove. The base on Heard Island closed in March 1955 when ANARE moved to Mawson Station.

Now to commemorate that anniversary, the callsign VI70HI is on air (December 19 – February 28) with the website QRZ.com noting all activity will be from mainland Australia, and not Heard Island. The activity will be on HF from 160 m to 10 m, SSB, CW, RTTY and possibly digital modes. A commemorative QSL card will be available via the QSL manager Charles M0OXO. He states that no QSL Cards should be sent via the bureau, as they will not be answered.

A roster system to use VI70HI is available with any inquiries to either Lee VK3GK or the VK Contest Club.

Plan ahead

21st Annual GippsTech Conference | 7 & 8 July 2018

The ZS6BKW antenna – build a superior alternative to the G5RV

Chris Meagher VK2ACD

Introduction

For many years my main HF antenna was a G5RV, suspended from a tree in inverted-V configuration. In conjunction with an 80 m dipole, this served me quite well until two years ago, when a large kangaroo snagged the coax running along the ground to the shack, completely ripping it out of the balun.

After first considering a repair, I decided that the antenna was overall too dilapidated and it would be better to start from scratch, to buy or make a new one. In researching the second option, looking for supplies of stranded hard-drawn wire and ladder line, I stumbled across the US website of 'Amateur Radio Supplies', selling both a traditional G5RV and a 'optimised' variant called the ZS6BKW. Further searches led me to other websites, in particular to an extensive comparative analysis (1) which convinced me that the ZS6 would be a better antenna, principally as it offered multi-band no-tuner operation. The urge to home-brew soon took hold and I started collecting the parts to construct one, following the way the commercial ones were made, and also using stainless hardware and heavier plastic parts for durability.

Two versions were built, using different types of wire and slightly different dimensions, one with bare stranded hard-drawn wire for home and one with insulated high-flex wire for portable use. This article describes the origins of the design, the basic aspects of construction and test results.

What is the ZS6BKW?

Invented by Louis Varney, the G5RV

has been a reasonably popular antenna, usable on most HF bands with a tuner and on 14 MHz direct. It is simple, light weight and easy to deploy in the field. It uses a centred wire dipole of total length 31.1 m (1.5 wavelengths at 14 MHz) and a parallel line "matching section" of 10.34 m x VF (velocity factor). The limitations of the G5RV will be well known by anyone who has used one. There exists a multitude of references and no doubt many opinions on this antenna but suffice to say that it came at a time well before computer modelling was available.

In 1985, Brian Austin, then ZS6BKW (now G0GSF) produced a revised design based on the G5RV, using computer modelling to optimise the dimensions for improved multi-band performance (2).

Austin, an electronics engineer, devised a computer program to model a range of values for the antenna parameters, then built and tested several antennas, over a range of heights, plotting the results on Smith charts. These tests included variants of his own design, and also the G5RV, and a variant described in 1981 by T. Nicholson, W5ANB in QST magazine, which offered improved performance over the G5RV, particularly on 7 MHz (3).

The resulting design featured a shorter dipole section of 27.9 m (not corrected for velocity factor), and a longer matching section of 13.6 m, not corrected for VF and calculated for 400 ohm parallel line. It claimed to offer a good match to 50 ohms on five bands – 7, 14, 18, 24 and 28 MHz. With a tuner, 3.5 MHz was also usable.

The original G5RV uses dimensions that are neat fractions of

wavelength, whereas the ZS6BKW is based on the well-established knowledge that somewhere on a balanced feedline there will be a point where there is a good match for a particular frequency. The modelling and testing done by Austin found the optimum dimensions where this point coincided fairly well for 5 amateur HF bands.

The impedance at the point where the dipole connects to the parallel line would vary substantially depending on the frequency, so there would be standing waves on the line, but any losses would be quite low on a parallel line. In the coaxial line attached, losses due to VSWR would be low, where the match is good, but high where the match is poor, thus making things worse on 10 and 21 MHz. Austin discusses this issue in some detail in a recent RadCom article (4).

Clearly there were advantages of this design compared to the G5RV, yet it seems not to be well-known. Recently, perhaps due to commercial availability, it seems that more hams are discovering what this simple antenna has to offer.

Working out the details

There were no exact plans available, so firstly I looked at the overall construction. The antenna needed to be robust and weather proof, so I adopted the method used in the commercial models, of encapsulating the dipole centre connection in PVC pipe fittings. I also adopted the method of using swage, thimble and eye-bolt connections to the centre, as an effective way to avoid wire wear and fractures. A simple ferrite bead

'choke' balun was added at the end of the parallel line to suppress currents flowing on the outer of the attached coaxial cable.

Figure 1 shows the basic arrangement.

The next step was to figure out the dimensions. The dipole length was no problem, starting with excess length and then folding back until the desired resonance was achieved. The final adjusted length was 13.8 metres each side, not including the loops at the support. The parallel 'matching' section was not so simple: the impedance and velocity factor had to be taken into account, and I spent some considerable time going through several sources of information, mulling over the best length. Eventually I settled on 12.31 metres (relying mainly on Austin's information in *Sprat* (5) which does not include approximately 40 mm inside the centre support and 20 mm inside the balun.

Note that the matching section length is very dependent on the impedance and velocity factor of the line. Recommended reading on this aspect is Austin's 1985 *RadCom* article (2).

Construction

Rather than use up space here with detailed parts list and instructions, I have put these in an article in the projects page of the Summerland ARC website at www.sarc.org.au. I thought it worthwhile though to mention the source of my materials, as this can be a stumbling block for any kind of home-brew project.

The wire and feeder was sourced from Davis RF in the USA. Similar materials are available from 'The Wireman'. I built two antennas; the first one used bare 7-strand hard-drawn wire 16AWG. With the second antenna, I used insulated high-flex wire 14AWG, for use in field operations. The feeder is 450 ohm 'window' line, of 16AWG stranded copper-clad steel. The ferrites for the balun are type FB-31-5621 obtained direct from

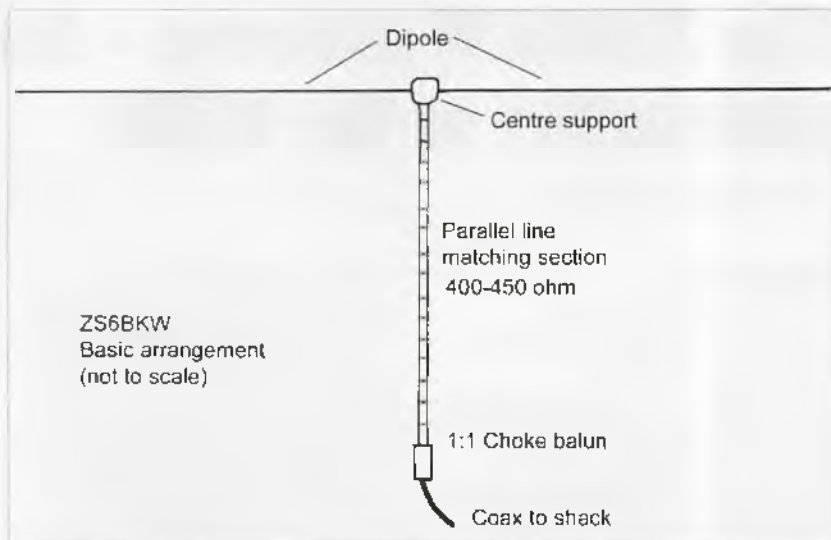

Figure 1: The basic arrangement of the ZS6BKW antenna.



Photo 1: The centre support.

Amidon Corp. The short length of coax passing through the balun is RG8-X, using the top quality timed variety with a second shield, from The Wireman.

The PVC pipe and fittings are standard class 18 water pipe ('HP' pipe) as sold by plumbing and hardware shops. The fittings are all stainless steel, from the Bolt Barn.

I used a Neoprene adhesive-sealant for encapsulating - 'Parfix' brand, from Bunnings.

This is non-corrosive and waterproof. Polyurethane sealant is also suitable. You could also use epoxy filler. If you don't encapsulate,



Photo 2: The window line soldered and ready to be potted.

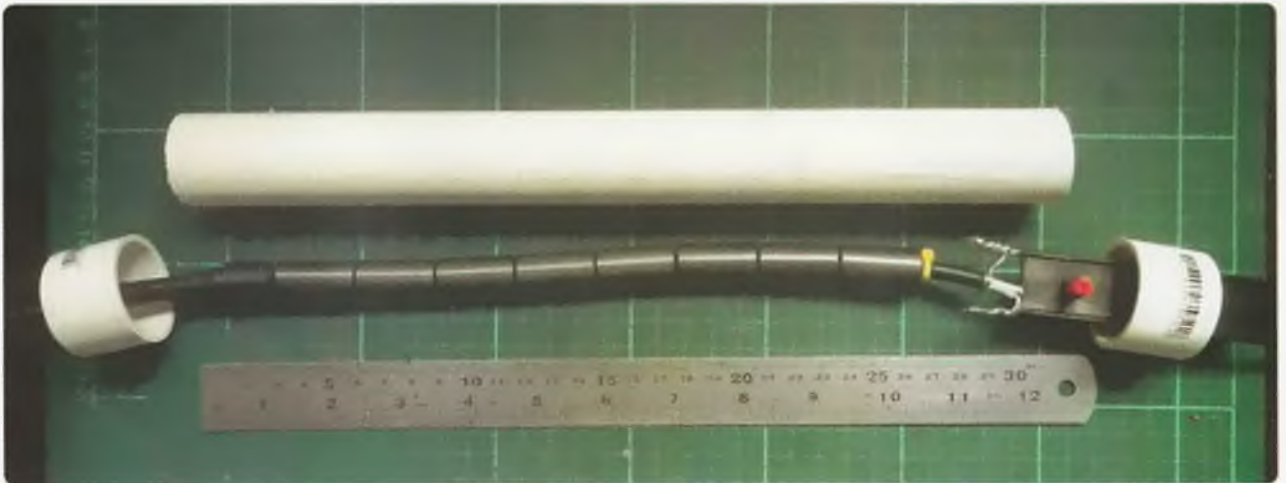

Photo 3: Assembly of the balun.



Photo 4: The complete ZS6BKW antenna.

you need to ensure good sealing at all entries to prevent water ingress.

Photos 1 to 4 give an idea of the construction.

Installation

Like its predecessor the G5RV, the antenna was designed to be installed as a flat-top dipole.

However it will work effectively in inverted-V configuration as long as the angle is not excessive. If space is limited, the ends could be

drooped, however this will affect the characteristics, but as to how much, I have no idea. If you can do it, flat and symmetrical is best.

The entire length of the window line should be clear of the ground. If this is not possible with the line vertical, it should be brought out on an angle and somehow fixed so that it does not lie on the ground. Also it absolutely must be kept well clear of anything conductive.

My home antenna is hoisted up into a tree with a halyard at a bit over 12 metres high, so that the balun was just touching the ground. The dipole ends are supported about six metres high with weighted lines running through pulleys attached to vertical supports.

I made three triangular outriggers from HP pipe to keep it about 500 mm away from the tree. This has helped to prevent tangles with the halyard rope and the climbing pegs in the trunk. Connection to the shack is via about 20 metres of RG213 coax.

Testing

Having completed the first antenna, tests were conducted with it installed as described above, at the input to the shack via 18 metres of RG-213 coax. After checking for continuity and shorts, adjustment of the wire lengths was done using an MFJ-259 analyser on 7 and 14 MHz. I had started out quite long and gradual trimming brought the minimum SWR around 7.05 and 14.2 MHz. An on-air test confirmed satisfactory TX and RX with no tuner at those frequencies.

A more thorough check was then done using a mRS mini VNA-pro analyser. The following plots show some of the results. Note that the vertical scale is logarithmic, so the 1.5:1 line is higher up than the middle of 1:1 and 1:2.

My results differ somewhat from the theoretical and practical results of others. There are several factors in play, and one of them would be the proximity and nature of the ground. My home installation

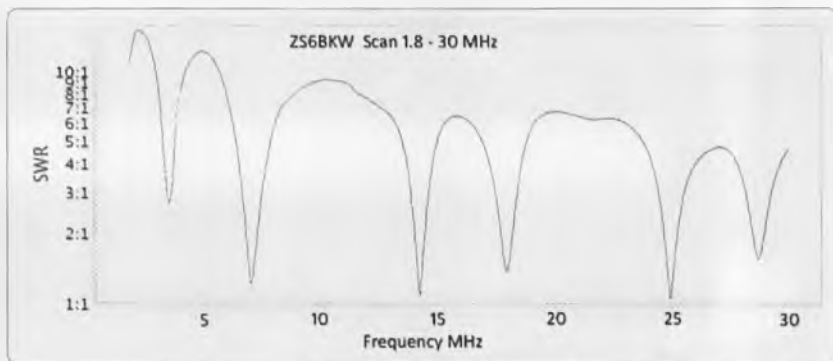

Figure 2: The full HF scan shows the dips for the five bands. Note the very good dips for 7, 14 and 24 MHz. 18 and 28 MHz are not as deep but still quite good, though some tuning would be desirable. 3.5 MHz is usable with a tuner. 10 and 21 MHz are poor.

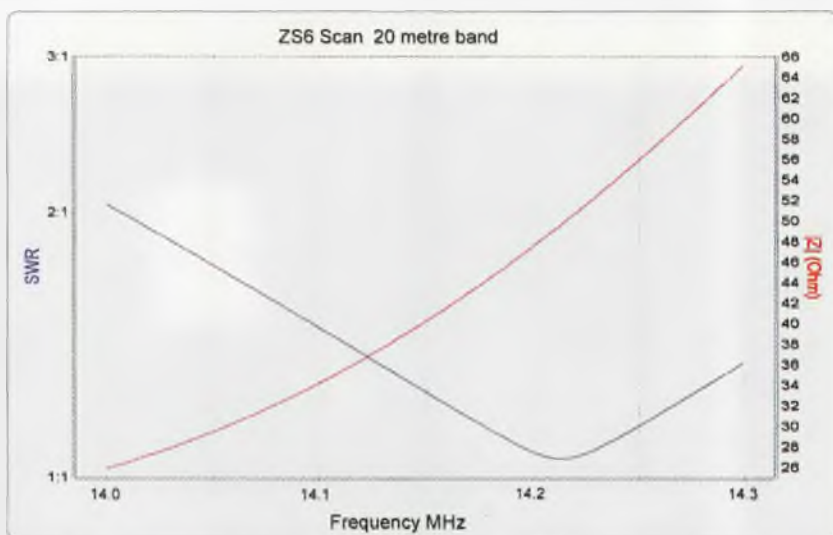

Figure 3: The 20 metre scan shows a good SWR curve, favouring the higher part of the band.

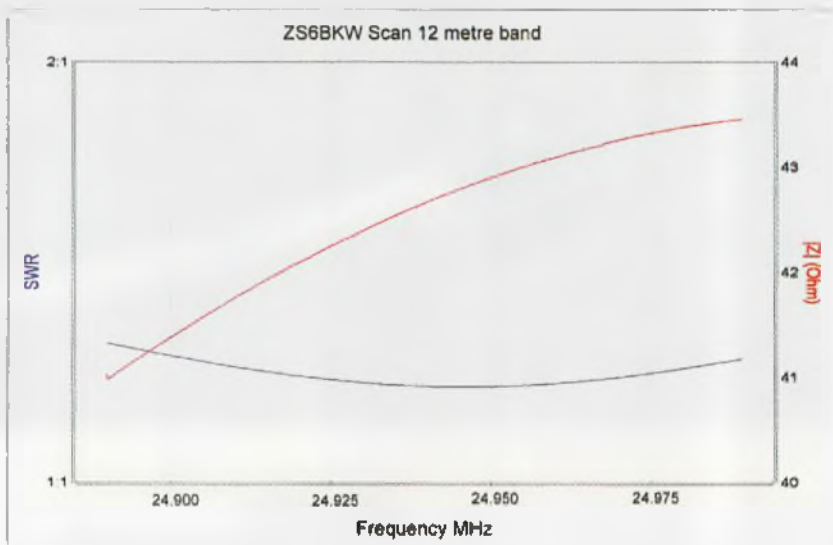

Figure 4: The 12 metre scan shows a very nice spread of low SWR across the whole band.



Photo 5: The ZS6BKW set-up 'inverted-V' at Cape Byron for the ILLW.

is over shallow soil formed on sandstone and shale. It may be that the relatively low height at the dipole ends is the likely cause of a downwards shift in frequency on 40 metres due to capacitive effect of the ground. Also the feedline length and velocity factor would be influential.

There was a difference in the final adjusted dipole length of my two antennas – 13.8 m a side for the one with stranded H/D wire and

13.17 m for the one with thicker, insulated hi-flex wire. It should be noted that I made the adjustment by folding back the excess length. Exactly what effect this would have compared to cutting off the excess, I am yet to determine.

On air results with the first antenna have been very pleasing, and I have been able to bypass the tuner almost all the time on the bands I use most, 40 and 20 metres. I am particularly interested

in trying 12 metres, a band I have largely ignored, and the fact that the SWR pattern there sits neatly across the band is very encouraging. The centre height is over ½-wave on 20 m, and this must be giving a reasonably low angle of radiation, as Europe long-path comes in quite well when conditions are favourable. It also performed well on 40 metres in the 2015 John Moyle Field Day.

The second antenna was tested with an MFJ-259 analyser, with the antenna about 30 degrees slope inverted-V, about 11 m up in a tree. The results are shown in Table 1.

This portable version was used in the 2015 Lighthouse Weekend (as VK2SRC/p). It was suspended inverted-V at about 8.5 m from a Clark mast, using an outrigger at the top to keep the feedline

Frequency (MHz)	SWR x:1	R (ohms)	X (ohms)	1.5:1 Bandwidth (kHz)
7.104	1.1	55	4	207
14.204	1.0	48	4	239
18.142	1.7	37	20	nil
24.952	1.1	43	3	267
29.146	1.8	26	1	nil

Table 1: ZS6BKW Version 2 test results.

away from the metal. Due to the reduced height, the feedline had to be looped about and run horizontally for 2 m, and this detracted somewhat from the SWR performance. Contacts were made to 24 lighthouses, across VK2, 3, 4, 5, 6, 7 and ZL in several hours before my voice gave out due to the flu.

My results with both antennas suggest that the ZS6BKW is overall clearly superior to the G5RV, even if only for the fact that it has three no-tuner bands (depending on how fussy you are), whereas the G5RV has only one.

Further thoughts

For someone with the time and energy, other combinations of dipole length, feedline, and installation may yield results more favourable on some bands and less so on others. One interesting idea is the use of a rigid adjustable section in the feedline (6).

The centre supports I made are rather heavy. For field use, a design with a simple backing plate with detachable connections would lessen the weight and make it more backpack friendly.

Summary

This article describes the ZS6BKW multi-band wire antenna and a

construction method designed to withstand severe winds and also provide a high level of protection from corrosion.

The built antennas provide a low to moderate SWR over much of the amateur bands of 40, 20, 17, 12 and 10 metres. 80 metres is also usable with a trans-match. The work done by Brian Austin is, in my opinion, a good example of how theoretical analysis and practical testing can be used to make significant improvements to an existing antenna design.

Acknowledgements

I would like to particularly thank the RSGB for providing copies of Austin's excellent RadCom articles. Thank you also Geoff VK2AGC (now silent key) for the loan of the mini-VNA pro analyser.

References

Cited references:

1. Le Blanc, Larry J. *ZS6BKW vs. G5RV*
www.w5ddl.org/files/Zs6bkw_vs_G5rv_20100221b.pdf
2. Austin, Brian *Computer-aided design of a multi-band dipole*
RadCom August 1985
3. Nicholson, T. *W5ANB Compact Multiband Antenna Without Traps* *QST* Nov 1981

4. Austin, Brian *Highs and Lows of the ZS6BKW*
RadCom April 2014
5. Austin, Brian *The ZS6BKW Antenna - from the horse's mouth, Sprat*, 130
6. Moore, Cecil W5DXP
Some useful ZS6BKW modifications
<http://w5dxdp.com/ZS6BKW80/ZS6BKW80.htm>

Further reading:

Cebik, L.B. *The G5RV Antenna system Re-visited Part 3: The Almost-No-ATU G5RV-Type Antenna*
<http://www.k2ck.us/g5rv.pdf>

Vincent, Martyn *The ZS6BKW multi-band HF Antenna Revisited, Sprat*, 129, Winter 2006
http://www.ab4oj.com/dl/sprat_zs6bkw.pdf

Varney, Louis *G5RV Multi-band Antenna - up to date, RadCom* July, 1984

Note: *RadCom* is the journal of the Radio Society of Great Britain

Sprat is a quarterly publication of the G-QRP Club.

Editor's note: This article was received by AR magazine in September 2015. We apologise for the excessive delay in its publication.

Over to you

Safety Warning for LiPo Cells

Hi Rod and editor *AR* magazine, I found something in *AR* Nov 2017, that refers back to you that I presume is a confusion in battery nomenclature and needs to be corrected publicly, since it could be dangerous.

Page 45: About LiFePO4 cells - there is also a reference in the same paragraph to LiPo cells, which are quite different beasts. The item appears to be about LiFePO4 cells. For the record: LiFePO4 cells have a nominal 'float' or full voltage of 3.25 V per cell, and a

maximum charge of 3.65 V. They are FULLY discharged at 2.7 V.

LiPo, or Lithium Polymer cells, have a max charge of between 4.1 and 4.3 V per cell, depending on the anode material and are discharged at approx. 3.2 V per cell.

The way the article reads, it encourages users to charge the LiFePO4 cell to 4.23 V which is a recipe for disaster! They are very different cells with very different chemistry and must not be confused.

I encourage the magazine and the author

to generate a correction with their local group and the magazine readers.

Regards,
Glen English VK1XX.

Editor: The confusion was by the author of the AHARS notes and the editing team missed the error. Lithium chemistry cells can be volatile, so users should check the chemistry and the recommended charging details for the exact battery that they are using.



Sydney Harbour Ferry Contest

Laurie Gordon VK2GZ

Patrick VK2FPAT was not only the youngest entrant in last year's Sydney Harbour Ferry Contest - he has won the coveted Harbourmaster Award for top individual score!

He was presented with his certificate and prize of a Power Pole kit at the recent AGM of the Waverley Amateur Radio Society. Patrick, who is nine, also received certificates for working from and to all ferry lines (Worked All Ferries Award). Though accompanied by dad Cameron VK2CKP, Patrick performed all contacts and log operation individually.

Cameron received his own certificates for working to and from all ferry lines.



Photo 1: Patrick VK2FPAT and Cameron VK2CKP receive their awards from Laurie VK2GZ.

Derrick VK2DEK was the second highest point scorer and Peter VK2PR third highest. Peter scooped the Gold Seafarer award for the greatest number of unique contacts on the day.

The early check-in prize draw was won by Sam VK2HAX. All participants who submitted a log received the "Billy Blue Award" - named after Sydney's original ferryman.

Next year the contest committee may have to consider an additional



Photo 2: Setting up the Rose Bay contest control station.



Photo 3: John VK2LWB with the bank of UHF/VHF rigs at the Rose Bay control station.

DX category following contacts via EchoLink from Brad VK2CEC working from the Ulmarra and Lawrence ferries on the Clarence River! The contest attracted participants from many parts of the state as well as DX visitors Soren ZL1SKL and Raphael HB9ESX.

This was the second annual Ferry Contest organised by the club, with numbers of participants slightly higher than for the inaugural event.

The aim of the contest is to work other operators on Sydney's ferries or the 36 public wharves by hand-held transceiver. Points are awarded for simplex, duplex and "eyeball" contact, with multipliers based on the number of ferries/wharves activated.

The end result is a scurry of enthusiastic hams ferry-hopping from wharf to wharf in all parts of



Photo 4: Raphael HB9ESX was the furthest DX home-call in the contest.

Sydney Harbour. The event has full co-operation and support from transport authorities.

A club station set up near the Rose Bay ferry wharf acts as contest control, event broadcast centre and popular meet-and-greet point.

In 2017 Sydney Harbour was particularly busy with tourists and locals taking advantage of the \$2.50 all-day fare - and no doubt encouraged by the warm sunny day after a week of rain.

Mark your calendar for this year's contest which will be held on Sunday March 11, 2018. Details will be found on the WARS website VK2BV.org and the contest Facebook page - search Sydney AR Ferry Contest.



EMDRC Hamfest 2018

Sunday 25 March 2018

Great Ryrie Primary School
51A Great Ryrie Street, Heathmont, Victoria

www.emdrc.com.au www.facebook.com/vk3er

\$6pp including one Raffle ticket and bottomless tea & coffee.

Doors open at 10 am.

Breakfast and morning tea available at the famous BBQ.

For Event Information or Table Bookings please visit the club website www.emdrc.com.au or email the committee vk3er@emdrc.com.au

Commercial and second hand traders, new & used bargains, Raffle prizes donated by our commercial traders, raffle drawn 12 noon.

Plenty of space for a chat with old and new friends.



Radiobooks.com.au

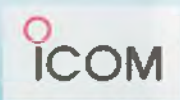



VHF/UHF - An Expanding World

David K Minchin VK5KK

Introduction

This month we have Leigh VK2KRR's regular WSPR report as well as a report from VK7AC on activity for December including Argentina on 50 MHz JT65 via Sporadic E! We also have another look at those ADF PLL based oscillators available online. Kevin's Meteor Scatter notes will be back in the next issue.

WSPR NOV/DEC 2017 Propagation Report

Leigh Rainbird VK2KRR reports on WSPR activity for November and December 2017...

"I hope that all readers have had a good Christmas and new year, some of you I believe have received the gift of propagation for Christmas, right on time. Around the Christmas period there has been a mix of Tropospheric Propagation and Sporadic E, even some double hop Es at times. Well done to everyone involved, even if signals at your QTH have been sparse, it still gives all involved a better idea of what the propagation is doing, just having a station on air is a great help.

In my previous article I wrote about how we can analyse the WSPR database to identify areas of high MUF Sporadic E, which may propagate 2 m band signals. I mentioned that, once low powered 6 m WSPR signals provide high strength decodes on short paths of 900 to 400 km, that 2 m should be propagating somewhere. Upon further investigation of this, at times, we have seen very good openings on 6 m with +dB signals on short paths, but no 2 m propagation. It appears to not be as straight

forward as it seems. Usually we can identify backscatter by weaker signal strengths, but this season there has been times when there has been very good signals on 6 m and it can be nearly impossible to work out what part of the sky they are coming from and we don't see 2 m propagation. Having said that, it does appear that 2 m openings are more likely when really short Sporadic E 6 m paths occur in the 400 to 700 km range, the 700 to 900 km 6 m paths seem to just be teasing us.

We currently have great numbers on 6 m WSPR, but still lacking on the 2 m band, particularly in VK4, VK6. For both bands it would also be great if we could find some stations in Alice Springs VK8 since it quite central and within E hop range of most places.

As the summer period is quite busy for this column report, I will only report on the more significant openings and paths.

50 MHz WSPR: *From about mid-way through November, Sporadic E began to become quite common on the 6 m band each day within Australia and also from the east coast of Australia to New Zealand. From around the beginning of December, double hop E paths from New Zealand to South Australia would occur nearly every day, then closer again toward the equinox we began to see triple hop paths from Western Australia to New Zealand. All detailed data is of course available from the WSPR database.*

We have been lucky to have Phil 3D2TS making his station available from Fiji. Phil also has a remote station in New Caledonia signing

as FK1TS that he has also made available on 6 m WSPR. A number of stations from VK and ZL have been able to make the path with either or both of Phil's stations.

We got a surprise on 22 December when Matt VK3PP near Hamilton was able to decode a 50 watt signal from Chris N3IZN in southern California at 2240Z at 13,059 km, signal strength only -25 dB. We had given up on anything further when an hour later Matt again received Chris another 2 times, a -24 and -25 dB. Then 20 minutes later at 0020Z Rhett VK3WE in Gippsland received Chris N3IZN at a slightly better -22 dB. That was it, and we have not seen any further Trans-Pacific paths at the time of writing.

Great to see all the stations on 6 m WSPR, especially those setting up for the first time, the more stations giving it a run the more interesting it can become. It really is great fun and does get very hectic at times when the band it's really going.

144 MHz WSPR: *We have had a number of interesting stations set up on 2 m WSPR for the summer. We have Lloyd VK4FP at Townsville, Andrew VK5MR out near Roxby Downs, Phil 3D2TS is often listening 2 m WSPR at Fiji. Hayden VK7HH has set up a remote 2 m WSPR station on Mt Lloyd to the west of Hobart. Numerous stations in New Zealand and the usual active stations on mainland Australia.*

While there have been numerous indications of high MUF sporadic E areas forming when observing 6 m WSPR data, it's been hard to get signals through on 2 m WSPR.



Photo 1: A Drone's view of LU5FF's 50 MHz antenna.

After intense monitoring of the 6 m WSPR signals for high MUF areas, at 0730Z on 4 December Hayden VK7HH near Hobart managed a sporadic E path with Wayne VK2XN near Narrabri, signal of -21 dB at 1443 km.

Then in the evening on 5 December Hayden VK7HH and Wayne VK2XN got another signal through on sporadic E at 1158Z, signal of -19 dB at 1443 km.

Beginning in the evening of the 9th till late morning of 10th December, a Tropo opening built up across the Bight path. Signals passed to or from Derek VK6DZ near Albany and linked up with Ian VK3YQCQ at 2420 km, Brian VK5BC at 1922 km, Steve VK3ZAZ at 2193 km, Norm VK3DUT at 2698 km, Phil VK5AKK at 1909 km, Alan VK3DXE at 2463 km, Tim VK3JTM at 2274 km, Peter VK5PW at 1952 km, Leigh VK2KRR @ 2664 km. Morning of 11 December, a signal made it through with from Peter VK5PJ to Hayden VK7HH's home station on Tropo at 1167 km, only -27 dB. A brilliant sporadic E opening occurred during the morning of 19 December where

Hayden VK7HH had paths with ZL2AKI, ZL2IT, ZL2JBK and ZL2TLF, with a maximum distance of 2511 km. At the same time Jeff VK5GF at Victor Harbour had a path with ZL2JBK of 3144 km and -12 dB. A great catch.

From the evening of 21 December through to the morning of 26 December there was a Tropo opening across the Bight. Derek VK6DZ had paths with Phil VK5AKK, Brian VK5BC, Steve VK3ZAZ, Leigh VK2KRR, Alan VK3DXE, Hayden VK7HH remote. The furthest path being Leigh VK2KRR at 2664 km, but also an amazing 2660 km from the VK7HH remote site. In the evening 23 December, Rhett VK3WE caught one brief E signal from ZL2IT at 2543 km which was a -20 dB. On the evening of 24 December, Hayden's remote VK7HH station captured an E path with Wayne VK2XN over 1443 km at a big +18 dB signal. In the afternoon of Christmas day 25 December, Len VK4ALF north of Brisbane captured a sporadic E path with Jeff VK5GF at 1690 km with a +7 dB, Tim VK3JTM at 1517 km and a +2 dB,

and Alan VK3DXE at 1478 km and a -3 dB signal."

All contributions on propagation and WSPR are welcome; just email Leigh VK2KRR at vk2krr@wia.org.au

VK7 50 MHz digital to Argentina

Norman VK7AC (QE38mp) reports... "The 6 m QSO with Javi LU5FF (FF99rf) in Argentina could be the first digital QSO between VK7 and LU ever. The following is a brief summary 6 m & 2 m propagation for December 2017.

4-12-2017 04:13 3D2TS FT8 6 m,
4-12-2017 04:15 3D2AG FT8 6 m,
4-12-2017 05:27 DU7/PA0HIP FT8 6 m.

8-12-2017 07:40 VK8MS FT8 6 m,
8-12-2017 07:57 TO 0908 ZL2.3.4 FT8 6 m,
8-12-2017 09:12 VK6HV FT8 6 m.

9-12-2017 02:53 ZL4LV FT8 6 m,
9-12-2017 03:56 5W1SA FT8 6 m.

13-12-2017 02:53 NH6Y FT8 6 m,
14-12-2017 08:30 DU7/PA0HIP FT8 6 m,
14-12-2017 23:11 3D2AG FT8 6 m,
16-12-2017 05:41 TO 0741 VK3,4,5 AND ZL; 1,3,4. FT8 6 m.

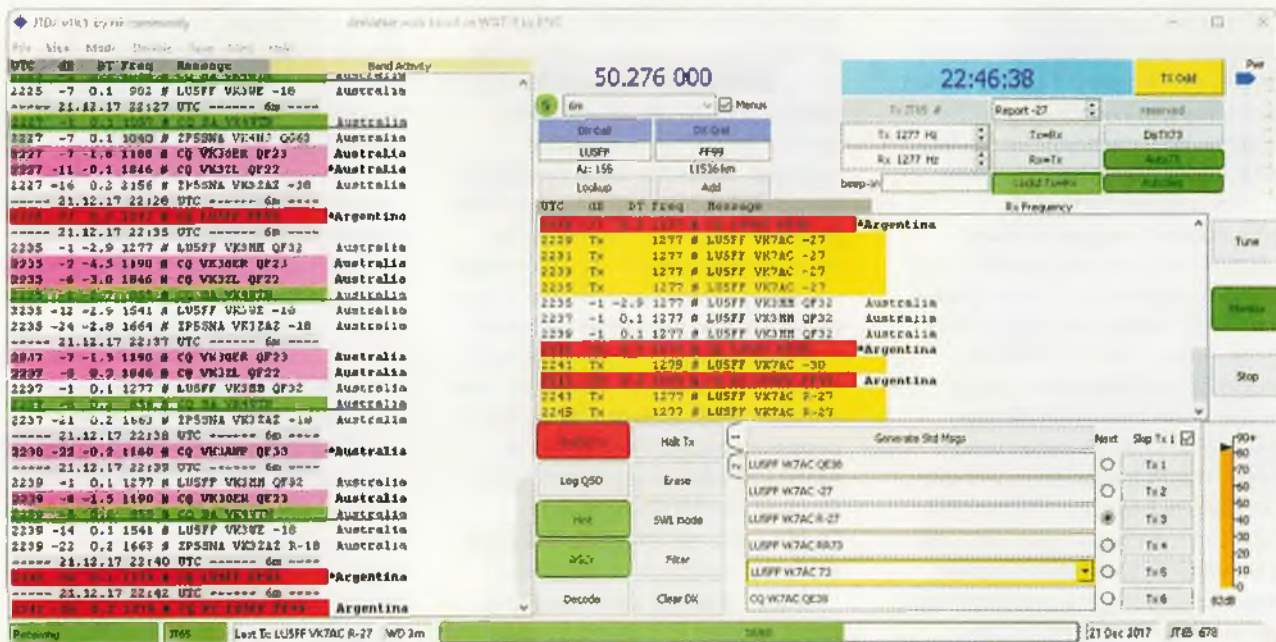

Photo 2: A Screen grab from VK7AC with LU5FF 50 MHz signals.

- 18-12-2017 23:50 ZL3RC SSB 2 m
- & 18-12-2017 00:05 ZL3NW SSB 2 m
- 21-12-2017 22:42 LU5FF JT65 6 m.
- 22-12-2017 04:38 FK1TS FT8 6 m,
- 23-12-2017 06:29 5W1SA FT8 6 m,
- 23-12-2017 06:40 VK6RZ VK6JI FT8 6 m,
- 24-12-2017 00:31 to 04:29 VK5, 6, 2 FT8 6 m.
- 27-12-2017 00:40 VK8GM VK2XD VK5MR VK2CCW SSB 6 m,
- 27-12-2017 07:57 H44DA SSB 6 m"

LU5FF also worked a number of VK3 stations (see Screen grab). The distance between LU5FF and VK7AC was 11510 km on a great circle path crossing close to the coast of Antarctica. LU5FF is located at San Justo, Central Argentina. The photo shows an aerial view of his antenna system taken from a Phantom 4 Drone. If you want to see more just Google "LU5FF Antenna" to find the YouTube video!

Those "Online" ADF4351/5355 PLLs revisited

In the 2016 series on Microwave Local Oscillators we discussed the ADF4351 and ADF5355 PLLs PCBs that had just become available

online. Whilst the price looked good, unfortunately the phase noise performance of all samples was only fair when compared to the original Analog Devices spec sheet for the same devices precluding their use for anything serious above their fundamental frequency. Now in 2018 the other sources for surplus PLLs have been "fished out" (Elcom and Verticom PLLs) so more work has been done to see if these cheap PLLs can be improved.

All PLLs need a low noise reference oscillator however PLLs

with internal VCOs have a few extra design requirements. The internal VCO on the same chip with digital circuitry means they are more sensitive to noise from both DC supply and digital lines. Also, most of these PLLs sold online use inexpensive 1.6 mm FR4 PCB so the grounding vias under the PLL chip and DC rail bypassing grounds are not optimum above 1 GHz. Worse still, some PCB designs have shortcuts like connecting all three PLL chip DC supply pins together with one chip capacitor bypass! The

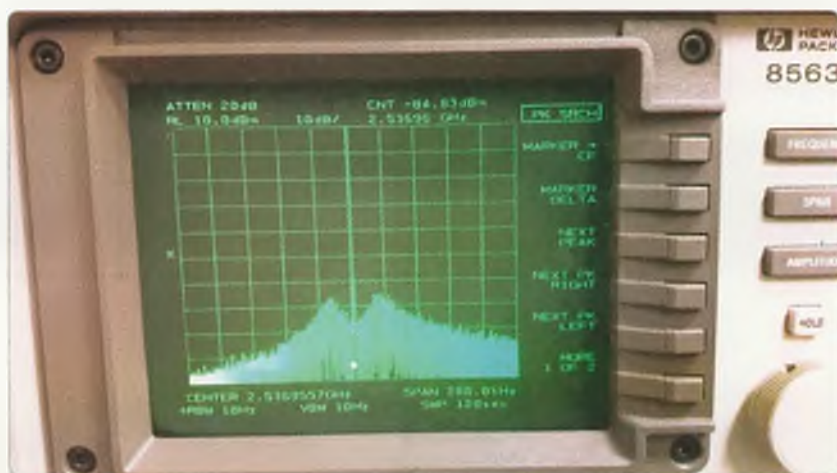

Photo 3: Spectrum analyser phase noise plot for ADF4351 PLL, with/without rail bypass.

DC bypass capacitors and chokes used with the DC regulator should be like the suggested circuit shown but some just have a single ??uF ceramic chip capacitor on the input and output terminals!

For a recent project, I constructed 3 separate G4JNT LTC6946 PLLs to run on 4.96, 5.32 and 5.976 GHz to be incorporated into 5760, 10368 and 24048 GHz transverters. The LTC6946 PLL works up to 6 GHz with similar phase noise characteristics as the ADF4355/5355 series (also 6 GHz). The PLL oscillators worked OK despite being on 1.6 mm FR4 PCB but the phase noise was still a bit under specification. I spent hours optimizing the programming but ended up focusing on the voltage rail components and DC rail bypasses to obtain the final improvements.

During these tests I found great differences in the actual contributed noise from different types (and sources) of voltage regulators. All

had the same noise specs quoted at "0.003%" of output voltage from 10 - 100 kHz but noise contributed varied up to 10 dB at +/- 50 kHz without any other component changes. To be fair, once the cheap "seconds" regulators sourced online were eliminated the results were much closer! Voltage regulator noise is easy to identify as it shows up as noise close to the centre frequency and looks like a double camel hump +/- 100 kHz of centre frequency (see photo). Using good quality tantalum bypass capacitors and genuine AMS1117 voltage regulators (from Element 14, RS Components, DigiKey, etc) got things to the point that they could not be improved.

After I finished the three PLLs, I built another PLL using a newer designed PCB by G8ACE. The small changes made around the PLL chip in locating tracks and extra ground vias saw another improvement in phase noise. I wish I had used these PCBs to start with!

Meantime, Brian GM8BJF has

done some work to improve the Phase noise on the popular online ADF5355 13 GHz PLLs. There are two main PCB variants (green and black) but both share the same circuitry and exhibit similar phase noise problems as the ADF4351 examples. Central to the noise problem would seem to be that they both use the same general purpose LT1733 series regulator (8 pin SOIC). These are intended to run 3.3 volts processors not microwave oscillators, the better low noise regulators specified in the Analog Devices data sheet have not been used as they cost 20 times more! Unfortunately the two different regulators have entirely different pinouts and circuitry so a straight swap is not an option.

Given that the existing regulator could not be changed on the ADF5355 PCB, an even simpler solution was found by just installing a super large low ESR capacitor across the output of the DC regulator! The actual value probably isn't critical but

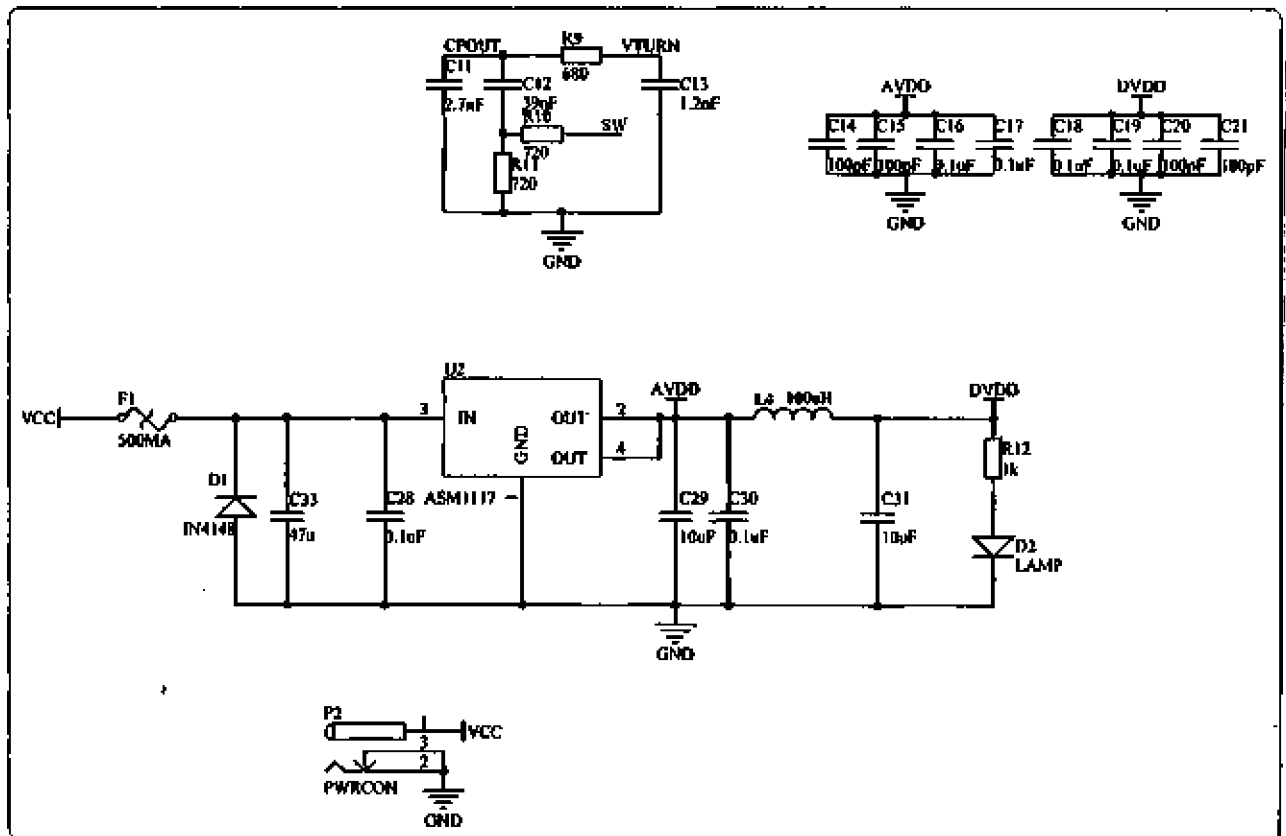

Photo 4: Suggested DC circuitry for the "Online" ADF4351 PLLs.

Brian used a 3300 uF 6.3V 105C low ESR Rubicom electrolytic capacitor mounted right on the output of the 3.3V and 5V regulators. He reported a >10 dB reduction in phase noise in the "hump" of the spectrum either side of centre frequency. If you have one of these PLL oscillators, do yourself a favour do the same modification! You will find genuine Rubicom capacitors online but local suppliers will also have something similar on the shelf. For more information on what Brian found please go to his website at <https://gm8bjf.joomla.com/>

As a simple test, I grabbed one of my un-modified "Bad" ADF4351 PLLs to see what the effect a

3300 uF capacitor would have on the output of the no name 3.3 V regulator. The PLL was programmed to a random frequency (2.53696 GHz), with non-optimised filter/charge pump settings and the original internal oscillator. Looking at the photo, the side left of centre has the capacitor in circuit and the right side has the capacitor removed. The span width is +/- 100 kHz, bandwidth is set to 10 Hz. The phase noise is lower on the left side vs. the right side and from +50 kHz onwards this is a good -10 dB. In reality, more needs to be done to this PLL but it is a big first step using just one 50 cent component. Changing the regulator,

using a clean external reference oscillator, upgrading the DC circuitry to that recommended and installing the PCB in a shielded box should improve things to the point of being usable.

In closing

Feel free to drop me a line if you have something to report. Contributions regarding club projects or proposed activities are always welcome. Just email me at david@vk5kk.com and I'll include in the column.

73
David VK5KK

AMSAT-VK



AMSAT Co-ordinator
Paul Paradigm VK2TXT
email: coordinator@amsat-vk.org

Group Moderator
Judy Williams VK2TJU
email: secretary@amsat-vk.org

Website:
www.amsat-vk.org

Group site:
group.amsat-vk.org

About AMSAT-VK

AMSAT-VK is a group of Australian amateur radio operators who share a common interest in building, launching and communicating with each other through non-commercial amateur radio satellites. Many of our members also have an interest in other space based communications, including listening to and communicating with the International Space Station, Earth-Moon-Earth (EME), monitoring weather (WX) satellites and other spacecraft. AMSAT-VK is the primary point of contact for those interested in becoming involved in amateur radio satellite operations. If you are interested in learning more about satellite operations or just wish to become a member of AMSAT-Australia, please see our website.

AMSAT-VK monthly net

Australian National Satellite net

The Australian National Satellite Net is held on the second Tuesday of the month (except January) at 8.30 pm eastern, that's either 9.30 or 10.30Z depending on daylight saving. Please note we will be taking check-ins from 8.20pm-ish. Check-in starts 10 minutes prior to the start time. The AMSAT-VK net has been running for many years with the aim of allowing amateur radio operators who are operating or have an interest in working in the satellite mode, to make contact with others in order to share their experiences and to catch up on pertinent news. The format also facilitates other aspects like making 'skeds' and for a general 'off-bird' chat. Operators may join the net via EchoLink by connecting to either the "AMSAT" or "VK3JED" conferences. Past experience has shown that the VK3JED server

offers clearer audio. The net is also available via IRLP reflector numbers 9558. In addition to the EchoLink conference, the net will also be available via RF on the following repeaters and links.

In New South Wales
VK2RBM Blue Mountains repeater on 147.050 MHz

In Queensland
VK1RRR Redcliffe 146.925 MHz -ve offset IRLP node 6404 EchoLink 44666

In South Australia
VK5TRM, Loxton on 147.175 MHz
VK5RSC, Mt Terrible on 439.825 MHz IRLP node 6278,
EchoLink node 399996

In Tasmania
VK7RTV 2 m. Repeater Stowport 146.775 MHz. IRLP 6616

In the Northern Territory
VK6MA, Katherine on 146.750, CTCSS 91.5, IRLP Node 6800

Operators may join the net via the above repeaters or by connecting to EchoLink on either the AMSAT or VK3JED conferences. Past experience has shown that the VK3JED server offers clearer audio. The net is also available via IRLP reflector number 9558. We are keen to have the net carried by other EchoLink or IRLP enabled repeaters and links in order to improve coverage. If you are interested in carrying our net on your system, please contact Paul via email. Frequencies and nodes can change without much notice. Details are put on the AMSAT-VK group site.

Become involved

Amateur satellite operating is one of the most interesting and rewarding modes in our hobby. The birds are relatively easy to access and require very little hardware investment to get started. You can gain access to the FM 'repeaters in the sky' with just a dual band handheld operating on 2 m and 70 cm. These easy-to-use and popular FM satellites will give hams national communications and handheld access into New Zealand at various times through the day and night. Currently only 50-50 is available. Should you wish to join AMSAT-VK, details are available on the web site or sign-up at our group site as above. Membership is free and you will be made very welcome.

Plan ahead

Eastern & Mountain District Hamfest 25 March 2018

WIA Radio & Electronics Convention & AGM Gold Coast 18 - 20 May 2018

Australia celebrates its Mills

Tony Falla VK3KKP

May falls right in the middle of our autumn here in central Victoria. It always seems to amaze our cousins over there in the UK that we can ever be cold here but, being in a climate similar to a desert environment, I can tell you that this area can have gloriously sunny days followed by clear, bitterly cold nights. And so it was on the 13/14 May when we attempted to put Andersons Mill at Smeaton on the air for Australia's first contribution to the Mills on the Air event.

The full story of how Cheryl and Alan Just moved to a house close to the mill many years ago and fell in love with it can be read here (1).

They organised, with the National Trust, Parks Victoria and many local organisations to have an Andersons Mill Heritage Weekend (2) where traditional crafts would be demonstrated and the mill would be open to the public. I'd been to several public events at this mill in summer and was taken by the beauty of the setting, alongside its power source, the Birch Creek and being from England as G8HIM and a member of the RSGB I knew something about the UK's Mills on the Air scheme (3).

Some time ago, Alan and Cheryl managed to contact Tony Marriott GM0GFL from the Zetland ARS in Shetland for advice. That club was associated with the Quendale Mill (4) and they were very helpful. Tony advised Alan and Cheryl to get in touch with their local radio club, which turned out to be the Central Goldfields Amateur Radio Group but the first I heard about it here in Castlemaine was an email from Alan and Cheryl who had



Photo 1: An overview of the mill precinct.

contacted Peter Rafferty VK3CC from that group and it was he who subsequently invited me to join the event along with any colleagues and other club members I could gather together.

During the preparatory meeting with members of the Central Goldfields Amateur Radio Group and the Bendigo Amateur Radio and Electronics Club we felt that all the radio arrangements were well in hand so I suggested that my part should be to use the event to promote amateur radio generally and help explain to the public what we were doing.

It was an 8 am start at the site on Saturday 13 May some two

hours before the site was open to the public. Bear in mind that it would be nine hours ahead of UK time so we were not in a hurry. We had the use of a concert lighting rig for towers and we were able to live in the stables which became our shack and home for the next 48 hours.

On-air conditions were poor and our operators were hard pressed to get contacts using club callsign VK3BI but they persevered all day and into the evening mainly on 40 metres and 20 metres, however tiredness and the cold took its toll and we all crept off to bed and slept as best as we could. I use my small van as a camper (and



and shared stories with the visitors and members of the public. It was surprising how many people told us they had a history with radio and electronics.

By Sunday I had a WSPR setup going with an FT-817 and I was able to demonstrate my new KiwiSDR. On the table outside I grabbed the attention of the kids playing heritage traditional games, organised by Clunes Neighbourhood House, with a demonstration of free-to-air satellite TV. I was then able to hand out leaflets from our national body, The Wireless Institute of Australia. By the end of the weekend I already had three email enquiries for more information. All this time the hard working radio team were inside making contacts and demonstrating radio communication to a continuous stream of visitors.

Late Saturday night a local farmer called in to the stables on his way home from work. He was a kid in WWII and remembers the time when the mill owners fell into bankruptcy and sold out to another company which installed electric motors to reduce their reliance on water power. But the wheel was no longer wanted or needed so the owners decided that, given the difficulty dismantling it, they would blow it up!

shack) when I go to the many folk festivals in Australia so I was well set up to keep warm. Some of the others decided to make better arrangements for the following night!

The Saturday was a bit of a shambles with my arrangements, as I had brought some rather technical stuff with me to entertain the public and most of it took a while to get going what with me talking to the public and trying to convince them to pop their heads in to the radio room. And Saturday was the day that we had a lot of visits from members of the local radio clubs. It was great to put faces to callsigns at last and we all chatted

Photo 2: The radio area was located in the stables on the left.



The locals protested and so, by a quirk of fate the giant water wheel remains intact and working.

It was stories like these and the interesting and devoted people we met that made the weekend so enjoyable for everyone. Check out Facebook for many photos of the event - look for Bendigo Amateur Radio and Electronics Club.

We left the packing up until Monday morning in case conditions improved to Europe and we could make a genuine mill contact (other than a successful Dun's Mill, Mt Barker, South Australia contact which appears to be Australia's second mill to join the scheme). However Cheryl Just and Tony Marriott were able to have a Skype chat on my laptop on Sunday morning and congratulations and thanks were offered all around.

I am now helping out with a website (2) that hopes to encourage other Australian mills and radio clubs to register for the scheme and participate in next year's event in May.

Tony Falla VK3KKP/G8HIM

Photos by Craig Terry VK3KLI.



Photo 3: Central Goldfields Amateur Radio Group members operating the station: Mick VK3GGG on the microphone with Tony VK3AJW looking on.

References

- (1) <http://www.weeklytimesnow.com.au/country-living/history-of-andersons-mill-in-smeaton-to-be-celebrated/news-story/ce20b57a6fed6da7e75665ddc407d6ac>
- (2) <http://www.adoptamillacrossaustralia.com.au>
- (3) www.mills-on-the-air.net
- (4) <http://www.quendalemill.co.uk>



AHOY - DON'T MISS THE SYDNEY AMATEUR RADIO FERRY CONTEST

Sunday 11 March 2018, 10.00 am to 4.00 pm (local).

Amateurs are invited to travel on Sydney's famous ferries in the only radio event of its type in the world!

See how many ferries you can ride - and get multipliers by visiting as many of the 36 wharves as you can.

It's a great day out travelling on beautiful Sydney Harbour. All you need is a hand-held (VHF/UHF) and an Opal Card (\$2.50 gets you all-day travel). Home stations can also contact ferries.

Full information, rules, scoring, awards etc at vk2bv.org
Organised by Waverley Amateur Radio Society - serving Amateurs since 1919.



DXTalk

Luke Steele VK3HJ
e vk3hj@wia.org.au

The sun continues to be very quiet with some sunspots visible in the last week of November; otherwise there have been an increasing number of days with no sunspots. So far in 2017, 28% of the days had no sunspots. Compare this with 2016, when 9% of the year had no sunspots and with 2009, where 71% of the year had no sunspots. Back in 2009, Low Bands had particularly good conditions, so there is an upside to the coming solar minimum.

DX worked or heard in November and December included: VK9MA Mellish Reef, workable all bands eventually, VK9CZ Cocos-Keeling, VK9N/M0VFC Norfolk Island, VK9LA Lord Howe Island, and VK9AR Ashmore Reef. VK9VKL Cliff on Christmas Island went QRT in mid-December, as he and his XYL are moving back to Perth. Special thanks to Cliff as he was our "fixer" who was able to procure just about anything the October VK9XI DXpedition needed. Nauru was on air in November with a group of Japanese operators visiting there. A Polish DXpedition was very active from St Barthelemy in the Caribbean Sea and a group of Germans activated Montserrat. In the Indian Ocean, S79K in the Seychelles was worked.

Low bands have been generally poor, with mainly Asian stations and some North and Central Americans heard in the evenings. Storm static has made it more difficult as we move into summer. 40, 30 and 20 m have been generally quite reasonable and 17 m has been active into the night time. High bands have been generally

quiet apart from the usual summer sporadic E propagation.

Upcoming DX

DXpedition activity scheduled for January and February includes the following:

ZC4A Cyprus Sovereign Base Area: 24 - 31 January 2018. Bob 5B4AGN and a DXpedition team will be active 160 - 10 m, mainly on CW. QSL via M0URX online QSL service. Your QSL card is not required.

3Y0Z Bouvet: on air from late January 2018. Bouvet "the most isolated island on earth" is Number One Most Wanted in VK/ZL according to ClubLog's analysis. Do your best to work this one. The VOACAP propagation predictions indicate this should be quite workable. See their website for the latest news. <http://www.bouvetdx.org/>

P29VXG Papua New Guinea: 1 - 7 February 2018. Haru JA1XGI plans operation from Rabaul, New Britain (OC- 008) 160 - 30 m, with a focus on Low Bands. QSL via LotW or JA1XGI. For more information see website <http://island.geocities.jp/P29vacation/>

HP8 Panama: 1 - 15 February 2018. Operators Mike W1USN and Bob AA1M will be operating as HP8/ home call on HF, CW, SSB and digital. QSL via LotW or home call direct or bureau.

C5DX The Gambia: 9 - 16 February 2018. The Sandringham (England) School Amateur Radio club DXpedition. A group of sixth form students and staff will visit the Farafenni Senior Secondary School in The Gambia. Operation

is planned on CW and SSB on HF. QSL via LotW or Club Log OQRS. For more information see website <https://www.qrz.com/lookup/c5dx>

FM/OH2IS Martinique: 18 - 28 February 2018. Ismo OH2IS will focus on Low Bands, using CW, SSB and maybe FT8. QSL via LotW or Club Log OQRS or via OH2IS direct.

TY1TT Benin: 20 February - 2 March 2018. Wim ON6DX will operate from Gran Popo, 160 - 6 m, CW, SSB and RTTY. Dates are tentative. QSL via ON6DX.

3D2EU Rotuma: 23 February - 16 March 2018 (OC- 060) . Tony 3D2AG, Heye DJ9RR, Ernoe DK2AMM, Hans DL6JGN and Ron PA3EWP plan operations on 160 - 10 m, CW, SSB and Digital. There will be two stations, a spider beam and verticals. QSL via DK2AMM. For more information see website <http://www.rotuma2018.de/>

DXpedition to Ducie Island announced

The Perseverance DX Group has announced a DXpedition to Ducie Island in October - November 2018. Ducie Island was last activated in 2008 and is currently listed as Number 27 Most Wanted on ClubLog.

So far, landing permission, visas and radio licence have been issued. A team of 14 operators will be on the island for up to 14 days. The team will depart from Mangareva, French Polynesia aboard the expedition ship Braveheart. Seven operating positions are planned for 160 - 10 metres, SSB/CW/Digital, including FT8.

The team so far includes:
Dave K3EL, Pista HA5AO, Les
W2LK, Heye DJ9RR, Mike WA6O,
Jacky ZL3CW, Arnie N6HC,
Steve W1SRD, Chris N6WM, Lacl
HA0NAR, Ricardo PY2PT, Walt
N6XG and Gene K5GS.

Keep up to date with news of
Ducie Island at the DXpedition
website <http://vp6d.com/>

St Brandon update

The callsign 3B7A has been
approved by the Mauritian
authorities for the April DXpedition
to St Brandon. The Northern
California DX Foundation has come
on board as a major sponsor.

Keep up to date with news at
the DXpedition website [http://www.
saintbrandondx.com/en](http://www.saintbrandondx.com/en)

Please email me with any DX
related news for inclusion in this
column. I am particularly interested
in hearing about DX worked or
heard in other states and from
newer DXers.

73 and good DX,
Luke VK3HJ

TAC Notes

John Martin VK3KM, TAC Coordinator

Beacons and FT8

The Barossa Valley 6 metre beacon VK5RBV has been switched off, to avoid interfering with stations running FT8. VK5RBV has been operating for many years on 50.315 MHz, but the developers of FT8 have nominated a worldwide operating frequency of 50.313 MHz, so VK5RBV will need to be relocated. It is also likely that similar clashes could occur in the future as more new digital modes come into use in the same part of the band.

The placement of our 6 metre beacon segment - centred on 50.300 MHz - was dictated by our licence conditions in the days of Channel 0 television. Below 52 MHz, operation in the eastern states was confined to the DX window at 50.000 - 50.300 MHz. So eastern state beacons were allocated just below 50.300 MHz, and western state beacons just above 50.300 MHz. But now we can progressively relocate our beacons as and when necessary to avoid any future clashes with digimode activity.

The sub-band 50.300 - 50.400 MHz is now recognised as digimode territory in all IARU regions. And 50.400 - 50.500 MHz has been adopted in Region I as the new recommended beacon segment. We will over time be able to follow the same pattern, and the existing band plan already makes provision for this change.

FT8 on 2 metres

FT8 is becoming popular on 2 metres. The software comes with recommended operating frequencies built in, but only for bands up to 6 metres. On 2 metres, our band plan has a group of spot frequencies recommended for modes of different bandwidths. The narrow band channel on 144.320 MHz is the logical one for FT8. It is noted that 144.313 MHz has also been used for FT8. But unless there are compelling reasons to do otherwise, I would recommend the band plan.

Safety warning & correction: Lithium batteries

ALARA notes page 45, AR magazine November 2017

Glen English VK1XX has identified a point of confusion found in the Adelaide Hills Amateur Radio Society report: specifically in the section headed "The September topic" on page 45.

About LiFePO4 cells: there is also a reference in the same paragraph to LiPo cells, which are quite different beasts. The article appears to be about LiFePO4 cells.

For the record:

LiFePO4 cells have a nominal 'float' or full voltage of 3.25 V per cell, and a max charge of 3.65 V. They are FULLY discharged at 2.7 V.

LiPo, or Lithium Polymer cells, have a max charge of between 4.1 and 4.3 V per cell, depending on the anode material, and are discharged at approx. 3.2 V per cell.

The way the article reads, it encourages users to charge the LiFePO4 cell to 4.23 V, which is a recipe for disaster!

They are very different cells with very different chemistry and must not be confused.

Thank you Glen for alerting us to the confusion which was missed during proof reading.

Contests

Trent Sampson VK4TS

✉ vk4ts@wia.org.au



Preparing for the John Moyle Memorial Field Day

Just how far can you bend the rules in the JMMFD and still get away with it?

Let's look at the Multi Op rules:

- 7) *Multi-operator stations may only use one transmitter on each band at any one time, regardless of the mode in use:*

Let's assume that we have a transmitter on SSB and a second transmitter also on SSB and they have sufficient distance between the antenna(s) not to cause interference (e.g. Flex, K3S, FT5000) by configuring an interlock that only allows one transmitter at a time (i.e. only one transmitter is on air). Rig one can call CQ and hold a frequency while rig 2 can tune the band working all the other stations in CQ Mode.

The configuration needs to ensure that two transmitters cannot transmit at the same time but here is a way to work all the others on the band while not losing your CQ (Run) frequency.

Contester of the Month

Holger Hannemann ZL3IO

Holger has qualified as our region's representative in the 2018 World Radiosport Team Championship (WRTC) in Germany WRTC – The Olympics of Amateur Radio contesting.

His qualification was an accumulation of scores in many contests of which only the top scores counted. <http://www.wrtc2018.de/en>

What is your favourite Contest?

While it is easy to get big runs when you are rare and one of the few multipliers like in CQWW DX, I like contests like the CQWW WPX more for the fact that it makes a more level playground as only being from a semi-rare country is not an advantage any more.

What is your favourite Rig?

Elecraft K3, a solid performer, easy to automate and one you can still fix it yourself.

What modes do you contest in?

I do CW and SSB contesting and occasionally some RTTY. I prefer CW. It's quiet, not as disturbing for others and allows fun even at low power or not so good conditions.

What is your favourite contest band and why?

I don't have favourite band. I like the high bands during the maximum due to the high rates you can

achieve. But I also like 40 m as it is a great DX-band.

What is your preferred Contesting Software?

Personally I use UCX Log. It's a contest and normal QSO software package offering an all in one tool with same functionality like the other favourite tools. But we also run N1MM for team contesting.

What is your preferred Mic and Key?

I use a Heil Pro Set for SSB contests and a Bose QC20 (in ear noise cancelling head phone) for CW contesting. We have a Schurr key for guest operators. I don't need a key as I do all via PC keyboard either via Function keys or in keyboard mode for chatting. I stopped using Elbugs or key in the early 90s.



Photo 1: Holger and Xenia (Father and Daughter) WRTC competitors with ZL3CW Jacky in front, also heading to WRTC 2018.



Photo 2: Multi band Yagi Stack, including 2 over 2 element on 40 m.



Photo 3: Awesome take-off with 80 m Four Square.

What is your "not so secret" weapon?

Preparation and pre-planning! I always set a target and have a strategy. Once started I'm dedicated and committed to the last minute! Otherwise I recommend having two or three directional antennas available per band to be able to switch instead of rotating. Sure 160 m is a challenge.

What is your best tip to a newbie contester?

Know the contest rules! Set yourself a target (time, QSO #, new country record) and go.

If you want to learn the most in a small-time frame, join a contest team. Team contesting is much more fun and less physical stress anyhow.

What are your aspirations in contesting?

I like competing and winning of course but I'm not good enough in physical sports anymore.

What would you like to improve in your skills and/or station?

I constantly try to improve both. The station or better antenna farm is constantly growing. I try to optimise the set up and automate as much as possible. I also try to learn.

Who is ZL3IO?

I'm 52 and an electrical engineer by profession (power electronics). I work in the field of industrial power protection. The job gets me around a bit and I spend between one third and half of the year travelling worldwide. The last 27 years I spent with my lovely Birgit (ZL2YL, ex DL7IQ) and we have two daughters. Saskia ZL2GQ is now 21 years old and currently studying at Victoria University in Wellington. Xenia ZL4YL is now 15 and still at high school.

Birgit and I are from the former East Germany where I made my licence with 18 – Y31IO, Y58IO, DL7IO and today ZL2IO. Job and hobby got us around a bit. I have travelled 78 countries so far and have operated from over 30 DXCC on five continents. Some of my ex calls are 3D2IO, 3D2IO/R, 8Q7IO, 9J2Z, 9H3M, A31IO, DL7IO, HU1M, H44IO, J48IO, T28IO, TN2M and YJ0AIO.

Our contest call in New Zealand is ZM4T. We are a local contest group on the east coast of the North Island near Napier. The station is hosted at our home and uses K3 plus KPA500 amplifiers. There is a variety of mono and multi band antennas available:

10 m: 1 x 6 elements and 3 x 4 elements
15 m: 1 x 5 elements, 2 x 3 elements
20 m: 1 x 5 elements, 3 x 3 elements
40 m: 1 x 3 elements, 2 x 2 elements
80 m: 4 square, dipole
160 m: vertical, dipole

Contest Terms

Dupe: Duplicate contact

NIL: Not in Log

Busted: Incorrect logging

Unique: Callsign in one log only.

M2 (Multi Two): Multiple operators Two Transmitters

MM (Multi Multi): Multiple Operators Multiple Transmitters

Lockout: A device that stops multiple transmitters keying at once outside contest rules

Trent VK4TS is the administrator of VK Contest Club (VKCC) web (www.vkcc.com) and Facebook pages and has been an active contester since the 1970s.

Emails can be sent to vk4ts@wia.org.au

Silent Key

Don Richardson VK2KDR

76 years of age.

Don had a remarkable mind and hands from building houses, boats to early computers. His last proper job was with the NSW railways as a technician in the radio branch. He was part of a team that installed radio repeaters for communication between country link trains.

When David Hill was the railway supremo, he would always call for "Mr Fix It" when there were problems. He spent the last 20 years living in Tallong (near Goulburn) in a kit house which he built. He had a weekly country and western musical program on the Goulburn Community Radio System which

he enhanced. Sadly he spent the last two months in hospital, which was to no avail.

Vale Don.

Alex Theakston VK2DTX



Wireless Institute of Australia

2018 Callbook

Available now

John Moyle Field Day Contest 2018

Denis Johnstone VK4AEN/K3ZUX

17 - 18 March 2018

0100 UTC Sat - 0059 Sun

I wish all entrants good luck, and look forward to hearing some of you on air during the contest!

N.B. new email address: jmf2018@wia.org.au will be set up close to the event for entries and you can check out latest info at <http://www.wia.org.au/contests/>

Overview

1. The aim is to encourage and provide familiarisation with portable operation, and provide training for emergency situations. The rules are therefore designed to encourage field and portable operation.
2. The contest takes place on the third full weekend in March each year, and runs from 0100 UTC Saturday to 0059 UTC Sunday, 17 - 19 March, 2018.
3. The contest is open to all VK, ZL and P2 stations. Other stations are welcome to participate, but can only claim points for contacts with VK, ZL and P2 stations.
4. Single operator portable entries shall consist of ONE choice from each of the following (e.g. 6 hour, portable, phone, VHF/UHF):
 - a. 24 or 6 hour;
 - b. Phone, CW, Digital or All modes;
 - c. HF, VHF/UHF or All Bands.
5. Multi-operator portable entries shall consist of ONE choice from each of the following (e.g. 24 hour, portable, phone, VHF/UHF):
 - a. 24 or 6 hour;
 - b. Phone, CW, Digital or All modes;
 - c. HF, VHF/UHF or All Bands.
6. Home and SWL entries shall consist of ONE choice from each

of the following (e.g. 24 hour, portable, phone, VHF/UHF):

- a. 24 or 6 hour;
- b. All modes;
- c. HF, VHF/UHF or All Bands.

Multi operator stations are not permitted in the Home Category. If a Home Station works the same station regularly on any band or any mode they should submit their log to verify those contacts (See sect. 17 below).

Scoring

7. Portable HF stations shall score 2 points per QSO. CW only contacts to score 4 points per QSO for contacts with either home or portable stations.
8. On VHF/UHF portable stations for Phone and Digital each contact scores 2 points per contact, and CW contacts score 4 points. In addition the VHF/UHF Portable stations shall add a distance score of the following on 6 m:
 - a. 0-49 km, 2 points per QSO;
 - b. 50-99 km, 5 points per QSO;
 - c. 100-149 km 10 points per QSO;
 - d. 150-299 km 20 points per QSO;
 - e. 300-499 km 30 points per QSO;
 - f. 500 km and greater, 2 points per QSO.
9. Portable stations shall add an additional distance score on 144 MHz and higher:
 - a. 0 to 49 km, 2 points per QSO;
 - b. 50 to 99 km, 5 points per QSO;
 - c. 100 to 149 km, 10 points per QSO;
 - d. 150 to 299 km, 20 points per QSO.
 - e. 300 km and greater, 30 points per QSO.
10. For each VHF/UHF QSO where more than 2 points are claimed,

both the latitude and longitude of the station contacted or other satisfactory proof of distance such as the 6-figure Maidenhead Locator must be supplied.

11. Home stations shall score:
 - a. Two points per QSO with each portable station.
 - b. One point per QSO with other home stations.
 - c. For VHF/UHF QSO Home stations shall add as a distance score on 6 m:
 - i. 0-49 km, 1 points per QSO;
 - ii. 50-99 km, 2 points per QSO;
 - iii. 100-149 km 5 points per QSO;
 - iv. 150-299 km 10 points per QSO;
 - v. 300-499 km 15 points per QSO;
 - vi. 500 km and greater, 2 points per QSO.
 - d. Home stations shall add as a distance score on 144 MHz and higher:
 - i. 0 to 49 km, 1 points per QSO;
 - ii. 50 to 99 km, 2 points per QSO;
 - iii. 100 to 149 km, 5 points per QSO;
 - iv. 150 to 299 km, 10 points per QSO.
 - v. 300 km and greater, 15 points per QSO.

Log Submission

12. For each contact: UTC time, frequency, station worked, RST/serial numbers sent/received and claimed score. (VHF and above location of other station and distance showing the Lat/Long or Maidenhead Locator to 6 figures for the station worked.)
13. All logs must be accompanied by a summary sheet showing: call sign, name, mailing address,

section entered, number of contacts, claimed score, location of the station during the contest, and equipment used, and a signed declaration stating "I hereby declare that this station was operated in accordance with the rules and spirit of the contest and that the contest manager's decision will be accepted as final". For multi-operator stations, the FULL names and all call signs (legible) of all operators must be listed.

14. The email address for this year's JMMFD contest should be setup a few days before the contest, and I would suggest to those who will be sending in your Logs electronically, to send in a test email with the words "TEST JMMFD 2018", in subject the line and also set the "READ REQUEST RECEIPT" flag (if it is available on your e-mail system.). Your call sign can then be added into the database for this year's contest. When actually submitting your log for the contest, if you do not receive an e-mail acknowledging receipt of your log, then the log has not been received.
15. Paper logs may be posted to "John Moyle Contest Manager, 27 Laguna Ave, Kirwan 4817 QLD". Alternatively, logs may be e-mailed jmfd2018@wia.org.au, vk4ae@wia.org.au, or snail mailed via the WIA Contest Manager, JMMFD, P.O. Box 2042 Bayswater, VIC 3153. Club stations must forward in the first instance an electronic version of their log. Club Stations who submit only a paper log will have that log returned as unreadable, due to the very large amount of work involved in entering and checking large paper logs.
16. The following formats are acceptable: Microsoft Excel or Word, ASCII text or the print log output file from electronic log programs such as VK Contest Log (VKCL). Logs sent by disc or e-mail must include a summary sheet and declaration, but the

operator's full name (legible) is acceptable in lieu of a signature.

17. Because of the altered publishing lead time of AR magazine Logs must be postmarked no later than 18 April 2018, and as the post is now so slow and unreliable, logs despatched on the last day might not arrive in time. Electronic versions of the log will be received until midnight 25 April 2018. Any logs received after this date will be returned as ineligible.
18. If any station works the same station multiple times on any band or on any mode, both stations should each enter a log to verify those contacts. This rule was introduced to overcome a problem experienced in previous contests where a portable station worked a significant number of home stations, but those home stations did not enter a log, so there were a very large number of unverifiable contacts.

Certificates and Trophy

19. At the discretion of the Contest Manager, certificates will be awarded to the winners of each portable section. Additional certificates may be awarded where operation merits it. Note that entrants in a 24-hour section are ineligible for awards in a 6-hour section.
20. The Australian WIA Affiliated club station, with the highest overall score will be awarded the President's Cup, a perpetual trophy held at the Executive Office, and will receive an individually inscribed wall plaque as permanent recognition.

Disqualification

21. General WIA contest disqualification criteria, as published in *Amateur Radio* from time to time, applies to entries in this contest. Logs which are illegible or excessively untidy are also liable to be disqualified.

Definitions

22. A portable station comprises field equipment operating from a power source, e.g. batteries, portable generator, solar power, wind power, independent of any permanent facilities and which is not the normal location of any amateur station. Mains power supply is not to be used for any part of the portable installation lighting or even battery-charging.
23. All equipment comprising the portable station must be located within an 800 m diameter circle.
24. A single operator station is where one person performs all operating, logging, and spotting functions.
25. A single operator may only use a call-sign of which he/she is the official holder. A single operator may not use a call-sign belonging to any group, club or organisation for which he/she is a sponsor except as part of a multi-operator entry.
26. A multi-operator station is where more than one person operates, checks for duplicates, keeps the log, performs spotting, etc.
27. A multi-operator station may use only one call sign during the contest.
28. Multi-operator stations may only use one transmitter on each band at any one time, regardless of the mode in use.
29. All stations, both Single and Multi-operator stations must submit a separate log for each band.
30. Logs submitted electronically can use a separate Excel worksheet for each band linked to a summary sheet. A typical example is shown at <http://www.wia.org.au/contests/> which can be copied and adapted for the individual use of either a single or multi operator station.
31. Any station operated by a club, group, or organisation will be considered to be multi-operator by default and are not to use the permanent club facilities.

32. None of the portable field equipment may be erected on the site earlier than 28 hours before the beginning of the contest.
33. Single operator stations may receive moderate assistance prior to and during the contest, except for operating, logging and spotting. The practice of clubs or groups providing massive logistic support to a single operator is, however, totally against the spirit of the contest. Offenders may be disqualified, and at the discretion of the Contest Committee, may be banned from further participation in the contest for a period of up to three years.
34. Phone includes SSB, AM, Simplex FM and Simplex D-STAR.
35. CW includes CW hand or computer generated. Fully automatic CW operation is not permitted. CW contacts will score 4 points for HF and 4 points for VHF & UHF contacts plus the distance points.
36. Digital modes such as PSK31, RTTY, and packet may be used in the contest, but if they are, they shall be classed as Digital. Other modes such as ATV may be used and will be classed as Digital for scoring. Digital contacts will score points at the same rate as Phone.
37. All amateur bands may be used except 10, 18 and 24 MHz. VHF/UHF means all amateur bands above 30 MHz. Note: On 50 MHz, the region below 50.150 has been declared a contest free zone, and contest CQs and exchanges may only take place above this frequency. Stations violating this rule may be disqualified.
38. Cross-band, cross-mode and contacts made via repeaters or satellites are not permitted for contest credit. However, repeaters may be used to arrange a contact on another frequency where a repeater is not used for the actual contact.
39. Stations may make repeat contacts and claim full points for each one. For this purpose, the contest is divided into eight consecutive three-hour blocks: 0100-0359, 0400-0659, 0700-0959, 1000-1259, 1300-1559, 1600-1859, 1900-2159, 2200-0059 UTC. If you work a station at 0359 UTC a repeat contact may be made after the start of a new block providing they are not consecutive, or are separated by at least five minutes, since the previous valid contact with that station on the same band and mode.
40. Stations operating on Phone must exchange ciphers comprising RS plus a 3-digit number commencing at 001 for each band and incrementing by one for each contact.
41. Stations operating on CW must exchange ciphers comprising RST plus a 3-digit number commencing at 001 for each band and incrementing by one for each contact. Where the CW contact is with an overseas station that is unable or unwilling to give a valid serial number, the serial number shall be assumed to be 001.
42. Portable stations shall add the letter "P" to their own cipher, e.g. 59001P.
43. Multi-operator stations are to commence numbering on each band with 001.
44. Receiving stations must record the ciphers sent by both stations being logged. QSO points will be on the same basis as for Home Stations, unless the receiving station is portable.
45. The practice of commencing operation and later selecting the most profitable operational period within the allocated contest times is not in the spirit of the contest, and may result in disqualification. The period of operation commences with the first contact on any band or mode, and finishes either 6 or 24 hours later.

If anyone wishes to contact me privately to discuss rules etc., my home phone number is (07) 4723 4229, and my snail mail and e-mail address are as shown in the Log Submission section above.

-Denis Johnstone VK4AE/VK3ZUX

Silent Key

Col Whale VK4CU

10 December 2017

Sadly, The Grim Reaper has recruited another Master Telegraphist with Col's passing. I first met him in 1992 when as VK4CMY & RANRS member, I visited the ex-HMAS Diamantina to guest operate VK4RAN. Somewhere, I now have a to-be treasured photo Col took of me in the shadow of the B40 receiver drumming away on air, simply because I had thought to take my Vibroplex speed key along for the

outing: Col said that was very respectful.

Having both spent years as professional telegraphists with high-speed operating experience gave us plenty of ammunition that day for chatting, exchanging "war stories" and knowing smiles. I relocated to VK5 in February 2000 and in later years worked Col a few times on HF. It was Col, in about 2009, who loaned me his ship's copy of the A618/ACAS original BR manual when I found

myself in ownership of the very A618 Navy transmitter that I had aboard minesweeper HMAS Ibis in the mid-1960s. I have always felt privileged to know him.

The ranks of quality ICW telegraphists such as Col are ever-thinning. Vale Col and smooth seas, matey!

VK4CU de VK5BUG trn OM AR VA

SOTA & Parks

Allen Harvie VK3ARH

✉ vk3arh@wia.org.au

SOTA

The final months of 2017 were busy.

SOTA saw 140+ activations by 42 activators from 109 sites. Given the contentious weather (setup in rain and hail not uncommon) and touchy propagation (80 m activations increasing), not a bad effort!

The excitement coming from VK7: VK7 has a treasure trove of remote serious summits which always attracts attention when being activated. Two such activations from the Cradle Mountain Lake St Clair National Park (VKFF-0117) with Derek VK3KX/7 from VK7/CH-005 (Ducane Range) <https://ducane2017.blogspot.com.au/> and Marcus VK5WTF/7 from VK7/CH-001 (Mt Ossa).

VK activators were active even further overseas with David VK2NU activating four ZL1 summits and Andrew VK3ARR activating a couple of summits whilst in England.

We also had visitors to our shores with Simon G4TJC activating six summits in VK2 and VK1 over a couple of days, Simon G7WKX activating Mt Feathertop, Mt Bogong and Mt Tennent and Robert M0VFC activating summits in VK2 before hopping across to ZL for another couple.

Parks

Both the annual KRMNPA and WWFF weekends were held in November.

WWFF saw 250+ activations for approximately 60 activators across 170 sites. The always popular and annual, Keith Roget Memorial National Parks Award (KRMNPA) Activation Weekend, was held between 10 and 13 November and a few weeks later, the 2017

VKFF Activation Weekend saw the activators coming out again.

KRMNPA weekend saw a total of 39 VK3 National Parks activated across the 4-day period by 21 operators. The number of Parks activated was a slight decrease from 2016; however the enthusiasm was not down. The KRMNPA award is for National Parks in Victoria and is well supported with interstate activators travelling to join the fun.

John VK2AWJ activated six Parks across the 4-day KRMNPA weekend then continued to activate a total of 11 Parks as he travelled through Gippsland and then home. John is a regular activator and KRMNPA participant and only has a handful to go to gain to qualify as activated all VK3 National Parks.

Tony VK3XV managed to activate six Parks across the four days being Great Otway National Park, Hattah-Kulkyne National Park, Kara- Kara National Park, Little Desert National Park, Murray Sunset and finally Wyperfeld National Park. Murray Sunset National Park provided considerable excitement as Tony and Sheryl were "attacked" by a very fast and largish Willy Willy then were "buzzed" by a swarm of bees. Seven stings in total! Sheryl took a bowl of water and placed it 50 m away from the radio to move the swarm, which worked - to ensure the radio was not compromised.

Paul VK5PAS/3 and Marija VK5FMAZ/3 again made the journey from the Adelaide Hills, taking two weeks to activate 27 Parks (WWFF included) and six SOTA activations in a major Parkpedition. More info as to Paul and Marija's adventures checkout Paul's blogs - <https://vk5pas.org/>

Malcolm VK3OAK went to the Lower West of VK3 to activate Cobboboonee National Park, Lower Glenelg National Park, Mount Richmond National Park and finally Budj Bim National Park.

Allen VK3ARH started with two in the North-east of the state being Burrowa-Pine Mountain and Chiltern-Mt. Pilot and Brisbane Ranges National Park.

Peter VK3PF activated three parks over the weekend being Mornington Peninsular, Tarra-Bulga and Morwell National Parks.

Brett VK3FLCS/p was able to get out and activated Greater Bendigo National Park, Heathcote-Graytown National Park and Kinglake National Park.

Peter VK3ZPF/p was once again busy across the weekend activating Lake Eildon and Yarra Ranges National Parks.

Peter VK3TKK/p was out with activations to the extreme south for Wilsons Prom National Park and also from French Island National Park.

Mick VK3GGG continued his quest to qualify KRMNPA as VK3PMG with activations of the Budj Bim and Grampians National Parks. Chris VK3FHCT joined Mick for his first activations.

Rex VK3OF/p and Greg VK3BRQ/p activated Barmah and Lower Goulburn National Parks. This year Rex and Greg managed to avoid storm activity that made their 2016 activations difficult.

David VK3TUN activated Terrick Terrick NP on Saturday and on Sunday activated from Mount Ida in Heathcote-Gray Town NP. His setup was a K2 and trapped 40/30/20 m dipole. Weather was hot but the propagation was not. He gained

ten contacts from Terrick Terrick but only seven from Heathcote. Still a good result for me with two new parks activated, three new VK3 national parks contacted and another couple of park to park contacts.

Joe VK3YSP and Julie VK3FOWL were once again kept busy running the VK3SRC call sign (School Amateur Radio Club Network) this year from the Churchill National Park picnic shelter area.

Warren VK3BYD/p travelled to the Warby Ovens National Park and was successful in making both SSB and CW park contacts.

Bernie VK3BFH qualified Point Nepean National Park using a "man Pack" Low Power rig: only a few contacts but still a great effort.

Marc VK3OHM managed a few contacts before having some "political difficulty" with an overzealous ranger (very rare!) from the Dandenong Ranges National Park. Thanks for your patience Marc.

Hiro VK3EHG and daughter Nozomi (no callsign yet) enjoyed operating from Organ Pipes National Park on Saturday morning. Hiro had 20 QSOs using only the 40 m Band, including CW mode with KX3 (5 W) and Inverted V dipole antenna.

It was a great weekend. Thanks again to Tony VK3XV for all his work behind the scenes with organising KRMNPA. It's a great event that serves to promote and has introduced many of us See: <https://www.amateurradio.com.au/awards/>

Two weeks later saw the 2017 VKFF Activation Weekend for the World Wide Flora Fauna program. This year there was activator representation from all States and Territories around Australia. There were alerts for 60 VKFF sites posted on ParksPeaks across 89



Hiro VK3EHG and daughter Nozomi (no callsign yet) operating in Organ Pipes National Park.

activations for 42 activators. Results are slowly coming out and we know there were at least 75 unique sites activated over the weekend.

WWFF has a newly developed Agenda, which can be found at <http://wwff.co/agenda/>

When planning a park activation, placing an alert on the Agenda, along with ParksPeaks - <http://parksnpeaks.org/>, will attract attention and help with gaining the required contacts to qualify.

Upcoming activities

1 Feb 18

VK1 and VK3 SOTA Day

1 Mar 18

VK8 SOTA Day

10 Mar 18

VK/ZL/JA - EU S2S QSO Party
06:30 to 08:30 UTC

10-11 Mar 18

5th SANPCPA weekend

9-12 Nov 18

KRMNPA activation weekend

73 & 44 to all.

Allen VK3ARH

Participate

**VK3 Annual SOTA conference & get together
Moorabin & District Radio Club**

17 February 2018



VK2news

Tim Mills VK2ZTM
e vk2ztrn@wia.org.au

This year is the fiftieth anniversary since Australian Amateurs were given the privilege of establishing repeaters – although a few, like 'Fred' at Orange and some at other locations had already been testing the 'waters'.

As we start into 2018, a few clubs have their meetings and activities while others delay until February. Oxley Region ARC has already commenced their activities with the monthly meeting on the first Saturday and the mid monthly on the third Friday. Another early starter is the Central Coast ARC with a lecture and demonstration on Drones on Saturday the 20th and licence assessments on Saturday the 27th. There will also be assessments held at the 60th Wyong Field Day on Sunday 25 February. This year's CCARC Field Day at the Wyong Racecourse, which has been renovated with new facilities like the air conditioned venue, which will be used by the Traders. The Flea Market will use the covered area which was previously the Trader's area. Contact the Field Day committee for further information.

The first of the ARNSW bi-monthly Trash & Treasure will be on Sunday 28 January and then on the last Sunday of the odd numbered months through the year. The ARNSW Home Brew Group also meet on T&T days at Dural and they have planned their next 'QRP by the Harbour' on Sunday 4 February at the previous location in Concord.

On 5 March 2018, ARNSW will commence the Monday evening Upgrade course and the first Foundation weekend on the 10th and 11th. Inquiries to education@arnsw.org.au On Saturday 17 March 2018 nominations for the ARNSW committee will close and the AGM to be held on Saturday 28 April 2018. There is the regular Trash & Treasure on Sunday 26 March 2018. Some new ARNSW clothing merchandise has been added to the range which can be checked out on the web site www.arnsw.org.au The 2018 edition of the ARNSW magnetic calendar has reverted back to a landscape format. Feedback on the preferred format is sought.

There are some Sydney based Foundation weekends in February 2018 with Waverley ARS on the 10th and 11th and St. George ARS will have theirs on the 17th and 18th. I would like to hear of other assessments to include in these notes but remember the new schedule for the bi-monthly AR, so give plenty of notice.

Also in February the Hunter Radio Group start up their monthly meeting on the second Friday evening, usually at the NBN TV studios in Newcastle. They are one of the clubs providing a relay of VK2WI News through the Newcastle VK2RNC on 146.975 MHz. St. George ARS is another with the first meeting this month. Also HADARC are back but have decided to have a dinner in place of the mid

monthly on 13 February 2018 and will resume the monthly Mt. Colah meeting on the 27th. Their Chatswood repeater has become DMR only on 438.350 MHz with a -5.4 MHz offset.

NSW WIGEN has advised that the annual Trek for Timor, deferred last year due to the bush fire risk, has been rescheduled for 5 May.

Former Sydney Amateur Neil VK2TGD moved to the NT some years ago, becoming VK8NH and a resident of Katherine. Neil also became involved with the NTES and in a team of three was involved in a flood rescue in 2011 at the Edith River. Last November Neil was awarded the Governor General Commendation for Brave Conduct for his part in this rescue.

73
Tim VK2ZTM.

ARNSW UPGRADE COURSE

Monday evenings

Commencing 5 March

FOUNDATION WEEKENDS

March, May, July, September
& November

education@arnsw.org.au

Plan ahead

John Moyle Field Day

17-18 March 2018



VK5news Adelaide Hills Amateur Radio Society

Christine Taylor VK5CTY

Christmas and New Year greetings to all, members and friends.

The BUY AND SELL was a great success again, despite the rather hot day.

Equipment was bought and exchanged and friendships were renewed for another year.

A very different November meeting

We had two speakers at the November meeting.

Firstly, Joseph VK5FLDR who is a white stick operator. He told what it is like to be totally blind. It is something none of us could imagine. There are so many things we simply take for granted that are much more difficult without sight. No it didn't stop Joseph from getting a paying job. He has a BSc and works for the Blind Institute as a screen reader programmer.

He has also a number of published books. It is only within amateur radio that he has encountered problems. None of the major manufacturers are interested



Photo 1: AHARS Hamfest.



Photo 2: AHARS Hamfest.



Photo 3: Group photo at AHARS Meeting with Maas.

in making radios for the blind. He had a number of different handheld radios on which he demonstrated the good and the bad applications for the visibly handicapped. There are some pieces of equipment available in the US, a much bigger market, but none are available in Australia. Perhaps this is something we, as amateurs, should be working for in our feedback to manufacturers.

There have been blind amateurs in VK for many years, in fact one organised the venue for a Federal Convention in Hobart. He had pressured the PMG (in those days) to understand that lack of sight did not make him any less safe around Electricity, in fact it may have made him safer.

The members were most impressed at how well Joseph had

adapted equipment to allow him to enjoy amateur radio.

The second speaker was introduced by Neville VK5XB/VK8NT; Maas currently VK5FAS was to be in Adelaide for only a week and a half but he wanted to meet some of Neville's friends and to talk to us about amateur radio in Japan. He has held a licence for 15 years. He lives 300 km from Tokyo (fortunately many km away from the tsunami in 2011) and found there were few amateurs nearby when he got his licence. One day he heard a DX station and made a contact. CW was fine for exchanging signal reports but he soon realised that to make a voice contact he would need to learn English. So he did. And he put us to shame: his English was beautiful.

One of the DX contacts he made was with Neville in Darwin. Over

the 35 years of their friendship they became good friends such that he and his wife spent their honeymoon in Darwin enjoying barramundi. In the week and a half in Adelaide, Maas made over 150 QSOs and participated in the all Asian Contest; and still had time to sightsee! At Maas' request, a group photo of all the members present that night was taken.

AHARS Christmas Dinner and New Year Picnic

The dinner at the Aldgate Hotel was excellent. The meals were very good and the company was great. There were just fewer than 60 present and the numbers for the picnic in the Rotary Park near the Bridgewater Mill promise to be around the same number.



Hamfest 2018

Sunday 18th February
Italian Sports Club of Werribee
601 Heaths Rd, Werribee VIC 3030

NEW VENUE 4 TIMES THE SIZE OF LAST ONE



Tables are available at \$20.00 each includes 1 entry please contact Andy Kay VK3VKT on 0409 160 948 or vk3vkt@gmail.com

- * GREAT VENUE * HEAPS OF PARKING *
- MAJOR AND MINOR DOOR PRIZES
- *ALL UNDERCOVER AND INDOORS
- *BACON AND EGG BREAKFAST *AND SASUAGE SIZZLE LUNCH
- *FREE TEA AND COFFEE
- * THE ONLY WESTERN SUBURBS HAMFEST

Entry is only \$7.00

(Doors open from 10am entry tickets will be on sale from 9am)

"ticket includes one free draw in the major prize" extra tickets available for purchase.

Call in on VK3RPS 439.725 tone 91.5 or 145.245 Simplex

Latest News Icom Australia will now be attending with 2 tables full of gear to see

Plan ahead

WIA Radio and Electronics Convention and AGM 2018 Gold Coast

18 - 20 May 2018



Tony Collis VK3JGC

The South Channel Fort - Radio Telegraph Project

Once again Marita Batna, a PhD candidate from Monash University, is liaising with the GARC via Calvin VK3ZPK for it to participate during 2018 - 2019 in establishing a Public Engagement Interactive Communications Link between the 120 year old man-made island, South Channel Fort, in Port Philip Bay and, initially, the Queenscliff Maritime Museum with which the GARC already has an established working relationship; other museums in the vicinity are planned to come on line at a later date.

During her presentation Marita introduced Keith Quinton, historian with the Queenscliff Fort, who then gave a presentation covering the history behind the man-made Fort. The island Fort itself is 100 m long by 50 m wide and was initially used in the early gold rush days and later war times, protecting Melbourne with the ability to electrically explode mines under any approaching enemy ships. From the 1890s to 1916 around 100 officers lived and worked on the island. For more historical detail regarding the South



Photo 1: Marita Batna and Michael Morgan.



Photo 2: Keith Quinton.



Photo 3: The GARC tables at the Ballarat Hamfest.

Channel Fort's history (Part 1) covering the period 1876 to 1882, go to <http://www.mhvhv.org.au/?p=6081>

Since 1995 the Fort has been managed as part of the Mornington Peninsular National Park for penguin and seabird conservation, with public access permitted only during daylight hours.

Whilst at its embryonic planning stage, it is perceived that during early 2018, the GARC will pay a visit to the Fort carrying out tests on communication paths back to the Queenscliff Maritime Museum, on different bands and power levels; also exploring the potential of establishing a permanent Low Interference Potential Device (LIPD) and possibly even a Geocache located somewhere on the Fort. Project details and timelines will be made available when confirmed.

Ballarat Hamfest

This year the GARC, identifiable by their traditional Hawaiian outfits worn at these occasions, as well as having a great day out, had their most successful sale of equipment to date.

Northern Corridor Radio Group (NCRG)

The NCRG had a reasonably active couple of months. Many members of the club spent a few weekends cleaning up the club premises and even more members had very robust dialogue about what should and shouldn't be given a sea berth!

We held our annual car boot sale on the third December which was well patronised as usual.

On 15 December, we held our annual Christmas Party with 30 members and a few visiting amateurs also attending. A great time was held by all.

Plans are now afoot to replace the 30 m tower used for the 15 m mono-bander and also the 40 m mono-band Yagi as well. We hope to start these projects early in the New Year. This is going to allow us to get back to the pointy end of the major contests.

On behalf of the NCRG, I'd like to wish all VK6 amateurs a merry Christmas and a Happy and Prosperous New Year.

73 from Steve VK6SJ

Ham College

In 2017 Ham College ran six weekend long Foundation licence courses and, after assessment, 38 candidates became eligible for a Foundation licence. In addition, we ran a Standard level course in the early part of the year and, together with others wishing to upgrade to various levels, another 23 assessments were carried out. Together with club members travelling to provide assessments and one remote assessment, the College saw Advanced amateurs successful on 75 occasions. This does not happen without significant planning and commitment.

Congratulations to College members, Assessors and facilitators who made this all happen.

Looking forwards: Expressions of interest for upcoming Foundation, Standard, Regulations and Advanced courses and assessment can be found on the College Website (hamcollege.com.au).

In addition, the College is trying to spread the load and is asking for volunteers to give their time and knowledge to assisting with courses. If you can volunteer, please let us know. As always, the College meets at 6.00 pm on the second Tuesday of the month with the first meeting for 2017 being 13 February 2018 at the College rooms at the Lynwood Scout hall inside the Whaleback Golf Course in Parkwood. All are welcome and we hope to see you there.

73 de Andrew VK6AS, College Enrolments Officer

Avon Valley Amateur Radio Group

I have been listening to all manner of exotic stations from the Northern Territory to as far away as Texas USA chattering away on our normally sleepy 2 metre repeater during my drive home from work; no not a case of super ducting or unusual sporadic E propagation, we have just had an AllStar node installed at the VK6RAV repeater at Hoddy's Well in the Avon Valley. If you haven't heard of AllStar, it is a VOIP repeater and gateway linking system similar to IRLP or as it was described to me 'IRLP on steroids'.

Technical details:

VK6RAV	Hoddy's Well	147.275+ MHz	AllStar Node: 45472
VK6RKN	Kellerberrin	147.325+ MHz	AllStar Node: 45473
VK6-HUB	Perth, Western Australia	AllStar Node: 42732	

A truly remarkable feature among the many of the AllStar system is the quality of the audio. It is no exaggeration to say it is most often impossible to distinguish between stations on the repeater proper and stations linked via the AllStar network.

On Sunday 3 December 2017, Bob VK6VGN installed two AllStar nodes, one at the VK6RAV Hoddy's Well repeater and the other at VK6RKN Kellerberrin repeater. This work included the replacement of the older repeaters with new Icom radios, the new All-Star controllers and Raspberry Pi computers.

The Kellerberrin repeater had no internet on site, so a Ubiquity microwave link was also installed to present internet to the site from a location in town.

Bob was assisted by Jim VK6CA, Bruce VK6LAW, myself VK6YSF and my two young sons Andrew and Lewis, not present was Peter VK6PK who organised the project with meticulous detail and along with Bob was critical to the final success of the project.

At the time of writing both the VK6RAV and VK6RKN repeaters are linked with the VK6 Hub (Perth) which interconnects a number of other repeaters around the state and the country. The final nominal linking arrangement will be reviewed in the near future with the view that the new higher volume of air traffic not detract from existing local activity.

Give us call.....

73

Peter VK6YSF

NewsWest

WA Amateur Radio News - VK6ARN
- produces a weekly news bulletin for radio amateurs, short wave listeners and people interested in our hobby across VK6 and far beyond. Available on-air on most amateur bands, on-line via vk6.net and on-demand via podcast, NewsWest continues to inform

and promote the hobby as it has done since 1931. We now have broadcasts in VK2, VK3, VK4, VK7 and VK8 as well as check-ins from across the globe for people wanting to hear news about amateur radio. If you'd like to find out more, check out the website at <http://vk6.net/>, or send an email to newswest@vk6.net with your story. If you'd

like to broadcast our weekly news, you can. Download the audio from the website and transmit it at your convenience, no permission required, but please broadcast the show as-is. Let us know and record your callbacks afterwards via email to newswest@vk6.net - we look forward to hearing from you.

73s de Onno VK6FLAB

Promote our hobby

Have you considered using your unwanted *Amateur Radio* magazine to promote the hobby and the WIA?



Consider taking it to the office of the local health professional (doctor, dentist, etc.).

You never know, **you might stimulate someone** to consider taking up our hobby!

Wireless Men & Women at War



Wireless Men & Women at War

Young men and women who behind the scenes, were able to successfully use their developed skills in such a way as to make a difference - sometimes a big difference brought about largely by their interest in private radio communications. Read more...

Visit the WIA Bookshop at: www.wia.org.au/members/bookshop/page_data.php?id=258



VK7news

Justin Giles-Clark VK7TW

e vk7tw@wia.org.au

w <https://groups.yahoo.com/neo/groups/vk7regionalnews/info>

North West Tas. Radio & TV Group (NWTR&TVG)

<http://www.vk7ax.id.au/atvgroup/>

End of 2017 celebrations saw an excellent roll-up and a great BBQ thanks to Bob VK7MGW, Ursula VK7FROO and Lucas VK7LSB. The club showed its appreciation to the Ulverstone Lions Club for use of their facilities during the year by inviting Lions Club members along. A general meeting was held after the BBQ and received reports about the excellent JOTA/JOTI activities in the NW of VK7.

Northern over 70s SOTA Activists

There is a group of over 70s in Northern Tasmania who are taking

being active to a whole new level. They call themselves the Northern Over-70s SOTA Activists and they recently held their Christmas lunch and 37 potential SOTA enthusiasts attended. It was held at Glebe Gardens, a popular venue in Launceston. The attendees listened to various tales of mountain climbing in NE Tasmania including the struggle up Mt. Leventhorpe on Flinders Island.

Northern Tasmanian Amateur Radio Club

<http://www.ntarc.net/>

Congratulations to NTARC member Alan VK7BO for winning first place in the Oceania Division of the 2017 Russian WW Digital Contest. I understand the certificate is a work

of art and will be displayed in the NTARC clubrooms. The end of year celebrations were popular with members and the new addition of a Pianola complete with many rolls thanks to Joe VK7JG, XYL Phyl, Stefan VK7ZSB and family was a great treat! This addition now has the NTARC committee looking for song books to match the Pianola rolls.

BBQ lunch continued to BBQ tea and many stayed to enjoy a whole day of celebrations with many Christmas treats along the way. A rolling Christmas raffle saw many people leave with something special.

NTARC have applied to relicence the 70 cm repeater on Mt



Photo 1: Over 70s SOTA Activators. L2R: Peter VK7PD, Al VK7AN, Joe VK7JG and Bob VK7ZRF.

Arthur as VK7RJG in recognition of the decades of contribution made by Joe VK7JG to NTARC and the state-wide repeaters systems. Once this repeater is in place, NTARC intend to re-start a weekly club net on VK7RJG. NTARC are looking for a team of net coordinators and if you are interested then contact the secretary@ntarc.net.

WICEN Tasmania (South)

<http://www.tas.wicen.org.au>

Every two years the Scouts hold the Sir Ernest Clark Trophy that involves Scout patrols from around Tasmania converging on an area and engaging in a competition testing a range of Scouting skills. This year it was again on the Property "Rockton" near Oatlands. The WICEN crew provided communications from the hill Spion Kop. The Scout patrols have to complete many widespread activity nodes around the property.

They were also scored on their overnight camping competency.

Thanks to WICEN crew - Garry VK7JGD, Roger VK7ARN, Peter VK7TPE and Rod VK7TRF.

WICEN held their annual end of year lunch at the Royal Yacht Club of Tasmania with 30 people attending. A special feature of this year's event was the music played by Helen XYL of the author on her harp. Celtic music was a feature and it was appreciated by those attending. Thanks Helen.

Radio and Electronics Association of Southern Tasmania Inc

<http://www.reast.asn.au/>

Congratulations to Tony Sayers VK7FAJS who recent gained his Foundation licence following an assessment. REAST was treated to two outstanding presentations at the end of November and beginning

of December 2017.

Dr Justin Thurley from Huon Aquaculture gave the members a fantastic presentation on the technology behind the aquaculture industry. There were four areas covered - Data and analytics, Automation, Infrastructure and Operational technology. There is a huge amount of networking and real-time data feeds including being able to see the fish feeding and this was demonstrated live! A huge thank you to Dr Justin Thurley for an amazing presentation, and Murray VK7ZMS for organising Justin to come along.

The REAST presentation night for December 2017 saw Dale Hughes VK1DSH present *The International Governance of Amateur Radio & the role of the IARU*. Dale was in Hobart for a conference and agreed to give the club a presentation on his important work with the IARU and ITU.



Photo 2: Clark Trophy Operators L2R - Garry VK7JGD, Roger VK7ARN, Peter VK7TPE and Rod VK7TRF (photo courtesy of Roger VK7ARN).



The International Governance of Amateur Radio & the role of the IARU

Presentation to REAST
6 December 2017

Dale Hughes VK1DSH

Based on a talk by Peter Young VK3MV
given at the July 2017 GIPPSTECH conference

Photo 3: Dale Hughes VK1DSH (photo courtesy of Justin VK7TW).

Dale covered the role of the International Telecommunications Union and International Amateur Radio Union (IARU) which was founded in Paris 1925, noting that the WIA was a founding member society. Dale then covered the regions and how it feeds into preparations for the World Radio Conferences. Dale then went through his role as Chair of Working Group 5A-1 on Land mobile, amateur & amateur-satellite services. Dale finished off with some of the other activities the IARU undertakes like the monitoring service and took a look at the Radio Regulations and the many Footnotes! The example used was 5 MHz and the difficulty with getting access to this band due to Defence using it for the Jindalee Over the Horizon Radar system and that means it's a national defence argument. A huge thank you to Dale for coming along and giving us a great talk.

The REAST experimenter's nights have had a distinctly digital theme, covering FT8 with Rex talking us through the use of Low Density Parity Checking (LDPC) codes for QRA64 and FT8. LDPC supplies strong Error Correction which means that if it decodes at all it will be right – almost all the time. Rex then went through his Aircraft Scatter experiments on 2 m with Ron VK3AFW using FT8. Rex also showed his YU7EF design 6 m four element ultra-portable and light Yagi antenna and admitted he as hooked on FT8 on 6 m! Steve VK7OO took us through his 20 m magnetic loop using the design from Jim Tregellas VK5TR using high pressure aluminium coated plastic gas pipe. Thanks Steve.

SK Peter Blundstone VK7KPB/VK7ZPB

It is with sadness that we inform you that Peter VK7KPB has become silent key.

Peter was born on Flinders Island, 11 March 1935 and died in the Flinders Island Multipurpose Centre on 2 December 2017 aged 82.

Barclay was his property name, located in the Strzelecki Range National Park on Flinders Island. Peter farmed Barclay for most of his life and was licensed as an amateur radio operator for over 30 years. He enjoyed activating IOTA OC195 and was an active operator, logging many contacts for this rare location.

Peter commenced training with the Marconi School of Wireless as a commercial radio operator and his graduation certificate is dated 1 June 1952.

He was the TV Technician for Bass Strait islands, mainly the Furneaux Group for several years.

Alan VK7AN recalls that he first encountered Peter on Flinders Island some 30 years ago: he then informed me that he held a Commercial Operator's Certificate

of Proficiency for many years. After many hours trying to track down this certificate, it was found in an archive cabinet.

This was forwarded to WIA head office for approval to become a licensed radio operator on amateur radio frequencies.

Finally allocated VK7ZPB, two years later Alan being a registered Examiner and Barry VK7BE arrived

on Flinders Island to conduct a CW exam, of which he passed with flying colours, bringing back past memories from the Marconi School of Wireless training.

Peter was an active operator with many QSL cards still being received from the bureau.

Many hours in the early days were occupied with the late Bill Carter VK7AK, who was based

on Flinders Island with the PMG, experimenting with VHF contacts in AM mode to New Zealand on a regular basis.

Later in life Peter became Mayor of Flinders Council for several years.

Sadly missed.

Vale Peter VK7KPB.

(AI VK7AN)

Should we close the QSL Bureaus?

John Seamons VK3JLS - WIA National and Inwards QSL Manager

e vk3jls@wia.org.au

With such an intriguing headline, you might well question why I'm asking such a thing, having only recently been appointed into a QSL Bureau role! Am I already trying to extricate myself from the role because I see no future for the WIA QSL Bureau or for that matter any QSL Bureau?

No, I'm prompted to write on this theme because of a recent post from a VK amateur on one of the local social media amateur radio websites. That post stated:

"I think it is time us hams showed that we can put archaic processes in the past & embrace more efficient systems.

It is time we closed QSL Bureaus...

It is time we made setting up a Logbook of the World account part of the examination & license process.

If you want paper cards send them direct... it is much quicker & it isn't being subsidised by your fellow hams...

Here endeth my sermon!

For foreign amateurs LoTW is FREE. Yes, proving your identity initially is a pain but once you get past that it makes life so much easier. Wouldn't it be nice if the WIA could set up an

arrangement with the ARRL to do ID checks for VKs?"

There were a few social media responses to this, but I didn't really see strong support of this "sermon". So are we seeing the end of the Bureaus as we know them? If we look at the list of IARU Bureaus (noting that there are other Bureaus around the world that are not IARU affiliated) since the year 2000, there have been 26 DX Bureaus that have closed; in the last five years, six have closed. Most of these have been from smaller countries, while the larger countries' Bureaus still operate quite strongly.

Within our own Bureau system, we have a lot of volunteers who work tirelessly behind the scenes to make the system work as effectively as possible, to ensure that cards are posted to overseas Bureaus and that inward cards are delivered to the end user. Each year, the WIA Bureaus handle over 90,000 QSL cards, at a postage cost of around \$4,500 per annum. That works out to around \$1 per Member per year. So yes, those WIA Members who do not use the Bureau process are each subsidising their fellow Bureau-using amateurs to the tune of 2 cents per week.

Exchanging paper QSL cards

to confirm a two-way contact is a tradition that dates back to the beginning of Amateur Radio. Today, many amateurs prefer to confirm QSOs electronically with Logbook of The World (LoTW), or eQSL; however there still remain those who like to swap paper cards. (Regularly on social media, local amateurs post pictures of cards happily received from the "QSL fairy", either direct or via the Bureau!)

But what of LoTW and eQSL? Globally there are 111,000 users of LoTW out of an estimated population of 3 million operators (approx. 3.7%), and there are 277,000 unique users of eQSL (9.2% of the ham population). In VK there are 885 registered LoTW users or 6% of all VK amateur licences. So while these systems are growing, have they yet reached a user penetration to warrant the closure of QSL Bureaus?

Exchanging QSL cards directly with your QSO partner can be very expensive. If you calculate the cost of postage to send an envelope overseas, plus any money enclosed to cover the return postage and the cost to purchase those "green stamps", a single direct QSL card request can cost up to eight dollars or more. Confirming QSOs

electronically is a rapid and cost-effective way to earn QSO credits for awards but, for the paper card collector, the QSL Bureau does offer a cheaper alternative to the direct QSL method. While some amateur organisations levy charges for the use of the Bureau, the WIA provides it as a service to its Members – costing roughly \$1 out of your annual subscription. I personally receive 4 deliveries of cards per year, with roughly 15 cards per delivery. The only cost to me is in posting 4 SASEs to the VK3 Bureau and my \$1 to the WIA. 60 cards for \$6 seems like a pretty good deal, on the basis that I am not in a rush to obtain those cards.

The argument often used is that it can take years to get a card

through the Bureau; but it can also be a short timeframe. (Recently I received a Bureau card from G land within 2 weeks of the QSO; admittedly I was sorting some inward cards at the National Bureau, when I pulled this card from a recent delivery). Changes in our Inward Bureau operations will mean that even for the smaller States/Territories, their Bureaus will get deliveries of inward cards at least every 3 months, no matter how few cards are to be posted.

And let's not ignore ClubLog and the OQRS online method of receiving Bureau (or direct) cards without even having to send your own card. Many DXpeditions use this process, and you can receive free Bureau cards in a relatively

short time frame.

So, back to where this article started; should we close the QSL Bureaus?

Are the Member benefits available worth the minimum outlay required?

Is it a "tradition" that we should continue, or is it an "archaic process" that we should put in the past??

Good DX and I wish you many QSLs (LoTW, eQSL and Cards!!)

John Seamons VK3JLS

(Any Member interested in using the Bureau service, need only register themselves with their State or Territory Bureau. Refer to the Callbook or the WIA website for contact details).

Silent Key

John Morris VK2BES

John began life during the Great Depression of the late 1920s and by the age of six was accustomed to a succession of itinerant jobless men coming to the house for a meal in return for some odd jobs.

Since his father was in secure employment as the Inspector of Engineering for the then PMG, he was imbued with the idea that a public service job was the best way to get ahead in life. Frequent moves until the outbreak of WW2 finally found him in Melbourne where his father was in charge of the PMG workshops which produced communications equipment for the services. Now, with stable living conditions, he excelled at high school passing the Leaving Certificate near top of the class.

He joined the Air Force just as the war was ending and obtained a posting rising to the rank of Pilot Officer.

On discharge, he joined the Dept. of Civil Aviation in the Air Navigation and Safety Section.

He had the chance to enrol at University and although his main interest was Science and Engineering, he was advised to do Commerce at the University of Melbourne on

the grounds it may lead to future managerial positions.

During his time there, he joined the MUR (Melbourne University Regiment) and made a firm friend whose father was a brigadier in the Regular Army. The result of this is that he enrolled in the Regular Army and was sent to Japan to serve with the Occupation Force.

In the meantime, the Korean War had broken out and John was sent to Korea to serve with the Commonwealth Division.

On return to Australia, he went back to study full time to the University of Melbourne and graduated with a BA, Diploma of Education and a post graduate Diploma of Psychology.

He joined the Education Dept. and taught maths and science at Burwood High School for five years before transferring to the Psychology Branch and later became the first Research Officer of the Victorian Education Department.

John obtained a scholarship from the Dept. to go to the US and applied to do a Ph.D. at the University of California at Berkeley. He had not lost his position in the Army Reserve and so obtained a posting with the 7th

Infantry while doing his University work. He worked in the Intelligence Staff of the Division during the Cuban Missile Crisis. To be in the planning staff during that crisis was a great experience.

He returned to Australia and obtained a position as Senior Lecturer in the Department of Psychology at the University of Wollongong where he remained until retirement.

It was around this time he rekindled an interest in the technical side of communications and so studied for and gained his Amateur radio callsign VK2BES.

He was active on air in the Illawarra region right to the end.

Always interested in the cutting edge of amateur radio, he was experimenting with Magnetic Loop antennas the day before he passed away.

John was married to Evelyn, a lovely Japanese lady, the marriage lasting sixty years until her death in 2012. She accompanied him throughout those years in many countries and careers with patience and faithful companionship.

Vale John, a great friend,
Steve VK2BGL.

WIA Contest Website



To keep up to date with all of the major Australian contests, including rules and results, at the WIA Contest Website at:
www.wia.org.au/members/contests/about

Historical changes 60 years ago shape today

Jim Linton VK3PC

The year 1958 was the International Geophysical Year and saw the start of many technical things we have today. During that year the Earth's magnetosphere was discovered plus a number of other notable milestones.

The year was important in the development of Amateur Radio and electronics generally.

On 4 January, Sputnik 1 fell to Earth having been launched on the previous 4 October.

The first successful American satellite, Explorer 1, launched on 31 January. The space race had begun.

In July the US created the National Aeronautics and Space Administration or NASA.

The Soviet Union was first in space, but the USA launched the world's first communications satellite on 18 December, and planned to go to the moon.

On 11 February we had the strongest solar maximum, based on records of 400 years.

Sunspot Cycle 19 was enjoyed by those of HF and 6 metres.

Meteor scatter and stacked Yagis on VHF had grabbed the imagination of radio amateurs as they explored both the meteor scatter and the ionosphere on 6 metres.

SSB was starting to emerge. The development in the 1960s combining the receiver and transmitter in the one box certainly helped SSB to become the dominant phone mode on our bands.

The Advanced Research Project Agency began to link research organisations with each other.

Little did those involved realise that their work would lead to the now ubiquitous Internet we have

today.

On 12 September, Jack Kilby demonstrated the first integrated circuit, and the principle of optical lasers was set out by researchers at the Bell Laboratories in December.

We have certainly seen since a shrinking in size with a boost in power from a plethora of devices.

The Citizens Band began in the United States, where the 11-metre band was taken from Amateur Radio – that started a global trend for that industrial, scientific and medical band.

Although technology has exploded, modern Amateur Radio has too, it's still nice to reflect that a radio amateur using 1958 sets can still communicate with those made 60 years later.

Silent Key

George Lionel Frank Collie VK2ZDC

1934-2017

It is with great regret that I announce the passing of George. He passed away just a few weeks after entering a nursing home near Wyong. He left this world peacefully in his sleep on 22 November 2017 aged 83.

George was a founding member of the Central Coast Amateur Radio Club Inc. and remained an active member throughout his life until his last year when illness overtook his enthusiasm. I first met George in 1969 up on the Central Coast of NSW where he operated a TV business in Wyong; later he transferred and expanded his business and family along with Helen his wife to The Entrance. There they raised their two sons David and Paul and daughter Michelle as well as running a combined TV sales, repair rental and antenna business until his retirement when George and Helen moved to Gorokan. In Gorokan, George continued his amateur activities mostly centred on ATV. He was not a rag chewer but



could always be found on our ATV.

Liaison frequency 147.450 MHz FM: George could always be found during field days on the ATV stand helping to run the demonstrations or give words of advice to visitors or greet old friends; all this without

missing a year from 1974 up until the year of his passing. George also belonged to the local men's shed; a local light aircraft group where he flew his home made light aircraft and also was a member of the local prostate support group where he gave a number of lectures and encouragement having overcome the disease completely up to the time of his passing. He also overcame a heart attack some years ago and remained very healthy and active until this year.

George will be sadly missed by Helen, David, Paul, Michelle and their respective children and families and his vast number of friends, especially my wife and I. We will treasure forever the vast store of wonderful memories he has left us all.

The memory of the righteous is for a blessing.

Farewell my friend.

Vale George Lionel Frank Collie.

Victor Barker VK2BTV.

Four Australian Ground Stations provide HAMTV Chain for ARISS contact

Francesco De Paolis IKØWGF

Saturday, 11 November, 2017 at 1116 UTC, 1216 local time, students by "Icaria Alpi", Rutigliano, Italy, I.I.S.S. "T.Fiore-C.Sylos", Terlizzi, Italy, and Liceo Scientifico "Valdemaro Vecchi", Trani, Italy established a ARISS contacts with ESA astronaut Paolo Nespoli IZØJPA, on-board the International Space Station.

This was a telebridge contact performed by Amateur radio ground stations VK4KHZ located at Glenden, Queensland, Australia.

Liceo Statale "Icaria Alpi" is a Secondary School which offers different courses for students aged 13-18. It was founded in 1973 as dependent school and it became autonomous in 2006. Since 1997 we offer two experimental courses: Scientific Studies and Technologic Studies. In 1998 a Linguistic course and a Social Sciences course were added. During this period the school has grown from 9 to 30 classes of students. According to the Gelmini Reform, we teach some subject, such as Maths, Physics and Science, using CLIL methodology. Our school is located in a small town in Southern Italy, about 20 km from Bari, in a rural area mainly concerned in fruit and vegetable export. The teaching staff and pupils are open to changes and innovation. In 2011 we took part in the Comenius Partnerships "Maths is everywhere" which aimed to give a new dimension to Maths teaching to applying new methods and to learn maths as a part of everyday life.

The high school I.I.S.S. "T.FIORE-SYLOS" in Terlizzi is characterized because it ensures a basic training extensive and deeper in science than in the humanities, with an emphasis on the study of foreign languages. It provides cultural and methodological tools to understand in depth the reality through the acquisition



Paolo IZØJPA getting things set up for the ARISS HamTV contact. Image captured by Martin Diggins VK6MJ.

of rational, creative, design and critical attitudes in front of different situations, phenomena and problems. It promotes the development of knowledge, skills and competencies consistent with capacities and personal choices, depending on the continuation of studies or of inclusion into the world of work. In the scientific laboratory are made chemical, physical and biological experiences such as the measurement of the pH using indicators; the analysis of cellular tissues of animals and plants; the separation of mixtures through filtration and paper chromatography; the test of the law of Boyle; the determination of the density substances and the volume of materials; experiences on the kinematics of a material point, on the principle of Archimedes and on the laws of dynamics.

Liceo Scientifico "Valdemaro Vecchi" provides students with a sound preparation that is mainly grounded on both the knowledge of scientific subjects, supported by the development of logical and critical abilities, and an efficient self-study method. Beside the traditional path offered by the "liceo scientifico" (high school specializing in scientific subjects) aimed at studying the connection between scientific culture and humanistic tradition, we

also offer the "applied sciences" option which provides the students with really advanced competences in the studies relevant to a scientific and technologic culture.

Mentor Francesco De Paolis IKØWGF proposed to the Radio Contact coordinator a joint contact and proposed the schools to share the event, alternating questions from both sites. Mr. Michele Mallardi, coordinating the events, agreed and set up a combined direct. The questions were read, alternatively, by students from Citadella Mediterranea della Scienza, Università di Bari, Italy. More than 300 students, parents, visitors and media attended to the event. Contact was established at 11:16 UTC, 12:16 local time, with NA1SS. Astronaut Paolo Nespoli IZØJPA answered 14 questions. Signals from the ISS were loud and clear during the ISS pass.

In addition, the on-board HamVideo transmitter was operational for the ISS pass and streaming video was available at: <https://ariss.batc.tv/hamtv/>

Excellent job by all the Australian stations active also for the HamTV reception, thanks to Martin VK6MJ, that had HamTV before AOS by Shane, we saw Paolo wearing headset and get ready for the contact. This is once more a great demonstration on the huge added value of having HamTV on-board!

This was the first chained HAMTV event performed by Australian GSs and merged on BATC.TV during an ARISS scheduled contact.

One regional television station and one newspaper covered the event.

73 de Francesco IKØWGF

New digital mode for LF/MF

Murray Greenman ZL1BPU

Three years ago ZL2AFP introduced a weak-signal QSO mode specifically for the LF/MF bands. The mode has now been updated and enhanced, and is capable of comfortable QSOs at down to -25 dB SNR, so almost as sensitive as WSPR.

However, the new WSQCall V1.00 is a QSO mode, and also has selective calling capability, plus automated responses and the ability to send and receive files. The protocol is the same as for FSQCall, so should be familiar to existing users.

The WSQCall signal is just 50 Hz wide, is easy to tune, and experience has shown that it will fit between carrier QRM lines on 630 metres. What's more, WSQCall V1.00 also has three notch filters available to knock out carriers. These notches are adjustable in frequency, width and depth.

Operating at only 0.5 baud, WSQCall achieves a respectable 5 WPM through the use of a special alphabet and very efficient character coding. This is a true real-time QSO mode with no timing restrictions,

not just a beacon.

We have been using this new version for reliable 300 km 630 m contacts DURING THE DAY, and the range at night should exceed 1000 km.

You can now read an introduction and download the software for WSQCall V1.00 from: <http://www.qsl.net/zl1bpu/MFSK/WSQweb.htm>

73,
Murray ZL1BPU

Over to you

Amateur Radio and being physically disabled

This article was 'inspired' by my own personal situation in being somewhat physically disabled with reduced mobility and general function after an accident in early 1988 which is getting progressively worse with passing time. I was first licensed in 1985 and antenna work was an early interest and an ongoing passion and I sometimes think back to the weird and wonderful antennas I put up in those days completely by myself, prior to my permanent spinal cord injury in early 1988.

There are even a few old photographs around to prove it! I have mostly accepted the mobility limitations that are now part of my daily life and the difficulties that entails but every now and then, certain things I hear 'annoy' me. A while back on a certain local 80 m club net, the subject of 'towers' was

discussed, with the net controller's strong inference that every amateur should have a 'tower' in the backyard.

I listened for the duration of the lengthy discussion and as far as I can recall, there was no mention of amateurs in my situation with serious physical disabilities and antennas for people in that situation. By the end of the net I'll admit that I was feeling more than a little angry, to be perfectly honest. As it presently stands, for various complex reasons, I cannot call out much in the way of assistance in the form of able bodied help and I am indeed fortunate to have one or two moderate height pre-existing metal pipe masts with pulleys installed and twisted silver rope in place to enable basic antennas to be erected for the various HF bands.

Members of my local gym have also assisted me with mast lowering and maintenance, for which I am most thankful. They are about the only helpers that I can call on now! I am also aware of a progressive amateur radio club further South in VK4 who are quite happy to assist amateurs needing assistance with antennas. That is indeed a most admirable attitude!

Thinking back to that 80 m net, I still cannot believe the attitude of some on that net who have apparently clearly forgotten all about the 'Amateur Operators Code' and only seem to care much about making big scores in DX contests! With people with attitudes like that, sometimes I am ashamed to be called an Amateur Radio Operator.

Felix Scerri VK4FUQ
Ingham, Queensland.



Wanted



Articles and high quality photographs for **Amateur Radio** and **Callbook**.

See <http://www.wia.org.au/members/armag/contributing/>

An alternative and affordable antenna elevator type mast

Dale Anderson VK4NBX

The advantages of this type of antenna mast construction are:

- (1) The accessibility to the antenna for maintenance.
- (2) Able to be brought down in bad weather, electrical storms etc.

This construction comes in three parts.

- (i) Mast construction.
 - (ii) Elevator or antenna carrier construction.
 - (iii) Foundation.
- (i) The mast consists of 1, 1.5 or 2 treated and machined 6 metre Koppers logs, ordered at 175 mm in diameter from your larger hardware outlet. I joined two of these logs using 50 x 50 mm x 5 mm thick x 1200 mm long angle iron on three sides of the join and the main up and down carrier track for the fourth side.

The track itself consists of 100 mm wide x 5 mm thick flat plate to run the full length of the mast. This steel is available in either Black (cheapest) or Gal. When ordering my steel track, I ordered from the ground up as follows:

- 1 x 1 metre, 1 x 6 metre, 1 x 5 metre

By mounting in this order, it allows an overlap of 1 metre at the main joint. The bottom 1 metre section is designed to be removable to allow easy fitting or removal of the carrier assembly. The track is spaced off the joined posts by square washers 5 mm thick. These washers are also available at larger hardware outlets

The track mountings are spaced approx. 500 mm apart along the length of the track. For track mounting bolts I used Hex



Photo 1: The stub mast and rotator carrier.



Caption 2: The stub mast and rotator carriage installed on the carrier rail.

Head 100 mm long x 10 mm Gal coach screws, except those marked on the mast.

The Eye Bolt, which is on the opposite side of the mast

to the track about 2/3 the way up, allows for a lifting point. The mast foundation holes are 800 mm apart.

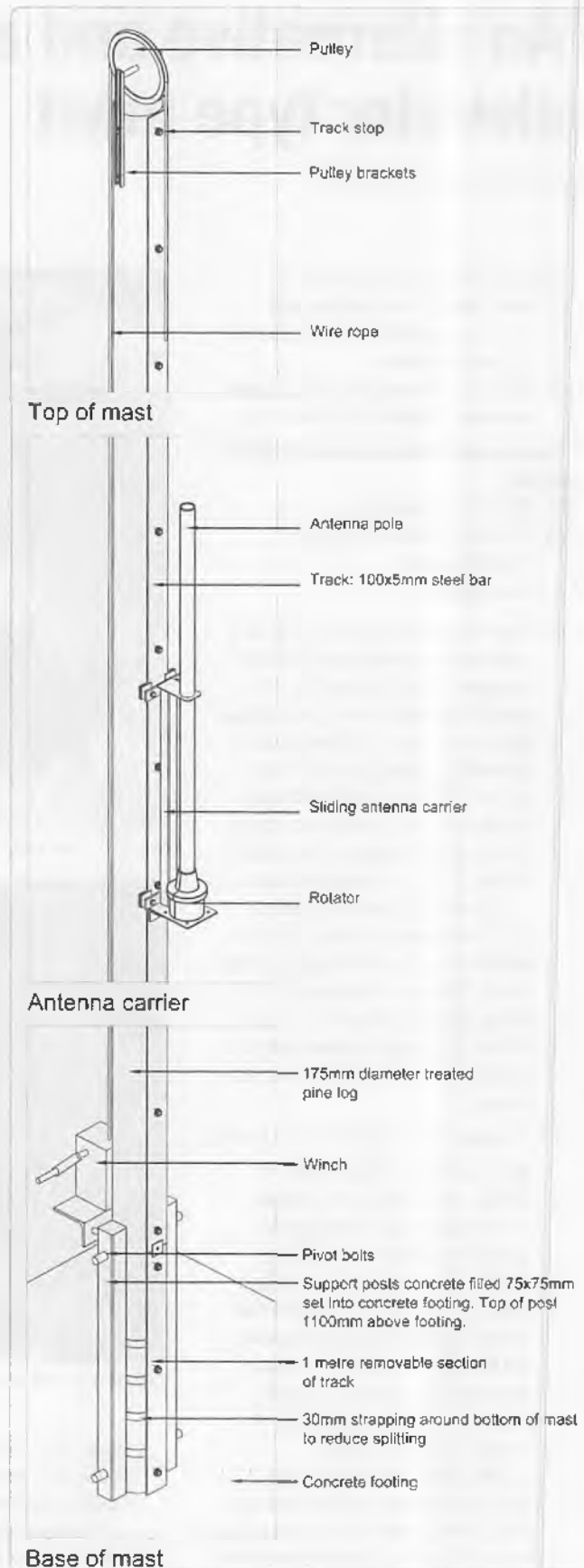
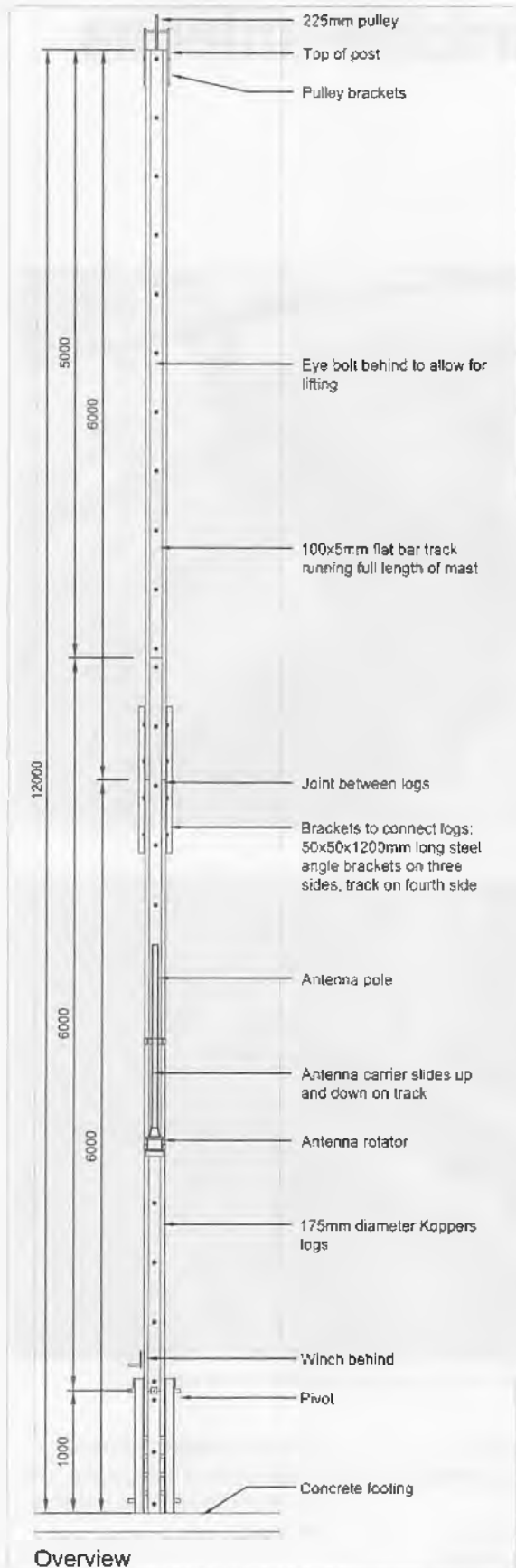

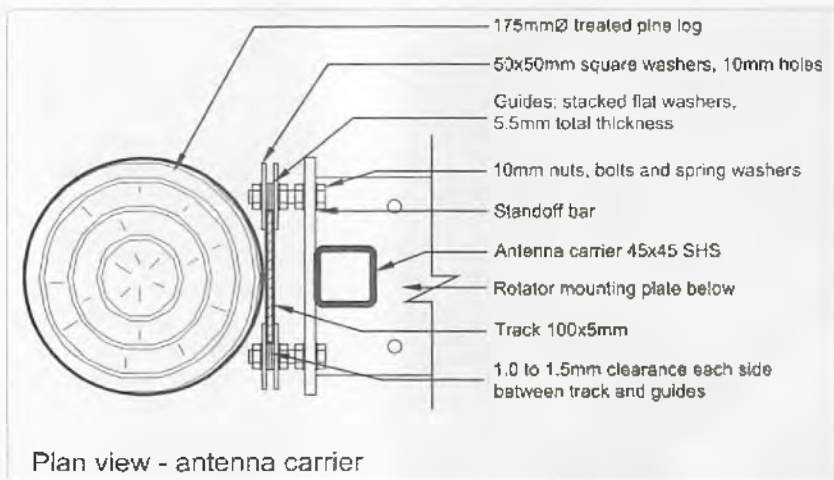

I mounted a 9 inch pulley atop the mast, using aluminium tube spacers to centralize the pulley from the outside mounts. At the bottom end of the mast, I banded either side of the mounting holes to prevent

splitting. For this I used 30 mm strapping I found kicking around the shed.

The welding joint on the track, needed to be smoothed off 30 mm in on either side, both front and back to allow for smooth carrier

operation. Last but not least, a bolt put in the track at the top as a stop for the carrier.

Very Important.

(ii) The antenna carrier body is made of 45 mm x 45 mm square section steel 900 mm long. The two stand-off bars are 8 mm thick, 40 mm wide x 180 mm long. Construction of each stand-off bar can be seen in Figure 2 and also Top of Mast photo.

The bolts (10 mm) supporting the sliders, may be any length depending on the distance needed to clear bolt heads, going down the centre of the track.

I cut off any protruding bolt after the last nut. At the bottom of the carrier, a steel plate is welded on to carry a rotator.



Photo 3: Another view of the stub mast and rotator carriage in position on the carrier rail.



Photo 4: The rotator, stub mast and carriage in position on the mast prior to elevation.



Photo 5: The mast base with the mast ready to elevate to the vertical position.

I used a Yaesu G450A rotator. At the top of the carrier, a greased friction bearing was used. The antenna support pipe is 50 mm Gal. I chose 1.5 metre of pipe which brings the antenna to about eye level when down.

(iii) The foundation consists of two x75 mm x75 mm x 1800 mm long 4 mm gauge square section steel posts, spaced 179 mm apart to allow the mast including the banding to fit snug. I left 1100 mm of the posts above the concreted hole, for mast mounting. The two 20 mm mast mounting holes in the steel were spaced 800 mm apart, making sure I left enough gap at the very bottom for swing up.

Just below the top mounting hole on each post, is another 20 mm hole at 90 degrees to the mast mounting hole. This hole on each post is to take 20 mm threaded rod for an adjustable large angle iron bracket to be used as a stop, when the mast becomes vertical upon lifting. It also doubles as a winch mount.

Photo 6: The stub mast assembling carrying a Yagi into position.





Photo 7: The winch to raise the carriage assembly up the track.

This winch mount and stop are to be on the opposite side of the mast to the track, when mast is up. The hole in the ground for the foundation I made 1.8 metres deep. After the mast went up, I filled both posts with concrete.

Summary

As with any amateur mast construction, it should always be safety first, particularly raising the mast. This mast is heavy; I used a Gin Pole and a 4WD vehicle. Anyone wishing to use this design or part thereof, I would be happy to email more photos.

My email address can be found on qrz.com/
VK4NBX,...

Photo 8: Detail of the carriage assembly on its guide track.



Hamads

FOR SALE – VIC

Hy-Gain TH6DXX 6-element Triband (10, 15, 20 m) amateur beab with balun & instruction manual. Kenpro KR-400 HD rotator, with instruction manual. Hills 20 m 3-section crank-up & guyed mast with additional 3 m mast, including instruction manual & wind calculations. Miscellaneous cables, gut wires and assembly aids, including jib & 2 hand winches which allow one man assembly.

Total \$2200. Call Tony VK3BYJ 03 9887 0294 or 0409 701 250. Boronia VIC.

GIVE AWAY – QLD

Over 40 years of AR magazine (1959 – 2001) approx.. 95% complete. Free to a good home that will preserve, protect and expand the collection. Also contains some QTC inserts (VK4 supplement). Collect Brisbane. VK4BJ QTHR Ph 0438 220 742

FOR SALE – QLD

Moonraker 32 H/S 9.5 m / 32ft. HF vertical antenna, in 3 sections c/w S.S. insul. guys, insul. base. Has been used, now in storage and in good condition. \$150 ono. Less mount bracket. Kevin VK4KWT Mareeba 0428839469.



Contributions to *Amateur Radio*

AR is a forum for WIA members' amateur radio experiments, experiences, opinions and news.

Your contribution and feedback is welcomed.

Guidelines for contributors can be found in the AR section of the WIA website, at <http://www.wia.org.au/members/armag/contributing/>

Email the Editor:
editor@wia.org.au

About Hamads

- Submit by email (**MUCH PREFERRED**) or if written and mailed please print carefully and clearly, use upper AND lower case.
- Deceased estates Hamads will be published in full, even if some items are not radio equipment.
- WIA policy recommends that the serial number of all equipment for sale should be included.
- QTHR means the address is correct in the current WIA Call Book.
- Ordinary Hamads from those who are deemed to be in general electronics retail and wholesale distributive trades should be certified as referring only to private articles not being re-sold for merchandising purposes.
- Commercial advertising on these pages Contact admanager@wia.org.au
- Copy to be received by the deadlines on page 1 of each issue of Amateur Radio.
- Separate forms for For Sale and Wanted items. Include name, address STD telephone number and WIA membership number.

'Hamads'
PO Box 2042
BAYSWATER VIC 3153
hamads@wia.org.au

AMIDON FERROMAGNETIC CORES



tts systems

Phone 03 5977 4808. Fax 03 5977 4801
info@ttsystems.com.au



11- 13 Port Road, Queenstown, SA 5014

Quality Products for the Radio Amateur

JACKSON BROS variable and trimmer capacitors, reduction drives and ceramic stand-offs

HAMMOND transformers, enclosures and chassis's

DSE HIBOX large plastic waterproof enclosures

ANDELI GROUP indicator lights, relays and switches.

Pay by credit card, EFT or PayPal

CALL (08) 8304 2000

sales@cooksoncontrols.com.au
www.cooksoncontrols.com.au

Studying for the Standard or the Advanced Licence?



Here are 4 books that will get you there.

TAKE A LOOK AT www.gscott.com.au

for more information and order form.
635 Edmonson Avenue
Albury NSW 2640



Have you held an amateur licence for 10 years or more?

If so, then you are invited to
join the

RAOTC

A \$5 joining fee, plus \$18 for one year or \$32 for two years, gets you two interesting 64 page **OTN Journals** each year, **PLUS** good fellowship, and a regular broadcast of news and events.

More information and a membership application are available from our web site at www.raotc.org.au or write to:-
PO Box 107, Mentone VIC 3194 or
email:- raotc@raotc.org.au or
call Secretary: Ian Godsil VK3JS
on 03 9782 6612 .

TRADE PRACTICES ACT

It is impossible for us to ensure that the advertisements submitted for publication comply with the Trade Practices Act 1974. Therefore, advertisers will appreciate the absolute need for themselves to ensure that the provisions of the Act are strictly complied with.

VICTORIAN CONSUMER AFFAIRS ACT

Advertisements with only a PO Box number address cannot be accepted without the addition of the business address of the advertiser or seller of the goods.

ADVERTISERS INDEX

Cookson Controls	64
Future Systems	11, Inside Back Cover
Ham Radio House	13
Icom	Back Cover
Jaycar	7
TET-Emtron	9
Amidon	64
Yaesu	Inside Front Cover



FUTURE
SYSTEMS

Beautifully Simple

Remote so easy it's practically magic

Flex-6400 from \$3300
Flex-6400M from \$4999
Flex-6600 from \$6250
Flex-6600M from \$7800
Flex-6700 from \$10,900

FlexRadio Systems[®]
Software Defined Radios

Buy a FlexRadio and get started
with SmartLink™ today



SmartSDR for iOS now available for iPad on the App Store

futuresystems.com.au | sales@futuresystems.com.au | +61 8 6336 9610
Prices as of December 2017, subject to change at any time without notice. See website for details

ICOM

IC-7610

RF Direct Sampling Evolution



7-inch Color Display
with Touch Screen
Function

Multi-Dial Knob
for Smooth
Operation

Customized VCXO
Is Used for the
Master Clock

Dual Receivers, Dual
Spectrum Scopes

To find out more information about Icom's Product range email sales@icom.net.au

www.icom.net.au