

Amateur Radio

Volume 87
Number 2 ▶ 2019
Price: \$12.50 incl GST

www.wia.org.au



Review: RadioSport RS60CF headset

- ▶ Build a scaler network analyser
- ▶ The Hotham SOTA Summit
- ▶ 19th IARU ARDF Championships



0002 685062

The Conclusive Choice

1- Pulling out weak signals during extremely harsh band conditions

VC-Tune

Unparalleled damping characteristic of -70 dB maximum attenuation

Newly developed VC-Tune RF Preselector with high precision stepping motor drive provides outstanding attenuation characteristics

VC-Tune further improves the high performance RF μ -Tuning system design adopted in FTdx9000, using a remarkable miniaturization design while producing an unparalleled attenuation characteristic of maximum attenuation -70 dB. A high precision stepping motor drives a variable capacitor to continuously cover the band as it follows the movement of the selected frequency by the operator. Fine-tuning for optimum improvement point is also available by MPVD (Multi-Purpose VFO Outer Dial) placed outside the VFO dial.

VC-Tune (7MHz, Span 20MHz)

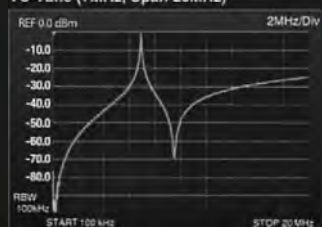

Maximum Attenuation: -70 dB
 -3 dB Bandwidth: 62kHz

Band Pass Filter (7MHz, Span 20MHz)



VC-Tune + Band Pass Filter (7MHz, Span 20MHz)



VC-Tune
(Variable Capacitor Unit)



In Homage to the Founder of Yaesu - Sako Hasegawa JA1MP

FTdx101MP 200W

HF/50MHz TRANSCEIVER

The Ultimate

FTdx101D 100W

HF/50MHz TRANSCEIVER

YAESU
The radio

YAESU Authorized Dealer

Andrews Communications Systems
Shop 8, 41-51 Bathurst Street, Greystanes NSW 2145
Tel: +61-2-9636-9060
URL: www.andrewscom.com.au

YAESU Authorized Service Center

Andrews Communications Systems
Shop 8, 41-51 Bathurst Street, Greystanes NSW 2145
Tel: +61-2-9636-9060, Fax: +61-2-9688-1995
E-mail: radioandrews@hotmail.com

Strictly HAM Pty. Ltd.

Shop 12B Church Street Bayswater Vic. 3153
Tel: +61-3-9729-7656
URL: www.strictlyham.com.au

VK Radio Repairs

347 Settlement Rd, Thomastown Victoria 3074
Tel: +61-3-9010-5070, Fax: +61-3-8682-8748
E-mail: yaesu@vkradio.com.au



Amateur Radio

The Journal of the Wireless Institute of Australia

Volume 87
Number 2
2019
ISSN 0002-6959

Editorial

Editor

Peter Freeman VK3PF
editor@wia.org.au

Technical Editor

John Morrissey VK3ZRK

Publications Committee

Peter Hartfield VK3PH
Ewen Templeton VK3OW
Kaye Wright VK3FKDW (Secretary)
WIA Office Bruce Deefholts VK3FBLD

All circulation matters
nationaloffice@wia.org.au

How to submit material Secretary

AR Publications Committee
PO Box 2042
BAYSWATER VIC 3153
or armag@wia.org.au

Letters to Editor

Editor AR Magazine
PO Box 273
Churchill Vic 3842
or editor@wia.org.au

Hamads

'Hamads'
PO Box 2042
BAYSWATER VIC 3153
hamads@wia.org.au

Advertising

All enquiries to
Advertising Manager
AR Publications Committee
PO Box 2042
BAYSWATER VIC 3153
or admanager@wia.org.au

Registered Office

Unit 20 11-13 Havelock Road
BAYSWATER VIC 3153
Australia
Phone: 03 9729 0400
Fax: 03 9729 7325

Production Deadlines

All articles, columns, hamads and
advertising booking for the next issue by
19 April 2019.

The contents of Amateur Radio are Copyright
Wireless Institute of Australia © 2017

Technical

**A 35 to 4400 MHz Scalar Network
Analyser** 10

Jim Henderson VK1AT

Review: RadioSport RS60CF headset 18

Peter Freeman VK3PF

6 metre optimised 4-element Yagi 48

Jack Albers VK2TUT

**Junk nostalgia and dangerous
projects** 62

Peter Parker VK3YE

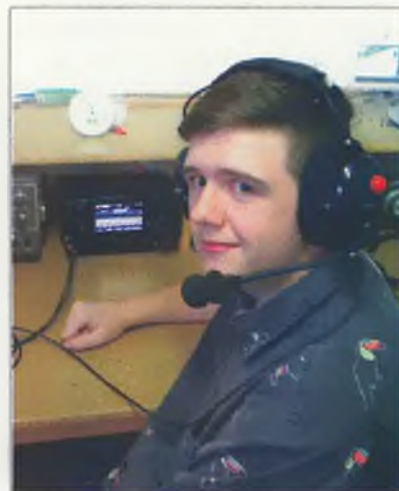

This month's cover:

*This month's cover shows a young would-be
amateur operating the local Club station, under
supervision, with the RadioSport RS60CF
headset. Read the review of the headset on
page 18.*

Contributions to Amateur Radio



Amateur Radio is a forum for
WIA members' amateur radio
experiments, experiences,
opinions and news. Manuscripts
with drawings and/or photos are
welcome and will be considered
for publication. Articles attached to
email are especially welcome. The
WIA cannot be responsible for loss or damage to any material.
Information on house style is available from the Editor.

General

Notice of Annual General Meeting 5
WIA Board

**19th IARU World ARDF
Championship** 6

Jack Bramham VK3WWW

TAC Notes 9

John Martin VK3KM

Mills On The Air 2019 17

Tony Falla VK3KKP

A blast from the past 20

Tony Boddy VK6DQ

SOTA Hotham Summit Weekend 2019 30

Gerard Hill VK2IO

70th Urunga Radio Convention 2019 60

Ken Golden VK2DGT

Columns

ALARA 45

Board Comment 3, 4

DX Talk 23

Contests 28

Editorial 2

Hamads 63

Over to You 22

Silent Key 39, 44, 47, 55

SOTA & Parks 37

VHF/UHF – An Expanding World 48

WIA Awards 26

WIA News 4

VK2 News 43

VK3 News 36, 54

VK5 News 25

VK6 News 56

VK7 News 40

Back Issues

Back issues are available directly from the WIA National Office
(until stocks are exhausted), at \$6.00 each (including postage
within Australia) to members.

Photostat copies

If back issues are unavailable, photocopies of articles are
available to members at \$2.50 each (plus an additional \$2 for
each additional issue in which the article appears).

Disclaimer

The opinions expressed in this publication do not necessarily
reflect the official view of the WIA and the WIA cannot be held
responsible for incorrect information published.

Amateur Radio Service

A radiocommunication service for the purpose of self-training, intercommunication and technical investigation carried out by amateurs; that is, by duly authorised persons interested in radio technique solely with a personal aim and without pecuniary interest.

Wireless Institute of Australia

ABN 56 004 920 745

The world's oldest
National Radio Society, founded 1910.

Representing

The Australian Amateur Radio Service

Member of the International Amateur Radio Union

Registered Office of the WIA

Andersson House

Unit 20, 11 Havelock Road

Bayswater, Victoria, 3153

Tel: (03) 9729 0400 Fax (03) 9729 7325

email: nationaloffice@wia.org.au

<http://www.wia.org.au>

All mail to

PO Box 2042 BAYSWATER VIC 3153

Business hours: 10am – 4pm weekdays

National Office

Executive Administrator Bruce Deelholts VK3FBLD

Board of Directors

President Justin Giles-Clark VK7TW

Vice-President Gregory Kelly VK2GPK

Directors Marcus Berglund VK5WTF

Peter Cleo VK8ZZ

Dr Harry Edgar VK6YBZ

Aidan Mountford VK4APM

Secretary Peter Cleo VK8ZZ

Treasurer Vacant

Coordinators

AMSAT Paul Paradigm VK2TXX

ARDF Jack Bramham VK3WWW

Australian ARSS Shane Lymd VK4KHZ

Awards TBA

Clubs Ted Thrift VK2AHA

Contests Craig Edwards VK8PDX

John Moyle Field Day Denis Johnstone VK4AE

Editor 'AR' Peter Freeman VK3PF

EMC/EMR Gilbert Hughes VK1GH

Standards Phil Wait VK2ASD

Ron Cook VK3AFW

Noel Higgins VK3NH

John Martin VK3KM

Peter Wollenden VK3RV

IARU Region 3 Director Peter Young VK3MV

Monitoring Service Peter Young VK3MV

ITU Conference & Study Group

Brett Dawson VK2CBD

Dale Hughes VK1DSH

QSL Curator National Office

Repeater Peter Mill VK3ZPP

Andrew Chapman VK4DF

Webpage Robert Broomhead VK3DN



Editorial

Peter Freeman VK3PF

Some more radio fun in the field

I have managed a few outings to play radio in the field, despite some very hot and windy weather.

January was very hot and dry in Gippsland, so I ventured out on only a small number of occasions to activate some Parks for VKFF/WWFF. Otherwise, I did my best to hunt other activators from home when propagation allowed.

I also participated in the now annual Hotham SOTA Summit – a weekend based in a ski lodge at Hotham Heights with trips out each day to summits in the region. You can read a report in this issue from Gerard VK2IO, who participated for the first time this year. It is a very different experience being out in the field activating summits with others on the same summit and others on nearby summits compared to the usual solo activations. The camaraderie experienced whilst out activating several summits in a day and then during the evenings back at the lodge makes participation in such events very rewarding.

February also saw a couple of Park activations, one in South Gippsland and another at Point Cook following the WANDARC Hamfest.

One huge advantage of operating in the field is that one often experiences a lower noise level compared to a suburban location – a great incentive to make the effort to travel to a new Park and enjoy some "radio therapy".

Changes in Assessment system

As mentioned elsewhere in this issue, the WIA is no longer involved in the Assessment and certification system on behalf of the ACMA. The contract has been awarded to the Australia Maritime College (AMC), part of the University of Tasmania.

As an Assessor for the WIA, I have heard little information regarding the new system other than a request to indicate possible interest in becoming involved with the new provider.

Until further information is provided and the AMC starts to offer assessments through their new system, it looks as if little will be occurring for those wishing to gain, or to upgrade, an Amateur Radio qualification in Australia. I am sure that many are waiting patiently for further details to be published.

Field Day

Due to our publication schedule and postal transit times, you may have missed the John Moyle Field Day Contest, scheduled for the weekend of 16/17 March this year. Those reading this Editorial on the WIA website or in the Digital Edition of the magazine will have only a few days until the event.

The John Moyle Field Day is a fun contest which promotes setting up a station in the field and making contacts. The contest was one of my early introductions to portable operation, with the University Radio Club which would mount a multi-band multi-operator effort for the weekend on a hilltop near Trentham, north east of Melbourne.

Perhaps your local Club will be making an effort to participate? If so, consider joining them, even if only for a few hours. Alternatively, listen out on the bands and support those in the field by making contact with all the stations that you can copy. There are sections for home stations as well as portable stations. You can find the Rules on the WIA website under *Members, Contests*.

Until next issue,
Cheers,
Peter VK3PF



Board comment

Justin Giles-Clark VK7TW

What a difference a month or two makes!

The ACMA has announced that the successful tenderer for the delivery of Amateur Radio licencing and administration is the University of Tasmania through the Australian Maritime College. The Board congratulates the University.

The Board is progressing the Transition-Out Plan and been able to deliver to the ACMA all the Commonwealth Intellectual Property specified by the previous Deed prior to a new Deed being signed. This supports a timely transition to the new provider.

The WIA Board sincerely thanks all WIA volunteers, assessors and learning facilitators that have been involved in the previous examination systems over the past 20+ years for their incredible contribution to the hobby of amateur radio.

This is a landmark opportunity in the history of amateur radio in Australia. It is the view of the WIA Board, the WIA Education Group and many members we have spoken with, the transition to the AMC will allow the WIA to re-focus its resources on delivering all of the objects of Institute. The WIA has a 100 year plus legacy of serving the amateur community. It will continue to do so into the future with your support.

Representation

Dale Hughes VK1DSH has recently spent two weeks at the World Radio Conference 2019 (WRC-19) Conference Preparatory Meeting (CPM) in Geneva. Dale is representing Australia for WRC-19 agenda items 1.1 (50 MHz) and 9.1.6 (Wireless Power Transfer). The CPM develops the final documents which contain the various 'methods'

used to address WRC-19 agenda items at the WRC itself.

There is also preparation happening for the last Asia-Pacific Telecommunity (APT) Conference Preparatory Group - APG 19-5 before WRC-19 and this will be held from 31 July - 6 August 2019, Tokyo, Japan. This will form the final view of the APT that will be taken to WRC-19 in October 2019.

WRC-19 is being held in Sharm el Sheikh, South Sinai, Egypt from the 28 October to 22 November 2019 and will see more than 2500 delegates from over 160 countries attending. There is a punishing schedule being finalised that will see the spectrum management agenda set for the next four years.

Promotion

The RSGB's Commonwealth Contest is one of the oldest radio contests in existence starting back in 1931. All British Empire countries would participate and in 1935 the contest became the 24-hour British Empire Radio Union or BERU and then the Commonwealth Contest in 1976.

The contest took place on 9 - 10 March 2019, from 10:00 to 10:00 UTC. All operation is on CW and you can find the rules at the RSGB HF contest site at: <https://www.rsgbcc.org/hf/rules/2019/rberu.shtml>

There are two Australian teams participating along with six Wireless Institute Australia headquarters stations: VK2WIA, VK3WIA, VK4WIA, VK5WIA, VK6WIA and VK7WIA. Thanks to Steve Ireland VK6VZ who is the Australian team coordinator.

The WIA IT team has been

working on transitioning our IT systems to more contemporary arrangements. The WIA is pleased to announce that this service will be expanded to include a G-Suite account (including E-Mail, Google Docs, Google Sheets, Google Drive and many other applications in the Google portfolio) for those members who would like it.

To clear the backlog of repeater assignments the WIA Board has decided to engage commercial frequency assigners to undertake this work on behalf of the WIA. Once the backlog is cleared, the WIA will review effectiveness of the external assigner pilot process as input for longer-term repeater application process improvements, both to WIA processes and also the ACMA processes.

The WIA Board has decided to offer complimentary reward memberships of the WIA for amateurs who are newly qualified. If you received an AOC (Foundation, Standard or Advanced) at any time since the first of January 2018 and are not a member of the WIA, you are eligible for a complimentary 1 year WIA membership. If you are already a WIA member (now, or when you receive your qualification in the future) you are eligible to receive a 1 year membership extension or a \$100 discount off a 5 year membership. If this is you, or someone you know all that is needed is a completed WIA membership form and a copy of the relevant AOC qualification showing the date of qualification being later than 1 January 2018 and email it to support@wia.org.au

Continued on page 4

The WIA Board is also working with ALARA to align its complimentary reward membership program with complimentary membership of ALARA for female amateurs. Contact ALARA for details of this program: treasurer@alara.org.au

Education

The WIA met with the Department of Communications and the Arts (DOCA) to discuss radio amateur representation at the forthcoming WRC-19. It is the job of WRC to

review, and, if necessary, revise the global Radio Regulations, the international treaty governing the use of the radio-frequency spectrum & geostationary-satellite and non-geostationary-satellite orbits.

During the meeting the WIA presented information on the amateur and amateur-satellite service that is relevant to Australia's preparations for WRC-19. The information included details of the WIA, the IARU, the advocacy work undertaken by both the WIA and IARU, the range of

activities that amateurs undertake in pursuit of their interests and how amateurs are involved in various community activities. The IARU is the International Amateur Radio Union, of which the WIA is a member society representing Australia. It was a productive and informative meeting and the WIA thanks DOCA for making time to meet and discuss core amateur service issues.

Finally, huge congratulations to both Phil Byrne VK2MOC and Raffy Shammay VK2RF on both being awarded a 2019 Order of Australia Medal for services to the community.

WIA news

Fishnet beacons shout out

Nick VK2DX has just posted to the 600 m group a reminder about the fishnet beacons down low between 1,700 kHz and 2,900 kHz. These are devices that fishermen leave floating near their nets to enable them to locate and retrieve their nets.

The call has gone out for reports about these devices off the coast of Australia and New Zealand.

Nick received two of these devices at the Wyong Hamfest on the weekend and bumped into another MF/LF experimenter Dimitrios VK1SV.

Information about these devices can be found on Nick's page: <http://genesisradio.com.au/VK2DX/fishnet.html>

He is looking for reports for a night or two listening for these beacons. The fishnet page has the frequencies and identifiers. An SDR receiver makes this task super easy.

Ultimately, Nick is looking for multiple reports of the same beacon plus as many different ones that you can log.

Send report directly to Nick and his contact details can be found at the bottom of his fishnet web page.

He will post a summary and New Zealand reports are especially welcome.

News from Geneva

During the period 18/2/2019 through 28/2/2019 the 2nd session of the

Conference Preparatory meeting (CPM19-2) towards the 2019 World Radiocommunication Conference (WRC-19) was held in Geneva. The purpose of CPM19-2 is:

"In accordance with Resolution ITU-R 2-7, the CPM shall prepare a consolidated Report on the ITU-R preparatory studies and possible solutions to the WRC agenda items, to be used in support of the work of World Radiocommunication Conferences".

The CPM report is a complex document of nearly 700 pages and it covers all of the WRC-19 agenda items. This text contains the initial negotiating positions for work at WRC-19 and it is important that the amateur service can influence the development of the text so that the interests and needs of the amateur service are reflected as much as possible.

Amateurs, either as members of National delegations or representing the IARU, are taking part in the various meetings that are revising and refining the CPM report. Prior to CPM19-2, representatives of various national amateur societies (ARRL, RSGB, JARL, DARC, WIA etc.) have worked with their administrations to develop national views on all WRC-19 agenda items and these views have been taken into account at CPM19-2. As an ITU Sector Member, the IARU has direct input to CPM19-2 providing a global of amateur needs.

Amateurs have a number of important issues on the WRC-19 agenda including a possible new amateur allocation in the 50 - 54 MHz frequency

band in ITU Region 1. While this appears to be a Region 1 issue it is important that any WRC-19 decisions on the issue do not affect the Radio Regulations in Regions 2 and 3. There are also other issues that may affect a number of microwave bands including our allocations in the 5650 - 5850 MHz, 24 - 24.25 GHz and 47 - 47.2 GHz frequency bands. Another issue of concern is that of Wireless Power Transfer for Electric Vehicles which has the potential to cause significant interference in the MF and HF amateur bands if poorly implemented.

The Australian delegation at CPM19-2 is led by an officer of the Department of Communications and the Arts. The other Australian delegates represent the ACMA, Department of Defence, Australia's maritime, aviation, mobile and satellite communication interests and the amateur service. All together there about 1400 delegates from many of the ITU member states and sector members attending CPM19-2.

Amateur Radio Fees

The Australian Maritime College has provided the fee schedule for amateur radio statutory and non-statutory services.

This covers statutory examinations and non-statutory call sign recommendations, recognition of prior learning and re-issuing of certificates.

Martin Crees-Morris
Manager – AMC Amateur Radio
Australian Maritime College
University of Tasmania

The schedule of fees can be found on the WIA website.

Continued on page 5



Notice of Annual General Meeting

Wireless Institute of Australia

Saturday 24 May 2019
PARK ROYALHOTEL
Darling Harbour, Sydney NSW

Business

1. To receive and consider the Annual Financial Statements, Directors Report and Independent Auditors report for the year ended 31 December 2018
2. To announce the results of the election of Directors
3. To transact any other business that may be brought before the meeting in accordance with the Institute's Constitution

Notice is hereby given that the Annual General Meeting of The Wireless Institute of Australia will be held at Park Royal Hotel, Darling Harbour SYDNEY NSW on Saturday 24th May 2019 at 9.00am

By Order of the Board

Peter Clee VK8ZZ

Secretary

1 March 2018

Note:

A member is entitled to appoint one proxy only who must be another Member or a representative of another Member, and that proxy is entitled to vote on a show of hands or on a poll. The Instrument of Proxy is downloadable from the WIA web site (Information about the WIA), or upon written request to the National Office.

While non-members of The Wireless Institute of

Australia are welcome to attend the Annual General Meeting, at the Open Forum, only members are entitled to vote, and will be identified by a coloured card at the time of registration.

Members must register and receive identification cards and documents at the registration table which will be open outside the meeting room from 8.00am. Section 250S of the Corporations Act provides that the chair of an AGM must allow reasonable opportunity for the members as a whole at the meeting to ask questions about or make comments on the management of the company.

Open Forum:

Immediately following the Annual General Meeting, an Open Forum will be conducted. An additional detailed report will be submitted on behalf of the Board, and the Institute's co-ordinators and those responsible for particular aspects of the Institutes activities will be asked to submit a written report which will be available for those attending the forum. Any major issues affecting each area of responsibility will be identified and the author of each report who is present will be given the opportunity to briefly comment.

Members are encouraged to discuss any matter arising from any of the reports, and to raise any other matter affecting Amateur Radio or the Institute. This format will avoid any restriction arising from the requirement to give notice of business to be formally raised at the AGM.

WIA news

Continued from page 4

Welcome to new WIA Director

The Board extends a welcome to Dr Harry Edgar VK6YBZ to the Board of the WIA.

The last Board meeting of the WIA accepted the nomination of Dr Harry Edgar to fill a casual vacancy on the Board.

Dr Harry Edgar has a Bachelor degree in electronics and a PhD in Telecommunications from what is now Northumbria University UK. He spent four years as Senior Lecturer,

then Head of Department and Acting Dean of Faculty of Engineering and Communications at what is now Leeds Beckett University UK teaching final year degree telecommunications students, research and PhD student supervision.

He then spent eleven years at Curtin University Perth teaching final year telecommunications students and PhD student supervision. Harry has spent many years in engineering, technical development, management and troubleshooting in power control and process control systems.

He has a post grad Certificate in Law specialising in Contract Law from Notre Dame University and has spent 13 years in state government Main Roads in Contract Management, Contract Superintendent and Contract Development and Writing. He has experience in business management, organisation and operational troubleshooting, investment and start up development experience.

19th IARU World ARDF Championship

Jack Bramham VK3WWW



Photo 1: Opening Ceremony in the rain.

Over the week 2-8 September 2018, 300 plus competitors from 29 Countries attended the 19th IARU World ARDF Championships held in the Gangwon-Do Province of South Korea. Host Society for the event was the Korean Amateur Radio League (KARL). A total of six

Photo 2: Ewen VK3OW.



competitors travelled from Australia for the event. They were: W21 Nelly Mejevaia (SWL from VK4), M21 Kristian Ruuska VK3FDAC, W60 Jenelle Templeton VK3FJTE, M60 Peter Cole VK3ADY, M70 Ewen Templeton VK3OW and I VK3WWW.

Sunday 2 Sept. was arrival day and as most of the Australian team travelled at different times, we actually did not come together until our arrival at the Hanwha Resort Complex in Sokcho. Being a very large resort, all of the teams including team officials, Coaches, Jury, Organisers and even Masseurs (yes some teams take things very seriously) were all able to stay at the one venue.

3 September: Training and Opening Ceremony

Weather was not great for the training as there was intermittent light rain which caused a few issues. Training was split into four sections. In the morning transmitters were set up for the Sprint and FoxOr events. Both

use the 80 m band and after lunch transmitters for the 2 m and 80 m Classic ARDF events were switched on. These training events are extremely important so you can test out receivers and compare signal strengths between the different power levels etc. That evening was the Opening Ceremony. As the Ceremony was about to start, the rain was quite consistent and as the ceremony was outdoors, it was a problem. I don't know where they came from but the organisers had access to hundreds of cheap ponchos which made sitting in the drizzling rain bearable (see photo). Speeches and introductions were all kept to a minimum. Isn't that how all ceremonies should be?

4 September: Event 1 FoxOr

For this event, competitors, depending on age categories, need to find up to five transmitters. Weather was better and a lot warmer. For the four team members from Melbourne, it was hot, but for Nelly our VK4 representative

Photo 3: Jenelle VK3FJTE.



No go Zone!
Nth. Korea



Photo 4: Jack VK3WWW at the DMZ.

conditions were the same as she left them a few days earlier in Brisbane. FoxOr is a combination between Orienteering and ARDF. Each of the transmitters only put out milliwatts of power so you need to navigate to a circle on the map and from anywhere in the circle you should be able to hear the signal. Now I don't want to make excuses but these are the World Championships and just to make the top ten is a great achievement. Well done Ewen and Jenelle they each took seventh place. I did a pretty fast time but due to some incredible stuff-ups (that I am famous for) I actually came last.

Each evening, Ewen and I would attend the team leader meetings. At these meetings things are usually quite civilised but at times can get pretty hostile. Fortunately for us, English is the official language for International ARDF. One of the items that came up at the first meeting was the banning of all transmitting devices in the quarantine area and on the course. This used to mean things like HTs and mobile phones, etc. But, these days with the advent of smart devices, smart watches, Bluetooth TX/RX and even the humble still or video camera. You have to be on the ball for if you disobey the ban then it is possible that the whole team could be disqualified. As a consequence of this rule I was not allowed to take my camera into the compound as it had an installed WIFI Chip. Hence we have no photos taken at the start. We were able to have our cameras transported to the finish but it took a few events for this system to actually work. First time we tried it, our gear never arrived at the finish but we were able to collect it back at the hotel.

After my miserable performance in event 1, I was eager to make amends during event 2. Well, was I wrong? Event 2 was probably the toughest event I have ever competed in. Three of the four of the events required very good mapping skills for, if you don't keep in touch with the map, it was very easy to attempt a shortcut to the transmitter only to find the undergrowth was so thick in places it was nearly impossible to make any headway. And, dragging a 3-element 2 m Yagi as

jaycar

\$49⁹⁵

Mini-D 2 x IOW Class-D Amplifier kit

KC5530

Features on-board volume control, low-power shutdown mode and over-temperature/ current protection. Highly efficient, so there is no need for a heatsink!

• PCB: 85 x 46 mm

Kit is supplied with double sided, solder-masked and screen-printed PCB, and all SMD components pre soldered to the PCB.

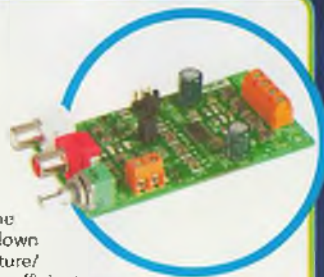

\$43⁹⁵

Breadboard - 1660 Tie Points

PB8816

400 distribution holes, 1280 terminal holes. Mounted on a metal plate. 3 banana terminals. Rubber feet. 157(W) x 237(H)mm.



\$5⁹⁵

Plug to Plug Jumper Leads 150mm

WC6024

Pack of 40 jumper leads of various colours for prototyping.



\$29⁹⁵

Wireless at War Book - by Peter Jensen

BM2490

Features 250 photos and diagrams, and tracks the use of wireless technology in war. This book is basically about radio technology and the Australian army. A great read for wartime and radio enthusiasts.

• Softcover 352 pages
• 225(H) x 150(W)mm



\$4⁹⁵

Toroid (or Ring) Cores - Pk2

L01238

Material L15 size A35 x B21 x C13mm.



click & collect

buy online &
collect in-store

zip own it now, pay later

Valid until 30 April, 2019

To order phone 1800 022 888 or visit www.jaycar.com.au



Photo 5: Nelly Mejevaia SWL.



Photo 6: Kristian Ruuska VK3FDAC.



Photo 7: Peter Cole VK3ADY.

well just made it worse. Looking at the results for event 2 there were many competitors that did not find all their allocated transmitters and also in a lot of cases were overtime and hence disqualified. Event 3 and 4 were not as difficult as event 2 and our team did a lot better.

Early in the competition Ewen and I attended a Region 3 ARDF Group meeting. In attendance were representatives from China, Korea, Japan, Thailand, Mongolia, USA and two new societies representing

Hong Kong and Macau. At this meeting our main discussion points were future Region 3 ARDF event hosts. At this stage our next Region 3 Competition in 2019 will be hosted by China in the Jiangsu Province near Shanghai Palace. Host Society is CRAC "Chinese Radio Amateur Club" - was CRSA "Chinese Radio Sports Association". At this stage it looks like WIA is pencilled in to host the event in 2021 but as there is interest to host from some other societies

who have not hosted before, we may not be hosting until 2023.

During any international event there is usually some time or an entire day set aside for a cultural event. For this event we were taken to the De-Militarised Zone at the border between North and South Korea. As we were staying in Sokcho, a coastal town, we were not too far from the border so the bus trip did not take very long. We found the border area very interesting and well worth a visit. After seeing the DMZ we were taken to a very modern museum which told the Korean Peninsula story very well. We can only hope that one day the two Korea's will be able to resolve the differences and Unify.

On behalf of the team I would like to thank the KARL for a very well run event. Meals, accommodation, transport and events were all excellent and they have set the bar very high for future World and Regional Championships.

On the final night we were all invited to a banquet where we were able to exchange gifts with competitors and get to know more about them and where they come from. One interesting question we were asked was "How can we do



Photo 8: ARDF team in Korea.



Photo 9: ARDF team.

ARDF in Australia when everything is out to kill you?" As we all know, Snakes and Spiders are not a real problem but I wonder how a European would handle a Magpie attack. HI.

Following the Championships, I note that a lot of the Region 3 Officials and some IARU council members headed off to the IARU Region 3 Council meeting held in Seoul. I note one of the discussion groups for the meeting was about attracting new people into the hobby and I am sure ARDF

appeared on the list of discussion points.

For the Australian team we all departed together on Saturday 8 September and the four team members from Melbourne all took

the same flights back to Australia leaving Nelly behind in Korea to have a look at some of the sights.

Notable observation

This was the second time four of the team members were using the DF1FO designed 80 m Receivers. These receivers are a big improvement over what we have been using in past events. I plan to do an equipment review in a future edition of AR.

Results

As you can see from the results table below, Ewen and Jenelle did pretty well with three top ten finishes each.

Jack Bramham VK3WWW
WIA ARDF Coordinator

Name	Age Category	Foxor	1st Classic	Sprint	2nd Classic
Nelly (SWL)	W21	22	No place	18	Did not run
Jenelle VK3FJTE	W60	7	Overtime	7	5
Kristian VK3FDAC	M21	24	24	21	11
Peter VK3ADY	M60	28	Overtime	27	26
Jack VK3WWW	M60	29	Overtime	28	25
Ewen VK3OW	M70	7	8	5	19

TAC Notes

John Martin VK3KM

FT8 Segments

The 160 metre band plan has now been updated to recognise the use of 1840 - 1843 kHz for FT8 operation. And on 40 metres, the band plan now recognises the use of 7074 - 7080 kHz for FT8 activity.

There have also been some interference issues between FT8 operation on 7074 kHz (USB) and

WICEN voice activity on 7075 kHz LSB. The logical remedy, at least for now, is to move the recommended WICEN frequency down 1 kHz to 7074 kHz LSB.

In the longer term, WICEN groups may wish to consider making use in the future of the IARU Region III recommended emergency frequency of 7110 kHz.

Plan ahead

Operate within the band plans:

<http://www.wia.org.au/members/bandplans/about/>

A 35 to 4400 MHz Scalar Network Analyser

Jim Henderson VK1AT

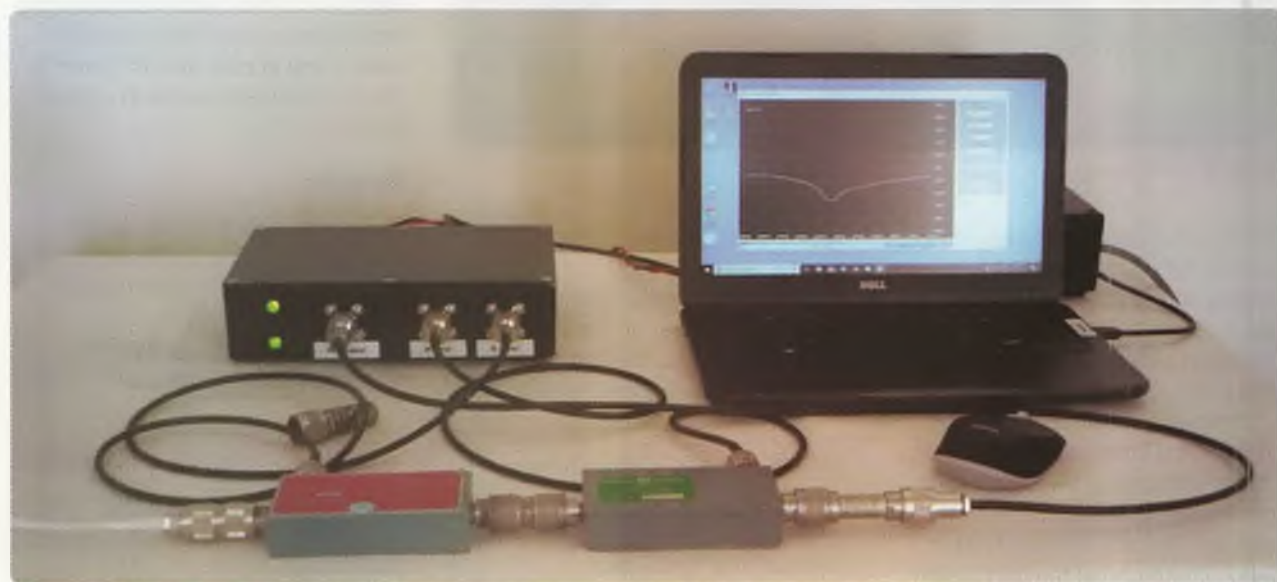

Photo 1: The Scalar Network Analyser with strip-line directional couplers.

Introduction

A scalar network analyser is a basic item of test equipment for amateurs constructing antennas, filters, hybrids, amplifiers and simple cable assemblies at frequencies above

30 MHz. The challenge is to design a high-performance unit which is simple to construct and calibrate. By combining pre-built modules controlled by an Arduino with a laptop hosting the user interface,

a unit can be constructed which requires only basic RF construction skills.

A scalar network analyser is used to measure gain / loss on a two-port device or input return loss

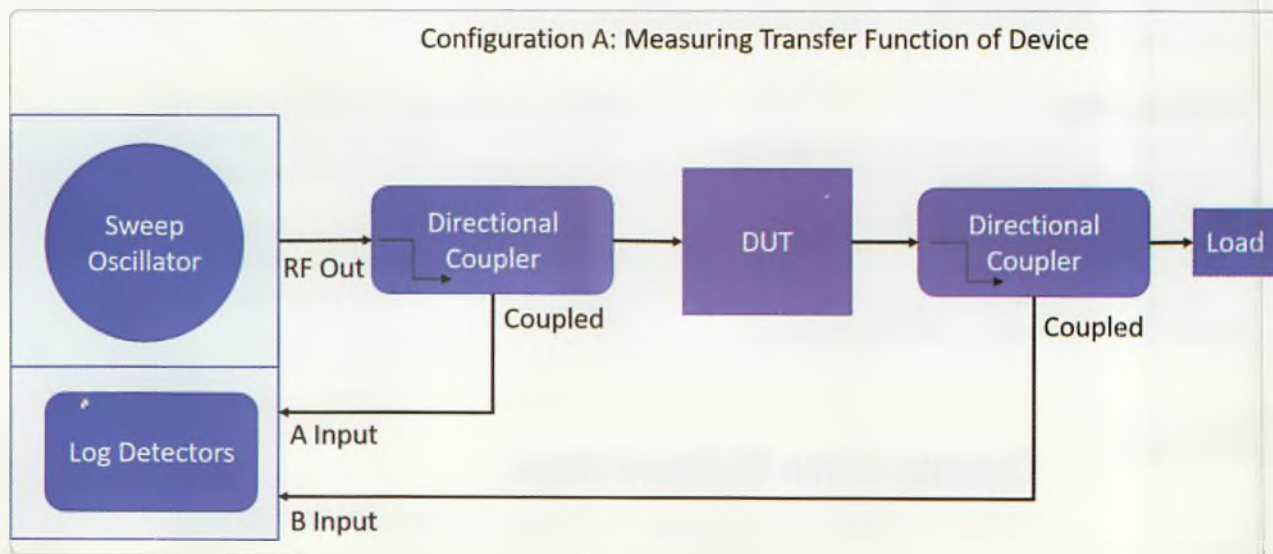

Figure 1: The classic configuration for measuring two port transmission gain / loss.

Configuration B: Measuring Input Return Loss of a Device

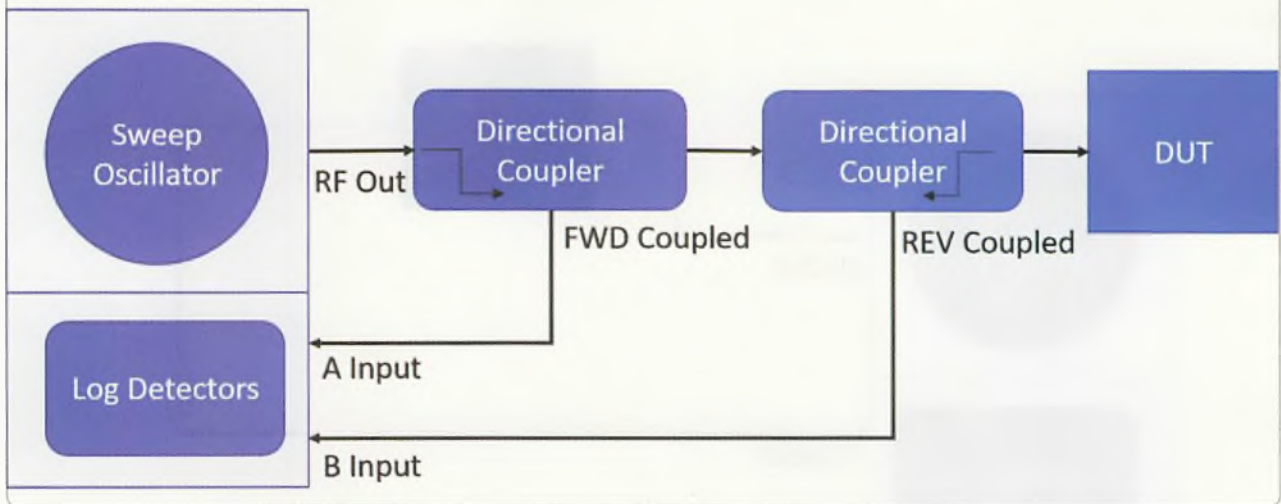

Figure 2: Measurement of input return loss.

on a two-port or single-port device. It consists of a sweep oscillator and two RF log detectors. The basic test configurations are shown below. The DUT is the device under test.

Configuration A shows the classic configuration for measuring the transfer function of a two-port device.

Configuration B shows the configuration for measuring the input return loss of a device.

For configurations A and B, ratio measurements (A/B or B/A) eliminate the effect of level variations at the input of the device with frequency. Use of identical directional couplers eliminates the

impact of the directional coupler on the measured response. Alternately for transfer function measurements you can use a power splitter on the input of the DUT to provide a reference to port A and connect port B directly to the output of the DUT. If the DUT has gain or the coupled level is high a suitable attenuator

Configuration C: Measuring Transfer Function of Device – Normalise Mode, Set Reference

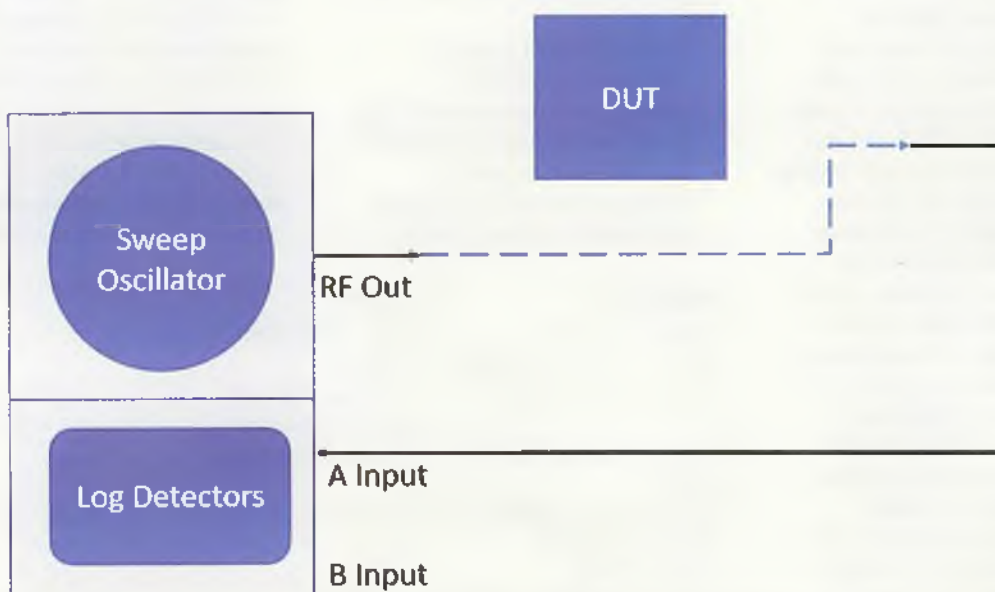

Figure 3: Normalise mode, setting the reference.

Configuration C: Measuring Transfer Function of Device – Normalise Mode, Measure DUT

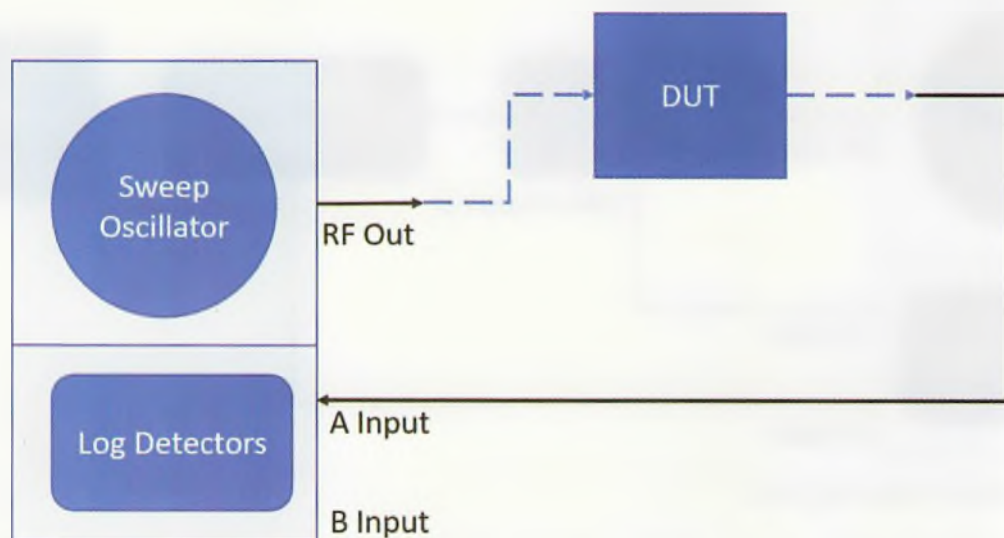

Figure 4: Normalise mode, measuring the transmission gain / loss.

needs to be inserted at the input of the DUT or in other strategic locations to ensure the inputs are not overloaded.

Configuration C shows the unit operating in normalise mode. If you select Normalise A or Normalise B, the last trace for A or B will be saved and the difference in level between the saved reference trace and subsequent traces will be displayed. This is a very useful mode if you wish to do gain or loss measurements on a DUT and you wish to account for the cable losses to the device or you do not have directional couplers. You remove the DUT and connect the input and output cables together, select Normalise A or B, insert the DUT and you now have a swept output which shows the Gain or Loss of the DUT eliminating the effect of the cables or level changes with frequency in the swept oscillator output. You can use a similar technique to measure return loss using a single directional coupler. Measure the forward coupled power, select normalise and reverse

the coupler to measure return loss.

Basic Parameters

The basic performance parameters for the unit described in this article are detailed in the table below:

Circuit Description

Three modules form the heart of the unit:

- An ADF4351 PLL board designed by SV1AFN.
- An ADL5519 dual input RF Log Detector designed by SV1AFN
- An Arduino Nano which manages the two RF modules and communicates with the PC.

The ADF4351 is a fractional N, PLL chip which covers the frequency range 35 MHz to 4400 MHz. It is configured through an SPI interface via six 32 bit registers. In this application it is configured in low spuri mode rather than low noise mode. For use in sweep applications the PLL has a fast lock mode which changes the characteristics of the loop filter to increase the loop bandwidth for a period of time while the PLL locks before reverting to a narrow loop bandwidth for steady state operation. Unfortunately the SV1AFN module does enable this

Parameter	Values
Frequency Range	35 to 4400 MHz
Minimum Span per division	10 kHz
Sweep Oscillator output	+1 dBm at 35 MHz, peaking at +5 dBm in the 2 to 3 GHz range dropping to -4 dBm at 4.4 GHz
Dynamic Range A and B Inputs	-5 dBm to -55 dBm
Accuracy over Dynamic Range, Differential Measurements	±1dB over 40 dB, ± 2 dB over 50 dB
Cross talk isolation between A and B Inputs	> 30 dB between 35 MHz and 3.6 GHz

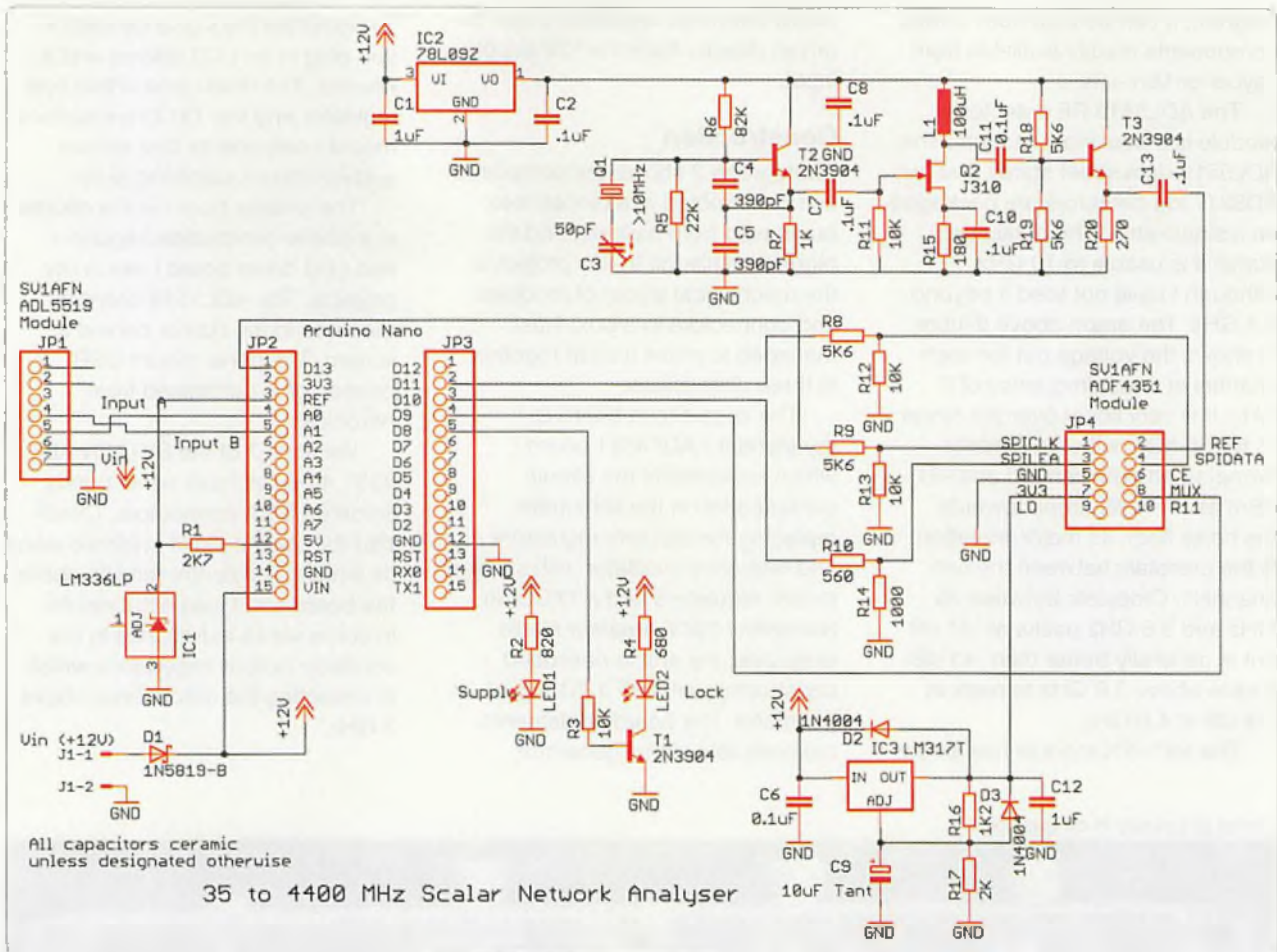

Figure 5: Circuit Diagram.

feature and it is not used in this project. As an alternative cyclic slip reduction is used to reduce lock times within a narrow loop bandwidth.

The PLL is configured for a 10 kHz minimum step size. Consequently the unit cannot be used for narrow IF filters but given its lower frequency limit is 35 MHz it is not targeting this application. Each sweep includes 200 data points or a lesser number of points if the frequency span is less than 2 MHz.

The latest version of the SV1AFN PLL Board has pads under the reference connector for installation of an on board 10 MHz TXCO as the frequency reference. I haven't tried to install one on the board. The PLL Board does not include an on board 3.3 V regulator to power the

ADF4351 chip. The circuit diagram shows a 3.3 V regulator based on an LM317T regulator. The board draws around 134 milliamps. If

operated from a 12 V supply the regulator needs to have an effective heatsink. An external reference oscillator is shown in the circuit

Figure 6: ADL5519 output voltage at 2 GHz.

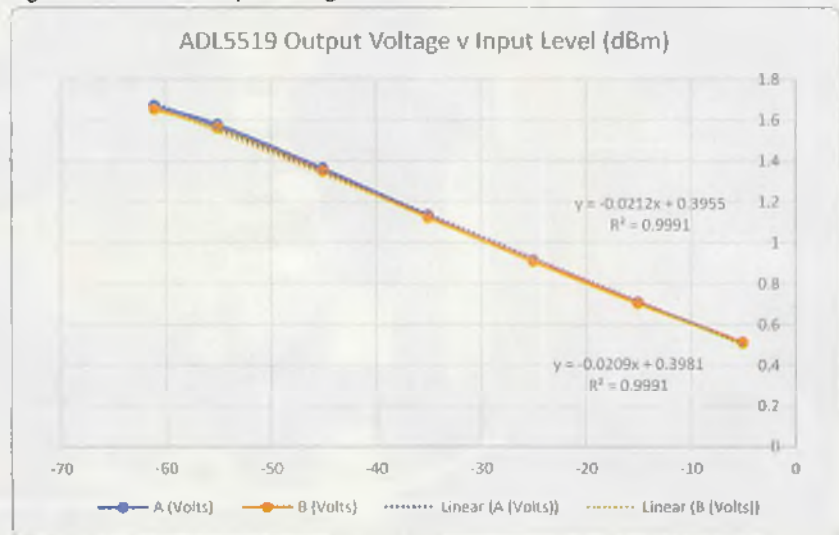

diagram; it can be built from leaded components readily available from Jaycar or Mini-kits.

The ADL5519 RF detector module is a dual input module. The ADL5519 data sheet states that two AD8317 log detectors are packaged on a single chip. The datasheet states it is usable to 10 GHz, although I have not tried it beyond 4.4 GHz. The graph above (Figure 6) shows the voltage out for each channel at a test frequency of 2 GHz. It is very linear over the range -5 to -55 dBm with the linearity dropping off between -55 and -61 dBm as the level drops towards the noise floor. Its major limitation is the crosstalk between the two channels. Crosstalk between 35 MHz and 3.6 GHz peaks at -31 dB but is generally better than -41 dB. It rises above 3.6 GHz to peak at -18 dB at 4.0 GHz.

The SV1AFN module has an on-

board low noise regulator; it can be driven directly from the 12V supply input.

Construction

Photograph 2 shows the completed unit constructed in a diecast box purchased from Jaycar. I find the biggest challenge in any project is the mechanical layout of modules and connectors in a box. I just managed to make it all fit together in three dimensions.

The large circuit board is my standard ADF4351 board which implements the circuit configuration in the schematic, replacing the discrete regulators and reference oscillator with surface mount regulators and a TXCO. In November 2017 *Amateur Radio* magazine, my article described constructing an ADF 4351 signal generator. The board implements the complete signal generator.

To complete the signal generator you plug in an LCD display and a keypad. The down side is that one regulator and the TXCO are surface mount components that require surface mount soldering skills.

The smaller board in the middle is a power distribution, regulator and LED driver board I use in my projects. The ADL5519 board is mounted in the corner behind a screen. The panel mount USB connector is purchased from Altronics.

Versions 2 of the SV1AFN ADF 4351 modules have some poorly soldered SMA connectors. Check that the middle pin is soldered along its length. The centre pin sits above the board and I suspect it results in some series inductance in the oscillator output impedance which is impacting the output level above 3 GHz.

Photo 2: Layout in diecast box.

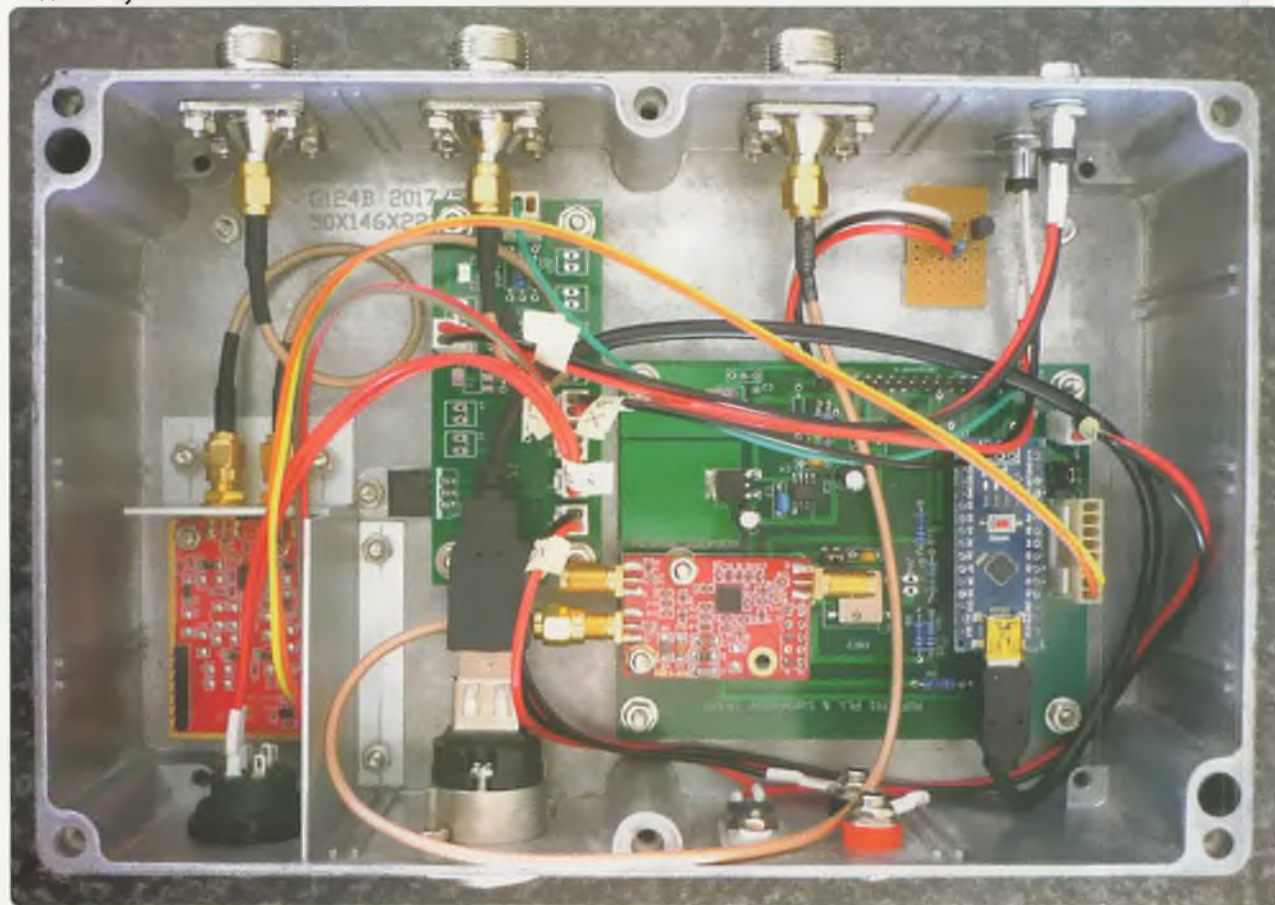

Calibration

The Windows application reads a calibration text file on start up. The default calibration file contains the following values:

COM3, 35, 4400, -5, -55, -5, -55

Value 1	Default Comport Number
Value 2	Lower Frequency Limit
Value 3	Upper Frequency Limit
Value 4	Channel A, Value Read with -5 dBm Input
Value 5	Channel A, Value Read with -55 dBm Input
Value 6	Channel B, Value Read with -5 dBm Input
Value 7	Channel B, Value Read with -55 dBm Input

The unit's initial calibration matches the ADF5519 module in my system.

To calibrate the inputs for your ADF5519 module start with the default values in the calibration file as detailed above. Using a signal generator, select the frequency you wish to use as the calibration frequency (say 2 GHz), input levels of -5 dBm and -55 dBm to each channel input and note the corresponding levels. Then update the calibration file with the values you noted for your system. Your file might look like:

COM3, 35, 4400,-6,-53, -7,-54

From this point on when the application starts up it will include calibration values for your unit.

Although the unit is only calibrated at one frequency, the differential accuracy over the complete frequency range is quite good. You can check this with a variable step attenuator using normalise mode.

To accurately calibrate the frequency output measure the reference frequency with an 8 digit counter. Substitute this reference frequency in the Arduino sketch in the line where the reference frequency is set.

Windows User Interface

The Windows application is written in C#. It is a simple interface

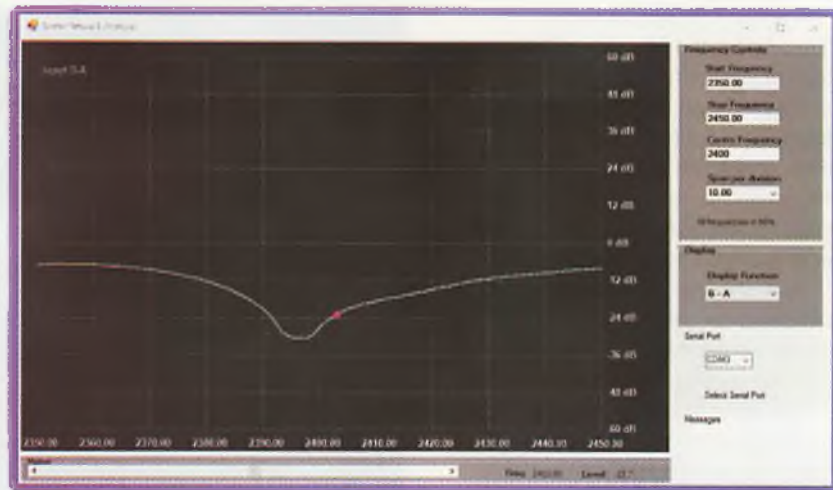

Figure 7: The Windows user interface, showing the swept return loss for a 13 cm Yagi.

with a fixed window size and fixed scales on the y axis of the graphical display. The start and stop frequencies or centre frequency and span can be set in the Window. The display mode is also selected in the window. Alerts are displayed in a message box. A marker can be manipulated via a scrollbar to make exact measurements along the trace. A screen shot of the windows user interface is shown below.

The Windows application communicates with the Arduino via a USB port. The serial port number is set in the configuration file. It can also be changed via the interface.

I have deployed the application to laptops running Windows 7 and Windows 10 without any issues.

Display Modes

The analyser has seven display modes:

Mode	Units	Description
A	dBm	A Input Level
B	dBm	B Input Level
A and B	dBm	A and B Input Levels
A-B	dB	Input A - Input B
B-A	dB	Input B - Input A
Normalise A	dB	Delta between stored reference sweep and current sweep on Input A
Normalise B	dB	Delta between stored reference sweep and current sweep on Input B

The display modes are self-explanatory with the exception of Normalise mode. When normalise mode is selected the last trace is stored and all subsequent traces displayed consist of the delta between the current trace and the stored trace. When you change one of the frequency controls it drops out of normalise mode reverting to the standard A or B display mode as the stored sweep will no longer be valid.

If the input level to A or B exceeds -5 dB, an input overload alert is activated and the level displayed is set at -4 dBm. The A, B or A and B modes are useful for initially ensuring levels are in the correct range. Measurements are made using one of the four differential modes.

Directional Couplers

Directional couplers for use at VHF, UHF and SHF are based on two design approaches: for HF through to UHF they are based on RF transformers wound on balun cores or toroids, at UHF and SHF coupled transmission lines in a strip-line or microstrip configuration are utilised. Photograph 3 shows a homebrew transformer based directional coupler based on a balun core, a Mini-circuits transformer based coupler for VHF frequencies and a strip-line coupler for S and C Band.

The two critical parameters for a coupler are the flatness of the frequency response from the input to the coupled port and the directivity. Directivity is defined as the ratio of the power measured at the coupled port with power fed to the input (forward coupling) and alternately power fed to the output port (reverse coupling).

Mini-circuits make a wide range of directional couplers both unpackaged and packaged. Mini-kits manufacture a directional coupler covering 5 MHz to 1000 MHz based on a Mini-circuits unpackaged module. A wide range of directional couplers are available on the surplus market in the US. I have built a number of transformer-based couplers which work extremely well up to 30 MHz in terms of a flat coupled frequency response and high directivity but after taking the utmost care in construction they tend to deteriorate in terms of their directivity in the VHF frequency range. The homebrew coupler pictured had directivity measured as 23 dB at 30 MHz, 20 dB at 200 MHz and 15 dB at 400MHz. (The coupled port frequency response of the homebrew unit is flat within .7 dB to 400 MHz.) This directivity is comparable to the performance of the coupler in the Mini-kits unit up to 200 MHz, but the coupler in the Mini-kits units maintains this directivity to 700 MHz. Note that if you wish to measure a return loss of 20 dB with 1 dB accuracy the directivity needs to be better than 30 dB. I would recommend buying an unpackaged Mini-circuits unit and building it up on a PC board or buying packaged units new or second hand.

Components and Software Supply

The ADF4351 and ADL5519 modules are available from SV1AFN in Greece. Delivery is prompt if he has the ADF4351 modules in stock but they tend to fly off the shelf. All other components are available from Jaycar or Mini-Kits.

If you would like a copy of the Arduino sketch and a deployable version of the windows application,

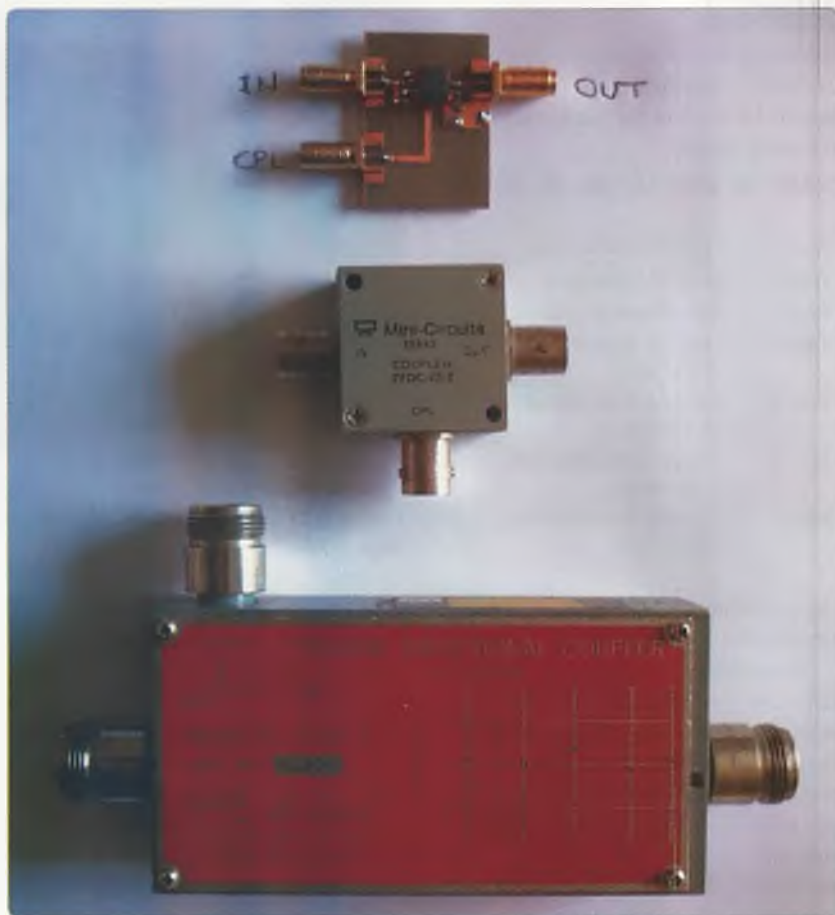

Photo 3: VHF homebrew, and commercial transformer couplers with a microwave strip-line coupler.

please email me at VK1AT@wia.org.au

If you are interested in building a unit based on my standard ADF4351 printed circuit board send me an email. I can arrange to have some bare boards manufactured; the major component of the cost will be the postage.

Conclusion

The major limitation in performance is the cross talk between the A and B inputs when making differential measurements between the two channels. This is generally not a problem with return loss measurements where the directivity of the directional couplers is likely to limit performance rather than the level of crosstalk. It can be a problem with two port transmission measurements when sweeping lossy components such as filters where a

large dynamic range is required. For measuring two port transmission characteristics, I find normalise mode is the most useful mode. It removes the impact of cable and connector losses, variations in the oscillator output level or mismatches in the characteristics of pairs of directional couplers and allows you to achieve the full 50 dB dynamic ranges. It also works well if you only have one directional coupler for return loss measurements.

Despite the limitations in dynamic range using two transducers this is a very capable piece of kit. It allows the amateur to make measurements with a level of accuracy that in the recent past required access to a \$60,000 Hewlett Packard scalar network analyser.

Mills On The Air 2019

Tony Falla VK3KKP



Radio club display set up, ready for business.

Australia joined the Mills on the Air event in 2016 with the activation of Andersons Mill, Smeaton, closely followed by Dunn's Mill, South Australia.

The following year, several mills in Maryborough, Victoria joined the scheme.

Originally a UK event, the weekend now includes mills in Europe and we hope a few more will sign up from Australia.

All mills, including flour mills, carpet mills, paper mills and sawmills qualify.

They don't need to be open to the public but some will be open on the day because the event is timed to occur on a heritage mills weekend - 11 and 12 May 2019.

Andersons Mill will be open to the public so Bendigo Amateur Radio and Electronic Club will again be taking the opportunity to set up a display for the public.

Watch a short video from 2018 at <https://www.youtube.com/watch?v=T29LmVgWDf8>

If your club or individuals would like to activate a mill just ask the

permission of the persons or relevant body that cares for the mill and set up an amateur station in the grounds.

Register with millsontheair@gmail.com in the UK and supply me with photos and information so we can include your story on the adoptamillcrossaustralia.com.au website.

Tony VK3KKP

For more information join the Facebook group: Central Victorian Amateur Radio Newsletter.

WIA Contest Website



To keep up to date with all of the major Australian contests, including rules and results, at the WIA Contest Website at:

www.wia.org.au/members/contests/about



Review: RadioSport RS60CF headset

Peter Freeman VK3PF

The RS60CF headset is the top of the range of the *RadioSport* headsets and incorporates a boom microphone. The entire range of amateur radio headsets from *RadioSport* were specifically developed for amateur radio use. As with the RS20S receive-only headset reviewed in Issue 3 2018 edition of *Amateur Radio* magazine, all units are a product of Arlan Communications.

The headset supplied for review came fitted with the M350-ADJ microphone and the CS6-ICM Headset-To-Radio (HTR) cable to suit the Icom radios in use at this station. Also supplied was the "M360 Electret-Condensator Microphone, Communications Range, Close-Talk EM56 - High Output".

The RF Solutions website has a comprehensive listing of HTR cables and recommended microphone for a range of transceivers from eight manufacturers, making it simpler for the buyer to make an appropriate choice of both cable and microphone for your radio. One can also request guidance by clicking the "Enquire about product" button on the product web page and completing the form which appears.

Like the RS20S headset, the unit came well packaged and feels

solid as one removes it from the packaging. The initial appearance is very similar to the RS20S headset, with two notable differences: the boom holding the microphone and a red button on the left speaker unit.

When the box was opened, you first see the four sheets of instructions and information on the headset and the optional components. The top sheet is headed with large red letters: "Read Me First!" The sheet gives

you valuable information on how to adjust the headset, stressing the importance of wearing the unit correctly. It outlines the features of the headset and the headset to radio cable and outlines optional accessories that you might consider. There are also some brief notes regarding care of the headset. The next sheet describes the design and features of the various "RadioSport Close-Talk Communications Microphones", including the

The RS40CF headset in use.



differences between dynamic and electret microphones and a list of the available microphone elements. One sheet describes the Headset-To-Radio cables. The final sheet outlines the available external PTT switches and adapters. Logically, this information should be read prior to purchase so that you have made appropriate selections!

The supplied cable was in a Ziploc® bag in the box with the headset. The cable has a Switchcraft miniXLR locking connector to match the socket on the left speaker unit. The other end of the cable has an alloy 8-pin microphone connector to suit Icom HF desktop transceivers plus a flying lead terminated with a 3.5 mm stereo plug, together with a 3.5 mm to 6.35 mm stereo adapter, with the audio plus and adapter in a gold coloured finish. The flying lead sits about 39 cm from a junction on the cable assembly. The junction incorporates a switch labelled STEREO and MONO, allowing one to use the headset on radios fitted with only a mono audio output: switch to mono connects the input from the audio connector through to both speakers.

The right speaker unit has a 3.5 mm stereo socket which enables the parallel connection of another headset for a second operator or logging assistant.

The headset is designed for use with either a foot switch or with VOX operation. The red PTT button on the left speaker unit is available for use if you are away from the desktop hand/desk PTT switch or foot switch and are not using VOX. The button is a momentary action

button, so it works like a standard PTT switch.

The look and feel of the headset is similar to that of the RS20S headset. The features of the two headsets are very similar. Construction is solid, with the headband made of matt black finish stainless steel, covered with a pillow-top cushion. The ear cups have a polished carbon-fibre look surface that is easily cleaned and are fitted with gel cushions with removable and washable cloth covers. The headset is comfortable to wear for extended periods. The reduction in background noise is prominent – immediately noticed when the headset is placed in position. The head band has the same adjustment capacity as the RS20S headset.

The microphone sits at the end of boom, about 22 cm from the middle of the pivot point on the left ear cup. All microphones are designed with noise cancelling, requiring that the microphone is positioned directly in front of your mouth to ensure best performance from noise cancelling and voice frequency response.

The microphone comes with a foam sock which prevents breath and/or wind noise entering the microphone.

With the frequency response range of 300 to 8000 Hz, both the supplied microphone elements exceed the frequency response required for typical amateur voice modes. Any transceiver will reduce the frequency response range according to the fixed or adjustable settings available with the transceiver. Changing microphone

elements is simple: undoing two Philips head screws allows the fitted element unit to be unplugged and the new element to be plugged in and secured with the two screws. There are also two set screws on the microphone contacts which are hidden under the bottom of the foam microphone sock. It is easiest to remove the foam wind sock before plugging the new element module into position and securing it with the screws and then replace the wind sock.

Reports of signal audio quality received whilst using the headset with either element were excellent. Minimal adjustments were required to my standard settings set on the transceiver – it was simply plug-and-play, with a quick check of levels when first using the headset with the M350-ADJ element. The microphone gain level needed to be reduced with M360 high output element. The headset was simple to use and extremely comfortable to wear. Sound quality on receive was excellent. The headset was used with VOX operations, using the red PTT button on the headset and also with a footswitch. Operation was simple.

The headset comes with a five year warranty. If needed, spare parts are readily available.

Price \$410 for the headset, plus an additional \$125 or \$140 for the matching HTR cable to connect to your radio. Additional microphone units are available in the range \$60 to \$80.

Thanks to RF Solutions for the extended loan of the review unit.



Wireless Institute of Australia **2019** Callbook

Available **Now**

A blast from the past

Tony Boddy VK6DQ February 2019

I know this is not radio stuff but it is a bit electronicky. I spent so much of my electrical career as a trouble shooter. Just had the knack of being to see into the black magic innards of electronics that were creeping more and more into things electrical. Not always. I remember back in my apprenticeship days when we used to come across any electronic stuff that had let the smoke out we would throw our hands up in horror and send for the spooks. I can tell you we really believed that these jokers came straight out of the twilight zone. We, I mainly, kept out of that for years even though I used to dabble in the electronic side of things with a bit of interest in radio. That all changed as I ventured further into my job.

Years later I was camp maintenance electrician of a mining camp at Shay Gap in North Western Australia. The camp commandant, I used to call him, was Bob De-Laurie, helleuva nice bloke – a Canadian. I had much to do with him because he was the camp administrator, we talked a lot. He came to me after hours one night “The camp movie projector has died”. “What do you mean, it’s died?” Two nights a week there were movies, I usually did not go. There were two projectors, one dud, and the second with a bit of lightfooting by the projectionist to keep continuity when changing reels was OK but now number two projector had lost sync. I didn’t know much about projectors so had to learn pretty quickly about the synchronous shutter in the light output line that enabled the picture to be seen. Without that shutter the picture was just a blur. Now both machines were dead.

There was a bit of a fuss and a whole angry mob of mine workers

without their entertainment. Had a quick bo peep at the innards and found that the centrifugal clutch on the synchronous shutter drive had thrown the friction pad. What the hell am I going to do with that? The end of my trusty leather tool belt was about the right thickness so I chomped a bit of that off trimmed it up and riveted in into place with some rivets made from a bit of copper wire from my toolbox. Bingo we had a projector again. The grumbling from the quite mad audience died down and Bob sort of cajoled me into fixing the other projector as well. Fortunately it was only the same sync problem, another piece off the end of my tool belt saw to that. With two projectors on line there was no delay in changing reels and continuity was seamless. The anger from the crew dissipated pretty rapidly when both projectors came into play. My camp electrician status went straight up to guru level. Could have had free beer for life after that but I don’t drink. Played projectionist for a while because I was interested and became quite a good friend to Bob De-Laurie mainly, I think, because I saved his bacon.

Bob said to me one day. “Got an old radio that you may like to have for spare parts if you want”. Now radio parts did not turn me on much because all of my stuff was electric and heavy duty. “Thanks Bob”, mainly because I had no wish to offend him and he really thought he owed me. The radio would have been a pretty good unit in its day but the removalists has really knocked it around. Modern transistor job with a bundle of bands and I expected good audio because it had a nice speaker. Pulled it all to bits, the loopstick was in a dozen bits and there were

about 20 or so wires all broken away from the connection points across the PCB and band switch. Those were the days when I could really see so I was able to match up the wires by looking very carefully at the ends and the points where I guessed they may have come from. That all looked OK but what about the loopstick. The ferrite was really in a mess and there was no way I could get spares 2000 km up in the bush. I figured the loopstick was a magnetic circuit anyway and it would work just as well as a series connected job. It was a job too. Borrowed some PVA glue from the camp carpenter and glued all the bits together with one layer of paper to hold it in place.

It was indeed a magic radio. I couldn’t take it from Bob, so I gave it back to him. He would not take it. We came to an agreement that we would share it and whoever went home first would have it. Both of us were due to ship out at about the same time so it sounded a bit fair. I did go before Bob, the radio became mine and served me well for many years. He came to Perth on his way back to the States and I arranged a billet for him at my mother’s place till he went home. Still could not get Bob to take his radio back, it was mine for sure. That episode reawakened my interest in Radio. Still, life gets in the way and I just did not have the time to follow up my dream. We did move to New Zealand where I had the time to study and become an Amateur Radio Operator. In the meantime I had begun to specialise in troubleshooting. I was the bloke they called when everyone else failed. I never gave up and always there was a good result. Amateur radio opened up so much for me, electronics in industry was

everywhere and without knowledge of it in some way you were stuck being just an ordinary wire jerker. Not for me. It was good. I learned much and gained a good reputation for fixing the impossible. All this story so far is to lead you into one of those magic fixes. Magic because none of it scared me anymore.

The Kiwis are a pretty economical lot; they need to get the best out of everything. So they brought some pretty sophisticated machinery into NZ from all over the world. In the end I could read English, German, French and Italian drawings. Just could not hack it with the Chinese or Japanese though. Chinglish and Japlish just never sat right with me and the Russians really gave me some gyp. Getting back to NZ economy, they used to mill timber, some was pretty rough, too many knots and shakes to make decent lengths of anything. They were cutting the knots out of really shonky pine and finger jointing 150mm long bits together to get longer timber. But the best was the laminated beams. They did use longer timber for that and some of the bigger beams were indeed magnificent. I got involved with it because the company I worked for became agents for a gigantic RF laminator.

Can't for the life of me remember the name now, it was over 40 years ago. The machine was very similar to a sandwich maker with the exception that it was a press that worked in a downward direction with a secondary press that squeezed in from the sides. If you can imagine a sandwich maker three meters long and one and a half meters wide that would squeeze up to one hundred and fifty millimetres thick. The top and bottom plates were the capacitor in a gigantic tank circuit. They were tough as old boot stainless and their main job was to hold the loose bits of timber flat while the side press came in to hold them all together. It was quite a process. There were roller tables on the output side of

the press and flat tables on the input side. The operators would juggle shorter bits of timber to maintain the right width and make sure there were not too many ends lined up to create a weak spot. In other words the joins in any of the lines has to be well staggered. There were about four operators feeding timber in keeping it all lined up and also coating the sides of the timber with glue.

The big 27 MHz oscillator was powered by a fifteen kilowatt tube the like of which I had never seen before nor probably will ever see again. I reckoned you could fit two sumo wrestlers inside, it was that big. Once the timber was coated with urea-formaldehyde glue, rolled into the press then squeezed flat and together it was treated to a fairly heavy dose of RF to set off the glue to hold it all together strongly enough to be moved through the press and be stacked. Beams could be made to almost any length as long as timber was inserted and as long as there was space on the output rollers to take it. The beam would left to cure to full strength, normally for 24 hours and then it could be used. It was possible to make unlimited length beams and they did make some thirty meters long. The oscillator had many safety features built in and the one that was causing us trouble was the auto overload setup.

If perchance there was glue build up in the RF path between the top and bottom plates of the press, excessive RF would flow through the glue line, the oscillator would sense this and give the whole thing a big burst of energy. Normally the glue line would be burnt away but if it was not, the burst of energy circuit would repeat four more times then shut down for a manual inspection and clearing. The circuit was quite simple, each clearing burst had a relay that would lock out the RF cycle for a few seconds. If the fault was cleared it would reset and resume operation. If the fault remained it would cycle the burst of

energy circuit till it was cleared or it reached the fifth shot at which time it would lock out the press until the fault was cleared and the lockout manually reset.

Our problem was that there was no lockout, the press kept cycling after the fifth shot. This thing sounded like a slow firing 50 calibre machine gun. All a bit scary when you have never seen a machine like this before. The worry here was the damage that could be done to the oscillator with a continuing run in safety mode. The circuit was available, new machine benefits hey, so delved into that and found that each burst cycle was locked out by a tiny relay coupled with an LED indicator to let the operator see what was happening. Why was the fifth cycle not locking out? Lots of measuring, static values of each component, checking voltages and comparing the five stages of lockout gave me consistent results. That looked OK but what about the function, how did it work?

Each burst shot energised a relay which was operated by a pulse triggered SCR. The relay would pull in, the LED would light up and the combined currents of them both was sufficient to hold the SCR conducting and the relay would lock out the machine. A timer would fire the oscillator again until the fault was cleared automatically or burst five relay locked everything out. Burst five relay was not working! Well it was but not properly. Every component checked OK. What was holding number five relay on or not on in this case, the holding current through the SCR. Checked the data on the little SCR and found it to be in the low milliamp range. Was the current of both the relay and the led combined enough to keep the SCR conducting? Easy job here just swap the relay or the led out to find out. It was the weekend so could not buy a thing; I was also a thousand km from home and my personal supplies. The relay checked out resistance wise so flagged that away, pulled the LED,

that looked OK but when I pulled one of the others from the circuit and ran a load test on both I found the current of the suspect LED was only 10 mA, the other was 20mA. Did it make a difference? Sure did. The problem I had was no spare LEDs.

Ten lousy milliamps difference in a 20 cent LED current was stopping a million dollar machine operating. That ten milliamps was essential to maintaining the hold on current in an SCR circuit, I had no wish to make changes to the manufacturer's circuit lest it become non-standard. I bridged out shot five and

reconnected shot four to lock out the machine just for running up trials and we were able to finalize the installation and testing for a Monday start-up. After Monday a green LED was purchased and installed. The company for whom we installed the press was happy and so was I to be able to return it to the original circuitry. All this fault finding stuff is not as difficult as it seems: systematic, methodical checking is the best way to go. Correct diagnosis of symptoms will find the cause of a problem. That applies to most situations. Having circuit diagrams is a big bonus because

it gives one somewhere to theorise hairy problems. It can be done with no circuitry but the path to success in that case is longer and slower. Having data books on hand to look at device specifications is also valuable. You can't hold it all in your head. Sorry it's not really radio related but the 27 MHz made me chuckle when I thought about the RFI that the NZ chicken banders would have encountered when this great beast was running. It was not a clean signal.

Over to you

Just a rant

Justin Giles-Clark VK7TW
President WIA
17 February 2019

Dear Justin,

Just a few thoughts:

Having been an amateur for almost 40 years, as one could imagine, I have done and seen many things. I have had an advanced licence for all of my 40 year term, an Assessor's certificate, been president and founding member of clubs here and there and an active WIA member. What disappoints me most is the negativity that abounds within any organization no matter what one tries to do to combat it. Not everyone is the same. One would not like it to be so, lest different ideas and thoughts never come to light.

My job as President was to chair meetings, hopefully keeping them flowing and promoting constructive debate during which the club members would decide in which direction they would like the club to move. Hopefully I would have enough knowledge of the club constitution and matters discussed to offer advice where needed to make sure the wishes and ideas of the club were put into practice. Many times the membership would make decisions that I personally disagreed with. That's OK, my role

was advisory not dictatorial.

I have been a member of the WIA for many years. It costs me, so does my role as Assessor but to be an Assessor I have to be a WIA member. The WIA is effectively my union, my representative at IARU conferences, my liaison with the ACMA and till recently the organization which has lobbied the ACMA for the privilege of conducting Assessments. My membership has allowed me to put something back into Amateur Radio and I am happy with that. Now comes the bad bit, I have had contacts with Amateurs who are vehemently anti-WIA. OK the WIA had a few issues, maybe still has but in all of my dealing with the WIA I have had my requests dealt with promptly and with fairness.

Without the WIA or a like organization we would not be on air. In the past the executive has worked hard to preserve and advance the position that we all hold in the world. I owe a great deal to those who have made things Amateur possible for me and so many others who I have been able to help into our fraternity. I have also met many who are totally anti-WIA but still hold their hands out for grants from the WIA whilst denigrating them entirely. There are factions who have taken as much as they can from the WIA but

have been fanatical about destroying the very organization which has continued to support them in their chosen hobby.

Whilst we do now have an "opposition" group who are doing all they can to destroy the WIA, I do not think they have the membership or infrastructure to accomplish that. To me it seems that they are driven by hate. The main thrust of that hate is that the WIA charges too much for licences, they want it all for free. Strange even though the ACMA sets the licence fees, they blame the WIA. Of course there is a great deal of angst against the volunteer executive and directors because it is thought that they get paid. The opposition of course infiltrated the WIA and wanted an overnight reform of its structure. Those who may be just a little enlightened know that such changes do take time. The many who are looking but refusing to see so far have not offered a viable alternative to the WIA. They are hell bent on its destruction.

I for one will remain a member. I thank all of the WIA executive and directors for the input now and the past to ensure that our great hobby remains just that, great.

Best regards,

AW Boddy VK6DQ



Participate

EMDRC Hamfest 2019 | Sunday 24 March



DXTalk

Luke Steele VK3HJ
e vk3hj@wia.org.au

Activity on most HF bands increased over summer as usual, with many DXpeditions in all parts of the world to chase. Solar conditions remained very quiet, with just a few small sunspot groups appearing and the Solar Flux Index only occasionally rising above 70. Despite this, the lower HF bands were quite active, but little is happening above 15 m.

Around the bands

Forty, 30 and 20 m continue to offer DX to most parts of the world almost daily. Low Bands are patchy, with 160 m good to Asia most evenings, and later in the summer, Central American and Caribbean stations were worked. HK1MW in Colombia has been quite strong some evenings on 160 m. A few North Americans have also been worked on Top Band, and that path should improve towards the Autumn Equinox. Eighty metres has been better, with Asia, Pacific, the Americas and Europe being workable many nights.

Here is a report from Antoine 3D2AG on his successful DXing on 6 m and 2 m over summer.

"Equipment is IC-7300, Cushcraft A50-5S, 5-el Yagi 8 m high and ACOM 600S linear, and Cushcraft A144-20T for 2 m, both on 6 m high galvanized pipes with quick-dismount PVC mating system in case of cyclones. Rotation is via "Armstrong" method.

QTH is Suva, Fiji RH91FV and I have clear take-off to the East but very poor to the North due to houses, and the central chain of mountains of the island rising to about 1,000 metres.

My 6 m season really started to open with a 'bang' on 30 November,

around 2230 UTC with a big VK/ZL opening lasting until about 0430 UTC. ZL1s, ZL2s, VK1s, VK2s and VK4s were worked with S9 signals on FT8, CW and SSB. The band went quiet again until 4 December, with a small opening to ZL1, ZL2 and ZL3 from 0630 to 0713 UTC on FT8. At around 0000 UTC on 5 December, a really massive opening to VK/ZL took place, lasting until about 0630 UTC. The whole of VK/ZL mainland area was worked (ZL1-ZL4; VK1-VK8) including four VK6 stations (VK6CPU, VK6RZ, VK6KXW and VK6AKT) at over 6,400 km.

On 7 December at 2333 UTC, I worked my first South American station of the season (Dale CE2SV), via the strange southern path (multiple Es? SSSP?). Contacts were on 50.276 using JT65 mode, as this mode was found to be the best to decode the weak long-haul signals over this path. A group of Oceania stations and South American stations ritually meet each day starting about 1900 UTC on the Region 2 ON4KST internet chatroom, coordinating operations (SA transmits even periods, OC/VK/ZL odd). Another massive 6 m opening to VK/ZL took place on 15 December, again with all mainland areas worked. At 0826 UTC on that day, the first ever 6 m WSPR contact between 3D2 and VK6 was made (VK6CPU, -29dB, 6405 km). Another huge VK/ZL opening took place on 17 December, but no further South American contacts. That changed on 21 December at 2243UTC, when LU5FF was worked on JT65 mode (-25 dB) and on 22 December, starting 2259 UTC again CE2SV, LU7FA, and LU5FF were worked/heard. LU7FA was worked again on 24 December, 0025 UTC.

On 26 December starting 2245 UTC, again CE2SV, LU7FA, LU5FF and LU7FIN were worked. Signals were so strong that a FT8 contact and CW contact were made with CE2SV, with 559 reports both ways. The opening lasted more than one hour with CE2SV. More Es 6 m openings occurred over the Christmas/New Year period with VK/ZL, including a contact both on FT8 and WSPR with VK6ADF in OG70 (6,592 km!). On 27 December at 0314 UTC, the first ever 2 m (144.489 MHz) tropospheric link was established between VK and 3D2 (WSPR-2 mode, VK2MAX, -21 dB). Nothing further took place with North or South America, despite VKs/ZLs working into NA on 3 January. I decoded a couple of North American N6 and W6 stations briefly (-20 dB FT8) but the opening did not last long enough for any QSOs. On 6 January starting around 0100 UTC, a massive 2 m opening took place between 3D2 and ZL1, and I worked three stations on FT8, CW and SSB with S9 signal strength. This opening lasted about one hour and did not occur since. The bands went very quiet again from 7 January."

DX Heard or Worked

Six metre DX featured through December and January, with many ZL stations worked, including ZL7DX Chatham Islands, along with the usual JA, some DU, and even some NA and SA. Antoine 3D2AG was very active on 6 m, and he continues to be very active on HF.

Matthew VK0HZ at Davis Antarctic Base was worked on 20 m SSB in early January. Norbert VK0AI pops up from time to time from Macquarie Island using FT8. Nob XZ2B has been active on 15 m CW

in Myanmar. Eddy XV1X is regularly on CW from Vietnam. Michael S79AA was on air from Mahe, Seychelles during January. Gerhard HC8GET was on air from Galapagos during January. Nob ZL7/JA0JHQ operated from Chatham Islands during January. Milan E51DWC was on air in his third visit to Rarotonga, South Cook Islands. Vlad UA4WHX has been active from a number of Indian Ocean Islands.

Larger DXpeditions were also active in January and February, including 9LY1JM Sierra Leone, V84SAA Brunei, XX9D Macao and T31EU Central Kiribati.

The P29VCX IOTA DXpedition was cut short after equipment was stolen after they had only been a few days at Manus Island.

IDT Chad DXpedition changed to Uganda

The Italian DXpedition Team DXpedition to Chad that was planned for March has been put on hold, due to the security situation in that country.

Their DXpedition to Uganda, originally planned for September – October this year, will now be conducted 13 to 25 March.

Norfolk Island

Operators Chris VK3QB, Luke VK3HJ, Patrick VK2PN, and David VK3BDX will be operating from Pacific Palms on the northern part of the island in early April. Operating on HF, with a focus on Low Bands. Modes, CW, SSB and FT8. SOTA activation is planned from Mt Bates (certain) and Jacky Jacky (very much dependent on weather and sea conditions).

3Y0I Bouvet Island

At the time of writing, the Rebel DX Group has not left Cape Town, and is awaiting final refitting and licensing for their vessel "Atlantic Tuna". The ship is about to do a series of sea trials. They state that they will go when they are ready to go. This may soon, or much later in the year. For more information visit their website: <https://www.rebeldxgroup.com/tag/3y0i/>

Upcoming DX

DXpedition activity scheduled for December and January includes the following:

PJ7AA Sint Maarten (NA-105), 3 - 30 March. AA9A operating on 80 - 10 m, maybe 160 m. Mainly CW and FT8 with some SSB. QSL via AA9A.

A52ZB, A52IC Bhutan, 6 - 9 March. Operators JH1AJT, DJ9ZB, E21EIC. 160 - 10 m, CW, SSB and FT8. QSL A52ZB via DJ9ZB and A52IC via E21EIC.

FO/OK2ZI French Polynesia (OC-046), 6 - 12 March. OK2ZI operating from Tahiti, 40 - 10 m, CW, SSB and digital. QSL via LotW, or Club Log.

KG4AS, KG4SC Guantanamo Bay (NA-015), 6 - 13 March. N4SIA operating as KG4AS and KP2L operating as KG4SC from the Naval Station Radio Club station, on HF, CW, SSB and FT8. QSL via home calls.

C6AKT Bahamas (NA-001), 8 - 16 March. M1KTA operating from near Glass Window Bridge, Eleuthera Island, 80, 40, 20, 15 and 10 m CW. QSL via LotW.

7P8LB Lesotho, 8 - 16 March. Team of nine operators at Molengoane Lodge, HF bands with a focus on Low Bands, and FT8. Also using SSB and CW. QSL via M0OXO. For more information see: <http://www.la9vpa.com/7p8lb/qsq.html>

9G2DX Ghana, 9 - 20 March. Team operating on HF, with plan to activate WFF sites. QSL via LotW and eQSL.

XR0ZRC Juan Fernandez (SA-005), 11 - 27 March. Team of six operators on Robinson Crusoe Island. 160 - 10 m, CW, SSB and FT8. QSL via LotW. For more information see: <https://dxpedition.wixsite.com/xr0zrc>

E51AUZ, E51NPQ North Cook Islands (OC-014), 12 - 25 March. DL1AUZ operating as E51AUZ and DM7PQ operating as E51NPQ from Manihiki Island. QSL via home call. For more information see: <https://www.qrz.com/db/E51NPQ>

5X3C Uganda, 13 - 25 March. The Italian DXpedition Team will be operating from grid locator KJ60hd,

160 - 10 m, CW, SSB, RTTY and on FT8 as 5X3E. QSL via LotW. For more information see: <http://www.i2ysb.com/joomla5/>

8P6DR Barbados (NA-021), 13 March - 17 April. G3RFL operating on 80 - 10 m, CW and RTTY. QSL via LotW.

5V7EI Togo, 14 - 26 April. EIDX Group, team of 13 operators, on 160 - 10 m, CW, SSB, digital. QSL via LotW or M0OXO. For more information see: <https://5v7ei.com/>

E6ET Niue (OC-040), 18 March - 2 April. 5B4ALX operating 160 - 6 m, SSB, CW and RTTY, with some FT8. QSL via Club Log. For more information see: <http://www.5b4alx.cloud/e6et-niue-2019/>

TO2BC, French Guiana. 21 March - 22 April. DL7BC operating 40 - 10 m, mainly SSB. QSL via LotW.

VK9N Norfolk Island (OC-005). 1 - 14 April. DXpedition callsign TBA. VK3QB, VK3HJ, VK2PN and VK3BDX operating HF, CW, SSB, FT8, focus on Low Bands. Planned SOTA activation of Mt Bates, and Jacky Jacky. QSL via LotW or VK2CA.

XT2AW Burkina Faso, 6 - 16 April. DF2WO operating from Ouagadougou. HF, CW, SSB, RTTY and FT8. QSL via M0OXO or DF2WO direct.

J20DX/p Djibouti, 14 - 20 April. MM0NDX and MM0OKG operating from Moucha Island (AF-053) and Sept Frere Island (AF-059). Dates tentative. QSL via LotW or Club Log. For more information see: <https://j20dx.com/>

KH8 American Samoa (OC-045), 15 - 22 April. OZ0J and OZ1RH, DXpedition callsign TBA. On HF, CW, SSB and digital. QSL via LotW or Club Log. For more information see: <https://kh8.oz0j.dk/>

Please email me with any DX related news for inclusion in this column. I am particularly interested in hearing about DX worked or heard in other states, and from newer DXers.

73 and good DX,
Luke VK3HJ

Phil Storr VK5SRP



AHARS goes into recess in December and January each year except for our lunches at the Blackwood RSL on the second and fourth Fridays and a picnic towards the end of January.

After holding the picnic in the Bridgewater Park for many years and either self-catering or using local service clubs, we shifted the event to the Marion RSL. What prompted us to do this was the difficult parking because of the proximity to a popular restaurant and the popularity of the park with family groups. The terrain is also very uneven and, as most of our members are getting on in years, this causes problems with those who have limited mobility. The Marion RSL is not in the Adelaide Hills but nowhere is very far from the Adelaide Hills in Adelaide.

They offered us a very good deal on providing lunch and the facilities are great with inside seating with air conditioned comfort if the weather was hot or inclement or the great outdoors under old shady trees. As it turned out the day was perfect and the 54 people who attended sat outside and enjoyed the "great outdoors". The RSL is staffed by volunteers and they did a great job of providing us an enjoyable BBQ and the bar provided a wide range of beverages at very reasonable prices.



Part of the large group enjoying lunch at the Marion RSL.

We were so impressed with the reaction of those who attended we are shifting our annual Buy and Sell to this location for 2019 and this will be on the third of November this year. Plenty of parking in the grounds and the RSL will provide breakfast for those who need it. This event is also a social get together for local amateurs and there are plenty of indoor tables and chairs to sit around and catch up with old friends.

Our "shack" is situated within a Girl Guides facility in Blackwood where there is a large hall and two sheds. We have one of the sheds as our shack and it is used for Saturday coffee mornings, for training and assessments and technical lectures. The Girl Guides local management were so impressed with what we did with this old shed that they asked us if we could do the same with the second shed for them. We have made a start on insulating

and fitting a ceiling and making it secure; we have had trouble with vandals in the past. The site no longer hosts a Girl Guide Group; it is now used as a training and storage facility. We anticipate we have about four more weekend work bees to complete converting the shed into a safe, clean and secure facility for the Guides.

If you would like to keep informed about the activities at AHARS you can visit our web site and look at our PDF version of the calendar. This is updated regularly as it is hard to plan a year ahead in detail. Go to www.ahars.com.au, click on the more tab at the top of the page and then Upcoming Events and under the BIG PDF logo you will find the latest version of our calendar.

Phil Storr VK5SRP
President,
Adelaide Hills Amateur Radio Society



WIA Awards

Marc Hillman VK3OHM/VK3IP

Below are listed all New awards issued from 2018-12-15 to 2019-02-14, plus all updates to DXCC awards.
Go to <http://www.wia.org.au/members/wiadxawards/about/> to use the online award system.

New awards

DXCC Multi-band (1)

#	Call	Name	Mode	Band	Count
212	DD0VU	Jens Knoepchen	Open	40 m	143
213	DD0VU	Jens Knoepchen	Digital	40 m	127

DXCC Multi-band (3)

#	Call	Name	Mode	Band	Count
135	DD0VU	Jens Knoepchen	Open	40-30-20 m	374
136	DD0VU	Jens Knoepchen	Digital	40-30-17 m	342

DXCC Multi-band (5)

#	Call	Name	Mode	Band	Count
94	VK3BDX	David Burden	Open	80-40-30-20-17 m	743
95	VK3OHM	Marc Hillman	Open	40-30-20-15-10 m	715

DXCC Multi-mode (Digital)

#	Call	Name	Count
78	VK4SN	Alan Shannon	110
79	VK3KTT	Steven Barr	115
80	DD0VU	Jens Knoepchen	158

DXCC Multi-mode (Open)

#	Call	Name	Count
466	DD0VU	Jens Knoepchen	178

Grid Square

#	Call	Name	Mode	Band
365	VK4HAT	Rob Powell	Digital	HF
366	DD0VU	Jens Knoepchen	Open	HF
367	DD0VU	Jens Knoepchen	Phone	HF
368	DD0VU	Jens Knoepchen	CW	HF
369	DD0VU	Jens Knoepchen	Digital	HF

Worked All States VHF

#	Call	Name	Mode	Band
223	VK3KTT	Steven Barr	Open	6 m
224	VK3AWG	Christopher Bellmont	Open	6 m
225	VK3AWG	Christopher Bellmont	Digital	6 m
226	VK3WE	Rhett Donnan	Digital	6 m

Worked All VK Call Areas HF

#	Call	Name	Mode
2383	SQ5NRY	Pawel Stobinski	Open

DXCC updates

DXCC Multi-band (1)

#	Call	Name	Mode	Band	Count
4	VK2CA	Allan Meredith	CW	30 m	215
3	VK2CA	Allan Meredith	Digital	20 m	200
54	VK3EW	David McAulay	Digital	20 m	214
162	VK3AWG	Christopher Bellmont	Digital	20 m	179
175	VK3JLS	John Seamons	Digital	20 m	134
190	VK3BDX	David Burden	Digital	20 m	174
6	VK2CA	Allan Meredith	Open	20 m	317
17	VK6WX	Wesley Beck	Open	20 m	217
34	VK3KTT	Steven Barr	Open	20 m	231
76	VK3JLS	John Seamons	Open	20 m	224
108	VK3AWG	Christopher Bellmont	Open	20 m	233
161	VK3WE	Rhett Donnan	Open	20 m	120
189	VK3BDX	David Burden	Open	40 m	194
205	VK5SA	Chris Levingston	Open	20 m	139
35	VK3KTT	Steven Barr	Phone	20 m	210
107	VK3AWG	Christopher Bellmont	Phone	20 m	159
169	VK3JLS	John Seamons	Phone	20 m	204

DXCC Multi-band (3)

#	Call	Name	Mode	Band	Count
18	VK2CA	Allan Meredith	CW	30-20-17 m	598
66	VK3EW	David McAulay	Digital	30-20-15 m	575
111	VK2CA	Allan Meredith	Digital	20-17-15 m	485
132	VK3BDX	David Burden	Digital	40-30-20 m	494
17	VK2CA	Allan Meredith	Open	20-17-15 m	893
30	VK3SX	Bob Robinson	Open	20-15-10 m	707
69	VK3KTT	Steven Barr	Open	20-15-10 m	559
112	VK6WX	Wesley Beck	Open	40-20-15 m	498
119	VK3JLS	John Seamons	Open	20-17-15 m	437
126	VK3AWG	Christopher Bellmont	Open	20-17-15 m	515
131	VK3BDX	David Burden	Open	40-30-20 m	528
31	VK3SX	Bob Robinson	Phone	40-20-15 m	700
68	VK3KTT	Steven Barr	Phone	20-15-10 m	510

DXCC Multi-band (5)

#	Call	Name	Mode	Band	Count
20	VK2CA	Allan Meredith	CW	40-30-20-17-15 m	928
21	VK3EW	David McAulay	CW	40-30-20-17-15 m	1408
35	VK7CW	Steven Salvia	CW	40-30-20-17-15 m	1179
79	VK3EW	David McAulay	Digital	40-30-20-17-15 m	875
34	VK7CW	Steven Salvia	Open	40-30-20-17-15 m	1243
47	VK3SX	Bob Robinson	Open	40-20-17-15-10 m	1004
93	VK3AWG	Christopher Bellmont	Open	40-30-20-17-15 m	722
94	VK3BDX	David Burden	Open	80-40-30-20-17 m	743
52	VK3SX	Bob Robinson	Phone	40-20-17-15-10 m	984

DXCC Multi-band (7)

#	Call	Name	Mode	Band	Count
9	VK2CA	Allan Meredith	CW	40-30-20-17-15-12-10 m	1210
10	VK3EW	David McAulay	CW	80-40-30-20-17-15-12 m	1814
14	VK7CW	Steven Salvia	CW	40-30-20-17-15-12-10 m	1539
6	VK2CA	Allan Meredith	Open	40-30-20-17-15-12-10 m	1823
15	VK7CW	Steven Salvia	Open	40-30-20-17-15-12-10 m	1627

DXCC Multi-band (9)

#	Call	Name	Mode	Band	Count
12	VK3EW	David McAulay	CW	160-80-40-30-20-17-15-12-10 m	2143
1	VK3EW	David McAulay	Open	160-80-40-30-20-17-15-12-10 m	2796

DXCC Multi-mode (CW)

#	Call	Name	Count
87	VK4SN	Alan Shannon	149
178	VK6RZ	Peter Drew	334
202	VK2CA	Allan Meredith	311
223	VK6WX	Wesley Beck	211
234	VK3KTT	Steven Barr	157
249	VK3FZ	Roger Stafford	229
257	VK3AWG	Christopher Bellmont	145

DXCC Multi-mode (Digital)

#	Call	Name	Count
19	VK2CA	Allan Meredith	257
20	VK3EW	David McAulay	299
25	VK3DHM	Marc Hillman	178
47	VK3AWG	Christopher Bellmont	206
63	VK4YMB	Andrew Burns	119
66	VK3JLS	John Seamons	143
67	VK4CAG	Graeme Dowse	204
71	VK3BDX	David Burden	219
72	VK3VM	Stephen Ireland	146
79	VK3KTT	Steven Barr	115

DXCC Multi-mode (Open)

#	Call	Name	Count
370	VK3KTT	Steven Barr	272
385	VK2ND	Ian Hawkins	142
394	VK3JLS	John Seamons	244
397	VK3AWG	Christopher Bellmont	271
413	VK3WE	Rhett Donnan	170
418	VK4SN	Alan Shannon	163
448	VK4YMB	Andrew Burns	119
452	VK5SA	Chris Levingston	162
458	VK3BDX	David Burden	228
459	VK3VM	Stephen Ireland	147

DXCC Multi-mode (Phone)

#	Call	Name	Count
583	VK2ND	Ian Hawkins	133
602	VK3AWG	Christopher Bellmont	199

Wireless Men & Women at War

Young men and women who behind the scenes, were able to successfully use their developed skills in such a way as to make a difference – sometimes a big difference brought about largely by their interest in private radio communications. Read more...

Visit the WIA Bookshop at: www.wia.org.au/members/bookshop/page_data.php?id=258

Wireless Men & Women at War



Authoritative history of the wireless men and women who served in WWI and WW2

The Wireless Foundation of Australia

Ross Hull Memorial VHF-UHF Contest 2019: Results

Retiring contest manager: John Martin VK3KM

This year the overall winner is **Barrie Burns VK6ADI**. This is his second win - the first was in 2011. The runners-up are Brian Farrar VK2AH, Ted Thrift VK2ARA and Rob Heyer VK2XIC. Congratulations to these big scorers and to all others who sent in very impressive logs. Congratulations also to Robert Garland VK4LHD, who took out the

digital sections. It is good to see continued interest in DX working and hopefully the activity level will continue to rise. One interesting point is that the focus of activity for the contest for many years was VK3 and VK5, but this has not been the case in the last few years. Hopefully there will be more VK3 and VK5 activity in the future.

Speaking of years to come, lately I have got into the habit of retiring from the contest. Now I have discovered that habits tend to go on forever unless you really give them up! So, this is definitely the final for me. Best wishes to my successor, and to future entrants.

And regarding the future of the contest, more to follow soon.

Call	Name	50 MHz	144 MHz	432 MHz	1296 MHz	2.4 GHz	Higher Bands	TOTAL
Section A: Analog modes, best 7 days								
VK6ADI	Barrie Burns	3202	96	10	-	-	-	3308
VK2AH	Brian Farrar	852	417	250	144	-	-	1663
VK2ARA	Ted Thrift	640	468	310	152	50	-	1620
VK2XIC	Rob Heyer	282	210	180	3044	240	-	1216
VK2BLS	Darrell Harman	52	228	255	192	170	-	897
VK7MO	Rex Moncur	48	66	65	336	30	-	545
VK4JAZ	Grant McDuling	300	-	-	-	-	-	300
VK2VIN	Vinnicio Rinaldi	2	201	45	-	-	-	248
VK7TW	Justin Giles-Clark	12	27	45	144	-	-	228
VK2KQB	Keith Bradshaw	14	21	35	56	70	-	196
VK4LHD	Robert Garland	-	12	-	24	-	-	36
Section C: Analog modes, best 2 days								
VK6ADI	Barrie Burns	3024	42	-	-	-	-	3066
VK2ARA	Ted Thrift	378	150	130	40	20	-	718
VK2AH	Brian Farrar	396	87	140	40	-	-	663
VK2XIC	Rob Heyer	120	99	40	80	60	-	399
VK2BLS	Darrell Harman	12	144	135	48	40	-	379
VK7MO	Rex Moncur	40	51	40	152	30	-	313
VK4JAZ	Grant McDuling	300	-	-	-	-	-	300
VK2KQB	Keith Bradshaw	16	27	40	40	40	-	163
VK7KWB	Bryan Watson	-	12	0	16	-	-	138
VK2VIN	Vinnicio Rinaldi	-	99	20	-	-	-	119
VK7TW	Justin Giles-Clark	4	15	25	64	-	-	108
VK2KFJ	Steven Blanche	2	3	5	8	10	60	88
VK4LHD	Robert Garland	-	12	-	16	-	-	28
Section B: Digital modes, best 7 days								
VK4LHD	Robert Garland	-	-	96	-	-	-	96
Section D: Digital modes, best 2 days								
VK4LHD	Robert Garland	-	-	90	-	-	-	90

Ross Hull Contest Winners since 1950

1950 - 1951	VK5QR	R. Galle	1985 - 1986	VK3ZBJ	G. L. C. Jenkins
1951 - 1952	VK5BC	H. Lloyd	1986 - 1987	VK3ZBJ	G. L. C. Jenkins
1952 - 1953	VK4KK	A. K. Bradford	1987 - 1988	VK5NC	T. D. Niven
1953 - 1954	VK6BO	R. J. Everingham	1988 - 1989	VK5NC	T. D. Niven
1954 - 1955	VK4NG	R. Greenwood	1989 - 1990	VK3XRS	R. K. W. Steedman
1955 - 1956	VK3GM	G. McCullough	1990 - 1991	VK3XRS	R. K. W. Steedman
1956 - 1957	VK3ALZ	I. F. Berwick	1991 - 1992	VK3XRS	R. K. W. Steedman
1957 - 1958	VK3ALZ	I. F. Berwick	1992 - 1993	VK3XRS	R. K. W. Steedman
1958 - 1959	VK3ALZ	I. F. Berwick	1993 - 1994	VK3XRS	R. K. W. Steedman
1959 - 1960	VK4ZAX	D. R. Horgan	1994 - 1995	VK3XRS	R. K. W. Steedman
1960 - 1961	VK3ARZ	W. J. Roper	1995 - 1996	VK2FZ/4	A. Pollock
1961 - 1962	VK5ZDR	M. J. McMahon	1996 - 1997	VK2FZ/4	A. Pollock
1962 - 1963	VK4ZAX	D. R. Horgan	1997 - 1998	VK2FZ/4	A. Pollock
1963 - 1964	VK5ZDR	M. J. McMahon	1998 - 1999	VK3XPD	A. P. Devlin
1964 - 1965	VK3ZER	R. W. Wilkinson	1999 - 2000	VK3EK	R. G. Ashlin
1965 - 1966	VK3ZDM	J. R. Beames	2000 - 2001	VK4TZL	G. R. McNeil
1966 - 1967	VK5HP	J. H. Lehmann	2001 - 2002	VK4TZL	G. R. McNeil
1967 - 1968	VK3ZER	R. W. Wilkinson	2002 - 2003	VK3EK	R. G. Ashlin
1968 - 1969	VK5ZKR	C. M. Hutchesson	2003 - 2004	VK3EK	R. G. Ashlin
1969 - 1970	VK3ZER	R. W. Wilkinson	2004 - 2005	VK3UH	L. Mostert
1970 - 1971	VK4ZFB	E. F. Blanch	2005 - 2006	VK4TZL	G. R. McNeil
1971 - 1972	VK5SU	J. W. K. Adams	2006 - 2007	VK3KAI	P. Freeman
1972 - 1973	VK5SU	J. W. K. Adams	2007 - 2008	VK1DA	A. Davis
1973 - 1974	VK5SU	J. W. K. Adams	2009	VK3EK	R. G. Ashlin
1974 - 1975	VK5SU	J. W. K. Adams	2010	VK2ARA	E. Thrift
1975 - 1976	VK5SU	J. W. K. Adams	2011	VK6ADI	B. Burns
1976 - 1977	VK4DO	H. L. Hobler	2012	ZL3TY	R. McQuarrie
1977 - 1978	VK3OT	S. R. Gregory	2013	VK4CDI	P. Moat
1978 - 1979	VK4DO	H. L. Hobler	2014	VK2ARA	E. Thrift
1979 - 1980	VK3ATN	T. R. Naughton	2015	VK2ARA	E. Thrift
1980 - 1981	VK6KZ	W. J. Howse	2016	VK2AH	B. Farrar
1981 - 1982	VK6KZ	W. J. Howse	2017	VK2ARA	E. Thrift
1982 - 1983	VK6KZ	W. J. Howse	2018	VK2ARA	E. Thrift
1983 - 1984	VK6KZ	W. J. Howse	2019	VK6ADI	B. Burns
1984 - 1985	VK3ZBJ	G. L. C. Jenkins			

Contest web page: <http://www.wia.org.au/members/contests/rosshull/>

WIA DX & operating Awards



WIA offers a range of operating awards, including DXCC, VHF & UHF and many other awards.

Details can be found at: <http://www.wia.org.au/members/wiadxawards/about/>

SOTA Hotham Summit Weekend 2019

Gerard Hill VK2IO

The fourth running of the annual Mt Hotham SOTA Summit was held on the weekend of 2-3 February 2019. There were twenty-one starters, mostly from VK3 with a contingent from VK1 and VK2. The event is wonderfully organised by Brian VK3BCM and partner Kathy and based in the lodge at Hotham Heights that they manage during the snow season. This proved to be comfortable and in a convenient location for both the mountains and the local pub. The attendees were Ron VK3AFW and Ruth, David VK3IL, Peter VK3PF, Phil VK3BHR and Kathy, Andrew VK1DA, Compton VK2HRX, Ken VK3KIM and daughter Chantal, Leigh VK3SG, Glenn VK3YY, Sid ZS5AYC and Adele ZS5APT, Alan VK3FABT, Allen VK3ARH, Paul VK3HN, Gerard VK2IO and Wade VK1MIC.

Planning

Before the trip Brian had issued a list of possible routes that would make up day trips around a group of summits. The sheer number of possible routes was impressive. Having no knowledge of the interrelatedness of the summits I went to the SOTA maps web site and brought up a page showing all of the summits in the area and studied their positions. In that way it was possible to understand the routes on offer. Overlaying the North East (VE), East Gippsland (VG) and West/South Gippsland (VT) summits gave comprehensive coverage of the region around Mt Hotham.

Thursday

Compton VK2HRX and I set off Thursday morning from Sydney and stopped in Canberra and Cooma. We crossed over the Murray River and camped on the VK3 side at Tom Groggin. I set up HF there and

activated Alpine National Park for the evening on 40 m SSB. This was the only activation where mobile phone coverage was not available via the big T.

Meanwhile Ron activated Mt Porepunkah and then encountered a tree on the way to VK3/VE-097 and had to abort the activation. He stayed in Bright overnight.

Friday

The first of February is a special one in the SOTA calendar and this year marks the 7th anniversary of SOTA in Australia and the 6th anniversary of SOTA in VK1. An increased level of activity was expected and indeed three operators in VK1 went out and activated summits to celebrate.

The first summit Compton and I activated for the trip was Mt Pinnibar VK3/VE-009 where we enjoyed clear views to the horizon and a taste of the scenery and operating conditions for what was to come. I set up the Elecraft KX3 and homebrew ZS6BKW doublet antenna and on 40 m we had our first summit-to-summit (S2S) contact with Ron VK3AFW at VK3/VE-104 near Tawonga. Later we worked Peter VK3PF at VK3/VT-018 north of Dargo. Then a contact with Andrew VK1AD at Mt McDonald VK1/AC-048 on 80 m surprised me as Andrew was also using a ZS6BKW antenna. Unfortunately Tony VK1VIC at Mt Ainslie VK1/AC-040 was within the skip zone and unworkable on 40 m. We stayed on the summit through the UTC date changeover allowing us to work Andrew and Peter a second time for extra S2S points.

Next summit activated was Mt Gibbo VK3/VG-004 arriving at lunchtime. Peter VK3PF had moved on to White Timber VK3/VE-060 and was first in the log and luckily

Andrew was still at Mt McDonald so we could work him again for a new S2S, this time on 40 m. Bill VK1MCW had travelled just south of the ACT to Livingstone Hill VK2/SM-093 and I was able to work him on 15 m CW with very weak signals via ground wave. By that stage Tony VK1VIC had left Mt Ainslie, so I was happy to have two of the three VK1 activators logged. Ron VK3AFW had moved on too and was now at Ebenezer Range VK3/VE-081. We were able to work on 40 m SSB then I stayed on to complete at least four CW contacts as I try to do on every summit. Allen VK3ARH answered the CW call from Mt Wombat VK3/VU-002 starting a nice run of S2S contacts. Brian VK3BCM for his first summit of the trip had walked out to Mt Loch VK3/VE-005 right near Mt Hotham and was worked on 80 m SSB. Glenn VK3YY was also at his first for the trip, Sam Hill VK3/VG-049 and was worked on 40 m SSB. Sam Hill was our next planned activation and a lot closer to our ultimate destination in Hotham Heights.

It took quite a while to reach Sam Hill. On the way we drove past Mt Hope VK3/VG-014 that Compton had activated on the trip last year. The rough 4WD tracks gave way to bitumen roads and Compton re-inflated the tyres while I climbed a bank on the (unsuccessful) hunt for one of the activators on 2 m. While mobile, on HF we worked Peter VK3PF at Basalt Knob VK3/VE-039 and Blue Rag Range VK3/VE-015 and Glenn VK3YY who had moved on to Mt Livingstone VK3/VG-045. The second contact with Peter was 40 m CW, but Compton did not have a key, so I improvised by whistling into the microphone. Yes Peter did notice and gave me a 4 for readability but still a 9 for tone

so my whistling can't have been too bad.

We arrived at Sam Hill at 5 pm for a quick activation in order to reach the digs at a reasonable time.

Wade VK1MIC and Andrew VK1DA had left Canberra in the morning and encountered a fallen tree on their way to Mt Big Ben VK3/VE-105. Rather than clear the road with the prospect of more fallen trees, they went to Mt Porepunkah VK3/VE-098 instead. I completed a 40 m CW S2S contact with Andrew and Compton made a 40 m SSB contact with Wade. On CW Allen VK3ARH was worked at VK3/VE-178 and Paul VK3HN at The Horn VK3/VE-014. We missed working Leigh VK3SG who had activated Mt Porepunkah VK3/VE-098 on 2 m earlier in the afternoon.

Arriving at Anton Huette Lodge in Hotham Heights, there was time for a quick meet-up before walking down to The General for dinner and drinks with some of the group. Sunset at the pub was lovely and discussions began on planning activations for the following day. Returning to the lodge after the pub closed; there were new arrivals to meet and more planning (and drinking) to do. Brian VK3BCM had cunningly prepared A3-sized maps of various areas of the mountains which illuminated discussions. There was some concern over bushfires reported near Mt Phipps, Mt Nugong and Mt Gibbo and in the end they were not a threat and could be disregarded.

Saturday

At breakfast there was more last minute planning before all set off in groups or individually. The basic plan was to meet back at the Mt Hotham summit in the late afternoon and then head for dinner in time for our dinner booking at The General.

Expedition leader

Brian VK3BCM was planning a route with four or five drive-up summits to the south-west of the lodge. He hosted our special visitors from South Africa Adele ZS5APT and Sid ZS5AYC who had flown from Brisbane to take part in the trip. Joining Brian were Andrew VK1DA and Wade VK1MIC in one vehicle, Ken VK3KIM and daughter Chantal in another vehicle and Compton VK2HRX and myself Gerard VK2IO in another vehicle. With a convoy of eight activators it was mass activation territory. What could possibly go wrong!

A second group with Peter VK3PF, Leigh VK3SG and Paul VK3HN planned a route to the north-east of the lodge with four summits.

A third group with David VK3IL, Glenn VK3YY, Allen VK3ARH, Phil VK3BHR and Kathy were off to activate five summits to the east of the lodge.

That left Ron VK3AFW to paddle around the summits he wanted to do and he chose to follow the big group for the first summit. Alan VK3FABT stayed by the radio in the lodge to amass as many contacts as possible.

The first group was last to set off for the day but had the shortest distances to where there were summits on the route. It was all four-wheel drive territory with lovely

scenery and slow bush tracks. First stop was at the saddle between The Twins VK3/VE-017 and VK3/VE-023. With 150 m plus vertical climb to each of these they were not in contention on the day. However Rik VK3EQ was activating in the area and already at the top of The Twins. We were all able to work him on 2 m.

Mt Murray VK3/VE-025 was the first activated with a total of nine amateurs on the summit including Ron VK3AFW. There were two HF stations and two 2 m stations running all at once and a bunch running around with 2 m handhelds. Most operated from the carpark except Ron who took his 2 m beam higher up the hill to get away from the RF soup. Luckily the second group had reached VK3/VE-053 and the third group had reached Mt Nugong VK3/VG-018.

So we all tried to work each other to claim our summit-to-summit points. Just about all these contacts were done on 146.5, so you can imagine the frenetic activity. Peter VK3PF in the second group also had an HF setup so we were able to bypass the mayhem and make a leisurely 40 m CW contact. Brian VK3BCM also had HF running and was only about 30 m away so there was some desense.

Andrew VK1DA was happy to use my KX3 to make his CW contacts. Compton VK2HRX set up a 2 m slim-Jim antenna so that longer range contacts would be possible.

Rolling out of the carpark just before the UTC date change we headed on to the second summit. It had been decided that due to time constraints we would not head all the way to Mt Sarah and instead go to Mt Selwyn VK3/VE-049. Approaching the summit the final section is a steep track with very deep ruts, however one does not learn this until part way up.



Photo 2: The homebrew transceiver built by Phil VK3BHR.



Photo 3: Glenn VK3YY holding the Yagi and Phil VK3BHR on Mt Nugong.



Photo 6: View across the mountains at sunset.

Compton VK2HRX attempted the climb but had to reverse back gingerly due to lack of traction. The tyres were still at road pressure. No-one else in the group attempted it in their vehicles but most of us had no trouble on foot. The only trouble was finding parking for four vehicles.

Brian VK3BCM set up an HF station down the track and operated with Adele ZS5APT and Sid ZS5AYC.



Photo 4: Gerard VK2IO/3 set to operate.

Photo 5: Ken VK3KIM, Adele VK3/ZS5APT, Brian VK3BCM (standing) and Sid VK3/ZS5AYC activating on Saturday afternoon.

I set up an HF station right at the summit and Compton set up a 2 m station with Andrew and Wade utilising our stations as before. This time there was no desense on HF. Two hours had elapsed since the first summit so we had got out of sync with the other groups. We were able to catch Ron who had gone to Mt Blue Rag VK3/VE-021 and Rik VK3EQ who had gone to Big Hill VK3/VE-059 after also doing Mt Murray VK3/VE-025.





Photo 9: Part of the group chatting over nibbles on the summit of Mt Hotham.



Photo 7: VK3BHR operating 2 m FM from The Horn.



Photo 10: Phil VK3BHR watching Andrew VK1DA/3 and Wade VK1MIC/3 operating on Mt Hotham. Note the small 23 cm Yagi on the rear tripod.



Photo 8: Peter VK3PF operating 40 m CW on Mt Hope.



Photo 11: Allen VK3ARH, Phil VK3BHR and David VK3IL on Mt Nuniang.

Then, up popped Peter VK3PF in the second group now at Mt Gibbo VK3/VG-004. We'd totally missed them on their second summit Mt Sassafras VK3/VE-029. The third group were such a long distance away we could not work them on 2 m; just listen to others working them. We were at the westernmost point of our trek and they would have been at the easternmost point Mt Nunniong VK3/VG-011 about 100 km away with the Mt Hotham range in between. We'd missed them at their second summit Mt Bindi VK3/VG-017 too. Staying an hour on our summit did however allow Ron to be worked on a new summit, this time Blue Rag Range VK3/VE-015.

With time running against us we retraced our steps along the track to work a summit in-between. That is except for Andrew and Wade who went on a quest for fuel at Bright leaving three vehicles to tackle VK3/VE-066. Again Brian and I set up HF stations, this time with antennas inline end-to-end. They were not that far apart but we could still operate on the same band so had 40 m CW and 40 m SSB running at the same time. I missed having Andrew join me to make some CW contacts so it seemed a much quieter activation. Brian had prime position at the top of the hill for his station and so was commanding all the spectators. We were out of sync with the second group who had not yet reached Mt Hope VK3/VG-014. The third group had moved on to Brumby Hill VK3/VG-012 and were workable on 2 m this time. Also workable was Rik VK3EQ at VK3/VE-024. Half an hour on this one was enough to make all contacts giving time to do one more activation before dinner.

Compton and I headed to a summit 8 km west of Mt Hotham called VK3/VE-030, the site of a former helipad. Everyone else headed to the summit of Mt Hotham VK3/VE-006 for the biggest activation of the trip including Rik VK3EQ. I set up the HF station

as usual and Compton set up a station with HF and 23 cm and also brought out the PC to try FT8. We were on opposite sides of the hill to guarantee no desense since Compton planned to run relatively high power. I was able to work seven amateurs at Mt Hotham on 2 m FM as well as Andrew VK3JBL at Mt Torbreck VK3/VN-001 103 km away on a hand-held. At the time I did not realise the distance – he sounded like just next summit.

At Mt Hotham Andrew VK1DA had set up a 23 cm transverter fed by an FT-817 into a 4-element Yagi. Using that, about a dozen activators there worked Compton on 23 cm FM with his 16 element loop Yagi. Then they turned their attention to Mt Torbreck where VK3JBL was running a patch antenna and 120 mW on 23 cm. Remarkably, summit-to-summit contacts were completed all round, a magnificent achievement.

Wade set up and operated on 20 m FT8 using a Raspberry Pi modem in order to work some DX. He qualified the summit by using a non-standard FT8 frequency and spotting through the usual SOTA channels. There were operators in EU standing by, some on summits to try and make a S2S contact.

Compton attempted to operate on FT8 on both 23 cm and HF but was beaten by the gremlins. Best DX was Andrew VK1DA working EA on 20 m CW. I worked a JA summit on 20 m CW and Wade VK1MIC worked around Asia on 20 m FT8.

After the excitement we all headed to The General for a feed and debrief, and when it closed back to the lodge for some convivial communal mutual beverage appreciation.

Sunday

Planning for Sunday was a little different in that some were staying on and others were heading home. After discussions the night before with David VK3IL, we decided to do the circuit that group three had done on Saturday to the east of the

lodge. Joining Compton and myself in group 4 were Peter VK3PF, Leigh VK3SG, Andrew VK1DA and Wade VK1MIC.

Brian VK3BCM, Adele ZS5APT and Sid VK5AYC formed group 5 and activated four summits southeast of the lodge in the Omeo Valley.

David VK3IL and Glenn VK3YY paired up as group 6 and activated three summits to the west of the lodge before heading home. They started at Mt Murray VK3/VE-025 then drove back to the saddle and climbed The Twins VK3/VE-017 and then VK3/VE-023 so must have been feeling energetic.

Ron VK3AFW flew solo again and activated three summits on the southeast side of the lodge in the Omeo Valley starting with Sam Hill VK3/VG-049, The Knocker VK3/VG-016 followed by Mt Phipps VK3/VG-015 and Mt Birregun VK3/VT-020.

Paul VK3HN and Allen VK3ARH had less time so just activated Mt Loch VK3/VE-005 which is an easy walk from Hotham. Paul went there very early and Allen three hours later.

Rik VK3EQ also activated Mt Loch with Paul VK3HN then continued with three more summits to the northwest of the lodge: Ebenezer Range VK3/VE-081, Albion Point VK3/VE-080 and Mt Porepukah VK3/VE-098.

Phil VK3BHN activated three summits to the northwest of the lodge: The Horn VK3/VE-014, The Hump VK3/VE-019 and Mt Porepukah VK3/VE-098.

So our group 4 set off for Mt Nugong VK3/VG-018 and on the way we visited the historical Washington Winch, a cable logging system. Once at Mt Nugong all systems go with my HF setup and Andrew VK1DA with a 2 m beam to work the other summits. Peter VK3PF wanted to make four CW contacts and then whiz off to the next summit so we could all get in more S2S contacts and oh by the way, it would be great to get there by UTC date change in 45



Photo 1: Compton VK2HRX/3 operating on Mt Pinnibar.

minutes time! Peter used his KX2 on my antenna to speed through the contacts while travelling companion Leigh VK3SG secured four on 2 m FM. The summit was very windy, so one end of the doublet was moved to anchor the squid pole into the wind. Once the advance party left it was a leisurely time for the rest of us.

40 m propagation on Saturday had been poor with a huge skip zone. There had been feedback from VK1 that they were unable to hear us. I vowed we would make more use of 80 m to help with S2S contacts and chasers. Ultimately, 80 m was not needed as 40 m was in great shape on Sunday.

Before UTC rollover we had summit contacts with Ron at Sam Hill, David at Mt Murray and Allen at Mt Loch and then five minutes before the UTC date change up popped Peter and Leigh at the next summit Mt Bindi VK3/VG-

017. They'd made it by the skin of their teeth and we were all happy to make the S2S contact before and after the date change. From the summit I also worked Sid at Mt Delusion VK3/VG-026 and Ron at The Knocker VK3/VG-016.

After a 90 minute stay at Mt Nugong we continued around the circuit to Mt Bindi and stayed another 90 minutes there. I picked up summit contacts with Sid at Mt Baldhead, Ron at Mt Phipps, Glenn and David at The Twins, Phil at The Horn, Adele at VG-064, Peter at our next summit Mt Nunniong VK3/VG-011 and Leigh at Brumby Hill VK3/VG-012. Also worked was Warren ZL2AJ on 20 m SSB at a ZL summit. We spent so long there that two other activators had done two summits while we did only one. Peter and Leigh were now two summits ahead of us. We resolved to speed up our activations and they would stay on Brumby Hill

while we made up ground.

Moving on to Mt Nunniong the four of us did a quick 2 m activation with four contacts each and no HF. Peter had already activated it on 40 m CW, so the chasers were happy. Apart from Peter and Leigh at Brumby Hill, we worked Brian at Sam Hill VK3/VG-049 and Ron at Mt Birregun.

The short activation had bought us enough time to set up HF at the next summit Brumby Hill and we ended up spending an hour there. It was now the middle of the afternoon so all those heading home were now off their summits. Contacts were made with Peter and Leigh at our ultimate summit Mt Pendergast VK3/VG-022 and Phil at The Hump. Trying to make contact with Phil over the very long distance to his summit we found it necessary to stand in a particular spot on the hill otherwise only one-way communication was

possible. Warnings were received of an incoming storm that had already reached Mt Hotham.

Our last summit for the day was Mt Pendergast and again only time for a quick activation. HF would not be great anyway with the storm on the horizon. On this one we made no S2S contacts as everyone else was sheltering from the storm. Driving back to the lodge we did encounter it ourselves and there was some heavy rain and light hail. It had been a busy day with five summits activated. A BBQ for dinner at the lodge had been arranged and there was the traditional debrief.

Monday

Compton and I were up early Monday morning so that we could get out to Mt Hotham VK3/VE-006 and activate it like all the others had done on Saturday evening. We made loads of contacts with those at the lodge and then returned there ourselves. A woodpile outside the lodge needed moving into the

storeroom, so we all mucked in and set up a bucket brigade to shift it.

On the drive home to Sydney, Compton and I activated Mt Munday VK2/ST-053. Andrew and Wade visited Warren VK3BYD in Wangaratta and then at Holbrook visited Bernard VK2IB.

Many thanks to Brian VK3BCM and Kathy for organising and hosting us for the fourth running of this event. It seems to be getting more popular every year and is certainly the biggest SOTA activation on the calendar. It was great to meet so many new people that I've been in contact with via radio over the years. The exchange of ideas was amazing. It was also great to activate so many new summits, fourteen in all. Ron also did well with thirteen summits over the four days. Thanks also to Compton for driving and teaching me more about 4WDing. Andrew also reported that he learned a thing or two about his 4WD and gained some confidence in climbing steep rocky roads.

If you get the chance next year I would highly recommend joining in the Hotham trip.

References

SOTAmaps: <https://www.sotamaps.org/>

VK3HN video: <https://www.youtube.com/watch?v=kVx4TUTV6FM&t=1s>

VK1DA blog: <https://vk1da.blog/>

VK1DA photos: <https://www.flickr.com/photos/exposit/albums/72157678391986068>

VK1MIC video: <http://wadeabout.com/>

VK3AFW blog: <https://vk3afw.wordpress.com/>

VK3JBL report: <http://reflector.sota.org.uk/t/activation-of-mount-torbreck-vk3-vn-001/19451>

Washington Winch: https://en.wikipedia.org/wiki/Washington_Iron_Works_Skidder

Hotham 2019 Shared Photos: <https://photos.app.goo.gl/wc6VKJ9fTGmVUnxV8>



Redcliffe & Districts Radio Club Inc.

REDFEST 2019 13 April

The REDFEST Amateur Radio Hamfest will be held on Saturday 13 April 2019 at 9:00am.

You will find us at St. Michael's College on the Bribie Island Road.

On the Bruce Highway take Exit 152 and take the Bribie Island Road. St Michael's College and Abbey Museum are well sign posted on the left.

RF Solutions will be there. There will be prize raffles on the day.

VENDORS admitted at 7:00 am, \$10 per table. BREAKFAST is served from 8:00 am.

REDFEST opens at 9:00 am; \$5 entrance fee.

We start selling tables from 11 March 2019, so book early!

TABLE BOOKINGS: redfest@redclifferadioclub.org.au

CLUB WEBSITE: www.redclifferadioclub.org.au & we are also on Facebook.

SOTA & Parks

Allen Harvie VK3ARH
e vk3arh@wia.org.au

SOTA Anniversary

The start of February is the anniversary of the commencement of SOTA in Australia. VK3 was first off the start line on 1 February 2012. VK5 was next in October 2012, followed by VK1 in February 2013, with VK2 in September 2013. The other states and territories were added as the large mapping tasks were completed, or at least significant areas of the Associations were mapped to enable a start of the Association.

The VK1 group announced activations for the Friday in the lead up to the Anniversary date. The annual Hotham SOTA Summit had been announced late in 2018 for the weekend following the anniversary date. Several activators were travelling to the Hotham event on the Friday and added to the activations announced by the VK1 crew. As a result, there was plenty of SOTA action on the Friday and more activity over the weekend. An account of the Hotham weekend can be read elsewhere in this issue, thanks to Gerard VK2IO.

VK3 SOTA Conference

Once again the Moorabbin & District Radio Club organised a SOTA Conference in February. The theme for presentations this year was "SOTA and Parks for newbies". Almost inevitably, some topics were touched upon by more than one speaker. Whilst most of the audience were experienced SOTA

and Parks operators, there were several less experienced amateurs present. Everyone learnt something new during the day's presentations.

Glenn VK3YY kicked off proceedings with an "Introduction to SOTA". Peter VK3PF spoke of "Preparing for Portable", covering checklists, basic gear, things to put in your pack and selecting where to go. Conference Chair Ron VK3AFW spoke of "Selecting a Peak to Activate", including an overview of his useful document "35 Easy Day Trip SOTA Activations around Melbourne". In "Mapping for Parks and Peaks", Marc VK3OHM explained some of the features of the kmz files that he has prepared to assist amateurs around Australia – the files are available from the ParksandPeaks.org website. Andrew VK3ARR presented an "Update from the SOTA Management Team". Peter VK3ZPF gave a brief "Introduction to the VKFF program and the VK Portalog tool".

This year was a BYO lunch event, so the crowd split to find something to eat. After lunch, Glenn VK3YY talked about "Batteries for Air Travel", highlighting the benefits and pitfalls of the 18650 style Lithium batteries – his key message was to avoid the cheap units sold on eBay and invest in quality brand name cells. Wayne VK3WAM presented some "SOTA Statistics" focussed on the last year, plus an account of two "high" altitude activations he undertook in

California. Ron VK3AFW finished the presentations, talking about "Which Mode should I use?" After thanking the various presenters, Ron formally closed the conference and discussion continued for some time before the crowd started to dissipate.

It is expected that the various presentation files will eventually be posted to the Files section of the OZSOTA group website.

Parks

The sixth anniversary Activation Weekend for the VK5 National and Conservation Parks Award will take place on the weekend of 23/24 March 2019. Those intending to activate a Park in VK5 on the weekend are asked to notify Paul VK5PAS prior to the event (vk5pas@wia.org.au). For those outside VK5, it will be a good time to hunt some of the parks in VK5.

Summit to Summit Day

A small group of keen SOTA activators regularly organise events with the aim of hopefully making Summit to Summit (S2S) contacts with overseas activators. The next planned event is the afternoon of Saturday 6 April, with amateurs in Europe, Japan, New Zealand and locally already having indicated plans to participate. See the SOTA Alerts page at SOTAwatch.org.uk for more details and be ready for the fun and games in the 0600-0800 UTC time window.

Join your local club

Look under Radio Clubs
at www.wia.org.au

Interact with local amateurs.

Participate on regular **meetings** and **functions**.

Training and further **education** for amateurs, new and experienced.

Tony Hambling VK3XV
e arv@amateurradio.com.au
w www.amateurradio.com.au

ARV Council Election & Annual General Meeting

The 2019 Annual General Meeting of Amateur Radio Victoria is to be held at the rooms, 40G Victory Blvd. Ashburton 3147 on Tuesday evening 28 May 2019 at 8 pm.

All members and interested parties are invited to attend.

Keith Roget Memorial National Park "Grand Slam" Award to Peter VK3TKK

Peter VK3TKK has completed the huge task of achieving two KRMNPA Merit Awards: Activating all 45 VK3 National Parks and Working all 45 VK3 National Parks. This is the KRMNPA Grand Slam!

Peter commenced his VK3 National Parks portable activations in September 2013 and concluded Park # 45 with an activation of the Mitchell River National Park, during a dedicated "Parkpedition" to East Gippsland in January.

The January 2019, KRMNPA "Parkpedition" took Peter to the final six eligible VK3 National Parks: Errinundra NP, Lind NP, Mitchell River NP, Snowy River NP, The Lakes NP and Coopracambra NP.

Peter says "it's been a great journey to get this far, and a lot of fun." Peter now joins the growing list of KRMNPA Grand Slam Award recipients. Well done Peter!

VK3RTV update

The renovation of the new VK3RTV Surrey Hills site is well under way. Phil VK3GMZ reports: "Lots of people with hard hats and the old being replaced by the new". We believe that access to the site will be restored around the end of March, which will enable VK3RTV to get back on the airwaves.

Peter VK3BFG further adds "the output frequency will be 445.5 MHz, as was the case for the week long test period last year. Modulation has since been changed from QAM16 to QPSK, which will provide 7 dB Carrier to Noise (C/N) factor improvement over QAM16. This will give the signal significantly more

Coopracambra NP for the KRMNPA award.



reach than was the case for the test, which ran QAM16.

The initial up link frequency will be 1255 MHz DVB-S, Symbol Rate 3.5 Ms/s, FEC 3/4 as it was for the test. The reason for the reduced Symbol Rate is to improve the power bandwidth of the uplink signals. At 5 Ms/s the bandwidth was about 6.5 MHz, at 3.5 Ms/s the bandwidth is about 4.6 MHz."

Appropriate, rack mounted, cooling systems are currently being constructed and tested to ensure all new VK3RTV gear and systems will be kept operating at peak efficiency.

A full progress report on this exciting and much anticipated project will be provided to members via ARV "e news" and this column as developments occur.

ARV Homebrew Group

The Homebrew Construction Group of Amateur Radio Victoria aims to promote the good fellowship and exchange of ideas between amateurs who are enthusiastic builders of their own equipment. The meetings are generally very informal and commence with a "Show and Tell" session, where projects can be displayed and described. The following discussions usually generate a wealth of ideas for the new comer and experienced constructor alike. The session is followed by a guest speaker, when possible.

Homebrewing encompasses almost every aspect of our

hobby and those who might not necessarily regard themselves as dedicated homebrewers will find something of interest in this group.

Current member projects include:

Paul Taylor VK3HN: Compact transceivers/receivers for SOTA operation.

Joe Gonzales VK3YSP: Satellite tracking automation and FT817 interface

Andrew Kayton VK3KIS: A loop antenna with microcontroller tuning and an interface to an FT897. A GPS locked frequency reference.

Rob Whitmore VK3MQ: A patch antenna for 23 cm. A feed horn on 5.7 GHz for an offset dish. A simple field day CAT controller for the FT817/857/897.

Eric Christer VK3EAC: A PIC based LCR meter. Also a host of simple weekend projects that have been featured in the Homebrew Group newsletters.

Julie Gonzales VK3FOWL: Satellite tracking automation and CAT interface.

2019 meeting dates

2 March, 6 April, 4 May, 1 June, 6 July, 3 August, 7 September, 5 October, 2 November and 7 December.

Meetings are held at ARV 40g Victory Blvd. Ashburton 3147, commencing at 2 pm. All welcome! Contact Rob: vk3mq@

ammateurradio.com.au

Amateur Radio Victoria activations in 2019

HMAS Castlemaine

VK3WI will be activating the Museum Ship, HMAS Castlemaine, (Gem Pier, Williamstown) across ANZAC day, 25 April 2019.

International Lighthouse and Lightship Weekend 2019

VK3WI, will be active from the Williamstown Time Ball Tower once again for the 2019 ILLW Weekend and for the 2019 Remembrance Day Contest.

Both these events are being held on the same weekend in 2019: 17 & 18 August.

KRMNPA activation period 2019

The popular annual Keith Roget Memorial National Parks activation period will take place across four days in 2019: Friday 8 November - Monday 11 November.

This is the ideal method of increasing your VK3 National Parks tally for this prestigious Award.

VK3WI will get the ball rolling with an activation of the Brisbane Ranges National Park on Friday November 8.

All members are encouraged to participate in these outdoor events. Please contact Tony: vk3xv@ammateurradio.com.au for further information.

Silent Key

Ron Churcher VK7RN

We were saddened to hear of the passing of our amateur friend Ron Churcher OAM (ex VK7RN) on 20 January in his 93rd year.

Ron was a well-known identity in the North West Community and described by many as very friendly and gregarious which was indeed very true being involved in many community activities.

For many years, Ron held the Call VK7RN, relinquishing it a couple of years ago when his health started to decline.

He was very active in the North West Branch of WIA just prior to the WIA becoming a National Body for Amateurs and Radio Clubs being formed. Ron was of great assistance to Tony VK7AX in forming

the first Club in the North West "North West Tasmania Amateur Radio Interest Group".

He was a big HF operator and his favourite country was Canada.

Farewell, Ron we will all miss your gregarious and friendly banter.

Vale Ron VK7RN.
(Tony Bedolph VK7AX and Eric Van Der Neut VK7EV)



VK7news

Justin Giles-Clark VK7TW

e vk7tw@wia.org.au

w <https://groups.io/g/vk7arnews>



Photo 1: In Northern VK7 – Peter VK7ZPE (and VK7PD) setting up the 10 GHz gear on Mt Barrow ready for QSOs into VK3 (Photo courtesy of Peter VK7PD).

VHF/UHF Summer Field Day in VK7

Thanks to Peter VK7PD for this report on the VK7 activity during the Field Day.

A founding principle of field days is to spend time operating outdoors, test the range of communications equipment on the higher bands and most importantly have fun; this can involve all classes of licence and unlicensed enthusiasts alike.

Tasmania is well placed for such events; it has plenty of mountains and Bass Strait offers the challenge of distance for interstate contacts. The Strait is frequently blanketed by tropospheric inversion causing ducting that enables propagation over extraordinary distances for the frequencies affected.



Photo 2: In Southern VK7 – Richard VK7ZBX and Murray VK7ZMS setup on Mt Wellington (Photo courtesy of Richard VK7ZBX).

The starting time of 0100 UTC on Saturday saw at least seven stations setup in lofty locations: VK7ZBX and VK7ZMS on Mt Wellington; VK7HH on Mt Lloyd, remotely operated; VK7MO at home on Tolmans Hill; VK7JAM on Mt George; VK7PD with 2nd op, Colin at White Hills and VK7MD near Burnie. A number of home stations in all areas were on hand to provide local contacts as range permitted. Bands on which some were equipped to operate included 6 and 2 m, 70, 23, 9 and 3 cm.

On Saturday voice contacts on FM and SSB were made between the higher altitude southern stations and those in the north on at least some of the above bands. VK7JAM made some contacts to the South, VK7MD, some local and interstate. The NTARC club station VK7TAZ was operated by President VK7ZIR after their January meeting, with contacts on four bands including 23 cm.

On Sunday morning several QSOs were had around the Southern area on bands up to 23 cm. Meanwhile VK7PD and VK7ZPE set up operation on the northern slope of Mt Barrow. Numbers and grid squares were exchanged with VK3s on 6 and 2 m plus 70 cm, 9 cm and 3 cm. VK3ALB was particularly pleased to receive an S9+ report for his 9 cm signal, considering he was only running 800 mW!

VK7 had 23 stations participate in the Field Day and nine submitted logs and activity took place on seven bands from 6 m to 3 cm. Thanks to all stations who participated.

North West News

North West Tas. Radio & TV Group (NWTR&TVG)

<http://www.vk7ax.id.au/atvgroup/>

The Annual General Meeting was held on 2 February with the following club positions filled for 2019:

President: Shirley Hardstaff
VK7HSC

Vice-President: Steven Lloyd VK7LA
Secretary: Georgie Lloyd VK7FGJL
Treasurer: Eric Van Der Neut VK7EV
Executive: Kirsty Williams
VK7FKKK.

Northern News

Bass Strait Crossing with microwaves

The week before the Summer VHF/UHF Field Day saw Hayden VK7HH on Mt George overlooking George Town and the Tamar Heads in Northern VK7. Hayden setup equipment for 432 MHz, 1296 MHz and 2.4 GHz. Peter VK7ZPE and Peter VK7PD also bought along equipment for 3.4 GHz.

The exercise had been planned to coincide with promising conditions of tropospheric propagation according to the Hepburn Charts across to VK3 and several VK3 amateurs setup on hilltops and Mt Buninyong near Ballarat.

Hayden had recently acquired a Bulgarian 2.4 GHz transverter and power amplifier and this was tested. Signals were initially exchanged on 70 cm, 23 cm and 13 cm. VK7PD eventually exchanged signal reports with a very patient VK3PY on 3.4 GHz. The 23 cm Yagi was turned south and an SSB contact was made with VK7MO in Hobart.

In all, five contacts were made on 70 cm, two on 23 cm, two on 13 cm and one on 9 cm on SSB and a couple using digital modes. Thanks to Peter VK7PD for the report.

Radio and Electronics Association of Southern Tasmania Inc.

<http://www.reast.asn.au/>

<https://www.facebook.com/reasttas/>

We congratulate Maurice Hawke VK7FBLR and Jet Holloway VK7FJET who passed their Foundation licence just before Christmas at REAST's last Foundation licence training day for 2018.

Just before Christmas there

was a record number of 13 stations in the greater Hobart area participating in the 23 cm QSO party. Peter VK7PD participated from Launceston making a total of 14 stations on 1296 MHz. In part the activity was driven by Murray VK7ZMS and Justin VK7TW both undertaking SOTA activations on 1296 MHz.

The 23 cm QSO party is every Sunday straight after the broadcast and we look forward to new stations joining in. We start on 1296.150 FM all beaming toward Mt Wellington from 10:00 am and at 10:30 am beam to Launceston on QRA64-C.

The 2019 REAST Committee is:

President: Sean Lincolne VK7FAZE

Vice President: Clayton Reading
VK7ZCR

Secretary: Murray Southwell
VK7ZMS

Treasurer: David Goodrick VK7FABE

Committee Members: Paul Pruss
VK7FPCL, Ben Short VK7BEN.

The Experimenter's Nights have continued to be a hub for experimentation, development, learning, discussion and fun! Some of the highlights from the last two months are: Freshly crafted 1.296 GHz Collinear vertical antenna used by VK7TW for the SOTA activation on Mt Wellington; Rex VK7MO, Richard VK7ZBX, Larry VK7WLH and Jet VK7FJET using the differential GPS heading rig that was put together by David VK3HZ for the recent trip to ZL for the world record setting 10 GHz EME contact. This consists of two units with differential GPS and these units are placed 10 m or so apart and they communicate with each other via the 900 MHz ISM band and provide a bearing from one to the other to within 0.1 of a degree. Mike VK7DMH showed off some very nicely made 2 m and 70 cm turnstile satellite antennas. Ben VK7BEN showed off his new handheld satellite Moxon/Yagi antenna and a great satellite application for iPhone that enables you to point both in

elevation and azimuth through a nifty alignment pointer on the screen.

Steve VK700 described a RaspberryPi and Arduino controlled GPS locking project for the Grandfather Clock he purchased. Alan VK7KAJ and Richard VK7RO were both experimenting with SGC SG239 automatic antenna tuning units. Ron Cullen has built 5.6 GHz clover leaf antennas and now has a jig to accurately solder them together. Ron used these for an audio and video link from his remote controlled aircraft. The DATV studio is coming along with audio and video streams into Open Broadcaster Studio for streaming.

Errata in the Jan-Feb 2019 AR magazine – The author of the Silent Key Notice for Joe Gelston VK7JG was Peter Dowde VK7PD.

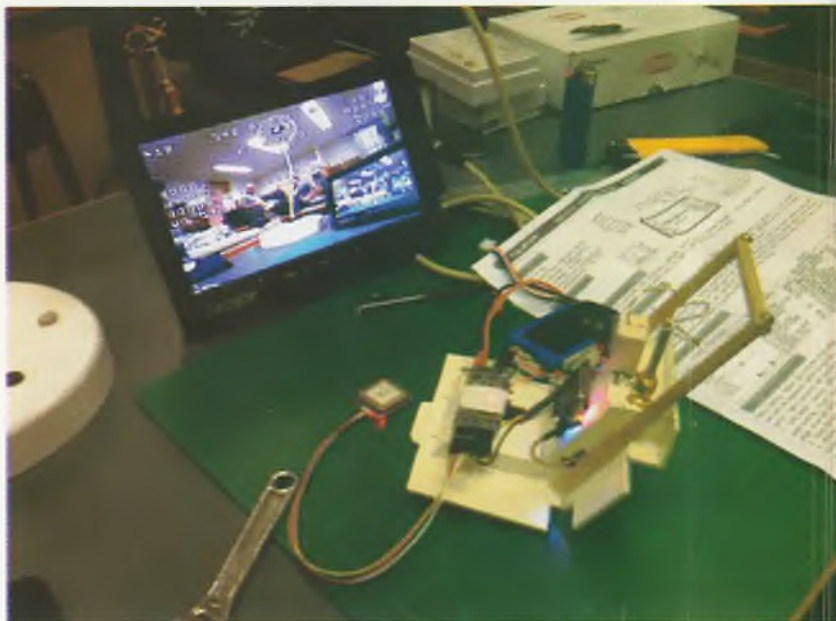

Photo 3 – Ron Cullen 5.6 GHz AV link and On Screen Display unit for radio controlled fixed wing aircraft. (Photo courtesy of Justin VK7TW)



AMSAT-VK

AMSAT Co-ordinator
Paul Paradigm VK2TXT
email: coordinator@amsat-vk.org

Group Moderator
Judy Williams VK2TJU
email: secretary@amsat-vk.org

Website:
www.amsat-vk.org

Group site:
group.amsat-vk.org

About AMSAT-VK

AMSAT-VK is a group of Australian amateur radio operators who share a common interest in building, launching and communicating with each other through non-commercial amateur radio satellites. Many of our members also have an interest in other space based communications, including listening to and communicating with the International Space Station, Earth-Moon-Earth (EME), monitoring weather (WX) satellites and other spacecraft. AMSAT-VK is the primary point of contact for those interested in becoming involved in amateur radio satellite operations. If you are interested in learning more about satellite operations or just wish to become a member of AMSAT-Australia, please see our website.

AMSAT-VK monthly net Australian National Satellite net

The Australian National Satellite Net is held on the second Tuesday of the month (except January) at 8.30 pm eastern, that's either 9.30 or 10.30Z depending on daylight saving. Please note we will be taking check-ins from 8.20pm-ish. Check-in starts 10 minutes prior to the start time. The AMSAT-VK net has been running for many years with the aim of allowing amateur radio operators who are operating or have an interest in working in the satellite mode, to make contact with others in order to share their experiences and to catch up on pertinent news. The format also facilitates other aspects like making 'skeds' and for a general 'off-bird' chat. Operators may join the net via EchoLink by connecting to either

the "AMSAT" or "VK3JED" conferences. Past experience has shown that the VK3JED server offers clearer audio. The net is also available via IRLP reflector numbers 9558. In addition to the EchoLink conference, the net will also be available via RF on the following repeaters and links.

In New South Wales

VK2RBM Blue Mountains repeater on 147.050 MHz

In Queensland

VK4RRC Redcliffe 146.925 MHz -ve offset IRLP node 6404 EchoLink 44666

In South Australia

VK5TRM, Loxton on 147.175 MHz
VK5RSC, Mt Terrible on 439.825 MHz IRLP node 6278,
EchoLink node 399996

In Tasmania

VK7RTV 2 m, Repeater Stowport 146.775 MHz, IRLP 6616

In the Northern Territory

VK8MA, Katherine on 146.750, CTCSS 91.5, IRLP Node 6800

We are keen to have the net carried by other EchoLink or IRLP enabled repeaters and links in order to improve coverage. If you are interested in carrying our net on your system, please contact Paul via email. Frequencies and nodes can change without much notice. Details are put on the AMSAT-VK group site.

Become involved

Amateur satellite operating is one of the most interesting and rewarding modes in our hobby. The birds are relatively easy to access and require very little hardware investment to get started. You can gain access to the FM 'repeaters in the sky' with just a dual band handheld operating on 2 m and 70 cm. These easy-to-use and popular FM satellites will give hams national communications and handheld access into New Zealand at various times through the day and night. Currently only SO-50 is available.

Should you wish to join AMSAT-VK, details are available on the web site or sign-up at our group site as above. Membership is free and you will be made very welcome.

Due dates for publication

Dates for submission can be found at the bottom of the page:

<http://www.wia.org.au/members/armag/contributing/>



VK2news

Tim Mills VK2ZTM
e vk2ztm@wia.org.au

Autumn is here

Well it's now autumn and hopefully generally better weather throughout the country. There is a varied range of activities in VK2 in this period. The annual Central Coast field day conducted by the CCARC was held in late February at the Wyong Race course venue. In March, ARNSW held an antenna building day at the Dural site where Foundation and other licensees were invited to construct a 40 metre dipole and a coax feed line. Westlakes ARC have a car boot sale scheduled on Saturday 30 March at their Teralba club rooms; 9 am start. The Waverley ARS held their fourth Ferry Contest on and around Sydney Harbour on Sunday 10 March.

In April ARNSW has their AGM scheduled for Saturday 13 at the VK2WI Dural site; 11 am start. The annual Urunga Convention, running since the 1940s, is on again over Easter in the village of Urunga on the mid north coast of VK2.

Into May, the annual WIA AGM is in Sydney, hosted by the Waverley ARS in their Centenary year. There will be other AGM activities round Sydney which were not known when these notes were compiled. Some of these will be covered by VK2WI News closer to their event, if advised to VK2WI. This is done by an email to: news@arnsw.org.au

By now we should know the new licensing and assessment arrangements. Regardless of the new arrangements, there is still the role of clubs and groups to provide training to candidates to get them ready for the examinations.

Developments at VK2WI Dural

At the VK2WI Dural site, work continued on the new 40 m mast to replace the ageing shorter [30 m] triangular repeater antenna tower. The concrete slab was poured in December, a mere 100 tonnes. In January the three section concrete pole was delivered, assembled and erected. It is located in the space between the original VK2WI brick building and the Centenary Building. The next stage of the work is for the mounting of the three bays of brackets and the antennas for 6 and 2 m and 70 and 23 cm, along with the hard line coax feeders. While this upgrade was undertaken, it provided an opportunity to install underground coax cabling to feed the various HF antennas. Once the mast is commissioned, the old tower will be demolished. In February the disturbed earthworks between the two buildings was landscaped and grassed.

Most of us are aware of the poor propagation on HF at the moment. This is most noticeable with the VK2WI callbacks where no two transmissions are ever the same. To help overcome these coverage gaps VK2WI has been trialling an internet streaming in real time. Go to arnsw.org.au/audio. You can also listen back to recent news bulletins or to a few of the talks and presentations. One that is available is the December 2018 talk by Dick Smith VK2DIK. For some time the evening VK2WI News has included the segments produced by Onno VK6FLAB – on: What use is an F

Call – of which he produces one a week.

The increasing interest in the newer digital modes has required some adjustments to the HF Band Plans. On 80 m, the world-wide segment suggestion for digital operation extends up to 3600 kHz. This now impacts on various club and general nets, including the VK2WI news bulletin which is celebrating its half century on 3595 kHz. The equipment on this and most of the VK2WI broadcast system is crystal locked, of which a replacement these days is both rare and expensive. A decision is being considered to move, but to where? To many users any frequency is 'theirs'. Some thought is being given to a move to 3695 kHz. It could keep the Morse transmission on 3699 company. The Morse and most lower frequency beacons are off line in news bulletin periods to enable reception of callbacks against the usually poor propagation. The 10 m beacon VK2RSY on 28.262 MHz has returned to its former vertical antenna.

The next Trash & Treasure at ARNSW will be on the usual last Sunday of the odd numbered month – 31 March. Car boot sellers will be in a new spot to avoid the new landscaping. This time it's mainly a collection of mantle AM radios. Mark VK2XOF looks after the ARNSW T&T but there will be slowing of this activity for a short while. Any inquiries should be directed to office@arnsw.org.au rather than the usual 'disposals'.

Around the clubs

Hunter Radio Group resumed their Monday evening bulletin in February using their 2 m and 70 cm repeaters. They have a summary of VK1WIA, VK2WI and local news. Port Stephens ARC have commissioned a 70 cm repeater at GanGan on 439.700 MHz.

The Illawarra ARS have a net on Saturday morning at 9:30 am using their various 2 m repeaters plus EchoLink. Oxley Region ARC had a successful antenna shoot out in February; their April Friday evening meeting will be a week later, on 26 due to the Easter period. The

June long weekend Oxley Region Field Day will be on again round Port Macquarie on the Saturday and Sunday; the venue is still being determined. The Field day dinner on Saturday evening is again at the Golf Club. Port Macquarie is a popular holiday destination so book accommodation early, if required.

For some it has been AGM time and in February the Summerland ARC at Lismore held theirs with the committee comprising Duncan VK2DLR as President and Roger VK2LRB as Vice President.

Secretary is Paul VK2PMG and Treasurer Kris VK2KWW. The

committee has Brian VK2FMAN, Dave VK2ZDR and Rob VK2ELH. Their 6 m repeater, located at the club rooms, is off air with an antenna problem. Also in February the Chifley ARC in Western Sydney held their AGM with Len VK2CBL holding down the role of President, Treasurer and Public Officer. Veselko VK2VES is Vice President and Ray VK2ME as Secretary. The committee members are Graham VK2GJL, Ward VK2HBZ and Ray VK2ELO. Chifley ARC meets every Saturday afternoon.

73

Tim VK2ZTM

Silent Key

Trevor Bruce Hoodless VK2RU (ex-VK2ACZ)

12/05/32 – 30/04/18

Trevor was born in Wagga Wagga and was the eldest son of Henry and Emily Hoodless. He grew up on the family property "Clansford" and attended the Glen School in his primary years before going to boarding school in Canberra, then finishing his schooling in Wagga Wagga.

Trevor married Valerie Foole on 01/10/55 and then returned to Tumbarumba to build a home on the family property "Blue Hills". They had one daughter, Christene.

In addition to running the property with cattle and sheep, Trevor was able to further pursue his long held interest in radios and new technology and began studying for the Amateur Operators Certificate of Proficiency which he obtained on 16/09/60.

Trevor became well known in the local area as the man to repair radios and, in later years, televisions. As a result of this he



began more formal studies to become a qualified Radio Technician. He worked extensively with Tumbarumba Shire Council maintaining all of their radio networks. Trevor had a significant role in the installation of television equipment for the ABC and Commercial Stations on Ike's Mount and he was instrumental in setting up the community radio station, Radio Upper Murray.

Trevor supported the local community in

many ways including maintaining radios and speakers used for rodeos, pony club and sporting events at the Tumbarumba Show Ground. He was the local Bush Fire Brigade Captain and then a Group Captain. On Australia Day 2016, Trevor received a Special Achievement Award from Tumbarumba Shire Council for his contribution to the local community.

In more recent years Trevor was unable to continue his work due to his age and ill health but he continued to use and maintain his extensive collection of radios in his shack.

Trevor passed away twelve days before his 86th birthday after a short illness.

Trevor will be remembered for helping everyone. He touched a lot of lives.

Christene Hoodless.

Submitted by John VK4QA.

MEMNET

The Wireless Institute of Australia

Register

Login

Have you registered for MEMNET yet?

Go to www.wia.org.au click on 'For Members', then click on 'Log into MEMNET', and register... it's very simple.

If you have already registered for MEMNET but have not received a confirmation Email we may not have your correct email address.

Please email memnet@wia.org.au with your email address, name and membership number.

If you are changing your email address, please *remember to update* your information in **MEMNET**.



ALARA

Jenny Wardrop VK3WQ

SK Raija Ulwin SM0HNV

It is with great sadness that we report the passing of Raija Ulwin SM0HNV. Raija joined ALARA in 1989 and was sponsored by Bev VK6DE.

Many members who attended ALARAmeeets from 1996 onwards would have met Raija, as she attended the ALARAmeeets in Perth in 1996, which Bev organised, Brisbane in 1999, Murray Bridge in 2002 and Mildura in 2005.

She was one of the founding members of SYLRA, the Scandinavian Young Ladies Radio Association. SYLRA (pronounced Silra) was formed by YLs from all the Scandinavian countries because they felt that there were too few ladies to form separate groups in their own country.

We believe that she may also have been instrumental in starting the YL International Meets, which saw YLs travel to places in many parts of the world for the Meets. In 2011 one was held in Glenelg, South Australia, organised by Tina VK5TMC and her team of VK5YLs.

Raija was a quiet person who hated having her photo taken but had a great sense of humour when you got to know her. She was also very hospitable, as many YLs found when they went to visit her in Sweden.



Photo 1: Raija SM0HNV

Marilyn VK5DMS remembers:

"Many memories of Raija at several meets and meeting her in Stockholm in 2007 and being taken by train to her apartment for a meal - a wonderful evening. Vale Raija."

Our President, Shirley VK5YL, shares this memo:

"Fond memories of a wonderful lady. I met Raija at the Mildura Meet (2004) and remember well the 'hurry up' when the storm was arriving along the river. I motioned to Raija for her to go first and she fair ran up those stairs. She told me afterwards that she did lots of walking/running etc in Sweden and the stairs were so easy for her. We then shared

Photo 2: Charter boat disappearing in rain squall.



some bubbly at the winery".

Vale Raija SM0HNV.

Lyn Battle VK4SWE's report

Lyn VK4SWE has been living up to her surname on this year's annual boating holiday, doing 'battle' with the elements; dodging high seas and cyclones!

Delayed for a week in Townsville due to strong winds, then dragging the anchor during a squall in the Whitsundays (along with all the other boats in the bay, including a super-yacht), she and OM Tex eventually bolted back north, during a gap in the weather, to try to get home to Sweers Island before Cyclone Owen struck. Fortunately,

the cyclone tracked well north of the island, with only 30 knots of wind and 22 mm of rain.

Lyn had dismantled her hex beam again, as she did for Cyclone Nora earlier last year and although it can be a very fiddly process re-threading the big spider-web style antenna, it does help to ensure sound sleep at night knowing that it cannot be damaged should the dreaded "Category 4-5" destructive winds occur. Lyn also points out that these decisions need to be made



Photo 3: VK4SWE Re-assembling Hex Beam.

well in advance of the cyclone actually making landfall, so that hams are not out trying to lower towers and masts in adverse conditions, risking injury or structural damage.

During her few weeks in the Whitsunday area, she was able to operate maritime mobile, working stations as far afield as the Cook Islands, Fiji, and getting a SWL report from Hawaii. Most contacts were on 20 m SSB but she also made several contacts on CW with ham buddy VK4CC, using a tiny McMurdo 'spy key' given to her by fellow ANZA member Ian VK3IDM. The compact size and sealed construction of this key makes it ideal for portable ops.

Unfortunately, this year Lyn did not get ashore to activate any islands for the IOTA Islands On The Air award scheme, hopefully next year but she said "I did put the antenna up on the boat a few times and join in the ANZA Net. It is funny when the boat swings on the anchor rope, my signal reports change from 59 to 55!"

Meanwhile, Lyndall VK4ZM has also been busy and here is a summary of coming events for the Townsville Amateur Radio Club in 2019...

The calendar for 2019 is already starting to fill up for TARCadians with multiple comms support for the Townsville City Auto-sports Club, The Magnetic Island to Townsville swim and the Whitsunday Endurance riders who are also holding the QERA State Championships in September. Social events include the Oz Day weekend at Bluewater and the Cardwell Gathering over the long weekends in January and October as well as Nighthawk and JOTA.

If anyone is in the area and would like to find out more about these events or even participate just look up The TARC (inc) web page for information and contact details.

Here's wishing everyone a very Happy and Prosperous 2019 with lots of contacts and DXing.

Photo 4: Lyndall and the Buoys.



We hope that any amateurs living in Townsville and other parts of far North Queensland, were not badly affected by the flooding. Our thoughts are with you all.

Lyndall VK4ZM

SYLRA Meeting

We have received some information from Ingrid LA8FOA and Unni LA6RHA about the SYLRA meeting to be held in September this year.

The meeting will take place in the vicinity of Oslo from **5 September until 8 September, 2019.**

All information will be on the SYLRA web page and they will inform you when the information is available and the registration is open.

The **registration form** will also be available on the web page.

(Please see ALARA Newsletter 168 for more information.)

Please, send all your enquiries about this meeting to lullen55@gmail.com

We hope to see as many of you as possible at the SYLRA meeting.

Best regards from Ingrid LA8FOA and Unni LA6RHA.

VK3 ALARA Lunch dates 2019

March 23 arranged by Heidi VK3FHID in Bendigo.

May 25 arranged by Margaret VK3FMAB.

July 27 arranged by Robyn VK3WX ALARA Birthday.

September 28 arranged by Kaye VK3FKDW at Braybrook.

November 30 arranged by Jenny VK3WQ Xmas at Sunbury.

If you are visiting from interstate at these times, please get in touch with Jean VK3VIP (VK3 State Rep) or any of the other VK3 Committee Members. We would love to see you. ♪

VK5 ALARA lunches are held on the second Friday of each month. (Contact Jean VK5TSX, VK5 State Rep).



Photo 5: VK3 ALARA Ladies Lunch. Back Row Judy VK3FJAG, 2nd row L to R Jean VK3VIP, Cristina VK3FCRS, Pat VK3OZ, Margaret VK3FMAB and Diane VK3FDMP. Front row Kaye VK3FKDW, Elsie and Carla.

If other States hold regular lunches please let me know and I will be happy to publish them here.

Speaking of which...

The VK3 ALARA ladies held their

lunch a week early, on Saturday 19 January, a week earlier than usual, because of the Australia Day long weekend holiday.

The lunch was held at the RSL in Glen Waverley. It was a lovely sunny

day and not too hot.

Eight ALARA members and their OM'S were present, with lots to talk about.

Silent Key

Bob Searle VK3CSR

It was with sorrow that the Geelong Amateur Radio Club was informed of the passing of Bob Searle VK3CSR.

Bob was a stalwart of the club and occupied a number of Committee positions including Treasurer for a number of years.

He is especially remembered for the part he played in the construction of the VK3RGL Mt Anakie Amateur Radio Hut, being primarily responsible for the brick-laying which was undertaken with such professionalism that the "Shack" has weathered the worst conditions imaginable on the mountain.



Bob's principal mode of communications was on the HF bands on which he participated in many national and international radio competitions and exchanged contacts with other Amateurs across the Globe. The GARC has resolved to name the Mt Anakie repeater site the Bob Searle VK3CSR Hut

We pass on our sincere condolences to Glenda and their extended family.

Barry Aply VK3SY.

6 metre optimised 4-element Yagi

Jack Albers VK2TUT



Photo 1: Detail showing the join in the boom.

Some insight into what I wanted to achieve:

At onset, I wanted to create a Yagi that didn't have the inherent problems normally associated with element failure; that is the elements breaking or damaging the Boom.

The Yagi parts

Boom
Elements
Mounting hardware
Impedance match

The Boom

The Boom was

made from 75 x 50 mm rectangular aluminium. I used 2 x 3 metre lengths bought from Bunnings. I



Photo 2: The boom with element mounting plates mounted.

Specifications

Gain	10.35 dBi (8.2 dBd)
Front to Back Ratio	20 - 25 dB
Maximum Power Input	1 kW PEP
VSWR at resonance	Less than 1.5:1
Impedance	50 ohm
Frequency Range	50 - 54 MHz
Boom length	3.8 metres

needed 2 lengths as 1 was too short. I also bought a 1 metre length of 75 x 75 mm aluminium angle to extend the boom. I joined the 2 lengths of 75 x 50 mm boom by using the angle. The angle was cut to two lengths of 330 mm. I then cut 1 side of the angle to 50 mm to suit the boom. I put 1 piece under and 1 piece over the boom to encircle it. This was then pop riveted to the boom with a good overlap on both pieces (Photo 1).

Element Mounting Plates

I purchased three nylon cutting

boards that were 370 mm x 230 mm by 8 mm thick. The size of the boards doesn't matter but the thickness does; they must be 8 mm or thicker. These were obtained from a discount shop and were Cuisine Essentials boards. I cut three pieces at 150 mm square out of two boards and cut the handle off the other board



Photo 3: The elements made up ready to mount.

for the driven element support. I drew pencil lines from corner to corner on the three square boards to aid in placement. I drew another pencil line down the centre of the boom to aid in placement. I drew a pencil line down the larger board down the middle in each direction. These boards were then clamped to the boom and drilled and bolted at the right distances.

Spacing the Boards

Bolt the reflector board first at one end of the boom. The large board for the driven element was mounted next at 1334 mm between centres. I used the lines on the boards to accomplish this as one line sat on the line on the boom and the other was used for spacing.



Photo 4: The mast to boom bracket.

The first director board was next and set at 1019 mm between driven board and itself. The second director board was the last to be mounted at 1149 mm from the first director, as before. I left my boom longer than needed and now trimmed the boom length. Now set the boom aside.

Elements

I used 15 mm aluminium tubing and 12 mm aluminium tubing from Bunnings. I cut the 15 mm into 1 metre lengths and the 12 mm into 1200 mm lengths. You will need 4 x 15 mm lengths and 8 x 12 mm lengths.

Now cut a slot into the ends of the 15 mm lengths so that they can clamp down. Insert the 12 mm into the 15 mm and using stainless hose clamps clamp these at the following lengths:

- For 50 - 51 MHz set reflector to 1499 mm, driven to 1441 mm the D1 to 1397 mm and D2 to 1372 mm.
- For 50.5



Photo 5: Detail of an element to boom mounting.

- 53 MHz set reflector to 1441 mm, driven to 1384 mm, D1 1343 mm and D2 to 1318 mm.
- For 51 - 54 MHz set reflector to 1410 mm, Driven to 1351 mm,

boom so this was placed at the balance point of the boom. I then bolted a square plate 300 x 300 mm with two bolts through the boom and two bolts through the angle, and I then fitted two U bolts to the plate to suit the mast.

I used two U bolts to ensure that the Yagi was unable to move from where I bolted it.

Element mounting

I mounted my elements using 15 mm full saddles: these were bought from eBay. You can use mild steel galvanised or nylon or stainless as I



Photo 6: Detail of the mounting and feeding of the driven element.

D1 to 1311 mm and D2 to 1292 mm.

Set the elements to the most used section of the band and a tuner will take care of the rest.

Set the elements aside.

Mounting the boom

To mount the boom on a mast I firstly bolted a piece of 330 mm long 75 mm aluminium angle to the bottom of the



Photo 7: The Yagi mounted at my QTH.

did but they are very expensive and hard to obtain. If you are worried about corrosion between the elements and saddles put a turn of insulation tape around the element where the saddle sits.

I would suggest that you now mount your boom on a clothes hoist or similar. Now mark the middle of the elements. The elements can now be placed on their boards keeping the mark on the centre line on the boom.

Place a saddle over the element near the edge of the board; bolt them down using suitable stainless bolts with nuts and spring washers after drilling the boards. Note: Use a square to ensure the elements are square to the boom.

The bolts needed for this antenna were obtained from a local engineering shop. I haven't specified bolt sizes or lengths as

they are dependent on materials used.

Note

The driven element needs to be mounted so there is a gap between the middle and between the elements.

I tried different spacing for best match and ease of tuning and found a 40 mm (1½ inch) gap to be the best option.

Once you have mounted the elements you need to make the impedance match – a piece of RG213 coax 2060 mm (81 inches) long. Now bare the ends of the RG213 enough to allow lugs to be fitted and the centre conductor of each end to be attached to the inner end of each driven element and the combined braid to be secured back to the boom – see Photo 6.

Your Coax feedline connects

to the other side of the driven elements as shown in Photo 6.

The impedance match is looped back onto the boom towards the reflector and secured with tape or cable ties. I used self-amalgamating tape.

I used my analyser to tune the antenna when completed. This is now completed by moving the outer element portions in and out slightly. You can also try to vary the gap between the driven elements: I settled on 40 mm (1½ inch).

As you can see the 6 metre Yagi at the bottom of the closest mast is straighter and stronger than the other two Yagis. The same principle can be used for any Yagi, as I believe that mounting the elements with two saddles out wide is much stronger than commercial antennas.

Jack VK2TUT



VHF/UHF - An Expanding World

Dr Kevin Johnston VK4UH

Meteor Scatter Report

This edition: "New VHF Logger" on its way. Activity report for January and February, Forthcoming events and Meteor Showers

And first some good news to start this month's report. As most regular VHF operators were aware the VHF-Logger, a service most of us had come to rely upon, is reaching end of life. After many revisions and updates, over many years, the end of the tunnel is in sight and lights were off. The imminent loss of this invaluable service has prompted a group response from the VK-ZL community. I am delighted to advise that a completely new and fully modelled application, to take the place of the VHF-Logger, has been created by a group of writers and is now at an advanced stage of testing before general release. More information will follow and it is hoped that all of the historical archived data and information stored within the old logger will be available in due course within the new application.

There has now been an almost seamless and almost painless transition in operating modes, for Meteor Scatter operation, with the introduction of the V.2 MSK144 mode available in both of the software platforms WSJT-X and MSHV. The revised and upgraded versions of MSK144 and FT8 in V 2.0 involved the adoption of a 77-bit information payload and were introduced worldwide at the end of 2018. Since this was incompatible with the existing 75-bit protocols, which will not be decoded by the new versions of the software, it was essential that everyone moved together. In VK and ZL this transition just happened and all stations are

now benefitting from the improved performance of these new versions. So, the current "standard" meteor scatter operating mode is MSK144 v 2.0 using 15 second transmission periods. Any stations yet to try or upgrade will find the free software and operating Information available from either the WSJT-X or MSHV websites, the URLs for which are to be found at the end of this report. Some additional operating information and advice is also covered below.

The summer period of the year, in each hemisphere, is typically associated with enhanced Meteor Scatter propagation. The "tilt" of the earth's axis towards the sun, during the summer months, enhances the ablation of meteors entering the earth's upper atmosphere and maximises the number of usable returns (radio pings and burns). January and February are generally considered the best time of the year here in VK. This annual peak is superimposed on the daily cycle of enhanced propagation occurring immediately before and after dawn each day. Added to this pattern are the periods of enhanced meteor numbers related to meteor showers that occur on very predictable dates each year. That being said meteor returns do occur at all hours of the day and night and through all seasons of the year and the background source of the meteors is an entirely random process. Even during the best times of the year, the summer early morning periods, sometimes propagation is very poor and few contacts are to be made. Conversely, sometimes propagation is amazing even without a meteor shower going on. One such event occurred on Sunday 2 February

2018 where enhanced meteor scatter propagation literally lit up the waterfalls for operators across the eastern and southern states. On both 144 MHz and 50 MHz strong and prolonged burns lasting from many seconds to several minutes at a time were observed. There are reports from around the call-areas and some video clips available for viewing on the "Meteor Scatter VK-ZL" Facebook page showing these events. The video clips were captured very roughly by mobile phone camera at the time but are well worth a look if you have never actually seen a "really good burn". With 15 second operating periods, single meteors were producing ionised trails strong enough and prolonged enough to reflect signals continually across several transmitting periods. It was possible to complete contacts during a single burn.

It has been gratifying to see a number of new, and some returned, callsign appearing on the screen during the weekend activity sessions. One of the major hopes in writing a column like this, or giving talks about meteor Scatter propagation, is to encourage others to give it a try for themselves. As with many new things, there is fairly daunting learning curve to be negotiated. In previous years I have written light-hearted guides to "Surviving your first Meteor Scatter QSO" and I intend to revise such a guide for the next edition encompassing the use of MSK144 in place of the now heirloom FSK441 mode.

The next major showers on the calendar will be the Lyrids Shower peaking around 23 April 2019. The Lyrids is a Class 1 - Major Meteor

Shower, ZHR predicted up to 18 meteors/hour due to the orbit of the earth around the sun crossing the previous path of Comet Thatcher (C/1861 G1.).

Activity sessions

The weekend activity sessions run on Saturday and Sunday mornings from before dawn (around 20:00 UTC or earlier) until propagation fails.

Frequencies: 2 m 144.230 MHz, 6 m 50.230 MHz Current Preferred Mode MSK144 Version 2.0 15 second periods.

Southerly stations running 1st period beaming North, Northerly stations running 2nd period beaming South.

Register with VK-ZL Meteor Scatter Facebook Page (Closed group of AR operators) for up to the minute advice and information.

Contributions for this column are as always welcome. Please e-mail to vk4uh@wia.or.au

Kevin Johnston VK4UH
Brisbane

Software upgrades

Version 2.0 software upgrades can be downloaded from:

<https://physics.princeton.edu/pulsar/k1jt/wsjsx.html>
lz2hv.org/mshv

or google **WSJTx** or **MSHV** for the websites.

GippsTech 2019

The annual GippsTech conference is coming. With a reputation as a premier amateur radio technical conference, GippsTech focusses primarily on techniques applicable in the VHF, UHF and microwave bands, especially for weak-signal contacts.

GippsTech 2019 will be happening on the weekend of 13 and 14 July, at Federation University Australia Gippsland Campus in Churchill, Victoria, about 170 km east of Melbourne.



Call for papers

Anyone wishing to share information with others is invited to submit a title and brief summary of your planned presentation to the Conference Chair Peter VK3PF as soon as possible. Please be sure to indicate your expected length of presentation: it could be a short 10 minute item through to a detailed presentation of up to an hour.

We look forward to seeing you at GippsTech in July.

Further details will be available from the
Eastern Zone Amateur Radio Club website: <http://www.vk3bez.org/>



VK3news Geelong Amateur Radio Club

Tony Collis VK3JGC

“The Rise of Machine Intelligence and why they want to know all about you.”

Peter Judd, the Newsroom Operations Manager for Rupert Murdoch’s News Corporation Australia, gave the GARC a VERY enlightening presentation on the above topic and where it currently is and where it is going.

Amongst the some of the many current AI implementations discussed were:

- The newest Amazon Store in the USA which has no staff, just a number of cameras that monitor customers selecting items from shelves and then billing them on the way out.
- Driverless cars which are pre-programmed to make life or death decisions in the event of a potential road accident.
- Dynamic pricing where the information collected on the ‘prospective purchaser’ will modify the declared price at the point of purchase.
- Voice simulation where a person’s voice accent and other pronunciation characteristics and can be replicated to say anything the programmer wants.

In spite of the current AI developments above, Peter’s estimation is that the technology is analogous to the development of a 6-year old person, which leaves a pretty scary prospect for where it will go when it reaches adulthood!



Photo 1: President Lee VK3PK with Peter Judd.

The presentation was very interactive with the club members throughout the session and the GARC was very appreciative of Peter taking time out from his busy schedule to give it.

Peter is working across more than 100 newspapers in Australia and was the former editor of the Geelong Advertiser for 13 years and



Photo 2: Tony Devine GM5BAO with Lee VK3PK.

Digital Editor of the Daily Telegraph in Sydney. Peter also edited The Echo, the Geelong News and the Ballarat Courier. Currently, he is leading a data journalism initiative across News Corporation, finding and telling news stories using programmatic technologies, such as Python. He has been coding since he went to Deakin University in 1978.

GARC in the Park

The annual GARC in the Park took place at the rotunda in Eastern Gardens Geelong and was well attended by GARC members and their partners.

The usual BBQ offerings of sausages and burgers, this time cooked by Calvin VK3ZPK, to allow President Lee to mingle more with the guests. Amongst those present was Tony Devine GM5BAO, on holiday in VK land, a friend of Nick VK3TY.



Photo 3: Calvin VK3ZPK, Head Cook.

Participate

Redcliffe & Districts Radio Club Inc - REDFEST

13 April 2019

Silent Key

David Hubert Johns VK7DJ

It is with sadness that we inform you of the passing of David Johns VK7DJ on the seventh of January 2019 aged 89.

David was born on 29 August 1929 and was well known to many as the gentleman engineer.

After Graduating from the University of Tasmania with a Bachelor of Science, David wintered at Macquarie Island in 1954 and Mawson in 1957.

He always attended the ANARE Club Tasmanian Mid-Winter dinner and in 2018 was the last person to stand in the count back of "Calling the Years".

It was while he was at Macquarie Island he obtained his first callsign - VK1DJ, as VK1 was allocated to stations from the Australian Antarctic Territory. On 1 June 1956, VK1 was reallocated to the ACT, and VK0 replaced VK1 in the Australian Antarctic Territory. David used VK1DJ for his Mawson Visit in 1957. His trip to Mawson left Australia on 22 November 1956, when he flew to New Zealand and travelled down on the USC Glacier. This was a momentous day for Broadcasting,



as it was the advent of TV in Australia with the broadcasting of the Melbourne Olympic Games which started on that day. 1957 was also the International Geophysical Year, and David was awarded the Polar Medal for his time, as well as having Mt Johns named after him.

David worked for many years in the PMG and Telecom and struck up many friendships through this workplace. He won a scholarship

with the Confederation of British Industry to study broadband radio bearers with the General Electric Company and the British Post Office. This took him to Coventry in England for 12 months in 1966 - 67. While he was in England he had a British Amateur Radio Callsign G5VKS. David retired in 1989 and often said he did not know how he had time to work.

David joined the CMF (today's Army Reserve), and spent time in 1969 in Vietnam during the war with the Royal Australian Engineers. He rose to the Rank of Lt Colonel, and was Colonel Commandant of the Engineers Corps in Tasmania on his retirement from the Army in 1979. David has had a long association with the Anglesea Barracks Military Museum. David was regularly seen marching in ANZAC day parades under the Royal Australian Engineers banner.

Vale David.

(Andrew Johns VK7AJ - David's Son)



Moorabbin and District Radio Club.

PO Box 58 Highett 3190

VK3APC

*** Saturday 11 May, 2019 ***

HAMFEST 2019

Location – Southern Community Centre - Rupert Drive, Mulgrave
Melways Reference 80 F4 (Enter via Huxley Ave off Police Rd.)

* GREAT VENUE * PLENTY OF SPACE

* Major and minor door prizes

The Moorabbin & District Radio Club have much pleasure in inviting you to participate in VK3's biggest annual hamfest

Snacks and hot food will be available – FREE TEA & COFFEE!

Talk in via 439.900 MHz 70 cm VK3RSE

PRIZE DRAWS: Every entry ticket goes into the draw & additional tickets on sale

SALES: NEW - Importers and suppliers of amateur equipment & accessories.

SALES: USED - Preloved ham gear & accessories, PC's & bits & pieces

All inside and undercover. Demonstrations of Radio equipment and accessories.

ENTRY ONLY \$7.00

(Doors Open 10 am – entry tickets on sale prior)

(includes free draw in the major door prize...)

Tables available at \$20 each, (1.8m long)

includes lunch voucher.

Please contact:

Lee Moyle VK3GK. Tel: BH/AH (03) 9705 1051

Email: vk3gk@aanet.com.au

Graeme Lewis VK3GL. Tel AH: (03) 56295994 or

Mobile 0418 171 601

Email: vk3gl@bigpond.com

Webpage - www.mdrcl.org.au

Ham College

Ham College has returned invigorated from its summer recess. The new combined regulations, standard and advanced course is underway under the tutelage of the VK6 News editor Steve VK6SJ! The first Foundation course of the year and our regular assessment day have taken place although we still welcome input from the new assessment organisation as the College is sure that many changes, hopefully all positive for the future of amateur radio, will be revealed.

The College is committed to provide educational and training programmes and assessments if possible, depending on the new regulations. All of the College's educational material for Foundation licences is available free, on line in the spirit that is amateur radio, on the College website. This web site contains large amounts of information and has a portal to allow anyone interested in amateur radio to make contact and also express an interest in attending courses or taking assessments.

The College attempts to be responsive as soon as is practically possible and welcomes enquires. Go to Hamcollege.com.au and express an interest is all that is required. Go on, why don't you enrol to become a licenced amateur or to improve your knowledge, skills and responsibilities or perhaps even more importantly to engage with the club as a volunteer and get more people into and advance in our hobby!"

73 de Andrew VK6AS
enrolments officer on behalf of Kathi VK6KTS, President.

Bunbury Radio Club

The Club's March meeting will be held on Saturday 9 March, beginning at 1400 hrs, at 21 Halsey



Photo 1: The 160 m vertical antenna at NCRG.

Street, South Bunbury. At this meeting we discussed the forward program of technical talks. The following were agreed upon:

- Feb Beginner's guide to ASFB
- Mar Quiz
- Apr IP audio
- May How to QSL
- Jun Kit building
- Jul AGM
- Aug Learning Morse
- Sep Linux and Raspberry Pi

Richard VK6VRO continues to make improvements to the club broom with the installation of new benches and audio-visual equipment.

Welcome to our new member Simon Hall, who is very keen to sit

for his Foundation licence. However, just as arrangements were being made, current changes to the assessment process has thrown a spanner in the works. We also have a couple of members who were girding their loins to upgrade existing licences who will also have to wait a bit.

Work on the upgraded VK6RBY repeater set-up continues apace. Thanks to Danny's VK6FDRW generosity the air conditioner has been installed. Robert VK6TJ is investigating the pros and cons of a Raspberry Pi based IRLP mode for the repeater.

Any South West based amateur

(or anyone interested in radio or electronics) is more than welcome to join and participate in our activities. Because so many of our members come from near and far, we are evolving into a semi "virtual" club. Consequently, regular attendance at meetings is not a requisite for membership. The annual fee is only \$50.00. Those wishing to join can contact the Club via our Secretary, Richard Ayre on 0439 940 253, or vk6brc@wia.org.au. Further details can be found on our website at <http://www.bunburyradioclub.com>.

73 Norman VK6GOM

West Australian Repeater Group (WARG)

It's great to see WARG providing information for the VK6 club news section once again!

Changes at some of our sites, along with a few equipment and antenna issues at others mean WARG has many opportunities for site work and improvements in the year ahead. Due to the hard work and initiative of several members, some of these are already being resolved – thanks are due to Bon VK6ZGN and Matt VK6ML for work on the VK6RDM Fusion and DMR repeaters; and to Antony VK6TG and Rob VK6LD for their efforts in getting the 10 m repeater VK6RHF back on line, particularly VK6TG for rebuilding the 10 m RX and UHF linking system.

Work is also scheduled for VK6RMW at Mt William near Yarloop in the south west. This repeater survived the devastating bushfires of 2016; however much other site infrastructure was significantly damaged, including the mast which hosted VK6RMW's antennas. The owners of this site chose not to rebuild their facilities or renew the mast and WARG was required to vacate it in mid-2018 prior to its demolition. Fortunately we have been able to make favourable arrangements to move VK6RMW to one of the other masts on site, with work planned to establish new

antennas and move the equipment to a better housing. Thanks are due to Mac VK6MM for his ongoing work in keeping VK6RMW on air and solving many problems resulting from the fire and site move.

At Mt Saddleback, 100 km south-east of Perth, we have been advised of changes to the mains electricity distribution on this site which will require conversion of the VK6RMS repeater to operate from a solar supply.

Antenna and mast maintenance work is also needed at Perth area repeaters VK6RAP, VK6RLM and at VK6RCT Cataby, 150 km north of Perth.

In addition to site working bees, WARG continues to meet monthly on the first Monday of each month or the second Monday if the first is a public holiday. Meetings are scheduled for 11 March, 1 April, 6 May (our AGM) and 10 June. Meetings take place at the 1st Pelican Point Sea Scouts facility at 12 Australia II Drive in Crawley. Visitors and prospective members are welcome; doors usually open about 19:00 for a 19:30 start; tea, coffee and refreshments are available and there's usually time for socialising before and after the meeting. February's meeting featured a demonstration on testing



Photo 2: "G tower" at NCRG.



Photo 3: The NCRG EME antenna radome.

and tuning 2 m cavity diplexer filters and it is hoped to have a wider range of technical presentations at future meetings.

The Sunday morning Technical and General nets also continue from 10:30 local time on 2 m repeater VK6RLM with remote connection possible via AIISTAR or EchoLink.

More details are on WARG's web site, which is www.warg.org.au; and also features an updated repeater status page, thanks to the work of Carsten VK6PCB. Emails can be sent to Secretary@warg.org.au

73, and Best Regards,
Anthony VK6AXB

Hills Amateur Radio Group (HARG)

The members have been busy at the club with Harry VK6YBZ marshalling the troops into action to raise some funds for some new equipment. Harry was fantastic in arranging a sausage sizzle at the local Spud Shed just down the road in Kelmescott. This coincided with the activation of the special call signs VI6PEACE and VI6LWF so Dan VK6NAD did a fantastic job of organizing the portable station to be on show to the public. We had Onno VK6FLAB running F-Troop, Reg VK6BQQ running the Friday night Tech Net (Ontario time) as well as

other club members operating the station. To overcome the scourge of HF noise in the city, Rob VK6LD let us use his remote rig station. The media turned up and we got a great spread in the local paper. It was a fantastic day with many people dropping in to see what was going on.

We were recently able to borrow a high voltage insulation tester and members were able to see how good those second hand vacuum capacitors really were. We also tested a wide spaced air dielectric butterfly capacitor to breakdown. I can tell you that watching it crack over with nearly 15 kV on it was impressive. The guys operating HF were not so impressed, coming in to find out what was wiping out the bands. Thoughts then turned to how we might be able to hook a Morse key to it but that's for another time.

Coming up at the club, we have some great talks planned on how to QSL and HF propagation and DXing. Steve VK6IR is a font of knowledge and we are lucky to have him share his expertise and experience. We are heading out again for the John Moyle Field Day, planning to operate from top of Mt Dale in the Avon Valley National Park. We always have a great time when we take to the bush and this overnigher should be no exception. After that our efforts will turn to our HARGfest, the club's buy sell & swap day. This year it will be held on 14 April at the same great venue in Lesmurdie.

HARG Meetings are held twice a month at their club rooms at the Paxhill Guide Hall near the corner of Brady and Sanderson Roads in Lesmurdie. The social and practical meeting is held on the second Saturday of the month and the last Saturday of the month has the general meeting, often with a technical talk or demonstration. Doors open at 1.00 pm for a sausage sizzle and the meeting starts at 2.00 pm. More information at www.harg.org.au.

73 de Ray VK6ZRW

Northern Corridor Radio Group

Well Christmas didn't seem to slow anything down at the club, with a reasonable amount of work being carried out around the club and a good attendance at the January meeting.

We re-wired the remote station rotator that turns our SteppIR as well as worked on issue we are having with the rotator itself.

The remote station was relocated from the equipment room (which is currently not air conditioned) to the second radio room which is much cooler. The PC was also replaced with a newer model with an SSD which is much quicker and more reliable.

The comms trailer is being prepared for the John Moyle Memorial Field in March. The trailer now has a winch up tilt-over mast, Cushcraft 3 element triband Yagi and we are thinking about doing some high gain wire antennas for the DC bands, (40, 80 & 160). We will be going to Poruma National Park for the third year in a row. Hopefully there is a particular kangaroo that sported a headache from last year that doesn't recognise Wayne VK6EH this year! There is looking like a good attendance at the field day this year.

Work on the EME station is ongoing. Our civil crew, (who aren't always that civil!) are now looking at how we mount the dish cage. We had considered putting it on the roof of the equipment room (which would also cool down the room) but this is looking a little impractical so now we are looking at relocating it closer the building but not so close we lose some of the horizon. Once the dish is relocated, there isn't much else to do than put it on the air! The dish is an ex-Telstra satellite dish mounted inside a spherical radome, and gyro stabilised. It's a pretty good piece of kit and I can't



Photo 4: The Carine Tower and 20 m Yagi at NCRG.

wait to see it on air!

At the last meeting, the club voted in favour of purchasing a second SPE amplifier to replace or augment the Emtron valve amplifier the club has had for a long time now. This will allow us to have good amplifiers in both radio rooms (the Emtron will go to the second radio room), which should improve our contest capability. Then we just need to actually do some contests – something we are planning to get

back into this year given we have finished most of our construction works.

Over Christmas, we continued to upgrade the club's repeaters and soon we will be replacing the 2 m repeater with a reasonably new system using Eclipse2 RFT repeaters made in Sydney.

73 de Steve VK6SJ
Publicity Officer for the NCRG

Participate

HARGFEST Hills Amateur Radio Group Hamfest

14 April 2019

70th Urunga Radio Convention 2019

Ken Golden VK2DGT

The 2019 Urunga Radio Convention will be on again this Easter, 20 and 21 April 2019, Saturday and Sunday. It marks the 70th Convention, the longest running "Fox Hunt Convention in Australia.

From its early beginnings at the "Do Me" boat shed at Urunga (Anchors Wharf is there now) in 1949, Crief Retalick VK2XO Jack Gerard VK2ADN, Bryan Slarke VK2ZCQ, Arnold Austin VK2ADA and other dedicated amateurs kept it running for many years.

Fox hunts and convention activities on both days: quizzes, raffles, trade tables available, pre loved gear, etc.

Why not make it a break from your busy lifestyle and slow down a bit at quiet restful "Urunga" "where the rivers meet the sea".

The social gathering for the Saturday night dinner and 70th Celebrations will be at the Ocean View Hotel. The Hotel was the site



Photo 1: Guides Foxhunting at JOTA 2018. Another side of Amateur Radio, The Guides and Scouts look forward to this "Fox Hunting" run by URC. State of the art digital sniffers are now used.

of many of the early Conventions; the old historic Silver Cups are on display there.

The dinner will be followed by the ever popular Saturday Night Fox

Hunt (Fox OR 6 Tx different freq. 2 m). Safety vests are available, participants may need a light (see Ken VK2DGT at the convention). The 2018 convention went

Photo 2: 40 m Hunt participants.





Photo 3: Saturday night Dinner at Club.



Photo 4: Paul and grand kids did okay.



Photo 5: Victorian Team - Overall Winners.

off without a hitch and was well attended, with many Fox hunters competing for "Arnold Austin Memorial Award" and the "Brian Clarke Memorial Award" overall for two days. Mobile and Pedestrian Hunts.

Venue: Senior Citizens Hall,
Bowra Street, Urunga
Ken Golden VK2DGT
WIA Urunga Radio Convention Inc.
Email: krgolden46@hotmail.com
Pn.02 66523177

Web: Urunga Radio Convention:
<http://www4.tpgi.com.au/goldy2/>
(or search engine) <http://members.dodo.com.au/fox35664/>



Photo 6: Robyn Golden - Ladies Door prize.

Your Entry Into Amateur Radio



New Foundation Manual is available now

Visit our Bookshop:
http://www.wia.org.au/members/bookshop/page_data.php?id=113

Junk nostalgia and dangerous projects

Peter Parker VK3YE*

Spark transmitters and crystal sets in the early low-frequency days were simple things built on timber 'breadboards'. Stiff wires with beautifully formed corners connected the parts. The same construction continued when tubes replaced crystal detectors in the 1920s.

The big change happened when receivers went from battery to AC power. Voltages rose. Hum became a problem. Shielding became essential, especially with higher gain superhet circuitry. And stray inductance and capacitance from long leads on breadboards degraded performance especially on higher frequencies.

Production had to be faster to make radio affordable to people. Manufacturers changed to metal chassis with direct connections underneath. So did the more progressive amateurs, encouraged by Ross Hull (more on him later).

Though it was the Great Depression, the ham with little money probably still built their two-valve transmitter on an exposed breadboard made from packing crates or tea chests. The times encouraged expediency over safety. Receivers were made without power transformers to drive down costs. Although, to be fair, this was also commercial practice, particularly in the US with its lower mains voltage.

As late as the 1960s, a famous American mechanics magazine article described a sausage cooker project made by passing AC mains voltage through sausages. Reputable designs had interlocks to remove power when the lid was removed, though backyard copies often didn't. Even today, YouTube shows videos of even cruder versions with forks and power cords. And across the Atlantic

you don't have to be very old to recall the British quirk of consumer goods being sold without plugs and householders wiring their own.

For amateurs though one event changed everything when it came to electrical safety:

The death of Ross Hull in 1938, 80 years ago last year

Ross Hull was an Australian-American amateur pioneer. He was active in the early Trans-Pacific HF tests and pioneered UHF communications. He was recruited by the ARRL to run their lab and edit QST.

But not for long. His promising career was cut short in 1938. Ross Hull was electrocuted when he put his hand across 6000 volts when experimenting with television apparatus. He was 36.

The death sent shockwaves through the amateur fraternity.

Every old-timer worthy of name knows the story of Ross Hull.

More importantly the lesson it taught.

That badly contained electricity spares no one; not even the best and brightest.

The ARRL and QST immediately began a safety campaign.

Safer design and construction practices were encouraged. For example: earthing, switching, fusing, shielding and insulation. The 1920s open breadboards and Depression era transformer-less designs were discouraged.

Radio leagues and magazine publishers felt a sense of duty to their members and readers. For the most part, editors refused publication of projects thought to be unsafe. If something slipped past you can be sure there would be critical letters in the next issue. This is self-regulation by informed

amateurs at work.

Amateurs still got electrocuted or fell from towers. But overall, the hobby probably got safer even in the US whose RF output power limits and amplifier voltages were and remain higher than those in the UK and Australia.

Just as awareness of the horror of war falls with the departure of those with first-hand experience, the same is also true of electrical safety amongst amateurs.

Solid state circuitry reduced the number of us with high voltage experience. People still build transmitters but mostly low voltage QRP. Fewer run external amplifiers. And how long ago did this or any other amateur magazine feature a high-voltage project? Even if you didn't build it you probably saw warnings about the hazards involved or learnt about construction practice.

Articles today are as likely to be on a website or video as in a magazine. That's great in that there's instant publication and audience feedback. But there is seldom technical editing. So you are just relying on one person's unverified word. Viewer and reader beware!

Nostalgia is another factor. Perhaps I'm drawing a long bow, but hear me out.

Nostalgia, at its best, ranges from funny tales of past embarrassments to a contemplation of history's lessons. Amateur radio is richer for these stories. And we can be thankful to those who share their recollections in articles and videos before they become lost.

But there's also bad or junk nostalgia. People with chips on their shoulders may take refuge in a rose-coloured version of history that never really happened. In technical

fields, junk nostalgia can become an atavistic anti-intellectual cult whose followers let 50 years of knowledge slide from memory. Which seems odd given the effort they probably spent learning when younger.

Good (and bad) nostalgia can influence the projects we build. Junk nostalgia in projects is so bad that they are better left unbuilt; for instance, crude Depression era transmitters built on scraps of wood complete with exposed high voltage connections.

Such contraptions are nostalgia's potentially dangerous face. It's as if Ross Hull, who advocated better construction practices, had lived and died in vain.

Why would one not at least build something of good post-war design with parts safely behind a front panel on a properly earthed metal chassis? Speaking of which, I trust that your supply earthing is intact and not sacrificed to the false god of hum prevention expediency?

Part of the reason is that high voltage timber chassis junk nostalgia projects (eg 'pine board transmitters') are being promoted in videos and magazines by prominent hams who should know better.

Maybe they do indeed know better. A pine board project might be safe in their hands.

For instance, they are perfect radio amateurs. So perfect that if they have children or grandchildren they never visit. Their shack is always locked. They never operate equipment when tired. They wear insulated gloves at all times. One hand is always behind their back. Capacitors are always discharged. They never accidentally bump something. Equipment is never left on unattended. They are never ever careless or suffer memory lapses. And they never trip over a cord that could send a project crashing.

The list could go on.

But their audience may not be as perfect as them. Remember what I said before about today's ham having less experience of high voltages than those 60 years ago.

Good defensive design for electrical safety assumes Murphy's Law. If it can go wrong it will go wrong. It assumes the user is fallible – that is human. Not just you but people around you and any future owners of the equipment.

How do you know this? It might be possible if you're giving a live talk, where your audience is close

and known. But it cannot be the case for a web article or video. Here your audience is distant and unknown. They may be anyone from the unqualified to the highly experienced.

So a degree of prudence is called for when it comes to projects being described.

My personal view is that high voltage open pine board transmitters and the like should not be described as practical projects to an unknown audience. At best they are a historical curiosity, the product of an era when enthusiasm was high and money was low. Things have changed and the financial pressure to cut corners ceased long ago.

Sure, build a solid state rig on an open board, if you're willing to bear the shortcomings. But if you wish to recreate high voltage tube gear, power transformer-based designs from later in the valve era are a better choice. These typically used safer metal cabinets and were better designed. And the improved performance is likely to make them still practical to use today.

(* vk3ye.com & youtube.com/vk3ye



Participate

World Amateur Radio Day

18 April 2019

Hamads

FOR SALE – VIC

'TEN-TEC' Antenna Tuner (Model 1215)
Built from kit. Does work. Excellent condition. Surplus to requirements.

Circuit Type: High Pass "T" Network

RF power rating: 200W max.

Frequency Range: 1.8 - 30MHz

Output Matching Range: SWR up to 10:1

\$170 (plus postage if any)

Contact: Alex VK3AMX (03) 9850 7493 (Melbourne)

FOR SALE – QLD

YAESU G-1000DXA heavy duty rotator. gwo but no cable but will have the necessary connectors for same included.

Contact Merv Deakin VK4DV 0448985537 or email vk4dv1@gmail.com

WANTED – VIC

Sherwood Engineering SE-3 AM Sync Detector to suit Palstar R30A. Contact: Paul Mitchell at vk3tpm@bigpond.net.au



Contributions to *Amateur Radio*

AR is a forum for WIA members' amateur radio experiments, experiences, opinions and news.

Your contribution and feedback is welcomed.

Guidelines for contributors can be found in the AR section of the WIA website, at <http://www.wia.org.au/members/armag/contributing/>

Email the Secretary:
armag@wia.org.au

AMIDON FERROMAGNETIC CORES



ttssystems

Phone 03 5145 6179

info@ttssystems.com.au

Studying for the Standard or the Advanced Licence?



Here are 4 books that will get you there.

TAKE A LOOK AT
www.gscott.com.au

for more information and order form.
635 Edmonson Avenue
Albury NSW 2640



Have you held an amateur licence for 10 years or more?

If so, then you are invited to
join the

RAOTC

A \$5 joining fee, plus \$18 for one year or \$32 for two years, gets you two interesting 64 page *OTN Journals* each year, **PLUS** good fellowship, and a regular broadcast of news and events.

More information and a membership application are available from our web site at www.raotc.org.au or write to:-
PO Box 107, Mentone VIC 3194 or
email:- raotc@raotc.org.au or
call Secretary: Bill Roper VK3BR
on 03 9584 9512.

About Hamads

- Submit by email (**MUCH PREFERRED**) or if written and mailed please print carefully and clearly, use upper AND lower case.
- Deceased estates Hamads will be published in full, even if some items are not radio equipment.
- WIA policy recommends that the serial number of all equipment for sale should be included.
- QTHR means the address is correct in the current WIA Call Book.
- Ordinary Hamads from those who are deemed to be in general electronics retail and wholesale distributive trades should be certified as referring only to private articles not being re-sold for merchandising purposes.
- Commercial advertising on these pages Contact admanager@wia.org.au
- Copy to be received by the deadlines on page 1 of each issue of Amateur Radio.
- Separate forms for For Sale and Wanted items. Include name, address STD telephone number and WIA membership number.

'Hamads'

PO Box 2042
BAYSWATER VIC 3153
hamads@wia.org.au

TRADE PRACTICES ACT

It is impossible for us to ensure that the advertisements submitted for publication comply with the Trade Practices Act 1974. Therefore, advertisers will appreciate the absolute need for themselves to ensure that the provisions of the Act are strictly complied with.

VICTORIAN CONSUMER AFFAIRS ACT

Advertisements with only a PO Box number address cannot be accepted without the addition of the business address of the box-holder or seller of the goods.

ADVERTISERS INDEX

Cookson Controls	64
Icom	Back Cover
Jaycar	7
Amidon	64
Yaesu	Inside Front Cover



Don't forget to register for **MEMNET**.

The WIA AGM 2019

Taffy Shammay VK2RF



The **WIA AGM Conference 2019** will be held in the heart of Sydney CBD, commencing 6 pm Friday night 4 May at the Marconi Room at Sydney Town Hall with canapes and drinks. At the Sydney Town Hall, in 1930 Marconi astounded the world by turning on the lights as a radio relayed from his yacht anchored in Genoa, Italy.

This night will celebrate the 100th Anniversary of the Waverley Amateur Radio Society, with speaker David Duffy, author of *Secret Code Breakers*, and showcasing various historical presentations regarding early Amateur Radio icons in Sydney.

After the 9 pm conclusion, delegates can walk a short distance to the various mesmerizing VIVID Light Sound exhibits which commence this night.

Moving on to 25 May, the formal WIA AGM will commence at the impressive Parkroyal Hotel, Darling Harbour. After lunch, the theme of the conference technical presentations will be "a Spectrum of Opportunities". No doubt there will be captivating and fascinating insights.

Partners are not forgotten, with two well planned tours, one showing off Sydney seaside suburb attractions, or travel to the famous and spectacular heights of the Blue Mountains. Centrally located retail therapy is also an option, or combine both!

The Conference Dinner will be served at the Parkroyal Hotel, with renowned keynote speaker Professor Fred Watson, astronomer extraordinaire, whose father was an amateur.

After dinner concludes, there will be a further opportunity to walk across to Darling Harbour and

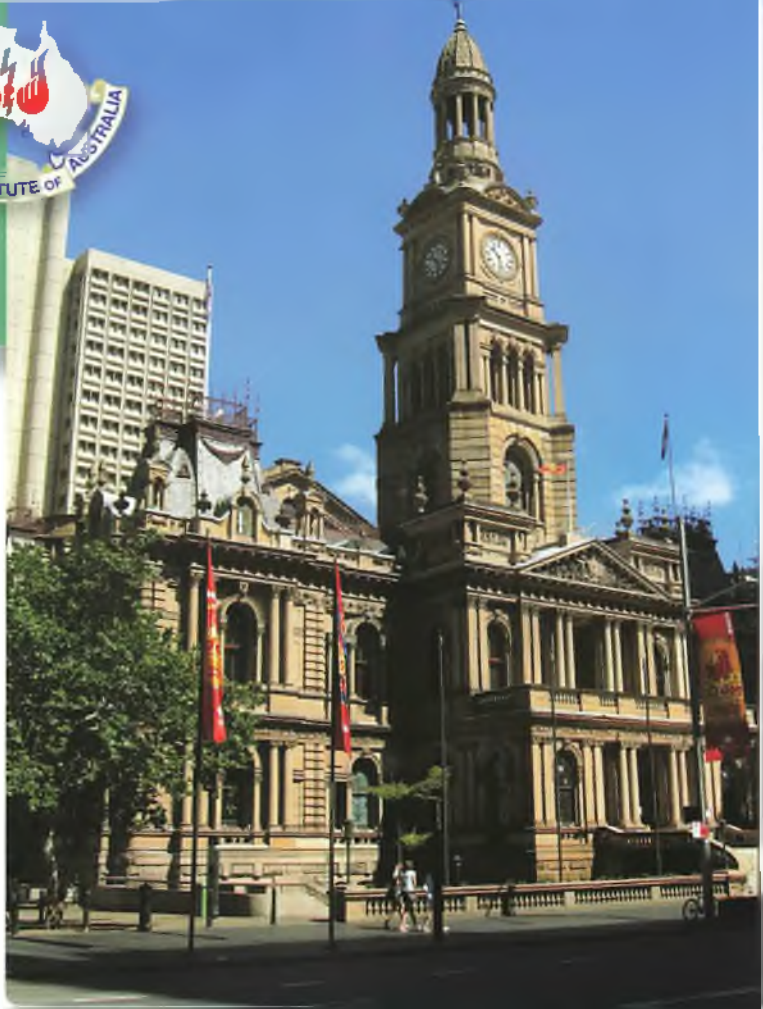

■ Sydney Town Hall 2006. By Greg O'Beirne - Own work, CC BY-SA 4.0, <https://commons.wikimedia.org/w/index.php?curid=51662081>

catch up on the VIVID spectacular exhibits that you might have missed Friday night.

And then on Sunday 26 we get transported to Dural, expansive home of Amateur Radio NSW, who will welcome you at their weekly broadcast station, with commercial exhibits, lunch, and further inspiring technical presentations. A mini field day!

Some delegates may also choose to visit the Kurrajong Radio Museum instead.

Sunday night is the last chance to experience VIVID, or just roam the many Sydney attractions.



Amateur Radio NSW, Dural.





INTRODUCING THE NEW **IC-9700**
Direct Sampling Now Enters the VHF/UHF Arena



✉ :sales@icom.net.au

🌐 : www.icom.net.au

☎ : (03) 9549 7500