

Amateur Radio

Volume 87
Number 3 ▶ 2019
Price: \$12.50 incl GST

www.wia.org.au



IC-9700 VHF/UHF all mode transceiver



- ▶ Simulate your circuits with LTSpice
- ▶ Calling CQ
- ▶ Rescue on Mount Bogong
- ▶ Space junk and Australis OSCAR-5

ISSN 0002-6859

03



9 770002 685055

The Conclusive Choice

2- Intuitively grasp changes in the strength of the signals

3DSS (3-Dimensional Spectrum Stream)

Having an informative Waterfall display is one of the advantages of SDR technology. The FTDX101 utilizes our sensational newly developed 3DSS (3-Dimensional Spectrum Stream) system in addition to a conventional Waterfall display that flows from the top to the bottom.

The 3DSS display is a remarkable completely new system that displays the constantly changing band conditions in three dimensions (3-D) with the frequency as the horizontal axis (X axis), the signal strength as the vertical axis (Y axis), and the time axis as the Z axis. The operator can effectively view the constant changes in a signal's strength as the signal flows to the back of the screen giving you a sensation of traveling in Time Space.

The 3DSS exhibits a colorful easily viewed presentation that contains the outputs from both the Narrow band SDR and the Direct sampling SDR within one common screen. The display color of each SDR output can be selected to please the eye of each individual FTDX101 user. The operator can effectively see the close-in QRM situation from the Narrow band SDR output while at the same time easily observe activity across the whole band from the Direct sampling SDR output - On the same screen at the same time.



3DSS (3-Dimensional Spectrum Stream)



In Homage to the Founder of Yaesu - Sako Hasegawa JA1MP

FTDX101MP 200W

HF/50MHz TRANSCEIVER

The Ultimate

FTDX101D 100W

HF/50MHz TRANSCEIVER

YAESU
The radio

YAESU Authorized Dealer

Andrews Communications Systems
Shop 8, 41-51 Bathurst Street, Greystanes NSW 2145
Tel: +61-2-9636-9060
URL : www.andrewscom.com.au

YAESU Authorized Service Center

Andrews Communications Systems
Shop 8, 41-51 Bathurst Street, Greystanes NSW 2145
Tel: +61-2-9636-9060, Fax: +61-2-9688-1995
E-mail: radioandrews@hotmail.com

Strictly HAM Pty. Ltd.

Shop 12B Church Street Bayswater Vic. 3153
Tel: +61-3-9729-7656
URL : www.strictlyham.com.au

VK Radio Repairs

347 Settlement Rd, Thomastown Victoria 3074
Tel: +61-3-9010-5070, Fax: +61-3-8682-8748
E-mail: yaesu@vkradio.com.au



Amateur Radio

Volume 87
Number 3
2019
ISSN 0002-6659

The Journal of the Wireless Institute of Australia

Editorial

Editor

Peter Freeman VK3PF
editor@wia.org.au

Technical Editor

John Morrissey VK3ZR

Publications Committee

Peter Hartfield VK3PH
Ewen Templeton VK3OW
Kaye Wright VK3FKDW (Secretary)
WIA Office Bruce Deefholts VK3FBLD

All circulation matters

nationaloffice@wia.org.au

How to submit material

Secretary
AR Publications Committee
PO Box 2042
BAYSWATER VIC 3153
or armag@wia.org.au

Letters to Editor

Editor AR Magazine
PO Box 273
Churchill Vic 3842
or editor@wia.org.au

Hamads

'Hamads'
PO Box 2042
BAYSWATER VIC 3153
hamads@wia.org.au

Advertising

All enquiries to
Advertising Manager
AR Publications Committee
PO Box 2042
BAYSWATER VIC 3153
or admanager@wia.org.au

Registered Office

Unit 20 11-13 Havelock Road
BAYSWATER VIC 3153
Australia
Phone: 03 9729 0400
Fax: 03 9729 7325

Production Deadlines

All articles, columns, hamads and
advertising booking for the next issue by
21 June 2019.

The contents of Amateur Radio are Copyright
Wireless Institute of Australia © 2017

Technical

IC-9700 VHF UHF all mode
transceiver 13

Peter Freeman VK3PF

Use of the IC-9700 on Weak Signal
Digital Modes 20

Rex Moncur VK7MO

Circuit Simulation for the
Homebrewer 21

Phil Hutchings VK4PG

Australis OSCAR 5, the ABC's
Conversations & 8.4 million
cane toads? 27

Peter Wolfenden VK3RV



This month's cover:

*The new IC-9700 all-mode software defined
radio for 2 m, 70 cm and 23 cm bands. Read
the review commencing on page 13. Image
courtesy of Icom Australia.*

General

"No one replies to me": The secrets
of successful CQ calling 6

Peter Parker VK3YE

WIA Election Declaration 20

John Marshall

Amateur radio assists in mountain
rescue 25

Phil Shields VK2CPR

Book Review: Getting Started in EME 26
(Earth-Moon-Earth transmissions)

Kevin Johnston VK4UH

Profile for new WIA Director 63
Mike Alsop VK8MA

Mike Alsop VK8MA

Columns

ALARA	29
Board Comment	3, 4
DX Talk	35
Editorial	2
Over to You	63
SOTA & Parks	48
VHF/UHF – An Expanding World	37
WIA Awards	50
WIA News	5, 12
VK1 News	60
VK2 News	59
VK3 News	52, 61
VK6 News	53
VK7 News	32

Contributions to Amateur Radio



Amateur Radio is a forum for
WIA members' amateur radio
experiments, experiences,
opinions and news. Manuscripts
with drawings and/or photos are
welcome and will be considered
for publication. Articles attached to
email are especially welcome. The

WIA cannot be responsible for loss or damage to any material.
Information on house style is available from the Editor.

Back Issues

Back issues are available directly from the WIA National Office
(until stocks are exhausted), at \$8.00 each (including postage
within Australia) to members.

Photocopy copies

If back issues are unavailable, photocopies of articles are
available to members at \$2.50 each (plus an additional \$2 for
each additional issue in which the article appears).

Disclaimer

The opinions expressed in this publication do not necessarily
reflect the official view of the WIA and the WIA cannot be held
responsible for incorrect information published.

Amateur Radio Service

A radiocommunication service for the purpose of self-training, intercommunication and technical investigation carried out by amateurs; that is, by duly authorised persons interested in radio technique solely with a personal aim and without pecuniary interest.

Wireless Institute of Australia

ABN 56 004 920 745

The world's oldest

National Radio Society, founded 1910.

Representing

The Australian Amateur Radio Service

Member of the International Amateur Radio Union

Registered Office of the WIA

Andersson House

Unit 20, 11 Havelock Road

Bayswater, Victoria, 3153

Tel: (03) 9729 0400 Fax (03) 9729 7325

email: nationaloffice@wia.org.au

<http://www.wia.org.au>

All mail to

PO Box 2042 BAYSWATER VIC 3153

Business hours: 10am – 4pm weekdays

National Office

Executive Administrator Bruce Deetholts VK3FBLD

Board of Directors

President Justin Giles-Clark VK7TW

Vice-President Gregory Kelly VK2GPK

Directors Marcus Berglund VK5WTF

Peter Clee VK8ZZ

Dr Harry Edgar VK6YBZ

Aidan Mountford VK4APM

Secretary Peter Clee VK8ZZ

Coordinators

AMSAT Paul Paradigm VK2TXT

ARDF Jack Bramham VK3WWW

Australian ARISS Shane Lynd VK4KHZ

Awards TBA

Clubs Ted Thriif VK2ARA

Contests Craig Edwards VK8PDX

John Moyle Field Day Denis Johnstone VK4AE

Editor 'AR' Peter Freeman VK3PF

EMC/EMR Gilbert Hughes VK1GH

Standards Phil Wait VK2ASD

Ron Cook VK3AFW

Noel Higgins VK3NH

John Martin VK3KM

NTAC Peter Wolfenden VK3RV

Historian Peter Young VK3MV

IARU Region 3 Director Peter Young VK3MV

Monitoring Service Peter Young VK3MV

ITU Conference & Study Group

Brett Dawson VK2CBD

Dale Hughes VK1DSH

QSL Curator National Office

Repeater Peter Mill VK3ZPP

Andrew Chapman VK4DF

Webpage Robert Broomhead VK3DN



Editorial

Peter Freeman VK3PF

Contributions to your magazine

We are always looking for contributions to the magazine: articles or even a column. A column might not appear every issue, so if you have any ideas about a new column, feel free to send in a proposal. If you do not wish to commit to preparing something every second month, then consider an article or series of articles.

We see that in some states, the Clubs contribute their local news to a state scribe who collates a summary document for the state. In other states, we have some Clubs who forward their own news direct for publication – some regularly and some occasionally. It is good to see a contribution from VK1 in this issue.

You can find information on how to contribute material on the magazine pages on the WIA website: <http://www.wia.org.au/members/armag/contributing/>

All articles are reviewed prior to publication. Technical articles are also reviewed by the Technical Editor team in addition to the normal review process. Given that we are limited in the space available, some articles will need to wait until space is available. Technical articles may need additional time for processing. Authors need to be patient.

When you submit an article, you should receive acknowledgement with a registration number. You may not hear from the Publication Committee team again – the article may simply be processed and then await publication. It is a case of no news is normally good news.

We currently have a number of technical articles being processed, but have very few general articles. So your contributions would be appreciated – tell us about your latest notable Amateur Radio activity.

Until next time,
Cheers,
Peter VK3PF

Democracy in action

This issue is due for delivery in south east Australia a few days before a major opportunity for all eligible to exercise their duty: to vote in a Federal election.

For members of the WIA, that responsibility did not need to occur this year, as the number of nominations for Director was less than the number of vacancies. Thus all nominees were declared elected unopposed. A statement of this outcome is elsewhere in this issue.

Your next chance to exercise your rights as a member of the WIA is at the forthcoming Annual General Meeting (AGM) to be held in Sydney on Saturday 25 May. Those members of the Board who did not nominate and whose term ends this year will be able to step down after the conclusion of the AGM.

In addition to the AGM, an Open Forum will be held. In the Open Forum, members may raise questions for the Board to answer.

All WIA members are able to attend the AGM and Open Forum.

Many attending the event will also be paying the registration fee which includes lunch and access to the Conference sessions in the afternoon, plus the events at ARNSW in Dural on Sunday.

There will be optional Partners' Tours and the Conference Dinner on Saturday evening.

I look forward to meeting up with many of you at the events.

I have answered the call for volunteers to help with a SOTA information table at Dural on Sunday. I understand that the table is to be a meeting place for all interested in SOTA and Parks activity. Feel free to drop by the table and discuss any questions that you may have about either or both programs.



Board comment

Justin Giles-Clark VK7TW

Happy significant birthday to Waverley Amateur Radio Society (WARS)! WARS turns 100 in 2019 and I am looking forward to the Friday night celebrations that kick off the WIA Annual General Meeting (AGM) and Conference weekend.

This is my last Board Comment as I step down as President and Director at the May AGM. I hope to catch up with many of you at the AGM Conference weekend. It has been a wonderful two years and I encourage people to become actively involved in running your National Representative Body. As a Board member you get to shape the hobby in small (occasionally larger ways) and this can be extremely satisfying.

As a volunteer organisation the WIA is only as good as those that volunteer and the leadership that guide and support them. When I came onto the Board two years ago it was during a period of considerable negative sentiment toward the WIA and Board. The 2017 election resulted in new Board members being elected except for one returning member. The new Board took on the task of rebuilding and stabilising the WIA and this has been successful from a finance and administration perspective. We have delivered a small surplus in 2018 and the 2019 budget indicates a small deficit in the 2019 year, even though we are spending over \$40,000 sending delegates to the World Radio Conference.

The Board has been actively working on a technology refresh in the organisation and committee revitalisation. Both are delivering and will continue to deliver better outcomes for members. The WIA

is moving to cloud hosting of administration and support systems and this further reduces the overhead costs for the organisation. The committee revitalisation has seen the refresh of a number of committees with new blood. The revitalisation is ongoing and has now turned to the technical committees.

Membership, however, is still a work in progress, as the WIA only attracted 191 new members in 2018 and only represents 150 affiliated clubs and using the insurance coverage that the WIA facilitates only represents one third of the amateur radio population in VK. To enable the WIA as the National Amateur Representative body to approach and work with the government and the regulator to the benefit of the hobby, we need strong representative membership. This is a continuing challenge for the new Board.

As a scientist - when confronted with an issue, a hypothesis is formed and I look to the evidence to support or not support it. It is then a cycle of hypothesis adjustment and evidence re-run. When I started in the new Board two years ago the hypothesis presented to me was of an organisation on its 'last legs'. The evidence gathered over the last two years certainly does not fit this hypothesis and I have been regularly adjusting the hypothesis with ever more positive outlooks and I am sure the new Board will continue testing and adjusting.

As President you become a 'lightning rod' for the organisation and you experience the best and the worst behaviour of the amateur community along with needing to balance time and resource pressures. I thank the amateur radio community for the opportunity to

serve as President and Director for the last two years and look forward to continuing my involvement in a number of areas.

What has the WIA been up to over the last two months?

Representation

Dale Hughes VK1DSH has attended the Australian Communications and Media Authority (ACMA) - Australian Radiocommunications Study Group 5, Terrestrial services meeting and presented on Agenda item 1.1 (50 MHz). The meeting covered the new Department of Communications and the Arts (DOCA) arrangements in preparation for World Radio Conference 2019 (WRC-19).

The ACMA released their Draft Five Year Spectrum Outlook and millimetre wave planning document and the WIA Spectrum Strategy Committee is preparing a submission from the WIA. The document has provided an indicative timetable for reforming the LCD and getting access to 60 m as well as reforming the amateur qualification system by making it part of the Australian Qualifications Framework. This will have significant impact on the delivery of amateur radio training within Australia.

The WIA will be attending the last meeting of the Asia-Pacific Telecommunity (APT) Conference Preparatory Group - APG 19-5 will be held from 31 July - 6 August 2019, Tokyo, Japan. This will form the final view of the APT that will be taken to WRC-19 in October 2019.

WRC Preparation - WIA will be spending about \$40,000 on sending representatives to Egypt to represent amateurs in VK at that

Continued on page 4

world forum. This is a significant outlay for an organisation that has an operating budget of \$500,000. WRC-19 is being held in Sharm el Sheikh, South Sinai, Egypt from the 28 October to 22 November 2019 and will see more than 2500 delegates from over 160 countries attending.

I encourage members to read the 2019 Open Forum Report from Dale as this outlines the huge contribution that is being made to represent amateur radio at these national and international forums.

The WIA has met with the ACMA a few times to discuss the future of amateur radio licencing, the implementation of the new Radio Communications Act, implementation of the new parameter based licencing and the formation of the Syllabus Review committee.

The relationship with the ACMA is a precarious one - on the one hand the ACMA is divesting itself of everything administrative and this provides opportunities. This appears to be due to resourcing constraints placed on the organisation and this creates a shift from an organisational culture of prescriptive technical regulation to an organisation that runs and promotes enabling legislation and policy with industry driven self-managing frameworks. This ACMA divestment represents a real challenge and risk for the amateur community. This manifests itself in what appears to be the regulators decreasing responsiveness to all things amateur radio when in fact this is due to the amateur community's lack of acceptance of a self-regulation trajectory. This needs to change and it will be painful

Promotion

By the time this goes to print the WIA IT team would have transitioned a number of IT services

and this is the start of a complete refresh of IT infrastructure in the WIA. This will see improved membership services, website and social media interfaces and the automation of many existing and future membership services.

The pilot of the new ticketing systems has proven successful and the Board has voted to roll this out to all areas of the WIA. All incoming and outgoing communications, requests, incidents, etc. will eventually go through the ticketing system. This becomes the platform for the automation of many services.

The focus on reducing the backlog of repeater assignments is paying off with the work being undertaken by commercial frequency assigners on behalf of the WIA as a pilot process. The learnings from the pilot process will inform the long-term process that the WIA will adopt.

The WIA continues to provide complimentary reward memberships of the WIA for amateurs who are newly qualified. If you received an Amateur Operators Certificate of Proficiency (AOC) (Foundation, Standard or Advanced) at any time since 1 January 2018 and are not a member of the WIA you are eligible for a complimentary 1-year WIA membership. If you are already a WIA member (now, or when you receive your qualification in the future) you are eligible to receive a 1-year membership extension or a \$100 discount off a 5 year membership. If this is you, or someone you know, all that is needed is a completed WIA membership form and a copy of the relevant AOC qualification showing the date of qualification being later than 1 January 2018 and email it to support@wia.org.au. It is great to see the Australian Ladies Amateur Radio Association (ALARA) come on board with this initiative offering complimentary ALARA membership for newly licenced female amateurs.

Education

Given the turnover of staff at both DOCA and ACMA - the WIA at all meetings that amateur radio representatives attend are educating the attendees about the hobby and heritage of amateur radio. Reminders like amateur radio service and the amateur radio satellite service is embedded in the International Radio Regulations (International treaty signed by the 190+ United Nations member states that includes Australia) - Section 25:

1.56 Amateur service: A radiocommunication service for the purpose of self-training, intercommunication and technical investigations carried out by amateurs, that is, by duly authorised persons interested in radio technique solely with a personal aim and without pecuniary interest.

1.57 Amateur-satellite service: A radiocommunication service using space stations on earth satellites for the same purposes as those of the amateur service.

Another facet that the WIA reminds the decision makers about is that there is a global federation of national associations of radio amateurs in more than 150 countries, the International Amateur Radio Union (IARU) that has been providing frequency coordination services for the amateur service and satellites free of charge for many years. The WIA will continue to vigorously advocate and educate regulators to ensure that they are fully aware of their obligations in the amateur service space.

Finally, I would like to announce that the WIA will be introducing the Brenda Edmonds WIA Education Award at the AGM in Sydney. Brenda's family has given permission to create an award in her name with a focus on education to the amateur radio community. The WIA looks forward to receiving nominations for this award for the 2020 AGM.

On behalf of the WIA Board
73

Justin VK7TW



Australian CubeSat to use 76 GHz

The IARU Satellite Coordination Panel has announced the amateur radio frequencies for the Australian 76 GHz CubeSat CUAVA-1 that is expected to launch in July 2019.

CUAVA-1 is a 3U CubeSat and the first CubeSat project of the new ARC Training Centre for CubeSats, Uncrewed Aerial Vehicles (UAVs), and their Applications (CUAVA), whose primary aim is the education and training of people, mostly PhD students, for the space sector.

With significant heritage from the QB50 CubeSat INSPIRE-2, CUAVA-1 is a 3U CubeSat that will link with the international radio amateur community for outreach, training, and increased data downloads, observe the Earth with a novel multi-spectral imager, use a GPS instrument to explore radio occultation and the reception of GPS signals scattered off the Earth as well as provide a backup determination of the CubeSat location, investigate plasma environment and associated space weather with radiation detectors, and explore the performance of a new communications payload.

This mission addresses issues of radio technique interesting to the radio amateur community in the following ways:

- 1) Global Radio Amateur Participation in Mission and Data Downlinking. We will work with radio amateurs and other groups to receive and decode the spacecraft beacon and downlinked data, with subsequent transfer to the internet database (ideally the SatNOGS database).
- 2) Student and Radio Amateur Participation in the Ground station. We will train students and desiring radio amateurs in the setup and use of a ground station hosted by the University

of Sydney and then have these people operate the ground station (including control of the satellite and managing the uplink and downlink) and transfer downlinked data into an internet database (ideally the SatNOGS database).

- 3) Radio Wave Propagation. The ionosphere, thermosphere, and lower atmosphere have multiple effects on the propagation and absorption of radio waves and microwaves.
- 4) Communication Protocols. Modulation techniques that will be investigated for the high-speed communications experiment include QPSK, 16-QAM and CPFM. If successful, this technology for wavelengths below 10 cm will increase the data transfer rates by at least four orders of magnitude while also decreasing the sizes of antennas and the associated spacecraft.
- 5) Radiation Effects on Electronic Components. The Low Earth Orbit (LEO) environment is protected from cosmic rays, solar particles, and particles trapped in the Van Allen Belts by Earth's magnetic field.
- 6) Attitude and Position Determination. Reception and analysis of GPS signals by the on-board GPS receiver will determine the spacecraft's attitude and location as a function of time, thereby determining the satellite's orbit.

Proposing to downlink telemetry on 9k6 GMSK AX25 on UHF and high speed downlinks on 2.4 GHz, 5.6 GHz and 76 GHz. Planning a launch from Japan in July 2019 into a 400 km orbit.

These frequencies have been coordinated by the IARU:
Downlinks: 437.075 MHz, 2404.000 MHz, 5840 MHz and 76.800 GHz
Uplinks: 145.875 MHz,

2404.000 MHz and 5660.000 MHz.

ACMA Amateur Licence Fee Increases

The latest review (April 2019) has just been undertaken and amateur licence fees have increased.

The ACMA uses a system of apparatus licence types to apply common licence conditions to categories of radiocommunications services.

Amateurs use non-assigned apparatus licences. Non-assigned licences are issued when an individual frequency assignment is not required.

There are two types of fees applicable to apparatus licences:

1. administrative charges to recover the direct costs of spectrum management
2. annual taxes to recover the indirect costs of spectrum management and provide incentives for efficient spectrum use.

Indirect costs are those that cannot be directly attributed to individual licensees. These activities include international coordination and domestic planning and interference management.

The new fees applicable to the Amateur Service are:

A new licence fee is now \$80 (was \$76).

A licence variation fee is now \$51 (was \$49).

The licence renewal fee is now \$55 (was \$52).

Issuing a Repeater or Beacon Station Frequency Assignment Certificate is now \$29 and variation of a Repeater or Beacon Station is now also \$29.

Licence renewal is your responsibility

We occasionally hear stories regarding an amateur that did not receive a Renewal of Apparatus

Continued on page 12

“No one replies to me”: The secrets of successful CQ calling

Peter Parker VK3YE (*)

A CQ is a general call to any station. It is used when you wish to establish contact with anyone anywhere. One of the finest traditions of amateur radio, calling CQ epitomises our hobby's open ethos. It's what sets us apart from other electronic communication. Unless we're telemarketers or spammers we rarely phone random numbers or send random emails, for example.

Like fishing you never know what you might catch. Sometimes

it's nothing. Other times it's a surprise. For instance, a DX path that you didn't think was open, someone you hadn't worked for years or even an amateur in your childhood home town. Simple joys like these are missed by those who limit their activity to the same groups and skeds day after day.

Again, like fishing, there is only one rule: You must have a line in. The longer it's in the better. In other words, the more you call the luckier you get – regardless of location

or equipment. Some catches will quickly follow one another while there will be long waits between others. But in all cases the greater challenge of making contacts outside a net gives more reason to be satisfied with your station and operating. And there's a wider benefit for amateur radio; bands are more occupied and interesting if instead of 30 people on a single net frequency the same number is spread across the band in separate conversations.



Photo 1: Calling CQ from a sought after location can increase your chance of replies. These include islands, national parks, SOTA peaks and lighthouses, such as pictured here.

"I tried calling CQ once but no one replied".

That's a common beginner lament. Given the current sunspot count one might blame "conditions" and rarely call again.

Old timers unwittingly encourage this sentiment by claiming that "conditions now are the worst they've been for 40 years". Put such stories in the same category as the tales fishermen tell about the size of their catch. People's memories can play tricks. I can't tell you the number of naysayers who have claimed 'worst ever' conditions for at least the last four sunspot lows. They can't all be right.

That is not to say that success will be automatic. Unscheduled contacts on some quieter bands and modes are difficult at any time. With our amateur population so thinly spread across numerous bands and modes, you probably won't get a reply to the first call you make. However, there are things you can do to greatly increase your success rate. This comes down to meeting the five needs set out below.

Need 1: A good-sounding station

Unlike replying to someone else's call or joining a net, where there are people guaranteed to be listening. A station calling CQ needs a transmission that is strong enough to arouse the curiosity of people tuning across the band or watching their transceiver's spectrum display. You need to be readable without too much effort – not everyone will persist with a barely discernible signal buried in noise.

This is why you need a station that will be clearly heard. This does not necessarily mean 400 watts to monoband Yagis on all bands. Even 5 watts to a well-built magnetic loop can attract replies if you pick your frequency and time carefully. Though bear in mind that it's a numbers game; the more stations that can hear you over their local noise, the more replies you will get.

It pays to go over your station from microphone to antenna to examine all possible sources of loss or degradation.

How often have you compared various signals on an HF net? You may hear someone running 100 watts and moving your S-meter above band noise. However, their audio is bassy and muffled, causing them to be heard but not easily understood. Others ask for repeats of their call sign. In contrast a weaker 10 watt station with penetrating audio gets identified first go

You need to sound like that second station to attract replies to your CQ calls.

Communications rather than studio quality is the goal. Aim to be understood through fading and interference without sounding muffled, thin or distorted. Forget expensive desk microphones, equalisers and transceivers; there is no relationship between cost and audio quality. Even a cheap rocking armature or electret microphone and 30 year old transceiver can produce suitably penetrating audio if set up correctly.

jaycar think. possible.

JUST
\$109

GME 2W UHF transceiver TX677

Compact and lightweight, featuring a flexible detachable antenna.

- Switchable power output (2W/0.5W)
- Up to 9km range
- 80 Channels
- Scan, CTCSS & VOX function
- Recharge via USB
- Backlit LCD

DC9048



GME

NOW
\$59⁹⁵

Desktop magnifying LED lamp

- 100mm 3-dioptre lens
- Adjustable Stand
- Ultra bright LED lamp
- Mains powered

QM3552



Digital vernier calipers

- 5-digit LCD
- 0 - 150mm (0-6") range
- Resolution 0.01mm / 0.0005 (repeatability same)
- Includes battery

Budget
TD2081 **\$13.95**
Professional, Stainless Steel
TD2082 **\$39.95**



FROM
\$13⁹⁵

ONLY
\$350

Aerial ferrite rod with coil
Small ferrite rod complete with pre-wound standard broadcast band coil.
LF1020

ONLY
\$475

60 - 160pF miniature tuning capacitor
Used in most transistor radios. Supplied with 35mm dia. plastic knob and screw.
RV5728

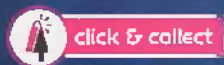

buy online & collect in-store

zip own it now, pay later

Valid until 30 June, 2019
To order phone 1800 022 888 or visit www.jaycar.com.au

What are the ingredients of communications-quality audio? Frequency response is one. The high frequency parts of your voice (around 2 or 3 kHz) are critical to readability. If your microphone's output is mainly lows then it may 'crowd out' needed readability-producing highs. Excessive bass could be due to the microphone's frequency response or a mismatch between it and the transceiver. A fix could involve some bass-cut audio filtering such as something as simple as a series capacitor in the microphone connection. The right values will pass the high frequency parts of your speech but roll off the lows. Conversely, if highs are too prominent then a 10 to 100 nF capacitor in parallel with the microphone will roll them off. Some transceivers may even have settings, perhaps buried in a menu, that allow transmit audio frequency response tailoring.

Something you don't want is background noise being transmitted. This can be a problem with desk microphones. People think they're better than hand microphones due to their price. But if you speak too far from them you will need to increase the microphone gain to sufficiently modulate the transmitter. Unfortunately, this can result in echo and extraneous noise that reduces readability. Less microphone gain and closer talking will reduce room noise pick-up. But not too close as this can cause popping. Hand, boom or headset microphones are popular choices, with top contesters often favouring the latter.

Microphone gain and speech processing settings are important. Microphone gain that's too low gives weak audio while excessive gain can lead to distortion, extraneous noise and potentially also a wide transmission that interferes with people on adjacent frequencies.

Speech processing, if available, can be beneficial but only to a point. A little processing makes your signal



Photo 2: Setting up outside can lower receive noise levels and allow you to hear replies from people who would otherwise be in the noise if at home.

punchier and easier to read by bringing up the quieter parts of your voice. Too much causes distortion and amplifies extraneous noise. If you come across a voice with a whirring noise behind it then it is quite likely someone running a linear amplifier, cooling fan and excessive speech processing.

Some more advanced SSB transceivers let you set the transmit bandwidth and/or low and high cut off frequencies. Or you may be able to adjust the frequency of the beat frequency oscillator relative to the crystal filter. A narrow filter bandwidth can sound punchy but nasal while a wider bandwidth is more mellow. Adjusting the BFO lets you go from (say) a standard 300 Hz to 2700 Hz bandpass up to a 500 to 2900 Hz (or down to a 100 to 2500 Hz range). This is interesting to experiment with but the default settings for most transceivers should normally be fine.

Other audio problems can arise from RF feedback or an inadequate power source. RF feedback can be caused by a badly shielded microphone cable, inadequate earthing or being very close to the antenna or a radiating feedline. Both these faults cause audio distortion and/or frequency pulling, especially on voice peaks.

You can hear the effect of various audio adjustments by listening to yourself on a local receiver. Unfortunately, this does not fairly simulate reception under

noisy conditions like distant stations experience. Another possibility is asking your contacts for critical audio reports. This is better but not ideal as not everyone can recognise the more subtle audio deficiencies that harm readability under difficult conditions.

A superior way is to monitor your signal on a remote web-SDR. These receivers can be used by anyone curious about what can be heard in different states and countries. You want one a sufficient distance away so that your signal is only a little stronger than background noise. If you're in eastern Australia, one in Western Australia or New Zealand will work for tests on 3.5, 7, 10 or 14 MHz propagation permitting. Drop your output power (if necessary) so that your signal is barely stronger than band noise and adjust your audio levels and frequency response to deliver the best readability with your voice.

FM is different to SSB but still needs attention to transmit audio. Many cheaper VHF/UHF rigs have poor audio level or deviation. Even if your signal is fully quieting, low audio can make reception difficult, especially for mobile stations. As with SSB, a good sounding 10 watt signal will probably be more effective than a higher power signal with poor audio. There are fewer internal adjustments than for HF rigs but a different microphone may help. Sometimes you can keep the

original housing and substitute a new electret element. Or you may find the hole in the microphone's case is too small or the microphone element needs to be repositioned to line up with it.

While digital mode signals are decoded by computer rather than ear, audio is no less important. Excessive audio level can increase your signal's bandwidth and interfere with transmissions either side. Key things to look for include freedom from hum and freedom from RF feedback via interface cables and over-driving. Your speech processor should be switched off when using digital modes.

Over-driven audio can happen because the audio from your computer is much stronger than the millivolts required by your transceiver's microphone connection. While both your computer and transceiver probably have level controls, adjustment may still be difficult as both will need to be set low. A way around this is to include an audio attenuator in your computer – transceiver interface cable or box. This attenuator can either be variable (with a potentiometer) or fixed with two resistors forming a voltage divider. Audio drive is then more easily adjusted. A suitable level is just below where the transmitter output power stops increasing as audio input is boosted. The other thing to remember is to set your transmitter's RF power output to approximately one-third what you'd run it on SSB to prevent final stage overheating due to the 100% duty cycle of many digital mode transmissions.

The audio quality equivalents for Morse code transmissions are key clicks and chirp. Modern transceivers are generally satisfactory in this regard provided that power supply capacity is sufficient and the transceiver is not being over-driven. Like good pronunciation on SSB, good sending quality on Morse

is important. Again, people are more likely to reply to a well-sent but slightly weaker transmission compared to one that's strong but has its letters run together.

Need 2: Efficient feedline and antenna

It's little use having a good sounding signal only to have most of it lost in inefficient feedlines, baluns and antennas.

Coaxial feedline can deteriorate with age and moisture. It can impose high losses if subject to large impedance mismatches such as may occur if trying to use an antenna on too many bands. Baluns have a habit of collecting water and connections to elements can corrode.

Variations in bandwidth or antenna coupler settings compared to when you first built or bought an antenna can give clues as to whether anything has changed and needs looking at.

Then there are those antennas that were never any good on transmit to start off with. These include poorly built magnetic loops, trapped verticals over lossy ground, short end-fed wires or simple-looking antennas that claim multiband operation with odd-looking 'matching transformers' at the expense of efficiency. These types of antennas can work – after a fashion – but are inefficient across multiple bands. Inefficient antenna systems convert much of their applied RF energy to heat. This is apparent if running high power (lossy traps, loading coils, capacitors or baluns tend to melt) but less so with low power, where the losses are no less real and the need for an efficient antenna is greater. If you have no other antenna alternatives you can still make contacts but they are more likely to come from replying to other peoples' CQ calls than people replying to yours.

Try to erect antennas with low inherent losses even if you have to make compromises and your

installation looks like it shouldn't work. For example, a loop that is irregular rather than square or a dipole that zig-zags to fit in your yard will perform acceptably well and definitely better than the compromise antennas listed above.

The above is not to say that small well-built antennas (e.g. some magnetic loops) aren't good but that efficient construction is easier if you can make the antenna more than about 70% of full size (e.g. a doublet that's 3/8 wavelength end to end if you can't fit in a half wavelength dipole).

When looking over your station for potential losses, consider potential easy improvements to boost transmission and reception. These could include moving antennas away from likely RF noise sources, increasing their height or upgrading the feedline. Even three or four metres extra can increase the number of stations who can hear and reply to you.

Need 3: As quiet a receiving environment as you can manage

Have you ever heard a strong station call CQ, attract replies but keep calling regardless? This could be for several reasons including large differences in transmitter power or antennas, interference from other stations or constantly high noise on receive. Only the strongest replies can be heard by these 'alligator stations' with all mouth and no ears.

Being an 'alligator station' is a particular handicap if you're working towards SOTA or national parks awards. This is because many portable stations are running low power. They can hear you and other portable stations easily, whereas you at home with your high noise level may have difficulty hearing them. Possible solutions include separate receive antennas, directional loops or even a remote receiver located in an RF quiet area.

Need 4: Understand propagation and activity patterns

We have numerous bands and frequencies available. Each has distinct propagation and activity patterns. Just because there is propagation does not mean there's activity. And, conversely, a band can be active even if propagation isn't anything special.

Be aware of your location with respect to concentrations of other amateurs. For example, if you are more than about 100 km from a capital city, the activity you hear on VHF and especially UHF will be less than that heard by metropolitan dwellers. Similarly, someone in central Australia may struggle on 1.8 or 3.5 MHz but succeed on 7, 10 and 14 MHz due to the properties of these frequencies.

The highest activity is found on the 3.5, 7, 14 and 144 MHz amateur bands. Unless you are remote, signals should be audible on each of these bands for large parts of the day or night. 1.8, 10 and 432 MHz also often sees daily usage in many areas. Bands like 18, 21, 28, 50 and 1296 MHz see less regular activity. But don't write them off. When open they can be busy and signals extremely strong, especially on 28 and 50 MHz. Regional variations

also exist due to local activity sessions and nets on bands/modes like 1.8 MHz AM and 144 MHz SSB. Persistent listening and reading of various websites and forums will provide clues here.

Table 1 shows distance workable and activity level by time of day and frequency. It is approximate and seasonal. For example, good summer conditions can bring 10 m, 6 m, 2 m and 70 cm alive, with much more than local coverage possible. Whereas winter's relative absence of static makes bands like 160, 80 and 40 m more usable. Operating mode can also be decisive and there can be a trade-off between efficiency and popularity. For example, at least within VK and on the VHF/UHF bands more operate SSB/FM than CW. Voice modes may be less efficient than CW but their greater popularity compared to CW means that more people are likely to be around to reply. On the other hand, CW penetrates better so may produce results, especially with low power or for DX contacts, that SSB doesn't. The same is also true amongst voice modes where SSB offers better results than FM, but the latter sees more routine activity on the VHF/UHF bands.

The solar cycle along with day to day conditions also affects

distances spanned. For example, 7 MHz offers blanket coverage during high sunspot years but skips over closer areas when solar activity is low (as current). However, on these occasions, its daytime range may be greater due to lower ionospheric absorption. 3.5 MHz may be a better pick for contacts within your own state during such conditions.

Very roughly, HF frequencies above 10 MHz support longer distance communication during the day while frequencies below 10 MHz travel furthest at night. The same pattern exists for medium distances except the optimum frequency is lower. For example, an 800 km contact such as between Sydney and Melbourne may be best achieved on 7 MHz during the day or 3.5 MHz at night. Sometimes periods around an hour after sunrise or an hour before sunset produce transition conditions that produce the strongest signals on particular paths.

Day/night variations are much less on the VHF and UHF bands. However, they still exist. For instance, the higher chance of sporadic-E on 50 MHz during the late morning to afternoon, or tropospheric ducting on 144 and 432 MHz for longer distances around dawn and dusk.

Table 1: Table one shows distance workable and activity level by time of day and frequency. All distances in table listed as numerals are distances in kilometres (km).

() Wide seasonal variations. High in midsummer, moderate in midwinter, low at most other times.*

Band (MHz) >	1.8	3.5	7	10	14	18-24	28	50	144	432+
Time										
Early morning	Moderate 0 - 500	Moderate DX	High DX	Moderate DX	Low Local	Low Local	Low Local	Low Local	High Local	Moderate Local
Late morning	Low Local	Moderate 0 - 300	High 500 - 1000	Moderate DX	Moderate DX	Low DX	Moderate* 500 - 2000	Low 500 - 2000	Moderate Local	Low Local
Midday	Low Local	Low Local	Moderate 300 - 1000	Moderate 600 - 2000	Moderate 800 - 3000	Low 1000 - 3000	Moderate* 500 - 2000	Moderate* 500 - 2000	Moderate Local	Low Local
Early afternoon	Low Local	Low Local	High 500 - 1000	Moderate DX	Moderate 800 - 3000	Moderate DX	Moderate* 500 - 2000	Moderate* 500 - 2000	Moderate Local	Low Local
Late afternoon	Low Local	Moderate 0 - 300	High 1000 - 3000	Moderate DX	High DX	Moderate DX	Moderate* 500 - 2000	Moderate* 500 - 2000	High Local	Moderate Local
Early evening	Moderate 0 - 500	High 0 - 3000	High DX	Moderate DX	Low Local	Low Local	Moderate* 500 - 2000 (Dec - Jan)	Low Local	Moderate Local	Low Local
Overnight	Moderate DX	Moderate DX	Moderate DX	Low Local	Low Local	Low Local	Low Local	Low Local	Low Local	Low Local

Medium frequencies – that is our 472 kHz and 1.8 MHz bands – are different again. Their ground wave can produce solid contacts day and night out to 100 km or more. Night produces a somewhat extended range, with sky wave assisting the always-present groundwave. DX is possible but foreign signals are rarely as strong as you might hear on 3.5 or 7 MHz. Noise on receive and antennas on transmit are the main challenges here but you can console yourself that they are shared and have been overcome by those active on these bands.

Need 5: Operating technique and persistence

Having established a good sounding station and got an idea as to what distances and activity to expect on various bands at different times, operating technique is the next need. Listening is the first part of this. On the higher HF bands listen for the International Beacon Project (IBP) beacons on 14.100, 18.110, 21.150, 24.930 and 28.200 MHz. These frequencies are time-shared by multiple beacons around the world, taking carefully timed turns to transmit. In addition, tune the beacon segments on bands above 28 MHz. While you're at it keep tabs on contacts in progress, stations tuning up and those calling CQ themselves. All this listening will give an idea of propagation and activity.

Reply to any CQ calls heard before originating a call yourself. If there are none, choose a frequency. Firstly, it should be consistent with the band plan as published at wia.org.au Secondly it should be selected to avoid creating interference to others and them interfering with you. This means a spacing of at least 3 (preferably 5 kHz) from an occupied frequency on SSB and at least 1 (preferably 2 kHz) from an occupied frequency on CW. Finally, position yourself near where most people tune when they are looking for contacts on a particular mode. As an example,

your chance of a reply is less if you call CQ on 7.295 MHz SSB than 100 or 150 kHz lower which are more popular with more people tuning by. On the other hand, you wouldn't want to be too low if seeking US contacts due to restrictions in their band plans which differ from ours.

A major part of frequency selection is putting yourself in the clear. On bands like 80 metres at night you can generally hear most of the stations that others do. However, this is not true of the higher HF bands where there is a large dead zone between about 50 km and the point where signals return to earth several hundred to a thousand kilometres distant. During low sunspot years (such as now) 7 MHz can also behave like that. The problem here is that a frequency you think might be clear might in fact be occupied by stations 300 km away. You don't hear them and they don't hear your enquiry as to whether the frequency is in use. No one is at fault but someone 1000 km away may hear both signals but read neither.

This problem often comes up during popular contests when the bands are busy. At least in VK, many stations favour calling on multiples of 5 kHz. Maybe it's the satisfaction of round numbered frequencies. Whatever it is there is no need for it since nearly all of us are frequency agile and the HF bands are not channelized. I've heard stations call and give up as they did not know they were transmitting on a busy frequency. The chance of being in the clear if you pick a frequency ending in 2, 3, 7 or 8 kHz is greater as there is less likely to be someone right on it. Another thing you can do is to move frequency if there are no replies after numerous calls on one that initially seemed clear to you.

Commence your call once you have selected a band, assessed activity and found a clear frequency. Its length depends on the number of people around and the pace of operating. A CQ call on an FM satellite is short due to the need

to share short satellite passes. A CQ call for a contest is brief due to heightened activity. CQ calls are also short if you are sought after such as if activating a DX location, summit or national park and you know there are people waiting to work you. Such short calls may include announcing your callsign once and listening for five to ten seconds before recommencing.

Other styles of activity or operating support a slower pace of calling. For example, if the band is quiet or it's a time of day few are around. Announce CQ several times; repeat your callsign in phonetics and repeat all over again two or three times before announcing that you are listening. The aim is to catch the casual listener tuning by or the ham in the shack watching their spectrum display. It could be your call that alerts others that the band is open. Marginal conditions also suit longer calls with phonetics as several repetitions may be required for listeners to copy your callsign. Don't go overboard though - long unbroken calls test listener's patience and few will be enticed to wait for a chance to reply. Another courtesy to listeners is to listen well and sufficiently long for responses. Give your ear's inbuilt automatic gain control a few seconds to recover and hear weak signals. Those who call CQ but leave only tiny gaps are excluding all but the strongest stations from replying.

Most respondents will give up, spin the dial and find a more patient station to call.

Careful listening is important. If you think you hear a signal say 'QRZ?' or 'Who is calling?' Listen carefully; leaving a longer gap in case they repeat their callsign with phonetics. You may put on headphones or switch in filters or preamplifiers if this makes reception better. If something is heard keep asking for their callsign until you can identify letters and then the complete call. The correct receipt of a caller's callsign is fundamental



Photo 3: An audio filter can assist reception of weak signals, especially if there is interference on an adjacent frequency. Here is a crude one, using a cup and a salvaged speaker, for CW.

to making a contact; avoid saying much more until each of you have copied and confirmed callsigns. Should nothing be heard invite the station to call later if conditions improve and resume calling CQ.

Be persistent in your calling. You probably won't get a reply to your first, second or even third CQ call unless there is a contest. Make at least 15 to 20 minutes' worth of calls per band to give yourself

a fair go. People are switching on, tuning around and switching off all the time. Conditions may also change. You don't want to have someone respond only to miss them as you switched off or changed frequency too soon. More advanced transceivers have automatic CQ callers to take the drudgery out of calling. Or, if yours doesn't, you can use a computer, voice recorder or microcontroller to make one.

One trap that some fall in to, is dependence on propagation charts or predictions. While certain times may maximise your chance of success, I still recommend occasionally listening and calling at odd times. You never know someone else might have the same idea and a reply may be forthcoming, even if it's a local. And if it's someone further away? Then you will have demonstrated the limitations of using unfavourable solar numbers or a lack of signals heard as a reason not to call. The serendipity of such contacts is one of the joys that those who call and answer CQ experience. Such luck rarely comes to those who confine their operating to fixed time skeds and nets.

Conclusion

Whatever the frequency or mode, the art of calling CQ and making unscheduled contacts lays at the essence of amateur radio. Follow the tips presented for increased success, regardless of your station, antenna or output power. And if you do make a noteworthy contact, drop a short note to the AR editor; he will be happy to feature it here and the rest of us will enjoy reading about it.

(*) vk3ye.com & youtube.com/vk3ye

WIA news Continued from page 5

Licence – Renewal Notice.

This sometimes occurs when a Renewal Notice does not arrive via the postal system or is delayed in the postal system.

Amateurs are reminded that it their own responsibility to know when their licence falls due and to ensure that the licence fee is paid.

ACMA endeavours to send renewal reminders. This comes in two forms: an initial reminder that a licence will be due for renewal in 90 days, and then an Invoice for Renewal in 30 days.

If you do not pay the fee on time, ACMA allows a grace period of 60 days.

If you find that your licence is no longer valid due to non-payment, you should contact the ACMA immediately. A new invoice can be generated if you make contact within the grace period. If contact is made via telephone, you may be able to make payment immediately with a credit card.

You should check that the ACMA has a valid email address for you, as email is the preferred method for issuing notices for renewal.

If you fail to pay the licence fee before the end of the grace period, you may need to go through the

process of applying for a callsign, with no guarantee that your previous callsign is still available.

Licence renewals and the initial issuing of licences has always been a function of the ACMA. Previously, WIA was involved in the Callsign recommendation process, a process now administered by Australian Maritime College. Any concerns regarding the issuing of an initial licence invoice or of a renewal notice should be addressed to the ACMA.

IC-9700 VHF UHF all mode transceiver

Peter Freeman VK3PF



Photo 1: The non-identical twins: the IC-9700 and the IC-7300.

Those interested in the world of VHF, UHF and microwave communications have been discussing the newest offering from Icom since a sample was displayed at the Tokyo Ham Fair in August 2017. Promised as the first transceiver using Software Defined Radio (SDR) architecture covering the 2 m, 70 cm and 23 cm bands, amateurs around the world have been speculating on the features and likely performance of the IC-9700. Of recent weeks, the speculation was primarily about the selling price in various markets and then the likely delivery dates of the first units into the amateur markets in various continents.

At first glance, the IC-9700 looks very much like the first SDR offering from Icom: the IC-7300 HF and 50 MHz transceiver. The IC-7300 was the first offering from one of the major amateur transceiver manufacturers to deliver a Direct Digital Sampling and Direct Digital Synthesis transceiver. Other offerings were available in the market place from other manufacturers, but at the time they required a separate computer to

drive the transceiver. The IC-7300 delivered a SDR but with a familiar user interface built in: VFO knob, a colour display and several familiar control buttons. It also introduced a very detailed set of optional features and settings available via the touch screen display and associated menu system.

The new IC-9700 delivers many of the features of the IC-7300 but in a VHF/UHF transceiver. In addition to the colour touch screen display and comprehensive settings menus, the transceiver gives a real-time spectrum scope and a waterfall display. In addition to the 2 m and 70 cm bands, the IC-9700 has the 23 cm band built in as a stock item. In the predecessor transceivers (IC-910 and IC-9100), the 23 cm band was a relatively expensive optional module. The IC-9100 could also have an optional module added to give access to D-STAR (Digital Smart Technology for Amateur Radio) Digital Voice (DV) mode, with an associated low-speed digital data capability.

The IC-9700 delivers D-STAR built in to the unit, with the higher speed Digital Data (DD)

mode available on 23 cm. It also includes Satellite mode, using any combination of two of the three bands. The transceiver comes with three antenna connectors: an SO239 socket for 2 m socket, and separate N type connectors for the 70 cm and 23 cm bands.

System architecture

Similar to its HF relatives, the IC-7300 and IC-7610, the antenna connector for either the 2 m or 70 cm band connects to a band-specific preamplifier/attenuator module before passing to a band pass filter (BPF). The signal path then passes through an RF switch before going to an analogue-digital converter (ADC) to be digitised. The digital signals from the ADC then pass to a Field Programmable Gate Array (FPGA) IC for processing. The FPGA has several outputs: recovered audio to a Digital to Analogue Converter (DAC) to pass to the speaker or headphones, to the CPU for processing and to produce the scope displays, or to a DSP unit for processing DV signals. In the case of the 23 cm band, the incoming signal passes

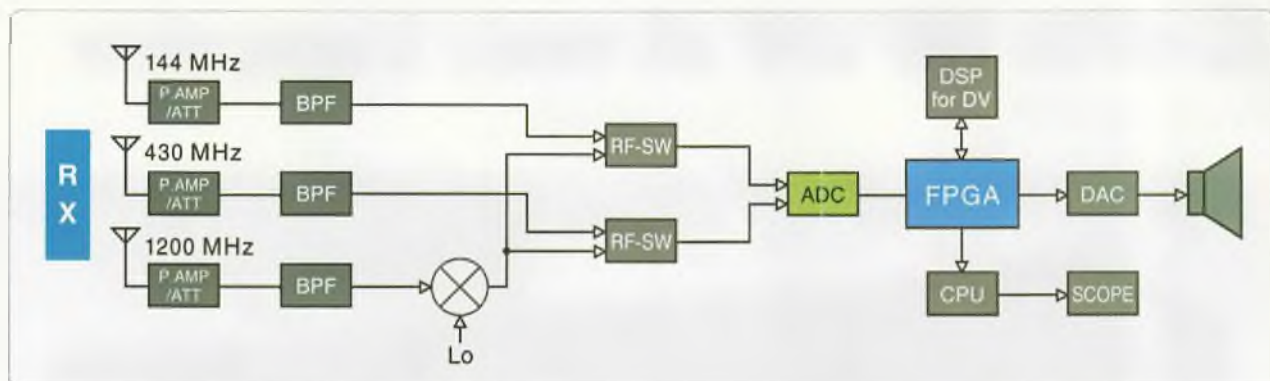

Figure 1: IC-9700 functional block diagram.

from the BPF to a mixer for a single conversion stage to an IF frequency (311 – 371 MHz) and thence to the RF switch and into the ADC for sampling. See Figure 1.

The process for transmit is similar, but in the reverse direction: Audio frequencies are sampled by an ADC; the digitised audio is processed in the FPGA and then produced as an RF signal at the required frequency by a DAC. The RF signal will then be processed with appropriate filtering and amplification on its way to the RF connector.

Control of the transceiver is via a number of typical switches and knobs, with additional controls accessible via the touch screen display. The first Menu level gives quick access to the more commonly used options. Settings which are typically rarely changed after they are first configured are in lower level menus, notably through the SET menu on the first level Menu screen.

The IC-9700 can receive on two bands at the same time, with two independent receivers. The bands must be different, but any mode can be in operation on each receiver. The radio can operate full duplex, so you can transmit on one band whilst still receiving on the second band.

Unpacking

The box is of different form factor to that for the IC-7300. On opening the box, you will see the Basic Manual in a plastic bag resting on

a cardboard divider. Removing the divider reveals the next layer, with the HM-219 hand microphone, DC power cable and supplied accessories sitting in the middle section. Supplied items include two 25 A fuses, one 5 A fuse and a 3.5 mm (1/8") stereo plug for use for connecting a CW key or paddle. Lifting out this layer leads to the radio sitting in its foam plastic bag. The radio comes with a protective plastic film across the colour TFT display. Most users will wish to remove the film to enable easier access to the soft control buttons displayed on the menu system. Screen protector films are available on the market for the IC-7300 and should fit the IC-9700. A web search should bring up several options.

The 96-page Basic Manual is also available for download on the Icom Australia website, as is a brochure. Readers considering purchasing the radio might consider reading both the brochure and the Basic Manual to assist in your deliberations. Also available for download from the Icom global site are an Advanced Manual (173 pages), a CI-V Reference Guide (27 pages) and an instruction sheet and the installation package for the CS-9700 software. At the time of receipt of the radio, it appears that at least one page (page 2-2) was missing from the Basic Manual, both the hard copy supplied with the radio and the downloadable version. The Japanese language Basic Manual has pages 2-1 to 2-3. Icom

was alerted to the issue and have released a revised manual available for download. The pages concerned cover some of the basic connection features to the rear connectors, including USB and the accessory (ACC) connectors. If needed, download the revised Basic Manual from the Icom Australia website.

Connectivity

In addition to the three RF connectors and the DC power connector, there are several other connections available on the radio.

The front panel has the usual 8-pin microphone connector in the lower left corner, with a 3.5 mm stereo headphone jack located above the microphone connector. The front panel also has an SD card slot on the lower right edge.

The rear panel has the three antenna connectors and the DC power connector running across the upper portion. To the left there are two connectors below the 144 MHz antenna socket: an Ethernet connector (LAN) and an SMA socket for inputting a 10 MHz reference signal (REF). To the right hand side of the cooling fan, you will find the remaining connectors: an eight pin DIN Accessory (ACC) socket, a 2.5 mm stereo Data jack (DATA), a USB Type B port (USB) for connection to a PC, a 3.5 mm stereo jack (KEY) for a straight key or paddles, a CI-V remote control jack (REMOTE), two 3.5 mm mono external speaker jacks (EXT-SP SUB and EXT-SP MAIN), and a Ground terminal (GND).

The USB connector is flexible, with similar functions to those on the IC-7300 and IC-7610. It installs on a PC as both a communication port and as a sound card. The radio can output decoded RTTY data, demodulated audio signals or a 12 kHz IF signal, accept AF modulation input, interface for CI-V commands, clone the settings data using the CS-9700 software or remote control using the optional RS-BA1 version 2 software. It should be noted that the version 2 of RS-BA1 software must be purchased.

The LAN port can also be used for several functions: time synchronisation via an NTP server, outputting the demodulated AF signal or a 12 kHz IF signal, remote control using the optional RS-BA1 software, D-STAR Gateway communication or data communication for D-STAR DD mode.

For amateurs attempting weak signal communications, the radio can be set to support external low noise preamplifiers supplied by the user. This includes the older Icom preamplifiers which are no longer in production.

Getting on air

Connecting up the radio to a power supply, antennas and connecting the microphone was simple: the labelling on the rear of the radio gives a clear indication of each connection. The loan unit came supplied with firmware version 1.04. The main batch of radios arrived a couple of weeks later, with firmware version 1.05 installed.

I soon had a screen displaying odd ball (for local usage) frequencies in 2 m and 70 cm – the unit supplied was one of the USA variants, so the default frequency fit with USA band plans. It was simple to tune to the local repeater for 2

m and I soon also had the local 70 cm repeater output on screen. All of this without looking at the Manual – many features are similar to those on the IC-7300. I soon figured out how to switch between the Main and Sub bands: a long press of the MAIN: AF / RF/SQL centre button. Looking at the labels reveals that a long press on the centre button of the SUB: AF / RF/SQL centre button switches off the SUB band, leaving only one band active.

I soon had the basic Menu settings correct to set both the Duplex and the CTCSS Tone and had my first contacts on the 70 cm repeater. I had not adjusted any of the other controls, such as microphone gain or any of the Tone controls. I received comments that I sounded slightly different to normal, but I am sure that I could adjust settings to fix that difference: something to explore when I had more time to explore the radio.



I next dialled up the local 2 m and 70 cm beacons and immediately had signals from both, right on frequency when in CW mode. I could not yet check the 23 cm beacon as I had no antenna connected.

As with the IC-7300, the received audio quality sounds clean and crisp, being very pleasant for listening. Reports on the transmitted audio were also good.

I then started exploring the radio further, this time in conjunction with reading the manual. As with any SDR, there are many settings to configure. The basic configurations are covered in the Basic Manual. The first step should be to examine Section 1 of the Basic Manual, which describes the Panel features, including the various screens displayed on the touch screen display, together with lists of the available options on several of the screens. Section 2 covers the

basic installation and connections with references to some additional information later in the manual.

Section 3 covers basic operation, describing the fundamentals of changing frequency, band, mode, the dual watch feature, selecting Main and Sub bands, and several other basic options. These include setting microphone gain, an important setting if you are to not upset other amateurs when transmitting.

Section 4 examines most of the functions and controls required for Receiving and Transmitting, including several key controls.

Section 5 covers the controls for the Spectrum Scope and Audio Scope displays.

Section 6 describes the various tasks that make use of the optional SD card, including saving current settings and importing and exporting data.

Section 7 describes the Satellite

Communications settings.

Section 8 gives an outline of each of the options under the SET mode menus.

Section 9 describes the Clock settings and the operation of the NTP time synchronisation function.

Section 10 covers basic maintenance operations, cloning, rest and troubleshooting.

Section 11 lists the Specifications, whilst section 12 lists the available Options.

Section 13 gives details of the various Connectors.

More detailed settings and operational requirements are included in the Advanced Manual.

The "new" digital modes

Most amateurs are aware of the explosion of activity on the HF bands of the "new" digital mode FT8, which is included in the WSJT-X software suite. Many amateurs on VHF, UHF and



microwaves have been using other WSJT modes for many years. Readers of the *VHF/UHF - An Expanding World* column would be aware that WSJT modes have transformed operations on the weak signal segments of the VHF, UHF and microwave bands. Some of those modes require excellent frequency stability and accuracy to yield the best weak signal performance. Many keen operators were expecting that the inclusion of a 10 MHz Reference port on the IC-9700 meant that they would be able to reference lock the radio with a good quality 10 MHz frequency source – many operators currently use GPS-locked 10 MHz frequency sources to lock their radio master oscillators to the correct frequency, thus giving accurate frequency readout without any associated frequency drift.

As currently configured, the IC-9700 only has the capability of performing a “REF adjustment”, allowing a “rough frequency calibration using the external reference frequency signal”. This option is several layers deep in the SET menus. Once performed, the reference frequency is set close to the external reference. On exiting the function, the reference oscillator continues to behave as it would normally. See the comments in the break out box on digital modes regarding frequency stability.

At the time of writing, most of the software packages have not yet added the IC-9700 to the list of supported radios. This situation is changing rapidly as software authors are approached by users to add the new radio. As an interim measure, operators have been changing the CI-V address setting to that of another of the Icom transceivers, typically the IC-7300 or the IC-9100.

Operating any of the new or more established soundcard digital modes should be simple, once you have the radio and computer set up correctly. Once all the settings are correctly configured, CAT control

and bidirectional audio between the radio and the computer can occur using only the USB cable, in a similar fashion to the operation of the IC-7300 and IC-7610.

Filter bandwidth can be set to as wide as 3.6 kHz with “Sharp” shoulders, giving increased bandwidth available for the modes such as FT8, MSK441, ISCAT-B and QRA64-E. See the break out box on digital modes for further comments.

A number of advanced features are available for operating CW and RTTY. The user can store up to eight (8) memories for each of CW, RTTY and Voice. The radio will decode RTTY signals. It is simple to access the required control and display screens, with detailed explanations available in the Advanced Manual. The Advanced Manual also explains how to record audio made whilst in a contact and recording Voice TX memories.

There are many other functions to explore, such as Tone and DTMF, Memory operation, setting Scans, interfacing and using an external GPS receiver. There are detailed descriptions on using D-STAR DV and DD modes. D-STAR users will find the GPS functions useful if using the radio portable or mobile, where the position data can assist in locating the nearest repeater.

CS-9700 Programming Software

About a week after the loan radio was acquired, the free CS-9700 Cloning/Programming software became available on the Icom Global site. The software runs on Windows 7 and above. Initially, read the instructions document, then download and install the package. Connecting to the radio is simple via the USB port. I started with the USB cable plugged into the radio with the radio turned on. After installing the CS-9700 software package, I plugged the USB cable into the computer. Provided that the required driver software is already installed, the software will open and should auto-detect the radio

COM port. If this does not occur, try clicking the Search button.

The programming software can also be used to read and save information via an SD Card.

The radio has 99 memory channels per band, which should be sufficient for most users. To import a repeater list, you need to create a CSV file, as cut/copy and paste from another application is not available. The programming software instructions are good at explaining how to setup the PC and radio for import / export but do not explain the CSV input format required. To determine the format, I created a couple of memory channels, saved them to the radio, exported the CSV file and inspected its contents. One can then create a CSV file in the right format to load into the radio.

Switching between memories and VFO is a single button (V/M), scanning the memories is easy; as is repeater operation once the memory channels have been programmed. You can select memories by number or rotate the MULTI knob to manually select them. Switching between bands is easy via the touch screen or by pressing the AF knob to switch between A and B. The radio can only dual watch two different bands i.e., you cannot monitor two channels on the same band.

The SD card can also be used to transport firmware upgrades. Note that it is recommended that the user save the existing radio settings to an SD card prior to performing a firmware upgrade.

RS-BA1 software

Icom also have for sale the RS-BA1 IP Remote Control software package. The software is now in Version 2, which adds additional functionality for the transceivers with dual receivers. The user must purchase version 2 or above to support this radio. The software allows most functions of the transceiver to be controlled from a local PC connected to the radio, or over the internet. The software



can also be used with several other Icom radios.

The software has not been included in this review.

Operational tests

In general, the radio is easy to use. Received audio is excellent. Reports of transmitted audio have been positive. Some users have reported noticeable frequency drift when using the radio on SSB on 70 cm and 23 cm.

Satellite operators have been reporting excellent performance, once they have software settings correctly configured for the radio.

Once configured, the radio is easy to use in D-STAR modes.

A number of tests were conducted to assess performance parameters. Some quick tests were undertaken on the unit supplied for review, with more detailed tests

conducted on a retail purchased transceiver. We were impressed with the performance figures obtained, with the receiver performance easily better than the specifications in the Icom documentation. Transmitter performance was as specified.

Frequency stability was checked on the 23 cm band after allowing the test unit to warm up for at least two hours. The test signal was a GPS locked signal generator operating at 648 MHz, with a clear stable second harmonic audible in the receiver. The received signal was within 5 Hz of the expected frequency. The test transceiver had been updated to Firmware version 1.06, which was released 19 April 2019. The firmware update improved the performance of the Reference Auto-Calibration routine.

A test of transmitter frequency stability showed a drift of 2 Hz over

a 2-minute transmit period using WSPR mode, which is considered acceptable. Several users have reported unacceptable levels of frequency drift. It seems that there is some variability between individual radios.

Tests on two units failed to observe any power spike upon commencing transmitting. The observations were made using a spectrum analyser with a peak-hold function, and with a suitable fast oscilloscope. Some users on the IC-9700 Group at groups.io reported tripping of protection circuits in attached amplifiers. These issues were resolved by changing the TX Delay setting from the default OFF to a value such as 15 or 30 ms. The setting can be found via: MENU, Function, Tx Delay. Some users have expressed opinions that longer delays may be

desirable, especially where the user is driving a microwave transverter with the IC-9700. It is possible that such longer delays might be introduced via a firmware update in the future, but other interfacing solutions are possible, such that the longer delay occurs via an outboard sequencer unit which only activates the transceiver after the transverter has reached the desired state before RF is sent.

One US amateur is well regarded for his independent tests of transceivers and receivers: Rob Sherwood NC0B. Rob has given permission for us to reproduce the results from testing his IC-9700 on the 2 m band, as well as comparative test results from the IC-9100, IC-275H and FT-736. See Table 1. For those interested in more detailed test results, Rob's findings will be available for download from the WIA website page for this issue. Readers can also visit Rob's website: <http://www.sherweng.com/table.html>

Most of the data on the Receiver Test Data page relates to HF transceivers and receivers. Table 1 shows a selection of VHF

capable transceivers and receivers measured on the 2 m band extracted from Rob's data. The noise floor and sensitivity measures for the IC-9700 are at the head of the pack. The filter rejection measure is exceptional, at 100 dB.

Issues to consider

There appear to be some issues if the amateur wishes to work at the extremes of performance and thus require a truly stable frequency source. The author considers the implementation of the use of the external 10 MHz reference in the current manner to be a significant disappointment – many possible purchasers were expecting that the presence of the input port indicated that a quality external reference would be able to lock the master oscillator, as seen in the IC-7610 and IC-R8500. Depending upon the detailed architecture used, it might be possible for the Icom engineers to develop a firmware solution which overcomes the frequency drift observed by several users.

For the amateur interested in exploring the weak signal segments of the bands, there will be another

challenge to solve. The IC-9700 will only transmit on one band at a time. Accordingly, only a single PTT line is available on the 8-pin DIN interface connector on the rear of the transceiver. Anyone wishing to interface the transceiver to external power amplifiers will need to consider their switching options. It might be possible to set the transceiver to use an external preamplifier and thus use the DC signal available on the individual band coaxial line for switching. Another option would be the use a PIC or other microcontroller (Arduino, RaspberryPi, etc.) together with suitable sequencing (software and/or hardware) to control the radio's PTT line in conjunction with a main PTT switch, using the band data available from the CI-V signals (either via the USB port or the CI-V port), to ensure that all receive preamplifiers are protected and power amplifiers and radio are only activated after all devices are in the required transmit configuration.

To be fair to the manufacturer, some of these issues represent challenges that the amateur wishing to work at the limits would expect to have to solve.

Table 1: Receiver test data from Rob Sherwood NC0B.

Device Under Test	Noise Floor (dBm)	AGC Threshld (uV)	dB	100kHz Blocking (dB)	Sensitivity (uV)	LO Noise (dBc/Hz)	Spacing kHz	Front End Selectivity	Filter Ultimate (dB)	Dynamic Range Wide Spaced (dB)	kHz	Dynamic Range Narrow Spaced (dB)	kHz
Icom IC-9700	-131 -145 ^a	0.7 0.18 ^b	3	111	0.35 0.082 ^b	130 138	10 50	B Bandpass	100	74	20	74	2
Icom IC-9100	-133 -141 ^b -141 ^c	2.4 1.0 ^b 0.39 ^{b1}	3	N.A.	0.36 0.15 ^b 0.130 ^c	119 136	10 50	B Bandpass	N.A.	101 ^f	20	71 ^f 60 ^g	2
Icom IC-275H 2 metres	-136 ^a	0.25	3	122	0.11	124 141	10 50	B Bandpass	75	85	20	63	2
Yaesu FT-736R 2 metres	-141	1.3	3	125	0.11	128 143	10 50	C Bandpass	80	88	20	66	2
Icom IC-R8600 Second sample S/N 02001177	-131 -142 ^b -130 ^{ab}	2.40 0.67 ^b	3	125	0.40 0.12 ^b 0.49 ^{ab}	144 148	10 50	B Half Octave	>100	109 ^{ab} 88 ^{ac}	20	107 ^{ab} 88 ^{ac}	2
Icom R9500	-127 -130 ^b -135 ^{b1}	1.1 0.25 ^b 0.16 ^{b1}	3	119	0.7 0.2 ^b 0.11 ^{b1}	134	10	B Bandpass	80	110 ^f	20	85 ^f	2

The data in the above table are reproduced with permission. The original data are published at the Sherwood Engineering Inc. web site: <http://www.sherweng.com/table.html>

The site includes explanatory notes and a key to annotations.

Overall impressions

The reviewer and several other local amateurs interested in VHF/UHF weak signal communications have been truly impressed with the performance of the IC-9700. It will be a very useful addition to the radio shack of anyone interested in operating on the bands covered by the transceiver.

All other users will find the IC-9700 covers most operational requirements in a visually attractive

package with an excellent user interface. As one would expect with a transceiver with the capabilities of the IC-9700, the user will need to commit some time to reading the manuals and exploring the menu system to utilise the radio at its best.

Acknowledgements

I thank the others whom have contributed ideas and information to assist with the preparation of

this review: Peter Hartfield VK3PH, Ewen Templeton VK3OW, Ralph Edgar VK3WRE, Rex Moncur VK7MO and Rob Sherwood NC0B.

We thank Icom Australia for the loan of the transceiver for evaluation.

Recommended Retail Price is \$3575.00 including GST. At the time of writing, local retailers are displaying prices of \$2399.00 to \$2495.00 including GST.

Use of the IC-9700 on Weak Signal Digital Modes

Rex Moncur VK7MO

The IC-9700 brochure describes an SMA socket marked "10 MHz Reference Signal Input". If you are like me, you might have assumed that this meant that the radio is capable of being locked to a 10 MHz reference, such as derives from a GPS disciplined oscillator. Unfortunately, this is not what it seems and not like the IC-7610 HF radio which allows the radio to be locked to a 10 MHz reference.

The purpose of the SMA socket on the IC-9700 is solely to allow you to calibrate the radio to an external

reference. But after this is done and even if you continue to apply the 10 MHz external reference, the radio is free to drift until you calibrate it again. The main source of the drift results from the fan turning on and off. This produces drift of up to 30 Hz at 2 metres and 300 Hz at 23 cm over four minutes. As a result of this drift the radio is unsuitable for weak signal digital modes such as WSPR, JT65 and QRA64 with the sub-modes normally used on the bands for which the radio is designed. In this respect it is not

as stable as the IC-910 with high stability oscillator and is thus a major step backwards if you want to work weak signal digital modes. This is a significant disappointment as the radio has so many other excellent features.

A detailed report on the use of the IC-9700 for weak signal digital modes is on the WIA web site, at the bottom of the page for this magazine issue:

<http://www.wia.org.au/members/armag/2019/may/>



WIA Election Declaration

WIRELESS INSTITUTE OF AUSTRALIA
PO Box 2042
Bayswater
Victoria 3153 Australia
Phone: + 61 3 9729 0400
Facsimile: + 61 3 9729 7325
www.wia.org.au
nationaloffice@wia.org.au
ABN 56 004 920 745

I, John Marshall, the returning officer of the Wireless Institute of Australia hereby declare that in accordance with The WIA Constitution, Clause 14.1c and the Regulations (as amended November 2017), nominations were called for four positions to be vacated after the 2019 AGM. Vacancies on the Board will be created by the retirement of Peter VK8ZZ, Greg VK2GPK, Justin VK7TW and Marcus VK5WTF at the conclusion of the 2019 AGM. The retiring members were all eligible to re-nominate.

The vacancies were advertised and nominations sought in the November / December edition of *Amateur Radio* magazine.

I further declare that three nominations were received to fill the four vacancies as advertised. An election is therefore unnecessary.

Accordingly, I hereby declare that the following members have been elected unopposed to the position of Board Member of the Wireless Institute of Australia.

Michael Alsop VK8MA *new Director*
Greg Kelly VK2GPK *returning Director*
Peter Clee VK8ZZ *returning Director*

These members have been elected for a period of two years from the conclusion of the 2019 Annual General Meeting of the WIA.

John Marshall
Returning Officer
WIA Election 2019
5 April 2019

Circuit Simulation for the Homebrewer

Phil Hutchings VK4PG

Abstract

Circuit simulation is a useful tool for homebrewing by radio amateurs. LTSpice is a well-used and free simulation tool.

This article gives examples of circuits drawn using the LTSpice schematic editor. It also shows sample simulation output, and some hints in using LTSpice as a guide for "ugly construction".

A personal journey

For me, homebrewing radio circuits are very satisfying. And while I'm still very much a novice, this part of our hobby has been made so much easier with the ready availability of free circuit simulation software.

It is interesting to wind the clock back thirty five years and reflect

on my first moderately successful attempts at building an 80 metre superheterodyne receiver. Back then, I had a soldering iron and nothing else. It was a case of slavishly following instructions to build the complete multi-stage unit, then applying power and seeing if it worked.

In the intervening period, family and work intervened and I laid down the soldering iron. It's only now that I'm mostly retired, that I have the time to truly learn better homebrewing techniques. It has helped that I have now equipped my home workshop with some basic trouble shooting tools:

- A digital multimeter;
- An aging, but effective, signal generator; and

- A digital storage oscilloscope (DSO).

The multimeter was new, but the other items were opportunistic purchases from online websites. I found that using these was not intuitive and the online community is a great source of knowledge. There's usually a reason the why the DSO is not doing what I expect and often this is due to an incorrect setting. Once the DSO has been mastered, it becomes invaluable for monitoring performance and trouble shooting.

I have also equipped my workshop with a good soldering station, high quality solder, liquid flux and a PCB holder – vital to keep my hands free while soldering.

Figure 1: A simple LTSpice circuit (a one-transistor RF preamp) with simulation output.

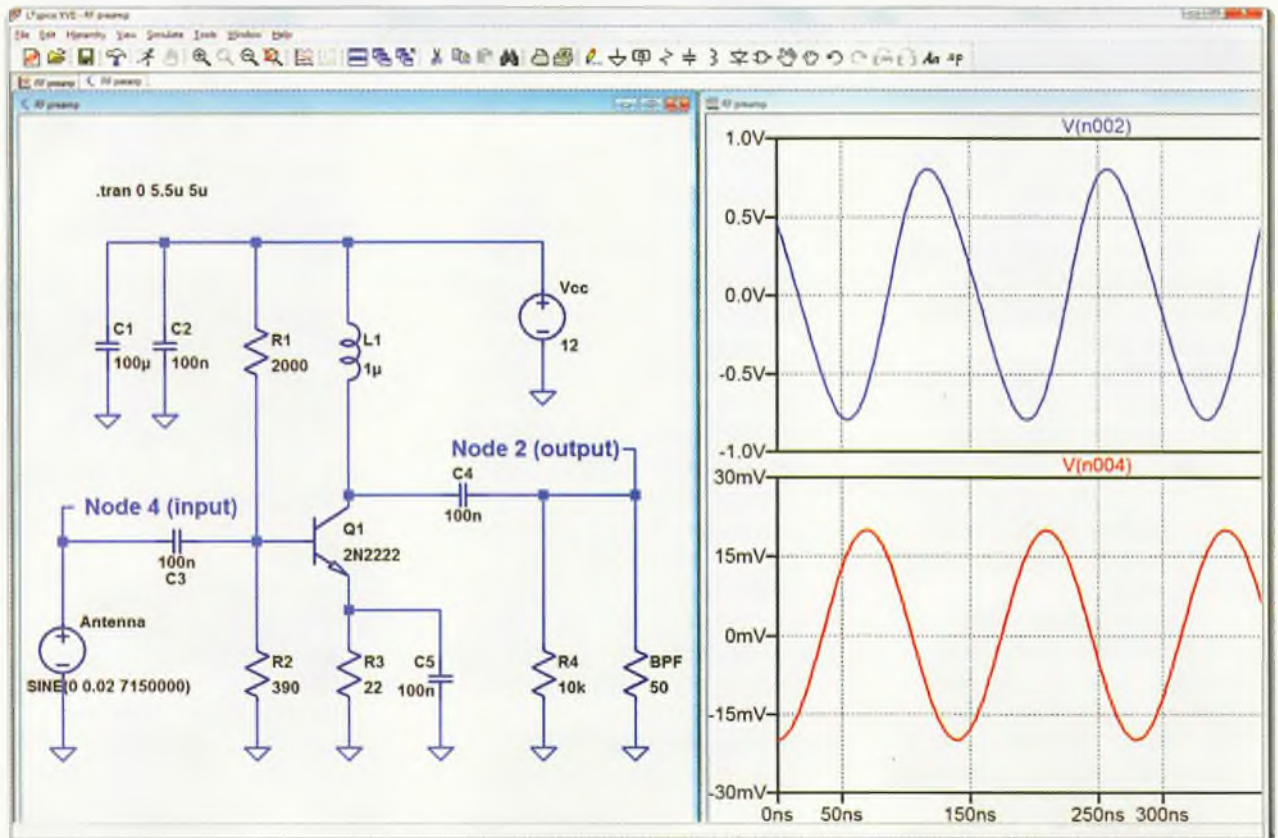

The other great resource I use is free – LTSpice for circuit simulation. I have a trusty aging PC on the workbench with the ability to simulate and test any circuit I am building. It simultaneously runs both LTSpice and the article (or YouTube video) describing the circuit I am building. For example, the circuits in this article are part of a simple 40 m SSB transceiver which was designed and excellently described on YouTube by ZL2CTM: <https://www.youtube.com/watch?v=dhhsiTyXhdU>

Building and testing circuits in stages is a great protocol. Step by step construction minimises heartache, but also maximises learning. ZL2CTM's simple and well-spaced out bread board arrangement is easy to replicate.

What is Circuit Simulation?

Circuit simulation is a computer tool to show how electronic circuits will work. Circuit simulators comprise three components:

1. **Schematic Editor.** This is a graphical tool for quick and easy drawing of the circuit. The user picks and places components (resistors, capacitors, transistors and even ICs) into a circuit. They are connected by a "wire" and values assigned to each component (e.g. 580 Ω or 1.5 μF). It is then easy to simply move components around. Circuits can be readily edited and expanded.
2. **A Simulation Engine.** This is the "brains" which calculates the quiescent voltages and currents and then the reaction of the circuit to any inputs. It uses mathematical models of each component to calculate voltage and currents.

There are several types of simulations possible. It is possible to see the operating point of any transistors and ICs. Then a "Transient" analysis calculates voltages and currents at all points at nanosecond intervals as the circuit responds

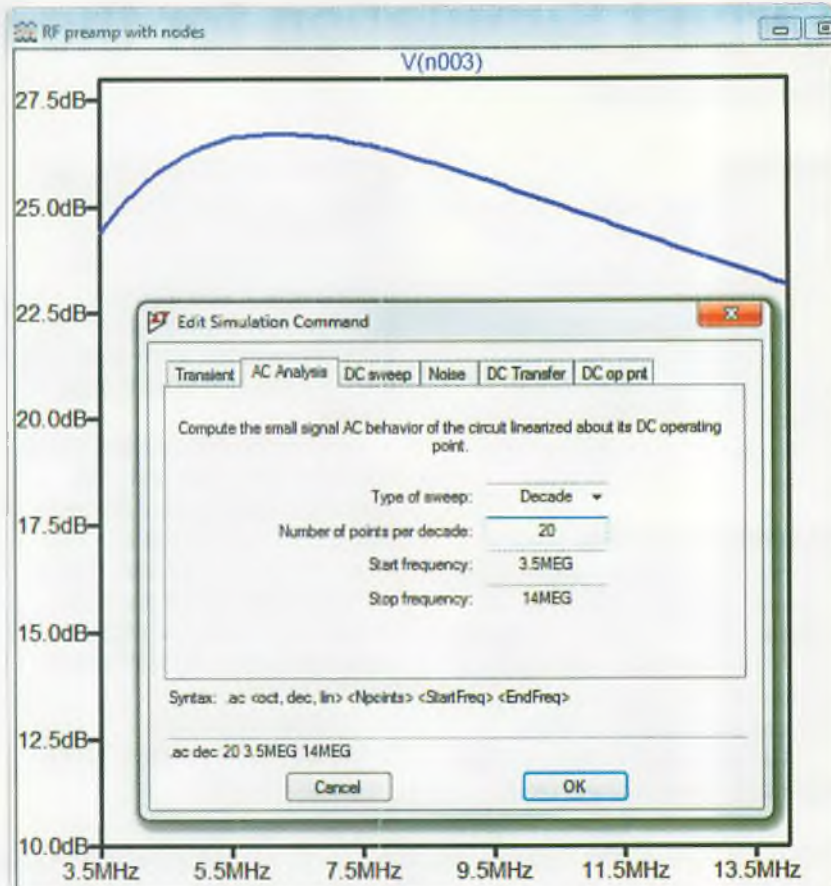

Figure 2: Frequency sweep on RF Preamplifier.

to an input signal.

It is also useful to check how circuits perform over a given frequency range. For example, to see how a 40 m band pass filter will perform over a range of inputs from 3 MHz to 10 MHz.

Image 2 shows the gain in dB of the simple one-transistor RF pre-amp over the 3 MHz to 14 MHz range. The box shows the simulation settings used to produce this graphical output. In this circuit, the key component is the 1 μH RF choke in the collector circuit. With LTSpice, it is simple to play with various values of any component to see what gives acceptable multi-band performance.

3. **Graphical Display.** Once a simulation has run, the screen splits into two side by side tiles – one showing the circuit,

and the other showing a blank oscilloscope-like screen. The display simulates an oscilloscope so it is easy to interpret.

The user can select nodes (or components) with a "probe", just like in the real world, to display voltages (or currents). The user can set the time interval of interest. With the mouse, the user can zoom in and read the voltages and currents.

LTSpice

There are several free circuit simulation programs available. It is worthwhile delving into the background first.

The grandfather of them all is SPICE (*Simulation Program with Integrated Circuit Emphasis*). Laurence Nagel from the University of California, Berkeley, developed

SPICE1 and presented it in 1973, making it now 46 years old. Over the years, this core simulation engine has been refined to allow for easy circuit drawing and graphical output. When old time engineers said "we will SPICE a circuit", that meant to prepare a circuit simulation. The core source code was made readily available, and several versions are now downloadable.

LTSpice is a free and well maintained version of SPICE, suitable for hobbyist use. It is freeware produced by semiconductor manufacturer Linear Technology. It can be readily downloaded from: www.linear.com/ltspace

It is worthwhile reading the LTSpice IV "Getting Started" guide, on the Linear Technologies website. There is also a Yahoo LTSpice user group and many well-prepared YouTube video guides for new users.

LTSpice has built-in generic models for popular discrete components, such as 2N2222 transistors. It also has a full range of its own brand ICs, but often

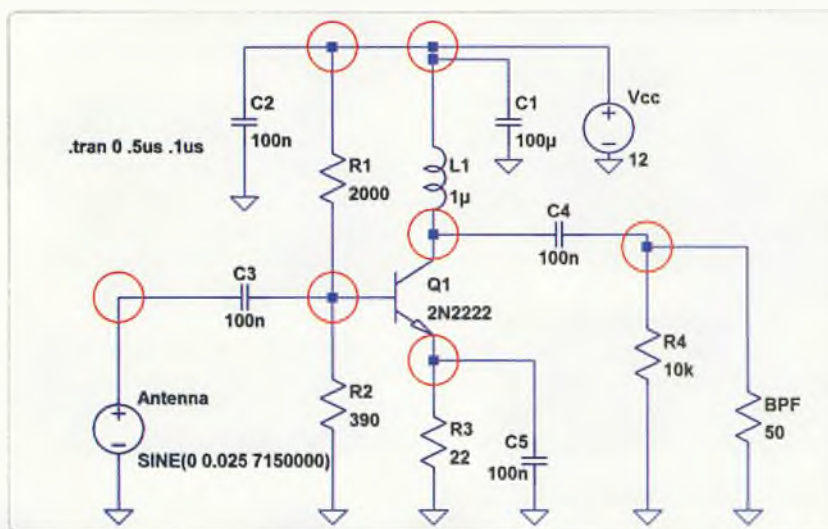

Figure 4: Nodes marked out on LTSpice.

not more popular ICs such as an LM386. This means that the user has to download and install a model for a component if it is not already built in. The Yahoo LTSpice user group is a good source of downloadable models.

How I Use LTSpice

I find that preparing an LTSpice simulation is a quick and useful first step in any homebrew project.

For starters, it forces me to understand the circuit. I lay it out on the screen first, thinking through what each component does. I still often fall into the same trap as new users – forgetting to add at least one ground point. Without that, LTSpice cannot run.

Once complete, I run a "Transient" simulation and graph the input and output voltages. This shows me that the circuit as laid out is correct and working (or not!).

I then run the probe over each important node (each transistor base and collector) and make a note of simulated quiescent voltages. I can also measure important items like collector currents. Knowing the quiescent state is a great troubleshooting tool. My rule is to always check these on the actual circuit with a multimeter before testing it for performance.

Once I'm comfortable that I understand the circuit and it is working correctly, I then think about laying it out for actual construction. As a big fan of "ugly construction" using copper pads superglued onto a PCB ground plane, identifying nodes is my next step. I just add ground points to each component that will be soldered to the ground plane. It is then a simple matter of placing pads onto a pre-drawn grid and soldering. I use Mesquares,

Figure 3: Audio amp with LM386 (the .inc lm386.sub directive on the circuit tells LTSpice to use a downloaded model for that component).

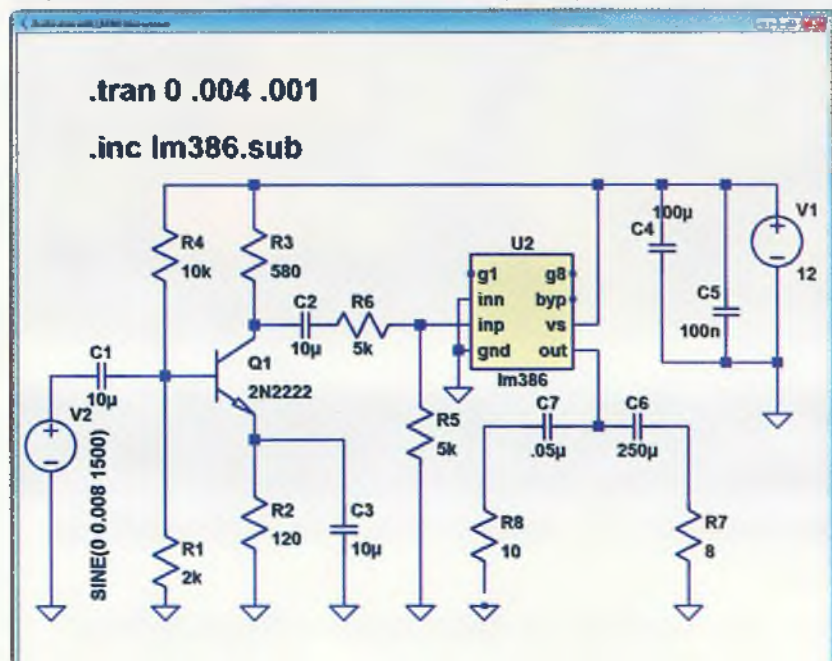

available from www.qrpme.com. These are 6 mm square pre-tinned copper pads. Jaycar has similar pads for sale, called Anchor points, in 3 mm and 5 mm diameter circles.

Using this style of construction means that one can almost exactly replicate a schematic diagram on a PCB, without requiring etching of a circuit board.

LTSpice also generates a bill of materials. This is vital to check that all components are to hand and collected into a plastic bin ready for assembly. If I am feeling ultra-

precise, I will tick them off on the BOM list as they are placed and soldered.

Finally, once the real circuit has passed the test on quiescent voltages and currents, it's time to test performance. It is always satisfying to cross-check actual performance on the DSO with the LTSpice image side by side.

All circuits have their limits. With LTSpice, it is easy to increase input voltage to an amplifier say, and see when non-linearity starts to occur.

LTSpice – A Handy Tool for the Homebrewer

To sum up: it is worth adding LTSpice to your home workshop. It is a simple, easy to use tool that shines light into your electronic circuits. There are plenty of YouTube videos which will guide you as a new user. Once you know your way around the basic commands, it is reasonably intuitive to use.

Photo 1: Ugly construction, RF preamp.

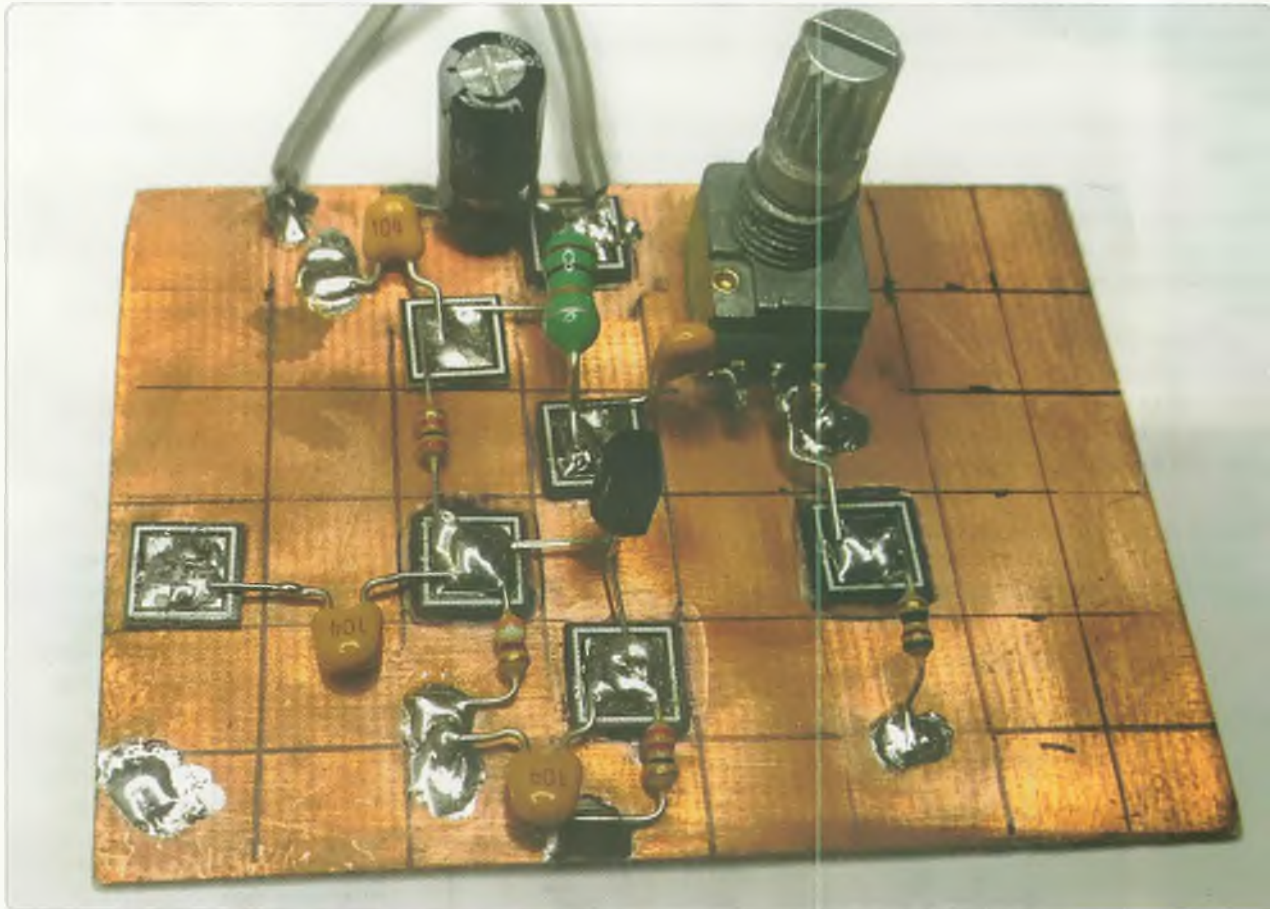

WIA DX & operating Awards



WIA offers a range of operating awards, including DXCC, VHF & UHF and many other awards.

Details can be found at: <http://www.wia.org.au/members/wiadxawards/about/>

Amateur radio assists in mountain rescue

Phil Shields VK2CPR

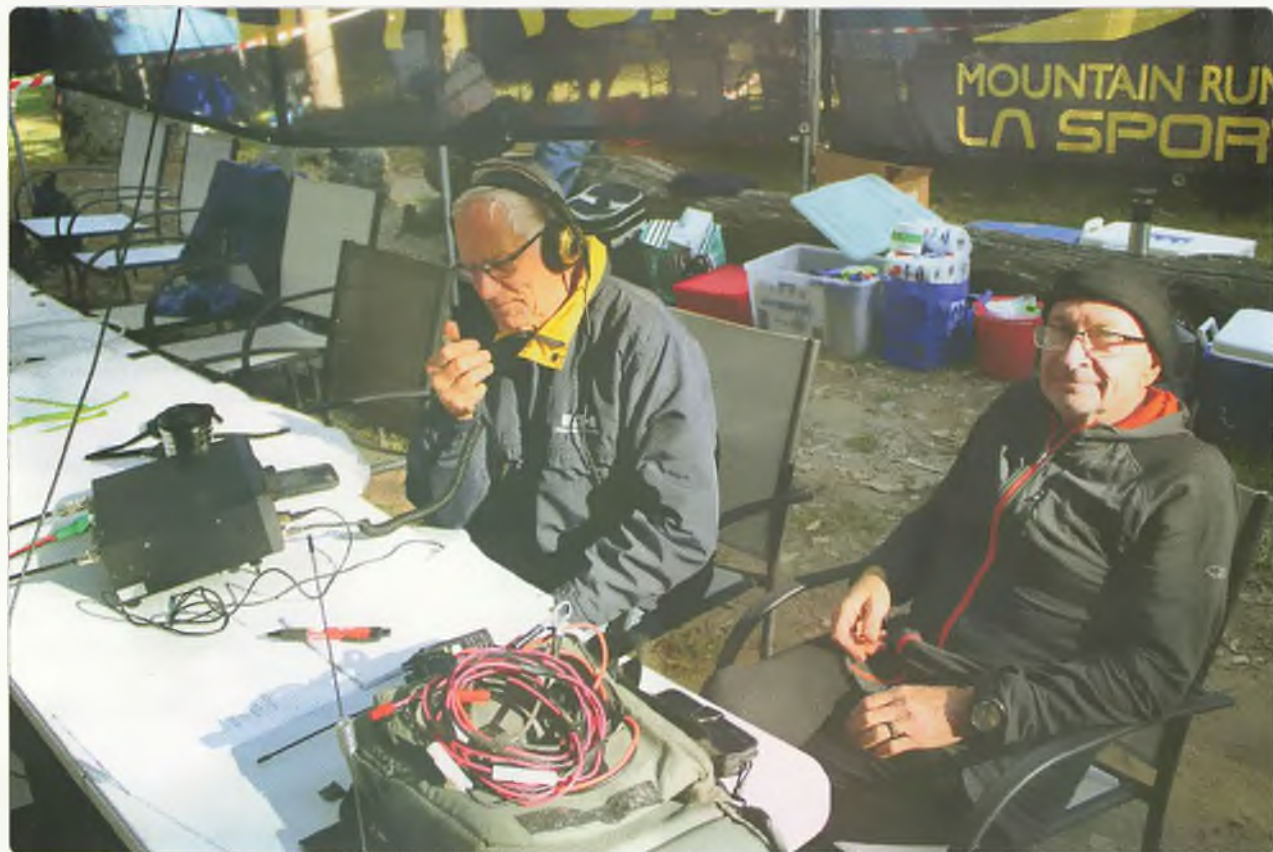

Stafford VK2AST and Pete VK2CIM operating the base at Mountain Creek.

Every year members of the Lake Hume Amateur Radio Group (VK2AHA) provide communications for the Mt Bogong conquestathon. Mt Bogong is Victoria's highest peak at 2000 metres. The conquestathon is conducted on Sunday during the Victorian Labour Day long weekend.

Runners start at the Mountain Creek camp area and run up the 'Staircase'. They ascend to the summit which is about 21 km and eventually descend back into the Mountain Creek camp area.

At approximately 1330, Mark VK3ASC the summit operator, called Mountain Creek base manned by Stafford VK2AST and Pete VK2CIM (pictured) that a runner was in urgent need of assistance between Bivouac Hut and the summit.

Mark's partner Kathleen, who is a Registered nurse, responded from the summit to assess the patient and gave coordinates on arrival. CPR was commenced and a rescue helicopter dispatched.

Meanwhile, Tom VK3FTKG

the operator at Bivouac Hut, was dispatched toward the runner from the opposite direction. With the incoming helicopter heading for the coordinates, Tom made sure runners did not evacuate down the mountain via that route. Despite challenging steep remote terrain and heavy fire helicopter traffic in the area, the runner was successfully evacuated to Melbourne; a flawless operation and job well done by all involved.

Participate

**2019 S.E.R.G. Annual Convention and the
Australian Fox Hunting Championships**

8 - 9 June 2019

Tony4 Fox Hunting Fun in Townsville

22 June 2019

Book Review: **Getting Started in EME** (Earth-Moon-Earth transmissions)

Authors: Stephen Appleyard G3PND and Phillip Malme G4PQP

Publisher: Radio Soc. of Great Britain 2019

ISBN: 9781 9101 9363 3



This recently published book, written by a group of UK amateurs, has been published by the RSGB, our sister representative society. The text outlines the personal journey of the authors to successful EME operation.

Over 12 easy to read chapters, the authors cover the absolute basics of EME (Moon-Bounce) operation which probably represents the most esoteric area of Amateur Radio. The book outlines the basic principles of this mode of extreme weak signal operation and

the challenges to be overcome in order to make QSOs by reflecting signals off the face of the moon.

The physical problems and technical challenges to be overcome are clearly explained, in text and diagrams with the minimum of mathematics or complicated formulae.

Chapters cover the history and development of EME since the first successful use in the 1940s, the idiosyncrasies of the orbit of the moon around

the earth and basic information on the antenna and equipment requirements to propagate signals over the almost half-million km round trip, in order to overcome the enormous signal path losses and propagation anomalies involved.

The effects of antenna design across a number of amateur bands, background noise and the bizarre propagation effects involved in EME, including Faraday Rotation, Spatial Offset, Doppler Shift and Ground Gain, are explained by the authors in simple and easily

understandable terms without the use of "frightening" mathematics.

The introduction of digital modes for EME in 2001, including JT65, is also well covered. This quantum leap for the amateur community with the introduction of WSJT and JT65 took EME from the province of the super dedicated enthusiasts, with massive investment in QRO stations, super sensitive receiving equipment and enormous antenna arrays, into the realm of the ordinary suburban backyard ham.

The final chapters offer practical advice on establishing a successful EME station and on the installation and use of the current machine generated mode software available to the hobby.

Overview

It is often said that EME represents the last and most challenging aspect of Amateur Radio. "It would only have to be a bit more difficult and it would not be possible at all". This new book is exactly what it says on the box. It offers an introduction to EME and is clearly intended for amateurs who have had minimal or no previous experience with this type of operation. While not being a comprehensive textbook on the subject, it is perfect for that intended purpose.

The book is available in paperback and digital formats through the RSGB Bookshop.

Kevin Johnston VK4UH

Plan ahead

Operate within the band plans: <http://www.wia.org.au/members/bandplans/about/>

Australis OSCAR 5, the ABC's Conversations & 8.4 million cane toads?

Peter Wolfenden VK3RV, WIA Historian

A book about Space Junk, recently written by Australian Space Archaeologist, Dr. Alice Gorman was reviewed and discussed in the ABC's radio program Conversations with Richard Fidler on 10 April 2019.

The official definition of Space Junk is along the lines of: "Something that does not now, or in the foreseeable future, have a purpose".

The studio interview (and thank goodness it was not done over a distorted mobile phone circuit as so many ABC and other broadcasters do these days) is a fascinating and informative program covering many aspects of space launches and their resultant space junk which in time could threaten present and future space programs.

Australia's Woomera Rocket Range, initially created as a military testing range for UK work, was, during the 1960s and 70s the second busiest launch range in the world, behind Cape Canaveral USA. It was involved in the European Launcher Development Organisation (ELDO) which preceded the European Space Agency and was working on the Europa rocket. Sadly now, both Woomera and AO-5 are part of Australia's largely forgotten and even abandoned space history. Woomera grew greatly during the 50s and even had an amateur radio club station VK5WC, operational from 5 October 1953.

About half way through the 52 minute ABC program, up popped "Australis OSCAR 5" and a conversation surrounding it, Australia's first conceived, designed and built satellite. However, Australis OSCAR 5 was unfortunately relegated to being the second Australian satellite to



Photo 1: The Australis OSCAR-5 satellite.

be launched into space – and not from Australia. WRESAT-1 (Weapons Research Establishment Satellite) was launched from Woomera on 29 November 1967 effectively gazumping AO-5 from being the first into orbit!

Dr Alice Gorman and Richard Fidler had "done their homework" about AO-5. They knew when

and where it was built during the mid-1960s and the fact that it was ready for launch in 1967. In reality AO-5 was on board a Boeing 707 en route to the USA on 1 June 1967. Unfortunately its launch was delayed in the USA, also a subject touched on in the radio program.

Then the program took an interesting and unexpected turn!

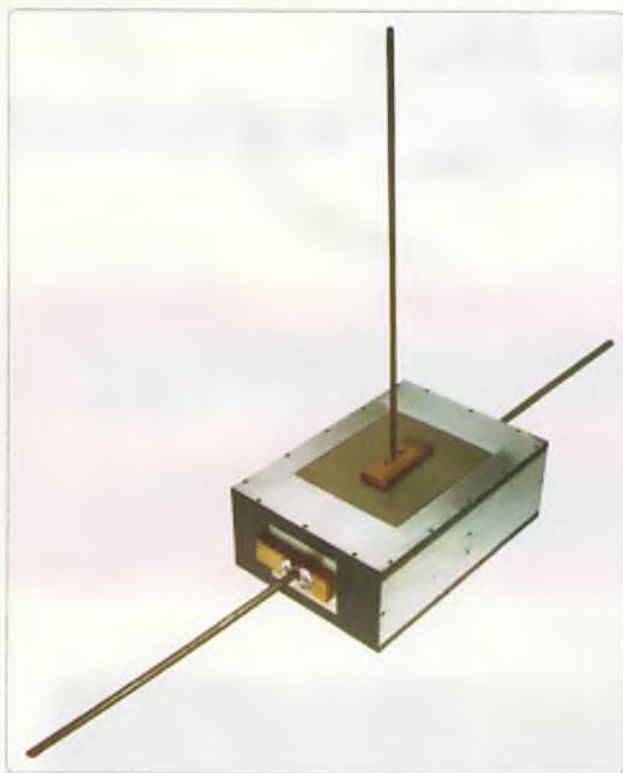

Photo 2: Satellite Model - Australis Oscar 5, 1970.
 Photographer: Benjamin Healley. Source: Museums Victoria.
 Copyright Museums Victoria / CC BY (Licensed as Attribution 4.0 International).

Dr Gorman suggested that AO-5, still orbiting the Earth is part of Australia's space heritage. It could be considered as space junk, but then she went onto suggest that it does indeed have a "future foreseeable purpose", for now it also has Cultural significance: It represents Australia. It was a Community Amateur Volunteer Project. It was a useful project of co-operation world-wide. And it is not a big collision risk.

Indeed it can now be considered as a piece of Australia in orbit and has more value remaining there than being recovered and sitting in a museum somewhere on Earth.

To Richard's question, "How much space junk is in orbit?", Dr Goreman replied, "estimated between 23,000 and 29,000 bits of stuff larger than 10 cm and millions and millions of pieces smaller than 10 cm."

A very Queensland assessment of space junk weight was: more

than 8.4 million Cane Toads and presumably this includes Elon Musk's orbiting Tesla sports car! The Cane Toad Index is possibly quite appropriate as cane toads are spreading out of control and effecting our Earthly environment, not unlike unwanted space junk!

You can locate the complete radio program, *The Truth about Space Junk* at:

1. Dr. Owen Mace, one of the original Melbourne University students involved in the building of AO-5 wrote a book about it, released in September 2017, "*Australis OSCAR 5*" published by ATF Press Adelaide, ISBN: 9781925309805.
2. **References.** *Amateur Radio* magazine published an article in March 2018 (Volume 86, Number 2, 2018), under the title of "*50 years old and still circulating*". It contains many references.
3. **Web site.** The AO5 web site: <https://australis-oscar5.weebly.com/> contains a lot of interesting historical information and links to other web sites well worth a visit.
4. **The book.** "*Dr Space Junk vs The Universe, Archaeology and the Future*", by Alice Gorman, Newsouth Books, ISBN: 9781742236247.

<https://www.abc.net.au/radio/programs/conversations/alice-gorman/10968774>

I hope you find it as interesting as I did and personally, I believe that we should be investigating and supporting the process of classification of AO-5 as part of Australia's and the world's, Space and Amateur Radio Heritage. Next year, on 23 January, is the 50th Anniversary of the actual launch of AO-5 from the Vandenberg Air Force Base, USA.

If you would like to know more about Australis Oscar 5, the following should help:

1. **A book on AO-5.**

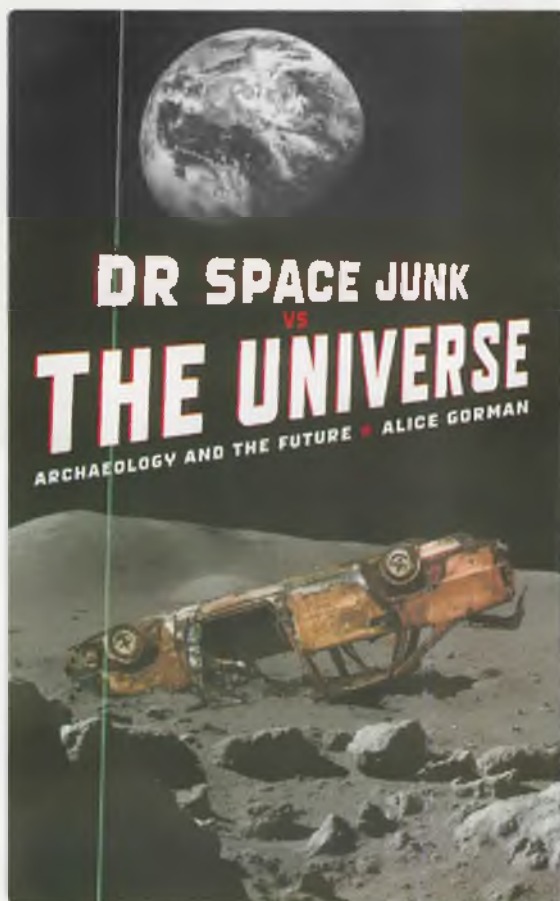

Photo 3: The cover of Dr Gorman's book.



ALARA

Jenny Wardrop VK3WQ

ALARA Survey Outcomes

During 2018 ALARA conducted a survey through the newsletter to find out what initiatives members would like ALARA to undertake to encourage and maintain the number of ladies engaged in amateur radio. The committee discussed the initiatives at its February meeting and here are the outcomes.

Apart from the newsletter, the main activity of ALARA is the ALARAMEet and it was decided that a grant would be provided to the Bendigo ALARAMEet to be held in 2020. We would like as many members as possible to attend and will keep the costs as low as we can.

We agreed to provide one year's complimentary membership to any female operators who receive new qualifications. We are coordinating with the WIA on this. They have recently introduced free WIA membership for one year for all new operators and for female operators this will be extended to include ALARA membership.

We will be considering more financial assistance to women and girls studying for their licences once the present assessment procedures have settled down.

Also under consideration are grants for individuals or clubs who provide training for young people to learn amateur radio or electronics skills. This needs some more discussion and coordination but we plan to implement something, hopefully, later this year. Meanwhile we have made a donation to ARISS (Amateur Radio on the International Space Station) which encourages amateur radio interest particularly in



Photo 1: Joan VK5BJB (This photograph is courtesy of the Mildura Weekly).

school groups.

If you have further suggestions in relation to the activities of ALARA please let your state representative know, or get in touch with any committee member.

Linda Luther VK7QP

"Mrs Joan, The Lighthouse Lady"

Joan Beevers VK3BJB has to be one of the best known faces in Mildura. She has appeared in the Mildura papers many times over the years with her amateur radio activities, but one of the nicest surprises was when she was awarded Life Membership of the Sunraysia Radio Group late last year.

It all started back in the 1970s when Joan helped her late husband, Ray VK3BRB, to study for his amateur radio licence by writing down little notes to help him pass the exam. Some of it obviously "stuck" and it wasn't long before

she too had a callsign.

After she got her licence a new world opened up to Joan but it was when she started learning Japanese, initially just for fun, that things really changed. Joan discovered that she could understand some of the conversations on the radio between Japanese operators and Mildura just happened to be in the right spot to relay information between boats that could not hear each other; or between stations in Japan and boats in the Southern Ocean. Sometimes it was messages to and from families of deep sea fishermen, who were often at sea for long periods of time.

In 1988 Joan became the first female Net Controller for the All Japanese Maritime Mobile Net. She also arranged an "Australian Style" wedding in Mildura for a Japanese sailor and his bride. But her most famous exploit was helping a solo sailor 71 year old Katsuya Sakai, when his yacht Naruto suffered engine failure, which also disabled his satellite navigation equipment. Joan tried to direct him to land and also alerted the authorities of his position; but he got caught up in a cyclone, and every time Search and Rescue got to the co-ordinates, the boat had drifted off again.

By the time the Coast Guard had located Mr Sakai and towed him into Cairns Harbour, he had not slept for two nights and had only a cupful of petrol to run the generator to power the radio. It is highly likely that without Joan's help he would not have made it to land. No wonder the Japanese called her "Mrs Joan, the Lighthouse Lady".



Photo 2: Susan VK3FZZY and Noriko 7K3EOP.

an exhibition at the National Gallery and we visited her house. The garden was very nice and they have an excellent Teddy Bear and Golliwog collection. We had a happy time and understood each other. I am looking forward to meeting them again someday in Japan. Noriko Tokura 7K3EOP.

Tea. But first we also helped to prepare some of the food... Sue had underestimated how long it would take but no one minded helping. The food was delicious and the table looked very festive. As her OM, Richard, is an astronomy buff, we also had to inspect his "Dome". In fact we managed to cram 14 or 15 people into what is officially a two-man dome!!

The day was topped off with a barbecue and a look at the stars before we headed home. Altogether, a lovely January ALARA luncheon in SA.

Some people volunteer for so much

Also from Christine.... Jenny VK5FJAY has been a St John Ambulance volunteer for over 50 years. She is also part of the Scout Radio Group and most recently she and her OM Kevin VK5AKZ spent two weeks volunteering at the International Scout Jamboree held at Tallem Bend SA. Kevin was

From Noriko 7K3EOP - My Melbourne Trip

I went to see Susan VK3FZZY and Brendan VK3OY with my daughter and granddaughter at the end of March 2018. We were very surprised to receive presents from her along with three special Birthday cakes, which we took back to Japan. Susan showed us Melbourne City,

The VK5 January ALARA luncheon...from Christine VK5CTY

The usual venue used for the VK5 ALARA luncheons closes for January, so this year Sue VK5AYL offered to host a "High Tea" at her home on Hindmarsh Island, south of Adelaide. There were 11 YLs and OMs there to enjoy the High

Photo 3: The VK5 ladies preparing the high tea. From Left to Right: Meg VK5YG, Cecily Herden Y1F of VK5ZK, Lesley VK5LOL, Marilyn VK5DMS, Christine VK5CTY, Sue VK5AYL and Shirley VK5YL.





Photo 4: The "two person" dome.

manning the Amateur Radio tent but Jenny was looking after over 250 Scouts each day, as they learned about drones and how to use them. Let's hope they don't try out their skills near airports!!

Jenny has also been a JP for more than 20 years, another unpaid service to the community. Some of the stories she tells about the ungrateful people for whom she signs papers are amazing. There seems to be no recognition that this service is a volunteer one.

Well done for giving your time to help out Jenny. Australia depends on its volunteers.

Thank you to all who contributed to this edition. By the time the next issue goes to print we will have a new Committee. I would like to take this opportunity to also thank our retiring President, Shirley VK5YL. For someone who was initially reticent to take over the President's position, she has done a fantastic job of keeping us all in line, with her usual good humour and skills. Thank you Shirley from the Committee and all ALARA members. Jen VK3WQ.



Photo 5: Jenny VK5FJAY.



Wireless Institute of Australia **2019** Callbook

Available **Now**



VK7news

Justin Giles-Clark VK7TW

e vk7tw@wia.org.au

w <https://groups.io/g/vk7arnews>

Meet The Voice 2019

<http://meetthevoice.org/>

On 24 March 2019, the Meet The Voice (MTV) event was held at Ross in the beautiful midlands of VK7. The MTV event is a chance for many amateur to meet face to face with other amateurs who they only talk to on the radio. This year it was in a new venue of the Ross Recreation Grounds and this was met with unanimous approval. There was a bunch that camped and caravanned overnight before the event on the grounds. There were many car boots and ute trays out in the carpark doing brisk trade. Some demonstrations showed SDRs, rotator controllers and a live demo of soldering aluminium.

The Sewing Circle Trophy for 2018 for the most loquacious amateur went to Cedric VK7CL. Congratulations Cedric. Then Dick VK7DIK and Dani VK7FREQ drew the raffle prizes. The main prize of the FT-2800 donated by Ross VK7ALH went to Idris VK7ZIR. The beautiful blue bear made by Peter VK7PL's XYL Lois was won by Kevin VK7HKN. Catherine VK7GH won the hamper of goodies thanks to Dani and the wine donated by Geoff VK7GW and XYL Jenny was won by James VK7JAM and Shirley VK7HSC. A huge thank you to Dani and Greg VK7GX for the entire organisation that went into the MTV event and we look forward to the next one. Mark your calendar for Sunday 22 March 2020.

John Moyle Memorial Field Day Weekend March 16 -17

The following report is from Peter VK7PD and provides some



Photo 1: Previous awardee Dick VK7DIK awarding the Sewing Circle Trophy to Cedric VK7CL. (Photo courtesy of Justin VK7TW.)

interesting history on the founder of the contest. Some of us still remember that fateful day in 1960, when, opening the latest edition of Radio TV and Hobbies to read Neville Williams' editorial recording the death of editor John Murray Moyle VK2JU. They were the days when most electronics projects related to radio. It was the beginning of the transistor era but most projects relied on valves and most amateur radio gear was either CW or AM. Construction was laborious but relatively straight forward. Using a metal chassis, building required basic tools and test equipment was usually limited to a multimeter, an SWR bridge and maybe a dip oscillator.

They were my school days. I well remember listening to VK7AK (SK) on a 2-valve receiver I built to

a design in Radio TV & Hobbies. Many post WW2 amateurs in Australia built receivers and transmitters designed by the RTV&H staff headed by John Moyle. Although technology has changed markedly, his influence lives on. Little wonder that radio amateurs in Oceania hold an annual day of commemoration.

Among those VK7s who participated in the Field Day this year were James VK7JAM on Mt George, The NTARC club station VK7TAZ supervised by Kevin VK7KJL, Hayden VK7HH and Richard VK7ZBX on Mt Wellington, Murray VK7ZMS in Hobart, Peter VK7ZPE and Peter VK7PD on Mt Barrow then White Hills. VK7JAM was possibly the only VK7 to have VHF contacts across Bass Strait. Meanwhile VK7TAZ had 16



Photo 2: Group photo of attendees at the Meet The Voice event in 2019. (Photo courtesy of Justin VK7TW.)

contacts into VK and ZL on 40 and 20 metres. VK7HH had a 9 cm voice contact with VK7ZMS then with VK7PD on 23 cm, 13 cm, 9 cm and 2 metres, then again on 13 cm with VK7ZPE. VK7ZBX also had a contact with VK7PD on 23 cm. There were probably other VK7s participating of whom I was not aware at the time of writing. I wish to extend my apologies to anyone thus affected; you are just as important.

North West News

North West Chat & Show group

Saturday 2nd March 2019 saw the first North West Chat & Show group, at the Penguin Sports Centre on the North West coast organised by Tassie's second oldest YL amateur Shirley VK7HSC. Shirley felt there was a need for amateurs to meet up, from any club or non-club members, or people who were interested in radio, to talk radio, play radio, or bring items to have a chat about.

The first event attracted 12 amateurs and friends, from the North West and North. Some interesting equipment was bought

along and discussed. There was a good spread of food for afternoon tea and the meeting wrapped up around 5 pm with everyone looking forward to the next one.

North West Tas. Radio & TV Group (NWTR&TVG)

<http://www.vk7ax.id.au/atvgroup/>

The NWTR&TVG held a BBQ on 9 March 2019 at Legion Park Ulverstone. It was well attended with amateurs and families enjoying perfect weather on the March long weekend. The group was also joined by many member amateurs who came along to socialise and chat. Thanks to Shirley VK7HSC for the report and thanks to all who came along on the day.

Northern News

Northern Tasmanian Amateur Radio Club (NTARC)

<http://www.ntarc.net/>

NTARC held a Special General Meeting (SGM) in April for a proposed rule change to allow electronic banking. A general meeting after the SGM was held and quickly completed so attendees

could enjoy a hearty supper.

The NTARC Technical Nights are back for 2019 with many interesting activities being held. The following is a quick summary: Ross VK7ALH brought in a mint condition Hewlett Packard 417A VHF detector, Simon VK7FSRM was installing Skywave Linux, Peter VK7PD showed his 3.4 GHz preamp with a gain of 14 dB, Colin VK7ZCF, Peter VK7ZPE, James VK7JAM and Ebenezer VK7AT were discussing cathode ray tubes, John VK7FJFD and Peter VK7KPC were discussing and analysing HF multi-taped vertical antennas.

Peter was also preparing the fox hunt equipment ready for the next Scout activity and André VK7ZAB was reprogramming the call sign of the foxes, Peter VK7PD, Colin, Idris VK7ZIR and Bernie VK7BR were busy drilling holes in fibreglass rods in preparation for a Club project to build 23 cm Yagi antennas – jig supplied by Rex VK7MO. Peters VK7SP and VK7KPC were also busy upgrading software on a Raspberry Pi for marine navigation and were then looking at WSPR results on another Pi setup.

Southern News WICEN Tas (South)

<http://wicentas.com/>

The crew from WICEN were involved with the Portland Riders Equine Endurance event at Pyengana on 30 March. This was an 80, 40 and 20 km ride in and round the beautiful forests and farmland of Pyengana, Goshen and Gould's Country. There were three checkpoints and base at Pyengana. The ride went without incident and was enjoyed by all of the WICEN operators.

Radio and Electronics Association of Southern Tasmania Inc.

<http://www.reast.asn.au/>

<https://www.facebook.com/reasttas/>

A shout out to Alan Williams VK7AM/GM3MHD who in a recent post on the VK7 Amateur Radio news group let drop that he had been licenced for 70 years and 44 of those years he has been a member of the WIA. Wow! On Ya Alan!

The REAST March presentation was given by Brian Coleman G4NNS. Brian was holidaying in Australian and pardon the pun but "the stars aligned"! Brian gave us three presentations starting with a history lesson on Radio Astronomy including the giants of Karl Jansky and Grote Reber. Then Brian went on to the types of electromagnetic radiation including thermal, synchrotron, free-free and spectral line types. Brian then went onto using radio stars or supernovas to help setup and calibrate your radio telescope and used one of the Goonhilly large dishes as an example. Brian went through his home station where he has home-brewed most of the control and RF equipment and he has achieved a T_{sys} of 48 K without artificial cooling.

Brian then went on to his association with the Goonhilly GHY6 dish. This facility was used

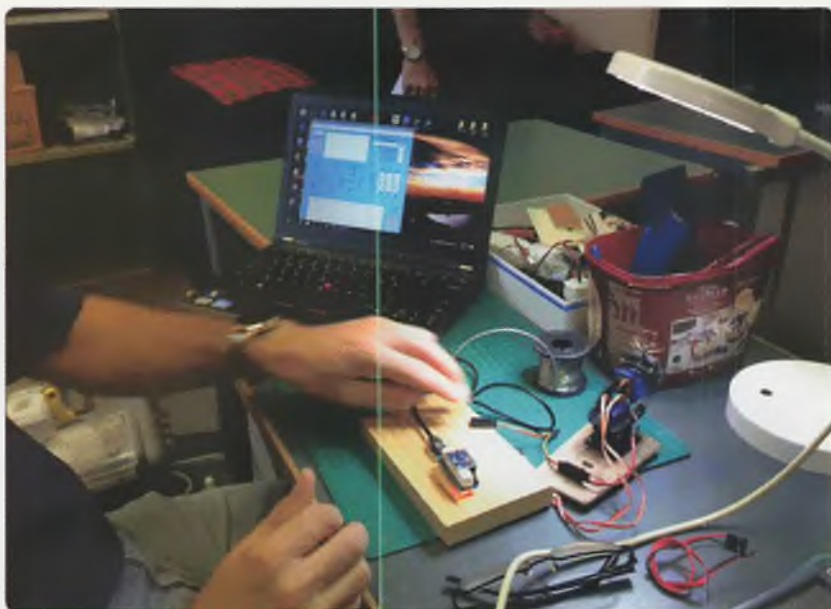

Photo 3: Ron Cullen 5.6 GHz AV link gyro to first person display controller for radio controlled fixed wing aircraft. (Photo courtesy of Justin VK7TW.)

by British Telecom for Trans-Atlantic television feeds via low earth orbiting satellites but these days are not used anymore. These dishes are now operated by Goonhilly Earth Station and one of these dishes - GHY6 - became available for use by amateurs on 3.4 and 5.7 GHz. GHY6 is a 32 m dish that was involved with setting up links to the ISS for HAMTV when UK astronaut Tim Peake was on the ISS. More amateurs including Brian were invited to utilise the dish for amateur radio. This included the upgrading of the positioning system to control the dish in a more modern way.

Brian was also involved with the BBC program *Great British Railway Journeys* by Michael Portillo visiting Goonhilly. Brian was able to bounce Michael's voice off the moon.

The REAST Experimenter's nights are still popular and the following is a summary of some of the activities: Ron Cullen bought along his Sonic Modell ZOHD Dart XL radio controlled plane, Ron has also been working on a steerable AZ/EL AV antenna to follow the

First Person View goggles, Paul VK7FPCL soldered together an interesting capacitor discharge rig along with some interesting QRPGuys kits, Hayden VK7HH, Richard VK7ZBX, Murray VK7ZMS and Justin VK7TW were all deep in 3.4 GHz panel transverters. Hayden bought along a nice PC controlled VNA microwave generator that he was using for a 3.4 GHz signal generator. Rex VK7MO has been testing his GPS heading indicator after some programming improvements from David VK3HZ. The unit is now stable to use in the field.

John VK7FJPA bought in an interesting AWA HF radio complete with Antenna Tuning Unit. Justin has been getting the DATV studio back online for a re-launch after Easter. Alan VK7KAJ bought along a Number 10 set - made by RCA covered VHF from the 1950s. Larry VK7WLH bought along his SDR-Kits Vector Network Analyser along with a six metre loop antenna and showed the analysis of the loop antenna.

Participate

GippsTech 2019

13 - 14 July 2019



DXTalk

Luke Steele VK3HJ
• vk3hj@wia.org.au

Fairly steady HF conditions continued into autumn, with lots of DXpeditions large and small around the world giving us something to chase, along with various special event stations, IOTA activations and Contests. Solar activity lifted slightly from time to time and FT8 kept some activity going on otherwise quiet bands.

Around the bands

Activity on the Low Bands was good through into early autumn, with lots of Asian, North American, Central and South American and Caribbean stations through our evenings and Europe and even some Africans available in the mornings. The 40, 30 and 20 m bands remained fairly reliable. Higher bands 17 and 15 m were busy at times mainly with FT8 activity and there was even a bit of Asia, Pacific and North America from time to time on 12 and 10 m.

DX Heard or Worked

March was a busy month for DX, with a number of DXpeditions active, including HD8M Galapagos, A52IC and A52ZB Bhutan, FO/OK2ZI French Polynesia, 7P8LB Lesotho, 3B8XF Mauritius, and 5X3C Uganda. Club station S01WS in Western Sahara has been quite active too. Back in our region were E6AF Niue, V19NI Norfolk Island, P29LL Papua New Guinea, also XR0ZRC Juan Fernandez and C5DL The Gambia.

3Y0I Bouvet Island

The Atlantic Tuna finally departed in late March, and was only 70 nautical miles from Bouvet when it was damaged in a storm. As some critical navigation aids were

damaged, the captain decided to return to Cape Town for repairs. The team is determined to get to Bouvet, but it will likely be next summer.

For more information visit their website: <https://www.rebeldxgroup.com/tag/3y0i/>

J20DX Djibouti

Unfortunately this IOTA DXpedition struck a snag. MM0NDX and MM0OKG had all their radio gear impounded on arrival at Djibouti Ambouli International Airport! Due to time constraints, they had to cancel activation of AF-059. Their equipment was still not forthcoming, so they had to cancel the rest of their activity and return home.

Macedonia now North Macedonia

The former Yugoslav Republic of Macedonia, recently known as "Macedonia" is now known as "North Macedonia". There is no change in DXCC Status.

V19NI Norfolk Island

Operators Chris VK3QB, Luke VK3HJ, Patrick VK2PN and David VK3BDX enjoyed a fortnight in Norfolk Island, with a total of 9441 QSO, with 4477 Unique Callsigns and 101 entities worked. Portable activations included Norfolk Island National Park VKFF-0392 and Mount Bates SOTA NO-001.

Upcoming DX

DXpedition activity scheduled for May and June includes the following.

J79U, J79TA **Dominica**, 7 - 15 May. Thomas SM6CXU and Tore SM0T will be operating 160 - 10 m, with

a focus on Low Bands, mainly CW. QSL via M00XO.

FW/G0VJG **Wallis & Futuna** (OC-054), 8 - 22 May. Nobby G0VJG is planning activation of Wallis Island, with a possible side trip to Futuna Island (OC-118). He will be on SSB and FT8, 40 - 6 m. Nobby also plans to operate from Fiji as 3D2AS for a few days before and after Wallis. QSL via M00XO.

XV9BO **Vietnam**, 13 - 19 May. Tom DL7BO will be operating from Mui Ne, 160 - 10 m, CW, SSB, RTTY and FT8. QSL via LotW or DL7BO.

9M6NA **East Malaysia**, 23 - 28 May. Saty JE1JKL plans operation from Labuan Island (OC-133), with a focus on 6 m FT8 on 50.313 and 50.323 MHz, and in Fox/Hound mode on 50.318 MHz. He will be active in the CQ WPX CW Contest. QSL via LotW, or Club Log. For more information see website: <https://jsfc.org/je1jkl/9m6na.html>

CQ WPX CW Contest, 25 - 26 May. For rules see website: <http://www.cqwpw.com/rules.htm>

5W **Samoa**, 1 - 10 June. Gustavo CX2AM, Humberto CX3AN and Rainer CX8AB plan operation from Upolu Island (OC-097), on 80 - 6 m, CW and SSB. Callsign TBA.

S9A **Sao Tome & Principe**, 6 - 18 June. A team of seven operators plan activity from Sao Tome Island (AF-023), using CW, SSB and FT8 on HF. QSL via EB7DX.

Next IDT DXpedition Announced

The Italian DXpedition Team has announced their next DXpedition, to Liberia in September/October this year. They will have two callsigns: A82X for CW and SSB, and A82Z

for Digital modes.

For more information visit their website: <http://www.i2ysb.com/ldt/>

South Orkney DXpedition Announced

The Perseverance DX Group has announced their next venture will be to South Orkney. This entity was last activated in 2011, and has moved up in the Most Wanted list to No. 13 globally, and No. 8

for VK/ZL. Planning has begun for a DXpedition for up to 15 days in February/March 2020 on Signy Island AN-008. Callsign TBA. The team will sail from Punta Arenas, Chile aboard the RV Braveheart. They plan seven stations, operating 160 - 10 m, SSB, CW and Digital modes.

For more information visit their website: <https://sorkney.com/>

Please email me with any DX related news for inclusion in this column. I am particularly interested in hearing about DX worked or heard in other states, and from newer DXers.

73 and good DX,
Luke VK3HJ



AMSAT-VK

AMSAT Co-ordinator
Paul Paradigm VK2TXX
email: coordinator@amsat-vk.org

Group Moderator
Judy Williams VK2TJU
email: secretary@amsat-vk.org

Website:
www.amsat-vk.org

Group site:
group.amsat-vk.org

About AMSAT-VK

AMSAT-VK is a group of Australian amateur radio operators who share a common interest in building, launching and communicating with each other through non-commercial amateur radio satellites. Many of our members also have an interest in other space based communications, including listening to and communicating with the International Space Station, Earth-Moon-Earth (EME), monitoring weather (WX) satellites and other spacecraft. AMSAT-VK is the primary point of contact for those interested in becoming involved in amateur radio satellite operations. If you are interested in learning more about satellite operations or just wish to become a member of AMSAT-Australia, please see our website.

AMSAT-VK monthly net

Australian National Satellite net

The Australian National Satellite Net is held on the second Tuesday of the month (except January) at 8.30 pm eastern, that's either 9.30 or 10.30Z depending on daylight saving. Please note we will be taking check-ins from 8.20pm-ish. Check-in starts 10 minutes prior to the start time. The AMSAT-VK net has been running for many years with the aim of allowing amateur radio operators who are operating or have an interest in working in the satellite mode, to make contact with others in order to share their experiences and to catch up on pertinent news. The format also facilitates other aspects like making 'skeds' and for a general 'off-bird' chat. Operators may join the net via EchoLink by connecting to either

the *AMSAT* or *VK3JED* conferences. Past experience has shown that the VK3JED server offers clearer audio. The net is also available via IRLP reflector number 9558. In addition to the EchoLink conference, the net will also be available via RF on the following repeaters and links.

In New South Wales
VK2RBM Blue Mountains repeater on 147.050 MHz

In Queensland
VK4RRR Redcliffe 146.925 MHz -ve offset IRLP node 6404 EchoLink 44666

In South Australia
VK5TRM, Loxton on 147.175 MHz
VK5RSC, Mt Terrible on 439.825 MHz IRLP node 6278,
EchoLink node 399996

In Tasmania
VK7RTV 2 m. Repeater Stowport 146.775 MHz, IRLP 6616

In the Northern Territory
VK8MA, Katherine on 146.750, CTCSS 91.5, IRLP Node 6800

We are keen to have the net carried by other EchoLink or IRLP enabled repeaters and links in order to improve coverage. If you are interested in carrying our net on your system, please contact Paul via email. Frequencies and nodes can change without much notice. Details are put on the AMSAT-VK group site.

Become involved

Amateur satellite operating is one of the most interesting and rewarding modes in our hobby. The birds are relatively easy to access and require very little hardware investment to get started. You can gain access to the FM 'repeaters in the sky' with just a dual band handheld operating on 2 m and 70 cm. These easy-to-use and popular FM satellites will give hams national communications and handheld access into New Zealand at various times through the day and night. Currently only 50-50 is available.

Should you wish to join AMSAT-VK, details are available on the web site or sign-up at our group site as above. Membership is free and you will be made very welcome.

MEMNET

The Wireless Institute of Australia

Register Login

Have you registered for MEMNET yet?

Go to www.wia.org.au click on 'For Members', then click on 'Log into MEMNET', and register... it's very simple.

If you have already registered for MEMNET but have not received a confirmation Email we may not have your correct email address.

Please email memnet@wia.org.au with your email address, name and membership number.

If you are changing your email address, please *remember to update* your information in MEMNET.



VHF/UHF - An Expanding World

David K Minchin VK5KK

Introduction

This month we have a report on the VK5 Microwave Dxpedition as well as the VK Microwave operator's survey conducted by Iain VK5ZD. Also more on experiments on 122 GHz to extend the VK record, the IC-9700 is finally out and Kevin VK4UH's ever popular Meteor Scatter notes.

Microwave Dxpedition to VK1, VK2, VK3 & VK4

Late in 2018, VK5ZD proposed to VK5ZT and VK5KK that instead

of doing another "EU mmWave Dxpedition" why not do the same type of "driving trip" in Eastern states of VK? Whilst we don't have the same high mountains (2,000 to 3,000 metres) as in Europe, we do have some good accessible peaks in along the Great Divide that do provide a few places to work on 10 GHz and above. And as we have been working with a number of groups in VK2 and VK3 on developing equipment together, it was time to pay a visit! As there are many anecdotal

stories about the trip beyond the room available for this column, the following is just a summary of when and where the trip went. Full details are to be presented at the WIA AGM in VK2 on 24 to 26 May as well as an article for publishing.

The first step in the planning was to find out who actually has equipment in the various states, so Iain set about gathering information from various operators (see next article). From early feedback it was clear there were two areas of

Photo 1: Doug VK4OE (left) and Iain VK5ZD (right) Stations.



interest, the lower microwave bands and the 24 GHz and above. VK5ZD and VK5ZT also had keen interest in conducting light wave experiments so this was to be included.

The second part of planning was the where and when. The idea emerged to include a contest weekend in the trip when the weather is "mild" so the John Moyle Memorial Field Day (JMMFD) was picked (16 - 17 March). From the responses it was clear that VK3 would be the best choice for the JMMFD, so we had the first part of the trip decided. As the much publicised VK4 "23 on 23" lobbied the next weekend, it made sense to participate in that as well! Seeing VK4 is only 1680 km away (!) from Melbourne, we then decided to go via Canberra to work the VK1s then head to Sydney to work the VK2s on their microwave groups Tuesday night hook up! The plan evolved further, instead of going up the coast from Sydney it was decided check out Mt Canobolas near Orange and pay a visit to Dave VK2JDS to try everything out up to 122 GHz before heading north to VK4.

Given the various locations and possible paths it was decided that we would split into two groups as we usually do in Europe. Iain VK5ZD and David VK5KK would each equip a car with a complete set of 1.2 GHz to 122 GHz equipment. Two complete sets of light wave equipment were to be supplied by VK5ZD and Tim VK5ZT.

15/3/2019 We leave Adelaide head towards VK3. VK5ZD travels to the Otway ranges (QF11qh) while VK5KK/ZT travel to Mt William (QF12gt), distance between both locations 177 km. Contacts made on 10, 24 & 47 GHz (equal National record) between VK5ZD/3 & VK5KK/3. Weather conditions (mist and clouds) closed in quickly as it got dark and unfortunately light wave experiments were not successful.

16/3/2019 VK5KK/ZT travel to the Kinglake lookout (QF22pl) whilst VK5ZD travels to a hill about 10 km west of Geelong (QF21cu), path 118 km. Contacts made 59 both ways on all bands from 1296 MHz to 76032 MHz. Participated in the JMMFD working a dozen VK3s from

1296 MHz to 10 GHz. Light wave tests were done that night but light pollution from Melbourne killed any chance!

17/3/2019 VK5KK/ZT travel to Mt Donna Buang Lookout (QF22uh) whilst VK5ZD travels to Mt Buninyong (QF12xi), path 154 km climbing the 18 metre high lookout at Mt Donna Buang. It was soon apparent that a tree had grown about 3 metres higher right in the middle of the path! Contact was made okay on 10 GHz but signals only 56 with QSB on 24 GHz, nothing heard above. VK5KK/ZT then travelled to an alternate site at Mt St Leonard (QF22sk), path distance 141.1 km. Despite high dew point and smoke haze 59 SSB contacts were made between VK5KK/3 and VK5ZD/3 on 24 GHz and 47 GHz. A successful 76 GHz contact followed with 56 SSB both ways setting a new national distance record.

18/3/2019 After an overnight stay at Wangaratta, we travelled towards Canberra. On the way we stopped at Albury to check out the Huon Hill lookout. VK5ZD/3 went

Photo 2: David VK5KK's Station 1296 to 76 GHz.





Photo 3: Iain VK5ZD, 47 GHz at McCarthy's Lookout, QLD.

to a location close to the lookout (QF33lu) whilst VK5KK went south to a clear spot along the road 5.1 km. A contact was made on 122 GHz, 51 both ways. On dusk VK5ZD/1 went to the Mt Ainslie lookout (QF44nr) and VK5KK/ZT travelled to an old abandoned church near Graben Gullen (QF45ql), path distance 84.2 km. Contacts were made on 24 GHz, 47 GHz and 76 GHz 59 on SSB between VK5ZD/1 and VK5KK/2. Finally we had clear conditions, VK5ZT/2 and VK5ZD/1 had a successful light wave contact voice contact. Ian's light was the brightest thing on the horizon!

19/3/2019 Before leaving Canberra VK5ZD went the Question Science Museum car park (QF44nq) whilst VK5KK/ZD went to Mt Ainslie (QF44nr), path 3.7 km. A contact was made on

122 GHz, 51 both ways. Dew point was again quite high (18 C). We then travelled towards Sydney towards our next destination, Bellbird Lookout (QF56hl) near Kurragong Heights. We encountered heavy rain and storms along the way, if this was Europe we would be on the side of the road working 10 GHz rainscatter! It was wet when we arrived at the lookout, so we went to the nearby Archibald Hotel to discover it had an even better view of the city! It was a quiet night so the proprietor allowed us to set up under the front covered area out of the rain. We participated in the VK2 microwave group net that night working VK2YAC, VK2XAX on both 1296 and 2403 MHz as well as VK2FLR on 1296 MHz. For more info on the group look out "VK2 Microwave Users Group" on <https://groups.io>

20/3/2019 We stayed overnight in Katoomba then headed towards the Orange/Bathurst area. VK5ZD and VK5ZT travelled to Dave VK2JDS's mountain location (QF46pv) whilst VK5KK headed to Mt Canobolas (QF46lp), 1395 m ASL. VK5KK/2 work both Dave VK2JDS and VK5ZD/2 on 3 GHz, 10 GHz, 24 GHz, 47 GHz and 76 GHz over the 40 km path, signals 59 on all bands. VK5KK then headed to VK2JDS's where we stayed the night playing with 122 GHz in the dark!

21/3/2019 VK5ZT/ZD headed north towards a hill near Wellington (QF47ld) whilst VK5KK headed back to Mt Canobolas (QF46lp), path 95.7 km. Contacts were made on 24 GHz, 47 GHz and 76 GHz with 59 signals. VK5ZD/ZT then drove onto the Siding Springs Observatory (QF48mr), 1165 m ASL west of

Coonabarabran. Contact was made over the 230 km path on 10 GHz with QSB indicating some variable path conditions, never a good sign! No signals were heard on 24 GHz and above. The path is not visual line of site but just "radio line of sight". Unfortunately the peak where the radio telescope is located was not accessible, so a site lower down the hill had to be used.

22/3/2019 This was a "transit" day to VK4 from Coonabarabran to an overnight farm stay about 20 km out of Warwick, QLD. Originally we were to lob much closer to Brisbane but had to change plans as the 23 on 23 had been shifted to Sunday 24, so it didn't clash with the NSW election! At this point it wasn't clear where anyone would be operating. As we had to book accommodation for the next night, we took an each way bet and decided to split up

again next day and stay near where we would operate on Sunday.

23/3/2019 VK5ZD headed north to Toowoomba and VK5KK/ZT headed towards Tamborine. This gave us a few options to try at either end over 100 to 125 km paths for the 23 on 24. VK5KK/ZT took a trip to Kamarun Lookout (QG61nu) 700 m ASL to check the location out for Sunday. Saturday evening VK5ZD went to the Gus Beutel lookout (QF62cp), 765 m ASL and VK5KK/ZT went to Mt Tambourine West (QG62ob), path distance 116 km. Contacts were made on 24 GHz and 47 GHz however signals were only CW copy on 76 GHz. It had been raining at both ends of the path and Dew Point was around 21 C! An attempt was made on Light wave again but no success.

24/3/2019 The VK4 23 on 23/24 day! Iain VK5ZD returned to the

Gus Beutel lookout (QF62cp) and VK5KK/ZT to Kamarun Lookout (QG61nu). We were all set up by 10.00 am and contacts were quickly had on all bands from 1296 MHz to 47 GHz over the 127 km path. No other portable stations were out as it would seem the start time had also been changed to 12 pm! Unfortunately, that gave us a very small window as we had to leave by mid-afternoon so we could start our journey back to Adelaide (2040 km) to get back Tuesday afternoon (one of us had to fly out the next day!).

Doug VK4OE joined Iain and also worked VK5KK on 5760 MHz, 24 GHz and 47 GHz with 59 signals. VK5KK also worked VK4CDI on 47 GHz. VK4AQF and VK4AFL were also worked on 1296 MHz, 2403 MHz and 3398 MHz. VK4CSD was heard but not worked on 5760 MHz from Kamarun. 76 GHz signals were

Photo 4: David VK5KK, 122 GHz System Mt Ainslie, Canberra.



again CW copy only with dew point running over 20C for most of the day. However a JT4F contact was completed at 0305 UTC +6 dB both ways between VK5ZD/4 and VK5KK/4. Doug VK4OE also copied VK5KK/4 over the same path but no sign of Doug's signal. VK4CSD and VK4FB were the only other stations with mmWave equipment out, successfully working over 15 km on 122 GHz on the day. We packed up then drove 500 km to Mores.

25/3/2019 Another transit day, this time from Moree to Broken Hill (1040 km!) No activity but plenty of kangaroo's, goats, sheep, wild pigs, deer, dingoes and cows on the road!

26/3/2019 We left Broken Hill and whilst driving through the hills to the west thought we would give some mobile operation going waveguide to waveguide on the mmWave Bands. VK5KK/2 found a roadside clearing on a hill inside VK2 (QF07nw) while VK5ZD drove on and found a roadside area 28.5 km away that was just line of sight. Mobile contacts were made on 24 GHz, 47 GHz and 76 GHz on FM. As long as we kept the cars side on signals were 59!

We arrived back in Adelaide mid-afternoon, after covering 5800 km and activating numerous grid squares. We found some great spots along the way that deserve a second visit so yes there will be another trip coming up!

VK Microwave Directory

In preparation of the "Microwave Dxpedition" Iain VK5ZD conducted a microwave operator survey during January and February 2019 to get some idea of where operators are located to plan the trip. The final result lists of VK1 to VK7 stations that either responded or were seen to be active in the past 12 months from information gathered from other sources. The information gathered includes a home grid locator as well as the various bands the station is potentially capable of operating on.

The survey result is by no means complete but lists 57 stations

capable of operating on at least one Microwave band i.e. a band above 1296 MHz. There are also quite a few additional stations (not listed) capable of operating on 1296 MHz only. Statistically it gives a picture of activity in each area. No surprises in that VK3 has by far the biggest number of operators (24) followed by VK5 (9) with the highest pro rata percentage vs amateur population.

The intention is to publish the list regularly to promote activity and assist new operators locate someone who can be a partner for Microwave experiments. If you aren't on the list or have information updates please email Iain VK5ZD at iain@vk5zd.com. It would be good to include any information on ZL operators as well as this will be most useful during summer DX!

122 GHz is Active!

122 GHz activity has outstripped a few of the other mmWave bands in recent months, spurred along by the availability on eBay of the missing link, the CMA 382400AUP 40.7 GHz +20 dBm Tripler. These originally came from Will Jensby (W0EOM) and are of known quality, previously you needed to speak some German to obtain ones that weren't "seconds" that usually had low power above 40 GHz. The MA4E1310 80 GHz Flip diodes used in the 122 GHz mixer then came through Doug, VK4OE.

Stations known to be active now include VK2JDS, VK2DAG, VK3CV, VK3LN, VK3NH, VK4FB, VK4CSD, VK5KK and VK5ZD. VK4CSD and VK4FB set a new 122 GHz National distance record of 21 km in early April (details not confirmed at the time of going to press). Needless to say, stay tuned for more records as the dew point drops!!

76 GHz on Australian CubeSat

The IARU has now allocated the amateur radio frequencies to be used for the CubeSat "CUAVA-1" developed by the Australian Research Council (ARC) Sydney,

NSW. The CubeSat will use a range of amateur microwave bands including 76.8 GHz (downlink). The CubeSat is scheduled for launch in July 2019 from Japan into a 400 km (LEO) orbit.

CUAVA-1 is a 3U CubeSat and the first satellite project for the new ARC Training Centre that also works on Un-crewed Aerial Vehicles (UAVs). The aim of the centre is to provide training for people entering into the Space industry. The following frequencies have been allocated by the IARU.

Downlinks: 437.075 MHz, 2404.000 MHz, 5840 MHz and 76,800 MHz

Uplinks: 145.875 MHz, 2404.000 MHz and 5660.000 MHz

Downlink telemetry will be 9K6 GMSK AX25 on 437 MHz and high speed links on the Microwave frequencies. There are a whole raft of experiments planned to study propagation, drag and etc. For more information go to <https://cuava.com.au>

IC-9700 hits the streets

In what is probably the most anticipated release for VHF/UHF operators in the last decade, the IC-9700 144/432/1296 MHz transceiver became available in April 2019. This is the first commercially available direct sampling SDR Transceiver for 144 MHz and 432 MHz on the market (1296 MHz is down converted). It has a number of unique features that enables it to cover many different types of operations all in one box. Elsewhere in this issue there is a review of the transceiver however the next few paragraphs will focus on some early tests around frequency stability.

The transceiver's quoted stability is +/- 0.5 ppm is easily equal to or better than any other standard optioned VHF/UHF transceiver past or present. The IC-9700 uses a single tiny 49.152 MHz VCTCXO (a Voltage Controlled Temperature Compensated Crystal Oscillator!) for all frequency generation in much the same fashion as other

current release transceivers. In tests, the transceiver easily betters its minimum spec and is more than sufficient for SSB use and will enable JT65 and WSPR signals on 144 MHz to be decoded (when receiving only). However when you heat the transceiver (i.e. when transmitting and air is circulated by the fan), the frequency will start to move after a minute or so. As the fan doesn't directly cool the 1296 MHz section the effect is only marginally worse than 144 MHz. Maybe not so much an issue for SSB but a totally different story should you be using Digital modes.

If the transmit duty cycle is 50% (JT65) the master oscillator will settle at down at a higher temperature and be stable enough to use on 144 MHz, you just need to periodically use the auto calibrate function (see further). If you are using a lower duty cycle mode like WSPR the oscillator will drift back to its cold spot a few minutes after transmitting. As you most likely aren't keeping an eye on the transceiver, the frequency will start to wander through the WSPR 200 Hz window.

Current production IC-9700s do have some rubber foam over the shield containing the 49.152 MHz VCTCXO circuitry as well as the underside of the PCB. This would help minimise vibration issues as well as providing some degree of thermal insulation. It is possible some early examples don't have this rubber hence the reason for some of the varying reports on temperature drift? It has been suggested that the fan be enabled on low at all times to help stabilise the temperature inside as soon as a rise is detected; this has been done on a number of other transceivers and sounds like an easy firmware update.

In reality, for Digital modes used for weak signal and EME, stability (and resetability) needs to be in the order of < 10 ppb. To date, no commercial VHF/UHF transceiver has been designed to come anywhere near this requirement

hence the solution has been to add an external PLL circuit to lock the 49.152 MHz Oscillator to a GPS or Ovenised 10 MHz reference. So when a small SMA connector labelled "10 MHz" appeared on the rear panel of advanced IC-9700 prototypes, a few of us got excited! However, closer to release it became apparent that the purpose of this 10 MHz input was not to actively "lock" the 49.152 MHz oscillator but to provide an "auto calibrate" function that could be manually selected through a menu option.

Those familiar with the IC-7300 HF/50 MHz transceiver will recognise the same menu item, the only difference with the IC-9700 is the addition of a fine tune control and the "AUTO ADJ" button. The IC-7300 implementation is more manual i.e. set the frequency to all zero's then zero beat on WWV or a 10 MHz reference using the Ref Adjust slider. The "Auto ADJ" button on the IC-9700 sets the frequency within about +/- 2 - 6 Hz depending on the band (V1.06 firmware). You can then use the "Fine" slider to get it exactly spot on if you like but you will find yourself chasing your tail after a while.

The frequency adjustment process goes through a number of steps plus or minus the frequency to calibrate the 49.152 MHz oscillator. This takes 3 to 5 seconds; the steps are audible and can be up to 20 to 30 Hz on 1296 MHz depending on how far the 49.152 MHz oscillator is off frequency. As a calibration system this is perfectly fine but too slow and "granular" for active frequency control when compared to a PLL that responds in a linear fashion in milliseconds.

We don't know the capabilities of the hardware so it there could well be a firmware solution at some point in the future however for now the only solution for those who need <1 Hz stability will be to use an external PLL to lock the 49.152 MHz oscillator. As the oscillator arrangement is similar to that used in other transceivers that

have been externally locked, the solution could end up being much the same. Whilst it may seem an "oddball frequency", 49.152 MHz is a commonly used in a number of other SDR radios and is a simple binary multiple of commonly used audio sample rates (48/96/192 kHz). On first analysis, a PLL scheme would not be too hard to implement.

After using the transceiver for a couple of weeks, it is clear that for general use it is in a class of its own. Sitting next to a well-used IC-910H and the family heirloom TS-790A, it is a pleasure to listen to the SDR receiver in the IC-9700. The transceiver has endless options, half of which you may never use but hours of fun trying out! In the Sherwood test, the receiver was found to have less than 2 dB noise figure on 144 MHz compared to the usual 4 - 6 dB of most transceivers. The transceiver does have a range of front-end configurations to manually deal with strong signals so it should outperform all but high end transverter/transceiver combinations in contest work. And as an IF radio for Microwave/EME transverters it shows great promise once PA overshoot issues are controlled.

Full respect to Icom, they have designed a magnificent SDR transceiver to cover all bases at a very low price point so understandably it can't be all things to all people. This is the first batch of what will be a very long running product so no doubt there are some features that the hardware may be capable of that have yet to be implemented. The IC-7300 has had six firmware updates in the past two years that have enhanced standard features within the constraints of its hardware. And for those that need <1 Hz stability out of the box that will be the clincher ... what is the capability of IC-9700 hardware?

ON4KST Logger

The retirement of the "VKLogger" chat pages has created a bit of a void in instantaneous reporting

of activity. All praise to Adam VK4GHZ for hosting this service for as long as possible however support for the software platform was eventually dropped. Facebook groups or Twitter can't handle this traffic anywhere as effectively as a dedicated chat channel. For quite a few years we've used the ON4KST logger when active in Europe so it is good to see the migration of VKs and ZLs to the Region 3 50 MHz and 144/432 MHz chat group. To join go to <http://www.on4kst.com/chat/start.php> and register. At this point there is only a communal Microwave chat page but that makes interesting watching during European contests. VKs and ZLs are encouraged to use it to give them a bit of competition especially on 24 GHz and above!

In closing

Feel free to drop me a line if you have something to report especially on VHF as we currently do not have a "VHF Editor"! It doesn't talk much to put a few lines together and helps spread the load. Just email me at david@vk5kk.com

73

David VK5KK

Meteor Scatter Report

Dr Kevin Johnston VK4UH

This month: "Achieving and Surviving your first Meteor Scatter contact" - an introduction for newcomers to Meteor Scatter operation, VK-logger update, Forthcoming Events and Meteor Showers, MS Activity session information.

Achieving and surviving your first Meteor Scatter contact

VHF Meteor Scatter operation is almost unique in that there will be multiple stations transmitting exactly on the same frequency and at exactly the same time and yet QSOs are still possible with the minimum of mutual interference

between very distant stations. This is only made possible by the bizarre properties of this mode of propagation where specific paths between individual stations open for a fraction of a second, while other nearby stations receive nothing or at fractionally different times. Signals from different stations become separated in time. Even the propagation prediction mode, WSPR, which also used common frequencies, relies on random transmitting periods to get around the inevitable "clashing" of signals. Co-frequency operation of this type however can be quite daunting, especially for operators new to Meteor Scatter, as getting something wrong with timing or transmitting periods will lead to complete obliteration of any nearby stations.

Back in 2015, just after taking on the coordination of this column, I published an introductory article entitled "Achieving and Surviving your first Meteor Scatter Contact". This was intended to be a simple and light-hearted guide to help "new" operators get up and running by outlining all the main steps to follow and the common pitfalls to avoid while climbing up the steep learning curve. At that time the vast majority of M/S activity was on 2 m only and operation was almost entirely using the FSK441 mode, from the early WSJT software platform, with 30-second transmit periods.

Much has changed over the intervening period. FSK441 mode has been relegated to being an heirloom mode, via a succession of pretenders to the throne and has now been universally superseded by the new Forward Error Correction (FEC) mode MSK144 utilising 15-second periods. Even the new MSK144 mode itself went through a complete revision in the last 12 months to become the current standard in VK-ZL and around the world. At the same time the "meteoric" rise in digital activity across many HF and VHF bands,

following the introduction of the FT8 mode, has meant that there are now vast numbers of station already fully equipped for Meteor Scatter operation – if they did but know it. It is time for an update to the guide both for newcomers to Meteor Scatter and for those who may have been previously active on FSK441. There are now several freeware platforms, currently available to amateurs, which support the MS modes.

With the change to MSK144, which provides far more sensitive and accurate decoding of short duration pings and the adoption of shorter transmission periods, has come changes in operating procedures including the reporting system, QSO format and the adoption of auto-sequencing i.e. QSO advance. Some things however remain the same. The weekend activity sessions continue on the same focus frequencies and at the same times and the protocol for the selection of transmit periods is unchanged. With the change to 15-second transmit periods, 1st (even) periods now start at 00 and 30 seconds in each minute and 2nd (odd) periods start at 15 and 45 seconds. As is common in all areas of enterprise, not all changes bring improvement. The adoption of the new FEC mode, although allowing more reliable decoding of short and weak meteor pings, places restrictions on the format of the transmitted message (string). Older modes allowed complete freedom albeit within a 23-character limit which were used to our advantage. MSK144 however limits the allowable transmitted string to a small number of predefined allowable messages. It is no longer possible to be in QSO with more than one station at a time by careful formatting of text. MSK144, as it is today, is strictly one-on-one.

Firstly – Why Bother? Meteor Scatter (MS) propagation will allow contacts to be easily made on 144 MHz out to distances of around 2,300 km, way beyond the normal

range on 2 m except under the exceptional band conditions. QSOs are possible therefore between the eastern and southern state capital cities and across to ZL from the southern call area. QSOs can be achieved on almost any day of the week under flat-band conditions. Even on 50 MHz, MS propagation can allow contacts when no other mode of propagation is available.

So what's needed? The basic entry level setup is already to be found in many modest VHF SSB and digital stations. Any stations set up to use any Machine Generated Modes (MGM) including WSPR, JT65 or FT8 will be already be usable for MSK144 just be selection of the appropriate mode. Almost any basic transceiver running about 50 watts or more will suffice. GPS frequency locking is not required, "Ordinary" SSB frequency accuracy and stability is adequate. MSK144 mode is designed to allow for a degree of Doppler Shift of signals and can decode signals even 200-300 Hz off-frequency, which would render an SSB signal completely unintelligible. Even operating SSB most operators will recognise a small frequency offset between their rigs and the stations they are working. It is easy with a little practice to compensate for this offset in each particular radio. For an antenna a 6-8 element 2 m Yagi beam above 10 m in height is adequate and indeed close to ideal. Much larger antenna arrays, with a very narrow beamwidth, may actually be counter-productive. Meteor Scatter signals may come across an arc of azimuth in the sky and too sharp an antenna may miss the outliers. A 3-element beam on 50 MHz or even a simple horizontal dipole will suffice for that band. Unlike for EME or satellite operation, antenna elevation control is not required; most distant stations will be received at low elevation angles. Mast head pre-amplifiers are not required either. Unlike EME communication, signals received by M/S are frequently loud, well above

the noise floor and are easily heard in the loudspeaker. Received pings are generally strong, they are just very brief. While it is possible to achieve contacts with lower power or even with vertical antennas this is going to be hard and frustrating work at both ends of the QSO.

Software and computer requirements: On the digital side, any station already set up to run any of the Machine Generated digital Modes will likely already have all the hardware required. The computing power required to run MSK144 in either of the currently available platforms (WSJTx or MSHV) is very modest and easily achievable by most desk or laptop computers, with just about any OS, likely to be still in use. MGM is based around audio signals generated and decoded in the computer being transmitted and received via the normal microphone/earphone-speaker audio in-out path of an ordinary unmodified SSB transceiver, using only the normal SSB voice bandwidth. Some form of interface is required to transfer the audio in and out, between the transceiver and computer, at an appropriate level and without interference from RF, mains hum or other sources. The interface also has to allow the computer to operate the PTT of the transceiver for transmission. There are many homebrew and commercially available solutions including off-the-shelf options including the SignalLink and Rigblaster modules. These are effectively outboard USB soundcards designed for this purpose. Many current radios, from all three major manufacturers, and several current SDR rigs, come complete in-the-box with on-board USB interfaces capable of dealing with audio in and out, PTT and often CAT frequency control via a single USB cable to the computer. The current MGM software versions come with the necessary drivers to facilitate this for a fool-proof installation.

At the time of writing there

are two main options for software platforms WSJTx and MSHV, which support MS modes. These are available free of charge to the amateur community from their respective software design teams. Links to the source sites are given at the end of this article. Ensure that only the latest versions are used and must include Ver.2 of MSK144. Previous versions are no longer available for download as they are entirely incompatible.

Column space available precludes a key-by-key instruction book for operating MSK144 mode in either WSJTx or MSHV. Whichever platform is selected, take the time to print out and read the instructions about configuring the software to arrange the audio in and out paths and levels and the PTT control. Operators will need to familiarise themselves with the basic on-screen controls and identify the transmit period selection as above; transmit activation and the method of capturing incoming callsigns. Both platforms have a "TUNE" facility which confirms correct operation of the PTT and enables a single tone to be transmitted for adjustment of the correct audio levels and power. On receive both platforms allow control of incoming audio levels to optimise the operation of the waterfall display. In my own experience using the SignalLink type interfaces and with a number of different radios and using the direct USB linking to the on-board interface in several Icom radios, the software configured itself with minimal input from me other than selecting an appropriate address and baud rate. It is worth taking the time to familiarise yourself with the various screens and on-screen controls in whichever platform is used. Using the older FSK441 mode it was often impossible to try a local contact, to get everything working, as the mode could not decode a constant amplitude signal. This is no longer an issue with MSK144 and a local contact is a good thing to try before joining one of the main operating sessions.

Next you will need a basic understanding of how a Meteor Scatter QSO runs, what exchanges will occur and what the reports will be received in MSK144.

The exchanges: As with any other mode, most MSK144 M/S QSOs will start with a CQ. In both platforms, the QSO steps are pre-loaded into TX windows (Tx1 to TX6 or 7.)

The sequence runs: CQ: CALL with received Report (in dB): "R" Reply with receive report (in dB): RRR (all info exchanged): 73 : CQ.

The two stations involved move ALTERNATIVELY through these steps, it is not necessary for both stations to repeat every one. With 15 second periods this can best be done by activating the "auto sequence" facility available in both platforms. This facility automatically inserts a received signal report and changes the transmit message appropriately as each step is received. This is NOT an auto-QSO system and still requires operator input to commence a QSO and to restart CQ once a QSO is complete.

The When and Where and the Timing – the last few jig-saw puzzle pieces

It is often said that only two things are needed for successful Meteor Scatter operation: patience and insomnia. For reasons that can't be covered in depth here Meteor Scatter is predominantly an early-morning mode of propagation. Although meteor returns (pings) occur at all times of the day and night and across all seasons of the year, the best conditions occur in the Pre-dawn period during the summer months. Here in VK there are two regular weekend activity periods on 144 MHz and 50 MHz. These are where most new operators will achieve their first QSO.

The activity periods run early on Saturday and Sunday mornings

between 19:00 and 21:00 UTC or later during the summer, when Meteor activity is most conducive to good propagation. Activity may start earlier in the summer months as the northern states and New Zealand are already well past dawn by 19:00 UTC.

The primary M/S operating (focus) frequencies in VK and ZL are 144.230 MHz on 2 m and 50.230 MHz on 6 m with the radio set to USB. Receive levels in MSK144 should be set up to show background noise on the horizontal waterfall display and around 0 dB in the level bargraph on background noise.

Which Period for Transmission?

Each minute is divided into four, 15-second, transmission periods. The First (even) Periods run from the top of the minute (0 seconds) until 15 seconds and from 30 seconds to 45 seconds in each minute. The Second (odd) Periods run from 15 seconds to 30 seconds and from 45 seconds back to 0 seconds in each minute.

The transmission period is selected by the operator by checking (ticking) the "TX-First" or "Tx-Second" box on the main screen in either software platform. Obviously any two stations trying to work each other must be transmitting in the opposite periods in order to hear one another and achieve a QSO. To make this work properly the computer clocks at either end of the QSO must be accurately set to within a second or two of each other. There are many ways this can be achieved, the easiest of which is by the use of internet time servers or from GPS signals. There are many applications to achieve this, some automatic, or just a manual time-sync by the operator at least every 30 mins or so. This needs to be practiced and confirmed in advance of appearing on the activity sessions. Perhaps less obvious however is that each station must be transmitting in

the SAME period as any nearby stations. If period or timing is not correct then you risk transmitting when your close neighbours are trying to receive, and trust me, this "isn't popular".

During the normal weekend activity sessions, a convention has evolved in VK for selection of the appropriate operating period. Northern stations, i.e. VK4, always transmit 2nd Periods and beam south. Southern stations i.e. VK3, VK7 and VK5 always transmit 1st Periods and beam north. Stations in the middle call areas i.e. VK2 and VK1 change period depending on the day. On Saturday mornings they will operate 2nd Periods and beam south to work into VK3, VK7 and VK5 etc. On Sundays they operate 1st Periods and beam north to work into VK4. Obviously, such a protocol can't work for everyone all the time. Using this protocol, clearly it isn't possible to work from VK5 to VK3 for example – but then why would you want to? At this short range normal tropospheric propagation would probably work anyway. During the weekend activity periods it is essential that all stations follow the protocol, on 2 m and 6 m, and stick to their correct periods, to prevent local QRM to their neighbours. If other paths are to be tried then by all means do so outside of the activity periods or QSY to an alternative frequency.

Pit-falls to avoid

As explained above, where two stations are in range of each other by tropospheric or other propagation modes then they must be transmitting in the same period otherwise they will cause QRM to each other. This can be a problem for stations operating away from the major capital cities and towards state border lines. In such circumstances the usual

Call-Area protocols may have to be reversed. It is best to seek advice from a local and follow what they do. As a general rule when you start out, you should not be

hearing loud continuous signals while you are receiving. If you can then something is wrong, most likely you are transmitting in the wrong period. Loud local signals heard at the beginning or end of every period suggest that either you, or a station local to you, have computer clock timing issues. Remember you will potentially be sharing the single operating frequency with several other operators. Good operating practice requires us all to do everything possible avoid interference to other stations.

Bear in mind also that when your system is live, any audio from your computer that you would normally hear in the computer speakers, will key the transmitter and will go to air. During Meteor Scatter activity periods there will be many stations operating on the same frequency, some distant and some local. Any audio unintentionally transmitted out of turn or in the wrong period will deafen you neighbours. Take the time to disable all other computer sounds in the mixer panel and switch off applications such as e-mail or VK-Logger notifications, I-tunes and Skype etc. which will otherwise go to air. Likewise, when operating any digital mode, ensure that the normal station microphone is closed and beware of VOX, otherwise shack sounds will also go to air during transmission and can corrupt the transmitted signal.

Where to point the Antenna

In general, you point your antenna in the approximate direction of the stations you are trying to work. In reality however the meteor trails giving rise to the signal reflections (pings) we hear can occur over a wide azimuth arc extending on either side of the direct heading. This phenomenon gives rise to two "hot-spots", A and B, one on either side of the direct beam heading. Depending on the time of day and season, one or other of the hot-spots statistically produce more reflections than the other. Best results occur by beaming towards this hotspot. Both

WSJTx and MSHV software provides advice on which of the two hotspots is likely to be the most productive for optimum beam heading. When a callsign is placed in the "To radio" box, the software looks in a data base for the grid-square of that station. If the gridsquare is known then the software calculates the distance, elevation and direct heading (azimuth) from your station. In addition, the software also indicates which of the two Hotspots (A or B) and beam heading, is likely to be best at that time. Look for this on the main screen. If the gridsquare is not found in the data base then this can be added manually and saved for another occasion.

That first QSO

If the opportunity arises it is well worthwhile joining in with another MS operator during an activity session. This will provide an invaluable overview of the operating procedure and the flow of making a contact. Otherwise here is a skeleton checklist for that first contact:

Install the software; Insert your callsign and grid-square into settings.

Familiarise yourself with the basic operating controls for your chosen software, set up the radio and interface and get it all working in advance. I recommend users monitor the outgoing "machine-gun" MSK144 audio. This helps you to recognise the incoming pings and frequency offsets etc.

Set up and test computer clock syncing.

Set the alarm clock for early and take coffee to the shack by 19:30 UTC for one of the weekend activity sessions. Allow the rig time to warm up and the frequency to stabilise.

Select 144.230 MHz on 2 m or 50.230 MHz on 6 m +/- your own rig offset. Select USB. Point the beam appropriately.

Run your chosen software and select MSK144 mode. Ensure "Monitor" is on. "AUTO" off at this stage i.e. receive only at this stage.

Set basic parameters and audio

levels as above. Background noise should be visible on the waterfall screen, the level set to about 0 dB.

Select the period you wish to operate as outlined above.

Wait and be patient. Meteor pings come in random order. Sometimes there is nothing for several periods followed by multiple pings in the next. As you are not yet transmitting, you will be receiving both periods. Signals from any stations local to you will be heard for the whole of one period, these should decode reliably using MSK144 mode. If local signals are not decoding or DF is indicating a frequency discrepancy then the dial frequency on your radio may need to be adjusted accordingly. Listen now for "pings" in the other period. These will give a "Pzzzit" sound in the speaker and will leave a coloured trace on the receive waterfall. Successful decodes should occur immediately in the received text screen. Once identified, the received callsign can be transferred to the "To radio" window. It doesn't matter if that station is already in QSO, you can call them. Activate transmission and reply.

If you are hearing pings but not getting decodes then there are a number of possibilities. The sounds you are hearing may not be MSK144. Maybe static or birdies etc., just keep listening. You may be too far off frequency. In this case the pings will not sound like your transmitted signal and the "DF" indicated in the data screen may give you a clue. If both stations are exactly on the same frequency then DF=0. If the DF is above + or - 200-300 Hz on all the stations heard then decoding may become erratic. Rule of thumb if DF is indicating large negative values move your rig LF in frequency by this amount, if large positive DF values move HF by this amount, and try again. Worth checking too that your RIT or shift is not turned on. Having completed your first QSO then try calling CQ and wait for the fun.

Hopefully this will have given you enough background information and some advice on the common pitfalls of MS operation for you to confidently attempt your first M/S QSO. This article was only intended to get you started with this truly fascinating aspect of the hobby. Once you succeed with your first completed QSO you will probably be hooked!

Meteor Showers

The next major showers on the calendar will be the Eta Aquarids Shower expected to peak around 7 May 2019. The Eta Aquarids is a Major Class 1 shower and one of the best events on the annual MS calendar. The Predicted ZHR may reach 70 meteors/hour and occurs when the orbit of the earth around the sun takes us through trails of debris remaining after the passage of Halley's Comet through our solar system.

VK-Logger

Over previous columns the imminent loss of the VK-Logger facility was discussed. The current logger is approaching end-of-life and requires a complete ground-up replacement as the existing software is no longer supported. Some of the existing facilities have already stopped functioning. The remainder will shortly be lost. There were promising signs that a completely new application was in the pipe-line. Unfortunately, the size of this major project has prevented a new logger becoming available in the time frame available for a rebuild. It is likely now that a replacement will only be possible as a collaborative effort across VK and ZL. Time to step up. Who has the time and the enthusiasm and the pre-requisite PHP scripting skill-set to contribute to this project?

Activity Sessions

The weekend activity sessions run on Saturday and Sunday mornings

from before dawn (around 20:00 UTC or earlier) until propagation fails.

Frequencies: 2 m 144.230 MHz, 6 m 50.230 MHz Current Preferred Mode MSK144 Version 2.0 15 second periods.

Southerly stations running 1st period beaming North, Northerly stations running 2nd period beaming south.

Register with VK-ZL Meteor Scatter Facebook Page (Closed group of AR operators) for up to the minute advice and information.

Contributions for this column are as always welcome. Please e-mail to vk4uh@wia.or.au

Kevin (KJ) VK4UH

References

MSK144 Version 2.0 software upgrades can be downloaded from:

WSJTx <https://physics.princeton.edu/pulsar/k1jt/wsjsx.html>

MSHV 1z2hv.org/mshv

or google WSJTx or MSHV for the websites.



OXLEY REGION AMATEUR RADIO CLUB 44th ANNUAL FIELD DAY Saturday and Sunday 8 & 9 June 2019



TRASH & TREASURE

TRADE DISPLAYS (Sunday Only)

FOX HUNTS (Saturday and Sunday)

HOME BREW COMPETITION

FREE COFFEE, TEA & BISCUITS

www.orarc.org | Talk-in frequency 146.700 MHz (91.5 Hz CTCSS) Station Callsign VK2BOR

\$5 ENTRY | WAUCHOPE SHOWGROUND HALL
Field Day Dinner - Saturday 8th PORT MACQUARIE GOLF CLUB

Contact: HENRY LUNDELL VK2ZHE email: vk2bor@orarc.org

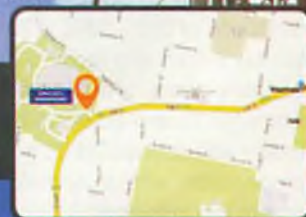

SOTA & Parks

Allen Harvie VK3ARH
• vk3arh@wia.org.au

Propagation conditions continue to be variable, with zero sunspots visible for extended periods. Most SOTA Activators have been able to easily qualify their summit with Chasers from further afield, with some closer in Chasers frustrated by hearing only the other Chasers and not the Activator, especially when the distance to the summit has been in the 120 to 300 km or more when the 40 metre band has been in use.

Most SOTA and Parks Activators still find 40 metres the “bread and butter” band, with 20 m yielding more distant contacts. All Activators have been finding at least a few closer in Chasers/Hunters by the use of 80 m, regardless of the time of day. At times, stations in southern Victoria have heard nothing on 40 m from Activators in Tasmania, the Victorian High Country, southern NSW and even the ACT region. If the Activator has tried 80 m, contacts have been possible, even though the 80 m band is often noisy during daylight hours.

Despite the propagation conditions, there has been a good level of activity over the last two months. Parks activations have been numerous, with a few SOTA operators venturing into the hills, especially on weekends.

SOTA

Perhaps the most notable news for SOTA was the “VK ZL JA – EU UK S2S” event on 6 April 2019. Discussions between Andrew VK1AD, Mike 2E0YYY and Ed DD5LP resulting in the nomination of 066 – 0800 UTC on Saturday 6 April as a focus for attempting contacts between summits in VK/ZL and Europe, timed to coincide with anticipated long path propagation, with JA operators welcome to join in the fun.

The local afternoon was rather busy on-air. There were 23 operators spotted on Parks&Peaks during the activity period from VK1 through to VK7, plus ZL. There were many S2S contacts made within VK, plus some Summit to Park contacts. Some operators had a little success with a small number of S2S contacts to Europe, with propagation described by many as “poor to ordinary”. There were a large number of operators spotted on SOTAwatch in Europe plus some in Asia.

VI9NI activated Mt Bates VK9/NO-001 on Norfolk Island in Norfolk Island National Park (Commonwealth) (VKFF-0392).

With Easter just prior to ANZAC Day, there were a few Activators out and about over the period. Parks activity dominated, but several summits were also activated.

Gerard VK2IO travelled to participate in the Urunga Convention, activating Parks and SOTA summits on his trip north. He spent several days after the event based near Coffs Harbour, including some more Parks and SOTA activations.

Your scribe hiked into The Governor VK3/VE-046 to activate on ANZAC Day. This was my second attempt to reach the summit, the first being after an activation of Eagles Peak earlier this year with Tony VK3CAT and David VK3IL. On that occasion, the steep terrain dictated a strategic withdrawal whereas this instance was over two days with around 10 hours of walking via the ‘easy’ track. Once on the summit, there was no 40 m NVIS propagation, so contacts came slow but I managed to qualify the summit with 40 m and 20 m CW and SSB. Time on the summit was short due to the time required to

return to camp and then back to the car. The walk out was completed with the aid of a torch. This was only the second activation of this remote summit. You can find a more complete description of the activation on my blog: <https://vk3arh.net/2019/04/26/25042019-vk3-ve-046/>

Parks

National coordinator Paul VK5PAS has again been busy.

In early March, he announced two new Awards in the VKFF program: VKFF Top Foundation Hunter and VKFF Top Foundation Activator. The Awards aim to encourage greater participation in the VKFF program by Foundation licence holders.

The new Awards complement the existing Top Operator Awards. As at 24 April, the Top Hunter standings saw Gerard VK2IO leading the pack on 234 parks, just one in front of John VK4TJ. Peter VK3PF is in third place with 229 parks. On the Activator front, the Top VKFF Activator is Mike VK6MB with 37 parks. In second place is Peter VK3TKK with 33 parks. And in third place is Rob VK4AAC with 20 parks. *Please note that on Logsearch in the Top Activator classification you will see two figures in the ‘Refs’ column. The second figure in brackets shows the total number of parks activated. The first figure is the number of those parks where 44 QSOs were reached (thus qualifying the park for WWFF). The Top VKFF Activator award is based on the number of parks activated where 10 QSOs were reached (the VKFF threshold).

Together with the State coordinators, Paul has been adding

new Parks in some states. April saw 19 new references added in VK4, 13 in VK5 and 43 in VK7. Special thanks go to Marc VK3OHM for the bulk uploads, to Peter VK3PF in finalising some details, and also to the State coordinators. Paul will be collating further additions in VK5 and is waiting for coordinators in other States for their suggestions. Paul has a long list for new additions in VK3, but the international rules restriction additions to only 500 per year for any country. Several of the new Parks had already been activated at the time these notes were prepared.

Mike VK6MB continues to be active in VK3 and southern VK2. Mike will be travelling until August and has a goal of activating all Victorian National Parks for the Keith Roget Memorial National Parks Award whilst he is based in VK3.

Greg VK4VXX/6 continues his journey in VK6 and has been active around Perth and the SW. Greg typically camps for a small number of nights in a National Park before moving on to the next Park.

Peter VK3TKK has made a number of day trips activating Parks. He typically has quite a long day broken up with short activations in a Park, mainly within VK3. On any one trip, he may revisit a previously activated Park or activate one or more Parks which had not yet been activated. His mode of operation means that the Hunters need to

remain alert and keep an eye on the Spots page on ParksNPeaks.

WWFF Australia migrates from Yahoo

The discussion list wwffaustralia has moved from Yahoo groups to Groups.io. You can find the group at: <https://groups.io/g/wwffaustralia/>

VK5 National Parks & Conservation Parks Award Anniversary Weekend

March 23 and 24 saw many operators active in South Australia to celebrate the sixth anniversary of the VK5 National Parks and Conservation Parks Award. Activators in other states ventured out, given the prospect of many possible Park to Park contacts due to the high activity in VK5.

18 Activators had registered to activate 30 Parks in VK5 over the weekend. Tony VK3XV/5 made a long trip over two weeks activating Parks across VK5. Combine this list with those who did not register prior to the weekend and those joining in from Parks in other states; there was a high level of on-air activity.

ParksNPeaks

To meet the demand for current and historical activity an API giving access to spotting and site information as well as application interaction (Android based VK-Logger by Peter VK3ZPF and iOS ParksNPeaks app by Sue VK5AYL) has been developed. The web site

itself has been upgraded in the background over the last month to use said API and introduce closer integration with coming updated SOTAwatch site. The direction this information can go is only limited to users imaginations. For more information contact me at support@parksnpeaks.org

Coming events

This issue should appear just prior to the WIA AGM and Conference in Sydney on 25/26 May. It is expected that a SOTA display will be part of the activities on Sunday at ARNSW at Dural. Most helpers are also Park Activators, so feel free to drop by the display for a chat or to catch up.

With winter approaching, the seasonal bonus period will begin in southern states in mid-June. Chasers can expect the more intrepid Activators to be out on the summits seeking to gain the bonus points available for summits more than 1200 metres high, unless the weather conditions are terrible.

Volunteers required

I've been kept very busy over recent months, with updates to ParksNPeaks, my day job and family commitments, and it is a struggle to find time to make an occasional activation trip, let alone keep up with preparing these notes! I am looking for volunteers help going forward. Please contact Allen vk3arh@wia.org.au





WIA Awards

Marc Hillman VK3OHH/VK3IP

Below are listed all New awards issued from 2019-02-15 to 2019-04-14, plus all updates to DXCC awards.

Go to <http://www.wia.org.au/members/wiadxawards/about/> to use the online award system.

New awards

Antarctic

#	Call	Name	Mode
104	VK3GA	Graham Alston	Open
105	VK3GA	Graham Alston	Digital

DXCC Multi-band (1)

#	Call	Name	Mode	Band	Count
214	VK5GR	Grant Willis	CW	20 m	102
215	VK3MH	Brendan Bryant	Open	20 m	124

DXCC Multi-band (3)

#	Call	Name	Mode	Band	Count
137	VK3VM	Stephen Ireland	Open	40-30-20 m	339

DXCC Multi-band (5)

#	Call	Name	Mode	Band	Count
96	VK3BDX	David Burden	Digital	80-40-30-20-17 m	763
97	DL5XL	Felix Riess	Open	20-17-15-12-10 m	1040
98	VK6WX	Wesley Beck	Open	40-30-20-17-15 m	726

DXCC Multi-mode (CW)

#	Call	Name	Count
8260	DL5XL	Felix Riess	276
261	TA6N	Taskin Akansel	120

DXCC Multi-mode (Digital)

#	Call	Name	Count
81	JH3LIB	Takaaki Tanaka	145
82	VK6WX	Wesley Beck	107
83	WL7CG	Alan Sorum	105
84	HK5NLJ	Alvaro Gomez	114
85	VK3MH	Brendan Bryant	138
86	TA6N	Taskin Akansel	129

DXCC Multi-mode (Open)

#	Call	Name	Count
467	WL7CG	Alan Sorum	110
468	HK5NLJ	Alvaro Gomez	133
469	VK8GM	Gregory Mair	207
470	VK3MH	Brendan Bryant	118

DXCC Multi-mode (Phone)

#	Call	Name	Count
626	VK3BDX	David Burden	108
627	VK8GM	Gregory Mair	187
628	VK3MH	Brendan Bryant	118
629	TA6N	Taskin Akansel	127

Grid Square

#	Call	Name	Mode	Band
370	VK3KTT	Steven Barr	Digital	HF
371	VK6WX	Wesley Beck	Digital	HF
372	HK5NLJ	Alvaro Gomez	Open	HF
373	HK5NLJ	Alvaro Gomez	Digital	HF
374	HK5NLJ	Alvaro Gomez	CW	HF
375	JM7GTK	Nobuyuki Kanazawa	Digital	HF
376	JM7GTK	Nobuyuki Kanazawa	Open	HF
377	VK3MH	Brendan Bryant	Open	HF
378	VK3MH	Brendan Bryant	Digital	HF
379	TA6N	Taskin Akansel	CW	HF

Worked All VK Call Areas HF

#	Call	Name	Mode
2384	VK3VM	Stephen Ireland	Open
2385	VK3VM	Stephen Ireland	Digital
2386	JH3LIB	Takaaki Tanaka	Digital
2387	VK3JL	David Rolfe	Open
2388	VK3BDX	David Burden	Open
2389	DL5XL	Felix Riess	Open
2390	VK4TJF	James Fleming	Phone
2391	JM7GTK	Nobuyuki Kanazawa	Digital
2392	JM7GTK	Nobuyuki Kanazawa	Open

DXCC updates

DXCC Multi-band (1)

#	Call	Name	Mode	Band	Count
33	VK4TJF	James Fleming	CW	20 m	143
43	VK7CW	Steven Salvia	CW	20 m	281
97	VK6WX	Wesley Beck	CW	20 m	148
148	VK3GA	Graham Alston	CW	20 m	220
199	VK5BC	Brian Cleland	CW	30 m	106
3	VK2CA	Allan Meredith	Digital	20 m	202
54	VK3EW	David McAulay	Digital	20 m	216
149	VK3GA	Graham Alston	Digital	20 m	215
164	VK5BC	Brian Cleland	Digital	20 m	158
190	VK3BDX	David Burden	Digital	40 m	179
207	VK3VM	Stephen Ireland	Digital	20 m	123
17	VK6WX	Wesley Beck	Open	20 m	219
32	VK4TJF	James Fleming	Open	20 m	187
34	VK3KTT	Steven Barr	Open	20 m	236
100	VK3GA	Graham Alston	Open	20 m	293
165	VK5GR	Grant Willis	Open	20 m	195
189	VK3BDX	David Burden	Open	40 m	202
11	VK3EW	David McAulay	Phone	20 m	339
35	VK3KTT	Steven Barr	Phone	20 m	211
39	VK6WX	Wesley Beck	Phone	20 m	174
101	VK3GA	Graham Alston	Phone	20 m	201
142	VK8GM	Gregory Mair	Phone	20 m	127

DXCC Multi-band (3)

#	Call	Name	Mode	Band	Count
18	VK2CA	Allan Meredith	CW	30-20-17 m	600
37	VK7CW	Steven Salvia	CW	30-20-17 m	772
134	VK3GA	Graham Alston	CW	40-20-17 m	460
66	VK3EW	David McAulay	Digital	30-20-15 m	582
104	VK5BC	Brian Cleland	Digital	40-30-20 m	434
111	VK2CA	Allan Meredith	Digital	20-17-15 m	491
121	VK3GA	Graham Alston	Digital	40-30-20 m	516
132	VK3BDX	David Burden	Digital	40-30-20 m	522
17	VK2CA	Allan Meredith	Open	20-17-15 m	894
36	VK7CW	Steven Salvia	Open	30-20-17 m	811
48	VK5BC	Brian Cleland	Open	20-17-15 m	726
69	VK3KTT	Steven Barr	Open	20-15-10 m	565
73	VK3GA	Graham Alston	Open	20-17-15 m	731
112	VK6WX	Wesley Beck	Open	40-20-15 m	509
120	VK5GR	Grant Willis	Open	40-30-20 m	519
131	VK3BDX	David Burden	Open	40-30-20 m	563
2	VK2CA	Allan Meredith	Phone	20-17-15 m	759
23	VK3EW	David McAulay	Phone	40-20-15 m	987
49	VK5BC	Brian Cleland	Phone	20-15-10 m	613
68	VK3KTT	Steven Barr	Phone	20-15-10 m	512
86	VK3GA	Graham Alston	Phone	20-15-10 m	461

DXCC Multi-band (5)

#	Call	Name	Mode	Band	Count
20	VK2CA	Allan Meredith	CW	40-30-20-17-15 m	931
21	VK3EW	David McAulay	CW	40-30-20-17-15 m	1411
35	VK7CW	Steven Salvia	CW	40-30-20-17-15 m	1184
76	VK5BC	Brian Cleland	Digital	40-30-20-17-15 m	700
79	VK3EW	David McAulay	Digital	40-30-20-17-15 m	888
92	VK3GA	Graham Alston	Digital	40-30-20-17-15 m	769
96	VK3BDX	David Burden	Digital	80-40-30-20-17 m	763
31	VK5BC	Brian Cleland	Open	40-20-17-15-10 m	1162
34	VK7CW	Steven Salvia	Open	40-30-20-17-15 m	1247
72	VK3FZ	Roger Stafford	Open	30-20-15-12-10 m	906
73	VK3GA	Graham Alston	Open	40-30-20-17-15 m	1137
94	VK3BDX	David Burden	Open	80-40-30-20-17 m	805
98	VK6WX	Wesley Beck	Open	40-30-20-17-15 m	726
2	VK3EW	David McAulay	Phone	40-20-17-15-10 m	1609
19	VK2CA	Allan Meredith	Phone	20-17-15-12-10 m	1137
33	VK5BC	Brian Cleland	Phone	20-17-15-12-10 m	953

DXCC Multi-band (7)

#	Call	Name	Mode	Band	Count
9	VK2CA	Allan Meredith	CW	40-30-20-17-15-12-10 m	1213
10	VK3EW	David McAulay	CW	80-40-30-20-17-15-12m	1817
14	VK7CW	Steven Salvia	CW	40-30-20-17-15-12-10 m	1544
6	VK2CA	Allan Meredith	Open	40-30-20-17-15-12-10 m	1828
15	VK7CW	Steven Salvia	Open	40-30-20-17-15-12-10 m	1631
24	VK5BC	Brian Cleland	Open	40-30-20-17-15-12-10 m	1562
35	VK3FZ	Roger Stafford	Open	40-30-20-17-15-12-10 m	1168
42	VK3GA	Graham Alston	Open	80-40-30-20-17-15-10 m	1383
8	VK3EW	David McAulay	Phone	80-40-20-17-15-12-10 m	2183

DXCC Multi-band (9)

#	Call	Name	Mode	Band	Count
12	VK3EW	David McAulay	CW	160-80-40-30-20-17-15-12-10 m	2150
1	VK3EW	David McAulay	Open	160-80-40-30-20-17-15-12-10 m	2806

DXCC Multi-mode (CW)

#	Call	Name	Count
207	VK4TJF	James Fleming	176
222	VK5BC	Brian Cleland	192
223	VK6WX	Wesley Beck	214
234	VK3KTT	Steven Barr	161
240	VK3GA	Graham Alston	265
245	VK4CAG	Graeme Dowse	167
249	VK3FZ	Roger Stafford	230

DXCC Multi-mode (Digital)

#	Call	Name	Count
19	VK2CA	Allan Meredith	260
20	VK3EW	David McAulay	300
29	VK5BC	Brian Cleland	228
33	VK7CW	Steven Salvia	146
36	VK6SJ	Stephen Kennedy	119
55	VK3GA	Graham Alston	242
65	VK3FZ	Roger Stafford	157
67	VK4CAG	Graeme Dowse	207
71	VK3BDX	David Burden	222
72	VK3VM	Stephen Ireland	150
79	VK3KTT	Steven Barr	131
82	VK6WX	Wesley Beck	107

DXCC Multi-mode (Open)

#	Call	Name	Count
345	VK4TJF	James Fleming	206
370	VK3KTT	Steven Barr	276
375	VK2TTP	Peter Pratt	167
376	VK6WX	Wesley Beck	267
390	VK6SJ	Stephen Kennedy	171
419	VK3GA	Graham Alston	318
458	VK3BDX	David Burden	232
459	VK3VM	Stephen Ireland	150

DXCC Multi-mode (Phone)

#	Call	Name	Count
572	VK2TTP	Peter Pratt	167
573	VK6WX	Wesley Beck	224
575	VK3KTT	Steven Barr	254
584	VK6SJ	Stephen Kennedy	134
598	VK3GA	Graham Alston	285
626	VK3BDX	David Burden	108

Tony Hambling VK3XV
e arv@amateurradio.com.au
w www.amateurradio.com.au

ARV Council Election & Annual General Meeting

A reminder to members that the 2019 AGM will be held in the rooms (40G Victory Blvd Ashburton) on Tuesday 28 May at 8 pm.

Nominations closed for Council positions on 26 February and as nominations did not exceed vacancies, no election is required.

Ice damage at Mt Hotham APRS repeater

A routine inspection of the APRS installation at Mt Hotham resulted in ARV spending in excess of \$1000 on a replacement antenna. Riggers have been booked to install the new aerial prior to the snow season.

The original antenna, constructed of welded stainless steel, has had a tough time as can be seen in the photos. Hopefully the new one will last several years.

On the same trip, the Mt Porepunkah voice repeater has had new antennas installed and new repeater hardware is under construction to enable it to run on the allocation of available power from the solar installation.

VK3 QSL Bureau

Paper QSLs are still very much in demand, as evidenced by the continued high number of cards processed by volunteers of ARV at the VK3 Bureau in Ashburton. The VK3 QSL bureau is operated and supported for our members and members of the WIA only. Users must be registered to benefit from this important and popular



Ice damage to Mt. Hotham APRS antenna.

ARV service. Registered users nominate a distribution point, which may be a club or the ARV office, in which case a slot will be allocated in a rack at 40 G Victory Blvd from which, after sorting, the cards can be personally collected on Tuesday's during normal office hours. Another popular collection method is to supply the Bureau a few stamped, self-addressed envelopes and QSL cards for the appropriate registered user can then be mailed out when sufficient numbers have accumulated. QSL Cards for non-members of the WIA or ARV or otherwise unregistered members are held for a maximum of twelve months before returning them to the WIA headquarters for archiving.

Clearly marked Outward going VK3 cards should be sent to 40 G Victory Blvd Ashburton 3147.

Full information on the VK3 Bureau, including Registration forms, can be accessed via the Amateur Radio Victoria website.

2019 Diary Dates

ARV Homebrew Group

2019 meeting dates

4 May, 1 June, 6 July, 3 August, 7 September, 5 October, 2 November and 7 December.

Meetings are held at ARV 40 g Victory Blvd. Ashburton 3147, commencing at 2 pm. All welcome!

Contact Rob: vk3mq@amateurradio.com.au

International Lighthouse and Lightship Weekend 2019

VK3WI will be active from the Williamstown Time Ball Tower once again for the 2019 ILLW Weekend and for the 2019 Remembrance Day Contest.

Both these events are being held on the same weekend in 2019: 17 & 18 August.

KRMNPA activation period 2019

The popular annual Keith Roget Memorial National Parks activation period will take place across four days in 2019: Friday 8 November - Monday 11 November.

This is the ideal method of increasing your VK3 National Parks tally for this prestigious Award.

VK3WI will get the ball rolling with an activation of the Brisbane Ranges National Park on Friday November 8.

All members are encouraged to participate in these outdoor events. Please contact Tony: vk3xv@amateurradio.com.au for further information.

Jim Rumble VK6RU Perpetual Trophy

The Wireless Institute of Australia Western Australia Division created the Amateur of the Year Award in 1977. In 2000 the Award was renamed the Jim Rumble Amateur of the Year Award, in honour of VK6RU, a former President of the Division and the VK6 QSL Manager for an incredible 61 years. It has been 20 years this year since Jim went SK.

The award is supposed to be an annual award and has been awarded 18 times since 1977 to some illustrious names from the past including Wally Green VK6WG, Harry Atkinson VK6WZ, Mal Johnson VK6LC, Art VK6ART, Mark Dunning VK6WV and many others.

Keith VK6KB has been contacted by one of Jim Rumble's sons regarding the above trophy. He was asking what had happened to it and if it was reinstated could he be invited to present it. Keith has offered to take the job on and would like to propose the conditions for the award of the trophy.

It was awarded to the WA Amateur who contributed most to Amateur Radio in VK6 in the preceding 12 months.

Keith suggests that each club/group consider a suitable candidate from their own membership and send me the name and reason for the nomination. Keith will then contact all the groups who have provided a candidate and hopefully we can all come up with an overall "winner" for want of a better term.

Jim Rumble's son would like to present the trophy and it has been suggested this could happen at the NCRG Hamfest in late August each year.

Keith asks that presidents or representatives of each group please contact me with their details and the candidate's details

preferably before the end of July 2019.

Keith looks forward to hearing from WA Clubs as soon as possible to get this rolling again.

Hopefully this will then become an annual event as it was always intended to be.

73 Keith Bainbridge VK6KB

NewsWest PerthTech 2019

NewsWest ran what is now expected to be an annual event on 2 March at the Bassendean Seniors Hall. The event was free and provided a full day of presentations from Phil Harmon VK6PH on High Efficiency Linear Amplifiers, Hank K9LZJ/VK6AW on his remote station in Ohio, Rex Moncur VK7MO on his exploits with EME, Chris Chapman VK3QB on EMR and interference reporting, Peter Parker VK3YE on QRP portable operation, Steve Kennedy VK6SJ on EMR Requirements for amateur radio stations and Peter Clee VK8ZZ with an update on the activities of the WIA.

The event was very popular and had around 50 attendees. A raffle was held at the end of the event with Brenton Meadows VK3CM winning the first prize of an Icom IC-7610 HF transceiver. Both RASA and the WIA had tables, along with displays of microwave systems, QRP equipment, Commercial HF Networks and Flex SDR operation.

The event was run extremely well and was a credit to Bob VK6POP and Andrew VK6AS with many helpers from across the ham community in Perth and further afield. Planning for the 2020 event is now in progress and personally, I can't wait!

The NewsWest team produce a weekly broadcast that is appended to the weekly WIA broadcast that is mainly focussed on WA topics

and is very popular. Producing the broadcast is a labour of love that is driven by a small group of hugely dedicated team members. They are always looking for material but most importantly, more volunteer members for the News Team. Contact Bob VK6POP or Andrew VK6AS if you want to become a member of one of the best news groups in VK.

Great job Bob and Andrew and on behalf of all VK6 amateurs, thank you!

73 Steve VK6SJ

Ham College

Ham College has started its Standard, Advanced and Regulations course and so the club rooms are a hive of activity on Tuesday evenings. The first Foundation licence weekend has taken place and the college is pleased to announce that all of the attendees have sat and passed their AMC assessments. In addition, a further Standard and Regulations AMC Assessment has also been successfully completed. The paperwork is different to that of the previous provider but it is clear that a significant amount of effort has gone into simplifying the form filling. As for all new systems there are some glitches but these are being worked through. It is still the College's wish to have online delivery of assessments as this will streamline the whole process. The College is interested in sponsoring any current holder of an AOCIP to become an AMC assessor, so why not approach us and get on board with assisting people to gain access to or increase their privileges and responsibilities in our hobby.

Bunbury Radio Club

The Club's June meeting will be held on Saturday 8 June, beginning

at 1400, at 21 Halsey Street, South Bunbury. At this meeting we plan to discuss the various programs and methods of logging and QSLing.

Once again it has been a relatively quiet month with our focus on technical discussions at our monthly meetings. These discussions have been generated quite a bit of interest, with the topics flowing onto other items of interest to members. We have three items each meeting:

1. "Bob's Corner" where Bob VK6TJ raises an issue for discussion among the attendees to test their knowledge and get the rusty brain cells operating;
2. "Help Corner" where members are invited to raise a problem (Ham Radio) they are experiencing in the shack. This activity has become very useful to members solving several problems, including how to deal with recalcitrant neighbours.
3. Finally, the major activity is a presentation on a subject of their choice from club members. At the April meeting Bob VK6TJ spoke on digital audio. This was very interesting as Bob was able to go into greater depth than the average ham would normally experience in his conventional training.

Norman VK6GOM has now been accredited as an Assessor under the AMC system. He plans to arrange some assessments, probably in June.

A presentation in January has sparked some interest in ADS-B with a small number of members setting up to work this system.

Any South West based amateur (or anyone interested in radio or electronics) is more than welcome to join and participate in our activities. Because so many of our members come from near and far we are evolving into a semi "virtual" club. Consequently, regular attendance at meetings is not a requisite for membership. The annual fee is only \$50.00. Those wishing to join can contact the

Club via our Secretary, Richard Ayre on 0439 940 253, or vk6brc@wia.org.au. Further details can be found on our website at <http://www.bunburyradioclub.com/>

73 Norman VK6GOM

Friday Night TechNet

Reg VK6BQQ/VE3BQQ runs the world wide attended EchoLink net called the Friday Night TechNet - which despite being run from Jandakot in Perth, is actually held at 0000Z each Saturday morning (8 am Perth time), which is 2000 local time in Toronto, Canada.

The second half of the net is called the "Flying Pigs Bet, which is devoted to aficionados of all things aviation and is also an interesting listen.

The nets are held on the Techlink Conference node, EchoLink node 9229.

On 12 April, the net marked its 900th consecutive weekly net. Congratulations to Reg and his team for this impressive milestone.

Hills Amateur Radio Group (HARG)

The HARG has had a busy couple of months.

The group again headed out portable for the John Moyle Field Day, setting up almost at the peak of Mount Dale. Whilst those in the east reading this might expect something quite high, in WA, when we use the word mount, we really

mean big hill. Hi. Mt Dale is the highest point in the Darling Range just east of Perth and being only a 40-minute drive from the club's shack makes an ideal location for the field day. Several members met at the club on Friday afternoon and packed up the gear. They headed out, and before dark, had set up the gazebo, put up the loop and had the radio gear fired up. Conditions on HF were, to be kind, a little difficult. VHF and UHF was helped by the height of the hill. In the past few years, being so high and exposed, we have had to spend time making sure the gazebo didn't blow away and keeping ourselves warm. This year, we had to open up the gazebo to try and get some breeze through. It was unusually warm. We didn't break any records but certainly had fun.

At our March meeting we were treated to Steve VK6IR giving us the run down on QSLing. Steve has previously run the WA QSL bureau and been the club's QSL manager. He has worked over 330 countries and is currently trying to achieve 9-band DXCC digital. He is almost there with the elusive 160 m still to go. Steve has forgotten more about QSLing that most of us have learned. Will be giving another talk soon titled "The DX Sniper" and is sure to help you chase that elusive DX in these low sunspot times.

Last weekend the group held its HARGfest. Despite the inclement

Photo 1: A view of HARGfest.



weather, there was a great turnout and some bargains were had. It is great to see some representation from the industry and especially pleasing to see TET Emtron, DX Radio Systems, Bushcomm and Terlin take tables at the event. As usual, there was great interest in the raffle and no surprise, with prizes donated by DX Radio Systems, Bushcomm, TET-Emtron and Farmcomms. There is a great deal of preparation that goes into the smooth running of such an event and thanks must go to all who put in behind the scenes and to those who made it happen on the day. At the risk of leaving someone out, special thanks needs to go to Ron VK6HRB & his XYL Dot, Bryan VK6PVC, Harry VK6YBZ, Alan VK6PWD, Peter VK6LB, Steve VK6IR, Dave VK6NDR, Brock VK6VBC, Steve VK6VLF and Alasdair VK6ATX. The now famous HARGburgers were again popular, and to date there have been no reports of food poisoning, always a good sign Hi!

HARG officially meets at their clubrooms inside the Paxhill Guide Hall, located at 5 Sanderson Road in Lesmurdie. We are always there on the 2nd and last Saturday of each month but can often be found there on other Saturdays. Doors are open at 1:00 pm and we usually kick off with a BBQ. More information can be found at www.harg.org.au or on our Facebook page @hillsarg. Visitors are always welcome.

73

Ray VK6ZRW

Northern Corridor Radio Group

We have had a lot happening at NCRG over the past 2 months.

We participated in the John Moyle Field Day at Paruna Wildlife Sanctuary. Paruna Wildlife Sanctuary, just outside of Perth, forms an important wildlife corridor along the Avon River, between Walyunga and Avon Valley National Parks. The property supports a rich diversity of habitats and has



Photo 2: The NCRG crew for the JMFD 2019.

been the site of several successful mammal reintroductions, including the Black-flanked Rock-wallaby and the Tammar Wallaby. This year marks our third visit to the park for the JMFD. We had a triband HF Yagi, attached to the comms trailer now owned by the club, dipoles for the DC bands and a triband vertical for 6 m, 2 m & 70 cm. It was a great social activity for the club with a good percentage of the club turning up. Lots of radio was played over the weekends but a few headaches experienced in the mornings!

We also participated in the CQ-WPX contest in March in the Multi Op, single TX category, marking the first major contest using the new gear purchased for the club over the last 12 months. We gave our new SPE-2K a good workout (it coasts along at 400 W 24-7), Ultra beam UB6-40 Yagi and the trusty old Kenwood TS-990 a good workout; making 1090 contacts for a score of 2,168,748 points.

On the subject of contesting, NCRG throws out the gauntlet to other clubs in VK to participate in the Remembrance Day contest in August. NCRG holds the current record for most points in the contest and is looking to increase this record in 2019.

Planning for our 2019 Hamfest is now well and truly under way with a number of new initiatives planned to maintain our record of being the "Hosty with the Mosty" and largest amateur event in WA. We are considering activities to cater not only for active amateurs, but also those new to the hobby, children of hams and partners as well. We are looking to expand the Homebrew contest with additional categories and some great prizes. The always popular Hamfest raffle will again be run, with a new and modern radio being purchased for the main prize. The event will be held in the Cyril Jackson Hall in Ashfield, Perth on 25 August.

The NCRG is always looking for new members and welcomes any prospective members at our Sunday morning gatherings at 0830 at the club, as well as at our monthly business meeting at 1930 on the third Tuesday of each month. At any point in time, the club has 3-4 projects in progress so there is plenty of scope for participation in club activities and projects. The club is one of the better set up club stations in VK and is also one of the more successful contest stations.

73 Steve VK6SJ – Publicity Officer for the NCRG

Southern Electronics Group

Katanning Hamfeast was held Friday 5 April, 2019 at the Royal Exchange Hotel. Weather for the day was great and thanks to everyone who made the trip. The conversation and drinks flowed freely during the day and everyone sat down for a hearty lunch.

I think there was in excess of 35 attendees as I had originally booked for 30, then we added some extra chairs and still ran out of room! Faces were put to callsigns, new friendships were made and old acquaintances renewed.

Thanks to Brian VK6WG for the photo of the day which gives you some idea of how busy was the gathering.

Jennifer from Future Systems had a live demonstration of the Flex 6700 remote HF transceiver operating and the Hamfest raffle had an array of prizes and was well supported.

First prize in the raffle was a portable shortwave receiver and won by Peter Morris from Cranbrook. Peter is a SWL and a new member to SEG. He is currently studying for his licence and hopes to sit for his assessment soon.

Second prize was won by Alek VK6APK, third prize went to Rick VK6XT and fourth prize was won by Steve VK6VZ. Other prizes were also won by Alisdair VK6ATX, Brian VK6WG, Gary VK6GS, Hazel VK6LR XYL, Max VK6FN, Bob VK6ZGN and Phil VK6GX.

Some attendees also took up the offer by Gary VK6GS of a private museum tour in Katanning afterwards.

It is very encouraging to see so many come along to the day and many thanks again to everyone who attended Katanning Hamfeast.

Hopefully see you all at Bridgetown Hamfeast in October 2019.

73, Rob VK6LD

WA VHF Group

The WA VHF Group is pleased to present a few notes on its activities recently and most importantly, what will be a final call for registration



Photo 3: The Katanning Hamfeast 2019 gathering.

of items / anecdotes of interest for the up-coming Communications Exhibition to be staged at Wireless Hill the former Coastal Radio station "VIP", featuring the many contributions made by Amateurs to the communications art since 1900.

In regards the normal Group activities we continue apace with satellite communications primarily with AO-91 and AO-92. Member Robert VK6FRDM has had several successful QSOs with David VK5DG and VK5DG/3 when activating parks. Robert's mainstay antennas are dual band Yagi and Lindenblad. Our "core group" of satellite communicators continues to experiment to find the "ideal" locations and setup to achieve consistency in our results. Activity Days have been thin on the ground due to conflicting events; however they remain a much appreciated feature of the Group. Several of our satellite-specific antennas were on display at last weekend's Hills Amateur Radio Group, HARGfest, and attracted considerable interest.

And now to the Exhibition

In concert with the Wireless Hill Telecommunications Museum in the City of Melville, the WA VHF Group is facilitating a Grand Exhibition highlighting the Amateur aspect of their "Communications from 1900 to the present" professionally curated exhibition. As most Amateurs will

realise, developments in radio communications have often come about as a direct result of Amateur experimentation. After all, Amateurs have the freedom to "go where no one has been before" without fear of financial penalty or political loss of face and in a spirit of friendly cooperation.

Contributions are sought VK-wide, or VK and ZL if you wish! Or beyond! Just because it is being hosted in VK6 does not and should not limit wider participation. This is about Amateur Radio, not just about VK6.

Think of the many World records that have been set, both terrestrially as well as via the Moon and aircraft of various kinds. Alf Traeger and his pedal-powered radio - what a contribution to the health and community of outback Australia! Also "Winnie-The-War-Winner" built from scrap behind enemy lines in WWII and many other examples not so well known. Without Amateurs willing to try something new, usually on a shoestring budget, would communications as we know it have developed to the present degree?

And this is exactly the point of our (Amateur Radio) place in the Exhibition.

Many of those contributions are not well documented again thanks largely to their source. They are ideas that were locked away in brains, some (many?) of which are now SK. But perhaps you, reading

this now, recall some of those operators and their achievements. It could be an anecdote. It could be a circuit diagram, experimenting with a new concept. It could be a QSL card, or the photograph of an award.

The Exhibition will attract many students from Primary and Secondary – and possibly even from Tertiary education. Help share with them, the milestones that Amateur Radio has helped to create. Will they build crystal sets?

One valve radios? Probably not, but just as visitors marvel at the sight of large steam engines of all kinds in their respective Museums so too can the present generation come to realise the importance of what has gone before in communications, that gives them their ubiquitous mobile phones of today. And perhaps even be inspired by it.

This is a long-winded way of saying...

Please, REGISTER NOW if you think there is something "buried in the shack" or in the old "grey matter" that relates to the above - a home brew coil, capacitor, a switch, a modification, or even a full transceiver - consider dusting it off and sending us a photograph or the item if transport cost is reasonable. Your items will be well cared for

Photo 4: Dish Antenna at the ARISS ground station.



and insured and returned to you if desired at the conclusion of the Exhibition. QSL cards? Likewise. Photocopy of a significant page in your logbook... all grist to the mill.

Anecdotes too; oral histories form a key aspect of the display. Within WA we have available experienced oral history takers. Perhaps we can arrange that in other States, too. If unsure please make contact. On our website, www.wavhfgroup.org.au/exhibit, you will find more information and a web form for logging submission of items. Or contact us at our committee@wavhfgroup.org.au email address but the former web form is better as it ensures that submissions are not accidentally overlooked.

But this is genuinely the last call. We soon need to hand over the list to the Exhibition curators so that they can develop a public-friendly and inspirational display. Once they have called "time" then later items may not be included because of the logistics associated with mounting any Exhibition of significance.

Your piece in this puzzle is needed NOW.

Thanks for reading,

Denis VK6AKR for the WA VHF Group

Peel Amateur Radio Group

PARG started the New Year off with a bang. We successfully ran our annual Swap Meet in February with a good number of Amateurs coming from North of Perth and South of Mandurah.

Everyone had a great morning. This is the first of the SWAP meets for the year with other VK6 clubs running theirs later in the year. It is always a great morning catching up with others to have a chat, win some prizes and having a feed.

Club member Martin VK6MJ has found time to rebuild his ARISS ground station antenna array, with a little help from Martin VK6FEEE.

PARG has been fortunate in receiving a small grant from the City of Mandurah. This community grant has enabled the group to



Photo 5: The TH3 beam on its mast.

replace its unreliable Chinese built generator with a state of the art Honda generator. On the first deployment of the recently purchased PARG1 mobile communications trailer the Honda generator proved itself whilst we were testing a couple of different noise filters. Both noise filters helped to reduce RF noise coming from the inverter type generator. Our pneumatic Clark mast was deployed to test out a very much used Hy-Gain TH3 antenna for the Rockingham Scout Group.

PARG ran a successful portable John Moyle Memorial Field Day station on a farm property just out of Mandurah. The club callsign VK6ARG ran hot over the 24 hours and many good lessons were learned over the weekend. A little drama occurred when the station was hit with an unexpected willy-willy which resulted in an upturned Gazebo and a smashed squid pole antenna.

We were very fortunate to be hosted by club member(s) James VK6MNX and Robert VK6FRAB. That weekend Terry VK6TTF enjoyed trialling his recently built Hex Beam antenna.

The club will be running two sausage sizzles for fundraising this year, on May 11 and August 31 at the new Bunnings Store in Mandurah. These are the two biggest fundraising events for the year apart from our annual SWAP Meet. At each sausage sizzle our



Photo 6: The trailer and gazebo.

Mobile Communications Unit, PARG1, is fully setup for displaying the hobby of Amateur Radio. PARG1 is also a great place for members to relax when not on duty slaving over the hot BBQ!

PARG has busy times ahead as it is participating in the inaugural PARG/State Emergency Service

joint emergency communications training morning in late May. This is a great opportunity for PARG members to work with the local SES unit, and to demonstrate how amateurs can contribute in times of emergency.

In early June we will be having



Photo 7: The Hex Beam antenna.

our AGM, with voting of the new committee.

73 Paul Gardner VK6LL



S.E.R.G.
55th Annual Convention
and
Australian
Fox Hunting Championship

Sat and Sun
8-9 June 2019
Scout Hall
Margaret St Mt GAMBIER



- Home Brew Competition
- Trading Tables
- \$5 entry + Door Prize
- Strictly Ham
- Free Come and Try Radio
- Guest Speaker
- Tea Coffee and Food avail
- Sunday Night Roast dinner





VK2news

Tim Mills VK2ZTM
e vk2ztm@wia.org.au

With winter just round the corner, let us hope for an improvement in HF propagation so that many can enjoy more on air activities. This May 2019 is a busy month in VK2. For some clubs their AGM has come around again like at Westlakes ARC and HADARC. There is also the WIA AGM in Sydney, the last time here was in 2006 which was the first AGM held in the WIA restructure. It was held in Bankstown. Part of the Convention program this year is a visit for some delegates to VK2WI at Dural on the Sunday [26 May] with displays, talks and a look over the facilities. Other delegates have the option of a visit to the Kurrajong Radio Museum. Keep an ear on VK2WI news –

10 am and 7.30 pm EST for details and updates. Many VK2 Clubs provide regular news segments. Here is an invite to other VK2 clubs and groups to provide segments. Just email your submission to news@arnsw.org.au by the Friday evening for the following Sunday.

Mid North Coast Field Day

June is the time for the annual Oxley Region ARC Field Day on the mid north coast of VK2. Again this year it will be held in Wauchope, this time at the showground on Saturday 8 and Sunday 9 June. The Wauchope Showground permits camping, so it is possible to stay on site in your own motor home, caravan or tent with power and amenities. The Saturday evening dinner is at the Port Macquarie Golf Club. With Port being a popular holiday location, especially on long weekends - book accommodation early. Check out the ORARC item elsewhere in this issue of AR.

The Northern Rivers WICEN

Group, a function of the Summerland ARC, decided to disband. Their members will remain operational as part of WICEN NSW. The Mid North Coast WICEN group meets in Port Macquarie on the first Saturday of the month following the Oxley Region ARC monthly meeting at SES HQ. WICEN NSW, based in Sydney, is now meeting monthly for training at the VK2WI Dural site, an all-day event on the first Sunday of the month.

Still in the north - the New England region has been linking the various repeaters into a common network. The 70th Urunga Convention was held in the Urunga Village over Easter. First started in 1949 - it has not missed a year since then. It is very much a Fox Hunter's dream of almost continuous events.

ARNSW AGM

ARNSW held their AGM in April with over 50 members in attendance. Of importance this time was two special resolutions. The first was to change the name of the company from the former *Wireless Institute of Australia - New South Wales Division* to the name currently in use - being *Amateur Radio New South Wales*. The second resolution was to adopt a new Constitution to replace the one that was in current use. Both Resolutions passed and were adopted by all present at the meeting. Audio of the meeting is available on the ARNSW streaming service www.arnsw.org.au/audio. The NSW Division was registered as a company in 1922, having been formed as the first Institute in 1910, giving ARNSW a history back 109 years. The former name is being registered and retained. The replaced Constitution had been in place, with minor adjustments, since 1976.

The ARNSW committee this year has had only one change

with Paul VK2APA retiring and with John VK2JV joining. The continuing committee members are Mark VK2XOF, John VK2LJ, Al VK2OK, Mathew VK2YAP, Tim VK2ZTM, Ray VK2ASE, Eric VK2VE and Bob VK2CAN. The new constitution provides for two year committee terms with alternate half committee elections each year.

Training & Activities

In March both ARNSW and the Oxley Region ARC held 40 metre dipole making days. Between them, over 35 dipoles came into existence. The next ARNSW Foundation and assessment weekend is set down for 13 and 14 July. Inquiries to education@arnsw.org.au The Waverley ARS, celebrating their Centenary, will hold their annual auction at the Rose Bay club rooms on Saturday 13 July.

The new 40 metre pole at VK2WI for the VK2RWI repeater network is getting ready for the cabling and antenna installation. A view of the pole has become the wall paper background image on the ARNSW Home Page. The grassed area between the VK2WI transmitter building and the Centenary Building - more than 500 square metres - is growing well. The VK2RSY 23 cm beacon has had its oscillator module replaced which should provide improved stability. This is a CW beacon with horizontal polarization running about 25 watts. The network of VK2RSY beacons, have in various forms from 10 m to 23 cm, been operational since the 1970s. With more activity these days becoming digital with WSPR, FT8 and others, does the continuous CW beacon still have a place? They are after all a big consumer of electricity with often little acknowledgement of their existence or apparent use.

73
Tim VK2ZTM



VK1news Canberra Region Amateur Radio Club

Wade Smith VK1MIC

As VK1 slips closer to winter's grip, there has been a flurry of activity across the territory from supporting infrastructure upgrades and installing beacons to a big SHF SOTA event.

Typically, the shoulder seasons between the blistering summers and the snow locked winters, sees the maintenance of the repeater infrastructure and beacon upgrades, particularly VK1RGI, located on Mt Ginini which is housing 2 m and 70 cm repeaters as well as the regionally significant APRS VK1RGI Digipeater. The most recent visit saw reduced wind loading work, electrical upgrades as well as the installation of a 23 cm beacon.

The beacon is transmitting on 1296.410 MHz into a horizontally polarised PCB big wheel antenna approximately 12 m up the tower. This beacon has two sequential modes - CW and GE1 followed by a short period of a steady carrier. This follows the installation of the 144.410 MHz beacon installed at the VK1RBM site in central Canberra which also has two sequential modes - CW and GE1 followed by a short period of a steady carrier.

Reception reports would, of course, be most appreciated to enable us to judge the performance of these beacons - direct email of reports to the Canberra Region Amateur Radio Club



Photo 1: Mt Ginini site after maintenance work.



Photo 2: SHF SOTA.

(CRARC) committee email address committee@crarc.ampr.org

On Saturday 23 March 2019, Andrew Moseley VK1AD as the VK1 SOTA Area Manager, organised a VK1 SOTA '23 on 23' event where SOTA tragers, like minded SOTA activators, have the opportunity to join others for a local SOTA Summit to Summit (S2S) fest on 23 cm 1296 MHz, SSB, CW and FM modes.

SOTA activators included:

- Compton VK2HRX/P at Mt Gibraltar 163 km north-east
- Jim VK1AT/2 at Mt Cowangerong 43 km east
- Andrew VK1AD/2 at Mt Mundoonen - 70 km north
- Al VK1RX/2 at Spring Range - 40 km north
- Bill VK1MCW at Mt Stromlo - 17 km north
- Chris VK1CT at Mt Majura - 24 km north-east

Our local VK1 23 cm chaser group is just as impressive and includes: Rob VK1KW, Jason VK1JA, Ian VK1BG, Matt VK1MT, Chris VK1DO/VK2DO, Rod VK2TWR, Dale VK1DSH and the occasional

contact with Dimitris VK2COW. In Sydney 276 km north-east Mike VK2FLR and Compton VK2HRX took an interest in the hunt for VK1 23 cm signals.

Andrew maintains a pretty impressive blog specifically about SHF portable operations <https://vk1sotaon23cm.wordpress.com/>





VK3 news Geelong Amateur Radio Club

Tony Collis VK3JGC

The Grand Opening of the Newly Refurbished GARC Club House

On Saturday 6 April, all GARC members together with the families of both Ken Jewell VK3NW and Bob Searle VK3CSR were invited to attend the grand opening of the newly refurbished club house for a midday BBQ followed by an official opening at 2 pm after which, afternoon tea and savouries at 3 pm.



Photo 1: Ken Jewell VK3NW.



Photo 2: Bob Searle VK3CSR.



Photo 3: The new look entrance to the refurbished GARC Club House.

In addition to the opening, there was the naming ceremony of the newly refurbished radio room to honour Ken Jewell VK3AKK/ NW (SK) and naming of the Mount Anakie Radio Hut to honour Bob Searle VK3CSR (SK), both of whom were very instrumental in those GARC projects.

In all, over 60 persons attended the event of which the family of Ken and Bob were represented by some

26 guests and partners as well as other acquaintances of Ken and Bob on this important day at the GARC.

The event was conducted by Barry VK3SY who introduced the three speakers, firstly the GARC President, Lee VK3PK followed by Bert VK3TU and finally Peter VK3WK; all of which reflected on the significant contribution over many years, by both Ken and Bob to the GARC.



Photo 4: It was standing room only during the presentation conducted by Barry VK3SY.



Photo 5: Ken's son Chris with the plaque.

The Ken Jewell Radio Room plaque was unveiled in the presentation room and his son Chris is shown standing by its position on the window wall of the refurbished Radio Room.

To date, after several months of renovation, the club house now has a brand new toilet facility, a new workshop, new front entrance and a smart kitchen, in addition to the

completely refurbished Ken Jewell Radio Room. This still leaves the Presentation Room and Lounge to be renovated.

The refurbishment of the GARC Club house thus far was accomplished by the club members themselves, principally Lee VK3PK, Rex VK3ARG, Bert VK3TU, Alan VK3LCD and Nick VK3TY; the outcome of which was worthy of "The Block".



Photo 6: Peter VK3WK on air in the new Ken Jewell Radio Room.

GippsTech 2019

The annual GippsTech conference is coming. With a reputation as a premier amateur radio technical conference, GippsTech focuses primarily on techniques applicable in the VHF, UHF and microwave bands, especially for weak-signal contacts.

GippsTech 2019 will be happening on the weekend of 13 and 14 July, at Federation University Australia Gippsland Campus in Churchill, Victoria, about 170 km east of Melbourne.

Call for papers

Anyone wishing to share information with others is invited to submit a title and brief summary of your planned presentation to the Conference Chair Peter VK3PF as soon as possible. Please be sure to indicate your expected length of presentation: it could be a short 10 minute item through to a detailed presentation of up to an hour.

We look forward to seeing you at GippsTech in July. Registration opens **late May**.

Further details will be available from the Eastern Zone Amateur Radio Club website: <http://www.vk3bez.org/>



Profile for new WIA Director Mike Alsop VK8MA

Hi all from Mike VK8MA in Katherine in the NT. Having retired during 2018, I would like to play a far more active role in the operations of the WIA.

I was first licenced in 1966 as VK3ZYB and have held VK6, VK5 and VK8 callsigns.

In my professional life I spent nearly 40 years in Broadcast Radio and Television starting as a junior tech and ending as the station manager of several radio stations in Australia. In 2004 I took a complete change of direction and thru the Australian Bureau of Meteorology and Los Alamos Laboratory in the USA, I then worked in eight countries until 2018 and retirement. This work evolved into using my private company and employing five staff throughout the world while I managed operations from Katherine.

In that time I held several overseas callsigns: C21MA, 5U7MA, CU4AX and ZD8MA.

The interest in amateur radio went back to my youth starting as a registered short wave listener in VK3 (L1375) in approximately 1962. Over the years I have installed, maintained and operated low and high power Broadcast AM & FM transmitters and television transmitters.

My experience as a company director ensures I am prepared to take on the responsibility as a WIA Director with a view to ensuring smooth operation in fairness to all Australian Amateurs, especially now I have the time to devote to our special interest.



Over to you

Reply to *Just a rant*.

To the Author, Tony Boddy, and WIA et al:

On behalf of all of the WIA volunteers, Board members included as they are volunteers,

Well Said!

Many affiliated club members may remember that for about 10 years I used to do the admin work to renew their Liability insurance. I did that work as a volunteer for about three months each year. There were well over 100 clubs involved and a lot of "Goods" and "Bads" in the process. The baddest were the clubs who could not give a toss and I could damn well wait until they were ready to reply. The fair enoughts were as always a bit slow but when they did reply, it was complete and ready to submit. The "Goods" were very few, say about 10 or so out of the whole lot. They actually responded when asked and Oh Dear! they said "Thank You". It is those few Thank you's that make volunteers line up to do it all again next time, just as your Board members do.

You have hit the target with comments about the WIA but you left out one of my greatest dislikes. That is people having a whine about something that has or has not happened and lay the blame at THE WIA, I have said this many times. There is no "THE WIA", it is a collective group of people who put substance into Amateur Radio in Australia.

As you say, without the WIA we may not exist or may have many of our privileges curtailed. Everybody who bags the WIA should pause for a moment and check to see how sound their gripe really is. Perhaps it is the Whole Board who do not agree with the views of just one person, You?

Is it one of the many volunteers who try hard but happen to miss on something? Or is it one of those lazy lot who, you have been told, are being paid for their time? Maybe those who told you that they were being paid, also got it all wrong because they did not PAY ATTENTION and LISTEN. Whatever the reason for your gripe, just remember, they are volunteers who work for the good of the whole group, and now where were you when **volunteers of this kind were needed**. Too busy airing your views against the whole organisation, without a shred of evidence or truth but you wanted to be heard, and anyway you felt that there should be **"Somebody Else"** who can volunteer. **News for you**, having read the WIA members list many, many times, Somebody Else, is definitely **not** a WIA member.

Kept the worst for last. Thank you for pointing the finger at those miserable buggers who have set out to damage the WIA and its members, including me, in any way they can, just to serve their own ends. I hope that their

supporters, if they have any, soon wake up to the kind of people they are. I also hope that they are aware that the day WILL come when Australian Maritime College will also say **NO!**

The sooner that day comes, the better for Amateur Radio in Australia. What is it that they say? **You can fool some of the people some of the time but you cannot fool all of the people all of the time.**

Amateurs, WIA or not, I do not need you to argue with me, I need you to think carefully, find the facts, and then argue with those who would for no more than personal vengeance, do anything they can to take away our hobby. Maybe they have overlooked, they will also lose theirs. Speaking of losing our hobby, that group have now approached ACMA, claiming to represent You, Me and many other Australian amateurs. Do you really want these rat bags fragmenting the amateur relationship with ACMA?

I could name these people but it is better that you ask: **Who are they and what is their problem?**

Oh, that's right, they probably have a USA licence, so Australia can get Stu...ed!

EC Thrift VK2XA

WIA Honorary Life Member





Contributions to *Amateur Radio*

AR is a forum for WIA members' amateur radio experiments, experiences, opinions and news.

Your contribution and feedback is welcomed.

Guidelines for contributors can be found in the AR section of the WIA website, at <http://www.wia.org.au/members/armag/contributing/>

Email the Secretary: armag@wia.org.au

AMIDON FERROMAGNETIC CORES



tts systems

Phone 03 5145 6179
info@ttssystem.com.au

Studying for the Standard or the Advanced Licence?



Here are 4 books that will get you there.

TAKE A LOOK AT
www.gscott.com.au

for more information and order form.
635 Edmonson Avenue
Albury NSW 2640



Have you held an amateur licence for 10 years or more?

If so, then you are invited to
join the

RAOTC

A \$5 joining fee, plus \$18 for one year or \$32 for two years, gets you two interesting 64 page *OTN Journals* each year, PLUS good fellowship, and a regular broadcast of news and events.

More information and a membership application are available from our web site at www.raotc.org.au or write to:-
PO Box 107, Mentone VIC 3194 or
email:- raotc@raotc.org.au or
call Secretary: Bill Roper VK3BR
on 03 9584 9512.

About Hamads

- Submit by email (**MUCH PREFERRED**) or if written and mailed please print carefully and clearly, use upper AND lower case.
- Deceased estates Hamads will be published in full, even if some items are not radio equipment.
- WIA policy recommends that the serial number of all equipment for sale should be included.
- QTHR means the address is correct in the current WIA Call Book.
- Ordinary Hamads from those who are deemed to be in general electronics retail and wholesale distributive trades should be certified as referring only to private articles not being re-sold for merchandising purposes.
- Commercial advertising on these pages Contact admanager@wia.org.au
- Copy to be received by the deadlines on page 1 of each issue of Amateur Radio.
- Separate forms for For Sale and Wanted items. Include name, address STD telephone number and WIA membership number.

'Hamads'

PO Box 2042
BAYSWATER VIC 3153
hamads@wia.org.au

TRADE PRACTICES ACT

It is impossible for us to ensure that the advertisements submitted for publication comply with the Trade Practices Act 1974. Therefore, advertisers will appreciate the absolute need for themselves to ensure that the provisions of the Act are strictly complied with.

VICTORIAN CONSUMER AFFAIRS ACT

Advertisements with only a PO Box number address cannot be accepted without the addition of the business address of the box-holder or seller of the goods.

ADVERTISERS INDEX

Icom	Back Cover
Jaycar	7
Amidon	64
Yaesu	Inside Front Cover



Don't forget to register for **MEMNET**.



WIRELESS INSTITUTE OF AUSTRALIA

2019 Callbook



The 2019 WIA Callbook contains:



- Callsign and address of all Australian amateurs
- Contact details for Australian amateur radio clubs
- Repeater and Beacon lists
- Current band plan information
- Useful information for Foundation Licensees

Available now

ICOM

INTRODUCING THE NEW **IC-9700** Direct Sampling Now Enters the VHF/UHF Arena

**NOW
AVAILABLE**



✉ :sales@icom.net.au

🌐 : www.icom.net.au

☎ : (03) 9549 7500