

Amateur Radio

Volume 88
Number 2 ▶ 2020
Price: \$12.50 incl GST

110 Years
Anniversary
1910-2020



www.wia.org.au

Romance of Radio Restoration



Build:

- ▶ Simple Dummy Loads for HF > UHF Rig Testing
- ▶ Signal Generator Covers 54 MHz > 13.6 GHz
- ▶ Switch Reference Sources for your FT-817
- ▶ DIY HF Transceiver (continued)

ISSN 0002-6859

02



9 770002 685031

C4FM/FM 144/430MHz Dual Band Mobile

High Visibility and Resolution QVGA Display with Exceptional Operability
Real Dual Band Operation V+V/U+U/V+U/U+V & Simultaneous C4FM Monitoring

FM Friendly Digital : AMS (Automatic Mode Select)

System Fusion II Compatible

WIRES-X Portable Digital Node Function

- **Wide Range RX Coverage : 108 ~ 999.99 MHz**
- **Easy to Operate II (E2O-II) : New User Interface for Easy Operation**
- **New Memory Auto Grouping (MAG) Function**
- **New Multi-Channel Standby (MCS) Function**
- **High-Speed 61 Channel Band Scope**
- **Easy Hands-Free Operation with Built-in Bluetooth® Unit**

C4FM/FM 144/430 MHz DUAL BAND
50 W DIGITAL MOBILE TRANSCEIVER

FTM-300DR



YAESU
The radio

YAESU Authorized Dealer

Andrews Communications Systems
Shop 8, 41-51 Bathurst Street, Greystanes NSW 2145
Tel: +61-2-9636-9060
URL : www.andrewscom.com.au

YAESU Authorized Service Center

Andrews Communications Systems
Shop 8, 41-51 Bathurst Street, Greystanes NSW 2145
Tel: +61-2-9636-9060, Fax: +61-2-9688-1995
E-mail: radioandrews@hotmail.com

Strictly HAM Pty. Ltd.

Shop 12B Church Street Bayswater Vic. 3153
Tel: +61-3-9729-7656
URL : www.strictlyham.com.au

VK Radio Repairs

347 Settlement Rd. Thomastown Victoria 3074
Tel: +61-3-9010-5070, Fax: +61-3-8682-8748
E-mail: yaesu@vkradio.com.au



Amateur Radio

Volume 88
Number 2
2020
ISSN 0002-6859

The Journal of the Wireless Institute of Australia

Editorial

Editor in Chief

Roger Harrison VK2ZRH
editor@wia.org.au

Technical Editor

Eric Van De Weyer VK2VE
Ewen Templeton VK3OW
Phil Fitzherbert VK3FF

Publications Committee

Bruce Bathols VK3UV
Dr Brian Clarke VK2GCE
David Burden VK3BDX
Ian Godsill VK3JS
Carmel Morris VK2CAR
WIA Office Bruce Deelhols VK3FBLD

All circulation matters

nationaloffice@wia.org.au

How to submit material

AR Publications Committee
PO Box 2042
BAYSWATER VIC 3153
or armag@wia.org.au

Letters to Editor

Editor AR Magazine
PO Box 2042
BAYSWATER VIC 3153
or editor@wia.org.au

Hamads

'Hamads'
PO Box 2042
BAYSWATER VIC 3153
hamads@wia.org.au

Advertising

All enquiries to
Advertising Manager
AR Publications Committee
PO Box 2042
BAYSWATER VIC 3153
or admanager@wia.org.au

Registered Office

Unit 20 11-13 Havelock Road
BAYSWATER VIC 3153
Australia
Phone: 03 9729 0400
Fax: 03 9729 7325

Production Deadlines

All articles, columns, hamads and
advertising booking for Issue 3 - 2020 by
12 August 2020.

The contents of Amateur Radio are Copyright
Wireless Institute of Australia © 2020
All Rights Reserved.

Technical

The romance of restoring real radios 6
Phil Wait VK2ASD

**Homebrew HF Transceiver project
Part 2 Transmitter** 12
Luigi Destefano VK3AQZ

**Wide-range signal generator covers
54 MHz to 13.6 GHz** 30
Jim Henderson VK1AT

**Simple dummy loads for rig testing
at HF and higher frequencies** 35
Jim Tregellas VK5JST

**Automated Reference Switching for
the Yaesu FT-817** 44
Keith Gooley VK50Q



This month's cover:

*Jessica appreciates the romance of a 'real
radio', a Hallicrafters SX-62A. See our feature
article, beginning page 6.*

General

Callbooks: Their continuing value 26
Part 2

Peter Wolfenden VK3RV

Errata 34
WIA

AMSAT in Turmoil 48
Greg Kelly VK2GPK

Columns

ALARA 60

Board Comment 3, 4

Contests 56, 58, 63

DX Talk 50

Editorial 2

Over to You 43

Silent Key 37, 43, 46, 61, 62

SOTA & Parks 52

VHF/UHF - An Expanding World 38

WIA News 4, 5

VK2 News 47

VK6 News 59

VK7 News 54

Contributions to Amateur Radio



Amateur Radio is a forum for
WIA members' amateur radio
experiments, experiences,
opinions and news. Manuscripts
with drawings and/or photos are
welcome and will be considered
for publication. Articles attached to
email are especially welcome. The
WIA cannot be responsible for loss or damage to any material.
Information on house style is available from the Editor.

Back issues

Back issues are available directly from the WIA National Office
(until stocks are exhausted), at \$8.00 each (including postage
within Australia) to members.

Photostat copies

If back issues are unavailable, photocopies of articles are
available to members at \$2.50 each (plus an additional \$2 for
each additional issue in which the article appears).

Disclaimer

The opinions expressed in this publication do not necessarily
reflect the official view of the WIA and the WIA cannot be held
responsible for incorrect information published.

Amateur Radio Service

A radiocommunication service for the purpose of self-training, intercommunication and technical investigation carried out by amateurs; that is, by duly authorised persons interested in radio technique solely with a personal aim and without pecuniary interest.

Wireless Institute of Australia

ABN 56 004 920 745

The world's oldest

National Radio Society, founded 1910.

Representing

The Australian Amateur Radio Service

Member of the International Amateur Radio Union

Registered Office of the WIA

Andersson House

Unit 20, 11 Havelock Road

Bayswater, Victoria, 3153

Tel: (03) 9729 0400 Fax (03) 9729 7325

email: nationaloffice@wia.org.au

<http://www.wia.org.au>

All mail to

PO Box 2042 BAYSWATER VIC 3153

Business hours: 10am – 4pm weekdays

National Office

Executive Administrator Bruce Deelholls VK3F8LD

Board of Directors

President Gregory Kelly VK2GPK

Vice-President Aidan Mountford VK4APM

Directors Peter Clee VK8ZZ

Dr Harry Edgar VK6YBZ

Aidan Mountford VK4APM

Mike Alsop VK8MA

Secretary Peter Clee VK8ZZ

Coordinators

AMSAT Paul Paradigm VK2TXI

ARDF Jack Bramham VK3WWW

Australian ARIS Shane Lynd VK4KHZ

Awards Graham Alston VK3GA

Clubs Ted Thrift VK2ARA

Contests Craig Edwards VK8PDX

John Moyle Field Day Denis Johnstone VK4AE

Standards Ron Cook VK3AFW

Noel Higgins VK3NH

NTAC John Martin VK3KM

Historian Peter Wolfenden VK3RV

IARU Region 3 Director Peter Young VK3MV

Monitoring Service Peter Young VK3MV

ITU Conference & Study Group

Brett Dawson VK2CBD

Dale Hughes VK1DSH

QSL Curator National Office

Repeater Peter Mill VK3ZPP

Andrew Chapman VK4QF

Webpage Robert Broomhead VK3DN

Information Systems Joseph Mullins VK5FJDE



Editorial

Roger Harrison VK2ZRH

I am reminded, of all things, of a song from the soundtrack of the movie *Sleepless in Seattle*, 'Back in the Saddle Again'.

It's what happens when there's a call for volunteers and you put your hand up. So that's how I came to be appointed as Editor-in-Chief by the Board. I had no inkling when I emailed the Secretary. I just offered to assist. And I still hold down a fulltime day job.

As I have a background over many years in former careers in journalism and publishing as editor of Australian electronics magazines – including *Electronics Today International* (ETI) and *Australian Electronics Monthly* (AEM) – many readers will remember them, the board felt that my expertise and experience was appropriate. I also served terms as editor of trade journals *Manufacturers' Monthly* and *Electronics News*.

Before all that, I practised at being an editor, producing a newsletter for VHF-UHF amateur radio enthusiasts, called *6UP*, which some of you may recall, also.

Now for the bad and better news

As we all know, Issue No. 2 of *AR* magazine for 2020 has been delayed. Somewhat.

However, the goal of the Publications Committee, with the support of the WIA Board, is to complete publication of all six issues for 2020.

That means that our objective is to produce one issue a month from August through December (counts on fingers . . .), as Issue No.1 was published before the summer bushfires had all burned out and COVID-19 took hold.

The new Publications Committee has held online meetings and we have all gotten to know one another – or, at least, know each other a little better. Fortunately, the Committee has a mix of some members continuing from the past and some new people.

As a group, there is a range of experience and expertise that can be brought out to tackle various components of the job at-hand. I have found our meetings to be friendly and collegiate, with members eager to get on with the job in front of us.

My long experience reminds me that every publication management system is *different* in one way or another.

I have been working with 2019-20 President Greg Kelly VK2GPK who – last year – took on the central task of producing *AR* magazine – the *herculean* central task, I might add – as it's no job for the uninitiated.

There are always 1000-and-one decisions to be resolved, each with an impact on many others. And every issue is different in large and small ways.

So let me pay tribute to all those who have striven to-date to maintain the momentum of *AR* production, especially under the uncertain circumstances prevailing over the recent past.

Blame for this situation cannot – *and should not* – be heaped on anyone or any group – as so many disparate forces have produced it. Time to wipe clean the slate and start 'from taws'.

73

Roger VK2ZRH
Editor in Chief



Board comment

Greg Kelly VK2GPK

There is a fairly common saying, "May you live in interesting times", usually attributed as a translation of an ancient Chinese curse¹ masquerading as a blessing. 2019 was certainly an "interesting" year for the WIA, and to-date 2020 has shaped up as an even more "interesting" year for the WIA, our members and their families – but mostly not in a good way due to the combined effects of drought, raging bushfires and then the Covid-19 disease impacts. I personally have been heavily impacted with my rural NSW property being almost completely burnt in a bushfire (actually an out of control back-burn) in January.

Yet these challenging times are not all bad news, one of the two main Amateur Radio equipment vendors in Australia reported sales were up 183% during the initial pandemic lockdown, and the WIA National Office reported sales of the WIA Foundation Manual were running at 4 to 5 times normal volumes. Plus there has also been a significant uptick in on-air activity.

CubeSats: The WIA continues to support space satellite experimentation within Australia, and has been asked by the CSRIO to support an allocation of Amateur spectrum for a forthcoming CubeSat via the IARU. Currently, we receive one or two of these requests each year.

Magazine: There has been considerable delay due to unforeseen events in 2020 to AR Magazine issues 2 and 3.

¹No actual Chinese source or proverb has ever been verified.

These stem from various factors culminating from the work effort being delegated upward to the WIA President. After getting 3 issues over 6 months completed, my availability became heavily impacted early this year by a number of non-WIA issues that demanded my attention. Despite some inappropriate and non-factual public statements to the contrary, I am still working in conjunction with a new volunteer editor-in-chief and a new volunteer PubCom secretary. The current plan is to publish all six issues due this year.

WIA Callbook: Peter Wolfenden's two-part article, 'History of the Callbook', concludes in this issue of AR magazine. This article highlights the role played by a callbook in chronicling the changing make-up of the Australian Radio Amateur cohort over time and many generations.

The Australian Callbook production was outsourced to the WIA (Victorian Division) in the mid-1950s by the regulator of that time (PMG Radio Branch). The WIA currently has a perpetual licence to publish a derivative work from the ACMA RRL data for Radio Amateurs which has been in place for two decades.

However, we are currently at a stalemate. ACMA have stated, both face-to-face and then via email, that if we publish another WIA Callbook under our licence, then they will unilaterally cancel the licence.

This highly unsatisfactory position which has potentially thwarted all future editions of the WIA Callbook was solely precipitated by the actions of a "splinter" radio amateur association that published a globally searchable pdf extracted as an illegal RRL

derivative work. This resulted in, not unreasonably, a furore of complaints to ACMA.

The ACMA / WIA stalemate apparently stems from advice ACMA sought and received from the OAIC (Office of the Australian Information Commissioner) regarding privacy relating to the abovementioned illegal licence details extract that was published online. On the OAIC website, they describe their role as "We are the independent national regulator for privacy and freedom of information". Currently Angelene Falk is both the Information Commissioner and Privacy Commissioner. Her two roles are quite different, the first is concerned with ensuring public access to Government information in the public interest under the Freedom of Information (FOI) legislation. The second role, in regard to privacy, is to ensure customer information collected by organisations – those with revenue exceeding \$3M per annum and subject the Privacy Act - is used ONLY for the purposes for which it is collected and that such customer information otherwise remains private and protected.

At this stage, the WIA has not been privy to either the content of the request from ACMA to the OAIC, or of the response but we will be seeking to find out via FOI. It will be highly enlightening to see how the OAIC could view RRL licence holder information that is clearly in the public domain already, by virtue of Federal legislation, as private data and subject to the Privacy Act.

The stalemate remains a work in progress to reach an ACMA / WIA mutually satisfactory result – if

Continued on page 4

there are legal eagles that are willing to help, please contact the WIA National Office.

Please note that the WIA has had a long standing policy of allowing radio amateurs to opt out of having their details, such as address, published in the WIA Callbook. Many amateurs, including myself, have a PO box as their address. Hopefully if future editions are published, the WIA is of the view that no street address will be included by default, however will facilitate opt-in for contact details, whether it be a mailing address or email.

Repeater Assignments: One area of some member frustration that the Institute has addressed is reducing the backlog of repeater

assignments, due to dependence on a single assigner. This work is currently being undertaken by commercial frequency assigners on behalf of the WIA as a pilot process. The learnings from the pilot process will inform the long-term process that the WIA will adopt. At the moment, the WIA is incurring the full cost of using external frequency assigners – this won't continue past the pilot process as these costs will have to be recovered unless the WIA can harvest member capability in having its own team of frequency assigners.

110 Year Anniversary: Despite the impact of two world wars, various internal ructions over the decades and two pandemics, the WIA continues the legacy

initiated 110 years ago by a small group of keen radio and electronic enthusiasts. The WIA is at its heart a DIY organisation, not a government department, just members with a common interest and we need YOU! To mangle JFK's words: Ask not what the WIA can do for you, but what you can do for the WIA!

The WIA today, more than 110 years since it was founded, exists entirely due to the continuing contribution of many volunteers over many generations - consider becoming one of these volunteers and contribute, even in a small way, to the future of this great hobby.

73

Greg VK2GPK, WIA President.

WIA news

WIA 5 Year Spectrum Outlook (FYSO) Submission

The Australian Telecommunications Media Authority (ACMA) five-year spectrum outlook (FYSO) provides an overview of the technology, market and policy drivers likely to shape the demand for spectrum over the next five years, as well as spectrum management priorities and the ACMA work plan. Every year, they seek feedback on the draft FYSO, ahead of settling the final FYSO.

The draft FYSO forms a key part of the ACMA engagement and transparency with industry and the community on spectrum management priorities.

The WIA response covers the following:

- 2200 – 3400 MHz band
- 47 GHz band
- 2300 – 2302 MHz band
- 435 – 438 MHz band
- 5351.5 – 5366.5 MHz allocation
- 70 MHz allocation
- education, examination and certification

- non-assigned amateur and outpost licensing arrangements
- compliance and enforcement
- revised callsign structure
A copy of the WIA submission is available on the WIA website, at: www.wia.org.au/newsevents/news/2020/20200701-1/documents/WIA%20Submission%20on%20FYSO.pdf

The WIA wishes to thank the members of the WIA Spectrum Strategy group who volunteered their time in preparing this submission for the benefit of all Australian amateurs.

Source: WIA

WIA DX Awards Program – New Triple Play Awards

The WIA Awards Committee is pleased to announce the availability of Triple Play DXCC Awards. A "Triple Play" is when you work a DXCC entity on all three modes – Phone, CW and Digital. These new awards are designed to encourage operation consistently across all

three modes.

Triple Play awards are available for single band, multi-band, and multi-mode (ie. any-band). Endorsements, including Honour Roll and Excellence, are also available as per the other DXCC awards.

Triple Play has also been added to the annual DX Leaderboard competition as a new category. Refer to the WIA website for more details.

Source: WIA Awards Committee

Carbon Fibre Portable Mast

Portable Specialist, SOTABEAMS, has released a new telescopic carbon fibre portable mast. The Carbon-6 has an extended length of six (6) metres, but weighs only 300 grams! Its packed length is just 43 cm. The Carbon-6 is designed for light-duty operations and is best suited supporting the centre of an end-fed wire antenna in an inverted-V formation.

Source: sotabeams.com.uk

Japan AR Band Expansion

Effective on 21 April 2020, Japanese amateurs can operate in expanded frequency segments on the 160m and 80m bands, as follows:

- 1800 – 1810 kHz All Modes (New segment)
- 1825 – 1875 kHz All Modes (New segment)
- 3575 – 3580 kHz All Modes (New segment)
- 3662 – 3680 kHz CW, NB Phone/Image (New segment)

Source: Japan Amateur Radio League (JARL)

New IARU EMC Coordinator Appointed

June 2020: The International Amateur Radio Union (IARU) Administrative Council has appointed Martin Sach G8KDF as global EMC Coordinator. Martin succeeds Tore Worren LA9QL, who has served in this volunteer position since 2017.

Electromagnetic Compatibility (EMC) is a major challenge for all radiocommunication services. Radio amateurs are experiencing increased interference caused by unwanted radio frequency emissions from a wide variety and rapidly growing number of electronic devices.

The mission of the IARU EMC Coordinator is to ensure that the concerns and needs of radio amateurs are effectively addressed in international standards bodies, particularly CISPR and the ITU, as well as in regional telecommunications organizations and at the national levels through IARU member-societies. Assisting in the effort is a network of volunteers with expertise in the field of EMC.

Source: IARU (iaru.org)

New Foundation Manual

Your Entry Into Amateur Radio

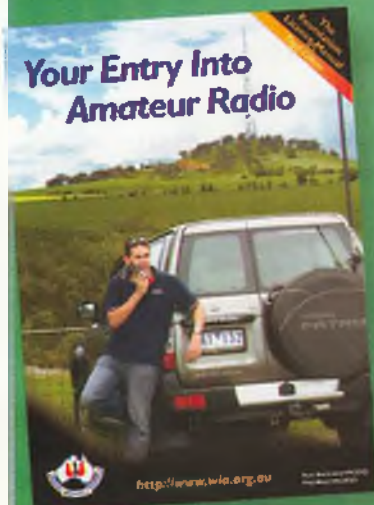

Available now

Visit our Bookshop:

http://www.wia.org.au/members/bookshop/page_data.php?id=112

jaycar

think. possible.

Build a Blue LED Cube 4 x 4 x 4

NEW

Learn to Solder Kit

Turn 64 x blue LEDs, a circuit board, handful of components, and an Arduino® UNO compatible board (XC4410 sold separately) into an animated LED cube. Watch the LEDs alternate between fifteen different patterns. Instructions to program your own patterns included. KM1097 RRP \$19.95



maycar

4x4x4 Kit & Arduino® Compatible UNO!

KM1097 + XC4410 TOTAL VALUE \$49.90

BOTH FOR \$39.90
SAVE \$10

Grey Vented ABS Enclosures

Protect your project from unwanted fingers or objects.

- Satin textured finish
- Moulded standoffs
- Snap-fit assembly

40 x 40 x 20mm HB6114 \$3.95

60 x 60 x 20mm HB6116 \$5.45

80 x 80 x 20mm HB6118 \$5.95

FROM \$3.95



RF Transceiver Module

Adds a versatile 433MHz radio to your Arduino® project allowing two-way wireless communication between Arduinos. Includes antenna.

- 1.9-3.6VDC operating voltage
- Controlled via SPI.

XC4522

JUST \$19.95

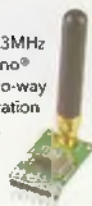

2.4GHz Wireless Transceiver Module

Based on the NRF24L01 transceiver IC, this module allows communication on the license free ISM band. Supports on-air data rates of up to 2Mbps. XC4508

JUST \$9.95

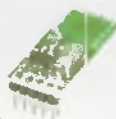

ARDUINO® STARTER KIT

This official kit from Arduino® includes all the essentials to get you started. Kit includes UNO board, breadboard and plenty of prototyping accessories. Perfect gift for a young electronics enthusiast or maker in the making. XC9200 See website for details

ONLY

\$169

NEW



Shop online!

Free delivery on online orders over \$99
Conditions apply. See website for details.



click & collect

shop online & collect in-store

zip
own it now, pay later

Valid until 31 August, 2020

To order phone 1800 022 888 or visit www.jaycar.com.au

The romance of restoring real radios

Phil Wait VK2ASD



Photo 1: Featuring impressive design inside and out, my Hallicrafters SX-62A makes a statement as a real radio.

In the first couple of weeks of the COVID-19 isolation I'd reconditioned my Collins S-Line and KWM-2 "boat-anchors", fixing all the annoying small bugs and bringing them up to factory spec. In desperation, I'd even turned to rejuvenating a 1950s HMV Little Nipper mantle radio.

It wasn't too long before I was searching eBay for some other interesting project – especially a general coverage receiver. I absolutely needed a general coverage receiver, and, as the Rolling Stones say, "sometimes ... you get what you need".

Hallicrafters

After looking at a Collins 51S1 (particularly, the price) and Hammarlund, Racal, National, etc radios, I pretty much settled on Hallicrafters.

The Chicago-based Hallicrafters company was founded in 1932 by William J. Halligan, a radio parts salesman. From modest beginnings Halligan grew the company into a most prolific manufacturer of radios and later televisions, exporting to 98 countries after only a few years of operation. Early success came with the SX-9 Super Skyrider, a 9-valve single conversion superhet

receiver covering 545 kHz – 42 MHz, and boasting the use of metal valves, iron-core iF transformers and a crystal filter. State of the art technology for 1936 and costing only US\$90, (US\$1680 today, based on US CPI increase.)

During WW2, amateur radio was silenced and production turned to military equipment, most notably the BC-610 transmitter and associated equipment, which was known as the SCR-299 mobile communications unit (i.e. truck-mounted). The SX-28 receiver was also a great success, and working examples of both are commonly found in collections.

After the war, Hallicrafters' civilian production returned in 1946 with the S-38 receiver and the SX-42 in 1947; the SX-42 was designed by industrial designer Raymond Loewy, said to be the father of industrial design and responsible for everything from steam locomotives to Coca-Cola bottles.

The SX-42 was a massive, 15-valve general coverage receiver with a band-spread dial calibrated for the amateur bands, and featuring the new FM broadcast band at 88–108 MHz. The original frequency allocation for Edwin Armstrong's new FM Broadcasting was 42–50 MHz – the SX-42 could receive both the old and new FM bands.

The SX-42 was taken along on the Gatti-Hallicrafters Expedition to British East Africa (roughly the same area as Kenya) where the expedition proposed to explore the legendary Mountains of the Moon, said to be the source of the Nile River, and carry out radio research (funded by Hallicrafters and featured in its advertising for years).

The boom years for Hallicrafters were 1945 through 1963, when the company made a huge range

of professional, amateur, and consumer radio and television products. The last Hallicrafters amateur radio receiver was the SX-117, a triple conversion superhet released in 1965. Halligan eventually sold Hallicrafters to the Northrop Corporation who, in the face of strong competition from Japanese manufacturers, ceased amateur radio production by 1972. By 1980, any remnant of the company had completely vanished.

Owing to the huge number and variety of Hallicrafters receivers manufactured, they are still readily available for reasonable prices, especially the S-38. Some parts are being remanufactured by specialist companies, such as Radiodaze and Hayseed.

Late nights, eBay, and a bottle of red

I found myself on eBay looking at a most impressive SX-62A general coverage receiver up for auction. A 'real radio', without doubt.

Introduced in 1948, with manufacture running through to 1963, the SX-62 and the later SX-62A/AU were very capable receivers for the serious shortwave listener,

covering 540 kHz to 109 MHz in six bands. The design was electrically similar to the SX-42 but, unlike it, had a very large and impressive looking slide-rule dial, with the selected band illuminated.

Like all other Hallicrafters receivers with the 'X' in the model name, the SX-62 is equipped with a crystal filter. It also has a crystal calibrator with dial adjustment, switchable selectivity, a BFO and noise limiter, and wideband FM reception above 27 MHz, with 10 Watts of 'hi-fi' audio from push-pull 6V6s – all you needed to fill the most opulent, stately parlour of the era.

If you visit the ARRL hamfest at Dayton Ohio, a trip to the US Airforce Museum is a must. You can see an SX-62 mounted in the back of "Columbine III", the Lockheed Constellation used as Air Force One by President Eisenhower. It is said that US President Kennedy also used an SX-62 to listen in to the world during the cold-war years. When released in 1954, the price of an SX-62A was US\$350, or about US\$3330 today.

Peering at the SX-62A offered on eBay, it looked to be in excellent



Photo 2: The author and his Collins S-line rigs, reconditioned early during the COVID-19 lockdown.



Photo 3: The band you select is lit-up behind the impressive slide-rule dial.

physical condition, but was a non-worker – perfect for me! Only one problem – it was heavy, and it was in New York!

Late one night after a couple of reds, and a rush of blood to the head, I bid on it. I paid too much, (in Australian dollars, it would have been about right, but I was working in US dollars) and the freight from New York was about twice the eBay estimation – more than the cost of the receiver! I think I was secretly hoping that somebody else would beat me to it, but nobody was that silly.

About three weeks later, a very large box arrived on the veranda to the consternation of my wife. Weighing in at 29 kg, these things are a struggle – no wonder the courier was looking flustered. To the seller's credit, it was exactly as advertised, extremely well packed, and hopefully Corona virus-free after three weeks in transit, (New York was a Corona pandemic hotspot).

On the downside, the SX-62A lacks a bandspread control and has no product detector, no S-meter,

and only a fixed BFO, which makes SSB reception difficult, at best. Although only a single-conversion superhet, it's complicated – the IF frequency is switched between 455 KHz for the bottom four bands and 10.7 MHz for the top two bands. There are two 6AG5 RF amplifier stages, with the first switched out for the bottom two bands. Six selectivity settings are provided using a combination of IF tuned circuit switching and a crystal.

Not surprisingly, a six-band receiver with switched RF amplifiers and two IF frequencies makes for a very complex band-switching arrangement. Add the fact that the bandswitch also switches the HT voltage to the RF amplifiers and you have the possibility of a major repair problem if something goes wrong. Damage to the 20-section bandswitch from a high-voltage flash-over, possibly due to crud build-up over years, or some previous restoration enthusiast using the wrong cleaning fluid, could be a major show-stopper.

Although there are descriptions on the internet about how to repair

a damaged bandswitch using dental scrapers and epoxy resin, it sounded like a real show-stopper to me. I think I was lucky.

Refurbishment, or restoration?

Luckily, this receiver was in top physical condition, so let's call this refurbishment rather than restoration. As far as the chassis is concerned all I needed to do was blow off the dust and clean the metal down with a toothbrush dipped in Safewash cleaner, wiped away with a damp cloth. I cleaned the dreaded band-switch with copious amounts of professional non-residual contact cleaner and made sure that there was nothing left that could attract dirt.

The first issue was a broken dial string and, after much cursing, I finally worked out I was trying to restring it backwards! Most of the valves measured within spec on my ancient Taylor Model 45 valve tester (which measures gm); even valves that carried the original Hallicrafters brand were still OK! That was a real saving over buying a full set of

15 replacement valves. The dial string and a few replacement valves were provided by Antique Electronic Supply.

The next job was to replace all the electrolytic and paper capacitors – all 45 of them! This is a must-do because some of the old paper high tension bypass capacitors on the RF amplifiers are downstream from the bandswitch, so a shorted capacitor could fry the switch contacts. I used 'Illinois Capacitor'

600 V metallised polyester film capacitors sourced from Digikey, but just about any type of capacitor would be an improvement over the originals fitted when the radio was manufactured. Axial types make it easier. Although replacement canned electrolytic capacitors are available from Hayseed, there is plenty of space under the chassis for inserting axial electrolytic capacitors. I left the old can-type electrolytic in place on the chassis, but cut it out of the circuit. Original mica and tubular ceramic capacitors rarely fail, so I left them all alone.

I was not expecting to have to replace very many resistors – wrong! Most were well outside their 10% tolerance, and many were 30-50% high, so they all got the chop.

In those days when the radio was manufactured, the practice was to wrap component leads through and around solder terminals. I suspect this may have been more an aid to construction than anything else, but it does make replacement tricky and time consuming if you want to unwrap the old leads. To absolutely minimise the risk of damage to the band-switch from tugging and twisting, I left the old



Photo 4: The top view of the chassis reveals the power supply and audio stages on the left, the two IF stages and detectors lined up through the middle and the front end RF sections on the right. Note the specially-built tuning gang that serves for the MF, HF and VHF bands.

lead-ends wrapped around the wafer-switch terminals. Several components were so deeply buried that I needed to remove the chassis side panel to gain access, and then just cut-out the body of the old component and soldered-in the new component using the old leads.

With this level of complexity, if you're restoring a vintage radio, I really suggest you only replace one component at a time and test each section as you go. It's amazing how an interruption will occur at the most critical time – one component's location is fairly easy to work out, but more than one can become mind-bending.

After about a week of late nights, I hooked it up through a Jaycar 110 V isolation transformer, stood back, and switched-on. It worked! Sort-of. An antenna even produced some broadcast and FM stations, but not much on shortwave.

All the manuals for Hallicrafters (and almost everything else) are freely available from the Boat Anchor Manual Archive (BAMA), and they contain a table of voltage readings for each pin of each valve and a tuning procedure. All voltage readings were found to be within the

specified 20%, so all it needed was a tune-up to restore performance, which was slow but fairly straightforward (though the crystal filter adjustment description is vague and still eludes me). There are some capacitors inside the discriminator can that often need replacing apparently, but mine seemed OK on alignment. Even tuning the FM section is easy because it can be done with an AM

signal generator.

Would I do it again?

Certainly – it was a lot of fun and a real learning experience. Starting with a brand such as Hallicrafters, Hammarlund, National, or Collins is a real plus because there were huge numbers made of most models, and they have excellent on-line resources and a large pool of enthusiasts. If importing anything, I would certainly buy one in the best physical condition you can find, simply because the cost of freight is so high it doesn't make sense to import junk. I have always found US-sourced equipment to be good – maybe the American penchant for heated basements in homes is kinder to electronics than an Australian backyard shed.

This receiver is now my daily listener. Its audio is superb. It's a great pity that shortwave broadcasting seems to be going the way of buckle-up boots, but there are still some national broadcasters transmitting in English, such as India, China, and Korea, etc; even Voice of America (VOA).

I think this receiver will remain in my shack for a long time, but maybe I'll start looking again soon.

Handy parts sites

- <https://www.radiodaze.com/>
- <https://www.digikey.com.au/>
- <https://www.tubesandmore.com/>
- <https://hayseedhamfest.com/>

Hallicrafters History

- <https://www.madeinchicagomuseum.com/single-post/hallicrafters/>
- <https://swling.com/blog/tag/hallicrafters/>
- Listening on the Short Waves - 1945 to Today, Jerome S. Berg, 2008, ISBN 798-0-7864-3996-6

Support

- <http://bama.edebris.com/manuals/>
- Facebook: Vintage Amateur Radio Equipment (Boat Anchors)
- Facebook: The Hallicrafters Radio Club



Photo 5: The unexciting rear view shows the external speaker connections adjacent to the power cord, while the antenna connections are at the right.

Thanks also to Steve VK4VN for his sage advice, especially about cleaning the bandswitch, and to the Hallicrafters Facebook group.

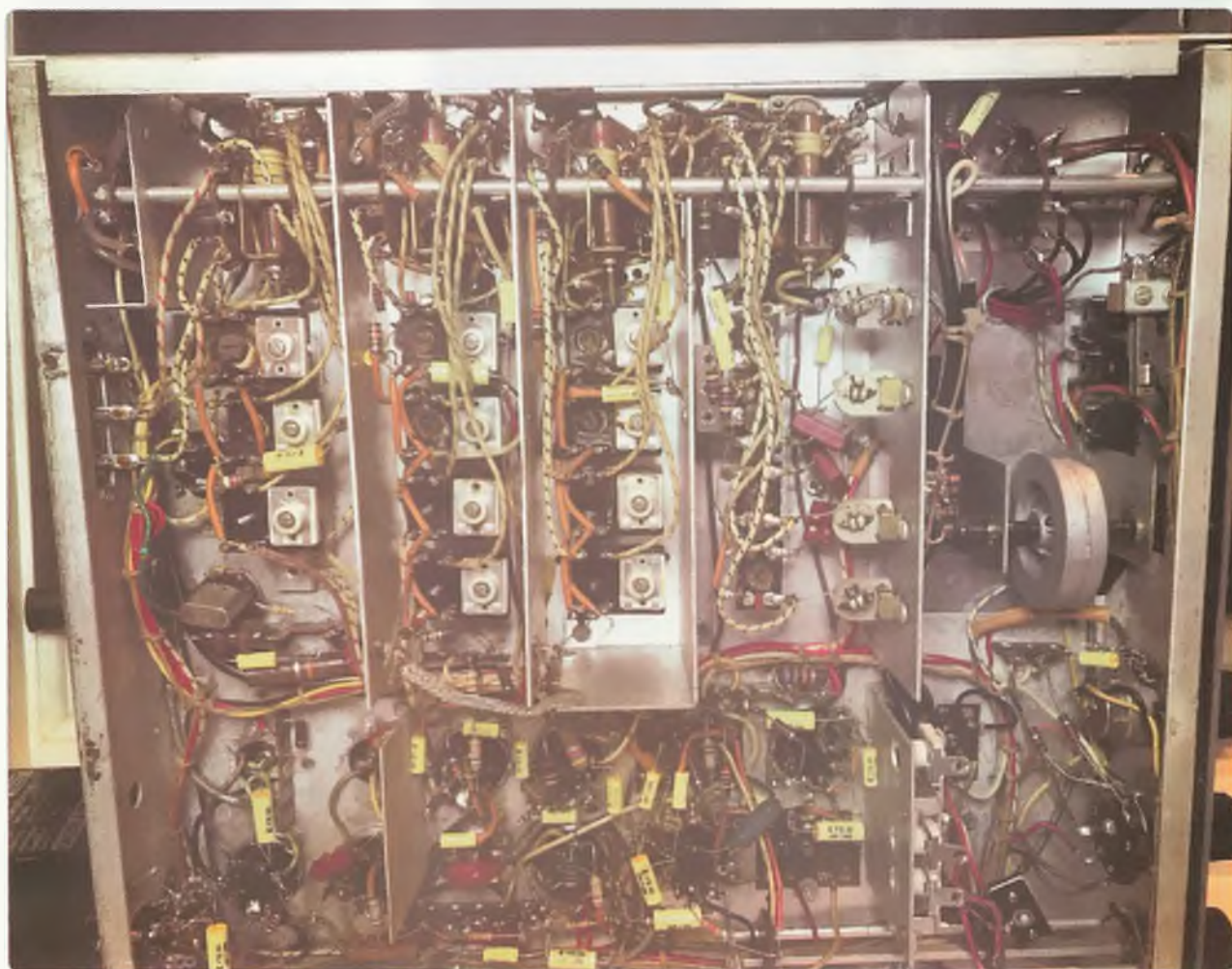

Photo 6: On the chassis underside, you can see the shaft of the enormous band selector switch running along the top, from the front to the back of the chassis. The array of mica trimmer capacitors are for the two RF 'front end' stages. Note the flywheel, which gives a certain 'feel' when tuning across the bands. Also note the 500 kHz crystal about half way down the chassis rear, to provide signals from its harmonics to "calibrate" the dial.

Homebrew HF Transceiver project

Part 2 Transmitter Third article

Luigi Destefano VK3AQZ



As advised in the previous issue, this significant project has been divided into parts, to be published over six editions of the magazine. Having completed the introduction and receiver in the first article, the second article completed the description of the receiver. This is the third article, which starts the description of the transmitter.

Transmitter Balanced modulator

The transmitter modulator circuit is shown in **Figure 16**. This consists of a 1496 configured as a balanced modulator as per the datasheet. The BFO crystal feeds the carrier input at a level of 425 mVpp. The amplified microphone signal feeds

the signal input at a level around 50 to 150 mVpp.

There is a fair bit of latitude with the carrier and input levels, as can be seen by the curves in the datasheet. The output consists of a double sideband, suppressed carrier signal around 9 MHz. Carrier suppression is achieved by adjusting VR1. Around 50 dB of suppression can be achieved with the 1496. Output level can be adjusted by varying VR3, and is useful for trimming the level into the next stage. Generally, setting VR3 to 1k should be satisfactory. Carrier suppression will also depend to some extent on this gain setting.

The output of the balanced modulator is tuned to 9 MHz,

helping reduce unwanted signals due to harmonics of the BFO and other mixing products. Conversion gain is also improved. Bias resistor R9 is lower than that used in a receiver mixer, resulting in improved signal handling ability.

The 1496 is also used to generate an AM signal. The modulator is unbalanced by adjusting VR2, which is switched in by a relay in the AM mode. This is adjusted for 100% modulation of the carrier with speech.

A test tone and waveform monitor is handy when adjusting the carrier level. As a side note, an old CRT CRO makes a good waveform monitor. The AM carrier power output, without modulation, should be set at around 50 W, or less.

The 100 W RF power amplifier cannot handle an AM carrier of 100 W due to the extra power that occurs in the sidebands. One needs to be mindful of the PA heatsink capability. With an SSB speech signal, the average power may only be 10% of the peak power, so the heatsink requirements do not need to be too large. However, on AM or FM, a heatsink that is adequate for SSB may be inadequate for continuous carriers, such as AM or FM.



Photo 1L: (From the end of the Second Article) Speaker amplifier and input switching boards before wiring.

Transmitter Balanced Modulator

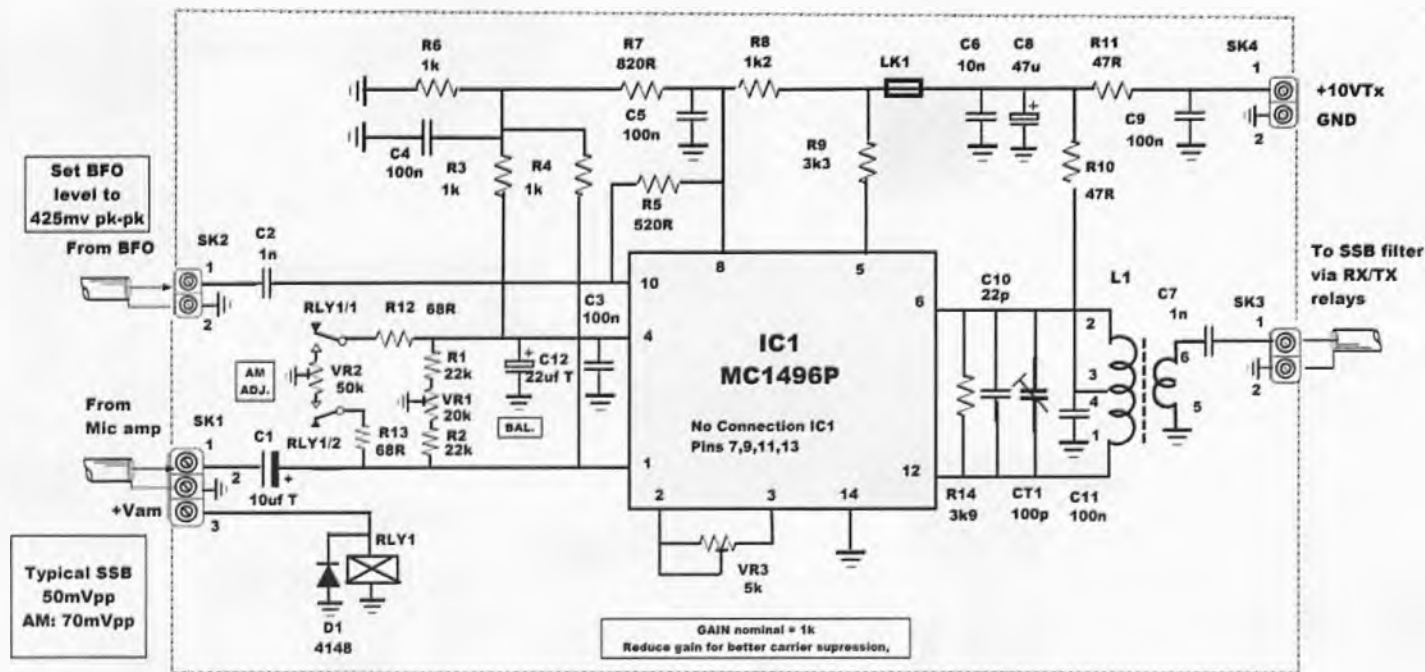

**L1 is 13T
trifilar 26B&S
(0.3mm)
T50/2 core**



Figure 16: Transmitter Balanced modulator.

Microphone compressor

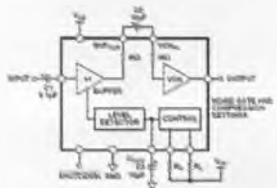
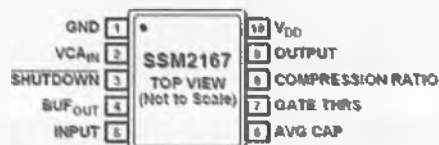
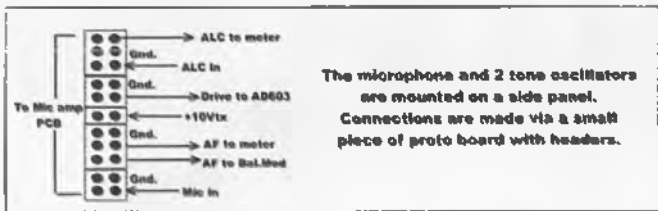
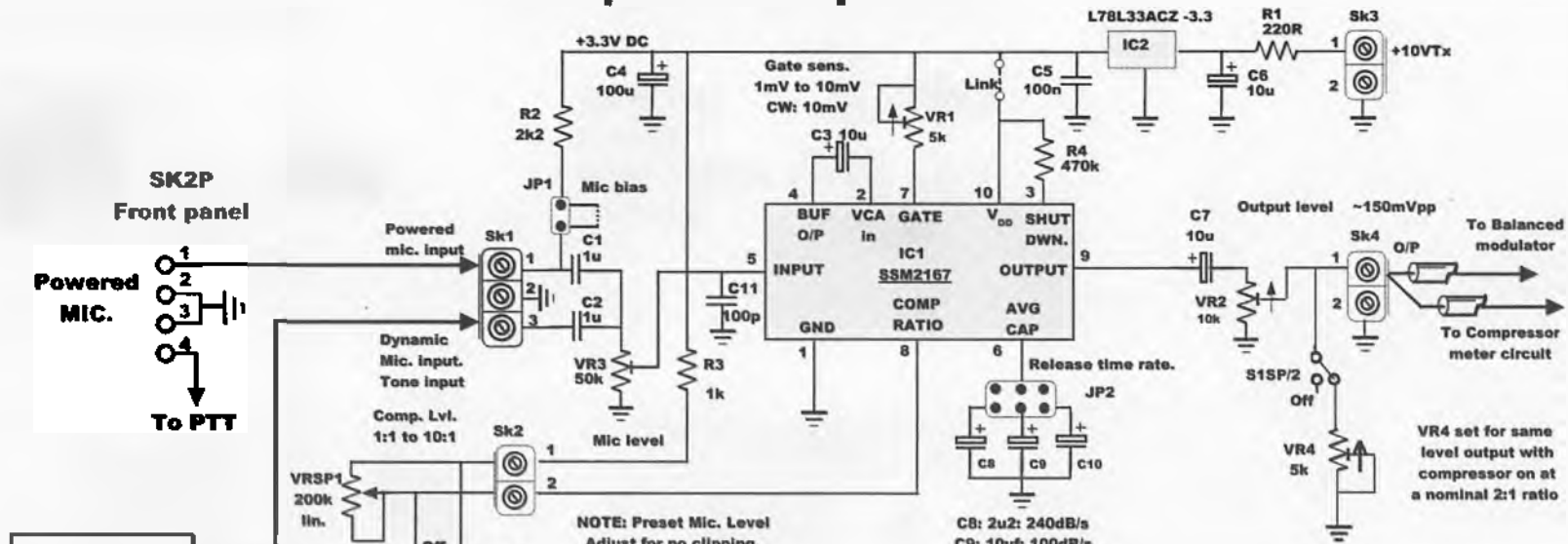

Figure 17: The microphone amplifier and compressor is based on a surface mount device (SMD) that integrates all the functions.

Microphone amplifier and compressor

The microphone amplifier and processing circuit is shown in **Figure 17**. This circuit uses a small SMD integrated circuit which contains an inbuilt compressor, limiter circuit, and noise gate. A discreet component system with these functions would contain quite a large number of parts. This integrated circuit saves space and performs quite well. The SSM2167 is one of a family of speech processing circuits. It is not the most sophisticated IC, but it was readily available and inexpensive. The down side of using this device is that it is very small and requires some skill to mount on a printed board. I used a suitable PCB adapter purchased on eBay, which has pins that plug the adapter into a standard 2x5 pin 0.3" DiL socket.

The IC contains a compressor with a variable ratio from 1:1 to 10:1. The release speed can also be selected. I have a small header and jumper that allows me to select three different release rates. The noise gate is also adjustable. Overall, the device works quite well with low distortion. During limiting it does not clip the input but rather varies the gain so as not to exceed a particular level. However, the compressor function will increase the overall output signal level when the input level is below limiting.

For example, the graph in figure 7 of the datasheet shows that if you have an input level of -50 dBV, the output will increase from -30 dBV to -20 dBV if the compression ratio goes from 1:1 to 2:1. The knee, or rotation point, in this IC is fixed internally at 63 mVrms input. So, I have added a trimpot across the output, which is switched in when the compressor function is enabled. I am not a great fan of compression but it can be handy at times. Trimpot VR4 is set so that the output level does not alter when 2:1 compression is switched in; 2:1 is about as much compression as I want to use.

A sample of the audio output is rectified and sent to the panel meter as an indication of the approximate level of compression. The meter will indicate a higher average level with compression. Ideally, the meter should indicate the compression as a ratio. However, I was unable to find any parts of the circuit that gave me a steady indication of the compression ratio pot setting. One could use a double-ganged pot for the compression adjust pot, VRSP1, and measure its resistance or a voltage from it, as a meter indicator. The compression ratio is accurately related to the potentiometer resistance. However, for now, I am using the rectified level as an indication of compression.

My microphone is a rather good handheld Midland CB dynamic microphone. It also contains an inbuilt amplifier. I prefer microphones with inbuilt amplifiers as they are more resistant to RF feedback. The microphone amplifier and compressor stage does not need to raise much gain.

My microphone puts out between 50 mVpp and 100 mVpp. If using a powered microphone, the output from the IC may need to be trimmed back so as not to overdrive the modulator.

If you are using a non-powered microphone, the gain in this IC will most likely be enough. A 1496 balanced modulator does not require a lot of audio on the signal input. **Photo 2B** shows the microphone amplifier compressor board. Note the small SSM2167 IC mounted on a plug-in adapter DIL board. The socket, in this case, is made out of 5-way, 0.1" female PCB headers.

Two-tone oscillator

The transceiver contains a two-tone test oscillator, shown in **Figure 18**. This is very handy when testing the transmitter for intermod distortion and output power levels. One tone is also used as a tune-up signal when adjusting the microphone gain control, drive levels, and antenna tuning unit. The 700 Hz tone can also be used for generating CW.

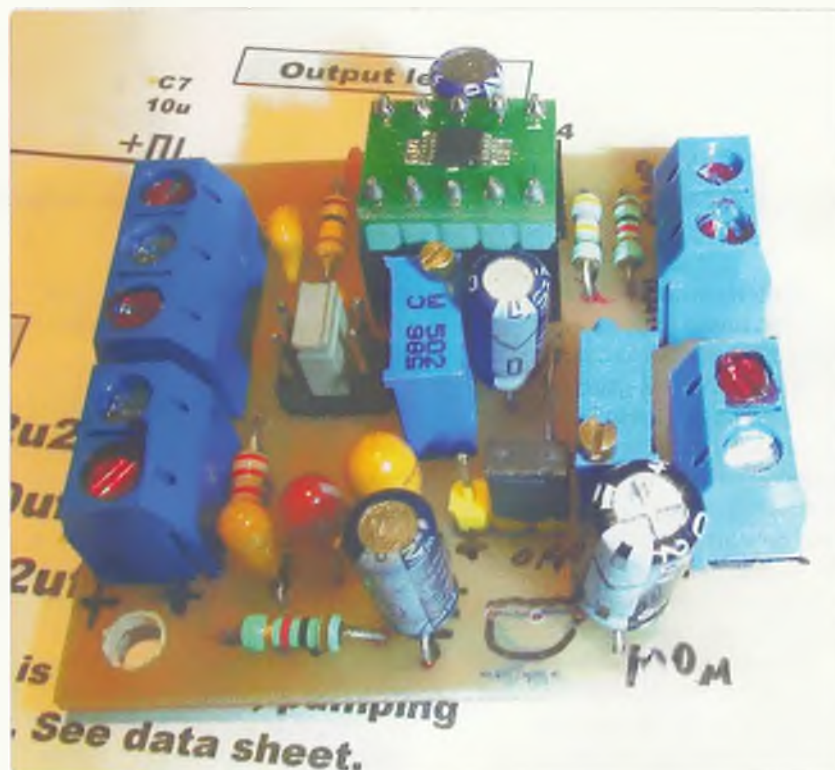

Photo 2B: The mic amplifier compressor board. Note the SSM2167 IC mounted on a plug-in adapter DIL board.

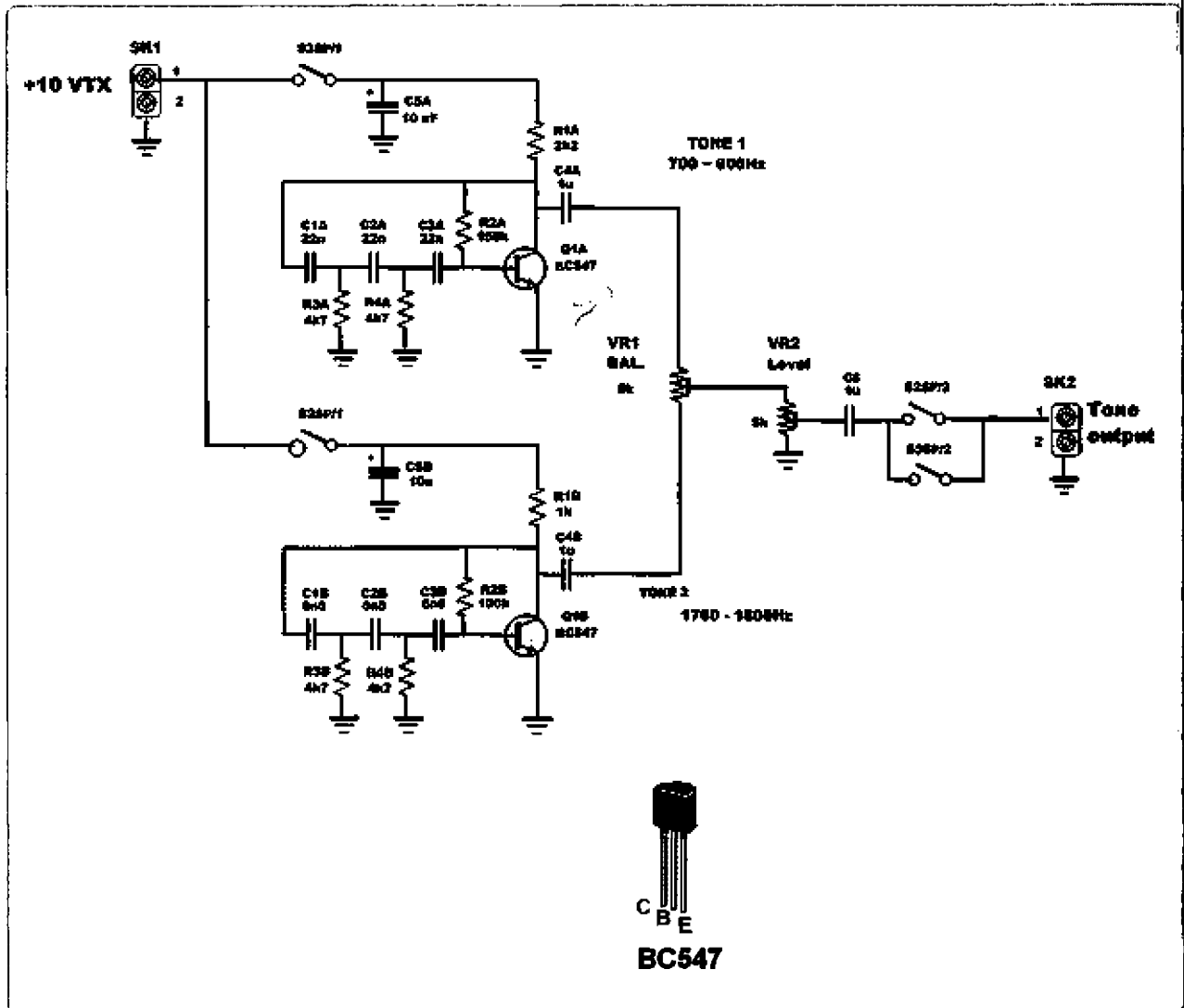

Figure 18: The two-tone oscillator is based on a simple phase-shift network design for each oscillator, each different by about 1 kHz.

The tone oscillators are a common phase-shift network design. The harmonic output is not brilliant, but it is good enough for my purposes. I also have a low distortion two-tone test unit designed by VK5JST which I plug into the microphone socket for more critical testing (Reference 10). If I had more room in the case I would have used that design as it produces nice clean tones.

The output of the tone oscillator is fed across the microphone input connector on the compressor amplifier. Its level is set about the same as the peak levels from the microphone. Photo 2C shows

the two-tone oscillator board. It is mounted to a subpanel using the two toggle switch shafts.

Transmitter band mixer

The circuit for this is shown in Figure 19. It features an SBL-1 double-balanced diode mixer. The output of the balanced modulator is passed through the crystal filter unit and fed into this stage at a level of around 50 mVpp, and the VFO, at a level of 300 mVpp. Both signals are further amplified and buffered by 2N5109 amplifiers, which supply sufficient level to the SBL-1 inputs and provide a resistive source.

Diode balanced mixers require

higher levels of drive than mixers like the 1496. The output of the mixer feeds a grounded-gate FET amplifier. Diode mixers generally need to see a wideband resistive load, and diplexers are commonly used. In most cases, the output is only at the one frequency such as the IF and diplexers work in that situation. In my case, the mixer is required to output on a wide band of frequencies. The J310 FET grounded-gate stage seems to work quite well. In Reference 1, there are also examples where the diode mixers feed common emitter amplifiers with a low value base bias resistor.

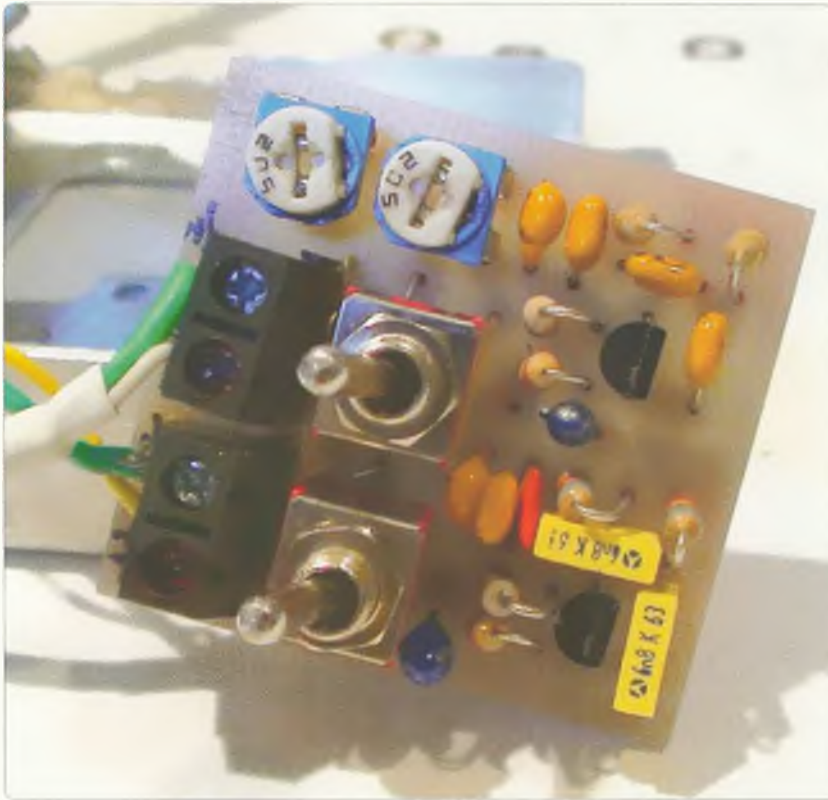

Photo 2C: The two-tone oscillator board. It mounts to a subpanel with the two toggle switch shafts.

The J310 amplifier feeds a bank of top-coupled tuned circuits. There is one filter section for each of the 10 amateur bands. The component details are shown in **Table 3** and the circuits in **Figure 21**. These filters are switched by small relays fed from the VFO logic system. Using double-tuned circuits with trimmer adjustments is a bit easier than using fixed bandpass filters, which would require accurate 50 ohm source and terminating impedances. The top coupling needs to be adjusted so that the filters cover the bandwidth of each amateur band. The tuned circuits are also stagger-tuned. In some cases, they may not be flat across the entire ham band, so you may want to favour the most used portion of the band and increase the manual drive control for the remaining section to achieve full power.

Initially, I used a 1496 mixer but found the mixer output varied considerably with frequency and

required some form of AGC to try and obtain an even output on all bands. The SBL-1, on the other hand, is flat well beyond 50 MHz. So, despite requiring higher levels of VFO drive, the flat response from 160m to 6m was a big plus.

Initially, I fed the mixer output through the receiver front end filters and preamps (hence the reason I had put a strong gain-controlled 2N5109 stage in the receiver front end) but found that having to manually retune the tuned circuits when changing bands was a nuisance. If the receiver was only covering the amateur bands, it would not be a big problem. However, the receiver tuned circuits were designed for continuous coverage from 100 kHz to 54 MHz. That meant there was a possibility that they may have been peaked outside the ham bands and not been noticed. This may have resulted in transmitting small mixer products outside the amateur

bands, and also having reduced drive on the main signal. Hence, it was decided to add separate filters and amplification in the transmit path following the band mixer. This also simplified the transmit/receive switching and transmit ALC circuit.

The output of the switched filters feeds an AD603 RF amplifier, similar to that in the receiver IF stage. The log linear gain control is a bonus in this application, and is used for the transmitter ALC-SWR protection and manual drive control. It can handle quite high levels of RF with low distortion and has proven to be quite good. The output of this amplifier feeds a 10 W PA drive amplifier that has plenty of gain and requires around 300 mVpp of drive. So this amplifier does not need to raise much gain. However, the 40 dB of gain adjustment is a convenient means of RF drive control.

Transmitter mixer filter relay driver

The 10 tuned circuits in the transmit mixer stage are switched by small relays. These are driven by an interface circuit between the VFO logic system and the relays. The circuit of the relay interface is shown in **Figure 20**. The VFO system outputs 5-volt logic level signals for each of the 10 amateur bands. Eight of these signals also select the receiver input tuned circuits. However, the requirements between the two are quite different.

The transmit filters are only required when the VFO system is inside an amateur band, while the receive filters are needed to cover the entire range from 100 kHz to 54 MHz. In this design, the eight receive filter logic signals drive a premade 8-way relay board sold as an Arduino module. On the other hand, the transmit filters require 10 logic signals.

The extra logic signals were added to the software after it was realised that it was better to have 10 filters in the transmit mixer rather than try to use one filter for, say,

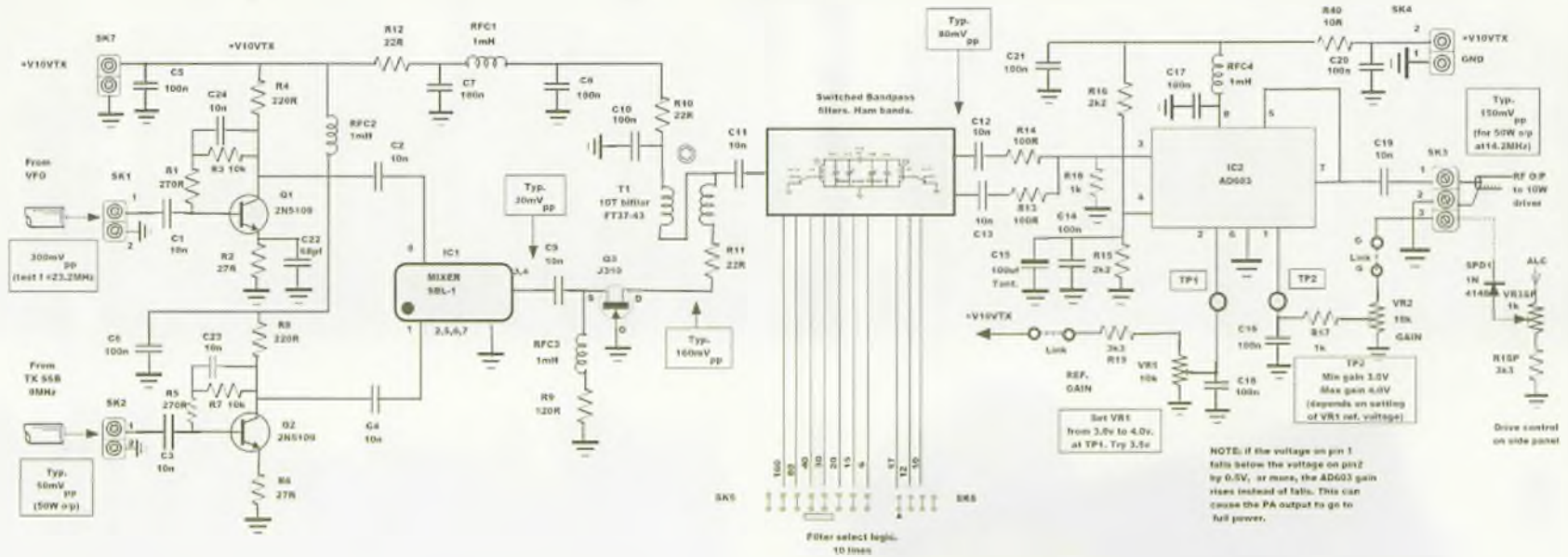

The RF levels shown were measured at 14.2MHz output at 50W. The RF output level of the AD603 is determined by the drive and ALC control voltage to the AD603. The resulting ALC feedback loop adjusts the RF level so as not overdrive the 10W and 100W stages. The AD603 does not need to raise much gain and is used as a level control.



Figure 19: Transmitter Band mixer.

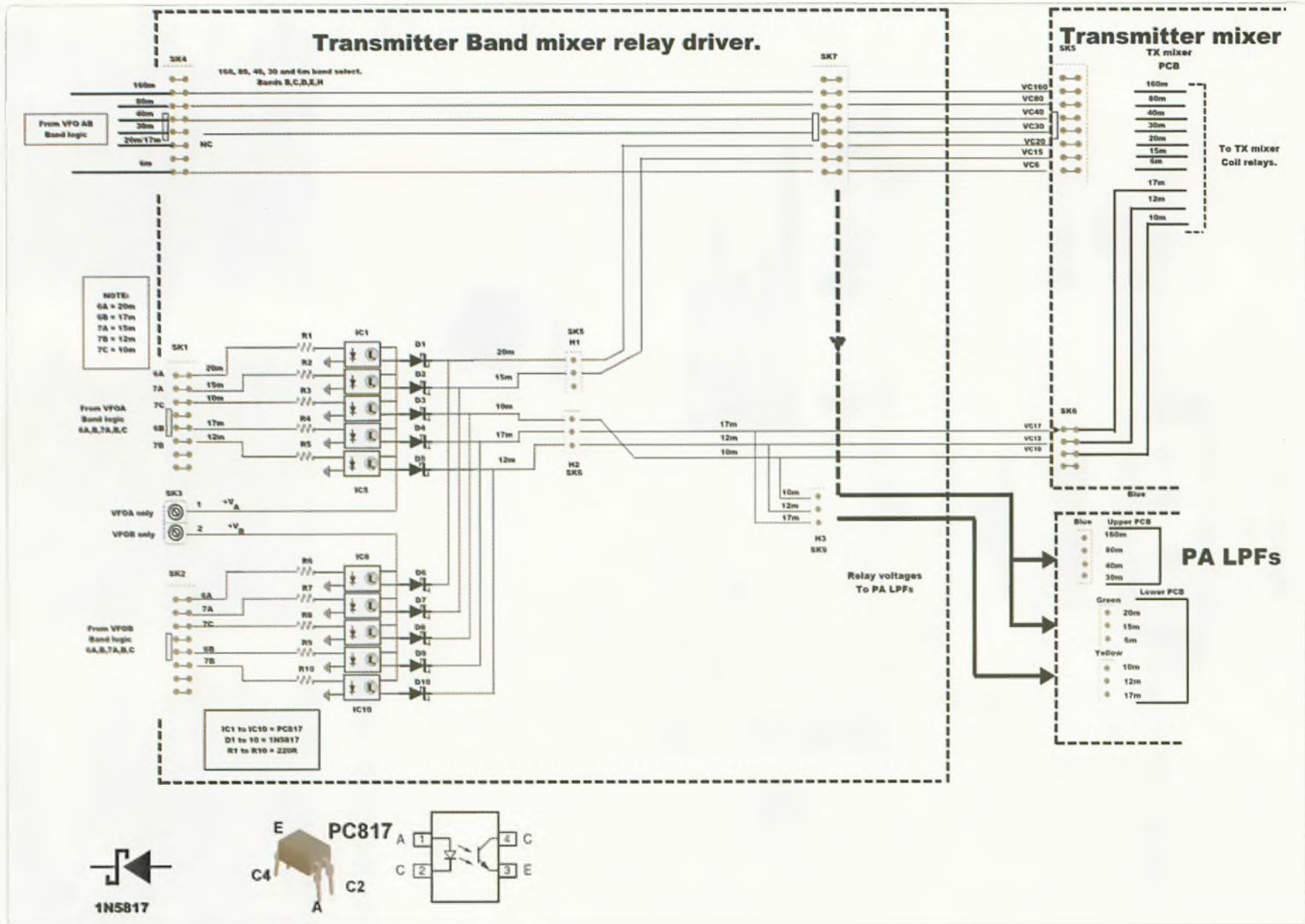

Figure 20: Transmitter Band mixer relay driver.

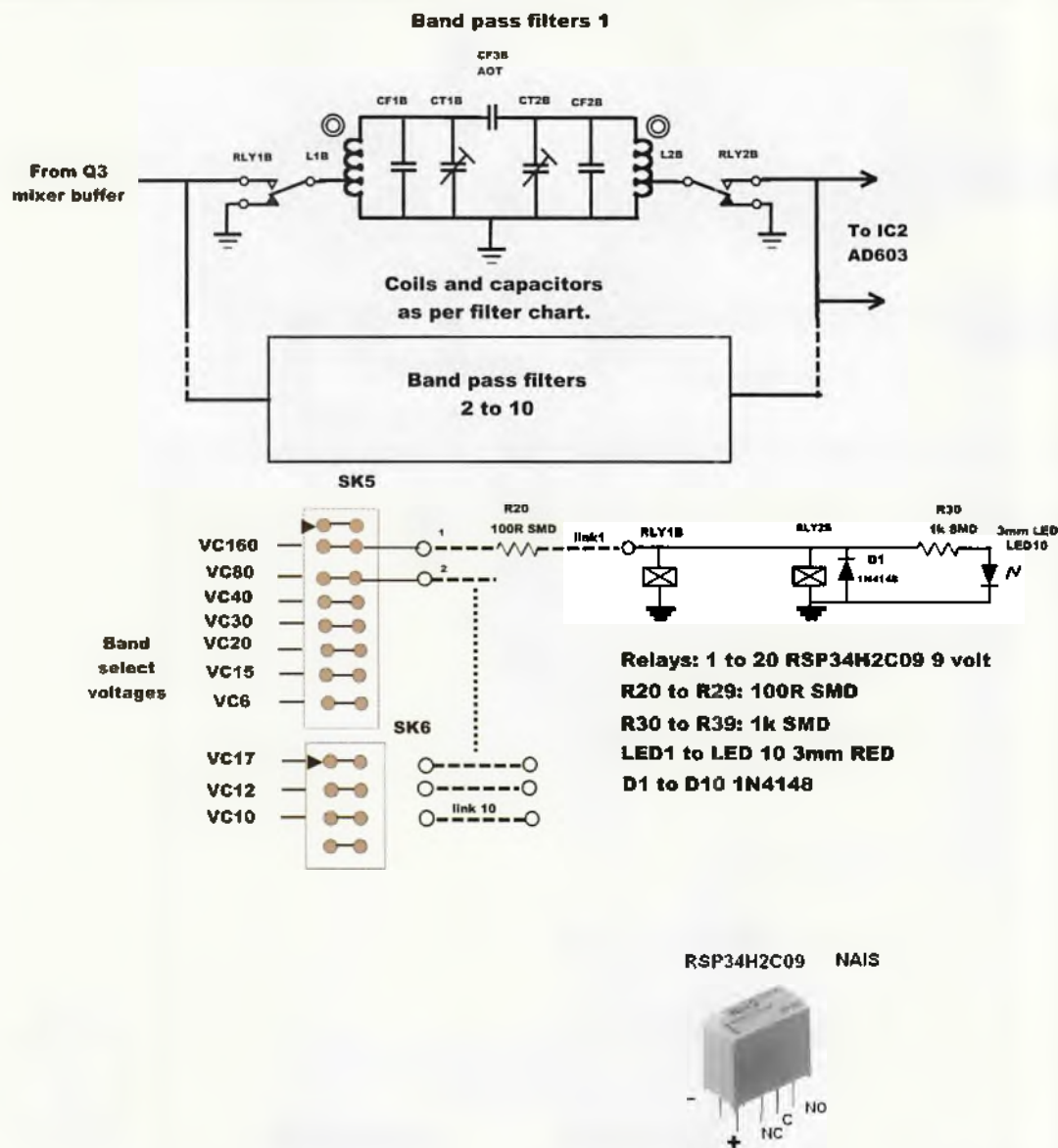

Figure 21: Transmitter Band mixer filters.

two bands like 15m and 17m. The double-tuned circuits could not cover such a wide range. Whilst discussing this point, the 100 W PA output filters are actually low-pass filters designed to reduce harmonic levels. In that case, there are only eight filters used to cover the 10 amateur bands, since it is possible to place the cut off frequencies of the low-pass filters to cover two close bands.

When looking at the circuit of the transmit filter relay drivers, you

will notice the mix of the 8-band logic and the extra logic to cover 10 bands. The software and hardware of the VFO logic system was more of a patch-up. If one was starting again, I would have written the band logic to cover the 10 bands and provided a relay interface on one board for 10 sets of relays. However, for now, what I have works, and I needed to move on and complete the rest of the project.

The transmit filter relay board uses some PC817 opto-couplers

between the Arduino output pins and the relays. The Arduino output voltage is five volts, whereas the relay lines require 12 volts. The actual relays I used are very small 9-volt ones purchased from a surplus store at a low cost. Since there are 20 relays used, purchasing surplus relays in bulk saves a lot of money. One can also use switching diodes here, but I found that using switching diodes requires around the same PCB real estate as small relays by the time you add the RF

Reference	Value	Notes
C1,2,3,4,9,11,12,13,19,24,23	10nF	Disk ceramic
C5,6,7,8,10,14,16,17,18,20,21	100nF	Monolithic
C15	100uF 25v	Electrolytic Low ESR or Tantalum
C22	68pF	Disk ceramic
Filters	See table 2 and TX filter circuit drawing	
IC1	SBL-1	Diode mixer
IC2	AD603	
Q1,Q2	2N5109	
Q3	J310	
R1,5	270R 5% 0.6W	
R4,8	220R 5% 0.6W	
R2,6	27R 5% 0.6W	
R3,7	10k 5% 0.6W	
R9	120R 5% 0.6W	
R10,11,12	22R 5% 0.6W	
R13,14	100R 5% 0.6W	
R15,16	2k2 5% 0.6W	
R17,18	1k 5% 0.6W	
R19	3k3 5% 0.6W	
R40	10R 5% 0.6W	
RFC1,2,3,4	1mH	RF choke
SK1,2,4,7	2 way 5.08mm	Screw block terminats
SK3	3 way 5.08mm	Screw block terminats
SK5	2x8 pin male PCB boxed IDC verticle header	
SK6	2x4 pin male PCB boxed IDC vertical header	
T1	10 turns, bifilar, FT37-43, 0.5mm enamelled copperwire	
VR1,2	10k trim pot	

Table 3.

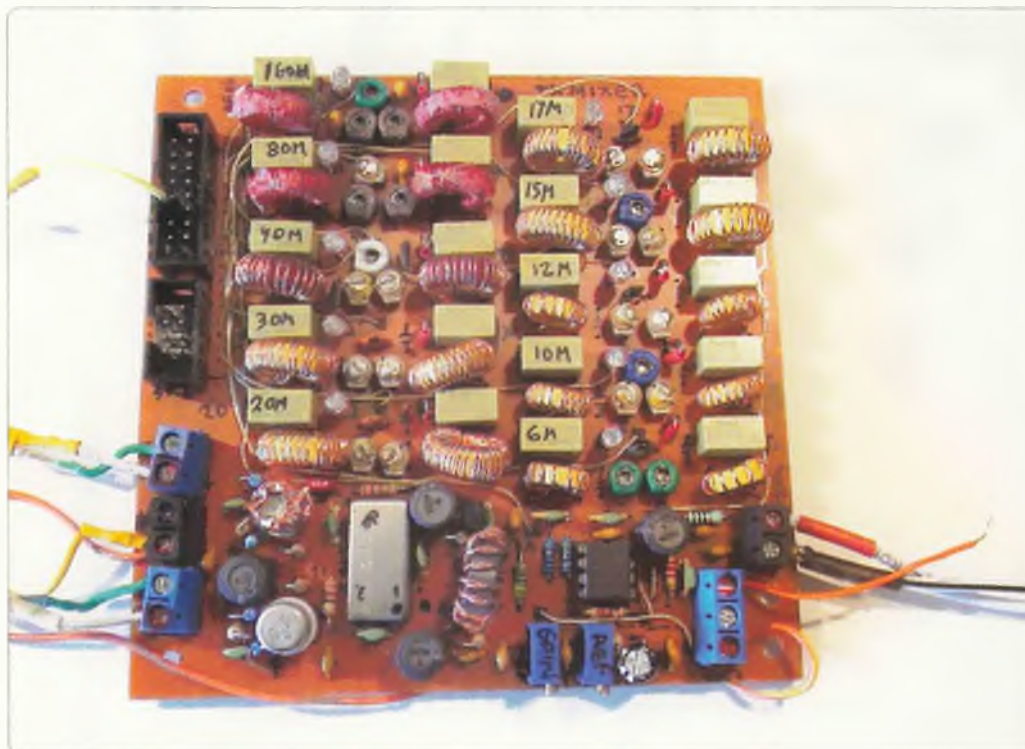

Photo 2D: The transmit mixer board incorporates the bandpass filters all using toroidal coils. The SBL-1 mixer is the rectangular metal package, and the AD603 low level Tx drive amp is the 8-pin DIL at lower right. Note the use of small 9-volt DPDT relays.

chokes or other filter components around the diodes.

As it happens, I have put switching diodes on small PCBs with pins that match the foot print of some of these relays. This enabled me to compare the two methods. Relays work very well, whereas I found that diodes can be prone to RF pickup, depending on your wiring and layout. PIN diodes are also not necessarily distortion free due to short charge lifetime inside their intrinsic layer at low frequencies. See Reference 4, page 255.

Photo 2D shows the transmit mixer board, bandpass filters and the gain-controlled AD603 transmit low level drive amplifier. Note the use of small 9-volt DPDT relays.

Transmitter Band mixer filters

The transmit mixer filters are double-tuned circuits, fixed tuned for each band. These are shown in Figure 21, with the coil details in Table 3. The tuned circuits are stagger tuned in order to cover the width of each ham band. In some

cases, they may not be flat across the entire ham band so you may want to favour the most used portion of the band and increase the manual drive control for the remaining section to achieve full power.

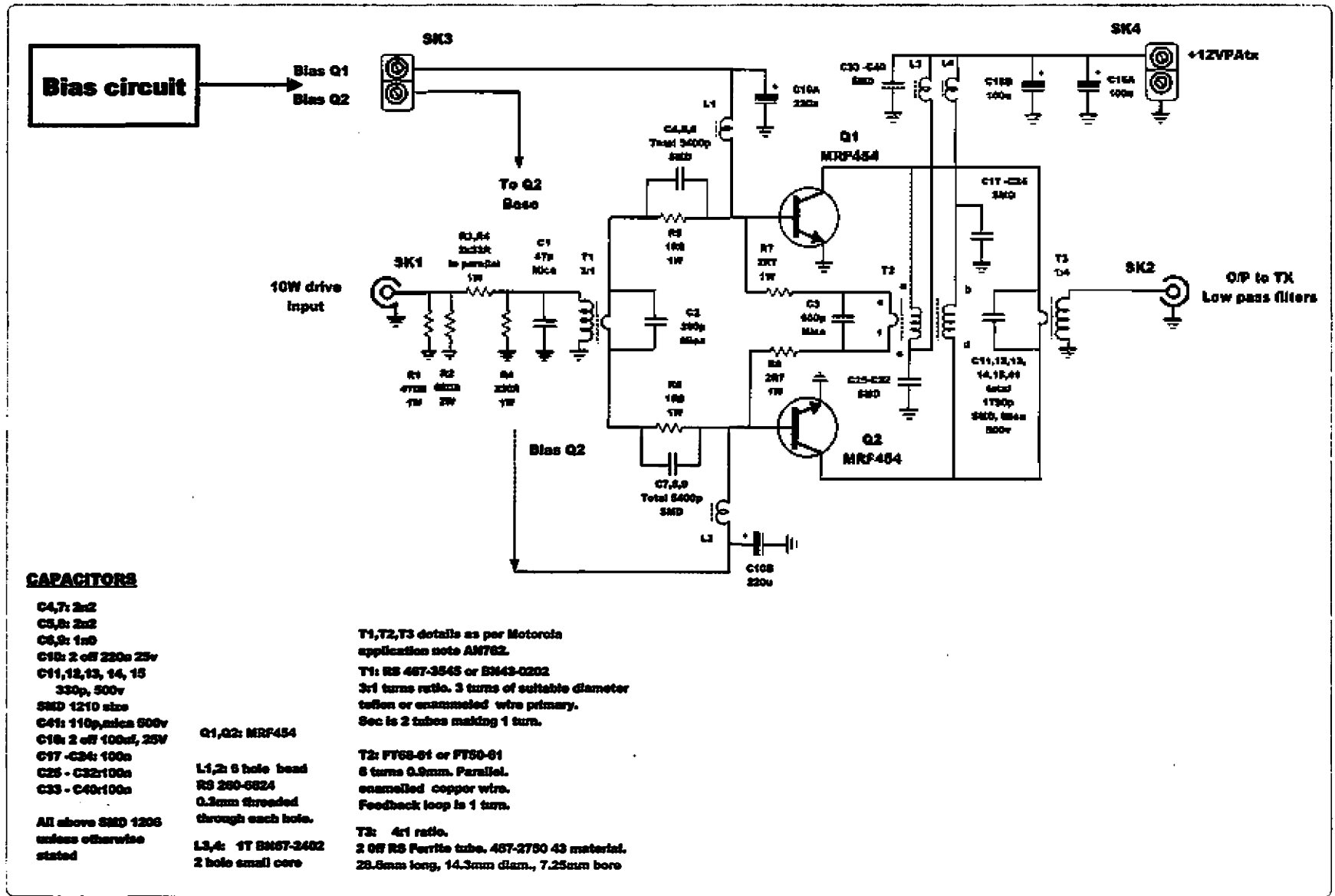

Figure 22: 100 W RF Power amplifier.

The 100 Watt PA stage and driver

The output of the AD603 transmit mixer amplifier feeds a 10 W amplifier purchased from an Australian kit supplier (Reference 9). It consists of a broadband design using a pair of RD16HHF1 RF FETS. The specified amplifier input drive is -5 dBm (356 mVpp) for 10 W output. It also incorporates a bypass circuit on receive.

In my application, I have disabled the receive bypass as I am feeding this stage into a 100 W amplifier. Details of this amplifier can be obtained from the kit supplier. The cost of the kit was quite reasonable when you consider it came with a first-class PCB, all the parts, and genuine RD16HHF1 power FETS. I should add here that there are a number of vendors on the web that sell inferior, or "fake", semiconductor devices,

so consider purchasing the more expensive devices from reputable suppliers, even though the cost may be higher. This definitely applies to high power FETS and transistors. I have received a number of high power LDMOS devices that turned out to fail almost as soon as power was applied. On closer examination, they contained much smaller dies inside the packages.

The 10 W amplifier feeds a 100 W power amplifier comprising a pair of matched MRF454 transistors. The circuit of the amplifier is shown in Figure 22. The bias circuit is shown in Figure 23. The design is from the Motorola application note AN762, which is available on the web. The 10 W driver output is actually dropped by 3 dB to ensure the 10 W stage sees a 50 ohm load. I have found that some FET amplifiers become unstable if they feed a reactive load.

The input impedance of the 100 W stage may not present a purely resistive load all the way up to 54 MHz, so the pad is a precaution. In addition, the 100W stage does not require the full 10 W of drive for 100 W output. The gain of the 100 W stage varies from 13 dB at 2 MHz, up to 14.5 dB at 14 MHz, and then back to 13 dB at 30 MHz. At 54 MHz, it is considerably lower at around 4 or 5 dB. For an output power of 100 W, the input only needs to be around 5W at most.

The 100 W PA performs quite well. I have measured 2nd order intermod products around -35 dB across the bands at power levels of 100 W. The actual power capability of the design is around 140 W. The published third harmonic levels range from -15 dB at 2 MHz to -35 dB at 30 MHz. Therefore, good low-pass filters are essential on the output of this amplifier. My

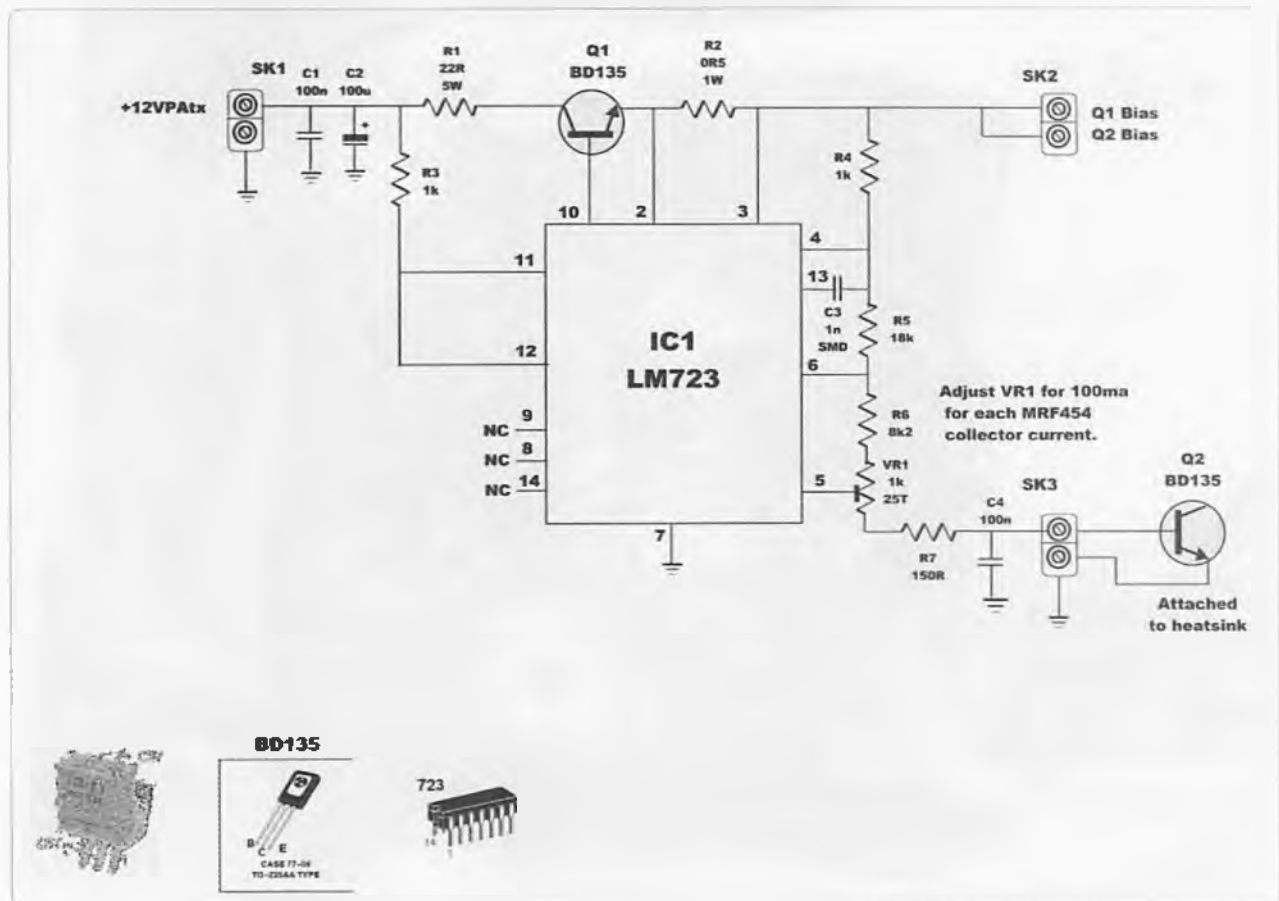

Figure 23: 100 W RF Power amplifier bias.

measurements are better than the published figures, but still not really good. The bias settings can be reasonably high. The application note suggests anything from 100 mA of idling current per transistor in Class AB. You can actually run them as high as Class A, providing you have lots of cooling. I run mine at around 150 mA per device as this gives lower intermod distortion and harmonic level.

I did not use the PCB layout in the application note since it was rather complex and it used a round can version of the bias regulator. I used a 14 pin DIL package for the LM723 regulator so I placed that on a separate small PCB. The power transistors were mounted on a heatsink made up of several pieces from the junk box, which had to fit in the available space on

the back panel. I prefer to keep the high power stages outside the case to minimise the possibility of RF getting into other circuitry. It has paid off, as there is no sign of RF causing problems inside the case. It also means the ventilation of the heatsink is outside the case.

The remaining parts of the amplifier are mounted on a piece of double-sided PCB material. One side is a full layer of copper earth plane. The other side has etched lands and tracks to take the various components in "Manhattan style". Component leads and SMD bypass capacitors are soldered on the top surface. Plenty of copper foil and pins connect the bottom layer to the earth connections on the top layer. It seems to work okay as the stability is very good and such a board is not hard to make using a

waterproof pen and tape.

I have also added a small 3" fan on the inside face of the rear panel, which blows air through some holes over the PA transistors. It was salvaged from a desktop PC and has a small, rather tinny, speaker with it. I also have a 3-wire, 4", 12-volt PAPT fan outside the case nearby on the bench with a thermistor that controls the fan speed. The thermistor is on a lead and sits inside part of the heatsink. It is not really needed but it is handy if the area at the back of the desk gets a bit warm. That can happen when you first start commissioning the amplifier and you are running full power tests.

Under normal SSB use, the amplifier runs quite cool. The MRF454s are now quite old, but I must say they are very robust.

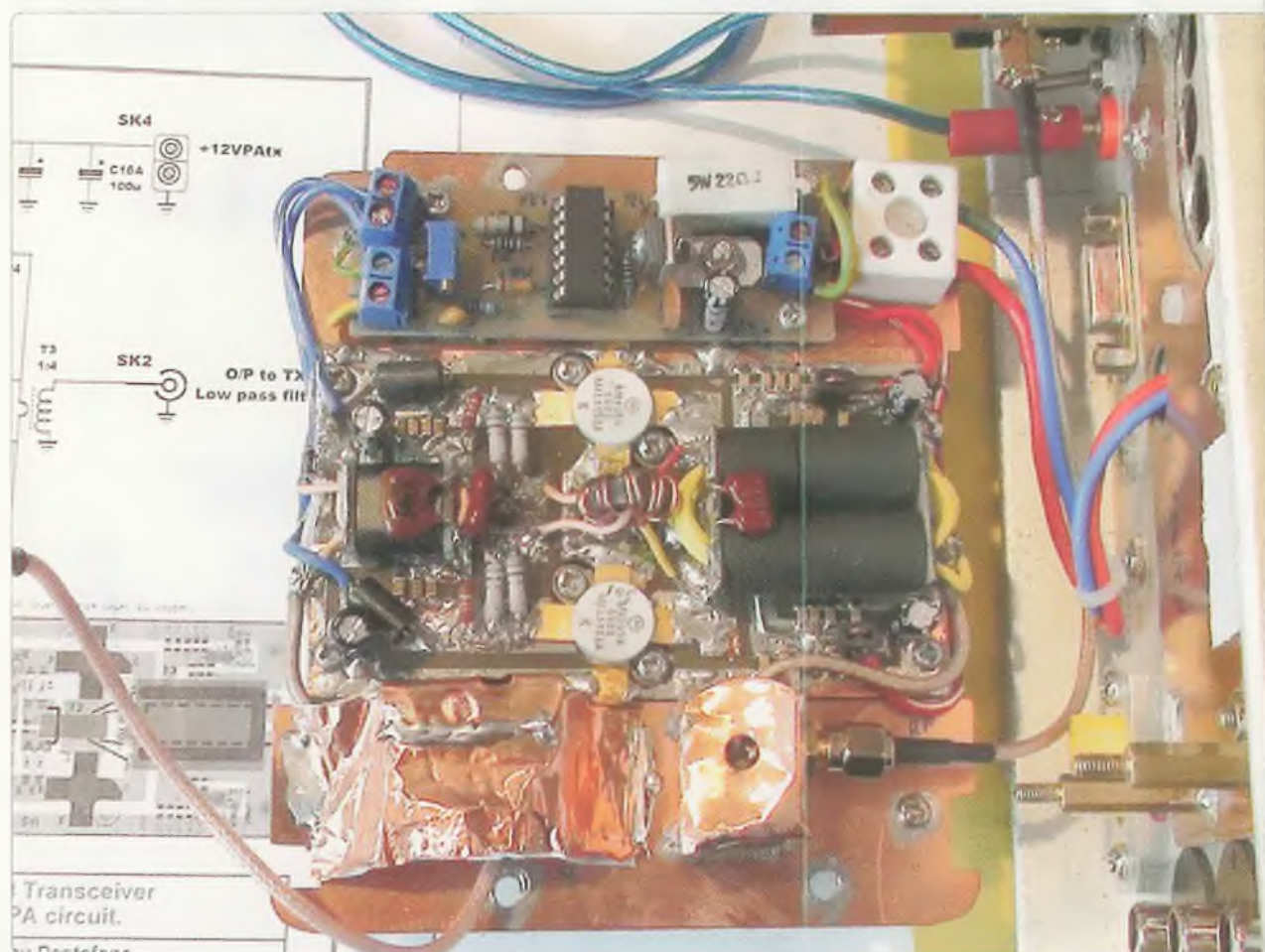

Photo 2GA: The 100 W PA; note the pair of MRF454 transistors and the tubular ferrite output transformer. The bias circuit board is mounted at the top, here.

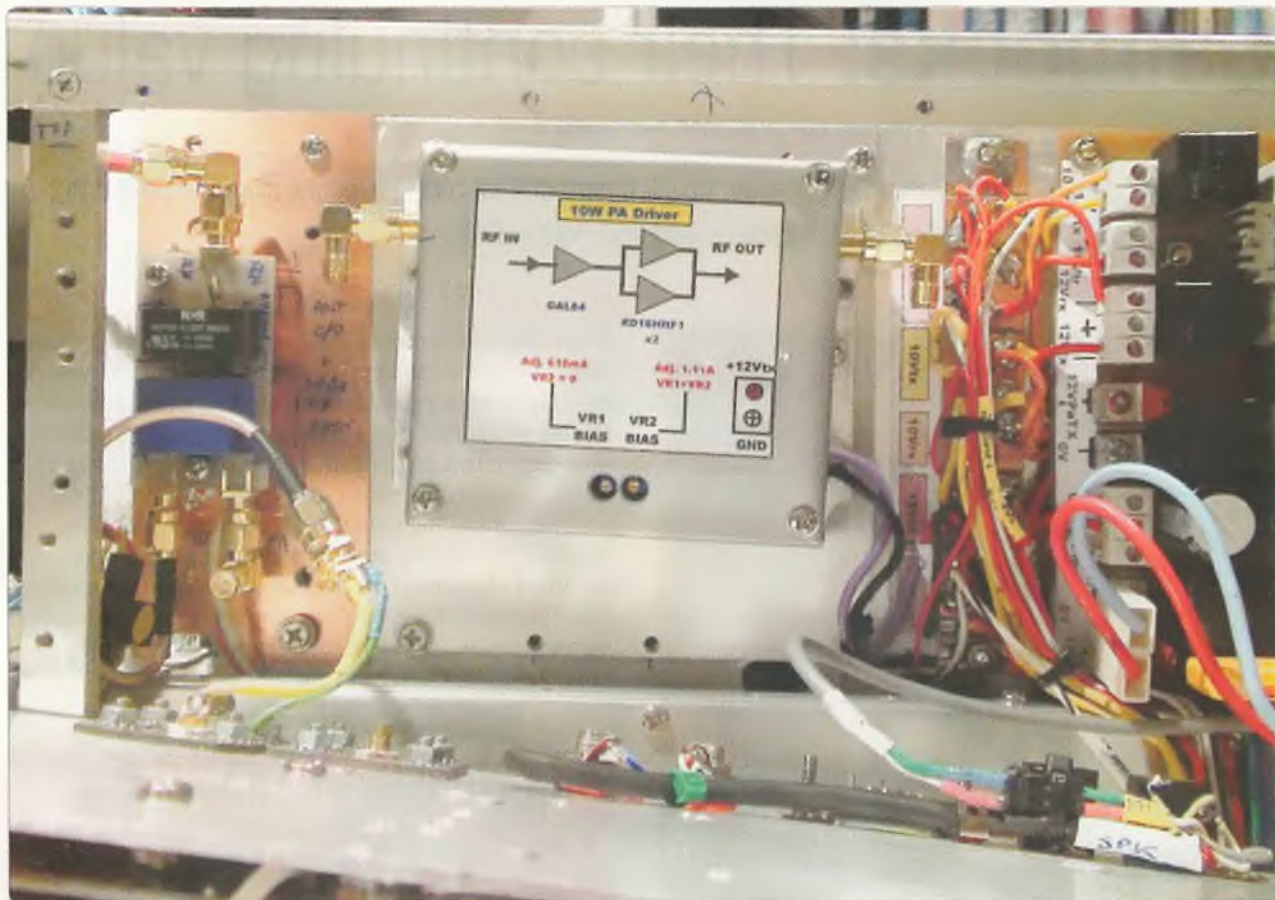

Photo 2GB: The 10 W PA driver unit is a locally-sourced kit, from Mini-Kits.

I have done some terrible things to this amplifier, such as high SWR, no loads, overdriven it, and it has survived. I have two pairs of matched devices and have not needed to use the second pair.

I have done some work with the IRF type FET devices and destroyed a few in the process. They appear to be far less tolerant of open circuit loads and too much drive. And there was my bad experience with the sad tale of the fake LDMOS devices. Unfortunately, good, genuine 100 W FETS are not cheap, so I will defer buying them till sometime in the future when they become cheap enough to blow up!

If you are thinking of constructing a power amplifier like this, you need to use good quality high voltage capacitors such as 500 Volt mica and SMD ones. If you want to use ceramic capacitors,

avoid the use of multilayer, or small monolithic ceramic capacitors; they are not suited to carrying high levels of RF current. Basically, multilayer ceramic capacitors are made of several layers of thin conducting material separated by the dielectric. These layers are very thin and can be destroyed easily one by one if made to handle high RF currents. You sometimes see them used in lower power amplifier designs running around 5 to 10W, where the typical multilayer capacitor voltage rating of 50 V can be exceeded, or as coupling capacitors carrying some level of RF current.

Single layer, high voltage disc capacitors, have only one conducting surface layer each side of the dielectric, and can handle the RF current better. They're still not as good as mica or ceramic discs designed for high RF current, but at

least some order of degree better than the small multilayer units.

Photo 2GA shows the completed 100 W power amplifier. Photo 2GB shows the 10 W PA driver unit, which I mounted on the subpanel at the rear of the case.

References

These are listed in-full at the end of the 2nd article, on p.16 of Issue 2, 2020.

4. Radio Communication Handbook, Thirteenth Edition, RSGB Publication.
9. Mini-kits in South Australia. <http://www.minikits.com.au/>
10. Jim Tregellas, A low distortion two tone oscillator, Amateur Radio, June 2013, Wireless Institute of Australia, pages 14 -17.

Callbooks: Their continuing value

Peter Wolfenden VK3RV, WIA Historian

(Part 2)

In this part, we cover the development of Australian callbooks from the post-WW2 era through to the present and their role in QSLing

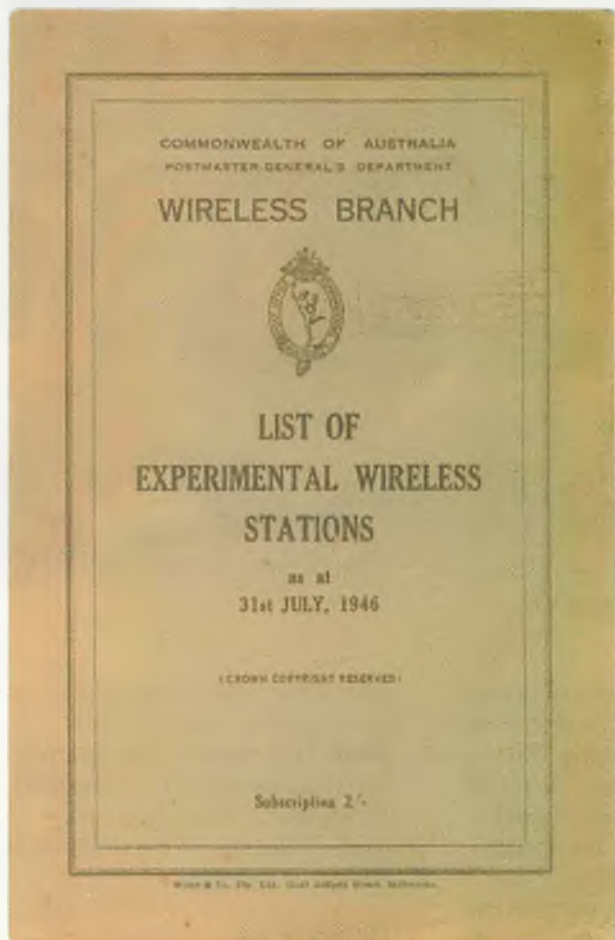

Photo 5: The first post-WW2 Callbook – a slim volume of 48 pages.

Peace returned to us in August 1945 and by December, the Post Master General's (PMG) Department – the licensing authority – had begun issuing amateur licences. Examinations started in January 1946, with AOCIP Certificate No.4 issued in late February 1946.

July 1946 saw the PMG publish the first callbook following the war. It had 44 pages and was just a listing of the 1,594 licenced Experimental stations. The Crown Copyright publication only included callsigns, names and addresses – no other information at all!

In December 1948, another PMG Callbook was issued. Now grown to 70 pages, it listed 2,570 Experimental Amateur callsigns – a significant increase

to the pre-war numbers. ACT stations were still included within VK2, and stations located in the Antarctic were listed under the individual's originating state. There was no use of the VK1 prefix. The name of the callbook was changed from a *List of Experimental Wireless Stations* in 1946, to a *List of Amateur Wireless Stations* in 1948.

The substantial growth of 1000 stations, or 60% in about 18 months, was no doubt because of the numbers of returned servicemen who were "bitten by the communications bug" while on service. This increase was extremely important to the growth and stability of amateur radio, clubs, and the WIA at that time.

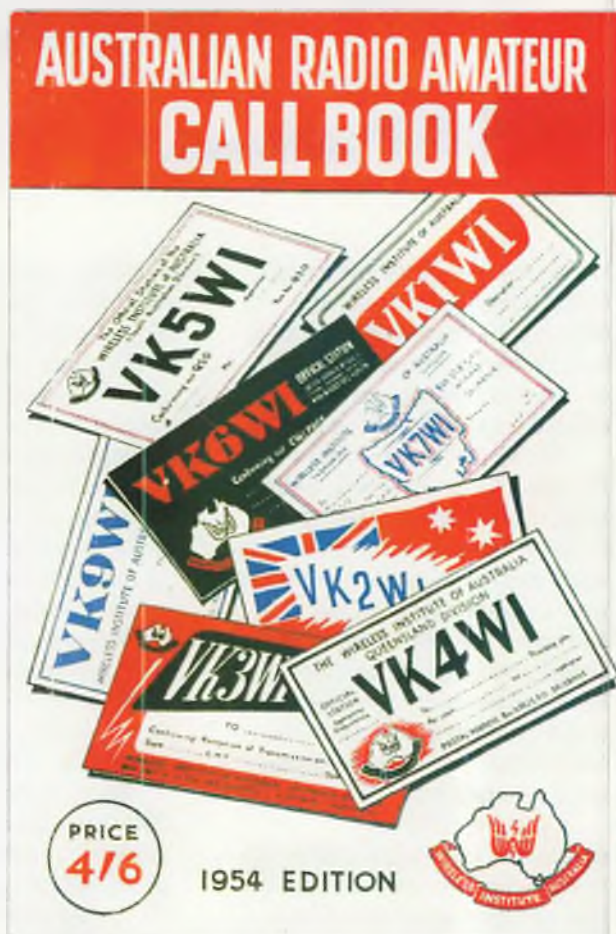

Photo 6: The 1954 Callbook left one in no doubt about its primary purpose – QSLing.



"WALTHAM DAN"
THE BARGAIN MAN
 OF
SYDNEY and MELBOURNE
 Australia's largest mail order house for ex-Government
RADIO, ELECTRICAL, and
SCIENTIFIC EQUIPMENT
 Write tonight for the current issue of our Catalogue
 of the latest bargains of Radio and Radar Equipment.
 (Enclose 3d. to cover postage.)
WALTHAM TRADING CO.
 Sydney Mail Order: Box 23, P.O. Oxford St., Sydney, N.S.W.
 Sydney Retail Store: 26 Oxford Street, Sydney, N.S.W.
 Melbourne Mail Order: P.O. Box 523, Melbourne, C.I. Vic.
 Melbourne Retail Stores: 219-221 Swanston Street and
 225 Flinders Street, Melbourne, C.I. Vic.

Photo 7: A prominent advertiser of 1954 was the Waltham Trading company. Many amateurs of the era, with a newly-minted licence, went shopping in Waltham's for suitable military surplus equipment to adapt to amateur radio use.

About two years later, in 1950, *Radio and Hobbies* (*R&H*) magazine published a 120-page book entitled *The Australian Shortwave Handbook*, aimed at the amateur and shortwave listener. It used the same format as *R&H* magazine and contained a callsign listing, together with a wide range of additional relevant material for the amateur and shortwave listener, including aerial and circuit designs for the home constructor. The editor was John Moyle VK2JU, a well-known and well-respected amateur and WIA member. He was also editor of *Radio and Hobbies*. The John Moyle Memorial National Field Day is named in his honour.

Later, John attended the World Radio Conference in Geneva, on behalf of the Institute and amateurs of Australia, as an accredited member of the Australian Delegation. This was an extremely important and costly conference held between August and December 1959. The Conference reflected on the large range of changes in communications technology that occurred during WW2 and the potential consequences resulting from a multitude of new spectrum demands by a growing number of users. ⁽¹⁾

The WIA 1954 Callbook

This was the first produced by the Institute since 1914 and listed some 3,008 stations. It was published with the authority of the PMG's Department by the Victorian Division WIA, which was also the producer of *Amateur Radio* magazine on behalf of all WIA Divisions. The book was smaller than the earlier *R&H* publication and had now resolved into more of a basic operators handbook containing not only station listings, but also official material supplied by the PMG's Department – "Information Concerning Operation of Amateur Wireless Stations in Australia (Published by arrangement with the Postmaster-General's Dept.)"

The Foreword included: "For the general information of Amateurs, complete listings of the world's QSL Bureaux and the frequencies and wave lengths of National and Commercial Broadcast Stations." The New South Wales (VK2) listing still included amateurs located in the Australian Capital Territory. The VK1 Prefix at that time was allocated to Antarctica and Cocos-Keeling Islands.

Although the AOLCP (Amateur Operator's Limited Certificate of Proficiency) became available from January 1954, the new licensees were too late for inclusion in the 1954 book, the content of which was firmed-up in late 1953. The 1955 issue therefore carried the details of that first group of 97 AOLCP amateurs who had all passed the same Theory and Regulations exams as "Full-calls", but without the Morse requirement. The "Z Calls" (callsign format VK#Zxx) operation was limited to VHF, 50 MHz and all bands above. The total number of amateurs listed in 1955 was about 200 more than in 1954 and there were 35 VK1 (Antarctica) Departmental cancellations.

Over the ensuing years, as the amateur population increased, the WIA Callbook also gradually increased in both physical size and number of pages, reaching over 100 around 1990. The additional pages provided more detail of the new interests and activities being pursued by much of the fraternity. Many pages were dedicated to the use of VHF and UHF Repeaters, together with Beacon information. Also included were Band Plans from HF to 47 GHz, ATV repeaters and large listings of Shortwave Listeners (SWLs) who were generally non-licensed members of the various State WIA Divisions. Also published were many pages from the Department of Communications, providing information and operating conditions. The Callbook was again growing.

The 2000 Callbook

The 2000 Callbook was a bumper edition of 200 pages, referred to as *The WIA Yearbook*, which had developed into a very comprehensive operators' manual, providing ready access to not only the recommended and mandatory Amateur Operating Conditions and Procedures, but also Institute activities. The Australian Communications Authority (ACA) material covered 11 pages. The concept had been explored

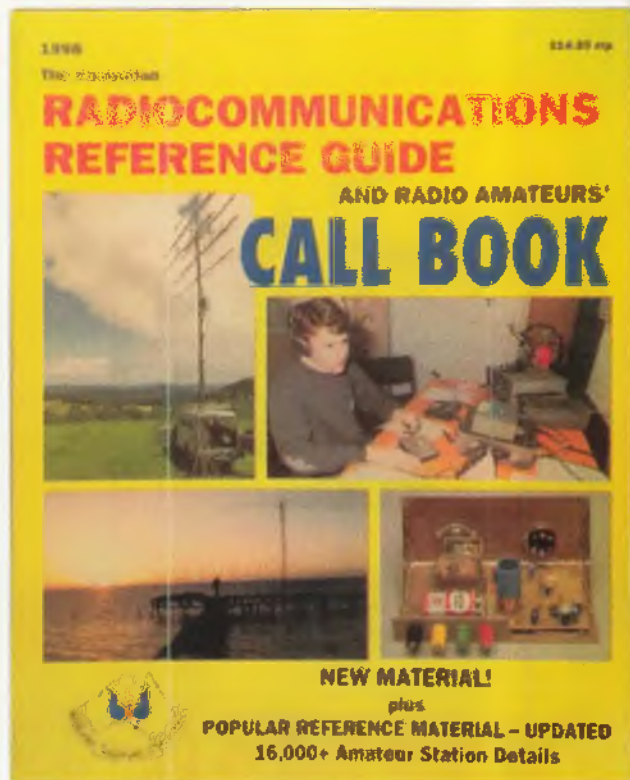
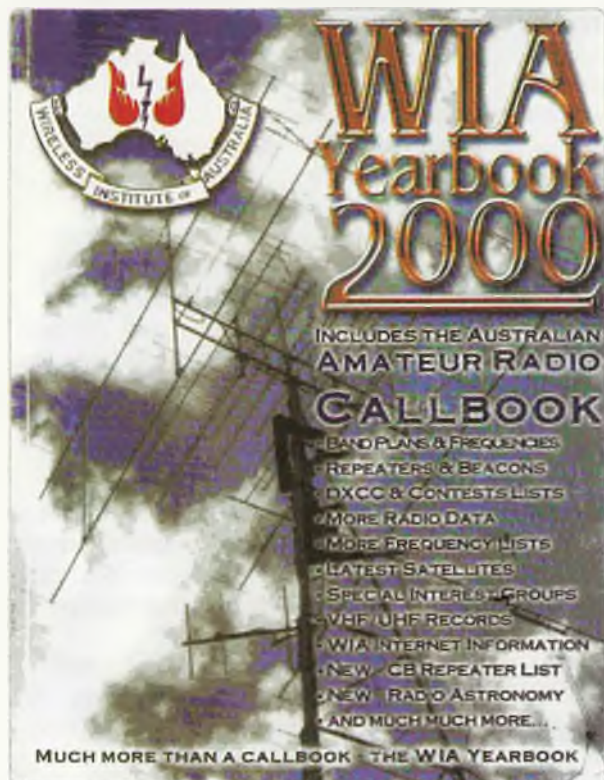

Photos 8 and 9: There were several instances where the Callbook was styled as more of an 'annual reference' concept – such as these 1998 and 2000 publications, for example.

earlier, in the 1998 *Australian Radiocommunications Reference Guide and Radio Amateurs' Call Book*. This ran to 158 pages and carried topical information and articles covering packet radio, use of the internet, low frequency non-directional beacons (NDBs), reflecting the changing interest of amateurs (Ed.)

In each of these annuals, WIA information embraced a very large range of activities and reference material, including some comprehensive pages on how to promote the hobby at club and personal levels, perhaps worth revisiting today. They also contained contact information for the many WIA volunteers scattered across Australia, the people who conducted much of the day-to-day work for the Federal and State functions of the Institute, together with the growing number of Accredited Examiners.

Non-voting or Associate WIA members (generally non-licensed members) were known as SWLs or

Shortwave Listeners. Over the years their numbers varied. By 2000, SWL listings had dropped in number by about 500, from 727 in 1990 to 224, as shown in later callbooks.

Another useful source of information contained in the callbooks, but often overlooked, is the President's or Editor's Comment/Foreword. Frequently, these reflected on the previous year's events and sometimes pre-empted actions likely to take place during the current year, especially in regulatory matters. It can be a good source of chronological information for researchers.

Callbooks and QSLs

As previously mentioned, callbooks over the years have been used as an address resource for sending QSL cards. Most historians would say that the first QSL cards were exchanged around the time that international shortwave communication was realised during the early to mid-1920s.

The RSGB book, *The Bright Sparks of Wireless*, suggests that

W.E.F. (Bill) Corsham may have been the first, at least in Europe, to have produced QSL cards during the early 1920s. An example of his card, dated 1922, is included in the book although, in reality, the example shown appears to be a blank card with only the date of Jan 1922 filled in. (2)

Was it the same in this part of the world? Well, probably. But here, most amateurs were not granted access to the spectrum following WW1 until late 1922. A search of the WIA QSL Card Collection has produced a few interesting results. One is written comment of a 1913 QSO on the back of a 1961 card from VK5HY, Arthur Cotton, a very active South Australian amateur. Arthur was involved in many Institute functions over the years, from the earliest days of the WIA SA Division and before. In 1913, he was XVS and his 1961 contact was with VK5ON, Chas. Other XVT, his old "1913 spark mate", from the same Adelaide suburb of Glanville.

We are still searching the WIA QSL Collection for the oldest

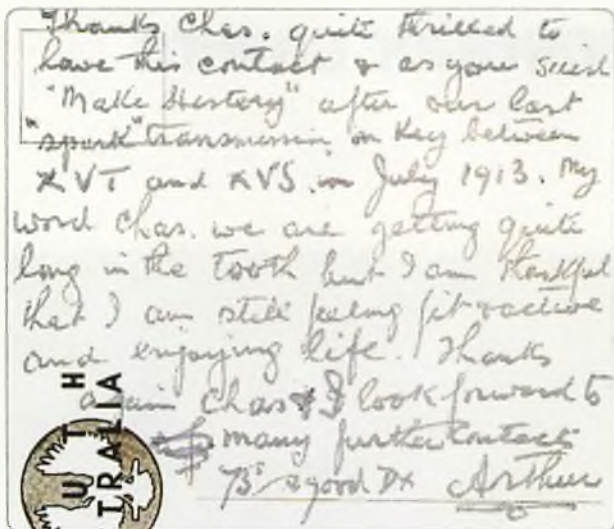

Photo 10: Details of the XVT-XVS contact of 1913.

Australian QSL card with complete details.

Another "card", recently discovered online, is an even earlier transmission report – an acknowledgement from one of our most notable early experimenters, H.W. (Walter) Jenvey of Red Bluff and Point Lonsdale/Queenscliff, fame. Although Jenvey was Chief Postal Electrical Engineer for Victoria, he had been privately experimenting with wireless since about 1898, during his own time and at his own expense. He considered himself an amateur. (3) (6)

Although, not a QSL card as such, but definitely a confirmation, the report in Photo 11 is in the form of a telegram dated November 17, 1900. The telegram was sent by Jenvey from the Doncaster Post Office to Mr F.W. Chambers, an Electrical Engineer with the Melbourne Electricity Supply Company, who was transmitting from his home in Heidelberg. Jenvey was located at the Doncaster (water?) tower where he had set up his receiver. The telegram, complete with a few minor errors, "garbles" in the cryptanalytical environment, but here, by apparently miss-reading the Morse code by the PMG's telegraphist, provides us with a couple of errors that are capable of being corrected if you understand the activity and people behind it. This pre-Federation telegram is probably our earliest written wireless reception report, complete with date and time together with a very encouraging signal report. (4)

A few months later, Jenvey made his historical and widely reported two-way communications with the HMS St George, an escort ship to the HMS Ophir, conveying the Duke of York to and from the Australian Federation celebrations in Melbourne. This is the first recorded ship-to-shore wireless communication in the Antipodes. Recorded is the correct word here, because an inked paper-tape recording survives from the contact between Jenvey and the St George. (5)

Walter Jenvey's son, William Jenvey A3AY (later VK3AY), addressed the Radio Amateurs' Old Timers Club in Melbourne during 1978, where he reinforced the

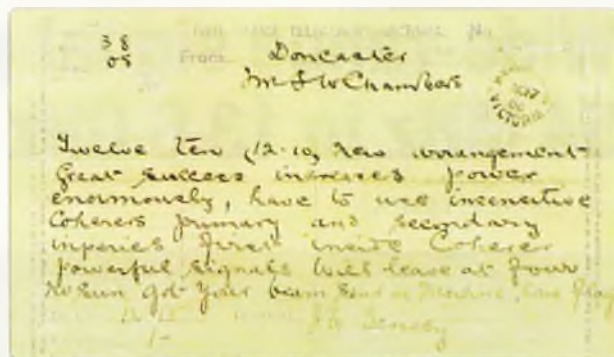

Photo 11: 1900 Report by telegram. Photographer: Rodney Start. Source: Museums Victoria. Copyright Museums Victoria. (Licenced as Attribution 4.0 International)

private aspects of his father's early wireless experiments. Bill was Chief Engineer for the Australian Overseas Telecommunications Commission during the 1960s and in many ways followed in his father's footsteps in ship-to-shore communications. (3) (6)

A Final, Final

The current Callbook lists about 14,600 station callsigns, plus another 500-odd beacon and repeater licences. There are 23 pages of WIA, Club details, and general information including Electro-magnetic radiation (EMR), an essential matter that amateurs need to manage these days. Also, there are three pages focused on Foundation calls and advice for the newly-licenced operator. The Australian Repeater Directory, Band Plans and International information to help the DXer, all make up the 176 pages of the 2019 callbook.

Australian callbooks contain a lot of historical information covering a great range of subject matter. Through them, it is possible to track many aspects of our interests and see how and why legislative changes became necessary. They also form a record of legal and social changes associated with amateur radio in this country over the years. And of course, a current issue is a worthwhile, readily available source of information for the active amateur.

References

- (1) 1959 Geneva Report, <http://www.wia.org.au/members/history/reports/documents/Geneva> ITU 1959 - John Moyle
- (2) The Bright Sparks of Wireless, G.R. Jessop, Radio Society of G.B., 1990, ISBN 0 900612 9 59, p33
- (3) Bill Jenvey OA3AY (Son of H.W. Jenvey), 1978, Sounds of Amateur Radio CD, Vol.2, WIA 2010.
- (4) Telegram Jenvey to Chambers, 7 Nov. 1900, <https://collections.museumvictoria.com.au/items/369574>
- (5) WIA100 - An Arena of Wonder - QSP, Part 1, Amateur Radio, Melbourne, February 2010, p23
- (6) Radio Genesis Australis, N. Burton, Mariner Magazine, March-April 1968, p206-208

Wide-range signal generator covers 54 MHz to 13.6 GHz

Jim Henderson VK1AT

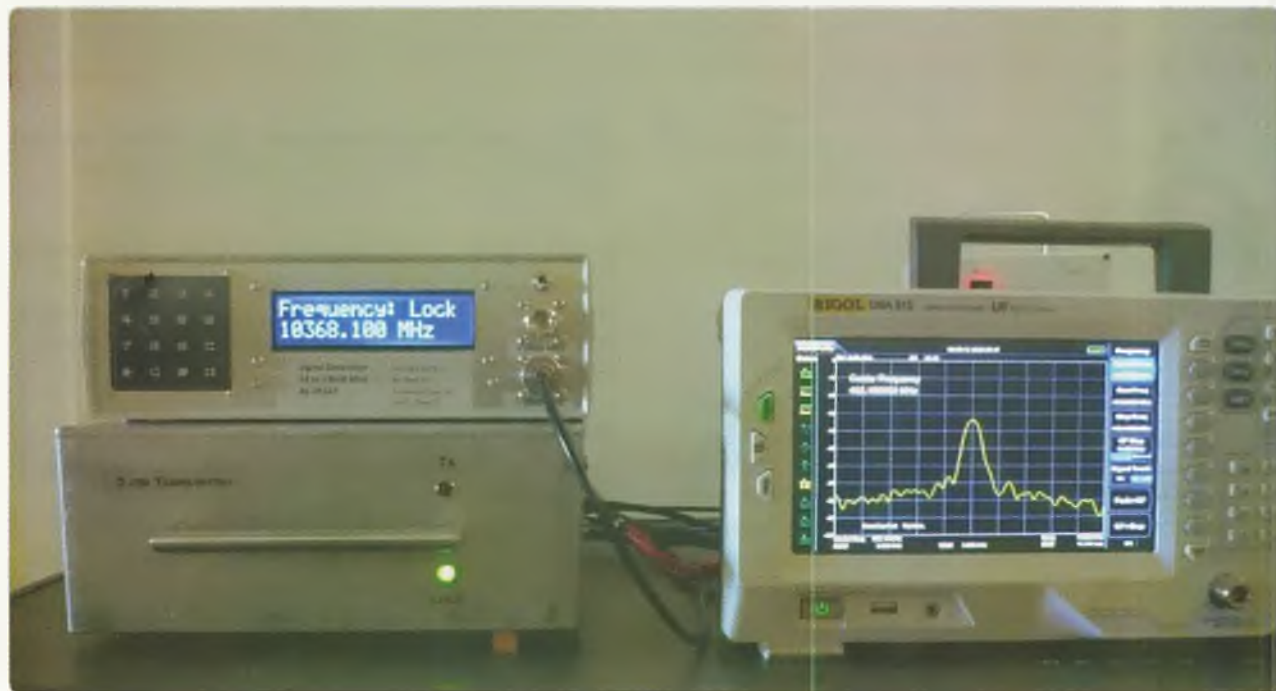

Photo 1: ADF 5355 Signal Generator input to 3cm band transverter.

Introduction

I had previously built a 35 to 4400 MHz signal generator based on the ADF4351 PLL board developed by Makis Katsouris SV1AFN (see: www.sv1afn.com/en/), described in the November 2017 issue of *AR* magazine. I have used this board and the software I developed in a number of projects, including transverters for the 1296, 2403 and 10,368 MHz bands (the latter with a tripler). It is a great performer as both a signal generator and microwave local oscillator. I decided it was time to try developing a similar signal generator based on the ADF65355 that covers the 54 MHz to 13.6 GHz frequency range.

My signal generator is based on an ADF5355 PLL chip integrated on a board available online through eBay or Bangood. The board is marked as 'ADF5355X EVAL NWDZ V2.0'; it includes regulators for the ADF5355 and a 25 MHz packaged oscillator with a balanced output for the ADF5355 reference. I developed the Arduino software to drive the board based on my experience with the ADF4351 signal generator development.

About the ADF5355 PLL

The ADF 5355 is a fractional-N frequency synthesiser.

The output frequency is:

$$VCO_{out} = f_{pd} \times N$$

$$f_{pd} = REF_{in} \times \left[\frac{1+D}{R \times (1+T)} \right]$$

$$N = INT + \left[\frac{FRAC1 + \frac{FRAC2}{MOD2}}{MOD1} \right]$$

REF_{in} is the input reference frequency

D is the REF_{in} doubler bit (1 or 0)

R is the divider value for the reference input (1 to 1023)

T is the REF_{in} divide by 2 bit (1 or 0)

INT is the 16-bit integer value

FRAC1 is the numerator of the primary modulus (0 to 16,777,215)

FRAC2 is the numerator of the auxiliary modulus (0 to 16,383)

MOD2 is the programmable auxiliary fractional modulus (2 to 16,383)

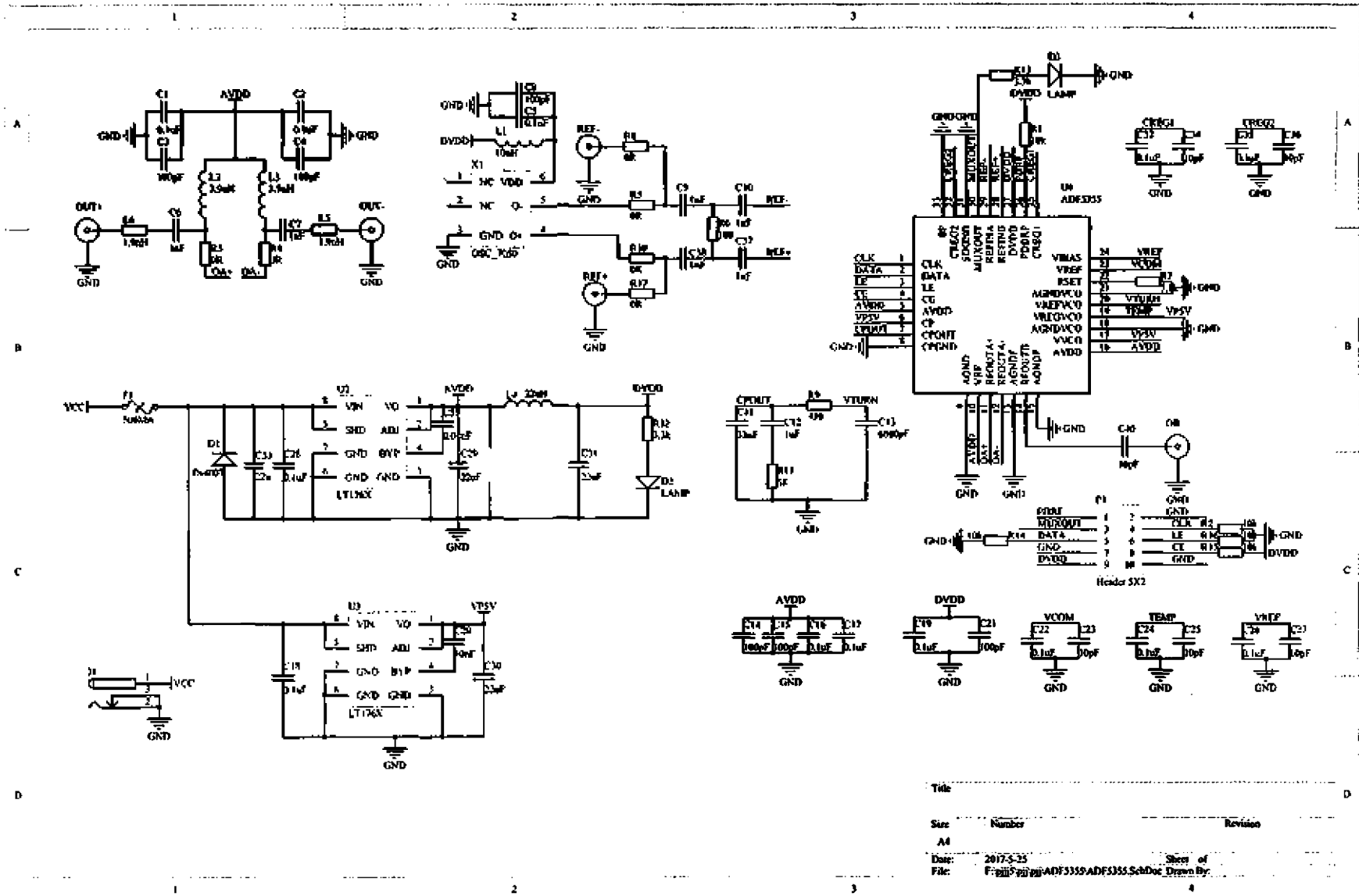

Figure 1: Schematic of the ADF5355 board.

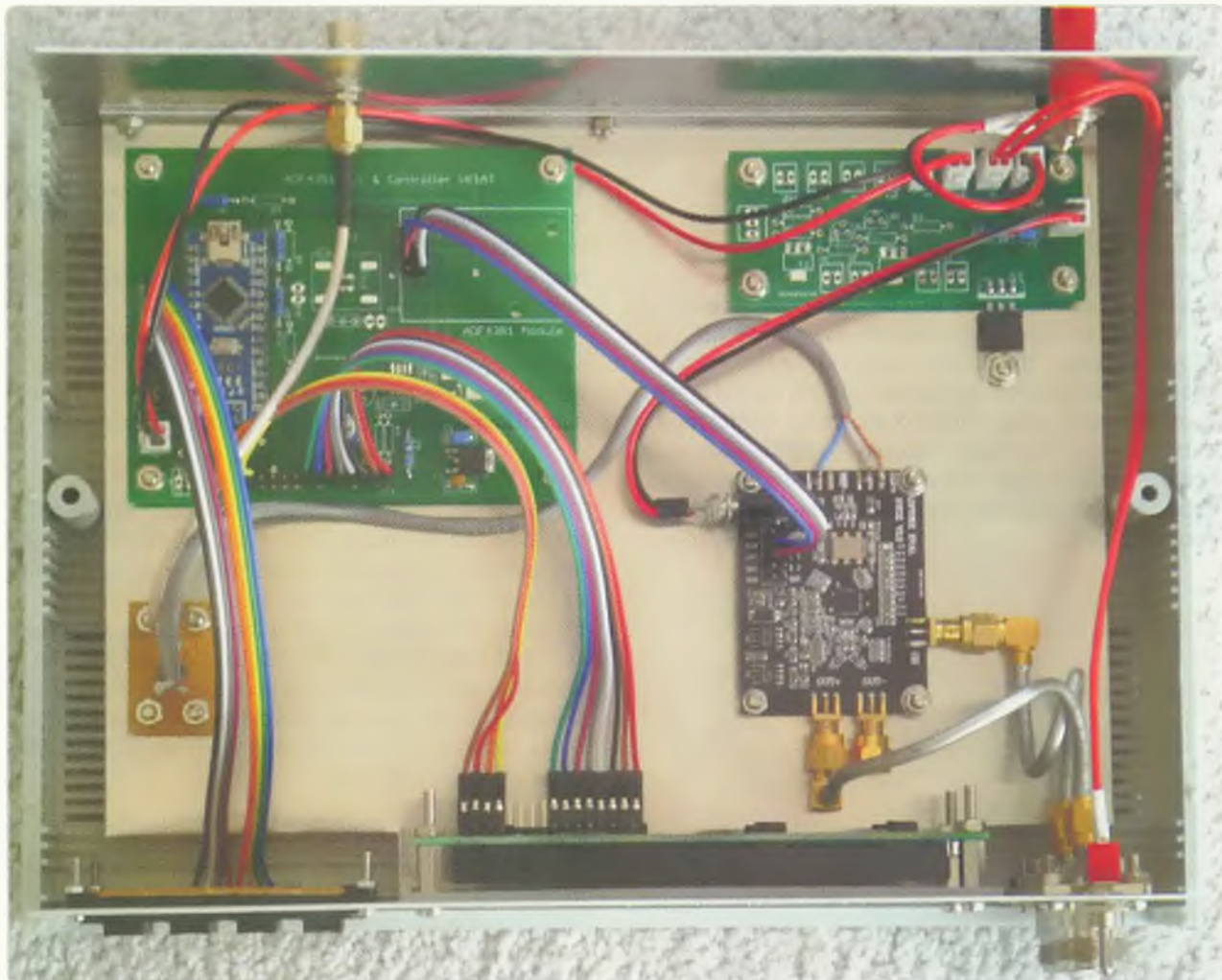

Photo 2: How I laid out the various hardware items in a commonly available instrument enclosure.

purchased have 2k resistors to ground. The schematic I found shows 10k resistors. This is a critical difference as the SPI inputs require a series resistor to reduce the 5 V logic level from the Arduino to 3.3 V. With a 2k input termination resistor, this value is 1k. Quite different from the value required for a 10k termination.

Hardware

The hardware implementation is straight forward. The signal generator circuit diagram is shown in Figure 2. Photograph 2 shows an internal view of the signal generator. To simplify the wiring, I used one of my standard ADF4351 boards minus the ADF4351. The ERM1602-1 is a large format LCD display available from Mini-Kits (www.minikits.com.au) or eBay. Note that its pin-out is slightly different from a standard LCD display. Pins 15 and 16 are at the other end of the connector. An Arduino Nano is used as the processor.

The ADF5355 board operates from 6 V, not 5 V (as I discovered). A LM7806 regulator provides the 6 V supply.

I have provided two output connectors for the low and high bands. The software enables the appropriate output.

Performance

The onboard reference oscillator is not particularly stable. If you connect the signal generator to a 2403 MHz transverter, the SSB receiver output frequency wanders up and down a kilohertz or so. It was decided to use an external GPS reference to eliminate any stability issues in the microwave frequency range. I use a 20 MHz reference as standard. If you check through the code you will find the reference set to 20 MHz in the following line of code.

```
REFin64[1] = 20000000; //Reference frequency in Hertz
```

If you wish to change the reference frequency, you must change this line of code.

To minimise common mode noise injected into the reference inputs, the differential reference input on the board was used. A bifilar-wound input transformer was

assembled with two turns on a BN-73-2402 Fair-Rite core. This will be suitable for reference inputs in the 10 MHz to 25 MHz range. 100 ohm resistors are mounted across each reference input to tie the inputs to 0 V. To use the external reference inputs, remove R5 and R10 from the board.

As the output divider produces a square wave, odd-order harmonics appear in the output spectrum. At a practical level, this is no great disadvantage and is irrelevant when driving a double-balanced mixer or inputting a spot frequency to a receiver or transverter.

The output level varies considerably across the frequency range. The doubler output in the higher frequency range is low compared with the output in the lower frequency range. Figure 3 shows the output level with frequency. The lower output in the higher frequency range is not an artifact of the board, the Analog Devices datasheet also indicates that the output is lower in this frequency range.



Figure 3: Showing the variation in output level versus frequency for the ADF5355.

The phase noise pedestal was measured at 1450 MHz. It is approximately -85 dBc/Hz, measured 20 kHz from the carrier, which appears to be 15 dB worse than predicted by the performance curves in the datasheet. The performance is about 5 dB worse than my ADF4351 signal generator.

It is recognised that the on-board regulator is noisy and it has been recommended in articles to connect a low ESR electrolytic capacitor (say, 1000 uF) across the 3.3 V supply output. I tried this and it had no impact on phase noise whatsoever.

It is predictable that this fix does not work. The single-pole low-pass filter formed by the dynamic output impedance of the regulator (at audio frequencies), in combination with the electrolytic, results in a cutoff frequency above 20 kHz, resulting in a filter that is ineffective in suppressing the regulator noise.

At 10,368 MHz, the signal generator has FM sidebands at a modulation frequency of 1.85 kHz, 24 dB down on the carrier. The board as supplied is not suitable as a local oscillator for a 3 cm transverter.

User Interface

The generator implements the same user interface as the ADF4351 signal generator. Frequency input is via a keypad after pressing the A key. The frequency is input as M...M*KKK. The frequency input is terminated by the # key. The decimal point or the kHz component do not need to be entered if the frequency is in MHz. The frequency can be stepped up and down via the B and C keys. The step size can be changed by pressing the D key, toggling the step size with the B and C keys, and terminating the input with #.

Summary

The ADF5355 board works well as a general purpose microwave signal generator. However, the internal reference is not suitable as a microwave reference. A GPS-locked external reference eliminates any problems with frequency stability. The board is not suitable as a local oscillator for 3cm band transverters, given the FM sidebands close to the carrier. An ADF4351 with an external multiplier for the 6cm or 3cm bands is a higher performance, lower cost option.

If you are interested in building the signal generator, email me at vk1at@wia.org.au and I will email the Arduino sketch.

Errata

K3NG Based Azimuth / Elevation Rotator Controller for Microwave and EME Application

This was published in Issue No. 5, 2019. There are two errors in the article:

- 1) On page 10 in the schematic of the Rotator Connections / Control, there is a ground missing on Relay 5 (RLY5) for the middle NO and NC contacts. These should match the connections shown for Relay 6 (RLY6).
- 2) On page 11 in the dotpoint list for the Buttons and Control Lines, the following pin numbers are incorrect:
 - #define pin_sun_pushbutton_calibration should read 32 not 34
 - #define pin_moon_pushbutton_calibration should read 33 not 35

Apologies for these errors. Justin Giles-Clark VK7TW.

Simple dummy loads for rig testing at HF and higher frequencies

Jim Tregellas VK5JST

Some 10 years back, the design and manufacture of a good high-power dummy load typically involved a detailed study of how to incorporate a large, nichrome film, tubular pyrex glass resistor into a 50 ohm transmission line, and get rid of a lot of heat at the same time.

Today, it is much easier. A search of eBay or AliExpress using the search term *50-ohm dummy load* will reveal a number of resistors with very low stray inductance specifically made for use in radiofrequency (RF) loads. These are typically available in 50, 100, and 200 ohm values, with power ratings of 100 or 250 watts, and are mounted on flat metal plates with mounting centres that match the mounting screw spacing on SO239 and N-type RF panel-mount connectors. Even better, their price is typically AU\$6.00 or less!

These are thin-film resistors that are enclosed between two insulating plates of aluminium nitride which, in turn, are thermally bonded to a metal mounting plate. Aluminium nitride is both an excellent electrical insulator and a great heat conductor, which is second only to beryllium oxide (BeO) in its thermal properties. However, unlike BeO, which is horribly toxic, aluminium nitride is intrinsically safe when properly handled.

Properly mounted, with heatsink paste and very short leads, such a "250 watt" resistor will provide an excellent dummy load with a rating of at least 100 watts, with a frequency response flat to around 2 GHz. Of course, the 250 watt rating is only valid at 25°C and must be significantly de-rated for operation at higher temperatures.

These resistors are typically sold on AliExpress under the brand name



Photo 1: Thin-film, high-power rated resistors suited for making simple dummy loads for rig testing.

RFR and have two basic styles. In one type, the resistor element is earthed at one end via the metal mounting plate and so only has one connecting tag. The second type features a completely floating thin film resistor and has two connecting tags.

Although RFR provides no data for the breakdown voltage between the thin-film resistor and its mounting plate, the maximum on any one resistor is about 223 Vp. A check with a 1500 V megger reveals that the breakdown voltage is above that. So, these two-tag resistors are ideal for use in a series chain of resistors where part of the chain is at a RF voltage well above

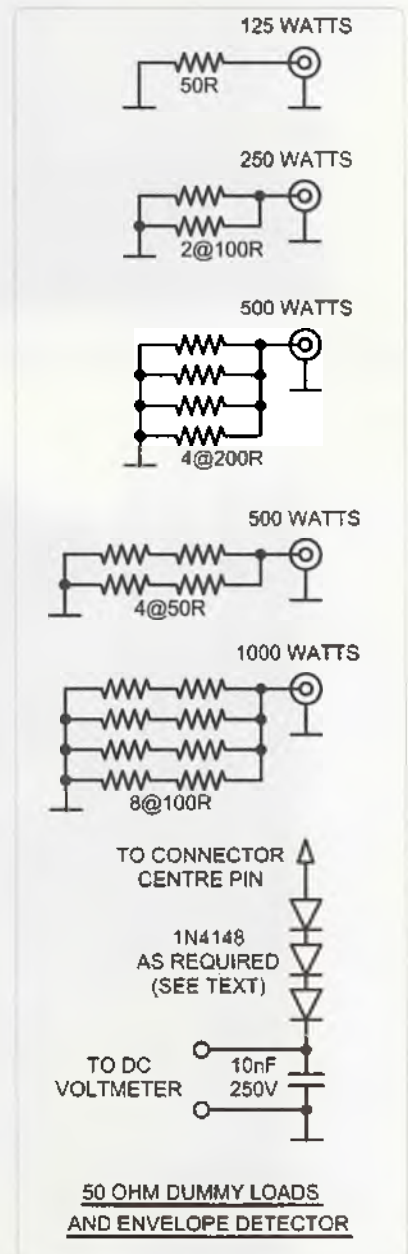

Figure 1: Ways to achieve wanted load ratings.

ground. As the peak voltage existing at a power level of 1000 watts in a 50 ohm system is 316 volts, there

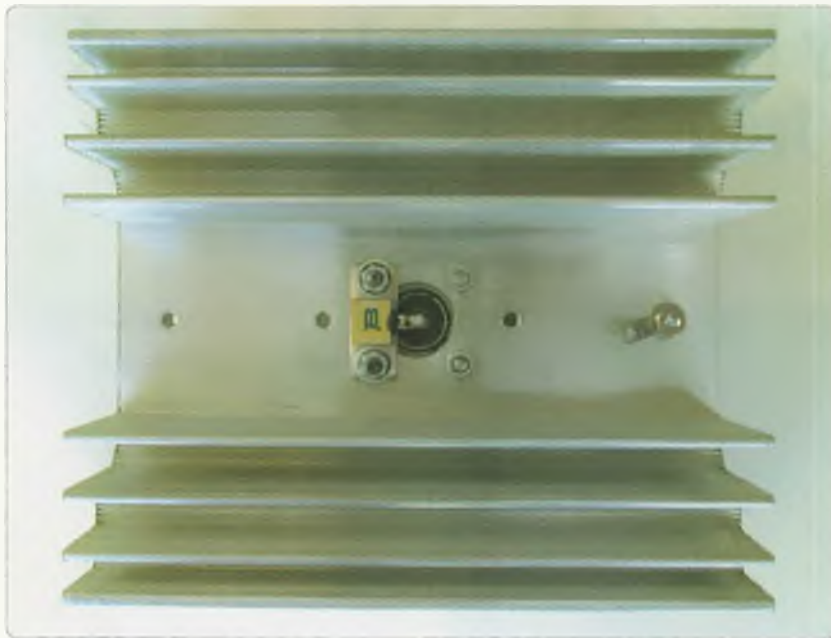

Photo 2: A heatsink, a coax socket and a thin-film resistor – it's simple, alright.



Photo 3: Multiple resistors in series/parallel arrangements enable high power rated dummy loads. The addition of a diode envelope detector, as per Figure 1, enables voltage measurement related to power, as per Table 1.

is a BIG safety margin. Figure 1 shows how various combinations of these “250 watt” resistors can be connected to form 50 ohm loads with different power ratings.

Adding a useful feature

A very useful feature to add to such a load is a peak-responding envelope detector. This allows load power to be easily measured using a standard high impedance analog multimeter and can thus be used to check SWR/power meters. Some digital multimeters may not withstand the high RF environment, may give erroneous readings, or fail permanently. The load with detector can also be turned into a cheap and very accurate power meter by permanently adding a series resistor and appropriately calibrated analog meter. For powers up to 100 watts, use three 1N4148 diodes in the detector; powers up to 500 watts need at least five 1N4148 diodes. The ceramic capacitor should have a rating of at least 500 Vdc. Power in 50 ohm systems can be read from Table 1, or can be calculated accurately from the following relationship:

$$\text{Power (watts)} = (V_{\text{peak}} + \text{diode drop})^2 / 100$$

Where: V_{peak} = peak dc meter reading
 diode drop = no. of diodes x 0.7 V

- diode drop of 0.7 Vdc is approximate, it may be lower. Note that this formula is only correct for symmetrical waveforms (e.g. carrier without modulation).

DC VOLTMETER READING	WATTS OUT
29.5	10
42.6	20
52.6	30
61.1	40
68.6	50
75.4	60
81.6	70
87.3	80
92.9	90
97.9	100
109.7	125
120.4	150
130.2	175
139.3	200
156.0	250
171.1	300
185.0	350
197.9	400

Table 1: Use this table to read off power into the load.

Heatsinks

Heatsinks have two important properties: these being their thermal resistance to the ambient environment, and their thermal mass. The first is specified in degrees Celcius per watt ($^{\circ}\text{C}/\text{W}$) and is determined by the surface area of the heatsink and the conductor cross-section used to get the heat away from the place it is generated and out to the place where it will be dissipated to atmosphere. A good heatsink will thus have many fins, each being fed by metal of heavy cross-section. The thermal resistance of such a heatsink can be massively reduced by a small fan

blowing air through the fins.

The thermal rating in $^{\circ}\text{C}/\text{W}$ becomes most important when a load dissipates continuous power. Note that very few sinks have thermal resistances in free air of less than 0.5°C per watt (check out Jaycar and Altronics). Four hundred watts of continuous power will therefore raise the temperature of such a heatsink by 200 Centigrade!! Fans and other techniques of conducting heat away hence become mandatory under these conditions.

The second property is the thermal mass (almost never specified). Simply put – the larger

and more conductive the lump of metal is, the smaller the temperature rise will be for a short-term blast of power, independent of whether fins are present or not. Thermal mass is most important in low duty cycle applications.

For most amateur work, the heatsinks shown in the photos are excellent for short-term, very intermittent tuning up (under 20 seconds) at powers up to 400 watts. Typical dimensions are 150 x 105 x 40 mm, with a weight of 500 grams. For continuous power, either use a larger heatsink, add a fan, or a bucket of water.

AMSAT-VK

AMSAT Co-ordinator
Paul Paradigm VK2TXT
email: coordinator@amsat-vk.org

Group Moderator
Judy Williams VK2TJU
email: secretary@amsat-vk.org

Website:
www.amsat-vk.org

Group site:
group.amsat-vk.org



About AMSAT-VK

AMSAT-VK is a group of Australian amateur radio operators who share a common interest in building, launching and communicating with each other through non-commercial amateur radio satellites. Many of our members also have an interest in other space based communications, including listening to and communicating with the International Space Station, Earth-Moon-Earth (EME), monitoring weather (WX) satellites and other spacecraft. AMSAT-VK is the primary point of contact for those interested in becoming involved in amateur radio satellite operations. If you are interested in learning more about satellite operations or just wish to become a member of AMSAT-Australia, please see our website.

AMSAT-VK monthly net

Australian National Satellite net

The Australian National Satellite Net is held on the second Tuesday of the month (except January) at 8.30 pm eastern, that's either 9.30 or 10.30Z depending on daylight saving. Please note we will be taking check-ins from 8.20pm-ish. Check-in starts 10 minutes prior to the start time. The AMSAT-VK net has been running for many years with the aim of allowing amateur radio operators who are operating or have an interest in working in the satellite mode, to make contact with others in order to share their experiences and to catch up on pertinent news. The format also facilitates other aspects like making 'skeds' and for a general 'off-bird' chat. Operators may join the net via EchoLink by connecting to either

the "AMSAT" or "VK3JED" conferences. Past experience has shown that the VK3JED server offers clearer audio. The net is also available via IRLP reflector number 9558, in addition to the EchoLink conference, the net will also be available via RF on the following repeaters and links.

In New South Wales
VK2RBM Blue Mountains repeater on 147.050 MHz

In Queensland
VK4RRC Redcliffe 146.925 MHz -ve offset IRLP node 6404 EchoLink 44666

In South Australia
VK5TRM, Loxton on 147.175 MHz
VK5RSC, Mt Terrible on 439.825 MHz (IRLP node 6278, EchoLink node 399996)

In Tasmania
VK7RTV 2 m. Repeater Stowport 146.775 MHz IRLP 6616

In the Northern Territory
VK8MA, Katherine on 146.750, CTCSS 91.5, IRLP Node 6800

We are keen to have the net carried by other EchoLink or IRLP enabled repeaters and links in order to improve coverage. If you are interested in carrying our net on your system, please contact Paul via email. Frequencies and nodes can change without much notice. Details are put on the AMSAT-VK group site.

Become involved

Amateur satellite operating is one of the most interesting and rewarding modes in our hobby. The birds are relatively easy to access and require very little hardware investment to get started. You can gain access to the FM 'repeaters in the sky' with just a dual band handheld operating on 2 m and 70 cm. These easy-to-use and popular FM satellites will give hams national communications and handheld access into New Zealand at various times through the day and night. Currently only SO-50 is available.

Should you wish to join AMSAT-VK, details are available on the web site or sign-up at our group site as above. Membership is free and you will be made very welcome.

Silent Key

John Ward VK7NJW

It is with sadness that we announce the passing of John Ward VK7NJW, also fondly known as "Whirlybird". He was not a well-known operator, but was very active in the

80s and 90s and had been inactive until about a year ago. With some valued help from some old timers, he returned to the airwaves with new antennas and a DMR Radio.

He renewed some old contacts with great enthusiasm. With his falling health old mates rallied to help out. Ever friendly, he was a great operator well in to his eighties.

Vale John.



VHF/UHF - An Expanding World

David K Minchin VK5KK

Introduction

This edition again focuses on the various records that have been broken, both locally in VK/ZL including 134 GHz, as well as in a new 122 GHz world record in the USA (both using Silicon Radar modules). Also, there is a preview of the "VHF and Above Construction series" starting next edition!

First VK to ZL 10 GHz QSOs over a 2040 km Path

As noted in the last column, the VK - ZL path has now been bridged on 3.4 and 10 GHz. Rex VK7MO has provided the following article that dives into the opening to provide an in depth analysis

"Over a 3 day period from 30 December 2019 to 1 January 2020 the Hepburn charts showed an intense duct between the East Coast of Australia and the West Coast of New Zealand. VK7MO supported by VK2MAX set up at Crescent Head in New South Wales, Australia and ZL3RC about 14 km North of Greymouth on the West Coast of the South Island of New Zealand.

Key findings and results were:

- Single tones were detectable on 10 GHz whenever we tried throughout the three day period.
- QRA64-D was decodable whenever we tried on the first and third days (Murphy, in the form of a drifting GPSDO, struck on the second day).
- 10 GHz SSB contacts were made at 3/1 both ways on the first day and 5/3 both ways & 5/5 both ways on the third day peaking at 5/7. (See video at: www.youtube.com/watch?v=QrgxiKxs4ek)

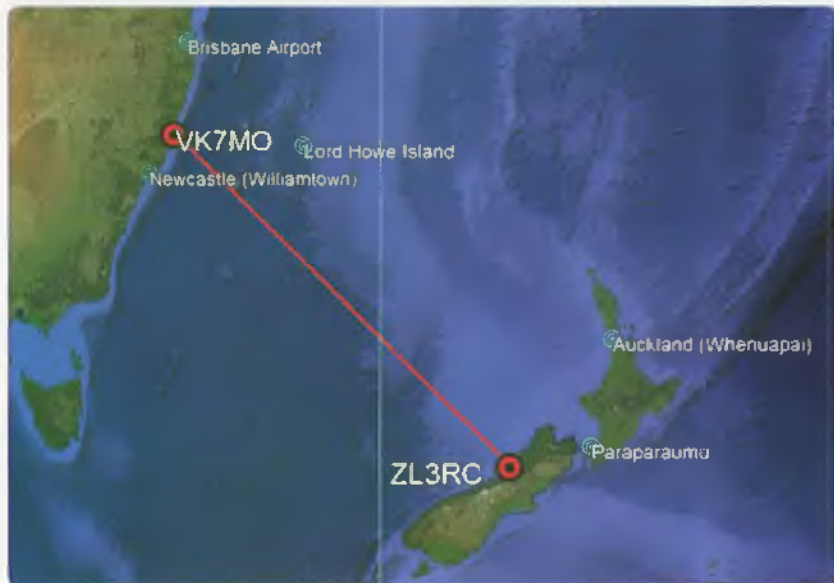

Photo 1: The 2040 km Path between VK7MO, Australia and ZL3RC, New Zealand. Blue circles are radiosonde sites.

- Test showed no skewing or azimuth spreading of the signal direction with the azimuth signal levels dropping in accordance with antenna beam widths.
 - Test showed that elevation gave strong signals from around +2 degrees to -2 degrees somewhat larger than the antenna beam widths suggesting the one can enter the duct over a range of elevation angles or by reflection from the sea.
 - There was very rapid QSB of up to 20 dB on 10 GHz on a time scale of a few seconds compared to minutes or more on 432 MHz suggesting that QSB rates increase in proportion to frequency.
 - 10 GHz showed significant spreading of up to 15 Hz which compared to 432 MHz appears to be proportional to frequency.
 - Based on radiosonde data at Newcastle, Brisbane, Lord Howe Island, Auckland and Paraparaumu, the height of the duct varied significantly around the same high pressure system over the three days of the tests -- from around 400 metres to over 2000 meters.
 - Comparisons of Signal to Noise between 432 MHz and 10 GHz (taking account of system performance and absorption) suggest no significant duct losses related to frequency for this particular duct.
- Locations and Path:** New Zealand Location: 14 km North of Greymouth: Lat 42.329643° South, Lon 171.264907° West, height 47 metres, Grid locator RE57pq. Australian Location: Crescent Head New South Wales, Lat 31.193450° South, Lon 152.979217° West,



Photo 2: ZL3RC's portable station.

height 72 metres, Grid locator QF68it.

Equipment ZL3RC: 10 GHz: 1.1 m cut-up petal dish (40.3 dBi, 3 dB beamwidth +/- 0.9 degrees) DB6NT LNA (0.7 dB noise figure) and DB6NT 60 watt PA, antenna alignment with Google Earth to a rock in the sea. 432 MHz: 14 element Yagi (16.9 dBi) cable loss 0.3 dB, FT991 noise figure of 4 dB, 50 watts.

Equipment VK7MO: 10 GHz: 76 cm dish (36.9 dBi, 3 dB beamwidth +/- 1.3 degrees), DB6NT LNA (0.7 dB noise figure) and DB6NT 60 watt PA. Antenna alignment with VK3HZ differential GPS to within 0.1 degrees. 432 MHz: 12 element Yagi (15.9 gain) cable loss 0.3 dB, IC9700 (2 dB noise figure pre-amp on) running 70% to give 50 watts output.

Initial 10 GHz QRA64-D QSOs and tests started at 2354 UTC on 29 December (30 December local in VK/ZL). Photo 5 shows 10 GHz Decodes at VK7MO end with best of -12 dB ZL3RC reported best signals of -11 dB. Note that QRA64-D tends to compress S/N reports at high levels and -11 dB is actually around plus 5 dB.

Analysis of conditions

Photo 6 shows that duct intensities are generally much more negative than the -157 N/km necessary

to achieve refraction around the curvature of the Earth.

Glen VK1XX has analyzed and compared a typical 432 MHz and 10 GHz file as in Photo 7. The green graph shows the instantaneous frequency values while the Red graph is a 10-point running mean. From these graphs it is reasonable to assume that the long term drift on 432 MHz is due to drift on ZL3RC's FT991 and that the short-term frequency variations of around 0.3 Hz on 432 MHz compared to up 4 Hz and more on 10 GHz are due to propagation - this is consistent with the propagation frequency variations being proportional to the increase in frequency.

Radiosonde data can be used to determine absorption based on an ITU method (Attenuation by atmospheric gases ITU-R P.676-8 (10/2009) Annex 2 Equation 22a). At 10 GHz, there are significant differences in absorption between the top and bottom of the duct. VK3OE considers that, at 10 GHz one should calculate the absorption near the bottom of the duct. As we only have radiosonde data at both ends of the path the best we can do is average the absorption, as shown in Photo 8.

Comparison of System Performance between 432 MHz and 10 GHz (with and without absorption)

Calculations show the performance of the 10 GHz equipment to be about 14 dB better than that used for 432 MHz. However, when one takes account of estimated absorption, 10 GHz is significantly worse - down by around 6 to 13 dB. This difference was reflected in lower measured S/N at 10 GHz and suggests that there is no significant loss in the duct with frequency providing one takes account system performance and absorption.

I would like to thank Glen English VK1XX and Steve Hutcheon VK4ZSH for their input, which led to



Photo 3: VK7MO/2's portable station (note differential GPS antenna's for bearings).

some useful revisions. For interest, the radiosonde data on University of Wyoming Web links are as follows. Standard Resolution Radiosonde data <http://weather.uwyo.edu/upperair/sounding.html> High Resolution, 2 second Radiosonde data <http://weather.uwyo.edu/upperair/bufr/aob.shtml>" Thank you Rex VK7MO, but it doesn't end there

New VK National record on 1296 MHz and first Tasmania to New Zealand Contacts on 1296 MHz.

Hayden Honeywood VK7HH reports ... "On 30 January 2020 (31 Jan local time) an intense duct developed (see Hepburn Chart here), which seemed to provide the prospect of contacts from Tasmania to New Zealand. Much discussion was had in the week beforehand and several stations decided to try and participate.

Due to the high fire danger and subsequent closure, Mt Wellington was ruled out as a possible spot to operate. Murray VK7ZMS, Richard VK7ZBX and Hayden VK7HH set off to operate from One Tree Hill near Kingston Tasmania (322 meters) whilst Rex VK7MO operated from home near Hobart (320 meters), hoping to work Roger ZL3RC on 10 GHz.

Hayden, Richard and Murray arrived on site shortly after 6am local time and commenced setting up and the first contact was made to Nick ZL1IU on 2m at 5/5 by Murray. Richard then worked Nick on 70cm at 5/1 both ways. Murray also worked Nick on 432. This is Murray's first contacts to ZL on 2m and 70cm. Congratulations Murray!

Then, at 2008 UTC, Rex worked Nick 5/6 on 1296 MHz, the first contact between VK7 and ZL on 23cm and a new state record at 2432.6 km, settling a long-held frustration having not worked back in 2006 when a similar opening occurred.

Then, 9 minutes later, at 2017 UTC, Hayden worked Nick 4/1 both ways on 1296 from his remote site,

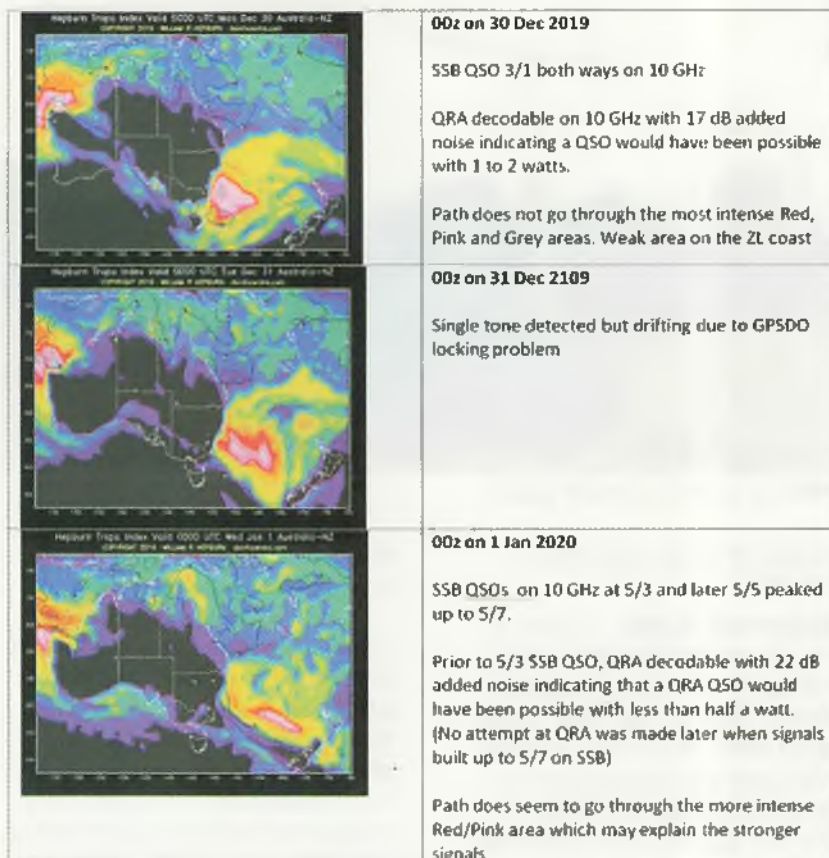

Photo 4: The Hepburn charts at 00z on the 3 days from 30 December.

UTC	dB	DT	Freq	Message
2354	-16	1.4	969	:- VK7MO ZL3RC -16 0
2356	-15	1.3	969	:- VK7MO ZL3RC -16 0
2358	-13	1.3	969	:- VK7MO ZL3RC 73 0
0000	-15	1.4	969	:- VK7MO ZL3RC 73 0
0002	-14	1.4	969	:- VK7MO ZL3RC -13 0
0004	-14	1.3	969	:- VK7MO ZL3RC RRR 0
0006	-15	1.3	970	:- VK7MO ZL3RC 73 0
0022	-14	0.3	969	:- VK7MO ZL3RC -13 0
0024	-13	0.3	969	:- VK7MO ZL3RC RRR 0
0026	-12	0.3	970	:- VK7MO ZL3RC 73 0

Photo 5: Initial QRA-64 Decodes on 29/12/2019.

Date	Newcastle	Lord Howe Island ^{1st}	Brisbane	Paraparaumu	Auckland
30/12/19 0000z	-634 (417)	-2400 (985)	-813 (1740)	-203 (2353)	-181 (1829)
31/12/19 0000z	-97 (770)	-2302 (903)	-219 (2009)	-587 (2134)	-230 (1177)
1/1/20 0000z	-387 (866)	-646 (973)	-1004 (1467)	-235 (1051)	-326 (981)

Photo 6: Duct intensities with duct heights.



Photo 7: Comparison of spreading between 432 MHz (top graph) and 10 GHz (bottom graph).

Date	432 MHz	10,368 MHz	Difference
30/12/19 0000z	5 dB	26 dB	21 dB
1/1/20 0000z	5 dB	32 dB	27 dB

Photo 8: Average absorption data bottom of the duct (Newcastle and Paraparumu).

any other bands above 1296, despite repeated attempts."

A video discussion of these contacts may be downloaded at <https://www.youtube.com/watch?v=4J59WIB0cIM>

New World Record on 122 GHz!

The previous world record on 122 GHz of 131 km was set in Austria between OE3WOG and OE5VRL in 2013 using bare harmonic mixer and tripler equipment. Precision lathe machined 400 mm and 1200 mm diameter (!) prime focus dish antennas were used. The best recorded receiver noise figure for a bare mixer on 122 GHz is 27 db. The new Silicon Radar modules have brought new levels of receiver performance with a real world noise figure in the region of 12 to 15 db. So, all that was needed now was some cool and dry band conditions between two mountains to try and extend this record!

On 17 February 2020, contact was made on 122 GHz between Mike Lavelle K6ML, on Mount Vaca, California (CM88WJ75ON) at 835 metres above sea level, and Oliver Barrett KB6BA (at 1225 UTC), and Jim Moss N9JIM (at 1250 UTC), both on Mount Umunhum, California (CM97BD18VJ) at 1016

31 km West of Hobart (950 metres AHD) the 2nd contact between VK7 and ZL on 23cm and a new National and State record at 2458.9 km. This breaks the current National Record which was set in 1988 between VK3 and 6 by 3.8 km.

Later contacts were made on 2m with varying signal strengths throughout the morning to ZL1SWW, ZL1TPH and ZL3RC. Attempts at 10 GHz with Roger ZL3RC were frustrated when Roger's intermittent GPSDO re-appeared. Unfortunately, despite Hepburn predictions, conditions were not strong enough for

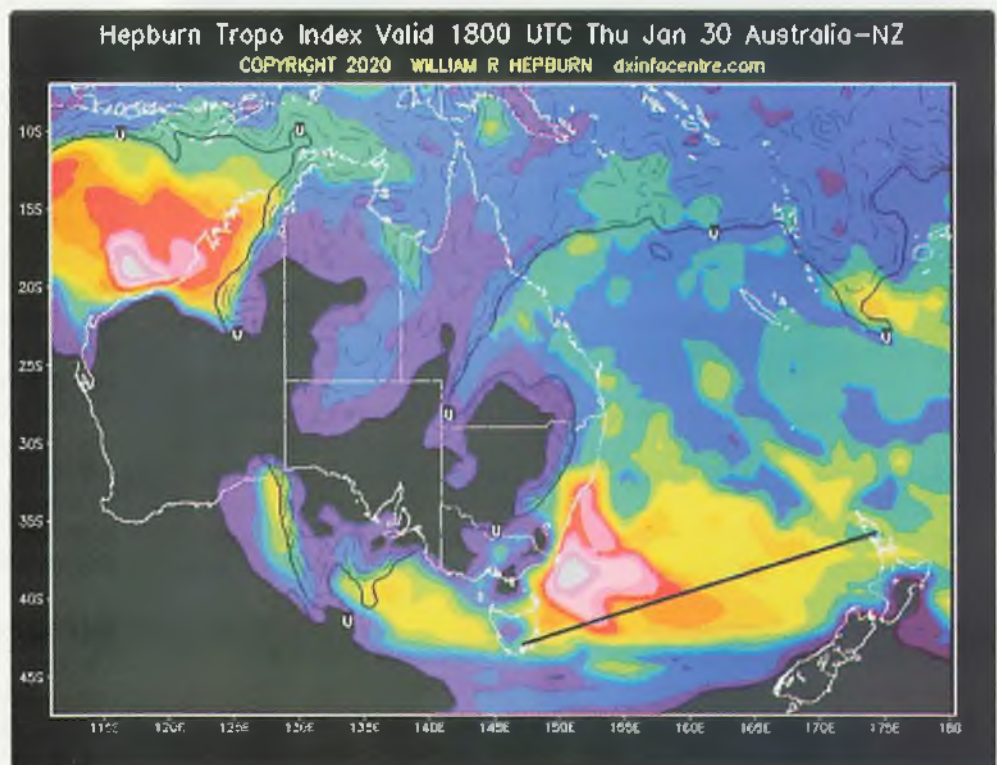

Photo 9: Hepburn chart for 1296 MHz VK7 to ZL1 30/1/20.

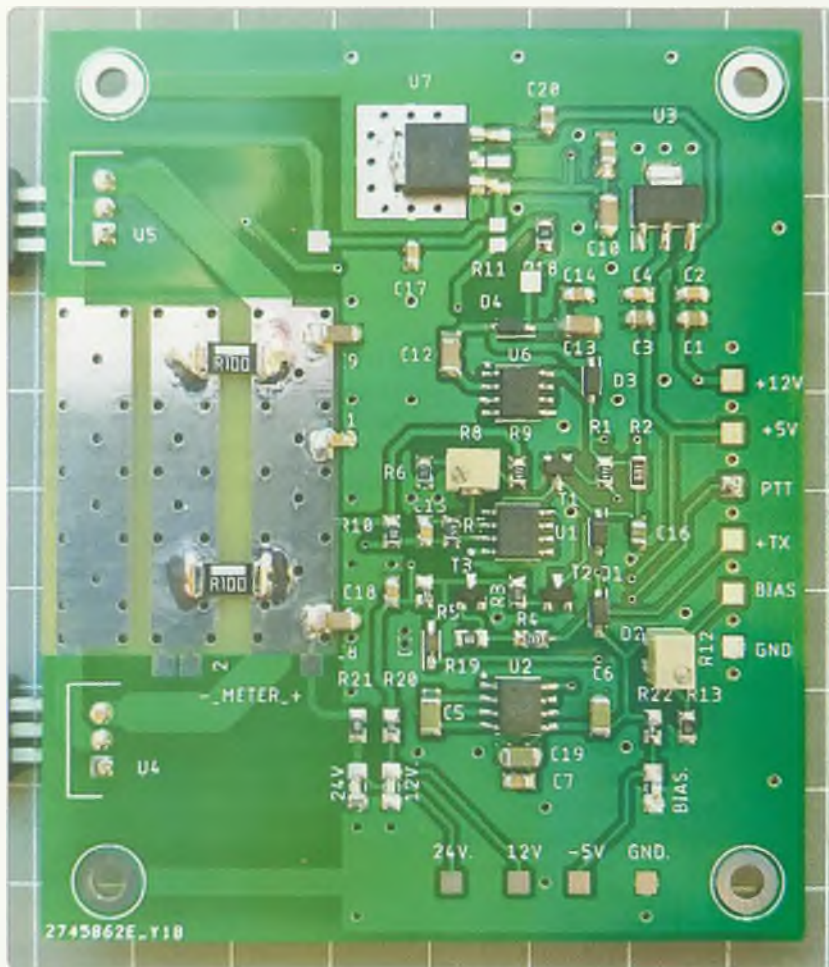

Photo 10: GasFET/GaN amplifier Power Supply – VK5KK.

metres above sea level, for a distance of 139 km (+8 km to the existing record).

The dew point was -11°C and the air temperature was 15°C . The calculated path loss was about 225 dB, and atmospheric loss was calculated to be approximately 0.35 dB per kilometre. CW was used as the 122 GHz signals were very weak (7 dB above the noise in 22 Hz; -13 in 2500 Hz equivalent) with [fading] down to the noise floor.

Antennas were first aligned on 24 GHz with signals 71 dB above the noise. Once that was done, bands were changed and signals were heard right away on 122 GHz. Both stations employed 600 mm satellite TV dishes with Silicon Radar TRX_120_001 (exposed patch antennae) based modules

running less than 0.5 mW. Both systems used image reject receivers to gain an extra 3 dB noise figure advantage. The narrow radiation pattern of the module under-illuminates the dish so the actual effective diameter is probably more like 350 – 400 mm. This way, you can actually illuminate the best part of the dish, finding that spot is only done through a lot of trial and error!

Details on the equipment used for the 122 GHz World Record have been published in the ARRL Microwave Update proceedings for 2019.

New Australia Record on 134 GHz!

On 11/06/2020, a new 134 GHz record was set by Andrew Anderson VK3CV and Noel Higgins VK3NH

between the “Sky High” restaurant on Mt Dandenong and the base of the fire lookout tower at Kangaroo ground, just over 19 km. The previous National 134 GHz record of 3.8 km achieved by Stefan VK4CSD and Roland VK4FB in December 2019 using DL2AM-style bare mixers.

The weather conditions were average, Mt Dandenong 8°C , 80% RH, 1025 mB, and Kangaroo Ground 7°C , 75% RH, 1025 mB. While Andrew, located at Kangaroo Ground, could see the Sky High site, Noel had no visibility of Kangaroo Ground due to the mist, so had to search in the general direction through a gap in between the trees until he heard his unit operating in beacon mode on CW. They then proceeded with a contact on FM mode.

The equipment used both ends use the yet to be released Silicon Radar TRA120_031 wideband transceiver chips that cover 122 and 134 GHz. These are the replacement for the chips used in the current VK3CV design for 122 GHz published in Dubus 3/19.

Online path loss calculator for 24 GHz and above

As previously covered, Iain VK5ZD's website that displays the calculated path loss for 24, 47, 76, 134 and 241 GHz has become a well-used resource to quantify mm-wave band conditions. The website can be found here: <http://weather.vk5microwave.net/Weather.aspx?State=H>

There is also a path loss calculator available on this link that allows live meteorological data to be entered for any site, anywhere in the world. <http://weather.vk5microwave.net/Calculate.aspx>

VHF and Above Construction series

I was looking through some of the very old VHF notes columns (1950s) in both “Amateur Radio” and “Radio & Hobbies” magazines; in almost

every one, there was a circuit or construction discussion included. Admittedly, this was a time when equipment was mostly homebrew, but that part of the hobby has had a bit of a renaissance in recent times. Even if you buy a readymade and tested module, you still need to add some electronic or mechanical trickery to use it.

Previously, I have published the 24-part Microwave Primer series that ran in this column from 2000 to 2002 and, more recently, the smaller SDR and PLL technology series. These were more where-to-find-it articles. However, from the next column, we will feature real live projects (mostly) designed in VK/ZL, with either a full kit through a vendor or at least a PCB available to work with.

As a teaser, the next column

will detail a VK5KK-designed power supply for a GasFET or GaaN amplifier in the 40 to 250 Watt output category that requires between 10 Vdc and 28 Vdc. The design includes an adjustable low voltage-drop regulator (1.2 Vdc margin), capable of up to 15 Amps continuous output. The bias supply can provide up to 150 mA with full failsafe shutdown of the Drain supply for bias failure. Drain current meter connections are provided for the direct connection of a meter (analogue or digital). Either PTT (ground) or +12 Vdc to trigger TX with LED confirmation of voltage rails. See Photo 10 for the basic layout of the 85 mm x 70 mm PCB.

Future columns will include a PLL-locked high frequency reference (input 10 MHz, output

25 – 150 MHz) intended for use with microwave PLLs but also can be used for “rig locking”. Towards the end of the year, I will publish a 6 – 13 GHz PLL source capable of direct digital modulation and some more updates on the “VK5 122 GHz” advanced transceiver published in Dubus 2/20.

In closing

Feel free to drop me a line if you have something to report, especially on VHF, as we currently do not have a “VHF & Up Editor”! It doesn't take much to put a few lines together and helps the diversity of this column. Just email me, at: david@vk5kk.com

73s

David VK5KK



Over to you

Are beacons still useful?

Sir,

in *Amateur Radio* Issue 3 of 2019 (page 59), Tim Mills VK2ZTM in his VK2 Notes questioned the usefulness of the VK2RSY beacons – and in particular, the 1296.420 MHz beacon – in these days of digital modes.

A casual inspection of VK Spotter entries show that beacon spots appear many times every day. Only recently, VK2RSY on 1296.420 attracted spots from Sydney,

Wollongong and Canberra reporting reception and comments on its precise frequency.

The use of digital modes has, in fact, given beacons a new lease of life in that digital software is now used to monitor beacons on a consistent basis. Beacons now supplement digital modes, as with ONOEME and JT65 on 1296 EME. Indeed, many beacons are now transmitting on various JT modes (something I do not advocate myself) in addition to the usual CW.

So let's keep the VK2RSY beacons on-air. And GPS-locking would be a useful improvement.

Regards

Michael Farrell VK2FLR

Submitted 31/08/19

(Editor's note: both VK2ZTM and VK2FLR are now silent keys – noted elsewhere in this issue).



Silent Key

Bill Catchpoole VK5AU

Sadly, William Edward Catchpoole, VK5AU, passed away at the Klemzig Nursing Home on the 4th of November 2019, just six days shy of his 91st Birthday.

Bill was born and raised in Queenstand and joined the Royal Australian Navy (RAN) as a cadet officer after graduating. Following a 5-year stint in the RAN, Bill married Claire in 1958 and commenced working for the former Weapons Research Establishment (WRE) in Woomera, where his first son, David, was born in 1959.

After some three years in Woomera, Bill and family moved to Adelaide where his second son, Andrew, was born and Bill worked at WRE in Salisbury, just north of Adelaide. He, along with the rest of the “Woomera team” shifted employment to the RAAF in the early 1990s, after the RAAF took over responsibility for the Woomera Range. He retired in 1993.

Bill's main interest in amateur radio was operating CW, although in later days he also took an interest in satellite

communications. Our reciprocal callsigns apparently aroused some amusement when we had a chat on 2m. It was very easy to get tongue tied.

After Claire, Bill's other love was his 22-foot (7-metre) yacht, Gannet. Bill was also keen on orienteering, a hobby apiarist and in later years a member of Probus. Vale Bill Catchpoole, VK5AU, a colleague and a friend for 39½ years.

Submitted by Antony Bell VK5UA

Automated Reference Switching for the Yaesu FT-817

Keith Gooley VK50Q



The FT-817 radio with the top cover removed showing the reference switch near the front centre, the original reference on the left, and the coax cable entry on the rear panel.

The FT-817 is arguably one of the most popular amateur radios made to-date. I enjoy taking mine out to portable locations and also using it as the IF radio for my collection of microwave transverters, which span the spectrum from 1.2 GHz to 24 GHz. I now have the local oscillators (LO) in the transverters locked to a 10 MHz GPS-derived reference so that I can be sure that they are close to the required frequency. This is certainly not necessary for FM operation, but for SSB it is nice to be close so

that you are not chasing signals up and down, especially on the higher bands.

In order to be on the right frequency, of course, it is necessary for the transverter LO to be on-frequency, and in addition, the IF radio needs to have its reference close to that required. Although this is desirable for SSB, it is essential for DX operation with some of the digital modes, such as WSPR.

Initially, I used my station GPS reference, which, at the time,

was a home-brewed copy of a GPS Disciplined 10 MHz quartz oscillator designed by Iain VK5ZD. Later, I decided to order a GPSDO from Makis SV1AFN, who has an excellent website with lots of nice, well-made goodies (www.sv1afn.com). His GPSDO has the advantage that it has two outputs that can be on just about any frequency you like, both disciplined to a high order of accuracy. You can order the unit ready-programmed, or do it yourself. I ordered mine with

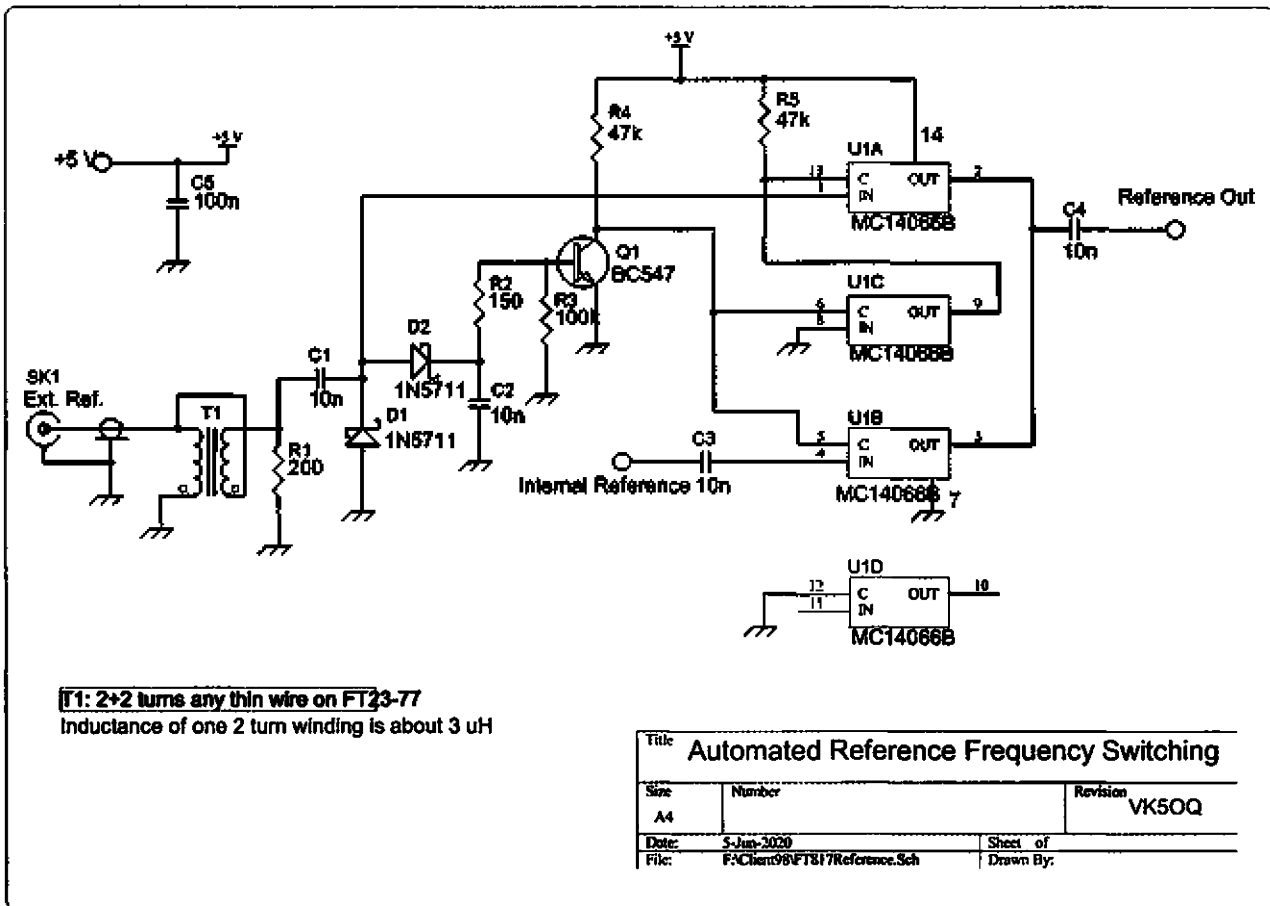

Circuit of the Reference Switch is straightforward, with no 'critical' components.

one output on 10.000 MHz and the other I programmed myself for the FT817 reference frequency, which is 22.625 MHz.

The level out of the GPSSDO is not very high at about -12 dBm, so an amplifier was required to bring it up to about 6 dBm, and this step included a 3 pole low-pass filter with a notch on the 3rd harmonic. The details are not included here as they occur outside the FT-817 case.

On the rear panel of the FT-817, at the top left corner looking at the front of the radio, there is a convenient space for fitting an SMA socket for the external reference. I used a bulkhead mounting coax connector for this purpose. Clearly, drilling a hole in the diecast alloy housing should be done with great care to avoid damaging internal components. I started with a 2 mm pilot hole drilled at low speed and moved up to the final 6.3 mm

diameter hole in a couple of steps.

How it works

The switch-over from internal to external reference is performed automatically when the external reference is applied. The circuit to do this is shown in Figure 1. The external reference is first applied to a 1:2 step-up transformer with a 200 ohm load. The transformer core is an FT23-77 ferrite toroid, available from Mini-Kits (www.minikits.com.au), but any small core would do, provided the two turns give an inductance of 2 to 5 uH and the core fits in the available space. The external reference signal is rectified by schottky diodes D1 and D2 and the resulting dc is enough to saturate transistor TR1. This transistor can be any one of many small signal NPN audio transistors, including BC107, BC547, 2N2222 etc.

The actual switching is performed by a CMOS analog switch, MC14066B, but a 4066 from any manufacturer should do. The four SPST switches in the 14-pin package operate such that, when the logic level on the control input is high, the switch is on and the resistance between in and out is low – about 250 ohms for the Motorola part. With no external reference applied, the transistor is off and its collector voltage is close to five volts. This switches U1B on and the internal reference signal passes to the output. At the same time, U1C is also turned on, grounding the control input of U1A, which is then off.

When an external reference of sufficient amplitude is applied, the TR1 collector being low causes U1B and U1C to be open. U1A's control input – pin 13 – is high, so U1A is on and the external reference passes

to the output and becomes the reference for the radio.

Construction and fitting

Physically, the switch is constructed on a piece of strip board which fits on the Main PCB of the radio where the optional IF filter would go (see the photo). It is fastened to the PCB with double-sided foam tape. If your radio already has the optional filter fitted, you will have to find another spot. There are not many choices, as an open area of the PCB towards the front left is occupied by the speaker when the top cover is in place.

The existing internal reference is lifted from its place near the rear left of the board and stuck to the PCB near the front of the board, again with double-sided foam tape. Three

wires connect it to the new switch unit, +5 V ground, and the internal reference signal. I scrounged a 3-pin socket from some defunct gear to place on the pins that provided +5 V ground and reference to the original reference PCB. Three wires then connect the 3-pin socket to the switch unit.

Conclusion

I have described the design and installation of a switch that will disconnect the internal reference of a Yaesu FT-817 and connect an externally-applied reference signal that would normally be of greater accuracy and stability. This increased accuracy is desirable when the transceiver is used as an IF radio for the microwave bands and also for some digital modes.

FT-817 External Reference Switch

Parts List

SMA female bulkhead connector FT23-77 toroid
IC type MC14066B or similar
NPN transistor BC547 or similar
Diode 1N5711 2 off
Resistor 200 ohms 0.25 W
Resistor 150 ohms 0.25 W
Resistor 100k ohms 0.25 W
Resistor 47k ohms 0.25 W 2 off
Capacitor ceramic 10 nF 4 off
Capacitor ceramic 100 nF
Strip board 18 holes by 8 holes
Short length of small diameter coax
Hook-up wire, Solder pins etc.

Silent Key

Michael Farrell VK2FLR

Mike Farrell VK2FLR became a silent key on 13 November 2019, in the company of close family. Widely known and respected among the global moonbounce community, and the Australian VHF-UHF fraternity, he was an enduring presence in amateur radio in Australia over 50 years, and some 40 years on the world scene.

Born in the country town of Temora, New South Wales (NSW), he was only 71 and full of more plans to travel with his wife, Patsy, and projects on-foot to upgrade his 23cm EME station and 2m antenna system.

An inveterate home-constructor, Mike was a "true amateur" in that his professional career was in economics and nothing to do directly with radio or electronics. His abiding interest in such technologies began at a young age, according to his sisters, who were sometimes roped-in to his escapades that



Mike Farrell VK2FLR in his Glebe attic shack, September 2019. Photo from Kevin VK4UJ.

involved sophisticated use of primitive wireless sets and suchlike.

Mike gained his AQLCP (Limited certificate of proficiency) in February 1970 and was first licensed as VK2ZNA in April that year. Having skilled-up with Morse code, Michael succeeded

in gaining his AACP – then known as the "full licence" – in May 1971. He was issued the callsign VK2AM that July.

He went on to establish some enduring records on the air. Mike set the current Australian 6m short-path DX record on 27 November 1991, working Joel CU3/N6AMG in the Azores at 19,424 km distant, very nearly the antipodes. The previous month, he had worked GJ4ICD in Jersey. To see and hear what he achieved on 6m with a small station at inner-city locations, visit: www.qsl.net/vk2flr/index.htm

On 2m, Mike set an EME DX record in 1999 by working CT1DMK on 4 September, a terrestrial distance of 18,152.4 km.

The art of VHF meteor scatter in Australia was given a fillip by Mike's seminal article on the subject, "144 MHz Meteor Scatter in the Southern Hemisphere, published in this magazine in February 1997.

Much missed.

Join your local club

Look under Radio Clubs
at www.wia.org.au

Interact with local amateurs.

Participate on regular meetings and functions.

Training and further education for amateurs, new and experienced.

Silent Key: Timothy Ian Mills VK2ZTM, VK2UJ

Tim passed away suddenly at Beecroft on the 8th of May 2020, aged 81 years. He was born on the 26th of April 1939 in Waverley Hospital, Sydney.

In his early years, Tim grew up on his family's property to the North of Gilgandra, in the Central West of NSW. Later he was educated at The Scots College in Sydney and upon leaving school, he was employed by James Watt Electrical. The company had major contracts but perhaps for Tim the most important was his work for the Grain Board of NSW. Here, he was able to maintain his connection with the land in his own way, spending many years working on electrical installations at sites throughout NSW.

Tim joined the WIA NSW Division in 1958. Licensed as VK2ZTM, he was one of the early holders of the Limited Licence, which had only become available in 1954. In later years, he also took out VK2UJ but was always known as VK2ZTM.

Tim was a tireless volunteer who made consistent contributions to Australian Amateur Radio; from the earliest days at the VK2WI Dural site working bees to the Wireless Institute Centre at Atchison Street in Crows Nest, and later at Amateur Radio



Tim VK2ZTM, pictured at a recent event at the Amateur Radio NSW Dural facilities. He lived through a vivid era of Australian amateur radio history – ranging across the post-WW2 era when the Limited Licence was very new, through periods of challenge and change that saw the introduction of the Novice Licence during the CB radio boom, and the NL's off-shoots – the Intermediate and Novice Limited licences – all swept away in the early-2000s when the three-tier structure came into being – Foundation, Standard and Advanced.

House in Parramatta where he served on the WIA NSW Divisional Council as President, Secretary, Councillor, and on the Board of ARNSW, of which he was still an active member until his passing. His contribution also included long membership of WICEN, and active participation in events such as the annual City-to-Surf run and the Hawkesbury Canoe Classic.

Tim's passion for documenting the events and history of Amateur Radio resulted in numerous contributions to published articles and lectures, both within the Amateur Radio community and beyond. He also maintained involvement from the beginning of the WIA NSW *Bulletin* in the 1960s, to the current-day *VK2 news* in the printed pages of *AR*, and especially in the operation of the VK2WI broadcast station at Dural. This covered preparation and presentation of material for VK2WI News bulletins since the station's earliest days. He was still on the broadcast roster at his passing.

Tim Mills VK2ZTM is immediately recognised by several generations of Amateur Radio operators. Tim was made a Life Member of ARNSW in 2004 in recognition of his continuing outstanding contribution to Amateur Radio. His continuous service over seven

decades is unsurpassed.

Tim is survived by his two sons, Andrew and Bruce.

Vale Tim VK2ZTM.

(Writer's note: I am especially grateful to Henry Lundell VK2ZHE for providing much of the historical detail in this article).

AMSAT in Turmoil

Greg Kelly VK2GPK

The *Radio Amateur Satellite Corporation* (as AMSAT is officially known) was first formed in 1969 as an educational organisation. Its goal was to foster global Amateur Radio's participation in space research and communication. AMSAT was founded to continue the efforts, begun in 1961, by Project OSCAR, a west coast USA-based group that built and launched the very first Amateur Radio satellite, OSCAR, on 12 December 1961, barely four years after the launch of Russia's first Sputnik. AMSAT continues to the present day and operates in conjunction with the International Amateur Radio Union (IARU) to manage Amateur Radio satellite telecommunications and spectrum allocations.

This is a recent 2020 letter to all AMSAT members (*Ed: the letter is unedited, and retains US spelling*):

"After fifty years of AMSAT providing amateur radio with a presence in space, the organization has recently become under attack by two of its own Directors. These two Directors, Thompson and Stoddard, began their attack on the organization with a series of accusations and threats starting in 2018. In response, the President of AMSAT under the authority of the Board of Directors, sought legal counsel to protect the organization and receive guidance. As a result of those authorized legal services, AMSAT adopted one new policy and modernized another. There were several other legal expenditures related to the continued threats along with some

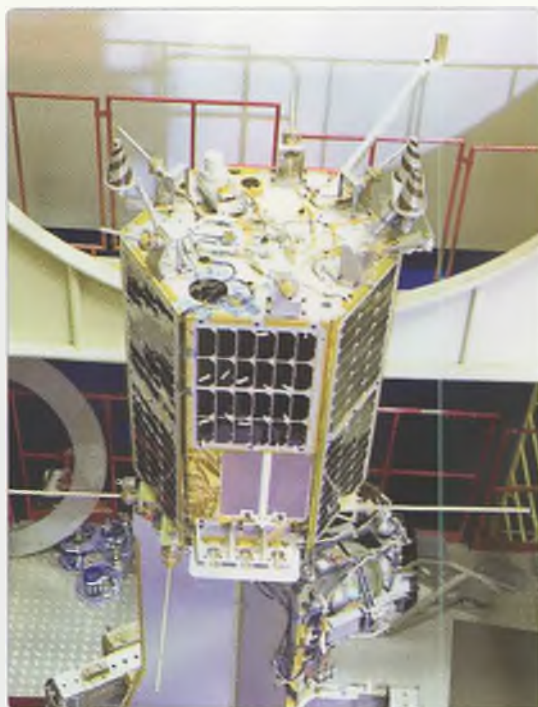

Launched on Boxing Day in December last year, RS-44 is a small scientific satellite built in Russia by Information Satellite Systems (ISS) Reshetnev and students of the Siberian State Aerospace University (SibSAU) Krasnoyarsk. It is designed to provide amateur radio communications and to develop promising technologies. It features a hexagonal prism structure with body-mounted solar cells and an inverting 2m/70cm transponder accessible through a sophisticated array of antennas, seen here. [AMSAT-UK]

operational legal expenditures including trademark renewal and space policy development. By alleging that some of the legal expenditures driven by their own actions were "unauthorized," both Directors Thompson and Stoddard have attempted to disrupt and possibly defame the organization to which they were elected to serve. To publicly attack the integrity and honor of all those who previously served as Officers and Directors of AMSAT while making egregious claims is shameful. Throughout this entire saga, AMSAT acted in an appropriate manner consistent

with what is required of a corporation.

The AMSAT Board of Directors and Senior Officers were advised by President Joe Spier in March 2018 that Michelle Thompson had made complaints of discrimination and harassment against several Officers and Directors. The President was concerned about a possible lawsuit against AMSAT and was especially concerned that the fact that AMSAT did not have a policy against discrimination or harassment could lead to a default judgment against the Corporation in any lawsuit. With full knowledge and consent of the Board, the President retained an attorney both to develop a non-discrimination and non-harassment policy and to advise him while handling the complaints under the new policy. In April 2018, the Board unanimously passed the attorney-developed policy. An investigation was then conducted, with the President reporting the results to the Board in May 2018. With no credible accusations found to be in violation of AMSAT's policies, the complaints were closed.

In the Spring of 2019, after months of public personal attacks by Patrick Stoddard against an AMSAT Director related to his duties as Vice President – Operations, the President decided to act. With the full knowledge and consent of the Board, the President sought legal counsel to advise him on proposed sanctions against Patrick Stoddard. The extent of the sanctions was a temporary moderation of his posting status on the AMSAT-BB email reflector and revocation of

his IT system access. This situation resulted in an attorney-developed revision to the AMSAT Acceptable Use Policy that the Board unanimously passed in June 2019.

In July 2019, Patrick Stoddard complained that the Secretary's execution of the Board of Directors Election was contrary to our bylaws. It was mirrored by online claims that the Secretary was inept, and that the election would be conducted illegally. The President and Secretary, again with the full knowledge and consent of the Board, sought legal advice on the conduct of the election under our bylaws.

Following the 2019 election, the President continued to work with an attorney on a conflict of interest policy related to a newly elected AMSAT Director for a potentially competing organization. Specifically, Director Thompson is a Director of Open Research Institute which solicits funding for amateur radio satellite service projects. Current AMSAT governing documents are not equipped to handle these potential conflicts. Being that Open Research Institute sent a campaign mailing in 2019's Board of Directors election, there is at minimum the appearance of conflict with regards to Director Thompson. AMSAT did not provide a copy of its membership mailing addresses to Open Research Institute.

The 2019 Board Meeting held on October 16-17 in Arlington, VA was the first face-to-face meeting that included Directors Thompson and Stoddard as voting members. During that meeting, it was discovered that Director Stoddard was secretly recording the meeting without the knowledge or permission of other Board Members, AMSAT officers, or others that were sitting as observers. Often, privacy laws require that any recordings be done with the consent of those being recorded. In the past, the AMSAT Secretary may record the meeting to assist in the development of meeting minutes,

but such recording was done with the full knowledge and acceptance of the Board. When Director Stoddard was asked about his recording, he stated that it was for personal use only. The Board, well aware of the 'sensitivities' between Board members, made the reluctant decision to allow Director Stoddard to continue his personal recording following his assurance that nothing from the recording would be shared with others outside the Board. Following the Symposium, Director Stoddard did not offer to share his recording with other Board members. He then used the recording to publicly quote others without their permission with intent to take things out of context which means he broke his commitment to keep the recordings 'personal'. This of course has further eroded trust within the Board and reduces Director Stoddard's reputation for keeping promises made to his Board colleagues.

In January 2020, a demand letter arrived at AMSAT from an attorney representing Directors Thompson and Stoddard. The demand letter alleged AMSAT was preventing the Directors from performing their duties by denying access to corporate record, specifically an archive of the previous Board of Directors' email discussions. After enduring months of demands by Directors Thompson and Stoddard, President Spier resigned the next day after receiving the demand letter. The Executive Vice President of AMSAT contacted the attorney for guidance to deal with the issue. Shortly thereafter, a new President was elected and continued to work through this issue with the attorney. The new President made a decision quickly to ensure no corporate records would be denied access to any Director, ensured the email archives were restored to visible status, and made a public statement affirming the position of transparency and equal access to corporate records.

None of this was kept secret

from the Board. AMSAT never sought legal advice to harass or intimidate members or candidates as alleged by Directors Thompson and Stoddard. Legal services were retained to provide guidance to the organization on the handling of unique situations that AMSAT had never faced before.

While these legal expenses were an unfortunate use of funds that could have been used for AMSAT projects, the Board and Senior Officers believed it to be necessary to protect the Corporation. Additionally, AMSAT gained a firm policy on handling allegations of discrimination and harassment as well as a modernized Acceptable Use Policy for our email message boards.

Allegations have been made that other "unauthorized" legal expenses were incurred to another attorney. These "unauthorized" expenses relate directly to AMSAT's mission – our trademark attorney that has been renewing AMSAT's trademarks for many years. This is a standard, periodic administrative expense of the Corporation. Allegations have also been made that the officers exceeded a cap that the Board imposed on expenses to another firm. The Board capped expenses related to the development of an ITAR/EAR policy. A few thousand dollars of the total disbursements to that firm were related to legal advice concerning the exportation of Linear Transponder Modules to Canada under our partnership with the Radio Amateurs of Canada. This was an Engineering project expense related to, but distinct from the eventual development and adoption of an ITAR/EAR policy. These expenses were, as before, undertaken with the full knowledge and consent of the Board.

It is absurd for two newly elected board members to make accusations of unauthorized expenditures when it was in part the actions of Directors Thompson and Stoddard prior to their election that forced the Board at that time to

take appropriate action to seek legal counsel to protect the corporation.

The only power that Directors have is when the Board is in session and Board members make their vote. Individual Directors do not dictate day-to-day management of the Corporation but instead have oversight as a Board. Likewise, the President is elected by the Board and is responsible for the day-to-day management of the Corporation, keeping the Board informed of events and actions that have a significant impact on AMSAT. When appropriate, the Board votes on key decisions and strategic direction. At other times, the President when informing the Board of key concerns, provides the Board an opportunity to provide feedback

and consensus. Unless the Board provides guidance to modify the President's intended actions, the President has done due diligence in keeping the Board apprised of actions that will be taken.

The effectiveness of a Director is based on how well that individual can work with their colleagues and create an atmosphere of collaboration and common purpose. Threats, innuendo, and public shaming via Internet blogs do not create an atmosphere for honest and respectful discussion. A poisonous atmosphere makes it impossible for good ideas to be heard. Such an environment causes further mistrust when an accuser does not ask questions in a nonthreatening manner to better

understand how the Board takes actions or how it functions before making judgements or public accusations.

Despite these unfortunate distractions by Directors Thompson and Stoddard, many dedicated volunteers work every day fulfilling AMSAT's promise to Keep Amateur Radio in Space. Thank you for being a member and supporting AMSAT.

Signed on behalf of AMSAT".

A PDF copy of this letter may be downloaded at https://www.amsat.org/wordpress/wp-content/uploads/2020/07/20200710_AMSAT_Leadership_Explains_Legal_Expenses.pdf

Source: AMSAT



DX Talk

Steve Barr VK3KTT
• vk3ktt@gmail.com

In this issue, I would like to introduce Steve VK3KTT as the new author for the DX Talk. VK3HJ is handing over the reins after compiling this column for several years – Ed.

About myself

Luke VK3HJ asked me to assist with the DX Talk column of *Amateur Radio* magazine. He said it's best if I was to introduce myself. Many of you may remember me under my old callsign VK3MEG. I have been very active since 2011, when I first obtained my Foundation Licence. The following year I upgraded to a Standard, where I remained happily for many years, clawing my way up the DX ladder with my 100 watts, mainly in SSB. Along the way, I also picked up CW and finally dipping my toes in the digital modes a few years later.

With 290 DXCCs confirmed, rest assured you will find me in the thick of pileups, regardless of operating mode. If I can hear them at my humble suburban station, I will be making every effort to work them.

My edge in DXing is the information I gather about the DXpedition station I am trying to get in my log. I will learn as much as I can about any DXpedition I'm wanting to work and I very much enjoy sharing the knowledge because I get nearly as big a kick out of someone else working an ATNO that I have pointed them to, than working them myself.

It is for this reason that I started the Facebook™ group known as "VK DX Chasers", where every VK/ZL DXer is welcomed. I have only two main rules: 1. No AR politics, and 2. No disrespecting other

people or the modes they choose to operate by – SSB, FT8, RTTY, CW, to name but a few. This group has become a great source of info and spot sharing, with many times live DX spotted and 10+ VKs getting into the log. We need to show the DX-peditors that we are there, and the best way is in a group.

I hope to see you all there – happy chasing!

Around the bands

January was a mixed month here at VK3KTT with openings to Europe in SSB and CW as well as FT8.

ZC4UW from the UK bases on Cyprus were causing some excitement, with a strong dedicated team, including Michael G7VJR the founder of Club Log. VKs didn't have much trouble working this one as the boys kept a sharp ear out for

us with many new slots being filled here.

T6AA Robert in **Afghanistan** was also around with a great signal on all bands from 80 m up. Also noted here was P29ZL in Papua New Guinea, 3D2AG/P from Rotuma, and notably 4U1UN, the United Nations headquarters, is back on the air. Also E44RU the Russian Robinson Crusoe team in Palestine, CP5CL from Bolivia was worked on 20 m FT8, which reminds me – I must send off for a CP card to get it confirmed, not many LoTW ops from there.

Vasily ER4DX club station in **FT8** makes an appearance as ER4KAA. Vasily has a huge station and is mainly on SSB and is quite often the first Moldovan worked by VKs. Janus SP9FIH appeared on Norfolk Island as VK9NK for a three-month stay. ZL7DX from Chatham Island; Chris was worked on 6m but also on 80m FT8. EP4HR in Iran has been popping up on 17 m FT8. He has a good signal on my dipole and does use LoTW. I worked a new one with the Polish DXpedition to The Gambia putting C5FUD in the log on 30 m FT8 on my dipole at 8 m high.

February saw HU1DL put **EI Salvador** on the map with the German DXpedition who had great

signals and first class operators working all modes. KC4USV appeared from the McMurdo station in Antarctica on 20 m FT8; keep an ear out for them.

There was also the small operation with C21PF and crew from **Nauru**. At the end of the first week in February 5I5TT and 5I4ZZ, the Italian DXpedition Team arrived on Zanzibar Island (IOTA AF-032) and gave two full weeks of good signals, and then we had 5H4WZ from Pemba Island (IOTA AF-093) appear with even better signals. Your reporter working them surprisingly well on 80 m CW, then a few minutes later working French DXpedition E44CC on 80 m FT8.

The low bands were jumping with so many DX-peditions to work, it was like a full-time job keeping up! On the same day as 5H5WZ and E44CC worked on 80m, FS/VA7XW was worked long path on 30m CW and then TN/UA9FGR was worked on 20m FT8 from the Republic of Congo. The next morning there was a weak signal on 40m CW and Luke VK3HJ put a spot on VK DX Chasers Facebook group and 9Q1C appeared out of the noise with slow CW and a 519 signal to put another All Time New One in the bag for me. Lastly, we had 9N7AM from

Nepal who had good signal but had trouble hearing due to local noise.

Other news

St Peter & Paul Island

PQ0S was to be activating St Peter & Paul Island around mid-March but was put on hold due to another group having extensive plans in place for a much larger DXpedition.

Swains Island W8S

The March 10 – 25 DXpedition to Swains Island was postponed due to complications arising from travel restrictions caused by the current Corona Virus situation. They have rescheduled to September 23 – October 6 this year. The Swains 2020 Team thanks you for your understanding.

T30ET Tarawa Atoll DXpedition Postponed

Owing to newly-imposed quarantine requirements due to the Corona Virus situation, this DXpedition scheduled for March has been postponed to October. An alternative destination may need to be selected.

Please support Steve with your DX news and information (Ed.).



GippsTech 2020 would normally be held in early July, at Federation University Australia Gippsland Campus in Churchill, Victoria, about 170 km east of Melbourne.

Having due regard to the current situation worldwide and locally caused by the COVID-19 pandemic and noting the existing restrictions having been imposed by governments in Australia, together with the likelihood that the health situation may worsen as we move into the local winter:

It is with regret that the Eastern Zone Amateur Radio Club Inc. has decided to CANCEL the event for 2020.

We look forward to seeing you at GippsTech 2021 in July 2021.

Eastern Zone Amateur Radio Club website: <http://www.vk3bez.org/>

SOTA and Parks

Allen Harvie VK3ARH

✉ vk3arh@wia.org.au

Summer is usually a busy time for SOTA & Park activations. The nature of portable activations is being able to get out into the parks or at a summit. The summertime fires have impacted many sites across Australia. As a result, activations were limited to safe, secure sites or not at all for some associations.

Photo 1 shows what happened to the main power supply on Peak Alone, VK2/SC-008. Located in the mid-South Coast region of NSW, the area suffered a firestorm late last year.

This site used to support Telstra, Vodaphone, RFS and GRN communications, St John



Photo 1: Summer fire destruction atop Mount Alone in southeast VK2.

Ambulance, RMS and trees. WICEN NSW is now using solar power to maintain communications.

So, let's switch to a lighter

topic and hear about KRMNPA activations from David Giles VK5DG.

Keith Roget Memorial National Parks Award via satellite

Looking back through the log, I made my first KRMNPA contact back in 2011. Since then, operation was sporadic but by 2018, I gradually got up to 25 parks as hunter and activator on HF.

Like many accidents, it was a series of seemingly unrelated events that gave me the idea of doing some of the parks via satellite in September 2018.



Photo 2: David VK5DG on the foggy summit of Mount Pilot in Chiltem-Mount Pilot NP using the first portable setup in July 2019.

I live in Mount Gambier, just outside southwest VK3, so I was able to activate the odd park or two during weekends and trips to VK3 for other reasons.

After activating the 12th park via satellite, I sent an email off to Tony VK3XV explaining what I had done and asked whether it was a good thing. He sent back an enthusiastic reply (and the first KRMNPA certificate for satellites) so I started planning on activating the other 33 by the end of 2019.

I made three "park-peditions" during July, August and November. I usually attend GippsTech during July. This year (2019), I took some extra time off to activate 13 parks in 10 days. Some of the highlights were my only night time activation (Mornington Peninsula NP), mode L/v (23 cm up/ 2 m down) on AO-92 (The Lakes NP), operating in gale force winds and heavy rain (Wilson's Promontory NP), snow and ice (Mount Buffalo NP), and our first time over the Great Alpine Road. There is some magnificent country out there.

The August park-pedition concentrated on the Melbourne parks and to catch up at the VK3 Portable Activities gathering in the Dandenong Ranges NP. For those who were there to witness my lack of success, it was due to operator error. The rain didn't help. I went on to activate six parks around Melbourne over the next three days and Great Otway NP on the way home.

The November park-pedition was for the KRMNPA weekend and the aim was to get the last eight parks. These were the six in far East Gippsland, Baw-Baw NP, and finishing up on French Island NP. These are the most difficult of them all, with plenty of mountains and trees.

Portable satellite operation needs a different approach to HF. Some say satellites are too easy, since you know when they are available. That is true, but you have to be fully set up in a suitable location and know where to point the antenna before the satellite comes over the horizon. Often, it

will have just gone by the time you find a suitable spot! Then you have to contend with the usual satellite problems of tracking uplink and downlink frequencies in opposite directions on two different bands, with different rates of Doppler shift, while pointing the antenna(s) at an object moving at 7 km/s at a distance of 500 to 4000 km away, and adjusting for polarisation changes due to the satellite tumbling and Faraday rotation. With your other hand you're either pressing the PTT or logging. Don't forget to speak when this is happening and make sure you can hear yourself on the downlink. It takes some practice!

Location is important, you can't go just anywhere in the park. Ideally, you want to drive straight to a location with a clear view of the sky down to zero degrees elevation in all directions. Parks such as Port Campbell NP and Budj Bim NP are close to that. Others, such as Alfred NP and Lind NP, are nigh on impossible as they are full of dense forest. The rest are somewhere in between and some research is required to select potentially good places. Often, the best sites are just outside the park boundary.

To a satellite operator, trees are a nuisance and the parks are usually full of them. They are good at soaking up 70cm, especially when wet. I was in a clearing in Cobboboonee NP where the minimum elevation was about 20 degrees but I could hear the 2m signal earlier by pointing my antenna in the opposite direction at the reflection off the trees.

Added to that, you have to be prepared to ignore any weather during a satellite pass. The rain gods also know when the satellites are coming over. I got wet on plenty of occasions when it was dry before and after the pass. At French Island NP that scenario was uncanny.

Interference is less of an issue than on HF. I don't have to worry about powerline noise, but on one occasion (Mt Ida in Heathcote-

Graytown NP), between me and AO-91's 2m downlink was a pager transmitter. That was loud in headphones.

I started off by taking as much gear as I thought I would need and had quite a setup. Gradually, I trimmed this down from being transportable/luggable to a fully portable setup. For French Island, you need to be portable; for other parks it was a definite advantage to be able to walk up to summits and get away from the road.

In addition, I also had the aims of using both FM and linear satellites, as well as accessing the transponder for the full pass. This allowed me to make contacts to all of VK and ZL. I could have used two handhelds and limited myself to the FM satellites SO-50, AO-91, and AO-92, and this would have worked for most of the time, but there are some parks in the log that are contacts only on linear satellites. In total, about 200 QSOs from 140 satellite passes were made.

So, what came out of it? My wife and I got to see parts of VK3 we had not visited before. We even got to see snow in Australia. She came along for most of the ride and was a great encouragement. I now have a fully portable setup that I can use at any time from any park. Along the way, some others earned enough contacts for an award – that was very satisfying. For the last few parks, some HF operators managed to have a go on the FM birds. My thanks to those who had to deal with my fading signals and frequency drift, as well as being there at the other end.

Finally, if you have a favourite mode or band, then give Tony VK3XV a call and see if you can try something special.

Annual SOTA Summit

The annual SOTA summit was cancelled and is being rescheduled. Watch OZSOTA@groups.io, or for more information contact Brian VK3BCM, at: bcmcdermott@tpg.com.au





VK7news

Justin Giles-Clark VK7TW

✉ vk7tw@wia.org.au

🌐 <https://groups.io/g/vk7arnews>

23cm QSO Party

Each Sunday at 10:00 am after the WIA and VK7 Amateur Radio Broadcasts, there is a gathering of amateurs on 1296.15 MHz and numbers have been progressively increasing each week.

In mid-April, numbers peaked at 15 participants, with 13 in Hobart and two in Launceston.

This increase has been in no small part due to the semi-regular 23 cm antenna-building workshop days that Rex Moncur VK7MO hosts. These workshops have seen the building of well over 20 Yagis and the objective is to get 23 participants on 23cms!

From 10:30 am on a Sunday, a number of Hobart stations beam north to Launceston on 1296.2 MHz using the digital mode QRA64-D. Hobart stations transmit first period.

During these COVID-19 times and with many people working from home, the 23cm frequency of 1296.15 MHz is monitored by many stations around Hobart and they are happy to have a chat during the day. Just put out a call and you never know who might come back!

John Moyle Memorial Field Day in VK7

Thanks to Peter VK7PD for this field day information. Peter reminds us that the namesake of the contest is John Moyle VK2JU (SK) who was editor of a technical magazine, which subsequently became Electronics Australia through its various iterations from 1939 until his untimely death in 1960; he was also Australian delegate to the IARU in 1959-60.

During John's magazine editorship, first as Radio & Hobbies and subsequently rebadged as

Radio, TV & Hobbies, he described many projects for the radio amateur that were widely-built and used. Little wonder an annual field day is held in his honour in Australia, New Zealand and Papua New Guinea.

This year, the field day ran between midday local time on Saturday 21 March to midday Sunday 22 March 2020. There were 13 VK7 stations who participated.

Some of the portable stations included Peter VK7KPC at Ross, Justin VK7TW/P in Hobart, and a group of three NTARC members (Andrew VK7DW, James VK7JAM and Peter VK7PD) using the club's call sign VK7TAZ/P at White Hills. QSOs happened on HF, 2m, 70cm, 23cm and 10GHz.

Meet the Voice

<http://meetthevoice.org/>

Owing to COVID-19 restrictions, the annual 'Meet the Voice' radio event on 22 March 2020 at Ross was cancelled. However, an intrepid group of no more than ten (the restriction at the time) gathered at Ross for a small presentation.

The previous holder of the Sewing Circle Trophy was Cedric VK7CL, who presented the trophy to the



Photo 1: Cedric VK7CL (right) presenting the trophy to Ross VK7ALH. (Photo courtesy of Peter VK7PD)

'most loquacious amateur for 2019', who is Ross VK7ALH. All agreed that Ross passed that qualification with flying colours...HIHI!

Please note that the Sewing Circle Net returned to 3.64 MHz in April, and can be heard from 5:00 pm each night. All are welcome to join.

Northern News

Northern Tasmanian Amateur Radio Club (NTARC)

<http://www.ntarc.net/>

Prior to the COVID-19 restrictions NTARC held a shack clearance and deceased estate auction at the NTARC clubrooms in February, with a good attendance on the day. The main hall was full of goodies spread over numerous tables, all nicely numbered and ready for our Auctioneer, Nic VK7BEE. The bidding was fierce and the auction and lunch was appreciated by all who attended.

There were also technical sessions held leading up COVID-19 restrictions that included the following highlights: Trevor VK7TB and his design and construction of an RF amplifier to drive his dual magnetic loop antenna; Peter VK7KPC had his Nano-VNA set up showing filter sweeps and his home brew 6m linear amplifier; Ross VK7ALH and his vintage test and amateur equipment; David VK7YY and Bernie VK7BR and their long wire antennas; and Simon VK7FSRM – resident computer guru and a night focussing on a variety of APRS equipment.

While the COVID-19 social isolation period is in place – NTARC has instituted a Technical Net on 3.567 MHz to replace the Wednesday night Technical

sessions. This net starts from 7:30pm and the Net Controller is Nic VK7BEE, using the club callsign VK7TAZ. The inaugural net saw 14 stations involved. The DISCORD online communications application was also used simultaneously, with Paul VK7KPA 'hosting' the NTARC Tech Net Group.

Southern News

Radio and Electronics Association of Southern Tasmania Inc.

<http://www.reast.asn.au/>
<https://www.facebook.com/reasttas/>

We congratulate Richard Hewson, who passed his Foundation licence assessment earlier this year, along with David Stejskal VK7FAAB, who passed his regulations assessment.

As part of the clubrooms improvements, two new heat pumps have been installed that have been very generously funded through a Tasmanian Community Grant. They will substantially reduce the power consumption relating to the heating and cooling of the clubrooms. Thanks to Scott Hutchins VK7HVK and his team for the installation.

Prior to the COVID-19 restrictions, REAST held an innovative and Interesting Shack and Portable Operation Ideas Forum. This night was born from a group looking at pictures and videos of various amateur's shacks.

Amateurs are resourceful people who have been re-purposing, recycling and re-using things for a very long-time. The forum covered a range of topics, including power connectors, cable management and storage in the shack, lightning protection, towers and tower design, surface mount jigs, battery connections, cable tidies using Velcro, SOTA squid pole anchors, utility bags, 18650 lipo batteries recovery and usage, use of PVC pipes to route cables and coaxes and tilt over tower designs. The forum was broadcast and recorded and can be found on the REAST YouTube channel at <https://youtu.be/HkaB-tDILPc>

Our Digital Amateur Television (DATV) Experimenter's Nights continued pre-COVID-19 and included the following highlights: the author with his latest GPS Disciplined Oscillator project with a Trimble Thunderbolt, a TAPR Distribution Board and the KJ6OWL Thunderbolt LCD; Richard VK7ZBX and his 1296 MHz PA project; Starlink satellite applications including heading outside to see the train of satellites flying through the sky; Jet VK7FJET showing his very impressive scratch-built GPS-disciplined oscillators and phase mixers; Rex VK7MO with his fully collapsible 432 MHz Yagi that fits in a suit case; Ron Cullen was showing his latest radio-controlled passion which are DF-65 sailing boats and reviews of the latest Low-Key and OTN or Old-Timers News from the Radio Amateurs Old Timers Club of Australia.

Post COVID-19 restrictions, we started DATV "Working from the Shack" Experimenter's Night, which saw the anchor in the DATV studio and call-ins conducted via the 2m repeater, YouTube streaming chat channel and DMR TG 3807.

We included some interesting 10 GHz dish projects, and then using Zoom to involve Warren VK7WN, Rex VK7MO, and Alan VK7KAJ on a recollection of the Australian Antarctic Division's (AAD) Icebreaker – Aurora Australia that sailed into Hobart from Macquarie Island on 25 March 2020 for the last voyage on charter to the AAD. Our third "Working from the Shack" session was a Zoom shack tour and interview with Richard VK7ZBX. These are all available on the REAST Tas YouTube channel - https://www.youtube.com/channel/UC64To_tq1E7Pfk1pqtX_vRw

In this time of COVID-19, the REAST Committee wanted to enable club members to meet face to face 'virtually' and the marvels of the Zoom meeting and collaboration software are now being used to enable this to happen.

The first of these meetings happened mid-April, attracted 16 members and was very well received. We thank Hayden VK7HH and the University of Tasmania for the use of this facility.



Photo 2: Participants in the REAST Virtual Club Meeting. (Photo courtesy of Justin VK7TW)

The 2020 Oceania DX Contest

Martin Luther VK7GN
- vk7gn@wia.org.au

Satellite image of Oceania from Wikipedia (image in public domain) https://en.wikipedia.org/wiki/File:Oceania_satellite.jpg

The Oceania DX contest for this year will be held on the weekends of 3-4 October for phone, and 10-11 October for CW, between 0600Z Saturday and 0600Z Sunday. View the full rules online, at: www.oceaniadxcontest.com

We can be proud that this is one of the oldest contests in Amateur Radio. In 1934, the Victorian Division of the WIA organized an international radio contest to celebrate the Centenary of the founding of Melbourne. It was organized under the leadership of Bob Cunningham VK3ML. Prizes were more than plaques and certificates. First prize was an RCA 852 tube. Other prizes included more tubes and some meters.

The enthusiasm of VK3ML is contagious!

"My – the ether just reeks of DX – take a large breath and sample it! Taste those Gs (they go well for breakfast, as one author once said), those Fs, Ws, Yls etc? They are our meat for October, so go to it and polish up that gear and start working DX, just to get the "atmosphere" prior to the big event."

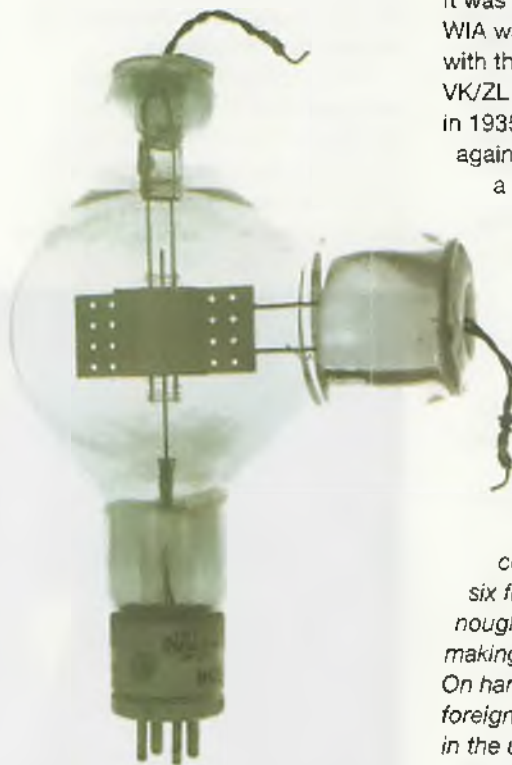

In the early days, an RCA 852 triode like this was offered as a prize. With 2 kV on the anode, and about 23 W drive, it was rated to produce some 75 W output.

Early success

The event was held over four consecutive Saturdays in October.

It was such a success that the WIA was encouraged to join with the NZART to create the VK/ZL International DX contest in 1935. This new contest was again organized by VK3ML and a committee. They created a serial number system similar to those in some sprint contests now. The number is arrived at in this way:

Each participating station in VK/ZL and all other countries allots himself a number consisting of three figures, say 456. The complete serial must contain six figures, so he adds three noughts for his first contact, making the number now 456000. On handing this number to the foreign station, a receipt is given in the usual manner, and a similar number is handed back in return. For example, 222879 might be received. Now, the first three figures of the received number, 222, are to take the place of the 000 in the original number, making the next serial number to be transmitted 456222, which will be handed to the next station contacted."

It is a lot easier today, where we just start with 001 and progress by one for each contact. Hence, giving out 001,002,003 etc.

In those days contacts were not usually on the same frequency (*Ed: each operator used separate frequencies as transmitters were mostly crystal-controlled and generally on different frequencies*). That rather stops the technique of listening to the number given out by the CQing station on the previous contact and just adding one! It was also pre-computer, don't forget.

Caught-out!

The contest was again held over four weekends in October – Saturday 1700 GMT to Sunday 1700 GMT! Contacts could only be made once on each weekend but could repeat up to four times over the month.

Only one mistake was made in the rules. They wanted to encourage 28 mc (MHz) activity, so they offered a 500-point bonus for 28 mc contacts. However, they were unclear as to whether this was a one-off bonus for just the first contact on the band or was a bonus of 500 for each and every 28 mc contact made!

This was made even more critical as the band opened very well and some stations made a lot of contacts all over the world. VK4BB made 61 contacts on 28, and in that were W, J, F, ON and G.

They resolved the 500-point uncertainty by awarding two certificates in each category. Results were calculated using the two different interpretations of the rules. Good lesson for all contest organisers to make sure they are clear on what a rule really means!

The other interesting category was the handicap section. The result was calculated by taking the claimed score and dividing by transmitter power. Resulting in points per watt. However, there were only two formal entries in this category. The committee chose to calculate a handicap score for all stations running less than 50 watts.

Tables were headed 'Australian and New Zealand Logs', 'American Logs', and 'British and Foreign logs'. It was the days when BERU (British Empire Radio Union) meant something!

The largest number of receiving logs came from Germany. I wonder if this was part of radio training for the developing military!

The goal of the contest was achieved. It is the same as our current goal for the Oceania Contest. Get the rest of the world to look for stations down this way so that we can make more contacts over long distances.

Everything then was hand-keyed CW, homemade equipment and limited antennas. All logging was done by hand, with possibly the odd typewriter in use. Mostly, you called 'CQ' for a while then tuned the band to see if anyone was calling you.

Compare that to today, where even cheap secondhand transceivers are capable of performance the boys and girls in 1935 could not even dream would

happen. We can connect our equipment to a computer so that the frequency is automatically logged. On CW the computer can also do the keying. Once the contest is over, a couple of keyclicks turns the log into a Cabrillo file that can be emailed or entered via an internet page.

Logging – it's not a chore

There are a number of logging support programs to make operating in the Oceania contest a pleasure not a chore. Consult the web page at: www.oceaniadxcontest.com/html/tips.html

Sometimes, I still do the old-fashioned way for small country contests. Paper logging. Paddle CW – I feel the Straight Key is an unnecessary punishment for those who have to listen to my shambling technique. Old age and wobbly fingers make the paddle bad enough for the operator trying to hear me!

Motivation for operating a contest is as varied as the human beings that enter! Some try to work new DX, new countries, new islands, and so on. Others are just happy to make contacts; contests make sure that a lot of people are on at the same time. This often creates the magic of bands opening that had seemed to be closed. Some want to win: to win overall, to win their section, to win their state or beat last year's score. Join us in October handing out serial numbers and making contacts.

Why you get on is less important than having fun! This is a hobby that has many facets; there is always something you can do.

Rules

Contest Period

PHONE: Contest: 0600 UTC Saturday 3 October to 0600 UTC Sunday 4 October 2020

CW: Contest: 0600 UTC Saturday 10 October to 0600 UTC Sunday 11 October 2020

Note the 0600 to 0600 UTC times.

Exchange

RS(T) report plus a progressive contact serial number starting at 001; M2 and MM entries are to use a separate serial number for each band.

Full rules

Full Rules are at www.oceaniadxcontest.com

Aim

The aim of the contest is to promote HF contacts with stations in the Oceania region.

The Object

The object is for:

- Oceania transmitting stations to contact stations both inside and outside Oceania.

- Non-Oceania transmitting stations to contact stations inside Oceania.
- Oceania receiving (SWL) stations to copy contest stations inside and outside Oceania.
- Non-Oceania receiving (SWL) stations to copy contest stations inside the Oceania region.

Contact Points

Each QSO is credited twenty points on 160 M; ten points on 80 M; five

points on 40 M; one point on 20 M; two points on 15 M; and three points on 10 M.

Multiplier

The multiplier is the number of different valid prefixes worked. Note that the same prefix may be counted once on each band for multiplier credit.

The Final Score

The final score is the sum of the

Contact Points multiplied by the Multiplier.

Logs

Electronic logs, submitted in Cabrillo format, are preferred and are mandatory for stations logging more than 50 contacts.

Submit your Cabrillo log file using the on-line submission form on the web site, at:

www.oceaniadxcontest.com

WIA Contest Champion 2019 Results

Peter Richardson VK2PR - Contest Champion Scorer

The WIA Contest Champion is awarded annually for the best combined effort in WIA-sponsored contests. It recognises those who have participated in multiple WIA contests and submitted logs throughout the year.

There was a total of 350 contestants during 2019.

The winner of the Peter Brown VK4PJ trophy for 2019 is Lawrie Mew VK5LJ, with a score of 540 points. Lawrie entered six out of the nine eligible contests

and won 1st place in The John Moyle, Harry Angel, and VK Shires contests, along with 2nd place in the Remembrance Day, Oceania CW, and Trans-Tasman Low-Band contests. Congratulations to Lawrie. He also won the 2018 Peter Brown trophy.

- 2nd place went to Brendan Bryant VK3MH with a score of 368 points.
- 3rd place went to Alan Shannon VK4SN with a score of 344 points.

- 4th place was Allan Mason VK2GR with a score of 320 points.
- Equal 5th place went to Rob McKnight VK2MT and Diane Main VK4DI, each with scores of 296 points.

Top 10 results are shown in the list below and full results can be viewed online, at: wia.org.au/members/contests/contestchampion/

Year 2019

Callsign	Name	Ross Hull	John Moyle	Harry Angel	RD Contest	Oceania Phone	Oceania CW	VHF UHF FD	Trans Tas	VK Shire	Total Score
VK5LJ	Lawrie Mew	0	100	100	80	0	80	0	80	100	540
VK3MH	Brendan Bryant	0	100	0	100	48	0	60	60	0	368
VK4SN	Alan Shannon	0	80	80	60	36	0	0	48	40	344
VK2GR	Allan Mason	0	60	80	100	0	80	0	0	0	320
VK2MT	RC McKnight	0	36	100	0	0	0	0	100	60	296
VK4DI	Diane Main	0	0	100	36	100	0	0	0	60	296
VK3HY	Gavin Brain	0	100	40	0	0	0	100	0	0	240
VK2IG	Michael Dower	0	0	80	80	0	0	0	80	0	240
VK5SFA	Steve Adler	0	0	40	100	0	0	0	100	0	240
VK2PR	Peter Richardson	0	100	0	80	36	0	0	0	0	216

Plan ahead

Operate within the band plans:

<http://www.wia.org.au/members/bandplans/about/>

Peel Amateur Radio Group

The Peel Amateur Radio Groups' PARGFEST swap meet was run very successfully on the morning of Sunday February 9th. The event was held once again at the Bortolo Pavilion in Mandurah, which is well-located and has much appreciated air conditioning!

Attendance was just under 100 people, making it the best PARGFEST ever. Special thanks to Mark from TET-Emtron and to Jaycar Mandurah for sponsoring the event, once again.

The four lucky winners of our raffle prizes were Alek VK6APK, Bruce VK6CX, Ian VK6FDIG and Stephen VK6ZRA.

On the day, we had the best attendance of PARG club members, new, current and old. It was also great to receive good reports about the good value, quality hamburgers made that morning by our hard-working catering volunteers, Robyn, Jean & Michelle.

Paul Gardner – VK6LL
President – Peel Amateur Radio Group Inc.

Christmas Island Amateur Radio Club

Earlier this year, the club held its first skype-based monthly meeting, which will be the way meetings will be run from now onwards.

The new club station site is still under negotiation. We are hoping to have some space next to the Recreation centre, which is close to the highest point on the island, but

certainly with a 360-degree view of the horizon; so, should be a cracker of a site.

A few members are beginning to plan a trip to the island, most likely in the second half of the year (hopefully, before the wet season sets in) to get the new station under way. We would welcome other assistance as well so if you have always wanted to visit VK9X, then this would be a good opportunity! The date will also be driven by when we actually get a place to move to. If you are interested, Contact Doug Haig VK9JD, on 0448 583 699.

Ham College

We held a one-day workshop in January to begin re-thinking how we deliver courses at Ham College. We ended up with 10 people attending, including members and interested parties. We really appreciated everyone's input and we now have quite a few more instructors to spread the load between.

One of the outcomes of the meeting was to determine that we needed to split Standard and Advanced courses once again (we combined them last year), but this time the Advanced course will be immediately after the Standard course, and be an extension course rather than teaching the complete Advanced course from scratch.

Anyone wanting to go the Advanced level from Foundation or no licence just needs to do the Standard course, then follow straight through to the Advanced

extension course. We will be teaching the Standard course over a period of 22 weeks, and advance extension over eight (8) weeks.

The other subject of discussion was on better preparation for modules (some doing this better than others – I am one of the others!). Kathi VK6KTS has volunteered to use her extensive career in teaching to run train-the-trainer style courses at Ham College prior to the Standard course. We are also starting lesson nights an hour earlier, so that anyone struggling can pop in early and work through issues prior to the class starting at 7pm.

We also discussed how we might engage more with the WA-based clubs to get some more buy-in to the College.

Northern Corridor Radio Group

Our main activities in January/February were to carry out some remedial work on the UB6-40 Yagi to stop it from turning on the tower, and to make some modifications to the 20m mono-band mast. The 20m antenna was removed and the mast changed to make it easier to tilt over, and we will not be putting the 20m Yagi back up on this mast. The mast will be used to support our 160m and 80m wire antennas.

We have also been working on the log book system being used at the club (using HRD), and getting our Clublog eQSL and ARRL integration back under control. 



Wireless Men & Women at War

Young men and women brought about largely by their interest in private radio communications.

Read more and visit the WIA Bookshop at:

www.wia.org.au/members/bookshop/page_data.php?id=258



ALARA

Jenny Wardrop VK3WQ

Well, when I wrote the last ALARA column, I certainly never envisaged the world that we find ourselves in now. The Corona Virus has turned everyone's world upside down. The one consolation for us as Amateurs is that we can at least talk to our friends, or strangers, without having to invoke the two-metre rule, which was included in a message from my local radio club.

*"Hi Everyone,
Tomorrow, Macedon Ranges ARC
will be using the guidelines below.*

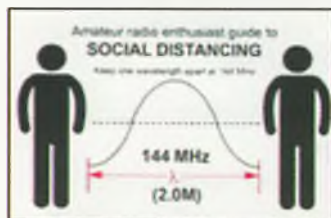

Photo 1: Two Metre Spacing.

1000 hrs, VK3RMM Repeater, 1st Wednesday of the month, Coffee get together.

2000 hrs, VK3RMM Repeater, The weekly Wednesday Club net.

Those feeling a little uneasy about such close contact may choose 80-metre spacing:

1100 Hrs, 3.685 MHz. Monthly Coffee get together.

2030 Hrs, 3.685 MHz. H/F Club net.

See you on the air tomorrow.

Regards, Graeme VK3NE
(Secretary)"

ALARAmeet postponed until October 2021

Unfortunately, because of the virus, it has been decided to the postpone 2020 ALARAmeet, which was to be held in Bendigo during October this year. However, it will now take place

from 1st to 4th October 2021, still at the Shamrock Hotel, Bendigo. We realise that this will disappoint many of those who were intending to go this year, but hopefully 2021 will see an even better ALARAmeet.

VK3 Report

Well 2020 has not got off to a good start. First, all the bushfires around the country, and now this Corona virus which many people have died from. Many radio clubs have had to put their meetings on hold and Hamfests are not taking place.

ALARA held our first lunch for the year on January 25th at the RSL in Ringwood. We were pleased to host Greg, Kaye VK3FKDW's' son, his wife Irinna and son Finnian, from Germany, who had returned to Australia for her funeral, and came with Kay's partner Denis VK3BGS. A very big thank you to Judy VK3FJAG and Jim VK3ZKK for organizing the lunch. Needless to say, the VK3 lunches are on-hold for the foreseeable future.

Photo 2: Left to right, Jean VK3VIP, Pam VK3NK, Irinna, Pat VK3OZ, Greg, Diane VK3FDM, Jen VK3WQ, Denis VK3BGS, Margaret VK3FMAB, Judy VK3FJAG and Robyn VK3WX. Front, Elsie and Finnian.



On the following Wednesday, 29th January, Kaye's funeral was held and was well attended by many ALARA members and other radio amateurs. An ALARA scarf was draped on the coffin. Kaye will be missed by all who knew her.

On March 14, we held a lunch for Jeanne Socrates VE0JS, the lone "Round the World" sailor, at the RSL in Glen Waverley. Jeanne is a very interesting lady, and everybody enjoyed talking with her.

I was sad to learn that Sallie AE5OM has become a silent key. Sallie was one of my sponsors who attended the International YL Meet in Adelaide in 2012.

Everybody stay safe and healthy.
Cheers, Jean VK3VIP

Have you tried FreeDV yet?

With all this free time that many of us now find ourselves with, I thought that you might be interested in one radio mode that has taken over our household!



Photo 3: ALARA VK3 ladies with Jeanne Socrates VE0JS. Back row left to right: John VK3DQ, Carla (ALARA member), Jean VK3VIP, Lino VK3EI, Denis VK3BGS, Margaret VK3FMAB, Judy VK3FJAG, Jim VK3KZZ. Front row: Murr Elsie, Jeanne VE0JS.

Back in 2013, my partner, Peter VK3RV, came across an odd looking trace on his PSK31 computer 'waterfall'. He finally discovered that it was something called FreeDV, a relatively new digital mode for voice. It was 2015 before he met David Rowe VK5DGR, the Australian facilitator and developer of FreeDV and purchased one of his 'little blue boxes'. After many local contacts with our 'neighbour', John VK3IC, a long-time friend in Queensland, another Peter, also purchased 'one such blue box' (an SM1000) and they were delighted by the 'noise-free' quality of the signals consistently received over the longer path on 20 m to Queensland.

I have been friendly for many years with Ngaire ZL2UJT and her husband Graeme ZL2APV. A chance postscript by Peter to Graeme, on an email that I was

writing to Ngaire, elicited the information from Graeme that he, too, had the ability to work FreeDV, but had never found anyone to talk to! Subsequently, as has been documented in a previous copy of AR, Ngaire and I had what we believe to be the first (and maybe the only!) YL two-way cross-Tasman contact to date with FreeDV in April 2016; but, fast forward to more recent times.

On Christmas Eve 2019, Klaus 4E1ADW, operating from Tagytay Philippines, was heard and contacted on 20m, using the 700D FreeDV mode (just 1.6 kHz bandwidth) while we were staying in Murray Bridge SA. Over the next few days, Klaus was worked many times by several people throughout VK. A result of this contact with Klaus was an email connection with Jose, LU5DK1, a very keen FreeDV

operator in Coronel Pringles, Argentina.

The long and short of all of this, is that on January 18, Peter heard Jose calling "Peter VK3RV" on a weak and fluttery 20m signal and the word "ARGENTINA", clearly displayed in the FreeDV Text Bar. But, unfortunately, a direct contact was not made.

Peter then entered a very steep learning curve about using remote SDRs (Software Defined Radios). I won't go into

all the details here, but an article has been drafted for AR by Peter and David, which will reference the recent DX contacts on 20m and the use of SDRs that both David and Mark VK5QI had used for testing long paths with FreeDV some years ago, and more recently with Jose.

I quote Peter from that draft article: "... But there is the 'sting in the tail' of this story. Part way through that first SDR-based contact (with LU5DK1), I passed my head-set over to Jenny VK3WQ, who called and had a good contact with Jose using her own callsign. Jose was in raptures! Working his first YL on FreeDV, encouraged him even further to say that her voice was far better than mine using the mode! And then, at the finish of the contact, suggesting that I should hand the control of my station over

Silent Key

Rex Foord VK3ARG

Rex joined the Geelong Amateur Radio Club (GARC) in 1958 and obtained his first Amateur Radio Licence in 1961, receiving the call sign VK3ZKB, subsequently gaining VK3ARG in 1964.

He was a long-serving, respected and revered member of the Geelong Amateur Radio Club. Having received Life Membership in 2015, he was awarded the prestigious Ray Cowling Award in 2018 for promoting the ideals of Amateur Radio for a period of fifty-seven years.

Prior to the inauguration of WICEN,

a small GARC sub-committee, which included Rex, was invited by the Geelong City Council to consider facilitating communications in support of the regional St John Ambulance and Red Cross in times of emergency, which came to fruition during the 1985 Otway fires.

As a member of the WIA, he made a significant contribution to furthering Amateur radio as an invigilator, instructor and assessor to enable potential members to obtain their Amateur licence. His experience as a TAFE teacher, and breadth

of knowledge, enabled the entry of many into our hobby.

Months before his death he made a substantial contribution to the refurbishment of the GARC clubrooms.

Rex was a former Scout Master and member of the Army Reserve for 37 years within both the Royal Australian Artillery and Royal Australian Electrical and Mechanical Engineers, rising to the Rank of Warrant Officer Class 1.

He will be sadly missed.

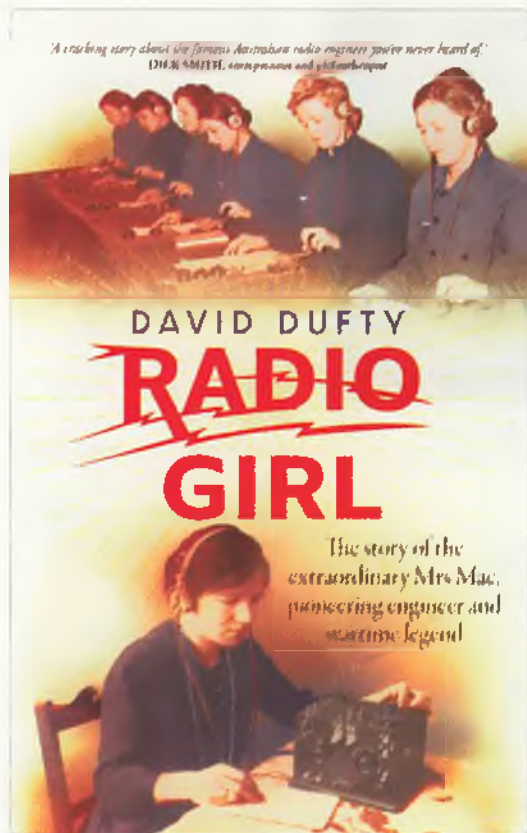

Photo 4: The Cover of "Radio Girl" In the November/December issue of AR, I wrote of author Dr David Dufty and his book "The Code Breakers of Central Bureau". I mentioned at the time that he was writing a book on Florence McKenzie. Well, "Radio Girl", the story Of Florence Violet McKenzie, went on-sale at the end of April. Florence McKenzie OBE A2GA/VK2FV/VK2GA was the first Australian licensed YL and the first Female Electrical Engineer, plus so much more.

to Jenny! Much hilarity ensued! Of course, this "better transmission" was only due to the band conditions which obviously peaked at the time that Jenny had her contact that night!" Well, that's Peter's version of the story anyway!

So, to fill-in spare time, get your laptop, open freedv.org and download the software, interface your computer with your transceiver (plenty of information on the web as to how to do it) and have a go at using a largely Australian-developed, digital voice mode for HF or VHF. It will certainly help fill in your spare time! And thank you David for your dedicated work over the years – even if it has disrupted our household during these unusual times!

David was to have spoken to us at the ALARAmeeet 2020 Saturday night dinner, which, as you know, has had to be cancelled. However, he has

indicated that he will be happy to speak to us at ALARAmeeet 2021. Something to look forward to, as he is a very good speaker!

David has also said that, if you buy your book beforehand, he will be happy to sign it in Bendigo in 2021. The book costs \$29.99 and is published by Allen & Unwin. For further information you can Google David Dufty and/or the Allen & Unwin websites.

Wanted

ALARA Historian/Librarian

ALARA is currently looking for a new Historian/Librarian. I am the current holder of that title, but have decided that six years is enough as, at the moment I am wearing four ALARA hats!

Although the majority of the ALARA Archive is held at the WIA office at Bayswater, most of it has now been digitized, which means that you no longer have to live in Melbourne, or even Victoria, as much of it is on hard-drives. I will be happy to continue with the digitizing and will give whatever help I can to the next Historian.

Expressions of Interest should be forwarded to the Secretary, Jean VK5TSX at secretary@alara.org.au
33, Jen VK3WQ



Silent Key

Frank Beech VK7BC

Many DX chasers in VK and beyond would have encountered serious competition from VK7BC. Charles Frank Beech, known to us as Frank, was born on 6 August 1933. He grew up in England and went on to radio school around the age of 16, where his love of radio began. From there he became a merchant marine radio officer for over 10 years; traveling the world on various ships. During this time he became licensed as a radio amateur with the call sign G3PVL.

In 1965, Frank emigrated to Australia with wife Paddy and son Chris. Frank had visited Tasmania in his travels, having spoken to radio mates over time, and made the decision to call Tasmania home; he acquired the call sign VK7BC.

Frank and Paddy bought a lovely block of land in Legana, northern Tasmania. By some strange coincidence, the block was large enough to accommodate two full-length 80m dipoles, plus various vertical antennas. There was even room enough to build the family home!

With a merchant marine background it's not surprising that Frank was an avid CW man. The walls of his shack were adorned with many award certificates earned over many years; these include Antarctica and IOTA awards.

Only some can be seen in the photograph. Frank was a member of WIA, RSGB, CQDX (UK), RAOTC, ARRL and the Royal Naval Amateur Radio Society (RNARS).

Frank worked for several electronics firms then, later, at his own Public Address business from which he retired in the late-1990s. Retirement gave him the opportunity to pursue amateur radio in earnest, which he certainly did to within a few weeks of his death on 14 November 2019.

He is survived by wife of 54 years, Paddy, son Chris, granddaughter Ashley, and great-grandchildren Hamish, Isabelle and Hunter.

This information was given by Paddy and Chris; it is gratefully acknowledged. Vale Frank

73, Peter VK7PD

Ross A. Hull Memorial VHF-UHF Contest 2020: Results

Rob Heyer VK2XIC - Contest manager



Ross A. Hull 1902 - 1938

First place this year went to Ted Thrift VK2ARA, who achieved a Total Combined Points result of 2912 points.

Ted first took the first place honour in 2010, and again in the years of 2014, 2015, 2017 and 2018.

Overall second place this year was taken out by Barrie Burns VK6ADI, with a Combined Total Points score of 2456. He was last year's winner.

Congratulations to all entrants.

It's good to see continued interest in area of VHF and UHF, and particularly the stations working DX.

There is no doubt about it, the numbers of contesters has fallen off from previous years and this fall off does set a large challenge for me, in particular. Being new to the role, I found the process not as straight forward as I had hoped.

I would like to thank John Martin VK3KM for his assistance helping me to deal with the difficulties I encounter. Also, I would like to

Results Summary

Call	Name	50 MHz	144 MHz	432 MHz	1296 MHz	2.4 GHz	3.4 GHz	5.7 GHz	TOTAL
VK2ARA	Ted Thrift	1010	516	520	576	290	-	-	2912
VK6ADI	Barrie Burns	2260	126	70	-	-	-	-	2456

Section A: Best of 7 days, analog modes

Call	Name	50 MHz	144 MHz	432 MHz	1296 MHz	2.4 GHz	3.4 GHz	5.7 GHz	TOTAL
VK6ADI	Barrie Burns	1992	3	5	-	-	-	-	2000
VK2ARA	Ted Thrift	830	270	215	128	70	-	-	1513
VK2AH	Brian Farrar	198	204	210	136	-	-	-	748
VK2BLS	Darrell Harman	88	288	175	112	70	-	-	711
VK2XIC	Rob Heyer	4	60	100	128	-	-	-	292
VK2LDW	David Wolff	10	39	55	64	-	-	-	168
VK2FDSD	Daniel Demaagd	-	33	50	-	-	-	-	83

Section C: Best of 2 days, analog modes

Call	Name	50 MHz	144 MHz	432 MHz	1296 MHz	2.4 GHz	3.4 GHz	5.7 GHz	TOTAL
VK6ADI	Barrie Burns	982	3	5	-	-	-	-	990
VK2ARA	Ted Thrift	406	150	130	32	20	-	-	738
VK2BLS	Darrell Harman	68	138	125	32	20	-	-	339
VK2AH	Brian Farrar	8	147	125	24	-	-	-	304
VK2LDW	David Wolff	4	21	35	48	-	-	-	108
VK2XIC	Rob Heyer	4	18	35	40	-	-	-	97
VK2FDSD	Daniel Demaagd	-	15	25	-	-	-	-	40

Call Letters	VK1	VK2	VK3	VK4	VK5	VK6	VK7	ZL	FK8	H44	TOTAL
No. Contacts	1	1,070	9	22	28	47	3	15	4	1	1,200

thank the contestants for their patience as their certificates were issued later than I would have liked.

I encourage those who took part in the 2020 Ross Hull Memorial VHF - UHF Contest to participate in the 2021 contest.

To lift the numbers of entrants for next year, it is my goal to make contact with many stations who have not thought of being part of the Ross Hull Memorial VHF-UHF

Contest and urge them to submit a log. The aim is to boost the total number of contacts for the period of the 2020 event.

Hopefully, we will see a rise in the numbers of stations in VK1, VK3, VK7 and more stations worked on DX, like ZL, FK, H44, as well as our VK8 and VK9 stations.



Contributions to *Amateur Radio*

AR is a forum for WIA members' amateur radio experiments, experiences, opinions and news.

Your contribution and feedback is welcomed.

Guidelines for contributors can be found in the AR section of the WIA website, at <http://www.wia.org.au/members/armag/contributing/>

Email the Secretary:
armag@wia.org.au

AMIDON FERROMAGNETIC CORES



tts systems

Phone 03 5145 6179
info@ttssystems.com.au

Studying for the Standard or the Advanced Licence?



Here are 4 books that will get you there.

TAKE A LOOK AT
www.gscott.com.au

for more information and order form.
635 Edmonson Avenue
Albury NSW 2640



Have you held an amateur licence for 10 years or more?

If so, then you are invited to
join the

RAOTC

A \$5 joining fee, plus \$18 for one year or \$32 for two years, gets you two interesting 64 page *OTN Journals* each year, PLUS good fellowship, and a regular broadcast of news and events.

More information and a membership application are available from our web site at www.raotc.org.au or write to:-
PO Box 107, Mentone VIC 3194 or
email:- raotc@raotc.org.au or
call Secretary: Bill Roper VK3BR
on 03 9584 9512.

About Hamads

- Submit by email (**MUCH PREFERRED**) or if written and mailed please print carefully and clearly, use upper AND lower case.
- Deceased estates Hamads will be published in full, even if some items are not radio equipment.
- WIA policy recommends that the serial number of all equipment for sale should be included.
- QTHR means the address is correct in the current WIA Call Book.
- Ordinary Hamads from those who are deemed to be in general electronics retail and wholesale distributive trades should be certified as referring only to private articles not being re-sold for merchandising purposes.
- For commercial advertising on these pages Contact admanager@wia.org.au
- Copy must be received by the deadlines on page 1 of each issue of *Amateur Radio*.
- Use the separate forms for **For Sale** and **Wanted** items. Include name, address STD telephone number and WIA membership number.

'Hamads'

PO Box 2042
BAYSWATER VIC 3153
hamads@wia.org.au

TRADE PRACTICES ACT

It is impossible for us to ensure that the advertisements submitted for publication comply with the Trade Practices Act 1974. Therefore, advertisers will appreciate the absolute need for them to ensure that the provisions of the Act are strictly complied with.

VICTORIAN CONSUMER AFFAIRS ACT

Advertisements with only a PO Box number address cannot be accepted without the addition of the business address of the box holder or seller of the goods.

ADVERTISERS INDEX

icom	Back Cover
Jaycar	5
Amidon	64
Yaesu	Inside Front Cover
Future Systems	Inside Back Cover



Don't forget to register for MEMNET.

Beautifully Simple

Remote so easy it's practically magic

Flex-6400 from \$3,550

Flex-6600 from \$7,075

Flex-6700 from \$12,400

 **FlexRadio Systems®**
Software Defined Radios

Buy a FlexRadio and get started
with SmartLink™ today



SmartSDR for iOS now available for iPad on the App Store

futuresystems.com.au | sales@futuresystems.com.au | 08 6336 9610

Prices as of July 2020, are subject to change without notice



ICOM

FIRST IN TECHNOLOGY

The IC-705

HF/VHF/UHF MULTIMODE PORTABLE TRANSCEIVER



* The antenna and antenna connector in the photo are after-market products.

Be Active!
In the field with the IC-705

- HF/50/144/430 MHz Multimode, including the D-STAR DV Mode
- RF Direct Sampling System
* The down-conversion IF sampling method is used for 25 MHz and above.
- Real-Time Spectrum Scope and Waterfall Display
- Large Touch Screen Colour Display
- Compact and Lightweight Design * Approximately 1.1 kg, including the battery pack.
- BP-272 Battery Pack or 13.8 V DC External Power Source
- Maximum Output Power 5 W (BP-272), 10 W (13.8 V DC)

■ Making your field operation more fun and stylish



Multi-Function Backpack
LC-192

HF/50/144/430 MHz
MULTIMODE 10 W TRANSCEIVER

IC-705

Supplied Accessories

HM-243 Speaker-microphone, BP-272 Li-ion Battery Pack, OPC-2421 DC Power Cable



sales@icom.net.au



www.icom.net.au



(03) 9549 7500