

Amateur Radio

Volume 88
Number 5 ▶ 2020
Price: \$12.50 incl GST

110 Years

Anniversary

1910-2020



www.wia.org.au

Build open feeders Surviving coax anxieties\$

- ▶ DIY antenna switch-&-meter project
- ▶ Snag satellites with 2-band Yagi kit
- ▶ An arboreal aerial! 😬 Really, dude?
- ▶ DIY HF Transceiver – deeper into it

ISSN 0002-6859



05

770002 685062

The radio... **YAESU**

Inherent Passion and Inspiration

Hybrid SDRs (Narrow Band SDR & Direct Sampling SDR)

2kHz RMDR 123dB+

2kHz BDR 150dB+

2kHz 3rd IMDR 110dB+

Ultra Low-Noise Local Oscillator System; 400MHz HRDDS (High Resolution Direct Digital Synthesizer)

2kHz Phase Noise -150dBc/Hz

VC-TUNE (Variable Capacitor Tune) signal peaking

Maximum Attenuation -70dB

3DSS (3-Dimensional Spectrum Stream) visual display view up to last 25 seconds of band conditions in real time

TX Signal Purity

TX Phase Noise -150dBc/Hz (TX 14MHz 2kHz separation)



* Microphone M-1: Optional

In Homage to the Founder of Yaesu - Sako Hasegawa JA1MP

FTDX101MP 200W

HF/50MHz TRANSCEIVER

- External Power Supply with 100mm Front Speaker, FPS-101 included
- VC-Tune unit x 2 (MAIN and SUB bands) included
- 300Hz Crystal roofing filter (MAIN band) included
- 600Hz Crystal roofing filter (MAIN and SUB bands) included
- 3kHz Crystal roofing filter (MAIN and SUB bands) included

The Ultimate

FTDX101D 100W

HF/50MHz TRANSCEIVER

- VC-Tune unit (MAIN band) included
- 600Hz Crystal roofing filter (MAIN and SUB bands) included
- 3kHz Crystal roofing filter (MAIN and SUB bands) included

YAESU
The radio

YAESU Authorized Dealer

Andrews Communications Systems
Shop 8, 41-51 Bathurst Street, Greystanes NSW 2145
Tel: +61-2-9636-9060
URL: www.andrewscom.com.au

YAESU Authorized Service Center

Andrews Communications Systems
Shop 8, 41-51 Bathurst Street, Greystanes NSW 2145
Tel: +61-2-9636-9060, Fax: +61-2-9688-1995
E-mail: radioandrews@hotmail.com

Strictly HAM Pty. Ltd.

Shop 12B Church Street Bayswater Vic. 3153
Tel: +61-3-9729-7656
URL: www.strictlyham.com.au

VK Radio Repairs

347 Settlement Rd, Thomastown Victoria 3074
Tel: +61-3-9010-5070, Fax: +61-3-8682-8748
E-mail: yaesu@vkradio.com.au



Amateur Radio

Volume 88
Number 5
2020
ISSN 0002-6859

The Journal of the Wireless Institute of Australia

Editorial

Editor in Chief

Roger Harrison VK2ZRH
editor@wia.org.au

Technical Editors

Eric Van De Weyer VK2VE
Ewen Templeton VK3OW
Phil Fitzherbert VK3FF

Publications Committee

David Burden VK3BDX
Dr Brian Clarke VK2GCE
Ian Godsil VK3JS
Carmel Morris VK2CAR
WIA Office Bruce Deefholts VK3FBLD

All circulation matters

nationaloffice@wia.org.au

How to submit material

AR Publications Committee
PO Box 2042
BAYSWATER VIC 3153
or armag@wia.org.au

Letters to Editor

Editor AR Magazine
PO Box 2042
BAYSWATER VIC 3153
or editor@wia.org.au

Hamads

'Hamads'
PO Box 2042
BAYSWATER VIC 3153
hamads@wia.org.au

Advertising

All enquiries to
Advertising Manager
AR Publications Committee
PO Box 2042
BAYSWATER VIC 3153
or admanager@wia.org.au

Registered Office

Unit 20 11-13 Havelock Road
BAYSWATER VIC 3153
Australia
Phone: 03 9729 0400
Fax: 03 9729 7325

Production Deadlines

All articles, columns, hamads and
advertising booking for Issue 6 - 2020 by
12 November 2020.

The contents of Amateur Radio are Copyright
Wireless Institute of Australia © 2020
All Rights Reserved.

General

When governments ruled the aether 40
Peter Wolfenden VK3RV,

Ross Hull Memorial VHF-UHF Contest 58
Rob Heyer VK2XIC

Technical

Building your own open feeders – 6
simples

Roger Harrison VK2ZRH and
Andy Sayers VK3ES

A novel arboreal aerial for the 630m 17
and 160m MF bands

Leigh Turner VK5KLT

Build this antenna switch with 21
power-and-SWR meter for the
HF bands

Jim Tregellas VK5JST

Snag satellites with this 2-band 26
Yagi kit

Andy Keir VK2AAK

Homebrew HF Transceiver project 28
Part 3 VFO System

Luigi Destefano VK3AQZ

Switch that coil, change them ohms 38

Nigel Dudley VK6NI



This month's cover:

The parallel conductor, air-dielectric –
"open-wire" – feedline has big advantages
over coax. You can make it yourself, for one
– especially with rod or tube. But, wait! The
"good books" aren't much help! Solving the
feedlines' fields with software, as seen in
these images by Andy VK3ES, provides the
answers. From page 6.

Columns

| | |
|------------------------------|--------------|
| ALARA | 60 |
| Board Comment | 3 |
| Contests | 58 |
| Editorial | 2 |
| Meteor Scatter Report | 50 |
| Over to You | 53 |
| Silent Key | 57 |
| Space News | 54 |
| SOTA & Parks | 56 |
| VHF/UHF – An Expanding World | 44 |
| WIA News | 4, 5, 20, 25 |
| VK6 News | 62 |

Contributions to Amateur Radio



Amateur Radio is a forum for
WIA members' amateur radio
experiments, experiences,
opinions and news. Manuscripts
with drawings and/or photos are
welcome and will be considered
for publication. Articles attached to
email are especially welcome. The

WIA cannot be responsible for .css or damage to any material.
Information on house style is available from the Editor.

Back Issues

Back issues are available directly from the WIA National Office
(until stocks are exhausted), at \$8.00 each (including postage
within Australia) to members.

Photostat copies

If back issues are unavailable, photocopies of articles are
available to members at \$2.50 each (plus an additional \$2 for
each additional issue in which the article appears).

Disclaimer

The opinions expressed in this publication do not necessarily
reflect the official view of the WIA and the WIA cannot be held
responsible for incorrect information published.

Amateur Radio Service

A radiocommunication service for the purpose of self-training, intercommunication and technical investigation carried out by amateurs: that is, by duly authorised persons interested in radio technique solely with a personal aim and without pecuniary interest.

Wireless Institute of Australia

ABN 56 004 920 745

The world's oldest

National Radio Society, founded 1910.

Representing

The Australian Amateur Radio Service

Member of the International Amateur Radio Union

Registered Office of the WIA

Andersson House

Unit 20, 11 Havelock Road

Bayswater, Victoria, 3153

Tel: (03) 9729 0400 Fax (03) 9729 7325

email: nationaloffice@wia.org.au

<http://www.wia.org.au>

All mail to

PO Box 2042 BAYSWATER VIC 3153

Business hours: 10am – 4pm weekdays

National Office

Executive Administrator Bruce Deetholts VK3FBLD

Board of Directors

| | | |
|-----------------------|----------------|--------|
| <i>President</i> | Gregory Kelly | VK2GPK |
| <i>Vice-President</i> | Lee Moyle | VK3GK |
| <i>Directors</i> | Peter Cleo | VK8ZZ |
| | Phil Shields | VK2CPR |
| | Oscar Reyes | VK3TX |
| | Scott Williams | VK3KJ |
| <i>Secretary</i> | Peter Cleo | VK8ZZ |

Coordinators

| | | |
|---|------------------|---------|
| <i>AMSAT</i> | Paul Paradigm | VK2TXT |
| <i>ARDF</i> | Jack Bramham | VK3WWW |
| <i>Australian ARISS</i> | Shane Lynd | VK4KHZ |
| <i>Awards</i> | Graham Alston | VK3GA |
| <i>Clubs</i> | Ted Thrift | VK2ARA |
| <i>Contests</i> | Craig Edwards | VK8POX |
| <i>John Moyle Field Day</i> | Denis Johnstone | VK4AE |
| <i>Standards</i> | Ron Cook | VK3AFW |
| | Noel Higgins | VK3NH |
| <i>NTAC</i> | John Martin | VK3KM |
| <i>Historian</i> | Peter Wolfenden | VK3RV |
| <i>IARU Region 3 Director</i> | Peter Young | VK3MV |
| <i>Monitoring Service</i> | Peter Young | VK3MV |
| <i>ITU Conference & Study Group</i> | | |
| | Brett Dawson | VK2CBD |
| | Dale Hughes | VK1OSH |
| <i>OSL Curator</i> | National Office | |
| <i>Repeater</i> | Peter Mill | VK3ZPP |
| | Andrew Chapman | VK4QF |
| <i>Webpage</i> | Robert Broomhead | VK3DN |
| <i>Information Systems</i> | Joseph Mullins | VK5FJDE |



Editorial

Roger Harrison VK2ZRH

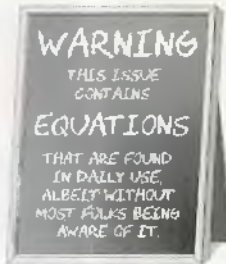

Courtesy Carmel Morris VK2CAR

During a recent Publications Committee meeting, we discussed “themed” issues for the magazine. Perhaps the last issue (No.4) could rightly be recognised as the “Portable” issue! With three reviews of Icom’s latest rig – the IC-705 – pitched at the portable operations market, each from different perspectives, plus a ‘featurette’ on local portable operations under COVID-19 restrictions, *Covid*, a *Clansman*, a *Codan* and *QRP in a clamshell*, and even a neat segue from the *SOTA* and *Parks* column into the third IC-705 review, the issue was laden with the pleasures of portable play.

Back to PubCom’s discussion – the first topic that sprang to the collective mind of the Committee was antennas. And, what use is an antenna without a feedline? Accordingly, I present another themed issue for this era – on *Antennas and Feedlines*.

Hence, our feature is on the practicalities of designing and building your own open feedlines (careful . . . *equations!*). The feature DIY project is an antenna switch for the shack with a built-in power-and-SWR meter, from the indefatigable Jim Tregellas VK5JST. It’s nicely set off by an article on a novel arboreal aerial for the MF bands. Also, we have a review of a dual-band (2m/70cm) Yagi kit, and a review of an automatic antenna matcher/tuner kit. Even our VHF/UHF and Meteor Scatter columnists have thrown-in some cogent catchwords on antennas.

COVID constrictions

Like everyone else, I have been struck by the mainstream media’s concentration on the strictures of COVID-19 lockdown. No doubt

about it, dealing with the pandemic is a *serious* business. Lives and livelihoods are at stake.

Be that as it may, the cartoonists have at least been able to pick out some of the lighter sides of the general situation. They caused me to wryly reflect on my early career when I worked at Casey Station in Antarctica over 1970-71. The ‘everyday’ limitations of living and working at an Antarctic research station compared to living and working under COVID-19 lockdown struck me.

Indeed, the Australian Antarctic Division’s powers-that-be back then were concerned about the mental well-being of station inhabitants. In the “personal manual” every expeditioner received, suggestions were offered on relieving mental tensions from the limits of station life.

Today’s COVID “lockdownees” can look out the window or walk around the block and see green trees, and busy gardens. Locked-down in Casey, all there was to see was white, relieved by grey buildings, grey rocks, and grey masts, with perhaps a few orange vehicles scattered about. You couldn’t pop out to the shops or go out to a park.

In this era, some broadcaster shlock jocks have had a riot complaining. Lockdown? Lockdown! The egregious irony struck me about the comparative circumstances of 2020 versus 1970. For the life of me, I can’t see what those pusillanimous pussyfooter broadcasters have to properly complain about. Those who surely had the most to complain about lately – VK3s, mostly – have “taken it on the chin”, kept calm and carried on!

Board comment

Phil Shields VK2CPR and Lee Moyle VK3GK

Member benefits re-boot: On 25 September, the Board announced a suite of membership initiatives, leveraging a new WIA Members' card. Several vendors have teamed up with the WIA to provide a range of discounts and savings to WIA members when using their services or purchasing goods from them. All you need to do, in most cases, is produce your membership card or quote your current membership number for online purchases.

The membership card is similar to a test conducted in the middle of the year to determine the feasibility of email as a distribution conduit – this was problematic, so we decided to use MemNet to deploy the card PDFs.

The card displays your call sign, (up to two may be shown), your membership number, membership expiry date and a list of all the current vendors participating in the benefits program – yep, that's new, too.

If you are renewing your membership or are a new member, your membership card is simply downloaded from the WIA website via Memnet by¹:

- 1) Login to Memnet with your membership number (or call sign) and Password
- 2) On the 'MY WIA' Page, select 'Pay Invoice'
- 3) Select 'Receipt' button on the most recent invoice shown
- 4) Print out your last receipt
- 5) Cut out, fold and (optionally) laminate your Membership Card ready for use.

Discounts will vary, depending upon the retailer. Some very deep discounts are being offered by the major electronics component retailers listed on the card.

Depending on your purchases and chosen supplier, the realised annual savings alone can easily be in the order of several times

the initial cost of your annual WIA membership subscription! Conditions of use, a list of current vendors and other information relating to the new program will soon be listed on the WIA website.

Imitation: They say that imitation is the sincerest form of flattery. In the digital sphere, pretending to be someone else is called 'spoofing'. 'Spoofing' is poorly policed on most social media because these platforms are organised like 'walled gardens'. That is, they give the illusion that nothing exists in the wider internet outside the wall. This is logical, as their primary purpose is to keep you within the wall for as long as possible. So, please be aware that there are one or more spoof pages purporting to be the WIA and it is often difficult to tell them from the real thing at first glance. Find the real WIA: <https://www.wia.org.au> or <https://www.facebook.com/wiavk>

Spectrum Intruders: For HF band enthusiasts who have been active on the bands recently, you may have experienced better propagation, especially in the higher frequencies. Along with that come intruders to our bands, whether in the form of Over the Horizon Radar (OTHR), taxis on 10m FM, or just the annoying fishing boats, usually all from our northern neighbours. The WIA's IARU Monitoring System (WIMS) is a part of the IARU's global monitoring activities of the Amateur Service across all three IARU regions. Australia belongs to IARU Region 3 (R3). Information is shared with other national societies within the R3 region and other regions to assist with locating and identifying intruders.

The WIA has a long established arrangement whereby amateurs can report possible unauthorised (non-amateur) transmissions in our primary HF bands to the WIMS Coordinator. The WIA's IARU Monitoring System

Coordinator is Peter VK3MV, email via: intruders@wia.org.au. Reports of identified intruders are also lodged with the relevant spectrum management administration to facilitate removal action to be taken.

The WIA IARU Monitoring System is an agreed mechanism between the Australian Communications and Media Authority (ACMA) and the WIA to identify and then instigate compliance action to remove non-amateur intruders that are causing substantial interference to Australian amateurs in our primary Amateur HF bands. The ACMA interprets substantial interference as "that level of interference which degrades reception by a considerable degree". The ACMA is obliged under the WIA IARU Monitoring System mechanism to investigate and, as much as is practical, resolve intrusions into amateur HF bands where Australian amateurs have Primary status.

The agreed procedure between the ACMA and the WIA for forwarding intruder complaints from the WIA is a nine-point process, which can be found on the WIA website, at: www.wia.org.au/members/protecting/about/

Summary: The WIA Board and the many other volunteers who support our 110 year young organisation are continually working on current programs and new initiatives to increase the relevance and value of WIA membership. Whether that be via international representation to the International Amateur Radio Union (IARU), the International Telecommunications Union (ITU), at World Radio Conferences (WRCs), local representation to the ACMA (Australian Communications & Media Authority) or the AMC (Australian Marine College). It is also providing support and benefits at an operational level at local WIA affiliated radio clubs, or in the home and 'ham shack' directly via our new benefits program.

73

¹ Note that this card process will not work for complimentary "Newly Licensed" one-year \$zero memberships.





16 November, the birth of electronics

The 16th of November 1904 was the 'birth' of electronics, the day British scientist John Ambrose Fleming applied for a patent on the first practical electronic device – the “thermionic diode.”

It was the first simple vacuum tube. It had a metal plate (anode) spaced a short distance from a filament (cathode), rather like an electric lamp filament. A current could flow in only one direction between the two, which enabled the conversion of alternating current to direct current.

The device first found application as a diode detector in receivers and, later, as a power rectifier for ac-to-dc power conversion.

Fleming's valve was the forerunner of all vacuum tubes, which dominated electronics for 50 years.

The Institute of Electrical and Electronics Engineers (IEEE) has described it as “one of the most important developments in the history of electronics.” It is on the List of IEEE ‘Milestones for electrical engineering’. The American Institute of Physics recognised the 100th Anniversary of Electronics during its 51st Annual Symposium and Exhibition over 14-19 November 2004, in California.

Fleming is also noted in the annals of radio communications

as, in 1901, he designed the transmitter used by Marconi for the first transmission of radio waves 3500 km across the Atlantic, from Poldhu, in England, to Nova Scotia, in Canada.

Fleming's diode was used by the Marconi company in its maritime receivers until around 1916, when it was replaced by the triode (developed by the US inventor, Lee de Forest), accompanied by scurrilous patent battles lasting years. Kind of a metaphor for the electronics industry ever since. Nevertheless, vacuum tube technology has *not died of old age* and disappeared!

Revised syllabus for Foundation licence

Changes to the syllabus for Foundation licence examinations have been made to bring it into line with earlier changes to the licence conditions secured by the WIA after some years of lobbying.

The spectrum regulator, the Australian Communications and Media Authority (ACMA), has advised the Australian Maritime College (AMC), which oversees amateur licence exams, that it must ensure the amateur radio examinations it conducts (including those by its accredited assessors) are based on the revised Foundation syllabus.

The revised syllabus is available online, at: www.amc.edu.au/industry/amateur-radio/syllabus

Australian Foundation licensees are now permitted to:

- use transmitters built by themselves, or others
- use all digital modes (including those not yet invented).
- use a smartphone to operate their station remotely
- supervise an unlicensed person on-air.

The WIA produced a supplement last year to its popular

Foundation Manual (3rd Edition), which covers these changes. The supplement is available online, here: https://wia.org.au/newsevents/news/2019/20191105-1/documents/Foundation_Manual_Supplement_Nov_2019.pdf

ZL loses 5 MHz access

New Zealand amateurs lost access to the two trial frequencies they were permitted to use – 5353 and 5362 kHz – from late October.

The New Zealand Defence Force advised that it was not willing to approve another renewal of the 5 MHz trial allocation and licence that prevailed in ZL.

The new amateur band at 5.3 MHz was allocated world-wide to the Amateur Service on a secondary basis in late 2015 at that year's World Radiocommunication Conference (WRC-15).

While the trial is over for ZL amateurs, the New Zealand Association of Radio Transmitters (NZART) says it will continue to work with the regulator to see if there are other ways of providing New Zealand amateurs with access to the 60m band.

US amateurs lose 9cm band

Despite concerted opposition from the ARRL and others, the USA's communications regulator, the Federal Communications Commission (FCC), ordered the “sunsetting” of the 3.3–3.5 GHz (9cm) amateur band from 9 November.

US amateurs had secondary access to the band; this is common for allocations in other countries, too (e.g. Australia).

The FCC's decision allows current amateur activity on the band to continue, “grandfathering” the amateur operations, subject to a later decision. The FCC proposed two deadlines for amateur operations to cease on the band.

WIA news

The first would apply to the 3.4–3.5 GHz segment, the second to 3.3–3.4 GHz. The FCC will establish the dates once it reviews additional comments, the ARRL reported. See: www.arrl.org/news

146-147 MHz access for UK amateurs continues

Amateurs in the UK were allowed temporary access to the 1 MHz extension to the 144-146 MHz (2m) band for a year, expiring on 31 October 2020.

The UK spectrum regulator, Ofcom, has agreed to make the 1 MHz extension available for a further year.

Those wanting to use the band extension have to apply online for a Notice of Variation, which is issued free and is available to all UK Full licence holders.

The band extension is intended for technical and experimental work and should not be used for modes or operations that normally take place in the 144-146 MHz band, advised the Radio Society of Great Britain.

US amateurs battle introduction of licence fees

The USA's spectrum regulator, the Federal Communications Commission (FCC) has launched a proposal in October to charge fees for radio amateur licence applications, renewals and upgrades. The proposal affects all FCC services and does not single out amateur radio.

The American Radio Relay League (ARRL) is strongly opposed to the proposal, has lodged formal opposition with the FCC and is urging members to add their voices to the ARRL's by filing opposition comments of their own.

Under the proposal, says the ARRL, amateur radio licensees would pay a \$50 fee for each amateur radio application for new licences, licence renewals, upgrades to existing licences, and vanity call sign requests.

"The FCC has also proposed a \$50 fee to obtain a printed copy of a license", said the ARRL. "Excluded are applications for administrative updates, such as changes of address, and annual regulatory fees."

US amateurs have not had to pay application fees for some years. For more details, visit the ARRL Newsletter, at: www.arrl.org/arrlletter?issue=2020-10-29#toc01



New Foundation Manual

Available now

Visit our Bookshop:

http://www.wia.org.au/members/bookshop/page_data.php?id=113

jaycar

think. possible.

24-PCE LOCK PICKING KIT WITH PRACTICE PADLOCK

Supplied with a transparent practice padlock so you can see how the various mechanisms operate.

- 20 Different picks
- 3 Torsion wrenches
- Automatic tension tool TH2200



JUST
\$39⁹⁵

Note: Jaycar will not accept responsibility for any unlawful use of this item. It is intended for private (personal security) and hobby (locksport) use only.

2-PCE CYLINDER PRACTICE LOCKS

A great compliment to the lock picking set above (TH2200).

- 2 Different types of cylinders
- See-through design
- 2 Keys for each lock TH2202



IDEAL FOR HOME UNIT
BLOCK MANAGERS

JUST
\$19⁹⁵
PR

AUSTRALIAN HAM RADIO HANDBOOK

This handbook helps you become a radio amateur, set up a station and make contacts on air. An ideal read for anyone interested in taking up, continuing in or returning to amateur radio.

- Softcover 145 pages
- 255(H) x 204(W)mm
- BM2492



ONLY
\$24⁹⁵



PORTABLE DAB+ RADIOS

- Radio Data Stream (RDS) function for receiving digital information.
 - 20 radio presets.
 - Clock and alarm with sleep mode.
- DAB+ & FM Radio AR1690 \$59.95**
DAB+ & FM Radio with Bluetooth* AR1692 \$99.95

FROM
\$59⁹⁵

Shop online!

Free delivery on online orders over \$99
Conditions apply. See website for details.



click & collect

buy online
& collect in-store



own it now, pay later

Valid until 30 November, 2020

To order phone 1800 022 888 or visit www.jaycar.com.au

Building your own open feeders – simples

Not when the handbooks are wrong, dude!

Roger Harrison VK2ZRH and Andy Sayers VK3ES

Here's the solution for designing and building your own open feeders for impedances of 250 ohms or below and saving the anxiety over coax.

Once upon a time – as all good fairy tales start – an exploration into making a parallel transmission line (aka “feeder”) for an antenna project (by VK2ZRH) quickly unravelled from an expected linear progression among articles, papers, and the solid “good handbooks”, to become an obsessive search that led down a raggedly fascinating path of discovery about transmission lines, textbooks, equations and *serious* software.

The parallel conductor, air-dielectric transmission line – “open-wire, balanced line” – has manifest advantages of simple construction and low loss, whether manufactured or homemade. That's not news to any amateur who's been licensed for a few years, nor to engineers and technicians educated in radiocommunications technologies and practice.

Since the ‘pioneering era’ of wireless technology development, transmission lines of pretty much every conceivable configuration have been investigated and described in textbook tomes (eg. ITT, 1968; Lo & Lee, 1988). Amateur radio handbooks have generally confined

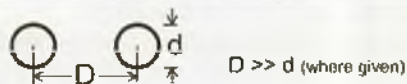

$$Z_0 \approx 276 \log_{10}(2D/d)$$

$$Z_0 = 120 \cosh^{-1}(D/d)$$

$$Z_0 = 119.9 \ln[(D/d) + \sqrt{(D/d)^2 - 1}]$$

$$Z_0 \approx 120 \ln(2D/d)$$

Panel A. The four commonly used “traditional” equations for calculating the impedance of open-wire parallel transmission lines, published in various engineering textbooks and amateur radio handbooks. Where $D \gg d$ is given as a ‘limit’, it doesn't give much guidance. Is it 2:1, or 10:1? NB: later in this article, the nomenclature is changed, such that the centre-to-centre spacing – D here, become s – and d here (line diameter) becomes D .

Image A: Illustrating the fields created around square-section, close-spaced parallel feedlines. In the larger figure, the encircling lines each show constant values of field strength, while the inset shows field intensity contoured in ‘false colour’. Note the field concentration at the points of each square section and between the parallel faces. Note, also, how the field strength falls away quickly the further out you go left and right, but doesn't decline as fast going up and down. The face-to-face spacing here (s) equals the side dimension of the square (D). Thus, the $s/(s + D)$ ratio is 0.5. From Figure 9, the impedance is about 134 ohms; it remains the same with feedlines of different sizes, provided you maintain the ratio. Images created by Andy VK3ES, Phasor Innovation Pty Ltd, www.phasorinnovation.com.



their descriptions to a narrower range of transmission line types, to those available as commercial-off-the-shelf (COTS) products or those practicable for home construction (eg. ARRL, 1989; Orr, 1987).

Where these textbooks and handbooks include equations to calculate the impedance of parallel conductor transmission lines, with few exceptions they don't include the fact that the equations, being approximations, have limits. Or, where a 'limit' is included, it's vague or non-specific. See *Panel A*. Somewhere along the way, with the effluxion of time, the notion that such equations had limits went missing.

Perhaps it's because many applications call for parallel transmission lines with impedances of 300, 450 or 600 ohms. However, the "traditional" equations for calculating the impedance of parallel transmission lines give inaccurate results when you want impedances below about 300-250 ohms.

With the help of Andy (VK3ES) and his 3D electromagnetic field simulator, I (VK2ZRH) derived cubic equations to calculate the impedance of close-spaced parallel transmission lines of round and square cross-section. These equations enable construction of balanced, parallel transmission lines to an accuracy better than commercial off-the-shelf (COTS) products. Helpfully, these equations have been incorporated into free antenna and transmission line design suites developed by Australian amateurs: *Yagi Calculator*, by John Drew VK5DJ, and *EME Calculator*, by Doug McArthur VK3UM (SK).

A little history

Custom and practice over decades has generally focused on open-wire lines of 300, 450 and 600 ohms impedance, predominantly involving applications at frequencies below 30 MHz. That takes care of the HF amateur bands. While commercially-made open-wire transmission lines have been available for decades, generally targeting high power RF applications, open-wire transmission lines lend themselves to home construction and the well-known amateur radio handbooks have featured them since the inception of such publications.

The advent of television saw the introduction of low-cost commercially-made balanced transmission lines of 300 ohms having a solid plastic dielectric separating the wires – the ubiquitous "TV ribbon". Its principle features were low loss at VHF TV broadcast frequencies and low cost, compared to the alternative of coaxial cable.

The log-periodic dipole antenna project I (VK2ZRH) started on was to cover the Australian VHF-UHF TV channels between 170-800 MHz. I decided on all-metal construction with the array feedline supporting the dipole halves as twin booms, as illustrated in **Figure 1**. This has the advantage that, with suitable choice of array feedline impedance, coax can be used for the antenna feedline, making a self-balun by threading it through one boom (Lo & Lee, 1988).

For the pair of booms serving as the antenna's feedline line, I chose square-section aluminium extrusion for simple mechanical construction. All I needed to work out was how to space the twin booms to get the required

Image B: Close-spaced round-section parallel feedlines, illustrating the surrounding fields they create. Here, as with the image at left, in the larger figure, the encircling lines each show constant values of field strength, while the inset shows field intensity contoured in 'false colour'. Note the field concentration between the closest parts of the feedlines and the similar – but different – way the field strength falls away around the feedline. The ratio of the centre-to-centre spacing (s) to the diameter of these round-section feedlines (D) happens to be 1.66. Hence, from Figure 15, the impedance is about ... 134 ohms! Here, again, that will hold with feedlines of widely different sizes, provided you maintain the ratio.

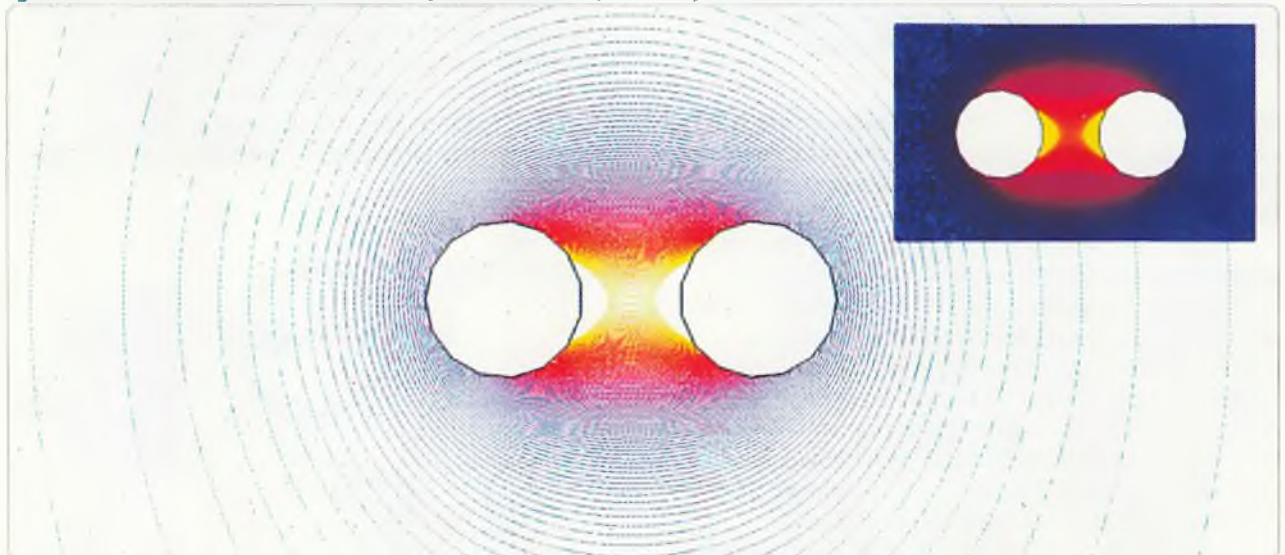

feedline impedance. Couldn't be hard, I thought. Others had done it before me. But, trawling the internet and the readily available literature didn't reveal the essential details. So, I had to start from scratch.

While log-periodic dipole antenna design software is obtainable from various sources, including free



The 300 ohm feedline of yesteryear, widely known as "TV ribbon".

downloads from the internet, at the time, all the readily available/affordable ones seemed to be pitched for HF or limited VHF applications, without refinements that I needed, or details on array feedline configurations. For my purposes, I chose the design approach set out by Lo & Lee (1988), which met my requirements, except in one respect – physical design of the array feedline.

The design process revealed that, juggling the dipole impedances and setting an array feedline impedance of

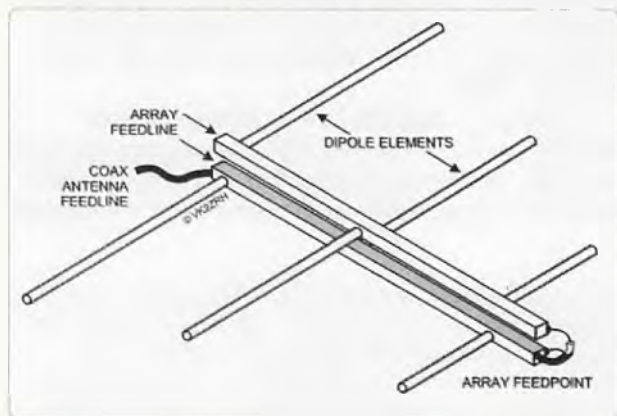

Figure 1: Log periodic dipole array (LPDA) with twin-boom array feedline and coax feed. I wanted to calculate the impedance of the square-section array feedline.

100 ohms would result in a 75 ohm feedpoint impedance and an easy self-balun. The big question was: how to design a 100 ohm, air-dielectric, square-section feedline?

I spent quite some effort trying to adapt microstrip design practices, but that proved a frustrating dead end. I posted a question to the VK-VHF Reflector about calculating the characteristic impedance of square-section parallel lines. Answers alerted me to the idea that, in RF applications, there is an "equivalent" round-section conductor for a given square-section conductor. For a square-section width, W , the electromagnetic equivalent round-section conductor of diameter (D) is 18% larger (Schmidt), as illustrated in Figure 2.

The idea was to substitute the "equivalent" round-

section conductor diameter in the different equations for parallel transmission lines found in the various amateur handbooks and engineering texts.

However, while "rounding the square" is applicable to antenna elements, I discovered that it does not apply in the case of parallel transmission lines as I got inconsistent results from using the equations commonly published. Quite a puzzlement. Rounding the square, in this case, is a *non sequitur*.

Solving the puzzle

Having followed the discussion on the VK-VHF Reflector, I (VK3ES) sent Roger a solution using an application known as CST Studio Suite, see Figure 3.

This was a start. Keith Malcolm VK1KM (SK) suggested that it would be really useful to have a table of common square tube sizes at various spacing ratios for common or otherwise useful impedances.

However, CST Studio Suite has the facility to do better than that, so I ran a series of simulations for a few common square-section extrusion sizes: 6.0, 12.0, 19.05 (¾-inch) and 25.4 mm (1-inch), producing an Excel table of results for face-to-face spacings ranging from 1 mm to 65 mm. The results are graphed in Figure 4.

The graph was intriguing. As you can see, the form of each curve is a "natural log" – a logarithm to the base 'e', an irrational number, approximately 2.718281828 (to 9 places). It is a constant widely encountered in nature, in exponential growth and decay, the charge and discharge characteristics of capacitors, etc. But, more on that shortly. First, a short tutorial on how CST works is required.

CST Studio Suite is a general-purpose electromagnetic simulator employing the Finite Integration Technique (FIT), first proposed by Thomas Weiland in 1976-77. Unlike most numerical calculation methods, FIT "discretizes" the integral form of Maxwell's equations, rather than the commonly known differential set.

The calculation problem is broken down by creating an arbitrary 'space' (the calculation domain) which is divided into an enormous grid of individual cells, as in Figure 5. Having broken down the problem into a complex mesh of cells, Maxwell's equations are solved discretely for each individual cell and the results summed.

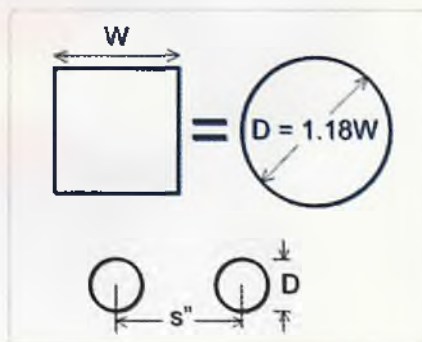

Figure 2: Substituting the 'round equivalent of square'. It works for antenna elements, not with transmission lines.

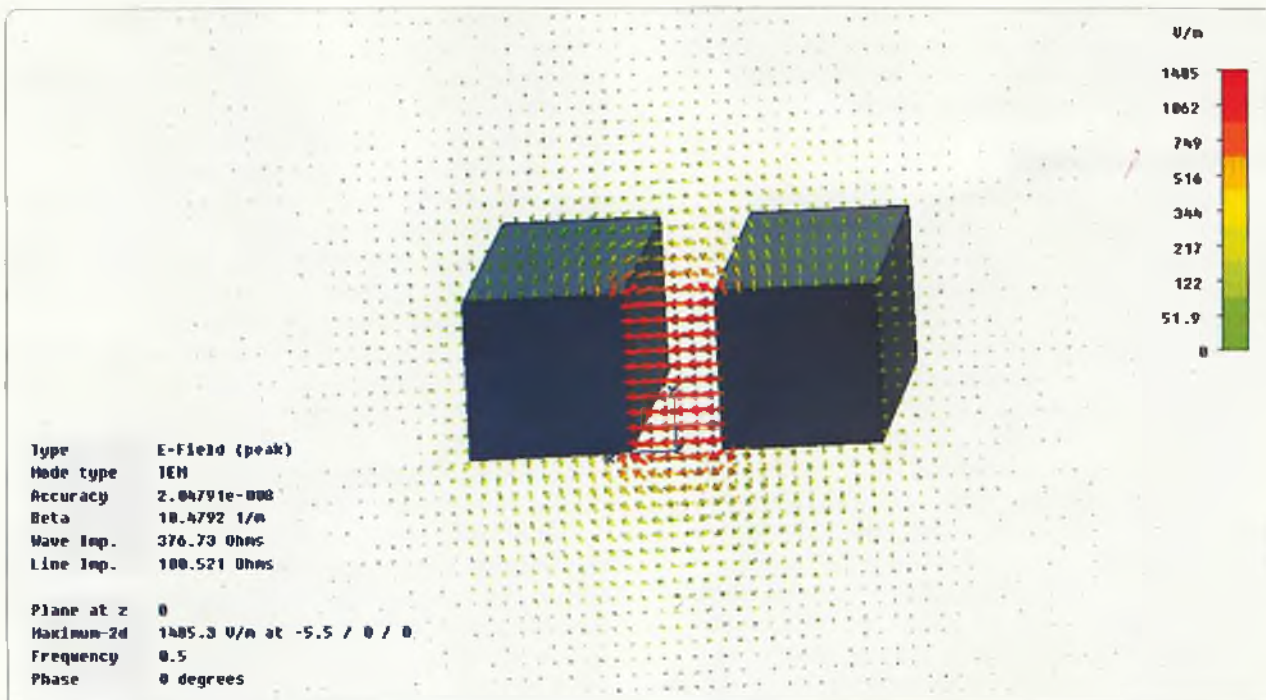

Figure 3: Deriving square-section line impedance (Z_0) using CST Studio Suite.

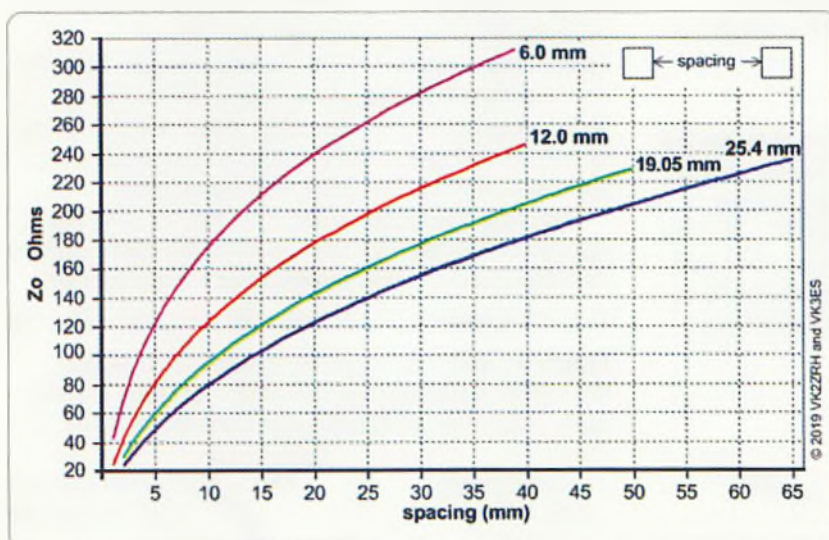

Figure 4: Set of Z_0 curves for four common square aluminium extrusions. A 100 ohm line can be made from lines of 19.05 mm extrusion spaced 11mm apart (face-to-face).

CST Studio Suite features a number of “solvers” for use in particular applications. These are:

- Time Domain – for broadband, low-Q structures;
- Frequency Domain – a general purpose narrowband solver;
- Eigenmode – for highly resonant structures;
- Integral – for electrically large structures;
- Particle – for valves, TWTs and even particle accelerators;
- Electrostatic;
- Magnetostatic; and
- Thermal.

The square-section transmission lines were modelled inside a large bounding box with open (absorbing) boundaries, with the 3D structure and surrounding space meshed very finely. I ended up using the frequency domain solver for convenience (a single sample at 500 MHz) but the broadband result using the time domain solver proved exactly the same.

The simulation produces three-dimensional E and H fields for the entire structure – in this case, an open-circuit transmission line about 50 mm long (to satisfy the minimum number of mesh lines for stability).

Because we aren't interested in the 3D fields or S-parameters, I used a post-processing macro to calculate the port impedance. This is done by integrating the 2D fields over a large

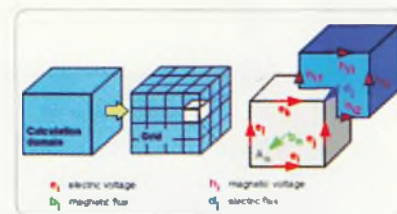

Figure 5: CST's approach to solving Maxwell's equation using a 'grid' of discrete cells.

area surrounding the structure in the plane of the port. All in all, it's a computationally inefficient way to solve a relatively simple 2D problem, but it's accurate and fast and the software is setup to do parameter sweeps.

Finding an equation

So, back to the curves in Figure 4. We discussed whether a single equation could be found or "fitted" to the data from CST. While a set of curves is useful, an equation has wider application over more circumstances. Keith VK1KM had a go at producing a fit using the facilities in Excel. The result, **Figure 6**, was a fairly straightforward equation in loge ('natural' log) form. The equation is an average of the family of curves and the differences – the errors – get away from you outside a very narrow range. Another way had to be found.

For the four extrusion sizes, I (VK2ZRH) plotted Zo (from the CST 'Field Solver' curve) versus the ratio of face-to-face spacing over centre-to-centre spacing (s/D , or s/s''), a different expression of the shape factor, shown in **Figure 7**. Here, $D = W + s$. I then over-plotted the curves of Zo versus s/D for a couple of likely log_e (\ln) equations. It looked promising, but these two curves only cross the CST Field Solver curve (solid line) at two points, arrowed in **Figure 7**.

I noticed the solid line had the shape of a snake – a flattened S-curve, which is described mathematically by a cubic equation:

$$Y = a + bx + cx^2 + dx^3 - \{1\}$$

The problem now was to determine the values of the factors a, b, c and d for this application (x is the shape factor s/D). Quite a few mathematical software suites available will perform this function – for a price (eg. Matlab)! Kind of using a sledgehammer to crack a nut. I wasn't going to do it with paper, pencil and pocket calculator as I remembered doing the 'exercise' when I was an engineering student (with a slide rule – taking half a day)!

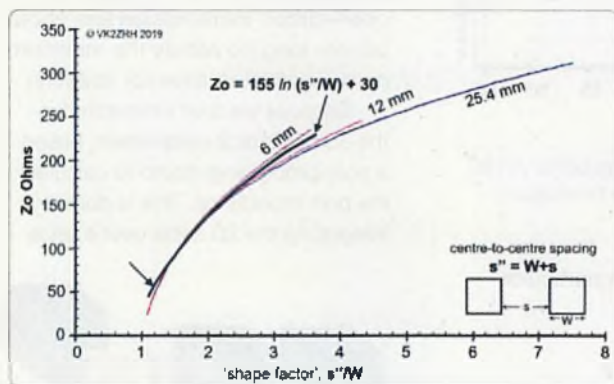

Figure 6: Throwing a fit! Trying to find – by 'fitting' – a curve that comes close to a set of different curves. The X-axis is the transmission line's 'shape factor', ie. the centre-to-centre spacing divided by the width of the square extrusions. The curve for the 19.05 mm extrusion is buried beneath the others.

Fortunately, I remembered the free open-source software website Source Forge had all sorts of mathematical tools available, and its ZunZun site does the job. (ZunZun is the common name of the smallest living bird, *Zunzuncito*, or bee hummingbird, endemic to Cuba. Go figure). It provides 2D curve fitting and 3D surface fitting. The code has moved to GitHub: <https://github.com/zunzun/zunzunsite3#start-of-content>. You will need to sign-in and may require some python skills to assemble a usable application to plot curves from a set of text data. A pity that the original program is no longer "click and run".

Meanwhile, Andy used CST to generate tables of Zo for transmission line sets using six common square extrusions (6.35, 9.5, 12.7, 16, 19.05 and 25.4 mm) with face-to-face spacings of 1-50 mm. This provided an extensive data set in Excel tables. **Figure 8(a)** is the plot of that data set, from ZunZun. Note the slight 'scatter' in the plotted data.

I've changed the nomenclature here so that, now, D is the dimension of the square-section extrusion and s is the face-to-face spacing. When building parallel transmission lines with square-section extrusions, it's much easier to work with face-to-face spacing measurements than centre-to-centre. Again, the X-axis is the shape ratio of face-to-face spacing over centre-to-centre spacing [$s/(s + D)$]. Using $s + D$ as the denominator compresses the range of numbers for the critical axis. The s/D ratio from the Field Solver tables is greater than 200:1.

I generated a cubic curve-fit, plotted in **Figure 8(b)**. The curve departs from the data a little at the far top end, but we're probably beyond the useful applications once we hit a Zo of 300 ohms. Beyond the last dot at the lower left, the curve-fit is in wishful thinking territory!

Not only does ZunZun generate the curve fit, but it also generates the four coefficients of the cubic equation that describes it. Here's the resultant cubic equation:

$$Zo = 0.45 + 344[s/(s + D)] - 345[s/(s + D)]^2 + 411[s/(s + D)]^3 - \{2\}$$

Figure 9 shows the "cubic for squares" plot without the clutter. Note that the curve does not reach the zero point. Accuracy deteriorates below about 15-16 ohms

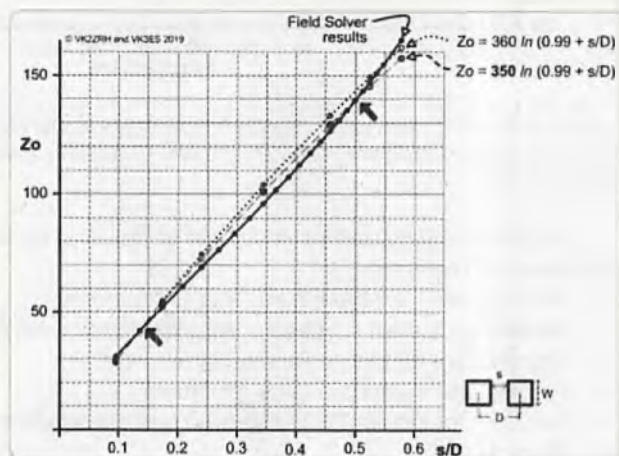

Figure 7: A different kind of fit. Squint and you'll see that the solid line is S-shaped.

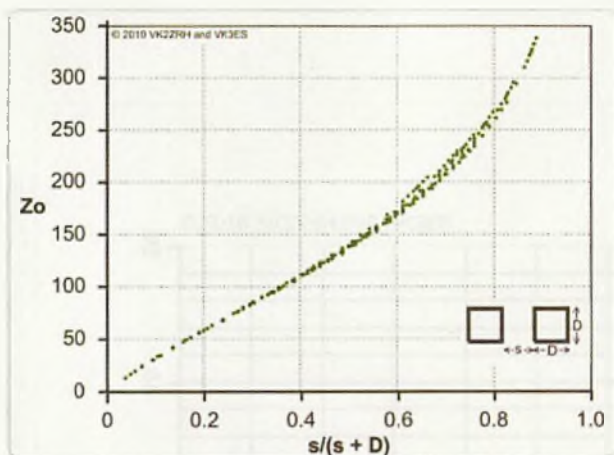

Figure 8(a) : Plot of the data.

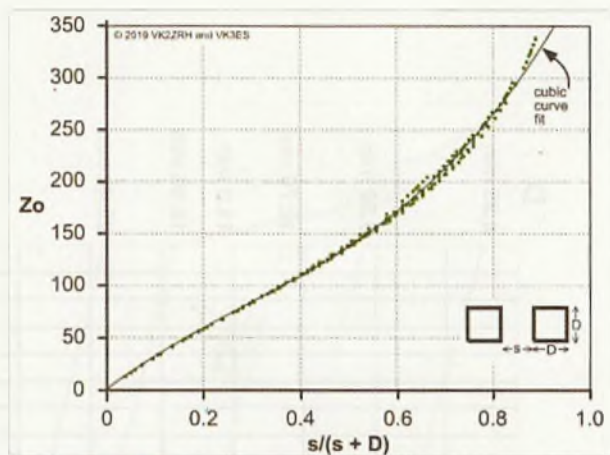

Figure 8(b) : The cubic curve fit.

Zo and a shape ratio of 0.04 (didn't have any data, anyway!). In any event, in the lower left corner, that first coefficient of 0.45 begins to assume some significance.

Construction tolerances also become quite stringent, as you have to deal with fractional millimetre dimensions in some instances. A shape ratio of 0.04 is exemplified by 25.4 mm extrusions spaced by 1.1 mm! Fortunately, there's little call for 12.5 Ohm transmission lines – but it could be done.

The beauty of a cubic equation is that you can do the arithmetic on a four-function calculator – or a slide rule!

The snake-bend of the curve in Figure 9 would appear to derive from a balance between the strength of the field between the faces and the sum of the fringing fields surrounding the lines. At wide spacing, the fringing fields have proportionally more influence. As the spacing narrows, the between-faces field begins to dominate until it has the dominant influence.

The question that arises next is, how “good” is the equation's fit ?

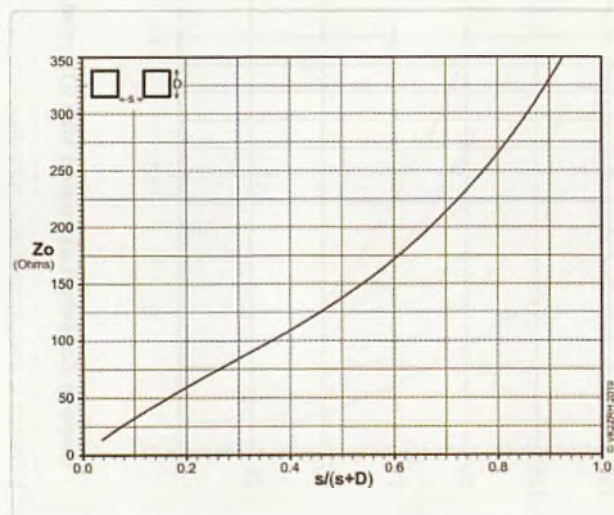

Figure 9. Zo versus the shape ratio for close-spaced square-section parallel transmission lines.

| Size (mm) | s/(s+D) | Zo (CST) |
|-----------|----------|----------|
| 12.7 | 0.282486 | 78.844 |
| 25.4 | | 79.838 |
| 12.7 | 0.35533 | 97.438 |
| 25.4 | | 99.083 |
| 6.35 | 0.386473 | 104.949 |
| 12.7 | | 105.550 |
| 19.05 | | 106.385 |
| 25.4 | | 107.559 |
| 12.7 | 0.541516 | 150.031 |
| 25.4 | | 154.920 |
| 6.35 | 0.653951 | 186.820 |
| 12.7 | | 190.023 |
| 25.4 | | 200.162 |

Table 1. Scatter in the Zo calculated results.

Figure 10 is a plot showing the absolute error, in ohms, for the cubic equation versus the CST data set. Worst error is about +/- 4% between 200-250 ohms. Note the ‘family’ of curves. This is an artefact of the family of data – six extrusions of different dimensions. Note how closely they converge below about 120 ohms.

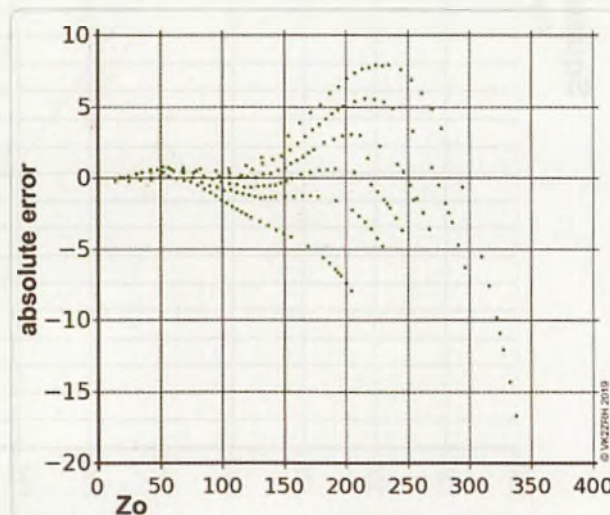

Figure 10. Absolute error, curve-fit Zo versus Zo data from CST tables, for square-section lines.

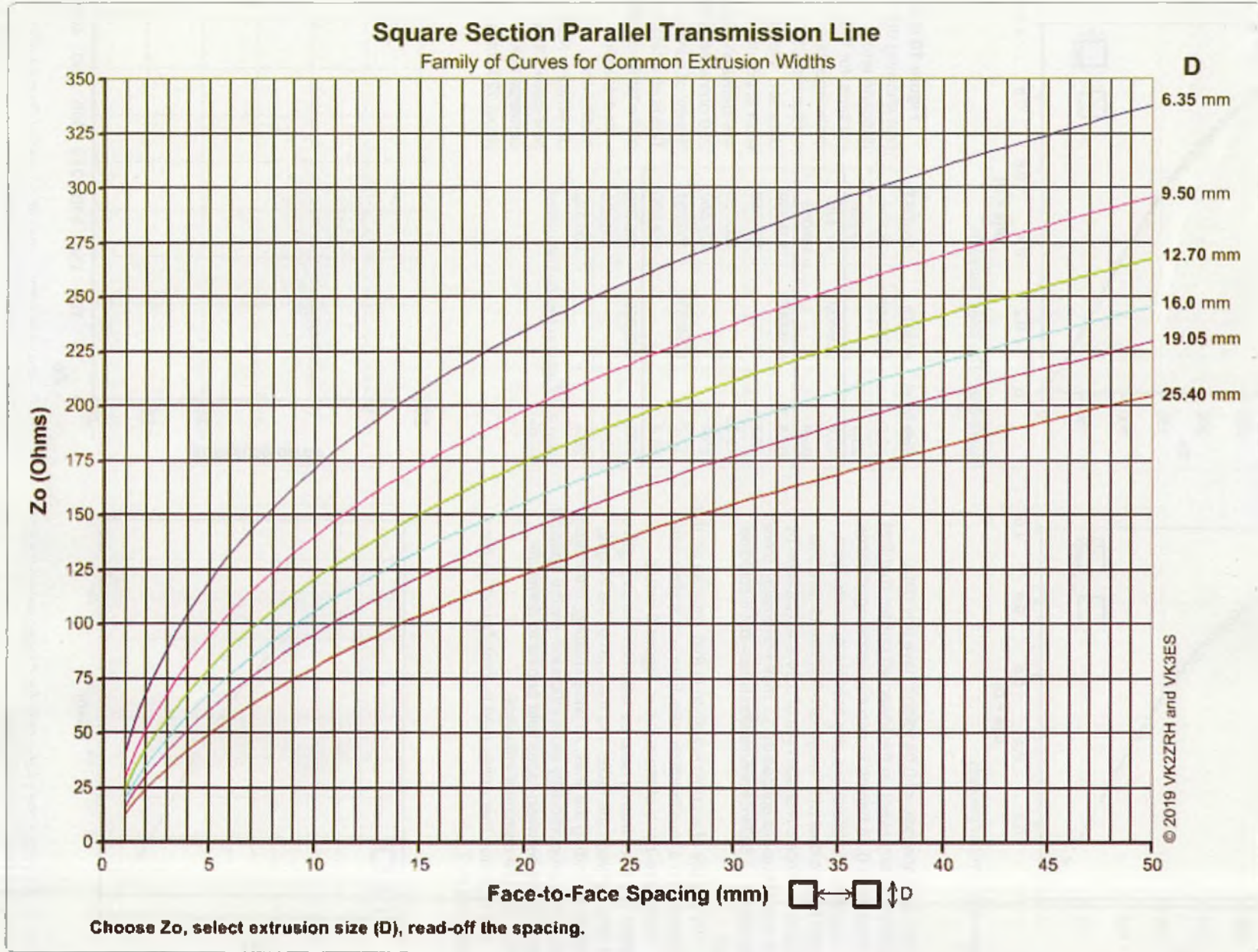

Figure 12. Family of transmission line impedance curves for common square-section aluminium extrusions with face-to-face spacings from 1 mm to 50 mm.

Commercial off-the-shelf (COTS) coax isn't this good!

Something I (VK2ZRH) noticed in the CST data tables was a small 'scatter' in the impedance calculated by CST for different square-section sizes for the exact same shape ratio, $s/(s+D)$, which I have illustrated here in **Table 1**.

For the same shape ratio, Z_0 increases as the square-section size (D) increases. Perhaps this phenomenon is an artefact of the FIT calculation methodology.

As the exercise using CST to this stage had assumed 'perfect' conductors, I wanted to know what difference specifying aluminium made, and if rounded corners on the extrusions mattered. After all, in the 'real world', square-section parallel transmission lines would use commonly available aluminium extrusions. Andy produced a set of curves for a 19.05 mm square extrusion, with 0.5 mm and 1 mm corner rounding, without rounding, and for a perfect conductor.

Figure 11 shows there's negligible difference.

A simple, direct way to design a square-section parallel transmission line is to take the desired Z_0 then read-off the required spacing from a family of curves for different extrusion widths using **Figure 12**.

For common values of Z_0 and square extrusions, **Table 2** provides an 'easy pick' table.

A new twist: variable-impedance line

It occurred to me (VK2ZRH) that, by rotating one or both

| Z ₀ ohms | 6.35 | 9.5 | 12.7 | 16 | 19.05 | 25.4 |
|---------------------|------|-----|------|----|-------|------|
| 50 | | 2 | | | 4 | 5 |
| 75 | | | | 6 | 7 | 9 |
| 100 | | | 7 | 9 | 11 | 14 |
| 150 | | | 15 | 19 | 22 | 28 |
| 200 | 14 | 20 | 27 | 33 | 38 | 48 |
| 300 | 37 | 52 | | | | |

Table 2. Face-to-face spacings (s) for common square extrusion sizes (D), both in mm, against common values of Z_0 . Fractional-mm spacings are excluded to make 'easy picking'.

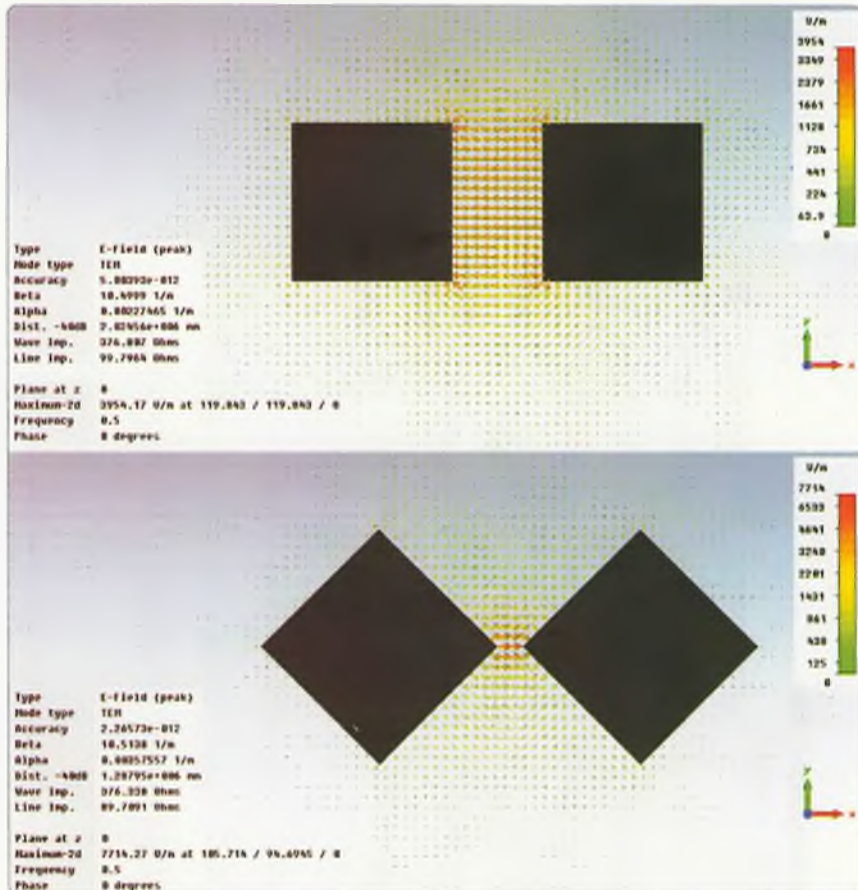

Figure 13. Square-section extrusions offer the possibility of variable impedance by rotating one or both lines.

lines of a square-section parallel transmission line, one could adjust the impedance. So Andy explored this situation with CST, illustrated in **Figure 13**.

Here, two 12.7 mm width extrusions are spaced 20 mm centre-to-centre, giving a face-to-

face spacing of 7.3 mm and a Z_0 of 99.8 ohms. With both lines rotated, Z_0 falls to 89.7 ohms, a variation of 10.1 ohms, or 10%. With only one line rotated, you get about 40% of the total change (ie. 4 ohms in this case). At wider spacings, the variation is much less – about

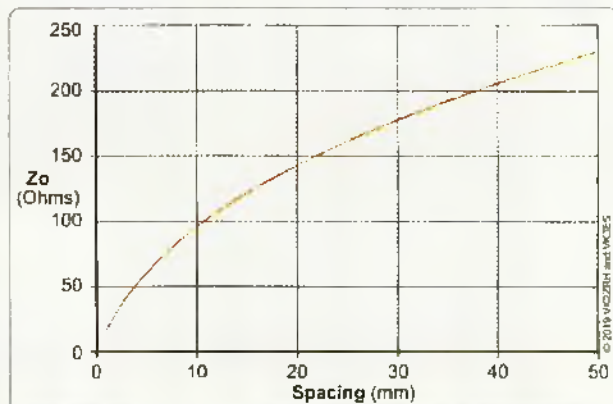

Figure 11. Comparison of 'real world' conductors versus 'perfect world' conductors.

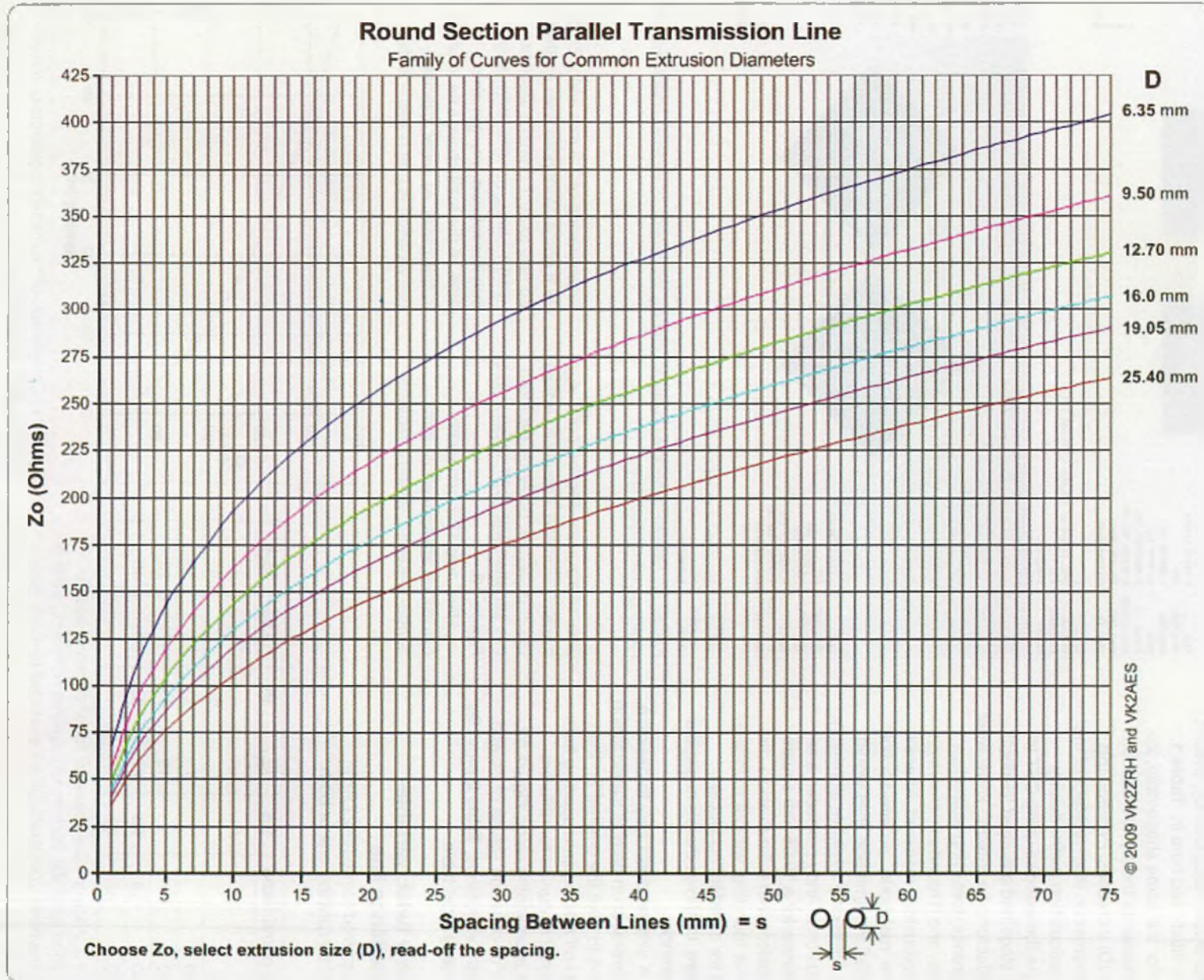

Figure 18. Family of transmission line impedance curves for common round-section lines (rod or tube) with between-line spacings from 1 mm to 75 mm.

3 ohms at 12 mm face-to-face spacing and 130 ohms Zo.

Another take on variable impedance is the tapered line, where the lines aren't parallel, but spaced wider at one end than the other. This affords a transition from a higher impedance at the wide end to a lower impedance at the narrow end – the same principle as used in the well-known delta-match for dipoles.

Close-spaced round-section parallel feeders

Having learned that the commonly quoted equations for parallel transmission lines (Panel A) have limits and determined a way to calculate the impedance of close-spaced square-section transmission lines, we decided to embark on doing the same for round-section lines.

The handbook and textbook sources hinted that the shape ratio of s'' (centre-to-centre spacing) to D (diameter of lines) should be greater than 2 or 2.5. Andy and I decided to check this out and, indeed, it proves to be correct. CST was used to generate tables of Zo for six common round-section extrusion sizes (rod, tube or wire) at spacings of 1-75 mm.

I then compared the CST Zo values to values calculated from the four common handbook equations in Panel A, plotting the differences – Figure 14. The X-axis is the shape factor s''/D . The Y-axis is the difference, Δ . It's a logarithmic scale to amplify the differences so that they are easily discernible. Here, 1.01 = 1% difference; 1.1 = 10% difference, 2.0 = double, or half.

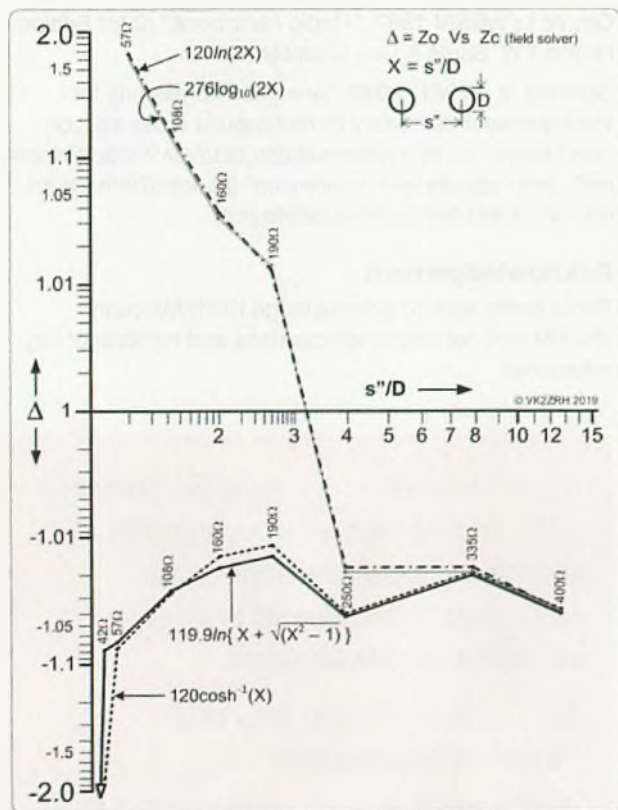

Figure 14. Accuracy of handbook equations (for round-section lines) – Zo – versus calculated results from CST – Zc. The four equations here are those illustrated in Panel A.

Impedance comparisons were made for s''/D ratios from 1.04 through 12.5.

As is evident, the handbook equations' results neatly converge for s''/D ratios above roughly 3.8, diverging sharply for s''/D ratios below about 3.2. Note the 'pairing' of equations. Above an s''/D ratio of 4, the handbook equations' results are all a few percent lower than the CST Zo values. This reflects the fact that the equations are approximations.

For s''/D ratios less than 2, the plots for the four equations diverge sharply. Accuracy of the four handbook equations (Panel A) rapidly deteriorates for s''/D ratios below 2.

These results begged the question: Could a cubic equation be found to 'fill the gap' for round-section parallel transmission lines with s''/D ratios below 2? Indeed it could, and here it is, equation {3}, also plotted in Figure 15:

$$Z_o = 972(s''/D) - 481(s''/D)^2 + 86(s''/D)^3 - 547 \quad - \{3\}$$

The same process was used to derive this cubic equation and plot, as was used to derive equation {2} for square-section lines. Again, the absolute error plot, Figure 16, shows the results can be better than for COTS coax line.

Figure 17 shows Zo results from equation {3} plotted over the comparison curves of Figure 14 (Panel A equations). This shows that Zo calculations using {3} overlap the handbook equation results for s''/D ratios between 2.0 and 2.5 and have better accuracy, falling within the +/- 2% difference range.

Equation {3} yields very good results for impedances ranging from 50 to 170 ohms. With close spacings at low impedances, construction tolerances may prove a challenge.

The conclusion is inescapable that low impedance parallel transmission lines, with Zo below 50 ohms down to perhaps 12.5 ohms, are more practical to construct with square-section extrusions. As before, with square-

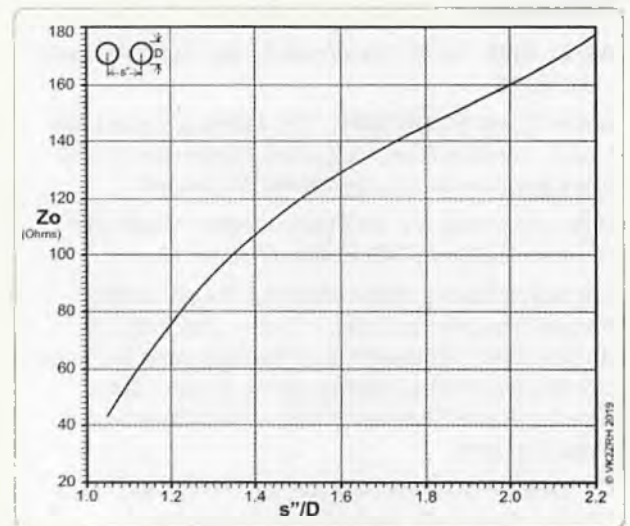

Figure 15. Transmission line impedance – Zo – versus shape ratio (s''/D) for close-spaced round-section parallel transmission lines.

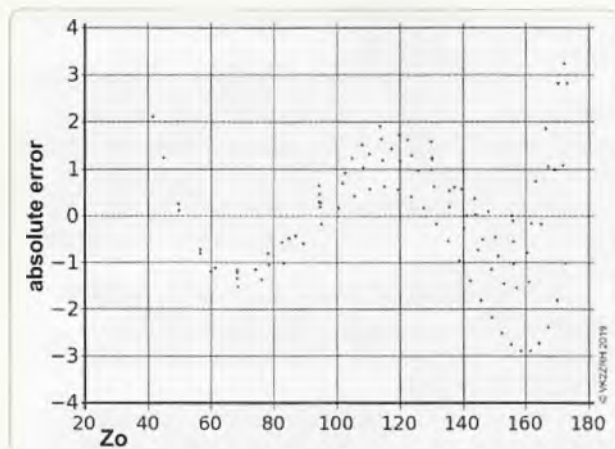

Figure 16. Absolute error, curve-fit Z_o versus Z_o data from CST tables, for round-section lines.

| Z_o ohms | 6.35 | 9.5 | 12.7 | 16 | 19.05 | 25.4 |
|------------|------|-----|------|----|-------|------|
| 50 | | | 1 | | | 2 |
| 75 | | | | 3 | | 5 |
| 100 | | | | 6 | 7 | 9 |
| 150 | | | 11 | 14 | 16 | 21 |
| 200 | 11 | 16 | 21 | 27 | 31 | 41 |

Table 3. Face-to-face spacings (s) for common round extrusion sizes (D), both in mm, against common values of Z_o . Fractional-mm spacings are excluded to make 'easy picking'.

section line, Andy has produced a family of curves for different round-section extrusion sizes (tube or rod), providing Z_o versus spacing – as in Figure 18.

Table 3 is another "easy pick table" of spacings for common Z_o values when using round-section extrusions.

References

- ARRL, 1989, "ARRL Handbook for the Radio Amateur", Chapter 16.
- Butler, Lloyd VK5BR 1991, "The Merits of Open Wire Lines", Amateur Radio magazine, September, <http://users.tpg.com.au/lldbutler/MeritsOWLLine.pdf>
- Dulin, J.J., Velej, V.F. & Gilbert, J. 1991, "Electronic Communications", TAB Books, Chapter 13.
- Harrison & Sayers, 2009 "Round & Square Section Parallel Transmission Lines – Theory, Practice and Applications". Proceedings of the Gippsland Technical Conference 2009, published by the Eastern Zone Amateur Radio Club (Australia), www.vk3bez.org/gippstech.html.
- ITT 1968, "Reference Data for Radio Engineers", 5th Edition, Howard W. Sams & Co., Chapter 22.
- Lo, Y.T. & Lee, S.W. 1988, "Antenna Handbook – Theory, Applications, and Design", Van Nostrand Reinhold Company Inc., Chapters 9 and 28.

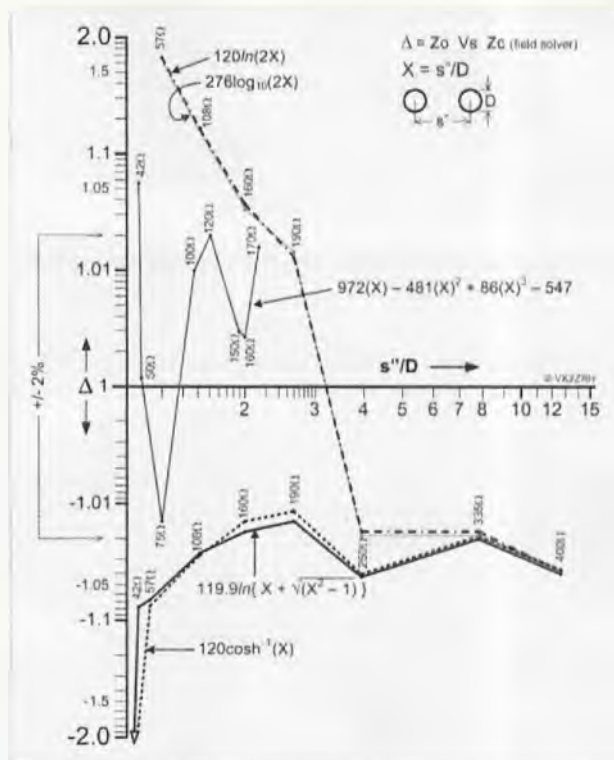

Figure 17. Equation (3) for round-section lines fills the gap for s''/D ratios below 2.5 with good accuracy.

Orr, W. I., W6SAI 1987, "Radio Handbook", 23rd Edition, Howard W. Sams & Co., Chapter 21.

Schmidt, K. W9CF, 2008, "Analytic expressions for the equivalent diameters of rectangular cross section conductors" (at <http://fermi.la.asu.edu/w9cf/articles/conf.pdf>), and "update with references" (at <http://fermi.la.asu.edu/w9cf/articles/update/update.pdf>).

Acknowledgement

The authors wish to acknowledge Keith Malcolm VK1KM (SK) for helpful discussions and retrieval of key references.

The cubic equations developed and presented in this article have been incorporated into antenna and transmission line design applications in the following publically available, free software suites:

Yagi Calculator, by John Drew VK5DJ:
www.vk5dj.com/yagi.html

EME Calculator by Doug McArthur VK3UM (SK):
www.vk3um.com/eme%20calculator.html

A novel arboreal aerial for the 630m and 160m MF bands

Leigh Turner VK5KLT

The intriguing notion and application of tree structures *per se* – that is, using a tree as an antenna, rather than just for supporting one – performing as effective radio antennas has been present in both amateur radio and professional military radio communications circles for decades. Much of the impetus for the latter interest stemmed from US Army sponsored research during the Vietnam War era for improving radio propagation and communication efficacy in dense jungle terrain with high attenuation.

Introduction

Healthy living trees possess a fluid-rich outer cambium layer transporting nutrients comprising ground water and inorganic mineral ions from the soil to support tissue growth and maintenance of the trunk, branches, and foliage, keeping the entire tree structure alive. This upward movement of fluid being conducive to the conduction of electrical current and, if an RF current could be caused to flow within the tree outer fluid layer, then electromagnetic (EM) radiation will naturally ensue, according to classical Maxwell's equations governing EM field generation.

Owing to the poor conductivity and associated resistive loss of the xylem and phloem sap transportation fluid inside the living tree, antenna resonance effects will be low along the trunk's ionic conductor cambium layer being co-opted as the vertical "radiating element" supporting the RF current flow. Tree trunk antenna structures have been shown to, and will indeed radiate, but just not as efficiently as their traditional metallic conductor antenna element counterparts.



A tree is a 'natural' vertical with 'included ground'. Inset: trunk cross-section showing location of the important cambium layer. The tree pictured is a *Eucalyptus deenei* growing in NSW; provided by Tim Johnson (DRNSW).

So, is the idea of loading up a tall tree trunk as an antenna an absurd and futile exercise in nonsense folly? Perhaps the answer to this vexing question depends on

the situation and what one's aerial performance expectations are, and most importantly, how that loading and current excitation technique is attempted.

The crux of the challenging problem here is how to maximally induce that RF current longitudinally into the ionic fluid laden, relatively high resistivity (circa 30 – 200 M Ω) peripheral tree tissues.

Practical considerations

The commonly deployed approach of simple shunt feeding and matching via a single point nail driven into the trunk and RF voltage excited against a ground stake, is fraught with potential power transfer related issues and debate as to where the dominant radiation is emanating from. Is it the tree, or the feed wires, imbalance radiating common mode currents, and/or incidental radiation from the peripheral transceiver apparatus?

A key finding from the US Army investigations about how to optimally induce the RF current in the tree trunk was the deployment of a toroidal coupler, or resonant current transformer, comprising a flexible air-cored torus-shaped coil of self-supporting wire large enough to be uniformly spiral wrapped around the tree trunk.

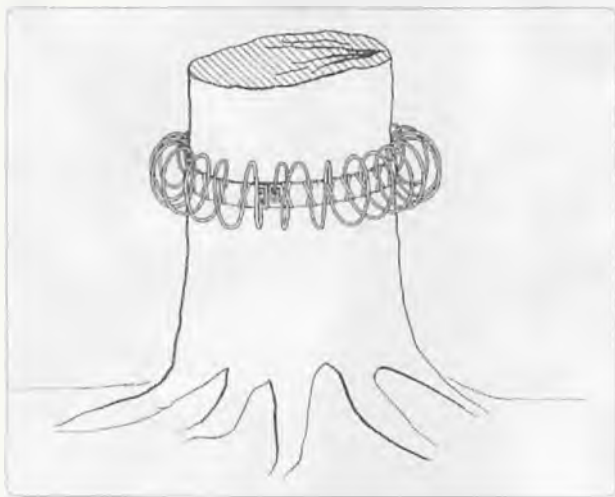

Figure 1: The toroidal coupler encircling a tree trunk, dubbed a Hybrid Electromagnetic Antenna Coupler.

The coiled coupler becomes an H-field magnetic loop antenna forming the primary winding of a current

transformer, with the tall vertical tree trunk forming the single-turn secondary. The toroid carrying RF current causes a useful EM field and RF energy to be radiated with the aid of the tree structure on which the toroid coupler is mounted.

Because of the RF energy-transferring toroid's intrinsic electric and magnetic field properties, the military developers gave it the descriptive name HEMAC, an acronym for Hybrid Electromagnetic Antenna Coupler.

The coil's large pitch of the air-core turns results in a desired 'leaky' magnetic structure and when used as a distributed coupler surrounding the tree trunk, prevents undue concentration of the localised magnetic or electric fields which would otherwise cause excessive losses in the adjacent tree tissue. Figure 1 illustrates the typical deployment configuration of the HEMAC on the tree trunk.

Some brief theory

The transceiver is connected to the toroidal coupler as illustrated in Figure 2. The helical coil's self-inductance is series resonated by a variable capacitor such that maximum RF current flows in the coil at resonance.

An adjustable impedance matching ATU / L-match or T-match tuning box, etc. preferably having a balanced output and capable of matching the low (several ohms) equivalent series-tuned load impedance to 50 ohms is interposed between the toroid coupler and the radio transceiver. The balun is a 1:1 Guanella current type.

When the variable capacitor is adjusted to resonance, the RF current is peaked, as indicated on the RF ammeter, and driven through the toroid coil around the trunk. The resulting uniform circumferential magnetic field around the tree trunk induces a secondary current by transformer action that flows longitudinally up and down the outer fluid layer of the tree trunk.

This CT / current transformer action is illustrated in Figure 3 and is wholly consistent with the laws of electromagnetism. If the healthy living tree is a reasonable electrical conductor then RF power will be duly radiated from it, and by reciprocity, RF signals received.

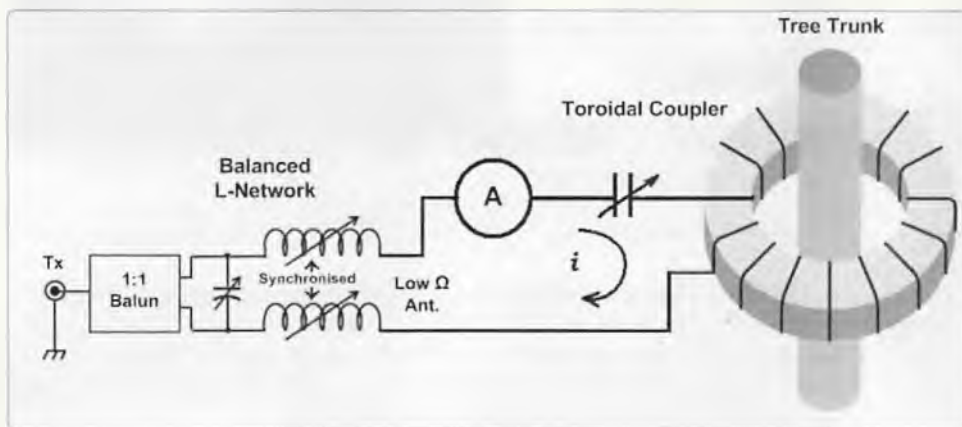

The antenna terminal voltage is the product of the effective length of the tree antenna times the incoming incident V/m electric field. The antenna voltage divided by the

Figure 2: Circuit diagram of the HEMAC. The variable capacitor is adjusted to maximise the current flowing through the toroidal couple around the tree trunk.

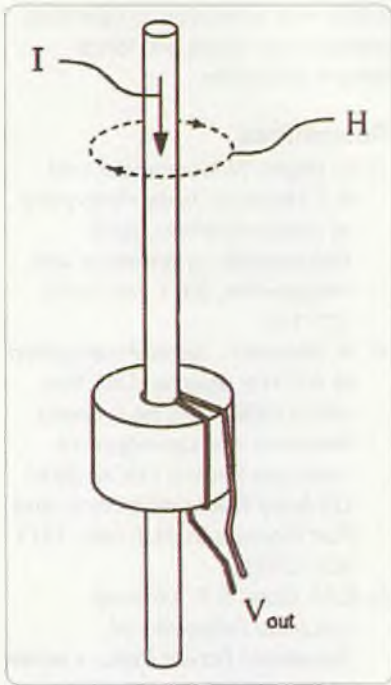

Figure 3: Illustrating the vertical current flow induced in the tree trunk's cambium fluid layer.

self-impedance of the antenna element governs the antenna current. The movement of the antenna current in the conductive sap fluid generates the H magnetic field, which is picked up by the toroid coupler.

The magnetic flux density, or B field, in the coupler is generated by the H field. The magnetic flux Φ in the toroid is produced by the cross-section of the core and the B field. The changing magnetic flux Φ produces the voltage output in the turns of the winding and delivered to the receiver.

From the geometry of the HEMAC and the tree to which it is coupled, we would expect the radiation field to be vertically polarized and omnidirectional in terms of azimuth.

In explaining and understanding the operation of the composite coupler-tree system, a useful analogy can be made. The coupler mounted on the tree may be thought of as a large whip antenna, the tree trunk comprising the vertical whip, the foliage top loading

capacity, and the root system and the earth to which it is conductively connected forms the electrical ground or counterpoise for the tall whip radiator element.

HEMAC design and construction guides

For tree excitation operation in the 630m MF band (472–479 kHz), the HEMAC toroid comprises 23 uniformly spaced helical turns of wire 3–4 mm thick (for example, substantially self-supporting 6mm² stranded yellow-green PVC covered electrical wire) with a nominal 250 to 300mm coil diameter and an overall torus diameter of approx 1 to 1.5m, to fit the desired tree trunk.

The HEMAC is placed around the trunk at around about 1m height above ground. The plurality of self supporting turns of rigid wire are typically attached to an adjustable wide flat belt arrangement having a fastening means whereby the toroid is easily strapped around the tree trunk of various circumferences.

The HEMAC can also be viewed as a helical antenna, with its axis bent into a circular shape or a loop. However, it differs in respect of being electrically small in relation to a wavelength, with no standing waves in the toroid coil windings and with a substantially uniform RF current throughout the entire coil when excited in the 472 kHz range. This MF coil exhibits an inductive impedance up to about 2 MHz and is thus useful for exciting tree structures on both the 630m and 160m amateur bands.

The number of turns and the turn diameter can be varied to accommodate various frequencies and transmitter powers. Higher frequency operation requires fewer turns, and higher power, and greater turn diameter, so that the power density does not become excessive and cause undue localised dielectric losses within the adjacent tree tissue.

For higher 80m and 40m band HF operation, a 12-turn helix winding with a nominal 200 to 250

mm coil diameter yielding a large open pitch will be found to be optimum when the concertina coil is expanded and uniformly wrapped around the tree trunk.

Deployment guidelines

Tall evergreen conifers and pine tree families located in well-watered areas would seem good candidate choices for loading up as useful MF/HF antennas.

It is recognized that a vertical monopole antenna having a length equal to one quarter of a wavelength at the operating frequency provides a desirable vertically polarized, omnidirectional radiation pattern. Finding a tree about 40m tall is not unreasonable or uncommon, even in some suburban backyards, and will enable a practical realization of a quarter-wave radiator element on the 160m topband. Even on 630m, such a significant radiating element length will radiate useful power and yield communication utility.

Now here's where things get interesting. If there is a dense cluster of adjacent trees with their foliage crowns interleaved forming a contiguous canopy, together with an interleaved subsoil root system such that the tree trunks, the tree crowns, and the soil and roots form a plurality succession of distributed closed path loops around which RF current can flow, then a greatly expanded area of radiating elements that form a large n-loop array is beneficially achieved.

In this unique manner, a single strategically placed HEMAC is capable of exciting an entire forest zone into a gigantic antenna array! Depending on the spatial disposition of the chosen tree constellation and the location of the coupler, the forest may be converted to either an omnidirectional, or a directional end-fire radiator, if the coupler is mounted on a tree which is at the end of a linear line.

If the plurality of RF currents is in the lower portion of the HF band where the wavelengths are of the

order 40 to 80 metres, the quarter-wavelength is 10 to 20 metres, and this figure is equal to the distance between the forest floor and the underside of the canopy foliage for many typical forests. Thus, the space under the tree crowns acts as a giant resonant cavity or radiating 'leaky' waveguide in the HF region.

When you get beyond the novelty and hyperbole, there aren't any magic or miracle antennas; there is always an explanation for how antennas perform when you know and understand enough about their design and deployment environment.

For example, the dominant radiation contribution in the tree antenna scenario might well come from system elements that aren't initially considered to be part of the real antenna, but rather attributed to spurious sources like the feedline, power cables, ground wires, mic cables, the person holding / operating the equipment, etc. In any unconventional antenna, particular care must be exercised in eliminating these spurious radiation sources lest one might be easily misled. The ATU and balun should be placed at the HEMAC location to ensure HEMAC balance and feed symmetry is maintained,

and suppression of any radiating common-mode currents on the coax feedline to the transceiver. One must be wary of seemingly miracle antennas, especially those that cannot be fully explained by using conventional analysis techniques as they probably do not perform well at all compared to a well established and characterised reference antenna.

Conclusion

While not a trailblazing DX-enabling antenna, the novel arboreal aerial will perform a competent job in establishing reliable local and medium distance communication for local and national amateur radio net operation.

The technique is particularly useful when a stealth antenna is desired or where an expedient quickly deployable and demountable field antenna is required. The simple hybrid coupler-based tree trunk excitation technique is scalable from MF to operating at the higher frequencies of 3.5 and 7 MHz.

The unconventional method discussed here provides fertile ground for fruitful novelty antenna experimentation and quirky exploration. Such structures add a

whole new dimension to operating portable and parks and forest reserve activation.

References

- 1) K. Ikrath, W. Kennebeck and R.T. Hoverter. *Trees Performing as Radio Antennas*, *IEEE Transactions on Antennas and Propagation*, 23. 1 Jan. 1975, 137-140.
- 2) K. Shrivseth. *Signal Propagation at 400 kHz using an Oak Tree with a HEMAC as an Antenna*. Research and Development Technical Report, ECOM-3534. US Army Electronics Command. Fort Monmouth. N.J. Nov. 1971. AD-735330.
- 3) E.M. Gora, S.P. Yanoviak, *Electrical Properties of Temperate Forest Trees; a review and quantitative comparison with vines*. Canadian Journal of Forest Research <https://doi.org/10.1139/cjfr-2014-0380>
- 4) A. Ganthaler, et al, *Noninvasive Analysis of Tree Stems by Electrical Resistivity Tomography; unraveling the effects of temperature, water status, and electrode installation*. <https://doi.org/10.3389/fpls.2019.01455>

WIA news

Diversity and inclusion in amateur radio

A small team of Australian amateurs recently launched a new international club to promote and embrace diversity among enthusiasts in the radio hobbies.

Michael VK3FUR says that the Pride Radio Group exists as a safe and friendly community for people from all walks of life to discuss and experiment with radio while showing pride in their identity. The Group has been issued the callsign VK3PRG and has obtained a US callsign KJ7RTA.

Membership in the Pride Radio Group is free; it claims they have already attracted over 100 signups.

Activities include a global net, a future contest and special events to promote the group and build a community. More details on the Pride Radio Group website, at: <https://prideradio.group/>

Spectrum sell-off in Peru bad news for radio amateurs

Peru's Ministry for Transport and Communications (MTC) plans to sell-off spectrum in the 3.3-3.8 GHz ('3.5 GHz') and 24.2-25.5 GHz ('26 GHz') bands, over the heads of existing band occupants.

The MTC has allowed telecom operators holding spectrum in the 3.5 GHz band to use these frequencies to provide mobile

broadband services, such as 5G. MTC modified the national frequency allocation plan to allow carriers to provide some services other than those originally assigned for the spectrum.

Peru expects to launch a spectrum tender for 5G technology in the first half of 2021, awarding frequencies in the 3.5 GHz band and the 26 GHz band. This impacts the two Amateur Service allocations of 9cm and 12mm.

In the USA, the ARRL and local microwavers are fighting against similar impacts on the 9cm band. More online, at: www.bnamericas.com/en/news/peru-clears-use-of-35ghz-band-for-5g

Build this antenna switch with power-and-SWR meter for the HF bands

Jim Tregellas VK5JST

Domestic harmony was the motivation for this project. Our house contains two hams, one of whom is messy and experimental (me).

Before I finished this project, typically, my wife would discover that she could not join her favorite net (the ANZA net, daily at 0515 UTC on 14.183 MHz) because her favorite radio was not connected to anything as a result of me fooling about, and a total mess of cables had to be sorted first. Something needed to be **done**.

This article is essentially a design study, because every ham station will be different in terms of its switching needs. Hopefully, the principles outlined will assist those who want to build an antenna switch to make a station that is easy to operate.

Design goals and ground work

I had two fundamental goals: that the switching unit would operate over the HF range and at power levels of up to 400 watts.

Now, in a 50 ohm system, 400 watts creates a voltage of 141 Vrms at a current level of 2.83 amps. Hence, relays or switches designed for 250 Vac mains operation would probably be OK.

Next was the most important consideration of **isolation between radios**. How much isolation was needed to protect the input of an inoperative radio from the output of a radio running at 400 watts? Interestingly, I have never seen any amateur radio equipment manufacturer publish a maximum input to their receiver beyond which damage will occur.



Photo 1: I housed my antenna switch project in an ABS plastic case, 260 x 190 x 80 mm (width, depth, height). I replaced the front and rear panels with 3 mm-thick melamine coated MDF to suit this project. Either operator at this station can select any of three transceivers to connect to either the G5RV multi-band HF antenna, or the Yagi HF beam. Domestic bliss prevails!

Experimentation showed that the best isolation which could be obtained across a set of open relay contacts was about 45 dB at 30 MHz, due to the stray capacitance of the relay's structure. Now, 45 dB down on 400 watts is 12.65 milliwatts, or a voltage level of 795 millivolts in 50 ohms.

Given that one of the tests on any 'good' receiver is blocking and intermodulation – testing at an input level of 100 millivolts RMS into 50 ohms (-7 dBm), a 795 millivolt input (~0.8 V) to such a receiver is probably easily survivable without damage occurring. This thought is backed up by the maximum safe input level allowed on many spectrum analysers (essentially, wideband receivers) of typically 1 volt RMS.

It is also worth reflecting that the maximum power dissipation allowed in the base-emitter region of any small signal transistor is about 25% of its specified collector dissipation. So, a 300 milliwatt device like a BC108 can safely dissipate around

75 milliwatts in its base-emitter junction, meaning that this power level can be safely tolerated by the first semiconductor in a receiver structure. FETs can typically tolerate around 5 volt swings on their gates, too, and so a picture forms of 1-2 volts RMS being a safe maximum level at a typical receiver input.

None the less, 45 dB of isolation provides a very small margin of safety, and considerably better levels of inter-channel isolation are desirable.

I set 65 dB as my design goal, which translates to an input power level of 126.5 microwatts, or 79 millivolts into 50 ohms, which is still a huge signal, but SAFE.

Note that such a target for inter-channel isolation thus demands at least two sets of contacts in series in the switching, and, as I wanted to take no chances with an unreliable relay misbehaving (say, contacts sticking), and consequently blowing the front end out of an expensive receiver, this meant using two relays in series for safety. If one relay could

ALL RELAYS ARE 24 VOLT TYPE JQX-115F

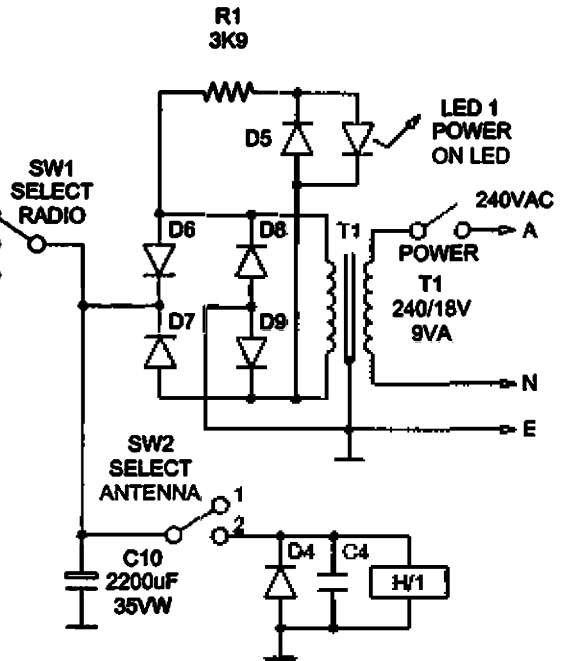
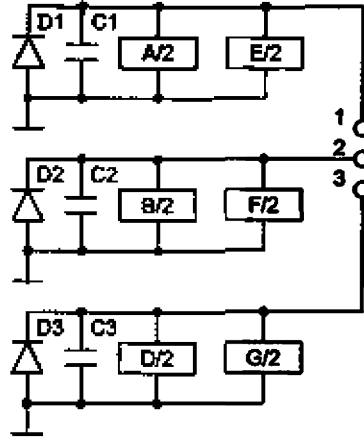
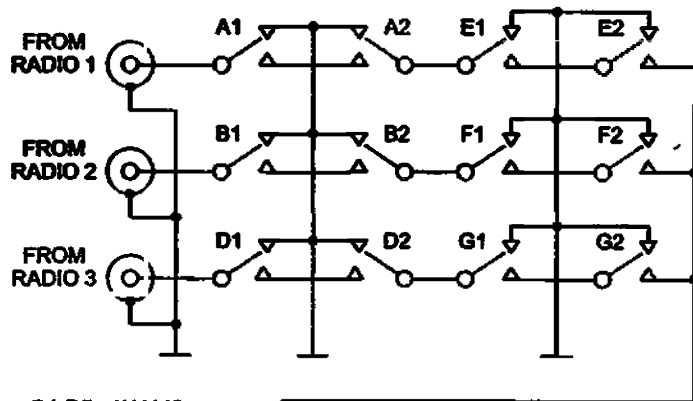

- D1-D5 1N4148
- D6-D9 1N4004
- D10-D11 1N5711
- C1-C5 100nF 50V
- C6-C9 10nF50V
- LED1 5mm RED

T1-T2 22T OF 0.4MM D.
ON FT50-43 TOROIDS

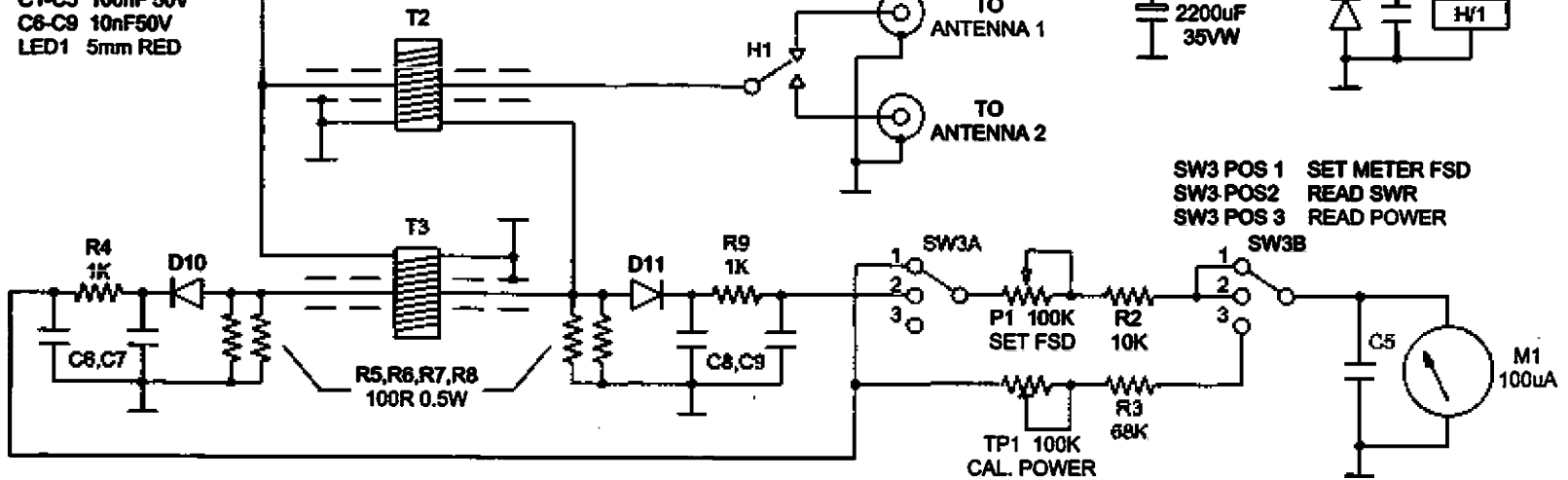

- SW3 POS 1 SET METER FSD
- SW3 POS 2 READ SWR
- SW3 POS 3 READ POWER

HF ANTENNA SWITCH

COPYRIGHT VK5JST OCTOBER 2020

Antenna Switch circuit.



Figure 1: I used these PCB-mounting relays, designed for switching 250 Vac.

fail and on the figures above, there should still be no damage.

As an added precaution, relays with dual contact sets were used, with unused contacts being grounded. This reduces massively the signal leakage across a set of contacts, with the inter-channel isolation now being largely determined by stray coupling and grounding in the printed circuit layout.

So, What relay to use? Over the years, I have collected a huge assortment of relays. Scratching through my junk box produced a number of possible candidates.

Having removed the case from several relays with a bench grinder, I finally settled on a readily available unit, type JQX-115F. This is shown in Figure 1. Note the heavy duty contacts on short vertical support arms. The self-inductance and stray capacitance of the relay contacts are thus very small. The relay contacts are rated at 240 Vrms at 8 amps.

Measurement shows the contact gap is 0.4 mm. Air has a breakdown voltage of around 3000 volts/mm at sea level, which means the flashover voltage for these contacts should be around 1200 volts, and

Megger measurements confirmed this. The contacts actually withstood 2000 V with no flashover, probably due to their beautifully rounded shape.

Consequently, there is a substantial safety margin when operating at 400 watts in a 50 ohm system (141 Vrms, 2.82 amps). These relays are available with both 12- and 24-volt coils; I chose the 24-volt version. If you happen to have the 12-volt version available, then the power supply in the project will need modification.

Achieving 65 dB interchannel isolation

Another design goal was to use a cheap plastic case (Altronics H0482, 260 x 190 x 80 mm). I have a cutting laser, and by replacing the front and rear plastic panels with 3 mm-thick melamine coated MDF, I can easily cut out both panels and all holes, as well as engraving all labeling.

But a plastic box would mean that all RF areas would have to be carefully screened to prevent RF leakage into the ham shack.

This is achieved by laying out a double-sided printed circuit board (PCB) to just fit inside the back panel of the case, with the top of

the PCB having an extensive ground plane. Interconnections on the PCB bottom between relay switches are done with 50 ohm strip lines, ensuring that the switch exhibits low SWR.

Radiation from the rear of the PCB into the ham shack is prevented by using a second ground plane in the form of a solid metal sheet to which the rear of all antenna sockets (SO-239) are bolted, shown in Figure 2 (on page 25). Of course, if a metal case is used, this second ground plane is not required.

Construction is easy, because the PCB can be used as a drilling template for both the rear panel and its associated sheet metal ground plane. So, all RF is essentially confined to this big PCB and the associated ground plane, which makes up a closely-spaced sandwich structure. The end result is at least 68 dB of isolation at 30 MHz between the two closest, physically adjacent channels.

The optional RF power and SWR meter

This structure uses the "Stockton bridge" as its basis, which is the only VSWR/power measuring circuit of which I am aware that does not require tweaks and fiddles to set it up. It is one of the many bridge designs created and patented in the 1950s by Warren Bruene WOTTK of the Collins Radio Company.

Its design is simple. Take a look at the lower lefthand side of the circuit. The current in the 'single-turn' primary of the current transformer, T2, is 2.82 amps at an input power of 400 watts. After a bit of back and forth, I settled on 22 secondary turns on an FT50-43

The circuit is quite straightforward. The power supply (top right) is a conventional capacitor input full-wave bridge rectifier to power the relays (and the Power On LED!). The power transformer is a common PCB-mounting model, with 240 Vac primary and two 7.5 V secondaries, connected in series. A Stockton Bridge circuit, at lower left, samples the transmitted RF passing between the transceiver and antenna. The FT50-43 toroids are widely available (e.g. Minikits). Switch SW1 selects which transceiver you are using, while SW2 selects which of two antennas is connected to the transceiver in use. Switch SW3 selects the operation of the VSWR/Power metering circuit. Potentiometer P1, operated by the front panel knob for "Set FSD", sets the full-scale meter deflection when reading VSWR. Potentiometer TP1 – a trimpot inside the case – is used to set the meter reading when calibrating it for reading power.



Photo 2: All the antenna and transceiver sockets are mounted to the rear panel, with the "switching magic" happening behind it.

toroid. This gives the largest output voltage possible (swamping the turn-on voltages of D10 and D11), without over-dissipating the bridge load resistors R5-6-7-R8.

The secondary current is $2.82/22 = 128.2$ mA, giving an output voltage of 6.4 Vrms across the 50 ohm bridge loads at 400 watts. After detection, this gives about 8.9 Vdc

into the meter circuit.

To calibrate the power meter, use a non-inductive 50 ohm load with a peak responding detector and multimeter, as described in my article in *AR* magazine No.2 – 2020, pages 35 to 37 (*Simple dummy loads for rig testing at HF and higher frequencies*).

Note that, if you wish to just use the switching functions of this project, then the RF power and SWR circuits can be easily bypassed on the main PCB by using a coaxial cable jumper. Also note that, if you include this feature, the bridge structure needs careful screening to prevent RF in the shack.



Photo 3: Internal view of the antenna switcher, showing the relay switching board mounted to the rear panel, the Stockton bridge VSWR and RF power meter section at left, mounted to a 'ground plane' of an un-etched PCB. The VSWR/power sensor circuit comprises two ferrite toroids wound with 22 turns of enameled wire and a 'single turn' primary – a length of coax with the shield grounded at one end (only); you can see that each length of coax has the shield grounded at the opposite end to the other. The simple power supply is at right. Although I used a PCB, the circuit is so simple it's not necessary.

Epilogue

So, that's it. Hopefully, you now have enough information to build a switching and metering system for your own well-appointed radio shack and station, with its many transceivers and antennas. Note that the switch described in this article cannot be reversed, i.e. transceivers and antenna connections reversed. There is insufficient isolation for safety between the current antenna connectors.

As a final comment, if readers want a copy of the main printed circuit board, or a print of the meter scale, please email me, at: endsodds@internode.on.net.

Copyright © J.S. Trogallas VK5JST October 2020

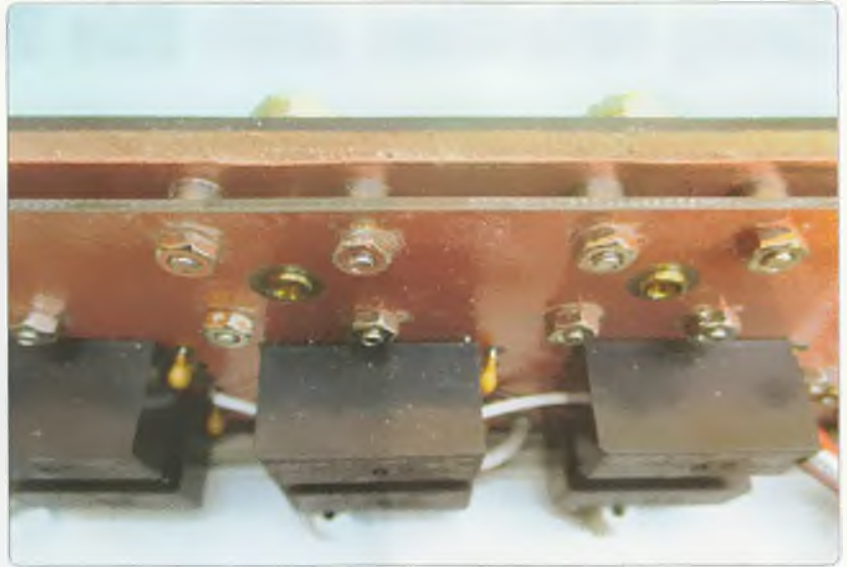

Figure 2: Close-up view of the rear panel, showing the "second ground plane" in the form of a solid metal sheet that is clamped to the inside rear of the panel, behind all the antenna sockets.

WIA news

Are we there yet?

Solar Cycle 25 has begun, says the US's National Oceanic and Atmospheric Administration (NOAA).

The Solar Cycle 25 Prediction Panel, an international group of experts co-sponsored by the National Aeronautics and Space Administration (NASA) and NOAA, has announced that solar minimum occurred in December 2019, marking the start of a new solar cycle.

Because our Sun is so variable, it can take months after the fact to declare this event.

Sunspots are an indicator of solar activity, often as the origins of giant explosions – such as solar flares or coronal mass ejections (CMEs) – which can fart solar material, light, and energy, into space.

"As we emerge from solar minimum and approach Cycle 25's maximum, it is important to remember solar activity never stops; it changes form as the pendulum swings," said Lika Guhathakurta, solar scientist in the Heliophysics Division at NASA Headquarters in Washington.

NASA and NOAA, along with the Federal Emergency Management Agency and other federal agencies

and departments, work together on the National Space Weather Strategy and Action Plan to enhance space weather preparedness and protect the nation from space weather hazards.

NOAA provides space weather predictions and data from satellites to monitor space weather in real time.

Space weather predictions are also critical for supporting the US's space program spacecraft and astronauts.

Surveying this space environment is the first step to understanding and mitigating astronaut exposure to space radiation. Scientists are working on predictive models so they can one day forecast space weather much like meteorologists forecast weather on Earth.

To determine the start of a new solar cycle, the prediction panel consulted monthly data on sunspots from the World Data Center for the Sunspot Index and Long-term Solar Observations (SILSO), located at the Royal Observatory of Belgium in Brussels, which tracks sunspots and "pinpoints" the solar cycle's highs and lows. Australia's Space Weather Services is another World Data Centre (www.sws.bom.gov.au).

"We keep a detailed record of the few tiny sunspots that mark the onset and rise of the new cycle," said

Frédéric Clette, SILSO's director and one of the prediction panelists. "These are the diminutive heralds of future giant solar fireworks. It is only by tracking the general trend over many months that we can determine the tipping point between two cycles."

With solar minimum behind us, scientists expect the Sun's activity to ramp up toward the next maximum, predicted to be in July 2025.

Doug Biesecker, panel co-chair and solar physicist at NOAA's Space Weather Prediction Center (SWPC) in Boulder, Colorado, said Solar Cycle 25 is anticipated to be as strong as the last solar cycle, which was a below-average cycle, but not without risk (in terms of space weather).

"Just because it's a below-average solar cycle, doesn't mean there is no risk of extreme space weather," Biesecker said. "The Sun's impact on our daily lives is real and is there. SWPC is staffed 24-7, 365 days a year because the Sun is always capable of giving us something to forecast."

NOAA has a new satellite, the Space Weather Follow-On L-1 observatory, which launches in 2024, before Solar Cycle 25's predicted peak. More information on sunspots and the solar cycle is in *AR* magazine, Issue 3, 2020, pp 11-15.

Snag satellites with this 2-band Yagi kit

Andy Keir VK2AAK

For portable and field day excursions, I often look for items I can use that are not only compact and easily transportable, but can also serve multiple purposes. That's why this particular antenna appealed to me.

In browsing online a while ago, I came across this dual-band 70cm + 2m yagi antenna kit, sporting five elements on the UHF band and three elements on the VHF band – all on the one boom. In days of yore, before electromagnetic field calculation software (see: *So you want to use software for antenna modelling?*, by Brian Clarke VK2GCE, *Amateur Radio magazine*, Vol.88 No.4 2020, pp 9-11), doing this was a no-no!

Usefully, the antenna kit is supplied disassembled, as a kit of 'parts', which was sent inside a PVC tube.

The antenna is unbranded and is sold through various auction and classifieds sites, usually in the price range of \$120 to \$140. I purchased mine around a year ago through that well-known on-line auction site from a seller in NSW.

I usually prefer to homebrew my antennas and, being a penny-pinching ham, actually paying for them goes against the grain a bit. But, sometimes, the convenience aspect outweighs the economic factors and this is one such case.

Assembling the kit

The antenna is constructed from stainless steel. The fairly thin gauge, square section boom is 1100 mm long. The elements are made from 3.5 mm diameter hollow tube.

Assembly is very straightforward. The position of every element is clearly marked along with the respective position on the boom. Match-up each element with the corresponding



Photo 1: This modest-cost dual-band Yagi comes as a kit that can be assembled and disassembled for portable field use. The white tube is the PVC tube that it came packed in. The tripod is part of an old projector screen stand, obtained from the local tip shop. (I have a few similar tripods which I use to mount small Yagis, dishes or panels on when I go out playing portable radio).

number on the boom.

No tools are required, it is simply a matter of screwing each element into the appropriate threaded insert in the boom, then assembling the

two gamma matches for each driven element, one for 70cm and one for 2m. The ease of assembly is clearly demonstrated in Photos 2, 3 and 4.



Photo 2: The stainless steel elements are light and strong, with a threaded ferrule that fits a captive nut on the boom.



Photo 3: Assembly and disassembly is a snack.



Photo 4: The feedpoints of each Yagi are adjacent to one another; this shows the gamma match assemblies used to set the feedpoint impedance of each antenna. A pity that the SO-239 socket isn't really designed for this sort of application, but it has given no trouble.

Standard mounting of the antenna is by means of a supplied plate that attaches to the rear of the boom. A pair of U-bolts that fit the plate allow mounting the antenna to a mast. I used the supplied PVC tube as a mast, as you can see in Photo 1.

As the boom is only drilled to suit vertical polarisation mounting, in my case, as I wanted horizontally polarised mounting, I modified (read "cut some slots in") the PVC tube to also facilitate a mid-boom horizontal mounting point with the antenna



Photo 5: The finished product is light, yet robust (like the user!).

held in place with an "occy" strap. That arrangement allows me to swap between horizontal and vertical in just a few seconds.

My antenna is not mounted permanently outdoors, it lives in the shed and comes out when I want to play satellites or is pulled apart and put in the boot of the car if I'm going out in the field. As such I cannot comment on longevity in the wild. However, all stainless steel construction counts for a lot.

Technical performance

Various claims are made by the various sellers as to gain. I would take most of the claims with a pinch of salt. I haven't measured gain but, subjectively, performance seems quite adequate.

The VSWR of each antenna can be adjusted with the gamma matches to vanishingly low figures, and maximum power handling

is generally quoted as "up to 50 watts". I run up to 10 watts from my dual-band handheld rig, or a mere 6 watts from my FT-818ND, so no risk of melting anything here!

I have worked the various currently operational satellites, as well as making terrestrial QSOs on 2m and 70cm SSB. By the way, Photo 1 was taken in my back yard. That is Mount Talawahl in the background. I was using a Baofeng UV5R to work AO91/AO92. The Baofeng has since been sold and replaced with a different handheld.

While the antenna is ideal for portable and field day use, it is equally at home working the "easy" satellites, such as AO91, AO92, or the new cross-band repeater on board the International Space Station (ISS).

All-in-all this dual-band Yagi kit a very useful item. I'm happy with it.

Homebrew HF Transceiver project

Part 3 VFO System 2nd article

Luigi Destefano VK3AQZ

Having two separate VFOs requires additional circuitry, which makes the design more complex. If you do not require two separate VFOs, or all the amateur bands, the VFO system can be considerably simpler.

In my case, each VFO needs to access all the band relays. The Arduino outputs for the two VFOs feed some tristate buffers that are enabled by either VFO A or B, depending on which one is active. This 8-band logic switch is shown in **Figure 35**. This section drives an Arduino 8-channel relay board purchased on the web (**Photo 3HB**). This board also contains a short delay in the power feed to the relays.

At switch-on, the Arduino output pins go on and off randomly as the Arduino sets them up as either inputs or outputs. This takes about two seconds, during which time the relays clatter on and off. The delay circuit holds back a 5-volt supply to the optocouplers on the relay board, preventing the relays from operating until the pins settle down. In addition to the 8-band logic, there is extra band logic which enables optocouplers feeding the relays selecting the transmit mixer filters for VFO A or VFO B (see **Figure 20**, p.19, *AR* Vol.88, No.2).

Mode switching

The VFO system also includes switching to select the VFO modes. The modes are: (a) VFO A receive and transmit, or (b) VFO B receive and transmit, or (c) receive VFO A and transmit VFO B.

The circuit of the mode switching is shown in **Figure 32**. These modes are standard on most transceivers. Mode selection is done with a rotary switch on the front panel. Although the switch is

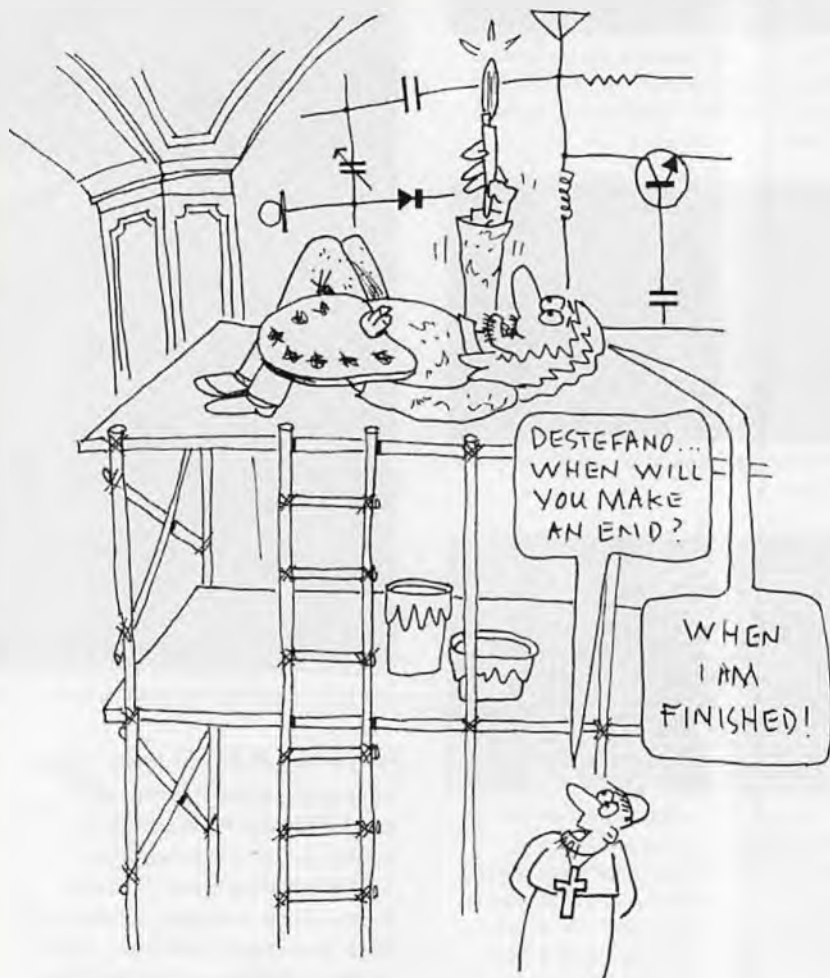

In the 1965 American film, The Agony and the Ecstasy, about the life of Michelangelo (starring Charlton Heston), the artist gets a commission from the Pope (starring Rex Harrison - no relation) to paint the ceiling of the Sistine Chapel. There are repeated scenes in which the Pope, enquiring how long Michelangelo is taking, walks into the Chapel and calls to Michelangelo high up on scaffolding, "When will you make an end?!", and Michelangelo replies, "When I am finished!" The parallels with VK3AQZ's article series about this project struck us when a reader enquired in the same way. - Editor in Chief, VK2ZRH. Cartoon by Carmel Morris VK2CAR.

mechanical, the switching is actually electronic, which means it can also be switched by a processor or external computer.

The circuit also contains a rotary switch for USB, LSB, AM and tune, and future FM, for each

VFO. The switched voltages select the required BFO and crystal, as well as sending a logic signal to the processors that display the selected modulation mode and move the VFO frequency so that the frequency display is correct for each

VFO relay driver

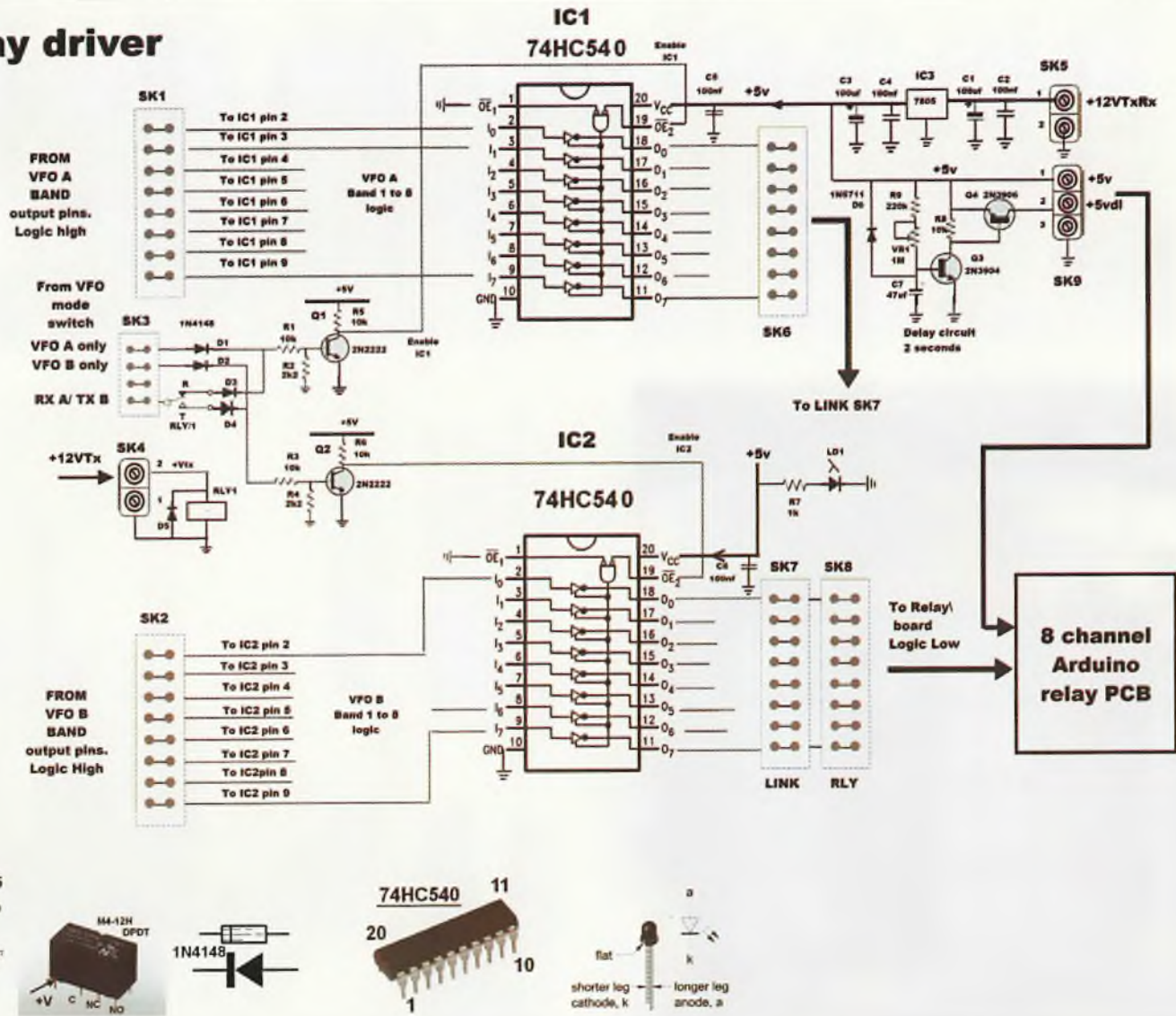

Figure 35: VFO encoder relay driver.

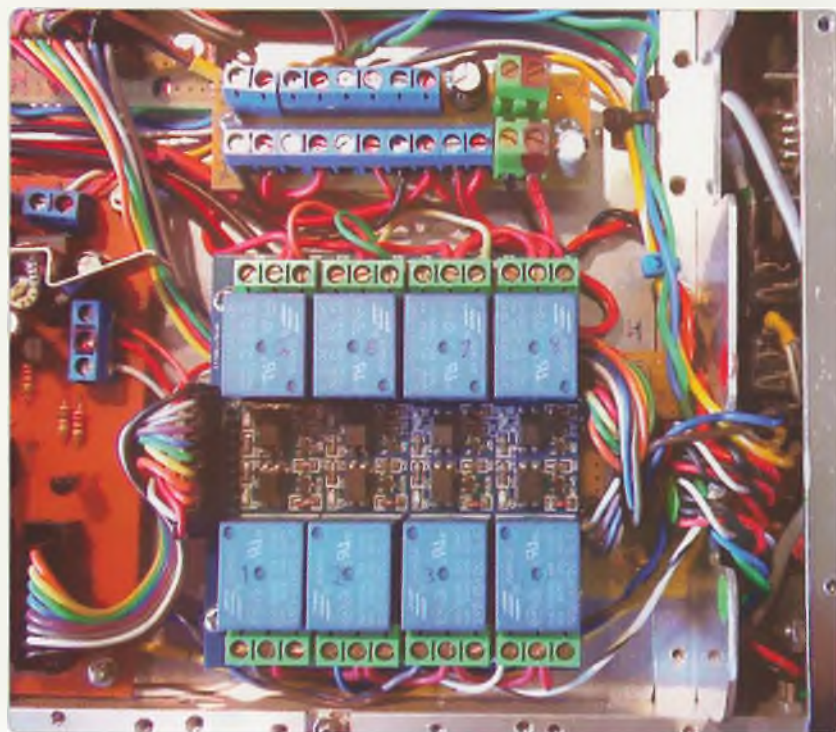

Photo 3HB: The Arduino 8-channel relay board – a module bought on the web.

mode. The documentation in the software sketch details the shifts involved for each mode.

Owing to a simplification in the switching, both VFOs display the

mode for the selected VFO. For instance, if VFO A is selected with USB, USB is also displayed on the VFO B display. When VFO B is selected, its modulation mode

| | | |
|-----------|---|-------------------------|
| Encoder A | VFO A Encoder | Rotaswitch PC66-121 |
| Encoder B | VFO B Encoder | Bourns ENAIJ-B28-L.0028 |
| LED1,2 | Green LED | |
| LED3 | Red LED | |
| R1,2 | 1k | |
| R3,4 | 100R | |
| S1A,B | Up Step momentary button | |
| S2A,B | Down Step momentary button | |
| S3A,B | Memory store momentary button | |
| S4A,B | Reset momentary button | |
| S5A,B | Memory read momentary button | |
| S6 | Sync A/B. VFO A encoder controls both A and B | |
| S7A,B | VFO enable | |
| SK1 | 2x4 Pin Boxed Header | On VFOA |
| SK2 | 2x4 Pin Boxed Header | On VFOB |
| SK3 | 2x6 Pin Bboxed Header | On VFOA and B panels |

Figure 30 VFO A B Encoder controls

| | | |
|-------------|--------------------------------------|--|
| D1 | 1N4148 | |
| SK1,2,3,4,5 | 2x4 pin PCB mount male boxed headers | |
| RLY1 | M4-12H 12v DPDT mini | |

Figure 30 Encoder logic PCB

is displayed instead, and on both displays also. So that is small code modification for the future.

Dial-it up!

The rotary encoder circuit is shown in **Figure 30**. Each VFO has its own rotary encoder, although you could use one encoder for both. In my case, the main dial knob can tune both VFOs, which is handy if you are using one for the RIT function. However, I have not added code to ensure both have the same step size, which is a future project modification. So, in the sync mode, both VFOs have to be set for the same step size. The encoders can be disabled by switching off the power to the encoders with a locking push button. This can be used to lock the frequency. A green LED lights up when the encoder is enabled.

Figure 30 also contains the circuits of the momentary push buttons for memory read and write, step size up and down, and processor reset. Also shown is the encoder logic circuit. To sync VFO B to VFO A, VFO A's encoder is switched to VFO B's input and the VFO B encoder is disconnected so as not to interfere with the pulses. A small DPDT relay is used for this switching. This could also be done with logic gates, but the relay is easy to implement.

Figure 31 shows the transmit enable circuit. The VFO processors put out a logic high when they are tuned within the amateur allowed frequencies. This logic signal operates a relay in series with the PTT and manual transmit circuit.

The band logic for each VFO is required to switch band filters. For instance, if you have VFO A on 80 metres and VFO B on 40 metres, you need the receive filters, the transmit mixer filters, and the PA low-pass filters to also switch. So switching from VFO A to VFO B requires additional circuitry that selects the required filters.

If you only have one VFO, this extra circuitry would not be needed.

VFO Mode switching

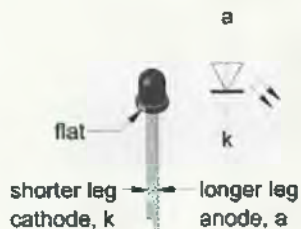
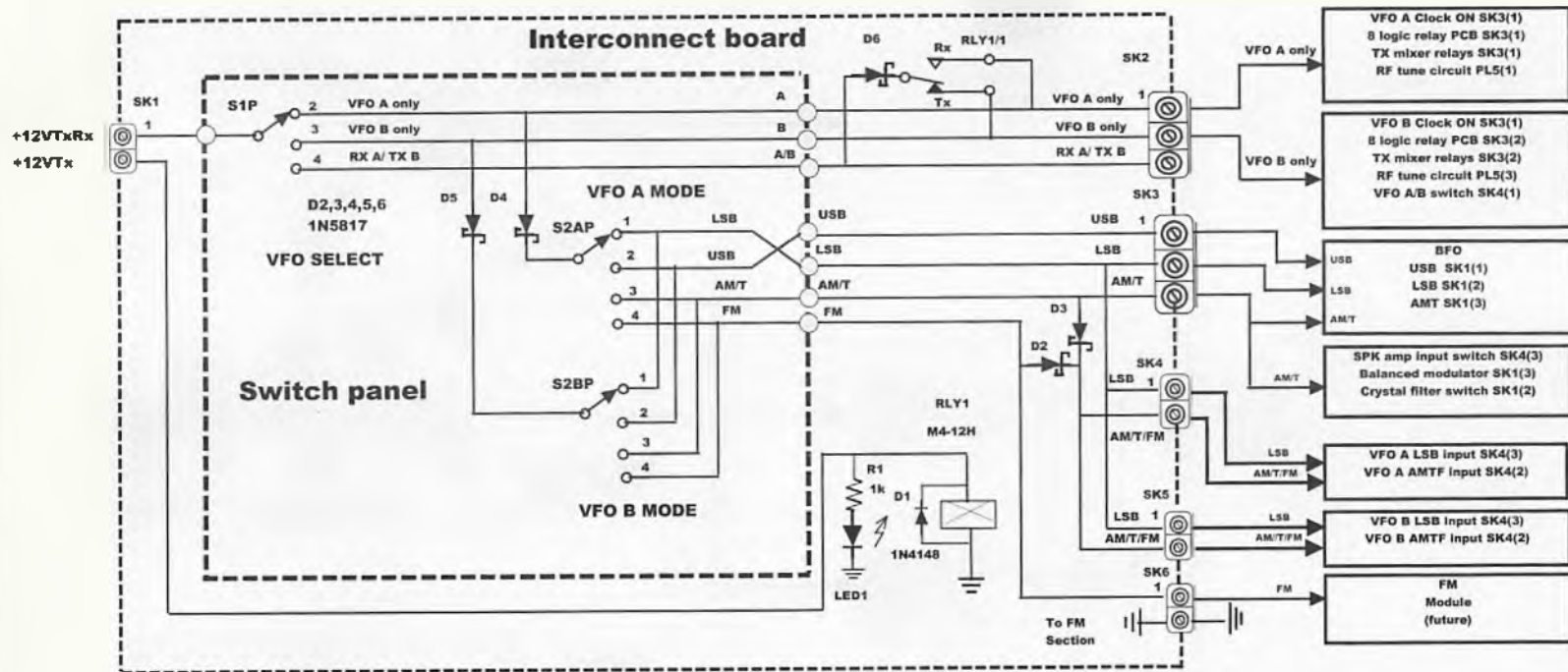

RY12W-K
or similar
12VDC relay
sensitive coil

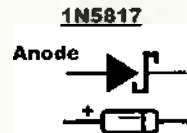

Figure 32. VFO mode switching.

VFO Encoder and button circuits.

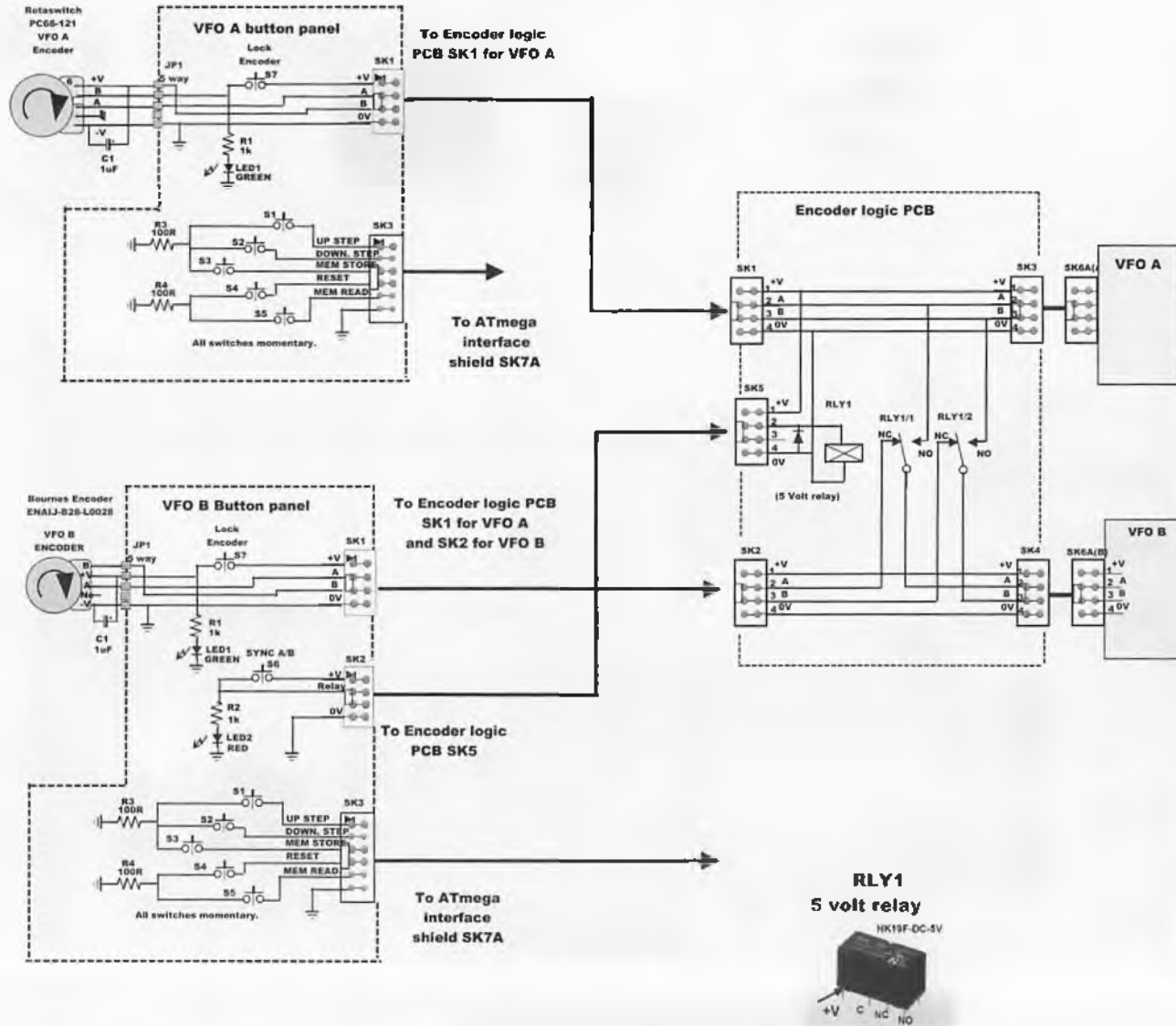
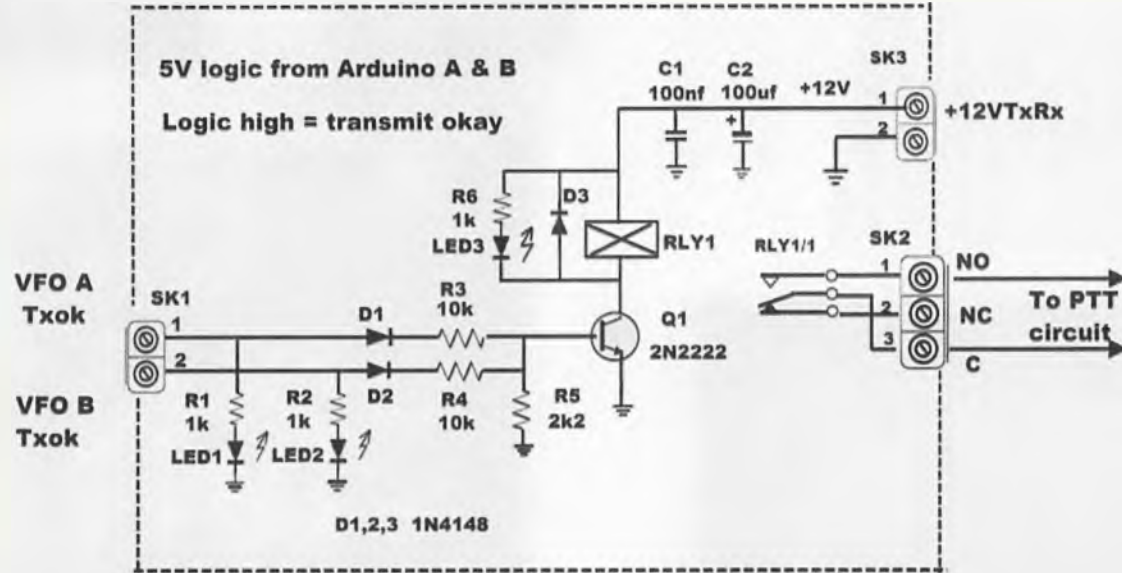

Figure 30. Showing the VFO encoder circuitry and momentary pushbuttons.

VFO Transmit enable circuit.



2N2222



1N4148

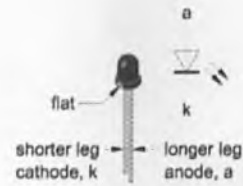

Figure 31. The VFO 'transmit enable' circuit.



Photo 3GA. The VFO mixer driver amplifier is on a small board housed in a box made of PCB offcuts.

This would be essential if cross-band operation was required. The same logic also switches voltages to the RF tune pots controlling the varicaps in the receiver tuned filters so that retuning of pots is not necessary when switching VFOs.

When switching between VFOs, the VFO not in use is disabled by a logic signal that switches the Si5351 output off using the clock on/off command. This is necessary since two VFOs in the same case, on or near the same frequency, will interfere with each other. Initially, I just used a relay on the output of the VFOs; however, there was still enough leakage that could be heard.

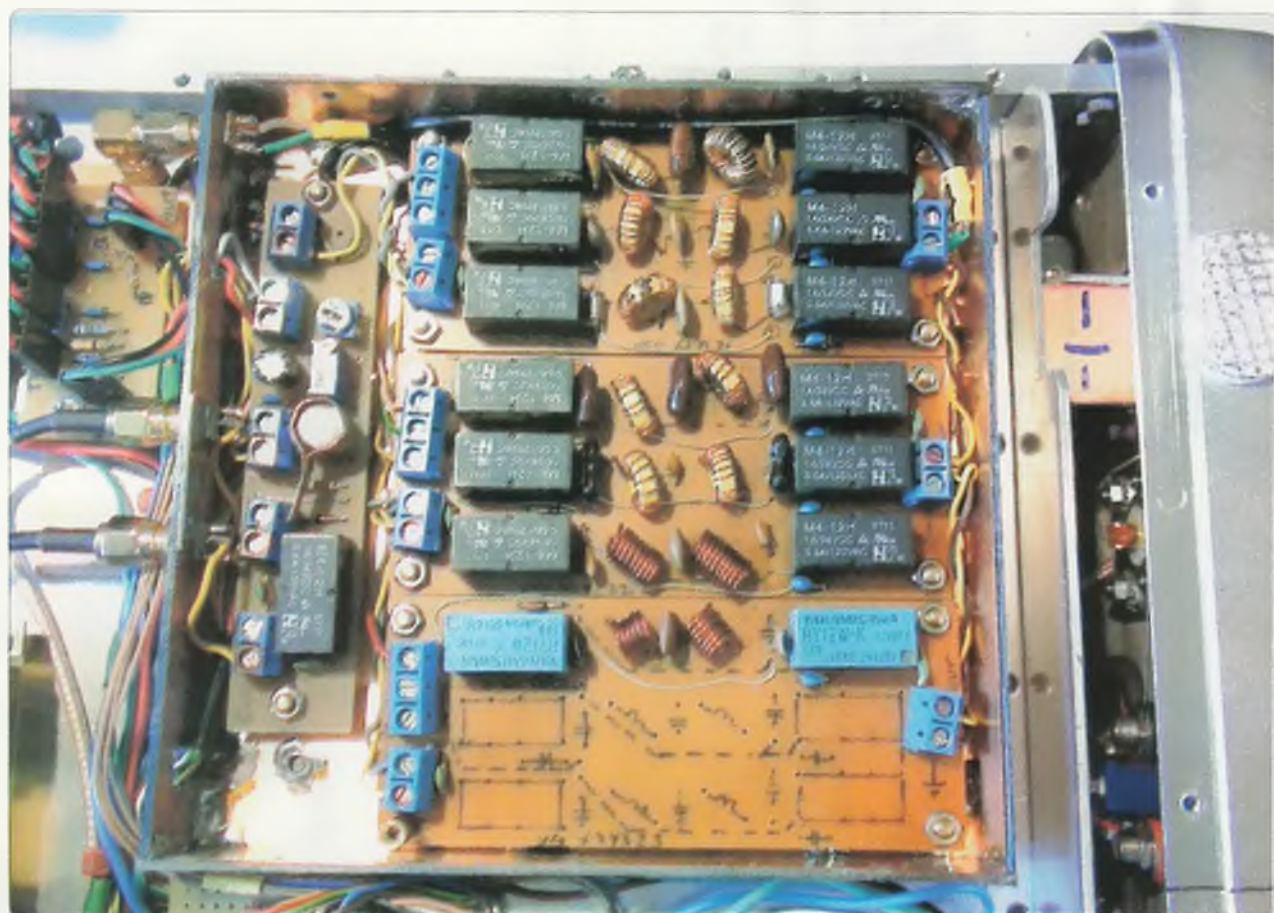

Photo 3GB. The VFO low-pass filters. See Figure 34.

VFO A B SWITCHING

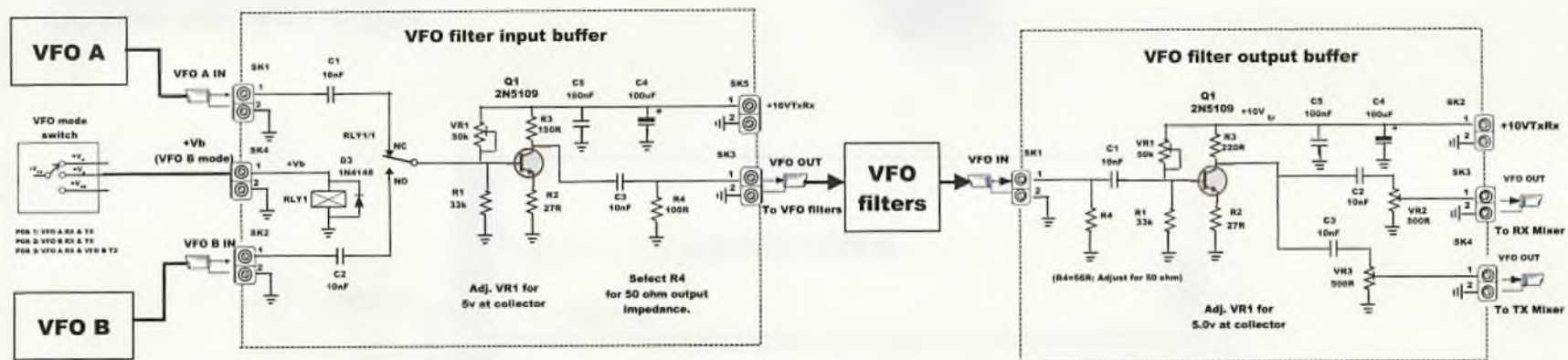
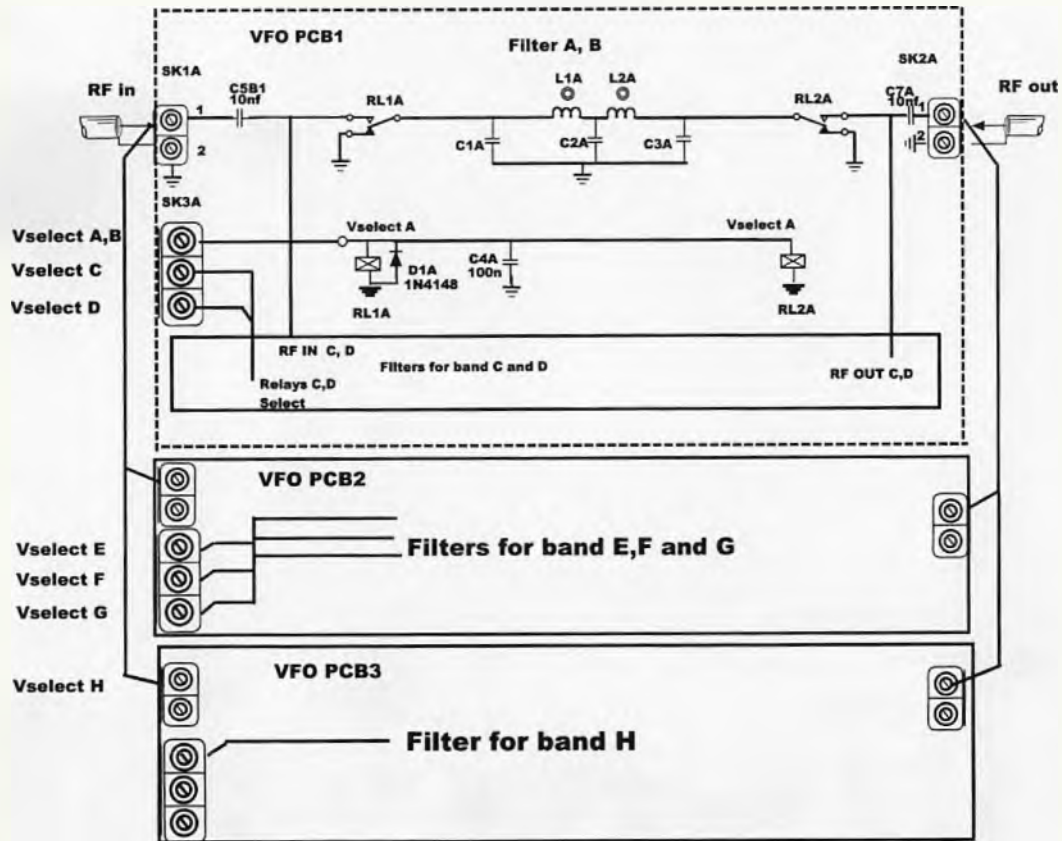

Figure 33. Switching of VFOs A and B.

VFO filters.



VFO filters A,B,C and D on PCB1
 VFO filters E,F,and G on PCB2
 VFO filter H on PCB3

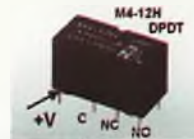

Figure 34. The VFO filters are switched in and out with relays.

| | | |
|-----------|----------------------|-----------------------|
| D1 | 1N4148 | |
| D2,3,6 | 1N5817 | |
| LED1 | 3mm Red LED | |
| RLY1 | M4-12H 12v DPDT mini | |
| SK1,4,5,6 | 2 way 5.08mm | Screw block terminals |
| SK2,3 | 3way 5.08mm | Screw block terminals |

Figure 32 VFO and Mode switching circuit components.

| | | |
|--------|---|--|
| D5,4 | 1N5817 | |
| S1P | 3 position single pole rotary switch.panel mount. | |
| S2P,3P | 4 position single pole rotary switch.panel mount. | |

Figure 32 VFO mode switch panel components.

From VFO to BFO

The Si5351 has three clock outputs and, in the original software, the other outputs were used to provide BFO signals. However, for a similar reason, these outputs could not be used. The physical separation of the clock outputs on the tiny Si5351 chip is very small. So leaving a BFO signal of around three volts peak to peak running within atoms of the VFO output was just asking for interference.

In my rig, the BFO function is supplied by crystals, which makes it easy to trim to the right frequency. If you use a separate Si5351 chip, then that can be used in place of the BFO crystals. There are some kit suppliers on the web that sell modules to do that using simple programming to set the frequencies. The BFO signal also needs to be very well screened from the IF amplifier input where it can affect the AGC system.

The VFO outputs are switched and buffered by a broadband 2N5109 amplifier (Photo 3GA). This, in turn, feeds a bank of low pass filters which limit the VFO harmonics as the Si5351 output is a square wave.

Some mixers work better with a good symmetric square wave. However, I prefer to feed the 1496 type mixers with a sine wave. My experience with the Gilbert cell mixers, like the 1496, is that the output is cleaner without the harmonics mixing with noise and anything else that makes its way

into the mixer. So, I have a series of low-pass filters that are relay-switched by the VFO logic.

Both VFOs use the same filters (Photo 3GB). The buffer amplifiers on the input and output ensure the filters are terminated in or near 50 ohms and to lift the output to levels high enough to feed the mixers.

The 1496 mixers do not require much signal, but diode mixers, like the transmit mixer, do. The circuits of the filters and buffers are shown in Figure 33 and Figure 34, while Table 7 lists the component values.

The Arduino software I am using is titled "AQZ_ATmega2560_VFO_V20.ino". This file or "sketch",

with the "ino" extension, needs to be loaded into the Arduino IDE program along with some libraries for the Si5351, rotary encoder, and an EEPROM library, which handles long integers. The EEPROM library supplied with the Arduino setup requires long integers be split into bytes. The EEPROMex.h version does that for you.

These libraries will be supplied with my version of the main program. My program has lots of comments so it should be easy to follow. You can tell by the version number I have had lots of goes trying to get it right!

At some point during the development of the software I wised-up and lashed up a testing jig with a third Arduino, an LCD display, a rotary encoder, push buttons, switches which were a duplicate of the ones on my panels, and LEDs representing the band logic and other outputs. This made it a lot easier to alter the software and test the results without affecting the two units that, by now, were installed in the rig.

Continued next issue.

Table 7. VFO filter component values

| Software relay | Band | Freq. MHz | VFO RANGE MHz | VFO Chebyshev LPF filters. NOTE 4. | Fco MHz | C1,3 | C2 | L1, 2 | Coil Turns |
|----------------|------|-----------|---------------|------------------------------------|---------|--------------|-----|-------|------------|
| 1 | A | 0.1-1.0 | 9.1-10.0 | 12 | | 360 | 560 | 887nH | 17 |
| 2 | B | 1.0 -2.0 | 10-11 | | | Use filter A | | | |
| 3 | C | 2.0-4.0 | 11-13 | 15 | | 270 | 470 | 709nH | 15 |
| 4 | D | 4.0-8.0 | 13-17 | 20 | | 220 | 360 | 532nH | 13 |
| 5 | E | 8.0-14 | 17-23 | 25 | | 180 | 270 | 426nH | 12 |
| 6 | F | 14-21 | 23-30 | 33 | | 130 | 200 | 322nH | 10 |
| 7 | G | 21-30 | 30-39 | 50 | | 82 | 130 | 212nH | NOTE 2 |
| 8 | H | 30-54 | 39-63 | 75 | | 42 | 75 | 145nH | NOTE 3 |

NOTE 1: Coils for bands A to F on a T37-6 toroid

NOTE 2: Air wound coil for band G: 10 turns, 5mm diam., 9mm long, 0.9mm wire.

NOTE 3: Air wound coil for band H: 7 turns, 5mm diam., 6mm long, 0.9mm wire.

NOTE 4: 5th order Chebyshev. 0.2dB ripple filter design.

Switch that coil, change them ohms Match that load, or the rig will moan*

Nigel Dudley VK6NI
e ndudley@linet.net.au

Antenna matching and **antenna matchers** are a perennial topic of interest. Here's a review of a low-cost 'automatic' antenna matcher/tuning kit that can be bought online. Its purpose is to improve the power transfer between the transmitter and the load presented by the antenna, matching the specified load impedance of the radio (50 ohms) to the combined input impedance of the feedline and the antenna.

Recently, I was looking for a simple (read cheap) HF auto antenna matching/tuning unit on eBay to add to the other portable equipment I have and came across a unit designed by N7DDC and rated at 100 watts. It was available in a kit for a delivered cost of around AU\$60.

The kit provided is just the circuit board and required components. I used a \$10 plastic case from Jaycar to complete the build. The connectors are SMA type, not particularly useful for HF, so SO239 connectors were added to the case, with short coax cable links to the on-board SMA connectors. A 12 V socket for the DC power supply was included, but there was no push button to initiate the tuning, so one came from my junk box.

You can buy a built-up unit in a metal case on eBay for around AU\$130. It is a matter of preference and the depth of your pockets as to which way you go. The basic circuit is a low pass L network. It should be noted that this is simple coaxial impedance matcher, there is no provision for balanced line or single wire connections.

Putting it together was easy. All the SMD components are pre-soldered to the printed circuit board (PCB), leaving a few discrete components to mount along with the coils, toroids and relays.

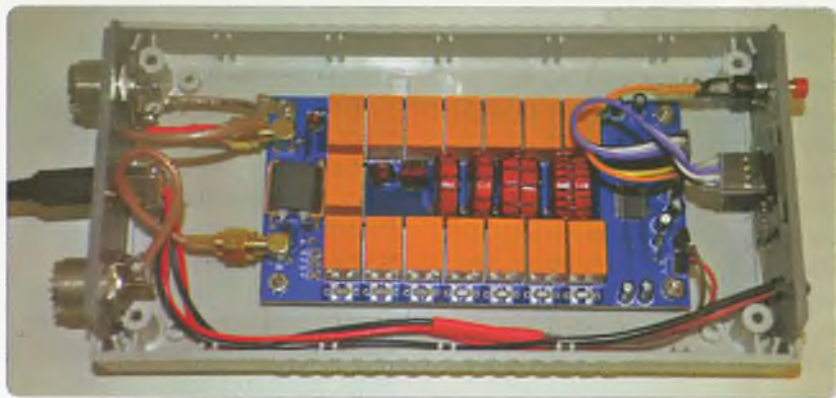

Figure 1: My assembled antenna "auto-tuner" kit, designed by N7DDC.

The coils and toroids are wound with the wire supplied; tedious but not difficult. The exception to this was the SWR-sensing binocular transformer TI/T2. The instructions are not particularly clear "TANDEM MATCH, DN43-202 AMIDON CORE 1:10".

Internet searching eventually came up with a response by the designer to a query on a chat page saying "10:1 transformer therefore ten turns"; fine if you understand the terminology as there are two secondary windings. In the end, I decided to wind five turns on each side as that was what the photo of the completed unit seemed to indicate. Readings on the display when operating indicate this is the correct solution.

Mounting the unit in the case was easy and the supplied headers and wire connectors made for neat connections. The completed unit is

shown in Figure 1.

The supplied OLED display provides clear readings, but beware the Data and Clock lines are reversed on the board compared to the display; hence, care must be taken to make sure they are correct.

Once built and mounted in the case, my unit worked first time.

Operation

Start-up is in by-pass mode. A long press of the button puts it in 'tune mode' and applying around 10 watts AM with an antenna connected, the unit tunes various combinations of capacitance and inductance until it obtains a satisfactory SWR.

The RF power is displayed, along with the capacitance and inductance used. I was able to tune a random length of wire through all HF bands and six metres. The

* With apologies to Oscar Hammerstein II, who wrote the famous lyrics to the song Ol' Man River - "tote that barge, lift that bale" - from the musical, *Show Boat* (en.wikipedia.org/wiki/Ol%27_Man_River).

power meter is a bit optimistic on 6m, but reasonably accurate on other bands.

Auto-tuning operation cuts out at around five watts RF power. So, if you wanted it to work reliably with a QRP rig, an adjustment to the windings of T1/T2 may be needed.

On standby, the unit draws 32 mA, which increases as relays are switched in. The maximum current I observed was 120 mA. The relays are non-latching so the current draw of the unit in a portable set up would have to be considered.

A short press of the button resets the tune and all relays drop out.

There are two additional points to connect buttons. One switches by-pass on temporarily, and a second press resumes the previous tuned settings. The second button turns on auto-mode, which the unit remembers and it is therefore possible to use the unit without any external controls, auto-tuning commences as soon as power is applied.

The unit is also designed to be used as part of a home-brewed

transmitter, with provision for switching when tuning. However, there are no memories to save settings from band to band.

There was no documentation with the unit. A message to the seller resulted in two documents. One is the schematic with the coil winding details and the second is an article by the designer David N7DDC, discussing modifications and settings that can be changed.

The build would be so much easier if a simple layout and interconnection diagram were supplied. That being said, any reasonably experienced constructor should be able to put it together. It is a simple unit, but it works well.

How do auto-matchers work?

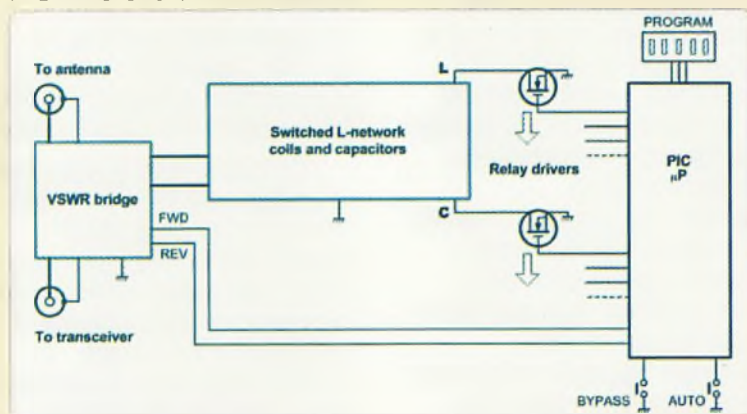

Generic auto-matcher block diagram.

Many simple auto-matchers or -tuners are based on a block diagram like this one. The objective is to transfer power between the transmitter and the antenna as efficiently as possible, matching the specified load impedance of the radio (50 ohms) to the combined input impedance of the feedline and the antenna. Antenna matcher or antenna tuner are just equivalent names for a device that does the same thing, albeit, 'tuner' is a technical misnomer.

The general arrangement uses a VSWR sensor, a simple microprocessor (uP) having lots of input/output (I/O) lines and a series of inductors (coils) and capacitors, arranged so that each can be switched in or out using relays, to form an L-network between the antenna and the rig.

The L-network is a simple inductor-capacitor (LC) circuit that can be used to match a wide range of impedances in RF circuits, particularly where the input and output are unbalanced, as is the case with coax feedlines. Any RF circuit application covering a narrow frequency range (e.g. an amateur HF band) is a candidate for an L-network match.

Visit: www.electronicdesign.com/technologies/communications/article/21800910/back-to-basics-impedance-matching-part-2

The VSWR bridge senses the forward (FWD) and reflected (REF) RF powers when the rig provides some power to the antenna. The processor runs a program that 'hunts' through the combinations selected by the relays until the FWD-to-REV ratio is maximised. A 'bypass' pushbutton sets the unit to bridge the antenna to the rig, while the 'auto' pushbutton sets up the uP to match the rig to the antenna automatically when RF is provided. **Roger Harrison VK2ZRH**

Specifications

These were obtained from the internet and confirmed with the author, VK6NI.

100 Watts tuner, 7x7 (7 capacitors x 7 coils) based on PIC 16F1938.

PC board dimensions: 120 mm x 62 mm.

Required power supply range: 10 - 15 Vdc

Max current: 450mA

Max working power: 100 watts

Max measured power: 150 watts

Minimum power for tuning start: 1 watt

Recommended maximum power while tuning, not above 30 watts (after tuning you can set 100 watts and work on this power)

Minimum measured power: 0.1 watt

Step for measurement on powers under 10 watts: 0.1 watt

Step for measurement on powers above 10 watts: 1 watt

Power measurement accuracy: 10%

Maximum inductance set: 8.5 uH

Minimal step for setting inductance: 0.1 uH

Maximum installed capacity: 1870 pF

Minimal step for setting capacity: 10 pF



When governments ruled the aether

Peter Wolfenden VK3RV, WIA Historian

Amateur radio in Australia 100 years ago – Part 2

The Wireless Institute of Australia had its genesis 110 years ago at a meeting of like-minded people called together in Sydney by George Taylor. That meeting took place on 11 March 1910 at the Hotel Australia in Sydney's Martin Place, at which the *Institute of Wireless Telegraphy of Australia* was inaugurated, soon changing to the *Wireless Institute of Australia*.

All Australian experimental wireless stations were closed down at the outbreak of World War One, as happened in many other countries. The Australian Call Book for 1914 listed 401 licensed Australian Experimental stations.

Summary of Part 1

With the formal end to WW1 being proclaimed in late June 1919, wireless experimenters sought the return of licensing and the ability to conduct experiments in transmitting and receiving.

The nascent technology was developing apace, but the licensing debate dragged on, despite the sterling advocacy of such leading lights as the well-known industrialist Ernest Fisk, later to establish the iconic AWA company.

By 1920, vacuum tubes – valves – had entered the wireless arena, and receiver experiments using valves in amplifiers and regenerative detector circuitry saw the government's regulatory brake issue receive-only licenses specifying non-regenerative receivers. But, no transmitting licenses, yet.

A new era dawns

Signs of real hope for experimenters appear on the horizons. The Post Master General's Department finally regains spectrum control from the Navy.

Interest in wireless continued to grow, but all licensed experimental activity was still confined to receiving only. Max Howden, in a recorded interview during 1950, recalled that the "forced concentration" on receivers at that time, finally resulted in a significant advantage for him and other aspiring DXers. He said:

".....An argument started as to how far the continuous wave signals did travel and the old mathematical argument arose that you could go on dividing one by two to infinity and you never got to nothing! So from that it was decided that a

signal was never entirely faded out – it was only a matter of building a sensitive enough receiver and it would be possible to hear the signals from the American amateurs who were able to transmit while we were not; so we concentrated on receivers....." (14)

The Sydney Morning Herald for 17 July 1920 reported on a scheme proposed by the Council of the WIA NSW Division. The report included:

".... As distinct from the commercial and military uses of wireless, the construction and operation of experimental apparatus is a class of study and pastime which attracts a very large number of people of both sexes and of all types. In Australia today, there are between one and two thousand wireless experimenters....." (15)

This appears to have been a very timely and valid announcement by the NSW Division that helped keep the matter of experimenters and their needs in front of the public and pressure on the government, although the official number of licensed experimenters at that time was more like 500.

The persistent demand of the Navy to retain control of the spectrum following WW1, continued to cause much angst amongst amateurs and others interested in developing wireless.

So, while the Navy was still in control, experimenters could do little other than lobby, keep the matter in the public arena and reluctantly accept the situation – at least the Navy was now making receiving licenses available.

An excerpt from an unpublished history on Amateur Radio in



Photo 1: Commercial amateur radio gear from the 1910-20 era. Even 100 years ago, amateur stations weren't all-homebrew!

Australia by George Glover VK3AG, provides an indication of the feeling that prevailed between the amateur experimenters and the Navy at that time:

"The return of peace after the First World War saw the control of communications in the hands of the Navy which august body greatly opposed to the resumption of amateur activities. With the support of the Hon. W.M. Hughes [Prime Minister], amateurs were able to finally convince Commander Creswell that they were fit and proper persons to be entrusted with licences. In the beginning these licences or permits were restricted to receiving only. (16)

During mid-September 1920, it was apparent that a major change was imminent when newspapers, including the *West Australian*, under the heading "Wireless Stations Transfer to the Postal Department, reported:

"During the next few days the control of the various wireless stations throughout Australia will pass to the Postmaster General's Department from the Naval Department, this decision having been arrived at recently by the Federal Government..." (17)

The news quickly resonated amongst experimenters. They felt this was definitely a positive move

Photo 2: Mr James Malone, Controller of Wireless.

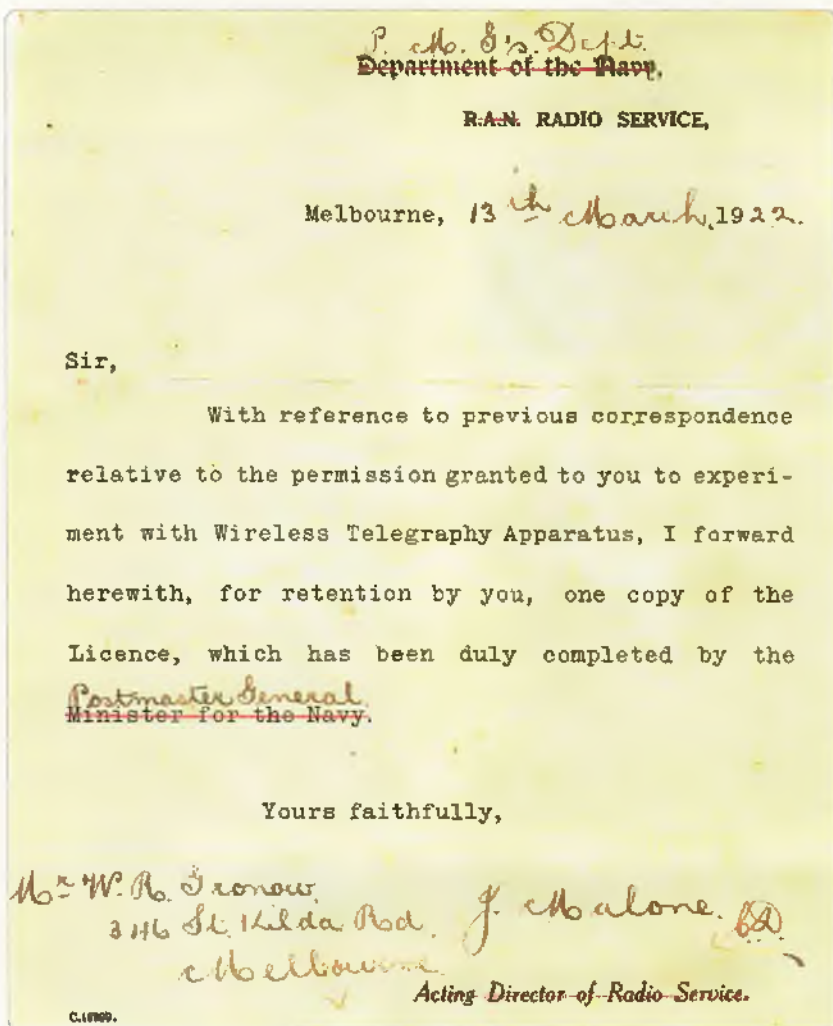

Photo 3: An early PMG Dept letter for receive-only licence. Economy in paper – or driving the point home?

by Government and was a further step towards them getting back onto the airwaves, hopefully, very soon!

A new Controller of Wireless, now within the PMG's Department was appointed. Mr. James "Jim" Malone. He oversaw many major advances in radio communication in Australia during his watch, but now, besides the politicians, he was the man amateurs had to focus on to put their case.

Mr Malone had largely grown up through the ranks of the Department commencing as a telegraph messenger in 1898, progressing to engineering positions in Sydney, Goulburn and Queensland. During the war years, he was the instructor

in wireless at the Wireless School in Moore Park Sydney, then served in France in charge of all Australian Flying Corps (AFC) wireless activities. He was awarded the Military Cross.

Following the war, he dedicated time to studying the latest wireless communications systems, particularly in the UK at the RAF Wireless Experimental Establishments at Biggin Hill and Woolwich. After leaving England, some five months was spent in investigating wireless and allied subjects in America and New Zealand on the journey home to Australia.

Jim Malone was therefore well versed with current wireless

NEW WIRELESS REGULATIONS.
ENCOURAGING AMATEURS.
USE OF TRANSMITTING APPARATUS ALLOWED.
LICENSE FEES REDUCED.
MANY RESTRICTIONS LIFTED.
MELBOURNE, November 21.
 New regulations for the control of wireless communication in the Commonwealth were approved by the Governor-General (Lord Bury) in Council yesterday afternoon, and will come into force on December 1. These regulations, which are very comprehensive, were made available today. They effect important alterations in

Photo 4: Extract from The Queenslander, 2 Dec 1922.

concepts and applications when appointed to his new position of Controller of Wireless. The amateur fraternity was pleased to see his appointment, together with the PMG's Department being given control of the spectrum of which Malone was placed in charge. Jim Malone was a practical man of experience and appears to have been a very methodical and dedicated officer and, as it turned

out, approachable and generally sympathetic towards experimenters, providing them good advice over the years. (18)

However, the battle to convince government that Australian experimenters should be allowed to transmit had to continue. WIA Divisions, clubs, individuals, and local wireless magazines continued to pressure the regulators, pointing out amongst other things, that the use of wireless, or radio, would generate employment and enhance technical education, especially amongst younger experimenters. They also maintained that the development of wireless would also lead to new and significant industries within Australia. This was to be proven to be the case.

By September 1921, there were about 500 licensed receiving stations and a clutch of transmitting permits granted to Universities, WIA Divisions (for training and news purposes) and a few clubs. (19)

Federal Parliament House was the scene for a statement by Prime Minister Hughes on 28 July 1922. A number of questions about the newly proposed Wireless Telegraphy Act were asked in the House; one being:

"Will he [PM] see that the Wireless Company [AWA] does not interfere with the enforcing of the wireless laws, and that those laws are enforced by Government officials, so that there will be Government control by disinterested



Photo 6: A 1922 advertisement in Wireless Weekly for a commercial broadcast radio receiver by Radio House, a firm that lasted through to the 1970s. The Wireless Shop advert, by "F. V. Wallace, Electrical Engineer" is none other than Florence Violet Wallace - later McKenzie ("Mrs Mac"), one of the founders of Wireless Weekly and Australia's first licensed female radio amateur.

officials to guarantee the proper working of the company's stations and the unrestricted working by amateurs?"

The Prime Minister replied: "Yes; the administration of the Wireless Telegraphy Act and Regulations is being carried out by Government officers only." (20)

Amateur radio returns!
 The first edition of Wireless Weekly, published on 4 August 1922, reported on page 1, "A Promise by Mr. Hughes to amateurs". The new regulations were duly promulgated and made effective from 1 December 1922. This action finally, and formally, brought amateur radio back to life in Australia. There were many sighs of relief! (21) (22)

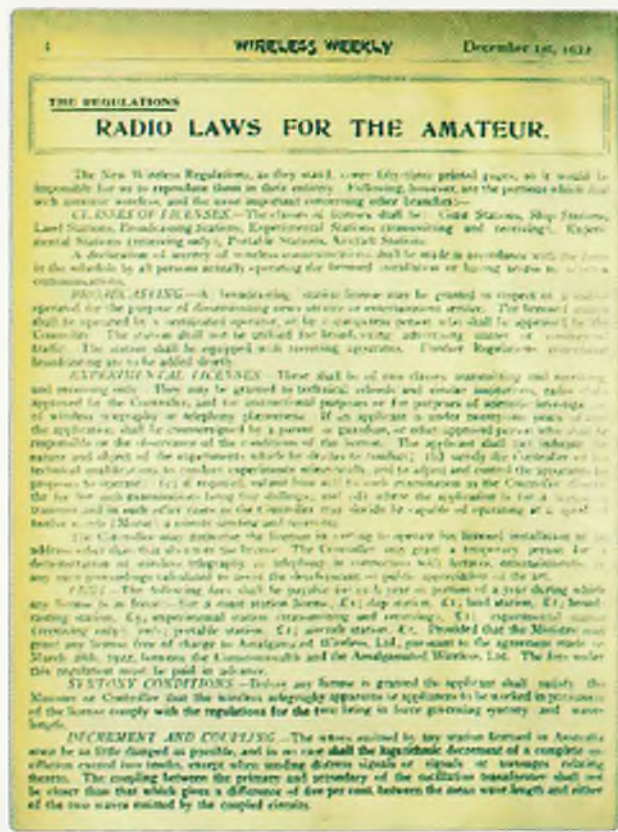

Photo 5: Wireless Weekly announces Radio Laws for the Amateur, in its edition of 1 Dec 1922.

The initial Navy – receive-only – licence fee was £2 (\$160 today). This was reduced in May 1923 to £0/10/- for a receiving licence and £0/10/- for a transmitting licence. Thus, a transmitting amateur had to pay a total of £1/-/- (\$80 today) for both licences.

Before WW1, spark transmission was used by both amateurs and professionals, but big changes were about to take place, largely initiated by amateur experimenters. The change was in the form of low-powered, two-way, short-wave, international communications! Amateurs here were pro-active in this development, largely resulting from the refining of receivers

as mentioned earlier and led by forward thinking amateurs such as Ross Hull.

A new era, and world, was about to open up!

References

- (14) *The Sounds of Amateur Radio*, Volume 1, WIA, CD, (original cassette 1985), 2010
- (15) *Wireless. Scheme for Amateurs*, Sydney Morning Herald, 17 July 1920, p13
- (16) *History of Amateur Radio in Australia*, Un-published, G. Glover VK3AG, c1950 pA1
- (17) *Wireless Stations Transfer to the Postal Department*, West Australian, 14 Sept. 1920, p6
- (18) *Mr. James Malone, Chief Manager Telegraphs and Wireless, Australia's Leading Radio Engineer*, Australasian Wireless Review, Sydney, June 1923, p24
- (19) *Amateurs and Wireless*, Argus, Melbourne, 13 September 1921, p9
- (20) *Question in House of Representatives*, Hansard No.30, 28 July 1922, p917
- (21) *A Promise – Mr Hughes to Amateurs*, Wireless Weekly, Sydney, 4 August 1922, p1
- (22) *Radio Laws for the Amateurs*, Wireless Weekly, Sydney, 1 December 1922, p4

Wireless Men & Women at War

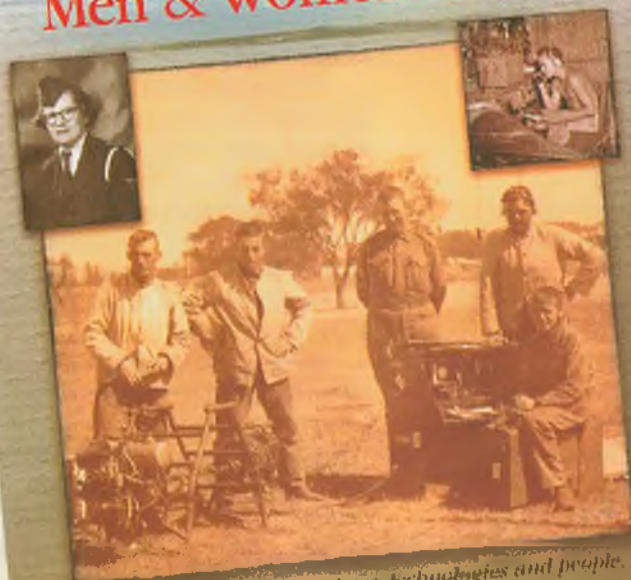

Australian stories of the times, technologies and people
from WW1 to the 1960s



The Wireless Institute of Australia

Wireless Men & Women at War

Young men and women who used their skills from a personal interest in radio, made a difference.

Read their **amazing stories**.

100 pages, large format.

Buy it from the WIA Bookshop at:

www.wia.org.au/members/bookshop/page_data.php?id=258



VHF/UHF - An Expanding World

David K Minchin VK5KK

In this edition of the column, we have a report from Rex VK7MO on optical digital communications using 30-minute transmit periods. Also, we have the third of the "VHF and Above Construction series", this time looking at conical feedhorns and Cassegrain reflectors on 24 GHz and above (in keeping with this issue's theme of antennas and feedlines), as well as another flashback from my column 20 years ago!

Optical Communication with FST4 and FST4W

While visible light (405 to 790 THz) is about 5000 times higher in frequency than say 122 GHz, there has long been interest in experimenting with light over paths approaching theoretical line of sight (LOS), and further, using cloud cover as a common 'reflection' target to extend the distance limit.

LED light sources have helped this along; being capable of producing collimated light at higher levels of power than the milliwatts (or for 122 GHz, microwatts!) of power we use on mmWave bands. And as for mmWave bands, digital modes can be used to extend the working distance. Rex Moncur VK7MO and Richard Howlett VK7ZBX report:

"Joe Taylor, K1JT, and the WSJT development group kindly invited us to participate in pre-beta testing the new modes of FST4 and FST4W, which can run with TX periods as long as 1800 seconds, to achieve decodes down to as low as -45 dB on the WSJT scale."

"These modes appeared to have potential for optical communication, and we dusted off 474 Tera Hz

| UTC | dB | D2 | Freq | Message | |
|--------|-----|-----|------|----------------|-------------|
| 0926 | -19 | 0.4 | 1480 | VK7ZBX QE37 37 | FST4W - 120 |
| 0928 | -20 | 0.6 | 1480 | VK7ZBX QE37 37 | |
| 0930 | -22 | 0.5 | 1480 | VK7ZBX QE37 37 | |
| 0932 | -23 | 0.4 | 1480 | VK7ZBX QE37 37 | |
| 0934 | -23 | 0.6 | 1480 | VK7ZBX QE37 37 | |
| 0936 | -25 | 0.5 | 1480 | VK7ZBX QE37 37 | |
| 0938 | -18 | 0.1 | 1480 | VK7ZBX QE37 37 | |
| 094130 | -23 | 0.5 | 1480 | CG VK7ZBX QE37 | FST4 - 30 |
| 094330 | -16 | 0.3 | 1480 | CG VK7ZBX QE37 | |
| 094430 | -15 | 0.5 | 1480 | CG VK7ZBX QE37 | FST4-15 |
| 094515 | -15 | 0.5 | 1480 | CG VK7ZBX QE37 | |
| 094545 | -14 | 0.3 | 1480 | CG VK7ZBX QE37 | |
| 094615 | -14 | 0.4 | 1480 | CG VK7ZBX QE37 | |
| 094645 | -14 | 0.4 | 1480 | CG VK7ZBX QE37 | |
| 094715 | -14 | 0.5 | 1480 | CG VK7ZBX QE37 | |

Figure 1: Signals received on a 153 km non-line-of-sight cloud bounce path with various FST modes and TX periods reduced from 120 seconds down to 15 seconds. Note that the propagation improved as the test proceeded -- presumably due to changes in the clouds.

equipment originally described in DUBUS 4/2008 and DUBUS 1/2/3/2009. Initial tests were conducted over a 22 km non-line-of-sight path between our homes and showed that FST worked extremely well even with strong QRM from city lights.

The receiver used a 10x10 mm silicon avalanche photo diode with a 400x400 mm Fresnel Lens producing a 1-degree beamwidth, DUBUS 3/2009 fig 5 page 78. Following testing with a 60-LED transmitter, this was reduced to a single Luxeon III Red LED with a 22 mm torch type lens (10-degree beamwidth). It was possible to reduce power down to 100 mW optical and still achieve decodes in clear air (particle scatter) over a non-

line-of-sight path with the 1800 second period on FST4W (decodes in the range -40 to -45 dB)."

"At the other extreme we were able to achieve decodes at -14 dB over a 153 km non-line-of-sight path by running 50 watts optical with a 10 degree beamwidth 60 LED transmitter

(front cover of DUBUS 4/2008) using the fast FST4-15 mode (15 seconds TX periods) and by bouncing off clouds (Fig 1)."

"After completing the 153 km path VK7ZBX returned to his home location which has a very poor take-off, as shown in Fig 3. To our surprise signals were similar - reaching -13 dB. This seems to confirm that signals were reflected from very high-level clouds in line of sight to both ends."

"Back in 2009, a one-way optical distance of 288 km was achieved using the experimental mode Weak Signal Communicator (WSC) by VK3HZ, refer DUBUS 4/2009 page 92. WSC took 25 minutes to exchange two callsigns and a report and was estimated to work to -44



Figure 2: 153 km path from a good take-off at Mt Wellington at VK7ZBX's end, but still well short of line-of-sight when you take account Earth curvature.



Figure 3: 133 km path with very poor take-off.

dB on the WSJT scale. Thus, it appears that both programs have similar performance. The fact that a 153 km non-line-of-sight path was achieved in just 15 seconds with FST4 suggests there is considerable room to increase the distance under suitable cloud conditions."

"The advantages of FST4 compared to WSC are:

1. Its very narrow bandwidth (less than 1 Hz for the 4 tones with 1800 second periods) allows one to work between QRM which is generally on harmonics of 50 Hz due to arc type street lamps or 60 Hz due to the frame frequencies of outdoor video display signs.
2. It does not require the use of GPSDO locked sound cards.
3. As FST4 is provided in WSJT-X it is widely available and easy to use for those familiar with the WSJT modes."

"A useful facility on WSJT-X is the ability to send a single tone using the "Tune" button. This puts the energy of the 4 tones of FST in one bin and gives around a 6 dB improvement in detecting the presence of propagation using the Linear Average "Yellow" graph provided under the WSJT-X waterfall. On 1800 second periods this facility allows detection of propagation down to -50 dB."

"One interesting issue, not directly related to the new modes, is that our testing showed that on the 22 km path the 10 degree beamwidth 50 watt transmitter is about 10 dB better than the 1 degree beamwidth 50 watt transmitter (picture on back of cover of DUBUS 1/2009) used for the previous 288 km non-line-of-sight optical record. This is despite the fact that the 1-degree transmitter

is a better match to the 1-degree receiver.

This might be just the difficulty of alignment, or poor illumination of the Fresnel lenses. There could also be some propagation issues we are yet to understand, in that there is a larger scattering volume with wider beamwidth. If we can use the physically smaller 10-degree beamwidth transmitter for longer distances, it will make portable operations much easier, as well as easing alignment issues. More testing is required to understand this."

Construction Series Part 3

Conical horn feeds and Cassegrain reflectors for mmWave bands

As I need some more time to finish the PLL-locking part of series, for the third part of the construction series we will look at the design and construction of matched conical horn feeds and Cassegrain reflectors for use with a dish antenna.

A full description of the mathematics between all three components is beyond the room available in this column, so this will be a quick overview! Simon Kildal (and others) published several papers in the 1980s that can be found with Google, which have more information.

If you have a dish and Cassegrain already designed to work together for the frequency range desired (i.e. a Nuraid 38 GHz dish), then all that is required is to design a matching feed.

If you only have a dish, then you will need to design the other two elements to match the dish. All components being "matched" is important. The following information is what I have found after a lot

of experimenting and resources available. I will also explain why splash plate feeds are a poor compromise at mmWaves.

A Cassegrain reflector is a convex hyperboloid that, when properly illuminated, will spread the radiation pattern to fully illuminate a dish antenna to produce a 'collimated' plane wave beam. The geometrical condition for radiating a collimated, plane wave beam is that the feed antenna is located at the far focus of the hyperboloid, while the focus of the dish antenna coincides with the near focus of the hyperboloid.

The Cassegrain reflector and the feed antenna are located on the central axis of a prime focus dish, with the feed far enough from the Cassegrain so that the wavefront is parallel when it reaches it. Ideally, this should be as close as possible to the apex of the dish antenna to reduce the waveguide length to the transverter. As waveguide has real loss at mmWaves, several dB can be gained v. a 'splash plate' or 'shepherd's crook' feed where the waveguide needs to run all the way to the dish focal point.

Importantly, the Cassegrain reflector design is primarily dependent on the main dish reflector f/D figure (ratio of focal length to aperture size), a practical far-focus distance so the feed position is just in front of the apex of the main dish.

A Cassegrain can be used with any size dish with the same f/D (plain optics). However, a rule of thumb is that the Cassegrain is usually >10% of the main dish diameter to achieve good efficiency. The efficiency increases with the Cassegrain diameter and the upper limit is only one of blockage.

It is quite common to use a Cassegrain of up to 25% diameter at mmWave, as blockage is still negligible (~ 7%). The minimum far-focal distance to the feed is determined by the Rayleigh distance (where a parallel wave front is achieved) being > 10 wavelengths.

This minimum distance also sets a minimum practical dish size, conical horn feed design and some limitations on the Cassegrain design.

If you have a matching dish and Cassegrain already, you can reverse engineer the combination, although a bit of trial and error will get you close. I sliced the radome off a Nurad assembly some years ago to work out the main dish f/D (= 0.4) and measure up the Cassegrain.

After some calculations, it closely confirmed that the focal point is ~ 40 mm from the apex of the main dish with an 18 dBi horn. Calculations also revealed that the dimensions were a compromise below 30 GHz but seem designed more for 30-40 GHz. This explains why they work so well on 47 GHz and are still very usable at 76 GHz.

Care and feeding of a Cassegrain

The feed antenna is usually a conical horn that is dimensioned to illuminate the Cassegrain reflector in much the same way as a prime offset focus dish, i.e. approximately the -10 dB points of the feed pattern line up with the reflector edges.

Whilst the f/D for a prime focus dish is usually 0.3 – 0.4, placing a conical feed as near as possible to the apex of the main dish results in a far-focus f/D of ~ 1.0, or greater, for the Cassegrain.

The conical horn needs to be designed for a dish with an f/D = 1.0 (or so), and hence has a narrower beam than that for an offset dish with an f/D = 0.6.

The best resource to help design a conical feed can be found

| CASSEGRAIN ANTENNA DESIGN CALCULATOR | | | | | |
|---|--------|--------|-------------|---------|-----------------------|
| W1GHZ 2019 | | | | | |
| ENTER INPUT PARAMETERS HERE (Bold blue numbers) | | | | | |
| Frequency | 47.000 | | | GHz | |
| Units: | mm | inches | Wavelengths | | |
| Dish diameter | 600 | 23.6 | 04.2 | | |
| Dish f/D | | | | 0.38 | |
| Feedhorn equivalent f/D | | | | 0.98 | |
| Feedhorn diameter | 14.7 | 0.579 | 2.267912 | | |
| Feedhorn Phase Center (negative = inside horn) | | | -0.11 | | |
| Wavelength | 6.371 | 0.251 | 1 | | |
| Dish Focal Length | 129.2 | 5.0 | 20.0 | | |
| Dish Illumination half angle | | | | 60.4 | degrees 1.09 radians |
| F Feedhorn Illumination half angle | | | | 28.8 | degrees 0.500 radians |
| Feedhorn (prime focus to rim) | 227.4 | 12.9 | 51.4 | | |
| Space attenuation for main dish | | | | 0.39 | dB |
| Space attenuation for subrefl dish | | | | 0.95 | dB |
| Flange and illuminator taper: | | | | 12.7% | dB |
| Enter desired illumination taper: | | | | 12.8% | dB |
| VNA or SWR Taper: | | | | | |
| Feedhorn illumination half angle | | | | 23.8 | degrees 0.416 radians |
| Feedhorn equivalent f/D | | | | 1.01 | |
| Minimum subreflector diameter | 10.6 | 1.073 | 7.88 | | |
| Subreflector focal length | 18.9 | 3.297 | 9.16 | | |
| Subreflector f/D | | | 3.16 | | |
| d_subfl_min | | | | 0.96 | |
| Maximum subreflector efficiency (CMB losses less blockage loss) | | | | 67.8% | |
| Feedhorn blockage half angle | | | | 7.3 | degrees 0.127 radians |
| VNA (or feedhorn blockage) - increase subreflector diameter to eliminate feedhorn blockage: | | | | | |
| Minimum subreflector diameter | 13.0 | 3.98 | 8.88 | | |
| Subreflector focal length | 62.6 | 2.666 | 9.23 | | |
| d_subfl_min | | | | 0.89 | |
| Subreflector efficiency (CMB losses plus blockage loss) | | | | 68.2% | |
| Feedhorn blockage half angle | | | | 6.9 | degrees 0.120 radians |
| Enter desired subreflector diameter: | | | | 20 | in wavelengths |
| or go back and change feedhorn | | | | | |
| With desired subreflector diameter: | | | | | |
| Subreflector focal length | 145.4 | 1.848 | 23.26 | | |
| d_subfl_min | | | | 0.71 | |
| Subreflector efficiency (CMB losses less taper loss) | | | | 74.8% | |
| Cassegrain loss = | | | | -1.2576 | dB |
| Overall efficiency, and efficiency on feedhorn PHASEPAT curve (as f/D): | | | | | |
| | | | | 1.01 | and multiply by 0.749 |
| CASSEGRAIN SUBREFLECTOR GEOMETRY: | | | | | |
| Feedhorn blockage half angle | | | | 2.6 | degrees 0.046 radians |
| Subreflector diameter at dish rim | | | | 2.64 | |
| Hyperbola eccentricity | | | | 2.22 | |
| Hyperbola a | 23.8 | 1.26 | 5.54 | | |
| Hyperbola b | 68.2 | 2.888 | 10.49 | | |
| Hyperbola c | 74.2 | 2.921 | 11.44 | | |
| SUBREFLECTOR POSITION: | | | | | |
| Apex to Dish focal point | 48.8 | 1.695 | 6.48 | | |
| Apex to Feed Phase Center | 107.6 | 4.236 | 16.69 | | |
| Feedhorn Flare half distance = | | | | 10.8% | |

Figure 4: W1GHZ Cassegrain calculator spreadsheet.

on W1GHZ's website, here www.w1ghz.org/antbook/chap6-4a.pdf. Also look for the HDL_ANT_32_V4p1.exe file on his website; this will calculate the actual design and E/H pattern of the conical horn.

Obviously, there are quite a few interactional calculations to be done, so we have busted Myth #1 that you can get away with any randomly curved sub reflector! It may even be worse than a splash plate!

The calculations are complex but, luckily, W1GHZ created a spreadsheet many years ago that analyses all factors to produce the Cassegrain design. It has a

couple of assumptions that may need some experimentation to optimize, but it is far easier than doing all the maths.

A Cassegrain can be made optimum over one octave in frequency i.e. 40 to 80 GHz, but usually will still work at 1.5 times that range with some adjustment of the focal length. The spreadsheet can be found here: www.w1ghz.org/antbook/conf/Cassegrain_design.xls

Figure 4 shows the calculations for the Cassegrain design I have used with a 600 mm NEC dish on 47 GHz for the current VK record of 182 km.

You can set target the Cassegrain diameter (in wavelengths) and try different far-focus distances until you get a satisfactory combination. The hyperbola parameters for the Cassegrain design are then calculated at the bottom (a, b, & c). To convert these parameters to an actual design file (STL, DXF, 3MF, etc) you can use the freeware program OpenSCAD with a script found here: www.thingiverse.com/thing:2750924.

This file can then be converted to G-code used for manufacturing the Cassegrain.

Remember that Cassegrain needs to have a metal reflective surface so does not need to be made of metal; a far easier solution is to 3D print one and cover it in kitchen foil! If you have a 3D printer you will know all the next steps needed. If you don't have one, enlist the help of a friend with one to do this for you.

For the ones that I have printed, I have used the finest resolution setting (0.06 mm layers) and 1.5 mm walls, with 50% in-fill. Rather than

use poor quality PLA, I have used PET that has a much higher melting point, as the back is always flat, no warping occurs, hence the resultant shape is perfect.

While you can use aluminium foil to cover the reflector, I found 50 mm-wide thin copper foil with an adhesive backing to be much better. **Photo 1** shows two examples, the large 125 mm diameter one is for a NEC 600 mm dish, the smaller for a Procom 250 mm dish. You will find this online in a few places, as it is commonly used in electric guitars to shield the preamp recess in the main body from AC pickup!



Photo 1: 3D printed Cassegrain reflectors with adhesive copper foil covering.

For a conical horn, a CAD designed/machined horn is best (**Photo 2**), but there is nothing stopping you from making one up from waveguide or brass tube with a hobby brass horn (**Photo 3**). Just remember that brass tube as waveguide is *lossy* at mmWave, so try to use copper or aluminium. Also, the internal surface of drawn tube is not machined smooth, so contributes to losses.

Fun fact #1, why are splash plates (penny feeds) such poor performers at mmWave frequencies? There are several

contributing issues, the most significant is that the flat plate geometry results in a series of in-and-out of phase beams that create dead zones in the main beam. This results in a donut pattern of radiation, where only part of the dish produces a collimated plane wave.

On 10 GHz, a splash plate can have a ~30% antenna efficiency vs ~65% achievable with a direct feed. As the wavelength is 3 cm, there will probably only be one donut area with a sweet spot for the feed that illuminates better than half of

the dish area. If the dish is accurate at 10 GHz this will result in ~ 4 dB loss that we can probably live with.

But, as you go higher in frequency, it gets a whole lot worse. With the shorter wavelength, there will now be multiple donut areas spread across the same dish, each with a slightly different focal point. Only one donut can be truly effective at any time as the other donut(s) beams converge/diverge the main beam as noted by a vagueness in the focal point. The various beams combine or cancel out, resulting in a dish that has a broad peak, or worse, still two main peaks either side of straight ahead!

The effective efficiency of the dish can drop from a poor 30% to as low as a 5% (measured on 122 GHz!).

Fun fact #2, if you want to check the focal point and the accuracy of a small dish for use on mmWaves, you can use the sun as an energy source. You will need a solid tiltable mount and feed support that is central to the dish centre line to which you can attach a movable target.

To make the dish reflective you can use two (or more) aluminium foil strips running from edge to edge across the dish. Alternatively, I have



Photo 2: CAD design for a 47 GHz conical feed horn for a Nurad dish.



Photo 3: Hand fab 76 GHz conical feed horn with 600 mm NEC dish; very sharp!

found that simply wetting the dish surface with a garden hose will make it reflective enough to light up a target for a few minutes. I use thin Teflon sheet; paper works, but it will catch fire quickly with an accurate dish!

The aim is to determine that the actual focal point is central and sharp in all three planes. The 'spot' should be a fraction of the wavelength you will use the dish at, so that means < 1 mm at 122 GHz. If the spot is not sharp at any point, then the dish is not quite a parabola, or it's bent. The gain will be much lower than theoretical and suffer the same "donut" radiation problem a splash plate does, even with a good Cassegrain feed.

If you would like more information on how to couple the RF zero into various transceivers in the column, please let me know and I will include more details in a future column. Next issue, we will look at the PLL project that reference locks 25–200 MHz TCXOs to improve the phase noise floor of microwave PLLs.

What happened 20 years ago

The headline from my November 2020 column, "6 Metres .. Ok who has the keys!!"

Overall, the Spring Equinox, just passed, has been a bit of a fizzer, maybe re-enforcing that this cycle is still yet to perform properly. A lack of extension propagation modes has kept most of the lower half of VK quiet. Meanwhile, to the west and up north,

Don VK6HK(SK) reports ...
"A good day in Perth yesterday, Wednesday 18th - Some log extracts... Band was open earlier than 0400Z, but I was out with the XYL. 0407Z KH7L, 0500 - 0615 JA's, 0626 HL1LTC, 0648 7M4BEP/5 (Alerting alternative JA prefix...), 0724 BY9AA, 0745 HL5XF (Hrd), 0748 DS2DKW (Hrd) (Another alternative for Korea...), 0832 4W6UN/B (Hrd), 0647 9V1UV, 0943 YB0AN (Hrd), 1052 EY8CQ, 1153 9M6BAA, 1219 VR2XMT,

VK7s' 23cm QSO party successes

Back on 6 December 2015, there were a few stations in the Hobart area that were getting increasingly keen to operate on 23cm. Under the expert guidance of Rex Moncur VK7MO, it was suggested that we start a 23cm QSO party straight after the National and Local broadcasts each Sunday morning to see if there was interest and to explore how well the various stations could communicate.

Another purpose was to encourage the improvement of antennas and systems.

On that first Sunday, Murray VK7ZMS operated as net controller from Mount Wellington on 1294.0 MHz FM. At the time, we mused that

if we all pointed our beams toward Mount Wellington, it could be a reasonable passive reflector. The call went out to anyone who had 23cm gear to dust it off and get on air after the broadcast.

Well, that was nearly five years ago and now we regularly have 15-20 stations call-in for the QSO party after the broadcast on 1296.15 MHz FM voice and two-to-three stations on 1296.2 MHz WSJT-QRA-64 between Launceston and Hobart.

In fact, 1296.150 MHz has become the new 'chat channel' in Hobart, with everyone pointing their beams towards Mount Wellington. There will usually be someone come back to a call.

Rex VK7MO has built many boom drilling templates and hosted three antenna workshops, building 23cm Yagis using fibreglass electric fence posts and aluminium welding rod for elements. He estimates there are at least 20-30 of these Yagis out in the VK7 amateur community. Thanks Rex.

Many amateurs have bought, and are using, the Bulgarian SG-Labs 23cm transverters and solid-state power amplifiers. Then, along came the Icom IC-9700 multi-band (2m/70cm/23cm) multi-mode rig and many amateurs adopted it. There are also some, including me, using older 23cm rigs, like the Icom IC-1271 and IC-12 handhelds.

All this hard work, experimentation and improvements resulted in 23 amateurs on 23cm on both the 10th and 17th of May 2020, with 21 in Hobart and two in Launceston.

The levels of experimentation has not declined since then, and the use of 23cm in the Remembrance Day contest and VHF/UHF Field Days attests to the popularity of the band in VK7.

Justin Giles-Clark VK7TW



VK7TW's 1296 Yagi pointed at the passive reflector of Mt Wellington (photo by VK7TW).



1296 MHz Yagi workshop at OTH of Rex VK7MO (photo by VK7MO).

1224 9M6BAA (Now 9+10)" ... Don VK6HK

Ron Graham VK4BRG(SK) reports ... "Some interesting 6m propagation 0054 to 0107 UTC on 18/9/2000.. commencing with a normal F2 opening to the San Diego area. Then I was called by K7CW in CN87 grid (Washington State). He had a pronounced and rapid auroral flutter on his signal. Some discussion took place and he said he had to beam East to work me. I asked if there was any aurora activity, he was aware of and he replied that the aurora had been visible as far south as Nth. Washington State. Four other contacts took place with stations in that general area; as far north as VE7 and as far east as western Montana, all with the same flutter and with them beaming east." "Immediately following, stations around the Colorado area were worked with what appeared normal F2. That propagation continued for another 20 minutes. I think the stations worked via the aurora were via F2 to somewhere in the US and this linked up with the auroral propagation at that end. I experienced a similar situation last cycle with a KL7 in Alaska. We both tried various beam headings during that contact, but he HAD to beam somewhere close to east to work me. I still remember him saying he was beaming to the Great Lakes area."

And on 25/10/2000 "Well, finally had a reasonable 6m opening to Europe last evening 25/10/00. 0640 YO4BCZ 4-2 KN45, 0703 UT5JCV 5-2 KN64, 0732 YO4FRJ/P 4-2, 0736 UT4IO 5-5 to 5-9 KN88, 0807 OH5CW 5-2, 0809 OH7KM 4-2, 0853 YL3GJ 5-7 KO26. Quite a long opening, and difficult operating conditions!! Wally, VK4DO (SK), had a similar opening over a similar time period." ... Ron, VK4BRG

Sadly Don, Ron and Wally are no longer with us. Those who remember the era will acknowledge that they were regularly active on 6m and above. Sunspot cycle 23 'sort-of' peaked in 2001 with low numbers and have yet to recover.

More on what happened 20 years ago next month!

Digital Amateur TV activities

Last month's report from VK1 on digital ATV activity has stirred up some interest. At the last EARC technical night, Iain VK5ZD demonstrated both DVB-T (Standard Definition) on 2.4 GHz, and DVB-S on 1.2 GHz.

While DVB-T is more difficult to generate unless you have access to ex-commercial equipment, DVB-S is quite achievable and good results can be obtained for relatively static images (low symbol rates) using comparatively inexpensive equipment. For reception of DVB-S, any modern satellite digital tuner can be used for 1.2 GHz, with a preamp.

It would be good to connect with more groups experimenting with analogue or digital ATV so we can share what is being done. Just email me details of your group's activities and I will include them in the column. If there is sufficient interest, I'll put together a "how to get started in DATV" part in the construction series.

Online path loss calculator for 24 GHz and above

As previously covered, Iain VK5ZD's website that displays the calculated path loss for 24, 47, 76, 134 and 241 GHz has become a well-used resource to quantify mmWave band conditions. The website can be found here:

<http://weather.vk5microwave.net/Weather.aspx?State=H>

There is also a path loss calculator available on this link that allows live meteorological data to be entered for any site, anywhere in the world: <http://weather.vk5microwave.net/Calculate.aspx>

In closing

Feel free to drop me a line if you have something to report or a project you are working on, it doesn't take much to put a few lines together and helps with the diversity of this column. Just email me, at david@vk5kk.com

73

David VK5KK



Have you registered for MEMNET yet?

Go to www.wia.org.au click on 'For Members', then click on 'Log into MEMNET', and register... it's very simple.

If you have already registered for MEMNET but have not received a confirmation Email we may not have your correct email address.

Please email memnet@wia.org.au with your email address, name and membership number.

If you are changing your email address, please remember to update your information in MEMNET.



Meteor Scatter Report

Dr Kevin Johnston VK4UH

VHF Meteor Scatter: an introduction to operating practice in VK Part 3

In this part of the series, I cover the equipment requirements to establish an effective Meteor Scatter station, the software options, other computer-related factors, and finally, the practical aspects and protocols for successful Meteor Scatter operating.

So what do I need to set up a Meteor Scatter station?

In truth, most of the basic requirements for an effective MS station are already to be found in many VHF shacks.

Let's consider each component in a little more detail, starting with the transceiver at the centre of any station. That starting point is an SSB rig capable of operation on the band of interest. Just about any transceiver manufactured in the last 20 years, capable of basic SSB operation, will be suitable. There is no special requirement for any great degree of frequency accuracy or stability.

Digital machine generated modes (MGMs), as used for Meteor Scatter, have to be tolerant of a fair degree of frequency discrepancy. Since the meteor trails themselves are moving, Meteor Scatter signals are typically subjected to a degree of Doppler shift and the software decoders have to allow for this. In general, MS decoding software is capable of compensating for Doppler shift that is otherwise sufficient to make an SSB signal unintelligible. If a rig is stable

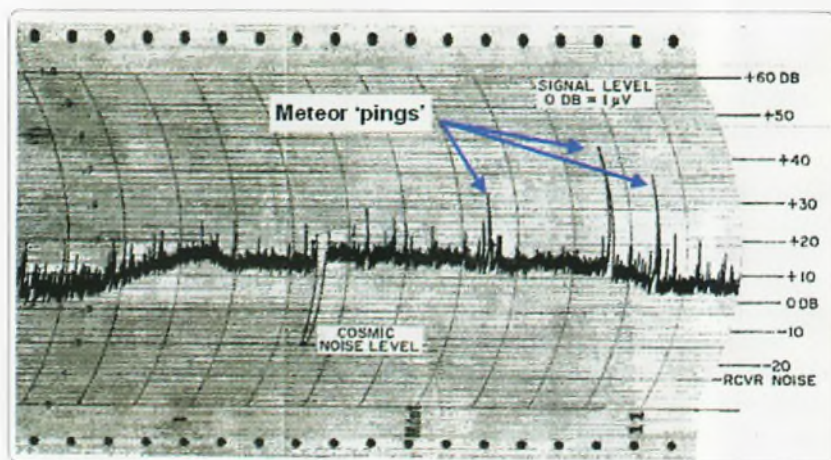

Photo 1: Vintage chart recording of a signal showing meteor 'pings', which can reach strengths of 20-30 dB above the signal level.

enough to work SSB, then it is likely to be OK for MS.

Some operators elected to frequency-lock their rigs to high-accuracy standards, such as GPS, but this is not essential. In practice, it is generally sufficient to simply compensate for any frequency inaccuracy of an individual rig, with a little practice, by listening to the "sound" of received meteor pings and the frequency offset which is indicated by the computer software itself.

What about transmit power level?

The current VK power output limit for digital transmissions, for both Standard and Advanced licences, is 120 watts pY (mean power). Most stations will run as close as possible to this level.

While it is possible to make contacts with lower power levels, it becomes substantially more difficult. Firstly, as discussed previously, this is because it is not possible to use antenna gain to compensate for lower transmit power, which inevitably reduces the number of received meteor pings. The narrower horizontal beamwidth of larger antenna arrays misses signals returning on different beam headings.

Secondly, meteor scatter does not follow the usual "3 dB extra in gives 3 dB extra out" rule. Higher transmit power increases both the received signal strength AND the duration of the received signal above a threshold. So, 3 dB extra in can deliver much more than 3 dB extra out. See Figure 1.

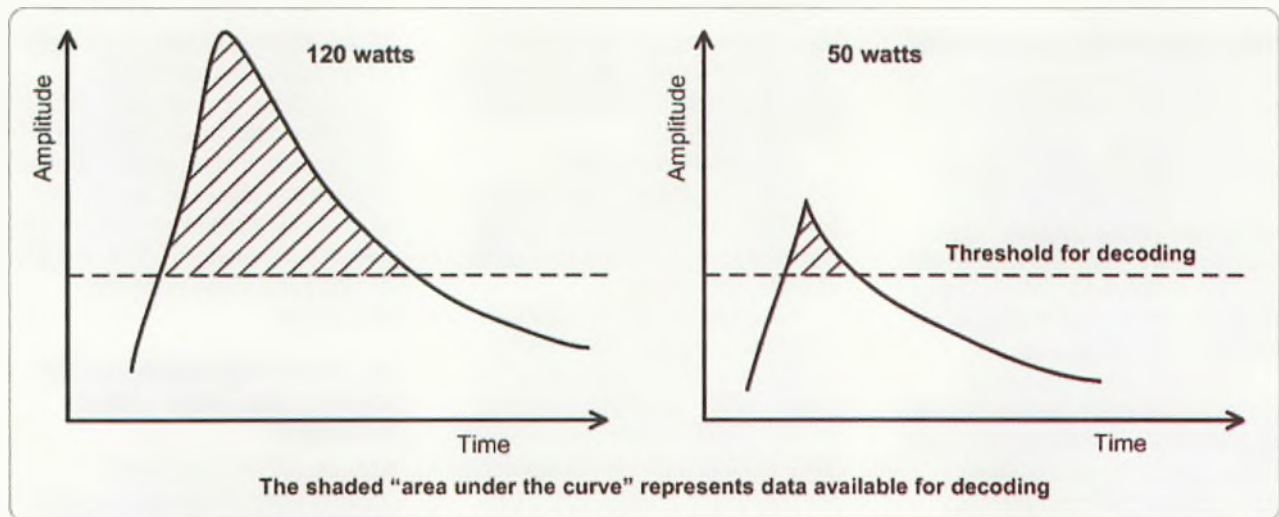

Figure 1. Illustrating the 'threshold' effect with different transmitter powers.

As most operators will be aware, the ACMA will, under appropriate circumstances, allow operation at higher power levels than permitted under the "normal" licence conditions. Special high-power permits for "celestial communication", which encompasses both EME and Meteor Scatter, can be applied for.

Be aware, of course, that a standard "barefoot" SSB rig, nominally rated at 100 watt pep, is unlikely to be able to operate at this power level for sustained periods of time. All current operators running MS modes are effectively running full-power, key-down carrier while on transmit for at least 50% of the time. Few SSB radios are designed for this duty cycle and are prone to

overheating and frequency drift (etc) if this were tried.

Many operators elect to operate their rig at lower power levels as drivers for an amplifier, also under-run to the 120 watt output level, to avoid overheating or overstressing either transceiver or amplifier. Power supplies for both rig and amplifier should be capable of sustained key-down operation at the power levels in use.

As discussed earlier, digital MS signals are generated and decoded by computer as audio tones and are passed through the standard audio pathway and filters of an unmodified SSB transceiver. The practicalities of this are shared by all other MGM modes, including FT8, RTTY, SSTV, JT65 etc. Some form of interface is

required to pass the audio signals, on both transmit and receive, between computer and radio.

The audio signals must be transferred at appropriate levels to prevent overdriving and consequent distortion, and must be free of any noise, hum loops or potential RF interference in a ham shack setting. The interface also has to allow the computer software to command the transceiver PTT line to alternate between transmit and receive.

There are many homebrew designs and commercial interfaces available for this purpose. The Signalink and Rigblaster interfaces are popular examples. These interfaces are effectively outboard computer soundcards, linked via USB cables between computer and radio.

Many current generation radios, from all the major manufacturers, have inbuilt soundcards that allow all of these functions, audio-in, audio-out, PTT control, and often CAT frequency and rig control via a single USB cable with no intermediate interface at all. The current generation of MS software platforms are pre-populated with drivers for such modern radios as standard, to take full advantage of these facilities.

Photo 2: To run digital modes with your older rig, you need an interface unit, such as this Signalink.



What about the computers?

The requirements for computers for the current MS software platforms are very modest. Just about any laptop or desk machine with any OS that is still supported will be adequate for this purpose. Many operators are even successful with Arduino or Raspberry Pi modules. Software versions are available for both 32- and 64-bit systems.

One essential requirement, however, is a high degree of time accuracy from the computer clock. Since one of the prerequisites for successful MS operation is transmission and reception in specific time periods, in conjunction with many other stations on exactly the same frequency, then accurate computer clock timing to something better than one second is essential.

This can be achieved by a variety of means, including a number of internet-based time servers or even using GPS-derived clock correction, where internet access is not available. I currently rely on the "NetTime" app for this purpose.

What sort of antennas are best?

As touched on earlier, horizontal antennas are generally required. This is adopted primarily since the mechanics of MS reflections favour horizontal polarization and, secondly, to avoid the 26+ dB cross-polarization loss.

There is a trade-off between antenna size (gain) and beamwidth. Meteor returns may arrive across a wide arc of headings and hence too narrow a horizontal beamwidth may "lose" more returns than are gained by the extra gain. A single 8-10 element Yagi is a common "sweet-spot" choice.

In theory, vertical stacking of Yagis may offer some advantage by providing enhanced forward gain by reducing the vertical beamwidth but without reducing horizontal beamwidth. Apart from the disadvantage of complexity, returns

from stations closer than 1000 km may be lost by this approach due to their high angle of arrival of signals from this distance.

Unlike EME or satellite operation, elevation control is not generally required as most signals of interest will be arriving at angles close to zero elevation.

It is important from a historical viewpoint to be aware that there is a variety of other modes created for meteor scatter operating, including FSK441, ISCAT, PSK2K, and MSKMS. Most of these have been relegated to heirloom status at the current time.

What software do I need for Meteor Scatter?

What mode is required?

The current "Standard" mode for Meteor Scatter, at the time of writing, is MSK144 ver.2 running 15 second transmit periods. This digital mode is available as a component of two software platforms WSJTx and MSHV (ref 1.). Both software platforms are freely available to download, free of charge, for the amateur community by their respective creators.

MSK144 ver.2 is the only mode that should be used during VK activity sessions, which I outline below.

The fundamental cornerstone of digital meteor scatter operation is one of massive repetition. A short message string, with a maximum of 23 characters, is transmitted over and over again and at a sufficiently high data rate that the entire string can be propagated over a single 100ms meteor ping.

There is formal agreement within the amateur community, arising from decades of weak signal operating, as to what constitutes the minimum requirements for a valid QSO. These apply to meteor scatter operation and are not unlike the exchanges used for other digital modes such as FT8 or for EME etc. These minimum requirements involve the two-way exchange of callsigns between stations, the two-way exchange of

signal reports and finally confirmation that all the required exchanges have occurred. To prove beyond reasonable doubt that a valid contact has occurred, there is agreement that there must be the exchange of some piece of information that could not be predicted or assumed. In this context, the signal report itself fulfils this requirement.

So, once I establish my MS station, how does a QSO proceed?

Both the WSJTx and MSHV platforms set out the logical steps (message strings) for a QSO and both are capable of auto-advancing the transmitted data strings as each step is achieved.

Consider a QSO between two fictitious stations VK4ABC and VK5XYZ:-

As with most QSOs the starting point is usually a CQ call. The software creates a string containing CQ, the station callsign and a 4-character maidenhead gridsquare. e.g. [CQ VK4ABC QG62]

This string is transmitted repeatedly for 15 seconds in one of two periods (time slots). The "FIRST" or "EVEN" period runs from 0 - 15 seconds and from 30 - 45 seconds in each minute.

The "SECOND" or "ODD" period runs from 15 - 30 seconds and from 45 - 60 seconds in each minute.

At some point, a meteor return will occur and the string will be decoded by the distant station VK5XYZ. That station will now call the VK4:

e.g. [VK4ABC VK5XYZ 08]

For clarity, the agreed format (order) is that the destination station callsign is always put first and the originating station callsign is put second. The +08 is the signal report, in dB above noise, which is automatically derived by the software from reception of the original CQ message. This string is then sent repeatedly in the other time period until it is received.

At some later point, a meteor return will occur and that string will be decoded by the VK4. Once received, the VK4 would then respond with:-

e.g. [**VK5XYZ VK4ABC R14**]

The same format applies, showing the intended recipient is VK5XYZ. The "R14" indicates "Roger" (I have received my report) and my report to you is +14 dB.

The logical response once that string is received would be:

e.g. [**VK4ABC VK5XYZ RRR**]

RRR means "Roger Roger Roger", and indicates that the return report has been received and all required information has been exchanged.

At this point, the QSO is actually complete and valid.

Most stations using internet-based reporting systems, such as VK-Spotter, would make a log entry and post the QSO as complete.

Although the QSO is complete, station VK5XYZ will not yet be aware of that fact and would keep on transmitting his message.

As a courtesy, to allow the VK5 to move on, the following confirmation may be sent:-

e.g. [**VK5XYZ VK4ABC 73**]

All done and dusted!

When does Meteor Scatter activity occur?

When could I try to make contacts?

What frequency should I use?

Right at the beginning we discussed that meteor returns may occur at any time of the day and on any day of the year. Also, that there is a marked "peak" just before dawn and during the spring and summer seasons.

To take advantage of these peaks, in VK and ZL, there are two long-established activity periods over each weekend. These occur on Saturday and Sunday mornings throughout the year from before dawn until MS propagation fades. Typically, from around 19:00 UTC and running for 2-3 hours depending on the number of active stations. Other times during the day or night may be used during meteor showers when enhanced activity is dependent on the position of the individual meteor shower in the sky.

During these activity periods most operation is conducted on the same focus frequency which is encompassed in the VK and ZL band plans for this type of activity

On 2m the primary focus frequency is 144.230 MHz (secondary 144.330 MHz)

On 6m the primary focus frequency is 50.230 MHz (no agree secondary at this time)

There are no designated MS frequencies for 10m or 70cms – operation on these bands is usually arranged ad-hoc by ops.

Many well established stations operate synchronously on both frequencies.

Which time period should I use for my transmissions?

This is probably the most important question to be clear about.

In our region, the current operating practice is for all stations to use the same frequency, which is a different protocol and practice to that used in other parts of the world. This reflects our relatively low density of amateur stations spread over a very large geographical area and optimises our chances of making contacts within this region.

Selection of the correct time period is pivotal to successful Meteor Scatter operation and will be covered in detail in the final part of this series.

References

MSHV: lz2hv.org
(latest version 2.46)

WSJTx: <https://physics.princeton.edu/pulsar/K1JT/wsjsx.html>
(latest version 2.2.2)

It is strongly recommended that the user guides for the software be downloaded from the above sites and fully read before using these modes on-air for the first time.

Over to you

Amateur Radio magazine quality

Hi Roger,

Thanks for the quality of the recent issues.

As an amateur who has just returned to the hobby after being absent for nearly 50 years while working overseas, I find it extremely valuable.

The basic articles on various new aspects of amateur radio (at least to me) are a great learning curve.

Technical content, like the homebrew transceiver are very informative, as well.

Keep up the great work.

Regards,

Allen Tighe VK6ART





Photo 1: The international space station (ISS), showing its solar panels deployed (European Space Agency photo).

20 years of amateur radio on the ISS

On November 2nd in the year 2000, astronauts of the Expedition 1 crew reached the International Space Station (ISS) to live and work on board, marking the beginning of uninterrupted human occupation aboard the orbiting laboratory.

The Expedition 1 crew launched from the Baikonur Cosmodrome in Kazakhstan.

Soon after the first crew's occupation, following concerted work by the ARISS organisation – Amateur Radio on the International Space Station – astronauts with amateur licences began to install and use amateur radio equipment on the ISS.

The ARISS program enables students across the world to experience the excitement of talking directly to crew members aboard the ISS. As it passes overhead on its orbit, students have about

nine minutes to ask a series of questions, which the astronauts answer. Students in Australia, Africa, Europe, and North America have participated.

Such experiences can inspire students to pursue careers in science, technology, engineering, and mathematics, as well as engage them with radio science technology through amateur radio.

More than 100 people visiting the ISS, including astronaut crew members, and other visitors, have contacted Earth via amateur radio. More than 1300 contacts via amateur radio have been made between the ISS and schools and other organisations on Earth. See www.ariss.org.

New astronauts get ham licences

Among the latest astronauts to take up amateur licences are NASA crew member, Kayla Barron, who

completed her introductory course in June and received basic ham radio operations training in late September. She recently tested and received the call sign KI5LAL.

European Space Agency (ESA) astronaut, Matthias Maurer, passed his amateur radio exam in late July, and is now licensed as KI5KFH.

Astronauts Shane Kimbrough KE5HOD, and Shannon Walker KD5DXB, completed the refresher course earlier this year. Two other new astronauts are in the queue.

45-year old amateur satellite still going!

AMSAT-OSCAR 7 (AO-7), launched in 1975 and the **oldest** amateur radio satellite still in operation, sprang to life after its orbit returned to full illumination by the Sun in late September, forecast to continue until around 26 December.

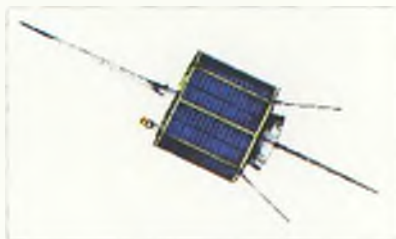

Photo 2: AO-7 is feeling its age. At 45 years old, it likes working when bathed in full sunlight.

AO-7 only works when it's receiving direct sunlight and shuts down when in eclipse as it has no working batteries.

AMSAT advised that AO-7 will likely switch between mode A (2m up/10m down) and mode B (70cm up/2m down) every 24 hours. Users are reminded to employ only the minimum necessary power and to avoid "ditting" to find your signals in the passband, which can bounce

the entire passband up and down and sometimes even cause the transponder to reset to mode A.

Further, AO7 has beacons on 29.502 and 145.975 MHz, used in conjunction with Mode A and Mode B/C (low-power mode B), respectively. A 435.100 MHz beacon has an intermittent problem, switching between 400 mW and 10 mW, AMSAT reports. See www.amsat.org.

Chinese amateur satellite launches delayed

The Chinese Amateur Satellite organisation, CAMSAT, says the CAS-7A launch has been postponed until May 2021, and CAS-5A until next June.

According to a report from the ARRL, CAMSAT's Alan Kung BA1DU, said "Because of COVID-19, many things have been

delayed." He said an announcement would be made closer to the announced launches.

New President and Board for AMSAT

At its Annual General Meeting on 18 October, the AMSAT Board of Directors elected a new President – Robert Bankston KE4AL, of Dothan, Alabama USA. He succeeds Clayton Coleman W5PFG.

Coleman commented, "With the talented and capable individuals sitting on AMSAT's new Board and its officers, I am confident in a bright future ahead for AMSAT and the amateur radio satellite service."

There was a period of turmoil within AMSAT over 2018-2020, reported in this journal, Volume 88, Issue 2, pp 48-49.

AMSAT-VK

AMSAT Co-ordinator
Paul Paradigm VK2TXT
email: coordinator@amsat-vk.org

Group Moderator
Judy Williams VK2TJU
email: secretary@amsat-vk.org

Website:
www.amsat-vk.org

Group site:
group.amsat-vk.org



About AMSAT-VK

AMSAT-VK is a group of Australian amateur radio operators who share a common interest in building, launching and communicating with each other through non-commercial amateur radio satellites. Many of our members also have an interest in other space based communications, including listening to and communicating with the International Space Station, Earth-Moon-Earth (EME), monitoring weather (WX) satellites and other spacecraft. AMSAT-VK is the primary point of contact for those interested in becoming involved in amateur radio satellite operations. If you are interested in learning more about satellite operations or just wish to become a member of AMSAT-Australia, please see our website.

AMSAT-VK monthly net Australian National Satellite net

The Australian National Satellite Net is held on the second Tuesday of the month (except January) at 0.30 pm eastern, that's either 9.30 or 10.30Z depending on daylight saving. Please note we will be taking check-ins from 8.20pm-ish. Check-in starts 10 minutes prior to the start time. The AMSAT-VK net has been running for many years with the aim of allowing amateur radio operators who are operating or have an interest in working in the satellite mode, to make contact with others in order to share their experiences and to catch up on pertinent news. The format also facilitates other aspects like making "skeds" and for a general "off-bird" chat. Operators may join the net via EchoLink by connecting to either

the "AMSAT" or "VK3JED" conferences. Past experience has shown that the VK3JED server offers clearer audio. The net is also available via IRLP reflector number 9558. In addition to the EchoLink conference, the net will also be available via RF on the following repeaters and links.

In New South Wales
VK2RBM Blue Mountains repeater on 147.050 MHz

In Queensland
VK4HRC Redcliffe 148.925 MHz -ve offset IRLP node 6404 EchoLink 44666

In South Australia
VK5TRM, Loxton on 147.175 MHz
VK6RSC, Mt Terrible on 439.825 MHz IRLP node 6278,
EchoLink node 399996

In Tasmania
VK7RTV 2 m. Repeater Stowport 146.775 MHz. IRLP 6616

In the Northern Territory
VK8MA, Katherine on 146.750, CTCSS 91.5, IRLP Node 6800

We are keen to have the net carried by other EchoLink or IRLP enabled repeaters and links in order to improve coverage. If you are interested in carrying our net on your system, please contact Paul via email. Frequencies and nodes can change without much notice. Details are put on the AMSAT-VK group site.

Become involved

Amateur satellite operating is one of the most interesting and rewarding modes in our hobby. The birds are relatively easy to access and require very little hardware investment to get started. You can gain access to the FM "repeaters in the sky" with just a dual band handheld operating on 2 m and 70 cm. These easy-to-use and popular FM satellites will give hams national communications and handheld access into New Zealand at various times through the day and night. Currently only SO-50 is available. Should you wish to join AMSAT-VK, details are available on the web site or sign-up at our group site as above. Membership is free and you will be made very welcome.

Plan ahead

Operate within the band plans:

<http://www.wia.org.au/members/bandplans/about/>

SOTA and Parks

Allen Harvie VK3ARH

✉ vk3arh@wia.org.au

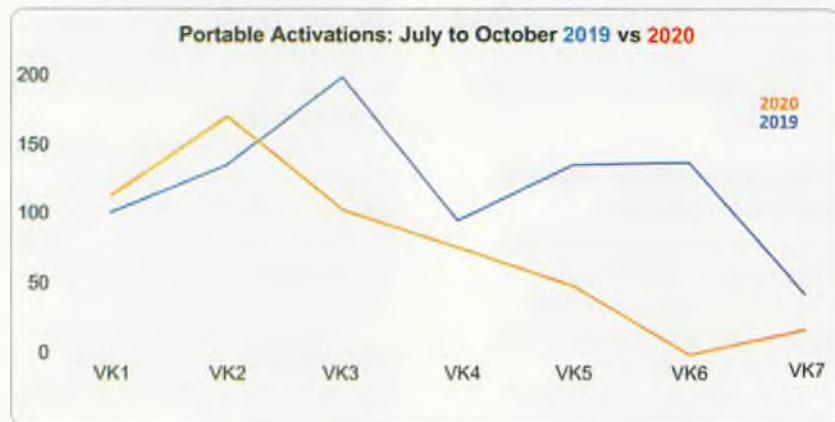

Portable activity

Unsurprisingly, 2020 is continuing to be an unusual year. The activations graph shows the number of WWFF and SOTA activations for each state by year. VK1 and VK2 have maintained levels of activations (10% increase), while activations across the rest of Australia have declined. VK3 activations show a particularly marked drop. Regional VK3 activators are finally cautiously able to get out, but those still in the metro remained under restrictions up to the deadline to submit this issue's column (mid-October).

As it stands, in early October, we were not anticipating dramatic easing of lockdown restrictions, so there were limited opportunities for activations in a two-hour period within 5 km of home.

ZL activity has increased in 2020 (107 activation) compared to the same period in 2019 (84). They are all SOTA activations and all early in the morning. Great for VK chasers on the weekend!

New Parks for WWFF

September saw VK2 receive 95 new parks for the WWFF program. Thanks go out to those involved. Gerard VK2IO researched and

prepared the initial documentation for these parks, Marc VK3OHM then analysed and verified the data and prepared it in the format required to upload into the WWFF Directory. Paul VK5PAS followed by doing final checks and submitting for approval. As a result of the data quality, this is typically overnight.

Once listed and verified, the sites are added to www.wfffaustralia.com and ParksnPeaks.org. Now, activity can be spotted by chasers and activators can post alerts. It's not all over yet;

VK2IO from VK2/ST-039 during VK1 Winter SOTA QSO Party.



Marc continues to process site data and generate boundary files for all our WWFF sites. They are published from ParksnPeaks.org under the Maps tab, at: <https://parksnpeaks.org/viewMaps.php>.

Boundary and Site files

The site location and boundary files are in KMZ format, which can be loaded into Google Earth, or Garmin basecamp. They show the parks' boundaries and, where relevant, multiple parcels involved with a park, which greatly simplifies the planning of activations. You will also find data for VK and ZL SOTA sites, including indicative activation zones.

Participation

Despite winter and restrictions, there is still quality activity. Tait VK1HAB went off on a multi-day outing into the Bramina. We were able to watch his progress as the 1 W APRS packets reached over 100 km. Ian VK5CZ trekked all the way out to Black Hills and back, as well as through Wilmington. VK2IO

proceeded to activate some of the new WWFF sites. Peter VK3PF is off and activating with regional restrictions easing and winter bonus period fast expiring. VK1 activations are growing due to their great access, which is keeping the VK3 chasers sane.

Activation criteria

When searching through the activations history, I noticed a lot of new activators. I will quickly touch on the activation criteria. You can participate in KRMNPA, WWFF or VKFF from a mobile, so long as it and your antenna are within the boundary of the park and the park is listed.

For SANPCPA and SOTA, the operations are portable, so your activation is self-powered and cannot be dependent on a vehicle. Basically, you could drive away from the station. A HT operating simplex in the metro areas elegantly qualifies for portable – and exercising.

For SOTA, your operation must be fully independent from any vehicle and within the Activation Zone. (AZ). The activation zone is the area 25 metres from the peak of the summit.

Going crAZy!

The SOTA KMZ files now highlight activation zones (AZ). This is really useful when trying to verify operating positions where the summit is on private land (VK2/SY-001), but the AZ is huge, or to clarify valid positions (VK3/VC-003) where the AZ is also large and the site experiences high numbers of visitors; hence, you may desire to

operate from a position as far away from others as possible.

I'm currently using the AZ view to identify opportunities on local private land looking for public access to the AZ. The AZ data from PnP shows the fill plane, which is placed at the published SOTA height, thus showing the 25 metre intersection with the terrain.

This is a great tool but has to be taken with slight scepticism, Google Earth terrain heights are not accurate, so the plane may appear higher than it should be, the summit may be being displayed lower than it should be or even in open space. Because the height is measured on a grid of 150 m, some peaks may get their top truncated.

If you're looking at mapping and it does not look right, don't get too worried, reposition the plane of the summit, and then manually adjust the full to take into account the 25 m zone. This will give you a reasonable representation of the shape and extent of the AZ. From this data, I will still need to verify on-site and expecting terrain and cover to be the challenge.

Regardless of all the planning, mapping and photos used during planning, the AZ measure is always relative to conditions. So, despite verifying with GPS on-site, or the data (having come from reputable sources [Government?] and sites checked) doesn't match a site 100%, then SOTA uses the concept of "spirit". As long as you have taken reasonable steps to verify that you are in the AZ, then the activation will be OK.

Once in the right spot, you have

to secure contacts. Right now, the bands are still doing whatever they want, so best take an 80m antenna and don't forget to submit your logs, here:

- SOTA – <https://www.sotadata.org.uk/en/>
- WWFF to the regional co-ordinator – <https://parksnpeaks.org/showPark.php>

PnP iOS app v2.2.2 released

This release is to align to later iOS releases, fixes layout issues and enhances logging. Version 2 has come a long way and is proving to be a powerful tool.

The app is available from the Apple Store (Parks & Peaks id 1218671045), and full documentation from Sue's site: <https://vk5ayl.com/home/>

Upcoming

While you can activate parks any time, November is typically busy for parks activations with both KRMNPA and WWFF weekends hosted during the 11th month. This year, for the first time, the annual KRMNPA weekend has had to be cancelled.

The 2020 VKFF Activation Weekend is still to be held on Saturday 28th and Sunday 29th November Australia-wide. I hope you are out there activating or chasing from a safe location.

So, at this point, nothing in the calendar and we continue to await the post-COVID world.

73 & 44,
Allen VK3ARH



Silent Key

John Kennedy VK3AIG

On 9 October 2020, Gordon VK3FGC advised that WICEN member John Kennedy VK3AIG became a silent key the previous evening.

Gordon conveyed condolences to John's family from the membership at WICEN Vic.

John became a member of WICEN Vic in 2004. He was active in amateur radio

in the Ballarat area, being the treasure of the Ballarat Amateur Radio Group (BARG) around 2005.

There is a clip on YouTube of Ralph VK3JL working John in 2019 on 2.4 GHz, running 15 mW. <https://www.youtube.com/watch?v=W4JPahhlor0>

Thank you John for your service.

73, Mark Hudson
Communications Officer, Membership Officer and ordinary state member of WICEN Victoria.



Ross Hull Memorial VHF-UHF Contest 2021

Rob Heyer VK2XIC, Contest Manager



Pictured in his Melbourne shack about 1924, Ross Hull 3JU, was at the time honorary Federal Secretary of the WIA. Later, in America, he pioneered use of the amateur bands above 30 MHz and demonstrated that atmospheric conditions extended the frequencies beyond the line-of-sight horizon.

The next Ross Hull Contest will run through the month of January.

Work as much DX as you can during the month, then send in your log. You can enter your log for the best seven days in the contest period, or the best two days, or both. You can count Summer Field Day contacts (one contact per station per band per day) in your Ross Hull Contest log.

Logs are due in by 15 February.

The Contest

The WIA maintains a perpetual trophy in honour of the late Ross A. Hull and his pioneering achievements in VHF and UHF operation. The contest is open to all amateurs. Certificates will be awarded to all entrants, including certificates for the top scoring amateurs in each licence class.

Duration

0000 UTC 1 January 2021 to 2400 UTC 31 January 2021.

In Eastern Summer Time, that is 11am on 1 January 2021 to 11am on 1 February 2021.

Sections

- A: Best 7 days, analog modes.
- B: Best 7 days, digital modes.
- C: Best 2 days, analog modes.
- D: Best 2 days, digital modes.

Digital modes are defined as those in which the decoding of the received signal is done by a computer.

Entrants may submit logs for more than one section.

General Rules

One callsign and one operator per station. Stations may operate from any location. You may claim one contact per station per band per UTC day.

Repeater, satellite, EME and crossband contacts are not permitted. Split frequency operation is allowed. For example, on 50/52 MHz.

Calling frequencies on each band should be kept as clear as possible so as not to interfere with other stations making or listening for calls. If contact is established on a recognised DX calling frequency (i.e. 50.110, 144.100 etc), stations should QSY up to .150, or higher, to make the contest exchange.

All rulings of the contest manager will be accepted as final.

Contest Exchange

For Section A or C, entrants must exchange RS (or RST) reports plus a serial number. Serial numbers need not be consecutive.

NOTE: For propagation modes such as meteor scatter, or short-lived sporadic E openings, it is sufficient to exchange callsigns plus two further digits that cannot be predicted by the other station.

For Section B or D, exchange callsigns plus two further digits that cannot be predicted by the other station.

While not an essential part of the contest exchange, Maidenhead locators may also be exchanged as an aid to distance calculations.

Logs

Logs must contain the following for each contact:

- Date and UTC time.
- Frequency and callsign of station worked.
- Reports and serial numbers sent and received.
- The contesting station must include their own grid location in the log for the purposes of checking distance claims.
- Approximate location or grid locator of station worked.
- Separate scoring columns for each band would be helpful.

Scoring

Scoring will be based on the best seven (7) UTC days nominated by the entrant.

For each contact, score 1 point per 100 km or part thereof (i.e. up to 99 km: 1 point, 100 - 199 km: 2 points, etc.).

Multiply the total by the band multiplier, as follows:

| 6M | 2M | 70cm | 23cm | Higher Bands |
|----|----|------|------|--------------|
| X2 | X3 | X5 | X8 | X10 |

Then total the scores for all bands.

Please use the following format for your scoring table. If you wish, you can cross-check by adding the daily totals across the table, but please make sure that you include the separate band totals. See the Table at the end of this article.

A cover sheet and scoring table is included in the postings on the WIA web site. Copies can also be obtained from the e-mail address given below.

Penalties

Minor errors may be corrected and the score adjusted.

Repeated use of recognised DX calling frequencies (especially when the reports indicate strong signals) may lead to disqualification. Inclusion of any false log entries will lead to disqualification.

Entries

Paper logs may be posted to the Manager, Ross Hull Contest, PO Box 1838, Wollongong NSW 2500.

Electronic logs can be e-mailed to rosshull@wia.org.au.

Acceptable log formats include: ASCII text, RTF, DOC, DOCX, XLS, MDB, PDF, or any Open Document format.

Please note that steps are being taken to upgrade the Ross Hull Memorial VHF / UHF Contest logging to the standard of other contests, eg: Cabrillo format.

This will not be the case for the 2021 Contest. Further information will be issued at a later time.

Logs must be received by 15 February 2021. Early logs would be appreciated.

Note on Calculating Distances

Absolute accuracy is not required. You just need to know whether each station is above or below the nearest multiple of 100 km, so you can use a compass to draw 100 km circles around your location on a map.

Alternatively, you can use contest logging software that can calculate distances. If so, you will need to exchange 6-digit Maidenhead locators to get an accurate distance measurement.

You can also calculate distances from 6-digit Maidenhead locators using a computer program that is available on the Ross Hull Contest page of the WIA web site.

Contest web page: <http://www.wia.org.au/members/contests/rosshull/>

Cover Sheet

Logs must be supplied with a cover sheet containing:

- Operator's callsign, name and address.
- Station location (if different from the postal address).
- Section(s) entered.
- A scoring table set out as the example below.
- A signed declaration that the station has been operated in accordance with the rules and spirit of the contest, and that the contest manager's ruling will be accepted as final.

TABLE – scoring example

| Date | 6M | 2M | 70cm | 23cm | 13m | Etc |
|-----------------|-----------|-------|-------|-------|-------|--------------------------|
| Day 1 | xxx | xxx | xxx | xxx | xxx | |
| Day 2 | xxx | xxx | xxx | xxx | xxx | |
| 2 Day Subtotals | xxx + xxx | + xxx | + xxx | + xxx | + xxx | = xxxxx (2 DAY SUBTOTAL) |
| Day 3 | xxx | xxx | xxx | xxx | xxx | |
| Day 4 | xxx | xxx | xxx | xxx | xxx | Etc. |
| 7 Day Totals | xxx + xxx | + xxx | + xxx | + xxx | + xxx | = xxxxx (7 DAY TOTAL) |

Pages from the Past

From front page of The Herald newspaper (Melbourne) Saturday October 5th, 1957

MAN-MADE MOON ALOFT

Amateur Wireless Operators all over Australia were alerted today to listen for the Russian "moon".

The Federal President [error, he was Secretary] of the Wireless Institute of Australia, Mr L.D. Bowie, broadcast the alert over the Federal station VK3WIA.

RADIO "HAMS" ON ALERT

He will act as co-ordinator receiving information about the position of the satellite.

Tomorrow divisional stations in all States will include the "keep alert" message in their usual Sunday morning sessions. ¶



ALARA

Jenny Wardrop VK3WQ

Results of the 40th ALARA Contest on 29 - 30 August 2020

| Name | Callsign | Result | Notes |
|-----------|----------|--------|---|
| Linda | VK7QP | 829 | Top overall, Top Phone, Top VK7 member |
| Catherine | VK7GH | 766 | Honourable Mention |
| Michelle | VK2FMYL | 348 | Top Foundation License ALARA member, Top Echolink, Top VK2 member |
| Alisha | VK2FASH | 280 | Honourable Mention |
| Lilly | VK2FLIC | 280 | Honourable Mention |
| Jennifer | VK3WQ | 246 | Top VK3 Member |
| Bev | VK6DE | 189 | Top VK6 Member |
| Norma | VK2YL | 154 | |
| Lyn | VK4SWE | 124 | Top VK YL CW, Top VK4 Member |
| John | VK2YW | 113 | Top VK2 OM |
| Leslie | VK5L0L | 102 | Top VK5 Member |
| Shirley | VK5YL | 87 | |
| Dot | VK2DB | 86 | |
| Steven | VK5ST | 83 | Top VK5 OM |
| Paula | VK8ZI | 78 | Top VK8 Member |
| Shirley | VK7HSC | 69 | |
| Tina | VK5TMC | 68 | |
| Peter | VK7KPC | 64 | Top VK7 OM |
| Rhoderick | VK2TTL | 54 | |
| Catherine | VK2FCAZ | 49 | |
| Yern | VK2KJJ | 45 | |
| Geoff | VK5RK | 45 | |
| Bryan | VK3LF | 39 | Top VK3 OM |
| Stephen | VK3VLF | 24 | |
| Angela | VK7FAMP | 23 | |
| Garry | VK3XCI | 20 | |
| Randall | VK6WR | 20 | Top VK6 OM |
| David | VK2JDR | 14 | |
| Cheryl | VK1CB | 10 | |
| Alexey | NW7M | 10 | Top DX OM |
| Philip | VK2NE | 10 | |
| Graeme | VK6MIL | 10 | |
| John | VK2AWJ | 5 | |

ALARA Contest 2020

What a turnout! This year COVID 19 made all our lives more difficult than ever but Amateurs across the world embraced their hobby even more.

Conditions on the air haven't been the best, but who cares, in a pandemic we can still communicate with each other under slightly less favourable

conditions and with so many options. One of the girls in the contest even used Echolink from her hospital bed!

Summary

ALARA Members: 17
YL Non-members: 1
OMs (incl. 1 DX OM): 15
TOTAL LOGS: 33

A big thank you to all the OM's who joined in and gave the girls points, even if they didn't put in a log.

Congratulations to Linda VK7QP for taking the top position. Her hard work and determination paid off.

We had 10 girls using Echolink this year; Michelle VK2FMYL took out the top prize. Michelle told me that the noise level at her QTH makes operating HF impossible.

CW was also a favourite mode this year for four YLs who made the attempt. Lyn VK4SWE took out the top prize for this mode. Many of these girls entered the contest with CW for the first time, practising with each other on a weekly basis and thoroughly enjoying themselves. Watch this space, I'm sure it will increase next year.



Photo 1: Alisha VK2FASH.



Photo 2: Lilly VK2FLIC.

I wanted to make mention of two very young YLs, Lilly VK2FLIC and Alisha VK2FASH, who shared the mic with each other, both with equal numbers. They worked very hard during the contest and I'm sure we'll hear a lot more from these girls.

Looking forward to next year's contest and seeing many more participants. Thank you so much for taking part and supporting ALARA.

From Sue VK5AYL – Contest Manager

It was a real pleasure this year to work Lilly VK2FLIC and Alisha VK2FASH in the ALARA Contest. They were both recipients of grants in the ALARA Grants Scheme and to hear them obviously having so much fun, was terrific.

It is also pleasing to hear that Alisha has just been re-elected Secretary to the Wagga Amateur Radio Club. Lilly has ventured further afield and has been on the Y.A.C.H.T. (Young Amateurs Communication Ham Team) youth net, based in the US. If you, or a YL that you know, are thinking of getting a licence or upgrading to the next level, you might like to be part of our Grants Scheme, too. The information is on our website, at: <https://alara.org.au/>



Photo 3: Catherine VK7GH.

Although a little older than Lilly and Alisha (hi), Catherine was also awarded an Honorable Mention for the many hours she put in to the Contest. But, as she explains, that was not her most pleasing achievement that weekend.

"I am very pleased that I made 28 contacts by CW in the Oceania CW Contest in the weekend (of

the ALARA contest). My first CW contest with the big boys, a bit nerve-racking. The only on-air practice I have had previously are the regular ones I have had with Lyn VK4SWE, so thanks to her too."

Kaye Wright VK3FKDW SK

This obituary for Kaye should have been published earlier in the year; however, even though it is a bit late, I felt that Kaye should also be acknowledged for the many ways she contributed to ALARA.

It is with great sadness that we report the passing of Kaye Wright VK3FKDW.

Kaye had been suffering for the past year and finally succumbed to Motor Neurone Disease. Our condolences go to her partner Denis VK3BGS and her family. Her son Greg, daughter-in-law Irinna, and grandson Finnian flew from Germany before Kaye's passing, and were featured in an earlier ALARA column.

Kaye passed the Foundation licence in a "YL only" course over the weekend of 31st May - 1st June 2014, and became VK3FKDW, joining ALARA that weekend.

In May 2015 Kaye became the new Newsletter Editor for 2015 - 2016, a position in which she continued to do an excellent job until September 2019 when she resigned due to illness.

She was part of the organising team for ALARA's 40th Anniversary celebrations in July 2015, and made the beautiful "Wattle covered" birthday cake. Kaye was also a member of the organising committee for the proposed 2020 ALARAmeeet in Bendigo, until she was forced to stand down as her illness progressed. She was

secretary to the WIA Publications Committee for several years until again she had to resign due to illness around July 2019.

Kaye organised several VK3 ALARA lunches, and attended many more. Always willing, she also helped on the ALARA stand at many Hamfests.

Kaye will be greatly missed by her many friends in ALARA

Valé Kaye VK3FKDW

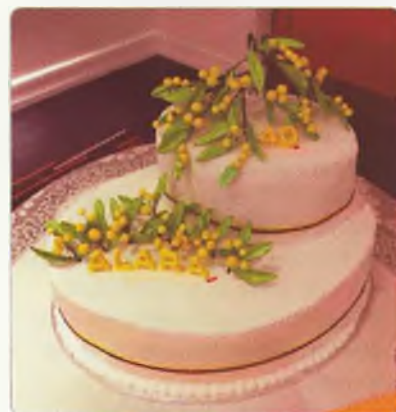

Photo 5: The 40th Anniversary cake.

(Kaye's funeral was attended by many ALARA members, their OMs, and other amateurs. An ALARA Scarf was draped on her coffin).

ALARA Monday night nets

The net runs every Monday night, with the first and third Mondays on Echolink. The third Monday night net is both Echolink and HF (80m, 3.570 MHz). Times are: Summer - 1000 UTC, and Winter - 1030 UTC.

The ladies would love to have some other YLs join them, including new Foundation calls. The Echolink Nets have been particularly well attended of late, perhaps one good thing that has come out of Covid-19!

33, Jen VK3WO

Join your local club

Look under Radio Clubs at www.wia.org.au

Peel Amateur Radio Group

Spring has sprung, and the Mandurians in the Peel Amateur Radio Group continued to be very active, despite a Spring storm in September that caused damage to five members' antennas.

Don VK6DON went out after the storm to chase galahs from his hex beam and thought "surely a couple of galahs couldn't do that!" The antenna had turned itself into an inverted-umbrella beam – the centre support post had snapped off and was floating, supported by only the coax and antenna terminations. I'm sure the neighbours were even more impressed than usual at his antenna.

What's more, the Windom antenna was also tangled up with the usually 30+ cocky hex beam. A team of Group volunteers soon headed over to Don's wind-swept antenna farm to lend a hand.

Taking Carmel VK2CAR's advice from AR Magazine Issue 3 (pp 8-10), Maurice VK6HLY had tried using his Bunnings clothesline Off-Centre Fed dipole to stop his trees from swaying too much in the storm; didn't work. Maurice was hoping that Tony VK6DQ, as a nearly 80 year-old qualified rigger (we actually have two in the Group - Martin VK6EEE is a professional rigger) would squirrel up some of the trees on his property and put up permanent pulleys for on-going antenna work.

Plus having just cracked the code on getting a squid pole helical to radiate well on 80m, Martin VK6MJ came out after the storm to find he now had two poles – one long, and one very short. Back to the drawing board. Up Rockingham way, Michelle and Warren also sacrificed their antenna farm to the wind gods – clean sweep – time to



Photo 1: Poor VK6DON's hex beam became an inverted umbrella after the September storm.

start afresh!

When not watching SSTV from the International Space Station, Martin VK6MJ took a break from his PhD studies to help get two more members operational on the 2.4 GHz mesh network – VK6HLY and VK6FAAJ. PARG now has 17 members with VOIP speaker phones connected; the network is also connected to the VK6RMH 2m repeater via a conference number, allowing multiple members to access the repeater irrespective of how far away they are.

Martin and Mark VK2KI were recently heard experimenting on the 2.4 GHz mesh network and 3.600 MHz to identify the source of overload interference from Martin's HF transmitter that was triggering the repeater via the mesh-to-repeater link. The Mandurah repeater also has an Echolink connection, via VK6MJ-L – all welcome to call in and say g'day to

the Mandurians.

The terrific PARG nets on 3.600 MHz have continued, with a number of members re-discovering the joy of HF operation. At times, all stations have been 5x9 at the VK6XT Broomhill remote HF station that I use, and on good nights, with the increased use of noise-cancellers, everyone can hear everyone.

Several members have built or are building the VK5TM noise-canceller kits, and the November TechTalk night on 17 November will see a discussion on the theory of anti-phase noise cancellation, and a comparison of the MFJ-1026 noise canceller with the very simple VK5TM kit.

Both Terry VK6TTR and Maurice VK6HLY continued to be impressed with the 80m receive audio on their Kenwood TS-920 and TS-520 respectively. The rest of us enjoyed the nostalgia of following the slow

drift of the non-synthesised rigs; in my case, VK6XT's IC-7300 at the remote HF station didn't have a clarifier control, so we all had fun chasing each-other around the band.

Tony VK6DQ went out to the shed during one net and swapped the feed configuration of his antenna – his signals went down a little, but his audio quality improved – go figure! Tony also came up with a new term: "as an experiment". "As an experiment", he tried not transmitting through his antenna tuner. A few of us could use that one from time to time.

Tony also went out on a limb and claimed that his antennas would never succumb to the weather – but would he tell us if they did? Perhaps they'd become another 'experimental configuration'? Tony's been motivated to write another antenna article for AR Magazine. Go Tony – we're looking forward to learning more!

Also on 80m, President Geoff VK6GHD managed to avoid neighbourly consternation with his semi-stealth squid-pole helical, using a water-weighted beach umbrella base. Nice signals from his balcony – just needs a noise canceller and he'll be able to hear as well as he gets out. Amazing how much fun it is to operate nets on 80m compared to the ever-reliable on-air nights on 2m. Pity not everyone can operate on 80 due to neighbourhood covenants – but where there's a will.

In September, Paul VK6LL and Martin VK6MJ gave a presentation to the Mandurah PROBUS group on amateur radio, including a demonstration of 2m, and Martin gave a brief on the Amateur Radio International Space Station Schools program, including his role as a Telebridge station. There'll be lots of grandparents now pestering local schools to join the ARISS program.

President Geoff VK6GHD visited the Cape Leeuwin lighthouse and, following discussions with the manager, PARG has received an invitation to operate portable

at that location. Geoff has also sought clarification on the status of the Foul Bay lighthouse from the International Lightship and Lighthouse Weekend (ILLW) authority. Irrespective of its status for the ILLW, Foul Bay remains a good option for a pedestrian portable expedition to coincide with a future simultaneous portable activation of Capes Naturaliste and Leeuwin.

The Group has decided to run a trial 80m Slow CW Contest in February. Back in the mid-1980s, the WA Division of the WIA ran a similar contest, which turned out to be a real hoot for those of us who hadn't touched a key since the AOCPC exam. There probably won't be time for the rules to be formulated and advertised in AR Magazine, so the first one may be held within the Group. However, if you'd like to be looped-in on this exciting event, contact our Secretary David VK6FAAZ: parg_secretary@iinet.net.au

Well done to the brave souls who ventured to Mount William in March for the John Moyle Field Day contest – third in the 24 hour multi-op, all-band, all-mode category. Bruce VK6CX also came first in the 24 hour home station VHF all mode category.

PARG meetings are now at 1900 WA time on:

- 1st Tuesday of the month - 2m net on VK6RMH
- 2nd Tuesday of the month - 80m net on 3600 kHz with 3595 as a backup
- 3rd Tuesday of the month – Technical Talk / Workshop meeting at the SES HQ in Greenfields and via Zoom Videoconference - links to YouTube videos of the TechTalks are available in the Workshop/ Technical area on the Group's website: www.parg.org.au

The Group is keen to encourage new members. People new to Amateur Radio who would like to find out more about the hobby, or perhaps get a helping hand toward

getting an amateur license are most welcome. More experienced amateurs will find that the Group is a terrific way to share both technical and social aspects of amateur radio. Contact the Secretary, David VK6FAAZ parg_secretary@iinet.net.au, or check the website www.parg.org.au, for more information.

Cheers,
Mark Bosma
VK6QI / VK2KI

Northern Corridor Radio Group

NCRG continues to remain active through these challenging times. The Group's EME shack is on a short hold while the lease gets sorted. This is expected to be resolved during November so the new capability can be in place over Christmas.

NCRG is hoping to restart courses and exams from December onwards. Please contact the club if you are interested. See: www.ncrg.org.au/

The Group participated in the Oceania DX Contest again as VK6NE, fielding a Multi-op Single Tx team this year, with around 1100+ contacts for the 24-hour period. The contest team had a great time, and the score should be competitive.

About nine members are now heavily in the planning phase for an activation of Cocos-Keeling Islands (VK9C) in March-April 2021. The activation will be in vacation mode, but with nine members there, should be fairly active. More on this in the next edition.

The Group made its facility available for the Ellenbrook Scouts this year for JOTA, with many scouts and cubs participating on-air on HF.

Some wholesale changes to how we welcome new and prospective members to the club is bearing fruit and brought in six or seven new members over recent months. The club meets informally every Sunday morning at 0830; formally at 1930 on the 4th Tuesday of each month.

73, de Steve VK6SJ



Contributions to *Amateur Radio*

AR is a forum for WIA members' amateur radio experiments, experiences, opinions and news.

Your contribution and feedback is welcomed.

Guidelines for contributors can be found in the AR section of the WIA website, at <http://www.wia.org.au/members/armag/contributing/>

Email the Secretary:
armag@wia.org.au

AMIDON FERROMAGNETIC CORES



tts systems

Phone 03 5145 6179
info@ttssystems.com.au

Studying for the Standard or the Advanced Licence?



Here are 4 books that will get you there.

TAKE A LOOK AT
www.gscoff.com.au
for more information and order form.
635 Edmonson Avenue
Albury NSW 2640



Have you held an amateur licence for 10 years or more?

If so, then you are invited to
join the

RAOTC

A \$5 joining fee, plus \$18 for one year or \$32 for two years, gets you two interesting 64 page *OTN Journals* each year, PLUS good fellowship, and a regular broadcast of news and events.

More information and a membership application are available from our web site at www.raotc.org.au or write to:-
PO Box 107, Mentone VIC 3194 or
email:- raotc@raotc.org.au or
call Secretary: Bill Roper VK3BR
on 03 9584 9512.

About Hamads

- Submit by email (**MUCH PREFERRED**) or if written and mailed please print carefully and clearly, use upper AND lower case.
- Deceased estates Hamads will be published in full, even if some items are not radio equipment.
- WIA policy recommends that the serial number of all equipment for sale should be included.
- QTHR means the address is correct in the current WIA Call Book.
- Ordinary Hamads from those who are deemed to be in general electronics retail and wholesale distributive trades should be certified as referring only to private articles not being re-sold for merchandising purposes.
- For commercial advertising on these pages Contact admanager@wia.org.au
- Copy must be received by the deadlines on page 1 of each issue of *Amateur Radio*.
- Use the separate forms for **For Sale and Wanted** items. Include name, address STD telephone number and WIA membership number.

'Hamads'

PO Box 2042
BAYSWATER VIC 3153
hamads@wia.org.au

TRADE PRACTICES ACT

It is impossible for us to ensure that the advertisements submitted for publication comply with the Trade Practices Act 1974. Therefore, advertisers will appreciate the absolute need for them to ensure that the provisions of the Act are strictly complied with.

VICTORIAN CONSUMER AFFAIRS ACT

Advertisements with only a PO Box number address cannot be accepted without the addition of the business address of the box-holder or seller of the goods.

ADVERTISERS INDEX

| | |
|----------------|--------------------|
| Icom | Back Cover |
| Jaycar | 5 |
| Amidon | 64 |
| Yaesu | Inside Front Cover |
| Future Systems | Inside Back Cover |

Wash your hands!



Don't forget to register for MEMNET.

EVERYWHERE MEANS EVERYWHERE.

We're for every corner of the earth. So much so, it's led to revolutionizing the ham radio industry as the leader in design of software defined radios. Because when you're looking to connect with people and places that may or may not even be on the map, you better have the best partner in technology on the planet. To learn more about our boundary-pushing products, visit flexradio.com/FindEverywhere



FlexRadio

Find Everywhere

IT'S A TOY. THE SAME WAY A 3.0 LITER, TWIN-TURBO, 450 HORSEPOWER, SPORTS CAR IS A TOY.



**FUTURE
SYSTEMS**



+61 8 6336 9610



sales@futuresystems.com.au



www.flexradio.com.au

ICOM

FIRST IN TECHNOLOGY

The IC-705

HF/VHF/UHF MULTIMODE PORTABLE TRANSCEIVER



* The antenna and antenna connector in the photo are after-market products.

Be Active!
In the field with the IC-705

- HF/50/144/430 MHz Multimode, including the D-STAR DV Mode
- RF Direct Sampling System
* The down-conversion IF sampling method is used for 25 MHz and above.
- Real-Time Spectrum Scope and Waterfall Display
- Large Touch Screen Colour Display
- Compact and Lightweight Design * Approximately 1.1 kg, including the battery pack.
- BP-272 Battery Pack or 13.8 V DC External Power Source
- Maximum Output Power 5 W (BP-272), 10 W (13.8 V DC)

■ Making your field operation more fun and stylish



Multi-Function Backpack
LC-192

HF/50/144/430 MHz
MULTIMODE 10 W TRANSCEIVER

IC-705

Supplied Accessories

HM-243 Speaker-microphone, BP-272 Li-ion Battery Pack, OPC-2421 DC Power Cable



sales@icom.net.au



www.icom.net.au



(03) 9549 7500