

THE
All Electric
RECEIVER
BY
VK-3GT

*A.C. Receiver Design, Construction
and Maintenance; Transformer and
Power-Pack Building; Electrical
Gramophone; Best Circuits; Trouble
Elimination; All Australian Call
Signs; Valve Data.*

**A "LISTENER IN
HANDBOOK**

26

Er. 5557

Come to
HARTLEYS
 for all your
RADIO
 REQUIREMENTS

Everything for radio . . . from the first insulator to speaker
 . . . may be obtained at Hartleys. If it's new, Hartleys have it.
 Besides keen values and comprehensive stocks, Hartleys are so
 handy to the station!

The SILVATONE
RADIOLA and COSSOR Sets

Hartleys are Victorian Distributors for these famous sets.
 Hear them in Hartleys showroom on 1st floor, or arrange for a
 demonstration in your own home. Call or write for Free Set
 Catalogue.

So handy to the station! Drop in at Hartleys on your way
 home for Philips, Radiotron, Cossor, Marconi and Osram valves,
 or reputable makes of "A" and "B" batteries. Agents for
 Magnavox Dynamic Speakers.

Latest Branch at 411 Bourke Street (near John Danks)

HARTLEYS
 opp station
270 FLINDERS STREET
MELBOURNE
 and at **148**
SWANSTON
STREET
 (Near Town
 Hall)

Smile away! smile away!
Hear what Charlie has to say!

Q

The Best Entertainment on
the air is provided by

3DB

The Herald Broadcasting
Station, Melbourne

500 Watts.

255 Metres.

Q

The delightful informality of this Station
has made it the most popular in Australia

Men Are Amazed at Their Strength!



BRITON, Genuine Maker of Men!

Still More Amazing Proof!

"I have tried other systems, but nothing to equal yours."—T. H. Whittaker, C., Vic.

"I feel the wonderful benefit of it; my chest has increased rapidly. When I started with you I made the greatest investment I ever made in my life, and I thank you again for your wonderful course." — J. S. Buchan, T., N.S.W.

"In such a short time I have developed myself wonderfully." — L. King, B., N.S.W.

"I am more than satisfied." — R. Marsden, M., Qld.

"I am astonished at the way my chest has grown." — F. B. Wilkinson, Sydney.

"I wish to thank you for the way you have instructed me. My chest and shoulders have developed wonderfully, and I have been told by friends that I look a 'new man.' Wishing you the best of success, and assuring you that I will always be glad of recommending your course." — H. L. Hoffman, Sydney.

"I am developing fast, and feel much better. I am certainly very much surprised that one could possibly show such improvement as I have shown in only 14 days." — E. R. Whan, A., N.S.W.

"I must say the results are far beyond my expectations, and I am absolutely satisfied." — N. Burgess, M., N.S.W.

THESE LETTERS AND HUNDREDS MORE MAY BE SEEN AT MY OFFICES AT ANY TIME.

ALFRED J. BRITON,

Dept. H.B.,

107 Pitt Street, Sydney, N.S.W.

After this Free Book Shows Them the Way to Great Muscular Power!

GET THIS BOOK NOW! Whether you are weak or strong—sickly or healthy—young or old—overweight or underweight—regardless of WHAT your condition may be, send for it NOW! It will show you how men just like yourself have grown STRONG. It will show you the way to a superbly-built body—to broad shoulders, powerful muscles, a deep chest, slim waist-line, to splendid health and vitality in every organ of your body.

Make This Test Tonight

Before you step into your pyjamas tonight, stand in front of the mirror and look yourself over. Are you proud of the man you see? Is he a strapping, broad-shouldered husky, with arching chest, and rippling bands of solid muscle? Would you bet on him in a fight?

Be fair to yourself. You can't expect the respect of men or the admiration of women if you're a physical weakling. Let me get to work on that body of yours. Let me build a man who'll be PROUD to step out in a bathing suit. This free book shows how EASY it is. You'll never know what this book is WORTH to you until you've read it for yourself. It may change your entire life. It's a revolution in body-building and muscle-building. It's crammed full of pictures and matter that will make you open your eyes. Thousands of men have thought it worth while to invest a 6d. stamp to get their copies. That's all it will cost you. No obligation—no salesman will call. YOU will be the judge and jury. Mail the coupon or write — TODAY.

I Don't Promise You Results I GUARANTEE THEM!

I GUARANTEE to put two inches of solid muscle on your arms; to increase your chest five inches; to develop your neck to a size larger collar; to add three inches of powerful development to your thighs, two inches to your calves; to give you a firm, slim waist-line, that will make you take in a notch or two in your belt. And I don't ask you to take my word for it—I don't promise anything—I back every statement with an ironclad GUARANTEE.

I've done all this for others. I can do it for you. Get the PROOF—send for my amazing new book—NOW! It's FREE!

"Secrets of Muscular Strength"

What gives the wrestler his terrific muscular power? Not stimulants or drugs. No! The power that he has acquired YOU can get in your own home. You can have terrific strength in your body like the wrestler has. You can emerge out of your shell into the glories of muscular manhood—and this book will show you how! Get it while it's FREE—NOW!

Be A Briton! — Send NOW!

ALFRED J. BRITON, Dept. H.B., 107 Pitt St., Sydney, N.S.W.

IT Dear Sir,—Please send me absolutely FREE and without any obligation on my part what covers a copy of your latest book, "The Secrets of Muscular Strength—And How to Acquire It." I enclose 6d in Stamps for postage.

IS NAME

RE FULL ADDRESS

E STATE

(Please Write or Print Very Plainly.)



October, 1930.

RADIOKES

Precision Products for all A.C. Receivers

Power Transformers

(For All Types of Valves)

Power Chokes
Voltage Dividers
Bias Resistors



WIRE WOUND RESISTORS

For all Purposes.
See Page 78 for
Details.

All Coil Kits, Resistor Banks, Transformers and Chokes for all

LOFTIN WHITE AMPLIFIERS

RF Chokes
Wave-traps
Neutralising Condensers
Midget Condensers
Differential Condensers

COIL KITS
for all
CIRCUITS

Sub-panel Brackets
Art Metal Cabinets
Vernier Dials
Chasses
Box Shields

Metropolitan Electric Company Ltd.

126 SUSSEX STREET, SYDNEY

Agents:

EDGAR V. HUDSON,
53-55 Charlotte St.,
Brisbane.

A. G. HEALING LTD.,
155 Pirie Street,
Adelaide.

Victorian Agents and Distributors

G. P. Embelton & Co.

579 BOURKE ST., MELBOURNE
Phone C. 9133

Who give free technical information to all users of Radiokes apparatus. Write or Phone.

Agents:

CARLYLE & CO., 915
Hay Street, Perth.

W. & G. GENDERS PTY.
LTD., Launceston and
Hobart, Tasmania.

ABEL, SMEETON LTD.,
Customs St., E. Auckland,
New Zealand.

For Constant Speed
Ample Torque
Noiseless Operation---

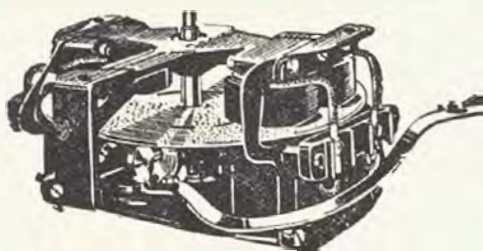

Available in
Australian
Manufacture
from January, 1931

"G.E." Phono-Motor

The design of a good phono-graph calls for use of a motor giving ample torque at constant speed. Noiseless operation is also essential. The "G.E." phono-motor as used in practically all the best phonographs has all these essential characteristics as well as other patented features.

£8-17-6

Price, complete with turntable and speed regulator, nickel finish, including Sales Tax, £8/17/6.

R.C.A. Radiotrons

UNIFORMITY—that is the Keynote of R.C.A. Radiotrons! It assures extra efficiency in any A.C. set! This uniformity is a result of sound design followed by precision in manufacture. Forty-one different inspections and tests ensure that any two Radiotrons of the same type *are* uniform. Durability, tone, volume and all round excellence are as dependable in one Radiotron as in another, and barring accidental damage, their service will be equally long. From all Radio dealers and wholesalers, or direct from the A.G.E.



**AUSTRALIAN
GENERAL ELECTRIC**
Australian General Electric Company, Ltd.

New Radio Showrooms — Cr. Queen & Little Collins Sts., Melbourne

Melbourne, Sydney, Adelaide, Brisbane. Also at Albury, Colac and Maifra.

West Australian Agents: Atkins W.A. Ltd., Perth. Tasmania: Oliver & Oliver, Hobart and Launceston.

INDEX

	Pages
Aerial system	69
Amplification—Audio frequency types of	49
Amplifier combination	89
Anode feed system	20
"A" power—Obtaining of	15
Bias—Calculation of resistance values	23
"C" eliminator	22
Resistance methods	22
Battery method	24
"B" power supply	18
"C" bias—Obtaining of	22
Call signs	101
Choke—Construction of filter	36
Copper wire tables	30, 31
Crackling noises—Elimination of	45, 46
Design—Some notes on	39
Detector stage power filter	20
Early radio	13
"Edison effect"	13
Eliminator—Operation of	15
Filament—Materials for	14
Centre tapped resistance	24
Emission of	14
Power supply for	15
Filter—Mains type	46
Circuit for	19
Generator and motor type	46
Interference type	46
Foreword	9
Four valve combination	75
Full wave rectifier circuits	18, 19
Fundamentals	13
Glossary of wireless terms	94, 101
History	11
Hum—Elimination of	44
Impedance coupled amplifier	52
Installation rules	70
Instruments—Types of	71
Loftin-White amplifier	49
Matching detector impedance	58
Matching valves, transformers and speakers	55
Meters—Types and operation of	117

INDEX (Continued)	Pages
Microphone—Construction of	91
Motor-boating—Elimination of	45
Output—Speaker types of	55
Output transformer charts	57
Pick-up—Gramophone type—Connections for	62
Theory of operation	61
Tracking of	63, 119
Plate resistors—Calculation of values	65
Power pack—Assembly of	41
Push-pull amplifier	53, 113
Receiver—Filament wiring of	40
Fault finding in	45
Layout details of	39
Maintenance of	123
Points to watch in construction	41
Rectifier—Action of	16
Plate supply types, makes	26
Receiving valve types	21
Resistance charts—Types, makes, etc.	78, 79
Selection of the loud speaker	122
Seven valve combination	90
Screening	73
Speaker—Coupling methods	56
Symbols, charts	42
Three valve combination	87
Transformer coupled amplifier	54
Transformer—Calculation of power	27
Construction of	28
Core construction	32
Design of	28
Depth of winding	36
Function of	28
Methods of mounting	36
Primary winding and core chart	29
Shielding of	38
Types of wire	36
Rules of construction	25
Winding details	35
Wire gauges	32
Transformer—Output charts for	57
Trouble finding	43
Two valve combination	81
Using output transformer charts	59
Valve assembly—Power types of	13
Valves—Operation of	14
Valves—A.C. type characteristics	48, 60, 66, 72
Voltage dividing methods	20
Voltmeter—Multi reading type	71
Wire tables	30, 31

HEAR THE WORLD WITH A SUPER WASP !

DESIGNED by
Grimes, Geloso, and Kruse—
world-famous radio engineers—
this all-waves receiver embodies
the super-sensitive Pilotron
screen-grid valve and specially
developed Pilotron 227.

The result is smooth, vibration-
less reception, easily controlled,
flexible — covering the entire
broadcast band from 14 to 500
metres— *local or international
reception*

PRICES:

Pilot A.C. Super Wasp Kit.

£20/10/-

Power Pack, Valves and all accessories
extra.

£19/12/6

Pilot Super Wasp (Battery Operated) Kit

£19/10/-

Valves and all accessories extra.

£15/2/-

Easy Terms If You Wish

Harringtons
LTD.

Established 41 years.
Photo. Radio and Cine
Merchants.

266 COLLINS ST., MELB., C.I.
Opp. Centreway. Tel. Cent. 4070



Real Undistorted POWER

Output with this new Super-power Valve



OSRAM PX 4 (Super-power)

For A.C. Mains
Sets and Radio
Gramophones

CHARACTERISTICS

Filament Volts	4.0
Filament Current	0.6 amp. approx.
Amplification Factor	8.5
Impedance	1.050 Ohms.
Mutual Conductance	3.3 ma/v.
Anode Volts	200 max.
Anode Dissipation	10 watts max.
Max. Grid Bias	38 volts*
Undistorted Output	1.6 watts

PRICE, 30/-

Those who know the true meaning of power output in valves will realise that a last stage valve is judged in terms of power output—**UNDISTORTED** power output.

Osram PX 4, with a dissipation of 10 watts and an undistorted output of 1.5 watts, truly is a remarkable member of the Osram family.

It is designed with characteristics so that, with an anode voltage of only 200, undistorted output hitherto only possible with valves of the 400 volt class, is obtained.

Its extremely low impedance makes it ideal for push-pull type of amplification, extraordinary depth of reproduction being fully realised.

*For details of the full range of Osram A.C. Valves, see Page 48.

The New

Osram ac Valves

Made in England
at the famous
Osram Lamp Works

LOUIS COEN WIRELESS
PTY. LTD.
63 Swanston Street.

VICTORIAN DISTRIBUTORS:
A. J. VEALL
168 & 247 Swanston Street
302 Chapel Street. Prahran

A. G. HEALING
LIMITED
167 Franklin Street.

Advertisement of the British General Electric Co. Ltd. Head Office: 104 Clarence St., Sydney, and at "Magnet House," 590 Bourke St., Melb., C.1.

FOREWORD

THAT the All-Electric Receiver is popular needs no stressing. It automatically came into being when the indirectly-heated valve was conceived.

It will retain its popularity until something better even than valves is discovered.

With its birth came its troubles. The valves would not stand up to the strain; they soon lost their power of emission — behind the reception was a strong undercurrent of "hum"—reaction was sudden and fierce—there was a liability towards minor or severe electric shocks—speaker windings would not stand the higher power—and there was the additional current consumption at so much per unit to be considered.

Most of these disabilities have been overcome. Results obtainable from the all-electric set are now ahead of the best of battery-operated receivers. The worries of batteries have been eliminated.

With the All-Electric Receiver, all that is necessary is to plug it into the power point, connect the aerial, earth, and loud speaker to the respective terminals, and stations are there for the tuning.

When my young friend, Geoff. Thompson, mooted the idea of writing a text-book dealing with the intricacies of All-Electric set construction, it was at once seen that he had "picked a winner." Inquiries proved that there was no such book on the market, and that the demand for it was great.

A preliminary examination of his "copy" has shown me that he has provided just what the public wants, and therefore the book is sure to be popular.

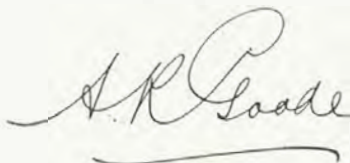

Technical Editor,
The Listener In.

THE LISTENER IN, through the medium of its free information service, has kept in close touch with the radio public for many years. The enormous number of queries regarding the all-electric receiver over the past 12 months has resulted in the preparation of this handbook.

THE ALL-ELECTRIC RECEIVER HANDBOOK

By
Geoffrey G. Thompson, (VK3GT)
of The Listener In Technical Staff

TO radio we can assign the title "Greatest Wonder of the Age." For such it is. To go back over a period of only five years will reveal the remarkable progress which has been achieved in the transmission and reception of music and speech. It is not very long since the man who spent all his spare hours in the study of radio was termed a fanatic, yet now wireless is the most popular of hobbies.

Radio has solved some of the greatest problems of life and has aided progress in every direction. The radio receiver has become a musical instrument—a necessity in every home. It provides us with the latest news, sporting results, the best of music culled from the world, and brings to our very armchairs the voices of the world's greatest men, and the best of entertainers. A few years hence will see television in full swing. This phase of radio is developing with marvellous rapidity, and already theatre audiences in U.S.A. have witnessed as well as heard the performers at some distant studio.

The history of radio has been in itself remarkable, and we have become so used to the wonders it can perform that we are no longer sceptical when ideas hitherto considered impossibilities are demonstrated. The successful experiments conducted by Thomas A. Edison in his little laboratory, some fifty years ago, spelt the commencement of radio as we now see it. Edison was ridiculed because of his attempts to obtain light by means of electrical power, but his successful demonstrations soon showed the possibilities of the new wonder. Who would have thought that the heating of a filament to incandescence within a vacuum could have anything to do with the transmission and reception of radio signals? Yet this discovery, coupled with those of two other great investigators, resulted in the valve which revolutionised radio.



An example of modern receiver design. A typical all-electric radio gramophone combination.

Fundamentals of the A.C. Valve

*Operation of directly and indirectly heated types—
How the valve functions—Obtaining filament supply
from the mains—The action of the thermionic rectifier*

SOME years after Edison's discovery, Dr. Fleming noted that current would pass from metal placed outside an incandescent lamp, through the glass to the filament. This effect, the "Edison Effect," was inexplicable at the time, but this did not prevent experimenters from utilising this discovery. The introduction of the plate into the incandescent lamp led to the discovery of the rectifying properties of this combination, which, because of its ability to pass current in only one direction, was named the valve. The two element valve was used to replace

crystal receiver there was no method at the time whereby the received signal could be magnified.

Early Radio

Without the vacuum tube, or valve, broadcast transmission and reception as we have it today, would be impossible. Until the advent of the two and three element valves, crystal receivers and spark transmitters, using ridiculously high power and having small range when compared with the low power valve transmitter of today, were

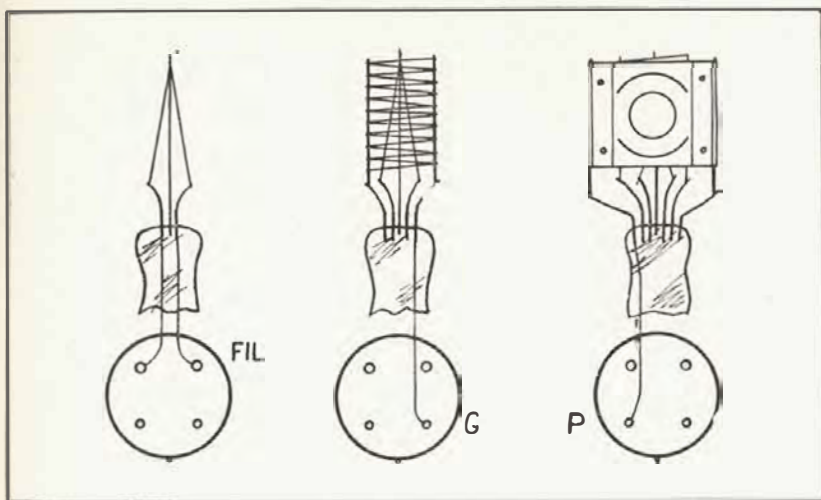

Fig. 1.—The construction and assembly of an a.c. power valve, showing how its three elements connect to the U.X. type base. First the heavy gauge thoriated or oxide coated filament supported on the glass pinch. In the centre is the grid mesh surrounding the filament. Finally the pressed nickel plate surrounding the grid and filament.

crystal detection, but only because of its reliability, and not because of any improvement in the sensitivity of a receiver by its use. It required the introduction of a third element, the grid, by Dr. Lee de Forest, to cause radio to go leaping and bounding towards its present state of near-perfection. The introduction of this third and controlling element enabled the thermionic valve to perform things undreamed of. It enabled a received signal to be amplified. The ability of the valve to do this alone was a valuable enough discovery, since in the

used for communication. Transmission in the days of the spark was seldom reliable over more than several hundreds of miles, and ships fitted with such equipment after a day or so out of port were able only to communicate with sister ships within a limited range.

How the Valve Functions

The receiving valve depends for its operation upon a stream of electrons given off in a vacuum by a heated metal filament. The power to

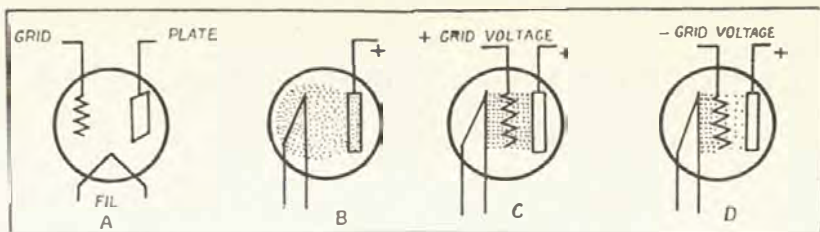

Fig. 2.—A—Symbol for three element valve. B—Electrons given off by a heated filament attracted to the positively charged plate. C—The positively charged grid causes increase in the electron flow to the plate. D—The negatively charged grid causes decrease in the electron flow to the plate.

heat the filament may be derived from batteries or from the alternating current light socket by means of a suitable step-down transformer. Fig. 1 shows the standard three element valve and how the filament grid and plate elements are connected to the four prongs of its U.X.

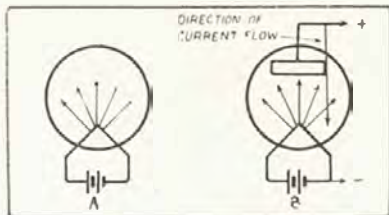

Fig. 3.—A—Electrons given off by the filament form a space charge in the vacuum of the tube. B—Electrons attracted to a positively charged plate provide a path for the flow of current from plate to cathode.

type base. In the case of thoriated filament types, thorium is used in the making of the filament material. The use of a thoriated filament results in greater electronic emission at lower filament temperature. The oxide coated filament has deposited upon its base of nickel a layer of a mixture of barium and strontium oxides, which give off a great number of electrons when the filament is heated to a dull red. This type of valve is called a dull emitter, since the glow from its filament can rarely be seen through the mirror-like deposit covering the inside of the bulb.

This deposit is only incidental to the valve's manufacture, and plays no part in the reception of signals. In order that a high degree of vacuum be obtained, each tube is placed in a pumping machine which removes most of the air the bulbs contain. After sealing, the residue of air is burnt up by the flashing of magnesium inside the tube. The magnesium is flashed by

placing the valve within the field of a high frequency coil. Flashing of the magnesium results in the deposit forming on the inside of the tube.

Filament Emission

In Fig. 3a we have a heated filament giving off electrons. By placing a positively charged plate in the vacuum containing the filament, electrons will be attracted to this plate as in Fig. 3b. This is a case of unlike charges attracting, as any schoolboy will know. If a voltage is applied across the plate and filament, current will flow from plate to filament across the path provided by the electron flow. Figs. 2c and 2d show the grid introduced into the vacuum containing the heated filament and the positively charged plate. If a positive voltage is applied to the grid more electrons will be seen to be attracted to the plate, while if the grid is made negative, the reverse is the case, and fewer electrons reach the plate from the filament, depending on the extent to which the grid is negatively charged.

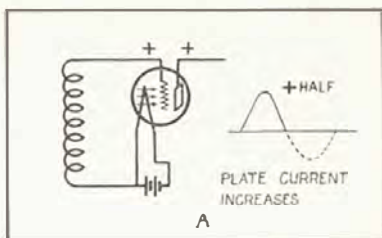

Fig. 4a.—The effect of applying an a.c. voltage to the grid of a valve. The grid at the positive alternation.

Figs. 4a and 4b show what happens when an alternating current is applied to the grid circuit of a valve. When the grid is at the positive half of the alternating current cycle, more plate current will flow, while, when it is at the negative half, the flow will be less. By applying

an a.c. voltage to the grid of the valve, we vary the number of electrons reaching the plate of the valve in accordance with the wave form of the impressed a.c. voltage. This results in similar changes in the flow of plate current. These plate current changes are on a much larger scale, and so the signals are amplified.

It may be seen from this why the grid is called the control element. The grid controls the electron flow from the filament or cathode to the plate. Grid changes resulting in a smaller or greater number of electrons reaching the plate will cause similar changes in the plate current. A very weak signal voltage upon the grid of a valve will result in a greater signal voltage possessing the same characteristics, in plate circuit of the valve, when the grid is correctly biased.

Were it possible to make a filament consisting of a material to give off sufficient electrons without heating, no filament battery or supply source would be needed.

In practice, however, we must resort to the heating of metals and oxides to obtain our electron supply in the thermionic valve.

Filament Current from the Mains

In any valve we require a supply of electrons for its operation. The source of this electron supply may be a heated thoriated or oxide coated filament, or, in the case of the indirectly heated or

a.c. valve, a cathode separately heated. Since the alternating light socket current supply is of audible frequency, its direct application to a receiving combination for the heating of filaments will result in rattles, hums and other noises, which may completely obliterate signals, should they be picked up at all. But the problems concerning the elimination of these noises

when endeavoring to secure filament lighting current from the mains have been solved by the perfection of the indirectly heated valve. The indirectly heated valve is used in the more sensitive stages of a receiver combination, such as the r.f. detector and first amplifier stages, when the slightest a.c. in-

duction in the grid or plate circuits of these stages would result in loud noises in the form of hum in the receiver output. By the correct use of a combination of direct and indirectly heated valves, the whole filament supply may be obtained through the medium of step-down transformers, from the a.c. supply mains. In the indirectly heated valve, the heater supply current is a.c., although d.c. from "A" batteries may be used, this being uneconomical, however, since the current drawn by the heater is high in comparison with that taken by the directly heated filament of a d.c. valve of the same type.

The writer has often been asked why a receiver cannot be fitted for complete operation from the light socket,

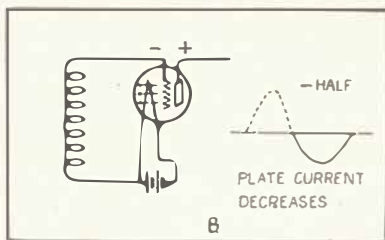

Fig. 4b.—The grid at the negative alternation.

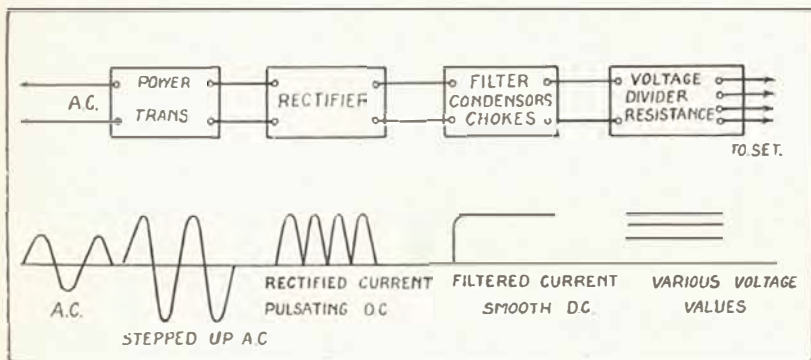

Fig. 5.—Illustrating the functions of the parts of the B power unit. First the a.c. mains voltage is stepped up by the power transformer. The stepped up voltage is rectified by means of the plate power rectifier. The rectified voltage is smoothed out by the filter. The filtered power is divided by means of a resistance or resistances to obtain values suitable for the operation of the various stages of a receiver combination.

simply by the use of a "B" and "C" eliminator and an "A" transformer, retaining the old valves. The answer to this question is that were alternating voltages to be applied directly to the filament of say a 201A valve in a detector, r.f. or first amplifier stage

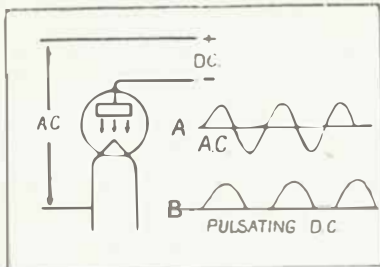

Fig. 6.—Illustrating the action of the valve rectifier. Current flows from plate to filament when the plate is at the positive half of the a.c. current cycle.

of a receiver combination, bad hum would result. The filament of such a valve consists of a very fine strand of material only a fraction of the thickness of a hair of one's head. Since the alternating current supply swings from negative to positive 50 times a second, the filament because of its frailty will vibrate and introduce modulation into the plate circuit of the valve, the subsequent stages amplifying the noise to such an extent that satisfactory reception is impossible. The indirectly heated valve then is used in detector and first amplifier stages, and more often than not in r.f. stages. Obviously if the filament of a valve were to be of heavy construction it would not vibrate when obtaining its heating current from an alternating current source, and this is the principle upon which the directly heated tubes such as the UY226 operates. This directly heated tube may be used in r.f. and first amplifier stages. Although the filament of this type of directly heated a.c. valve is of rigid construction, a.c. noise will creep into the circuit if this valve is used as a detector. For this reason it is essential that the detector stage valve be indirectly heated. In most of our receiver arrangements which we later describe, we are advising the use of indirectly heated tubes in r.f. and first audio amplifier stages as well as in the detector, in order to preclude any possibility of hum originating in these circuits.

It must not be thought that a single discovery resulted in the completely a.c. receiver. Complete electrification of the radio receiver has come about

gradually over the past four or five years. As long ago as six years, the writer used a completely a.c. operated amplifier. First we had the "B" eliminator, which has been very efficient since it first came into use. With "B" batteries eliminated, what then prevented complete electrification several years ago? The supply of "A" current from the light socket was the problem. We were just beginning to get along with the cumbersome and seldom reliable "A" eliminator when the indirectly heated valve arrived, and solved all our troubles. The "A" eliminator consisted generally of a step down transformer, rectifier and filter system. The filter capacity required the use of as high as one thousand microfarads in order to secure the pure d.c. output necessary. In order that the current drawn from the eliminator might not be high, the voltage output of these eliminators was generally in the vicinity of 30, to permit series wiring of the filaments. A habit of turning the controlling resistance a little too far would result in the valves of a receiver being damaged. With bulkiness, high cost and other disadvantages to its credit, it is no wonder that the advent of the a.c. valve caused the idea of using the "A"

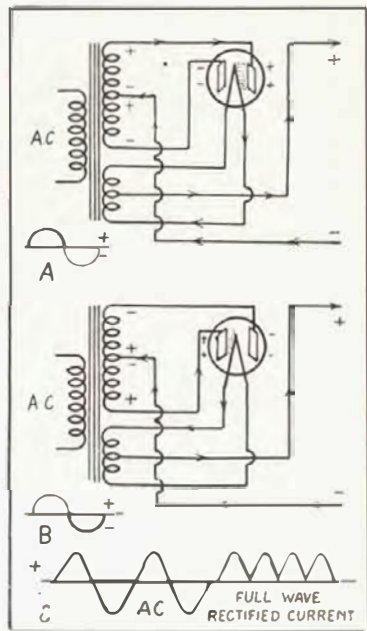

Fig. 7.—The action of the full wave thermionic rectifier. A—Current passes from one plate to filament when this plate is at the positive half of the a.c. cycle. When the current reverses its polarity, the other plate rectifies the other half of the cycle.

eliminator in its several forms to be completely dropped. Next to the a.c. valve and step down transformer method, the idea of using a small capacity accumulator in conjunction with a trickle charger is a reliable one, and has been used by many for years with quite satisfactory results. The incorporation of a battery and trickle charger in a self-contained receiver would not be worth while, taking into consideration the convenience of using a.c. valves and a step down transformer.

Light Socket "B" Supply

In order to obtain plate power from the a.c. mains supply, it is necessary that we convert the a.c. available at the light socket or power point into hum-free direct current. We depend upon the action of a valve to transform the alternating current into direct current, the action of a filter to smooth out the output from the rectifying valve, and a means of obtaining different voltages for the operation of the various stages of any particular receiver combination. We will deal with the parts of the "B" eliminator in this order.

In order to secure a.c. voltages suitable for our requirements, we use a transformer, the primary of which is fed by the mains supply, the secondary of which delivers a high voltage suitable for application to the rectifier, and one or more rectifier or filament heating secondaries. The design of the transformer for a certain job will enable any number of secondaries required being used. We have, say, a three valve receiver. The r.f. valve may require a heater voltage of 2.5, the detector valve may require 1.5 volts, while the amplifier may require four volts. Separate secondaries for each filament or heater may be wound. Having secured a high enough voltage at the secondary terminals of the B transformer, we require some means of rectifying the a.c. voltage. This rectifier may take two forms. It may be a thermionic type, or a gaseous conduction type. The former type depends upon the thermionic rectifying action, the "Edison effect" of a two element valve, the latter upon a short path rectifying action in a gas-filled tube. The former method is to be recommended, and it has gradually superseded the gaseous conduction type of rectifier.

There is a number of gaseous conduction type rectifiers requiring a heater voltage. These rectifiers are generally satisfactory in their operation. The QRS range of rectifiers includes a number of these types which

will deliver upwards of 400 mills. output.

The Raytheon gaseous conduction types are used in many of the older types of eliminator circuits. These rectifiers do not require the use of a heater voltage in order that they may pass normal current.

The electrolytic type of rectifier, because of its messiness and the attention it requires, is seldom used in the up-to-date plate power supply equipment. We do not recommend use of this type by the home set builder, and for this reason we have not dealt with the theory of its operation, its construction, or the circuits in which it may be used. Dry metal rectifiers are suitable only for rectifying of low voltages. Such a rectifier could not be used, therefore, for the rectification of the a.c. voltage available at the high voltage transformer secondary. This type of rectifier is generally used to supply the six volt field of this type of dynamic speaker. The rectifier delivers a d.c. output, which usually requires very little filtering.

Any power valve may be used as a thermionic rectifier by using it as a half wave rectifier, the plate connection to the rectifier being made to both the grid and plate terminals of the tube. An amount of current that the valve will safely withstand in an amplifier circuit without overheating is all that can be expected from a valve used as a rectifier in this manner.

The larger types of power valves, such as the 210 or the 250, may be used successfully as rectifiers over long periods. These valves can be expected to deliver at their rated voltages about the same current as their plates will draw when correctly operated in an amplifier circuit.

On page 21 we give circuits showing how any receiving power valve may be used as a half wave rectifier, or two of them as a full wave rectifier.

Thermionic type rectifiers depend upon air cooling to keep them from becoming dangerously hot when they are operated under normal circumstances. In the receiver, therefore, they must be installed in such a manner that air is free to circulate through the containing cabinet.

In designing the power pack, the thermionic type of rectifier should be used, since it is generally trouble-free and, in the full wave types, the power available from the rectifying circuit is easily filtered. These notes will reveal that the "B" power supply is a very simple affair, and is generally easier to assemble and wire than the average two valve receiver.

The A. C. Receiver Power Supply

Advantage of the thermionic rectifier—The action of the rectifier — Operation of the filter — The voltage divider—The anode feed system.

YOU are all familiar with the B eliminator. The use of such a device does away with "B" batteries, and permits plate current being obtained from the a.c. light socket. Then, if we can eliminate the "A" battery by the correct use of direct and indirectly heated valves, it only requires a "B" eliminator to do away completely with batteries, and have a completely a.c. supplied receiver. There is then nothing complicated about the a.c. receiver.

There was a time when the intending set builder could look over a set of commercial construction and see for himself how to go about the job. Things are different now, as all you enthusiasts know, and the complete enclosure of the a.c. receiver combinations in shields and cans has lent the up-to-date receiver an air of mystery which it is the intention of this handbook to dispel. There is nothing mysterious or difficult about the a.c. receiver. Certainly, there are numerous problems which may crop up, but by reading through this book the a.c. set builder will find that he has equipped himself with sufficient knowledge to enable him to go about the job intelligently. Those of you who intend experimenting with various a.c. circuit arrangements of your own would be wise to take particular note of the principles involved in the calculation of electrical values.

Home Set Construction

There are thousands of enthusiasts who cannot afford to purchase a ready-built-up a.c. combination. These people probably do not wish to involve themselves in a maze of technicalities from which they may never extricate themselves, and it is more for these that this book is intended. Since

a lot of intending set builders set about the job of receiver construction, not with the idea of experimenting and messing around generally, but with the object of obtaining a receiver which will give faithful reproduction of broadcasting stations and gramophone records, and may be called a musical instrument, it is only necessary for these constructors to follow accurately the details given for B eliminator construction, receiver assembly, and to adhere strictly to the values given. Should trouble of some sort prevent satisfactory reception, it is only a matter of consulting the notes on trouble shooting to locate the fault in double-quick time.

A number of vital rules must be adhered to in the assembly of the completely a.c. receiver. Care in design and adherence to details will always result in success.

It is half the battle to commence the construction of a receiver with confidence in one's ability. The mystery surrounding radio transmission and reception has mostly departed, and every effect to be noticed in a receiver combination can be accounted for. We know that by using certain components, valves, etc., we can build a receiver which will give the best results. There is nothing mysterious about it at all. Were it possible to secure, say, six of every one component required for a receiver assembly, each one of each six components being identical in construction and electrical characteristics, six identical receivers to give identical results could be constructed.

"B" Power Supply

Presuming that the power valves of our receiver require a d.c. plate voltage of 250, this will mean that when using full wave thermionic recti-

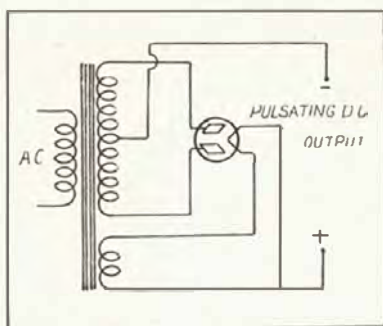

Fig. 8.—The standard circuit for the full wave thermionic plate supply rectifier, which will deliver a pulsating d.c. output.

fication, with a rectifier suitable for the voltage and the current which it is required to deliver, we will need a high voltage transformer secondary delivering 325 volts either side of the centre tapping. In the construction of the eliminator, we are confronted by no "A" supply problems. The obtaining of "A" supply is merely a matter of winding the correct number of secondary turns to deliver the voltage

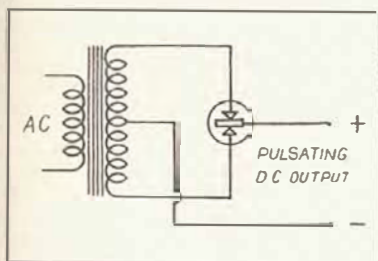

Fig. 9.—The circuit for the gaseous conduction type of rectifier.

required, for the operation of any particular valve filament or heater.

Our problems, then, are in the obtaining of "B" and "C" power. Consult Fig. 8. This shows a transformer and rectifier arrangement to deliver a pulsating d.c. voltage to a filter. Full wave rectification is used. One plate rectifies during each half of the "A.C." cycle. The rectifier may be a UX280 or any of its prototypes, or any other full wave thermionic rectifying valve, with suitable characteristics. The valve is selected when it is known what voltage and current is required by a particular receiver. Taking into consideration voltage drop across the rectifier (this is normally 50-100 volts in good full wave rectifier tubes), knowing the maximum voltage the receiver will require, we will know what a.c. voltage will be required each side of the high voltage centre tap. Say that the maximum voltage required to operate a four valve combination was 250, and that the maximum current that would be drawn would be 80 milliamperes. On looking at the valve charts several types suitable for operation at 325v. and to pass 100 milliamps would be seen to be suitable for this purpose. Since the voltage required is 250, and the voltage drop across the full wave rectifier and the filter may be 75, a voltage of 325 each side of the high voltage centre tap will be needed, at the transformer secondary. The rectifier filament heating secondary must supply the voltage required by the filament of the type of rectifier used. Pulsating d.c. with a generous amount

of a.c. ripple is available at the output from the rectifier. By use of a filter consisting of an inductance and condenser combination, we can smooth out the ripple in the rectifier output, and obtain a pure output at the various positive tapplings, free from any a.c. component. Suffice it to say that the iron cored inductance and condenser combination will accomplish this.

The theory of operation of the filter, or in fact any other part of a.c. power equipment, or the a.c. receiver or any part of it, is, in itself, involved, and it is the intention that this handbook be of a practical nature, and suited to the man who wishes to build his own receiver from the information he has himself gathered and combined into what he thinks will suit his own particular requirements. Proceeding further, we will notice that we have a negative terminal and a number of positive terminals. By use of a voltage dividing resistance, besides the maximum voltage available from the eliminator, we are able to secure lower voltages suitable for the operation of the various stages of a receiver combination other than the final amplifier stage which requires the maximum voltage, since the voltage output from the eliminator has been designed to suit the final stage power valve. Each positive tapping is by-passed to negative.

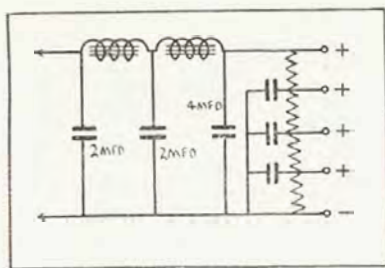

Fig. 10.—The filter and parallel type of voltage divider, which will provide pure power at different voltages suitable for the operation of a receiver.

The correct selection of filter condensers is important. If, say, a voltage of 250 is to be available from the eliminator, condensers tested at 500 volts a.c. at least should be used. In order that there may be always a margin of safety the use of filter condensers tested at an a.c. voltage of twice the d.c. voltage they are to filter, is advisable, since the breaking down of a filter condenser may cause much damage which would have been averted had this suggestion been adhered to. For by-passing of lower positive tapplings, condensers

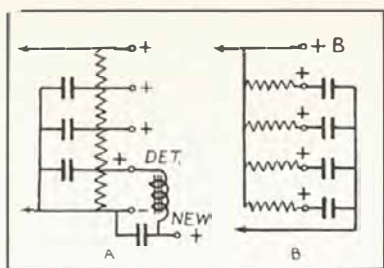

Fig. 11.—A—Detector stage plate power supply hum prevented by use of a small choke and by-pass condenser. B—The anode feed system of supplying various plate supply voltages to the stages of a receiver combination.

tested for as low a voltage as 200 d.c. may be used. Telephone condensers are suitable for the by-passing or filtering of any d.c. voltage lower than 100. It is inadvisable to use these condensers for continuous operation at higher voltages than this, since they would be liable to break down. The use of two filter chokes properly by-passed permits best filter action being obtained. The same effect is available by use of a centre-tapped choke. The choke consists of a laminated iron core having an air gap, upon which are wound a number of turns of wire. The core gap prevents saturation of the core material and consequent inefficient operation of the choke. The transformer and filter choke construction details will be given in full in later pages. The construction of voltage dividing resistors is inadvisable as it calls for use of fine wire, difficult to obtain, which can only be satisfactorily worked by use of the proper machinery. Filter condensers must also be purchased, since it would be impossible for the home set builder to obtain materials and spend the time and work necessary for the production of these components.

Fig. 12a. shows the connections for the standard voltage divider, such as the Radiokes Pilot or Electrad 10,000 ohms type. Each tapping of the divider is by-passed by a small condenser having a capacity of between .01 and 2 mfd. This capacity may be as high as 4 mfd. on the detector positive tapping should the occasion demand. The divider consists of a resistance winding on a tubular former, tapings being taken at a number of places for the securing of intermediate voltages. Fig. 12b. shows how a number of separate resistances may be used. Here the divider functions merely as a single resistor divided into a number of sections. Wire wound resistors of good construction must be used here.

The Anode Feed System

Fig. 11b shows what is known as the "Anode Feed System." This method of feeding different positive voltages to the various stages of a receiver has everything in its favor. In using any of the paralleled or series methods when a single tapped resistor is utilised, it stands to reason that alteration to the load on one particular tapping of the resistor will result in changing voltages at the terminals of the other positive tapings. This results in back coupling which may cause distortion, even though by-passing of each positive tapping be carried to extremes. Mullard or Ferranti type wire wound tubular resistances are particularly suited for use in the anode feed system. In the design of a receiver we know what positive voltages for the various stages will be required, and by use of the information later supplied, it will be found a simple matter for the set builder to calculate for himself the resistance values he will require.

The detector stage of a receiver is most susceptible to a.c. induction noises and to the slightest of ripples in B power supply. This stage may introduce a bad hum into a circuit should the plate power supply be slightly uneven. In many cases, the set builder would proceed to fill up all the available space in his receiver with more filter condensers connected across the maximum positive lead at either side of the filter choke. This procedure may often be unnecessary, since the detector stage is the only one affected. Fig. 11a shows how an

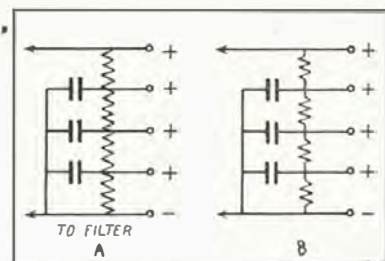

Fig. 12.—A—The parallel resistance dividing method, using a single resistance. B—The parallel resistance method using separate resistances.

a.f. transformer primary winding and a 2 mfd. capacity filter condenser may be connected to clean up the detector plate supply, and eliminate detector stage hum. This point will be of particular interest to the man whose calling is that of servicing receivers.

Our notes on trouble shooting and power pack testing will be of particular interest to servicemen. Power supply equipment costs money and should be saved wherever possible.

Among the thousands of people interested in the construction of a.c. receiver equipment are many boys who will not be prepared to spend a great deal of money on power supply equip-

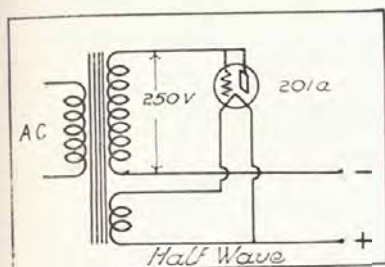

Fig. 13.—Showing how a single 201A type receiving valve may be used as a half wave rectifier.

ment. The full wave eliminator rectifier is a costly tube, but the 201A type of receiving valve may be used in its stead, if it is not called upon to deliver more than the current it will safely pass. It would be wise for those who have little money to outlay in the purchase of gear not to be too ambitious. A pair of 201A receiving valves connected in a full wave rectifying circuit may be called upon to deliver 15 mills. safely. This current at a voltage of no more than 120 at the d.c. output terminals is adequate to supply a small receiver for the home.

Fig. 13 shows how the single 201A valve may be connected in a half wave rectifier circuit which will deliver a current of no more than 8 mills at 120 volts.

Fig. 14 shows how a pair of 201A's may be connected in a full wave rectifier circuit, to deliver a current of no more than 15 mills at 120 volts. The 201A must not be abused, and currents of greater magnitude cannot be expected of a tube of this type. These half and full wave rectifier circuits remain the same for any power valves such as the 171, the B405, etc., should these be used for rectifying. The grid and plate of each valve should be connected together and used as the plate connection to the rectifier to obtain greatest output. Using a pair of 201A's, a home made transformer, a home made choke, and assembling the gear oneself, will result in the production of a highly efficient "B" eliminator

delivering a maximum of 120 volts at 15 mills., for a cost of less than £2. Provided sufficient care is taken in transformer and choke assembly, the finished pack will be as reliable and efficient as any commercially built power pack. Included in the £2 is the "A" supply, while a bias resistance or two may send the cost of a complete A.B.C. eliminator up to about £3. The cheapness of the eliminator is certainly not in keeping with its efficiency, for the job will give highly satisfactory results. Things are certainly improving when the home set builder may rig up complete power supply equipment for less than the cost of a couple of sets of "B" batteries. Without "B" batteries, dry cells, accumulators and battery chargers, the cost of operating a receiver becomes a mere matter of a few added pence to the light bill, and payment of the annual licence fee.

The success of the A.B.C. power pack depends upon its correct construction, adjustment and operation. The overloading of any piece of equipment by as much as 1 per cent. is strictly taboo.

On page 122 we have gone into the subject of upkeep. It will be found that current consumption by the average radio-gramophone combination is

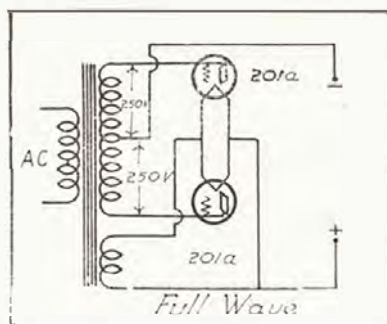

Fig. 14.—Showing how a pair of 201A type valves may be used in a full wave rectifier circuit. Long life from these tubes or ordinary power tubes may be expected if they are correctly operated.

remarkably low, in most cases, operating cost being less than one half-penny per hour's use. The maintenance of the properly built all-electric receiver becomes the mere renewal of receiving valves and rectifiers as these lose their emission. A pair of push-pull final stage power valves might give constant service for as long as three years when correctly operated. The first cost of the all-electric receiver is the last.

Obtaining Negative Grid Bias

The "C" eliminator—Resistance methods—Calculation of bias resistor values

IN obtaining a constant B power supply we have solved the problem of obtaining "C" bias. By use of resistors we may bias any stage of a receiver combination.

Fig. 15 shows probably the best method of obtaining negative grid bias.

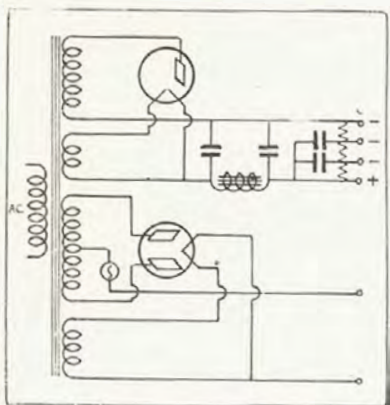

Fig. 15.—Using a separate "C" eliminator supply.

The idea makes use of a separate rectifier, filter and voltage dividing system, and is to be recommended. In this arrangement an extra filament heating secondary for the "C" rectifier tube and a "C" voltage secondary winding delivering 150 volts is neces-

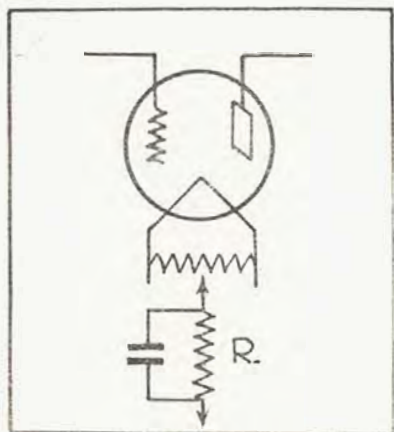

Fig. 17.—Biasing the grid of a directly heated valve.

sary. The "C" dividing resistance should be of the tubular wire wound type, having a resistance of 5000 ohms. The resistor should be fitted with a number of collars, the position of which may be varied along the resistor, the number of these tappings required depending upon the number of C negative connections needed for any particular receiver combination. The plate voltage applied the 201A for the obtaining of a maximum "C" voltage of about 50 will be 150 volts. The exact number of turns will not be important since the voltage available at the "C" eliminator output may be varied to obtain any required value. The condensers used for the filtering of the "C" supply may be of the 200 volts test type. Telephone condensers here will be found quite reliable. The "C" filter choke may consist of an

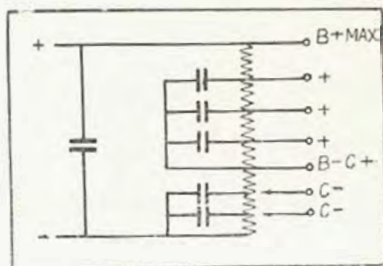

Fig. 16.—The extended "B" eliminator resistance method.

a.f. transformer primary. Provided the resistance does not drop the output voltage down to too low a maximum value, a transformer secondary may be used to give better filter action. The "C" dividing resistance will take a "bleeder" current of approximately 5 mills. which will enable the "C" rectifier to operate evenly.

The method certainly requires two extra transformer secondary windings, an extra rectifier valve and a little more filter apparatus, but it is trouble free, will give constant output, the bias voltages varying in accordance with the plate voltages should there be mains voltage fluctuation, as there generally is on any power supply line. In our circuits we will show the resistance method of obtaining bias. It will be

seen that the "C" eliminator idea is straightforward and may be used in conjunction with any of the circuits published on later pages. The method possesses no disadvantages, since the "C" rectifier valve will last for years, provided its rated filament voltage is not exceeded. The voltage is low, therefore there will be no possibility of the "C" filter condensers breaking down, while since no current is taken from the "C" supply, there will be little chance of the filter choke (transformer winding) burning out, unless, of course, the C supply wiring shorts across. The average five milliamperes taken by the "C" dividing resistor will generally be insufficient to damage the transformer winding constituting the filter choke of this supply.

Extension Resistance Method

Fig. 16 shows how, by an extension of the plate voltage dividing resistance of any B eliminator, "C" negative connections may be obtained. The resistance is generally of about 10,000 ohms, tapings being taken for the various "C" values required.

The disadvantage of this method is that slight hum in the plate power supply may sometimes make its appearance in the grid circuits of vital stages. If care is taken the methods shown in Figs. 17 and 18 will be quite satisfactory. The method shown in Fig. 17 of connecting the bias resistor in the centre tap lead may only be used

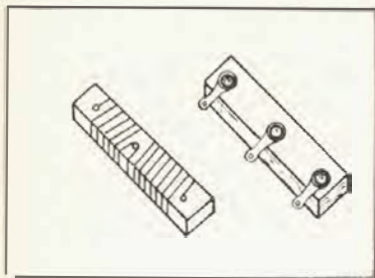

Fig. 19.—A suggestion for the construction of a centre tapped filament resistor, using a piece of fibre or asbestos, three boot eyelets, three solder lugs and some nichrome wire.

when the transformer filament or heater secondary supplies only one stage, that stage being the one to be biased.

The method of connecting the biasing resistor in the cathode lead is most generally used in indirectly heated circuits. The method shown in Fig. 18 is used when a stage using

indirectly heated valves requires to be biased, the transformer secondary heating these valves supplying no other than the particular stage to be biased.

The formula for calculating the bias resistor value required for any particular valve is quite simple:—

$$\frac{RBV}{I} \times \frac{1000}{I} \text{ equals } R$$

where RBV is the required bias voltage, I the plate current in mills. and R the value of the bias resistor required.

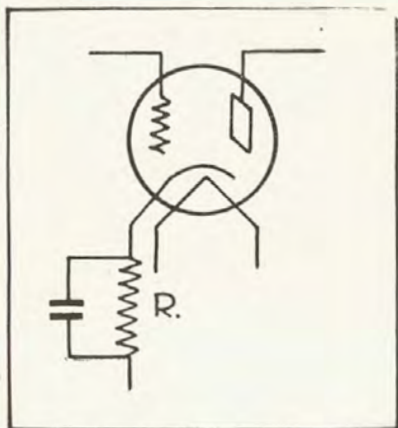

Fig. 18.—Method when using an indirectly heated valve.

For example: We have a B405 valve in an amplifier circuit. This valve is to take a plate current of 8 mills. when its rated voltage is applied to its plate. Looking at the valve chart we will find that a bias voltage of 18 is required when operating the valve under normal conditions. We have then the required bias voltage and the plate current in mills., which is all we need to discover what value of bias resistance will be required.

Following the foregoing simple formula:—

$$\frac{18 \text{ volts}}{8 \text{ mills.}} \times \frac{1000}{1} \text{ equals } 2250 \text{ ohms.}$$

Each bias resistor should be bypassed, the value of the capacity usually being .1 mfd.

Battery Bias

Since the incorporation of resistance biasing methods results in additional gear and additional places for something to go wrong, we may use battery

bias in many cases. Flat torch batteries may be used for biasing, and since the bias voltage required is seldom above 30, eight of these may be bound together and fitted into a small ducoed metal case, tappings being taken at the required voltages beforehand. The life of such a bias battery is its shelf life, and this is generally 18 months or more. A by-pass condenser of .01-1 mfd. capacity should be used to by-pass each "C" lead to this bank of "C" batteries. Bias resistors are expensive, and the use of the "C" eliminator method which we first described also requires the purchase of an extra rectifier valve and additional filter gear and secondary windings, so that this suggestion is submitted for those who do not wish to spend more money than necessary in putting together the cheapest possible receiver combination to give satisfactory results. Actually the battery method is the most trouble-free and reliable in its operation, and it is only the thought of having a dry cell battery in their a.c. receiver that would prevent many from using it.

The B negative connection to any valve supplied by a filament or heater a.c. voltage must be taken to the exact centre of this voltage. By use of the necessary instruments, a transformer secondary may be tapped at its electrical centre. Generally the home set builder is unable to do this satisfactorily. The trend in commercial receiver design is for each separate secondary filament or heater winding to be resistance centre tapped.

Fig. 19 shows how a non-inductive centre tapped filament resistor is made. The former consists of a small strip of asbestos or fireproof substance, two feet of gauge 32 nichrome wire being wound in opposite directions from the centre of this strip of material. The transformer secondary connections are made to the outer leads of the resistor, the centre tapping being where the separate and opposite windings connect together.

Since an incorrect or displaced centre tapping may often result in hum, particular care must be given to the construction of the centre tapped filament or heater resistor. It is preferable to mount the resistor next the filament or heater terminals of the valve it is to be used in conjunction with. A 100 or 200 ohms potentiometer may be used instead of this centre tapped resistor. Such a component although obtainable for a few pence would take up valuable space in a receiver combination, so that the asbestos or fibre resistance strip method is to be preferred if an equal amount of wire is

used on each side of the centre tap. These resistors, in order to make a neat job, should be mounted upon small blocks of ebonite drilled to facilitate their being easily fastened to a wooden or metal baseboard by use of wood screws or machine screws.

Selecting the Bias Resistor

Having calculated a bias resistor value, when purchasing the resistor, select a type which will pass the current to be taken by the plate of the valve to be biased. Plate current drawn by a power valve may be as high as 50 milliamps, so that it is important that a resistance of sufficiently heavy construction to pass the current safely be used.

Bias resistors for r.f. amplifier circuits may be types to pass five milliamps. The detector stage bias resistor, if anode bend rectification is used, may be of the ordinary grid leak metallised filament type. A heating bias resistance will change in its value, so that a resistance to suit the particular valve with which it is to be used must be selected, not only for its resistance, but also for current carrying capacity. See pages 70 and 79 for data on the various makes and types of resistors suitable for plate voltage dividing and biasing purposes.

Bias resistor values should not be calculated until the power pack has been secured and its output tested for maximum voltage. When this voltage is discovered, it will be known whether we will be able to supply the final stage power valve with its maximum plate voltage, and calculate resistances accordingly. In calculating the bias resistor value for a final stage push-pull amplifier, it must be remembered that here, the one bias resistor is being used for the two stages, and there will be twice the current flowing through the resistor. The value of the resistor should then be half that required for a single valve of the type used in the push-pull stage of the combination. In most cases, reference to our valve charts will show what bias resistor will be required for any type of amplifier valve.

In order to ensure that the correct bias will be placed upon the grids of the amplifier valves of a combination, the use of variable bias resistors is to be recommended. The Electrad Tru-volt power type ranges are particularly suited for this purpose, since they will handle a fairly heavy current. A milliammeter inserted in series with the plate lead of each amplifier valve in turn will indicate immediately when the correct adjustment to the variable resistor has been obtained and the valve is receiving its correct plate current.

Rules of Transformer Construction

Before attempting the design or construction of power pack equipment, read carefully the following rules.

ALWAYS wind transformer primaries and secondaries with wire of sufficient gauge to carry the current required of it. (In calculating wire gauges refer to the current carrying capacity of copper wire table.) On pages 30 and 31.

* * *

In designing a transformer core always use sufficient dimensions for the total secondary wattage to be drawn. (Refer here to the transformer primary and core size table.) On page 29.

* * *

Wherever feasible, use filter and bypass condensers tested at twice the voltage they are to withstand in the receiver or power pack.

* * *

Never use a paralleled voltage divider of insufficient resistance. Calculate by means of details supplied later the resistance required for the particular maximum voltage available from a power pack. The use of too low a paralleled dividing resistor will result in waste of power, possible damage to rectifier, heating and possible burning out of the dividing resistor, and finally inability of the power pack to deliver full voltage.

* * *

Always operate a rectifier underloaded. When selecting a rectifier for a particular purpose make sure that you have calculated correctly the maximum current it is to pass, and leave a margin. (Refer here to our table of characteristics of different makes of reliable rectifiers.)

* * *

Never vary the output voltage of a power pack by use of a filament controlling rheostat on the rectifier filament. This will result in what is known as crystallising of the filament and will result in short life of the rectifier.

* * *

After calculating the wire gauges required for filament heating secondaries, use wire two gauges heavier. The reason for this is that immediately the

filament of a valve is switched on it draws a current of about twice the normal current value of the tube. The resistance of the tube gradually increases until current drops down to its normal value. When operating a number of valves from the one secondary, the winding would be overloaded were the actual gauges calculated to be used.

* * *

Remembering that in the "B" power supply unit we are handling fairly high d.c. voltages, insulate all leads accordingly. In wiring up a power pack to deliver no more than 120 volts spaghetti sleeving may be safely used. In higher voltage jobs use good quality thick rubber walled flex.

* * *

When attempting the shielding of transformer or filter choke gear, leave sufficient spacing between terminals and the shielding material, filling up the space between the device and the shield to prevent vibration.

* * *

Don't lose sight of the fact that a high voltage secondary winding, whether to supply 100 volts or 1000 volts, may be dangerous to human life. Act accordingly and keep your hands well away from apparatus when it is connected to the light socket. Don't be afraid of wearing out the light or power point switch. If you must fiddle around with gear while it is in operation, use only one hand, keeping the other well out of the road. A severe shock through the fingers of one hand is seldom fatal, but it will teach a lesson.

* * *

If these rules are adhered to, long life of power pack apparatus, efficiency of operation free from all troubles associated with poor construction and design, will be secured. A thermionic rectifier properly treated may give constant service for as long as two years, while transformers and chokes should be everlasting if they are constructed with some margin for overload.

PLATE SUPPLY RECTIFIERS

PHILIPS TYPES

TYPE	RECTIFICATION	FIL		MAX. a.c. PLATE VOLTS	MAX OUTPUT in Ma's
		Volts	Amps.		
1560	Full Wave	5	2	300	125
1562	Half Wave	7.5	1.25	750	110
505	Full Wave	4	1	400	60
506	Full Wave	4	1	300	75
373	Half Wave	4	1	220	40
1201	Full Wave	2.5	1.5	300	75

OSRAM TYPES

U5	Full Wave	5	1.6	400	60
U8	Full Wave	7.5	2.4	500	120
U9	Full Wave	4	1.0	220	75

COSSOR TYPES

612BU	Full Wave	6	.4	250	50
660BU	Half Wave	6	4	1000	150
412R11	Full Wave	4	1	250	70
412SU	Half Wave	4	1	250	70
624BU	Full Wave	6	2	550	60
825BU	Full Wave	7.5	3	550	120
44SU	Half Wave	4	.4	200	20

MULLARD TYPES

DU 2	Full Wave	4	1.1	240	40
DU 10	Half Wave	4	1.1	240	40

RAYTHEON TYPES

Ray X280	Full Wave	5	2	350	125
Ray X281	Half Wave	7.5	1.25	750	85
Type BH	Full Wave (gaseous)	—	—	350	125
Type BA	Full Wave (gaseous)	—	—	350	350

RADIOTRON TYPES

UX 280	Full Wave	5	2	350	125
UX 281	Half Wave	7.5	1.25	700	85

PILOTRON TYPES

P 280	Full Wave	5	2	350	125
-------	-----------	---	---	-----	-----

Note:—Max. a.c. input volts is the maximum voltage which may be applied to the plate of a half wave rectifier, or to each plate of a full wave rectifier. The type 280 rectifier will be found to be the most suitable for the average two, three or four valve combination.

Power Transformer Construction

Dealing with core construction, calculation of probable winding space, selection of wire gauges, construction of chokes, etc.

THIS is an important subject, and will be of vital interest to all those who intend constructing their own power pack equipment. The information available in the following notes will be suitable for the design of A.B.C. transformers, step down or step up transformers suitable for any requirements.

We have received probably thousands of queries from persons contemplating transformer construction.

In order to satisfy their wants, it was found necessary to supply each enquirer with a reply almost in the form of a constructional article on the subject. This takes time, and is seldom sufficient for the enquirer, since what he really needs is a text book on the subject of transformer design. Hence this book.

Success at home transformer design and assembly may be achieved if care is taken and correct methods are used. Never build a transformer hurriedly. If you must have an a.c. receiver in a hurry, purchase the transformer and filter choke rather than build up shoddy jobs.

Difference In Outputs

It is possible that every transformer built by different constructors from one description would be different in their voltage outputs. The discrepancies in each different job can usually be accounted for by difference in the electrical characteristics of the core material of each transformer. Slight difference in the spacing of windings would result in different secondary voltages being obtained. This shows the necessity for the careful checking of filament and heater secondary output voltages after completion of the transformer. The possibilities of voltages being too high or low are so great that one must not think of connecting the transformer into a circuit before it has been tested for secondary voltage outputs. If you cannot borrow the necessary meters, take the transformer to some reliable radio engineer. The few shillings spent in this way will save the worry involved in trying to

obtain good results, when the voltages may be low, or in the damage which would inevitably be done to the valves if voltages were to be a little high. There are too many factors governing transformer construction to expect two similar home designs to behave in exactly the same manner.

The transformer changes power at one voltage to power at another voltage. In a small power transformer of good design we may obtain 80 per cent. of the power which goes into the transformer primary at the secondary terminals of the device.

See Fig. 20. Here we have an iron core, upon one arm of which is wound a primary. This primary is fed by the mains. On the other arm we have the secondary, which may deliver a voltage lower or higher than the input voltage, depending upon the number of secondary turns.

The Watt is the unit of electrical power, and is the product of voltage and current.

We have an electrical device taking a current of one ampere at 200 volts. The power taken by this device is therefore voltage times the amperage, or 200 watts.

We will say that we have a step down transformer operating from the 200 volts supply. The secondary delivers four volts. A current of 10 amperes is taken from this secondary. This means that the power taken from the secondary is 40 watts. Since the output of the transformer is 40 watts when it is in operation for our particular purpose of supplying some electrical device requiring four volts at ten amperes, a power of 40 watts must be taken from the 200 volts mains supply by the primary (actually this would be the case in a 100 per cent. efficient transformer, but core losses and other losses reduce the efficiency to 80 per cent., so that 80 per cent. of the power taken by the primary is available at the secondary). At 200 volts the primary current will then be one-fifth of an ampere (still considering the transformer to be 100 per cent. efficient).

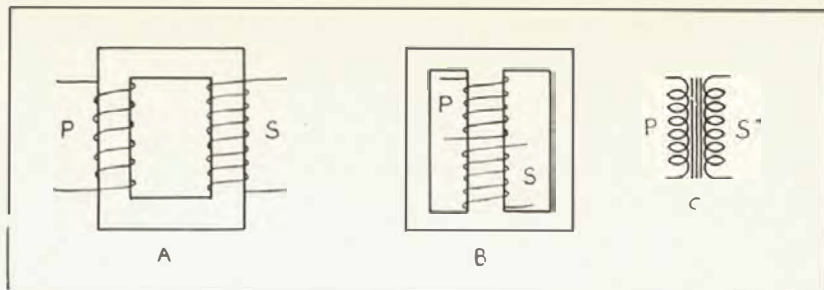

Fig 20.—(A) A primary and secondary wound on an iron core. (B) The shell type core. (C) The sign used to represent a transformer in a circuit diagram.

Fig. 20 shows the standard four-sided core and the shell type in which E-shaped core pieces are used. Since the construction of E-shaped pieces would be out of the question as far as the home set builder is concerned, we will deal with the type of core which can be built up of strips of stalloy.

Fig. 20c shows how the transformer is represented in a circuit diagram.

The design of a power transformer calls for careful consideration of the work it is to perform. A transformer should be designed for a particular purpose, the device never being subjected to overload.

Fig. 21 will give an idea of how to design core and winding space. (a) This is the worst possible design, the result of which would be an efficiency of about 20 per cent., if any. (b) Here the design is a little better, but it is still unsuitable. (d), (e), and (f) are the best practical designs for the

home set builder to follow. Here the primary and low voltage secondaries are wound on one arm of the four sided core, while the high voltage secondary, and bias voltage secondary, if used, are wound on the opposite arm of the transformer core.

When we connect the primary of a transformer to the mains a small magnetising current will flow at no load. This sets up what is known as magnetomotive force and flux lines go round the transformer core. This flux links the primary and secondary windings. The flux induces a counter voltage in the primary, which prevents this winding from taking a great current and burning up. It also induces a voltage in any turn or turns of wire placed around any of the four sides of the transformer core.

Were a d.c. voltage to be applied to the transformer primary this would cause a field to surround the core,

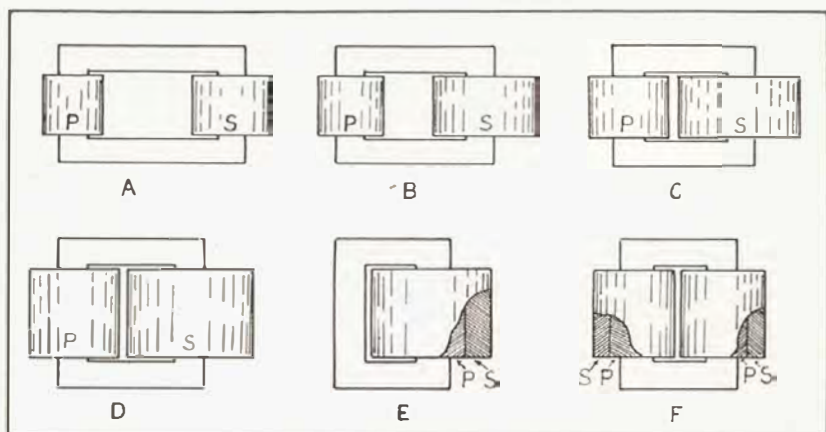

Fig 21.—(A) One of the poorest possible designs. (B) Slightly better, but not good. (C) An improvement, but still poor. (D) A much better design which may be followed by the home power pack builder. (E) A type in which only one arm of the core is occupied. (F) Another good design in which half the primary is wound on each of two opposite core arms, and half of the high voltage secondary over each half primary winding.

Transformer Core and Primary Winding Details for Various Wattages

PRIMARY INPUT WATTAGE	PRIMARY WIRE GAUGE	PRIMARY TURNS PER VOLT.	MINIMUM PERMISSIBLE CORE CROSS SECTION
12	28	6	1in. x 1in.
15	26	5	1in. x 1in.
20	26	5	1in. x 1in.
25	26	5	1in. x 1in.
30	26	5	1½in. x 1½in.
35	26	5	1½in. x 1½in.
40	26	5	1½in. x 1½in.
50	24	5	1½in. x 1½in.
75	24	5	1½in. x 1½in.
100	22	4	1½in. x 1½in.
150	22	4	1½in. x 1½in.

Note:—The 12 watt specifications will be the smallest required.

We have shown in the notes on transformer design how the total power in watts taken by a receiver may be calculated. This wattage, plus a quarter of the total, should be compared with the above table, when designing a power unit. Always use the next larger specifications if the calculations result in a slightly greater wattage than any of the above types.

Primary turns per volt means that this number of turns is wound for every volt of the mains supply, i.e., Using a 5 turns per volt primary will require a primary winding of 1000 turns, if the supply voltage be 200, or 1250 if the supply be 250 volts.

but since this field would not move, no secondary voltage would be induced. If this d.c. primary current were to be interrupted by means of a contact breaker, voltage would be induced in the secondary. The building up and breaking down of the field surrounding the transformer core by interruption of the d.c. current flowing in the primary fulfils the requirements of a moving field, as is the case when an alternating voltage is applied to the transformer primary. It is not necessary that the current reverse its direction as with a.c., that a transformer may function.

The ratio of secondary turns to primary turns is the same as the ratio of secondary voltage to primary voltage, but only when 100 per cent. efficiency is secured. In the small power transformers we build for the a.c. receiver, the efficiency will be 80 per cent. if construction is good. There are a number of causes of loss of efficiency in a transformer. Power is lost in eddy currents set up in the iron. This power is dissipated in the form of heat.

Power is lost due to hysteresis of the core iron, and in heating of the copper windings. Poor design of the core and shape of windings, and poor winding will result in loss in efficiency. The larger the core the fewer turns required on primary and secondary. Since transformer iron (stalloy) is cheaper than copper wire, the use of big cores is advisable. Iron which is most easily de-magnetised will give greatest efficiency. Soft iron or silicon steel should be used. This material may be obtained cut to any size from the Melbourne Electric Supply Co., at Richmond, Victoria.

If, when the primary is connected to the mains, the winding becomes warm, and the current taken from the mains is fairly heavy, it will be known that the core is inadequate or the primary turns per volt are too small for the cross section size of the core, or there is a short in this or one of the secondary windings. The regulation of a transformer in which a margin for overload has been allowed

COPPER WIRE TABLE

Gauge S.W.G	Diam. in.ch.	Resistance ohms per 1000 yds.	Current rating in amps. 1000 amps per sq. in.	S.C.C.	D.C.C.	S.S.C.	D.S.C.
				lb.	lb.	lb.	lb.
Approx. weight per 1000 yds.							
10	.128	1.865	12.868	152.32	154.56		
11	.116	2.272	10.568	125.44	127.68		
12	.104	2.826	8.495	99.80	101.30		
13	.092	3.612	6.648	78.30	79.60		
14	.080	4.776	5.027	59.40	60.70		
15	.072	5.897	4.072	48.30	49.10		
16	.064	7.463	3.217	38.40	39.00	37.46	37.66
17	.056	9.747	2.463	29.20	30.00	28.71	28.89
18	.048	13.267	1.809	21.00	22.30	21.12	21.28
19	.040	19.105	1.256	15.10	15.70	14.69	14.85
20	.036	23.59	1.017	12.34	12.80	11.92	12.07
21	.032	29.85	.804	9.81	10.20	9.43	9.57
22	.028	38.99	.615	7.57	8.00	7.24	7.34
23	.024	53.07	.452	5.56	5.94	5.33	5.38
24	.022	63.16	.380	4.70	5.07	4.49	4.54
25	.020	76.42	.314	3.91	4.25	3.72	3.76
26	.018	94.35	.254	3.19	3.51	3.02	3.06
27	.016	113.65	.211	2.67	2.83	2.51	2.55
28	.015	139.55	.172	2.20	2.35	2.06	2.09
29	.013	165.27	.145	1.87	2.02	1.74	1.77
30	.012	198.80	.120	1.58	1.71	1.46	1.48
31	.011	227.2	.105	1.39	1.51	1.27	1.30
32	.0108	262.1	.091	1.22	1.33	1.11	1.14
33	.0100	305.7	.078	1.06	1.17	.95	.98
34	.0092	361.2	.066	.91	1.01	.81	.84
35	.0084	433.2	.055	.75	.87	.68	.70
36	.0076	529.2	.045	.63	.74	.56	.58
37	.0068	661.1	.036	.51	.62	.45	.47
38	.0060	849.1	.028	.41	.51	.36	.37
39	.0052	1130.5	.021	.32	.41	.27	.29
40	.0048	1326.7	.018	.28	.37	.23	.25

Above is a copper wire table for Standard Wire Gauges giving the diameter of each gauge in inches, the resistance in ohms per 1000 yards, current carrying capacity of each gauge, and the approximate weight per 1000 yards of the different types of insulated wire.

The table is a necessity when calculating the gauges of wire, the winding space and the amount of wire required for the construction of any type of transformer. By means of the table shown above and that on page 31, the transformer table and the details on transformer and choke construction, complete information to enable the building of any particular type may be obtained.

COPPER WIRE TABLE

TURNS PER LINEAR INCH OF DIFFERENT TYPES.

Gauge S.W.G.	Enamelled	S.C.C.	D.C.C.	S.S.C.	D.S.C.	Gauge S.W.G.
10		7.35	7.04	7.64	7.55	10
11		8.06	7.69	8.41	8.30	11
12		8.93	8.48	9.35	9.22	12
13		10.0	9.43	10.5	10.4	13
14		11.4	10.6	12.1	11.8	14
15		12.5	11.6	13.3	13.1	15
16	15.0	14.1	13.2	14.9	14.6	16
17	17.1	15.9	14.7	16.9	16.5	17
18	19.8	18.5	17.2	20.0	19.4	18
19	23.7	21.7	20.0	23.8	23.0	19
20	26.1	25.3	21.7	26.3	26.0	20
21	29.4	26.3	23.8	29.4	28.2	21
22	33.3	29.4	26.3	33.3	31.8	22
23	38.8	33.3	29.4	38.5	36.4	23
24	42.1	35.7	31.3	42.1	40.0	24
25	46.0	38.5	33.3	46.0	43.5	25
26	50.6	41.7	36.7	50.6	47.6	26
27	55.9	44.6	37.9	55.1	51.6	27
28	61.4	48.1	40.2	60.4	56.2	28
29	66.2	51.0	42.4	65.2	60.2	29
30	73.3	54.4	44.7	72.0	67.1	30
31	77.8	56.8	46.3	76.3	70.9	31
32	83.0	63.3	50.5	81.3	75.2	32
33	88.9	66.7	52.6	87.0	80.0	33
34	98.0	70.4	54.9	93.4	85.5	34
35	106.0	80.6	61.0	101.0	91.8	35
36	116.0	86.2	64.1	110.0	102.0	36
37	128.0	92.6	67.6	120.0	110.0	37
38	143.0	100.0	71.4	133.0	121.0	38
39	168.0	109.0	75.8	149.0	134.0	39
40	180.0	114.0	78.1	159.0	142.0	40

Above is a copper wire table giving the turns per linear inch of different types of insulated Standard Wire Gauges. This table will come into use when calculating the probable depth of primary or secondary windings and the amount of wire required.

in the selection of wire gauges and transformer sizes will be good.

The Design and Construction of Small Power Transformers

Transformer construction is perhaps tedious when several thousands of turns of wire have to be wound, but the use of some form of winding gear will enable the job of winding the turns to be carried out speedily. All

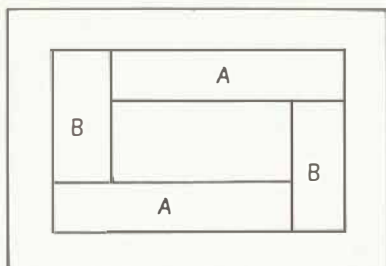

Fig 22.—Showing how the first layer of core pieces will be placed. The 1st, 3rd, 5th, 7th, 9th, etc., layers will be placed in this position. The core pieces marked B are the same size. The core pieces marked A are the same size. Two different sizes of core pieces are needed when making a rectangular core.

the transformers we require to build for Australian conditions will operate from a 200-250 volt 50 cycle a.c. mains source.

The transformers we require for the operation of almost any sized home radio-gramo. combination outfit will be comparatively low power jobs. The total power required by the average radio combination outfit should rarely be greater than 100 watts. A transformer to deliver this or smaller power may be compactly made from the following details.

In the design of a transformer, the object should be to make the finished job as compact and as square as possible. Careful attention to design will result in a transformer possessing these characteristics. Before attempting the purchase of materials and the construction of the transformer, set out a design of actual size upon paper. Some idea of the size and shape of the finished job will be obtained, faults in design can be rectified, and materials can be ordered with a much better knowledge of what is required.

The Wire Table

The tables on pages 30 and 31 will require to be consulted from time to time in designing our power transformer.

The construction of shell and circular core type transformers is be-

yond the home set builder unless the core material in the form of E and circular shaped pieces are available. All our designs will use the square or oblong core, which may be built up of strips of stalloy material. L shaped pieces may be used if they are readily obtainable. (Refer again to Fig. 20 a, b, c and d.)

Building the Core

The design of a transformer core calls for a knowledge of what power the finished transformer is to supply. For a certain power a certain cross section of core and turns per volt ratio must be used. Refer to the core and primary winding table on page 29.

When designing a power transformer for a particular purpose an approximate idea of the power to be taken from its secondary winding or windings is necessary. We quote an example to follow in building a transformer to suit a certain type of receiver.

Let us assume we intend the construction of an A.B.C. transformer to supply a four valve radio combination. The combination may have yet to be built, but we know what circuit and combination of valves is to be used. The r.f. valve heater requires a voltage of 4 and a current of .9 ampere. Since wattage is the product of amps and volts, the power taken from the heater secondary to supply this valve is 3.6 watts. The detector valve heater also requires 4 volts at .9 ampere, a power of 3.6 watts. The first amplifier stage may be equipped with a valve requiring a heater voltage of 2.5 at a current of one ampere, or a power of 2.5 watts. Two power valves with directly heated filaments are used in a push-pull circuit as final stage amplifier of this particular combination. Each of these valves takes 5 volts at 1½ amperes. The filament power consumed by these valves is then 12½ watts. So

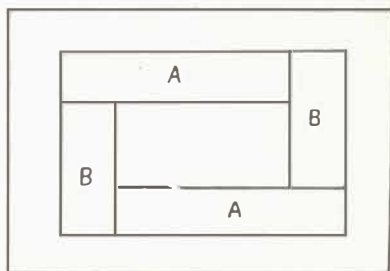

Fig 23.—Showing how the second layer of core pieces will be placed. The 2nd, 4th, 6th, 8th, etc., layers will be placed in this position.

much for filament power, which will total 22.2 watts.

Now for the plate power. Looking at the valve charts we will find that our r.f. valve takes a plate current of 3 mills., the detector valve about 1 mill., the first amplifier valve 7 mills., and the final stage valves 60 mills. A total of 71 milliams. The maximum

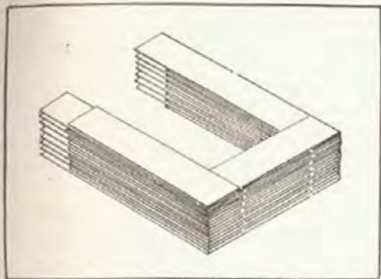

Fig 24.—Showing the built up core with one arm removed for the placing of the windings on the core.

plate voltage we require for the operation of the push-pull power valves is 300. Then 300 volts x 71 milliams—(71/1000 amp.) gives a power of 21.3 watts, or, say 22 watts.

The multiplying of volts and amps. to obtain the power in watts is simple indeed. When multiplying volts and amps. it must be remembered that a milliamp. is one-thousandth part of an ampere. The simple multiplication of these two values to find wattage will enable the designer to find out exactly what power he is to take from his transformer, before he starts its construction.

The total secondary power necessary then is 43.5 watts plus the wattage drawn by the rectifier filament when using a thermionic rectifier. This would be 10 watts using a type 280 rectifier. This means that, allowing 80 per cent. efficiency in the transformer, the primary input power will be 20 per cent. greater than the power taken from the secondaries. Referring to the chart shows that the sizes given for the 75 watt job will be most suitable since the total primary input power will be over 50 watts, and in all our construction work we will be allowing a margin for overload.

Then for this transformer, the chart shows that a primary winding consisting of 5 turns of gauge 24 wire for every primary volt is required, the cross section of the core being no less than $1\frac{1}{2}$ inches x $1\frac{1}{2}$ inches.

By knowing the heater and filament voltages required by the valves of our receiver, the plate current taken by each valve when supplied with its

normal plate voltage, and by referring to the wire table and the core table, we have in our possession sufficient information for us to know what gauges of wire will be required for the various transformer windings. Simple mathematics cover all the calculations we may require to make.

Having discovered the power that the primary will draw from the mains supply when it is in operation, reference to the transformer chart on page 29 shows what primary turns per volt, primary gauge, and core cross section will be needed. All that remains then for the completion of the design is to calculate the probable space the windings will occupy, this determining the size of the window, and the outside measurements of the core, the cross section measurements being known.

Calculation of Probable Winding Space

Presuming that we have settled upon the 75 watts core section and primary winding details for a particular job, reference to the wire table shows that gauge 24 d.c.c. wire occupies 32 turns to the inch. Allowing one measurement of the window to be 2in., then a single layer of primary turns will require 64 turns. Allowing a little extra depth for separation of layers with waxed paper, by dividing this number of turns into the total primary turns required (5 x mains voltage; in case of 200 volts supply 1000 turns), this giving the number of layers. The number of layers divided by the turns per inch of this gauge of wire gives the depth of the winding in inches, plus a little extra if layers are separately insulated with waxed paper.

We now have the length (2in.) and the depth ($\frac{1}{2}$ in.) of the primary. The same procedure is followed in the calculation of secondary turns. Gauge 30 wire, which is what will be required if a total of 100

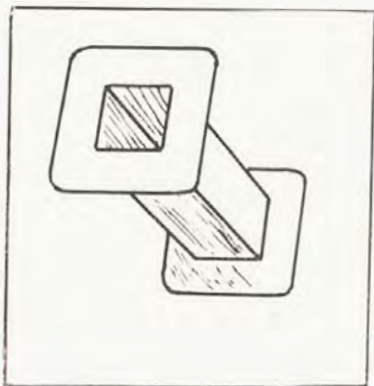

Fig 25.—Bobbin details. The bobbin should be made of fibre sheet.

mills. is required of the high voltage secondary, occupies 60 turns an inch. A single layer of these turns (2in. long layer) will occupy 120 turns. Knowing this and the total number of secondary turns required will give the depth of the winding. Since it is difficult to wind the heavy gauge filament secondaries neatly, extra space should be allowed for these.

The result of calculation of winding space in the foregoing manner will permit the finished windings to almost completely fill the window, this making for greatest efficiency in the finished job.

Calculation of Wire Gauges

In the case of the primary winding this is covered by the primary and core cross section details chart.

The secondary gauges required will vary with each different power pack designed for a particular purpose. Say a receiver combination will draw a current of 70 mills. from the high voltage secondary. Wire to carry 100 mills. should therefore be used in winding this secondary. Knowing what current is required of each low voltage secondary winding, by reference to the wire table, the gauge of wire required will be known.

In using paper to separate the windings of a transformer, use thin waxed material. Thick paper will result in heating, which might result in breakdown were this to be carried to extremes. See that the core material is cut rightangular. Good joints will result in highest efficiency being obtained. Poor joints will result in serious losses in efficiency. After having built up a core, the sides should be hammered so that the laminations fit tightly together. After this is done the core may be bound round with a few turns of twine on each arm to hold it together, when it may be held in a vice while the finished bobbins are pushed over their respective arms after one side of the core has been removed.

The diagram shows how a drill stock may be used to facilitate winding when no other convenience is handy. Use of this idea will enable turns to be wound tightly and evenly. Many other suggestions will offer

themselves to intending constructors, for the speedy and even winding of turns.

It should be the aim of the builder to follow as closely as possible the design depicted in Figs. 21 d, e and f.

Since the average efficiency of the low-powered transformers we may build for radio work will be 80 per cent., this means that some of the power going into the primary will not be available at the secondary terminals of the transformer. This power will

be 20 per cent. lost in the transference of energy from the primary to the secondary. Using five turns per volt on the primary of a transformer requires that six turns or thereabouts be wound for every secondary volt. The extra secondary turn compensates for the loss which occurs in the transference of energy

from primary to secondary circuits.

In the winding of transformer primaries "B" and "C" voltage secondaries and chokes, a revolution counter is more a necessity than a luxury, since after winding several hundreds of turns it would be very easy to mix things up and lose track of the turns wound. S.C.C. wire is preferable to enamelled wire, and heavy types of insulation such as d.c.c. or d.s.c. would occupy too much space.

Core Assembly

In building up a core it is advisable to do this in the corner of a wooden box, such as a large cigar box with two sides removed. This will keep the corners of the core right angular.

Each core lamination should be coated with thin shellac on one of its sides, or both sides to make a thorough job of it. When building the core place the shellaced sides upwards if they are coated on one side only. The insulation of the laminations in this manner makes for highest efficiency.

After the core has been built up to the required thickness one side may be knocked out and finished windings

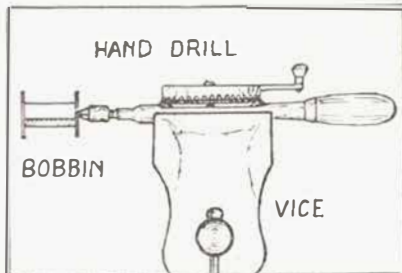

Fig. 26.—A suggestion for winding the bobbin. The idea makes use of a hand drill and a means of supporting the device.

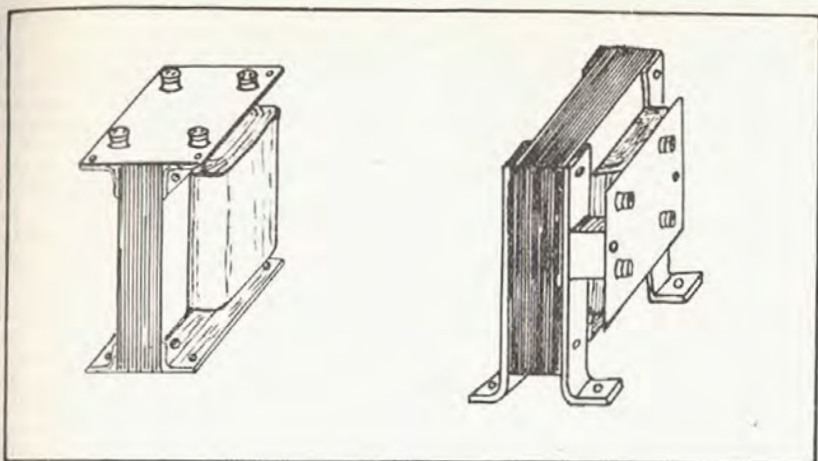

Fig 27.—Two suggestions for mounting the transformer. The first makes use of channel iron.

placed over their respective arms on the core, after which the side of the core removed should be replaced piece by piece.

In our primary turns table, primary turns of 4, 5 and 6 turns per volt are needed. Since there is always the possibility that the transformer may be used in a different locality to that for which it was designed, or the mains supply voltage may be changed, tapings should be taken on the primary for operation at 200, 230 and 250 volts. This means that for a five turns per volt primary the total winding should be 1250 turns, tapings being taken at 1000 and 1150 turns. The connections to these tapings may be made by use of small flex.

Winding Details

The possibility of shorted turns or layers must be carefully guarded against when winding. Winding will best be carried out by use of primary and secondary bobbins, as shown in Fig. 25. The material for the making of the bobbins should be thin fibre sheet. After calculating winding space, window size and cross section of any particular transformer, the bobbin size details will be known. It is advisable to make the inside measurements of the bobbin slightly bigger than the cross section of the core, in order that they may be slipped over the core arms without difficulty. The cheeks of the bobbins should be securely glued and reinforced. Various winding methods will suggest themselves to the builder. One is depicted in Fig. 26, which shows how a drill stock may be fastened to speed up the winding of a bobbin. In winding, each layer should be brushed over with thin shellac after its completion, and then wrapped round

with a sheet of thin waxed paper. This paper will prevent the possibility of a short between layers, and will provide an even base for the next layer to be wound upon. In winding the secondaries, wind the high voltage secondary on one arm and the heater and filament secondaries on the other arm. The rectifier filament secondary may be wound over the high voltage secondary. The connections to the ends and the centre tapping of the high voltage secondary winding may be made by use of small gauge flex. Flex tapings should be securely anchored to prevent their being accidentally pulled out when finishing the transformer. It would be discouraging to have the flex lead connecting to the beginning of a high voltage secondary pulled out after completion of the winding. All flex joints should be properly soldered. If a number of reels of wire are used for one winding, all joins should be properly soldered and insulated.

Winding Space Measurements

In order that the novice will understand how the core window and winding space should be calculated we will go into this subject more minutely. Presuming again that we are using the 75 watt type primary and core section sizes, we will need gauge 24 wire on the primary. For a 200 volts mains supply then a primary winding consisting of 1000 turns of this wire will be needed, since the primary turns are five per volt. The average length of the winding in the ordinary A.B.C. transformer is 2in. This gauge of wire will wind 40 turns to the inch, as shown in the wire table. Thus, multiplying this number by the two-inch long winding space will

give the number of turns required for one layer. By dividing this number into 1000 (1150 in the case of 230 volts, and 1250 in the case of 250 volts supply voltage), we know how many layers will be required.

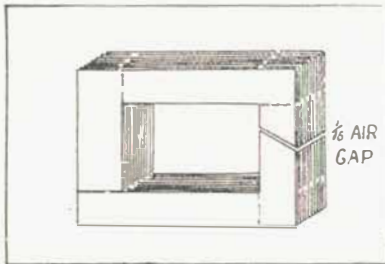

Fig. 28.—Choke core details. The core is built up in the same manner as the transformer core, the air gap being cut with a hacksaw.

Primary Winding Depth

Knowing the number of turns per inch gauge 24 d.c.c. wire occupies, it is only necessary for us to divide the turns per inch by the number of layers to secure the depth in inches that the winding will be. The depth will be slightly greater than calculated, since thin waxed paper used between each layer will increase the depth of the winding space. The same procedure is used in the calculation of low and high voltage secondary windings. In building the transformer, design the windings, using 2in. as the length of the window upon which the windings will be wound, this being the average length of winding for the obtaining of a good square design. Set everything out on paper, using actual size measurements.

Waxed Separating Paper

Waxed paper should be used to separate the layers of a high voltage secondary. Shellac should be used to hold the turns solidly into position. In winding, the object should be to make the bobbins into solid blocks of windings. Loose windings are not to be tolerated. After finishing bobbins, bind them with Empire cloth or tape. Twine may be used to further strengthen the windings. In winding heater and filament secondaries, it would be inadvisable to wind these one over the other, since each secondary will most probably require to be adjusted when the finished transformer is being tested for voltage after its completion. These low voltage secondaries should therefore be wound in sections over the primary winding, so that each winding may be got at and adjusted should the occa-

sion demand. The necessity for testing low voltage secondaries can be seen.

Between the power transformer primary and the high voltage and filament secondaries, it is commercial practice to wind a single layer of gauge 24 d.c.c. wire connecting one side of this winding to "B" negative, and leaving the other side of the winding disconnected. This winding is known as an astatic winding, and will often prevent hum caused by modulation without the necessity of using the line filter.

Types of Wire To Use

In building a transformer at home we possess none of the delicate winding machinery available to the commercial set builder. For this reason it would be wise to rule out enamelled wire when contemplating the winding of a transformer. This wire may be quite satisfactory when properly handled, but the risk of shorted turns is too great when winding the turns by hand. The result of two shorted turns would be a ruined transformer. The use of d.c.c. or d.s.c. wire is advisable, since this insulation can be handled without fear of the wire baring at any place. This type of insulation will occupy slightly greater winding space, but, considering its safety, its use is advisable.

Methods of Mounting

Upon the mounting will depend a great deal of the efficiency of the whole job. Fig. 27 suggests two methods of mounting. All can be made to look very neat when done properly. Wooden blocks or steel strips are used to clamp the core tightly. On no account should a transformer core be drilled to take mounting bolts. This practice will result in much loss of efficiency.

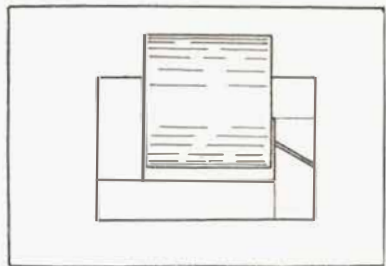

Fig. 29.—The core fitted with the finished windings and ready to be mounted.

After clamping, the finished transformer should be silent when it is connected to the mains. If the transformer has been solidly built there should be little or no hum when

the transformer is operating under load. If the bobbins containing the windings are a little loose on the transformer core after this has been bolted, small wooden wedges should be used to hold primary and secondary bobbins rigidly. Loose windings will result in hum which may completely spoil the operation of a receiver.

The Terminal Strip

After mounting the transformer, a bakelite or ebonite terminal strip should be prepared. This should be equipped with sufficient terminals to take the transformer leads. The primary terminals, of which there will be four if tapings have been taken for different mains voltage operation, may be mounted on one side of the transformer, all the secondary terminals being on the other side. Connections to the heavier gauge secondaries may be made by use of heavy lighting flex, which will handle a heavy current without heating. Take great care not to mix up the secondary connections when proceeding about the mounting of the transformer. It would be advisable to fasten a small brass tag to the end of each flex lead emerging from the bobbins, marking each one as the connection is taken. These brass tags may be left fastened to the flex leads for good, as should by accident the connections to the terminals be forgotten, the tags will save the bother of testing the secondary windings for voltage by use of suitable a.c. voltmeters. No doubt many of you constructors perusing these notes know from past experience how paper tags have a habit of becoming dislodged and may be the cause of endless trouble. Mark clearly on the mounting material next the various terminals what these are, mounting secondary connections in pairs. In any of our transformers the only winding to be centre tapped will be the high voltage secondary. When mounting don't forget that in the case of the high voltage secondary we are dealing with voltages up to a thousand (the total secondary voltage for a combination using type UX210 or UX250 power valves would be around 1000). Particular care must be paid to insulation and all leads should be properly sleeved or surrounded by sufficient insulation.

Heater and filament transformer construction requires the same care and attention to design and construction as with the larger A.B.C. types. For powers from 3 watts up to 20 watts, which in this field of transformer uses is about the maximum required of a low voltage

secondary, lin. x lin. cross section will be required. It will be seen that the window and outside measurements of a transformer core are dependent entirely upon the space occupied by the windings. The winding of the heavy gauge filament heating secondary of a step-down transformer for this purpose must necessarily be done by hand, since the gauge of wire will be heavy if the secondary is to supply five or six valves of the same filament and heater series. A step down transformer may be equipped with any number of low voltage secondaries within reason, provided the core is designed accordingly. The details available in the foregoing notes are applicable for the construction of any step-up transformer to deliver upwards of 1200 volts at its secondary terminals, this being probably the highest voltage we will meet with. The construction of any type may be undertaken with confidence and safety provided the rules are strictly adhered to and the constructor does not attempt to branch out with ideas of his own until he has developed sufficient knowledge for him to do this with intelligence. The same rule applies to separate heater transformers should these be used, as would be the case when building a commercially built "B" or "B" and "C" eliminator into an a.c. circuit and these should be tested for voltage output at the secondary terminals at home by use of a reliable voltmeter or by a reliable radio engineer or engineering firm as with A.B.C. types.

Filter Choke Construction

Since the only filter choke we require is one of 60 henries centre tapped, this will be the only type, the construction of which we will discuss. The 60 henry centre tapped type is most generally used in power pack construction.

The winding of a filter choke will be found to be infinitely more tedious than the winding of a transformer, since the number of turns is 4 or 5 times as great. The winding is, however, straightforward, and the number of turns may be only approximate, it making little difference whether the tapping is taken at the electrical centre of the choke winding or not. The cross section of the core for our choke of 60 henries will be 1½ in. x 1½ in., and will be built up in the same manner as the transformer core. The gauge of the wire used will depend upon the current the choke is to carry so that this will depend upon the load to be placed upon the plate supply

part of the eliminator. Whenever calculating the gauge of wire required for a high voltage secondary or a choke winding, never forget to add the "bleeder" current drawn when a paralleled voltage dividing resistance is used, to the total plate current to be drawn by the receiver combination. When the amount of current the choke winding is to carry has been calculated, the wire table may be consulted and a gauge to pass this current selected. It is advisable to use wire which is one gauge heavier than that which will just carry the current to be passed through the choke. If we are careful in the winding of the choke we may use enamelled wire since there is a very minute voltage difference between turns of the filter choke, and the possibility of breakdown unless due to a fault in the wire or the winding is remote indeed. Each layer should be separated with waxed paper in order to prevent shorting of layers should the enamel chip. The paper will render the winding of each layer a much easier operation.

The number of turns required for a 60 henry choke upon a $1\frac{1}{2}$ in. x $1\frac{1}{2}$ in. core is 12,000 tapped at 6000 turns. In order to prevent unevenness in winding, this tapping may be taken at the end of one of the layers, the connection being taken by means of a small gauge flex lead securely fastened to the wall of the bobbin used to contain the choke winding.

In designing a filter choke, one half of the winding may be wound on one core arm, the second half of the winding on the opposite core arm. Care must be taken not to connect the two sections in opposition, otherwise the choke will be ineffective. These windings must be connected in series. If they are connected in opposition (two outer or two inner turns together), their inductance will cancel out and render the choke ineffective. The centre tapping may be taken at the point where the end of the first winding connects to the beginning of the next. The choke should be mounted in the same manner as the transformer, connections being made to a strip containing three terminals. The choke may be shielded if the points mentioned in the notes on transformer shielding are adhered to. A loose shield surrounding a filter choke may vibrate, setting up an unpleasant noise. As with the transformer, the actual measurements of the choke and the size of window should be set out on paper before ordering materials or attempting the construction. Here again the outside measurements of the core are dependent upon the space

which the winding will occupy. Anchor the flex connection to the beginning of the choke winding well. It would be a calamity indeed if this connection were to be pulled away on completion of the job.

Saturation of choke core is prevented by the cutting of a $1/16$ th inch gap in the core. This can best be accomplished by use of a hacksaw after the core has been clamped into a vice. Fig. 28 shows how the gap should be made in the choke core. After finishing the winding, bind the bobbin round with Empire cloth or tape. This finishes off the job, giving it a neat appearance.

Shielding of Transformers and Chokes

In shielding a transformer, ordinary tin may be used. If, however, the shield is merely placed over the transformer and fastened into position, the changing magnetic field surrounding the transformer core for some few inches will cause the shield to rattle, setting up a noise which would prevent satisfactory operation. This could be overcome by the use of asbestos wadding packed tightly between the transformer and the shield. This complicates construction, however, and is not absolutely necessary. Manufacturers of transformers for "B" eliminator work usually surround the transformer with a shield filling up the space with molten wax. For obvious reasons this should not be done by the home set builder, since it renders well nigh impossible the servicing of the transformer, should anything happen to the windings. Sawdust would accomplish the same thing as the asbestos wadding, and it could be tightly packed in the spaces between the transformer and the case, although when using the latter material we must consider the fire hazard.

Any can maker would assemble cans in the form of shields for chokes and transformers for a few pence. The material used should be gauge 26 black iron sheet. The finished cans should be fitted over the device to be shielded, and after the space between has been filled up with asbestos wadding or sawdust should be securely screwed or bolted down to a small baseboard to which has been fastened another piece of the iron the same size as the base of the can. The finished can or cans may be ducoed by use of a small hand duco gun in any color required, the result being an excellently finished job, even if the gun is not handled too expertly. A quarter of an hour's experiment with the gun will soon show how to manipulate it correctly.

Some Notes on Design

Dealing with the advantage of the thermionic rectifier, the selection of a cabinet and points to watch in a.c. receiver construction.

USING the thermionic full wave rectifier it will be seen that the outer leads of the high voltage secondary connect one to each plate of the rectifier valve as in Fig. 8. The plate connections to this valve will be to the grid and plate terminals of the U.X. type valve socket housing it. The rectifier filament secondary connects to the two F terminals of the UX socket containing the rectifier. From this combination we can secure a pulsating direct current output. By use of a filter and voltage dividing system we can obtain pure direct current suitable for the application of the various stages of a receiver.

Suggested Layout

The diagram on page 83 suggests how the transformer, filter choke, rectifier, by-pass, and filter condensers and voltage dropping resistors might be assembled to best advantage in the layout for a two-valve combination using a regenerative detector and one stage of transformer coupled amplification. The use of a wooden baseboard makes it a little difficult to build the power supply and receiver combination compactly. The use of a sub panel, however, renders the job of mounting the gear within an average sized cabinet an easier one, since voltage dropping resistors, filter and by-pass condensers and connections may be made underneath the baseboard as in commercial practice. There is really no need for this type of construction. The a.c. receiver and gramophone combination has superseded the old mechanical reproducing gramophone. Why not

build the home set into a console cabinet which may be obtained built to your own specifications for as low as £4? This would simplify construction considerably, by allowing the power supply and receiver to be built into the form of separate units. We will go further into this subject later.

Since we do not possess the facilities available to the commercial set builder we cannot expect to make our power pack apparatus as compactly as he can. The average commercial transformer is wound with enamelled wire, which saves a deal of space in power pack assembly. The extra space taken up by the home built power pack might rule out the table type receiver, unless it is built into two separate sections, this being poor practice.

Use a Thermionic Rectifier

The use of the thermionic rectifier is to be recommended. This type of rectifier if used in a full wave circuit will give a d.c. output which can be easily filtered out to supply hum-free plate power to the stages of a receiving combination. Using this type of rectifier requires that a centre tapped filter choke of 60 henries be used in conjunction with two 2 mfd. capacity condensers and one of 4 mfd. capacity for filtering as in Fig. 10, in conjunction with the voltage dividing resistance or resistances and by-pass capacities. In laying out the transformer, rectifier and filter apparatus, keep the transformer and choke cores at right angles and five or six inches apart if possible. The rectifier valve and by-pass and filter choke may be mounted between the transformer and the choke. In connecting up the power



Fig 30.—A suggested design. This type of cabinet may be used for the installation of any of the receivers we have described in later pages.

supply gear use small thick walled rubber flex which is better suited for the job than any other wiring material. There is no hard and fast rule for connecting. Make connections short and to the point, thoroughly soldering whenever a solder lug presents itself. If it is a choice between using a terminal or a solder lug, choose the latter, since good soldering will make a connection which will last forever. The days of busbar wiring have departed. It is now realised that short point to point connections give best results, though this method may not look so well. In the power pack con-

leads being brought across the base-board to the front left hand edge or wherever the transformer may be located, the flexed leads being kept the furthest distance possible from every other connection in the circuit.

Combinations using several stages of r.f. are usually built into the console type cabinet with a built-in magnetic or dynamic speaker. The problems associated with the correct spacing of power pack apparatus and the receiving circuit, when the whole of the apparatus is mounted in the single table type cabinet, are done away with, since the power pack may

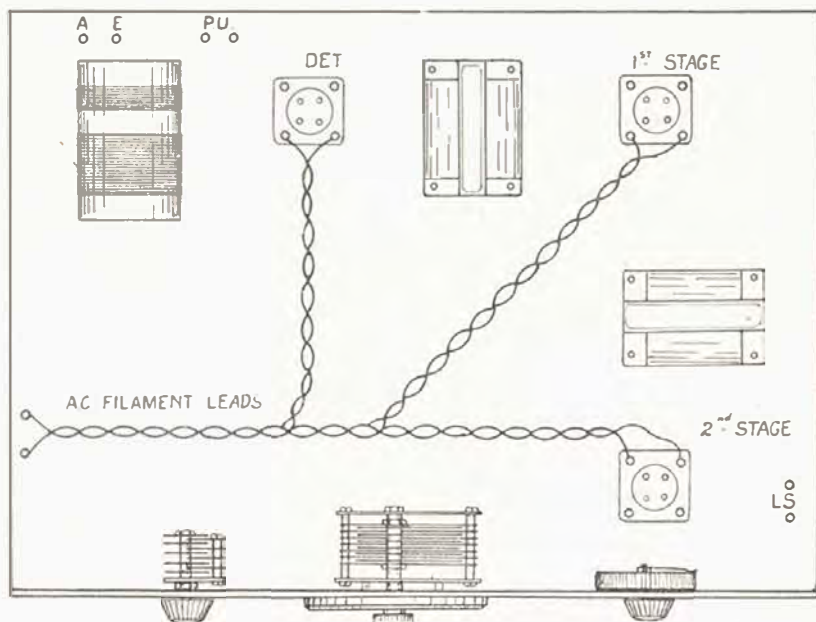

Fig. 31.—The correct wiring in of a.c. heater and filament leads is of the utmost importance. The diagram suggests how components for the average two, three or four valve combination should be placed. By wiring the a.c. filament and heater supply leads in this manner there will be little possibility of induction in any part of the circuit from this source.

struction for any job, a $4\frac{1}{2}$ volt torch globe socket should be connected in the centre tap from the high voltage transformer secondary. This globe will light when the receiver is in operation and may be used for the illumination of a panel dial. The globe provides a highly reliable fuse should a filter condenser break down or a short occur in any other part of the circuit.

Wiring the Filaments

Fig. 31 shows how the filament wiring should be done in the average three or four valve receiving circuit. R.F. and a.f. coupling devices are kept at the back of the baseboard, the heater

be mounted at the bottom of the cabinet.

Fig. 30 suggests a design for a cabinet to contain the home radio combination. The cabinet as already mentioned could be obtained in this design for as low as £4, while a complete gramophone motor and turntable could be obtained for £1/15/. This design is suitable for any of the combinations we describe in later pages. It might be thought that to install a simple a.c. two valve arrangement in such a cabinet might be out of place, but we must think of the receiver not as a wireless set of the years past, but as a musical instrument to take its place in the home.

It must have appearance, must be simple to operate, and trouble free. And to achieve these requirements it is only necessary to adhere to rules applying to correct construction and adjustment.

Don't Worry Over d.x.

The craze for long distance reception has long since passed. It has been recognised that the receiver which will bring in New Zealand at good speaker strength need not be the set to give good faithful reproduction of the local broadcasting stations. Our local programmes have been proved to be as good as any in the world, and in receiving interstate and distant stations we are accomplishing nothing out of the ordinary since this has been done for years. If you must experience the thrill of long distance reception, why not break into the short waves and do the job properly?

A review of the American periodicals will show that over there at least two r.f. stages are used in all receiver combinations. Reception in the U.S. is a problem, since there are thousands of broadcasting stations on the air all to be separated. The object of using these r.f. stages is mainly that of obtaining sufficient selectivity to enable separate reception of the various transmissions. Each additional tuned r.f. stage improves the ability of a receiving set to separate a number of transmissions to be heard on closely adjacent wave lengths. The object of the r.f. stages here is not with the intention of bringing in far distant stations, but to feed a healthy signal into the detector circuit—a signal which is free from traces of other transmissions. Invariably single dial control is used in these five, six or seven valve combinations, and since the first cost is the last, upkeep being so low as to be not worth taking into consideration, the use of a circuit employing one or more r.f. stages is advisable. It is a strange fact that some people will willingly pay £200 or more for a mechanical piano, yet will quibble at the price of the gear necessary for the assembly of a receiver. The player piano might rarely be played some months after its purchase, but the receiver would be used every day of the week, every week of the year, and at ridiculously low cost when power consumption is considered.

Power Pack Assembly

The construction of our own transformer and filter choke has cut the cost of the power pack down considerably, and completes the apparatus we

may build ourselves. We need, then, to purchase only filter and by-pass condensers of the required values and voltage dividing resistors of the values needed for our particular purpose. Revert to Fig. 10. Here we have a filter circuit comprising the filter choke we have completed and a number of filter and by-pass condensers and a means of obtaining various voltages below maximum by use of a dividing resistance. It will be seen that the filter circuit is very simple indeed, and that by presenting the transformer and rectifier circuit, and the filter and voltage dividing circuit separately, a better idea of the arrangement may be had by the beginner. Fig. 12 shows two voltage dividing methods. The first makes use of a single tubular resistance. In Fig. 12b a number of resistances are used. Fig. 11b shows the anode feed system which has now come into general use by commercial receiver manufacturers. This method is to be recommended, and we would advise its use in all receiver combinations. It will be noticed that each positive tapping is by-passed. The value of the by-pass condenser is usually 1 mfd., but sometimes it may be as high as 4 mfd. on the detector positive tapping. The use of the small choke and 2 mfd. capacity filter condenser, as in Fig. 11a, will clean up the detector stage plate supply without the use of such a high capacity here as 4 mfd.

Points to Watch













































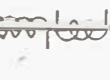







The a.c. receiver consists merely of any of the standard two or more valve combinations with which you are familiar, fitted with directly and indirectly heated valves to give a hum-free signal output when supplied with an a.c. "A" supply and plate current from a "B" eliminator.

Commercial practice utilises a directly heated type of r.f. and first a.f. stage valve. The results are usually satisfactory in the factory built receiver, but we recommend the use of indirectly heated tubes in r.f. detector and first a.f. stages. The possibilities of hum originating in any of these stages is rendered remote if rules of construction are closely followed.

A.C. carrying heater and filament leads have a field surrounding them for some inches. Since this field would induce minute a.c. voltages in other wires in the vicinity, particular care and attention must be paid to the wiring of the heaters and filaments in any circuit. The a.c. carrying leads, which may be of small flex, should be tightly twisted together and kept well away from grid and plate leads, tuning coils and condensers, and bias resistors.

Circuit Symbols

By becoming familiar with the symbols used to represent the components of the receiving circuit, no trouble will be experienced in following any diagram.

	Aerial		Push-Pull Audio-Frequency Transformer		Full-Wave Rectifier Gaseous Type		Lightning Arrestor
	Ground		Frequency Meter (Wavemeter)		Two-Element Voltage Regulator Valve		Filament Switch (5 P 5 T)
	Loop Aerial		Fixed Resistor		Three-Element Voltage Regulator Valve		NO Connection Between Wires
	Counter-Poise		Variable Resistor		Photo-Electric Cell		Connection Between Wires
	Variable Condenser		Potentiometer		Neon Glow tube		Telephone Jacks
	Fixed Condenser		Filament Ballast		Electrolytic Rectifier		Microphone Transmitter
	Condenser Block		Three-Element Valve		Ammeter		Fuse
	RF Inductance or RF Choke		Three Element Valve A.C. Heated Cathode Type		Voltmeter		Battery (Polarity Indicated)
	RF Transformer		Screen Grid Valve		Electro Dynamic Speaker		Lamp
	Variometer		Screen Grid A.C. Valve		Telephone Receiver		O.C. Generator
	Tapped Inductance		Half-Wave Rectifier Valve Filament Type		Full-Wave Dry-Electrolytic Rectifier		Alternator
	A.F. Choke		Full-Wave Rectifier Valve Filament Type		Piezo-Electric Crystal		Transmitting Key
	Iron Core Transformer				Crystal Detector		Buzzer
							Phonograph Pick-Up Magnetic Type
							Heavy Dotted Lines To Indicate Grounded Shielding

The above symbols may differ slightly in various diagrams.

TROUBLE-FINDING CHART

Dealing with the location of hum—Location of shorts by the effects to be noticed — The location and elimination of other noises.

This subject is one of such complexity that it requires a special chapter of its own. It deals with the location and elimination of faults, and will be of particular interest to the home set builder and the service-man.

A fault in the a.c. receiver may completely baffle the set owner, but if a knowledge of how to set about a search for the trouble is had, the problems involved lose much of their difficulties.

A.C. receiver faults may divide themselves up into several groups, each group being subdivided. Every fault in the a.c. receiver can be accounted for.

We will deal with these groups in the following order:

No Plate Voltage at Power Pack Terminals

Look for the following:—

RECTIFIER.—Have this tested for broken filament or lost emission. Lighting of the filament does not indicate that the tube is in order, since operation of its filament at excessive voltage for some time will result in the inability of the valve to rectify.

FILTER CHOKE.—Test this for broken winding or shorted turns. A temporary repair, if the choke is broken down, may be effected by shorting across the half of the choke which is broken down.

TRANSFORMER.—Test high voltage secondary for open circuit. Examine torch globe fuse, if one is used, for breakdown. If heater and filament secondary or secondaries are delivering voltage, it will be known that the transformer primary is o.k. If maximum voltage is available, and no voltage is obtained at the lower positive tapplings, examine plate voltage dividing resistors for breakdown. When the extended dividing resistance "C" bias method is used, test this for breakdown. Test the rectifier filament heating secondary for breakdown. Give the usual overhaul in searching for broken connections.

Low Plate Voltages at Power Pack Terminals

RECTIFIER.—If the emission of this tube is partly lost, voltage output will drop to a low value. If the rectifier is extremely warm, look for a broken-down filter or by-pass condenser or condensers. Test rectifier filament heating secondary for voltage. If below normal, output will suffer, and the filament of the tube will be very short-lived.

FILTER CHOKE.—Poor connection in the choke or arcing between the ends of a broken turn might result in a high resistance being developed in this component. Test the choke for continuity. When using the series field dynamic speaker, test the speaker field for continuity. Shorting across of the filter choke will soon show whether this is at fault.

TRANSFORMER.—Test transformer high voltage and rectifier filament heating secondaries for voltage output. Shorted primary or secondary windings will result in reduced output and heating of the transformer.

FILTER CONDENSERS.—A broken-down filter condenser will result in reduced output voltage. If a broken-down condenser develops a very low resistance, a heavy current will be drawn from the rectifier, which will cause the torch globe fuse to burn out if this is used. A broken-down by-pass condenser will result in burning out of voltage dividing resistances. The breaking down of any condenser in the power pack might result in damage to the rectifier through overload. Test receiver for broken-down by-pass condensers, faulty valve, or a short in the

wiring. Disconnect power pack output from receiver, and test for voltage. If voltage becomes normal, it will be known that the fault is in the receiver.

VOLTAGE DIVIDER.—Too low a paralleled voltage dividing resistance will result in a heavy “bleeder” current being drawn from the rectifying circuit. This would result in heating of the transformer and possible damage to the rectifier. Under these conditions, a power pack would not deliver maximum output voltage. Use of the anode feed system will prevent the possibility of this happening. Resistances suitable for the parallel dividing of over 250 volts are not available.

RECEIVER.—A short in the receiver could cause damage to the power pack equipment and output voltage to drop. Test for:—

- Broken-down plate by-pass condensers.
- Shorting of any of the B positive leads.
- Internal valve short between elements.
- Broken-down a.f. transformer.
- Shorting reaction condenser.
- Short between component and metal chassis (if used).
- Search for shorting between connections.
- See that jacks do not touch metal panel (if used).

Loud or Mild Hum

RECTIFIER.—If operated at too low a voltage, a power pack may hum. If a rectifier has been subjected to an overload, or through constant use has lost emission, hum may be caused in this quarter. Have rectifier tested for emission.

TRANSFORMER.—Shorted turns or layers of transformer primary or secondaries will result in hum. Shorted turns or layers will result in a heavy primary current being drawn from the mains, and possible burning up of the windings.

FILTER.—Broken-down filter or by-pass condensers will result in hum. In a newly built power pack, insufficient filter may cause hum. Shorted turns or layers may render a filter choke inoperative. If no difference in hum is noted when the choke is shorted out of the circuit, it will be known that it is at fault. If a choke is wound with two sections, and these are connected in opposition, the choke will be ineffective, and will cause hum until the connections to one section are reversed.

LINE VOLTAGE.—If this is low, in some cases hum may result. Test mains for voltage of the supply.

RECEIVER.—In a newly built receiver, one in which hum has just developed, or one in which hum has always been prevalent, consult the following trouble-finding chart:—

- Grid or plate connections parallel with a.c. carrying leads.
- Broken-down grid bias resistor or by-pass condenser.
- Too long pick-up switch lead (when pick-up connects in grid circuit of detector stage).
- Broken-down a.f. transformer.
- Displacement filament centre tap. If a centre tapped filament or heater secondary is used, try substitution with a centre tapped resistor.
- Incorrect design will result in inter-coupling, which will result in hum. Follow layout details carefully.
- Placing of tuning condensers, r.f. or detector valves, grid leak and condenser or tuning condensers within the field surrounding an unshielded power transformer or filter choke, will result in the introduction of hum into the circuit.

SPEAKER.—Poorly filtered dynamic field supply current may result in hum in this quarter. In the case of the separate supply of the field winding by use of dry metal rectifier, use of an electrolytic high capacity filter condenser across the field terminals should eliminate the trouble. Improper filtering of the plate power supply will result in dynamic speaker hum when using the series power pack type field supply.

VALVES.—If the foregoing points are found to be in order, have the valves tested for emission. You may be unfortunate enough to strike a valve in which the filament or heater emission is o.k., but which will introduce a hum into a circuit.

DETECTOR.—The detector stage is the most sensitive of the whole receiver combination, and care must be taken to prevent any possibility of induction in this stage. Twist filament and heater a.c. current carrying leads, keeping these well away from the grid leak and condenser, tuning coils and tuning condensers. Slight plate supply modulation not apparent in the r.f. and amplifier stages might cause detector stage hum. The method of using a small filter choke and condenser in the detector plate supply should eliminate this trouble.

R.F. AMPLIFIER.—Hum caused by modulation makes its presence known only when tuned to a station. Look for the following in the r.f. stage:—

Keep a.c. heater leads away from the r.f. tuning coils and condensers.

Use properly filtered screened-grid power supply.

Properly choke and by-pass all r.f. plate and screen-grid leads (when using ordinary or s.g. tubes).

Try extra filter on r.f. plate supply.

Do not attempt to use ordinary d.c. valves in the r.f. stages.

Motor-Boating

Motor-boating is a common trouble when using a "B" power unit. It is usually due to the inability of certain positive tappings of the unit to supply the current required, or may be due to inability of series resistors to pass the required current.

POWER PACK.—Inadequate by-passing of positive tappings. Use larger by-pass or filter capacities to prevent motor-boating.

PLATE SUPPLY RESISTANCES.—If these are by-passed with too low a capacity, motor-boating will result. Use up to 2 mfd. capacity by-pass condensers. The anode feed system when properly applied will definitely prevent motor-boating.

Crackling Noises

Crackling and rushing noises, which may be weakly audible, or at full speaker volume, can be divided into two sections:—

1. Noises due to faults in receiving equipment.
2. Noises picked up by the mains supply or the aerial system.

Receiver Faults

Crackling or rushing noises in the receiver or power pack could be due to any of the following:—

RECEIVER.—Broken-down by-pass condenser.

A.F. or r.f. transformer short.

Arcing across to negative of any of the B positive leads.

Faulty grid leak, plate or grid coupling resistors, or coupling condensers (in resistance-capacity coupled amplifier).

Broken-down grid condenser.

Faulty elements in one of the valves.

Loose solder connections. Securely solder leads whenever a solder lug presents itself. Use a solder lug in preference to a terminal.

Arcing across ends of broken wire in plate voltage dropping resistances.

POWER PACK.—Internal rectifier short.

Broken transformer primary or secondary, causing intermittent making and breaking of the circuit.

Broken-down filter condenser.

Intermittent shorting of filter choke turns or layers.

Look for arcing across of the dividing resistors.

Look for broken-down by-pass condenser.

Overhaul for loose or broken connections.

Arcing across of power transformer windings to earthed core.

Arcing across of choke coil windings to earthed core.

Interference Noises

Most d.c. electrical equipment will set up crackling and other forms of noises in the receiver

ALL kinds of electrically operated devices tend to set up noises which may interfere with radio reception. D.C. motors and generators are probably the worst offenders, and when the trouble is particularly bad, the offending motor or generator should be equipped with apparatus to prevent these noises emanating and causing interference.

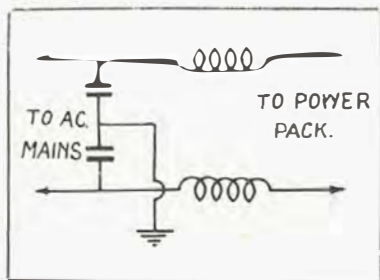

A line filter will prevent interference noises from reaching the receiver from the mains supply. The coils consist each of 150 turns of 18 d.c.c. former or slot wound. The condensers should be of .1 to 2 mfd. capacity.

It has often been said that electrical interference noises cannot be eliminated in the receiver. This is not absolutely correct, since by use of mains supply filter we can rid our receiver of many of the noises which hitherto prevented satisfactory reception. It is only when the noise is picked up by the aerial system that we must eliminate the interference at its source.

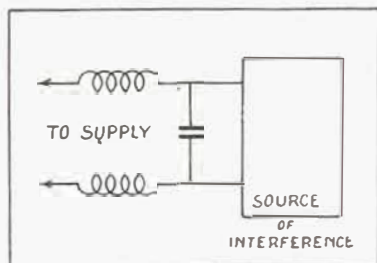

The line filter applied to equipment which is causing interference noises. The details of this filter are the same as for the receiver filter. The condenser should be of about 1 mfd. capacity.

The diagram shows how two coils and two condensers are connected in the mains supply leads to prevent noises reaching the receiver from this source.

The filter will in some cases eliminate broadness of tuning, and will tend to reduce hum caused by modulation. The coils consist of 150 turns each of gauge 18 d.c.c. wire, layer wound on a bobbin equipped with a lin. winding space. The turns must be wound evenly, the layers being separated with Empire tape to provide an even base for the next layer. The condensers should be each of 2 mfd. capacity, and should be of the 1000 volts test type.

Noises caused by electric trams or trains cannot be eliminated at the receiving end, and all that can be done is to get into touch with the tramway and railway authorities, asking them what they can do to eliminate the nuisance.

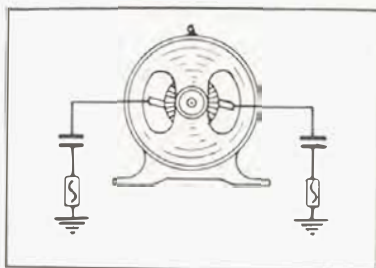

Condensers of about 1 mfd. capacity connected in series with 10 amp. fuses between the brushes of a d.c. motor or generator and ground.

When the aerial and earth leads are disconnected from the a.c. receiver, and the mains supply filter is used, no interference noises will be heard. If, when the aerial is connected, interference prevents satisfactory reception, this noise may only be prevented at the source, since under these circumstances the trouble cannot be eliminated or minimised at the receiving end.

The diagram shows how a d.c. motor or generator may be treated to prevent its causing interference. The coils are of the same type as described for the mains filter. The wire must, of course, be able to handle the current the generator is supplying, or the current

the d.c. motor is drawing from the mains supply. For safety, a 10-ampere fuse should be inserted in series with each condenser.

A reed type battery charge will set up interference which may cause trouble over a radius of some hundreds of yards. The interference can, in the majority of cases, be eliminated by the connecting of a four-microfarad condenser across the contacts of the vibrating reed. In order to prevent interference from getting into the power supply, chokes as described for the mains filter should be inserted, one in each of the supply leads to the charger. By treatment in this manner, the writer has, for the experiment, used a reed type battery charger, charging at 8 amperes, in the same room as a five-valve receiver, interference being barely audible when listening to interstate transmissions.

The writer has known a case when arcing between the windings of a power transformer and its earthed case has been put down to electrical interference picked up by the mains supply. This trouble took the set-owner over three months to locate, and this after several letters had been written to the light supply authorities. The use of the mains filter will prevent meter noises from causing trouble in the receiver. A faulty light or power meter may prevent satisfactory reception, without use of the filter.

The noises from internal combustion engines may be considerably reduced or eliminated by insertion of a 10,000 ohms resistor in series with each spark plug lead. The plug leads should be shielded by use of thin copper strip, which should be wound around the leads and earthed.

Fifty-cycle hum may be picked up and induced in a receiver by proximity of a.c. carrying leads to the aerial, lead-in, or earth leads. The remedy is to run the aerial at right angles to lighting supply wires, and to try altering the position of aerial and earth leads.

The writer struck a baffling case in a receiver which set up a very loud

hum, completely obliterating reception, after the receiver had functioned perfectly for four or five minutes after being switched on. The fault was finally traced to a faulty indirectly heated valve, in which the heater, due to a mechanical trouble, touched the cathode after the tube reached a certain temperature.

Electrical Equipment

Doctors' and dentists' and other medical equipment may often set up interference noises. Whenever these are experienced there is usually little possibility of preventing the noise in the receiver. A letter to the owner of the equipment may usually suffice, since, by application of the line filter and treatment of motors by means of condensers and the necessary chokes, the trouble may be reduced to a minimum. If no steps are taken by the owner or operator of the interfering equipment, a letter should be written to the radio inspector explaining matters.

Usually the owner of electrical equipment which may be causing interference will be only too glad to know when his equipment is causing interference, since interference noises in many instances would indicate poor adjustment or faults in the apparatus.

Interference caused when using farm lighting equipment can be prevented by treatment of the generator when using an oil engine, and by treatment of both generator and ignition system when using a gas engine, using the methods we have already described.

If the home set builder takes the greatest care when he is building a receiver, and obtains the best of gear, he should expect few of the troubles we have mentioned; but since any particular one of them is liable to crop up, it has been necessary for us to discuss them all. The majority of these troubles were to be experienced in the old battery receivers, so that there is really nothing extra difficult about the a.c. receiver, if the rules of construction and adjustment are closely observed.

A.C. Valve Characteristics and Bias Resistor Values

OSRAM TYPES.

TYPE	PURPOSE	FIL		PLATE		Neg grid bias at normal plate voltage.	IMPEDANCE (ohms)	VALUE OF BIAS RESISTOR (ohms)
		Volts	Amps.	Volts (max.)	Ma's (normal)			
MH4	Gen. Purpose	4.0	1.0	200	2.7	3.0	23,000	1,100
MHL4	Gen. Purpose	4.0	1.0	200	8.4	6.0	8,000	2,500
ML4	Amp.	4.0	1.0	200	19.0	22.0	3,000	11,000
MS4	Res. Cap and r.f. Amp.	4.0	1.0	200	2.4	1.5	500,000	625
P215	Amp.	2.0	0.15	150	8.3	12.0	5,000	1,430
P240	Amp.	2.0	0.4	150	18.0	24.0	2,500	1,330
PT240	Pentode	2.0	0.4	150	17.0	9.0	55,000	5,000
P410	Amp.	4.0	0.1	150	9.0	10.5	5,000	1,050
P425	Amp.	4.0	0.25	150	17.0	16.5	2,300	910
PX4	Amp.	4.0	0.6	200	50.0	33.0	1,050	660
PT425	Pentode	4.0	0.25	150	15.0	7.5	50,000	5,000
P610	Amp.	6.0	0.1	150	9.3	9.0	3,500	10,000
P625	Amp.	6.0	0.25	250	24.0	24.0	2,400	1,000
P625A	Amp.	6.0	0.25	180	28.0	30.0	1,600	1,070
PT625	Pentode	6.0	0.25	250	26.5	15.0	43,000	2,884
LS5	Amp.	5.25	0.8	400	26.0	40.0	6,000	1,538
LS5A	Amp.	5.25	0.8	400	33.5	112.0	2,750	3,343
LS5B	Amp.	5.25	0.8	400	7.5	10.5	25,000	1,400
LS6A	Amp.	6.0	1.6	400	63.0	93.0	1,300	1,462

COSSOR TYPES.

215 P	Amp.	2	.15	150	10	7.5	4,000	1500
41 MHF	R.F. or Det.	4	1.0	180	5.4	3.0	14,000	554
41 MLF	Amp.	4	1.0	180	9.0	6.0	7,900	660
41 MRC	Res. Cap and r.f. Amp.	4	1.0	180	2.75	3.0	20,000	1090
41 MP	Gen. Purpose	4	1.0	180	12.0	9.0	5,000	850
41 MXP	Amp.	4	1.0	180	38.0	24.0	2,000	631
41 MSG	S.G., R.F.	4	1.0	130	.5	1.5	500,000	3000
625 P	Amp.	6	.25	200	25.0	12.5	2,500	500
620 T	Amp.	6	1.6	400	50.0	70.0	1,400	1400
660 T	Amp.	6	4.0	120	120.0	120.0	1,000	1000
680 P	Amp.	6	.8	400	25.0	40.0	6,000	1600
680 XP	Amp.	6	.8	125	25.0	125.0	2,750	5000
680 HF	Amp.	6	.8	400	8.0	6.0	20,000	750
41 XP	Amp.	4	1.0	240	35.0	30.0	1,400	857

Audio Frequency Amplification

A few notes dealing with the merits and demerits of the various forms of amplification.

Audio frequency amplification is the process of amplifying the signals from a detector to such a degree that they may operate a loud speaker. The amplifier of the radio gramophone combination may incorporate as many as three stages. The first stages are voltage magnifiers. The final stage valves are power valves to deliver sufficient energy to drive a loud speaker. In the following notes we deal briefly with the different types, of which there are four. The push-pull method will be seen to possess greatest possibilities as far as the home set builder is concerned, there being few adjustments to be made to obtain good quality results. For ordinary purposes, we recommend the use of a single transformer coupled stage, followed by a pair of medium power valves in push-pull. The first transformer coupled stage may be substituted for two resistance-capacity or impedance coupled stages, any of the three combinations giving excellent results. The Loftin-White method would appear a little expensive as far as the home set builder is concerned. The single transformer coupled method requires large tubes and power packs to deliver the same output as the push-pull amplifier, but for ordinary receiving purposes generally gives quite satisfactory results when good quality apparatus is used.

The Loftin-White Amplifier

IT is now some two years since Loftin and White, the designers of the well-known constant-coupled circuit which had some considerable vogue in England some time ago, devised a new form of direct-coupled amplifier system. Work on the new amplifier was held up, owing to the inability to obtain high MU tubes necessary for the arrangement.

The amplifier is really the result of American manufacturers' search for a less costly amplifier system, which could be incorporated in their receivers to lower cost of production. As far as the manufacturer is concerned, the developments in this form of directly-coupled amplifier have eliminated the costly a.f. transformer construction, and reduced the number of stages necessary for the obtaining of the same output. But when the home constructor attempts to assemble the system, the catch lies in the various resistances, most of which cannot be obtained here in Australia, and their cost. Wire wound resistors are costly

components to purchase, and with some inferior types we cannot depend too greatly upon their rated values.

Circuit Values

Accompanying is the circuit of the amplifier, giving constants for UY224 and a UX245 tubes. The elementary

principle of the amplifier is exactly the same as that of the standard resistance-capacity coupled circuit, which we have known, usually in the form of a three-stage arrangement, for some years. The voltage drop produced by a signal in a resistance in the plate circuit of the first tube, is impressed directly upon the grid of the next tube in the

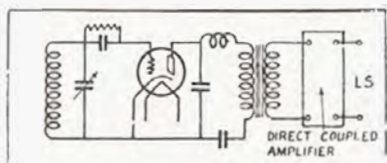

Showing how r.f. and detector stages may be coupled by means of a transformer to the direct coupled amplifier. An endeavor to use the screened grid valve of the amplifier as a detector will seldom meet with success since the r.f. stages of a receiver combination would be thrown out of balance were this to be attempted.

new circuit. This method differs from the standard resistance-capacity coupled circuits, which uses a condenser to couple grid and plate circuits. The coupling condenser introduces a loss of power, and also introduces a certain amount of distortion, due to the fact that condensers of too low capacity will pass lower

The standard Loftin-White circuit arrangement using types 224 in the first stage, and type 245 in the second stage. Substitution of different types of valves will require new calculations to enable the new resistance values to be obtained. Should there be hum in this amplifier, the use of extra filter capacity on the "B" supply should eliminate this trouble. When using a pickup in conjunction with a detector or r.f. and detector arrangement, it may be left permanently connected in the cathode lead of the 224 type valve. Connect the pickup between the cathode terminal at the valve socket and the 50,000 ohms wire wound bias resistor. A detector stage may be coupled to the input of the amplifier by means of an audio frequency transformer. Volume may be controlled by use of an 0-500,000 ohms variable resistance connected across the secondary terminals of this transformer.

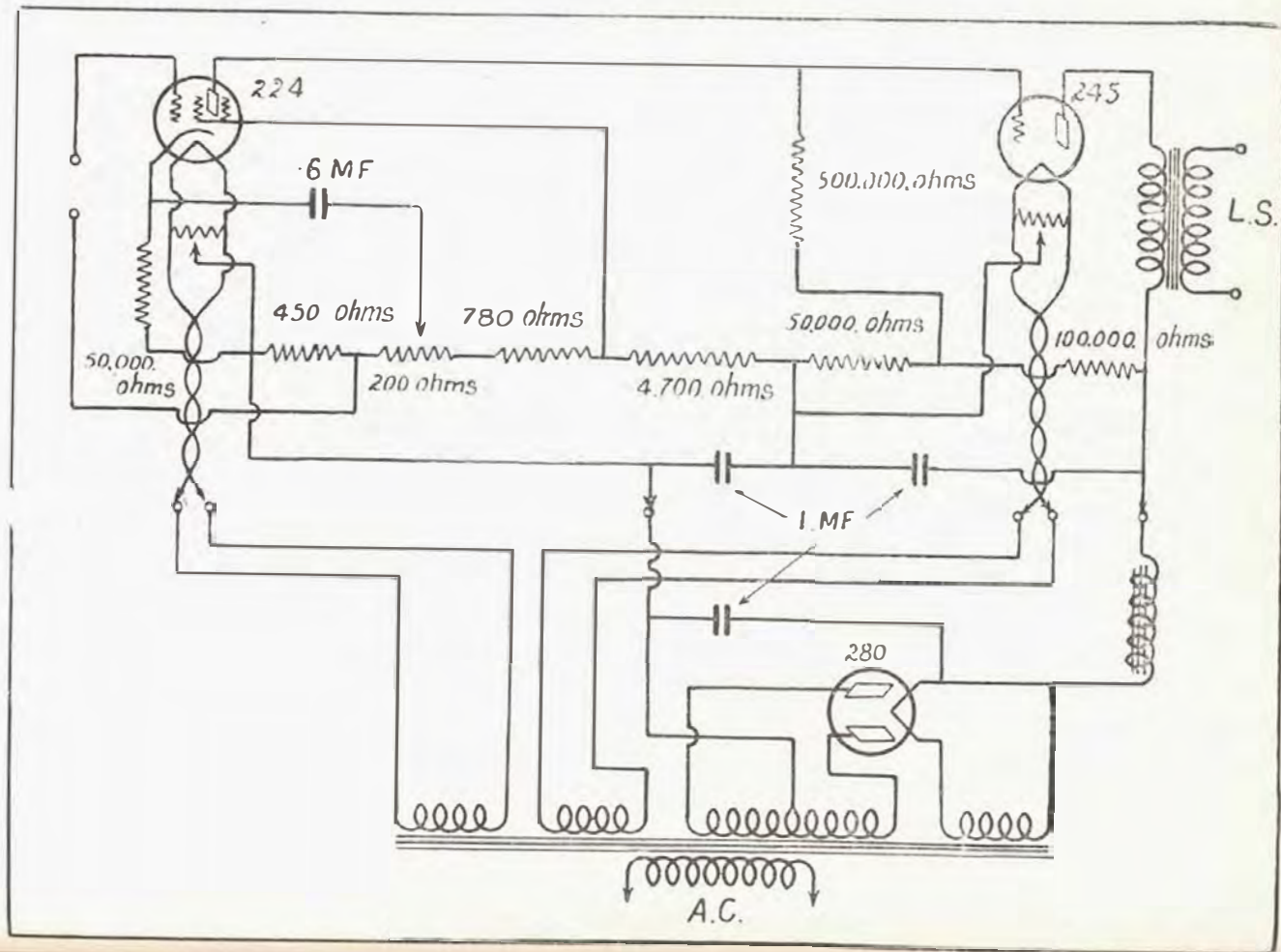

frequencies with difficulty and that too high a capacity will result in muffled reproduction.

These disadvantages of the resistance-capacity coupled system are removed by use of the new system. Directly coupled circuits are not absolutely new, since they have been used for special purposes for quite a number of years. In these directly coupled arrangements, large "C" bias voltage is necessary, not only to function as a bias for the tube, but also to balance out the large positive voltage applied to the plate of the circuit tube. The diagram on this page shows a method used several years ago before the practice of obtaining all power from the light supply reached its present state of perfection. The elimination of the plate by-pass condenser makes for improved quality reproduction, and permits a high gain per stage.

The Stumbling Block

In the calculation of resistance values in this circuit, the home set builder meets with difficulties if he tries to incorporate tubes other than those advised in the circuit he possesses. Our advice is to adhere strictly to the types of valves and their resistance values, as shown in the accompanying circuit.

Since even a high resistance voltmeter has an appreciable value between its terminals, such an instrument cannot be used to determine with any degree of accuracy the voltage drops across the Loftin-White resistors.

It is therefore necessary to determine the voltages in the circuit by application of Ohm's law. The values of the resistances and the currents flowing through them are used as the two values in the obtaining of the voltage drop values. For example. Through the 100,000 ohms resistor a current of 1.5 milliamperes is found to be passing. Multiplying the resistance by the current in amperes gives 150 volts, which is the drop across the resistor.

The reason for strict adherence to circuit details may be seen by the foregoing, since there are such a number of factors to be taken into consideration that the home set builder, if he is to build a Loftin-White amplifier,

he must accept what is shown him in a circuit diagram without branching out with ideas of his own.

A number of difficulties are to be experienced in the coupling of the Loftin-White amplifier to a detector circuit. Grid leak detection should be used, coupling between amplifier and detector being effected by use of a fairly high ratio a.f. transformer of good make.

Unless resistances of the required values can be readily obtainable, the construction of this type of amplifier is not to be recommended, since values must be absolutely correct if results are to be expected.

As a gramophone amplifier, the system is to be recommended, if this is to be its sole use. The two stages are capable of amplifying the impulses generated in the average gramophone pick-up to a sufficient extent to give all the volume required for ordinary purposes.

The use of wire wound resistors throughout the amplifier is to be recommended. Provided these resistances are of the required value, and will pass the current they are required to handle safely, they may take any form. When the current does not exceed three or four milliamps., variable types such as the Electrad may be used with satisfactory results. Adjustment to these

resistances may then be carried out by use of a milliammeter and actual testing after the amplifier has been put into operation.

Provided the resistances used are capable of handling the current to flow through them, the system is generally trouble free, and provides adequate volume, with excellent quality, with a minimum of tubes and gear.

On no account should grid leak type resistors be used in the circuit. Always allow a sufficient margin for overload in the selection of resistances from the types shown on pages 70 and 79. Use of resistances unable to pass the current will result in utter failure to get the amplifier operating, since the value of each resistance will vary considerably were each one to warm up through inability to carry the current required of it.

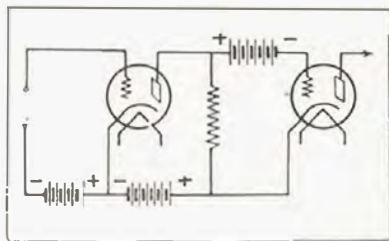

The original type of direct coupled amplifier circuit using batteries.

The Impedance Coupled Amplifier

IMPEDANCE or choke coupling is similar to the resistance-capacity coupling method, excepting that a choke is used in place of the plate resistance in the latter type of amplifier.

Resistance capacity coupling calls for higher plate voltages. The use of a choke does not require that extra plate voltage to overcome the plate resistance be used.

The voltage drop across the plate choke is coupled to the grid of the amplifier tube via the coupling condenser. The grid leak serves the same purpose as in the resistance capacity method.

In order that distortionless amplification be obtained, with this form of amplifier, the choke must be large. The power in the plate circuit of a tube is divided between the internal resistance of the tube and the external impedance which is furnished in this case by the choke coil. The drop of voltage across the choke is coupled to the grid of the following tube with but slight loss, and it is this voltage applied to the grid of the next tube which builds up the signal strength. The voltage drop across the resistance in the tube is lost so far as amplification is concerned.

In actual practice it will be found that with the resistance of the external impedance three times as great as the

impedance of the tube, nearly 100 per cent. of the tube's maximum possible voltage amplification will be available for magnification, by the next tube.

The impedance of the choke changes with the frequency, its impedance becoming greater as the frequency increases. The impedance required should be calculated at the lowest frequency the amplifier is to handle. This will, in good amplifiers be around 30 cycles. The following gives some idea of the values of inductance required for various amplifier plate impedances to be met with:—

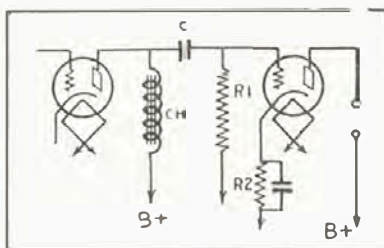

The circuit for the impedance coupler. CH is the plate choke, C the coupling or by-pass condenser, R1 the grid resistor of the coupler and R2 the amplifier stage bias resistance.

Tube Impedance (ohms.)	Inductance (henries)
2,000	38
5,000	100
10,000	200

Impedance coupling, when properly adjusted, will give very high quality amplification.

Since the reactance of the coupling condenser is low, the grid leak resistor is practically in parallel with the plate impedance, and so if its value is too low this will result in distortion. For this reason it is advisable to use this type of amplifier only as an intermediate stage and not for final stages, where a low grid leak value would be needed.

The Resistance Capacity Amplifier

IMPROVED design of a.f. coupling transformers over the past two years has led to gradual disuse of the resistance-capacity method. This method was superior some years ago, before transformer coupling gear reached its present state of near-perfection, and less was known about the matching of valves and amplifier coupling equipment.

Three stages of resistance capacity coupling are needed to give the same magnification as the average two-stage transformer coupled arrangement. The system permits the use of a high impedance tube in the first or second stages without distortion. Three properly adjusted resistance coupled stages will give very pure amplification.

The resistance coupling method may be used to precede a transformer coupled single or push-pull power stage. The method is generally free from back coupling effects, since its non-inductive resistors stand less chance of inducing a.c. noises into the circuit. The use of the anode feed system prevents motor-boating in this type of amplifier.

The amplifier functions as follows:—

Flow of plate current through a plate resistance of a resistance coupler causes a voltage drop across this resistance. The changes in the voltage drop across this resistance are by-passed to the grid of the next tube through a coupling capacity. The purpose of the grid resistor is to allow

the excess negative charges to leak off or escape from the grid of the second tube. Were these charges allowed to accumulate, they would finally force the grid to such a negative voltage that no plate current would flow, and the tube would block. This effect will be produced when a grid leak resistor in such an arrangement breaks down or gradually develops a higher resistance. Good quality grid resistors should be used, while plate resistors should be wire wound. Too high a grid resistance may result in popping noises, more commonly known as "motor-boating." In the average resistance coupled amplifier, plate resistances of 100,000 ohms are used, these values not being critical.

In a first stage amplifier, the grid resistance should have a value of between $\frac{1}{2}$ and $\frac{3}{4}$ megohms. In a final stage single or push-pull arrangement, grid leaks of as low as a $\frac{1}{2}$ -megohm should be used. The by-pass con-

denser capacity is important. Too high a value will result in muffled reproduction, lacking in color, while too low a value will prevent the amplifier from passing the lower frequencies, the result being thin reedy signals. The average capacity will lie between .006 and .1 mfd.

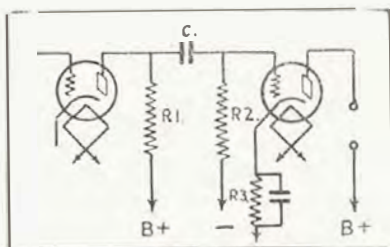

The circuit for the resistance coupler. R1 is the plate resistance, C the coupling or by-pass condenser, R2 the grid leak resistor and R3 the amplifier bias resistor.

Push-Pull Amplifier

THE purpose of the push-pull amplifier is to obtain the greatest degree of distortionless amplification when using medium power tubes. An indication of what the push-pull amplifier accomplishes can be had in the following comparison.

A single UX250 valve requiring a plate voltage of around 450 and a special power pack is used in a single transformer coupled stage. By application of a signal input to this single stage, we can swing the grid of the 250 type valve to a certain extent, without distortion. A pair of type 171 tubes are used in a push-pull amplifier stage

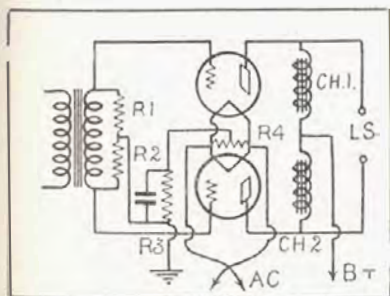

Showing how two resistances, R1 and R2, or a potentiometer of high resistance, may be used in conjunction with an ordinary transformer as the input transformer. The choke method of speaker coupling is suitable only when the speaker impedance is greater than twice the impedance of one of the push-pull power valves. R3 is the amplifier bias resistor.

requiring about 250 volts from a normal-sized power pack. The amount of signal input required to obtain maximum grid swing without distortion, when using a single 171, will be almost twice that amount when two of these tubes are used in push-pull. This means that the pair of small power tubes will handle as much, if not greater volume than the big 250 type valve without distortion. Imagine, then, a pair of the 250 type valves in a push-pull circuit. Such a combination would be far too big for ordinary purposes, and from the valve charts we can select small power tubes, which may be economically operated in a push-pull circuit, to give all the volume we may require in the home gramophone combination.

The only disadvantage of push-pull is the cost of the coupling transformers. The saving in power pack equipment and power consumption would soon balance the little extra spent on these transformers.

By use of a pair of grid leak resistors of 250,000 ohms each, we can use an ordinary a.f. transformer of good quality in place of the push-pull input transformer. When a reliable make of transformer is used in this manner, good results may be expected. This hint will cut the cost of the push-pull amplifier considerably. It may often be cheaper to purchase a pair of iron-cored chokes of about 30 henries each, to use in place of the more usual output transformer when using a fairly high impedance magnetic type cone speaker. If a

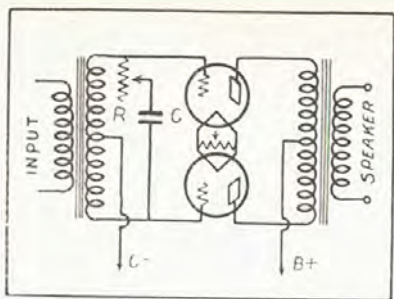

A method of tone control in the push-pull amplifier circuit. The condenser C and the resistance R comprise the tone arrangement.

transformer is used, a type which will match the valves used in the push-pull stage, and the speaker, must be selected.

The accompanying diagram suggests a tone control method. The use of such a control brings about a certain amount of distortion, it must be admitted, but manufactured distortion may often tend to improve a receiver's performance.

The advantages of push-pull can be summed up in the following:—

Ability to handle greater volume without distortion.

Necessity for using only small power tubes.

Saving in power pack gear, since, when using push-pull, plate potentials of over 300 volts are seldom required for ordinary purposes.

Any disadvantages of the system would be merely in the cost of the coupling apparatus.

On page 113 is an interesting discussion on the theory of the push-pull amplifier. Those of you who are technically inclined will find the details of greatest use in understanding how the system works.

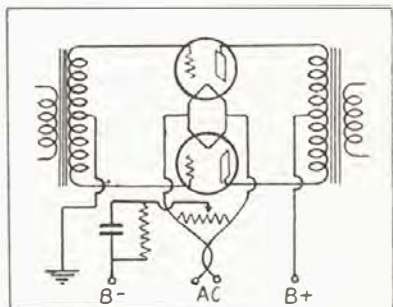

The standard push-pull a.c. amplifier circuit using push-pull transformers.

Transformer Coupling

TRANSFORMER coupling in the a.f. amplifier will give distortionless amplification if good apparatus is used. It is the most generally used, since it requires little or no adjustment in the finished amplifier.

In a two-stage transformer coupled arrangement it is usual to use a higher ratio in the first stage than in the second. This is not best practice, and better all-round results will be obtained if a low ratio job of about 3—1 ratio is used in the first stage, and one of about 5—1 ratio in the second stage. By 5—1 ratio this means that the secondary turns are a little more than five times the primary turns, in order to give a voltage step up between the windings. This makes greatest use of the a.c. power available in the plate circuit of a valve detector or amplifier.

Combinations of transformer and any other forms of coupling may be used in a single a.f. amplifier.

One of the most popular amplifier combinations is one using impedance coupling in the first stage, this stage driving a pair of transformer coupled push-pull tubes.

In mounting the transformers into a receiver combination, see that they are placed as far apart as convenient, with their cores at right angles. Use of the anode feed system has prevented much of the back coupling effects which usually caused trouble in old receiver arrangements.

Transformer coupling was the first type of coupling to be used extensively in the earlier receivers, and it has lived

through many new ideas in amplification. The majority of commercially-constructed receivers are equipped with transformer coupling in their amplifier stages. Good a.f. transformers and correct valves are essential for distortionless magnification of signal energy.

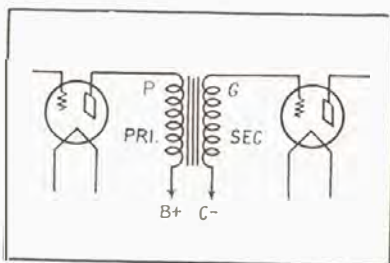

The circuit for the transformer coupled amplifier.

Matching Valves, and Transformers

Telling in simple language how to select amplifier coupling equipment, valves and speakers for any particular combination.

ANY electrical device which delivers power will deliver greatest possible power when the unit which forms the external load is at least equal to the internal impedance of the source of the power.

In the earlier days of radio, reproduction was far worse than a bad gramophone, little attention being paid to anything but gain in the audio frequency amplifier. It is only during the past two years that the home set builder has realised that he cannot pick valves, transformers and other coupling devices indiscriminately. Our object in the matching of a valve to the coupling device following it is to obtain a balance between the plate impedance of the valve and the impedance of the load, which may be in the form of a transformer primary, a choke, or a resistance, depending on the form of amplification used.

The impedance of the plate circuit of a tube is measured in ohms, and should be equalled or exceeded by the impedance of the coupling device, or the loud speaker, when the speaker is connected directly into the plate circuit of a final stage amplifier valve.

The impedance of a tube is composed mainly of the resistance of the electron stream between plate and filament. In the tube characteristics chart is the plate-filament resistance of each type of valve, which is given under the heading of impedance.

The impedance of a transformer primary, choke or plate resistance changes considerably with the frequency, while the impedance of the tube may remain practically constant. It is therefore impossible to match a valve and coupling device at all frequencies. The band of audible frequencies which will require to be handled in an amplifier will be mostly between 100 and 3000 cycles. The impedance could then be matched at the medium frequency, which will be around 1500 cycles. This is the most economical method, but better all-round results can be obtained if the impedance is matched at still lower frequencies, this calling for a larger inductance, or resistance, depending on what form the coupling device may take.

It is not possible always to learn the impedances of many makes of trans-

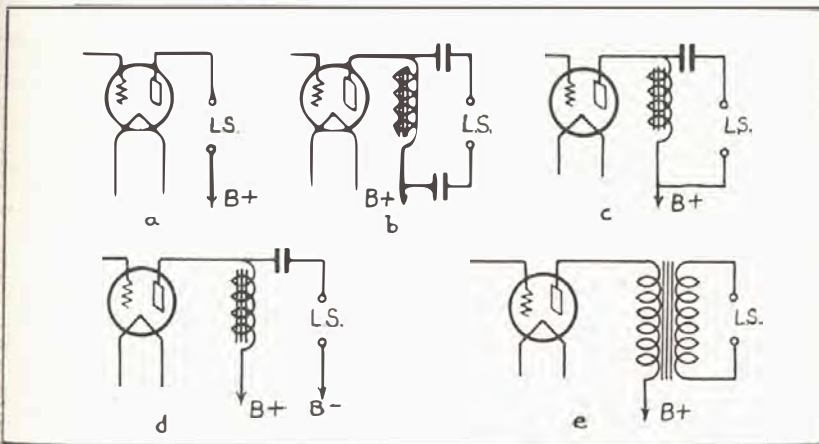

(A) Speaker connected in plate circuit of power tube. (B) The condenser choke output method when using fairly high impedance magnetic type speakers. (C) Choke and condenser method when using a single condenser. (D) Choke and condenser method with one side of the speaker connected to negative. This method will prevent the possibility of a.f. feedback from speaker leads. (E) The transformer method which may be used with any type of speaker provided it is of the correct ratio.

formers and valves. Until makers of tubes realised the necessity for an accurate idea of the plate impedances of the tubes they manufactured, we were in the dark here, too, but now we can depend to a large extent upon the characteristics supplied by valve makers.

It would therefore appear advisable and the safest thing to do, to purchase coupling devices with which a fairly accurate idea of their characteristics can be obtained. By knowing the primary impedance of a transformer, the simple consulting of a valve chart of the make we intend using will reveal a type suitable for our requirements which has an impedance the same as or lower than that of the primary winding. We can be assured that best quality amplification will be available in our amplifier if we observe this point.

Plate Resistances

When a plate coupling resistance is used it is a simple matter to select a valve suitable for operation with the 100,000 ohms. plate resistor, which is the usual value for this resistor in the resistance-capacity coupling arrangement. Regardless of the amount of power which a power valve may draw from the power pack, greatest use of this power cannot be had unless it has something to work on, and we can make greatest use of this power by careful attention to the selection of valves and coupling devices when designing a receiver.

Coupling the Loud Speaker

The types of output filter using a plate choke and condenser or condensers for the coupling of a loud speaker to a final stage amplifier will be found quite successful with electro-magnetic types. Success will not be met with if this form of output device is used to supply power to the voice coil of a dynamic type speaker.

See diagram —A. Here we have the loud speaker connected directly in the plate circuit of the final stage amplifier valve. In the newer types of low impedance amplifier valves, plate current consumption is high, and would be liable to damage the fine wire used in the construction of the average electro-magnetic cone type loud speaker. Any of the filters shown in B, C, D or F may

be used to isolate the d.c. from the speaker windings, supplying the speaker with signal energy which actually drives the speaker.

In B we have a choke and two condensers. The choke, in every instance, should have an inductance of around 65 henries, the value not being especially important. The value of the by-pass condensers in B should be no less than 2 mfd. The condensers should be of good construction.

In C we have a choke and one condenser. This condenser should be no less than 1 mfd. capacity. The disadvantage of this method is that one side of the speaker is at positive potential, and when the final stage valve is being supplied with a plate voltage of 300 or more, contact with the speaker terminals might be dangerous.

In D we have probably the best of the choke-capacity coupled arrangements. Here the speaker connects to B negative, which is at earth potential. This is the type of filter to be recommended, since one side of the speaker is at earth potential, and there will be less possibility of feed-back occurring and no danger through contact with the speaker terminals. In E a transformer is used to couple the speaker to the final stage valve.

Output Transformers

The output transformer is the most generally used method of coupling the speaker to the plate circuit of the power valve in commercial practice. The set manufacturer's design permits him to select a certain type of power valve, a certain type of speaker, and enables him to build a transformer which will make greatest use of the signal power available in the plate circuit of the power valve for the driving of the speaker.

Since the impedance of the voice coil of a dynamic speaker may be as low as 20 ohms., this type of speaker cannot be matched with the comparatively high resistance of any of the power amplifying valves available without the use of a suitable transformer.

The output transformer must then be a step-down one, having a primary impedance the same as or greater than the plate impedance of the power tube, and a secondary impedance no greater than the impedance of the speaker winding.

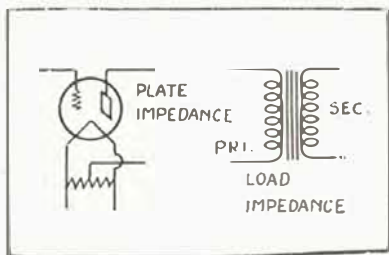

The plate impedance and the load impedance in the form of an a.f. transformer primary, plate resistor or plate choke, depending upon the form of a.f. coupling used in the amplifier.

If it is necessary to use a low impedance tube and a high impedance speaker, the output transformer must necessarily step up the voltage available at the transformer primary. For instance, we have a power valve having a plate resistance of 1500 ohms. We wish to supply an electro-dynamic

power type speaker having an impedance of 2500 ohms. with signal energy available from the amplifier equipped with this low impedance tube. The impedance of the primary would be 1500 ohms., the impedance of the secondary about 2500 ohms. The voltage available at the transformer secondary

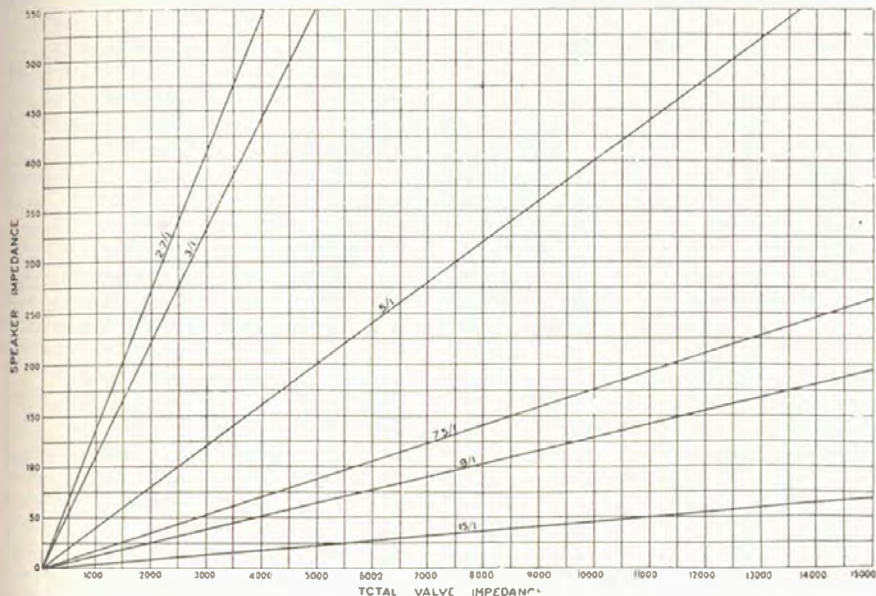

A graph which will enable the type of push-pull output transformer required to be obtained when the plate impedance of the power valves and the impedance of the speaker are known. The plate impedance of one push-pull tube should be doubled. This chart applies to ordinary cone or horn type speakers.

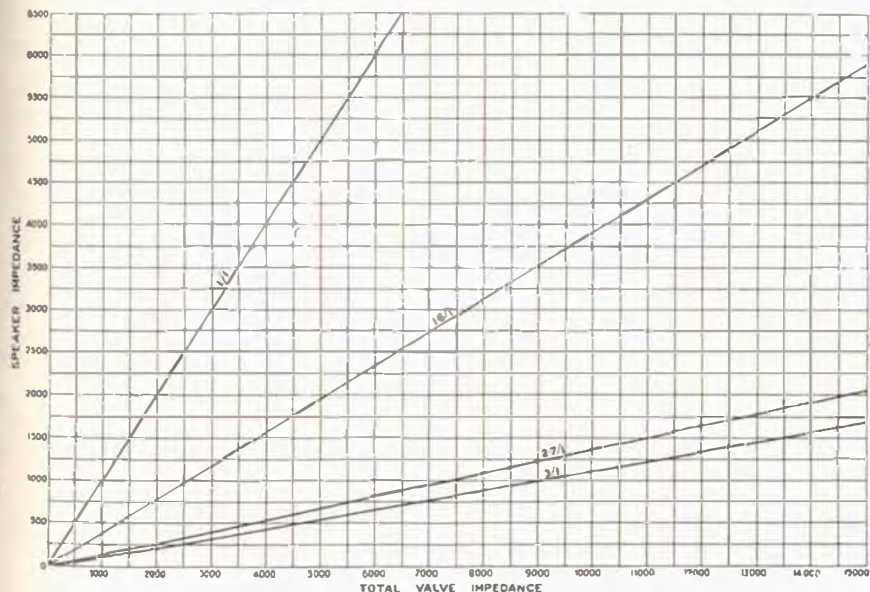

Graph for ordinary cone or horn type speakers. When plotting a point by means of plate and speaker impedance values on any of these charts use the ratio on the line which is nearest the point obtained.

would be greater than the voltage at the primary, since the transformer must step up. The power at the secondary terminals will be almost the same as the a.c. power into the primary, taking into consideration the small percentage of energy lost in the transfer-

ence of energy from primary to secondary.

Matching Detector Impedance

It is advisable in receiver design to obtain as near a match as possible between the detector plate impedance and

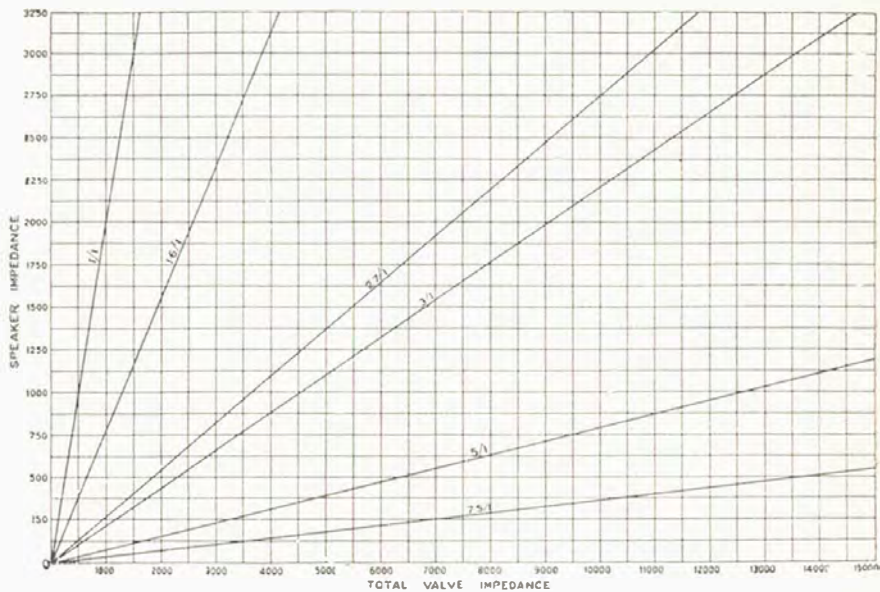

Graph for moving coil dynamic speakers. In calculating speaker impedance, this value in ohms may be taken as twice the d.c. resistance of the speaker field winding since its impedance remains sensibly constant over the whole range of audible frequencies.

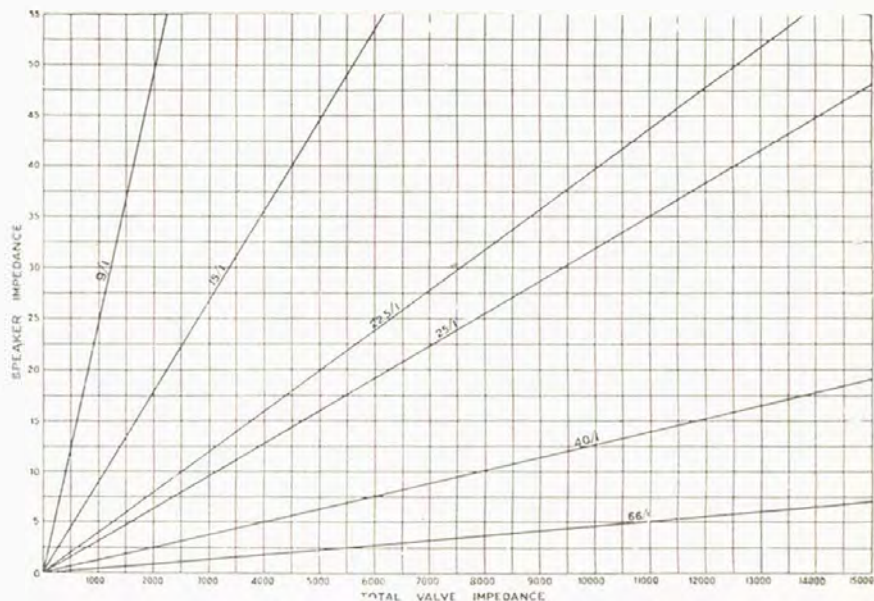

Graph for moving coil dynamic speakers. In reading any of these charts, the valve impedance value is measured out along the bottom side of the graph, the speaker impedance value up the left hand side of the graph. The points are drawn upwards and across respectively, the point being taken where the lines intersect. Whichever ratio line is nearest the point should be used. These charts are for Ferranti type output transformers.

the impedance of the primary of the coupling transformer, or the plate coupling device, whether it be in the form of a resistance or a choke. Generally, detector valves have a fairly high plate resistance, this being an average of 15,000 ohms. The detector should therefore be connected to a high impedance primary if transformer coupling is used. A transformer having the necessary large primary winding will probably be a low ratio type, but this will not matter, the gain in signal strength being high, because we are making greatest use of the signal energy available in the plate circuit of the detector valve.

If the plate of the detector is connected to a choke, the choke should have a large inductance and consequently will have a high impedance. The grid resistance of an impedance coupled amplifier directly following the detector will have a value of $\frac{1}{3}$ megohm. If a resistance-capacity coupled amplifier is used after the detector valve, a proportionately high plate resistance should be used, the detector plate voltage being higher to overcome the extra resistance in the plate circuit of the detector tube.

It will be seen that the selection of valves to suit coupling devices, and coupling devices to suit the loud speaker, is probably the most important consideration in the design of an amplifier which can be expected to deliver signals with the lowest possible degree of distortion. In a properly designed amplifier in which attention has been paid to the requirements in coupling equipment, distortion may not be greater than two per cent., this amount being so small as to be unnoticeable in the speaker output.

In purchasing a coupling transformer, choke or resistance, ask for the impedance of the devices. If you cannot obtain satisfactory answers, consider some make which is known to be reliable and which publishes the impedance curves of its coupling devices. Without knowledge of these values the home set builder is working in the dark and cannot hope to obtain the same

high quality results he has heard commercial jobs deliver.

The whole thing is really simple and involves nothing more than a comparison of the values of the valves we think will be most suitable for our requirements, and the values of the plate impedances of the coupling devices we are to use, whether these be transformers, impedance units, or resistance-capacity units, in accordance with the foregoing rules.

Using the Graphs

It will be a simple matter to follow the output transformer graphs we have shown on pages 57 and 58. Since push-pull possesses so many advantages in the a.c. operated amplifier, we have published these charts, which will enable an idea of the ratio required for any combination of power amplifier and magnetic or dynamic speaker.

We will presume that we have built a push-pull amplifier using a pair of type 250 volts in push-pull in the final power stage. We also have a magnetic type speaker, such as the Mullard or the Philips Baby Grand. Presuming again that the speaker has an impedance of, say, 2000 ohms., on looking at the valve chart we find that the plate impedance of the 250 type valve is 1800 ohms. The plate impedance will be twice the impedance of one valve, since we are using push-pull. The total plate impedance is then 3600 ohms. We now have the two values required to ascertain the most suitable output transformer we will need. Looking at the second chart, we measure up to the point on the side of the graph where 2000 ohms. will occur, and along the bottom of the graph to the point where 3600 ohms. will occur. On drawing a line across from the speaker impedance point, and a line upwards from the total valve impedance point, we will find that the nearest ratio line to the point where the lines intersect in the graph is the 1.6-1, which should be used. This means that a transformer, having a step-down ratio of 1.6-1 should be used. The charts will simplify considerably the problem of the selection of a suitable output transformer.

A.C. Valve Characteristics and Bias Resistor Values

MULLARD TYPES

TYPE	PURPOSE	FIL		PLATE		Neg grid bias at normal plate voltage.	IMPEDANCE (ohms)	VALUE OF BIAS RESISTOR (ohms)
		Volt:	Amps.	Volts (max.)	Ma's (normal)			
PM 252	Amp.	2.0	0.3	150	—	—	2,600	—
PM 22	Pentode	2.0	0.3	150	—	—	62,500	—
PM 4	Amp.	4.0	0.1	150	—	—	4,450	—
PM 254	Amp.	4.0	.18	150	—	—	2,000	—
PM 24	Pentode	4.0	.15	150	—	—	28,000	—
PM 24a	Pentode	4.0	.275	300	—	33	53,000	—
PM 6	Amp.	6.0	.1	150	—	—	3,550	—
PM 256	Amp.	6.0	.25	180	—	—	1,850	—
PM 26	Pentode	6.0	.17	150	—	—	25,000	—
DFA 8	Amp.	4.5	.85	400	—	9	15,000	—
DFA 6	Amp.	4.5	.85	400	—	36	4,500	—
DFA 7	Amp.	4.5	.85	400	—	150	2,850	—
DFA 9	Amp.	6.0	.6	250	—	30	2,000	—
DO 20	Amp.	7.5	1.3	425	—	48	2,000	—
102 T	US Type	2.5	1.5	180	—	12	6,650	—
AC 4	US Type	5.0	.25	180	—	25.5	1,450	—
AC 3	US Type	1.5	1.1	180	—	9.0	7,800	—
S 4V	S.G., R.F.	4.0	1.0	150	—	4.5	1.33 meg.	—
354 V	Gen. pur.	4.0	1.0	180	—	10	14,000	—
164 V	Gen. pur.	4.0	1.0	180	—	10.5	6,650	—
104 V	Amp.	4.0	1.0	180	—	10.5	2,850	—

Radio and the Gramophone

Some notes dealing with the gramophone pickup, how it functions and how it should be used.

FAR from being the death of the gramophone industry, radio has boosted it tremendously, and now the two are closely allied, the combination providing us with our own lecture room, music hall, news service and a host of entertainments to choose from.

It was the development of radio that lifted the gramophone industry out of the groove into which it had necessarily fallen through the inability to record by other than mechanical means.

The improvement of the audio frequency amplifier and the studio microphone changed everything, and very soon this equipment was used to operate an electro-magnetic cutter. Gradual improvements have resulted in the present day faultless recordings with which you are familiar.

The gramophone pick-up is simply a reversal of the operation of the electric cutter. In conjunction with a properly constructed and adjusted amplifier, the electro-magnetic gramophone pick-up may be used to reproduce electrically recorded discs with wonderful results.

If the broadcasting programmes do not please us, we can select our favorite recordings, something that will soothe and put us in a better humor, and make us realise that it is ourselves and not the programmes that are at fault. We can arrange an evening's programme of our own, and hear the recordings with all their original tone and color.

What is the Gramophone Pick-Up?

The faithful reproduction of gramophone recordings is dependent upon whether the wave form of the voltage developed in a pick-up is in exact accordance with the shape of the record track. A number of things may crop up to prevent this obtaining of voltage which will be in exact accordance with variations of the record track.

Faraday's conception is that lines of force start at one pole of a magnet and finish up in the other. These lines of force, as many schoolboys will know, may be seen by placing thin paper over a magnet and sprinkling its surface with fine iron filings. Should soft iron be introduced into the field of the magnet, the lines of force will tend to crowd into it and increase among themselves. Changing the position of the soft iron, which will hereafter be recognised as the armature, will affect materially the lines of force in the circuit formed by the pole pieces, air gaps and the armature.

The pick-up consists of a horseshoe magnet to the poles of which are fastened two pole pieces, around which are wound two coils connected in series. An armature completes the arrangement. To the armature is fixed the needle, which should be attached in such a manner that it becomes an extension and part of the armature.

Lines of force exist through the pick-up coils. Changing of the position of the armature will affect the

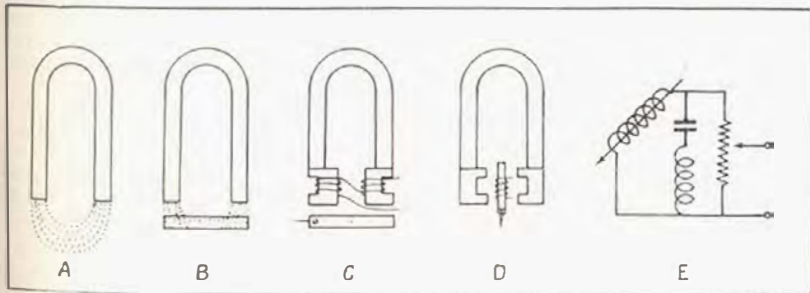

(A) Magnetic lines of force beginning at one pole end up in the other pole. (B) Magnetic lines of force crowd into a soft iron armature placed within the field of the magnet. (C) The horizontal type of pick-up. (D) The vertical type of pick-up. (E) Showing how the scratch filter and volume control are connected to the pickup.

number of lines of force permeating these coils. As in the principle of all electrical generating devices, the cutting of the lines of force permeating a coil will, by induction, introduce a voltage into that coil, and current will flow if the ends of the coil are connected together. The voltage developed in the coil or coils is in direct proportion with the speed at which the armature moves.

The pole pieces of the pick-up are used merely to concentrate the field of the magnet upon the armature, so that a small movement of the arma-

The armature in many types of pick-ups is supported on rubber. If the armature were to be allowed to move freely upon its pivot, it would be immediately drawn over to one of the pole pieces and held there. If the rubber support is too rigid, the pick-up will not respond faithfully to the form of the sound track and will be hard on recordings. The output from a heavily damped pick-up will be small, requiring greater amplification to obtain the same output volume were the pick-up to be correctly adjusted.

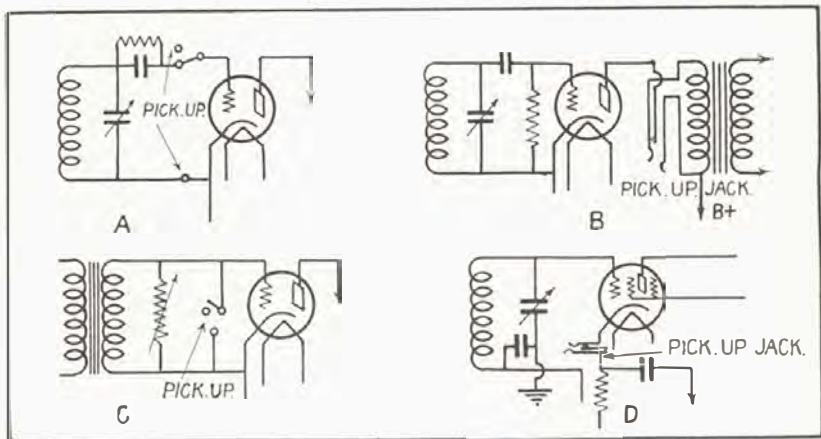

Methods of connecting the pickup into the receiver circuit. (A) Connected by means of an anti-capacity switch between the grid and cathode leads of the detector valve. (B) Connected by means of a jack to the primary of the first a.f. transformer. (C) Connected by means of a switch across the secondary terminals of the first a.f. transformer. (D) Connected in the cathode lead. This is the method generally used in the Loftin-White arrangement. The idea is one of the best since the pickup may be left connected permanently in the circuit.

ture will result in large changes in the field existing across the air gap. The operation of the gramophone pick-up is merely a reversal of the operation of a loud speaker. Alternating voltages through the speaker windings cause changes in the strength of the speaker magnets. The diaphragm of the speaker will vary in accordance with the changing currents through its windings.

The electro-magnetic method of changing the mechanical vibrations available on the record track into electrical impulses has lived after the discarding of carbon, capacity, oscillator, quartz and hot wire systems, all of which may have been still in use had they possessed the same degree of mechanical practicability available in the electro-magnet method.

It would be wise when purchasing a pick-up to obtain a guarantee that it may be changed if need be. The trying of several types of different make will soon reveal a good one.

Again, if insufficiently damped, the armature would tend to over-shoot the mark during loud passages. This would introduce bad distortion in the form of blasting. The happy medium in damping must therefore be struck, and if the output from a newly acquired pick-up, or one which has lost its original tone, is by no means good, simple adjustment to the tension on the armature supports may often put matters to rights. Rubber, often being used as an armature supporting medium, will perish after several years, when the sudden poor performance of a pick-up will probably be found to be due to this cause.

The output voltage of a pick-up is dependent to a large extent upon the strength of its magnets. Should the magnet be jarred or become weak from other causes, the output will suffer in consequence, and re-magnetising may be necessary.

It is important that the pick-up armature be exactly centred between the two pole pieces, as a few thousandths of an inch to one side may often result in distortion.

Needle scratch may often spoil the performance of a radio combination. Therefore, it should receive some little attention if prominent in the speaker output when using the pick-up.

The use of a filter in the form of a coil and a condenser connected across

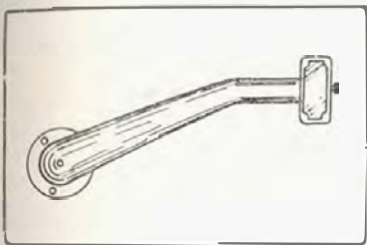

The cranked tone arm method.

the pick-up output is advisable. The combination of coil and condenser which will give satisfactory results with the average pick-up, is one of 1500 turns and a condenser of .006 mfd. capacity. A 1500 turns honeycomb coil may be used, but a former wound coil using gauge 36 or 38 wire will prove quite satisfactory. Since needle scratch is of a high audible frequency the filter will absorb some of the higher register as well as needle scratch, but the loss of a few high notes is generally out of all proportion to the considerable reduction in the background of needle noise.

The problem of needle scratch involves the careful selection of needles for each particular type of pick-up.

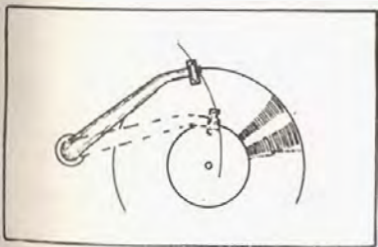

Showing how the cranked tone arm tracks without error over the whole recording.

Certain needles are best adapted to particular types of pick-ups. It is advisable, therefore, when testing out a new type, to obtain every possible variety of needle, carefully noting the effect of each one.

The writer's experiments with different types of pick-ups have shown that with certain types, the use of soft tone steel and fibre needles will bring about an almost complete loss of the upper register, bass reproduction being over-emphasised and the general tone being altogether poor. The same pick-ups have often put up brilliant performances when used in conjunction with loud tone needles. The reverse is the case with other types, since often the use of loud tone needles will completely spoil a pick-up's performances by causing too violent movement of the pick-up armature, the result being distortion whenever the pick-up might strike a loud passage.

Still, other types will operate equally well with any type of needle, the only apparent difference being in the output voltage.

Once a certain type of needle has been settled upon, it may be used throughout the life of the pick-up, the volume control being used to control the amount of speaker output.

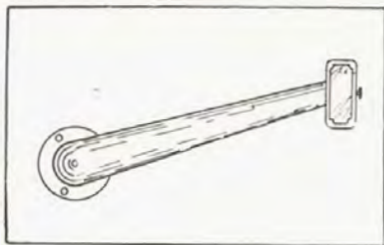

The correct effect is produced by use of a pick-up mounted at an angle.

As with all other forms of radio apparatus, pick-up construction has improved over the past two years and adjustment should seldom be necessary. It is handy to know how to go about its adjustment should anything happen, and that is the reason for our dwelling for these several pages upon this subject.

Connecting the Pick-Up

In small radio combinations, it is general practice to connect the pick-up across the detector stage grid leak, and condenser, or between the grid and cathode of this stage. This practice will be found ideal when using small two or three valve combinations. When push-pull is used, use is no longer made of the step up available in the detector when using it as a first stage amplifier, volume being sufficient when connecting the device before the first amplifier stage.

Here the pick-up may be connected to the transformer primary by means of a pick-up jack, as shown in the accompanying diagram. It may be connected across the secondary terminals of the first amplifying transformer, or between the grid and cathode. In some circuit arrangements the pick-up is permanently connected in the circuit by its being placed in series with the cathode. This method has its advantage, since it requires no switching arrangements, and its extended leads will stand less chance of picking up a.c. induction, which might get into the circuit.

The leads to a pick-up are seldom less than two or three feet in length. Connected in the grid circuit of a detector or first amplifier stage, these long leads may cause trouble by introducing hum into the circuit. It is usual practice to connect the pick-up core or case to earth. This will, in nearly every case, definitely prevent the possibility of hum being introduced into the circuit in this quarter. The framework of all gramophone motors should be connected to earth in the radio combination. Use a very short pick-up lead from the grid of a detector valve to the pick-up switch or terminal, or reception when using the radio will be spoiled.

The Electrical Gramo Motor

The design of the light socket operated gramophone motor has reached the stage when constant speed of the turn-table unaffected by line voltage variations is obtainable.

In the design of a combination to incorporate an electrically operated turntable, care must be taken to prevent the possibility of a.c. noise being introduced into the circuit. The design must be made accordingly, the motor being placed as far as is conveniently possible away from the components of the receiver. It may be necessary in some cases to completely shield the motor, using a soft iron shield box.

Correct Tracking

The movement of the pick-up armature must be at right angles to the record track.

If the gramophone record is examined under a suitable magnifying glass, the groove in which the needle rides will be seen to be of irregular shape. It is this shape of the track which imparts to the needle the side to side motion, which causes a voltage to be generated in the pick-up device. The tracks of the record will be seen to move, within limits, alternately nearer and farther from the centre of the record, instead of in a perfect spiral.

This deviation in the form of the track constitutes the wave form of the recorded music or speech. In order that this wave be faithfully transferred via the needle to the pick-up armature, as the record rotates, it is absolutely essential that the plane of the vibrating needle shall be at right angles to the mean line of the groove or track. If this condition is observed, the pick-up is said to possess good "track alignment." If at one or more sections of the record this is not the case, the pick-up is then said to have "tracking error."

Since the usual type of tone arm ends in a pivot, the pick-up itself must turn through a definite angle as it passes across the surface of the record. Whether this angle is going to assume alarming proportions will depend upon whether the tone arm position is correctly calculated.

There have come on to the market several special types of tone arms which will eliminate "tracking error." Since the tone arms are usually expensive, the fact that the amount of "tracking error" with the ordinary tone arm properly treated, may be reduced to negligible proportions, will show how use of these special types is unnecessary.

It is a curious fact that many people who go to considerable time and expense in building and adjusting and gramophone and radio combination do not even consider the problem of correct tracking of the pick-up. No doubt it is an oversight, but the question of correct needle tracking is far too important to be overlooked.

It may seem strange, but it is a fact that the great majority of sound boxes fitted to the old mechanical gramophones did not track correctly. Since incorrect tracking will result in serious distortion of wave form of any recording, it goes to show that it is only during the past 12 months that the average public has come to realise the importance of correct tracking.

Apart from the fact that incorrect mounting of the pick-up tone arm will invariably result in distortion, the needle, when out of track, is worn to a chisel shape which, being turned through an angle as it traverses the record, digs into the sides of the grooves, resulting in damage to the disc in very short time.

One of the biggest advantages of the pick-up lies in its gentle treatment of recordings. We do not require a great output from the pick-up; we can obtain this in the amplifier system. Care and attention to recordings will result in their lasting for years. A well-designed pick-up, not too heavily damped, takes very little power from a

recording, its output being only one per cent. of that required for the operation of the old mica mechanical sound-box. But, we can only make use of these big advantages by correct alignment of the pick-up.

It would perhaps be advisable to clear up a misconception. It is a general idea that the point of the pick-up needle should coincide with the centre of the turntable spindle when the tone arm is swung across to the centre of the record. This is quite wrong, and if a pick-up is so set, you

may be sure that alignment is incorrect.

Obviously, the ideal type of pick-up tone arm would be one in which the pick-up moved in a straight line across the record. The tracking error of a 9in. tone arm properly bent may be reduced to less than three degrees.

The method we suggest makes use of a cranked tone arm.

We have gone more thoroughly into the subject of correct alignment of the pick-up on page 119.

Calculation of Plate Resistor Values

Simple mathematics cover the calculating of voltage dividing resistor values.

WE have already shown how the value of bias resistors may be discovered for any particular stage. The calculation of voltage dropping resistors is just as simple and makes

use of the formula R equals $\frac{E}{I}$

Where I equals the current in amps, E the voltage, and R the resistance.

Example—

We design a power pack to deliver a maximum voltage of 250, which is the voltage required for the operation of the type of final stage amplifier valve we are using. The first amplifier valve we are using is shown on the valve chart as requiring a plate voltage of 120, at which potential the valve draws 10 mills. when correctly biased. Now we require to know what series resistance will be required to drop the maximum 250 volts to 120. Subtracting 120 from 250 gives us 130 volts. Now the required resistance value equals voltage not required divided by the plate current in amps.

The voltage not required is 130, the plate current is 10 mills. or 1-100th of an amp., then

$$R \text{ equals } \frac{130}{1} \div \frac{1}{100} \text{ equals}$$

13,000 ohms. This type of resistance should be of the wire-wound tubular type available in Mullard or Ferranti ranges. This resistance may appear to be high, but it is of the right value for this particular purpose. The method of using separate resistances in the supplying of

each stage of a combination with its required plate voltage serves a treble purpose. The method prevents back coupling with its resultant distortion, which can be eliminated only by use of costly by-pass condensers, which will occupy considerable space. The method prevents motor boating in a receiving circuit. Further, this type of tubular resistance is mounted in sockets in the same manner as a huge grid leak. This means that in the event of the resistance breaking down it can be easily replaced. The breaking down of a paralleled voltage dividing resistor will result in possibly hours of work in removing the resistor and its replacement. It will be seen, therefore, that the use of separate dividing resistances for each stage is advisable, since the method possesses every advantage and not a single disadvantage. Another point is that no "bleeder" current is taken when using this method of voltage dropping. This means that the rectifier will give longer life, since it does not require to pass this extra current, and no power is wasted. Since the final amplifier stage receives the maximum voltage available from the eliminator, the average number of resistances required will be three. Whenever more than one stage is to be supplied with the same plate voltage, a single resistor is used, the total plate current taken by the stages to be supplied by the single resistance being used in calculating the resistance value. The whole thing is ridiculously simple, and should present no difficulties to the home set builder.

A. C. Valve Characteristics and Bias Resistor Values

PHILIPS TYPES.

TYPE	PURPOSE	FIL		PLATE		Neg grid bias at normal plate voltage.	IMPEDANCE (ohms)	VALUE OF BIAS RESISTOR (ohms)
		Volts	Amps.	Volts (max.)	M'as (normal)			
E415	Gen. Purpose	4	.9	150	6	6	7,500	1000
E424	Gen. Purpose	4	.9	150	3	4.5	8,000	1500
E409	Amp.	4	.9	150	12	9	3,000	800
E442	S.G., R.F.	4	.9	200	1.5	1.25	—	500
E442s	S.G. Det.	4	.9	200	3	3	—	—
E435	Res. Cap and R.F. Amp.	4	.9	200	3	1.5	35,000	750
E438	Res. Cap and R.F. Amp.	4	.9	200	2.5	3	25,300	1200
F424	U.S. Type	2.5	1.75	180	4	1.5	—	375
F109a	U.S. Type	1.5	1	200	9	12	6,000	1600
F209a	U.S. Type	2.5	1.75	200	8.8	12	6,000	1200
F203	U.S. Type	2.5	1.5	250	35	50	1,170	1500
F704	U.S. Type	7.5	1.25	450	55	84	1,800	1520
C603	U.S. Type	6	.25	180	18	40	1,500	2000
B105	Power	1.3	.15	150	8	18	5,000	2250
B205	Power	2	.15	150	7	18	4,200	2570
B405	Power	4	.15	150	8	18	2,500	2250
B605	Power	6	.12	150	9	18	2,800	2000
B203	Super Power	2	.19	150	12	30	2,000	2500
B403	Super Power	4	.15	150	15	30	2,000	2000
E408	Super Power	4	.9	400	26	30	4,000	1150
D404	Special Power	4	.65	200	30	30	1,000	1000
C443	Pentode	4	.25	300	22	22	40,000	1000
C643	Pentode	6	.25	300	21	20	40,000	1050
E443	Pentode	4	.9	400	30	35	33,000	1160

Note:—Types marked U.S. have characteristics similar to those of the different types of American made tubes, and may be substituted for these types without alteration to values.

Selecting Valves for a Combination

A few notes dealing with the types of valves to be used for different purposes

MUCH a variety of types and makes of directly and indirectly heated general purpose and power valves are available that the home set builder is liable to become a little bit confused when he attempts to select several types for his own particular requirements.

The selection of detector and first amplifier stage valves calls for no particular attention to characteristics, since we can select valves from the charts especially suited for these stages.

The type of power valve required will depend upon what is to be expected of the particular combination.

The 245 type of valve in a single stage amplifier arrangement driven by a detector and first stage amplifier will give adequate volume for ordinary requirements, while a pair of these tubes as final stage tubes in a push-pull amplifier will provide ample volume for dancing or parties should the occasion demand.

No more than 300 volts plate supply will be required for the average home receiver, so that power valves to draw, in conjunction with the other valves of the combination, no greater plate current than the 125 mills. the 280 type of rectifier will deliver, should be used. On looking at the chart, the set builder will find quite a number of thoroughly reliable types of different makes all suitable for our purpose.

If for instance, we have an output transformer to suit a dynamic speaker on hand, we should ascertain the impedance of the primary of the transformer and use a final stage power valve having an impedance the same as or lower than that of the primary.

When it is intended to use a dynamic speaker, or a special type of electromagnetic speaker in conjunction with an output transformer, make sure that you can obtain valves to suit the transformer primary and vice versa when ordering material.

In American practice the directly-heated 226 type valve is used for r.f. amplification and in the first stage amplifier of any receiver combination. Careful adjustment will prevent hum in these stages.

Use of indirectly heated r.f. and first amplifier valves is to be recommended, however, since their use will lessen the

possibility of hum occurring in the circuit.

The 227 type of valve may be used successfully as a detector or first stage amplifier. Prototypes of all the American type valves are available in all the English makes. In the charts, these have been marked "U.S." type, and are specially made to possess the same characteristics as the American tubes to enable their being interchanged should the occasion demand.

It is the contention of the American set designer, that low voltage filament or heater tubes should be used in the r.f., detector and first amplifier stages of any receiver combination. His reason is that the field surrounding a wire carrying such a low potential would be less liable to introduce hum into a circuit by induction. This is no doubt true to a certain extent, but results will show that little hum is to be experienced when using the four volt indirectly heated Philips, Osram, Mullard and Cosmor types.

For any single amplifier stage following a detector circuit, the power pentode will be found to be highly satisfactory, when used in conjunction with fairly high impedance magnetic type speakers.

It is best practice to use separate heater and filament secondaries for the final power stage, and the preceding stages of a combination. The winding of a separate heater secondary for each tube in a circuit is to be recommended. This certainly means a little more work in building the transformer and making filament resistors, but the results will be well worth while.

In order that we may drive a speaker so that volume for all requirements may be obtained, we require the power stage of a receiver combination to deliver a certain amount of power.

By the selection of a power valve or valves for our particular purpose, we can obtain distortionless power for loud speaker operation. The essential characteristic of the power valve is low impedance. The lower the impedance of a valve, the greater will be its plate current consumption under normal operating conditions.

It may be safely said that the power available for the driving of the speaker is only one-fifth of the plate power drawn by the power valve. However,

when we take into consideration the fact that a single watt of signal power may be sufficient to operate the speakers of a talkie theatre, we may realise that even if four-fifths of the total plate power is wasted, we can still achieve our object of obtaining plenty of volume without distortion by use of medium power equipment.

The cost is lowered and construction of a power pack considerably simplified if push pull is installed. For small power work a pair of type 171s, Philips C603s, Mullard PM252s, Osram P625As, or Cossor 625Ps will be quite sufficient when used in a push pull amplifier and driven by a regenerative detector and single stage amplifier. The biggest type of power tube we will need for home use will be the type 245.

If a power pack is already on hand it will be possible to consult the valve charts on pages 60, 66 and 72, and select power valves of any particular make which may be fancied by the intending constructor. The rectifier valve chart on page 26 will reveal the power the particular type of rectifier used in the pack will deliver, while rough calculations of the total plate power required by a receiver combination will soon permit the correct types (to draw no more power than the pack will deliver) to be selected.

The type 280 rectifier valve, because of its all round suitability, is most generally used. Valves also suitable

are the Philips type 1560, Osram U5, Raytheon X280, and Pilotron P280.

As in every other part of the a.c. receiver a margin for overload should be left in the rectifier. If the power pack output requires to be 400 volts at 100 milliamps for, say, a five-valve combination using 250 type power valves, the rectifier must be one which will pass 120 mills., since to operate a rectifier valve so that it delivers a trifle more than its rated maximum output will shorten its life considerably. Consulting the rectifier chart, we would find that a pair of type 281s, a Cossor type 825BU, an Osram type U8, or a pair of Philips type 1562s would be needed. It should be possible to hold one's hand upon the rectifier when it has been operating for some time. If the valve or valves, when using half-wave rectification, become too hot to touch, they are being overloaded and will be short lived. Properly treated and operated at an underload, the average thermionic rectifier can be expected to give some 2½ years' service. A point to note in installing the rectifier is to allow ventilation for the free passage of air through the power pack portion of the receiver combination. The thermionic or gaseous conduction type rectifier depends to a large extent upon air cooling for its efficient operation, and its life will be lengthened if care is paid to this point when building a receiver.

The Aerial System

Erecting the antenna for the a.c. receiver—Good earth required—Rules require use of lightning arrester.

THE first consideration which will arise when erecting an aerial will be as to whether it should be short or long. The use of the "B" eliminator and heater transformer for the supply of total power to a receiver has tended towards broadness of tuning in the a.c. receiver. This broadness of tuning is invariably not a receiver fault, but is due to the pick-up of signal energy by the mains supply wires. Use of the two coils and series condensers in the form of the mains supply filter we have already described will, in most cases, prevent much of this broadness.

Generally speaking, the long aerial and the multi-wire types should never require to be used when the nearest broadcasting station is situated within a distance of some 15 miles. The country listener has an advantage over his city brother in that he can use a big aerial to feed a strong signal impulse to his receiver with little or no possibility of transmissions interfering with each other, even though the receiving circuit used might be inselective.

For average use the single wire type running straight down from the top of a single mast to the position where the lead-in tube is located, will be found satisfactory. Such an aerial will give sufficient signal pick-up when the mast used is 25 to 35 feet in height, and the overall length of the aerial is no more than 75 feet.

Regarding the material used for the aerial, it is not very important what type of wire is used, since it is doubtful if any difference in reception would be noticed if different materials were to be tried.

For the indoor aerial we may use any small gauge flex or even gauge 18 or 20 d.c.c. wire, pushed down behind the picture moulding, the lead down to the receiver being concealed behind a conveniently placed picture as it is brought down the wall.

The use of the loop aerial is inadvisable since it is generally suitable only for special purposes, such as direction finding. An aerial placed around the four sides of the walls of an average sized room will give a

greater signal pick-up than we could hope to obtain with the loop, which requires to be tuned and usually adds another control to the tuning arrangements.

The aerial is becoming less and less important as the efficiency of valve receiving circuits improves. In most cases all that we require is a wire round the room or a 50 or 60 feet length of wire outside strung along the fence. It must be remembered that if property be insured against fire, it is necessary to equip any form of outdoor aerial with an arrester and lightning switch in accordance with the regulations laid down by the underwriters.

Actually if an aerial were to be struck by lightning the arrester would not be of any assistance, since in the remote cases known where this has happened there has usually been nothing left of the aerial or the arrester.

A good earth connection still retains its importance, since it may do a lot to help good pure reception free from hum and other noises. Whenever the water-pipe is more than 15 feet or so away from the receiver, bury a kerosene tin some three or four feet below the surface in clay soil, soaking thoroughly, and soldering a heavy gauge bare flex wire to a number of points on the tin. A copper or brass sheet may also be used if this material is handy.

Should it be found that an aerial fastened behind the picture moulding gives insufficient signal pick-up in a certain location, and for appearance sake it is not desired to erect an outdoor aerial, a highly efficient system may be installed between the roof and ceiling, using 3-22 copper wire or gauge 16 or 18 d.c.c.

Naturally, the further the receiver may be away from the nearest broadcasting station, the longer the aerial may be without the receiver becoming inselective. Use as long an aerial as possible, which will enable reception without interference.

Fire Underwriters' Installation Rules

Regulations applying to the erection of aerial systems for receiving stations only

RULES laid down by the Fire Underwriters' Association for the erection of outdoor aerial equipment on property covered by fire insurance read:—

(a) Antennas outside of buildings shall not cross over or under electric light or power wires, nor shall they be so located that a failure of either antenna or of the above-mentioned electric light or power wires can result in a contact between the antenna and such electric light or power wires.

Antennas shall be constructed and installed in a strong and durable manner, and shall be so located as to prevent accidental contact with light and power wires by sagging or swinging.

Splices and joints in the antenna span, unless made with approved clamps, or splicing devices, shall be soldered.

Antennas installed inside of buildings are not covered by the above rules.

NOTE.—Outdoor antennas should be of rugged construction, held securely in place, and kept well away from electric light and power wires.

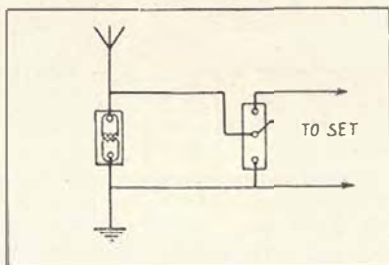

Showing how an approved arrester and lightning switch is connected

The size of the antenna will depend on the span: for the ordinary receiving antenna about 100ft. long, No. 3/20 gauge soft drawn copper wire may be used, or other wire of equivalent strength. Where the span is long, or where the antenna crosses other wires, it should be larger.

(b) Lead-in wires shall be of copper, approved copper-clad steel, or other approved metal, which will not corrode excessively, and in no case shall they be smaller than No. 3/20 S.W.G., except that approved copper-clad steel not less than No. 18 (0.044) S.W.G. may be used.

Lead-in wires on the outside of buildings shall not come nearer than twelve (12) inches to electric light and power wires unless separated therefrom by a continuous and firmly fixed non-conductor that will maintain permanent separation. The non-conductor shall be in addition to any insulation on the wire.

Lead-in wires shall enter building through a non-combustible, non-absorptive insulating bushing.

NOTE.—Although desirable from a signalling viewpoint to prevent partial grounding in wet

weather, these rules do not require the insulating of lead-in wires, except where they pass through the building wall, where a bushing is specified. This is to protect against possible contact with wires, pipes, or other grounded metal, which may be concealed in walls.

(c) Each lead-in wire shall be provided with an approved protective device properly connected and located (inside or outside the building), as near as practicable to the point where the wire enters the building. The protector shall not be placed in the immediate vicinity of easily ignitable material, or where exposed to inflammable gases or dust or flyings of combustible materials.

The protective device shall be an approved lightning arrester which will operate at a potential of five hundred (500) volts or less.

The use of an antenna grounding switch is desirable, but does not obviate the necessity for the approved protective device required in this section. The antenna mounting switch, if installed, shall, in its closed position, form a slant around the protective device.

NOTE.—The protecting device should be an approved lightning arrester; the use of cheap, home-made devices is not permissible.

(d) The ground wire may be bare or insulated, and shall be of copper or approved copper-clad steel. If of copper the ground wire shall not be smaller than No. 3/20 S.W.G., and if of approved copper-clad steel it shall not be smaller than No. 18 S.W.G. The ground wire shall be run in as straight a line as possible to a good permanent ground. Preference shall be given to water piping. Gas piping shall not be used for grounding protective devices. Other permissible grounds are artificial grounds, such as driven pipes, plates, cones, etc.

The ground wire shall be protected against mechanical injury. An approved ground clamp shall be used wherever the ground wire is connected to pipes or piping.

NOTE.—The proper connection of the antenna to the ground minimises the lightning hazard. A satisfactory ground and properly run ground wire are of primary importance.

WIRES INSIDE BUILDINGS

(e) Wires inside buildings shall be securely fastened in a workmanlike manner, and shall not come nearer than two (2) inches to any electric light or power wire unless separated therefrom by some continuous and firmly fixed non-conductor making a permanent separation. This non-conductor shall be in addition to any regular insulation on the wire. Porcelain tubing or approved flexible tubing may be used for encasing wires to comply with this rule.

(f) The ground conductor may be bare or insulated, and shall be of copper, approved copper-clad steel, or other approved metal which will not corrode excessively under existing conditions, and in no case shall the ground wire be less than No. 3/20 S.W.G., except that approved copper-clad steel not less than No. 18 (0.044) S.W.G. may be used.

The ground wire may be run inside or outside of building. When receiving equipment ground wire is run in full compliance with rules for Protective Ground wire, in Section (d), it may be used as the ground conductor for the protective device.

Measuring Instruments

The use of meters is essential if success is to be expected in home receiver construction.

THE a.c. voltmeter plays an important part in the construction of the a.c. receiver. Such an instrument is expensive, and it would be well worth 10/- to borrow an instrument reading up to 400 volts and another reading up to 10 volts, if this can be done. The high voltage meter will indicate if the voltages on either side of the high voltage centre tapping are equal. If they are not, it will be a simple matter to reduce the turns on one side, or add turns to the other side, depending upon whether the output voltages are more or less than required.

The low voltage reading a.c. meter will be invaluable in the checking up of filament and heater voltages. If these voltages are too low, the tubes will not be able to operate at maximum efficiency, while, if they are a little high, filament and heater life will be short.

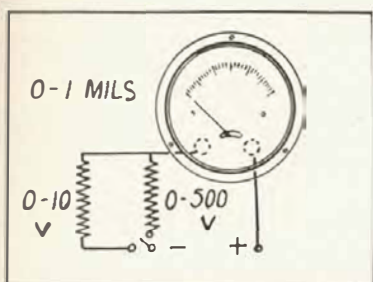

Two resistances, one of 10,000 ohms, the other of 500,000 ohms, are connected in series with an 0-1 millimeter to read from 0-10 and from 0-500 d.c. volts.

Some types of d.c. reading meters will give a reading when connected to an a.c. source, but this reading is invariably false, and it is only safe to rely upon a good quality thermocouple type a.c. reading meter.

A high resistance d.c. voltmeter reading up to 500 volts will be invaluable in the checking up of plate voltages in the power pack and in the receiver. The low reading d.c. voltmeter will be invaluable for the checking up of low voltage speaker filter supply current. Such a meter will soon indicate whether

the speaker rectifier is at fault, if this type of supply is used.

The milliammeter is not an ornament. It is a necessity and should be used in putting a circuit into operation, even though it may not be left permanently connected in the circuit.

An 0-1 Ferranti milliammeter, by use of series resistances may be used for the measuring of high or low voltages.

Below is a chart giving the values of resistances which may be used to extend the range of an 0-1 d.c. milliammeter for all general purpose d.c. voltage measuring work.

The meter could be fitted into a box equipped with several of these resistances, a switch arm and studs, so that it might be used for general purpose work. The readings, if good resistors are used, will be very accurate.

The milliammeter in conjunction with two resistances, these being 10,000 ohms and 500,000 ohms, could be used to measure all the d.c. voltages to be encountered in the a.c. receiver.

Since such a voltmeter as this has a high resistance, it can be used to get a very accurate idea of the voltage drop across anode feed and biasing resistors.

The importance of measuring the plate current consumption of voltage and power amplifier stages cannot be too greatly stressed. If on the insertion of a milliammeter in the plate circuit of a power valve, the current reading is found to be considerably greater than the maximum current value allotted this valve in the chart, it will be known that the plate voltage is excessive, or that insufficient bias is being used on this particular stage.

The milliammeter is not absolutely necessary as a distortion indicator, since the home set builder will agree that he is equipped with ears which will best judge the quality of the results.

We will not require to use an a.c. ammeter, since by checking up on valve filament and heater secondaries, and rectifier filament heating secondaries, for voltage, on finding these correct, we can rest assured that the valves are drawing their normal filament current values.

	Desired Full Scale				Reading of Meter			
Volts Resistance (ohms.)	10	20	30	50	100	200	500	
	10,000	20,000	30,000	50,000	100,000	200,000	500,000	

A.C. Valve Characteristics and Bias Resistor Values

RAYTHEON TYPES

TYPE	PURPOSE	FIL		PLATE		Neg grid bias at normal plate voltage.	IMPEDANCE (ohms).	VALUE OF BIAS RESISTOR (ohms)
		Volts	Amps.	Volts (Max.)	M'as (normal)			
224	S.G. Amp.	2.5	1.75	180	4	1.5	400,000	400
227	Det. & Amp.	2.5	1.75	180	—	13.5	8,000	2,250
226	R.F. & A.F.	1.5	1.05	180	7.5	16.5	7,000	1,500
245	Amp.	2.5	1.5	250	32	51.5	1,900	2,000
171A	Amp.	5.0	.25	180	20	27	2,000	1,500

RADIOTRON TYPES

220	R.F. & A.F.	1.5	1.05	180	7.5	13.5	7,000	1,500
227	Det. & Amp.	2.5	1.75	180	—	—	8,000	2,250
112A	Amp.	5	1.25	150	9.5	10	4,700	1,000
120	Amp.	3.3	.132	135	6.5	22.5	6,300	3,200
210	Amp.	7.5	1.25	425	18	40	5,000	2,250
250	Amp.	7.5	1.25	450	55	84	1,800	1,720
245	Amp.	2.5	1.5	250	32	50	1,900	1,500
171A	Amp.	5.0	.25	180	20	40	2,000	1,500
224	S.G. Amp.	2.5	1.75	180	4	1.5	400,000	450

PILOTRON TYPES

112A	Amp.	5	1.25	150	9.5	10	4,700	1,000
171A	Amp.	5	.25	180	20	40	2,000	1,500
224	S.G. Amp.	2.5	1.75	180	4	1.5	400,000	400
226	R.F. & A.F.	1.5	1.05	180	7.5	13.5	7,000	1,500
227	Det. & Amp.	2.5	1.75	180	—	—	8,000	2,250
245	Amp.	2.5	1.5	250	32	50	1,900	1,500

Screening in the Receiver

Metal may be used to prevent intercoupling between r.f. and detector stages of a receiver combination

SHIELDING is the practice of surrounding parts carrying or producing electro-magnetic or electro-static fields. Every conductor carrying an alternating current is surrounded by an electro-magnetic field. Every conductor having an electric charge is surrounded by an

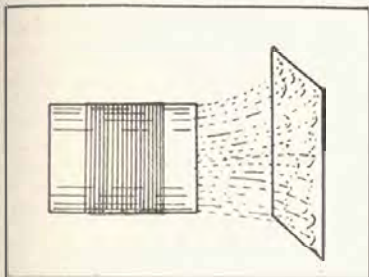

Showing how lines of force surrounding an inductance interrupted by a conductor are dissipated in the form of eddy currents in the shielding material.

electro-static field. These fields will produce electric charges in other conductors in their neighborhood.

The higher the frequency of the alternating current carried by a conductor, the more widespread will be the field surrounding this conductor.

In the r.f. stages of a receiver nearly every connection is surrounded by a widespread field, which in the majority of home-built receivers produces opposing currents in these stages which will make for inefficiency and poor operation of the r.f. and detector portions of the receiving circuit.

A field which surrounds a coil or a condenser or any conductor carrying high frequency alternating currents as are to be met with in the radio receiver, travels freely through air or any other insulator. Should the path of the field be intercepted by a good conductor, the lines of force of which the field is composed will enter the conductor, but few will pass through it. Lines of force are dissipated in the form of eddy currents in the conductor or shield. These eddy currents destroy the field, and are dissipated in the metal shielding material.

If it were practicable to use widely separated stages of a receiver combination, there would be no need for shielding, but when we wish to build a com-

pact receiver, we must, in many cases, resort to shielding, if back coupling is to be prevented.

The field surrounding an r.f. tuning coil in a receiver may extend for some six or eight inches. The field surrounding a wire carrying a fairly heavy plate current may extend as far as 1½ in. around the conductor.

Copper is recognised as being one of the best shielding materials, and its use is advisable. Tinned iron is useless for ordinary purposes, as far as receiver shielding is concerned. Its use will result in losses and poor efficiency in the r.f. stages of any receiver combination.

The complete boxing of screened grid r.f. stages is advisable. The screened grid valve plate lead should be shielded by binding this connection with thin copper foil strip, which should be earthed. It is good practice to separately shield the r.f. valve, as well as completely enclosing the r.f. stage or stages in metal boxes. In modern receiver practice it is usual to find all the tuning condensers of a multi-stage receiver combination completely shielded, while all tuning coils are separately shielded. The shielding of inductances calls for the use of small diameter tuning coils.

In a neutralised r.f. stage, the use of a single piece of shielding material placed between r.f. and detector stages will do a lot to help the prevention of any tendency towards oscillation in the r.f. stage or stages. The neutrodyne

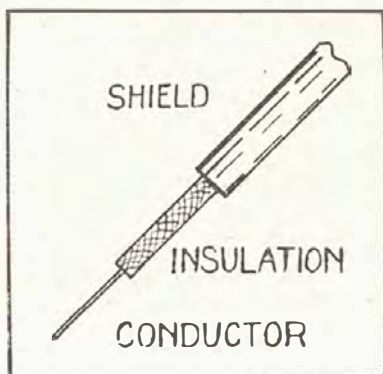

Shielded wire may be used with success in the wiring of r.f. stages. Thin copper strip may be used to bind insulated conductors.

makes use of inductances placed at a certain angle to prevent their fields interacting.

In a receiver using a single r.f. stage, the r.f. stage and detector coils should be placed at right angles. This will result in a minimum of coupling between the two coils.

Iron or steel should never be used for the shielding of r.f. circuits. It has a high radio frequency resistance, and its use will result in serious losses.

The shielding of power transformers and filter chokes should be carefully done, otherwise noises and rattles will spoil the operation of these devices. It is commercial practice to embed the transformer by pouring molten wax into the space between shield and transformer or choke. This practice is not to be recommended by the home power pack constructor, as it will definitely prevent servicing of the job should anything happen to its windings. There are many, however, who will purchase transformer and filter choke gear ready made, since these may be had quite cheaply now.

Interaction between transformer coupled audio frequency amplifier stages is usually the result of incorrect design or poor wiring. In apparently incurable cases, soft iron of about gauge 24 may be used to shield these stages.

Some experiments were undertaken by the writer to determine the relative merits of copper and tinned iron sheet when used for the shielding of radio frequency carrying stages.

Several boxes were made consisting of several thicknesses of tinned iron and copper sheet, the dimensions of all boxes being identical and the lids fitting closely. An oscillator was placed in each box in turn, and a sensitive receiver, completely shielded, placed some yards away in the same room. It was found that copper was far superior to tinned iron of any thickness. It was found that a tuning coil could be placed within an inch of a copper shield without any serious losses occurring, while if the same coil were placed within three inches of a tinned iron shield serious losses would occur.

At the lower audible frequencies of around 200 cycles, it was found that any of the usual shielding materials, and tinned iron were of little or no value for shielding. Soft iron will, however, restrict the magnetic field surrounding an a.f. transformer core.

A point to remember in shielding is never to allow a tuning coil to come closer than an inch to a shield. There is no need, however, for the coil to be

placed further than 1½ in. away from a shield.

It has been stated erroneously on numerous occasions that by covering the back of a panel with tin foil, shielding will be satisfactory. Foil is far too thin to be of any use for shielding purposes, and it will be found to be quite ineffective in most instances.

Hum may often be introduced into a circuit when the field surrounding a power transformer, filter choke or rectifier permeates the tuning coil. This hum can often only be eliminated by shielding of the coil. Aluminium canisters, such as are available from any hardware store are particularly suitable for this purpose, and may be obtained for a few pence.

When using a metal panel all earthed components may be mounted directly upon the panel. General a.c. receiver construction practice uses a metal aluminium or copper chassis, all connections to ground being taken to the metal by means of suitable machine screws and solder lugs. A point to note is to always connect tuning condensers across the inductances they are to tune, by means of connections and not through the metal of the chassis.

Shielding is effective in finishing of a job. It is not always possible for the home set builder to construct power pack gear which will have the finished appearance of the commercial article, and this is where shielding comes in useful if it is used for no other reason than that of improving the appearance of a finished receiver.

Many home builders of electric receivers are puzzled when a hum prevents satisfactory reception of the more powerful broadcasting stations, while signals may be quite perfect when listening to weaker transmissions. This effect is due to induction. A field surrounds the tuning coil. Obviously this field will be stronger and will extend further when the circuit is tuned to resonance with a powerful signal. If this field extends sufficiently in a poorly designed receiver, it will cut the fields surrounding power pack apparatus, the result being the introduction of a.c. noise into the circuit. When tuned to weaker transmissions, the field surrounding the tuning coil does not extend so widely, the lower powered transmissions being boosted up in the detector stage itself by use of regeneration or feedback. Shielding of the tuning coil would in most cases eliminate the hum on the power powerful transmissions. However, in the case of particularly bad design, the use of shielding might not cure the trouble completely.

A Four Valve Radio-Gramophone Combination

A receiver using a regenerative detector stage followed by two amplifier stages, the final stage in push pull.

ONE of the best all-round combinations incorporates a regenerative detector stage, followed by a single amplifier stage using an indirectly heated valve driving a push-pull final power stage.

This combination will give adequate volume on all transmissions, the output when using a pick-up and recordings being sufficient for dancing in a medium-sized room.

In this particular combination a stage of resistance capacity coupling is used between the detector and power stages. This stage may be replaced by impedance coupling or by the more usual transformer coupling.

The coils should be wound in the same manner as in the two-valve receiver. There need be no shielding in this circuit. The tuning condensers C1 and C2 should be of the same capacities as the condensers in the two-valve circuit. The grid condenser C3 should be of .00025 mfd. capacity. The condensers C4, 6, 7 and 8 are by-pass condensers of .1 mfd. capacity.

The resistance R1 is the grid leak, its value lying between 1 and 3 megohms.

The resistance R2 is the plate resistor of the coupler, and should be of

100,000 ohms., and wire wound. The resistance R3 is the grid resistance of the coupler, and should be a 500,000 ohms. potentiometer, such as the Electrad.

The resistance R4 is the detector stage plate voltage dropping resistance, its value being calculated in the usual manner.

The resistance R5 is the first stage amplifier bias resistor.

The resistance R7 is the final stage amplifier bias resistor. The value of this resistance will be half the value required by one of the type of power valves used in the final push-pull stage.

The resistances R8 and 9 are the centre tapped filament resistors.

The condenser C5 is the coupling condenser, and should be of .006 mfd. capacity. In some cases a value of .01 mfd. here may be better.

The condenser C9 is the 4 mfd. capacity filter condenser.

The condensers C10 and C11 are 2 mfd. capacity filter condensers.

CH is the centre tapped filter choke of 60 henries.

X is the torch globe fuse. The type of rectifier used will, of course, depend on the types of valves to be used in the receiver combination. If the

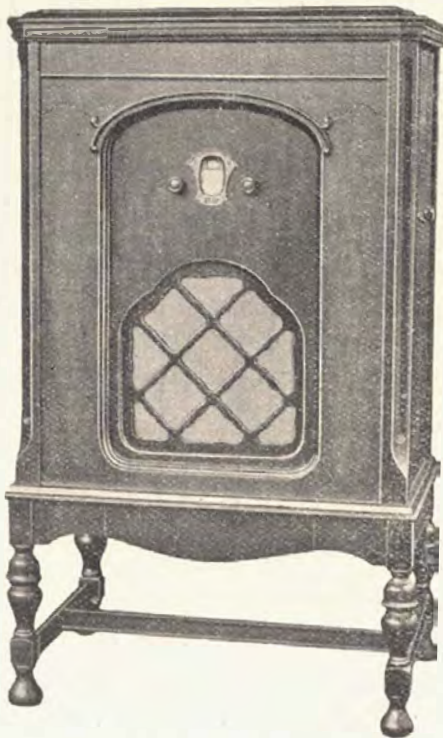

The "Grand Vizier," a commercial design by the Astor manufacturers. The speaker may be a dynamic or cone type fitted into the bottom of the cabinet. The cabinet design is after period style, and illustrates the trend of present-day ideas in housing radio-gramophone combinations.

A four valve radio-gramophone combination using a push pull final stage amplifier. The circuit is complete in every detail. Separate filament heating secondaries must be used for the detector and first amplifier stage, and the final stage push pull amplifier as shown. The panel light may be seen connected across the final stage amplifier filament heating secondary. If a dynamic speaker is used, its field winding may be used to replace the filter choke when the series power pack type field is used.

The direct method of aerial coupling may be replaced by the aperiodic method shown in the dotted lines on page 80. The resistance-capacity coupled amplifier stage may be replaced by impedance, double impedance or transformer coupling if preferred.

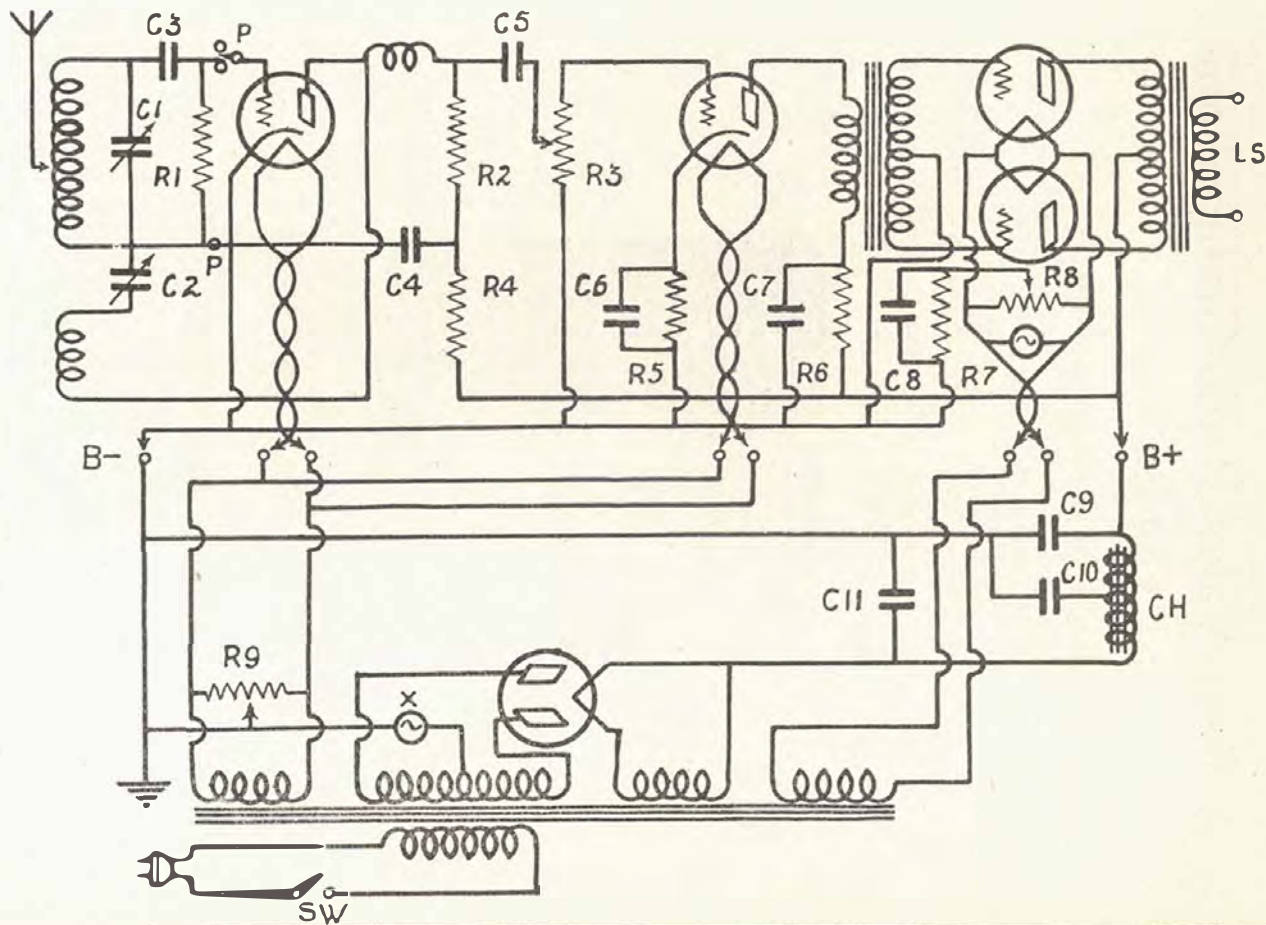

final stage valves were to be type 250s, a pair of 281 type half-wave rectifiers, in conjunction with a power transformer of the necessary size, would be necessary. For ordinary purposes a rectifier to deliver 300 volts at a maximum of 100 milliamps. will be suitable.

The power pack details must, of course, be decided upon before the plate voltage dropping and bias resistor values are calculated.

Before purchasing transformers, valves and speaker, read carefully through the notes on the matching of impedances.

When a fair amount of power is required, a pair of type 245 tubes in the push-pull stages will provide sufficient power to drive a big dynamic speaker. A high impedance indirectly heated tube may be used in the resistance-coupled stage, while an indirectly heated detector tube such as the type 227 or the E415, or any other of the English or American indirectly heated tubes possessing suitable characteristics may be used.

In operation, the receiver will tune in the same manner as the two-valve receiver, or any battery-operated regenerative set, with which you have been familiar. If voltages and resistance values are calculated carefully before attempting the construction of the receiver it will just be a matter of purchasing the parts, assembling them, and finally switching on the receiver and operating it.

This type of receiver is particularly suited for installation in the console type of cabinet. Fitted with an illuminated dial, the panel of the receiver will provide an excellent appearance. The circuit shows how the dial light may be supplied by the power valve filament secondary.

If it is intended that a dynamic be used, the series power pack type of field winding should be specified.

The field winding may then take the place of the filter choke, the centre tapping being disregarded. If hum is prominent in the speaker output, the field winding may be connected in series with the filter choke. The resistance of the field may drop the voltage a little, but insufficiently to affect the operation of the receiver.

In purchasing power valves for the push-pull final stage of the combination, see that they are evenly matched.

Have several valves inserted in the dealer's valve tester at the same filament voltage, noting the plate current reading for each valve. Select two valves which give somewhere near the highest reading, and give most nearly the same plate current reading.

The method of aerial coupling in this circuit may be replaced by aperiodic coupling, as shown in the dotted lines in the two-valve circuit. If the mains filter is used, selectivity with the tapped grid coil will be found to be quite sufficient for the majority of localities. Those who are unfortunate enough to be situated within one or two miles of one of the powerful broadcasting stations must use a tuned r.f. stage if stations are to be separated, and the use of the mains filter will be a necessity.

Obviously we cannot give bias and plate resistor values in the circuit diagram since these will vary with each different type of valve used, and with each different type of rectifier and power pack. Resistance values should not be calculated until the voltage available at the output terminals of the power pack has been tested with a load of about 40 mills. across the pack. Use a high resistance voltmeter to obtain an accurate reading.

We would suggest that the builder of any of these receiver or amplifier combinations invest in an 0-1 milliammeter, in conjunction with a switch arm and studs and resistances, as shown in page 71. Use of a 10,000, a 250,000 and a 500,000 ohms resistance will provide a three range instrument to give highly accurate voltage readings of from 0-10, 0-250 and 0-500.

Before calculating plate voltage dropping resistor values it is essential to ascertain the exact maximum plate voltage available from the eliminator when the pack is under a load nearly similar to that placed upon it in supplying the receiver.

Calculation of power details will have shown the total plate current to be drawn by the valves of the combination. By use of a milliammeter, a load in the form of a resistance should be adjusted to draw this current value, the voltage across the high voltage terminals of the pack being ascertained by use of the high reading voltmeter. This will give accurate information to work on when calculating plate resistor values.

Types and Makes of Resistances

RADIOKES TYPES

(Wire Wound)

TYPE	RESISTANCE (ohms)	CURRENT CAPACITY (Max. Ma's)	TYPE	RESISTANCE (ohms)	CURRENT CAPACITY (Max. Ma's)
H2	200	75	MD565	5,650	100
H2A	250	"	MD440	4,400	100
H3	300	"	M10	1,000	50
H3A	350	"	M10A	1,070	50
H3B	375	"	M11A	1,153	"
H4	400	"	M12	1,200	"
H4A	450	"	M12A	1,250	"
H5	500	"	M13A	1,384	"
H5A	550	"	M15	1,500	"
H6	600	"	M15A	1,562	"
H6A	650	"	M16A	1,636	"
H7	700	"	M18	1,800	"
H7A	750	"	M20	2,000	"
H8	800	"	M21	2,100	"
H8A	833	"	M22A	2,250	"
H8B	850	"	M25	2,500	"
H9	900	"	M33A	3,340	"
H9A	970	"	M35	3,500	"
H10	1,000	"	L3	3,000	25
H14A	1,475	"	L3A	3,500	"
H20	2,000	"	L4	4,000	"
L6	6,000	25	L4A	4,500	"
L7	7,000	"	L5	5,000	"
L7A	7,500	"	EH6	600	100
L10	10,000	"	EH6A	650	"
L12A	12,500	"	EH7A	750	"
L15	15,000	"	EH8A	818	"
L20	20,000	"	EH12A	1,280	"
A20	20,000	4	EH14	1,400	"
A25	25,000	"	VH15	1,500	100
A50	50,000	"	SD129	12,900	60
A75	75,000	"	MD729	7,290	100
A100	100,000	"	MD590	4,700	100

FERRANTI TYPES

(Wire Wound)

—	100,000	5	—	15,000	10
—	75,000	5	—	10,000	10
—	60,000	5	—	8,000	15
—	50,000	5	—	6,000	15
—	40,000	5	—	5,000	15
—	35,000	5	—	4,000	20
—	30,000	5	—	3,000	30
—	25,000	10	—	2,000	40
—	20,000	10	—	1,000	45

Types and Makes of Resistances

ELECTRAD TYPES

(Wire Wound)

TYPE	RESISTANCE (ohms)	CURRENT CAPACITY (Max. Ma's)	TYPE	RESISTANCE (ohms)	CURRENT CAPACITY (Max. Ma's)
B2	200	353	C5	500	316
B3	300	289	C7.5	750	259
B4	400	250	C10	1,000	224
B5	500	224	C20	2,000	158
B7.5	750	182	C50	5,000	100
B8	800	177	C60	6,000	91
B10	1,000	158	C75	7,500	82
B12.5	1,250	141	C100	10,000	71
B15	1,500	129	C150	15,000	58
B20	2,000	112	C250	25,000	45
B22.5	2,250	105	C500	50,000	32
B25	2,500	100	C1000	100,000	22
B30	3,000	91	D2	200	610
B35	3,500	84	D3	300	500
B40	4,000	79	D5	500	387
B45	4,500	75	D7.5	750	316
B50	5,000	71	D10	1,000	274
B60	6,000	64	D20	2,000	194
B70	7,000	60	D50	5,000	122
B75	7,500	59	D60	6,000	112
B100	10,000	50	D75	7,500	100
B150	15,000	41	D100	10,000	87
B200	20,000	35	D150	15,000	71
B250	25,000	32	D250	25,000	55
B500	50,000	22	D500	50,000	39
C2	200	500	D1000	100,000	27
C3	300	406			

VARIABLE TYPES
(Power Wire Wound)

T50	5,000	71	T250	25,000	32
T100	10,000	50	T500	50,000	22
T150	15,000	41			

PILOTRON TYPES.

967	15	—	352	10	—
966	225	—	354	20	—
959	900	—	356	50	—
954	650	—	358	75	—
965	750	—	200	200	—
955	850	—	400	400	—
962	1,000	—	904	4	—
963	1,500	—	906	6	—
956	1,200	—	910	10	—
958	2,000	—	920	20	—
951	2,250	—	930	1,000	—
964	3,000	—	931	1,000	—
953	10,000	—	932	2,000	—
960	12,700	—	935	400	—

The circuit of the receiver and power pack can be very easily followed in this diagram of the complete arrangement. The dotted lines show how aperiodic aerial coupling may be used if desired. By taking tappings at the correct places on the grid tuning coil however, selectivity for most requirements will be quite satisfactory. This circuit will give best results when using a fairly high impedance magnetic type cone speaker such as the Mullard Music Maker or the Philips Baby Grand, or any other reliable makes. Fitted into a baffle board there would be little to beat the magnetic type speaker used in conjunction with this receiver. The condensers C7, C8 and C9 are the filter condensers and should be mounted in the power pack. The power pack should be separately installed and tested, the connections between the unit and the receiver being by means of six flex leads.

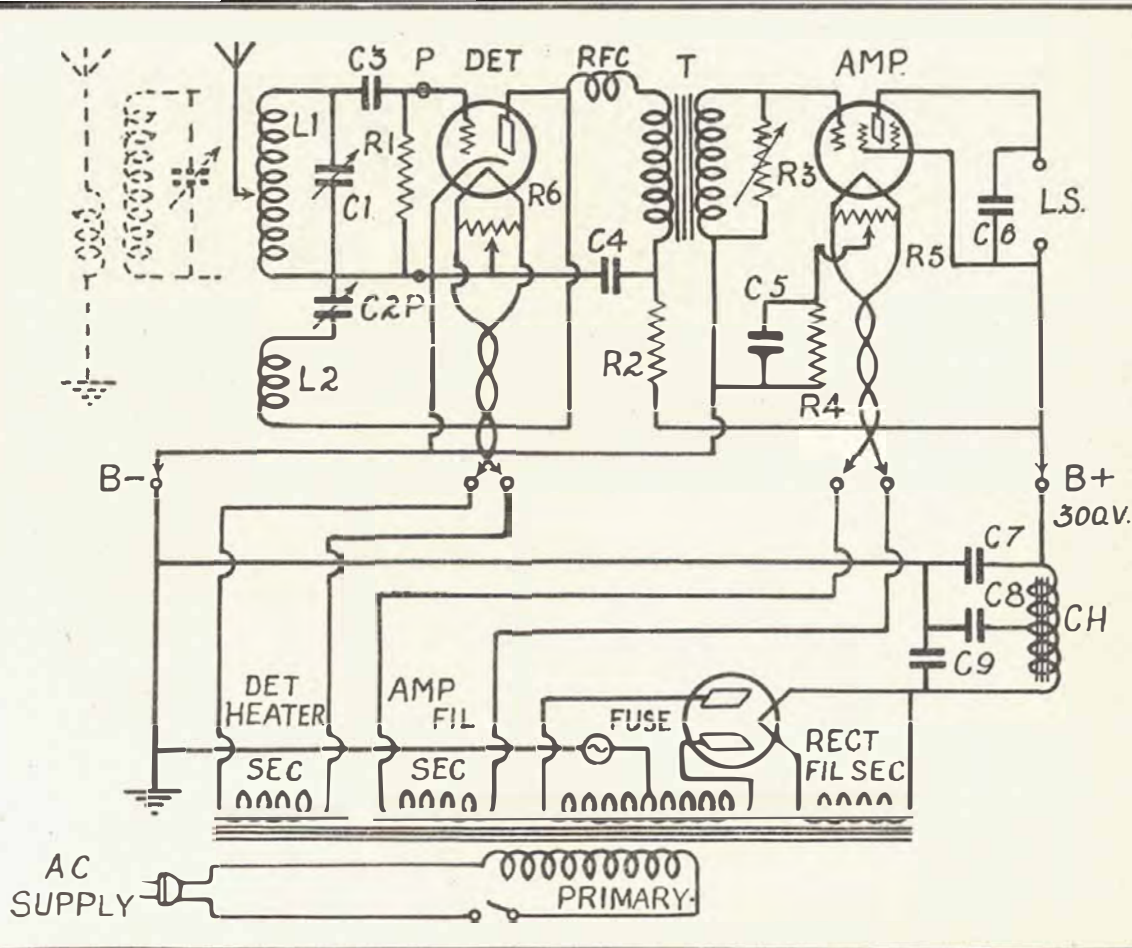

A Two Valve Radic-Gramophone

An easily built combination which by use of a pentode valve, will provide sufficient volume for average requirements.

BY use of a pentode valve, sufficient gain will be available in a single amplifier stage following a regenerative detector circuit, to obtain sufficient volume from this combination to provide good speaker reproduction of the broadcasting stations and gramophone recordings.

Actually, the volume available from this two-valve combination will be almost, if not as great as that from a three-valve receiver using ordinary tubes in the two amplifier stages.

The circuit is really the "Improved Reinartz Two" electrified. So popular has the battery version of this circuit become, that it has been reprinted on three occasions to supply the demand for copies. The tuning arrangement is a standard one, and the method of aerial coupling makes best use of the signal energy picked up by the antenna system.

Reference to the circuit diagram of the power pack and the receiver will show that the arrangement is very simple and easily followed. There will only be six connections between the power pack and the receiver. These will be the two a.c. filament heating secondaries, the B negative and the B positive. Simple, isn't it? If you have read through the notes on power pack design and construction, you will have no difficulty in following the simple circuit of both receiver and power pack.

Here we have a list of parts required to build the complete receiver.

- Tuning condenser (C1) .0005 mfd.
- Tuning condenser (C2) .00015 mfd.
- Grid condenser (C3) .00025 mfd.
- By-pass condenser (C4) .01 mfd.
- By-pass condenser (C5) .01 mfd.
- By-pass condenser (C6) .002 mfd.
- Grid leak (R1), 2 megohms resistance.
- Plate voltage dividing resistor (R2), 200,000 ohms.
- Volume controlling resistance (R3), 0-500,000 ohms.
- One 3-1 a.f. transformer.
- One U.Y. type valve socket.
- One U.X. type valve socket.

Two 20 ohms. centre tapped filament resistances (R5, R6).

R.F. choke.

Six clamp type terminals.

Several yards of small single flex.

Vernier dial for tuning condenser.

Bakelite or metal panel (depending upon design).

Some gauge 20 copper wire and spaghetti.

Coils as described.

Wooden baseboard or metal chassis (depending upon design).

Power Pack Parts

- One power transformer.
- One 60 henry centre tapped choke.
- U.X. 280 type rectifier and socket.
- Two 2 mfd. capacity filter condensers (C8, C9).
- One 4 mfd. capacity filter condenser (C7).
- One torch globe and socket.

Before attempting the construction of the receiver the design of the containing cabinet should be settled upon. The cabinet may be of metal or of wood. Since the combination will give excellent reproduction of disc recordings, the outfit could well be installed in a standing cabinet. This design would permit the power pack being built into the form of a compact unit, which could be placed at the bottom of the cabinet with the loud speaker.

If a metal cabinet is settled upon, the tuning condensers and the volume control need not be mounted on a panel. They can be loosely wired into the circuit, to be mounted to the metal of one side of the cabinet when installing the receiver. This design will have an excellent appearance if an illuminated drum type dial is used.

Review Of The Parts

The TUNING CONDENSER C1 should be of the s.l.f. type preferably. This condenser may be fitted with a drum or any other form of dial.

The REACTION CONDENSER C2, which is the one of .00025 mfd. capacity, may be a 23 plates midget type, after the style of the Radiokes type.

The midget type of condenser here will render construction a more simple matter, since it will take up little space.

The GRID CONDENSER C3 should be of the mica dielectric type preferably. Leakage in such a condenser can do a lot to upset the operation of the detector stage.

The BY-PASS CONDENSER values are not especially critical, and may lie between .01 and .1 mfd. capacity.

The LOUD SPEAKER BY-PASS CONDENSER C6 should have a capacity of no greater than .002. There is a slight tendency in the pentode valve towards emphasis of the higher frequencies. The prominence of these frequencies is reduced by use of the speaker bypass condenser, the effect of its use being to improve reproduction. The GRID LEAK resistance R1 should be of a good quality metalised filament type. The value required may vary in each different receiver, so that in order to obtain best possible results in the detector stage it would be wise to try several values between 1 and 5 megohms, noting the effects when using each. This applies to any detector valve circuit.

The PLATE VOLTAGE DIVIDING RESISTOR, since plate current consumption by the detector valve will be no greater than $1\frac{1}{2}$ mills. under normal conditions, may be an 0-250,000 ohms. variable type, such as the Electrad. The use of such a variable resistance is to be recommended, since it will enable the plate voltage applied the detector stage to be varied. Care must be taken not to adjust the resistance so that too small a value is included between its terminals, otherwise too high voltage will be applied the plate of the detector valve, the excessive plate current flow damaging the resistance.

The VOLUME CONTROLLING resistance R3 should be an 0-500,000 ohms. type. The volume control is necessary. Volume with this re-

ceiver may often be excessive, so that the use of some control is advisable. The writer has found the method of shunting the transformer secondary with the volume controlling resistance to be the most satisfactory method in nine out of ten cases.

The A.F. TRANSFORMER may be of 3-1 or greater ratio. Use a good reliable make of component, since the expenditure of a few extra shillings here will be well worth while.

The UY TYPE VALVE SOCKET is a five point type and contains the indirectly heated valve.

The UX TYPE VALVE SOCKET contains the amplifier valve, the fifth connection to the pentode being taken to the terminal at the base of the valve.

The BIAS RESISTOR must be of a wire wound type, since it must carry the total amplifier plate current. The 20 ohms. CENTRE-TAPPED FILAMENT RESISTANCES across the two valve socket filament terminals may be constructed from nichrome wire, as has already been shown.

The R.F. CHOKE may be a commercial type, or it may be home constructed. A very efficient choke may be made by bolting two 1 in. diameter fibre

discs together using a brass machine screw and an $\frac{1}{8}$ in. fibre spacing washer $\frac{1}{8}$ in. in diameter. The former may be filled up with gauge 40 or finer insulated wire.

The clamp type TERMINALS will be needed for the aerial and earth connections and speaker and pick-up connections.

The single FLEX will be used for filament and "B" connections between the receiver and power pack.

The VERNIER DIAL if of the illuminated drum type will greatly enhance the finished receiver. If using the illuminated type see that neither connection to the dial light goes to the frame, otherwise there will be a partial short across whichever secondary the lighting supply is obtained from.

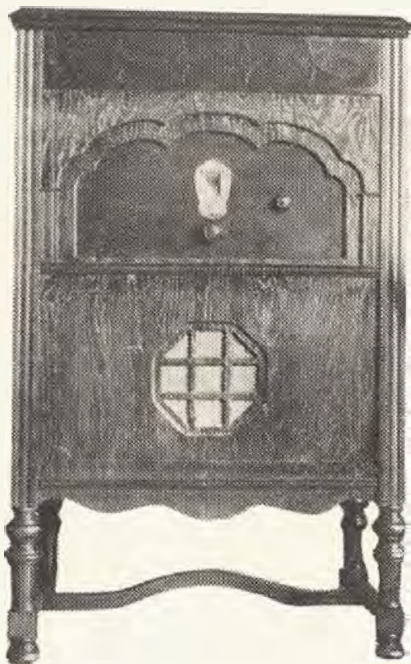

An example of home cabinet construction showing design suitable for Radio-Gramophone combination described in this article.

The SPAGHETTI and gauge 20 copper wire will be used for connections in the receiver and power pack.

The Power Pack

In the design of the POWER TRANSFORMER we will need two separate filament heating secondaries, a rectifier filament heating secondary and a plate supply secondary. The use of the separate filament secondaries is advisable, since by use of a single secondary, the heater of the detector valve would be at a positive potential with regard to the cathode of this valve.

The transformer can of course be purchased ready made at quite reasonable cost.

The receiver may be constructed to take an ordinary power valve in the amplifier stage, but the volume obtainable from the receiver if this were done would hardly be sufficient for ordinary purposes.

The 60 HENRY CENTRE TAPPED FILTER CHOKE may be constructed from details already given on this subject.

The FILTER CONDENSERS should be of the 600 volts test type.

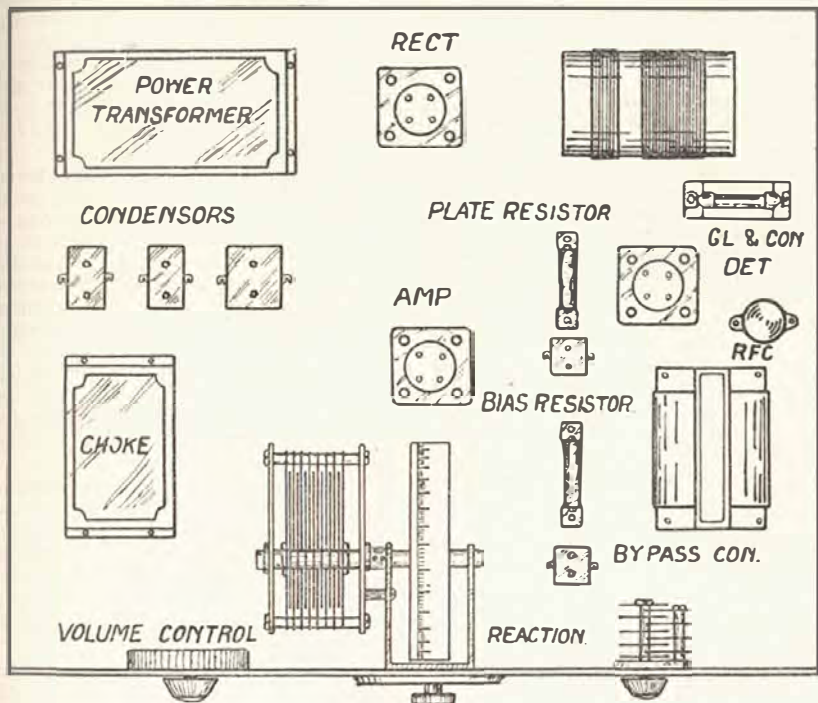

Layout details for the circuit, showing how the various components should best be placed to prevent any possibility of interaction in any part of the circuit.

This might result in detector stage instability.

The voltage of the various secondaries will depend upon the receiving and rectifying valves we are to use.

In order to supply the pentode valve with its maximum plate voltage, a U.X. 280 type rectifier in conjunction with a high voltage secondary delivering 350 volts either side of the centre tapping will be needed. Referring to the chart we would find that this type of rectifier requires a filament heating secondary to deliver five volts. By following the notes on transformer design, it will be possible, after the valves and rectifier have been selected, to determine the wattage size that will be needed.

The TORCH GLOBE functions as a fuse in the power pack. Should a short occur in the receiver, or one of the filter or by-pass condensers break down, the globe will burn out before any damage can be done.

The power pack gear may be mounted in a corner of the table type cabinet, if one of these is used, or it may be built on a separate baseboard and housed at the bottom of a console type or standing gramophone cabinet.

Construction

In laying out the receiver and power pack parts it would be advisable to follow the layout diagram as closely as possible. The diagram will give the

correct idea of how to go about the spacing of the components, although it is not drawn to scale.

The tuning coils should be placed so that there is at least six inches to spare between them and any of the filter, transforming or rectifying gear. The coil L1 consists of 45 turns of gauge 24 d.c.c. wire, wound on a 4in. length of 3in. diameter former, and tapped at the 35th, 40th and 42nd turns. The tappings should be taken in the form of small loops. The coil L2 consists of 20 turns of the same gauge wire wound at the end of the first coil and in the same direction as this coil.

The coils should be mounted so that they do not come within six inches of the transformer rectifier or filter gear. The pick-up terminals should be mounted within four inches of the detector valve socket. If a pick-up switch is used it must be mounted next the detector valve socket, and should be of the anti-capacity type, being operated from the gramophone turntable or the panel by means of an ebonite rod.

Commence the wiring by connecting a length of flex to the aerial terminal. A small alligator clip is fastened to the end of the flex. This clip will connect to any of the three tuning coil loops.

The beginning of the 45 turns coil connects to the fixed plates of the tuning condenser C1 and to one side of the grid condenser C3.

Connect the other side of the condenser C3 to the grid terminal of the detector valve socket, one side of the grid resistance R1 and to one of the pick-up terminals.

Connect the other side of the 45 turns coil to the movable plates of both tuning condensers C1 and C2, the B negative and earth terminals, and thence to the other side of the grid leak R1, the cathode terminal of the detector valve socket, the other pick-up terminal, the centre tapping of the detector stage filament resistance, one side of each of the by-pass condensers C4 and C5, the F terminal of the secondary of the a.f. transformer, one of the volume control terminals and to one side of the bias resistor R4.

If a metal chassis is used all these connections to the B negative and earth terminals can be taken to the metal.

Connect the beginning of the reaction coil to the fixed plates of the reaction condenser C2. Connect the end of this coil to the plate terminal of the detector valve socket and to one side of the r.f. choke.

Connect the other side of the r.f. choke to the P terminal of the primary of the a.f. transformer. Connect the B terminal of the transformer to one side of the plate resistance R2 and to the other side of the condenser R4. The other side of the resistance R2 connects to the B positive terminal.

Connect the grid terminal of the transformer secondary to the other side of the volume controlling resistance R3 and to the grid terminal of the amplifier valve socket.

The plate terminal of this socket connects to one of the speaker terminals and to one side of the condenser C6. The other speaker terminal connects to the other side of the condenser C6 to a length of flex and to the B positive terminal. This flex will connect to the terminal at the base of the pentode valve.

The centre tapping of the amplifier filament resistor connects to the remaining side of the resistance R4, and to the remaining connection of the by-pass condenser, C5.

Connect the outside connections of the filament resistors across their respective filament terminals.

Tightly twisted flex leads will connect the two filaments to the two filament heating secondaries of the power pack.

This completes the wiring of the receiver.

Power Pack

Connect the transformer primary terminals to a pair of flex leads connecting to a mains supply plug. Connect the ends of the high voltage secondary one to each plate of the rectifier valve. The plate connections to the U.X. type rectifier valve socket will be to the G and P terminals of the socket.

Connect the rectifier filament heating secondary to the F terminals of the rectifier valve socket. Connect one of these terminals to one side of the 60 henry filter choke and to one side of the first 2 mfd. capacity filter condenser.

Connect the other side of the choke

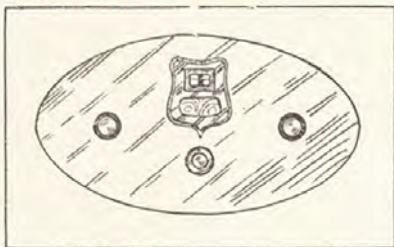

When fitting the finished receiver into a console cabinet, the panel will be similar in appearance to the above diagram.

to one side of the 4 mfd. capacity filter condenser and to the B positive terminal of the pack. Connect the centre tap of the choke to one side of the second 2 mfd. capacity filter condenser.

Connect the high voltage secondary centre tap to one side of the torch globe socket. Connect the other side of this socket to the remaining connection of each of the filter condensers and to the B negative terminal of the pack.

This completes the wiring of the pack.

Since the rectifier filament heating secondary is at positive potential with regard to all other windings, it should be well insulated with Empire cloth. Several layers of the cloth should be used, in order to ensure absolute safety. Since the power pack is to deliver 300 volts, wire the pack carefully. It would be preferable here to use thickly walled rubber flex for the wiring.

Adjustment

Before installing the power transformer it should of course be tested for accuracy of the secondary voltage outputs.

After wiring receiver and power pack and checking over the connections several times, the mains plug may be plugged into the power point or light socket, after connecting the aerial, earth and speaker to their respective terminals. A few seconds after the receiver has been switched on a faint hum will be heard. Most of this hum will disappear after a few more seconds and on turning the reaction control quickly a "plop" will be heard, this indicating that the receiver is going into oscillation.

After baring the coil loops, connect the clip to one of them, and on turning the tuning dial, stations will be heard, their strength being boosted up by use of the reaction control, with the volume control including the full resistance between its terminals.

Whichever loop gives the right degree of selectivity and volume should be used.

On connecting a pick-up to the pick-up terminals and playing it upon a disc recording, volume should be sufficient for an average sized room when the volume control is fully open.

The type of speaker used with this receiver may be any of the power magnetic types.

For ordinary purposes nothing bigger than this simple little two valver will be required. It is easily assembled, and may be used in conjunction with any commercial make of "B" eliminator and filament transformer.

The length of aerial required will depend on the proximity of the nearest broadcasting station and the tuning coil tapping used. The tapping nearest the earth end of the tuning coil will give greatest selectivity but least volume. The highest tapping will give greater volume, but selectivity will not be as good.

Any general purpose type of indirectly heated valve may be used in the detector stage, provided it is supplied with the correct filament voltage. Any pentode valve which requires a maximum plate voltage of 300 or 400 will be suitable for the amplifier stage.

Before attempting the calculating of bias resistor or plate resistor values decide on the voltage the power pack is to deliver, and the type of valve to be used in each stage of the receiver combination. After installing the power pack, it would be well worth while to have the high voltage output tested by use of a high reading d.c. voltmeter. This will provide accurate information to enable the resistance values to be calculated correctly. If the power pack delivers 320 volts, it would be advisable to make calculations for a maximum voltage of 300 or even 290, since, under load, the output voltage will drop this 20 or 30 volts.

Before installing the receiver in a console type cabinet with built-in speaker, read the notes on howling. Mechanical feedback will prevent the satisfactory operation of any self-contained receiver, and would be a source of mystery to the home-set builder were he not familiar with the source of the howling and its remedy.

Important

In obtaining power to light the dial light, use either of the filament heating secondaries. Do not use the rectifier heating secondary—this winding is at a positive potential, and its use might result in shocks or shorting of the plate power supply.

Referring to the layout diagram, it would be advisable to mount the rectifier valve nearer the power transformer than shown so as to keep this valve well away from the tuning coil former. The pickup terminals or sockets may be mounted at the back of the baseboard or sub-panel near the grid leak and condenser. The speaker output terminals may be on the baseboard or sub-panel near the reaction condenser on the right of the set. The filament resistors may be mounted in the power pack or at the heater terminals of the valve sockets. The sockets are shown merely to indicate their position, the detector stage socket being of course a UY type to accommodate the indirectly heated detector valve.

The circuit for the Band Pass three. The r.f. stage is highly selective and in many localities interstate reception may be expected. The r.f. stage should be completely shielded from the detector stage. See that the tuning coils do not come closer than $\frac{1}{2}$ in. of the shielding material. A pick-up may be connected into the grid circuit of the detector valve. Sufficient volume for average requirements may be expected when playing records. The centre tapped filament resistor R8 may be mounted in the power pack or at the heater terminals of r.f. or detector valves. In wiring up the circuit be sure to connect the primary coil of the band pass coupler the right way round. It might be advisable to try using the coil both ways round when operating the receiver, noting the effects of each connection.

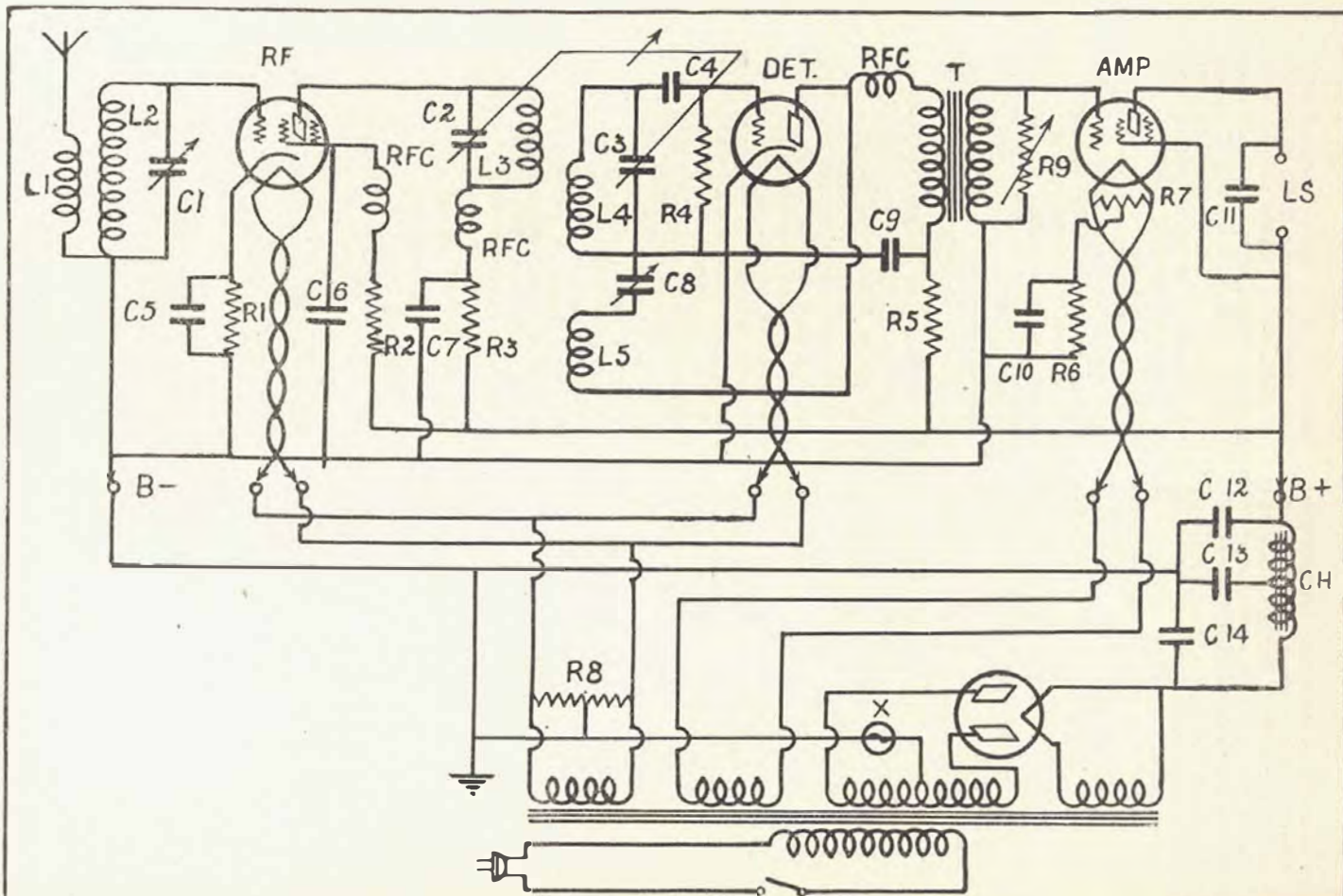

A "Band-Pass" Three

A combination from which good speaker reception of all local broadcast and experimental stations may be expected. The original receiver brought in interstate transmissions without interference from local stations.

WHILE for ordinary purposes the two-valve Reinartz receiver using a pentode valve will be quite sufficient, in order that we may receive the weaker amateur transmissions with good volume, the use of a tuned stage of r.f. may be necessary.

In the a.c. screened grid valve we are able to obtain a high gain, provided proper coupling methods are observed. It is useless to expect the screened grid valve to operate satisfactorily when it is connected into a socket formerly occupied by an ordinary tube in an r.f. stage.

This three-valve receiver makes use of what is known as the "band-pass" method of r.f. coupling. The system is highly selective if care is paid to the matching of the band-pass coils. With this three-valve receiver the writer has tuned in interstate stations at good speaker volume when situated some four miles from 3LO's aerial.

The three valve arrangement may be compactly built, volume, when using a pick-up, being sufficient for the average sized room with any recording.

In this circuit the r.f. stage must be completely shielded if best results are to be expected.

Circuit Constants

The coils L1 and L2 are the aerial coupler toroidal coils of the Radiokes Band-pass coil kit.

The coils L3 and L4 and L5 are the coupling coils of the Radiokes kit. Since the coils must be carefully balanced to match, it is advisable for anyone attempting the construction of this receiver to invest in the commercially made coil kit if satisfactory results are to be expected.

The tuning condensers C2 and C3 are ganged to operate from the one dial control. The condenser C1 is separately controlled.

The condenser C8 is the reaction condenser and may be a 23 plates midget. The condenser C4 is the grid condenser, and should be of .00025 mfd. capacity.

Since a commercially made coil kit must be used if satisfactory performance is to be obtained, use of the tuning condenser capacities advised by the coil kit makers is advisable.

The condensers C5, C6, C7, C9, and C10 are .1 mfd. capacity by-pass types of good make and tested to 500 volts d.c. The condenser C11 should be of .002 mfd. capacity.

The resistance R1 is the r.f. stage bias resistor. Its value may be obtained from the chart depending upon what type of a.c. screened grid valve is to be used.

The resistance R2 is the screened grid voltage dropping resistor. Its value may be calculated, as we have shown, by use of the screened grid current consumption value, and the voltage not required.

The resistance R3 is the r.f. plate voltage dropping resistor, the value of which may be calculated by use of the plate consumption value and the plate voltage not required.

The detector plate resistance R5 should be calculated in the same manner as the r.f. plate and screened grid resistors.

The resistance R4 is the grid leak of about two megohms.

The resistance R6 is the amplifier bias resistor. The resistance R9 is the 500,000 ohms volume control.

The resistances R7 and 8 are the filament centre tapped resistors.

The condenser C12 is a 4 mfd. capacity filter condenser. The condensers C13 and 14 are of 2 mfd. capacity each.

X is the torch globe fuse for the protection of the equipment, in the event of a short.

CH is the 60 henry centre tapped filter choke.

In the construction of the power pack, the same procedure should be gone about as in the two-valve receiver. The rectifier may be a 280 type.

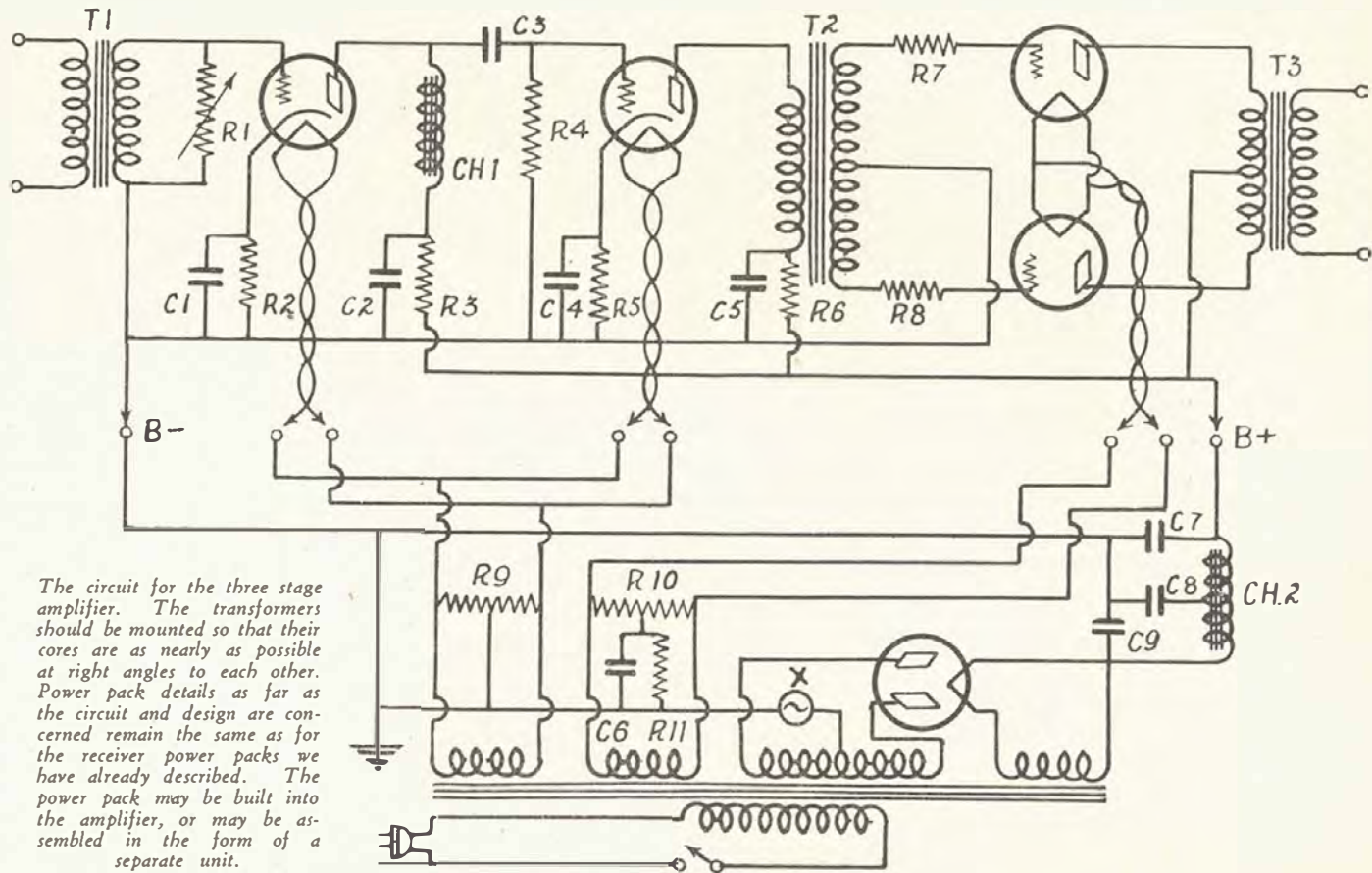

The circuit for the three stage amplifier. The transformers should be mounted so that their cores are as nearly as possible at right angles to each other. Power pack details as far as the circuit and design are concerned remain the same as for the receiver power packs we have already described. The power pack may be built into the amplifier, or may be assembled in the form of a separate unit.

A Public Address Amplifier

*Which may be used to provide music for
dance or party*

THE improvements in receiver design over the past two years have been mainly at the audio frequency end. We have learned more about power valves and how these in conjunction with a.f. coupling equipment and speakers should be matched.

This amplifier circuit is easily built and adjusted, provided the work is gone about in accordance with the notes we have given, and will be capable of distortionless amplification of the impulses from a gramophone pick-up or microphone.

The transformer T1 is the input transformer. To its primary may be connected the output from a receiver, pick-up or microphone. A modulation transformer is, of course, used when a microphone is to be operated in conjunction with the amplifier.

The resistance R1 is an 0-500,000 ohms. volume control. The resistance R2 is the first stage amplifier bias resistor. R3 is the first stage plate voltage dropping resistor. R4 is the impedance coupling resistor of $\frac{1}{2}$ megohm. R5 is the second stage valve bias resistor. R6 is the second stage plate voltage dropping resistor. R7 and 8 are suppressing resistors of 500 ohms. each, used to prevent the possibility of distortion due to a tendency towards oscillation in the push-pull circuit. R9 is the first and second stage centre tapped heater resistance. R10 is the push-pull stage centre tapped filament resistance. R11 is the push-pull stage bias resistance. The value of this resistance will be exactly half that required for a single valve of the type used in the push-pull stage.

C1, C2, C4, C5 and C6 are by-pass condensers of between .01 and .1 mfd. capacity. C3 is the impedance coupling condenser, the capacity of which will be .01 mfd. The transformer T2 is the push-pull input transformer. This may be an ordinary 1-5 ratio transformer across the secondary of which is connected an 0-500,000 ohms. potentiometer, as shown on page 53. The use of this idea will do a lot to help keep the cost of the amplifier down.

The choke CH1 is the detector plate choke, having a fairly high inductance.

The condensers C7, C8, C9 and the choke CH2 comprise the filter portion of the power pack.

X is the torch globe fuse.

Construction of the amplifier is straightforward, and if the components are properly spaced, and the filament wiring put in correctly, there will be no trouble through induction noises. The filter condensers C8 and C9 are both of 2 mfd. capacity. The condenser C7 is of 4 mfd. The choke should be the 60 henries centre tapped type.

The impedance coupled stage may be replaced with transformer coupling if desired. A transformer having a ratio of about 1-3 should be used. If this is done, volume may be controlled by connecting the resistance R1 across the secondary terminals of this transformer. A pick-up may be connected to the primary terminals of the input transformer or in any other of the positions we have shown.

The selection of final stage power valves will depend on what volume is to be required. If a dynamic speaker of the series power pack type of field is used, the field may be connected in place of, or in series with, the filter choke.

T3 is the output transformer, the ratio of which will be ascertained by reference to the output transformer charts.

The centre tapped filament resistors may be mounted in the receiver or in the power pack portion of the combination. The power transformer primary switch is not necessary if it is intended that the receiver be switched off at the wall plug, or light socket.

If this amplifier is used in conjunction with r.f. and detector stages, it may be installed at the bottom of a console cabinet, the r.f. and detector portion being fitted behind the panel. By doing this, the possibilities of hum through induction is rendered remote indeed, if care is taken in the wiring of the a.c. heaters or filaments of the r.f. and detector portion.

The amplifier can be very compactly built and can be fitted into a space no longer than 14 inches, no wider than 10 inches and the height of the valves or transformers. The choke method may be used to replace the output speaker transformer when using the amplifier in conjunction with a magnetic type speaker having a fairly high impedance.

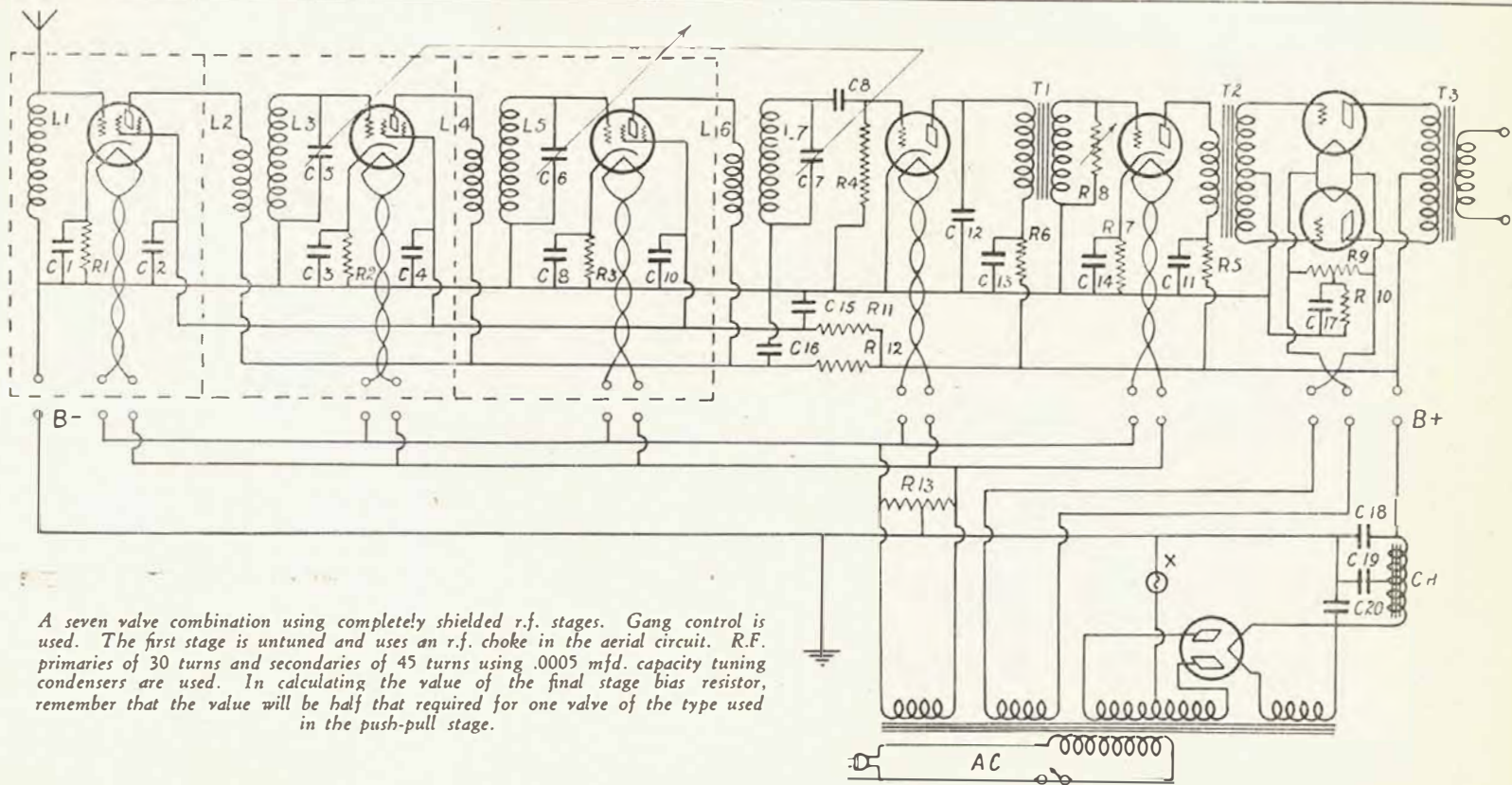

A seven valve combination using completely shielded r.f. stages. Gang control is used. The first stage is untuned and uses an r.f. choke in the aerial circuit. R.F. primaries of 30 turns and secondaries of 45 turns using .0005 mfd. capacity tuning condensers are used. In calculating the value of the final stage bias resistor, remember that the value will be half that required for one valve of the type used in the push-pull stage.

An Experimental Microphone

Constructional details of a useful instrument which will ensure the success of the public address system and will be of particular interest to experimenters.

WHILE the ordinary telephone microphone can often be put to good use for transmitting and public address purposes, it is usually erratic in its performance, while quality of reproduction is not of the best.

The block type of microphone, depending upon the variation of the resistance of a carbon layer for its operation, is capable of very faithful reproduction of music and speech. This type of microphone is still used for outside broadcasting by broadcasting stations.

The construction of a satisfactory microphone has been the stumbling-block to many, but only because of lack of constructional information.

The writer has used this type of microphone with considerable success for a number of years. An idea of the quality of reproduction available when using this type of microphone may be had by those who once listened to VK-3GT when this station was transmitting on the 200 metre band.

The design of this particular microphone is such that it will withstand such rough usage as would be met with in portable equipment. The design makes use of a solid block of black-wood, dimensions 5in. x 4½in. and 3½in. deep. This wooden block may be polished, depending upon whether good

appearance in the finished instrument is desired.

In Fig. 1 we see the front of the wooden block. Two ¼in. carbon rods are fitted into the block through two holes carefully drilled down through the top of the wooden block. Between the rods a channel ¼in. deep is cut. This channel will contain the carbon granules.

Fig. 2 shows how the holes will be drilled down through the top of the block, and how the wooden section to contain the carbon granules will require to be removed. The carbon rods make contact with the ends of the carbon layer.

After drilling to take the rods, which should be 4in. long, and making the recess to take the granules, drill a hole down through the top of the block until the channel is reached, as shown by the dotted lines in Fig. 3.

This hole is to permit the recess to be filled with granules after the diaphragm is put in position.

The diaphragm consists of clear mica split down to the thickness of tissue paper. After the rods have been polished and the recess cleaned and smoothed down with fine emery paper, the diaphragm, which should be 4in. x 3½in., should be securely glued to the surface of the block. Care must be taken to see that the mica does not crinkle when glueing into position. Secotone may be used as a satisfactory sticking medium.

We now have a diaphragm across the surface of the wooden block, and behind the diaphragm a carved out 3in. x 2½in. section to a depth of ¼in. The carbon rods occupy ¼in. of each end of the section removed.

Connection to the microphone is maintained per medium of two copper caps which fasten securely to the top of each of the carbon rods. The diagrams show the leads from these rods are connected to two terminals mounted on an ebonite strip at the back of the block.



Finished view of the original microphone. The job is built for portability and will stand rough handling. A protective mesh is used to prevent damage to the mica diaphragm.

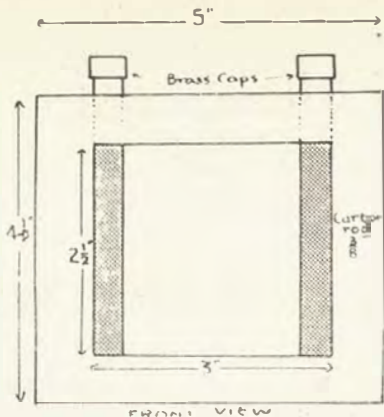

Front view of the block showing how the carbon rods are fitted into the block.

The channel now requires to be filled with granules. Here is where the trouble lies. The home manufacture of these carbon granules is a difficult procedure, results seldom being satisfactory, since the granules must be free from dust, and polished. The best we can do is to endeavor to obtain the material we require from any of the telephone companies. What is known as C.B. carbon, used for telephone work, will prove very successful in this microphone. Coarse carbon as contained in the ordinary telephone microphone cannot be used. The material should be of the same consistency as beach sand, or finer, if it is possible to obtain it. Carbon of this type is expensive, but since less than one ounce will be needed, the total cost of the finished job would be but a fraction of the cost of a commercial job to give the same distortionless reproduction.

Fig. 3 shows how a strap for carrying or supporting of the microphone is fastened into position by means of five small wood screws.

In order to give the job a finished appearance, a frame, the window measurements of which are 3 in. x 2 1/2 in., and the outside measurements 4 in. x 3 1/2 in., is fastened to the face of the wooden block. The frame may be of copper, brass or zinc, or any other handy material.

The object of the large wooden block is to prevent possible jarring of the block by sound impulses, the tendency, if this should happen, being towards distortion of the signals. The microphone does not require to be supported in any manner.

The photograph of the original microphone shows how a wire gauze and ebonite strips are used to protect the mica diaphragm. It is a visitor's ten-

dency to poke a finger through the mica, so that the use of the protecting gauze might be deemed advisable if the instrument is to be used for public address work. Instead of terminals, a long flex lead is used to connect the microphone to the amplifier input. In this particular microphone, connection to the carbon rods is maintained by long brass machine screws taken through the sides of the wooden block. These machine screws, in this particular design, support the carbon rods, these being only the length of the granule channel.

Other materials may be successfully used for the diaphragm. A good piece of the thin transparent paper used for the wrapping of sweets will often prove successful when put to this use, while different thicknesses of stretched rubber will give varying degrees of success.

It is important that the carbon material be free from particles of dust, or other foreign materials.

Gold plated brass or copper electrodes may be used in place of the carbon rods. The use of such electrodes, however, is not absolutely necessary, since by careful cleaning and polishing of the carbon the amount of hiss will be well below signal level, and can be eliminated by use of a resistance across the secondary terminals of the microphone coupling or modulation transformer.

The output from this type of microphone when magnified by use of a two stage transformer coupled amplifier, will give good headphone strength. This means that if the secondary of the

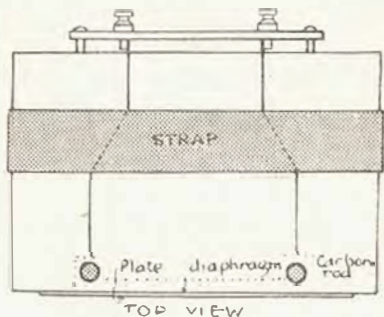

Looking down on the microphone. Connections to the terminals at the back are taken from the metal caps fitted to the carbon rods.

modulation transformer is connected in the grid circuit of the detector valve of a receiver using two transformer coupled stages, the final stage being push-pulled, the volume of the output will be sufficient to drive a speaker at good strength. It may be necessary in many cases to use a separate micro-

phone amplifier in the form of a single stage supplied by a 45 volts B battery and a C battery to supply the "A" current to a .06 type d.c. four volt filament valve.

In order that the microphone may be coupled to a circuit, so that best use will be made of the impulses which it generates, a transformer will be needed. A modulation transformer, because

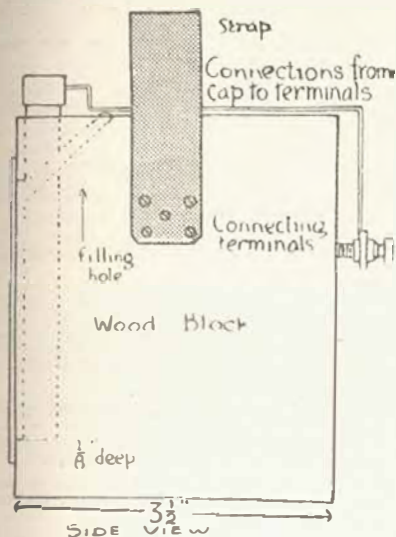

Side view of the microphone showing how the strap is fastened and giving sectional details.

of its name, no doubt, may be an expensive thing to purchase. Any type of loud speaker output transformer having a ratio of 20-1 or greater, may be used as a modulation transformer. The primary of the transformer connects to the grid circuit of the amplifier, the secondary of the transformer is connected in series with a microphone battery and the microphone.

The voltage of the microphone battery is not important, since it may be between 6 and 60, the only difference being in the output. For average purposes a six volt accumulator will suffice, or, if six volt valves are not used, or the amplifier is an a.c. operated job, then a 22½ volts heavy duty B battery can be used, which will give long service, since the current consumption is around 15 milliamperes.

The use of a fixed resistance of 10,000 ohms. connected across the secondary terminals of the modulation transformer (the primary terminals when using an output transformer for this purpose) will improve reproduc-

tion by practically eliminating the high-pitched hiss. The use of the resistance does not reduce the signal strength to any appreciable extent.

For studio work, the microphone will give excellent reproduction of solo instruments, such as the violin, banjo or saxophone.

When reproducing piano, or orchestral music, some strategy must be used in the placing of the microphone, but a little experiment will soon reveal its best position for any particular purpose.

The microphone cannot of course be used in the same room as the loud-speaker, or feed-back results, which sets up a loud howl. The receiver or amplifier, microphone and pick-up should be installed in one room, the loud speaker in any other room, depending on where it is required.

With the microphone, the gramophone pick-up, and a receiver, we have a home broadcasting outfit which will do a great deal to make a party a great success, particularly at a children's party, since, if secrecy is observed, birthday greetings and all manner of things likely to cause amusement, may be put over from some hidden corner of the house.

The microphone in conjunction with modulation transformer and exciting battery would be a valuable adjunct to the set builder in testing the gain of amplifiers. The photograph is of a portable microphone built by the writer. In this design, the carbon rods are only as long as the recess, contact to them being maintained by means of long machine screws through the sides of the block. Blocks of ebonite and many wood screws have been used for all fastenings in order that the microphone will withstand rough usage as would be met with in portable equipment.

The carbon granules should not be tightly packed. They should be allowed to settle after having been poured through the filling hole into the recess. It is not essential that the recess be absolutely filled with the granules.

It is essential that the carbon rods be polished. These should be purchased new and velvet or silk should be used to give them a good finish when installing them. Do not touch the rods with the fingers after they have been polished and fitted into the block.

Smaller sized blocks may be used, but if this is done, the finished instrument may be more susceptible to vibration with the possibility of distortion.

A Glossary of Wireless Terms

Definitions of the terms met with in this handbook

- ALTERNATING CURRENT.**—In an alternating current the voltage rises from zero to its maximum value, whatever potential this may be, then falls back to zero and continues below zero on the negative side, the same value as it rose on the positive side, then coming back again to zero. This positive rise and fall, which commences at zero and ends at zero, is called one cycle, or one period. The number of complete reversals of the current per second is called the periodicity or frequency of the current. In the case of the ordinary a.c. house lighting supply, there are 50 reversals of the current per second.
- AUDIO FREQUENCY.**—Audio frequencies include all of the frequencies of vibration of sound waves which can be detected by the human ear. The lowest audible frequency is about 20 cycles, while the highest frequency which may be audible to some may be as great as 10,000 cycles.
- AMPERE.**—The unit for measuring the flow of current. One ampere is the rate of flow of an electrical current which flows through an electrical circuit whose resistance is one ohm, at a potential of one volt. Amperes do not measure the quantity of electricity, but only the amount of current flowing through a conductor in any given time.
- AMPERE HOUR.**—The quantity of electricity which passes through a circuit in an hour when the rate of the current flow is one ampere. The number of ampere hours is obtained by multiplying the number of amperes flowing through the conductor by the number of hours during which the flow continues. This unit is used principally for the measuring of the capacity of storage batteries.
- AMPERE-TURN.**—One complete turn of a conductor through which current at a rate of one ampere is flowing. The flow in amperes multiplied by the number of turns in the coil will give the number of ampere turns. The unit is used to measure the magnetic strength of a coil or electro-magnet.
- ABSORPTION, Dielectric.**—The loss of energy due to absorption of portion of the initial charge of a condenser by the material used to separate the plates of a fixed condenser. It assumes no importance in air spaced tuning condensers.
- ADMITTANCE.**—The reciprocal of the impedance of a circuit. It is measured in ohms, and its symbol is usually "Y."
- ALTERNATION.**—One half of one complete cycle of alternating current.
- ALTERNATOR.**—A generator to produce alternating current power.
- ALUMINIUM.**—The resistance of this metal is about 1.5 times that of copper of the same size. It is particularly useful for shielding purposes, since it is light, and possesses suitable characteristics for the canning of r.f. stages.
- AMATEUR.**—A person who follows the science of radio for the love of the game. The amateur must not be confused with the "novice," for he may be a highly specialised person.
- AMMETER.**—An instrument used for the measuring of current flow in a circuit. A milliammeter measures current flow in thousandths of an ampere.
- AMPLIFICATION.**—The measure of the increase in voltage, amperage or both, in a radio signal as it passes through the various stages of a receiver combination. There are two kinds of amplification—voltage and power.
- AMPLIFIER.**—An arrangement of valves and coupling devices in which the voltage or power of a received signal may be increased. There are principally two types of amplifier—radio frequency and audio frequency. In the first type, signals are amplified before they reach the detector. In the latter, signals are amplified after they have been made audible by the detector.
- AMPLITUDE.**—The highest voltage or amperage reached by an alternation of an alternating current.
- ANGLE, Electrical.**—A complete cycle of alternating current is considered as consisting of 360 degrees. One half cycle, which is one alternation, then, consists of 180 electrical degrees, one half alternation 90 degrees, and so on.
- ANION.**—A negative ion. Ions formed at the plate of a valve are called anions, those at the filament cations.
- ANODE.**—An electrode through which current enters an electrolyte, a vacuum or any other medium, on its way to the negative of the source of the current. The positive terminal of a battery is the anode. The plate of a valve is called the anode.
- ANTENNA, or Aerial.**—Wires suspended above ground in conjunction with an aerial coil to form an oscillatory circuit, which will respond to signals sent out by broadcasting stations.
- ANTI CAPACITY.**—The procedure taken to see that the smallest possible capacity exists between conductors or components in a circuit.
- ARRESTER.**—A device used for protection of aerial equipment against static or lightning. The arrester consists of a spark gap over which static electricity in the aerial will arc across the arrester gap to ground.
- ATMOSPHERICS.**—Static disturbances caused by electrical charges in the ether which affect radio reception. Static noises are particularly strong in tropical regions, where they may sometimes prevent reception for some months of the year.
- ATTENUATION.**—The decrease in strength of radio signals, which is caused by absorption of signal energy as signals strike objects in their path. The amount of attenuation in the case of long-wave broadcast transmitters depends upon the character of the land over which the signals have to pass.
- AUDIBILITY.**—A measure of signal strength as it affects the human ear. Degrees of audibility are generally specified according to the number of times a signal is louder or clearer than when it is just discernible. A signal may be audible at good strength, and yet be affected by interference. For this reason, readability signals QSA 1-QSA 5 are now used, in conjunction with the audibility signals R1-R10.
- A.W.G.**—American wire gauge.
- BACK COUPLING.**—Feedback in a receiving circuit.
- BAKELITE.**—A phenol compound, which possesses unusual insulating properties, and is used in all electrical work. In the receiver, bakelite is generally used as panel material.
- BALANCING.**—This is the process of neutralising the r.f. stages of a receiver combination to prevent back coupling from plate to grid circuits.
- BALANCING CONDENSER.**—The neutralising condenser used in the prevention of feedback or backcoupling in the r.f. stages of a receiver combination.

- BATTERY B.**—The battery used to supply plate potential for the operation of the tubes of a receiver. The battery may have a potential as high as 350 volts.
- BATTERY, A.**—The battery which supplies the source of filament power for the operation of the tubes of a receiver.
- BATTERY, C.**—The battery which is used for biasing of the grids of the tubes in a receiver combination.
- BEACON, Radio.**—A transmitting station, which sends out signals to be picked up for navigation purposes by ships or aeroplanes.
- BEAM.**—System of transmission which directs the transmitted energy into a definite direction in the form of a beam.
- BEAT FREQUENCY.**—Any alternating current of one frequency may be combined with alternating current of another frequency. When their amplitudes are nearly equal another current is produced. This is called the beat frequency.
- BEE SWAX.**—An animal wax free from acid and dull yellow in color, possessing good insulating properties.
- BIAS.**—In order that a tube may operate on the best portion of its curve, a grid voltage is applied the grid of the tube. This is called bias.
- BINDING POSTS.**—American name for terminals.
- BLANKETING.**—The effect produced by the signals from a powerful station in receivers in the vicinity of the station's transmitting aerial. The station's signals force their way into the circuit, no matter where it is tuned, by shock excitation.
- BLOOPER.**—American term for a radiating receiver.
- BLUE GLOW.**—When the gases of a tube ionise, the tube will emit a blue glow. Ionisation may be brought about by gases emitted by the metals of the tube's elements, if it has been overloaded.
- BODY CAPACITY.**—The capacity existing between body and the parts of a radio receiver. Body capacity may prevent the satisfactory operation of an incorrectly designed receiver.
- BOOSTER.**—Term applied to an r.f. stage which may be added to a receiver to improve its sensitivity.
- BRASS.**—A metal obtained by alloying copper and zinc in various proportions. Used for shielded purposes in the r.f. stages of a receiver.
- BROADCASTING.**—A class of radio communication which consists of the sending out of programmes for entertainment. The broadcasting band extends from 200 metres to 550 metres.
- BUS BAR.**—Term applied to fairly heavy gauges of tinned copper wire used for the connecting up of electrical devices.
- BUZZER.**—An electrical device which emits sound in the form of a buzz. It may be used for code practice.
- B.W.G.**—Birmingham wire gauge.
- BYPASS.**—A condenser used for the conducting of alternating currents back to the negative of their source.
- CAMBIC INSULATION.**—A cloth possessing insulating qualities.
- CAPACITY.**—The ability of any device to contain electricity. The capacity of a device is the amount of electricity it will retain. The unit for measurement of capacity is the farad, but for practical purposes the microfarad, which is one-millionth of a farad, is used. Capacity exists between two conductors which are at different voltages, and are separated by an insulating material.
- CARBORUNDUM.**—Used for detection in a crystal receiver.
- CARRIER WAVE.**—The signal produced by a transmitting station. The carrier wave is modulated according to music and speech.
- CAT'S WHISKER.**—Usually in the form of a small spiral of steel wire to maintain contact with a sensitive spot of a crystal.
- CATHODE.**—The electrode connected to the negative of the current source. In the case of a directly heated valve the filament; in an indirectly heated valve, the material which is heated by the heater.
- CELERON.**—An insulating material similar to bakelite.
- CERESIN WAX.**—An insulating wax used for the impregnation of electrical equipment.
- CHARACTERISTIC.**—The quality of any device, showing its behavior under certain conditions.
- CHARGE.**—The electricity which is retained by a capacity. The amount of power retained by a storage battery.
- CHARGER.**—Any device which will supply direct current for the charging of storage batteries.
- CHASSIS.**—The metal framework of an a.c. receiver combination.
- CIRCULAR MIL.**—The area of a circle whose diameter is one-thousandth of an inch. This term is applied to the area of the cross section of wire gauges.
- CODE.**—A system of short and long signals used to represent characters, for wireless telegraphy communication.
- COIL.**—An inductance in a receiver consists of a coil. Any turns of wire may be called a coil.
- COMPASS, Radio.**—A receiver fitted with a directional loop for the obtaining of bearings aboard ship from another ship or coast stations.
- CONDENSER.**—Any device which will retain an electrical charge.
- CONDENSITE.**—An insulating substance.
- CONDUCTIVITY.**—The conductance measured in mhos through a centimeter cube of a conductor is called the conductivity of that conductor. Conductivity is a measurement of the current-carrying ability of different size conductors.
- CONDUCTOR.**—Any path through which an electrical current may flow. All wires used in electrical work are conductors.
- CONSOLE.**—An ornamental receiver cabinet, in which is installed a completely self-contained radio receiver combination.
- CONTACT.**—The touching of any two conductors, to ensure that current will flow between them.
- CONTINUOUS CURRENT.**—This is direct current in which the current flows in only one direction.
- CONTINUOUS WAVE, or C.W.**—The carrier wave produced by a valve transmitter.
- COPPER.**—The most important of all metals in radio work.
- COPPER CLAD.**—Steel wire is often copper-plated. Such wire may be used in aerial construction.
- COPPER OXIDE RECTIFIER.**—A device using specially treated copper for the conversion of a.c. into uni-directional current.
- CORE.**—The iron centre of a transformer or choke is called the core. The purpose of the core is to concentrate magnetic lines of force through the centre of the winding, to render easier the passage of these lines of force.
- COUNTERPOISE.**—A wire or wire network used instead of an earth connection as part of the receiving system.
- COUPLER.**—Any arrangement of inductances, condensers or resistances so placed that there is magnetic or electrostatic coupling between the circuits.
- CRYSTAL DETECTOR.**—Usually a mineral ore, which possesses the property of allowing current to pass in the one direction only.

- CURRENT.**—The flow of electricity through a circuit is called the current, and is measured in amperes or milliamperes.
- CUSHION SOCKET.**—A shock-absorbing socket.
- CYCLE.**—One complete change of an alternating current from zero to positive, then to negative and back to zero, is called a cycle.
- DIRECT CURRENT.**—Current which flows in one direction.
- DOUBLE COTTON COVERED.**—Applied to the insulation material covering a wire.
- DECREMETER.**—An instrument which measures the decrement or damping effect in an oscillatory circuit.
- DETECTOR.**—Any device which makes radio signals audible.
- DETUNING.**—As this implies, this is the opposite of tuning.
- DIAL.**—An attachment to the control of an electrical device to enable different readings being taken when the position of the device is altered.
- DIAPHRAGM.**—Usually of metal. The material which is affected in a loud speaker or headphones by the changes in the strength of the magnets of the reproducing device.
- DIELECTRIC.**—Any material through which electrical force may act is a dielectric.
- DIODE.**—A valve having only two elements, a plate and a filament. A half wave rectifier would be termed a diode.
- DISTORTION.**—Unfaithful amplification or rendition of an original sound or combination of sounds.
- DIVIDER.**—Usually in the form of a resistance or resistances for the obtaining of various potentials below the maximum value available from a device.
- DRIVER.**—A source of high frequency energy to supply power to a radio circuit.
- DX.**—The abbreviation for long distance.
- DYNE.**—The unit of physical force.
- EARTH.**—The connection to ground from a receiver or electrical device.
- EBONITE.**—Hardened rubber possessing high insulating properties.
- EDDY CURRENT.**—Currents produced by the absorption of electromagnetic or electrostatic fields by conductors.
- ELECTRICITY.**—The cause of all electric or magnetic effects. The electron theory explains electricity, but we only know it by the effects it produces.
- ELECTRODE.**—Either terminal of an electrical source may be called an electrode.
- ELECTRODYNAMIC.**—The action of a current upon itself, by the action of two currents upon each other, or by the action between electric currents and magnets.
- ELECTROLYTE.**—The solution in which the passage of electricity causes changes in the nature of an electrical current is called an electrolyte.
- ELECTROMOTIVE FORCE.**—The force which will produce a flow of current in a conductor. Electromotive force is measured in volts. Its abbreviation is E.M.F.
- ELECTRON.**—The smallest quantity of negative electricity that may move by itself between atoms of matter.
- ELECTROSTATIC.**—The field which exists between the plates of a condenser is called an electrostatic field. It exists between the positive charge of one plate and the negative charge of the other.
- ELIMINATOR.**—Usually refers to a device which enables a battery to be eliminated by use of power from the light socket.
- EMISSION.**—The electrons given off by a heated filament.
- ETHER.**—Is not a material thing, and so exists everywhere. We postulate its existence, since this provides an explanation of many peculiar happenings.
- EVACUATION.**—Term applied to the removal of gases from a valve in the course of its manufacture.
- FARAD.**—The unit of measurement of electrical capacity.
- FEEDBACK, or Back Coupling.**—The feeding back of energy from the plate circuit to the grid circuit of a valve. Feedback will result in oscillation and difficulty of control in the r.f. and detector stages of a receiver circuit.
- FIELD electromagnetic.**—The space occupied by the lines of force of a magnet. If the field is produced by an electromagnet, the field is called an electromagnetic field. There is no difference in the action of magnetic lines of force whether they are produced by a magnet or an electromagnet.
- FIELD, Electrostatic.**—Between any two electrically charged bodies there exist lines of electrical force which form an electrostatic field between the two charged bodies.
- FILAMENT.**—The heated metal in a valve, which provides the electron supply necessary for the valve's operation.
- FILTER.**—A combination of condensers or coils, which will separate direct current from alternating current, or alternating current of one frequency from alternating current of a different frequency.
- FIXED CONDENSER.**—A condenser whose value is fixed at the time of manufacture.
- FLEMING VALVE.**—A valve incorporating two elements, a plate and a filament, and used for the detection of radio signals.
- FREQUENCY.**—The number of complete alternations of an alternating current which occur in a second.
- FULL WAVE RECTIFIER.**—A rectifier which rectifies both alternations of an a.c. current.
- FUSE.**—A wire which will burn out if required to pass more than a certain current. It is used as a protective device.
- GANG CONDENSER.**—A condenser having two or more separate sections of the same capacity and operating in unison from the one control.
- GONIOMETER.**—A form of direction finder employing two loops mounted in fixed positions. The goniometer is used for the detection of the source of radio frequency impulses.
- GRID.**—The control element of the valve.
- GRID LEAK.**—A high resistance used in valve detection circuits.
- HARD RUBBER, or Ebonite.**—An insulating substance used as panel and mounting material in electrical work.
- HARMONIC.**—A frequency which is an integral multiple of the fundamental.
- HEADPHONE.**—An electromagnetic device for the changing of alternating currents into sound impulses.
- HEAVISIDE LAYER.**—A supposed layer of ionised gas said to exist some 60 miles above the earth's surface, and enabling reception by reflection of the sky wave emitted by a transmitting antenna, hundreds or thousands of miles away from the transmitter.
- HETERODYNE.**—When currents of two different frequencies flow in the same circuit they will produce a new frequency, which will be equal to the difference of the first two frequencies, or is equal to the sum of the first two frequencies. When two different frequencies combine to form this new frequency they are said to heterodyne. The new frequency is called the heterodyne frequency.

- HIGH FREQUENCY.**—All radio currents are of high frequency. The terms high frequency and low frequency have relative value only. Compared with the house supply, 50 cycle current, a current of 500 cycles would be said to be of high frequency.
- HIGH FREQUENCY GENERATOR.**—A radio frequency oscillator is a generator of high frequency oscillations.
- HOWLING.**—This may be caused by feedback, or may be the heterodyne frequency.
- HYDROMETER.**—A graduated float used to measure the density of storage battery electrolyte with view to discovering the condition of the battery.
- HYSTERESIS.**—When alternating current is applied to a dielectric between the plates of a condenser, there is a lag in the dying away of the electrostatic field in the dielectric. This action is similar to the lag in a magnetic field, and is called dielectric hysteresis.
- I.C.W.**—Interrupted continuous wave.
- IMPEDANCE.**—The resistance or opposition to the flow of alternating current in a circuit when this circuit contains in addition to ohmic resistance inductance capacity or both. Impedance is measured in ohms.
- IMPULSE.**—Any force acting over a brief period is called an impulse.
- INDOOR AERIAL.**—Any wire system in the house for use in the picking up of radio signals.
- INDUCTANCE.**—Any change of current in a circuit which will cause generation of electromotive force in that circuit. The unit of inductance is the henry. Any coil may have inductance.
- INDUCTANCE, Magnetic.**—The action of producing magnetism in iron or steel by the action of lines of force or a magnetic field is called magnetic induction. In a transformer the lines of force in the field set up by the primary winding will magnetise the core by magnetic induction.
- INSULATION.**—Any material which will not conduct electricity.
- INSULATOR.**—Any piece of insulating material used for its insulating properties.
- INTERFERENCE.**—Any kind of signal other than the desired signal. Interference may be caused by atmospheric or electrical equipment, or by the clashing of two or more broadcast transmissions.
- ION.**—When a molecule is broken into two parts, the parts are called ions.
- JACK.**—This is a device for making various changes in the circuit of a receiver. Generally used for the plugging of the loud speaker or headphones into different stages of a receiver combination.
- JACK SWITCH.**—A switch operating on the same principle as a jack, but with a control knob.
- JAMMING.**—Another name for interference between two or more stations.
- KENOTRON.**—A two element type of rectifying valve. This type of tube is exhausted to a high vacuum in the same manner as any thermionic valve, since it depends upon the passage of current across an electron stream for its operation.
- KEY.**—The lever which operates the contacts of a jack type multi point switch is called a key.
- KILO.**—A prefix meaning one thousand. For instance, a kilocycle is one thousand cycles.
- KILOCYCLE.**—The frequency (wave length) of a broadcasting station is usually measured in kilocycles.
- KNIFE SWITCH.**—A single blade switch which may be used as an aerial switching for the connecting of aerial to ground when the receiver is not in use.
- KNOB.**—A small attachment for fixing to the shaft of any device, the value of which requires to be variable. The knob is usually knurled and fitted with an indicating arrow.
- KNURLED.**—The edge of a knob or dial is grooved for the easy handling of the control. This grooving is called knurling.
- LAMINATION.**—Any single layer of a large number of layers is said to be a lamination. Transformer and choke cores are made from laminated soft iron or silican steel. Insulators are often laminated to improve their resistance to the flow of current.
- LAMP, pilot.**—Used for the illumination of a drum type dial, or for the indication that a receiver is in operation. The lamp is usually mounted behind a small red glass button in the receiver panel.
- LAMP SOCKET AERIAL.**—A device incorporating one or more fixed condensers for utilising the signal pick-up of the mains supply lines for use as an aerial for the operation of a receiver.
- LAYOUT.**—Term applied to the setting out of the components of a receiving circuit, or power pack, or any electrical equipment.
- LEAD-IN.**—The wire connecting the aerial proper to the aerial terminal of a receiver. The aerial and lead-in may be one and the same wire.
- LEAK, grid.**—A high resistance used in valve detector and oscillator circuits. For ordinary receiving purposes the values required lie between 1 and 5 megohms.
- LEAKAGE, surface.**—The minute flow of current which may pass across the surface of an insulating substance is called the surface leakage. Volume leakage is the leakage which occurs through the substance of the insulator.
- LEVEL, noise.**—The noise level refers to the strength of interfering noises such as static, motor or generator interference. Any signal which is above noise level can be amplified and made intelligible.
- LIGHTNING ARRESTER.**—A device installed to convey heavy static charges in a receiving aerial safely down to ground. It is not a protection against lightning, however, but is needed if property is insured.
- LIGHTNING SWITCH.**—A switch used to short aerial to ground when the receiver is not being used or during a storm.
- LITZENDRAHT.**—A very fine stranded wire generally used in the winding of low resistance r.f. coils for operation at wave lengths below 200 metres. Below this wave length the r.f. resistance of this wire becomes greater than that of single copper wire.
- LOADING COIL.**—A coil used to increase the effective inductance of a tuning coil, so that a circuit may be tuned to lower frequencies.
- LOAD.**—Any form of reactance, impedance or resistance in a circuit may be called a load.
- LOCKING SWITCH.**—A filament or power switch fitted with a key to enable a receiver or electrical device to be locked.
- LOOP.**—A number of turns of wire wound on a frame work and used for direction finding or portable work.
- LOOSE COUPLING.**—See coupler.
- LORENZE COIL.**—A special form of tuning coil wound basket fashion. Seldom used in modern receiver construction.
- LOUD SPEAKER.**—A device used for the conversion of alternating current at audible frequencies into mechanical vibrations.
- LOW FREQUENCY.**—See Audio Frequency.
- LOW LOSS.**—Parts which are said to be low loss are understood to have low radio frequency resistances and slight absorption of r.f. energy.
- MECHANICAL RECTIFIER.**—A vibrating reed fitted with contacts which may be used for the rectifying of alternating current.
- MEG.**—A prefix meaning one million. For instance a megohm, one million ohms.

- MERCURY.**—A heavy silver-colored metal, the only metal which is liquid at ordinary temperatures.
- METRE.**—A metric unit of length. One metre is equal to 39.37 inches.
- METERS.**—Any instruments which may be used to measure electrical values in an electrical circuit. An ammeter measures the flow of amperes. A milliammeter measures the flow of current in milliamperes. A voltmeter measures voltage.
- METER, frequency.**—Or wavemeter, used for the calibrating of frequencies. Such a meter may be calibrated and plotted against curves for each meter coil for the calibrating of receivers for wave length.
- MFD.**—Microfarad.
- MHO.**—A unit of measurement of conductivity, the opposite of resistance. The word mho was formed by spelling ohm backwards.
- MICA.**—One of the most important of dielectric materials. It is a mineral which, found in its natural state, occurs in laminated crystalline form.
- MICA CONDENSER.**—A condenser, usually a fixed type, in which the dielectric is of mica.
- MICARTA.**—An insulating material similar to bakelite.
- MICA DIAPHRAGM.**—A diaphragm fitted with a soft iron button, and used in some of the older types of headphones and horn type loud speakers and forms of reproducers.
- MICRO.**—A prefix meaning one millionth part of. For instance microfarad, one millionth of a farad, or microhenry, one millionth of a henry.
- MICROMETER DIAL.**—Term applied to vernier dial giving a very fine adjustment.
- MICROPHONE.**—A device which converts sound vibrations into electrical vibrations of the same frequency. Broadcasting condenser and carbon layer type microphones are capable of producing variable currents of frequencies identical with the original sound vibrations.
- MICROPHONIC NOISES.**—Applied to ringing noises, or howling when the valves of a receiver are tapped. Particularly noticeable and troublesome in the older types of dull emitter tubes of very low filament consumption. Seldom encountered in the indirectly heated and power types of a.c. tubes.
- MILLI.**—Prefix meaning one thousandth part of. For instance milliampere, or one thousandth of an ampere.
- MMFD.**—Micromicrofarad.
- MODULATION.**—The process of varying the amplitude of a carrier wave in exact accordance with the sound produced at the microphone.
- MORSE CODE.**—See code.
- MOTOR-GENERATOR.**—An electric motor operating from a mains supply or battery source, driving a generator.
- MU.**—A Greek letter which is the symbol for the amplification constant of a valve.
- MUTUAL CONDUCTANCE.**—A characteristic of a vacuum tube.
- NEGATIVE.**—An electrical pressure less than that of earth. Negative parts of a circuit are said to be those towards which current is said to flow.
- NEGATIVE BIAS.**—See Bias.
- NEUTRAL.**—Neither negative nor positive, at zero electrical pressure, or the pressure of earth.
- NEUTRALISING.**—The process of preventing oscillation or feedback in the r.f. and detector stages of a receiver or transmitter.
- NEUTRALISING CONDENSER.**—Balancing condenser.
- NEUTRODYNE RECEIVER.**—A process of r.f. amplification evolved by Hazeltine.
- NODE.**—A point in a series of vibrations or waves at which there is no motion in any direction. In an alternating current, the nodes are the points at which there is no flow of current in either direction or at which there is no voltage.
- NODEN VALVE.**—A cell of an electrolytic type rectifier.
- NON-INDUCTIVE.**—A winding in which turns are wound so that it has no inductance.
- OHM.**—The unit of measurement for electrical resistance to the flow of current. One ohm resistance in a circuit will allow one ampere to flow when the pressure is one volt.
- OSCILLATION.**—In a vacuum tube is brought about by feeding energy back from plate to grid circuits to set up a motion in the grid circuit which will cause the valve to remain in a state of oscillation when supplied with power.
- OSCILLATOR.**—Any device which produces radio waves or audible oscillations is called an oscillator.
- OSCILLOGRAPH.**—A device which makes a visible record of the changes in voltage or current in an electrical circuit. The record may be made upon a photographic film or may be observed upon a ground glass.
- OUTPUT TRANSFORMER.**—A transformer using to couple the power stage of a receiver to the reproducing device it is to drive.
- OXIDE COATED FILAMENT.**—Pure Tungsten steel used in the older types of receiving valves required to be heated to high temperatures in order to obtain an electron emission. By coating the filament with certain oxides, the filament need only be heated to a low temperature in order to secure the same filament emission.
- PANEL.**—The part of the receiver which carries the controlling devices. Panels usually consist of insulating materials, although in some cases they may be of metal. A sub-panel is the shelf or shelves used to support the components of the circuit.
- PAPER CONDENSER.**—A fixed condenser using waxed paper as its dielectric.
- PARAFFIN WAX.**—An insulating wax used for impregnation purposes.
- PD.**—Abbreviation for potential difference.
- PEAKED TRANSFORMER.**—A transformer designed to amplify a certain frequency more than other frequencies. This type of transformer may be used in the amplifying stages of a receiver which is to receive code signals.
- PERIOD.**—The time which is required to complete any action. The period of an alternating current is the time required for it to pass through one complete cycle.
- PERMEABILITY.**—A measure of the ease with which any material, usually iron, carries electromagnetic lines of force or flux.
- PERMITTANCE.**—The capacity of a condenser is called the condenser's permittance.
- PHASE.**—The position which an alternating current may be occupying.
- PHONE, head.**—A device which changes the rise and fall of current in a circuit into sound waves.
- PHONE JACK.**—A socket fitted with contacts for the plugging of a plug fitted with headphone connections, into a part of a circuit.
- PHONE PLUG.**—The plug used for the plugging into a jack.
- PHOTO-ELECTRIC CELL.**—A cell which changes light variations into current variations of the same frequency.
- PIGTAIL.**—A flexible connection between a moving and stationary parts of a component.
- PITCH.**—The frequency of tone.
- PLATE CURRENT RECTIFICATION.**—A method of detection of radio waves in a valve detector circuit.
- PLATE CURRENT SUPPLY UNIT.**—A "B" eliminator for the obtaining of power from the light socket.
- PLATE IMPEDANCE.**—The resistance of the electron path between the plate and filament or cathode of a vacuum tube.
- PLATE.**—One of the principal elements of the thermionic tube.
- PLATE BATTERY.**—"B" battery.
- POLARITY.**—The relative value of electrical pressure when referred to the earth's pressure as zero. The points of higher pressure than that of earth are said to be positive, while those at a pressure of less than that of earth are said to be negative.
- PORCELAIN.**—Used as an insulating material in electrical work.

- PORTABLE.**—Referring to the ability to transport any combination of electrical equipment.
- POSITIVE.**—Any electrical pressure above earth. In an electrical circuit, current is assumed to flow from positive to negative.
- POST.** Binding.—American name for terminal.
- POTENTIAL.**—A measure of electrification or degree of electric charge of a point in a circuit or an electrical field.
- POTENTIAL DIFFERENCE.**—The difference in the voltage of two points which causes a flow of current from the higher voltage to the lower.
- POTENTIOMETER.**—A resistance equipped with a sliding arm, and three terminals connecting one to each end of the resistance and one to the sliding arm.
- POWER AMPLIFIER.**—Usually applied to the final stage amplifier of a receiving circuit.
- POWER TUBE.**—A valve having low plate impedance used for the obtaining of big currents and variations in the plate circuit of the tube for the production of sufficient power to drive a reproducing device.
- POWER UNIT.**—A device used to furnish power for a receiver or amplifier from the light supply mains.
- PRESSURE, Electrical.**—Voltage or E.M.F.
- PRIMARY WINDING.**—Refers to the input winding of an a.f. or r.f. coupling transformer, or power transformer.
- PULSATING CURRENT.**—A current which flows in one direction in a circuit, but whose voltage rises and falls.
- PUSH PULL AMPLIFIER.**—An arrangement whereby twice the signal input passed by a single tube may be handled by two tubes. The push pull amplifier enables distortionless power for the driving of a loud speaker at medium plate voltages using small power tubes.
- QUARTZ.**—A material possessing high dielectric properties. Specially cut quartz possesses the valuable property of oscillating when a voltage is applied to it. The frequency of the oscillations is dependent upon the thickness of the quartz. The oscillations produced by the quartz may be used to control the grid of a valve oscillator.
- RADIATING RECEIVER.**—An oscillating receiver which feeds back into the aerial causing interference in neighboring receiver when the oscillating receiver is tuned to heterodyne the signals from a broadcasting station.
- RADIATION.**—The action by which radio waves are sent out from a transmitter aerial system.
- RADIO FREQUENCY AMPLIFIER.**—An amplifier which increases the voltage of signals picked up by the aerial system before these reach the detector.
- RADIO FREQUENCY TRANSFORMER.**—A combination of coils for the coupling of r.f. and detector stages.
- RADIO TELEGRAPHY.**—Radio communication by means of code in the form of dots and dashes to represent characters. Radio telegraphy may be used with modern valve transmitters or the old spark type transmitters.
- RADIO TELEPHONY.**—Transmission of voice and music as in broadcasting.
- RATIO.**—The quotient obtained by dividing one number by another number. Thus the ratio of 8 to 4 is 2 to 1.
- REACTANCE.**—Reactance is the name given to the opposition to the flow of alternating current when this opposition is caused by inductance in a coil or capacity in a condenser. Reactance may be measured in ohms.
- REACTIVATION.**—With the thoriated type of filament, a valve which has lost its emission may be rejuvenated or reactivated by application of a fairly high filament voltage with no plate supply to the valve. Oxide coated filaments cannot be reactivated.
- REACTOR.**—A coil used to oppose the flow of alternating current.
- RECEIVER.**—A combination of components for the reception of radio signals.
- RECEPTION.**—The receiving of radio signals by means of a receiver.
- RECTIFIER.**—Any device which allows the passage of current in only one direction is called a rectifier.
- RECTIFIER, fullwave.**—A rectifier which rectifies both halves of the alternating current cycle.
- RECTIFIER, gaseous.**—A type of rectifier depending upon the ionization of a gas within a sealed glass bulb.
- RECTIFIER, half wave.**—A rectifier which rectifies only half of the alternating current cycle.
- REGENERATION.**—Action by which part of the energy of the plate circuit of a tube is fed back to the grid circuit. The plate circuit energy is added to the energy in the grid circuit. By means of regeneration the tube itself can be made to increase the input voltage.
- REGENERATION CONTROL.**—Usually in the form of a rotor coil or a reaction tuning condenser.
- REGENERATIVE RECEIVER.**—A receiver in which detector stage regeneration may be had.
- REGULATOR TUBE.**—A valve used for the regulation of plate supply eliminators.
- RELAY.**—A device containing two electrical circuits, the flow of current in one circuit causing the second circuit to be closed for as long as current flows in the first circuit.
- RELUCTANCE.**—Opposition to the flow of magnetic lines of force is called reluctance.
- REMOTE CONTROL.**—The controlling of an electrical device at a distance.
- REPEATER.**—A relay of any type may be called repeater.
- RE-RADIATION.**—Oscillation in some types of receivers not using r.f. stages may cause re-radiation which will send out a signal, the frequency depending upon the wave length to which the receiver may be tuned. Re-radiation may cause interference in neighboring receivers.
- RESISTANCE.**—The opposition to the flow of current offered by conductors through which the current flows. The opposition to the flow of alternating current by condensers or inductances is called reactance.
- RESONANCE.**—The tuning of two circuits to the same frequency, or the tuning of a receiver to the frequency of an incoming signal.
- RESONATOR.**—A name for the ordinary loud speaker.
- RHEOSTAT.**—A resistance the value of which may be varied. The purpose of the rheostat is to control the voltage applied to any electrical device.
- RIPPLE.**—A sound caused by the slight rise and fall of the voltage of a direct current, or an alternating current. Ripple is the sound audible in a speaker output when an a.c. receiver has not been correctly designed or adjusted and hum is present in the speaker output.
- ROTOR.**—A moving part of a condenser, a variometer, a variocoupler, or the tickler coil as in a Browning Drake receiving circuit.
- SATURATION.**—As the number of ampere turns acting upon a piece of iron is increased, the number of magnetic lines of force in the iron increases very rapidly up to a certain point, which is the saturation point of the iron.
- SELECTIVITY.**—Selectivity is the ability of a receiver to discern between the various transmissions, and receive each station separately without interference. Selectivity depends upon the design of the receiver and the proximity of the broadcasting stations.
- SENSITIVITY.**—The measure of the ability of a receiver to magnify weak signals without distortion.
- SHIELDING.**—In order to prevent interaction between electrical circuits metal is used to prevent the intercoupling of electrostatic and electromagnetic fields.
- SHOCK EXCITATION.**—See interference.
- SHUNT.**—An alternate path for the flow of electricity across a device, such as an ammeter, is called a shunt.
- SHUNTING CONDENSER.**—A condenser inserted in parallel with another condenser or an inductance.

- SIDE BAND.**—One half of a wave band. In broadcasting, the width of a modulated carrier wave averages ten k.c. Each side band is then five k.c. wide.
- SIGNAL.**—Any energy sent out by any form of transmitting apparatus and picked up by a receiver is what is generally known as a signal.
- S.S.C.**—Single silk covered. Single or double silk covering may be used for the insulation of copper wire.
- SILVER.**—The best conductor of all metals. Its use is impracticable, however, owing to its cost, so that copper is more generally used.
- SKIN EFFECT.**—When direct current flows through a conductor it is evenly distributed throughout the body of the wire. With alternating current of high frequency, the current tends to flow on the surface of the conducting material. This is known as the skin effect.
- SOCKET. Valve.**—The device which supports the thermionic valve and makes contact with the legs of its base.
- SOFT TUBE.**—One in which the valve has not been exhausted to a high vacuum, a small amount of gas remaining. Such a tube is particularly suitable as a detector, but because of the presence of the gas, will not permit the application of high voltages as would be encountered in amplifier stages owing to ionization of the gas.
- SOUND.**—Any motion of air which is distinguishable by the sense of hearing. Sound may be carried by means of the air, or by materials. Sound moves through air at the speed of 1087 feet per second.
- SPACE CHARGE.**—The free electrons which are given off by a heated filament and which play no part other than the prevention of highest degree of efficient operation, in a tube.
- SPAGHETTI.**—A sleeving material for the covering of connections.
- SPEAKER.**—A device to transform the electric current variations into sound waves.
- SQUEALING.**—The noise produced by tuning an oscillating detector circuit to the frequency of a transmitter signal, or by free oscillation in a receiver or amplifier.
- STABILITY.**—Freedom from oscillation, or ease of control or constancy of operation in a receiving or transmitting circuit.
- STABILISING.**—The prevention of free oscillation in a receiver or amplifier circuit.
- STATIC.**—A form of interference produced by atmospheric electricity. An aerial may be charged with static electricity during a wind or rain storm. Static discharges may cause interference some thousands of miles from their source, and so far no means for the prevention of the noises without reduction in almost the same proportion, of the signal itself, has been perfected.
- STATOR.**—The stationary part of a variable condenser, variometer, vario-coupler, etc.
- STEP UP AND STEP DOWN TRANSFORMER.**—One in which the primary voltage is stepped up or down.
- STRAIGHT LINE CONDENSER.**—One in which wave lengths are evenly spaced over the condenser dial.
- STRANDED WIRE.**—Several lengths of the same gauge bare or insulated wire, bound into a single cable.
- STRAYS.**—Another name for static or atmospheric.
- STRESS.**—The force which is applied to a substance and tends to place a strain upon it.
- SUB-PANEL.**—A shelf which supports the components of a receiver combination to better the design or to enable wiring to be performed neatly, or with less difficulty.
- SUPERHETERODYNE.**—A type of receiving circuit in which the incoming signals are heterodyned to a new frequency which is amplified by untuned intermediate stage to be made audible by a second detector. The new frequency is called the intermediate frequency.
- SURGES, Power Line.**—Sudden increases of voltage of the power supply mains are called surges.
- SUSCEPTANCE.**—A part of the admittance in a circuit, the remainder being conductance.
- SWITCH.**—A device for opening and closing a circuit or circuits.
- SYMBOLS.**—The signals used in circuit and electrical diagrams for the representation of electrical devices.
- SYNCHRONOUS.**—Actions occurring at the same time and in the same manner are synchronous.
- TANTALUM.**—A metal used in any form of electrolytic rectifier for trickle battery charging.
- TANDEM CONDENSERS.**—A gang condenser in which two or more sections of the same capacity are operated from a single control.
- TAPPED COIL.**—A coil in which means is provided for the connecting to any required turn.
- TAPE, Insulating.**—An adhesive tape commonly used in electrical work. Several kinds are available. The most common is friction tape made of fabric impregnated with rubber compounds, or in the cheaper types, pitch or tar.
- TELEGRAPHY.**—The communication by radio using the international code.
- TELEPHOTOGRAPHY.**—The transmission by radio or by wire of photographs, or diagrams.
- TELEVISION.**—The transmission through the medium of radio waves, of moving images. Television is recognised as being distinct from picture transmission.
- TERMINALS.**—Threaded rods fitted with fastening nuts and washers and a suitable thumb screw head for the simple connecting of wires. An electrical instrument may be provided with terminals for its connection into a circuit.
- TESTER, Valve.**—An instrument fitted with volt and milliammeters to test valves for emission, or internal short or broken filament, or any other fault.
- THERMIONIC RECTIFIER.**—A vacuum tube rectifier, in a half wave type, consisting of a plate and a filament in a vacuum, and depending upon an electron stream given off by a heated filament for its operation.
- THORIATED FILAMENT.**—Active thorium emits copious electrons when heated to a low temperature. By including thorium in the nickel steel filament metal, a valve filament may give off sufficient electrons when heated to but a low temperature. After having been aged, active thorium comes to the surface of the filament of a newly-made tube. A thoriated filament may be reactivated.
- THREE ELEMENT TUBE.**—The ordinary directly heated power valve or battery filament type of valve is a three element tube consisting of the grid, plate and filament.
- THROTTLE CONTROL OF REGENERATION.**—The controlling of feedback in a regenerative detector stage by means of a variable capacity.
- TICKLER.**—The reaction coil rotor of a three coil tuner or regenerator.
- TIGHT COUPLING.**—The very close coupling of two inductances with view to obtaining greater energy by induction in one of the inductances.
- TONAL QUALITY.**—The ability of a receiver to reproduce broadcast programmes without perceptible distortion means that the receiver possesses good tonal qualities.
- TOROIDAL.**—A form of tuning coil.
- TRAIN, Wave.**—A series of radio waves is called a wave train. If the amplitude of the waves does not diminish, the train is called CW or continuous wave.
- TRANSFORMER.**—A device for transferring energy from one alternating current circuit to another.
- TRANSFORMER, Audio Frequency.**—The transformer used to couple the plate circuit of a tube to the grid circuit of the following a.f. amplifier stage.
- TRANSFORMER, Auto.**—A transformer having its primary and secondary windings conductively connected.
- TRANSFORMER, Microphone, or Modulation.**—The transformer through which the current variations produced by speech into the microphone is coupled into a circuit.
- TRANSMISSION.**—The process of radiating signals by means of apparatus for the generation of radio waves.

TRAP, Wave.—A device, the object of which is to prevent or reduce interference from one particular station.

TRICKLE CHARGER.—A battery charger, the charging rate of which is low, is called a trickle charger.

TRIODE.—Another name for the three element thermionic valve.

TUNER.—The part of the receiver which selects the transmissions is called the tuner. The tuner includes all tuning inductances and variable condensers.

TUNGSTEN.—A metal which is now less used for the manufacture of valve filaments.

TUNING.—The process of causing oscillatory circuits of a receiver to resonate with the frequency of the signals to be received is called tuning.

TWO-ELEMENT TUBE.—Any vacuum tube having a filament and a plate in its construction.

VALVE.—The device which renders possible radio transmission and reception as we now have it. The valve consists of a filament or a cathode, a control element and an anode, and in some tubes, extra screening grids.

VARIABLE CONDENSER.—A condenser, the capacity of which may be varied by means of a control.

VARIABLE GRID LEAK.—A grid leak resistance, the value of which may be varied by means of a control.

VARIOMETER.—A form of tuning device consisting of a rotor coil inside a stator coil.

VERNIER CONDENSER.—One in which a very fine adjustment of capacity may be obtained.

VERNIER DIAL.—A dial for the obtaining of a very fine adjustment to the valve of a tuning condenser.

VOLT.—The unit of electromotive force or electrical pressure. One volt is the pressure required to send a current of one ampere through a circuit whose resistance is one ohm.

VOLTMETER.—A meter for measuring e.m.f. or pressure.

VOLUME.—Volume is a measure of the loudness of sounds.

VOLUME CONTROL.—Volume may be controlled by several means in a receiving or amplifier circuit. All these means are called volume controls.

WATT.—The practical unit of electrical power. A power of one watt is produced by one ampere at a pressure of one volt.

WATT-HOUR.—A unit of electrical work. One watt-hour is the work done by one watt in an hour.

WAVE.—A wave is a disturbance of some elastic substance, the disturbance having a regular period of frequency. A sound wave is a disturbance in air. A radio wave is a disturbance in ether.

WAVELENGTH.—The distance, measured in meters, which is covered by one complete radio wave in space, from the peak of one positive alternation to the peak of the next positive alternation.

WHEATSTONE BRIDGE.—A bridge for the measurement of unknown resistance values.

WIRING.—The process of connecting up a receiving or electrical circuit.

Stations of the NATIONAL BROADCASTING SERVICE

Call Sign	Location.	Fre- quency	Wave- length.	Power
		K.C.	M.	Watts.
2BL	Sydney, N.S.W.	855	350	5000*
2FC	Sydney, N.S.W.	665	451	5000
2NC	Newcastle, N.S.W. (Relay)	1245	241	2000*
3AR	Melbourne, Vic.	620	484	5000
3LO	Melbourne, Vic.	800	375	5000
4QG	Brisbane, Q.	760	394.5	5000
4RK	Rockhampton, Q. (Relay)	930	322	2000*
5CL	Adelaide, S.A.	730	412	5000
6WF	Perth, W. Aust.	690	435	5000
7ZL	Hobart, Tas.	580	516	3000

*In the Aerial.

All the above-mentioned stations are operated by the Postmaster-General's Department for the National Broadcasting Service, with the exception of Station 7ZL, which, until it is transferred to the National Broadcasting Service on December 14, 1930, will continue to be operated under licence granted to Tasmanian Broadcasters Pty. Ltd. The programmes for all stations except 7ZL are supplied by the Australian Broadcasting Co. Ltd.

BROADCASTING STATIONS

Other than those of the National Service.

<i>Call Sign</i>		<i>Frequency Kilocycles</i>	<i>Wavelength Metres</i>	<i>Power Watts</i>
NEW SOUTH WALES—Metropolitan—				
2GB	Theosophical Broadcasting Station, Ltd., Adyar House, 29 Bligh St., Sydney	950	316	3000
2KY	Trades and Labor Council, Trades Hall, Goulburn St., Sydney	1070	280	1500
2UE	Electrical Utilities Supply Co., Radio House, 617 George St., Sydney	1025	293	250
2UW	Radio Broadcasting, Ltd., Paling's Buildings, Ash St., Sydney	1125	267	500
<i>Country</i>				
2AY	Charles Rice, Radio House, 610 Dean St., Albury	1320	227	50
2HD	W. W. Johnston, Civic Centre, Newcastle	1415	212	600
2MK	Mockler Bros., Howick St., Bath- urst	1155	260	250
2MO	M. J. Oliver, Gunnedah	1500	200	50
2XN	G. W. Exton, Lismore	1340	224	50
VICTORIA—Metropolitan				
3DB	3DB Broadcasting Station Pty. Ltd. Box 685, G.P.O., Melbourne	1180	255	500
3KZ	Industrial Printing and Publicity Co., 24-30 Victoria St., Carlton, N.3.	1350	222	200
3UZ	Oliver J. Nilsen & Co., 45 Bourke St., Melbourne	930	322	500
<i>Country</i>				
3TR	Gippsland Broadcasting Service, Trafalgar, Ltd., Trafalgar	1280	234	50
3BA	Ballarat Broadcasters Pty. Ltd., 215 Raglan St., Ballarat	1300	231	50
QUEENSLAND—Metropolitan				
4BC	J. B. Chandler and Co., 43 Ade- laide St., Brisbane	1290	233	200
<i>Country</i>				
4GR	Gold Radio Service, Ruthven St., Toowoomba	1020	294	150
4MK	Williams' Agencies Ltd., Mackay . .	1190	252	100
SOUTH AUSTRALIA—				
5AD	Advertiser Newspapers Ltd., Way- mouth St., Adelaide	1310	229	300
5DN	5DN Pty. Ltd., 2-4 Montpelier St., Parkside	960	313	500
5KA	Sport Radio Broadcasting Co. Ltd., 81 Flinders St., Adelaide	1200	250	1000
WESTERN AUSTRALIA—				
6ML	Musgroves Ltd., Lyric House, Mur- ray St., Perth	1010	297	300
TASMANIA—Metropolitan				
7HO	Findlays Pty. Ltd., 80 Elizabeth St., Hobart	890	337	
<i>Country</i>				
7LA	Wills and Co. Pty. Ltd., 7 Quad- rant, Launceston	1130	273	100

Experimental Transmitting Stations

AUTHORISED POWER—25 WATTS

FREQUENCIES	WAVELENGTHS
60,000 KC—56,000 KC	(5 m. — 5.35 m.)
30,000 KC—28,000 KC	(10 m. — 10.7 m.)
14,400 KC—14,000 KC	(20.8 m. — 21.4 m.)
7,300 KC—7,000 KC	(41 m. — 42.8 m.)
4,000 KC—3,500 KC	(75 m. — 85 m.)
1,990 KC—1,715 KC	(150.8 m. — 175 m.)
1,715 KC—1,200 KC	(175 m. — 250 m.)

Every call-sign in the list below bears prefix VK.

NEW SOUTH WALES

2AB—A. V. Badger, 13 Emmett St., Crow's Nest.	CM—C. D. MacFarcan, Agnes St., Strathfield.
2AC—A. C. Edwards, Wallace St., Eastwood.	2CR—L. V. G. Todd, Denison St., West Tamworth.
2AD—A. L. Dixon, 83 Concord Rd., Nth. Strathfield.	2CS—L. T. Swain, 9 Frederick St., Waratah.
2AK—K. J. Claffey, Tarrandale, Den- illiquin.	2CU—D. D. Campbell, Ulmarra, Clar- ence River.
2AL—A. S. Littlejohn, 3 Emmerick St., Leichhardt.	2CW—C. J. Williamson, Dutton St., Yass.
2AO—A. O. Friar, Ulmarra.	2CZ—G. W. Exton, 173 Molesworth St., Lismore.
2AR—W. H. Hudson, 1 Terrace Rd., Dulwich Hill.	2DE—W. P. Renshaw, Lord St., Rose- ville.
2AS—A. J. Smith, 27 Station St., Harris Park.	2DG—D. G. Campbell, Sunny Ridge, Kyogle.
2AU—J. P. Cureton, Church St., Bur- wood (formerly VK2AY).	2DJ—F. B. Cooke, Namoi Rd., Northbridge.
2AV—A. W. Thurston, c/o A. Henry, Clareville Ave., Sandringham.	2DP—J. Grant, cr. King and Pitt Sts., Stockton.
2AW—A. W. Dye, 44 Martin Rd., Centennial Pk.	2DS—R. R. Davis, "Bromley," 3 Flat, Gladswood Gardens, Double Bay.
2AZ—A. Z. Anslow, Griffiths St., Bal- gowlah.	2DW—D. J. Wilson, 14 Macauley St., Leichhardt.
2BB—E. B. Crocker, 38 Roseby St., Marrickville.	2DY—D. G. Lindsay, Burgoyne St., Gordon.
2BC—N. J. Hurl, Northcote Ave., Killara.	2DZ—E. W. Burrows, Bundabarra, Evelyn St., Concord.
2BF—L. E. Forsythe, c/o N.S.W. Navy League, Nos. 5 to 8 Region Headquarters, Cary St., Drummoyne.	2EA—E. F. Fitzgerald, Kenny Rd., Bargewood, via Maroubra.
2BK—F. N. Leverrier, Wentworth Rd., Vaucluse.	2EC—E. C. Crouch, 7 Spencer Rd., Mosman.
2BM—B. Martin, 59 Gardyne St., Bronte.	2EF—Amalgamated Wireless (A'sia), Ltd., Althorne, Beaconsfield Pde., Lindfield.
2BN—F. W. Kimpton, Moon St., Bal- lina.	2EK—E. F. Kenny, 30 Falconer St., Ryde.
2BS—H. B. Sunter, 32 Village High Rd., Vaucluse.	2FA—Australian Aero Club, 16 Bar- rack St., Sydney.
2BV—Waverley Amateur Radio Club, 89 Macpherson St., Waverley.	2FB—Australian Aero Club, 16 Bar- rack St. Sydney.
2BW—W. H. Barker, 12 Wallace St., Concord.	2FG—F. Gibbons, 126 Ben Boyd Rd., Neutral Bay.
2CB—C. Butterworth, 19 Thomas St., Wallsend.	2FK—F. Welch, "Roselby," Clarke and Kurraba Rds., N. Syd- ney.
2CC—University of Sydney.	2FL—F. L. Lee, Merrigang St., Bow- ral.
2CD—C. W. Drew, 7 Roscrae Ave., Randwick.	2FM—F. A. Murray, 26 Park Av., Mos- man.
2CF—C. J. F. Collard, King St., Lorn, West Maitland.	2FP—E. J. Baker, 13 Veda St., E. Hamilton.
2CJ—C. J. Callaby, 26 Flavelle St., Concord.	
2CL—G. Caletti, "Glenshea," Pen- rose.	

- 2FS—A. C. Smith, 18 Sackville St., Maroubra.
- 2FT—L. R. Filmer, "Bundee," Brighton Ave., Toronto.
- 2GA—Mrs C. R. McKenzie, cr. Richard and George Sts., Greenwich.
- 2GG—G. S. Gow, 161A William St., Sydney.
- 2GH—R. L. Gibson, Alstonville, Richmond River.
- 2GL—Richmond River Listeners' League, 64 Ballina St., Lismore.
- 2GN—H. G. Goddard, 33 Victoria St., Nth. Sydney.
- 2GP—C. S. Mackay, Urunga.
- 2GQ—E. Barlow, Perry St., Mudgee.
- 2GB—A. Robinson, "Carrickfergus," Regatta Rd., Five Dock.
- 2GS—A. G. Simmonds, "Gunton," Marsh St., Arncliffe.
- 2GV—G. V. Hume, 44 Reynolds St., Cremorne.
- 2GW—W. G. Woolnough, "Callabonna," Park Ave., Gordon.
- 2HB—J. Bonnington, 84 Birriga Rd., Bellevue Hill.
- 2HC—H. K. Carter, Yarraman Nth., Quirindi.
- 2HG—J. F. Mackel, "Alster," Devonshire St., Chatswood.
- 2HH—H. H. Davis, "Otiira," Torrington Rd., Strathfield.
- 2HK—H. W. Nicolle, 59 Albyn Rd., Strathfield.
- 2HL—H. C. Laphorne, 1 Bowen St., Chatswood.
- 2HM—H. A. Marshall, 94 Francis St., Bondi.
- 2HO—H. Hart, 11A Fairlight Cres., Manly.
- 2HP—H. F. Peterson, Hamilton St., Coogee.
- 2HQ—N. C. Pottie, 86 Birriga Rd., Bellevue Hill (formerly VK2NC).
- 2HR—J. Duffey, 16 Stanley St., Waverley.
- 2IJ—A. H. Gray, 5 Flat, The Maples, Killara.
- 2IN—J. Payne, 58 Boronia St., Kensington.
- 2JA—A. J. Mead, Shirley St., Byron Bay.
- 2JC—E. J. Cawthron, "Coota," View St., Concord.
- 2JD—J. B. Davies, 69 Fitzroy St., Burwood.
- 2JH—J. V. Hutchison, 1 Holbrook Ave., Kirribilli.
- 2JI—A. Dawson, 6 Keir Ave., Hurlstone Park.
- 2JJ—J. W. Jennison, "Wallaroo," Mathoura.
- 2JK—J. H. S. Brown, "Shadwell," Chelmsford Ave., Botany.
- 2JL—J. L. Young, Cowabee, Coolamon.
- 2JO—R. C. Caldwell, 17 Ruthven St., Waverley.
- 2JP—J. H. A. Pike, 14 Sarnier Rd., Greenwich.
- 2JQ—G. A. M. Nell, Wentworth Ave., Canberra, F.C.T.
- 2JR—J. G. Reed, 7 Henson St., Summer Hill.
- 2JT—C. F. A. Luckman, "Aldersey," Wangee Rd., Lakemba.
- 2JV—C. D. Roberts, 49 Greenwich Rd., Greenwich.
- 2JW—E. J. Williams, 51 Ocean Ave., Edgecliff.
- 2JX—P. Adams, 41 Cremorne Rd., Cremorne.
- 2JY—J. W. Young, "Yothahnee," Eastern Rd., Turramurra.
- 2JZ—A. S. Mather, 14 William St., Singleton.
- 2KB—A. Fairhall, 7 Sturdee St., New Lambton.
- 2KC—R. H. Fry, Moontah Ave., Killara.
- 2KG—K. N. Greenhalgh, 43 Veda St., Hamilton.
- 2KH—S. R. Crichton, Cotterills Bldgs., Melbourne St., East Maitland.
- 2KJ—W. H. Cramond, 14 Gatacre Ave., Lane Cove.
- 2KL—E. N. Maguire, 163 Victoria St., Lewisham.
- 2KT—L. M. Seccombe, 43 Clarence Rd., Rockdale.
- 2KU—I. W. Archibald, 49 Fraser St., Dulwich Hill.
- 2KV—J. H. Roger, 33 Military Rd., Newcastle.
- 2KW—A. Grant, Taylor's Arm, Roadside, Macksville.
- 2KZ—E. M. Austin, Stanford St., Kurri Kurri.
- 2LA—D. St. J. P. Soraghan, 2 Spencer St., Rose Bay.
- 2LD—L. H. Dodds, 29 Woodland St., Marrickville.
- 2LE—A. J. Ryan, Block 7, Section 25, Kingston, Canberra, F.C.T.
- 2LG—J. W. Wallace, 119 Faithfull St., Goulburn.
- 2LH—Leichhardt and District Radio Club—35 Albert St., Leichhardt.
- 2LI—J. Rayner, 28 Lincoln St., Stanmore.
- 2LL—L. S. Lane, Weethalle.
- 2LM—L. M. Wilson, Malboona Station, via Mudgee.
- 2LO—L. N. Schultz, "Waraba," Burns Bay Rd., Lane Cove.
- 2LP—L. P. R. Bean, Artarmon Rd., Artarmon.
- 2LQ—T. N. Griffin, 40 William St., Hornsby.
- 2LS—L. H. Hellyer, 62 Farr St., Rockdale.
- 2LU—E. T. Prentice, "Malalah," Penrose St., Lane Cove.
- 2LV—J. Chessell, 38 Frazer St., Dulwich Hill.
- 2LX—H. C. Crisp, 2 Macquarie Rd., Undercliffe.
- 2LY—R. H. Shaw, "The Nest," Tunstall Ave., Sth. Kensington.
- 2LZ—W. E. C. Bischoff, 180 Chandos St., Crow's Nest.
- 2MA—Amalgamated Wireless (A'sia) Ltd., 47 York St., Sydney.
- 2MB—Amalgamated Wireless (A'sia) Ltd., Radio-Electric Works, Knox St., Sydney.
- 2MD—Amalgamated Wireless (A'sia) Ltd. (Portable Station).
- 2MC—Amalgamated Wireless (A'sia) Ltd., "Althorne," Beaconsfield Parade, Lindfield.
- 3ME—Amalgamated Wireless (A'sia) Ltd., Pennant Hills, Sydney.
- 2MF—Amalgamated Wireless (A'sia) Ltd., Radio Receiving Centre, La Perouse.

- 2MG—Amalgamated Wireless (A'sia), Ltd., "Bryn," Kissing Point Road, Turramurra.
- 2MH—C. E. Morton, "Saida," Underwood Road, Homebush.
- 2MI—Amalgamated Wireless (A'sia), Ltd., "Gunyah," King's Rd., Vaucluse.
- 2MR—J. E. Stewart, 9 Gorrick St., Mayfield.
- 2MS—Mat. Spitzkowsky, 65 Everton St., Hamilton.
- 2MU—J. Nangle, Observatory, Sydney.
- 2NB—N. T. O. Buchanan, 21 Waratah St., Manly.
- 2NI—H. B. Hammond, 40 Market St., Naremburn.
- 2NS—T. Evans, 193 Rockett Street, Bathurst.
- 2OB—L. W. Mashman, 8 Donnan St., Bexley.
- 2OG—G. J. Menon, 6 Grosvenor St., Croydon.
- 2OJ—E. N. Arnold, 610 Olive Street, Albury.
- 2OL—H. L. Watson, Shoalhaven St., Kiama.
- 2OQ—A. Skene Smith, 9 Wilfield Av., Vaucluse.
- 2OU—S. W. L. Wardle, Woodford Leigh, Clarence River.
- 2OW—P. Evans, 15 Centennial Ave., Randwick.
- 2OZ—J. D. Olle, 17 Eccles Ave., Ashfield.
- 2PC—Proving Radio Club, 29 Blairgowrie St., Dulwich Hill.
- 2PK—N. G. Beard, Wentworth Rd., Wentworthville.
- 2PX—H. D. Ackling, "Leala," 76 Market St., Bankstown.
- 2PZ—C. Cowan, 139 Congewai Street, Aberdare.
- 2QT—A. H. Mutton, 31 Stafford St., Stanmore.
- 2RA—R. A. Priddle, 158 Rockett St., Bathurst.
- 2RB—R. E. Beljon, 92 Lawrence St., Lithgow.
- 2RC—R. Chilton, Chilton Ave., Wahroonga.
- 2RE—R. M. E. Rees, 5 Flat, "Valna," Alfreda St., Coogee.
- 2RF—W. R. Felton, 44 Gladstone St., Belmore.
- 2RJ—R. J. Fagan, Sunnyside, Mandurama.
- 24L—A. R. Litchfield, "Springwell," Cooma.
- 2RM—R. A. MacFarlane, Wakaden St., Griffith.
- 2RO—R. W. Turnbull, 2 Ethel Street, Burwood.
- 2RS—R. O. Scott, "Spring Vale," Gundagai.
- 2RT—R. J. Turner, 250 Sloane St., Goulburn.
- 2RU—P. Fretten, 30 Ada St., Concord.
- 2RV—R. V. Thomas, 10 Nancy St., North Bondi.
- 2RW—R. W. Custer, 10 Telegraph Road, Pymble.
- 2RX—H. C. St. John, 82 Gibbes St., Rockdale.
- 2RZ—J. M. Atkinson, 104 Prince Albert St., Mosman.
- 2SA—W. E. Salmon, 51 Knowles Ave., North Bondi.
- 2SG—S. G. Tonkin, 610 Dean Street, Albury.
- 2SH—A. Short, Young St., Lambton.
- 2SK—S. D. Kaufman, "Emohruo," Edison St., Belmore.
- 2SM—W. W. Caldecott, "Broxbourne" Field Ave., Manly.
- 2SS—A. E. Wright, Coledale.
- 2ST—S. E. Tatham, "Coomerah," Coomerah Crescent, Darling Point.
- 2SW—C. L. Southwell, 40 Princess St., Brighton-le-Sands.
- 2SX—C. W. Slade, Rockleigh, Lang St., Croydon.
- 2TM—H. E. A. Turner, 13 Erith St., Mosman.
- 2TW—T. R. W. Bushby, Mark Street, Hunter's Hill.
- 2TY—T. R. Troy, "Glenroy," Great Northern Rd., West Maitland.
- 2UR—C. J. Henry, Bridge St., Uralla (formerly VK2CH).
- 2UK—H. L. Sigal, 91 Jersey Road, Woollahra.
- 2VS—V. S. Stanley, Radio Station, Carlingford.
- 2VZ—Reg. Garth, 85A Dolphin St., Coogee.
- 2WB—W. N. Bullivant, Charles St., Albury.
- 2WC—W. Cavanagh, 176 Cowper St., Goulburn.
- 2WD—G. W. Dukes, 43 Arundel St., Forest Lodge.
- 2WE—Standard Telephones and Cables, Ltd., Myrtle House, Myrtle St., Chippendale.
- 2WF—R. W. Faulks, 207 Victoria St., Ashfield.
- 2WG—W. D. Graham, 44 Cameron St., Rockdale.
- 2WH—W. H. R. Stitt, "Wandary," Forbes.
- 2WI—Wireless Institute of Aust. (N.S.W. Division), 44 Gladstone St., Belmore.
- 2WJ—W. J. Peel, 3 Chapman Street, Summer Hill.
- 2WK—W. D. Kennedy, The Rectory, Helensburgh.
- 2WP—W. F. Potter, Fletcher Street, Helensburgh.
- 2WS—W. S. Breden, Kitchener Parade, Newcastle.
- 2WT—C. R. Watt, Warrenfels, Ten-terfield.
- 2WU—L. Macdonald, 43 Catherine St., W. Maitland.
- 2WX—R. Wray, "Esmar," Jellicoe St., Hurstville.
- 2WY—W. L. Butters, "Illawarra," Lamont St., Bermagui South.
- 2WZ—W. J. Zech, 124 Parramatta Road, Ashfield.
- 2XA—H. K. James, 12 Rosemount Ave., Summer Hill.
- 2XI—W. A. Craig, 22 Irrara Street, Croydon.
- 2XK—J. A. Heavey, 55 Storey Street, Maroubra.
- 2XL—W. R. B. Forwood, 72 St. Mark's Road, Randwick.
- 2XR—A. T. Halloran, 25 The Crescent, Mosman.
- 2XY—S. W. Maguire, 21 Blake St., Rose Bay.
- 2XZ—R. T. Vowles, 71 Links Ave., Concord.
- 2YB—Croydon Radio Club, 12 Wallace St., Concord.
- 2YG—R. C. Allsop, "Navola," Chelmsford Ave., Roseville.

- 2YH—W. H. Hannam, 23 Prince Albert St., Mosman.
 2YJ—R. H. Sainsbury, 6 Wallaroy St., Concord.
 2YK—R. E. Abbott, Parkes St., Dor-rigo.
 2YZ—W. D. Johnston, 1 Searle St., Ryde.
 2ZH—W. A. Anderson, Harwood Island, Clarence R.
 2ZJ—A. W. Simpson, 23 Sibbick St., Five Dock, Sydney.
 2ZK—A. G. Henry, Clareville Ave., Sandringham.
 2ZL—W. Otty, "Hurst Villa," Killing-worth.
 2ZN—J. W. Cottrell, 63 Beach St., Coogee.
 2ZO—T. R. Willmott, Coramba Rd., Grafton.
 2ZR—J. C. Pinnell, 95 Livingstone Rd., Marrickville.
 2ZU—N. S. Gilmour, "Kulnura," Thrupp St., Neutral Bay.
 2ZY—H. F. Coffey, 20 Byng Rd., Maroubra.

VICTORIA

- 3AB—J. W. Leonard, 18 Love St., Black Rock, S9.
 3AD—J. A. Davey, 28 Cole St., Elst-ernwick, S3.
 3AF—A. F. W. Bent, 33 Griton Cres., W. Geelong.
 3AG—A. J. G. Glover, 45 Watt St., Box Hill, E11.
 3AH—A. H. Faul, 3 St. Leonards Ave., St. Kilda, S2.
 3AJ—E. Salamy, Timor St., Warr-nambool.
 3AK—N. V. C. Cansick, 297 Hawthorn Rd., Caul., SE8.
 3AL—A. D. Kerr, 1214 Sturt St., Bal-larat.
 3AM—A. Forecast, 22 St. George's Rd., Malvern, SE5.
 3AN—A. Newberry, Indi Ave., Red Cliffs.
 3AP—R. D. Morris, 61 Bealiba Rd., Caulfield, SE8.
 3AQ—Marist Bros.' Coll. (Bro. Gon-zales), Kilmore.
 3AS—A. F. Stow, 721 Rathdown St., N. Carlton, N4.
 3AT—A. W. Thomson, "Arbroath," Ridley St., Sunshine.
 3AU—S. H. Milligan, 78 Nicholas St., Chilwell.
 3AW—A. Wilkins, 12 Kalymna Gr., E. St. Kilda, S2.
 3AX—H. D. Boast, 105 Cochrane St., Elsternwick, S4.
 3AY—W. W. Jenvey, Draper St., Ormond, SE14.
 3AZ—A. E. Avard, 1 Hawthorn Rd., Northcote, N16.
 3BB—W. F. Brown, 19 Mackay Cres-cent, South Warrnambool.
 3BC—Brighton Radio Club, Higin-botham Hall, Brighton Library Bldg., Bay St., Brighton, S5.
 3BD—E. H. Cox, 16 Talbot Ave., E. St. Kilda, S2.
 3BG—L. Osburne, Terang.
 3BH—C. R. Whitelaw, 12 Fairholm St., Camberwell, E6.
 3BK—S. C. Baker, 237 Clarendon St., S. Melb., SC5.
 3BL—J. C. Fitchett, 13 Holmwood Ave., Brighton, S5.
 3BM—H. K. Love, Valency Rd., E. Malvern, SE6.
 3BO—J. B. O'Hara, 30 Burns St., Maryborough.
 3BP—J. H. Hood, 6 Alexander St., E. St. Kilda, S2.
 3BQ—W. F. M. Howden, "Vavau," Greenwood Ave., Ringwood.
 3BR—Brodribb Bros., 6 Piedmont St., Box Hill, E11.
 3BW—A. Woolnough, Fenwick St., Portarlington.
 3BX—H. W. Berry, 5 Acheron Ave., S. Camberwell, E6.
 3BY—H. Holst, 27 Bambra Rd., Caul-field, SE7.
 3BZ—G. I. Morris, Boundary Rd., Mordialloc, S12.
 3CA—C. A. Hughes, 1 Vera St., Wil-liamstown, W16.
 3CB—W. F. Sievers, 26 Lesney St., Richmond, E1.
 3CC—University of Melbourne, Carl-ton, N3.
 3CF—C. I. Falconer, 13 Norris St., Surrey Hills, E10.
 3CJ—C. J. Manning, 486 High St., Glen Iris, SE6.
 3CK—E. Cook, Boundary St., Kerang.
 3CQ—F. G. Canning, 159 Domain Rd., S. Yarra, SE1.
 3CR—C. H. Bennett, 80 Sydney Rd., Brunswick, N10.
 3CS—C. J. Sabelberg, 100 Station St., Port Melbourne, SC7.
 3CW—C. A. Walters, 54 Normanby Ave., Thornbury, N17.
 3CX—A. G. Brown, 8 Mangarra Rd., Canterbury, E7.
 3CY—R. A. Parker, 163 Prospect Hill Rd., Canterbury, E7. (For-merly VK3RA.)
 3CZ—A. I. Berry, 15 Kembra St., Hawthorn, E2.
 3DC—S. A. Embling, 296 Williams Rd., Toorak, SE2.
 3DH—I. Morgan, 21 Paxton St., E. Malvern, SE5.
 3DJ—D. A. J. Stocks, 49 Middlesex Rd., Surrey Hills, E10.
 3DL—D. Leber, 402 Bridge Rd., Rich-mond, E1.
 3DO—J. M. Dobbyn, 6 Wills St., Glen Iris, SE6.
 3DS—"Age" Radio Club, "Age" Office, Collins St., Melbourne, C1.
 3DX—J. J. Kermond, 4 Lava St., Warrnambool.
 3EF—H. W. Maddick, 89A Spray St., Elwood, S3.
 3EL—N. J. Boyd, Pearce St., Caul-field, SE8.
 3EN—A. Leonard, Drouin.
 3ER—E. H. W. Read, 147 Lygon St., Brunswick, N11.
 3ES—E. S. Yorston, 184 Hawthorn Rd., Caulfield, SE8.
 3EW—E. W. Hughes, 19 Glenhuntly Rd., Elwood, S3.
 3FB—Trafalgar and District Radio Club, Treloar Buildings, Con-tingent St., Trafalgar.

- 3FC—F. T. Clark, 66 Armstrong St., Middle Park, SC6.
- 3FO—F. Olsen, 10 New St., Hampton, S7.
- 3FY—Fitzroy Radio Club, 72 Newry St., N. Fitzroy, N7.
- 3GD—G. T. Davies, 165 Blyth St., Brunswick, N11.
- 3GH—W. M. Hale, Ben Nevis, Harvey St., Anglesea.
- 3GJ—A. J. Hoy, 115 Skene St., Warrnambool.
- 3GK—S. C. McLean, 41 Pental Rd., Caulfield, SE7.
- 3GL—G. L. Barthold, 72 Union St., Malvern, SE3.
- 3GM—G. R. McCulloch, 511 Havelock St., Ballarat.
- 3GN—H. G. Selman, 18 Belfast St., Geelong.
- 3GO—T. Stephens, "Ngarveno," Huddle St., Essendon, W5.
- 3GS—G. S. C. Semmens, 16 Glengyle St., Moreland, N13.
- 3GT—G. Thompson, 62 Flinders St., Melbourne, C1.
- 3GU—H. Chapman, 1 Noel St., Ivanhoe, N21.
- 3GW—H. G. Williamson, Rainbow.
- 3HA—H. Blackman, 44 Osborne Ave., E. Malvern, SE6.
- 3HB—H. L. Byrne, 41 Wolseley Gr., Brighton Beach, S5.
- 3HC—H. Cliff, 3 Riverview Rd., Essendon, W5.
- 3HD—H. L. Doyle, 98 Claremont Av., Malvern, SE4.
- 3HH—F. Maughan, 15 Staniland Ave., Malvern, SE4.
- 3HJ—K. Heitsch, 305 Mitcham Rd., Mitcham.
- 3HK—V. H. George, 199 Rosanna Rd., Heidelberg, N22.
- 3HL—A. T. Hutchings, "Byron Avon," Callawadda.
- 3HM—E. L. Hutchings (Mrs.), "Byrn Avon," Callawadda.
- 3HR—A. H. Reid, 3 Kingston St., E. Malvern, SE5.
- 3HW—F. Hattam, 18 Greenhill St., Castlemaine.
- 3JB—J. R. Kling, "Glenmore," Balwyn Rd., Balwyn, E8.
- 3JD—J. F. Dunleavy, 132 Surrey Rd., S. Yarra, SE1.
- 3JJ—J. J. McMath, 54 St. Vincent Place, Albert Park, SC6.
- 3JK—J. K. Herd, Ryley St., Wangaratta.
- 3JM—R. W. Bryson, 149 Eglinton St., Kew, E4.
- 3JO—C. L. Ruck, 3 Glentilt Rd., E. Malvern, SE6.
- 3JP—H. E. H. Michell, 2 Erindale Av., Ripponlea, S4.
- 3JR—C. J. Rainbow, 18 Arthur St., Preston, N18.
- 3JS—J. Schultze, 24 York St., Glenferrie, E2.
- 3JU—H. E. J. Phillips, 178 Mitcham Rd., Mitcham.
- 3JW—R. W. Bruce, 51 Tooronga Rd., E. Malvern, SE5.
- 3JY—J. W. Murray, 317 George St., Fitzroy, N6.
- 3KA—J. J. C. Sharp, 3 Seach St., Caulfield, SE8.
- 3KB—A. L. Kissick, 860 Sydney Rd., Brunswick, N10.
- 3KH—E. W. Anderson, 32 Belmont Av., E. Malvern, SE6.
- 3KI—J. M. Mabbitt, "Long Lake," Lake Boga.
- 3KL—C. H. Philpot, Derrinallum.
- 3KO—G. Fowles, 138 Mitford St., Elwood, S3.
- 3KP—F. Monteath, 24 Pt. Nepean Rd., Elsternwick, S4.
- 3KR—K. R. Rankin, Boundary St., Kerang.
- 3KS—E. W. Simms, 22 Epping St., Malvern, SE5.
- 3KU—R. A. Hipwell, Swan Hill.
- 3KY—S. G. Mann, 9 Hinton St., Glenhuntly, SE9.
- 3LC—R. Burke, 3 Hartbury Av., Elwood, S3.
- 3LE—L. Lockhart, 112 Addison St., Elwood, S3.
- 3LG—L. G. Glew, 22 Elphin St., Newport, W15.
- 3LJ—L. J. Simmons, Colombo Rd., Belgrave.
- 3LK—Geelong Radio Club, Fenwick St., Geelong.
- 3LM—E. L. Lee-Archer, 55 Aintree Rd., Glen Iris, SE6.
- 3LP—L. A. Paul, 137 St. George's Rd., N. Fitzroy, N7.
- 3LS—R. T. Busch, 20 Wordsworth St., Moonee Ponds, W4.
- 3LU—C. T. McPherson, 67 Droop St., Footscray, W11.
- 3LW—C. Hiam, 56 William St., St. Kilda, S2.
- 3LX—L. P. McGuire, Hume St., Wodonga.
- 3LZ—C. A. Ellis, 10 Thompson St., Williamstown, W16.
- 3MA—Amalgamated Wireless (A/sia) Ltd., 167 Queen St., Melbourne, C1.
- 3MB—A.W.A., Ballan Transmitting Centre.
- 3MC—A.W.A., Rockbank Receiving Centre.
- 3MD—A.W.A. (Portable Station).
- 3ME—A.W.A., Braybrook, Vic.
- 3MH—M. H. Stuart, Beam Station, Rockbank.
- 3MI—J. R. Alsop, 28 Molesworth St., Kew, E4.
- 3MJ—J. Martin, 417 Rae St., N. Fitzroy, N7.
- 3ML—R. H. Cunningham, 1 Dalny St., Malvern, SE4.
- 3MP—S. V. Hosken, Queen St., Surrey Hills, E10.
- 3MS—L. J. Moore, "Avalon," Pine Gr., Ormond, SE14.
- 3MT—The Working Men's College, Latrobe St., Melbourne, C1.
- 3MU—R. R. Mackay, 54 Patterson St., Princes Hill, Carlton, N3.
- 3MY—I. D. Money, 8 Maling Rd., Canterbury, E7.
- 3NG—N. E. Gunter, 129 Normanby Rd., Caulfield, SE7.
- 3NM—N. McLeod, 11 Spring Rd., Caulfield, SE8.
- 3NN—H. R. Brown, Yanac.
- 3NO—G. E. Nolte, "Suva," 9 Kendall St., Elwood, S3.
- 3NQ—J. D. Watson, "Wattleville," Darlington, via Camperdown.
- 3OC—R. Ohrbom, 22 Gordon St., Coburg, N13.
- 3OR—M. D. Orr, Lake Meran, Kerang.
- 3OT—R. M. Cameron, "Manuka," Coonil Cres., Malvern, SE4.
- 3OW—G. L. Templeton, "Carinya," Coleraine.

- 3PA—P. J. Anderson, 6 Walter St., Westgarth, N16.
- 3PB—P. A. Burbidge, 10 Grandview St., Moonee Ponds, W4.
- 3PJ—V. L. Smyth, 130 McIvor St., Bendigo.
- 3PK—C. H. Smith, 96 Harp Road, East Kew, E5.
- 3PM—G. Frew, 97 High St., Glen Iris, SE6.
- 3PP—Capt. A. E. Payne, 554 Toorak Road, Toorak, SE2.
- 3PR—W. R. Jardine, 264 Buckley St., Essendon, W5.
- 3PT—R. C. Peterson, 88 Eglinton St., Moonee Ponds, W4.
- 3PX—N. S. Taylor, 273 Burke Road, Camberwell, E6.
- 3QH—J. F. Feldman, Forest St., S. Geelong.
- 3QW—J. A. Muir, 14 Violet Cres., Brighton, S5.
- 3RB—R. Buzzacott, 532 New St., Elsternwick, S4.
- 3RC—R. G. Clay, 65 Gillies Street, Fairfield, N20.
- 3RF—R. W. Field, 42 Orrong Cres., Caulfield, SE7.
- 3RG—R. L. G. Blake, 29 Doveton St., Castlemaine.
- 3RH—I. R. Hodder, "Eromanga," Glenorchy.
- 3RI—Victorian Railways Institute Wireless Club, Flinders St., Melbourne, C1.
- 3RJ—R. E. Jones, 23 Landale Street, Box Hill, E11.
- 3RK—T. E. Evans, 11 Brunswick Rd., E. Brunswick, N10.
- 3RL—R. Lighton, 206 Alma Rd., East St. Kilda, S2.
- 3RO—W. E. Brennan, Transportation Branch, Victorian Rlys., Spencer St., Melbourne, C1.
- 3RP—R. L. Payne, 39 Retreat Road, Newtown, Geelong.
- 3RS—R. C. Shortell, 421 Inkerman St., St. Kilda, S2.
- 3RU—R. A. Durand, 6 Trumper St., Camberwell, E6.
- 3RX—C. Serle, 1 Torrington St., Canterbury, E7.
- 3RZ—P. Ashley, "Illowa," 50 Poolman St., Caulfield, SE8.
- 3SA—L. R. Simpson, 35 Queen St., Ararat.
- 3SK—Royal Australian Naval Reserve Radio Club, Naval Drillroom, Port Melbourne, SC7.
- 3SL—L. W. Southwell, c/o Mrs Neal, High St., Seymour.
- 3SP—I. R. Pearson, Clyde Rd., Berwick.
- 3SW—S. W. Gadsden, 20 Fellows St., Kew, E4.
- 3TB—T. Barnes, 150 Epsom Road, Ascot Vale, W2.
- 3TC—T. P. Court, 4 Sorreit Avenue, Malvern, SE4.
- 3TM—A. H. Buck, 10 Maynard St., E. Preston, N18.
- 3TX—W. S. Tregear, 22 Cole Street, Upper Hawthorn, E3. (Formerly 3TR.)
- 3UI—R. M. Dalton, 611 Burke Road, Camberwell, E6.
- 3UK—V. E. Marshall, 5 Fordholm Rd., Hawthorn, E2.
- 3UX—G. W. Steane, 149 Toorak Rd., S. Yarra, SE1.
- 3VP—C. W. Baker, 101 Williamson St., Bendigo.
- 3VR—R. N. Abbott, 44 Barkly St., St. Kilda, S2.
- 3VS—V. J. Spicer, 389 Pt. Nepean Rd., Mordialloc, S12.
- 3WA—W. A. G. Wilson, 215 Raglan St., S. Ballarat.
- 3WD—W. Dempsey, Centre Dandenong Rd., Cheltenham, S22.
- 3WG—W. R. Gronow, 346 St. Kilda Rd., Melb., SC1.
- 3WH—A. W. H. Chandler, "Cliffs House," Beach Rd., Beaumaris, S10.
- 3WI—Wireless Institute of Australia (Victorian Division), Ashburton; secretary, 3 Bent St., Caulfield, SE8.
- 3WJ—S. M. Sandford, "Roslin," Welsh St., Kyneton.
- 3WK—E. W. Soumprou, 917 High St., Thornbury, N17.
- 3WL—J. E. de Cure, 35 Higginbotham St., Coburg, N13.
- 3WM—W. J. M. McAuley, "Mia Mia," Union St., Brunswick, N10.
- 3WO—G. G. Hall, 128 Milton Pde., Glen Iris, SE6.
- 3WR—N. M. Templeton, "Willima," Coleraine.
- 3WS—W. M. Sweeney, 10 Foam St., Elwood, S3.
- 3WT—Wireless Institute of Australia (Victorian Division), (Aero Section), Aerodrome, Bulla Road, Essendon, W5.
- 3WU—Wireless Institute of Australia (Victorian Division), (Aero Section), Aerodrome, Bulla Rd., Essendon, W5.
- 3WX—W. J. Nicholls, 24 Victoria St., Williamstown, W16.
- 3XA—G. J. Waters, 32 Lorne Rd., E. Prahran, S1.
- 3XC—Xavier College, Kew.
- 3XF—M. C. Chaffer, 41 Norwood Cres., Moonee Ponds, W4.
- 3XI—H. Duggan, Raglan Pde., East Warrnambool.
- 3XO—F. J. Adams, "Bambra," 11 Moule Ave., Middle Brighton, S5.
- 3XW—C. A. Cullinan, Bayview, Diggers Rest.
- 3XX—J. Givens, 19 Logan St., Canterbury, E7.
- 3YL—Miss A. Marshall, 650 Dandenong Rd., Murrumbeena, SE9.
- 3YN—D. J. Harkin, 32 Maghull St., East Brunswick, N.H.
- 3YW—C. C. Waring, 80 Balwyn Rd., Canterbury, E8.
- 3YN—B. Hardie, 22 Missouri Ave., Garden Vale, S4.
- 3YZ—A. McKeown, Geelong "Exide" Battery Service, Little Malop St., Geelong.
- 3ZA—E. L. A. Sims, 187 Mansfield St., Thornbury, N17.
- 3ZK—F. H. Badley, "Worthing," Beach Crescent, Sandringham, S8.
- 3ZN—M. Israel, "Attossa," Station St., Burwood, E13.
- 3ZO—J. A. Cunliffe, 97 Madeline St., Preston, N18.
- 3ZR—L. Snaith, 41 William St., Newport, W15.
- 3ZX—O. G. Oppenheim, 33 Saturn St., Caulfield, SE8.
- 3ZY—M. Ireson, "Yaldwin," Kyneton.

QUEENSLAND

- 4AB—W. F. Bardin, Archibald St., Fairfield.
- 4AC—A. C. Walker, Oxford St., Sandgate.
- 4AF—A. F. Marshall, Fisher St., Clifton.
- 4AJ—A. C. Jackson, cr. Ashby and Gilbert Sts., Fairfield.
- 4AK—J. Milner, Woodland St., Ashgrove, Brisbane.
- 4AL—B. W. Munro, Gordon St., Hawthorne.
- 4AM—H. M. Mackenzie, Horatio St., Annerley.
- 4AS—A. W. Soden, Ipswich Rd., Annerley, South Brisbane.
- 4AT—A. Bauer, "Bauerville," Rose St., Annerley.
- 4AW—A. E. Walz, cr. Eton St. and Sandgate Rd., Nundah.
- 4AZ—F. V. Sharpe, "Ashton Hall," Old Sandgate Rd., Woolloowin.
- 4BB—R. J. Beatson, First Ave., Wilston.
- 4BD—B. D. Grimes, Tarragindi Rd., Annerley.
- 4BH—H. G. Brown, Newtown St., Booval.
- 4BJ—J. G. Brown, Gordon St., Aramac.
- 4BS—C. F. Grummitt, Proe St., Fortitude Valley.
- 4BW—A. Couper, off Lloyd St., Mareeba.
- 4BY—E. C. Arnold, 31 Chalk St., Woolloowin.
- 4CF—C. Fortescue, "Matlock," Arthur St., Toowoomba.
- 4CG—C. H. Y. Gold, Drake St., Hill End.
- 4CK—E. L. Norris, "Parkview," Hume St., Toowoomba.
- 4CM—Dr. V. McDowall, Observatory Tower, Wickham Terrace, Brisbane.
- 4CU—C. Walker, c/o S. Smyth, Ruthven St., Toowoomba.
- 4CW—A. T. Buck, Geebung, North Coast Line.
- 4DA—E. Eggleton, Q.A.T.B., Herries St., Toowoomba.
- 4DH—Miss D. Harriss, Longreach.
- 4DO—H. L. Hobler, 8 Lennox St., Rockhampton.
- 4EG—E. E. Gold, Lindsay St., Toowoomba.
- 4EI—State Engineer, General Post Office, Brisbane.
- 4ES—E. N. Sagar, "Moonthalia," Douglas St., Greenslopes.
- 4FB—F. S. Beech, Bennett's Rd., Coorparoo.
- 4FK—V. F. Kenna, "The Laurels," Allen St., Hamilton.
- 4GA—G. A. Shearer, State School, Fontainebleau, Gayndah.
- 4GG—G. Heilbrom, "Euroa," Clayton St., Chinchilla.
- 4GH—G. N. Harley, Thorn St., Ipswich.
- 4GK—A. H. Mackenzie, Fire Station, Wynnum.
- 4GO—G. Oxlade, cr. Badger Ave. and Irving St., Newmarket.
- 4GW—G. W. Ham, "Warroon," Gympie St., Northgate.
- 4HB—H. E. Baker, Gowrie Station, Charleville.
- 4HK—H. C. Kinzbrunner, Cloncurry.
- 4HL—H. L. Miller, Lloyd St., Coorparoo.
- 4HW—H. D. Walsh, "Vailima," Toorak Hill, Hamilton.
- 4JB—O. E. Alder, 16 Old Sandgate Rd., Albion.
- 4JG—C. J. Grant, cr. Victoria Pde. and Old Sandgate Rd., Woolloowin.
- 4JH—J. H. Williams, 64 Nelson St., Mackay.
- 4JL—J. P. Love, "Glen Kedron," 1st Ave., Kedron.
- 4JO—S. L. Fittell, Gympie.
- 4JR—S. A. McMurtrie, Brisbane Rd., Booval, via Ipswich.
- 4JU—F. W. Nolan, 71 Herbert St., Brisbane.
- 4JW—H. P. C. Larsen, Cambridge St., Charters Towers.
- 4KG—R. M. Nicholson, "Coombermartin," Ilfracombe.
- 4KH—W. S. Argaet, "Kingsley," Kingsley Tce., Wynnum South.
- 4KW—A. G. Cannon, Sandgate Rd., Toombul.
- 4KX—M. R. Cran, "Codrington," 228 Boundary St., West End.
- 4KZ—C. C. McG. Couchman, Kaimkillenbun, via Dalby.
- 4LH—L. F. Hitchcock, 128 Kedron Park Rd., Woolloowin.
- 4LJ—L. J. Feenaghty, Dickson St., Woolloowin.
- 4LK—J. W. Sutton, Moreton St., New Farm.
- 4LJ—L. J. Lumb, "Loloma," Waterworks Rd., Ashgrove.
- 4LS—L. S. B. Williams, Salisbury St., Indooroopilly.
- 4LW—C. R. Morris, 20 Elizabeth St., Rosalie.
- 4MF—D. C. Winterford, "Morlan-court," Collins St., Annerley.
- 4MM—M. M. O'Brien, Fewings St., Toowong.
- 4NA—N. W. Atkinson, Alynbrook, St. Osyth St., Toowong (formerly 4WK).
- 4N—Townsville Radio Club (N. Stockton), Railway Department Reserve, Townsville.
- 4NW—T. W. Starkie, "Pendarves," Sandgate Rd., Nundah.
- 4PG—P. J. Golden, "Ben-my-Chree," Waterview Ave., Wynnum Heights.
- 4PL—P. L. Grant, Enderley Rd., Clayfield.
- 4PN—R. F. Roberts, Cambridge St., West End, Sth. Brisbane.
- 4RA—R. A. Atkinson, Burke St., off Ipswich Rd., South Brisbane.
- 4RB—R. J. Browne, 25 Church St., Toowong.
- 4RG—H. J. Stephenson, C. W. Stephenson, Thorrold St., Woolloowin.
- 4RJ—Rev. R. J. R. Delbridge, Methodist Parsonage, Childers.
- 4RI—Central Technical College, George St., Brisbane.
- 4RO—P. Wood, Moffatt St., Ipswich.
- 4RR—R. Rose, c/o A. Rose, Chemist, Longreach.
- 4RW—W. Rohde, "Maranoa," McCook St., Red Hill.

- 4SM—W. G. Ikin, River Rd., New Farm.
 4SP—F. W. Stevens, cr. 5th and 10th Ave., Windsor.
 4TA—T. M. Alexander, "Innisfail," Wickham Tce., Brisbane.
 4TC—Toombul Radio Club, Eton St. and Sandgate Rd., Nundah.
 4UK—H. V. Herschel, 171 Abbott St., Cairns.
 4VH—H. M. Wooster, cr. Mitchell and McKinlay Sts., Townsville.
 4WA—W. A. Young, Granville St., West End, Brisbane.
 4WB—W. H. Bright, Hume St., Nth. Toowoomba.
 4WH—W. E. Hagarty, Woompoo St., Longreach.
 4WI—Wireless Inst. of Aust. (Qld. Division), c/o L. J. Feenaghty, Dickson St., Woolloowin.
 4WN—Woolloowin Radio Club, Willmington St. (c/o F. J. Thomas).
 4XK—G. Richards, Burnett St., Ipswich.
 4XN—V. E. L. Nissen, Condamine St., Dalby.

SOUTH AUSTRALIA

- 5AC—V. R. P. Cook, 10 Grant Ave., Rose Park.
 5AE—J. M. Honor, Alpha Road, Prospect.
 5AM—P. Kennedy, 77 Edmund Ave., New Parkside, Unley.
 5AQ—Sacred Heart College, Glenelg.
 5AW—A. W. Kelly, c/o Lyndale Winery, Lyndoch, S.A.
 5AX—A. H. Traeger, Brigalow Ave., Kensington Gardens.
 5BF—F. G. Miller, Eleanor Ter., Murray Bridge.
 5BG—H. A. Kauper, 6 Rothbury Ave., Tusmore.
 5BJ—R. A. Bruce, 1 Henry Street, Glenelg.
 5BK—J. Crivell, Edithburgh Road, Yorketown.
 5BP—R. B. Caldwell, 53 Hughes St., Unley.
 5BR—Blackwood Radio Club, Waite Street, Blackwood.
 5BW—J. G. Phillips, 31 Partridge St., Glenelg.
 5BX—A. L. Saunders, Kent Street, Glenelg.
 5BY—D. R. Whitburn, cor. Cudmore Ave. and Sprod Ave., Toorak Gardens.
 5BZ—W. E. Launder-Cridge, "Pareora," Henley Beach Road, Brooklyn Park.
 5CF—C. F. Trott, P.O. Box 32, McLaren Vale.
 5CM—R. M. Anthony, 3 High Street, Unley Park.
 5CX—C. E. Moule, 146 Young Street, Parkside.
 5DA—S. R. Buckerfield, Abbotsbury Place, Evandale.
 5DC—E. Shepard, 12 Capper Street, Kent Town.
 5DO—D. O'Leary, 2 Hyde Street, Tusmore Gardens.
 5DP—H. E. E. Brock, 34 Barnard Street, North Adelaide.
 5DR—P. W. Dear, 21 Maitland Terrace, Seacliff.
 5DX—D. G. Taylor, 67 Victoria St., Forestville.
 5FT—J. S. Fitzmaurice, St. Andrew's St., N. Walkerville.
 5GA—G. R. Anderson, Kingscote Ter., Kingscote, Kangaroo Island.
 5GH—Mt. Gambier High School, Mt. Gambier.
 5GR—G. B. Ragless, South Road, P.O., St. Marys.
 5HG—H. M. Cooper, 51 Hastings St., Glenelg.
 5HY—A. A. Cotton, 15 Broadway, Colonel Light Gardens.
 5IT—I. Thomas, 15 Eynesbury Ave., Kingswood Park, Mitcham.
 5JA—P. J. Brewer, 21 Douglas St., Parkside.
 5JC—F. Currie, 45 Carlisle St., Glenville.
 5JH—V. Chennell, 53 Osmond Ter., Norwood.
 5JM—Wayville Radio Club, 313 Young Street, Wayville.
 5JO—A. A. Reimann, 20 Grenfell St., Kent Town.
 5JW—J. W. Wilkin, 67 Hill Street, North Adelaide.
 5KJ—E. C. McLoughlin, "Lynton," Port Lincoln.
 5KM—F. Kempster, 9 Francis Ave., Fullarton.
 5KW—K. Wadham, 5 First Ave., Helmsdale.
 5LF—L. F. Sawford, Margaret St., Rosewater.
 5LK—F. G. Annear, Carrow.
 5MB—H. M. Brown, 24 Northcote St., Torrensville.
 5MR—M. E. Richard, 5 Trevorten Ave., Glenunga.
 5NC—Norwood Radio Club, 69 Osmond Ter., Norwood.
 5OM—J. E. Vardon, 11 Belle Vue Place, Unley Park.
 5PM—P. A. Messenger, c/o J. H. Murch, Wills St., Largs.
 5QP—K. M. Theel, 81 First Ave., St. Peters.
 5RB—R. Bedford, Cottage Hospital, Kyancutta.
 5RC—A. R. Cameron, 330 Kensington Rd., Leabrook.
 5RE—H. Hobcroft, Box 160, Renmark.
 5RG—R. C. Gurner, 220 Glen Osmond Rd., Fullarton Estate.
 5R1—South Aust. Railways Institute, North Ter., Railway Station, Adelaide.
 5RJ—D. M. Hancock, 14 Railway Ter., Kadina.
 5RK—M. Clayton, 15 Lindfield Ave., Edwardstown.
 5RM—R. M. Parker, 57 Newbon Street, Prospect.
 5RN—H. E. Edwards, 16 Princess St., Croydon.
 5RW—Westbourne Radio Club, 14 Avenue Rd., Unley Park.
 5RX—G. W. Luxon, 8 Brook St., West Mitcham.
 5SF—S. F. Ackland, 74 John Rd., Prospect.

- 5SR—Signals (South Aust.) Radio Club, Keswick Barracks, Adelaide.
 5WA—W. K. Adamson, 46 Woodfield Ave., Fullarton.
 5WB—H. B. Wilson, 313 Young Street, Wayville.
 5WH—W. H. Barber, 50 Somerset Ave., Cumberland.
 5WI—Wireless Inst. of Aust., cor. Cudmore and Sprod Avenues, Toorak Gardens.
 5WO—Walleroo Radio Club, Wildman St., Wallaroo.
 5WP—W. S. Pitchford, 318 Wakefield St., Adelaide.
 5WR—W. M. Richards, 32 Charlbury Rd., Medindie Gardens.
 5WS—West Suburban Radio Club, 44 King St., Mile End.
 5XK—A. J. Hewitt, 233 Henley Beach Rd., Torrensville.
 5ZK—Adelaide Radio Club, 15 Lindfield Ave., Edwardstown.

WEST AUSTRALIA

- 6AG—W. E. Coxon, 5th Ave., Inglewood.
 6AK—University of West Aust., Perth.
 6AW—A. Williams, Wittnoom Street, Collie.
 6BB—J. C. Park, 29 Suburban Road, Mill Pt., Sth. Perth.
 6BC—B. Congdon, 75 Gloster Street, Subiaco.
 6BN—A. E. Stevens, Strickland St., South Perth.
 6BO—A. E. Grey, 40 Archdeacon St., Nedlands.
 6BW—C. D. McLauchlan, 14 Clydesdale St., Victoria Park.
 6CJ—E. J. Darley, Darley St., Perth.
 6DA—F. W. Saw, Earl St., Albany.
 6DH—D. C. Hardisty, 2 Duncan St., Victoria Park.
 6DW—D. W. Edgar, Glentromie, New Norcia.
 6FG—F. H. Goldsmith, 27 Cooper St., Nedlands Park.
 6FH—F. A. Hull, Pingrup, via Katanning.
 6FL—F. C. Lambert, 1 Brandon St., South Perth.
 6FM—F. May, c/o Post Office, Dwellingup.
 6FT—F. Tredrea, 53 Fairfield St., Mt. Hawthorn.
 6GB—G. B. Sutherland, 36 Fairfield St., Mt. Hawthorn.
 6GM—G. A. Moss, Willis St., Cottesloe Beach.
 6HD—H. T. Davies, 19 Harley St., Highgate Hill.
 6HE—H. E. Cox, Marine Terrace, West Geraldton.
 6JJ—T. J. Jewell, 52 Leitchfield Street, Victoria Park.
 6JR—F. G. Clinch, Mill Villa, Greenough.
 6JS—J. Squires, Cannington Terrace, Cannington.
 6JW—J. W. Watson, 4 Balmoral Street, Victoria Park.
 6KX—H. T. Simmons, 1091 Hay St., Perth.
 6KZ—C. H. Vernon, R.A.A. Forts, Albany.
 6LG—L. G. Wilson, 19 Jubilee St., South Perth.
 6LS—L. Symonds, 111 Glyde St., Cottesloe Beach.
 6MN—S. J. Madden, 166 Chelmsford Rd., North Perth.
 6MO—Magnetic Observatory, Watheroo.
 6MU—M. S. Urquhart, Marmion St., Cottesloe.
 6NG—J. E. Clough, Homer St., Narrogin.
 6NK—D. B. Knock, Wyndham.
 6NO—N. Turnbull, 207 Roberts Rd., Subiaco.
 6PK—P. E. Kernick, 12 Fremantle Rd., South Perth.
 6RH—R. A. Hull, Pingrup, via Katanning.
 6RJ—J. R. Tapper, 24 Davies Road, Claremont.
 6SA—S. C. Austin, cnr. Forest and Hensman Sts., S. Perth.
 6SR—Subiaco Radio Society, 75 Gloster St., Subiaco.
 6SW—S. E. Worth, Orrong Rd., Riverdale.
 6VK—J. Vincent, 124 Varden Street, Kalgoorlie.
 6VP—Victoria Park Radio Club, 12 Fremantle Rd., South Perth.
 6WA—Amateur Radio Transmitters' League of Western Australia, cr. Forrest and Hensman Sts., South Perth.
 6WI—Wireless Institute of Australia (West Aust. Division), Y.A.I. Buildings, Murray St., Perth.
 6WK—T. W. Ruse, 138 Bennett St., East Perth.
 6WM—W. B. Morris, 5 Leura Street, Hollywood.
 6WP—W. R. Phipps, 31 Fremantle Rd., Victoria Park.
 6WR—W. D. Rodda, 17 Bay Road, Claremont.
 6WW—S. W. Watson, 27 Clive Street, West Perth.
 6WX—I. E. Waddell, Grey St. East, Albany.

TASMANIA

- 7AB—A. C. Smith, 21 High St., Launceston.
 7AG—J. C. Milne, "Askrigg," Gretna.
 7AH—F. W. Medhurst, "Cranleigh," Beach Road, Lower Sandy Bay.
 7AR—C. F. Johnson, "Huendon," Ryder St., West Hobart.
 7BM—E. C. Sheldrick, 15 Richards Ave., Launceston.
 7BQ—L. J. Crooks, 64 Frederick St., Launceston.
 7CH—C. Harrison, Rokeby Rd., Belterive.
 7CS—A. C. Scott, 14 Law Street, Launceston.
 7CW—C. Walch, 36 Bath Street, Battery Point.

7DX—W. T. Watkins, 146 Warwick St., Hobart.
 7ET—E. S. Howard, 50 Lampton Ave., Moonah.
 7GD—G. A. Douglas, "Lochleven," Gormanston.
 7GH—G. L. Hall, Waddamana.
 7HL—H. F. Lovett, 14 Summerhill Rd., West Hobart.
 7JK—J. F. Heine, 210 Macquarie St., Hobart.
 7JR—T. C. Kitto, Cherry Rd., Trevallyn, Launceston.

7LJ—L. R. Jensen, 59A Pedder Street, Newtown.
 7OM—R. D. O'May, 55 Grosvenor St., Sandy Bay.
 7RS—R. S. Hope, 210 George Street, Launceston.
 7WI—Wireless Institute of Aust. (Tasmanian Division), Room 12, 66 Liverpool St., Hobart.
 7WJ—W. J. Norman, Eddystone Point Lighthouse, N.E. Tasmania (c/o Customs House, Hobart).
 7WM—W. A. Martin, 2 Salvator Rd., West Hobart.

Some Notes on Howling

Audio frequency oscillation or howling may be the result of poor design or insufficient attention to certain details.

HOWLING is in every instance caused by oscillation of a circuit or circuits at an audible frequency. Audio frequency oscillation may be in the form of motorboating when the frequency of the oscillations is low. The oscillations may be of any pitch between a low growl and a high squeal. Poor design in many instances will result in this howling. The oscillation is caused by energy feeding from the end of a circuit back to its beginning. If two transformers are mounted so that the field surrounding them will interact, oscillation at audible frequencies will inevitably occur.

Care in design will prevent the possibility of howling, due to interaction between the a.f. stages of a receiver. Howling when tuned to the wave-length of a station is due to oscillation of r.f. or detector circuits. In the detector stage the reaction control should be manipulated so that the receiver is on the verge of oscillation when receiving weaker transmissions. Do not allow the receiver to howl when tuned to a station. If the howl is insistent no matter where the tuning dial may be placed, it will be known that a.f. oscillation is the cause of the noise.

Whether the detector valve be installed in a shock absorbed socket or not, sound waves from the speaker will cause this valve to vibrate if it is even slightly microphonic.

This vibration sets up a low howl which gradually increases in its intensity until it reaches maximum strength when signals are completely eliminated. The cabinet may be the medium which will conduct the sound waves from the speaker to the detector valve. This is another instance of feed-back from the output to the input of a circuit. In this case it is mechanical feedback. When the detector valve

commences to vibrate, it receives power in the same manner as a pendulum. This power is available in the form of the sound waves or vibrations from the speaker. Vibration of the valve causes vibration of the elements of the valve's construction. Vibration of the elements causes modulation of the plate circuit power, this modulation being amplified by succeeding stages.

A SIMPLE REMEDY

By use of a shock-absorbed detector valve socket and a leaden weight we can cause the valve to vibrate, but with a very low periodicity. This means that, although the valve will vibrate, the frequency of the vibrations will be far too low to affect reception. The weight should be moulded so that it is in the form of a dome, which will remain on the top of the detector valve when placed into position. The leaden weight should be connected to ground via the B negative by means of a piece of flex.

Similarly, the first stage amplifier valve of a receiver combination, if microphonic, will set up oscillation noises. The same remedy applies to this valve. R.F. or final stage valves, even if they are extremely microphonic, are seldom affected by sound waves from the speaker.

In older types of receivers using horn type speakers, the remedy was to place the receiver in a position well away from the receiver.

In building a receiver, the chassis and speaker must be insulated from the cabinet by means of some shock-absorbing material, such as thick felt.

This will prevent the chassis vibrating at audible frequencies. Vibration will always introduce distortion.

Theory of the Push-Pull Amplifier

We have already discussed this type of amplifier in brief, practical language. This system is so important that for the benefit of those technically inclined we here deal with the theory of its operation.

PUSH-PULL amplification existed, of course, before 1927, the year of the introduction of the A.C. tube, but proof of its existence could scarcely be found by examining the radio sets of that date. Power valves, so-called, like the 171, had supplanted the 201-A in the last audio stage and push-pull amplification was just rising out of obscurity so far as radio design was concerned. Then the A.C. valve appeared, rather effectively, and audio amplification had to be given another look because there was no power valve of the heater-cathode type. Followed then the screen grid valve, which with a minimum of trouble began to feed the audio valves large chunks, some of which could not be digested equably.

So, and for other reasons which will presently appear, two valves were put in a see-saw circuit to compose the last audio stage. More and more manufacturers sat up and took due notice, the phrase became more familiar to the man who builds his own, the design engineer was forced to admit its existence and began using it. Today the majority of set manufacturers are employing push-pull, and next season even more sets will have at least one push-pull audio stage.

The circuit has some very curious twists that make it a godsend. Consider, first, its ability to handle large inputs. In Figure 1 transformer T represents the coupling between the output of an audio stage and the push-pull stage. The induced voltage across the transformer appearing as k-l has some value, say, 80 volts. If m is the midtap of the secondary there are 40 volts between k and m and 40 between m and l. If k is 80 volts positive with respect to l then k is 40 volts positive with respect to m and m is 40 volts positive with respect to l. As m is connected to the cathode (which in the three-element valve is the filament) of each valve through the grid resistor R_g and as k and l are the respective grids, then valve A has impressed on its grid a potential of 40 volts positive with respect to cathode and valve B correspondingly has its grid 40 volts negative with respect to its cathode.

What has been done is that 40 volts have been impressed on each of two valves instead of 80 volts on one valve. Wherefore, instead of using a type 250 valve with a special power pack we are enabled to use two 171-A's. Our example of an 80-volt input may seem somewhat far-fetched and under "normal" conditions would be. For comfortable volume in the average home one watt of energy to the loud speaker is more than sufficient. To supply this an input to the last valve considerably less than 80 volts (approximately 30 volts) would be enough. But too many listeners are desirous of allowing their neighbors to hear something for nothing; they demand and insist on volume. So, instead of 171-A valves in the last stage, which would be sufficient, we have 245's and 210's.

The best reason for using valves in push-pull lies in the elimination of distortion. Let us review somewhat this action of the circuit, and by taking more details than we usually consider see if we cannot get a clear grasp of the why and how.

By figures 2, 3 and 4 we shall first see why there is distortion with amplification. In figure 2 we see the static

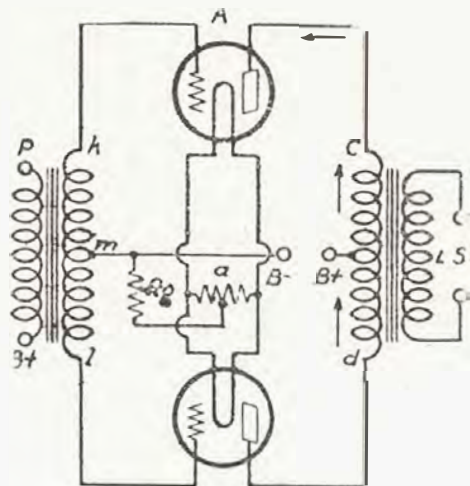

CONVENTIONAL
PUSH-PULL CIRCUIT
FIG 1

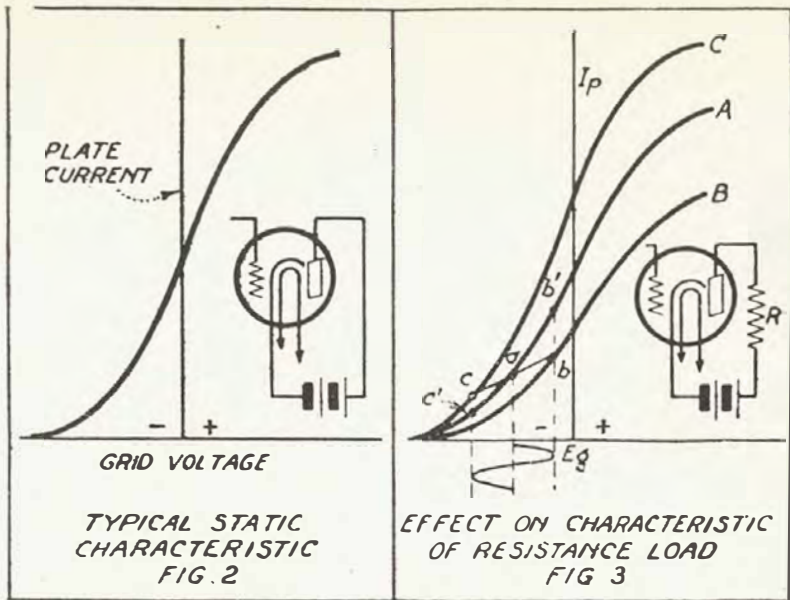

characteristic of the valve showing the relation between grid voltage and plate current. The static characteristic shows the action of the valve when the plate is connected to the B battery directly. This is the curve usually shown, but does not portray the situation under which the valve actually operates. In radio sets we put some sort of load into the plate circuit and in the audio stages this usually takes the form of a resistance or transformer.

What Happens With Resistance ?

Let us see what happens to the characteristic when we put a resistance into the plate circuit. In Figure 3 we put such negative bias on the grid that we begin to operate at point "a" of the middle curve. An incoming wave begins to swing on the grid. During the positive half of the wave the grid voltage becomes less negative and the plate current increases. But this increase of plate current produces a voltage drop across **R**, the load resistance, the plate voltage across the valve becomes less and the plate current does not rise along curve **A**, but goes to some point on curve **B**, which is the static characteristic of the valve at the lower plate voltage. The plate current actually rises along line **a-b**. Similarly, on the negative half of the incoming wave the current falls back along **a-c** to curve **C**, which is the characteristic of the valve at a plate voltage above curve **A**.

If we look carefully at line **b-c**

along which the valve has operated we see that it is practically a straight line. What is more important to note is that line **c-b** is more straight than line **c'-b'**, on which we would have operated with no load in the plate circuit. We know that operating along a curved line means that our output does not exactly follow our input, while when the valve is operating on a straight line each input variation is exactly duplicated in the output circuit. And, as has been pointed out several times by technical writers, when the output does not exactly follow the input we can resolve the output into a fundamental that follows exactly and a harmonic which represents distortion. The effect of a resistance load then has been toward the prevention of harmonic distortion. The dynamic characteristic becomes practically linear when the load resistance equals or is greater than the valve's resistance. We now know one reason for the good reproduction obtainable with a resistance-coupled amplifier.

Figure 4 shows an audio transformer as the load. Point "a" will be, as before, the point around which we operate. On the positive side of the incoming wave the grid, becoming less negative, tends to increase the plate current as before. But the load circuit contains inductance as well as resistance, and the effect of inductance is to discourage any change in the current through it or to slow it up. Which is what happens. The plate current does not follow the grid variations instantly, but marches up to point **b**, lagging the

input voltage, as shown by a-b. If we plot all the points for various grid potentials we obtain a loop as our dynamic operating characteristic between curves B and C where there are the curves for the maximum and minimum plate voltages, as before. The effect of impedance in the plate circuit then is to cause distortion. However, if the resistance is large compared with the inductance, and the load impedance is high, this distortion is materially lessened and the loop tends to approach the straight line of the resistance load.

And now we know that a valve with

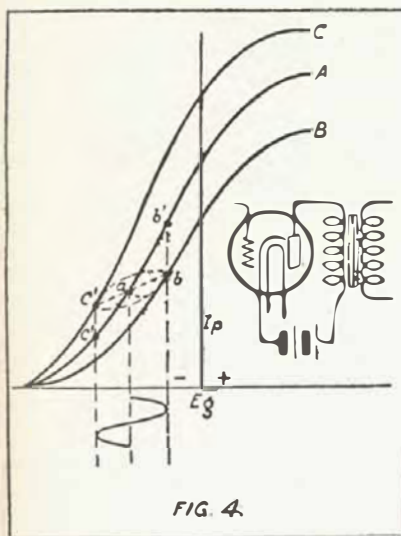

FIG. 4.

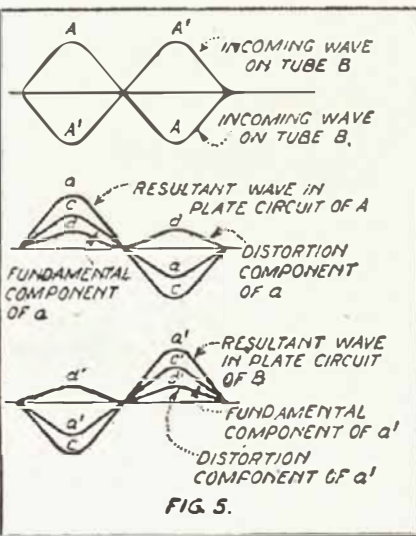

FIG. 5.

a load that is not pure resistance will produce distortion, and that this distortion will be considerable if the output impedance is small. But, and this is what we have been getting around to through several paragraphs, push-pull will eliminate this distortion, and, therefore, can be used even when a low impedance output is necessary.

Push-Pull Kills Distortion

Just how this is accomplished we will be able to see with the help of Figures 5 and 1. Curve A in Figure 5 represents the shape of the plate current of valve A of Figure 1. This curve we may resolve into curves "c" and "d" where "c" is the fundamental that exactly represents the impressed wave on valve A, and "d" is the component of A, representing the distortion of the incoming wave by the valve. Wave "d" has twice the frequency of "c" and is called the second harmonic. Similarly, if A is the wave in the output of valve A, A' is the

wave shape from valve B because, as has been explained previously, the impressed voltage on valve B is 180 degrees later after it has been applied to valve A. In the same way this wave is broken up into c' and d'. Now we note that curves c and c' are directly opposite, or 180 degrees out of phase as we say; while curves d and d' coincide. If c and c' are directly opposed this means that when c is going from plate to cathode of valve A, c' is going from cathode to plate of valve B. As d and d' are exactly in phase, each will have the same direction at any instant with respect to its own plate.

Now we refer to Figure 1 and see what this means. Let us assume that the instant that we are viewing matters curve C is going through valve A from plate to cathode. Then c' must be going through valve B from cathode to plate. Their respective directions through the output transformer at this instant are indicated by the arrows. The result we see is that c and c', which exactly represent the wave impressed on the grids, are going through the transformer in the same direction. As these waves have the same value, the current through arm a-b, which is the difference between c and c', is zero, and the path of the waves is from cathode of one valve to plate of the same to plate of the other, to cathode of the second, along the filament wiring to cathode of the first. This may be better understood by means of Figure 6a, where A represents the voltage generated in valve A, and B that generated in valve B. A and B are represented as bat-

teries for the sake of convenience and clarity; actually, of course, they are A.C. generators. The letters a, b, c and d refer to the corresponding parts of Figure 1, with the transformer regarded as a centre tapped resistance.

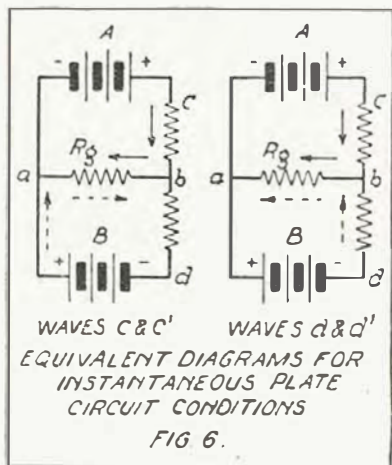

The full arrows show the direction the current produced by A tends to take and the dotted arrows show the direction of current produced by B. If b is the true centre tap and the two voltages A and B are alike the currents in arm a-b are 180 degrees out of phase, or exactly opposed to each other, and the result is that there is no signal current in the arm through R_g and the current through c-d is the sum of that produced by A and B.

Now, let us see what happens to d and d', the distortion waves. These, we see from Figure 5, are exactly in phase, and we may use Figure 6b to represent the condition. The full arrows and dotted arrows show the respective currents as before. Now the situation is a little more interesting. A sends current through c-b and R_g , while B is sending current through a-b and R_g . The result is that R_g has both currents flowing through it in the same direction, while the output transformer has a current going through one-half of its primary in one direction and equal current going through the other half in the opposite direction. To see what this means we shall have to recall some very simple fundamental electrical laws.

And these are: (1) That a voltage is induced in a winding whenever a flux (magnetic field) is varying through the winding; (2) that the flux is directly proportional to the current producing it; (3) that the flux is in phase with the current producing it; (4) that the

voltage produced by the flux bears a fixed relation to the flux.

Applying these laws to our circuit, we may consider that two fluxes have been set up in the transformer by the two currents through the primary. These two fluxes, being in phase with their currents, are 180 degrees out of phase with each other because the currents producing them are directly opposed through the primary. Each flux produces a voltage in the secondary. But as the fluxes are out of phase the voltages are also exactly out of phase and buck each other. The result is that there is zero voltage at the terminals of the transformer, which means that the distortion currents have had no effect and will not appear in the speaker. This result will also be true for the fourth, sixth and other even distortion harmonics, because in each case we will have the condition of Figure 6b, where there are equal polarities across the transformer, and the result, as we have just found, is zero.

Just for the sake of satisfying a mild curiosity, let us investigate what the effect of odd distortion harmonics would be. If we take curve A of Figure 5 and draw its third harmonic, as shown in Figure 7, and compare this with a-a of Figure 6, we note that our third harmonic has maximum point at the same time as the maxima of curve a, but

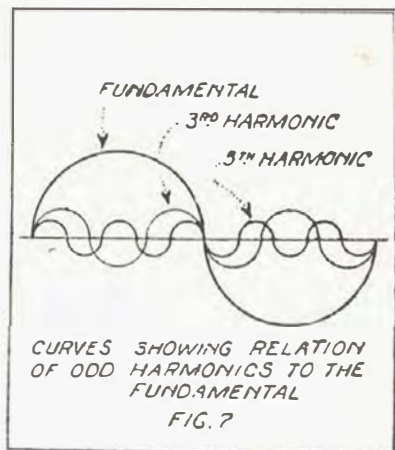

that these points are opposite in phase with respect to the maxima of curve a; that is, one is positive when the other is negative. Which means, if we refer to Figure 6a, that we have essentially the same condition, except that the polarities of batteries A and B are interchanged. Third harmonics as well as other mild distortion harmonics then will appear in the loud speaker.

Types of Measuring Instruments

Dealing with the principles of operation of a.c. and d.c. reading meters

METERS are essential to any electrical circuit where absolutely correct registrations must be available to ensure accurate working. This is admitted by all whose work brings them in contact with such trades and sciences as radio.

There are three principal types of measuring instruments employed for the determination of the voltage or current in any circuit. They are the hot wire type, the moving coil, and moving iron types and the thermo-couple type of meter.

The moving-coil pattern is similar in principle to a small motor. A motor comprises in essentials a magnetic field produced either by a permanent magnet or an electro-magnet, in which is situated a coil or a wire or a series of coils wound in a suitable formation. When current is passed through the coils there is a torque or twisting action which causes the armature or moving portion to rotate.

The moving-coil instrument employs a simple coil only, which is free to rotate in a strong magnetic field produced by a permanent magnet. It cannot rotate indefinitely, but is restrained by a spring, so that the torque or twisting force produced by the current passing through the coil has to overcome the resistance of the spring. The stronger the current the more will it succeed in doing so, and the greater will be the deflection or rotation of the coil, and the larger will be the scale reading produced by the pointer attached thereto.

Moving-coil type instruments can be made very sensitive. They will respond to very small currents or voltages, and what is more, they can be designed to absorb very small currents in giving the particular indication required. The advantage of this is obvious, for if we were to measure the voltage of a "B"

battery with a voltmeter that takes twenty milliamps to operate it, we would be putting a heavy drain on the battery which may run it down more than the actual use on a receiver. For direct current work, the moving-coil instrument remains pre-eminent where an instrument of precision is required.

For alternating current work, the moving-coil instrument cannot be used. It is well known that the direction of the magnetic field produced by a coil depends upon the direction of the current passing through it. Since the whole operation of a moving-coil instrument is the result of the interaction between the fixed magnetic field and that produced by the coil carrying the current, it follows that the direction of motion of the pointer will be dependent upon the direction of the current flowing through the instrument.

An alternating current, as we have seen, flows first in one direction and then in the other. That is to say, the current rises to a maximum, passes through zero to a maximum in the opposite direction, and then falls to zero again fifty times in every second. Moreover, the pulses of current in one direction are identical

with those in the other.

The effect on the moving coil in a measuring instrument, therefore, is that a momentary impulse in one direction is succeeded by an equal and opposite impulse in the opposite direction. If the needle were able to follow the variations, then it would fluctuate on either side of the zero point. In the majority of cases, however, it is not able to respond in the time available and consequently it gives no indication whatever. Thus an instrument of the ordinary moving coil type is quite useless for measuring alternating currents.

Moving-iron instruments are gener-

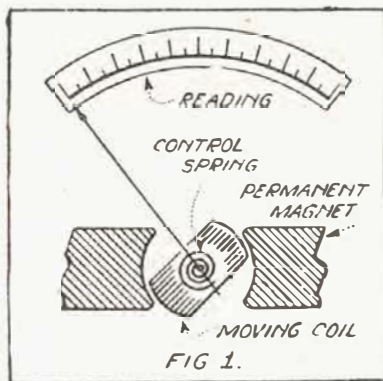

Fig. 1.—An instrument which has a coil rotating in a strong magnetic field.

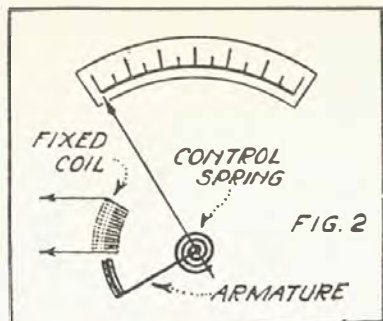

Fig. 2.—Another type which is said to be not so sensitive.

ally less delicate than moving-coil instruments as far as actual construction is concerned, so that they are somewhat cheaper to manufacture. On the other hand, they are not so sensitive as the moving-coil type, so that first of all it is not possible to read such small currents or voltages, and, secondly, the current taken by a moving-iron instrument is considerably greater than that taken by a moving-coil meter to give a corresponding indication.

The third class of instrument is the hot-wire type. The heating effect of a current is dependent only on the strength, but not upon the direction. This, therefore, gives us another method of measuring alternating current, and this type of instrument is used to a considerable extent.

In its simplest form the hot-wire ammeter consists of a fairly long thin wire of phosphor bronze, through which the current to be measured is passed. The passage of the current causes the wire to heat up, and in so doing to expand. Thus the wire, instead of being tightly stretched, sags in the middle when the current passes. By an ingenious arrangement shown this sag is made to produce a definite pull on a small cord or chain which passes round a pulley wheel acting on a pivot. The rotation of this pulley wheel operates a long pointer which travels over the scale and gives an indication of the current.

Moving-Iron Type

These meters depend for their action upon the magnetic force exerted by a coil on a simple piece of iron.

The magnitude of such a pull is dependent on the strength of the current, but the iron will be attracted irrespective of the actual direction of the current flowing through the coil. If, therefore, we arrange for our instrument to act upon a principle such as this it will still give an indication if an alternating current is passed

through it, and it can, therefore, be used to measure such current.

The average value of an alternating current or voltage chosen for comparison is the Root-Mean-Square, which is the square root of the average of the current or voltage squared at any instant. If, therefore, the moving-iron instrument is to be satisfactory, the reading it gives should be proportional to the square of the current flowing through it, and this is actually the case.

If we double the current we produce four times the effect. Such an instrument, therefore, would register the average value of the magnetic effect experienced from moment to moment, and since the magnetic effect in each case depends upon the square of the current, the total response of the meter is proportional to the mean of the current squared. The R.M.S. value is the square root of this figure, so that a moving-iron instrument will give us a definite comparison between the R.M.S. or rated values of current or voltages as required.

Since the instrument depends on square law, however, it will be obvious that it cannot have a uniform scale, such as is the case with a moving-coil instrument. The scale will tend to open out toward the top end. This, however, is a difficulty associated with all alternating current instruments which must obey a non-linear law in order that they shall not be affected by the variation in direction of the current.

A simple moving-iron type of instrument consists of a coil of wire at the end of which is a small rod of iron, which is carried on the end of an arm pivoted in some suitable manner. When a current passes round the coil the iron rod is sucked into the coil, the attraction increasing with the current.

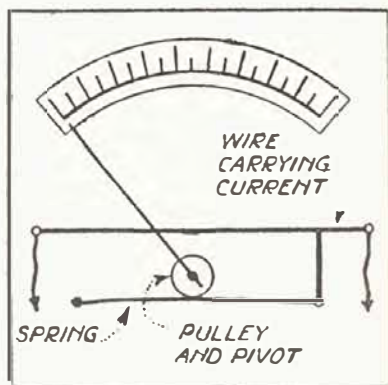

Fig. 3.—Hot-wire ammeter depends upon the expansion of a short piece of wire.

Correct Tracking of the Pick-Up

Some notes which show how the pick-up should be aligned, and how tracking error will spoil reproduction and ruin recordings.

HOW often is heard the cry, "Oh pick-ups are not what they're claimed to be!" Certain it is that, as in other objects, the quality of a pick-up is governed by its cost. But even expensive and electrically perfect units have disappointed their owners. And here again the cause is not the pick-

were badly designed. Now, however, it is difficult to find a gramophone with a badly tracked needle—when it uses an ordinary sound box, for the addition of a pick-up can completely throw out needle alignment.

What "Tracking" Is

Tracking is seeing that the line-of-needle runs completely with the groove of the record in which the needle is running. Fig. 1 shows a needle correctly aligned and one which is badly tracked. The wavy line represents the grooves in the record, and the arrows indicate the direction in which the record is moving.

Needle alignment is easily thrown out, especially if an adaptor has to be used, or if the pick-up attaches towards the left of the tone-arm. Line-of-needle indicates an imaginary line drawn along the needle and continued through the sound box or pick-up and tone-arm. Obviously the needle lies directly in this line.

In some tone-arm and pick-up combinations the line-of-needle will be found to run directly in the tone-arm pivot centre, as shown in Fig. 2, although in many others it will pass far to the left or right of this point.

Fig. 3 shows a fantastically shaped tone-arm to which a pick-up is attached. In the ordinary course of events the line-of-needle would pass

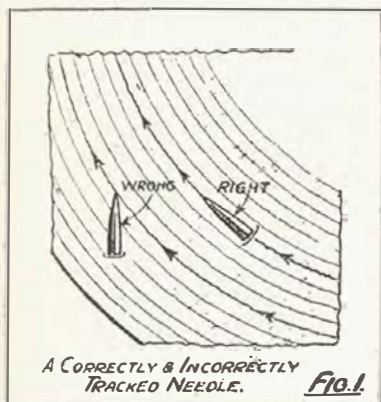

up, but the owner's careless use. The term "foolproof" cannot be applied to pick-ups.

In the first place, a pick-up to operate at its best and impose the least wear upon records should offer a definite needle-pressure, dependent, of course, on its own individual design. The needle should also be set at a correct angle, and run tangentially with the record grooves. Needle track alignment is one of the most important phases of pick-up reproduction. This might be called tracking. And here is one of the most common causes of pick-up "failure." If the pick-up needle is badly out of track results are bound to be poor and records will soon be ruined. It is safe to say that here is the cause of most complaints. A mechanically sound instrument can be made to deliver bad, positively bad, results simply because it is not permitted to function correctly. Vendors of phonographs and pick-ups would do well to exhaustively instruct purchasers in the correct use of a pick-up.

When the gramophone boom started many years ago manufacturers rushed instruments on to the market which

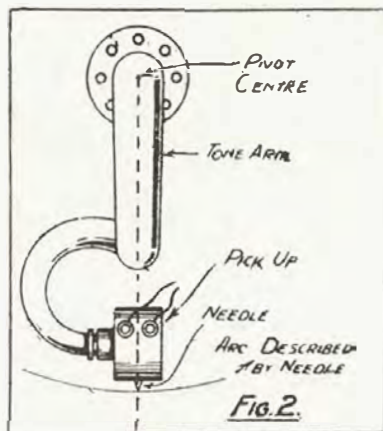

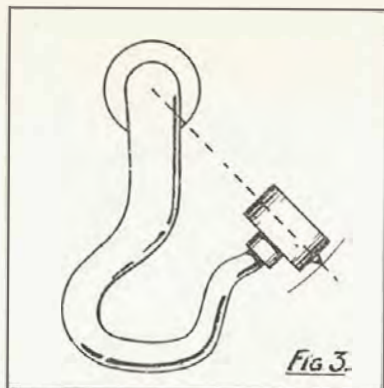

to the right of the tone-arm pivot, but the pick-up has been bent round to make it hit the pivot centre. This is shown merely for explanatory purposes.

As a tone-arm swings, the needle describes an arc across the record. The line-of-needle swings as well. The needle's arc of travel need not be taken into consideration here. What we should be concerned with, however, is the changing line-of-needle. Unfortunately, it does not follow that the needle is adapting itself to the various grooves on the record.

Fig. 4 shows how to judge whether or not a needle is correctly tracked. Here is a method of ascertaining the correct line-of-needle for any point on the record—

Cut a piece of paper exactly the size of a record, and place this on the turntable. Make a dot at the point where the needle is resting. Draw a line from the centre of the record through this dot and another at right angles to the first line, cutting this exactly at the dot. The second line gives the correct line-of-needle.

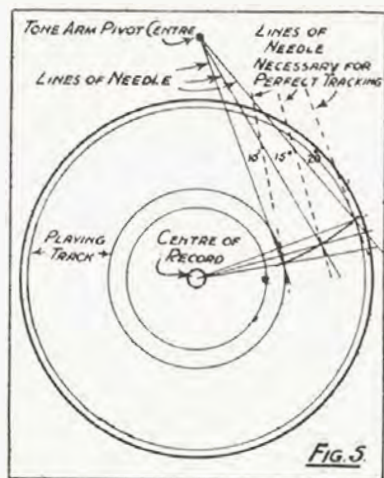

You can proceed in the same way at any point of the needle's travel.

Many gramophones have their tone-arms fitted at the top centre of the cabinet platform, as indicated in Fig. 5. If the line-of-needle runs back to the pivot centre and the needle point can rest on the exact centre of the record (according to common practice) then the needle alignment is about ten degrees out at the innermost groove, 15 degrees at a point midway in the playing portion of the record, and 20 degrees out of alignment at the edge of the record. This is presupposing the use of a 7½-in. tone-arm and a certain 12-in. record. In other cases the error might be worse.

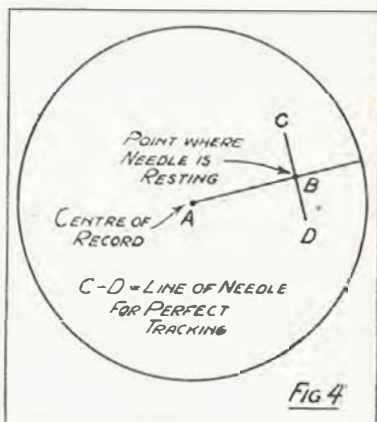

Damage Easily Caused

Obviously, serious record damage can be caused with a needle so far out of track and reproduction must suffer. At 20 degrees a chiselling effect must inevitably result and the walls of the grooves be shaved down. A groove in the record is really a wavy line (see Fig. 1), which causes the needle to swing to and fro—were the needle at right angles to the track it could only act as a cutting point.

With the tone-arm fixed centrally as in Fig. 5, it will be seen that the needle-alignment is definitely bad at first and gets worse towards the edge of the record. By shifting the tone-arm over to the right, as in Fig. 6, so that there is perfect needle alignment when the needle is in the middle of the playing area of an average record, ensures that the maximum error will not exceed 10 degrees. But even this is too much when the record is travelling much slower and the waves in the surface are closer together. Towards the outer grooves it may not matter quite so much, although it is here that record wear is most noticeable. This error may be decreased, and even removed.

by lengthening the tone-arm, but this is not always a practicable move. The shifting of the tone-arm may give best results, but there are other means, too.

Go back to a central tone-arm mounting (Fig. 7) with perfect tracking at the innermost groove, but which

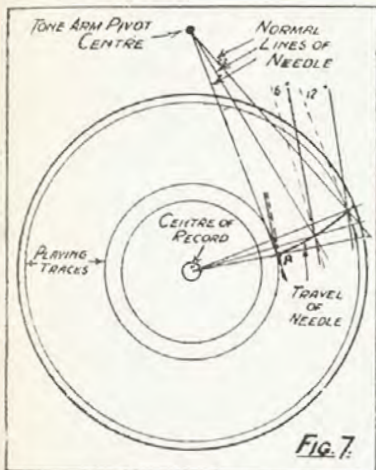

gradually becomes worse towards the outermost grooves, so that as the needle starts it is rather bad, but gets better towards the centre. This is working the right way, and if there must be an error let it be as small as possible and towards the outer edge. With a 7½ in. tone-arm a maximum error of about 12 degrees results. This would be less were the tone-arm longer.

How may the line-of-needle be altered so that it corresponds with perfect alignment at the point A? The pick-up might be bent, as at Fig. 7A, but in the majority of cases this would mean bending the tone-arm.

The best plan would be to move the pick-up over by using an adaptor as at Fig. 8 to bring the needle to a point 1½ in. to 2 in. out of line with the tone-arm on to the right.

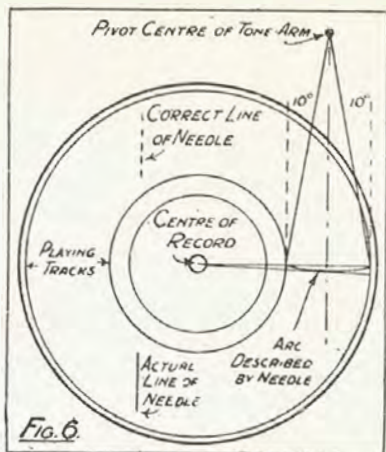
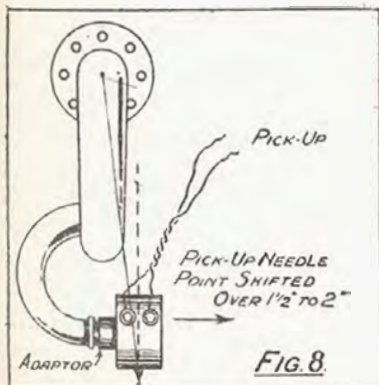

One of the most troublesome faults in reproduced music is what is known as swinging. A swinger is a record whose central hole is not accurately placed, and can be detected by watching the sound box as the record is being played. The misplacement of the hole is due to the wearing of the die during the manufacture of the record. Swinging trouble may be easily cured. Make a note at which point on the record the sound-box swings out farthest. Having ascertained this, draw

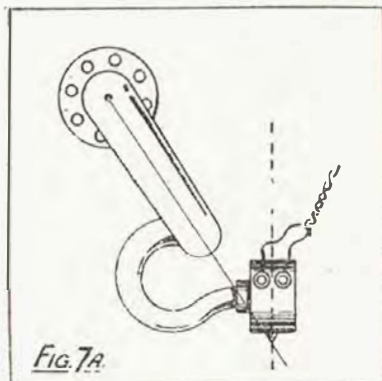

a thick line in pencil or pen on the paper label from the centre hole outwards exactly in line with this movement. Then with a moderately small round file the central hole should be enlarged in the direction of the line so that it takes an oval character. The enlargement should correspond with the degree of swing. When playing the record place it in position on the turntable and press it over as far as possible in the direction opposite to that of the mark on the label. Owing to its weight and the friction of the material on which it rests, it will maintain this position and play correctly.

Selection of the Loud Speaker

Use of the correct reproducing device makes for best reproduction.

IF we go to a great deal of trouble to secure a receiver which will deliver plenty of volume without distortion, we must make best use of this signal energy by the careful selection of a reproducing instrument suitable for our requirements.

For average requirements the electro-magnetic cone speaker is to be recommended. Fitted into a baffle board, a magnetic speaker such as the Philips Baby Grand or the Mullard Music Maker would be capable of delivering all the volume required to more than fill the average size room. Such a speaker will give faithful reproduction, provided the correct type of output arrangement is used.

The dynamic speaker is used in the more powerful receiver combination, since the various types will handle practically all the undistorted power we may have available. In matching this type of speaker, it is necessary that its impedance be known. The impedance of the voice coil may be taken as twice the d.c. resistance of the coil. The d.c. resistance of the voice coil can be ascertained by use of a milliammeter and a small battery, the voltage of which is known. The simple formula R equals E divided by C is used, where R is the d.c. resistance of the coil, E the voltage of the battery, and C the current in amperes when the coil is connected in series with the meter and the battery.

It is usually undesirable to fix dynamic speakers into baffle boards which would be used with the ordinary magnetic type speaker. The baffle board for a dynamic type speaker should seldom require to be bigger than 2ft. x 2ft., while boards as big as 5ft. x 5ft. may be used with the magnetic type speaker without over emphasis of the lower frequencies.

Hitherto, the electro-dynamic speaker has suffered from over emphasis of the lower range of audible frequencies. While in most cases pleasing to hear, such reproduction is not natural, and would not be apparent when listening to signals by means of headphones after the detector stage of a receiver. In later types design has enabled this effect to be practically eliminated, permitting the speaker to reproduce faithfully over the whole range of musical frequencies, with no undue prominence to any particular frequency or band of frequencies.

The dynamic type speaker requires a power supply for its operation. This power is used to excite the field in the speaker's construction. The power may be derived from the power pack of a receiver combination or amplifier, from a battery, or from a separate mains supply.

The series power pack method will be found quite satisfactory when using fairly large power tubes. The field here is connected in place of or in series with the filter choke of the power pack. The current drawn by the plates of the valve of the receiver combination is sufficient to generate the magnetising force required for the speaker to operate.

A trickle charger could be used to supply the power necessary for the operation of a six volt field winding. Trickle chargers which have been thrown out of commission by the installation of an a.c. operated receiver, can be brought into use again, since it is cheaper to purchase a dynamic speaker without a power supply. The ability of the charger to pass the current required must first be ascertained before purchasing a speaker. The electrolytic types will be particularly suitable, while those using a low voltage rectifier valve, as in the Philips chargers, would require to be equipped with an electrolytic "A" supply filter condenser, which would require to be connected across the output of the charger. Some types of higher rate chargers cannot be used without extensive filter arrangements, the cost of which would not be worth while, the money being better spent in the purchase of a speaker which incorporates its own power supply.

In many instances, the output transformer incorporated in a dynamic speaker which we may purchase, may not suit the plate impedance of the power valves we are using. This might require the use of a separate output transformer installed in the receiver, the connections to the voice coil being removed from the secondary terminals of the speaker transformer, and connected instead to the secondary terminals of the new transformer. Unless the speaker is equipped with an output transformer having a centre tapped primary winding, it would be necessary to purchase a suitable push-pull output transformer. The transformer charts should be consulted in any case.

Maintenance of the Receiver

Cost of operation very small when compared with the old battery operated receivers.

IF, in the home assembly of our all-electric receiver, we have followed closely the rules of construction, and have allowed a margin for overload in every part of the circuit, we may expect trouble-free operation for many years.

The cost of maintaining the properly constructed and adjusted a.c. receiver involves only the purchasing of new valves and rectifiers for replacements.

The modern a.c. valve may be expected to give as long as two years' service when used in the home receiver, and supplied with the correct voltages required for its operation. The application of too high a filament or heater voltage to the a.c. valve will render maintenance costs high, since, by exceeding even slightly, the "A" voltage required by a valve, we will shorten its life materially.

The rectifier valve particularly may fail to give long service. This may be due to the application of too high a filament voltage, too high a voltage on each of its plates in the case of a full wave rectifier, too low a paralleled voltage dividing resistance, or too high a current drain by the plates of the valves of a receiver or amplifier combination. When calculating the plate power required for the operation of any receiver combination, we should see that there is absolutely no overloading of the rectifier valve. It would be cheapest in the long run to select a rectifier which will deliver half again as much plate current as may be required by the total valves of a receiver. This will permit the rectifier to be operated at normal temperatures if care is taken to see that air circulates through the power pack section of the containing cabinet.

We will presume that we are using a four volt indirectly heated valve in the detector circuit of a receiver combination. If we operate the heater of this valve at its rated "A" voltage we may expect as long as 3000 hours' service from this valve before it will lose its emission and cease to give service. Operating the same valve with a heater voltage of five, the life of the valve may be as much as halved. The necessity for the correct heater voltage may be seen from this example, which applies to directly or indirectly heated receiving valves or rectifiers.

If we have selected filter and by-pass condensers of reliable make to withstand twice the d.c. voltage they are to handle, it will be a very rare happening for one of these to break down. Provided we have used the torch globe fuse in our power pack, no damage would be done were this to happen in either the receiver or the power pack circuits.

In the same manner, when selecting a fixed resistance for any particular purpose we should make sure that it will handle half again as much current as it is required to pass. This will make for a high degree of safety and long life in these parts of the circuit. If the anode feed voltage dividing method is used, the breaking down of a resistor will not cause much inconvenience, since it only means a test for continuity of the resistances, the one which is discovered to be faulty being replaced by another of the same value by the simple insertion in the resistance holder.

Poorly constructed a.f. transformers or chokes may last for a very short time in the a.c. receiver. Acquaintance with set service work reveals that the modern serviceman never visits a job without a transformer of each make in his kit, even though he may not take resistances or other components with him. It must be remembered that the transformer primary must pass the whole of the plate current required by the valve preceding it. If the transformer winding is a poor affair, done with very fine wire, long service cannot be expected. The transformer primary may cause reception to cease suddenly and mysteriously, or it may prolong itself in the form of crackling noises, which may exist in a receiver output for months. In many cases involving faulty a.f. transformers, the crackling or sizzling noise starts some time after the receiver has been working. Usually the set owner puts the blame on other parts of the set, usually the valves—he may even go so far as to replace them with new ones—the transformers seldom being suspected.

Then if the parts used throughout the construction of our all-electric receiver are selected to allow a wide margin of safety, we can expect our set to be everlasting, requiring only renewal of

the valves every two years or so. No batteries to bother about, no wires all over the place, no costly battery renewals, the all-electric receiver is the answer to the Broadcast Listener's prayer.

It is a very simple matter to calculate what it will cost to operate our a.c. receiver. We will say that the cost of power available from the light socket is fourpence per unit. Those who have built their own power pack equipment know what primary power is to be consumed. Owners of commercially built receivers can get a fair idea of the power drawn from the light socket by calculating the power drawn by the filaments of all valves, including the rectifier, and the plate power drawn by the

valves of the combination. Adding about 30 per cent. to the power obtained will give, roughly, the power which will be drawn by the power transformer primary from the a.c. mains when the receiver is in operation. We will say that the power drawn by the primary of our power transformer is 50 watts. A unit is a kilowatt or a thousand watts of electrical power. Then $50 \text{ over } 1000 \times 4d.$ gives the cost of operating the receiver for an hour—a mere fraction of a penny. The average a.c. receiver will be found to barely turn the light meter disc around, so there will be no need to bother about installing a power point for the special benefit of an all-electric receiver.

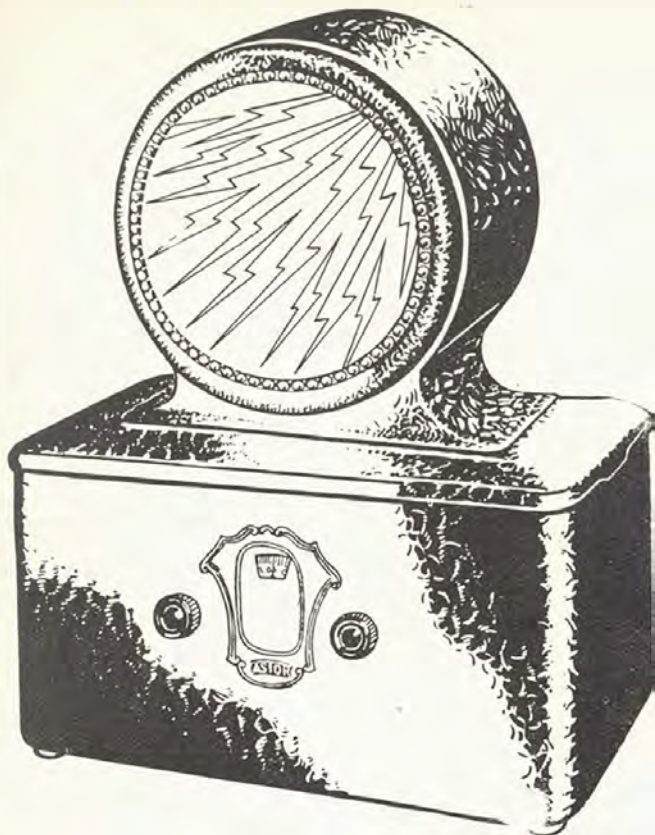

ULTRA MODERN

DYNAMIC POWER RADIO

THE trend is definitely to electric Dynamic radio; and here again Astor leads with the new dynamic range of models. Just released, at new protection low price, the Astor Sindbad Dynamic, presenting the latest electric power chassis 3 valves and rectifier (4 valves in all) with dynamic speaker, incorporated in extremely compact metal cabinet of ultra modern design. With phonograph pick-up terminals provided.

No aerial is required. The Astor Sindbad Dynamic can be operated in any room by just connecting it to light or power socket.

The **ASTOR SINDBAD Dynamic**

£21/15/-

Or on Easy Terms, 7/11 Weekly

Full particulars from

NOTE.—Price Higher
in other States.

LOUIS COEN WIRELESS Pty. Ltd.

63 Swanston Street, Melbourne, or any Astor Dealer

The Components and Instruments which are a Delight to
Serious Experimenters and Music Lovers



TRANSFORMERS

*Have been designed to give the truest reproduction possible of
achievement*

Examine the curve and see the Tremendous Amplification over the
Whole Musical Scale.

Audio

A.F.4.	3 1/2/1.
A.F.3.	3 1/2/1.
A.F.5.	3 1/2/1.
A.F.6.	7/1.

Input Pushpull

A.F.3.C.
A.F.5.C.
A.F.5.C.C.

Output

O.P.1.	1/1.
O.P.2.	25/1.

Output Pushpull

O.P.3.C.	1/1.
O.P.M.1.C.	1/1, 1.6/1, 2.7/1.
O.P.M.2.C.	3/1, 5/1, 7.5/1.
O.P.M.3.C.	9/1, 15/1, 22.5/1.
O.P.M.4.C.	25/1, 40/1, 66/1.



We shall be happy to advise. — Write us for Literature.

A. BEAL PRITCHETT (Aust.) Ltd.

150 QUEEN ST., MELBOURNE, C.1, & 17 PARKER STREET, SYDNEY.
Telephone Cent. 1255. Telephone M. 4318/9.

REMEMBER! FERRANTI — for Quality Reproduction

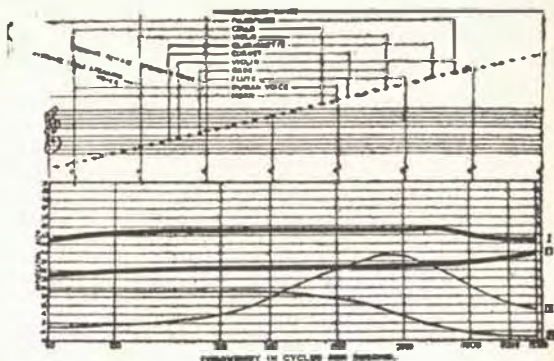

Curve 1.—The Ferranti A.F. 5 Transformer,
with a 17,000 ohm valve ($M=14\frac{1}{2}$).

Curve 2.—The Ferranti A.F.5 Transformer,
with a 10,000 ohm valve ($M=9\frac{1}{2}$).

Curve 3.—A Cheap Transformer

Curve 4.—Resistance-capacity Coupling.

FERRANTI METERS

An absolute necessity where true reproduction
is desired. A milliammeter is the
surest means of ascertaining the correct
functioning of the set and a Ferranti volt-
meter that each component has correct
voltage.



Hundreds of Amateurs
and Thousands of Listeners
Gambled on MULLARD'S

And **WON**

GREATER VOLUME
GREATER DISTANCE
COMPLETE RECEPTION



Mullard

THE MASTER VALVE

British Made.

FOR ALL THE NOTES AND CLEAR SPEECH

Mullard's have made a Valve for Every Circuit, and are still LEADING with New Developments.

P.M. 224.

A.C. Indirectly heated Screened Grid. Heater voltage, 2.5V. Heater current, 1.75 amps. Max. Anode voltage, 180 V. Screen voltage, 90 V. Mutual Conductance, 1.m.a./volt.

P.M.245.

Power Valve. Fil. volts, 2.5; Fil. current, 1.5; Max. Anode voltage, 250; Ampl. Factor, 4; Anode impedance, 1600. Mut. Cond., 2.5/m.a./v.

P.M. 280.

Rectifying Valve.— Fil. volts, 5 volts; Fil. current, 2 amps. A.C. Plate voltage, 300 V. (per plate). D.C. output, 125m.a.

MULLARD
SPEAKERS
Volume of
Quality.



Model "C."—Best Speaker at Low Price.

Model "H."—Rivals Moving Coil Reproduction.

MULLARD WIREWOUND RESISTANCES

for Critical Circuits.
Sizes 5000 ohms to 400,000 ohms.



MULLARD CARBONISED CELLULOSE RESISTANCES

Sizes 50,000 ohm. to 5 megohm.



WRITE US FOR DESCRIPTIVE LITERATURE

A. BEAL PRITCHETT (Aust.) Ltd.

150 QUEEN ST., MELBOURNE, C.I. & 17 PARKER ST., SYDNEY
Telephone Cent. 1255. Telephone M. 4318/9.

MULLARD MASTER PRODUCTS

Wholly set up and printed in Australia
by
UNITED PRESS PTY. LTD.,
62-74 Flinders Street,
Melbourne, Australia.

Sydney Office: Lisgar House,
Wynyard Square.

ATTENTION !

The Listener In

Australia's Premier Radio Weekly

Has originated hundreds of

New Wireless Receiver Circuits

The Weekly Features include:---

Plans for the construction of sets of proved performance — diagrams and details, with complete lists of components. Technical articles dealing with all phases of set building with the latest advice concerning valves, transformers, etc.,—

R a d i o
Wrinkles

Consult The Listener In Radio Doctor

This Service is free to all subscribers

All the Programmes of All Australian Broadcasting Stations

A Section for Women Pages for Children and a

£25 WEEKLY PICTURE £25
PUZZLE COMPETITION

3d. THE LISTENER IN 3d.
is obtainable at all Newsagents and Bookstalls.

The Largest

Stock of Radio

Parts in Victoria

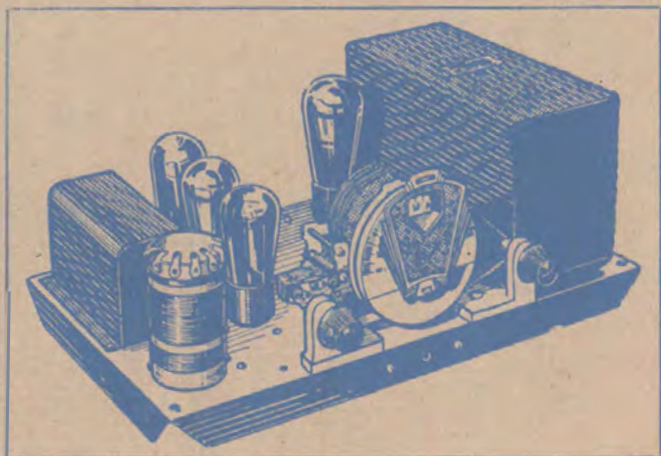

Transformers, Chokes, Resistances, Condensers, Assembled Chassis. (As illustrated.)

Complete Parts for A.C. and Battery Receivers—All Parts Mentioned in This Book.

AWAIT YOUR SELECTION AT

VEALLS 3 BIG STORES

The Recognised House for Radio and Electrical Goods.

243-249 SWANSTON ST., MELBOURNE

Cent. 2058 (5 lines)

168-172 SWANSTON ST., MELBOURNE

Cent. 10524 (2 lines)

302 CHAPEL ST., PRAHRAN

Wind. 1605