

THE  
AUSTRALASIAN

APRIL 1, 1938  
VOL. 2— NO. 12  
PRICE, 1/-

# Radio World

Registered at the G.P.O.,  
Sydney, for transmission  
by post as a periodical.



—See Page 8

● "COMET DUAL-WAVE FOUR": RADIOKES "1938 MONEYSAVER":

● PORTABLE 5-METRE TRANSCEIVER: MIDGET 3-WATT AMPLIFIER:

● NEW CROWN PUSH-BUTTON KIT: ELIMINATING MAN-MADE INTERFERENCE.



For better and brighter programmes . . . revalve with

THE WORLD'S STANDARD RADIO VALVES!



NEW MICRO-SENSITIVE

RADIOTRONS

AUSTRALIAN GENERAL ELECTRIC  
Sydney, Melbourne, Brisbane  
Adelaide, Hobart

AMALGAMATED WIRELESS (AWA) (A/SIA) LTD.  
47 York Street, Sydney  
167-169 Queen St., Melbourne

NATIONAL ELECTRICAL & ENGINEERING CO. LTD.  
Wellington  
New Zealand



# Three Triumphs For **FOXRADIO!**

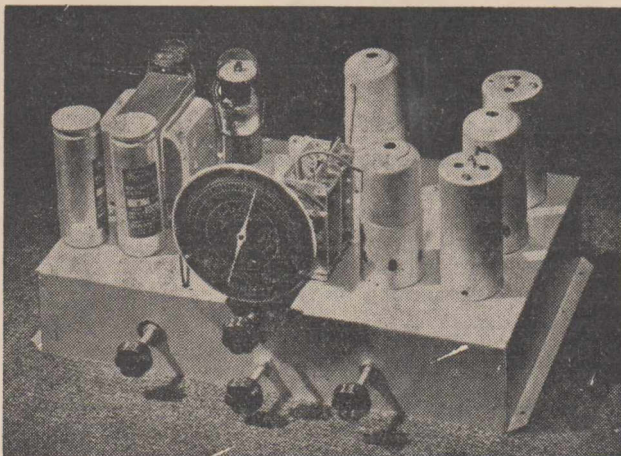
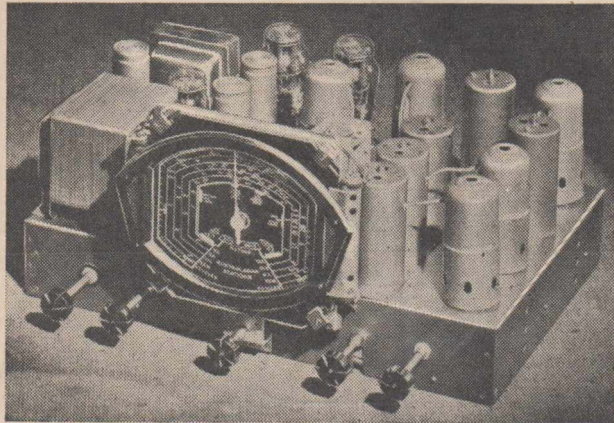
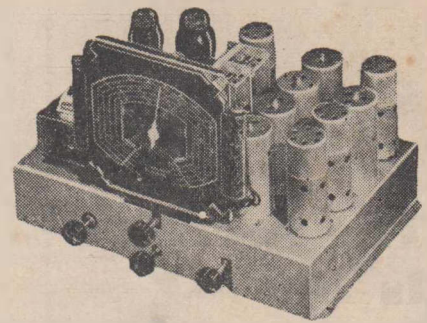

## **FOXRADIO**

Coil Kits were specified exclusively for these three sensational receivers:—

### ● 1938 FIDELITY DUAL-WAVE SIX

Over three watts of output, with superb quality of reproduction, is obtainable from this six-valve dual-wave superhet, described in the January and February issues of "Radio World." Incorporating a 6D6 r.f. stage, sensitivity and selectivity, are exceptionally high. A quality receiver anyone would be proud to own.

### ● DE LUXE FIDELITY EIGHT

A de luxe version of the receiver described above, the "Fidelity Eight" incorporates a seven-watt high fidelity audio amplifier using push-pull 2A3's in the output. Razor-edge selectivity, amazing sensitivity, tremendous power and superb fidelity of reproduction make this set easily one of the most outstanding performers yet designed in this country.

### ● SKY-KING DUAL-WAVE FIVE

Breaking all records for ease and economy of construction, coupled with amazing all-round performance, this "4/5" is a set anyone can build with perfect results. Despite its advanced design and outstanding features, it can be built for only £10/19/6 (valves and speaker included).

**CALL OR WRITE FOR OUR QUOTE ON EITHER THE FOXRADIO COIL KIT OR COMPLETE KIT OF PARTS FOR ANY OF THESE EXCEPTIONAL RECEIVERS.**

Special complete kits of parts at special prices have also been prepared for the "PORTABLE 5-METRE TRANSCEIVER," "3-WATT MIDGET AMPLIFIER" and the "1938 MONEY-SAVER," described in this issue. Quotes sent by return mail. Take advantage of our speedy mail service . . . goods packed and despatched within 24 hours of receipt of your order.

## **FOX & MacGILLYCUDDY LTD.**

MERINO HOUSE, 57 YORK STREET, SYDNEY.

Telephone: B 2409-10 . . . . . Telegrams: Foxradio.





## The Secret Is In The Coils!

You cannot expect 100 per cent. peak performance using coils that are only 40 per cent. efficient. Crudely-wound coils on "moulded mud" formers MUST bring disappointing results, particularly on the short waves, where one indifferent component can mean tremendous loss in signal strength. Wire gauge, turns, spacing, connections, former material . . . every detail must be scientifically planned if the last ounce of DX is to be obtained.

That is why, when building any "Radio World" receiver using plug-in coils, you should INSIST on the special RAYWAY LOW-LOSS HIGH-GAIN as specified and used by the Editor. Follow the designer's lead and ensure that you will duplicate his results.

RAYWAY coils are precision-wound on low-loss plug-in formers manufactured from the highest grade imported bakelite. They cost no more than inferior makes; so insist on RAYWAY.



Complete coil kits are available for any of the following "Radio World" shortwave and all-wave receivers:—

- "All-Wave All-World Two"
- "Eaglet Shortwave Two"
- "Empire Shortwave Three"
- "All-Wave Bandspread Two"
- "Empire All-Wave Three"  
(A.C. & battery models)
- "Battery Communications  
Seven"
- "Amateur Communications  
Eight"
- "Jones' Super-Gainer"

If unobtainable from your local dealer, write direct to:—

### Standardised Products

629 PARRAMATTA ROAD,  
LEICHHARDT, SYDNEY,  
N.S.W.

'Phone - - - LM 5957

# THE AUSTRALASIAN RADIO WORLD

Incorporating the  
**ALL-WAVE ALL-WORLD DX NEWS.**

Managing Editor:  
A. EARL READ, B.Sc.

Vol. 2.

APRIL 1, 1938.

No. 12.

## CONTENTS:

Comet Superhet Four .....	3
Crown Releases Push-Button Kit For Set-Builders .....	6
Portable Five-Metre Transceiver .....	9
Radiokes 1938 D.W. Moneysaver Superhet .....	14
Pre-Selector Unit Sharpens Tuning, Increases Gain .....	16
50-Watt Transmitter For New Power Limit .....	18
Infinite Baffle Aids Tonal Fidelity .....	20
Shortwave Aerials For DX Reception (1) .....	23
"Eaglet" Gives Outstanding Performance .....	26
Building A Midget Three-Watt Amplifier .....	27
DX Contest Winner Has Logged Over 100 Countries .....	30
Tracking Down Power Interference (1) .....	31
What's New In Radio .....	33
The All-Wave All-World DX News .....	37
Sun-spot Activity Now Approaching Maximum .....	38
Shortwave Review .....	39
Hourly Tuning Guide .....	42
Fourth "Radio World" S.W. DX Contest .....	46
Round The Shacks (8) .....	46
DX News And Views .....	47
VK Amateur Transmitters—Additions And Amendments .....	47
Index Of Technical Features, "Radio World," Vol. 2 .....	48

The "Australasian Radio World" is published monthly by Trade Publications Proprietary, Ltd., Editorial offices, 214 George Street, Sydney, N.S.W. Telephone BW 6577. Cable address: "Repress," Sydney. Advertisers please note that copy should reach office of publication by 14th of month preceding that specified for insertion.

Subscription rates: 1/- per copy, 10/6 per year (12 issues) post free to Australia and New Zealand. Subscribers in New Zealand can remit by Postal Note or Money Order.



# The . . . . Comet Superhet Four

This new 3/4 superhet using latest Radiokes DWU dual-wave coil unit gives full 4/5 performance. Valves used comprise EK2 octode, 6F7 pentode i.f. amplifier and triode first audio, EBL1 diode detector, A.V.C. voltage generator, and output pentode, with rectifier.

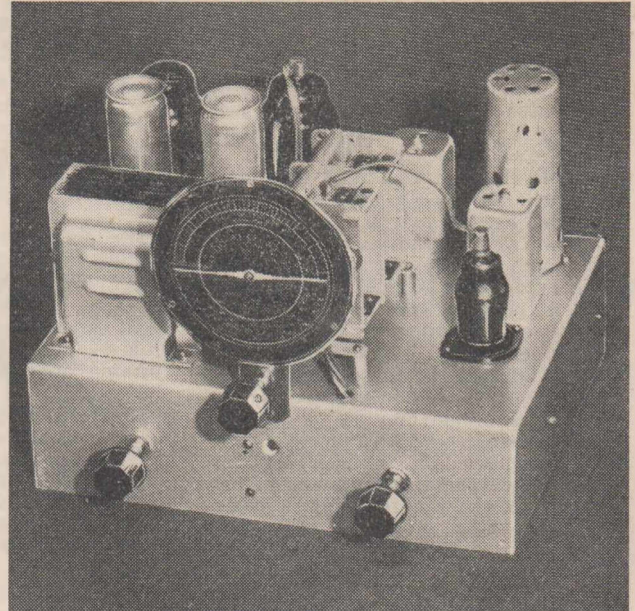

In last month's issue an article was published discussing the design of a two-valve (excluding rectifier) superhet, using an EK2 octode as mixer oscillator, followed by the new Philips EBL1 duo-diode output pentode. From the performance point of view this little set gave surprising results, though gain was scarcely sufficient to give consistently good reception from local stations using only a short indoor aerial.

For this reason it was stated that a new design would be developed incorporating an additional valve—an i.f. amplifier used in conjunction with two iron-cored i.f. transformers. This new receiver is illustrated above.

### 6F7 Serves Two Functions.

As a worth-while experiment, a 6F7 was incorporated, rather than a conventional i.f. amplifier such as the 6D6. The pentode section of the 6F7 was used as i.f. amplifier, with the separate triode section as first audio amplifier interposed between the detection diode of the EBL1 and the output pentode section of this valve.

This arrangement enables full five-valve performance to be obtained from only four valves.

Using the American glass types as an illustration, this special 3/4 superhet is roughly equivalent to the conventional 4/5 superhet using a 6A7 mixer, 6D6 i.f. amplifier, 75 diode detector, a.v.c. voltage generator

and triode audio amplifier, driving a 42 power pentode, with an 80 as rectifier.

In the "Comet" (the circuit of which is given below) an EK2 is used as mixer, with the pentode section of a 6F7 as i.f. amplifier. One diode of the EBL1 is used for a.v.c. and the other for detection, the output from the latter being applied to the grid of the 6F7 triode section, which acts as driver to the output pentode portion of the EBL1. To permit the use of a standard power transformer, an 80 rectifier has been substituted for the EZ2 used in the 3-valve model described last month.

The coil unit used was the latest Radiokes dual-wave kit, with a pair of Radiokes MIC-465 iron-cored i.f. transformers.

### Full Description Next Month.

Though the design has not yet been completely finalised, preliminary tests have already proved it an exceptional performer, inter-State reception being obtained using only two feet of wire as an aerial. Performance on the short waves is equally good.

Full constructional details, together with a detailed test report, will be published next month.

Circuit of the "Comet," which is shown in completed form above. Less expensive to build than the average 4/5 superhet, because one valve less is used, the "Comet" nevertheless gives an equally good performance. Full constructional details will be published next month.

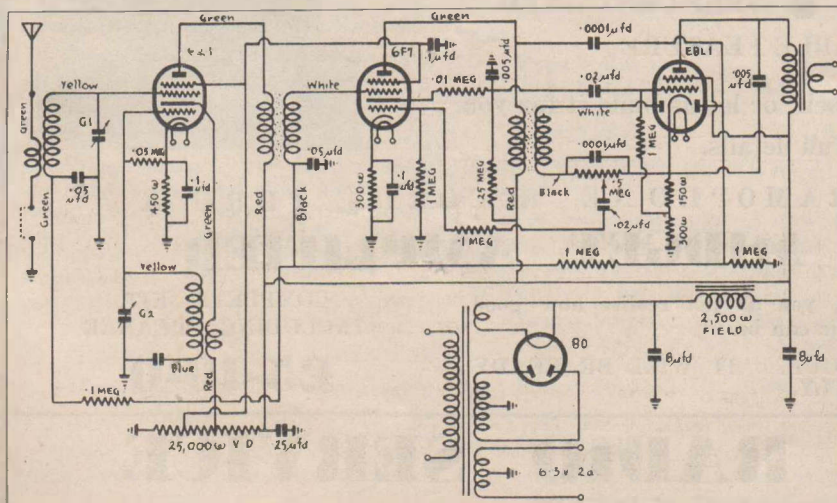



**Australian Trained Radio Servicemen's Institute— Queensland Division.**

By W. J. HUDSON.

The examination for "A" grade certificates for radio mechanics was held on March 16, twenty candidates being examined. It is proposed to hold the exam. for country members on April 16.

Country groups who wish to hold an exam are requested to forward the name of the local postmaster, policeman, schoolteacher or other approved person who is willing to supervise. Certificates endorsed by the Queensland Electrical and Radio Federation will be issued. There is also a pocket folder copy available to show an employer.

There are now 135 financial members in Queensland, and lectures are being forwarded to country members.

A number of inquiries for membership have been received from talkie servicemen, who have no organisation. Anyone interested in joining the A.T.R.S.I. can see me personally in Rockhampton, Townsville, or Cairns, as I visit those ports twice a month. Persons who are in any centre where there is a branch are advised to address the local branch or write to K. Elliot, secretary A.T.R.S.I., Brisbane. There seems to be plenty of work in Queensland for radio mechanics at award wages, but employers are demanding a certificate, so the organisation

should become important in the future.

**Gladesville Experimental Radio Club Notes & News.**

By The Secretary.

Although the above club has been meeting for about two months now, considerable difficulty is being experienced in finding permanent quarters.

The class for A.O.C.P. students is in full swing under the control of Mr. F. Warren, VK2LY. Morse instruction is also given every meeting night under the capable supervision of Mr. Fryar, VK2NP. Immediately suitable quarters are obtained the club will instal its own transmitter, application having already been made for the license and call sign.

The membership of the club is in the vicinity of twenty, of which there are about a dozen licensed hams, and three members intend sitting for their tickets at the forthcoming examination.

It is proposed in the near future to run morse lessons over the air, probably on 40 and 20 metres. The club is running a contest for transmitting members over the last three week-ends in March, and the first week-end in April. A morse code sending and receiving contest is being held early in April for those not holding tickets.

Activities of the club's transmitting members are as follows:—VK2NP is getting among the DX down on 20

m., also contemplating 'phone; VK2AEX is having trouble with his crystal oscillator and intends to go on "80" for the winter months; VK2AHR and VK2AHK are still pounding away on "40" with nice c.c. signals; VK2LY is off the air indefinitely; VK2XH is also down on "20" and getting some DX; VK2EW and VK2KJ are occasionally on 40 metres.

Enquiries as to club membership may be made direct to the secretary, Mr. R. Ellis, 180 Morrison Road, Ryde, or at the meetings, which are held every Tuesday night—for the present in the Douglas Credit Hall on the Main Road, Gladesville.

**German S.W. Festival Programme.**

From April 1 to 10, on the occasion of the fifth anniversary of the German Shortwave Station, Broadcasting House, Berlin.

Call.	Metres.	Sydney.	N.Z.
DJA	31.38		
DJB	19.74	15.05-2.00	16.35-3.30
DJS	13.99		
DJE	16.89	15.05-20.50	16.35-22.20
DJQ	19.63		
DJQ	19.63	23.10-1.00	0.40-2.30
DJE	16.89		

DJA and DJB transmit for South-Asia; DJE, DJS and DJQ for East-Asia. Announcements of programme changes and supplements will be made daily after the news.

SEE THE "RADIO WORLD"

**5 Metre Transceiver**

ON DISPLAY AT OUR STORE

- EFFICIENT
- COMPACT
- ECONOMICAL
- UP-TO-DATE
- RELIABLE
- SELF-CONTAINED

EVERY DESIRABLE FEATURE

Buy the Kit and build it yourself, or let us build it for you.

Write for full details.

PLAY YOUR GRAMOPHONE RECORDS THRU A

**3 WATT MIDGET AMPLIFIER**

Until you have tried an Amplifier, you do not realise how good recorded music can be.

WRITE FOR OUR 1938 CATALOGUE. IT WILL BE READY SHORTLY.



COMPLETE KIT, INCLUDING SPEAKER

**£5-10-0**

**PRICE'S RADIO SERVICE**

D. G. McINTYRE

546 ANGEL PLACE

— SYDNEY



THE  
RADIO  
PIONEERS

# Fear's Radio News

F. J. W. FEAR & CO. - - - - 31 Willis Street, Wellington  
New Zealand :: Telegrams : "FEAR"

FEAR'S  
FOR  
EVERYTHING  
IN RADIO

An Advertisement inserted by F. J. W. FEAR & CO., New Zealand.

## FIVE-METRE PORTABLE TRANSCEIVER IS SENSATIONAL PERFORMER Special "FEAR" Kit Now Available

Only two valves are used in this latest portable five-metre transceiver, for which amateurs in both city and country will find endless applications. Join the rush to the ultra high frequencies, which offer a new and fascinating field for experiments, by assembling our special FEAR transceiver kit, prepared exactly in accordance with the designer's specifications.

WRITE FOR OUR DETAILED QUOTE.

### ● New RADIOKES Money-Saver Cheapest 4/5 Yet.

Latest kit-set release by Radiokes, the "1938 Moneysaver" promises to outstrip all others in popularity. Designed to give the maximum in results from five metal valves, this new "Moneysaver" is a superb performer, though remarkably cheap to build.

WRITE For Our DETAILED QUOTE

### ● Sensational Performance From Four Valves!

Giving full 4/5 performance, the "Comet" 3/4 superhet reviewed this month promises to be the most outstanding design in midget receivers released for some years.

WRITE For Our ADVANCE QUOTE

### ● 3-Watt Midget Amplifier Has Endless Uses.

To provide an audio channel for experimental t.r.f. or superhet tuners, as a gramophone record amplifier, for obtaining speaker reproduction from one and two-valve shortwave sets: these are only three of the many uses to which the compact but powerful midget amplifier described this month can be put.

WRITE For Our DETAILED QUOTE

### ● Latest American Lines For Set-Builders And Amateurs TAYLOR TUBES.

Taylor Tubes, owing to their low price and sturdy construction, have

proved in America to be one of the most popular of the wide range of transmitting tubes. They are adaptable for all frequencies up to and including 56 M.C. The T.20, as well as being an excellent Class "C" amplifier, is capable of giving excellent results as a Class "B" audio tube delivering under such conditions 70 watts of audio. The T.55 meets the requirements of those amateurs, increasing power and unable to go to the expense of high-priced tubes.

T.20 or T.Z.20 . . . . .	23/- net
T.55 . . . . .	65/- net
H.66 . . . . .	16/- net

### U.T.C. ALL THE WAY.

A U.T.C. Varimatch Transformer will match any known modulator tube or Class "C" tubes available to-day, or that may be introduced in future months. Improve your quality and efficiency by specifying U.T.C. all the way.

Type V.M.0 . . . . .	27/6
Type V.M.1 . . . . .	£2/2/6
Type V.M.2 . . . . .	£3/2/6
Type V.M.3 . . . . .	£4/17/6

### NEW SHIPMENT OF MICRO-PHONES.

A further shipment of the well-known Veletron microphones and Shure and Astatic diaphragm crystal microphones has just arrived.

Bruno Veletron with 25ft. of special cable . . . . .	£4/17/6 net
Astatic D.104 . . . . .	£5/15/- net
Shure 70 S.H. . . . .	£6 net

### LATEST MEISSNER COIL ASSEMBLIES.

We have just landed supplies of

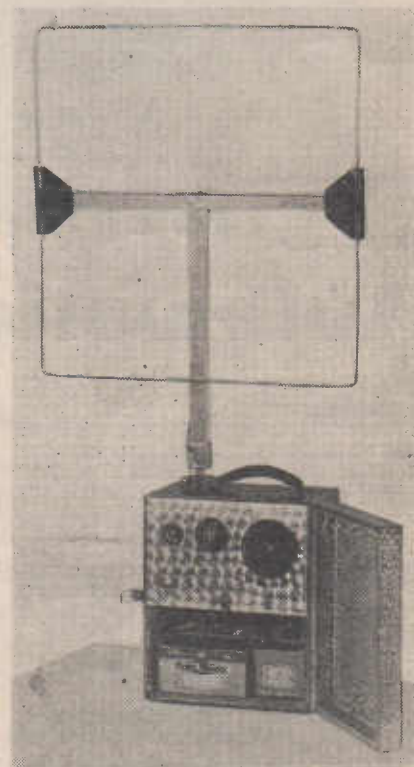

"Meissner" quality coil assemblies, coil units, and i.f. transformers. Write for full details. (Model No. 7512 box gives continuous coverage from 5 to 555 metres. Only six leads to connect.)

### RED-HOT OR WHITE-HOT . . . THEY'LL TAKE IT !

Eimac Transmitting Tubes are the biggest step forward in design and performance in the field of radiation-cooled tubes made in over a decade. Tantalum Plates and a special non sag thoriated tungsten filament. Eimac Tubes will stand a greater overload than any other Transmitting Tube of similar rating.

Type 35T . . . . .	£3/7/6 net
Type 100 T.L. or T.H. . . . .	£5/9/6 net
Type 250 T.H.,	£10/15/- net



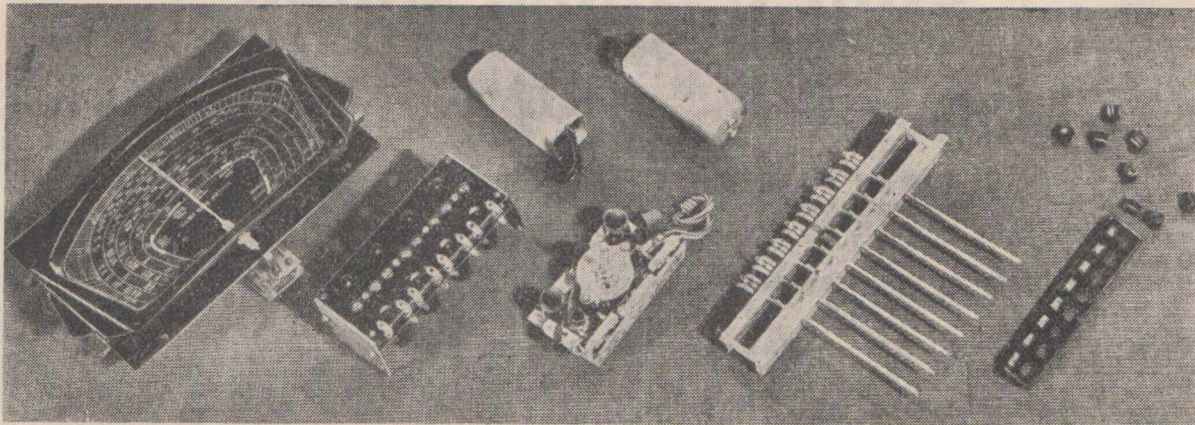

The Crown FK/8 Foundation Kit incorporates (left to right) station-calibrated full-vision dial, type PB/8 push-button unit, D-2 dual-wave unit (with permeability-tuned i.f. transformers above), push-button switch, and escutcheon with knobs.

## Crown Release . . . . .

# Automatic Push-Button Kit For Set-Builders

**T**HAT 1938 is going to be a "push-button tuning" year is now more than apparent from the many recent commercial receiver releases, most of which incorporate automatic tuning in one form or another.

It is also obvious that this new development has come to stay. The average listener spends approximately 90% of his time tuned into local stations, and the idea of selecting any station at will merely by pushing a labelled button is too attractive to ever fall into the discard.

### Frequency Drift Must Be Guarded Against.

The idea of push-button tuning is simple in conception, but in practice it presents one serious difficulty that if not guarded against can result in endless trouble. Theoretically, push-button tuning could be incorporated in the conventional 4/5 superhet by connecting across the aerial and oscillator grid windings pairs of semi-variable tuning condensers that could be pre-tuned to each local station, a suitable switch being provided to throw each pair of condensers in or out of circuit at will.

In practice, however, the problem is not as simple of solution as this, mainly because of the inability of pre-set condensers to hold their setting accurately over a period of time. In other words, slight capacity variations cannot be effectively guarded against.

In the aerial grid circuit, any such slight changes are not in the least important, as tuning in this circuit

is comparatively broad, but in the oscillator grid circuit absolute permanency of the inductance/capacity value required for each station is essential. The slightest drift results in "off-station" tuning, with its resultant distortion, which becomes more severe as the drift increases.

The component manufacturers who so far have released push-button coil kits have taken various steps to ensure against frequency drift, the problem having been very successfully overcome by Crown Radio Products Pty. Ltd., whose recently-released push-button coil kit is illustrated above.

The type PB-8 unit shown to the right of the tuning dial is designed for use with the new Yaxley push-button switch (shown on the extreme right) and provides for up to eight stations. Compact, yet highly efficient, it may be used with either pentagrid or octode battery or A.C. valves.

The advantages of push-button tuning, with particular reference to the design and application of the new Crown unit illustrated in the accompanying photographs, are explained in the article below.

### Permeability-Tuned Oscillator Circuit.

In accordance with standard practice, a row of eight pre-set trimmers provides automatic tuning for the aerial grid circuit, while frequency drift in the oscillator section is effectively overcome by the use of permeability tuning, which entirely eliminates the need for condensers.

For each station a separate iron-core coil is provided, the core acting as a plunger within the coil. By turning a special alloy screw attached to the core, the latter can be moved up or down within the coil, thus providing a means for varying the inductance.

After each coil has been accurately tuned, permanency of setting is assured by a lock-nut. In practice, a "spin-tight" spanner, formed from a 3in. length of hollow tubing, is placed over the lock-nut, which is loosened. The centre screw controlling the iron core plunger is then adjusted



# Sensational CROWN Release!

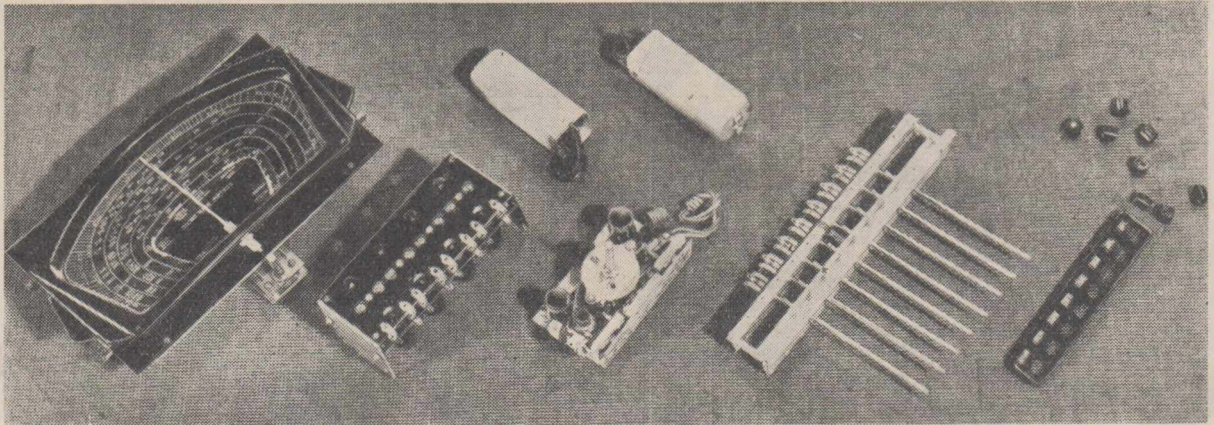

## Eight-Station Automatic Push-Button Kit Incorporates Permeability Tuning

### ● PB/8 TUNING UNIT

The Crown type PB/8 automatic tuning unit provides for eight stations, and may be used with pentagrid or octode battery or a.c. mixer valves. Extremely small, yet highly efficient, the unit incorporates the following features:—

**PERMEABILITY TUNING:** Permanency of alignment is guaranteed by eight compact litz pye-wound permeability tuned oscillator coils, mechanically locked by 1/4 in. hexagon brass locknuts and lock-washers.

**UNIVERSAL TO ALL STATES:** All PB/8 Tuning Units cover the full Broadcast band of 550-1500 k.c., each coil having a coverage of 300 k.c., thus embracing every station in each State. Escutcheon station nameplates for all States supplied with each Foundation Kit.

**COMPACT SIZE:** The unit has been made remarkably compact, the aerial section being mounted above the oscillator section, and all trimmers being adjustable through the top bakelite panel.

**PRICES**

FK8 Foundation Kit, comprising units shown above, complete with chassis . . . . . £9/9/-  
FD3 Dial . . . . . 2/-

### ● FK/8 FOUNDATION KIT

Illustrated above is the FK/8 Foundation Kit designed for use in a standard 4/5 dual-wave superhet, incorporating automatic tuning (see circuit published on page 44).

On the extreme left is the Crown full-vision station-calibrated dial, designed to mount directly on the condenser gang. Next is the PB/8 push-button unit, with the latest Crown type ISP-465 permeability-tuned i.f. transformers above, and the ID-2 dual-wave box to the right. On the right is the special Yaxley press-button switch designed for automatic tuning, together with escutcheon. On page 8 is illustrated the specially designed chassis base supplied with each Foundation Kit.

**NOTE:** If desired, any of the individual units may be obtained separately for use in converting ordinary receivers to push-button tuning.

PB8/S Tuning Unit, complete w/switch . . . 79/6  
PB/8 Tuning Unit only . . . . . 45/-  
ID/2 D/W Kit . . . . . 49/6  
ISP-465 I.F. Transformers . . . . . 12/6

Write for full description and instructional data on push-button tuning, and please mention Aust. Radio World

# Crown Radio Products Pty. Ltd.

51 MURRAY STREET, PYRMONT, SYDNEY.

Phone . . . . . MW 2628

Telegrams . . . . . "Crownradio," Sydney.

**DISTRIBUTORS:**

**SYDNEY:**

Bloch & Gerber Pty., Ltd.  
John Martin Pty. Ltd.  
Lawrence and Hanson Ltd.  
Martin de Launay Ltd.

**MELBOURNE:**

G. P. Embelton & Co.  
A. J. Veall Pty. Ltd.

**ADELAIDE:**

A. G. Healing Ltd.

**TASMANIA:**

W. & G. Genders Pty. Ltd.

**BRISBANE:**

A. E. Harrold.  
Trackson Bros. Pty. Ltd.  
J. B. Chandler & Co.

**PERTH:**

Atkins (W. A.) Ltd.  
Carlyle & Co.

New Zealand Factory Representative: Arnold & Wright, Levy Buildings, Manners Street, Wellington.



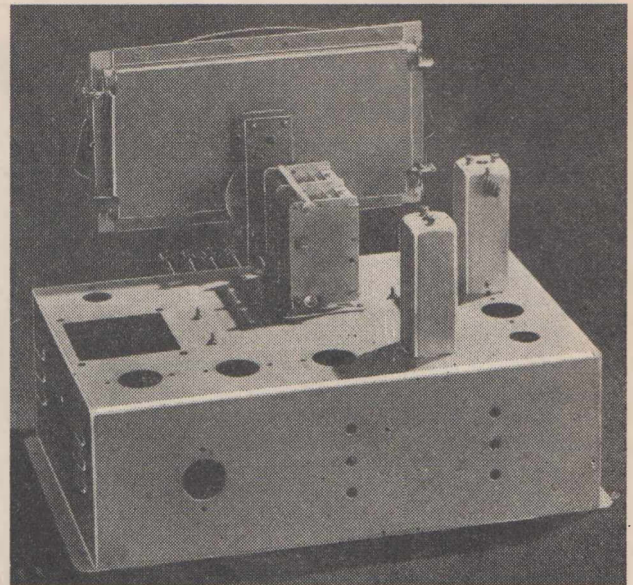
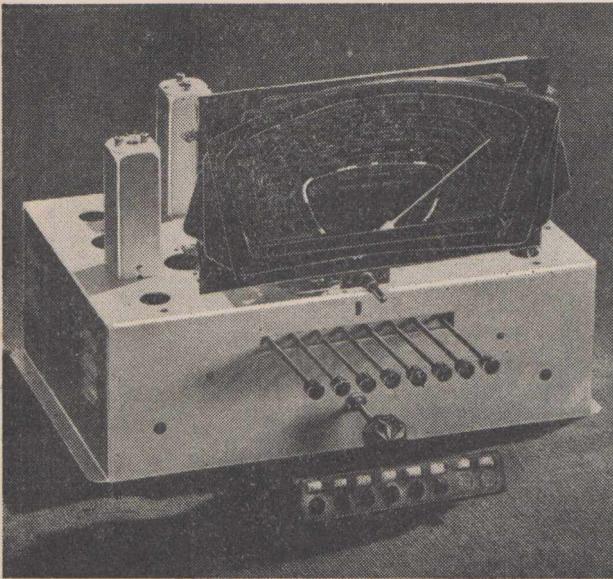

Front and rear views of the Foundation Kit mounted on the special 4/5 superhet chassis that is available from Crown distributors.

by means of a screw-driver passed down inside the hollow "spin tight," and finally the lock-nut is tightened. The special spanner required is manufactured by Crown, and will be available with the kit from all distributors.

All trimmers and screws are adjustable through the top panel of the push-button unit, and the lugs on the latter are arranged to coincide with those on the switch, as illustrated in the under-chassis view.

The unit provides for eight separate bands, the frequency coverage of each being such that all the main stations in each State are covered. Frequency range of each band is as follows:—

BAND.	AERIAL	OSC'TOR
	CIRCUIT	CIRCUIT
	K.C.	K.C.
No. 1	550-1000	550-750
No. 2	550-1000	630-1030
No. 3	740-1250	630-1030

No. 4	740-1250	820-1200
No. 5	950-1500	820-1200
No. 6	950-1500	1100-1500
No. 7	950-1500	1100-1500
No. 8	950-1500	1100-1500

**Circuit For Dual-Wave P.B. Superhet.**

Elsewhere will be found the circuit, with full constants, of a 4/5 dual-wave superhet incorporating push-button tuning. The complete Crown foundation kit produced for this receiver is illustrated in the photograph at the head of this article. The type D/2 dual-wave unit is shown in the centre, with the two permeability tuned i.f. transformers above it.

**Highly Stable Oscillator Used.**

To ensure high stability, a Colpitts oscillator circuit with two equal 500 mmfd. mica condensers controlling the oscillation is used with the PB-8 unit. This circuit is particularly stable, and is ideal for use with push-

button tuning.

The converter stage may appear a little strange at first glance, but in reality it is a standard D.W. converter stage with a switch (S.W.I.) for changing from gang to automatic tuning. SW2 is the push-button switch.

**Wiring The Box, Unit And Switch.**

When wiring this section, commence by mounting the P.B. switch and box, and wire all leads except

**This Month's Front Cover.**

This month's front cover shows a view of the huge 200 k.w. transmitter at Rugby, England, equipment for which was made by S.T.C. From the giant aerials of this station are flung the voices of all Nations to the four corners of the earth over the International Radio Telephone System.

those to which the "gang/auto switch" (SW1) connects. Then wire the "gang/auto" switch, keeping all leads as short as possible.

Next, solder one lug of each section of the P.B. switch (the same lug on each), together using 18-gauge tinned copper wire. Do this to both banks of the P.B. switch (SW2).

The lead on the bank nearest the bottom of the chassis connects to the

(Continued on page 44)

The positions of the aerial and oscillator trimmers on the PB/8 unit are shown in this sketch.

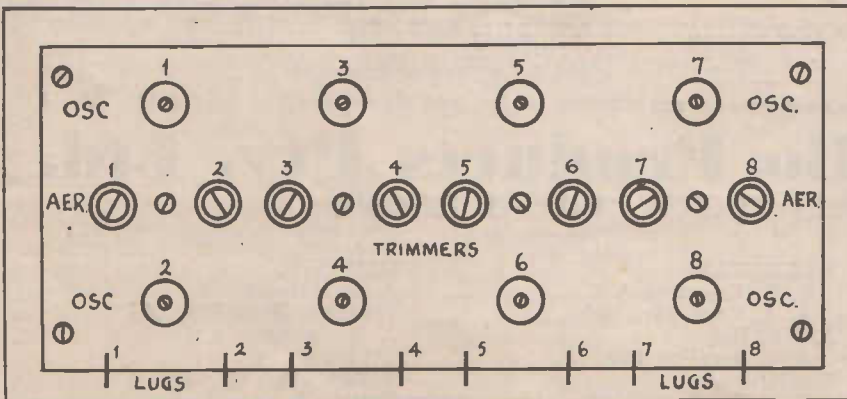



# A Portable Five-Metre Transceiver

Many and varied applications will be found by amateurs for this two-valve portable 5-metre transceiver, designed and described . . . .

by Don B. Knock (VK2NO)  
(Radio Editor, "The Bulletin")

Right: A view of the completed transceiver, showing the special directional aerial devised to give maximum efficiency in minimum space. Consisting of two halves of a twisted pair doublet bent into a square, it gives excellent signal gain.

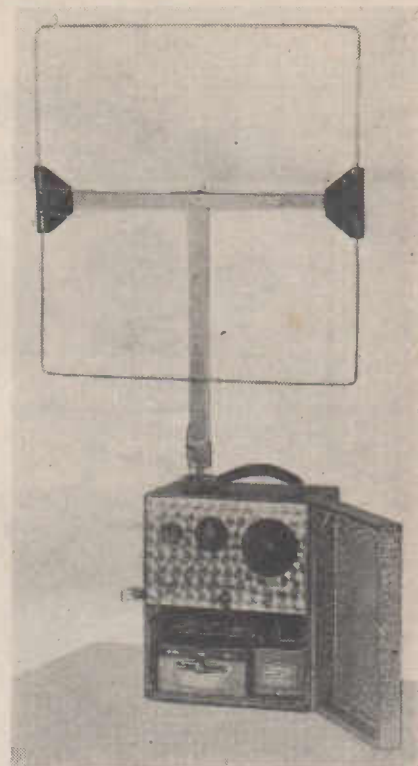

In the last year or so, apparatus for transmission and reception on the ultra short waves has advanced very considerably; so much so that there is no problem attached to the designing of a 56 m.c. station for home use, any more than there is any particular obstacle in putting a crystal-controlled 20-metre 'phone or c.w. station on the air.

Valve design is mainly responsible for the fact that we can in these days put out a rock-steady signal on "five"

with all the ease of the lower frequencies, and with plenty of r.f. output to boot. There is in fact little or no excuse for the utilisation of anything but a well-designed 5-metre station for the home location, which could not be said only three years ago.

Apart from the question of the fixed station, there will always be considerable use for portable equipment in varying forms. Although it has limitations normally, the arrangement of apparatus described as a

"transceiver" has certain uses in which it excels. It uses a minimum of gear and it does a thoroughly reliable job for swift "short-haul" telephony traffic over limited distances.

Should Be Used With Discretion.

At the outset it is necessary to emphasise that it is definitely not the kind of equipment for home use in crowded localities, for the type of receiving circuit necessarily employed can cause havoc in the way of re-radiation.

But this matters little where two stations of the transceiver type are used out in open country, or in places where any other ultra short wave stations are far from the vicinity. The only interference they could cause would be between the two stations, and this is of no account for the reason that one is transmitting while the other is receiving, and vice-versa. Both are unlikely to be receiving at the same time. In describing this equipment, the writer therefore appeals to readers to refrain from making up such gear if it is intended to be used at the home station. Interference with other amateurs is sure to be the result, and will call down just wrath on the offender's head!

This transceiver, and another ex-

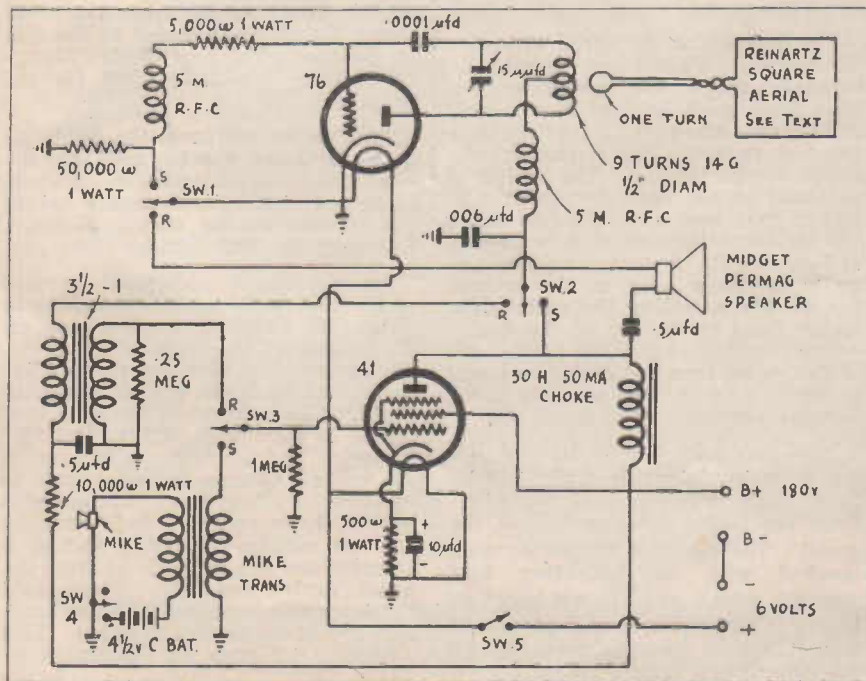

Circuit of the transceiver, which uses a 76 and 41 for both receiver and transmitter, a four-pole double-throw switch being used to make the change-over.





These close-up views provide all the detail necessary for the layout and assembly of the transceiver. Note the method of mounting the 76 horizontally to ensure short leads, and the tuning condenser extension shaft employed for the same purpose.

actly similar, was made up for special work between two points only; such as when timing motor-cycle or car races, or to provide a link with a distant speaker working through a normally inaccessible public address system. For the latter purpose, the transceiver is particularly useful. It can be taken to points where microphone amplifier cables cannot be easily laid. With another at the P.A. end, a perfect speech link is provided with as much if not more reliability than if lines were laid.

#### Special Directive Aerial Used.

In order to get the best from the signals at both ends, a directive aerial system has been evolved, following on suggestions made recently by John Reinartz, exponent of the now well-known circular aerial. In this case it involves merely bending the two halves of a twisted pair doublet aerial into a square shape, as shown in the diagram and photograph, and providing a suitable mounting for rotation.

When a half-wave doublet is made in this shape, it assumes highly directive properties, and contrary to expectations, gives real signal gain. It does a much better job at five metres than is obtained with a vertical

half-wave doublet, and the results obtained are quite surprising. It is better if anything than the twin type circular aerial and much simpler to construct.

The diagram of the aerial gives the dimensions. Two 4-foot lengths of three-sixteenths hard-drawn copper tube form each half of the aerial, making an assembly no more than two feet square. This is particularly handy for portability. The tubing is flattened at the ends for about two inches, then bent and bolted to bakelite strips at the end of a cross-arm of light wood. A centre wooden upright carries a plug at the bottom for quickly mounting the aerial in a socket fixed to the top of the transceiver carrying case. The feeders are of flex wire, terminating in two plugs to connect with two sockets fixed through the top of the case.

The directivity is quite marked, giving a horizontal angle of about 40 degrees with radiation (and reception) from the feeder junction side of the aerial. The directive properties were checked with an indicating field strength meter, and are not based on theory alone. The aerial works so well that it is strongly recommended for any 56 m.c. mobile equipment.

#### The Transceiver Circuit.

The apparatus is entirely self-contained, with the exception of the filament supply, which is taken from a small six-volt accumulator connected through a plug and socket at the side of the case. The new Clyde "Plugg-In" battery would be ideal for this purpose.

Two valves are used, the combined oscillator-detector being a 76, and the combined modulator-audio pentode being a 41. All the necessary valves are marked on the circuit diagram, including the coil details.

As no doubt individual readers might like to fit such an outfit into an already existent carrying case, no dimensions of the chassis are given. The writer first obtained two similar cases, and made the chassis assembly to fit. The transceiver itself is contained in the upper portion, and "B" batteries and microphone battery in the lower. Change from transmit to receiver is effected by a four-pole double throw switch. Such switches are not readily obtainable, though a compact one can be made up from the usual Yaxley assembly. Those used by the writer happened to be on hand, and are of rotary construction. This switch is indicated in the circuit by SW1, SW2, SW3 and SW4. As an



# CLYDE'S GREATEST IMPROVEMENT the WORLD'S FINEST RADIO BATTERY



Provision is made with these auxiliary positive and negative leads for connection to any ordinary battery terminals, while your PLUGG-IN is being re-charged.

The world is introduced to Clyde's Plugg-in Radio Battery . . . the great feature of a plug in, foolproof battery top is exclusive to Clyde Plugg-in Radio batteries. No radio batteries, superior to Clyde, are made . . . Clyde Batteries only are used for gun and fire control in the Royal Australian Navy . . . the Postmaster-General's Department and many other public services. Insist on Clyde Batteries and get the utmost in service and value.



## CLYDE 'Plugg-in' RADIO BATTERIES

"PATENT PENDING"

**The Clyde Engineering Company Ltd., Granville, N.S.W.**

Branches at SYDNEY, MELBOURNE, BRISBANE, ADELAIDE, PERTH, HOBART, LAUNCESTON.



### FIVE-METRE TRANSCEIVER—List of Parts.

- 1—chassis and panel to specifications.
- 1—carrying case 14in. x 12in. x 8½in. (internal dimensions).
- 1—15 mmfd. variable condenser (Raynart, Eddystone, Radlokes).
- 1—tuning coil, wound to specifications.
- 1—4 P.D.T. toggle switch.
- 1—S.P.D.T. toggle switch.
- 1—3½—1 audio transformer (Radlokes).
- 1—microphone (Regal).
- 1—microphone transformer (see text).
- 2—5m. R.F. chokes (Radiomac).
- 1—30-henry 50 mill. choke (Radlokes).
- Frame and plated copper tubing for Reinartz aerial (see text), with mounting socket and plug.
- 1—5-pin, 1—6-pin wafer sockets.
- Insulating bushes for variable condenser.

#### FIXED CONDENSERS:

- 1—.0001 mfd. (Simplex, Solar).
- 1—.006 mfd. (Simplex Solar).
- 2—.5 mfd. (Simplex, Solar).
- 1—10 mfd. dry electrolytic (Solar).

#### RESISTORS:

- 1—1 megohm (E.T.C.)
- 1—.25 megohm 1-watt carbon (E.T.C.).
- 1—50,000 megohm 1-watt carbon (E.T.C.).
- 1—10,000 megohm 1-watt carbon (E.T.C.).
- 1—5,000 megohm 1-watt carbon (E.T.C.).
- 1—500 megohm 1-watt carbon (E.T.C.).

#### VALVES:

- 1—76, 1—41 (Radlotron, Raytheon, Philips)

#### SPEAKER:

- 1—5in. per mag. speaker, 2,500 ohm field, input transformer to match single 41 (Rola DP5B).

#### BATTERIES:

- 3—60-volt light duty "B" batteries (Ever-Ready).
- 1—4½-volt "C" battery (Ever-Ready).
- 1—6-volt accumulator (Clyde).

#### MISCELLANEOUS

- 2 doz. ⅜in. bolts and nuts, solder tags, wood screws, plug and socket for "A" battery connections, 2 large banana plugs and sockets for aerial connections, 6.3v. pilot lamp and socket, push-back.

alternative, two ordinary double-pole double-throw toggle switches can be ganged together.

#### Super-Regenerator Used In Receiver.

On the receiver side, the 76 acts as a super-regenerator of the self-interruptor variety, and audio amplification to the midget Rola permag. speaker is via the 3½ to 1 audio transformer and the 41 pentode. No vernier tuning dial is needed, just a pointer knob and scale, for the reason that a super-regenerator tunes quite broadly. The presence of the carrier-wave from the other station is indicated by the cutting out of the super-regenerative hiss, something like a tuning hole in the ordinary regenerative type of receiver.

On the transmit side, the 76 takes over duty as an ultra-audio oscillator with a lower grid-leak value, and as such it generates a surprising amount of r.f. with only 180 volts on the plate. More voltage than this is emphatically not recommended. At 240 volts the 76 valve is inclined to block and fail to respond immediately when changing back to receive. Three Ever Ready, 60-volt light duty B batteries comprise the plate supply.

The 41 pentode takes on the job of modulator, and in conjunction with a single button hand microphone of the "neophone" type gives ample speech level. This can be checked by watching the effect on the pea-lamp of an absorption meter tuned to the frequency and held near the oscillator coil or aerial.

A 4½ volt "C" battery is used for the microphone, which plugs into a jack on the panel. It must be removed when the gear is out of use, or the battery will be run down through the microphone.

#### Improvised Microphone Transformer.

The microphone transformer is made from an old audio transformer with a broken down secondary or primary. The defunct winding is removed and a new winding of 250 turns of 28 d.s.c. wire put on. This is the new primary for the microphone circuit.

The tuning condenser is a 15 mmfd. Raymart or Eddystone with ceramic insulation, and the valve socket for the 76 a ceramic type. As will be seen from the chassis view a

76 is mounted in a horizontal position on a piece of bakelite. Leads are kept very short in this way, and the coil is soldered directly across the stator and rotor of the condenser. The condenser, being at high potential on both sides, must be insulated from earth.

For the panel control, a short length of ¼-inch erinoid rod and an insulating coupler are used. The rod projects through a panel bushing and the pointer knob is fitted with the condenser scale.

For the 5-metre band, the coil has 9 turns of 14 enamelled copper ½-inch inside diameter, with the turns spaced the diameter of the wire. The outfit could be used on 2½ metres by fitting a coil of 4 turns ⅝-inch diameter. In this case, the Reinartz aerial would be only 1 foot square (2ft. each half).

Coupling to the aerial is made by a single turn of stiff wire around the oscillator coil at the centre. This is the point of lowest potential, and the correct position for coupling the twisted pair line. The latter should not be twisted tightly together, only for one or two twists throughout its length, otherwise the loading of the aerial plus the line may cause a dead-spot in the receive side.

The r.f. chokes are standard 5-metre types, and can be bought ready made from Price's Radio Service, Angel Place, Sydney, or made up on old glass pigtail resistor formers, with about 50 turns of 36 d.s.c. wire.

Beyond these details there is little to know about the construction, except that all leads to the 76 are necessarily short owing to the position of mounting the valve. The chassis assembly is made up with a sub-panel, the change-over switch being underneath. On the panel, a dial lamp indicator is used to show that the filaments are switched on. This is a 6-volt pea-lamp fitted to a holder projecting through the panel. The filaments are switched on by means of the switch SW5, also on the panel. This switch is not an essential, as the outfit can be switched off by merely removing the "A" battery plug from the socket on the side of the case.

The permag-speaker is fitted to the front of the panel, and gives ample reception volume. It is fitted with an input transformer to suit a 41 pentode. The modulation choke (Heising

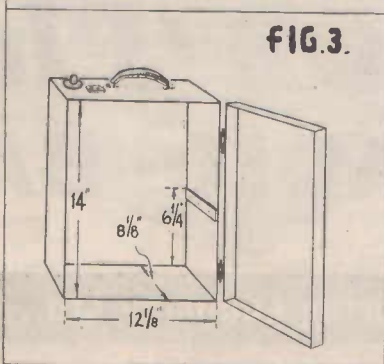
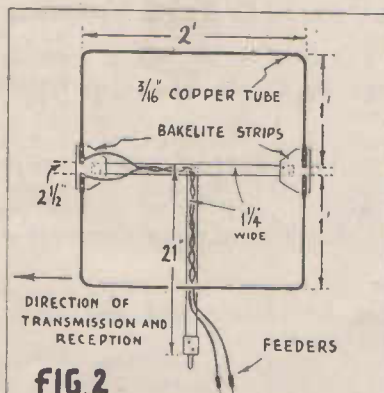

Fig. 2 gives full details covering the construction of the Reinartz aerial, while Fig. 3 shows internal dimensions of the carrying case.



system) is an ordinary 30 henry 50 m.a. filter choke.

**Results Obtained.**

Although this transceiver was looked upon in the first place as being intended for use over ranges of not more than two miles, the tests showed it to be capable of much more than this.

When tested between the writer's home station and mobile points, it was found to give R8/9 speech as far away as nine miles, provided that the aerial was turned in the right direction. Which is the correct direction is easily determined by listening to the distant signal and rotating the aerial until maximum strength is secured.

Two such transceivers as this type can be very useful on amateur field days in the country, and would provide endless amusement. It is needless to point out the many commercial applications for such gear.

**Operation Without Transmitting License Is Illegal.**

A final point to observe, however, is a very important one. Apparatus of this nature cannot be made and operated without an experimental transmitting and receiving license. Readers not yet in possession of the amateur license who may be interested in trying their hand with such apparatus, should forget about it until that exam. is taken. Illegal radio operation calls for heavy penalties in these times, and would furthermore jeopardise future legal operation for some time to come. The 56 m.c. band is no place where piracy can be indulged in "under cover" in these progressive days, any more than on the lower frequencies.

**Operation Pointers.**

For those "hams" who have not used transceivers, the following should be noted. The transceiver transmits on the same frequency used for reception, assuming that the tuning control is not moved when changing over. Two such stations in communication will therefore be operating on approximately the same frequency. That is one limitation of the transceiver, but it is of no account for point-to-point working between two similar stations.—VK2NO.

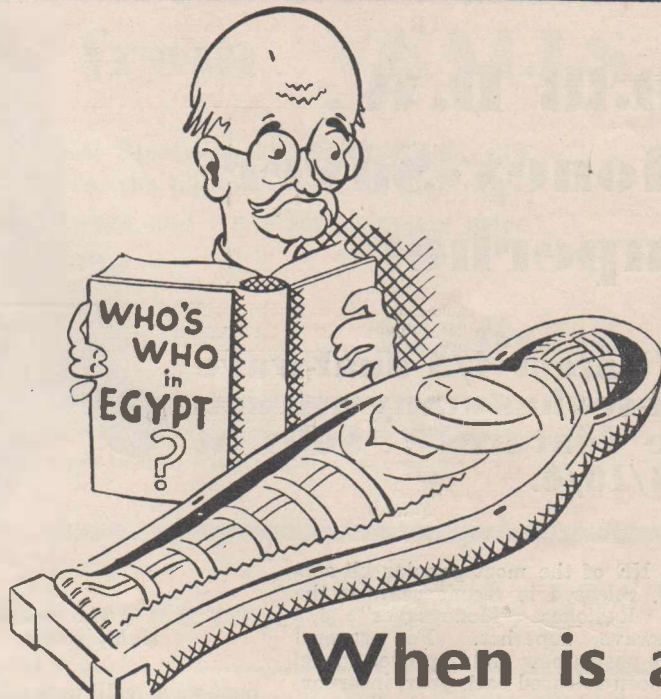

**When is a MUMMY a DADDY?**

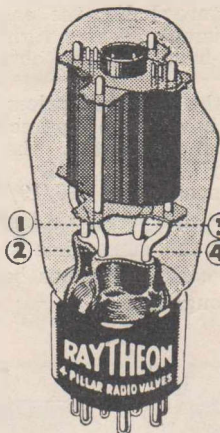

Maybe the Egyptians knew . . . maybe they started winding the other way to establish the distinction—but to us they're all just mummies!

Metal valves are causing the same difficulty with valves. They all look alike—nothing to distinguish one from the other—they're all just valves to the average radio owner. Now, with glass it's different—or even glass-metal. The buyer can look inside and, if he's shrewd, make SURE he's getting the valve with the four pillars. But with metal valves, the inside story is as untold as the identity of the Egyptian mummy.

But there's no mystery about Raytheon—metal or no metal. They're made by the greatest manufacturers in the valve business—the people who have already become famous for the only 4-pillar on the market. And—joyful news all listeners-in—glass . . . metal . . . or glass-metal . . . a Raytheon costs no more than ordinary tubes!



*This patented container allows your Raytheon to be tested before you buy, without breaking the carton on the guarantee seal!*

**RAYTHEON  
4 PILLAR VALVES**

If unobtainable from your local dealer, write to Standard Telephones & Cables A/asia. Pty. Limited, 258-274 Botany Road, Alexandria.



## Radiokes . . . .

# 1938 D.W. Money-Saver Superhet

**Latest 4/5 dual-wave kit-set has many attractive features : Sells at £6/19/6.**

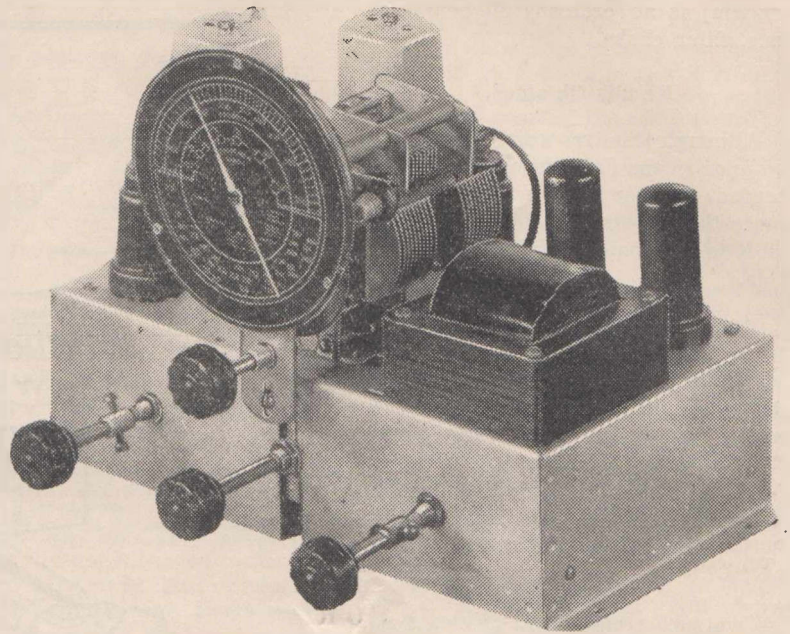

The completed receiver. The three lower controls are, left to right, volume control, wavechange switch, and tone control.

ONE of the most popular kit-sets released in recent years is the Radiokes "Moneysaver" 4/5 dual-wave superhet. For several years past a new and improved model has been released each year, incorporating new type valves and other up-to-the-minute developments in set design. With every model, particular attention has been paid to obtain the maximum possible performance from five valves, consistent with simplicity of assembly and alignment, and low cost.

### Many Attractive Features.

Like its predecessors, the "1938 Moneysaver" just released by Radiokes Pty. Ltd. is already assured of widespread and continued popularity among set-builders. An excellent performer on both wave-bands, "star" features of this year's model include the use of the latest Radiokes DWU

dual-wave coil unit, high-gain i.f. transformers, and all-metal valves throughout. Though more compact than last year's model, it is even simpler to assemble and align, an excellent feature being the ease with which consistent tracking right across both wave-bands can be obtained.

Despite the fact that prices of raw materials have risen appreciably in the past few months, the "1938 Moneysaver" kit-set sells without valves or speaker at £6/19/6 complete—18/- cheaper than last year's model. At the same time the high quality of components has been preserved throughout.

### Metal Or Octal-Based Valves Can Be Used.

The circuit (overleaf) shows that a 6A8 has been used as mixer oscillator, followed by a 6A7 i.f. amplifier, with a 6Q7 as diode detector and first audio amplifier. The output pentode is a 6F6, with a 5Z4 as rectifier. If desired, octal-based glass equivalents of these valves can be used, corresponding "G" types to those mentioned above being: 6A8G mixer, 6U7G, 6B6G and 6F6G, an 80 being used as rectifier. If these valves are used it should be remembered that it is necessary to fit valve shields on the 6A8G, 6U7G, and 6B6G.

An attractively-printed folder, de-

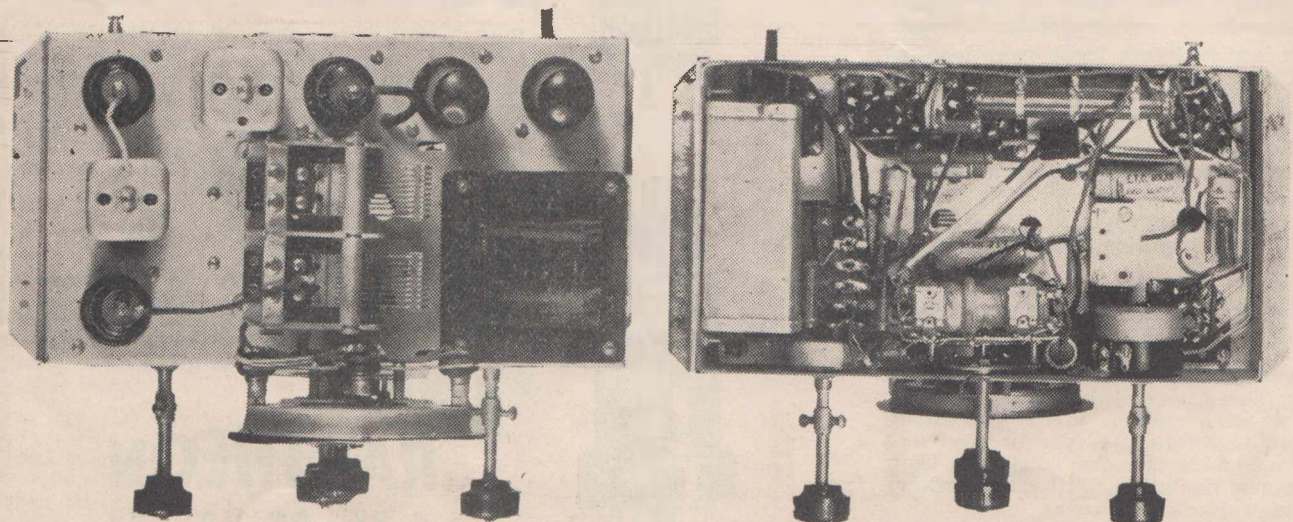

These photographs show above and under-chassis views of the assembled and wired receiver.



# Special Offers from VEALLS

Vealls, with 6 big Radio and Electrical Stores packed with goods, can offer you an unequalled choice . . . from the biggest stocks in Australia. Note the special prices listed on this page and write for complete price lists—POST FREE!

**BUILD THE THREE-WATT MIDGET AMPLIFIER . . . . . £6-7-6**

For only £6/7/6 Vealls will supply the complete parts required to build the three-watt Midget Amplifier described in this issue. Price includes the necessary Radiotron Valves and Rola 8-20 speaker. Freight paid to your nearest railway station. It pays to deal with Vealls.

VEALLS FOR  
EVERYTHING RADIO

VEALLS FOR  
EVERYTHING ELECTRICAL

**THE COMPLETE PARTS TO BUILD THE 5-METRE TRANSCEIVER . . . £9-15-0**

(Microphone and Transformer extra as selected.)

See the complete constructional details elsewhere in this issue and note Vealls keen low price for the complete kit of parts . . . everything except the microphone and transformer.

GET THE HABIT \_\_\_\_\_ TRY VEALLS FIRST . . . AND ALWAYS

THE FASTEST MAIL ORDER  
SERVICE IN AUSTRALIA

VEALLS PAY FREIGHT ON  
RETAIL ORDERS Excepting Batts.  
and Cabinets.

## Build the PORTABLE 4 in a CABINET

The Outdoor Portable 4, undoubtedly Australia's most popular 4-valve Battery Portable, may be bought for only 11 Gns. . . . the complete kit—everything including valves, speaker and cabinet. Write for full constructional details.

For those who wish to build the "Portable 4" chassis into a standard mantel or console cabinet, Vealls will supply the complete kit—everything except cabinet for only 10 Gns.  
Mantel Cabinets from . . . . . 32/6  
Console Cabinets . . . . . 37/6, 42/6, 47/6, up to 85/-

# VEALLS

Letters: Box 2135T, G.P.O., Melbourne.  
490 Elizabeth St., 243 and 168 Swanston St.,  
Melb. 299 Chapel St., Prahran. 3-5 Riversdale Rd.,  
Camberwell. 97-99 Puckle St., Moonee Ponds.  
Phone: F 3145 (6 lines).



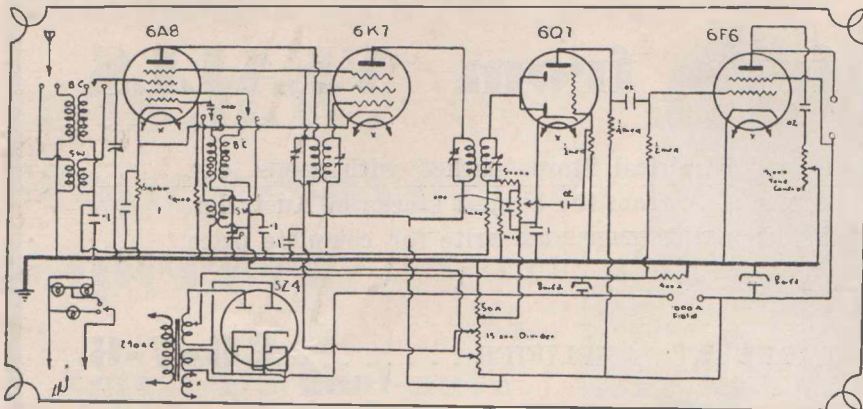

Circuit of the latest Radiokes "Moneysaver," which uses metal valves throughout.

scribing in detail the assembly and alignment of this kit, is available to "Radio World" readers free on re-

quest from Messrs. Radiokes Pty. Ltd., Box 58, P.O., Chippendale, Sydney.

**Pre-Selector Unit Sharpens Tuning, Increases Gain.**

Since writing you last I have completed the pre-selector unit as described in the March 1937 "R.W." I built it ahead of my S.W. eight-valve home-built set, and must say it is all that you have stated it to be. Signals are clearer, tuning sharper, noise level down (especially for my QRA). signal strength up, and I recommend

members to commence immediately and build the excellent unit for the coming DX season, and so log that "hard to get" station on the crowded 20 m. band.

I haven't done a great deal of dx-ing of late, owing to lack of time, but I find in the early mornings a good many "G's" are coming through at good strength, and in the afternoons the 20 m. band is crowded with W's. K6's, KA's, CE's, VS's and VU's in

the evenings. The following are a few heard recently:—

W1JFG, W8MPX, W4HX, W4CDG. W9KIG, W9DXZ, K6CGK, etc J2NG, J2MI, VS7GJ, VU2CQ, XU8MC, XU8RB, HS1BJ, XZ2EZ, G2NA (good R8 this one), G5LU, G5DT, G5LW, G8MA, G5ZG, G6TZ, G8NJ, GI2CC, VE2MW, CE1BE, CN8AB, PAOMQ, ZL2BI and ZL2QL.

QSL's to hand of late are:—VK's 7LZ, 7YL, 6WZ, 6MU and 6WS; VE5VO, G2ZP, G6DT, G5VM, G5NI, J2MI, LU8AB, LAIG, ZU6AF, K4SA, H17G, VS7GJ, HAS3, FT4AG, F3GR, K6NZQ, W3EOZ, W3EGG, W8HZU, W6LYM, W7DNP, W7BCU, ZL2QL, ZL4CU, VU2LL, and a few other W's.

I have to-day received a letter from a radio friend in England asking if I would forward a copy of the "Radio World" to him, so it is getting popular even over there.—W. M. Chapman (AW112DX), Waterloo, Sydney.



**"Bandspread Two" At Sea.**

With my "Bandspread Two" I get very fine results, especially on the short waves. I listened to a football match in Edinburgh one night last month off Cape Otway, and used a Baldwin unit speaker with an old "dragon fly" horn, and the result had to be toned down as it was too loud. Truly a remarkable performance.—F. W. Neilley, Newcastle, N.S.W.

WHAT EVERY RADIO DEALER HAS BEEN WAITING FOR

**Calstan Multimeter Model 136**

with New High Sensitivity 20,000 ohm per volt meter

Just released by Slade's Radio Pty. Ltd. . . . the largest manufacturers of TEST EQUIPMENT in the COMMONWEALTH . . . and added to their most comprehensive range of Precision Test Equipment . . . Model 136 Multimeter is an outstanding achievement in the Test Equipment field with AN ENTIRELY NEW AND DISTINGUISHED METER SCALE OF 7 INCHES LONG . . . the whole instrument itself a handy portable size and built in the usual Calstan compactness.

Model 136 A.C./D.C. . . . Price £12/12/-  
D.C. . . . Price £10/10/- Plus Tax

The Ranges are as follow:

MEASURES CURRENT AS LOW AS 2 MICO-AMPS.  
A.C./D.C. VOLTS: 2½, 5, 50, 250, 1,000.  
OHMS: Zero to 50 Megohms in 4 Ranges.  
M/A's: 1, 5, 50, 250.

The large meter, like all Calstan meters, features steadfast calibration, unexcelled accuracy, and clear jet black markings on the 7 inch scale. Each of the 72 parts forming a Calstan meter is finished in a workmanlike manner and all meters subject to oxidation are Cadmium Plated.

**SLADES RADIO PTY.**

LANG STREET  
UJ 5381

CROYDON, N.S.W.  
UJ 5382

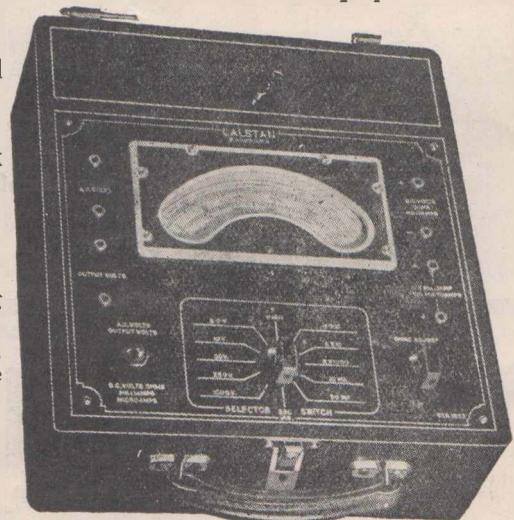



**BEFORE YOU BUY  
YOUR NEW RADIO SET**

**ASK YOURSELF  
THIS QUESTION**



*"Why do practically all leading radio set manufacturers make Air Cell operated models?"*

Because the Eveready Air Cell is the most advanced form of current supply ever introduced into the construction of country radio . . . because the Eveready Air Cell eliminates the necessity for the man on the land or for those away from power lines to continue to put up with the cost and inconvenience of frequently recharging heavy accumulators . . . and because the Eveready Air Cell, under normal conditions of use, gives more than a year of trouble-free service. **REMEMBER!** No more recharging of batteries whatsoever if you buy an Air Cell operated radio.

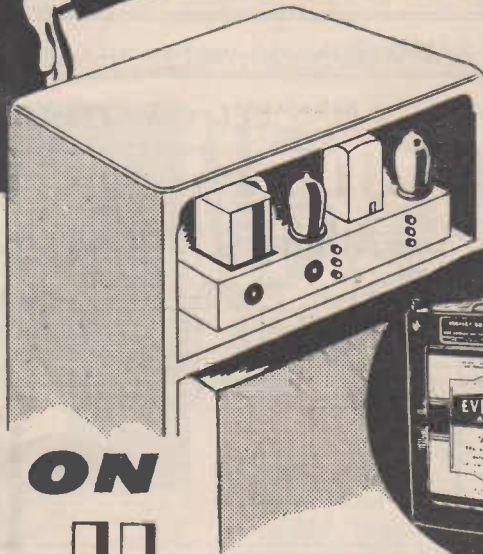

**POST NOW**

**DECIDE ON  
Air Cell  
OPERATED  
RADIO**

**POST NOW!**

The Ever Ready Co. (Aust.) Pty. Ltd.,  
Harcourt Parade,  
ROSEBERY, SYDNEY, N.S.W.

Dear Sirs,

Please send me your 32-page book on the Eveready Air Cell and Air Cell operated radio sets. It is understood that this will place me under no obligation whatsoever.

NAME \_\_\_\_\_

ADDRESS \_\_\_\_\_

R.W. 4/38

THE EVER READY CO. (AUST.) PTY. LTD., SYDNEY



# 50 - Watt Transmitter For New Power Limit

A TRANSMITTER has been designed in the laboratory of Amalgamated Wireless Valve Co. Pty. Ltd., to take full advantage of the new 50-watt limit of input now existing on experimental transmitters. This transmitter is suitable for operation on either or both 'phone and c.w., and should be found extremely satisfactory from all points of view.

Designed to take advantage of the new 50-watt power limit for amateur stations, the transmitter described below uses as final amplifier one of the new 809's operating under its maximum Class C telephony conditions.

## 6V6G Crystal Oscillator And Doubler.

The first stage is Radiotron 6V6G, used as a crystal oscillator. This valve has been found to be very satisfactory in such a position, and since it has a high second harmonic in the output it is preferable to pentode types for frequency doubling. The valve operates either as a straight crystal oscillator at crystal frequency or as a tritode oscillator on the second harmonic. Consequently by the use of a 40-metre crystal, it is possible to obtain operation on both 40 and 20-metre bands.

The output of the 6V6G oscillator gives ample drive to the grid of the 6P6 buffer, which operates under maximum class C conditions to deliver a power output of approximately

18 watts. This stage is shown with a neutralising condenser in order that maximum stability may be obtained, even with somewhat limited screening. The neutralising arrangement may be omitted in cases where screening is sufficiently complete, although it is a desirable feature in all cases. The neutralising condenser itself is constructed merely by twisting a short length of wire around the plate lead and adjusting the capacity by the number of turns.

## New 809 Final Amplifier.

The final amplifier is a Radiotron 808 high mu. triode operating on both 'phone and c.w. under its maximum

Class C telephony conditions, which are:—

- Plate volts . . . . . 600 volts
- Plate current . . . . . 83 m.a.
- Power input . . . . . 49.8 watts
- Typical Power Output, 38 watts

When operated on c.w., the valve has ample reserve of power-handling ability, although this cannot be used owing to the limitation of power input. The adoption of a constant supply voltage on both c.w. and 'phone simplifies the circuit arrangement.

## Two Power Packs In Series.

The voltage which is required by the transmitter is much higher than that available from any rectifier used

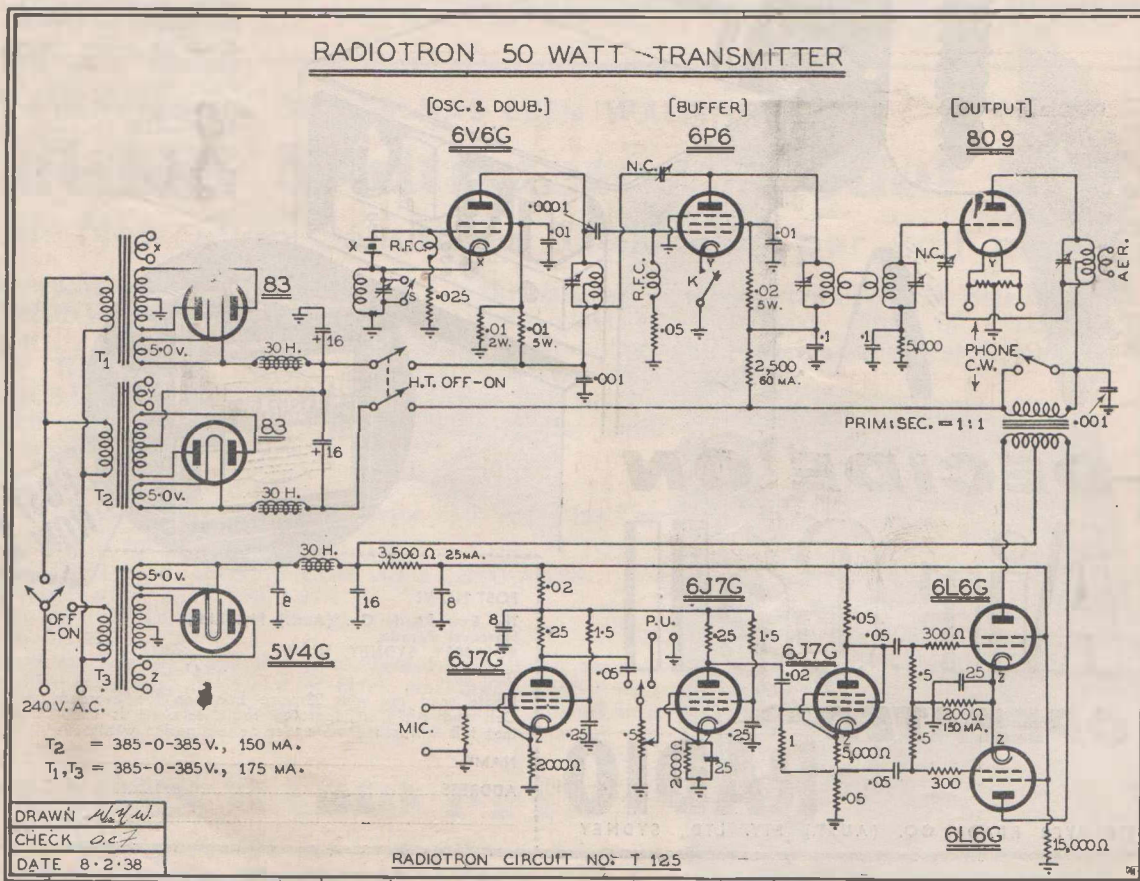



for receiving purposes, so that a pair of Radiotron 866 mercury vapour rectifiers would normally be necessary. However, as will be seen from the circuit diagram, by combining in series the outputs from two standard power packs, the required voltage is obtainable at a lower cost.

In this circuit two Radiotron 83 valves are used as rectifiers, each having its own separate transformer and filter. Due to the series connection, a convenient source of low voltage for the crystal oscillator is obtainable by tapping to the junction of the two units. This power supply arrangement is, however, merely a suggestion, and may be replaced by any other power pack delivering the correct voltage and current, provided that the regulation is sufficiently good.

**6L6G's In Push-Pull for Modulator.**

In order to modulate an input to the final stage of about 50 watts, it is necessary to have available at least 25 watts of audio power. A suitable modulator is shown in the diagram, and will be seen to consist of two Radiotron 6L6G valves in push-pull Class AB1, giving an output of slightly over 25 watts. The earlier stages in the modulator consist of a 6J7G pre-amplifier, 6J7G voltage amplifier and 6J7G phase-splitter. This latter operates under conditions of very low

gain, and is used merely in order to avoid the use of a transformer.

The overall fidelity of this arrangement is excellent, and since the 6L6G valves operate into a nearly constant load, the harmonic distortion is very low. This modulator is not recommended for use on a loudspeaker load owing to the danger of high voltages being present in the plate circuit, due to the rise of impedance of the loudspeaker at high frequencies.

The pre-amplifier valve, which is shown as Radiotron 6J7G, could with advantage be replaced by the non-microphonic Radiotron 1603, which is specially intended for use in this application. If it is desired to use the 6J7G valve in this position, it may be necessary to select a suitable valve having the least tendency towards being microphonic.

Provision for a pick-up is shown on the input to the second stage of the modulator. If a sensitive microphone is used, with an output of over 0.2 volt r.m.s., the pre-amplifier stage may be omitted and the input taken to the pick-up terminals. The power supply for the modulator is obtained from a separate transformer rated at 385-385 volts, 175 m.a. The rectifier is Radiotron 5V4G, and the filtering arrangement is shown in the circuit diagram.

A suitable modulation transformer could be constructed as follows:—

Cross sectional area of core, 1.25 sq. inches.

Length of magnetic path, 11 inches.

Length of air gap, .015 inches.

Primary turns, 3000 turns 30 S.W.G. enamel (centre tapped).

Secondary turns, 3000 turns 30 S.W.G. enamel.

For best results, the windings should be wound in sections in the following order:—

Winding 1: 750 turns primary.

Winding 2: 1500 turns secondary.

Winding 3: 1500 turns primary (centre tapped).

Winding 4: 1500 turns secondary.

Winding 5: 750 turns primary.

A similar construction is used in transformer T7 described in Radiotronics, No. 76, page 43.

If operation on c.w. only is desired, the modulator and modulation transformer may be omitted and a very simple type of transmitter is the result. This could easily be built up as a unit and the modulator added at a later date without losing any efficiency with either arrangement, and without any necessity for alterations in the transmitter.

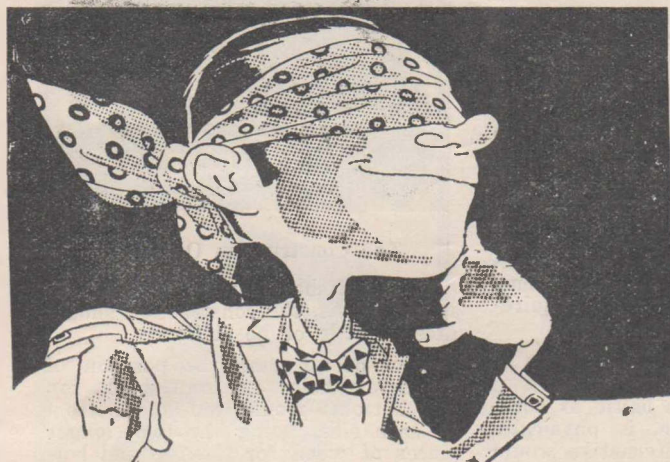

*No guesswork!*

**With "RAYMART" Reception**

Used extensively overseas by "Men who know," Raymart "Craft A Creed" Short Wave and Ultra Short Wave equipment readily recommends itself to all amateur enthusiasts. E.O.I. cable now available. Get in touch with "The Friendly Wholesale House" for full particulars.

Everything radio and electrical at the lowest prices in the State.

Same-day service a specialty.

**RAYMART**  
CRAFT A CREED

SHORT WAVE & ULTRA SHORT WAVE TRANSMITTING GEAR

TELEPHONE: BW 3109 (2 lines).  
TELEGRAMS: "JONMAR," SYDNEY

**JOHN MARTIN** PTY LTD **RADIO & ELECTRICAL SUPPLIES**

116-118 CLARENCE STREET, SYDNEY.



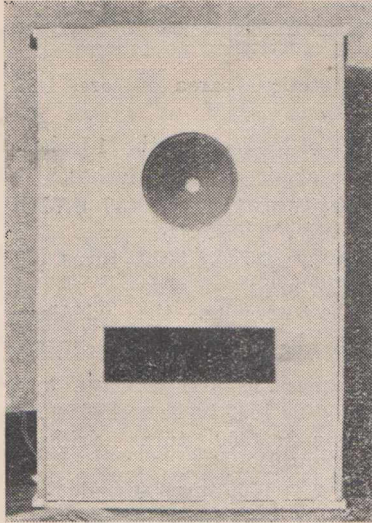

Photographs Nos. 1 to 3 on the right show (top) a front view of the completed baffle, with speaker mounted in position; (centre) a rear view with the back and speaker removed, and (bottom) a rear view, with back removed, showing padding and speaker.

★

Photograph No. 4 on the left shows a front view of the reflex baffle.

★

# Infinite Baffle Aids Tonal Fidelity

A marked improvement in fidelity of reproduction is achieved by this practical application of the infinite baffle principle. Written for the "Radio World" . . . . .

by T. O'DONNELL and W. J. PHELPS.

**T**HE subject of present-day audio reproduction has been covered very completely, but it would appear that until recently the average high fidelity enthusiast has paid little attention to improved applications of baffling.

In order to obtain efficient reproduction of the lower frequencies, it is necessary to separate the air behind the diaphragm or cone from that in front of it by means of a large plane board—generally made of wood—called a baffle. Otherwise the air in front of the diaphragm, when compressed, returns to normal pressure by escaping to the back of the diaphragm, instead of compressing the air exterior to itself and so propagating a sound wave.

It will be observed that by surrounding the speaker cone assembly with suitable material, the air path is extended according to the area of material used. This has the effect of placing a large air load on the speaker cone and correspondingly moves a larger volume of air, thus aiding fidelity and sensitivity. The low frequencies, where the time be-

tween successive compressions is greatest, requires a longer air path than high frequencies to reproduce them efficiently; in other words, the bigger the baffle the lower the cut-off frequency. It is evident, therefore, that if it were possible to construct a baffle of infinite dimensions, the previously-mentioned requirements would be fulfilled.

### "Infinite" Baffling.

The necessity for a baffle as such, while being desirable, is physically impossible, but an alternative would be to build a baffle in which the speaker cone acts on a totally enclosed volume of air.

Under these circumstances, the condition exists whereby the larger the volume of air sealed to the back of the diaphragm, the lower will be the bass cut-off, and correspondingly lower attenuation of bass notes will be achieved. Having discussed the requirements and principle involved, an "infinite" baffle will be described, having dimensions found eminently suitable for general requirements.

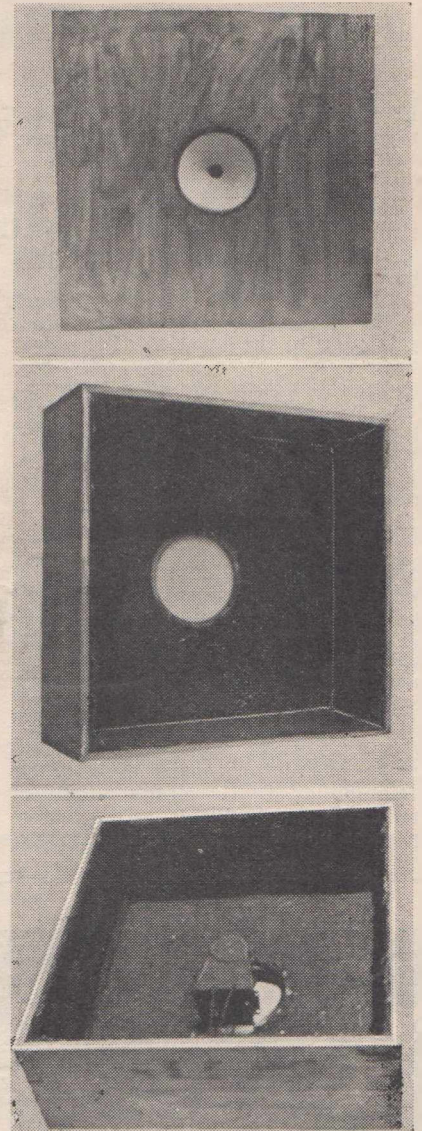

The Construction Outlined.

If the timber is purchased cut to specifications, the construction should present little or no difficulty.

First of all mark the position of the screw holes on front, back, top and bottom; mount top and bottom to each side, using the two longer pieces of wood for the top and bottom respectively. The front portion has at least 16 screws around its edge, this number being necessary to ensure solidity. Attach the front of the baffle (36" x 36" x 3/4" ply) to the square framework previously assembled, leaving the back to be fitted when necessary.

Padding of the inside walls can now be proceeded with, care being taken to lay the cow-hair underfelt as close as possible to the wood by means of large drawing pins. The back (inside) is padded similarly, leaving approximately one inch from each of



**EXTRA TESTS  
EXTRA SPEED**

**.. yet you pay  
no more for  
TRIPLETT**



1200-E.



1220-A.

666.

Test equipment by Triplet is designed to make servicing simpler, faster, and more precise. Manufactured in the new Bluffton (Ohio) factory, one of the most modern in America, Triplet instruments are made under the most modern and ideal conditions.

Triplet gives you MAXIMUM PROTECTION AGAINST OBSOLESCENCE, LIGHT WEIGHT, PORTABILITY and INSTRUMENT CASES ARE INTER-CHANGEABLE . . . yet Triplet test equipment costs little more than ordinary equipment.

**MODEL 1200-E UNIT.**

25,000 OHMS PER VOLT D.C. measurements are resistance readings to 40 megohms with this new super sensitive Volt-Ohm-Milliammeter. Instrument reads D.C.: 10-50-250-500-1000 volts at 25,000 ohms per volt; 0-50 microamperes; low ohms, backup circuit, 1/4 to 1000; 40,000 ohms, 4 and 40 megohms; A.C. 10-50-250-500-1000 volts. Price . . . . . £11/15/-

**MODEL 1220-A UNIT.**

For servicing sets using metal, glass-metal or glass tubes. Has five sockets — with standard RMA markings. Panel also includes eight automatic switch type and ten single action jacks. Makes all series and parallel meter connec-

tions through the set sockets to all parts of the circuit. Automatic in operation. Used in conjunction with any Triplet Volt-Ohm-Milliammeter. Extra connections may be added, when necessary, at a very slight cost. Price . . . . . £4/5/-

**MODEL 666.**

Model 666 Universal Pocket Volt-Ohm-Milliammeter A.C. and D.C. voltage ranges; D.C. milliamperes, low and high ohms scales. Selector switch for all instrument readings. Slips easily into the coat pocket. Has all the advantages of larger volt-ohm-milliammeters, plus the convenience of compactness. Indispensable for measurements of A.C. or D.C. volts, ohms and milliamperes. Full-view scale. Price .. £7/15/-



**W. G. WATSON & CO. PTY. LTD.**

279 CLARENCE STREET, SYDNEY.  
398 POST OFFICE PLACE, MELBOURNE.

KING & BOLTON STREETS, NEWCASTLE  
91a CURRIE STREET, ADELAIDE.

And at Perth, Hobart and Launceston.



**THOROUGHNESS  
IN  
EVERY DETAIL**

. . . take  
**OVERLOAD**  
for example . . .

The Simplex standard voltage test is characteristic of Simplex thoroughness employed in the production of mica condensers.

Every Single Simplex Condenser is Tested at 1,000 Volts A.C. and D.C.

Before reaching this final and most severe of tests, Simplex condensers are checked and re-checked in every stage of production . . . .

There is no possibility of a faulty condenser leaving the Simplex Factory.

With Simplex condensers you are assured of the utmost in reliability, permanency and accuracy.

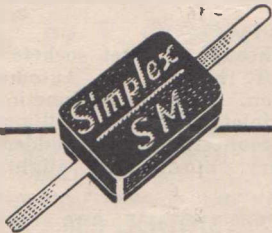

Above is the Simplex Moulded Bakelite type "S/M" (actual size), available in capacities from .000005 microfarads to .01 microfarads.

Type P/T (Pigtails) measuring only  $\frac{5}{8}$  in. by  $\frac{5}{8}$  in. — capacity range .000005 microfarads to .001 microfarads.

## SIMPLEX CONDENSERS

"FAVOURER BY  
FAMOUS FACTORIES"  
Manufactured by Simplex Products Pty. Ltd., 716 Parramatta Rd., Petersham, N.S.W.

'Phone LM 5615.  
AGENTS IN ALL STATES.

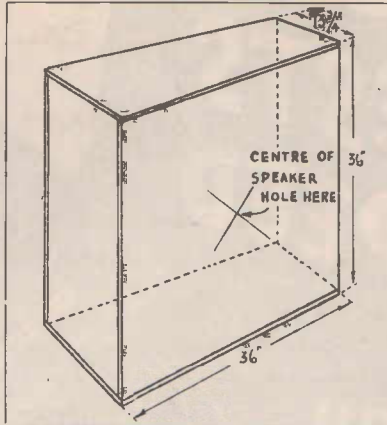

Full dimensions for making the infinite speaker baffle described in the accompanying article are given in this sketch.

the four edges, so as to facilitate the screwing on of the back.

The baffle is now in readiness for the speaker to be attached, and finally, the back is screwed on, the speaker cable being brought through a small hole cut in a convenient position.

### Speaker Requirements.

The matter of choosing a speaker if one is not already on hand, will be left to the individual constructor, depending on his particular taste and requirements. However, it can safely be stated that, irrespective of the type used, the infinite baffle will enable it to provide better low-note response than is obtainable with the average flat board. It is recommended, however, that if possible, a speaker with a large diaphragm be used, to achieve even better performance.

Opportunity was afforded of making some practical tests with various makes of high fidelity speakers now being released and selling at a very reasonable figure. Furthermore, tests were conducted with the older types produced about nine years ago, the only alteration being to re-wind the field coils, this being necessary in order to reduce hum level accentuated by the use of the infinite baffle principle. On a high quality amplifier, the reproduction from the high fidelity speakers was really fine, while that from the older types was most satisfactory, and really astonishing in consideration of their age.

### Reverberation Damping.

When a diaphragm acts on a totally-enclosed volume of air, the reverberation set up as a result of sound waves generated by diaphragm action must be absorbed before they have a chance of being reflected back to the source of generation. This

shows just how essential it is to provide a high degree of absorption when using a speaker under these conditions.

### Principle of Operation.

Having covered the practical application of the infinite baffle principle, it is desired to point out that as a result of investigation and experiment, audio outputs of up to 10 watts can be handled safely by a baffle of these specifications, this being more than sufficient for average room level and small hall requirements.

The diaphragm when repelled from the field magnet causes an extremely small partial and instantaneous vacuum to be created, depending on the frequency actuating the diaphragm. Thus it will be seen that the vacuum created and the compression on the inward travel, will be proportional to the actuating frequency and power output.

As previously stated, the front of the diaphragm compresses the air exterior to itself, but by reason of the fact that the front is operating on an extremely large volume of air, which in comparison to the enclosed air, does not compress to the same degree; therefore, providing the cubic content of enclosed air preserves a sufficiently high ratio in respect to the distributed vacuum, the diaphragm does not travel with any undue velocity during periods of attraction to the field magnet.

It will be obvious that for higher power outputs where the movement of the speaker diaphragm is greater, it will be necessary to employ a larger enclosed air space—in other words, a larger baffle utilising the previously-explained principle.

However, for reasonable portability and for average home use, this is not always practicable. Photograph No. 4 illustrates a baffle of rectangular shape with closed-in back and completely padded similar to that just described, but operating on the reflex principle by employing an aperture below the speaker diaphragm.

As the operation of this type is entirely different to that of the infinite baffle, in so much as the internal compression acts on the air in the aperture and through oscillation creates an auxiliary source of sound, it is not intended to enter into a discussion on its action.

In conclusion, it might be suggested that if it is found the actual shape of the infinite baffle does not meet with requirements, it can be constructed

(Continued on page 34.)



# Shortwave Aerials For DX Reception . . (1)

**U** NDOUBTEDLY one of the most important aspects of radio as a hobby is to be found in the widespread appeal of short-wave listening and dxing. With the number of powerful short-wave broadcasting stations always increasing, dxing has become a real art. To-day the average S.W.L. is usually possessed of highly efficient receiving equipment; but, in many cases, the results obtained are scarcely as good as could reasonably be expected, largely because of the fact that very little thought is given to the problem of erecting a really efficient receiving aerial.

Assuming that no further improvement can be made in the receiver itself, the DX fan should turn his attention to the choice of a good aerial. At once he is faced with a difficulty, which arises from the fact that there is no best all-wave aerial; since any length of free wire in space acts as an interceptor of radio frequency energy at one fundamental frequency and the harmonics of that frequency.

Secondly, it must be remembered that every aerial is possessed of directional qualities. Actually, the vertical aerial is the least directional of all; and, under ordinary circumstances, when absolutely in the clear, it is omnidirectional, that is it will receive signals equally well from all directions.

However, it is usually impossible to erect any aerial absolutely in the open, and therefore even vertical aerials do become possessed of definite directional qualities. As the average S.W.L. is unable to measure the directional qualities of an aerial, it is better for him to construct one in accordance with theory, and trust that it will function as desired.

### Simple Half-Wave Doublet.

The simplest of all aerials is the single half-wave doublet, as shown in diagram 1. This should have a length equal to one-half the wavelength in metres of the band on which reception is most desired. Of course, signals on wavelengths greatly removed from the resonant frequency of this aerial will be received; but it will only function really well at or near its natural wavelength.

As regards its directional qualities, the single half-wave doublet is directional broad-side—i.e., at right angles to the axis of the wire. Accordingly it should be situated with this fact in mind—with its broad-side facing the more-difficult-to-log stations.

Shortwave enthusiasts wanting to obtain the maximum possible DX will be interested in this article, which discusses the theory and application of many popular types of special receiving aerials.

By F. R. and A. H. GRAHAM.

### Improving the Half-wave Doublet.

The half-wave doublet may be greatly improved by altering its length and/or by varying the method of connecting the lead-in.

The Johnson Q is an example of this, having two quarter-wave halves with a quarter-wave matching stub (see diagram 2).

The Johnson Q operates only on the frequency for which it is designed; and care must be taken to en-

sure that the quarter-wave sections are exactly the required length. A convenient formula for calculating the length of any half-wave aerial is—

$$L = M \times 1.56$$

Where L equals Length in feet and M equals wavelength in metres.

### Johnson Q Data.

Wavelength (Metres)	1/4-wave Feeder Section.	1/2-wave Aerial (in 2 1/4-wave halves)
10 m. Amateur band ..	8ft.	16ft. 1 1/2 in.
20 m. Amateur band ..	16ft. 5in.	32ft. 11in.
40 m. Amateur band ..	32ft. 9in.	65ft. 4in.
19 m. B/C band ..	15ft. 4in.	30ft. 7in.
25 m. B/C band ..	19ft. 10in.	39ft. 7in.
31 m. B/C band ..	24ft. 6in.	49ft.
49 m. B/C band ..	38ft. 2 1/2 in.	76ft. 5in.

The spacing of the feeders in the quarter-wave matching stub is rather critical, and the line must be kept taut. Each side of the line must be of the same length, and must be symmetrical with respect to the ground. Any bends must be gradual if losses are to be reduced to a minimum. In addition the transposed transmission line must be kept at right angles to the aerial for a distance at least equal to one-third of the total length of the aerial.

A further variation of the half-wave doublet is effected by increasing the length of each section of the aerial to a half wavelength (i.e., the total length is equal to a full wavelength). As in the case of the Johnson Q the twisted lead-in is attached not to the centre of the aerial, but to a quarter-wave matching stub, in which the wires are spaced from 4 to 6ins. apart. (See diagram 3.)

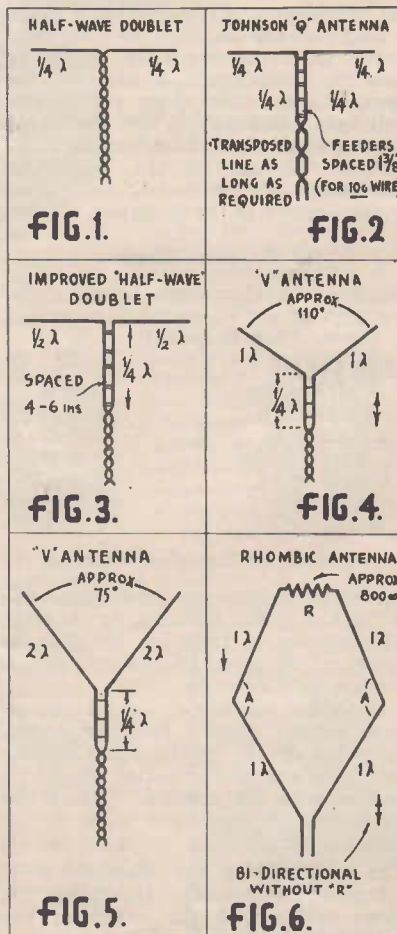





I BUY  
RADIO PARTS  
AND I WANT  
THEM GOOD

YOU can take it for a positive fact that the products we sell are the very best you can get. But you'll have to see for yourself just how pleasingly low are our prices and how snappy our service! If you have not yet seen how far you can make your money go, and what good service you can get, for your next radio requirements come to—

**Martin de Launay  
Pty. Ltd.**

Cr. Clarence & Druitt Sts., Sydney  
M 4268 (4 Lines)  
Cr. King & Darby Sts., Newcastle  
New. 959 (2 Lines)  
86 Keira St., Wollongong  
Woll. 681

Telegrams:  
"Martindel," Sydney and Newcastle.

WE CAN GIVE  
YOU THAT  
AND PLENTY  
BESIDES.

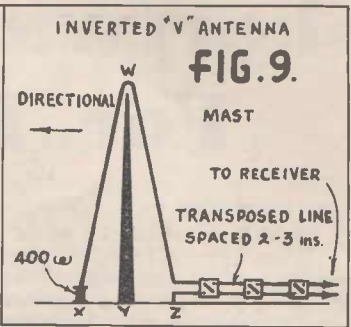
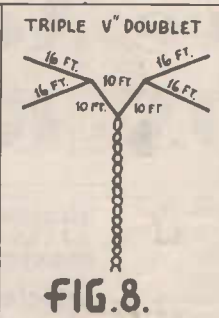
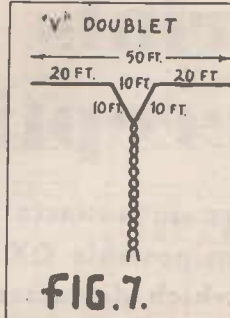

This aerial will also function very efficiently on a wavelength equal to twice its total length in metres. Thus if designed for 20 m. reception, it will give good results on 40 m.

The directional qualities of both these improved half-wave doublets are much the same as those of the simple half-wave doublet, being, if anything, more pronounced—there is less endwise pick-up.

**The "V" Antenna.**

Next to the single wire aerial, the easiest to construct for directional effects is the "V." Two examples of this are shown in diagrams 4 and 5. In diagram 4 the side wires are a full wavelength in length, and form an angle of 110 degrees; they are connected to a quarter-wave matching stub (as in diagrams 2 and 3). In diagram 5 the side wires are longer, each two wavelengths, and the angle is accordingly less, 75 degrees.

These "V" aerials are extremely directional—bi-directional, as shown by the arrows in the diagrams (4 and 5).

**"V" Antenna Angles.**

(Setting out the angle between the two legs of a "V" aerial for various leg lengths.)

Leg-Length in Wavelengths)	Angle.
½ wavelength ..	160 degrees
1 wavelength ..	110 degrees
1½ wavelengths ..	90 degrees
2 wavelengths ..	75 degrees
3 wavelengths ..	65 degrees
4 wavelengths ..	50 degrees

**Diamond, or Rhombic Antenna.**

A considerable improvement on the "V" aerial is the diamond, or rhombic aerial shown in Diagram 6. This is simply a "V" aerial backed up against another "V."

The diamond aerial should not be tilted in any plane. In other words, the poles should be the same height, and the plane of the aerial should be parallel with the ground. Tilting the aerial merely interferes with its directional qualities.

In constructing the diamond it is important to consider the angle A, which varies with the length of the sides (see table below).

**Diamond Antenna Angles.**

Length of Sides (in wavelengths)	Angles (see diagram 6)
1 wavelength ..	60 degrees
1½ wavelengths ..	80 degrees
2 wavelengths ..	95 degrees
3 wavelengths ..	115 degrees
4 wavelengths ..	125 degrees

If the terminating resistance, R (diagram 6), is included, the diamond aerial is not critical with respect to frequency, and gives an evenly good performance over a wide range. In this respect it is much superior to the aerials previously discussed. With the inclusion of R the aerial is uni-directional as indicated in diagram 6.

With the elimination of the resistor (R), we have a tuned diamond aerial which is quite suitable for U.H.F. work. It is bi-directional (diagram 6).

**The "V" Doublet.**

The "V" doublet (diagram 7) is probably the best aerial for all-wave reception. It differs from the elementary doublet, which tends to favour certain frequencies and reject others.

The "V" doublet is coupled to the transmission line by the converging "V." This makes the doublet respond uniformly to a wider range of short-wave signals; and the "V" matches the doublet more perfectly to the transmission line, so that the signal transfer is smooth. The reason for this is simple. At the top, where the spacing is wide, the characteristic impedance is high and comparable to that of the doublet, at the bottom, where the wires are close together, it is low to match the low impedance of the transmission line.

The "V" doublet illustrated in diagram 7 will give reasonable results between 16 and 50 metres, with the optimum response on 16 and 25 metres.

**The "Triple V" Doublet.**

The "Triple V" doublet shown in diagram 8 is essentially the same as the standard "V" doublet of diagram 7. Its chief advantage lies in the fact that it requires less space—having a span of only 40 feet, instead of the 50 feet required by the "V" doublet.

As in the case of the "V" doublet the dimensions given in the diagram



# ONLY £6-19-6

and giving a marvellous performance on shortwave and broadcast bands, yet **ANYONE** can build it in spare time!



**so CHEAP**  
to build that  
thousands can  
afford it!

**so EASY**  
to build that  
every man or boy  
can assemble it  
in his spare  
time!

## RADIOKES 1938 DUAL-WAVE "MONEY-SAVER" KIT SET

**D**ESCRIBED in this issue of "Radio World" is the finest Kit-Set RADIOKES have ever produced. Finest, because its performance is so good, its price is so low, and its assembly is so astonishingly easy!

You, for instance, need no technical knowledge to assemble this set, because when designing it, RADIOKES engineers used multi-purpose Radiokes components which cut wiring right to the minimum. So, if you want a really good radio, at a really low price, you can confidently buy the Radiokes 1938 Dual-Wave "Money-saver" Kit-Set. You'll be getting something pretty good. Its wave range covers 16 to 50 metres short-wave and 1500 to 550 kilocycles broadcast band. On the short-waves you hear all the world. When

testing, Radiokes engineers quickly pulled in Russia, France, Germany, Java, England; America, Hawaii, Japan and some others not identified. You will do even better. On the broadcast band, at about one-third volume control, all interstate and country stations roared in at full room strength.

Be sure of this. You will not get anything better for twice or three times the money, either in performance, all-round quality, or value. So why not build your own radio, when it is so cheap and easy. Cut out middleman's profit and get a better radio at a lower cost. The Radiokes 1938 Dual-Wave "Money-Saver" Kit-sets cost only .. **£6/19/6** complete to the last nut and bolt, but not including valves and speaker.

### FREE

Art folder describing the Radiokes "Money-Saver" Kit-Set. Write for your copy now, to Radiokes Pty. Ltd., Box 58, Chippendale, Sydney.

## Use this Radiokes Coil-Kit in the "Comet D/W Four"

Get the finest value for your money with the "Comet Dual-Wave Four" by using the Radiokes C.K.M.S. Coil-Kit in its construction. The Radiokes Coil-Kit costs only 35/- retail, and includes—

1 DWU Dual-Wave Unit

- (17/6),
- 2 5-465 I.F. Transformers, and
- 1 IP-7 padding condenser.

Available from all good radio dealers and wholesale houses throughout Australia and New Zealand.

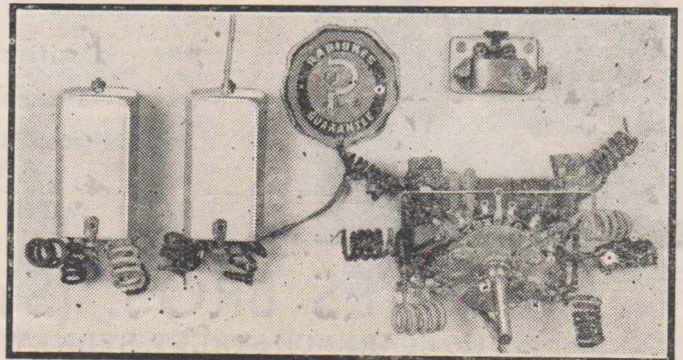



are designed to give good performance over the short-wave broadcast bands.

**The Inverted "V."**

The inverted "V" aerial (shown in diagram 9) consists of a wire supported in the form of an inverted "V" by a tall pole. One end of the wire is grounded through a non-inductive resistor of 400 ohms, whilst the other end is fed to a transmission line, which is transposed at convenient intervals.

This aerial is sharply directional from "X," as shown in the diagram. It is particularly suitable for reception from a given station or direction.

The length of the "V" portion of the aerial determines the wavelength at which greatest signal strength is obtained. Data for construction is given in the accompanying chart.

**Where Length of Side Equals 3/4 Wavelength.**

W.L. (Met.)	Height (W-Y)	Base (X-Z)	Tot. Lgth. Wire (X-W-Z)
17	39' 3 1/2"	28' 2 1/2"	83' 7"
20	43' 3 1/2"	32' 9 1/2"	98' 3 1/2"
25	59' 1"	41' 3 1/2"	123'

**Where Length of Side Equals 1 1/4 Wavelengths.**

17	54' 1"	83' 7 1/2"	139' 6"
20	65' 7 1/2"	98' 3 1/2"	164'
25	82'	124' 9 1/2"	205'

(To be continued next month.)

**"Eaglet" Gives Outstanding Performance.**

May I ask for your guidance as to adding an r.f. stage to my battery-operated "Eaglet Two," built up 15 months ago from the first issue of "R.W.," using 15 as detector and 30 as audio?

As I have had such wonderful results with this little set, I am desirous of still keeping to same detector and audio portion (with only alteration replacing 30 with a 1D4). I am enclosing a circuit of proposed addition and would be pleased if you would kindly check over and give any suggestions which will be gladly accepted.

Without the earth at the present time the 20 m. band is absolutely alive with signals, both c.w. and 'phone. As I am a telegraphist and very interested in the c.w. side of listening, you can believe me the little "Eaglet" sure pulls 'em in on the speaker to save having headphones on for code.

As many of our fellow members of the Club have already stated, we sure have a mag. to be proud of in the "R.W.," and long may it reign.—W. H. G. Dawson (AW121DX), S.A.

[The circuit you enclose is quite in order, and should give excellent results. Glad to know the "Eaglet" is performing well, and that you like "R.W."—Ed.]

**First VK in Clare, S.A.**

Clare has its first licensed "ham" station. Mr. W. H. Scott, who obtained his A.O.C.P. last year, has been allotted the call-sign of VK5HS, and has been on the air about three weeks. VK5HS uses very low power at present—approximately 4 1/2 watts—on 40 metres. His rig is crystal-controlled, and the circuit is the popular tritet using a 42. He has worked VK's 2, 3, 4, 5 and 6, on this low power. First QSO was with South Australia's only YL ham—VK5YL at Murray Bridge—who gave him a royal welcome to the ranks.

Mr. Scott, being an old telegraph operator, finds no difficulty with the c.w. rules now in force. His aerial is a full-wave 40-metre centre-fed Hertz with twisted feeders. The receiver is a battery three-tube. It is to be hoped that the advent of one "ham" in Clare will inspire some of the radio gang to greater efforts to obtain their own stations.

The past President of the Clare Radio Club, Mr. W. Dempsey, who has been away from Clare for some considerable time, spent three enjoyable weeks back with the gang recently.—A. J. Marten, Vice-President, Clare Radio Club, S.A.

**CARBON TYPE**



**POTENTIOMETERS**

Incorporating Ferranti Resistance Element and Tip  
With and without switch.

Positive in Action. Robust in Construction.

Designed and Manufactured in Australia.

List Price, 250,000 ohms and 500,000 ohms with switch  
6/6 each, without switch 4/6 each.

WRITE OR 'PHONE FOR TRADE DISCOUNTS.

**NOYES BROS. (SYDNEY) LTD.**

115 CLARENCE STREET, SYDNEY. 'Phone: B 7581 (10 lines).

11 WATT STREET, NEWCASTLE.

197 ELIZABETH STREET, BRISBANE.



# Building A . . . Midget Three-Watt Amplifier

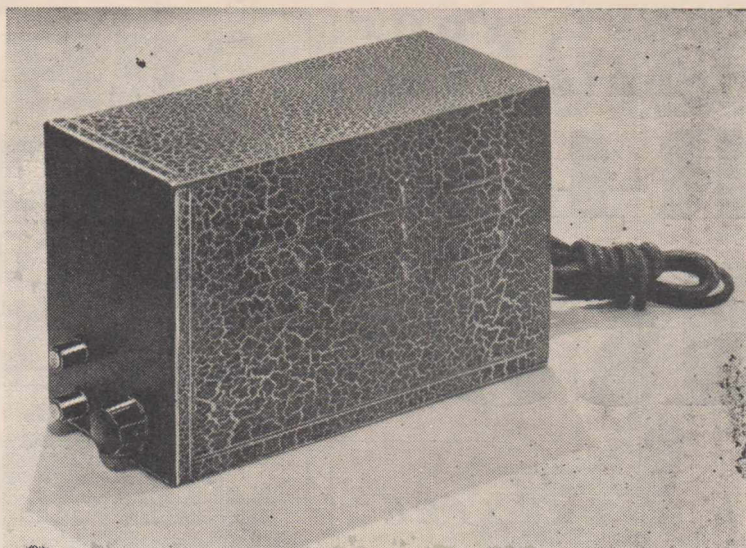

This compact, self-contained amplifier will be found invaluable for many applications in the service or home workshop.

The amplifier is built into an attractive crackle-finished metal case measuring only 4" x 6" x 9".

ONE of the most useful pieces of equipment that can be built for any workshop is a small, self-contained amplifier unit, such as that illustrated in the accompanying photographs. The many uses to which it can be put are out of all proportion to the low cost of its assembly.

The circuit shown below uses a 6K7 connected as triode in the driver stage, resistance capacity coupled to a 6F6 output pentode. With 250 volts on the plate and screen of this valve, three watts of output can be obtained, which is more than ample for ordinary use; in fact, it is sufficient for p.a. work in small halls. The rectifier is a 5Z4, the metal valve equivalent of the well-known 80.

### Back Bias Eliminates By-Pass Condenser.

Back bias has been employed for the 6F6 rather than self-bias, primarily because it eliminates the need for a high capacity dry electrolytic required across a self-bias resistor. As well, for the sake of compactness, a pair of 8 mfd. semi-dry electrolytics have been used in the smoothing filter instead of the more conventional wet type.

Full dimensions of the chassis required are given in a sketch elsewhere. The dimensions of the metal case used to house the amplifier are 4in. x 6in. x 9in.

### A Simple Layout.

The input terminals, with a 500,000-ohm potentiometer as volume control mounted across them, are located at one end of the chassis, and the speaker socket and power flex grommet at the other. The only other components mounted on the chassis comprise the power transformer and three valve sockets.

The parts required are listed in a panel elsewhere, while the photographs and diagrams (on this page and overleaf) show full details of the assembly and wiring, both of which are particularly straightforward.

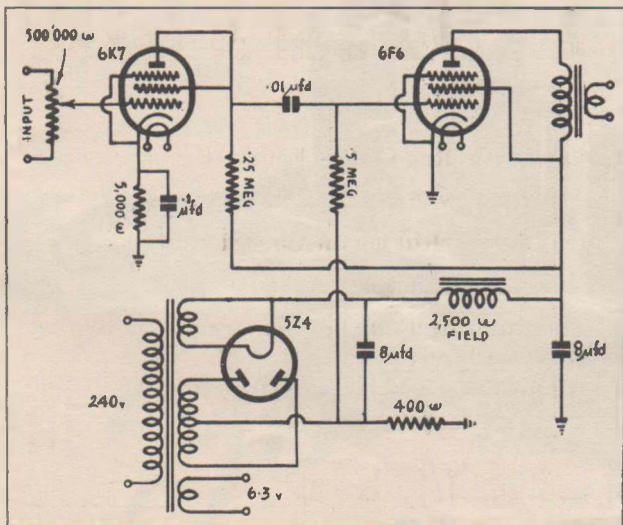

Circuit of the amplifier, which uses metal valves throughout, though octal-based glass equivalents could be used if desired.

### THREE-WATT MIDGET AMPLIFIER—List of Parts.

- 1—chassis to specifications.
- 1—power transformer (Radiokes MU60).
- 3—octal sockets.
- 1—4-pin wafer socket.
- 1—500,000 ohm potentiometer (Radiokes).
- FIXED RESISTORS:**
  - 1—.5 meg. 1-watt carbon (E.T.C.)
  - 1—.25 meg. 1-watt carbon (E.T.C.)
  - 1—5,000 ohm, 1-watt carbon (E.T.C.)
  - 1—400 ohm wirewound (Radiokes).
- FIXED CONDENSERS:**
  - 1—.01 mfd. tubular (Simplex, Solar).
  - 1—.1 mfd. tubular (Simplex, Solar).
  - 2—8 mfd. dry electrolytics (Solar).
- VALVES:**
  - 1—6J7, 1—6F6, 1—5Z4 (Phillips, Radiotron, Raytheon).
- SPEAKER:**
  - 1—3in. speaker to match single output pentode, 2,500 ohm field (Eola)
- MISCELLANEOUS:**
  - 1 red, 1 black Dalton spring terminals;
  - 2 doz. 3/16 in. x 3/16 in. nuts and bolts,
  - hook-up wire; 1 yard tinned copper wire, 2 yards power flex and plug,
  - rubber grommett.



# Boost your Signals from R4 to R9+

**"NOISEMASTER"**  
Aerial Kit drags up signals out of the mush to overload your speaker

**D**O mush and hellish noise drown these sought-for, rarely heard distant stations? Let the "NOISEMASTER" Engineered All-Purpose Aerial Kit drag them in and boost up signals to overload your speaker. "NOISEMASTER" wipes out noise and local static, and boosts up signals, even as much as from R4 to R9 plus!

No one else would ever dare make such a claim —no other aerial of ANY TYPE can give you such incredible performance, because "Noise-master" is the only Aerial Kit authorised to use the wonderful American invention "ANTENNEX." It acts like a purifier and cleans out every trace of locally created noise, leaving all stations beautifully clear at astounding volume.

Besides, you get in the "Noise-master" Kit 200 feet of special aerial wire, 12 specially designed transposition blocks, earth clamp, lead-in strip, screws, lightning arresters, etc. Easy to-follow instructions and drawings with each Kit enable you to set up your aerial in a very short time. No testing. No doubt. No delay. Once "Noise-master" is fitted, your noise-troubles end! Send this special form for your "Noise-master" Aerial Kit NOW, and have revealed to you a glorious new thrill in reception that makes you feel your set is now again.

**Send for yours without Delay**

Antennex (A'sia.) Corporation  
Box 3868 T, G.P.O., Sydney.

Send me right away your "Noise-master" Kit. I enclose 52/6 in postal notes, money order, cheque. (Add exchange to country and interstate cheques.)

NAME .....

ADDRESS .....

A.R.W 4/38.

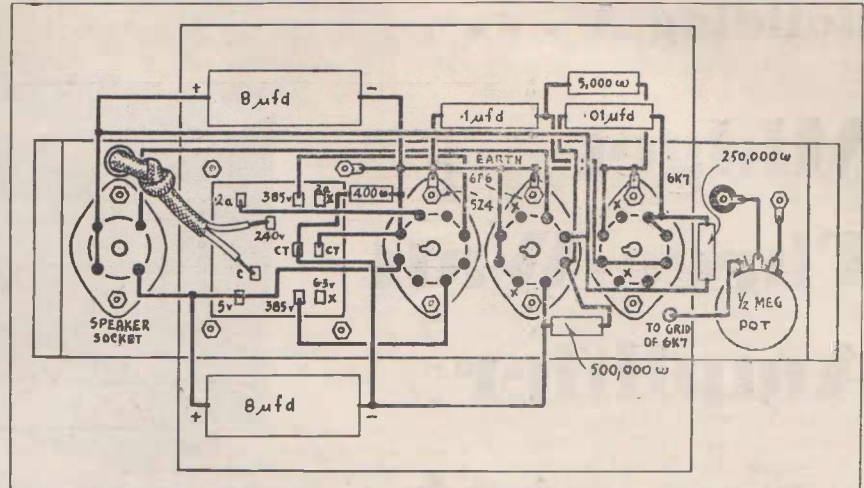

The complete under-chassis wiring of the amplifier is shown in the sketch above.

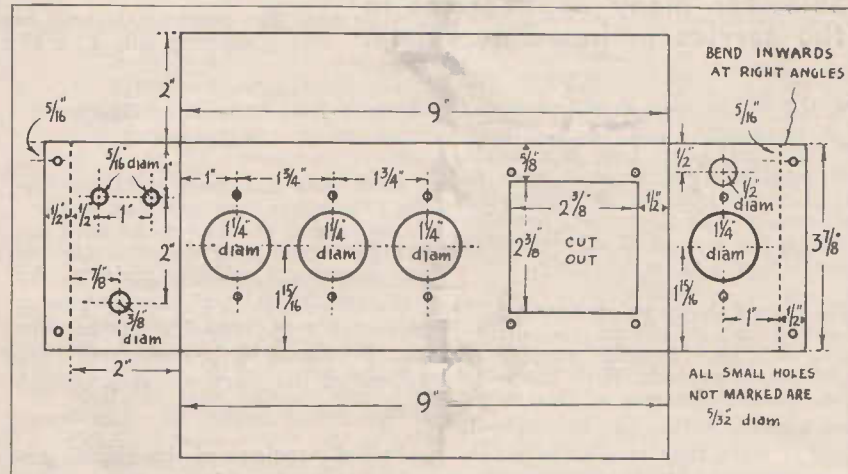

Dimensions for stamping and drilling the sprayed steel chassis are given in this sketch.

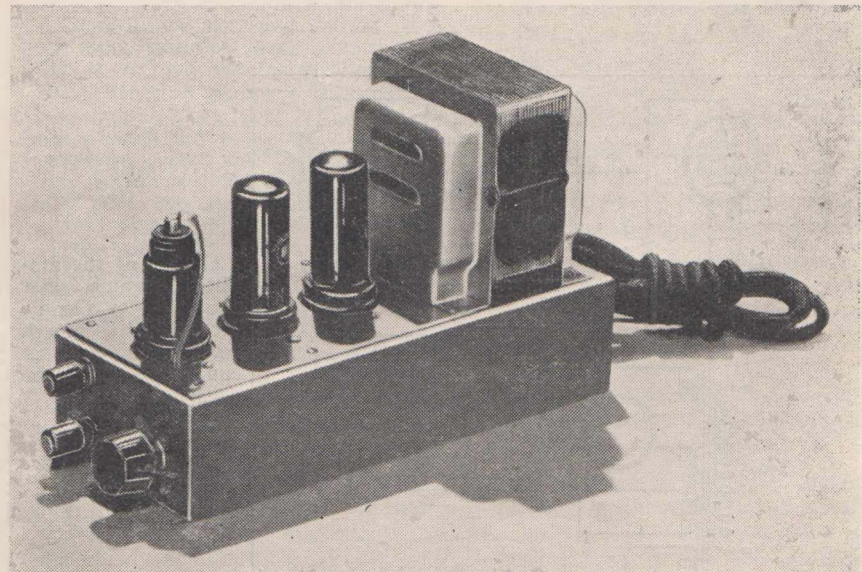

A view of the completed amplifier, with cover removed.



# TESTED THROUGHOUT MANUFACTURE

*They are in the forefront of  
the radio industry*

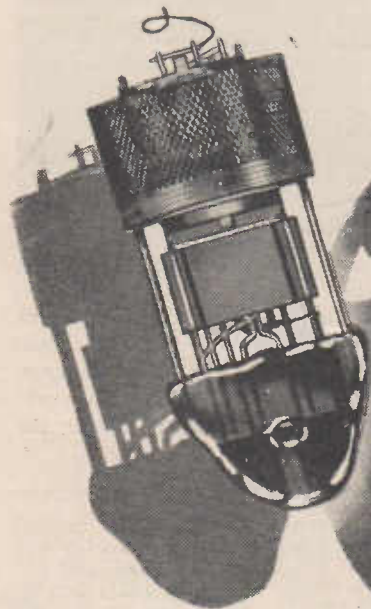

PRECISION  
ENGINEERING  
*makes* KEN-RAD  
MORE DEPENDABLE  
giving sweeter  
toned reception



Closely inspected during every phase of construction to ensure greater accuracy, Ken-Rad have well-earned their characterisation of "The Fine Valves of Radio." They provide increased volume . . . sweeter tones . . . and longer life.

ALWAYS REPLACE WITH

# Ken-Rad



THE *Fine* VALVES OF RADIO

Factory Representatives:

**E.T.C. INDUSTRIES LTD.**  
SYDNEY AND MELBOURNE.



# DX Contest Winner Has Logged Over 100 Countries

**Operates Two Receivers: Uses R.C.A. Spiderweb Antenna.**

By R. SIMPSON

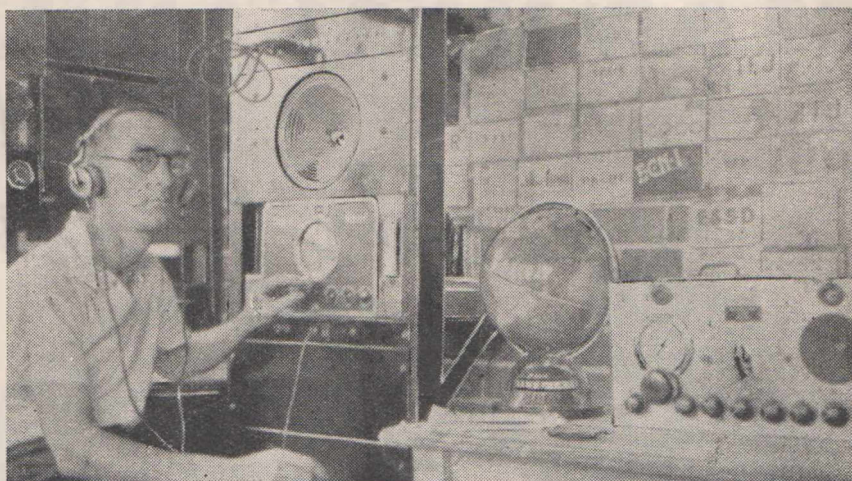

Dyer R. Simpson, of Sydney, winner of the second "Radio World" Shortwave Contest, at the controls of his home-built 10-valve Silver Marshall receiver. On the right is Mr. Simpson's version of the 13-valve Radiotron senior communications receiver, while in the centre is the Replogle combination world globe and time converter donated by the "Radio World" as first prize in the contest.

I first began serious short-wave listening in 1935—before then I had only eight QSL cards from overseas stations.

From then on, however, I have been a very enthusiastic listener, my receivers growing from a small converter in 1935 to my present set-up—a 10-valve Silver Marshall receiver and a 13-valve Radiotron Senior Communications set, both constructed by myself. However, it should not be imagined that these big receivers are essential; I can assure any listener just taking up the hobby that a modest 4-valve T.R.F. receiver will give surprisingly good DX—I know, as I used one during the whole of 1936.

My antenna is now an R.C.A. Spiderweb, which I imported from U.S.A. It is 56ft. high, direction N.N.E. by S.S.W. Before this was installed I had a Johnson doublet.

My main success has been with the Central and South Americans, who are sometimes rather hard to receive in certain locations. On going through my weekly notes for 1936 and 1937 which I contributed to N.S.W., Victorian and Western Australian radio publications, I find I was first in Australia to report over 90% of all new commercial stations, or stations audible for the first time in Australia. This was the case for both 1936 and 1937.

A large proportion of these loggings were just sheer luck—just happening to be listening when a new station was testing. Another thing which has helped me is a slight knowledge of Spanish, which is very useful in identifying the Central and South Americans.

At the present time I have heard stations in 112 different countries, and actually have verifications from 91 different countries. I now write only to new stations just opened and stations in countries not previously heard.

Some of my best verifications are HRN, ZEB, FZE8, ITK, PRF5, XEDQ, LZA, TG2X, CEB, YV3RC, ZTJ, LRU, LRX, FIQA, CJRO, CJRX, PDK, and the following amateurs:—Y12BA, ES5D, ZB1H, VQ4CRO, I1IT, OK1BC, VQ8AF, YN1OP, HP1A, OZ3FL, YJ1RV, FM4AF, VP4TK, EA8AF.

**Now Concentrating On Ultra High Frequencies.**

I am now concentrating on the ultra high frequency stations, as these are very interesting. I already have verifications from W6XKG and W9XAZ, and have just heard W9XJL on 11.36 m. and two police stations on 9.9 m.—W6XPA and W6XFE. These police stations are a good outlet for DX when one has exhausted all the other bands. Another 9.4 m. station was heard recently—KOIL, of Omaha, Neb. No short wave call is given, only the broadcast call.

Some interesting 20 m. 'phone stations have been heard during the last few weeks, best of which were YR5ML, VO6D, G12UU, ST6KR, ZP2AC, FR8VX, and also T12RC on 10 metres.

The recent "Radio World" contest in which I was awarded the prize was the first I have ever entered, and naturally I was very pleased to win it. I would like to take this opportunity of thanking the publishers of "Radio World" for such a handsome trophy.

## "Sky King" Pulls Them In.

Recently I sent you my views on the performance of the "Sky King." Below is a list of stations logged between 4.50 p.m. and 6.10 p.m. on March 14, on the 20 m. amateur band. QRM was exceptionally heavy and logging was difficult—I do not think it necessary to include any of the VK stations, as the "Sky King" naturally brings all VK's in when conditions are fairly good.

Here is the list:—VE5OT and VE5ACN, Vancouver; LU1HI Argentina; W2AZ, W6EQI, W6ZH and W6NCW, W8-DNP, CIH, BDD, XE2XC and XE1GK; G6DT, G5RV; FA3HC Algeria; K6CMC and K6LFV. Also VK 2's, 3's, 4's and 5's, especially VK5's.

A few days ago I heard an American working VR6A, of Pitcairn Island. I believe the radio apparatus was only left at the Island at the beginning of this month.—John T. Waterhouse (AW362DX), Killara, Sydney.



# Tracking Down Power Interference . . . (I)



Chanex type H 11 metal-cased condenser suppressor unit, capacity .5 mfd. + .5 mfd., designed for connection to large D.C. motors, generators, and at power points, etc. Fuses are incorporated.

## How Interference Arises.

There are three main classes of interference, in the broad sense of the word, of which only one comes within the scope of this article. They may be broadly classified as follows:

- (a) Interference from other stations or nearby listeners.
- (b) Natural interference due to atmospheric disturbances.
- (c) Interference from industrial plant or domestic equipment.

In the case of (a), the remedy lies in an improvement in the tuning properties of the set, and in the case of (b), it is beyond the scope of this paper to attempt to deal with atmospheric disturbances, which, however, do not constitute a large proportion of the interference problem of to-day.

In the city areas atmospheric disturbances do not cause a great deal of trouble, excepting, of course, on the short wave end, more trouble being experienced in the country areas from this source. Interference of this nature is easily discernible from interference generated by apparatus, and commonly referred to as "man-made static," mainly by reason of its lack of regularity in interfering. "Man-made static" is generally of a more regular character, and more consistent.

We now come to the third type of interference, that generated by industrial or domestic plants. This interference is generally recognised by either crackles, roaring noises, clicking and similar irritations, which point to it being created by interfering apparatus.

The simplest form of this type of trouble is that of an electric motor of the commutator variety. Such motors contain a commutator, which is mounted on the shaft and contains a large number of segments. Carbon brushes rest on this commutator, and

change the connection from segment to segment as the machine rotates. There must clearly be a rapid change of current at the instant of the change-over. This sudden change of current produces a pulsating magnetic field, which, in association with the stray capacities in the generator, sets up a train of electro-magnetic waves of high frequency. This then acts as a small transmitting station producing periodic but irregular trains of wireless waves, which are capable of being picked up by the ordinary radio receiver. It should be noted that in the foregoing explanation it has not necessarily been assumed that there is any actual sparking taking place at the commutator. High frequency interference can be generated by a motor, which is running without any sparking at all, due to the rapid change in current which must occur at the instant of commutation.

This high frequency energy generated by the interfering apparatus can reach the receiver in four different ways:

### (a) Direct radiation.

Wireless waves generated at the source of the disturbance will travel through the air in the same way as from a transmitting station. They will be picked up by the receiver accordingly.

### (b) Direct conduction.

The high frequency disturbances may be conducted along the mains network from the apparatus and ultimately enter the receiver.

### (c) Mains radiation.

This is a corollary from the last form of transfer. The high frequency energy is conducted along the mains where it is re-radiated from the house-wiring, which acts as an excellent transmitting aerial.

### (d) Re-radiation.

The energy is transferred to some subsidiary radiator, such as the power line, telephone line, steel girders, poorly earthed drain pipes, gas or water supplies, etc., and is radiated from there on to the receiver.

## (a) DIRECT RADIATION.

As a general rule direct radiation is quite local in effect. It rarely extends more than a few yards. Consequently this is not a common form of disturbance. The best remedy lies in the connection of "Chanex" condenser suppressors to the actual interfering plant.

## (b) CONDUCTED INTERFERENCE

This form of interference is the least common form. It occurs only with mains operated receivers, and is usually of a different character, being of the low frequency nature due to irregularities in the voltage, particularly with D.C. supply. High frequency disturbances sometimes do enter the receiver in this way, but in such cases the interference is almost certainly present in the form of mains radiation as well, and this latter channel swamps the direct conduction so that this form of disturbance can be ignored except in very special cases.

## (c) MAINS RADIATED INTERFERENCE.

The majority of cases of interference fall into this category, where the interference is conducted along the mains to the house, and then radi-

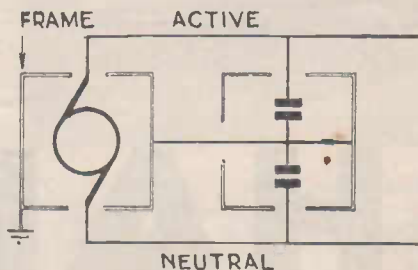

CHANEX TYPE H.11  
USED WITH EARTHED APPARATUS

Figure A.



ated from the wiring of the house on to the aerial.

Although by the time the interference has reached the house it is very much less in intensity than it was at the source, it is now in an ideal condition to cause trouble. It has a free run of the electric network and in addition there is a large collecting system—the receiving aerial—situated relatively close at hand, so that the interference can be quite considerable. Interference in this way may be transferred as much as two miles from the source, so that the seriousness of the problem can be readily appreciated.

Fortunately this form of interference is easy to dispose of. The obvious remedy is to stop the interference at the actual source, i.e., by connecting "Chanex" condenser suppressors to the actual piece of apparatus generating the high frequency energy. Also it is quite possible to prevent this form of interference by connecting "Chanex" suppressor units at the point of entry to the house. (See figure "A.")

**(d) RE-RADIATED INTERFERENCE.**

Even this type of interference is troublesome from the point of view that even if the entry of mains radiated interference is checked at the

the receiver is located, re-radiated in-point of entry to the house wherein interference can still be a disturbing factor. The adjoining house, for example, if wired for electricity, may still prove a source of interference.

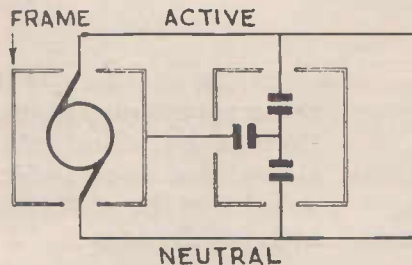

CHANEX TYPE H 12. or H.14. USED WITH UNEARTHED APPARATUS

Figure B.

although the disturbance would be less severe, as it is slightly further away. This proves the value of suppressing the interference at the actual source, as against the idea of suppressing it only at the point of entry to the particular house in which the receiver is being operated.

The remaining type of interference, that re-radiated from overhead lines and metallic structures generally, is

best overcome by the use of the shielded type of lead-in. The aerial should be located well clear of any possible source of re-radiation, and provided with a shielded lead-in of the doublet type, and interference from the wiring of adjoining buildings can thereby be reduced to negligible proportions. It will be noticed, of course, that in general, battery sets are less prone to interference than mains operated sets. Conducted interference is, of course, impossible with the battery sets, while, in addition, the use of a battery set implies that electric light is not available in the house. Consequently, the most fruitful source of interference, radiation from the mains, may be absent. Re-radiated interference, however, can still be present, as, for example, if a vacuum cleaner or sewing machine motor is being operated close to the set. These types of interference are easily remedied with "Chanex" condenser suppression units. (See figure "B").

**Analysis Of Interference.**

A summary of the procedure to adopt in analysing interference is as follows:—

- (1) Disconnect the aerial and earth and short circuit the aerial and earth terminals. With the battery set this will remove all trace

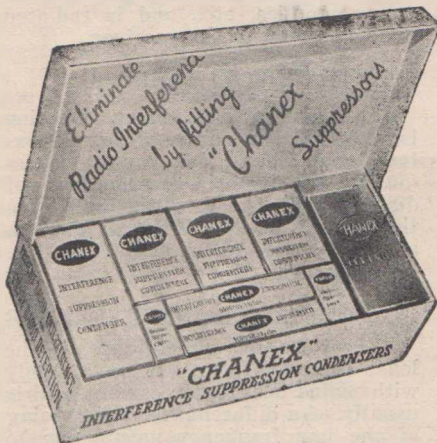

**FREE BOOK.**

This free book is a complete treatise on the causes and suppression of Radio Inductive Interference and will prove very instructive and helpful in opening up a new avenue of business. Supplies of this book will gladly be forwarded to you on application to any of our offices or distributors as listed below.

# SUPPRESS INTERFERENCE

The contents of the Chanex Kit will handle the majority of all generated interference. The Chanex Suppressors conform to all regulations and are built to British Standard Specifications 613/1936, and have been approved for connection to the mains by all Electricity Supply Authorities.

The Kit contains:—

2-Type H11, 2 x .01 @ 3/- ea. 6 0

2-Type H11, 2 x .1 @ 3/9 ea.	7 6
2-Type H11, 2 x .5 @ 7/6 ea.	15 0
1-Type H11, 2 x 1mF @ 9/6 ea.	9 6
2-Type H12, 2 x .1+ .006 @ 4/6 ea.	9 0
2-Type H14, 2 x .1+ .006 @ 7/6 ea.	15 0
2-Type H15, 2 x .1 @ 7/- ea.	14 0
2-Type H17, .5 @ 4/- ea.	8 0
<b>RETAIL VALUE</b>	<b>84 0</b>

# CHANEX

**DUCON CONDENSER Pty. Ltd., 73 Bourke St. Waterloo, Sydney**

"Cornhill Chambers,"  
450 Collins Street,  
MELBOURNE, C.I., VIC.

P. H. Phillips,  
123-5 Charlotte Street,  
BRISBANE, Q'LAND.

Wm. T. Matthew,  
95 Grenfell Street,  
ADELAIDE, S.A.

Carlyle and Co.  
915-917 Hay Street,  
PERTH, W.A.

Arnold and Wright,  
Levy Building,  
Manners Street,  
WELLINGTON, N.Z.



nals; sign flashers; electric typewriters; incubators; telegraph relays.

**WHIRRING OR WHINING NOISES**  
(often accompanied by crackling).

Adding machines; barbers' clippers; beauty parlor equipment; cash registers; dental machines; dictaphones; dish washers; dough mixers; electric fans; home lighting plants; floor polishers; generators; humidifiers; small blowers; electric addressographs; lifts; refrigerators; telephone magnetos; toy electric mains; vacuum cleaners; valve grinders; washing machines; hair dryers; massage machines; motor generators; portable electric drills; printing presses; sewing machines.

**RATTLES, BUZZES AND RAPID CLICKING NOISES.**

Buzzer and trembler bells; vibrating rectifiers; dental machinery; dial telephones; lift controls; motor car ignition systems; sewing machines.

**CRACKLING OR SPLUTTERING NOISES.**

Bad connections; defective light or power sockets; lift controls; high tension lines; tramcars; loose connections in house wiring; partially earthed power line.

Direct radiation from interfering plant is in two parts. The first is the radiation from the machine itself, and the second is radiation from the wiring immediately adjacent to the machine.

In most cases complete cures can be effected by the connection of "Chanex" condenser suppressors or condenser choke suppressors at the terminals of the machine, which will not only minimise the direct radiation to a large extent, but it will prevent mains borne interference being carried from the machine along the supply network.

Next Month: Suggested Methods of Suppression.

**VK2ME, 3ME And 6ME —  
Transmission Schedules  
For April**

The following transmission schedules will be observed by shortwave stations VK2ME, VK3ME and VK6ME during March:—

VK2ME (31.28 m., 9590 k.c.)

	Sydney Time	G.M.T.
Sundays:	4-6 p.m.	0600-0800
	8 p.m.-Mdt.	1000-1400
Monday:	12.30-2.30 a.m.	1430-1630

VK3ME (31.5 m., 9510 k.c.)

Melbourne Time G.M.T.

Nightly  
Monday to 7 p.m.-10 p.m. 0900-1200  
Saturday  
(inclusive)

VK6ME, Perth (31.28 m., 9590 k.c.)  
Perth Time G.M.T.

Nightly  
Monday to 7 p.m.-9 p.m. 1100-1300  
Saturday  
(inclusive)

# What's New In Radio

A monthly review of latest releases  
in sets, kit-sets, and components

**Details Of Fidelity Tuner  
In Latest "Radiotronics"**

Articles in "Radiotronics" No. 84 (published by Amalgamated Wireless Valve Co.) of interest to servicemen, set-builders and amateurs include those with the following titles: "Radiotron Fidelity Tuner" (with continuously variable selectivity), "Improved Audio A.V.C." (using a 6L7G as bias-controlled audio amplifier), and "Radiotron 50-Watt Transmitter" (circuit and accompanying article are reproduced elsewhere in this issue). Details are also given of five new Radiotron releases—the 814 transmitting beam power tetrode,

6K8 all-metal triode hexode, 6J8G triode heptode, 6C8G twin triode and 6Z7G class "B" twin amplifier.

Included with each copy of this latest "Radiotronics" is an index covering technical articles contained in issues released during 1937.



**Latest Bulletins From Ducon.**

Bulletins Nos. 14 and 15 just to hand from the Ducon Condenser Co. Pty. Ltd., deal respectively with new type Sirufer iron-dust cores, and with the wide range of semi-dry electrolytic condensers made by this company.

## PALEC

### VOLT - OHM - MILLIAMMETER

"The Palec" Model M5 is a reliable and an accurate multirange Instrument equipped with our large 5in. type Meter.

RANGES: D.C. Volts, 10-100-500-1,000 (at 1,000 ohms per volt).

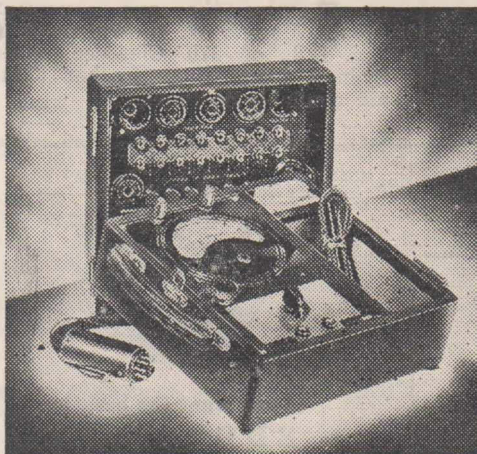

Ma's, 1-10-50-1,000,  
Ohms, 0-2000, 20,000-200,000,  
2,000,000.

The latter range is obtained by connecting an external 45 volt battery to the terminals provided. The instrument is supplied in a well fitted leatherette case complete with test prods.

MODEL M5. Trade Price £5/17/6,  
Plus Tax.

MODEL MA5 has four additional ranges of A.C. and Output Volts. Trade Price, £7/19/6,  
Plus Tax.

**ANALYSER SELECTOR**

A special Analyser Selector which is easily fitted into the removable lid of Model M5 (see illustration) can be supplied. This Unit enables voltage and current readings to be readily taken at all points of American or Octal type Valves, without removing the chassis from the cabinet.

Price £2/15/- extra.

\* Send for new 16-Page Catalogue

Manufactured by

## Paton Electrical Instrument Co.

90 Victoria Street, Ashfield, Sydney



Manufacturers of Cathode Ray equipment, Meters and full range of Testing equipment.



Bulletin No. 14 describes recently-landed samples of four new core shapes, full application data being given. Bulletin No. 15 gives full details, including capacity, working and peak voltages, colour-coding of leads and list prices of Ducon types EVA, EK, EKA, ESA and ELI semi-dry electrolytic condensers.

★

### Crown Re-Form Into New And Larger Company.

The following statement from the directors of Crown Radio Manufac-

turing Co. Pty. Ltd. (in voluntary liquidation) has been received from Mr. J. B. Philips, managing director:

Due to the phenomenal increase of business experienced by the company since its formation in March last year, it has been found necessary to reconstruct and strengthen the finances of the company. This involves voluntary liquidation and the formation of a new company, which will be known as Crown Radio Products Pty. Ltd., and this company will acquire the business formerly known as Crown Radio Manufacturing Co. Pty. Ltd.

The company is in a solvent position and will definitely pay all its creditors in full.

The board of directors has been strengthened, and the names of additional directors will appear in due course.

Crown Radio Products Pty. Ltd. will continue the policy responsible for the success of the original company, and with improved facilities will provide even better service and products to its patrons.

The directors of the original company take this opportunity of thanking their supporters, and anticipate with pleasure the continuance of the happy relationships established.

★

### Erie Resistors And Potentiometers.

The following data concerning Erie resistors and volume controls was supplied by the sole Australian agents, Messrs. W. G. Watson & Co. Pty. Ltd., of 279 Clarence Street, Sydney, from whom further details are available on request.

Erie moulded carbon resistors are made in various wattage ratings, and can be supplied to any desired resistance value from a few ohms to several megohms. The standard type is available in quarter, half, one, two and three-watt capacities, and the insulated or ceramic cased type in half or quarter-watt capacities.

Erie volume controls can be supplied in resistance values between 3000 ohms and 5 megohms, either in the form of linear or graded control. The standard grading gives 10-15% of the total overall resistance at 50% rotation of the moving arm, tolerance plus or minus 20%.

The minimum hop-off resistance for graded types is less than 0.1% of the total overall resistance, and for linear types, less than 0.2% of the total overall resistance.

The volume control element is of the graded carbon type, having the resistance material deposited on to a high grade papolin ring. The rotating arm is of the three-finger type, constructed of nickel silver, which obviates the possibility of uncertain and noisy operation. Contact is effected with the moving arm by means of two nickel silver spring wipers travelling on a nickel silver ring, the spindle of the control being insulated from the moving arm.

★

### Huge Extension of S.T.C. Factory.

In spite of the high cost of building at the moment, S.T.C. have decided to proceed immediately with the erection of the first two stories of a huge multi-story building as an addition to their present factory at Alexandria, Sydney. Each of the two

### Infinite Baffle.

(Continued from page 22.)

to the specifications of this latter illustration, and possibly might be more suitable for drawing-room use.

### Material Required.

- 1½ yards cow-hair underfelt.
- ½ doz. 1½" plated wood screws.
- ½ doz. 2" countersunk wood screws.
- ½ doz. 2" roundhead plated wood screws.
- 1pkt. large-size drawing pins.
- 1 piece 7-ply 36" x 36" x ⅝" (front" with hole cut to suit speaker.
- 1 piece 5-ply 36" x 36" x ½" (back).
- 2 pieces pine, 34¼" x 13¾" x ⅞" sides.
- 1 piece pine, 36" x 13¾" x ⅞" (top).
- 1 piece pine, 36" x 13¾" x ⅞" (bottom).

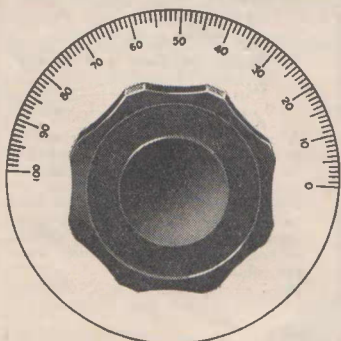

Cat. No. 1085. Precision slow motion of 6-1 ratio. Vernier readings to 1/10th degree.

26/-

(Vernier plate not shown)

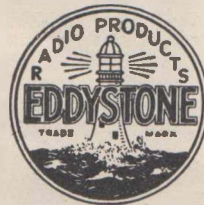

If you want the best, buy  
— EDDYSTONE —

WHO ELSE OFFERS OVER 100  
COMPONENTS ?

CATALOGUES FREE.

Australian Representative—

**R. H. CUNNINGHAM, VK3ML**  
1449 High Street, Glen Iris, S.E.6, Vic.

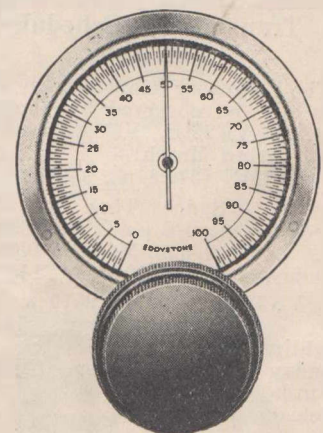

Cat. No. 1070. Dual speed ratios of 20-1 and 100-1. Oxydised relief silver finish. 18/6 nett.



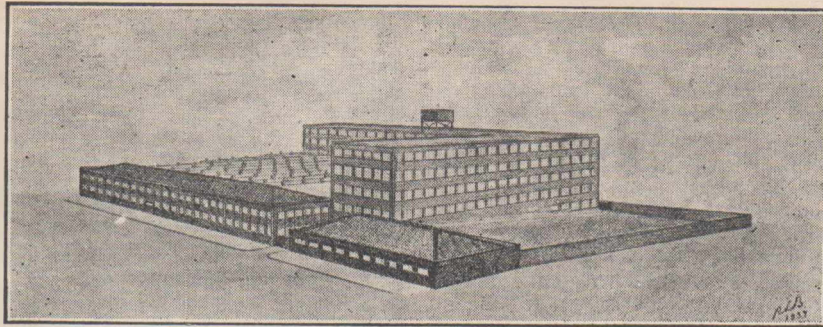

An artist's conception of what the S.T.C. plant will look like when finally completed. The first two floors of the multi-story building shown are now being erected.

floors will give another 15,000 square feet of space.

The extra accommodation is urgently needed for new lines of manufacture, and, it is anticipated, will bring S.T.C.'s factory pay-roll up to 700 persons. It is expected that the additional buildings will be accupied in July. The illustration above shows what S.T.C.'s plant will look like when finally completed.



**New Calstan 20,000 Ohms Per Volt Multi-meter.**

A current of only 50 micro-amperes is required for full-scale deflection

with the new Calstan Model 136 20,000 ohms per volt multi-meter recently released by Slade's Radio.

Ranges are as follow:—D.C. and A.C. volts, 0-2.5-10-50-250-1000 volts; M.A., 100 microamps., .1-10-50-250 M.A., ohms, four ranges, 0.1 ohms to 5 megohms.

Housed in a black leatherette-covered case measuring 11" x 12" x 5," a carrying handle and removable lid are provided, space being allowed for leads, etc.

Further details are available free on request from Slade's Radio Pty., Lang Street, Croydon, N.S.W.

**Stromberg-Carlson Controlling Interest Now In Australia.**

It was announced recently by Mr. L. P. R. Bean, chairman of directors, and managing director, of Stromberg-Carlson (A'sia) Ltd., that there had been a re-alignment in the control of his company, resulting in that control passing from American to Australian interests. Hitherto, the control of the Australian company has been, by a slight margin, vested in the American company, but, in accordance with the arrangements made between Mr. L. P. R. Bean and Mr. Wesley M. Angle, president of the American Stromberg-Carlson Company, who is at present in Australia, the control has now substantially passed into Australian hands; the American company retaining a minority interest in the business.

Highly satisfactory arrangements were arrived at whereby the Australian company, over a very long period in the future, will have the use of all the patents and technical services of the American company, and will have the right to trade in the valuable trade name of Stromberg-Carlson throughout Australasia and all other parts of the British Empire (excepting Canada and Newfoundland), and also in certain islands adjacent to the Commonwealth of Australia.

There has been no alteration in the

**Sure Proof Of Leadership!**

ROLA, The World's Finest Speaker, is once again specified by the "Radio World" . . . for the 5-metre transceiver, 3-watt amplifier, and two receivers described in this issue!

● **ROLA MODEL DP-5-B**

is ideal for use with the "Comet Dual-Wave Four" and the Radiokes "1938 Moneysaver." A new 6 3/4 in. model, it incorporates the la'es patented Rola dust-proof and acoustic filter assembly. The Rola DP5B meets the exacting requirements of car, radio and mantel set construction.

● **ROLA MODEL 5-6**

is used and specified for the 5-metre transceiver described this month. The smallest speaker in the Rola range, the 5-6 is a 5in. model designed for all applications where space is at a premium. It is remarkably sensitive, and power handling capacity ensures satisfying service.

● **ROLA MODEL K-8**

is recommended for use with the 3-watt midget amplifier described on page 27. A highly efficient 8in. model, it is favoured for all types of console receivers as monitor and sound films installations and for hotel and school equipment.

Rola reproducers are standard with the world's radio and amplifying systems . . . proof positive of Rola Quality!

THERE'S A  
**Rola**  
TO SUIT EVERY  
PURSE & PURPOSE

DISTRIBUTORS AND FACTORY SERVICE FOR N.S.W.  
**Geo. BROWN** AND CO.  
PTY. LTD.  
267 Clarence Street, Sydney . . . . . (Phone M 3437)  
Sole Australian Agents for **ULTIMATE RADIO**



management of the Australian company.

★

### "Plugg-In" Radio Batteries Are Latest Clyde Innovation.

The new Clyde "Plugg-In" battery top illustrated below consists of a moulded hard-rubber cover with a



two-pin, non-reversible socket. Connection to the positive and negative terminals is made by means of lead-coated brass straps, moulded into the cover, with lugs at each end to fit over the battery terminals.

At these two points a recessed hole is provided in the cover, and the cover is fitted to the battery and held securely in position by screwing down the red and black positive and negative terminal nuts. By this means the necessary connections are made. Reverse connections are impossible, as the provision of moulded bosses prevent the cover being fitted to the battery in any but the correct position.

The leads from the receiver are connected to the battery by means of a non-reversible adaptor, which plugs into the socket in the cover. When the battery is due for re-charging, provision has been made for connection to any ordinary radio or car battery charger by means of an adaptor with leads and clips, and further provision has been made for an adaptor connecting to flex, terminating in a light socket.

The accumulator is remarkably compact and complete, and the whole appearance is a distinct improvement on the usual type of radio batteries.

The advantages of this innovation are that the accumulator is completely enclosed, and therefore cannot col-

lect dust deposit; acid is not splashed and short circuits caused by metal objects falling on terminals are impossible. What is most important, no clips are necessary for connecting battery to receiver.

This "PLUGG-IN" accumulator will also appeal as a portable lighting unit, and without doubt will find great favour among yachtsmen, campers and motorists, as well as proving of great benefit to country people for emergency lighting.

Supplies are now available, and full particulars may be obtained from the Sales Department, The Clyde Engineering Co. Ltd., Sydney and branches.

★

### Philips Barretter Type 1941.

Philips specialise in the manufacture of regulating lamps for automatic current control under various circuit conditions, including series-connected valve heaters in receivers designed for a.c./d.c. operation (states Philips Technical Communication, No. 66). Voltage fluctuations are a serious drawback to the efficient operation of valves connected in series with a voltage-dropping resistance, and under these circumstances the valve heaters are likely to suffer overheating or underheating depending on the voltage fluctuation of the mains. (See T.C. No. 35.)

The advantages accruing in the use of a current regulating device such as the Philips 1941 Barretter are thus easily appreciated, particularly since this lamp controls at 300 m.a., which is the heater current rating for the 25A6G, 25Z6G and other valves suitable for a.c./d.c. operation. Philips barretters are resistance units in which the resistance element (an iron wire) is enclosed in a glass bulb containing hydrogen. An important advantage in using barretter tubes is that they offer more practical possibilities due to the regulation characteristic. The regulation char-

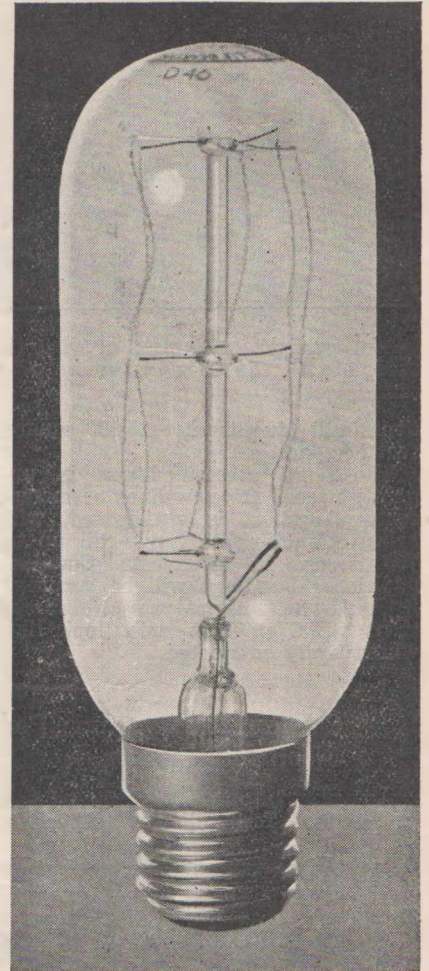

The Philips 1941 barretter.

acteristic for the 1941 is reproduced in Fig. 1 and this shows a regulating range of 77 to 200 volts.

This rating represents the voltage drop across the barretter, and must not be confused with the mains voltage.

(Continued on opposite page)

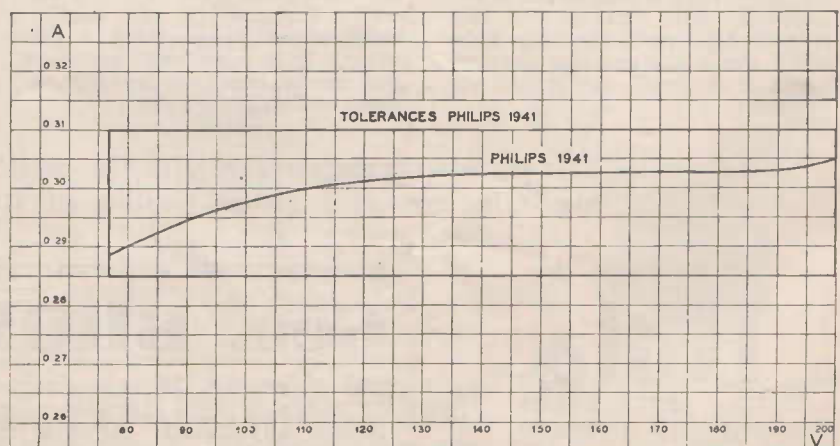

Fig. 1—Regulation characteristic of the Philips 1941 barretter.





# The All-Wave All-World

Official Organ of the All-Wave All-World DX Club

# DX News

## DX News and Views

### B.B.C. Card Is NOT Verification.

In a previous issue I read where the B.B.C. Daventry, England, was unlikely to verify reports. Regarding this matter I sent a report last November, 1937, and I received a QSL card, and also a small book from the B.B.C. posted to me on January 8, 1938, in London.

The book describes the Empire Broadcasting Service and also deals with technical articles on transmission, receivers, aerials, interference on short waves, wavelengths and reporting interference on short waves, etc.—H. Hindle (AW322DX), Premier, N.S.W.

[Unfortunately, you will find that the card you received from the B.B.C. is NOT a verification; merely an acknowledgement of receipt of your report.—Ed.]

### Full Details of HS8PJ.

I have just received a card from HS8PJ, in Bangkok, Siam. Details and schedule are as follows:—

Transmitter is crystal-controlled, wavelength is 31.54 m. or 9510 k.c. (now changed to 31.58 m. or 9500 k.c.), power 5 k.w. Schedule: Thursdays 2000-2200 (Siam time), 13-15 (G.M.T.) Also on 19,020 k.c. Monday same time. Address is Experimental Broadcasting Station, HS8PJ, Saladang, Bangkok, Siam.

I have decided to overhaul the equipment here, and when finished it will consist of a six-valve triple-wave receiver, a short-wave superhet and a 6L6 power amplifier to use when stations are required on the speaker. I am very interested in Alan Graham's shortwave notes; he is doing great work, especially on 10 metres.—W. E. Carton (AW308DX), Wellington, N.Z.

### Phillips 1941 Barretter.

(Continued from opposite page)

The property of barretters to maintain current constant at a variable voltage between certain limits is based on the fact that from a certain

current intensity upwards, the resistance of the tube increases, this increase being approximately proportional to the voltage increase.

### Characteristics.

Regulating range . . . 77-200 volts  
Regulated current . . . 300 mA.  
Max. operating voltage . . . 200 volts

Max. voltage across the tube when switching on . . . 250 volts(a)  
Overall length . . . 3 1/8" (approx.)  
Maximum diameter . . . 1 3/8" (approx.)  
Base . . . Edison Screw.

(a) The total voltage for the valve heaters in series with the regulator must be at least 52 volts.

The following is a suggested valve combination for an a.c./d.c. receiver employing series heater wiring and the 1941 barretter for heater current regulation on 220-240 volt mains.

- 6D6 or 6U7G—r.f. amplifier.
- 6A7 or 6A8G—Mixer stage.
- 6D6 or 6U7G—i.f. amplifier.
- 75 or 6B6G—Detection, a. v. c. rect., and a.f. amplifier.
- 43 or 25A6G—Output penthode.
- 25Z5 or 25Z6G—Rectifier.

The total voltage for the heaters of the above valves connected in series is 75 volts, and assuming 220 volt mains, the voltage across the 1941 would be 145 volts, which is within the limits for satisfactory control.

## ALL-WAVE ALL-WORLD DX CLUB Application for Membership

The Secretary,  
All-Wave All-World DX Club,  
214 George Street,  
Sydney, N.S.W.

Dear Sir,

I am very interested in dxing, and am keen to join your Club. The details you require are given below:

Name.....

Address.....  
[Please print both plainly.]

My set is a.....

[Give make or type, number of valves, and state whether battery or mains operated.]

I enclose herewith the Life Membership fee of 3/6 [Postal Notes or Money Order], for which I will receive, post free, a Club badge and a Membership Certificate showing my Official Club Number.

(Signed).....

[Note: Readers who do not want to mutilate their copies of the "Radio World" by cutting out this form can write out the details required.]



# Sun-Spot Activity Now Approaching Maximum

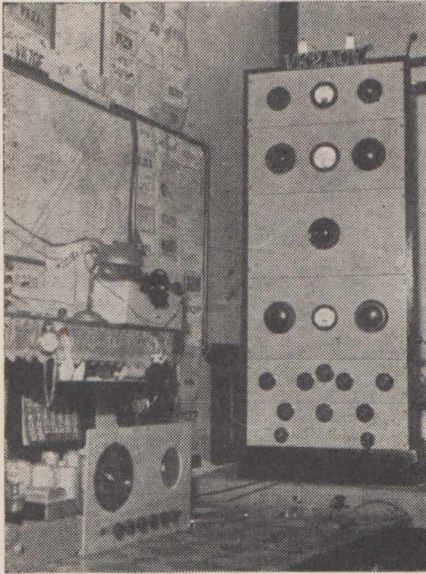

Lakemba radio club member Jim Alsop operates this up-to-date station under the call-sign VK2ACY.

**May Result in Record DX on Ultra Short Waves :  
Epidemic of Call-sign Piracy by Unlicensed Transmitters :  
Lakemba Radio Club Notes and News.**

by W.J.P.

last practically all lines in the district were affected, besides others in Christchurch and Nelson. The disturbances were reported for several weeks, and are not expected to disappear for some considerable period.

★

## "Joey's" Over-Active.

Complaints received from a number of licensed amateurs indicate that unlicensed operators are at the present time carrying their activities a little too far. Not satisfied with breaking the regulations regarding the operation of a transmitter before sufficient qualifications have been obtained, some are going so far as to "steal" a licensed man's call-sign.

Rather serious cases of such procedure were revealed at a recent meeting of the Lakemba Club. Mr. R. G. Thorburn, VK2AIP, mentioned that he had received a communication from the radio inspector's department regarding a rough A.C. signal, changing frequency and causing severe interference on the band, allegedly coming from his station. VK2AIP, on consulting his log book, found that he was not on the air at the time, and furthermore, his transmitter is crystal-controlled, the reports entered being T8 to T9.

VK2AHX then reported that he had been receiving QSL cards for QSO's he had never conducted, while VK2OD also displayed reports "on his 40-metre transmissions," although he has been off this band for a considerable period, and finally VK2HB stated that his call-sign was being used on 20-metre telephony.

VK2DL also complains of his call-sign being used, in particular by a 'phone station operating out of the

band, resulting in a note to this effect from the Radio Inspector.

With regard to listeners' reports, due allowance must be made for errors of misinterpretation of call letters, there being so many on the air at the present time, but when such reports get too numerous and amateur QSL cards are received, then it becomes obvious that all are not making errors, and some irresponsible person is to blame.

★

## 2ACY Uses Radiotron Junior.

VK2ACY, owned and operated by Jim Alsop, of Ernest Street, Lakemba, has been active on various amateur bands for the past seven years. The original call-sign was 2CY, but as this was required for commercial use, a recent alteration was made. The present transmitter, a photograph of which is shown above, is four stage crystal-controlled, using a 47, E408, E408 and a DET1. The modulator is a seven-tube affair, with P.P. 250's in the final in Heizing modulation.

The receiver shown at the left is an eight-valve Radiotron Junior. WAC has been obtained, and altogether 42 countries have been worked on C.W. and 9 on telephony. The antenna system is a half-wave Zepp, 66ft. long, with 45ft. feeders.

The operator has been a member of Lakemba Club practically since its foundation, when amateurs in the district between Canterbury and Bank town numbered about half a dozen. To-day, however, in one location there are to be found 14 within a half-mile radius.

In a recent issue of "Radio World" reference was made to the effect of sun spots on radio transmission and reception. The year 1938 should prove a most interesting one in this regard, especially in view of the fact that 1938-9 will not only mark the worst end of the eleven-year cycle, but it will witness the greatest sun-spot activity for 40 years.

The actual effect it is going to have on general reception is somewhat uncertain, but astronomers are none too cheerful in their predictions regarding radio conditions during this period.

However, listeners may console themselves with the thought that scientists are not always absolutely correct in their forecasts. Exceptional radio conditions were promised for 1932-3, when the sunspot cycle was at its lowest point, but nothing very unusual resulted in the way of reception. However, as has previously been suggested, this year may be a record one as far as wavelengths below 10 metres are concerned.

According to a correspondent in the Wellington district of New Zealand, severe interference has been caused to the telegraph services, due to sunspot activity in conjunction with magnetic earth currents and the Aurora Australis displays. The lines most effected were those running east and west, although on January 17





# Short-wave Review

CONDUCTED BY

## ALAN H. GRAHAM

### Latest Information re South Africans ★ Reports Sought on PCJ's Transmissions ★ Full List of 20-Metre Calls Heard ★ Re- ports from Observers ★ Hourly Tuning Guide.

**A**T long last complete data is to hand regarding the South African Broadcasting Corporation's stations. At present four transmitters are in use. They are located in Klipheuvall (ZRK), Durban (ZRD), Roberts Heights, near Pretoria (ZRH), and Johannesburg (ZRJ); and use 5 k.w., 10 watts, 5 k.w., and 200w., respectively. The latest available schedules for these stations are as follow:—

**ZRD, Durban, 48.78m.:** Daily, exc. Sunday, 2.45-3.45 p.m., 6.30-10.30 p.m.; Daily exc. Monday, midnight-6.45 a.m.; Sundays, 11 p.m.-2.30 a.m. (Monday); Mondays, 3 a.m.-6.20 a.m.

**ZRH, Roberts Heights, 31.5m.:** Daily, exc. Sunday, 2.45-3.45 p.m., 8-10.30 p.m.; Sundays, 6 or 6.30-7.30-8 p.m.

**ZRH, Roberts Heights, 49.94m.:** Daily, exc. Monday, 1-7 a.m. (Sundays till 7.45 a.m.); Sundays, 11 p.m.-3 a.m. (Monday); Mondays, 3.15-6.15 a.m.

**ZRJ, Johannesburg, 49.2m.:** Daily, exc. Sunday, 2.45-3.40 p.m., 6.15-10.30 p.m.; daily, exc. Monday, midnight-2.30 a.m.

**ZRK, Klipheuvall, 31.23m.:** Daily, exc. Sunday, 2.45-3.40 p.m., 6.20-10.20 p.m.; Daily, exc. Monday, midnight-2.40 a.m.; Sundays, 7-8.30 p.m., 11 p.m.-2.40 a.m. (Monday).

**ZRK, Klipheuvall, 49.2m.:** Daily, 3-7 a.m.; Mondays, 3-6.20 a.m.



#### Ultra-High-Frequency Bands.

Reception on the U.H.F. bands continues to be interesting, even if not very outstanding. Several broadcast stations are putting in passable signals on both 9 and 11 metres; namely, W6XKG, W9XAZ and W9XJL on 11 metres; and W9XUY and W9XPD on 9.49 metres. W9XUY has been the best of these stations, with a

steady R 6-7 signal practically every morning for some weeks past.

The police bands are just fair, although reception is possible much later than last month—reasonably strong signals being audible well on into the afternoon. Fort Worth and Los Angeles are the best for the month on 9.06 and 9.9 respectively.

#### Hurstville Club Welcomes Readers To A.O.C.P. Classes.

The Hurstville Amateur Radio Club, located at 316B Forest Road, Hurstville, has just commenced classes, covering all subjects—Theory, Regulations and Morse Code—to the standard required for the A.O.C.P. Meeting nights are each Thursday, and all are welcome to come along.—J. G. Calvert (VK2VT), Secretary.

#### Latest Station News.

##### United States.

W1XK has a new programme of great interest to DX listeners. It is entitled "Radio Round the Clock," and consists of the latest information and schedules for shortwave stations, together with details of special DX broadcasts. It is on the air at 7 a.m. every Tuesday.

W6XBE is the call of the new 20 k.w. General Electric station located at Belmont, California. It will operate on 31.48 and 19.56 metres.

W9XHW.—Confirmation is to hand that W9XHW is operating on 9.49 metres; relaying the CBS station WCCO from midnight till 3 p.m. daily.

##### Colombian Republic.

The movement towards the 60-metre band continues. In addition the call-letters of a number of the stations have undergone alteration. For details see the additions to the "Radio World" station list.

##### British Honduras.

A new country is on the air for the real DX fans. XIK-2, Belize, British Honduras, is now operating on 28.25 metres. Its schedule, from 10.30-10.45 a.m. on Wednesdays, Fridays and Sundays, is not very convenient for Australasian reception, but a catch like this is worth a lot of patience.

##### Cuba.

More and more Cubans on the air. And how they alter their frequencies! A wavelength a day keeps the S.W.L. guessing should be their slogan. It is almost impossible to publish an accurate list of frequencies. COCA, relaying CMCA, on 32.96 metres is the latest comer. QRA is Galiano No. 102, Habana.

##### China.

XGOX seems to have gone for good this time, together with the majority of the 'phone stations heard some time ago. Only XRV (apparently a new edition of the old XTV), Canton, is being reported at present. This transmitter operates on 31.6 metres; usually contacting KWV, Dixon, California.

##### France.

Further information to hand regarding the new French station mentioned last month, reveals that the call is TPB; the power 100 k.w.; and the wavelengths, 25.3, 31.41 and 49.65 metres.

##### Italy.

An interesting new station, not yet reported in this country, is Radio Milano on 28 metres.

Radio Roma is putting quite a number of new transmitters on the air. 2RO-5 and 2RO-6 will soon be testing on 19.77 and 19.61 metres, respectively.



### PCJ Requests Co-operation of Club Members.

PCJ is most desirous of receiving further reports on its Australian programmes, broadcast every Tuesday evening from 6.30-8 p.m. The co-operation of A.W.A.W. DX Club members is especially requested by the Short-wave Editor for the following dates: April 12, 19 and 26. Detailed reports on reception on these evenings may be forwarded either to the S.W. Editor, or to Philips Radio, Box 2703-C, Sydney.

★

### News Broadcasts In English From Overseas Stations.

In view of the complicated international situation at the present moment, listeners should be interested in the following details of English news sessions broadcast by the more important short-wave stations.

England: 2, 4, 7.15 and 10.40 a.m.; 1.25, 8 and 11.30 p.m. (For transmitters in use at these times see Hourly Tuning Guide.)

Germany: 5, 7 and 11.15 a.m.; 1.30, 5 and 10 p.m. (For transmitters in use at these times see Hourly Tuning Guide.)

France: 6.10 a.m. (TPA), 2.30 p.m. (TPA4), 7.40 p.m. (TPA3), and 10 p.m. (TPA2).

Japan: 6 a.m. (JZI), 9 a.m. (JZJ), 3.30 p.m. (JZJ, JZI), and 11 p.m. (JZJ).

Czecho-Slovakia: Daily 7 a.m. (OLR3A, OLR3B); Tuesdays, Thursdays, Saturdays, 12.45 p.m. (OLR3A, OLR2B).

Italy: 2, 5.40, and 10.35 a.m.; 9 p.m. U.S.S.R.: 10 a.m. (RAN).

Poland: 9 a.m. (SPW, SPD).

Yugo-Slavia: 7.30 a.m. (YUA).

Canary Is.: 11 a.m. (EJA43).

South Africa: 6 a.m. (ZRH, ZRK).

★

### REPORTS FROM OBSERVERS

Mr. G. O. La Roche (West Australia).

Conditions are rather good, especially in the mornings; although daylight reception is very poor.

The new Rome stations are coming in very well. I am doubtful of their correct calls and exact frequencies, but 1RF on 25.1 metres is very good, and 1RA on 30.4 metres very fair. So far they only seem to work in conjunction with 2RO-4, 31.13 metres, in the mornings.

HVJ, 19.84 metres, has been pushing through a beautiful signal lately.

SPW is audible once more at fair strength; and the other Polish station on 26 metres, SPD, puts in a weak signal.

One never knows when a new Cuban will make an appearance these days. COBC is now hovering around 30

metres. (Originally listed on 32.98 metres.—S.W. Editor.)

XEXA was a welcome stranger after a long absence. They came in with a fair signal on 48.61 metres. The same morning exercises to a piano accompaniment.

The 20-metre amateur band is very poor in the evenings; only KA's and a few W's. In the early mornings, 3-4 a.m. (Perth time), the G's are good, mostly working South Africans.

Mr. V. D. Kemmis (N.S.W.).

I have found receiving conditions excellent in my particular location. I don't think I have ever logged so many Europeans in such a short space of time as I have during the past few weeks. There are literally dozens of G's, F's, PA's, etc., coming through in fine style from around 5 to 6.30 p.m. E.S.T.; many being R 7-9 on speaker.

As far as the broadcast bands are concerned, I have not spent very much time on them. However, several interesting loggings included HRJ (29.64), XEXA (48.61), HP5F (49.59) and ZRH (49.94).

Mr. J. C. Linehan (South Australia).

DX for the last week or so has been surprisingly good. The best amateurs received here include the following:—VE1BW, Nova Scotia, Canada; YV1AP (America, Paris), Venezuela, who is heard practically every night at 6 p.m. (Adelaide time); VS2AR, Malaya; HI7S, Dominican Republic; and K7FBE, Alaska.

As conditions have been so good on the amateur frequencies, I have not listened very much on the broadcast bands. However I have found GSH (13.97), GSJ (13.93), VPD2 (13.45), KZRM (31.35), W2XE (19 and 25), and VQ7LO (49.31) best.

The way conditions are shaping here at present, I think we are in for some extra good DX within the next week or so, as the DX stations are not fading out as they were some time ago.

Verifications just to hand are from W1AA, HS8PJ, CO6OM, FB8AD, ZS5CL (ex ZU5Z), and W2XGB. The last-mentioned sent a nice letter verifying my report of December last. When logged they were testing on 34.64 metres, with an output of 5 k.w.; and using a special directional antenna aimed at San Francisco.

Mr. A. E. Bruce (South Australia).

Conditions have been only fair this month, with only one or two bright spots when the 20-metre amateur band opened up with a vengeance and stations just rocked in.

Morning conditions have been rather better, with the Americans on 19 metres really good—W2XE and W8XX. In the afternoons reception is reasonably good, and very consistent from one day to another. In the evenings conditions vary a good deal

from day to day. PCJ are heard excellently, and their increase in power seems justified. The German stations have been outstanding, especially on 19 metres.

Several good loggings have been made on the 20-metre band, including HH2G, XZ2DX, VE1EI and VE3ACK. Conditions on this band are best between 7 and 10.30 p.m. (Adelaide time).

Mr. H. A. Callander (Tasmania).

Reception this month has shown an all-round improvement, especially on 20 metres. On this band the English amateurs have been very good around 6.15 p.m. E.S.T.

On March 10 I heard a very interesting test being conducted through W2IXY on 20 metres. W2IXY was relaying the 56 meg. phone of W2GNJ. The relay first went to GI2CC, Northern Ireland then to PAOZN, Holland, and finally to VK2IQ. I followed the relay from 7.50-9 p.m., and without exaggeration, it was as clear as any local station.

Best amateur loggings include VR6A, Pitcairn Is., HH3X, K7FBE, LA8C, VS1AI, and FN8B

ZLT, Wellington, has been exceptionally strong this month on 27.15 metres, working London.

Mr. J. K. Sorensen (Queensland).

Since returning from my recent holiday I have found DX conditions considerably improved. The 20-metre amateur band is alive with W's. The most sought-after amateur at present is VR6A, Pitcairn Island. On several occasions it has seemed as if every amateur in America has been calling him. VO1I was another interesting logging this month.

25 metres has been the outstanding broadcast band. KZRM on 25.31 metres is very strong around midnight. Other good stations on this band include JZJ and Rome.

PCJ are not very loud here, despite their increased power, being only R 3-4 after 7.30 p.m.

The Archerfield aerodrome has been logged again, and I have written for full details.

Mr. R. Russell (New Zealand).

I have noted a great improvement in conditions this month, and have found the DX full of interest. I have only been able to listen from 5-9 a.m., and from 6-8 p.m. during recent weeks, and have found these periods providing wonderful reception from Europe and North Africa. (Times are New Zealand time.)

(Mr. Russell's list of amateurs logged contains the following: 30 G's, 24 F's, 2 ON's, 3 PA's, 2 I's, 3 HB's, 2 OZ's, 2 EI's, 5 CT's, 1 GM, 1 GW, 2 CN's, and 3 SU's. And then he wonders why Australian dxers refer enviously to the loggings of Enzed-ders!—S.W. Editor.)



**Mr. E. Neill (Queensland).**

I have found conditions improved on all wavelengths up to 80 metres. The usual German and English stations are simply romping in here. OLR2B were exceptionally good on 49 metres on several nights this month.

Of the early morning stations, the Americans are outstanding around 6 a.m. Later in the morning RNE are about the best of the 25 metre stations.

In the late afternoons HBO are strong.

Verifications to hand this month are from YV4AB, K6OQE, G2AK, D3ANK, OE3AH, ON4SS and ZT6X. The arrival of these cards means that I have now V.A.C.



**DX Highlights Of The Month  
—From Observers' Reports.**

1. Some exceptional loggings on 49 metres by Messrs. La Roche and Kemmis:—  
 XEXA, Mexico City, 48.61 metres.  
 HP5F, Colon, Panama, 49.59 metres.  
 CR7AA, Lourenco Macques, 48.87 metres.  
 ZRD, Durban, 48.78 metres; using only 10 watts. Reported by Mr. La Roche.  
 ZNB, Mafeking, 50.84 metres.
2. Outstanding results on 20-metre amateur band. See list of calls heard in special amateur review.
3. Remarkable reception of D.E.I. transmitters by Mr. La Roche. His monthly report lists the following:—  
 PMY (58.3), YDL-2 (62.37),  
 YDH-3 (85.96), YDG-3 (86.46),  
 YDO-2 (87.46), YDL-4 (87.98),  
 YDH-5 (92.31), YDO-4 (94.38),  
 YDG-3 (95.24), YDH-6 (95.85),  
 and YDA (98.0). Surely fine DX when the noise-level on these low frequencies is taken into account.



**AMATEUR REVIEW.**

The past month has seen some amazing DX on the 20-metre band. All Observers reported greatly improved conditions; and the lists of calls heard forwarded by Messrs. Kemmis and Russell in particular were very fine.

Listeners should note that all South African amateurs now use the ZS prefix; ZT and ZU will now be reserved for broadcast stations.

**Amateur v. S.W.L. Controversy.**

Of late we have received a number of complaints from DX club members relative to the failure to answer reports even when complete details of

reception are given, and return postage is enclosed.

Of course, this is a very controversial subject, and much can be said for both sides. The amateurs contend that many S.W.L.'s fail to set out adequate details, and often neglect to enclose return postage. Moreover, there are some who write to amateur stations reporting signals, which they obviously did not log. A well-known Indian amateur received a number of QSA 5 R 7-8 reports on phone, when operating on C.W.; and there was also an American who received reports on 20-metre sigs. when operating on 160 metres.

On the other hand, one can readily understand the indignation of the conscientious S.W.L., who sticks to the rules of the game, and forwards a really informative report, complete with the inevitable I.R.C., and then receives no reply. It seems rather unjust that he should suffer for the shortcomings of others. One enthusiastic S.W.L. whose report card is the most attractive the writer has seen, forwarded over thirty reports to Oceanic amateurs (KA, K6, etc.), and, after the lapse of more than sufficient time for replies to be received, has one verification to hand!

**ROUND THE SHACKS**

Amateur operators desirous of having their transmitters and activities featured under this heading are requested to forward details to "Reporter," C/- "Radio World," 214 George St., Sydney. Articles should be similar in style to those already appearing in the series, and should, where possible, be accompanied with photographs of operator and transmitter.

After an experience like that one would be justified in looking askance at amateurs who state that they are willing to QSL all correct reports which give all them helpful information. But such a case is, we trust, the exception rather than the rule; and S.W.L.'s should be able to look forward to at least 50% QSL's if they give value for value—an informative report with return postage for a card.



**CALLS HEARD.**

**Europe.**

- France: F3GR, F3HL, F3HM, F3JD, F3KH, F3OO, F3MF, 3NR, F3GM, F3HK, F3DC, F3LX, F3QD, F3XN, F3XT, F3KI, F3KR, F3DI, F3JI, F3VC, F3II, F3MQ, F3GE, F3HL (Callander, Sorensen, Linehan, Kemmis, Russell).  
 England: G2AK, G2HK, G2PU,

- G2RV, G2TR, G2UT, G2XV, G2MQ, G2BY, G2RX, G2AI, G2MR, G2RB, G2OV, G5LU, G5NA, G5OV, G5QN, G5RV, G5XJ, G5ZG, G5XV, G5QZ, G5SY, G5PJ, G5LK, G5XP, G5QM, G5ML, G5TP, G6DT, G6JF, G6LK, G6WX, G6XR, G6FS, G6FN, G6OS, G6LP, G6LU, G6GO, G6FR, G6JQ, G6GZ, G6NL, G8IY, G8MA, G8MX, G8QC, G8MI, G8MS, G8MJ, G8OA, G8SB (Kemmis, Russell, Linehan, La Roche, Callander, Sorensen).

Scotland: GM2UU, GM5NW (Kemmis, Linehan).

Northern Ireland: G12CC (Kemmis, La Roche).

Wales: GW8HI (Kemmis).

Switzerland: HB9CL, HB9J, HB9G, HB9AY (Kemmis, Russell, Linehan).

Norway: LA1F, LA1G, LA8C (Russell, Kemmis, Callander).

Belgium: ON4BC, ON4BG, ON4US, ON4AU, ON4DJ (Callander, Kemmis, Russell).

Denmark: OZ9R, OZZU, OZ2S (Kemmis, Russell).

Holland: PADJA, PAEO, PAMQ, PAMZ, PADA (Kemmis, Russell).

Greece: SV1KE (Kemmis).

Italy: I1CH, I1CA (Russell).

Portugal: CT1QG, CT1GM, CT1PM, CT2AZ, CT2BP (Russell).

Irish Free State: EI3J, EI8L (Russell).

**Africa.**

French Morocco: CN8AV, CN8MU, CN8MZ (Russell, Kemmis).

Spanish Morocco: EA9AH (Kemmis).

Algeria: FA3HC (Kemmis).

Egypt: SU1CH, SU1RD, SU1KG, SU1CW (La Roche, Russell).

Southern Rhodesia: ZE1JA (La Roche).

Madagascar: FB8AD (Kemmis).

**Asia.**

French Indo-China: F18AC (Kemmis, Callander, La Roche).

French India: FN8B (Callander).

Japan: J2MI, J2NG, J2NF, J2FK, J2KJ (Russell, Kemmis, Callander, Bruce, La Roche).

Dutch East Indies: PK1EX, PK1MX, PK1VY, PK1GL, PK1PK, PK2WL, PK3GD, PK3RR (Russell, Kemmis, Bruce, Callander, La Roche).

Malaya: VS1AI, VS2AS, VS2AK, VS2AR (Kemmis, Callander, Linehan, La Roche).

India: VU2BG, VU2CQ (Kemmis).

China: XU2HB, XU8MC (Kemmis).

Burma: XZ2DX, XZ2EZ (Kemmis, Bruce, Linehan).

Philippine Is.: KA1AF, KA1AP, KA1BH, KA1MG, KA1MH, KA1ZL, KA1ME, KA1JR, KA2OV (Kemmis, Sorensen, Callander, Linehan, La Roche).

Hawaii: K6BJJ, K6BNR, K6CGK, K6CMC, K6JPD, K6JLV, K6KGA, K6KKP, K6LKM, K6MML, K6MTE, K6MVV, K6NZQ, K6OFW, K6OJI,



K6OQE, K6KGS, K6KMB, K6KVA, K6NCR, W6OGM (portable) (Kemmis, Callander, Sorensen, La Roche, Bruce, Linehan).

**Australasia And Oceania.**

New Guinea: VK9DM (Kemmis).  
Pitcairn Is.: VR6A (Callander, Russell, Sorensen, Kemmis).

**North America.**

Newfoundland: VO1I, VO6D (Sorensen, Kemmis).  
Canada: VE3KX, VE3ACK, VE3AHP, VE4HQ, VE4SS, VE5OT, VE5BO, VE1BW, VE5ACN, VE5EO, VE5VP, VE1EI, VE9DW (Bruce, Linehan, Callander, Kemmis).  
Alaska: K7FBE (Callander, Kemmis).

**South America.**

Chile: CE1AH, CE1AO, CE1AP, CE3AA (Kemmis).  
Uruguay: CX3BL (Kemmis).  
Ecuador: HC1FG (Kemmis).  
Colombian Republic: HK3LDC (Kemmis).  
Argentina: LU1DJ, LU1HI, LU1HA, LU2BG, LU9BV (Kemmis).  
Brazil: PY2BP (Kemmis).  
Zenezuela: YV1AP, YV1AQ, YV4AX, YV5AB, YV5AZ (Kemmis, Linehan).

**Central America.**

Mexico: XE1LK, XE2FC (Kemmis).

**West Indies.**

Porto Rico: K4SA (Kemmis).  
Cuba: CO2RH, CO2AU, CO2EG, CO2WW, CO2WZ, CO2JJ (La Roche, Kemmis).  
Dominican Republic: HI7S (Linehan).  
Haiti: HH2G, HH3X (Bruce, Callander).

**20-Metre Amateur Frequencies.**

14,000	FB8AF	HI3N
14,004	EA9AH	14,120 ZU5L
14,020	LU1HI	n CO2JJ
14,025	ZS2N	14,130 VU2CQ
14,030	SU1KG	ZU5Z
	XU8HW	14,140 ZS6AJ
14,035	ZS1C	CN8MI
14,040	ZT1M	KA1CS
14,055	ZS1AL	14,180 KA1MM
14,060	ZU6P	14,200 KA1HS
	KA1AP	14,240 K6BNR
14,075	ZS6T	14,254 KA1JR
	ZS6AJ	14,260 LA1F
14,080	LU1DJ	14,300 VO6D
	CO2LY	XU8HN
	VS6AG	ZT5S
	ZS1J	14,320 CN8AM
	T12RC	14,330 VS2AS
	J2MI	14,345 VR6A
14,085	ZT5P	14,350 FR8VX
	ZT6AL	FR8AB
	OQ5AA	ZU6AF
14,090	ZS1B	14,355 ZS6AA
	ZE1JR	14,360 HB9J
	ZS3F	14,365 ZS3F
	ZS6AG	ZU6AF
14,100	CN8AF	14,368 OX2QY
	PK4WS	14,380 ZT6AK
	PK1VM	14,400 ZS6AY

# HOURLY TUNING GUIDE

## When And Where To Search

By ALAN H. GRAHAM.

In order to assist beginners and less experienced dxers, it is intended to publish monthly a special tuning guide, setting out at what times to listen for the more easily logged stations. It should be noted that the guide is not intended to cover all stations audible; for full details as to when and where to look for the best catches are given elsewhere. Moreover, the fact that a station is shown as being on the air at a particular time is no guarantee that reception must follow as a matter of course.

All times are given in Australian Eastern Standard Time.

Key to abbreviations used: S, Sundays only; M, Mondays only; T, Tuesdays only; W, Wednesdays only; Th, Thursdays only; Sat, Saturdays only.

Midnight to	25.53 GSD
1 a.m.	27.27 PLP
13.97	GSH 28.48 JIB
13.99	DJS 29.24 PMN
16.86	GSG 48.7 VPB
16.88	PHI 49.83 DJC
16.89	DJE 49.9 COCO
19.63	DJQ 58.3 PMY
19.68	TPA2 70.2 RV15
19.74	DJB
19.8	YDC
19.82	GSF 13.97 GSH
19.83	GSD 16.86 GSG
27.27	PLP 16.89 DJE
28.48	JIB 19.63 DJQ
29.24	PMN 19.74 DJB
30.61	XGOX 19.82 GSF
30.78	COCQ 19.85 DJL
31.38	DJA 25.4 2RO
31.28	VK2ME 25.49 DJD
(M)	25.53 GSD
31.45	DJN 48.7 VPB
31.49	ZBW3 49.31 VQ7LO
31.55	HS8PJ 49.83 DJC
(F)	
31.8	COCH 16.86 GSG
32.09	COCB 16.89 DJE
32.59	COBX 19.63 DJQ
33.2	COBZ 19.66 GSI
48.7	VPB 19.74 DJB
49.9	COCO 19.85 DJL
49.98	Rangoon 25.2 TPA3
58.3	PMY 25.49 DJD
70.2	RV15 25.53 GSD
1-2 a.m.	31.13 2RO
13.97	GSH 31.55 GSB
13.99	DJS 49.31 VQ7LO
16.86	GSG 49.59 GSA
19.63	DJQ 49.83 DJC
19.68	TPA2
19.74	DJB
19.8	YDC
19.82	GSF
19.84	HVJ
19.85	DJL
25.0	RNE
25.4	2RO
25.49	DJD
2-3 a.m.	13.97 GSH
16.86	GSG
16.89	DJE
19.63	DJQ (M)
19.66	GSI (M)
19.74	DJB (M)
19.85	DJL
25.2	TPA3
25.49	DJD
25.53	GSD
31.13	2RO
31.55	GSB
49.31	VQ7LO
49.59	GSA
49.83	DJC
4-5 a.m.	16.86 GSG
19.6	GSP
19.65	W2XE
19.66	GSI
19.85	DJL
24.52	TFJ
25.2	TPA3
25.49	DJD
5-6 a.m.	16.86 GSG
16.87	W3XAL
19.56	W2XAD
19.6	GSP
19.65	W2XE
19.66	GSI
19.67	W1XAL
19.72	W8XK
19.85	DJL
22.0	SPW
(T, Th, Sat)	24.52 TFJ
25.23	TPA3
25.48	DJD
25.53	GSD
27.17	CSW
28.93	EAJ43
29.04	ORK
31.13	2RO
31.28	PCJ
(M, W, Th)	31.41 OLR3A
31.55	GSB
49.59	GSA
49.83	DJC
6-7 a.m.	16.86 GSG
16.87	W3XAL
19.56	W2XAD
19.6	GSP
19.65	W2XE
19.67	W1XAL
19.72	W8XK
19.85	DJL
22.0	SPW
(T, Th, Sat)	25.0 RNE
25.2	TPA3
25.42	JZJ
25.49	DJD
25.53	GSD
27.17	CSW
31.13	2RO
31.28	W3XAU
31.35	W1XK
31.41	OLR3A
31.46	JZI
31.55	GSB
49.59	GSA
49.83	DJC
7-8 a.m.	16.87 GSG
19.56	DJR
19.56	W2XAD
19.63	DJQ
19.65	W2XE
19.72	W8XK
19.74	DJB
19.76	GSO
8-9 a.m.	19.56 DJR
19.56	W2XAD
19.63	DJQ
19.72	W8XK
19.74	DJB
19.8	YDC
22.0	SPW
25.45	W1XAL
25.49	DJD
25.61	TPA4
30.31	CSW
31.09	CS2WA
31.13	2RO
31.27	HBL (S)
31.32	GSC
31.35	W1XK
31.38	DJA
31.41	OLR3A
9-10 a.m.	19.56 DJR
19.56	W2XAD
19.63	DJQ
19.72	W8XK
19.74	DJB
19.8	YDC
22.0	SPW
25.45	W1XAL
25.49	DJD
25.61	TPA4
30.31	CSW
31.09	CS2WA
31.13	2RO
31.27	HBL (S)
31.32	GSC
31.35	W1XK
31.38	DJA
31.41	OLR3A

25.53	GSD	19.85	DJL
29.04	ORK	25.0	RNE
31.13	2RO	25.2	TPA3
31.55	GSB	25.42	JZJ
49.31	VQ7LO	25.45	W1XAL
49.59	GSA	25.49	DJD
49.83	DJC	25.53	GSD
		27.17	CSW
		31.09	CS2WA
		31.13	2RO
		31.28	W3XAU
		31.32	GSC
		31.35	KZRM
		31.35	K1XK
		31.38	DJA
		31.45	DJN
		31.46	JZI
		31.48	W2XAF
		31.55	GSB
		31.58	PRF5
		49.83	DJC
		8-9 a.m.	
		19.56	DJR
		19.56	W2XAD
		19.63	DJQ
		19.65	W2XE
		19.72	W8XK
		19.74	DJB
		19.76	GSO
		25.0	RNE
		25.2	TPA3
		25.42	JZJ
		25.45	W1XAL
		25.49	DJD
		25.53	GSD
		30.31	CSW
		31.09	CS2WA
		31.13	2RO
		31.27	HBL (S)
		31.28	W3XAU
		31.32	GSC
		31.35	KZRM
		31.35	W1XK
		31.48	W2XAF
		31.49	LKJ1
		31.55	GSB
		31.58	PRF5
		38.48	HBP (S)
		31.46	JZI
		9-10 a.m.	
		19.56	DJR
		19.56	W2XAD
		19.63	DJQ
		19.72	W8XK
		19.74	DJB
		19.8	YDC
		22.0	SPW
		25.45	W1XAL
		25.49	DJD
		25.61	TPA4
		30.31	CSW
		31.09	CS2WA
		31.13	2RO
		31.27	HBL (S)
		31.32	GSC
		31.35	W1XK
		31.38	DJA
		31.41	OLR3A



31.45 DJN	31.48 W2XAF	8-9 p.m.	19.71 PCJ (W)	19.74 DJB	16.89 DJE
31.49 LKJ1	3-4 p.m.	13.93 GSJ	19.74 DJB	19.76 GSO	19.56 DJR
31.48 W2XAF	13.99 DJS	13.97 GSH	19.76 GSO	19.8 YDC	19.63 DJQ
31.55 GSB	16.89 DJE	13.99 DJS	19.8 YDC	19.82 GSF	19.68 TPA2
38.48 HBP (S)	19.63 DJQ	16.86 GSG	19.85 DJL (S)	19.7 OLR5A	19.74 DJB
49.1 GSL	19.74 DJB	16.89 DJE	25.0 RNE (W)	19.85 DJL (S)	19.76 GSO
10-11 a.m.	19.85 DJL	19.63 DJQ	25.4 2RO	25.4 2RO	19.8 YDC
19.56 DJR	25.42 JZJ	19.71 PCJ (W)	25.57 Saigon	25.57 Saigon	19.82 GSF
19.63 DJQ	25.61 TPA4	19.74 DJB	27.27 PLP	27.27 PLP	19.85 DJL
19.74 DJB	31.28 VK2ME	19.76 GSO	28.14 JVN	28.14 JVN	25.4 2RO
19.8 YDC	(S)	19.8 YDC	29.24 PMN	29.24 PMN	25.42 JZJ
25.26 W8XK	31.38 DJA	25.53 GSD	30.23 JDY	30.23 JDY	25.57 Saigon
25.49 DJD	31.45 DJN	25.57 Saigon	30.61 XGOX	30.61 XGOX	27.27 PLP
25.61 TPA4	31.46 JZI	27.27 PLP	31.28 VK2ME	30.78 COCQ	29.24 PMN
31.13 2RO	49.18 W3XAL	28.14 JVN	(S)	31.28 VK6ME	30.61 XGOX
31.25 RAN	49.5 W8XAL	29.24 PMN	31.28 VK6ME	31.28 VK2ME	30.78 COCQ
31.32 GSC	4-5 p.m.	31.28 VK2ME	31.38 DJA	(S)	31.28 VK2ME
31.38 DJA	13.99 DJS	(S)	31.38 DJA	31.35 W1XK	(S)
31.41 OLR3A	16.89 DJE	31.38 DJA	31.45 DJN	31.38 DJA	31.35 W1XK
(M)	19.63 DJQ	31.45 DJN	31.45 VPD2	31.45 DJN	31.38 DJA
31.45 DJN	19.74 DJB	31.49 ZBW3	31.49 ZBW3	31.49 ZBW3	31.45 DJN
31.48 W2XAF	19.85 DJL	31.55 VK3ME	34.0 VPD3	31.8 COCH	31.46 JZI
31.49 LKJ1	25.42 JZJ	31.45 VPD2	44.64 PMH	32.09 COBC	31.49 ZBW3
31.55 GSB	31.28 VK2ME	34.0 VPD3	48.7 VPB	32.59 COBX	31.51 HS8PJ
11 a.m.-noon.	(S)	44.64 PMH	49.5 W8XAL	44.64 PMH	(Th)
19.56 DJR	31.38 DJA	70.2 RV15	58.3 PMY	48.7 VPB	31.8 COCH
19.63 DJQ	31.45 DJN	9-10 p.m.	70.2 RV15	49.5 W8XAL	32.09 COBC
19.74 DJB	31.46 JZI	13.93 GSJ	10-11 p.m.	49.98 Rangoon	32.59 COBX
25.26 W2XK	49.5 W8XAL	13.97 GSH	13.93 GSJ	58.3 PMY	33.2 COBZ
25.49 DJD	5-6 p.m.	13.99 DJS	13.97 GSH	70.2 RV15	44.64 PMH
25.61 TPA4	13.99 DJS	16.86 GSG	13.99 DJS	11 p.m.-midnight	48.7 VPB
31.13 2RO	16.86 GSG	16.89 DJE	16.86 GSG	13.93 GSJ	49.5 W8XAL
31.25 RAN	16.89 DJE	19.63 DJQ	16.89 DJE	13.97 GSH	49.9 COCO
31.32 GSC	16.89 DJE	19.68 TPA2	19.63 DJQ	13.99 DJS	49.98 Rangoon
31.38 DJA	19.63 DJQ	19.7 OLR5A	19.68 TPA2	16.86 GSG	58.3 PMY
31.41 OLR3A	19.74 DJB				70.2 RV15
(M, T, Th, Sat)	19.76 GSO				
31.45 DJN	25.23 TPA3				
31.48 W2XAF	25.53 GSD				
31.55 GSB	28.14 JVN				
Noon-1 p.m.	31.28 VK2ME				
19.56 DJR	31.38 DJA				
19.63 DJQ	31.45 DJN				
19.74 DJB	31.55 GSB				
25.26 W8XK	6-7 p.m.				
25.49 DJD	13.99 DJS				
25.53 GSD	16.86 GSG				
31.28 PCJ (F)	16.89 DJE				
31.32 GSC	19.63 DJQ				
31.38 DJA	19.74 DJB				
31.41 OLR3A	19.76 GSO				
(T, Th, Sat)	25.23 TPA3				
31.45 DJN	25.53 GSD				
31.48 W2XAF	28.14 JVN				
31.55 GSB	31.28 VK2ME				
1-2 p.m.	(S)				
19.56 DJR	31.38 DJA				
19.63 DJQ	31.45 DJN				
19.74 DJB	31.55 GSB				
25.49 DJD	7-8 p.m.				
25.53 GSD	13.99 DJS				
25.61 TPA4	16.89 DJE				
31.28 PCJ (F)	19.63 DJQ				
31.32 GSC	19.71 PCJ (W)				
31.38 DJA	19.74 DJB				
31.41 OLR3A	25.23 TPA3				
(T, Th, Sat)	25.57 Saigon				
31.45 DJN	28.14 JVN				
31.48 W2XAF	31.38 DJA				
31.55 GSB	31.45 DJN				
2-3 p.m.	31.49 ZBW3				
25.61 TPA4	31.55 VK3ME				

## Have Your "RADIO WORLD" Posted To You Direct

Readers who want to take the "Radio World" on a subscription basis and have their copies posted to them direct each month are invited to complete the coupon below (annual sub. 10/6). New readers are advised that all back numbers in Volumes 1 and 2 are still available, price 9d., post free for copies in Volume 1 (May 1936 to April 1937) and 1/-, post free, for copies in Volume 2 (May 1937 to April 1938).

Enclosed please find remittance for 10/6, in payment for an annual subscription to the "Australasian Radio World," commencing with the.....issue.

Name.....

Street and No.....

City..... State.....

Country.....

Note.—N.Z. Subscribers can remit by Money Order or Postal Note.

THE AUSTRALASIAN RADIO WORLD,  
214 George Street, Sydney,  
N.S.W., Australia.



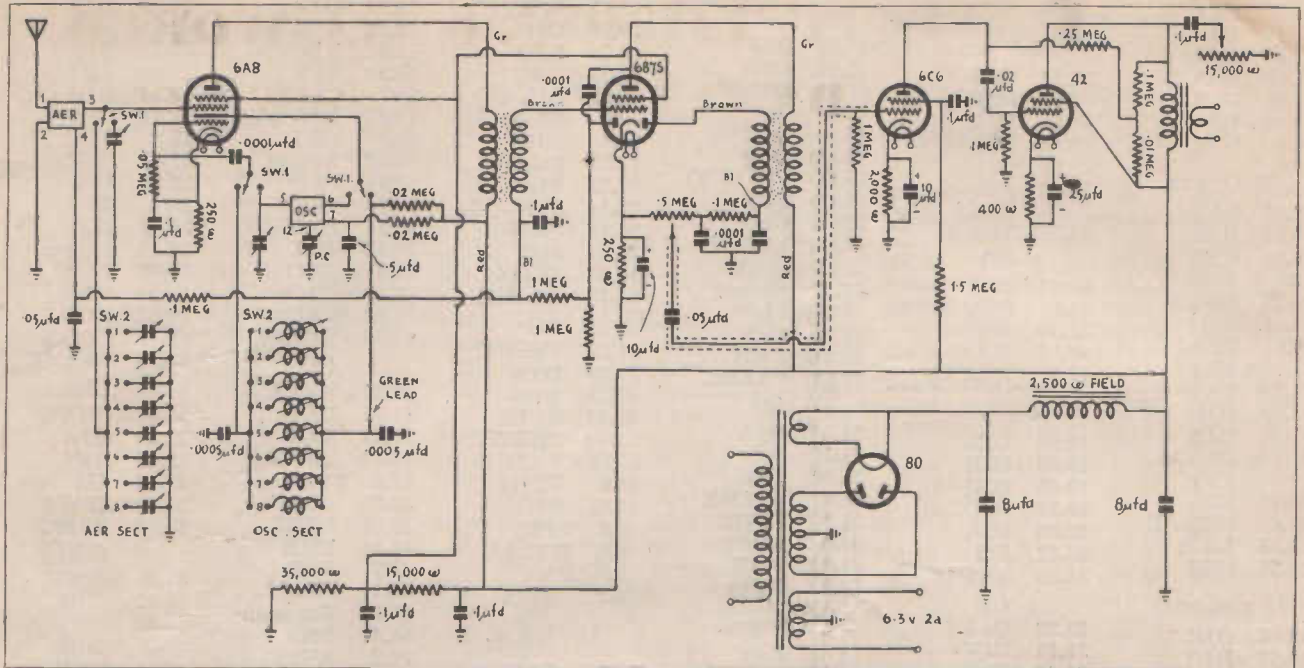

Circuit of a modern 4/5 dual-wave superhet with push-button tuning, designed around the Crown FK/8 Foundation Kit. Though shown separately above, the paddler is incorporated in the D-2 unit. The grid lead of the first i.f., labelled "B" above, is black.

**Crown Push-Button Kit.**

(Continued from page 8)

aerial section of SW1, while the lead on the other bank connects to the oscillator grid section of the SW1. From this same lead a 500 mmfd. condenser (+ 2½% accurate) connects to a good earth connection.

To one lug of each section of SW2 (both banks), connect lengths of 20-gauge tinned copper wire of sufficient length for connection to the tuning unit.

The PB-8 unit is mounted on the chassis so that the two banks of lugs are adjacent to the lugs on SW2. The lugs are wired to the switch, in the following manner:—

The bottom bank of lugs on the unit (oscillator section), connect to the bottom bank of lugs on the switch. The first lug on the unit connects to the first lug on the switch, the second lug on the unit to the second lug on the switch, and so on, until the eight lugs on each are wired. The tinned copper leads should be kept as short as possible, and covered with spaghetti. No leads to the switch should cross.

The top bank of lugs on the unit and switch are wired similarly to the bottom bank. The copper braid should be covered with spaghetti and run direct to earth. The remaining

green lead connects to the plate section of the "gang/auto" switch. Also, from the same lug, a 500 mmfd. condenser (+ 2½% accurate) connects to earth. This completes the wiring.

**The Alignment Procedure.**

All that is necessary now is to align the receiver. The following procedure must be followed:

- (1) Align the i.f. stages accurately to 465 k.c. and seal. Make sure that i.f. transformers are accurately

adjusted and well sealed afterwards, because any drift subsequently will completely upset the P.B. adjustments.

- (2) Completely align the box on broadcast and shortwave, and seal the trimmers.
- (3) Set the trimmers on the PB-8 unit, as follows: (A diagram is published elsewhere showing the positions of all trimmers.)

Start with No. 1 circuit and adjust the oscillator trimmer until the station desired appears. Then adjust

This under-chassis view illustrates the location of the push-button unit and switch, and dual-wave unit.

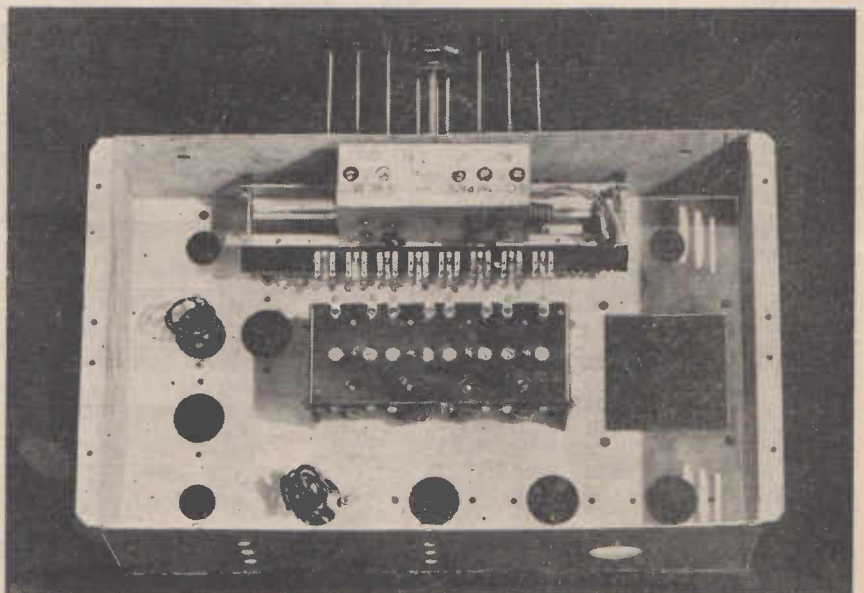



The aerial trimmer to track—repeat process with all the other bands. It will be noticed that more than one station appears for each band. This is quite in order, the unit being designed so that a selection of stations is available on each band.

A locking nut is provided on the oscillator trimmers for locking the trimmer in place when adjusted. All that is necessary is to tighten the nut and then re-adjust the trimmer slightly to make sure it is correct. This will prevent frequency drift. The aerial trimmers may be sealed with sealing wax on similar material.

**Unit On Display For Set-Builders.**

Set-builders who would like to examine this latest Crown push-button tuning kit are invited to call at Messrs. John Martin Pty. Ltd., 116-118 Clarence Street, Sydney, where a foundation kit ready mounted on a chassis is on display.

**Colour Code of D/2 Dual-Wave Box.**

- Aerial Section.
- No. 1 on circuit—Green.
- No. 2 on circuit—Frame of box.
- No. 3 on circuit—Brown (out back of box)
- No. 4 on circuit—Black.
- Oscillator Section.
- No. 5 on circuit—Black (out back of box)
- No. 6 on circuit—Yellow.
- No. 7 on circuit—Brown.
- No. 12 on circuit—Wired internal.

**DIAL LIGHT SWITCHING COLOUR CODE.**

- (Leads twisted together)
- Red . . . . . Common
- B/C lights . . . . . Green
- S.W. . . . . Yellow

**Shortwave Reception Review.**

Since joining the club about eight weeks ago I have logged and reported to 80 stations (all s.w.), and have received about 25 verification cards. Reception has not been too good lately, with QRN all day and every day.

Daventry have been very consistent, especially on 31, 25 and 19 metres in the early evening, and 31 metres in the early morning. Paris has been excellent here on 25.60 metres from 2.30 p.m. onwards. News is broadcast in English from 2.30 to 2.45 p.m., and is received very clearly. Of an evening, VPD2 and KZRM are always fair on 31m., and Japan on 25 and 28m. can often be heard.

**ALL-WAVE ALL-WORLD DX CLUB . . . New Members**

- AW262DX—Harold Jensen, C/o. Walker's Radio Service, Clifton, Q'land.
- AW261DX—D. H. Bull, 12 Lambeth Road, Mt. Eden, Auckland, New Zealand.
- AW263DX—Lindsay Furner, Cowabbie Street, Coolamon, N.S.W.
- AW264DX—William Edward Neilsen, Box 28, Laidley, Q'land.
- AW265DX—A. J. Bewsher, 8 High Street, Burnie, Tasmania.
- AW266DX—Miss Evelyn M. Curnow, 21 Anderson Street, Surrey Hills, E.10, Victoria.
- AW267DX—Miss P. E. Stevens, 8 Raglan Street, South Melbourne, S.C.5, Vic.
- AW268DX—Mervyn W. Eglington, Bray Street, Murwillumbah, N.S.W.
- AW269DX—E. McCartney, 36 Boyce Street, Taree, N.S.W.
- AW270DX—Cecil C. G. Job, 15 Napier Street, Drummoyne, Sydney, N.S.W.
- AW271DX—Gwen Irene Evans, 99 Links Avenue, North Strathfield, Sydney.
- AW272DX—Vaughan C. Webb, Box 71, Kyogle, N.S.W.
- AW273DX—Francis Joseph Coghlan, 139 Booth Street, Annandale, Sydney.
- AW274DX—Thomas P. Gardner, 527 Lane Street, Broken Hill, N.S.W.
- AW275DX—John J. Doyle, "Norwood," Gresford, N.S.W.
- AW276DX—Ken Wallis, Marlee, via Wingham, N.S.W.
- AW277DX—J. E. Sorbell, Silkwood Post Office, Nth. Q'land.
- AW278DX—Charles Robert Bell, 18 Kenny Street, Cairns, Nth. Q'land.
- AW279DX—Colin C. Robertson, Thangool, via Rockhampton, Q'land.
- AW280DX—D. F. Ohye, Leslie Street, Nundah, N.E.3, Brisbane, Q'land.
- AW281DX—William J. Lander, Jnr., 5 Turnbull Road, Narrow Neck, Devonport, Auckland, New Zealand.
- AW282DX—Errol F. Sims, 44 Quayle Street, Battery Point, Hobart, Tasmania.
- AW283DX—M. D. Hudson, C/o. T. W. Goford, Radio Hut, Mt. Isa, Nth. Q'land.
- AW284DX—Bruce A. Harding, 79 Kincaid Street, Wagga Wagga, N.S.W.
- AW285DX—Ian Leslie Griffin, Marong, via Bendigo, Victoria.
- AW286DX—Stanley George Herbert, Glenlea, Trangie, N.S.W.
- AW287DX—Eiler Larsen, Booyal, Isis Branch, Q'land.
- AW288DX—Ronald McGovern, "Heatherbell," Stewart's River, N.S.W.
- AW289DX—Hessel Thomas Smith, 3 Fortheringham Street, Taree, N.S.W.
- AW290DX—Keith D. Vincent, 85 Gisborne Street, Wellington, N.S.W.
- AW291DX—Stephen Stanworth, 21 Roe Street, North Bondi, Sydney.
- AW292DX—David W. McNeill, "Laureston," Bellerive, Tasmania.
- AW293DX—Fred Finch, Lennon Street, Wiluna, Western Australia.
- AW294DX—A. Hickey, C/o. Bulk Supplies, Canowindra, N.S.W.
- AW295DX—S. W. D. Wilson, Box 62, Cummins, South Australia.
- AW296DX—Eric N. Pitman, C/o. L. R. Pitman, Esq., P.O. Box 51, Roma, Queensland.
- AW297DX—Walter Arnold Shaw, C/o. Findlay's Ltd., Rook Street, Devonport, Tasmania.
- AW298DX—W. Johnstone, 95 Awaba Street, Mosman, Sydney.
- AW299DX—Edward P. Twynam, Richlands, Taralga, N.S.W.
- AW300DX—Leslie Wilson, 26 Lamette Street, Chatswood, Sydney, N.S.W.
- AW301DX—Victor David Kemmis, "Brampton Hall," 49 Kurraba Road, Neutral Bay, Sydney, N.S.W.
- AW302DX—Wallace Robert Armstead Lake, Pensions Dept., Trafalgar Street, Nelson, New Zealand.
- AW303DX—Aloysius McRae, "Jasmine," Bettington Street, Merriwa, N.S.W.
- AW304DX—Henry Alexandra Callander, 1 Franklin Street, West Hobart, Tasmania.
- AW305DX—Francis Clifford Dubbo, Main Street, Beenleigh, Queensland.
- AW306DX—Alex Maule, Fire Station, Patea, New Zealand.
- AW307DX—Mrs. M. M. Anselme, 16 Hartley Street, Rozelle, Sydney.
- AW308DX—W. E. Carton, 30 Agra Crescent, Khandallah, N.5, Wellington, New Zealand.
- AW309DX—R. Reszkowski, Wirrabara, South Australia.
- AW310DX—Bert Lutener, Buena Vista, Central Street, Penhurst, Sydney.
- AW311DX—Thomas W. J. Stafford, Campbell Street, Donald, Victoria.
- AW312DX—A. Fred Jay, 44 Etela Street, Belmore, N.S.W.
- AW313DX—H. Clyde Craig, "Cranbrook Hall," New South Head Road, Rose Bay, Sydney.
- AW314DX—Thomas W. M. Cantrill, Post Office, Geurie, N.S.W.
- AW315DX—George Bird, "Wilbedeen," Hobby's Yards, via Newbridge, N.S.W.
- AW317DX—Robert C. Meadows, 60 George Street, Mackay, Q'land.
- AW316DX—J. K. Sorensen, "Fairholme," Station Road, Gympie, Q'land.
- AW318DX—C. W. Bryant, Logan Road, Holland Park, South Brisbane, Q'land.
- AW319DX—Noel James, 97 West Botany Street, Arncliffe, Sydney, N.S.W.
- AW320DX—Stanley G. Drury, 21 Mary Street, St. Leonards, Glenelg, S.A.
- AW321DX—L. E. H. Mallinson, River View Hotel, Mackay, Q'land.

(To be continued next month)



W8XK has been fair in the afternoons on 31m., and W2XE is best here of the W's in the early mornings, although on the 20th it was 10 per cent. till closing at 9 a.m. VK9MI was one of the best stations of the week, being received at Q5, R9.

ZLT4's broadcast of the arrival of the airmen was excellent—also their short talk with VLZ during a lull in the broadcast. Their description of the Comet plane's departure was Q4, R8. HBO (26.31m.) 4.50 a.m. on the 12th was 100%—gave a list of changes in times and wavelengths for future broadcasts to Africa early in April.

Following is a list of amateurs logged during the last couple of weeks:—W's 3FAY, 6LLQ, 6MHL, 2KR, 3ANH, 6JT, 9FJ, 9IPS, 9ARA, 8AAJ, 6ZH, 6BUQ, 1CMD, 9JOL, 6CDO, 2AZ, 2AXT, 2WQ, 6IDY. Ve's 5AC, 5OT, 3AKP. Vk's 4CO, 4RX, 4HA, 4CW, 4PL, 4BN, 4EC, 4XW, 4GA, 2QR, 2WQ, 2AX, 2CJ, 2ADN, 2XFW, 2ZB, 2AEZ, 2AEY, 2AEP, 2AFS, 2OJ, 2KR, 2AZ. K's A1ME, 6KGA, 6LDY, CE1AH, CE1AO. VK3's BM, GR, ZX, XD, ZJ, PH, QK, PE,

ZZ. VK5's GM, TR, AC, BF, FL, VK6LW and VK6HT. VK3ME was the loudest and clearest station I have ever heard (Q5, R9, on one particular night), is usually Q4, R8. I have only mentioned stations heard clear enough to give a good report on, say, copy 80%.—A. R. Payten (AW352DX) Coff's Harbour, N.S.W.

### "Radio World" Fourth Short-wave DX Contest Closes On May 1.

The fourth "Radio World" Short-wave DX Contest will close on May 1, and entries can be forwarded at any time up to this date. The rules are as follows:—

1. For this Contest a trophy (a Replage World Globe with time converter, value 59/6) will be awarded to the reader who submits the best individual verification.

2. Verifications from any short-wave station between 5 and 100 metres may be submitted. Thus cards from broadcast, commercial, radio-telephone and amateur transmitters are

all eligible.

3. All verifications must bear a date (a post-mark on the card or envelope will suffice where no date is given on the actual verification); and the frequency on which the station has been received must be clearly indicated.

4. Only verifications of reception between July 1, 1937, and closing date will be eligible.

5. In judging the entries, the judges will take into account the power of the station received, the frequency on which the station was heard, and the type of receiver used.

6. There is no limit to the number of verifications which may be submitted by any entrant.

7. The decision of the judges will be final; and the result of the third competition will be announced in the June, 1938, issue of "R.W."

8. All entries should be addressed to the Shortwave Editor, and should be endorsed "DX Competition." All verifications submitted will be returned by registered post as soon as possible after the closing date.

—The Shortwave Editor.

## Round The Shacks . . . (8)

### - W9FWN -

(Contributed by L. Schnitzerling, Warwick, Queensland.)

"**C**Q VK de W9FWN."—How many Australian and New Zealand amateurs have heard this call, and quite possibly worked the "live wire" ham behind this call? Well, reproduced herewith is a photo of the equipment used by W9FWN (Red Wing, U.S.A.) and of the man behind the works.

The photo shows the transmitter and power supply racks; also the receiver used. The rack on the left, from bottom to top, houses the following gear (1) 120 watt (output) modulator, (2) exciter stage (6L6, 46, 46). (3) RK20, (4). A pair of O3A's in push-pull (1800 volts at 300 to 350 mills).

The rack to the right of this houses the power supplies, of which there are quite a few. 2-400 volts, 1-650 volts, 1-1,000 volts, 1-1800 volts. At the bottom of the rack are the 866's for the 1800-volt supply and above this are the 866's for the 1000-volt supply.

The receiver, which quite enhances the appearance of the shack, is a National-100. Two double-button "mikes" are used as well as the usual type of key. A "bug" can be seen located on top of the receiver.

Since this rig was built the first



six contacts were with VK and ZL hams, so if this should meet the eyes of those hams concerned, it should surely be of interest to them.

9FWN has mostly been on 20 m., mostly with 'phone. He has also been dxing a bit on 5 m. Adjoining his location is a 150-foot hill, formed into a park with power (a.c.) laid on,

so could anyone wish for a finer location to set up a 5-metre rig?

9FWN has been operating also on 10, 40 and 80 metres, with quite a number of contacts on each band. He is always pleased to contact amateurs on this side of the globe, so VK's and ZL's hearing him should give him a call.



# DX News and Views

A page for  
letters from  
DX readers

★ ★ ★

### Latest Loggings On Shortwave.

A few of my latest loggings are:—VK2's AX, BK, CJ, EH, EQ, JY, KD, ME, MJ, OM, UV, WQ, ABS, ADU, ADX, AEP, AEY, AGE, AIN, ADH and QF. VK3's BM, ME, TW. VK4's AA, AK, AO, FE, HA, JD, JM, JU, LQ, NO, SU, XM, XN and XW. VK5's WD, KD, HL and MF. W1JWW, W2JRR, W5SQQ, W9HEV, W9HEZ, W9XVX, W9WJJ, KZRM, K6HGA, K6DFW, K6JBD, K6KGA, KA1AF, J2MI and VR6A.—M. E. Eglington (AW268DX), Murwillumbah, N.S.W.

### QSL Exchange Bureau.

Mr. Louis Robertson, Derby Road, Milford, Connecticut, U.S.A., would like to exchange SWL cards with other readers.

### Moroccan Amateur Wants Reports.

CN8AV would like reports on his 20-metre 'phone, and will QSL. For his address, Meknes, Morocco, is suf-

ficient.—J. A. Ackerman, 34 Park Road, Carlton.

### Lessening Cost Of Veries.

The majority of dxers send I.R. coupons to stations for QSL cards. As these coupons cost 7d, it is a costly hobby when 3d. is added for postage to the overseas country. A cheaper method is to purchase from any stamp dealer mint stamps of the country from which the veri. is wanted. These will cost on an average 2d. or 2½d.

The following rates are given for return postage from the various countries named:—

Alaska, Port Rico, Hawaii, Guam, Virgin, 1s.; Samoa and U.S.A., 3c; Belgium 1f; Burma, India 1a. 3p; Canal Zone 3c; Canada 2c; Ceylon 9c; Czechoslovakia, 1k 50h; Chile, 1p 80c; China, 5c; Colombia Rep., 10c; Cuba, 4c; Denmark, Finland, Sweden, Norway, 20 ore; Dominican Rep., 4c; Ecuador, 30c; Fiji, 1½d.; France, 75c; Germany, 15; Hongkong, 15c; Eire,

1½d.; Japan, 4s; Mexico, 10c; Mozambique, Portugal, 1R; Java, 10; New Zealand, 1d.; Philippine Is., 6c; Spain, 15c; Siam, 15c; Indo-Chine, 15c; Uruagay, 8c. Bolivia and Brazil do not accept International Reply Coupons.—J. A. Ackerman, 34 Park Road, Carlton.

### Latest Shortwave Loggings.

Just a few lines to thank you for the certificate, badge and report forms, the last being excellent. I had never received any verifications until I joined the Club and began using its report forms, and now I have nine "veries" and am expecting more. Calls heard during February are as follows:—

20 m. Amateurs: W's 2AL, 2JKQ, 2A10, 4AH, 4DSY, 4BMR, 1JFG, 6VQS, 6FCL, 8NJT, 9ODQ (U.S.A.), K6KGA, K6VJA (Hawaii). Commercials: VPD (Fiji Islands, 20 m.), TI4NRH (Costa Rica, 31.02 m.), CE1AH (Chile, 20 m.).—W. Bantow (AW353DX), Edithvale, Victoria.

## VK Amateur Transmitters

### Additions And Amendments To List Of Experimental Stations For February, 1938

NOTE.—All call-signs given below should be prefixed by the letters "VK."

### Experimental Stations.—Additions.

Call Sign.	Name.	Address.
2AIW	Hall, W.,	Dubbo Street, Coonamble, N.S.W.
2AIY	Cullerton, H.,	84 Alice Street, Ramsgate, N.S.W.
4WX	Ham, T. E.,	River Terrace, Chelmer, S.W.3, Brisbane, Queensland.
2AIX	Radclyffe, L. E.,	Alt Crescent, Ainslie, Canberra, F. C. T. (portable).
3EY	M.C.C.E.S. Social Club,	Heffernan Lane (sub-station), 608 Little Bourke Street, Melbourne, C.1.
2AIZ	Nolan, G. R.,	138 Blues Point Road, North Sydney, N.S.W.
2ZZ	Clarke, W. R.,	Olive Street, Asquith, N.S.W.
2AJA	Rich, M. C. W.,	"Tanga," Stanton Road, Balmoral, N.S.W.
3AH	Miller, A. H.,	32 Brinsley Road, E.6, Victoria.
3VT	Thompson, M. M.,	5 Riversdale Road, E.2, Victoria.
3US	Robertson, A. E.,	176 Auburn Road, E.2, Victoria.
5DY	Davey, R. W.,	199 Torrens Road, North Croydon, S.A. (portable).
2AJB	Curle, G. C.,	41 Cardigan Road, Chullora, N.S.W.
3QC	Plowman, B. McL.,	"Arlcurra," Rowcliffe Street, Bendigo, Victoria.
6HS	Simpson, H. B.,	36 Bruce Street, Leederville, W.A.

### Change Of Address.

6MS	Sander, J. H.,	Albany Road, Cannington, W.A.
3KR	Rankin, K. R.	
2RT	Felton, W. R.,	29 Collins Street, Belmore, N.S.W. (See also alterations to call signs.)
3YY	Harkin, D. J.,	R.A.A.F., Pearce, W.A. (See also alterations to call signs.)
2VJ	Jarvis, V. J. E.,	C/o. 2RG, 'Ulong Street, Griffith, N.S.W.
3LP	Paul, L. A.,	35 Austral Avenue, Preston, N.18, Vic.
2JH	Hutchison, J. V.,	7 Cobham Avenue, West Ryde, N.S.W.
2ZW	Grimmett, S. U.,	352 South Terrace, Bankstown, N.S.W.
2PG	Gosnell, R.,	17 Middleton Avenue, North Bondi, N.S.W.
5TR	Turner, R. R.,	337 Angus Street, Adelaide, S.A.
3TU	Irvine, J. F.,	922 Burke Road, Balwyn, E.8, Vic.
3DF	Irvine, C. J.,	922 Burke Road, Balwyn, E.8, Vic.
2AQ	Duffy, J.,	Prince Street, Grange, Brisbane, Qld. (See also alterations to call signs.)
2AGH	Hall, G. G.,	17 Albyn Road, Strathfield, N.S.W.
2WW	Nash, W. R. C.,	55 Mulgrave Road, Cairns, Qld. (See also alterations to call signs.)
2SR	Emmelhainz, A. E.,	66 Margaret Street, Petersham, N.S.W.
2VR	Wheeler, A. R.,	11 Alton Avenue, North Strathfield, N.S.W.
5MH	Baty, R.,	Torrens Road, Challa Gardens, S.A.
5LW	Kelly, R. D.,	58 Fairford Street, Unley, S.A.
6KS	Anderson, K. S.,	241 Hay Street East, Perth, W.A.
2AGO	Wilson H. G.,	38 King William Street, Greenwich, N.S.W.
2YB	Lewis, W. J.,	C/o. R.A.A.F., Pearce, W.A. (See also alterations to call signs.)



2MR—Manly District Radio Club, East Esplanade, Manly, N.S.W. (Postal address, P.O., Box 644FF, Sydney.)

### Alterations To Call Signs.

3YY—Harkin, D. J., 77 Agg Street, Newport, W.15, Vic. Now VK6YN. (See also changes of address.)

2RT—Felton, W. R., C/o. R. H. Jones, 319 Princes Highway, Kogarah, N.S.W. Now VK2RF. (See also changes of address.)

2AQ—Duffy, J., 1 Wilfield Avenue, Rose Bay, N.S.W. Now VK4AQ. (See also changes of address.)

2WW—Nash, W. R. C., 255 West Street, Crows Nest, N.S.W. Now VK4WN. (See also changes of address.)

2YB—Lewis, W. J., C/o. J. B. Corbin, 39 Mitchell Street, McMahons Point. Now VK6YB. (See also changes of address.)

## “Radio World” - Vol. 2

May 1937 . . . April 1938

### INDEX OF TECHNICAL FEATURES

#### A:

- ✓ Across the Atlantic on 5 Metres ..... June, 1937
- ✓ Amateur Game, Breaking Into the (5) to (13)—  
May '37-Feb. '38 (Inc.)
- ✓ Amateur Radio, 25 Years In (1) to (9)—  
May '37-Jan. '38 (Inc.)
- ✓ Amplifier, High Fidelity Uses Push-Pull 2A3's—  
August, 1937
- ✓ Amplifiers, Public Address, Give 15 and 25 Watts  
Output ..... December, 1937
- ✓ Amplifier, Push-Pull 2A3's Give 13.5 Watts Output—  
September, 1937
- ✓ Amplifier, Midget 3-Watt ..... April, 1938

#### D:

- ✓ Designing Vibrator Type “B” Eliminators ..... July, 1937
- ✓ DX Two-Band Junior Transmitter ..... September, 1937

#### E:

- ✓ Eliminators, Designing Vibrator Type “B” .... July, 1937

#### F:

- ✓ First S.W. DX Contest ..... November, 1937

#### H:

- ✓ High Fidelity Amplifier Uses Push-Pull 2A3's—  
August, 1937
- ✓ Home-Built Talkie Plant Gives Excellent Results—  
August, 1937
- ✓ Image Frequency Interference on Short Waves—  
May, 1937

#### I:

- ✓ Improved Operating Conditions for 1C6 on S.W.—  
November, 1937
- ✓ Installation Regulations ..... July, 1937
- ✓ Interference Eliminating Man-Made ..... April, 1938
- ✓ Inverse Feedback Conquers Pentode Tone ..... May, 1937

#### M:

- ✓ Making a Reiss Microphone ..... December, 1937
- ✓ Multi-Band Transmitter Uses Unique Assembly—  
August, 1937

#### N:

- ✓ New Adelaide Station Has Up-to-date Transmitter—  
November, 1937
- ✓ Nine-Channel, Ultra S.W. Radio Telephone Link—  
October, 1937

#### P:

- ✓ Public Address Amplifiers Give 15 and 25 Watts  
Output ..... December, 1937
- ✓ Push-Pull 2A3's Give 13.5 Watts Output—  
September, 1937

Power Pack for “Empire All-Wave Three” (A.C.  
Version) ..... Jan. and Feb., '38

Portable Four, Outdoor ..... October, 1937

#### R:

##### RECEIVERS.

- Advance 1937 Radiokes Kit-Set ..... October, 1937
- “Amateur Communications A.C. Superhet”—  
June and July, 1937
- “Amateur Communications Battery Superhet”—  
December and January, 1937
- Crown Air-Cell Pentagrid Seven ..... August, 1937
- “De-Luxe Fidelity Eight” ..... November, 1937
- “Eaglet All-Wave Two” ..... June, 1937
- Eight-Valve T.R.F. .... January, 1938
- “Empire All-Wave Three” (Battery Version)—  
May, 1937
- “Empire All-Wave Three” and Power Pack (A.C.  
Version) ..... Dec. '37-Jan. '38
- “Fidelity Dual-Wave Six” ..... February, 1938
- “Jones Super Gainer” ..... July, 1937
- “Outdoor Portable Four” ..... October, 1937
- “Sky-King Dual-Wave Five” ..... August, 1937
- “Tom Thumb Portable Two” ..... September, 1937
- VK2NO Advanced U.H.F. Receiver ..... February, 1938
- Radiokes 1938 Moneysaver ..... April, 1938
- “Comet Superhet Four” ..... April, 1938

✓ “Radio Aid,” Explorers Track Down Noises—

- July, 1937
- ✓ Radio Aids Flying Doctor ..... November, 1937
- ✓ Radio Locates Missing Plane ..... September, 1937
- ✓ Regulations, Installation ..... July, 1937
- ✓ Radio Step by Step (8) to (16) ..... May '37 to March '38
- ✓ Round Table Hook-Up ..... Aug. '37-Feb. '38
- ✓ Round The Shacks (1) to (8) ..... Aug. '37 to April '38

#### S:

✓ Stations, World Short-wave ..... January, 1938

#### T:

- ✓ Trans-Pacific DX on 10 Metres ..... July, 1937
- ✓ Transmitter, DX Two-Band Junior ..... September, 1937
- ✓ Transmitter, Multi-Band Uses Unique Assembly—  
August, 1937
- ✓ Transmitter, New Adelaide Station Has Up-to-date—  
November, 1937
- ✓ Transmitter, 50-Watt For New Power Limit—  
April, 1938
- ✓ Transceiver, Portable 5-Metre ..... April, 1938

#### U:

✓ Ultra S.W. Radio Telephone Link, Nine-Channel—  
October, 1937

#### V:

✓ Valves in the Making (1), (3) .... Jan., Feb., March, 1938

✓ V.K. Amateur Calls ..... October, 1937

#### W:

✓ World Short-wave Stations ..... January, 1938

✓ Waves, Image Frequency Interference on Short—  
May, 1937



**EVERYTHING**  
to build the  
**"SYMPHONY"** £14  
**BATTERYLESS FOUR**

Everything — Valves, Accumulator, Speaker, etc., to build the wonderful 4-valve dry-batteryless receiver that operates from a 6-volt "A" battery. This set was tried and proved in the "Listener In" Laboratories and described in the "Listener In" dated December 12th.

Remember, Veall's pay freight on all Victorian Retail orders except radio cabinets.

**ORDER YOUR KIT TODAY**

**A Set Builder Says—**

READ THESE RESULTS, as obtained by a set builder in the North-West District:—

"Even during the daytime, with an inside aerial of only 10 feet, I easily tune in any Victorian or South Australian stations that I want. I can also get several New South Wales stations. Selectivity and tone are incomparable, and there are no unwanted noises.

"It is a real live set—there is no messing with the controls to get stations. Turn the dial to the station wanted and it is there. The volume control is very efficient. A local-distance switch is not needed. Thanking you for a jolly good set."

**GREATER DISTANCE—**  
**—LESS NOISE**



BRING IN NEW STATIONS. Local static vanishes and reception improves 20 per cent. to 73 per cent.

KIT embodies everything necessary for a perfectly engineered transposed aerial, including the patented Antennex aerial energiser unit.

Price—the complete kit. **52/6**

**Vealls have the Fastest Mail Order Service in Australia**

An expert staff gives every order individual attention. Accurate, speedy execution of all orders and . . . Veall's pay freight on all Victorian retail orders, excepting radio cabinets, and interstate retail orders, excepting batteries and cabinets. Try Veall's with your next order . . . the most comprehensive stocks in Australia.

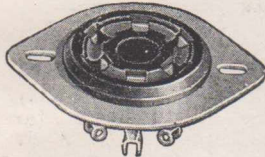

**"AMPHENOL,"**  
**THE PERFECT**  
**VALVE SOCKET**

4, 5 & 6-pin . . 6d. each  
7 & 7a-pin . . 7d. each  
8-pin Octal . . 9d. each

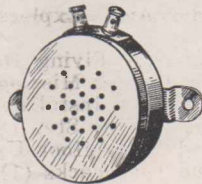

**"MEHNE" ULTRA HITONE**  
**BUZZER**

All metal case, 2 in. in diameter. A perfect high tone for Morse practice or testing . . . 5/9 each  
MEHNE, 3, 5 and 8 volt .5 amp. Bell Transformers.

**5/6 each**



**THE NEW**  
**ORMOND SLOW MOTION**  
**DIAL**

For short-wave sets. Test equipment, etc. An accurate dial with hair-line divisions, all geared, no backlash. New stocks just landed. 2 3/4 in. diameter. Price . . . . . 9/6 each

**THE NEW**

**Piezo Self-Tracking Pickup**

Tracks perfectly on either 10-12 or 16-inch records. Cuts down needle scratch by 50%. Gives greater life to records.

**Price £5/5/-**

Vealls have complete stocks of all Electrical Household Labour-saving Devices and Appliances. Irons, Toasters, Grillers, Fans, Radiators, Washing Machines, Vacuum Cleaners and Leonard Electric Refrigerators. See our General Catalogue or write

for leaflets. Choose from the biggest stocks in Australia and—Veall pay freight on all retail electrical orders excepting batteries. Address all correspondence to Box 215T, G.P.O., Melbourne.

**VEALLS RADIO & ELECTRICAL STORES**

490 Elizabeth Street, Melbourne.  
168 Swanston Street, Melbourne.  
3-5 Riversdale Road, Camberwell.

243 Swanston Street, Melbourne.  
299 Chapel Street, Prahran.  
97 Puckle Street, Moonee Ponds.

Phone F 3145 (6 lines).



# Hear the World's Highest Powered S.W. Station—Philips PCJ—on the World's Finest Receiver—a Philips Radioplayer

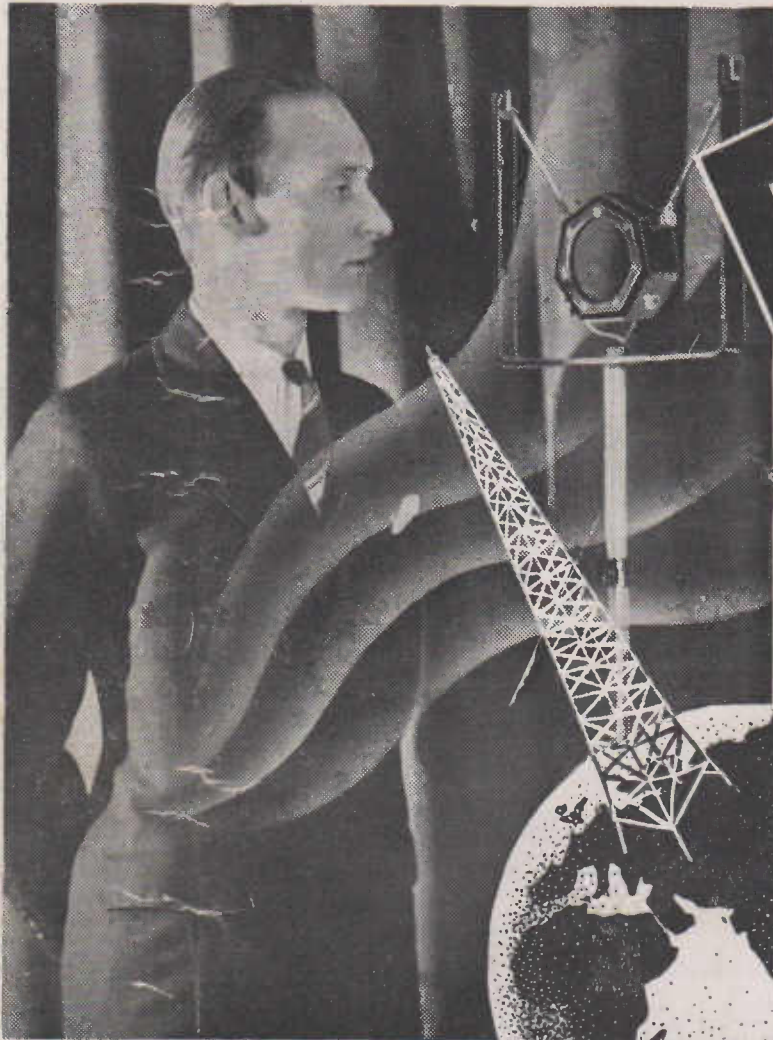

*listen to -*

# PCJ

THE HAPPY  
STATION  
OF PHILIPS  
RADIO

## SPECIAL BROADCASTS

Each Tuesday night, from 6.30 p.m. to 8.30 p.m. Eastern Australian Standard Time, PCJ, the world's most powerful short-wave station, transmits a special programme in English for Australia and New Zealand on 19.71 metres.

Listen to the hello calls from across the world to Australians.

**T**HROUGHOUT the whole world Philips Radioplayers are accepted as the world standard of radio performance. You can hear PCJ, London, Paris, Berlin, and all the famous short-wave transmitters if you own a dual-wave Radioplayer.

# PHILIPS

 *radioplayers*

Broadcast models from 16 guineas.

Dual-wave models from 24 guineas.

Terms available from your local Philips Accredited Radioplayer Retailer.

