

**THE
AUSTRALASIAN**

PRICE, 1/-

Registered at the G.P.O.,
Sydney, for transmission
by post as a periodical.

Radio World

VOL. 4 NO. 11

APRIL, 1940

● **16-PAGE
AMPLIFIER
SECTION**

● **HOW TO USE
VALVE AND
CIRCUIT TESTERS**

● **BEDSIDER
T.R.F. TWO
FOR PHONES**

● **AMPLIFIER
CHAMPIONSHIP
DETAILS**



The Modern Sergeant-Major with His "Astatic" Microphone. See Page 5.
(Photo—courtesy "Daily Telegraph.")

IT'S RIGHT!

— *for price and quality*
— *for servicemen*
and experimenters

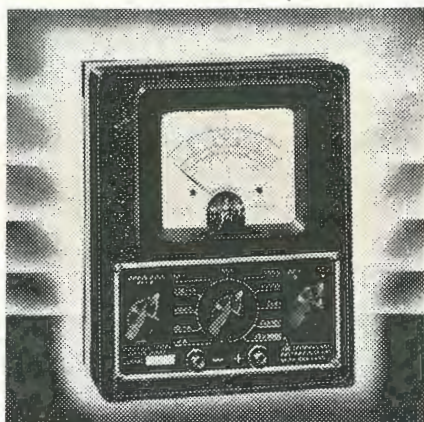

"M" Series Multimeters

For years PATON ELECTRICAL testing equipment has been renowned for its wide application of use . . . for the laboratory where important developments are made . . . for the serviceman who must be assured of reliability and accuracy . . . for the experimenter who desires maximum results.

PATON ELECTRICAL have confidence in recommending for the use of servicemen and experimenters two of their most popular lines . . . the "G" series Oscillator and the "M" Series Multimeters . . . right in price and performance ability.

You can be sure of a very wide scope of tests with this equipment on all types of radio receivers. Write immediately for fully detailed catalogues and prices to—

ALL LEADING DISTRIBUTORS

Prices subject to alteration without notice.

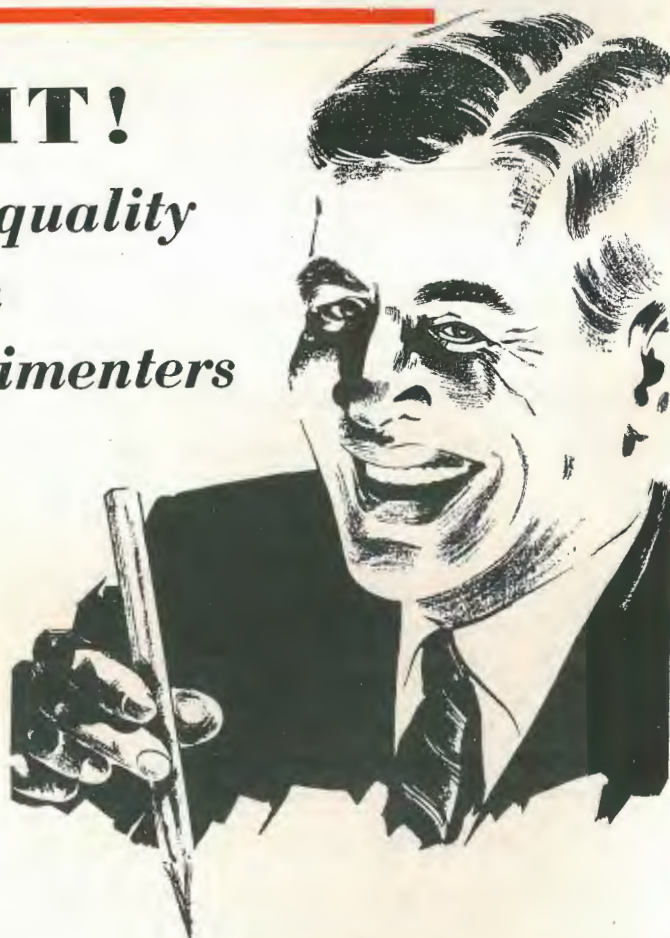

"G" Series Oscillators

PATON



Electrical

PATON ELECTRICAL PTY. LTD., 90 VICTORIA STREET, ASHFIELD.

'PHONES: UA 1960...1982

The Australasian Radio World, April, 1940.

The Australasian
RADIO WORLD
Incorporating the
ALL-WAVE ALL-WORLD DX NEWS

Vol. 4. APRIL, 1940. No. 11.

CONTENTS:

CONSTRUCTIONAL

"Junior" Short-wave Converter	3
"Bedsider" 2-valve Battery T.r.f.	7
"R.E." Portable Kit-set	16
"Scout" Battery-operated T.r.f.	38
"R.C.S." Version of the Picnic Portable	14

GENERAL ARTICLES

Letters to the Editor	13
Radio Saves the Fruit Crop	13
Air-Test No. 1	37
Hints and Tips	42

TEST EQUIPMENT

Valve and Circuit Testers	9
Laboratory Service for Readers	43

SHORT-WAVE SECTION

The Month's Loggings	34
Station Schedules and Changes	33
Special Notice to DX Club Members	36

AMPLIFIER SECTION

Amplifiers for Home Use	17
Amplifier Championship	19
"Baby Grand" Amplifier	21
"Big Boy" Power Amplifier	29
"Fundamental" Power Supply	25

JUNIOR TECHNICAL

Soldering	44
Naval Wet Cell	45

TRADE NOTES

Amplifier Equipment	20
Marse Code Kit	42

SPEEDY QUERY SERVICE

Answers to Readers' Problems	47
------------------------------------	----

The "Australasian Radio World" is published monthly by A. G. Hull. Editorial Offices: 117 Reservoir Street, Sydney, N.S.W. Telephone FL 2842.

Advertisers please note that copy should reach office of publication by 14th of month preceding that specified for insertion.

Subscription rates: 1/- per copy, 10/6 per year (12 issues), post free to Australia and New Zealand.

A GIANT

In Performance

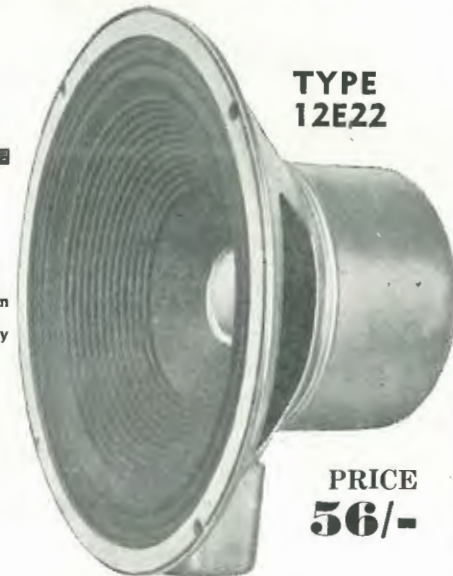

**TYPE
12E22**

- High Fidelity Reproduction
- Exceptionally Wide Frequency Range
- Greater Output
- Electrically Welded

**PRICE
56/-**

Unrivalled for either P.A. or receiver equipment, the Amplion 12E22 offers features not to be found in any other speaker, regardless of type or price. Power handling is 13 to 20 watts maximum, transformers are sealed and insulated from core and the tonal quality and fidelity of reproduction are positively unequalled.

AMPLION

Electrically Welded LOUD-SPEAKERS



New "Big" 7-inch.

The "BIG" 7-inch Amplion Speaker supersedes 6½- and 8-inch types, and gives fidelity of reproduction superior to any other speaker in its class. Power handling is 8 to 12 watts.

PERMAGS. 5," 7" and 12" types freely available from Dealers throughout Australia.

Write NOW for latest Amplion Speaker Data, Publication 88C, free and post free.

AMPLION (A/sia) Pty. Ltd.
 382 KENT ST., SYDNEY.

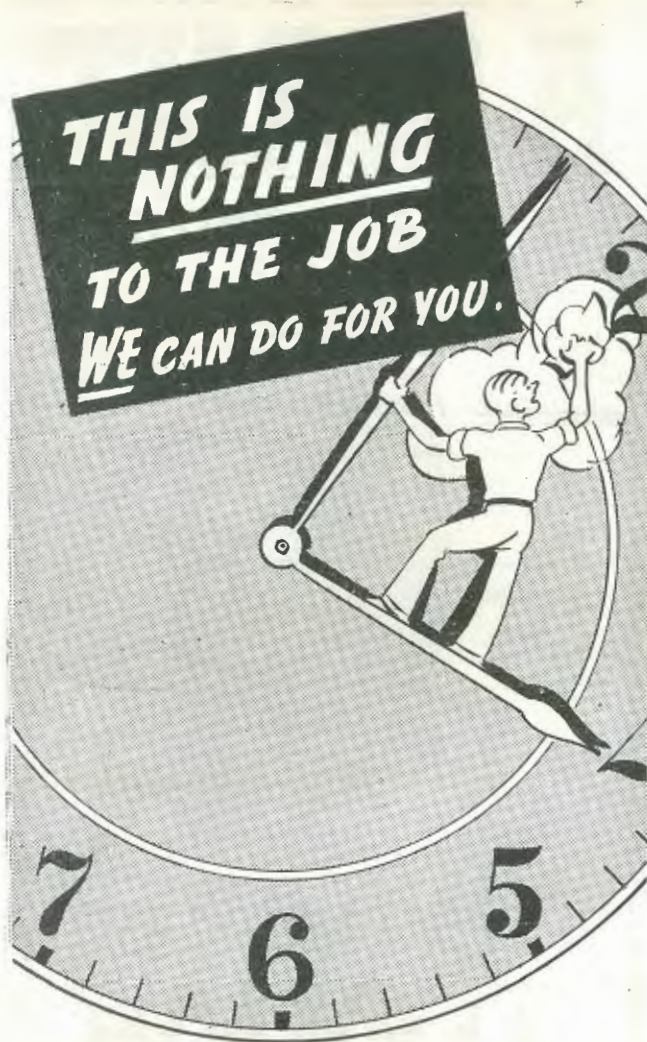

MARTIN de LAUNAY'S SERVICE Saves Time!

WE'RE in the radio and electrical business to help you—to supply you with the best products—to save you money—to give you the best service in town. We do this because we know it's **GOOD BUSINESS** to treat customer's right. You can't beat efficiency and business-like methods. Like to try our service?

To get one of our **ROTARY RESISTOR COLOUR CODE INDICATORS** FREE AND WITHOUT OBLIGATION, pin this advertisement to your letterhead and post to us.

MARTIN de LAUNAY PTY. LTD.

Cr. DRUITT and CLARENCE STS., SYDNEY. M 2691 (5 lines).
And at NEWCASTLE and WOLLONGONG.

Editorial



First of all I want to thank you all for the wonderful reception you have given me and the effective help. Apparently hundreds of my friends, whom I have never had the pleasure of meeting, have shown themselves to be true friends by spreading the news, and it has travelled far and wide at great speed.

One big result has been a tremendous increase in my mail and 'phone calls and what with trying to get out a bigger and better issue, and catch up with my correspondence, I have put in the busiest month I can ever remember.

It has been good fun, of course, because it has been so successful. I don't think anybody minds working hard when they can easily see that they are progressing.

Particularly gratifying has been the response to our offer of a technical query service by return mail, and to our offer of laboratory service, although both of these have added greatly to the amount of work to be done. Additional staff has been obtained, however, and from now on we should have little difficulty in keeping abreast of the work involved.

It is with regret that I have to announce that a change has been found unavoidable in connection with our short-wave review.

Mr. Alan Graham, who has conducted this section in such fine manner for some time has gone into camp and so will not be able to contribute these notes for future issues.

My luck holds, however, and I consider that I have been most fortunate in being able to obtain Mr. L. J. Keast to carry on the work. Mr. Keast has been a prominent short-wave listener for years and a keen contributor to leading journals. We feel sure that Mr. Keast will carry on the short-wave review in grand style.

Speaking of changes, you will notice a couple of new features in this issue, a page for letters to the editor, and a Hints and Tips page, contributed by Walter G. Nichols, one of radio's pioneer experimenters, a fine artist and a man with a keen appreciation of the finer points of radio theory and practice.

Work in connection with the amplifier championship is way ahead of me at the moment as I have been so busy with other things. Keen interest has been shown however, and that is what matters most. Already I have had several entries and bookings for seats, also applications for positions on the judging staff, and on the organising committee. These things should be straightened out in the course of the next few days, so if you have anything you want to say about the contest I'd appreciate a letter immediately. It's your contest and I want you to see that you get your share of the work, interest, and enjoyment.

—A. G. HULL.

JUNIOR SHORT-WAVE CONVERTER

Listen direct to the news sessions from overseas short-wave stations with this one-valve converter, which makes any broadcast receiver into a powerful dual-wave set at a cost of only a couple of pounds.

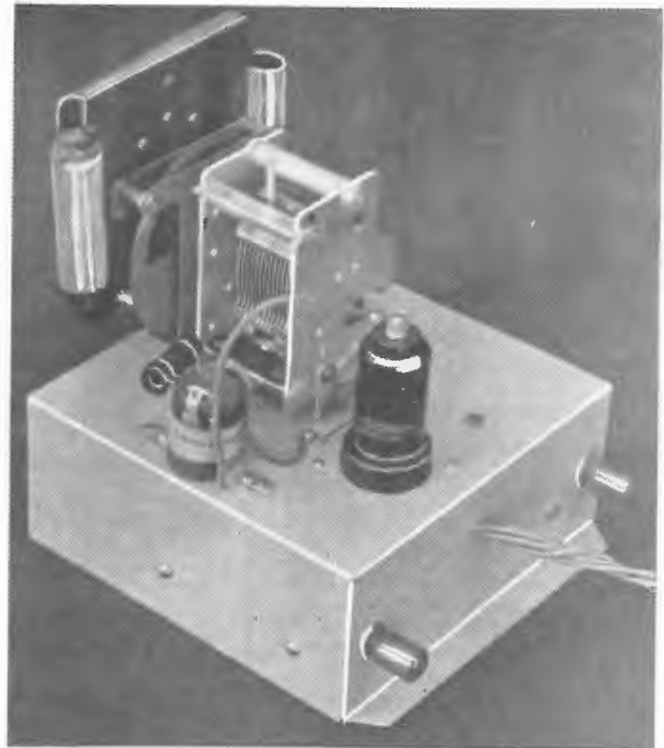

THE manner in which the news service from the B.B.C. is re-broadcast from the local stations leaves much to be desired. Apparently on account of some arrangement, only ten minutes of the news is broadcast. As a result many listeners are buying dual-wave receivers so that they can tune in to the B.B.C. direct. But those who already possess a receiver which they like, and want to keep, do not need to buy a dual-wave set. Their

present set can be converted into a dual-waver by means of a short-wave converter. Here is a description of an especially simple type of short-wave converter which can be built up in an hour or two, even by a novice. Results are undoubted and no alignment or adjustment of any kind is required. The complete kit of parts can be purchased for a modest sum. Results with the converter fitted to a reasonably good broadcast set are

just as good, and in many cases better, than those obtained with a dual-wave set.

The original converter shown in the photographs was tested on a dual-wave set, and by throwing over the switch we were able to compare results directly, and we found that the converter was even more powerful than the dual-waver, but with slightly greater noise. For all practical purposes the results were identical for any station, as it was seldom necessary to use the full power of the set to which the converter was attached.

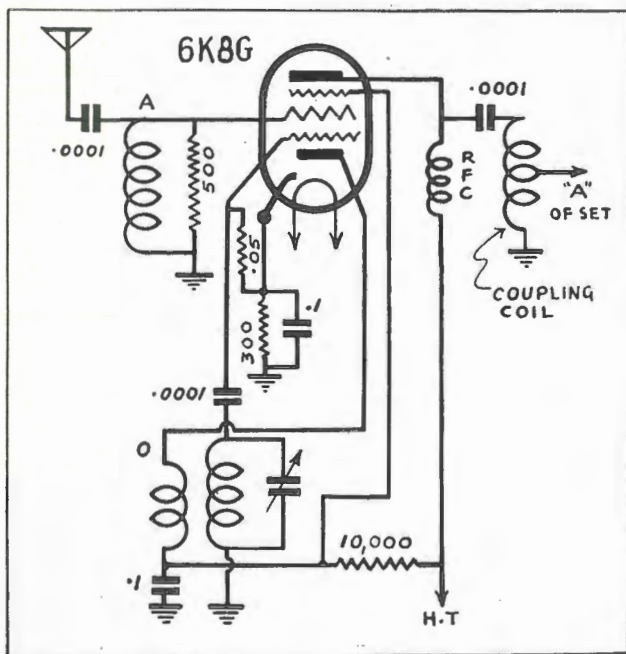

Schematic diagram of the circuit, showing the simplicity of the arrangement. A single-gang condenser does all the tuning and no alignment adjustments are required.

What It Is.

The short-wave converter consists of a single valve, used as a frequency changer, so that when it is attached to a broadcast set we have a double superheterodyne. The converter changes the short-wave signals to make them suitable for amplification by the receiver in exactly the same way as the receiver amplifies ordinary broadcast signals.

The Circuit.

This particular converter uses the most simple arrangement imaginable, as the aerial circuit is only roughly tuned to the incoming signal, by means of a special bobbin coil with a 500-ohm resistor shunted across it. This circuit is thus roughly tuned to all short-wave signals between about 15 and 40 metres, with its peak about 25 metres.

The oscillator circuit, however, follows conventional lines and is sharply tuned by means of a single-gang tuning condenser. Although theory

WESTERN CABINETS

are specified exclusively
for the

- PICNIC PORTABLE
 - 1940 COMPANIONETTE
 - DAVENTRY D/WAVER
 - DANDY THREE
- and the
- WONDER ONE

described in recent issues of
"Radio World."

● In every case the cabinet for the original model was built by us to the Technical Editor's specifications, and by ordering a Western you can be sure that your chassis will fit as accurately as the original.

● Each cabinet is strongly built, with dovetailed joints to ensure the greatest rigidity, and is covered in the latest airway-canvassed leather-cloth. (A variety of tonings to suit individual tastes is available).

Prices on Application.
CABINETS FOR ALL
PURPOSES.

● For years we have specialised in making cabinets for mantel radios of all types, for portables, and for test equipment.

● Our new factory is equipped to fulfil orders for one case, or for one thousand, while heavy stocks of latest covering materials in a variety of tonings enable us to offer clients a product that is the last word in smartness and durability.

**WESTERN
MANUFACTURING CO.**

18 THIRD AVENUE,
FIVE DOCK, SYDNEY.

'Phone - - - UA 3444.

SOUTH SEA ISLAND.

With the local amateurs off the air, the 20-metre phone band offers an unique opportunity for quite a number of unusual foreign amateurs to be picked up in the afternoons.

Mr. L. J. Keast, of Randwick, tuned in to the Pan-American Air Base at Canton Island on Good Friday at about 4.30 and heard a long talk between the boys there and friends in California.

A glance at the globe might suggest that this little island in the Phoenix Group, just south of the Equator, would be anything but pleasant in which to be domiciled.

Remarks heard from the Americans after three months in this delightful spot, as they term it, were drawing comparisons between Canton Island and Catalina, one chap saying the former could beat Catalina sixty ways, the average temperature in the rock pools in which they frequently bathed being 80 degrees.

Well, maybe they are making history, but under what conditions.

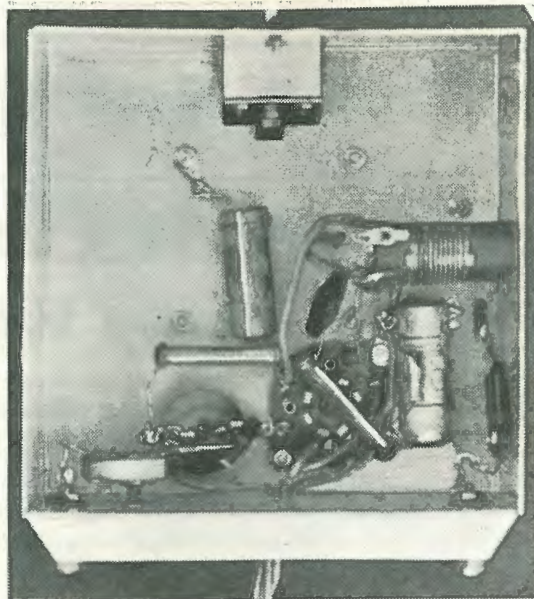

A photograph of the wiring.

would indicate that the overall selectivity of the arrangement is unlikely to be as great as with accurately tuned circuits for both oscillator and aerial circuits, in practice it is found that the selectivity is quite sufficient for all normal requirements and actually helps quite a bit as tuning is not such a delicate operation as with a dual-wave set.

In its simplest form the converter depends on the receiver to supply it with current for the heater of the valve and high tension supply, but if

these points offer any difficulty it is simple enough to include a separate power supply or a separate heater supply in the converter unit.

Most modern broadcast receivers use 6.3-volt valves and the heater supply will usually stand the extra drain of .3 of an ampere without any difficulty. Similarly, the high tension can be tapped, either with a couple of leads soldered into the internal wiring of the set or else by means of an adaptor unit fitted under one of the valves.

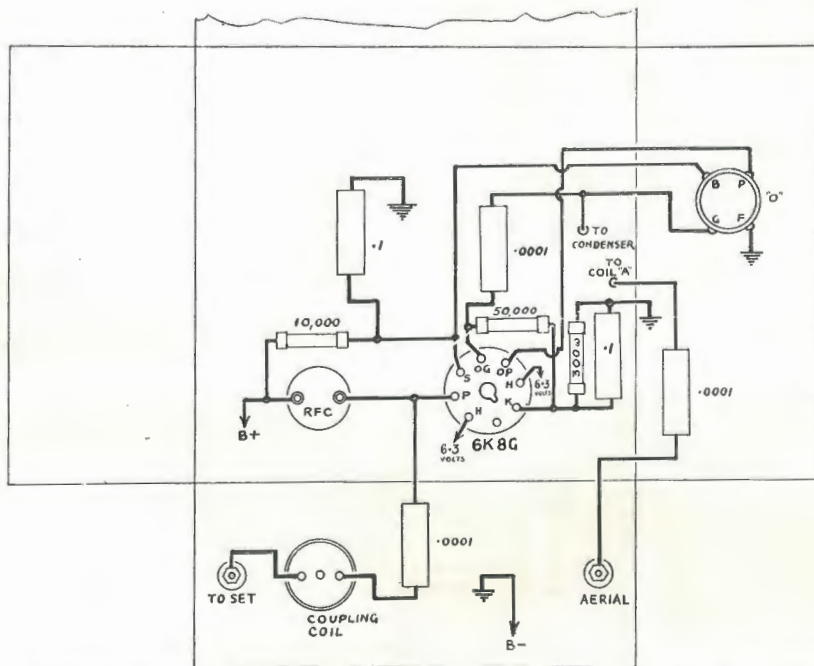

By comparing this diagram with the photograph above you will find that the wiring presents no problems.

The Parts.

First item on the parts list is the base, and ready drilled bases can be obtained from all radio dealers who handle parts. The base measures six inches square and two and a half inches deep.

The coil kit consists of the special bobbin type of aerial coil, and a small oscillator coil with four lugs. Made up by the coil people is also the special coupler unit which is needed to feed the output of the converter into the aerial terminal of the receiver.

A small resistor of about 500 ohms is required to shunt the aerial coil unit, and in order to safeguard against any difficulty which might arise if this resistor had abnormal distributed capacity or inductance, it is safest to get a resistor with the coil kit, and of the same brand, and the correct type.

A single-gang tuning condenser is required, and, of course, a small dial of suitable type and with suitable mounting to fit the ready-drilled base which you obtain.

Three resistors, three mica condensers and two tubular condensers complete the minor components, values for these being clearly specified in the parts list.

OUR FRONT COVER.

The picture on our cover shows the part that modern sound equipment is playing in the army. The photograph was taken at the Wallgrove (N.S.W.) Light Horse camp, where a power amplifier puts out the orders so that they can be heard over a radius of two miles. The microphone used is one of the "Astatic" type D104 crystal units. These are popular for public address and amplifier work on account of their high efficiency.

A certain amount of sundry hardware is also required and may vary according to individual taste. In the original chassis there were about four yards of hook-up wire, twelve "eighth" screws about half an inch long, with nuts, two insulated terminals, one cap clip for the valve, three solder lugs, and four three-sixteenth inch spacing washers to go under the gang condenser to allow a neat mounting of the dial. Other components on the parts list

include the octal socket and a radio frequency choke. This latter item should be of reasonably good quality if best results are to be obtained.

Assembly.

First step in the assembly is to fit the valve socket, with the key notch of the centre hole pointing into the corner, so that the valve socket connections will then agree with those of the picture diagram. This diagram will also indicate how a solder lug is mounted under one of the valve socket screws, where it is used as the earthing point for one of the tubular condensers, the earth of the oscillator coil, and also the converter end of the "B" negative lead from the set.

The terminals can be mounted in the rear of the base, care being taken that they are effectively insulated from the metal of the base, as otherwise the converter will not operate, as the signal will be grounded.

The coupler coil is mounted up in the rear of the base, handy to the output terminal and the radio frequency choke just below it, with one terminal close to the plate terminal of the valve socket.

Before mounting the tuning condenser a wire is soldered to the lower centre terminal of the fixed plates,

FOXRADIO

MORSE CODE PRACTICE SET!

Since the outbreak of war, thousands of people throughout Australia have commenced learning the Morse Code. You can be prepared, too . . . by ordering this efficient, low-priced FOXRADIO Morse Code Practice Outfit.

THE KIT COMPRISES:

- P.M.G. pattern Morse key.
- Special high-pitch audio sounder.
- Eveready 4½-volt battery.
- Morse Code chart, showing alphabet, punctuation marks and numerals.

17/6
POST
FREE

TRY US FOR THAT "RADIO WORLD" KIT!

We maintain a special department under the supervision of a skilled technician to fulfil orders for "Radio World" kits. The special stocks we carry of all components used and specified by the Technical Editor enable us to give split-second service at unbeatable prices on all orders, large or small. WRITE NOW FOR OUR QUOTATIONS ON THE KITS DESCRIBED IN THIS ISSUE.



FOX & MacGILLYCUDDY Pty. Ltd.

(In Liq.)

MERINO HOUSE, 57 YORK ST., SYDNEY.

Telephone: B 2409-10.

Telegrams: FOXRADIO.





LIGHTENS THE TASK
WHEN **RADIO**
TAKES A HAND.

Radio brings to your home the joyous music and constant companionship that lightens all duties and provides more leisure hours.

★ ★ ★

A second set banishes loneliness, widens knowledge and creates that happy atmosphere which is so conducive to good health.

★ ★ ★

For constant reliability be sure that the second set you choose is equipped with

RADIOTRON
VALVES

★ SEALED FOR
YOUR PROTECTION



Advt. of Amalgamated Wireless Valve Co. Pty. Ltd.



To Destroy
"TONE BOGEY"
Re-valve with
RADIOTRONS

The valves in the sealed cartons

and this wire runs through to the underside of the base when the tuning condenser is mounted in place.

On the top of the base, alongside the tuning condenser, goes the aerial bobbin coil, with the 500 ohm resistor soldered across its two terminals, one of these being earthed and two wires attached to the other. Of these two wires one has a clip attached and connects to the cap of the valve, whilst the other runs through to the underside of the base, being connected to the input terminal through a .0001 mfd. mica condenser.

Wiring.

The rest of the wiring is on the underside of the base, and the work of carrying it out is quite a simple matter if the picture diagram is followed carefully.

The lead from the tuning condenser goes to the "G" terminal of the oscillator coil unit, which is the top end of the heavy winding. The coil is colour coded in order to make the connections easy to follow, but this

from the receiver.

Just how you are going to get this power depends on what you have decided to do. If you are in doubt about your ability to understand the problem, your best plan is to get the dealer who supplies the parts to supply an adaptor to fit under the output valve of your set, which should be type 42, 6F6, 6F6G, or 6V6G. With this adaptor on the ends of the power supply wires it will be just a matter of plugging it in under the output valve whenever you want to get short-waves, and then changing over the aerial from the set to the con-

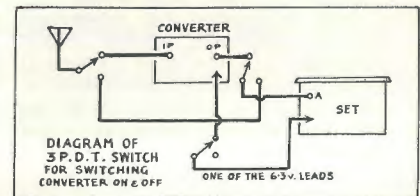

verter, and connecting the output terminal of the converter to the aerial terminal of the set by means of a short piece of hook-up wire.

If you have a certain amount of practical knowledge of radio matters you will find it is simple enough to fit a switch so that the converter can be left permanently connected, and then you can play either broadcast or short-waves as you desire at the throw of a switch, just as though your set were a real dual-waver.

As a guidance for those who want to put up the installation completely in this way we show a brief diagram of the switching.

Operation.

Once the converter has been properly connected the short-wave stations are brought in by setting the dial of the broadcast set to the top of the band, around 550 k.c. and on a spot which is clear from broadcast stations. The tuning of the dial of the converter should then bring in the short-wave stations, with the volume controlled by the ordinary volume control of the set.

Greater care is needed for tuning in short-wave stations than for ordinary broadcast stations, but this presents no difficulty after you have had a little practice at it.

One of the most important things is to get an idea of the relationship between the numbers on the dial and the wave-length being tuned, and so a point should be made of listening in to station announcements to get the wave-length and then jotting this down with the dial number on which that particular station was heard.

As with any short-wave listening it is highly desirable to know when and where to look for stations, and our short-wave review pages will be found invaluable in this respect.

"JUNIOR" SHORT-WAVE CONVERTER

List Of Parts.

- 1—Base, 6" x 6" x 2½."
- 1—Single gang condenser (R.C.S.)
- 1—Dial to suit (Efcro)
- 1—Special coil kit (Radiokes, R.C.S.)
- 1—Coupler unit (Radiokes, R.C.S.)
- 1—Radio frequency choke (Radiokes, R.C.S.)
- 1—50,000 ohm 1-watt resistor (I.R.C.)
- 1—10,000 ohm 1-watt resistor (I.R.C.)
- 1—500 ohm 1-watt resistor (I.R.C.)
- 1—300 ohm 1-watt resistor (I.R.C.)
- 2—.1 mfd. tubular condensers (Solar, T.C.C.)
- 3—.0001 mfd. mica condensers (Solar, T.C.C.)
- 1—octal valve socket (Tasma)
- 1—6KSG valve (Ken-Rad, Radiotron, Brimar, Philips, Mullard).

terminal might be checked, as this particular coil which we happened to get hold of was incorrectly coded, and might have caused quite a bit of bother to an inexperienced builder who followed it out implicitly. As the windings are easy to see, you can check them up. The heavy winding is the grid coil, and should connect up the earth (solder lug) and the tuning condenser. The fine-wire winding should connect the oscillator plate terminal of the valve socket, pin No. 6, to the screen terminal, pin No. 4. The wire from this No. 4 terminal should run to the end of the fine wire winding which is nearest to the end of the heavy winding which runs to the gang.

Power Supply.

The final part of the wiring job is to put in four wires, each a couple of feet long, to carry the power across

The BEDSIDER

*Two-valve battery-operated receiver
for headphone use only*

by **DON. B. KNOCK**

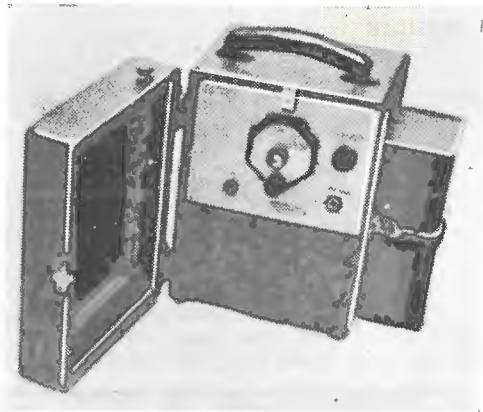

Ready for use.

It is a strange paradox that in outdoor Australia the portable receiver attracted little or no attention for many years, whereas in England, as far back as 10 years ago, the portable type comprised the bulk of the market both in commercially produced and home construction designs.

With the revolutionary development of the now most useful 1.4 volt dry cell valve, however, the portable receiver came into its own and the demand for portables swept the Australian market in a rising tide. With primary interest centring on the news broadcasts of war bulletins by stations everywhere, the self-contained portable of compact and light design became at once a most desirable receiver to have on hand for immediate use under varying circumstances. Such circumstances as periods of military service in camp prompted the writer to put together a collection of components in the form of a small receiver particularly suited to the purpose. In all it is a simple T.R.F. job employing only two valves; a 1N5G and 1G6G with small dry cells for headphone reception.

The latter feature is particularly desirable in surroundings where other people in the immediate vicinity don't want to be disturbed late at night

after a hard day, and it is no effort to put on the headphones and snap the switch on the panel of the receiver conveniently placed alongside one's bed.

THE "BEDSIDE" TWO List Of Parts.

- 1—Base and panel
- 1—Two-gang condenser
- 1—Dial to suit (Efco)
- 2—Coils as specified (Radiokes, R.C.S.)
- 1—Radio frequency choke (R.C.S., Radiokes)
- 1—Reaction condenser (R.C.S., Ray-mart)
- 1—.01 mfd. mica condenser (E.T.C., T.C.C.)
- 1—.002 mfd. mica condenser (E.T.C., T.C.C.)
- 2—.00025 mfd. mica condenser (E.T.C., T.C.C.)
- 1—.0001 mfd. mica condenser (E.T.C., T.C.C.)
- 1—.25 mfd. tubular condenser (T.C.C., Solar)
- 1—20,000 ohm 1-watt resistor (I.R.C., Bradley)
- 1—50,000 ohm 1-watt resistor (I.R.C., Bradley)
- 1—100,000 ohm 1-watt resistor (I.R.C., Bradley)
- 1—2 megohm 1-watt resistor (I.R.C., Bradley)
- 1—Switch
- 2—Octal sockets (Tasma)
- 1—1N5G, 1—1G6G valves (Brimar, Radiotron, Ken-Rad, Philips, Mullard).
- 1—Pair headphones
- 1—"A" cell (Ever-Ready)
- 2—"B" batteries (Ever-Ready)
- 1—Portable case, if required (Western)

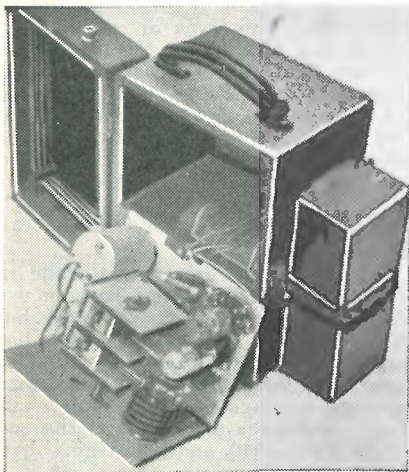

A view showing the chassis.

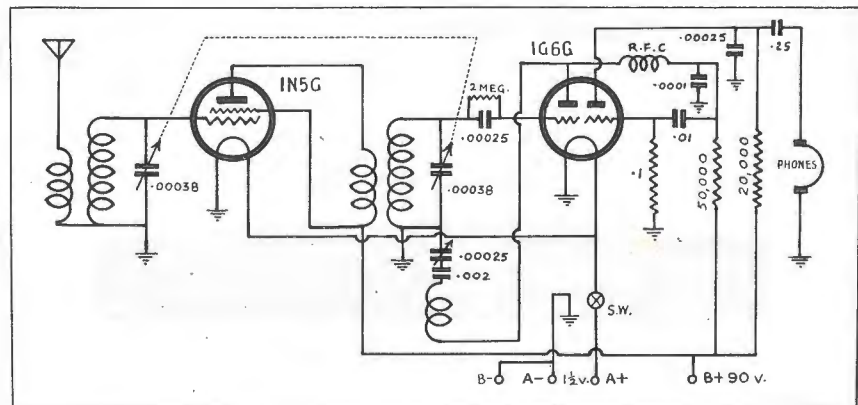

Schematic diagram of the circuit.

BESIDDER (contd.)

R.F. amplifier is used with a 1N5G, preceding a 1G6G in which one triode section is a regenerative detector of the Reinartz variety, and the other triode the audio amplifier for head-phone output. The tuned circuits use a standard 2-gang condenser and the coils are standard for the broadcast range with the proviso that a reaction winding is needed for oscillation control by means of the .00025 mfd. (or .0001) variable reaction condenser. The experienced constructor can easily set to and make up suitable coils,

which are fundamentally quite simple, but coils specially for the job can be obtained in Radiokes and R.C.S. brands.

In the writer's case the originals were home-made on Sirufer cores, the R.F. coil (with aerial coupling) in the grid circuit of the 1N5G being screened. The detector coil unit with primary coupling and reaction coil happen to be left unscreened but that is merely because there just wasn't enough room on the chassis for a coil can.

The circuit diagram should be self-explanatory. There are no audio

windings to break down in humid weather conditions, as audio transformers have a habit of doing when used ordinarily with D.C. through the primary, and space is further conserved by resistance-capacity coupling of the audio section. All necessary resistor and capacity values are marked and it will be seen that the headphones are shunt-fed by a .25 mfd. tubular condenser and 20,000 ohm resistor.

The writer doesn't believe under any circumstances in using high resistance headphones (2000 ohms) with D.C. through them.

That is all there is fundamentally to this receiver and for power supply all that is needed is a 1½-volt dry cell of the bell battery kind for the filaments and a 90-volt portable type B battery.

The .002 mfd. fixed condenser in series with the reaction condenser is merely a safeguard against a prematurely run down "B" battery if the reaction condenser plates should accidentally short.

Valves have also been known to go west through such a defect in a variable condenser, so that the fixed condenser is well worth inclusion. The 2-gang variable condenser for tuning will not need trimmers if the coils are individually padded, as they usually are nowadays, but if home-made coils are used a condenser gang plus trimmers will be useful.

Tuning procedure is simple enough, just a matter of tracking the tuned circuits, and if the coils are commercial jobs there won't be any trouble about that.

Results:—

Using the receiver with an indoor aerial about 25 feet long in a Sydney Eastern Suburb there is plenty of pep on all the Sydney stations, with volume to spare. Selectivity is excellent with iron-cored coils and one or two distant stations have often been heard well. The illustrations show a frame aerial wound inside the lid of the case. This was an experiment which was abandoned, the idea being to use the loop as the tuned grid circuit in the R.F. amplifier. It could be done with a lot of cut and try but the idea isn't worth the trouble in a small receiver of this class. In a superhet it can be of course another story where sensitivity is quite high and a certain amount of tracking can be sacrificed.

The original receiver was made in September, 1939, and has been in use daily in two militia camps under hot weather conditions, and since then has served to get the late news whilst at ease in Sydney, with several occasions of long sessions of programme chasing. As this is written it is the end of January, 1940, and the original batteries are still going strong. It is a truly economical little friend to have around the place anywhere.

JONMAR KITSETS

— NEVER LET YOU DOWN! —

Kitsets for all "Radio World" circuits are completely and carefully assembled by experts, only matched components are used throughout, and all parts are tested before packing. Thousands of Jonmar Kitsets are now giving full satisfaction—why should you be satisfied with anything less than a JONMAR Kitset? You save time, money and disappointments—Jonmar Kitsets never let you down!

COLLARO
ELECTRIC INDUCTION
MOTOR

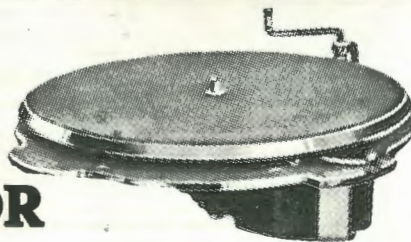

TYPE AC37 (12" Turntable)

- Dust and grit-proof.
- Self-aligning, self-oiling bearings.
- Cushioned drive ensures regular speed.
- Free from electro-mechanical troubles.

For the "Baby Grand" and "Big Boy" Power Amplifiers, specify COLLARO Induction Motor, Type AC37. Fully patented, the Collaro has features that guarantee you complete efficiency in operation. Write now for prices and details.

RAYMART
CRAFT A CREED

RAYMART SHORT-WAVE AND ULTRA-SHORT-WAVE GEAR.

World-famous for design and construction, Raymart is unequalled for the quality of results it gives. Insist on Raymart for the BEST RESULTS!

"The Friendly Wholesale House"
For Everything Radio and Electrical at the
Lowest Prices in the State.

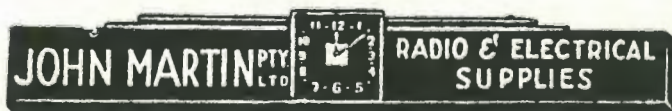

116-118 CLARENCE ST., SYDNEY.

Telegrams: "Jonmar," Sydney.

Telephone: BW 3109 (2 lines).

How to use a Valve and Circuit Tester

By LANCE GRAHAM

This article on the use of the latest type of valve and circuit testers is the fore-runner of a series from the pen of Mr. L. B. Graham, principal of the Australian Radio College. We feel sure that our readers will appreciate these articles, as Mr. Graham is recognised as one of Australia's authorities on the handling of test equipment.



Mr. L. B. Graham.

WITH the development of modern receiver design and complex valves, service operations have lost the simplicity which they possessed in the days of the two and three valve regenerative types of receiver. The "Screwdriver" and "soldering iron" type of equipment is no longer sufficient in these times of complicated circuits.

The tubes used in modern receivers may be any one of several hundred different types and there is such a multiplicity of different types of resistors and condensers and other components, that it would be difficult and expensive to carry a complete stock of parts. This means that the old method of testing valves, components, etc., by substituting new ones is almost impossible.

It is desirable then to have some method of testing the tubes, condensers, resistors and other components. Voltages and currents of a radio receiver. To carry out these tests satisfactorily would require a tube tester, condenser tester, and an A.C.-D.C. Multimeter, making a considerable amount of equipment to carry round.

When all of these are combined in one case the value of such an instrument is easily discernible.

Practical Servicing.

An instrument such as the valve and circuit tester which combines the above service equipment is really a development resulting from years of practical servicing of radio receivers. The days of the serviceman who infrequently achieved success with the aid of screwdriver and pliers, a bit of luck and a lot of guesswork gave place to the gentleman who carried a voltmeter and whose work was more effective, because of this instrument.

With the introduction of A.C. sets and screen grid tubes came an increase in the number and importance of resistors in a receiver's make-up, consequently some method of measuring resistances became an essential part of service equipment. Current readings proved desirable and were added to the meter, resulting in a volt-ohm-milliammeter which forms an excellent piece of service equipment in either its D.C. or A.C./D.C. form.

Before tube testers became general,

an analyser unit which could either be complete in itself or a unit to be used in conjunction with a multimeter, was widely used for obtaining an idea of tube conditions and for a quick analysis of the voltages, etc., applied to the tubes.

This system had two main disadvantages, first, the circuit design and valves had to be known before the tube condition could be ascertained, and second, the long leads between the set and unit may under certain conditions create oscillation, completely upsetting the readings.

The tube checker then came into prominence, allowing tubes to be tested for short circuits between elements, and filament or cathode emission. This tester supplied its own power and was entirely independent of the receiver.

The multimeter and tube tester are essential to modern scientific service operations and it is a natural sequence that these two devices, together with electrolytic, paper and mica condenser tests plus an output meter, necessary for modern sensitive superheterodynes, should be included in the

one piece of test equipment. This piece of equipment we now term a "valve and circuit tester" or a "combined tube checker and multimeter."

Routine Method.

To fully appreciate the uses to which these instruments may be put, we will take as an example a set which has to be serviced and apply the tester in a normal routine method of localising the fault.

In all service work it is desirable to follow a definite method of finding trouble. The order you follow comes naturally from practical experience and will in every case depend on the symptoms given by the set. In practically every case it is advisable to test the tubes before anything else is done. They are one of the most likely causes of complaint, are easy to get at, and with the aid of the tester they can be readily checked. Again even though they may not be responsible for the complaint, a weak one may be discovered, resulting in the sale of a new tube.

Valve Tester Operation.

The valve tester section of the valve and circuit tester is brought into operation by plugging in to the A.C. mains or connecting to a 6-volt battery. The line voltage adjustment should be set according to the operation details set out by the manufacturer. The filament switch is set to its correct position and the tube tested firstly for shorts and then for emission. The shorts test should be carried out with the filament or cathode heated, as shorts often occur due to the expansion of elements when heated. If the tube tests are questionable a new tube may not be necessary, it

The "Palec" valve and circuit tester, which is very popular with radio servicemen.

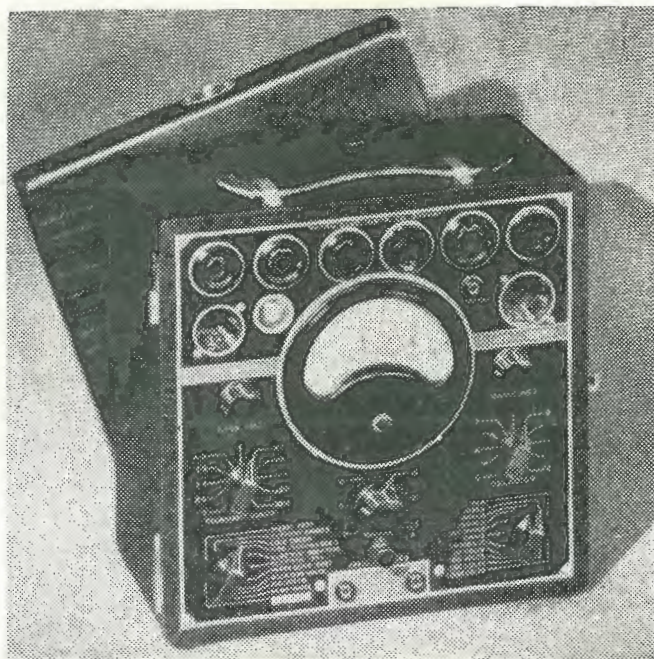

should be pointed out to the owner that the tube does not need replacing at present but its life will probably be short and a spare would be desirable in case of sudden failures. This applies particularly to tubes such as rectifiers and power tubes which are heavily loaded under normal operating conditions.

The tube testing section will pay for itself in very short time, because your customer can actually see the condition of the valve and seeing

carries much more weight than explaining.

Condenser Checking.

Condensers create a good percentage of the service calls and some method of checking these is essential, as they give no external indication whatsoever, and no satisfactory test can be applied with an ordinary ohmmeter. The chief offenders are the electrolytic types; this is natural, as they depend for their action on a liquid electrolyte, which like all other liquids dries up in time.

The filter condensers in an A.C. set can create numerous troubles, not only hum, but distortion, motor boating, oscillation, and a first detector which will not oscillate may be due to faulty electrolytics, without them being bad enough to cause a noticeable increase of hum in a set which is otherwise well filtered. The electrolytic leakage test is exceptionally handy as it gives an indication of the condition of these condensers.

It should be noted that the oscillation and first detector trouble may be cured by use of a .5 mfd. tubular condenser from B+ to earth. This is the correct method, as replacing the electrolytic will only fix the trouble for a short time, and also the old electrolytic may be quite satisfactory for the purpose of filtering power frequencies.

New electrolytics and ones which have not been used for some time should be left under test as long as there is any movement in the meter's needle. This movement is due to the slow forming of the dielectric and is quite normal.

When using the Calstan Model the "Electrolytic Range" potentiometer should be set at zero, the electrolytic clipped on, and the range slowly advanced to its correct setting. This



The "Calstan," another popular unit of modern design.

prevents the needle flying hard over at the moment of contact. Similarly connecting the test leads together with the range set at higher than "2" may result in damage to the meter.

High Voltage Tests.

When testing high voltage types there is a considerable voltage difference between the test prods, and they are quite capable of giving an unpleasant although not in the least dangerous shock.

Electrolytic types should be tested at voltages as close as possible to but not greater than their rated working voltage. Voltages in excess of the rated amount will create undue leakage and may class a good condenser as bad. The reverse is true with low voltages. Any greatly excessive voltage may irreparably damage the condenser.

The test of paper or tubular type condensers in the receiver may now be carried out. This operation uses a neon flash test. Flashing at infrequent intervals or once only represents a good condenser; no flash is the sign of one which is open circuited or too small to read, while a pronounced and continuous glare represents a leaky condenser, which should be discarded. A very faint continuous glow may be noticed, representing a very small leakage, as an ordinary by-pass con-

SUNDRY HARDWARE.

It should be noted that, in addition to the components listed for the sets described in this issue, there should be added sundry hardware.

This includes a power flex or battery cable, wire, screws, soldering tugs, mounting brackets for condensers and dials, clips for valve caps, knobs, dial lights and similar odds and ends.

denser this may be passed as O.K., but should be discarded as a coupling condenser. Care should be taken to make sure that this glow is not due to the leakage through the hands, resulting from holding the leads.

One end of the condenser should always be disconnected from other parts of the circuit as even a very high resistance will show a definite glow on the neon lamp.

Resistance Tests.

The resistance unit of the valve and circuit tester is a very handy one. In both the Calstan and Palec it consists of a number of ranges, one very low, one medium, one high and a very high range. The latter range differs from the others in that it necessitates plugging the instrument into the A.C. power, or connecting the 6v. battery. The zero adjustment of this range is

controlled by the line voltage switch.

In servicing, the medium and high ranges would be used for practically all the resistors in an average set. The high range will give an indication of resistances up to 500,000 ohms, but for accurate reading of values from 200,000 ohms it is necessary to use the very high range. The very low and very high ranges are desirable additions to an ohmmeter. A large percentage of the resistors used in present-day circuit design exceed 200,000 ohms, and without an extremely high range it is impossible to get anything but an extremely slight indication of continuity.

The low range can be used to simplify and speed up a large number of service operations. It allows shorts across coils to be detected without disconnecting half the circuit and the resistance of dry, badly made, and corroded joints can quite easily be picked out.

Some trouble is being experienced at present with intermediate transformers four or more years old. The windings of these transformers develop poor joints, etc., due to corrosion inside the windings. The effect in an intermediate immediately following an autodyne first detector may prevent the tubes from oscillating, par-

(Contd. on page 15)

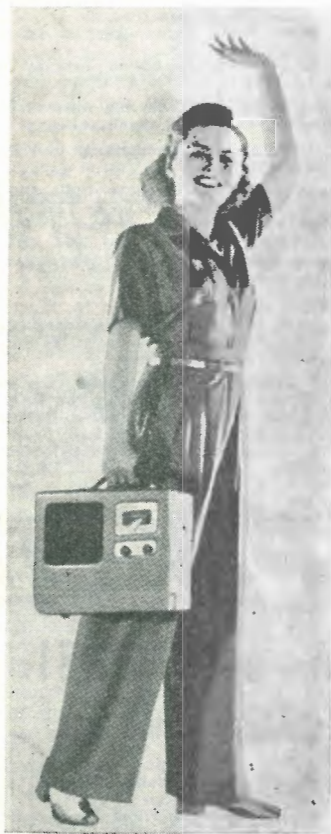

More Profit for YOU

With

BREVILLE PORTABLE RADIO

Portables are extremely popular—
Are you taking advantage of this demand?

There are Four Profit-making Breville Portables

MODEL 168—5	VALVE DUO PORTABLE	20 GUINEAS
MODEL 169—6	VALVE DUO PORTABLE	23 "

DUO Models operate from either A.C. Mains or Batteries. Both Electric and Battery Units are included in the attractive Cabinet.

No external gadgets, plugs or cables to fuss with.

MODEL 156—4	VALVE BATTERY PORTABLE	16 GUINEAS
MODEL 157—5	" " " "	19 "

Both Models 169 Duo and 157 Battery have R.F. Valve for maximum sensitivity.

(Prices 1 guinea higher in W.A., S.A., and Queensland)

SEND THIS COUPON FOR FULL PARTICULARS OF THESE PROFIT-MAKING BREVILLE PORTABLES, AND ATTRACTIVE DISCOUNTS. T.P. Sales Financed.

Manufactured and fully guaranteed by

BREVILLE RADIO PTY. LTD.

67-73 MISSENDEN RD., CAMPERDOWN, N.S.W.

Also at Newcastle and Brisbane. Distributors in all States.

NAME

ADDRESS R.W.1.4.40

Reliable

TEST EQUIPMENT



223A MULTITESTER

SLADE'S RADIO PTY. LTD. have definitely established themselves as the leading manufacturers of High-grade Radio and Electrical Testing Equipment, and in "CALSTAN" 223A Multitester they present an instrument with outstanding advantages . . . ONLY THE CALSTAN MULTITESTER HAS ALL THE FEATURES set out below.

- Combines the multiple functions of a Valve Tester and Multitester.
- A new type meter with a high-grade aluminium face, which will not crack or warp in any climate . . . it is large, and all ranges can be read with the greatest possible speed and accuracy. It is a really high-grade movement housed in an expensive moulded bakelite case. Requires only a small mounting space . . . no mounting screws are visible and all threaded portions are brass inserts, firmly moulded into the case during the process of its manufacture.
- New style, permanently-etched, finger-proof panel.
- Can be operated from either 6-volt accumulator or A.C. mains.

- Available with internal or external vibration, as required.
- Tests every valve on the Australian market, including the new 1.4-volt series.
- Tests Electrolytic Condensers, and Paper and Mica Condensers.
- Measures A.C. volts up to 1250, Output volts up to 1250, D.C. volts up to 1250, D.C. Milliamps up to 250, Ohms from $\frac{1}{2}$ Ohm to 10 Megohms.
- Set in a good quality leatherette Carrying Case.
- Unconditionally guaranteed for twelve months. These, with other features too numerous to mention, make the CALSTAN Multitester the ultimate in Portable Testing Equipment.
- The Calstan 223A Multitester tests everything in the set from the grid at the first valve to the plate of the power valve. Thousands of these Calstan Multitesters have been sold and are still giving complete satisfaction.

HIGH GRADE INSTRUMENTS

at LOW PRICES
223

MULTITESTER
(For A.C. Mains Only)

£16/2/6

223A
MULTITESTER
(Dual-operation)
£17/17/-

CALSTAN
(CALibrated to STANDARD)
TEST EQUIPMENT

MANUFACTURED
BY

SLADE'S RADIO PTY. LTD.

LANG STREET, CROYDON . . . Phones UJ5381-82

Makers of Highgrade Radio & Electrical Testing Equipment

Distributors: N.S.W.: Radio Equipment Pty. Ltd., Martin de Launay Ltd., Bloch & Gerber Ltd., United Radio Distributors, John Martin Ltd., Electric Service Co., Newcastle. QUEENSLAND: Chandlers Pty. Ltd. SOUTH AUSTRALIA: Radio Wholesalers Ltd., Adelaide. WEST AUSTRALIA: Norman L. Burnell & Co., 13 Queen Street, Perth. VICTORIA: Australian General Electric Ltd., Melbourne; Arthur J. Veall Pty. Ltd.; Hartley's Ltd., Flinders Street, Melbourne. TASMANIA: Oatlands Garage, Oatlands. NEW ZEALAND: New Zealand Electrical Equipment Co. Stocks also available from Turnbull and Jones, all branches.

Snipers' Post

GOOD WISHES.

Dear Sir,—Tons of luck in your new venture, and may I venture that your collaboration with Don Knock is very appropriate and augurs well for the future of all dabblers in pure radio. I know you both.

I was impressed with the lines you are starting on, quite sound and extremely interesting. I can't say that I was over-impressed with the amplification idea in the Standard. It seems to me to have been built up too much. I still use the favourite family receiver, my original Standard. I liked, however, the idea of using a separate power pack.

That article on Donald was a gem. It gives us a kick to get something unorthodox.

"Mystery" Barnes is also an asset. How about reviving that controversy?—Yours, etc.,

F. PILE.

Macksville.

COIL BOXES

Dear Sir,—I wish to take exception to the observations about coils in your article "Beyond the Gates," in the March issue.

I, too, have built a number of successful battery sets, but my experience with coils has been just the opposite. On the one or two occasions when I tried to wire up separate coils to a switch I ran into no end of bother. I always use the coil bracket units and find that the latest types give easily the best results in every way. I have had particularly fine results on both broadcast and short-waves with the Crown D36 unit and also the R.C.S. DW25.

Otherwise the issue was fine, and I wish you the best of luck,—Yours, etc.,
Broken Hill.

"SERVICER."

INSTABILITY

Dear Sir,—It is with great pleasure that I find you are back in circulation again. I could hardly believe my eyes when I got the last issue of "R.W." I never missed a copy of "—" for nine years, mainly because of your technical articles, and what I could learn from them. After it was converted into a women's weekly and kindergarten issue I just had to dump you, so you can imagine my enjoyment to find you back on your real job again.

I never had a failure with any of your circuits, except the last one I built, and that was the all-wave job. I got instability and oscillation and I am damned if I could get it out.

Well, I just bought a complete new kit of parts, and I have built the 1940 Standard, and blow me down a man-hole if I have not got the same trouble. I do not blame the set. I just seemed to have developed the knack of making them oscillate. The

KEEN BUT FORGETFUL.

In an air-mail letter rushed from Clunes, Victoria, we received the following letter:—"Dear Sir,—I feel it is my duty to write and say that I like the Junior Section, the Query Column and also the Wonder One, in the March issue of the Radio World. Please find enclosed 1/- in stamps for which please send another March issue."

The stamps were duly enclosed, but the writer forgot to mention either his name or his address.

We await further instructions.

short-wave band is 100%, no dead spots or whistles anywhere, but the broadcast band in the middle and around 2CO, whacko, does she howl and plonk, plonk, plonk?

I have a multi-tester and an oscillator. Resistors are O.K., voltages right, condensers O.K., and the tone and volume all that can be desired, but why this instability? Please assist me, as I am about to change my hobby. I do not think anything is so discouraging as this complaint.

Here are the symptoms:—2GB will come through excellently, and then, when the signal starts to fade and the A.V.C. starts to function, plonk, plonk, plonk she goes. This happens with an aerial 20ft. long; with a piece of wire 3ft. long I get no squealing anywhere and reasonable volume, but with a 3ft. aerial I can get no short-waves.

Wishing you the obvious success that you will have as editor of "Radio World."—Yours faithfully,

J. W. RUSSELL.

Griffith, N.S.W.

AMPLIFIER CONTEST

Dear Sir,—Being keenly interested in your proposed amplifier contest, I would like to submit the following suggestions.

Have the initial judges check amplifiers with two records, one of outstanding merit and the other a frequency recording. To be more elaborate, they could lumber all the necessary equipment around and plot a

(Contd. on page 16)

RADIO SAVES THE FRUIT CROP



Old radio valves, hung up amongst the fruit, will scare away birds. Recently a fine crop of figs was obtained in this way, whereas in years past it has always been eaten by bul-buls and starlings.

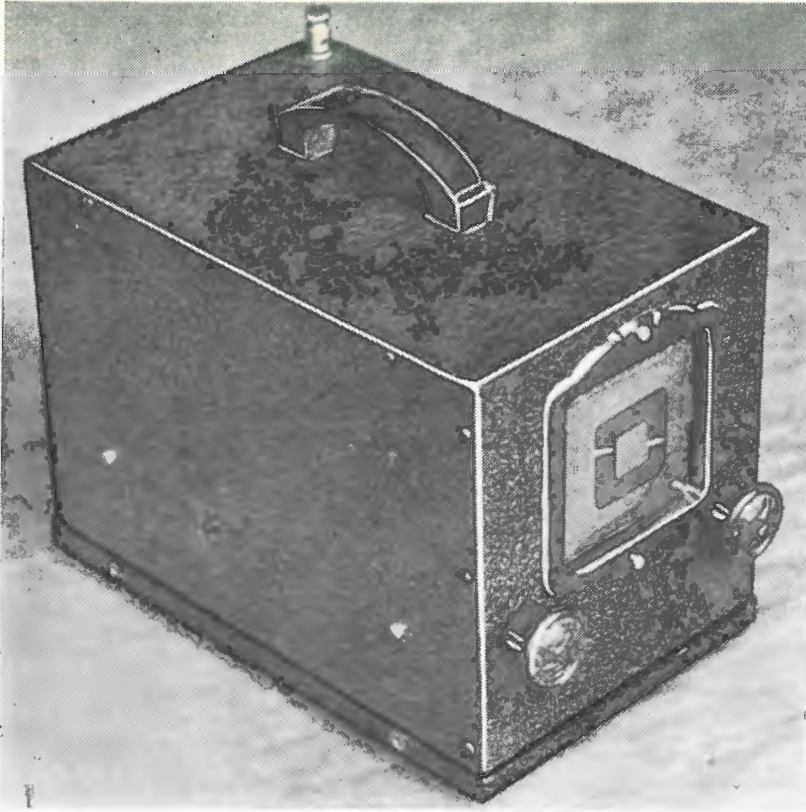

A SPECIAL R.C.S. VERSION of the **Picnic Portable**

Probably the smallest and lightest of all the small and light portables yet described in Australia, this modification of our "Picnic Portable" is self-contained, with loud-speaker and battery equipment, in a case measuring $5\frac{1}{2}'' \times 6\frac{1}{2}'' \times 9''$.

A photograph of the complete set.

TAKING the Picnic Portable circuit from our November issue as his starting point, one of the engineers at the R.C.S. factory built himself a small portable. We happened to catch a glimpse of it one day, and it was such a snappy little job that we decided that a few photographs of it would be of great interest to our readers, so here they are.

The Circuit.

The only modification in the circuit was to change over to automatic bias, as this makes for simpler battery connections, eliminates the need for a "C" bias battery, and allows better service to be obtained from small batteries, as the effective bias is lowered when the batteries are nearly run down. As a result the batteries can be used right down to the last dreg of current.

The Batteries.

The battery equipment consists of a filament cell, known as type Q313, which measures $1\frac{1}{4} \times 1\frac{1}{4} \times 4\frac{1}{2}$ inches, and two 45-volt "B" batteries, type Q308. These measure $1\frac{3}{8} \times 2\frac{3}{4} \times 4\frac{1}{2}$ inches, each. As can be gauged from the dimensions given, these batteries are very small, compared even to the normal batteries in other portables, but they are stock lines and no difficulty should be found in obtaining replacements.

The batteries fit under the actual

chassis, in the bottom of the steel box which holds the set.

The Bias Resistor.

The main bias resistor, through which the full high tension current passes, to give a suitable voltage drop for the correct biasing of the 1D8GT, has a resistance of 800 ohms. Actually a slightly higher value, such as 1,000 ohms, will still allow good performance from the set, and yet save the drain on the batteries by a milliamp or two, so as to obtain long life from them.

The Case.

This steel case, by the way, measures only $9 \times 5\frac{1}{2} \times 6\frac{1}{2}$ inches, not taking the handle into consideration, or the aerial which consists of an adjustable extending rod in the original receiver. A short length of wire could be used instead if so desired, but of course a loop aerial would not be recommended with a steel case.

The Chassis.

The chassis measures just under $5\frac{1}{2}$ inches wide, 8 inches long and is only one inch deep. Having the base so shallow makes it necessary to pack

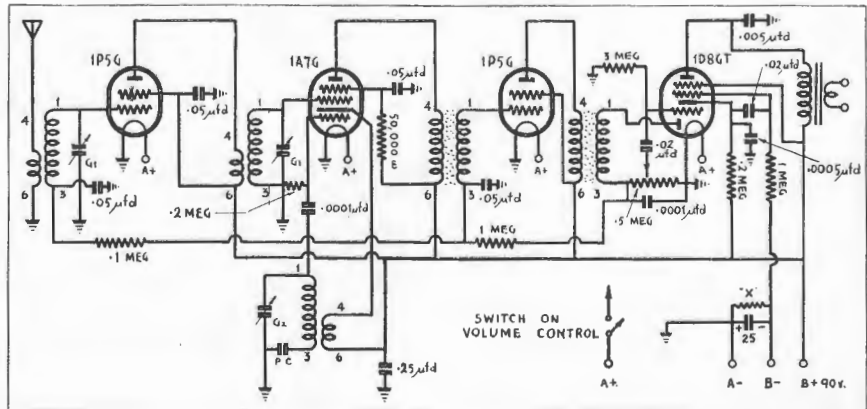

The circuit diagram showing the automatic biasing arrangement.

in the components neatly, but saves a bit of room when you come to the overall dimensions necessary to accommodate the chassis and batteries.

The Filament Resistor.

Apparently there have been cases

of the 1.4 volts for which the filaments are designed.

As a complete safeguard against such trouble it is now recommended that a small resistor, of about a quarter of an ohm, should be inserted in one of the filament leads to allow a small drop in the voltage. It should be noted that the resistor needs a resistance of only a quarter of an ohm, not a quarter of a megohm as recently misunderstood by one of our readers, who fitted a quarter-meg. resistor and found that the set did not work!

Further Details.

Further details about the circuit, and additional information which could help anyone about to build up this job can be obtained from our issues of October and November last. Both these issues are available from our Back Dates Department, at 9d. each, post free.

"R.C.S. PICNIC PORTABLE."

List of Parts.

- 1—sprayed steel chassis (Acorn)
- 1—carrying case
- 1—coil kit, including 1 aerial, 1 r.f., 1 oscillator coil, with 2 465 k.c. i.f.'s and padder (Radiokes, R.C.S.)
- 1—midget 3-gang condenser (Stromberg-Carlson)
- 1—midget tuning dial (Efco)
- 2—brown bakelite knobs
- 1—5 megohm potentiometer with switch (I.R.C.)
- 4—octal wafer sockets
- 4—midget grid clips
- 1—banana socket and 2 plugs
- FIXED CONDENSERS:**
- 3—.0001 mfd., mica (T.C.C.)
- 1—.0005 mfd., mica (T.C.C.)
- 1—.005 mfd., mica (T.C.C.)
- 2—.02 mfd., tubular (T.C.C.)
- 4—.05 mfd., tubular (T.C.C.)
- 1—.25 mfd., tubular (T.C.C.)
- 1—.25 mfd., electrolytic (T.C.C.)
- FIXED RESISTORS:**
- 1—3 megohm 1/3-watt carbon (I.R.C.)
- 2—1 megohm 1/3-watt carbon (I.R.C.)
- 2—.2 megohm 1/3-watt carbon (I.R.C.)
- 1—.1 megohm 1/3-watt carbon (I.R.C.)
- 1—700 ohm bias resistors (I.R.C.)
- VALVES:**
- 2—1P5G's, 1 1A7G, 1 1D8GT
- SPEAKER:**
- 1—5in. permanent magnet speaker to match 1D8GT (Rola)
- BATTERIES:**
- 2—45-volt type Q308 "B" batteries (Eveready)
- 1—1½-volt type Q313 "A" battery (Eveready)
- MISCELLANEOUS:**
- 2 doz. 3/8in. nuts and bolts, insulating washers for aerial socket, push-back (solid and flexible), solder tags, rubber-covered aerial wire, 4 1in. bolts and 6 nuts for mounting gang.

reported where the new 1.4-volt valves have not given satisfactory service, due to the applied voltage being in ex-

THE STORY OF R.C.S.

We regret that, owing to pressure on our space, we have had to hold over the instalment of the Story of R.C.S. which was scheduled for this issue.

CIRCUIT TESTERS (contd. from p. 11)

ticularly at the low frequencies, and in the case of any other winding will result in low sensitivity, crackles and fading.

The resistance of the average 465 k.c. i.f. is low, approximately 20 to 50 ohms, in the case of single wire windings and 10 to 15 ohms for litz wire. With this low original resistance it is difficult to notice any variation on the average ohmmeter.

As the resistance varies with different makes of i.f. transformers the test of the windings must be one of comparison. Each of the four coils in the two transformers should have approximately the same resistance, if any difference is noticed, or, if the

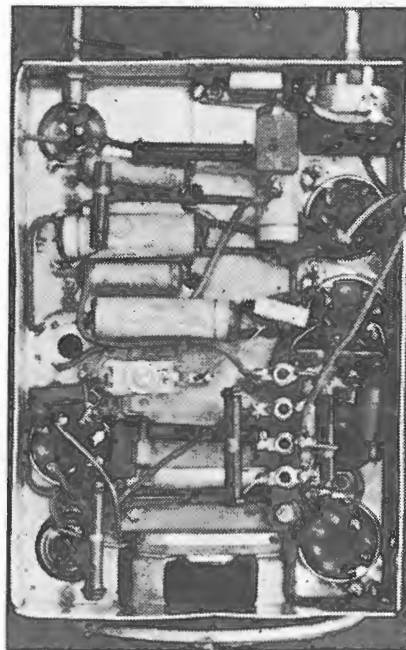

A photo of the wiring.

needle fluctuates, a trial replacement of the i.f. should be made.

The same test may be applied with this very low range to other coils, radio frequency choke, power transformer primaries and tube filaments or heaters, in fact, in any cases where low resistance makes reading with an ordinary ohmmeter difficult, if not impossible.

Output Meter.

An output meter is included for the alignment of sets in conjunction with a modulated oscillator. The test leads are connected to the plate of the output tube and to earth.

A valve and circuit tester represents an ideal in service equipment. Its uses are many and varied and increase as the operator becomes more experienced in its use and application.

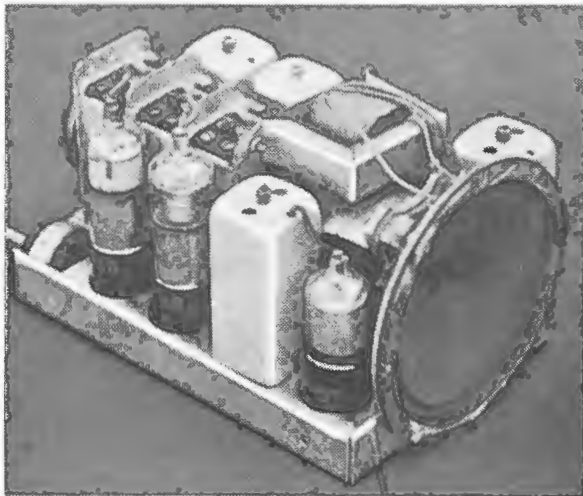

Two views of the chassis, showing the layout of the parts.

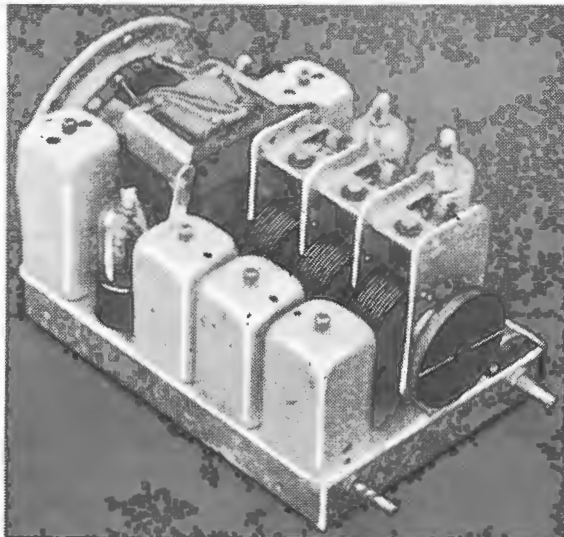

The R.E. Portable

For the benefit of those who want to build a modern portable receiver for themselves, the Radio Equipment Company has produced a most complete and carefully chosen kit of components for a neat and effective little four-valve job which has many attractive features.

The portable embodies all the best features of receivers of this type, with a built-in loop aerial and also a terminal for the connection of an external aerial when long-range results are required. In practice the external aerial is seldom required, as the two i.f. stages of amplification give the set ample sensitivity to bring in stations from near and far at full loud-speaker strength on the loop.

Another advantage of the two i.f. stages is that a really effective automatic volume control is achieved, so that when swinging over the dial hardly any difference in volume level can be noticed at any particular setting of the volume control.

Included in the kit is a most attractive carrying case, finished in aeroplane cloth and of dimensions just

Here is the R.E. portable as it appears when built up, and below you see the circuit.

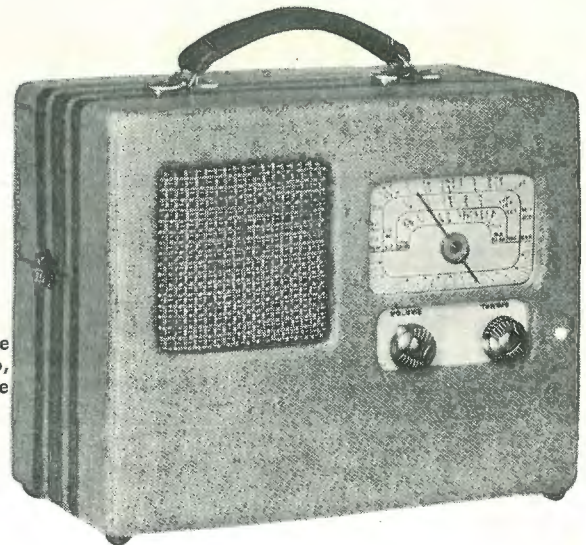

large enough to hold the portable chassis, speaker and battery equipment.

The dial supplied with the kit has the station call signs clearly marked, so that the alignment procedure is greatly simplified as correct padding adjustment can be checked by the way in which the stations line up with the dial markings.

Altogether the kit appears to be a

most complete and carefully selected one, and it should be just the thing for those of our readers who want to build a little port.

Further details, with full constructional instructions, picture diagrams and several photographs of the chassis, are available free of charge from Radio Equipment Pty. Ltd., E.S. & A. Bank Building, Broadway, Sydney.

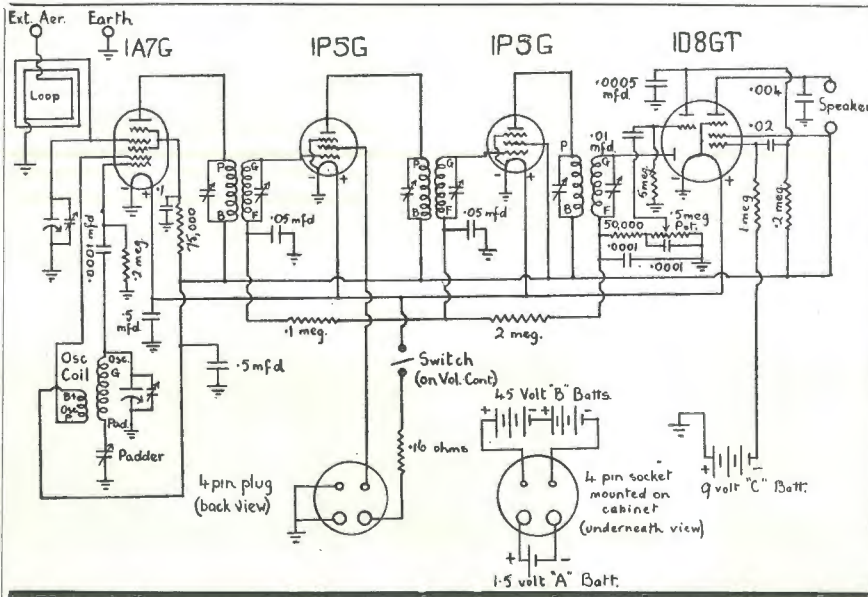

of each class would compete for the final.

Another point which I think is worth while is that all recordings should be of the same type, if possible, by the same band or combination, the recordings to be selected by a committee of technicians and musicians and provided by the sponsor just prior to the performance, entrants to draw lots for their number. If it is not over the fence, might

Dear Sir,

A perusal of the copy sent has convinced me that A. G. Hull has lost none of the punch he for so many years displayed in the old "Wireless Weekly," and in consequence I have pleasure in enclosing subscription for the next twelve issues.

S. BAKER,
Radio Sales and Service.
Springvale, Vic.

Sniper's Post

(Contd. from page 13)

graph of each individual contestant's effort.

I feel sure that under such circumstances everyone would be satisfied about getting a fair go.

During the '34 competition I could not help wondering if the judging audience could recall, by the time they had listened to all the competitors,

what the first few really sounded like. Of course the winner's amplifier was of outstanding merit and at no time was there any doubt of his success, but had several efforts been near the money, judging might have erred towards one of the final contestants. This time might it not be better to run heats. I would suggest that amplifiers be divided into four groups—A, AB, B, and others, then the winner

I suggest that all finalists receive a small prize of sufficient value to cover expenses, apart from the major prizes.

At this juncture I am asking you to reserve me a seat should my own effort not come up to the required standard to justify my attendance on its behalf.

Wishing you every success.—Yours sincerely,

P. BRINDLE.

Bondi.

Fidelity Amplifiers for Home Use

In this article are many practical hints about the operation of amplifiers for the reproduction of gramophone recordings. If you are not quite satisfied with the results you are getting at present we suggest you check over the various points dealt with.

THIRTY-FIVE years ago gramophones were all the rage, and no family home was complete without a gramophone and at least half-a-dozen records, always including "Blue Danube Waltz," "Poet and Peasant" overture, "On the Road to Mandalay" and one or two comic monologues.

Thirteen years ago electrical reproduction became known in Australia and created quite a sensation among music lovers. To this day I can recall every atom of the thrill I had when I first heard a "Panatropé." My eldest brother was one of the first to import a "loud-speaker," which actually consisted of a dynamic speaker built into a cabinet with a power amplifier.

It cost lots more than I could afford at that time.

It was not until 1930 that I found that it was possible to attain comparable results with cheaper equipment, when I first built a Loftin White direct-coupled amplifier. Ever since that day I have enjoyed countless hours of music of a quality infinitely beyond the standard of the ordinary canned music from a cheap radio set.

Yet strangely enough few people appear to appreciate just what can be done with a comparatively cheap amplifier unit. I know, because more

than 50% of the people who have strayed into my home, and heard my amplifiers, have gone away with a gleam in their eyes and proceeded forthwith to build something similar for themselves!

Easy To Build.

Amplifiers are especially easy to build, and they do not require even the simple adjustments usually associated with the building of a radio set.

The cost is not great either, and, as examples of what can be done, we have in this issue the full details of the building of two amplifiers which we can thoroughly recommend as capable of giving reproduction which cannot fail to impress.

There are several minor points to be watched, however, and the old proverb about the chain being only as strong as its weakest link applies very well to amplifier practice.

In a nutshell each and every one of the following factors should be carefully considered, checked and proved correct before an amplifier can be said to be thoroughly satisfactory:—
(1) The record must be a good one;
(2) the needle must be new; (3) the turntable must revolve at the correct speed; (4) the speed of the turntable



This micro-photograph shows how a gramophone needle looks after playing through one recording. On the left is a new needle for comparison.

must not vary with the load imposed by the weight of the needle; (5) the pick-up must be in good condition, of a good type, and properly matched to its input impedance; (6) the amplifier must have satisfactory frequency response and other characteristics, and must operate within the limit of its capabilities; (7) the speaker must be thoroughly energised, have correct load, and be of a type capable of handling a wide range of frequencies; (8) the speaker must be adequately baffled to allow proper low note response; (9) the speaker must be so placed that the acoustics of the room in which it is used will allow proper reproduction.

Take these nine factors into account and you will be well on the way to getting proper performance from your amplifier. Let us consider each point more thoroughly.

Records.

Recording technique has improved vastly from time to time, and records more than a few years old are almost sure to be incapable of giving similar results to those obtainable from the latest recordings.

Even the latest recordings vary quite a bit. Some are recorded locally, some made up from dies sent from overseas, others are imported direct. Not that this means much in itself, for some of the local recordings are well able to hold their own with records made in any part of the world, but it naturally follows that there are recordings and recordings.

Individual taste also enters into the picture and there are deeply-dyed gramophone enthusiasts who will argue for hours about the merits and demerits of recordings.

Choosing recordings is a bit of a

Only records and the gramophone give you the music you want when you want it.

If it were just an impersonal matter, you might be satisfied with any music that came your way. But music is made of emotions; it moves you as deeply as great literature or drama. And because it is changeable, diversified, impressional, it can only have meaning when you determine what it shall say. Radio, wonderful as it is, cannot do that for you. But records and a gramophone can. That's because records, with their all-embracing scope, impose no limitations of time or distance on what you may hear. Records give you the permanent company of the world's most famous artists.

You can hardly expect to be entertained by a personal appearance of a Heifetz, a Tibbett, or a Gigli in your own home. Yet, lacking only their physical presence, you can be. For, with records and a gramophone, you can turn your living-room into an opera house, symphony hall, ballroom, or theatre from night to night—choose the performers you like, select what they shall sing or play and pay no heavy penalty of price.

—From an advertisement.

SPECIAL AMPLIFIER SECTION

task, for the usual scheme of playing over recordings in the shop doesn't amount to much if you have to play them over on a worn-out acoustic gramophone, as is usually the case. Even some of the alleged "good" electric amplifiers in the city shops are far from being capable of showing up the imperfection of the recording in the same way as your high-fidelity amplifier.

Scratch.

Needle scratch presents a problem with a really good amplifier, for the greater the fidelity, the better (or should we say worse?) will be the reproduction of any scratch. Normally with modern recordings which have been used carefully, with a new needle for every playing, the scratch is not really troublesome unless the amplifier or speaker happens to have a peak in the reproduction around the scratch frequency.

There is no simple way of cutting out the scratch and still allowing the full high-note response. Tone controls can be used to lop off the scratch frequency, but the high note response goes with it. Tuned filters can be devised to take out a patch of highs around the scratch frequency, but, needless to say, they seriously affect the fidelity of the reproduction.

Needles.

The main thing to watch with needles is that the needle should be a fresh one for every record, unless of a special semi-permanent design.

Keen enthusiasts can also detect plenty of difference between one type or brand of needle and another, but we think that you need to be very keen to appreciate the difference in results, for example, between H.M.V. loud-tone needles and Columbia "Talkie" needles.

There is no doubt, however, that sometimes a recording is hard on the

needle, so that towards the conclusion the needle is badly worn.

Speed Of Turntable.

The speed of the turntable is most important, and the whole key of the recording can be changed if it does not revolve at the 78 revolutions per minute for which it is intended.

To check the speed of a turntable the most effective way is to make a stroboscope.

A stroboscope consists of a number of thick lines radiating from a circle and we give on this page an example of one. This can be cut out, pasted on to a piece of cardboard and a suitable hole cut in the middle. When this is laid on the top of the recording the actual speed can be checked by watching it closely under the light of an electric lamp operating from an alternating current supply, as found in the suburbs of all the capitals, and most of the country towns. By half closing the eyes the stroboscope will be seen as a number of blurry black and white outlines, and if these appear to be moving backwards or forwards the speed is incorrect and should be adjusted until the lines appear to be quite stationary.

Torque.

The stroboscope should be fitted and used when the record is actually playing under the weight and drag of the pick-up, so that it will indicate the speed of the record under normal playing conditions.

The stroboscope, however, will not reveal a peculiar form of distortion which can be caused by a gramophone motor which does not have sufficient torque.

Most modern motors have ample reserve of power and they can be depended upon to maintain the speed of the record at a constant figure, even if there are deeply cut grooves. But a few years ago there were motors

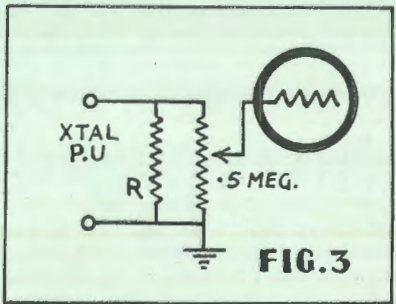
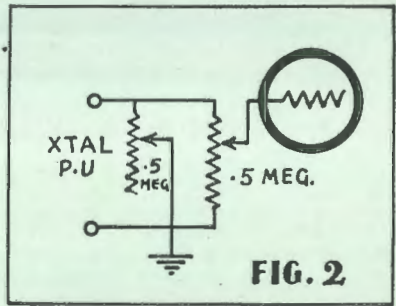
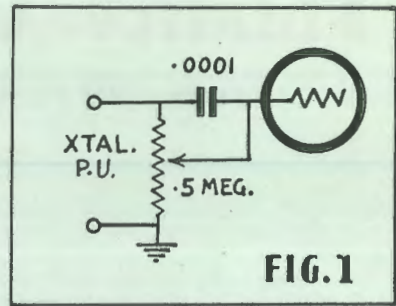

Diagrams showing various ways of changing the loading for a crystal pick-up to change the frequency response. Fig. 1 shows a way of retaining brilliance at low volume levels. Fig. 2 shows how to make the load adjustable. Fig. 3 shows how a quarter or half meg. resistor should be fitted if the low notes are too boomy.



By cutting out this diagram and pasting it on to a piece of cardboard you can make a stroboscope which will let you check the speed of your turntable, while the record is actually playing.

on the market which made good quality reproduction impossible, as they would momentarily slow up when the needle was dragging over a deeply-cut groove. This resulted in a peculiar grunting-like reproduction of the heavy passages and such motors were referred to as "woggy."

To test for torque we suggest putting a finger on the turntable while the record is playing and it should then take some considerable pressure before the stroboscope indicates that the speed has been affected.

Pick-ups.

Gramophone pick-ups are available in a wide range of list prices and, as may be expected, there is usually quite a close relationship between price and

performance. The cheaper magnetic or amateur type pick-up can be depended upon to give completely satisfactory results, but their actual fidelity is seldom as good as that obtained from the more expensive types of pick-ups.

For ordinary reproduction of dance numbers and such recordings the cheap magnetic pick-ups are worthy of recommendation, but for the music lover who is really out to get the most perfect reproduction possible within the limits of his purse we suggest that at least £4 to £5 should be allocated towards the purchase of a superior type of pick-up.

Crystal pick-ups have an advantage in the high voltage output of which

they are capable as the gain of the actual amplifier can be kept low, thereby avoiding hum trouble and allowing a simpler circuit.

Frequency Response.

A few years ago we passed through a hectic period in amplifier history, known as the days of straight-line curves.

Early in the piece the frequency response of the amplifier meant something, and many of the early audio transformers lacked an ability to handle a wide band of frequencies. As transformers were improved, the manufacturers tried to impress upon buyers the ability of the transformers to handle all frequencies by producing curves, alleged to show the perform-

ance of the transformers. It soon became evident that these "curves" were being drawn with a ruler, and were quite straight. To-day it is readily admitted that it is quite a simple matter to produce an amplifier which will handle all the frequencies likely to be found on any commercial recording, or handled by any available pick-up or reproduced on any existing type of loud-speaker.

It is not so much the design of the amplifier which limits its performance. Far more important is the quality of the associated equipment, especially the items mentioned above.

As regards frequency response, both of the amplifiers described in this issue are capable of doing justice to any equipment likely to be obtained, and the finished result is mainly a matter of the quality of such equipment.

Power Output.

A vital factor, however, is that of power output.

No matter how straight the frequency response curve of an amplifier, no matter how fine the quality of the associated equipment, the result is going to be horrible to the ears if the power output capabilities of the valves are exceeded.

Any form of overloading as regards signal voltages, is certain to result in drastic distortion.

On this account an amplifier with at least 3 watts power output rating is needed to supply the average room, where the level of the output will be kept to a watt or so for the better part of the reproduction, the maximum power being used only on the peaks. **Speakers.**

Loud-speakers also vary over a wide price range, being available from around £1 up to £15 and even higher. To make the selection of a suitable speaker easier, however, we would take the risk of saying that for all practical purposes the amplifier enthusiast can keep his thoughts concentrated on the speakers listing between £2 and £8.

The cheaper twelve-inch models, listing between £2 and £3/10/-, have been greatly improved over the past few years, and they will fulfil all normal requirements, but those to whom money is as nothing the high-fidelity types listing up around £8 will be found to be capable of handling high power and giving years of faultless service.

No matter what type of speaker is used it must have the field coil adequately energised. The amplifiers described in this issue are capable of giving adequate energising to the medium-priced 12" speakers, such as the Amplion 12E22 and the Rola K12, both of these speakers incidentally having been tested on the original amplifiers and found to give results right up to standard.

(Contd. on page 31)

Amplifier Championship

The announcement in our last issue in reference to the Amplifier Championship which is to be conducted this year by A. G. Hull, on behalf of the "Australasian Radio World," has created a great amount of interest amongst amplifier enthusiasts and the radio trade.

Pressure of work has not allowed us to get ahead with preliminary arrangements as fast as we would have liked but it is already very evident that there will be no difficulty in getting together a formidable prize list.

First to announce a donation to the prize fund was Mr. Colin Smith of Rola speakers, who was pleased to offer a Rola type G12 high-fidelity loud-speaker valued at £8.

Next to offer a contribution was Mr. Ron Bell, of R.C.S. Radio Pty. Ltd., who said that he would like to encourage the contest and was prepared to let us have one of his latest five-band Communications-type tuning unit kits, valued at £13/13/9.

Offers of support from several other firms have also been received, and a full list of prizes will be drawn up, and should be ready for publication in next month's issue.

A number of readers have written in to make enquiries about the rules and regulations, and the general tenor of these letters is rather inclined to be one of humility. In most cases the owners of the amplifiers seem to be very dubious about the reproduction being able to hold its own in a large auditorium. For the benefit of others who may feel doubtful on this point we would like to mention that our present ideas are along the line of having all of the amplifiers tested in a comparatively small room, with an audience of between 25 and 50 persons, about six to ten amplifiers being tested on each night, the whole contest being divided into a series of heats, semi-finals, and finals.

In this way every competitor would have a chance of getting impartial judging.

It is anticipated that it will be possible to allow each competitor who is defeated in a heat to re-enter for a second trial. This should mean that if a competitor fails in his first test on account of misunderstanding the acoustics of the room or for any other reason, he will have a chance to justify himself at a further heat, say in five or six weeks time.

It has been suggested that only entrants should be allowed to do the judging, and although this idea has several points to recommend it we feel sure that a more representative type of judging committee should be present, at any rate at the final.

There are a number of minor problems which are sure to arise, but we have no doubt that an acceptable set of rules and regulations can be drawn up before the contest starts.

If you have any suggestions to make about the general conduct of the contest, these will be welcomed by A. G. Hull, 117 Reservoir Street, Sydney.

The Australasian Radio World, April, 1940.

PICK-UPS.

Despite the vogue for crystal pick-ups, the older magnetic type is still widely popular, undoubtedly because of its comparatively low cost and good all-round performance.

Among prominent makes on the Australian market are the Amplion and Garrard, listing at 37/6 and 35/-. respectively. High output, approximating one volt, is a feature of both, while curves supplied by the manufacturers indicate very good overall frequency response. Both makes are in wide demand among manufacturers of table and console model radiograms, and represent excellent value at the prices quoted.

GRAND MOTORS.

As regards gramophone motors and motor-pick-up combinations, there is a wide variety of models available both in the Collaro and Garrard makes.

Messrs. John Martin & Co. Pty. Ltd., of Sydney, advise that large stocks have just been landed of Collaros—the two fastest-selling types being the A.C.37 230-volt a.c. induction motor and the A.C.37 radiogram unit, comprising motor, pick-up, 12" turntable, and needle cups. All Collaro motors are fitted with automatic start and stop equipment.

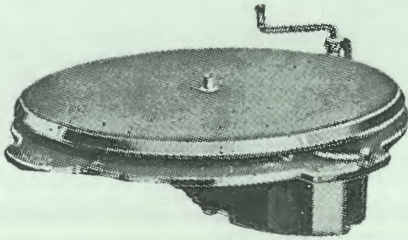

The "Collaro" Motor.

Trade Notes

Right: The Amplion pick-up.

Below: The Garrard automatic record-changing turntable.



AUTO. RECORD CHANGER

The Garrard automatic record changer illustrated on this page will play eight 10" or 12" discs, switch off automatically at the end of the last record. Of simple and robust design, the unit comprises a Garrard motor and record-changing mechanism, mounted together with pick-up on a plate ready for installation in a cabinet.

The model illustrated (R.C.10) is for a.c. operation, and is priced at £10/15/6. A universal model is also available at slightly extra cost.

Copies of the latest Garrard catalogue listing and illustrating all types of motors, pick-ups and accessories, are available free to readers writing Messrs. Reg. Rose & Co. Pty. Ltd. at the address given above.

SPEAKERS

As every amplifier enthusiast knows, the choice of speaker used is of vital importance. As 12" models are generally chosen for amplifier work, only this type will be dealt with in the following brief review of models available.

In the Rola range, the F12 is the cheapest model, listing at 41/-. It is identical in appearance and generally similar in perform-

(Contd. page 32)

Build A Prize-Winning Amplifier with PHILIPS VALVES



Out of 178 competitors in Mr. A. G. Hull's Amplifier Championship of 1934 emerged the winner—completely equipped with Philips Valves.

You, too, can build a champion amplifier by using only Philips Valves—made in Australia to the world's highest standards of accuracy and efficiency. An amplifier is no better than the valves employed in its construction; that's why you'll find that technicians who want perfect reproduction choose quality components—and Philips Valves, of course!

Should you require any technical assistance on the choice of valves and other components, remember that the Philips Office in your city or State is entirely at your service. Write or 'phone your nearest Philips Branch now!

PHILIPS VALVES

MADE BY THE WORLD'S LARGEST RADIO MANUFACTURERS

BABY GRAND

Amplifier Unit

Capable of reproducing gramophone recordings with amazing realism, this unit is quite simple to build, and the cost is moderate.

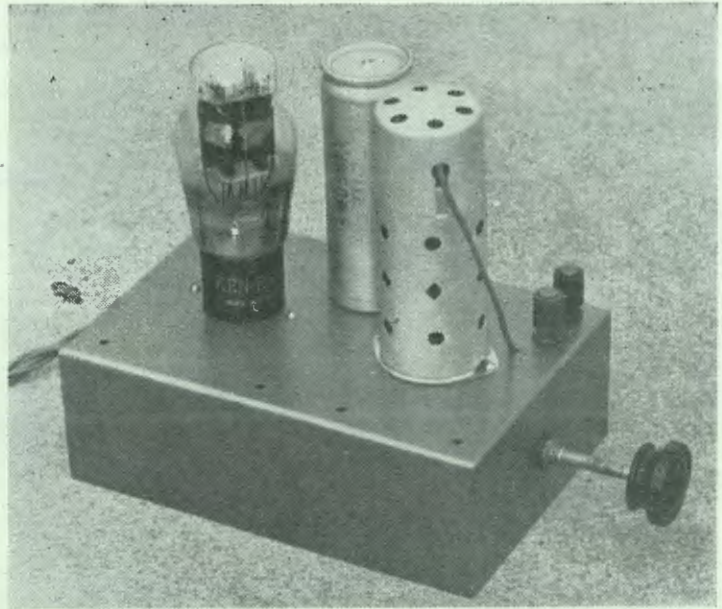

A general view of the unit.

BABY GRAND is an amplifier which will fulfil the requirements of the average man to a T. It has ample power output for the ordinary home, has just as perfect a response curve as any of the big amplifiers, low distortion and only sufficient audio gain to allow full power output from a crystal pick-up. This comparatively low audio gain makes it possible to build the amplifier up without expensive de-coupling or filter circuits and yet keep the hum level so low that it is not possible to hear the slightest trace, even when the volume control is right up and no record playing.

To those who don't know what an honest $3\frac{1}{2}$ -watts of power output really sounds like, this little amplifier is likely to come as a shock when they hear it in operation. It can make a 12-inch speaker fairly throb on a modern recording, yet sounds fine even when turned down to soft volume levels. It is always difficult to get impressive performance from any amplifier at low volume levels, but this one is somewhat better than the average in this respect, the use of triode valves in both stages helping to keep the distortion down, so that the reproduction, coming out without a

background of hum, is always impressive.

The Circuit.

The actual circuit is the product of several months of spare time research, mostly by the cut and try method. It started out originally as a direct-coupled job, with a pentode feeding a beam power valve, was changed to a triode driver, still direct-coupled, then back to pentode and beam power valve with inverse feed-back and eventually we gravitated to the two triodes, with a careful selection of resistor and condenser values for resistance-coupling. We feel confident that it is quite impossible to get more attractive performance from any two similar valves at present listed.

We cannot stress too clearly that the amplifier is designed for one job, and does that to perfection. The work we refer to is simply to get the utmost from modern recordings, using a crystal pick-up. It does not have sufficient gain for use with old armature-type pick-ups, it is not suitable for use with a microphone, and, lastly, it has such a clear high-note response that worn-out recordings sound even worse than usual.

The Speaker.

All our original work on this amplifier was carried out with one of the medium-priced 12-inch speakers, and we strongly advise the use of a speaker of this type. Some of the smaller speakers are capable of good performance, but we feel sure that the few shillings extra for the bigger speaker is money well spent. On the other hand we doubt if we can say that one of the expensive high-fidelity

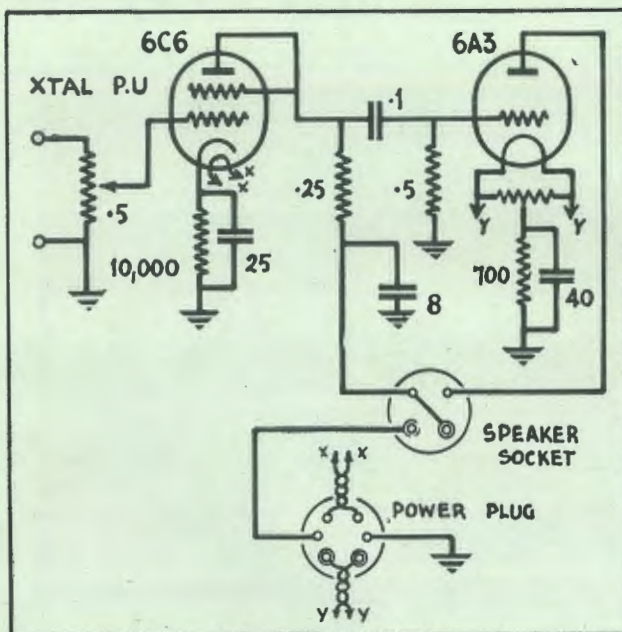

Here is the circuit diagram, showing that the design is conventional, and the exceptional performance is obtained by keen attention to detail.

**YOU'LL NEVER
LOSE A
CUSTOMER**

*...by giving him
the best.*



No other Resistor offers all these outstanding characteristics:

- Accuracy. Permanence.
- Absence of Noise.
- High Voltage Insulation.
- Complete Sealing Against Moisture.
- Metallised Resistance Principle.
- Crack and Break Proof.
- Vibration Proof.
- High Frequency Performance.
- Colour Coding and Marking.

THEY STAY PUT.

1/2 watt (Type BT 1/2 w.)	9d.
1 watt (Type BT1w.)	1/-
2 watt (Type BT2w.)	2/-
3 watt (Type F3w.)	3/6

Wm. J. McLellan & Co.

BRADBURY HOUSE,
55 YORK STREET,
SYDNEY.

type of speakers is worth its weight on this amplifier. In the first place, it would not be thoroughly energised, and then again, there is no need to have a speaker capable of handling terrific power output, as this amplifier isn't going to deliver it.

Construction.

The actual building of the amplifier is as simple as A.B.C., especially as the power supply unit is built up separately, so that the actual "Baby Grand" unit consists of only two valves and a handful of minor components. Ready-drilled bases are available and so one of these should be obtained.

The first step is to mount the sockets and the electrolytic condenser, remembering to put the base of the valve can over the top of the six-pin socket.

Next step is to fit up the six-pin plug with leads long enough to suit your requirements, which incidentally should be as short as reasonably possible, and not on any account longer than about three feet.

The plug leads can then be wired into the amplifier. The two leads

"BABY GRAND' AMPLIFIER UNIT

List Of Parts.

- 1—Base, size 7 1/2 x 5 x 2 1/2
- 1—.5 meg. volume control (I.R.C., E.T.C.)
- 1—Centre-tapped resistor 75 ohms (R.C.S., Radiokes)
- 1—700 ohm 3-watt resistor (I.R.C., R.C.S.)
- 1—10,000 ohm 1-watt resistor (I.R.C., Bradley)
- 1—250,000 ohm 1-watt resistor (I.R.C., Bradley)
- 1—500,000 ohm 1-watt resistor (I.R.C., Bradley)
- 1—.1 mfd. tubular condenser
- 1—25 mfd. electrolytic condenser (T.C.C., Solar)
- 1—40 mfd. 150-volt electrolytic (Ducon)
- 1—8 mfd. electrolytic filter condenser (Solar, T.C.C.)
- 1—6-pin plug (Marquis)
- 3—Sockets—2 4-pin, 1 6-pin (Tasma)
- 2—Valves—1 6A3, 1 6C6 (Brimar, Kenrad, Radiotron)
- 1—Speaker, 2,000 ohms field, 2500 ohms load (Rola, Amplion)
- 1—Crystal pick-up (Astatic)
- 1—Gramophone motor (Dual, Collaro, Garrard)

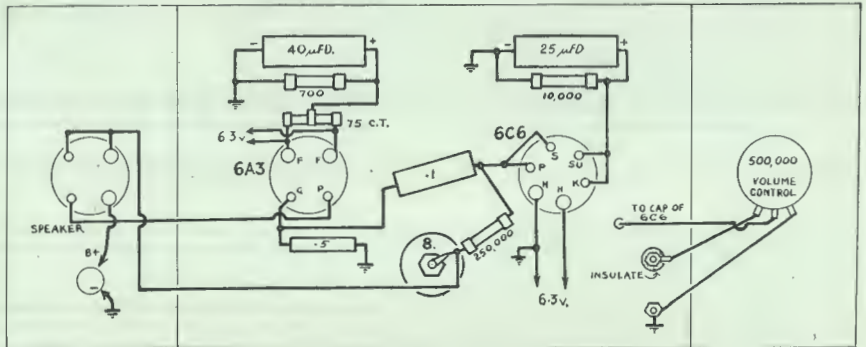

By comparing the photograph below with the picture diagram above, it becomes a simple matter to identify the components and follow out the wiring.

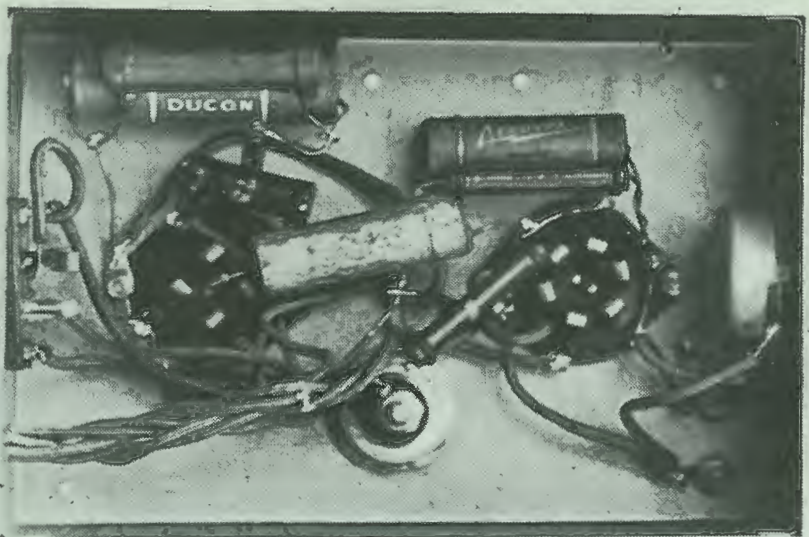

from the two fat pins of the plug are for the filament of the 6A3, and so these go to the lugs for the two fat holes of the four-pin socket, with the small centre-tapped resistor soldering on to these lugs at the same time.

The two pins from the opposite side of the plug are wired up to the two filament lugs of the six-pin socket for the 6C6, and one of these lugs is then earthed to the base or to a ground wire.

Of the two remaining pins the one from the plate pin runs to the one of the filament pins of the speaker socket, thus connecting up to the field of the speaker.

The other filament pin on the speaker socket is considered as our main high tension supply, and so connects to one of the small pins of the speaker socket, to the centre terminal of the electrolytic condenser and to one end of the 250,000 ohm (quarter megohm) resistor which feeds the combined plate and screen of the 6C6 type valve. The remaining pin of the speaker socket connects to the plate pin of the 6A3 socket.

The 700 ohm resistor, with the 40 mfd. by-pass condenser across it runs from the centre-tapping of the centre-tapped resistor to earth. It should be noted that this electrolytic condenser is rated 40 microfarads to work on 150 volts and has polarity, i.e., one end is positive, painted red and must go to the centre-tapped resistor, whilst the other end is negative, painted black and must go to "earth." Similar in this respect is the 25 mfd. electrolytic condenser which is across the 10,000 ohm bias resistor which runs from the combined suppressor and cathode of the 6C6 to earth. This condenser, however, needs to be rated 25 microfarads with a working voltage rating of either 25 or 40 volts. Be sure that you get the polarity of both of these condensers right!

Input.

Two terminals are required for the

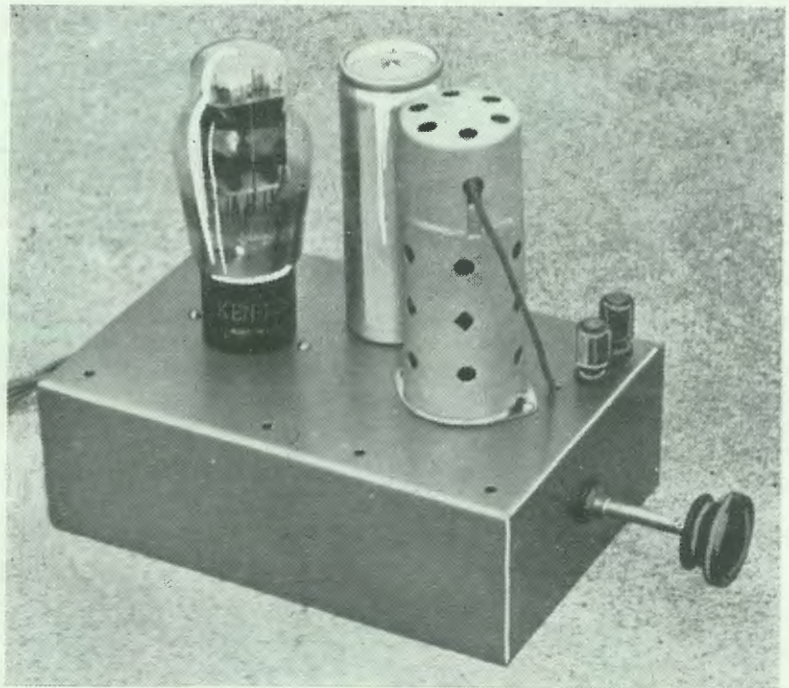

Another view of the Baby Grand unit.

input, one being insulated, whilst the other is earthed. The volume control is built into the unit, as few crystal pick-ups have this item fitted as standard. In order to make the volume control operate in a clockwise direction, it is necessary to get the terminals connected correctly, as per our picture diagram, and of course the centre terminal connects up to the cap of the 6C6, no shielding of any kind being fitted to this lead.

The volume control should have a resistance rating of 500,000 ohms (half a megohm), but sometimes it is found a sound scheme to try the effect of fitting resistors in parallel with the volume control to note the effect of

feeding the crystal pick-up into a lower load. This is done in practice by fitting a half or quarter meg resistor across the input terminals while the amplifier is in operation and noting the effect on the quality of the reproduction and arranging to suit.

Needless to add, the whole success of the amplifier depends on its proper operation, and we hope that no one will build and operate this amplifier until they have read fully the other articles on amplifier work which are published in this issue. We refer particularly, of course, to the use of an adequate baffle board, and the acoustic arrangement of same.

MAKE SURE OF MAXIMUM EFFICIENCY AND LONGEST LIFE

ADOPT AS YOUR STANDARD

Mullard
M A S T E R
RADIOVALVES

CHOOSE MULLARD FOR THAT PRIZE-WINNING AMPLIFIER!

Chosen the valves for that prize-winning amplifier yet? If not, you'll be interested to know that **MULLARD** offer an exceptionally wide range of output valves, in both American and Continental types.

There is a MULLARD type for every purpose . . . for amplifiers with single or push-pull output, Class A, Class AB, or Class B . . .

Our Free Technical Service is at your disposal for assistance with any circuit or valve application problems you may encounter. Send stamped, self-addressed envelope to address given below.

MULLARD-AUSTRALIA PTY. LTD. 367-371 KENT STREET, SYDNEY. Telephone: MJ4688

HOME RADIO CONSTRUCTORS

YOU BENEFIT EVERY TIME
 When you deal with Radio Equipment Pty. Ltd..
 the Radio Kit Specialists. .

YOU BENEFIT FROM—

- Keenest possible prices.
 - Same-day service.
 - All parts tested before despatch.
 - Free advice upon any of your technical problems.
 - All parts as specified by the technical editor.
 - Best quality components only used.
 - We are radio engineers and thoroughly understand all your needs.
 - We will DESIGN and quote for special radio set and test equipment kits.
- Be like every other wise radio enthusiast—get the habit of getting the Radio Equipment quote first for anything in radio.

HOT OFF THE PRESS!!

Send for the big free book telling you all about Radio Kits. You owe it to yourself to read this book before you decide upon your Radio or Test Equipment kit. It's free and post free to you. Send coupon below for your copy NOW!

SPECIAL ATTENTION TO COUNTRY ORDERS!

Get Our Special Quote for
 all "Radio World" Circuits

- JUNIOR
- ATOM
- BEDSIDE TWO
- 1940 SCOUT
- AMPLIFIERS
- WONDER ONE
- DANDY THREE
- WORLD STANDARD

SEND COUPON NOW FOR FREE COPY OF
 RADIO BUYING GUIDE

EVERY RADIO MAN NEEDS THIS FREE BOOK

Packed full with exciting news, details and prices of the kitsets you want to build. Send for it NOW. Radio Equipment are M.O. suppliers to any part of Australia or Papua of the latest and best in Radio. When you build a Radio Equipment Kit you build a job that not only looks professional, but IS professional.

RADIO EQUIPMENT PTY. LTD.

E.S. & A. BANK BUILDINGS, BROADWAY,
 (opposite Grace Bros.), SYDNEY.
 Phone: M 6391 and M 6392
 Telegrams: "Raquip," Sydney.

RADIO EQUIPMENT PTY. LTD.,
 E.S. & A. Bank Buildings, Broadway (opp.
 Grace Bros.), Sydney. Phone: M6391-2.

Please send me without obligation on my
 part a free copy of your RADIO BUYING
 GUIDE.

NAME

ADDRESS

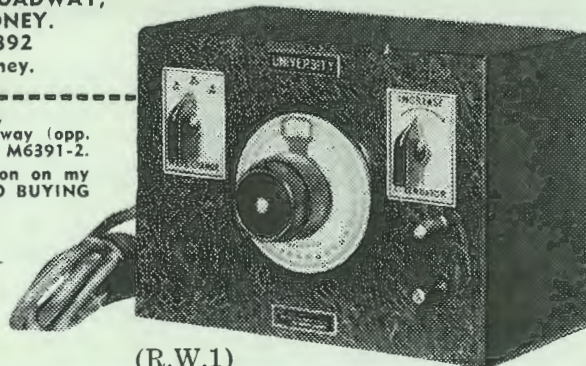

(R.W.1)

- 1940 Oscillator Kits
 - 1940 Multimeter Kits
- etc., etc., etc.

Read in this book how you can build
 the new A.C. or Battery-operated oscil-
 lators at small cost. All Service-
 men's and Set Builders' requirements
 are catered for. We are distributors
 for Paiec and Calstan Test Equipment
 and are the recognised experts on all
 "Radio World" circuits.

Fundamental Power Supply Unit

We can strongly recommend this power supply unit to all experimenters. Although a little more costly than the conventional power transformer it has a hundred uses and should give years of service.

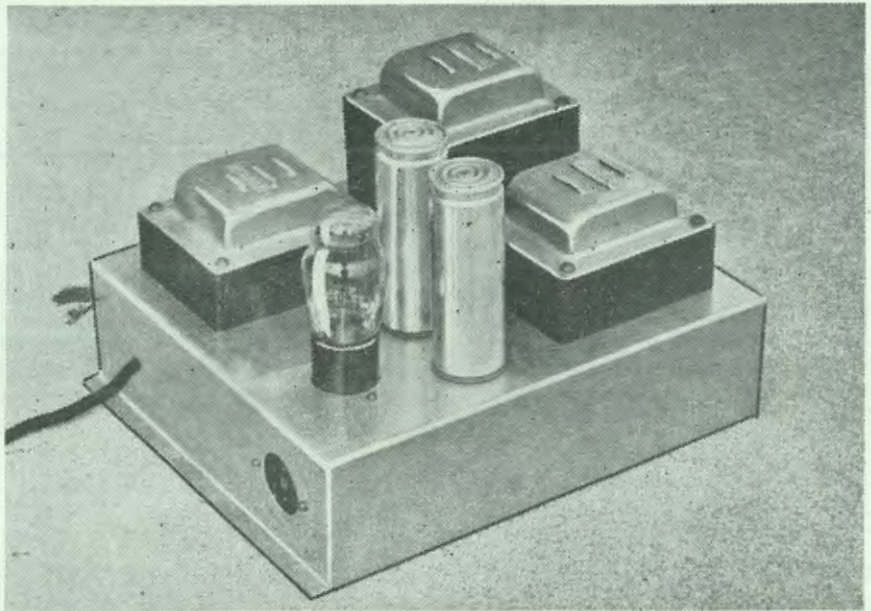

THE true amplifier enthusiast will never be satisfied with just one amplifier. Perfection is never attained and part of the joy of every keen enthusiast is to dream of the next amplifier he is going to build and how much better it will be than the last!

These dreams are endless, for there are dozens of different ways of making amplifiers and most of the circuits have features of their own to make them attractive to certain types of ears.

Such experimenting is interesting

and instructive work, and need not cost much at all.

The main thing is to get a power supply which can be adapted to suit a number of different amplifiers, so that when the circuit is changed the power supply unit can be retained.

For our own personal use we have been using just such a universal type of power supply unit, and we feel sure that a description of it will be of great interest to others who contemplate going into the amplifier side of the hobby in a thorough way.

This unit is also recommended for

the two amplifiers described in this issue and for the "World Standard" receiver, which was fully detailed in last month's issue.

For Future Sets.

It is also our intention, as far as practicable, to make most of our future receiver and amplifier designs suitable for operation from this same unit.

A separate power unit has much to recommend it, especially one such as this, which has separate filament and high tension transformers, with tapped primaries, so that the effective voltages can be varied over a wide range.

A filter choke is included and two large filter condensers.

These features, together with the fact that the unit can be located a foot or two away from any components likely to pick up hum by induction, mean that in practice your amplifier or receiver can be made entirely hum free, quite a big factor in getting lifelike reproduction. Nothing mars reproduction more than a background of steady hum. Even if you don't actually notice it when you are listening it must be responsible for the headache and fed-up feeling which you get after half-an-hour's intensive listening.

Given a distortion-free amplifier and a clean background we find that it takes hours before being able to resist the temptation to put on just one more record!

Economy Dodge.

The idea of using two separate transformer units for high tension and filaments turns out to be a good economy dodge, too. To make up a single transformer with ample current reserve and plenty of filament windings would cost a lot, as special size laminations would be required.

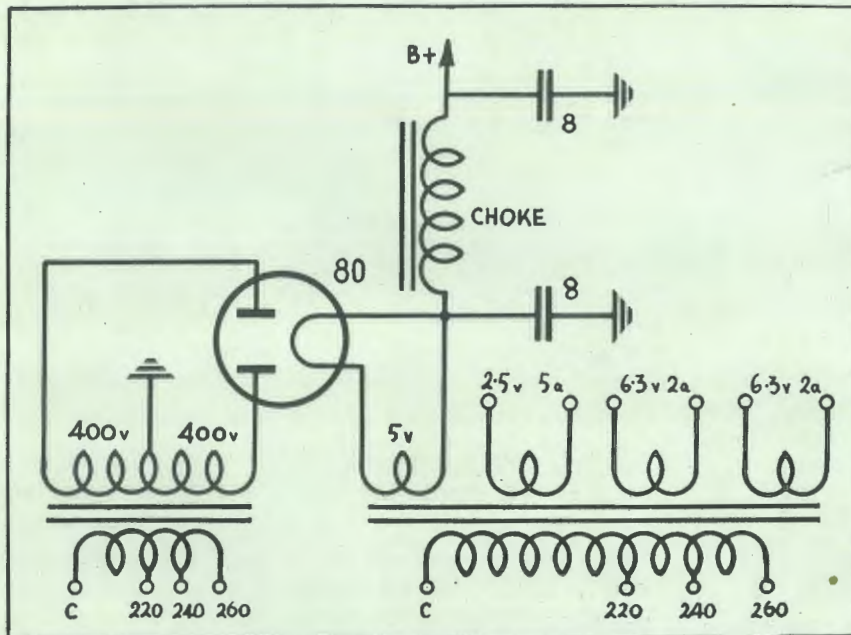

Two separate power transformers are used, allowing filament and high tension voltages to be varied independently.

SPECIAL AMPLIFIER SECTION

But the two separate transformers can each use standard laminations, and the power transformer factories can turn out the two units a lot cheaper than they would be able to turn out a special transformer to do the same work.

Construction.

The job of building the power unit is very simple, especially if you get a suitable kit of parts, with a ready-drilled base to take the power transformers. Large cut-outs are needed for the terminal strips, and cutting these is quite a job, even in aluminium.

The drilled bases also have the advantage of being made of steel, which makes them more rigid and able to stand up to the weight of the transformers without bending.

Winding.

The wiring job is simple, too, and all you have to do is to follow out the picture diagram which has been prepared for you by our staff artist. You will notice that a six-pin valve socket is used for the outlet. This socket is quite shock-proof, and allows a neat and efficient way of plugging in a six-pin plug from the amplifier or receiver with which it is to be used. We suggest that the two filament pins of the socket should be used for the filament supply of the output valves, the two pins diagonally opposite for the heater supply for the other valve or valves, and the "P" terminal for the high tension. The remaining pin is used for the

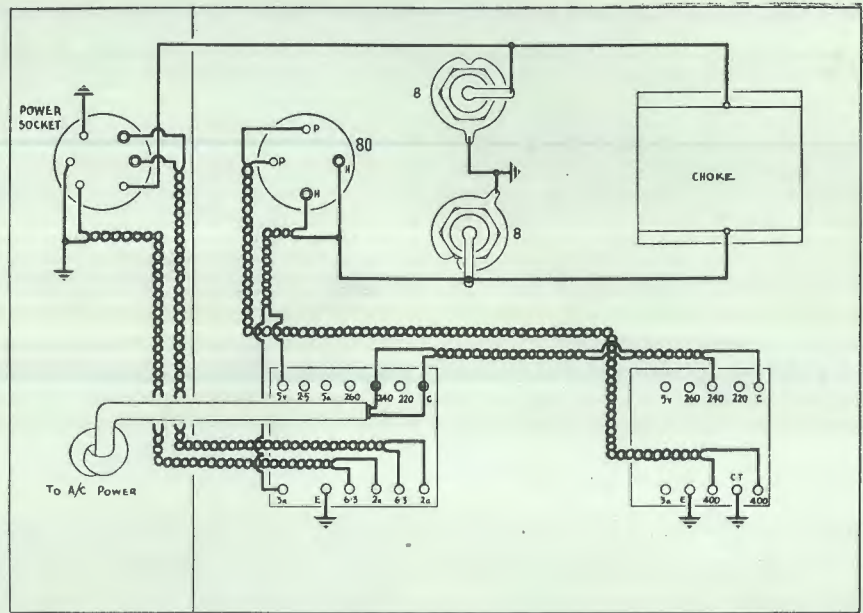

As will be seen from this picture diagram, the wiring is very simple.

earth return.

The speaker socket is located on the receiver or amplifier chassis.

The Rectifier.

The rectifier valve to be used can be the good old 80 type, a 5Z3, or an 83. By using an octal socket for the rectifier valve, one of the 5Y3 or other

octal-based type of rectifier valves can be used. We find that the old 80 is the daddy of them all. Although we shouldn't mention it, we have often overloaded the 80 with anything up to 600 volts and it just doesn't seem to make any difference. In fact, we have had better luck with

KEN RAD
The Fine Valves of Radio

SPECIFY SUPER-SENSITIVE

Factory Representatives: Ken-Rads!

Ken-Rad Valves are recognised to-day as world leaders, because of their superior construction and the uniformity of quality that characterises each single valve. Specified by leading radio manufacturers the world over for the quality of their reception, you, too, should insist on super-sensitive Ken-Rads!

E.T.C. INDUSTRIES LTD. SYDNEY AND MELBOURNE

the 80 than with the 5Z3, although the 5Z3 has heavier ratings, according to the valve manufacturers.

The Power Lead.

Care should be taken with the power flexible lead. Make sure that the lead is soldered to the terminal strip very effectively, and then tie a knot in the lead so that any pull on it will be taken against the base. This will mean that the leads cannot be pulled off the terminal strip. Where the flex goes through the hole in the base a rubber grommet should be fitted so that the insulation of the flex will not be frayed by contact with the sharp edge of the metal.

The Electrolytics.

Good quality electrolytic condensers should be used, as these components are probably the least reliable of the components used in modern receivers. Even at the best they seldom last longer than a year or two before they

FUNDAMENTAL POWER SUPPLY UNIT

List Of Parts.

- 1—H.T. transformer 400/400 at 150 mills., with primary tapped for 200, 220, 240 and 260.
- 1—Filament transformer, 2.5., 5, and two 6.3-volt windings, with primary tapped as above
- 1—Filter choke, 150 milliamp.
- 2—Electrolytic filter condensers (Solar, T.C.C.)
- 2—Sockets—1 4-pin, 1 6-pin (Tasma)
- 1—Suitable base
- 1—Rectifier valve, type 80 or 5Z3 (Ken-Rad, Brimar, Radiotron, Mulard, Philips)
- 1—Power flex lead

start to lose their efficiency. We like the 600-volt types, even if they do cost a shilling or two more than the 500-volt ones.

Even if the 600-volt type are used, a point should be made of never switching on the power unit unless an amplifier or receiver is plugged in to offer a load. Without load, the actual high tension might rise to a point where the electrolytic condensers are in danger.

Voltage Adjustments.

Normally the unit will be used with the power supply feeding into the primaries of the power transformers, according to the line voltage.

For example, in Sydney suburban areas the 240-volt terminals will be used, and the output voltages will be as marked. But if long leads are used to supply the heater current to a number of valves in a receiver there may be a voltage drop in the leads. This can be counteracted by shifting the input to the 220-volt terminals on the filament transformer unit. This will leave the high tension voltage unchanged.

If the unit is to be used with a small amplifier, such as "Baby Grand," the high tension voltage can be lowered by using 240-volt power input to the 260-volt terminals of the high tension transformer, and this will reduce the actual high tension voltage by about ten per cent.

SPECIAL AMPLIFIER SECTION

ACCESSORIES AND PARTS FOR RADIO SETS ARE BEST BOUGHT AT

MURDOCH'S

CRYSTAL SET KITS

An ideal set for beginners. Build it if you live within 25 miles air-line from national or powerful "B" class stations. No batteries or upkeep. Set of parts includes panel, condenser, coil, dial, crystal detector and complete instructions and diagrams. Complete kit guaranteed to work, 13/6. Extra equipment needed: Aerial, 4/6; Headphones, 12/6.

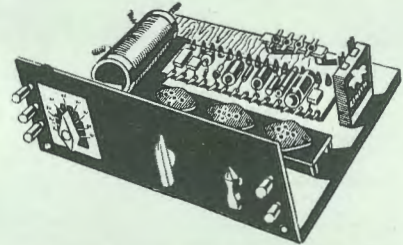
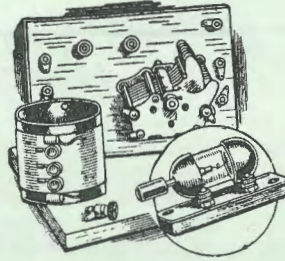

VALVE SET KITS

ONE VALVE KIT

This set has a day-time range of 100 miles and covers Australasia after sunset. Complete kit of parts includes drilled bakelite panel, condensers, coil, rheostat, etc., and easy diagrams and instructions. Guaranteed to receive when built, 30/-.
One-valve set accessories, necessary unless already on hand. Headphones, 12/6. Valve and "A" and "B" batteries, 25/-. Aerial kit, 5/6. Complete kit, 70/-.

30/-

THREE VALVE KIT.

Operates a speaker at full volume like a 20-guinea set. Improved Reinartz circuit. Automatic free bias, dispenses with "C" battery. Sensitive and powerful output valve. Kit includes easy diagram and instructions panel, base, dials, sockets, etc. WITH THREE BONUS VALVES FREE (Murdoch's choice). Guaranteed to work. 47/6.
Extra equipment needed: 6-volt accumulator (motor cycle size), 21/-. 60-volt "B" battery, 15/-. Loud-speaker (dynamic), 36/-. Aerial equipment, 4/-. Special price with all batteries and speaker, £5/15/-.

47/6

PARTS FOR ALL "RADIO WORLD" SETS

BAKELITE PANELS
Cut to order. Black, 3/4 d. per square inch.



CONDENSERS, RESISTERS, VALVES, COILS, SPEAKERS AND ALL ACCESSORIES are available at Murdoch's.



DIALS

SATIN FACED ALUMINIUM CARILLION DIALS, 3 1/2" high. Black pointer. For 1/2" or 3/8" spindles, 1/9.

CATALOGUE FREE ON REQUEST

CRYSTAL DETECTORS
Glass enclosed on bakelite base with terminals. Complete with super-sensitive crystal, 3/6. Red Diamond complete Perikon tubular double crystal detector, 5/6.

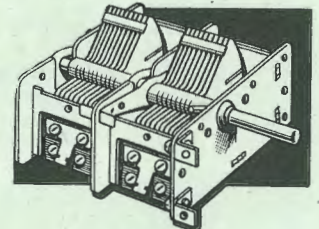

ELECTRIC PICK-UPS

B.T.H. EDISWAN PICK-UPS, 32/6.
Columbia, 37/6.
B.T.H. Crystal, 77/6.

FREIGHT paid on all goods in this advertisement, except batteries and valves. We send half freight paid per goods rail in New South Wales. Kindly write to Desk C52.

- One-gang condenser, spindle, .0004, 7/6
- Two-gang condensers, spindle, .0004, 9/6.
- Four-gang condensers, spindle, .0004, 10/6.
- MIDGET REACTION CONDENSERS. Imported English "Premier" condensers, trolitul insulation ball-bearing, extra heavy brass plates.
 - .00025 (250 mmf.) 7/11
 - .00016 (160 mmf.) 7/6
 - .0001 (100 mmf.) 5/11

MURDOCH'S LTD. Sydney

There is a "TOPS"
to Everything and

GARRARD

Gives it to YOU for 1940



Price:

35'-

Studio Reproduction

Ample Volume

Minimum Record Wear

Correct Tracking

Good Frequency Response

★ There is always a winner in every field . . . in pick-ups for 1940, it's Garrard. This year Garrard sets a new standard in pick-ups — its many exclusive features give it extra eye appeal — extra ear appeal.

Investigate the Garrard to-day — its extra big features make it distinctive . . . its tonal reproduction is superb.

In price, too, Garrard sets a new pick-up standard — glance at left at that startling figure — 35/-, Never before has it been possible to obtain a Garrard at such a price.

Individually boxed in attractive cartons, when you buy a Garrard you are assured of buying a pick-up with which no one has tampered.

Outstanding pick-up . . . sensationally low prices . . . isn't that what you've been waiting for?

Doesn't that spell VALUE?

Remember, not only in the pick-up field is Garrard the "tops" — Garrard motors lead the way, too! — for Garrard manufactures a motor for every purpose. Induction motors, universal motors, heavy duty motors, record changers, etc., etc. No matter what your requirements, Garrard can suit you.



REG. ROSE & CO. PTY. LTD.
ELECTRICAL · RADIO · AUTOMOTIVE & GENERAL MERCHANDISE
58 MARGARET ST. SYDNEY

PHONE
BW2114

TELEGRAPHIC
"ESOR"
SYDNEY

BIG BOY

Power Amplifier

Capable of delivering better than ten watts of power, with practically no distortion and no hum, this amplifier uses only a handful of resistors and can be built very cheaply.

CALCULATED on a basis of power and quality, "Big Boy" is a wonderful proposition in amplifiers. It uses only three valves and a handful of minor components, yet delivers enough wallop to tear the voice coil off the cone of even the biggest speakers available, and with quality of reproduction which is unsurpassed, even in elaborate push-pull jobs using expensive audio transformers.

It is particularly simple to build, and not at all beyond the ability of even the raw novice.

To operate it is a thrill, if for no other reason than the way in which it positively makes the windows rattle with its power.

The Circuit.

The circuit, frankly, is an adaptation of the old original "1933 Standard" which I designed in that year, but of course it has been brought up

to date by the use of the latest beam power valves. It closely resembles the amplifier unit so fully described by the writer in the July, 1936, issue of that world-famous technical journal, "Q.S.T."

In a nutshell, it consists of a triode driver (made up by tying plate and screen of a pentode) with loads in both cathode and plate circuits, giving phase splitting to allow perfect push-pull, with inverse feedback provided by the non-bypassing of the cathode bias resistor. Second harmonic distortion which is more or less normal in the beam power valves is completely cancelled out when they are in perfect push-pull. As a prominent technician murmured the other day as he listened to the original amplifier, "It's the first time I ever heard pentodes sound as though they were triodes."

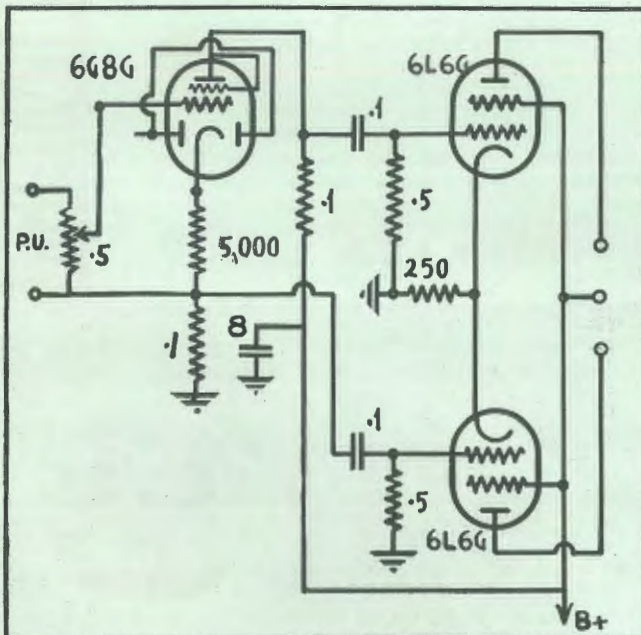

Circuit of the amplifier showing the simple phase changer and audio amplifier valve.

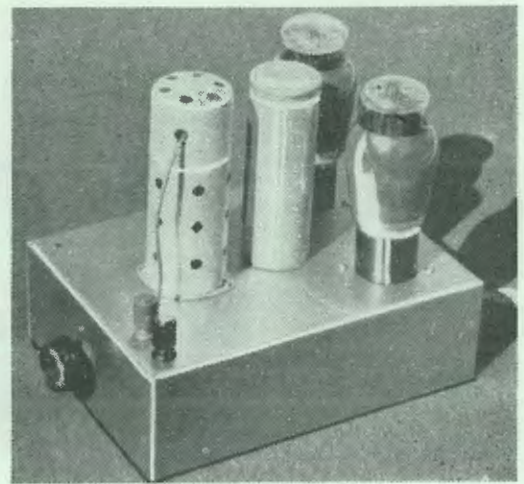

A photo of the unit.

Construction.

Construction of the amplifier is considerably simplified by the use of the separate power unit, and by the use of a ready-drilled base. This base has been drafted out to allow all of the minor components to solder directly into place and to hang by their own leads or lugs.

First job on getting the kit of parts is to "tin" all the soldering lugs of the sockets, and components with a thin coat of solder, scraping the metal to get it clean, applying a smear of flux and then wiping on the solder with a clean and hot iron. To get the lugs all properly tinned is about half the battle of soldering, and soldering is the only difficulty in the construction of these amplifier units and their power supply.

Wiring.

First part of the wiring is to connect up the heaters of the two 6L6G valves, and connect these up with the leads from the two fat pins of the six-pin plug which serves to connect the amplifier unit with its power unit. Next connect up the other heater leads to the two heater pins of the 6G8G socket, these being numbers 2 and 7 on this socket, numbering off from the key, and running clockwise, looking at the underside of the socket. These pins are also the heater pins in the case of the two 6L6G valves, too. The rest of the wiring is simple enough, the main idea being to follow out the picture diagram, comparing with the photograph if there is any doubt, and checking with the schematic diagram of the circuit.

A point to watch is that both input terminals are insulated from the base and neither lead from the pick-up is earthed. With a crystal pick-up this is quite in order and no hum trouble is likely to occur on this account. If by any chance one side of the input happens to get earthed, the amplifier immediately loses all gain, and oper-

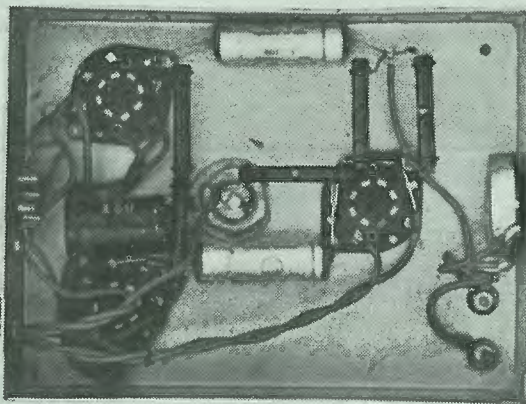

"BIG BOY" POWER AMPLIFIER

List Of Parts.

- 1—Base, size 6 x 8 x 2 1/2
- 1—Electrolytic condenser 8 mfd. (Solar, T.C.C.)
- 1—250 ohm 10-watt resistor (I.R.C., R.C.S.)
- 1—5,000 ohm 1-watt resistor (I.R.C., Bradley)
- 2—100,000 ohm 1-watt resistor (I.R.C., Bradley)
- 2—500,000 ohm 1-watt resistor (I.R.C., Bradley)
- 1—500,000 ohm volume control
- 2—.1 mfd. tubular condensers, 600v. (Solar, T.C.C.)
- 3—Octal socket, 1—5 pin
- 1—6-pin plug
- 2—Terminals
- 1—6G8G, 2 6L6G valves (Radiotron, Ken-Rad, Brimar)
- 1—Speaker, 1,000 ohm field, 5,000 ohm p/p load (Rola, Amplion)
- 1—Crystal pick-up (Astatic)
- 1—Gramophone motor (Collaro, Garrard, Dual)

By comparing the photograph at left with the diagram below, it is easy to recognise all the components.

ates at very low volume. We mention this point as it is about the only difficulty likely to be encountered.

Testing.

Before operating the amplifier it is a wise precaution to check up the connections to the plug and power supply, as the valves can be ruined if the high tension output of the power unit is applied to the filaments through faulty connections.

A sure check is to leave the rectifier valve out, and then switch on the unit and make sure that the three valves in the amplifier heat up inside to a dull glow. If they do not heat up properly, don't insert the rectifier until you find out why they don't. If

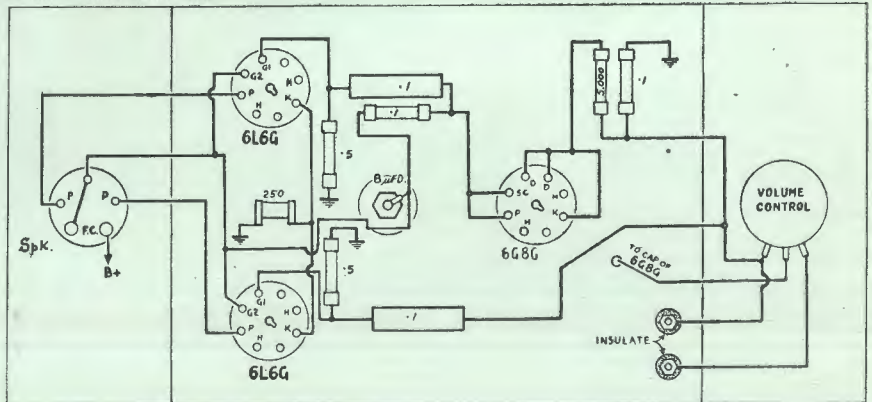

PRECISION PRODUCTS ETC ENGINEERED FOR EXTRA ENDURANCE

Component parts with the high quality necessary for successful set construction can always be found in the E.T.C. range.

E.T.C. Solar and E.T.C. Yaxley components, scientifically designed and precision constructed, have not been excelled in their inherent quality—the characteristic "E.T.C." is your guarantee of the best results under the most exacting conditions.

<p>E.T.C. SOLAR Mica Capacitors "Triple-sealed" Paper Capacitors Electrolytic Capacitors</p>	<p>E.T.C. YAXLEY Potentiometers Dual and All-wave Switches</p>
---	---

Manufactured by—
E.T.C. INDUSTRIES LTD. SYDNEY AND MELBOURNE

all appears O.K., on the other hand, the rectifier can be inserted, the unit switched on again, while a watchful eye is kept on the rectifier valve. If it shows any blue glow or flash inside the unit must be switched off again instantly. If the rectifier filament heats up to a dull red, all should be well, and with the volume control advanced flicking the finger on the needle in the pick-up should be heard through the speaker. Then a record can be tried.

Trouble.

If any trouble is encountered, a check with the picture diagrams, circuit and photographs should indicate what is wrong, but if all else fails you can use our laboratory service, it being only a couple of hours' work for us to check over all components and ensure that the amplifier is in perfect nick.

AMPLIFIERS

(Contd. page 19)

It is also necessary to make sure that the input transformer of the speaker has the correct ratio to allow a proper matching of the impedance of the output valve. This matter is taken care of if the speaker ratings are according to the specifications laid down in the parts lists.

Baffle Boards.

No loud-speaker, will give anything like normal low-note response unless it is mounted with suitable baffling. If the speaker is just left to stand in the open the highs will be sent out fairly well, but air displaced by the cone in making reproduction of a low note will simply escape around to the back of the cone and the necessary air pressure will be lost. With a cabinet a certain amount of baffling is obtained, but usually this baffling is influenced by cabinet resonances and the true amplifier enthusiast finds that a separate baffle board for the speaker is one of the shortest cuts to improved fidelity.

In practice it is found that for normal household use a baffle board of not less than three feet square should be used for a ten or twelve-inch speaker, still larger if at all practicable.

The board should be a solid piece of pine about three-quarters to an inch in thickness, or made up of laminated wood about half an inch thick. Another good baffle board is made up out of celotex or other acoustic material, an inch thick.

A suitable hole for the speaker is cut about the middle of the board. Theorists can prove that the hole should not be centred in the board, and also that a slightly irregular shape is to be preferred to a square, but for all practical purposes the above baffle board will be found to be quite suitable.

Rola G12

Permanent Magnet Version

is by far the Best
Speaker for the
Amplifiers describ-
ed in this Journal

Because—

- Rola G12 possesses amazing efficiency and gives you far more sound for a given input than will any ordinary speaker.
- Rola G12 PM needs no current for excitation. By using a choke in place of a speaker field in your amplifier, G12 PM can be used to improve any radio receiver or amplifier and can be operated at a considerable distance from it. Ideal in all battery receivers.
- Rola G12 PM is a true high-fidelity instrument giving flawless quality of reproduction over a wide range of frequencies.
- Rola G12 PM is extensively used in theatres, dance halls, public address and paging systems and in home radio. Rola G12 PM is moderately priced for so fine an instrument.
- Although G12 PM is easily the best speaker for your amplifier, Rola has at least 26 other speakers that will take the full output of your "BABY GRAND" amplifier and at least 17 other speakers that can be confidently used with "BIG BOY."
- Write immediately for full details of Rola's extensive range of speakers.

Rola Co. (Aust.) Pty. Ltd.

The Boulevard and Park Avenue
Richmond, E.I., Victoria J 5351
116 Clarence Street . . . Sydney
N.S.W. 8 5867

New Zealand distributors:
SWAN ELECTRIC COMPANY LTD., 208 British Chambers, High Street, Auckland. N.Z.

MANUFACTURERS OF THE WORLD'S FINEST SOUND REPRODUCERS

AND NOW FOR THE FIRST TIME—

A Portable-Mantel Radio

with Communications Receiver Performance!

Produced in response to insistent requests for a handy-sized first-class high-quality performance Receiver specially adapted to the exacting tropical conditions of the Islands. Ideal for Boat Owners, Builders, Race Enthusiasts, Business Men and all who want last-minute reliable official news from any part of the world—there's nothing on the market to equal it for range, tone, volume, selectivity and general performance! Don't buy a Radio Set until you've investigated the "ULTIMATE"—it'll stand any test and surpass anything you've ever heard!



Special Features: Magic Eye Tuning, Six Gang Band Spreading Condenser, Spin Tuning, Logging Hand, Simplified Control, Precision Selectivity, All Main Channel Coverage, Lovely Casing, Detachable Lid, etc., etc.



GEORGE BROWN & CO. PTY. LTD., 267 Clarence St., Sydney.

POST COUPON FOR DETAILS

GEORGE BROWN & Co. Pty. Ltd.,
267 Clarence Street, SYDNEY.

Without obligation to me, and post free, please send me details of the "ULTIMATE" Portable-Mantel Radio Set.

Name

Address

Acoustics.

Last but not least comes the problem of acoustics, and on this subject it would be possible to write books and still leave the hopeful amplifier enthusiast without any practical guide to overcoming the difficulties encountered in the acoustics of the particular room in which the amplifier is to be used.

We find that the best way is to make up an extension cord for the speaker, one about six feet long, so that the position of the baffle board can be moved about a bit. By doing actual practical experimenting in this way a vast difference will be noted, and the final placing of the baffle

board can be decided according to taste.

The amplifier should be tested in different rooms, and a marked difference in results should be noticed. For example, in the bathroom it should be possible to retain the full brilliance of the reproduction, even with the volume control almost fully retarded, but in a room with a heavy carpet, curtains and cushions similar brilliance will only be heard when the volume is up to full.

Experimenting with acoustic effects is most interesting work and we feel sure that the man with sufficient initiative to have got as far as this with us will soon settle his own problems of acoustics.

SPEAKERS (contd. from page 20)

ance to the K12, listing at 50/-, except that, having a lighter magnet and field coil, it is slightly less efficient. Features of both models include the famous Rola permacentric construction and isocore transformer, while excellent frequency response is a characteristic of both.

The de luxe model Rola G-12, listing at £8/12/-, gives substantially even response from 50 to 7500 cycles. A high fidelity design, the G-12 has exceptional power-handling ability coupled with a ruggedness of assembly that make it ideal for all kinds of amplifier work.

Latest 12" electro-dynamic models in the Amplion range comprise types 12E12 standard model listing at 43/-, and the de luxe 12E22 listing at 56/-.

Electric projection welding of the cone housing, centring ring, magnet yoke and pole plate ensures high sensitivity and trouble-free operation. Other features include tropically sealed transformer and one-piece moulded cone.

Shortwave Review

Conditions Good ★ More New Stations Heard ★ Further Details of Byrd Expedition Transmitters ★ 20-metre Conditions Improve ★ South Americans Plentiful ★ QSL Exchange Bureau. Full List of Month's Loggings.

Review of Conditions.

Once again we are able to report very satisfactory conditions during the past month. Practically all our correspondents throughout Australia and New Zealand speak of good reception during most of the night and day. Again we are able to list several new stations, whilst an unusually large number of rarely heard transmitters are included in the list of the month's loggings.

Readers should be prepared to concentrate on the higher frequency bands during the next few months, as conditions on 13, 16 and 19 metres should be at their best.

More New Stations.

Readers should find much to interest them in the list of the month's loggings. The following new stations are listed.

The new Indian station at Delhi can be logged on 11870kc., 25.26m. It can be heard from 9.30 p.m. with a native programme, with the news in English at 10.30 p.m., as from **VUD-2**. It is also reported around 3 p.m., carrying the same programme as **VUD-3**.

The unidentified South American mentioned in last month's issue as transmitting on the same frequency as **WBOS** turns out to be a Colombian, as was suggested. It is **HJAB** (ex-**HJ1ABB**), c/n 9570kc., 31.35m., and is located at Barranquilla. It is to be heard in the early mornings, though it is more than a little difficult to log.

Another new station heard during the month is the German **DJW** on 9650kc., 31.09m. It is heard best in the late afternoon.

An interesting station reported from New Zealand is **ZMEF**, located on Sunday Island, which has been heard contacting **ZIL-5** during the late afternoons on 92200kc., 32.61m.

Calls Unknown.

No calls are yet known for the many new Russian stations recently placed in service. The latest of these has been heard just below **DZC**, on approx. 29.85m. Reference is made elsewhere to the other new Russians.

Another unidentified station is a German carrying an Eastern programme around 7 a.m. on approx. 29.1m. (just above **ORK**).

Amateur Bands.

Our amateur band observers' reports indicate a considerable improvement on last month. A feature is the number of South American stations listed; with amateur transmissions banned in so many countries, it seems that 20-metre fans will be able to concentrate on the Latin-Americans, from whom a good percentage of QSL's will be obtained if comprehensive and informative reports are forwarded.

Latest Station Schedules and Changes

We gratefully acknowledge the assistance of the "Universallite," the N.Z. "DX-tra" and the Cuban Shortwave Club in the compilation of these notes.

Uruguay.

Stations **CXA-3**, 6075kc., 49.35m.; **CXA-4**, 6125kc., 48.98m.; **CXA-6**, 9620kc., 31.19m.; **CXA-10**, 11895kc., 25.23m.; and **CXA-18**, 15300kc., 19.61m., operated by S.O.D.R.E. (Servicio Oficial de Diffusion Radio Electrica, Mercedes 823, Montevideo), are now on regular schedule. It is reported that they verify all correct reports, returning reply coupons.

Also reported is **CXA-14**, 11800kc., 25.42m., relaying the Argentine station, **LS-6**, "Radio Mitre."

Colombia.

Despite the general movement of Colombian stations to the 62-metre band, several are still operating on 31 and 49 metres. Reference is made elsewhere to the new station, **HJAB**, on 31 metres. Whilst on 49 metres we find **HJAD**, 6160kc., and a new transmitter at Medellin, **HJDE**, 6145kc. The latter relays **HJOK**, and uses the slogan, "La Voz de Antioquia."

Costa Rica.

A new station is reported as operating on 6380kc., 47m. Call is **TIWS**, and location Puntareanas.

U.S.S.R.

Over the past few months a number of new Russian stations have been heard. Although no details of their call-signs are available, it is believed they operate on the following schedules:—

On 7512kc., 39.89m., 6-9.15 a.m. daily.
On 11630kc., 25.79m., 9 p.m.-4 a.m. daily, except Sunday, when from 10 p.m.
On 11940kc., 25.13m., 7-8 a.m. daily.
On 7360kc., 40.76m., 7-8 a.m. Mondays only.
On 8060kc., 37.22m., 6-6.30 a.m. daily.
On 14720kc., 20.38m., 8.30-9.30 a.m. daily.
No schedules are available for the transmitters on 9690 and 11645kc.

England.

Full details of the B.B.C. transmissions may be of interest.

Acknowledgments.

In addition to reports from the following Official Observers—Messrs. Johns, Cushen, Hastings, Taylor, Chapman, Bantow, Linehan and Pepin—we very much appreciate hearing from Messrs. Blight (AW554DX), Washfold (AW257DX) and Goucher (AW536DX).

Once again we would like to appeal to other readers to forward us their reports once in a while. Even a few lines will be greatly appreciated. And don't forget to let us have any suggestions for additional features for the shortwave section. Reports should reach us by the 14th of the month, and should be addressed to the Shortwave Editor, 117 Reservoir Street, Sydney.

Empire Service:—

Transmission 1: 4-8 p.m.: **GSB** (till 6.15 p.m.); **GSF** (from 6.30 p.m.); **GSE** (from 6.30 p.m.); **GSC** (till 4.45 p.m.); **GSP** (from 5 p.m.); **GSI** and **GSD**.

Transmission 2: 8.40-11.45 p.m.: **GSH**, **GSG**, **GSJ**, **GSD**, **GST** and **GSY** (from 10 p.m.)

Transmission 3: Midnight-2.30 a.m.: **GSF**, **GSV**, **GST**, **GSG**, **GSD**.

Transmission 4a: 2.52-6.30 a.m.: **GSI** (from 3 till 4.30 a.m.); **GSC** (from 4.30 a.m.); **GSP** (from 4.35 a.m.); and **GSD**.

Transmission 4b: 6.50-9 a.m.: **GSC**, **GSD**, **GSF** and **GSB**.

Transmission 5: 9.25-12.15 p.m.: **GSL**, **GSC**, **GSE**, **GSD**, **GSB**.

Transmission 6: 12.37-3.30 p.m.: **GSC**, **GSL**, **GSD**, **GSB**.

Foreign Language Service:

For Latin America: 6.50-9 a.m.: **GSF**, **GSA**, **GRX** and **GSB**; 9.25 a.m.-12.15 p.m.: **GSE** and **GSD**; 12.40-3.30 p.m.: **GSB**; midnight: **GSV**, **GSW** and **GSO**.

For Europe: 2.55-11 a.m.: **GSA** and **GRX**; 3.25-8.15 p.m.: **GSA** and **GRX**; 8.45 p.m.-2.30 a.m.: **GSW** and **GSO**.

For the East: 2.55-4.25 a.m.: **GSP** and **GSC**.

Mexico.

The latest station reported from Mexico is **XEHX**, Banco Nacional de Mexico, testing on 11110kc., 27m.

Yugo-Slavia.

Latest details of English sessions from Belgrade, now heard through **YUA** and **YUC**, are:—Talk in English; daily at 5.30 a.m. news in English daily at 7.30 a.m.

Byrd Expedition.

Further details are available regarding the Byrd expedition stations in the Antarctic.

Telephone stations with the calls, **KRTA**, Snow Cruiser; **KRTC**, East Base; and **KRTK**, West Base, will operate on 6425kc., 46.7m.; 9135kc., 32.8m.; 11060kc., 27.1m.; 12862kc., 23.32m.; 23100kc., 12.9m.; and 30660kc., 9.7m.

Amateur calls allocated are **KC4USA**, West Base; **KC4USB**, East Base, and **KC4USC**, Snow Cruiser. They will operate on 7075kc., 14150 kc. and 28300kc.

The Month's Loggings

Stations not listed last month are indicated by an asterisk. All times are Australian Eastern Standard.

SOUTH AMERICA

Peru

OAX4J, 9340kc., 32.12m., Lima: Still heard quite well on Sunday afternoons till closing slightly after 4 p.m.

***OAX5C**, 9390kc., 31.95m., Ica: Reported from N.Z. Best on Sundays around 4 p.m.; English announcement at close (Johns).

Ecuador

HCJB, 12460kc., 24.08m., Quito: Quite a strong signal some nights between 10 and 11 p.m. Also heard at times around 1 p.m. testing with amateur stations, and using call **HC1JB** (Chapman, Goucher).

Colombia

HJFK, 9740kc., 30.8m., Pereira: Not as loud as previously, but still fairly good opening at 10 p.m. (Cushen).

***HJAB**, 9570kc., 31.35m., Barranquilla: New station heard in early mornings. See reference elsewhere.

Chile

CD-1190, 11910kc., 25.19m., Valdivia: Still reported from N.Z. Closes at 1.30 p.m. with organ selection, time signal and chimes.

***CB-1180**, 11970kc., 25.06m., Santiago: Reported from N.Z. Heard from 12.30 p.m. till closing around 2 p.m.

Argentine

LRA-3, 11730kc., 25.58m., Buenos Aires: New Station listed for first time last month. Heard some mornings between 7.30-8.45 a.m. Announces as "Radio Splendid" (Bantow).

Uruguay

***CXA-8**, 9640kc., 31.12m., Colonia: Agoin being heard on Sundays till 4 p.m. Announces as "Radio Belgrano," relaying station in Buenos Aires, Argentine.

CENTRAL AMERICA

Panama

***HP5G**, 11780kc., 25.47m., Panama City: Station listed for first time in these columns. Heard testing late Sunday afternoons, relaying **HOA**. QRA is Box 1121 (Cushen, Washfold).

HP5A, 11700kc., 25.64m., Panama City: Still heard at good strength from 10 p.m.

HP5K, 6005kc., 49.97m., Colon: Regular night station, opening at 10 p.m.

Guatemala

TGWA, 15170kc., 19.77m., Guatemala City: Very good signal on Monday mornings around 7 a.m.; closes 7.45 a.m. (Linehan).

TGWA, 9685kc., 30.96m., Guatemala City: Still heard in afternoons; till 3 p.m. weekdays, and sometimes later on Sundays, with special DX programmes (Johns).

TGWB, 6480kc., 46.2m., Guatemala City: Heard on Sundays with same programme as **TGWA** (Johns).

***TGIX**, approx. 6200kc., 48.4m., Guatemala City: New station reported from N.Z. Heard calling Habana, Cuba, at 6 p.m. on Sundays. Possibly using **TG2's** frequency (Cushen).

Costa Rica

TIPG, 9615kc., 31.21m., San Jose: Still heard from 10 p.m.

***TIEP**, 6690kc., 44.82m., San Jose: Not listed for some time, but now heard quite well after 10.30 p.m. Announces as "La Voz del Tropico" (Cushen).

El Salvador

***YSP**, 10400kc., 28.85m., San Salvador: This most unusual station is being heard in N.Z. Signals are weak, and the best time for reception is around 3 p.m. (Johns).

WEST INDIES

Cuba

***COCM**, 9805kc., 30.60m., Habana: Again reported from N.Z. around 3.30 p.m. Signals weak, but improving (Johns).

COCH, 9437kc., 31.8m., Habana: Heard at various times; probably best now in afternoon at 3.30 p.m. Also in early morning,

and sometimes at night. See also new frequency of 6460kc., where call **COHI** is used (Johns, Goucher).

***COBZ**, 9030kc., 33.32m., Habana: Now being heard on Sunday afternoons till as late as 5 p.m.

COCQ, 8825kc., 33.98m., Habana: Now heard best in afternoons, especially on Sundays till about 4.30 p.m. (Johns).

***COJK**, 8665kc., 34.64m., Camaguey: Reported from N.Z. on Sundays, signing at 4.30 p.m. Weak (Johns).

COHI, 6460kc., 46.44m., Sta. Clara: Now very good, opening at 10 p.m. Also heard in N.Z. around 3 p.m. (Johns, Cushen, Goucher).

COCQ, 6360kc., 47.17m., Habana: Heard well at night on this new frequency (Johns).

COCW, 6324kc., 47.4m., Habana: Still fairly good at night (Washfold).

Dominican Republic

HIIN, 12486kc., 24.03m., Trujillo City: Still heard with weakish signal around 10 p.m. (Cushen).

NORTH AMERICA

Mexico

XEQQ, 9680kc., 30.99m., Mexico City: Heard best during last half-hour of transmission. Uses four-note chime and announces in English on closing at 4 p.m. (Johns).

XEWV, 9503kc., 31.57m., Mexico City: Regular afternoon station, best from 3.30-4 p.m. (Washfold, Johns).

***XEQQ**, 6035kc., 49.75m., Mexico City: Have been unable to log this new station, but it is being heard in N.Z. till close at 12.30 p.m.

***XEBT**, 6000kc., 50m., Mexico City: Heard sometimes around midnight.

Canada

***CHNX**, 6130kc., 48.94m., Halifax: Reported from N.Z., where it is heard at times from 11 p.m., despite QRM from **MTCY** (Cushen).

***CJCX**, 6010kc., 49.96m., Sydney: Reported from N.Z., with fair signal around 10 p.m. Bad QRM at times (Cushen).

United States

WNBI, 17780kc., 16.87m., Bound Brook: Heard fairly well in mornings, though fading bad at times. Also around midday and improving at this time (Pepin, Bantow, Johns).

WGEA, 15330kc., 19.56m., Schenectady: Fairly good signal in mornings, till close at 9.15 a.m. (Bantow).

ROME ON A NEW FREQUENCY.

Mr. L. J. Keast, of Randwick, reports hearing Rome on 17780 kilocycles.

When listening in on Saturday afternoon, March 23, at 1.45, he was attracted by a surprisingly strong carrier on the 16-metre band. Certain it could not be an American at this hour at such strength, he waited for an announcement and sure enough it was forthcoming. At 1.46 the well-known voice of the Eastern Speaker of E.I.A.R. said: "This is Rome calling. This is 2RO-20 on a frequency of 17780 kilocycles. a wavelength specially prepared for our listeners in South America. Please report to, 2RO-20, E.I.A.R., Rome, Italy."

KGEI, 15330kc., 19.56m., San Francisco: Much better reception of this station in N.Z. Heard in early afternoons (Johns, Cushen).

WCAB, 15270kc., 19.65m., Philadelphia: A good signal in the mornings around 7 a.m.

WRUW, 15130kc., 19.83m., Boston: Nice signal in mornings, closing at 8 a.m. (Bantow).

WPIT, 11870kc., 25.27m., Pittsburgh: Good strong signal in the morning, 7-9 a.m., with Spanish programme (Pepin).

WCBX, 11830kc., 25.36m., New York: Fairly good signal around 7 a.m. (Bantow).

WRUL, 11790kc., 25.45m., Boston: Very nice signal some mornings between 7 and 8 a.m.

WRUW, 11730kc., 25.58m., Boston: Not used very often now; sometimes after 8 a.m.

WRCA, 9670kc., 31.03m., Bound Brook: Quite a good signal in late afternoons (Cushen, Johns, Pepin).

WCAB, 9590kc., 31.28m., Philadelphia: Another good afternoon station; best 4-5 p.m.; news at 4.55 p.m. (Cushen).

WBOS, 9570kc., 31.35m., Boston: Considerably louder than last month; best 4-5 p.m. (Cushen).

WGEA, 9550kc., 31.41m., Schenectady: Fair signal in the mornings around 8.30 a.m. (Cushen, Pepin, Bantow).

WGEQ, 9530kc., 31.48m., Schenectady: Best between 6 and 7 a.m., though sometimes at good strength till much later (Cushen, Johns).

KGEI, 9530kc., 31.48m., San Francisco: One of best of Yanks; strong signals in afternoons, and also from 10 p.m. till well after midnight.

***WCBX**, 6170kc., 48.62m., New York City: Reported from N.Z.; excellent signal at 4.30 p.m. Also uses 6120kc. (Johns, Cushen).

WLWO, 6060kc., 49.5m., Cincinnati: Now being heard quite well at night; opening at 8.45 p.m. (Johns, Washfold).

AFRICA.

Kenya

VQ7LO, 6083kc., 49.31m., Nairobi: Still one of regular early morning stations; signals fair. Relays B.B.C. news at 4 a.m. (Cushen).

Ethiopia

I2AA, 9650kc., 31.09m., Addis Ababa: Heard with quite good signal in wee small hours; 1-2 a.m. (Cushen).

Mozambique

CR7BE, 9640kc., 31.12m., Lourenco Marques: An excellent signal is heard from this new station; 5-7 a.m. (Goucher).

***CR7BH**, 11718kc., 25.6m., same location: Heard from 8 p.m. on Sundays with religious service.

Algeria

TPZ-3, 8960kc., 33.48m., Algiers: still being heard well in N.Z. in early morning; closes 7 a.m. O

Madagascar

***Radio Tananarive**, 9695kc., 30.94m.: Heard at fair strength from 1 a.m. till 2.30 or 3 a.m.

***Radio Tananarive**, 6060kc., 49.5m.: Heard at same time as 9695kc. transmitter. Better signal.

South Africa

ZRK, 6098kc., 49.2m., Klipheuvall: Heard at fair strength in the early mornings; from 3-7 a.m.

ZRH, 6007kc., 49.94m., Roberts Heights: Also at fair strength till closing at 6.30 a.m.

AUSTRALIA AND OCEANIA

Australia

VLR-3, 11880kc., 25.25m., Lyndhurst: Used to relay A.B.C. programme till 5.15 p.m. (Washfold, Pepin, Bantow).

VLW-3, 11830kc., 25.36m., Perth: Good signal during afternoon (Washfold, Blight, Pepin, Bantow).

VLQ-2, 11870kc., 25.27m., Sydney: Used for special overseas broadcasts by Ministry of Information.

VLW-2, 9650kc., 31.08m., Perth: Heard at good strength at night from 8.15 p.m. Also reported on 9560kc., 31.38m., but doubtful if this frequency will be used much on account of QRM from **DJA** (Washfold, Pepin, Blight, Bantow, Cushen).

VLQ, 9615kc., 31.21m., Sydney: As **VLQ-2** (Washfold, Blight, Bantow).

VLR, 9530kc., 31.32m., Lyndhurst: Relays A.B.C. programme from 5.30 p.m. (Washfold, Pepin, Bantow).

Fiji

VPD-2, 9535kc., 31.47m., Suva: Now on new schedule; 7-8 p.m. (Cushen).

New Caledonia

FK8AA, 6122m., 49m., Noumea: Now rather difficult to log; best after 6 p.m. On Thursday and Saturday only.

Sunday Is.

***ZMEF**, 9200kc., 32.61m.: 'Phone station reported from N.Z. Not on regular schedule, but heard between 4.30 and 5.30 p.m.

QSL Exchange Bureau.

L. R. J. Knighton, 245 Armagh St., Christchurch, New Zealand.
 A. W. Eddy, "Galval Farm," Irwell, via Christchurch, N.Z.
 J. E. Gardner, 706 Williamson Building, Cleveland, Ohio, U.S.A.
 Ronald E. J. White, P.O. Box 493, St. Johns, Newfoundland.
 G. H. C. Molier, Pijnboomstraat 104, The Hague, Holland.
 A. H. Tempeloors, Amazonestraat 27, Amsterdam, Holland.
 Van Dixhoorn, Mauritsstraat 8, Breda, Holland.
 Lewis Sakurada, P.O. Box 14, Lanikai, Hawaii.
 Clement McColgen, 2905 Alphonse Pl., Honolulu, Hawaii.
 George C. Lindo, 1914 South Beretania St., Honolulu, Hawaii.
 Isamu Kaneshiro, 1642 Kinoole St., Hilo, Hawaii.
 Luis Diez A., P.O. Box 21, Retalhuleu, Guatemala.

THE EAST

Philippine Is.
KZRH, 9660kc., 31.06m., Manila: Strong signal nightly from 8.30 p.m. (Washfold, Bantow).
KZRM, 9570kc., 31.35m., Manila: Strong signal from 8.30 p.m. (Washfold, Blight, Pepin, Bantow).
KZIB, 9500kc., 31.58m., Manila: Not quite as strong as other Manila stations on 31m. (Washfold, Pepin, Bantow).
KZEG/KZRF, 6140kc., 48.86m., Manila: Very strong at night: (Washfold, Blight, Pepin, Bantow).
KZIB, 6040kc., 49.67m., Manila: Good signal at night (Washfold).
Japan
JZK, 15160kc., 19.79m., Tokyo: Heard at various times during the day and night. Good in early morning and forenoon (Pepin).
JZJ, 11800kc., 25.42m., Tokyo: Good strong signal at night from 10 p.m.; also in the early morning (Pepin, Bantow, Washfold).
JVW-3, 11720kc., 25.6m., Tokyo: Not as strong as formerly; heard nightly from 6.45 p.m.; also at 7.10-7.30 a.m. (Washfold, Bantow).
JZJ, 9535kc., 31.46m., Tokyo: Nightly at 10 p.m.; but mixed up with **KGEL** in some localities (Bantow).
JYW, 7258kc., 41.34m., Tokyo: Excellent signal in the early morning; English session at 6 a.m. Very strong (Cushen, Pepin, Bantow).
Hong Kong
ZBW-3, 9525kc., 31.49m.: Continues to be one of the most consistent night stations at good strength (Washfold, Blight, Bantow).
India
VUD-3, 15290kc., 19.62m., Delhi: Still being heard in N.Z. during mid-afternoon, 2-3 p.m. (Johns).
***VUD (?)**, 11870kc., 25.26m.: New Indian station thought to be located at Delhi (although station list shows **VUM**, Madras, on this frequency). Heard very well at night relaying **VUD** on 31m., with news at 10.30 p.m. also heard relaying **VUD-3** between 2 and 3 p.m. by N.Z. listeners (Johns, Chapman Bantow).
VUD-2, 9590kc., 31.28m., Delhi: Excellent signal from 10.30 p.m. with news in English. (Washfold, Pepin, Bantow).
 Also the four transmitters on 60-61 metres. Reception of these signals is marred by high noise-level. Strongest signals are from **VUB-2**, 61.48m., and **VUC-2**, 61.98m. (Pepin).
Malaya
ZHP, 9690kc., 30.96m., Singapore: Still a good signal, widely heard despite QRM at times (Washfold, Johns, Blight, Pepin, Bantow).
ZHJ, 6080kc., 49.3m., Penang: Still heard fairly well on most nights (Cushen, Pepin, Washfold).
French Indo-China
Radio Saigon, 11780kc., 25.47m.: One of best signals heard at present. Now verifies with attractive card (Washfold, Blight, Pepin, Bantow).

***Radio Boy-Londry**, 9680kc., 30.97m., Saigon: Reported from New Zealand, and heard once in our locality. Testing between 10 p.m. and midnight.

***Radio Volonte**, 7100kc., 42.25m., Saigon: Reported from N.Z. Heard around 11.30 p.m.

***Radio Boy-Landry**, 6210kc., 48.28m., Saigon: Reported by our Vic. Observer; heard at 10.15 p.m. at fair strength (Bantow).

China
XGOX, 15190kc., 19.75m., Szechwan Province: Heard at excellent strength from about 7 p.m. (Pepin).
XGOY, 11900kc., 25.21m., some location: Continues to be heard at same strength and at some times as in previous months (Washfold, Blight, Pepin, Bantow).

XMHA, 11855kc., 25.3m., Shanghai: Heard at fair strength at night (Washfold).
XGOK, 11650kc., 25.75m., Canton: Heard quite well after 9 p.m.; signals often spoilt by code QRM (Johns, Bantow).

***XHHB**, 7970kc., 37.6m., Shanghai: New station (previously listed in January). Reported from N.Z.; heard at great strength at 10 p.m.; modulation poor (Cushen).
XPSA, 7000kc., 42.8m., Kweiyang: Excellent signal nightly around 9.30 p.m. (Johns, Bantow).

Dutch East Indies.
YDB, 15310kc., 19.6m., Bandoeng: Heard at good strength in W.A. in the afternoons (Pepin).
YDC, 15150kc., 19.8m., Bandoeng: One of most reliable stations on the air; heard from 9 a.m. and at night (Washfold, Blight, Pepin, Bantow).

PLP, 11000kc., 27.27m., Bandoeng: N.I.R.O.M. relay station (Pepin).
PMN, 10260kc., 29.24m., Bandoeng: As **PLP** (Pepin).
YDB, 9550kc., 31.41m., Bandoeng: Heard best around midnight; excellent signal in the west (Pepin).

PMH, 6720kc., 44.64m., Bandoeng: Strong consistent signal at night (Pepin, Bantow).

***YDX**, 7220kc., 41.55m., Medan, Sumatra: Reported from W.A. Good signal at night (Pepin).

YDD, 6045kc., 49.63m., Bandoeng: Fairly strong signal around 10 p.m. (Bantow).

PMY, 5145kc., 58.3m., Bandoeng: Not very strong, and marred by heavy QRM. Opens at 8.30 p.m. (Johns, Pepin).

YDE-2, 4810kc., 62.37m., Solo: Quite good signal above noise; opens 8.30 p.m., but best after 9.30 p.m. (Johns, Pepin).

YDA, 3040kc., 98.68m., Tandjongpr.ok: Good signal in W.A. (Pepin).

Manchukuo
MTCY, 11775kc., 25.48m., Hsinking: Fair signal from 7 a.m.; news at 7.15 a.m.

MTCY, 6125kc., 48.98m., Hsinking: Fair signal at night after 11 p.m. (Cushen).

***JDY**, 9920kc., 30.24m., Dairen: Not heard in our locality for some time, but heard in W.A. from 10 p.m. (Pepin).

Thailand
HSP-6, 7968kc., 37.56m., Bangkok: Good signal from 11 p.m. (Blight, Pepin).

Burma
XYZ, 6007kc., 49.94m., Rangoon: Still heard with fair signal around midnight (Cushen, Pepin, Bantow).

—, 6056kc., 49.54m., Rangoon: New frequency for Rangoon station; same programme as **XYZ**.

Taiwan
***JFO**, 9636kc., 31.13m., Taihoku: Heard in W.A. around midnight (Pepin).

JIE, 7295kc., 41.13m., Tyureki: Heard in W.A. with fair signal around midnight (Pepin).

EUROPE

Portugal
CSW-6, 11040kc., 27.17m., Lisbon: Fine signal in early morning around 5 a.m.

ALL-WAVE ALL-WORLD DX CLUB

Application for Membership



The Secretary,
 All-Wave All-World DX Club,
 117 Reservoir Street,
 Sydney, N.S.W.
 Dear Sir,

I am very interested in dxing, and am keen to join your Club. The details you require are given below:

Name.....

Address.....

(Please print both plainly.)

My set is a.....

(Give make or type, number of valves, and state whether battery or mains operated).

I enclose herewith the Life Membership fee of 3/6 [Postal Notes or Money Order], for which I will receive, post free, a Club badge and a Membership Certificate showing my Official Club Number.

(Signed).....

(Note: Readers who do not want to mutilate their copies of the "Radio World" by cutting out this form can write out the details required).

CSW-7, 9740kc., 30.8m., Lisbon: A good steady signal in the mornings at 7 a.m. (Chapman, Bantow).

Sweden

SBT, 15155kc., 19.8m., Motala: Now heard on Sunday evenings with religious service (Cushen).

SBP, 11705kc., 25.63m., Motala: Heard on Sundays, opening at 5.57 p.m.; church service later (Cushen, Goucher).

Turkey

TAP, 9465kc., 31.8m., Ankara: Remains one of best morning signals.

Holland

PHI-2, 17770kc., 16.88m., Huizen: Fair signal just before 11 p.m.

PCJ-2, 15220kc., 19.71m., Huizen: Fair signal from 10.40 p.m.

Spain

EAQ, 9860kc., 30.43m., Madrid: Heard very irregularly at the present time.

***FET-1**, 7070kc., 42.3m., location uncertain: Reported from N.Z.; heard at 8 a.m. with announcement, "Radio Ariba Espana."

Yugo-Slavia

YUC, 9505kc., 31.56m., Belgrade: Good signal in morning, but spoilt by **GSB**.

YUA, 6100kc., 49.18m., Belgrade: Still heard in the early mornings with good signal (Johns).

Switzerland

HBO, 11402kc., 26.32m., Geneva: Heard on Sundays around 5-6 p.m., good signal.

Vatican City

***HVJ**, 15120kc., 19.83m.: Heard around 6.30 p.m. on occasions (Linehan).

***HVJ**, 11740kc., 25.55m.: Heard around midnight with excellent signals (Cushen, Chapman).

Belgium

ORK, 10330kc., 29.04m., Ruyssedele: Now putting in a fine signal in the early morning (Goucher).

Albania

***ZAA**, 7850kc., 38.2m., Tirana: Reported with weak signal from N.Z., closing at 6.30 a.m.

Norway

LKV, 15170kc., 19.78m., Oslo: Still heard with weakish signal around 2 a.m.

***LKQ**, 11735kc., 25.57m., Oslo: Heard in N.Z. on Sunday evenings around 8 p.m. (Cushen).

Canary Is.

***EJF-43**, 10360kc., 28.96m., Tenerife: Agcin being heard in early morning, with English news around 6.30 a.m. (Chapman).

Italy

All Italian stations reported at good strength.



Mr. L. J. KEAST, our new Short-wave Editor, who will take charge of this section, as from next month's issue.

France

Same stations as were listed in March issue. **U.S.S.R.**

Many new transmitters now audible; for details see "Latest Station Changes and Schedules" column.

Germany

A new station being heard at present is **DJW**, 9650kc., 31.09m.

Ultra-High-Frequency Notes.

Conditions Still Improving.

As was predicted last month, conditions on 9-11 metres improved slightly at the beginning of March. The 10-metre amateur band still provides the best U.H.F. reception, although only W's and K6's have been heard recently. On 11 metres the usual three or four broadcast stations are heard weakly; whilst the police bands are just beginning to open up again, with weak signals noted on 31900 and 33100kc.

Amateur Bands Review.

As mentioned elsewhere, conditions on 20 metres have improved considerably during the past month, and we are able to list a good number of South American and Eastern stations.

Conditions on 10 metres have failed to improve very much, and only the usual W and K6 stations have been heard.

CALLS HEARD

(Compiled from reports forwarded by Messrs. Washfold, Cushen, Chapman, Blight, Pepin, Linehan, Hastings, Taylor and Goucher)

10 Metres.

United States: **W- 2DXT, 3GUM, 3QM, 4FCC, 4GCU, 5ACL, 5ERV, 6CIW, 6DLV, 6ELB, 6FAH, 6FH, 6IKH, 6LJR, 6MWK, 6NXK, 6OQK, 6OXC, 6PHX, 6POW, 6POZ, 6QXV, 6RIU, 6RKL, 6RML, 6RRU, 7EL, 7FPS, 7GLX, 7HK1, 7HYF, 7HYP, 7FPY, 8FGV, 9ABZ, 9BCX, 9BRZ, 9DOX, 9DRQ, 9DUQ, 9EKD, 9EMF, 9JHM, 9MHF, 9NND, 9QCD, 9YVK.**

Hawaii: **K6- KYI, LNP, MXM, OQM, PCW, PLZ, PRR, QLG, QXU, RVI.**

20 Metres.

South America: **CE- 1AF, 1AL, 1AM, 2AC, 2AM, (Chile); PY- 2AC, 2FO, 2AF (Brazil); CP- 2AC, 8AI (Bolivia); OA- 3B, 4R, 4AI (Peru); LU- 1AA, 1QA, 5HE, 7BK (Argentina); YV- 1AM, 5AK (Venezuela); HC2CC (Ecuador); HK- 3CY, 4DA (Colombia) ...**

Central America: **T12RC (Costa Rica).**

West Indies: **CO- 2MA, 6OM, 8JK (Cuba).**

Europe: **EATAV (Spain).**

Pacific: **KF6JEG (Canton Is.); KB6ILT (Guam); KF6QKH (Baker Is.); K6- MVA, GAS, OJI, BNR, PTW, CYK, NZQ, QHU, PCF, LKN, OTH, PIT, IVU, NYD, LCV, MTE (Hawaii).**

The East: **XU- OA, 1A, 1B, 4ST, 4LA, 5YT, 6MK, 6MJ, 6PF, 8LA, 8ZA, 8RJ, 8IA, 8MC, 8MY, 8RB, 8AM, 8HJ (China); J8CI (Korea); J- 2NG, 2NF, 2XA, 5CW (Japan); PK5- HL, 2LZ, 3BD, 3AR, 4JD, 4CT, 4ES, 4KS (D.E.I.); KA- 1SM, 1CW, 1LB, 1ME, 1BH, 1OZ, 1MV, 1CS, 1MN, 1YL, 1AF, 1FH, 1BN, 1SF, 1BD, 1AP, 1RB, 1BB, 1PJ, 1AC, 1GC, 1EL, 1JJ, 1FX, 3BW, 4SC, 4RP, 4LH, 7HB, 7FF, 7TT, 7RF, 8AA (Philippines).**

THE BROADCASTING STATIONS OF NEW ZEALAND.

Call-sign	Location	K.C.	M.
2YA	Wellington	570	526
1YA	Auckland	650	461.3
4YZ	Invercargill	680	441.2
3YA	Christchurch	720	416.4
2YB	New Plymouth	760	394.5
4YA	Dunedin	790	379.5
2ZH	Napier	820	365.6
2YC	Wellington	840	356.9
1YX	Auckland	880	340.7
2ZP	Wairoa	900	333.1
2YN	Nelson	920	325.9
3ZR	Greymouth	940	319
2ZJ	Gisborne	980	306
2YD	Wellington	990	302.8
4ZM	Dunedin	1010	296.9
4ZD	Dunedin	1010	296.9
1ZB	Auckland	1090	275.1
2ZB	Wellington	1130	265.5
4YO	Dunedin	1140	263
2ZM	Gisborne	1150	260.7
3YL	Christchurch	1200	249.9
4ZB	Dunedin	1220	245.8
1ZM	Auckland	1250	239.9
4ZC	Cromwell	1280	234.2
1ZJ	Auckland	1310	228.9
3ZB	Christchurch	1430	209.7

DX CLUB MEMBERS.

SPECIAL NOTICE.

Members of the All-Wave All-World DX Club are advised that they should make a point of replenishing their stock of stationery immediately, as all paper prices have risen, and we expect that within a few weeks it will be necessary to increase prices by at least 25%.

While stocks last the following stationery is available at the old prices, as shown.

REPORT FORMS.—Save time and make sure of supplying all the information required by using these official forms, which identify you with an established DX organisation.

Price 1/6 for 50, post free.

NOTEPAPER.—Headed Club notepaper for members' correspondence is also available.

Price 1/6 for 50 sheets, post free.

DX CLUB STICKERS.—Enlarged two-colour replicas of the Club badge, in the form of gummed stickers, designed for attaching to envelopes, QSL cards, etc.

Price 5 dozen for 1/6, post free.

DX CLUB LOG SHEETS.—Designed by the Short-wave Editor, these headed and ruled log sheets are indispensable to dxers who wish to keep a simply-prepared and accurate list of loggings.

Price 3 dozen for 1/6, post free.

ULTIMATE PORTABLE

by A. G. Hull

I HAVE heard many of my friends talk of the capabilities of the "ULTIMATE" receivers, but it is some years since I actually tested one myself. Friend Shaw, well-known short-wave observer, often remarked of what he had done with "ULTIMATE," and also Mr. Keast, who has been a foremost short-wave listener for many years, and who uses "ULTIMATE" exclusively.

So, when Mr. Eaton, of the distributors, George Brown & Co. Pty. Ltd., suggested that I might like to take home one of the new portable mantel "ULTIMATES," I readily agreed, feeling sure that I would be interested in a portable with such a name. But I was considerably astonished when Mr. Eaton first showed me this new "ULTIMATE" model.

It is an entirely new conception of a portable.

Usually when we talk of a portable we refer to one of the new midget battery jobs, which can be carried around like a handbag. But the "ULTIMATE" portable mantel should not be confused with this type of set, as it is both larger and heavier.

The new "ULTIMATE" portable mantel is not a portable in the accepted sense of the word, but it is an entirely new thought in receiver design and we feel certain that it is

BRIEF SPECIFICATIONS.

VALVES USED: 6K7 r.f. amplifier, 6K8 mixer, 6K7 r.f. amplifier, 6H6 diode second detector and a.v.c. rectifier, 6F5 first audio amplifier, 6F6G power output pentode, 80 rectifier, 6U5 Magic Eye.

BAND COVERAGE: Short waves, 13 to 33 metres; medium waves, 40 to 100 metres; broadcast band, 1500 to 550 k.c.

CONTROLS: Tuning, waveband switch, tone control and combined volume control and on/off switch.

MAIN TECHNICAL FEATURES: Six-gang condenser gives exceptionally high gain and semi-bandspread tuning on the short waves; "spinner" tuning dial with logging pointer ensures smooth, accurate tuning; multi-coloured dial scales are etched on glass; visual volume control indicator; inverse feedback output circuit ensures excellent tonal quality.



The new Ultimate is an entirely different type of portable, with a full-size 8-valve chassis and communications-type performance.

going to offer a strong appeal to the true radio enthusiasts.

It is an elaborate EIGHT VALVE model, available for a.c. operation. Alternatively there is a vibrator model suitable for operation from an accumulator. It is fitted in a most attractive type of portable cabinet, as you will see from the photograph.

We can't imagine anything more ideal for what we might term transportable use. By that we mean for home use and then to be put in the car and taken on board a cruiser, taken away for use in the week-end shack, or for the traveller who is to tour the Islands or something like that. Above all, it is a super-powered all-waver, with true communication-type performance on the short-wave bands, and yet it can more than hold its own with the big console jobs when it comes to the broadcast band.

The short-waves are covered in two bands, the first from 13 to 33 metres and the second from under 40 to over 90 metres.

A six-section tuning condenser is switched with the wave-bands, so as to get easy tuning for the short waves, and in conjunction with the fly-wheel type control knob it is just as easy to tune in overseas short-wave stations as it is the local broadcasters. The receiver has TERRIFIC SEN-

SITIVITY and if the volume control is fully advanced it is possible to hear anything which is in the ether. The more powerful overseas stations come through clearly with the volume control turned well back, and dozens of others are there for those enthusiasts who are prepared to take them with the background of noise which is inseparable from the work of dragging in a faint signal on a super-sensitive receiver. Stations which I tried to get on an ordinary dual-waver, but which were only a slight hiss on the dial, were brought up to full speaker strength on the "ULTIMATE."

In a nutshell, the "ULTIMATE" is a set which we can strongly recommend to the keen listener who wants a receiver with performance right out of the ordinary and who is able to pay the price of such a quality job.

When this receiver is used as a mantel the lid is removed from the sliding type hinges. The receiver may then be placed in the convenient horizontal position for tuning. The illustration does not show the rubber cushions on which the receiver rests when in this position, but they are fitted for the protection of the surface on which the radio is placed.

The distributors are George Brown and Company Pty. Ltd., of 267 Clarence Street, Sydney.

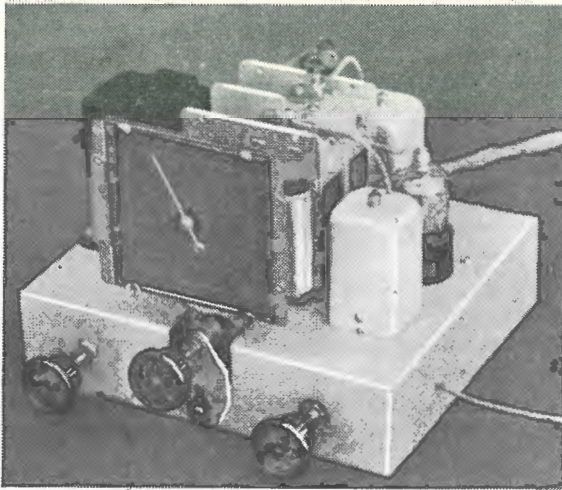

A general view of the chassis.

The 1940 SCOUT

Using only two valves, this modern version of one of our most popular battery-operated receivers is capable of giving results quite out of proportion to its modest cost. The circuit is a t.r.f. one.

TO-DAY the superhet is supreme, and we doubt if there is a t.r.f. type of receiver available in factory-made models to-day. Which is a state of affairs much to be deplored, for the humble t.r.f. set has its own place in the scheme of things. Although not as selective as the superheterodyne circuit, the t.r.f. receiver is simple and cheap to build, does not need any delicate adjustment or alignment and will give excellent service within the limitations of its capabilities.

A couple of years ago we featured a simple t.r.f. type of battery receiver, named "The Scout," and it proved exceptionally popular, mainly, we fancy, because it offered unequalled value. For the cost of the parts the performance was exceptionally good. The construction and adjustment were so simple that hundreds of novices built up "The Scout," and, without exception, their reports on results were full of praise.

The advent of the latest types of battery valves makes it possible to re-design this circuit and offer it again as an even better proposition.

The same performance is retained, yet the number of valves used is cut down from three to two, simply by using that remarkable combination valve, the type 1D8GT.

This valve actually consists of two separate sets of elements in the one glass bulb, yet does not cost twice as much as an ordinary valve, and does not take anything like the amount of current which would be taken by two separate valves carrying out the same work.

Performance.

As might be expected, the selectivity is not up to the standard of a superheterodyne, but otherwise the little set is a fine performer, with ample range to bring in stations from near and far, and with nice tone and

sufficient power for ordinary room strength with the loud-speaker.

Current Drain.

The actual figures for the current drain of the receiver are interesting to those who have advanced far enough to appreciate such points.

Only 90 volts of high tension are needed, and the drain is then about 8 milliamps when working at full strength. With this low current drain it becomes quite possible to use light duty batteries and get months of service from them. With standard

or heavy duty batteries about a year's service should be obtained from each pair.

The filament current drain is .15 of an ampere at 1.4 volts, and this can be obtained from a single dry cell, or one of the special cells which have been introduced for use with these new valves. Compared to the old idea of three heavy duty "B" batteries and an accumulator, the cost of the battery equipment for this set is only about half the amount which would have covered a set of batteries.

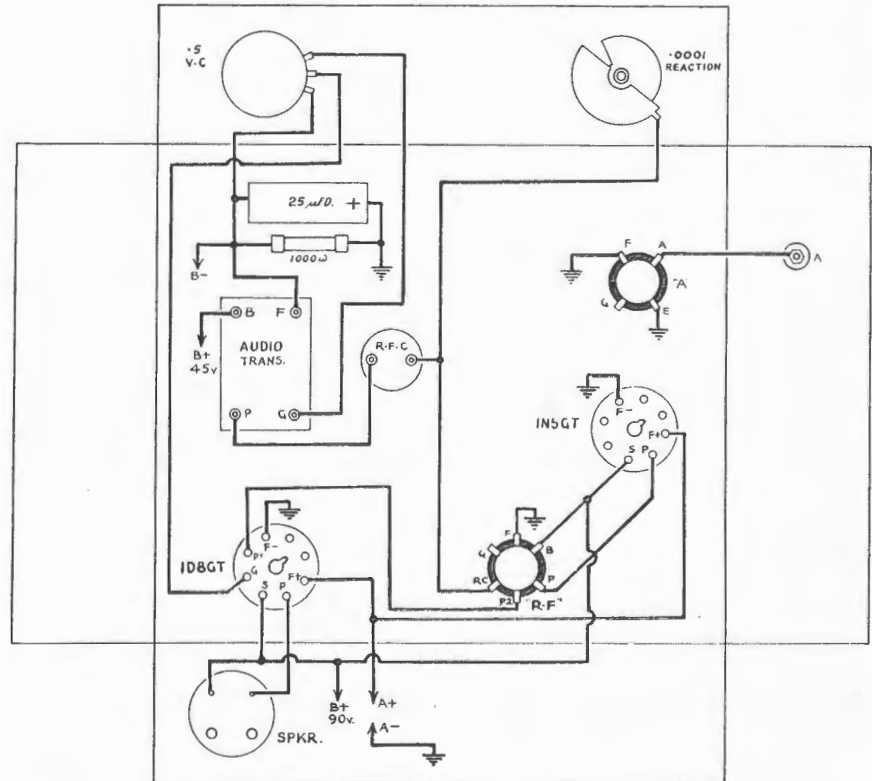

The picture diagram of the wiring.

No "C" bias battery is required, as a resistor between "B" negative and "A" negative carries the total current of the receiver and gives a voltage drop sufficient for biasing the pentode portion of the output valve. Actually this takes about 8 volts away from the effective high tension available, and if greater power is required it would be possible to amend the circuit a shade to allow a bias battery to be used.

The Circuit.

The circuit used follows conventional t.r.f. practice, with an r.f. amplifier stage using a 1N5GT valve. The triode portion of the 1D8GT is used as a leaky grid detector, with reaction. This is transformer coupled into the pentode portion of the 1D8GT, which is capable of giving grand power output when used with only 90 volts of h.t.

The reaction is controlled by a reaction condenser in the shape of a 14-plate midjet condenser with a nominal capacity rating of .0001 mfd.

The Parts.

Running through the list of parts required for "The Scout" we first come to the base. Ready-drilled steel bases for this set are available at all radio dealers who handle parts, and one of these bases should be used so as to be sure to get proper layout and arrangement of the components.

Coils.

A great deal depends upon the efficiency of the coils used in a set of this type, in fact, it might be said that the performance of the coils governs the final performance of the set, other things being equal. As

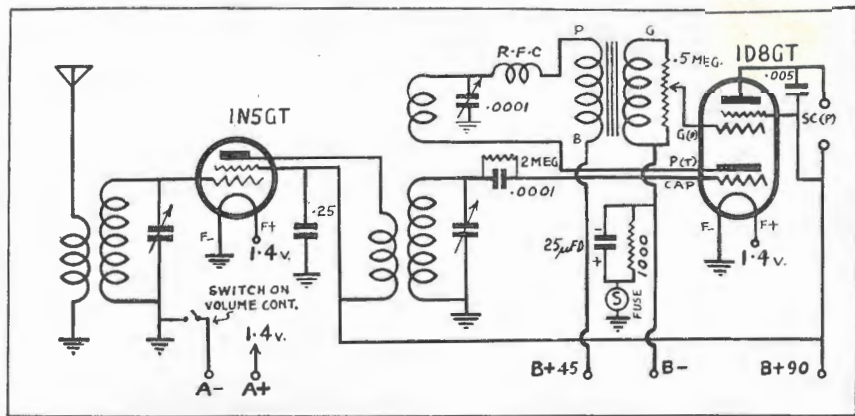

The schematic diagram of the circuit. Note the automatic biasing arrangement which means such battery economy.

usual, the right type of coils to use are the coils which are specially designed for this type of work. They are available in both R.C.S. and Radiokes brands.

Although home-wound coils could be used with a set of this type, it is not possible to obtain the same degree of efficiency as obtained by the coil factories with their bunch-wound coils of litz stranded wire, with iron cores and high-impedance primaries.

Fortunately, the modern coils are not expensive, so that there becomes little point in trying to use home-wound coils.

Tuning Condenser

A two-gang tuning condenser is required and this condenser should have trimmers fitted. Many dual-wave receivers use gangs which do not have

trimmers, the trimmers being mounted in the dual-wave tuning box. One of the dual-wave condensers would be quite unsuitable, so this is an important item to watch when you are getting your kit of parts together. At the same time attention should be paid to the selection of the dial.

There is quite a shortage of small dials of attractive type for a set of this kind, most modern dials being of the elaborate edge-lit types, with dual-wave scales and dimensions which make them quite unsuitable for a snug little set like the "Scout." The dial shown in the photographs was about the most suitable we could find.

Audio Transformer

The audio transformer is one of the ordinary 3½ or 5 to 1 ratio audio

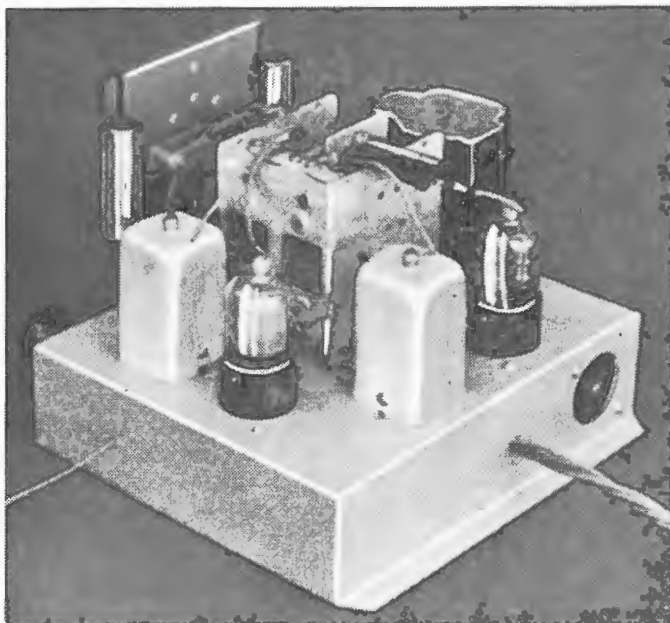

Two views of the "Scout" chassis. The one on the left gives a good idea of the wiring and under-panel layout.

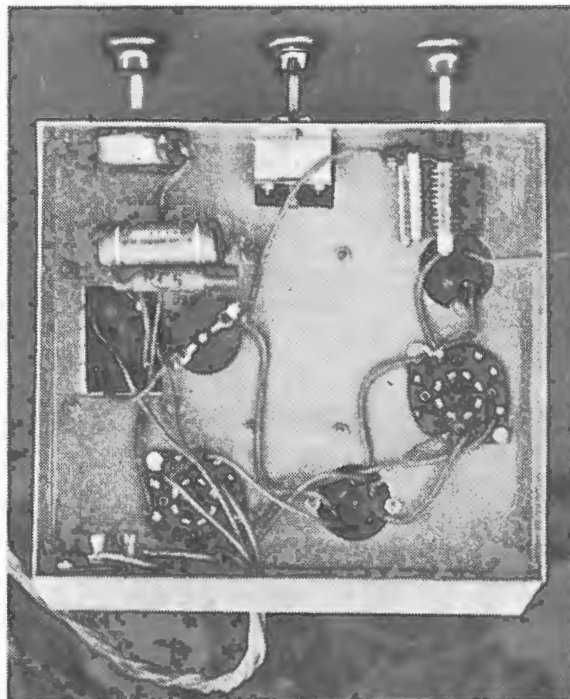

Two Ways to cut the Cost of Country Radio



Here's two ways to cut the cost of country radio. One is to buy one of the new 1.4-volt country sets. Uses only two "B" batteries, instead of three, and an improved Eveready "A" Battery that eliminates the need for the inconvenient accumulator with its frequent re-charging costs

* * *

Another way is to insist on Eveready Radio Batteries every time you buy a new set or make replacements. Long recognised as "Australia's Best Batteries," they give a smoother flow of power and a longer period of serviceable life.



For details of latest 1.4-volt country radios, write to Dept. RW.
EVEREADY (AUST.) PTY. LTD., SYDNEY, N.S.W.

transformers intended for class A amplification, and although the quality of the transformer has a bearing on the tonal quality of the finished receiver the matter is not of great importance as even the cheaper types of modern transformers appear to be capable of giving quite good performance.

Volume Control.

Normally the reaction control is used for controlling the volume, but on strong local stations it is sometimes desirable to have an additional control, and this takes the form of a potentiometer fitted across the secondary of the audio transformer, with the grid of the pentode portion of the 1D8GT going to the moving arm so that a portion of the signal developed in the secondary can be picked off for the output valve. This auxiliary control is also helpful in stabilising the set, and cuts out any tendency to "threshold howl" and such-like troubles which are sometimes encountered in high-gain sets using reaction.

For convenience the filament switch can be included in the volume control, so that on fully retarding the volume the set is switched off.

In the original receiver we did not use this type of switch as we were working on the job over the Easter holidays and discovered at the last moment that we did not have a volume control of the right type on hand. Little difficulty will be found, however, in connecting up a combined volume control and switch if one of these items is obtained with the kit.

Reaction Condenser.

The reaction condenser can be any small condenser with a capacity of about .0001 mfd. As will be noticed in the photographs, the original receiver used one of the old-style 23 plate midgets, but we would recommend the use of one of the newer 14 plate types, as the one used was a little on the big side, especially as regards its minimum capacity, so that with a short aerial the set was a little inclined to be unstable down at the very bottom end of the dial. One of the latest types of 14 plate midgets should be a sure cure for this minor difficulty, if it should be encountered.

Minor Components

The rest of the components consist solely of small resistors and condensers, which are all standard lines and need no explanation.

Assembly

The actual assembly of the components on to the ready-drilled base is just as simple as the assembly of a small meccano model, being merely a matter of fitting screws and nuts as required.

Wiring

The wiring job is also particularly easy and straightforward with this set, and anyone with a knowledge of soldering should have no trouble in following out the picture diagram.

Above the base there is a little wiring to be done to the two terminals for the fixed plates of the two-gang tuning condenser. From the first section two leads are required, one running to the G terminal of the aerial coil unit, and the other to the cap clip of the 1N5GT.

To the other terminal is soldered a lead running to the G terminal of the r.f. transformer coil, and also the grid leak and grid condenser for the detector. By mounting these up at the tuning condenser a short and direct connection can be arranged to the cap of the 1D8GT, and although it

minals of the B battery it is almost certain that both valves will be immediately ruined. Blowing out expensive valves by accidental application is a heart-breaking business and every precaution should be taken, BEFORE such an accident happens. As a safety measure some people prefer to have the "A" leads about a foot or eighteen inches long, but the B battery leads about three feet long. By making sure that the B batteries never come closer than within two feet of the chassis there is never any chance of an accident to

the filaments.

To get back to the operation of the set, the filament circuit should be tested by fitting the "A" cell and watching inside the valves to see that the filament lights up properly. The valves do not emit a bright light, but by carefully peering inside the valves it should be possible to see the thin filament heated up to a dull red. If the filament heats up in this way it is usually safe to go ahead with the connection of the B battery, and the set is then ready to tune in stations as required.

THE 1940 SCOUT List Of Parts.

- 1—Chassis to suit
- 2—Special coils (R.C.S., Radiokes)
- 1—Two-gang condenser to suit
- 1—Dial for condenser (Efco)
- 1—Audio transformer (Radiokes, R.C.S.)
- 1—.5 meg. volume control with switch
- 1—Reaction condenser (R.C.S., Radiokes)
- 1—Radio frequency choke (Radiokes, R.C.S.)
- 1—700 ohm 3-watt resistor (I.R.C., R.C.S.)
- 1—.0001 mfd. mica condenser (E.T.C., T.C.C.)
- 1—.005 mfd. mica condenser (E.T.C., T.C.C.)
- 1—.25 mfd. tubular condenser (Solar, T.C.C.)
- 1—25 mfd. electrolytic condenser (Solar, T.C.C.)
- 1—1N5GT, 1—1D8GT valves (Ken-Rad, Brimar, Radiotron, Mullard, Philips).
- 1—1.4-volt "A" cell (Ever-Ready)
- 2—45-volt "B" batteries (Ever-Ready)
- 1—Permagetic speaker (Rola, Amplion)

does not look as neat as mounting the grid condenser and leak under the base, it is more efficient to do it the way we show in the photograph.

Speaker Connection

The speaker is plugged into a valve socket in order to get a simple and easily detached method of connecting it. Care should be taken, however, to make sure that the plug of the speaker is wired up to suit the wiring of the speaker socket. This is an important point as the 1D8GT can be badly damaged if the high tension voltage is applied to the screen and not the plate, as is the case if the set is connected up without the speaker in circuit.

Operation

After the set has been completed and the winding thoroughly checked the valves should be fitted, also the speaker and then the A battery connected. The B batteries meantime should be kept well in the background.

If by any accident the A leads from the set come in contact with the ter-

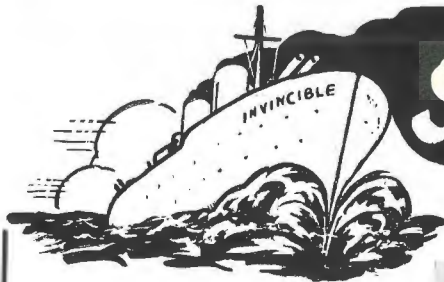

SERVICE!

THE WONDER ONE

THE DANDY THREE.



THE DANDY THREE IS THE MOST REMARKABLE SUPERHET we've handled for some time. It employs only 3 valves, yet gives 5-valve performance. We have handled quite a number of this popular receiver and excellent reports have come to hand from all parts of Australia. EASY TO CONSTRUCT, and results are guaranteed. DETAILED PRICE LIST ON REQUEST.

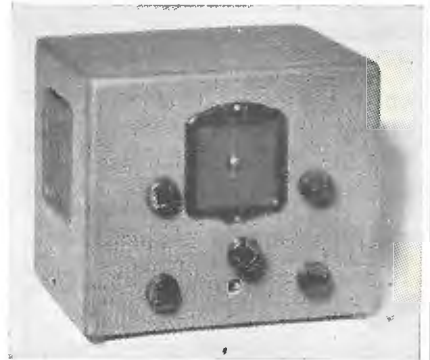

THE WONDER ONE is something quite out of the box, and represents the last word in super efficiency. LOUD SPEAKER RESULTS WITH EASE. BUILD IT YOURSELF—IT'S SIMPLE! READY DRILLED CHASSIS AND EVERYTHING AS USED BY THE TECHNICAL EDITOR IS INCLUDED IN AN INVINCIBLE KIT-SET. WRITE FOR OUR DETAILED PARTS LIST. OUR PRICES ARE RIGHT.

- "JUNIOR CONVERTER"—makes any set a dual waver.
- "1940 SCOUT"—2-valve battery t.r.f. of moderate cost.
- "BABY GRAND"—fidelity amplifier for home use.
- "BIG BOY"—power amplifies extraordinary.
- "FUNDAMENTAL POWER UNIT"—ideal for keen experimenters.

FULL KITS FOR THE ABOVE NOW READY.

During the past ten years we have been closely associated with—

A. G. HULL

and his many successful circuits, and we are specialists in kits for the circuits he is giving in "Radio World." We are in close touch with Mr. Hull, we have tested the original receivers detailed in this issue, noted the components used and we can give you kits of identical parts so that you can be certain of success.

DON'T WASTE TIME—WRITE TO US FOR A QUOTATION.

A Reply by return mail guaranteed.

Invincible Radio & Electrical Pty. Ltd.

SHOWROOMS: 102 CLARENCE ST., SYDNEY.
NORM COHEN, Manager.

PHONE: BW 4115.

HINTS and TIPS

by *Walter G. Nichols*

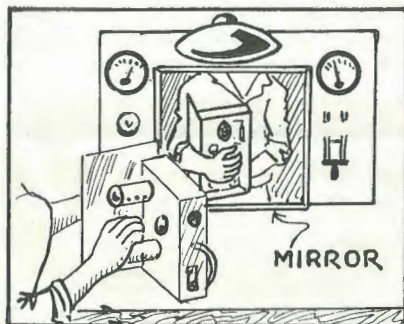

Assembly And Wiring Made Easier.

An old mirror hung at the back of your work bench will simplify your next set wiring job. The underside of the chassis will be in full view in the mirror, even when you are working on the top. Wires can be inserted in holes, and components on the underside can be located readily. The mirror can be installed in the middle of your test panel as illustrated.

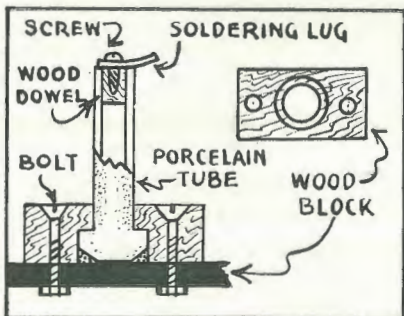

Easily Constructed Stand-off Insulators.

Inexpensive stand-off insulators can be easily constructed from ordinary electrical porcelain lead-in tubes. The large end of the tube is clamped to its support by a small counter-sunk block of wood. A short section of wood dowel is forced into the other end of the tube and secured with thick shellac. A small wood screw is then passed through a soldering lug and screwed into the dowel. After passing the tube through the counter-sunk wood block, secure assembly to supporting surface by small bolts or long wood screws as per sketch.

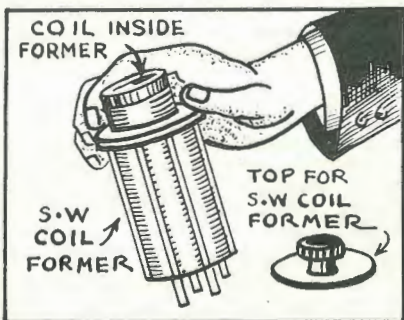

A Handy Short-wave Coil Hint.

Short-wave enthusiasts know that plug-in short-wave coils have to stand up to a good deal of rough usage during their existence. Sometimes when being pulled out of their socket in a hurry the insulation gets scraped off by striking condenser plates, etc., or whilst lying about the bench get some nasty clouts from pliers, etc., ac-

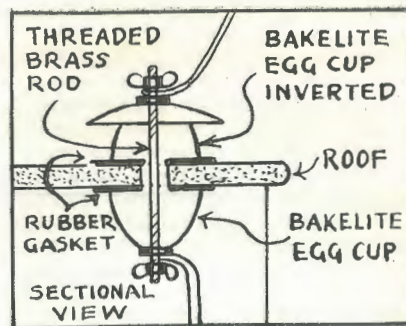

cidental dropped on them. Perfect protection can be afforded by winding the coils on a slightly smaller former and then slipping them inside a standard former using this former as a container.

Home-made Doublet Insulators.

Ordinary porcelain cleats of the type used for open wire lighting circuits make very efficient spreaders, doublet antennas and feeders. The antenna or feeder wires are best secured to the insulator by first passing one wire through each hole and then binding them with short lengths of thin wire as shown. Transposition blocks can also be made by simply crossing two such cleats and lashing them together.

Hooded Lead-in Insulator.

Expensive hooded rain and waterproof lead-in insulators can be inexpensively made by obtaining from one of the chain stores two egg cups (made from one of the plastics), one being an ordinary egg cup, the other having a small plate attached.

Invert the egg cup with the plate attached and used as the top or outside section of the insulator, the plate acting as the hood. The whole assembly is held together by the threaded rod which passes through both egg-cups. Make sure the rod does not contact the roof and slip rubber gaskets between egg cups and roof to ensure a waterproof joint.

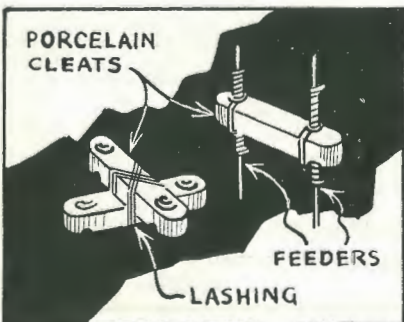

Morse Code Practice Outfit

Illustrated here is the Foxradio morse code practice outfit, released this month by Fox and Macgillycuddy Pty. Ltd., of 57 York St., Sydney. Designed to meet the keen demand that has arisen for morse practice sets since the outbreak of war, this Foxradio kit comprises a smooth-actioned P.M.G. pattern key, special high-note buzzer, 4½-volt battery, and a morse code chart. Altogether it is an excellent little outfit, just the thing for those who want to learn the code, and reasonably priced at 17/6 for the complete outfit, post free.

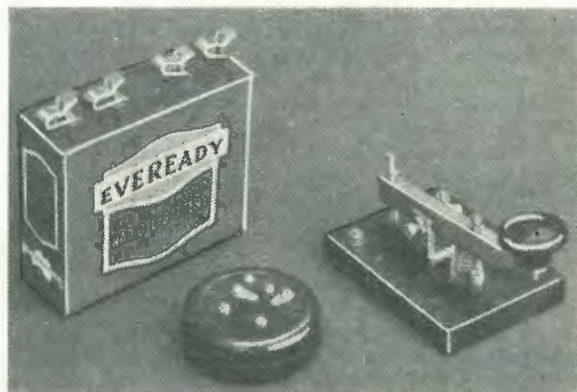

Important Announcement

LABORATORY SERVICE FOR READERS

For the assistance of bona-fide amateur set builders, we are installing laboratory equipment at our head office, 117 Reservoir Street, Sydney.

At this laboratory we will inspect and test receivers built up according to constructional articles published in this or any future issues of Australasian Radio World.

We will not carry out repair work, or make adjustments or alignments, but we will be prepared to inspect and test the receiver, and report on its performance.

If not up to standard, we will indicate what we think should be done to obtain normal results.

A nominal fee of 2/6 will be charged for the service.

THE TESTS.

Briefly, the receivers will be tested as follows:—First, the valves will be checked for emission and mutual con-

ductance, the electrolytic condensers tested for capacity and leakage, wiring tested for high-resistance joints, and the main resistors and condensers will be checked to make sure that they are according to their ratings.

Then the receiver will be tested for comparative performance with an oscillator and output meter and finally the receiver will be tested on the air under normal running conditions.

CONDITIONS.

Normally the service will take about 24 hours to perform, and receivers left for inspection on one day should be ready to be picked up by 5 p.m. on the day following.

In the event of the service proving even more popular than we anticipate, a slightly longer period of time may be required for the inspection.

Receivers forwarded from distant readers will be un-packed and re-packed without extra charge, but no

freights or carrying charges will be paid.

Great care will be exercised in the handling of the receivers entrusted to us, but we cannot accept any responsibility.

NEW ERA.

This progressive step marks a new era in the history of radio set building as a hobby and should do much to foster the movement, which is at present enjoying greater popularity than at any time in the past.

When broadcasting first started practically every receiver was home-built and the amateur set builder was prominent. To-day, the hundreds of thousands of factory-built sets rather overshadow the efforts of the amateurs, although, numerically, they are stronger than ever.

Now, with this remarkable guarantee of performance, we anticipate further popularity for our constructional articles.

— MAKE SUCCESS A CERTAINTY — WITH A VELCO KITSET

When you buy a Velco Kitset you buy an up-to-the-minute receiver which when assembled will equal in performance any modern commercial set on the market. Success is a certainty with a Velco, for every circuit is carefully illustrated and described in detail — you can't go wrong.

VELCO HIGH FIDELITY A.C. FIVE.

A High Fidelity 5-Valve A.C. Superheterodyne Receiver which gives wonderful results. Beautiful tone, critical selectivity and remarkable sensitivity give this set a tremendous range. You will log stations from all parts of Australia with the High Fidelity Five. The kit is absolutely complete, with valves and 10-inch Magnavox Speaker. Easy step instructions make construction simple, even to those completely inexperienced in set building. Write for full details and description, free.

COMPLETE KIT ONLY 11Gns.

VELCO MASTER BATTERY FIVE.

A modern 5-Valve Superheterodyne such as the Velco Master Five is essential to the country listener, giving him maximum sensitivity and that critical selectivity so necessary for the separation of stations on adjacent wavelengths. The Velco Master Five is a wonderful distance getter and features include Automatic Volume Control, Automatic Bias and Inverse Feedback, eliminating distortion and increasing the gain of the receiver. Remarkably low battery consumption. Complete kit includes valves, speaker, batteries and accumulator. Write for full details and description, free.

COMPLETE KIT ONLY £11/17/6

ARTHUR J. VEALL PTY. LTD.

Address letters to Box 2135 T, G.P.O., Melbourne, C.I. Office: 490 Elizabeth St., Melbourne, C.I. Branches at 168 and 243 Swanston St., Melbourne; 299 Chapel St., Prahran; 3 Riversdale Rd., Camberwell; 97 Puckle St., Moonee Ponds. Telegrams: "Artveall," Melbourne. Phone: F 3145 (6 lines).



The JUNIOR TECHNICAL SECTION

Conducted by A. J. BARNES

Part 1

SOLDERING

LACK of a working knowledge of the art of soldering has turned many people from the fascinating pastimes of radio or model construction. It is impossible to wire a modern radio chassis without at least a few soldered connections—the uses of soldering in addition to this particular work are legion.

Radio chassis soldering may be placed in a class of its own—the simplest class. No matter what the size or circuit may be, the soldered connections will always be made in the same way with the same materials. Boiled down, this means that the only type of soldered junction in a circuit consists of one tin lug and one or more wire ends. By the time we have completed a chassis we have had plenty of practice at this particular soldered joint! But how do we start? Well—

Radio Soldering.

We must have a source of heat to melt the solder and also to bring the joint to the same temperature as the molten solder. The most convenient source of heat is a hot "iron," which, strange, to say, is always made of copper! The soldering iron enables us to direct both heat and molten solder just where we want it and nowhere else.

An electric soldering iron is undoubtedly the best type, not only because of convenience and cleanliness in working, but because once it has reached the proper temperature it stays so until the current is switched off.

Chaps who have no power available can get along quite all right with the ordinary iron (a small one), which is heated over a spirit lamp or fire, etc.

If a fire is used it is a good idea to poke in first a piece of water pipe and then slide the iron inside this pipe. By so doing we keep ashes away from the tinned surface.

The other two items of equal importance are the solder and the flux. For radio work these are best used combined in the form of "resin cored solder." A tin of paste flux will also be handy for "tinning" the iron and the occasional untinned lug or wire, etc.

Tinning.

The point of the iron must always be "tinned," which simply means that it is brightly coated with solder. If the iron was not tinned, the formation of copper oxide would not allow the heat to properly reach the solder and joint. Furthermore, the tinning allows us to melt a piece of solder and carry this "blob" to the joint.

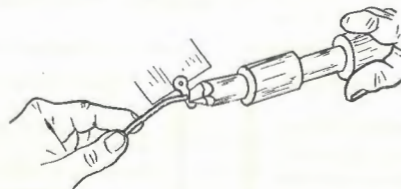

To tin the iron we heat it, quickly file the point until bright metal shows, dip it in the tin of paste and then rub it over with solder. From now on we know that the iron has reached the proper heat when solder pressed on the point of the iron melts immediately.

Most wires and lugs will have already a bright coat of tin, but occasionally we come across a plain copper or brass lug or copper wire. These items must be given a coat of solder before the point is made. As before, we scrape until bright metal shows, apply a little paste, and rub over with a hot tinned iron.

Making A Joint.

Say we are going to join a piece

of "push-back" hook-up wire to a lug on a power transformer or valve socket, etc. Here we go, step by step, assuming that the iron is already properly hot:—

(1) Press the point of the iron and the end of the resin-core solder on to the lug until the solder runs and forms a "blob"—not pasty, but liquid in appearance.

(2) Slide back the insulation of the wire for half an inch. Dip the projecting end of the wire in paste flux and then coat with solder.

(3) With one hand hold the tinned end of the wire against the blob of solder on the lug. At the same time rest the wrist on the chassis.

(4) Press the wire into the blob with the iron until the solder melts and the wire is covered. Hold steady until the solder sets.

(5) Give the wire a good "yank" to make sure that the joint is all that it should be!

Our Query Column.

We are going to have our own Junior Technical query column. Queries need not necessarily be about articles that appear. If there is anything you would like to know about hobby work tell us and watch for your answer in the query column.

Send your letter to the Editor, with the envelope endorsed "Junior Tech."

* * *

REPLIES.

R.A., Murray Bridge.—Thanks for the nice remarks. Yes, special files for dressing the softer metals are obtainable. These are of a special self-cleaning cut known under trade-names such as "Pansar," "Dreadnought," etc.

* * *

R. McM., Wollongong.—Yes, quite a useful vice may be purchased for less, but the one recommended will stand plenty of hard work.

A Novel Wet Cell

When a dry cell has apparently completed its useful life we usually find that the zinc can is corroded and the paste solution, between the can and the inner sack, has dried up.

By converting old dry cells into wet cells we can draw further useful current at the same voltage. The life of cells so made will depend on the condition of the zinc cans.

To make the conversion, we take the old cell just as it is and punch a dozen

or so nailholes in different places through the outer paper cover into the zinc can. On no account drive the nail right into the sack; the can should merely be punctured.

Now we stand the cell in a glass or earthenware jar containing a saturated solution of common salt or better still, sal-ammoniac and water.

In a few moments the solution percolates through and our wet cell is ready for use.

If Zinc Gone.

It may happen that the zinc is too far gone to be of use, or perhaps the terminal has fallen off. If such is the case all is not lost—we can make up a "sac-eeclanche" cell.

To do this we carefully peel away the outer portion of the old dry cell until we come to a calico bag tied with string, from the centre of which projects the carbon (positive) electrode. Carefully wash this sack, wrap it with a layer or two of linen or calico and fit over it a new negative electrode, consisting of a sheet of zinc or heavily galvanized iron curved to a cylindrical shape with a wire or terminal attached. Immerse the assembly in the jar of solution and once again we have an emergency "juice" supply ready for action.

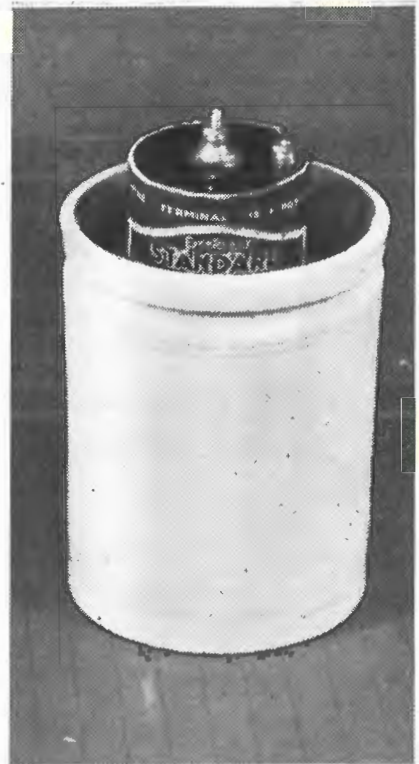

Here is the complete cell, ready for use. It is made up from a run-down "A" cell, a suitable jar and some salt water. The cell is capable of delivering quite an amount of current. Incidentally the experiment is an interesting and instructive one.

The Workshop

GAUGE NUMBERS

"Half-a-pound of copper wire 64 point 08 thousandths of an inch in diameter, please."

Sounds rather formidable doesn't it? How much simpler to ask for half a pound of 16 gauge copper wire! Yes of course.

Gauge numbers are used to indicate the thickness or diameter of sheet metal, wire, nails and screws. We use the British Standard Wire Gauge (S.W.G.) in this country for measuring the thickness of sheet metal, nails and wire. A piece of metal of a certain gauge number will have a thickness equal to the diameter of a nail or wire of the same gauge number.

As the gauge number becomes larger, so does the thickness or diameter decrease. A forty gauge wire for example is very much thinner than a 16 gauge wire.

Wood screws are gauged in a different manner. In this case a large gauge number represents a screw of large diameter, whilst as the number decreases, so does the diameter. Quite the opposite to the wire gauge.

Here is a rough table handy to remember.—

16	S.W.G.	equals	$\frac{1}{8}$	inch
12	"	equals	$\frac{3}{8}$	inch
10	"	equals	$\frac{1}{2}$	inch

* * *

Electrolytic Hint.

Just because an electrolytic condenser has a white deposit on the top it does not necessarily follow that the condenser is useless, but it is always safest to replace.

Electrolytics are quite cheap, and after a year or two of service they are seldom as efficient as when new.

Many minor faults in receivers can be traced to faulty electrolytics and it's fairly safe to suspect the electrolytics before any other components.

Have Your "RADIO WORLD" Posted To You Direct

Readers who want to take the "Radio World" on a subscription basis and have their copies posted to them direct each month are invited to complete the coupon below (annual sub., 10/6). New readers are advised that all back numbers in Volumes 1, 2 and 3 are still available, price 9d., post free, for all copies up to and including the December, 1938, issue, and 1/-, post free, for subsequent numbers.

Enclosed please find remittance for 10/6 in payment for an annual subscription to the "Australasian Radio World," commencing with the.....issue.

Name

Street and No.

City State.....

THE AUSTRALASIAN RADIO WORLD
117 Reservoir Street, Sydney.

Build Your Sets With

R.C.S. TROLITUL THE BETTER COMPONENTS

R.C.S. DUAL WAVE UNITS

Type DW24, as illustrated, consists of Aerial, R.F. and Oscillator Coils, Wave Change Switch, the necessary B/C and S/W Trimmers and Padder mounted on a rigid steel base, wired up ready to assemble in a set utilising 465 k.c. and an R.F. Stage. The bands are S/W 16 to 50 metres, and B/C 1500 to 550 k.c.

	Retail Price
DW24 for A.C. operation	£3 7 6
DW25 for battery operation	£3 7 6

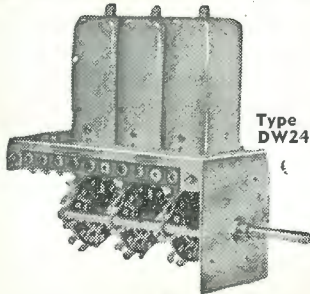

Type DW24

R.C.S. TROLITUL MIDGET CONDENSERS

R.C.S. Midget Condensers are made in two types, using Trolitul supports, thus guaranteeing practically no loss. The 14-plate equals old style 23-plate capacity. The M.C. type may be gang-ed.

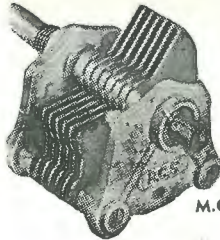

M.C. Type

STAR AND M.C. MIDGETS

Max. Min. Cap. Cap.	STAR	Retail	M.C.	Retail
mfd.mmf.d.Pts.	Cat. No.	Price	Cat. No.	Price
10 3 2	CV43	3/6	CV41	6/9
15 3 3	CV35	3/9	CV42	7/3
25 3.5 4	CV36	4/-	CV43	7/10.
35 4 5	CV37	4/3	CV44	8/6
50 4 7	CV38	4/9	CV45	9/-
70 5 9	CV39	5/4	CV46	9/6
100 6 14	CV40	5/11	CV47	10/3

R.C.S. AUDIO TRANSFORMERS AND CHOKES



Long experience in the production of highly efficient transformers, combined with extensive research into raw materials and design, has resulted in the production of an audio transformer of excellent performance and complete reliability.

TB4—"A" Class Cat. No.	Retail Price
TA1 Audio Choke, Bakelite Case	18/6
TM1 Modulation Transformer—Power	30/-
TB4 Single Input "A" Class Bakelite	20/-
TB5 Push Pull "A" Class Bakelite Case	21/-
TB6 Input "B" Class Bakelite Case	18/6
TB35 "A" Class High Fidelity Steel Case	67/6
TB36 "B" Class Input High Fidelity Steel Case	67/6
TE37 "AB" Class Bakelite	28/6

THE JUNIOR S/W CONVERTER

Type	Price
Type K136 Special Coil Kit	13/9
Type CV50 Tuning Condenser	9/-

THE 1940 SCOUT

Type	Price
Type K137 Coil Kit	13/-
Type TB4 Audio Transformer	20/-
Type CV40 Midget Condenser	5/11
Type RF86 R.F. Choke	1/-
Type R37 700 Ohm Resistor	10d.

FOR THE AMPLIFIERS

Type	Price
Type R95 250 Ohm Resistor	5/6
Type R19 75 Ohm CT Resistor	10d.
Type R37 700 Ohm Resistor	10d.

ATOM CRYSTAL SET

Type	Price
Type K138 Coil	6/6
Type CV50 Tuning Condenser	9/-

THE BEDSIDE TWO

Type	Price
Type K139 Coil Kit	13/-
Type CV40 Midget Condenser	5/11

R.C.S. POTENTIOMETERS AND RHEOSTATS

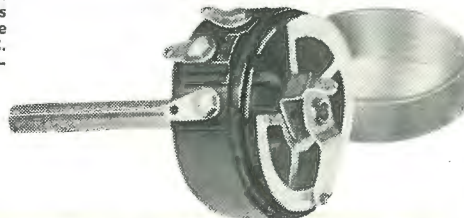

The R.C.S. Volume Controls are the result of improved and new methods of manufacture, together with alterations in design and final testing. Noiseless, they are constructed so as to cut off all volume.

	Cat. No.	Retail Price
6 ohm Rheostat	● 25 Amp. PT40	5/-
10 " "	● 25 Amp. PT38	5/-
20 " "	● 25 Amp. PT39	5/-
30 " "	● 25 Amp. PT34	5/-
400 " Potentiom.	50 M/A PT46	5/-
1000 " "	35 M/A PT47	5/-
2500 " "	30 M/A PT49	5/-
5000 " "	30 M/A PT51	5/-
10000 " "	20 M/A PT52	5/-
15000 " "	20 M/A PT53	6/6
20000 " "	15 M/A PT54	6/9

NEW R.C.S. DIALS

For some time we have felt that we should provide dials for use with coils of our manufacture, thus assuring perfect tracking. The dials illustrated are the result of considerable thought and engineering experimentation in our laboratory. Both types are single glass Dual Wave dials, the type DA-2 having been designed especially for use with our Five Band Communications Receiver coil kit, and the "H" type condenser. Type DA-1 is a standard Dual Wave dial for use with R.C.S. Coils and the "F" type condenser.

DA-1. Standard D/W Dial. Retail Price, 22/6.

DA-2. Communications Dial. Retail Price, 22/6.

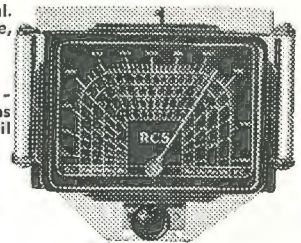

Illustrated Type DA-2

R.C.S. TROLITUL INTERMEDIATE TRANSFORMERS

The new R.C.S. Trolitul I.F.'s are extremely stable, due to new methods of construction made possible by the use of Trolitul formers and base. No loose wires to shift and alter frequency. Positively the best I.F.'s yet produced.

Cat. No.	Retail Price
Air Core, 465 k.c.	
IF107. 1st I.F.	7/6
IF108. 2nd I.F.	7/6
Iron Core, 465 k.c.	
IF109. 1st I.F.	11/-
IF110. 2nd I.F.	11/-
Air Core, 175 k.c.	
IE68. 1st I.F.	7/6
IE69. 2nd I.F.	7/6

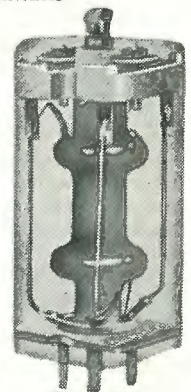

Type IF107

Obtainable from your local dealer or direct from—

R.C.S.

RADIO

PTY. LTD.

50 GLEBE ST., GLEBE.

'Phone: MW 2405

SPEEDY

QUERY

SERVICE

Conducted under the personal supervision of A. G. HULL.

"Gypsy" (Lismore) is surprised that we specified the 6L6 type valves in the "World Standard."

A.—When the first shipment of the original metal type 6L6 valves arrived, a few of them gave trouble, but this is often the way, and seldom indicates that there is anything seriously wrong with the valves as a type. That was about four years ago, and ever since the introduction of the "G" type glass equivalents we have never heard the slightest complaint about these valves as a type. Our own experience with them has been completely satisfactory and we have subjected them to all sorts of overloads without any trouble at all. We got more than forty watts of actual power output out of a pair of them in a modulator unit for a transmitter by considerable overload, but still no trouble. We have every confidence in these valves standing up to plenty of work in the "World Standard."

B.E. (Mudgee) is planning to build a dual-waver with 1.4-volt valves.

A.—Yes, the circuit is quite O.K. as circuits go, but we have considerable doubt about the idea of using the 1A7G on the shorter wavelengths. We also doubt the use of the 1N5 in the r.f. stage. Both of these valves were designed for portable set use in the first place, and, although they have been reasonably successful in ordinary sets, we have heard that the 1N5 does not handle a strong signal input well, and the 1A7G is inclined to be unreliable on shorts. New types of valves which should be more suitable are the 1B7G and the 1P5G, which have just been released in the States. Although not available in all brands, we think you will be able to obtain them in at least one good brand.

H.A. (Steebatham, Vic.) asks for further details about the L5 Amplion speaker mentioned in the "Beyond the Gates" article in the March issue.

A.—The L5 is not a current model in the Amplion range and this explains why you do not find it listed. The L5 was a very expensive speaker, about £8 list price, if memory serves right. There are plenty of first-class permagnetics available, and if you really want to handle such high-power we suggest the Rola 12" high-fidelity model permagnetic, which will readily carry the full power output of the amplifier you have in mind. The type number is G12, and the list price £11. Another excellent speaker for your purpose would be the Amplion type 12P64, listing at £5/10/-.

A.S.E. (Cook's Hill) wants to know where he can obtain a ready-drilled base for the "Dandy Three."

A.—You should have no trouble in obtaining a ready-drilled base from the radio dealer who supplied the rest of the components. Doubtless he won't have the base in stock, as it would be a big job to keep a stock of every new set design which comes out, but he should be able to get one for you within a day or two if ordered. There are two large factories in Sydney doing nothing else but stamping out metal bases for radio work, and with their big presses it is only a matter of a few minutes to punch out a base when they have the plan on hand.

A.S. (Katoomba) wants to know whether he can get short-wave coils to add to his present set to make it into a dual-waver.

A.—Yes, coils can be obtained, together with a six-bank two-throw switch which will need to be wired in. If you have plenty of room under your present base, and it is deep enough to accommodate the coils and switch, you will find the job is simply one of wiring up and hoping for the best. If short of room a complete re-build will be necessary, in which case we would strongly advise you to scrap the present coils and use a complete coil assembly unit, like the one used in the "World Standard" described in last month's issue.

S.C. (Richmond, Vic.) refers us to a statement in the March issue about permagnetic speakers needing to be cheaper and better.

A.—Yes, we seem to have given the wrong idea there all right. Our intention was to indicate that the best types of permagnetic speakers use imported magnets, which are expensive, and difficult to obtain at present on account of exchange and shipping difficulties, not to mention that overseas steel works are putting their energies into more serious business than loud-speakers. As a matter of fact, we have not the slightest hesitation in acknowledging that the local permagnetics are well up to world standard and in their respective classes there is no need for them to be made any better. We note that you do agree that lower prices would make permagnetics more popular, but there is no easy way of overcoming this problem at present.

O.L.S. (West Preston) writes at great length on the subject of vibrators, but, even after reading through twice carefully, we can't decide whether he is referring to the vibrators for turning car battery juice into high tension or multi-vibrators for padder alignment.

A.—We can only suggest that you write again, setting out more clearly what you aim to do. The multi-vibrators for padder alignment are available from prices around £7. The car-type vibrators for eliminating "B" batteries in car sets are available in a number of different styles and types ranging from about £5 to £10.

A.G. (East Kew, Vic.) finds that the valves in his set get very hot and is worried lest this indicates trouble.

A.—No, generally speaking, modern valves run very hot, far too hot to touch and yet this does not indicate that anything is wrong. If the set appears to be operating in the normal way, with plenty of power and no distortion we don't think you have anything to worry about. It might be a good plan to feel the electrolytic condensers (aluminium gadgets) sticking up near the exposed valves, and see that these are not getting hot, and that they are not overflowing white fluid. The electrolytics should keep cool, and if running hot they will need replacement, as a leakage is indicated. Such a leakage could cause the rectifier valve to overheat.

C.D. (Wahroonga) is interested in quality reproduction and wants a candid opinion about stereoscopic speaker arrangements.

A.—To be perfectly frank we don't favour the stereoscopic idea on the lines you mention. Stereoscopic speakers arranged in this way can give a very impressive performance, but after you have become accustomed to them the out of phase effect seems to become more prominent and it is distasteful to anyone who has been accustomed to distortionless reproduction. Naturally tastes differ, and the effect is not so clearly noticed by different people. Even if the speakers themselves are correctly phased, it is not to be expected that the sound from both will reach the ears of the listener at exactly the same time, hence the overlapping phase. If you are really keen on the idea we wouldn't like to take the responsibility of putting you off it, so why not make a point of hearing on the stereoscopic installations and then judge for yourself.

3 HANDBOOKS FOR EVERY EXPERIMENTER

RADIOTRON DESIGNERS' HANDBOOK

Price 3/4

Post free

RADIO AMATEURS' HANDBOOK

Price 10/-

Postage 10d.

JONES' RADIO HANDBOOK

Price 12/-

Postage 10d.

McGILL'S AGENCY

183-185 ELIZABETH STREET, MELBOURNE.

(The G.P.O. is opposite)

Send for our free catalogue on all technical subjects.



RADIOTRON VALVES are supplied in factory-sealed cartons — YOUR guarantee that the valve you buy is new. The carton must be destroyed to remove the original valve . . .

For more enjoyable radio entertainment



Advt. of Amalgamated Wireless Valve Co. Pty. Ltd.



H.L.C. (Cairns) has been using one of the original A.G. Hull high-fidelity amplifiers of 1934, with 50 type output valves and asks why these valves are not more popular.

A.—Very glad to hear from you and to know that the old amplifier is still going so well. As a matter of fact it is very hard to find anything likely to beat that job for performance, and it is still a popular circuit with those who can afford it. Those final words are really the key to the matter of popularity. The 50 type valves are expensive themselves and the high voltage needed for them makes it necessary to use expensive transformers and expensive filter condensers. On account of its low impedance, and other characteristics, the 50 is a great valve for amplifier use and we wouldn't be at all surprised if they are prominent in the coming Amplifier Championship.

* * *

G.M.C. (Vaucluse) enquires about doublet aerials for receiving.

A.—Undoubtedly an efficient aerial is a help, but this particular business about doublet aerials seems to have been just another one of those fashions that come and go, something after the style of ladies' hats.

We detailed a doublet in our Volume 1, Number 1, four years ago, and copies of this issue are still available. We doubt if anything much in this way has appeared since.

Personally we find that there is little to beat a single wire, as high as possible and a lead in of twisted flex, with one side of the flex open at the top and the two bottom ends going to the two ends of the primary coil. By this means any noise picked up by the lead-in is bucked out.

* * *

T.T. (West Ryde) sends for a special circuit.

A.—Sorry, but we are unable to handle queries of this type, as the designing of a special circuit for any one reader would take so much of our time which we find fully occupied working on matters of general interest to thousands of readers. If you care to let us have 6d. for a back issue, we can let you have one with a full description of a circuit very close to what you need.

* * *

J.J.L. (Hexham), dealing with petrol-driven model aeroplanes, asks for recommendations in regard to suitable types of torch batteries for flying batteries. He asks whether the A.G.H. who recently won the championship contest at Newcastle was our A.G.H.

A.—It all depends on the weight which you are prepared to carry. For ordinary Sunday afternoon flying, such as showing friends how the models fly, we suggest the big cycle lamp batteries. For competition work, a pair of U2 type will be O.K. and if you are prepared to handle it carefully, using boosters for starting and not using it more than necessary you may be able to get away with a 1000 type torch unit, getting about six to ten flights out of a battery if it is fresh to start with. That was our A.G.H., enjoying a lucky day.

* * *

R.P. (Ashfield) has obviously been looking at the communications receivers advertised in "Q.S.T." Not unnaturally, his mouth waters and he wants to know what can be done about it.

A.—Yes, we know all about those American communications sets, but we can't solve the problem. To try and import one at present would be quite out of the question, with the exchange and duty problems the way they are at present. It isn't the circuit that creates the difficulty and we have on hand the actual schematics of some of the best of them. It is the efficiency of the components that get them the results and the minor components like the dials and knobs give them the glamour. We feel certain that sets of this type would sell well, in limited numbers, if any local manufacturer turned them out at a price.

"Loffin Whitist" (Newcastle) writes at great length about the continued satisfaction which he has obtained from an old direct-coupled amplifier using a 224 and a 245.

A.—Yes, we know only too well the remarkably fine results which can be obtained from these amplifiers. We had a great amount of experience with them and handled dozens and never had any difficulty in getting them to operate to perfection. We don't agree that they went by the board on account of their unreliability. In our opinion the difficulty was that the high tension voltage was so high that it became necessary to use many non-standard components. This was especially troublesome in the matter of filter condensers, only the largest and most expensive paper condensers could be used and these were a poor financial proposition compared with the cheap electrolytics which came into vogue, but which were suitable only for use on voltages around the 350 to 400 volt mark. The frequency response of the direct-coupled amplifier was good, with an especially good high-note response, but quite as effective a response can be obtained from any well-designed resistance-coupled amplifier.

* * *

"Dizzy" (Brisbane) is keen to obtain a set of dual-wave coils for 175 k.c. intermediate transformers.

A.—So far as we know, the coil manufacturers do not list, and will not supply dual-wave coils for use with this intermediate frequency.

SPEEDY QUERY SERVICE.

Readers should note that our radio information service has now been re-organised and we offer two distinct forms of assistance.

Letters received by the 15th day of any month will be answered in these columns in the next issue. There is no charge for this service, no coupon is required and all readers and their friends are invited to use the service for any queries dealing with radio, photography, model aeroplanes, and any other subjects for which we are likely to be able to get helpful information.

The other service is for a reply by mail, and in this case a fee of 1/- is charged.

Every effort will be made to get replies to such queries away within 24 hours, but no guarantee of this can be given, as there may be times when pressure of other work will make it necessary to hold over queries for a day or two. Answers to such queries are limited to a single sheet of letter paper, and there is no hope of such a service covering the design of special circuits, the calculations for special power transformers, coil windings, etc.

Address all correspondence to
AUSTRALASIAN RADIO WORLD,
 117 Reservoir Street,
 Sydney.

A TERRIBLE PREDICAMENT

What's he to do? His reed pipe's blocked and that snake looks nasty. That's the way many set-builders feel after having bought "bargain" valves and found them to be faulty, with no replacement guarantee.

There is one sure way to avoid such a costly predicament, and that is to use



only BRIMAR VALVES as recommended by the Editor of "Radio World" for all receivers described in its pages. You will avoid valve trouble, and gain prestige as a radio man who really knows his valves.

BRIMAR VALVES are available in every possible type including a complete range of the new 1.4-volt series.

Your nearest Brimar Distributor has ample stocks, and can assure you prompt delivery.

BRIMAR

VALVES

BRIMAR DISTRIBUTORS

New South Wales: Standard Telephones & Cables Pty. Ltd., 252-274 Botany Rd., Alexandria.

Standard Telephones & Cables Pty. Ltd., 71 Magellan St., Lismore.

S.T.C. Radio Sales and Service. 389 Hunter St., Newcastle.

Queensland: Trackson Bros. Pty. Ltd., 157-9 Elizabeth St., Brisbane.

Victoria: Noyes Bros. (Melbourne) Ltd., 597-603 Lonsdale St., Melbourne.

Standard Telephones & Cables Pty. Ltd., Bourke St., Melbourne.

Western Australia: M. J. Bateman Ltd., Milligan St., Perth.

Tasmania: W. & G. Genders Pty. Ltd., 69 Liverpool St., Hobart, and 53 Cameron St., Launceston.

South Australia: Radio Wholesalers Ltd., 31 Rundle St., Adelaide.

New Zealand: Standard Telephones & Cables Pty. Ltd., Trojan House, Manners St., Wellington.

N9 621.38405 AUS

LIA

WHO'S TALKING ABOUT "BUSINESS AS USUAL?"

Never Did Radio Offer More UNUSUAL Scope For Ambitious Men!

Make no mistake young man, Radio is to-day on the threshold of tremendous expansion. Already the signs are plain to see . . . Receiver sales are sky-rocketing, more and more Government and defence contracts are being placed, and the industry already is exploiting every avenue in its endeavours to secure trained men. I want to help you participate in the boundless possibilities that Radio now offers—take you in hand, young man, train you, guide you, help you, like I have thousands of other keen, ambitious fellows, and fit you for a job with a real future.



L. B. GRAHAM, Principal, Australian Radio College.

PRESENT CONDITIONS Are made to order for Radio

Much as we deplore present conditions, they can have nothing but a beneficial effect on Radio. People are news-hungry as never before—that means more sets sold. Many radio parts and much costly equipment, previously imported, must now be made here in Australia, and that means a ceaseless search on the part of our manufacturers for skilled radio engineers—alert, capable young fellows, with the vision that can keep pace with a young industry and the vigour and enthusiasm that Australia needs to make her a world industrial power.

Let me put you on the right track NOW!

How would you like to be a design engineer, television engineer, sales-service engineer? Let me train you for one of these good jobs. Just think for a moment what this can mean to you. Home of your own—good banking account—your own car—money to spend on all those extra things you wanted.

HOW TO GET INTO RADIO

First thing for you to do if you wish to find out the facts about Radio is to send for this big, free book, "Careers in Radio and Television." It's a book you should read. Thickly illustrated with photos of Radio, Television Equipment, and Engineers at work, this book will show you definite steps you can take for a better job—how YOU can succeed in life.

POST COUPON NOW!

You needn't give up your job—your source of income—you don't have to leave home at all. I'll bring my training to you. You'll master it during your spare moments. A few hours each week has enabled hundreds of students to accomplish unbelievable results through A.R.C. training.

Australian Radio College Pty. Ltd.

BROADWAY, SYDNEY (Opposite Grace Bros.)

MAIL COUPON NOW MAIL COUPON NOW

To MR. L. B. GRAHAM, Principal, Australian Radio College Pty. Ltd., Broadway (opp. Grace Bros.), Sydney. 'Phone: M 6391-2.

Dear Sir, I am interested in getting ahead. Please send without obligation on my part the free book, "Careers in Radio and Television."

NAME

ADDRESS A.R.W.1.

MAIL COUPON NOW

MAIL COUPON NOW



What Students Say

The following are extracts taken from unsolicited letters sent by A.R.C. students to the College:—

From C.G., of Oatley, N.S.W.: " . . . Before turning to radio professionally, I had (during the depression) found it impossible to obtain employment in the line for which I was qualified. Thanks to your aid, I was placed in a position within two weeks of my exam."

From W.J.M., of Gippsland, Victoria: " . . . There must be a shortage of trained men all right. I get offers ever so often . . . one was the promise of a branch managership."

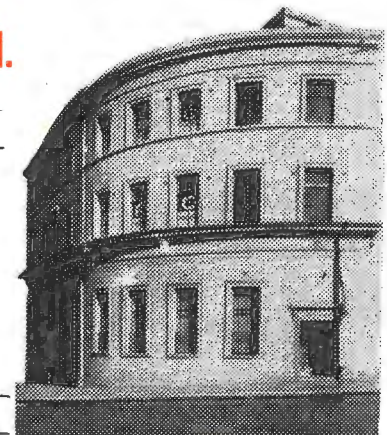

Earn While You Learn at Home

I will show you how to earn good spare-time money while training for a radio career. Many A.R.C. students earn £3 and up to £6 per week at spare-time work. This is in addition to their regular work.

Costs Little

Think of this—for a few pence each day—actually less than many fellows spend on tobacco, you can prepare yourself for a good pay position in Radio Television. Have you the ambition to bring yourself into line with one of these fine openings? Remember, you can learn A.R.C. training in the privacy of your own home or at A.R.C. work benches.

Jobs Found

Once you are prepared with the necessary training, the A.R.C. Free Employment Service will help you to find a job. Do you know at times the demand for A.R.C. trained men is so great we have to refuse offers of good positions?

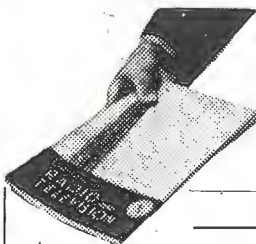

Mail Coupon Now