

SEA LAND AND AIR

VOL. V.—No. 50

MAY 1, 1922

PRICE 1/-



TO ENJOY LIFE TO ITS FULL
HEALTH
 ○ ○ ○

R NERVES UP BY TAKING
THE NUTS
 MADE ○ ○ ○

✓
 Not to be removed
 from the Library.
 By Order of
 The Library Committee.

COMMONWEALTH OF AUSTRALIA
 LIBRARY OF THE PARLIAMENT
 5-SEP 1924



RIGGING GEAR

AND REQUISITES OF ALL
 :: DESCRIPTIONS ::

RIGGING SCREWS, SHACKLES, THIMBLES, ROPE
 AND CORDAGE, SWIVELS, HOOKS, ETC., ETC.

LARGE ASSORTMENT OF LIGHT AND HEAVY
 LIFTING BLOCKS, HAULING AND RUNNING GEAR



STEEL AND IRON WIRE ROPES

RYLANDS BROS., (ENGLAND)

LARGE STOCKS ON HAND

MANILA ROPES OF ALL SIZES



SHIPS' FITTINGS

BINNACLES, COMPASSES, ANCHORS, CHAINS,
 BLOCKS, FLAGS, PAINTS, LAMPS, LOGS, CANVAS,
 :: AND GENERAL SHIP CHANDLERY ::

BOAT OARS AND IMPLEMENT HANDLES



SOLE SELLING AGENTS FOR:
 THE AUSTRALIAN BOAT OAR CO.'s PRODUCTS

W. KOPSEN & CO. LTD.

'Phone: City 8289 70 Clarence St., Sydney

“SEA, LAND and AIR”

THE AUSTRALIAN NATIONAL MONTHLY

— OF —

TOPICAL INTEREST

Edited by S. E. TATHAM.

CONTENTS

(All Rights Reserved)

	PAGE.		PAGE.
Topics of the Month:		What Do You Know?	108
Bridging the Gap	83	New Wireless Era in Australia ..	114
Helping our Hospitals	84	Shipping Intelligence	129
Life and Work in Fiji	85	Aviation in Australia	131
K.K.K.	89	Junior Mechanics Section	134
Newcastle's Old Wrecks	93	Wireless Institute of Australia ..	136
A Great Airman	94	Wireless Notes	137
Nature Study in Outback Australia.	96	The "Helsby" Twin Wiring System	139
Convicts of New Caledonia	101	Women and Sport	141
H.M.A.S. <i>Adelaide</i> at Sea	103	The Motor World	142
A Man Who Sought Experience ..	104	Humour of the World	152
When Courage Counts!	106	Brief Mention	160

The Editor will be pleased to receive, for consideration, contributions on Aviation, Wireless, the Navy, Mercantile Marine or other subjects within the scope of *Sea, Land and Air*. All MSS., photographs, drawings, etc., submitted must bear the sender's name on back and be accompanied by postage stamps for return if unsuitable. Although every care will be taken of all contributions received, no responsibility is accepted.

All Editorial communications should be addressed to:
THE EDITOR, *Sea, Land and Air*, 97 CLARENCE STREET, SYDNEY.

All business communications to: THE MANAGER.

Sole European Agents: THE WIRELESS PRESS, LTD., 12 AND 13 HENRIETTA STREET, LONDON, W.C. 2.

Sole Agents for United States of America: WIRELESS PRESS INC., 233 BROADWAY, NEW YORK.
Singapore: KELLY & WALSH.



BRITISH MANUFACTURE

Full particulars obtainable from the N.S.W. Agents

William Adams & Co. Limited

175 CLARENCE ST., SYDNEY

HOWARD SMITH CHAMBERS, WATT ST., NEWCASTLE, N.S.W.

COSMOS LAMPS

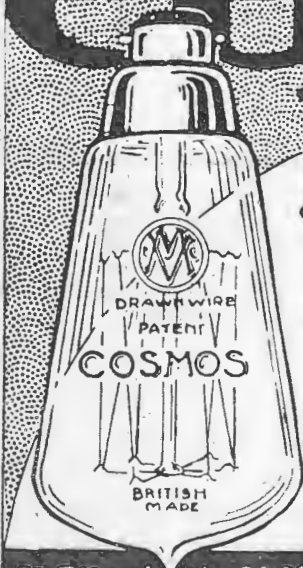

Give a perfect light,
Strong & Economical.

METROPOLITAN Vickers

ELECTRICAL

CO. LTD



21 Elizabeth St. Melbourne.

304 Kent St. Sydney.

SEA LAND AND AIR

AUSTRALIA'S
NATIONAL
MONTHLY

VOL. V.

MAY 1, 1922.

No. 50.

TOPICS OF THE MONTH

BRIDGING THE GAP

EVERY Australian who has the advancement of his country at heart will welcome the business enterprise displayed by the Federal Government in making arrangements for the establishment of direct wireless communication between Australia and the outside world. That private enterprise has been given the opportunity (in partnership with the Government) of carrying out this huge undertaking is a matter for all-round congratulation since it will ensure the control thereof being placed in the hands of business men.

It is beyond question that the average person has awakened more to the possibilities of direct wireless communication since the agreement was ratified on behalf of the Commonwealth Government than was thought possible a few months ago. It has brought home to the lay mind that the march of science, so far as wireless telegraphy is concerned, has reached a stage where it can offer us a partnership in world affairs through the exchange of news, promptly and cheaply, that will advance Australia's interests perhaps more than the most optimistic amongst us can yet picture.

Australia's geographical isolation from the great centres of the world has long been

recognised as the greatest bar to her progress. Can it be wondered then that every invention which looked like playing a part in bridging the gap between us and our kinsfolk overseas, with whom we have so much in common, was hailed with delight. The sailing ships of the old days gave place to speedy modern liners; the building of cross-continent railway lines shortened the time involved in transporting mails from Australia to the Old Country, and all the time the cables were being utilised in flashing to and fro the official, commercial and press news, which is after all the life-blood of modern business.

While progress along these lines was being recorded the evolution of wireless was going steadily on. Like all similar inventions which aim at accomplishing the seemingly impossible, wireless telegraphy had to demonstrate its use and practicability before popular imagination began to champion its cause. How it did this is a matter of recent history, and it is safe to say that no invention, ancient or modern, has such a splendid record of service in the saving of human life to its credit as this newest creation of man's inventive genius.

In less than two years Australia will have a high-power wireless station, three times as powerful as any at present in existence, capable of transmitting and re-

ceiving direct wireless messages to and from all parts of the world.

Not the least important feature about the undertaking is that the cost of messages will be reduced by one third from the outset, and the heavy volume of business, rendered possible by the speed with which wireless messages are transmitted, will unquestionably ensure the success of the enterprise from a business point of view. When the undertaking is in full working order there is little doubt that Australia will benefit materially in every direction. The free exchange of news and views will enable a bond of mutual understanding to

be established with the peoples of other countries, which will ultimately remove many of the misconceptions regarding Australia, and our trade relations stand to be considerably strengthened and developed by the speed and economy with which we will be able to glean of the doings in the world's markets. Altogether, the establishment of direct wireless marks an era in the progress of Australia which is likely to become historic. Not often is it given to a Government to inaugurate, in conjunction with private enterprise, such a great national undertaking as the linking up of Australia with the outside world by wireless is destined to be.

HELPING OUR HOSPITALS

THERE are few institutions which deserve so well of public generosity as our hospitals. The volume and importance of the work they do, year in and year out, in ministering to the needs of the sick and suffering is beyond estimation, and if the people of Australia attempted to adequately recompense in gold those who labour so unselfishly in carrying out the work of these great institutions, the price would indeed be a high one.

There is no gainsaying the fact that the needs of suffering humanity rightly constitute the first call upon the charity of the people. Sickness and accidents are the common lot of mankind, a fact which probably accounts for the willingness to help each under such circumstances, which is almost as strong in the average person as the instinct of self-preservation itself.

The problem of financing the public hospitals, particularly in New South Wales, has long been a difficult one. The present system whereby the huge expenditure necessary to meet their needs is subscribed by charitable appeals, backed up by a Government subsidy, has many drawbacks and, at the same time, a number of virtues.

It is obvious that the fees paid by patients are totally inadequate to meet the huge sum necessary for the upkeep of the hospitals, and as the service rendered by the medical and nursing staff is largely based upon a humanitarian desire to relieve the sufferings of their fellow creatures, it naturally follows that an appeal to the general public for monetary

assistance for the same good cause will always bear fruit. It would be a thousand pities if anything were done to interfere with the flow of public generosity in the support of our hospitals, but at the same time it is bad business to allow the efficiency of any of these institutions to be threatened through an insufficiency of funds to carry on. However, until such time as another scheme is devised, hospital committees will have to depend largely upon public generosity to enable them to continue their noble and ever-increasing work. They are on good grounds, however, in appealing for public support, and it can safely be said that the last proposition to which people will ever turn a deaf ear is to contribute funds to ensure a continuance of the work of helping suffering humanity.

Apart from the immeasurably useful service rendered by the nursing and medical staffs of our hospitals, too much praise cannot be bestowed upon those gentlemen who voluntarily undertake the onerous task of serving upon the various committees which play such a great part in hospital management. They, too, are actuated by the highest motives, and surely the example they set should be sufficient to loosen the purse-strings of public charity whenever an appeal is made. It must never be said that the people of Australia are so wrapped up in selfish pursuits as to turn a deaf ear to the call of such noble institutions as our hospitals for the means to carry on their great work.

LIFE AND WORK IN FIJI

TWO RACES THAT WILL NOT MINGLE

MAKING THE COLONY SELF-SUPPORTING

Sir Maynard Hedstrom, Managing Director, Morris, Hedstrom, Limited, Fiji, was born in Levuka, Fiji, in 1872, and educated at Wesley College, Melbourne.

He has been a Member of the Legislative Council of Fiji for fourteen years, representing the Eastern Division, of which Levuka forms a part. He has been three times returned unopposed, and has been for some years Senior Elected Member of the Council and a Member of the Executive Council. Sir Maynard was created a Knight Bachelor at the beginning of this year, and is the first non-official resident of the Western Pacific Islands to be so honoured.

A representative of "Sea, Land and Air" had an interesting interview with Sir Maynard during his recent visit to Sydney, and the following article is based upon information gleaned at that meeting.—ED.

THE picturesque group of islands known as Fiji, lying about one thousand and eight hundred miles north-east of Sydney possess more than a passing interest to Australians. The place is famed as a great sugar producing centre, the Colonial Sugar Refining Company, Limited, having big interests there.

Quite recently the labour question became troublesome, and cast a general air of depression over the islands. The company is the biggest employer of labour in the colony, and quite naturally they contend that the wages they pay must be regulated to correspond with the price their product is fetching in the world's markets. In pre-war days the Indian labourer who had completed his term of industrial service was paid 1s. 6d. per day. The increase

in the cost of living rendered a rise in this sum necessary, and up till February 25 of the present year they drew 2s. 6d. a day. On that date the Company announced a reversion to the old rate, at the same time

giving an assurance that they would supply sugar and other essentials of Indian diet at fixed prices approximating to those of pre-war days. The Indians did not take too kindly to the proposition, contending that the cost of living had not come down sufficiently to make living possible on 1s. 6d. a day.

Different to Australian Conditions.

In speaking of such low wages the fact must not be lost sight of that the standard of life of the Indians in Fiji is totally different to that prevailing in Australia. Practically every Indian has his own plot



Sir Maynard Hedstrom.

of land, on which he grows a big proportion of his own foodstuffs, as well as keeping a couple of goats. His wants in life are few and simple, and with the above-mentioned provision he is able to maintain a standard of life such as he desires. The position of the Colonial Sugar Refining Company in regard to wages is better understood when it is remembered they have to compete with other tropical countries in the growth and manufacture of sugar, which would be impossible unless a readjustment on the wartime scale of payment was made.

A section of the planters in Fiji some time ago considered the advisability of importing Chinese workers into the colony, but the experience in Samoa practically settled the question against such a course, owing to the heavy cost of recruitment and transportation. There was some doubt, too, as to whether the British Government would be in favour of such a scheme, and the viewpoint of some of the colonists who attach a great deal of importance to their responsibility towards the Fijians was, that in the interests of the latter, the importation of large numbers of Chinese coolies would be inadvisable. A further proposal to import some of the ten thousand American negroes who had formerly been employed on the Panama Canal works was promptly turned down.

A Mixed Population.

The population of Fiji, as might be expected, is a mixed one, and consists of Fijians—a blending of Polynesian and Melanesian blood—the lower class Indians recruited in their native country by the paid agents of the Fiji Government, and comparatively speaking, a handful of Europeans.

Fijians a Charming Race.

The Fijians, who numbered at the time of the 1918 estimate over eighty thousand, are a charming, hospitable and law-abiding people. Even a stranger travelling through the big islands of the colony would be much safer than if journeying through the average Australian city. When one accepts the hospitality of the Fijians there is no need to place his possessions under lock and key, or even out of sight. The law of hospitality is sufficient to ensure everything belonging to the guest being treated as sacred, and one has to experience

this unusual but highly commendable absence of necessity to guard one's property before the full significance of such a high code of honour can be appreciated.

The Fijians are looked upon in many quarters as a lazy, indolent race, but this is to a great extent a mistaken impression of people whose ultimate aim in life is not the possession of an untold store of worldly wealth. Like most people who get their living easily, they are content to let matters go quietly along, and the productive qualities of their land is such that it requires no great effort on their part to produce sufficient on which to live. At the same time it is only fair to say that the Fijian will work splendidly for a spasm, and when one or more of them undertake a task they will toil at it unceasingly until it is completed. Then, of course, comes the inevitable reaction—a period of freedom from work. Before the advent of motor launches it was no uncommon thing for a crew of five or six Fijians to row a whale-boat from Levuka to Suva, a distance of over fifty miles, with no break except a short stop for meals. This was certainly a test of grit and endurance, and the Fijian, as on many similar occasions, came through it with flying colours. One thing the Fijian labourer objects to is working in the sugar fields. He considers the work too laborious and monotonous, but on the other hand he takes rather kindly to labouring amongst the coconuts, a class of work which resembles the conditions of his daily life. Like most of the Island races, the Fijians are at home in the water, and in case of disaster overcoming any craft in which they happen to be, they are chivalrous enough to think first of saving any members of the party who cannot help themselves. On one occasion a European was out sailing with four or five Fijians when a sudden squall upset the boat. The natives quite enjoyed the experience of being precipitated into the water, and when the white man came to the surface the first thing he heard was the native crew calling to each other, "Look after the white man." Two of the Islanders swam to him, and, placing an oar under each arm, told him that there was no danger and that they would soon have the boat baled out and righted. This incident is typical of their behaviour in all cases of a similar nature.



GLIMPSES OF FIJI.

(1) A typical native hut. (2) Governor of Fiji inspecting a native school. (3) Crossing a stream at Tova Estate. (4) View of Viti Levu Bay from Tova Estate.

A Contrast in Races.

A striking contrast is revealed in a study of the life, characteristics, and conduct of the Fijian and Indian races. The former, of course, have no traditions of any ancient civilisation; they are children of Nature; but the latter are descendants of a people whose culture and achievements stretch back through centuries.

In speaking of Indians, those living in Fiji only are referred to. Most of them were recruited from the lowest class of people inhabiting India, and are not in any sense representative of that great portion of the British Empire. In fact so strong is the national and racial pride of the Indians at home that they object to further immigration to Fiji, and lose no opportunity of letting the world know that those of their countrymen already there do not, in any sense, represent, so far as honesty and general standards of living go, the people of the homeland. For about forty years these recruited Indians have been entering Fiji, and to-day they represent a class who are adepts at dissimulation, and the practice of all the most wily tricks one could well imagine.

In marked contrast to the Fijian huts, which are substantial, clean and comfortable, the Indians' places of abode are sordid structures, sometimes built of old slabs and flattened out kerosene tins. The Fijian homes are usually picturesquely located, with fruit trees and ornamental shrubs surrounding them; but the Indians of Fiji as a rule have no love for either beauty or cleanliness, and a white man would prefer to sleep in the open rather than spend a night in the average Indian hut.

Maintaining Separate Identity.

Perhaps one of the most remarkable features in connection with the Fijian and Indian races is that despite the fact that they have lived and worked side by side for about forty years, each has maintained its separate identity. There has been practically no mingling of blood and certainly none of ideals. To-day they represent to the student of human nature a stream of water, one half of which is clear as crystal and the other muddy and discoloured, and running down the centre is the sharply defined line of demarcation. It is rarely one comes across cases like this, particularly amongst native races, who usually

care little for the ideals of racial purity.

The Indians in Fiji were recruited by the agents of the Fiji Government and transported to Fiji free of charge, in consideration of which they worked for five years at a fixed rate of wages. At the end of that time they were at liberty to take up land, start trading, or follow any other occupation, and after completing ten years' residence in the colony they are entitled to free repatriation to their own country. There are no longer any indentured Indians in Fiji—the last of the indentures were cancelled more than twelve months ago, and it is very unlikely that any more Indians will be introduced into the colony under any agreement for industrial service.

Europeans.

Contrary to the usual belief the European population of Fiji are a hard-working people. The office hours both for professional and business men are ordinarily from about 8 a.m. to 5 p.m.. Possibly the assumption that the white population in Fiji takes things easy springs from the old tradition that the Pacific Islands are a land of perpetual sunshine, of laughing girls and idle hours—the original home of the lotus eaters.

Developing Local Industries.

The stock-raising industry, which is yet only in its infancy, promises to play a big

part in the future of Fiji. The colony is free from droughts, and as a result grass and other herbage grows luxuriantly. As an evidence of how well cattle thrive, it might be mentioned that on the rich river flats it is possible to fatten one beast to the acre all the year round. A small export trade in cattle to Samoa is now carried on, and during the war two or three lots were sent to Sydney and realised very satisfactory prices. A good deal of beef is consumed in the colony; the Fijians being fairly heavy meat eaters when opportunity offers; but the Indians, of course, will not touch beef, the cow being to many of them a sacred animal.

Quite recently an area of about eighty thousand acres, known as the Tova Estate, has been taken up with the object of devoting it exclusively to stock raising. A large quantity of canned beef is imported into Fiji, and it is the ultimate intention of the promoters of this new enterprise to supplant the imported article with their own product, canned on the spot.

A biscuit factory is now in course of erection for the Pacific Biscuit Company, an enterprise with which Messrs. Hackshalls, Limited, of Sydney, is closely identified, and soon Fiji will be eating its own biscuits instead of those made in Australia.

It is all part of a very laudable ambition to make this rich British possession in the South Pacific self-supporting.

He is happier who has power to gather wisdom from every flower and wake his heart in every hour to pleasant gratitude.—*Wordsworth*.

We should all choose that brave career in which we can do most and best for mankind.—*Stevenson*.

No amount of pay ever made a good soldier, a good teacher, a good artist, or a good workman.—*Ruskin*.

All the greatest men live in their purpose and effort more than it is possible for them to live in reality.—*Ruskin*.

To acknowledge a sympathetic and unshaken confidence in all men, rich and poor, white and black, learned and ignorant, civilized and savage, churchman and

dissenter, saint and outcast, this is to have found spiritual peace.

We are all travellers in the wilderness of this world, and the best that we can find in our travels is an honest friend.—*Stevenson*.

There are so many things, best things, that can only come when youth is past, that it may happen to many of us to find ourselves happier and happier to the last.—*Eliot*.

Be the noblest man that your present faith, poor and weak and imperfect as it is, can make you.—*Brooks*.

In the long run men hit only what they aim at, therefore though they should fall immediately, they had better aim at something high.



STRANGEST SOCIETY ON EARTH

AMERICA'S GREAT SECRET ORGANISATION

Most people have heard of the "Ku Klux Klan"—the great secret organisation of America which wields a powerful influence on the society of that country. Very few, however, have any idea of how and why it works, and the following account of its activities will therefore prove of absorbing interest.—Ed.

WOE betide the unfortunate individual who incurs the displeasure of the Ku Klux Klan. No matter what his standing in the community may be, he has no "pull" with this strange organisation which metes out justice, according to its standard of ethics, to high and low alike.

The question is frequently asked: Who are the "K.K.K.?" To supply a satisfactory answer is about as easy as attempting to describe the number, stature and characteristics of the inhabitants of other planets. A dozen or so have voluntarily revealed their identity, but beyond that the *personnel* of the organisation is shrouded in mystery. One instance of the strength and financial standing of the society is revealed in the purchase of the Lanier University of which their "Imperial Wizard"—at the time Professor of History—was made President.

The enemies of the "K.K.K." comprise practically all those who because of their nationality, religious faith, or other disabilities, are ineligible for membership. Socialists, Radicals, members of the American Federation of Labour and various other bodies are unfriendly towards the Ku Klux Klan for various reasons; but in spite of all this opposition the society claims to be enrolling

members at the rate of over a thousand a week.

Some of the alleged exploits of the "K.K.K." are worthy of a place in fiction, so unreal do they sound; but whether the Society or its enemies are responsible is a question not easy to decide.

In one populous city of America a well-known physician was escorted from his home to a waiting motor car by two smartly dressed strangers. To a lonely spot he was taken, where numbers of white-robed figures surrounded the car, lifted the unfortunate man out, divested him of his clothes and proceeded to tar and feather him. When this had been completed he was hoisted into the car again, driven to the city and deposited in a public square, from where he had to make his way home amidst the taunts of a jeering crowd.

On another occasion the negro cotton-pickers of a Texas village had declared their intention of not entering the fields until higher wages were paid. A remarkable change came over the scene when a placard, signed "K.K.K.," was hoisted warning all idle persons to find work at once. The warning was instantly acted upon, and next day not an unemployed negro was to be found in the village.

Yet another instance of the arbitrary methods attributed to the Klan is revealed in the treatment meted out to a solicitor, who was taken from his office by a group of unmasked men, carried to a lonely spot and there severely whipped. Not content with this, his assailants plastered him with tar and ordered him to leave the town at once, under pain of death. They further charged him to tell the sheriff about the assault, and whether he did so or not the fact remains that no one was apprehended for the crime.

The responsibility for outrages like these is officially denied by the Klan Society, which contends that such acts are perpetrated by its enemies with a view to injuring its reputation. Likewise the cases where men have been found bound and gagged by roadsides, and who told fearful stories of the terrible treatment meted out to them by members of the Society, are repudiated by that body, in spite of the fact that letters have appeared in the newspapers in which the writers boasted that acts like those mentioned have been meted out in the cause of justice by the Klan.

It is not surprising that such controversies should cause a cleavage in the ranks of the organisation, and several district heads have withdrawn from this remarkable society and devoted their attention to the apparently profitable occupation of exposing the secrets of the "K.K.K." These stories have been copyrighted by some of the big newspapers of America, but although a good deal of speculation has been indulged in concerning the outrages for which the Klan has been blamed, no mention was made of them in the newspaper articles.

Instead, these contributions were chiefly devoted to personal attacks upon some of the chiefs of the order, who were credited with being possessors of large quantities of illicit whisky in spite of national prohibition. Allegations of attempts to stir up religious and racial prejudices are also charged against the Klan.

As might be expected, such wide publicity has riveted the attention of governors and mayors all over the States upon the activities of the Ku Klux Klan, and in practically every instance an official ban has been put upon the Society.

Investigations into its working have been demanded, and even the President of the

United States has been appealed to by the National Reform Bureau and kindred associations to issue a proclamation denouncing the Klan.

As a reply to these outbursts Colonel W. J. Simmons, of Atlanta (otherwise known as the "Imperial Wizard"), head of the "K.K.K.," has announced that he welcomes the fullest investigation. He denies the outrages, and declares that the aim of the Society is to co-operate with the officers of the law in ensuring that a white man's government of the Anglo-Saxon kind which built America shall prevail under the Stars and Stripes.

Klansmen in every State in the Union point mysteriously to the decrease of a crime wave that for a time threatened to overrun the country with revolutionary ideas and organisations. Known Klansmen are not boasting; they do not tell tales of how it was done. They do not even claim credit for what is popularly understood to be the work of the police and secret service.

Nevertheless, curious things have happened in many places. One odd affair occurred in Chicago. One night more than two thousand persons were initiated as Knights of the Ku Klux Klan in one of the great public parks. Next day the Chief of Police declared that, should a masked parade of the Klan be attempted, such as had taken place in other cities, it would be broken up—by force if necessary. The city fathers also placed a ban on the "K.K.K.," as many other city fathers have done elsewhere.

Later on the same Chief of Police asked for an enquiry into his own police force, numbering five thousand, on the ground that he believed at least half of them to be the "bootleggers," *i.e.*, traffickers in illicit whisky.

Prominent members of the Klan declare that their activities are directed solely against the master criminals who are responsible for the crime wave existing in America at the present time.

If the duly-elected officers of justice are too few to cope with the criminals, the members of the Klan offer to assist as volunteers. When this assistance is indignantly refused and the officials declare there is no need for any secret society, "invisible" or otherwise, to combat crime, what else are the Klansmen to do, they

ask, but to remain invisible and fight the underworld with its own weapons?

Some months ago ten thousand coal-miners in the State of West Virginia formed into an army, and with one of their own members as leader, marched on the mines. Acts of violence resulted in several murders, and a sheriff gathered a posse and declared that the men should not cross his county line. Despite this the miners marched on, and requests went forward to the President from the Governor of the State, the constabulary, and thousands of citizens for a declaration of martial law and the assistance of Federal troops.

Then followed delay after delay, purposeful of course, for martial law might precipitate civil war. Just as the position appeared desperate hundreds of city volunteers banded themselves together, closed their offices and shops and went to the sheriff's assistance. The miners hesitated. An army general came and surveyed the situation, troops were mobilised, and a proclamation of martial law awaited the President's signature.

But the signature was never attached, nor were the troops needed. The miners had been led by agitators to believe that public sympathy would be with them in an appeal to arms. Bearing in mind that one of the avowed objects of the "K.K.K." is to prevent unwarranted strikes by foreign labour agitators, the question was freely asked at the time: Had the Klan anything to do with averting the trouble? Only the members of the organisation itself could supply a definite answer.

The "K.K.K." also includes in its scope of activities the prevention of outbreaks of mob violence and lynchings. An instance of its mysterious power in this direction was afforded some time ago in Oklahoma when a terrible race war threatened as a result of a conflict between a handful of blacks and whites. The sheriff found himself unable to restore order, and the situation looked full of ugly possibilities when, by common consent, hundreds of determined citizens closed their businesses and put themselves at the authorities' disposal. The result was an immediate restoration of order; both blacks and whites being forced to abandon their hostile intentions.

The origin of the "K.K.K." is to a certain extent shrouded in mystery. On one hand the present day society claims

to be a revival of an old organisation of the same name which sprang into existence after the American Civil War, and in three years wiped out the "Carpet Bag" régime imposed upon a conquered people by selfish politicians. In those days white Southerners were made to bow before their former black slaves, and a reign of terror and oppression prevailed generally. The Klan alleges that those conditions have today been superseded by an overwhelming wave of secret crime; hence the justification for its present day existence.

During the period when the Klan was practically non-existent bands of robbers and other desperadoes used the name of the Society as a cloak for the pursuit of an orgy of crime, and enemies of the "K.K.K." have made use of these acts to discredit it wherever possible. But this strange secret organisation has not sat down quietly and allowed defamers to heap undeserved coals of blame upon its head.

Colonel Simmons has in his possession, according to Klansmen, several documents signed and sworn to by alleged victims of the Ku Klux, proving that some, at least, of the alleged outrages perpetrated in its name were done deliberately to discredit it. One "victim" admitted to having himself bound and gagged and left desolate by the roadside in order to injure the "K.K.K." Another alleged victim of tar and feathers is said to have confessed that he and his friends arranged the episode for the same reason.

During the war period of 1917-18 every State in America organised an army of citizen volunteers—men debarred by age or physical disability from enlisting—to assist the authorities in tracking down German spies and keeping criminals in check. It is believed that every Klansman served in this great army, and as a direct result thereof the numerical strength of the Society increased considerably, thus evidencing that no opportunity is lost of gathering members into the fold.

About two years ago the "K.K.K." decided to advertise itself. A publicity agency undertook to do the work, and did it so well that the organisation is in many respects the best advertised "speciality" in the United States of America.

Quite recently a Congressional investigation into the organisation and activities of the Ku Klux Klan was commenced in America, but it came to a sudden and

dramatic end without any official reasons being given for its abandonment. During the inquiry Colonel Simmons collapsed in the witness stand while giving evidence, his final words being to call on Heaven to forgive his detractors.

About the same time a Klan parade that was being held in a Texas town was stopped by a sheriff and his deputies. A disturbance followed, during which the sheriff was shot and several others wounded. The next act in this little drama was the preparation of a sworn statement signed by hundreds of citizens, putting the entire blame for the disturbance on the sheriff, who, it was asserted, interfered with a peaceful assembly.

Some time later a well-known evangelist conducting revival services in a southern State announced that he had received a

letter from the "K.K.K." threatening him with death unless he left the community at once. The sequel to this was provided next day when a committee of the Klan visited the missionary and assured him that he need have no fear, as the letter had not been written by any member of the Society.

In Oklahoma a band of white-robed figures practising their ritualistic ceremonies in a pasture were deliberately fired upon by a sheriff's posse and, according to the sheriff, one was wounded. Excitement was caused in a Michigan town by revelations that a strong Klan organisation existed among the students and faculty of its university, though no one could discover the name of a single member.

Such, in brief, is a history of this strange Society, the exploits of which have come to the ears of people the wide world over.

MOTOR BOAT'S FLYING DINGHY



A tiny flying boat carried on a motor boat belonging to Mr. Grover C. Loening, the well-known American yachtsman and aeroplane builder. The 'plane is little larger than the motor boat's dinghy seen alongside. Mr. Loening has christened his motor boat "Argus, Jnr.," after the famous British aeroplane-carrier "Argus."

NEWCASTLE'S OLD WRECKS

HOW THE "ADOLPHE" MET HER DOOM

TOLL OF OYSTER BANK

By G. M.

VISITORS to Newcastle by steamer have doubtless often wondered what story is attached to the wreck of the big French barque *Adolphe*, which lies on the northern breakwater. For eighteen years it has lain there, being one more addition to the relics of several other sailing ships, which previously came to grief on that ill-fated spot. Amongst them is numbered the *Cawarra*, wrecked on July 2, 1866, the *Colonist*, *Wendouree* and the *Regent Murray*, the last named of which met her fate during April, 1899.

How the "Adolphe" was Lost.

The *Adolphe* was a new steel vessel of three thousand two hundred and four tons gross, and measured three hundred and thirteen feet long by forty-five feet beam. She was commanded by Captain Layee, and was bound from Antwerp to Newcastle in ballast. On the morning of September 30, 1904, she was attempting to enter port in tow of the *Victoria* and *Hero*, when the former's tow-line parted, and the *Adolphe* was soon drifting towards Oyster Bank. Before anything could be done she was lifted high on the crest of a huge wave and deposited almost on the spot where the mouldering wrecks of the *Lindus* and *Wendouree* lay.

Immediately the distress signals were fired from Port Scratchely, and the pilot steamer *Ajax* and the lifeboat were soon in readiness to render assistance to the crew of the ill-fated barque. The huge white-crested breakers which broke over her continually soon brought further disaster, and the firing of the second gun denoted that the *Adolphe* was a total wreck.

The scene at time was grand, but awe-inspiring. The barque was almost constantly enveloped in wreaths of spray, which leapt nearly fifty feet into the rigging.

The Rescue.

The *Ajax* steamed to a position between the wreck and the fog-bell on the southern

breakwater, and fired three rockets in the hope of getting a line aboard. The first two fell short, and the third passed through. The huge seas breaking over the doomed barque rendered it impossible for anyone to remain on deck long enough to haul a line aboard, and it was not until the wreck settled down on the rocks that the lifeboat was able to get astern of her, and after the greatest difficulty get a line aboard and make fast until she was able to work her way to the lee of the vessel. Then followed an heroic fight on the part of the lifeboat's crew. Huge waves swept over them in quick succession, and to the anxious watchers and the still more anxious crew of the *Adolphe*, it seemed that their superhuman efforts would fail before the onslaught of the foam-crested breakers. But brave hearts and iron wills and muscles belonged to those men who were fighting so strenuously to save their fellow human beings, and after countless reverses they gained the vessel's side, and took on board the whole of the crew. To regain the shore was a comparatively simple task after the tremendous difficulties that had already been overcome, and the crew was taken to the shelter of the Sailor's Home.

A Dreaded Spot.

The Oyster Bank is a spot dreaded by every mariner who enters the northern port. It is invariably given as wide a berth as possible, and the remains of several fine vessels which lie buried there are a constant reminder of the danger awaiting any master who, in an unguarded moment, takes his vessel so close that the curling breakers can claim another victim. Quite a number of requests have been made that the bank be blown up, but it still remains as a menace to navigation.

A GREAT AIRMAN

SIR ROSS SMITH'S UNTIMELY DEATH

MAN WHO COULD ILL BE SPARED

HERE are few people in Australia to whom the name of Sir Ross Smith is not a familiar one, and throughout the length and breadth of the land where the fame of his exploits had spread he was spoken of and looked upon as one of the great men of aviation. That he well deserved this distinction was evidenced by the courage, resource and enterprise which characterised all his endeavours, particularly the world-famous flight to Australia, when with his equally dauntless companions, his brother Sir Keith Smith and Lieutenants Shiers and Bennett, he performed a marvellous feat in the face of untold difficulties and hardships.

Not only did this feat bring honour and glory to those who performed it, but it brought Australia into the limelight as few other things could have done. It demonstrated that the men whose courage and ambition had been severely tested in the fierce crucible of war were likewise able to rise to the occasion in days of peace, and perform sterling service in pioneering the airways of the world for the great and useful part which aviation is destined to play in our future trade and commerce.

It was no passing hero worship that an admiring world bestowed on Sir Ross Smith when his great flight to Australia was accomplished, it was a genuine tribute of admiration at the performance of a task which had previously been looked upon as impossible. Such was the spirit of the man who conceived and carried out this great undertaking that when honours were showered upon him, he felt a greater pride at the service he had done his country and the profession he loved than at his own personal aggrandisement. While experts and enthusiasts were boasting of the future of aviation Sir Ross Smith demonstrated in a practical manner that communication between England and Australia by air was possible, and doubtless it was his faith and zeal which inspired

those who have since urged the formation of an Imperial airship service between Britain, Asia, Africa and Australia.

One of the saddest features in connection with the gallant airman's untimely end was that he was about to launch out on another world-flight, which, all going well, would have added fresh lustre to his name. But Fate willed otherwise, and to-day Australia, in fact the whole Empire, is poorer by the loss of the star airman of her flying service. His spirit, however, will still remain as a guide and inspiration to those who will follow in his footsteps. From palace down to hamlet the feeling of regret when the news of the unfortunate happening was flashed round the world was both deep and sincere, and coupled with it a genuine sympathy went out to his relatives who had lost a son and brother of whom they were justly proud.

Sir Ross Smith's companion in the tragic happening in England was Lieutenant Bennett, who lived a few minutes longer than Sir Ross. Lieutenant Bennett was a skilled air mechanic, and with Lieutenant Shiers he performed yeoman service in the great flight to Australia. In fact Sir Ross Smith declared after the flight that the credit for the success of the undertaking belonged to the two mechanics whose skill and tireless energy kept the engines going throughout that long journey. Lieutenant Bennett only sailed from Australia a few months ago to join Sir Ross and Sir Keith Smith on their second world-flight. By his death aviation has also suffered a serious loss, for the part which he and his fellow mechanics play in furthering the interests of aviation is almost, if not quite, as great as that of the most skilled pilots.

The late Lieutenant Bennett was highly popular, and was the recipient of a number of presentations on the eve of his departure from Australia.

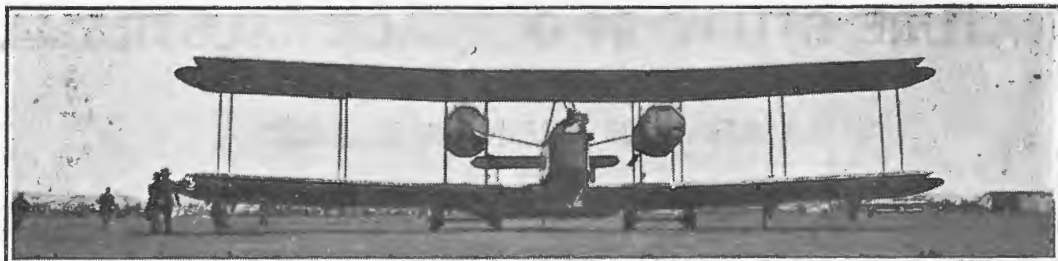

The famous "Vickers-Vimy" aeroplane in which the trail from England to Australia was blazed by the late Sir Ross Smith, together with Sir Keith Smith, Lieutenant W. H. Shiers and the late Lieutenant J. M. Bennett.



The late Lieutenant J. M. Bennett,
M.S.M., A.F.M., A.F.C.



The late Sir Ross Smith, K.B.E.,
M.C. (bar), D.F.C. (2 bars), A.F.C.



Two views of the "Vickers-Viking" amphibian, in which the late Sir Ross Smith, with his brother Sir Keith Smith and the late Lieutenant J. M. Bennett, proposed to make a round-the-world flight. It was while testing this machine that the unfortunate accident occurred.

NATURE STUDY IN OUTBACK AUSTRALIA

ANIMALS' CURIOUS HABITS

HOW THE NATIVES WIN A LIVELIHOOD

By FRANCIS BIRTLES

Most people are interested in Nature study, particularly when it comes to reading of the habits of animals, birds, and fishes which inhabit the little-known portions of Australia. During his tour across the continent Francis Birtles had many opportunities of observing animal life, and the following pen-picture of what he actually saw and learned will prove of absorbing interest.—ED.

THE Flinders River alligators, which are also known as estuary crocodiles, are enemies alike of man and beast. They live in salt water channels and rivers, and grow to a length of over twenty feet, with a body height of three feet, and would weigh up to two tons. They have short, bull-dog-like snouts, armed with canine-like fangs; the two front lower teeth projecting upwards through the top jaw when the mouth is closed.

There has been a good deal of scientific controversy as to whether the alligator has a voice. Without any doubt I have heard their bellowings, which sound like a drowning bullock's subdued roar. Often at night they have startled me with this bellowing grunt, and then the resounding smack of their powerful tail on the water as they stun any large fishes which may be swimming past. Dingoes and scrub wallabies form their favourite meal, and, sometimes, as though to show their gigantic strength, an old bull alligator will come out on to dry land, catch a bullock by the hindquarters for preference, and with front claws drag the beast to earth, and then, seizing him with his powerful jaws, haul the frantic animal into the deep waters. The most dangerous of these saurians are the young, active males. They are keen hunters, and I have followed tracks from the river's edge to a lagoon seven miles inland. The craving for a change from salt to fresh water probably accounts for this long-distance stroll. These are the man-eaters, who drag human beings or dogs from nearby camps. The real "old men alligators" cannot, owing to their girth and weight, go more than a few

hundred yards away from the water's edge; but they are dangerous when in water, and the lone fisherman will do well to carry on the gentle art of Izack Walton from an overhanging tree trunk or steep cliff bank. On the Nicholson River, Gulf of Carpentaria, every old bull alligator apportions off a section of the stream to himself, and is lord of all he surveys. He will haunt the locality for scores, probably hundreds of years—as he is long-lived, and is believed to exist for a period of four hundred years. With all senses alert, and keen as those of a good watch-dog, coupled with the accumulated wisdom of years, he is hard to get a shot at whilst the weather is warm. When the cold monsoon winds sigh through the mangroves, and the slimy mud-beds are chilled and in shadow, aboriginal "binghi" puts new points on his spear shafts and prowls around about these depots. The aboriginal is cunning and a great believer in telepathy, and whilst stalking the alligator he tries to keep his thoughts off his objective. A grasshopper rises some distance away in the long grass; "gohanna there," says binghi to himself, and then he hears some scratchings inside a hollow gum-tree, "possum up tree," and so on, while all the time he is getting nearer to the sleeping saurian. The native treads softly, for inside of the alligator will be stored hundreds of marble shaped pebbles, which he reckons will tell the old man that "blackfellow come up."

A Crocodile's Nest.

At this period the female builds up a three-foot high mound of earth and decayed vegetable matter. A few yards away

a drain-like hollow is made, and during the nesting season this accommodates the vigilant mother, who keeps her greedy spouse away, as he would fain swallow eggs, nest and all. About sixty eggs, in appearance like oval-shaped tennis balls, are laid. These are covered over with grass and wet mud by the parent, who also frequently carries water in her mouth and empties over the vile-smelling heap. The heat, generated by a kind of spontaneous combustion, brings the brood to life—reminding one of the origin of the Phoenix of tradition. When hatched the young are about nine inches long, and full of valiant hissing fight they head away for the water, where, bobbing about like corks, they rest with their noses against a stranded log. On the surface of the ten-foot deep pool, bubbles burst, and pieces of white, fatty matter and oil float around, which the young devour. The mother has crept along the bottom and vomited. This is how she nourishes her young. Coming to the surface, she allows the little reptiles to mount on her tail, the serrated edges of which act as a shield against the flowing waters. On the banks of this waterhole the natives have carved on a tree a large representation of an alligator. This is an aborigine monument commemorating the valiant deed of their present-day king, who, unaided, speared and killed an alligator.

Out on the plains, away from the creeks, grass fires are burning furiously. In the foreground an old gin, stooping over the entrance to a burrow in the ground, is singing furiously for a meal, in the shape of a five-foot iguana, which has taken shelter underground from the oncoming flames. Why the singing should make the reptile come out would have to be explained scientifically, but, to my belief he does so as a protest against the horrible concert which is being held against his front door. With swinging head he emerges, and is promptly "passed one" with a heavy yarn stick. The old lady feels him all over—he is fat, so with a grunt of satisfaction "gohanna" is transferred to the hot coals.

Tribal Marks.

All the aborigine women in this locality have two front teeth of the upper jaw broken off short. This is done by hitting the teeth sharply with a piece of flint. In some cases the top of the forefinger of the

left hand is cut off. The head and outer portions of the limbs are scarred deeply from wounds self-inflicted as a sign of mourning for dead relatives. On the biceps of the arms the skin is raised in long lines by making an incision and filling it with earth. These are the tribal marks by which both male and female are recognised. As an instance of how apparently insensible to pain these natives are, I have several times, amongst various tribes, noted the toes missing from their feet. This has been caused by the aboriginal sleeping near to the camp fire, and whilst still in the "land of Nod" unwittingly using his pedal extremities as fuel. At first I could not credit this, but there is no doubt that it is true.

On the banks of the river the ti-trees grow as high as sixty feet, and have a girth up to ten feet. The bark of the ti-tree is used by the natives for the manufacture of head-dress for corroborees, being bound together with nigger's hair cord. It is also used for sheaths for spear heads and stone surgical instruments, whilst in the wet season shelter huts are constructed with it. Soft blankets are also made from the bark, and in these the chubby, rolling-eyed piccaninnies are wrapped. The bark is also ground into powder between two stones and used as antiseptic for wounds.

The Wild Bees' Hive.

Wanting some sweetstuffs, and seeing the small, fly-like, harmless wild bee gathering up moisture on a claybank, I touched the insect with a light flake of sticky paper bark. This adhered to the busy little worker, and away it flew straight upwards, thus indicating that the hive was not far distant. If the insect flew away in a slanting straight line it would mean that its home was some distance away. In the hollow branch of a fresh-water mangrove, I found the supply of honey, or rather a sticky sugar-like mass of large pea-shaped, wax-coated globules, possessing an excellent flavour.

It is a favourite dainty amongst white people outback. Alas! I know now too much from my courses of Nature study. No more do I devour the luxurious delicacy. One day I smelt a smell. Investigation showed a dead wild-dog, and hard at work were hundreds of native bees scraping up the fat and transferring it to their hind legs. And this is some of the

material used in making that "delicious" wax covering.

Nearby was a giant ant-bed of remarkable formation, showing that these termites have some knowledge of engineering foresight. Up to a height of twenty feet the column rose, and then deliberately bent over and outwards to meet the branch of a nearby tree, following this down to the trunk and back to the ground, the whole forming a rude archway. Some other ant-beds point due north and south in a wedge-shaped, up-ended formation. These are called "magnetic ant-beds," and are believed to be caused by some magnetic attraction on the methods of these termites whilst working during the hours of darkness. But sun and weather conditions may more likely be the cause of this regular structure amongst the hundreds built on the plains.

A Tropical Night's Camp.

My camp that night was made miserable through my blankets and swag falling down on to a patch of spear-grass seeds—vile things, which have to be picked out one by one, involving a day's work. These work into the flesh and have to be dug out with the blade of a penknife. A night-hawk perches silently on top of my oblong cheese-cloth mosquito net, myriads of minute sand-flies and midges frantically endeavour to get inside through the fine meshes; a shriek from a wood-mouse is followed by the guttural chuckles of a blood-thirsty owl; mosquitoes trill their shrill hymns of hate outside, and huge bat-like flying foxes fight and chatter amongst the ti-tree blossoms overhead. A rumbling noise comes from the bottom of the river, where a barramundi is hunting the smaller fishes and crabs amongst the loose cobble stones in the bed of the stream. Below my position on the high bank a rushing waterfall splashes, caused by dozens of pelicans fishing in a semi-circle in a shallow lagoon nearby.

Hunting Weapons.

Most of the hunters have a small ball of opossum fur tied in a band around their necks. This they place between their teeth when spear-throwing, to prevent the teeth from grinding together when making the vicious, energetic lunge. Various kinds of spear heads are carried wrapped up in paper bark, and these are quickly changed on to the wooden shaft, according to the

class of game wanted. Boomerangs are of three classes. A heavy, five-foot, slightly curved fighting weapon; a light "come-back" missile, used mostly for killing birds, and sometimes also in warfare, and an acute-angled, heavy boomerang which hurtles along the ground, turning somersaults in its rapidly revolving progress. This is used for kangaroos and other ground game, and also in tribal fights.

The spears are of two varieties, barbed and hooked points being used out on the open plains, and the sharp, plain-pointed spear amongst the tangled growth of forest country.

A nulla-nulla, or throwing stick is sometimes used. This is thrown so that it hurtles along sideways, and is used mostly to break the legs of the running quarry. Made in six-foot sizes of heavy wood, or cut from shale rock, it is used as a fighting weapon, the heavy weight being useful to break down the opponents guard. These natives are busily engaged looking for suitable material for the spears and boomerangs, so walking over to a fast-running clear stream I crawled out on to an overhanging pandanus palm with my rifle at the ready. Big, fat black-bream are lazily disporting themselves in the limpid depths, now and again coming up to the surface to grab some floating insects. Quickly I rub my hands on the palm trunk and light fluffy bark floats down to the water. Fish come up to investigate, and I discharge a high-power "30" amongst the shoal. Several drift down stream stunned. Seeing an extra large barramundi zig-zagging about and gasping, I dive head first in, grab the funny denizen in both arms, and hold him to my breast with one finger hooked into his gills. My yells for assistance bring up two of the niggers, who, grinning delightedly, help me out with my prize. Then I noticed that my arm was bleeding where the spiky fins had penetrated the flesh. Hastily running along the banks the natives deftly spear the rest of the floating fishes.

Stealing a Crocodile's Dinner.

It is now dinner time, at least for me. (The nigger takes his dinner at any and all times.) I cut slices from the big fish and grill them on hot embers. I find the flesh excellent. In the quietness of the mid-day hour, when we are all half asleep, I am brought to attention by a native

gently prodding my ribs with the butt end of a spear. Looking in the direction he indicates, I see a four-foot crocodile slowly crawling out on to an island sand-bank, and in his jaws a quivering barramundi. With a contented expression on his sardonic face, and his two forefeet planted firmly on the fish's ribs, he starts to chew the head. Slowly raising my rifle, I take aim and fire, but miss, and the crocodile back-pedals rapidly into his watery home, leaving the plump fish stranded on the island. The day is hot and I swim over and take my future meal in tow. Whilst finishing my nap this, too, is cooked in blackfellow's style.

On a little mud-bank, alongside of its slushy burrow, is camped an ogle-eyed walking fish, with big head and mouth, small body tapering to a point, and two seal-like flippers on each side. These provide means of progress in a series of six-inch bounds, and are also used when digging out holes in the mud. Into these burrows, when alarmed, the little creature dives head first, and then, inquisitively looks up from out of the murky waters.

The Nest of the Catfish.

In a clear little eddy pool a catfish is busy making its nest. Darting away in a lightning-like streak, it returns carrying a two-inch water-worn stone in its mouth. This is deposited amongst a circle of other stones which have already been placed there. The nest is about eighteen inches across. Circling around and around inside is another catfish, probably the female. Sleepily I read all these chapters of Nature's book. Over on the other side of the creek is a slime-covered log, splashed with white—a crocodiles' *siesta* camp. In the dark, gloomy background of ti-tree, pandanus, and other palm a white cockatoo gives warning squaks, and all the bush game become wary. Above the still surface of the water appears what look like two floating bubbles—they are crocodiles' eyes, peering above the stream. Presently they sink out of sight.

A Friendly Tribe.

The hoarse croak of crows and shrill screams of white cockatoos flying around in circles against the blue sky announce someone's approach. The blackfellows are alert immediately, and there is a crackling of dry boughs and waving of grasses, above which, bobbing up and down, are black

heads with white clay-covered headbands. Along our tracks they come, jaunty-looking bucks, spears in hand, heavily laden, meek and weary-looking gins with piccanninies on their shoulders, nondescript youths and maidens followed by a straggling pack of skinny, tick-bitten mongrels, which with exposed snarling teeth, and hair raised on backs, doubtfully greet the canine members of our tribe. "Wowser," a true "whiteman's dog," disdainfully ignores this low-down society. It is a friendly tribe from the southern tablelands, coming back from a visit to the northerly coast. The feminine section is loaded down with salt-pan salt. Mutual agreements allow of one tribe passing through another's country, especially when gathering salt. It is a point of honour not to interfere more than necessary with the local tribe's game preserves.

A 'Possum Hunt.

In reposeful attitudes the male members retail all the latest gossip. All the up-to-date local scandal is rudely and laughingly discussed. The ladies discreetly retire into the sombre recesses of the forest, from which presently smoke from a number of camp fires arises. Squatting on the ground with crossed legs, between which is a soft, dry, pulpy piece of wood, a hefty lad is busily engaged making a fire. On top of the wood a hard, pointed stick is twirled rapidly between the palms of his two hands. The resulting dust collected smoulders and then bursts into flame. On going into camp for the night, the food is scarce as usual, so they organise a 'possum hunt and march out in single file to the mangrove thickets. I see an eagle-hawk's nest, and climbing up find a young one. The natives taboo this in superstitious fear. Mosquitoes are now swarming all over my bare limbs, and the blacks do not escape their attention, so they hurriedly get a move on. An opossum sticks his head out of a hole, and up goes a nigger. He chops open the branch with an old blunt axe, grabs the hissing grey animal by the tail, smartly swings him around, and kills him with a sudden jerk. The rumpus disturbs some flying foxes, so we scout out looking for the main body. A call comes from down the creek, and all hands silently scamper to the spot. On the steamy atmosphere a dreadful smell arises, and a sound as of a thousand cat-fights comes from nearly overhead. Amidst

a dark mass of tropical scrubs, large, bat-like creatures over two feet across, are circling around in clumsy, hurtling flight. Tons of them are hanging upside down from the swaying, crackling branches, biting and clawing viciously at each other. Boomerangs are hurtling in and out of the swarm and spears are jabbing at the victims as they fall to the ground.

One nigger mongrel, yelping, blindly bolts out of the melee with a screeching, clawing vixen hanging over his face and savagely biting his ear. Dusk falls, back to

camp, and the blacks disappear in the darkness of the jungle scrubs. Fires burn up brightly. There is a hum of many voices. Meals are finished, and flaring bark fire torches show the natives to the creek where liquid refreshments are partaken of. The fire-stick also shows up any snakes and scares any "devil-devils" away. Out of the darkness baby wails arise, followed by soothing "songs." Outside my oblong camp mosquitoes sing shrilly. Lying in a bath of perspiration, malaria throbs in my aching limbs, and I dream the fervid, uneasy dreams of the Tropics.

HOW POWER IS CONDENSED



A remarkable photograph showing the enormous power of the modern aero engine. The locomotive weighing nearly 70 tons has the same horsepower (1,000) as the Napier "Lub" aero engine seen alongside. The "Lub" is the latest triumph in aero engine building, and is the highest powered aero engine in the world.

CONVICTS OF NEW CALEDONIA

By FRANK REID

IN olden times Botany Bay was considered to be about as distant a corner of the world as could well be found for the transportation of moral offenders, but France found a still more distant place to serve as a national dust-bin and a receptacle for the refuse of French society when she selected New Caledonia as a penal settlement. It was the official announcement made in 1895 by the French Government that they had determined to cease transporting criminals to New Caledonia that closed a period which to many interests of the South Seas was one of fear and friction. Negotiations towards some such result as that stated had been going on for many years, Australia more than once manifesting a desire to force the hand of British diplomacy, so real was the injury our colony sustained by the nearness of the penal settlement, and so great was the apprehension that that injury would grow in aggravating bitterness as the years went by. New Caledonia is seven hundred and thirty miles from the coast of Queensland, its capital, Noumea, being one thousand and fifty miles from Sydney; and venturesome spirits goaded by the system of control on the island, thought little of making a dash for freedom across these miles of sea. Many of these attempts were discovered before a start had been really made; and those who succeeded in getting out of French waters did not all live to see land again. A few, however, every year managed to reach the Australian coast, and they fondly imagined that their dangers were all over when they had once set foot upon this free land; but even then these hopes were, perhaps oftener than not, doomed to disappointment. As a rule the convicts landed on these shores penniless, half starved, and often unable to speak a word of English. Under such circumstances, it was almost impossible to pass themselves off as anything else than escaped convicts from New Caledonia; and as the Australian police kept a very vigilant look-out for such characters, there was little chance of ultimate freedom. The people of Australia generally professed considerable alarm lest the influx of these French criminals should pollute Australian

society. No doubt, a certain percentage of the few who reached our colonies remained here, and resorted to dishonest methods of living; but it was felt by many that our police exceeded their duty when they hunted up men whose original offences were trivial, and who showed a disposition to become honest citizens. When these men, just rejoicing in their new-found liberty, were arrested they were handed over to the tender mercies of French warders.

In 1893 seven New Caledonian escapees sighted the coast of North Queensland after a perilous trip of eighteen days in an open boat. They had stolen the boat from a publican on the island, stored it with eighty pounds of rice, sixty cocoanuts, and a small bag of biscuits, and committed themselves to the waves. When they reached the Barrier Reef the boat was capsized and men and provisions were precipitated into the sea. The breakers which capsized the boat washed it over into smooth water, where the men secured and righted it and continued the voyage, but now without a mouthful of food in their possession. Five days later they arrived at Whitsunday Island in the sorriest of plights, and were befriended by aborigines, until the Queensland police discovered and arrested them as escaped convicts. Persons arrested on this charge were tried by a special court and, if found guilty, were handed over to the New Caledonian authorities to be redelivered at the settlement.

Escapes like that narrated above were numerous, but escapes such as described were seldom so prompt or sure. The writer, when pearling in Barrier Reef waters, knew convicts who struck the mainland unobserved, and made their way into the bush, where they became station hands, or fell into the ways of the nomadic swagmen, and no particular notice was taken of them. Sometimes, too, they discovered friends of their own nationality, and were helped to successfully disguise themselves and their objects, and if they were found settled down, they were not interfered with. But when they were unlucky enough to put into any large town they mostly went to

the bad, or were caught and sent back.

The ordinary convict who reached a large town was, however, either tamely caught, or he dropped in among the dregs of the population, and applied himself industriously to some form of midnight law-breaking. He mostly took up the line which originally caused his deportation from France, and often displayed skill and presence of mind in his operations. Coining, burglary, safe-robbing, and waylaying the tippy or belated, were favourite exploits with this class of criminal; and sometimes the work was done with such perfection of detail that detectives knew the nationality of the perpetrator before they laid hands on him. It may have been that these escapees were not at any time so numerous as the Australian public asserted, but seeing that they so often came to light when gangs of thieves were captured, or a course of systematic crime was suddenly stopped, the general impression as to their numbers may not have been far astray.

In 1890 an aged woman in France gathered money and strength and courage to journey to the other end of the world to carry out a scheme that she had devised for the escape of her son, who was a convict in New Caledonia. Inspired by a mother's love, she actually succeeded in reaching Noumea, where she lived for a time among the civilian population and managed to communicate with her son. By-and-by the screw steamer *Rockton* was about to start for Sydney, and this old woman was a passenger. Without exciting any suspicion whatever, she had succeeded in getting on board a large box very plainly marked "this side up." When the ship had actually cleared the wharf, a sailor, regardless of these instructions, turned the box upside down, and was at once attracted by some commotion inside. This was reported to an officer, who in turn called a policeman from the shore and had the steamer stopped. The box was of course examined, and it was found that the lid had hinges and a bolt inside, and the contents were an armful of straw, a bottle of water, several boiled eggs, and the convict son of the old woman. They had purchased a ticket to Sydney for him, and it was intended that he should emerge from his hiding place at night and take his place among the other passengers. Perhaps the ends of justice were met more

fully by the return of this man to his bondage, but who can fail to feel sorry for the poor old mother, who, after such patient efforts to rescue her son, and having so nearly brought her clever plan to a successful issue, had to retrace her weary steps back to France with the knowledge that her son's lot had only been made harder by her endeavour to bring him home again.

The news of the cessation of transportation was received by the business portion of the New Caledonian community with undisguised ill-favour. The mineral resources of the island are very great, and are as yet but partially tapped. Chrome, cobalt, and nickel abound. The soil is fruitful; cocoanuts, bananas, and bread-fruit growing wild. Sugar-cane, coffee-planting, and other industries of a tropical character, promise to be profitable pursuits. With quick returns from these sources in mind, employers of labour naturally desired cheap workmen, and the convict system which obtained lent itself admirably to their needs. In 1879 the Government entered into a compact with Mr. John Higginson, a naturalised Frenchman and old Noumean resident, whereby he was granted the services of three hundred convicts for twenty years, at a charge of one penny per day per man, the Government agreeing to feed and clothe them during that period. In 1894 when seventy Chinese convicts landed at Noumea they were immediately hired out to applicants for their services. The sentences on these convicts ran from five to fifteen years, and the applicants paid the hiring bureau a trifling sum per year of sentence, and guaranteed to pay the convicts afterwards at the rate of twelve shillings per month.

It is now several years since New Caledonia entered the list of free countries. Though the change was injurious to some businesses, the general business of the island was favourably affected, and social and political life was improved. New South Wales ceased to be a convict settlement in 1839, Van Dieman's Land in 1853, and Western Australia in 1868; and in each case a new spirit appeared to breathe through the country when the convict flag was lowered. Progress, political, social, and industrial, was the record for the following years, and these improving factors have long since been noticed in New Caledonia.

H.M.A.S. "ADELAIDE" AT SEA

H.M.A.S. *Adelaide*, the latest and most up-to-date addition to the Australian Fleet, commenced her first sea trials early in April, and after being subjected to a very severe test in speed, steering gear, fuel and other points on which a satisfactory record must be shown before the cruiser will be taken over by the Naval authorities and put in commission, she emerged therefrom with flying colours.

maximum speed attained was twenty-six knots. This was considered highly satisfactory, as it was one knot over contract speed, and there is little doubt that after a couple of months it will be possible to exceed it by one or two knots an hour. The propelling machinery consists of two giant turbines, each developing thirteen thousand five hundred horsepower, which turn two propellers. The engines are the

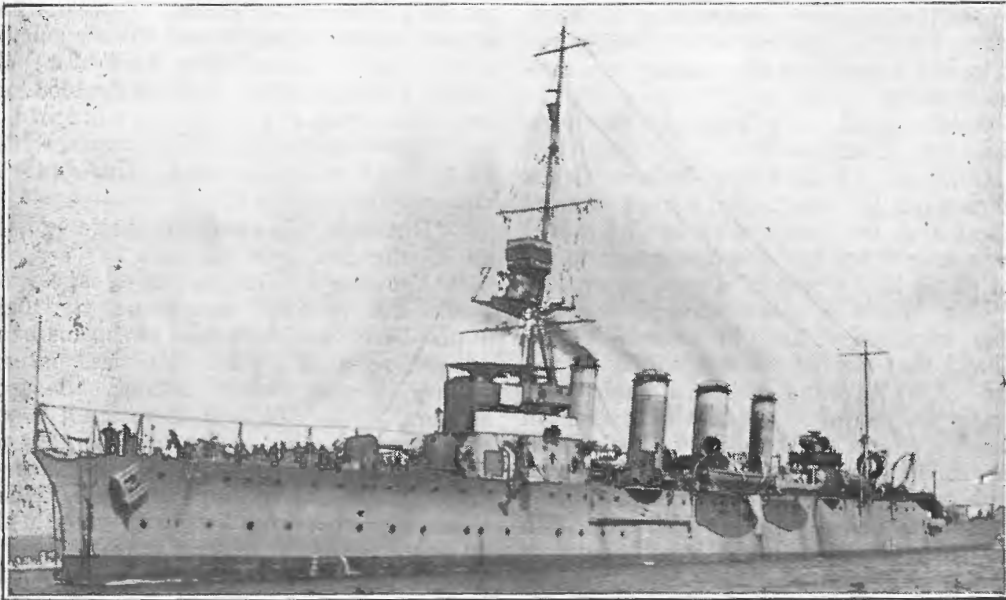

H.M.A.S. "Adelaide" ready for Sea.

The *Adelaide* was commanded by Captain Stephenson, with Engineer-Commander Starr representing the Naval Board, and Messrs. J. Payne (manager Cockatoo Island), T. Mundle (electrical installation manager), and J. Blundell (engineer manager) representing the builders. The cruiser possesses many new and wonderful inventions, the installation of which has made her practically the last word in Naval architecture.

Beyond a slight fault which developed in one of the turbines on the second day out the *Adelaide's* trials can be written down as highly satisfactory.

The speed test was held the first day, and under a combined coal and oil fuel the

largest turbines ever constructed in Australia, and expert engineers regard them as the finest machinery in the Commonwealth.

One of the most interesting installations on the *Adelaide* is the gunfire director. This is an electrical system which enables the control of the whole of the main armaments to be vested in one officer. In brief, it enables an officer to direct the fire, range, sight adjustment and gun-laying by means of a mechanical contrivance. A dial is moved to hit the target as desired, the movement being automatically transmitted to whatever gun or guns it is desired to fire. All the gunner has to do then is adjust his elevation, arrange his sights, and fire.

A MAN WHO SOUGHT EXPERIENCE

A STORY OF HOW HE GOT IT AND WHAT USE HE MADE OF IT

By PAUL J. HAAREN

In "Sunset Magazine"

GIBBS told us this. A few of us were sitting in the club gazing at the hurrying crowd below, and talking. The topic was experience; war, business, love, all kinds of experience. Gibbs squirmed in the leather chair beside me and gave all the signs of wanting to launch into a story.

"Speaking of experience, I ran into Kehoe this afternoon."

"Oh, yes?" I said this because Gibbs had seemed to direct the remark toward me. I did not know who in the world Kehoe might be, but was not going to let that stand in the way of a good story.

"Yes. He's a good example of the value experience has to some. 'Crazy Kehoe,' that's what he was called at college. Always doing what he ought not; always in trouble. Oddest character in college. Most of the fellows looked on him in dismay; didn't know whether to laugh or frown. Sort of shunned him.

"He was not unpopular exactly. With very little effort he could have been very popular. Played football—'varsity three years—in every 'Mask and Wig' show; had done quite enough to make himself eligible for 'Sphinx' or 'Friars.' But he never made 'em. The honour men were afraid to offer him a bid; he might turn them down.

"For some strange reason he took a fancy to me. Inflicted me with his presence, I called it then. Would drop into my room at the most unholy hours and, perched at the foot of my bed, hurl his wild ideas at my half-asleep head. He wanted to be a writer. Dreamed about it. Everlastingly talked about it. But never would write a word.

"At other times, when I could not escape, he would waylay me, dragging me off to his den. What an eerie cave of a place it was! Like stepping into a lunatic's idea of how one lived in Bagdad. Full of crazy trappings, hanging lamps, spears,

knives, guns, all sorts of queer things; proper trimmings for an imagination like his. From somewhere, the 'Med' school, I suppose, he had filched a complete skeleton and numbers of skulls. These he had strewn round the place, the skeleton rigged up so the slightest current of air would set it jiggling. It was damned unholy, that room. I would have laughed if it were not so deadly. The proper atmosphere for a writer, he said. This annoyed me.

"'But man,' I asked, 'if you're so keen on it, why don't you write?'"

"'Too busy. Got to have experience first. Got to read; got to get the right atmosphere'; and he would sweep his hand toward rows of books. Science, natural history, travel, some fiction; all good authors but on subjects as outlandish and exotic as his own mind. He'd tell me stories, true stories from the histories of India, Burma, the Malay peninsula. Knew them by heart and loved to mouth the queer names of the queerer places. Finally he got on my nerves so that I told him to keep away from me—I thought he was mad. He only laughed. Said he wished he were; that it would be a great experience.

"Out of college I soon lost sight of him. One day, at my office, in he walked and calmly announced he was broke; would I lend him a few hundred?"

"Where had he been? Oh, travelling round, out gaining experience—in fact had just returned from exploring the Amazon. He had gone down there with some sort of a scientific expedition and, on board the steamer coming home, had gambled away his two years' salary. I tried to persuade him to quit his damn foolishness. Offered to get him a job, but no, he had one, thanks. That's why he needed the money; passage money to Australia. He would write me from there and return my money first thing.

"He did send the money right enough. An express order, and with it one or two words to the effect that he was 'getting good experience herding sheep.' I laughed and forgot about him again.

"My thoughts were far removed from Kehoe when one day, quite a bit later, I had a telegram from San Francisco. He was in jail—needed two hundred to pay a fine. The least I could do was to help the beggar out, I thought, so I sent him the two hundred. I couldn't resist, however, inclosing a short lecture on the advisability of keeping out of jails. I made it stinging too, I can tell you.

"Two weeks afterwards the money came back. Not a word of thanks. Just a few bills in an envelope and a newspaper clipping describing a raid on a 'hop' joint in Chinatown. He was among those gathered in.

"That was too much for me. I am not my brother's keeper, but Kehoe had gotten on my nerves. I wrote him again. Gave him hell, to put it mildly. Among other things told him to get wise to himself and cut out the dope; he was no longer young, he must remember; youth could no longer be an excuse for his wildness. This brought an answer from him. He assured me he was not hitting the dope. Had been in the place merely to watch the others and observe the effects. Had simply been gathered in with them and being rather dilapidated in appearance, had been fined along with the rest. Good experience, however.

"That settled me. He could keep right on 'gaining experience' for all of me. I was through with him.

"But he was not through with me. A year later the 'phone rang and then informed me that a small loan of one hundred dollars would be appreciated. Kehoe was on the other end, of course.

"'Nothing doing,' I said.

"'You've got to,' he said, 'I'm going to be married this afternoon and it can't be done on a dollar fifteen.' I didn't believe him.

"'Prove it. Bring the girl up to my office and you'll get the hundred.'

"He did. Walked in with the sweetest little woman I ever saw. I gave him the hundred.

"'Kehoe,' I said, 'the girl has my sympathy.'

"'Why?'

"'You'll lead her a hell of a chase.'

"He smiled. 'Nope. I'm through. Going to settle down now and write.'

"And strange as it may seem, that is exactly what he did. Took a two-room flat in Brooklyn, on the Heights somewhere, and turned out good stuff that sold. I never saw him again, to congratulate him, until to-day. Lives out on Long Island somewhere now. Getting fat and has two kids."

Gibbs chuckled to himself as if there were something funny in what he had told. We waited for him to go on.

"Well?" said some one.

"Well, what?" said Gibbs.

"Where's the point?"

"Oh, don't you know Kehoe?"

I didn't know him. None of the others seemed to know him either.

"No, who in the world is Kehoe?"

"Why, Kehoe's the fellow who writes those homey little domestic stories for the magazines."

"Never read 'em. Don't recognise the name."

"Of course you've read 'em. Everybody does. His pen name is Betty Alden."

"Oh!" said I.

"Oh!" said the others.

What else could we say?

The time we spend in brooding over our misfortunes would better be invested in overcoming our difficulties.

* * *
If you are a victim of your moods, push right into the swim of things, and take an active part, with a real interest in what is going on around you. Associate with people. Be glad and happy, and interest yourself in others. Keep your mind off yourself. Get away from yourself by en-

tering with zest into the family plans, or the plans and pleasures of others about you.

* * *
There is no doubt that beauty was intended to play an infinitely greater part in civilised life than it has thus far. The trouble with us is that the tremendous material prizes in this land of opportunity are so tempting and alluring that we have lost sight of the higher things.

WHEN COURAGE COUNTS!

TRUE STORY OF A STEEPLEJACK'S TERRIBLE EXPERIENCE

STRIKING FEAT OF ENDURANCE

THE life of a steeplejack is not by any means devoid of incident. To the average person the task of scaling the immense heights to which these daring men go appears a hazardous one, but when in addition one is called upon to work for hours at a stretch at such lofty elevations where a slip means death, the risk and strain of the undertaking are magnified a hundredfold. And yet the steeplejack looks upon it as "all in the day's work," and men have been known to follow that occupation until sixty-five years of age—a time at which most workers are compelled by old age to retire from active participation in the game of life.

The world is frequently thrilled by exhibitions of bravery shown by men in critical situations, and at other times we are led to marvel at the coolness and resource of individuals when placed in circumstances where the flicker of an eyelid, so to speak, meant certain death.

One of the most striking instances of the latter occurred in America some time ago, where a steeplejack who had survived many hairbreadth escapes during his long career at the game, found himself, on his sixty-fifth birthday, in a position which tested his nerve and resource. And the irony of it all was that on the evening of the very day on which the old gentleman found himself marooned on a smoke stack one hundred and eighty-five feet in the air, he was to be tendered a birthday party by his friends.

It was a hot August morning when Steeplejack Elsbree proceeded to the base of the huge smokestack of the Pollak Steel Company at St. Bernard, near the city of Cincinnati. The tackle and rigging had been placed in position the previous day, and without loss of time Elsbree climbed into the swing seat and hoisted himself to the top of the stack.

All the morning he toiled in the blazing sun, and under his practised hand the work

proceeded rapidly. But steeplejacks, like all men, must eat, and to attempt to take a meal under such awkward circumstances and at such a giddy height was a habit seldom indulged in. So Elsbree prepared to descend, his first act being to adjust the ropes, which, however, had become hopelessly entangled by the high wind that was whistling around the stack. His first effort failed, but he tried again with, unfortunately, a like result. Then the horror of his position dawned upon him, but the courage and resource which had stood to him in so many tight positions never for a moment quailed. He realised that it was a case of self-help, and set to work to disentangle the lines. For hours he worked steadily, leaning dangerously far out of his precarious seat and throwing the ropes this way and that in a frantic endeavour to jerk them from the projection, just ten feet below him, about which they had become entangled. The sun was blazingly hot and the heat reflected from the steel stack was nearly unbearable. Finally he was forced to desist in his efforts to free the ropes, and merely hang on grimly, hoping against hope that he would not become prostrated by the heat and fall from his dizzy perch to the ground. The high wind that was the cause of all the difficulty now proved a friend, for it saved him from heat prostration.

It was useless for Elsbree to shout for help, because his voice would have been drowned in the din of the steel mill. An occasional observer from below could not tell that anything was wrong with the solitary figure high in the air, and at five in the evening, when the workmen left the mill, thousands passed beneath him, merely casting a casual glance skyward as they passed.

To the marooned man the sight of the workmen wending their way to the shelter of their homes where food and comfort awaited them was almost maddening. It

was useless expecting any help from them, for each time he had waved those tiny figures below had returned an answering signal, no doubt believing that the figure aloft was merely emphasising in playful mood the fact that from an earthly point of view he was so far above them. Soon darkness began to settle over the scene and still, despite his frantic efforts to free them, the ropes remained tangled. Hunger and thirst were by this time beginning to affect the unfortunate man, and his strength gradually ebbed away until further efforts became impossible, and all he could do was to clutch desperately at his seat and summon all his strength to fight off the stupor which threatened to overcome him.

Down below the non-descent of Elsbree passed unnoticed for some hours, but about 8 p.m. people began to suspect that something was wrong. An alarm was sent to the headquarters of the fire brigade, who came quickly to the spot only to realise their utter helplessness to render assistance owing to their ladders being too short to reach the marooned man. All they could do was to stand helplessly around and speculate as to what had happened to the unfortunate man above.

By and by the wind died down, and as the quietude of night spread over all it became possible to communicate with Elsbree by shouting. It was with difficulty that the steeplejack made himself heard, for he was weak and exhausted and a burning thirst made speech of any kind difficult. However, those below understood that he wanted food and water, and this was speedily procured and hoisted up on the one rope that remained free. The first few attempts failed, but about 11 p.m. a shout from the darkness above indicated that the half-famished man had succeeded in getting the food and water.

Then a happy idea struck one of the onlookers to make use of the powerful searchlight of the automobile fire engine to ascertain exactly how matters stood with the man above. With great difficulty the head of the engine was elevated sufficiently to allow the light to play on the top of the stack, and to the great relief of the watchers it was discovered that the food and drink had considerably revived Elsbree, so much so that he was able to reply to the shouted questions of the newspaper reporters who had by this time appeared on the scene.

His courage and resource were still undiminished, and a thrill went through the spectators when it was realised that he was about to take desperate measures to secure his release. Very slowly and very carefully he slid from his seat and with the searchlight to guide his movements lowered himself down the ropes. A momentary slip, and a thrill of horror went through the breathless watchers below, but instantly the old man recovered himself and reached the ledge, around which the rope was tangled, in safety. A brief pause, and then Elsbree, grasping the rope tightly with one hand and twisting it round his legs, began fumbling with the tangled lines. To the anxious watchers below it seemed an eternity of time before his efforts looked like being successful. Gradually, however, the ropes were freed one by one, and a cheer went up when it was seen that everything was again in working order. But could a man who had gone through the trying experience of being marooned for fourteen hours muster sufficient strength to lower the seat from the ledge above, take his place in it, and descend to earth.

An ordinary man might not have been able to do it, but Elsbree was not an ordinary man, and summoning all the skill and strength acquired during nearly fifty years at his hazardous occupation he accomplished the task. Once seated in the swing scores of willing hands steadied the lines while he made the descent, and once on solid earth again friendly helpers assisted him to the waiting ambulance, which bore him off to the hospital.

It was characteristic of the man that although the clock was striking midnight as the car moved off, signifying fifteen hours since he had made the ascent, he raised himself on one elbow and, speaking in a low voice to one of the reporters, said: "Put it in your paper to-morrow, that I'll be back here the following day to complete the job." And he was, for a day in hospital restored his strength sufficiently to enable him to complete the job without further mishap, and when his birthday party was held at a later date, his friends had one more instance of the courage and resource of their guest on which to compliment him.

WHAT DO YOU KNOW?

THE EDISON QUESTIONNAIRE: ITS AIM, RESULTS, AND COLLATERAL SIGNIFICANCE

AS TOLD BY MR. EDISON

PSYCHOLOGISTS to-day are vastly concerned with finding the right man for the job and the right job for the man. So far as they have to do with selecting men for mechanical work, their methods are well developed, definite, satisfactory in their results. But when it comes to picking brain workers the situation is different. It is not so easy to set a man's brain to work before your eyes and watch it function as it is to check up on his fingers. Procedure for the selection of executive workers is still chaotic, still leads to no definitely satisfactory or systematic results.

Yet it is here that the need is most keenly felt for testing a man's ability without actually putting him to work. If we select the wrong man to turn crankshafts, the loss is limited to the number of crankshafts he can spoil before we find him out. Such a loss may be heavy, but it is limited. The loss that may be caused by a weak executive is, on the other hand, quite without limit. Mr. Edison says that single mistakes of minor executives have cost him as much as five thousand dollars, and where it can be as bad as that he is lucky if it has not been worse. For let it be remembered, it is harder to locate a weakness in the executive force than one in the shop.

Mr. Edison has found out all this to his loss. "It costs too much," he says, "to learn whether a man is a good executive by trying him out on the job. So I made up my mind that we should have to have a formal test of some sort. This brought up the question of what we should look for; what is the most important qualification for an executive?"

"When I call upon one of my men for a decision, I want it right away. When his department calls upon him for a decision, it wants it right away. It's all very well to say that you have got to look up the data on which the decision will be based, that you know just where to look, that data and decision will be forthcoming tomorrow afternoon. But I want the decision now; the department wants it now. It isn't convenient for me to wait, and certainly it isn't convenient for a whole de-

When the newspapers first announced that Thomas A. Edison was trying out candidates for executive positions by setting before them a list of one hundred and fifty questions on all sorts of subjects, none of which had any direct connection with the work the men would be called upon to do if employed, there were many to scoff. The amount of information a man has in his head on general topics, the number of isolated facts which he can produce from the recesses of his memory in a given time, were stated to have no possible bearing upon his fitness for executive work. Mr. Edison, in the face of biting criticism as well as misdirected endorsement, went right on subjecting his applicants to his questionnaire, and putting to work the men who made the best showings. Enough time has elapsed for him to make now the unqualified statement that the results have justified this unusual mode of selection. Mr. Edison accordingly has been prevailed upon to tell, for the "Scientific American," just what his idea was in setting these questions and why it has worked out so well. The article on these pages is the result of three conversations with Mr. Edison, and contains the first authorized quotation in extenso of questions from his questionnaires.

partment to hang in the air for an indeterminate period waiting for an executive to find something out that he might have had right in his head. My business is just like any other; when a decision is called for it must be forthcoming. And the man who is to make it must have all the pertinent facts.

"On this ground it seemed to me that the very first thing an executive must have

is a fine memory. I asked myself if I had ever heard of a high-class executive who lacked this qualification. I hadn't; have you? Of course you haven't. So I determined that I should test all candidates for executive positions by learning what I could about their memories.

"Don't misunderstand me. Of course it does not follow that a man with a fine memory is necessarily a fine executive. He might have a wonderful memory and be an awful chump in the bargain. But if he has the memory he has the first qualification, and if he has not the memory he lacks the first qualification and nothing else matters. Even if after passing the memory test he turns out to be a failure and has to go, much motion and expense will have been saved by the immediate elimination of all candidates who lack this first requisite of memory.

"The questionnaire that has attracted so much attention and been the target of much criticism was got up on this basis. The only way I know to test a man's memory is to find out how much he has remembered and how much he has forgotten. Of course I don't care directly whether a man knows the capital of Nevada, or the source of mahogany, or the location of Timbuctoo. Of course I don't care whether he knows who Desmoulins and Pascal and Kit Carson were. But if he ever knew any of these things and doesn't know them now, I do very much care about that in connection with giving him a job. For the assumption is that if he has forgotten these things he will forget something else that has direct bearing on his job.

"This memory of ours works in two ways. The things that are always before you, that you are continually conscious of knowing, comprise an insignificant part of the contents of your mental warehouse. Every moment of your life from the time you were old enough to perceive things at all, facts and facts and more facts have been sifting into your mind through the things you see and the things you hear and above all through the things you read—through your every contact with the external world. Millions and millions of facts which have come into your mind in this way ought still to be there. They stay down under the surface until you call for them—then if you have a good memory you find them popping right out. A man

with a really fine memory of this type will often surprise himself by remembering a lot of things which he would not have supposed he had ever known, and which he can't for the life of him imagine how or when or where he learned.

"If I tell you something now, and you know that I am going to ask you about it to-morrow and that it is going to be important for you to know, you are a poor creature indeed if you can't make yourself remember it. If I tell you something that interests you exceedingly, it is mighty strange if that doesn't stick, too. But that is not the kind of memory that counts. Don't come here for a job and tell me that you can remember anything you want to, anything you consider worth remembering. Out of every thousand facts that present themselves to you, I should think that at least nine hundred and ninety come unobtrusively, without the slightest indication whether they are to be of any subsequent importance to you or not. If your memory is a success, it will reproduce—within the proper limits of human fallibility, of course—any one of these items, when and where you want it.

"Of course if I ask you one hundred and fifty questions at random, I am going to strike some low spots in your knowledge. I am going to ask you some things that you never have known at all. No two people have precisely the same background of facts. But I do not expect anybody to answer every one of my questions. They are selected with the thought that they shall deal with things taught in schools and colleges—things that we have all had opportunity to learn, facts to which we have all been exposed during the course of our education and by our ordinary reading. Their subject matter is of no importance—they must merely be things that my applicants may fairly be assumed to have been taught at some time. Everybody must necessarily have been exposed to a very large majority of them. But if any candidate should answer every question on his paper, I should want to know where he got his advance copy of the questions! I am not looking for one hundred per cent. grades; but I am looking for, and I think I am entitled to expect, ninety per cent. grades. A man who has not got ninety per cent. of these facts at his command is deficient either in memory, as discussed already, or in the power of acquiring facts,

as I shall presently make clear. And either deficiency is fatal for my purposes."

Mr. Edison's insistence upon memory as the object *par excellence* of his test surprised me, continues the writer in *Scientific American*. I had revolved the questionnaire in my own mind, and had succeeded in justifying it on a somewhat different basis. It had seemed to me that it was reasonable to insist that men going into the employ of the Edison industries, or of any industry of similar scope, be all-around men of parts; and that the questionnaire afforded a means of determining whether they were so, or whether their interests were so narrow that they had not taken the trouble to pick up the general knowledge of the world about them which they ought to have. But Mr. Edison made me see that this was not the point at all. Unquestionably, if he is sufficiently educated to hold down an Edison job, the man has been exposed to practically all of the facts called for by the questions. It is then not at all a matter of whether he has been sufficiently interested in them to retain them deliberately; it is merely a question of whether he possesses the automatic memory that retains them anyhow. If he has, as Mr. Edison says, he has satisfied the first requisite for an executive.

Mr. Edison has a little anecdote illustrating this point admirably. One of his foremen, passing through the shop under the eye of an inspector—a man who was hired on the basis of his A grade on the questionnaire—walked directly past two men who were sleeping at their benches. He apparently looked at them, but they made no impression on him—he didn't see them. He was manoeuvred about so as to pass them again; again his attention was not attracted by them. This is where, in Mr. Edison's estimation, the side of the picture opposed to mere memory comes in. You can't expect a man to retain what he has not taken in at all. And there was obviously an impediment between this man's organs of sight and his perceptions of things seen. He would be likely to fail in the questionnaire test through not having put his facts, in the first instance, in a secure enough place in the mental warehouse; through the same atrophy of the observational faculty he would be certain to fail repeatedly in the proper discharge of his executive functions.

"Somewhere between the ages of eleven and fifteen the average child begins to suffer from this atrophy, this paralysis of curiosity, this suspension of the power to observe. The trouble I should judge to lie with the schools, but its precise seat I would not venture to suggest. Perhaps it lies in a flagging interest, which leads quickly to the habit of listening without hearing, of looking without seeing—a habit which once fixed persists without regard of the existence or non-existence of interest. Whatever it is, it is clear to me that our schools and colleges are turning out men who not merely have failed to learn, but have been robbed of the capacity to learn."

Lest it appear that Mr. Edison exaggerates the conditions, I prevailed upon him to permit me to examine in detail a considerable number of the more unsatisfactory answer papers from a questionnaire that was set some months ago. I eliminated from consideration all men who were not indisputably college graduates. This left in my hands a considerable number of papers written by men who had gone clear through a university or college of rank, and had emerged with a degree. Practically all of them had, in addition, employment records justifying them in applying for a minor engineering job with prospects of promotion. I abstract some of the things these men knew that are not so.

Pittsburgh is seventy miles from New York; also one hundred and fifty and one hundred and sixty. The distance from St. Paul to Minneapolis is anything you please up to a maximum of two hundred and fifty miles; and those who know them for twin cities place them abreast one another, on opposite banks of the river.

Tierra del Fuego is in Mexico and it is in Spain. The Selkirk Mountains are in Sweden, Dakota, Tennessee, Scotland, Spain. The Wyoming Valley is placed by general consent in Wyoming. Kamchatka is a mountain in Japan. It is also "in the Adirondaeks." Albuquerque is in Louisiana, in Canada, and in French Africa. The capital of Maine is given as Portland and as Bangor, which might have been expected; and as Bengal! Two candidates have the rock of Gibraltar on their right as they enter the Mediterranean. Khartoum gravitates between China, India and Persia. Pamlico Sound is on Long Island, in Nova Scotia, and

in the place where we have always supposed Puget Sound to be. To make up for this we find Cape Race in Virginia, in North Carolina, and in "south-eastern South America." Montauk Point appears in Maine, in Connecticut, in Nova Scotia. The Gobi desert is in New Mexico and Arizona, but the earth's equilibrium is preserved by the presence of the Painted Desert in Asia and in Africa. The leading city of Newfoundland is Halifax (three votes), Vancouver, Sydney—and Nova Scotia again!

Camille Desmoulins is identified as painter and writer, as author and dramatist, as plain author, and as actor. Count Rumford "invented the baking powder that bears his name." One candidate took a chance on Machiavelli and described him as an artist; another man took a chance and reported him a painter and sculptor; a third conservative soul refused to take any chance at all and identified him as "an Italian." Plenty of men described James Watt as the inventor of the electrical unit that carries his name. Lord Kelvin was a distinguished economist and parliamentarian, and he invented the compass. Isabella's partner on the throne of Spain is given as Philip and as Alphonso (without any numeral). The wife of Napoleon III. is given as Marie Antoinette and as "Helen": Helen of Troy, no doubt. In reply to the specific question, "What king of Egypt built the great pyramid?" we are told Pharaoh and Pharoah and Pharaoh and Rameses and Ramasus, all of which I suppose might have been expected; then we are told Alexander, and we are told Archimedes! Genghis Khan appears to have had a checkered career as a Chinese Emperor, an "Indian character," a Turkish general, a philosopher of the same race, and the head of the Hungarian Soviet. The author of Robinson Crusoe was Robert Louis Stevenson, and Balzac was a Brazilian patriot.

Asbestos is a compound of magnesia and it is a product of blast furnace slag. The atmospheric pressure is usually given correctly, but it appears in one paper as seventy pounds and in another as seven hundred and seventy-six. Graphite is "the mineral base for making lead." Menhaden is a bay. The liquid used in fire extinguishers is carbon dioxide. Three candidates knew pepsin only as a flavouring, and one of them tells us it is got

"from the tree of the same name." Forty per cent. in favour of starboard as left seems pretty high. "606" is a war gas, and it is a washing powder. The geometric lathe is an instrument to measure the area of triangles.

Nothing could be easier than to name three leguminous plants: cabbage, lettuce and spinach. A second authority substitutes turnips for spinach, giving the same list otherwise. Conifers are described as trees that "bear fruit yearly"; as "broad-leaved trees"; as "trees like cypress and birch." If we had this chap up for oral examination we might learn why he groups these particular two instead of the crab-apple and the weeping willow. Asked to name eight fruit trees, several men stopped at six; one made the grade by including the grape, and another the blackberry.

Great diversity of opinion exists with regard to the prevalent beast of burden in the Andes. The mule has a plurality, hard pressed by the goat. The donkey receives honourable mention. There are two votes for the "lima" and one for the "alpecka."

The number of feet in a fathom varies from five through twenty-seven and thirty up to five thousand four hundred. Asked to guess the freight on a carload of oranges from southern California to Chicago, the candidates give figures running all the way from twenty dollars to two thousand dollars.

Where is metallic aluminium obtained? One man, determined not to go wrong, tells us "from aluminium ore." Asked to name ten different metals in commercial use, one man ran down at nine, one at seven, and one actually at five. Coal was included in one list, and one man named both steel and iron. Amber is described as a hard wood; and five men try to play safe by characterising it simply as "a substance."

The function of baking powder is given as the sweetening of the bread by preventing acidity and alkalinity, and (by two men) as the rendering of the bread more digestible. Another candidate reasoned that if the active principle of coffee is caffeine, that of tea ought to in all fairness be taffein. A very respectable majority of the candidates whose papers I saw replied to the good old chestnut "Why can't you boil eggs on the summit of Pike's Peak?" with the explanation that the low atmospheric pressure raises the boiling point of water to an unattainable height.

Another informs us it is because the proximity of the sun causes great heat.

Mr. Edison discussed the possible significance of all this at considerable length. On some phases of the matter he has very firm convictions; on others he is less decided or not at all. One angle on which we agreed thoroughly was that the low standards maintained in our schools and colleges have much to do with the phenomenon that has manifested itself in these questionnaires. Mr. Edison made a point here.

"If I had a man in my employ who was right only half the time, or a little more than half the time, he would last just about long enough for me to find him out—and that would not take very long. But our schools consistently and persistently give passing grades to students who are right a bare sixty per cent. of the time. I consider this a disgraceful procedure. If they can't teach the boys and girls to be right more consistently than that it is about time they admitted their failure and gave up the effort to teach them at all. In the good old days when a student had to be right practically all the time or take a caning and occupy a position of general disgrace, the school and the college produced far better results. I consider that a man who makes a grade of fifty on one of my tests has scored a total failure. Anybody who is not an imbecile ought to answer half my questions. It is after he has answered half and has started on the second half that the candidate should begin to find himself in some difficulty. Just looking at it in the superficial way, the way the schools look at it, the man who grades seventy is twenty points better than the man who grades fifty; the man who grades ninety is forty points better than the fifty man. But if we realise that fifty is the absolute minimum, and score on the basis of the candidate's performance with his second fifty, the man who makes a grade of seventy has really accomplished forty per cent. of what we have set before him, and the man who gets as high as ninety has answered eighty per cent. of the questions above the practical zero. There is a lot more difference between forty and eighty or between zero and forty than there is, respectively, between seventy and ninety, or between fifty and seventy. I have not the slightest use for a candidate who scales below seventy—

that is to say, who does less than forty per cent. of what I would hope that he might do. The seventy man I consider poor picking. It's the man who makes a grade of ninety, which is just twice as good as the weak brother's seventy, to whom I give serious attention.

"If our schools would stiffen their standards, and find a means of holding the intellectually lazy average student of the present day to these stiffened standards, we should find, I think, that the system of learning to-day and forgetting permanently to-morrow would go out of fashion. If the set, formal examination were given less prominence I should think that would help too. A student must be of low calibre indeed if, with printed text and written notes before him covering the entire work of the term, he cannot cram enough facts into his head and keep them there long enough to get past the examination. When he has done this, so far as his present state of mind is concerned, he seems to be through with those facts—finished; he is never going to want them again, or worry about them. The habit of forgetting, the habit of not even taking things into his consciousness except under certain extraordinary conditions, is a vicious and a subtle one which he is not able to shake off.

"I am not a schoolman; I do not propose to attempt a solution of the school problem. But the results of these questionnaires make it entirely clear that the problem exists, as I have stated it. Of the first seven hundred and eighteen men who attempted my questionnaire, only fifty-seven could be given the grade of seventy which, after being revised to a practical forty, means nothing but 'fair.' Only thirty-two attained a mark approaching ninety, enabling me to see where they had done four-fifths of what was set before them to do, and earning a grade of A."

No test, of course, is of value on its own grounds alone. The correlation must be shown to exist between the thing for which we are looking and the thing which we find. In plain ordinary language, the test must work. I interrogated Mr. Edison on this aspect of the case, and he was enthusiastic.

As fast as he finds them he takes his A men into his factory for training as executives. And they all turn out to be first-class executives. When he runs out

of A men he is sometimes tempted to step down, and try out some B men. And they turn out to make very poor executives. That ought to settle it.

Mr. Edison is not at all blind to the fact that his procedure has side-lights far removed from the main aim of testing memory. Some of these lend strength, some perhaps involve elements of weakness. One little item in which he is greatly interested is the ability of the candidates to read his questions accurately. One of his earlier questionnaires contained the question: "What was the name of the wife of Napoleon III.?" A disgracefully large proportion of the candidates stopped reading this question when they struck the familiar word "Napoleon," and answered "Josephine" or "Marie Louise." The inventor regards this as further demonstration of his belief that the sense which makes for assimilation of the things presented by the external world is atrophied. He also traces a connection between the careful reading of the question that leads to a correct reply, and the engineering instinct for identifying all the significant details of a problem and attaching to each its true weight.

That this failure to read understandingly is far from rare a few more quotations from answer papers may make clear. The mediocre man is utterly unable to establish the proper connections between his mind and the externals. When we ask him "What are the active principles of tea and of coffee?" he replies "They are mild stimulants," or "The soothing effect on the nerves," or "The extraction of the flavouring by means of dissolving in hot liquid." He includes a surety company and a national bank in the list of three prominent trust companies; to the question "How is sheet iron coated with tin?" he replies "To prevent corrosion."

One encouraging feature of this questionnaire business is to be noted. The college men, taken as a class, are bad enough. But they are so much better than the men who have not had any college that Mr. Edison has practically made the college

education a pre-requisite for positions of the sort to which these questionnaires lead. Mr. Edison can see where the colleges have failed measurably; but their failure shines like success in comparison with the failure of the schools beneath them. The colleges apparently teach their students, at least to some extent, how to read; for the questionnaires indicate rather clearly that the facts picked up by college men in the ordinary reading of book and newspaper stick fastest.

On the other hand, a new feature introduced into the questionnaires only a few days before I talked with Mr. Edison brings out an altogether discouraging result. To learn whether there are men who possess the mastery of process and the ability to reason while lacking the background of facts, Mr. Edison included in the current questionnaire five numerical problems that required merely the ability to reason and to handle elementary arithmetic. He had his examiners report on these five questions separately from the bulk of the paper. I cannot quote the questions because they are still "alive." But I can assure my readers that it would be a disgrace for any grammar school graduate to fail on three of them, for any high school man to miss the fourth, and for anybody in the world to fall down on the fifth.

Yet the results of these five questions were quite poor enough to justify any generalisations which Mr. Edison might make about the inability of the college man to use his brain. That they did not call for a specialised type of mind is indicated by the fact that the showings of the candidates on the five questions were strictly in proportion to their showings on the other one hundred and forty-five. Many of the answers were wrong in such a fashion that the slightest degree of thought would have made evident their absurdity and their inconsistency with the terms of the question. If an engineering graduate with engineering experience can't do simple arithmetic, Mr. Edison seems justified in demanding to be shown what earthly use there is for him.

Be assured that there is nothing which wounds a noble heart so deeply as when he perceives that his honour is doubted.

The boundary of man is moderation. When once we pass that pale, our guardian angel quits his charge of us.

NEW WIRELESS ERA IN AUSTRALIA

By F. M. CUTLACK

WIRELESS telegraphy is no longer confined to the fairyland of science.

It has been released into the working world, and the world henceforth will not be able to do without it. The first barrier was broken down when Marconi evolved the "tuned" wave, when the energy stored for transmission could be controlled for exact direction and regulation of its pulsation in the ether. There remained a second barrier before one side of the world could speak to the other by direct message: the electrical impulses at the receiving end must be magnified to permit of clear and easy reading. This has been achieved by the electronic valve, an invention which crowns Marconi's services in the higher civilisation of the world. Men know now what they can do with wireless, and look forward to a yet vaster range of activity; but they have perforce to speak of it in almost a new language, and for the most part they must convey their discoveries to the mind of the ordinary citizen in terms of symbol, or parallel in simple mechanical devices.

Between the world which makes daily use of the new wireless and the world which plods along with the more ancient electrical communications—the submarine cables and the land telegraphs—it is hardly too much to say that there lies a gulf as great as that between life in a highly civilised community and the rough pioneering of the Bush. The development in Europe and America, and even in the east of Asia, has been so remarkable as to constitute a challenge to Australia. The decision of the Commonwealth Government to enter this new world through the erection of a high-power wireless station has been made none too soon. Australia would not for much longer be able to carry on without such a station. She is far enough behind the outer civilised world in other respects. In Europe and America improved technical equipment has been demanded by the very circumstances of increasing populations and their multiplying business activities; here we have not yet even sufficient people to open up a

largely virgin country. Nevertheless we dare not delay by following the more roundabout path of development taken perforce by the older world. We must profit by experiment elsewhere, or fall early into decay. Every argument that introduced railways, motor transport, and the electric telegraph into undeveloped Australia revives now to press upon this Commonwealth the need for modern wireless stations.

The statement of the case from the defence point of view comes first by right of priority. When the Great War broke out all over the world in 1914, an immediate consideration of every Power was to disable or destroy its enemies' submarine cables, land telegraph lines, and accessible wireless stations. The Australian and New Zealand expeditions against German islands in the Pacific had primarily this objective—to seize or destroy German wireless plant. The *Emden* was caught and sunk during an attack on the British-Australian cable station at Cocos Islands, and a few months later the only cable across the Pacific from Australia was put out of action at Fanning Island by a German cruiser. The long dispute after Peace between the United States and Japan over mandated islands in the western Pacific centred about the control of Yap, whose only importance lay in the existence there of a cable station and a wireless station. The value and importance of submarine cables to a country at war is readily grasped. How much more valuable and important then are wireless stations? The war left no doubt about that. The hunters and the hunted in all the seas rely upon but one sense. They see and hear and know nothing save through the wireless aerial at their mastheads. Submarines track down their prey by the wireless compass, and by the same means merchant ships and military transports become alert to the danger of the invisible attack. For battle fleets at sea wireless is often the only possible link with the supreme command, whether that be afloat or ashore. A modern fleet action, even under independent com-

mand, cannot be controlled from the flagship without wireless. The importance of this same new power is doubly emphasised by the evolution of the new arm of air warfare. Airships and aeroplanes, without wireless, are hopelessly crippled in the performance of the duties required of them.

In considering the equipment of a country for modern war—that is to say, for the defence of itself or its cause—no government may henceforth omit the machinery for world-wide propaganda. War has become an affair not merely of enlisted armies and fleets, but of the whole people of nations engaged. A battle, or even a war, may not be lost, however severe a defeat in action, if the beaten side can manage to enlist the sympathy of the world's public opinion. Throughout the recent war, corollary to the armed conflict on the main fronts, there was carried on a constant struggle between the rival Powers for the allegiance of public sympathy in neutral nations. Despite Germany's morally bad cause, she contrived by the means of daily propaganda—distributed from her great wireless station at Nauen—to sway to a very important extent public opinion in neutral countries. Germany revealed during the war how completely she had made propaganda a fine art, and the Allies had to fight her in this field too, before they could seize victory within their grasp.

It does not require much imagination to picture a hostile attack upon Australia, either as a raid on our sea and cable communications, or in the stronger form of invasion. The effort would in each case be costly and require a mighty organisation, but the effect, in the event of the enemy's success, can be easily imagined. Our cables would be cut; even main overland telegraphs might suffer the same fate in more than one place. Our shipping would be driven into port. We should in the first act—situated as we are to-day—be cut off from communication with the outside world. We could not call for help or assist with information any naval expedition sent to relieve us. But a powerful wireless system would entirely alter the position. Until the enemy had landed a force sufficient to overcome local resistance and destroy the main wireless station in Australia, we should remain in touch with the outside world and with all parts of Australia, whatever happened to our submarine

cables or to the main land telegraphs which hug our coastline. We should, in fact, be still a useful force in action for co-operation with any relieving assistance, even though we had lost all control of our own seas and cable stations.

Our present wireless stations on the coast are feeble and obsolete, quite impracticable for the work, whether in peace or war, which Australia requires of wireless. The daily business life in Australian cities, and the work of development in the country, alike demand a wireless system of the utmost efficiency. Commercial and press communications with the outside world and within the Commonwealth have outgrown the present equipment. The cables to Europe and America are overloaded, and there is no need in this modern world for delays of even a few hours in transmission of messages. Apart from a high-power wireless system, the only remedy for the existing state of the cables is to lay down more of them, a remedy much the more expensive, for it would cost three times as much money to lay a new cable across the Pacific as to erect here a wireless station capable of speaking across the world. Cable stations, too, entail the repetition of messages *en route* between intermediate points; whereas, when the Australian main wireless station is erected and working, Australia will thereby be able to make speech with England—as England has already made it with Australia—in one fifteenth of a second.

The new wireless scheme will inevitably come to be used for communications in those sparsely settled parts of Australia which at present are without even the telegraph. It requires no effort of the imagination to foresee the spread of small private wireless installations into most big pastoral stations outback in order to catch a daily distribution of useful information and musical entertainment issued widely over the whole continent. Such a service is not possible with the present coastal chain of stations. Even at sea, on Australian ships within easy range of those existing stations, no arrangements exist at present for the supply of daily newspapers on board ship. To-day when a business man leaves (say) Sydney for Perth, he condemns himself to isolation from all news of the world's market movements or other events until he touches land again. The new arrangements for bring-



THE FEDERAL PARLIAMENTARY WIRELESS COMMITTEE, 1922.

Top Row: Mr. J. H. Catts, M.H.R., Mr. G. A. Maxwell, M.H.R., Mr. J. A. J. Hunter, M.H.R.

Middle Row: Mr. W. G. Gibson, M.H.R., Captain the Hon. S. M. Bruce, M.C., Federal Treasurer
(Chairman of the Committee), Mr. F. Brennan, M.H.R.

Bottom Row: Senator E. A. Drake-Brockman, C.B., C.M.G., D.S.O., Senator J. D. Millen,
Senator R. V. Wilson.

ing the coastal and ship wireless services under one commercial management will enable this deficiency to be overcome, and we may look forward to a business-like arrangement being established within the next twelve months.

More than one remote region of Australia is now being opened up by a civilian air service. The airmen anticipate an era when commercial and passenger aeroplanes will be covering a dozen important air routes into the interior, across the continent, or around parts of the coast where no railways run. In Western Australia and Queensland the value of such an air service has already been demonstrated, and at Broome people would regard the abandonment of the recently-started Perth air mail as a calamity. But for the fulfilment of these airmen's dreams of the future wireless is indispensable. Wireless connection is to the aeroplane on a busy route as vitally important as are signals to railway trains. The air-transport services must receive constant warnings of atmospheric conditions and storms; and each machine must carry with it the means, for emergency, of communicating instantly with any centre desired.

Whether we regard our nation as part of a great Empire which must organise itself for any eventuality, or as a member of a general brotherhood of nations working for the peaceful "federation of the world," we must recognise efficient wireless equipment as essential to our geographical situation. An international organisation is already working for the better local forecasting of weather conditions around the Pacific by means of interchange of observations between Australia, the western coast of America, the east of Asia, and northern Africa. Such a scheme can be possible only by means of big wireless stations at selected points—Lima, San Francisco, Shanghai, Sydney, Colombo, Cairo, Nairobi, for instance—which will permit of the issuing of a daily weather map of half the world just as we now prepare a daily weather map of Australia. The value of such a service to shipping throughout the Pacific cannot be exaggerated. But perhaps the highest utility of a big wireless station in Australia must be set down as its importance in our selected system of Empire government. The time is coming when perhaps the Empire would disintegrate without long-range wireless. The

mother country and the dominions have committed themselves to the recognition of each other as semi-independent nations, owning a common tie. Imperial federation in the sense of established control, even of foreign policy alone, from one centre, is impracticable. Attempt to carry out such central control would speedily snap any remaining bonds between the members of "the British Commonwealth of Nations." The Empire must go on in the path along which its peoples have, perhaps unconsciously, taken; its government must proceed by means of conference and interchange of views—conference not quadrennial, or even annual, but daily and through the readiest possible channel. Already the volume of daily cable messages between local dominion governments within the Empire is tremendous. From this consideration, above all, the traffic system must be revised, and wireless ultimately will enable the Prime Minister in Canberra to speak to the Prime Minister in London almost as promptly as though they occupied rooms within one and the same building.

At the present time Australia, it might almost be said, has no wireless stations. There are, it is true, about twenty establishments, dignified by the name of wireless stations, at points around the coast, but their range is insignificant, they perform little useful service, and they cost the Commonwealth a loss of £60,000 annually. Over any range greater than three hundred miles the majority of them cannot speak to ships on trade routes which connect Australia with the outside world, though they are able normally to receive messages from those ships from any distance up to about one thousand miles. They are monuments to the stagnating influence of government control upon an industry in which, under private enterprise elsewhere, there has been steady and pronounced progress in scientific development.

The first practical experiment with wireless in the Commonwealth occurred in 1905. In that year the Marconi Company of Great Britain, in order to demonstrate the possibilities of wireless, sent out Captain Walker and two mechanical experts—Mr. H. M. Dowsett and Mr. Densham—to erect wireless stations at Queenscliff, in Victoria, and Devonport, in Tasmania. These were one and a half kilowatt fixed-spark stations, fitted with magnetic detec-

ters for receiving. The demonstration was successful and communication was entirely satisfactory. But the time was not yet ripe in Australia for the further construction of such stations. Public enthusiasm lagged; nothing further was done for some years. The Federal Parliament went so far as to produce the first Wireless Telegraphy Act (in 1905) for the regulation and use of wireless stations and apparatus within the Commonwealth. Having acquitted itself of that, Parliament forgot all about wireless until Admiral Henderson made his report in 1911 on the measures to be taken for the naval defence of Australia.

Admiral Henderson saw the needs of Australia in the matter of wireless from a purely naval point of view and he dealt with it as a science which had reached its final stage of development. His recommendations obviously did not take into account either the fact that experiments were steadily perfecting long-distance communication, and that in such a field Government control would be hopelessly behind private enterprise; or that there were other uses for a national wireless system besides the admittedly important one of assisting a fleet at sea in times of war. Admiral Henderson's scheme was for the erection of two systems—one of "high-power and one of medium-power stations; but it should be noted that stations spoken of in terms of "high-power" ten years ago would be spoken of to-day as comparatively low-power stations. The former were required "primarily to transmit messages from the central authority to the fleets at sea when the fleets are within the effective range of these stations, and, secondarily, to inter-communicate between themselves as an alternative means to land-lines or cables." The medium-power stations were to be used for "the normal ship-to-shore communication purposes of the Fleet. Many of these stations will be able to do a large amount of ordinary commercial working and should be encouraged to do so." There should, proceeded the report, be three high-power stations—one near Sydney, one near Perth, and one at Port Darwin; and thirteen medium-power stations. The high-power stations were to be capable of sending a message at any hour of the day or night over a distance of one thousand two hundred and fifty sea miles; the others were to have an effective range of five

hundred miles on any selected wave-length between six hundred and one thousand two hundred and fifty metres.

The Federal Government lost no time in calling for tenders for the "high-power" stations—they seem absurdly short-ranged affairs to-day—and two tenders were received: one from the Marconi Company of Great Britain, and one from the Telefunken Company of Germany. The Germans seemed more anxious to erect Telefunken stations in Australia than to make profits, and they quoted a price so low that the British Company could not compete except at a loss. The contract was accordingly given to the German Company, and stations were erected at Pennant Hills, near Sydney, and at Applecross, near Fremantle. When, however, these were built the Government did not know what to do with them. Their power was too great for work with ordinary coastal shipping. Their range was too short for communication with lands beyond Australia. Pennant Hills station, for instance, was supposed to be able to speak to New Zealand; but could not carry out a service with that Dominion on anything like an adequate scale—that is to say, regularly during the busy hours of the day.

The next event in the history of wireless in Australia was the formation of a company in Australia and New Zealand to buy out the patent rights of the Telefunken Company. The new enterprise appeared as the Australasian Wireless Company. A few ships were fitted with wireless, but no land stations in Australia, for wireless development ashore was "a Government monopoly," as Admiral Henderson had suggested that it should be.

Early in the year 1911, Mr. E. T. Fisk arrived in Australia. He was sent here by the Marconi Company in London to establish branches of the British Company to conduct business in Australia, New Zealand and the Pacific Islands. Mr. Fisk had joined the English Marconi Company in 1905, and had gained wide experience in all branches of wireless work, technical, commercial and operating in England, Canada and the United States. In 1909 he had been on a special mission in the Arctic icefields and had there demonstrated the value of wireless to the Newfoundland sealing fleets. The period between 1911 and 1913 was one of great unrest in the wireless world of Australia. The Marconi

Company claimed that the Telefunken system infringed its patents, and the Commonwealth Government, through its monopoly, became a third party in the dispute.

In order to proceed with its scheme for a coastal chain of medium-power stations, the Commonwealth Government had in 1911 engaged in London the services of Mr. Balsillie as "wireless expert." That coastal chain was to be only part of a system which has never been completed. Within it was designed a second circuit in the interior of land stations. Judging by the loss of public funds resulting from the erection and working of the coastal chain of stations, the Australian people may well be grateful that the interior circuit was never erected. The "wireless expert" engaged by the Government in London was brought to Australia to supervise the construction of the coastal chain of medium-power stations and to act as advisor to the Government in the legal contention arising over patent rights as between the two big wireless companies. Instead of solving the Government's problems this only increased them, because the expert, Mr. Balsillie, erected stations of his own design, which immediately caused further complications.

Acting under instructions from the Marconi Company, Mr. Fisk initiated legal action against the Commonwealth for the infringement of Marconi patents in the Balsillie stations. After some three years of desultory litigation the dispute was settled in June, 1914, by the Government agreeing to pay for the right to use the patents, and the agreement covered the use only in those particular stations which had been erected.

During these years there was so little scope for wireless development in Australia, owing to the Government monopoly on the one hand and the costly litigation on the other, that all parties were losing money. This state of affairs resulted in the formation of a new Australian Company to purchase the patent rights of both important systems, and the business of the Australasian Marconi branch and the Australasian Wireless Company. This new Company was financed in equal shares by British and Australian capital, and was entitled Amalgamated Wireless (Australasia) Limited. At the present day 66 per cent. of the shares are held in Australia, 6 per cent. in New Zealand, and 28 per cent. in Great Britain.

From this point, the years 1913 and 1914; the narrative, to be followed clearly, must be allowed to proceed by division into four sections—the development in the science of wireless communication through experiments conducted both in Australia and by the four great wireless corporations in Europe and America; the growth of a home industry along with the enterprise of a local company in Australia; the efforts which have led up to a practicable scheme of direct wireless communication between



Mr. E. T. Fisk, Member Inst. R. E.,
Managing Director,
Amalgamated Wireless (Australasia), Limited.

Australia and Great Britain, and the debates concerning an Empire-wide wireless connection from which has emerged the present contract between the Federal Government and the Amalgamated Wireless Company. These sections of the story may be followed in the order thus set down.

It will not be necessary to labour the explanation of the fundamental factors in the transmission of wireless. They are the

production of electrical energy and the imparting of it to the ether in the form of impulses which can be caught at a receiving station—or rather a succession of impulses in the dot-and-dash signals of the Morse code. Marconi succeeded in signalling by wireless over a very limited range in 1896, but the problem which immediately arose was: How to speak to one receiving station without speaking to all others within range? How to confine the message solely and simply to one direction and one station in that direction? For in the first successful trials of the new invention it was found that the operation of one station disturbed the operation of every other within its range.

An illustration of the problem recently given in order to present it to the mind of the ordinary man and woman is this: Imagine a large hall containing a piano. Imagine a pistol shot fired inside that hall. The violent commotion set up in the ether by the crack of the pistol shot will set jangling every wire in the piano. Each wire will vibrate energetically, and each will give off the energy received in the form of the note to which that wire is tuned. Marconi's first wireless message was like that pistol shot. Every wireless aerial within range received it. It was irradiation of energy into the surrounding ether as general as the formation of waves when a stone is flung into a pond. The piano analogy will point the direction of experiment to which scientists devoted their study. If the energy represented in, and expended in, one burst by that pistol shot could be controlled and transmitted in one particular note, that is one selected wave-length, it would be found that only one wire of the piano in the hall would "sing" in response to it. The others would remain entirely unaffected. The concentration of wireless experimenters was, therefore, towards a means of "tuning" wireless waves. The demand on the transmitting aerial must, it was recognised, be a double demand; it must at once be a good radiator (that is, it must give off energy quickly and vigorously), and a good vibrator or oscillator (that is, it must be able to keep most of its energy and give off only a little at each impulse). But these two functions require of an electrical circuit exactly opposite properties. Marconi in 1900 solved the problem by producing two elec-

trical circuits—one designed to store quantities of oscillating energy, and the other a good radiating circuit. By magnetic coupling of these circuits he enabled the radiating circuit to draw upon the oscillating circuit. Further, he adjusted, or harmonised, the rate of vibration in these circuits so that they worked together. He "tuned" his former pistol shot to a certain note or wave-length. With two similarly harmonised circuits at the receiving station, tuned to the same frequency as the pair of circuits at the sending station, the analogy of the solitary responding wire of the piano board was achieved. Regulation of impulse and confined (*i.e.*, selected) wave-length opened up a vast new field in wireless. The first result of Marconi's discovery was to increase the range of wireless communication from a few miles to about three thousand miles.

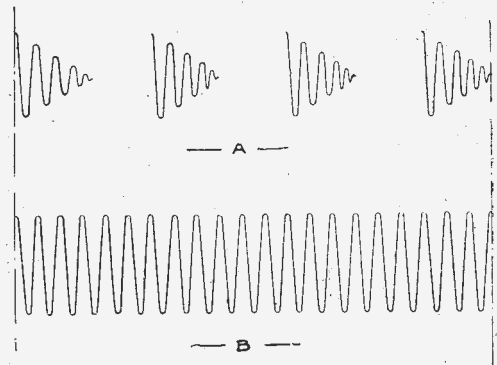

"A" damped waves; "B" undamped, or continuous wave.

The wireless "waves" so produced—the basis upon which the world worked for some years—were what are termed "damped waves," that is, decaying waves. The direction of research was next towards the production of "continuous waves," waves in which the oscillation imparted at the transmitting aerial would not decline. This is illustrated by diagram above. It was recognised that the improvement of really long-distance wireless communication depended largely upon the finding of a means of ensuring maintained energy of the oscillating impulses discharged into the ether. By dint of ceaseless experiment three methods were eventually devised to produce the "continuous wave." They were (1) the arc, (2) the alternator, and (3) the valve.

(1) The arc is based on the principle of the electric lamp. The discovery of its value in the promotion of the continuous wave in wireless was made by Duddell. His arc had severe limitations, but these were overcome first by Dr. Poulsen, a Dane, and more recently still further improvements were evolved by Professor Pedersen, an associate of Poulsen. Poulsen's adaptation is, however, now fourteen years old. Arc stations still have a tendency towards interference with other stations, and the alternator and the valve systems have been rapidly replacing the arc. None of the modern trans-ocean stations being erected to-day are to be equipped with the arc. Within the British Empire the rights of the Poulsen-Pedersen Wireless System were owned by the British and Overseas Engineering Syndicate, which was recently merged into the Poulsen Wireless Company, of London.

(2) Of alternator designs the three best known are the Goldschmidt, the Alexanderson, and the Bethenod-Latour. The alternator does not suffer from the limitations of the arc, is highly serviceable, and is efficient in tuning. It does not interfere with other stations. Its chief drawbacks are that it requires very careful handling, constant attention, and in the event of a breakdown of the machine it is difficult to repair. It possesses elasticity in wave-length, but not so much as is desirable for long-distance wireless. With the alternator the wave-length can be varied, but not sufficiently for certain services. The earliest effective alternator was the Goldschmidt, which was installed by the Germans before the war at Eilvese, in Germany, and Tuckerton, in the United States. These stations, originally experimental and installed at great cost, still conduct a commercial wireless service across the Atlantic. The Telefunken Company in Germany also produced a high-power continuous-wave system with a combination of high-frequency alternators and frequency multipliers; the system was markedly successful and was used during the war at the celebrated Nauen station near Berlin, which distributed German war news daily to the world, and whose messages could be read easily and regularly in Australia. The French Wireless Company purchased the world rights of the Goldschmidt alternator just before the war, and has produced an alternator (the Bethenod-Latour) similar

in many respects to the Goldschmidt. This alternator has been successfully used at the French high-power stations at Bordeaux and Lyons. One of the most efficient alternators is the Alexanderson, now being installed in all the stations of the Radio Corporation of America.

(3) The most advanced, efficient, and elastic method of generating continuous waves is the thermionic or electronic valve. In the future the valve will probably be an essential element in every wireless system. In both sending and receiving it gives unequalled efficiency, and for long-distance transmission it has two great advantages: (1) Its elasticity in wave-length, and (2) it is not so liable to breakdown.



Dr. J. A. Fleming, M.A., D.Sc., original inventor of the electronic valve.

If anything should interrupt the working of one or two units at a station, the station can still continue to work with slightly reduced power.

The original inventor of the electronic valve was Dr. J. A. Fleming, a noted English scientist, and his discovery was developed in conjunction with Marconi and his experimental staff. The principle of the valve is simply that of the ordinary electric light bulb, and it was with such a model that Dr. Fleming first carried out

his experiments. The scientific basis of these experiments, which have led on to the present valve design, is the phenomenon discovered many years ago by Edison—that besides giving forth light, the incandescent filament of the electric bulb is constantly throwing out an invisible electric stream, consisting of particles of atoms known as electrons, and this stream bombards the interior of the glass bulb on all sides. The electrons are really very minute charges of negative electricity. In the magnifying valve used in wireless a wire mesh, or grid, introduced by Dr. L. De Forest, is placed within the bulb around the central filament, but without touching that filament. The grid, again, is surrounded by a metal plate. The stream of electrons now reaches this plate per medium of the grid and the space between. The properties of the electronic stream upon which the valve system depends are two—its easy path for a positive current, and its extreme sensitiveness to impulse. When the valve is connected with a battery—positive pole to plate and negative to filament—the required current is set up. The aerials of the wireless station, receiving faint impulses from across the world, are connected with the wire grid within the bulb. Faint though these impulses are, they affect at once the sensitive electron stream; the impulses alternate very rapidly from a positive to a negative direction; correspondingly the current in the battery attached to the valve is changed with the alternation of the electron stream, which is a section of its circuit; and thus the wireless impulses received from abroad are magnified at the receiving end sufficiently to be heard not only at the operator's ear-piece, but also by one standing many yards away from the instrument.

Such may stand as a brief explanation of the principle of the all-important valve invention. The English Marconi Company has constructed, and is operating, the only high-power valve stations working in the world to-day. One of its recent stations, though designed for a range of only three thousand miles, can send messages as far as Australia. Moreover the electronic valve offers the only practicable means of wireless telephonic communication, and all wireless telephone stations at present in existence use this method. Rights to the valve master-patents have been acquired by all the four leading wireless companies in the world. Those companies are: the Mar-

coni Wireless Telegraph Company, in the United Kingdom; the Compagnie Generale de Telegraphie Sans Fil, in France; the Radio Corporation, in the United States, and the Telefunken Company, of Germany. The exclusive Australian rights for all systems—arc, alternator, multiplier, and valve—are held by Amalgamated Wireless (Australasia) Limited.

Contemporaneously with this development in scientific apparatus and the growth of big controlling interests abroad, there have arisen in Australia, slowly but surely, important wireless business and business interests. In 1913, the year of the acquisition of Marconi and Telefunken rights in Australasia, Mr. E. T. Fisk became general manager of the reorganised Amalgamated Wireless, and began to build up the company on a comprehensive basis. Services were established in Australasian ships and a certain amount of contract work was done in New Zealand and the Pacific Islands. When the war broke out in 1914 the company placed the whole of its services, organisation, and equipment unreservedly at the disposal of the Federal Government, which practically took charge of the company's staff. The company supplied men and equipment for the expeditions to Rabaul and Samoa, and equipped and operated the military transports. A notable feat was the erection on Garden Island, Sydney, in three days, of a complete wireless station for the Navy's use. A sound and progressive manufacturing business has been built up, and the company's managers, technical assistants, superintendents, skilled employees, clerical staff, and labourers, are all procured and trained within Australia. In 1913 its employees totalled one hundred and one; to-day that number has risen to four hundred and twelve, and the progress has been specially marked since 1919. Australia, through this company, has access to all confidential information arising out of the research work of the principal wireless companies of the world. Australian-made apparatus is installed in over two hundred merchant ships trading to all parts of the world. During the war Amalgamated Wireless received a large order to manufacture in Australia the whole of the wireless equipments for merchant ships then being built for the British Ministry of Shipping in Japan and China. On one occasion during the war two operators and an installation

were sent hurriedly to Noumea in consequence of a breakdown in the Australian-Noumea cable. A wireless station was constructed in Noumea in the course of a few days, and this station subsequently dealt with all the New Caledonian cable traffic. The Australian works manufacture all locally-required electronic valves and other equipment, and the company has the right to send members of its staff to be trained at an important British works, where every type of valve is made. Its workshops produce a variety of high-grade electrical instruments, medical and X-ray apparatus, instrument-parts for totalisators, automatic telephone equipment, and the like. An important activity is the establishment in Sydney, Melbourne and New Zealand of training schools through which already six hundred pupils have been passed for various wireless services.

This growth on the business side is the background of some years of experiment carried out by Mr. Fisk personally—years of experiment which have been of the utmost importance to the national progress of Australia. Mr. Fisk has long possessed his own wireless receiving station at Wahroonga, N.S.W. While on a visit to England in 1916 he arranged with the Marconi Company for the conducting of regular daily experiments from Carnarvon station in co-operation with his Wahroonga station. His aim was not only to show that regular signals could be received from across the world, but also to demonstrate over a long period that waves from European stations reach Australia not as freaks, but constantly and regularly. He was bent upon developing an adequate receiver through the medium of the valve system. He wished to discover what wave-length served best over the twelve thousand miles of distance and how daily circumstances and the seasons of the year affected wave-length. These experiments entailed the development of apparatus at the Australian end and careful observation of natural conditions. By 1918 Mr. Fisk had evolved a receiver-combination which gave practically continuous results—a receiver which was adopted by his company as a standard instrument. With this apparatus in 1918 he received the first direct wireless message which passed between England and Australia. On September 22, 1918, the Prime Minister (Mr. Hughes), and the Minister for the Navy (Sir Joseph Cook), who were

then in London, sent to Mr. Fisk, at Wahroonga, for the Australian Press, two messages which drew definite public attention to the fact of direct wireless communication. The time occupied in the transmission of any one signal in these messages was about one fifteenth of a second. The secret of success was the magnifying valve, and with the same device was given a public demonstration in wireless telephony before the Royal Society of New South Wales.

The need for the installation of some Empire-wide system of wireless to serve the demands of government, defence, commercial, and press business, has for some time been recognised both in Britain and the oversea dominions. Late in 1920 and early 1921, subsequent to the demonstration of the possibility of communicating between Great Britain and Australia direct, a British wireless committee in London, presided over by Sir Henry Norman, drew up a scheme for an Imperial chain of wireless stations to the Far East and Australia. The stations were to be of limited range, since they were to operate by relay of messages, and the sites indicated were—Oxford, Cairo, Poona, Singapore, Hong Kong and Darwin. This proposed system was submitted to the Dominion Prime Ministers at the Imperial Conference in London last year, and it aroused opposition chiefly from Mr. Hughes, for Australia, who refused to countenance anything but a scheme for direct communication. The Conference resolved that "His Majesty's Government should take steps for the erection of the remaining stations (in the Norman wireless chain) for which they are responsible as soon as the stations are designed; that the Governments of Australia, the Union of South Africa, and India should take similar action as far as necessary, and that the Governments of Canada and New Zealand should also co-operate."

Mr. Hughes, in agreeing to this procedure, made clear the Australian attitude—which was noted in a second paragraph of the resolution—by stating that the Commonwealth would hold itself free to decide by what particular method Australia would co-operate in an Empire wireless scheme. This the Commonwealth Parliament has now done by approving the construction of a high-power station capable of speaking direct with Great Britain.

Thus Australia has honoured her undertaking, while the other Dominions remain inactive. According to recent reports neither India or South Africa are satisfied with the relay scheme, both preferring direct communication and commercial management, and since the British Post Office has failed to establish its Egyptian service it seems as if the Norman scheme will never be established.

In his opposition to the Norman relay scheme, Mr. Hughes had in mind the superior alternative of direct wireless communication with Great Britain which had been suggested to him before he left Australia. The arguments in favour of this alter-

delay. Thirdly, the construction of the station at Darwin would have vastly increased the cost of erection of the Australian terminal and of transmission of all oversea messages at the Australian end. The Australian main terminal, to secure the cheapest possible working, must be situated in the region of the greatest amount of traffic. To place it at Darwin would be to place it as far away as possible from business centres of the southeast, and to expose it conveniently to attack by any possible enemy. Even if Egypt and India, in their totally different circumstances and situation, were satisfied with the Norman chain scheme, doubt as to its service farther afield increases with the lengthening of the chain; Singapore, particularly from the Naval point of view, may yet raise its voice in opposition; for Australia the chain-system is quite out of the question.



The Right Hon. W. M. Hughes, P.C., K.C.,
Prime Minister of the Commonwealth of
Australia.

native were, and are, invincible. The chain of stations through Egypt and India to Port Darwin, as the main wireless connection between Australia and the centre of the Empire, entailed at least three distinct and decisive disadvantages. Firstly, invasion or internal insurrection in Egypt or India might easily cut a link in the chain. Secondly, messages from the Commonwealth would, even with assured security in transit, have to be repeated five times *en route* (including only one relay from, say, Sydney to the proposed Australian terminal station at Port Darwin), thus making for

The contract between the Federal Government and Amalgamated Wireless, Limited, under which Australia is to be equipped in two years' time with a main wireless station and a system of feeder stations in each State, will provide the Commonwealth with a thoroughly up-to-date direct wireless establishment. The main trunk station, to be erected probably near Sydney, will consist of a transmitting station and a receiving station situated about thirty miles apart. So efficient is the modern control of wireless that it will be possible to send from the one and receive at the other messages passing simultaneously across the world without any interference between them. The transmitting station will present an imposing spread of aerials upon towers eight hundred feet high. The receiving station, by contrast, will consist of simply two aerials about one hundred feet high. Underground cables will connect each of these stations with a central office in the city, from which the traffic will be controlled. The main station will ensure direct communication with Great Britain at high speed; and, as services may be arranged, Canada, the United States, South America, South Africa, and eastern Asia will all be within easy reach of its signals. In each of the two busiest States, New South Wales and Victoria, there will be established a feeder transmitting station and a similar auxiliary receiving area, to supply the main trunk system with, and distribute from it,

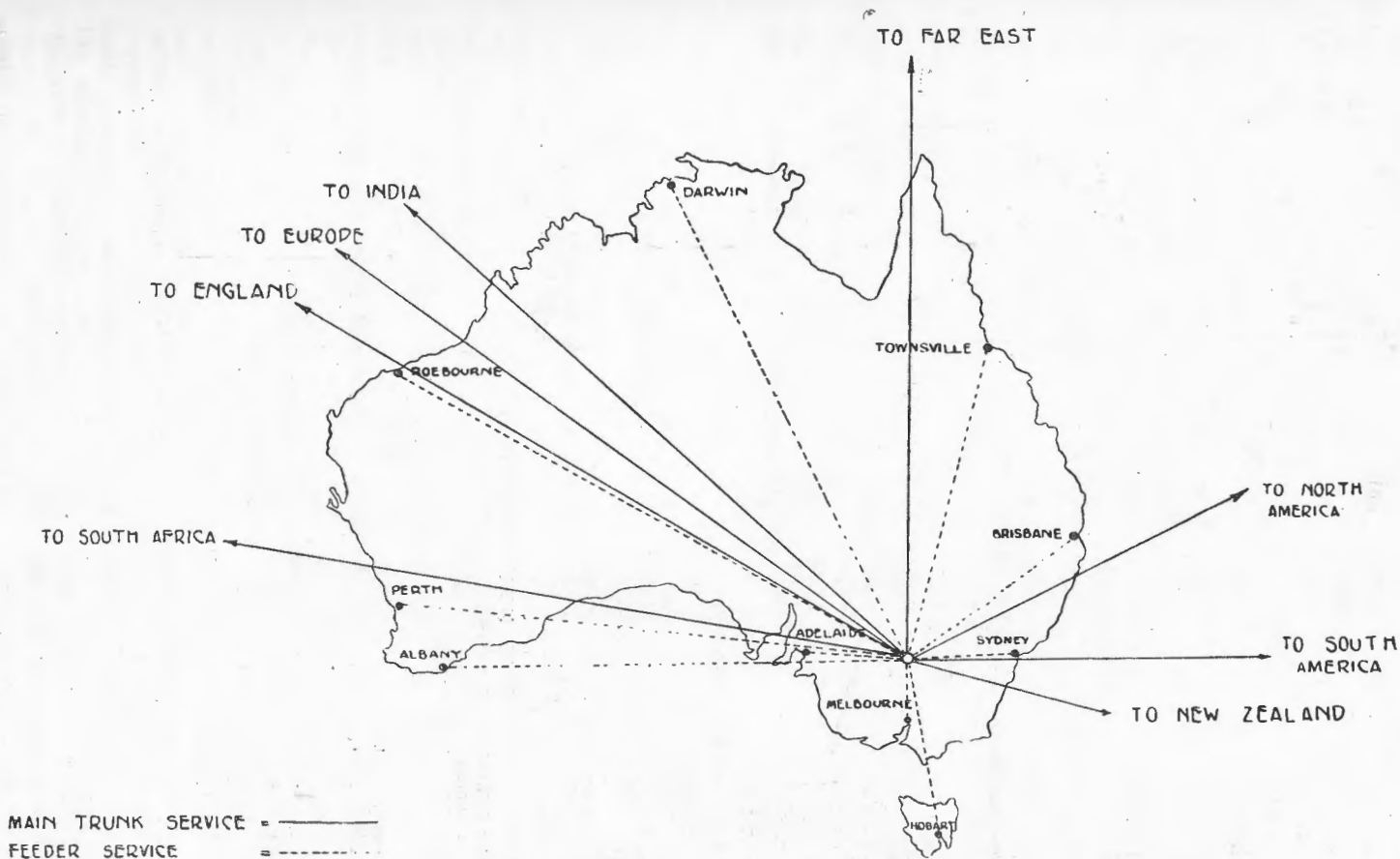

This Map illustrates the general arrangement of a complete Wireless Service for Australia.

Direct communication with United Kingdom.

Direct communication with North America and with all other countries establishing corresponding services.

Expansion of an existing successful manufacturing organisation.

Government saves £60,000 per annum, plus dividends.

Government control.

Commercial management.

All patent rights, present and future, of world's leading systems.

33½ per cent. reduction on Government and on all classes of commercial, social and press messages.

Complete wireless service, main trunk station adjacent to centres of commerce and defence.

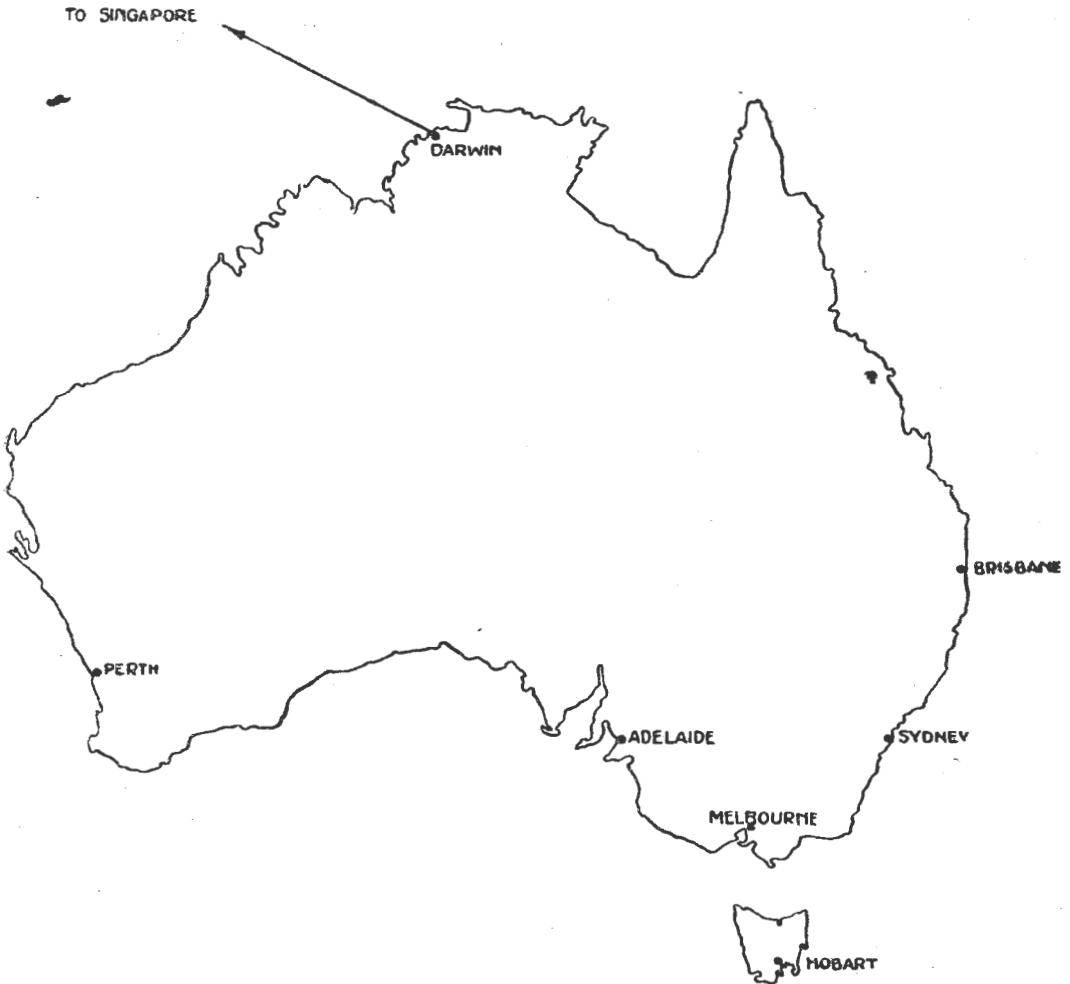

THE NORMAN SCHEME.

One Short range station.

Indirect communication.

Communication with Singapore only.

No provision for manufacturing in the Commonwealth.

Annual loss: £35,000.

Plus existing loss: £60,000.

Total loss £95,000, plus expenses for administration, legal and patent expenses, royalties and indemnities.

No reduction on Government messages.

Only 25 per cent. reduction on commercial and private messages.

No reference to press services.

No undertaking to erect stations or carry on services.

All risks taken by the Commonwealth.

One isolated station inaccessible and indefensible.

local wireless traffic. These feeder stations will be capable of communication with New Zealand and with the Pacific Islands. There will be also a special ship transmitting station for sea traffic. In the other four less busy States the arrangement for the present embraces in each, one composite feeder station for both local land work and shipping. In order to complete the coastal chain for ship communication small

coastal stations will be operated at Townsville, Darwin, and Roebourne. In Queensland, South Australia, Tasmania and Western Australia the feeder stations will be connected with a central city depot by direct telegraph lines.

At present the Commonwealth's chain of coastal stations involves the Federal Treasury in a loss of about £60,000 annually. This loss cannot well be avoided

under the present system, but with improved instruments and better commercial organisation, and combining the present limited service with the larger oversea services, Amalgamated Wireless (which under the contract will take over these stations forthwith) estimates that the loss can be eliminated in two or three years. The total capital required to absorb the existing services of the Commonwealth and the Company to establish the new system of main trunk station and feeder stations, and to carry on the complete organisation, is calculated at £1,000,000, which is a sum representing not more than the present yearly loss of £60,000 capitalised at 6 per cent. Of the 1,000,000 £1 shares, the Commonwealth Government will take up 500,001, and the remainder will be subscribed by the company and by the public. There will be seven directors on the board of the new enterprise, three appointed by the Federal Government and three by the other shareholders, with a seventh selected by those six.

The wireless company will derive its revenue from several sources, the principal ones of which will be:

- (a) Commercial trans-ocean service.
- (b) Coastal service.
- (c) Merchant marine service.
- (d) Inter-island and other auxiliaries.
- (e) Manufacture and sale of apparatus.

What Other Countries are Doing.

The coming Australian high-power wireless station will be one of the most powerful in the world. It is interesting, by way of comparison with the Australian scheme, to review shortly, the existing establishment of long-range wireless stations in other countries.

In Great Britain the Marconi Company has two long-range establishments at Carnarvon and Clifden conducting commercial trans-Atlantic services, one with Canada, and the other with the United States.

Canada has one Marconi station for commercial working with the United Kingdom, and a chain of very short-range stations along the river and Gulf of St. Lawrence.

In France there are two big plants capable of communicating with all parts of the world—at Bordeaux and Lyons. The French Government has made arrangements for construction of a world-wide system of French-commercial stations; this system includes direct communication between France and China, Madagascar,

India, West and Central Africa, the West Indies, the United States, and Tahiti in the Pacific. The station in Indo-China is to be a collecting and distributing centre for wireless traffic between China, Japan, British India, the Philippines, and New Caledonia. Bordeaux is already in direct wireless touch with Shanghai.

The United States has developed long-distance and internal wireless communication to a pronounced degree. The Radio Corporation, with the support of the United States Government, is extending these services to all parts of the world. Since 1918 America has had at least one station operating with a range of ten thousand miles, and recently the Radio Corporation completed at New York the Radio Central Station, one of the largest in the world, capable of speaking simultaneously with six different countries. This station was opened in November, 1921, when President Harding sent from it a message to twenty-eight countries around the world.

Italy already possesses long-range plants able to speak to her colonies in Somaliland and Eritrea.

The Dutch are preparing a direct wireless service between Holland and Java.

In Russia it was recently announced that the Soviet Government was constructing at Moscow a station which is to have a world-wide range.

Germany had at the outbreak of war an extensive wireless system covering most distant regions of the world. German stations conducted direct wireless traffic by two routes, between Germany and the United States, and German enterprise had constructed high-power plants in their colonies in Africa, the Far East, and the Pacific. Soon after the beginning of the war the big station at Nauen was increased in power to world-wide range. To-day Germany has working a third plant for trans-Atlantic traffic and is carrying on commercial wireless services with several European countries.

It is clear from these developments in other continents that some such decision as that recently made in Australia was imperative from whatever standpoint regarded. Wars are not yet finished in the world, and the soothing name of this home ocean of ours will not of itself afford us a permanent reassurance of progress in undisturbed peace. An adequate wireless equipment is essential in all future measures for our national defence. It is essential no less for the maintenance of a

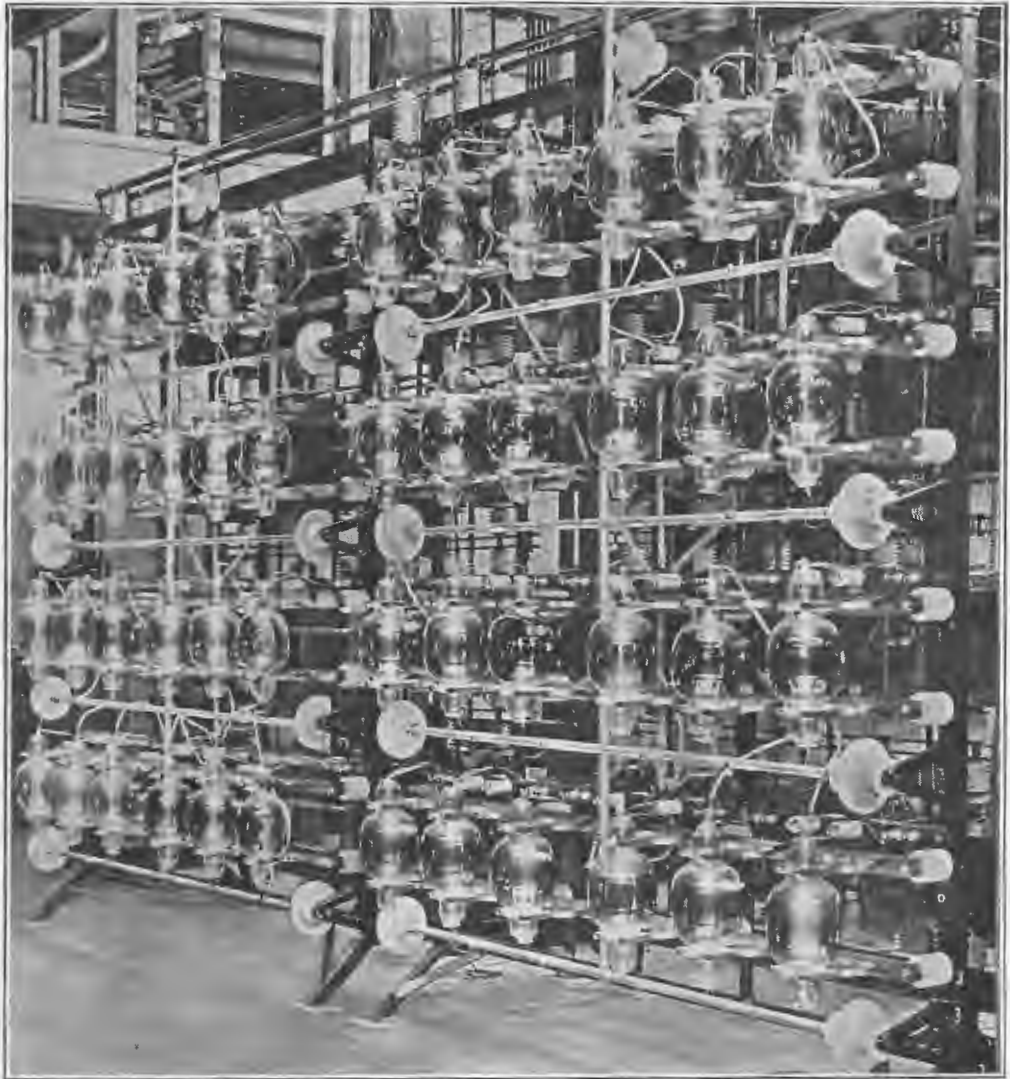

This illustration shows the Marconi Valve Transmitter employed in transmitting wireless test messages direct from Great Britain to Australia. This transmitter, the most powerful of its kind in the world, is composed of fifty-six valves.

harmonious policy of Empire government and administration; for the support of a common aim, and the rapid consultation thereby entailed, among all peoples of the British realm. Without it the idea of Britannic citizenship throughout widely-separated dominions must remain very much of a dream. The strongest ties weaken and decay through isolation of communities, and the separation and divergence of interests thus unchecked, if not actually encouraged. That the British peoples must stand together, or lose their present influence and prestige, is an accepted axiom; but they will not stand to-

gether, in sympathy, or policy, or daily working effort without ready, efficient, and cheap inter-communication.

Long-range wireless telegraphy and telephony provide the most efficient means to this end for the statesmen at the head of affairs, the public press, and the business interests in every British Dominion. The very seas between will no longer cut off travellers from constant touch with all parts of their own Empire and the rest of the world. Wireless is the supreme servant of Intelligence, and intelligence is the mainstay of civilisation, political education, nay, even survival of the race



FOR a small vessel like the Finnish ship *Slyfid* to successfully battle through no less than three severe hurricanes on her voyage to Australia, and sustain nothing more serious than the loss of a couple of sails and a yard, is an excellent performance and says much for her sea-going qualities, and the skill of her navigator and crew.

When two days out from Soderhamm a fierce south-east gale with high seas struck the vessel, and for five days while the hurricane raged her decks were flooded, and the lee rail was under water. The *Slyfid* was lying practically helpless when the storm abated and allowed a clear run to the North Sea.

More trouble awaited the *Slyfid* on entering Heligoland Bay. A fierce wind stirred up a dangerous sea, and so desperate did matters become that the vessel was hove to while the gale lasted. All the time she was in a serious position; the poop rail being practically under water and the cabins flooded.

Later in the voyage more hurricane squalls were experienced, during which several sails and one of the topgallant yards was blown away. Eventually Sydney was reached where the little vessel, bearing visible evidence of her severe buffeting, unloaded her cargo of timber.

"Orontes" Sold.

The well-known Orient liner *Orontes*, an old favourite in the Australian mail and passenger service recently changed ownership. According to English files a syndicate has purchased the *Orontes* for use as an exhibition ship. The steerage accommodation is to be dismantled and the

space used for display purposes. At the same time the *Orontes* is to be converted into an oil-burning vessel.

German Steamers.

Messrs. Gilchrist, Watt & Sanderson, Ltd., have been appointed the Australian agents for the German-Australian Line of steamers. The first steamer is expected to sail from Hamburg next month and should reach Australia early in August.

Large Boilers.

For the Commonwealth steamer *Euroa* recently launched at Williamstown, Victoria, Messrs. Thompson & Co., of Castlemaine, Victoria, have constructed three large boilers.

Each boiler is constructed of one and three-sixteenth inch mild steel plate; has a diameter of thirteen feet six inches, and is eleven feet six inches long. Without mountings each boiler weighs thirty tons.

Collision at Sea.

The Union S.S. Company's *Maori*, steaming at fifteen knots per hour, collided with the schooner *Zita* between Wellington and Lyttelton, New Zealand, recently.

The *Maori* carried away the *Zita's* bowsprit figurehead, part of the starboard bulwarks, night headlights on the portside, the port light, and also smashed seven stanchions.

At a Court of Inquiry subsequently held in Wellington it was found that neither captain was blameworthy and both were therefore exonerated.

"Cooma" Ashore Again.

The well-known inter-State passenger steamer *Cooma* again met trouble last month. The vessel left Brisbane with a large number of passengers for Sydney and Melbourne, and was proceeding down the Brisbane River, when rounding a bend in the river, seemed to lose steering way and ran aground, striking the Toombul Rocks.

The combined efforts of three tugs, assisted by the *Cooma's* own engines, failed to move the ship, which stuck there all the afternoon and evening. Eventually, between 11 p.m. and midnight, at full tide, the vessel was refloated and immediately continued her voyage.

mile-stone in the march of progress in the modern cargo steamer. The vessel, which is under the command of Captain Stirling, is a fine sample of modern shipbuilding and design. Captain Stirling, with thirty-eight years' service to his credit, is the commodore skipper of the Clan Line, and his previous visit to these shores was on the bridge of the *Clan McArthur*, now known as the *Berwickshire*. During the war Captain Stirling was for eighteen months engaged on the dangerous passage from Salonica to Egypt, and came through unscathed.

Launched some eighteen months ago from the Ayrshire Dockyard Company's slips, the *Clan Mactaggart* has since been

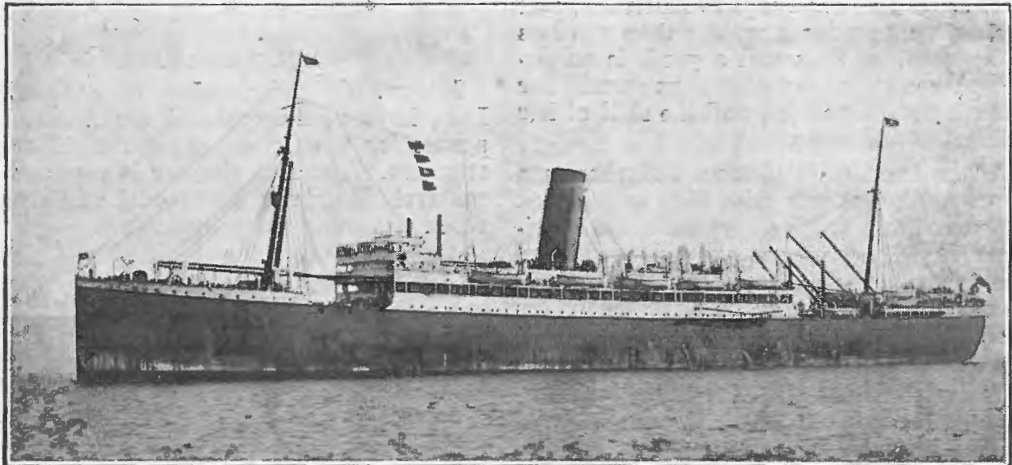

The New Aberdeen Liner "Sophocles, 12,300 tons.

"Sophocles" Arrives.

The first of the new Aberdeen liners, the *Sophocles* (12,300 tons), to reach Australia arrived last month, bringing a large number of new settlers from the Old Country. The voyage was satisfactory in every respect and a speed of thirteen and a half knots was maintained all the way from the Cape of Good Hope. It is expected that in the near future the Aberdeen Line will be running a regular monthly service of arrivals and departures at and from Australian ports.

* * *

New Clan Steamer.

The *Clan Mactaggart*, one of the latest additions to the Clan Line, marks another

engaged in the Indian trade, and is on her maiden voyage to Australia. Of a length of four hundred and fifty feet, beam fifty-seven feet nine inches, and depth thirty-seven feet six inches, the vessel has a gross tonnage of twelve thousand six hundred and five, accommodated in five large holds. She is fitted to burn either oil or coal, and from Sydney took sufficient coal to make Colombo, whence she will proceed to Calais, Dunkirk, and London by oil fuel. With coal beneath the boilers the ship develops an average speed of fourteen knots, which is excelled when oil fuel is brought into use. Propulsion is by a single screw turned by geared turbines.

Aviation Australia

Western Australian Aerial Service.

REGULAR weekly services are now being carried out by Western Australian Airways, Limited, between Perth and Port Hedland (one thousand and fifty miles) and mails are being delivered to towns *en route*.

In addition to the regular service between the towns indicated a considerable amount of useful work is being performed. We have read recently that the services of an eminent surgeon were urgently required at Carnarvon to perform an operation in the district, and that on account of the saving in time that was effected in his journey from Perth—about six hundred miles—the patient was soon out of danger.

A similar incident has been reported from Queensland. On March 2 a doctor was conveyed from Longreach to Barcardine in order to perform an urgent operation which was successfully carried out, after which the medical officer returned to Longreach in time for dinner.

Much work of this nature can be carried out in districts where existing means of communication are bad or non-existent, and the lot of the settlers outback can be brightened considerably, and the development of the huge areas, which are at present so sparsely settled, hastened in consequence.

A Help to Aviators.

It is expected that the new Federal Weather Bureau will be opened in Sydney within the next three months. Immediately this takes place publication will be made of a series of air observations for the information of aviators, particularly those engaged in conducting air mail services along recognised air routes. At each landing place for the receipt and delivery of mails a number of balloons filled with hydrogen will be flown at certain altitudes

for the purpose of ascertaining the peculiarity of the air currents and the velocity of the wind. The information thus obtained will be wired to the Bureau, where it will be classified by a special department, which will issue a daily air chart giving the air reading at different localities. The whole scheme will work in much the same way as the ordinary weather bureau service, and when in operation will unquestionably be of immense value to aviators.

A Speedy Flight.

Each week seems to bring forth fresh figures in the way of speedy flying, and the most singular feature about the whole thing is that in the cases mentioned no apparent attempt has been made to create new records.

The latest to perform an exceptionally fast flight is Pilot Jack Treacy, accompanied by Wing Examining Officer E. Fielding Jones. In an *Avro* plane they flew from Gilgandra to Sydney, approximately 440 miles by air in the smart time of 3 hours 20 minutes.

Imperial Air Service.

Recent advices received by the Prime Minister from the Australian High Commissioner in London contain particulars of the financial proposals in connection with the inauguration of an Imperial air service. A syndicate has agreed to take over airships, sheds, etc., build new ships and provide a weekly service to Australia at fares under present mail steamer rates. The capital of the syndicate will be £1,800,000 at 6 per cent, plus £2,200,000 $\frac{1}{2}$ per cent. debentures, both free from British taxation. It is proposed to issue £1,200,000 shares, plus all debentures, and the Governments of Great Britain, India and Australia will be requested to guarantee

interest on shares for ten years and on debentures until redeemed, both being a contingent liability only.

The Australian Government has not so far considered the matter, but when it does, if the scheme is approved of, it will submit the whole matter to Parliament for ratification.

* * *

ADELAIDE-BRISBANE MAIL SERVICE.

WELL-KNOWN AVIATORS ENGAGED.

THE organisation of the aerial service between Adelaide and Brisbane, *via* the Riverina and Sydney, is progressing rapidly.

The *personnel* (who will be supplied by the managing agents, Larkin Aircraft Supply Co., Ltd.) are all thoroughly efficient and experienced officers, who have been engaged in aviation and the preparation of an organisation capable of handling this mail contract for some considerable time.

Captain H. J. Larkin, D.F.C., Croix de Guerre, will be managing director. His aeronautical experience dates from April, 1916, when he transferred to the Royal Flying Corps from the A.I.F. At the end of the war he was one of the senior flight commanders in the Royal Air Force, and after the Armistice he was Acting Officer in Command of No. 87 Squadron, R.A.F. Major C. J. W. Darwin, R.A.F., reported on him as follows:

"He has held the appointment of Flight Commander for eighteen months. Besides being a gallant and skilful patrol leader, he is an excellent organiser, and always keeps his flight up to a high standard of efficiency. He is a sound judge of character, and as senior Flight Commander, has been a great assistance to me."

For over two years he has been managing director of the parent Company, which in the second year of its existence showed a profit of 14 per cent. on its paid-up capital. He has also been Honorary Secretary of the Society of Australian Aircraft Owners since its foundation in May, 1920. This Society has been almost solely responsible for the energetic propaganda work which has done so much to secure the recognition of the aircraft industry by the Government.

Captain Roy King, D.S.O., D.F.C., has been flying since 1916, when he joined the Australian Flying Corps as a pilot. His decorations make details of his war service

unnecessary. Since the war he has flown over forty-eight thousand miles and carried over two thousand passengers without accident. His flights include tours over the eastern States, and extend to Winton in Northern Queensland.

His careful flying has given him a very fine reputation, and his name is now a household word throughout the eastern States of Australia.

Captain G. C. Matthews, A.F.C., was the Wing Examining Officer of the Australian Flying Corps. The fact that the duties of this officer were to instruct instructors and pass out pupils after tuition, leaves no doubt as to his capabilities. He is the only pilot in Australia who holds an "Aerial Master Navigator's Certificate." In addition, he was passed "1A" at the Gosport School of Flying for Instructors. As a mercantile marine officer he holds an "Extra Master's Certificate," issued by the Board of Trade. The late Lieutenant-Colonel W. O. Watt wrote of him as follows:

"A very fine pilot and instructor. At Gosport in one of the earliest schools and Lieutenant-Colonel Smith-Barry (the Commanding Officer) tried to keep him. One of the finest pilots I know, and never 'flash'—a fine character and sound as a bell."

Lieutenant F. L. Roberts was an instructor in the Australian Flying Corps, and since the war has been actively engaged in commercial aviation. He was responsible for securing Government support for the maintenance of an air mail service between Sydney and Brisbane, and having flown over the route on numerous occasions since commencing flying in July, 1917, will be a very valuable pilot. Squadron Leader G. Williamson reported on him as follows:

"In addition to his ordinary flying work and the management of the Civil Aviation Branch, he carried out when necessary flights to Amsterdam on the occasion of the Aircraft Exhibition there. During the whole of my knowledge of Mr. Roberts as a pilot, he never broke a wire or made any landing or flight which was other than excellent."

Lieutenant F. S. Briggs, after the Armistice, was engaged on the London-Paris Air Service as a pilot for six months, during which time he is reported on by Lieutenant-Colonel W. H. Primrose, as follows:

"He is one of, if not, the best and keenest workers. He has safely carried many of the most important Cabinet Ministers in all classes of weather, and has never failed to get through."

He has flown eight hundred and five hours on thirty-two different types of aeroplanes. He is well-known in Australian aviation circles, and has established many records, including a flight from Brisbane to Melbourne in one day.

It would be difficult to find a more efficient band of aviators in Australia with the necessary qualifications for bringing an aerial service to a successful issue.

A number of flights have already been booked in advance, and it is possible that the whole of the accommodation for the first two months will be fully booked before the service opens.

The fares range from sixpence to one shilling per mile, according to distance travelled, and in every case it is cheaper to travel by air than by motor car, without taking into consideration the fact that the aeroplane is four to five times faster, and considerably more comfortable.

* * *

AERIAL DERBY.

Preparations are well in hand for the holding of the big Aerial Derby on Victoria Park Racecourse on Saturday, May 6.

An enthusiastic, hard-working committee is responsible for an excellent programme, and given favourable weather conditions there is little doubt that public interest in the carnival will manifest itself in a large attendance of people. The sight of an aeroplane winging its way through space never fails to attract attention, and it can be realised, therefore, what a thrilling spectacle will be provided when nearly a dozen 'planes shoot into space to engage in a speed contest over a circular course of fifty miles. This is but one of the events to be served up for the public, the complete programme being as follows:

(1) THE NEW SOUTH WALES AERIAL DERBY.—Course approximately fifty miles, in a close circle, to be fixed by the Committee. Entrance Fee, £3.

Prizes, Aerial Derby.—The entrant of aeroplanes which complete the course of approximately fifty miles in the fastest time will receive: (1) *Evening News' Cup*, to be held till the next annual contest; (2) a gold miniature of the *Evening News' Cup*, to be his absolute property, valued at £50; (3) cash prize of £20. Second Prize: Cash prize of £5 for the second fastest machine.

(2) AERIAL DERBY HANDICAP.—Due to the fact that the slower machines will have no opportunity of winning the Aerial Derby, the Committee has arranged to hold in conjunction with the actual Derby race, an Aerial Derby Handicap, and the prizes will be as follows: (1) Entrant of aeroplane winning the Handicap section will receive a gold miniature of the *Evening News' Cup*, valued at £50; (2) a cash prize of £20; (3) 75 per cent. of the total entrance fees obtained. Second Prize will receive: (1) Cash prize of £5; (2) 25 per cent. of the actual entrance fees obtained.

(3) EXHIBITION FLYING AND STUNTING COMPETITION.

(4) OSWALD WATT HANDICAP.—A Handicap race over a course of approximately thirty miles.

* * *

The Air Racing.

(With apologies to Mr. Kipling.)

When the last of the races is ended,
And the tanks are all emptied and dried;

When the cuts and the bruises have mended,

And the serious cases have died—

We shall rest, and faith, we shall need it—

Do nought for a month or two,

Till the people—seeking amusement—

Shall put us to race anew.

And the pilots that win shall be happy

For, passing the Judges' tent,

They shall spin and roll and side-slip,

And loop to their hearts' content;

They can do as they like for the moment;

They can glide or crash or fall;

Or can turn their noses upwards,

And never come down at all.

And most of the people will praise them,

Though some of the people will blame,

Saying they do it for money,

Saying they do it for fame.

Yet—each for the joy of the flying,

And each in his separate way,

Will put all his best in his racing

To make a success of the day.

—J.M.Q., in *The Aeroplane*

JUNIOR MECHANICS SECTION

In order to keep this section as bright and up-to-date as possible we seek the co-operation of our readers. By contributing simple constructional and experimental items—written in non-technical language that will occupy space varying from a small paragraph to a full page or more—accompanied by diagrams and illustrations, readers will materially assist. All contributions will receive our most careful consideration and, if accepted, will be paid for on publication.—Ed.

BUILDING A FOOT-POWER MACHINE FOR LIGHT WORK.

Old sewing-machines, which usually may be obtained at small cost from dealers, will make a useful small combination foot-power machine for the home workshop or for a repair-shop. At a cost of less than five dollars, the writer has just completed one that is a miniature machine-shop in itself—a hacksaw, jigsaw, emery-grinder, polishing-wheel, drill-chuck, and vise.

Obtain one sewing-machine frame with foot pedal and driving-wheel complete and three or more old machine heads. Mount

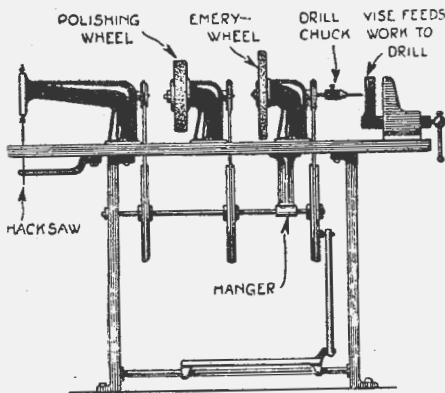

A machine-shop in miniature

a heavy plank top on the frame and fit up the machines as shown in the illustration.

The first will operate a hacksaw or fret-saw blade, clamped to the needle-shaft after the presser-foot has been removed. The blade passes through a slot in the table and is attached to a spring underneath.

The second head is sawn off near the pedestal, as shown, the shaft shortened and a bearing made of Babbitt-metal. The wheel is wood, covered with fine emery-cloth.

The third head is mounted in the same way and drives an emery-wheel. Into the other end of the spindle a drill-chuck is screwed. The work is held against the drill and fed to it by means of an ordinary bench vise. The end of the slide bar of the movable jaw will serve to press the work against the drill if the vise is mounted at the right height; and the vise itself will serve for light work, or even for heavy work, if substantial bench legs are placed beneath it.

In remodelling the frame shown, a hanger was provided for the long drive-shaft and the crank wheel turned around so that the driving crank is outside.

R. E. LEIBE, in *Popular Science*.

AN AMUSING MERCURY PUZZLE.

If a steady hand indicates steady nerves, this puzzle will afford an amusing test. The bottom of a shallow cigar-box is covered with a sheet of highly glazed cardboard. A small thimble (the smaller the better) is sunk in the wood so that its lower edge is flush with the floor of the box.

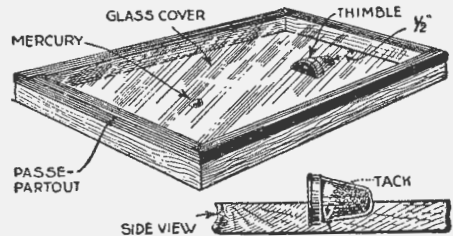

Try to put the mercury in the thimble

This can be done with a knife and the cardboard trimmed neatly around the thimble.

Sufficient mercury to fill the thimble half full is placed in the box and a sheet of glass is passe-partouted on top to serve as a cover. The object of the game is to get the mercury into the thimble.

HOW TO MAKE A SPARK DEFLECTOR GUARD FOR AN EMERY WHEEL.

A local machine shop has its emery wheel fitted with the spark deflector shown in the illustration. The guard is built up of sheet metal. An oblong strip of sheet metal was notched along the sides as at A and formed

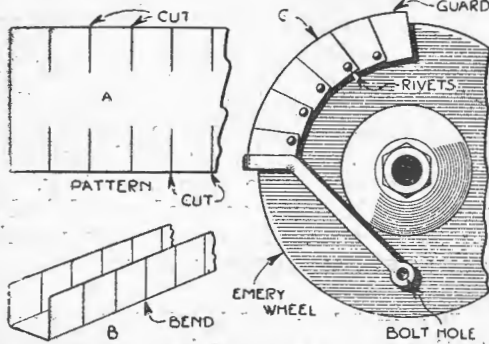

Guard for an Emery Wheel Made from a Piece of Sheet Metal

as in B. It was then bent in a curve as in C, the overhanging sections being secured with rivets. An arm fitted with a bolt hole for attaching to the frame, or wheel stand, was riveted on one end of the

guard. This guard served the purpose as well as one of cast iron, for deflecting the sparks.

J. M. KANE, in *Illustrated World*.

A COATING FOR TOOLS TO PREVENT RUST.

Heated vaseline to which a little powdered gum camphor has been added will be found a desirable and easily procurable mixture to prevent the formation of rust on tools and the like.

To protect bright or polished metal work from the ravages of rust, a mixture of one pound of lard, one ounce of powdered gum camphor, and a small amount of lampblack can be also used to advantage.

REFLECTED LIGHT AT THE BENCH.

Additional light on the vise may be obtained by placing a mirror on the wall back of the workbench in such a position as to reflect the light from a window. This will be particularly helpful in a cellar or other comparatively dark workshop whenever fine and accurate work has to be done on small parts.

Electrical Education

Never before has such timely and effective assistance been given to the Electrical Engineering world; never before has such a simple and clear text-book been written on the subject. It is the most practical work on Electrical Engineering yet published; it is new and compre-

hensive, embodying all the latest developments.

"Electrical Engineering" is the progressive man's guide.

IN EVERY BRANCH OF THE PROFESSION

It is indispensable to you.

"Electrical Engineering"

By Simmons (M.I.E.E.) and Avery (A.M.I.E.E.)

Three Volumes with 1000 Plates, Diagrams, Photos, etc.

Get the Set for FREE INSPECTION

Post this to-day

Simmons and Avery know the pitfalls of the Electrical Engineer; they know the uselessness of out-of-date text-books; they fully understand the great modern advances of Electrical Appliances; they know the need of the man at the bench, in the workshop, among the engines—the need for simple and practical text-books that will tell him in plain language all he wants to know about his work, help him to a greater understanding of the construction, functions, and use of the modern electrical machinery

FREE INSPECTION COUPON.

S.L.A.

WAVERLEY BOOK COMPANY,
218-222a Clarence Street, SYDNEY.

For free examination, please send me, with no obligation to purchase, the set of three volumes of "Electrical Engineering," by Simmons and Avery, all charges prepaid by you. If not satisfactory, I will return the set, at your expense, within seven days; otherwise, I will forward you 7/6 within seven days, and pay the balance on the books in seven monthly instalments of 7/6, and one of 5/.

Name

Address

.....

WIRELESS INSTITUTE OF AUSTRALIA

NEW SOUTH WALES DIVISION

ALL members and associate members are advised that the Club room is now available for their use between the hours of 9 a.m. and 9 p.m. Tables and chairs are there and a buzzer has been temporarily connected. After 7 p.m. the outer door of the building is closed and it is necessary to ring for the caretaker to secure admission. This outer door will be open to admit members on general meeting nights.

The first of the series of elementary lectures will be held on Tuesday, May 2, at 7.30 p.m., the subject being "Magnetism."

The series will be continued every alternate Tuesday thereafter, or other night as may be decided.

The programme of the Melbourne radio concerts on a wavelength of nine hundred and fifty metres, is as follows:

8.0 to 8.15: Musical selections played on a Vocalion machine.

8.15 to 8.30: Announcements and general wireless news.

8.30 to 8.40: Further musical selections on a Vocalion.

8.40 to 8.45: Straight "CW" for the benefit of Sydney, Adelaide and Hobart amateurs.

Members and associate members are warned against using valves, unless their speed qualification is up to twelve words per minute. Speed tests will be arranged upon application to Hon. Secretary, and those who have not qualified are advised to do so at once. Regular buzzer practice classes will commence in May.

* * *

It should be noted by all that the registration of the Institute is nearly complete. All associate members desiring to transfer to membership grade are advised that after the registration the conditions of transfer will be fully enforced, whereas they will be treated as foundation members of the new regime if their transfer is effected now.

* * *

All subscriptions are now due and should be forwarded to the Hon. Secretary as soon as possible, as the new year commenced on April 1.

* * *

The general meeting on April 11 deferred the annual general meeting till a date within three months.

SOUTH AUSTRALIAN DIVISION

THE monthly general meeting of the South Australian Division was held at the Y.M.C.A. Buildings, Gawler Place, Adelaide, on Wednesday, April 5. There was a large attendance, presided over by Mr. Hambly Clark.

Members expressed their pleasure at the accommodation which has been secured for the meetings, a large room having been secured under agreement for twelve months in the Y.M.C.A. Buildings.

The minutes of the previous meeting were read and confirmed.

Three new members were received into the Division and three applications were received.

Notices of meetings and competitions to

be held were received from the New South Wales Division which created much interest, and the Secretary was asked to thank the New South Wales Division for the notices which were received from time to time.

This Division does not issue notices of its meetings, it being thought that more publicity is gained by advertising the meetings in the local press, as well as by wireless transmission from the Division's station at Torrensville.

A feature of the meeting was the lecture on "The Fullerphone," by Mr. H. Hawke.

Mr. Hawke gave a very interesting description of the "Fullerphone," illustrating with a large chart the circuits used in

this instrument. He explained the working of it in a clear and thorough manner, and at the close of his lecture an instrument which he had brought along was opened up for inspection by those present.

Mr. R. J. Martin exhibited a variometer of the latest ball type and formers for winding same, which were constructed by a friend of his who is not a member. Mr. Martin explained the construction of the apparatus, which is very ingenious and very well made. It was decided to try and get Mr. Martin's friend to join up.

A vote of thanks was moved to the speakers who had given those present a very enjoyable and instructive evening.

During the business part of the evening, Mr. K. J. Martin was elected Vigilance Officer for this State, and it will be his duty to see that members' stations are kept in order, and also to report illicit aerials.

Will unfinancial members please remit their subscriptions as early as possible?

WIRELESS NOTES

MESSRS. E. T. Vears and W. C. Bolton, of Leura, on the Blue Mountains of New South Wales, a very enterprising pair of wireless experimenters, are now securing excellent results with their experimental wireless station.

In addition to intercepting messages from all Australian coast stations and ships at sea, they have heard such stations as Lyons (France), Pearl Harbour (Hawaii) and Cavite (Philippine Islands). They can also hear ships at sea working, and both they and their friends have enjoyed the wireless concerts radiated from Sydney and Melbourne.

Traffic Worked at 3,400 Miles.

The senior wireless officer of the Union S.S. Company's steamer *Tahiti* (Mr. E. M. Bain), when in Sydney recently, reported having maintained excellent communication over record distances on the last voyage across the Pacific.

Messages were exchanged between the *Tahiti* and the following stations at distances shown:

R.M.S. *Niagara*, 3,400 miles.

San Francisco, 3,300 miles.

S.S. *Ulimaroa*, 3,100 miles.

Sydney, 3,000 miles.

The receiving apparatus in the *Tahiti*, *Niagara* and *Ulimaroa* is the latest type of wireless receiver known as the P1 type, designed and manufactured by Amalgamated Wireless, Limited.

Additional to the above records, Mr. Bain further demonstrated the efficiency of the apparatus by intercepting music broadcasted by wireless from San Fran-

cisco when over three thousand miles away, and Denver, Colorado, at one thousand six hundred miles.

New Radio Association Formed.

The New South Wales Military Radio Association was constituted last month in Sydney. Its objects are to increase by voluntary effort the efficiency of the military radio service; to establish classes of instruction in all phases of radio work and other similar subjects; to endeavour to preserve and improve the conditions under which amateur radio experimenters operate. The Hon. Secretary, Mr. Mingay, can be communicated with by letter addressed care Military Engineers Depot, Moore Park Road, Sydney.

Wireless Concerts.

This form of entertainment is rapidly winning great popularity everywhere.

Last month a special concert by wireless was arranged by J. C. Williamson, Ltd., and Amalgamated Wireless, Ltd., in Melbourne for the benefit of crippled soldiers at the Anzac Hostel at Brighton, Victoria.

Mr. Jascha Spivakovsky, the Russian pianist, contributed two pieces to the novel entertainment, and Miss Maude Fane, Miss Madge Elliott, Mr. Cyril Richard, and Mr. Alfred Frith, all well-known artists of "the firm," rendered a number of excellent items.

The soldiers at the Anzac Hostel greatly enjoyed the entertainment and quite a large number of other land stations and

ships at sea over four hundred miles away also intercepted the concert.

Amalgamated Wireless, Ltd., Sydney, are now radiating by wireless special musical programmes on a wavelength of one thousand two hundred metres every Monday and Thursday, beginning at 7.30 p.m. and finishing about 9 p.m.

Experimenters in Sydney, suburbs and the country are intercepting the programmes and providing their friends with this form of entertainment, which in addition to being both unique and interesting is fascinating.

Further announcements regarding these concerts will be made in this column shortly.

* * *

Another Experimental Station.

The illustration shows the experimental station of Mr. R. D. Charlesworth, of Haberfield, Sydney.

The main receiver is combined for both short and long wave reception with one stage amplifier. The control arrangements are so grouped as to facilitate rapid tuning of signals.

From left to right the four large dials which are hand engraved are: Primary loading variometer; primary secondary

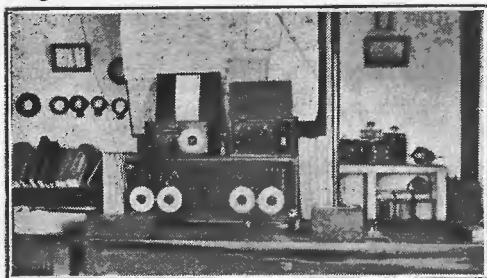

coupling; secondary tuning condenser, and regenerative variometer. The two main loading switches are for primary and secondary coils respectively.

The tuning range at present is from one hundred and eighty metres to four thousand five hundred metres on bank-wound coils, but this will be increased to twenty-four thousand metres by the adoption of change-over switch and honeycomb coils, which will be fitted on to the right hand side of the valve windows. Auditoron, Mulard and "R" type valves are used.

Above the cabinet on the left is a single valve portable set, range four hundred metres to one thousand four hundred and fifty metres. To the right of this is a smaller portable set which is calibrated and used as a wave-meter. A radio compass is also partly shown in the photograph.

The results obtained with these instruments are very satisfactory, and some very good work has been done on long-wave reception.

Quite So.

Biologist: "How many antennae have most bugs?"

Student (?): "Two, sir. One for sending, and one for receiving."

—R. E. Gower, in "Radio News."

* * *

Movements of Wireless Officers of Amalgamated Wireless, Ltd.

T. M. Alexander, to *Australport*, 1.4.22.

J. A. Cooper, from *Waikouaiti*, to *Malina*, 31.3.22.

H. F. Harman, from *Oonah* to *Carina*, 24.3.22.

D. W. Higgins, resigned from service, 7.4.22.

I. R. Hodder, from *Enoggera* to *Eromanga*, 10.4.22.

G. H. Hugman, to *Bombala*, 10.4.22.

A. E. Lawrence, from *Moeraki* to *Waikouaiti*, 31.3.22.

A. B. Monks, to *Hexham*, 19.4.22.

E. McPherson, to *Koolonga*, 28.3.22.

F. T. Neal, from *Kadina* to *Kanna*, 10.4.22.

L. H. Trenn, from *Canadian Cruiser* to *Eastern* (2nd), 11.4.22.

J. H. Wilken, from *Taiyuan* to *Levuka*, 18.4.22.

HUGHES & CO.

CIVIL and NAVAL TAILORS

SPECIALISTS IN NAVAL

AND

Mercantile Marine Uniforms

All work executed on our premises

BY EXPERTS

70-72 Erskine Street, Sydney

Established 1882

THE "HELSEBY" TWIN WIRING SYSTEM

IN view of the interest that is taken in the subject of metal-sheathed wiring systems it is not inappropriate to point out that the advantage claimed for the twin wiring system of British Insulated & Helsby Cables Ltd., are that it is (1) inexpensive; (2) easily and rapidly erected, fittings are few, it is adaptable and substantial, loose screws and small loose parts are practically eliminated; (3) neat in appearance and does not detract from that of existing decorations; (4) that efficient electrical continuity of the metallic sheathing of the cable is secured by the use of a bonding clamp of the same metal; and (5) that no special tools are required to aid erection.

The system is suitable for either a d.c. or an a.c. supply, and comprises single, twin or three-core cable, together with a range of fittings and accessories. The single wire is of circular

section, but the twin and three-core cable of flat section, and the over-all dimensions have been kept small, so as to assist unobtrusiveness when erected on the surface.

The metallic sheathing of the cable is composed of a special alloy of sufficient strength to provide a good protective covering for the cable without impairing its flexibility, and, at the same time, to prevent it sagging between properly spaced points of support. Moreover, the whole system can be quickly and cheaply erected with a minimum of labour and without the use of special tools; that it presents a neat appearance when installed, and complies fully with the requirements of the I.E.E. Wiring Rules, fire insurance companies, and electricity supply authorities.

The high-conductivity tinned-copper conductors are insulated with pure, vul-

canised rubber, and taped so as to possess distinctive colours; the cores are sheathed with a solid-drawn tube of special metal alloy.

Generally, tinned brass fixing clips and saddles are used, but for cleating cable in damp situations it is recommended that a metal strip of approximately the same composition as that of the cable sheathing should be used. The junction box is illustrated on this page, and comprises a tinned brass back-plate and cover and an annular bonding clamp. The back-plate is placed inside the latter, and the whole is secured to the wall by means of a screw through the hole in the plate. The bonding

clamp is provided with four slots, so that it may be used as a two, three, or four-way fitting, and continuity of the metal sheathing of the cable is secured by screwing down the small clamp-

ing pieces on to the sheath. The metal alloy of which the bonding clamp is made is of the same composition as that used for sheathing the cable, and when it is necessary to use a larger cable than 7/029 in. flat twin, the slots can be easily enlarged without aid of special tools, a pocket knife being all that is necessary. The fitting is supplied with all the loose screws and parts assembled, and it is never necessary to remove any of them completely; the long nuts embedded in the bonding clamp practically obviate the trouble experienced with stripped screw threads, while the cover for the fitting is simply sprung on to the base portion. Procelain insulated connections are used with the junction box. The New South Wales agents are Messrs. Wm. Adams & Co., Ltd., at Sydney and Newcastle.

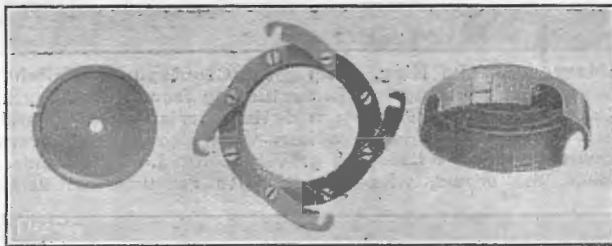

The Helsby Junction Box.

THE ROYAL WEDDING



Princess Mary, with the King, passing the Cenotaph in Whitehall on the way to Westminster Abbey. When returning from the Abbey and again passing this point Princess Mary had the carriage halted and handed part of her bridal bouquet to an officer, who placed the flowers on the Cenotaph, while Viscount Lascelles gravely saluted. The incident deeply touched the crowd, who cheered with renewed enthusiasm.



Mr. and Mrs. Lloyd George and their daughter Megan leaving Westminster Abbey after the ceremony. Others in the picture, from right to left, are: Mr. and Mrs. Austin Chamberlain, Sir Robert Horne, and Lord and Lady Birkenhead.

WOMEN AND SPORT

THE eternal question of the propriety of women participating in the various forms of sport which a few years ago were looked upon as man's sacred preserves is no nearer solution. Medical opinion for and against the wisdom of females undertaking such strenuous games as football, rowing, tennis, etc., has been freely quoted, but woman still sails serenely along, contending that despite what might be said to the contrary, no possible harm can result from indulging in any form of exercise provided the player has the physique and inclination for same. Physical culture is certainly of great value in building up the stamina of our race, and provided it is not carried to excess, it is a departure from the old methods of education which deserves every encouragement.

Of lady swimmers the world can boast many who have earned a high reputation for their proficiency in the natatorial art. Rowing, too, is a game at which women have won a fair measure of attention, and the Parramatta River (New South Wales) on Saturday, May 6, will be the scene of a contest for the Australian women's four-oar championship, in which crews from New South Wales, South Australia, Queensland and Tasmania will compete. The course will be a half-mile one, and the event is creating a great deal of interest. Some enthusiasts believe that the time will yet come when a world's single championship for women will be staged, just the same as in swimming and a number of other games in which the fair sex have attained a high degree of skill.



Just Before You Go to Sleep!

That's the time to get rid of the defects in your complexion. Wash your face in warm water, and while the skin is still damp lightly smear a little pure mercolized wax over your face and neck, and leave on until the morning. After a few nights of this treatment the blemishes on your skin should disappear.

Mercolized wax dissolves away the old dry skin and leaves behind a new, healthy complexion. Beauty is but skin deep—mercolized wax brings it to the surface. It is emphasized that this wax is quite harmless, and contains only the purest ingredients, being free from any poisonous mercury salts.

The meaning of the word "mercolized" is "active," and its activity is obtained from its oxygen content, which is Nature's own beautifier. As a general facial skin cleanser mercolized wax is unequalled, being in universal everyday use by up-to-date, discriminating women—husbands also find it beneficial for use after shaving, especially if the skin is chafed. It should always be used before the application of powder, as the wax will prevent the pores of the skin from becoming clogged and unhealthy.

All chemists can supply you with pure mercolized wax, in neat, original tins, containing sufficient to last from six to eight weeks. Price, 5/6 per tin, or from

DEARBORN (Australia) LIMITED

(Dept. L.A.)

279 CLARENCE STREET, SYDNEY

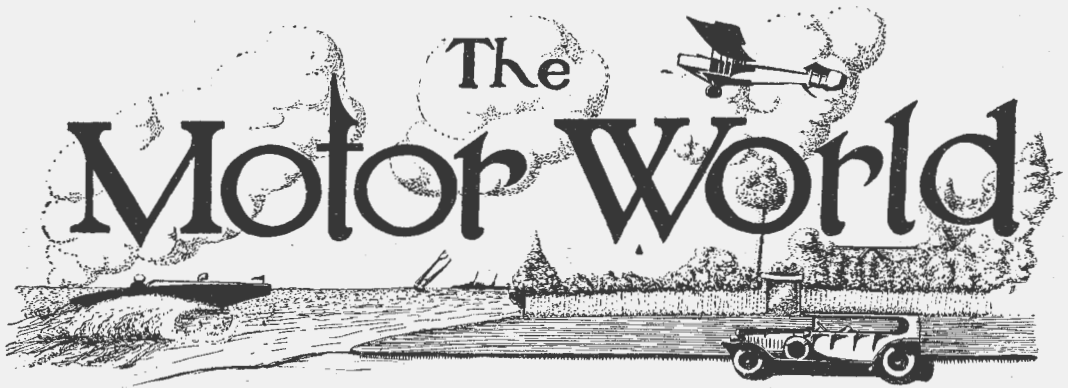

By "SPARKING PLUG"

Testing Australian Fuels.

MUCH prominence has been given by several papers in Melbourne to the demonstration held at Easter time to test the worth of Australian fuels, as announced in the January issue of *Sea, Land and Air*.

The demonstration, which must rank as one of the most important yet held in Australia, was organised by the Royal Automobile Club of Victoria. It was a demonstration by fifty-five motor vehicles of various types to prove that cars, motor lorries, tractors, and motor cycles will function perfectly on Australian-made fuels either alone or compounded with petrol. The run was in no way a competitive one, the vehicles being simply driven on fuel nominated by the entrant. Most of the vehicles used their standardised carburetor systems, in a few instances special atomisers being installed. The range of fuels comprised benzol, alcohol, shale spirit, crude spirit in full strength or united with benzine. At least fifty per cent. of the liquid used had to comprise Australian-produced fuel. The event was more than a success—it was a triumph.

The vehicles during the run appeared to pull just as well as on benzine. One tractor hauled a trailer carrying four tons of motor covers. It was a motley procession to look at, but one fraught with great possibilities, for anything that will help to develop our own fuel resources is of inestimable value to the automobile movement in the Commonwealth.

Now that the Automobile Club of Victoria has drawn public attention to the fact that all descriptions of motor vehicles can be run on home-produced fuels or fifty

per cent. of same, the Club will probably go further and organise a home fuel consumption test, over a course of four hundred miles. Such a test would prove valuable, as correct data would then be available as to the mileage and cost of running on the various fuels.

Do Motorists Bite or Bark?

Everything—except Fortune—seems to run in cycles, according to some philosopher who has never tried to back winners at Randwick.

The world is propelled on wheels, or rather wheels within wheels, and each successive generation witnesses the gradual disappearance of individualism and the substitution of collective effort or, in other words, organisation.

The Royal Automobile Club of Australia is the latest to throw down the gauntlet as an organisation.

At the recent general elections a number of questions were submitted to the various political candidates, but in the welter of stormier contentious issues, the influence or fear, of the motoring fraternity was not brought to bear as effectively as it might have been.

No one would advocate converting the Royal Automobile Club of Australia into a political party, and no one expects any member of the Club to vote for a candidate who is unacceptable on economic issues, simply because he pledges himself in favour of the Royal Automobile Club of Australia's questions.

But it is vitally urgent that motorists should remember that any and every privilege they possess to-day had to be fought for and won from an unsympathetic



DODGE BROTHERS

4 DOOR SEDAN

The number of those who prefer the sedan for use throughout the year is steadily increasing.

The reason is easily understood when you consider how adaptable it is to the frequent weather changes common to all parts of the country. Almost instantly it can be changed to accommodate itself to heat or cold, rain or shine.

It is well designed, well finished, well upholstered, roomy—and suited for use the year round.

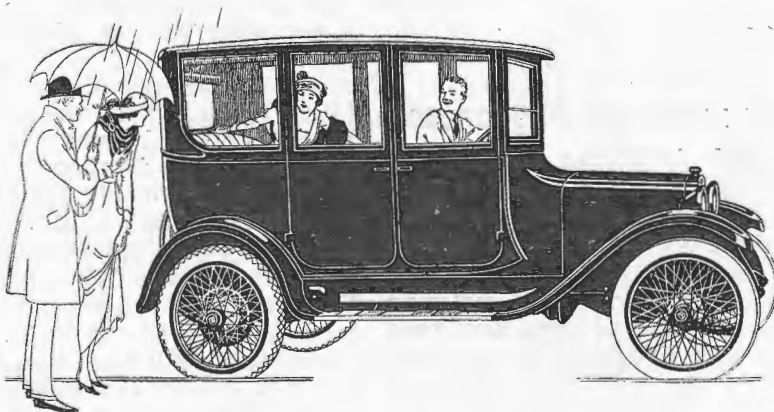

STANDARDISED MOTORS LIMITED

276-278 CASTLEREAGH STREET, SYDNEY

Telephone: City 987.

(Near Liverpool Street)

1/6/22

and conservative public, and, any further rights or privileges can be won only by uniting as a body and showing the politicians of the day that motorists possess a bite as well as a bark, and are determined to make use of it.

To those who doubt the wisdom of the R.A.C.A. in submitting questions to candidates, it is only right to point out that the whole social fabric is rapidly being changed and that whereas the family, from time immemorial, was always supposed to represent the unit of the State, to-day is the day of organisation.

The various schools of thought are the units of society and that school which can shout the loudest and punch the hardest is usually the one which commands greatest respect from the ever-increasing crop of prospective legislators.

Good roads and other matters of concern to the motoring and commercial community and indirectly to the community at large, are issues which can be legitimately submitted to any party or candidate.

With the R.A.C.A. instituting a vigorous publicity campaign on the eve of future elections with a determination to act as well as to threaten, members can look forward to having several watchdogs in the Assembly whose efforts will never relax until the motoring fraternity's legitimate desires are properly reflected in the Statute Book of the country.

* * *

UTILISING MUNITION FACTORIES.

Motor Trade in France Booming.

France is rapidly adapting itself to post-war problems and is directing its attention to "more production" in its various industries.

Considerable animation in the motoring industry is reported, and steps have been taken to exploit English and American automobile spheres with the object of gleaned latest ideas of any benefit to the industry in France.

Two experts from the Parisian metropolis have been wandering through American factories on an information quest, and their views, which eloquently admit a ray of light into the motor world of France, have received a good deal of publicity in American papers.

Attempt on Brisbane-Sydney Record.

Mr. Boyd Edkins intends to shortly make an attempt on the Brisbane-Sydney motor car record. The best for this inter-State run is Mr. F. Eager's 19 hours 38 minutes 30 seconds, a particularly fine performance, considering the nature of this six hundred and twenty-one miles route. Whilst the holder of the record selected the run from Sydney to Brisbane, Mr. Edkins, who will drive one of the latest 30-98 h.p. *Vauxhalls*, shod with Dunlops, will tackle the stiff proposition from the Brisbane end.

Only those motorists who have journeyed between the two capitals can realise what it means to negotiate this route under twenty hours, for, besides a deal of inferior road, there are hundreds of bad "v" gutters, which are a source of trouble to motorists even at a touring pace.

* * *

MOTOR CYCLING.

Successful Meeting at Easter.

Motor cyclists eagerly awaited the Easter carnival promoted by the Motor Cycle Club of New South Wales at Bathurst, the proceeds of which were devoted to the Bathurst Hospital.

On Easter Saturday the contests were held on the Bathurst racecourse, and on Easter Monday the events were confined to the road.

In the five miles championship for machines under 600 c.c., W. Conaulty scored by 10 yards on a $3\frac{1}{2}$ *Norton* from E. Schwer on a similar mount, with A. Batros (*Rover*) third. The winner's time was 5min. 54sec. D. Brewster (7 *Indian*) was rewarded for his journey all the way from Melbourne by winning the 10 miles State championship from F. Howarth (*Harley*) and J. R. Sidebottom (*Excelsior*).

The handicap racing was excellent, with W. Conaulty scoring another success in the Bathurst handicap of five laps for machines under 600 c.c. This time he rode a 4 h.p. *Indian*, and started from 15sec. Schwer (30sec.) was again second, and Munro ($3\frac{1}{2}$ *Norton*) from 30sec., third. A. H. Noad scored a double by taking the five laps for machines over 600 c.c. from 28sec., with T. Benstead (scr.) and J. B. Mills (15sec.) also on *Harleys*, in the places, and the side-car handicap on a *Harley* from the 8sec. mark. On this occasion Noad finished nearly a quarter of

The "SMITH"

Radamax Sparking

Plug Tester

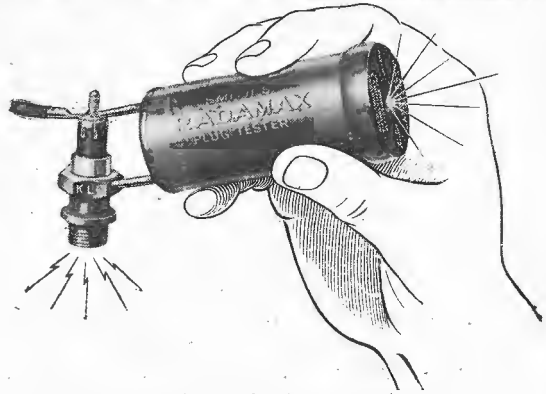

THE only Tester operating on sound, scientific principles—no other Tester is just as good—no other system will give accurate and reliable results.

Misfiring can be instantly detected—no adjustment required—infalible under all conditions.

The "SMITH" Radamax Sparking Plug Tester

SMITH, SONS & REES LTD.

Head Office: 30-32 Wentworth Avenue, Sydney

MELBOURNE
100 Flinders Street

ADELAIDE
99 Flinders Street

UNITED STATES
TYRES

ARE GOOD TYRES

SOLD EVERYWHERE

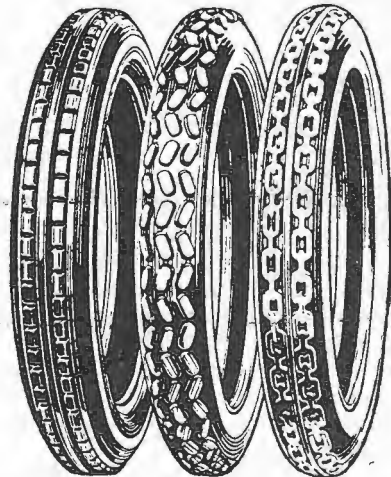

'Royal Cord' 'Nobby' 'Chain'

a mile in front of C. Wilson (7 *Indian*) and J. Mills (*Harley*).

On Monday the racing was confined to the road. Brewster had hard luck in the Senior T.T., his machine catching fire and being destroyed. This Senior T.T. race was 110 miles, for machines over 600 c.e., and W. Kessing, the Lithgow rider, scored from the 5min. mark from H. R. Hodgson (2min. 30sec.), and H. Riddel (8min.). Kessing, who rides well, won by a couple of minutes in 2hrs. 22min. 39sec., which was also the fastest time. W. Conaulty (4 h.p. *Indian Scout*) scored another success in the 66 miles Junior T.T. race from the 2min. mark. Brewster, from scratch, on a similar machine, was second, and E. Williams (3½ *Douglas*) third. The winner scored by 25sec. in 1 hr. 28min. 2sec.

The 44 miles all powers side-car race went to the consistent A. Noad on a 7 *Harley*, from 6min. 45sec. J. B. Miles (*Harley*) from 5min., and S. Roberts (scr.) on *Harley*, were second and third. Noad had a minute to spare in 1hr. 26sec.

Carnival at Victoria Park.

On Saturday, May 20, Victoria Park Racecourse will be the rendezvous of local motor cyclists.

A carnival has been arranged by the Motor Cycle Club of New South Wales, the programme of events being as follow:

Handicap, for machines under 600 c.e., in two heats, and a final novelty race, five laps handicap, for machines over 600 c.e., in two heats and a final, limited to thirty riders; five laps scratch race, all powers, limited to fifteen; three laps challenge race; and three laps side-car race in two heats and a final, limited to twelve starters.

Machine on Fire But Still Wins.

Eric Tyler, well known in this State, put up a plucky performance in winning the 60 miles side-car race over the Maffra-Sale-Stratford course on Easter Monday. Tyler won the race with a handicap of 4min. 15sec. in the riding time of 1hr. 27min. 45sec., on a *Harley-Davidson*, and also established fastest time. When little more than a quarter of a mile from the winning post, Tyler ran out of petrol, and his passenger endeavoured to pour petrol into the tank from a spare tin, with the result that the machine caught fire. The blaze was extinguished, and Tyler and his passenger pushed the machine a quarter of a mile to the finish, to receive an ovation.

Motorgrams.

The Secretary of the Royal Automobile Club (Mr. Harry C. Morgan) deserted his desk in Phillip Street for three weeks during last month, in favour of a well deserved holiday. Mr. Morgan is a courteous and painstaking official who commands the respect of all for his constantly uniform and obliging nature.

Competitions arranged for members of the R.A.C.A. are as follow:

May 13: One day touring reliability trial to Kurrajong—a delightful run.

June 24: Flexibility trial.

August 19: Hill climb at National Park.

Cars and trucks registered in the United States during 1921 totalled 10,449,785, the total fees amounting to 110,000,000 dollars. About one person in every ten would possess a car if an average were struck with the above figures as a basis.

Despite the fact that America finds it difficult to supply the Australian demand for cars on account of the orders flowing in from America, over half a million sterling worth of motor vehicles were imported from that country last year. England's share of Australia's imports was £350,000. Throughout 1921 Australia imported 3,481 motor vehicles. It has been estimated that there is one car to every sixty-eight persons in Australia.

GOOD SERVICE TO CAR OWNERS.

DODGE BROTHERS' POLICY.

Car owners, as a rule, have reason for being pleased with the outlook for better service department facilities and a resultant greater satisfaction in owning and driving a car. It is evident that manufacturers are placing more and more emphasis on this phase of their business, not only because it is being demanded by the car owners, but because it has been demonstrated by the few who have insisted upon good service from the very outset, that it pays in dollars and cents to keep a customer satisfied.

Mr. Kloster, of the Standardised Motors, Limited, the Dodge Brothers' dealer here, is one who knows what it means to represent a factory that is extremely particular about the sort of service its dealers provide.

IF YOU LACK

ONLY

A MOTOR CAR

in order to complete
your appreciation of
your surroundings

Consult US!

THE CARS WE HANDLE ARE THE

Gems of Their Class

They all carry our

THREE YEARS'
GUARANTEE

Sales arranged for either Cash or Terms

We are Sole Distributors
in New South Wales for

VAUXHALL

HUMBER

RENAULT

MERCER

and the New

Oldsmobile "4"

Telephones
City 926, 1179

BOYD, EDKINS LTD. 25 Wentworth Avenue, Sydney.



Superior
ELECTRIC IRONS

Although "Superior" Irons sell at a moderate price they have features which make them preferable. As with all "Superior" products they are adjusted to exactly the right heating capacity.

The beautiful finish of "Superior" heating appliances makes them an ornament to any table.

"SUPERIOR" ELECTRIC IRONS 37/6

" " TOASTERS 35/-

Austral Electric Limited

97 Clarence Street, Sydney

(Sole N.S.W. Agents)

"The factory has been steadfast and consistent in its service policy ever since the manufacture of Dodge Brothers' cars began," he said. "Keeping pace with the recommendations coming from headquarters, we have steadily developed our own facilities. Among the comparatively recent innovations of importance to the car owner is the flat rate system, which enables him to tell in advance just how much it can possibly cost him to have his car adjusted or repaired. A specified maximum time is allowed for each operation and he can see it all in black and white before the work is started.

"With more than seven hundred thousand cars already sold, it is not difficult to see why Dodge Brothers are so insistent on good service. The annual replacements among these seven hundred thousand alone call for a production as large as the total output of many factories."

Mr. Kloster's comments on Dodge Brothers' service policies are borne out by a recent article by Sanauel Hopkins Adams, in *Leslie's Weekly*. "Where the 1922 purchasing public is going to profit chiefly is not by buying cheaper," says Mr. Adams, "but in increased utility at lowered expense.

"Service," he adds, "is the trade word, a term often abused to the point of parody. But the new form of service, as projected, is so perfected and systematised as to comprise perhaps the most important development that the industry has known for years.

"That the initial cost of a car is not the principal item, is a lesson which has been hammered at the public in a series of highly effective advertisements. This principle of economical upkeep, Dodge Brothers have adopted as a fundamental principle.

"Now there are developments which indicate that any concern failing in its future to protect its clientele against exorbitant cost of upkeep, may as well get ready to go out of business; for the education which the Dodge Brothers started by advertising and precept is to be broadened to a scale which will enlighten the entire motoring public as to the wastefulness, inefficiency, and trickery in the repair business.

"The new service plan will at once eliminate uncertainty and the opportunity for the conscienceless dealer to make an unfair profit.

"To make the service station cheaper, quicker, and more efficient is the first aim of the new system. The factory will back up the improved standards by a new policy of its own, which is almost revolutionary; expressed in the slogan, 'Service first; let the new customer wait.' That is to say, satisfaction on sales already made takes precedence over new sales. All of which looks to the long distance policy of cheapening operation and thereby making it possible for more people to own and operate cars.

"The new service scheme represents the rare phenomenon of a three-way profit; to the factory on the sale of its equipment, to the service station in its augmented earnings, and to the owner in an unprecedented reduction of his bills."

* * *

How the Motorist Catches Cold.

If you see a motorist going around with a stiff neck it is ten to one that he caught it in his car. Men who ordinarily are not at all susceptible to draughts, who rarely, if ever, take cold, will succumb to a stiff neck acquired in the following manner, even in the warmest of summer weather. A tyre is changed or some other job is done about the car, involving sufficient labour to bathe the worker in perspiration. Then, when the job is finished, he jumps in, probably hatless and in his shirt sleeves, and drives several miles. The breeze cools him off quickly, but two or three hours later he begins to develop soreness and stiffness in neck and shoulders. To avoid this malady, the driver should cover himself well while driving, until he cools off, and a better plan is to postpone driving until he has dropped to normal temperature.

* * *

The man who wishes to do some work under his car and who wants to do it as comfortably as possible should try running the wheels up on a bank, and then securely blocking the car in this position. Taking up connecting rod bearings then becomes an easy, pleasant job. Likewise work on the rear axle, transmission or brake mechanism is greatly facilitated. In the first case the front wheels would be run up the bank and in the second case the rear wheels.

Exide

BATTERIES

THE FIRST BATTERY SERVICE.

Just as the Exide Battery was the first car-starting and lighting battery, so "Exide" Battery Service was first in the field, and is still foremost.

The Exide Battery Service Station is a world-wide institution. Batteries need attention, and no one is better qualified to give it than the "Exide" Agent.

His first care is not to sell a new battery. Whatever make of battery is on your car, Exide Service will make it last as long as possible. Only when replacement is essential will an Exide Battery be fitted. The long life and care-free service of the Exide will surprise you.

Exide Batteries are manufactured in U.S.A. by the Electric Storage Battery Co., Ltd., Philadelphia, and in England by the Chloride Electrical Storage Co., Ltd., Clifton Junction, near Manchester.

AUSTRALASIAN DISTRIBUTORS :

QUEENSLAND: Howard Motor Co., Ltd., Adelaide Street, Brisbane.

NEW SOUTH WALES: Gibson, Battle & Co., Ltd., Hunt Street, off Wentworth Avenue, Sydney.

VICTORIA: Sutherland & Ashman Pty., Ltd., Queen's Bridge (2 Maffra Street), Melbourne.

SOUTH AUSTRALIA: Unbehaun & Johnstone, Ltd., Rosina Street, Adelaide.

WEST AUSTRALIA: Unbehaun & Johnstone, Ltd., 404 Murray Street, Perth.

NEW ZEALAND: Hope, Gibbons, Ltd., Inglewood Place, Wellington.



A FORD'S GOOD WORK.

The ubiquity of the Ford has another illustration worthy of publicity in the Queenscliff-Swan Island railway. A Naval officer lent to Australia, and whose last appointment incidentally was that of engineer of the Straits of Dover mine fields, has rigged a one-ton lorry as shown in the accompanying illustration on an old simple three-foot rail trolley. The sprocket is five-eighths of an inch, and sprocket wheels are mounted on the lorry to fit the brake-housing on the truck on chocks of wood bolted to plates behind the spokes.

A high speed is possible on the level, but the island railway is old and out of repair and no risks are run. Ball-bearings are shortly to be fitted to the undercarriage,

It is interesting to know that an ordinary tractor of twenty horsepower would probably cost three times that of the *Ford* and trolley, whilst not possessing the double advantage of the latter.

* * *

An Unexpected Demonstration.

A somewhat exciting incident took place upon one of the most crowded days of Olympia Commercial Show, in the form of an exhibit ruining amok. Petrol vehicles have all to have their fuel most strictly removed before they enter the building, but electricians do not have to be discharged. Electric control gear is extremely simple, and in displaying his knowledge of the vehicle, a certain visitor put a control lever

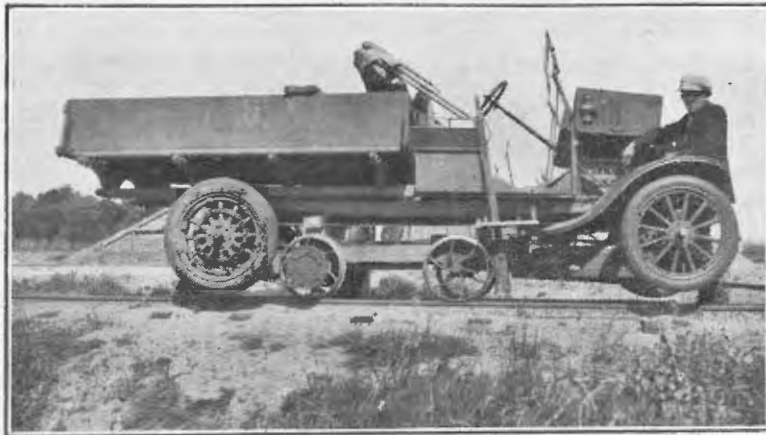

The Ford lorry which is performing such good service at the Queenscliff-Swan Island railway.

but the performance on old cast-iron blocks has been excellent for nearly twelve months. Trailers carrying one hundred and twenty workers and military have been towed at fast rates without strain. The petrol consumption is rather high, but this is easily explained by the fact that five-eighths of an inch of cast iron plummer block greased thrice daily can be worn down on the under-trolley in a fortnight, so that ball-bearings are anxiously awaited. The trolley lifts off and goes on the road under a simple gantry in five minutes.

The machine is always run forward on the three-mile track and reverses through a short loop at one end and by "lift and turn" at the other. It is mainly used to bring workmen and stores to and fro, but it is also utilised in tractor work of Commonwealth importance.

into the high-speed notch, with the result that the vehicle proceeded to crush an office into matchwood and to charge the adjoining stand, where, after other havoc, it was brought to rest by the passive resistance of a rival, in the form of a large petrol lorry, which refused to be shifted even by such surprise tactics. To avoid further possibilities of trouble the electricians thereupon had their wiring disconnected.

* * *

A Show Story.

A daring Ford owner stopped just past the outstretched hand of the policeman on point duty outside Olympia, and the officer was heard to remark, with withering contempt, "If you do that again, young fellow, I'll kick that adjective thing from under you!"

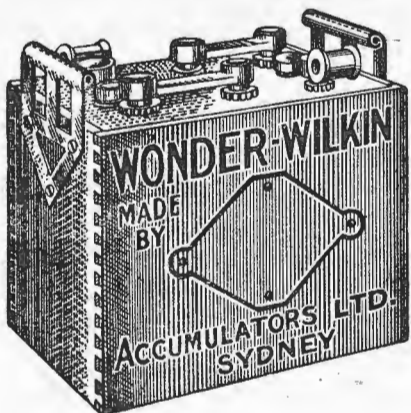

YOU buy a Battery to give you Starting and Lighting Service; but service cannot be seen.

The Battery may look good—most Batteries do.

You are dependent on the quality of the materials and workmanship used in manufactures for the satisfaction it will give you, backed of course by the attention you pay its operation.

“Wonder-Wilkin” Batteries

Made in Your Country

A local product, worthy of your interest, built on a foundation of faith in Australian raw materials and industry.

Bennett & Barkell Ltd.

Distributors,
Meagher Street, Sydney.

Accumulators Limited

Manufacturers,
Blackwattle Bay, Glebe.

When You Want
ACCESSORIES
For Your **CAR**

Remember

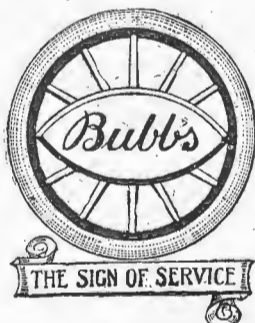

R. N. BUBB

The Motor Accessory House
4 & 6 Wentworth Avenue
SYDNEY
(Right at the Top.)

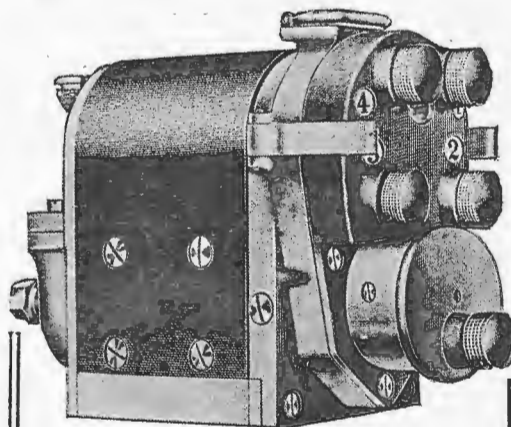

Magneto Repairs

Good, Prompt Work—At a Reasonable Price

For many years we have been specialising in the repairing of all makes and types of magnetos, and assure work of the highest standard.

MOODY & CO.

MAGNETO SPECIALISTS,
343 Kent Street, Sydney.
Phones: City 1740 and 1741.

HUMOUR OF THE WORLD

Getting out a magazine is no picnic. If we print jokes folks say we are silly; if we don't, they say we have no sense of humour. If we publish original matter they say we lack variety; if we publish things from other papers they say we are too lazy to write. If we don't go to church we are heathens; if we do we are hypocrites. If we stay in the office we ought to be out getting news; if we are out getting news we are not attending to our business at the office. If we wear old clothes we are not solvent; if we wear new clothes they are not paid for. What is a poor editor to do, anyhow? Like as not, some editor will say we clipped this. We did.—*Maryville (Mo.) Democrat-Forum.*

Rule Britannia!

A retired naval officer said that he could not understand "all this disarmament nonsense." No, sir! What would Britain be without her Navy? Had we forgotten Trafalgar? Was it not our glory and our tradition to maintain the freedom of the seas?

It was pointed out to him that this was an attempt—wise or not—to remove the menace from the seas.

"Hang it all, sir!" roared the old sea warrior, bristling. "What's the confounded sea for?"—*Tit-Bits (London).*

What the Lady Said.

Mrs. Smith's greatest ambition was to win recognition from her socially-prominent but discouragingly exclusive neighbour, Mrs. Browne-Jones.

You can imagine Mrs. Smith's satisfaction, therefore, when one evening her small son announced importantly, "Mrs. Browne-Jones spoke to me this afternoon."

"Why, Tommy, how nice!" beamed his mother. "What did she say to you?"

"She said, 'Take your hands off my hedge!'" —*Judge.*

A policeman had found a dog and returned it to the mansion from which it had strayed. The nurse-girl took the animal from him; at which the constable inquired:

"Do you have to take care of the dog?"

"Oh, no!" returned the maid. "They say I'm too young and inexperienced—I only look after the children!"—*London Weekly Telegraph.*

A guest in a Cincinnati hotel was shot and killed. The negro porter who heard the shooting was a witness at the trial.

"How many shots did you hear?" asked the lawyer.

"Two shots, sah," he replied.

"How far apart were they?"

"Bout like this way," exclaimed the negro, clapping his hands with an interval of about a second between them.

"Where were you when the first shot was fired?"

"Shinin' a gemman's show in the basement of de hotel."

"Where were you when the second shot was fired?"

"Ah was passing de Big Fo' depot."—*Success Magazine.*

Rector (giving lessons in school: There are still parts of the world where men eat each other. What do you call a man who eats another man?)

Small Boy: Greedy, sir!—*London Morning Post.*

"What are you plunging back into the water for, Pat? You just swam ashore."

"Shure, Oi had to save meself first. Now Oi'm going back to save Moike."—*New York Sun.*

Her Idea of Drudgery.

A little girl in a poor family has to wash a great many dishes. Someone began sympathising with her one day, remarking what "drudgery" it must be.

"No," she replied. "It's great fun. I have given every dish a name, and they are all my children—my dolls. I talk to them while I am washing them and drying them. I pretend that I am dressing them. I like to have them all nice and clean. And I'm sure they like me for looking after them so well. It's lots of fun."—*B. G. Forbes, in The New York American.*

Wireless Men !

MAGAZINES YOU WILL LIKE.

"THE WIRELESS WORLD"

Contains many elementary articles and valuable information for the experimenter. Written and edited by experts. Fully illustrated.

Published every fortnight.

PRICE, 1/2 per copy, post free.

Subscription rates:

One year (26 issues)	£1 6 0
Half year (13 issues)	13 0

"THE WIRELESS AGE,"

An American magazine presenting topical wireless news and information in a most attractive manner. The beginner as well as the advanced experimenter and professional wireless man are catered for.

Published once a month.

PRICE, 2/2 per copy, post free.

Subscription rates:

One year (12 issues)	£1 4 0
Half year (6 issues)	12 0

SPECIAL NOTE:

As all subscriptions are payable in advance, remittance **MUST** accompany order.

Send all orders to "The Wireless Press,"

97 CLARENCE STREET, SYDNEY.

Special Note

Become a subscriber and make sure of receiving each issue of

"SEA, LAND & AIR."

Fill in the Coupon below, clip and mail to us with cheque or bank note value 10/-

THE CIRCULATION MANAGER,

"Sea, Land & Air,"

Clarence Street, Sydney

Herewith enclosed 10/-, for which forward me "S., L. & A." for one year.

Name.....

Address

WIRELESS EXPERIMENTERS

If you want to obtain the very best results from the Wireless Music now being broadcasted by Amalgamated Wireless, use only S. G. Brown's Telephone Receivers.

Universally used by wireless operators.

Write for our new Price List containing all types of Experimental Wireless Apparatus

AUSTRALELECTRIC LIMITED

97 Clarence Street, Sydney.

422/4 Chancery Lane, Melbourne.

The Queensland Musical and Dramatic Times and Cinema Record

The only WEEKLY paper in the Commonwealth devoted to Music and the Drama.

N.S.W. residents interested in Queensland will find it full of information.

Pithy articles, analytical notes, all the musical and dramatic news.

SYDNEY AGENTS:

N.S.W. Bookstall Co. Ltd., George St.

Published every Thursday — Price 6d.

Thermionic Tubes In Radio Telegraphy and Telephony

by

JOHN SCOTT-TAGGART,
A.M.I.E.E., F.P.S.

This book has been written with a view to providing in a single volume an account of the practical development of the vacuum tube and its innumerable applications.

424 pages; 344 Diagrams and Illustrations.

PRICE, 30/-. Postage, 1/- extra.

From all Booksellers or

The Wireless Press
97 CLARENCE STREET, SYDNEY
422 Chancery Lane, Melbourne.
Australasia Chambers, Wellington, N.Z.

"DIAMOND DRY CELLS LAST LONGER"

You may install Diamond Dry Cells and then forget them! They do not develop those faults which though small result in expense, delay and grinding worry to the user

"DIAMOND CELLS GIVE HONEST SERVICE"

TO WIRELESS EXPERIMENTERS !!

H.T. Dry Batteries for Radlo Work

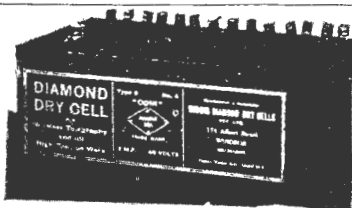

"Coni," 40 volts, 25/-.

TYPE 4 SPECIAL H.T. BATTERIES.

No.	Name.	Ext. Dimensions.	E.M.P.	Price
41	Vacuum	Inches. { 11 $\frac{3}{4}$ × 10 $\frac{3}{4}$ × 3 10 $\frac{3}{4}$ × 7 $\frac{1}{2}$ × 3 7 $\frac{1}{2}$ × 6 $\frac{1}{2}$ × 3 7 $\frac{1}{2}$ × 4 $\frac{1}{4}$ × 3	160	80/-
42	Audical		100	51/-
43	Mar		60	32/6
44	Coni		40	25/-
45	Jucon		30	21/-

AUSTRALECTRIC LIMITED

97 CLARENCE ST., SYDNEY.

422 CHANCERY LANE, MELBOURNE.

'PHONES: CITY 4254 (6 lines).

'PHONE: CENTRAL 7551.

TELEGRAMS: "EXPANSE" — ALL BRANCHES.



WIRELESS!

OVER 600 STUDENTS APPOINTED!

The Marconi Schools have already appointed over 600 STUDENTS as WIRELESS OFFICERS.

WE ARE NOW TEACHING

WIRELESS BY MAIL

SEND TO-DAY for particulars of our Specialised Home Study Course. With the limitless possibilities of Wireless, intending students should not delay.

WE GUARANTEE TO TEACH YOU UNTIL YOU ARE PROFICIENT.

All Marconi Home Study Students are supplied free with a Gramophone and Wireless Training Records, Reference Books, and Key and Practice Buzzer Set. These instruments, etc., become the property of the student.

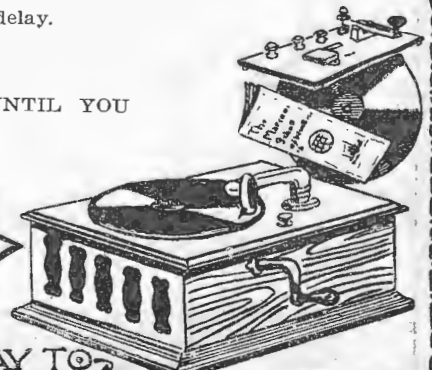

WRITE TO DAY TO

MARCONI SCHOOL OF WIRELESS
 97 CLARENCE STREET, SYDNEY;
 422-4 CHANCERY LANE, MELBOURNE.

Having purchased the
Plant and Stores of

GREAT COBAR LTD.

it will pay purchasers to
send us their enquiries.

A. GONINAN & CO.

— LIMITED —

ENGINEERS & IRONFOUNDERS

WICKHAM & COBAR, N.S.W.

Commonwealth Bank of Australia
 HEAD OFFICE SYDNEY.

BRANCHES ARE OPEN FOR THE TRANSACTION OF

General Banking Business

Established 1912

In the principal Cities and Towns of Australia and Rabaul (New Britain), and London (2).

Banking and Exchange Business of every description transacted within the Commonwealth, United Kingdom, Canada, United States and abroad

Agents and Correspondents throughout the World

Savings Bank Department

At all Branches and Savings Bank Agencies at 3049 Post Offices in Australia, Papua, New Britain, Solomon Islands, and the Pacific.



Head Office, Sydney.

Interest at the rate of 3½% up to £1000 and 3% on balance in excess of £1000 up to £1300, payable from 1st July, 1920.

1922

Sir DENISON MILLER, K.C.M.G., Governor

FLYING MEN

NEED THIS BOOK.

PRACTICAL AVIATION

Including

Construction and Operation

by

Major J. ANDREW WHITE.

A textbook containing all the knowledge of fundamentals required prior to elementary and advanced flying.

Each subject is presented by illustration and described completely for the reader without turning the page.

A broad treatment of subjects never before contained in general aeronautic textbooks.

Only a limited supply available.

Send for a copy NOW.

Price 18/6, post free.

From

THE WIRELESS PRESS,
 97 CLARENCE STREET,

INSURE with

**The Liverpool and London
 and Globe**

Insurance Company Limited

Assets Exceed £20,000,000

LOWEST RATES

Fire - Accident - Marine

Head Office for Australasia:

62 Pitt Street, Sydney

C. DANVERS, Manager for Australasia
 P. HEATH, Assistant Manager for Australasia
 W. B. CLARKE, Local Mgr. for New South Wales

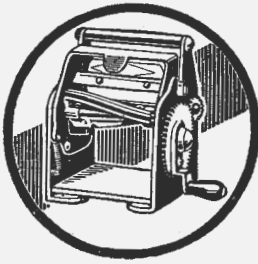

Rotastrop

SHARPENS SAFETY RAZOR BLADES

Gives a Life of 600 Shaves to Every Blade
AND YOU DO IT YOURSELF WHEN AND WHERE YOU PLEASE

ECONOMY PROMPTS YOU TO SEND 35/-

S. SCOTT-YOUNG LTD. "BROUGHTON HOUSE"
KING STREET, SYDNEY
COMMERCE HOUSE, MELBOURNE.

KITCHENER

LIMITED

Tailors & Mercers

Specialists in
NAVAL MILITARY
and
MERCANTILE MARINE
: : UNIFORMS : :

Regulation Badges, Braids, Buttons,
Caps, etc., always in Stock

Uniforms made at short notice

Price List on Application

227 George Street

Tel.: City 3449 (Near Bridge St).

R. HOFFMANN & CO.

58-60 Spencer Street
MELBOURNE

Phone: Central 6921

CUSTOMS, SHIPPING and
FORWARDING AGENTS

GENERAL CARRIERS

AGENCIES THROUGHOUT
THE WORLD

PRINTING is a silent salesman.
Our service will make a strong
appeal to discerning business men who
know the value of high-grade printing
as a business getter. Phone, City 1870

Commonwealth & Hunt Sts., SYDNEY

PHONE
CITY
1870



SHEPHERD & NEWMAN

COMPLETE PRINTING SERVICE

TYPOGRAPHIC ARTISTS
COMMERCIAL COLOR AND
HALF TONE PRINTERS.

Make Sure of receiving your copy of
 "SEA, LAND & AIR" by mailing 10/-
 with your full name and address to:
 "SEA, LAND & AIR,"
 97 CLARENCE STREET, SYDNEY

STERLING PLATING & MFG. CO
 (Late Stokes & Sons),
 225 CLARENCE STREET, SYDNEY.
 ELECTRO, SILVER, NICKEL AND BRASS
 PLATERS.
 All kinds of Lacquering, Gilding, Bronzing and
 Oxidising Done.
 Phone: City 6088.

W. & H. HENRY
 GENERAL WOODWORKERS
 Manufacturers of Office Furniture, Wireless
 Cabinets, Instrument Boxes, Etc.
 586 Darling St., Rozelle, Sydney
 Phone: W1304

BATSON & CO. LTD. PRINTERS, SYDNEY

BATSON & CO. LTD.
 ART AND COMMERCIAL PRINTERS,
 Bookbinders and Account Book Makers.
 Phone 8420. 99 CLARENCE ST., SYDNEY

BATSON & CO. LTD. PRINTERS, SYDNEY

**The India Rubber, Gutta Percha
 and Telegraph Works Co. Ltd.**

Manufacturers of
 EBONITE, C.M.A. WIRES
 and CABLES, LECLANCHE
 CELLS, TELEGRAPH
 INSTRUMENTS, PALMER
 CORD TYRES, &c., &c.

Sydney Branch
 279 GEORGE STREET

"BUILD YOUR OWN MODEL LOCOMOTIVE"

Model-makers' Supplies from—

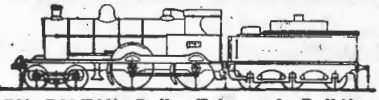

O. BURNABY BOLTON, Daily Telegraph Building
 King Street, Sydney

EDWARD WATERS & SONS
 (Established 1859)
 Patent and Trade Mark Attorneys
 905 CULWULLA CHAMBERS,
 67 CASTLEREAGH ST., SYDNEY
 Tel. City 1187 (And at Melbourne)

BACON & CO. LTD.

Blockmakers, Engravers
 Illustrators

31a PITT STREET
 SYDNEY

Phone City 4837.

For Service Telephone 1180 City

The Rapid Freight Despatch Co.

CUSTOMS, SHIPPING & FORWARDING AGENTS
 Broughton House, King Street, SYDNEY

JONES & PIKE Tel. 404 PET.

CABINET MANUFACTURERS

Specialties:
 LETTER FILING, CARD CABINETS
 AND GENERAL OFFICE FURNITURE
 Macquarie Street, Leichhardt, Sydney

N.S.W. ELECTROPLATING CO.

For Nickelling, Silverplating, Oxidising, etc.,
 Ring us. We pick up immediately by Motor
 Delivery and Re-deliver Early.

8 Parramatta Road, CAMPERDOWN, SYDNEY
 Phone L 2376

C M A
 Wires and Cables
JOHNSON & PHILLIPS LTD.
 212 Clarence Street, Sydney.

BRIEF MENTION

Would You——?

Would you be at peace? Speak peace to the world.

Would you be healed? Speak health to the world.

Would you be loved? Speak love to the world.

Would you be successful? Speak success to the world.

For all the world is so closely akin that not one individual may realise his desire except all the world share it with him. And every good word you send into the world is a silent, mighty power, working for Peace, Health, Love, Joy, Success to all the world—including yourself.—*Elizabeth Towne, in Success Magazine.*

Success Nuggets.

To hear always, to think always, to learn always, it is thus that we live truly; he who aspires to nothing and learns nothing is not worthy of living.

* * *

The more persistently we hold the prosperity thought, the more we strengthen and intensify it, the more we increase its power to attract prosperity.

* * *

Whatever page we turn,
However much we learn,
Let there be something left to dream of still!

* * *

A grouch and his customers are soon parted.

* * *

The most valuable "system" is a good nervous system.

A BOON TO MEN WHO SHAVE THEMSELVES.

Nowadays the number of men who shave themselves in preference to going to a barber is much greater than it used to be, and the reason thereof is not far to seek.

It is much more convenient and economical to perform the operation in one's own home, in addition to which the risk of contracting some skin disease, through

being shaved with the same instrument as others is entirely eliminated.

The advent of the safety razor solved the problem of home shaving for many men, and for travellers it proved the greatest possible boon. There was only one shortcoming, *viz.*, the expense involved in continually purchasing new blades.

This disability was, however, destined to be quickly overcome, and in *Rotastrop*, the machine which sharpens safety razor blades and is guaranteed to give a life of six hundred shaves to every blade, the owner of a safety razor found a device which practically ended his worries and troubles. The machine costs only 35s, but as it is practically everlasting it is easy to realise what a really economical proposition the outlay is. It can be successfully used by the most inexperienced man, and the pleasure and comfort attending a shave by a *Rotastrop* sharpened blade makes one wonder why the operation was ever looked upon with such feelings of dismay as is the case with the average man to-day.

Rotastrop can be purchased from S. Scott-Young, Ltd., 76 Pitt Street, Sydney.

EDUCATIONAL ANNOUNCEMENTS

'OSBORNE' LADIES' COLLEGE, EPPING

ONLY 14 MILES FROM CITY.

A Boarding School for Girls, in good climate. Pupils prepared for all Public Examinations.

Highest Results Attained. Excellent Health Record.

Fees Moderate.

For parents' Testimonials and Prospectus apply—

MISS VIOLET GIBBONS, Principal.

Morven Garden School

North Sydney.

is ideally situated in 25 acres of gardens and playing fields. School of Music (Director, Stefan Polotynski); Arts and Crafts School; Commercial School; Domestic Science School.

Prospectus for each on application.

Tel.: J 1613.

St. Joseph's College

HUNTER'S HILL, SYDNEY

A Boarding School for Boys conducted by the Marist Brothers

For Prospectus apply Brother George, M.A., Principa