

MITCHELL LIBRARY  
3 APR 1929

# Wireless Weekly

3<sup>p</sup>

INCORPORATING "RADIO IN AUSTRALIA & NEW ZEALAND"

VOL. 13. NO. 15.

FRIDAY, APRIL 5, 1929.

(Registered at the G.P.O., Sydney, for transmission by post as a newspaper).

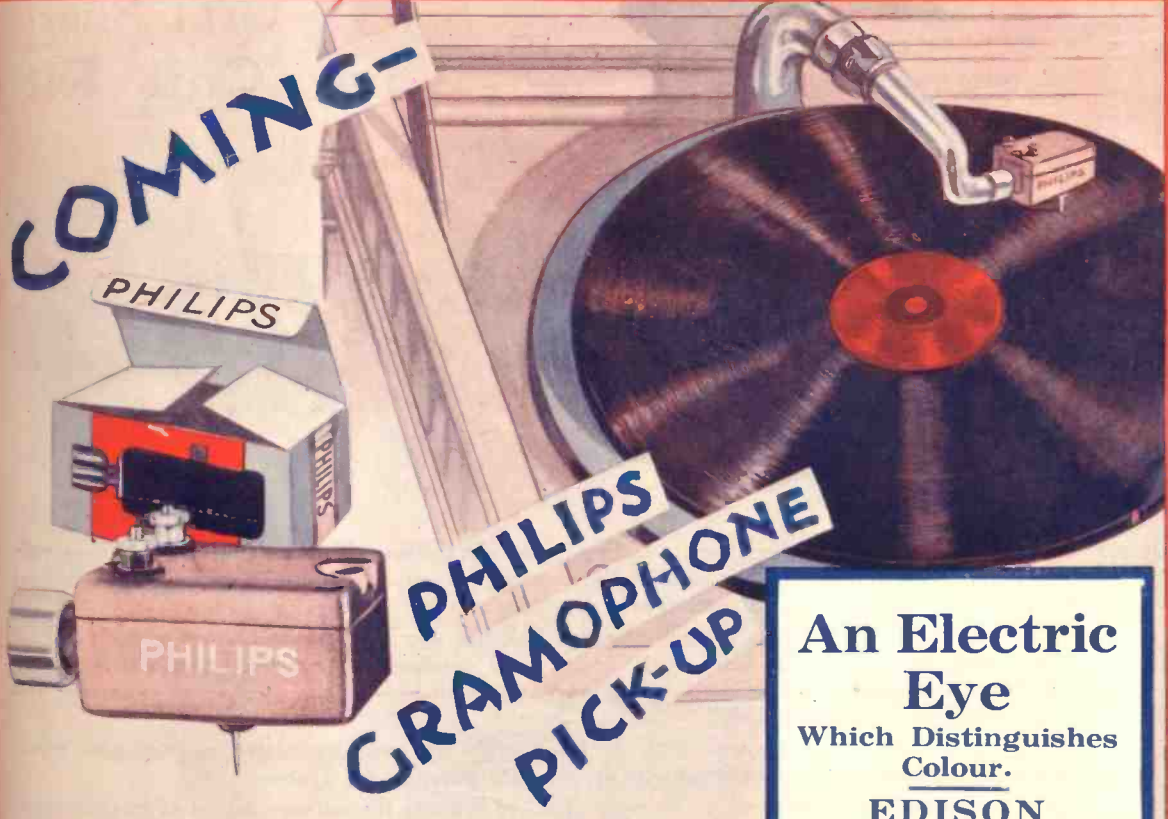

COMING-

PHILIPS  
GRAMOPHONE  
PICK-UP

# PHILIPS RADIO

## An Electric Eye

Which Distinguishes Colour.

**EDISON**

The Man and His Work.

The Simplest Shielded Wave-Trap

How to Build the Air-Wire

The Week's Broadcast Programmes

# THE AIR KING

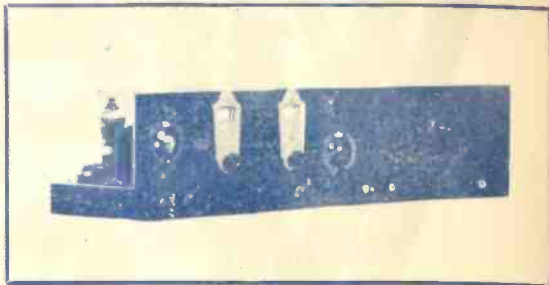

*That Excellent Receiver described in this Issue Specifies*



## Radiokes New Screen Grid Short Wave Coil Kit

**T**HE above kit represents the ultimate in Precision Short Wave Plug in Coil Kits. These coils have been built scientifically to meet all the exacting demands of high frequency work such as extremely low losses, rugged construction and permanency of calibration.

The skeleton pattern formers of highest grade bakelite support the windings with the least quantity of solid dielectric in the fields of the coils. The spacing between the turns makes for the lowest distributed capacity, and rigid rivetted framework tends to keep the mechanical properties and calibration as originally manufactured.

The interchangeable inductance units are fitted with six specially plated contact pins which engage in a suitable mounting base fitted with an accurate silver spring system.

This new mounting makes coil changing a pleasure because the velvety action of interchanging the coils in the base contacts is so simple, smooth and makes a positive electrical contact. This action can be repeated almost indefinitely without any risk of damaging the coil forms.

This kit, as illustrated, consists of four interchangeable R.F. transformers, mounting base and antenna coupling choke, and covers a range of 15 to 115 metres.

**PRICE, 72/6 per Kit**

Obtainable from all High-class Radio Dealers or direct from

**METROPOLITAN ELECTRIC CO., LTD.**

"RADIOKES HOUSE,"

126-128-130 SUSSEX ST., SYDNEY



# SIEMENS RADIO BATTERIES

Stand the test  
of TIME

PRICE.

25

Time is the Great Leveller. The value of a Radio Battery is measured by the time of its usefulness and efficiency during that time.

By efficiency it is understood that nothing less than 100 per cent. is worth while. It must deliver all that is called upon it to do to make your set function with precision and clarity. It is the most vital part of your radio equipment.

With a "SIEMENS" Battery you get long life, plus 100% efficiency. A "Siemens" is constructed to deliver these two vital essentials. A specially prepared Electrolyte is employed to overcome rapid deterioration.

The moment you install "SIEMENS" as part of your radio equipment you will begin to know what efficiency really is, and after months of heavy duty you will discover how economical, too! Cut out Battery troubles—hook up to Siemens.

BE SURE TO INSIST ON

# SIEMENS

## RADIO BATTERIES

British Built Throughout

ON SALE  
AT ALL  
RADIO  
DEALERS

ACCREDITED  
RADIO  
DEALERS  
APPLY  
FOR  
TRADE  
TERMS.

# SIEMENS (Australia) Pty. Ltd.,

257 Clarence Street, Sydney; 45 Watt Street, Newcastle; Melbourne, Adelaide, Brisbane, Hobart.

# PILOT Products of the World's greatest Radio Parts Plant

## Revised Prices !!

Owing to the heavy sales of Pilot Parts since Harringtons, Ltd., assumed the Australasian Agency, better buying arrangements have now been made, and it has been decided to pass on the benefits immediately. THE NEW PRICES ARE OPERATIVE FROM 1st APRIL, 1929.

In practically every instance prices have been appreciably reduced, and it is now a fact that PILOT-PRODUCTS OF THE WORLD'S GREATEST RADIO PARTS PLANT-COST THE AUSTRALIAN USER NO MORE THAN COMPETING LINES.

## PILOT PARTS FOR THE "AIR KING" RECEIVER

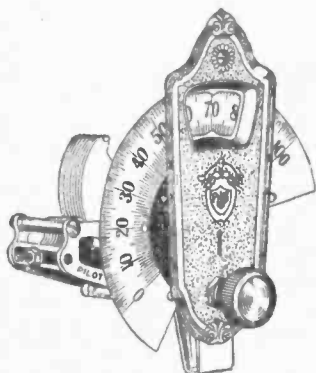

No. 1282L.  
Illuminated Vernier Dial,  
with Bulb.

Most of the world's radio experts show a distinct preference for Pilot Parts. For the "AIR KING" receiver, announced in this issue, the technical editor of Wireless Weekly largely specifies Pilot. We recommend the following parts for use in this receiver:—

Catalogue No.	Description	New Price operative from April 1st.
1608.—2	Pilot .00016 S.L.F. Variable Condensers, each	10 6
123.—2	Pilot .0001 Midget Variable Condensers, each	8 0
1282L.—2	Pilot Illuminated Vernier Dials, with bulb, each	14 6
1279.—2	Pilot Art Dials, each	6 9
930.—30	ohm Pilot Rheostat, each	3 6
42.—	Bakelite Toggle Switch	2 9
206.—6	Pilot Sockets, each	3 0
212.—	U.Y. A.C. Valve Socket	3 0
180-4.—	Wasp Kit of 5 Coils	60 0
205.—6	UX Valve Bases, each	1 3
V.M. 80.—	Micrograd	5 0
391.—3½	to 1 Ratio A.F. Transformer	17 6
760.—	Pilotohm 5 Meg Gridleak	1 6
61M.—	Fixed Condenser, .00025, with Clips	2 6
64.—	Fixed Condenser, .002, with Clips	2 6
68.—	Fixed Condenser, .006, with Clips	3 0

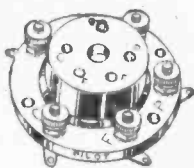

No. 212.  
UY Socket.



No. 391, 3½ to 1.  
Ratio A.P. TRANSFORMER.

# Harringtons LTD.

386 GEORGE STREET.

Branches all States and New Zealand.



Vol. 13, No. 15  
Friday,  
April  
5,  
1929.

# Wireless Weekly

*Incorporating Radio in Australia & New Zealand*

Address:  
51 Castle-  
reagh St.,  
Sydney.  
Phones:  
B7148-9.

## EDISON—World's Greatest Inventor

*Only the rise of the industrial era could have produced Edison—the greatest inventor the world has known. His scientific applications are estimated to-day to be worth more than three thousand million pounds.*

THE history of the world is but the biography of great men, said Carlyle, and nothing is more true of the history of radio and electrical activity than this. And more than this, the history of electricity can be encompassed in the biographies of a very few great men, almost all of whom began humbly.

Thomas Alva Edison is one such man. Not many great inventors began more humbly, and few have had more influence on the commercial applications of electrical principles which have revolutionised contemporary progress than he.

### SAID HE WAS "ADDLED"

Edison went to school for three months. That was all the formal education he ever received. He afterwards described himself as pretty consistently at the foot of his class. To an inspector his teacher reported him as "addled." But it is of interest to note that Sir Isaac Newton when a lad, was considered rather a dunce; that James Watt, the inventor of the modern condensing steam engine, stood poorly in his classes; and that regarding Sir Humphry Davy, the eminent English chemist, one of his teachers later declared, "While he was with me I could not discern the faculties by which he was so much distinguished." Time proved their quality, as it did Edison's.

The biography of Edison, but recently written ("Edison—the Man and his Work," by George S. Bryan, Angus and Robertson) shows him to have not the phenomenal brain, or the genius sometimes painted, but a steady, observant man who won through through sheer doggedness. Indeed, far from being the brilliant scientist, the following story told of him shows him to be like many experimenters of to-day.

When Edison joined the Boston office of a large telegraph company as an operator his colleagues "saw only an uncouth-looking young fellow, clad lightly for such freezing weather. They thereupon put their heads together to rag the new arrival from the "woolly west." A seat at a special table was finally given to him. He was to take press from New York for the "Boston Herald," but he did not know that his fellow-operators had arranged to have the message sent by one of the speediest men at the New York end. Having begun slowly, the sender increased his pace until he had reached the limit of his ability; but Edison continued to receive with ease. Then the New York man tried slurring the words and running them together; but Edison's experience in Cincinnati and Louis-



ville had made him fully equal to this kind of thing. At last, when the message was about completed, Edison opened the key and advised New York, "Young man, change off, and send with your other foot." It is not recorded that Edison's associates attempted anything further.

This incident has probably had its counterpart with many hundreds of radio amateurs since then. Similar stories of Edison's early life show him to be keenly observant, and tackling the problems he set out to solve with determination and patience rather than brilliant inspiration.

### WHY EDISON REMAINS DEAF.

An amusing story is also told of Edison which shows him in another light in his later years:—

"Ernest E. Calkins, a New York advertising man, refused, as did Edison, to let deafness become an affliction. Calkins once asked Edison, as one deaf man to another why he of all men had not tried some electrical device for making hearing easier. According to Calkins, Edison replied, 'Too busy. A lot of time is wasted in listening. If I had one of those things my wife would want to talk to me all the time.'"

The invention of the first phonograph was a simple incident.

"John Kruesi had seen Edison accomplish some pretty amazing things," says Mr. Bryan, "but John's credulity had its limits. One day, in the autumn of 1877, Edison handed to him a sketch of a model to be made as piecework, and on the margin of the sketch was a memorandum of what Edison thought the right price for the job—18 dollars. Kruesi set to work. He tried to figure out what such a queer affair was for; then he went to Edison and asked him; he thought the whole scheme ridiculous. His business was, however, to complete the model; and so the model was completed, and John stood by to see what would happen.

### "MARY HAD A LITTLE LAMB"

"There was no denying that the model did look rather odd. On a wooden base a metal shaft, having a thread cut in it (like a horizontal screw), and with a handle at one end, was mounted upon two supports. The shaft ran through a metal drum, into whose surface had been cut a spiral groove. On either side of the drum was a little tube, and over the inner end of each little tube was stretched a parchment diaphragm. In the centre of each diaphragm was a steel needle.

"Kruesi was positive the thing would be a failure. So was Carman, foreman of the machine shop, who (according to the accepted story) backed his opinion with the bet of a box of cigars. Edison thereupon proceeded to act in a highly absurd manner. He put a thin sheet of tinfoil around the drum. Then he started to turn the handle of the shaft, while at the same time into one of the little tubes he declaimed in stentorian tones that immortal lyric, 'Mary Had a Little Lamb.' Then he turned the shaft backwards to the starting point, drew away the first tube, adjusted the other, and once more turned the shaft forward. Out from the machine, faintly but surely, came the voice of Edison reciting the class adventure of Mary and the lamb.

"'Mein Gott im Himmel!' cried out John Kruesi. Carman admitted that the bet was lost. The entire staff began to collect about this marvellous cylinder, whence somehow had issued the ghost of speech. Edison's own feelings may be judged by his later words: 'I was never so taken aback in my life. . . . I was always afraid of things that worked the first time!' The machine was the world's first phonograph. To-day it is carefully preserved.

(Continued on Page 8.)

# BETWEEN YOU AND ME AND THE MICROPHONE

## Before His Peers

RACE results were coming through from Ascot between eleven and twelve at 2FC. Suddenly it became necessary for someone in the studio to make an announcement, and Mr. J. A. Hall, one of 2FC's smart young men, was the only one there to make it. The time came; and young Mr. Hall looked through the control room windows and saw three crack announcers, Mr. Cochrane, Mr. Bessemer, and Mr. C. R. Hall, watching him. It is a tribute to his ability that his announcement did



not sound at all nervous.

## Padre Donald MacLean--Pirate

RATHER a good joke has got into circulation about Capt. Donald MacLean, the famous story-teller of 3LO, and one dear old lady has written to the studio enquiring if there was any truth in it. It appears that he mentioned in one of his blood-curdling talks from 3LO that Australian waters had never known the romance and drama of the Spanish Main. One listener thought he detected a note of regret in Capt MacLean's voice, and said "wouldn't it be exciting if the captain ran amok some time and organised a band of pirates in the country." From this grew a rumor that Capt. MacLean said he would like to do something of the kind, and as the rumor spread, it assumed the alarming stage of reality, and soon (according to rumor) the pirates were actually at work. Is it any wonder that the dear old lady who had heard the famous pirate story-teller deliver an excellent sermon from the pulpit of a Collins Street Church, wrote anxiously inquiring if he had really run amok.

## That Hat

MR. ERIC BESSEMER is now wearing a hat. This may not seem extremely extraordinary, until we say that for three and a half years Mr. Eric Bessemer has not worn a hat. It is interesting to notice that the hat-wearing coincides with Mr. Bessemer's rising to the position of announcer for 2FC 2BL. You may hear him sometimes during 2FC's midday sessions and on Sundays; and sometimes from 2BL at night. And he took Captain Stevens' place when the Captain was away with a certain influenza. But why an announcer's position specially requires the use of a hat we don't know. Personally, we think he's just putting it on.



## Simile

AN "Exiled Australian" wrote to 2BL from New Zealand, saying that the children's session came through like a whiff of boronia. Mr. Basil Kirke and Company are now in search of a piece of boronia to see whether this is a compliment or not.

## The Strays' Night Out

Two naughty little X's were out upon the spree—

Said the larger to the smaller, "Now just you follow me!"

Without another word they slid down Woop Woop's aerial wire.

Which, being highly polished, set their little pants on fire.

They tripped upon the lead-in cone, and bumped against the brad;

Said the smaller to the larger, "That's the biggest bump I've had!"

They slid right down the lead-in wire and to the S.R. switch.

Which made the operator say some words that rhyme with "itch."

Dizzily on careered these strays, until they struck the grid.

And gaily down this spiral stair the little devils slid;

They then came to the "Milky Way," which flows 'tween grid and plate—

Said the larger to the smaller stray, "Come! Hurry! We'll be late!"

Now, everything in this good world begins right at your birth.

And these little X's ended, where we all end—in the earth.

G.J.F.

## No Peanuts, by Request

ALTHOUGH we have not noticed it before Mr. Basil Kirke has been announcing 2BL evening programmes for some time in the following manner:—

"2BL presents a programme of music." This method of announcing a programme has many merits; but it hardly seems complete. Mr. Kirke has scarcely made as much as possible of his idea. We make the following suggestion:—

"2BL presents  
A PROGRAMME OF MUSIC.  
Announced by Mr. Basil Kirke.  
Monitored by Mr. Charles Youngson.  
Specially adapted by Miss Gwen Gibson.  
Programme supervisors: Mr. Oswald Anderson and Mr. G. Vern Barnett.  
Accompanist: Mr. G. Vern Barnett.  
Guaranteed under the Pure Food Act by Mr. Ray Allsop.

Outside lines and transmissions by courtesy Mr. McNeil.

A NEW SOUTH WALES BROADCASTING COMPANY, LIMITED, PRODUCTION Passed by the National Board of Review."

Then the announcer could enumerate the characters. We think this would be a great idea. How much we all like it at the pictures!

## The Whistlers

THERE are many ways of whistling. One may purse one's lips; one may blow through one's teeth; and Brigadier-General Sir Granville de Laun Ryrie has been known

to entertain dinner parties by whistling through a pair of fingers previously, and of set purpose, placed in the military mouth. But only two methods are availed of during our whistling competition—the tooth method, of which Mr. Phil Mountain was the solitary exhibitant; and the pursed-lips method, which was demonstrated in various degrees of advantage by the remaining competitors.

It is now possible for us to say that Mr. Harry Graham was highly incensed with Mr. Phil Mountain for what he termed Mr. Mountain's unfair usage of double and triple tonguing; but we believe this quite unjustified, as we never could see anything fair in whistling or in love or in war. Anyhow, Mr. Harry Graham turned his back on the control room while he whistled. Then Mr. Harry Croot had a try; but why he should wish to whistle when he can sing so charmingly is beyond our comprehension. Mr. Les Austin's whistling gained an extra snappiness from the dancing movements of his head; and Mr. Carlton Fay—told us afterwards that he had been whistling, and what was wrong with it, anyway? We didn't know, but we thought it was a little out of tune; whereas Mr. Fay told us he had done that especially to prove his merit, as very few people could whistle consistently out of tune. Anyhow, someone rang up shortly afterwards to find out whether Mr. Fay was in a position to take pupils; and on the following day there was a package of canary seed waiting for Mr. Fay at the offices of the New South Wales Broadcasting Company, Limited.



## The Watchful Eye

UNCLE BAS had a peculiar request made to him the other night, while he was telling the bedtime stories. The Newtown District Ambulance men had found a little child and taken her to the ambulance station, where she was considerably upset. Nothing the ambulance men could do would cheer her up. So at last they rang up 2BL and asked Uncle Bas to give the child a call. Uncle Bas complied immediately; and the child heard her own name, and some cheery words through the ambulance station's loud-speaker. Everything



in the garden was lovely, especially as the same call proved the means of finding the child's parents. For one little child, at least, the omniscience of Uncle Bas is established.

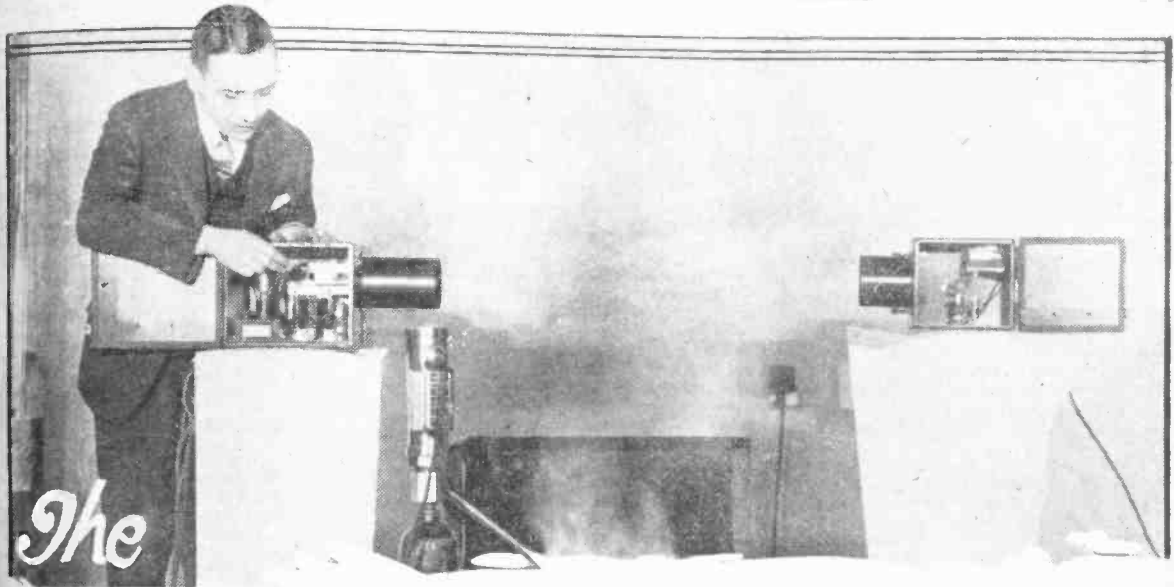

# The Electric Eye

*John V. Breisky, research engineer of the Westinghouse Electric and Manufacturing Co., demonstrating still another use for the photo-electric cell, or electric "eye"—that of extinguishing fires. He threw a lighted match on the pan in centre, containing petrol and kerosene. The first cloud of smoke instantly operated on the "eye" (left), which in turn automatically released carbon dioxide from the cylinder at left of pan and extinguished the fire immediately.*

WE think of machinery as responding to mechanical contact, sensitive, we may say, to the application of power.

It is a surprising thought that a mechanism can be made to operate in response to the effect of color, an attribute one had supposed, of the eye and brain alone. But the eye and brain may be deceived, and so there has been developed a machine that indicates and makes a permanent record of exact color values in any sample that is placed before it.

Are you not sometimes puzzled when you are choosing a color that must match exactly a given sample? Can you detect the red in a piece of black cloth? Can you see the individual colors that go to make up tan? In that interesting combination, cerise, can you see the blue and yellow, in addition to the red?

Makers of paints and dyes and pigments, makers of soap, lard, syrup, flour, and many diverse commercial products know of the difficulties that surround their efforts to secure positive and uniform results in color matching. But their troubles are in the way of being solved by an electrical contrivance now under development by the General Electric Company, supervised by Professor A. C. Hardy, of the Massachusetts Institute of Technology, whose invention of an ingenious mechanism has been placed in their hands for rounding into commercial form.

White light passed through a prism, as everybody knows, will paint upon a screen a band of the successive colors of the spectrum. Light reflected from a colored object, similarly treated, will produce a band of like proportions, but varying along its length in the matter of light intensity. If the object is blue, for example, that part of its band is brightest which occupies the same relative position as that occupied by blue in the standard spectrum. A means was sought to measure and automatically record the degree

of brightness at the successive parts of such a band, as compared with the brightness of the corresponding points of the spectrum from a standard of white light. The method is as follows:—

The standard spectrum and the light band from a color sample are flashed alternately in rapid succession upon a surface, across the face of which a plate with a narrow slot is slowly moving.

Through this slot, as it travels from the position of violet to that of red, the alternating flashes, in a narrow beam, enter

*A mechanism which is sensitive to color is the subject of this article. A development of the uses of the photo-electric cell it will match, and sort colors even more accurately than the human eye.*

If there is no difference of intensity between the rays from the standard white and from the color sample, no current flows through the cell, but, if one light is stronger than the other, the fluctuation causes current to flow. This current, after amplification by radio apparatus, energises a motor, which immediately changes the opening of a shutter, thereby increasing or decreasing the light from the standard white, until (in a moment) there is equality of the two light beams. Then the current ceases until further unbalancing occurs, which is automatically corrected, as before.

This same motor also changes the position of a pen that is drawing a curve on a chart attached to a revolving drum driven at constant speed by another motor. When the chart has completed its revolution, the slot has traversed the full length of the spectrum, and at each stage the light from the sample has been equalled by the light from the standard, the position of the pen changing with each increase and decrease of the latter.

The line drawn by the pen is a permanent record of the color characteristics of the sample, expressed in percentage of the intensity values of the white light spectrum. Having produced a curve from one sample, any other sample that writes an identical curve

gives "documentary evidence" that their colors match.

To produce the alternate flashes of light from the sample and the standard, their rays are intercepted by a revolving disc, which stands between them a little to one side. The disc has alternate segments of transparent and opaque glass. Rays from the white standard pass directly to the prism

through the transparent segments, and are stopped by each opaque segment. Alternately, the rays from the sample are caught by the opaque segments, which have mirror surfaces, and are reflected by them to the prism. Thus there is thrown upon the prism a rapid succession of flashes,

first from the sample, and then from the standard, as the disc revolves, and each, in turn, spreads its own spectrum, across which moves the slit that feeds a narrow beam to the photo-electric cell.

The chart on which the curve is drawn has a length that is proportional to the visible spectrum of white light, from violet to red. If the curve registers low on the chart at both ends, it shows that there is little, if any, red or violet in the sample. If there is a sharp rise midway between, it shows strength of blue or green. In other words, an ordinate of the curve at any point measures the prominence, in the sample, of the color located in that particular part of the standard spectrum.

With this mechanism an important step has been taken toward the practical solution of a problem that has long affected both the buyers and the producers of colors and colored substances. Accurate measurement of color is the first concern of manufacturers of fabrics, particularly in the delicate shades which often deceive the eye. Color control is also of basic importance in the making of inks, paints, dyes, paper, and lubricating oils.

In fact, a great number of industries have their color problems.

Most colors, as we know them, are far from pure—they are mixtures of various wave-lengths. And that is the reason why some colors which seem to be alike in sunlight differ so much from one another when viewed by artificial light. The prism will show that a sample of a certain green dye contains a little of every color, a decided proportion of red, but a maximum of green, bluish green, and yellowish green.

One of the interesting exhibits in connection with this color analyser is a card containing samples of three pieces of black cloth. All look alike in the daytime, and it might seem that there would be no real reason for using dye No. 1, costing more than twice as much as either of the others. Under artificial light, however, there is a decided difference. Specimen No. 1 remains black, No. 2 becomes greenish, and No. 3 assumes a rusty tinge. It is such differences as these that are shown accurately by the new apparatus.

Should a new color be developed by originators of fashion at Paris, a photoradiogram of the color analysis curve can be sent to New York, and there duplicated by dye experts before the arrival of the actual sample. The new color analyser entirely eliminates human judgment, as it automatically

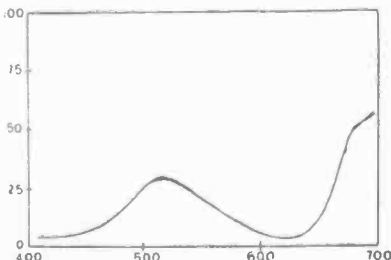

Color Value Curve expressed in reflecting power percentage at successive wave lengths of the Spectrum.

measures the color of any substance, and it does so with speed and precision, making, at the same time, a record by which it is possible to match that shade at any time, instead of depending on a color standard which itself is subject to fading.

Previous methods of color comparison have depended on the eye, thus introducing the uncertainties of the human equation. The new device is wholly mechanical, and the time required to draw the characteristic curve of a color sample is about one minute.

The ability of electric eyes to see has be-

come a matter of definite routine test, which does not differ much from the testing of human eyes.

They are tested by measuring the variation in current passed through a given cell from absolute blackness to a certain and known light intensity. The source of light, in the form of an electric lamp of known candle-power, can be moved nearer or farther away from the cell by means of a holder moving on a calibrated slide, while the response of the cell is measured by delicate meters.

The action of the electric eye is relatively simple. There is a cathode or electron-emitting substance, in the form of a deposit, on the inside surface of the glass bulb. In front of this cathode deposit is either a ribbon loop, in the case of the small bulbs, or a wire in the case of the long tubes, serving as the anode. The negative terminal of a battery is connected with the cathode and the positive terminal with the anode. In pitch blackness there should be no current flowing through the cell. However, with increasing light an increasing current flows from cathode to anode. The current is quite small, being measured in microamperes. However, the output of the cell is connected with a vacuum tube amplifier, which in turn operates a sensitive relay or other device, which is to be controlled by the varying light intensity.

## "The CAPTAIN" TO HIS "COMRADIOS"

### Coming Events

**THURSDAY, April 4:** Aspham Old Girls' Union, annual meeting at Edgecliff.

**Saturday, April 13:** Scots College, annual cricket match, Past v. Present.

**Wednesday, April 17:** Scots College O.B.U., annual dinner at The Carlton, 7 p.m.

**Wednesday, June 26:** Scots College O.B.U., annual dance at the Ambassadors.

### About Smoking

**Q**UITE a small storm has broken over "The Captain's" head after my remarks on smoking last Sunday morning. Some of my correspondents go wide of the track and mention 'Varsity men who do well enough athletically, and yet pay their respects to My Lady Nicotine. I never had any thought in my mind about 'Varsity men at the time. I did say, and I still say, that any schoolboy who smokes is a fool to himself, and disloyal to his team.

For that matter, no athlete of any age can hope to do his best if his lungs are not kept clear of tobacco fumes. Look at the self-denial practised by the Oxford and Cambridge eights. "The Captain" is no preacher, but it is plain common sense that pure lungs go with vibrant energy, rich clear blood, flexible steel muscles, and bounding, all-round, sparkling health. Give me a team packed with life and vim and I'll wipe the floor with a better grade team in a stiff tussle, where the power to last out counts in the end. I smoke a bit myself now, but my big sporting days are past, and I know I could never have got the good times I did on the field if I had tried to train on nicotine. So there!

### Tennis Racquet

**I** CANNOT advise J.T. (Vaucluse) on the correct weight of a tennis racquet. You see, I don't know your age, height, or weight. And it depends on all three. You can only pick a racquet by feeling and swinging it. Any four leading sports stores have skilled advisers. If you like, I shall meet you one Saturday morning at one of the stores and help you. I shall always be glad to do so in helping any schoolboy (or schoolgirl) to

*(Being notes from the happy personal chats to past and present schoolboys and schoolgirls and their parents all over Australia and New Zealand. Conducted by "The Captain" every Sunday morning from station 2FC, Sydney.)*

choose their special "implement" of sport in this way. Drop me a line and make an appointment.

### Personal

**P**ERSONAL notes have been sent by "The Captain" this week to "Max" (Rozele), M.E. (Bankstown), J.L. (Kogarah), D.P. (Parramatta), S.B.L. (Manly), "Jones" (Bourke), T.W. (Albury). The matters were purely personal, and not of any general interest to listeners. All letters, comments, questions should be addressed to "The Captain," c/o 2FC, Sydney. You must sign your name, but only initials are mentioned over the air, or a pen-name, just as you prefer.

### Liniment

**I**N spite of my last week's warning I have written evidence of stiff limbs already, through overdoing kicking the football at the beginning of the season. The best liniment is olive oil, eucalyptol, and methylated spirits in equal quantities. Purchase a little of each (say 2oz. each), at the chemist's so as to be sure of quality. Bore a hole in the cork with a small gimlet or red-hot skewer. This allows the mixture to be shaken on to the hand in proper proportions. Better keep a whole cork as well in case you carry the bottle about. Always have someone else rub you. No one can massage himself properly. Lie down and keep the muscles limp, not stiff. And, for goodness sake, tell your massaging friend not to slap you! It's all in gentle but firm rubbing. Tired, stretched muscles are soon put back in place then, and you feel very fit.

### Cricket for Girls

**I** AM sorry to fall out with J.S. and P.M., two of my girl comrades, on the sub-

ject of cricket for girls. I never did approve of it. My point is that the accidental knock at cricket can generally be recovered from by a boy. He is physically built to withstand blows which a girl may never quite get over. A man with a crooked nose, a scared cheekbone, a bumpy elbow, a deformed finger may even cause a certain admiration for his "honorable wounds." But a girl owes it to herself just to be her own very nice, neat, self, and has no right to spoil her looks or general appearance. Girls, it simply isn't done! Stick to hockey (that's bad enough), basket ball (best of all your winter games), basket ball (best of all your winter games). And, what's the matter with good old tennis all the year round?

### The Captain's Book List

**T**HE following Australian books have "The Captain's" special recommendation:—

"Mystery Gold" (Bartlett Adamson), 2/6.  
"The Vanished Tribes" (James Devaney), 6/.

The first is a very thrilling tale of an Australian boy's adventures in a wonderful island of the Pacific.

"The Vanished Tribes" is a book for all time. The stories and legends of our Australian natives are treated by a man who knows them intimately. The tales are most movingly written and for many a year, your odd moments, will be delightfully filled when you pull this book down, just to read once more any one of the many entrancing bush stories of the tribes.

### An Australian Poem

**R**EAD A. B. Paterson's fine bush poem, "The Story of Mungrel Grey."

### Greeting

**A**ND now, until next week's WIRELESS WEEKLY comes along, and until you all join me over the air from 2FC, next Sunday morning, at 10.15 a.m., I give you my usual greeting: "Good wishes to you all, comrades. Chèerio!"

—THE CAPTAIN.



# USING A FLOUR DUSTER TO SHIELD A WAVE-TRAP

How a domestic "bargain" considerably increases its usefulness in the eyes of the radio fan through certain applications to shielding wave-traps.

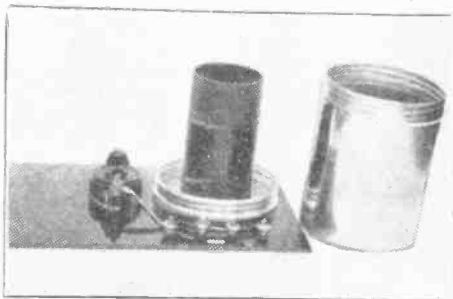

The cheapest possible shielded wave-trap and the simplest to build. A few shillings and a few minutes which may improve your reception.

(By DON. B. KNOCK, Associate Technical Editor)

THE bargaining instinct is usually attributed to the fair sex, but the resourceful wireless "fan" has a fair share of it also. The result is that articles that were certainly never intended to do duty in connection with wireless reception, find their

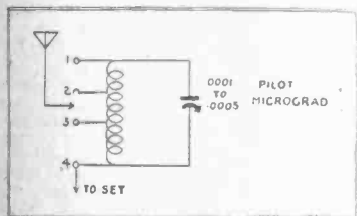

way to his work-table, and behold—a product rivaling the efficiency of the commercial article is the result.

There are many accessories which may be literally constructed from odds and ends, one of these being the humble wave-trap. The other day an ardent "Wireless Weekly" reader, Mr. Webb, of Maroubra, deposited on our office table the subject of this brief article. Just a little wave-trap, but a shielded one.

How many readers realised that such a domestic utensil as a flour-duster makes an excellent screening canister for the average two-inch diameter coil? Frankly, I will admit that I, for one, did not, and on looking over this wave-trap I realised that the idea of the flour-duster had much to commend it. These aluminium utensils may be obtained at any of the large domestic stores in Sydney,

and are well suited to wireless application for the following reasons. They have a diameter of three inches, and a length of four inches, and are fitted with a handle at the side. The lid is a perforated screw top disc, and this is where this unoffending household embarks upon its sojourn in radio-land.

The handle is removed; this is done quite easily with a pair of pliers, as the aluminium is very soft, and the rivets hammered tight into the holes, and then filed down. It will be obvious that if the lid is placed

ceiver is situated fairly close to a broadcasting station. If the set is made properly, and the screens are a really good fit, it will be possible to tune in 3LO without any interference, or, at least very little from 2BL.

Nevertheless, there are many users of wireless receivers which are using screened sets, and are still unable to totally eliminate a slight background from the local station, and would like to get over the trouble. Imperfect screening may be the cause or re-radiation from a near-by listener's aerial may have a lot to do with it. Just here is where the wave-trap steps in and gives a good account of itself.

I have had a lot to say recently about wave-traps (for they are one of the most useful of aids to good reception), and that my remarks have been justified has been

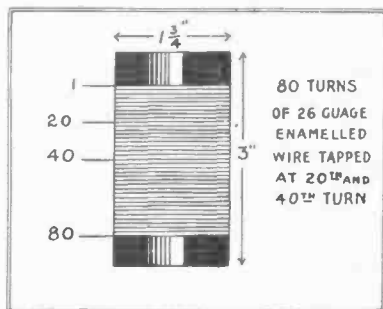

upside down on a flat surface, the canister itself may be screwed into the lid in a vertical position. What could be better than this for screening coils with the advantage that the screen is removable?

It is a long time now since "Wireless Weekly" pointed out the advantages of screened coils in minimising direct pick-up from a nearby station, and the use of these home-made screens will enable those readers who are interested to carry out an interesting little demonstration.

One point before proceeding, however. These flour-dusters are provided with perforated lids, in order to sprinkle the flour. The lid must be fitted underneath with a disc of aluminium or foil to cover the holes entirely, or the screening will not be complete.

Just think how easy it will be to make, for instance, a screened neodyne, by the use of these canisters. Supposing you have just made such a set, and wish to examine the real screening value of the screens. The effect will be more noticeable where the re-

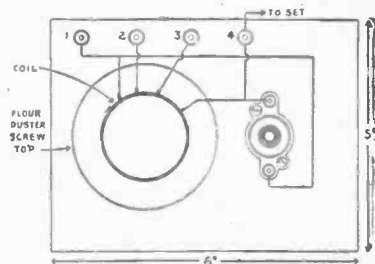

shown by appreciative correspondence. Very well, then, you are suffering from interference, and would like to make a wave-trap with a minimum of expense. Here is the way, but you had better not acquire the family flour-duster, or domestic wrath may be called on your head.

By a quick visit to Woolworths, or elsewhere, a triumphant exit may be made with the "gadget" you want, at the price of a packet of cigarettes—one shilling and sixpence! Call in at the radio dealer's on the way home and get a piece of scrap bakelite, measuring about six by five inches, a former



1 1/2 in. in diameter, and 3 in long a .0001 to .0005 mfd. micrograd condenser four terminals, and a small reel of No 28 enamelled copper wire.

Arrived home, and armed yourself with the hand-drill and a pair of pliers—the rest is easy. Drill some small holes in the former, and wind on 80 turns of the wire, twisting loops at the 20th and 40th turn for the tappings. Screw the lid of the canister to the bakelite with the screw part looking upward, so that the canister may be screwed into it.

Do not forget to slip a disc of soft or sheet aluminium underneath, to cover the perforations. The screw that holds this to the bakelite may also serve to hold the coil in the centre by cutting a disc of cork or wood to fit the inside of the former, and passing the screw through the whole lot. The ends of the coil and the tappings are taken down through the metal and the bakelite, and covered with "spaghetti" where they pass through. The four terminals are arranged on one side of the bakelite and the variable condenser adjacent. Wire it up as in the accompanying diagrams—and there you

are—a perfectly efficient shielded conductively coupled wave-trap for a mere song! Connect the aerial to whichever tapping gives the best results of 1, 2, and 3, with No 4 to the aerial terminal of the set. Nothing in it is there? On testing the original at Randwick, I found that an ordinary three valve Reinartz, which was not too selective on 2BL, allowed easy reception of 3LO with quite a large aerial and no background from the local station. On removing the screen from the trap the background became annoying—so the flour-duster was giving a good account of itself.

# The Edison Chronology

(Edison: World's Greatest Inventor  
—Continued from Page 3)

in the Victoria and Albert Museum, South Kensington, London."

It is the astounding chronology of Edison's inventions which seems so formidable to the humble radio experimenter

## AN EDISON CHRONOLOGY.

- Born at Milan, Erie County, Ohio, February 11 ..... 1847
- In the cellar of the house at Port Huron, Michigan, fits up the first Edison laboratory ..... About 1857
- Becomes a newsboy on the Grand Trunk Railway ..... 1859
- Issues "The Weekly Herald," from a railway car ..... 1862
- Learns telegraphy from J. U. Mackenzie at Mount Clemens, Michigan ..... 1862
- Works in a local telegraph office at Port Huron ..... 1862-1863
- Is a railway telegraph operator on the Grand Trunk at Stratford Junction, Ontario, Canada ..... 1863
- Is a roving telegrapher in the central west ..... 1863-1866
- Goes to Boston as an operator ..... 1863
- Invents his vote-recorder, his first patented invention ..... 1868
- Arrives in New York, and becomes superintendent of the Gold and Stock Telegraph Company ..... 1869
- Invents the unison device and other improvements in stock-tickers; also the "Universal" stock-printer ..... 1869
- Opens in Newark, New Jersey, a shop of his own, where he builds stock-tickers ..... 1870
- Aids Christopher L. Sholes, inventor of the first practical typewriting machine, in making an improved working model ..... 1871
- Works on the automatic telegraph; develops duplex and quadruplex telegraph system; invents the mimeograph and electric pen; begins researches in telephony ..... 1872-1875
- Removes from Newark to Menlo Park, New Jersey ..... 1876
- Opens up the possibilities of Bell's telephone by inventing the carbon transmitter, applying it to a closed circuit, and introducing an induction coil; invents the electro-motograph, the principle of which was later applied to his loud speaking telephone ..... 1876
- Invents the phonograph ..... 1877
- Improves the phonograph; begins his study of electric lighting ..... 1878
- Works on incandescent electric lamps, putting into circuit on October 21 one that establishes the general principle on which success is based ..... 1879

- Develops new type of dynamo, having greatly increased efficiency; plans and works out his system of incandescent electric lighting, including means of distributing, controlling, and measuring the current, as well as appliances for the lamps; publicly exhibits the system at work at Menlo Park, December 31, 1879) ..... 1879-1880
- Invents the magnetic ore separator ..... 1880
- Builds his pioneer electric railway line and makes experiments in electric traction ..... 1880-1882
- Opens offices in N. York for the purpose of introducing his electric lighting system; establishes the first commercial manufactory of incandescent lamps, also shops for turning out dynamos, underground-tube conductors, junction-boxes, meters, chandeliers, switches, sockets; devises his "three-wire system" of distribution, first installed at Sunbury, Pennsylvania ..... 1881
- Opens the first commercial electric-lighting central station in the United States at 255-257 Pearl St., New York, September 4 ..... 1882
- Removes his laboratory and headquarters to West Orange, New Jersey ..... 1887
- Develops the improved wax-cylinder phonograph ..... 1887-1890
- Invents the motion-picture camera (kinetograph) ..... 1891
- Develops and manages his ore milling enterprise, solving its engineering difficulties and providing necessary inventions ..... 1891-1900

- Enters the Portland cement industry; invents the "long kiln"; introduces the "poured" house; invents and perfects the alkaline storage battery; produces a new form of business phonograph and introduces his "Universal" electric motor to be used with this machine ..... 1900-1910
- Develops a phonograph of greatly improved type, using disc records ..... 1910-1914
- Introduces the "talking motion picture" (kinetophone) ..... 1912
- Introduces the telescribe and the transophone ..... 1914
- Unable to obtain phenol (carbolic acid) from abroad, devises a process for making synthetic phenol, and opens a plant that within a month produces a ton a day ..... 1914
- Becomes president of the Naval Consulting Board of the United States ..... 1915
- Evolves plans and develops inventions for the United States Government ..... 1917-1918
- Improves his existing inventions; conducts chemical experiments; manages his business undertakings ..... 1919—
- What other living man can produce such a record! Inventions estimated to-day to be worth £3,120,000,000, although, of course, not all to Edison himself. It is this amazing fact which disheartens the ambitious. What else is left to invent? But listen to Edison himself in a questionnaire:—
- Q.—"Do you believe that the domain of electricity has practically been explored and charted, or is it still an unexplored realm, destined still further to contribute to the happiness and wonderment of mankind?"
- A.—"The Electrical Age is just starting."
- But, we should also note that the same questionnaire by this wise old man ends with a sombre note.
- Q.—"In view of the future possibilities for wholesale destruction of human life and property through scientific discoveries since the armistice, do you believe that another world war is probable? Will not the certainty of the appalling destruction of another great war act as a restraining force upon all nations of the earth?"
- A.—"I think it will oppose any large wars and restrain them."
- Q.—"Do you believe that civilisation is retrograding, or that the present moral laxity and unrest are indicative of a new phase of human life and a great change for the better?"
- A.—"I believe civilisation is advancing, but the great war and the rapid advance in scientific methods makes it seem queer. It is the rapid transition that makes it so."
- Q.—"If the population of the world continues to increase at the rate of the past half-century, what will be the result in two hundred years?"
- A.—"War."

### THE SPECIAL NIGHT

Sonia Hardie.

The tea is over early,  
For it's Old Time Night;  
None would miss an item  
Of the programme bright.  
Move the table backwards,  
Pile the chairs on top.  
3LO have started—  
It's an Old Time Hop.

Hear the dreamy waltzes  
Of the long ago,  
On the air they're floating  
Straight from 3LO.  
Now then for the Lancers,  
Hold your partner tight,  
We enjoy each moment  
Of the Old Time Night.

Can you still remember,  
In the days of yore,  
Bill's old concertina  
And the old barn floor?  
The tea is over early,  
For it's Old Time Night;  
Who would miss an item  
Of the programme bright!

# £300 TO BROADCAST TESTS

*The cricket broadcasts in New South Wales during the past season have probably not been previously exceeded in interest. The reliability and extent of the service have called for a great deal of organisation and expense on the part of the Broadcasting Company.*

WHEN the programme covering the English tour and the Sheffield Shield matches was laid before the directors of the New South Wales Broadcasting Co. Ltd., they decided that no stone was to be left unturned which would prevent offering to devotees of the national game the best facilities of broadcasting. Every game was to be covered by the fullest possible descriptions, and, above all, special attention was to be paid to the Test matches in the four States. That the decision of the Board has been fully honored, is borne out by the many expressions of appreciation which have been received at both the company's studios. Among these messages are quite a number from prominent players as well as from men directly interested in the government of the game. One from an English visitor, Mr. H. R. Ruthven, expressed the value of this service in rather an interesting way. He said:—

"An unfortunate accident prevented my going to Brisbane to see the first Test match. This meant that I was confined to my room at my hotel, but being the fortunate possessor of a portable wireless set, I was determined at least to hear the scores. To my surprise, however, I received much more than the bare scores, for from time to time a progressive description of the day's play was conveyed to me over the air. It seemed to me almost impossible to believe that at a distance of over 600 miles away from the match, I could have got so much descriptive information so rapidly upon its actual performance. When I return to the old country, I shall not be backward in letting my friends know how well catered for, by the Sydney stations, are the cricket lovers resident in New South Wales."

Perhaps it would not be out of place here to make available to listeners some of the enormous detail which has had to be covered to keep them in touch with the games that have been played during the cricket season. The preparation of the descriptions of the Test matches alone occupied one hundred and eight-one hours, and filled over seven hundred and forty sheets of foolscap. Four hundred and twenty-four trunk calls were linked up, and over 2500 miles of trunk lines were brought into operation during the games, while the actual transmission time in telling the progressive story of these matches occupied sixty-seven hours twenty-two minutes. The cost to the company in giving this service totalled nearly £300. Commencing at 12 o'clock each day of the Tests, the programmes of 2BL and 2FC were so arranged that both stations were available for the descriptions of the games right up till the close of play. Records were established in several directions covering the total mileage in land lines used, the synchronisation of transmissions from both stations,

and the progressive description of the whole series of Test matches.

Throughout the season the Post Master General's Department has shown the maximum of consideration in making available the trunk lines, without which the story of the Tests could not have been told.

It is interesting, in view of the present controversy which is being waged in another State, as to whether broadcasting from the Sports Grounds has a tendency to interfere with attendance, to note that the whole five Test matches have been broadcast. Yet an official statement published during the past week, states that, during the English tour—every match of which was broadcast—well over £90,000 has been taken at the gates, and that the attendance and takings have created a record for the whole period over which these Tests have been carried out.

## Country Interest in Cricket

THERE have been many comments on the fact that big cricket has excited much more interest this season than during any previous season. A certain amount of enthusiasm is always expected during the tour of the English team, and large attendances at the matches are not surprising. But this year the enthusiasm has not been confined to the people who attended the matches; cricket has been the subject of conversation and discussion everywhere. And it has not been confined to the cities where the matches have been played. Country people have evinced as much interest in the progress of the games as the more fortunate city dwellers who are able to see the matches played.

It is well known that anyone with a wireless receiver situated within the day range of a city station, say 3LO Melbourne, is sure to have many callers during the afternoon. Whether it be a halfdresser's shop, an hotel, or a private house, if the loud speaker is giving out the description of the game there is sure to be an audience.

And therein lies much of the reason for the increased interest in cricket: broadcasting has brought it closer to many thousands of people. Many of them, of course, unfortunately would be unable, owing to distance and other disabilities, to go to the Cricket Ground; but their interest has not been allowed to flag as it would had there been no broadcasting of the Test matches. There are others, however, whose interest in the sport was not a particularly live one; normally they would be content to read the results in the papers. But when they spend some of the Saturday afternoon listening to the description of the Test instead of doing their usual garden drill, it is inevitable that a deeper and livelier interest is awakened. The result is that first opportunity they endeavor to see the match.

The broadcasting companies in Australia deserve much public commendation for their sporting services. Attractive items such as descriptions of cricket and football matches, horse races, etc., were included in the Australian programmes long before the stations in England and America took such a close interest in sport. Even now the sporting services of the English stations are far behind those of the principal Australian stations.

These services are specially valuable to country listeners whose opportunities for participation in amusements and entertainments are much less than those of the city residents. It is a good sign that the country listeners' interests are thus looked after by the broadcasting companies.

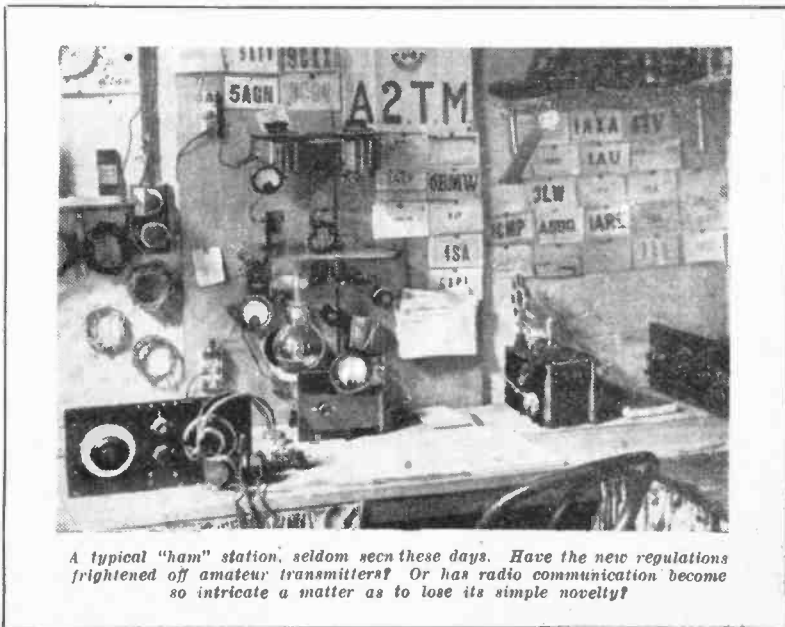

*A typical "ham" station, seldom seen these days. Have the new regulations frightened off amateur transmitters? Or has radio communication become so intricate a matter as to lose its simple novelty?*

# INLAND WIRELESS COMMUNICATION

*How radio benefits the outback listener-in, and some recent efforts to increase inland radio communication*

(Notes by Our Melbourne Correspondent)

**W**E in the cities, with every modern convenience that city life can offer, seldom think of the inconveniences and disadvantages of living in the far distant parts of the country. There are advantages of a very attractive kind in urban life not very far removed from cities; but the lack of facilities for comfortable living outweigh the attractions of life in the interior. That is in Central Australia, and other wide and lonely districts far off the beaten track.

To those people, or some of them at any rate, some amelioration of their conditions has been brought about during recent years by means of radio. Now it is not necessary to wait for weeks—or months—for some items of news, the broadcasting stations regularly supply items of news which enable the man in the interior to keep abreast of the times. Be it the result of a Test match, a horse race, a Parliamentary election, or other news matter, 3LO, Melbourne, has it in one session or another, and the distant listeners, tuning in at the advertised time, learn the result, or get the news just as soon as the farmer or settler many hundreds of miles nearer to the broadcasting station.

Recent expeditions to the Valley of Palms in Central Australia, in which 3LO co-operated, showed the surprised visitors that, at many inland homes—tents, huts, or homesteads—the familiar wireless aerial was in evidence. The long evenings were relieved of their monotony by the strains of music and song from distant cities.

Apart from reception of broadcasting station programmes, it was noted that a very commendable effort was being made by the Presbyterian Inland Mission in connection with wireless and aviation. Eight or ten wireless stations have been established for use by settlers. Those "stations" comprise crude and rugged equipments specially designed for service in the severe climates of the interior, and specially adapted to un-

skilled or comparatively unskilled attention by the "operators." The Mission authorities had in mind the use of wireless sending and listening sets by local residents, settlers, drovers, etc., much in the same way that telephones are used in the country districts.

For many years the Federal Government had been requested to provide some means of communication—by telegraph or telephone—but all to no avail. Apparently it was more desired to look after the man on the land nearer the capital cities. This condition of affairs was known to the Mission authorities who took on themselves the task of providing some means of communication. To make the service workable, financially, the equipments were designed for rough usage, and local settlers were given tuition in the care and operation of the sets.

The scheme has not yet been completed, not all of the stations have been established, but the scheme is proceeding in its development as planned. It will be possible to send and receive messages at most of the settlements near and north and west of Alice Springs; and the settlers will also be able to utilise their sets for listening to the broadcast programmes.

### Oliver Peacock

**(O) LIVER PEACOCK**, whose breezy rendering of "Hustling Hinkler" is still remembered by crowds of listeners, will be at 3LO on April 9 in a budget of popular numbers well suited to his pleasing light baritone.

### "The Geisha"

**T**HE musical comedy, "The Geisha," by Sydney Jones, will be given from 3LO on April 10 under the direction of Madame Ethel Ashton, who will be assisted by some clever Melbourne artists. The production is in the capable hands of Maurice Dudley.

### Vida Lugg at 3LO

**MISS VIDA LUGG**, who is giving a combined piano and vocal recital from 3LO on April 9 is well known in musical circles and to Victorian listeners. She has toured with concert parties on many occasions, is a graduate of the Melbourne University, and holds the degree of Bachelor of Music.



**KERRY KELLY**, who is at present providing entertainment for 3LO kiddies



**MARION LIGHTFOOT** and her band are back at 3LO

### Versatile Pianiste at 3AR

**A** SHORT piano recital will be given from 3AR on April 13 by Emily Davis, who is already favorably known to listeners.

### Tree Planting Conference

**(O) N** April 10 the speeches in connection with the Annual Tree Planting Conference will be broadcast by 3AR. The conference is under the patronage of the Rt. Hon. the Lord Mayor of Melbourne, and the delegates are constituted of the "Curators of Public Parks and Gardens from all parts of the Commonwealth, and already a large attendance has been assured.

### Blind Institute Concert

**A** SPLENDID concert programme, arranged by the secretary of the Royal Victorian Institute for the Blind, will be given on April 10, and broadcast by 3AR.

### Life's Facts and Fancies

**T**HE series of talks dealing with "Life's Facts and Fancies," given by Dr. Loftus Hills from 3AR, is creating much interest among women who want to know "Why."

## Licenses Show Radio Development in Six Months

*The progress of broadcasting in Australia during the last six months is well indicated by the figures herewith. The numbers of licenses taken out, cancelled, and lapsed are shown here.*

Month.	NEW SOUTH WALES					Net Increase.	Ratio to 100 of Population.
	Licenses in force.	New Licenses.	Cancelled Licenses.	Net Increase.	Ratio to 100 of Population.		
1928.							
September	87,622	4,256	1,831	2,425	3.63		
October	88,783	2,805	1,651	1,154	3.67		
November	90,177	2,917	1,627	1,394	3.72		
December	91,709	2,573	1,141	1,532	3.78		
January, 1929	92,681	2,145	1,173	972	3.83		
February, 1929	94,404	2,498	776	1,723	3.87		
Totals	94,404	17,294	8,098	9,200	3.87		

• Increase of 87 per cent. of Commonwealth total.

VICTORIA					
1928.					
September	142,697	3,531	2,276	1,253	8.15
October	141,988	2,535	3,135*	609	8.12
November	143,250	2,534	1,269	1,265	8.19
December	141,890	2,088	3,445*	1,360	8.11
January, 1929	141,279	2,150	2,761*	611	8.08
February, 1929	141,642	2,136	1,773	383	8.07
Totals	141,642	14,974	14,659	315	8.07

\* Decrease.

QUEENSLAND					
1928.					
September	25,673	582	649*	63	2.84
October	25,566	498	604*	107	2.83
November	25,235	518	849*	331	2.77
December	25,224	394	404*	11	2.77
January, 1929	24,761	414	877*	463	2.72
February, 1929	24,543	340	558*	218	2.68
Totals	24,543	2,746	3,941*	1,195	2.68

\* Decrease.

SOUTH AUSTRALIA					
1928.					
September	21,305	691	472	217	3.70
October	21,514	548	341	209	3.73
November	22,019	572	188	505	3.81
December	22,113	369	268	101	3.81
January, 1929	22,420	557	257	300	3.78
February, 1929	22,682	467	305	262	3.93
Totals	22,682	3,304	1,711	1,594	3.93

WEST AUSTRALIA					
1928.					
September	3,348	99	98	4	.97
October	3,644	85	89*	4	.97
November	3,830	64	77*	14	.96
December	3,814	65	81*	14	.95
January, 1929	3,810	96	91	5	.95
February, 1929	3,820	54	53	1	.95
Totals	3,820	463	489*	26	.95

\* Decrease.

TASMANIA					
1928.					
September	3,645	292	38	165	1.72
October	3,853	246	36	210	1.82
November	3,946	137	46	91	1.87
December	4,117	211	42	171	1.85
January, 1929	4,204	169	82*	87	1.99
February, 1929	4,198	201	207*	6	1.99
Totals	4,198	1,166	451	715	1.99

\* Decrease.

COMMONWEALTH					
1928.					
September	284,690	9,361	5,364	4,002	4.54
October	285,550	6,717	5,856	860	4.56
November	288,457	6,842	3,336	2,307	4.59
December	288,374	5,900	5,381	417	4.59
January, 1929	289,164	5,531*	5,241	290	4.60
February, 1929	291,289	5,696	3,571	2,125	4.61
Totals	291,289	39,947	29,349	10,598	4.61



# The Four Functions of BROADCASTING

For several reasons, among them a slight operation. Mr. Allsop has not been able to continue his series of articles on Large Scale Amplification. Next week, however, he will deal exhaustively with this subject.

By RAY ALLSOP (Associate Technical Editor).



**T**HE receiving apparatus of a radio broadcasting system is required to perform three, and, preferably, four functions. The three are: Selectivity, conversion of electrical energy from radio to audio frequency, and conversion from electrical energy to sound. The fourth is amplification.

The first two, selectivity and detection, are the essential functions of a radio receiving set. While it is not within the scope or purpose of this article to discuss in detail various types of radio receiving sets, some general discussion will be given of the functions of the set in so far as they affect quality. Similar consideration will also be given to the other functions of the receiving apparatus.

## AMPLIFICATION.

**T**HE function of amplification is desirable, and often necessary, in order to bring the energy received by the aerial up to a point where it can produce sounds loud enough to be easily heard. This is particularly the case where loud-speakers are used to perform the third function.

While it is a relatively simple matter to provide amplification without distortion, it is in performing this function that serious distortion is now introduced in many receivers, particularly when the amplification is in the audio frequency range, or when it is obtained by regeneration. The provision of amplification without distortion is largely a matter of proper design, based on a knowledge of the characteristics of the valves used and means for coupling stages together. A common offender in audio frequency amplifiers is the transformer, although with proper design it can be made to function satisfactorily.

## SELECTIVITY.

**I**N performing the function of selecting the radio wave which it is desired to receive, and discarding others, there is a conflict between the degree of selectivity (or sharpness of tuning) and width of the frequency band, for the reproduced sound is to be 5000 cycles, and both side bands of the radio carrier are to be received. Obviously all other waves within a band width of 10,000 cycles will also be received. Further, because it is not possible with the resonant method of selectivity to let through without distortion of this 10,000 cycle band (and at the same time cut off absolutely all other waves, near the edges of this band) the set will respond to a wider range of frequencies.

There are, generally speaking, two types of selective means used in radio sets, one a circuit containing one or more adjustable resonant elements and the other a circuit having a fixed selective element with adjustable means for converting the received radio waves into waves of frequencies which will pass through the selec-

tive element. With the first type of selectivity, which includes the selectivity obtained with regeneration, the distortion of the reproduced sounds is obviously not fixed, but will vary with the sharpness of tuning used.

With the second type of set, the selectivity is fixed in the design, and involves, therefore, a pre-determined compromise between distortion of reproduced sounds and degree of selectivity. Fig. 1 illustrates quantitatively what this compromise entails, and also the range of distortion which may be obtained with a set of the variable selectivity type. Curve A shows the characteristic for one stage of audio frequency amplification in a particular, which is seen to cause appreciable distortion only at low frequencies. As the distortion caused by radio tuning affects only the higher audio frequencies, curve A corresponds to a set with no radio selectivity. Curves B, C, and D indicate the effect of increasing degrees of selectivity. These three degrees of selectivity are such that if there is an interfering signal having the same intensity in the ether as the signal being received, but having as carrier frequency 10,000 cycles higher or lower, it will produce air audio signal at the output of the set 10, 20, and 40 transmission units respectively lower than the level of the signal being received. In other words, a receiving set having the characteristic B, which is very desirable from the quality standpoint, will be much less selective against interference than one having the higher distortion characteristic D.

As an example of a practical compromise, curve E shows the characteristic of a set of the fixed selectivity type, which was designed for general all-round use in receiving both local and long-distance broadcasting. In this set a frequency 10,000 cycles higher or lower than the frequency to which the set is tuned suffers a loss of 34 transmission units.

The fixed selectivity type of set has some advantage in that its operation is definite, and is less likely to give poor quality

due to improper operation. The operation of this type of set can be materially improved by employing for the fixed selective element a band pass filter. Such filter has the advantage that the characteristic of the transmitted range can be made practically flat for any desired band width, and to present large attenuation for frequencies outside the band. For example: With a well-designed filter of this type, the characteristic of the transmitted audio frequency band can be made practically flat up to 5000 cycles, and the discrimination against other signals can be made even greater than that given above for curve D.

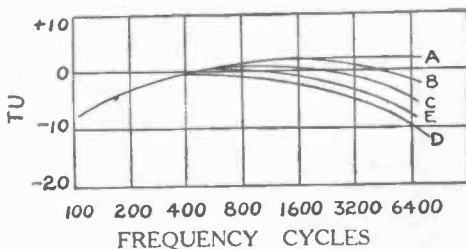

Variation of Audio Frequency Response Characteristic of Radio Sets with different degrees of selectivity. Selectivity expressed in terms of attenuation for radio frequency: 10,000 cycles from frequency for which set is tuned. Curve A attenuation 0 T.U.; Curve B attenuation 10 T.U.; Curve C attenuation 20 T.U.; Curve D attenuation 40 T.U.; Curve E. set with fixed selectivity.

# PROGRAMME PERSONALITIES

## The Imperial Russian Trio

**ARVED NORIT**, the violinist, of the Imperial Russian Trio, playing at 3LO, hails from Riga, where he was born. His musical education, commenced in Riga whilst very young, was continued at the Moscow Conservatorium, and supplemented later in Paris. His technique is brilliant, and quite equal to that of some of the best-known amongst solo players in Europe. He plays with a considerable depth of feeling, and his interpretative skill and rendering of some of the finer passages in the trios is a delight to hear. With experience in playing as solo violinist in the great concert halls of Moscow, Petrograd, Berlin, etc., and with the further advantage of having played as a member of the Trio for over five years, his work, either as soloist or as one of the Trio, is always of the first rank. His pitch and tone are always true, even on the most delicate of harmonics. Mr. Norit has a very large repertoire.

**IVAN BERZINSKY**, 'cello player, also comes from Riga. With an early training in that city, afterwards augmented by study at the Moscow Conservatorium, and aided also by his great natural gifts as a musician, he has developed a style and technique which is masterly and finished to a degree seldom heard. In softer passages his delicacy of touch is truly remarkable, and his phrasing reveals a mind which is in touch with the intentions of the composer of the piece which he plays. Mr. Berzinsky has experience of playing in many countries, including Russia, Germany, Austria, Italy, and France, in each of which countries he has appeared in many of the principal con-

cert halls. He brings to us a personality of rare charm, and expounds to us, when playing, the inner meaning of the compositions which he plays with an understanding broadened by his travels, and also by his contact with men of culture and attainment in the great centres which he has visited. Mr. Berzinsky, outside his musical sphere, is an accomplished man, and as technical chemist during the great war was in charge of the manufacture of high explosive and also of tear gas.

**VASSILI ILSTER**, the third member of the Russian Imperial Trio, who also comes from the Baltic city of Riga, supplemented the early training which he received in that well-known European centre by studies at the Moscow Conservatorium, afterwards going to Prof. Schnabel, at Berlin, who is world-renowned as a teacher of the pianoforte. Mr. Ilster's work in the trio is by no means the least important, and is always performed with intelligence and with a delicacy of insight. As accompanist to either of the two other members of the trio in their solo work his playing leaves nothing to be desired. He is an exponent of calibre of such composers as Chopin, Brahms, and many of the lesser known modern composers.

The Imperial Russian Trio, as a trio, is equal to any of the first-class trios in Europe or America at the present time. Their playing of the classical works of Beethoven, Brahms, Hadyn, Mozart, Tschalkowsky, Arensky, or Cesare Franck is of the highest order. Equally, their rendering of the more popular items always maintains a dignified standard, whilst losing nothing of the verve and tilt and passion which is so often demanded in order that the composer's outlook and intentions may be fully conveyed to the listener. The secret of their perfect renderings apart from the fact that each is a first-rate soloist, lies in their "ensemble" playing. It will be granted that it should be the aim of each member of a trio to cultivate this subordination of the individual, as soloist, to the greater demapd of the concerted piece. They are included in the programmes at 3LO and 3AR for several weeks to come.

## Dorrie Ward

**MISS WARD** became famous with the Mosman Musical Society. With them she has played in more comic operas than she can remember. When the war was being fought, Miss Ward was one of the most prominent among the "Cheerio Girls" visiting camps and battalion dinners, and often singing in Martin Place and recruiting depots. War-worker is the word although war is entirely foreign to Miss Ward's character and disposition. Her friends say, "Dear Dorrie Ward," just as, long ago people said, "Sweet Nell of Old Drury."



DORRIE WARD

When 2BL began business, Miss Ward began singing from 2BL, and has sung from 2BL regularly since then. Ballads. The good old pre-war ballads, which seem still to retain their popularity against the latent jazz parvenus. Especially in the country, says Miss Ward, the people seem to like the old ballads, or modern songs in the same style, while in Sydney they have a large following.

Miss Ward is also an active member of the R.S.P.C.A., for while she cares artistically for the feelings of the New South Wales listeners-in, she has almost as much solicitude for her dumb friends.

## The Cat's Tale

THE stage entrance of Her Majesty's Theatre, which is also the entrance to 2FC and the offices of the New South Wales Broadcasting Company Limited, is the home of a Cat, the colour of which is not easily perceivable. Now this cat is an adventurous cat; and not once, but many times, it has entered the 2FC lift with artists, etcetera, a piece of bravery for which we envy it, and has been transported to those higher regions where souls pour out through microphones in large quantities. The other day it called into the accountant's office. "How do you do, Cat?" said Mr. Miller. "Very well, thank you," answered the Cat, and curled itself up and went to sleep, proving that cats may blow in

where artists fear to tread. After about an hour, the cat evinced a desire to see the manager, and strolled into Mr. Anderson's office. "I'm not here on business," said the cat, "I just dropped in to see how you are getting on." "My dear chap," said Mr. Oswald Anderson, who likes all animals, but prefers cats. "My dear chap, you are very welcome." So that when Mr. Anderson's Secretary came in, she found Mr. Anderson with the cat in his arms, talking exciting business through the telephone—a most touching picture. Interviewed afterwards, the cat said very modestly: "It is not every cat that can boast of having been taken up by Mr. Oswald Anderson; but it has been my life's ambition; and I am very proud of its accomplishment. My favourite dish is milk; and I like nothing better for breakfast than a hambone. I attribute my success in life—in fact, I attribute my life itself—to the fact that I have never ventured out on the streets of Sydney."



The Imperial Russian Trio. Left to right: Vassili Ilster, Arved Norit, and Ivan Berzinsky.

# The Microphone Presents

## SCANDAL

COSMO HAMILTON'S famous play is the next of the Varna productions to be given at 2BL, on the evening of April 10. Beatrice Vanderdyke is a modern, well-to-do young woman, and mixes freely with a number of



WILLIAM HUME, a leading member of the H. W. Varna Co.

men in a high-class, but rather advanced sphere of life, and is on a visit to York, at that gentleman's studio. Her mother and sister come to her there, and rail at her for being with York, making stinging reference to the scandal that is fixed on her in consequence. To clear herself, she remembers that one Franklin lives near, and tells her mother she is engaged to

him. The marriage is celebrated, without any apparent love on either side, and the action of the play is based on this strange unity. Some listeners have written to say they seem to lose interest at being told the complete story beforehand, so it is proposed to give them an opportunity of following over the air the remainder of the story.

## "The Smith Girls"

UNDER the "nom de guerre" of "The Smith Girls," four well-known Gilbert and Sullivan artists will commence a season from 3LO on April 7 and present a variety of programmes both grave and gay. Their first Sunday programme will contain quartette arrangements of the well-known hymns, "Eternal Father," "Abide with Me," and "Peace, Perfect Peace."

## The Woman Hater

JACK STOCKS, billed as "The Woman Hater," who has just completed a successful season at the Tivoli, will be on the air at 3LO on April 8, when his original style of humor will speedily make him a favorite with audiences. He is one of the most popular comedians of the London vaudeville stage and whenever he makes his appearance dressed for the part in a "reach me down" suit and a pair of carpet slippers, it is always the sign for an outburst of applause. His songs, which are his own parodies on popular and up-to-date ditties, always deal with the seamy side of married life, treated in an irresistibly funny manner, and his woe-begone expression all adds to the laughter-making quality of his turn.

## "The Messiah"

ARRANGEMENTS have been completed by 3AR to broadcast the performance of "The Messiah," the thirteenth concert to be given by the Croydon Musical Society at the Mechanics' Institute on April 13.

## COMING FEATURES AT 2BL AND 2FC

DATE:	TALKS	
	2FC	2BL
FRI., 12th APRIL	2.45: Mrs. Scott— "Our First Theatre."	3.10: Captain A. C. C. Stevenson— "The Story of the Taj Mahal."
SAT., 13th APRIL	10.35: "Redgum"— Gardening.	11.30: G. Cooper— Gardening.
SUN., 14th APRIL	6.0: S. H. Borden— "The Vatican Palace."	6.0: Our "Cherry" Society Chat, by Uncle Frank.
MON., 15th APRIL	9.0: Lucille Bruntnell— "Henry Lawson and the spirit of the Australian bush."	10.0: G. J. Hill— "The Idiosyncrasies of the Motor Car."
TUES., 16th APRIL		9.0: C. V. Bucheritz— "Great Writers I have Met"—Mark Twain.
WED., 17th APRIL	9.0: "Tales by the Story-teller."	4.10: A talk by Basil Kirke.
THURS., 18th APRIL	9.0: Graham Kent— A talk on Bridge.	4.10: "Milk Week Campaign"—a talk in connection with this campaign.

## MUSIC — COMEDY — DRAMA

FRI., 12th APRIL	8.20: Ashfield Choral Society Radio Elstedford winners.	10.0: By courtesy of J. C. Williamson, Ltd., 2nd Act of "Hit the Deck."
SAT., 13th APRIL	8.0: Hospital concert party—Lawisham Hospital.	8.0: "The Trambahours," entertainers.
SUN., 14th APRIL	8.45: Madame Evelyn Grey—Dulcettone solos.	8.30: Mandy Band.
MON., 15th APRIL	8.20: Muriel O'Malley and John Warren, vocal duets.	8.20: Roseville Musical Society, excerpts from "The Grisha."
TUES., 16th APRIL	8.0: Marrickville Silver Band.	8.0: Conservatorium Quartet and Oliver King, basso.
WED., 17th APRIL	8.0: Royal Apollo Club Concert.	8.0: "An hour with an old sea sailor," directed by W. E. Lewis.
THURS., 18th APRIL	8.15: Competition.	8.15: "Romance," directed by Lucille Bruntnell.

## A Teller of Tales

IN case readers may not recognise the significance of the word "Tusitila," the name by which Capt. Donald MacLean will in future be known at 3LO, let us hasten to explain that it is an Hawaiian term, meaning "Teller of Tales," and was given by the natives to the distinguished author, Robert Louis Stevenson, who lived for many years on one of the islands, and used to gather the natives about him and tell them tales of adventure. This is an ideal title for Capt. MacLean, for he is a teller of tales "par excellence," and his stories of the Spanish Main and the days of the pirates are certainly stories of adventure. He is about to commence on a new series, entitled "The Feats of the Mighty," and though it would spoil anticipation to enlarge upon the title, we may say the series will be more thrilling and venturesome than any that have yet been told.



CAPT. MACLEAN, or "Tusitila."

## Popular Bass Baritone

AFTER a brief absence from the studio Alex. Witherspoon, the popular bass baritone, will be singing from 3AR on April 7.

## Oratorio Singer

WILL DAVIS, whose fine bass voice has often been heard over the air from 3AR, will be singing from the studio on April 12. Mr. Davis is well-known in N.S.W. as a concert and oratorio artist of much ability, and as a bass soloist he holds the championship cup of New South Wales. He has done good work with both amateur and professional operatic societies, and his wide range of voice, especially the lower register, enables him to sing numbers that the average bass vocalist has to set aside. Apart from his solo work he is a member of the Lyric Male Quartette, who are well and favorably known in musical circles.

## "Emmaus"

LOVERS of choral music should not miss this fine programme to be broadcast by 3AR from Scots Church on April 9, when the cantata, "Emmaus," will be given. Special interest is attached to this work, written by Herbert Brewer, for it was composed by special request and performed at the Gloucester Triennial Musical Festival in September, 1901. The performance is under the direction of the organist and choirmaster (E. Mansley Greer), the soloists being Annie Caddell (soprano), Madame Gregor Wood (contralto), Colin Thompson (tenor), and Leslie Paul (bass).

# Wireless Weekly

Incorporating "Radio in Australia and New Zealand."

FRIDAY, APRIL 5, 1929.

## RADIO ENERGY

SOMEONE has estimated that it takes less energy than that required by a fly walking across a window pane to actuate the average receiving set.

This does not mean, of course, that a fly expends the large amount of power which is sometimes put into a radio set, but the power received in the aerial from the broadcasting station, which remains the same whether crystal set or all-electric super-het is used to receive it. In other words, only the minutest amount of radio energy is necessary for the reception of broadcast programmes.

A more accurate calculation shows that one watt of power would operate eight hundred million receivers, which immediately places the efficiency of broadcast waves as probably the lowest efficiency found anywhere in engineering.

It is doubtful whether a 5000 watt broadcasting station actually delivers a total of a tenth of a watt to its whole listening audience. That is to say of its 5000 watt output, only a hundred microwatts, or less, get through to their destination. The other 4,999,900 microwatts are frittered into space and into metal structures and earth deposits.

Radio broadcast reception at all is possible only because of the marvellous sensitiveness of our ordinary receiving sets. The faint energy quantities which listeners' receiving sets are able to detect and amplify into audible programmes comprise one of our everyday miracles.

An ordinary five-valve receiver will receive "good programmes" with a signal intensity of 50 microwatts per metre. Assuming an aerial height of five metres (about fifteen feet) giving 250 microvolts (or one four-thousandth of a volt) available potential, and assuming an aerial resistance of 50 ohms, Ohm's law readily shows that the primary energy received out of the ether would be 800,000,000ths of one watt. In other words, one watt of power would operate 800,000,000 such receiving sets.

This one 800,000,000th of a watt (an electric radiator takes about 500 billion times this power), though faint beyond

the grasp of human mind, is, however, no less a perfect fabric of all the complex frequencies, tones, and shades of the orchestra or voice it carries, and when amplified produces the rich compelling sound pictures we know.

Thus you have a picture of the energy quantities involved in broadcasting. On the one hand the prodigious—and necessary—wastes of transmission, and on the other the extraordinary power of recovery of faint signals possessed by the average receiving set.

Next time you approach your set think of it more respectfully—as one of the most wonderful things invented by man.

## A Daniel Come to Circus

CAPTAIN STEVENS went down to Wirth's Circus to describe what he saw for the benefit of young Australia. The cages were arranged in a ring, which was completed by ten impressive elephants in leg irons. Notabilities present included, France, the lion; Jesse, the nine-year-old baby elephant; Princess Alice, the hundred and forty seven year-old elephant; Mr. Mooney, the elephant man; two beautiful, feline, snarling black panthers; Mr. Peterson; several performing bears; several performing lions; Peter, the diminutive clown; a leopard with ten-inch whiskers; a zebra with her tail, a small Shetland pony; a troupe of performing horses; Mr. Higgins (who might be a retired general, or a movie commissioner), the

horse trainer; a tribe of monkeys; the broadcasting company's operators, and, of course, Captain Stevens, who has seen most of these animals in their uncivilised state in India and in Africa. Before the show commenced, the captain rehearsed a lute with the aid of Mr. Mooney. "This elephant," said Mr. Mooney, "can talk." He manoeuvred himself in between the legs of several other elephants which were standing about, and whispered into the elephant's ear. After a little coaxing the elephant emitted a sound which reminded us of the squealing of a stuck pig, or motor car brakes suddenly applied. "There you are," said Mr. Mooney, "he is saying good evening to everyone. Now you try." "Me!" exclaimed Captain Stevens. "Yes, you'd better do it," said Mr. Mooney. "I can't talk into that thing," and he indicated the microphone with a gesture of contempt. The captain looked at the elephant, then at the massive heels of the several elephants at its flanks. Then he handed his stick to one of the bystanders, and his pipe to another, with the air of a man making his final bequests, and strode towards the elephant's ear. The elephant saw him coming and playfully—you know how playful elephants can be—extended his dear little trunk to be caressed, and to caress. At the same time a nearby elephant raised his sweet little hind leg several feet from the ground. The captain hopped out of harm's way, and stared very hard at the eager trunk and the raised hind leg. "All right," said Mr. Mooney "I'll make him speak for you." The description afterwards went over very well, and the captain is much to be complimented on his handling of an exceptionally difficult broadcast.

## The Young Idea Gets Radio - - - No. 4



Next week Henry settles the juvenile radio problem for good and all.



# THE SAFETY VALVE



Readers are urged to express their opinions on matters pertaining to broadcasting. If you have some grievance, if you have some constructive criticism to offer, here is your chance for expression--your safety valve. The

editor assumes no responsibility for statements made by readers and published on this page, as opinions of correspondents do not represent our editorial policies or beliefs. Anonymous letters are not considered.

### Programmes Earlier

Dear Sir,—Being in the position to hear many ideas of listeners, may I suggest that the evening programmes on Monday, Tuesday, Thursday, and Friday be commenced one hour sharper. During the forthcoming winter months, I am sure it would be a boon to many around these parts. The usual bedtime is 9 to 9.30 p.m., and if the big programmes were started at, say, 7 p.m., instead of 8 p.m., we could sit and listen to a good programme before we became tired. I think you will find many who will back this up.  
Yours, etc.,  
Abermain. CESSNOCK.

### Heard KNX Also

Dear Sir.—Seeing where Mr. Russell, of Bega, tuned in KNX, Hollywood, California, I wish to state that I also tuned in KNX on 3/3/29. They were very clear on a Snell three-valve set, using a 199 valve in the last audio socket. KNX generally closes down about 7 p.m. This evening they did not close down until about 7.30 p.m. Two accordion numbers were played at 7.20. The announcement was "KNX Hollywood, California." I heard this announcement twice. I have not heard this station as loud since, but they are there every evening, and close down about 7 p.m. I would like to know if Mr. Russell got KNX on this date, as he could see I was right.—Yours, etc.,  
Wollongong. K. FARQUHAR.

### Seconded

Dear Sir.—Glad to see letter signed L. Reddeman. I have thought for a long time that publishing detail programmes of inter-State stations for morning and afternoon sessions was a waste of space—a schedule of times of early transmission, and detail of evening programmes is all that is necessary. Thus, may I suggest you get our readers' experiences with the different receivers you have published details of; personally, I would like to know if anyone has tried out the "Aberdeen." Under ordinary conditions, is it selective enough?  
Yours, etc.,  
Sydney. W.G.H.A.

### "I'm Really Fed-up"

Dear Sir.—In "Wireless Weekly" (8/3/29) letters of some quarrelsome friends were published, including one who said he came from Gladesville; but being inconsistent afterwards signed his suburb as Oatley. He also describes himself as being a wower, to which I quite agree. At present, Sunday programmes are all piffle. The services at night are not worth listening to, with the exception of the Manly Band, which puts on a decent programme. I am FED UP with all this "snivelling stuff." It gets on my nerves.

As for Miss King and "Broadminded" (mind as broad as a sheet of paper) they do not know what they are talking about. I am not asking for too much jazz, only one station for the many real Aussies who are not WOWSERS.

Miss King seems to think that I take no notice of religion, judging by the way she speaks in her letter; but I fear she is mistaken. At present there is only one station which broadcasts a DECENT programme on Sunday night. That is 2UW.—Yours, etc.,  
Belmore. "FED UP 2."

### 4QG's Bedtime Hour

Dear Sir.—Your correspondents in March 1 issue both raise a very interesting point, and I feel obliged to defend, at least, one outfit of "Uncles" whom I fancy your correspondent, "Disillusioned," has not heard much of. Due, no doubt, to his location; here we are very much closer to the N.S.W. "A" class stations, but, due to various reasons there is only one bed-time story station worth listening to, and those who regularly tune in 4QG, especially Saturday evenings, will discover that all the things "Disillusioned" mentions are quite wrong for this station. Uncle Ben and Miss Brighteyes put over about three-quarters of an hour of real solid entertainment for anyone—kiddies or grown-ups—a regular "crowd round the speaker, and not miss a word" sort—also, what about the nights the versatile Sandman, who appears to be able to play anything from a Jew's harp to a Wurlitzer organ, and his dummy Percy? Kiddies or adults that are not amused and interested by these artists are hard to please. Likewise, to-night (Saturday) the list of birthdays took 2½ minutes exactly. Two people read them out quickly.

Yes, Sir, if Sydney stations could only re-broadcast 4QG for the kiddies occasionally there would be a very different flavor in the air.—Yours, etc.,  
Gunnedah. M. OLIVER.

### Programmes

Dear Sir.—With regard to the inter-State programmes published in "Wireless Weekly," I think L. Reddeman's idea (W.W., 22/3/29) is a sound one, as there are no listeners in our town who can get inter-State programmes in the day time, but who, like myself, would appreciate the inter-State evening programmes set out more clearly, most especially 3LO.  
Yours, etc.,  
Lawson. G. L. MIALL.

### Classed!

Dear Sir.—In reading the three replies to "Fedup 2," who believes that a bright Sunday is more appreciated by the pleasure-loving Australian than a Sunday consisting of defunct sermons and ancient hymns, their writers may be classed as follows:—Miss King is a sentimentalist; "Fairgo" is a comedian that will never make a critic; while "Broadminded" is a person who does not know his own mind.

"Fairgo" asserts that he is an Australian, but his ideas are those of a wower; then, in order to show his disapproval of his opponent's mental state, he mentions "Gladesville." Well, well! "Fairgo" ought to be an authority on that. Maybe he has the experience.

"Broadminded" states that there are many who are debarred from attending church services. Very well, why not let one station broadcast church services, and the other set out on music. Then, again, he states that he hopes all dance music is kept off the air. Is that "broadminded"?

Yours in disgust,  
"FEDUP 1."  
Belmore. Gayndah.

### Opposed

Dear Sir.—In response to your request for readers' opinions of the curtailment of inter-State programmes in "Wireless Weekly," I think they should be left as they are, giving the complete programmes. In spite of the most interesting matter that you publish besides, I believe that "Wireless Weekly," without its programmes, would suffer badly in its sales. I would go further, and say that I cannot understand anyone using a wireless set outside the city belt without it, for that reason alone.

But to put our position out West more clearly, we only get one man a week, and have no other means of knowing what is going to be broadcast. Then again we are much the same distance from inter-State stations 3LO and 4QG as our Sydney stations, and use them all.

Broadcasting stations in all States are doing more every day in the broadcasting of all kinds of daily sports and public events, which most of us far away listeners enjoy, and without our programmes we would be lucky to tune in at the right time.

In reply to L. Reddeman, of Orange, I would point out that there is very little difference in the layout of the programmes, except that the print is smaller for the inter-State stations, and their night session is not spaced out, but it is not at all difficult to follow any of it right through. Let us have the whole of the programmes. Mr. Editor, even if you have to leave out something else. In conclusion, let me congratulate you on the quality of your paper, and the spirit in which it is conducted.  
Yours, etc.,  
"WEST OF BOURKE."

### Programme Style

Dear Sir.—Just a few grumbles for "Safety Valve" re printed programmes. Your new style is no good. We want our programmes printed similar to the 2FC and 2BL programmes. The way the evening sessions of the other stations are jumbled up makes it most difficult for one to select the items required.

Re Stadium broadcast. It is no good broadcasting six or seven rounds of a contest, and, when matters are becoming interesting, switch off to jazz at the studio. It's like purchasing a novel with the last chapters torn out. The blame is placed with the Stadium authorities, but I think the broadcasting stations are not agreeable to pay sufficient remuneration for the concession of broadcasting Stadium events.  
Yours, etc.,  
E.W.E.

# WHERE IS THE ROYAL ARCADE?

The Royal Arcade, the Headquarters of the Sydney shop of the Economic Radio Stores, runs from George Street to Pitt Street, between Park and Market Streets, near the Palace Theatre.

WHERE THE DISCRIMINATING RADIOIST CAN SEE

## The Wonderful "Renown Three" Set

*Exactly as Described in "Wireless Weekly"*

THE ORIGINAL ECONOMIC B'LIMINATOR KIT WHICH BROUGHT THE PRICE OF ELIMINATORS WITHIN REACH OF ALL. PRICE, 59/6.

THE NEW AMPLO "B" ELIMINATOR WITH 4—  
B plus adjustments. PRICE, 79/6.

ECONOTRON VALVES UX 199 FOR THE  
ECONOMIC SET BUILDER. 6/9 each

"RENOVN" COIL KITS WOUND ON NATURAL  
BAKELITE EXACTLY TO SPECIFICATIONS, 13/6

ALL ELECTRIC THREE VALVE SET—SEE OUR  
SUPER-SELECTIVE MASTERPIECE, £27

HERE IS THE ELECTRIC WONDERSSET WITH 7  
VALVES, MARCONI LOUDSPEAKER, IN NEAT  
MAPLE CABINET—JUST PLUG IT IN. £55.

THIS SET GIVES AMAZING VOLUME ON INTER-STATE RECEPTION

DON'T FORGET WE STOCK THE SAME GOODS AT ALL OUR STORES

<p>LUZERNE HARD RUBBER RADIO PANELS. 12 x 7 x 3-16, 4/3   21 x 7 x 3-16, 7/6 18 x 7 x 3-16, 6/6   24 x 7 x 3-16, 8/6</p>	<p>ALUMINIUM PANELS for the AIR KING SIX VALVE SET, 34 x 8 x 18 Gauge. Price 5/8</p>	<p>A 63 to 1 VERNIER. THE KARAS MICROMETRIC SUPER DIAL, 17/6.</p>
--	--	---

*"Yours for Lower Prices and Service that Satisfies"*

# THE ECONOMIC RADIO STORES, Address Mail Orders, 492 George Street, Sydney

COUNTRY CLIENTS.—Our parts are absolutely guaranteed to give satisfaction. Send your orders to us conditionally that your money is refunded if you are not satisfied with the goods upon receipt of same. Goods must be returned to us within ten days. We Pay Carriage on All Orders of 10/- and over, except on Batteries, Cabinets, Loud Speakers, and C.O.D. parcels. Valves and goods specially procured cannot be exchanged. Terms Cash. No discounts.

**SYDNEY**  
25 New Royal Arcade,  
near  
Palace Theatre.  
'Phone, M6138.

**NEWCASTLE**  
13 Union Street,  
off  
Hunter Street West.  
'Phone, New. 1622.

**PARRAMATTA**  
Corner Church and  
Macquarie Streets.  
'Phone, UW 9601.

**ORANGE**  
120A Summer Street.  
'Phone, Orange 735.

# The AIR KING

## PART II



**H**AVING explained at length the vitals of the AIR KING, and hoping, at the same time, that its formidable appearance has not frightened the reader away, the actual constructional details now call for attention.

Aluminium and bakelite form the basis of the structure, and, contrary to expectation, it is easier than the original ALL EMPIRE receiver in the assembly, for the reason that front panel controls below the level of the sub-panel are mounted on the bakelite itself, the aluminium sheet for the screening behind being smaller by two inches than the panel.

The bakelite front panel measures 34 x 8 x 1-8 inches, and it is rather important that sheet bakelite no thicker than 3-16in. is used, for the reason that, after the aluminium panel is attached, a little trouble may be encountered with those controls mounted on both aluminium and bakelite. If tin sheet bakelite is used, the condenser shafts for the reaction and the volume control potentiometer may not project through far enough for the knobs or dials to grip. The sheet of aluminium for the back of this front panel measures 34 x 6 inches, and should be of 14 to 16 gauge at least. This applies to all the aluminium used for the sake of rigidity.

Lay the sheet of bakelite on the bench and mark off four positions with the centre-punch, two at the top corners and two inside a pencil line drawn along the panel two inches from the bottom. Drill these with a 1-8in. drill, and countersink the holes for 1-8in., countersunk headed screws.

Next place the sheet of aluminium underneath the bakelite sheet so that it is square with the top edge of the sheet. This will leave a strip at the bottom uncovered by the aluminium two inches in width. With the point of a scriber mark off through the four holes the positions on the aluminium, and then remove the bakelite, afterward drilling the aluminium correspondingly.

Bolt the two together by four 1-8in. countersunk headed screws. These four screws will not, of course, be sufficient to hold the two securely together, and it will be necessary to repeat the drilling and countersinking at intervals along the edges to make a solid job of the two. You may use ordinary nickel-headed screws, but it looks much better when

the receiver is complete with countersunk screws, as they may be touched over with a little black lacquer to conform with the black front panel.

Before continuing I wish to advise those who are not used to handling sheet metal not to buy their aluminium in one sheet and attempt to cut it up to the required sizes by means of the hand shears. It is a tedious, arm-aching business, to say the least of it, and the sheets are sure to be bent and distorted, apart from which the edges will require filing square—not by any means an easy matter. The sheet aluminium for the AIR KING can be obtained from retailers advertising in WIRELESS WEEKLY, cut to size with smooth square edges, that

*This week we publish Part II. of the "Air King," by Mr. Knock (Associate Technical Editor), with full details for its construction. The "Air King" is the most powerful of all the short-wave receivers which have been described in "Wireless Weekly," and is designed especially for the broadcast listener.*

do not require any attention, with consequent saving of time and labor.

So far we have the panel combination erected. Cut with the hacksaw four pieces of the angle strip about two inches long each. Drill two holes in each on one side, and, laying the bakelites on its front with the aluminium uppermost, place these four strips at regular intervals along the bottom edge of the aluminium sheet, taking note of the front panel drilling diagram to keep these clear of the positions for the various controls.

Mark through the holes drilled in these strips the positions on the aluminium sheet, arranging the strips so that the side at right angles to the sheet is flush with the bottom edge. Drill through the bakelite and aluminium, countersink the front, and screw the strips up firmly.

The next thing to do is to drill two holes in the other side of each strip. The aluminium sub-panel measures 34 x 8 inches, and this is placed on the bench so that a 34-inch edge is just projecting over the edge of the bench. Place the front panel with the strips projecting at the back vertically in front of this projecting edge of the sub-panel, so that the four strips rest over it, making sure at the same time that the edge of the sub-panel is hard up against the bakelite underneath the strips. It is an easy matter to now mark off through the two holes in each strip and then drill the sub-panel to correspond. Bolt this to the strips rigidly with ordinary 1-8in. cheese headed screws, and the result is that you have an assembly of bakelite and aluminium front panel and aluminium sub-panel ready for the sub-panel brackets.

This is a rather long receiver, and two sub-panel brackets would be insufficient to stop sagging in the middle, so that at least four are required. One may either use the brackets available as standard on the market or follow the idea used in the original AIR KING.

Four strips of bakelite are cut measuring 8 x 2 x 1/4 inches. These may be seen in the underneath view of the receiver, and are assembled by the aid of more angle strip underneath at convenient intervals, being bolted both to the sub-panel and bakelite base of the front panel.

There are three screening partitions in the assembly of the receiver, one to separate the first and second RF, the second RF from the detector, and the detector from the audio amplifiers. These partitions measure 8 x 6 inches, but do not worry about mounting these until later on, or you may be faced with a little trouble in trying to get the hand-drill around corners when you wish to drill through them.

One may be mounted now—the one between the second RF and detector, as on the detector side of this is mounted a three-plate midget variable condenser for aerial coupling to the grid circuit of the detector if required. The next step is to mark off all positions for controls on the front panel, according to the drilling diagram, and to tackle the biggest problem first; which is the mounting of the two PILOT vernier dials.

# UNUSUAL SIZE OF RECEIVER ASSISTS LAYOUT OF PARTS

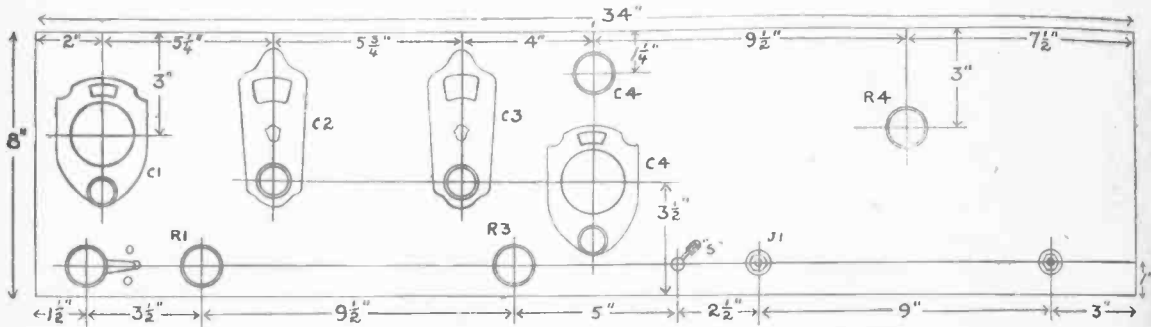

The template supplied with the dial shows exactly where drilling must be done to cut away the aperture for the indicator dial, and the knob drive at the bottom. Do not worry about insulating the frame of the dials from the aluminium, as the condenser is mounted directly on the frame by the rotor alone, and the whole is earthed with the A positive and B negative.

When the holes are drilled for the aperture it is a matter of a minute to cut away the bakelite and aluminium with a fine pointed chisel in between the edges of the holes, thus removing the inside. There is no need to file up the edges afterward, as the part of the dial front plate which projects through will be well clear of the edges.

When the dial mounting is finished fix the two .00015 condensers in position, as this will show you how much space is available in the compartments for other components. The two Midgets, .0001 (C4) are next mounted with their respective controls: a plain knob for the top one and a baby vernier dial for the one underneath. The rotors of these two condensers are also earthed to the aluminium, so it is advisable when drilling the holes for the mounting of these two that the threaded portion is a neat fit in the hole, allowing the brass ring against the

collar to come hard up against the metal.

If you are not sure that the electrical contact is complete test through with a dry cell and a pair of 'phones, touching the aluminium and the rotor to complete the circuit. Next mount the .00015 logarithmic condenser in place for the tuning of the 1st RF stage. The rotor of this, as will be seen from the circuit, is also earthed. The potentiometer R4 for the volume control, must be carefully insulated from the aluminium, this presenting no difficulty, as the one hole fixing may be provided with a bakelite bush and a mica washer to keep back the potentiometer from coming into contact with the metal.

The rest of the controls are below the level of the sheet of aluminium covering the back of the front panel, and are all in the low frequency side of the circuit. They comprise the aerial switch, the RF rheostat, the 400 ohm potentiometer, the filament switch, and the double and single circuit jacks; and the mounting of these is done in the way you have always been accustomed to with a bakelite panel.

Next we come to the lay-out of the components carried on and under the sub-panel, and reference to the schematic wiring diagrams will indicate with the photographs

where each should be placed. The best thing to do before starting to drill holes for such components as valve sockets, etc., is to stand each item on the sub-panel and move them about until you are satisfied that they are in the most suitable positions for keeping wiring as short as possible.

When this is done, mark off each component in turn, and drill the sub-panel for the bolts, subsequently mounting in position the screening partitions. In the first RF compartment we have the first tuning condenser C1, an AWA UX valve socket (with the aerial coil wound on the circular portion), for the home-made midget coils, a Benjamin English type socket for the MULLARD PM14 (UX socket if PHILIPS A442 used), and a type C1 Brachstat or corresponding Amperite. On the side of the first bakelite sub-panel bracket are two terminals for aerial and earth connections.

The second RF compartment carries the tuning condenser C2, an AWA UX valve socket for the A442, the screen-grid coil mounting, and a type C1 Brachstat or Amperite. In the detector compartment are the tuning and reaction condensers, C3 and C4, an AWA UX valve socket for the A615 detector, the UY socket for the "Wasp" coils, the RF choke RFC3, the .00025 grid condenser C9, the 5 meg. grid leak and mounting R2, the .002 isolating condenser C10, and the three plate midget condenser C6, for use when it is required to tune on the detector circuit minus RF. This latter condenser is arranged on a small strip of bakelite on the side of the screening partition between the second RF and detector compartments. A long screw running through a bakelite bush keeps the condenser away from the metal.

Finally we pass along to the audio section, where are mounted the following:—The volume control potentiometer R4, three AWA or Pilot UX valve sockets, a Ferranti AF5 transformer for the first stage (alternatives here may be Philips, AWA Ideal, or Pilot moisture proof), a Mullard or Ferranti 100,000 resistance R5, a Ferranti AF5C push-pull input transformer, and a Ferranti OP6C push-pull output transformer. The rest of the components, by pass condensers, RF chokes and battery connections, are carried under the sub-panel.

The method used for battery connections allows an instant disconnector of the set for examination at any time, and for the reason plug and socket connections are pro-

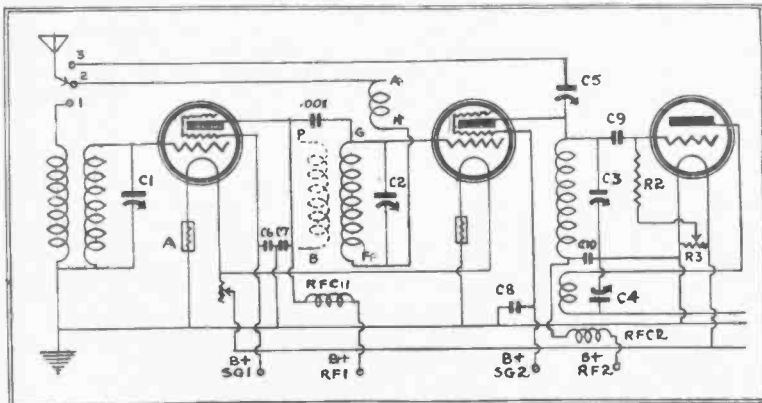

Theoretical Circuit Diagram, illustrating alternative method of coupling first and second R.F. stages. The primary coil in this case is not used. Compare with main circuit diagram on opposite page.



# EFFICIENCY ON BOTH BROADCAST AND SHORT-WAVE BANDS

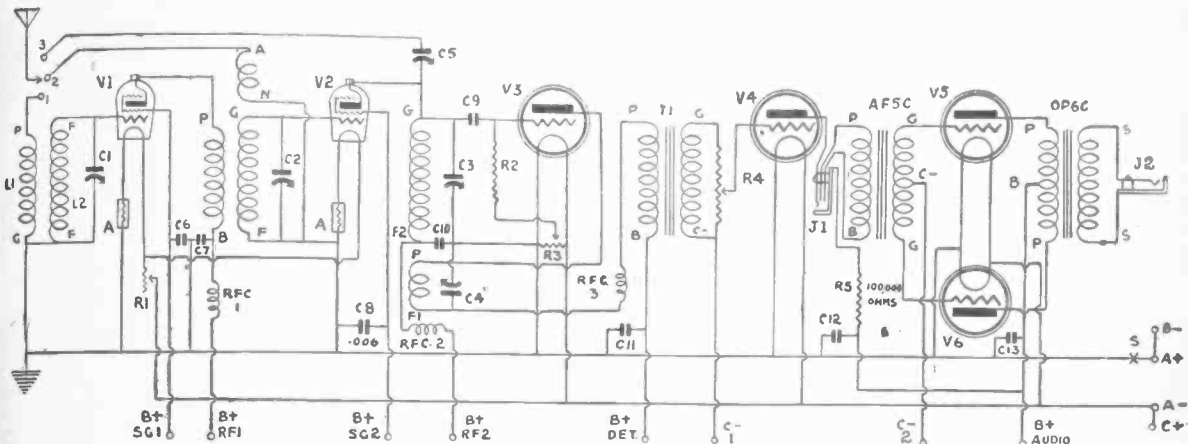

vided for all but the C battery connections, which are made through two terminals. Looking at the back view of the AIR KING, it will be seen that behind the RF compartments—at the back edge of the sub-panel—are four sockets in two pairs. These are for the B positive RF and B positive SG plugs. These sockets are of the flush mounting type and first made their appearance in Australia with the old Sterling receivers at the commencement of broadcasting, and were used because they happened to be lying around. They are very suitable for the purpose owing to the large diameter but any plugs and sockets similar to these may be used. Those I used in the MIDGET RF FOUR, turned out by Colville Moore or Economic Radio Stores are equally suitable.

Under these two compartments behind the sockets mounted on the strip of bakelite are placed the by-pass condensers C6, C7, and C8, and the Radiokes RF chokes in the B positive RF leads RFC1 and RFC2. In the long space underneath the detector and part of the audio compartment are the by-pass condensers C11 and C12, with the battery connections arranged on the back edge of the sub-panel. The Alpha six point plug is used with two of the points left out.

At first it was my intention to use this plug for all the B battery connections, but it was soon discovered that a considerable amount of interaction appeared to be present, and that RF was somehow getting back to the audio side of the set. Hence the reason for the separate B positive and RF and SG sockets behind the RF compartments. The four pins that are used on this plug carry the supplies to the B positive for the detector (pin No. 3), C positive (pin No. 4), B positive audio (pin No. 5), and B negative (pin No. 6).

I simply quote which pins I used for the purpose, but this is of no importance, and the constructor may use any he thinks fit. By using the numbers I quote, however, the wires are kept well spaced where they leave the plug socket.

The connections for the A battery are made through two more of the Sterling sockets, and in this case a large diameter one is used for the positive and a small one for the negative, so that if the plugs are used spaced accordingly on a piece of bakelite it will not be possible to reverse them accidentally. I believe that a few of these old plugs and sockets may still be obtained, as they were used in the old type receivers. Finally, on the long stripe of bakelite are the two terminals for the C battery connections.

Quite a lot of ingenuity may be exercised

in the wiring up of the receiver. This is where the metal chassis has another benefit besides screening and elimination of hand capacity. For instance, where the valve sockets are concerned, the A positive (except in the case of the two RF valves) has to connect directly to earth. As the earth is throughout the receiver the whole metal chassis, the best thing to do is to make the connection at the nearest point. The nearest point is naturally the head of one of the brass screws holding the socket to the sub-panel, and the only length of wire used here is about half an inch long, from the A positive terminal of the socket to the head of the screw.

The wiring mostly used is No. 16 tinned copper covered, with insulating sleeving, but in many leads where the high voltage supply passes through the metal I used Celatsite flexible insulated wire, with the additional precaution of a length of "spaghetti" slipped over. If the constructor feels at all doubtful about taking the chance of insulation in this way, and prefers to push each lead with bakelite, let me ask him to bite through a piece of "spaghetti" to see how tough it really is!

The wiring of the AIR KING should be carried out systematically, dealing first with the filament circuits. The A positive and B negative are first joined together at the bat-

## LIST OF PARTS FOR THE "AIR KING" RECEIVER

- 4 lengths of aluminium angle strip.
- 1 Bakelite or Formica panel, 3 1/4 x 8 x 1/8 inches.
- 1 sheet aluminium panel (1 1/2 gauge), 3 1/2 x 6 inches.
- 1 sheet aluminium panel (sub), 1 1/2 gauge, 3 1/4 x 8 inches.
- 4 sub-panel brackets.
- 3 aluminium partitions, 8 x 6 inches.
- 2 Pilot .00015 SLF variable condensers.
- 1 JH or AWA Logarithmic .00015 variable condenser.
- 2 Pilot .0001 Midget variable condensers.
- 2 Pilot back of panel Vernier dials (type 1282).
- 1 Kurz Kasch Vernier dial (reaction control).
- 1 Eimco Baby Velmo Vernier dial (1st RF control).
- 1 30 ohm. variable rheostat.
- 1 400 ohm. potentiometer.
- 1 CH battery switch.
- 1 switch arm and 3 contact studs.
- 1 double circuit telephone jack.
- 1 single circuit jack.
- 1 Royalty 0 to 500,000 ohm. potentiometer.
- 7 AWA anti-vibration valve sockets.
- 1 Benjamin anti-vibration English base valve socket (for Mullard PMJ4).
- 1 Pilot UY AC valve socket (for weap coils).
- 1 Pilot Wasp coil kit, 17 to 500 metres (detector circuit).
- 1 Radiokes screen grid coil kit (2nd RF circuit).
- 6 old UX valve bases (1st RF circuit), for home-made coils.
- 2 Brachstats (type 1C), for RF valves.
- 1 Pilot 3-plate Midget variable condenser (detector circuit aerial coupling).
- 1 Pilot, Philips, or AWA Ideal 3 1/2 to 1 ratio audio transformer (1st stage).
- 1 Ferranti AF5C push-pull input transformer.
- 1 Ferranti OP6C push-pull output transformer.
- 1 Mullard or Ferranti 100,000 ohm resistor, with mounting (voltage drop to 1st audio).
- 1 Mullard 5 megohm grid leak, with mounting (detector).
- 3 Radiokes RF chokes.
- 1 Sangamo .0025 grid condenser.
- 1 Sangamo .002 fixed condenser.
- 1 Sangamo .006 fixed condenser.
- 3 TCC 1 microfarad by-pass condensers.
- 2 TCC 2 microfarad by-pass condensers.
- 1 Alpha 6-point battery plug, with connector.
- 6 pin plugs and sockets (A battery and B positive RF and SG connections).
- 4 terminals.
- Valves used:—
- Mullard PMJ4 1st RF (Philips A442 alternatively).
- Philips A442 2nd RF.
- Philips A 615 detector.
- Marconi DEP 610 or Radiotron UX 112A 1st audio.
- 2 Philips B605 or Mullard PM256 push-pull audio.
- 1 130-volt grid bias battery.
- 150-volt B battery supply. Philips B eliminator may be used on audio stages.

# CHECK WIRING CAREFULLY WITH THEORETICAL CIRCUIT DIAGRAM

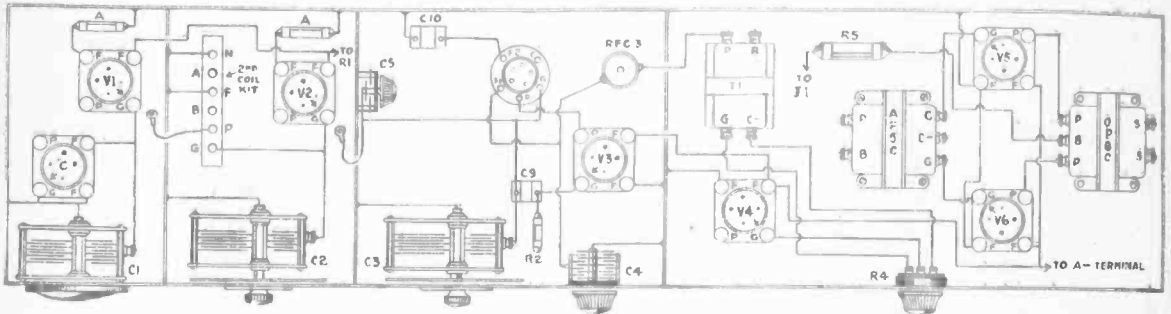

tery connections at the back. This means that number six pin of the Alpha plug is connected to the A positive socket.

Looking at the circuit diagram the reader will see on tracing along the A positive lead exactly which points are common with this. Start at the aerial end of the set, and go along. First we have one end of the aerial coupling coil (wound on the UX socket top), one end of the grid coil and the rotor of C1. The A positive of the first RF valve connects through the Brachstat or Amperite before reaching the metal. Then we have one side of the two by-pass condensers C6 and C7.

Continuing along to the second RF stage we come along to the rotor of C3. This, like C1, is already automatically earthed in the mounting. The coil intended for reaction in the Radioket screen-grid kit has the side N connected to the metal (referring to the coil mount) with the other side A afterward joined to stud 2 of the aerial switch. Next the A positive of the second RF valve passes through the automatic resistance before reaching the metal.

Passing to the detector, the rotors of the tuning and reaction condensers C3 and C4 are already earthed as before, and all that is necessary here is to join the A positive of the detector valve to one side of the 400 ohm potentiometer (R3) to the .002 isolating condenser C10 and to the metal. Reaching the audio side of the set the A positive terminals of all three valve sockets are common to earth, and one side of the by pass condensers C12 and C13.

This shows the reader what a great amount of wiring is simplified by the use of the metal chassis. After this the A negative and C positive connections are joined together, and a long bus-bar taken along under the sub-panel for branch leads to the A negative of each valve socket, and the variable rheostat R1 for the RF valves. The rest of the wiring may be followed readily enough from

the back of panel wiring diagrams. Although the AIR KING is shown in the photographs with only the screening partitions erected, it is an advantage to entirely enclose the RF and detector compartments as in the AIR EMPIRE receiver.

The set will work quite well as it is, and in any case should be tested in this form as one may want to make a few alterations and adjustments. If the RF and detector stages are completely boxed in there will be less interference from power leaks from the lighting system and other extraneous noise, for it must be remembered that the AIR KING is probably the most powerful of short-wave receivers yet designed for the international broadcast listener.

Now about battery supply. A total of at least 150 volts will be required, as not only have we got to supply two RF stages, but a super audio amplifier. If dry batteries are used, do not expect them to last too long. My advice is to use a wet B battery of the Oldham, Philco, or Dionold type, or as an alternative to feed the RF and detector circuits from a wet B plate supply, and the audio from a Philips B eliminator with the B negatives common. If you do this, remember that you can charge the B batteries with the eliminator—a tip worth knowing!

The more heavy duty the loud-speaker is designed for, the better it is used with the AIR KING, as the set will drive two MAGNAVOX dynamic power operated speakers at full volume.

Having all the sources of supply ready place all the valves in their sockets, and the corresponding coils for whatever wave-band required in their respective mountings. Connect up the C battery, giving the first stage about 43 volts to start, and the push-pull about 12. This will want readjustment later on. Next join up the B positives, giving the two RF plate supplies about 120 volts, and the screen grids 80. They may be varied

independently for best results when the set is in operation. The detector needs anything from 50 to 70 volts, and the audio the full voltage available. Connect up the B negative last, and then the A battery. Keeping the RF rheostat turned right on, place the aerial switch on stud No. 1, which throws the aerial right over to the detector, via the midget coupling condenser C5.

Supposing we are on the 30 metre band, advance the reaction condenser controlled by the baby vernier dial until the circuit goes into oscillation with a soft swish. If this does not happen, and the action is sudden and harsh, vary the potentiometer R3, and note if there is any improvement. If not a change of grid leak is advisable so you had better keep one or two handy with values from 2 to 10 megohms. The plate voltage on the detector will also have considerable effect on the smoothness of oscillation control.

Possibly you will find that oscillation is quite smooth and pleasant, but on rotating the tuning dial controlling the condenser C5, oscillation suddenly stops, and it is necessary to "chase" it with the two reaction condensers. This effect is due to wind spots caused by resonance with the fundamental or a harmonic of the aerial system or surrounding objects. At this point the midget coupling condenser C5 shows its worth.

You will find on decreasing the capacity of this little condenser that a position will be reached where even and constant oscillation takes place over the whole tuning range of the dial. Do not decrease it any more than is necessary, as it has one disadvantage, and that is that it upsets the calibration of the detector circuit at each different setting. This does not matter so much, as we are only using the detector circuit for preliminary searching.

Locate a signal, it matters not whether telegraphy or telephony, and then back off the reaction condenser to a point just before

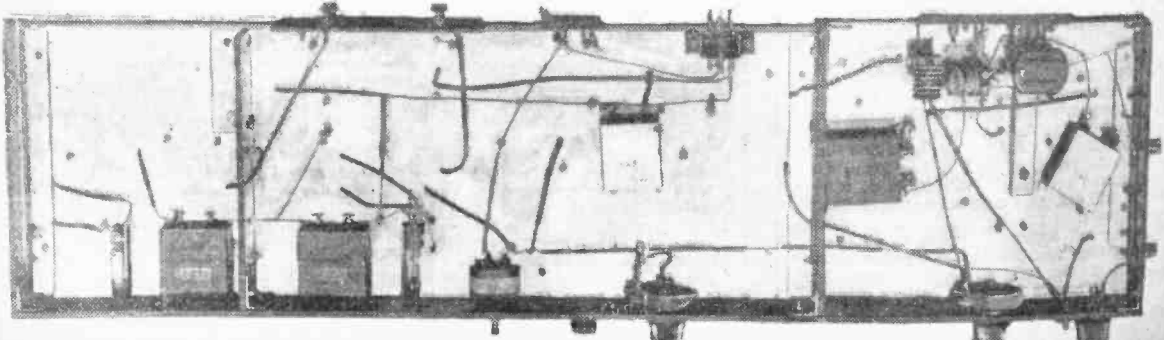

# KGO, PHI, 5SW, PCJ, WGY RECEIVED LIKE LOCAL STATIONS

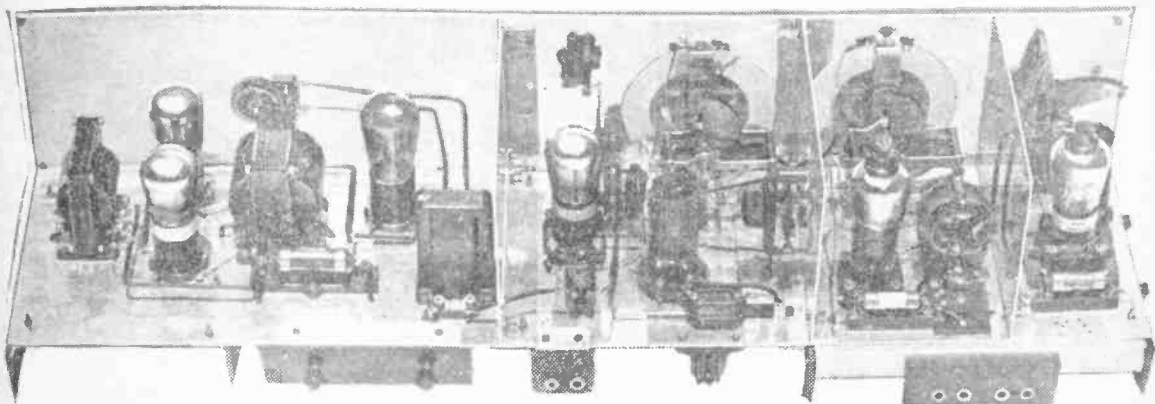

oscillation ceases—checking up at the same time on the tuning control.

Having done that, the next procedure is to throw the aerial switch to stud 2, and turn on the RF rheostat R1. Both RF valves will be burning, but the first one will not have any material effect on the second. If you have the correct Radiokes coil in this second RF stage, you will find (if an E voltages are right), that at approximately a corresponding reading with the detector dial, a resonance peak will be reached, and the oscillation has will greatly increase in intensity.

In all probability the signal will disappear temporarily, but a balancing up of the two controls and reaction will suddenly bring that signal back with a force you little expected. As the rheostat is controlling both RF valves, the next thing is to throw the aerial switch to stud 1, and repeat the process with the first RF tuning control C1. The signal might have been comparatively weak when you started, but now it is unbearably loud, in fact, uncomfortable.

A word of warning. Do all this tuning with the headphones plugged in the first jack. Do not plug the 'phones into the output with the volume control full open, or you might injure your ears.

After satisfying yourself that the circuits are working properly, as they should without any fuss or trouble, the loud speaker may be plugged in, and you can sit down to a real tour around the world.

The first time I tested the AIR KING the new Philips station PHI at Hulzen, in Holland, was conducting tests, which I fervently hope will be a regular feature every day. The carrier wave seemed to hit the dynamic speakers with terrific force, and after backing off on reaction and checking with the de-

detector potentiometer. It was indeed difficult to realise that the station was literally at the other end of the world. The strength was exactly as a local station, with practically no fading, and the whole of the transmission listened to in comfort.

On the next occasion (Sunday afternoon, March 10), I accidentally dropped across KGO, Oakland, California, U.S.A., in the vicinity of 20 metres. For three hours, from 3 p.m. to 6 p.m., this programme was listened to at enormous volume, the time corresponding to 9 p.m. to midnight Pacific Coast time on Saturday night. There was not the slightest suggestion of fading, and every word and item announced was perfect, it being particularly interesting, as the dance orchestra playing was Mr. Frank Ellis's Californians, once so well known at the Sydney Palais Royal.

Night after night the Javan stations, working duplex telephony with Koetwick, in Holland, are extremely strong, and whereas with the ordinary short-wave receiver, it is often hard to clear up the modulation, although the carrier is strong, the RF stages of the AIR KING make up for it amply. Tuning on the amateur transmitting frequencies is not too difficult in the hands of one accustomed to tuning weak telegraphy signals. In fact, it is quite easy at 40 metres, but the "ham" intending to start work on the AIR KING will do better to construct it with three plate midget tuning condensers instead of the .00015 condensers, and to match his coils up with this small capacity, so that the tuning dials show the amateur bands over the scale and nothing more.

One thing I have not done with the AIR KING is to attempt RF amplification at

28,000 KC—10 metres. It was quite efficient with the MIDGET RF FOJER, owing to the small capacities and coils, but apart from the reason that the AIR KING was primarily designed for the BCL, I do not consider it practicable to use more than one screen-grid RF stage at such a high frequency, except by the Super-Het method.

Even below 20 metres the amplification of the first RF stage of the AIR KING begins to fall off, but this will not worry the BCL, as most of the transmissions of interest are above this wavelength.

In conclusion, I advise all who build this king of short-wave receivers to at least box in entirely the first RF compartment, otherwise a little trouble will be run across in hand capacity when tuning this stage, owing to the proximity of the aerial to the hand.

Once the receiver is installed and working as the original does, the operator will no longer sigh for further fields to conquer, for whatever is in the air on the short-wave bands the AIR KING will get it when audibility and conditions are favorable in any degree, and do not forget that at the same time, by plugging in the "Wasp" coil for the 500 metre band you have only to throw the aerial to stud 3, and at once the receiver becomes a normal broadcast receiver, but of unusual excellence in quality and volume.

In this case the RF amplification is left off, and if you are concerned about using it; it is, after all, not a very hard job to make your own coils suitable for the RF amplifier to plug in the existing mountings.

And so, here is the AIR KING—a real ruler of the short waves!

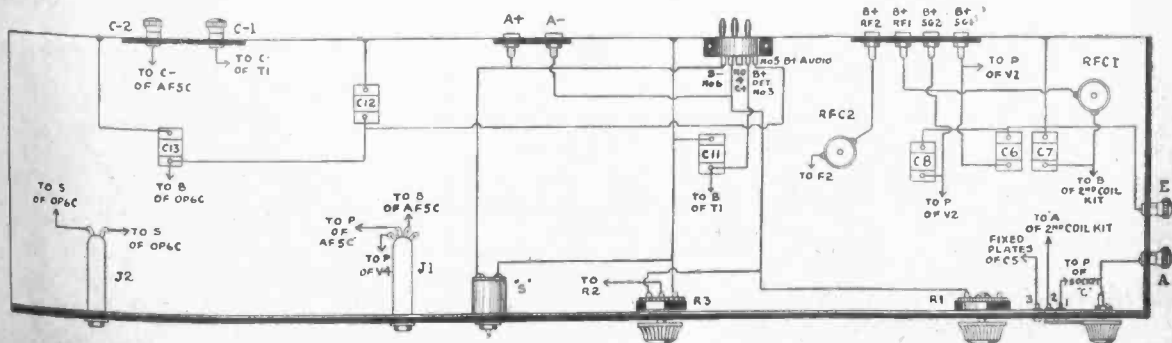



Don B. Knock selects the  
**KING OF TRANSFORMERS**  
 for the "AIR KING" RECEIVER

*Majestic*



*Reality*

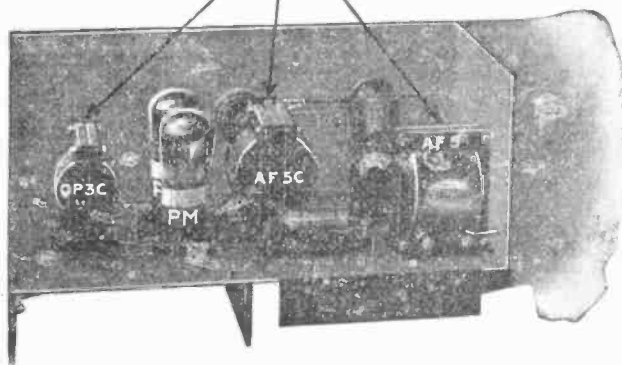
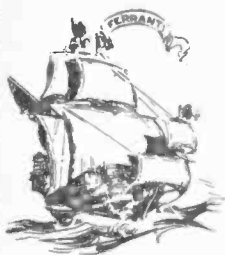

**AS STURDY AS THE GALLEONS OF OLD**

*Semper*



*Fidelis*

---

We do not guarantee perfectly satisfactory reproduction unless all  
 Audio Transformers in the receiver are of Ferranti Manufacture

---

*Dealers communicate with*

**A. BEAL PRITCHETT (Aust.), LTD.,**  
 17 PARKER STREET, SYDNEY

# PROVING RADIO

**No. 15** Our previous study of rectification helps us to understand the action of the valve and crystal in rectifying radio signals. We treat of the composition and the action of the valve, and the part played by each element. We understand why a thorough knowledge of the electronic theory is necessary.

**I** WONDER how many of my readers can by now tell me what rectification is? Rectification has been referred to several times throughout these series, and there is a reason for this. The main component in any radio receiver is the rectifier. Another name given to this component in a radio receiving set is the detector. Actually the detector rectifies the incoming signal, changing alternating currents to direct currents. In some receivers this rectifier is the simple crystal, and in others the valve is used.

The valve consists of a glass bulb, which is exhausted of air to the greatest possible degree, making it a vacuum. Inside are three elements, which are known as the filament, the plate, and the grid.

The filament is shown as a semi-circle, the plate as a square or oblong mass, and the grid as a wavy line. The glass tube covering

wire which forms the filament. What happens? If you read last week's article you will know that electrons commence to move around the wire. These electrons move at

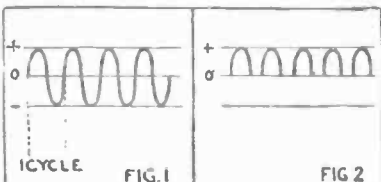

a tremendous rate, and collide with each other many thousands of times per second, so that a great number of these minute particles of negative electricity are thrown off from the filament.

This action also takes place in an ordinary lamp globe, and it was through this that Dr. Lee De Forest decided (upon noticing that sometimes a black deposit formed on the inner side of the globe) that electrons were being forced off from the filament, and being repelled by other electrons (like signs repel) they were forced to the glass. Later, Professor Fleming reasoned that, as unlike signs attract, these electrons could be made to flow in one direction across the vacuum by placing a metal plate, positively electrified, near the filament, in order to attract the electrons. This was done, and, as a result, we had the first valve, known as the Audion, or two electrode valve. Results with the two electrode valve were only equal to the crystal detector, with which we are all more or less familiar, until another great innovation came. This was the grid, and we shall deal with it later.

In the meantime, a glance at Fig. 4 will give us a better understanding of the action that takes place inside a valve. You will notice that the electrons forced off from the filament are attracted to the plate (or anode—how many of you have forgotten about the anode and cathode?) and you will also see that, by increasing or decreasing the potential of the plate, and thus the E.M.F. between plate and filament, the flow of electrons can be varied at will. As a complete circuit must be formed before any current will flow, the electrons first jump from the cathode (filament) and leap across a gap to the anode (or plate). This gap, which will necessarily contain a large amount of electrons, is termed the space charge. From the plate the electrons travel by means of a conducting wire back to the filament, and so the action goes on.

This only happens, of course, whilst the plate is at a positive potential. If we were to place a negative potential on the plate, this would repel the electrons (which are particles of negative electricity) because like signs repel.

It must be remembered that the valve only allows electrons to pass from the filament to the plate. No electron can pass from the plate to the filament, since the plate is cold, and does not emit electrons. The filament, however, becomes red or white hot, and electrons are thrown off for a short distance. However, the positive nuclei will tend to bring these electrons back to the filament to

a certain extent, but, owing to the immediate proximity of other electrons, the outer particles will be discharged into space, and attracted to the plate.

The three-electrode valve was made by the addition of the grid. It was found that a current could only be induced to flow in one direction through the valve (which, incidentally, makes it a rectifier), but, by adding a grid, or third electrode, between the filament and the plate, the electron flow could be controlled very easily and very considerably. The slightest change in the grid potential means a big change in the quality of electrons picked up by the plate.

Such changes of grid potential are caused by the grid being coupled electrically to the aerial circuit, in which electrons are surging up and down.

For example, if the charge on the grid is neutral, and the charge on the plate is positive, the grid will have no effect on the flow of electrons to the plate. If a positive charge, however, is placed upon the grid, this will attract the electrons, pulling them away from their respective nuclei on the

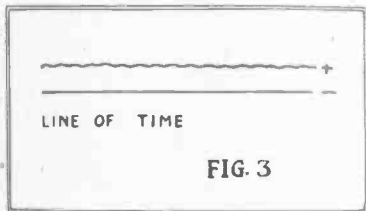

these "elements" is shown in circuit diagrams as a circle. Look at any radio circuit using valves, and you will immediately grasp the idea.

The result of rectification is the same always, that is, if you rectify (as in a recent experiment) alternating current from the mains, you merely do away with one-half of each complete cycle. Thus, in Fig. 1, you see the A.C. wave before rectification. Fig. 2 shows the result after rectification. You will notice all the negative half-cycles have been removed, and only the positive half-cycles remain. There is a reason for our only making use of the positive half-cycle, and you will later understand why the negative half-cycle would be useless to us.

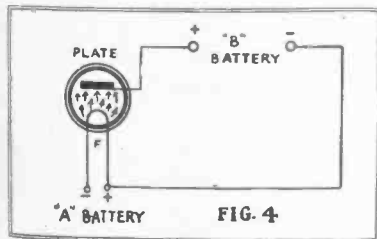

You will note that the waves shown in Fig. 2 are still alternating, though only in the one direction. This is called a rectified pulsating current, and by means of smoothing circuits we shall later be able to almost cut out this "ripple" and the resultant current would then be shown as in Fig. 3, which represents almost direct current. Direct current would be shown as an unwavering line.

An electric current is passed through the

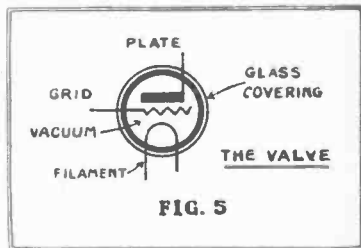

filament wire, and enabling a greater stream of electrons to pass to the plate.

However, this is but negligible in effect. The grid swing should be considered only as exercising a control upon the rate at which electrons are passing its vicinity. The electrons from the filament are alternately attracted to and repelled from the grid, according as the electrons fly away from or on to the grid in unison with the movements of those in the aerial.

The high plate voltage, however, will exert a heavy draw on the electrons as soon as

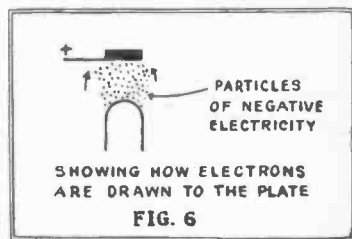

they are free from the filament, and thus enable an even heavier stream of electrons to flow to the plate. Owing to the velocity at which the electrons are travelling, and also to the structure of the grid, most of the electrons are not held by the grid, but



pass through it and on to the plate. An accumulation of electrons caught from the filament plate stream by the grid in its periodic condition, since they cannot escape (the grid being not a hot body), set up in time a hindrance to the correct transmission of signals from the aerial.

Hence this accumulation must be relieved by the device known as grid leak, which affords a high resistance directly conducting path by which the captured electrons can find their way back to the filament.

A GRID LEAK is used, then, outside the valve, and this enables the surplus electrons to leak back to the filament, where they are once more free to be cast into space. We shall not trouble our heads at this moment with the action or construction of the grid leak. Everything will be treated in good time.

You will also see that if a negative bias was placed on the grid, it would repel the electrons.

Some of our more advanced readers may inquire why a negative grid bias is used since a positive bias increases the electronic flow. The heresy that the grid potential has an appreciable effect on electron emission from the filament gives rise to this inquiry. The function of the grid, however, is always to CONTROL the flow, not to increase it. In some cases positive, and at other times, negative, bias is used on the detector or rectifying valve. Short-wave hams, at least, will understand how important it is that the detector grid is properly biased.

One of our readers pointed out that he was in a quandary regarding the direction of flow in and out of a battery, and wished me to give my reasons for my reply. The answer is that, contrary to late ideas, it is now firmly believed that current flows from negative to positive externally, i.e., outside of the battery, and from positive to negative internally. The reason why the external current flows from negative to positive is that there is a surplus of electrons on the negative pole, and when the negative pole is connected to the positive, these electrons flow round the external circuit until the positive pole is reached. The opposite is the case internally. The electrons, having become lodged on the positive pole, seek to

complete the circuit, and are aided in doing so, since the negative pole has lost a number of free electrons, leaving at the negative pole a number of positive ions, which readily attract electrons. So the cycle is completed, though the current is flowing from positive to negative internally and negative to positive externally.

### Proving Radio Club News

The following are the rules and constitutions of the "Proving Radio" Club, as drawn up by the executive committee at a previous meeting. (These will later be distributed to club members.)

**NAME:** The name of the club shall be the PROVING RADIO CLUB.

**CONSTITUTION:** The club will consist of an unlimited number of persons, divided into various district groups. These groups shall be subject to, and governed by, the rules and provisions of the club.

**PATRONS:** The general executive can at any time elect patrons to the club.

**OBJECTS:** The objects of the club are to form groups for the purpose of carrying out the course provided in the "PROVING RADIO" section of WIRELESS WEEKLY and other allied subjects which the club desires from time to time.

**TIME AND PLACE OF MEETINGS:** To be deemed practicable by the groups concerned.

**FEES:** The fees shall be 5/- per member on joining a group, with a weekly subscription of 1/- per week. The general executive has the power to strike a levy on members at any time.

**HOW FUNDS ARE APPLIED:** The general executive will purchase the material and distribute it to the various groups as required.

**QUORUM:** A quorum at any meeting of the executive must consist of at least one-third of the executive members.

**AUDIT:** The audit of the books of the club will be carried out quarterly, and the balance-sheet read by the group representative at the group meetings.

**UNFINANCIAL MEMBERS:** A member will automatically cease to be a member of the club after arrears of three weeks, except where exemption is made by the general executive.

**ALTERATION OF RULES:** These rules may be altered or rescinded by the general executive on the approval of the members of the club. Should any member desire to have any existing rules amended or rescinded, or desire to have any new rules inserted, he shall submit the proposed alteration at his group meeting. If the alteration is agreed to by the members of his group, the group



Mr. A. THOMAS, outside sales representative of Amplion (Australasia), Ltd. Mr. Thomas is well known in the Sydney trade, and is held in high regard by reason of his cheery disposition and willingness and ability in doing things.

representative shall notify the general executive at the next meeting of the executive.

**GENERAL EXECUTIVE:** The general executive will consist of a representative of each group, and a representative of WIRELESS WEEKLY. The executive shall meet once a week.

**PRESIDENT:** The president shall preside at all meetings of the general executive, and in the absence of the president a chairman will be elected to control the meeting.

**HON. ORGANISING SECRETARY:** The organising secretary is to give information regarding the club, and where practicable form groups, and generally boost the club. He shall also co-operate with the hon. treasurer in purchasing the materials required by the groups, and attend to the general business of the club.

**HON. TREASURER:** The treasurer will receive all subscriptions from the group representatives. He will keep a cash book, and have a banking account in the name of the PROVING RADIO CLUB.

**PRESS COMMITTEE:** The press committee will consist of two executive officers and a representative of WIRELESS WEEKLY, who will receive reports from the group representatives, and will be responsible for all press matter relating to the club.

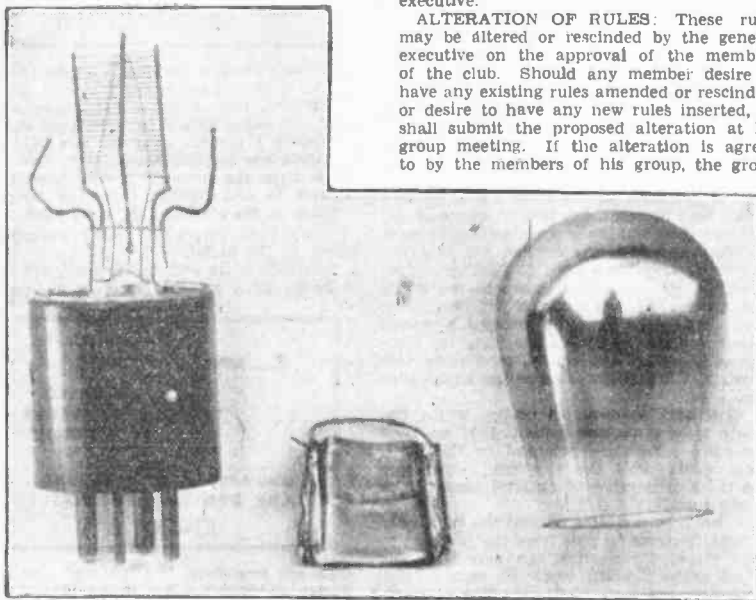

Showing the construction of an ordinary detector valve. The glass bulb has been removed, and the plate which fits over the filament, has been taken off in order to show the delicate filament wires. The plate is seen in the centre of the picture.

**WELCOME** to the Cremorne Group which has just been formed. The first meeting was held at 117 Milson Road, Cremorne, on Friday evening, March 22, and the following members were welcomed: J. Dempster, M. White, R. Sherwood, D. Allen, J. Singleton, S. Johnson, S. Hughes, T. Robinson. The following officers were elected: J. Singleton, president; M. White, treasurer; R. Sherwood, secretary. It was decided to hold a junk night on Wednesday, March 27, 1929, so as to cut the expenses of the group to a minimum. The first experiments on static electricity are to be carried out the same night. At the close of the meeting, we hope to carry out some tests with an electric pick-up. The new club will gladly welcome more members.

Owing to the fact that the executive meeting was postponed, other club reports are not to hand. One reader wishes to form a club at Newcastle, and his letter will be published next week. A consulting wireless engineer, at Petersham, has kindly consented to let a local club use his demonstration room and workshops for meetings.

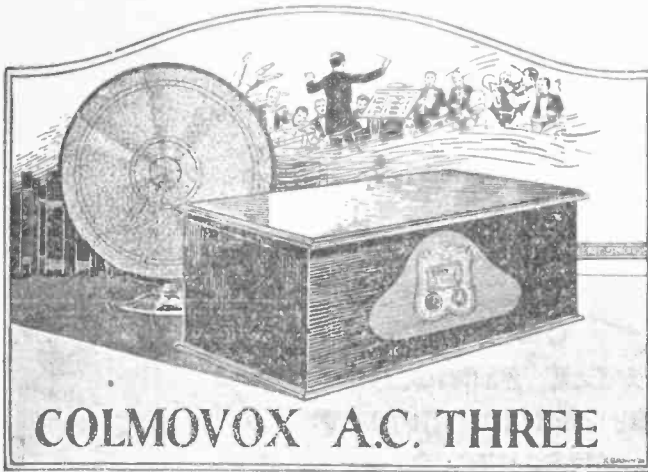

**COLMOVOK A.C. THREE**

## “COLMOVOK” RECEIVERS

Practically the oldest Receiver manufacturers in New South Wales! “Colmovox” Receivers have stood the test of time and are still in demand from those who buy recommended goods. “Colmovox” Receivers are guaranteed for twelve months, and are built to suit Australian conditions, being selective to a high degree, giving good, faithful reproduction, and they are moderately priced.

Our new Model AC3 Batteryless Receiver is the latest addition to our large range of Receivers, and intending purchasers should see this wonderful Receiver before they buy elsewhere.

	Cash Price.			Deposit.			Weekly.		
	£	s.	d.	£	s.	d.	s.	s.	d.
“Colmovox” All-Electric Three .....	29	0	0	5	0	0	9	8	
“Colmovox” All-Electric Five .....	48	10	0	11	0	0	15	11	
“Colmovox” Three-valve Receiver .....	17	10	0	3	0	0	6	2	
“Colmovox” Four-valve Receiver .....	28	0	0	4	0	0	9	8	
“Colmovox” Five-valve Receiver .....	33	10	0	6	0	0	11	8	
“Colmovox” One-valve Receiver .....	5	10	0	0	10	0	5	0	
“Colmovox” Crystal Receiver .....	3	10	0	0	7	0	3	6	

**ALL SETS ARE COMPLETE WITH LOUD SPEAKER, BATTERIES, ETC., AND INSTALLED FREE OF CHARGE**

Demonstrations given in your own home without any obligation.

## “AIR KING” RECEIVER

See Last Week’s Issue of “Wireless Weekly” for List of Prices for this Wonderful Receiver.

## Colville-Moore Wireless Supplies Ltd.,

10 ROWE STREET (Next Hotel Australia) SYDNEY  
 'Phone B2261 'Phone B2261

# BARGAINS

3 Valve A.C. Receiver, complete with Speaker.  
 Cash Price £24. Dep. £5; £1/15/6 Monthly.  
 3 Valve Battery Model, complete with Speaker and all Accessories.  
 Cash Price £14/10/. Dep. £3; 5/- Weekly.

	£	s.	d.
.06 Valves, Type 199 .....	3	6	
.25 Valves, Type 201A .....	4	6	
.00025, .00035, and .0005 Variable Condensers, with Dials .....	4	0	
Rheostats, from .....	1	6	
Emmco A.B.C. Eliminator .....	10	10	0
Balkite Trickle Chargers .....	3	0	0
Loud Speakers, from .....	15	0	
Transformers, from .....	7	6	
Triple Capacity “B” Batteries, 45 volt .....	17	6	
Single Valve Sets, complete with 'Phones and Batteries .....	3	10	0

### TERMS.

	Cash Price.		
	£	s.	d.
COLMOVOK “B” BATTERY CHARGER .....	5	10	0
Deposit 11/-. and 19 Weekly Payments of 5/6.			
COLMOVOK “A” and “B” CHARGER .....	6	10	0
Deposit 13/-. and 19 Weekly Payments of 6/6.			
EMMCO TRICKLE CHARGER ..	3	10	0
Deposit 7/-. and 19 Weekly Payments of 3/6.			
PHILIPS TRICKLE CHARGER ..	3	10	0
Deposit 7/-. and 19 Weekly Payments of 3/6.			
RECTOX TRICKLE CHARGER ..	5	10	0
Deposit 11/-. and 19 Weekly Payments of 5/6.			
PHILCO RECHARGEABLE WET BATTERY .....	8	15	0
Deposit 17/6, and 19 Weekly Payments of 8/9.			
OLDHAM RECHARGEABLE WET BATTERY .....	5	0	0
Deposit 10/-. and 19 Weekly Payments of 5/-.			
PHILIPS 372 ELIMINATOR .....	7	15	0
Deposit 15/6, and 19 Weekly Payments of 7/9.			
AMPLION AC7 SPEAKER .....	6	17	6
Deposit 14/-. and 19 Weekly Payments of 7/-.			
PHILIPS PCJJ .....	6	10	0
Deposit 13/-. and 19 Weekly Payments of 6/6.			

## RAILWAY RADIO

495a Rawson Chambers, Pitt St., Sydney.  
 'Phone: MA 5288.

# EMMCO'S RADIO PRODUCTS

ONLY  
RELIABLE PRODUCTS  
CAN BE UNCONDITIONALLY  
GUARANTEED

## A.C. Transformers

From Emmco's Factory now comes the A.C. or Power Pack Transformer, made up in an attractive metal case, crystalline finish, size 4½ x 3 x 2½ inches.

Manufactured in three types.  
Type "A," for Radiotron or similar A.C. Valves, 1½, 2½, and 5 volt tappings.

- PRICE** ..... 35/-  
Type "B," for Arcturus 15 volt A.C. Valves.  
**PRICE** ..... 30/-  
Type "C," for Philips A.C. Valves, 2 tappings.  
**PRICE** ..... 30/-



## Maxum "B" Eliminator

Surpasses All Others



In the Emmco Maxum "B" Socket Power Unit there is an improved "B" Eliminator designed to operate sets up to and including seven valves. Knob control allows a variation

of 20 volts for all tappings. Voltage can be changed to different valve requirements by altering the connections to the resistance stops in the case.

**PRICE** ..... £8/15/-

## A SOCKET POWER SUPPLY

Modernize Your Set

Simply install an Emmco "A" Socket Power Supply and any type of Emmco "B" Eliminator, and your set becomes an all electric—no batteries are necessary.

The "A" Socket Power works direct from the A.C. Main, and has an output 1 amp. at 6 volts—knob control, no alteration in the wiring necessary—just plug in.

**PRICE** ..... £12/12/-



## MELLOW METAL DIAL



Give your Set a finished appearance with this Emmco handsomely-engraved escutcheon. Wonderfully smooth action, strong friction drive hairline adjustment, and no backlash. For either clockwise or anti-clockwise movement. Mounting plate supplied.

An exquisite precise Vernier Dial, in oxydised silver finish.

**PRICE** ..... 9/6  
**PRICE** (same illuminated) .. 12/6

MADE BY ELECTRICITY METER MFG. CO. LTD.

Exclusive Factory Representatives,

MANUFACTURERS PRODUCTS PTY., LTD.,

139 Clarence Street, Sydney. 'Phone, BW 1328.

Sugden Place, off Little Collins Street, Melbourne.

# HITTING BELOW the BROADCAST BELT

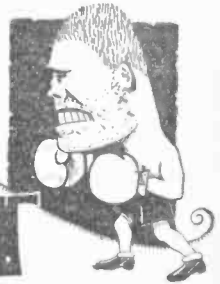

A NOTE which arrived from VK2RX characteristic of the feeling everywhere anent the 20 metre waveband just now. Leaving out the preamble: "Hi! This week I have worked four Frenchmen, two Belgians, one Englishman, eleven Americans, and one Czecho-Slovakian—the latter residing in Moravia, on the banks of the Danube, OK2YD. Verily, brother, we work weird-sounding stations these days! ETAOIN SHRDLU CMFWYP OM—meaning in Moravian. Very 73. VK2RX."

Yes, I quite agree with VK2RX's feeling of what a little fellow the world really is. For I also have hauled quite a goodly pile of the DX merchants. Circumstances have forbidden my sojourn at the key as long as some of my 20-metre colleagues, but in the short space of time spent there things have certainly been humming, like bees around the dial.

One of the first long-distance men I hooked up with during the last week was OA4S, in Lima, Peru. Ignoring the new system of code strength, he gave me one of those good old R9 reports, which at once made me think that the doublet aerial, having a nice, corrugated iron roof directly behind it in the direction of South America, was propagating a well reflected wave. Naturally the urge to speed up single on the key followed after a report like that—until the lad at the other end said: "Can't speak English." Somehow I think it was his enthusiasm that made him give that R9 report, and I felt like sending what a Brazilian had told one of our Aussies, "GTK—Quit the Kidding."

The Frenchmen have been well in evidence during the afternoons about 5 p.m., Sydney time, and no trouble is experienced in "raising" them. Among these are F8XZ, F8TBR, and F8XAQ. That "8XAQ" call is strongly reminiscent of a pioneer American station at Cazenovia, N.Y., who put the strongest signals across the Atlantic in 1922 during the first real DX tests between foreign hams.

A few Englishmen are to be heard occasionally, but they have been during the last two weeks very few and far between on 20 metres. There is a good reason for their silence, as they have all undoubtedly been busy with the ten metre tests.

Did any Australians hear G signals on ten metres? In my own case I have been greeted with silence—silence except for the power leaks and automobiles.

VK6SA, who is the Australian ten-metre pioneer, told me over the air that he has been heard in South Africa. After a long while I hooked up with friend W9EF on 20 metres. This American is about the best of the gang over there for a really interesting QSO. He always has something to yarn about, and is not like the usual run—you know the sort of thing—"Nil Hr Cu Agn 73 OM." W9EF believes in using his transmitter to good purpose. It is noteworthy how our South Australian friend VK5HG gets out when he is on the job. For a week or two he has been laid up in hospital, and every time I have hooked up with some remote part of the world I have been asked to pass greetings to Cooper. All the world's a stage, and VK5HG certainly one of the star players.

Talking of hams being laid up, those who have missed VK2YI will be sorry to hear that at the time of writing Phil has been down

## Short-wave and Amateur Notes by VK2NO

four weeks with typhoid. Let us hope that his piercing DC signals will soon be back again with us, and we can expect it when Phil is convalescing, because his Alvis speedster will be tabu for a while; but not so the shack, if we know Phil.

On Thursday evening, March 21, it was my pleasure to attend at the W.I.A. N.S.W. Division, a lecture by Mr. A. S. MacDonald, chief engineer of AWA, on the future of the Beam. A number of hams were present, and all agreed that they had learnt more about feeder systems, reflection, and fading in two hours than all the text books could tell them in a year. Not many realised that by using two receiving aerials, at least, three wave lengths apart, that in short-wave work fading may be taken well in hand. It seems incredible to think that there is such a difference in such close location, but tests show that it is so.

VK5AX, of Australian Inland Mission fame, is in Sydney at present making preparations for another journey outback. He is busy looking round for future schedules, and no doubt many N.S.W. hams will be only too pleased to oblige.

A letter from Mr. Russell Crane, who so kindly looks after the interests of the international BCL, sums up the situation at present. He says:—

"It should interest the readers of your short wave articles to notice that there is at present no need to get out of bed very early or sit up to early morning hours in order to get good overseas reception. It may also be of interest to know that the humble two-valve receiver using a Philips A 415 and a Philips penthode will bring good results at the present time. Bandoeng (Java) and PCL (Holland) may be heard almost any evening, the former on about 14 metres, and the latter on 18.4 metres. PCL League of Nations broadcast under a special call sign, and may be heard on Thursday from midnight to 12.30 a.m. PHI (Huisen, Holland) will transmit at the times indicated on list below. G5SW (London) may be heard at good strength from 6 a.m. to 8.30 a.m. every morning, except Sunday and Monday. There are, of course, a lot of others, such as PCJ, KGO, 7LO, etc.; but those stations indicated above are at the present time at good strength at reasonable hours. I am not advocating the use of a two-valve set in preference to the wonderful new multi sets that may now be built, but for those whose interest is not fully awakened to the extent of spending all their spare cash on new sets there is still plenty of interest to be got out of the two or even one valvers. I have found this to be particularly the case if high plate voltage is obtained from a reliable source, such as the Philips eliminator, which also provides bias voltage.

### THURSDAY, MARCH 14, 1929, AT ORONULLA.

"Station PHI (Huisen), transmitting from 11 to 12 (midnight), good strength, but touchy. Storm all evening; my set not working very well—a lot of background mush.

"Station PCL was on usual telephony with Bandoeng at fair strength till 12.15, when the following announcement was made:—"Here is

the League of Nations secretariat speaking to you; wave length, 18.46 metres. Very much regret. . . .

Choosing the wave length. . . . The languages in which the experiment will be made are English, French. . . .

from 14 to 14.30 G.M.T. wave length, 18.46 metres. . . . I now will ask my Australian colleagues to come before the microphone and speak to you." "Hello! I want to give the people in Australia and New Zealand some idea of the life we members of the Secretariat lead: First of all, I would like to call. . . . Mr. Kershaw. . . . While I was standing in the middle of the floor during this session. . . .

"This is not an hotel, as you know (note, I could get 95 per cent. but too fast for me to copy). Described the building, situation, etc., and the different committee rooms.

"In the Committee of Justice at this very moment a very important discussion is taking place." Committee of Experts. . . .

"Let us go downstairs a moment and look in at the Committee of Justice. We may find it a little difficult to get in there, as etc., etc. Most important of all, perhaps, you will find there permanent Court of International Justice. . . . I cannot help thinking, etc., etc. As far as one can gather. . . .

(reference then made to America's difficulties in coming into the Permanent Court of Justice. Long references to America and then Canada).

"Fourteen members of the committee had given their blessing to the proposals." (Rather bad surge just now).

"American papers referred to this as throwing kisses across the Atlantic.

"A letter has just come from the wife of an American member of the Secretariat about the model assemblies that are being held all over the States, 18 universities and colleges taking part. No one who knows the League of Nations could fail to be impressed with the exactitude, etc., etc. (Every word now clear)

"This, I think, is just an indication of the kind of spirit, etc., etc." Again referred to the model assemblies throughout America.

remarkable reproduction of the League's proceedings.

"Let us look in for a moment at the committee room which only a few days ago was the scene of discussion of considerable importance to Europe and the rest of the world. . . . Referred to Locarno Meeting of Council. . . . bitter controversy. . . . big scene expected during discussions re minorities.

"As a matter of fact, I have never seen such an enormous crowd as gathered, etc., etc. Crowded corridors. . . . they did not, however, witness the violent scene they expected. The German representative's speech was not at all violent, etc., etc., but was described by the journalists as a little academic.

"I would like those who are listening to this conversation to realise that what is going on in Geneva is of the utmost importance to individuals of Australia. The time has come for me to close. Good-bye to my friend, Mr. Kershaw, and any other good friends who have heard the transmission in Australia and New Zealand.

Please send reports to Information Section, League of Nations Secretariat, Geneva, Switzerland. Good-night." This was at 12.50, and PCL at once started to call Bandoeng.

# CONTROL THE WHOLE OF THE POWER TO YOUR RADIO

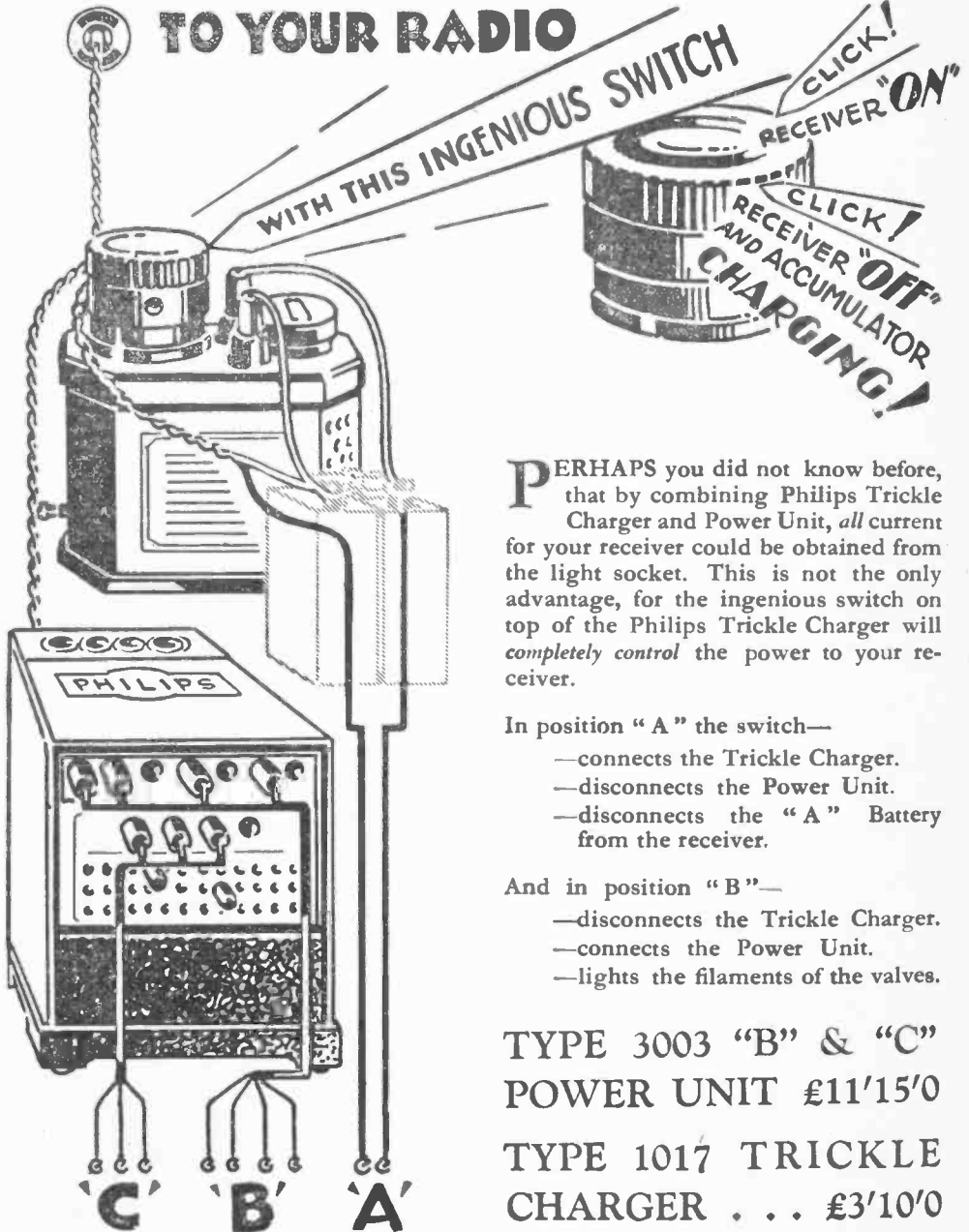

WITH THIS INGENUOUS SWITCH

CLICK!  
RECEIVER "ON"  
CLICK!  
RECEIVER "OFF"  
AND ACCUMULATOR  
CHARGING!

**P**ERHAPS you did not know before, that by combining Philips Trickle Charger and Power Unit, *all* current for your receiver could be obtained from the light socket. This is not the only advantage, for the ingenious switch on top of the Philips Trickle Charger will *completely control* the power to your receiver.

- In position "A" the switch—
- connects the Trickle Charger.
  - disconnects the Power Unit.
  - disconnects the "A" Battery from the receiver.

- And in position "B"—
- disconnects the Trickle Charger.
  - connects the Power Unit.
  - lights the filaments of the valves.

TYPE 3003 "B" & "C"  
POWER UNIT £11'15'0

TYPE 1017 TRICKLE  
CHARGER . . . £3'10'0

# PHILIPS

## POWER SOCKET APPARATUS



# Local Programmes, Friday, April 5

## 2FC

### EARLY MORNING SESSION

Announcer: A. S. Cochrane.

7.0: "Big Ben" and announcements. 7.2: Official weather forecast; rainfall; river reports; temperatures; astronomical memoranda. 7.7: "Sydney Morning Herald" summary. 7.12: Shipping intelligence; mail services. 7.15: Studio music. 7.25: Investment market; mining sharemarket; metal quotations; wool sales; breadstuffs markets; Inter-State markets; produce markets. 7.40: Studio music. 8.0: "Big Ben." Close.

### MORNING SESSION.

Announcer: A. S. Cochrane.

10.0: "Big Ben" and announcements. 10.2: Pianoforte reproduction. 10.10: "Sydney Morning Herald" news service. 10.25: Studio music. 10.30: A talk on Home-cooking and Recipes by Miss Ruth Furst. 10.45: From the Conservatorium Hall, Second Violin Session. Lecturer: Mr. Cyril Monk. 11.15: A.P.A. and Reuter's cable services. 11.20: Close.

### MIDDAY SESSION.

Announcer: A. S. Cochrane.

12.0: "Big Ben" and announcements. 12.1: Stock Exchange, first call. 12.3: Official weather forecast; rainfall. 12.5: Studio music. 12.10: Summary of news, "Sydney Morning Herald." 12.15: Rugby wireless news. 12.18: A reading. 12.30: Studio music. 1.0: "Big Ben"; weather intelligence. 1.3: "Evening News" midday news service; Producers' Distributing Society's report. 1.20: Studio music. 1.28: Stock Exchange, second call. 1.30: Popular studio music. 2.0: "Big Ben." Close.

### AFTERNOON SESSION.

Announcer: Laurence Halbert.

Accompanist: Ewart Chapple.

2.30: Programme announcements. 2.32: From the Conservatorium Hall, vocal repertory session, exemplifying oratorio, opera and song, with commentary on each section. Arranged by the Vocal Committee: Messrs. William Asprey, Frank E. Down, Roland Foster. Artists: Soprano, Madame Goossens-Vieroy; mezzo-soprano, Miss Heather Bell; contralto, Miss Marjorie Beeby; tenor, Mr. Robert Harper; baritone, Mr. Clem Williams; bass, Mr. W. Reginald Good; accompanist, Mr. Lindley Evans. 3.30: From the studio—Studio items. 3.45: A reading. 4.0: "Big Ben." Anne Luciano, soprano. 4.7: Popular music. 4.10: Romano's Cafe Dance Orchestra, conducted by Bennie Abrahams. 4.20: From the studio—Anne Luciano, soprano. 4.27: Studio items. 4.40: Romano's Cafe Dance Orchestra. 4.46: From the studio—Stock Exchange, third call. 4.48: Popular music. 5.0: "Big Ben." Close.

### EARLY EVENING SESSION.

Announcer: A. S. Cochrane.

5.40: The chimes of 2FC. 5.45: The children's session, conducted by the "Hello Man"; letters and stories; music and entertainment. 6.0: The Farmyard Five, from Kookaburra Gully. 6.30: Dalgety's market reports (wool, wheat, and stock). 6.40: Fruit and vegetable markets. 6.43: Stock Exchange information. 6.45: Weather and shipping news. 6.48: Rugby wireless news. 6.50: Late sporting news. 7.0: "Big Ben." Late news service. 7.10: Specially selected recital of dinner music reports. 7.30: A talk by James Peddie. F.R.T.B.A.

### EVENING SESSION.

Announcer: Laurence Halbert.

Accompanist: Ewart Chapple.

7.40: Popular music. 7.45: Programme announcements. 7.48: Studio items. 8.0: "Big Ben." Castle Palais Dance Band, winners in the recent Radio Elsteddoff conducted by the N.S.W. Broadcasting Co., Ltd.—

(a) "Jo-Anne" fox trot (Pinkard); (b) "It Goes Like This" fox trot (Friend); (c) "Don't You Love Me Any More" fox trot (Nelson).

8.12: Leo Rowan, tenor, winner in the recent Radio Elsteddoff, conducted by the N.S.W. Broadcasting Co., Ltd.

8.19: Sibley and Sayles, entertainers.

8.26: The Two Posters, instrumentalists.

8.36: Jack Kinson, basso—(a) "Mistress of the Master" (Phillips); (b) "Glory of the Sea" (Sanderson).

8.43: Castle Palais Dance Band, winners in the Radio Elsteddoff—(a) "I Can't Do Without You," waltz (Berlin); (b) "If You're Sorry I'm Sorry, Too," waltz (Porter); (c) "I Love No One But You," waltz (Spitaling).

8.55: Leo Rowan, tenor, winner in the Radio Elsteddoff.

9.2: Weather report.

9.3: The Two Posters, instrumentalists.

9.13: Jack Kinson, basso—(a) "Glory of the Sea" (Sanderson), (b) "Young Tom o' Devon" (Russell).

9.20: Castle Palais Dance Band, winners in the Radio Elsteddoff—(a) "Bless You, Sister," fox-trot (Robinson); (b) "I'm Wingin' Home," fox-trot (Tobias); (c) "Afraid of You" fox-trot (Cottler).

9.32: Sibley and Sayles, entertainers.

9.39: Castle Palais Dance Band, winners in the Radio Elsteddoff—(a) "Let a Smile Be Your Umbrella," fox-trot (Fain); (b) "Dear on a Night Like This," fox-trot (Conrad); (c) "Kiss Before the Dawn," waltz (Perkins).

9.56: To-morrow's programme.

9.58: Castle Palais Dance Band, winners in the Radio Elsteddoff, (a) "Sweetheart Memories," waltz (Burke); (b) "Siren Dream" fox-trot (Pollack); (c) "I'd Love to Baby You," fox-trot (Green); (d) selected.

10.28: Late weather report.

10.30: National Anthem. Close.

## 2BL

### MORNING SESSION.

Announcer: Eric Bessemer.

8: G.P.O. chimes; metropolitan weather report. 8.1: State weather report. 8.2: Studio music. 8.15: G.P.O. chimes; news service from the "Daily Telegraph Pictorial." 8.30: G.P.O. chimes; news service continued. 8.40: Information, mails, shipping, arrivals, departures, and sailings. 8.45: Studio music. 10.0: G.P.O. chimes. Close down.

### MIDDAY SESSION.

Announcer: Eric Bessemer.

11.0: G.P.O. chimes; 2BL Women's Sports Association session, conducted by Miss Gwen Varley. 11.30: Advertising hints; talk on "Diet and Health," by Miss Dorothea de Cleg-horne. 11.40: Women's Session, conducted by Mrs. Cranfield. 12.0: G.P.O. chimes; special ocean forecast and weather report. 12.3: Studio music. 12.30: Shipping and mails. 12.35: Market reports. 12.43: "Sun" midday service. 1.0: Studio music. 1.30: "Sun" news services. 1.40: Studio music. 2.0: G.P.O. chimes. Close down.

### AFTERNOON SESSION.

Announcer: A. C. C. Stevens.

Accompanist: Kathleen Roe.

3.45: G.P.O. chimes; popular music. 4.0: G.P.O. chimes. A. A. C. Stevens, "Catching Wild Elephants in India." 4.15: Millie Hansen, soprano—(a) "The Pipes of Pan are Calling" (Monckton), (b) "My Life is Love" (Tats). 4.22: Studio music. 4.32: Avice Garth, mezzo—(a) "A Dream Garden" (Phillips), (b) "Crying for the Moon" (Dickson). 4.39: "Sun" news service. 4.44: Popular items. 4.50: Millie Hansen, soprano—(a) "The Carnival" (Molloy), (b) "In the Garden of My Heart" (Ball). 4.57: Popular music. 5.5: Avice Garth, mezzo—"A Dream Garden"

(Phillips), (b) "Crying for the Moon" (Dickson). 5.12: Pianoforte reproduction. 5.22: Popular music. 5.35: Producers' Distributing Society's poultry report. 5.37: Features of the evening's programme.

### EARLY EVENING SESSION.

Announcer: Basil Kirke.

5.40: Children's session; music and entertainment; letters and stories. 6.30: "Sun" news and late sporting. 6.40: Special recital of dinner music records. 7.7: Aust. Mercantile, Land, and Finance Co.'s report; weather report and forecast by courtesy of Government Meteorologist; Producers' Distributing Society's fruit and vegetable market report; grain and fodder report ("Sun"); dairy produce report ("Sun"). 7.25: Mr. Pini and Miss Pini in advertising talks and nonsense. 7.55: Programme and other announcements.

### EVENING SESSION.

Announcer: Basil Kirke.

Accompanist: G. Vern Barnett.

8.0: G.P.O. chimes. Topical chorus. 8.2: By courtesy of J. C. Williamson Ltd. the first act of "Hit the Deck." 9.50: From the studio: David Craven and Maisie Otty, musical novelties—(a) Song, "Roll Along" (De Rose); (b) Piano novelty, "Brown Sugar" (Barris); (c) Song, "Sylvelin" (Sinding); (d) Piano novelty, "Keyboard Kapers" (Steele).

10.03: From the Hotel Australia, Cec Morrison's Dance Band.

10.2: Late weather report. 10.18: From the studio—David Craven and Maisie Otty, Musical Novelists: (a) Song, "Sally of My Dreams" (Kearnell); (b) piano novelty, "A Letter from Dixie" (Robison); (c) Song, "Sonny Boy" (Jolson); (d) piano novelty, "You Tell 'em Ivories" (Comfrey).

10.0: Chimes. From Hotel Australia: Cec Morrison's dance band.

10.12: From the Studio—Maisie Otty and David Craven.

10.22: From the Hotel Australia—Cec Morrison's Dance Band.

10.45: From the studio—"Sun" news service.

11.0: G.P.O. chimes. To-morrow's programme.

11.1: From the Hotel Australia—Cec Morrison's Dance Band.

11.30: National Anthem. Close down.

## 2GB

10.0: Music. 10.10: Happiness talk by A. E. Bennett. 10.20: Music. 10.30: Women's session by Miss Helen J. Beezling. 11.30: Close down. 2.0: Music. 2.5: Women's radio service by Mrs. Dorothy Jordan. 2.50: Music. 3.15: Close down. 5.30: Children's session by Uncle George. 7.0: Music. 7.30: Feature story. 8.1: Mrs. Thelma Lansdowne, contralto. 8.1: Mr. Reginald Duncan, violinist. 8.15: Mr. Leslie Herford, baritone. 8.25: Instrumental music. 8.30: Humorous interlude by Mr. Jack Win and Mr. Heath Burdock. 8.35: Miss Gladys Verona, soprano. 8.50: Miss Lila Graham, pianiste. 9.0: Weather report. 9.3: Address. 9.15: Miss Thelma Lansdowne, contralto. 9.25: Mr. Reginald Duncan, violinist. 9.35: Humorous interlude by Mr. Jack Win and Mr. Heath Burdock. 9.40: Instrumental music. 9.50: Mr. Leslie Herford baritone. 10.0: Dance music. 10.30: Close down.

## 2UW

### MIDDAY SESSION

12.30: Music. 1.0: G.P.O. clock and chimes; music. 2.30: Close down. 4.30: Musical programme.

### EVENING SESSION.

5.30: Children's hour, conducted by Uncle Jack. 6.30: Close down. 7.0: G.P.O. clock and chimes. Music. 8.0: To-day's anniversary. Music. 9.0: G.P.O. clock and chimes. Comments on Foreign Affairs by Mr. J. M. Prentice. 9.10: Music and request numbers. 10.30: Close down.

# Interstate Programmes, Friday, April 5

## 3LO

### MORNING SESSION.

Announcer, John Stuart. 11.0: To-day's radio recipe—"Chicken broth." 11.5: Grace Tyer's will speak on "Oreni Russian Writers and Their Stories"—Turgenev. 11.25: "Au Fait" will speak on "Fashions." 11.45: Under the auspices of the Health Department, Dr. Rowan will speak on "Health and Environment."

### MIDDAY SESSION.

Announcer, John Stuart. Accompanist, Agnes Fortune. Midday News Session. 12.0: Melbourne Observatory time signal. 12.1: Prices received by the Australian Mines and Metals Association from the London Stock Exchange this day; British official wireless news from Rugby; Reuter's and the Australian Press Association cables; "Argus" news service. 12.15: Newmarket stock sales; special report by the Associated Stock and Station Agents, Bourke Street, Melbourne. 12.20: The Station Orchestra. 12.35: Stanley J. Allen, tenor. 12.43: Stock Exchange information. 12.45: The Station Orchestra. 1.0: Meteorological information; weather forecast for Victoria, New South Wales, South Australia, and Tasmania. 1.8: The Station Orchestra. 1.18: Stanley J. Allen, tenor. 1.25: Bertha Jorgensen, violin. 1.32: The Station Orchestra. 1.45: Close down.

### AFTERNOON SESSION.

Announcer, John Stuart. Accompanist, Agnes Fortune. 2.15: The Station Orchestra. 2.25: Betty Ross Clarke will entertain with selections from modern poets. 2.32: The Station Orchestra. 2.42: James Hay, tenor. 2.49: The Station Quartette. 3.0: James Hay, tenor. The Birthplace of Great Hopes. 3.7: Miss Frances Frazer will speak on "Oeneva in History and Literature." 3.22: The Station Orchestra. 3.22: Lew Davey, natural whistler. 3.30: Alfred Acland, violin. 3.50: Betty Ross Clarke. 3.57: The Station Orchestra. 4.13: Thos. George, bass-baritone. 4.20: The Station Orchestra. 4.30: Lyle Davey. 4.37: Thos. George, bass-baritone. 4.44: The Station Orchestra. 4.54: "Herald" news service; Stock Exchange information. 5.5: Close down.

### EARLY EVENING SESSION.

6.0: Answers to letters, and birthday greetings, by "Billy Bunny." 6.25: Musical interlude. 6.30: "Billy Bunny" has a quaint little story to tell you.

### EVENING SESSION.

Announcer, Renn Miller. 6.50: Madame Soward will speak on "French Without Tears." 7.5: Stock Exchange information. 7.15: Official report of the Newmarket stock sales, by the Associated Stock and Station Agents, Bourke Street, Melbourne; latest 1 stock orders for new stock markets; fish market reports, by J. R. Borrett, Ltd.; rabbit prices; river reports; market reports by the Victorian Producers Co-operative Co., Ltd.; poultry, grain, hay, straw, jute, dairy produce, potatoes, and onions; market reports of fruit by the Victorian Fruitgrowers Association; "feet prices," wholesale prices of fruit by the Wholesaler Fruit Merchants' Association; citrus fruits. 7.30: News session. 7.43: today greetings. 7.45: "Lull of the Past." 7.49: Under the auspices of the Department of Agriculture, Gill, senior herd tester, will speak on "Breeding High-class Dairy Stock." 8.0: A Maker of History. 8.1: H. K. Love will speak on "Technicalities."

### NIGHT SESSION.

Announcer, John Stuart. Accompanist, Agnes Fortune. 8.15: Collingwood Citizens' Band—Selection, "The Ragged Dicks." 8.20: "We Four" Quartette—(a) "Serenade" (Fletcher). (b) "Swingalong" (Arr. Powdall). (c) "The Merry Old Wife" (Lid.). (d) "Silent Noon" (Vaughan Williams). 8.27: Collingwood Citizens' Band—March, "Newarth Castle." 8.42: Betty Ross Clarke is here again to entertain you with her delightful recitals. 8.49: Collingwood Citizens' Band—Selection, "La Traviata" (Verdi). 9.0: "We Four" Quartette—Claude Schelling, baritone. (a) "Cavatina" from "Faust" (Gounod). The Quartette—(b) "Madley of the South" (Pit). 9.7: The Imperial Russian Trio (Arved Norit violin, Ivan Berynsky cello, Vassili Ister piano)—"Serenade" (Schubert). "Cantabile" (Op.). "Some of the Mountains" (Grieg). "Once Upon a Time" (Lind). "Dance Characteristic" (Rebikov). 9.30: Betty Ross Clarke—Her 1st few items for to-night. 9.37: Captain Donald MacLean will continue his series of stories concerning "The Conquest of Peru." 9.50: The Collingwood Citizens' Band—Japanese Romance, "Popples." 9.55: Lyle Davey, natural whistler—"Trilling." 10.0: Tell Me, Lads. 10.1: Eric Welch will speak on to-morrow's races at Sandown Park. 10.15: The Collingwood Citizens' Band—Chorus solo, "Sad and Lonely," by Ada B. A. Rutherford. 10.2: "El Abencio." 10.3: "We Four" Quartette—(a) "The Last Chord" (Sullivan). The Quartette—(b) "The Last Chord" (Sullivan).

10.27: The Collingwood Citizens' Band—Selection, "The Vagabond King." 10.32: "Argus" new service; British official wireless news from Rugby; meteorological information; road notes, supplied by the Royal Automobile Club of Victoria; announcements. 3LO's weekly seasonal gardening reminders, compiled by Leslie Brunning. 10.40: Lyle Davey, natural whistler—"Bright as You Star." "Wing the Swallows Homeward Fly." 10.47: The Radio Revellers—"Honey" (Simons). "Alabama Stamp" (Creamer). "When the Right One Comes Along" (Gilbert). "One Alone" (Romberg). "The Desert Song" (Romberg). "It Goes Like This" (Caesar). "Under the Stars of Havana" (Coleman). "The Dancer of the Blue Danube" (Fischer). "Rose-time" (Hall). "Glad Rag Doll" (Ager). "All by Yourself in the Moonlight" (Wallis). "Mexican Serenade" (Terzag). 11.30: God Save the King

formation; Fenwick's stock report; announcements; standard time signals; to-morrow's sporting list; times reviewed.

### NIGHT SESSION

Announcer, A. V. James. 8.0: The Studio Orchestra—"King Mydas" (Ellenberg). 8.7: The Silkstone Apollo Club (conductor, T. Westwood)—chorus, "To Arms" (De Rille). 8.11: Vera Parker (contralto)—"When You Come Home" (Squire). 8.15: Erica Stuart (pianiste)—"Waltz Caprice" (Rubinstein). 8.19: The Silkstone Apollo Club—"Anvil Song" (Adams). 8.24: The Studio Orchestra—"Serenade" (Widor). 8.28: Annie Adams (soprano)—"Beat of a Passionate Heart" (Phillips). 8.34: T. Westwood (baritone)—"The Image of a Rose" (Leichardt), accompanied by the Silkstone Apollo Club. 8.40: D. Owens (tenorist)—selected. 8.44: Vera Parker (contralto)—"Sincerity" (Clarke). 8.50: The Silkstone Apollo Club—chorus, "Paradise Grove" (Hughes). 8.55: Erica Stuart (soprano)—"The Angels Have Changed My Name" (Coleridge-Taylor); "My Lord Delivered Donkeys" (Coleridge-Taylor). 9.0: Metropolitan weather forecast. 9.1: Week-end road information, officially supplied by the Royal Automobile Club of Queensland. 9.10: The Studio Orchestra—Characteristic "Branconation" (Kreiser). 9.15: The Silkstone Apollo Club—"The Derbyshire Ram" (Dr. Callcott). 9.20: Annie Adams (soprano)—"Big Lady Moon" (Coleridge-Taylor). 9.25: Vic Morris (bass)—selected. 9.28: Silkstone Instrumental Trio—Miss O. Wolley and Messrs. A. and G. Laurie—selected item. 9.34: The Royal Male Quartette—"Song of the Bow" (Aylward). 9.38: Silkstone Apollo Club—"Rolling Down to Rio" (Griegman). 9.42: Alex. Laurie (violinist)—selected. 9.47: The Studio Orchestra—march, "The Periscope" (Allen). 9.51: T. Westwood (baritone)—"The March of the Cameron Men," accompanied by the Silkstone Apollo Club. 9.55: The Silkstone Apollo Club—chorus, "March of the Arena" (De Rille). 10.0: "The Daily Mail" news. "The Courier" news; weather news. Close down.

## INDEX

### To Interstate Programmes

<b>FRIDAY, March 29—</b>	3LO, 3AR, 4QG, 5CL, 6WF, 7ZL	30
<b>SATURDAY, March 30—</b>	3LO, 3AR, 4QG, 5CL, 6WF, 7ZL	34
<b>SUNDAY, March 31—</b>	3LO, 3AR, 4QG, 5CL, 6WF, 7ZL	37
<b>MONDAY, April 1—</b>	3LO, 3AR, 4QG, 5CL, 6WF, 7ZL	40
<b>TUESDAY, April 2—</b>	3LO, 3AR, 4QG, 5CL, 6WF, 7ZL	44
<b>WEDNESDAY, April 3—</b>	3LO, 3AR, 4QG, 5CL, 6WF, 7ZL	48
<b>THURSDAY, April 4—</b>	3LO, 3AR, 4QG, 5CL, 6WF, 7ZL	52

## 5CL

### MORNING SESSION

Announcer, C. J. O'Connor. 11.0: G.P.O. chimes. Morning melodies. 11.15: Kitchen Craft and Menu talk; morning melodies. 11.45: Under the auspices of the St. John Ambulance Association, Mr. L. G. mid-day music will speak on "First Aid." 12.0: G.P.O. chimes; wireless news; general news service; British official news; S.A. railway information; Meteorological information; Lunch-hour recital; Meteorological information; close down.

### AFTERNOON SESSION.

Announcer: J. L. Norris. 2.15: Station Quartette, Madame Dorothy Back, soprano, Syd Hollister, comedian, Pat McLean, entertainer, Frank McCabe, baritone. 2.35: A short lecture, with illustrative recordings, by Horace Perkins, Mus. Bac., A.M.T.A. "The Works of Schumann." 4.55: S. C. Ward and Co.'s Stock Exchange information. 5.0: Close down.

### EVENING SESSION

Announcer: J. L. Norris. 6.0: G.P.O. chimes; birthday greetings, correspondence; songs and stories by "Miss Winton." 8.00: Mr. Keith Minchin will tell you more about the "Zoo: An Intergate of dinner music; Stock Exchange information. 7.6: General market reports. 5CL's sporting service, supplied by "Silvius." A musical interlude; Leo Theobald, second lesson on the Fox-trot.

### NIGHT SESSION

Announcer: J. L. Norris. 8.0: G.P.O. Chimes. 8.1: Unley Orchestra, Conductor, Mr. Norman Bellick—"Semiramide" (Rossini). 8.11: Gwen Collett, contralto—selected solos. 8.17: Syd Hollister, comedian, will entertain you. 8.23: Unley Orchestra—"In a Persian Market" (Ketyby). 8.28: Mostyn Skinner, baritone—"Zri" (Verdi). "The Night Rider" (Bryceson Theatre). 8.34: Malcolm Gillham, trumpeter (of the Unley Orchestra)—Selected trumpet solo. Pat McLean, entertainer—Selections from her repertoire. 8.43: Unley Orchestra—"Iolanthe" (Sullivan). 8.58: Ruth Naylor, soprano (winner of the English Elder Scholarship)—"Music when Soft Voices Die" (Roger Quilter). "In the Bud of the Morning" (Roger Quilter). 9.4: Meteorological information, including semaphore times. 9.5: Overseas grain report. 9.6: Syd Hollister, comedian. 9.12: Unley Orchestra—"In a Monastery Garden" (Ketyby). 9.17: Mr. C. T. Madigan, M.A., B.Sc., F.G.S., will speak on "Life in the Antarctic." 9.32: Unley Orchestra—"Spanish Review" (Bridging). 9.40: Gwen Collett, contralto. 9.46: Pat McLean, entertainer—Selections from her repertoire.

## 3AR

### MORNING NEWS SESSION.

Announcer, Maurice Dudley. 10.0: G.P.O. clock; market report; farm and station produce, fruit, fish, vegetables, etc.; shipping reports; ocean forecast; mail notices; express train information; news service, exclusive to 3AR; weather forecast.

### MORNING MUSICAL SESSION.

11.0: Ern. Hall's Radio Revelers. 11.20: Beautiful ballads. 11.30: The Radio Revelers. 11.50: Beautiful ballads. 12.0: The Radio Revelers. 12.30: British official wireless news; announcements. 12.30: Close down.

### AFTERNOON SESSION.

Announcer, Maurice Dudley. 3.0: Vocal variations. 3.15: Kerry Kelly, entertained. 3.22: The Imperial Russian Trio. 3.37: The Imperial Russian Trio. 3.52: Captain Donald MacLean. 4.7: Vocal variations. 4.17: Kerry Kelly, entertainer. 4.34: Vocal variations. 4.30: Close down.

### EVENING SESSION.

Announcer, Frank Hatherley. 6.0: A bravura of beautiful ballads. 7.10: News service; announcements. 7.30: Night ballads.

### MIDDAY SESSION.

Announcer, Frank Hatherley. 8.30: Transmission from Ballarat City Hall—Community singing. 10.30: From the Studio—mail information; shipping news service; announcements. God Save the King.

## 4QG

### MORNING SESSION

Announcer: Rita McAuffie. 11.0: Music; social news; lecture, "A cookery and household talk," by "The Etiquette Girl" (music); more social news; Wurlitzer organ. 12 (noon): Close down.

### MIDDAY SESSION

Announcer: R. Wright. 1.0: Market reports and weather information. 1.20: Lunch-hour music. 2.0: Close down.

### AFTERNOON SESSION

Announcer: H. Humphreys. 3.0: Orchestral music by the Tivoli Operatic Orchestra, under the baton of Mr. C. Groves. 3.30: Mail train running times; a programme of electrically reproduced records; orchestral music; afternoon news. 4.30: Close down.

### EARLY EVENING SESSION

Announcers: R. Wright and H. Humphreys. 6.0: Mail train running times; mail information; shipping news; dinner music; commercial announcements. 6.30: Bedtime stories, conducted by "The Sandman." 7.0: News in brief; Stock Exchange news; metal quotations; market reports; weather in-

9.52: Unley Orchestra—"Intermezzo" (Czibulka).  
 9.57: Ruth Naylor—  
 "Second Minuet" (Maurice Besly).  
 "Blackbird Song" (Cyril Scott).  
 10.3: Malcolm Gilham, trumpeter (of the Unley Orchestra).  
 10.6: Mostyn Skinner, baritone—  
 "Thou Art Risen" (Coleridge-Taylor).  
 "The Song of the Waggoner" (Breville Smith).  
 10.12: Unley Orchestra—"Pearl O' Mine" (Fletcher).  
 10.15: General news service; Meteorological information; SCL's sporting service, by "Silvius."  
 10.30: Modern dance numbers by the famous Radio Revelers.  
 11.0: God Save the King.

**6WF**

12.30: Tune in. 12.35: Markets, news, etc. 1.0: Time signal. 1.1: Weather bulletin supplied by the Meteorological Bureau of West Australia. 1.3: Selections by the Studio Trio: vocal items. 2.0: Close down. 3.30: Tune in. 3.35: Music from the Primrose Cafe de Luxe; vocal items from the studio. 4.30: Close down. 6.45: Tune in. 6.48: Picture stories for the kiddies by Uncle Duffy. 7.5: Light music by the Perth Piano Trio, comprising Mr. A. Lynch, violin, Mr. H. Shirley, piano, Mr. R. Brearley, cello. 7.30: Commercial and general information. 7.45: Racing talk by the sporting editor of the "Truth" Newspaper Co., Ltd. 8.0: Time signal. 8.1: First weather bulletin supplied by the Meteorological Bureau of West Australia. 8.3: Instrumental items by the Katoomba Duo. Vocal artists from the studio. 8.50: Late news items by courtesy of the "Daily News" Newspaper Co., Ltd. station announcements, ships within range announcement, late weather bulletin. 9.10: Description of wrestling match relayed from the Ringette, Subiaco Oval, by the sporting editor of the "Truth" Newspaper Co., Ltd. 10.0: Close down. 10.45: Metre Transmission.—Simultaneous broadcast on 104.5 metres of programme given on 1250 metres, commencing at 8.45 p.m.

**7ZL**

**MIDDAY SESSION.**

Announcer, Jack Broadbent. 11.30 to 1.30: General programme.

**AFTERNOON PROGRAMME**

Announcer, Jack Broadbent. 3.0 to 4.30: General programme.

**EARLY EVENING SESSION.**

7.15: Selections. 8.25: "The Story Lady" will tell a story to the little ones. 6.40: Answers to letters and birthday greetings by "Uncle David" and "The Story Lady". 6.45: Selections; "Mercury" news service; railway auction produce sales. 10.10: Hobart Stock Exchange quotations.

**EVENING SESSION.**

Speaker, A. M. O'Leary will speak on "Cricket Activities." 7.30: A studio concert by the Discus Ensemble and 7ZL artists. Accompanist, Lella Read; announcer, Jack Broadbent, Lella Read, pianolo. 7.34: Fred Herard, baritone—"Only One Word for Her" (Loughborough); "A Sailor's Prayer" (Keel). 7.41: Jas. Compton, cornet solo—"At Sunrise" (Code); "At Dawn" (Code). 7.47: Agnes Kerr, contralto—Selected. 7.54: Reginald Des-Orsard, organ solo—"Solenn Melody" (Davis); "Intermezzo" (Hallins). 8.1: Gwen Davidson, soprano—"Venetian Song" (French); "Deh Vieni" (Mozart). 8.8: Paul Whiteman and his Orchestra—"Chiquita"; "That's My Mammy" (Baer). 8.15: Fred Herard, baritone—"Harlequin" (Sanderson); "Le Coq" (Plegler). 8.22: Cherniavsky Trio, violin, cello, piano—"At the Brook"; "Scherza". 8.29: Agnes Kerr, contralto—Selected. 8.36: Mischa Elman, violin solo—"Country Dance" (Beethoven); "Hungarian Dances." A Minor (Joachim). 8.39: Gwen Davidson, soprano—"Swing Low, Sweet Chariot" (Burleigh); "Farewell to Summer" (Johnson). 8.45: J. M. Counsel—"An Hour with the Old Masters"; The History and Development of Music." 9.45: News session. 10.0: G.P.O. clock, chimes the hour. 10.1: Close down.

# Exide

## Celluloid Cased BATTERIES

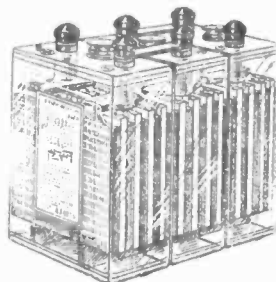

TYPE  
 CZ2.  
 20 40 amp. hours.  
 19/6  
 2 volt cell.

TYPE  
 CZ 3.  
 30, 60 amp. hours.  
 £1/3/-  
 2 volt cell.

Type CZ4, 40/80 amp. hours, £1/7/6, 2-volt cell

Prices include the Battery fully charged.

*Light—Transparent—Long  
 Lived—Economical*

Service Station:

### GIBSON, BATTLE & CO. LTD

HUNT AND COMMONWEALTH STREETS

(off Wentworth Avenue) SYDNEY. Phone M2771 (3 lines).

Delco-Remy; Autolite; North-east; Owen Dyneto  
 Car Electrical Service Station.

## VAR-LAC

Multi-Way Battery Cable  
 is Sold by the Yard.

Seven different colored leads under one water, acid and flame proof covering. No matter how far your batteries may be from your set VAR-LAC will reach them. Strip these untidy wires and use VAR-LAC Battery Cable. For Neatness, Convenience and Efficiency. Supplied in any length. If dealer is out of stock, write direct.

1/8 Per Yard.

BEAL PRITCHETT (AUST.) LTD.  
 17 PARKER STREET, SYDNEY.

# Local Programmes, Saturday, April 6

## 2FC

### EARLY MORNING SESSION.

Announcer: A. S. Cochrane.

7.0: "Big Ben" and announcements. 7.2: Official weather forecast, rainfall, river reports, temperatures, astronomical memoranda. 7.7: "Sydney Morning Herald" summary. 7.12: Shipping Intelligence; mail services. 7.15: Studio music. 7.25: Investment market, mining sharemarkets; metal quotations; wool sales; breadstuffs markets; inter-State markets; produce markets. 7.40: Studio music. 8.0: "Big Ben;" close.

### MORNING SESSION.

Announcer: Eric Bessemer.

10.0: "Big Ben" and announcements. 10.2: Pianoforte reproduction. 10.10: "Sydney Morning Herald" news service. 10.25: Studio music. 10.30: Last-minute sporting information by the 2FC Racing Commissioner. 10.40: Studio music. 10.45: A talk on "Gardening," by J. G. Lockley ("Redgum"). 11.0: "Big Ben." A.P.A. and Reuter's cable services. 11.5: Close down.

### MIDDAY AND AFTERNOON SESSION.

Announcers: Laurence Halbert. Ewart Chapple.

12.0: "Big Ben" and announcements. 12.2: Stock Exchange information. 12.4: Studio music. 12.10: "Sydney Morning Herald" news service. 12.15: Rugby wireless news. 12.20: Studio music. 12.50: From Randwick—Description of the official meeting of the A.J.C. Autumn Racing Carnival. During the afternoon from the studio the Castle Palais Band, successful competitors in the recent Radio Elsteddfod, conducted by the New South Wales Broadcasting Company, Limited, will play during intervals. 5.0: "Big Ben;" close.

### EARLY EVENING SESSION.

Announcer: A. S. Cochrane.

5.40: The chimes of 2FC. 5.45: The children's session, conducted by the "Hello Man," letters and stories; music and entertainment. 6.30: Dalgety's fruit reports (wool, wheat, and stock). 6.40: Fruit and vegetable markets. 6.43: Stock Exchange information. 6.45: Weather and shipping news. 6.48: Rugby wireless news. 6.50: Late sporting news. 7.0: "Big Ben;" late news service. 7.10: The 2FC Dinner Quartette, conducted by Horace Keats—(a) "Tel Me More" (Gershwin), (b) "Only the River Running By" (Hopkins), (c) "Gipsy Melody" (Knight), (d) "Gorgee de Bacchus" (Sylvia) (Debbes), (e) "Mother, I Still Have You" (Jolson).

### EVENING SESSION.

Announcer: Laurence Halbert.

Accompanist: Ewart Chapple.

7.40: Popular music.  
7.45: Programme announcements.  
7.48: Studio items.  
8.0: Charles Lawrence's Review—A fund of Humor, Song, and Story.  
10.0: From the Hotel Australia: Cec Morrison's Dance Band.  
10.15: From the Studio: Ina Thornton, popular vocalist.  
10.22: From the Hotel Australia: Cec Morrison's Dance Band.  
10.27: From the studio, late weather.  
10.39: From the Hotel Australia: Cec Morrison's Dance Band.  
10.54: From the Studio: To-morrow's programme.  
10.56: From the Hotel Australia: Cec Morrison's Dance Band.  
11.30: National Anthem; close.



Isobel Abrams (10), a member of Farmer's "Children's News" Radio Birthday Club, who broadcasts humorous songs and recitations from 2UF, during the Children's Hour.

and weather report. 12.3: Studio music. 12.30: "Sun" midday news service. 12.40: Studio music. 12.50: From Randwick—Description of the official meeting of the A.J.C. Autumn Racing Carnival. During intervals between races music by the Smart Set Trio; solos by George Phillips, baritone; dance music from Romano's. 5.0: "Big Ben;" Close.

### EARLY EVENING SESSION.

Announcer: Basil Kirke.

5.40: Children's session—Music and entertainment, letters and stories. 6.30: "Sun" news and late sporting. 6.40: 2BL Dinner Quartette—(a) "Scene Espagnole" (Lacombe), (b) "Valse Poudree" (Poppy), (c) "Tschalkowsky Melodies," (d) "Tress" (Rasbach), (e) "Sometimes" (Elizalde), (f) "Querida" (Simon). 7.7: Complete sporting and racing resume. 7.30: Mr. Pim and Miss Pam in advertising talks, handy hints, and nonsense. 7.53: An ad. special. 7.55: Programme and other announcements.

### EVENING SESSION.

Announcer: Basil Kirke.

Accompanist: Mr. G. Vern Barnett.  
8.0: G.P.O. chimes. Topical chorus.  
8.12: The Troubadours.  
8.17: Maheno Trio.  
8.30: Popular studio programme.  
9.30: Weather report.  
9.31: Romano's Cafe Dance Orchestra, conducted by Bennie Abrahams.  
9.40: From the studio—The Troubadours.  
9.55: Maheno Trio.  
10.5: Terence Nugent, tenor.  
10.12: Romano's Cafe Dance Orchestra, conducted by Bennie Abrahams.  
10.22: Terence Nugent, tenor.  
10.29: Late weather report.  
10.32: Romano's Cafe Dance Orchestra, conducted by Bennie Abrahams.  
10.57: To-morrow's programme. News service.  
11.12: Romano's Cafe Dance Orchestra.  
11.30: National Anthem. Close, conducted by Bennie Abrahams.

## 2GB

5.30: Children's session by Uncle George. 7.0: Dance music from studio. 8.0: Request evening. 9.0: Dance music. 10.0: Close down.

## 2UW

5.30 p.m.: Children's hour, conducted by Uncle Jack. 6.30: Close down. 7.0: Musical programme. 10.30: Close down.

## INDEX

### To Local Programmes

FRIDAY, March 29—	
2FC, 2BL, 2GB, 2UW	29
SATURDAY, March 30—	
2FC, 2BL, 2GB, 2UW	32
SUNDAY, March 31—	
2FC, 2BL, 2GB, 2UW	36
MONDAY, April 1—	
2FC, 2BL, 2GB, 2UW	38
TUESDAY, April 2—	
2FC, 2BL, 2GB, 2UW	42
WEDNESDAY, April 3—	
2FC, 2BL, 2GB, 2UW	46
THURSDAY, April 4—	
2FC, 2BL, 2GB, 2UW	50

## 2BL

### MORNING SESSION.

Announcer: Eric Bessemer.

8: G.P.O. chimes; metropolitan weather report. 8.1: State weather report. 8.2: Studio music. 8.15: G.P.O. chimes; news service from the "Daily Telegraph Pictorial." 8.30: G.P.O. chimes; news service continued. 8.40: Information, mails, shipping, arrivals, departures, and sailings. 8.45: Studio music. 10.0: G.P.O. chimes. Close down.

### MIDDAY SESSION.

Announcer: Eric Bessemer.

11.0: G.P.O. chimes; women's session, conducted by Mrs. Cranfield; what's on at the pictures and theatres; stock recipes for cake, pudding and dumpling. 11.30: Advertising hints. 11.40: Talk on "Gardening" by Mr. Cooper, Park Superintendent, City Council. 12.0: G.P.O. chimes; special ocean forecast



## Portable Voltmeter

Pattern 136: A most convenient De Luxe Portable Jewell Voltmeter. Beautifully finished of black bakelite, clock stand type of mount. Range of scale 0.7.5—150 volts. Push button switch mounted in the top of flange. Three long leads with phone tips. Connected permanently will show filament voltage. By pushing the button the "B" Battery voltage is read.

Write for

No Instrument Catalogue No. 15.e

## STROMBERG CARLSON

Australasia, Limited,

76 William Street, Sydney.

Tel. No. F4184. Telegrams: "Strom."

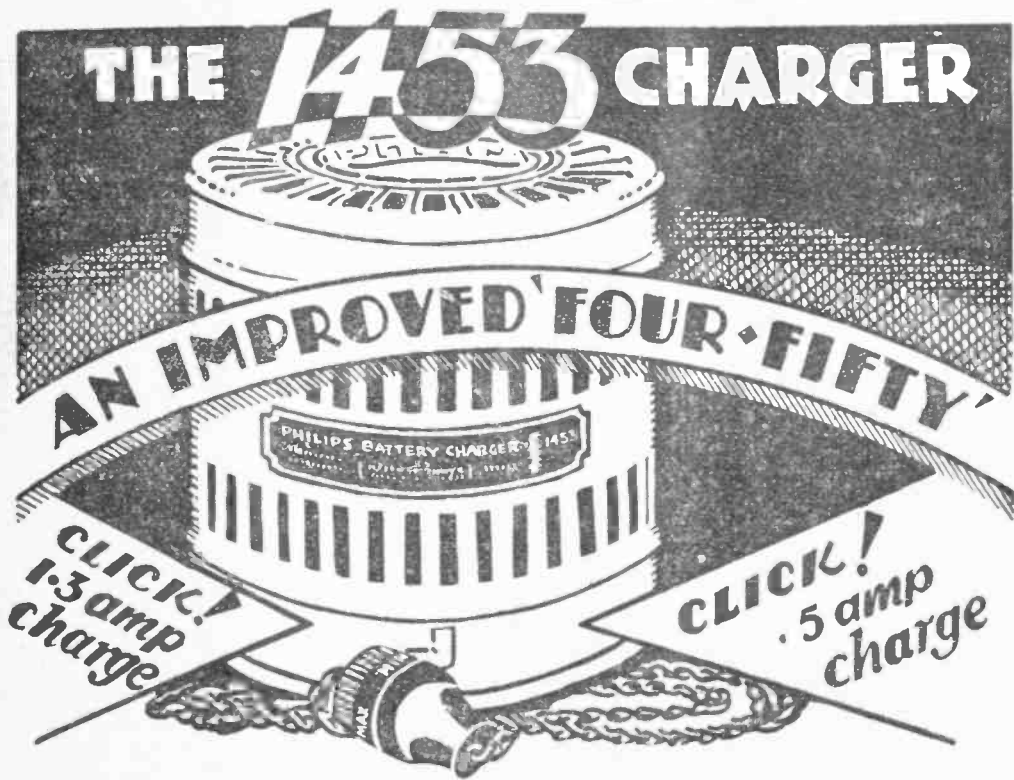

Philips Type 1017  
Trickle Charger with  
Power Control Switch  
£3/10/-

HERE is a new Philips Charger: an improved model of that most popular of all chargers—the "Four-Fifty." The construction is basically the same—the "Blue-Glow" still tells you that everything is just right—accidental shorting of the output leads still does no harm.

NOW a great improvement has been added in the "Rate Change" switch which in one position gives the accumulator a healthy "Boosting" charge of 1.3 amps and in the other a heavy trickle rate of .5 amp.

Ask your dealer about this 1929 Philips Product.

£4/15/-

For those who want a trickle charger solely, the Philips 1017 is just the thing. Write to us for details of its ingenious switch which can be wired to control "A," "B," and "C" Power to your receiver. Price, £3/10/-



**PHILIPS**

**BATTERY CHARGERS**

**FOR THE CAR AND RADIO OWNER—THE 366 CHARGER**



# Interstate Programmes, Saturday, April 6

## 3LO

### EARLY MORNING SESSION.

7.15 to 8.15: See Friday.

### MORNING SESSION.

Announcer, John Stuart. Accompanist, Agnes Fortune. 10.50: Eric Welch will speak on to-day's races at Sandown Park. 11.0: Radio Revelers. 11.10: Rita Hilton, soubrette. 11.17: The Radio Revelers. 11.27: Betty Ross Clarke. 11.34: The Radio Revelers. 1.44: Lysle Davey, natural whistler. 11.51: The Radio Revelers.

### MIDDAY SESSION.

Announcer, John Stuart. Accompanist, Agnes Fortune. 12.0: Melbourne Observatory time signal. 12.1: Metal prices received by the Australian Mines and Metals Association from the London Stock Exchange this day: British official wireless news from Rugby; Reuter's and the Australian Press Association cables; "Argus" news service. 12.30: The Radio Revelers. 12.30: Rita Hilton, soubrette. 12.37: Stock Exchange information. 12.42: The Radio Revelers. 12.52: Betty Ross Clarke. 1.0: Meteorological information; weather forecast for Victoria. New South Wales, South Australia, and Tasmania; ocean forecasts; river reports; rainfall. 1.10: The Radio Revelers. 1.20: Lysle Davey, natural whistler. 1.27: The Radio Revelers. 1.45: Close down.

### AFTERNOON SESSION.

Announcer, John Stuart. 2.13: Description of Hurdle Race, two miles, at Sandown Park races, by Eric Welch. 2.20: Description of the final match of pennant cricket competition, by Rod McGregor. 2.43: Description of Two-Year-old Handicap, five furlongs, at Sandown Park races, by Eric Welch. 2.50: Description of the final match of pennant cricket competition. 3.13: Description of the Sandown Plate, Sandown Park races, mile and a quarter. 3.20: Description of the final match of pennant cricket competition. 3.43: Description of the Sandown Park Handicap, mile and a quarter, Sandown Park races. 3.50: Description of the final match of pennant cricket competition. 3.55: Relay description of A. J. C. Plate, 2 1/2 miles, from Randwick Racecourse, Sydney. 4.13: Description of Sandown Purse, one mile, Sandown Park races. 4.20: Description of the final match of pennant cricket competition. 4.43: Description of Trial Welter Handicap, six furlongs, Sandown Park races. 4.50: Description of final match, pennant competition. 5.0: "Herald" news service. 5.10: Description of

the final match of the pennant competition. 6.0: Stumps scores.

### EARLY EVENING SESSION.

6.5: Sporting results. 6.10: Answers to letters and birthday greetings, by "Little Miss Kookaburra." 6.35: "Little Miss Kookaburra" will tell about "The Treasure of the Windmill."

### EVENING SESSION.

Announcer, Renn Miller. 6.50: Stock Exchange information. 7.10: Market reports. 7.15: News session. 7.25: Birthday greetings. 7.29: Out of the Past. 7.30: Frederick Chapman, A.L.S. F.G.S.—Commonwealth Palaeontologist, National Museum, will speak on "John Ray, F.R.S.—a Nature Student of the 17th Century." 7.45: A Maker of History. 7.48: Dr. J. A. Leach will speak on "Australian Chats."

### NIGHT SESSION.

Announcer, Renn Miller. Accompanist, Agnes Fortune. 8.1: The Station Orchestra—Selection, "Primrose" (Gershwin). 8.10: James Hay, tenor—Selections from his repertoire. 8.20: The Station Orchestra—Selection, "Lohengrin" (Wagner). 8.30: Betty Ross Clarke will give another of her inimitable short plays. 8.40: Frederick Hall—Piano solo with string accompaniment—"Caprice" (Raff). 8.50: A. Anderson, clarinet—"Andante and Polonaise" (Le Thiere). 8.55: Eric Welch will describe to-night's events at "The Stadium." 9.10: The Victorian Postal Institute Choir conductor, Geo. English; accompanist, Connie Finlayson—"Fermine Seel" ("Paist"). "Soldiers Chorus" ("Paist"). "Walders Chorus" ("Paist"). "Fire My Heart" ("Cloria in Excessis"). 9.40: The song feature of the week. 9.43: Lysle Davey, natural whistler—Request form.

10.0: Eric Welch will describe some more of the night events at the Stadium. 10.15: The Station Orchestra—"Scherzo" (Mendelssohn).

10.25: Lysle Davey, natural whistler—"Follies." "Follow Me If All Those Endearing Young Charms."

10.35: The Station Orchestra—"Jovous Youth" (Costes). 10.38: Late sporting. 10.44: The Radio Revelers—"Bonnie M. J. Burnett."

"Schneeberg" (Sissell). "The Irish Reel" (Zemzeznik). "Counting the Milestones" (Tilsley). "Daybreak" (Ebens). "The Town Avilliers" (Carlton). "Reminded Me" (Van Booth). "Old Rose Doll" (Ager). "All Be Yourself in the Moonlight" (Wallis). "Rendezvous for the River" (Moret). Selected.

11.0: God Save the King.

11.05: The Station Orchestra—"Jovous Youth" (Costes). 10.38: Late sporting. 10.44: The Radio Revelers—"Bonnie M. J. Burnett."

"Schneeberg" (Sissell). "The Irish Reel" (Zemzeznik). "Counting the Milestones" (Tilsley). "Daybreak" (Ebens). "The Town Avilliers" (Carlton). "Reminded Me" (Van Booth). "Old Rose Doll" (Ager). "All Be Yourself in the Moonlight" (Wallis). "Rendezvous for the River" (Moret). Selected.

11.0: God Save the King.

## 3AR

### MORNING NEWS SESSION.

Announcer, Maurice Dudley. 10.0 to 10.59: See Friday.

### MORNING MUSICAL SESSION.

11.0: Real rhythms. 11.50: British official wireless news; announcements. 12.0: Close down.

### AFTERNOON SESSION.

Announcer, Maurice Dudley. Accompanist, Rev. Brown. 3.0: The Station Orchestra. 3.10: Tom Semple, tenor. 3.17: The Station Orchestra. 3.20: The Station Orchestra. 3.29: Jessie Smith, contralto; the Russian Imperial Trio. 4.10: The Sundowners. 4.19: The Station Orchestra. 4.29: Jessie Smith, contralto. 4.36: The Station Orchestra. 4.46: Herbert Sanderson, baritone. 4.53: The Station Orchestra. 5.0: Close down.

### EVENING SESSION.

Announcer, Frank Hatherley. 6.0: Broadcasting His Master's Voice. 7.10: News service; announcements. 7.30: His Master's Voice again.

### NIGHT SESSION.

Announcer, Renn Miller. 8.0: All sporting results. "Did you know that?" 8.20: Transmission from the Assembly Hall, Collins Street, Melbourne—Concert by the British Musical Society of Victoria—Piano solo, (a) Impromptu in F sharp. (b) Etude in F. (c) Etude in E. (d) Scherzo in C sharp minor (Chopin). Gregor Wood, tenor. Isabel Adams at the piano. "Cameos, Three Greek Love Songs" (Lisa Lehmann). (a) Sweet Rhodocetes. (b) Fill Up the Cup. (c) If I Were but the Wind. Clarinet solo—Selected. Madame Gregor Wood, contralto. Isabel Adams at the piano—Songs—"See Picture" (Egar). (a) Sea Slumber Song. Quartet for strings—Bertha Jorgensen, Myrtle (b) In Haven.

Robertson, Dorothy Roxburgh, Tasma Tierman—"The Emperor" (Haydn). Gregor Wood, tenor; and Madame Gregor Wood, contralto—"Duet" (Regard, Danbilly). It was a Lover and his Lass (Mary Campbell). Pianist, Isabel Adams. 10.20: News service; sporting results; announcements. 10.30: God Save the King.

## 4QG

### EARLY MORNING SESSION

Announcer: T. Tyson. 7.43 to 8.30: See Friday.

### AFTERNOON SESSION

3.0: A programme of electrically reproduced records; mail train running times; this afternoon's news. 4.30: Close down.

### EARLY EVENING SESSION

6.30: Bedtime stories, conducted by "Uncle Ben." 7.15: To-day's race results in brief; general sporting notes. 7.30: Sailing notes by Mr. Fred Smith.

### NIGHT SESSION

Announcer: H. Humphreys. 8.0: From the studio—"The Studio Orpheans—opening number, "God Save Ireland" (Root). E. W. Muller (baritone)—"Away in Athlone" (Lahr). Ray Bruce (tenor)—"You Can't Have an Irish Name." Doris M'Innes (soprano)—selected. Octette—"The Dear Little Shamrock" (Cherry). E. Harper (baritone)—"For the Green" (Lahr). Francis Lane, (contralto)—"The Old Bog Road" (M'Fadden).

Tom Muller and the Studio Orpheans—humorous monologue—"A Little Bit of Heaven" (Ball). Octette—"The Meeting of the Waters" (Moore). Doris M'Innes (soprano)—selected. E. W. Muller (baritone)—"Bellevue" (Moore). F. Crane (baritone) and the Studio Orpheans—"Off to Philadelphia" (Haynes).

E. Muller, C. Rice, and F. Crane—vocal trio. "Cruiseken Law" (traditional) (Lahr). Octette—"Avenging and Bright" (Vene). G. Williamson (tenor)—"Danny Boy" (Old Irish Air).

F. Crane (baritone)—"Micky's Advice" (Lahr). Francis Lane (contralto)—"When Irish Eyes Are Smiling" (Hall).

Studio Orpheans—Octette, "Cockles and Mussels" (Lorkston).

Note: at suitable intervals, the main races will be described from the Speedway. 10.0: "The Sunday Mail" news; weather news. Close down.

## 5CL

### MORNING SESSION.

Announcer: J. L. Norris. 12.0: G.P.O. chimes; late selections, Sandown Park; Probable starters and selections for Victoria Park races; general news service; British official wireless news. 12.45: Riders and position for Persimmon Hurdles (two miles), Victoria Park. 1.0: Running description of Persimmon Hurdles, by Mr. Arnold Treloar. 1.15: Riders and position for Handicap (six furlongs and a half). 1.40: Running description of the Vicerox Handicap, by Mr. Arnold Treloar. 1.50: Sandown Park Race Result—Hurdle Race. 2.0: Resume of previous race results. 2.5: Riders and position for Tattersall's Cup (two miles). 2.50: Running description of Tattersall's Cup. Sandown Park race result—Two-Year-Old Handicap. 2.45: Riders and positions for Renown Steeplechase (about two miles). Sandown Park race result—Sandown Plate. 3.0: Running description of Renown Steeplechase. 3.20: Sandown Park race result—Sandown Park Handicap. 3.25: Riders and positions for Minoru Welter first division (nine furlongs). 3.0: Running description of first division of Minoru Welter, by Mr. Arnold Treloar. 3.50: Sandown Park race result—Sandown Purse. 4.5: Riders and positions for second division of Minoru Welter (nine furlongs). 4.20: Running description of second division of Minoru Welter. Sandown Park race result—Trial Welter. 4.45: Riders and positions for B. J. Jacob's Handicap (six and a half furlongs). 3.0: Running description of B. J. Jacob's Handicap. 5.3: Resume of previous race results. 5.10: Close down.

### EVENING SESSION

Announcer: J. L. Norris. 6.0: G.P.O. chimes and resume of late sporting; birthday greetings, correspondence; songs and stories by "The Watlie Lad." An interlude of dinner music. G.P.O. chimes; S. G. Ward and Co.'s Stock Exchange information. 7.45: Rev. G. E. Hale, B.A., will give an interesting talk on "Telepathy." 7.25: An operatic interlude. 7.35: G. C. Riley—talk on "Items of Interest." 7.45: 5CL's sporting service, supplied by "Sylvius." Including Victoria Park and Sandown Park Race results.

### NIGHT SESSION

Accompanist, Jean Finlay. Announcer: J. L. Norris. 8.0: G.P.O. chimes. 8.1: South Australian Railways Band. Conductor, Mr. J. Radcliffe. Overture—"The Crown of Diamonds" (Auber). 8.11: Margaret Pirie, contralto—"A Green Cornfield" (Michael Head). "Dawn Song" (May Brahe). 8.17: Syd Hodge, comedian in comicallities. 8.23: South Australian Railways Band. March, "Evertonian" (Greenwood). 8.30: Fred Quater, bass. "Songs"—"The Horn" (Egler). Monologue, "I Forget, I Forget" (Newton). 8.36: Pat McLean, entertainer. Selections from her repertoire.

# Resco Radio

When you see this name on a Radio Set you can rest assured that the finest material possible has been built into that set. That is why Resco Sets are renowned for their unflinching service, no matter under what conditions they are being operated.

Have your old set remodelled, so that you can get the same service as a new Rescot set. We give a 12 months' written guarantee with all sets that pass through our workshops.

WRITE TO DESK DD FOR TERMS AND PRICES.

## The Resco Radio Supply Co.

38a Pitt St., Sydney

(Near Quay).

B 1817, 'Phone.

- 3.42: South Australian Railways Band Selection, "Lightning Switch" (Hirst)
- 3.54: Linda Wald, soprano. "To a Wild Rose" (MacDowell).
- "Moon Enchanted" (M. Besly).
- 4.00: G.P.O. chimes.
- 4.01: Meteorological information, including Semaphore tides.
- 4.22: Overseas grain report.
- 4.33: South Australian Railways Band. Morceau, "The Turkish Patrol" (Michaels).
- 4.58: Margaret Pirie. "Still as the Night" (Behm).
- "Salam" (Lang).
- 4.12: A pianoforte recital by Hans Bertram (the pianist).
- "Allegro from Sonata No. 6" (Mozart).
- "Eastern Love Song" (Hans Bertram).
- "Fantasy Impromptu" (Chopin).
- "Serenade in D" (Moszkowski).
- 4.32: South Australian Railways Band. Selection, "Going Up" (Hirst).
- 4.47: Syd. Hollister, in "Hollisterisms."
- 4.48: Fred Guster. "Jogging Along the Highway" (Samuel).
- "The Warwickshire Woollen" (James).
- 4.54: South Australian Railways Band. Intermezzo, "Kittie's Courtship" (M'Kenzie).
- 4.59: Linda Wald. "O Western Wind" (Brahe).
- "Cupid" (Sanderson).
- 10.5: Pat McLean. Selections from her repertoire.
- 10.10: South Australian Railways Band. Foxtrot, "Dancing Tambourine" (Polla).
- March, "Marching Gun Guards" (Marshall).
- 10.13: SCL's sporting service, supplied by "Silence," including Victoria Park and Sandown Park race results. Meteorological information.
- 10.30: Modern dance numbers by the "Radio Revels."
- 11.0: God Save the King.

**6WF**

- 12.0: Tune in. 12.5: Racing anticipations. 12.7: Musical programme, including pianoforte solos by Miss Audrey Dean, station pianist; vocal items.
- 12.44: Markets, news, etc. 1.0: Time signal. 1.2: Close down. 2.30: Sporting section—Racing, cricket, and other sporting results will be broadcast at intervals of 15 minutes during the afternoon. 5.30 (approx.): Close down. 6.45: Tune in. 6.48: Bed-time stories by Auntie Amy. 7.12: Sports results.
- 1.0: Commercial and general information. 7.45: Music. 8.0: Time signal. 8.1: First weather bulletin. 8.3: Relay of dance music from the Temple Court Cabaret; Merv Lyon and his Symphonic Orchestra; vocal artists from the studio. 8.50: News items by courtesy of the "Daily News" Newspaper Co. Ltd., station announcements, ads within same announcement, late weather bulletin. 9.10: Programme continued from the studio and Temple Court Cabaret. 10.30: Close down.
- 10.5: Metre Transmission—Simultaneous broadcast on 104.5 metres of programme given on 1250 metres, commencing at 6.45 p.m.

**7ZL**

**MIDDAY SESSION**

Announcer: Jack Broadbent. 11.30 to 1.30: General programme. 2.15: Running description of Hurdle Race, 2 miles, Sandown Park Racecourse, Melbourne. 2.45: Running description of Two-Year-Old Handicap, 5 furlongs, Sandown Park Racecourse, Melbourne. 2.50: Close down.

**AFTERNOON SESSION**

Announcer: Jack Broadbent. 3.0: Chimes. 3.4: Transmission from the North Hobart Oval, cricket match, South Hobart v. North-West, described by A. M. O'Leary. 3.15: Running description of Sandown Plate, 6 furlongs. 3.20: South Hobart v. North-West described. 3.30: Description of the eight- or test championships, described by "Olympic." 3.45: Running description of Sandown Park Handicap, 1 1/4 mile. 3.50: South Hobart, North-West described. 4.15: Running description of Sandown Purse, one mile. 4.20: Cricket match described. 4.45: Running description of the Trial Handicap, 6 furlongs, Sandown Park. 4.50: All sporting results to hand. 5.0: Close down.

**EARLY EVENING SESSION**

Announcer: Jack Broadbent. 6.0: All sporting results to hand. 7.15: "Uncle David" and birthday greetings by "Uncle David." 7.15: News service; late sporting results of New Town Egg-laying Competition; homing and bowling.

**EVENING SESSION**

Announcer: Jack Broadbent. 7.30: Roy Johnson will speak on "Manual Training." 7.45: J. M. Counsel, L.B., will speak on "European Affairs." 8.0: G.P.O. clock chimes the hour. 8.6: A programme arranged by Madame Helen George and the Discus Ensemble—Madame Helen George (piano) "First Movement Sonata, Op. 53" (Waldstein); "Maria" (Bach-Gounod); Mrs. Norman Pierce (soprano) "Ave Maria" (Bach-Gounod); Robert Bedford (baritone), "Erl King" (Schubert); Madame Helen George (piano solo) "Sonata No. 10 in A Major," "Sonata No. 11 in A Major" (Scarlatti); John Harrison (baritone), "Nirvana" (Pindon); Mrs. Norman Pierce (soprano), "Au Printemps" (Gounod); "Obstinata" (Pontellies); Raymond Newell (baritone), solo, "Nocturne in F Major" (Chopin); "Ballade in A" (Chopin); Mrs. Norman Pierce (soprano), "Serenade" (Capes); "The Wren" (Lehmann); Peter Dawson (baritone), "Thou'rt Passing Hence" (Sullivan); Mrs. Norman Pierce (soprano) "Ecstasy" (Macca); Madame Helen George (piano) "Study" (Rubinstein). 9.45: News service; British official wireless news; Tasmanian district weather report; bowling, homing, and tennis. 10.0: G.P.O. clock chimes the hour. 10.1: "God Save the King."



# Giving SERVICE unexcelled by any other make of Battery of equal size and capacity

You've probably often spent much thought about your radio batteries—comparing the efficiency of their service with the price you pay for them. There's a virtue in always seeking value and economy in radio. No pleasure merits a continuous and costly drain on your patience and your finances.

Here are some features you will like about the famous "Ever-Ready" SUPER SERVICE 45 Volt H.T. "B" Battery. Consider its advantages carefully, and you will realise how much more in power, efficiency, and economy an "Ever-Ready" offers you.

1. Specially designed for use with multi-valve sets, of 4 or more valves.
2. Made up of 30 large cells in moisture-proof containers. Positive screw terminal taps at 18, 24, 30, and 45 volts.
3. Heavy gauge zinc containers, high grade chemicals perfectly balanced; efficient insulation.
4. Cells are larger and have 25 per cent. greater output capacity than those in most other Heavy Duty "B" Batteries selling at a higher price.
5. AUSTRALIAN MADE—FRESH FROM THE FACTORY TO YOU.
6. Used in conjunction with the "Ever-Ready" No. 126 C Battery, it represents the most economical radio battery service obtainable in Australia.
7. Noted for its long life, complete reliability, and noiseless flow of power.
8. Guaranteed by the largest manufacturers of dry batteries in the Empire.
9. Obtainable from all good radio dealers.

WHOLESALE DISTRIBUTORS:

THE EVER-READY CO. (Gt. Britain), LTD  
163 Pitt Street, SYDNEY.

**EVER-READY**  
**RADIO BATTERIES**

## Local Programmes, Sunday, April 7

### 2FC

#### MORNING SESSION

Announcer: A. S. Cochrane

- 10.0: "Big Ben" and announcements.  
 10.2: Studio music.  
 10.15: News service.  
 10.30: Studio music.  
 11.0: From St. Mark's Church of England, Darling Point—morning service, conducted by Rev. Canon E. Howard Lea.  
 12.15 (approx.): Close down.

#### AFTERNOON SESSION

Announcer: C. R. Hall.

- 2.30: Programme announcements.  
 2.32: Children's session, conducted by Uncle Frank, of the Cheer-Up Society.  
 3.0: "Big Ben" studio records.  
 3.30: From the Manly Band Rotunda, Manly Beach—the Manly Municipal Band, conducted by J. Pheloung.  
 5.0: "Big Ben" close down.

#### EVENING SESSION

Announcer: Laurence Halbert.

- 6.0: "Big Ben"; programme announcements.  
 6.2: Some impressions on "St. Peter's" by S. H. Bowden.  
 6.20: A programme arranged by Mischa Dobrinski—

Violin Solos, Mischa Dobrinski—

(a) "Poem" (Febich).  
 (b) "Tarantelle" (Wieniawski).

Piano solos Madame Dobrinski—

(a) "Andante and Rondo Capriccioso" (Mendelssohn).  
 (b) "Waltz in E Minor" (Chopin).

Violin Solos, Mischa Dobrinski—

(a) "Rondino" (Beethoven-Kreisler).  
 (b) "Siciliano and Rigandon" (Francoeur-Kreisler).

Musical Monologues, Madame Dobrinski.

(a) "Poor Jane" (Draper).  
 (b) "An Old Romance" (Hall).

Violin solos, Mischa Dobrinski—

(a) "Lullaby" (Regor).  
 (b) "Spanish Danse" (Sarasate).

- 6.50: From St. Stephen's Church, Phillip Street—Evening service, conducted by Rev. Hugh Paton.

Voluntary.

Sancius.

Prayer.

Hymn 308.

Lesson.

Paraphrase 54.

Lesson.

Anthem.

Prayer.

Hymn 170.

Sermon, "Joy"; preacher, Rev. Hugh Paton.

Prayer.

- Hymn 175.  
 Benediction.  
 Vesper Hymn.  
 8.30: From the "Victory" Theatre, Kogarah. Leslie V. Harvey at the "Christie" organ—  
 (a) "The Mikado" Selections (Gilbert and Sullivan).  
 (b) "Valse Triste" (Sibelius).  
 (c) "Sizilietta" (Von Blon).  
 (d) "Elizabeth's Prayer" from "Tannhauser" (Wagner).  
 8.50: Madame Emily Marks (soprano)—  
 (a) "I think" (d'Hardeiot).  
 (b) "Coming Home" (Willeby).  
 8.57: David Craven baritone—  
 (a) "Tangl" a Maori Lament (Alfred Hill).  
 (b) "The Star and the Flower" (d'Hardeiot).  
 9.4: From the studio—recital of selected records of world-famous artists.  
 9.14: From the "Victory" Theatre, Kogarah. Leslie V. Harvey at the "Christie" organ—  
 (a) "Agnus Dei" (Bizet).  
 (b) "C Sharp Minor Waltz" (Chopin).  
 (c) "A Perfect Day" (Bond).  
 (d) "Toreador Song" from "Carmen" (Bizet).  
 (e) "Romance" from Second Violin Concerto (Wieniawski).  
 9.34: Madame Emily Marks soprano—  
 (a) "Away in the West of Ireland" (Anderson).  
 (b) "Summer Skies" (Anderson).  
 (c) "Pleading" (Anderson).  
 Accompanied by the composer.  
 9.41: David Craven, baritone—  
 (a) "The Diver" (McMillan).  
 (b) "Inter Nos" (MacFadyen).  
 9.48: Leslie V. Harvey at the "Christie" organ—  
 (a) "Absent" (Metcalf).  
 (b) "By the Waters of Minnetonka" (Liewrance).  
 (c) "Loin du Bal" (Gillet).  
 (d) "William Tell" Overture (Rossini).  
 10.8: From the studio—recital of selected records of world-famous artists.  
 10.27: To-morrow's programme.  
 10.30: National Anthem. Close.

### 2BL

#### MORNING SESSION

Announcer: Eric Bessemer.

- 11.0: G.P.O. chimes.  
 Bathurst Street Central Baptist Church: Morning service, conducted by Rev. John Complin.  
 Organ.  
 National Anthem. Baptist Hymnal Version.  
 Invocation.  
 The Lord's Prayer (chanted).  
 Responsive Scripture Reading in selection from Psalms. Baptist Hymnal, No. 19.

- Gloria Patri (chanted).  
 Scripture Lesson Rev. 4-4 to 5-14.  
 Solo. Mr. Harry Burgin.  
 Intercessions and Offering of Thanks.  
 Announcements.  
 Offertory and Organ Selection.  
 Dedication of Offertory.  
 Hymn 153. Baptist Hymnal.  
 Sermon, "Our Risen and Triumphant Lord".

Text, Matthew 23-18.

Prayer.

Doxology.

Benediction.

Organ "Hallelujah Chorus."

12.15 (Approx.): From the Studio—

"Sun" news service.

12.30: Studio music.

2.0: G.P.O. chimes; close down.

#### AFTERNOON SESSION.

Announcer: Basil Kirke.

- 3.0: G.P.O. chimes.  
 Pleasant Sunday Afternoon Service, arranged by the Haberfeld-Five Dock Circuit.  
 4.30: From the Studio: A talk by E. J. Davidson, "A Brewer's House in Flanders."  
 4.40: Studio items.  
 4.55: Programme announcements.  
 5.0: G.P.O. chimes; closedown.

#### EVENING SESSION.

Announcer: Basil Kirke.

Accompanist: G. Vern Barnett.

- 6.0: G.P.O. chimes.  
 Children's session, conducted by Uncle Bas.  
 7.0: From the Randwick Presbyterian Church: Evening service, conducted by Rev. W. J. Grant.  
 Choirmaster, Mr. Geo. V. Sherring.  
 Hymnal, Presbyterian Revised Version.  
 Organ recital.  
 Hymn.  
 Prayer of Invocation.  
 Anthem by Choir.  
 First Scripture Lesson.  
 Hymn.  
 Second Scripture Lesson.  
 Solo or Duet.  
 Prayer and Lord's Prayer (chanted).  
 Announcements and Offertory.  
 Anthem by Choir.  
 Sermon.  
 Brief Prayer.  
 Hymn.  
 Benediction.  
 Vesper Hymn.  
 8.30: From the Manly Band Rotunda—  
 The Manly Band. Conductor: Mr. James Pheloung.  
 9.30: From the Studio: Molly De Gunst, soprano.  
 9.37: Peter Sutherland, basso.  
 9.44: Pianoforte solo by G. Vern Barnett.  
 9.50: Molly de Gunst, soprano.  
 9.57: Peter Sutherland, basso.  
 10.3: To-morrow's programme.  
 10.4: National Anthem; close down.

### 2GB

- 10.15: Organ music from St. Alban's Church, Redfern.  
 10.30: Morning service from St. Alban's Church. 12 noon: Close down.  
 5.30: Children's session by Uncle George. 7.9: Lecture from Adyar Hall. 8.0: Music from studio. 8.15: Sacred concert from Adyar Hall: the Rosenkranz piano. 8.23: Miss Heather Kinnaird, contralto. 8.30: Mr. Gerald Cashman, tenor. 8.37: Mr. Reginald Duncan, violinist. 8.45: Miss Gwladys Edwards, soprano. 8.52: Rosenkranz piano. 9.0: Miss Heather Kinnaird, contralto. 9.7: Mr. Gerald Cashman, tenor. 9.15: Mr. Reginald Duncan, violinist. 9.23: Miss Gwladys Edwards, soprano. 9.30: The Rosenkranz piano. 9.35: Close down.

### 2UW

- 10.30 a.m.: Music. 1 p.m.: Close down.  
 5.30 p.m.: Children's hour conducted by Uncle Jack. 6.30: Close down. 7.0: Musical programme. 10.30: Close down.

## Earn All You Can

### SAVE ALL YOU CAN—GIVE ALL YOU CAN

Such was the good advice of John Wesley. You are, of course, entitled to earn all you can, and no doubt are bending all your energies in that direction.

Nevertheless, what you save will, in the long run, probably count for more than what you earn.

Use the easy saving plan. Open a Commonwealth Savings Account, and be faithful to it, for the sake of your future needs, and that you may be able to give when it is your duty to give.

## Commonwealth Savings Bank of Australia

(Guaranteed by the Commonwealth Government.)

# Interstate Programmes, Sun., Apl. 7

## 3LO

### MORNING SESSION.

Announcer: Frank Hatherley. 10.30: Bells from St. Paul's Cathedral. 10.45: Express train information. British official wireless news from Rugby News. 11.0: Morning service from Mission Church, Russell Street, Melbourne. 11.15: Morning service from St. Charles Street, Melbourne. 11.30: The Interpretation of Life.

### AFTERNOON SESSION.

10.30: Bonola recital of world's most famous records. 11.0: Pleasant Sunday Afternoon Service. Announced from Wesley Church, Central Mission, 11.15: Melbourne Address. Mr. James MacDougal, president, Chambers of Manufactures. 11.30: Close down. 11.45: Shipping information. 12.0: Answers to letters and birthday greetings. 12.15: The children about "Bringing in the Sheaves." 12.45: Adult birthday greetings and programme announcements. 1.30: Bells from St. Paul's Cathedral, Melbourne.

### EVENING SESSION.

10. Evening (choral), from St. Paul's Cathedral, Melbourne. First Sunday after Easter. Canon Baxth.

### NIGHT SESSION.

10.30: Malvern Tramways Band—Overture, "Rosa et Noir" (Trussell).  
 11.0: "The Smith Girls"—"Sun of My Soul."  
 "Peace, Perfect Peace."  
 11.15: Professor Bernard Heinze (violin) and Mr. Lindsay Higgins (piano)—"Sonata" (Cesar Franck).  
 "Andante from Sonata in D" (Dvorak).  
 "Rondo" (Schubert).  
 11.30: Betty Ross Clarke will give a reading from the Psalms.  
 11.45: Malvern Tramways Band—Selection, "Luca di Lammermoor" (Donizetti).  
 12.0: "The Smith Girls"—"Happy Me Back to Old Virginny."  
 "Spolia."  
 12.15: Malvern Tramways Band—"Andante in G" (Bastiat).  
 12.30: News service. Announcements.  
 12.45: God Save the King.

## 3AR

Announcer: Frank Hatherley. 11.0: Morning service from Wesley Church, Central Mission, conducted by Rev. J. H. Cain. 12.15: British official wireless news. 12.30: Close down.

### AFTERNOON SESSION.

Announcer: Frank Hatherley. 3.0: Tourne, Tourne, Terpichore. Felix Weingartner and the Royal Philharmonic Orchestra. "Symphony No. 8" (Beethoven).  
 3.15: Organ selections. 4.0: Felix Weingartner and the Royal Philharmonic Orchestra, recorded in the Scala Theatre, London. "Symphony No. 5 in C Minor," op. 67 (Beethoven). 4.30: Close down.

### EVENING SESSION.

10. "Hör Raböbil." Stories for the children. 5.30 Close down.

### NIGHT SESSION.

Announcer: Frank Hatherley  
 Accompanist: Vera Howe.  
 8.0: Euterpe Entertains  
 Vocal and orchestral works of Brahms, Mendelssohn and Grieg.  
 8.15: The Strad Trio  
 Cecil Parke, violin; Myra Montague, piano; Frank Johnson, cello.  
 Trio, "Op. 164, Moderato, Scherzo in G Major (Ressiger).  
 8.30: The Sundowners.  
 Quartets, "I Got a Home" (Brown)  
 "Tim Trolling" (Frey).  
 8.45: The Strad Trio  
 Trio, "Op. 164 in G Major," continued. Andante, Finale (Ressiger).  
 8.57: Tom Temple, tenor.  
 "I'll Sing The Songs of Araby" (Clay).  
 "I Will Await Thee" (C. Clarke).  
 9.04: Cecil Parke (violin).  
 "Ave Maria" (Schubert).  
 "La Capricieuse" (Elgar).  
 "Goblin Dance" (Bazzini).  
 9.14: Alex Wetherpoon (basso).  
 "Within This Holy Temple" (Mozart).  
 "Resurrexit" (Homer).  
 9.41: Piano recital, George Findlay.  
 "Minuetto in E Minor" (Schubert).  
 "Romance in F Sharp" (Schumann).  
 "Valse Capricieuse" (F. Bridge).  
 "Rosemary" (P. Bridge).  
 "Dance Song" (J. Scott).  
 10.26: The Sundowners.  
 Quartets, "Berenade" (White).  
 "God is a Spirit" (Bennett).  
 10.33: The Strad Trio.  
 Trio, "Andante" (Schubert).  
 10.45: Alex Wetherpoon (basso).  
 "Amadei" (Lell).  
 "In Sheltered Vale" (Del Aqué).  
 NEWS SESSION.  
 9.30: News service. Announcements.  
 God Save the King.

## 4QG

### AFTERNOON SESSION

3.15: The concert by the Brisbane Federal Band (conductor, Mr. W. H. Davis) will be relayed from the Bolanic Gardens. 4.30: Close down.

### EARLY EVENING SESSION

6.30: Greetings to little listeners, and replies to letters.

### NIGHT SESSION

7.0: The complete evening service will be relayed from the Albert Street Methodist Church.

7.30: Evening service.

At the conclusion of the church service, the concert by the Brisbane Municipal Concert Band will be relayed from Wickham Park.

9.30: Close down.

## 5CL

### AFTERNOON SESSION.

3.0: Chimes. 3.15: A pleasant Sunday afternoon service from Maughan Church; preacher, Rev. W. H. Cann. 4.0: Chimes. Close down.

### EVENING SESSION.

Announcer: G. J. O'Connor.

6.0: Chimes.  
 6.1: Birthday greetings, correspondence, songs, and stories by "Miss Wireless."  
 6.30: "The Bird Lady" and "The Sunshine Songsters."  
 7.0: G.P.O. chimes.  
 7.1: Service from Maughan Church (Central Mission), Franklin Street, Rev. W. H. Cann's Jubilee Service; organist, Mr. M. Finlay.

### NIGHT SESSION.

Announcer: G. J. O'Connor.

Accompanist: Jean Finlay.

8.30: The Adelaide Trio.  
 H. Brewster-Jones, piano; H. Kugelberg, cello; Miss Bertha Jones, violin—  
 "Leaves" (Charpentier).  
 8.45: Victor Innes-Morcom, holder of the Winsloe Hall Singing Scholarship.  
 "The Floral Dance" (Moss).  
 "I'll Sing Thee Songs of Araby" (Clay).  
 8.51: Bertha Jones (violinist).  
 Meditation, "Thais" (Massenet).  
 Gavotte, "Mignon" (Thomas).  
 8.58: Ruth Naylor (soprano), holder of the English Elder Scholarship.  
 "Leaves" (Charpentier).  
 "Care Selve" (Handel).  
 9.4: A Pianoforte Recital by H. Brewster-Jones.  
 9.16: Victor Innes-Morcom, holder of the Winsloe Hall Singing Scholarship.  
 "Because" (d'Harlelot).  
 "Kashmiri Song."  
 9.23: H. Kugelberg, cellist, and Miss Bertha Jones, violinist.  
 "Romance" (Marschner), with piano accompaniment.  
 9.30: Ruth Naylor.  
 "Open Thy Blue Eyes" (Massenet).  
 "A Birthday" (Christina Rossetti).  
 9.36: The Adelaide Trio (H. Brewster-Jones, piano; H. Kugelberg, cello; Miss Bertha Jones, Violin).  
 "Elegia" (Arensky).  
 "Scherzo" (Arensky).  
 9.46: Mr. P. H. Nicholls, in one of his interesting talks, "The Century of General Booth."  
 9.52: General News service.  
 10.0: Close down.

## 6WF

10.25: Tune in. 10.30: Special half hour for the enthusiastic listener in. 11.0: Morning service relayed from St. Andrew's Church. 12.15: Close down.  
 3.30: Tune in. 3.35: Musical programme from the studio. 4.30: Close down. 7.0: Tune in. 7.5: Bed-time stories for the kiddies. 7.15: Music. 7.30: Evenson relayed from St. George's Cathedral. 8.45: Concert by the Perth City Band, relayed from Government Gardens, Perth, conducted by Mr. Lee Mc. Price. 10.5: Close down.  
 104.5 Metre Transmission—Simultaneous broadcast on 104.5 metres of programme given on 1250 metres, commencing at 7 p.m.

## 7ZL

### AFTERNOON SESSION

Announcer: J. M. Counsel. 3.0: Transmission from Davey Street Methodist Church, Hobart—Harvest Festival; musical programme arranged by Orpheus Club. 4.30: Close down.

### EARLY EVENING SESSION

Announcer: J. M. Counsel. 6.15: Chorus Singing. 6.45: Bertha Southey Bramhall will tell a Tasmanian fairy tale to the wee folk.

### EVENING SESSION

Announcer: J. M. Counsel. 7.0: Transmission from St. David's Cathedral, Murray Street, Hobart. 7.25: Transmission from Davey Street Methodist Church, Hobart; musical programme on the occasion of the Harvest Festival. 9.45: News service; British official wireless news; ships within wireless range; English affairs and news. 8.50: Close down.

## A STRONG FILAMENT

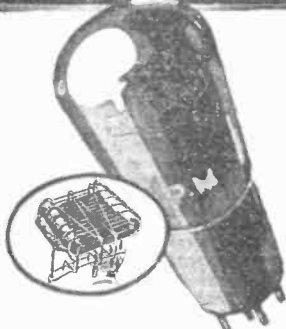

A Mullard P.M. Filament can be tied in a knot after more than 1000 hours' use. Remember that a filament is a piece of metal, thinner than a hair, and you will realise the enormous strength necessary to withstand such a strain.

Due to this quality, a Mullard P.M. Filament will give uniform unequalled results for amazing periods of time. In the words of Mullard users—"They last for years."

Added to this great strength the Mullard P.M. Filament has other advantages. Its huge emission surface ensures maximum volume together with an improvement in tone and it consumes only .075 amps.

There's not a valve to touch the Mullard P.M. Ask your radio dealer — he stocks them.

# Mullard

THE MASTER VALVE

## Local Programmes, Monday, April 8

### 2FC

#### EARLY MORNING SESSION.

Announcer: A. S. Cochrane.

7.0: "Big Ben" and announcements. 7.2: Official weather forecast, rainfall, river reports, temperatures, astronomical memoranda. 7.7: "Sydney Morning Herald" summary. 7.12: Shipping intelligence; mail services. 7.15: Studio music. 7.25: Investment market, mining sharemarket; metal quotations; wool sales; breadstuffs markets; inter-State markets; produce markets. 7.40: Studio music. 8.0: "Big Ben," close.

#### MORNING SESSION.

Announcer: A. S. Cochrane.

10.0: "Big Ben" and announcements. 10.3: Pianoforte reproduction. 10.10: "Sydney Morning Herald" news service. 10.25: Studio music. 10.30: The 2FC Racing Commissioner, late sporting news. 10.45: A talk on "Home Cooking and Recipes," by Miss Ruth Furst. 11.0: "Big Ben," A.P.A. and Reuter's cable services. 11.5: Close.

#### MIDDAY SESSION.

Announcer: A. S. Cochrane.

12.0: "Big Ben" and announcements. 12.1: Stock Exchange, first call. 12.3: Official weather forecast, rainfall. 12.5: Studio music. 12.10: Summary of news, "Sydney Morning Herald." 12.15: Rugby wireless news. 12.18: A reading. 12.30: Studio music. 1.0: "Big Ben," weather intelligence. 1.3: "Evening News" midday news service; Producers' Distributing Society's report. 1.20: Studio music. 1.28: Stock Exchange, second call. 1.30: Popular studio music. 2.0: "Big Ben," close.

#### AFTERNOON SESSION.

Announcer: Laurence Halbert.

Accompanist: Ewart Chapple.

2.30: Programme announcements. 2.32: Musical recital; a reading. 3.0: Popular music. 3.20: Mrs. A. P. Welling, pianist, "Variations F Minor" (Haydn). 3.30: Studio items. 3.40: Cliff Hanney, violinist—(a) "Hymn to the Sun" (Korsakoff-Kreisler). (b) "Serenade de Arlequin" (Drigo-Auer). 3.45: A reading. 4.0: "Big Ben." Mrs. A. P. Welling, pianist—(a) "C Sharp Minor Polonaise" (Chopin). (b) "D Flat Major Waltz" (Chopin). (c) "C Sharp Minor Waltz" (Chopin). 4.10: Romano's Cafe Orchestra, conducted by Bennie Abrahams. 4.20: From the Studio: Cliff Hanney, violinist—(a) "Midnight Bells" (Heuberger-Kreisler). (b) "Schon Rosmarin" (Kreisler), by request. 4.27: Popular music. 4.40: Romano's Cafe Orchestra, conducted by Bennie Abrahams. 4.46: From the Studio: Stock Exchange, third call. 4.48: Romano's Cafe Dance Orchestra, conducted by Bennie Abrahams. 5.0: "Big Ben," close.

#### EARLY EVENING SESSION.

Announcer: A. S. Cochrane.

5.40: The chimes of 2FC. 5.45: The children's session, conducted by the "Hello Man," letters and stories; music and entertainment; the Juvenile Orchestra. 6.30: Dalgety's market reports (wool, wheat, and stock). 6.40: Fruit and vegetable markets. 6.43: Stock Exchange information. 6.45: Weather and shipping news. 6.48: Rugby wireless news. 6.50: Late sporting news. 7.0: "Big Ben," late news service. 7.10: The 2FC Dinner Quartette, conducted by Horace Keats—(a) "Czardas, No. 5" (Michiels). (b) "Dans les Fleurs" (Berger). (c) "By the Tamarisk" (Coates). (d) "Carmen" (Bizet). (e) "Bird Songs at Eventide" (Coates). (f) "Bolero" (Fernandez-Arbo).

#### EVENING SESSION.

Announcer: Laurence Halbert.

Accompanist: Ewart Chapple.

7.40: Popular music. 7.45: Programme announcements. 7.48: Studio items. 8.0: "Big Ben," Studio Orchestra, conducted by Horace Keats—(a) Overture, "The Men of Prometheus" (Beethoven). (b) selection, "The Desert Song" (Romberg). (c) "Rhapsodie Russe" (arr. Nussbaum). 8.20: Euterpians Female Choir, competitors in the recent Radio Elsteddof, conducted by the N.S.W. Broadcasting Company, Limited—(a) "The Lord is my Shepherd" (Schubert).

(b) "To the Evening Star" (Bantock). (c) "You Stole My Love" (Macfarren).

8.30: Joan Fry, pianist, "Sonata in D Major" (Haydn).

8.40: Franco Izal, baritone—Italian group: (a) "Il Pavlucchi" prologue (Leoncavallo). (b) "Ideale" (Tosti).

8.47: Studio Orchestra, conducted by Horace Keats—(a) Introduction to third act, "Lohengrin" (Wagner). (b) selection, "H.M.S. Pinafore" (Sullivan).

8.4: Weather report. 9.5: A talk by Lucille Bruntnell, "A London Street Two Hundred Years Ago."

9.20: Euterpians Female Choir, competitors in the recent Radio Elsteddof, "Around the Winter Fire" (Gaul).

9.32: Joan Fry, pianist—(a) "Preludes" (Schutt). (b) "Dreaming Pierrot" (Schutt). (c) "Caprice" from "Carnival Mignon" (Schutt).

9.42: Studio Orchestra, conducted by Horace Keats, selection, "Martha" (Flotow).

10.2: Franco Izal, baritone—Spanish: (a) "Ay, Ay, Ay" (Freire). (b) "O Star of Eve" ("Tannhauser") (Wagner).

10.9: Studio Orchestra, conducted by Horace Keats, selected.

10.27: To-morrow's programme.

10.30: National Anthem; close.

### 2BL

#### MORNING SESSION.

Announcer: A. C. C. Stevens.

8 a.m.: G.P.O. chimes; metropolitan weather report. 8.1: State weather report. 8.2: Studio music. 8.15: G.P.O. chimes; "Daily Telegraph Pictorial" news. 8.30: G.P.O. chimes; news service continued. 8.40: Information, mails, shipping, arrivals, departures, and sailings. 8.45: Studio music. 9.15: Half an hour with silent friends. 9.45: Studio music. 10.0: G.P.O. chimes; close down.

#### MIDDAY SESSION.

Announcer: A. C. C. Stevens.

11.0: G.P.O. chimes; 2BL women's Sports Association Session, conducted by Miss Gwen Varley. 11.30: Advertising Hints; talk on "Diet and Health" by Miss Dorothea de Cleghorne. 11.40: Women's session, conducted by Mrs. Cranfield. 12.0: G.P.O. chimes; special ocean forecast and weather report. 12.3: Studio music. 12.30: Shipping and mails. 12.35: Market reports. 12.48: "Sun" mid-day news service. 1.0: Studio music. 1.30: Talk to children and special entertainment for children in hospital. 1.45: Close down. Note.—Race results of the trots will be broadcast by courtesy of the "Sun" Newspapers.

#### AFTERNOON SESSION.

Announcer: A. C. C. Stevens.

Accompanist: Kathleen Roe. 3.45: G.P.O. chimes; popular music. 4.0: A talk by Captain Fred Aarons on "Home Life and What It Means." 4.15: Gwen Neate, popular songs—(a) "Until Yesterday" (Sanders). (b) "Turn your Eyes to the Skies" (McKinlay). 4.22: Popular items. 4.32: Jeanette Rooney, contralto—(a) "Salaam" (Lang). (b) "If in the Great Bazaars" (Flinden). 4.39: Studio items. 4.49: "Sun" news service. 4.55: Gwen Neate, popular songs—(a) "My Little Dream Boat" (Coots). (b) "My Southern Home" (Shalson). 5.2: Studio music. 5.12: Jeannette Rooney, contralto—(a) "My Dear Soul" (Sanderson). (b) "Far Across the Desert Sands" (Flinden). 5.19: Pianoforte reproduction. 5.30: Racing resume. 5.37: Features of the evening's programme.

#### EARLY EVENING SESSION.

Announcer: Basil Kirke.

5.40: Children's session; music and entertainment; letters and stories. 6.30: "Sun" news and late sporting. 6.40: 2BL Dinner Quartette—(a) "The Kingdom of Flowers" (Ringelblum). (b) "There are Eyes" (Keyes). (c) "Wedgwood Blue" (Ketzler). (d) "Second Hungarian Rhapsody" (Liszt). (e) "Full Moon" (Woolmer). (f) "In Old Granada" (Hadley). (g) "Hindoo Song" (Bembere). 7.7: Australian Mercantile Land and Finance Co.'s report; weather report; forecast by courtesy of Government Meteorologists; Producers' Distributing Society's fruit and vegetable market report; grain and fodder report ("Sun"). 7.25: Mr. Pim

and Miss Pam in advertising talks and non-sense. 7.55: Programme and other announcements.

#### EVENING SESSION.

Announcer: Basil Kirke.

Accompanist: G. Vern Barnett.

8.0: G.P.O. chimes; topical chorus. 8.2: The Californians' Instrumental Combination from the Sonoma, conducted by Truman Bishop.

8.14: Alf. Lawrence and Nell Crane, entertainers—(a) "There's a Girl in Maoriand" (Lawrence). (b) "The Bush Cinderella" (Lawrence).

8.24: A novelty feature programme arranged by Jim Donnelly, "A Real Folks' Hour." A typical country town is depicted with all the local celebrities—the Mayor, artists of whom great things are expected, and of course the youthful incorrigibles.

9.34: Arthur Stendor, cornet solos.

9.41: Alf Lawrence and Nell Crane, entertainers—(a) "You Will Excuse Me, Won't You?" (Lawrence). (b) Songs of Yesterday, as they might have been written to today. Using chorus of "My Hero," "Just a Song at Twilight," and "I Passed by your Window" (arr. Lawrence).

9.51: The Californians' Instrumental Combination from the Sonoma, conducted by Truman Bishop.

10.1: Rae Foster, popular vocalist.

10.8: G. J. Hill, the idiosyncrasies of the motor car.

10.23: Rae Foster, popular vocalist.

10.30: Late weather report.

10.32: Castle Palais Band, winners in the recent Radio Elsteddof.

10.57: To-morrow's programme; late "Sun" news service.

11.12: Castle Palais Bnd, winners in the recent Radio Elsteddof.

11.30: National Anthem; close down.

### 2GB

10.0: Music. 10.10: Happiness talk by A. E. Bennett. 10.20: Music. 10.30: Women's session by Miss Helen J. Beegling. 11.30: Close down. 1.30: Adyan Camp Talks by Professor E. Wood. 2.0: Music. 2.5: Women's radio service by Mrs. Dorothy Jordan. 2.50: Music. 3.15: Close down. 5.50: Children's session by Uncle George. 7.0: Music. 7.30: Feature story. 8.0: Miss Betty Ramsey, contralto. 8.7: Miss Mollie Jones, pianiste. 8.15: Mr. Cecil Houghton, tenor. 8.22: Instrumental music. 8.30: A humorous interlude by Mr. Jack Win and Mr. Heath Burdock. 8.35: Miss Elsie Brown, soprano. 8.45: Mr. Phil Couchman, cornet. 8.55: A humorous interlude by Mr. Jack Win and Mr. Heath Burdock. 9.0: Weather report. 9.3: Address. 9.15: Miss Betty Ramsey, contralto. 9.25: Miss Mollie Jones, pianiste. 9.35: Mr. Cecil Houghton, tenor. 9.45: A humorous interlude by Mr. Jack Win and Mr. Heath Burdock. 9.50: Mr. Phil Couchman, cornet. 10.0: Miss Elsie Brown, soprano. 10.10: Dance music. 10.30: Close down.

### 2UW

#### MIDDAY SESSION.

12.30: Music. 1.0: G.P.O. clock and chimes. Music. 2.30: Close down. 4.30: Musical programme.

#### EVENING SESSION.

5.30: Children's hour, conducted by Uncle Jack. 6.30: Close down. 7.0: G.F.O. clock and chimes. Music. 7.45: Wireless talk; Hints and advice by Mr. E. Homfray. 8.0: To-day's anniversary. Music. 9.0: G.P.O. clock and chimes. Comments on Fore- and Affairs by Mr. J. M. Prentice. 9.40: Music and request numbers. 10.30: Close down.

**FULLER  
ACCUMULATORS  
LAST LONGER  
GILBERT-LODGE & CO. LTD.**



# Install these Accessories and have perfect Radio reception

Everything  
for the  
Radio  
Enthusiast

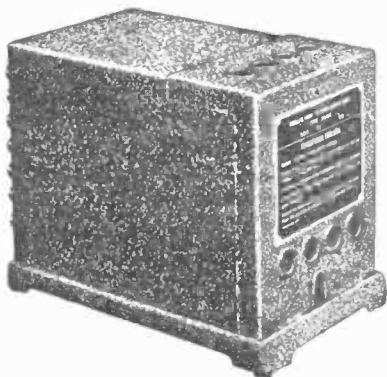

The following Philips lines  
are also stocked.

- Philips Trickle Charger
- „ A & B Charger
- „ B & C Eliminator
- „ Valves



PHILIPS STANDARD 1 "B"  
ELIMINATOR, 372.

Here is the most popular power unit  
in Australia, which, owing to a price  
reduction, is now actually a cheaper  
proposition than "B" Batteries.  
At its new price of £7/15/- there are  
none who need suffer the inconveni-  
ences of the dry battery.

Price ..... £7/15/-

The Philips Eliminator does  
away completely with your "B"  
Battery, and is used by simply  
plugging into the ordinary elec-  
tric light socket.

PRICE ..... £9/15/-

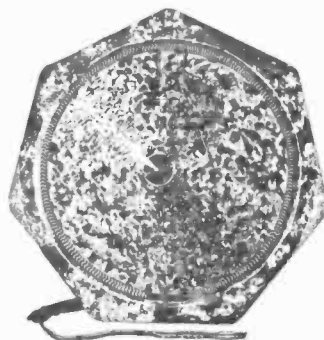

PHILIPS BABY GRAND LOUD  
SPEAKER.

This is a particularly fine baby model  
with an exceptionally clear tone and  
pleasing appearance. Splendid value  
at

£3/15/-

Easy Terms  
can be  
arranged if  
preferred.

OPEN UNTIL 9 p.m. FRIDAY

## Home Recreations (Australia) Ltd.

388 George Street, Opp. Beard, Watson's, SYDNEY



# Interstate Programmes, Monday, April 8

## 3LO

### EARLY MORNING SESSION.

7.15 to 8.15: See Friday.

### MORNING SESSION.

Announcer: John Stuart. 11.0: To-day's Radio Recipe, Date Roy. 11.1: Alga Parker will speak on "Stories to Tell the Children." "Memoirs of a London Doll." 11.25: Under the auspices of the St. John Ambulance Association, Miss Edith Wells will speak on "Home Nursing." 11.45: Under the auspices of the National Safety Council of Victoria, H. J. Book will speak on "Some Aspects of Safety."

### MIDDAY NEWS SESSION:

Announcer: John Stuart. 12.0: Time signal. Express train information. British official wireless news from Rugby. Reuter's and the Australian Press Association cables. News service. Newmarket stock sales. Entries for the market for Tuesday, Wednesday, and Thursday by the Associated Stock and Station Agents, Bourke Street, Melbourne. 12.20: Community Singing, transmitted from the King's Theatre, Russell Street, Melbourne. Ern Hall's Radio Revellers. Jack Stocks (by permission Tiroll Theatres, Ltd.). 12.4: Stock Exchange information. 12.43: Community singing resumed. 1.45: Meteorological information. Weather forecast for Victoria, New South Wales, South Australia, and Tasmania. Ocean forecasts. River reports. Rainfall.

### AFTERNOON SESSION.

Announcer: John Stuart. Accompanist: Agnes Fortune. 2.15: General programme, including the Station Orchestra, Valda St. Nicolay (contralto), Agnes Fortune (piano), Stanley J. Allen (tenor), Marion Lightfoot (soprano). One-act play, "Honors East," a trifle of powder and patches, by Albert E. Drinkwater. Violet Jackson (soprano), Joseph Barrile (tute). 4.55: "Herald" news service. Stock Exchange information. 5.5: Close down. 6.0: Answers to letters and birthday greetings by "Billy Bunny." 6.30: William C. Groves will tell the children more about "Sing Sing, a New Guinea holiday." 6.45: "Billy Bunny."

### EVENING SESSION.

Announcer: Frank Hatherley. 7.5: Stock Exchange information. 7.15: Market reports. 7.30: News session. 7.43: Birthday greetings. 7.45: Out of the last. 7.46: Under the auspices of the Department of Agriculture, J. Brake, senior inspector of Agriculture, will speak on "Wheat Growing: Varieties F. commenced by the Department." 8.0: A Maker e. History.

### NIGHT SESSION.

Announcer: Frank Hatherley.

Accompanist: Agnes Fortune.

- 3.1: The Station Orchestra. Overture, "Jelva" (Rieserger).
- 3.10: Gertrude Hutton (contralto)—  
"A Song of Autumn" (Elgar).  
"Chant Venetian" (Bemberg).
- 3.17: The Imperial Russian Trio—  
"Cercade" (Rachmaninoff).  
"Maarika Russe" (Clinka).  
"Berceuse" (Cui).  
"Inscuance" (Rebikoff).  
"Souvenir Dououreux" (Rebikoff).
- 3.47: Victor Harding (bass-baritone)—  
"Love That's True Will Live Forever" (Handel).  
"Moonlight" (Schumann).
- 3.54: The Station Orchestra—  
Selection, "Un Ballo in Maschera" (Verdi).
- 3.4: The Royal Victorian Liedertafel—  
Conductor: J. Sutton Crow.  
Pianist: J. F. Whitehead.  
Part Song, "Fair Rohtrant" (Welt).  
Part Songs—  
(a) "All Through the Night" (arr. by Greer).  
(b) "Marching Along."  
(c) "Give a Rouse."  
Part Songs—  
(a) "At Andernach in Rhineland" (Abt).  
(b) "The King's Messenger" (Bantock).  
Part Songs—  
"Frog's Cantata" (Hennig).  
3LO's "Tustalia" "The Teller of Tales".

- 9.34: Captain Donald MacLean—  
"Feats of the Mighty."  
9.49: The Station Orchestra—  
Suite, "Minnehaha" (Coleridge Taylor).  
10.0: News service. Meteorological information.  
British wireless news from Rugby.  
10.10: The Station Orchestra—  
Selection from "Spyll" (Jacobi).  
10.18: Gertrude Hutton (contralto)—  
"Walt" (d'Hardelet).  
"The Moon Drops Low" (Cadman).  
10.25: The Station Orchestra—  
Suite, "Queen of Sheba" (Goldmark).  
10.35: Victor Harding (bass-baritone)—  
"The Sea Gypsy" (Head).  
"Drums" (Meale).  
10.43: The Radio Revellers—  
"My Stormy Weather Pal" (Plantadosi).  
"Dawning" (Silver).  
"Do You?" (Plantadosi).  
"Colombo" (Nichols).  
"Under the Burma Moon" (Davis).  
"Sonny Boy" (Brown).  
"All by Yourself in the Moonlight" (Wallis).  
"Sally of My Dreams" (Kernell).  
"Glad Rag Doll" (Ager).  
"You're a Real Sweetheart" (Friend).  
Selected.  
11.30: God Save the King.

## 3AR

Announcer, Maurice Dudley. 10.0 to 12.30: See Friday.

### AFTERNOON SESSION.

Announcer, Maurice Dudley. 3.0: General programme, including The Strad Trio. Capt. Donald MacLean; Cecil Parkes, violin; vocal variations by "Gall-i-Curci" and "Cassano." 4.30: Close down.

### EVENING SESSION.

Announcer, Renn Millar. 6.0: General programme, including the Imperial Russian Trio. 7.15: News service; announcements.

### NIGHT SESSION

- Announcer, Renn Millar.  
Accompanist, Reg. Brown.
- 8.0: E. C. H. Taylor—  
"School Life and School Sport."  
8.15: Under the auspices of the Historical Society of Victoria, A. W. Greig will speak on—  
"The Foundation of Melbourne."  
8.30: Under the auspices of the Second Australian National Sunday School Convention, Rev. A. V. Ballard will speak on—  
"The Work of the Society."  
8.40: The Radio Revellers—  
"Do You?" (Plantadosi).  
"Colombo" (Nicholas).  
"Under the Burma Moon" (Davis).  
8.49: Jack Stocks—"The Woman Hater" (by permission Tiroll Theatres, Ltd.).  
"Dismal Ditties."  
8.52: The Radio Revellers—  
"Sonny Boy" (Brown).  
"Sally of My Dreams" (Kernell).  
"You're a Real Sweetheart" (Friend).  
9.1: Marion Lightfoot—  
Steel guitar selections.  
9.4: The Radio Revellers—  
"All by Yourself in the Moonlight."  
"Tokio" (Conder).  
"Where the Cot, Cot, Cotton Grows" (Kilen).  
9.13: Alan Adcock, entertainer—  
"The Daily Mail" news.  
9.16: The Radio Revellers—  
"Paradise" (Zemsenki).  
"Glad Rag Doll (Ager).  
"Cinnamon Cake" (Bernard).  
9.25: Jack Stocks—"The Woman Hater"—  
"Dismal Ditties."  
9.28: The Radio Revellers—  
"Avalon" (Townsend).  
"You Are Wonderful" (Ash).  
"Honeymoon Waltz" (Renault).  
9.37: Marion Lightfoot—  
Steel guitar selections.  
9.41: The Radio Revellers—  
"There Ought to be a Law Against That" (Friend).  
"Little Mother" (Raper).  
"Oh, Ya, Ya" (Frich).  
9.50: Alan Adcock, entertainer—  
"Deffy Ditties."  
9.53: The Radio Revellers—  
"Stars are the Windows of Heaven" (Malle).  
"That's Her, Now" (Ager).  
"Japansy" (Klenner).  
10.8: Jack Stocks—"The Woman Hater"—  
"Dismal Ditties."  
10.11: The Radio Revellers—  
"Constantinople" (Carlton).  
"In the Woodshed she said she Would" (Johnson).  
"Minnetonka" (Wallace).  
10.20: "Age" news service; announcements. God Save the King.

## 4QG

### EARLY MORNING SESSION.

Announcer: J. Tyson. 7.43 a.m. to 8.30 a.m.: See Friday.

### MORNING SESSION.

Announcer: Rita M'Auliffe. 11 to 12: General programme.

### MID-DAY SESSION.

Announcer: R. Wight. 1.0: Market reports and weather information; lunch-hour music. 2.0: Close down.

### AFTERNOON SESSION.

Announcer: H. Humphreys. 3.0: A programme of

records; mail train running times; news. 4.30: Close down.

### EARLY EVENING SESSION.

Announcers: H. Humphreys and A. V. James. 6.0: Mail train running times; mail information; shipping news. 6.3: Wurlitzer Organ. 6.35: Commercial announcements. 6.30: Bedtime stories conducted by "The Sandman." 7.0: News in brief; Stock Exchange news; metal quotations; market reports; Fenwick's Stock report; weather information; announcements; time signals. 7.45: Lecture, "The Children's Music Corner," conducted by "The Music Man."

### NIGHT SESSION.

Announcer: H. Humphreys.  
Arrangements have been made with the University of Queensland for the broadcasting of instructional matter in connection with the examinations which are to be held this year under the auspices of the Queensland Section of the Australian Music Examinations Board.  
On various nights authorities on the various grades will lecture from 4QG.

The scheme has been instituted with a view to affording country students an opportunity of being coached and instructed in preparation for the forthcoming examinations.  
To-night Mr. Eric Hayne will give a demonstration recital of music for grades 5 and 4, for violin. 8.0: From the Studio, demonstration recital. Studio Concert.

- 8.30: The Studio Orchestra.  
Overture, "Der Prinzregent" (Gilbert).  
8.37: Dorothy Mowlan (soprano).  
"May Dew" (Sterndale Bennett).  
"Loreley" (Liszt).  
8.44: Claude Walker.  
Ten minutes with Henry Lawson.  
8.54: The Studio Orchestra.  
Rag step, "Wild Cherries" (Snyder).  
9.0: Metropolitan weather forecast.  
9.1: Irene Elphinstone (contralto).  
"When Son is Sweet" (Sans Souci).  
9.5: Harry Borradaie (elocutionist).  
"The Woman who Understands" (Anon).  
"Snorkins" (Spurr).  
"Loyalty of Men" (Anon).  
9.15: Mrs. C. Williams (violinist).  
Selected (accompanied by the Studio Orchestra).  
9.20: Irene Elphinstone (contralto).  
"Had 'You But Known" (Denza).  
9.25: The Studio Orchestra.  
Selection, "Gems from Maritana" (Wallace).  
Sharman-Plane Recital.  
9.30: A short recital, Arthur Sharman (pianist) and Ivy Plane (soprano).  
Ivy Plane (soprano).  
"The Hand of a Friend" (Russell).  
"Advice" (Carew).  
A. Sharman (pianist).  
"Etude Op. 25 No. 1" (Chopin).  
"Valse Brillant Op. 18" (Chopin).  
Ivy Plane (soprano).  
"In a Poppy Field" (Parker).  
"Spring's a Lovely Lady" (Elliott).  
A. Sharman (pianist).  
"Valse Poco a Poco" (Franchetti).  
Ivy Plane (soprano).  
"Lament of Isis" (Bantock).  
"What's in the Air To-day?" (Eden).  
Arthur Sharman (pianist).  
"Hungarian Rhapsody No. 15" (Liszt).  
10.0: "The Daily Mail" news; "The Courier" news; weather news; close down.

## 5CL

### MORNING SESSION.

Announcer: J. L. Norris. 11.0: Chimes; morning melodies. 11.15: Kitchen craft and menu talk. 11.45: Miss Laurie M'Leod, of Weber, Shorthose, and Rice will speak on "Physical Culture for Women." 12.1: Mid-day music. 12.15: General news service. 12.35: British official wireless news. 12.52: S.A. Railway information. S. C. Ward and Co.'s Stock Exchange information. 1.1: Lunch-hour recital. 2.0: Close down.

### AFTERNOON SESSION.

Accompanist: Jean Finlay. Announcer: J. L. Norris. 3.0: Chimes; general programme, including: Studio Quartette; Meta Riedel, contralto; P. S. McLean, soprano; John D. Fraser, baritone; H. Bowke-Smith, banjoist; Lillian Pritchard, elocutionist. 4.1: A dialogue, entitled "Our Play." 4.55: S. C. Ward and Co.'s Stock Exchange information. 5.0: Close down.

### EVENING SESSION.

6.0: Chimes. 6.1: Birthday greetings, correspondence songs and stories by "Auntie Peggy." 6.55: S. C. Ward and Co.'s Stock Exchange information. 7.1: General market reports. 7.20: Mr. S. B. Opie, field officer, will speak on "Tobacco Growing." 7.30: The 5CL Twinkler Boys' Club.

### NIGHT SESSION.

- Announcer: C. J. O'Connor.
- 8.0: Chimes.  
8.1: Studio Orchestra  
Overture, "Coriolanus" (Beethoven).  
"Supplication Passionee" (Elliott).  
8.9: Beryl Counter (mezzo-soprano).  
"A Thrush's Song" (Travers).  
"Remembrance" (Salter).  
9.15: Lizette Poggia (violinist).  
Selected violin solos.  
8.21: Pat M'Lean (soubrette).  
Selections from her repertoire.  
8.27: Studio Orchestra.  
"Malaguena" (Moszkowski).

- "Indian Lullaby" (Herbert).
- 8.35: John D. Fraser (baritone).
- "Like to a Damask Rose" (Elgar).
- "Lullaby" (Schubert).
- 8.41: Tom King and Jean Finlay (pianists) will play together
- "Concerto in G Minor" 1st Movement (Saint-Saens).
- 8.51: Nora Shirely (contralto).
- "Hushed is My Lute" (Montague Phillips).
- "A Banjo Song" (Sidney Homer).
- 8.57: Studio Orchestra.
- "Dance Hongroise" (Delibes).
- 9.0: G.P.O. chimes.
- 9.1: Meteorological information, including Semaphore tide.
- 9.2: Overseas grain report.
- 9.3: Studio Orchestra.
- Waltz, "A Kiss Before the Dawn" (Perkins).
- "Vol de Sapete," from "Marriage of Figaro"
- 9.8: Beryl Counter (mezzo-soprano) (Mozart).
- "The Snowdrop" (Craigh).
- 9.14: An organ recital by Foxfall Robinson.
- 9.54: John D. Fraser (baritone).
- "A Brown Bird Singing" (Wood).
- "Loving Smile" (Gounod).
- 10.0: Vern Rogers (trumpeter).
- Selected trumpet solo.
- 10.1: Nora Shirely (contralto).
- "Sorrow Song" (Coolidge-Taylor).
- "Life's Girls" (Clutsam).
- 10.10: Studio Orchestra.
- "In a Persian Market" (Ketyby).
- 10.15: General news service. Meteorological information.
- 10.30: Modern dance numbers, by the "Radio Reveliers."
- 11.0: Close down.

**6WF**

12.30: Tune in. 12.35: Markets, news, etc. 1.0: Time signal. 1.1: Weather bulletin supplied by the Meteorological Bureau of West Australia. 1.3: Panatope hour, relayed from Messrs. Musgroves, Ltd., Lyric House, Perth. 2.0: Close down. 3.30: Tune in. 3.35: Afternoon tea programme relayed from the Carlton Cafe; vocal items from the studio. 4.30: Close down. 6.45: Tune in. 6.48: Bed-time stories for the kiddies by Uncle Duffy. 7.5: Light music by the Station Trio, comprising Miss Audrey Dean, piano, Miss Edna Waterman, 'cello, Miss Vera Waterman, violin. 7.30: Commercial and general information. 7.45: Talk by Lieut. Colonel Le Senef, director Zoological Gardens, South Perth. 8.0: Time signal. 8.1: First weather bulletin. 8.3: Band concert by the R.S.L. Band, conducted by Mr. G. Mellor. March, "The Conqueror" (Morehouse); waltz, "The Waltz Dream" (Strauss); popular, "Chiquita" (Wayne); selections, "Gems from Sullivan" (Hume); humoreske, "Three Blind Mice" (Douglas); fantasia, "A-Cluster of Classics" (Round); waltz, "You're a Real Sweetheart." 8.50: Late news items by courtesy of the "Daily News" Newspaper Co. Ltd.; station announcements, ships within range announcement, late weather bulletin. 9.5: Programme continued from the studio. 10.30: Close down.

104.5 Metre Transmission—Simultaneous broadcast on 104.5 metres of programme given on 1250 metres, commencing at 6.45 p.m.

**7ZL**

**MIDDAY SESSION**

Announcer: Jack Broadbent.—11.30 to 1.30: General programme.

**AFTERNOON SESSION.**

Speaker: "Aunt Edna." 3.0: G.P.O. clock chimed the hour. 3.4: Weather information. 3.15: A popular programme arranged by Columbia, including Alfred O'Shea, tenor; Australian Commonwealth Band, conductor Albert Ballie; Sir Harry Lauder, baritone; Paul Whiteman and his Orchestra; Charles Hamp, baritone; Jeanette Gerard, piano accordion solo; Schmidt, Orpheus Male Voice Choir; guitar duet; Gresham Singers. 4.15: "Aunt Edna" on "Fashion Modes for Males and Children." 4.30: Close down.

**EARLY EVENING SESSION.**

Announcer: Jack Broadbent.—8.15: Music; Little Meg Vinay will recite to the little ones: "This Little Teddy Bear," "Supplanted." 7.0: Answers to letters and birthday greetings. 7.15: News service; railway auction produce sales held at railway; Tasmanian district weather report; Hobart Stock Exchange quotations; announcements.

**EVENING SESSION.**

Announcer: Jack Broadbent.—7.30: Under the auspices of the Tasmanian University, Professor J. B. Bridgen will speak on "University and the Radio." 1.45: George Collis, Tasmania's champion wrestler, will speak on "Physical Culture." 8.0: G.P.O. clock chimed the hour. 8.6: Transmission from the Memorial Congregational Church, Brisbane Street: A concert programme arranged by James Marsh: Violin and organ—Hazel Guest, violin; James Marsh, organ. "Andante from Concerto, Op 64" (Mendelssohn); San Francisco Orchestra, "Serenade" (Moskowskij), "Aubade" (Auber); Edward Hawkins, song, "Mother of Mine" (Tours); W. Backhaus, pianist, "Liebestraum" (Liszt); song with violin, Hazel Guest, violin. Keith Semple, "Hosanna" (Granier); San Francisco Orchestra, "Liebestuet" (Bizet), "Berceuse" (Godard); Ignace Jan Paderewski, pianist, "Waltz in A Flat, Op. 42" (Chopin); Edward Hawkins, song, "When I Survey" (Hope); Covent Garden Orchestra, "Marche Militaire" (Schubert); song with violin, Hazel Guest, violin, "The Guard Thee" (Godard); de Puchman, piano solo, "Kovetlet" (Schumann); James Marsh, organ solo, "Pilgrim's Chorus" ("Tannhauser"), (Wagner). 9.50: News service; British official wireless news; Tasmanian district weather report. 10.0: G.P.O. clock chimed the hour. 10.1: Close down.

Use **OLDHAM**



Made under the Oldham Special Activation Process, which renders the plates immune to sulphation, Oldham represents 100 per cent. efficiency.

**ACCUMULATORS**

**COMPARE**

**THE THICKNESS OF THEIR PLATES**



THAT'S WHY

**OLDHAM**  
Accumulators need less re-charging

**NOYES BROS.,**

(Sydney), Limited, (Melbourne) Pty., Limited.  
 Sydney: 115 Clarence St. Melbourne: 495 Bourke St.  
 Newenham: 11 Watt St. Adelaide: 119 Pirie St.  
 Brisbane: Ferry House. Hobart: 30 Argyle St.  
 Elizabeth Street, Launceston: 35 George St.  
 Perth: J. R. W Gardam and Co.

## Local Programmes, Tuesday, April 9

### 2FC

#### EARLY MORNING SESSION

Announcer: A. S. Cochrane.

7.0: "Big Ben" and announcements. 7.2: Official weather forecast: rainfall; river report; temperatures; astronomical memoranda. 7.7: "Sydney Morning Herald" summary. 7.12: Shipping intelligence; mail services. 7.15: Studio music. 7.25: Investment market; mining share markets; metal quotations; wool sales; breadstuffs markets; inter-State markets; produce markets. 7.40: Studio music. 8.0: "Big Ben." Close down.

#### MORNING SESSION

Announcer: A. S. Cochrane.

10.0: "Big Ben" and announcements. 10.2: Pianoforte reproduction. 10.10: "Sydney Morning Herald" news service. 10.25: Studio music. 10.30: Last-minute sporting information by the 2FC Racing Commissioner. 10.40: Studio music. 10.50: Pianoforte reproduction. 11.0: "Big Ben"; A.P.A. and Reuter's cable services. 11.5: Close down. Note: Race results from Gosford

#### MIDDAY SESSION

Announcer: A. S. Cochrane.

12.0: "Big Ben" and announcements. 12.2: Stock Exchange, first call. 12.3: Official weather forecast; rainfall. 12.5: Studio items. 12.10: Summary of news, "Sydney Morning Herald." 12.15: Rugby wireless news. 12.18: A reading. 12.30: Studio music. 1.0: "Big Ben"; weather intelligence. 1.3: "Evening News" midday news service; Producers' Distributing Society's market report. 1.20: Studio music. 1.28: Stock Exchange, second call. 1.30: Studio music. 2.0: "Big Ben"; close down.

#### AFTERNOON SESSION

Announcer: Laurence Halbert.

Accompanist: Ewart Chapple.

2.30: Programme announcements. 2.32: A musical recital; a reading. 3.0: "Big Ben"; popular music. 3.30: Hilda Nelson, soprano. 3.37: Dorothy Farmer, pianist—(a) "Meditation" (Tschaikowsky); (b) "Poeme" (Scriabine); (c) "Soaring" (Schumann). 3.47: Studio reading. 4.0: "Big Ben"; Hilda Nelson, soprano. 4.7: Studio items. 4.17: Dorothy Farmer, pianist—(a) "Margaret at the Spinning Wheel" (Liszt); (b) "Etude in D Flat Major" (Liszt). 4.27: Popular music. 4.45: Stock Exchange third call. 4.47: Studio music. 5.0: "Big Ben"; close.

#### EARLY EVENING SESSION

Announcer: A. S. Cochrane.

5.40: The chimes of 2FC. 5.45: The children's session, conducted by the "Hello Man," assisted by Aunt Eily; letters and stories; music and entertainment. 6.30: Dalgety's market reports (wool, wheat, and stock). 6.40: Fruit and vegetable markets. 6.43: Stock Exchange information. 6.45: Weather and shipping news. 6.48: Rugby wireless news. 6.50: Late sporting news. 7.0: "Big Ben"; late news service. 7.10: The 2FC Dinner Quartette, conducted by Horace Keats—(a) "Bourree and Musette" (Morgan); (b) "The Count of Luxembourg" (Lehar); (c) "Humoresque" (Tschaikowsky); (d) "Barcarolle" (Offenbach); (e) "Entr'acte Mamselle Modiste" (Herbert).

#### EVENING SESSION

Announcer: Laurence Halbert.

Accompanist: Ewart Chapple.

7.40: Popular music. 7.45: Programme announcements. 7.48: Studio items. 8.0: "Big Ben"; Salvation Army Congress Band. 8.20: Norman Wright, tenor—(a) "Wondrous Art Thou" (Brahms); (b) "A Gentle Maiden" (Somervell). 8.27: A sketch by Gwen Sherwood and Laurence Halbert—Broadcasting the Norman Conquest" (adapted). 8.37: Freda Treweek, mezzo—(a) Aubade, "Le Roi D'ys" (Lalo); (b) "Soft-footed Snow" (Sigurd Lie).

8.44: Rene Rich, violinist—(a) "Capriccio Valse" (Wienalwski); (b) "Medley." 8.51: Salvation Army Congress Band. 9.6: Weather report. 9.17: To-night's feature—it is hoped to-night we will have a special opportunity of arranging a feature for listeners. 9.27: Norman Wright, tenor—(a) "Two Kentucky Love Songs" (Ring); (b) "At the Mid-Hour of Night" (Cowen). 9.34: A sketch by Gwen Sherwood and Laurence Halbert—"Consulting the Ectoplasm" (adapted). 9.49: Salvation Army Congress Band. 10.9: Freda Treweek, mezzo-soprano—(a) "Do Not Go, My Love" (Hageman); (b) "Songs My Mother Taught Me" (Dvorak). 10.16: Rene Rich, violinist—(a) "Moses Fantasia" (Paganini); (b) "Melodies of the Past." 10.25: Late weather report. 10.25: Studio Dance Band, conducted by Cec. Morrison. 10.57: To-morrow's programme. 10.59: Studio Dance Band, conducted by Cec. Morrison. 11.30: National Anthem. Close.

### 2BL

#### MORNING SESSION

Announcer: A. C. C. Stevens.

8 a.m.: G.P.O. chimes; metropolitan weather report. 8.1: State weather report. 8.2: Studio music. 8.15: G.P.O. chimes: "Daily Telegraph Pictorial" news. 8.30: G.P.O. chimes; news service continued. 8.40: Information, mails, shipping, arrivals, departures, and sailings. 8.45: Studio music. 9.15: Half an hour with silent friends. 9.45: Studio music. 10.0: G.P.O. chimes: close down

#### MIDDAY SESSION

Announcer: A. C. C. Stevens.

Note.—Race results from Gosford. 11.0: G.P.O. chimes; 2BL Women's Sports Association session, conducted by Miss Gwen Varley. 11.30: Advertising hints. 11.40: Women's session, conducted by Mrs. Cranfield; Sister Parry will speak on the work of the St. John Ambulance Association. 12.0: G.P.O. chimes; special ocean forecast and weather report. 12.3: Studio music. 12.30: Shipping and mails. 12.35: Market reports. 12.48: "Sun" mid-day news service. 1.0: Studio music. 1.30: Talk to children and special entertainment for children in hospital. 2.0: G.P.O. chimes: close down.

#### AFTERNOON SESSION

Announcer: A. C. C. Stevens.

Accompanist: Kathleen Roe.

3.45: G.P.O. chimes; popular music. 3.50: Romano's Cafe Dance Orchestra, conducted by Bennie Abrahams. 4.0: G.P.O. chimes; Madge Helmrich, contralto—(a) "Thoughts Have Wings"; (b) "Four Ducks on a Pond" (Needham). 4.7: Studio items. 4.10: Romano's Cafe Dance Orchestra, conducted by Bennie Abrahams. 4.20: From the studio, Roger Jones, baritone. 4.27: "Sun" news service. 4.30: Popular music. 4.40: Romano's Cafe Dance Orchestra, conducted by Bennie Abrahams. 4.50: From the Studio; Madge Helmrich, contralto—(a) "Easter Flowers" (Sanderson); (b) "Three" (Aylward). 4.57: "Sun" news service. 5.0: G.P.O. chimes; pianoforte reproduction. 5.15: Studio items. 5.30: Sporting resume. 5.35: Producers' Distributing Society's poultry report. 5.37: Features of the evening's programme.

#### EARLY EVENING SESSION

Announcer: Basil Kirke.

5.40: Children's session; music and entertainment; letters and stories. 6.15: Mr. Norman talks to the Bigger Boys. 6.30: "Sun" news and late sporting. 6.40: 2BL Dinner Quartette—(a) "Red Poppies" (Elliott); (b) "Smiles, then Kisses" (Ancliffe); (c) "The Street Singer" (Fraser-Simson); (d) "Reverie" (MacDowell); (e) "Trees" (Rasbach). 7.7: Australian Mercantile, Land and Finance Co.'s report: weather report and forecast by

courtesy of Government Meteorologist; Producers' Distributing Society's fruit and vegetable market report; grain and fodder report ("Sun"); dairy produce report ("Sun"); 7.25: Mr. Pim and Miss Pam in advertising talks and nonsense. 7.55: Programme and other announcements.

#### EVENING SESSION

Announcer: Basil Kirke.

Accompanist: G. Vern Barnett.

8.0: G.P.O. chimes; topical chorus. 8.2: Classic programme arranged by Alexander Sverjensky—(a) "Fantasia Cuisnor" (Mozart); (b) "Alla Turca" (Mozart); Alexander Sverjensky, pianist. 8.15: (a) "The Palanquin Bearers" (Shaw); (b) "The Lorelei" (Liszt); (c) "The Spent Flower" (Tipton); May Craven, contralto. 8.30: (a) "Romance in G Major" (Beethoven); (b) "Ballet Music" (Schubert-Kreisler); Lloyd Davies, violinist. 8.40: Agnes M'Diarmid, soprano—(a) "The Wind's in the South" (Scott); (b) "Supid" (Sanderson). 8.46: "Great Writers I Have Met: Bernard Shaw," by C. N. Baeyertz. 9.2: Weather report. 9.3: Agnes M'Diarmid, soprano—(a) "The Piper of Love" (Carew); (b) "Rain" (Curran). 9.10: "London, the Imperial Port," by T. R. Toovey, principal assistant to the London manager of the Port of London Authority. 9.20: Classic programme arranged by Alexander Sverjensky, second half—(a) "Trio in B Flat Major" (Schubert); Allegro moderato, Andante, Scherzo, Rondo; Alexander Sverjensky, pianist; Lloyd Davies, violinist; Jules Van der Klei, cello. 9.55: Late weather and "Sun" news service. 10.12: Celebrity record recital. 10.27: To-morrow's programme. 10.30: National Anthem; close.

### 2GB

10.0: Music. 10.10: Happiness talk by A. E. Bennett. 10.20: Music. 10.30: Women's session by Miss Helen J. Beegling. 11.30: Close down. 2.0: Music. 2.5: Women's radio service by Mrs. Dorothy Jordan. 2.50: Music. 3.15: Close down. 5.30: Children's session by Uncle George. 7.0: Music. 7.30: Talk from the Radio Service Department by Mr. Stan Crittenden. 8.0: Miss Edith Allen Taylor, mezzo-soprano. 8.7: Mr. Gregory Valentine, violinist. 8.15: Mr. Peter Templeton, baritone. 8.22: Instrumental music. 8.33: Humorous Interlude. 8.35: Miss Muriel Fieldwick, soprano. 8.45: Miss Belle Young, pianist. 8.55: A humorous Interlude by Mr. Jack Win and Mr. Heath Burdock. 9.0: Weather report. 9.3: Address. 9.15: Miss Edith Allen Taylor. 9.25: Mr. Gregory Valentine, violinist. 9.35: Mr. Peter Templeton, baritone. 9.45: A humorous Interlude by Mr. Jack Win and Mr. Heath Burdock. 9.50: Instrumental music. 10.0: Miss Muriel Fieldwick, soprano. 10.10: Dance music. 10.30: Close down.

### 2UW

#### MIDDAY SESSION

12.30: Music. 1.0: G.P.O. clock and chimes. Music. 2.30: Close down. 4.30: Musical programme.

#### EVENING SESSION

5.30: Children's hour, conducted by Uncle Jack. 6.30: Close down. 7.0: G.P.O. clock and chimes. Music. 8.0: To-day's anniversary. Music. 9.0: G.P.O. clock and chimes. Comments on Foreign Affairs by Mr. J. M. Prentice. 9.10: Music and request numbers. 10.30: Close down.

### FOK SALE

Amateur's surplus Wireless Components, Super Het Kit, 6 Bradley Sets, several Variable Condensers, 8 to 1 All-American A.F. Transformer, Rheostats, 199 Sockets and other Components. All as new. Cheap. Call and inspect.

DR. CHAFFER  
157 MACQUARIE STREET.

THE NEWEST THING IN RADIO  
**THE FIRST**  
 ALL-ELECTRIC 8 VALVE  
 "Super-het"

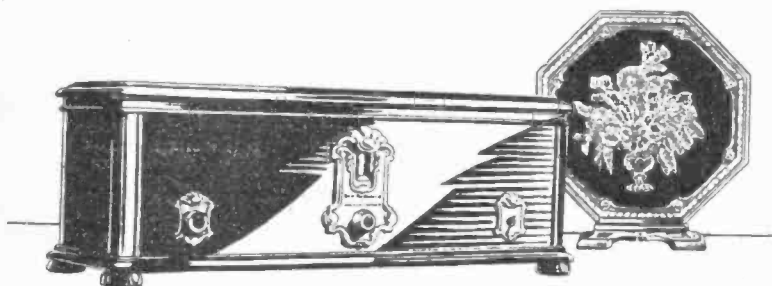

**T**ALK about a three, or four, or five valve set "bringing in interstate." Just hear this R.C.A. Receiver Model 60.

Eight powerful valves glowing from the unvarying current of the electric light supply. It's a super-het. The first light-socket receiver to embody the most selective circuit in radio. A compact table model in an exquisitely designed cabinet of veneered walnut.

Turn a single dial. Bring in a flood of melody from any broadcasting station in Australia and New Zealand (except W.A.) as if it were just over the hill. Cut out all interference sharply, even though you live in the shadow of a station. Roam round Australia for your entertainment. Move the dial

*Eight glowing valves! Brings in any station in Australia and New Zealand (except W.A.). Razor sharp, one dial tuning. Just plug in to a power point. Cost to operate no more than that of an ordinary 90-watt living-room electric lamp.*



an eighth of an inch and jump from one programme to another. Bring them in full and clear. The extra valves in this new R.C.A. Receiver mean smoother, clearer volume just as it's extra cylinders bring purring power to a straight-eight car.

The companion speaker to R.C.A. Model 60 is the new Loudspeaker Model 103, with its striking tapestry medallion and hand-carved effect. The new type cone and construction of the Model 103 enable it to handle the dance-pitch volume that the Receiver brings in with complete fidelity and lack of distortion.

We invite you to hear the Model 60 to-day --at the best radio dealers' showrooms.

**PRICE £85**

# 8 VALVE MODEL 60

53 King Street,  
Newcastle.

**AUSTRALIAN  
 GENERAL ELECTRIC**  
 Australian General Electric Company, Ltd.

Civic Centre,  
Canberra.

93-95 Clarence Street, Sydney.





# RADIO ENTHUSIASTS!

Take advantage of these prices to complete your Radio Sets,  
Eliminators, etc.

	s	d		s	d
General Radio Eliminator Transformers . . . . .	25	0	Pilot Arrow Knobs . . . . .		6
General Radio 30 Henry Chokes . . . . .	25	0	K.K. Vernier Knobs, from . . . . .	0	6
Centralab Radiohms (Heavy Duty) . . . . .	6	6	Beede "A" Battery Meters . . . . .	3	6
Muter .006 Condensers . . . . .	1	6	Talking Tape (50ft.) . . . . .	1	6
Powerplus 4mfd. Condensers 1000-V. . . . .	9	4	Precise 30 ohm Rheos. . . . .	2	3
Powerplus 2mfd. Condensers 1000-V. . . . .	5	6	Muter Fixed Condensers, .0075, .001,		
Powerplus .1mfd. Condensers 1000-V. . . . .	3	3	.00035, .0025, from . . . . .	1	0
Hydra 1mfd. Condensers . . . . .	2	11	Bradleyometers . . . . .	3	6
Hydra, 5mfd. Condensers . . . . .	2	11	Muter Resist. Coupled Amplifiers . . . . .	19	11
Muter .25mfd. Condensers . . . . .	1	6	Bradleyleaks, 12,000 ohms resist. . . . .	3	6
Compact .0005 Condensers . . . . .	5	11	Remler 6 ohm Rheostats . . . . .	2	6
Compact .00035 Condensers . . . . .	5	11	Honeycomb Coils (various) from . . . . .		6
Compact .00025 Condensers . . . . .	5	11	United Short Wave Kits: 20-600 Metres . . . . .	13	6
Pilot .0005 Condensers (used) . . . . .	7	6	United Short Wave 3-valve Sets . . . . .	135	0
Pilot 13-plate Condensers (Midget) . . . . .	4	6	Philips A306, 4-volt Valves, UX . . . . .	5	6
Pilot Sub-panel UX Sockets . . . . .		9	Philips A310, 4-volt Valves, UX . . . . .	5	6
Pilot .00025 Condensers . . . . .	1	3	Above Valves in English base . . . . .	2	0
Pilot .001 and .0005 Condensers (fixed) . . . . .	1	6	Acme Double Cone Speakers . . . . .	87	6
Pilot Non Solder 'Phone Tips . . . . .		3	Quam Speakers (Cone) . . . . .	55	0
Pilot Illuminated Vernier Dials . . . . .	6	6	Hegra Cone Speakers . . . . .	22	6
Pilot 4-inch Plain Dials . . . . .	1	9	Hegra Cones and Units . . . . .	12	6
Pilot 400 ohm Potentiometers . . . . .	3	6	Large Stock of Eliminator Transformers from		
Pilot Redi-Blox Units (Audio) . . . . .	21	6	Factory . . . . .	17	6
Pilot Redi-Blox Units (Det.) . . . . .	7	6			

Call or Write to

## UNITED DISTRIBUTORS LTD.

151 CASTLEREAGH STREET

SYDNEY

'Phone, M3004

# Local Programmes, Wednesday, April 10

## 2FC

### EARLY MORNING SESSION.

Announcer: A. S. Cochrane.

7.0: "Big Ben" and announcements. 7.2: Official weather forecast, rainfall, river reports, temperatures, astronomical memoranda. 7.7: "Sydney Morning Herald" summary. 7.12: Shipping intelligence, mails services. 7.15: Studio music. 7.25: Investment market, mining sharemarket, metal quotations, wool sales, breadstuffs markets. Inter-State markets, produce markets. 7.40: Studio music. 8.0: "Big Ben." Close down.

### MORNING SESSION.

Announcer: A. S. Cochrane.

10.0: "Big Ben" and announcements. 10.3: Pianoforte reproduction. 10.10: "Sydney Morning Herald" news service. 10.25: Studio music. 10.45: A talk on "Home Cooking and Recipes," by Miss Ruth Furst. 11.0: "Big Ben." A.P.A. and Reuter's cable services. 11.5: Close down.

### MIDDAY SESSION.

Announcer: A. S. Cochrane.

Note: Race results from Victoria Park. 12.0: "Big Ben" and announcements. 12.1: Stock Exchange, first call. 12.3: Official weather forecast, rainfall. 12.5: Studio music. 12.10: Summary of news, "Sydney Morning Herald." 12.15: Rugby wireless news. 12.18: A reading. 12.30: Studio music. 1.0: "Big Ben," weather intelligence. 1.3: "Evening News" midday news service. Producers' Distributing Society's report. 1.20: Studio music. 1.28: Stock Exchange, second call. 1.30: From the Pitt Street Congregational Church, organ recital, arranged by Lilian Frost. 2.0: "Big Ben." Close.

### AFTERNOON SESSION.

Announcer: Laurence Halbert.

Accompanist: Ewart Chapple.

2.30: Programme announcements. 2.32: A recital of selected records. 3.0: From Paling's Concert Hall, a students' recital, arranged by Cyril Monk—"Sonata" for two violins and piano (Handel), Lynda Simpson, Ruth Vernon, Florence Simpson; "Concerto in F Minor," 1st movement (Vivaldi), Lynda Simpson; songs, "Fairly in the Chimney" (Elliot), "Five Little Piccaninnies" (Anthony), Miss Stanton; "Sonata" for violin and piano, two movements (Dvorak), Ruth Vernon and Florence Simpson; songs, "June Music" (Trent), "Soul of Mine" (Barris), Miss Stanton; piano solo, "Island Spell" (Ireland), Florence Simpson. 4.0: From the studio, "Big Ben." C. S. Yarwood will speak on "Henry Lawson." 4.10: Romano's Cafe Dance Orchestra, conducted by Bennie Abrahams. 4.20: From the studio, popular items. 4.40: Romano's Cafe Dance Orchestra, conducted by Bennie Abrahams. 4.46: From the studio, Stock Exchange, third call. 4.48: Studio music. 5.0: "Big Ben." Close.

### EARLY EVENING SESSION.

Announcer: A. S. Cochrane.

5.40: The chimes of 2FC. 5.45: The children's session, conducted by the "Hello Man," assisted by Uncle Ted and "Sandy." 6.30: Daigety's market reports (wool, wheat, and stock). 6.40: Fruit and vegetable markets. 6.43: Stock Exchange information. 6.45: Weather and shipping news. 6.48: Rugby wireless news. 6.50: Late sporting news. 7.0: "Big Ben." Late news service. 7.10: The 2FC Dinner Quartette, conducted by Horace Keats—(a) "In a Hongkong Street" (Humphries), (b) "One Hour" (Longstaffe), (c) "Petite Suite de Concert" (Coleridge-Taylor), (d) "On the Moonlit Terrace" (Cazabon), (e) "Pearl o' Mine" (Fletcher), (g) "The March of the Toys" (Herbert).

### EVENING SESSION.

Announcer: Laurence Halbert.

Accompanist: Ewart Chapple.

7.40: Popular music. 7.45: Programme announcements. 7.48: Studio items. 8.0: Lindley Evans and Cyril Monk, a classical programme, under the direction of

Lindley Evans and Cyril Monk. Assisting artists: Marjorie Beiby, Gladstone Bell, Spencer Thomas.

9.0: Weather report. 9.1: Tales by the Storyteller. 9.16: Second half of the classical programme arranged by Lindley Evans and Cyril Monk.

10.20: Late weather report. Musical items. 10.27: To-morrow's programme. 10.30: National Anthem. Close.

## 2BL

### MORNING SESSION.

Announcer: A. C. C. Stevens.

8: G.P.O. chimes. Metropolitan weather report. 8.1: State weather report. 8.2: Studio music. 8.15: G.P.O. chimes. News from the "Daily Telegraph Pictorial." 8.30: G.P.O. chimes. News service continued. 8.40: Information, mails, shipping, arrivals, departures, and sailings. 8.45: Studio music. 9.15: Half an hour with silent friends. 9.45: Studio music. 10.0: G.P.O. chimes. Close down.

### MIDDAY SESSION.

Announcer: A. C. C. Stevens.

Note: Race results from Victoria Park. 11.0: G.P.O. chimes. 2BL's Women's Sports Association session, conducted by Miss Gwen Varley. 11.30: Advertising hints. 11.40: Women's session, conducted by Mrs. Cranfield. 12.0: G.P.O. chimes. Special ocean forecast and weather report. 12.3: Studio music. 12.30: Shipping and mails. 12.35: Market reports. 12.48: "Sun" midday news service. 1.0: Studio music. 1.30: Talk to children and special entertainment for children in hospital. 2.0: G.P.O. chimes. Close down.

### AFTERNOON SESSION.

Announcer: A. C. C. Stevens.

Accompanist: Kathleen Roe.

3.45: G.P.O. chimes. Popular music. 4.0: A talk by Basil Kirke. 4.15: Violet Hunt, contralto, a competitor in the recent Radi) Elsteddfod conducted by the N.S.W. Broadcasting Company, Limited—(a) "A Caution" (Hope), (b) "Do Not Go, My Love" (Hageman). 4.22: Studio items. 4.32: Hazel McGilvray, mezzo-soprano—(a) "My Dolly Dear," Cradle Song (de Sevrac); (b) "Mornine" (Rachmaninoff); (c) "Summer Storm" from song cycle, "The Life of a Rose" (Lehmann). 4.39: "Sun" news service. 4.44: Studio items. 4.54: Violet Hunt, contralto, competitor in the Radio Elsteddfod—(a) "My Curly-headed Baby" (Clutsam), (b) "Daffodils a-Blowing" (German). 5.0: G.P.O. chimes. Popular music. 5.10: Hazel McGilvray, mezzo-soprano—(a) "Nocturne" (Curran), (b) "The Charm of Spring" (Clarke), (c) "Rosa Resurget" (Lehmann), from the song cycle, "The Life of a Rose." 5.17: Pianoforte reproduction. 5.30: Racing resume. 5.37: Features of the evening's programme.

### EARLY EVENING SESSION.

Announcer: Basil Kirke.

5.40: Children's session—Music and entertainment, letters and stories. 6.30: "Sun" news and late sporting. 6.40: 2BL Dinner Quartette—(a) "Marche Russe" (Luigini), (b) "Gondolier Love Song" (Clarke), (c) "On With the Dance" (Coward), (d) "Chant de douleur ed d'Amour" (Dyck), (e) "There are Eyes" (Keyes). 7.7: Australian Mercantile Land and Finance Co.'s report; weather report and forecast, by courtesy of Government Meteorologist; Producers' Distributing Society's fruit and vegetable market report; grain and fodder report ("Sun"); dairy produce report ("Sun"). 7.25: Mr. Pim and Miss Pam in advertising talks and nonsense. 7.55: Programme and other announcements.

## EVENING SESSION.

Announcer: Basil Kirke.

Accompanist: G. Vern Barnett.

8.0: G.P.O. chimes. Topical chorus. 8.2: Cosmo Hamilton's "Scandal," produced by the H. W. Varna Company, by permission of J. C. Williamson, Ltd. Cast: Pelham Franklin, H. W. Varna; Malcolm Frazer, Gordon Shieling; Sutherland York, William Hume; Major Thatcher, H. J. Saller; Pewsey (valet), D. A. Sharp; Mrs. Vanderdyke, Muriel Conner; Beatrix Vanderdyke (her daughter), Meg Service; Honoria Vanderdyke (Beatrix's sister), Miss Barnetson; Mrs. Brown (housekeeper), Miss Taunton; Regina Waterhouse, Miss James; a Maid, Molly Peters. Scene: Act I, York's house in New York; Act II, Beatrix's bedroom in her country house; Act III, Franklin's house (a month later).

9.0: G.P.O. chimes. Weather report. 9.1: Romano's Cafe Dance Orchestra, conducted by Bennie Abrahams.

9.10: From the studio—Alfred Wilmore, tenor.

9.17: Claude Corbett will speak on "General Sporting."

9.32: Hazel M'Pherson, contralto—(a) "Yonder" (Oliver), (b) "To You" (Speaks).

9.39: Romano's Cafe Dance Orchestra, conducted by Bennie Abrahams.

9.50: From the studio—Alfred Wilmore, tenor.

9.57: Late "Sun" news service. 10.12: Hazel M'Pherson.

10.19: Romano's Cafe Dance Orchestra, conducted by Bennie Abrahams.

10.29: From the studio—Bernice Patterson, popular vocalist.

10.36: Romano's Cafe Dance Orchestra, conducted by Bennie Abrahams.

10.46: From the studio—Bernice Patterson, popular vocalist. To-morrow's programme.

10.55: Romano's Cafe Dance Orchestra, conducted by Bennie Abrahams.

11.30: National Anthem. Close.

## 2GB

10.0: Music. 10.10: Happiness talk by A. E. Bennett. 10.20: Music. 10.30: Women's session by Miss Helen Beegling. 11.30: Close down. 2.0: Music. 2.5: Women's radio service by Mrs. Dorothy Jordan. 2.30: Music. 3.0: Close down. 5.30: Children's session by Uncle George. 7.0: Music. 8.0: Miss Florence Gordon, contralto. 8.7: Mr. Tom Williams, violinist. 8.15: Mr. Clifford Lathlean, baritone. 8.22: Miss Ada Brook, pianist. 8.30: A humorous interlude by Mr. Jack Win and Mr. Heath Burdock. 9.35: Miss Gwen Selva, soprano. 8.45: Orchestral music. 8.50: Miss Florence Gordon, contralto. 9.0: Weather report. 9.3: Address by Professor E. Wood. 9.15: Mr. Tom Williams, violinist. 9.25: Mr. Clifford Lathlean, baritone. 9.35: A humorous interlude by Mr. Jack Win and Mr. Heath Burdock. 9.40: Instrumental music. 9.50: Miss Gwen Selva, soprano. 10.0: Dance music. 10.30: Close down.

## 2UW

### MIDDAY SESSION

12.30: Music. 1.0: G.P.O. clock and chimes. Music. 2.30: Close down. 4.30: Musical programme.

### EVENING SESSION.

5.30: Children's hour, conducted by Uncle Jack. 6.30: Close down. 7.0: G.P.O. clock and chimes. Music. 8.0: To-day's anniversary. Music. 9.0: G.P.O. clock and chimes. Comments on Foreign Affairs by Mr. J. A. Prentice. 9.10: Music and request numbers. 10.30: Close down.

# LEVENSON'S RULES

## THE LOW PRICE WAVES

: THE A-B-C OF RADIO BARGAINS :

<b>A</b> ERIALS, all 100ft. Electron Insulated 2/- Para Multi Stranded, Phosphor Bronze 2/6 3/20 Copper ..... 2/6 3/20 Enamelled ..... 3/6	<b>B</b> BATTERY. Like a Flash, 45 volts, Heavy Duty, 25/. Now ..... 15/- Battery Cable, 7 way, 1/3 yd.	<b>C</b> ONDENSERS. .00025 S.L.F. var- iable, Songbird ... 3/9 De Jur R.F. Chokes ..... 6/6 Silver Knight Chokes ... 4/6	<b>D</b> IALS, Bakelite. 3in. .... /6 4in. .... 1/- Diora Midget Vernier ... 3/6 Diora Baby Dial ..... 3/- Ormonde Midget Vernier 6/6
---	---	--	--

<b>E</b> ARPHONES. Light weight. All 4000 ohms ..... 10/6 Brandes 'phones' ..... 19/6 Trimmis 'phones' ..... 19/6 Magnus 'phones, 35/. Now 17/6	<b>F</b> ILAMENT SWITCHES. Push-Pull Panel Mount Switches, usually 2/3, Now ..... 1/- Fixed crystals, Harlie ..... 6/9 Fixed crystals, R.U.F. ... 4/6 "Rosco" Switch ..... 1/-	<b>G</b> RID LEAKS. Lissen, 2 meg., only 1/- Magnus, 1, 2, 3, 4, 5 meg. .... 1/- De Jur Grid Leak Clips ... 1/3 1 to 10 meg. .... 1/3	<b>H</b> YDROMETERS ... 3/6 Hydrometer Floats 1/6 "Marvel" ..... 4/6
--	--	--	--

<b>I</b> NSULATORS, 1d, 2d, 3d Insulated Staples, 3d doz. Spagheti, 5ft. lengths, 5d 38in. length ..... 4d Red, Black, Yellow, Green.	<b>J</b> ACKS. Jones' Non-solder Jack, D.C. .... 2/- Single or Double Jacks, 2/6. Now ..... 1/-	<b>K</b> ITS. De Jur 1929 Brown- ing Drake Kit ... 22/6 Midget Kits for 5 valve sets, 30/. Now ... 5/-	<b>L</b> ISSEN "B" BATTERIES. New process, just landed. 60 volts ..... 13/6 100 volts ..... 22/6 English make, and Best.
---	---	---	---

<b>M</b> ARCO COIL KITS Now to clear, 13/9 Marvellous Value. Lissen Audio Transformers 12/6	<b>N</b> EUTRALISING CONDENSERS Midget De Jur Variable Condensers, 4/6, 5/6, 6/6
--	---

<b>O</b> RMONDE .00035 Variable Condensers. 8/6 With 4in. Dial ..... 10/-	<b>P</b> ICK-UPS. The Genuine Gradeon Gramophone Pick-up, with adapter and control. List Price, 90/. Now ..... 30/- Bakelite panel, 3d sq. inch, any size cut.	<b>Q</b> UICK SALES. Amplion speakers. A.R. 38. Usually 50/-. Now 35/-. A.R. 58. Usually 80/-. Now 30/-. A.R. 67. Usually 42/3d. Now 30/-. A.R. 35. Usually 67/4. Now 40/-. Units Perfect. Flares Soldered.	<b>R</b> HEOSTATS. "FRONT" 30-ohm ..... Werc. Now. "MAGNUS" 30-ohm ..... 6/8 2/6 "MARWOL" 30-ohm ..... 4/6 1/6 "ANSCO" 30-ohm ..... 2/6 "DE JUR" ..... 2/6 Also Tappings 0, 10, 20, 50, 60 ohms.
--	--	---	--

<b>S</b> OCKETS. "MAGNUS" 3-conn. Werc 10/6; New 3/-. "DE JUR" EX Bakelite, 1/3. Aluminium UT Standard ..... 1/- "DE JUR" Castion ..... 2/- "DE JUR" Spring ..... 2/6 "DE JUR" UY ..... 2/6 "AMACO" Floating ..... 3/6 "SILVER KNIGHT" Short-wave Kit, 37/6.	<b>T</b> OOLS FOR RADIO. Cards of 7 Twist Drills, 1/9. Long Nose Plyers, 1/6. Breast Drills 5/6. Solder Sets ..... 2/- S.C.O. Austrian Trans- formers. Lissen Transformers, 3 to 1, 5 to 1 ..... 12/6	<b>U</b> NIVERSAL Universal 3 Coil Tuners. 13/9 De Jur 3 Coil Tuners ... 15/6 Transcontinental Tuners 8/6 Inter-State 3 Coil Tuners 15/-	<b>V</b> ALVES. Metro Vic., 2 volts U.X. base ..... 1/6 English base, 4 volts ... 1/6 Cleartron, 6 volts, U.X. 201A ..... 4/6 Radiotron, U.X. 201 ... 7/6
--	--	--	---

<b>W</b> IRES. 20ft. Speaker Cords 2/3 Double Flex, electric, 4d yd. Chromax insulated hook-up wire, 1/6 coil. Rubber covered hook-up Flex, 2d yd. Wave Traps ..... 17/6	<b>X</b> CELLENT VALUE. Lissen Speaker Units 13/9 German Cone Speaker Units ..... 13/6	<b>Y</b> 'S BUYERS NOTE. Stromberg Carlson Speakers. Usually £5/5/-. Now £3. "Ethernox." Usually £5/5/-. Now £3. German Cone Speaker ... 21/-	<b>Z</b> LAST, BUT NOT LEAST Seeravox Cone Speakers. The Silver Cone with the Silvery Voice. 50/-. Now ..... 30/-
--	---	---	---

MAIL ORDERS.

OUT OF TOWN FOLK NOTE.—Orders forwarded day of receipt. Please add freight. Truth in advertising. Sound Goods only offered. No old fashioned rubbish.

CATALOG.

Send 9d in stamps for Monster 1929 64-Page Catalog. Coupon attached, valued 4/-. refunded with first £1 order.

**LEVENSON'S**  
**RADIO** Established  
 23 years.

THE WIRELESS  
 STORE OF  
 THE COMMONWEALTH  
 —Ask any Radio Fan.

226 PITT ST.  
 SYDNEY.  
 Branch 86A Pitt Street,  
 Near G.P.O.

# Interstate Programmes, Wednesday, April 10

## 3LO

### EARLY MORNING SESSION.

7.15 to 8.15: See Friday.

### MORNING SESSION.

11.0: To-day's Radio Recipe. Steam Jam Roly (No. 1). 11.5: Miss L. D. Beavan will speak on "Home-made Confectionery." 11.25: Mrs. M. Callaway Mahood will speak on "The Art of Decoration." 11.45: Mrs. Clarence Weber will speak on "Physical Culture for Women."

### MID-DAY NEWS SESSION.

12.0: Melbourne Observatory time signal. Metal prices received from the Australian Mines and Metals Association from the London Stock Exchange this day. British official wireless news from Rugby. Reuter's and the Australian Press Association cables. "Argus" news service. Newmarket stock sales. Cattle sales report, bullocks and calves, by the Associated Stock and Station Agents, Bourke Street, Melbourne.

### MIDDAY SESSION.

12.20: General programme, including Jack Stocks, "The Woman Hater," 12.30: Stock Exchange. The Radio Revellers, Violet Jackson (soprano). 1.5: Meteorological information. Weather forecast for Victoria, New South Wales, South Australia, and Tasmania. Ocean forecasts. River reports. Rainfall Violet Jackson (soprano). 1.30: Speeches from the Rotary Club luncheon, transmitted from the Freemasons' Hall, Collins Street, Melbourne. 2.0: Close down.

### AFTERNOON SESSION.

Announcer: John Stuart. Accompanist: Agnes Fortune. 2.18: Description of Hume Jumpers' Flat Race, 1 mile 3 furlongs, Albury Cup meeting, by Eric Welch. The Station Orchestra. 2.48: Description of Maiden Plate, 5 furlongs, Albury Cup meeting. 3.24: Description of Members' Bracelet, 7 furlongs, Albury Cup meeting. 4.5: Description of Albury Gold Cup, 1 mile 3 furlongs, Albury Cup meeting. 4.38: Description of the Flying Handicap, 6 furlongs, Albury Cup meeting. 4.45: Special weather report for the benefit of listeners in the Redcliffs district. 4.52: News service. Stock Exchange information. 5.8: Description of the Novice Handicap, 7 furlongs, Albury Cup meeting. 5.15: Close down. During the afternoon results of the Mornington Races will be broadcast as they come to hand.

### CHILDREN'S HOUR.

6.0: Answers to letters and birthday greetings, by "John, the Piper's Son." 6.25: Musical interlude. 6.30: Captain Donald MacLean. 6.50: "John, the Piper's Son," has another funny story.

### EVENING SESSION.

Announcer: Frank Hatherley. Speaker: R. J. de C.

## FULLER ACCUMULATORS

### LAST LONGER

GILBERT-LODGE & CO. LTD.

### W. FURNESS,

1st Floor, Furness Chambers,  
KING'S CROSS, DARLINGHURST.  
Shields, Coils, and all Component Parts as used in the Tested 1928 Solodyne. Coils are guaranteed to proper specification. Shields Assembled if desired. Terms may be arranged.

### METAL CABINETS

Finished in Attractive Designs,  
Made By  
HARRY CRABB LTD.,

261 Riley St., City.  
Phone, FL 1887.

### TRANSFORMERS.

Built up to a specification and wound, lamination iron cut to any size from stock. Prices and Estimates on application.

O'DONNELL, GRIFFIN, and Co., Ltd.  
53 Druitt Street, Sydney.  
'Phones: M 2991 (3 lines).

Talbot, veterinary officer. 7.5: Stock Exchange. 7.15: Market reports. 7.45: Out of the Past. 7.48: Under the auspices of the Department of Agriculture, R. J. de C. Talbot, veterinary officer, will speak on "Control of Mastitis."

### NIGHT SESSION.

Announcer: Frank Hatherley.  
8.0: Studio presentation of "The Geisha," produced by Maurice Dudley. Musical Directress, Madame Ethel Ashton.

### Cast:

Q. Mimosa San ..... Florence Blitz  
Juliette Diamant ..... Ivy Carlile  
Miss Molly Seamore ..... Rose Clayden  
Reginald Fairfax ..... John Donovan  
Dick Cunningham ..... Stuart Olsson  
Arthur Cuddy ..... Frank Conrad  
George Grimston ..... Albert Harbord  
Captain Katana ..... T. James Lloyd  
Takamini .....  
Wun-Hi ..... Allan Bell  
The Marquis Imari ..... Edgar Chapple

9.30: University Commencement Night—Opening chorus "Frothblowers' Anthem."  
9.33: Norman Cust and his 'Varsity Melodists—Selections.  
9.40: Dental Delirium—  
"A Little Molar Melody."  
9.45: Trinity Minstrel Glee—  
"Carol from the Carolines."  
9.50: Sig. Sporamik Tonsillikoff, the Roystering Russian—  
Solo.  
9.53 'Varsity Melodists—  
Selections.  
10.0: Dexterous Dentals—  
"More Laughing Gas."  
10.5: A Few Moments with the Merry Meds.  
10.10: Ansaldo Deflato, the Operatic Accident—  
Solo.  
10.13: Trinity Minstrels—  
"Medusan Melodies."  
10.20: 'Varsity Melodists—  
Selections.  
10.28: 'Varsity Anthem—  
Chorus.  
10.30: The Station Orchestra—  
Selection, "Gloriana" (Primi).  
10.45: The Radio Revellers—  
"Roses of Yesterday" (Berlin).  
"Just Keep Singing a Song" (Sissell).  
"Minnetonka" (Wallace).  
"Glad Rag Doll" (Ager).  
"In the Woodshed She Said She Would" (John-Russan).  
"Constantinople" (Carlton).  
"Japansy" (Klenner).  
"All by Yourself in the Moonlight" (Wallis).  
"That's Her Now" (Ager).  
"Stars are the Windows of Heaven" (Malle)...  
Selected.  
11.30: God Save the King.

## 3AR

Announcer, Maurice Dudley. 10.0: See Friday's list. 10.30: The Victorian Treeplanters' Association Convention, 1929, held in conjunction with "Garden Week" transmission from the Y.M.C.A., Princes Bridge, Melbourne, official opening by the Rt. Hon. the Lord Mayor of Melbourne (Cr. H. D. Luxton, J.P.). 11.0: News service; announcements. 12.20: British official wireless news; announcements. 12.30: Close down.

### AFTERNOON SESSION.

Announcer, Maurice Dudley. 3.0: Orchestral and vocal works of Tschaiikowsky, Rimsky, Korsakoff, Rachmaninoff, and Kodalin. 3.45: The Imperial Russian Trio. 4.15: Selections by the Don Cosack Choir. 4.30: Close down.

### EVENING SESSION.

Announcer, Renn Millar. 6.0: General programme. 7.20: News service; announcements; sporting results.

### NIGHT SESSION.

Announcer, Renn Millar.  
8.0: Capt. C. H. Peters—  
"Books Wise and Otherwise."  
8.15: Under the auspices of the Boy Scouts' Association—W. D. Kennedy—  
"Boys and Birds."  
8.30: Transmission from the Royal Victorian Institute for the Blind—  
The Royal Victorian Institute Orchestra—  
Overture, "Light Cavalry" (Suppe).  
Jack Byrn, baritone—  
"Harlequin" (Sanderson).  
"The Desert Song" (Ronberg).  
Jack Murphy, flute—  
"Scherzino" (Chaminade).  
"Gavotte" (Gossec).  
O. Birtwhell, contralto—  
"The Little Damsel" (Novello).  
Woods and Payne—  
"Comedy Number."  
Master Nell West, piano—  
"Balancello" (Wacha).  
Fred. Sutcliffe, tenor—  
"An Evening Song" (Blumenthal).  
"Thank God for a Garden" (Del Reigo).  
The Royal Victorian Institute Orchestra—  
Popular Songs.  
Interlude—A short address by S. W. Hedger, superintendent and secretary.  
Lena Wilson, soprano—  
"It's Only a Tiny Garden" (Wood).  
"Down in the Forest" (Ronald).  
Albert Harris, violin—  
"Souvenir" (Drdla).  
Liesesfreud" (Kriessler).  
Vocal Quartet—  
"Doan Ye Cry, Ma Honey" (Noll).  
Austin Anderson—

"Sketches at the Piano."  
W. Rule, tenor—  
"I look into Your Garden" (Wood).  
Geo. "Macushia" (M'Murrough).  
"Fondle Me" (Chopin).  
"The Butterfly" (Laval).  
The Royal Victorian Institute Orchestra—  
"U.S. Cavalry March" (Lincoln).  
Musical director and accompanist, D. L. Palmer, superintendent and secretary, S. W. Hedger.  
10.30: News service; announcements.  
God Save the King.

## 4QG

### EARLY MORNING SESSION.

Announcer: J. Tyson. 7.43 a.m. to 8.30 a.m.: General programme.

### MORNING SESSION.

Announcer: Rita McAuliffe. 11.0: General programme; an hour with the ladies. 11.15: A talk on "Artistic Uses of Sealing Wax and Crepe Paper," by "Denise." 12.0 noon: Close down.

### MID-DAY SESSION.

Announcer: R. Wight. 1.5: Market reports and weather information; the Postal Institute Orchestra. 2.0: Close down.

### AFTERNOON SESSION.

Announcer: H. Humphreys. 3.0: A programme of records; mail train running times; news. 4.30: Close down.

### EARLY EVENING SESSION.

Announcers: R. Wight and H. Humphreys. 6.0: Mail train running times; mail information; shipping news; dinner music. 6.25: Commercial announcements. 6.30: Bedtime stories, conducted by "Little Miss Brisbane." 7.0: News in brief, and 7.45: Lecturette, by Professor J. K. Murray (Agricultural High School and College).

### NIGHT SESSION.

Announcer: H. Humphreys.  
8.0: Alf Featherstone and his Orchestra.  
Symphonic Fox Trot—  
"Paradise and You" (Packay).  
"I Never Dream" (Ellis).  
8.10: Mrs. M'Gregor (soprano).  
"Your Love" (Bonnas).  
"The Waking of Spring" (Del Riego).  
8.20: Alf. Featherstone and his Orchestra.  
Fox-trots—  
"Stomp With Me" (Shields).  
"Waiting for the Moon" (Brown).  
8.30: Ernest Harper (baritone).  
"Lighterman Tom" (Squire).  
"Pals" (Squire).  
8.40: Alf. Featherstone and his Orchestra.  
Jazz waltz "Lovely Nights in Hawaii" (Seaman).  
8.45: Dibbe and Dibb.  
Ten minutes' melody and patter.  
8.55: Alf. Featherstone and his Orchestra.  
Fox-trots—  
"Just an Ivy Covered Shack" (Davidson).  
"If All Depends on You" (Henderson).  
9.5: Metropolitan weather forecast; movements of lighthouse steamers.  
9.10: Margery Stuart (cellist).  
"Romance" (Androsio).  
"Rondo."  
9.20: Alf. Featherstone and his Orchestra.  
Fox-trots—  
"Quarids" (Simon).  
"All by Yourself in the Moonlight" (Wallis).  
9.30: Dorothea Hives (soprano).  
"Drake's Drum" (Newbolt).  
"East and West" (Kipling).  
"Wonder Thirst" (Masehead).  
9.40: Alf. Featherstone and his Orchestra.  
Jazz waltz, "Girl of My Dreams" (Clapp).  
9.50: Mary M'Neish (soprano).  
"A Brown Bird Singing" (Wood).  
"One Fine Day" (Puccini).  
9.55: Alf. Featherstone and his Orchestra.  
Fox-trots—  
"My Sugar" (Britt).  
"Angelia Mia" (Rapee).  
10.5: C. Rice (tenor).  
"If Little Birds" (Dichmont).  
"Give Me a Lonely Caravan" (Bath).  
10.10: "The Daily Mail" news; "The Courier" news; weather news.  
10.15: Alf. Featherstone and his Orchestra.  
Three-quarters of an hour's dance music.  
11.0: Close down.

## 5CL

### MORNING SESSION.

Announcer: J. L. Norris. 11.0 to 1: General programme. 1.53: Albury races. Result of Hume Jumpers' Flat Race, 1 mile and 3 furlongs. 2.0: Close down.

### AFTERNOON SESSION.

Announcer: J. L. Norris. Accompanist: Jean Finlay. 3.0: General programme, including Marcello Berardi; Lizette Foglia (violinist); John D. Fraser (baritone); Station Quartette. 3.40: Result of Albury Gold Cup. 3.50: Result of Albury Races. Resume of Albury Race results. 4.13: Albury Races, result of Flying Handicap. 4.43: Albury Races, result of Novice Handicap. 4.54: Resume of racing results. 5.0: Close down.

### EVENING SESSION.

Announcer: C. J. O'Connor. 6.0: Chimes. 6.1: Birthday greetings, correspondence, songs and stories.



by "Miss Wireless." 6.52: Albury Race results. 6.55: S. C. Ward and Co.'s Stock Exchange information. 7.0: G.P.O. chimes. 7.1: General market reports. 7.10: Rev. E. S. Kiek. a talk on "The Coming of the New Learning." 7.25: Boy Scouts' Corner. 7.40: N.C.L. Bluebird Girls' Club.

**NIGHT SESSION.**

Announcer: C. J. O'Connor.  
Accompanist: Jean Finlay.

8.0: G.P.O. chimes.  
8.1: Hindmarsh Municipal Band.  
Conductor, Mr. J. Radcliffe.  
"Crown Diamonds" (Auber).  
8.9: Margery Walsh (soprano)—  
"No, No, No" (Mottel).  
"Daddy" (Behrend).  
8.15: Pat McLean (entertainer)—  
Selections from her repertoire.  
8.21: Hindmarsh Municipal Band—  
"Rose Marie" (Friml).  
8.33: A One-act Play, entitled, "East End."  
Characters:  
Aggie, a Girl of Seventeen .... Bessie Francis  
Bert, a Young Man of Twenty-one ... Jack Ham  
Scene: Outside 17 Halcyon Road, Waltham, S.E.  
8.35: Hindmarsh Municipal Band—  
Fox Trot, "My Oriental Moon" (Reid).  
9.0: G.P.O. chimes.  
9.1: Meteorological information, including Sema-  
phore codes.  
9.2: Overseas grain report.  
9.3: John D. Fraser (baritone)—  
"Serenata" (Toselli).  
"Oh! That We Two Were Mayings" (Nevin).  
9.10: The Lady Mayores (Mrs. Lovington) Bony-  
thon) will speak on behalf of the Baby Health  
Centres Association appeal.  
9.15: Hindmarsh Municipal Band—  
March, "With Sword and Lance" (Starker).  
Waltz, "Ecstasy" (Baynes).  
9.22: Margery Walsh (soprano)—  
"I Love You Truly."  
Selected.  
9.25: A Pianoforte Recital by Paul Howard.  
"Two Preludes," op. 11 ..... Scriabine  
"Etude No. 1," op. 8 ..... Scriabine  
"Soaring" ..... Schumann  
"Au Jardin" (an Idyll) ..... Blakiron  
"Etude" ..... Chopin.  
"Widmung" (dedication) ..... Schumann-Liszt  
9.55: John D. Fraser (baritone)—  
"I Know of Two Bright Eyes" (Clutsam).  
"Banjo Song" (Homer).  
10.1: Pat McLean (entertainer)  
in bright, new numbers.  
10.6: Hindmarsh Municipal Band.  
Conductor, Mr. J. Radcliffe.  
Fox Trot, "The Sneak" (Brown).  
March, "The Digger" (Coble).  
10.15: General news service.  
Meteorological information.  
Albury Race results.  
10.30: Modern dance numbers by the "Radio  
Revelers."  
11.0: Close down.

**6WF**

12.30: Tune in. 12.35: Markets, news, etc. 1.0: Time signal. 1.1: Weather bulletin supplied by the Meteorological Bureau of West Australia. 1.3: "Care of the Sick," by Dr. Winifred Holloway, of London. 1.30: Music. 1.30: Close down. 3.30: Tune in. 3.35: Afternoon tea concert, relayed from the Primrose Cafe de Luxe; vocal numbers from the studio. 4.30: Close down. 6.45: Tune in. 6.48: Bedtime stories for the kiddies, by Uncle Duffy. 7.5: Light music by the Station String Trio. 7.30: Commercial and general information. 7.45: Talk by Mr. Hal McKail. 8.0: Time signal. 8.1: First weather bulletin. 8.3: Relay of dance music from the Y.A.L. ballroom, Roh Moyle and his orchestra; vocal numbers from the studio. 8.50: Late news items by courtesy of the "Daily News" Newspaper Co. Ltd.; station announcements, ships within range announcement, late weather bulletin. 9.5: Programme continued from the studio. 10.30: Close down.  
10.4: Metre Transmission.—Simultaneous broad-  
cast on 104.5 metres of programme given on 1250  
metres, commencing at 6.45 p.m.

**7ZL**

**MIDDAY SESSION**  
Announcer: Jack Broadbent. 11.30 to 2.0. General programme.

**AFTERNOON SESSION**  
Announcer: Jack Broadbent. 3.0: Chimes; weather information. 4.30: Close down. During the afternoon progress results will be given of the Bendigo races, Victoria; also Albury races, New South Wales.

**EARLY EVENING SESSION**  
Announcer: J. M. Counsel. 6.15: Transmission from the Beaumaris Zoo, Hobart—"Parrots!" 6.30: Bertha Southey Brammall will tell a Tasmanian fairy tale to the little ones. 7.0: Answers to letters and birthday greetings by Bertha Southey Brammall. 7.15: Advice on fruit sales from Melbourne; news service; Railway auction produce sales held at Railway; weather information; Hobart Stock Exchange quotations; results of ladies' golf championships.

**EVENING SESSION**  
Announcer: J. M. Counsel. 7.30: A. L. Butler, a well-known solicitor, of Hobart, member of the Council of Royal Australian Ornithologists' Union, will speak on "Economic Value of Some Tasmanian Birds." 7.45: Geo. Nation will speak on "Trees and Shrubs." 8.0: G.P.O. clock chimes the hour. 8.5: Recital of instrumental and vocal items by leading international artists, supplied by Paton's music warehouse. 10.0: G.P.O. clock chimes the hour. 10.1: Close down.

# "Farmer's Three"

Worth all of £17/10/- and more!

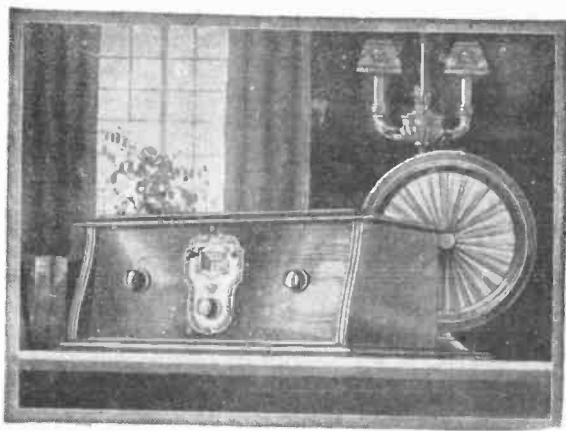

## Doesn't it all come round to this?

You know Radio's no longer a novelty. And if it's going to be a successful source of entertainment in the home, your receiver must be a good one; yet, of course, moderately priced. Well, that's just what "Farmer's Three" is, a reliable "Home" Set—priced and worth every penny of £17/10/0

As far as fine tuning is concerned, you've never controlled a set more responsive, more clearly selective. You've rarely heard a more beautifully realistic tone. Its upkeep is comparatively negligible. All accessories, with "Sonachorde" loud speaker, are included. The set is installed free in City and Suburbs. In technical design "Farmer's Three" represents a definite advance on sets of its type. If you know anything at all about wireless you'll realise this when you hear it. Come and do so without obligation in Farmer's—

Wireless Department, First Floor, Market Street

# FARMER'S

PITT, MARKET AND GEORGE STREETS, SYDNEY

## Local Programmes, Thursday, April 11

### 2FC

#### EARLY MORNING SESSION.

Announcer: A. S. Cochrane.  
7.0: "Big Ben" and announcements. 7.2: Official weather forecast, rainfall, river reports, temperatures, astronomical memoranda. 7.7: "Sydney Morning Herald" summary. 7.12: Shipping intelligence, mails services. 7.15: Studio music. 7.25: Investment market, mining sharemarket, metal quotations, wool sales, breadstuffs markets, inter-State markets, produce markets. 7.40: Studio music. 8.0: "Big Ben." Close down.

#### MORNING SESSION.

Announcer: A. S. Cochrane.  
10.0: "Big Ben" and announcements. 10.2: Pianoforte reproduction. 10.10: "Sydney Morning Herald" news service. 10.25: Studio music. 10.30: Last minute sporting information by the 2FC Racing Commissioner. 10.40: Studio music. 11.0: "Big Ben." A.P.A. and Reuter's cable services. 11.5: Close down.

#### MIDDAY SESSION.

Announcer: A. S. Cochrane.  
12.0: "Big Ben" and announcements. 12.2: Stock Exchange, first call. 12.3: Official weather forecast, rainfall. 12.5: Musical item. 12.10: Summary of news. "Sydney Morning Herald." 12.15: Rugby wireless news. 12.18: A Dickens reading, by A. S. Cochrane. 12.30: Studio music. 1.0: "Big Ben." Weather intelligence. 1.3: "Evening News" midday news service. Producers' Distributing Society's report. 1.20: Studio music. 1.28: Stock Exchange, second call. 1.30: Studio music. 1.50: Last minute sporting information, by the 2FC Racing Commissioner. 2.0: "Big Ben." Close down.

#### AFTERNOON SESSION.

Announcer: Laurence Halbert.  
Accompanist: Ewart Chapple.  
2.30: Programme announcements. 2.32: A musical recital. A reading. 3.0: "Big Ben." Pianoforte reproduction. 3.15: Popular music. 3.30: Genevieve Eppell, soprano—(a)

"Spring's Awakening" (Sanderson). (b) "The Fairy in the Chimney" (Elliott) 3.37: Studio items. 3.45: A reading. 4.0: "Big Ben." Cliff Cowley, baritone—(a) "Friendships" (Lohr), (b) "Dreaming of Home" (Besly). 4.7: Popular music. 4.17: Genevieve Eppell, soprano—(a) "Be You A-comin'" (Sanderson), (b) "Sunbeams" (Ronald). 4.24: Studio items. 4.38: Cliff Cowley, baritone—(a) "If Ever I Meet the Sergeant" (Bennet), (b) "One Hour" (Longstaffe). 4.45: Stock Exchange, third call. 4.47: Popular music. 5.0: "Big Ben." Close down.

#### EARLY EVENING SESSION.

Announcer: A. S. Cochrane.  
5.40: The chimes of 2FC. 5.45: The children's session, conducted by the "Hello Man." Letters and stories. 6.20: Music and entertainment. A safety first talk. 6.30: Dalgety's market reports (wool, wheat, and stock). 6.40: Fruit and vegetable markets. 6.43: Stock Exchange information. 6.45: Weather and shipping news. 6.48: Rugby wireless news. 6.50: Late sporting news 7.0: "Big Ben." Late news service. 7.10: The 2FC Dinner Quartette, conducted by Horace Keats—(a) "Pas des Amphores" (Chaminade). (b) "Serenade" (Moskowski). (c) "The Damsel" (Fletcher). (d) "The Southern Maid" (Simson). (e) "Romance" (Debussy). (f) "Schon Rosmarin" (Kreisler). Note:—The "Last Post" will be sounded from the Cenotaph at sunset.

#### EVENING SESSION.

Announcer: Laurence Halbert.  
Accompanist: Ewart Chapple.  
7.40: Programme announcements.  
7.42: A talk on bridge, by Graham Kent.  
7.55: Studio items.  
8.0: From the Dungowan, Martin Place. Smith Family half-yearly gathering. His Excellency the State Governor, Sir Dudley de Chair Smith will make an appeal for the installation of wireless in all hospitals.  
8.45: From the studio, official opening by the N.S.W. Broadcasting Co., Ltd., of the fair arranged by the Nepean-Hawkesbury District of the N.S.W. Ambulance Transport Service, held at Penrith.  
8.48: From the Dungowan, Martin Place, continuation of the Smith Family gathering.  
9.30: To-night's inter-State relay, a programme of dance music from 3LO.  
11.25: To-morrow's programme.  
11.30: Close.

### 2BL

#### MORNING SESSION.

Announcer: A. C. C. Stevens.  
8: G.P.O. chimes. Metropolitan weather report. 8.1: State weather report. 8.2: Studio music. 8.15: G.P.O. chimes. News from the "Daily Telegraph Pictorial." 8.30: G.P.O. chimes. News service continued. 8.40: Information, mails, shipping arrivals, departures, and sailings. 8.45: Studio music. 9.15: Half an hour with silent friends. 9.45: Studio music. 10.0: G.P.O. chimes. Close down.

#### MIDDAY SESSION.

Announcer: A. C. C. Stevens.  
11.0: G.P.O. chimes. 2BL's Women's Sports Association's session, conducted by Miss Gwen Varley. 11.30: Advertising hints. 11.40: Women's session, conducted by Mrs. Cranfield. 12.0: G.P.O. chimes. Special ocean forecast and weather report. 12.3: Studio music. 12.30: Shipping and mails. 12.35: Market reports. 12.48: "Sun" news service. 1.0: Studio music. 1.30: Talk to children and special entertainment for children in hospital. 2.0: G.P.O. chimes. Close down.

#### AFTERNOON SESSION.

Announcer: A. C. C. Stevens.  
Accompanist: Kathleen Roe.  
3.45: G.P.O. chimes. Popular music. 3.50: Romano's Cafe Dance Orchestra, conducted by Bennie Abrahams. 4.0: G.P.O. chimes. Ray Naughton, mezzo-soprano—(a) "The



Madame Emily Marks, who, with Harry Sherlock, will direct "Maritana" from 2BL to-night.

Birds Go North Again" (Charles), (b) "Here's to Love" (Rubens). 4.7: "Sun" news service. 4.10: Romano's Cafe Dance Orchestra, conducted by Bennie Abrahams. 4.20: From the studio—Geoffrey Baskett, boy soprano—(a) "Venetian Song" (Tosti), (b) "Salaam" (Lang). 4.27: Studio music. 4.40: Romano's Cafe Dance Orchestra, conducted by Bennie Abrahams. 4.50: From the studio, Ray Naughton, mezzo-soprano—(a) "Morning" (Speaks), (b) "I Love the Moon" (Rubens). 4.57: "Sun" news service. 5.0: Geoffrey Baskett, boy soprano—(a) "Glorious Devon" (German). (b) "Little Irish Girl" (Lohr). 5.7: Pianoforte reproduction. 5.17: Popular music. 5.37: Features of the evening's programme.

#### EARLY EVENING SESSION.

Announcer: Basil Kirke.  
5.40: Children's session—Music and entertainment: letters and stories. 6.30: "Sun" news and late sporting. 6.40: 2BL Dinner Quartette—(a) "Apple Blossoms" (Kreisler), (b) "Bolero" (Moskowski), (c) "The Cabaret Girl" (Kern), (d) "Adagio" (Sonata Pathe-tique) (Beethoven), (e) "The Blue Danube" (Strauss). 7.7: Australian Mercantile Land and Finance Co.'s report; weather report and forecast, by courtesy of Government Meteorologist; Producers' Distributing Society's fruit and vegetable market report; grain and fodder report ("Sun"); dairy produce report ("Sun"); weekly traffic bulletin. 7.25: Mr. Pim and Miss Pam, in advertising talks and nonsense. 7.55: Programme and other announcements.

#### EVENING SESSION.

Announcer: Basil Kirke.  
Accompanist: G. Vern Barnett.  
8.0: G.P.O. chimes. Topical chorus. From the Capitol Theatre—The Capitol Unit Entertainment.  
8.16: Concert programme arranged by Madame Emily Marks.  
9.0: Weather report.  
9.1: Two Tales by a Journalist.  
9.16: Studio production of "Maritana," directed by Harry Sherlock, in association with Madame Emily Marks. Principals: A. G. Ellis, Norman Francis, Eva Newbery.  
10.27: To-morrow's programme.  
10.30: National Anthem. Close.

## Reliable Fixed Condensers

for your electric sets  
where reliability  
is essential.

DOUBLE TESTED  
700, 1000, 1500, 2000  
4000 Volts.

All leading wholesalers  
stock them.

Manufacturers' Representatives

**H. HECHT & CO.**

181 Clarence St., Sydney  
WHOLESALE ONLY.

(Also at Melbourne.)

'Phone: MA 2892.

# The Marco Four!!

An easily and cheaply constructed four-valve receiver of outstanding sensitiveness and selectivity. We supply a circuit of the back-of-panel wiring with each set of parts.

**First Quality Parts at 3rd Quality Prices.**

	s	d		s	d
1 Bakelite Panel, 18 x 6	4	6	1 Push-Pull Panel Switch	1	9
1 Baseboard, 17 x 9	1	9	4 U.X. Sockets	5	0
3 Pilot .0005 Centraline Condensers	29	3	1 Sangamo Grid Condenser	2	9
3 Dora Vernier Dials	18	0	1 Aerovox Grid Leak	1	9
1 Sentinel Coil Kit	8	6	1 Ten Terminal Strip	0	9
2 Pilot Audio Transformers	20	0	10 Enamelled Engraved Terminals	3	4
2 Hoosic 30-Ohm Rheostats	4	0	18 lengths Bus Bars	1	3
1 Filament Ballast	3	0	3 lengths Spaghetti Tubing	0	9
1 Single Circuit Jack	1	6	Screws, etc.	0	9

£5/8/7.

**ACCESSORIES.**

	s	d		s	d
4 Philips Matched Valves	54	0	2 42-volt B Batteries	25	0
1 4-volt 45-amp. actual Accumulator	37	0	1 Ediswan 9-volt "C" Battery	2	6

£5/18/6

Or the COMPLETE OUTFIT,

£11

## PRICE'S RADIO SERVICE

Box 3326PP, G.P.O.

WINGELLO HOUSE, ANGEL PLACE

B4146

# Wireless Weekly

**52 ISSUES  
DELIVERED POST FREE  
FOR ONE YEAR**

"WIRELESS WEEKLY" gives you the complete broadcasting programmes from every important station in Australia a week in advance in addition to topical news and articles and a technical constructive article by a qualified radio man.

# 13/-

### SUBSCRIPTION FORM

To the Editor, "Wireless Weekly," 51 Castlereagh Street, Sydney.

Please forward "Wireless Weekly" for a period of .....  
for which I enclose ..... for .....  
(Add Exchange to Country Cheques.)

NAME .....

ADDRESS .....

Subscription Rates: 12 months (52 issues), 13/- post free; 6 months (26 issues), 6/6 post free.

# Interstate Programmes, Thursday, April 11

## 3LO

### EARLY MORNING SESSION.

7.15 to 8.15: See Friday

### MORNING SESSION.

Announcer: John Stuart. 11.0: To-day's radio report. Good sponge cake. 11.5: W. S. Hedger, Superintendent of the Royal Victorian Institute for the Blind, will speak on "The Work of the Institute." 11.55: Arcton Moreland will speak on "Mothercraft." 11.45: Miss B. Macaulay will speak on "The Basis of Temperament." 12.0: Midday news session. 12.20: Community singing, old-time choruses, transmitted from the Kings Theatre, Russell Street, Melbourne; conductor: Frank Hathery. 12.40: Stock Exchange information. 12.43: Community singing resumed. 1.45: Meteorological information. 1.52: Close down.

### AFTERNOON SESSION.

Announcer: John Stuart. Accompanist: Agnes Fortune. 2.18: Description of Hovell Hurdle Race, 2 miles, at Albury Cup meeting, by Eric Welch; general programme. 2.48: Description of Malden Handicap, 6 furlongs, Albury Cup meeting; general programme. 3.17: Description of President's Handicap, one mile, Albury Cup meeting. 3.25: Fritz Hart will speak to students of music. 3.48: Description of Table Top Stakes, 6 furlongs, Albury Cup meeting. 3.55: Rev. Wm. Bottomley will continue his series of talks on "Sigurd the Volung." by William Morris; general programme. 4.37: News service; Stock Exchange information; special weather report for the benefit of listeners in the Redcliffe district. 4.45: Eyesong, transmitted from St. Paul's Cathedral, Melbourne. 5.30: Acceptances and barrier positions for the Epsom Turf Club's races, to be held on Saturday, 13th instant. 5.35: Close down.

### CHILDREN'S HOUR.

6.0: Answers to letters and birthday greetings by "Bobby Bluegum." 6.30: "Bobby Bluegum."

### EVENING SESSION.

7.5: Stock Exchange information. 7.15: Market reports. 7.30: News session. 7.45: Birthday greetings. 7.45: Out of the past. 7.46: A dressing-room talk. 8.0: A maker of history. 8.1: Rod McGregor will speak on cricket.

### NIGHT SESSION.

Announcer: Frank Hasheley. Accompanist: Agnes Fortune.  
8.15: The Radio Revellers, "Rio Rita" (Tierney), "The Kink-a-Jou" (Tierney), "Next to Me I Like Me Next to You" (Bitto).  
8.24: Jack Stocks, "The Woman Hater" (by permission Tivoli Theatres, Ltd.).  
8.27: The Radio Revellers, "Anywhere is Heaven" (Beady), "Glad Rag Doll" (Ager), "Down Where the Sun Goes Down" (Jones).  
8.30: Rita Hilton, entertainer, "He's Tall and Dink and Handsome."  
8.39: The Radio Revellers, "Can You Blame Me?" (Goodwin), "I Want to be Alone with Mary Brown" (Leslie), "Tea Leaves" (Nichols).  
8.48: Victor Harding, bass-baritone, "Route March-in" (Stuck).  
8.51: The Radio Revellers, "Forty-seven Gingerbread Sailors" (Screry), "You Ought to Hear (Dink Lad)" (Baer), "A Bungalow, a Radio, and You" (Dempey).  
9.0: Rosina Down, soprano, "The Piper of Love" (Crew).  
9.3: The Radio Revellers, "Back in Your Own Backyard" (Johnson), "My Heart Stead Sill" (Rodgers), "Give Your Baby Lots of Lovin'" (Burke).  
9.12: Jack Stocks, "The Woman Hater," further experiences with the fair sex.  
9.15: The Radio Revellers, "When You Know Me" (Buden), "I'm Sorry, Sally" (Kahn), "My Blackbirds are Bluebirds now" (Friend).  
9.24: Victoria Harding, bass-baritone, "A Dinder Courtship" (Costes).  
9.27: The Radio Revellers, "Casablanca" (Evans), "Oh, Isabella" (Schuster), "Sweet Forget Me Not" (Lernzo).  
9.36: Rita Hilton, entertainer, "What Good is Good Mornin'?"  
9.39: The Radio Revellers, "Fancies" (Nichols), "In my Bouquet of Memories" (Lewis), "Mexican Seneade" (Terese).  
9.48: Rosina Down, soprano, "The Blackbird's Song" (Cyril Scott).  
9.51: The Radio Revellers, "Down by the Old Fing Gate" (Hassell), "I Don't Know Why I do It" (Wall), "Hum and Strum" (Meyers).  
10.0: News service; meteorological information; criticism of local wireless news from Ruby; announcements.  
10.15: The Radio Revellers, "Maybe I'm Wrong" (Harris), "Constantinople" (Carlton), "That Melody of Love" (Donaldson).

10.24: Jack Stocks, "The Woman Hater," has another hymn of hate.

10.27: The Radio Revellers, "There's a Rainbow Round My Shoulder" (Jones), "Oh, Is She Mad at Me?" (Friend), "High Up on a Hilltop" (Baer).

10.36: Rosina Down, soprano, "A Persian Song of Spring" (M'Burney).

10.39: The Radio Revellers, "When Love Comes Stealing" (Reise), "Sings Day Somewhere" (Rapee), "To-day, To-morrow, Forever" (Nichols).

10.48: Rita Hilton, entertainer, "I've Told Them All About You."

10.51: The Radio Revellers, "Who Knows" (Dixon), "The Fun Parade" (Gillespie), "I'm Crazy Over You" (Lewis).

11.1: The Radio Revellers, "Old Man Sunshine" (Dixon), "Wipin' the Pan" (Baer), "My Dream Sweetheart" (Hall), "Guess Whom Town" (Razali), "That Stolen Melody" (Fisher), "Lenova" (Gilbert), "There's a Ricketty Racketty Shack" (Turk) and request items.

11.30: God Save the King.

## 3AR

Announcer: Maurice Dudley. 10.0 to 10.59: See Friday's list. 11.0: Beautiful outland. 11.15: The Strad Trio. 11.33: Cecil Parkes (violin), 11.51: Frank Johnston (cello) 12.3: The Strad Trio. 12.20: British official news service; announcements. 12.30: Close down.

### AFTERNOON SESSION.

Announcer: Maurice Dudley. 3.0: General programme. 3.50: The Imperial Russian Trio. 4.30: Close down.

### EVENING SESSION.

Announcer: Renn Miller. 6.0: General programme; news service; announcements; acceptances and barrier positions for the Epsom Turf Club's races, to be held on Saturday.

### NIGHT SESSION.

Announcer: Renn Miller. Accompanist: Reg. Brown.  
8.0: Dr. Loftus Hills—"Life's Fancies and Fancies."  
8.15: Under the auspices of the Nurserymen and Seedsmen's Association of Victoria—E. Wiseman: "New Gardens."  
8.30: The Station Orchestra—"The Waltz Dream" (Oscar Strauss) "To-morrow" (Strauss).  
8.47: The Station Orchestra—"The Nightbirds" (Strauss).  
8.57: Thomas B. George—"When I was a Bachelor" (Gregory), "Fill a Glass with Golden Wine" (Quilter).  
9.4: The Station Orchestra—"Le Source Ballet" (Delebes).  
9.9: Transmission from the Cairns Memorial Church, Organist: Miss F. P. Thurman; conductor: R. J. Oehr—  
9.39: The Station Orchestra—"In a Persian Garden" (Lehmann).  
9.49: Gertrude Hutton, mezzo contralto—"Good Mornin', Brother Sunshine" (Lehmann).  
9.56: The Station Orchestra—"Cobweb Castle" (Lehmann).  
10.6: Thomas B. George, bass baritone—"Myself When Young" (Lehmann).  
10.13: The Station Orchestra—"Overture, 'Jelva'" (Reissiger).  
10.20: News service; announcements. God Save the King.

## 4QG

### AFTERNOON SESSION.

Announcer: J. Tyson. 3.0: A programme of records. 3.30: Mail train running times. 4.15: This afternoon's news. 4.30: Close down.

### EVENING SESSION.

Announcers: H. Humphreys and A. V. James. 6.0: Mail train running times; mail information; shipping news. 6.5: Wurilzer Organ. 6.25: Commercial announcements. 6.30: Bedtime stories, conducted by "The Sandman." 7.0: News in brief, etc. 7.45: Lecture, "On the Waiwaly," by Mr. J. P. F. Reid (editor "Queensland Agricultural Journal").

### NIGHT SESSION.

Announcers: A. V. James and H. Humphreys. Station 4QG will during the first part of the evening, entertain the soldier inmates of Ardoyne Hospital.  
8.0: From Ardoyne Hospital, the Studio Instrumental Quartette (conductor, F. Smith)—  
"Destiny Waltz" (Wood).  
Joe Dwyer and his pal, Jerry. Ten minutes of fun.  
Erica Stuart (pianist).  
"Lorely" (Seeling).  
Harry Borradaie (elocutionist).  
"I" (Kipling).  
"And Yet I Don't Know" (Weston and Lee).  
"The Vicar's Rectal" (Anon).  
A. N. Falk (baritone).  
"Drake Goes Wood" (Anderson).  
Miss G. Farg (violinist).  
Selected (accompanied by the Studio Instrumental Quartette).  
Doris M'Innes (soprano).  
"Roses of Picardy" (Wood).  
Fred Smith—two few minutes at the piano.  
Harry Borradaie (elocutionist).  
Selected.

9.0: From the Studio, metropolitan weather forecast.

9.1: From Ardoyne Hospital, the Studio Instrumental Quartette's Band.

A group of popular numbers.

9.6: Doris M'Innes (soprano), "Carmena" (Wilson).

9.10: Joe Dwyer and Jerry.

"Five minutes' more fun."

9.15: Erica Stuart (pianist), "La Bandoline" (Couperin).

"Scharzino" (Schumann).

9.20: A. N. Falk (baritone), "Mita Gians" (Newton).

9.25: The Studio Instrumental Quartette, March, "Entry of the Gladiators."

9.30: From the Studio—

Movements of the travelling dental clinic.

Erisbane Citizens' Band.

An impromptu programme by the Brisbane Citizens' Band (conductor, A. Kaefer).

Between band numbers—

Dorothy Mowlan (soprano),

"Sing Merrily To-day" (Phillips).

"The Fairy's Lullaby" (Needham).

10.0: "The Daily Mail" news; "The Courier" news; weather news; close down.

## 5CL

### MORNING SESSION.

Announcer: C. J. O'Connor. 11.0: General programme. 1.33: Albury Race. Result of Hovell Hurdle Race. 2.0: Close down.

### AFTERNOON SESSION.

Announcer: C. J. O'Connor. Accompanist: Jean Finlay. 3.0: Chimes. 3.1: Resume of previous race results and results of Malden Handicap and President's Handicap, Albury Races. 3.25: Result of Table Top Stakes, Albury Races. 4.1: Resume of previous race results. 4.2: Result of the Hightway Handicap, Albury Races. 4.24: Result of Murray Tilt Stakes, Albury Races. 4.55: S. C. Ward and Co.'s Stock Exchange information. 5.0: Close down.

## 6WF

12.30: Tune in. 12.35: Markets, news, etc. 1.3: Time signal. 1.1: Weather bulletin supplied by the Meteorological Bureau of West Australia. 1.3: Panatrophe hour, relayed from Musgrove's, Ltd., Lorne House. 2.0: Close down. 3.30: Tune in. 3.35: Afternoon tea concert relayed from the Carlton Cafe; vocal items from the studio. 4.30: Close down. 6.45: Tune in. 6.48: Bedtime stories for the kiddies by Uncle Duffy and Percy. 7.5: Light music by the Station String Trio. 7.30: Commercial and general information. 7.45: Talk by Mr. Fred Alexander "Current Events in World Politics." 8.0: Time signal. 8.1: First weather bulletin. 8.3: Vocal and instrumental artists from the studio. 8.50: Late news items, by courtesy of the "Daily News" Newspaper Co., Ltd.; station announcement, ships within range announcement, late weather bulletin. 9.5: Programme continued from the studio. 10.00: Close down.  
104.5 Metre Transmission.—Simultaneous broadcast on 104.5 metres of programme given on 1250 metres, commencing at 6.45 p.m.

## 7ZL

### MIDDAY SESSION.

Announcer: Jack Broadbent. 11.30 to 1.30: General programme. 1.30: Close down.

### AFTERNOON SESSION.

Announcer: Jack Broadbent. 3.0: G.P.O. clock chimes the hour; weather information. 4.15: A representative of the Child Welfare Association will speak on "Is Baby Underfed?" 4.30: Close down.

### EARLY EVENING SESSION.

Announcer: Jack Broadbent. 6.30: "The Story Lady" will tell a story to the wee folk. 7.0: Answers to letters and birthday greetings. 7.15: News service; Railway auction produce sales at Railway; weather information; Hobart Stock Exchange quotations; announcements.

### EVENING SESSION.

Announcer: Jack Broadbent. 7.30: Under the auspices of the "Come to Tasmania" Organisation, Aid. H. H. Facy will speak on "How to Spend a Holiday in Tasmania." 7.45: H. E. Reid will speak on "Australia's Unknown." 8.0: G.P.O. clock chimes the hour. 8.15: ZL's Community Singing—accompanied, Lella Reid; "All The Blue Bells of Scotland." 8.18: E. Elliot, solicitor—selection from "Pick-a-stick Papers." 8.33: A. W. Howe (tenor)—selected. 8.36: All "Drink to Me Only." 8.39: Mrs. E. A. Ethlam (contralto), selected. 8.42: All "Sweet and Low." 8.46: "Silver Threads among the Gold." 8.46: Mrs. W. Thompson (baritone), selected. 8.49: Miss Adelaide Blythe (elocutionist), selected. 8.52: All "When Irish Eyes Are Smiling." 8.55: J. Pat. A. All "Pal of My Terson (tenor), selected. 9.0: All "Pal of My Terson (tenor), selected. 9.05: A. W. Howe (tenor), selected. 9.4: All "All through the Night." "Last Rose of Summer." 9.12: Mrs. E. A. Ethlam (contralto), selected. 9.15: All "The Musical Boy." 9.18: Mrs. W. Thompson (baritone), selected. 9.21: Miss Adelaide Blythe (elocutionist), selected. 9.24: All "Sweet Genevieve." "Auld Lang Syne." News service. 9.28: Mlle. Columbia broadcast—9.45: News service. 9.50: British official wireless news; Tasmanian district weather report; mail notices. 10.0: Close down.

# Concerning That Interference

## Wallace Wave Trap Offers Solution

Write For Free Circuit and Instructions.

Not Only are Undesired Stations Eliminated, but Strength of any Difficult Station is Increased.

**YOU REQUIRE ONLY—**  
 Wallace Condenser 5/11  
 Small Panel .... 3/-  
 3in. dia. Former 2/-  
 1lb. d.c.c. Wire 1/6  
 Dial for Condenser 1/-  
 Two Terminals  
 Wire, and some  
 Screws ..... 2/6  
 15/11

READY-MADE,  
 FOR 17/6.

RESULTS ARE  
 GUARANTEED.

Prove that this is Not an  
 Idle Claim.  
**WALLACE WAVE TRAP**  
 KIT,  
 as Listed,  
 14/6,  
 IF SUPPLIED WITH  
 OUR FREE  
 INSTRUCTION  
 SHEET.

**ALREADY  
 WE HAVE HELPED  
 MANY BUILD THE  
 AIR KING RECEIVER.**

Let us assist you to build  
 this Remarkable Set.  
 Complete Kit of Parts

(As Listed in "Wireless Weekly"),

£21/5/9.

OUR EXPERTS' ADVICE IS FREE.

**VALUE.**  
 Quaker Condensers.  
 .0005 ..... 7/6  
 .00036 ..... 7/3  
 .00025 ..... 7/-

Anyone can  
 Make It.

Simple  
 and  
 Effective.

**SPECIAL.**  
 Exide Accumulators, 4  
 volt 20 amp.,  
 From 15/6.

We Supply Everything in Radio at Bedrock Prices.

### "The Wireless Shop,"

Miss F. V. Wallace

6 Royal Arcade, Sydney

THE OLDEST RADIO FIRM IN TOWN

Established 8 Years.

Phone, MA 5543

Two doors from George Street, opp. Q.V. Markets.

Same day service for  
 country clients.

Unqualified money  
 back guarantee.

ALAN BURROWS,  
 Manager.

Postage paid on all goods  
 except batteries and  
 speakers.

W. A. STEWART,  
 Asst. Manager.

## New Apparatus Tested & Approved



### The "Ultra" Air Column Speaker

"THE best radio set made is only as good as its speaker," is the slogan accompanying the new British Ultra reproducer. Great Britain has recently been paying particular attention to this all important side of radio reception, and in the new Ultra (the agents for which are Levensons' Radio, 216 Pitt Street, Sydney), and the discriminating Australian listener, has something which follows a new principle and well justifies its application. A special double action unit is attached to a rigid acoustic reproducer which is so designed as to incorporate specially designed air columns, thus giving the maximum for a minimum of space. No vibration is possible with the composition used for the construction of the air columns.



equal it. It is able to stand tremendous volume without overloading."

We have found in our own tests that all the claims made for the Ultra were fully substantiated, and, together with its pleasing appearance and very reasonable price of £6, the Australian radio user has at his disposal a reproducer which should be in great demand.

Writing in the British "Wireless Constructor," the editor (Mr. Percy Harris), says: "The over-exaggeration of certain low tones with a very poor high note response, which is so characteristic of many cone speakers, is absent from this instrument, the performance of which places it in the very front rank. We have yet to hear a commercial loud speaker which for quality of reproduction, combined with high sensitivity, can

## Safe for Mediocrity

THAT Australian programmes stand comparison with those given American listeners is the opinion of Mr. Alan Burrows, who has just returned from a business trip to the United States. "American programmes," he said, "have their bright spots, as the variety of talent is naturally very wide; and some of the 'chain' broadcasting is really remarkable. There are always world-famous artists from which to choose, who are usually willing to face the microphone—providing their contracts allow them—so the arrangement of brilliant programmes is a comparatively easy job. But for the most part the programmes from the average station—well, they are certainly doing their part in the noble cause of 'making the world safe for mediocrity!'"

Mr. Burrows, who is manager of "The Wireless Shop" (Miss F. V. Wallace), Royal Arcade, said there was not a great number of new ideas to be gained in the States, although he was able to bring back several new lines. Most of the larger manufacturers are occupied in making "A.C." sets.

### The Frothblowers' Anthem

LISTENERS who appreciate really clever humor, should not fail to tune in to 3LO on April 10, when the University students in the full thrill of Commencement revels, will give a highly-diversified entertainment. The programme will open with a spirited rendering of "The Frothblowers' Anthem," and will be followed by Carols from the Carolinas. A few moments with the Merry Meds and Medusan Melodies. The serious musical aspect has by no means been forgotten, for operatic solos will be given by Signor Sporadik Tonsillikoff, the Roy-stering Russian.



The WIRELESS WEEKLY

RADIO INFORMATION

Under the direction of

Ray Allsop

and

Don B. Knock

Associate Technical Editors

Service

Correspondence Answers only through these Columns (See Coupon Below)

D.J.S. (Aroncliffe).—"Could a 3.75 transformer be used in conjunction with the Countryman's One-valver? If so, please print a wiring diagram."

Answer: Yes, the transformer could be used in a stage of audio amplification. The circuit appeared in these columns on March 1, 1929

E.P. (Waverley).—"I wish to find out if you would procure the following WIRELESS WEEKLIES for me which I have missed, owing to holidays:—Volume 13, Nos. 1, 2, 3, 4, and 8. I want these, as I take a great interest in 'Proving Radio,' and intend to join the Bondi Group. I think this is one of the best schemes you have ever hit upon. I have just constructed the Reinartz Three, and am getting surprising results. It has wonderful volume, and is giving every satisfaction. I think it would be a wonderful plan to start an Exchange Column in your paper. Hope to see a reply in Queries Column."

Answer: Some reader may be able to supply the copies you require. The address is, Emil Perchan, Jr., 88 Oxford Street, Waverley. Glad you like the receiver mentioned. Your proposal has been considered before, but nothing definite has really been decided up to the moment.

E.B.T. (Hunter's Hill).—"For two years I have been using a two-valve Reinartz receiver. All Sydney stations come in very satisfactorily. When 2PC is off the air I can get 3AR on 'phones. Could you tell me how I may get 3AR, etc., on the speaker without adding another stage? The aerial is about 95 feet overall, using 4-voit valves."

Answer: You could not do much without an additional stage. Try increasing the height of your aerial, and if this has no effect, try a power valve in the audio stage.

R.W.S. (Mosman).—"What is the correct order of switching a set on and off. I am using an eliminator coil this switch A and have another switch for the filament supply. Call this switch A. Answer: Treat the eliminator as an ordinary dry battery. Switch off B first, then A."

D.W.V. (Lindfield).—"Must a radio dealer's license still be obtained in order to carry on retailing and set building business?"

Answer: This was cancelled some time ago, but a special license will change. Deal to their original license, will be necessary. This has been reduced from £10 to 24/-, the price of an ordinary license (2) "Can the business be advertised outside a private residence?"

Answer: Yes, but permission must be obtained. (3) "Does any restriction or patent prevent manufacturing B eliminators for sale?"

Answer: No.

W.R.G. (Jones Island).—"As I am a regular reader of your paper, I would be much obliged if you would help me with a problem I have. My set is a six-valve superhet, which I have worked O.K. for about nine months. I have been able to pick up 45 stations, including India, Japan, New Zealand, and Philippines, but during the last few months the set has not been working so well. The dial readings change for every station, i.e., 721 hardly changes at all but down near 7KV the reading changed about 20 degrees. The numbers remain like this and signals are weaker. The funny part about it is that when a storm comes up the numbers will change back to their original positions, but not until the rain begins pouring on the house. These numbers will remain as they are until the shower passes, and then gradually the music fades out, and I have to alter the dial reading. As signals are much stronger with other numbers, I would like to know the cause of this."

Answer: A fault in the aerial or earth system somewhere. If the earth is not making good contact, the action of the rain will alter the capacity and bring your dial readings back to normal. On the other hand, it may be that the aerial contacts are dirty, causing a high resistance, thus altering the tuning a little. You will find that by removing the earth lead, retuning of the set will be necessary. Test out aerial and earth connections, both inside and out of the set.

M.G.H. (City).—"When tuning in stations, particularly 2PC, on my three-valve 'Radiar' set, I have to disconnect the aerial and use the earth only, as I get very poor strength with both connected. As I have two aerials, one about 50 feet long, which I use for this set in my kitchen, and one about 100 feet, which I use for a one-valve set in my upstairs bedroom, I have tested set on both, with the above result. For my earth for the one-

valve set, I use a tap upstairs, the pipe from which continues down the wall to about two yards from the ground, where it branches into two pipes by means of an elbow, one pipe going through the wall to the tap in the kitchen (thus forming an earth for my three-valver), while the other pipe continues down the rest of the wall to the ground. I might state that Harry Wiles have tested this set and found it to be O.K. I have also had the one-valve set working separately off two earths and aerials.

Answer: Perhaps the aerial and earth terminals in the set have been reversed. Try placing the aerial lead on to the earth terminal, and vice-versa, and also try a .0001 fixed condenser in series with the aerial.

R.T.O. (Wollongong).—"I started off this afternoon to build the Renown Three, but got up against it straight away. I want you to tell me how you get on the 70 turn coil 5 taps and two ends with 15 turns between each tap and ends. I have drawn a rough sketch so that you will see what I mean. I think there must be a misprint somewhere. I shall be looking out for my 'Wireless Weekly,' the paper that I never miss—half, rain, and shine. While I am on the job, could I use 24-gauge silk wire instead of 28 D.O.C.?"

Answer: An error, which, however, was not of much magnitude, because this coil, being for the wave-trap, is not critical as to number of turns. Wind on 70 turns and tap every ten. Yes, the 24-gauge wire can be used.

R.T. (Wagga Wagga).—"I have a two-valve set, 1 stage R.F. and detector, using A615 in the detector socket. I find an A635 in the R.F. socket doesn't give as much volume as an A609. Should the 635 give more volume than the A609?"

Answer: Yes; but perhaps the valve is faulty. (2) "Volume increases as I turn the reaction condenser out. Why is this? I am using a thirt-turn reaction coil."

Answer: You have "silent reaction." The reason why volume is less when the plates are in is because the regeneration effect interferes with its own action. The .0005 condenser is too large for good reaction control. You should use a .00035 or a .00025, or else take a few turns off your reaction coil.

(3) "Using a B406 in the last stage of a four valve receiver, would an M.P.A. Cone Speaker suit?"

Answer: Admirably. (4) "What is the impedance of the A635 valve?"

Answer: 23,300 ohms.

E.H.W. (Masefield).—"Would you please give me full instructions on how to make a simple one-valve set for short waves?"

Answer: Sorry, but this is absolutely out of the question. There is no room in Queries for articles. Such an article as required by you will shortly appear in its proper place.

(2)—"Could you tell me how to make a crystal set tuned by a .0005 variable condenser suitable for an aerial 60 feet long?"

Answer: On a three-inch former, wind forty-seven turns of 24-gauge D.C.C. wire. Make tapings every tenth turn. Connect the aerial to a clip, and slide to one side of the crystal. The other side of the crystal should be connected to one side of the 'phones, and the other side of the 'phones to another clip, which also is connected to earth. With your two clips attached, one each end, vary their positions for tuning, and make final adjustments with the variable condenser, which should be con-

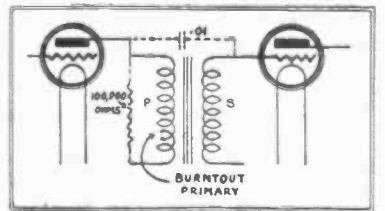

R. E. (Collaroy) has a transformer with a burnt out primary, and wishes to know how this can be repaired. The circuit explains itself.

nected across the coil, with the moving plates to the earth.

B.K. (Singleton).—"I am sending you a single-valve circuit, which may be of great interest to your readers and subscribers. The aerial is tuned by means of a variometer, while another is introduced into the anode to cause the set to oscillate."

Answer: Thanks very much, but the set is of the standard type, and is very well known. You are under the wrong impression regarding the aerial being tuned by means of the variometer. This variometer merely takes the place of the primary and secondary.

E.J.F. (June).—"I find that two Geopphone condensers supplied to me for the All Empire Receiver, and supposed to have a capacity of .0004 mfd., each have five rotor and four stator plates. The article recommends condensers with four rotor and three stator plates. What is the capacity of my condensers, and will they be O.K.?"

Answer: The capacity is .00015 mfd., and they are quite O.K. for the All Empire. (2) "I have been advised by a wireless firm to place a fixed .006 condenser in series with the .0004 condenser for tuning in the detector circuit, and to remove a number of turns from the detector coil."

Answer: The condenser is a safety device in case the plates of your condenser touch. There is no need to alter the turns on the coils.

(3) "Could old valve base coils, such as used in the Midget R.F. Four, be used with success in the All Empire? If so, would you give the number of turns required on the different coils to tune from, say, 10-100 metres?"

Answer: Quite O.K.; specifications same as for the Midget Four.

J.E. (Corralim).—"On reading through the construction of this week's receiver, The Renown Special Three, I was at a loss to understand the construction of coil L1. As there are only 70 turns, a tap to be taken at every fifteen, and the total for five taps would make it 75 turns."

Answer: An error, for which we have apologised. Wind 70 turns and tap every ten turns.

(2) "Which would give me better inter-State reception, the Harkness Three or the Renown Special?"

Answer: The Harkness Receiver is a good set, but it is beaten by the Reinartz, which is actually the circuit employed in the Renown Three.

M.C.J. (Bull).—"I have built a Marco Four, according to the wiring published in 'Wireless Weekly,' 1/2/29, and I am getting good results from it. My only trouble is that I get 2BL at about 80 degrees on the 2PC at 90 degrees. What could have to be done to bring the readings lower, so that I could get 7ZL?"

Answer: Increase number of turns on L4 until 2BL is received at about 50 degrees and 2PC at 75 or 80.

R.A.S. (Glebe Point).—"I have a three-valve Reinartz set, which gives good results on local stations, but distorts on inter-State stations. What is the remedy?"

Answer: The cause, first of all, is that you are trying to tune the set. You are using too much reaction. If you find an reducing regeneration, that the inter-State station cannot be heard, your best plan would be to add the R.F. stage, as in the Marco Four, when you will be able to listen to inter-State stations on the speaker.

T.D. (Newtown).—"I have Reinartz Three, but it is very unsatisfactory. The selectivity is no good, in fact, it is rotten, as I cannot separate 2KY from 2UE or 2GB. I get more interference from 2KY. Can you put me on to a good five-valve 'tricity'?"

Answer: Build up the Renown Special, or make the wave-trap up from the first part of the circuit, and add it to your set, when it will be similar to the Renown Special. More interference on 2PC is not the fault of your receiver. Some station is working right on 2PC's wave length, or it may be a harmonic. As everything is in code, it is hard to say who this station might be. Build the Berkeley set, if you would like something a little less laborious, try the Home Constructor's Five.

R.E. (Collaroy).—"Thanks for your reply to my query. It was worth waiting for, because I have had several men here trying to find out who much up with the set. Your suggestion proved to be correct, the primary of the first transformer was burnt out, and when transformer was replaced everything was fine. I am thinking of building a two-valve set for my boy, who delights in messing about

with my receiver, and, as it is not worth while buying much for a new transformer (he'll only sell the thing to bits), can you tell me if I could make use of the transformer with the burnt-out primary?"

Answer: Yes, if you connect a fixed resistance of 10,000 ohms across the primary of the burnt-out transformer, as shown, it may be used.

W.E.F. (Lismore).—"How can I apply 'C' bias to my G.P.?"

Answer: Disconnect the P-leads at present attached to the transformers. Connect the P-terminals to the negative side of the "C" battery (4 1/2 volts), and the positive side to the A negative terminal. Your letter has been used for will be in your Safety Valve.

(2) "I consider the Go-Getter not only a short-cut to the highest order, but also a very efficient and cheap set for use on the broadcast band."

Answer: Which will serve admirably to reply to many inquirers who are seeking for such a receiver.

W.A.I. (Coolumon).—"Recently I wrote asking if you knew whether the Australian Wireless Co. (Radios) had ceased business. If not, could you give me their address. To date I have received no reply."

Answer: This query has been replied to before through these columns. As no coupon was enclosed, you are evidently awaiting an answer per post. We do not reply to query letters per post. The business in question has ceased business. Please refund coupon.

G.F. (Bixlandon).—"I don't know whether or no you answer questions or not. Though I know it's rude to ask questions, I have a query matter that is about to ensue."

Answer: If it's rude to ask questions, then I've been terribly mislabeled. Your questions are welcome.

(1) "Would it be possible to send a message to Mars? I know you don't profess to dissipate as much knowledge as some professors, etc., who are trying to communicate with this planet, but I'd like your personal views. I am writing an article on the subject."

Answer: I should not think it possible if the Heaviside Layer theory is correct. (See "Proving Radio"). According to the Kennelly Heaviside theory, electro-magnetic waves spread out in all directions, but are refracted or bent back when they reach the Heaviside Layer at an angle equal to that at which it struck the layer. It, therefore, stands to reason that few, if any, ether waves could force themselves through the Heaviside Layer. Further, it has been proved that radio-frequency oscillations, ether waves, will not pass through a vacuum, and as the atmosphere gets very rarefied at small heights (when compared with the distance the wave has to travel), it is quite likely that there is no air, or practically no air, at a distance of, say, millions of miles from the earth's surface. Considering that it takes us an hour to hear electro-magnetic waves from the other side of the earth on any wave length (even then we get static and fading), it is unreasonable to suppose that it would be possible to transmit a message to Mars, even supposing that the Martians may equal to us. In addition, according to many scientists, the atmosphere of air belt round Mars is extremely rarefied. Again, it is hardly likely that Martians know Morse. Speech is an utter impossibility, since sound carries only a few feet in the atmosphere. Even if speech were used, and Martians were in existence, and we could surmount all the difficulties mentioned, it is not likely (considering that in this globe alone there are so many different languages and dialects, even if we could speak to the Martians, it would be somewhat of a wonder if they spoke English). However, quite a lot of books and articles have been written on the subject, which can be made very enthralling.

(2) "I should be obliged if you could give me the name of RADIO dated 2/27/28 on the Baby Transmitter, as I am having a go at the A.O.P.C. shortly."

Answer: Sorry we have no copies. Perhaps a reader may be able to oblige. Name and address of inquirer: L. C. Jackson, "Unley," Braemar Street, Beersden, Victoria. You must hold your A.O.P.C. that you have.

W.E. (Canley Vale).—"Can you tell me how to make a cheap wet 'B' battery?"

Answer: An article is later to appear on this subject, but, in the meantime, an interesting letter received from W.E.E. of Gayndah, may help you. On 17th March, 1928, I purchased 38 sac cells—these are small zinc cells to be connected in series, and cost 1/4 each in Brisbane, and are somewhat difficult to obtain. The cells were first filled with some dissolved sal-ammoniac, then a piece of paper was dissolved round each cell so that the edge came about half an inch above the cell; next, the cells were joined in a series to be connected to a 4 1/2-volt, and a carbin wax was melted over the top about 1/4-in. thickness. The pasted paper prevented the way from running away from the top of the cell, and allowed me to make each cell air-tight. This 'B' battery has been in constant use just twelve months to-day; nothing further has been done to the cells, and there has been no corrosion whatever externally, and the battery seems just as strong as when it was twelve months ago. The set used is a three-valve P.I. circuit. (Thanks W.E.E.)

A.E.R. (Bexley).—"During the transmitting of the unveiling ceremony at the Cenotaph, I distinctly heard a song. I tuned all round the dials, but could locate no station transmitting this matter. At times this station was louder than 2FC, and they could be heard only on 2FC wavelength."

Answer: This interference was a direct pick-up of 2UW on the amplifier in Marlin Place. This trouble is often encountered when an outside pick-up amplifier has to operate in close vicinity to another broadcast station. In these cases (Mr. Alltop advises the engineers in charge of the transmission have to use a wavetrapp on the lines. This interference was reported from several suburbs. 2FC broadcast: the Cenotaph ceremony.

"A Young Fan" (Galong).—"I have a pal who lives three-quarters of a mile from my place. We wish to set up communication by means of a small transmitter and a crystal receiver. Perhaps a spark transmitter and an elaborate battery supply would be O.K. I require a large voltage. I could use a step-up transformer. I have a Morse key and a sander. Is an ammeter essential to a transmitter?"

Answer: You must first hold an amateur experimenter's license, otherwise you are liable to very big fines. Spark transmitters are strictly forbidden, as they cause interference. A sander will not be of much use. The ammeter is not essential, but is desirable. A galvanometer or wavemeter will show when set is in oscillating condition.

(2) "Is it possible to get away without a transmitter's license?"

Answer: Not on your life!

(3) "If my demands cannot be overcome by you, please describe and give circuit of a short-wave crystal receiver that will tune from 10-80 wave-meters."

Answer: It would be no use to you if I did that! Before you can hope to obtain a transmitting license, you must learn that a receiving crystal cannot be made to tune below 200 metres to any advantage, and that wavemeters are very different things from wave length in metres. A wavemeter (which you have evidently confused), is an instrument used to determine the wavelength on which a transmitter is operating, and also to tune a receiver to any definite wavelength. Your best plan would be to follow "Proving Radio" series, when you should (at its termination) know quite enough to obtain your A.O.P.C.

A.M. (Maroubra).—"My sister has a crystal set, and when she tunes in her set it takes all the volume away from my set. All she has to do is to turn on her condenser and the cuts 2FC out and brings in 2BL, when she does not tune in. I can get the two stations quite good. The aerial is a twin one: cross-arms are 4ft. 10in. across. One aerial is 10m and one my sister's; can you tell me the trouble?"

Answer: Swap sets when sister's not looking! The trouble is that the two aerials are running parallel to each other, and evidently your sister's set is more sensitive than your own. You could fix this trouble by running your aerial in a different direction, or further away from the other aerial.

(2) "What difference does a fixed phone condenser do to a crystal set?"

Answer: Not much. Sometimes it is found that the tone is improved by shunting a fixed condenser across the telephones. During the period when electricity flows through the detector the voltage is applied across the telephone receiver, and also across the condenser in parallel with them. The short interval between the rectified half waves of the high-frequency incoming signals is thus smoothed over by the condenser, which gives to the receiver energy impulses during the previous half-wave pulsation. The action of receivers is thereby strengthened, but in many cases no appreciable difference will be noticed.

(3) "Does any variable condenser do for a crystal set?"

Answer: No. The capacity depends on the size of the coil. The total capacity is .0005mfid., and the main tuning coil for 50 turns of 24-gauge wire on a three-inch former.

(4) "In last week's WIRELESS WEEKLY, I saw S. A. Greene, of Adamstown, wanting a copy of your paper dated February 22, 1929, and will be pleased to forward it on to him if he gets in touch with me." Name, Arthur Mapstone, 53 Boyce Road, Maroubra.

Answer: Thanks. W.H. (Enfield).—"I have three G. and R. Thermionic valves, and it says on the box Universal Detector Filament 4 volt Plate detector 40-50. Amplifier, 80-100. I have made a one-valve amplifier and a one-valve set, but can get nothing. Isn't the amplifier any use?"

Answer: I suppose the G. and R. valves you have are the old type which are now being sold for 6d each in Sydney? In this case, your trouble will be that you are unaware (since this is not marked on the box) that the filaments require a very heavy ampereage. Dry batteries are not of much use, they are rather poor for very few minutes. A 40-amp accumulator will be required. It would be far better to purchase two general purpose type valves, such as Philips, Radiotron, Marconi, Six-Sixty, Mullard, or any other well-known type. It is better to buy cheap radio material, as it only means extra experience in the end.

"Nowood" (Punchbowl).—"Can 'C' bias be obtained as per attached sketch, using the components mentioned?"

Answer: Yes.

(2) "Can any valve other than that supplied be used with a Philips 372 Eliminator?"

Answer: Yes, but it is not advisable.

(3) "Is the primary of a Jefferson transformer suitable for use as an A.P.C., and capable of passing the current for 2443? The last stage used with an R.C.A. 102A speaker and 4mfid. condenser?"

Answer: No.

(4) "In a four-valve S.G. receiver, I find that an A415 as detector is unable to deal effectively with the load, and I am using the following: A442, B408, B408, B443. Can this be improved upon?"

Answer: Yes. Use a power valve as detector. Try a B406 also.

A.I. (Coolumon).—"Have Radair gone out of business?"

Answer: Yes.

A.W.S. (Stannore).—"What is the total plate current drain of the following valves when correctly biased—B443, B408, A415, A442, A408?"

Answer: About 30 milliamps.

(2) "Would it be O.K. to substitute five A442 valves for the ordinary ones in the R.F. side of a super-het. to obtain greater range and power on DX stations?"

Answer: Quite O.K.

C.J.J. (Arncliffe).—"I have a four-valve tuned-plate receiver, as given in WIRELESS WEEKLY, August 8, 1926, one of the old plug-in coil type, but wish to alter same to modern set, without any unnecessary cost. Could you tell me of suitable circuit, and where I could obtain plan of same?"

Answer: WIRELESS WEEKLY, March 22, 1929.

J.L.T. (Young).—"I am studying, and have nearly graduated to become an operator on boats. Where can a license be obtained, and what time of the year can it be obtained?"

Answer: Examinations are held in Sydney quarterly by the Radio Inspector, c/o P.M.G. to you.

(2) "Before a license can be granted, is it necessary for one to know generators, dynamos, and the like thoroughly?"

Answer: If you wish to take up ship operating, yes. The Commercial Certificate is considerably harder to obtain than an A.O.P.C.

(3) "It would be great if you could manage to 'squeeze' your excellent weekly a small article on the subject of sea-operating, as I am sure this will be highly appreciated by many."

Answer: Will see what can be done. We may be able to get such an operator to give us a short article. Did you read the story of the "Stirling" in a recent RADIO? One thing may be of some use: a recent operator to whom I was chatting once, told me of his initiation. He was when first went aboard) ordered about by one and all, and was set to cleaning brassware, officer's boots, and such other jobs. It was some little time before he found out that he himself was an officer!

W.I.C. (Botany).—"I wish to add a 'C' battery to the Reinartz Two. How should this be done. What is the advantage?"

Answer: See answer to N.E.P. (Lismore), about 14 queries back.

(2) "How many turns of 24-gauge wire should I wind on a 3-inch transformer for a crystal set to tune in to a station with a wavelength of 1250 metres?"

Answer: About 250 turns. Presume you want Perth? Pretty hard on a crystal set!

Mr. A. V. Withers, "Glen Roy," 58 Station Street, Tempe, N.S.W., writes:—"Could you kindly ask any of your readers through your columns if they could forward me the monthly periodical WIRELESS CONSTRUCTOR for May, 1927, which I will be glad to pay for. I require this particularly, as it contains a three-valve set called the "Signal Box," which is a Hale circuit, with a stage of R.F., employing standard six-pin plug-in coils, in order to endeavor to trace and remedy fault in a friend's set, the circuit of which is rather complicated?"

Answer: The WIRELESS CONSTRUCTOR is a British publication sold by Gordon and Gotch. W.E. (Mascoot).—"What is the test speed for an A.O.P.C. aspirant in Morse?"

Answer: Twelve words per minute.

J.F. (Melbourne).—"I am making the All-Empire, and would like to know if the new Radlokes short-wave coils for screen grid would improve the set, and if any alterations would be necessary to the circuit published by you in WIRELESS WEEKLY some months ago?"

Answer: These coils may be used, but the original coils will be just as good for the All-Empire.

(2) "Would this also apply to the coils in the other section of the set?"

Answer: Yes.

(3) "Would the use of Amperites prevent any chance of blowing out valves, and would they improve the set?"

Answer: Yes.

QUERY COUPON
If you are in difficulties about reception or set-construction, let us know, and we will endeavor to set you right. Make your questions brief to the point, and, whenever possible, show layout and wiring design. Under no circumstances will answers to queries be mailed by letter or by telephone. All answers will appear in the columns of this department in the order in which they are received.
The Radio Information Service, WIRELESS WEEKLY.
Please forward the accompanying queries to the Information Service Department. Enclose this coupon in order to indicate that I am a bona-fide reader.

**"MT. WARNING" (Murwillumbah):** "I am a car salesman, and the firm I work for have the agency of the Atwater Kent. I have sold a number of sets in the district, and have trouble with only two of them. Both these sets have cone speakers with power valves, 135 volts B, with 9 volts bias installed right in every way. They give excellent results, but are heavy on batteries. I have tried various makes of batteries, but they only last a couple of months. The sets have four Philips 609, one Radiotron 201A, and one Phillips 605. There is no other complaint—only the excessive use of B batteries. I would be very glad if you could put me wise through the information columns of your valuable paper."

**Answer:** Most "B" batteries of the dry type suffer during the summer. They should be kept in a cool, dry place. Advise use of eliminators. Then again, the power valve takes a much heavier milliamperage than the ordinary amplifier. The batteries could be made to last longer by using an ordinary amplifier in the last stage, such as a B69.

**E.K. (Queensland):** Please don't make your letter so long next time.

(1) "I am enclosing coupon, some questions, and a rather untidy diagram, but I hope you will be able to make it out. I have crossed out one wire drawn by mistake to F negative of detector."

**Answer:** Your coupon, questions, and blot received O.K.

(2) "Are the coils wound right? They each have turns as shown on 2 1/2-inch former (No. 30 D.S.C. wire), and a space nearly an eighth of an inch between primary and secondary."

**Answer:** The windings are O.K., but—

(3) "Would altering the space be better?"

**Answer:** Yes; make it quarter of an inch.

(4) "Do you think the set would give daylight reception of Sydney using two stages of S.G. before the detector?"

**Answer:** Quite likely, but it is hard to say. It will depend a great deal on local conditions at Warwick, and on the aerial system you use.

(5) "Would the quality suffer if I used two Ferranti transformers in place of the other unit mentioned?"

**Answer:** No. On the contrary, there will be a gain in volume, and also in quality of tone.

(6) "Please give a drawing showing how to connect two or more 4 1/2 bias batteries to get different grid bias."

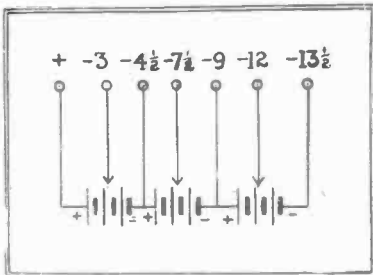

**E.K. Queensland, asks for a diagram showing how to connect up two "C" batteries in order to obtain various negative tapings.**

**Answer:** The circuit is shown here. Connect the positive terminal of the first battery to the negative of the second—and so on. Taps can be taken off anywhere along the batteries. Had it cut out all your "twiddly bits" owing to pressure of space. See below.

**L.H. (Gympie):** "Re attached diagram; could I make this into a short-wave receiver?"

**Answer:** Yes, by buying a complete set of S.W. parts with the exception of the baseboard, battery, switch, and valve socket.

**GENERAL:** Please note remarks to above correspondent. This includes you, E.K.

**L.H. (Gympie):** Another letter from you?

(1) "I have a three-valve set on which I get good loud-speaker strength from 4GC, 2FC, 2D, 10, 3AR, and Japaa—also 2GB very faint of phones."

**Answer:** Some receiver, that!

(2) "Is it a good performance?"

**Answer:**—

(3) "How could I get New Zealand and Japan as full speaker strength?"

**Answer:** Take your receiver there.

(4) "Now, regarding Morse telephony. I can hear two Morse stations; where are they situated?"

**Answer:** Telephony is the transmission of music or speech; Morse is usually via the carrier wave, which is broken intermittently. The two stations you hear are probably local amateurs on 200 metres, or ships and coast stations on 600 metres.

(5) "How do Morse stations operate, i.e., how do they receive messages? Do they write down dot, dash, etc., or A, B, and so on?"

**Answer:** Try copying down a Morse message from the local coast station dot by dot, and dash by dash yourself. No, the operator writes down the letter, not the Morse signs.

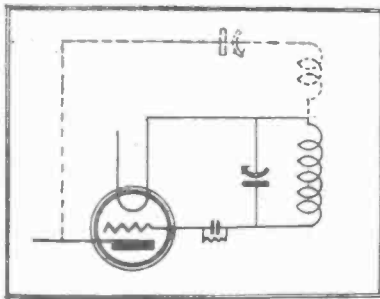

**L.F. (Epping) is using fixed reaction, and cannot get oscillation. He desires to use variable condenser reaction, and asks for the circuit which appears above. Dotted lines show additions.**

(6) "Where can I get a book on Morse code and abbreviations?"

**Answer:** Angus and Robertson. See also "Proving Radio." The abbreviations used in Morse appeared in the "Proving Radio" section on March 22. Thanks for your kind remarks.

**E.A.M. (Woy Woy):** "Would you be good enough to let me know where I could obtain the Hamill crystal receiver. Also the price?"

**Answer:** This set is not made as a commercial job. I made several inquiries for you, but radio shops pointed out that it would hardly be worth time making. The set, complete with phones, should not cost more than 30/. Try a small local dealer. If you know J.G.G., of Woy Woy, will you please show him how to write brief letters? Thanks.

**"REPAR" (Quigg Street, Lakemba), writes:** "I should like to get hold of a copy of WIRELESS WEEKLY dated February 1, 1929, containing the Marco Four, which I intend to build. I had the copy, but it was destroyed (unknowingly, of course). Trust you will keep this little journal at its present high standard."

**Answer:** Have published your query. Will some kind reader please oblige our inquirer? The name is Mr. W. J. Murphy.

**G.W.L. (Taree):** "Your previous letter may be here, but we cannot locate it. Suggest Coillville-Moore, Price's Radio, Economic Radio."

**H.A. (Bondi):** "How can I join the Bondi group of the Proving Radio Club?"

**Answer:** Ring the group secretary, Mr. L. R. Barker, M6681, during the daytime, or attend their next meeting at the address shown a couple of weeks ago on the club page.

**J.F.G. (Mosman):** "Re the two-valve short-wave receiver circuit printed in the February 22 issue. (1) Is the grid circuit connection to A plus or A minus optional?"

**Answer:** You will have to try both connections for best results.

(2) "Is the aerial series condenser C3, .00015 necessary?"

**Answer:** Yes.

(3) "If so, why?"

**Answer:** To eliminate dead spots on various wavelengths.

(4) "Could a fixed condenser be used? If so, what capacity?"

**Answer:** A fixed condenser would not be suitable unless it had the correct capacity, and this will depend on the length and capacity of your aerial.

(5) "Would a 250-turn duo lateral honeycomb oil be efficient as an R.P.C. in this circuit?"

**Answer:** It could be used, but is not very efficient. It is not so important as a B.C. receiver, but S.W. these things are very important.

(6) "Must I use 150 volts in the plate circuits?"

**Answer:** Only with the B-443.

(7) "Would any reader care to send me copies of WIRELESS WEEKLY which deal with the Go-Get-er, the De Luxe short-wave receiver, and the Wasp All-wave?"

**Answer:** We've asked anyway. The address readers, is Mr. J. F. Gowlard, 55 Middle Head Road, Mosman.

**"INTERESTED" (Newcastle):** "As a constant reader of your paper I would like to have your advice in regard to a difficulty I am in. I built the Marco Four some 18 months ago, and have since built a couple of them for friends. My receiver worked excellently until about a month ago, when it commenced to give a straining sound instead of throwing the sound clear of the speaker; this, together with crackles, was more pronounced in the evening than in the daytime. I replaced all the condensers and had all valves tested, and one new one inserted in place of a valve that was in a poor condition. Things now began to get worse, and it was hardly possible to get anything at all from the machine, but last night, after having disengaged the speaker plug and placed the speaker on the table I could hear faint music coming from the set. What was the cause of this phenomenon, and what is the matter with my set?"

**Answer:** One of the audio transformers was acting as the speaker. The vibrations made by the minute current flow caused sound waves to emanate from the transformer core. It is quite a common occurrence. The trouble in your set is a faulty transformer. It will probably be a burnt-out primary of the first transformer.

(2) "I should like to bring my machine back to its previous efficiency, which was very high. Might I also add that I have not been able to enmesh the reaction condenser without jamming the machine?"

**Answer:** Plates of condenser touching. This would cause a short, and may be the cause of the transformer trouble.

**VOLUME (Randwick):** "I have a crystal set with headphones attached, also a loud speaker. I can hear the speaker only at a distance of about two yards. Could you tell me how I could amplify the speaker, and could I get any adjustment that would rectify the matter?"

**Answer:** Build the one-valve amplifier which appeared in these columns recently.

**Y.A. (Glenreagh):** "I have a 210 valve. What can it be used for?"

**Answer:** In a receiver as an amplifier-power. In a transmitter as an oscillator.

**"ROPE" (Singleton):** "Am going to build the screen-grid short-wave Four-valve Midget, and would like to change over to Philips or Radiotron valves instead of the other type, of which I do not approve."

**Answer:** Proceed. Quite O.K.

**J.M. (Arcadia):** "We have a one-valve receiving set which worked perfectly until a few days ago. Now, when switched on, it gradually fades away until nothing can be heard, but if switched off, left for a few minutes, and then switched on again, it goes as well as ever for a little while and fades away again. Could you give us an idea of what is wrong?"

**Answer:** The "A" battery is flat. If dry batteries are used they will have to be replaced, but if an accumulator is used it should be re-charged.

**C.B. (Batlow):** "I have a five-valve Radiat set, and up till three days ago it has given me no trouble. I have had it one year and eight months. I have a constant whistling noise in the set when I take the speaker off the cabinet, but while the speaker is on top of the cabinet, set is quite all right. If I remove the speaker and place it elsewhere I get the whistling, but directly I place my finger on the two terminals of the speaker noise ceases."

**Answer:** Flat "B" batteries or faulty valve in last stage.

**C.N. (St. George):** "I have a Radiat five-valve set. Reception has been good up till February, when the town electric light was switched on. Daylight reception is impossible, though it was O.K. before."

**Answer:** As I have had so many inquiries from your district in connection with this, the interference eliminator was published on March 27 for your benefit. The local council should be advised.

**R.E.S. (Waverley):** "What is the distance (by sea) between Brisbane and Sydney? I don't know whether you'll be able to tell me or not, but I noticed you were able to advise a reader of the distance between these two places by air."

**Answer:** The distance between Sydney and Brisbane by sea is 508 miles.

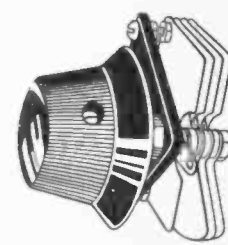

**Y.F.A. asks:** "What is a Midget condenser? Is it one with only a few plates?" **The answer is No! A Midget condenser is small throughout. A picture of one appears above. The plates usually have an area of about three square inches.**

(2) "If you have managed to answer that one, can you tell me the distance by sea from Gibraltar to London and Brisbane to London?"

**Answer:** Gibraltar to London, 1320 nautical miles. London to Brisbane, 13,100 miles. This latter, of course, is assuming that the ship travels round the Great Australian Bight. The distance will be slightly less, if the northern route is taken. The fares for London and Brisbane are taken for the Suez route. Hope this is what you want. Cannot advise off-hand distance when the Cape route or the Panama Canal route is taken. Any of the steamship offices will be able to give you further information on this subject.

**E.W. (Peterahum):** "Will I ruin my valves if I use a 100 amp. "A" battery instead of a 30 amp. battery?"

**Answer:** No. The 100 amp. battery will last considerably longer before it needs re-charging.

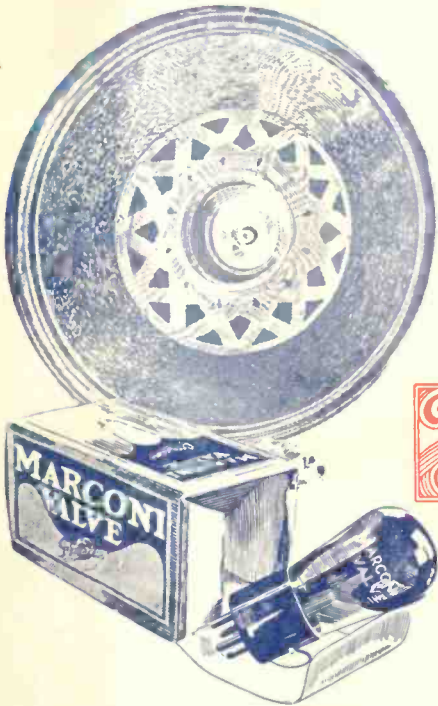

## The New Marconi Valves and Speakers

THE proved efficiency of the new Marconi valves and speakers is the result of years of careful research by the engineers of the Marconi Company, England.

Three years intensified research in loud speaker production introduces the ultimate in cone loud speakers—the new Marconi cone—This new loud speaker meets every exacting condition, bringing an entirely new conception of broadcast entertainment.

The new Marconi valves, available in two, four and six volt series, are noted for their economy of operation with regard to both "A" and "B" batteries. They ensure a maximum of undistorted signal strength with a minimum of current.

*Adjustment of the new Marconi Cone Loud Speaker is at the front. The cone is protected at the back by a metal bracket*

Price . . . £5

Obtainable all Radio Dealers

*The New Marconi Valves are packed on scientific principles. Risk of breakage during transit is obviated.*

Price 12/6

**MARCONI**  
**VALVES & SPEAKERS**  
 "as famous as the name they bear"



Amalgamated  Wireless  
 Australasia Ltd

SYDNEY, MELBOURNE, ADELAIDE and WELLINGTON, N.Z.



# AMPLION

## THE JUNIOR CONE A.C.2

Many thousands of Junior Cone Speakers are giving perfect satisfaction to their owners. This wonderful little Amplion is irresistible to the enthusiast with limited means. Your dealer will be glad to demonstrate.

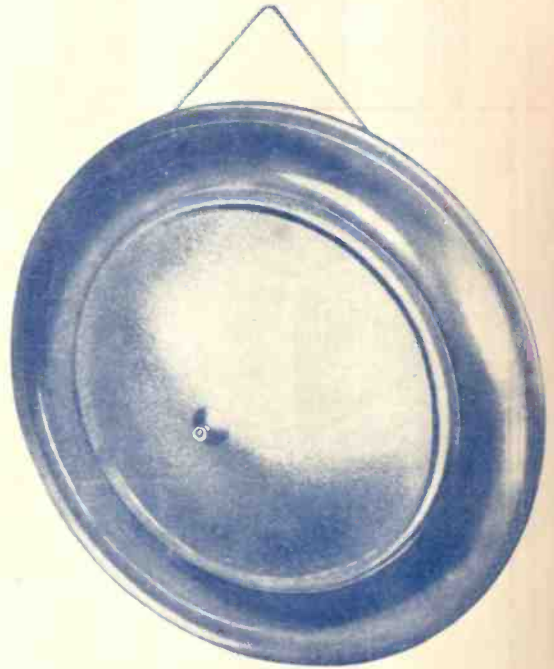

### 55/-

### EVERYONE

### CAN OWN AN AMPLION

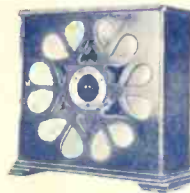

The popular AC4 Junior Cabinet meets the demand for low-priced cabinet model possessing the characteristic natural tone of the Amplion Cone range.

Oak \_\_\_\_\_ £4/7/6  
Mahogany \_\_\_\_\_ £4/12/6

Send the Coupon for Illustrated Literature.

Messrs. Amplion A/Sia Ltd.—Please forward me further particulars of Amplion Cone Speakers.  
Name \_\_\_\_\_  
Address \_\_\_\_\_

**AMPLION A/SIA LTD.**

**Bradbury House, 53-55 York Street, Sydney**

DISTRIBUTORS IN ALL STATES

W.W.8.