

2nd Birthday Issue!

JULY 1987 \$4.75 NZ\$6.50

Incorporating

Elektronics
Electronics



ROGER HARRISON'S AUSTRALIAN ELECTRONICS

Monthly

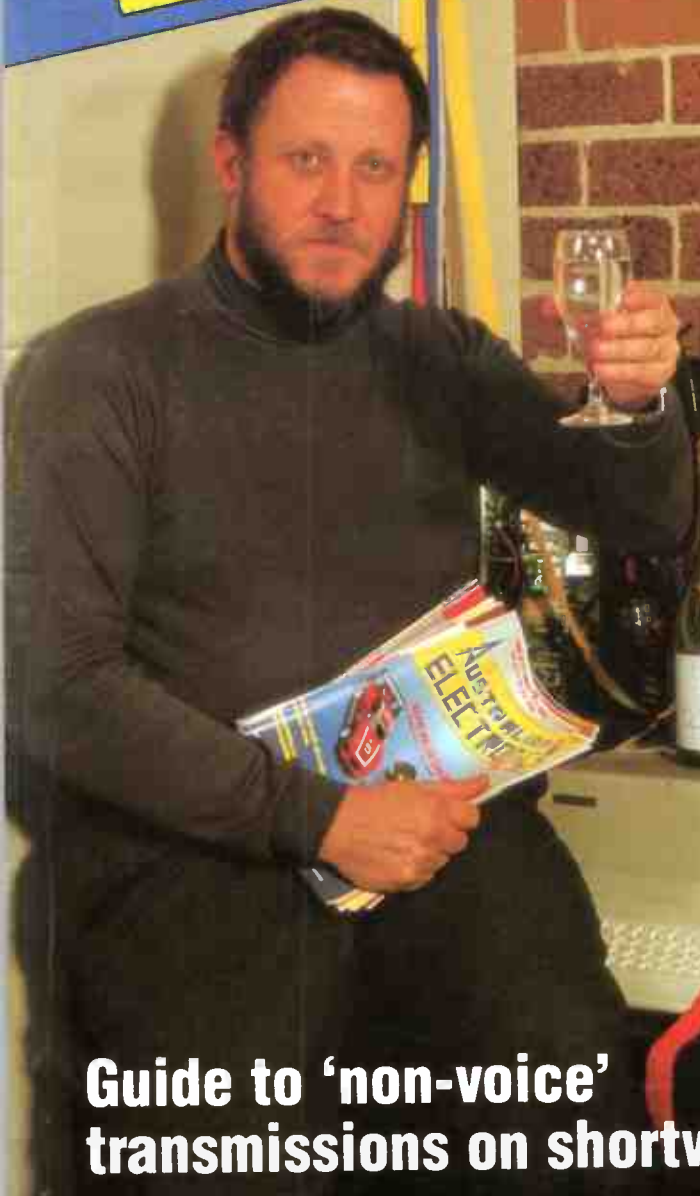

Build our stereo
balanced line driver

Get into
packet radio!

1986-87
INDEX

Guide to 'non-voice'
transmissions on shortwave

Ten-more, good buddy!
- the CBRs turns ten

PHILIPS DMM TO WIN

Good as Gold

FLUKE
1,000,000



The 70 Series Multimeters: the shining standard by which others are measured.

These multimeters are produced through advanced technology that assures you a wealth of product features. Giving you solid value for your money.

Security of a 3-year warranty.

A 3-year warranty reduces your cost of ownership. So you don't have to pay the price over and over for lesser-quality multimeters.

More features for your money.

Choose from either the basic 73 or the feature-rich 75 and 77. You'll find the features you need at the price you can afford. Touch Hold™ for capturing and holding readings. Audible tones to signal you for continuity. Autoranging for simple operation. And a sleep mode for extending battery life up to 2000 hours.

Made in the U.S.A.

Like other Fluke products these multimeters offer you uncompromised quality at competitive prices. So get your hands on a 70 Series Multimeter at leading electronics distributors nationwide.

FROM THE WORLD LEADER IN DIGITAL MULTIMETERS.



FLUKE 73, 75, 77

0.1%, 0.5%, and 0.3% basic dc accuracy	3-year warranty
Analog digital display	Audible continuity (75 & 77)
Volts, ohms, 10A, diode test	Range hold (75 & 77)
Auto range	Multipurpose holster (77)
2000+ hour battery life	Touch Hold function (77)

Talk to your local Elmecso distributor about Fluke —

- **A.C.T.** John Pope Electrical (062) 80 6576 • J Blackwood & Sons (062) 80 5235 • George Brown (062) 80 4355
- **N.S.W.** Ames Agency 699 4524 • J Blackwood & Sons • George Brown 519 5855 Newcastle 69 6399 • Bryan Catt Industries 526 2222 • D. G. E. Systems (049) 69 1625 • Petro-Ject 550 1388 • David Reid 267 1385 • W. F. Dixon (049) 61 5628 • Macelec (042) 29 1455 • Ebson 707 2111 • Selectoparts 706 3244 • Geoff Wood 427 1676 • Novacastran Electronic Supply (049) 62 1358
- **N. TERRITORY** J Blackwood & Son (089) 84 4255, 52 1788 • Thew & McCann (089) 84 4999
- **QUEENSLAND** Auslec (07) 8541661 • Petro-Ject (075) 91 4199 • St Lucia Electronics 52 7466 • Cliff Electronics 341 4655 • L. E. Boughen 369 1277 • Fred Hoe & Sons 277 4311 • The Electronic Shop (075) 32 3632 • Thompson Instruments (Cairns) (070) 51 2404
- **S. AUSTRALIA** Protronics 212 3111 • Trio Electrix 212 6235 • Industrial Pyrometers 352 3668 • J Blackwood & Son 46 0381 • Petro-Ject 363 1353
- **TASMANIA** George Harvey (003) 31 6533 (002) 34 2233
- **VICTORIA** Radio Parts 329 7888 • George Brown Electronics Group 878 8111 • G. B. Telespares 328 4301 • A. W. M. Electrical Wholesalers • Petro-Ject 419 9377 • J Blackwood & Sons 542 4321 • R. K. B. Agency 29 7336 • Sirs Sales (052) 78 1251 • Mektronics Co 690 4593 • Truscott Electronics 723 3094
- **W. AUSTRALIA** Atkins Carlyle 481 1233 • Dobbie Instruments 276 8888 • Protronics 362 1044

FLUKE®



A CELEBRATION

Well, didn't that year whizz by. It's our second birthday already! One of the most significant events for the magazine during the past year has been the incorporation of selected projects and articles from the British edition of the widely respected *Elektronik* from October '86. This has proved quite popular and we're very pleased at reader's response to it. It's also personally very satisfying to see that the three projects featured in our first issue are still stock kits with a number of suppliers, as are many of our projects since then, testifying to the acceptance of our choice and presentation of projects.

But enough of history. We've plenty more to offer for the future: projects like active loudspeakers for the audio enthusiast, an all-mode amplifier for the six metre amateur band, some more small computer add-on projects and whatever you prompt us to produce that's of popular interest! And that's not to mention the features we've got lined up. We'll shortly be doing an update on dial-up data services and looking once again (maybe annually?) at what's happening in CAD. But we can't give too much away too early!

All of us at the magazine would like to sincerely toast all you loyal readers and say, THANKS FOR STICKING WITH US FOLKS!

Roger Harrison VK2ZTB
Editor

Published by: Kedhorn Holdings P/L (Inc. in NSW), Fox Valley Centre, Cnr Fox Valley Rd & Kiole St, Wahroonga 2076 NSW. **Typeset by:** Authotype Photosetters P/L, 397 Riley St, Surry Hills NSW, and Tuldin, 19 Princes St, McMahon's Point NSW. **Printed in 1987 by:** Offset Alpine, Cnr Derby & Wetherill Sts, Silverwater NSW. **Distributed by:** Network Distributing, 52-54 Park St, Sydney NSW. *Cover Price \$4.75 (maximum and recommended Australian retail price only; recommended New Zealand price NZ\$6.50). Registered by Australia Post, Publication No: NBP 7435. ISSN No. 0815-5046.

COPYRIGHT: The contents of The Australian Electronics Monthly is fully protected by the Commonwealth Copyright Act (1968). Copyright extends to all written material, drawings, circuit diagrams, printed circuit boards, computer software and photographs. Although any form of reproduction is a breach of copyright, and we especially point out this extends to the construction of projects produced by our laboratory or our associates, we are not concerned about individuals constructing projects for their own private use, nor by bands for example, constructing one or more units for use in performances. Commercial organisations should note that no project or part project, including printed circuit boards produced by our laboratory or our associates and described in this magazine may be offered for sale, or sold, in fully or substantially assembled form, unless a licence has been specifically obtained to do so from the publishers, Kedhorn Holdings Pty Ltd, or from the copyright holders. We will take strenuous legal action against any person or firm found infringing our copyright as aforesaid.

LIABILITY: Whilst all efforts have been made to ensure that all constructional projects and circuits referred to in this issue will operate as indicated efficiently and correctly and that all necessary components to assemble the same will be available, no responsibility whatsoever is accepted in respect of the failure for any reason at all of the project or circuit to operate effectively or at all whether due to any fault in design or otherwise and no responsibility is accepted for the failure to obtain any components in respect of such project or circuit. In addition, no responsibility is accepted in respect of any injury or damage caused by any fault in the design of any such project or circuit aforesaid. The publisher accepts no responsibility for unsolicited manuscripts, illustrations, computer software or photographic material although all care will be exercised. Comments and test results on equipment reviewed refer to the particular item submitted for review and may not necessarily pertain to other units of the same make or model number.



EDITOR/PUBLISHER

Roger Harrison VK2ZTB

ASSISTANT EDITOR

Andrew Keir VK2AAK

DRAUGHTING

Kym Baillie

PRODUCTION COORDINATOR

Val Harrison

EDITORIAL ASSOCIATES

Ian Boehm VK3XCD

Neil Duncan VK3AVK

B. App. Sci. Dip. Ed. M. Ed. Studs

Alan Ford VK2DRR/G3UIV

FIAA MBIM

Tom Moffat VK7TM

Jonathan Scott VK2YBN

B. Sc./B.E. (Hons)

SPECIALIST SERVICES

Jamye Harrison

NATIONAL ADVERTISING MANAGER

Richard Parker

INTERSTATE ADVT. SALES

Victoria

Rowan Wyeth & Associates

1/128 Dandenong Rd, Dingley 3172

Ph: (03)551 1212

Queensland

Geoff Horne Agencies

PO Box 247, Kenmore 4069

Ph: (07)202 6813; Fax: (07)202 7133

Tlx: (07) AA41398 (Geoff Horne)

West Australia

Stephen Knight

Hugh Scott & Associates

122 Aberdeen St, Northbridge 6000

Ph: (09)328 9204

ACOUSTICAL CONSULTANTS

Robert Fitzell Acoustics Pty Ltd, AAAC

CONTRACT PROJECTS

Technical Systems Australia

ENQUIRIES

Advertising
(02)487 1207

Editorial
(02)487 1207

Technical

Only after 4.30 pm EAST

(02)487 1483

Roger Harrison or Andy Keir

SUBSCRIPTIONS

\$49.95 Australia,

overseas rates on application

EDITORIAL OFFICES

Fox Valley Centre

Cnr Fox Valley Rd & Kiole St

WAHROONGA 2076 NSW

POSTAL ADDRESS

PO Box 507, WAHROONGA 2076 NSW

FAX: (02)489 1265 TLX: 121822 (SY3296)

COPYRIGHT ©1987, KEDHORN HOLDINGS P/L

ADVERTISERS INDEX

COVERS

Elmeasco IFC
 Bose Australia IBC
 Tandy OBC

INSIDE

ACE Radio 57
 All Electronic Components 77
 Automatic ICE Co 37
 CLC 81
 Dick Smith Electronics 67-73
 Emona 58
 Emtronics 22
 Force Electronics 18-19
 Geoff Wood Electronics 44
 Hatadi 13
 Hi-Com Unitronics 78-79
 IPS Radio & Space Services 26
 Jaycar 63
 Kalex 91
 Kenwood 29
 Maestro 82
 Micro-Educational 84
 Philips Elcoma 9
 Powersonic 20
 Quality Trends 77
 Rosser Communications 14
 Scientific Devices 21
 Solarex 22
 Sound On Stage 16
 Statronics 7
 Sydney CB Centre 11
 Tega Electronics 77

COVER

Time for a celebration! It's our 2nd birthday. A toast to you, loyal readers, one and all! Pic - Allen Hedges. Design - Val Harrison.

PROJECTS TO BUILD

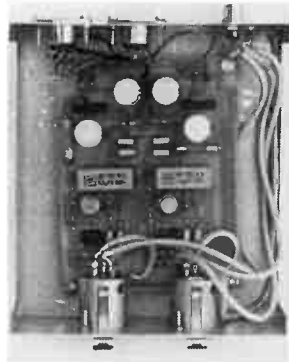

AEM6011 Audio Balanced Line Driver 59

A high performance unbalanced input to balanced output stereo line driver, ideal for active speaker systems.

AEM3505 Packet Radio System for the Commodore 64 74

If you've ever wanted to join the fun on packet radio, here's the low cost way to do it if you have a Commodore 64.



AEM2000 Lab. Standard Power Supply, Part 4 64

This month, it's the panel meter.

CIRCUITS & TECHNICAL

ELEKTOR IN AEM

Contents 33

Autoranging DMM to Build 45

Here's a great project! This DMM features an LCD display and is small enough for handheld operation.

Motorcycle Intercom 48

Simple, effective unit solves the driver-passenger communication problem.

DATA SHEET 76

The LH0002, featured in our 6011 Audio Balanced Line Driver this month.

FABULOUS OFFER!



Philips' PM 3055 50 MHz CRO! 27

Last chance!

PRACTICAL COMPUTING



SPECIAL OFFER

AEM4622 V.22 Modem 80

Build yourself a V.22 modem for modest cost and get flying at 1200 bps!

Software Review 82

A peek into "Mirror", a data communications package.

Dial Up 83

Roy Hill gets into digital signal processing.

Using the AEM4504 Speech Synth. on the BBC-B Computer 86

Here's how to hookup our popular low-cost speech synth. to the "Beeb" and get it talking with some simple software.

COMMUNICATIONS SCENE

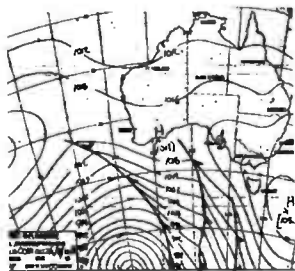

A Guide to Non-Voice Transmissions on SW

..... 24
Looking for radio facsimile (FAX) and radioteletype (RTTY) stations on the shortwave bands? Here's where to find the regulars.

A Guide to Digital Communications, Part 2

..... 28
Andy Keir concludes with a rundown on AMTOR and packet radio, plus where newcomers can seek help.

The Listening Post Package

..... 90
Build a decoder for your Apple, Commodore or Microbee and get into FAX and RTTY reception on HF with our pcb/software offer.

Literature Review

..... 91
Two new books for the communications enthusiast.

CONSUMER ELECTRONICS



And Ten-More Good Buddy!

..... 10
CB was "legalised" a decade ago. David Flynn gives us a personal reminiscence.

FEATURE

And Ten-More Good Buddy!

..... 10
CB was "legalised" a decade ago. David Flynn gives us a personal reminiscence.



NEWS & GENERAL

1986-87 INDEX

..... 93
Compiled by Corey Harrison.

News Review

..... 6
Guilt-edged capacitors?

Consumer News

..... 15
New Onkyo separates.

Professional Products

..... 20
Weather satellite Rx.

Spectrum

..... 23
Wireless video.

Retail Roundup

..... 56
Short form kits.

Project Buyers Guide

..... 56
Sourcing kits & bits

Bytewise

..... 81
New modem.

Letters

..... 8

Subscriptions

..... 97

The Last Laugh

..... 98

NEXT MONTH!



BUILD THIS LOW-COST STEREO AMP!

Have you noticed how kit stereo amps have gone up and up in price over the years? Sure, features and performance have improved, but what about the constructor who wants a "plain and simple" stereo amp? Well here it is!

A HIGH PERFORMANCE BALANCED MIC PREAMP

Here's a top performer, featuring very low distortion and a signal-to-noise ratio of 80 dB. And you can provide phantom mic powering up to 18 V.

SECTION INDICATION FOR A MODEL RAILWAY

Here's a unit that shows a train's position with a series of LEDs so you can "keep track" of the train on a large layout, particularly when you can't see it.

LASERS - AN OVERVIEW

Keep up to date on the world of laser technology. A must for students!

PUTTING THE AEM3500 AND AEM3510 TOGETHER

Here's how you combine the 3500 Listening Post (July '85) with the 3510 Simple RTTY Modulator (May '87) to get a complete RTTY terminal.



BIRTHDAY CONTEST

..... 17
Win a fabulous Philips digital multimeter!

While these articles are currently being prepared for publication, unforeseen circumstances may affect the final contents of the issue.

Gilt edged capacitors?

Amidst reports of a possible world shortage of tantalum, the prices of two small West Australian mining stocks, Vultan minerals Ltd and Greenbushes Ltd have increased dramatically in recent weeks.

Tantalum, which is the major product of these two companies, has been trading for around US\$21 a pound in recent times, but according to one report, may soon move up past US\$50 a pound.

Figures in a recent study by a Sydney broker infer that the world supply of tantalum, used in refined form to make tantalum capacitors, is less than half of demand.

The figures show that Greenbushes, originally a tin miner, produces 25% of the world's tantalum. Other major mines in Brazil and Thailand, produce about 60 tonnes a year.

The world consumption of tantalum dropped sharply between 1980 and 1981, but a subsequent recovery has seen the supply almost triple since then.

Whilst this situation will almost inevitably lead to an increase in the cost of tantalum capacitors, I don't think we are at the stage where we have to start stripping our old pc boards and queuing up at the stock exchange!

Spray painting with SQUIDS

Scientists at IBM have found a way to "spray-paint" large and complex surfaces with high-temperature superconductor material, raising the prospect of inexpensive, easy-to-apply magnetic shielding, computer wiring and other applications that might benefit from the material's unique properties and new-found workability, IBM say.

The new discovery followed just two weeks after IBM's announcement that it had made the first practical thin-film superconducting devices from the new materials — magnetic detectors called SQUIDS (Superconducting Quantum Interference Devices — see News Review last month).

Using a common industrial technique called plasma spraying, IBM has been able to coat

items of various sizes at approximately the same rate of speed one would expect to use to carefully spray-paint a car.

Plasma spraying is a technique used in manufacturing applications that quickly heats a material to thousands of degrees and instantly deposits the substance on a surface where it resolidifies. After coating, objects are annealed (heated), after which their coating becomes super-conducting.

IBM researchers believe they are the first to quickly and easily coat complex shapes such as pre-formed wires, contoured and flat surfaces and even tubes made from ceramic, quartz and metals — materials important in a number of industries.

IBM also has used this new discovery to make large high-temperature superconducting objects, to cover extensive areas and to produce, handle and employ large quantities of superconducting materials.

The materials — combinations of yttrium, barium and copper oxides, resemble flat black paint. After annealing, they become completely superconducting in the temperature range of liquid nitrogen, "warm" enough to be practical for many scientific and industrial uses. (Liquid nitrogen boils at 77 degrees above absolute zero.)

Most materials and wires that IBM researchers have coated become completely superconducting at between 60 and 82 degrees above absolute zero.

The IBM scientists say the new materials might be used for advanced scientific experiments, serving as an easy-to-apply and economical magnetic shielding. In addition to their ability to pass electricity without resistance, superconductors also are impervious to magnetic fields.

Superconducting "wires" for computer chip packages might also be made by plasma spraying, the scientists say. They



W.A. INDUSTRY SHOWS OFF

In past years, the Perth Electronics Show has been dominated by Japanese, European and other overseas consumer electronics manufacturers. However, last year, for the first time the Electronics Industries Association of W.A. (EIA) took space in a pavilion in order to "show off" the sort of high tech activities carried on in the west. It created quite some interest.

This year, the west's high-tech industries are again showing their capabilities with some 15 companies clubbing together to take a whole pavilion located just inside the Claremont showground's entrance.

The Perth Electronics Show this year runs from Tuesday 29 July (a trade day), through to Sunday 2 August.

Companies exhibiting in the EIA pavilion this year will be presenting equipment ranging across satellite communications to home security systems, printed circuit manufacture to energy management systems, etc.

Frank Krause, spokesman for the EIA, says membership ranges from small companies through to WA branches of major international business houses, such as Hewlett Packard and Wang.

have fabricated thin lines on typical substrates used in computers and have successfully coated tiny holes in these ceramic structures.

Substrates are used to support and string together scores and

even hundreds of such chips in modern computers.

Using such superconducting wires could prove useful in computers, since they would operate without electrical resistance.

There was movement at the station . . .

Mike Wilson, Managing Director of Dick Smith Electronics Pty Ltd in Australia and New Zealand, has announced his resignation from the company. Mr. Wilson, who joined the company in March 1984, intends to capitalise on his past experience in the computer industry and is examining several opportunities at this time.

Arista Electronics has announced the appointment of Mr. Peter Taylor to the position of Product Manager. Mr. Taylor joins Arista following nine years of service with Tandy Electronics where he was the assistant merchandising manager.

The board of Elmeasco Instruments Group announces that Mr. L. S. Altman will retire as managing director from the 18th May 1987, after a period of some 20 years with the company.

Mr. Altman will remain a director and a consultant to the group. Mr. Mike Collins, General Manager of Tech-Rentals Pty Ltd has been appointed a director and assumes the position of Acting Chief Executive Officer.

Elmeasco became a subsidiary of Tech-Rentals in 1984 and has grown to become one of the largest Australian owned electronic test and measurement companies in the country.

CHALLENGE

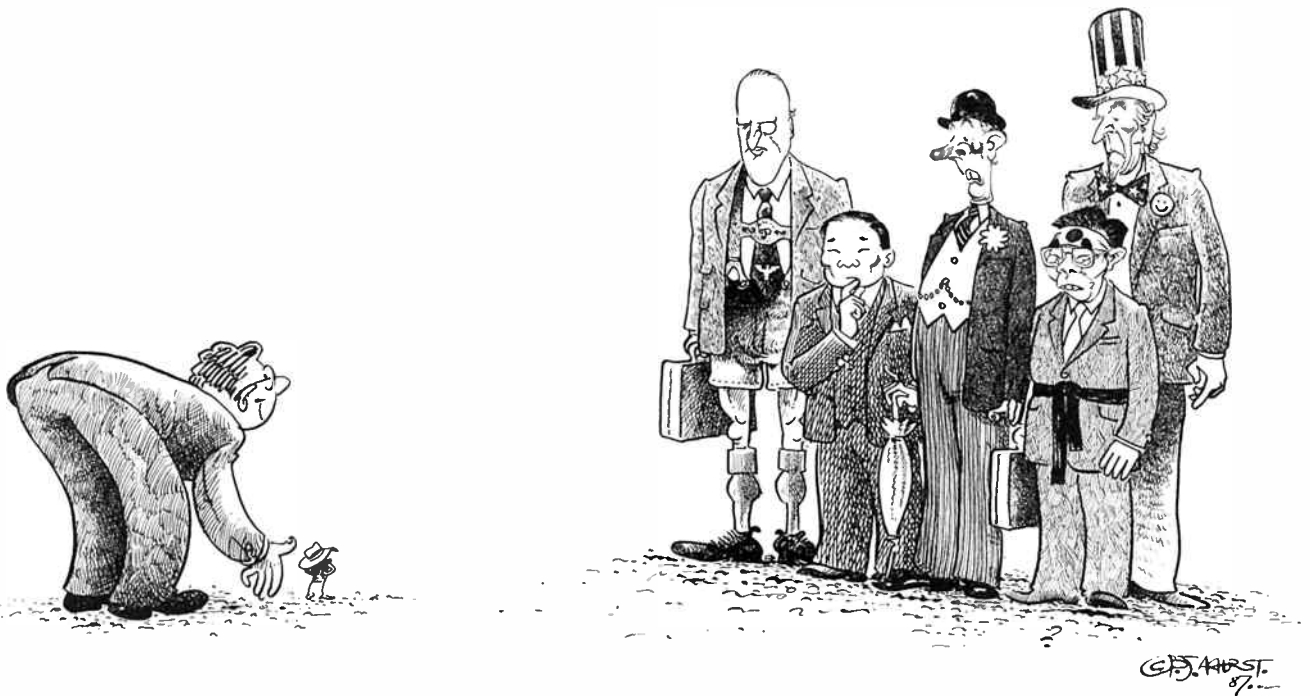

A CHALLENGE TO ALL POWER SUPPLY IMPORTERS WIN A FREE AD IN THIS MAGAZINE

WE THINK OUR AUSTRALIAN-DESIGNED AND MANUFACTURED OFF-LINE SWITCHING POWER SUPPLIES ARE THE **SMALLEST IN THE WORLD**. BUT BEFORE WE START BRAGGING ABOUT IT, WE THOUGHT WE'D BETTER CHECK.

IF YOUR PRINCIPAL'S 10 WATT, 20 WATT, 30 WATT, OR 70 WATT SWITCHERS ARE GREATER POWER DENSITY, WE'LL ADMIT IT IN ANOTHER AD IN THIS MAGAZINE. WE'RE SO CONFIDENT, GENEROUS TECHNICAL CONCESSIONS ARE BEING ALLOWED — GIVING YOU A KM START IN A MARATHON.

CONDITIONS:

Nominal Input Voltage must cover Australian "published" line conditions, i.e. 240V RMS 50Hz $\pm 10\%$. ***This is a concession, ours cover a wider range of 200-280V.*** At the nominated output power the supply shall operate at 50 degrees C ambient with a calculated MTBF of better than 30,000 hours with natural convection cooling — no fans — and no extra heatsinking. ***This is a concession — ours work at 60 degrees with 50,000 hours.*** Supply must have 2 or more outputs. ***Another concession — ours are triples.*** Supply must meet the usual International and local creepage, clearance, and breakdown voltage safety standards. Supply must regulate down to 20% load (ours 10%) Dimensions must be measured overall. Supply must be a standard catalogue item, or at least available within 16 weeks, i.e. not a highly experimental lab prototype. In the event of dispute, the assessment of an independent engineering firm shall prevail.

10 WATT OUTPUT

72 x 27 x 18 mm
4.683 watts per cubic inch

20 WATT OUTPUT

72 x 40 x 27 mm
4.215 watts per cubic inch

30 WATT OUTPUT — OPEN TYPE

127 x 58 x 24 mm
2.78 watts per cubic inch

30 WATT OUTPUT — FULLY ENCLOSED

127 x 58 x 27 mm
2.47 watts per cubic inch

70 WATT OUTPUT — FULLY ENCLOSED

136 x 71 x 32 mm
3.71 watts per cubic inch

70 WATT OUTPUT — OPEN TYPE

136 x 71 x 28 mm
4.24 watts per cubic inch

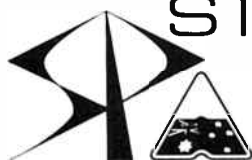

STATRONICS POWER SUPPLIES

Rifala Pty Ltd trading as Statronics Power Supplies
103 Hunter Street, Hornsby N.S.W. 2077 Australia
Telephone: (02) 476 5714. 477 5152

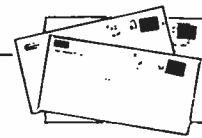

Text-to-speech

Dear Sir,

I have recently built the AEM4505 speech synthesiser project from the February 1986 issue of your magazine and was impressed by the quality of speech it produced. Since then I have been interested in updating to a text-to-speech synthesiser and heard that you produced such a project as a plug-in card for the IBM-PC, which uses the same speech synthesiser chip (SP0256-AL2) as the previous project. Unfortunately, I have been unable to find out which issues this project was in and do not know what project number it is.

Could you please inform me if you have back issues of your magazine with this project in and if you produce the necessary printed circuit board for it? Some idea of costs would also be appreciated.

P. Taylor,
Frankston, Vic.

The AEM4504 was a very popular project and I'm glad you were impressed by it. The text-to-speech synthesiser to which you refer is our project AEM4505, published in the June and July 1986 editions. Back issues or article photostats cost \$4.00, post paid.

This project could be used as a plug-in card for IBM-PCs or connected to either the serial or the parallel printer port of any computer and as you state, has the text-to-speech algorithm in an on-board ROM, the CTS256.

A complete kit for the AEM4505 is available from Hi-Com Unitronics at 7 President Lane, Caringbah 2229 NSW. Their telephone number is (02)524 7878 and their postal address for mail orders is PO Box 626, Caringbah 2229. They can also supply a pc board, we understand. The kit was recently advertised at \$125 which represents a very good saving (like about \$500!) over the cost of similar pre-built speech synthesisers we've seen.

Andy Keir

Amstradder fan

Dear Sir,

Having recently acquired an Amstrad 8256 PCW, my first home computer, lacking great keyboard skills and struggling to learn CP/M, I was grateful to read the article "Getting On Line" in the April AEM Amstradder Column.

I am thirsting for knowledge of my new computer, and I believe I have

purchased a really good, and quite professional, machine which will serve me for quite some time.

I find that most articles on computers tend to assume that every reader has full knowledge of all CP/M commands and codes etc, and as a result persons like me are left in a daze after reading, with a lot of time to be spent on experimenting to get things working.

I also realise that writers cannot treat each article as a training manual, but there is a point in between that would serve everyone well.

After all, the purpose of any article is to impart knowledge, and the success of such articles is to reach the greatest number of converts.

Thanks to Steve Holland for the article, and I will be watching your magazine for any future articles on the 8256 PCW.

Lawrie Sjoberg
Henley South S.A.

Kits in short form

Dear Sir,

I have noticed in recent months that a lot of discussion has been taking place about the high cost of kits to build magazine projects. There seems to have been a lot of talk but very little action because, as yet, none of the electronics retailers have started selling kits in partial form as far as I can tell. I will admit that some retailers did make a half-hearted effort by advertising "hard to get" components, but for the most part these seemed to consist of outdated stock and not parts for current kits.

I am a pensioner and as a result, have to run my hobby on a very limited budget. I simply can't afford to spend the money for some of these kits in one go. It's all very well for the stores to suggest using a credit card but not too many pensioners can afford the luxury. When are the retailers going to realise that they would increase their sales if they could offer the difficult to obtain parts as well as complete kits?

There are many projects I would have built if I could have stretched out the cost over a period of time but instead, I have just had to go without. I really feel that most of the electronics retailers have lost interest in helping the hobbyist. These days the salesmen don't seem to know anything about electronics and the companies seem to have turned a deaf ear to all the suggestions about short form kits.

I don't expect you to publish this letter because I'm sure your advertisers would

object to my criticism but at least it makes me feel a bit better to have aired my grievances and maybe, if you get enough letters, somebody might eventually give the market what it wants.

C. Hodgekiss
Blacktown, NSW

If you refer to the Retail Roundup page in this issue, you will find that at least one retailer has got their finger on the market's pulse. Dick Smith Electronics has announced the introduction of a service to provide customers with short form kits. Whilst initially this service will only be available for six of their more popular kits, they indicate that they intend to expand the service according to demand.

Apart from this service, there are some kits which have always been available from suppliers in short form. An example is our AEM4610 supermodem for which we supplied the pc board and EPROM.

As far as your comments about our advertisers are concerned, you need have no worries about our publishing your letter or indeed any letter from a hobbyist. Very many people who are employed in the electronics industry are also hobbyists, and that includes the staff at this magazine, so we are always eager to provide support or listen to comments from our fellows. If we think a letter has relevance to the hobby, we will make every effort to publish it.

Of course our advertisers are of great value to us, but it would be unfair to them and our readers if we were to allow them to dictate our editorial policies. This is a symbiotic industry, where the magazine and the advertiser depend on each other to address the needs and demands of the customer. It is reader/customer feedback that really determines editorial direction of the magazine and sales policies of the retailer, within practical limits.

Andy Keir

1 GHz counter problem

Dear Sir,

Some time ago I bought a kitset from Dick Smith for a 1 GHz frequency meter. According to the assembly manual that came with it, the meter featured in your July 1986 edition.

I struck a problem with the meter and rang Dick Smith but they couldn't help me. My problem is that the meter works perfectly on the 10 and 80 MHz scales but not on the 1 GHz scale. When I put

- to page 14 ▶

Philips SMDs offer a lot of room for improvement

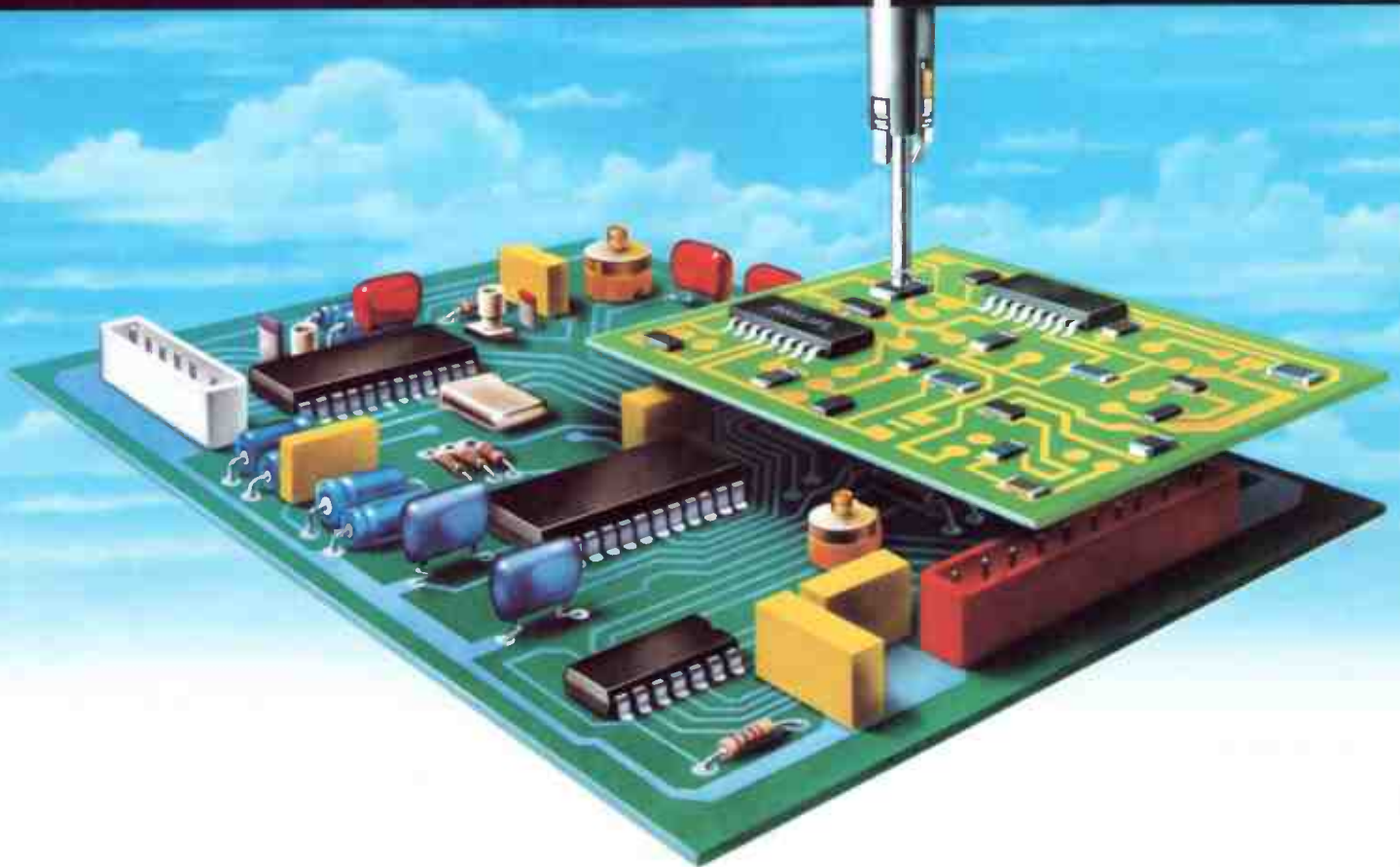

Philips Surface Mounted Devices give you plenty of room to improve the design, manufacture and performance of your products.

Because they not only take miniaturisation a major step forward, but also make circuit boards less costly and dramatically more reliable.

Smaller boards, closer placement, and because the devices are mounted on, not through the board, the designer can use both sides of the PCB.

Philips SMDs are designed for automation, and Philips is a leader in the specialised automation equipment to accurately site the SMDs. Your products are assembled faster, and more efficiently. And because these components are so

highly reliable, the failure rate – during manufacture and in the field – is significantly reduced.

So, before you begin a new design using conventional components, talk to Philips about SMDs.

We can give you exciting information about SMD applications by calling one of our offices below:

Sydney (02) 439 3322 Melbourne (03) 542 3333

Adelaide (08) 243 0155

Perth (09) 277 4199 Brisbane (07) 44 0191

or write to **Philips Electronic
Components and Materials**

11 Waltham Street,
Artarmon NSW 2064.



**Electronic
Components
and Materials**

PHILIPS

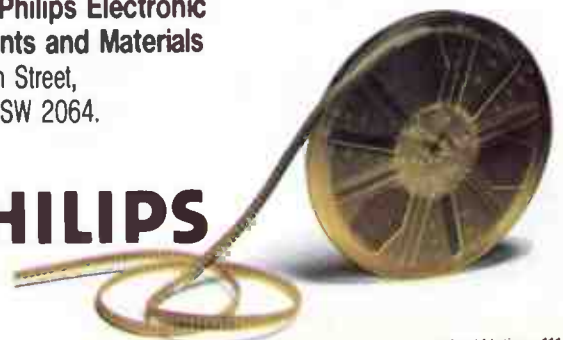

And ten more good buddy!

CB celebrates ten (legal) years. A personal reminiscence.

David Flynn

Whether it was public pressure or commercial interest that brought on the CB boom of the late 70s, resulting in the "legalisation" of the Citizens Radio Service in July 1977, has been lost in the detritus of history. David Flynn turns over the decade, digs up a few survivors for a nostalgic tour of the HF and UHF bands, and speculates a little on the future.

I REMEMBER starting with one of those 20-in-1 kit boards, given to me one Christmas, which probably gave my early interest in radio and electronics a bit of a kick-start. The school library had a collection of the WIA's *Amateur Radio* magazines, which were way above my level — it took me quite some time just to work out why they would call someone 'Bill, 2XYZ' instead of using his surname. Amateur radio was all too mysterious, too hard to grasp, and of course they didn't even have the novice licence until later.

But the library also had some American publications, such as *Popular Electronics*, which were much more readable, and I flicked through those like summer fire. Maybe I didn't understand it all, but at least it made electronics more of a friend than a stranger.

Around 1975, PE was really getting into CB radio as it reflected the 'consumer' aspect of electronics. Of course it later dumped CB for computers, dropped computers for high-tech audio and so forth, as the trends called for. So I went into CB from there, picking up copies of American mags like *s9* from the local second-hand book shop.

First gear

The first rig I used was a Universe 23 channel mobile, which came from Strato Communications in Parramatta, Sydney. Strator was to western Sydney CBers what Stonehenge was to the druids!

Then came the move to sideband, with a Contact AM/SSB from Peter Shalley in Killara on Sydney's north shore. After that, I went into UHF with one of the early Philips' FM320s. A lot of people run the 320s into the ground, but I still have a soft spot for them — just a weakness for 'first love', I suppose!

Current gear

Most of my operations today are on UHF CB. At one stage I had the lot — 27 MHz and UHF at home and in the car, and also amateur radios for 6m, 2m and 70 cm — plus a general coverage HF receiver. But you can only really use one bit

of gear at a time (unless you're cross-banding), and I never had time to get on air often enough. I'd turn on the UHF, and find enough friends that I'd never get around to the ham bands, let alone 27 MHz.

So I decided to start again from scratch, selling everything except the UHF CB radio — and I've never really got back onto any other band 'full time.'

The gear I run today, then — it's mostly UHF. I've got this fantastic but very tiny sports car, a Fiat X1/9 (the man has taste! I had one too, once — Ed.) which my local radio tech calls a 'lunchbox', and the only rig that would fit was a remoted-mounted Sawtron 990. That point aside, the Sawtron is a superb radio in every way.

There is also an Icom IC-40 UHF handheld, and a few options have made it very versatile indeed. Besides the usual portable use, it is great when you travel with some friends who are in another car — I can give them the Icom, set it up in a jiffy, and we're in contact whatever happens, wherever we go.

I only use HF CB when I'm travelling, so the car has been out-fitted with all the cables and connections necessary. It's a sort of instant 27 MHz — just add radio and antenna!

Favourite gear

My very favourite rig would have to be the Icom IC-4E. I know that may confuse some readers, because the 4E was a 430 MHz amateur radio . . . but in the early stage of the game there were no UHF CB handhelds. A few technical types figured out how to modify the 4E and lift her upstairs to 477 MHz — quite illegal, granted, but even though you took a risk using it, the response was enough for Icom to make a legal version of the 4E — the IC-40 — available.

So there was this full 40 channel UHF CB handheld, fully compatible with the great range of Icom accessories, and fitted with a few special receive mods that enabled you to keep an ear on a nearby band which was never dull. Definitely a rig I've fond memories of.

The only two HF rigs that stand out were the Tram D201

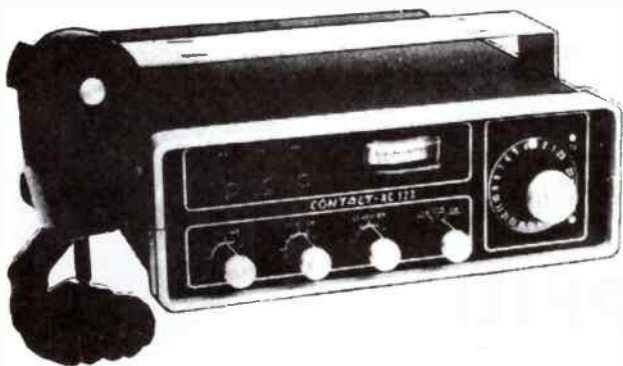



and a nicely converted Kenwood. The Tram was a real gem — a massive base station using valves, large knobs and a lollipop mike to resemble a vintage wireless from the 1930s.

I suppose some people will lash out at me for using a modified Kenwood especially as I once championed the cause of the fully by-the-book operator . . . but I'd got to the point where the quality of 27 MHz gear just wasn't good enough. I wanted to get active on the amateur bands, and up-grade my limited licence to play with 10 metres FM — as you may have guessed by now, the FM mode is my biggest interest.

So when Kenwood brought out their TS-660 'quad-bander', it was a god-send. The 660 was an excellent radio, with all the features and performance which amateurs expected, but CBers could never hope to see on 11 metres. It covered 15/12/10 and 6 metres, on USB/CW/AM/FM, but with only 10 watts output. That suited me fine, I've never been a power freak. I had coverage of 26-28 MHz wired in, dropped the CW for LSB, and quickly became a convert to 27 MHz FM!

That was all in the past of course, I wouldn't dream of running illegally now . . . really, truly!

Legalisation day

I was still at school, in Year 10, The morning CB was legalised was fantastic. It was on the news on the radio, and every mobile on their way to work was on air louder than ever.

We actually had a school excursion that day, to the St George Building Society head office in Hurstville — ironically, that building was the site for Sydney's first UHF CB repeater, on ch. 1/31, some years after.

Who remembers the queues at the P&T Licensing offices?

Where did it lead me?

In a round about way, it led me where I am today. I'd always liked writing, but not really the creative sort — more along the journalistic line. When CB became big news, and the magazines came out, I realised I could write about CB — my first articles were printed while I was still in school.

I underwent some technical training in radio-electronics for a while, but kept writing, and eventually threw in the traineeship to study film and TV production. Again, I began writing in that field, all of which eventually led me to my present job — but if CB hadn't given me something to write about, I don't think I would have ended up here.

I also became involved in the club scene, which was a great learning experience, training me in PR and made me realise that PR was my strength and I could make a career of it.

The less selfish part of it is that I met some of my very best friends on air (on UHF CB, actually). We have more in common than CB of course, and we've shared some wonderful times together.

What about "upstairs"

Understandably, there's only one guest of honour at this month's birthday party. That overweight, noisy but ever-so-popular kid with the initials 'HF'. His cousin, born that same day, isn't there. He was premature, but grew into a lean, proud and sometimes arrogant lad. Happy Birthday, UHF.

It's understandable, all the fuss over 27 MHz, the memories of pirates, AMers and those kings of the airwaves, the side-banders. 27 MHz was kicking and screaming for a long time before the DOC delivered it. ►

**THE
SYDNEY CB RADIO
CENTRE**

1469 PITTWATER RD. NARRABEEN, N.S.W. 2101. PHONE (02) 913 1616

The North Shore's Best Communications Centre SPECIALISTS IN:

- * MARINE RADIOS — UNIDEN, G.M.E.
- * CB — ELECTROPHONE, UNIDEN, PEARCE SIMPSON
- * UHF CB — PHILIPS, UNIDEN, ELECTROPHONE
- * SCANNERS, RADAR DETECTORS
- * ACCESSORIES — HEAPS OF THEM!

Not so, UHF CB. This band was created by the DOC at the same time as it introduced the 18 channel 27 MHz allocation. The first true 477 MHz radios didn't appear until mid-1978, which gave a year for speculation and prophecies of doom to be cast over the future of UHF CB.

It was a difficult time, certainly. No-one had any experience with this sort of thing. A channelised allocation in the upper end of the UHF commercial band, mass produced radios with an output of five watts, for use by almost anyone.

The biggest question was one of range.

Graham Pockett, who wrote for *CB Action* magazine at the time, remembers his initial apprehension about UHF CB for a number of reasons.

"One was that commercial UHF radios, even with 25 watts, didn't seem to have a lot of range, and our big thing as Cbers was power. Remember, this was the era of power, everybody had a linear amp, and everyone was going for bulk power. We hadn't realised in those days that power was not the answer for CB."

There was also the 'line of sight' axiom, underscored by the lack of knowledge about antenna systems and other matters taken for granted on 27 MHz. At the start, everyone from Dick Smith Electronics to AWA were eager to talk of their own plans for a UHF CB radio. Then the talk grew quiet, as they waited for Philips to test the water with their model FM-320 — which must rank as Australia's most eagerly-awaited CB radio.

CB Action founder and current editor, Pete Smith, described his first trial of UHF as a "most memorable experience."

"I realised that a whole new world was going to open up for the Australian Cber, and I was going to be a part of it." Ever the practical man, Smith also claimed one of the best advantages of the totally vacant 477 MHz band at the time to be, "no bloody breakers!"

If the proof of the pudding is in the tasting, then this dish went down well — with small businesses, farmers, and hobbyists who fled the insanity of 27 MHz.

"During this period of growth" remarks Pockett, "we had the same type of situation as was once on 27 megs. Older operators, in their late-20s to mid-30s, with no kids or bad language. It was overall a very pleasant medium to switch on to, and offered very reliable communications, which we hadn't expected originally."

Among the first hobbyist operators on the band was Leon Senior, today acknowledged as one of the "founding fathers" of UHF CB.

"It was pretty quiet on air, and we knew everyone in the area. There was still a lot of experimenting — most of us had mobile whips on our housegutters, and we discovered that if we put them up higher in the air we could get out better. Philips in Melbourne were on the air all the time, too, they must have given UHF to all their technicians and sales people.

"It all proved that UHF was better than what many people on CB magazine thought. At first they were unkind, but after they discovered it themselves, they swung around as well."

UHF was next to benefit from the introduction of repeaters. Yet the very first, says Senior, was short-lived indeed.

"It came on air on a Monday, and was taken down on Tuesday, Philips had fitted it with tone access, so no-one but Philips staff could use it. Everyone else protested against this, of course."

The repeater re-appeared in early November, 1979 — Melbourne Cup weekend. Philips not only removed the tone squelch to provide open access, but told Melbourne's UHF Cbers how to modify their radios to 'duplex' mode.

"This time" says Senior, "they put it up on Friday, and by Saturday morning everyone had the repeater modification,



and was using the repeater to talk to all these people we'd never been able to hear before."

With repeaters approved, 477 MHz took off. There are now almost 150 licensed UHF CB repeaters throughout Australia. These are financed and operated by individual hobbyists, communications stores, farmers, businesses and clubs — a cross-section of UHF users.

These users are the key to the success of UHF CB. In designing the service it did, the government — perhaps by accident — created not a replacement for 27 MHz, but a whole new realisation of what CB radio was all about.

Happy Birthday, 477 MHz!

Meanwhile, back at the ranch

If the first ten years of CB radio were filled with ups and downs for the users, then for the industry they were highs and lows of epic proportion. 'The industry' is, of course, any concern which stood to make money from CB radio. The manufacturers, importers/wholesalers, retailers and the CB magazines.

In year zero, they all flourished. CB was business. Big business. Cutting across the social spectrum as it did, you could buy a CB radio anywhere. From the larger department stores, down to chemists and even smoke shops. If there was a dollar to be made — and a quick one at that — then CB was where you could make it. The crash that followed came as no surprise to anyone who could see further ahead than their end-of-day cash statement.

In 1977, there were some 150 different brands of CB radio on the shelves — a figure taken from the DOC's list of approved equipment at that time. There were primarily turned out by a mere handful of Japanese manufacturers. That one was labelled 'Apollo' and another 'Sound 4' counted for little. Any design variation — a different name, a change to the front panel layout, the deletion of one control or inclusion of another — any of these require a minimum production run of 1000 rigs.

With 150 brands, that translates into 150 000 units. Allowing for a production run of greater than 1000 (not uncommon), and the existence of un-approved models, there could easily have been 200 000 to 300 000 CB radios heading into the Australian market.

These radios all arrived in the space of months. Yet, at an average of 1000 sets purchased each month, that supply would have lasted in excess of two years. Although the number of sets being purchased by the public was large, it could not be shared amongst so many brands and so many retailers or importers. This led to slow sales in some companies, which found themselves unable to pay their Japanese manufacturers when the time came. The result — bankruptcy.

The Expo company was one of the first to fall. They had to dispose of 65 000 radios, and did so at extraordinarily low prices. This started a chain of domino-effect bankruptcies. With massive amounts of equipment available at such low prices, people suddenly started buying Expo CB radios. (One ▶

WHAT DOES AN OLD PIRATE REMEMBER ABOUT 1977?

"The time the RIs nearly caught me . . . the morning they legalised CB . . . all the mates I met on air . . . and the day I bought my Pearce-Simpson Super Panther."

Quality. Performance Reliability, Value for Money.

Reasons why, ten years later, Pearce-Simpson is still Australia's leading brand of CB radio. And why, along with Cobra and Royce, Pearce-Simpson CB radios are today distributed nationally by Australia's No. 1 communications company – Hatadi Electronics. The names you'll remember – for years to come.

THREE OF A KIND

The Hatadi range of CB radios includes a variety of models. From AM to SSB, economy mobiles to deluxe base stations, and a full range of 477 MHz equipment. All with one thing in common – Hatadi's philosophy of the best radio gear your dollar can buy. Here are three new releases which meet that standard.



Cobra 18+

Now this is style! Smart looks to match the very latest car hi-fi gear . . . electronic channel change, innovative digital 'staircase' meter, and an extra large green LED channel display. There's also a PA facility, ch. 9 select, fully automatic noise limiter and convenient front-mounting microphone.



Super Tomcat II

The best-selling slim-line sideband, from Pearce-Simpson. Built to fit any car and any budget. RF gain control, green LED channel display, ANL/NB noise reduction circuitry, PA function and LED meter.



Royce AUS-100 UHF

The very latest in UHF CB, with features that work for you – like a ch. 11 reset and display dimmer. Front-mounting microphone, long fluted controls and compact size make this a perfect mobile UHF. Optional selcall/CTSS.

PLAY IT SAFE

. . . with the latest radar detectors from Cobra. Proven on the American highways and in Australia.



Trapshooter PRO II

When it comes to a radar detector, anything less than the best is just your first few hundred dollars up in smoke. The PRO II is Cobra's best. Super sensitive on both X and K bands, large signal strength/range meter, city/highway mute and sensor light.

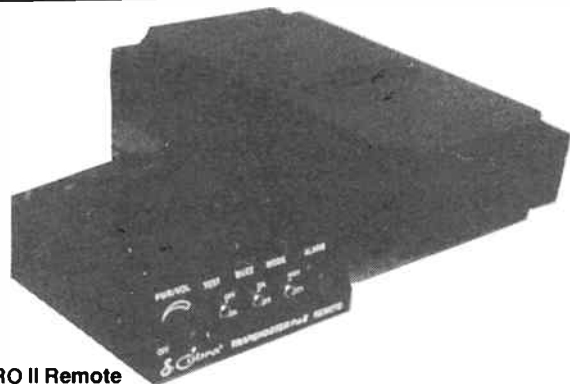

Trapshooter PRO II Remote

This specially designed model of the PRO II is ideal for hide-away mounting. Large radar sensor fits behind the grille, miniature control unit sits snug in your dashboard, console, even glovebox! City/highway mute, test mode, alarm light and dual X/K band reception.

Distributed by Trade Dealer Network throughout Australia



PEARCE-SIMPSON

Founder member of the CB Industry Association

20 WILMETTE PLACE
MONA VALE N.S.W. 2103 AUSTRALIA

TELEPHONE: (02) 997 7077 TELEX: AA122205
FAX: (02) 99 1229

HATADI ELECTRONICS
CORPORATION PTY LTD (inc in NSW)

Australia's No. 1 Communications Company

WHAT DOES THE FUTURE HOLD?

If the DOC doesn't just drop AM entirely, then 27 MHz will continue as before — more or less under its own weight and forward momentum.

UHF CB shows a continued potential which has only been fully realised in some areas. But it also shows that there are a myriad of uses for a high-quality, medium-range peoples' band. I think that the future of this is demonstrated by Japan's high-tech 900 MHz personal radio service — which has individually-addressable selective calling, carrier linking, the works.

I can see one possibility — that the DOC will take a slice from the 70 cm amateur band and open up a UHF PRS, ideal for personal husband-to-wife or business communications.

can't help thinking that this all came a bit late for the company).

Sales of other brands, already perilously low, dropped even further, forcing other companies broke, ensuring the chain would continue until the boom faded, and died. For years after, the Australian Cber was still buying radios from this source.

When time caught up, it was a new game entirely. The yen had strengthened against the dollar. The cost of components, labour and transport had risen. The smaller demand and lower production runs led to higher unit costs.

— from page 8

the oscilloscope on it, I found that the U664B chip was only dividing by two instead of 64 as the manual says it should. This is where I struck trouble as I have looked up all my data books and contacted Dick Smith but nobody has heard of this particular chip. I would like to obtain information on it's pinouts and specifications.

I have checked the board and soldering with a magnifying glass and everything looks alright. I wonder if you could help me as there may have been an errata in later copies of your magazine which unfortunately is difficult to obtain in the rather isolated area where I live.

P. Nicholls
Runanga, NZ

The frequency counter to which you refer was featured as a Star Project in our July 1986 edition and was designed by the R&D division of Dick Smith Electronics. I have contacted the designers at the head office of Dick Smith in Sydney and explained your problem to them.

The consensus is that you probably have a faulty U664B chip as they have not struck this problem in the past. Their advice is for you to contact your nearest Dick Smith store who will arrange a replacement for you. Whilst many of the specialised parts used in kits are not stocked by individual stores, DSE assure me that any part can be obtained by ordering through one of their outlets or dealers.

The U664B prescaler chip is manufactured by Telefunken and the pin numbering can be gleaned from the circuit diagram in your assembly manual or the magazine. There has been no errata published for this project.

Andy Keir

There is a saying. What fire does not destroy, it hardens. The survivors of 1977 are the established market leaders of today.

That boom period was also a springboard for the publishing industry, with both small and large companies catering for the thousands who suddenly wanted to read a magazine about CB radio.

The first of these was *CB Australia*. Initially appearing as a pull-out supplement within a 'Electronics Today International' in February 1977, it also retailed separately for 60¢, and then became a magazine in its own right. Editor was — Roger Harrison!

Soon after, from the Melbourne giant Newspress, came 'CB Action'. These two publications were to be front-runners, and occasional sparring partners, for years to come.

Others which sought a piece of the action were *CB Monthly* (lasting seven issues) and *CB Life* (first and only issue, November '77).

CB Australia and *CB Action* were perfectly poised to become rivals. 'Oz' was from Sydney, 'CBA' from Melbourne. One was constantly tongue-in-cheek, the other more serious. One went in for a broadsheet newspaper format, before moving to gloss pages, with monthly electronic projects — the other chose standard four-colour standard size with plenty

— to page 96

MODEMS

The Right
Modem is
easy to
find
— at
Rosser

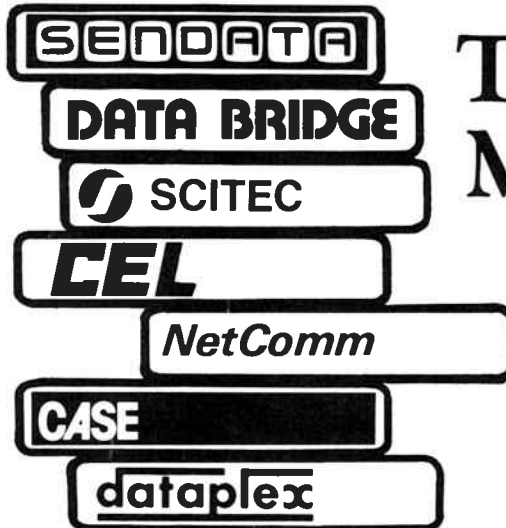

We stock the widest range in Australia selected from all the top manufacturers, so finding just the right model for your needs is easy. Plus we stock everything you need to get up and running straight away. Software, cables.... the lot!

We can deliver your complete modem system now so you don't have to wait weeks and weeks for supply. And as we select the best value products you will be pleasantly surprised at our competitive prices

Get your data communications on-line fast — Talk to us today.



ROSSER
COMMUNICATIONS

(02) 449 8233

Suite 4, The Pymble Professional Centre,
1051-1055 Pacific Highway, Pymble, 2073

New separates from Onkyo

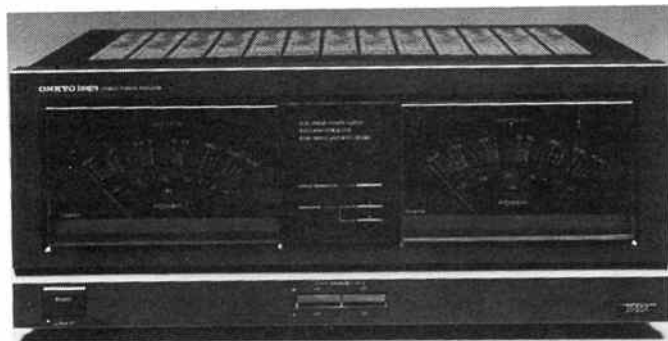

Onkyo's P304 pre-amp and the M504 power amp are the latest additions in their Integra range. These two new products are the successors to the popular P3033 and M5033 amplifiers and have been released in Australia by Hi-Phon Distributors Pty Ltd.

As members of the Integra family, the P304 and M504 employ Onkyo's "real phase" circuitry. This includes an additional real phase transformer in the power supply circuits of both channels which Onkyo claim results in enhanced sound reproduction, especially when using high quality speaker systems.

Onkyo say that the P304 and M504 units complete the Integra range of products that offers first-class sound reproduction for any domestic application.

For further information, contact Hi-Phon Distributors Pty Ltd, Unit 1, 356a-358 Eastern Valley Way, Chatswood 2067 NSW. (02)417 7088

New Neumann mics from Amber

Amber Technology has announced the release of a new shotgun stereo microphone system from Neumann. Designed for stereo location reporting in noisy environments, the RSM 190i system comprises

a shotgun stereo microphone with windscreen, a matrix amplifier and all connecting cables.

Neumann says the system is also ideal for stereo television, where soloists can be accentuated with presence and middle emphasis, whilst the orchestra can be picked up with a variable, wide bass width.

The RSM 190i can be operated hand held or attached to floor stands or booms. Outputs from the matrix amplifier are unaffected by disturbances caused by differing cable lengths through the use of balanced, transformerless circuitry. Both channels can be modulated without distortion up to a sound pressure level of 132 dB.

The system is stored in a robust, aluminium carrying case which can also accommodate a complete microphone mounted in a windshield, plus other equipment.

For further information, contact Amber Technology, Unit 6, Forestview Park Estate, Frenchs Forest 2086



W.A. HI-FI SHOW A SOUND SUCCESS

According to the organisers, the WA Hi-Fi Retailers Association Hi-Fi Show held in Fremantle's Esplanade Hotel in April was a major triumph for the retailers of Perth, and the industry. It proved that good hi-fi is alive and well and that there are lots of people who want to see and buy.

The industry-sponsored Battle of Perth's Best Jazz Bands and a recital from the 30-piece WA Mandolin Orchestra drew the crowds, as the picture shows. The idea was to enable people to hear acoustic music live, and give them something to identify with. This will continue next year, and Bose might sponsor a busker street contest, too.

A range of new products were unveiled, including some locally-made items. Almost 20 eastern-states industry executives flew over. The formula of live sound in the streets plus well-presented equipment in a decent listening environment was pronounced a success by all. The hi-fi show will complement the Perth Electronics show, the organisers say, running six months apart.



Sony disc jockey now for the home

Following the success of their disc jockey compact disc player for the car, Sony has released a house bound unit, the CDP-C10. It has a built-in changer for the 10 compact disc magazine and by selecting one of the various playback modes, you can sit back and enjoy in excess of 10 hours of musical enjoyment.

The CDP-C10 magazines are interchangeable with the CDX-J10 automotive disc jockey, allowing you to take a compilation of discs from the car to the house without removing the discs from the magazine.

You can manually select the playing order via the 21-key infra-red remote control or can use the "shuffle play" mode to select a disc at random and then randomly select the playing order until all the discs in the magazine are played.

The CDP-C10 is available through the Sony dealer network at a recommended retail price of \$1599, or contact Sony Australia Pty Ltd at 33-39 Talavera Road, North Ryde 2113 NSW. (02)887 6666.

"I've got MS — but I'm still smiling"

Like most people with MS, my symptoms are mild. They come and go, but in between, I'm fine.

Some people with MS are more disabled than I am. They need the activity therapy centres, the nursing homes and the many other services which MS Societies provide. For their sakes, keep up your donations.

MS
For more information about multiple sclerosis contact the MS Society in your state

A LITTLE LIGHT ON SOUND ON STAGE

The Sound on Stage staff pride themselves on having on display some of the finest production and studio equipment (including 2 to 24 track recorders) in Australia. Plenty of tape is always stocked so there is no fear of running out of the preferred Ampex 456 or Denon cassettes for your Tascam or Fostex.

STAGED FOR SOUND

Bring in your favourite compact disc and compare the range of JBL Studio Control Monitors, Electro Voice Centurys, Tannoys and NS-10s; all powered by Perreux power amps.

"What desk should I buy or hire?" . . . Just ask! Take a choice of Tascam, Fostex, Soundtracks, Soundcraft, Yamaha, AHB, D & R, and TAC.

What about signal processors?, with so many to choose from which one will suit you? . . . Boss, Yamaha, Roland, DBX, TC, Valley People, EMT, AMS, Lexicon and many more are on display.

Some P.A.s are also set up for demonstration eg. Martins, Yamaha, Turbo, E.V. and Session. You're welcome to come in and compare.

SOUND ADVICE

You do not have to fear the prospect of being assaulted by a rapacious salesman intent on taking your last hard earned buck . . .

If you're new to the industry, then the names Toivo Pilt (Toivo?) and Duncan McQuire may not mean much; until you look into their backgrounds and find a depth of music industry experience and talent.



Toivo Pilt, Manager of the Kent Street store, started his professional career around 1974 (he's not quite sure . . .) with "Sebastian Hardie" as Keyboard player, songwriter and arranger. Some of you might remember that John English was the original lead singer with S.H. Then to "Windchase", the first band that really cracked the lucrative o/s market. They're still getting royalties from Japan! Session work for Doug Parkinson, Ross Ryan, Jeff St. John and other notables were to follow.

It is interesting to note that Toivo has written eight documentaries for the American and Mexican governments over the years and still continues to write soundtracks when he's not yelling at the boss.



Duncan McQuire on the other hand, quiet and unassuming, electric bass player and one time winner of the Bass Player of the Year - Music Industry Award went a slightly different track.

After deciding that motor cycle racing had lost its attraction, he moved to Melbourne and started honing his bass skills on the pub circuit. Here came the break and he was invited to join "Ayers Rock" and toured the United States twice over a two year period. Music by itself was not enough though, he sought and found friends who were to teach him sound engineering. In his spare time, when the studios (no names here!) were empty, self tuition and sound jobs wherever and whenever he could get them led him to produce and engineer INXS' first album. Doug Parkinson got him to engineer his hit "I'll Be Around" and to cap it all off, the presentation of the Golden Reel Award to Duncan for the engineering of John English's live album "Beating the Boards". It went Platinum.

After a little break in the sun, a six months tour as sound engineer with "Jesus Christ Superstar" and after assisting his brother with several major video projects; Duncan was convinced that he should return full time to pro-sound equipment. He somehow landed in the lap of Toivo, (Toivo?), whom he had first met back in the "Windchase" days . . .

This of course leads us back to sound advice . . . Duncan and Mr. Pilt know what they're talking about. If you want to buy, hire or just learn . . . They know about the "Art of Sound".

THE ART OF SOUND

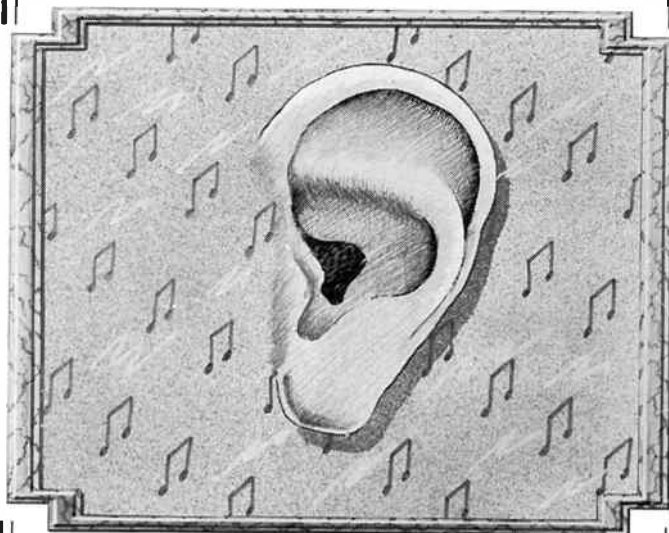

Everything from porta studios to 24 track recording, tape, mikes, amps and studio hire.

SOUND ON STAGE

400 Kent St, Sydney. 264 9783.

208 Pyrmont Bridge Rd, Glebe. 660 4555.

5 Byres St, Newstead, Brisbane. (07) 52 9083.

SECOND-BIRTHDAY CONTEST

WIN THIS SUPER PHILIPS DMM!

PM2618X/01



The Philips Series 18 digital multimeters are packed with features to meet all types of portable measuring requirements: from general servicing to both analogue and digital testing, R&D and even calibration!

The PM2618X/01 features a four-digit (+1) liquid crystal display, 0.1% accuracy, fourteen functions, measurement to 20 A and 100M, dB readout, a 200 kHz frequency counter, a highly sensitive analogue bargraph and logic testing to speeds of 10 MHz with duty cycle info included!

Don't miss this opportunity to own what is one of the top-line portable multimeter available today!

Prize kindly donated by Philips Test & Measurement Division.

All you have to do is answer the questions here, then tell us in 30 words or less why you'd desperately love to own this fabulous instrument!

RULES: You may enter as many times as you wish, but you must use a separate entry form for each entry and include a month and page number cut from the bottom of the contest page. You must put your name and address on each entry form and sign it where indicated. That is, photocopies are acceptable but an original month/page number from a copy of this month's magazine must accompany each entry form. The contest is open to all persons normally resident in Australia or New Zealand, with the exception of members and families of the staff of Australian Electronics Monthly, the printers, Offset Alpine, Network Distributors and/or associated companies. Contestants must enter their names and addresses where indicated on each form. Photostats or clearly written copies will be accepted if accompanied by an original page number and month cut from the bottom of this page. This contest is invalid in states where local laws prohibit entries. Entrants must sign the declaration that they have read the rules and agree to abide by their conditions. The winning entry will be drawn by the Editor whose decision is final; no correspondence will be entered into regarding the decision. Winners will be notified by telegram the day the result is declared and the winner's name and contest results published in the next possible issue of the magazine.

Send entries to:
Philips/AEM Birthday Contest
PO Box 507, Wahroonga 2076 NSW

Q1: You remember AEM's 1st birthday? What was the prize offered by Philips Test & Measurement (Scientific & Industrial)?

Q2: The 18 Series DMMs were reviewed in AEM's February 1986 issue. What does the last paragraph in Alan Ford's review say?

Q3: Consider the following numeric string: 166622800. No to-ing and fro-ing now! You've seen it before. Philips advertise it a lot. What is it?

Now, on a separate piece of paper, tell us in 30 words or less, why you'd desperately love to take home this prize!

Name

Address

Postcode

I have read the rules of the contest and agree to abide by their conditions.

Signed

July 1987 — Australian Electronics Monthly — 17

FUNCTION SELECTION	
Ω	1 k, 10 k, 100 k, 1 M, 10 M, 100 M (Manual only) < 10% ϵ \sim < 1% ϵ Ξ
V \sim	1 V, 10 V, 100 V, 1000 V, dB V \sim 50 Ω -47 ... +53.8 dB
V \sim rms	1 V, 10 V, 100 V, 1000 V, dB V \sim 600 Ω -51 ... +43.1 dB
Hz	19.999 kHz 199.99 kHz Gate open 1 s
Hz LOGIC	OPEN, bAd, Logic 1, Logic 0
Hz LOGIC ϵ	As Hz logic plus high tone = Logic 1 low tone = Logic 0 intermittent high tone = pulse(s)
CONT ϵ	Continuity check < 10% ϵ \sim < 1% ϵ Ξ Diode measurements 1 V, 1 mA
$^{\circ}$ C	-60 ... +200 $^{\circ}$ C with Pt-100 Ω probe PM9249
A \sim A \sim rms	20 mA, 200 mA, 2 A, 20 A

ZERO

- Selection of Relative Reference (press once)
- Recall of reference value (hold depressed in ZERO mode)

ARE YOU BEING SERVED?

- HAVE YOU GONE INTO YOUR LOCAL ELECTRONICS STORE RECENTLY AND FOUND IT'S TURNED INTO A TOY SHOP?
 - DO THE SALESMAN'S EYES GLAZE OVER AND BRAIN TURN TO JELLY WHEN YOU ASK A TECHNICAL QUESTION?
 - DO YOU FIND THAT YOU CAN'T ASK FOR SOMETHING WITHOUT KNOWING THE CATALOGUE NUMBER?
 - DO YOU PULL YOUR HAIR OUT AT THE LACK OF SERVICE AND INDIFFERENCE YOU GET?
 - DO YOU HAVE MASOCHISTIC TENDENCIES?
- IF NOT, WHY DO YOU SHOP AT THESE PLACES?

Have you got any LMR C4136 Quad Op Amps?...

NO, But We've got some Beaut Cuddly Bears that talk when You squeeze their footsies!...



WE ARE NOT A TOY STORE!

- BUT WE DO TRY OUR BEST TO LOOK AFTER OUR CUSTOMERS WITH SERVICE AS WELL AS PRICES.
- WE STOCK OVER 4,000 PRODUCTS FOR THE HOBBYIST AND THE TRADE.
 - WE HAVE FIVE STORES IN ADELAIDE FOR YOUR CONVENIENCE.
 - WE HAVE A FAST & EFFICIENT MAIL ORDER SERVICE FOR THOSE OF YOU WHO ARE UNFORTUNATE ENOUGH NOT TO LIVE IN THE SUNNY SOUTH!
 - WE'VE GOT MORE SPECIALS THAN A GOOSE HAS GOT PIMPLES (HAVE YOU EVER BEEN SERVED BY A GOOSE WITH PIMPLES?)

NOW HERE ARE SOME REAL SAVINGS FROM FORCE ...

**AEM 2000
100W LABORATORY
POWER SUPPLY KIT**

Refer A.E.M. article this issue for details.

\$479

BOURNS TRIMPOTS

3299W SQUARE MULTI-TURN NORMALLY \$2.75 NOW \$1.95	3006P MULTI-TURN RECTANGULAR NORMALLY \$2.60 NOW \$1.60	3386P SINGLE TURN HORIZONTAL NORMALLY \$1.45 NOW \$1.15	3386W SINGLE TURN VERTICAL NORMALLY \$1.25 NOW \$1.10	10 TURN PANEL POT NORMALLY \$14.95 NOW \$12.95

VALUES BETWEEN 10Ω AND 2MΩ AVAILABLE.

12V RELAYS

S.P. 12V
10 AMP.

~~\$4.95~~ **\$2.95**

**M2155
TRANSFORMER**

4-15V
1 Amp

~~\$7.95~~ **\$6.95**

**M6672
TRANSFORMER**

15-30V
1 Amp

~~\$13.95~~ **\$12.95**

**SPEAKER
CABLE**

~~\$20.00~~ **\$14.00**
P/ROLL

**STOP
PRESS**

New store
at
Findon, S.A.

**NOW
OPEN!**



VOLTAGE REGULATOR
Solar Charger Kit to suit Solar Panel. Ideal for boats, camping, etc. Charges at 13.7 or 14.7 volts.

\$24⁹⁵

\$89⁰⁰ **SOLAR PANEL**
18V 600mA

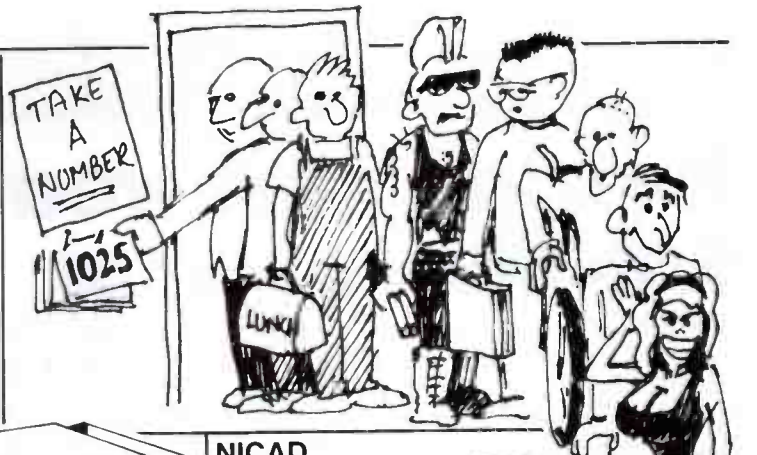

PORTASOL BUTANE SOLDERING IRON



Completely portable, take anywhere. 10-60 Watt variable.

\$49⁹⁵

\$59.95

INFRA RED DETECTOR (SPECIAL OF THE MONTH)

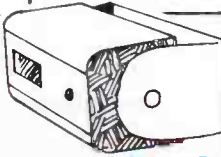

SA-209 Passive infra-red detector. 40 x 40 ft. @ 90°

\$79

\$119

NICAD CHARGING CABINET

Charges most sizes of batteries, even some watch batteries.



\$29⁹⁵

\$32.50

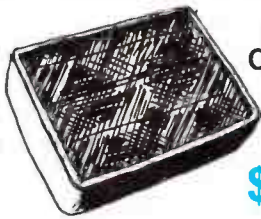

SOLAR BATTERY CHARGER

Suits 4 AA Batteries

\$14⁹⁵

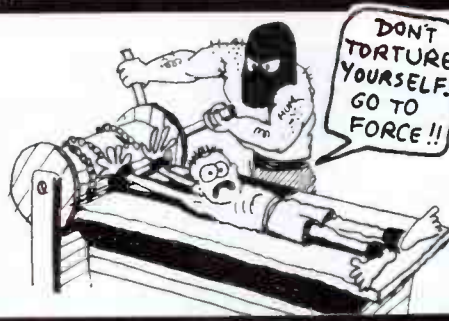

12V DC HORN SIREN



Building an alarm? **\$17⁹⁵**

\$29.95

NI-CAD BATTERIES

AA Normally \$3.50 NOW **\$2⁹⁵**
C Normally \$4.95 NOW **\$9⁹⁵**
D Normally \$15.95 NOW **\$9⁹⁵**
9V Normally \$22.00 NOW **\$19⁹⁵**



VIDEO SENDER

Plugs into your Video Recorder and watch from any room in the house.



\$59⁹⁵

12V DC STROBE



Red & Blue. **\$24⁵⁰**

\$27.50

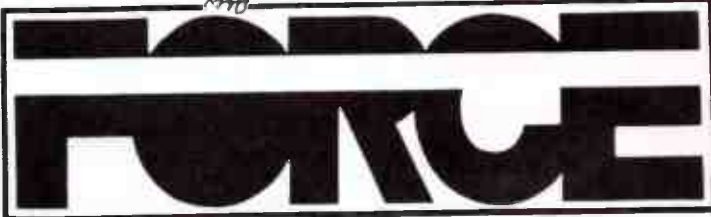
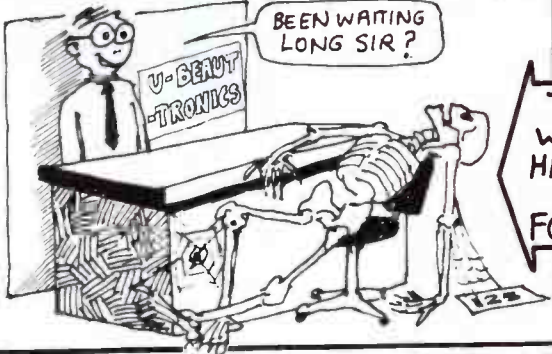

MAIL OR PHONE ORDERS TO ANY STORE.
STANDARD MAIL UP TO 2kg \$4
: O/N SERVICE UP TO 3kg \$700.
ROAD FREIGHT OVER 10kg \$10.00.

WE ACCEPT BANKCARD, VISA AND MASTERCARD.



ADELAIDE
203 WRIGHT ST.
(08) 212 5400

ENFIELD
445 MAIN NTH. RD.
(08) 349 6340

CHRISTIES BCH.
24 BEACH RD.
(08) 382 3366

BRIGHTON
504 BRIGHTON RD.
(08) 296 3531

FINDON
129 FINDON RD.
(08) 347 1188

New low cost weather satellite receiver

The Feedback WSR524 receiver released by AWA Measurement and Control Division is designed to automatically receive images from orbiting weather satellites.

Orbital information as well as the user's latitude and longitude is entered via an integral keypad and the internal compu-

ter uses this data to overlay a grid and the user's position.

The infra-red and visible images received are stored sepa-

ately and the picture may be faded between the two, both during and after reception.

Alpha-numeric characters at the bottom of the screen indicate the current time, the last entered user position and the

reception time of the picture on the screen.

Depending on the satellite pass, an area of up to 2500 kms around the user is displayed and different enhancement curves can be used to maximise the dynamic range of the received images.

For further information, contact **Measurement and Control division, AWA Technology Group, Unit C, 8 Lyons Park Rd, North Ryde 2113 NSW.**

Engineered With Vision



Built With Care

POWER-SONIC, a leading manufacturer of rechargeable batteries, offers a complete line of both sealed lead-acid and nickel-cadmium batteries, engineered to meet the toughest specifications. State-of-the-art design, meticulous quality control and time-proven performance are the reasons why engineers are specifying POWER-SONIC batteries; competitive prices and an outstanding track record for product reliability and on-time delivery have convinced buyers. For more information or a copy of our catalog, contact:

POWER-SONIC AUSTRALIA

13 Watson Rd, PADSTOW 2211

Ph: (02) 772 4522 Fax: (02) 772 4863

POWER-SONIC

SEALED RECHARGEABLE BATTERIES

New generation of soldering from Weller

Cooper Tools' range of Weller soldering stations has been released in an all-new series.

All stations are fitted with a new design detachable soldering iron stand which can be fitted to either side of the power unit or used separately for greater flexibility.

For further information, contact your Weller distributor or **Cooper Tools Pty Ltd, PO Box 366, Albury 2640 NSW. (060)21 5511.**

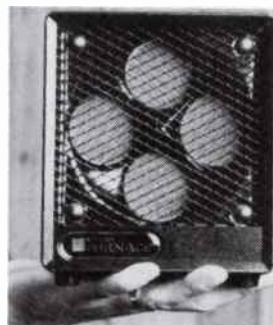

Six inch cube offers safe heat

Owing to its remarkable safety factors, a small cube - called the "Microfurnace" - that can be held in the palm of your hand, may be about to revolutionise electrical heating, we are told.

Originally designed for aircraft cockpits, the Microfurnace uses ceramic disc elements instead of the conventional coil type. The ceramic element operates at much lower temperatures, has a much greater life span and will not ignite objects poked inside the grill.

If objects are placed

against the unit, the heat output is automatically reduced, eliminating the chance of fire, the makers claim.

Although it only measures less than a six inch (150 mm) cube, the Microfurnace can heat and maintain the temperature of a fairly large room at 20 degrees Celsius.

At its maximum output, the Microfurnace consumes 1500 watts but as the area begins to heat, the consumption will decrease automatically.

The Microfurnace has been approved by the NSW Energy Authority and sells for \$199 per unit. Enquiries can be made between 9 am and 5 pm on the toll-free number (008)023 196.



New Scope soldering station

Scope Laboratories has recently announced the release of their new model ETC60L soldering station featuring infinitely adjustable temperature control from 200 degrees C to 470 degrees C without changing tips.

A three-colour LED bar read-out provides an indication of tip temperature and the soldering station uses zero volt switching which is useful when working on current sensitive components such as MOS ICs.

The ETC60L uses a powerful 60 watt element and should appeal to production engineers, technicians and advanced hobbyists. The price is expected to be around \$159 plus tax.

For more information, contact Scope Laboratories on (03)338 1566.

In house pcb prototyping

While successive waves of technological advances

have virtually automated the manufacture of pc boards from design to production, board prototyping, being an iterative task passing through several trial stages, must remain under close control of the designer.

Board manufacturers, being geared for mass production runs, of necessity must charge very high prices for prototype pc

boards, which can be a major design cost. Turn-around time is also a major consideration in the design cycle.

Making your prototypes "in-house" is the cost-effective solution, says Kalex, a specialist supplier of printed circuit making equipment from Victoria.

Kalex has designed a variety of light boxes and an etch tank

which are ideal for prototype pc board production in-house. Changing artwork and making a new trial board can be done very quickly. They market their equipment Australia-wide and now export to New Zealand and New Guinea.

For more information, contact Kalex, 40 Wallis Ave, East Ivanhoe 3079 Vic. (03)497 3422.

OSCILLOSCOPES

DUAL TRACE 20 MHz

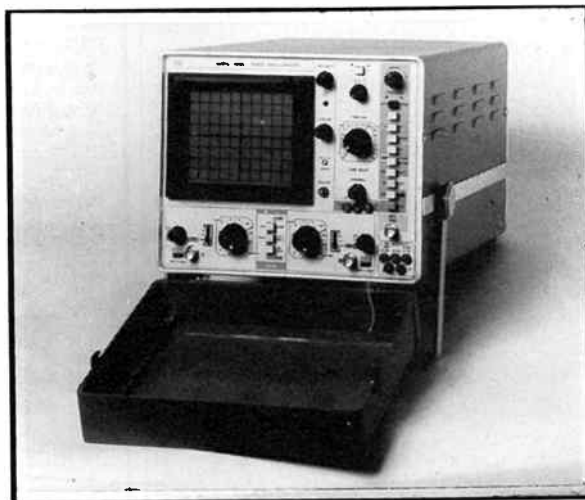

Model 3132 \$683 (Plus S/T)

(Includes Two Probes)

- * 2mV/div calibrated sensitivity on both channels
- * DC — 20 MHz Bandwidth
- * X-Y Operation
- * Algebraic Addition and Subtraction
- * 5" CRT
- * 40 ns/div to 0.2s/div timebase
- * 14 Trigger Functions
- * Triggering to 40 MHz
- * 2 Modulation
- * 10 × Div Display
- * Component Comparator
- * DC Source Triple Output



SCIENTIFIC DEVICES AUSTRALIA
PTY. LTD.

MELBOURNE
SYDNEY
ADELAIDE

(03) 579 3622
(02) 95 2064
(08) 255 6575

RELIABLE POWER FROM THE SUN

Solarex, world leaders in photovoltaic technology, manufacture solar power systems to operate reliably in the harshest climatic conditions that Australia has to offer. Whether it is in the Gibson Desert or on the summit of a Snowy Mountain Peak, the heart of a Solarex solar power supply system is a bank of Solarex Solartraction batteries providing a constant supply of electricity on demand. Solarex solar power systems can be found all over the country maintaining Australia's links with the rest of the world. Remote microwave repeaters, radio links, satellite tracking stations, air and sea navigation aids are all powered by Solarex systems.

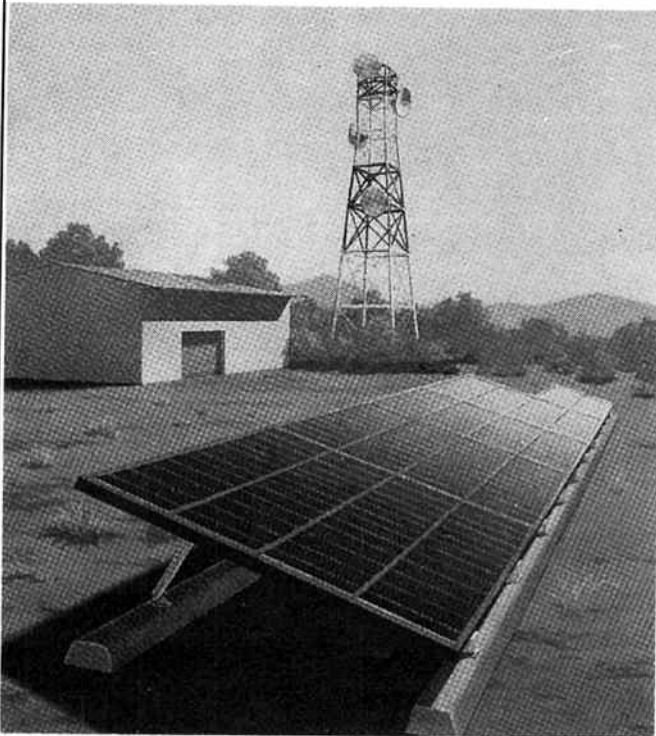

A Solarex solar power system is a reliable, cost effective means of producing DC power with the option of inverting to 240 volts AC 50 cycles if required.

All system components are manufactured in Australia and are thoroughly tested before leaving the factory to ensure a maximum trouble-free life with little or no maintenance. Solarex Pty. Limited is continually developing solar power systems not only for radio and telecommunications but also to provide power for remote homes, villages and for water pumping and irrigation.

SOLAREX PTY. LIMITED

78 Biloela Street Villawood N.S.W.

PO Box 204, Chester Hill, 2162

Tel: (02) 727-4455 Telex: AA121975

Fax: (02) 727-7447

NEW JRC HF Transceiver



JST-125

HF transceiver, specially designed for high performance, enhanced capabilities and ease of operation — features unique to JCR. With general coverage receiver, automatic antenna tuner (optional), two VFO systems, channel scanning, priority check, 72 channel memory capacity, digital RIT, several interference rejection circuits and PC remote control capabilities makes the JST-125 one of the three top transceivers on the market.

PRICE ONLY \$2889

BELIEVE IT OR NOT!

An incredible 2000 per cent per year growth in the number of PACKET RADIO OPERATORS has been recorded in the U.S.A. This packet revolution is fast coming to Australia and EMTRONICS is ready to serve you.

NEW PACKRATT PK-232 — Morse, Bandot, ASCII, AMTOR, and packet data controller in stock now! This six mode machine goes with any RS232 computer or terminal. Call for full specs. (NOW WITH FAX).

PRICE \$699

PK-64 WITH HFM64 also in stock. This Morse, Bandot, ASCII, AMTOR and packet controller is compatible with C-64 computer.

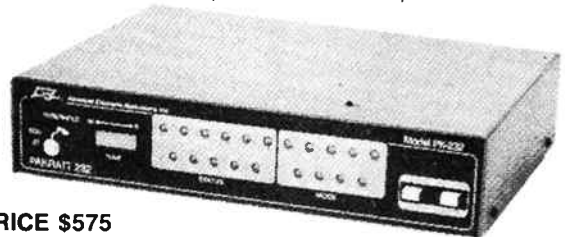

PRICE \$575

PK-87™ Packet Controller

The PK-87 is not just another copy it's much more. With all the packet program features of the Multi-mode PK-232, the PK-87 is an economical new TNC designed to bring you enhanced, completely compatible packet software plus new hardware features for improved packet operation.

PRICE \$349

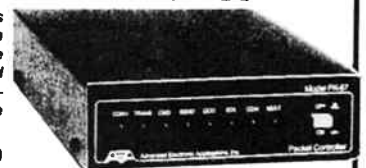

Software Enhancements

- AEA's exclusive "MBX" Mailbox Monitor command lets you read and save received data without confusing headers, call signs, or repeats
- New commands let you restrict the use of your station for connects and digipeater functions.
- Host mode for improved terminal program operation and development of specialized programs and applications.
- Compatible with existing W0RL1/WA7MBL PBBS/Mailbox/Gateway programs, with complete software command for remote selection of link rate, modem tone, etc.
- Autobaud routines for terminal data rates from 300 to 9600 baud (programmable down to 45 baud), and software control to set on-air data rates from 45 to 9600 baud.

Hardware Enhancements

- Eight front panel status indicators show Connect, Transparent, and Command modes; Multiple Connects, Data Carrier Detect, Push to Talk, Status, and Connect.
- High sensitivity (5 millivolts RMS), and dynamic range from 5 to 770 millivolts RMS.
- Rear panel AFSK output level adjustment from 5 to 100 millivolts RMS.
- One minute hardware watchdog timer provides system security in unattended VHF/UHF PBBS/Mailbox and digipeater operation.
- Modem disconnect circuits guarantee compatibility with future high speed modem applications and developments.
- Zilog 8530 SCC provides dependable hardware HDLC for higher speeds, and AMD 7910 for reliable modem performance without calibration.

CORRESPONDENCE
BOX 421
HAYMARKET NSW 2000



EMTRONICS
DATA COMMUNICATIONS EQUIPMENT

WE WELCOME
BANKCARD VISA
& MASTERCARD

MAIL ORDERS
WELCOME

NSW & HEAD OFFICE:
92-94 Wentworth Ave.
Sydney NSW 2000.
TLX: AA 73990
P.O. BOX K21.
Haymarket, NSW 2000.
Ph: (02) 211 0988
FAX: (02) 281 1508

VICTORIA:
288-294 Queen St.
Melbourne Vic 3000.
(Entrance from
Lt. Lonsdale St)
Ph: (03) 670 8551
or 670 0330
FAX: (03) 670 0671

QUEENSLAND:
416 Logan Road.
Stone's Corner
Old 4120
TLX: 144696
Ph: (07) 394 2555
FAX: (07) 394 4316

Wireless video transmitter standard released

The Department of Communications has released a draft standard which aims to protect television reception against possible interference from wireless video transmitters.

Video transmitters provide "wire free" connection, allowing a video recorder to operate some distance from one or more television receivers and such devices could interfere with a neighbour's reception, particularly when operated in blocks of flats or other high density housing.

The proposed standard would specify the performance and effective range for video transmitters and once it comes into force, any user who causes interference or transmits anti-social material could render themselves liable to prosecution under the provisions of the Radiocommunications Act 1983.

Copies of the draft standard may be obtained by writing to the Assistant Secretary, Operations branch, Department of Communications, Canberra, or by ringing (062)48 3800.

Frequency registers

Scanner enthusiasts who would like to find out just who it is they are listening to, will find the range of frequency registers from Captain Communications invaluable.

There are a number of registers, covering the entire LF, HF, VHF and UHF bands.

The registers provide full information on all listed frequencies, including transmit and receive frequencies (essential for duplex users), callsign, licenced user's name and transmitter location.

The Australian HF register contains over 400 pages and covers 2.009 MHz to 26.965

MHz. Price is \$38. The HF/VHF/UHF register covers 200-531 kHz, 1755 kHz-26.965 MHz and 30.075-1300 MHz. Price is only \$19.

The Australian VHF/UHF register is a state by state listing, covering 42.5-512.925 MHz and the Australian master register covers VHF and UHF for all states at \$100.

For further information, contact Captain Communications, 28 Parkes St, Parramatta 2150 NSW. (02)633 4333.

New Russian satellites launched

STOP PRESS: News from the UoSAT Mission control centre at the University of Surrey, UK informs us that at some time on the 23rd June 1987, two new Soviet amateur transponders were launched into low earth orbit.

Two separate transponders, RS-10 and RS-11 are thought to be "parasites" on the Cosmos-1861 spacecraft.

Early reports came from G3IOR who worked one of the spacecraft and subsequently many amateurs throughout the world have worked through the birds.

Through AMSAT North America, UA3CR reports the following details on the two new satellites:

Mode K uses 15 meters up and 10 meters down.

Mode T uses 15 meters up and 2 meters down.

Mode A uses 2 meters up and 10 meters down.



Millimetric attenuators

The compact O2 series of micrometer drive attenuators offered by Flann Microwave Instruments are suitable, the company says, for a wide range of applications and are economically attractive for low budget programmes and systems operating at millimetric frequencies.

Each instrument provides an attenuation range of 0 to 30 dB

and exhibits low insertion loss. The claimed calibration accuracy of the attenuators is ± 0.2 dB and the SWR is better than 1.07 for most models.

Attenuators with an extended attenuation range and extra calibration points can be provided. Customised units can also be provided to special order.

Further information is available from Flann Microwave Instruments, Dunmere Road, Bodmin, Cornwall PL31 2QL UK.

Mode KT uses 15 meters up and both 10 and 2 meters down.

Mode KA uses both 15 and 2 meters up and 10 meters down.

It may be of interest to those of you who have been following the articles on digital communications to know that the above news was downloaded directly from the UO-11 satellite and was subsequently disseminated via the network of packet radio bulletin boards in Australia.

Radio data modem

NetComm Australia Pty Ltd has announced the release of a new radio data modem which makes access to a remote data base a reality, they say.

Completely designed and manufactured in Australia, the new radio modem can provide

an error free data path over any standard commercial two way radio system or cellular phone system.

Unlike conventional modems which operate over telephone lines, the radio modem can operate on any two-way radio system, including VHF and UHF FM systems through to HF SSB systems.

To the business with mobile or remote sites, radio modems offer many benefits. The company's host computer can be directly accessed without the need for an operator and electronic mail or message handling can be catered for. An important aspect is the privacy of communications and the block exchange sequence protocol employed in this modem has the advantage of rendering messages unintelligible to the casual listener.

For further information, contact NetComm (Australia) Pty Ltd, PO Box 284 Pymble 2073 NSW, (02)888 5533.

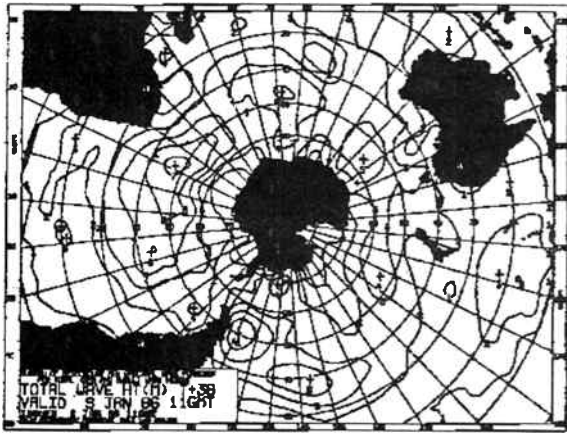

LA FRANCE POUR SA PART A MANIFESTE TOUTE L'IMPORTANCE QU'ELLE ATTACHAIT A L'ORGANISATION DES NATIONS UNIES COMME L'A MARQUE SOLENNELLEMENT LE PREMIER MINISTRE, M. PIERRE MAUROY EN PRENANT LA PAROLE AU DEBUT DE LA 37EME SESSION DE L'ASSEMBLEE GENERALE PUIS LORSQUE LE 28 SEPTEMBRE 1983, LE PRESIDENT DE LA REPUBLIQUE VINT FAIRE, LUI-MEME ENTENDRE LA VOIX DE LA FRANCE A LA TRIBUNE DES NATIONS UNIES.

MONSIEUR LE SECRETAIRE GENERAL, DES VOTRE NOMINATION A LA HAUTE FONCTION QUE VOUS OCCUPEZ VOUS AVEZ MARQUE AVEC FORCE L'IMPORTANCE QUE VOUS ATTACHEZ A CE QUE L'ORGANISATION RETROUVE LES PRINCIPES QUI L'AVAIENT FONDEE : 'NOUS NOUS SOMMES, DISIEZ-VOUS, SANS CONTESTE, BEAUCOUP ECARTES DE LA CHARTE CES DERNIERES ANNEES. NOUS SOMMES PERILLEUSEMENT PROCHES D'UN NOUVEL ETAT D'ANARCHIE INTERNATIONALE''. ET UN PEU PLUS LOIN VO

A guide to non-voice transmissions on shortwave

Roger Harrison

With a variety of interface units available to hookup to a shortwave receiver for decoding radio facsimile (FAX) and radioteletype (RTTY) transmissions using a computer, we've experienced a constant stream of enquiries for lists of frequencies for these non-voice transmissions on the shortwave bands.

OUR FIRST issue's feature project, the AEM3500 Listening Post RTTY/FAX/Morse decoder, has introduced many readers to the fascinating range of "non-voice" transmissions on the HF band. Radio facsimile transmissions, in particular, can provide a fascinating interest. Many FAX transmissions on the HF bands are from meteorological agencies, transmitting various weather synopsis maps and charts ("WX FAX") which can provide interesting, if not useful, information not available from generally published sources. The weather bureaus of Australia and New Zealand provide strong, easily picked-up transmissions from which quite clear weather analysis charts can be received. Some oriental news services use FAX to transmit news in kanji characters.

Radioteletype transmissions are legion. A great many are international news services or agencies. Weather bureaus exchange data in code, as well as transmitting information like weather satellite orbit details.

To receive the non-voice transmissions, you'll need a receiver capable of stable single sideband (SSB) reception, with a switch for selecting upper sideband (USB) and lower sideband (LSB) operation. The transmissions almost invariably employ frequency-shift keying to carry the digital data. If you don't know what sideband (upper or lower) a transmission employs, there's a simple international convention you can follow to sort out the signal and resolve it: below 10 MHz, use lower sideband (LSB); above 10 MHz, use upper sideband (USB).

The different transmissions have a characteristic 'sound'; RTTY is a staccato "burble", while FAX is a tone punctuated by a more or less regular "tic-tic-tic" with an occasional burst of sustained high-pitched tone (the synchronising pulse).

When receiving FAX transmissions, it is best to first attempt reception at 60 lines per minute (lpm), as this seems to be the most common transmission standard, and see if you get something sensible (patience, patience!). If not, then try another lpm rate.

The following listings are not intended to be exhaustive, but to provide a guide to known transmissions and 'active' frequencies. Whether you hear something on a particular frequency or not depends on a number of factors, including your latitude and longitude, the latitude and longitude of the station you are trying to receive, the time of day and season of the year, the current state of the sunspot cycle, conditions in the ionosphere, etc. So if you attempt receiving a transmission on a particular frequency and are unsuccessful, try again at another time. There are plenty of alternate frequencies to try. Even if your receiver has a digital frequency readout, it is best to tune a kilohertz or so either side of the given frequencies when searching for a transmission, as well as trying both settings of the sideband switch.

OK, we shall start with the facsimile transmission frequencies.

FAX

Undoubtedly the best FAX transmissions to 'cut your teeth' on when starting out are those from the Australian Bureau of Meteorology stations - AXM near Canberra and AXI near Darwin, and the New Zealand Meteorological Service's station, RMC Wellington. All transmit on pretty well continuous schedules, mostly FAX but a little RTTY thrown in giving weather and satellite orbit data in code.

AXM

You'll find this station on two frequencies:

5100 kHz, and
11 030 kHz.

It seems to be the Bureau of Meteorology's main one. On 5100 kHz it is generally well received on the eastern seaboard, day and night. Although, the further out you are, the more likelihood there is that reception will be poor or non-existent during the day owing to absorption in the ionosphere's D-region. If no good on 5100, try 11 030 kHz.

AXI

Here again, the station will be found on three frequencies:

7535 kHz,
10 555 kHz, and
13 920 kHz

The 7 MHz transmission is readily received in the north during the day, but can be swamped by layers of Asian broadcast stations during the night. The 10 MHz transmission is often well received up and down the east coast, across South Australia and southern West Australia.

RMC

This New Zealand station puts quite a strong signal into Australia. It may be readily heard all up and down the east coast at good strength. You'll find it on:

13 550 kHz

So much for the local weather stations.

International WX FAX

A number of WX FAX transmissions located in the orient to the north of Australia can be heard, often at good strength. There are three frequencies that provide fruitful results:

14 826 kHz,
17 068 kHz, and
18 130 kHz

They appear to originate in Japan, for they transmit weather synopsis charts of the Japan-Korea and east China region, and tables of upper wind and temperature data. The WX FAX pictures received will often contain noise "stripes" and show distortion. You will also often see "ghosting" on the pictures, the result of multipath propagation which is prevalent on these transequatorial paths.

WX FAX transmissions from North America can be received here, too. Two good frequencies to try are:

13 510 kHz, and
17 150 kHz

The 13 MHz transmission originates from Canada it transmits a lot of synopsis and analysis charts covering the whole of the US, as well as the North American continent. The 17 MHz transmission appears to originate from San Francisco.

European WX FAX transmissions may be copied on:

16 320 kHz

The origin of this transmission is uncertain (do readers have any clues, here?), but synoptic charts covering from the polar region to North Africa, Spain to the Middle East are copied.

Other FAX

As alluded to in my introductory paragraphs, some FAX transmissions originate from news services. The most prevalent is Taiwan's CNA. This is to be found on:

14 685 kHz

which is readily heard over most of Australia and New Zealand. For something a little different, try:

18 045 kHz

where you can find news FAX pictures being transmitted. You'll have to hold the print at arm's length, though, to see what it's all about!

Once you've had a little success at receiving FAX, you'll easily recognise FAX transmissions as you tune around and be able to eavesdrop at will.

RTTY

There are no end of RTTY stations to be found on the HF bands! Trouble is, many send strings of code – letters and numbers – that have no meaning unless you can decipher them. As mentioned earlier, there are a considerable number of news agencies transmitting stories, along with diplomatic networks and the like, all in plain text (albeit in a foreign language from some). You certainly get a different slant on the news!

There are a number of transmission frequencies that are readily received at good strength and provide excellent sources, particularly if you're new to this.

For listeners located in the southern states and New Zealand, the following stations are regularly heard:

Agence France Press (AFP), on

7542.5 kHz
10 730.6 kHz

Allgemeiner Deutscher (ADN), on

9968 kHz
10 552 kHz

Central News Agency (CNA), Taiwan on

7695 kHz
13 563 kHz

North Korean News Agency (KCNA), on

13 780 kHz

Reuters, on

6845 kHz
9120 kHz
10 960 kHz
14 514 kHz

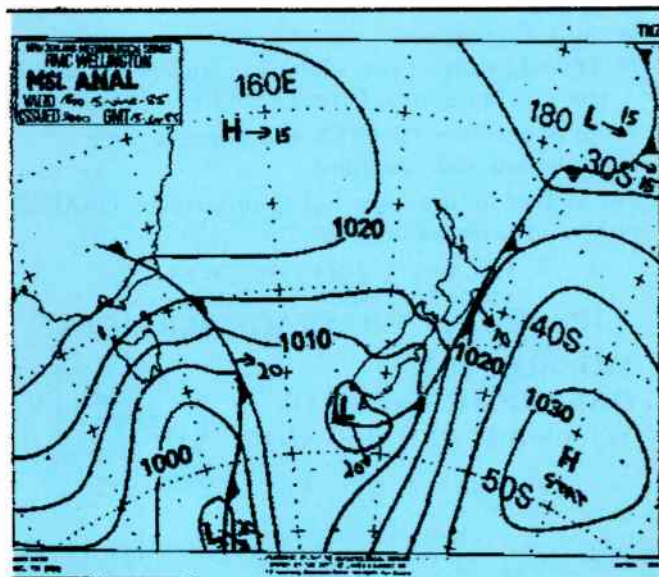

WX FAX from RMC Wellington, showing south-east coast of Australia, the Tasman sea and New Zealand.

Tsushin News Service, Kyodo Japan, on

8173.5 kHz
17 596 kHz

USSR news service (TASS) in English, on

6870 kHz
6950 kHz
7760 kHz
9110 kHz
10 270 kHz
11 470 kHz
12 085 kHz
13 410 kHz
14 510 kHz, and
14 700 kHz

United Press (UPI), on

9985 kHz
16 232.7 kHz
19 520 kHz

Xinhua News Agency, on

7250 kHz
9491 kHz
11 680 kHz
12 265 kHz
14 923 kHz

European WX FAX. The Scandinavian peninsula is readily seen in the upper left corner.

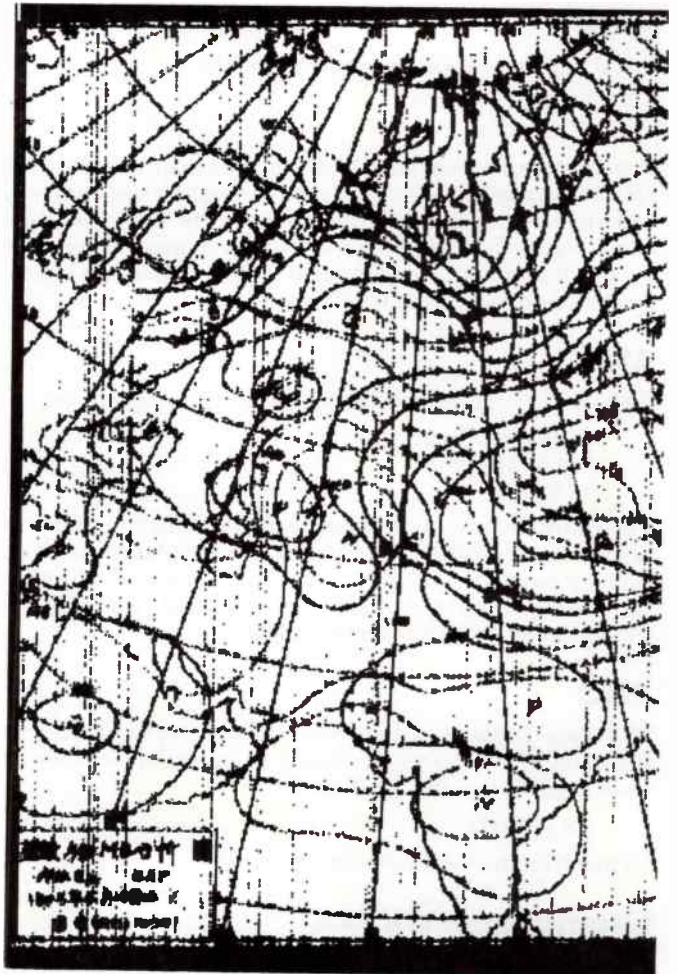

For listeners in the north and north east of Australia, the following transmissions should be reliably heard:

Allgemeiner Deutscher (ADN), on

9968 kHz
10 545 kHz
10 552 kHz

IPS GRAFEX PREDICTIONS TAKE THE GUESSWORK OUT OF HF RADIO FREQUENCY SELECTION

Grab a GRAFEX and, during any particular month, GRAFEX will recommend the best:

- *Times*
- *Frequency Bands*
- *Average radio wave elevation angles for radio wave propagation between any two places.*

From \$16 a year GRAFEX will improve your transmission and reception.

For further information and to order your GRAFEX predictions, please contact:

GRAFEX PREDICTIONS
Australian Government, Department of Science
IPS RADIO AND SPACE SERVICES

**P.O. BOX 702
DARLINGHURST 2010
Telephone: (02) 269 8617**



Name:

Address: Postcode:

Central News Agency (CNA) Taiwan, on

9088 kHz
13 561.5 kHz

Kuwait News Agency (KUNA), on

12 076.5 kHz
15 645 kHz

Maghreb Arabe Presse (MAP), on

14 573 kHz
18 495 kHz

Tsushin News Service, Kyodo Japan, on

8173.5 kHz
17 596 kHz

USSR news service (TASS), on

12 313 kHz
15 708.5 kHz

Xinhua news agency, on

12 265 kHz
14 365 kHz
14 923 kHz

To conclude

If you keep a listening watch on a few favourite news transmissions, you'll find a whole new world of news not seen in the local papers. Often, you'll get the news before it becomes news here. At the very least you'll get a different view!

A bit of perseverance with the FAX transmissions can yield some fascinating pictures and provide the ammunition for a few arguments with the TV weatherman, apart from letting you know what the weather chart will look like ahead of when it's published or appears on TV. 📡

It's the end of the financial year. Here's an
UNREPEATABLE OFFER!

Snap up
 this superlative

50 MHz dual-timebase Philips CRO!

FEATURES INCLUDE:

- Auto-set key sets amplitude, timebase and triggering
- 50 MHz bandwidth
- Sensitivity range 2 mV/div. to 10 V/div.
- Minimum 5 ns timebase sweep
- 100 MHz trigger bandwidth, plus trigger view facility
- Auto, manual and single-shot triggering
- Microprocessor control to 'think' for you
- 16 kV tube accelerator voltage
- Liquid crystal display control setting display
- Multi-function, menu-driven softkeys
- Menu/help functions
- Power supply operates over 90-264 Vac, 45-440 Hz.
- IEEE interface option
- Probe indication: x10, x100
- All-modular construction
- Built-in service program
- Reads like a book – top to bottom, left to right!

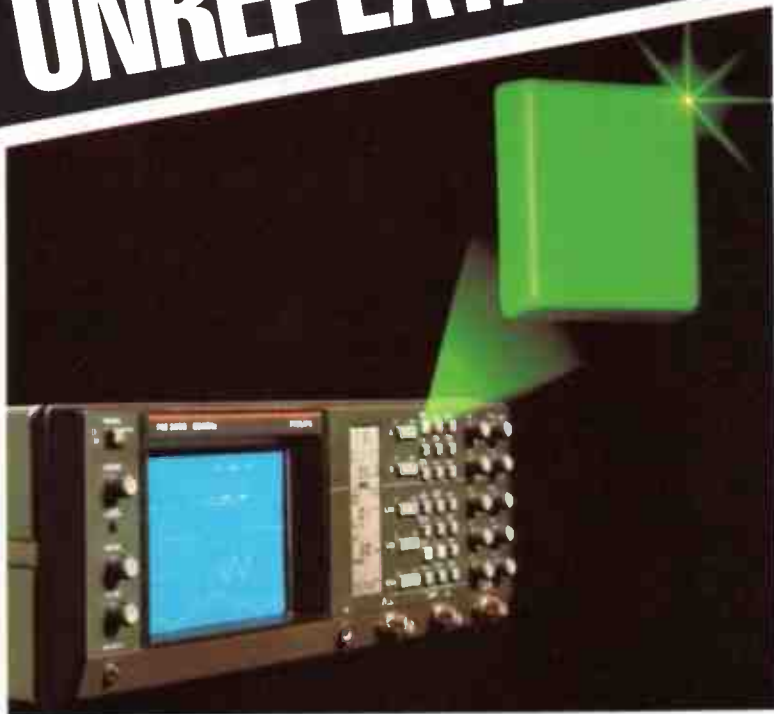

Now is the time to buy – take advantage of improved exchange rates and this very special offer on the Philips PM 3055 oscilloscope.

Just \$2795 (Normally around \$3000)

or **\$3354 tax paid.** (Normally around \$3600)

Delivered to your door
 for just \$20.

**SET OF 100 MHz
 PROBES TO MATCH,
 worth around \$200
 – FOR FREE!**

This special offer includes a pair of PM8936/09 probes, free! They feature 100 MHz bandwidth, x10 attenuation, 10M input impedance and 1.5m long leads.

Yes! This is the Philips PM 3055 that has set new standards in its class. Take this limited chance to buy a quality instrument that major electronic labs in government departments, defence establishments and industry are using. The latest production techniques have allowed Philips to produce this market leader instrument at TV set speed. And the faster they can be produced, the lower the price.

This offer is made to readers of Australian Electronics Monthly by Philips Scientific & Industrial, and the magazine is acting as a clearing house for orders.

**Don't delay,
 OFFER MUST CLOSE
 LAST MAIL 20 JULY 1987**

Fill out the coupon now and rush it to:

**Philips CRO Offer
 Australian Electronics Monthly
 PO Box 289, Wahroonga 2076 NSW**

When we reviewed the PM 3055 in the April issue, we were so impressed we just had to have one for the lab!

COUPON

Yes! I want _____ Philips PM 3055 oscilloscope(s) at \$2795 tax free, or \$3354 tax paid, with a free pair of PM8936/09 probes with each unit, plus \$20 for delivery.

TOTAL: \$ _____ sales tax no: _____

I enclose payment by:

Money Order Cheque Visa

Cheque or Money Order no: _____

(Government departments and institutions may proceed on official purchase order, but this coupon must be attached)

Please make cheques or Money Orders payable to "Australian Electronics Monthly"

Name _____

Company _____

Position _____

Address _____

Postcode _____

Signature _____

(Unsigned Credit Card orders cannot be accepted)
 Please allow for normal postal and bank clearance delays.

Bankcard Mastercard American Express

Credit card no: _____

Expiry date: _____

A guide to digital communications

Part 2 Andy Keir VK2AAK

In part one of this article, we discussed the historical development of digital communications modes as well as describing the various codes and protocols in use. In part two, we will concentrate on the techniques and operating practices employed by amateur operators as well as look at recent equipment.

ALTHOUGH we commenced Part 1 with a description of Morse code, I don't intend to pursue the subject in any detail. Morse code is not generally thought of as part of the "digital" family even though strictly speaking it could be regarded as such. Our only interest in Morse comes from the fact that it is often incorporated as an additional mode in the many multi-mode decoders that are now available.

As I pointed out in Part 1, Morse should be thought of as a "human" mode. It is not particularly suited to computer based systems and whilst a very useful mode in some circumstances, it is quite inefficient when compared to the other digital modes. In this article, we will confine ourselves to those modes which were designed for machines or computers from the outset.

RTTY operation

As far as the end result is concerned, it makes very little difference whether you are using the classic mechanical teleprinter or a modern "glass RTTY" based around a computer terminal, as the latter is designed to emulate the former.

To transmit RTTY we can use either frequency shift keying (FSK) or audio frequency shift keying (AFSK). FSK is generally used on the HF bands below 30 MHz and AFSK is used in VHF applications. Because most RTTY operators these days employ single sideband transceivers, we can use the same modulator for both FSK and AFSK.

Regardless of whether the voltage levels representing mark and space are dc signals from a mechanical teleprinter or TTL levels from a computer, the modulator converts these signals to audio tones. If we feed these tones to the microphone input of an SSB transmitter, the result will be FSK. If we feed the same tones to an FM transmitter, we will get AFSK. The difference between the tones representing mark and space is called the shift and in amateur applications is usually 170 Hz. It should be borne in mind that many SSB transceiver are

designed for the low duty cycle of voice modulation. When used for RTTY, an SSB transmitter will be operating at 100% duty cycle and you may have to reduce power to avoid exceeding the rating of the transmitter's final stage.

At the receiving end, the recovered audio tones are converted back to voltage levels to suit the equipment in use by means of a demodulator. It is usual practice to include some sort of filtering in the demodulator so that the system does not respond to extraneous noise in the recovered signal.

Operating RTTY is similar to operating on voice except that the two parties type to each other instead of talking. Like many other modes, RTTY has developed its own jargon and operating conventions. For the uninitiated, you may think you are reading a foreign language when first decoding a conversation between experienced operators. Widespread use is made of the "Q" code developed to speed up Morse code operations and details of their meaning can be found in most amateur radio literature.

Encouraged by the ready availability of simple, low-cost modems and computers, RTTY using AFSK on FM has become a popular mode on the VHF bands. A number of RTTY repeaters have been established in major cities and these often provide a "store and forward" mailbox facility similar to the popular telephone "bulletin boards".

AMTOR

AMTOR can be regarded as a form of RTTY but as explained in part one, offers the added advantage of error correction. Transmission and reception of AMTOR uses the same FSK techniques as normal RTTY and the modems employed are virtually identical. The difference with AMTOR lies in the way the characters are constructed using a seven-bit synchronous code as opposed to the five-bit asynchronous Baudot/Murray code.

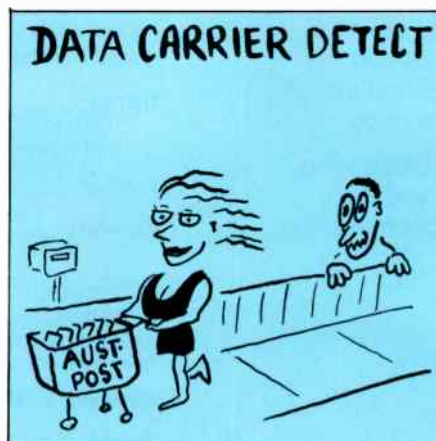
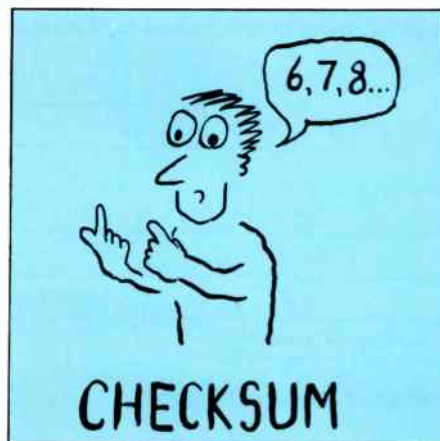

KENWOOD

R-5000 COMMUNICATIONS RECEIVER



ONLY \$1075 CAPTURE THE WORLD

The R-5000 is a new competition grade communications receiver which incorporates every conceivable operating feature. Designed for all modes of reception (SSB, CW, AM, FM, FSK), the R-5000 covers the frequency range from 100 kHz to 30 MHz, and with the addition of the optional VC-20 VHF converter, will also cover the 108 to 174 MHz range, again with all mode reception. The R-5000 has been designed with high performance in mind, and has an excellent dynamic range, together with carefully chosen operating facilities to match today's conditions. Micro-processor control is used for main functions, including dual digital VFO's, 100 memory channels, memory scrolling, memory and programmable band scan, and many other facilities.

FEATURES

Coverage is 2 MHz to 30 MHz in 30 bands, with an additional range from 108 to 173 MHz using the optional VC-20 VHF converter.

Advanced microprocessor control allows frequency, band and mode data to be stored, recalled, and displayed, even in the VHF band of the VC-20.

The RF circuits of the R-5000 have been designed to give a high dynamic range, and with the 500 Hz bandwidth selected (YK-88C option), the intermodulation free dynamic range is 102 dB, with a third order intercept point of + 14 dBm, and a noise floor of - 138 dBm.

*100 kHz to 30 MHz optional extra.

High stability frequency control.

The reference oscillator which determines the frequency stability and readout accuracy of the R-5000 is accurate to + or - 10 ppm within a temperature range of - 10 to + 50 degrees Celsius.

10 Hz step dual digital VFOs.

Built in dual VFOs operate independently of each other, and allow split frequency and split mode operation. The frequency steps are basically 10 Hz, giving that "True VFO" feel when tuning. The frequency steps are changed to 1 kHz in AM mode, and 5 kHz in FM mode.

Provision is made for the connection of both high and low impedance antenna systems.

Superb Interference Reduction.

Selectivity is enhanced by the use of dual crystal IF filters for SSB, and further features include IF shift and tunable notch filters. The IF filter selection system is fully flexible, in the same manner as the TS-440S transceiver, and offers automatic selection by mode, or manual selection according to the operator's requirements.

A dual mode noise blanker system deals effectively with both impulse noise as well as the "woodpecker".

Keyboard Frequency Selection

Frequencies can be entered using direct keyboard control, and a frequency lock switch prevents accidental frequency changes from occurring.

100 Memory Channels Capability

100 memories are provided, which store frequency, mode, and which antenna has been selected. Memory information can be scrolled to review contents of any memory channel.

Memory Scan and Programmable Band Scan.

Further memory facilities include memory scanning with programmable memory lockout, and programmable band scanning with centre stop for accurate on-channel tuning.

Plus a full list of other desirable features:

- Dual 24 hour clocks with timer
- Optional VS-1 voice synthesiser for frequency announcement
- Optional control by personal computer using the IF-232C interface
- Lithium battery backup of memory contents
- Built in AC power supply and option to use the receiver on 13.8 volt DC supplies
- High quality internal loudspeaker
- AGC time constant switchable fast/slow
- Switchable RF input attenuator (0 to 30 dB in 10 dB steps).

To summarise: the R-5000 from KENWOOD offers the operator a top performance communications receiver of the very highest quality, with all the features and functions which the discriminating user could demand.

With the R-5000, KENWOOD gives the dedicated listener a receiver which will match the performance of the very best transceivers available today.

KENWOOD ELECTRONICS AUSTRALIA PTY. LTD.
4E WOODCOCK PLACE, LANE COVE, SYDNEY, N.S.W. 2066. Ph. (02) 428 1455.

YOUR DEALER BELOW WILL GUARANTEE SATISFACTION

N.S.W.:
EMTRONICS — 94 WENTWORTH AVENUE, SYDNEY (02) 211 0988
REG STOCKMAN COMMUNICATIONS — CNR BANOCKBURN ROAD & SHIRLEY STREET INVERELL (067) 22 1303
WORNALD COMMUNICATIONS — 51 DENNISON STREET HAMILTON NEWCASTLE (049) 69 1999
MACELEC PTY LTD — 99 KENNY STREET WOLLONGONG (042) 29 1455
E & K COMMUNICATIONS — 14 DUTTON STREET DICKSON ACT (062) 49 6437
DX ENGINEERING — 158 GRANITE STREET PORT MACQUARIE (065) 84 9922
FRANK BOUNDY — LISMORE (066) 86 2145

INTERSTATE

VIC.:
PARAMETERS PTY LTD — 1064 CENTRE ROAD SOUTH OAKLEIGH (03) 575 0222
EMTRONICS — SHOP 5 288-294 QUEEN STREET MELBOURNE (03) 67 8131
BRIAN STARES — 11 MALMSBURY STREET BALLARAT (053) 39 2806
SUMNER ELECTRONICS — 78 KING STREET BENDIGO (054) 43 1977
TAS.:
HOBBY ELECTRONICS — 72 BRISBANE STREET HOBART (002) 34 4303
WATSONS WIRELESS — 72 BRISBANE STREET HOBART (002) 23 6751
MARINE & COMMUNICATION — 19 CHARLES STREET LAUNCESTON (003) 31 2711
VK ELECTRONICS — 214 MOUNT STREET BURNIE (004) 31 7733
QLD:
MITCHELL RADIO CO — 59 ALBION ROAD ALBION (07) 57 6830
EMTRONICS — 216 LOGAN ROAD STONES CORNER BRISBANE (07) 394 2555
S.A. & N.T.:
INTERNATIONAL COMMUNICATIONS SYSTEMS PTY LTD — 8 NILE STREET PORT ADELAIDE (08) 47 3688
W.A.:
WILLIS ELECTRONICS — 165 ALBANY HIGHWAY VICTORIA PARK (09) 470 1118
BAY RADIO — 22 GRACE STREET FERNDALE (09) 451 3561
FORD ELECTRONICS — 209 HANCOCK STREET DOUBLE VIEW (09) 446 4745

July 1987 — Australian Electronics Monthly — 29



Shown here is Brian Beamish VK4AHD who is the system operator of the very popular VK4BBS packet bulletin board. This picture shows the commitment which some operators make in terms of equipment, to provide a bulletin board which all suitably equipped amateurs can access. Brian will be well known to many readers in the Brisbane area where he is the manager of the Emtronics store.

The method of operating on AMTOR will depend on whether you are using the FEC or the ARQ mode. As explained in part one, the FEC mode is the one used for calling "CQ" or operating in a "net" comprising several stations. In use, the FEC mode is similar to standard RTTY but there are a few conventions that must be observed.

In RTTY, it is common to send a few lines of "RYs" before commencing your message. This is done to allow the distant station to tune your signal accurately and also so that older mechanical systems can get themselves "into gear". The RY characters are chosen because in the Baudot/Murray code they will test all five information bits. In AMTOR we use a synchronous seven-bit code which means that the distant station must have something to synchronise to. The distant station cannot synchronise to your typed characters so instead, we just pause for a few seconds without typing anything. This will result in a continuous stream of idle characters being sent which can be used by the distant station for tuning purposes as well as synchronization. It should be noted that the FEC mode operates at 100% duty cycle and the remarks concerning SSB transmitters when used with standard RTTY also apply in this case.

The ARQ AMTOR mode is quite different in operation as you need to know the other station's selective calling address (selcall) before you can make contact. When calling CQ in FEC mode, it is usual to include your own selcall so that the distant station can call you back using ARQ. As AMTOR is a mode specifically designed for computers, the actual commands which make the system perform the various functions will vary with the computer, interface and software in use.

Whilst the manuals provided with the various interfaces and software packages can be very helpful, I feel the best way to learn the intricacies of AMTOR operation is by talking to other amateurs who are familiar with the mode and who have learned all the tricks.

Packet radio

The low cost personal computer has been responsible for luring many enthusiasts away from the hobby of amateur radio in recent times. Packet radio may offer the incentive to many of these operators to once again become involved in radio by combining the two disciplines and this situation seems to be borne out by the fact that the packet mode has become the fastest growing area in the hobby today.

The packet mode can be used on both the HF and VHF bands, the only difference being the speed at which data is transferred and the tones produced by the modems. On the VHF bands, the most common standard is 1200 Baud using a modem based on the Bell 202 standard, the output of which is fed to an FM transmitter thus producing AFSK. On HF the

convention is to use 300 Baud with a narrow shift modem fed to an SSB transmitter which results in an FSK signal.

Despite the fact that there are usually dozens of TNC parameters which are user adjustable, only a few commands are used in general operation and once you have the TNC, computer and radio connected, it is a simple matter to make a contact. As an example, if VK2AAK wishes to talk to VK2ZTB, he simply types "CONNECT VK2ZTB". The TNC will key the transmitter and send a connect request packet. If VK2ZTB is available his TNC will reply and VK2AAK will see "CONNECTED TO VK2ZTB" displayed on his screen and the two stations may then simply type back and forth. To end the contact, one or other station types "DISCONNECT" and the logical connection will be broken.

PACKET RADIO BULLETIN BOARDS

One of the most interesting results from the marriage of computers and radio has been the establishment of numerous packet radio bulletin boards and mailboxes. These systems operate in a similar fashion to the well-known telephone type systems where an enthusiast equipped with a suitable modem can connect to the system and post or read messages and upload or download programs.

With typical ingenuity, amateurs have developed a sophisticated network of bulletin boards which not only provide the usual functions, but can also forward messages automatically to any destination station that is part of the network. As an example, I can sit at my computer and type in a message to an amateur in the USA and address it to him via a local VHF bulletin board. That bulletin board will then automatically forward my message through the network and via HF links to the USA where it will be routed to a bulletin board close to the intended recipient's location. The next time that amateur logs on to his local system he will be informed that there is a message for him. After reading my message, the overseas amateur can reply to me by the same method, going in the reverse direction.

Because the packet mode employs an error correcting protocol, you can be sure that any message you send through the system will arrive intact, regardless of how many stations it goes through on the way. Of course it's not only messages that can be sent in this way, computer programs, satellite predictions or indeed any sort of information that can be handled by a computer can be transferred.

It is perhaps due to the fact that we are becoming an information-based society that packet radio is experiencing such phenomenal growth. Amateurs have always had the ability to communicate, that's what the hobby is all about, but never before have we had the facility to create an integrated network such as is now being developed.

```
cmd: VK2OP-1
cmd:*** CONNECTED to VK2OP-1
[MSG:312]
VK2OP Bbs - Bondi NSW Australia
VK2OP >
L
Msg# TS Size TO @ BBS From Date Subject
434 F# 12111 ALL WA35AD 21-Jun Amsat News164 June 15, 1987
431 # 792-ALL @HF VK2AHX 21-Jun Disposal
427 B# 651 ALL @VK VK4BBS 20-Jun DISPOSAL NOTICE Please Read ASAP
426 B# 5731 ALL @HF VK4AJB 20-Jun Usat Bulletin #091
425 B# 2382 ALL @HF DU1UJ 20-Jun HAPN Bulletin No. 7
424 B# 3604 ALL @HF DU1UJ 20-Jun HAPN Bulletin Nos. 8 and 9
422 N 849 VK4BBS@VK4BBS VK2AHX 20-Jun Re: REF DISPOSAL
418 B# 1585 ALL W7LHO 18-Jun ARRL BULLETIN #47
415 BF 1513 ALL @VK4BBS VK2CZZ 18-Jun NOVICES TO GET VHF & RTTY
407 B# 612 ALL @T VK4BBS 18-Jun NO NTS TRAFFIC PLEASE
385 B# 2958 ALL VK4TTY 15-Jun S.E.O.T.G. News 08-Jun-87 2/4
384 B# 3112 ALL VK4TTY 15-Jun S.E.O.T.G. News 08-Jun-87 1/4
383 # 2324 ALL VK2EHQ 15-Jun pt 232 mods
382 B# 209 ALL @VK.ZXY VK4BBS 15-Jun Macrotronics Apple Software
380 F# 7825 ALL A18A 15-Jun SWL SCDX #1942 09Jun 1of1
379 B# 5609 ALL @HF VK4AJB 15-Jun Usat 2 Bulletin #090
365 N 574 ZL #ZL2AMD VK2XY 14-Jun EASTNET (VK) VHF PACKET FREQ.
367 # 827 ALL @VK VK2AHX 14-Jun Computer for Disposal
366 B# 3384 ALL ZL 3RD PARTY TRAFFIC
365 # 4520 ALL VK4BBS 14-Jun THIS IS PACKET ???
364 # 1370 ALL V:5ZZ 14-Jun dca 2059b
363 # 470 ALL VK4BBS 14-Jun ZL2AMD & K6BIRS
362 F# 6,15 ALL A18A 14-Jun SWL SCDX #1941 02Jun 1/1
361 # 15550 ALL N16A 14-Jun HOWTO.NTS (June 1987)
VK2OP >
B
*** DISCONNECTED
```

To give you some idea of the scope of the packet network, here is a screen dump taken from a session on the VK2OP bulletin board run by Nat, VK2OP of Bondi NSW. Just take a look at some of the callsigns in the message titles and you will see what I mean about packet becoming a global information and message system.

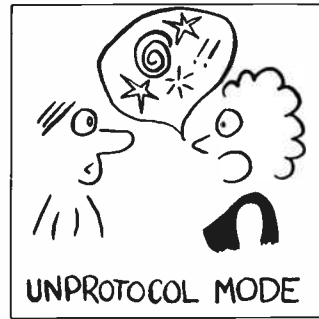
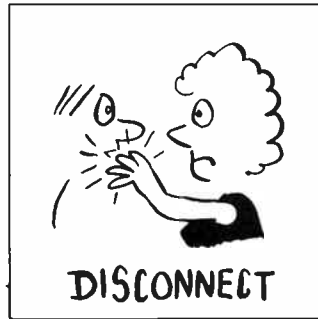
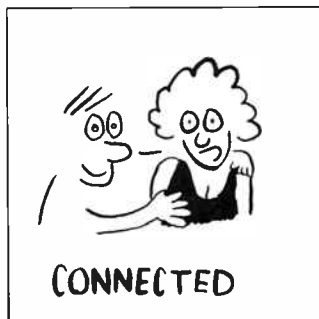

Because the TNC is connected to and controlled by a computer, it is possible to leave your system running and have all incoming messages stored or printed for later review. Many stations now operate packet bulletin board systems which operate in a similar fashion to the familiar telephone systems as well as providing automatic message forwarding over great distances using HF links or even orbiting satellites.

As you can see, the marriage of computers and radio provides a fantastic opportunity for experimenters to make a contribution. Those individuals who found that computers offered more chance for creative experimentation are now applying their knowledge of computers and software to the area of amateur communications and if allowed to progress, I can foresee the development of a global network the sophistication, reliability and scale of which would be beyond individual governments and corporations.

Where to find on-air activity

Modes such as RTTY, AMTOR and packet occupying bandwidths less than 2.5 kHz are described as "narrowband" modes. Most of the bands allocated to amateurs in Australia have designated segments set aside for narrowband operation and these usually coincide with similar allocations in international bandplans. Whist in most cases it is not mandatory

to obey these bandplans, the vast majority of amateurs adhere to this "gentleman's agreement". The narrow band segments for the Australian HF amateur bands are as follows:

- 1.825 MHz – 1.835 MHz
- 3.620 MHz – 3.640 MHz
- 7.040 MHz – 7.060 MHz
- 10.140 MHz – 10.150 MHz
- 14.070 MHz – 14.110 MHz
- 18.100 MHz – 18.110 MHz
- 21.075 MHz – 21.125 MHz
- 24.920 MHz – 24.930 MHz
- 28.050 MHz – 28.150 MHz

Of these bands, the segment between 14.070 MHz and 14.110 MHz will frequently provide the most activity as this band is favoured for "DX" operating. AMTOR signals will often be found between 14.850 MHz and 14.950 MHz whilst packet activity centres on 14.103 MHz and 14.107 MHz.

The VHF bands

On the VHF bands the narrowband segments are not so clearly defined, being based on convention rather than specific bandplans. Most operation takes place on spot frequencies and this is particularly true of the packet mode



THE AEA PAKRATT PK-232

If you're thinking of having a go at digital communications but don't know which mode to gear up for, why not try them all. With the PK-232, your computer and a transceiver or two, you can establish a digital station capable of operating on any of the popular modes without the hassle of finding separate interfaces and modems and the associated "rats nest" of cables and switching.

The Pakratt model PK-232 from Advanced Electronic Applications Inc. is a multi-mode interface designed to provide the amateur operator with a versatile digital communications station in an integrated package. The interface will allow operation on Morse, RTTY using the Baudot code, RTTY using the seven-bit ASCII code, AMTOR in both ARQ and FEC modes, and packet using the AX-25 protocol.

Operation and connection of the PK-232 is very straightforward and as the interface is controlled via a standard RS-232 port, it can be used with virtually any computer. Another advantage lies in the fact that all the software for controlling the various modes is stored in ROM within the unit so you don't have to search around for special programs to suit your computer.

Almost every parameter that you might want to change can be altered using simple commands from your computer keyboard. Morse speeds can be selected between five and 99 words per minute, RTTY speeds can be selected from 45, 50, 57, 75 and 100

baud in the Baudot mode and additionally 110, 150, 200 and 300 baud in the ASCII mode. Packet baud rates can be selected from 300 or 1200 baud or up to 9600 baud if using a suitable external modem.

The characteristics of the internal modem are automatically configured depending on the mode in use. On VHF packet the bandwidth is 2600 Hz, on HF it is 450 Hz and on CW it is 200 Hz. The demodulator is a limiter-discriminator type which is preceded by an eight-pole Chebyshev 0.5 dB ripple bandpass filter.

The front panel of the PK-232 has 21 LEDs to indicate the status as well as a LED bargraph tuning display, an adjustable threshold control and a switch to select either of two transceivers. The unit comes supplied with all the necessary cables for connecting two transceivers and all you have to provide is a set microphone plugs to suit and an external power supply of 12 to 16 V at one amp. The instruction manual is complete and extensive, covering all aspects of connection and operation. You will certainly need to refer to the manual when acquainting yourself with the PK-232, there are some 140 different commands which the unit recognises.

I have been lucky enough to have a PK-232 loaned to me for a few weeks and I haven't had so much fun in a long time. I have used the unit on my VHF packet bulletin board as well as having a go at HF packet, RTTY and AMTOR. The unit performed flawlessly and the HF modem in particular was one of the best I have encountered. AEA have certainly got their act together with this unit and it appears to me from the comments I have received from other users that this interface is the one by which all others will be judged.

If you would like to find out some more about the PK-232, why not call into one of the Emtronics stores who currently have stocks of the units. Emtronics have their head office at 92-94 Wentworth Ave, Sydney, phone (02)211 0988. If you live in the Brisbane area, you can call into the Emtronics store at 416 Logan Road, Stones corner and have a chat with the manager, Brian Beamish. Brian is well known amongst the packet fraternity and is the system operator of the very popular VK4BBS packet bulletin board.

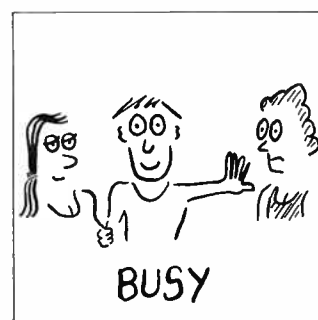
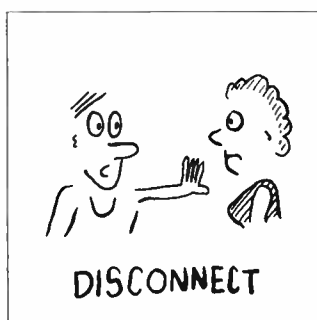
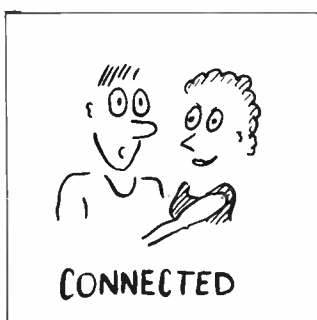
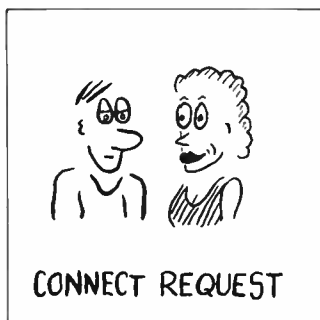

which relies on the common use of one frequency to support it's network style of operation. The AMTOR mode is predominantly used on HF and I am not aware of any operation on any of the VHF bands.

On the six meter band, the narrowband segment is from 52.080 to 52.100 MHz. Operation on the 6m band is spasmodic regardless of the mode in use, but activity usually peaks between November and February each year.

The two meter band is where the majority of packet operation currently takes place. The frequencies of 144.800 MHz, 147.575 MHz and 147.600 MHz are where you will find almost all the activity. There is no specific narrowband segment but the national calling channel for FSK RTTY is 144.075 MHz. There appears to be more RTTY activity on two meters FM using AFSK where the national calling frequency is 146.600 MHz.

The seventy centimetre band does not have a specific narrowband segment but the FSK calling frequency is 432.075 MHz. There is some packet operation on this band and the frequencies of 439.050 and 439.075 MHz are recommended for this mode. You can probably expect an increase in packet operation in this band as the mode gains popularity and high speed links become a reality.

Where to find advice

There are a number of societies and groups which have been set up by radio amateurs with a common interest in the digital modes. Most states and some major cities will have such an interest group, either as a separate body or perhaps as part of an existing amateur radio club. A good source of advice and assistance can usually be found by asking amongst amateurs already active on the modes of interest but perhaps the best approach is to contact one of the national groups who have wide resources and large combined expertise.

The Australian National Amateur Radio Teleprinter Society (ANARTS) have a large active membership who are involved in all aspects of digital communications. ANARTS

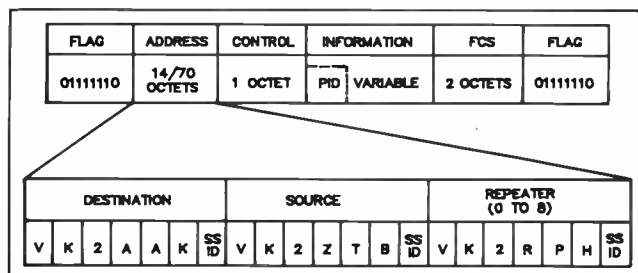

An example of the AX.25 frame format. Each frame is divided into "fields" and is normally preceded by 16-bit reversals for synchronization. The frame consists of the beginning flag, address field, control field, a network protocol identifier (PID), information field, frame check sequence (FCS) and an ending flag.

This example shows VK2AAK transmitting to VK2ZTB via a digipeater VK2RPH. The repeater address field is optional and may contain up to eight digipeater call signs.

are not simply involved in RTTY but have members who operate on AMTOR and packet as well. The address of ANARTS is PO Box 860, Crows Nest 2065 NSW. If writing, please enclose a self-addressed, stamped envelope as a matter of courtesy.

The Australian Amateur Packet Radio Association (AAPRA) whilst being a relatively newly formed group, already have a substantial membership including amateurs from all Australian states as well as the USA, New Zealand and Papua New Guinea. The activities of AAPRA revolve mainly around AX-25 packet radio and many members are engaged in research and development of sophisticated packet network systems. Several of the AAPRA members operate bulletin board and dedicated digipeater services and if you use these services it seems only fair to support the organization by becoming a member yourself. Plenty of assistance is available for new packet radio enthusiasts and the group also publish an excellent newsletter full of practical advice and interesting news.

For information about AAPRA, write to: **The Secretary AAPRA, 59 Westbrook Avenue, Wahroonga 2076 NSW** and include a self-addressed, stamped envelope.

Further reading:

The ARRL 1987 handbook for the radio amateur, published by the American Radio Relay League. This latest ARRL handbook contains an updated chapter on digital communications and provides a detailed description of the AX.25 packet protocol.

The amateur radio handbook published by the Radio Society of Great Britain contains some useful information on RTTY and AMTOR operating.



Another example of a packet bulletin board, this time closer to home. This system is run by the author and assistant editor, Andy Keir VK2AAK. During the day, the computer is used for writing the magazine, but after hours it becomes the VK2AAK bulletin board. This board has become the official system of the VK2 division of the Wireless Institute and will shortly change it's callsign to VK2AWI.

Elektor Electronics

in AEM

CONTENTS

PROJECTS

Spot Sine Wave Generator - 1	34
Spot Sine Wave Generator - 2	38
Auto-ranging Digital Multimeter	45
Motorcycle Intercom Unit	48
Printed Resistors	54

ARTICLES

Interfacing Atari ST & MSX Computers to SCART/TTL Colour Monitors ...	51
---	----



The projects and circuits chosen for inclusion in the Elektor section are selected on the basis of interest, local relevance and component availability. Intending constructors should consult our 'PROJECT BUYERS GUIDE' in this issue for a guide to component sources and possible kit suppliers.

The contents of this section are copyright,

© Uitgeversmaatschappij Elektor B. V. (Beek, the Netherlands) 1986.

Any infringement of this copyright will be prosecuted to the full extent, including unauthorised manufacture of pc boards intended for re-sale.

SPOT SINE WAVE GENERATOR — 1

by M G Weigl

This ultra-low distortion, 4-frequency, sine wave generator is a laboratory-grade instrument for testing and aligning AF circuits of almost any kind.

A spot frequency generator is primarily used for distortion measurements. It derives its name from the fact that it delivers one or more *fixed* output frequencies (*spots*), rather than a continuous range. The use of fixed frequencies makes it possible to tailor the generator such that it outputs each "spot" as a pure sine wave with significantly less distortion than would be attainable with a continuously variable instrument. The spot sine wave generator described in this two-part article has technical features that make it suitable for a wide variety of applications having to do with the analysing, testing, and setting up of high-end audio equipment. Its excellent performance is the more surprising in view of its simplicity, relatively low cost, and the use of standard, off-the-shelf components.

Design principles

Figure 1 shows the functional blocks that make up the spot sine wave generator. In essence, the sine wave is obtained by first generating a square wave, integrating this to make a triangular waveform, and feeding this in turn to a high-order low-pass filter, which then outputs the sine wave signal. This approach is based on Fourier's theory of signal synthesis and analysis, which proposes that a rectangular wave is composed of an infinite number of harmonically related sinusoidal constituents.

The 4 MHz clock oscillator in the spot sine wave generator is crystal-controlled, and drives a :16 divider to obtain a 250 kHz signal. After subsequent division by 25 and 2, a 5 kHz rectangular wave is available for integrating in an R-C network. The other three frequencies of the generator are obtained by

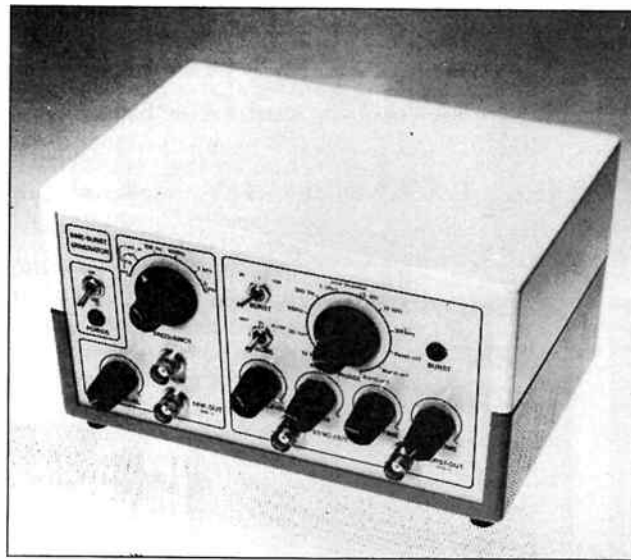

Spot sine wave generator Technical specification:

Output frequencies:	5 kHz, 1 kHz, 500 Hz, 100 Hz
Output voltage	1.5 V _{rms} (variable)
Frequency stability:	depends on quartz crystal.
Distortion:	0.008% (third harmonic).
Additional feature:	built-in tuning fork circuit, f = 440 Hz; V _{out} = 2 V _{rms} (variable).

dividing 10 kHz by 10 (1 kHz), 1 kHz by 2 (500 Hz) and 1 kHz by 10 (100 Hz).

The four rectangular waves are integrated with the aid of R-C combinations to obtain triangular waveforms. Each of these is passed through a low-pass filter to make the sine wave signals available for the driving of the burst-adaptor circuit via rotary switch S₄.

A useful boon of the spot sine wave generator is the built-in tuning fork circuit, which outputs a very pure and stable 440 Hz note.

Circuit description

The circuit diagram of the spot sine wave generator appears in Fig. 2. The central clock oscillator, IC₁, is controlled by quartz crystal X₁, whose operating frequency can be set to 4.000 MHz precisely by aligning trimmer C₅.

The Q₄ and Q₇ outputs of the ripple counter in IC₁ supply the 250 kHz clock for the spot

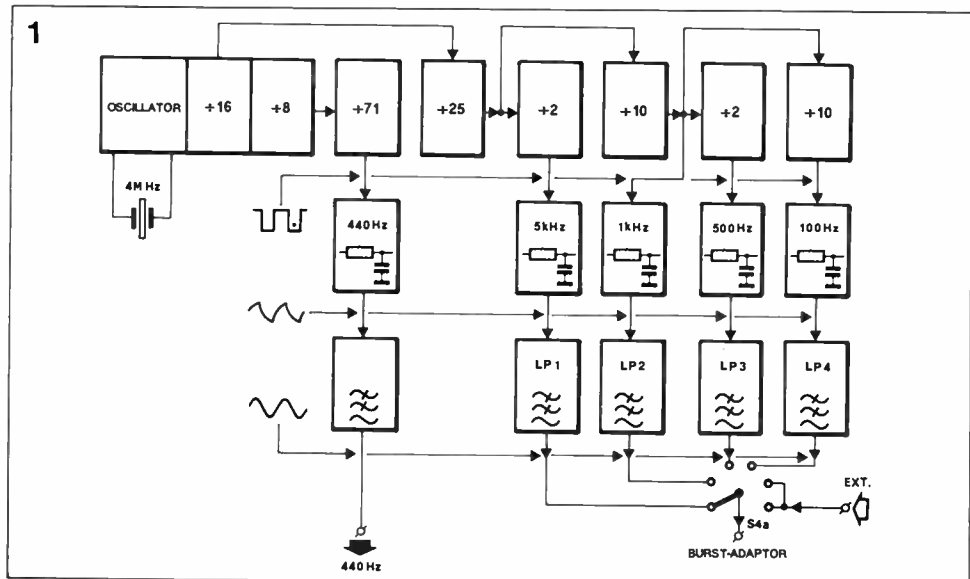

Fig. 1. Block schematic diagram of the spot sine wave generator.

2

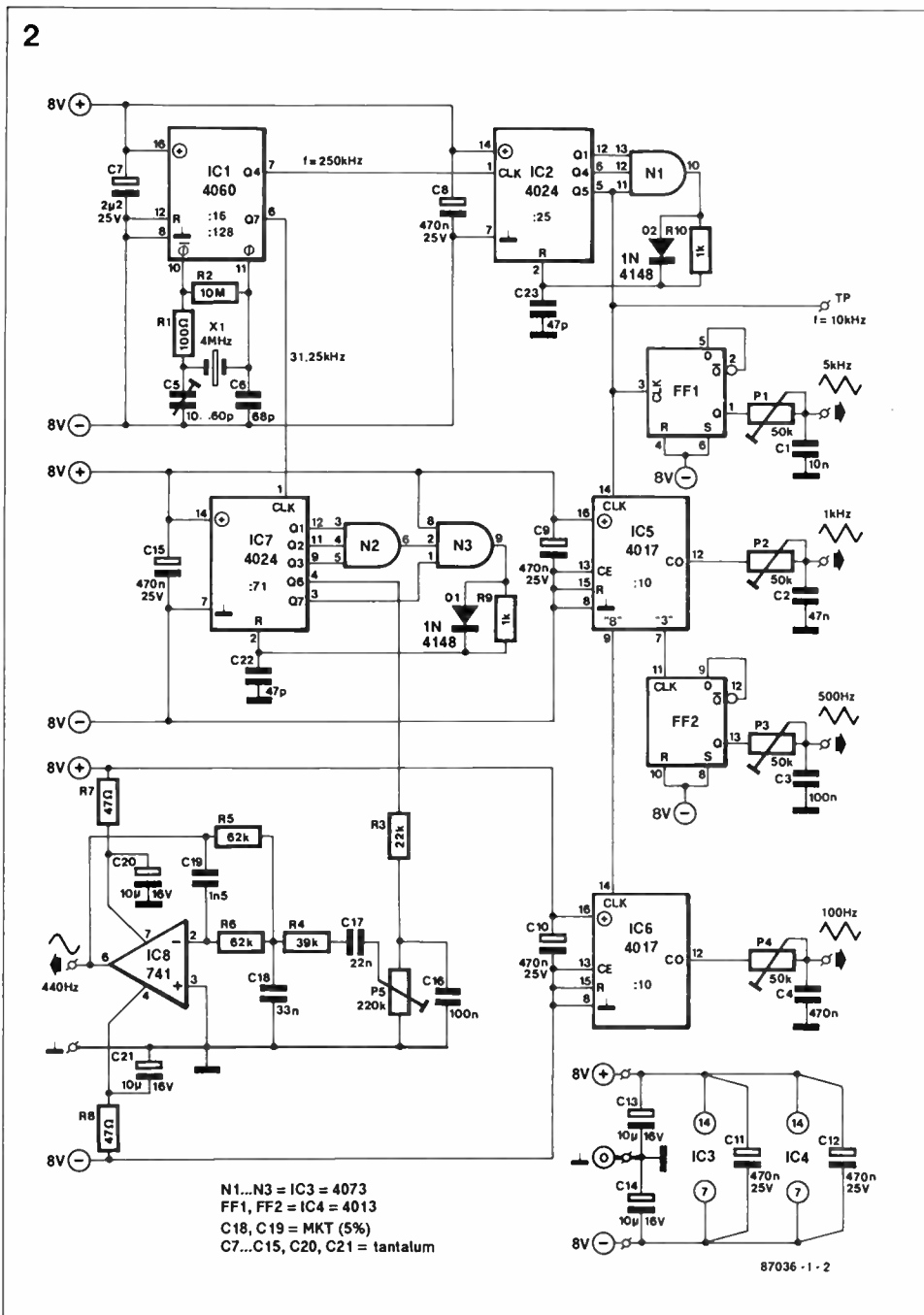

Fig. 2. Circuit diagram of the spot sine wave generator without output filters.

dividers, and the 31.25 kHz clock for the tuning fork, respectively. The 250 kHz signal is divided by 25 in IC₂. The slightly unusual divisor is obtained with the aid of a three-bit AND function, N₁, which resets the counter when Q₅ goes high. The 10 kHz signal at the Q₅ output is an asymmetrical rectangular wave which is made available at test point TP, and applied to the CLK inputs of FF₁ and IC₅. The bistable divides by two, and the 5 kHz triangular wave is obtained after integration in P₁-C₁. The counter divides by ten, and drives integrating network P₂-C₂ to provide the 1 kHz triangular signal. Bistable FF₂ and counter IC₆ likewise serve to deliver the 500 Hz and 100 Hz signals, respectively. The resistive part of each of the four integrating filters is a preset to enable setting the period to that of the incoming square wave. Example: P₁-C₁ should be aligned to give a period of 1/5000 = 200 μs. At this setting, the amplitude of the triangular signal is 63% of that of the input square wave. Therefore, the presets are readily adjusted by measuring the peak amplitude of both signals. Counter IC₇ is set up to divide the 31.25 kHz signal by 71 with the aid of AND gates N₂ and N₃. Ripple output Q₆ drives integrating network R₃-C₁₆. Preset P₅ is used to adjust the level of the 440 Hz triangular wave fed to the active low-pass filter set up around IC₈. This filter is a second-order Butterworth low-pass section with multiple feedback, dimensioned for a cut-off frequency of 440 Hz. The output is left DC-coupled, and may require a series capacitor to drive an amplifier.

3

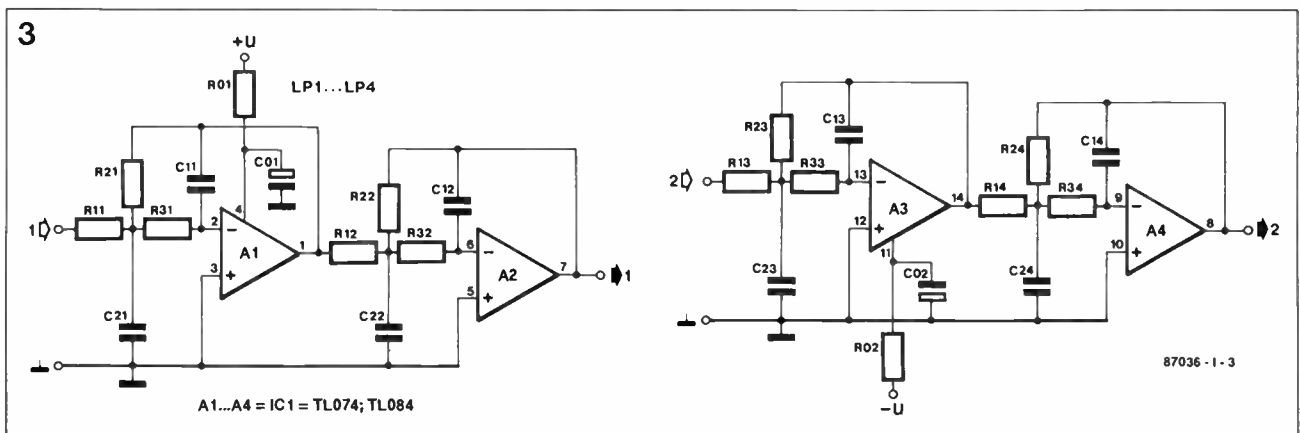

Fig. 3. Basic circuit diagram of the 8th order Butterworth filter. Output 1 goes to input 2.

Table 1

Technical data LP₁...LP₄.

Filter type:	Butterworth low-pass; 8th-order with multiple feedback.
Cut-off frequency (fc):	5 kHz (LP ₁) 1 kHz (LP ₂) 500 Hz (LP ₃) 100 Hz (LP ₄)
Filter coefficients:	A ₁ = 1.9616 A ₂ = 1.6629 A ₃ = 1.1111 A ₄ = 0.3902 B ₁ ...B ₄ = 1
Overall amplification:	$A_1 = \prod_{i=1}^4 A_{oi} = (A_{oi})^4 = 1$ ($f_{test} \ll f_c$)
Amplification of individual filter sections:	$A_{oi} = -1$ ($f_{test} \ll f_c$)

Calculation of component values in a filter section (see also the parts list to Fig. 5):

$$R_{1i} = R_{2i} / -A_{oi}$$

$$R_{2i} = \frac{A_i C_{2i} - \sqrt{A_i^2 C_{2i}^2 - 4 C_{1i} C_{2i} B_i (1 - A_{oi})}}{4 \pi f_c C_{1i} C_{2i}}$$

$$R_{3i} = B_i / (4 \pi^2 f_c^2 C_{1i} C_{2i} R_{2i})$$

$$C_{2i} / C_{1i} \geq 4 B_i (1 - A_{oi}) / A_i^2$$

Subscript *i* denotes filter section number (1...4).

The low-pass filters

To make pure sine waves from the four available triangular signals, an equal number of active low-pass filters is required. Fig. 3 shows the basic circuit diagram of the four-section, 8th-order Butterworth filter used in the spot sine wave generator. Note that the individual opamp sections are identical to the previously mentioned 440 Hz filter. Each of the low-pass filters LP₁-LP₄ is dimensioned as set out in Table 1. The calculations for the component values are based on those set out in *Halbleiterschalttechnik*, a standard reference work by Tietze & Schenk. The capacitors in the filter sections have been taken as the starting point for the calculation of the precision resistors to arrive at the correct cut-off frequency. This is so arranged because high-stability (1%) resistors are generally more easily available than precision capacitors. The theoretical

values of the resistors can be approximated to a reasonable extent by using series-connected 1% metal film types, as stated in the parts lists for the low-pass filters.

Construction

Figures 4 and 5 show the track layout and component mounting plan for the main generator board and one of four identical filter boards, respectively. The fitting of the various parts should not present serious difficulty when the overlay and the parts list are to hand. Make sure that the four filter boards are completed with the correct components, and use adhesives marked LP₁, LP₂, LP₃ and LP₄ with each filter to avoid connecting them to the wrong outputs on the main board.

Sv

4

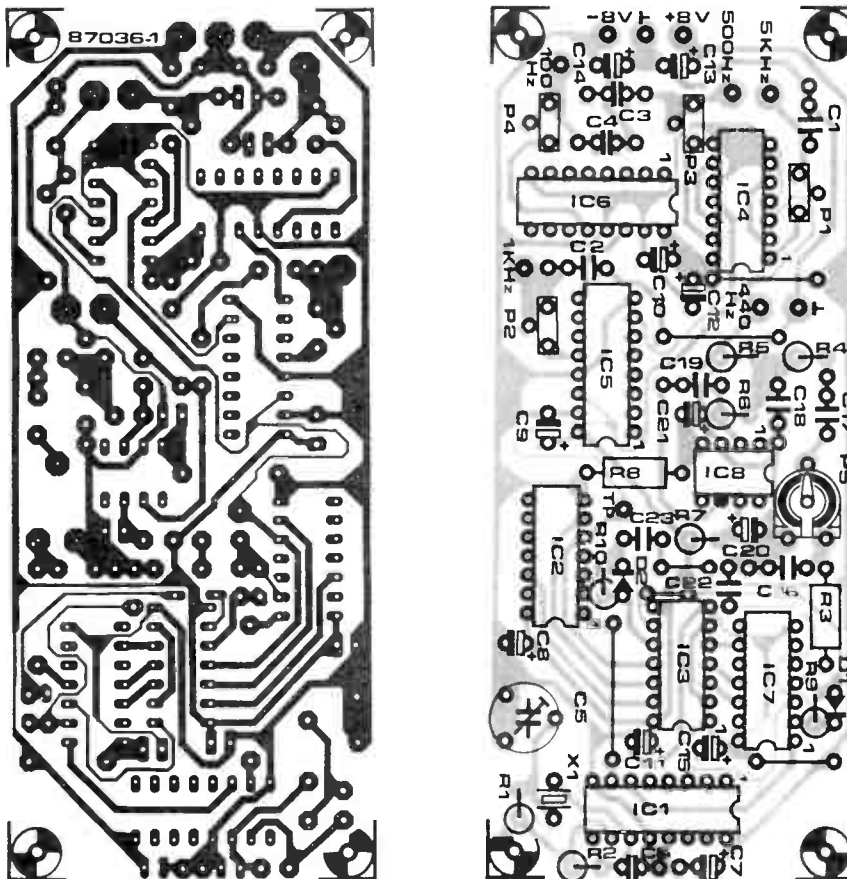

Parts list

(main board; see Fig. 4)

Resistors ($\pm 5\%$):

- R₁ = 100R
- R₂ = 10M
- R₃ = 22K
- R₄ = 39K
- R₅; R₆ = 62K
- R₇; R₈ = 47R
- R₉; R₁₀ = 1K0
- P₁...P₄ incl. = 50K preset for vertical mounting
- P₅ = 220K preset

Capacitors:

- C₁ = 10n
- C₂ = 47n
- C₃; C₁₆ = 100n
- C₄ = 470n
- C₅ = 60p trimmer
- C₆ = 68p
- C₇ = 2μ2; 25 V; tantalum
- C₈...C₁₂; C₁₅ = 0μ47; 25 V tantalum
- C₁₃; C₁₄; C₂₀; C₂₁ = 10μ; 16 V tantalum
- C₁₇ = 22n
- C₁₈ = 33n MKT 5%
- C₁₉ = 1n5 MKT 5%
- C₂₂; C₂₃ = 47p

Semiconductors:

- D₁; D₂ = 1N4148
- IC₁ = 4060
- IC₂; IC₇ = 4024
- IC₃ = 4073
- IC₄ = 4013
- IC₅; IC₆ = 4017
- IC₈ = 741

Miscellaneous:

- X₁ = 4.000 MHz quartz crystal

Fig. 4. The printed circuit board for the spot sine wave generator.

5

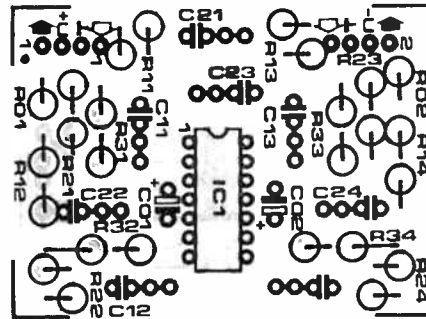
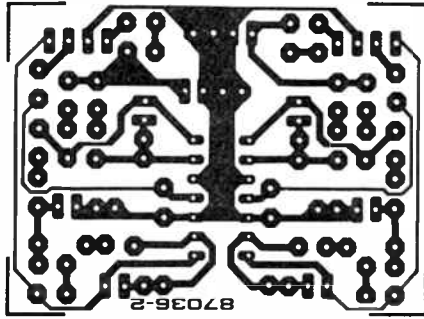

Fig. 5. The active filters are each constructed on a separate board of the type shown here.

Parts list

(low-pass filter boards LP1...LP4;
see Fig. 5).

LP1:

Resistors ($\pm 1\%$):

$R_{01}; R_{02} = 10RJ$
 $R_{11}; R_{21} = 118K7 (110K + 9K1)$
 $R_{12}; R_{22} = 89K86 (47K + 43K)$
 $R_{13}; R_{23} = 138K5 (130K + 8K2)$
 $R_{14}; R_{24} = 22K35 (22K + 360R)$
 $R_{31} = 82K57 (82K)$
 $R_{32} = 75K37 (75K)$
 $R_{33} = 107K6 (100K + 7K5)$
 $R_{34} = 30K23 (30K)$

Capacitors ($\pm 5\%$):

$C_{01}; C_{02} = 22\mu; 16V; 20\%$
 tantalum
 $C_{11}; C_{12} = 220p$
 $C_{13} = 100p$
 $C_{14} = 150p$
 $C_{21} = 470p$
 $C_{22}; C_{23} = 680p$
 $C_{24} = 10n$

Semiconductor:

$IC_1 = TL074$ or $TL084$

LP2:

Resistors ($\pm 1\%$):

$R_{01}; R_{02} = 10RJ$
 $R_{11}; R_{12} = 119K5 (120K)$
 $R_{12}; R_{22} = 63K79 (62K + 1K8)$
 $R_{13}; R_{23} = 69K24 (68K + 1K2)$
 $R_{14}; R_{24} = 50K78 (51K)$
 $R_{31} = 96K35 (91K + 5K1)$
 $R_{32} = 56K32 (56K)$
 $R_{33} = 53K8 (47K + 6K8)$
 $R_{34} = 68K7 (68K + 680R)$

Capacitors ($\pm 5\%$):

$C_{01}; C_{02} = 22\mu; 16V; 20\%$
 tantalum
 $C_{11}; C_{13} = 1n0$
 $C_{12} = 1n5$
 $C_{14} = 330p$
 $C_{21} = 2n2$
 $C_{22} = 4n7$
 $C_{23} = 6n8$
 $C_{24} = 22n$

Semiconductor:

$IC_1 = TL074$ or $TL084$

LP3:

Resistors ($\pm 1\%$):

$R_{01}; R_{02} = 10RJ$
 $R_{11}; R_{21} = 118K7 (110K + 9K1)$
 $R_{12}; R_{22} = 127K6 (120K + 7K5)$
 $R_{13}; R_{23} = 138K5 (130K + 8K2)$
 $R_{14}; R_{24} = 46K6 (47K)$
 $R_{31} = 82K57 (82K)$
 $R_{32} = 112K6 (110K + 2K7)$
 $R_{33} = 107K6 (100K + 7K5)$
 $R_{34} = 68K02 (68K)$

Capacitors ($\pm 5\%$):

$C_{01}; C_{02} = 22\mu; 16V; 20\%$
 tantalum
 $C_{11} = 2n2$
 $C_{12} = 1n5$
 $C_{13} = 1n0$
 $C_{14} = 680p$
 $C_{21}; C_{22} = 4n7$
 $C_{23} = 6n8$
 $C_{24} = 47n$

Semiconductor:

$IC_1 = TL074$ or $TL084$

LP4:

Resistors ($\pm 1\%$):

$R_{01}; R_{02} = 10RJ$
 $R_{11}; R_{21} = 119K5 (120K)$
 $R_{12}; R_{22} = 63K79 (62K + 1K8)$
 $R_{13}; R_{23} = 97K53 (91K + 6K8)$
 $R_{14}; R_{24} = 50K78 (51K)$
 $R_{31} = 96K35 (91K + 5K1)$
 $R_{32} = 56K32 (56K)$
 $R_{33} = 81K26 (82K)$
 $R_{34} = 68K7 (68K + 680R)$

Capacitors ($\pm 5\%$):

$C_{01}; C_{02} = 22\mu; 16V; 20\%$
 tantalum
 $C_{11} = 10n$
 $C_{12} = 15n$
 $C_{13} = 6n8$
 $C_{14} = 3n3$
 $C_{21} = 22n$
 $C_{22}; C_{23} = 47n$
 $C_{24} = 220n$

Semiconductor:

$IC_1 = TL074$ or $TL084$

Note: each low-pass filter is constructed on its own PCB Type 87036-2 (four pieces required).

TURN YOUR APPLE COMPUTER INTO AN INTELLIGENT PRINTING, DISK SAVING, VIATEL TERMINAL

FOR
\$299!

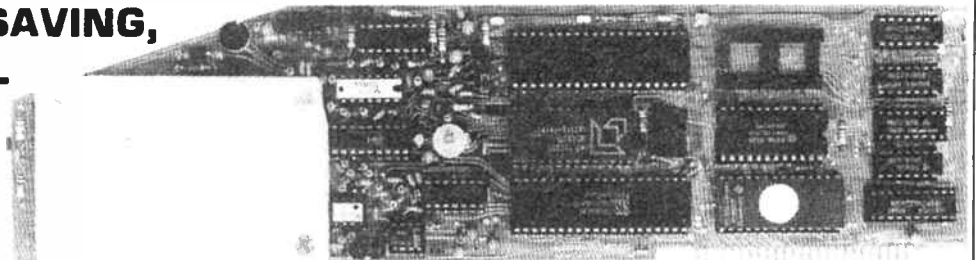

- Super intelligent direct connect complete modem system for the Apple II and Apple IIe. No additional hardware, cabling or software is required. Viatel and conventional Communication software is contained in hardware. Autoanswer, autodial and automode search. Incorporates a battery backed calendar clock.

- A keystroke converts it to a complete Viatel terminal. Viatel Frames can be easily dumped to disk, printer or memory while online and subsequently reviewed at leisure. Viatel Identification and phone numbers are stored and sent automatically. The modem is capable of acting as a Videotext host in a private closed user group network.

\$299 RETAIL (INCLUDES DELIVERY AND S/T)
AUTOMATIC ICE CO., 10 SMITH ST., CHARLESTOWN 2290 NSW
PHONE (049) 63 3188

SPOT SINE WAVE GENERATOR — 2

by M G Weigl

The article is concluded with details on the burst adaptor, and the construction of the instrument.

A *tone burst* is essentially composed of a controlled number of periods of an alternating voltage, usually a sine wave, and is used for testing and analysing the dynamic response of AF amplifiers, passive and active filters, and loudspeakers. In the case of the loudspeaker, for instance, a sine wave burst can be used to study the transient behaviour of a drive unit by measuring its acoustic output with the aid of a test microphone, fitted at a suitable distance in front of the cone. The signal from the microphone is then amplified and made visible on an oscilloscope. This method provides useful information about the occurrence of resonance effects, phase delay, ringing, etc., while it is also a practicable way of measuring the linear operating range of the drive unit under test. Since the burst is a relatively short signal, its duration being typically of the order of 5-10 periods, the loudspeaker can be driven to its full peak power capability without overloading the voice coil. In a response measurement based on the use of tone bursts, the pause duration is generally long relative to that of the burst, and hence allows sufficient time for the drive unit to cool off.

Pause, burst and phase

With reference to the block diagram of the burst extension, shown in Fig. 6, the signal from the pole of S_{4a} (see Part 1) is applied to sine wave amplitude control P_4 . The signal is then passed to a low pass filter, LP_{5b} ($f_c = 35$ kHz), to ensure the absence of spurious compo-

Burst adaptor extension for spot sine wave generator.

Technical features:

- Phase angle adjustable from 10 to 360°.
- Turn-on and turn-off phase angle are fully synchronous.
- Continuously variable Burst and Pause level.
- Continuously variable Burst and Pause duration.
- Also usable with other sine wave generators.
- Maximum input voltage: 5.6 V_{rms} .
- Maximum input frequency: 30 kHz.
- SYNC output for triggering an oscilloscope.

nents. A burst is obtained with the aid of electronic switch ES_1 , which is controlled with a pulse signal. During the pauses in the pulse train, ES_1 drives LP_{5a} ($f_c = 70$ kHz) with the attenuated signal available at the wiper of P_5 . During the active part of the switching pulse, LP_{5a} is fed with the full amplitude of the

sine wave signal. The control of ES_1 is effected with a composite signal, obtained by appropriate setting of the time constant, τ , of the signals Phase, Burst and Pause. The period of Sync is not adjustable, but is always much longer than that of the slowest signal (10 Hz) in the circuit.

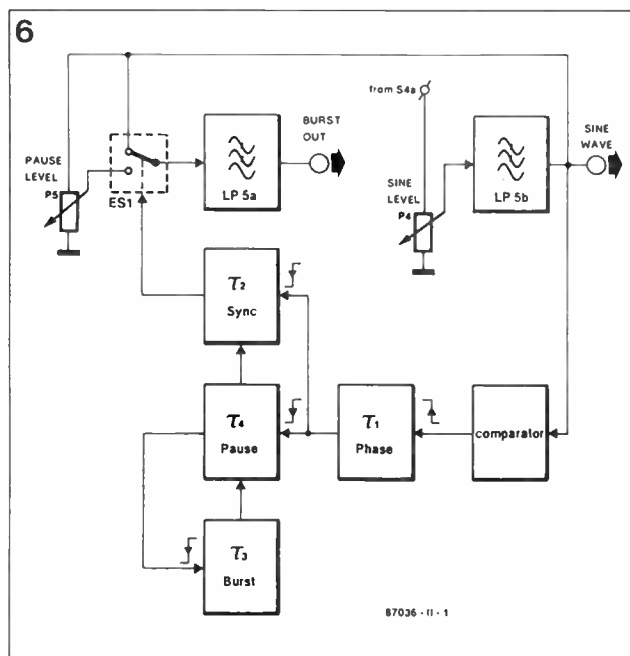

Fig. 6. Block diagram of the burst adaptor in the spot sine wave generator.

A burst of sine wave cycles

Figure 7 gives details on the connection of the burst extension to the sine wave generator described in Part 1 of this article. Low pass filters LP_1 - LP_4 are shown once more here to make clear that they are part of the circuit fitted onto the main busboard, which will be described in due course.

A simple ± 15 V supply based around IC_2 and IC_3 is accommodated on the busboard for feeding the filter modules.

Electronic switch ES_1 turns the sine wave on and off, and hence produces the burst with the aid of the CHOP signal. The amplitude of the sine wave is determined by the setting of P_4 (sine level), or P_5 (pause level), when CHOP is logic low or high, respectively.

The switch positions shown in Fig. 7 apply to the BURST OFF situation. Output signal TRIG controls the CHOP generator, and is shown disabled via ES_3 . The CHOP signal is therefore logic high, so that the sine wave is fed to the BURST output via P_5 , ES_1 and LP_{5a} . The same spot frequency is, of course, available at the SINE OUT socket, but the amplitude of the signal at this output and that at BURST can be adjusted separately with P_4 and P_5 . Both outputs should be terminated in 600Ω .

Electronic switch ES_2 is activated when a CHOP signal is required for processing an aperiodical signal, such as noise. In that case, an internal CHOP signal is obtained by passing the output from LP_4 (100 Hz) to the TRIG output. This arrangement enables ready use of the burst adaptor with a variety of externally applied signals.

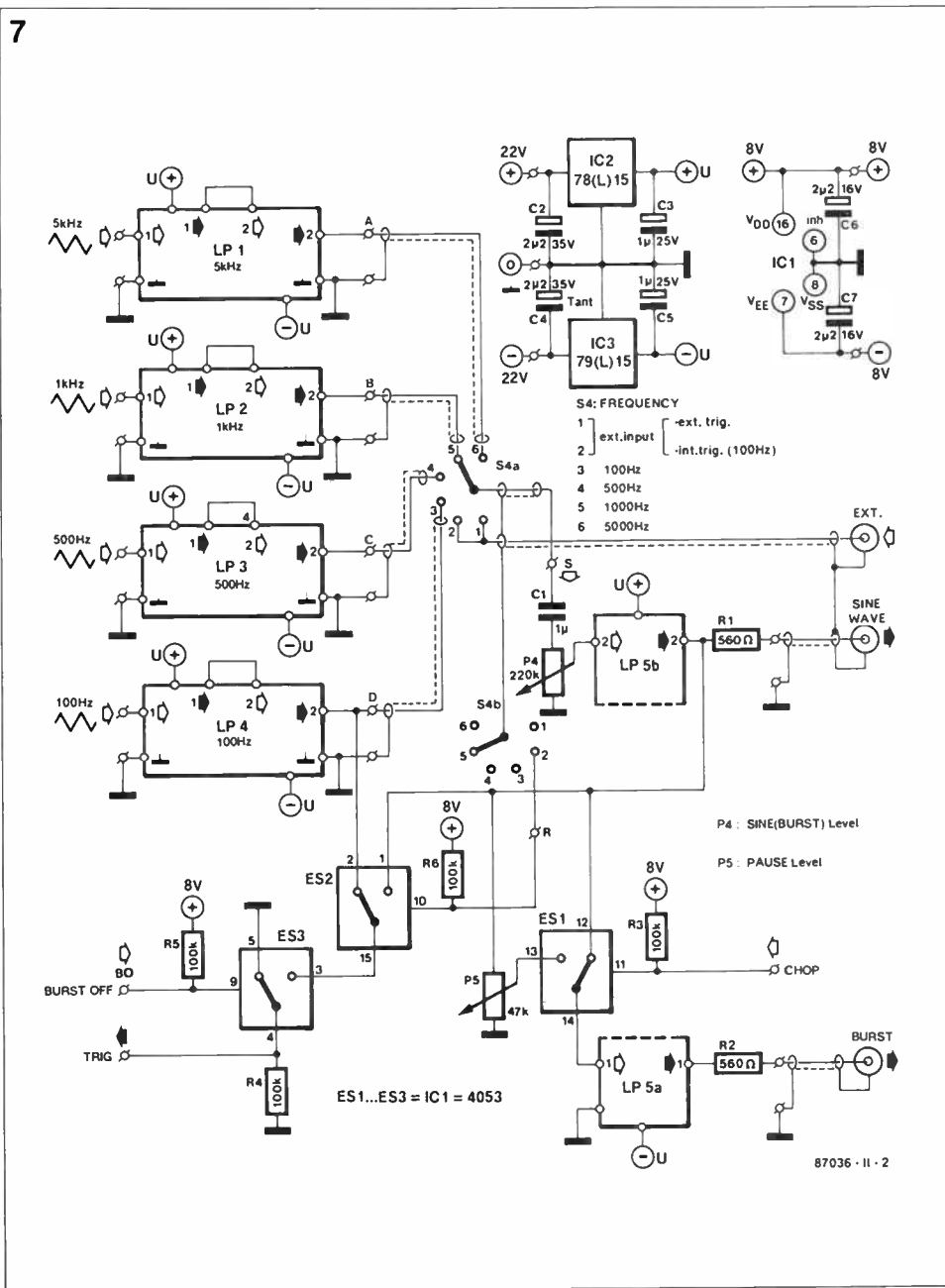

Fig. 7. The connections between the burst adaptor and the sine wave generator circuit. The control signals are routed with the aid of electronic switches.

The burst extension

The circuit diagram of the CHOP generator, i.e., the central part of the burst adaptor, appears in Fig. 8. Comparator IC1 converts any waveform at the TRIG input into a CMOS compatible, rectangular, input signal for monostable multivibrator MMV1, which is connected to trigger on the rising edge, and operates in the non-retriggerable mode, so that its mono time set with $P_1 + R_1 - C_1 \dots C_8$ must lapse before triggering can take place again. Rotary switch S1 and potentiometer P1 are the coarse and fine delay adjustments, respectively.

Since the TRIG signal is subject to delay before being converted into a usable CHOP signal, S1 and P1 in fact control the initial phase angle of the sine wave at the burst output.

The most important parameters of the burst are the duration of the pause and the number of periods, and these can be set as required with the aid of monostables MMV3 and MMV4, respectively. Potentiometers are provided to ensure precise adjustments for a particular application: P3 sets the length of the burst period, P2 that of the pause.

Monostable MMV4 can be disabled by the Q signal from MMV3 to keep the burst and pause periods well separated. When the burst is completed, MMV4 is enabled again, and can be activated with the next negative trigger pulse from MMV1, since output Q of MMV3 goes high again.

Monostable MMV2 synchronizes the onset point (phase angle) of the sine wave

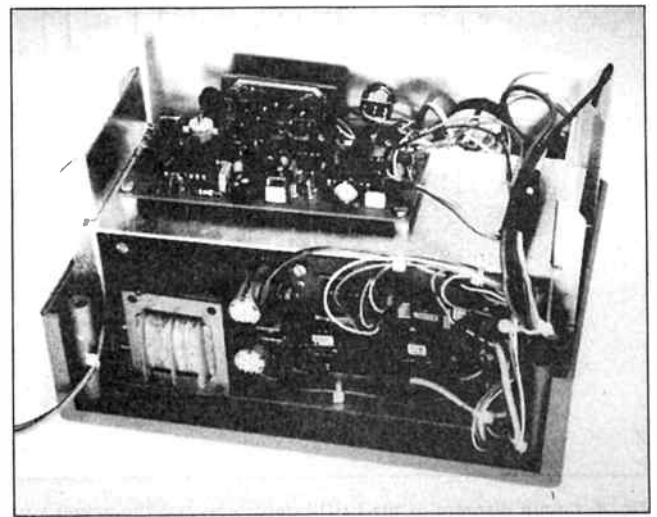
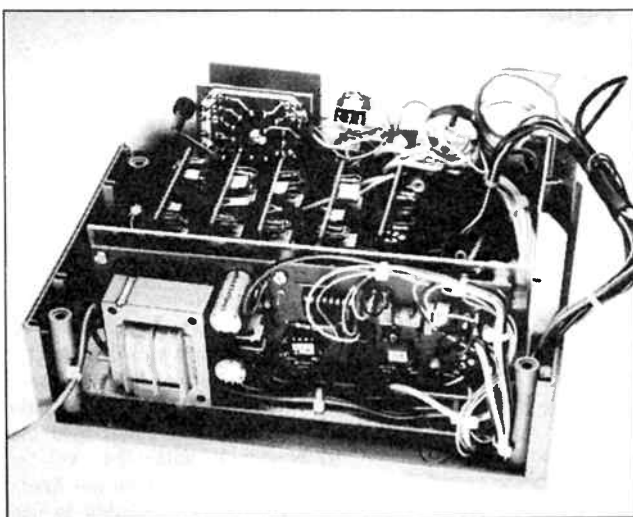

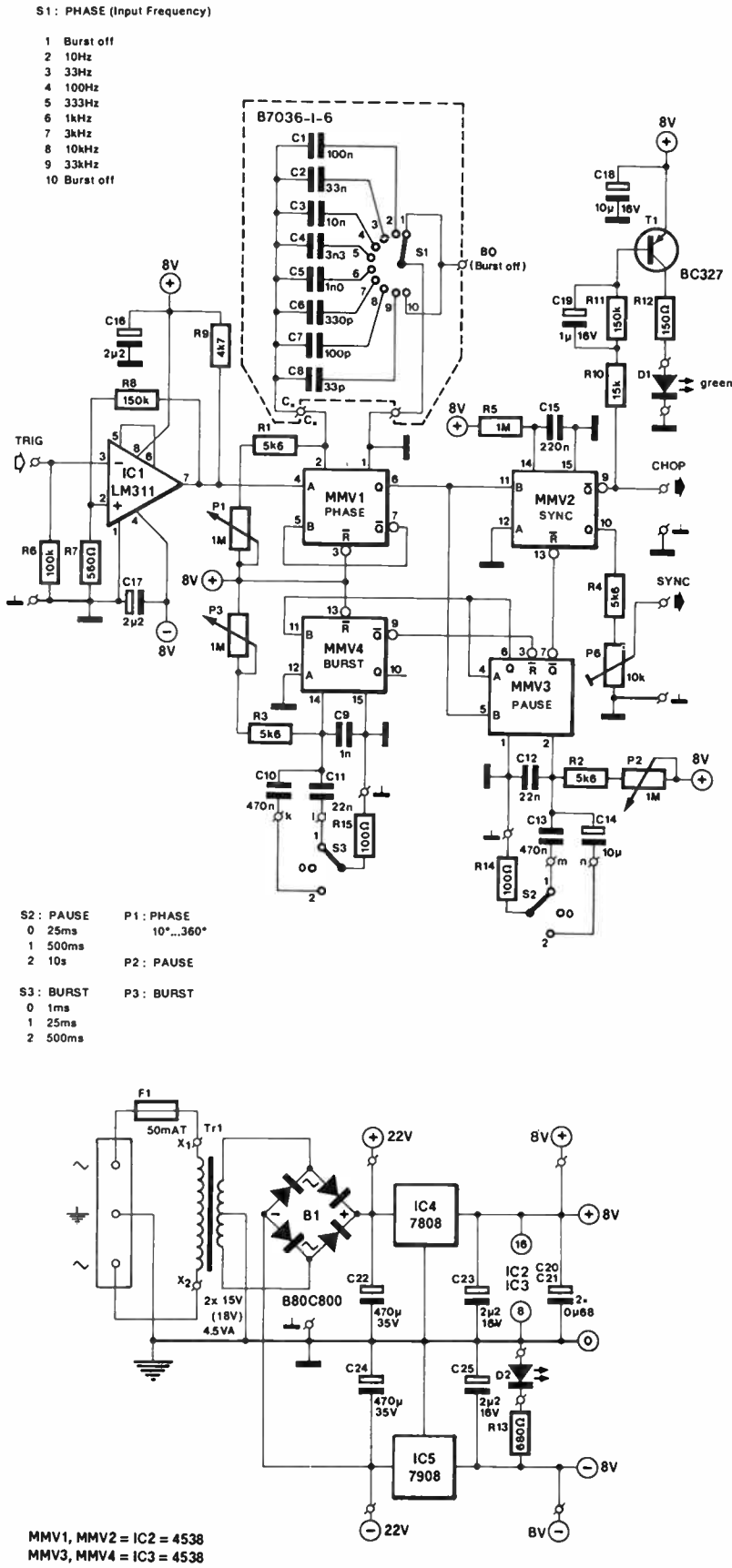

- S2 : PAUSE
- 0 25ms
 - 1 500ms
 - 2 10s
- P1 : PHASE
- 10°...360°
- P2 : PAUSE
- S3 : BURST
- 0 1ms
 - 1 25ms
 - 2 500ms
- P3 : BURST

burst. It is connected to trigger on negative pulse transitions (input A is grounded), but is reset during the burst pauses, because output Q of MMV3 is connected to its R input. When the pause has lapsed, MMV2 can be triggered again with the next negative-going pulse from MMV1. MMV2 remains set until a reset is forced by MMV3, because it is connected in the retriggerable mode, and its output period, set with R5-C15, is long relative to that of the lowest input frequency (>10 Hz). The turn-off instant of the CHOP signal is fixed with MMV1 reverting to its inactive state.

Briefly recapitulating the characteristics of the BURST signal: pause and burst duration are variable, and the entire signal can be phase-shifted over 10 to 360° to suit particular measurements.

The signal at output Q of MMV2 is attenuated in divider R4-P6, and fed to the SYNC output for triggering an oscilloscope. Output Q of the same monostable turns on LED D1 via driver T1. This makes it possible to see the burst activity from the instrument's front panel.

The power supply for the spot sine wave generator and its built-in burst adaptor is a conventional design based on a pair of integrated voltage regulators Type 7808 and 7908. The unregulated ±22 V output is connected to the regulators on the main busboard. LED D2 is the power indicator of the spot sine wave generator.

The low pass filters for the burst and sine wave outputs are shown in Fig. 9, while Table 2 summarizes their technical characteristics. Presets P1 and P2 enable nulling the offset voltage at BURST and SINE OUT, respectively.

Construction and setting up

Commence the construction of the instrument with fitting all parts on the main busboard shown in Fig. 10. It is possible to fit potentiometers instead of multiturn presets for P4 and P5. When this is opted for, soldering pins and wires are required to make the necessary connections. The low pass filters are also fitted onto the busboard with the aid of soldering pins (8 off per filter), but it is also possible to use

Fig. 8. Circuit diagram of the CHOP generator, and the power supply.

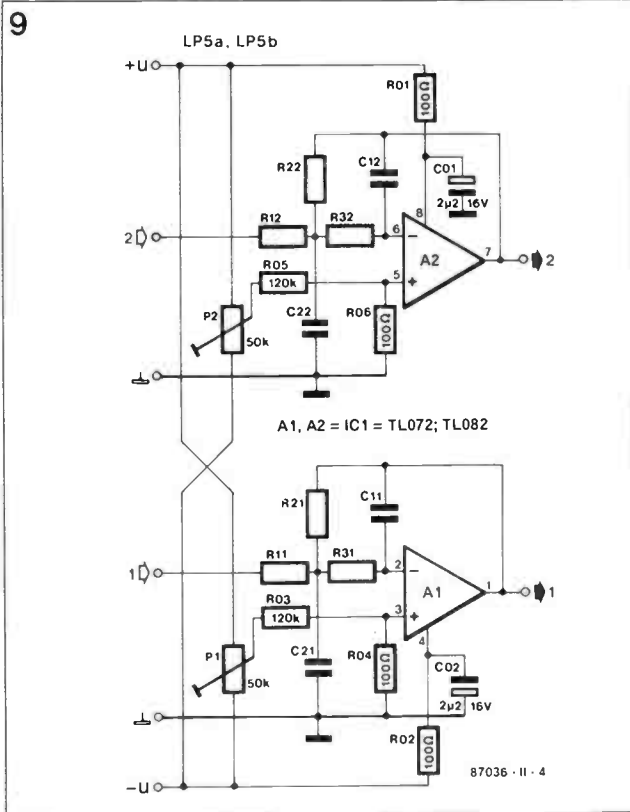

Fig. 9. The continuous sine wave and the sine wave burst are filtered prior to being output.

Table 2

Technical data LP5.

Filter type: Bessel low-pass; 2nd-order with multiple feedback.
 Cut-off frequency (f_c): 70 kHz (LP5a)
 35 kHz (LP5b)
 Filter coefficients: $A_1 = 1.3617$
 $B_1 = 0.618$
 Overall amplification: LP5a: $A_1 = A_0 = -1$ ($f_{test} \ll f_c$).
 LP5b: $A_1 = A_0 = -3$ ($f_{test} \ll f_c$).

Calculation of component values: please refer to Table 1 (LP1...LP4).

Parts list

(busboard, see Fig. 10)

Resistors ($\pm 5\%$):

$R_1, R_2 = 560R$
 $R_3 \dots R_6$ incl. = 100K
 $P_4 = 220K$ multiturn preset or 220K potentiometer
 $P_5 = 47K$ multiturn preset or 47K potentiometer

Capacitors:

$C_1 = 1\mu$ (MKT)

$C_2, C_4 = 2\mu 2$; 35 V; tantalum.
 $C_3, C_5 = 1\mu$; 25 V; tantalum.
 $C_6, C_7 = 2\mu 2$; 16 V; tantalum.

Semiconductors:

$IC_1 = 4053$
 $IC_2 = 7815$ or 78L15
 $IC_3 = 7915$ or 79L15

10

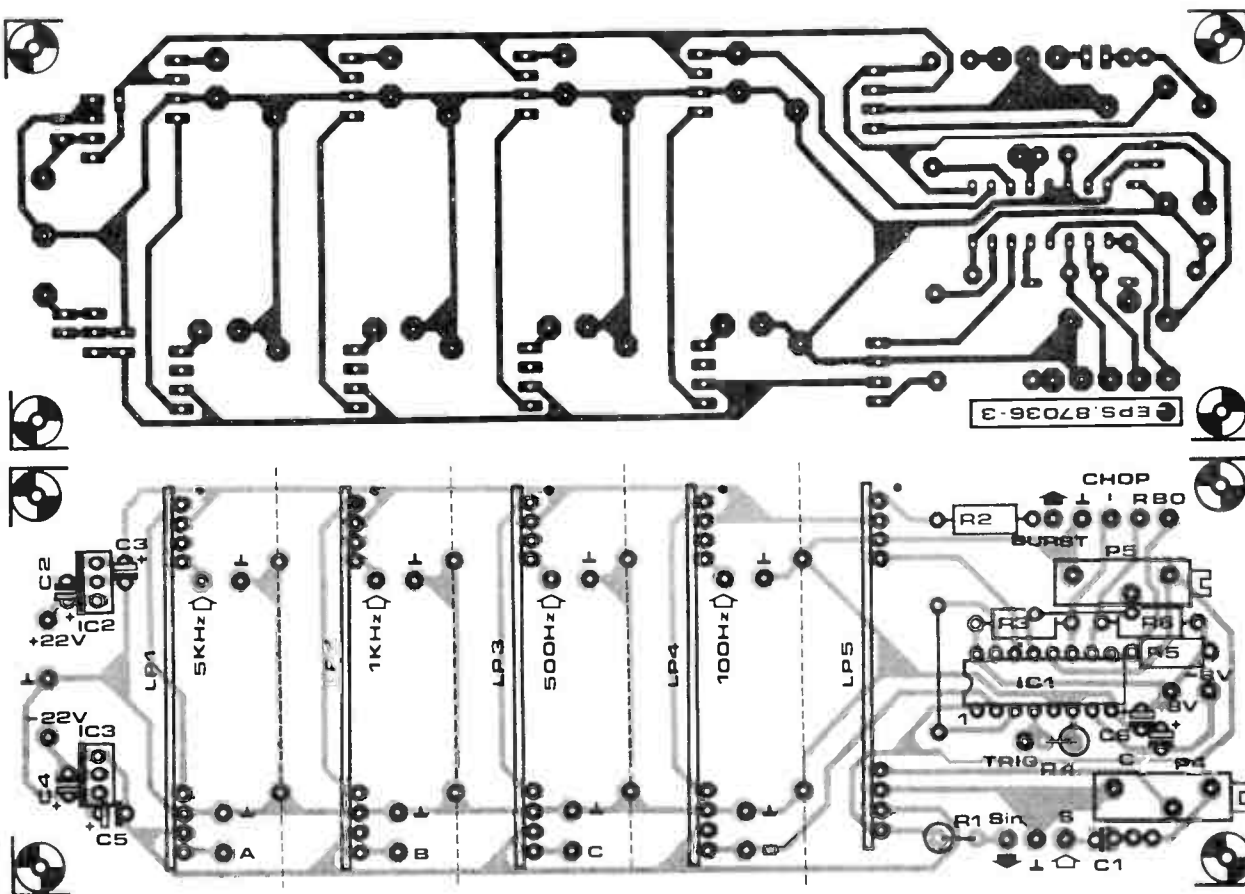

Fig. 10. The main circuit board for the spot sine wave generator holds the circuit shown in Fig. 7. The filter PCBs are fitted vertically.

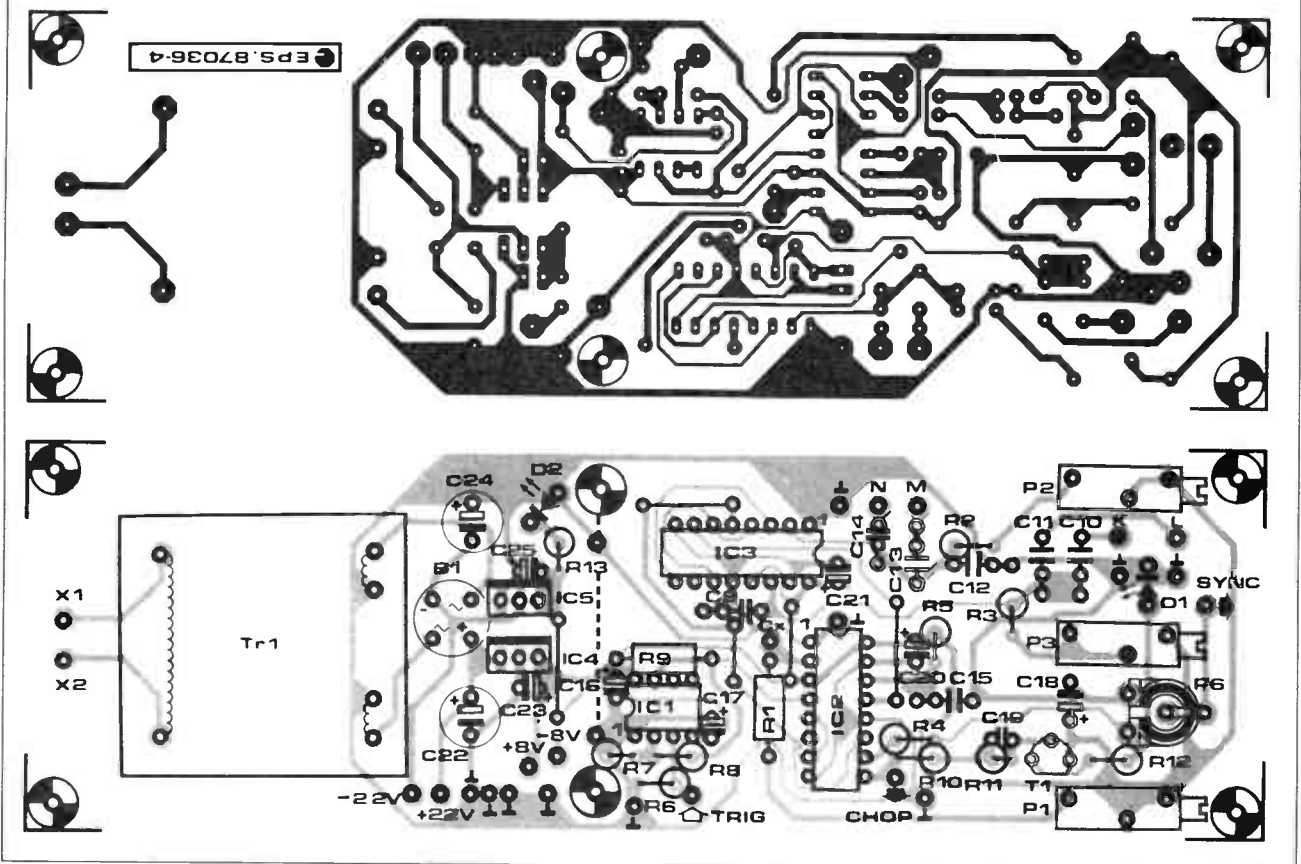

Fig. 11. This circuit board holds the power supply and the CHOP generator.

suitable mating PCB connectors. Note that holes have been provided on the main PCB to enable fitting metal screens between the filter modules.

Switch S_1 and associated timing capacitors and preferably fitted onto a separate PCB shown in Fig. 12. When this is not possible, each capacitor can be connected direct to the relevant switch contact, and each free capacitor terminal is then joined with the others to enable making a two-wire connection to the relevant points on the PCB.

The circuit board that holds LP_{5a} and LP_{5b} is completed as shown in Fig. 13.

Proceed with building the burst adaptor & supply PCB shown in Fig. 11. Potentiometers P_1 , P_2 and P_3 are mounted onto the instrument's front panel, and connected to the relevant points on the PCB with short lengths of screened wire, and soldering pins.

The power supply on the burst adaptor PCB is tested before fitting any of the ICs. Check the presence of ± 22 V and ± 8 V at the points indicated in the circuit diagram. When this ap-

Parts list
(see Figs. 11 & 12)

Resistors ($\pm 5\%$):

$R_1 \dots R_4$ incl. = 5K6
 $R_5 = 1M0$
 $R_6 = 100K$
 $R_7 = 560R$
 $R_8, R_{11} = 150K$
 $R_9 = 4K7$
 $R_{10} = 15K$
 $R_{12} = 150R$
 $R_{13} = 680R$
 $R_{14}, R_{15} = 100R$
 $P_1, P_2, P_3 = 1M0$ multiturn preset or 1M0 potentiometer.
 $P_6 = 10K$ preset

Capacitors:

$C_1 = 100n$
 $C_2 = 33n$
 $C_3 = 10n$
 $C_4 = 3n3$
 $C_5, C_9 = 1n0$
 $C_6 = 330p$
 $C_7 = 100p$
 $C_8 = 33p$
 $(C_1 \dots C_8$ incl.: see Fig. 12)
 $C_{10}, C_{13} = 470n$
 $C_{11}, C_{12} = 22n$
 $C_{14}, C_{18} = 10\mu$: 16 V tantalum
 $C_{15} = 220n$
 $C_{16}, C_{17}, C_{21}, C_{25} = 2\mu2$: 16 V tantalum
 $C_{19} = 1\mu$: 16 V tantalum

$C_{20}, C_{21} = 680n$: 16 V tantalum
 $C_{22}, C_{24} = 470\mu$: 35 V

Semiconductors:

$B_1 = 980C800$
 $D_1 = LED$ green
 $D_2 = LED$ red
 $T_1 = BC327$
 $IC_1 = LM311$
 $IC_2, IC_3 = 4538$
 $IC_4 = 7808$
 $IC_5 = 7908$

Miscellaneous:

S_1 = single pole 10-way rotary switch (see Fig. 12; use a 12-way type with adjustable stop).
 S_2, S_3 = SPDT switch with centre position.
 $Tr_1 = 2 \times 15$ V or 2×18 V; 4.5 VA for PCB mounting.
 $F_1 = 50$ mA delayed action fuse.
 Single-hole BNC sockets as required.
 Miniature SPDT mains switch.
 Mains entrance socket.

Suggested enclosure: Verobox
 Type 202-210368 (205 x 137 x 110 mm approx.).

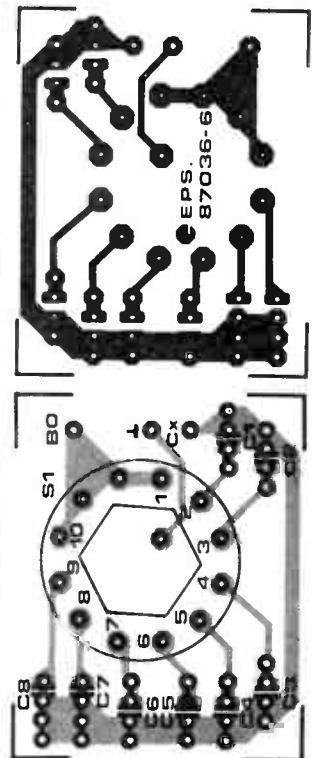

Fig. 12. Rotary switch S_1 for the phase angle setting can be fitted separately onto this board, along with 8 capacitors.

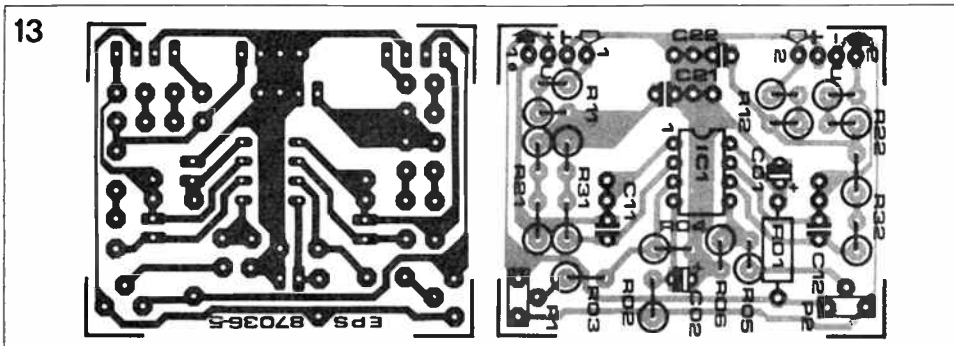

Fig. 13. This PCB holds the output low pass filters, and can be plugged onto the main busboard shown in Fig. 10.

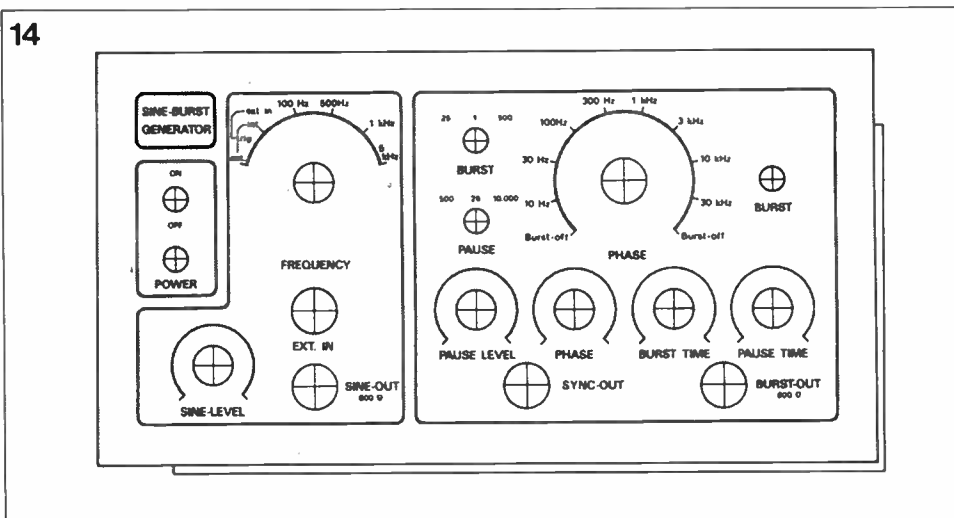

Fig. 14. Suggestion for a front panel foil for the spot sine wave generator (size: 197x104 mm).

pears to be in order, the supply is switched off, and the ICs are fitted. Turn the supply on again and check the operating voltage direct at the relevant terminals of the ICs. Screen the supply from the rest of the circuit by fitting a copper, brass or tinned metal sheet vertically onto the board, straight over the dashed line on the overlay. The screen is secured with two soldering pins.

The photographs of a prototype serve as a guide in fitting and interconnecting the boards in the Verobox enclosure. A suggestion for making a suitable front panel for this project can be found in Fig.14. The burst adaptor & supply PCB is fitted vertically near the rear panel of the enclosure. This makes it possible to install a metal screen between this board and those for the generator circuitry and the filter modules.

It is suggested to mount the completed PCBs in the following order. Commence with fitting all the necessary components onto the

front panel. The ± 22 V and ± 8 V supplies are provisionally connected to the main board, and the presence there of ± 15 V and ± 8 V is checked at all relevant points.

If everything is in order so far, the main board can be secured near the front panel of the enclosure. Refer to Fig. 7 for wiring details, and make sure that you use screened wires exactly as indicated in the circuit diagram, Fig. 7. Do not forget any of the ground connections. When you use potentiometers for P₄ and P₅, these must also be connected in screened wire. Prepare the wires for the supply voltages, CHOP, BO, TRIG and those for the connexion to the generator PCB, by soldering them to the appropriate terminals on the main busboard, and cutting the free ends to give suitable lengths to reach the relevant terminals on the burst adaptor & supply board and the generator board.

Now fit the burst adaptor & supply board in the enclosure, and connect the prepared

wires. Use screened wire for the connexions to the front panel mounted controls P₁-P₃, S₁-S₃, and the sync output socket. Connect LEDs D₁ and D₂, and pay due attention to the wiring of the mains ON/OFF switch, which is not shown in the circuit diagram because it is fitted as an external component.

The sine wave generator board is fed from the ± 8 V supply. The output socket for the tuning fork signal is fitted onto the rear panel of the enclosure. The generator board described last month is fitted on top of the main busboard, with a metal screen inserted between the two units—see the accompanying photographs of a prototype of the spot sine wave generator. The remaining wires from the main busboard and the supply are connected to the corresponding points on the generator board, and this finishes the construction of the instrument.

Sv

Parts list
(LP5a-LP6b; see Fig. 13)

Resistors: ($\pm 1\%$)

- R₀₁; R₀₂; R₀₄; R₀₆ = 100R.J
- R₀₃; R₀₅ = 120K.J
- R₁₁; R₂₁ = 19K58 (16K + 3K6)
- R₁₂ = 25K01 (13K + 12K)
- R₂₂ = 75K04 (75K)
- R₃₁ = 23K15 (18K + 5K1)
- R₃₂ = 51K6 (51K + 620R)
- P₁; P₂ = 50K preset for vertical mounting

Capacitors ($\pm 5\%$)

- C₀₁; C₀₂ = 2 μ 2; 16 V; 20%; tantalum
- C₁₁ = 47p
- C₁₂ = 22 p
- C₂₁; C₂₂ = 150p

Semiconductor:

- IC₁ = TL072 or TL082

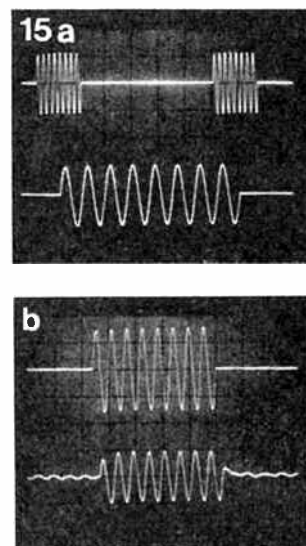

Fig. 15. Burst and continuous signal from the generator (15a), and the measured response of a typical squawker (15b).

AUTORANGING DIGITAL MULTIMETER

An accurate, fully protected, 3¾ digit meter that can be made with an absolute minimum number of components.

Digital multimeters are nowadays offered in many different styles and at very competitive prices. In spite of this, many enthusiasts remain convinced that building good quality test equipment for use in their workshop is a very rewarding pastime.

The digital multimeter proposed in this article is a versatile and remarkably user-friendly test instrument that has some features not commonly found in its price bracket.

Circuit description

The Type ICL7139 from GE-Intersil is a recently introduced, high performance, low power, autoranging digital multimeter IC, whose main technical data are summarized in Table I. When used as a DC voltmeter, the ICL7139 always displays the result of a conversion on the correct range. As can be seen from the front panel of the multimeter, shown in Fig. 3, the mode selector has but a single position for DC and AC voltage measurements. When set to DC voltage, the ICL7139 automatically selects one of four ranges to ensure optimum accuracy of the readout. For AC voltage measurement, the chip has one range: 400 V. The mode switch has a high (H) and a low (L) position for resistance and current measurements, and the ICL7139 automatically selects one of two ranges within these groups.

Four features of this design deserve attention. Firstly, the RMS (root-mean-square) value of 50 Hz sinusoidal input signals can be accurately measured in the 400 V AC range. Secondly, the use of a 3¾ digit LCD readout for the measuring



Auto-ranging DMM ICL7139

Technical characteristics:

- 13 ranges:
 - 4 DC voltage: 400 mV; 4 V; 40 V; 400 V
 - 1 AC voltage: 400 V
 - 4 DC current: 4 mA; 40 mA; 400 mA; 4 A
 - 4 Resistance: 4K Ω , 40K Ω , 400K Ω ; 4 M Ω
- Autoranging—first reading is always on correct range.
- On-chip duplex LCD driver includes 3 decimal points and 11 annunciators.
- No additional active components required.
- Low power dissipation: <20 mW.
- Battery life typically 1,000 hours.
- Average responding converter for sinewave inputs.
- Display hold input.
- Continuity output drives piezoelectric beeper.
- Low battery annunciator with on-chip detection.
- Guaranteed zero reading for 0 V input on all ranges.
- Accuracy: 400 V_{oc}: 1% of reading + 1.
 - all other V_{oc} ranges: 0.2% of reading + 1.
 - 4K Ω ; 400K Ω : 0.5% of reading + 8.
 - 40K Ω ; 4M Ω : 1% of reading + 9.
 - 4 mA; 400 mA: 0.5% of reading + 1.
 - 40 mA; 4 A: 0.2% of reading + 1.
 - 400 V/50 Hz: 0.2% of reading.
- Overvoltage protection with varistor or surge arrester.
- Current overload protection with fast fuse and diodes.

Principal data taken from manufacturer's preliminary data sheet.

ranges and associated display symbols. Thirdly, an on-chip supply level detector automatically warns of a flat battery by activating the LO BAT symbol on the display. Lastly, the proposed DMM has a built-in continuity tester that produces an audible signal when the measured resistance is less than 1K Ω . Also included is a hold function that enables "freezing" display readings.

With reference to the circuit diagram shown in Fig. 1, a few components require elaborating. Capacitor C₃ at the C_{INT} input of the DMM chip must be a high stability type with a tolerance of not more than 2.5%. The ratio (R₃ + R₄)/R₇ must be kept at 10:1 within 0.05%; the absolute values of the resistors are less important here. Resistors R₁ + R₂ and R₃ + R₄ can be matched with the aid of preset P₁. The value of R₅ and R₆ must be correct within 0.5% for optimum accuracy on the resistance measurement ranges. Precision resistors R₈ + R₉ and R₁₀ determine the accuracy of the current measurements: both their absolute value and the 10⁶:10 ratio to R₇ must be correct within 0.5%.

An autoranging voltmeter can not work reliably without proper protection against input overvoltages. Although a varistor would be capable of adequate surge suppression with a response of the order of 25 ns, its equivalent capacitance of about 200 pF makes it less suitable for the present application. A gas-filled surge arrester has a slightly longer response time, but a very low parasitic capacitance: in the Type B2B600 used here it is only 2 pF while the device gives very good protection of

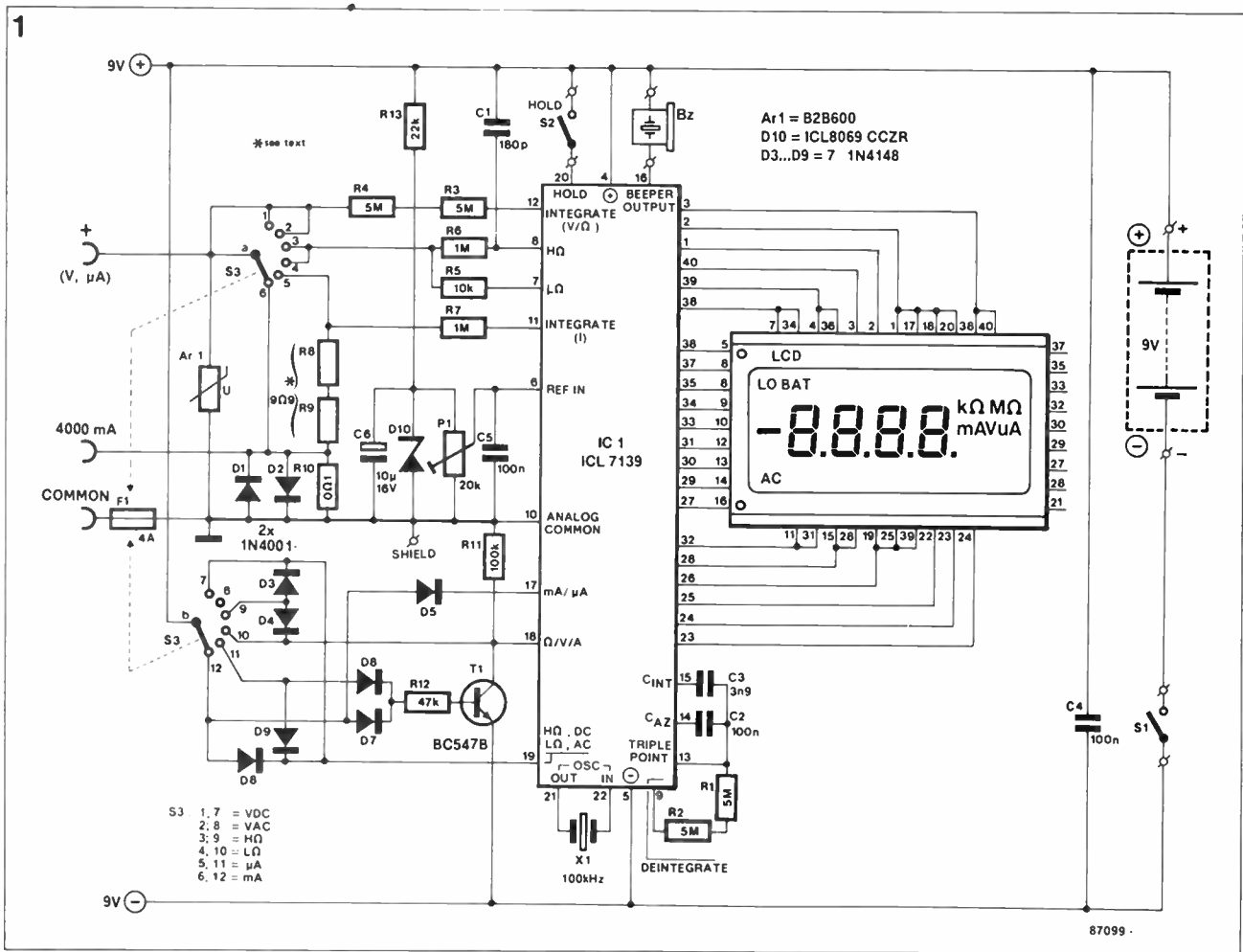

Fig. 1. Circuit diagram of the autoranging digital multimeter.

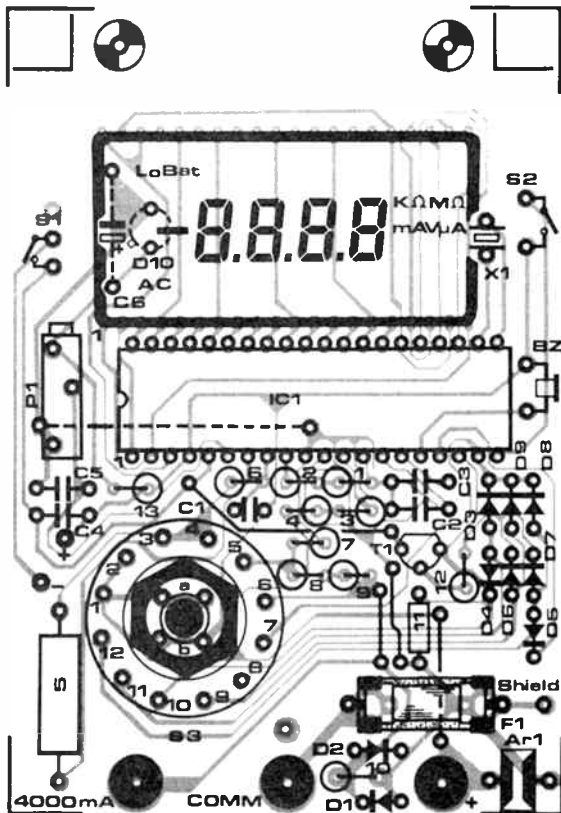

Fig. 2. The circuit board for the DMM fits in a standard Vero enclosure.

Parts list

Resistors ($\pm 5\%$):

- R₁...R₄ incl. = 5M0
- R₅ = 10K; 5 W
- R₆; R₇ = 1M0; 0.1%
- R₈ = 1R24F
- R₉ = 8R66F (R₈ + R₉ = 9R9; 0.5%)
- R₁₀ = 0R1; 2 W
- R₁₁ = 100K
- R₁₂ = 47K
- R₁₃ = 22K
- P₁ = 20K multiturn preset

Capacitors:

- C₁ = 180p
- C₂; C₄; C₅ = 100n
- C₃ = 3n9G polystyrene or silver-mica
- C₆ = 10 μ ; 16 V; axial

Semiconductors:

- D₁; D₂ = 1N4001
- D₃...D₉ incl. = 1N4148
- D₁₀ = ICL8069CCZR (GE-Intersil) ▽
- IC₁ = ICL7139 (GE-Intersil) ▽
- T₁ = BC547B

Miscellaneous:

- S₁; S₂ = miniature SPST slide switch.
- S₃ = double-pole, 6-way rotary switch for PCB mounting.
- F₁ = fast 4 A fuse with PCB mount holder.

- X₁ = 100 kHz miniature quartz crystal.*
- Bz = piezoelectric beeper PB2720 (TOKO), + +
- Surge arrester B2B600 (Siemens), +
- 9 V PP3 battery with clip-on leads.
- 3 off insulated 4 mm wander sockets.
- Enclosure Vero Type 65-2996H.
- Display Type 38D8R02H (LXD).#

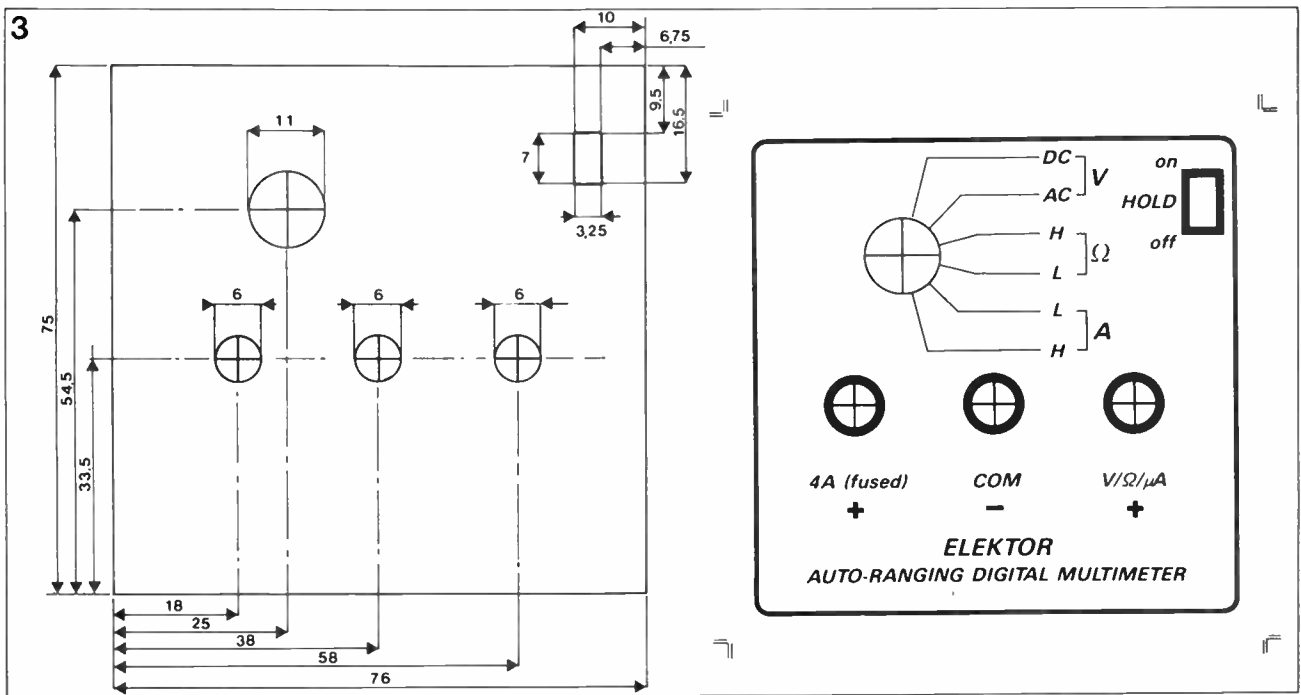
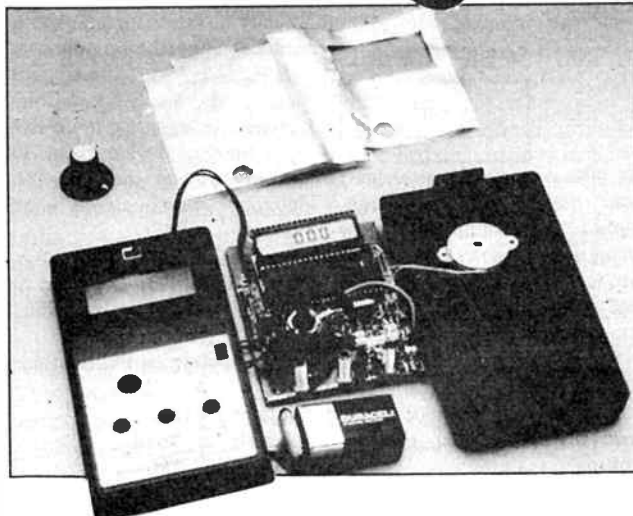
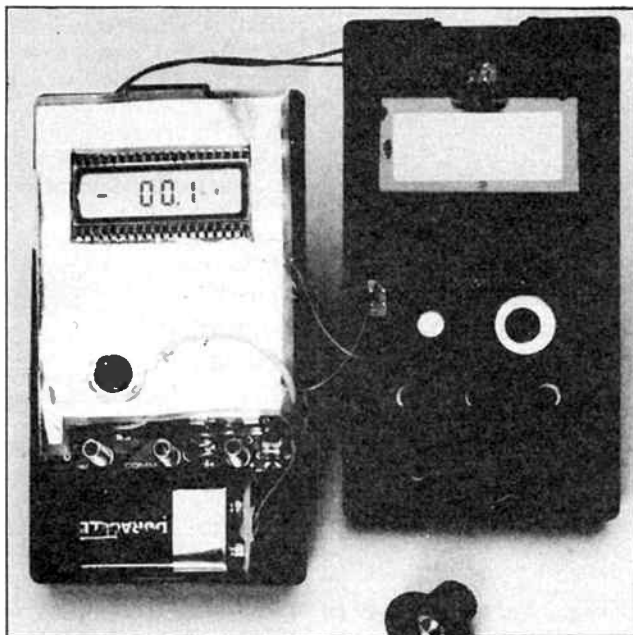

Fig. 3. Drilling template and suggested front panel foil for the DDM.



the sensitive inputs on the ICL7139. Diode D_{10} is a temperature-compensated, precision, 1.2 V reference. As already stated, the function of preset P_1 is not to set the voltage at the REF input of the DMM chip, but to compensate for the tolerance on the 5 M Ω resistors. Its adjustment is simply carried out with the aid of a sufficiently accurate digital multimeter, borrowed from a friend or a helpful electronics shopkeeper.

Rotary switch S_1 selects one of six measurements modes plus associated symbol on the LC display. Slide switch S_2 selects the HOLD mode. The multimeter is fed from a 9 V battery, and is switched on and off with S_1 . Since crystal X_1 clocks the RMS converter internal to the DMM chip, the stated value of 100 kHz is only valid for measuring 50 Hz input signals. For 60 Hz measurements, X_1 must be changed to a 120 kHz type.

Construction

The autoranging DMM is built on PC board Type 87099—see Fig. 2. The LC display is fitted into a wire-wrap socket or two sets of stacked terminal strips to ensure the required height above the circuit board. The three sockets for connecting the test leads are preferably mounted onto the enclosure lid to avoid excessive strain on the

PCB. The stated Vero enclosure has a battery compartment whose inside should be lined with expanded polystyrene. As shown on the accompanying photographs, a piece of aluminium foil is cut to size and insulated at both sides with self adhesive transparent foil. Great care should be exercised to avoid electrical contact between the aluminium foil and any component on the circuit board. A small area around the hole for the threaded part of the switch shaft should be left uninsulated. The screening foil is carefully secured by inserting it between a washer with a solder tag and the nut on the shaft of the rotary switch. A short wire is then run from the solder tag to point SHIELD on the printed circuit board.

R

INTERCOM FOR MOTORCYCLISTS

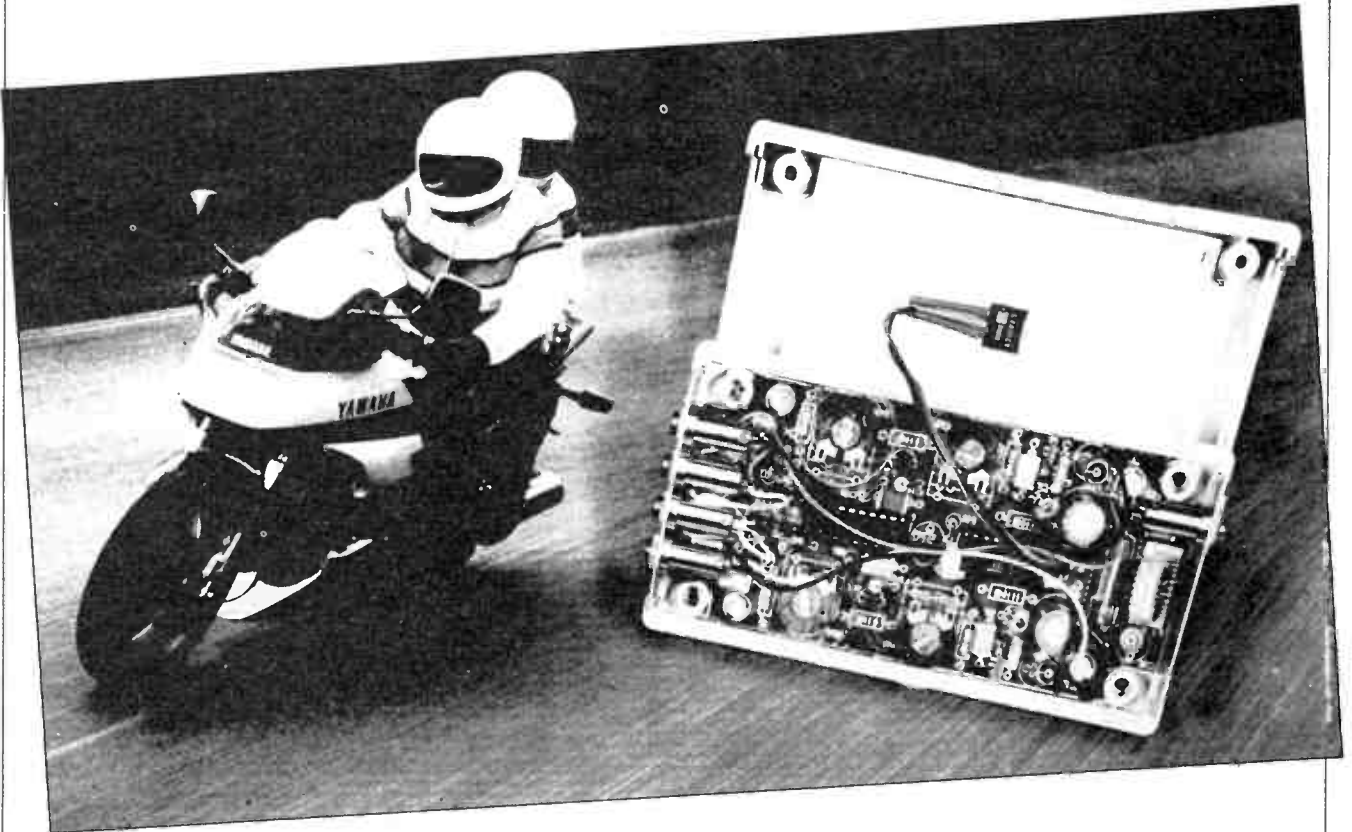

This advanced intercom enables motorcycle rider and passenger to chat undisturbedly while riding, thanks to effective ambient noise suppression and automatic muting facilities.

On a motorcycle, communication between the rider and the passenger on the rear seat is usually restricted to tapping on arms or gesturing in an effort to draw attention to noteworthy objects or events. The safety helmets and the ambient noise (wind, engine and traffic) make a normal conversation impossible, and many a motorcycle enthusiast is, therefore, confined to the noise in his own helmet. Even if he shouted at the top of his voice, his passenger would not hear him, although they sit quite close to one another. The intercom proposed here should appeal to all motorcyclists who recognize the dangers involved in gesturing

movements from the passenger while riding at relatively high speed. The unit is also eminently suited for instructing novice riders or those practising for work in a mail despatch service.

Noise cancelling and automatic mute

The circuit diagram in Fig. 1 shows that there are two microphones for the driver (channel A) and two for the passenger (channel B). This arrangement makes it possible to selectively suppress ambient noise. Electret condenser microphone

MC₂ supplies an AF voltage to the - input of opamp A₁, and MC₁ similarly drives the + input. The operation of the circuit becomes clear from studying Fig. 2, which shows the arrangement of the microphones and the headphone set in the helmet of driver and passenger. Referring again to channel A, MC₁ receives the spoken messages plus accompanying ambient noise, while MC₂ receives noise only. The differential amplifier in A₁ removes the noise component, so that the speech signal remains, and can be fed to IC₄ via C₅, P₁ and C₁₀. Stereo amplifier IC₄ functions as a double mono amplifier in this circuit. Its out-

put signal is fed to the headphone set of the passenger. The intercom has a built-in automatic mute facility, so that it is only operative when either the driver or the passenger starts to speak. The speech signal from opamp A₁ is applied to the - input of comparator A₂, whose threshold is defined with preset P₃ (MUTE B). Monostable MMV₁ is thus triggered by the peaks in the speech signal, and reverts to its inactive state when the speech pause is longer than about a second. Transistor T₂ then short-circuits the input of the headphone driver, IC₄. When a long enough speech signal is available, the collector-emitter junction of T₁ forms a

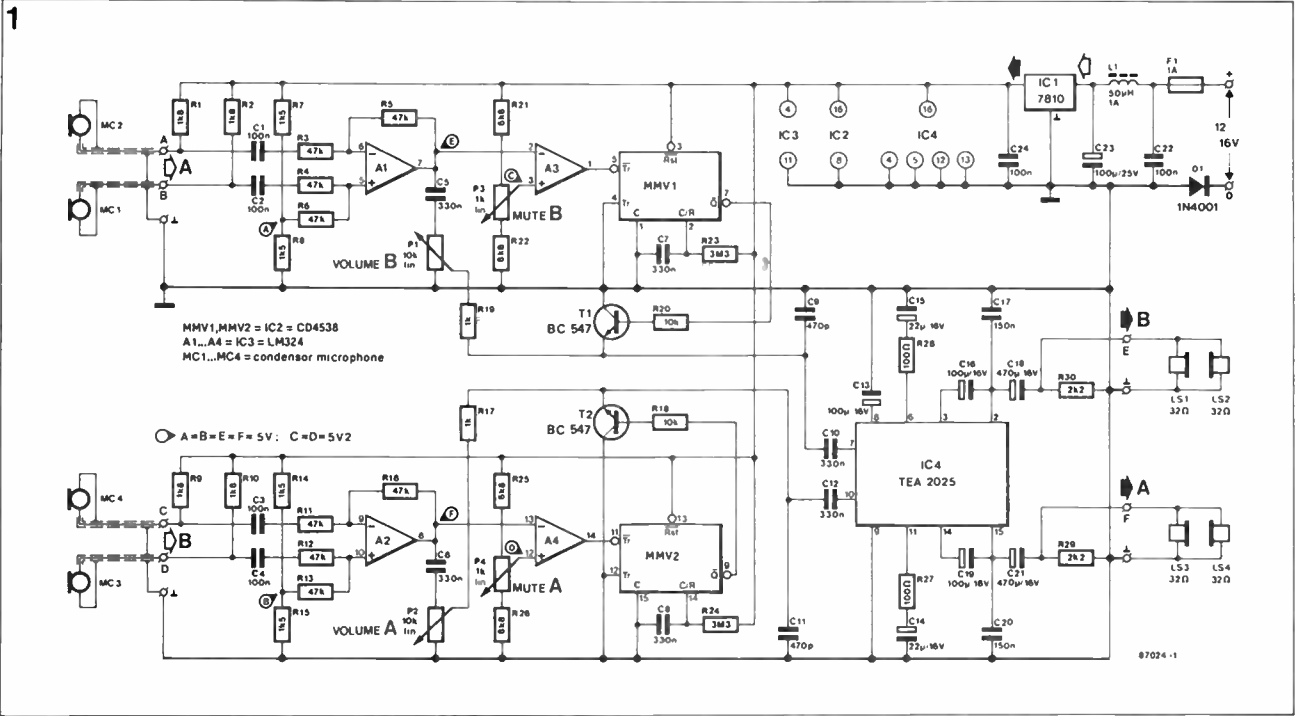

Fig. 1. Circuit diagram of the intercom for motorcyclists.

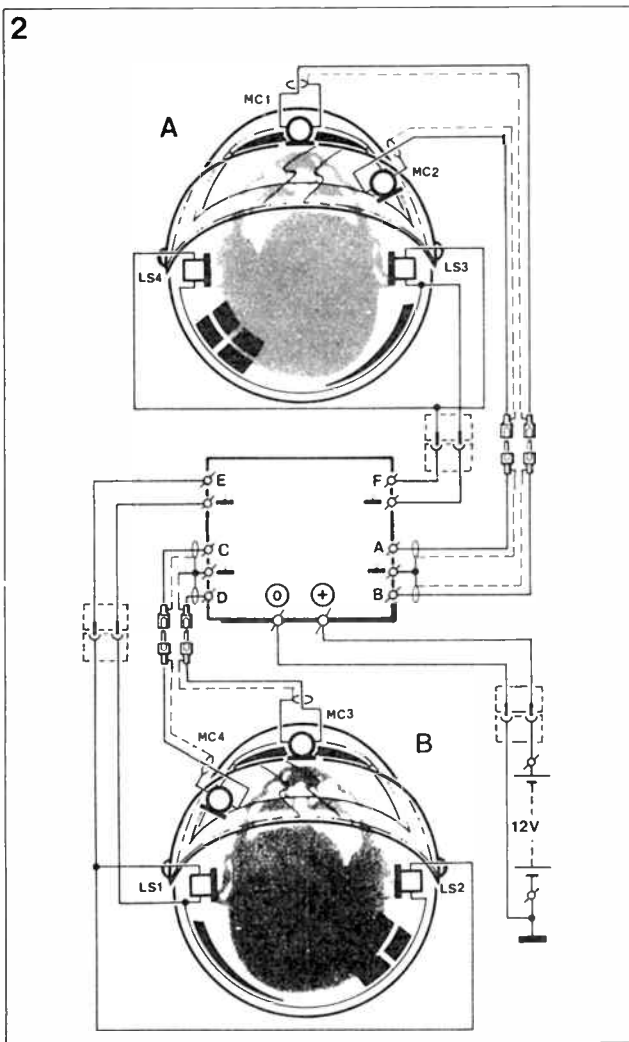
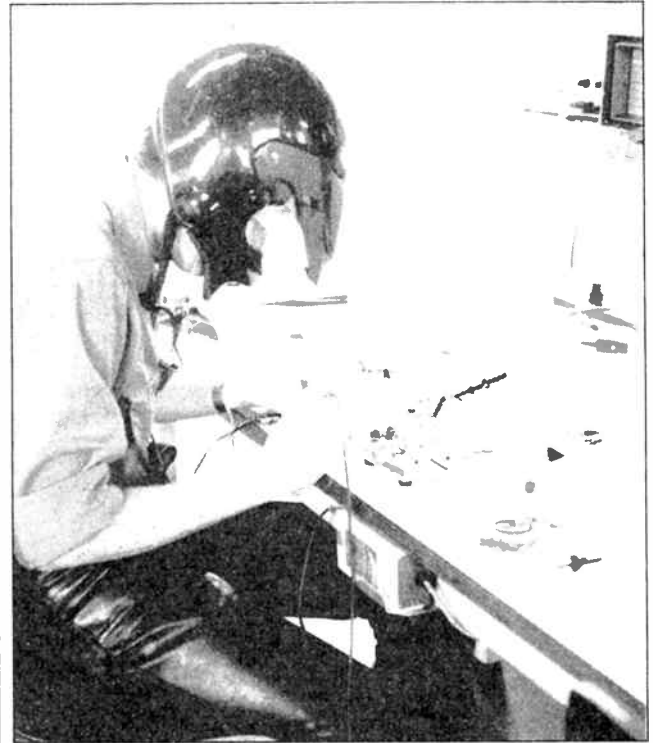

Fig. 2. This shows the preferred locations for the microphones and headphones inside the helmets.



Seen here is one of the designers working on a prototype.

high resistance, and the AF signal can reach the input of IC4.

The supply for the intercom is taken from the motorcycle's 12V battery with the aid of a 10V series regulator, IC1. Filter components L₁ and C₂₃ are required for suppressing alternator and other noise on the supply lines to the intercom, while D₁ affords protection against negative voltage surges.

Safety first

Figure 2 shows the preferred arrangement of the microphones and the loudspeakers (headphones) inside the safety helmets. The flat electret microphones are fitted underneath the lining inside the helmet to preclude head injuries. In this context, it is strongly suggested **not** to fit jack sockets in the helmet. A Walkman[®] headphone set is

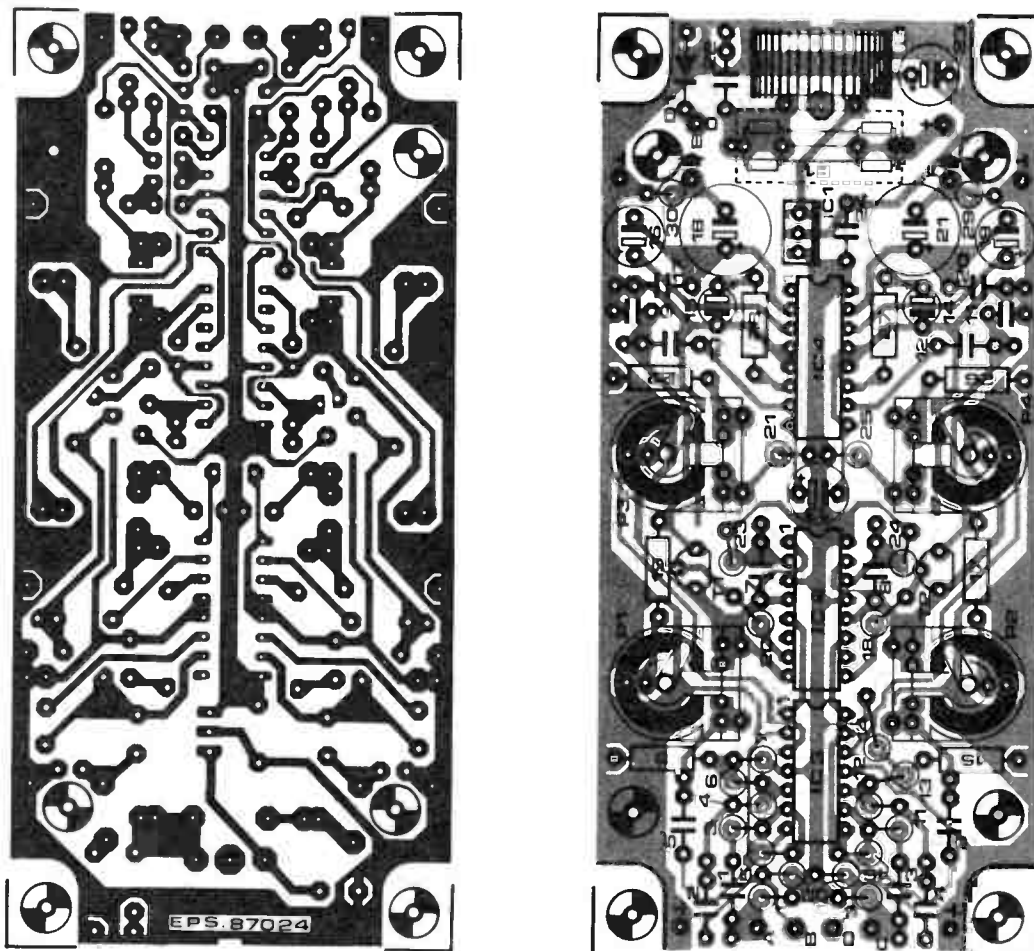

Fig. 3. The printed circuit board for making the intercom.

Parts list

Resistors ($\pm 5\%$):

R₁; R₂; R₉; R₁₀ = 1K8
 R₃...R₆ incl.;
 R₁₁; R₁₂; R₁₃; R₁₆ = 47K
 R₇; R₈; R₁₄; R₁₅ = 1K5
 R₁₇; R₁₉ = 1K0
 R₁₈; R₂₀ = 10K
 R₂₁; R₂₂; R₂₅; R₂₄ = 6K8
 R₂₃; R₂₄ = 3M3
 R₂₇; R₂₈ = 100R
 R₂₉; R₃₀ = 2K2
 P₁; P₂ = 10K preset for horizontal mounting.
 P₃; P₄ = 1K0 preset for horizontal mounting.

Capacitors:

C₁...C₄ incl.; C₂₂; C₂₄ = 100n
 C₅...C₈ incl.; C₁₀; C₁₂ = 330n
 C₉; C₁₁ = 470p
 C₁₃; C₁₆; C₁₉ = 100 μ ; 16 V; radial
 C₁₄; C₁₅ = 22 μ ; 16 V; radial
 C₁₇; C₂₀ = 150n
 C₁₈; C₂₁ = 470 μ ; 16 V; radial
 C₂₃ = 100 μ ; 25 V; radial

Semiconductors:

D₁ = 1N4001
 T₁; T₂ = BC547
 IC₁ = 7810
 IC₂ = CD4538
 IC₃ = LM324
 IC₄ = TEA2025 (ITT, Thomson)

Miscellaneous:

L₁ = 50 μ H; 1 A; toroidal 'suppressor' choke.
 F₁ = 100 mA delayed action fuse with PCB mount holder.
 MC₁...MC₄ = electret condenser microphone.

Suitable ABS enclosure (waterproof).

LS₁; LS₂ and LS₃; LS₄ = Walkman[®] lightweight headphones.

eminently suited for this intercom, since it has a sufficiently long cord fitted with a small plug at the end. A similar cord and plug combination should be used for the microphone connections. In case of an accident, cord and plug will break instantaneously and can not inflict injuries on the wearer of the helmet.

Construction

The circuit board for the intercom is very compact in view of the limited space for mounting it onto a motorcycle. Fig. 3 shows that many resistors are mounted upright, while all electrolytic capacitors are radial types for PCB mounting. The completed board is best cased in a strong, waterproof ABS enclosure with a built-in battery compartment to enable fitting the sockets. The cables to the helmets can be fed through small holes drilled into the associated lid.

The presets on the intercom board can be operated with the aid of short, home-made, shafts which are secured onto the central part of the wiper by means of two-component glue. When the adjustment is complete, the 4 holes in the intercom enclosure must each be sealed with a piece of waterproof adhesive tape.

St

From an idea by W. van Klooster & R. Baltissen.

INTERFACING ATARI ST AND MSX2 COMPUTERS TO SCART/TTL COLOUR MONITORS

Questions:

- How do I connect my Atari ST computer to the SCART input on the TV set?
- Is it possible to drive a TTL compatible colour monitor from an Atari ST, MSX1 or MSX2 computer?

Answers: See text!

Many owners of an Atari ST or MSX1/2 home micro appreciate the excellent graphics features these machines offer at a relatively low price. The best graphics effects, however, are only achievable with a colour monitor, and here a problem arises because a really good and 100% machine-compatible display is generally well out of the financial reach of the majority of users. As usual in the computer business, peripheral equipment is costly relative to the micro itself.

SCART and the Atari ST

Many TV sets are nowadays equipped with a SCART socket

at the rear to enable connecting VCRs and the like. If you own such a TV set, and an Atari ST computer, a medium-resolution colour system is within reach without having to spend a lot of money on a special monitor. The Atari Type 1040ST is simply connected to the SCART socket by means of a standard cable. Users of the Type 520ST should not have difficulty in making a suitable cable as shown in Fig. 1. If the TV set has a TV/AV selector, this should be set to AV (audio-video). If not, +10–12 V should be applied to pin 8 on the SCART connector to select the AV mode, which makes it possible to use the set as a monitor.

Colours on a palette

The least expensive of colour monitors are virtually always *IBM compatible*, which means they are equipped with standard TTL inputs for R, G, B and I (intensity), and are therefore capable of displaying 16 colours as shown in Table 1. It is seen that every colour is available in two saturation levels, depending on the logic state of the I bit.

On a SCART input, the colour signals are analogue, i.e., the voltage on the R, G and B line is proportional to the intensity of the corresponding chromatic component. Atari ST and MSX computers can switch between 8, fixed, intensity levels on the

analogue R, G and B line. In principle, therefore, there exist 8 shades of red, 8 of green, and 8 of blue, which in combination offer a choice of 512 colours. In practice, however, the computer can not support more than 16 colours at a time, and these must be selected from the available 512 with the aid of software.

What then is the difference between the 16 analogue and 16 digital colours?

In a TTL compatible RGB system, the 16 available colours are grouped

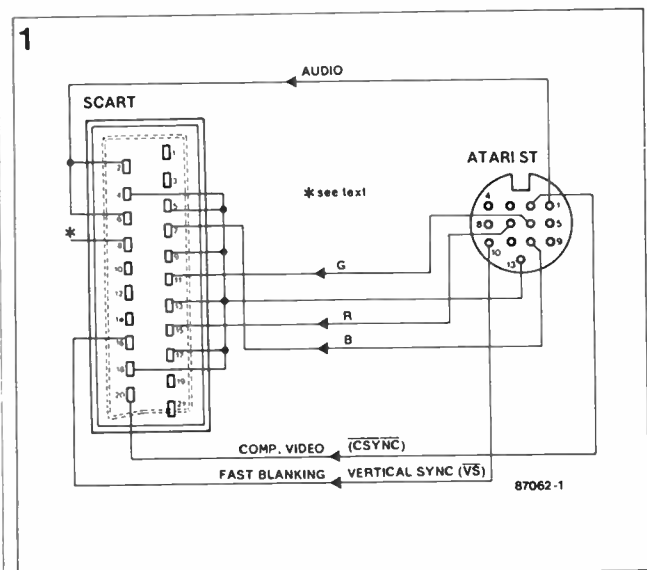
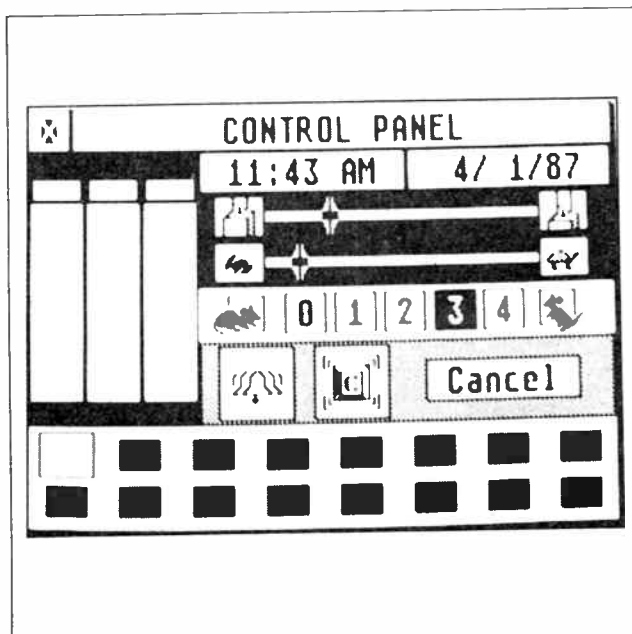

Fig. 1 Connections between an Atari 520 or 1040ST computer and a SCART input.

according to their saturation level, which is either 100% or 50%, depending on the logic state of the intensity (I) bit. The 16 analogue colours, however, can be composed at will thanks to the fact that the saturation of the red, green and blue constituents can be measured out individually: it is therefore possible to define an image starting from, for instance, only 8 shades of blue and 8 shades of red, omitting all other colours or shades thereof. This system has been adopted on the Atari computer and can be seen at work in the so-called *control panel*, a desktop utility of the GEM command system, and also in drawing programs such as DEGAS, NEOCHROME, and others. On an MSX2 computer, the choice between colours is effected with the instruction **COLOR=** and its three subsequent parameters. Most operating systems and games, however, do not enable the user to define the colour shades. The 16 colours are pre-defined by the supplier of the program, and are generally difficult to alter. These defaults are sometimes quite skilfully implemented, as in, for instance, the Atari programs from PSYCHOSIS/England. This observation is made here because it has important implications for the discussion to follow.

To be able to use an Atari or MSX2 computer in conjunction with an TTL compatible colour monitor, the analogue colour information must be digitized, i.e., converted to logic low and high levels. This can be done if it is assumed that the colour palette in the Atari computer is programmed as shown in the right-hand column of Table 1. It is seen that the number of colour shades is reduced from 8 to 3. Experiments went to show that colour level 4 selected from the control panel gave acceptable results for the 50% saturated shades, and level 7 for the fully saturated ones. Similarly, on an MSX2 machine, these colours are defined with instruction **COLOR=** as shown in the listing in Table 2. It should be noted that white, listed eighth in Table 1, is in reality a greyish shade. Consequently, genuine grey (RVBI=0001) can not be obtained from the proposed circuit without extending this with

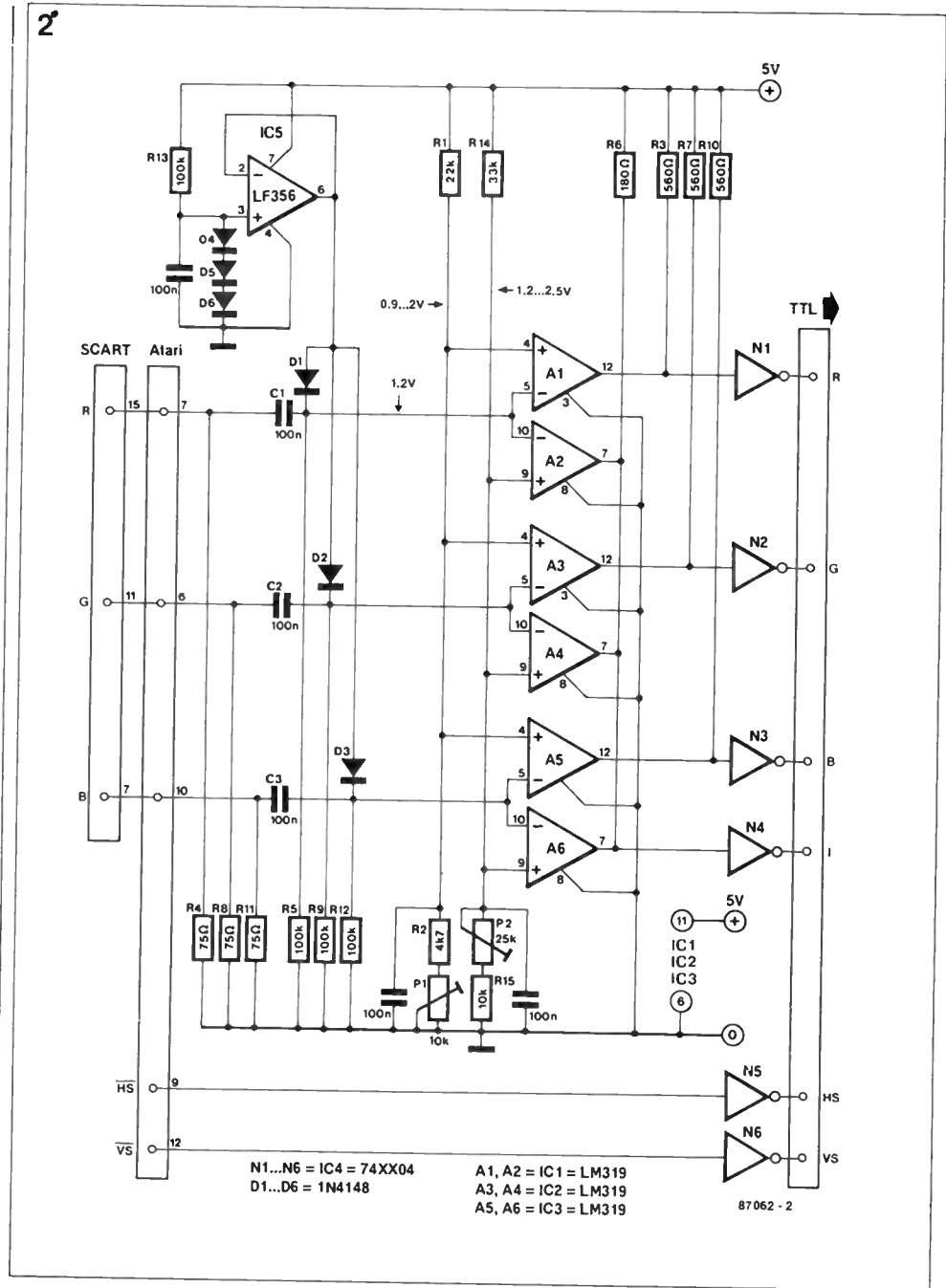

Fig. 2 Circuit diagram of the 15-colour TTL-RGB interface for Atari and MSX computers.

The converter about to be described in detail can thus output 15 of the 16 colours in Table 1, white being substituted by a light grey shade. It should be reiterated, however, that the listed colours are only obtainable when the relevant program makes provision for selecting levels 0, 4 and 7 on the RGB outputs. Intermediate levels generate colours that can not be reproduced with the present converter.

The converter

The analogue-to-digital RGB

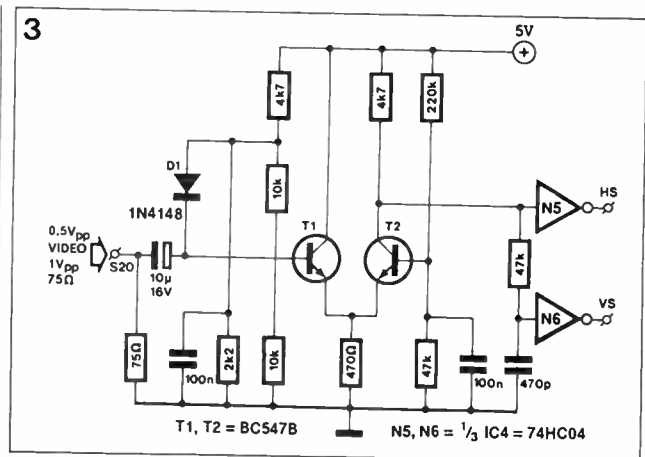

Fig. 3 The sync pulse separator for MSX2 micros.

converter proposed here makes it possible to drive an IBM compatible colour monitor from the analogue video output on an Atari computer, or from the SCART connector on MSX2 computers such as those from PHILIPS and SONY.

Details of the converter appear in Fig. 2. Three operational amplifiers, A₁, A₂ and A₃, compare the level of the analogue R, G or B voltage at the input with the potential supplied by voltage divider R₁—(R₂+P₁). The toggle point of the opamps is therefore set with the aid of P₁, and arranged to lie within a range that ensures clearly defined switch points as well as the absence of jitter on the digital outputs.

The open-collector (OC) outputs of the even-numbered opamps are connected in a wired-OR structure. The inverting input of each of these opamps is again driven by the analogue R, G and B signal, while the non-inverting inputs are commoned and held at a potential that can be adjusted with P₂. Whenever the voltage on any of the RGB inputs exceeds the threshold set with P₂, that is, when a 50% saturation level is switched to 100%, the relevant opamp toggles and pulls the input of N₄ low, so that the intensity (I) bit is activated. Note that each of the previously mentioned opamps functions as an OC inverter, whence the use of a pull-up resistor and a TTL inverter at each digital output. The adjustment of P₂ is satisfactory when all colours from Table 1 are correctly displayed (on an Atari, you can check this with the aid of the previously mentioned control panel).

An interesting feature of the present circuit is its built-in automatic offset leveller set up around IC₅. This ensures that the three incoming RGB signals have an equal zero offset. Voltage source IC₅ maintains an output potential of +1.8 V, generated with the drop across three series connected silicon diodes D₄—D₆, so that the direct voltage at all inverting opamp inputs is fixed at 1.2 V after subtraction of 0.6 V by D₁—D₃. These diodes pass current from IC₅ whenever an RGB input voltage is below 1.2 V, and so ensure a well-defined analogue low level. Capacitors C₁—C₃ serve to store the voltage difference so created. The common offset

was set to 1.2 V to remain within the specified input voltage range of the Type LM319 opamp. When this is fed from a 5 V supply, as in the present application, the minimum and maximum input voltages are stated as 1.0 V and 3.0 V, respectively.

IBM compatible colour monitors are synchronized with positive HS and VS pulses, whence the use of two inverters N₅—N₆ for negating the HS and VS signals from the Atari. Note that types 7404, 74LS04, 74S04, or 74HCT04 are all equally suitable for use in location IC₄.

MSX computers

Not all computers in the MSX family are equipped with RGB outputs. While MSX1 compatible micros can be used in conjunction with a normal TV set with perfectly acceptable picture quality, things are quite different when this is attempted with one of the more recently introduced MSX2 computers, simply because on the latter the screen resolution has been upgraded to 512 x 212 pixels, requiring a colour monitor for optimum graphics performance. SONY and PHILIPS computers in the MSX2 series have a SCART or DIN AV socket which makes it very easy to connect the RGB signals to the converter in Fig. 2. The synchronization signals, however, are not separately available, and must be extracted from the composite video signal by means of the circuit shown in Fig. 3. Note that inverters N₅ and N₆ are in fact those from Fig. 2, so that the remainder of the circuit in Fig. 3 is to be added to the preciously detailed converter for interfacing an MSX2 micro to an IBM compatible colour monitor. The set-up can be tested by running the MSX BASIC program in Table 2. This produces a row of vertical bars with the 15 available colours, arranged such that the 50% and 100% saturated versions of the colours are next to each other.

Owners of a SONY type HB75P, or any other MSX1 computer sporting a SCART output, can also use the proposed converter. Unfortunately, the colour shades are fixed on all MSX1 computers, making it impossible to display some of the colours in Table 1. The listing in

Table 1.

TTL levels				conversion	analogue levels		
R	G	B	I		R	G	B
0	0	0	0	black	0	0	0
0	0	1	0	blue	0	0	4
0	1	0	0	green	0	4	0
0	1	1	0	cyan	0	4	4
1	0	0	0	red	4	0	0
1	0	1	0	magenta	4	0	4
1	1	0	0	brown	4	4	0
1	1	1	0	white (grey)	4	4	4
0	0	0	1	grey	*	*	*
0	0	1	1	light blue	0	0	7
0	1	0	1	light green	0	7	0
0	1	1	1	light cyan	0	7	7
1	0	0	1	light red	7	0	0
1	0	1	1	light magenta	7	0	7
1	1	0	1	yellow	7	7	0
1	1	1	1	intense white	7	7	7

* See text.

Table 2

```

10 SCREEN7
20 COLOR=(1,0,0,0)
30 COLOR=(2,0,4,0)
40 COLOR=(3,0,7,0)
50 COLOR=(4,0,0,4)
60 COLOR=(5,0,0,7)
70 COLOR=(6,0,4,4)
80 COLOR=(7,0,7,7)
90 COLOR=(8,4,0,0)
100 COLOR=(9,7,0,0)
110 COLOR=(10,4,4,0)
120 COLOR=(11,7,7,0)
130 COLOR=(12,4,0,4)
140 COLOR=(13,7,0,7)
150 COLOR=(14,4,4,4)
160 COLOR=(15,7,7,7)
1030 ON STOP GOSUB 1100
1040 STOP ON
1050 FOR I=0 TO 15
1070 LINE(I*32,0)-(I*32+31),212),I,BF
1080 NEXT
1090 GOTO1090
1100 COLOR 15,4,4:END

```

87062-T2

Table 3

```

10 COLOR0,0,0
20 ON STOP GOSUB 90
25 STOP ON
30 SCREEN2
40 FOR I=0 TO 15
50 READ C
60 LINE(I*16,0)-(I*16+15),191),C,BF
70 NEXT
80 GOTO80
90 COLOR 15,4,4:END
100 DATA 0,1,12,2,3,4,7,5,6,8,9,10,11,13,14,15

```

87062-T3

Table 3 displays a set of vertical bars arranged in order of luminance intensity. It is possible to restore 9 or 10 out of the 15 available shades.

The RGB signals from the HB75P have a synchronization

component which would upset the operation of the comparators in Fig. 2. This can be effectively prevented by omitting D₆, so that the output voltage from IC₅ is reduced from 3 x 0.6 to 2 x 0.6 = 1.2 V. D

PRINTED RESISTORS

by K Bachun

Introducing an attractive alternative to hassling with lots of low value, high power, resistors in testing, designing and setting up power supplies, AF amplifiers, and the like.

Have you ever worked on a circuit whose operation depends largely on a power resistor with a value below some 0.5 Ω? The experiments usually start with fitting a "near guess" power resistor from the junkbox, and end in disappointment at finding that the required value can only be realized with a tangled network of series and parallel connected resistors of sundry values and power ratings. Then, if the circuit finally works, the question arises how much resistance has actually been fitted. This is not at all easy to find out, since the common ohmmeter is not suitable for measuring below, say, 5 Ω, and the tolerance on every individual resistor in the network makes it very hard, if not impossible, to calculate the total resistance. Further complications can arise if the replacement resistor proves unobtainable in the required power rating.

Low value resistors with a high power rating and adequate precision for most applications can be made relatively easily by

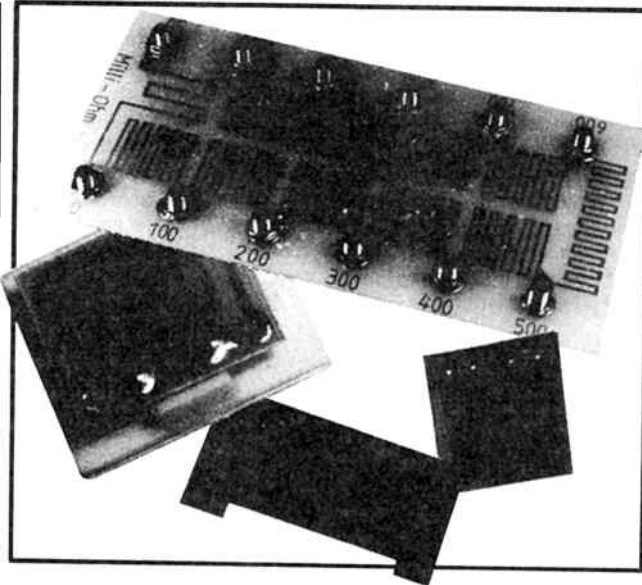

using the resistance of narrow, etched tracks on a printed circuit board. Most photo-resist boards have a 35 μm thick copper surface, and manufacturers generally specify a tolerance of ±5 μm. The resistance of a track can be calculated if it is known that the resistivity of electrolytic copper is 0.0178 Ω/mm²/m. Although copper is a highly

conductive substance, and hence enables making resistors with relatively small cross-sectional areas, the power rating of the resistors so made is surprisingly high, since the overall surface of the tracks is large relative to their cross-sectional area. Also, the use of epoxy boards ensures fairly good convection.

The good conductivity of copper results in relatively long tracks to achieve the required resistance. To save board space, the tracks can be arranged in a meander pattern, as will be seen further on.

The graphs in Fig. 1 show the correlation between track length and resistance for four track widths. The plotted lines were obtained from:

$$R = \rho L / A \text{ or } L = RA / \rho$$

where

R = the resistance in ohms;

L = the track length in metres;

A = the cross-sectional area of the track in mm²;

ρ = the resistivity of electrolytic copper: 0.0178 Ω/mm²/m.

As a convenient starting point for the calculations, the track width should not be less than 1 mm, so that post-etching irregularities do not derate the tolerance or the dissipation. For optimum heat distribution on the board, the insulating space between tracks should at least equal their width.

When the printed resistor is

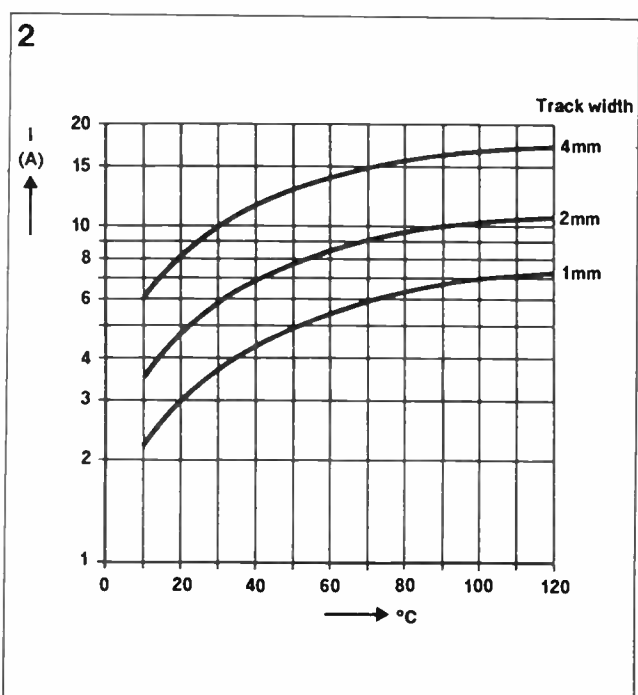
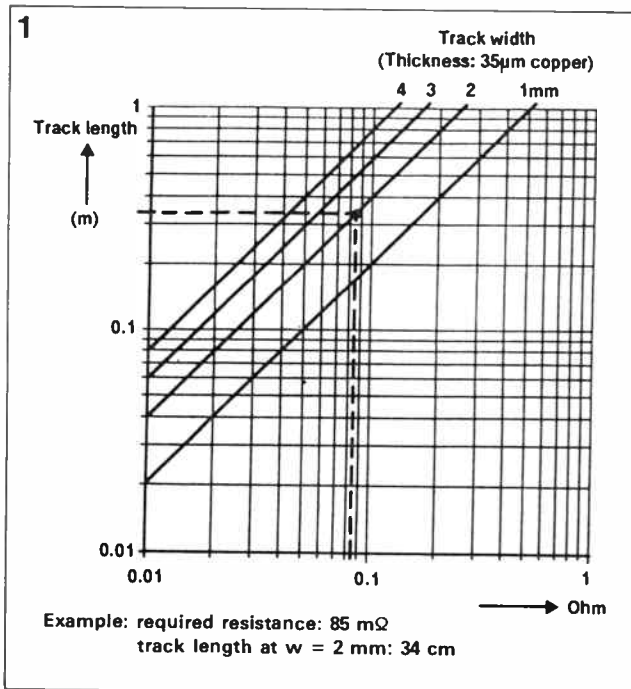

Fig. 1. Correlation between resistance and track length with four track widths as parameters.

Fig. 2. The increase in track temperature as a function of the current, plotted for three track widths.

meander-shaped, due account should be taken of the track length in the corners or curves. Although it is fairly difficult to establish the effective resistance in these areas, a reasonable approximation can be made to ensure sufficient accuracy for most practical applications.

The curves in Fig. 2 show the relation between the current passed through a track, and the resultant increase in temperature. The choice between a 1, 2 or 4 mm wide track can be made once the maximum permissible temperature increase, the ambient temperature, and the nature of the current (pulsed/continuous) have been established. To avoid the tracks being dislodged from the carrier, the temperature of the PCB must not exceed 80-100°C. Printed resistors will stand the occasional overload current, as long as this stays well below the point where the track burns out, and is not carried for excessive periods. Fortunately, the peak permissible current through a printed resistor is usually of the order of a multiple of the maximum continuous current rating. The stability of a printed resistor can be ensured by cooling it, reducing the effect of its temperature coefficient of about 0.4%/°C. Example: if the track width is 2 mm, and $I=8\text{ A}$: $t_r = t_a + 50^\circ\text{C}$, and the tolerance is 20%. Printed resistors can thus be made to requirement, and may take the form of plug-in units that enable straightforward exchanging in an experimental set-up.

Alignment of the printed resistor is feasible in those cases where when high precision is required, or where a current is to be accurately adjusted. The tracks are then made slightly longer than strictly necessary, and the required resistance is

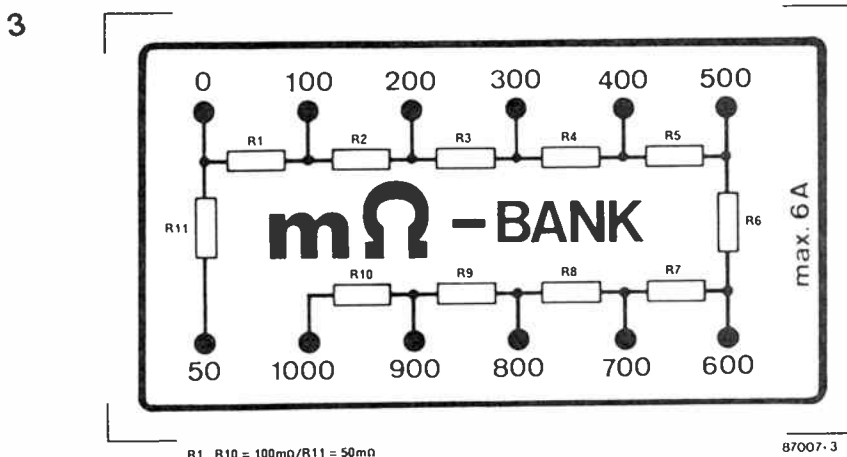

Fig. 3. Suggested front panel for the resistor bank.

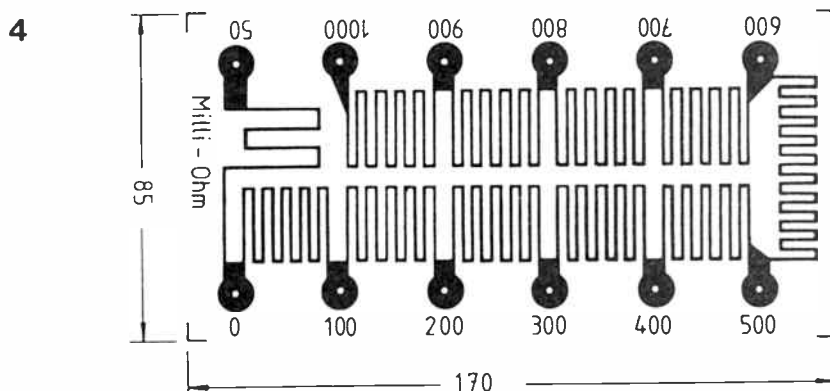

Fig. 4. Track side of the printed circuit board for making the milli-ohm bank (shown 50% reduced).

obtained with the aid of wire jumpers soldered onto a loop structure located in the middle of the track. Series connection of short tracks is a less favourable method, because the track junctions give rise to disuniformity of the cross-sectional area, derating the maximum current.

The PCB-based resistor bank shown in Figs. 3 and 4 should prove a valuable and versatile tool for experiments with high power resistors in the 50 mΩ to 1 Ω range. The bank is composed of 10 series connected 100 mΩ resistors, and 1 50 mΩ type. All joints are tapped, and

the addition of the 50 mΩ resistor makes it possible to create resistors in small increments.

The taps on the ladder network are made with 4 mm wander sockets, so that the bank is readily connected to a circuit with the aid of a set of flexible test leads (use sufficiently strong wire and good-quality banana plugs). A multi-pole switch for selecting the resistors was considered unsuitable in view of its cost and inevitable susceptibility to contact problems. The sockets are secured direct onto the PCB, as shown in the photograph, and

each nut and threaded body is carefully soldered to the track. The completed circuit board conveniently serves as the front panel of the resistance bank, whose enclosure should hold a fan to cool the tracks when these are to carry continuous, high, currents. A suitably rated fast acting fuse may be added to prevent tracks from burning out owing to high current surges.

CORRECTIONS

Facsimile interface

May 1987.

The following labels for machine language subroutines in Table 1 should be written in *lower case*:

PRINT; READ; ERR and END.

Dick Smith to introduce "short-form" kits

In response to "hundreds of requests" from Australian hobbyists, Dick Smith Electronics will introduce "short-form" kits from 15th August. The new system will initially be available for six of their popular kits as follows:

- Series 200 mosfet amplifier cat. no. K-3516
- HF amateur transceiver cat. no. K-6330
- 100 Watt VHF power amplifier cat. no. K-6313
- 1 GHz digital frequency counter cat. no. K-3437
- Radio direction finder cat. no. K-6345
- VK Powermaster power supply cat. no. K-3448.

You will now be able to order just the components required for the above projects, less hardware, transformers and the like. So, rather than paying for a project in one hit, which can stretch the budget a bit at times, you can buy the necessary requirements in more easily affordable installments as you build.

You place an order, make a part payment and the bits will be returned to the store where you ordered them in 14 days, DSE say. The rest of the items can be purchased later, as required. You'll find that, often, of the parts not included in the short form kit, like knobs and transformers, many are stock standard items which can be bought piece by piece as you need them, or taken from your personal stocks.

Mr. Peter Perry, DSE's new hobbyist manager, said in announcing the new initiative, "DSE has always considered the hobbyist our most important customer. In introducing this method of ordering, albeit for only six kits initially, we are supporting our commitment to the hobbyist.

"DSE has always been the leader in supplying what the hobbyist wants", he said, "and with the new short form system we believe we will yet again prove that we are supplying the

needs of the market".

Dick Smith intend to add more kits to the list each month or as demand requires. For further information, contact your nearest Dick Smith Electronics store.

Metallised poly capacitors from Jaycar

Jaycar Electronics are now stocking high quality 100n (0.1uF) metallised poly capacitors which are ideal for by-passing applications in and in audio circuits owing to their low self-inductance and low electro-mechanical distortion.

These capacitors have radial leads on a standard 10 mm spacing which simplifies printed circuit board design and facilitates component layout.

The Jaycar part number is RG-5125 and they cost just 32 cents each. For more information, contact your nearest Jaycar outlet or ring their mail order hotline on (02)747 1888.



New transformers

Here is the answer to the ever increasing price of imported toroidal power transformers, Jones Transformers.

PROJECT BUYERS GUIDE

The AEM6011 Audio Balanced Line Driver will present few difficulties to constructors. Firstly, Jaycar will be stocking it as a kit, right to the last nut and bolt. For constructors assembling the components for themselves, the only component not kept as a standard stock item at retailers is the LH0002 IC. However, Active Electronics in Melbourne and Geoff Wood Electronics in Sydney can supply your requirements.

The AEM3505 Packet Radio Unit for the Commodore 64 will also be stocked by Jaycar as a kit. In any case, the components are all widely stocked by retailers, so you will have no difficulty obtaining parts when it comes to the construction next month. The software, being customised, is only available through AAPRA, 59 Westbrook Ave, Wahroonga 2076 NSW. It costs \$45.00 and comes complete with a comprehensive manual.

The AEM2000 Lab. Standard Power Supply is being prepared as a kit, even as we write! Force Electronics in Adelaide will have kits ready to go out the door shortly, complete with a comprehensive construction manual and large circuit diagram.

This month's Elektor projects should present few traumas, if any. The Autoranging DMM will be stocked as a kit by Hi-Com Unitronics, we understand. Contact them on (02)524 7878. The Spot Sine Generator employs components that are generally available, except perhaps for the three-terminal regulators. For these, contact Geoff Wood Electronics in Sydney, or Active Electronics in Melbourne. Force Electronics in Adelaide may also be able to supply from their vast stock of semiconductors.

The Motorcycle Intercom employs the TEA2025 amp, which was also used in the Elektor Headphone Amp project from our October issue, last year. Hi-Com Unitronics are stocking it.

Good news for seekers of pc boards. Shortly, All Electronic Components in Melbourne will be stocking all the AEM pc boards, along with a considerable selection of the Elektor project boards published in AEM. Hi-Com Unitronics in Sydney is already stocking a range of AEM and Elektor pc boards and has plans to expand the range.

The JT-353 transformer is of balanced C-core construction, diagonally slot wound, which provides top efficiency and greatly reduces the external magnetic field. This is good news when attempting to reduce hum in audio amplifiers, the makers say. An alloy mounting bracket reduces the conduction of the field into the chassis where a steel chassis is used.

Dimensions are such that the transformer will fit within a 110 mm circle by 75 mm height. The weight is 1.85 kg and mounting is by four bolts at 40 X 90 mm

centres. It has four windings and electrical specifications for 240 V, 50 Hz input are:

- 35/35 V at 2.5 amps
- 15/15 V at 0.25 amps

The low interwinding capacity reduces the possibility of powerline interference in the form of control tones or switching transients and the isolation also conforms to Australian notions of safety, Jones claim.

For further information on the JT-353 transformer, contact Geoff Wood Electronics, 229 Burns Bay Rd, Lane Cove NSW. (02)427 1676.

SOUND SALE!

- 1 x Telex 300 high speed cassette duplicator complete with reel-to-reel and cassette master, with 6 slaves.
- Same again, with 12 slaves.
- 1 x Telex 300 spare parts.
- 3 x Otari cassette loading machines.
- 1 x Otari cassette loading machine with spare parts.
- 2 x Telex high speed re-winders.
- 1 x air compressor.
- 1 x vacuum pump.
- Assorted test tapes and running stock.

The lot! \$35,000 o.n.o.
Phone Tony Maughan
(075)32 8669

OPEN FOR BUSINESS: Monday to Friday 8.30 am to 5.00 pm. Saturday Morning 8.30 am to NOON.

A.C.E. RADIO

ELECTRONICS CENTRE

ESTABLISHED OVER THIRTY YEARS Phone: (02) 949 4871

10B/3 Kenneth Road, Manly Vale 2093

ETONE SPEAKER SPECIALS 38 cm (15 inch) WOOFERS

Model	Size	Cone Type	V.Coil	Reson Hz	Freq Hz	Watts Rms	Price Ea or 2 for
4180	38cm	Hi-Fi	8 or 15 Ohms	30	2" 3500	100	\$104.50 or \$205.00
4310	38cm	Straight surround	8 or 15 Ohms	45	40-6000	60	\$108.00 or \$212.00
4510	38cm	Straight surround	8 or 15 Ohms	45	40-6000	100	\$150.00 or \$294.00
4350	38cm	Hi-Fi	8 or 15 Ohms	30	30-4000	120	\$127.00 or \$251.00

Pack and Post for 1 speaker NSW VIC \$8.75; Q/T \$13.50; NT/WA \$17.50; SA \$11.50
Pack and Post for 2 speakers NSW VIC \$15.00; Q/T \$23.00; NT/WA \$30.00; SA \$20.00

ETONE 50 WATT RMS

A PAIR FOR \$60.95 OR \$34.95 EACH

RUGGED TOP QUALITY HI-FI WOOFER 30cm 8 ohms

- 90 DAYS FACTORY WARRANTY • FOAM POLY SURROUND
- STURDY SUSPENSION FOR RICH REPRODUCTION • 3.5cm VOICE COIL • FERRITE MAGNET • FREQ. RESPONSE . . . 35-4500Hz

P & P for 1 Speaker NSW \$4.80 VIC \$5.20 TAS \$6.25 WA/NT \$7.95 QLD/SA \$5.80
P & P for 2 Speaker NSW \$5.50 VIC \$7.20 TAS \$9.35 WA/NT \$11.45 QLD/SA \$8.20

POLYPROPYLENE CONE TOP QUALITY HI-FI WOOFERS

80hm Voice Coil — Foam Poly Surround —
Sturdy Suspension — Fitted Moulded Gasket —
Ferrite Magnet — 90 days factory warranty

Model	Size	Reson Hz	Resp Hz	Watts R M S	Price Ea or 2 For
12 POL 12"	25	30-4000	80	\$47.50	\$89.00
10 POL 10"	30	35-4000	60	\$42.95	\$79.95
8 POL 8"	35	40-5200	50	\$36.95	\$68.95

P & P for 1 Speaker NSW \$4.80 VIC \$5.20 TAS \$6.25 WA/NT \$7.95 QLD/SA \$5.80
P & P for 2 Speaker NSW \$5.50 VIC \$7.20 TAS \$9.35 WA/NT \$11.45 QLD/SA \$8.20
5" Polypropylene Mid-Range Speaker to suit above Woofers P.O.A.

BRIDGE RECTIFIERS

1.5 A 200 PIV is for \$3.95
10 A 150 PIV 5 for \$10.00
*** HEAVY DUTY ***
10 A 400 PIV \$3.75 ea.
15 A 400 PIV \$4.15 ea.
35 A 400 PIV \$4.99 ea.
10 A 1000 PIV \$5.95 ea.
15 A 1000 PIV \$6.50 ea.
35 A 1000 PIV \$7.50 ea.

3 WAY CROSSOVERS

200 Watts RMS
Crossover Freq. IKC and 5 KC
12db/Octave
\$34.95 ea. or \$65.90 a pair
P & P \$2.50 ea. P & P \$5.00 pair

microbee computer

COMPONENTS

Computer Keyboard Switches

1" for \$2.00 P & P \$1.50

New PC Boards (no components)

New PC Boards (components mounted)

AS PER JULY ADVERT.

* KONICA SPECIAL *

Floppy Disks Single Sided/Double Density
3 1/2 MF/1DD \$52.50/Pk of 10
P and P \$2.00

TRANSISTORS

BC337 20 ea OR 10 for \$1 70
BC 548 10 for \$1 00
BC 549 10 for \$1 00
BD139 70ea OR 10 for \$6 50
BD140 70 ea OR 10 for \$6 50
TIP31C \$1 20 ea 10 for \$11 00
TIP32C \$1 20 ea 10 for \$11 00
2N3055 10 for \$15 00
2N6027 80 ea OR 10 for \$7 50
2N646 \$1 30 ea 10 for \$12 00
GES2646 \$1 00 ea 10 for \$9 00
4N25 \$1 50 ea 10 for \$14 00
MJE350 \$1 00 ea 10 for \$7 50
MJE3055 \$1 80 ea 10 for \$15 00

P & P \$2.00

NEW FOR '87 YES WE NOW STOCK COMPUTER PRINTER PAPER

STANDARD FAN-FOLD

ACE871 (279x241)2500 ctn SINGLE PART
PLAIN 70 GSM BOND
PRICE \$48.59 ctn OR 5 - \$44.85 ctn
P&P SYD. METRO \$3.50 NSW \$4.80
QLD SA \$11.30 TAS \$13.25
WA/NT \$19.75 VIC \$8.70

ACE872 (279x381)2500 ctn 1Part Blue
H S 60 GSM B O M
PRICE \$41.47 ctn OR 5 - \$39.74 ctn
ACE873 (279x381)2500 ctn 1Part Blue
H S 60 GSM Bond
PRICE \$51.41 ctn OR 5 - \$49.27 ctn

ACE874 (279x381)2000 ctn Plain
70 GSM Bond
PRICE \$49.08 ctn OR 5 - \$47.03 ctn

ACE875 (279x241)2500 ctn 1Part EXACT
A4 Tear out clean edge perf
70 GSM Bond
PRICE \$58.75 ctn OR 5 - \$56.30 ctn

ACE876 (279x381)1000 ctn 2Part Blue
Half Shadow CARBONLESS
PRICE \$67.24 ctn OR 5 - \$64.43 ctn

ACE877 (279x381)750 ctn 3Part Blue
Half Shadow CARBONLESS
PRICE \$81.01 ctn OR 5 - \$77.65 ctn

ACE878 (279x381)500 ctn 4Part Blue
Half Shadow CARBONLESS
PRICE \$73.16 ctn OR 5 - \$70.12 ctn
REGULAR POSTAL RATES APPLY

* KONICA FLOPPY DISK *

3 1/2 MF 2DD \$72.03/PK
5 1/4 MD/2DD \$42.68/PK
P and P \$2.00

NEW FOR '87 CONVENIENT DISKETTE FILES

Includes Lock + 2 keys

Features

- Capacity: 50 pcs 3-1/2" diskette
- High impact plastic lid and base
- Easy access handle for opening and carrying

\$28.95 ea.

Features

- Double row display filing systems
- Protective racks for diskette separation
- Smoked PS plastic cover with lock
- High impact plastic lid and base
- Easy access handle for opening and carrying
- One hundred disk capacity 5-1/4" disk

\$26.95 ea.

★ ★ PROFESSIONAL VIDEO UNITS ★ ★

BRAND NEW IN CARTONS

14inch GREEN SCREEN MONITOR
COMPOSITE VIDEO INPUT

Cabinet & Fully Adjustable Swivel Tilt Base.
All metal construction, fully shielded.

**PRICE \$180.00 EA
LIMITED STOCK**

FREIGHT P.O.A.

Internal regulated power supply 12V/5VDC output with sufficient capacity to supply up to 2 disk drives & also power your computer.

TOP QUALITY JAPANESE 5.25" MINI FLOPPY DISKS

"DUE TO PRICE WE CAN'T MENTION BRAND"
SUPER VALUE PACK OF 10 DISKS
\$18.00/PK
P & P \$2.00

I.C.'s

LM555 10 for \$4.95
LM3301 10 for \$6.00
74S287 5 for \$5.00
74LS151 5 for \$5.00
7406 5 for \$5.00
7417 5 for \$5.00
7441 5 for \$6.00
MC1488 5 for \$7.50

ABOVE P & P \$2.00

12" Professional VDUs

Brand new in Cartons
Composite video input.

Green screen
\$180.00

Amber screen
\$185.00

P&P
NSW \$8.70, Vic \$13.20
Qld/SA \$16.20,
Tas \$18.45, WA/NT \$22.00



Credit card facilities now available after first registering following details with Ace Radio.
THIS IS FOR YOUR PROTECTION.

YOUR NAME:

CARD

NO:

EXPIRY DATE /

RESIDENTIAL ADDRESS

P.O. Box numbers unacceptable

SIGNATURE:

MIN ORDER \$20.00

FREE! 10 BC337 transistors. Mention this advert when ordering.

FOR POSTAL INSURANCE ADD: \$2.00 for parcel up to \$200.00 value plus \$1.00 for each additional \$100.00 value

World Radio History

KIKUSUI'S COS-5000TM SERIES THE OTHERS SIMPLY DON'T COMPARE

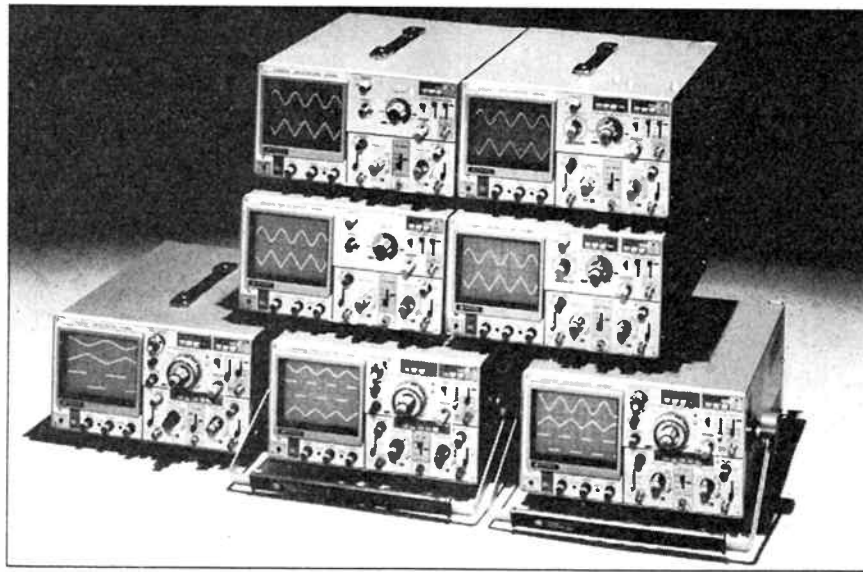

It's the standard features that make Kikusui CRO's exceptional.

The NEW COS-5000TM series offers standard features, normally only found on expensive, higher bandwidth scopes. Consider:

1 Bright and sharp signal traces with Automatic Linear Focus. This eliminates the need to readjust the focus during measurements between timebases. Even in high intensity, there are no blooming effects.

2 'Simultaneous' triggering of both CH1 and CH2. The VERT MODE displays both signals whether they are synchronised or not. An indispensable facility when troubleshooting between working and faulty boards.

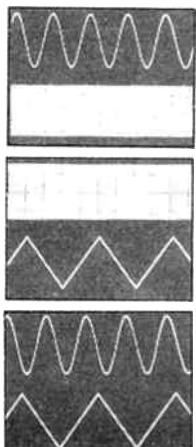

CH1
TRIG:CH1
CH2
CH1
TRIG:CH2
CH2
CH1
TRIG:
VERT MODE
CH2

3 Auto setting of the optimum triggering level. In AUTO TRIG LEVEL LOCK, a peak to peak detector locks onto and tracks the trigger signal. There is no need to reset the trigger level between measurements. The Manual Level Control provides superior triggering of complex waveforms or very low level signals.

4 Stable viewing of complex waveforms. The VARIABLE HOLDOFF control allows the easy viewing of waveforms such as uP or video signals with multiple triggering edges, caused by different frequency and level components.

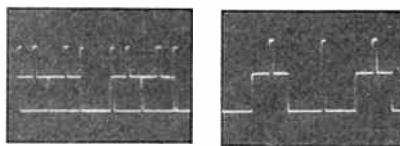

NO HOLDOFF WITH HOLDOFF

5 Simultaneous display of original and magnified waveform. Kikusui's ALTERNATING SWEEP MODE allows both the original waveform and the selected magnified portion to be viewed simultaneously.

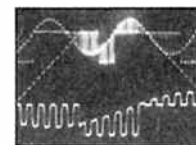

ORIGINAL
MAGNIFIED

6 Advanced new design using energy saving circuitry. The newly developed Dynamic Bias Circuit [PAT PEND] automatically controls the power consumption of the unit. Another feature in Kikusui's policy of continued innovation.

Features	5100TM	5060TM	5041TM	5021TM	5020TM
Bandwidth	100MHz	60MHz	40MHz	20MHz	20MHz
Channels	3	3	2	2	2
Vertical Sensitivity	1mV/DIV	1mV/DIV	1mV/DIV	1mV/DIV	1mV/DIV
Max Sweep Speed	2ns/DIV	5ns/DIV	20ns/DIV	20ns/DIV	20ns/DIV
Delayed Sweep	YES	YES	YES	YES	NO
Trigger Modes	CH1, CH2, VERT MODE, LINE, EXTERNAL				
Alt Sweep	YES	YES	NO	NO	NO
Delay Line	YES	YES	YES	NO	NO
Accel Voltage	18kV	12kV	12kV	2.2kV	2.2kV
Warranty	2 YEAR WARRANTY ON PARTS AND LABOUR				
Probes	2 QUALITY SWITCHABLE PROBES INCLUDED				

For more information call Emona at **(02) 519-3933**, 86 Parramatta Road, Camperdown 2050. Or write Emona Instruments, P.O. Box K720, Haymarket, 2000. FAX: (02) 550-1378.

EMONA
'THE TECHNOLOGY HOUSE'

An audio balanced line driver

David Tilbrook

Technical Systems Australia Pty Ltd

Here's a dual-channel (stereo) unbalanced input to balanced line output driver. Just the thing for driving an active loudspeaker system where the power amp(s) are in or with the speakers. Other applications for the unit include PA systems where line level signals have to be conducted over long distances, and bridging a pair of amplifiers.

THE CONCEPT of the electronic loudspeaker has been slowly taking shape over the last few years but, as yet, has not met with enormous consumer support. Nevertheless, the electronic loudspeaker concept is technically superior to the conventional passive loudspeaker and separate power amplifier.

In the conventional arrangement, the power amplifier is fed by long speaker cables to the input of a passive crossover mounted within the loudspeaker which divides the input signal into the separate frequency bands required by the individual drivers. The problems with this approach are enormous and will be dealt with in greater detail in articles describing the construction of electronic two- and three-way loudspeakers systems in months to come.

In the electronic approach, the power amplifiers are moved to within or adjacent to the loudspeaker cabinets and a separate power amplifier module is allocated to each of the drivers. The crossover function is provided by an electronic unit which supplies signals to the inputs of these power amplifiers. A long cable must then be used from the output of a preamplifier to the input of the active crossover fitted within the loudspeaker cabinet. Since the signal voltages in this wire are substantially lower than the signal voltages typically present in the speaker leads of the conventional arrangement, there is some danger of hum pickup within these cables if precautions are not taken and this is often seen as a disadvantage of the electronic loudspeaker. In fact, this is less of a disadvantage than may at first be apparent.

Although there is some possibility of hum pickup within these cables, such can be minimised, if not completely eliminated, by a combination of low driving impedance at the preamplifier end and by use of a balanced line driver. In the conventional approach, with separate amplifiers and loudspeakers, the long cables used to connect the output of the power amplifier to the loudspeakers can cause audible degradation of the sound quality and the reasons for this are not difficult to understand.

Of necessity, the designer of a conventional passive loudspeaker system must assume a constant voltage drive from the output of the power amplifier when designing the crossover and equalising the performance of the drivers. Unfortunately, no passive loudspeaker has a linear impedance curve. In fact, the impedance curve of most 8 ohm passive loudspeakers varies between about five and about 20-odd ohms across the audible frequency range. The presence of

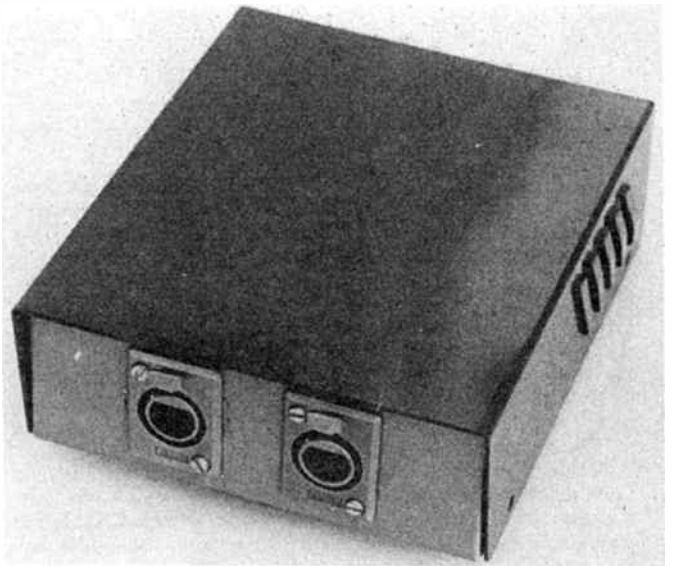

resistance and reactance in the speaker cables forms a potential divider with this non-linear impedance and causes a varying amount of power to be transferred to the loudspeakers across the frequency range. In other words, it is impossible to provide a situation of true voltage drive to the loudspeakers unless this effect is compensated for in some way.

Approaches

A variety of approaches has been used to overcome this problem in the past, one of which was to extend the pickup point of the negative feedback loop within the power amplifier all the way to the rear of the loudspeaker, rather than simply to the output terminals of the power amplifier. Power amplifiers employing this technique would normally be supplied with three terminals for each channel on their rear-panels, rather than two. Two of these terminals would form the conventional power amp output terminals and are connected by a standard speaker cable to the rear of the loudspeakers whilst the third terminal would be the negative feedback pickup point and would be taken via a third wire to the 'positive' ter- ▶

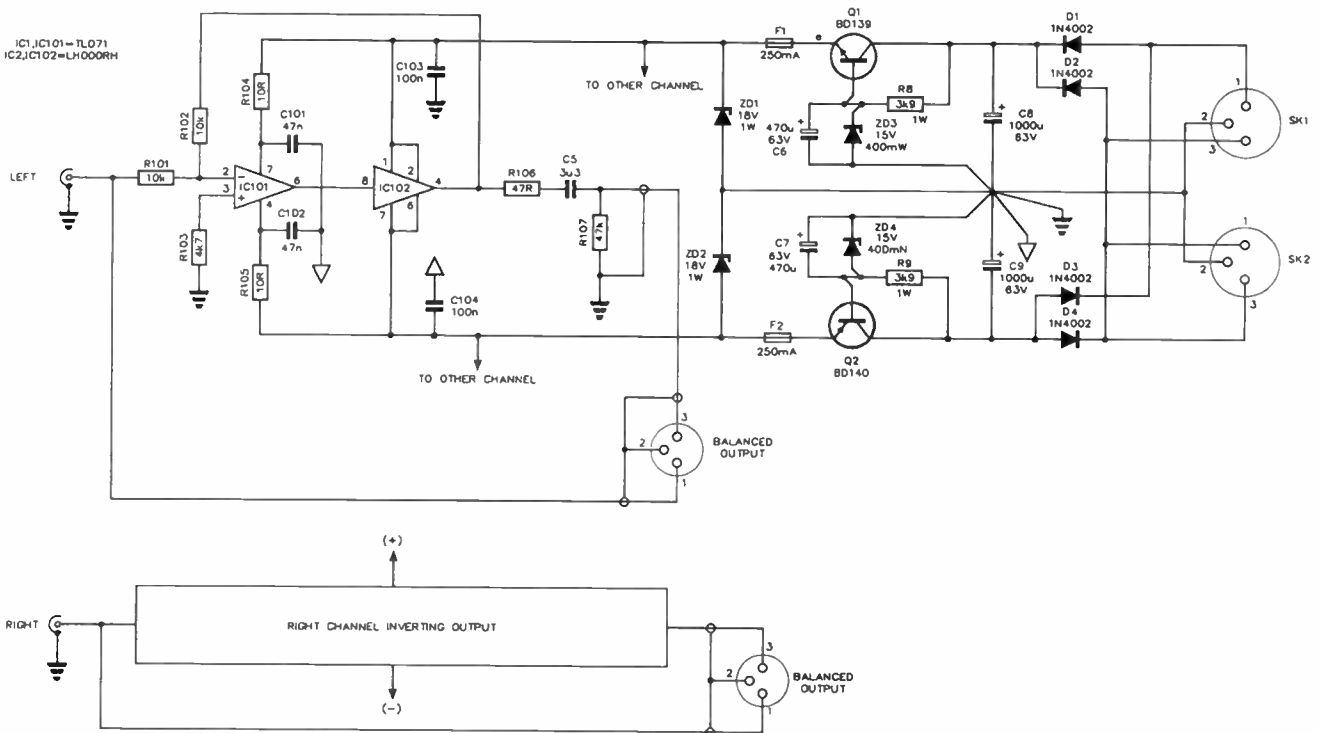

CIRCUIT OPERATION

The project is based around a TLO71 JFET op-amp which is configured to have a gain of -1 (i.e: unity gain, inverted output). The gain at this stage is determined by the ratio of resistors R102 and R101, and since these are both 10k, the overall gain at this stage is unity. Since the signal is applied at the inverting input of IC101, however, this stage will invert the phase of any signal applied to its input. To minimise dc offsets on the output of IC101, the resistance from the non-inverting input (pin 3) to ground must be approximately that of the resistance of pin 2 to ground. If it is assumed that the input is driven by an impedance significantly lower than 10k, then the total impedance connected from pin 2 to ground is approximately 5k. The value of R103 is therefore set at 4k7.

Resistors R104 and R105, combined with capacitors C101 and C102 respectively, provide supply decoupling which ensures freedom from any supply interactions between IC102 and IC101 which might otherwise cause instabilities. Power supply filtering for high frequencies is provided by capacitors C103 and C104.

The output of IC101 is fed to the input of the LH002H, IC102, a very high speed unity gain buffer, which provides a very low output impedance. A data sheet of this device is included elsewhere in this issue. As can be seen from the data, its distortion figures can become somewhat high. To overcome this problem, the LH002H is contained within the negative feedback loop of the TLO71 so that the total harmonic distortion resulting from IC102 would be reduced by the overall feedback.

Resistor R106 is fitted in series with the output of IC102 to decouple the output of the AEM6011 from the negative feedback

loop and thereby ensure complete stability of the circuit. Capacitor C5, a 3u3 metallised polyester type, provides dc decoupling, while the 47k resistor R107 ensures that the output side of C5 remains at ground potential.

The output of this circuit is applied to pin 3 of the XLR connector, whilst pin 1 of the XLR is supplied directly from the input. Signals applied to these two output points will therefore be out of phase.

The right and left channel inverting amplifiers operate in precisely the same way. Both are powered from a common regulated power supply employing a zener reference and a current amplifying series-pass transistor. The ac signal from the output of the AEM6000 power amplifier, or an alternative 30 Vac power supply, is rectified by the full wave rectifier formed from diodes D1, D2, D3 and D4 with capacitor input filtering provided by C8 and C9. Resistors R8 and R9 provide current limiting and supply the reference voltage zeners ZD3 and ZD4. The 470 uF capacitors C6 and C7 shunt noise generated by the zeners or 'stiffen' the voltage across the zener, preventing noise modulation of the supply rails. These reference voltages are supplied to the bases of Q1 and Q2 which function as current amplifiers and this circuit also functions as a 'capacitance multiplier' which provides quite good regulation.

Fuses F1 and F2, and zeners ZD1 and ZD2 have been included as a safety circuit in the event of a power supply failure. The simple regulator circuit employed here has a tendency in the event of failure, to supply over-voltage to the attached circuitry and in such event, ZD1 or ZD2 will be biased on and the appropriate fuse will blow. Under normal operation, the voltage on the two supply rails will be around 14.6 V and the 18 V zeners will be biased off.

minimal of the loudspeaker. In this way the negative feedback loop within the power amplifier can be used to compensate for signal voltages lost within the loudspeaker cable.

This technique has not been very popular for a number of reasons. The most important being that unless this extra speaker cable is fitted correctly, the amplifier would be completely without negative feedback and its enormous gain then would pose a threat to the loudspeaker.

The more popular and common approach to the problem of signal loss within the loudspeaker cables is to employ extremely good quality cables specially made so as to minimise the signal loss due to the resistance and reactance

of the speaker cables.

The problems associated with the loudspeaker cable are completely eliminated in the electronic approach because the input impedance of the electronic crossover is independent of frequency and is sufficiently high that negligible signal current flows in the cable between the preamplifier and the active crossover. Once problems associated with possible hum pickup are resolved, the output signal from the preamplifier will be far more accurately transferred to the input of the active crossover than is possible using a conventional pair of speaker cables between the output of a power amplifier and the input of a passive crossover.

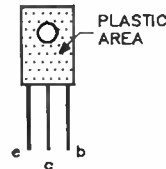
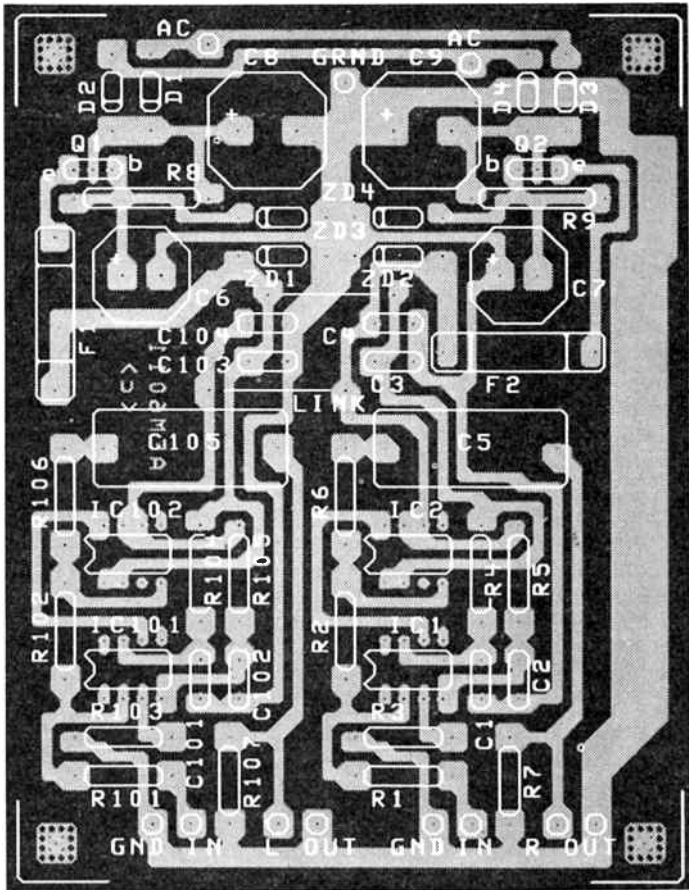

TO-126

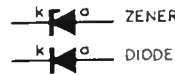

AEM6011 PARTS LIST

Semiconductors

IC1, IC101	TLO71
IC2, IC102	LH0002H
Q1	BD139
Q2	BD140
D1-D4	1N4002
ZD1, ZD2	18 V/1 W
ZD3, ZD4	15 V/400 mW

Resistors all 0.25 W, 5% unless noted

R1, R101	10k
R2, R102	10k
R3, R103	4k7
R4, R104	10R
R5, R105	10R
R6, R106	47R
R7, R107	47k
R8, R9	3k9

Capacitors

C1, C101	...	47n MKT or poly.
C2, C102	...	47n MKT or poly.
C3, C103	...	100n MKT or poly.
C4, C104	...	100n MKT or poly.
C5, C105	...	3u3 MKT or poly.
C6, C7	...	470u/63V RB electro.
C8, C9	...	1000u/63V RB electro.

Miscellaneous

AEM6011 pc board; F1, F2: 125-250 mA
 M205 type fuses; SK1, SK2 - 2 x 3-way DIN sockets; 2 x 3-way Cannon XLR sockets;
 2 x RCA sockets; metal cabinet 160 x 130 x 50 mm (DSE H-2762 or Jaycar HB-5444); shielded cable; hookup wire; four short spacers; solder lug, nuts and bolts.

Estimated cost: \$85-\$95

The project

This project describes a balanced line driver designed to convert the output of the AEM6010 Ultra-fidelity Preamplifier (Oct., Nov., Dec. '85) into a balanced output capable of driving a balanced line, to be connected to the balanced input of the AEM6503 Active Crossover (Feb. '86), employed in an active loudspeaker.

The output impedance of the AEM6010 preamplifier is around 47 ohms which is low enough to drive the long shielded cable from the output of the preamplifier to the input of the active crossover. All that is necessary to convert this to a balanced line is to provide an inverting amplifier with an output impedance also of around 47 ohms to match that of the 6010. The cable connecting the output of the balanced line driver to the input of the active crossover therefore consists of three wires rather than two; one shield which can be common, one 'inverted' line and one 'non-inverted' line.

The balanced input of the active crossover amplifies the difference in signal between these two active wires, and since these signals are exactly 180 degrees out of phase, the difference between them adds to produce a signal voltage twice as large as that in each of the wires. Any signal which is common to both the inverted and non-inverted lines ("common-mode" signals), however, will be greatly attenuated when the balanced input subtracts these two signals from each other.

Any hum induced in the cable, for example, will have much the same voltage and phase in both the inverted and

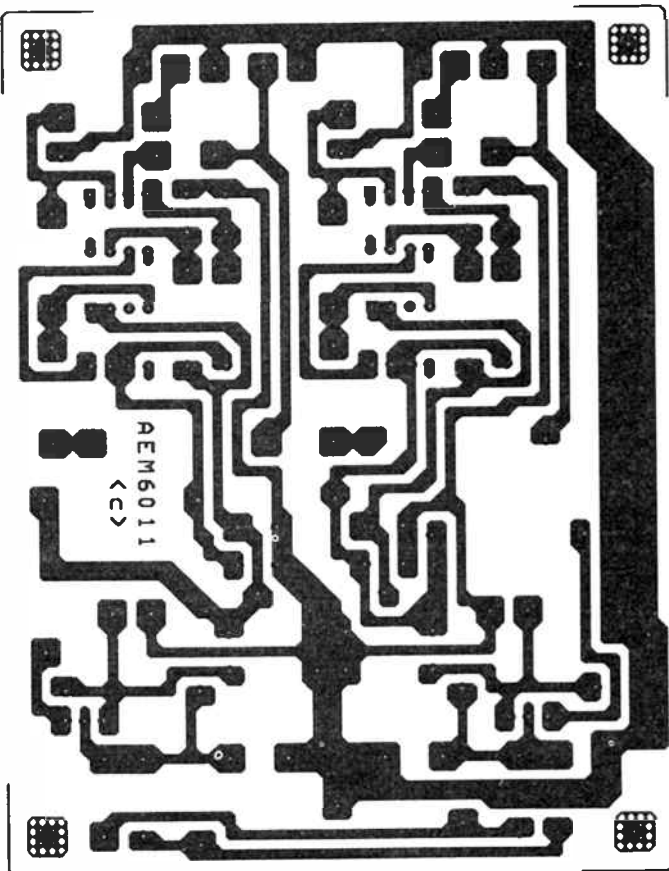

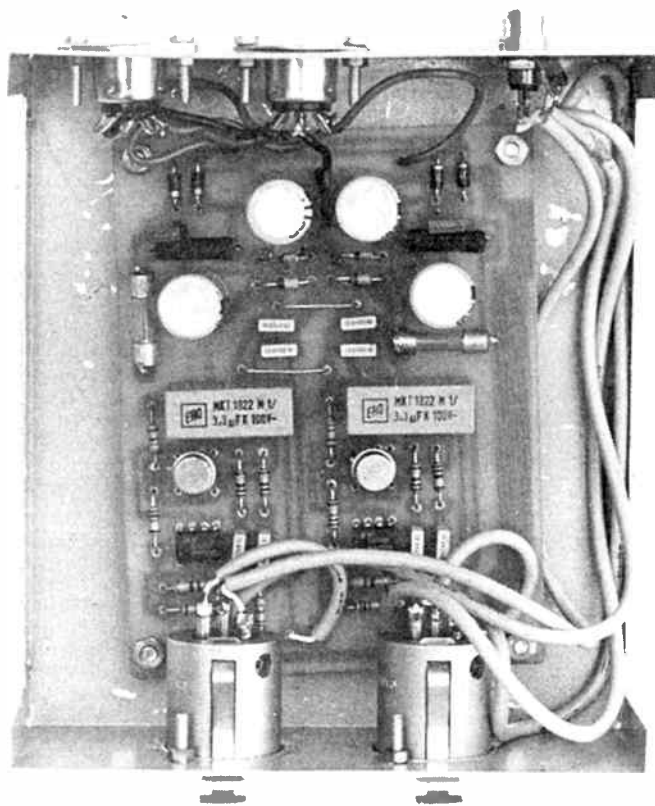

non-inverted signal lines and hence, is a common-mode signal. As the balanced input stage works with difference signals, it subtracts the hum signal common to each line, providing considerable rejection through cancellation. Cancellations never complete as the induced signals are never exactly equal in phase and amplitude, but the systems works well enough to drop induced common signals by around 30 or 40 dB if balanced shielded cable of good quality construction (to ensure good balance) is also employed.

Circuit highlights

Each channel of the AEM6011 balanced line driver consists of a TL071 high quality JFET operational amplifier connected to a National Semiconductors LH0002H high speed current amplifier. The output impedance of this device is significantly lower than that of a 47 ohm resistor placed in series with the output to set the output impedance to around 47 ohms, to match that of the 6010.

The unit is powered from the 30 volt ac line which is also used to power the 6010 Ultra-fidelity Preamplifier. To this end, two 3-pin DIN sockets have been fitted to the rear panel of the unit to facilitate connection to the DIN sockets on the rear of the 6010 preamplifier. Only one of the two DIN sockets is required for this purpose, the other one being supplied so that the power supply can be used to power further add-on modules at a later date.

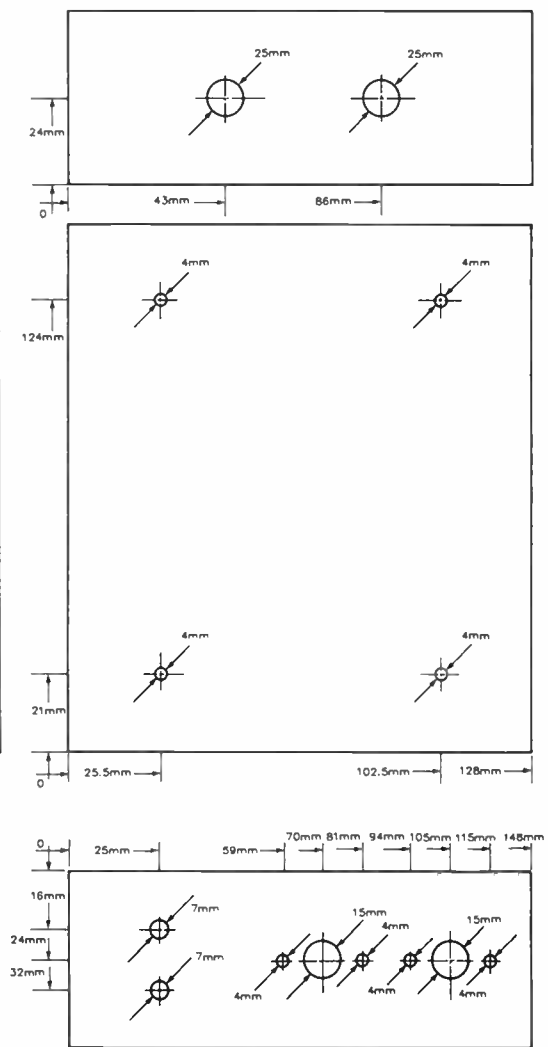
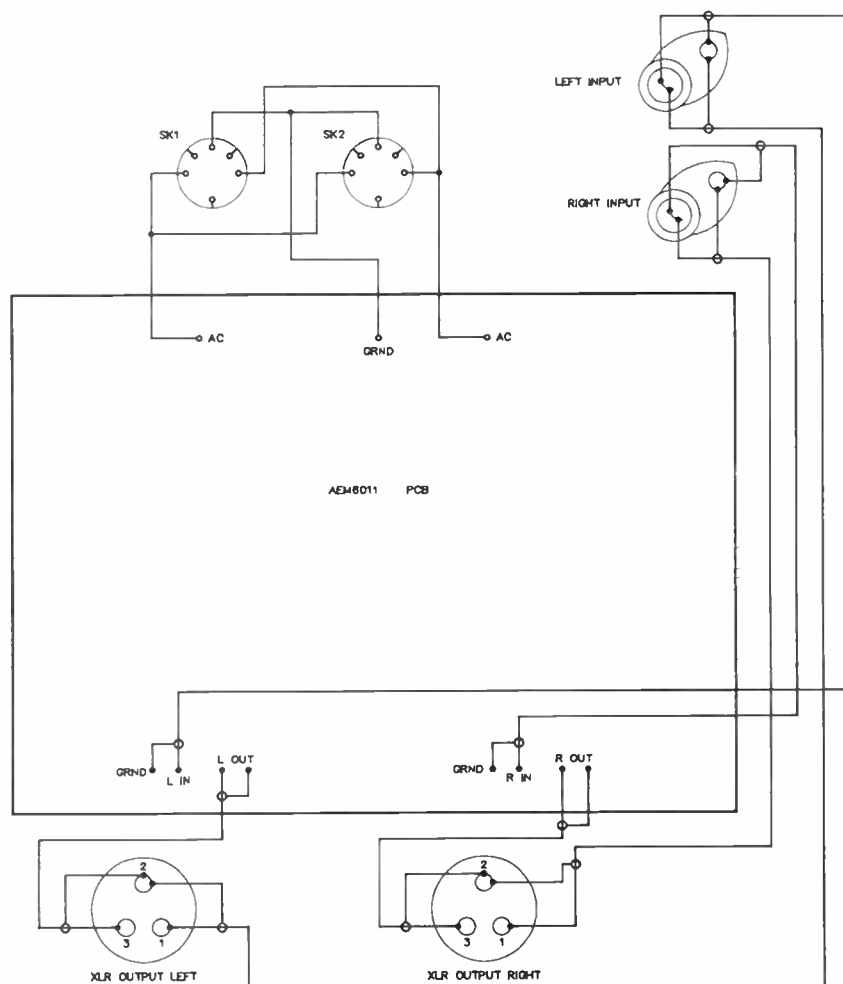

Construction

This is a relatively simple project to build, consisting basically of a single pc board housed in a small, simple metal cabinet. Before commencing the construction take the pc board and give it a thorough inspection for any anomalies that may have slipped in during the manufacturing process. Check for fine cuts or breaks in the tracks and for shorts between neighbouring tracks. These can often occur during the drilling of the pc board when fine slivers of copper can bridge between adjacent pads.

Begin construction with the resistors and links. Form the links from lengths of tinned copper wire. Follow with the small non-polarised capacitors, diodes and zener diodes. Be careful to follow the pc board overlay as to the correct orientation of the diodes and zeners. The two fuses should now be prepared for the board. It was decided to hard wire the fuses into position rather than use fuse holders. This is simply done by soldering a cut-off lead from a resistor to each end of the fuse. When doing this, however, be careful to do it quickly and not apply too much heat to the fuse as this may unsolder the fuse wire.

Position Q1 and Q2 before the larger power supply electrolytic capacitors as they are considerably more difficult to position after these capacitors are in circuit. When positioning the two transistors, be sure to follow the component overlay precisely. Q1 faces a different direction to that of Q2. To be absolutely sure of the pinout of the TO-126 package in which these components are housed, check with the diagram shown elsewhere in this article.

The larger 3u3 capacitors, C5 and C105, can now be inserted and soldered into position, followed by the electrolytic capacitors C6, C7, C8 and C9. These are polarised

components and hence need to be positioned accordingly. If these capacitors are inserted incorrectly, with reverse polarity, a breakdown of the dielectric within the capacitor will occur at first switch-on and may be damaged. To ensure the correct positioning, check with the overlay diagram.

The final components to be soldered to the pc board should now be the four ICs – IC1, IC101, IC2 and IC102. It is also essential here to be sure of the orientation of these ICs. They are available in two package types, the standard DIL package and the more commonly available round can package whose pinout is presented elsewhere in this article. In the round package, the tag on the case corresponds to pin 8.

The pc board should now be complete. However, before proceeding, it may be necessary to do a thorough check of the pc board to ensure there are no unwanted solder bridges between closely-spaced pads, poor joints, etc.

The box drilling details are relatively simple and the details for the prototype box are shown elsewhere in these pages. Finally, the board should be ready for attachment of the external wiring, which should be done before it is mounted in the box. If you are using the same or similar box to that used in the prototype, it will be necessary to mount the board before the XLR sockets as they extend a considerable distance into the box, inhibiting the mounting of the pc board. The wiring diagram should be consulted for the completion of the project. When soldering the shielded cable, be careful not to apply too much heat to the joint as this will melt the plastic coating surrounding the centre conductor, possibly resulting in a short to the shield.

When it's all together, one last check and you're ready to power it up and try it out. ♣

ACTIVE ARE NO LONGER IN SPRINGVALE, BUT JAYCAR IS

Jaycar Electronics has taken over operation at the well known
Active Electronics Store since June 1, 1987
All Jaycar stock and specials are available there.

**ADDRESS: Cnr. SPRINGVALE &
DANDENONG ROADS
SPRINGVALE
PHONE: (03) 547 1022**

Don't forget our other
Melbourne Showroom
45 A'Beckett Street, Melbourne
Telephone: (03) 663 2030

Jaycar
ELECTRONICS

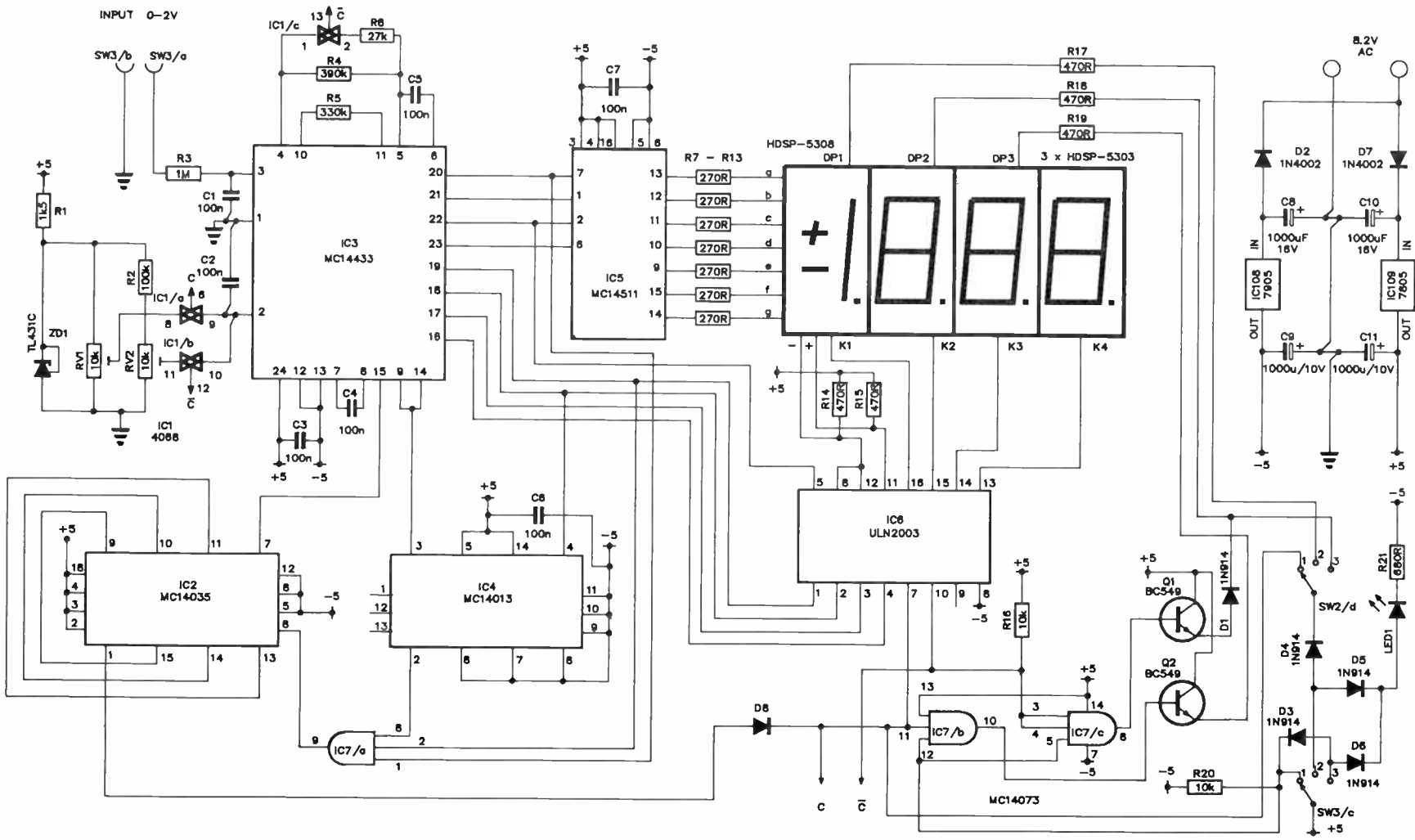

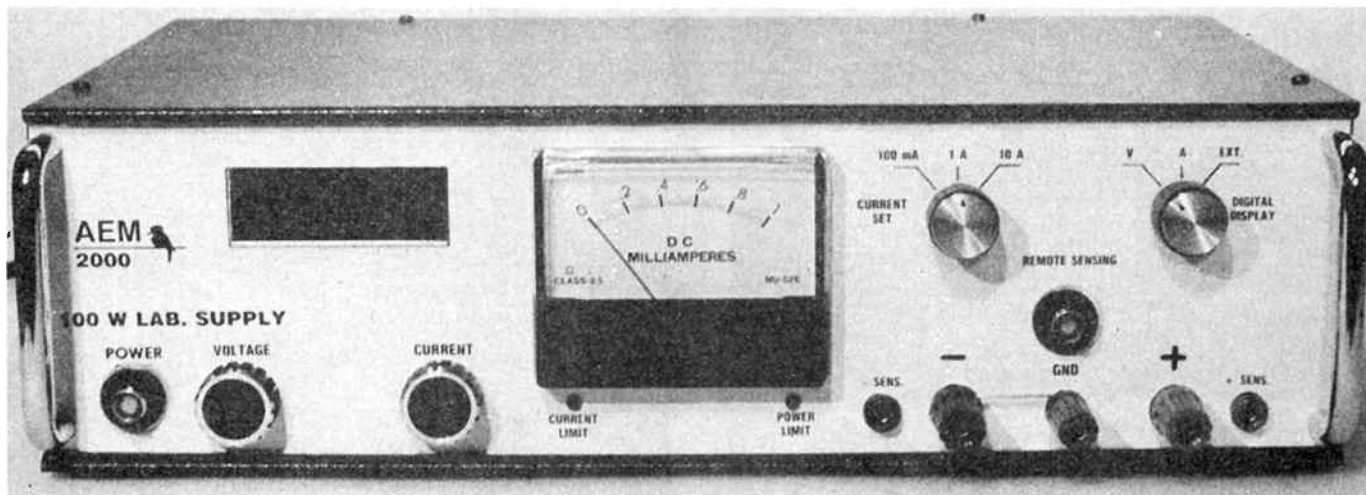

A true 'laboratory standard' 0-55V, 10A max. output power supply

Gerald Reiter

The digital panel meter is the subject of this month's article. The unit is autoranging, automatically providing the required readout accuracy on each range, for both current and voltage.

THE PANEL METER on the power supply is a two-range unit driving a 3½-digit 7-segment LED display featuring autoranging. Heart of the unit is a Motorola MC14433 DVM chip. It has two input ranges of ± 200 mV and ± 2 V which is externally 'scaled' via a resistive divider to 20 V and 200 V when selected to read volts, or 2 A and 20 A when selected to read current. Resolution on volts is 10 mV on the 2 V range, 100 mV on the 20 V range. On current, resolution is 1 mA up to 2 A, 10 mA from 2 A to 10 A. While 1 mA resolution is possible on the latter range, it's unnecessary as you'll rarely, if ever, need to set a current of, say, 8 A to an accuracy of 1 mA!

Looking at the circuit, you will notice the component numbering starts again and does not follow on from the rest of the circuit. The resistors start at R1, capacitors at C1, ICs at IC1 etc. Input to pin 3 of IC3, the MC14433, comes from the Digital Display switch, SW3, poles a and b. The RC network R3-C1 is a low-pass filter to stop display "dither" with any noise on the input. Pin 2 of the MC14433 is the reference input. A precision voltage reference is derived from ZD1, a TL431C precision voltage source. A different reference is required for each range which is provided by RV1 and RV1. The required reference is selected by either IC1a or IC1b, a pair of switches from a 4066 quad bilateral CMOS switch. Internal range selection

for the MC14433 is arranged by another switch from the 4066, IC1c, which switches R6 in and out.

Output from the MC14433 in multiplexed binary-coded decimal (BCD) format. IC5 is a BCD-to-7-segment display decoder/latch driver. It latches the appropriate segment outputs for each numeral, while IC6 provides drive for the selected numeral. The latter IC is an open-collector Darlington transistor array.

Autoranging is effected by IC2 (a four-stage shift register), IC4 (a D-type flip-flop) and some gates from IC7. The range 'top'/'bottom' is detected, the appropriate decimal point driven on and the MC14433 switched between ranges via IC1. Transistors Q1 and Q2 provide current drive for decimal points 2 and 3, respectively.

Two poles from the Digital Display switch, SW3 c and d, change the DP drive when switching between volts, current and external display. LED1 is turned on when SW3 is switched to external. This is a panel-mounted indicator.

Power for the unit is obtained from a spare 8.2 Vac winding on T2. Two half-wave capacitor input rectifiers (D2-D7 and C8-C10) provide a split rail supply, regulated by two three-terminal regulators, IC8 and IC9, providing -5 V and $+5$ V respectively. ►



LINDSTROM HAND TOOLS

The Superior Swedish Hand Tool



CLC AGENCIES

51 Armitree St.,
Kingsgrove NSW 2208

Tel: (02) 750 4005 Fax: (02) 708 5556

MEKTRONICS CO. PTY. LTD.

Corner City Rd. & Ferrars St.,
South Melbourne, 3205

Tel: (03) 690 4593 Fax: (03) 690 5082

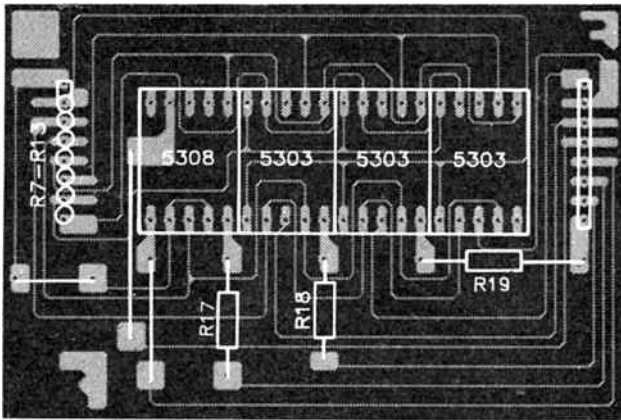

AEM2000 e, f PARTS LIST

Semiconductors

D1	1N914, 1N4148
D2	1N4002
D3-6	1N914, 1N4148
D7	1N4002
D8	1N914
DP1	HDSP-5306
DP2,3,4	HDSP-5303
IC1	4066
IC2	MC14035
IC3	MC14433
IC4	MC14013
IC5	MC14511
IC6	ULN2003
IC7	MC14073
IC8	7905
IC9	7805
ZD1	TL431C

Resistors

all 1/4W, 5%

R1	1k5
R2	100k
R3	1M
R4	390k
R5	330k
R6	27k
R7-13	270R
R14, R15	470R
R16	10k
R17-19	470R
R20	10k
R21	680R
RV1, RV2	10k trim pots

Capacitors

C1-7	100n MKT
C8-11	1000u/16V

Miscellaneous

AEM2000 e and f pc boards;
tinned copper wire.

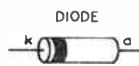
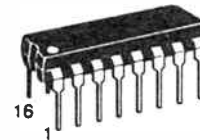
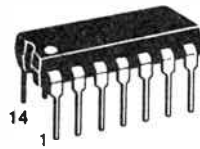

DIODE

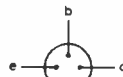

TRANSISTORS
BOTTOM VIEW

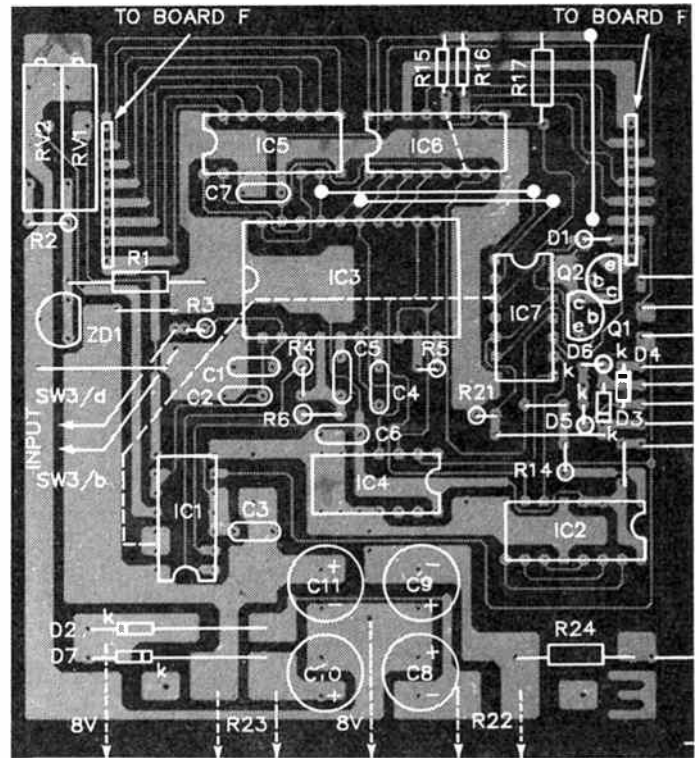

links, noting carefully where each is located. The link shown dotted is an insulated wire on the rear (copper) side of the board.

All the on-board resistors and diodes may be mounted next, followed by the transistors and ZD1. Watch the orientation of the semiconductors. Now mount all the capacitors, then RV1 and RV2. Now check the board thoroughly. Last of all, insert the ICs, taking care to orientate them correctly.

That's it for now, until we tackle the final assembly and wiring in the next part. ⚡

AEM Printed Circuit Service

Clear the air! — build our **AEM5501 Negative Ion Generator**. Providing around 8 kV output for best results, it's simple to build and low in cost. All parts readily available (Described Sept. '85)

Set of 3
pc boards.

\$18.35

inc. post & handling.

All boards manufactured on quality fibreglass substrate with rolled-tin over copper tracks and silk-screened component overlay.

Order pc boards by the project number and title. We do not stock complete kits or components. Send orders to:

Australian Electronics Monthly
PO Box 507, WAHROONGA 2076 NSW
(02)487 1207.

PLEDGE YOUR PLASTIC!
Bankcard, Mastercard,
Visa & American Express
accepted.

PAY BY PAPER!
Cheques or money orders OK.
Make them payable to
"Australian Electronics Monthly".

Copies of the relevant articles cost \$4.00 each post-paid.

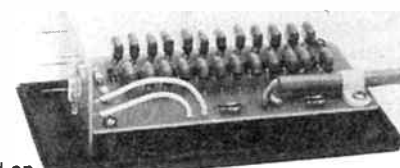

Construction

There are two boards, one containing the "electronics", the other, smaller, board the display. The latter mounts above the electronics board, supported by resistors R7-13 on one side, and a series of tinned copper wire links on the other.

Assembly of the boards is quite straightforward. Start with the display board. Locate the four displays on board, with the 5308 to the left (as you'd view it). Make sure they're correctly oriented. Then mount the three on-board resistors. Check the board, simple as it is, then set it aside. We'll come to assemble it to the other board later.

Now assemble the larger board. Each of the ICs is socketed and the sockets should be mounted first. Then insert all the

**ELECTION
1987**

DICK SMITH ELECTRONICS PRESENTS

NO BROKEN PROMISES..



- 100% APPROVAL RATING!
- WE LEAD THE OPPOSITION
- CAST YOUR VOTE BY AUGUST 1
- 56 POLLING STATIONS ACROSS AUSTRALIA!

• VOTE **1** FOR LOWER PRICES

SOMETHING TO SHOUT ABOUT WITH

You know why most politicians sound crook? Usually it's the voice (can't do much about that!) But more often than not, it's the croak microphone they're using. If they used one of these quality mics from DSE, they'd be much better off!

Tie Clasp Electret

Leaves hands free to kiss babies (and mothers), gesticulate rudely to interviewers, etc. Easily hidden for inconspicuous recordings, etc. Includes battery, 2m cable and 3.5mm plug. Cat C-1060

\$26⁹⁵

Hand-held Dynamic

General purpose 600 ohm mic with squeeze push-to-talk. Perfect for mobile PA use — you only have it on when you want to. Saves "open mic" fluffs! Cat C-1102

\$26⁹⁵



Measure the performance. Measure the saving!

Measure anything! 3.5 digit LCD meter is more than a multimeter, it tests capacitance too! One of our most popular models with service technicians, features 10 ohms range and 10A AC/DC ranges. Cat O-1460

Was \$99.00

NOW ONLY \$75



SAVE \$24

POLICY STATEMENT

Friends, Romans, Countrymen. Lend me your ears. We come to bury the opposition. Not to praise them.

You've probably noticed the opposition's behaviour lately. Misleading the Parliament and the People. Making false claims and promises. Promises they can't hope to keep. Claims like "No 1 for this" and "No 1 for that".

Come, come, honourable (?) members. You can see through that, can't you.

You don't need to be a Hawke to see that Dick Smith Electronics is the best place to feather your nest.

We don't want to labour the point, but some of the bargains we're doling out are so liberal it's almost like socialised electronics.

Like every campaign, it must end. We're extending it beyond the big non-event on July 11 — but it must end before August 1. That's if there's anything left!

Call in now to your nearest Dick Smith Electronics store; or use the handy postal voting form on page 7. Or even ring us up — there's a new twist!

Vote 1: Dick Smith Electronics. No 1 in Electronics.

TESTING, TESTING

Imagine the policy speech is about to begin — the leader walks up to the mic and nothing. The cable's u/s. EZ Checker Tests — first — with the length, for open, short, etc. A must for bands, clubs, churches, etc too. And look at the saving! Cat Q-1532



Was \$70.95

NOW ONLY \$59.95

I SPY WITH MY LITTLE EYE

What's the opposition doing? Find out with quality TASCO telescopes! Two models to choose from — at prices so low it causes questions to be raised in the house...

TASCO 49TR

What a beauty! 2x Barlow lens and 4 different resolutions: 64 x right up to 320 x! Diagonal prism and 800mm focal length give you a great view. Complete with sturdy tripod, finderscope and moon filter. Cat Y-1100

Was \$289
NOW ONLY \$199

BIG SAVINGS!

TASCO 132T

The Big Daddy! 3 inch mirror and 600mm focal length for superb vision. Bring the cosmos (no, not the cosmos) right into your living room (even under the bed if you wish. [Get it — a cosmo under every bed... oh, forget it!]) Variable power: 30 to 200 x. Cat Y-1105

Was \$499

WHILE STOCKS LAST \$399



in a hurry? You can order by phone on 0909/09 (2) 888 2105.

ANDREW... JEFF... This is the Cordless Phone you SHOULD have used!

The sensational Callmaster Cordless Phone. Use anywhere around the home, office, Parliament, etc. Up to 200m range. The very latest in technology for outstanding performance.

- Look at these amazing features:
- Use as wireless intercom as well as phone
- Answer calls at base as well as handset
- Dual channels to eliminate interference
- Programmable security code others cannot use!
- Plugs into any standard Telecom socket — no wiring needed!
- Can even replace your existing phone if you wish!

Sensational performer — we haven't seen a better one ANYWHERE IN THE WORLD! Cat F-5880
ALL THIS FOR ONLY \$349



All promises valid till 1st August, 1987 or while stocks last.

NO ASSETS TEST APPLIES —

If you haven't got the money easy terms available through



DICK SMITH ELECTRONICS

PTY LTD



These offers are really liberal; but we won't labour the point...

- ★ ★ ★ ★ ★ ★ ★ ★ ★ ★
- ★ **And everything you need to get that signal down . . .**
- ★ Co-ax cable: See elsewhere in this mailer for top quality 5C2V air-core low loss coax cable at a bargain price!
- ★ **9m Mast**
It's telescopic! When you want to get the antenna up, up and away — where the best signal is — use one of these superb masts. Comes with mounting hardware (needs guy wire). Heavily galvanized for long, long life. Cat L-4520
- ★ **Only \$110**
(Note: road freight only if ordered through OSXpress).
- ★ **Guy Wire**
180m roll suitable for complete guying of above mast. High breaking strain, galvanized steel wire. Cat L-4564
- ★ **\$44 roll**

- ★ **Chimney Mount**
If you have a chimney, this is great. (If you don't have a chimney, looks pretty stupid!) Double arm, single strap. Cat L-4154
- ★ **\$18.95**

- ★ **Barge Board Mount**
No, you don't need a barge! "L" shaped mount designed for vertical mounting off barge board or other vertical surface. Almost 1.4m long. Cat L-4150
- ★ **\$11.95**

- ★ **And down the bottom?**
Make your installation really professional and "finished" with these 75 ohm outlets. Small outlet mounts on skirting board. Cat L-4504
- ★ **\$4.95**

- ★ **Metal co-ax plug**
For best results, use the best plug — our metal co-ax plug is great. Easy to wire to TV coax. Cat P-2020
- ★ **\$1.50 ea**

- ★ ★ ★ ★ ★ ★ ★ ★ ★ ★

CB SENSATIONS

5W Marine Hand-held

Even the smallest boat can get into trouble. Get help fast with a hand-held. Nothing to leave in the boat, nothing to get pinched. And it has the same high output of in-dash models. 5W, 6 channel capacity (one channel fitted). Cat D-1126

BONUS! Two extra channels FREE! (Your choice!)

\$149

BITS 'N' PIECES
Replacement CB whip 150cm long, helically wound. For when your's gets broken or pinched! Cat D-4076

Was \$22.95 NOW ONLY \$19.95

BOOT MOUNT
Stainless steel mount for most car boots. Rubber bumpers mean no scratches. Accepts most antenna bases. Cat D-4514

\$25.95

FOLDING SHAPDOWN
Save your antenna from low flying car park's etc. Simply lift and fold over 5/16 thread for most antennas. Cat D-4507

\$8.95

UNIVERSAL MAGMABASE
Quality magnetic base complete with coax. Holds tight to ferrous surfaces even at high speed. Cat D-4515

\$34.95

SUPER HEAVY DUTY ANTENNA
Big! Massive 183cm high, with large spring base and coax. For big boats and their boys. Cat D-4078

\$99

SUNDOWNER UHF WITH BONUS!

UHF CB — away from the mugs and yahoos. Just like when you leave Parliament House. When you want the best from CB, you want the best. Uniden 40 channel UHF — from Dick Smith Electronics. Why put up with the rabble — when you can join the best? Cat D-1806

\$399

SUNDOWNER UHF H/HELD

For real practicality, the hand-held is hard to beat! Same 40 UHF channels as above, same performance — but it goes anywhere you go. And it's from Uniden — so you know it's the best. Cat D-1807

\$599

ANTITHEFT CB MOUNT

Slide-in CB mount to make it easy to get your CB in and out of the car. Lock it in the boot when you leave! All connections made with plated spring contacts. A must if you want to keep the CB! Cat D-4525

\$19.95

UHF ANTENNAS

High gain (6dBd each) antennas for mobile and base use on UHF CB. Mobile: Ground independent, complete with coax and base. Cat D-4015

Only \$49.95

Base: Colinear antenna with omnidirectional pattern. Terminated in SO-239 socket. Cat D-4011

Only \$49.95

Not enough Signal? SIGNALISE IT!

Improve received signal on 27MHz CB by up to 20dB. If that station is almost there, but not quite, the Signaliser can make all the difference. Simply installed in antenna lead, needs 12V. Cat D-3828

\$69.95

AUSTRALIA'S BEST VALUE AM/SSB CB

\$199 for an AM/SSB CB? It's amazing value — and there's no skimping on quality. Full legal power, fully approved licensable set gives you the power and performance you've dreamed of. A bargain! Cat D-1713

\$199



SEMICONDUCTOR SELLOUT

Boring, boring boring. Who wants to read through lists of components. That's as boring as a party political speech! Here's the reason: you'll save! There must be some components you need here — even if just for the junk box. Buy now before they put the tax up!

Type	Cat No	Was	Now
Transistors			
BFR91 RF transistor	Z-1691	\$3.60	\$1.00
3SK121GaAsFET	Z-1845	\$8.25	\$1.80
ZSC170 RF Transistor	Z-2512	\$2.95	\$1.95
AD161Ge Power trans	Z-1112	\$3.45	\$1.95
AD162Ge Power trans	Z-1110	\$3.45	\$1.95
ZSC2694 Power trans	Z-2505	\$44.95	\$31.60
2N5480 g/p	Z-2340	95c	35c
BC337g/p	Z-2190	40c	10c
IC's			
74LS373	Z-5295	\$2.75	\$1.00
74LS241	Z-5293	\$1.00	70c
7495	Z-5095	\$1.00	70c
7483	Z-5083	\$1.40	70c

4256	Z-5744	80c	70c
LM386	Z-6086	\$2.50	70c
74LS373	Z-4973	\$1.45	70c
74C221	Z-5378	\$2.10	70c
4044	Z-5644	90c	70c
74LS138	Z-5284	75c	70c
74LS74	Z-4974	85c	75c
LM78L15CZ 15V regulator	Z-6111	85c	70c
74157	Z-5267	85c	70c
74123	Z-5263	\$1.25	70c
74132	Z-4932	85c	70c
7414	Z-5024	90c	70c
4250	Z-5742	80c	70c
74LS175	Z-5291	\$1.50	70c

POTS, TOO... IS NOTHING SACRED?

7.5k SW W/W pot (metric)	R-6923	\$6.95	\$2.20
500k linear carbon imp	R-1812	\$1.20	70c
100k log carbon (imp)	R-1824	\$1.20	70c
20k dual linear (imp)	R-1836	\$1.20	70c
10k dual linear (imp)	R-1840	\$1.20	70c
50k dual log (imp)	R-1853	\$1.20	70c
1M log switch (imp)	R-1849	\$1.20	70c
50k log (imp)	R-1888	\$2.40	70c
2M linear (imp)	R-1823	\$1.30	70c
10k log (imp)	R-1814	\$1.30	70c
1M linear (imp)	R-1820	\$1.20	70c
10k log (imp)	R-1813	\$1.30	70c
10k linear (imp)	R-1806	\$1.20	70c
20k linear (metric)	R-6820	\$1.20	70c
	R-1806	\$1.20	70c
	R-6836	\$2.95	70c

BAD VIDEOS? GIVE 'EM A BOOST!

Copies, poorly recorded videos... they make watching hard on the eyes. Recording of political speeches are even worse. If your videos aren't the best, they could need a boost in level. This in-line amplifier boosts signals by about 10dB over entire VHF & UHF band. Simply installs between video and TV set, or even in long co-ax runs. Requires 9V at 100mA. Cat L-4202

\$29.95



Get stereo TV without getting a Stereo TV!



Don't throw out your TV — stereo TV can be yours for a fraction of the price. Our TV Stereo Decoder take signal from your antenna, decodes the stereo audio signal and feeds it to your hi-fi (video signal unchanged). Cat L-4905

- Easy to install
- 6 preset stations
- VHF and UHF
- Composite video output too for monitors.

STEREO FOR JUST \$199

MANUFACTURER'S BOOBOO

YOU REAP THE BENEFIT!

Yep, they blew it. The latest batch of these great cases failed our QC tests. They have minor marks and blemishes on them (probably dirty moulds) which won't affect wear. But they sure affect the price. The manufacturer said "Clear 'em": so here they go. 200 x 65 x 160mm plastic instrument cases — ideal for that project you're working on — at nearly half normal price. That's right: were great value at \$16.75. Imperfect models only \$9.45 each. Quick — while they last. Cat J-2505

\$9.95



METAL FILM PACKS SACRIFICED

Sacrificed ain't the word. The prices have been massacred!

Top quality, brand new, prime spec metal film resistors, 1% tolerance, 1/4 watt types, perfect for replacing carbon resistors in all your projects.

E-12 Metal Film Pack
300 pieces computer selected values. Cat R-7015
Normally \$17.55 NOW ONLY \$11.55

E-24 metal Film Pack
As above, but includes closer tolerance E-24 series. Cat R-7020.
Normally \$19.75 NOW ONLY \$12.75

HF AMATEURS OR CBERS... TVI A PROBLEM?

Here's the cure! Buy our Shinwa "Big Gun" Low-Pass filter for your transceiver at the normal price of just \$49.95, and we'll throw in THREE TV set high-pass filters FREE. That's enough for both next-door neighbours AND the bloke across the back fence! Suitable for HF transceivers to 30MHz.

Shinwa Low-Pass Filter D-7080 \$49.95
High-Pass TV Filters D-7084 \$3.25



DISCOUNTED HARDWARE TOO!

Missing Screw pack...
3mm pan-head switch screws, 10mm long. The ones you can never find! Cat H-1672 **Were \$1.05 pack 10, Now 85c**

Assorted Metrics
200 pieces of popular sizes. 2.5, 3 & 4mm. Cross, round and countersunk head. Cat H-1680 **Were \$9.95 pack, now \$6.80**

Metric Washers
680 (yes, 680!) pieces of various size metric washers. Over 100%! Cat H-1525 **Were \$2.50 Now \$2.25**

Self tappers
150 pieces of various small self tappers (pk). Cat H-1505 **Were \$2.15 pack, now \$1.95**

Grommets 100
Pack of 8 12mm diam grommets (9mm bore) — ideal for making your projects just that bit safer! Cat H-1719 **Were \$1.35 pack, now \$1.20**

Dick Smith Electronics 'No Broken Promises'

FANTASMAGORICAL METER MUSTER

Professional Quality Test Equipment at Hobbyist Prices

"4000 COUNT" BARGRAPH DIGITAL SHOWS ANALOG!

The usual complaint with a digital multimeter is you can't see changes. Problem Solved: this new LCD gives you the best of both worlds' digital accuracy, with an analog indication AS WELL which shows both magnitude AND variation at the same time! But there's even more than that: this outstanding design counts to 4000, rivaling the accuracy of 4.5 digit meters, while keeping the price down to 3.5 digit types! 4000 count means it has double the resolution of 2000 count meters. One of the best meters we've ever seen! Cat Q-1666

\$249



FREE CASE!

Buy our pocket analogue multimeter (Q-1010) for only \$16.95 and we'll throw in the protective case worth \$3.45. That's a great saving for a great little meter! Perfect for beginners, for around-the-home work. It's diode protected and has 12 ranges. Cat Q-1010/Q-1011

\$16.95
WITH FREE CASE!



DIGITAL LIGHT METER

The Prime Minister's XI need one of these when they play cricket. Accurate readout of light level for variety of scientific and sporting uses (photographers love 'em)! • 0-50,000 LUX • 150-200 hours continuous use Cat Q-1400

\$129



Alligator Clips Mini Size

Overall shroud length 32mm
Red Cat W-4550 Black Cat W-4552

40¢ each 10 up 35¢ each

Large Size
Overall shroud length 50mm
Red Cat W-4554 Black Cat W-4556

60¢ each 10 up 55¢ each

60¢ each 10 up 55¢ each

\$1.95 Black Cat W-4550 Red Cat W-4552 10 up \$1.75 each

Test Clips Mini Size

Overall length 45mm
Red Cat W-4550 Black Cat W-4552

90¢ each 10 up \$1.75 each

Large Size
Overall length 56mm
Red Cat W-4550 Black Cat W-4552

\$1.10 each 10 up \$1.75 each

137mm Overall length Red Cat W-4550 Black Cat W-4552

\$3.95 each 10 up \$3.20 each

\$50 OFF 4.5 DIGIT BENCH METER

Unbelievable accuracy! 0.05% (DC) up to 10 times more than a 3.5 digit DMM. With every range you'd ever need this is the ideal bench companion for service technicians, development labs, techs, schools... and the price is so affordable, for the hobbyist too! Cat Q-1550



Normally outstanding value at \$199
THANKS TO THE ELECTION IT'S ONLY \$149

LOGIC? There's not much of that in Canberra.

You could find out just how much with the DSE Logic Probe. 3 State Probe shows "high", "low" and "pulse" states, with power (5V DC) taken from the circuit under test. Low circuit loading, easy to use. Cat Q-1272



\$37.75

OUTSTANDING! 20 MEG CRO +++

It's much, much more than just a CRO — though it is one of the best around. 20 meg dual trace model with the most advanced features you'd ever want. But it's more: also has inbuilt component checker, tests transistors, inductors, capacitors, diodes, zeners, etc. Top value! Cat Q-1260

- 20MHz bandwidth
- Single or dual trace mode
- Compares more than favourably with "big name" brands

\$879



SAVE \$30 COLD AIR METER

The perfect item to take to the rally. Find out just how much hot air they're pushing out! This deluxe windspeed meter gives digital readout in km/h, knots, miles, m/s, etc with high accuracy. Scientific uses by the score, but also used to measure air conditioning, sports (yachting, sky diving, ballooning, etc etc) and much more. Cat Q-1405

\$129

REDUCED FROM \$159!



Auto Ranging Personal LCD

Small enough to carry in the pocket — it's just 10mm thick. And for the low, low price, you wouldn't expect all the features — super fast auto ranging, auto polarity indication, audible continuity and much more! Cat Q-1555

NOW ONLY \$49.95



- AC & DC voltages to 400V
- Resistance to 2M
- Continuity check to 200 ohms

NORMALLY \$54.95

ECONOMY LCD BARGRAPH

Similar to above meter, but this one features an "analog" readout only, it is in "bar graph" form to show you both the magnitude and variations. The bargraph shows the read figure, with the option of an expanded scale to get much better resolution.

- Includes a "data hold" button to allow readout "freezing"
- PLUS a "magnify" key to expand the scale by 5 or 10 times.
- Superbly easy to use and read.

\$149.95



WANT THE LOT?

- Multimeter
- Capacitance
- Transistors
- Continuity
- AND FREQUENCY

At last — everything in the palm of your hand. All the normal DMM features — including high 20A AC & DC reading — in this superb 3.5 digit model PLUS it also reads frequency to 200kHz. Cat Q-1505

\$159



ZIP RACK: THE 19" RACK SYSTEM FOR EVERYONE... AND IT WON'T BREAK THE BANK

Here it is: DSE's exclusive Zip-Rack. The most versatile rack system you'll ever find. It's the true multi-role system, allowing non-19" standard equipment, including ordinary desk-top equipment (eg test gear, audio and hi fi gear, etc) to be integrated with a 19" system. But there's much more to Zip-Rack. Assembly is delightfully simple: it just snaps together using the eight plastic corner pieces supplied. It's attractive — use in the home for your audio or video system just as much as in the lab, workshop, etc. It includes stand-off feet that allow maximum air flow around assemblies AND protects the surface underneath. It includes both front AND rear mounting facilities. It includes both front AND rear mounting facilities. The kit INCLUDES twelve Phillips head screws, nylon washers and captive nuts. Size just right for most applications: 19" wide x 24" high x 12" deep (if you need extra height, simply stack the Zip-Racks. When you want the ultimate in convenience, the ultimate in adaptability, you want the Zip-Rack. Exclusive to Dick Smith Electronics. Cat H-2470

All this for only \$149

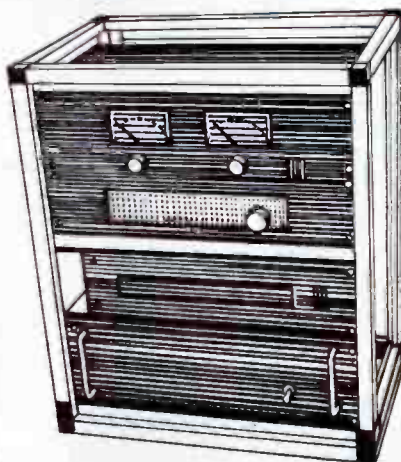

Zip-Rack Options

Zip-Rack Equipment Tray

If you want to integrate non 19" equipment, the easiest way is to use these nifty trays and simply sit the gear on them. Ideal for amateur, computer, CB, video & audio, test equipment, etc etc, up to 8kg. Each tray measures 485 x 330mm; just clips into place with 4 nylon clips supplied. Cat H-2471

\$22.55

Zip-Rack Hardware Pack

Allows you to mount 19" rack-mounting equipment direct to the Zip-Rack without using shelves. Cat H-2472

\$11.55

19" RACK MOUNTING CASE

Go on — put them on the rack! This quality case is perfect for standard 19" rack systems, suits Zip-Rack too (see right). Heavy gauge (3mm) front panel, top and bottom pre-punched to get rid of their hot air! Cat H-2481



NOW ONLY \$49.95

WAS \$54.95

Dick Smith Electronics 'No Broken Promises'

Questions will be asked
in the house about this...

Demo Computer CLEARANCE SAVE THOUSANDS \$\$\$

Sensational bargains in computers. Famous Olivetti brand computers at throw-out prices. These are either ex store demo, used by DSE, or stock repair returns. Therefore they aren't new — but neither's the price! Two different types to choose from, and these prices are so far below cost it would make our accountant cry!

**GUARANTEED TO WORK WHEN THEY LEAVE US*
BUT NO WARRANTY AT THESE STUPID PRICES**

* Except where indicated as non-working

OLIVETTI M-24 SYSTEMS FROM \$1295

Olivetti's magnificent M-24 computer system — includes Genuine Olivetti CPU, Genuine Olivetti Monitor and Genuine Olivetti keyboard. These originally sold for nearly four thousand dollars. But look at the price now! Your choice of hard disk or twin floppy units, these have been through our service department to ensure correct operation. So we know they work! IBM compatible machines, ready to run the world's biggest and best range of business software plus games, educational items, utilities, etc etc. 8MHz clock speed means it's nearly twice as fast as an IBM PC! Most units have 256K memory, but this cannot be guaranteed. It's a lucky dip!

• MONITOR • CPU • KEYBOARD

10 MEG HARD DRIVE
SINGLE FLOPPY
3 UNITS ONLY \$1995

DUAL FLOPPY
8 UNITS ONLY \$1295

OLIVETTI M-21 SYSTEMS

Not working, minor faults

The portable version of the M-24 — complete with integral screen and keyboard. Only 2 of these, and both have minor faults, which have NOT been repaired! But if you have any technical ability, you could almost certainly get these going without too much drama! And look at the price — way, way under cost — like about one third COST price!
Hurry — only 2 units. AND NOTE: NOT IN WORKING ORDER, BUT COMPLETE. FIRST COME, FIRST SERVED

BONDWELL 14: PARTS & SOFTWARE VALUE!

Here's another sensational offer. We have three Bondwell 14 CP/M machines. Two are complete — even have Wordstar & other "Star" software. One is not complete — it's been cannibalised for parts so is very much ONLY for parts value now. But here's the deal: **BUY THE TWO COMPLETE BONDWELLS FOR \$500** (that's about 1/3 price) and we'll throw in the "Ratted" one FREE! We're SURE any competent technician or advanced hobbyist could get at least one going — and probably BOTH!

2 COMPLETE, 1 INCOMPLETE

ALL 3 FOR \$500!

SOFTWARE SELLOUT TOO!!

NOTE: These are NOT current versions of software. But if you're interested in using a particular package, this is the way to find out about it without investing big \$\$\$!

LIMITED STOCKS ALSO — Some only few on hand. Definitely first come, first served! These will be gone almost as soon as this mailer is released!

OLIBIZ General Ledger	ONLY \$20
OLIBIZ Debtors	ONLY \$20
OLIBIZ Creditors	ONLY \$20
OLIBIZ Payroll	ONLY \$20
OLIBIZ Stock Control	ONLY \$20
OLIBIZ Professional	ONLY \$20
Electric Pencil	ONLY \$
Multipian	ONLY \$50
Perfect Filer	ONLY \$150
Dbase 1.1	ONLY \$100
Crcstalk 1.6	

NOTE: Strictly limited stock, available ONLY through DSXpress (Sydney), phone 008 22 6610 or 888 2105. Phone to order — can be despatched direct to you or through your nearest DSE store **FREIGHT FREE!**

Dick Smith Electronics 'No Broken Promises'

ALTERNATIVE TO TELECOM

Why pay any MORE to Telecom when the bargains in telephones and telephone products are at your nearest Dick Smith Electronics store?

LOOK MUM — NO HANDS!

• No hands operation
• No hands on the clock (it's digital!)

\$99⁹⁵

Value! The perfect phone for the home, the office — anywhere. Cat F-5104



WILL THE HONOURABLE MEMBER PLEASE ANSWER THE PHONE?

If you're tied up on important business, you could be missing important calls. Our budget Telephone Answering Machine will answer those calls for you. It's microprocessor controlled for reliability and uses standard audio cassettes. Just plug it in to any Telecom socket (use a double adaptor if you wish). Cat F-6130

• Single tape
• Monitor incoming calls too
• Voice operated remote control



NOW ONLY

\$199
WAS \$229

PHONE PLUG

Identical to Telecom's G25 phone plug approved by Telecom Engineering. Cat F-5117

\$4⁵⁰



PHONE SOCKET

Identical to Telecom's 610 phone socket approved by Telecom Engineering. Cat F-5118

\$4⁵⁰



DOUBLE ADAPTOR

Use where extension phone, answering machine, dialler, etc is required. Just plug it in to wall socket. Cat F-5112

\$9⁹⁵



EXTENSION BELL

Phone hard to hear outside? Or in other rooms? Plug in the telephone bell to your Telecom phone socket (adaptor supplied) and you have another bell up to 5m away. Cat F-5119

\$19⁹⁵



4-CORE CABLE

Same cable as used by Telecom for internal phone wiring. 4 core, single tinned copper insulated with blue, white, red and black pvc. Cat W-2120

75^c /metre
OR \$60.00 per 100m roll
— save \$8.00 ROLL



HERE'S VALUE

Quality jugs for lids



\$59⁹⁵

If you want real music quality (from your CD, for instance) try these superb dynamic phones. Comfortable, wide frequency response and great sound make these the ideal choice. Cat C-4180

AM/FM with PHONES

WAS \$27.50

NOW ONLY **\$19⁹⁵**



Go-anywhere music, sports (great at the footy!) with this mini system. AM/FM stereo radio PLUS quality phones at this low price. It's a steal! Cat A-5116

COMPLETE AUDIO ADAPTOR KIT

Problems with head-phone connectors? This will fit it. Includes 3.5m cord plus adaptors to fit virtually any combination, stereo or mono. Cat C-4180

\$14⁹⁵



COMPLETE VIDEO ADAPTOR KIT

Want to dub videos? Can't connect them? Yes you can — with this kit. We haven't found one video this cannot connect to! VHS, beta, 8mm, etc. Allows any mix and match you like. Cat W-1287

\$29⁹⁵



DON'T SHOUT: INTERCOM IT!

FM Duplex

Look! No wires! It just plugs into the mains socket. And duplex means full 2-way communication — just like a telephone. Attractive phone-style means it's great in noisy locations, too. Cat F-1015

\$99



4 Station Wired

All over the home, the office, the factory — 4 stations for great communication. Complete with connecting cable, battery operated system includes 1 master and 3 slaves. Cat F-1040

\$39



• NICAD SAVINGS • NICAD SAVINGS •
GET UP TO 400 CHARGES OUT OF OUR HEAVY DUTY NICADS.

Ideal for all your toys, radios...

Why buy Nicads?

You should expect at least 400 charges from a NiCad battery. If looked after, this can easily be doubled. Taking worst case, each charge for a AA cell costs about 1c (electricity costs are negligible). Compare this to 400 dry batteries at about 60c each... the savings are enormous!

But there's more!

A NiCad cell holds its voltage virtually constant over 90% of the discharge cycle. A dry cell starts dropping voltage immediately. You don't get the same 'drop off' in a NiCad as a dry cell. Therefore motors continue to run at the correct speed, lamps glow at the right brightness, and so on - very close to complete discharge.

And even more!

The internal resistance of a NiCad Cell is much lower than a dry cell. (less than 0.05 ohms Vs 0.4 to 0.8 ohms) Therefore devices which require high currents (e.g. photoflashes, high torque motors, etc) are much better off with NiCad cells than dry cells.

Still not convinced?

You can get much higher continuous current ratings in a NiCad cell than a dry cell. While not rated the same way, a dry cell discharged at 90mA is considered 'flat' (1.1V) after approx. 2.5 hours. A NiCad cell lasts almost 5.5 hours under the same conditions. Even under non-continuous discharge conditions, the NiCad cell wins hands down because the NiCad can be re-charged between uses!

Information on NiCads courtesy
 Pleassey Components Pty Ltd

BATTERY HOSPITAL

Eveready NiCad Charger
 Multi-size (AA, C, D or 9V) NiCad battery charger. Takes two 1.2V cells at a time or one 9V. Complete unit including plug-pack. Nothing extra to buy.
\$27.50

Multi-cell Charger
 Charge up to 4 batteries at a time - AA, C, D, 6V or 9V. AND you can also charge AAA, and button cells too! But there's more - a test meter to check NiCad voltage under load - the only way to check your battery properly. Fully approved plug-pack included.
\$34

CATCH ALL THE ELECTION ACTION ON TV

If you're a real masochist, you can watch the party political broadcasts, the ads, the promises, the name calling. It's fun, isn't it! OR you can put up one of these antennas and watch a whole new world of TV. Entertainment, even!

VHF PHASED ARRAY - FOR LONG DISTANCE

Superb performer on VHF at fringe and deep fringe ranges. Suitable for horizontal or vertical polarity (therefore it's ideal for Canberra and won't upset the polities or their mates!) Easy to install. Cat L-4025



\$99

VHF & UHF (in case they try to escape to UHF)

Get the best of both worlds. This economy model receives both VHF and UHF signals from one direction (note - single polarity!) Complete VHF band, plus UHF band 4 (channel 28 etc). Cat L-4027



\$39.95

NEED MORE GAIN? HOW ABOUT 60% MORE?

Extra gain on UHF band 4 for marginal signal areas, still with complete VHF band reception. It's the perfect all-round antenna - and it's easy to install because it has only one lead-in.

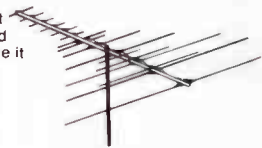

Cat L-4050

\$89

ALREADY HAVE VHF? HOW ABOUT UHF ONLY...

BAND 4

Economy band 4 (Channel 28) antenna for reasonable signal areas. Ideal too for those areas (like Canberra) where VHF has a different polarity to UHF and you're after every femtovolt. Cat L-4040



\$49.95

BAND 5

Economy band 5 (Channels 39 to 69) antenna, similar to above band 4 antenna. 10 element design with cross reflector (like a candidate who's just lost an election. Cross). Cat L-4035

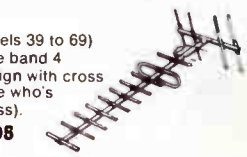

\$44.95

SUPER BAND 5

For poor UHF signal areas this big gun will give you top performance. If it's on the air, and capable of being received, receive it! 16 elements with adjustable corner reflector. Superb! Cat L-4045

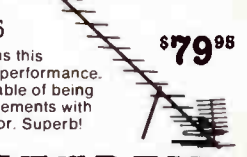

\$79.95

ELECTION BONUS!

FREE DIPLEXER WITH ANY ANTENNA ABOVE!!!

Free what? Diplexer. Accepts lead-ins from both UHF and VHF and brings them out with one lead - without the losses you'd get using an ordinary splitter back to front. Whew! That's what you get. And Free. Normally \$9.95 worth, free with any of the above antennas while the election fiasco lasts. Cat L-4470

NORMALLY \$9.95

Enjoy the best and save \$\$\$ with DSE kits.

Low cost alternative to pre-built amateur gear
 Here's amazing value: build your own 80 metre CW transceiver for under \$150! And even more: you build it section-by-section - you don't have to buy the lot at once. Famous British quality kits from CM Howes Communications, these three kits (each a separate, practical project) combine to form an 80 metre QRP transceiver with up to 5W output. Absolutely perfect for YRCS, Scout, school and club projects. And so affordable!

Receiver Module Kit:
 Operates over full 80 metre band with direct conversion receiver. Balanced mixer and FET VFO, all very easy to build on one PCB. 12V DC operated. Complete instructions with all components and PCB. Cat K-6236

\$59.95

Transmitter Module Kit:
 Stand-alone transmitter or add to receiver for 'transceiver' operation. Easy to build - all instructions included along with PCB and components. Adjustable output up to 5W - all you add is a power supply and key. It's that simple! Your choice of crystal locked (rock included) or optional VFO control. Cat K-6236

\$48.95

VFO Module Kit:
 Gives full VFO control over 3.5-4MHz - designed especially for above transmitter, but can also be used as a general purpose variable frequency oscillator. Even has provision for FM modulation to give phone capability. Instructions include various modifications and options - and alignment details. Cat K-6327

\$39.95

(Note: tuning capacitor not included in kit. Our R-2980 50pF tuning capacitor [\$6.95] will give approx 300kHz tuning range. Other capacitors will give different ranges)

KILOMETRES OF KABLE!

Just look at it all. There's enough here to tie up every politician in Australia. And the World. And everywhere else!

BUY YOUR CABLE BY THE 100M ROLL AND SAVE SAVE SAVE!

5C2V LOW-LOSS TV CO-AX.

Top quality foam dielectric double screen cable - ideal for building installations where it's got to last! 75 ohms, black outer insulation for ultra violet protection. Cat W-2082

NORMALLY \$85 (100M) 30'/METRE NOW \$65 ROLL

MINI FIGURE 8 TWIN LEAD

Light duty figure 8, ideal for alarm installation, speaker wiring intercoms, and other low voltage (eg 100V or less) work. One side of fig 8 is coded with trace for polarity conscious work. Cat W-2010

NORMALLY \$35 (100M) 30'/METRE NOW \$25 ROLL

SHIELDED AUDIO CABLE

Single shielded cable for mono audio applications (or use 2 for stereo!) - perfect for PA work, microphone leads, patch cords, etc. Standard grey insulation. Cat W-2030

NORMALLY \$40 (100M) 30'/METRE NOW \$20 ROLL

Dick Smith Electronics 'No Broken Promises'

The Big Guns of CB Antennas

Mobile One's DX95S DX means distance — and that's what you get from this little beauty. Little? It's a monster! Full 1/2 wave fiberglass whip with heavy duty base and spring plug fitted coax — just right for a 4WD, van, etc or the real poser! Strictly limited stock — now none left in warehouse — store stocks only! Cat D-4080

Last year's price near \$100 —

WHILE THEY LAST

\$49⁹⁸

DICK SMITH ELECTRONICS

FREE HOLE?

With every tapered reamer we supply this month, we promise to send a free hole, just so you get the idea! 4mm to 22mm. Ideal for chassis bashers and other project builders! Cat T-4920

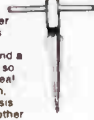

\$9⁹⁰

REALLY?

Yes, it's really a relay! A real horny one! 12V single pole horn relay with 20A contacts Cat S-7302

Was \$5.85
SAVE 50c

\$4³⁵



CHARGE IT!

Quality ARLEC 12V charger is just right for keeping your car battery topped up. AA charge overnight from flat will get you going next morning, too. If you're quick, save \$5.00! Cat M-9800

Was \$49.50

NOW \$44⁵⁰



AMATEUR TV TRANSMITTER

They won't let you start up your own TV station — but here's the next best thing, a mini TV transmitter, great for sending signals over short ranges. Accepts any video and audio input (eg use a video recorder — even use a video camera for "live to air"). Good for up to 20 to 30 metres or so — around the home is perfect. Cat D-2500

DON'T PAY \$100 OR MORE FOR OTHERS.

OUR PRICE:
\$69⁹⁵



GAIN (YAGI) ANTENNA

For amateur use only. Increase gain by 10dB for more serious experimental use in ATV. Note: this may allow signal to travel past boundaries of your property so could be illegal. Plugs into RF output on above transmitter. Cat D-2505



\$39⁹⁵

MORE CABLE BARGAINS

What a saving! Buy your hookup wire by the roll (100m) and save a whopping 33%! Yes, a big third off the price if you buy in bulk! Flexible, light duty hookup wire in all colours. 10x0.12mm (10/0048) PVC insulated

Red W-2220 Yellow W-2224
Lt Blue W-2228 Black W-2221
Green W-2225 Grey W-2229
Brown W-2222 D Blue W-2226
Cream W-2230 Orange W-2223
Purple W-2227 White W-2231

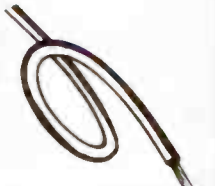

15c/m OR \$10 ROLL

A LITTLE LIGHT ON A DARK SUBJECT

Coloured light, no less! R95 coloured globes, ideal for discos, lightshows or coloured flood-lighting. ES base, in 4 colours

Yellow S-3851
Red S-3853
Blue S-3855
Green S-3857



ONLY \$5⁸⁸ ea

DON'T BLOW A FUSE

Blow a circuit breaker instead. Why mess with the fuse? With these safety breakers in your fuse box, all you do is flip the switch back on! Standard Federal pattern replace 99% uses

10A: P-5910
15A: P-5915
18A: P-5920
20A: P-5925

\$10⁹⁵ EACH

EDISON SCREW BASE

To cut above R95 coloured globes, PAR36 or other ES globes etc, with Edison Screw Base. Moveable over about 30° or so for perfect aiming! Cat P-3620



\$6⁸⁵ each

AC/DC? YOU NEED A MOVING IRON METER!

That's the beauty of a moving iron meter — it operates on both AC and DC — without need for diodes, etc. Calibrated 0 to 10 A perfect for power supplies, etc etc. Quality metering from DSE. Cat Q-2090



\$19⁹⁵

MORE THAN A METER

It's got all the usual features PLUS capacitance, transistor, diode and continuity checking. And it comes in this kinky yellow colour — just so you can find your multimeter amongst all the black and grey ones! High overload protection, too! Cat Q-1465

\$119

LCD Panel Meter

Make your projects snazzi! Give them the latest digital metering! 3.5 digit LCD meter is ideal for a range of uses, complete circuitry supplied for various applications. Includes mounting base. Cat Q-2200



\$54⁹⁵

SANGEAN MULTIBAND BRINGS YOU THE WORLD!

10 band portable to bring the world into your listening room! Features AM & FM broadcast bands, plus 8 shortwave bands between 2.3 and 21.95 MHz. That gives tons of bandwidth for casual short wave listening. Runs on 3 AA size batteries. Cat D-2834

\$89

AND ONE FOR THE KIDS!

Go on — give them a go! With this little cassette recorder they'll be on the stage in no time! Comes complete with its own mic — use it as a normal cassette — or as a mini PA system. They'll love it, and it's made really tough to be kid-proof! Cat A-4100

\$39⁹⁵



AM/FM DESK CLOCK RADIO

A bedside clock — or in the kitchen. Even a clock radio on the office desk. Just some of the uses for this one! Features AM and FM radio with alarm, plus digital clock with snooze control, etc. Neat! Cat A-4460



ONLY \$34⁹⁵

1/2 PRICE

DON'T TOUCH: that's what it says! Actually it bleeps at you when it senses light — makes a great alarm for medicine chests, desk drawers, etc etc. And look at our low, low price. Buy a duplicate for sales! \$8⁹⁵. Cat L-5086



WAS \$12.95
NOW \$6⁴⁵

MORE THAN A METER

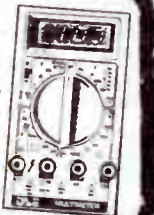

ECONOMY DMM

A push-button with all the usual DMM features — except price! Economy model features 20 ranges, with overload protection — but is priced way down. Just right for your first DMM — or for the tool box. Cat Q-1520

- Budget Priced
- Big on Performance!

ONLY \$49⁹⁵



OWN AN 8800?

Our boozie is your bargain! We've over-ordered FM module for the FRG-8800. Normally over \$50.00 each, our price just \$29.95! Hurry! Cat D-2824



TESTA BATTERY!

Why throw 'em out? Find out if they're really crook with this battery checker. Tests globes and fuses too — and gives batteries the right load to make sure they're ok. A must for the hobbyist, the service shop — anyone! Cat Q-1525

\$17⁹⁵

SAVE AROUND \$20!

DICK SMITH'S FAMOUS ZIPPY BOXES

GET DISCOUNTS LIKE YOU'VE GOT A FRIEND IN PARLIAMENT: SAVE 25% ON ANY QTY, ANY SIZE!

Beware of impostors and imitators! There is only ONE GENUINE Dick Smith Zippy Box. It's the one with the deep, ribbed sides for screwless pcb mounting (no, not screw loose like the opposition). Your choice of four popular sizes — there's one just right for your project. Keep a couple in the junk box; just in case!



NOW EVEN BETTER VALUE: ALL DSE ZIPPY BOXES ARE SUPPLIED WITH BOTH ALUMINIUM AND PLASTIC LIDS. YES, BOTH SUPPLIED AT THIS LOW LOW COST!

- Mini (28 x 54 x 83mm) Cat H-2855 \$2.30 ea LESS 25%
- Midi (41 x 68 x 130mm) Cat H-2853 \$3.15 ea LESS 25%
- Maxi (50 x 90 x 150mm) Cat H-2851 \$3.80 ea LESS 25%
- Giant (60 x 113 x 196mm) Cat H-2852 \$5.25 ea LESS 25%

CRAZY CRYSTAL PRICES!

Crazy prices for a great crystal. 5.12MHz — very handy for a timebase (eg 10kHz is a nice 9 steps away). Perfect for! Standard "mini" size case, two wire type ready for soldering into circuit. Cat J-1046

Just \$2⁵⁰ each

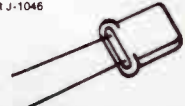

LAST MINUTE VOTE CATCHERS

BAN TV BROADCASTS

Aren't politicians boring on TV. Makes you want to turn off! But what do you do instead? Here's the answer: play an interactive video game. Both VHS and Beta types available, you don't need to be an expert because the game tells you what to do.

VHS GAMES

FLASH MATCH. Put your memory to the real test! If the boys in Canberra had one they might remember what they said yesterday. Cat Y-7000 \$29.95

FLASH MATCH JUNIOR. Same as above for aspiring politicians 6 to 12 years. Cat Y-7010 \$49.95

COMMERCIAL CRAZIES. Answer the wacky question about the Crazy Commercials. Plenty of laughs! A great test of memory and your bluff! Cat Y-7005 \$39.95

AUSTRALIAN HORSE RACING. The punter's special! All the thrill of a real race meet in the comfort of your home! Comes with tape, betting money and odds cards. Cat Y-7006 ONLY \$59.95

THESE PRICES HAVE DRIVEN US CRAZY!

You might have realised we have recently changed our range of screwdrivers to a new manufacturer. However, in all stores there are very limited stocks of the old model screwdrivers left. They're not seconds or imperfects, we just want to clear the stocks out of the way. **SO YOU SAVE SAVE SAVE!**

Mini Drivers: Flat Blade (T-4010) Philips (C1-4020)
WERE \$1.00 EACH, NOW 50¢ EACH

Stubby Drivers: Flat Blade (T-4060) Philips (T-4065)
WERE \$2.00 EACH, NOW \$1.00 EACH

Medium Drivers: Flat Blade (T-4070) Philips (T-4030)
WERE 90¢ EACH, NOW 45¢ EACH

STRICTLY LIMITED TO CURRENT STORES STOCKS
NO RAIN CHECKS!

Popular Drivers: Flat Blade only (T-4090)
WERE \$1.50 EACH, NOW 75¢ EACH

Heavy Drivers: Flat Blade only (T-4095)
WERE \$1.80 EACH, NOW 90¢ EACH

ARTHUR OR MARTHA? IT DOESN'T MATTER

Often it's hard to tell whether they're this or that. Until now, you could tell by looking at the watch value, includes alarm and timer. If your old watch has had the gong, try this one! Cat Y-1011 \$18.95

COUNT THE VOTES... OR CALCULATE SAVINGS

Sensational value for a pocket calculator. We've never seen a lower price! Pocket LCD calculator normally fantasmagorical value at \$4.95, now an amazing 25% off! At this price, buy a few for gifts. You won't find this price again! Cat Y-3060 \$3.95

THE PERFECT POLITICIANS: ROBOTS!

Imagine the possibilities... the mind boggles! Politicians that did what YOU wanted. Politicians that had your interests at heart. Politicians that didn't spend like it was going out of style. Oh bliss! Oh joy! We can but dream. Until then, have a robot of your own. And Save.

OMNIBOT. \$100 OFF

The big daddy of the Robot World. Program Omnibot to wake you in the morning, to remind you of important dates, greet guests, you name it. As used by many educational institutions to teach robotics. Cat Y-2050

LAST YEAR'S PRICE: \$445

WHILE STOCKS LAST: \$299



DINGBOT

He's a clown — he'll remind you of question time in the House! And he makes just about as much sense, jabbering on in his own language. Cat Y-2045 \$44.95

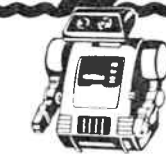

FLIPBOT

The one to keep kids (or Parliamentarians) amused for hours. Amusing acrobatic stunts keeps him (and them) going! Cat Y-205 \$22.50

Was \$22.50

NOW \$19.95

YOUR POLLING STATIONS!

NSW

Swift & Young Sts.
T55 Terrace Level
Shop 1, 65-75 Main St
613 Princess Hwy
Oxford & Adelaide Sts
Shop 2, 1B Cross St,
Warringah Mall
Campbelltown Mall Queen St
Shop 235, Archer St Entrance
147 Hume Hwy
164 Pacific Hwy
315 Mann St
4 Florence St
Elizabeth Or & Bathurst St
450 High Street
621-627 The Kingsway
173 Maitland Rd, Tighes Hill
Lane Cove & Waterloo Rds
George & Smith Sts
The Gateway High & Henry Sts
818 George St
125 York St
Treloar's Bldg, Brisbane St
263 Keira St

ACT

96 Gladstone St

VIC

Creswick Rd & Webster St
145 McCrae St
Shop 46, Box Hill Central,
Main St
Hawthorn Rd & Nepean Hwy
260 Sydney Rd
1150 Mt Alexander Rd
Nepean Hwy & Ross Smith Ave
Shop 9, 110 High St
291-293 Elizabeth St
Bridge Rd & The Boulevard
Shop 2, 141 Maroonah Hwy
Springvale & Oandenong Rds

ALBURY
BANKSTOWN SQ
BLACKTOWN
BLAKEHURST
BONDI JUNCTION

BROOKVALE
CAMPBELLTOWN
CHATSWOOD CHASE
CHULLORA
GORE HILL
GOSFORD
HORNSBY
LIVERPOOL
MAITLAND
MIRANDA
NEWCASTLE
NORTH RYDE
PARRAMATTA
PENRITH
RAILWAY SQUARE
SYDNEY CITY
TAMWORTH
WOLLONGONG

FYSHWICK

BALLARAT
BENDIGO

BOX HILL
EAST BRIGHTON
COBURG
ESSENDON
FRANKSTON
GEELONG
MELBOURNE CITY
RICHMOND
RINGWOOD
SPRINGVALE

(060) 21 8399
(02) 707 4888
(02) 671 7722
(02) 546 7744
(02) 387 1444

(02) 93 0441
(046) 27 2199
(02) 411 1955
(02) 642 8922
(02) 439 5311
(043) 25 0235
(02) 477 6633
(02) 600 9888
(049) 33 7866
(02) 525 2722
(049) 61 1896
(02) 88 3855
(02) 689 2188
(047) 32 3400
(02) 211 3777
(02) 267 9111
(067) 66 1711
(042) 28 3800

(062) 80 4944

(053) 31 5433
(054) 43 0388

(03) 890 0699
(03) 592 2366
(03) 383 4455
(03) 379 7444
(03) 783 9144
(052) 43 8804
(03) 67 9834
(03) 428 1614
(03) 879 5338
(03) 547 0522

QLD

157-159 Elizabeth St
166 Logan Rd
Gympie & Hamilton Rds
2nd Level, Western Entrance,
Redbank Shopping Plaza
Queen Elizabeth Or
& Bernard St
Gold Coast Hwy & Welch St
Bowen & Ruthven Sts
Kings Rd & Woolcock St
Cnr Pacific Hwy & Kingston Rd

SA

77 Grenfell St
Main South & Flagstaff Rds
Shop T25,
Elizabeth City Centre
Main North Rd & Oarlington St
24 Park Terrace

WA

Wharf St & Albany Hwy
66 Adelaide St
William St & Robinson Ave
Raine Square, 125 William St

TAS

Shop 40A, Lower Level,
Cat & Fiddle Arcade
NT
17 Stuart Hwy

And just in case you can't get into one of our 56 locations around Australia, you can take advantage of our special offer OSXpress postal vote system: simply fill in the form overleaf, tell us what you want and we'll make sure the promises are on their way as quick as greased lightning. And if you order more than \$100 worth, we'll even airfreight your parcel anywhere in Australia absolutely FREE!!!



Dick Smith Electronics 'No Broken Promises'

A complete packet radio system for the Commodore 64

Design – **A.A.P.R.A.**

Article – **Andy Keir VK2AAK**

Packet radio has become the fastest growing mode in amateur radio since the introduction of two metres FM. If you are intrigued by this mode but have been put off by the cost and difficulty of obtaining a TNC, then this project is for you.

IF YOU HAVE been following our series on digital communications, you will know what a versatile device a terminal node controller is. Unfortunately, there is no getting away from the fact that because of their complexity, they are not cheap, and it is this fact which has discouraged some enthusiasts from becoming involved in packet radio.

Well, hesitate no longer. In this project we will be describing a complete packet system suitable for use with one of the most popular home computers, the Commodore 64. This system will allow you to get going on packet with minimum outlay because the only hardware needed is for the modem and some switching. All the work normally done by the microprocessor in the TNC is performed by the C64 with the aid of some very clever software.

The design of the modem is based on that produced by the Australian Amateur Packet Radio Association (AAPRA). AAPRA is a non-profit amateur radio club whose sole interest is the furthering of AX.25 packet radio. The association welcomes enquiries from any amateur wishing to become involved in packet radio and they can be contacted by writing to: The Secretary, AAPRA, 59 Westbrook Avenue, Wahroonga, 2076 NSW. We have taken the opportunity in this presentation of the project to make a few minor alterations and enhancements to the original AAPRA pc board. These are designed to make wiring and interconnection a little easier.

The software for the project was written by Chris Mills VK4BCM and is an updated and enhanced version of that which was available in the public domain. This updated version is copyright to AAPRA and it can only be obtained from them. They will supply a customised version on disk together with an operating manual for \$45.00. You would be well advised to take advantage of this offer as earlier versions of the software are not guaranteed to perform as described and furthermore, you will be able to take advantage of new versions as they are released.

The circuitry

In this first article, we will describe how the modem works as well as providing some insight into using the software. We will be describing the construction of the modem in part two next month so in the mean time you might like to send off your software order to AAPRA so you'll be ready to go once you have completed building the project.

The hardware is actually quite simple, consisting of a modulator, a demodulator and some switching to control the press-to-talk input of the transceiver. The modulator is

designed around the well known Exar XR2206 function generator IC, a data sheet for which was published in last month's issue. As configured in this project, the 2206 will produce one or other of two tones, the frequency of which is determined by the resistors associated with pins 7 and 8 and the capacitor between pins 5 and 6. In this design, multi-turn trim pots have been used in the timing network so adjustment is straightforward.

The keying signal applied to pin 9 will determine which of the two resistors will be used as the timing element and in our case the TTL level data from the computer is applied to pin 9. Modems for VHF packet use are based on the Bell 202 standard which uses the tone pair of 1200 and 2200 Hz. The two trim pots are adjusted to produce these tones which are then fed to the microphone input of the transceiver.

The demodulator is based on another Exar chip, the XR2211 FSK demodulator/tone decoder. This phase-locked loop (PLL) based circuit was specifically developed for data communications and is ideal for our application in this project. To look at it in the simplest way, it is the reverse of the 2206 chip in as much as it takes audio tones as the input and converts them to TTL level signals suitable for input to the computer.

In common with other PLL circuits, we can, by the use of a few external components, determine what range of frequencies will be detected as well as the frequency of the on-board voltage controlled oscillator (VCO). Where the 2211 differs from most PLL chips is in its ability to detect whether the incoming tone is above or below the centre frequency. In our application, we know that the tones of the remote modem will be 1200 or 2200 Hz in accordance with the Bell specification so we set up the VCO to run exactly half way between those two tones, at 1700 Hz. Again we use a multi-turn trim pot for this adjustment to make alignment straightforward. When the 2200 Hz signal is present on the input, the 2211 will detect a tone higher than the centre frequency, when the 1200 Hz tone is present, the chip detects that it is lower than the centre frequency.

The remainder of the circuit is concerned with the power supply and switching of the transceiver's PTT line. The power for the modem is provided by an external supply of a nominal 12 V. The signals which are fed to the computer will need to be at TTL levels, so in addition we provide a 5 V rail by means of a 7805 voltage regulator fed from the 12 V rail.

Those of you who have examined the circuit diagram might be wondering why there is a 555 timer in there. Well, as the

modem is designed to interface with a transmitter, you can imagine the problems if the computer crashed whilst you weren't watching and left the PTT line closed. You would be putting a signal to air continuously, no doubt to the annoyance of others on the frequency. The 555 timer forms what is known as a "watchdog timer" which prevents the PTT line from staying on for more than a predetermined time.

With reference to the circuit diagram, it works like this. The PTT signal from the computer is normally high, going low when the computer wants to key the transmitter. When the PTT line is low, transistor Q2 will be turned off so its collector will be high. The collector of Q2 is connected to the reset pin (4) of the 555 which, when pulled high, allows the 555 to operate. The collector of Q2 is also connected to the base of Q3 and so as Q2 turns off, Q3 turns on thereby sending a short negative-going pulse to pin 2 of the 555 via the capacitor C13. Pin 2 of the 555 is the trigger, and when it sees a negative pulse, it will start the timing cycle sending pin 3 high and energising the PTT relay via Q4. The 555 is configured as a monostable, the period of which is determined by the resistor R21 and the capacitor C14.

If the computer releases the PTT whilst the 555 is still timing, transistor Q2 will turn back on thus sending pin 4 of the 555 low and resetting it. Pin 3 of the 555 goes low and the PTT relay de-energises. If on the other hand a fault occurs and the PTT line from the computer stays low, the 555 will eventually time out. Pin 3 will go low, the relay will de-energise and the circuit will remain in this condition until the PTT signal from the computer goes high again.

There is one possible problem with this scheme. Suppose we turned the computer off whilst power was still applied to the modem. The PTT line would go low and the transmitter would key up, clearly an undesirable situation. To overcome this, we power the 555 from the 5 V supply of the computer itself. Thus, if the computer is turned off, the 555 can never energise the relay.

Software

The software is responsible for all the hard work of assembling your input into packets ready for transmission and decoding incoming packets for display on your screen or printer. The AX.25 protocol used in this project is quite complex and would take a great many pages to explain. If you are insatiably curious, I'm sure that AAPRA could supply you with all the details, but in this project we will confine ourselves to the operational details of the software.

The software provides the following features:

- Convert with other stations, direct or via digipeaters.
- File transfers, program and sequential.
- Serial printer (ASCII or Baudot).
- CBM printer.
- Beacons with user-configurable times and text.
- CW identification.
- Digipeating (your station can act as a digipeater).
- Variable baud rates (300 Baud for HF or 1200 Baud VHF).
- Windows showing the progress of packets.

There are some 40 or so commands which can be used in normal operation, but the majority of these are used for setting various parameters which don't need to be altered very often. In addition to these commands, there is provision to change screen and character colours and also to perform various disk operations by the use of simple combinations of keystrokes. ▶

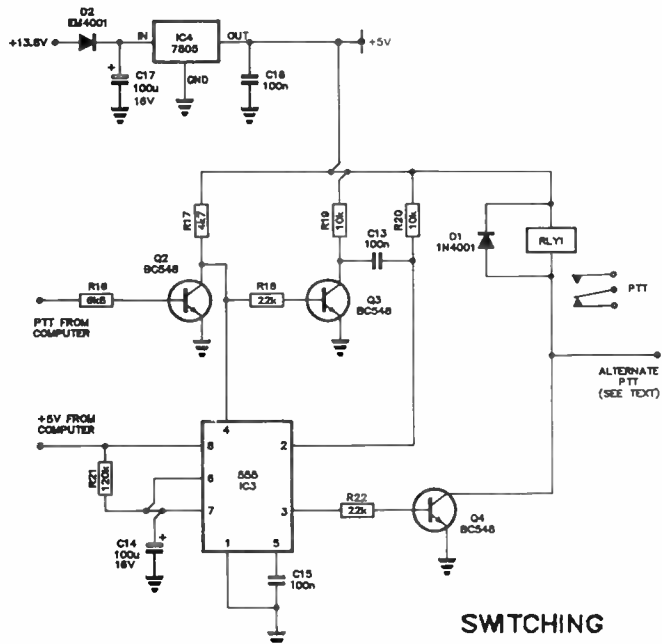
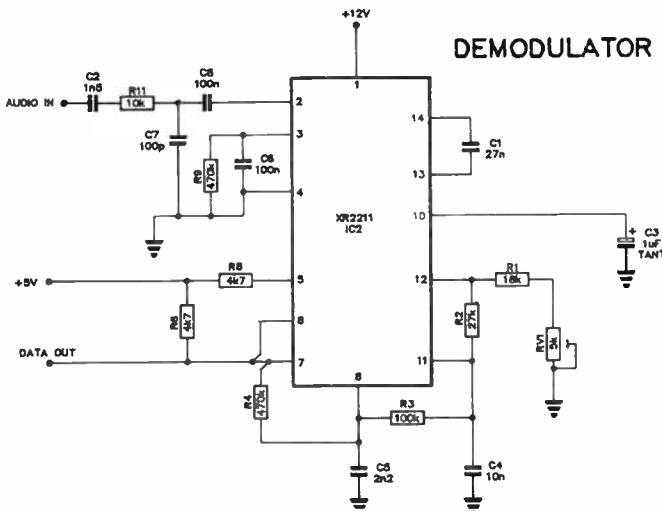
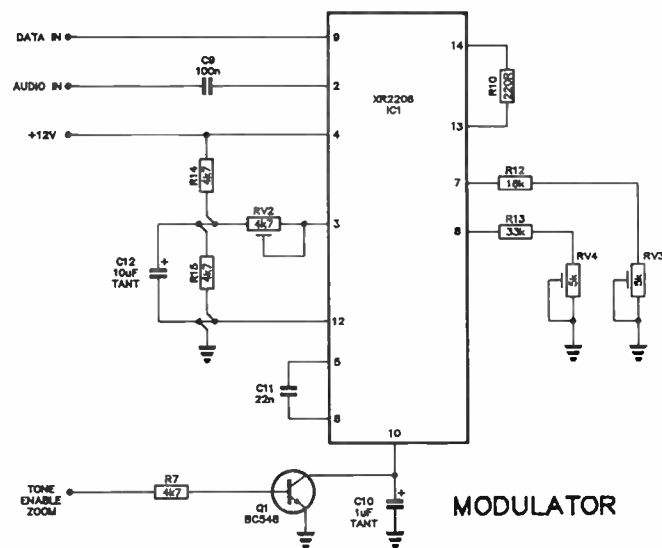



Schematic and Connection Diagrams

LH0002/LH0002C Current Amplifier

General Description

The LH0002/LH0002C is a general purpose thick film hybrid current amplifier that is built on a single substrate. The circuit features

- High Input Impedance 400 k Ω
- Low Output Impedance 6 Ω
- High Power Efficiency
- Low Harmonic Distortion
- DC to 30 MHz Bandwidth
- Output Voltage Swing that Approaches Supply Voltage
- 400 mA Pulsed Output Current
- Slew rate is typically 200V/ μ s
- Operation from ± 5 V to ± 20 V

These features make it ideal to integrate with an operational amplifier inside a closed loop configuration to increase current output. The symmetrical output portion of the circuit also provides a low output impedance for both the positive and negative slopes of output pulses.

The LH0002 is available in an 8-lead low-profile TO-5 header, the LH0002C is also available in an 8-lead TO-5, and a 10-pin molded dual-in-line package.

The LH0002 is specified for operation over the -55°C to $+125^{\circ}\text{C}$ military temperature range. The LH0002C is specified for operation over the 0°C to $+85^{\circ}\text{C}$ temperature range.

Applications

- Line driver
- 30 MHz buffer
- High speed D/A conversion
- Instrumentation buffer
- Precision current source

Electrical Characteristics (Note 1)

Parameter	Conditions	Min.	Typ.	Max.	Units
Voltage Gain	$R_S = 10\text{ k}\Omega$, $R_L = 1.0\text{ k}\Omega$, $V_{IN} = \pm 10\text{ V}$	0.95	0.97		
AC Current Gain	$V_{IN} = 1.0 V_{rms}$, $f = 1.0\text{ kHz}$		40		A/ma
Input Impedance	$R_S = 200\text{ k}\Omega$, $V_{IN} = \pm 1.0\text{ V}$, $R_L = 1.0\text{ k}\Omega$	180	400		k Ω
Output Impedance	$V_{IN} = \pm 1.0\text{ V}$, $R_L = 50\ \Omega$, $R_S = 10\text{ k}\Omega$		6.0	10	Ω
Output Voltage Swing	$R_L = 1.0\text{ k}\Omega$, $V_{IN} = \pm 12\text{ V}$	± 10	± 11		V
Output Voltage Swing	$V_S = \pm 15\text{ V}$, $V_{IN} = \pm 12\text{ V}$, $R_S = 50\ \Omega$, $R_L = 100\ \Omega$, $T_A = 25^{\circ}\text{C}$	± 10			V
DC Output Offset Voltage	$R_S = 300\ \Omega$, $R_L = 1.0\text{ k}\Omega$		± 10	± 30	mV
DC Input Offset Current	$R_S = 10\text{ k}\Omega$, $R_L = 1.0\text{ k}\Omega$		± 6.0	± 10	μA
Harmonic Distortion	$V_{IN} = 5.0 V_{rms}$, $f = 1.0\text{ kHz}$		0.1		%
Rise Time	$R_L = 50\ \Omega$, $\Delta V_{IN} = 100\text{ mV}$		7.0	12	ns
Positive Supply Current	$R_S = 10\text{ k}\Omega$, $R_L = 1.0\text{ k}\Omega$		+6.0	+10	mA
Negative Supply Current	$R_S = 10\text{ k}\Omega$, $R_L = 1.0\text{ k}\Omega$		-6.0	-10	mA

Note 1: Specification applies for $T_A = 25^{\circ}\text{C}$ with +12V on Pins 1 and 2; -12V on Pins 6 and 7 for the metal can package and +12V on Pins 1 and 2; -12V on Pins 4 and 5 for the dual-in-line package unless otherwise specified. The parameter guarantees for LH0002C apply over the temperature range of 0°C to $+85^{\circ}\text{C}$, while parameters for the LH0002 are guaranteed over the temperature range -55°C to 125°C unless otherwise specified.

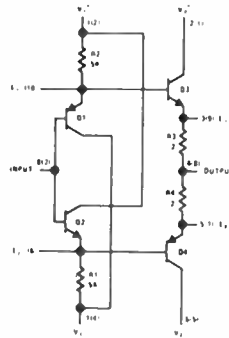

Pin numbers in parentheses denote pin connections for dual in-line package

Dual-In-Line Package

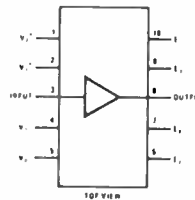

Order Number LH0002CN
See Package N10B

Metal Can Package

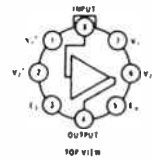

Order Number LH0002H or LH0002CH
See Package H08A

Typical Performance

Maximum Power Dissipation

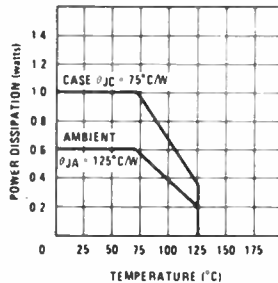

Input Offset Current

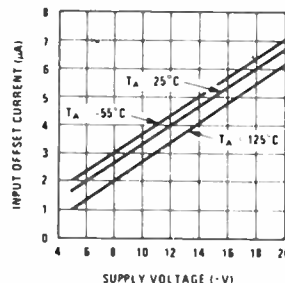

Positive Pulse

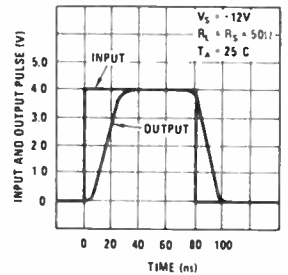

Negative Pulse

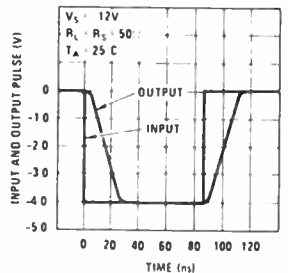

Absolute Maximum Ratings

Supply Voltage	$\pm 22\text{ V}$
Power Dissipation Ambient	600 mW
Input Voltage (Equal to Power Supply Voltage)	
Storage Temperature Range	-65°C to $+150^{\circ}\text{C}$
Operating Temperature Range	
LH0002	-55°C to $+125^{\circ}\text{C}$
LH0002C	0°C to $+85^{\circ}\text{C}$
Steady State Output Current	$\pm 100\text{ mA}$
Pulsed Output Current (50ms On/1 sec. Off)	$\pm 400\text{ mA}$

Supply Current

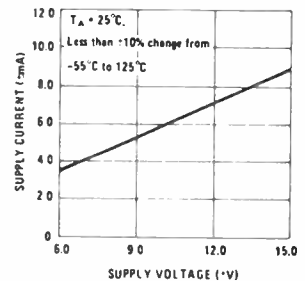

Frequency Response

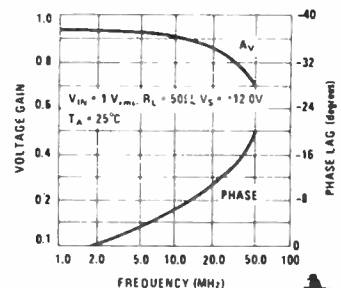

Most of the commonly available stand-alone TNCs use LEDs to give an indication of the current status. In this project, we use a screen window to provide status information and this will in fact give more information than simple LEDs. As an example, a normal TNC usually has a LED to indicate that there are un-acknowledged packets outstanding. Using the screen window in this software you are told exactly how many packets are still outstanding. Other information in the window will tell you the condition of the PTT line, the callsign of the last connected station, the current status of the connection and whether a disk file is open or closed.

At first sight, you may think that the software is going to be complicated to drive but in fact it is somewhat easier to come to grips with than the eighty or more commands of stand-alone TNCs. Much of the simplification is due to the fact that you no longer need all the commands to control the serial interface between the TNC and the host computer. In this project all the software is in the computer to start with. Believe me, you will find the nine or so pages of software instructions in the manual supplied with the software quite easy to assimilate when compared to the several hundred pages of information in the manual that came with the first stand-alone TNC I bought!

There is no doubt that interest in packet radio is increasing. If the article on digital communications has whetted your appetite, then hopefully this project will be the catalyst to get you going on the mode. This "software" TNC is in no way a compromise, it provides all of the features you could want and will allow you to join in the fun on packet at a considerable cost saving. You will be able to access the bulletin boards, send and receive programs or messages or just "chat" with your packet-equipped friends.

In part two of this project, to be published next month, we will describe the full details of construction and setting up as well as some suggestions for modifying the modem for use on HF. 



TEGA ELECTRONICS

**SPECIALISTS
IN
RADIO FREQUENCY,
COMMUNICATIONS
TEST EQUIPMENT
COMPUTERS**

**CATERING FOR
AMATEUR, COMMERCIAL,
GOVERNMENT**

Call in at:
**75 Grand Boulevard,
Montmorency Vic. 3094**
or phone:
(03) 431 1153
Terry and Gary (VK3ZHP)

AMEE/1

AEM and ELEKTOR PRINTED CIRCUIT BOARDS

Quality, roll-tinned, fibreglass printed circuit boards; complete with silk-screened component notation, are once again available from the kitset and component specialists: ex-stock and at affordable prices. Huge range of AEM, ETI, EA, HE, AEC and now ELEKTOR – PRINTED CIRCUIT BOARDS, KITS AND FRONT PANELS.

- Mail Orders
- Trade Sales
- Personal Shopping
- Export Orders
- Custom boards & panels

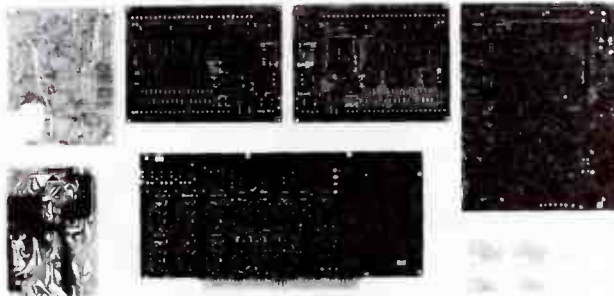

- Passive components
- Power devices
- Semiconductors
- Inductors
- Valves
- Only prime quality stocked

ALL ELECTRONIC COMPONENTS

Division of DOTHAIN Pty. Ltd.

118 - 122 LONSDALE STREET,
MELBOURNE, VIC. 3000, Australia
Telephone (03)662 3506 FAX (03)663 3822

Importers ● General Sales ● Radio Equipment ● Microwave Equipment ● Radar Equipment ● Pulse Techniques ● Industrial Electronics ● Instrumentation

YES! Please rush me my free kitset list and shortform component catalogue

Name _____

Address _____

State _____

P code _____

HI COM

HI COM

HI COM

COMPUTER CARDS

CA1601 Super XT 640K mother PCB 8088 CPU 4.77MHz 8 slots 8087 socket quality PCB	\$390.00
CA1602 Turbo XT 640K mother PCB v20 CPU 4.77 and 8MHz 8 slots 8087 socket quality PCB	\$440.00
CA1604 Turbo XT V20 with 1024k RAM	\$520.00
CA1610 Mini AT 1024K mother PCB 80286 CPU 6 and 10MHz 8 slots 80287 socket quality PCB	\$1,150.00
CA1612 Mini AT 1024K Main PCB 80286 CPU 6 and 12MHz 8 slots opt. 80287 quality keyboard	\$1,250.00
CA1613 Color graphic card RGB and composite, light pen ad'r	\$125.00
CA1615 Diskdrive card 4X360k D/D w/ cable	\$95.00
CA1617 Disk drive card short stem 2 int. drive with cable	\$69.00
CA1620 512K RAM card O RAM	\$135.00
CA1621 Printer card with cable	\$58.00
CA1625 High resol. monochrome and par. printer port adaptor	\$165.00
CA1616 Multifunction card 384K parallel serial clock and joystick ports w/ O RAM	\$190.00
CA1614 Same as CA1613 w/384K RAM	\$330.00
CA1616 Multi I/O card w/ clock/ parallel/2 serial/joystick	\$135.00
CA1617 Multi I/O plus card same as CA1616 w/ d/drive card	\$195.00
CA 1618 Serial card RS232	\$65.00

COMPUTER POWER SUPPLIES

CA1670 Power supply side sw 150W w/ 4 drive cables	\$150.00
CA1672 Power supply rear sw 135W 4 cable drives	\$175.00
CA1675 Power supply side sw 180W suit IBM AT 4 drive cables	\$245.00
CA1677 Power supply side sw 220W suit large AT PCB 4/D cables	\$295.00

VIDEO MONITORS

CA1800 Amber 12 inch monitor 18MHz Swivel base, RCA plug	\$199.00
CA1801 Green 12 inch monitor non-refl. Screen, swivel B. RCA plug	\$190.00
CA1803 Amber 12 inch TTL high res. suit both hercules & RGB of CGA	\$240.00
CA1805 Amber 14 inch TTL high res suit both TTL mono & RGB of CGA	\$285.00
CA1830 TVM 14 inch RGB colour monitor 640 x 200, AMB/GN/Colour	\$750.00
CA1833 TVM MD-3V 14 inch RGB colour monitor 640 x 200 6 back gd colours, video & audio I/P plus speaker	\$1,020.00
CA1837 TVM 14 inch EGA Col. monitor 640 x 350 Amb/gn/colour	\$1,150

DRIVES, BACKUPS & ACCESSORIES

CA1630 Computer case w/ hinged flip top and 8 slots	\$110.00
CA1631 Computer case w/rear SW	\$110.00
CA1622 Hard disk cont'ler 2HD	\$290.00
CA1625 Enhance colour graphic ADR 640 x 200/400 selectable	\$595.00
CA1642 5.25" DS/DD disk drive 360k half height Chinnon	\$250.00
CA1643 1.2 MB floppy drive NEC	\$295.00
CA1645 5.25" 1.2 MB chinnon drive Half height suit IBM AT/XT	\$295.00
CA1648 Miniscribe 21M hard disk fast access time, half HT	\$750.00
CA1650 Miniscribe 44M voice coil half ht	\$1,400.00
CA1652 44MB tape back-up for hard'k	\$995.00
CA1660 XT keyb'd 10 functions and 83 keys w/ 5 pin DIN plug	\$140.00
CA1662 AT/XT keyb'd 10 functions and extra large return 3 leds	\$165.00
CA1664 Deluxe auto AT/XT 101 keyb'd	\$220.00

COMPUTER SYSTEMS

CXE640 640K 8088 system w/ 2 drives colour graphics, parallel/serial clock/games ports Keyboard & 135W power supply	\$1,290
CX0646 1024K Turbo XT V20 CPU 4.77 & 8MHz, 2 drives, CGA parallel serial/game/clock	\$1,390
CX0650 Turbo AT 512K system with 2 floppy drives	\$1,950
CX0652 Turbo AT system w/1.2M drive & 20MB miniscribe hard disk 6 & 12MHz 1024K RAM	\$3,900
CX0655 Turbo AT 6/10MHz 80286 CPU 20MB hard disk 1.2MB floppy	\$3,600

If you need to add a 20MB
Miniscribe hard disk inc.
controller card **\$950.00**

PRINTERS

CP1000 Super 5 EP1000 dot matrix printer 100cps NLQ IBM GR	\$550.00
CP1001 Super 5 EP1201 dot matrix printer 120cps NLQ IBM GR	\$590.00
CP1002 Super 5 EN1802 dot matrix 180cps NLQ heavy duty	\$890.00
CP1005 Super 5 EN1805 dot matrix 180cps 15 inch paper NLQ W/LF select IBM GR 3K buffer	\$1,190.00
CP1100 Printer ribbon for EP1201	\$22.00

EXTRA BITS

Battery Back-up Power Supply

With noise filter
250 watts 15 minute back-up
..... **\$950.00**
500 watts 15 minute back-up
..... **\$1,150.00**

Power Surge Protection Magic Button

Plug in existing power outlet to
absorb power surge.
\$29.90

Tycor Power Line Filters

One of the best on the market with proven
test results. Removes transients over the
entire frequency range, attenuating up to
99% of all spikes and noises, 9 different
sizes from 1A (240 watt)
to 50A (12kW) price from **\$350.00**

SPECIALS

Handheld instrument case as used in
Barometer kit, Autoranging digital
multimeter **\$14.50**
Handheld Instrument case as used in EA
remote control kit **\$25.00**

COMPONENTS

2716	\$9.00	8284	\$7.50
2732	\$9.00	1488	\$1.10
2764	\$9.00	1489	\$1.10
27128	\$10.50	2102	\$6.00
27256	\$14.00	PAL16LB	\$11.00
RAM 4164 64Kx8	\$2.95	58167	\$18.00
RAM 41256-15		75452	\$2.50
256K x 8	\$6.50	CA3140	\$1.45
RAM 41256-12		AY3-1015D	\$12.50
256K x 8	\$7.00	AY5-3600	\$12.50
V-20 CPU		6502	\$11.00
70108D)	\$26.00	6522	\$11.00
8087	\$377.40	6802	\$9.00
8088-2	\$16.00	68B21	\$5.00
81C55	\$6.99	6809	\$16.00
8237	\$14.50	Z80A PIO	\$5.90
8250	\$22.50	Z80A CTC	\$6.00
8253	\$6.00	Z80A CPU	\$6.00
8255	\$6.00	Z80A DART	\$12.90
8259	\$6.00	Z80 UART	\$P.O.A.
8237	\$14.50	Z80 SIO	\$12.50
SL490	32 channels Transmitter		\$10.50
SL486	Infra red preamp		\$10.50
ML926	Channel 1-16 decoder mont.		\$16.00
ML927	Channel 17-32 decoder mont.		\$16.00
ML928	Channel 1-16 deconder latch		\$16.00
ML929	Channel 17-32 deconder latch		\$16.00
ML923	Analog & digital decoder		\$16.00
LD271	Infra-red LED		\$3.00
BP104	Infra-red receiver		\$3.00

POLYPROPYLENE CAPACITORS

KP Range Polypropylene capacitors 2.5% 63V 5mm spacing

100pF-470pF	\$0.70
560pF-1500pF	\$0.75
1800pF-12nF	\$0.85
15nF-18nF	\$0.90
MKP 1uF/250V	\$3.90
MKC 1.5uF/100V	
	audio \$2.50
Suzuki 2uF/440V modem	\$12.50

Other values on MKP, MKC available

MKT capacitors Full range

Electrolytic RB & Axial type from 1uF to 4700uF, 16V, 25V, 50V

Special electrolytics

100uF/100V axial EYMA	\$1.80
100uF/100V RB type	\$1.50
220uF/100V RB type	\$2.00
470uF/100V RB type	\$2.50
4700uF/100V CAN	\$13.50
10,000uF/100V CAN EYNA	\$59.00

Filter capacitors for computers

Miniature size monolithic ceramic blue caps	
0.033/50V	\$0.35
0.1uF/50V monolithic ceramic	\$0.35
AC Power Line Filter Capacitors	
0.01uF/250VAC	\$1.20
0.1uF/250VAC	\$1.60

RESISTORS

	Each
1/4watt 5% carbon film	\$0.04
1/2watt 5% carbon film	\$0.05
1 watt 5%	\$0.10
1/4watt 1% metal film	\$0.07
1/4watt 1% M/F low noise	\$0.12

Other high power metal films available

Elector professional mixer kit

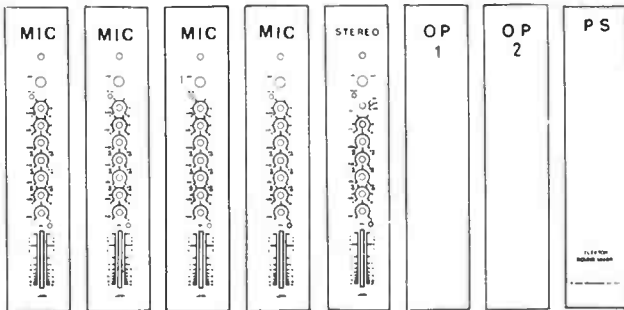

MODULES

All modules are silk screened, pre-drilled aluminium front panels with knobs, pots, connectors & components.

MIC	\$85.00	O/P2 HEADPHONE	\$95.00
STEREO MD	\$98.00	POWER SUPPLY	\$120.00
O/P1 UV LED	\$112.00		

BLACK ALUM. CASES

8 modules C1	350 x 380mm	\$55
12 modules C2	350 x 560mm	\$63
16 modules C3	350 x 740mm	\$70

Add-on Power Amp modules available **SOON!**

Elector Serial Digitiser kits

8 channels incl.
13 DIN connectors



\$175.00

AEM 4505 Text to Speech card

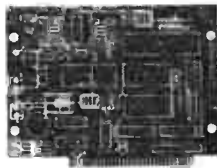

For your computer. IBM PC/XT/AT compatible. Serial version for others

\$149.00

AEM 6506 Workhorse Power Amp

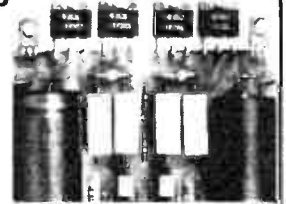

\$49.00

Tape Copier kit

For Commodore. Includes edge connectors



\$49.00

RS232 Conversion kit for Commodore



\$27.00

24 Way edge connector for Commodore



\$7.50

Elector 3.5 digit LCD panel

Kit 7106, 3.5 LCD panel and PCB only

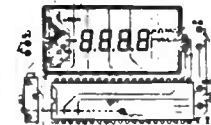

\$39.50

Elector Barometer Kit



Includes case and all components. Some parts available separately. \$159.00

Elector Autoranging 3.99 digital multimeter kit

PCB No. 87099



\$CALL

AEM 4605 Super Simple modem kit

300/1200/75 baud

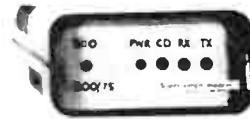

\$129.00

Experimental Plug-in cards for IBM PC/XT

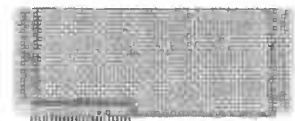

Short card \$30.00
Long card \$40.00
For Apple II+, IIe \$25.00

13 way DIN Connectors male or female \$4.50

All prices include sales tax.

I/LP TOROIDAL TRANSFORMER

VA PRICE DUAL SECONDARY VOLTAGE (Made in UK)

15	35.50	•••••
30	39.50	•••••
50	45.50	•••••
80	49.00	•••••
120	54.00	•••••
160	65.00	•••••
225	74.00	•••••
300	83.00	•••••
500	105.00	•••••
625	132.00	•••••

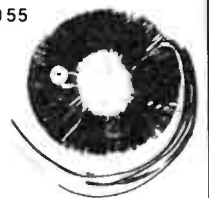

NEW PRODUCT!

INDOOR/OUTDOOR MOVEMENT DETECTOR

With 240VAC Switch. Passive infra-red movement detector with 240VAC input & 240VAC output to turn on light or doorbell. Built-in daylight sensor to mute output. Timer switch up to 20 minutes, complete with mounting brackets. Range up to 12M

\$180.00

HI-COM UNITRONICS INT. P/L

7 PRESIDENT LANE, CARINGBAH, N.S.W. 2229
PHONE: (02) 524 7878
P.O. BOX 626, CARINGBAH 2229

Visa, Bankcard and Mastercard Welcome

Mail Order	Postage
Less than \$50	\$3.50
\$50-\$99	\$4.50
\$100-\$250	\$7.00
Above \$250	\$10.00
Heavy items adds extra	

Here's a great offer, exclusive to AEM readers.

GET FLYING ON 1200 BPS!

BUILD THE "BIT STREAM FLYER"

— the low-cost way to high-speed dial-up data communications.



Looking to upgrade from your old V.21/V.23 modem? Here's how to do it without the expense of discarding your existing modem!

Build yourself this 1200 bps full duplex (V.22) modem and make that data really fly! The unit is used just like any other "dumb" modem. It works with any computer having an RS232 serial interface or adaptor. All you need is an RS232 serial cable to your computer and suitable communications software or terminal program.

Don't miss this opportunity to own a high speed modem and to enjoy the pride and satisfaction that comes from having built it yourself!

By special arrangement with the designers, you can obtain a complete kit to build the AEM4622 Bit Stream Flyer by Maestro for just

The components alone would cost you over \$200 at retail prices!

An optional plugpack power supply is available for an additional cost of \$14.00.

The kit is complete to the last detail; all components, semiconductors, switches, connectors, IC sockets and cabinet.

This offer is made by Maestro Distributors and the magazine is acting as a clearing house for orders.

\$179.00 Delivery, anywhere in Australia: \$7.00

OFFER CLOSES LAST MAIL AUGUST 31 1987.

DON'T DELAY, COMPLETE THE COUPON NOW AND SEND IT, TOGETHER WITH YOUR CHEQUE, MONEY ORDER OR CREDIT DETAILS, TO:

AEM4622 MODEM KIT OFFER
Australian Electronics Monthly
PO Box 507, WAHROONGA 2076 NSW

Or you can phone us and "pledge your plastic" to order. Call (02)487 1207 and give your name, address and credit card details.

COUPON Please deliver _____ AEM4622 Bit Stream Flyer Modem _____ Please include _____ plugpack(s) at \$14.00 each. kit(s) priced at \$179.00 each, plus \$7.00 for delivery.

I enclose \$_____ total, payment by (please circle method):

Bankcard Mastercard VISA AMEX

Card No. _____

Signature: _____

(Note: unsigned credit card mail orders cannot be accepted)

Name: _____

Address: _____

Postcode: _____

(Please allow for normal mail and bank clearance delays)

Cheque (No: _____)

Money Order (No: _____)

Make cheques or money orders payable to "Australian Electronics Monthly"

80 — Australian Electronics Monthly — July 1987

Cost effective auto-dial modem

Xiocon Pty Ltd, a Melbourne-based telecommunications development company, has released an auto-dial, auto-answer modem for \$250, including tax.

Drawing from advanced designs already utilized in a full range of OEM targeted modems, Xiocon has produced a full featured, cost effective modem for the entry level user.

The modem is fully Hayes compatible, Xiocon claim, with operating speeds of 300 bps, 75/100, 1200/75 and 1200 half duplex. It supports CCITT specifications V.21, V.23 and Bell 103.

The modem will support baud rate conversion from 1200/1200 to 1200/75 for equipment not supporting split speed operation.

Extra features include full screen displays and plain english operating status messages. For information contact Xiocon Pty Ltd, 1st floor, 685 Centre Rd, East Bentleigh 3165 Vic. (03)557 7931.

AutoCAD in Australia

Autodesk Inc, creator of AutoCAD, the world's most widely used computer-aided design and drafting software (as used in AEM!), has announced that it will be setting up a subsidiary in Australia to develop, market and distribute its products.

Autodesk stated that an agreement has been entered into between MicroMega Communications Pty Ltd, trading as Entercom Computer Company. A new wholly owned subsidiary of Autodesk will be formed, to be called Autodesk Australia Pty Ltd.

The Australian operation will be staffed by Australians and Autodesk intends for the new

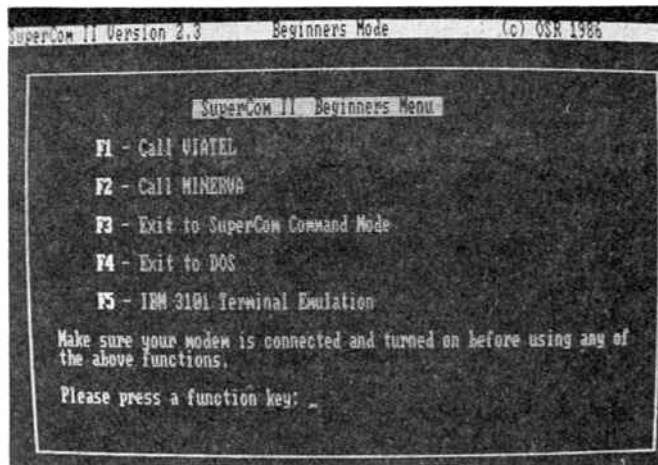

company to expand the current range of CAD/CAM products distributed in Australia and to manufacture and carry out any necessary research and development in Australia.

For more information, contact Debra Donegan, Entercom Computer Company, (03)429 9888 or Laura London, Autodesk Inc, (415)332 2344, ext 714.

New PC comms software

According to the distributors, PC Extras of Sydney, the new Supercom Executive provides flexible facilities for automated, unattended information gathering.

One of the advantages of an automated package such as this is to "try again" when attempting to access a remote dial-up system, PC Extras say.

With Supercom, you simply get the software to do all the dialling, either of one number, or a series of numbers in rotation. Supercom will even signal when it succeeds.

Another major use of this software is for unattended information gathering. Supercom can be instructed to dial up a remote system at a particular time, log on, gather and store information and log off again.

For further information, contact PC Extras, GO3 The Water-tower, Rosehill St, Redfern Hill 2016 NSW. (02)319 2155.

AEM Printed Circuit Service

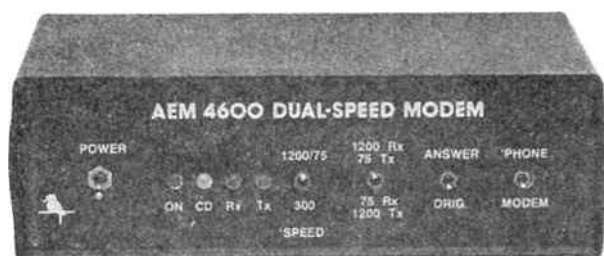

MAKE A MODEM!

The **AEM4600 Dual-Speed Modem** is quite a popular project. Get yourself on-line with the maximum features for the minimum cost. Features 300/300 and 1200/75 bps modes. Simple RS232 (serial) interfacing. All parts readily available. (Published Dec. '85)

All boards manufactured on quality fibreglass substrate with rolled-tin over copper tracks and silk-screened component overlay.

\$17.50 board has some faulty tracks & no components overlay but our package includes full instructions, plus post & handling charges.

Order pc boards by the project number and title. We do not stock complete kits or components. Send orders to:

SING WITH THE 6000 POWER AMP.

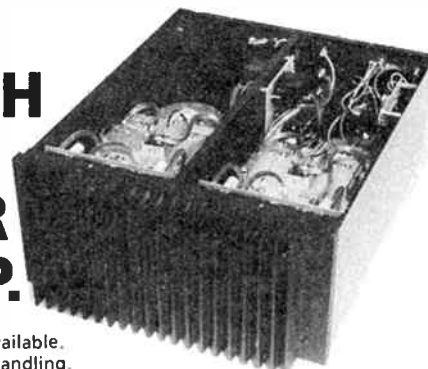

Components readily available. All prices inc. post & handling.

Up to 240 W (into 8 ohms) of clean, clear power! THD is rated below 0.005%, 3 dB bandwidth is 4 Hz to 130 kHz! Use as a stand-alone module (**AEM6000**) — **\$31.20** (Jun/July '86), or add our **AEM6504 Status Monitor** (Aug. '86) for clipping and fault protection — **\$50.60** the set

Why not get a stereo set, (makes the 6000 Stereo Amp) including the **AEM6505 Surge Limiter?** (Sept. '86) — **\$114.48**

Australian Electronics Monthly
PO Box 507, WAHROONGA 2076 NSW (02)487 1207.

Data dial-up through a looking glass

— some reflections on "Mirror"

Roy Hill

Computer "communications" programs have grown rapidly in recent years along with the burgeoning growth in data communications. When a company develops a product and announces it represents "the standard by which all others will be judged", it invites not just emulation, but to be outdone — and at a lower price. In hardware, IBM's PC would be the prime example. In the world of data comms software, there's MicroStuf Inc.'s "Cross-Talk" and SoftKlone Corp.'s "Mirror". We asked Roy Hill, conductor of our Dial Up column, to "... look into it."

I WAS ASKED by the Editor to take a sample package of the Cross-Talk clone "Mirror" home, play with it for a while and then offer my comments on its operation and the manner in which it emulated Cross-Talk.

Now, Cross-Talk rapidly established a market position at the top of the heap following its release and hence is widely known. Being into data comms, I have been a user of Cross-Talk, along with a variety of other programs of the genre. At the time of writing, I have "played" with Mirror for some six weeks and have come to know it reasonably well, so here goes...

Background

Firstly, I will assume you are at least familiar with the basics of a data comms software package of some sort. Simple ones have been around for many years, more sophisticated packages having sprung up in recent times.

Mirror was written by SoftKlone Distributing Corp. and is what its advertising claims it to be — a faithful emulation of the Cross-Talk Comms XVI program, Version 3.6, written by MicroStuf Inc. MicroStuf were so proud of their work of art, that they trumpeted it to the world as being the "... standard by which other programs will be judged." SoftKlone decided they would follow this "standard" and wrote the Mirror package to emulate all of Cross-Talk's existing features, plus a few additional dazzlers that even MicroStuf would be proud of.

At the time I saw Mirror first advertised, it was about the period that everyone was suing everyone else for "look-alike, work-alike" packages (and winning). I thought that if MicroStuf ever took SoftKlone to court over their package, the result would be exceedingly interesting. They did, and it was! The trial judge in the U.S. ordered SoftKlone to modify the status screen so that it no longer resembled Cross-Talk's. They have done so and I was able to secure the updated version, dubbed the 'Beta' version (V3.6.11), of the new program.

I am pleased to say that the new screens are far easier to use than the Cross-Talk style. For

me, Cross-Talk has always had two fundamental limitations — lack of pull-down menus and poor status screen layout. Thanks to MicroStuf's lawsuit, Mirror has fixed the latter problem (how's that for turning adversity into advantage), now how about pull-down menus?

Seeing is believing

Mirror is supplied on a single 360K floppy disc in IBM format and is not copy protected. SoftKlone encourage purchasers of the package to make a back-up and not use the master disc. Supplied with the package is a very thick operating manual of some 300 pages, and some advertising material for various U.S. dial-up services which would be fairly useless in the land of the Kookaburra and the Kangaroo.

With the release of the latest version, some updates to the manual will obviously be necessary. I am impressed by the way the new version fires up — the PgUp and PgDn keys can be used in conjunction with the Ctrl key to scroll through the current settings, which are divided into two screen halves. This is very helpful for changing one or two parameters before dialling.

After making the mandatory back-up, I thought that I should fire up Mirror without looking at any of the documentation — a practice that I would normally never indulge in. I felt this was justified as I am quite conversant with Cross-Talk and this was supposed to be a test of compatibility, which SoftKlone particular point up as a major feature. Mirror passed EVERY Cross-Talk compatibility feature that I could throw at it and I had great difficulty convincing myself that it was not Cross-Talk that I was in fact using. (No wonder about the court case!). Even the help screens were the same.

When I commenced the reviewing process, I used Mirror on my Data System/1 PC/XT compatible (... cloned software on a cloned computer, oh the irony! — Ed.). I later upgraded to an AT compatible (not without a very traumatic experience with my hard disk) and I can report Mirror works perfectly on

both machines, even in Turbo mode (10 MHz) on the AT. If only I could switch the phone lines to Turbo mode... now there's an idea!

After I had confirmed the compatibility of the software, the next step was to read the manual. This can often be an extremely daunting experience, as one of my "bete noirs" is computer documentation. It's usually done by the person who wrote the program and who obviously doesn't need a manual to help him/her out. The Mirror documentation was a pleasant surprise. It even has a workable index, although cross-referencing is not done particularly well — I had some trouble finding "change the Screen colour" in the index. It's under 'colour', not 'screen'. This, however, is a very minor fault compared to some manuals I've seen in which the index is either non-existent or only contains seven entries. As it turned out, I should have looked in the table of contents — "Color and Other Miscellaneous Topics" is a major chapter. Oh well!

Additional features

Mirror has several additional features not found in Cross-Talk, including two of special remark:

- 1) Mirror allows the user to start a LLearning sequence that remembers all the "log on" commands in a dial-up session and stores them for future use. Top marks!
- 2) Mirror allows file uploads and downloads to take place as background tasks. In fact, I found it very handy to download a file in the background mode whilst I was editing a file for uploading. I then had a Vlew of the uploaded file whilst Mirror was sending the edited file in the background. Top Marks again! Incidentally, Mirror doesn't have to go searching for your editor via a "path" command. Mirror has its own inbuilt text editor that uses Wordstar commands. This may or may not be an advantage, depending upon your current wordprocessor and views on Wordstar.

Mirror also has extended terminal emulation features — it can emulate 11 different terminals including a Televideo VT-52 and a VT-100. Very useful. Extended comms protocols are also supported, with XMODEM batch, YMODEM and HAYES being additional to those offered by Cross-Talk.

The length of the time-out delay[*] (the delay between the finish of one block of transmitted data and the start of the next) can now be defined by the user. Optional CRC error checking (a vital consideration) has also been added for file transfers. The Kermit transfer protocol has also been modified to allow for variable packet lengths and 'repeated character' compression option, which both serve to speed up file transfer under Kermit[*].

All of these additional features are well documented in the manual's Appendix B (eight pages of it), which explain all of the additional features in great detail. Those features marked with the [*] are only available in the new version. I was also very impressed in the way that the new version allows modification to set-up options — a great improvement over Cross-Talk. ▶

A look at digital signal processing

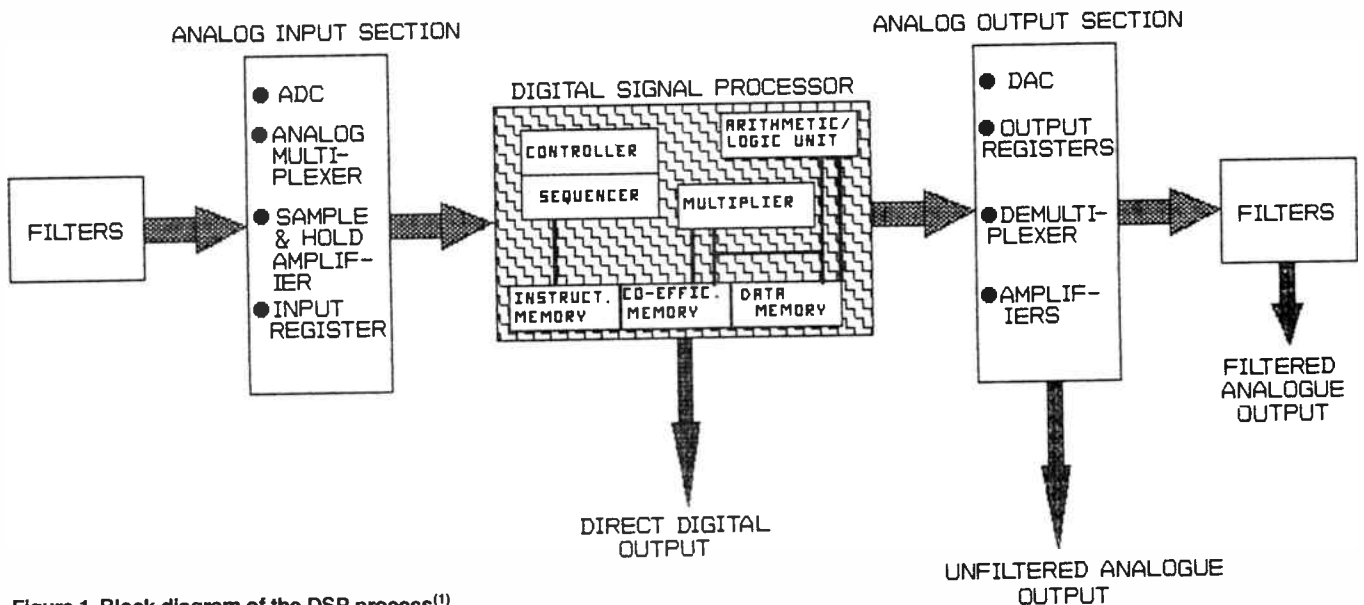

Figure 1. Block diagram of the DSP process⁽¹⁾.

I HAVE BEEN ASKED to explore the topic of Digital Signal Processing this month. DSP has been with us for quite some time now (since the late 70s), but it is only in the last four years that the business has really hotted up. The principle is quite simple, really. When Eckert and Mauchly were designing ENIAC, they had the choice of either opting for a digital system (10 discrete voltage levels) or a binary system (only two voltage levels). They chose the latter because a binary system is far less susceptible to line fluctuations than is a decimal one. With a binary system, there is either a voltage or there isn't one. Noise no longer becomes a problem.

Items of consumer electronics that have long been considered the domain of analogue circuitry are now giving way to digital processing. The colour TV set is a typical example. All of the modern sets are having virtually all of their traditional analogue components replaced with digital circuitry. About the only exception to this is the tube and its drive circuits.

One of the biggest moves in the DSP field is the proposal for a world-wide digital phone network (called Integrated Services Digital Network - ISDN for short). This topic will form a column of its own in a later issue. The basic principle behind DSP is shown in Figure 1 below:-

The analogue signal is passed through an optional filter (to

remove unwanted frequencies) and this signal is then passed to the analogue/digital (A/D) section. The A/D section includes an ultra-high speed A/D converter, capable of sampling at rates of up to 30 MHz. That's fast, believe me. The DSP itself is the second of the three modules; the third module is the Analogue Output Section. This section is also optional, as the processed digital signal can be used on its own, without the need for a digital-to-analogue converter (DAC) to re-convert it to analogue.

The applications for such devices are growing rapidly. Any application that requires the high speed processing of analogue data can use DSP as a means of accomplishing this. These include "robotics, where visual sensors can be used to command motion; military electronics and airborne systems, which need to process large amounts of data from radar, camera and radio inputs into commands and signals that alert other systems or guide aircraft; image processing, where digital signal processing is used to clarify images for medical, industrial or defense applications; graphics processing, to create simulated images for use in such equipment as flight simulators; and telecommunications, where it is necessary to transform voice-grade digital and analogue signals for transmission by satellite or cable."⁽¹⁾ New generation microproces-

MAESTRO DISTRIBUTORS

Calool St, Sth Kincumber 2256 NSW
ph: (043) 69 2913.

present

THE AEM4610
SUPERMODEM



A smart, stand-alone direct-connect serial modem • 6809 microprocessor controlled • plugs into any RS232 (serial) port • fully software controlled (Hayes-compatible) • auto-answer, auto-dial, auto-disconnect • 300/300 and 1200/75 bps CCITT V21 and V23 modes • IBM and Apple Viatel software available • automatic baud rate select • internal expansion slot • on-board speaker • plug-pack powered • 3 months warranty.

AEM4611 1200 bps full duplex add-on now available!

AEM4610 SUPERMODEM

\$349.17 ex. tax, \$399.00 inc. tax. Fully built and tested.

AEM4611 V22 board

\$173.58 ex. tax, \$199.00 inc. tax. Fully built and tested. Kit less EFG7515 — \$119.00. Kit complete — \$169.00

BANKCARD WELCOME

sors (in particular the TMS 32020) have chosen the DSP path to enable a large amount of parallel processing to take place and AMD (the "World Modem Chip" people) have produced a DSP variety of numeric co-processor, specifically designed for floating point operations (the AMD 29325). Here is a full list of these applications:

GENERAL PURPOSE DSP

- Digital Filtering
- Correlation
- Windowing
- Fast Fourier Transforms
- Adaptive filtering
- Waveform Generation
- Speech processing
- Radar and Sonar processing
- Electronic countermeasures
- Seismic processing

TELECOMMUNICATIONS

- Adaptive equalizers
- Spread-spectrum communication
- Timing generators
- Data-encryption & scrambling
- Signal modulation/demodulation
- Digital filtering
- Data compression

SPEECH PROCESSING

- Voice store & forward
- Speech synthesis & recognition
- Voice analysis

IMAGE PROCESSING

- Pattern Recognition
- Image Enhancement
- Radar & Sonar processing

INSTRUMENTATION

- Spectrum analysis
- Digital filtering
- Phase-locked loops
- Waveform generation
- Transient analysis

NUMERIC PROCESSING

- Arithmetic co-processing
- Scaling
- Double precision
- Fast multiplication & division

HIGH-SPEED CONTROL

- Robotics
- Missile guidance
- Motor control
- Feedback control

Figure 2. DSP applications are growing.⁽¹⁾

In next month's column, I will continue this discussion with a talk on how DSP will be applied to the 'phone network, on a world-wide basis.

Supermodem updates

The Supermodem has been re-designed, with many improvements. These improvements are due largely to the requests that we have had from owner/readers, chiefly through the letters you send to this column. So the message should be loud and clear – keep the letters coming! The analogue front end section of the 7910 has been improved to give a better signal-to-noise ratio. This should assist with data transmission over noisy lines.

The Supermodem now has an on/off switch and four LEDs to indicate status. They are for monitoring of Power, DCD, TxD and RxD. The latter two are red/green bi-coloured LEDs, which are used to indicate the direction the data is flowing. That is, Originate or Answer mode. The power connector has also been improved after complaints by users that it occasionally falls out in use. The speaker circuit has been completely overhauled. The transistor driver circuit has been replaced with an LM386 op-amp and the 70 mm speaker has been replaced with a 30 mm miniature speaker that is now mounted directly on the motherboard. The line isolation transformer is now a low mass type that is more efficient, yet takes up less space on the board.

The DB25 connector has been replaced with a DB9 connector, as only six to seven wires are actually used for serial

data. The system EPROM has been upgraded to V10 and the EPROM itself is now a 27128. One very interesting feature of the EPROM is that it now contains FORTH as the operating system and users will be able to write their own comms drivers in this language. The V10 EPROM also includes a power-on check of the system and indicates if a V.22 expansion board is present or absent. The V.22 board has also been modified – it now has far more tolerance to bad lines than previously.

Letters

We received a letter from Mr Tony Smith of Townsville, North Queensland, asking would we provide readers with details of his new BBS. We are only too pleased to do so! The BBS details are as follows:-

NAME: Townsville RBBS
PHONE: (077)74 1552
AVAILABILITY: 7 days – 24 hours
PROTOCOL: 300 bps, 8 data, 1 stop, no parity
ADDRESS: c/- MSO 5769, Townsville Qld 4810
SYSP: Tony Smith
SUPPORTING: Microbee, Amstrad, Generic CP/M, MS-DOS, Apple, Database, Comms & magazine contributions.

We wish Tony every success with his new BBS.

Novix FORTH chip

By the time you read this column, Chris Darling will have completed his initial trials of the Novix FORTH board pro-

FAIL-SAFE PROTECTION

FOR: CMOS MEMORY BACK-UP
STAND BY POWER
PRIMARY POWER SOURCE

DESIGN
1
NO.

COIN CELL SERIES

BH1000



BH906-S



BH906



BH800



BH500



- Fit all 12mm to 24mm dia. 3V coin-type lithium cells
- Design guarantees proper polarity
- Nickel plated stainless steel contacts

MPD's low profile coin type battery holders solder right to your PC board. Unique design assures easy battery insertion and removal without special tools. Ability to withstand temperatures from -55°C to +140°C and resistance to a wide range of solvents provide ultra-reliability.

Custom battery packs and holders on request. Call or write today for more details.

Memory Protection Devices Inc.
 36 South Mall, Plainview, NY 11803 • 516-454-0340 • Telex 7105815590

TOTYPE. This means that a fully working version (and hence the project) are not too far off now. The project will be aimed at the person who enjoys (or would enjoy) building a lightning fast computer as a kit. Chris likes to use the aeroplane analogy when he describes the board. Which would you rather pilot, the Concorde or an F18A? Both are relatively fast, although the F18A is much faster than ANY of the existing passenger planes. The Concorde is designed for maximum ease of piloting, whilst the F18A . . . Need I say more?

The Novix FORTH board will be the equivalent of the F18A – fast and utilitarian. The project will certainly not suit those people who think of their IBM or Mac as an electronic security blanket and who never do anything except use tried and trusted packages on their machines. Of course, a fair degree of soldering skill (techniques have been covered in this magazine in earlier issues) will be required, as will the ability to perform simple diagnosis. The proposed project will be something similar to the microprocessor evaluation boards of the late 70s-early-80s.

I can still remember my first computer – a SYM-1 made by Synertek Systems Inc (now defunct – the computer still works, so here's a case of a product outlasting the company that produced it). My SYM-1 taught me almost everything I know about micros (I learnt assembler and FORTH on the SYM) and it was a beaut machine for interfacing to instruments and experiments. The SYM gave a whole new meaning to the words "chip-frying basket." I had a 6522 VIA running at 110° C for two days, before I found out that I'd connected it to +12 V, instead of +5. "Friends" of mine irreverently suggested that I should try placing distilled water ice-blocks on the VIA as a cooling mechanism.

The Novix FORTH board will only have a limited amount of software available, but with Eric Lindsay volunteering to run a newsletter for the project, software exchange should be well taken care of. Chris has even suggested that he will be able to make the unit "stand alone." He envisages using IBM-type accessories, such as keyboards, floppies and yes, even a hard disk!!!

As I also mentioned in last month's column, I have included a diagram of the actual manner in which the chip handles instructions. One or more FORTH words are combined into a single 16-bit instruction, as shown in the diagram. The first four bits of the instruction detail the type of instruction (the Jump to Subroutine is encoded as a 0 in the highest of these four bits and the Return from Subroutine is encoded as a 1 in the same bit) – the remaining 12 bits control the ALU and its associated registers. This limits the processor to a 32K address space, but this is not as limiting as it first appears. For one, the chip uses word addresses, not byte addresses (effectively doubling the address space) and secondly, FORTH was almost designed with program overlay techniques in mind. Combined with very high speed bank switching, memory address limitations are a minor point.

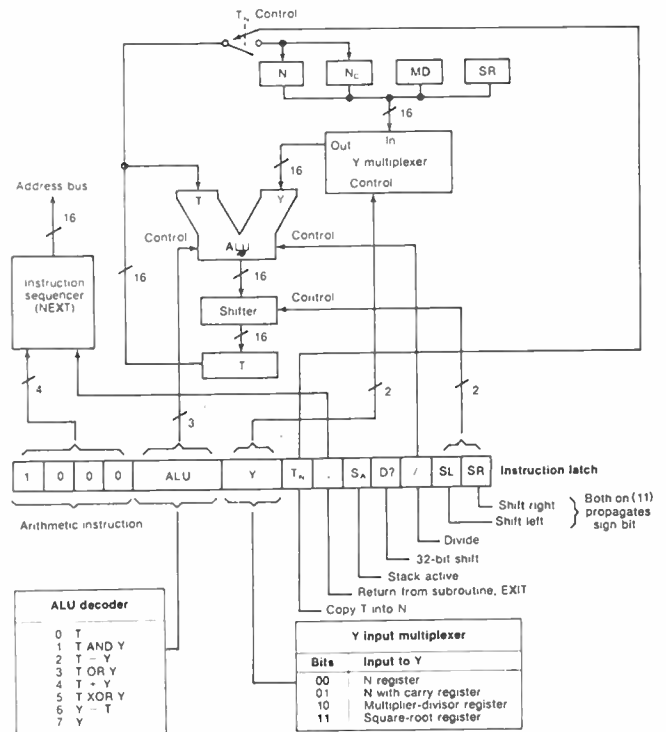

Figure 3. Details of the decoding of 16-bit instructions for the NC4000.⁽²⁾

The "T" register is the on-chip register for holding the value on the top of the stack and the "N" register is the on-chip register for holding the second top value on the data stack. This means that operations such as SWAP and DUP are VERY FAST to process.

The "T" register is one of the two inputs to the ALU. The other input is a multiplexed input, which places either the "N", or the "N with carry", into the ALU, or alternatively, the value in the Multiplier-Divisor register (MD) or the Square Root (SR) register are placed in the ALU and the appropriate operation is performed.

Please let us hear your comments and suggestions for the Novix project. Write to Dial Up, PO Box 507, Wahroonga 2076 NSW. Till next month . . .

REFERENCES:

1. "Signal Processing: A Big Switch to Digital", Electronics, August 26, 1985, pp 42-46 (McGraw-Hill)
2. "Forth Language Shapes the Structure of a 10 MOPS Chip", Electronic Design, March 21, 1985 (Hayden)
3. "Modem of the Future", AEM, April 1986, p.74.

<h1>FREE!</h1> <p>PUBLIC DOMAIN SOFTWARE</p> <p>Specify the computer you have</p>	<h2>IBM-APPLE-AMIGA</h2> <p>* Macintosh Library Discs</p> <p>Full of the best of the available Public Domain Software</p> <p>Send 6x36¢ stamps for postage.</p> <p>* Add \$10 for MAC 3.5" Discs</p>	<h2>MICRO-EDUCATIONAL P/L</h2> <p>8/235 Darby Street Newcastle 2300 (043) 26 4122</p> <p>Australia's Largest Computer Mail Order Company</p>
--	--	--

Using the AEM4504 low cost speech synthesiser on the BBC model B computer

Andrew Boon

Here's how to connect this popular project to the BBC model B so you can get it "talking" with a bit of software.

THERE ARE TWO WAYS in which the AEM4504 Speech Synthesiser (AEM, Feb. 1986) can be connected to a BBC Model B: the first is to configure the Speech Synthesiser to look like a printer socket; the second is to connect it to the User Port, in the same way as the Listening Post was connected (see AEM August 1986 for details). The first method makes programming very straightforward, simply turn the printer on with a VDU 2 command, and use a PRINT statement to send the allophone codes to the Synthesiser. The only drawback is, if you have a parallel printer, you can't use both printer and Synthesiser at the same time.

Consequently, I decided to connect the Speech Synthesiser to the User Port. The connections between the AEM4504 interface and the User Port are shown in Table 1.

AEM4504 INTERFACE	BBC USER PORT 20-WAY PLUG
1 +5V	1 +5V
2 —	
3 A6	16 PB5
4 A4	12 PB3
5 A2	8 PB1
6 —	
7 ARDY	4 CB2
8 0V	5 0V
9 SBY	2 CB1
10 —	
11 A1	6 PB0
12 A3	10 PB2
13 A5	14 PB4
14-16 —	14 PB4

TABLE 1: Interconnection Details

A 20-wire flat ribbon cable should be fitted with a 20-way insulation-displacement connector, to plug into the User Port. The individual wires of the cable should be separated at the other end, and those which are not used (i.e.: 3, 7, 9, 11, 13, 15, 17-20) should be cut off short. I soldered the remaining wires directly into the printed circuit board. Make sure that you start counting from the correct side of the cable — see Figure 1 for details.

The two programs (Phrase Composer and Phrase Dictionary) have been re-written for the BBC Model B, and are reproduced in part only. All DATA statements are identical to the original program. The major difference is the inclusion of a machine language routine commencing at line 5000 in both programs. Calling the procedure 'init' at line 125 causes the assembly language section to be assembled, and 'setup' at line 126 initialises the User Port of the VIA to send

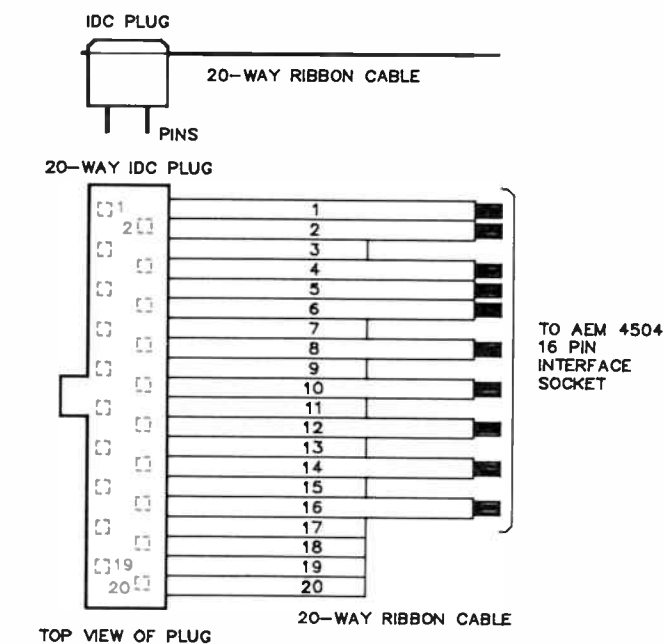

Connecting cable for AEM 4504 Speech Synthesizer to BBC User Port

Figure 1.

data to the Speech Synthesiser — looking for a busy signal on CB1 and sending a strobe pulse on CB2 whenever a data word is stored in the output register.

To Edit a phrase in Phrase Composer, or to input a new sentence in Phrase Dictionary, an 'E' is required — not ESCAPE as in the original. Line 127 informs the printer that no characters are to be ignored. Line 245 of the Phrase Composer puts a copy of line 150 onto the screen before ending, so that the line can be edited using the cursor control and COPY keys, before re-running with an amended phrase.

The length of the Phrase Dictionary is such that the only Mode useable is Mode 7, i.e.: the Teletex mode. In this mode some of the displayed characters are different from what is displayed on the keytops, e.g.:] is displayed as a left arrow. Ignore what is displayed, EXCEPT for the apostrophe ('). If you are adding words to the dictionary, or typing in the original words, you must use the pound symbol (£) in place of the apostrophe. For all other characters, the keytops are correct.

```

100 REM AEM4504 PHRASE COMPOSER
110 REM by Mark Bishop 22/7/85
120 REM BBC Model B version by Andrew Boon, 15/3/86
125 PROCinit: REM Assemble machine language portion
126 CALL setup: REM Initialise output port for speech synthesizer
127 *FX 6,0
130 GOSUB 260: REM Print title
140 GOSUB 280: REM Init. & read data into arrays RO%, R
150 W0%="TT2 EH SS PA3 TTI IH NG"
155 ED%="W0%: REM Save for editing
160 ON ERROR GOTO 240: REM Input error
170 GOSUB 310: REM Search array for allophone ASCII code
180 IF Q0%="N" THEN GOTO 240: REM Input error
190 PRINT W0%: CALL say, A0%: REM Print and speak phrase
200 K0%="INKEY$(0): IF K0%="" THEN 200
210 IF K0%="CHR$(69) THEN GOTO 245: REM Edit if 'E'
220 IF K0%="p" OR K0%="P" THEN GOSUB 440: GOTO 200: REM Print
230 GOTO 190: REM Speak again
240 S%="QLKBI*CGGGQ%": CALL say, S%: REM Input error
245 PRINT: PRINT * 150 W0%="": ED%="": END: REM Setup for edit
250 S%="AXAQsCwAQTAQPGKCGGGQ%": CALL say, S%: END
260 CLS: PRINT TAB(15) "AEM4504 PHRASE COMPOSER"
270 PRINT: PRINT: PRINT: RETURN
280 ON ERROR GOTO 250: REM Data statement error
290 DIM RO$(64): DIM R(64)
300 FOR I=1 TO 64: READ RO$(I),R(I): NEXT I: RETURN
310 B=0: W0%="W0%+" ": A0%=""
320 B=B+1: IF B>LEN(W0%) THEN 370: REM End of phrase
330 C=B: B=INSTR(W0%," ,C)
340 W1%=MID$(W0%,C,B-C): REM W1%=word to search for
350 GOSUB 380: REM Search array RO$(?) for W1%
360 A0%="Q"+A0%+"Q": GOTO 320: REM A0%=ASCII of word
370 A0%="Q"+A0%+"Q": RETURN: REM Add pause to end of phrase
380 L=1: H=64: N=0: REM L=lowest array #, H=highest, N=now
390 P=N: N=(L+H)/2: REM Previous #now, now=(low+high)/2
400 IF RO$(N)=W1% THEN LET Q0%="Y": RETURN: REM Found
410 IF RO$(N)<W1% THEN LET L=N+1 ELSE LET H=N-1
420 IF P<N THEN GOTO 390: REM Keep looking
430 Q0%="N": RETURN: REM Not found in array
440 CLS: VDU 2: REM Turn printer on
450 PRINT "PHRASE: ";W0%: PRINT
460 PRINT "ASCII: ";A0%: PRINT
470 PRINT: PRINT: PRINT: VDU 3: RETURN: REM Printer off
480 DATA "AA",88,"AE",90,"AO",87,"AR",123,"AW",96
490 DATA "AX",79,"AY",70,"BB1",92,"BB2",63,"CH",114
500 DATA "DD1",85,"DD2",97,"DH1",82,"DH2",118,"EH",71
510 DATA "EL",126,"ER1",115,"ER2",116,"EY",84,"FF",104
520 DATA "GG1",100,"GG2",125,"GG3",98,"HH1",91,"HH2",121
530 DATA "IH",76,"IY",83,"JH",74,"KK1",106,"KK2",105
540 DATA "KK3",72,"LL",109,"MM",80,"NG",108,"NN1",75
550 DATA "NN2",120,"OR",122,"OW",117,"OY",69,"PA1",64
560 DATA "PA2",65,"PA3",66,"PA4",67,"PAS",68,"PP",73
570 DATA "RR1",78,"RR2",103,"SH",101,"SS",119,"TH",93
580 DATA "TT1",81,"TT2",77,"UH",94,"UW1",86,"UW2",95
590 DATA "UV",99,"WH",112,"WU",110,"XR",111,"YR",124
600 DATA "YY1",113,"YY2",89,"ZH",102,"ZZ",107
610 REM End of listing
5000 REM Assemble Machine Code Routines.
5100 DEF PROCinit
5200 DIM O% 400
5300 FOR opt%=0 TO 2 STEP 2
5400 PAR=&600: REM Parameter Block.
5500 REM User Zero Page area.
5600 SIBadr=&B0: stradr=&B2: length=&B4
5700 OSBYTE=&FFF4: RDIO=&96: WRIO=&97: REM OSBYTE Commands.
5800 VDRB=&60: DDRB=&62: PCR=&6C: VIFR=&6D: REM VIA Registers.
5900 P%="O%: REM Set Program Counter.
6000 [
6100 OPT opt%
6200 .say LDA PAR \Check that only 1 parameter passed.
6300 CMP #1
6400 BEQ ok
6500 .error BRK \Here if more than one.
6600 ]
6700 ?P%=&45: REM Error Number.
6800 P%="P%+1
6900 *(P%)="Synthetic Speech Parameters": REM Error Message.
7000 P%="P%+LEN(*P%)
7100 [
7200 OPT opt%
7300 .ok BRK
7400 LDA PAR+3 \Check for a string variable.
7500 CMP #129
7600 BNE error \Branch if not.
7700 LDA PAR+1 \Set Zero Page for indexed indirect addressing.
7800 STA SIBadr \String Information Block address.
7900 LDA PAR+2
8000 STA SIBadr+1
8100 LDY #0 \Get string start address.
8200 LDA (SIBadr),Y
8300 STA stradr
8400 INY
8500 LDA (SIBadr),Y
8600 STA stradr+1
8700 LDY #3 \Get length of string.
8800 LDA (SIBadr),Y
8900 STA length
9000 .say:t LDA WRDIO \Is output flag set?
9100 LDX WUIFR
9200 JSR OSBYTE
9300 TYA
9400 AND #&10
9500 BEQ say:t \Branch if not ready.
9600 DEC length \Any more chars to send?
9700 BMI allsaid
9800 LDY #0
9900 LDA (stradr),Y
10000 TAY
10100 LDA WRDIO
10200 LDX WUIFR
10300 JSR OSBYTE
10400 INC stradr \Point to next char in string.
10500 BNE say:t
10600 INC stradr+1
10700 JMP say:t
10800 .allsaid RTS
10900 \

```

```

5600 .setup LDA WRDIO \Set all bits as outputs.
5610 LDX WUIFR
5620 LDY #&FF
5630 JSR OSBYTE
5640 LDA WRDIO \Set CB2 to pulse when data is output.
5650 LDX WPCR \But preserve setting of Port A (printer).
5660 JSR OSBYTE
5670 TYA
5680 AND #&OF
5690 ORA #&B0
5700 TAY
5710 LDA WRDIO
5720 LDX WPCR
5730 JSR OSBYTE
5740 LDY #0 \Send a Pause to begin.
5750 LDX WUIFR
5760 JSR OSBYTE
5770 RTS
5780 ]
5790 NEXT opt%
5800 ENDPROC

```

```

100 REM AEM4504 PHRASE DICTIONARY
110 REM by Mark Bishop 22.7.85
120 REM BBC Model B version by Andrew Boon, 20.4.86
125 PROCinit: REM Assemble machine language portion
126 CALL setup: REM Initialize output port for speech synthesizer
127 *FX 6,0
130 GOSUB 330: REM print title
140 GOSUB 370: REM init. & read data into arrays RO%, R1%
150 IF Q0%="N" THEN GOTO 300: REM error - not ascii order
160 GOSUB 470: GOTO 180: REM title 2nd part
170 CLS: PRINT TAB(2,5) "What would you like me to say next?"
180 GOSUB 520: REM enter phrase to speak
190 GOSUB 590: REM search array for allophone ASCII code
200 PRINT W0%: CALL say, A0%: REM print and speak phrase
210 REM select, edit, print or speak option
220 REM
230 K0%="INKEY$(0): IF K0%="" THEN 220
240 IF K0%="CHR$(69) THEN 170: REM 'E' instead of 'ESC'
250 IF K0%="p" OR K0%="P" THEN GOSUB 760: GOTO 230: REM print
260 GOTO 200: REM speak
270 REM error routines
280 S%="QLKBI*CGGGQ%": CALL say, S%: GOTO 170: REM error
290 PRINT "Data line #";Z+1;GOTO 310
300 PRINT " ";RO$(I-1); & " ";RO$(I); " NOT in ASCII order";
310 PRINT " - DATA statement error"
311 S%="AXAQsCwAQTAQPGKCGGGQ%": CALL say, S%: END
320 REM print title
330 CLS: COLOUR 0: COLOUR 129
340 PRINT TAB(5,1) "AEM4504 PHRASE DICTIONARY"
350 COLOUR 1: COLOUR 128: RETURN
360 REM init. & read data into arrays RO%, R1%
370 ON ERROR GOTO 290: REM data statement error
380 Z=0: PRINT TAB(5,4) "reading dictionary . . . . ."
390 READ F0%,F1%: Z=Z+1: IF F0%="" THEN 390
395 ON ERROR GOTO 390
400 Z=Z-1: RESTORE: REM due 'dataend'
410 DIM RO$(Z): DIM R1$(Z): RO$(0)="" : Q0%="Y"
420 REM
430 FOR I=1 TO Z: READ RO$(I): READ R1%(I)
440 IF RO$(I)=RO$(I-1) THEN LET Q0%="N": I=Z
441 REM error, data not in ASCII order
450 NEXT I: ON ERROR OFF: RETURN
460 REM title part 2
470 PRINT TAB(5,4) "Hello, I am your BBC talker!"
480 S%="Q(GnuDDFBZPBZD?S?SwuSB#WJWJsDDDQ?": CALL say, S%
490 PRINT TAB(5,5) "What would you like me to say?"
500 S%="QpXmp*ady-MFIPSDM-wTQ?": CALL say, S%: RETURN
510 REM enter phrase to speak
520 PRINT TAB(5,15) "lower case input only please,"
530 PRINT TAB(5,16) "separate groups by 1 space"
540 INPUT TAB(5,9) W0%
550 CLS: PRINT TAB(5,5) "searching dictionary . . . . ."
560 RETURN
570 REM search array for allophone ASCII code
580 ON ERROR GOTO 280: REM input error
590 B=0: W0%="W0%+" ": A0%=""
600 B=B+1: IF B>LEN(W0%) THEN 670: REM end of phrase
610 C=B: B=INSTR(W0%," ,C)
620 W1%=MID$(W0%,C,B-C): REM W1%=word to search for
630 GOSUB 690: REM search array RO$(?) for W1%
640 ON ERROR GOTO 280
650 IF Q0%="Y" THEN LET A0%="A0%+R1$(N)+"C": GOTO 600
660 REM A0%=ASCII of word
670 IF Q0%="N" THEN LET A0%="A0%+" ": GOTO 600
680 REM no word, add 'blank'
690 A0%="Q"+A0%+"Q": CLS: RETURN: REM add pause phrase ends
700 REM binary search S/R for word in array RO$(?)
710 L=1: H=Z: N=0: REM l=lowest array #, H=highest, N=now
720 P=N: N=(L+H)/2: REM previous #now, now=(low+high)/2
730 IF RO$(N)=W1% THEN LET Q0%="Y": RETURN: REM found
740 IF RO$(N)<W1% THEN LET L=N+1 ELSE LET H=N-1
750 IF P<N THEN GOTO 700: REM keep looking
760 Q0%="N": RETURN: REM not found
770 REM print phrase and allophone ASCII equivalent
780 CLS: VDU 2: REM turn printer on
790 PRINT "PHRASE: ";W0%: PRINT
800 PRINT "ASCII: ";A0%: PRINT
810 PRINT: PRINT: PRINT: VDU 3: RETURN
800 REM
1000 REM first data items MUST be in ASCII/alphabetical order
1010 REM and in LOWERCASE. Word then ASCII equivalent
1020 DATA "A","IEKQ"
1030 DATA "O","fSqu"
1040 DATA "I","pOK"
1050 DATA "10","MGK"
1060 DATA "11","SmGctK"
1070 DATA "12","MnG-Ac"
1080 DATA "13","jMSK"
1090 DATA "14","hWgMSK"
1100 DATA "15","hLhMSK"
1110 DATA "16","wLwMSK"
1120 DATA "17","wWgGcLkMSK"

```

1130 DATA "18","TQMSK"
1140 DATA "19","xFKMSK"
1150 DATA "20","MnGKMS"
1160 DATA "21","MnGKMSpOK"
1170 DATA "22","MnGKMSpM--"
1180 DATA "23","MnGKMSpvgS"
1190 DATA "24","MnGKMSpHwJg"
1200 DATA "25","MnGKMSpHfC"
1210 DATA "26","MnGKMSpLw"
1220 DATA "27","MnGKMSpwwGGcLK"
1230 DATA "28","MnGKMSpTQ"
1240 DATA "29","MnGKMSpXFK"
1250 DATA "30","vqS"
1260 DATA "31","JMS"
1270 DATA "32","JMSpOK"
1280 DATA "33","JMSpM--"
1290 DATA "34","JMSpvgS"
1300 DATA "35","JMSpHwJg"
1310 DATA "36","JMSpHfC"
1320 DATA "37","JMSpLw"
1330 DATA "38","JMSpwwGGcLK"
1340 DATA "39","JMSpTQ"
1350 DATA "40","JMSpXFK"
1360 DATA "41","hwJg"
1370 DATA "42","hwJgM"
1380 DATA "43","hwJgMpOK"
1390 DATA "44","hwJgMpM--"
1400 DATA "45","hwJgMvgS"
1410 DATA "46","hwJgMpHwJg"
1420 DATA "47","hwJgMpHfC"
1430 DATA "48","hwJgMpLw"
1440 DATA "49","hwJgMpwwGGcLK"
1450 DATA "50","hwJgMpTQ"
1460 DATA "51","hwJgMpXFK"
1470 DATA "52","hLHMS"
1480 DATA "53","hLHMSpOK"
1490 DATA "54","hLHMSpM--"
1500 DATA "55","hLHMSpvgS"
1510 DATA "56","hLHMSpHwJg"
1520 DATA "57","hLHMSpHfC"
1530 DATA "58","hLHMSpLw"
1540 DATA "59","hLHMSpwwGGcLK"
1550 DATA "60","hLHMSpTQ"
1560 DATA "61","hLHMSpXFK"
1570 DATA "62","wLIwMS"
1580 DATA "63","wLIwMSpOK"
1590 DATA "64","wLIwMSpM--"
1600 DATA "65","wLIwMSpvgS"
1610 DATA "66","wLIwMSpHwJg"
1620 DATA "67","wLIwMSpHfC"
1630 DATA "68","wLIwMSpLw"
1640 DATA "69","wLIwMSpwwGGcLK"
1650 DATA "70","wLIwMSpTQ"
1660 DATA "71","wLIwMSpXFK"
1670 DATA "72","wwGGcLKMS"
1680 DATA "73","TQ"
1690 DATA "74","XFK"
1700 DATA "75","DDDDDD"
1710 DATA "76","a","T"
1720 DATA "77","alarm","OmP"
1730 DATA "78","alex","ZmGiw"
1740 DATA "79","alexandra","ZmGiwZKUgO"
1750 DATA "80","all","wLwM"
1760 DATA "81","am","ZP"
1770 DATA "82","amateur","ZPZQqs"
1780 DATA "83","an","ZK"
1790 DATA "84","and","ZKU"
1800 DATA "85","april","TAINLn"
1810 DATA "86","are","Z"
1820 DATA "87","at","ZM"
1830 DATA "88","august","W)bOwQ"
1840 DATA "89","b","ZS"
1850 DATA "90","baby","A?TA?S"
1860 DATA "91","bath","?Tv"
1870 DATA "92","bather","?Tvs"
1880 DATA "93","bathing","?TvLl"
1890 DATA "94","be","?S"
1900 DATA "95","becky","?GiS"
1910 DATA "96","bee","?S"
1920 DATA "97","beer","?i"
1930 DATA "98","beth","A?Gj"
1940 DATA "99","birthday","A?s)AaGT"
2000 DATA "100","bite","A?FCQ"
2010 DATA "101","bites","A?FCQk"
2020 DATA "102","blank","A?mZKBi"
2030 DATA "103","bob","A?XxA?
2040 DATA "104","bread","?gGGQ"
2050 DATA "105","brett","A?gGCQ"
2060 DATA "106","brother","A?gOis"
2070 DATA "107","buy","?XF"
2080 DATA "108","by","?XF"
2090 DATA "109","byte","A?FCQ"
2100 DATA "110","bytes","A?FCQk"
2110 DATA "111","c","wus"
2120 DATA "112","calendar","jZZmGKAas"
2130 DATA "113","calling","HW-Ll"
2140 DATA "114","cat","jZBM"
2150 DATA "115","check","rGGBi"
2160 DATA "116","checked","rGGBiM"
2170 DATA "117","checker","rGGBjs"
2180 DATA "118","checkers","rGGBjsk"
2190 DATA "119","checking","rGGBjLl"
2200 DATA "120","checks","rGGBjw"
2210 DATA "121","clock","jmxXBj"
2220 DATA "122","close","jmwu"
2230 DATA "123","clown","jmk"
2240 DATA "124","collide","HOMFU"
2250 DATA "125","computer","jOPIqVQs"
2260 DATA "126","cookie","HjS"
2270 DATA "127","correct","jtGGAiAO"
2280 DATA "128","corrected","jtGGAiAMLAU"
2290 DATA "129","correcting","jtGGAiAMLl"
2300 DATA "130","corrects","jtGGAiAQw"
2310 DATA "131","crane","HgtK"
2320 DATA "132","crown","jgK"
2330 DATA "133","d","aS"
2340 DATA "134","daniel","aZKALQG--"
2350 DATA "135","darren","AaogK"
2360 DATA "136","data","axXAOs"
2370 DATA "137","date","aTBM"
2380 DATA "138","daughter","aWMs"
2390 DATA "139","day","AaT"
2400 DATA "140","december","USAwGp\s"
2410 DATA "141","dennis","aGKLw"
2420 DATA "142","disk","aLwui"
2430 DATA "143","divided","aLcFAaLAU"
2440 DATA "144","do","CaV--"
2450 DATA "145","drive","agFu"
2460 DATA "146","drives","agFuk"
2470 DATA "147","e","S"
2480 DATA "148","east","SwQ"
2490 DATA "149","eight","TQ"
2500 DATA "150","eighteen","TQMSK"
2510 DATA "151","eignty","TQMS"
2520 DATA "152","eleven","SmGcTk"
2530 DATA "153","emergency","SPsJGkws"
2540 DATA "154","engagement","GGKdTAJPGGKABM"
2550 DATA "155","engages","GGKdTAJLk"
2560 DATA "156","engaging","GGKdTAJLl"
2570 DATA "157","enrage","GKNTAJ"
2580 DATA "158","enraged","GKNTAJAU"
2590 DATA "159","enrages","GKNTAJLk"
2600 DATA "160","enraging","GKNTAJLl"
2610 DATA "161","error","GGQs"
2620 DATA "162","extent","GjwMGGKM"
2630 DATA "163","exterminate","GiwMsPLxTM"
2640 DATA "164","father","h(Rs"
2650 DATA "165","february","hGNvY_tS"
2660 DATA "166","fifteen","hLHMSK"
2670 DATA "167","fifty","hLHMS"
2680 DATA "168","fire","ht"
2690 DATA "169","five","hFc"
2700 DATA "170","fool","h^m"
2710 DATA "171","fools","h^mí"
2720 DATA "172","force","hzww"
2730 DATA "173","four","hLwJg"
2740 DATA "174","fourteen","hwJgMSK"
2750 DATA "175","forty","hwJgMS"
2760 DATA "176","freeze","hhNSK"
2770 DATA "177","freezer","hhNSks"
2780 DATA "178","freezers","hhNSksk"
2790 DATA "179","friday","hgFAaT"
2800 DATA "180","from","hgXP"
2810 DATA "181","frozen","hhNukGK"
2820 DATA "182","g","JS"
2830 DATA "183","gemini","JGLxF"
2840 DATA "184","glenn","AbmG1"
2850 DATA "185","h","TABr"
2860 DATA "186","happy","yZIS"
2870 DATA "187","has","{ZK"
2880 DATA "188","have","{Zc"
2890 DATA "189","hello","{Gmu"
2900 DATA "190","hertz","yYtQk"
2910 DATA "191","how","y"
2920 DATA "192","hundred","yOOkAagLLQW"
2930 DATA "193","i","F"
2940 DATA "194","idiot","LaALLLQO"
2950 DATA "195","in","LK"
2960 DATA "196","input","LKBi^Q"
2970 DATA "197","is","Lk"
2980 DATA "198","it","LCO"
2990 DATA "199","j","JGT"
3000 DATA "200","january","JZK_qtS"
3010 DATA "201","john","JXK"
3020 DATA "202","julie","Jq^S"
3030 DATA "203","july","J_mF"
3040 DATA "204","june","J_K"
3050 DATA "205","k","JGT"
3060 DATA "206","karen","jZgQgK"
3070 DATA "207","kilo","jLmu"
3080 DATA "208","know","xu"
3090 DATA "209","krissy","HqLwQs"
3100 DATA "210","l","GG--"
3110 DATA "211","live","mlc"
3120 DATA "212","m","GGP"
3130 DATA "213","march","P(r"
3140 DATA "214","mark","P(i"
3150 DATA "215","may","PT"
3160 DATA "216","mega","PGdO"
3170 DATA "217","memory","PGPXgS"
3180 DATA "218","mhz","PGDoytQk"
3190 DATA "219","microbee","PFABHguA?S"
3200 DATA "220","microbug","PFABHguA?WjB"
3210 DATA "221","minute","PLKLBm"
3220 DATA "222","minutes","PLKLBmk"
3230 DATA "223","modem","PuaAGP"
3240 DATA "224","monday","POOKaAT"
3250 DATA "225","month","POKl]"
3260 DATA "226","mother","POvs"
3270 DATA "227","my","PF"
3280 DATA "228","n","GGK"
3290 DATA "229","name","xTP"
3300 DATA "230","naughty","xLwWBSQs"
3310 DATA "231","nine","xFK"
3320 DATA "232","nineteen","xFKMSK"
3330 DATA "233","ninety","xFKMS"
3340 DATA "234","no","xu"
3350 DATA "235","november","xuQcGP\s"
3360 DATA "236","o","u"
3370 DATA "237","october","XiQW\s"
3380 DATA "238","of","Xc"
3390 DATA "239","on","XK"
3400 DATA "240","one","pOK"
3410 DATA "241","or","z"
3420 DATA "242","our","s"
3430 DATA "243","p","IS"
3440 DATA "244","past","l(wM"
3450 DATA "245","penelope","ABIGKmuIS"
3460 DATA "246","penny","ABIGKS"
3470 DATA "247","point","IEKQs"

```

3480 DATA "q","jq_"
3490 DATA "r","r("
3500 DATA "ram","gAZP"
3510 DATA "rebecca","Ns?GBH("
3520 DATA "ross","NXuw"
3530 DATA "s","GGuw"
3540 DATA "saturday","uwZB1sAt"
3550 DATA "september","wGI QGP\s"
3560 DATA "seven","uwGGcLK"
3570 DATA "seventeen","uwGGcLKMSK"
3580 DATA "seventy","uwGGcLKMS"
3590 DATA "sister","uwLwMs"
3600 DATA "six","wLw"
3610 DATA "sixteen","wLwMSK"
3620 DATA "sixty","wLwMS"
3630 DATA "son","wOK"
3640 DATA "sound","w KU"
3650 DATA "south","uw^j"
3660 DATA "space","wITw"
3670 DATA "statement","wAQTAQPGKQ"
3680 DATA "sunday","wW00KBaT"
3690 DATA "suz","wOK"
3700 DATA "suzanne","w-kZZK"
3710 DATA "t","MS"
3720 DATA "talker","MwAis"
3730 DATA "television","MGmLcLwLXK"
3740 DATA "ten","MGK"
3750 DATA "test","MGwAQ"
3760 DATA "testing","MGwAQL1"
3770 DATA "the","vX"
3780 DATA "their","JGGG"
3790 DATA "there","JGGG"
3800 DATA "thirteen","JMSK"
3810 DATA "thirty","JMS"
3820 DATA "this","RLw"
3830 DATA "thousand","J`kZKU"
3840 DATA "three","vgS"
3850 DATA "thursday","JtkAaT"
3860 DATA "tim","MVP"
3870 DATA "time","MFP"
3880 DATA "to","M--"
3890 DATA "today","M-aT"
3900 DATA "tuesday","MqKAaT"
3910 DATA "twelve","MnGAc"
3920 DATA "twenty","MnGKMS"
3930 DATA "two","M--"
3940 DATA "u","q_"
3950 DATA "v","cS"
3960 DATA "vision","cLfLLXK"
3970 DATA "w","aDA?_"
3980 DATA "want","nXKBQ"
3990 DATA "wednesday","nGGKKAaT"
4000 DATA "what","pXBQ"
4010 DATA "who","yy^-"
4020 DATA "with","nLV"
4030 DATA "x","GGBuw"
4040 DATA "y","nF"
4050 DATA "year","Y!"
4060 DATA "yes","YGwu"
4070 DATA "you","Y_"
4080 DATA "your","Yz"
4090 DATA "z","KGBU"
4100 DATA "zero","kSgu"
4110 DATA "dataend","zzz"
4120 REM data line "dataend","zzz" must be last data line
4130 END OF ORIGINAL PROGRAM LISTING
5000 REM Assemble Machine Code Routines.
5010 DEF PROCint
5020 DIM opt% 200
5030 FOR opt%=0 TO 2 STEP 2
5040   PAR=&600: REM Parameter Block.
5050   REM User Zero Page area.
5060   SIBadr=&B0: stradr=&82: length=&84
5070   OSBYTE=&FFF4: RD10=&96: WR10=&97: REM OSBYTE Commands.
5080   VORB=&60: DDRB=&62: PCR=&6C: VIFR=&6D: REM VIA Registers.
5090   P%=&0: REM Set Program Counter.
5100   [
5110   OPT opt%
5120   .say LDA PAR          \Check that only 1 parameter passed.
5130   CMP #1
5140   BEQ ok
5150   .error BRK          \Here if more than one.
5160   ]
5170   ?P%=&45: REM Error Number.
5180   P%=&P%+1
5190   $(P%)="Synthetic Speech Parameters": REM Error Message.
5200   P%=&P%+LEN($P%)
5210   [
5220   OPT opt%
5230   .ok BRK
5240   LDA PAR+3          \Check for a string variable.
5250   CMP #129
5260   BNE error        \Branch if not.
5270   LDA PAR+1          \Set Zero Page for indexed indirect addressing.
5280   STA SIBadr       \String Information Block address.
5290   LDA PAR+2
5300   STA SIBadr+1
5310   LDY #0
5320   LDA (SIBadr),Y
5330   STA stradr
5340   INY
5350   LDA (SIBadr),Y
5360   STA stradr+1
5370   LDY #3
5380   LDA (SIBadr),Y
5390   STA length
5400   .sayit LDA #RD10     \Is output flag set?
5410   LDX #VIFR
5420   JSR OSBYTE
5430   TYA
5440   AND #&10
5450   BEQ sayit         \Branch if not ready.
5460   DEC length       \Any more chars to send ?
5470   BMI allsaid
5480   LDY #0
5490   LDA (stradr),Y
5500   TAY
5510   LDA #WR10
5520   LDX #VORB
5530   JSR OSBYTE
5540   INC stradr        \Point to next char in string.
5550   BNE sayit
5560   INC stradr+1
5570   JMP sayit
5580   .allsaid RTS
5590   \
5600   .setup LDA #WR10    \Set all bits as outputs.
5610   LDX #DDRb
5620   LDY #&FF
5630   JSP OSBYTE
5640   LDA #RD10
5650   LDX #PCR
5660   JSR OSBYTE
5670   TYA
5680   AND #&0F
5690   ORA #&B0
5700   TAY
5710   LDA #WR10
5720   LDX #PCR
5730   JSR OSBYTE
5740   LDY #0
5750   LDX #VORB
5760   JSR OSBYTE
5770   RTS
5780   ]
5790 NEXT opt%
5800 ENDPROC

```

- from page 82

All file transfers I attempted worked without a hitch. I always use CRC error checking where possible and this feature of Mirror was a definite advantage over checksum error checking. File transfer was accomplished at 1200 bps full duplex and the selection of files contained both ASCII and binary executable files. No errors at all were encountered during the transmission, meaning that no blocks had to be re-transmitted.

As a fair summary, I would have to say that Mirror outshines Cross-Talk, showing improvement over that "standard" in virtually every respect. If Mirror and Cross-Talk were the same price, I would still prefer Mirror. However, at \$50, Mirror is around than one-third the price of Cross-Talk . . .

As a comms program I have no hesitation in recommending Mirror. At the price, I would probably even consider using it in preference to my favourite comms program, Procomm (by Shareware), simply because of the high quality documentation included.

The review copy (and the subsequent Beta version) was supplied by Delta Computer Systems, 13/83 George Street, Parramatta 2150 NSW. (02)633 4055.

ADMARKET

AMSTRAD SOFTWARE; bill payer and expense manager both on disk. Cost \$43 ea, sell for \$25 ea or both for \$40. Andrew, 58 Beaver St. East Malvern, 3145 Vic. Ph. (03) 211-2669.

RS232 TERMINAL, green screen, 24 lines by 80 characters, detachable keyboard \$125. David Lincoln, Gosford NSW. (043) 28 4559.

MEMORY BOARDS 32K, \$12.00 each. David Lincoln, Gosford NSW (043) 28 4559.

AMSTRAD CPC programs; Shareplay — real-time stockmarket simulation, colour graphics and sound. Tunessmith — create BASIC sound routines as complete programs, no music or sound command knowledge needed. Wordseek — puzzle generator, educ. and fun, joystick compatible. Disk versions \$25 ea. Tape \$15 ea. All three: on disk \$35, on tape \$25. Send SAE for more. V. Greaves PO Box 1942, Shepparton 3630 Vic.

FIX-A-KIT; repair/build your AEM/ETI/EA project for \$10 per hour (parts, p&p extra). No Charge for kits that can't be repaired (except p&p). Cliff (02) 757-4675 or Steve (02) 633-5897.

CONTACT wanted with TRS-80/Amstrad owners; programs, user's group services available. Write: Craig Tollis, P.O. Box 584, Port Macquarie, 2444.

FOR SALE. Siemens 100 teleprinter wired for use as a computer printer. Reliable and guaranteed; \$85. Frank Rees, 27 King St. Boort 3537, Vic.

VZ200/300 INFORMATION. The largest user group in the South Pacific area. Le VZ 200/300 OOP. Send S.A.S.E. to Mr. D'Alton, 39 Agnes St. Toowong 4066, Qld. Ph. (07) 371-3707.

VZ200/300 games tape packed with ten games of my own design. Send \$20 for the bargain tape (includes p&p) to: R. Lyon, Jamieson post office 3723. Ph. (057) 770-554.

The AUSTRALIAN ELECTRONICS Monthly



USE YOUR COMPUTER TO RECEIVE

- Radio Facsimile Pictures (FAX)
- Radio Teletype (RTTY)
- Morse Code (CW)

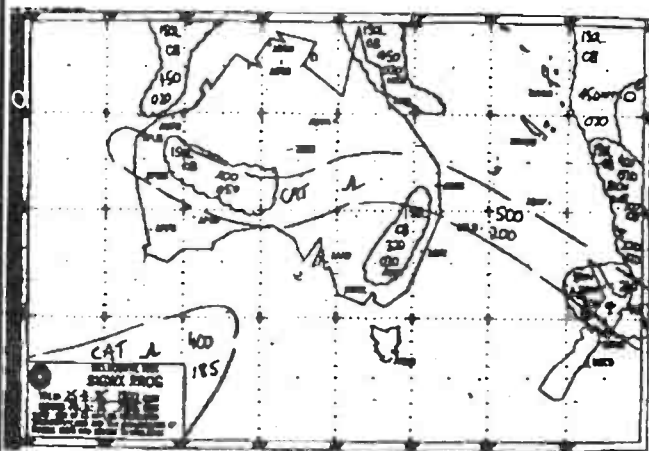

FAX picture

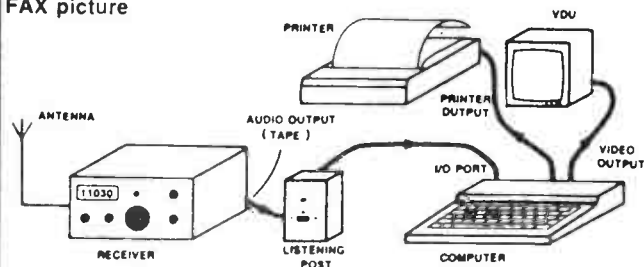

Decode **RADIOTELETYPE/RADIO FACSIMILE PICTURES** &/or CW using your computer and the AEM3500 Listening Post project.

COMPLETE THE COUPON NOW

(a photostat will do) and send us a blank C10 cassette or formatted disk to suit your computer.

- We will gladly re-record any software that doesn't run

Please rush me (tick choices):

- AEM3500 Listening Post software only
- AEM3500 Listening Post Package

to suit the:

Microbee & ... C.Itoh 8510-type ... Epson FX80-type printer	Commodore 64 (most printers)	Apple II (most printers)
--	---------------------------------	-----------------------------

DON'T FORGET TO INCLUDE YOUR NAME & ADDRESS

GET THE AEM3500 "LISTENING POST PACKAGE"

for your • Commodore 64 • Microbee • Apple II.

By building the *Australian Electronics Monthly* AEM3500 'Listening Post', a simple add-on decoder project for your computer and receiver, and using our software, you can receive weather map transmissions, amateur RTTY and foreign news services, plus amateur and commercial Morse transmissions.

There's a whole fascinating new world out there among the non-speech transmissions that were just an annoying 'burble' on your receiver previously.

The package comprises:

- Comprehensive constructional and operational details.
- A quality fibreglass pc board with printed components overlay.*
- Software on either cassette or diskette.

* Components necessary to complete the project are widely stocked by electronics retailers.

All for only **\$33** save over \$6!

Including post & handling

software only - \$23.50

Send to: **AEM Software Service**
PO Box 289 Wahroonga 2076 NSW

I enclose payment by: Cheque Money Order Credit Card
(circle your choice)

Credit Card No.:

Expiry Date: . . . / . . . / . . .

Signed: _____
(Unsigned orders cannot be accepted)

Cheque or Money Order No. _____
(* Please make cheques or Money Orders payable to 'Australian Electronics Monthly')



BETTER RADIO/TV RECEPTION by Ashok Nallawalla, Arthur T. Cushen MBE and Bryan D. Clark. Ashley Publishing, 1986. Soft covers, 130 pages, 210 x 280 mm. ISBN 0 9588532 0 7. \$19.95 inc. postage in Australia. Review copy from the publishers, PO Box 539, Werribee Vic. 3030.

SUBTITLED "A Non-technical Approach", this book "... aims to satisfy the needs of the listener who merely wishes to listen to a distant radio station reliably, as well as the enthusiast who wants to develop listening into a major hobby." I would have to say at the outset that the authors have largely achieved that goal.

All three authors are well-known in shortwave listening and SW broadcasting circles and their collective knowledge and experience is reflected in the breadth of coverage, detail and organisation of the book. If shortwave listening is thought of by some as "old hat", then this publication should entirely dispel that notion. Even if you only give minimal credence to Marshall McLuhan's "global village" concept where the world's scattered communities are glued together by global communications technology, then it is clear that shortwave broadcasting and communications still plays the major role for most of the world's population. And believe me, only a few hours spent listening to the international SW broadcasters will introduce you to a view of world events quite different to that served up by the local radio and TV news networks!

The book is organised in seven chapters: Radio/Television Reception - An Overview, The Broadcasting Bands, Receivers, Antennas, Advanced Topics, The Broadcasters, and The Hobby of Radio DXing. Four Appendices cover Log Sheets, Metrics for Radio/TV, Time Difference Chart and Useful Addresses. A comprehensive index is included. The authors have sensibly taken an 'international' approach and the material is not restricted to this part of the world.

Fundamental concepts of radio receivers, radio transmission, propagation and antennas is covered in a semi-technical way, written at such a level as to be understandable by anyone with a modicum of intelligence and the motivation to persevere. However, the lan-

guage is a little "loose" in places, and simplification makes some material misleading, I feel. The occasional point is wrong. On page 75, we are told the corner reflector antenna is a version of the Yagi. However, such examples appear to be few and, as a whole, the material is well-researched and well-written in a clear style with technical terms and jargon introduced in a natural manner and clearly explained.

Television is given the least coverage, only being touched on here and there in a few chapters, the greater emphasis being placed on mediumwave and shortwave reception. Good advice on purchasing equipment is included, along with practical advice on setting yourself up and how to go about getting the most from your interest. References to other literature - books and magazines - along with helpful organisations is covered in considerable detail, for the authors clearly recognise that there can be no one source of information or advice for such a diverse interest; one appendix lists "useful addresses", covering books, magazines, organisations, manufacturers and major retailers. All very useful, for newcomer and 'old hand' alike. For the record, the authors included a very favourable review of AEM, along with a variety of other publications, but I trust my remarks will not be seen as having been influenced by that.

While the use of computers in the hobby is introduced in Chapter 5, I was disappointed the authors didn't make more of the opportunity to detail how a personal computer can be used to decode the non-voice transmissions to be found littering the high frequency bands. Mention is made that computers can be used for such purposes, but it's left at that. Well, I suppose you have to limit the scope of the book somewhere.

The book was produced on a wordprocessor and 'typeset' using a near letter quality (NLQ) dot matrix printer. Most illustrations were obviously produced using a graphics package and dot matrix printer and a few suffer a little from the inevitable inadequacies. The conventional photographic illustrations included are generally of a high standard and well chosen. The cover is interesting and clearly conveys what the book's about. It contains a little 'joke' which had us intrigued until it was revealed by closer inspection, but you'll have to see the book for yourself. Clearly, the publication is a labour of love and it shows through. When I took up shortwave listening as a high school student, it was just the sort of book I yearned for, but never found. According to Radio Australia, it is the first such book published in Australia and I would agree with that.

All in all, Better Radio/TV Reception is a fine effort from a dedicated team of enthusiasts. If you're at all interested in shortwave listening, mediumwave DXing and related interests, I would recommend it as a necessary inclusion in your library.

- Roger Harrison

KALEX

UV MATERIALS

3M Scotchcal Photosensitive

		Pack Price	
		250 x 300 mm	300 x 600 mm
8001	Red/Aluminium	\$70.15	\$80.75
8005	Black/Aluminium	\$70.15	\$80.75
8007	Reversal film	\$38.20	\$51.40
8009	Blue/Aluminium	\$70.15	\$80.75
8011	Red/White	\$83.20	\$72.70
8013	Black/Yellow	\$83.20	\$72.70
8015	Black/White	\$83.20	\$72.70
8016	Blue/White	\$83.20	\$72.70
8018	Green/White	\$83.20	\$72.70
8030	Black/Gold	\$88.90	\$108.00
8080	Black/Silver	\$83.20	\$72.70

UV PROCESSING EQUIPMENT

KALEX LIGHT BOX

- Autoreset Timer
- 2 Level Exposure
- Timing Light
- Instant Light Up
- Safety Micro Switch
- Exposure to 22in x 11in

\$599.00 + ST

KALEX "PORTU-VEE"

- UV Light Box
- Fully Portable
- Exposure to 10in x 6in

\$199.00 + ST

PCB PROCESSING

KALEX ETCH TANK

- Two Compartment
- Heater
- Recirculation (by Magnetic Pump)
- Two Level Rack • Lid

\$595.00 + ST

RISTON 3400 PCB MATERIAL

SIZE INCHES	SINGLE SIDED	DOUBLE SIDED
36 x 24	\$90.00	\$117.00
24 x 18	\$45.00	\$ 58.50
18 x 12	\$22.50	\$ 29.25
12 x 12	\$15.00	\$ 19.50
12 x 6	\$ 8.00	\$ 10.00

All prices plus sales tax if applicable

KALEX 40 Wallis Ave.,
East Ivanhoe 3079
(03) 497 3422
497 3034
Telex AA 37678



ELECTRONIC COMPONENTS & ACCESSORIES
• SPECIALIST SCHOOL SUPPLIERS

AEM PRINTED CIRCUIT SERVICE

Our printed circuit boards are all manufactured on quality fibreglass substrate and feature rolled-tin over copper tracks and silk-screened component overlays.

AEM1500 METRONOME

A simple, low-cost project with variable beat from 'presto' to 'largo'. Operates from 9 V battery. (Aug. '85)

\$4.70

2500 AUDIO OSCILLATOR

A simple sine/square signal generator for the bench. It covers to 100 kHz and has output amplitude ranges from 30 mV to 3 V, fully variable. Separate sine and square outputs. (Dec. '85)

\$9.65

2600 PEAK RF POWER METER

This simple, low-cost project features a 10-LED bar display and can be made for power ranges from 5 W peak to 400 W peak. (April '86)

\$10.50

AEM3500 LISTENING POST

Our most popular project, by far! It decodes the audio from a SW receiver and, with software, allows your computer (Apple II/BBC/C64/Microbee) to decode RTTY, FAX and Morse. (July '85)

\$12.20

3502 SIGNAL-OPERATED CASSETTE CONTROLLER

Just the thing for taping signals picked up on your SW receiver or scanner while you can't attend. Simple to build, powers from 10-15 V. (Mar. '86)

\$9.20

4500 MICROTRAINER

Take the mystery out of micros. A great project for learning the 'guts' of microprocessing, without having to build a microcomputer. (Sept. '85)

\$28.50

4501 8-CHANNEL RELAY INTERFACE FOR COMPUTERS

Get your computer to control something! Hooks up to 8-bit parallel port or data bus. ('Bee — Oct '85, C64 — Sept '86).

\$13.00

4502 REAL TIME CLOCK

This project plugs into the Microbee's parallel port and gives accurate date/time etc. Battery-backed. (Nov '85)

\$10.50

4504 LOW-COST SPEECH SYNTHESIZER

This simple to build project employs the GI speech chip SPO256-AL2 which allows you to put together 'word parts' to make electronic speech. It employs 8-bit parallel interfacing. ('Bee interface — Feb. '86, with data sheet; C64 interface — July '86)

\$17.30

5501 NEG-ION GENERATOR

Clear the air! Our negative ion generator provides around 8 kV output. Simple and low-cost. (Sept. '85)

\$18.35

AEM6500 MOSFET AMP MODULE

A 'universal' amp module using the Hitachi MOSFETs and able to deliver 60 W with one pair or 120 W with two, into 8 ohms. (July '85)

\$9.70

6501 4-INPUT MIXER

A versatile mixer/preamp for a guitar amp or stage amp. Select resistors to select the input impedance of the channels. (Sept. '85)

\$20.40

6503 ACTIVE CROSSOVER

Here's a high performance four channel (use as many as you need) active crossover that's just right for that active speaker project! (Feb. '86)

\$34.40

9500 BEAT-TRIGGERED STROBE

Just the thing for discos and parties! Project can act as a manually variable strobe or, coupled to an audio source, flash in time with the beat. (July '85)

\$11.30

HOW TO ORDER

Order pc boards by the project number and title • All prices include post and handling • New Zealand purchasers add \$1.00 to these prices • Photostats of the pertinent articles cost \$4.00 each, post paid • With out-of-stock boards there may be a delay in delivery.

All cheques or money orders should be made payable to Australian Electronics Monthly.

Australian Electronics Monthly

PO Box 507, WAHROONGA 2076 NSW (02)487 1207.

PLEDGE YOUR PLASTIC!

Bankcard, Mastercard, Visa & American Express accepted.

PAY BY PAPER!

Cheques or money orders OK. Make them payable to "Australian Electronics Monthly".

You can buy the boards at our offices if you wish, at any time during business hours. We're located at the Fox Valley Centre, Cnr Fox Valley Rd and Kiogle St, Wahroonga NSW. The entrance is in Kiogle St.

literature review

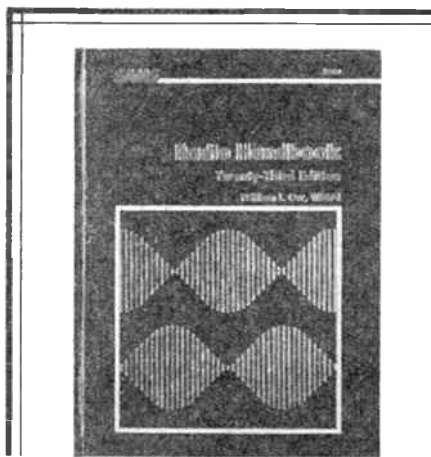

RADIO HANDBOOK, Twenty-Third Edition, by William I. Orr W6SAI, Howard Sams & Co., 1986. Hard covers, 28 chapters, 195 x 254 mm. ISBN: 0 672 22424 0. Review copy from the distributors, Pitman Publishing, Private Bag 19, South Melbourne 3205 Vic. \$75.00 rrp.

WILLIAM I. ORR is indeed a prodigious author of books pertaining to radio communications, but the Radio Handbook would be one text likely to be found on the "must have" list of any enthusiast's library. I still have a copy which I purchased in the early seventies and to which I make frequent reference. After reviewing the latest edition, I realise that it's about time I updated.

Intended as a "working text" as well as a reference book, the Radio Handbook contains information on almost every aspect of radio

theory and practice within its twenty eight chapters. For those who are studying for an amateur license examination or just need to refresh their memory, the introductory chapters provide full details of the fundamental principles. The references to amateur bands and licensing conditions are written for the American market and much of the information will not apply in Australia. Don't let this put you off, radio theory and practice is the same the world over so the majority of the contents are applicable wherever you live.

The Radio handbook is set out in logical order commencing with an introductory chapter on the hobby of amateur radio. Progressing through the fundamentals of electrical and electronic theory, the book continues with chapters covering transmission modes, portable operation, interference, receiving and transmitting techniques and equipment and propagation. The two chapters on constructing HF and VHF power amplifiers are very thorough and give complete constructional details for a range of high power amplifiers. How about a two kilowatt job on seventy centimeters! The book concludes with chapters covering antennae, test equipment, mathematics and calculations and miscellaneous data.

Whilst a good coverage of more familiar technology is provided (yes, there is a chapter on valves!), it is a little disappointing to find only a limited description of some newer modes. Packet radio for example, whilst being one of the largest growth areas in amateur radio, only rates a few paragraphs. I realise it is difficult to give in-depth descriptions of every aspect of the radio hobby in a single volume, but perhaps it would have been a good

idea to provide some reference to further reading for those readers wanting to know more. To be perfectly fair, some aspects such as packet have developed very quickly and it does take a lot of time to produce a book such as this.

Another area which seems a little lacking is in the field of solid-state design and construction, particularly with regard to power amplifier design. I can appreciate that many amateurs would be interested in the design and construction of kilowatt level power amplifiers based on valve technology, but not all countries allow their amateurs to run that sort of power, nor can a large number afford it even where it is permitted. It would have been nice to see some designs for intermediate level power amplifiers, particularly for VHF and UHF.

Despite these minor shortcomings, the new twenty third edition of the Radio Handbook will be just as much a "bible" to many amateurs as my old version has been to me. This is not the sort of book which will sit on your shelf gathering dust. In fact, if you're anything like me, you will end up with margins full of scrawled notes and the occasional page singed by the soldering iron!

Regardless of where your interest in the hobby of amateur radio lies, you will find it invaluable. No book ever written can possibly provide you with all the details on every aspect of a subject as complex and wide ranging as radio communications, but the Radio Handbook goes a long way towards fulfilling that goal. No amateur's library could be considered complete without a copy.

— Andrew Keir

THE WORLD WIDE HOBBY! AMATEUR RADIO ARE YOU A MEMBER OF THE WIA?

Why not become a radio amateur by joining the Wireless Institute of Australia? The Institute can assist and advise you in how to obtain a Department of Communications licence, which will allow you to communicate with others having similar interests in Australia and throughout the world.



The Wireless Institute of Australia is a non-profit society founded in 1910. Since its inception it has nurtured the interests of all Australian amateurs by liaison at all Governmental levels.

Apart from many other benefits as a member, you receive a monthly plastic encapsulated 64 page magazine called Amateur Radio in your letter box each month.

This magazine contains information on all aspects of the hobby such as Technical Projects, Hints and Kinks, Computer Programs, Free Classified Advertisements and Technical Reviews. Regular columnists give details of Contesting, Awards, DX News, Ionospheric Predictions and Solar Activity, Overseas News and VHF/UHF Activity, to name but a few.



SUPPORT YOUR HOBBY — become a member!

For further information, including a sample magazine, write to:
WIRELESS INSTITUTE OF AUSTRALIA
PO BOX 300
CAULFIELD SOUTH, VIC. 3162

Registered Address: 3/105 Hawthorn Road, Caulfield North, Vic.

BKP-AD87012

INDEX VOL. 2 1986-87

MAGAZINE PROJECTS

July '86	AEM3503 Satellite Fax picture decoder	68
	AEM6000 'Ultra-fidelity' MOSFET Power Amp Module, Part 2	56
	AEM4505 'Code-to-speech' Synthesiser, Part 2	49
	AEM4610 Super Modem, Part 4	40
Aug. '86	AEM6504 Power Amp 'Status Monitor'	37
	AEM9501 Dual Rail Power Supply Module	51
	AEM6000 'Ultra-fidelity' mosfet Power Amp, Part 3	44
Sept '86	AEM4605 Super Simple Modem	44
	AEM1501 Three-Chime Doorbell	40
	AEM6000 Stereo Power Amp	50
Oct. '86	AEM8501 Car Alarm	85
	AEM9502 Electric Fence Controller	90
	AEM5506 Lamp Saver	93
	AEM6013 Building the Vifa 3-Way Loudspeakers	97
Nov. '86	AEM2501 Pink/White Noise Generator	69
	AEM9502 Variable Output Electric Fence	74
Dec. '86	AEM9503 Rapid 12 Vdc NiCad Charger	68
	AEM9504 Flash-triggered 'Slave' Strobe	72
	AEM4506 Computer Frequency Counter Interface	80
Jan. '87	AEM6506 Workhouse Audio Power Amp	68
	AEM2502 Digital Data Status/Logic Probe	76
	AEM2505 RF dBm/Millivolt meter, Part 1	110
Feb. '87	AEM4611 V.22 Expansion Board for the Supermodem	92
	AEM2510 Workbench Power Supply	68
	AEM2505 RF dBm/Millivolt Meter, Part 2	106
Mar. '87	AEM2505 RF dBm/mV Meter	76
	AEM3504 Computer Interface for Yaesu Receivers	68
	AEM4611 V.22 Board for the Supermodem	88
Apr. '87	AEM6005 100 W 'U-F' Topology MOSFET Amp	57
	AEM2000 A 'Lab. Standard' 0-55 V 10 A Power Supply, Part 1	53
	AEM4507 Use Your Amstrad as a frequency counter	80
May '87	AEM6005 Upgrade Your Tilbrook 5000 Amp	56
	AEM3510 Simple RTTY Modulator	64
	AEM2000 Lab. Standard Power Supply, Part 2	68
June '87	AEM4622 Stand-alone V.22 Modem	66
	AEM6508 Clipping and Fault Indicator	62
	AEM2000 Lab. Standard Power Supply, Part 3	57

STAR PROJECTS

July '86	1 GHz, 8-digit Frequency Counter	82
Aug. '86	'Modem Coupler' for Commodore 64s and 128s	70
Oct. '86	Field Strength Meter	119
Dec. '86	70cm 50 W All-mode Booster Amplifier	100
Feb. '87	'Extended Pulse Burn' Electronic Ignition	74
Mar. '87	'PBUFF' - 256K Centronics-type Printer Buffer	92
Apr. '87	RF Attenuator Box	92

BENCHBOOK

July '86		94
Aug. '86		97
Sep. '86		97
Oct. '86		127
Nov. '86		79
Dec. '86		113
Jan. '87		102
Feb. '87		81
Apr. '87		74
May '87		94

COMMUNICATIONS

July '86	Simple Antennas for Weather Satellite Reception	78
Aug. '86	Radio Communicators Guide to the Ionosphere, Part 8	77
	Using the Listening Post on the BBC-B Computer	88
Sep. '86	Assembling Common RF Connectors	94
Oct. '86	Build an RF Field Strength Meter	119
Nov. '86	The Ionosphere and Radio Propagation - An Update	16

Dec. '86	All-mode 50 W Amp for 70 cm	100
Jan. '87	The Last Big Solar Maximum	106
Feb. '87	Mobile Communications - on the move, Part 1	11
Mar. '87	Radio Communicators Guide to the Ionosphere, Part 9	107
	Mobile Communications, Part 2	15
Apr. '87	Weather FAX and RTTY News Stations on Shortwave	96
	An RF Attenuator Box	92
May. '87	Menu Selectable CW Message Gen. Using the Microbee	78
June '87	A Guide to Digital Communications, Part 1	84
	Today's RF Test & Measurement Equipment	24

COMPUTING

July '86	Commodore Codex	38
Aug. '86	Review: Microbee 'Premium'	66
Sep. '86	Adapting the AEM4501 Relay Interface to your C64/128	77
	Add-on Keyboard for the Apple II+	82
	Screen Handling on the VZ-200/300, Part 1	89
	Review: A Brace Of Modems	86
Oct. '86	Review: Protel PCB	106
	Screen Handling on the VZ200/300, Part 2	110
	Dial Up	116
Nov. '86	The Amstradder	85
	Dial Up	87
	Commodore Codex	89
Dec. '86	Assembling a PC-compatible	86
	Memory Mapping and Computer Number Systems	90
	Review: The Impact Laser Printer	96
	Dial Up	98
Jan. '87	BeeBuzz	90
	Commodore Codex	85
	Amstradder	89
	Dial Up	82
Feb. '87	Review: Multitech 700 PC	96
Mar. '87	Dial Up	86
	Music, Sound and the Computer Age	100
Apr. '87	What's New in Modems?	8
	Dial Up	85
	Amstradder	84
	Commodore Codex	87
	BeeBuzz	82
May. '87	VZ-Epson Printer Patch, Part 1	86
	Dial Up	89
June '87	VZ-Epson Printer Patch, Part 2	74
	BeeBuzz	76
	Dial Up	80

CONSUMER

July '86	Perth Show Preview	17
Aug. '86	Chicago CES	22
Sep. '86	The 'Imaging Wars'	10
Oct. '86	Perth Electronics Show Roundup	31
Nov. '86	Imaging Wars - Reports from the Fronts	26
	Hi-Fi Review: Marantz PM-94	30
Dec. '86	Home Entertainment and Consumer Electronics, Part 1	12
Jan. '87	Home Entertainment and Consumer Electronics	25
Feb. '87	Hi-Fi Review - a Perfect Match	28
Mar. '87	Las Vegas CE Show	30
Apr. '87	Consumer to Win in DAT Versus CD Battle	76
May. '87	Recent Developments in Bass Speaker Designs	16
June '87	DAT Day Has Come	20

DATA SHEETS

Aug. '86	National JA Relays	62
Sep. '86	Telfunken U450B 3-Tone Ringer	59
Nov. '86	EFG7515 V.22 Modem Chip	79
Jan. '87	LM832 DNR Chip	98

June '87	XR2206	92
	EFG7515 (repeated)	95

FEATURES

July '86	Modern Fixed Capacitors, Part 1	11
Aug. '86	Profile – Dick Smith Electronics	55
Sep. '86	Relays	24
Oct. '86	CAD – Relieving the Design Drudgery	13
Nov. '86	The Ionosphere and Radio Propagation – an Update ..	16
Dec. '86	Home Entertainment and Consumer Electronics, Part 1	12
Jan. '87	Technology and the America's Cup	8
Feb. '87	Advances in Loudspeaker Technology	21
Mar. '87	Telecom's Mobilenet – A User's Review	10
Apr. '87	So What's New in Modems?	8
May. '87	So You Want to Buy a Multimeter?	10
June '87	Hardware Enhancements for PCs and Compatibles ..	10

NEWS & GENERAL

July '86	Ariane rocket crash	9
	Sony releases CD Walkman	15
	Philips' radical new CRO	19
	Microbee plug their '16-bit product hole'	37
	The Eager Eagle	55
	Low-cost local radio FAX	67
Aug. '86	Satellites & Lord Howe Is	9
	New NAD cassette deck	21
	New Fluke DMM	27
	The un-vanished thermistor	35
	TDK get into floppies	64
	Skitube communications	76
Sep. '86	Schools' radio data net	8
	Updating Compu-fi	19
	Philips' hybrid mic amp IC	22
	Piezo transducers	39
	Datacraft export to Japan	74
	New line of scanners	93
Oct. '86	Personal opinion	122
	Conjure magic	8
	Technics' digital piano	30
	In-circuit test instrument	20
	Jaycar Stocking Magnavox	83
	Where're the compatibles?	102
	Emergency services' radio link	118
Nov. '86	Heathkit arrives at DSE	6
	CD Storage solution	25
	Sourcing electric fence bits	67
	'SCRAM' keeps traffic moving	83
	Versa Tuner II	91
	Low-cost generator	95
Dec. '86	Electronics export drive	6
	New National camcorder	20
	New Tektronix CRO	24
	Low loss coax bargain	67
	Pocket RS232/V24 tester	78
	Wide range noise bridge	99
Jan. '87	Optic fibre links south to north	7
	Flat panel speakers	23
	Range of poly capacitors	67
	Tunneling transistor	92
	New 16/32-bit micro tester	81
	Philips study	104
Feb. '87	Electric vehicle races	6
	KEF's new flagship	18
	Finding RF chokes	67
	Upgraded power supplies	83
	Atari goes it's own way	90
	Amateur exam devolvement	99
Mar. '87	Control the bugs	6

	Profile – Statronics	26
	Cinema sound to surround	29
	Retailer supports Elektor kits	67
	Intel's new V22 chip set	85
	New audio connector	99
	Icom's new 'Micro-2' HT	106
Apr. '87	Brisbane-Adelaide optic fibre trunk	6
	Audio Show formula to watch	75
	Scope for wicked work	31
	Locally made XT/AT boards	79
	Pro amp is local product	17
	Sunspots bottom-out	91
May. '87	SQUIDs raise temps	6
	Palm-sized copier	15
	Anitech to sell Kenwood	18
	Remember this one, Sam	54
	New spectrum analyser	77
	Roland graphics boards	85
June '87	New courses launched	6
	TDK updates its range	18
	New low-cost generator	22
	Two new Jaycar stores	56
	Uproar over Novice 2m proposal	83
	Speedy mono graphics card	73

PRACTICALITIES

July '86	Simple Antennas for Weather Satellite Reception	78
Sep. '86	Modular Music Synth., Part 1	60
Dec. '86	Modular Music Synth., Part 2	29
Jan. '87	Modular Music Synth., Part 3	94
Apr. '87	Modular Music Synth., Part 4	65

REVIEWS

Aug. '86	Microbee 'Premium'	66
Sep. '86	Rosser Modems	86
Oct. '86	PROTEL-PCB CAD Package	106
Nov. '86	Marantz PM-94 amp	30
Dec. '87	Blectronics – Electronic 'Lego'	22
	Impact Laser Printer	96
Feb. '87	A Perfect Match – Nakamichi/B&W	28
	Multitech Plus 700	96
Mar. '87	Telecom's Mobilenet	10
Apr. '87	Philips PM 3055 oscilloscope	24
May. '87	Heathkit Digital Weather Station	31

TECHNICAL

July '86	Soldering in the Electronics Industry	23
	Modern Fixed Capacitors, Part 1	11
Aug. '86	Modern Fixed Capacitors, Part 2	58
Sep. '86	Relays	24
	Modern Fixed Capacitors, Part 3	66
	Project Modems Update	88
Oct. '86	Relays, Part 2	22
Nov. '86	Inside the Laser Printer	96
Jan. '87	Mikes on Stage, Part 1	16
Feb. '87	Mikes on Stage, Part 2	85
Mar. '87	Understanding Frequency/Period Counters	104
Apr. '87	Understanding Switched-Mode Power Supplies	19
	Adapting the EPB Ignition to Electronic Points	71
May '87	Recent Developments in Silicon Sensors	7
	Rechargeable Batteries	20

NOTES & ERRATA

Nov. '86	15
Dec. '86	8, 65
Feb. '87	66
Mar. '87	48
Apr. '87	50

INDEX VOL. 2 1986-87

ELEKTOR IN AEM – PROJECTS

Oct. '86	Serial Digitiser	35
	Headphone Amp	40
	Satellite Loudspeakers	42
	Loudspeaker Impedance Meter	47
	DC-Operated Battery Charger	54
	RMS-dc Converter	61
	Rodent Deterrent	62
	VHF Test Oscillator	68
	Heartbeat Monitor	74
	PCBs	80
Nov. '86	Guitar Equaliser	34
	VHF Filters	38
	VHF Amp.	43
	Superregenerative SW Receiver	46
	Darkroom Exposure Meter	48
	Atari Colour Video Interface	50
	Oven-compensated Oscillator	62
	Dec. '86 Barometer/Altimeter	34
	Car Radio Alarm	49
	Octave Generator for Guitarists	55
	Speech Processor with Background Suppression	60
	Guitar Fuzz Unit	61
Jan. '87	IR Remote Switch	34
	Electronic Balance	38
	Car Lights Monitor	46
	True RMS Meter	48
	Temperature Probe	65
Feb. '87	Portable Mixer# - 1	34
	Portable Mixer# - 2	49
	Portable Mixer# - 3	54
	Single-Trace to Dual-Trace CRO Converter	59
	PCBs	48, 66
Mar. '87	VLf Add-on Unit for Oscilloscopes	34
	Electronic Rain Gauge	39
	Mobile Studio Unit	61
Apr. '87	Valve Hi-Fi Preamp	34
	Bi-Phaser FX Unit	40
	SCART Video Adaptor for the IBM PC	43
	Stereo VU Meter	45
May. '87	Motional Feedback in Loudspeakers	34
	Valve Hi-Fi Preamp, Part 2	40
	Facsimile Interface	45
	Linkwitz Crossovers	51
Jun. '87	Midi Signal Redistribution Unit	34
	Midi & Disk interface for the Atari ST	38
	Metal Detector	40
	Capacitance Meter Project	45
	PCBs	52

ELEKTOR IN AEM – ARTICLES

Oct. '86	Loudspeaker Impedance Correction	47
	Inductors in Practice	65
	RF Circuit Design	68
	Electric Propulsion for Satellites	71
	Storage Oscilloscopes	76
Nov. '86	How Much Longer for Silicon?	56
	Magnetic Field Sensors	64
Dec. '86	Sound Sampling & Digital Synthesis	50
	Reproduction Problems with Nov.?	62
	The Battle for Super Television	63
	PCBs	66
Jan. '87	Watchdog Timer	42
	Analogue Wattmeter	43
	Filtering a Computer Connector	47
	Phonebell Simulator	47
Feb. '87	Loudspeaker Efficiency	62
Mar. '87	The Story of Cossor Radar	42
Apr. '87	Field Effect Optocoupler	48
May. '87	Motional Feedback in Loudspeakers	34
	Electronic Potentiometers	37
June '87	Introduction to dc Power Supplies	48
	Secondary Breakdown in Power Transistors	53

– from page 14

CB celebrates ten (legal) years.

of adverts. A typical CB Australia cover featured CB radios — CB Action preferred bikini-clad models with mike in hand.

In the long run, CB Australia closed in early 1979. CB Action continued until 1981, when it too became a casualty of the shrinking market and lack of enthusiasm.

But if the big boys couldn't do it, what was to prevent smaller, independent concerns from having a go? Ex-Action editor Graham Pockett was approached by a low-profile Melbourne publisher to start a new mag. Pockett quickly reunited the old team from CBA, added a few new twists, and CB Focus was born. Despite wide acceptance and growing sales, the publisher pulled out and CBF went out of focus in mid-1982.

Then followed a period when the only CB publications on the newstand came from England, where CB was undergoing a boom to parallel our own 1977-78 peak. It was a ludicrous situation — the gear was different, the mode and frequencies were different (27.6 — 28 MHz FM), and the UK scene held no relevance to Australia.

CB Action made a come-back as a quarterly in 1983, under the guidance of original editor Pete Smith. Again, the essence of the old CBA was still there — many of the same writers, advertisers, columnists — and by popular demand CBA went bi-monthly in 1986.

Writers for the CB magazines have been through the gamut — in demand, out of action, back in demand, idolised by some and scorned as 'know-alls' by others. So today, after the magazine boom from 1977-1979 — where are the disciples who wrote our holy books?

Roger Harison — editor of *CB Australia* and *Electronics Today International*, now Editor/Publisher of this very mag!

Pete Smith — original editor of *CB Action*, now editor of CBA once again; also editor and/or advertising manager for a dozen other publications of Newspress, including *Lets Travel* and *Amateur Radio Action*.

Graham Pockett — editor of *CB Action*, thence editor *CB Focus*; still in touch with the CB scene, but mostly involved in the transport industry.

Brendan Akhurst & famed *CB Australia* cartoonist, was also a policeman at the time! Now full-time cartoonist.

Dan Bartley — created the CBing truckie Terry Walker, who appeared in an immensely popular series of short stories in *CB Action* and *CB Focus*. Passed away July 1983.

Billy Payne — National Director of CREST and regular contributor to *CB Australia* — now a journalist/reporter in TV and radio.

Mike Hurst-Meyers — National Director of NCRA (National Citizens Radio Association) and regular contributor to *CB Australia* — currently works in computer programming and software.

Leon Senior — original UHF columnist and expert with *CB Action* and *CB Focus*; still very active on 477 MHz, vice-president of Melbourne's UHF Omega Radio Club, works in electronics componentry supply.

David Flynn — regular contributor for *CB Action* and *CB Focus* — still active with *CB Action*, and other local and overseas magazines; publicity officer in TV industry.

SUBSCRIBE! TO AUSTRALIA'S TOP ELECTRONICS JOURNAL

Roger Harrison's
**Australian
ELECTRONICS**
Incorporating
Elektor Electronics
Monthly

**The ionosphere and
radiowave propagation
— an update**

John Edmondson
RF Editor, Australian Electronics

So what's new in modems?

Andrew Eske
RF Editor, Australian Electronics

aem project 6005
**A 100 watt 'ultra-
fidelity' topology
MOSFET amp module**

David Fitzgibbon
RF Editor, Australian Electronics

**Recent developments
in silicon sensors**

J. Middlehurst
RF Editor, Australian Electronics

**Consumer to win in the
DAT versus CD battle**

Dennis Lingane
RF Editor, Australian Electronics

**Understanding
'switched-mode'
power supplies**

Roger Harrison
RF Editor, Australian Electronics



**EFG7515 CMOS
SINGLE CHIP DPSK AND FSK A/D
1000 212A BELL 100 V22 A/E**

aem data sheet



aem hi-fi review
**The Marantz PM-94
'digital monitoring' amplifier**

Robert Fitzell
RF Editor, Australian Electronics

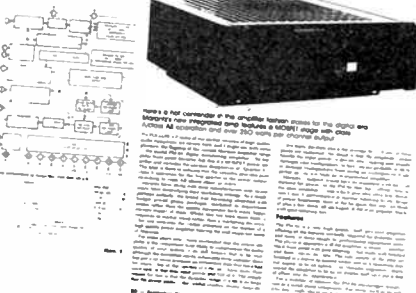

Australia's only independent technical electronics journal, providing a balanced coverage of the fields of audio, broadcasting, pro sound, video, communications, computing, engineering and technology.

For only \$49.95 for 12 issues, you get:

- **5 to 10 projects to build each month**
— the best from our Australian designers and the cream from the British Elektor.
- **Monthly Project Buyers Guide**
— each issue we detail where you can get the components featured in our projects as well as which firms are stocking kits of our projects.
- **Telephone technical enquiries**
— yes, you can speak to the editorial team direct and have your queries answered. We don't live in an ivory tower!
- **Hi-Fi, sound and video news, reviews & features**
— independent, professionally conducted reviews from Robert Fitzell Acoustics; features from well-known writers like Dennis Lingane and Malcolm Goldfinch.
- **Practical computing articles**
— a whole section each month devoted to electronics enthusiasts exploring computing and computing enthusiasts exploring electronics.
- **Communications coverage**
— news, reviews and practical features on RF techniques and radio communications, covering everything from circuit techniques to cellular radio, from satellites to amateur radio.
- **Topical technical features**
— covering consumer electronics, topical technological and scientific fields, current issues and circuit techniques.
- **What's new in the market**
— occasional features on new products and developments, giving topical and informative coverage of specific fields and product groups.

You'll find something to interest you every month in Australian Electronics Monthly, no matter what your special interest might be. The magazine is "sectioned" into categories for easy reading and easy reference, each section headed by its own news column.

If you've found AEM hard to get in your newsagent, **DON'T DELAY, SUBSCRIBE TODAY!**

If you work in electronics, communications, computing or servicing, a subscription to Australian Electronics Monthly could be tax deductible.

COUPON

Yes! Put me down for a subscription to Australian Electronics Monthly at \$49.95 for 12 issues. I am paying by (please circle payment method):

Cheque: (No:) _____

Money Order (No:) _____
(Cheques or Money Orders should be made out to "Australian Electronics Monthly")

Bankcard Visa Mastercard Amex

Card No: _____ Expiry: _____

Signature: _____
(Note: unsigned credit card orders cannot be accepted)

Name: _____

Address: _____

Postcode: _____

The Last Laugh



THE PHONETIC ALPHABET, where words are used to denote letters: CAT being "charlie-alpha-tango", is used by voice communications operators the world over to clearly and unambiguously spell text in messages. It should be well-known to many readers, even if only vaguely remembered from its use on some television soapie or police drama. Readers who remember British comedian Tony Hancock's famous "Hancock's half-hour" piece called "The Radio Ham" will surely recall his use of the phonetic alphabet.

The phonetic alphabet is, in fact, an agreed "standard" so as to avoid ambiguity. That's all fine and dandy, but where its use is unessential – such as when good conditions prevail on the amateur bands – there are those who like to express their individuality by devising new phonetics.

Well, overheard on a certain amateur band recently were a few chaps devising an all-Australian bicentennial phonetic alphabet. A fine and laudable project to publicise the celebrations on the 200th anniversary of European settlement on the eastern shores of Terra Australis, but one that we think would meet with not a little puzzlement from recipients.

"Australia" for A, seems fine and would be widely and readily recognised. "Buledelah" would clearly enunciate the letter B, but would, in itself, be meaningless apart from the problem that a large body of Australians cannot pro-

nounce the town's name correctly in the first place! Besides, it sounds like a term used to describe the negotiations of Italian politicians.

"Coonawarra" for C would be ambiguous unless the recipient appreciated Australian wine (otherwise it could equally stand for K), and would be unappreciated in certain states of the USA. Crocodile (as in Dundee), was favoured by some quarters.

"Dingo" would not have such problems, but would be unappreciated in a certain northern state of Australia, and is probably copyright to a certain national TV program!

"Ettamogah", while making clear the E, would not curry favour with cat lovers

the world over.

"Fosters" was a natural, except that the Canadians think it's their national drink!

There was much heated debate over the use of Koala or Kookaburra for K (we favoured the latter, naturally). Others favoured Kelly, for historical reasons. (King, after the colonial governor, would serve equally well, but obscurity ruled it out).

Try your callsign in bicentennial phonetics; here's VK2AAK, for an example – Vaucluse Kookaburra two Adaminaby Adaminaby Kookaburra. Or VK2ZTB – Villawood Kookaburra two Zetland Tantangara Buledelah! It has a certain ring to it, don't you agree? 

Please send me
more information on
the Bose Loudspeaker Range.

Name

Address

Postcode

AEM7

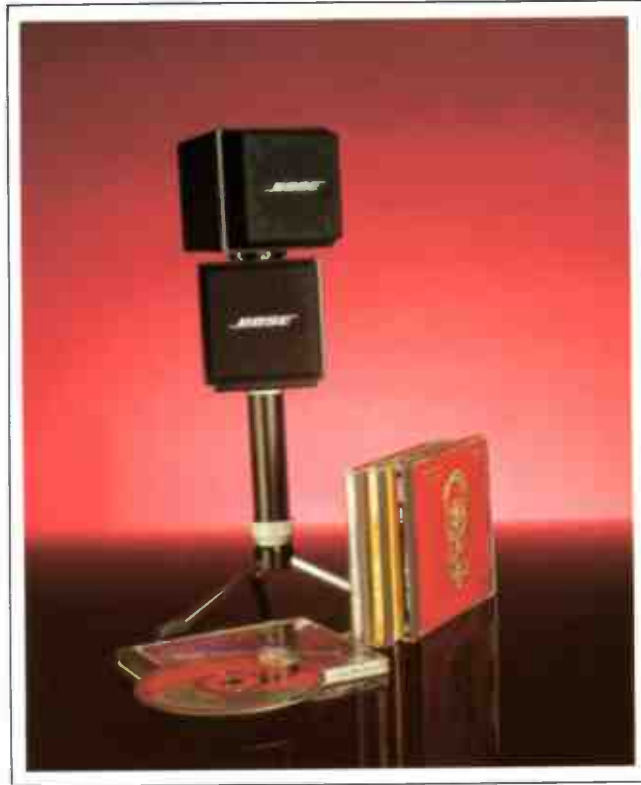

XTRAORDINARY . . .

You expect results when you have some of the best Research and Development facilities in the world together with over 150 of the best researchers.

"No one in our acquaintance who has heard these speakers has failed to be amazed and even awed by their performance. . . In our listening room, side by side with speakers costing three to five times as much, the AM-5 consistently produced the more exciting and listenable sound in A/B tests."

Julian Hirsch
Stereo Review April '87

For more information on all the Bose Loudspeaker Range and a copy of Julian Hirsch's review, contact:

Bose Aust. Inc.
11 Muriel Ave.
Rydalmere 2116 NSW
(02)684-1022

BOSE
Better sound through research.

Always a grand performance



Realistic[®] speaker systems

Tandy Electronics bring you Realistic[®] speakers for music lovers who won't compromise on sound quality or craftsmanship. In fact almost all of our range has a genuine walnut finish. From the mighty Mach Two[®] to our widely acclaimed Minimus[®] series, every Realistic speaker

system is engineered and manufactured to the most rigorous standards ensuring many years of trouble free listening. All Tandy Hi-Fi speakers carry a 5-year warranty. With a total of 18 models Realistic can offer you the right speaker for every conceivable situation and budget.

Tandy
ELECTRONICS

**WE SELL IT
WE SERVICE IT
WE SUPPORT IT**

• Trademark of Tandy Corporation, InterTAN Australia Ltd., being a registered user.