

# ELECTRONICS

Australia

HIFI  
NEWS

JUNE, 1976  
AUST \$1.00\* NZ \$1.20

**NORDMENDE  
TELECINE  
FOR SUPER-8  
MOVIE FILM**

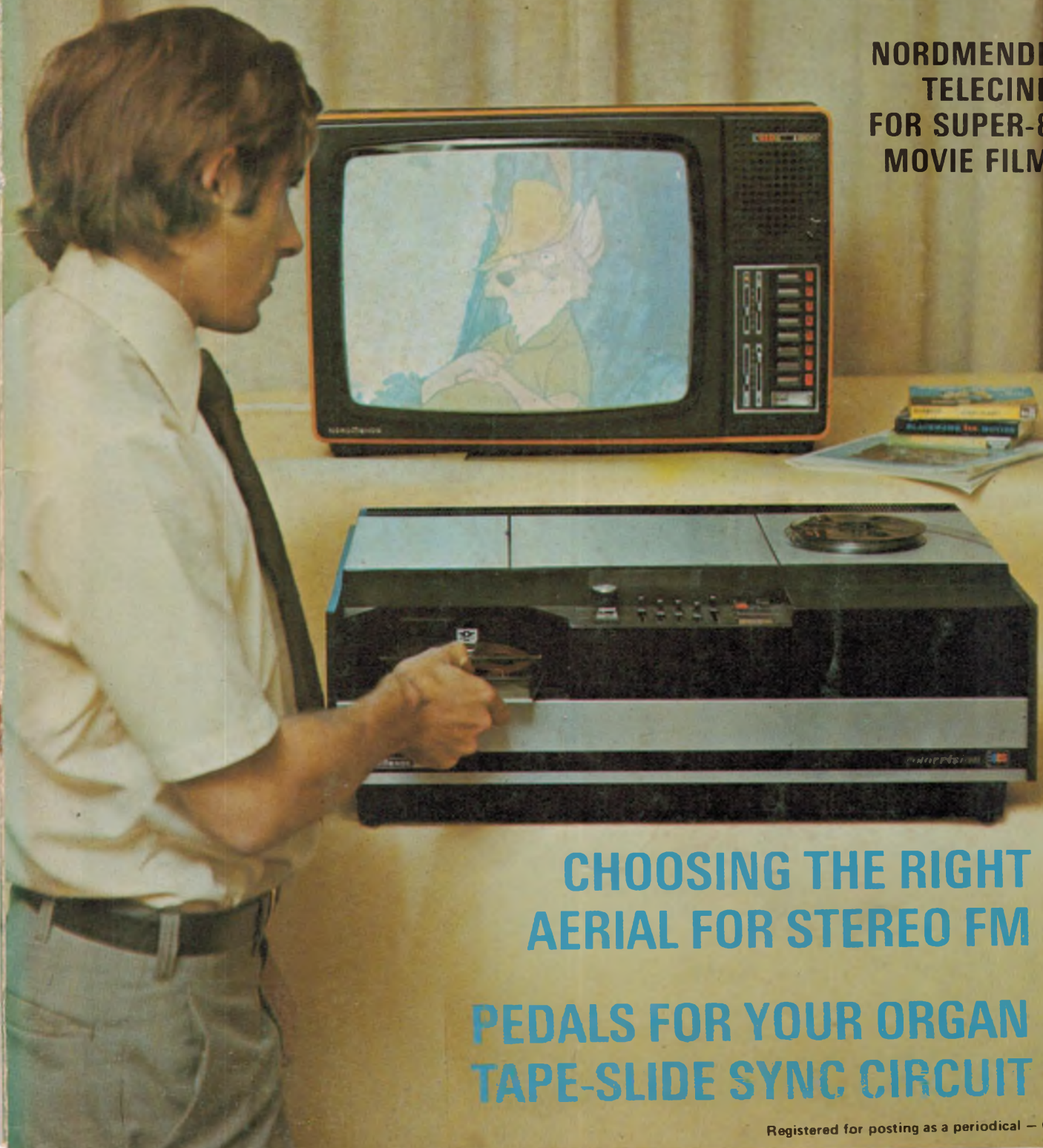

**CHOOSING THE RIGHT  
AERIAL FOR STEREO FM**

**PEDALS FOR YOUR ORGAN  
TAPE-SLIDE SYNC CIRCUIT**



## HOW DOES \$189\* SOUND? SUPERB!

The Sony PS2350 is a magnificent belt-driven turntable totally new in design and materials. The plinth is made of Sony's revolutionary new material BMC (bulk moulding compound), which is almost 100% acoustically dead. The 30 cms aluminium diecast platter and 4-pole hysteresis synchronous motor significantly reduce wow and flutter to under 0.06% (wrms) S/N ratio 63dB. The PS2350 has rubber disc supports to insulate the disc from vibration (a real hassle with conventional turntables). Here are a few of the PS2350's superb features: hydraulic cueing device, auto tone-

arm return, magnetic cartridge, reject mechanism and of course all the care and precision that people who understand good Hi-Fi have come to expect from Sony.

The price? \$189! Have a listen to the Sony PS2350 – we think you'll agree it's superb.

\*recommended retail price.

### “IT'S A SONY”

Hear the difference research makes

GAC.S.7611

For your nearest stockist call SONY Sydney 2.0221 Canberra 95.2100 Melbourne 874.8222 Brisbane 44.4488 Adelaide 268.3444 Perth 81.3422



# ELECTRONICS Australia

Australia's largest-selling electronics & hi-fi magazine

VOLUME 38 No 3

## CONTENTS—JUNE, 1976

### world of electronics and hi-fi



Developed from the earlier Playmaster 3-45L loudspeaker system, our new 3-41L system will stand comparison with commercial units costing a great deal more. We rate this as being one of the most easy-to-live-with speaker systems that we have ever come up with. Full constructional details commence on p36.

- 3 Editorial: Don't applaud—it's your money!
- 7 Hi-Fi News:  
*Tougher approach to RF interference—Marantz AM/FM tuners—Auto programming—Convoy International—Crossover networks*
- 14 Aerial systems for FM-stereo reception
- 19 Review: Sansui SR-525 direct drive turntable
- 21 Review: Otari MX-5050 series professional tape recorder
- 22 Review: Nakamichi 600 2-head cassette console
- 28 The fight against mercury poisoning
- 30 X-ray astronomy and the black holes of gravity
- 32 Flying spot scanner for super-8 colour films
- 74 Forum: A novice exam—in more ways than one

### projects and technical

- 36 3-41L speaker system—fidelity at a price you can afford
- 42 Playmaster Twin Twenty Five stereo amplifier
- 48 Build this simple LED level meter
- 54 The Sync-a-Slide automatic slide advance
- 58 Add a pedalboard to your 760 organ
- 64 An electronic pigeon guard
- 66 DC voltage reference uses precision regulator
- 71 Circuit and design ideas:  
*Wide range metronome—Low noise crystal oscillator—Versatile light alarm—Thermal overload cutout*
- 80 What's new in solid state: Other uses for a LED flasher IC
- 82 The serviceman: Mystery stories—with a difference
- 86 Introduction to digital electronics—6: Logic design practice
- 92 Electronics Australia data: Music frequencies
- 94 High gain power IC with overload protection
- 104 New products:  
*Trio PR-652 lab-type supply—Commodore SR4148 scientific calculator—Toroid & balun kits—CCTV sync generator—VXO controlled 144MHz SSB rig—6A slide switch—Twin 15V supply—Panels for organ*
- 114 Practical electronics demonstration: The Schmitt trigger

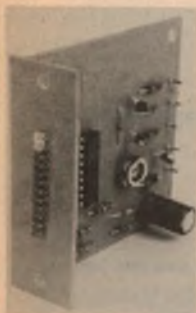

This simple LED audio level indicator can be used to monitor the output from your amplifier. By adding a simple transistor amplifier, it can also be used as a solid state VU meter. Details on p48.

### On the cover

Designed to play back super-8 movie film on a conventional colour TV receiver, this NordMende Colorvision CCS flying spot camera was recently submitted to us for review. The unit is shown here displaying a single movie frame on a companion NordMende 1800 (44cm) colour TV receiver. Our article on page 32 gives the technical details and summarises our impressions of the system.

### regular features

- 24 News highlights
- 96 Record reviews—classical
- 99 Record reviews—devotional, popular, jazz
- 110 Letters to the editor
- 112 Book reviews
- 117 The amateur bands
- 121 Shortwave scene
- 123 Information centre
- 126 Marketplace—classified
- 128 Index to advertisers
- 47, 125 Notes and errata

# Once again Europe sets the standard for speakers

## -and you install them yourself!



Sooner or later in the search for that perfect sound you come up against an inescapable fact. You have to turn to Europe.

Today's range of Philips High Fidelity Loudspeakers represents the finest that Europe has to offer. We can supply full instructions for you to install them yourself.

The Philips range comprises tweeters, squawkers and woofers which you can combine into systems to satisfy the hardest-to-please sound fanatic. Some of the systems are available in kit form complete with woodwork and full assembly instructions.

To assist you in your selection we supply full performance data and details on mounting and enclosure for each speaker.

If you would like to know more about these superb imported European units, then send in this coupon:—

#### Philips Electronic Components and Materials

Sydney.....	42 1261
Melbourne.....	.69 0300
Brisbane.....	277 4822
Adelaide.....	223 4022
Perth.....	.65 4199

Philips Electronic Components and Materials,  
P.O. Box 50, Lane Cove, N.S.W. 2066

Please send me details and enclosure  
information on your  
High Fidelity Loudspeakers.

Name .....

Address .....

Postcode.....



**Electronic  
Components  
and Materials**

# PHILIPS



## Editorial Viewpoint

### *Don't applaud—it's your money!*

A couple of weeks back, a letter from an overseas reader uncovered a series of very unpalatable facts. Let me recount the events as they happened:

The reader complained, with rather more sadness than bitterness, that he had recently been defrauded by one of our mail order advertisers. Late last year he had ordered an item, which had duly been supplied, but with a request for a further \$1.50 remittance to cover additional despatch costs. He had responded by enclosing \$20.00 in Australian currency in a registered letter, covering the previous short payment and a further order. Weeks passed and nothing happened.

Thinking that his money may have gone astray, he wrote again but the second letter was also ignored. This threw a serious doubt on the supplier—hence his letter to us to ask whether the firm did, in fact, have a reputation for shady dealing.

When we checked with the supplier, there was no sign of either letter in the normal mail register but further checking revealed that a registered letter from the particular overseas country had, in fact, been signed for about the relevant time. Then the story came out.

At least one employee in the company had been helping themselves to currency notes which customers had chosen to forward in registered envelopes, in lieu of cheques or money orders which would have had to pass through the system.

When we started to ask more questions, we found that pilfering from electronics suppliers was almost a way of life, made all the more easy, these days, by the small size and high monetary value of many of the components concerned.

The least pleasant story was one concerning a ring allegedly operating in a Sydney school, which specialised in the supply of electronic components. Anybody wanting a particular part would order it and, in due course, a member of the ring would steal one and sell it for half the marked price. A variation was to insinuate a member of the ring into a store on a part-time basis, so that they could undercharge appropriate customers.

As shown by a survey following the recent big Melbourne hold-up, a significant section of the public tends to tolerate dishonesty and even to see some kind of perverted heroism on the part of those who are game to buck the system. What we don't realise is that they are bucking—us!

The supplier in question didn't argue with the overseas customer who had been disadvantaged; as usually happens with most of our advertisers, they made good the loss to the overseas customer. And, of course, the results of pilfering, deceit and fraud all have to be absorbed.

But don't let's delude ourselves. If a company is to operate at a given profit level, every percent lost due to dishonest practice is a percent that has to be distributed across legitimate sales. So, if you're aware of someone pinching parts, don't be tempted to applaud them as heroes getting even with the system. Every time you spend a dollar legitimately, you'll be subsidising their activities.

—W. N. Williams

#### EDITOR-IN-CHIEF

Neville Williams  
M.I.R.E.E. (Aust.) (VK2XV)

#### EDITOR

Jamieson Rowe  
B.A. (Sydney), B.Sc. (Technology, NSW)  
M.I.R.E.E. (Aust.) (VK2ZLO/T)

#### ASSISTANT EDITOR

Philip Watson  
A.M.I.R.E.E. (Aust.) (VK2ZPW)

#### SCIENCE FEATURES

Greg Swain, B.Sc. (Hons. Sydney)

#### PRODUCT REVIEWS

Leo Simpson

#### TECHNICAL PROJECTS

David Edwards, B.E. (Hons. Tasmania)  
Ian Pogson (VK2AZN/T)

#### GRAPHICS

Robert Flynn

#### PRODUCTION

Daniel Hooper

#### ADVERTISING MANAGER

Selwyn Sayers

#### CIRCULATION MANAGER

Alan Parker

ON SALE THE FIRST MONDAY OF EACH MONTH

Printed by Dalley-Middleton-Moore Pty Ltd, of Wattle St, Sydney and Masterprint Pty Ltd of Dubbo, NSW, for Sungravure Pty Ltd, of Regent St, Sydney.

\*Recommended and maximum price only.

#### Editorial Office

12th Floor, 235-243 Jones Street, Broadway, Sydney 2007. Phone 2 0944. Postal Address: PO Box 163, Beaconsfield 2014.

#### Advertising Offices

Sydney—57-59 Regent St, Sydney 2008. Phone 699 3622.

Representative: Narcisco Pimentel.

Melbourne—392 Little Collins St, Melbourne 3000. Phone 67 8131.

Representative: Keith Watts

Adelaide—Charles F. Brown & Associates Ltd, 168 Melbourne St., North Adelaide 5006.

Representative: Tom Duffy 267 4377.

Perth—454 Murray Street, Perth 6000.

Representative: Jack Hansen 21 8217.

#### Subscriptions

Subscription Dept, John Fairfax & Sons Ltd, GPO Box 506, Sydney 2001.

#### Circulation Office

21 Morley Ave, Rosebery, Sydney 2018. Phone 663 3911.

#### Distribution

Distributed in NSW by Sungravure Pty Ltd, 57-59 Regent St, Sydney, in Victoria by Sungravure Pty Ltd, 392 Little Collins Street, Melbourne; in South Australia by Sungravure Pty Ltd, 101-105 Weymouth St, Adelaide; in

Western Australia by Sungravure Pty Ltd, 454 Murray Street, Perth; in Queensland by Gordon and Gotch (Asia) Ltd; in Tasmania by Ingle Distributors, 93 Macquarie St, Hobart; in New Zealand by Gordon and Gotch (NZ) Ltd, Adelaide Rd, Wellington.

#### Copyright. All rights reserved

Devices or arrangements shown or described herein may embody patents. Information is furnished without responsibility for its use and without prejudice to patent rights.

All manuscripts, photographs and other material submitted to Electronics Australia for publication must be accompanied by a stamped, addressed envelope. Contributions are submitted at the sender's risk, and responsibility for loss cannot be accepted by Electronics Australia.

# Nakamichi revolutionary new cassette systems

Nakamichi tape decks' many special features take them well beyond the capabilities of other cassette decks . . . and into a range that makes possible professional applications otherwise virtually unthinkable.



**NAKAMICHI 1000 TRI-TRACER** The Nakamichi 1000 probably represents the most advanced cassette deck ever made. Nothing has been spared to ensure a level of performance that rivals that of professional reel-to-reel recorders. Noise has been reduced to the vanishing point. Speed stability is unconditional. Frequency response has been extended to beyond audibility. Particular emphasis has been placed on reliability and ease of operation. To achieve these goals, conventional cassette technology had to be discarded and new, innovative solutions found. Foremost among them is the use of three completely separate heads for erase, record and playback.

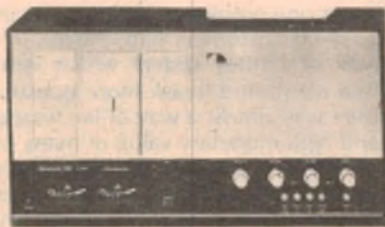

**NAKAMICHI 700 TRI-TRACER** The Nakamichi 700 was created in response to the demand for a machine that could offer the essential performance of our highly acclaimed Model 1000 Tri-Tracer, but at a more modest cost. Since a compromise in performance was unthinkable, the alternative was to simplify the design and develop new construction techniques that would permit cost reductions while maintaining quality. The 700 employs the same advanced transport system and shares most of the features of the more expensive model. Central to both Tri-Tracers are three separate heads, erase, record and playback.



**NAKAMICHI 500 DUAL-TRACER** extends cassette technology to in-the-field recording. The 550 employs Nakamichi's exclusive Focused-Gap head for extended high frequency response and extremely low distortion. With its own self-contained battery power supply, the Nakamichi 550 may also be operated from a car battery, or from a standard AC line (adaptors supplied). Professional 45 dB range, peak level meters attest to the unit's extended dynamic range and are especially useful during live recording sessions. Under rigorous field conditions or in your home the Nakamichi 550 is the perfect companion.



NAKAMICHI

**VICTORIA:** Allans Music (Aust.) Ltd, Melbourne 63 0451 • Encel Electronics Pty. Ltd. Richmond 42 3761 • Instrol Hi-Fi, Melbourne 67 5831 • Southern Sound, Melbourne 677 7869 • Southern Sound, Moorabin 97 7245 • Tivoli Hi-Fi, Kew 80 4956  
**N.S.W.:** Arrow Electronics, Sydney 29 8580 • Convoy Sound, Sydney 358 2088 • The Gramophone Shop, Westfield Shopping Town, Parramatta 633 2846 • Instrol Hi-Fi Pty. Ltd., Sydney 29 4258 : 290 1399 • Jock Leate Pty. Ltd. Hurstville 579 6399  
 Milversons Pty. Ltd. Brookvale 938 2205 • Milverson Pty. Ltd. Chatswood 412 2122  
 Milverson Pty. Ltd. Parramatta 635 3588 • Riverina Hi-Fi, Brookvale 938 2662 • United Radio Distributors Pty. Ltd, Sydney 232 3718 • Wests Pty. Ltd. Burwood 747 4444  
**QUEENSLAND:** Audio Laboratories, Milton 36 0080 • **TASMANIA:** Bel Canto, Hobart 34 2008 • W.A. Technical Services (W.A.) Pty. Ltd, Mosman Park 31 5455  
**A.C.T.** Pacific Stereo, Manuka 95 0695 • Duratone, Aintree Court, Phillip 82 1388.

To: Convoy International Pty. Ltd.  
 4 Dowling Street, Woolloomooloo. NSW 2011  
 Please send me your fully detailed brochure on  
 Nakamichi 1000  Nakamichi 700  
 Nakamichi 550  
 Name \_\_\_\_\_  
 Address \_\_\_\_\_



## Does your system hunger for one?

Hi fi systems also need the right kind of nourishment. One of the most effective ways of providing it is featured above: the AKAI AA-1020 AM/FM Tuner Amplifier.

It puts out 20 effortless watts RMS per channel (both channels driven, from 20 to 20,000 hz, no more than 0.4% THD into 8 ohms load). It comes with the kind of facilities that produce the best kind of sound. And at \$340†, the price isn't likely to turn you off.

But maybe your system hungers for a lot more power, in which case

you should see our more powerful models.

Of course, like all AKAI hi fi equipment distributed by AKAI Australia, it comes with our Complete Protection Plan\*. Which simply means 12 months full parts and labour warranty on all Tape Equipment, 2 years full parts and labour warranty on all Amplifiers, Turntables and Speakers and a lifetime warranty on all GX Tape Heads.

So, if your amplifier isn't all it should be, see your AKAI dealer. He'll put your mind at ease.

The AKAI Hi-Fi Professionals are **NEW SOUTH WALES — SYDNEY CITY AND METROPOLITAN** Sydney: Douglas Hi-Fi, 338 George Street; Duty Free Travellers Supplies, 400 Kent Street; European Electronics, 187 Clarence Street; Instral Hi-Fi, Cnr. Pitt & King Streets; Magnetic Sound Industries, 32 York Street; Jack Stein Audio, 275 Clarence Street. **Bankstown:** Selsound Hi-Fi, Cnr. North Terrace & Apian Way. **Burwood:** Electronic Enterprises, 11 Burwood Road; Edge Electrix, 31 Burwood Road. **Concord:** Sonaria Music Services, 24 Cabarita Road. **Cremona:** Photo Art & Sound, 287 Military Road. **Crows Nest:** Allied Hi-Fi, 330 Pacific Highway. **Hurstville:** Hi-Fi House, 127 Forest Road. **Liverpool:** Miranda Stereo & Hi-Fi Centre, 166 Macquarie Street. **Miranda Fair:** Miranda Hi-Fi & Stereo Centre, Shop 67, Top Level. **Mona Vale:** Warringah Hi-Fi, Shop 5, Mona Vale Court. **Parramatta:** Gramophone Shop, Shop 151, Westfield Shoppingtown. **Selsound Hi-Fi:** 27 Darcey Street. **Roselands:** Roselands Hi-Fi, Gallery Level. **South Hurstville:** Selsound Hi-Fi, 803 King Georges Road. **Summer Hill:** Fidelia Sound Centre, 93B Liverpool Street. **Sutherland:** Sutherland Hi-Fi, 8 Boyle Street. **Waitara:** Hornsby Hi-Fi, 71 Pacific Highway. **Westleigh:** Sound Incorporated, 16 Westleigh Shopping Centre. **NEW SOUTH WALES COUNTRY:** Albury: Habrecht's Radio & TV, 610 Dean Street. **Bega:** Easdowns, 187-191 Carp Street. **Bowral:** Fred Hayes, 293 Bong Bong Street. **Broken Hill:** Pee Jay Sound Centre, 364 Argent Street. **Gosford:** Gustord Hi-Fi, 163 Mann Street. **Miranda Stereo & Hi-Fi Centre:** Cnr. Donnonson & Baker Streets. **Moss Vale:** Bourne's Merchandising, 1 White Street. **Newcastle:** Ron Chapman Hi-Fi, 880 Hunter Street; Eastern Hi-Fi, 519 Hunter Street. **Nowra:** Nowra Hi-Fi, Shoalhaven Arcade. **Taree:** Taree Photographics, Graphic House, 105 Victoria Street. **Wagga Wagga:** Habrecht's Radio & TV, 128 Baylis Street. **Wollongong:** Hi-Fi House, 268 Keira Street; Selsound Hi-Fi, 2-6 Crown Lane. **A.C.T. Civic:** Allied Hi-Fi, 122 Bunda Street. **Fyshwick:** Allied Hi-Fi, 3 Paragon Mall, Gladstone Street. **QUEENSLAND:** Brisbane: Chandler's, 120 Edward Street; Chandler's, 399 Montague Road, West End; Stereo Supplies, 95 Turbot Street; Tel Air Electronics, 187 George Street. **Nambour:** Custom Sound, Currie Street. **Mt Isa:** The Sound Centre, West Street. **Rockhampton:** Chandler's, 144 Alma Street. **Southport:** Stokes Electronics, Scarborough Street. **SOUTH AUSTRALIA:** Adelaide: Ernsmiths, 48-50 King William Street; Flinders Trading Co., 55 Flinders Street; JB Electronics, 115 Gouger Street. **Blackwood:** Blackwood Sound Centre, 4 Comondell Parade. **Glenside:** Steiner Electronics, Conygham Street. **Moana:** Bob Carmen, 185 Commercial Road. **VICTORIA:** Melbourne: Douglas Hi-Fi, 191 Bourke Street; **Warrnambool:** A. G. Smith, 159 Liebig Street. **WESTERN AUSTRALIA:** Perth: The Audio Centre, 883 Wellington Street. **Calista:** Hub Hi-Fi, Kwinana Hub, Gilmore Avenue. **East Victoria Park:** Japan Hi-Fi, 889 Albany Highway. **Nedlands:** Audio Distributors. **Nedlands:** Audio Distributors. **Broadway Shopping Centre:** Broadway. **Midland:** Midland Audio, 16B Great Northern Highway. **Mosman Park:** Audio Distributors, 14 Glvde Street. **WA COUNTRY:** Bunbury: Aabel Music, 130 Victoria Street. **Kalgoorlie:** Hambley's Hi-Fi, Shop 13, Central Arcade, Hannan Street. **TASMANIA:** Burnie: James Loughran & Sons, 29-31 Wilgot Street. **Hobart:** Quantum Electronics, 181 Collins Street. **Launceston:** Wills & Co., 7 Quadrant. **NORTHERN TERRITORY:** Darwin: Pflitzers Music House, Smith Street.

\*The Complete Protection Plan does not cover equipment purchased outside Australia. †Recommended retail price only.

70613R

# AKAI

The name you don't have to justify to your friends.



PEERLESS FABRIKKERNE A/S is a DANISH company specialising in the development and production of loudspeaker units for the High Fidelity industry all over the world.

# KIT 20.3



8" WOOFER-L 825WG  
5" MIDRANGE-650 MRC  
2 1/4" TWEETER-MT225 HFC

# \$124 PER PAIR

SPEAKER KITS ONLY  
NO TIMBER

CROSSOVER FREQ.	1500 & 6000 CPS
POWER HANDLING	50 WATTS RMS
POWER REQUIREMENT	6 WATTS RMS
FREQ. RESP.	55-20,000 CPS
CABINET SIZE	20 LITRES

Sound pressure response curve for system 20-3.

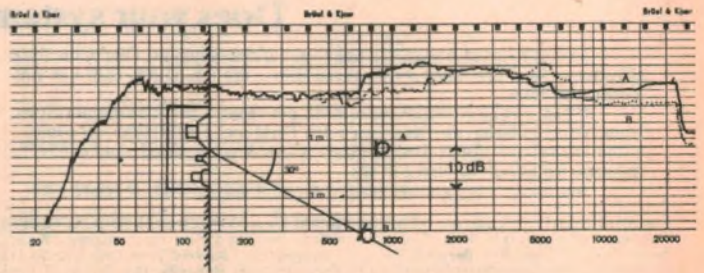

Curve A: Axial pressure response frequency characteristic measured as per DIN 45500.  
Curve B: Corresponding curve measured 30° from axis (normal listening direction by stereo).

Danish HI FI Southern Cross Plaza 638930 and Burke Road, Camberwell 824839 Melbourne Convoy Technocentre Woolloomooloo 3582088 Sydney.  
Danish HI FI Mount Lawley 710100 Perth Brisbane Agencies Audio Centre Fortitude Valley 219944 Brisbane.





# Hi Fi News

## Tougher approach to RF interference

Senator Barry Goldwater, in the USA, has submitted a Bill for consideration which shifts the onus for minimising RF interference problems back to the manufacturers of audio and other consumer electronic equipment. If the measure is adopted, new domestic audio and video devices will have to include a prescribed amount of in-built protection against penetration by external radio frequency energy.

The scenario is a fairly familiar one in urban areas, be they in the USA, Australia, or elsewhere.

John Citizen has a hifi amplifier system and/or a tape recorder, of which he is justly proud. It has worked fine for months—even years—but one day it produces a rapid-fire string of loud clicks which he ultimately recognises as a Morse Code transmission. Or maybe he is left in no doubt as an unmusical voice calls: "Hello CQ; hello CQ . . ." Or: "the handle here is Richard . . . Richard Smythe".

At first he is intrigued, then agitated as he realises that the occurrence is likely to be the harbinger of many more. He likes tape but certainly not ticker tape; nor does he want to be stabbed in the Back!

The following weekend, the cent drops as he spies a new aerial mast in a backyard a couple of doors up the street. The fellow's an amateur (or a "ham"); he's interfering with my beautiful hifi gear, and it's gotta stop! A protest is made, a letter is despatched to the

authorities and, in due course, a radio inspector wends his weary way to the respective addresses.

Most likely, the amateur transmitter will be found to be legal and in good working order and there's no real reason why the owner should not go on transmitting to his heart's content—and be hanged to the bloke up the street! But, in the interest of neighbourly relations, he will probably curtail his activities or offer some help to resolve the problem.

But, whether he deserves it or not, he

by  
**NEVILLE  
WILLIAMS**

## Marantz AM/FM tuners

Auriema (Australasia) Pty Ltd announce the completion of their new AM/FM stereo tuner range, as pictured above. All the tuners feature "gyro-touch" tuning dial, a phase lock loop stereo demodulator, and a highly competitive performance in their price class. Model 150 (bottom of picture) has specifications appropriate to the top of the range, extensive control facilities and a built-in oscilloscope for optimum tuning: price is \$795.00. Model 125 (immediately above it) has marginally less ambitious specifications and twin meters in place of the oscilloscope: price is \$459.00. The remaining tuners, model 112, and model 104 (top) sell respectively for \$299.00 and \$199.00. All tuners are covered by a 3-year warranty on parts, labour and specifications. (Auriema (Australasia) Pty Ltd, P.O. Box 604, Brookvale 2100.)

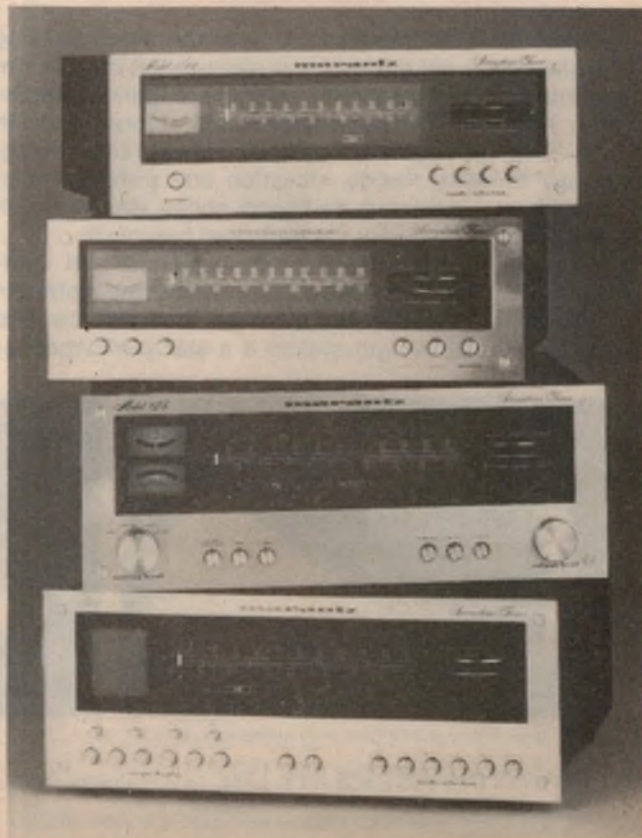

is cast in the role of the offender. Everything was fine until he arrived on the scene!

The real problem is that very little consumer audio equipment has much in the way of internal shielding or filtering to combat external RF energy. It is wide open to interference from modest transmitters nearby, broadcast stations in the vicinity, or more distant powerful radar scanners. One could also mention stray radiation from television receivers or switching impulses on the power mains; they can all gain access by way of input leads, speaker leads or power leads.

Much the same is true of domestic television receivers. For all their sophisticated circuitry and pretty colours, the picture is prone to interference from other legitimate transmissions, as evidenced by the troubles that followed the inauguration of FM/stereo broadcasts in Sydney and Melbourne. Or again, when radar emissions from ships, held up off Sydney by a harbour strike, interfered with TV receivers all up and down the coastal fringe.

Curiously, the adoption of modern solid-state circuitry has added to the problem. While transistors and integrated circuits permit—and encourage—very sophisticated design, they are more prone than valves to overload and cross-modulation in the presence of powerful radio frequency signals. The need for shielding and filtering is therefore more acute than ever.

The new measure submitted by Senator Goldwater is defined as: "S.3033. A bill to amend section 302 of the Com-

# Disco use challenges a cartridge... that's why Stanton is the first choice of disco pros, as it is of broadcast pros



"Bobby DJ warming up at Infinity disco, New York City"

Discotheques represent one of the most grueling professional situations for a pickup that can be imagined. Not only must the cartridge achieve a particular high level of sound excellence, it must do so in the "live" environment of back cueing, slip cueing, heavy tracking forces, vibration and potential mishandling . . . where a damaged stylus means much more than lost music; it means lost business.

For such situations Stanton designed and engineered a new cartridge . . . the 680EL. Its optimum balance of vertical stylus force, compliance and stylus shank strength makes it a star performer for

any physically demanding situation, whether it be disco or radio broadcast. However, if modesty of investment is critical, then choose the 500AL, a beautiful but tough performer that has become deservedly known as the "workhorse" of the broadcast industry.

If your need is for disc-to-tape transfer where the absolute in sound excellence must be achieved, the Stanton 681 Triple-E has to be the only choice. In fact, whatever the need . . . recording, broadcast, disco, or home entertainment . . . your choice should be the choice of the Professionals . . . STANTON.



"Larry Levan spinning at SoHo Place, award winning disco, N.Y.C."



"Dancing at Infinity"



For further information  
write to:

**LEROYA INDUSTRIES PTY. LTD.** 156 Railway Pde., Leederville, Western Australia 6007 Tel. 81-2930

**FOUNTAIN MARKETING LIMITED** P.O. Box 5029 • Auckland, New Zealand • Phone 763-064

## HIFI NEWS—continued

munications Act of 1934 to authorise the Federal Communications Commission to prescribe regulations with respect to certain electronic equipment that is susceptible to radio frequency energy interference”.

Speaking to the Bill, Senator Goldwater said:

“Mr President, I am pleased to introduce today a companion bill to legislation proposed by Congressman Charles Vanik of Ohio to drastically reduce the amateur and CB radio bugaboos of television interference, hi-fi interference, and other radio frequency interference to home electronics equipment.

“Most consumers do not understand that when they may encounter interference with their home television or radio set after an amateur or citizen band radio operator moves next door, the source is not a defect in the equipment of their neighbour but with their own radio or television receiver. It is perfectly legal and appropriate for the ham or CB radio operator to be using his or her unit and the fault lies with the radio, phonograph, or television equipment which is not, but could easily be, adequately shielded from unwanted signals. This interference can be corrected in almost all cases by the installation of simple filtering or shielding parts and could be accomplished most efficiently and economically if it were done by the manufacturer.

“Mr President, the bill I am introducing would help to clear up radio frequency interference not only in radio and television receivers, but in all home audio and visual electronic equipment. It would authorise the Federal Communications Commission to prescribe regulations with respect to home electronic equipment that is susceptible to this interference so that the equipment would operate free from such interference.

“Mr President, I ask unanimous consent that the bill be printed in the Record.”

One can well imagine hifi equipment manufacturers wincing at this proposed requirement—just one more thing destined to add to their design problems and to the ultimate cost.

Fortunately, it is not likely to represent too great an imposition. Strategically placed inductors and bypass capacitors in certain input, output and power leads can make a lot of difference, while shielding may involve little more than a preference for earthed metal panels rather than purely cosmetic plastics and woodwork. Only if the FCC set “impractical” standards for RF rejection would the problem multiply into a major one.

Curiously, although the occurrence of RFI (radio frequency interference) is well



*Charged with the responsibility of steering the Christian Broadcasting Association towards its own FM-stereo licence, Manager Ben Whitnall commissions Sydney's first full automated radio program equipment. It is currently being used in conjunction with the ethnic station 2EA.*

known in this country and elsewhere, little seems to have been said about it at an official industry level. There have been endless discussions about the rights and wrongs of specifying amplifier and other equipment performance, but you will look in vain for anything relating to rejection of unwanted signal energy.

Senator Goldwater's quite logical Bill is almost certain to start the ball rolling around the World. If equipment has to meet certain requirements to qualify for the American market, the necessary

design measures will be adopted by all international manufacturers, almost as a matter of course.

Having in mind the ever-increasing number of transmitters in use, perhaps it's just as well!

**AUTO PROGRAMMING:** What is claimed to be Sydney's first fully automated radio programming system was commissioned recently in the studios of the Christian Broadcasting Association, at Five Dock. Manufactured in Melbourne



*Claimed to be “eminently suitable for Australian conditions”, this new APAN AM/FM-stereo receiver, with AFC, offers 35W RMS per channel into 8 ohms, with both channels driven. It provides access for phono and tape, switching for two pairs of loudspeakers, twin tuning meters, well illuminated dial and generous control facilities. Specifications are good and the distributors claim that it represents outstanding value for their recommended retail price of \$299. For further information and specifications: Mr P. Harris, Ralmar Agencies Pty Ltd, 71-73 Chandos St, St Leonards, NSW 2065.*

# C.E.C. has a turntable to turn YOU on...



BD1000

## the ideal system starter BD1000 complete with EMPIRE 2000E cartridge

- Wow and flutter less than 0.12%.
- Rumble better than 40DB.
- Complete in fully imported base and cover.

Frequency response 10HZ to 30KHZ tracking 1 to 3GM.



BD7000

## for the audiophile BD 7000

- DC Hall motor—Servo controlled.
  - Built-in strobe light.
  - Fine speed adjustment.
  - Auto or manual operation.
  - Wow and flutter less than .04% (WRMS).
  - Signal to noise ratio 65DB (DINB).
  - Tracking weight 0.25 to 3GM.
  - J-shaped tone arm with hydraulic cueing.
  - Magnificent, fully imported base and cover.
- The BD7000 is supplied without cartridge.

The  turntable range includes the semi-automatic BA300 and fully automatic BA600. One of the four models is right for you. All have the famous C.E.C. 5-YEAR WARRANTY.



 harman australia pty ltd  
271 Harbord Road, Brookvale, Tel 939 29 22  
PO Box 6, Brookvale NSW 2100

---

## HI-FI NEWS—continued

---

by Consolidated Electronic Industries, the system is a vital part of a complete stereo re-equipment program initiated by CBA, partly in anticipation of on-going needs, and partly to be ready in the event of the Association being granted its own FM-stereo broadcasting licence.

CBA claim that they are in a particularly good position to take advantage of such a licence, having a multi-studio complex fully equipped and fully operational, and extensive experience at providing programs for existing AM broadcasters.

CBA are not saying too much about their proposed program format but it seems fairly evident that they are thinking along the lines of good quality middle-

*At right are the restyled premises which house Convoy International Pty Ltd. Keynote to the styling is the big "C" on the face of the building. For hifi customers, one suite is devoted entirely to B&O equipment. A second suite features a variety of top brands while a third is the "Connoisseur's Room".*



*At left, from Electrosonic: a single screen presentation unit type ES3601. It will superimpose slides, dissolve, or make snap changes. The unit is portable—in two handy carrying cases—and is completely self contained, with its own tape system and loudspeaker. Alternatively, it can be connected to an external type system and/or amplifier, and can be operated as part of a live presentation. Projectors are specially modified S-AV2000 carousel models.*

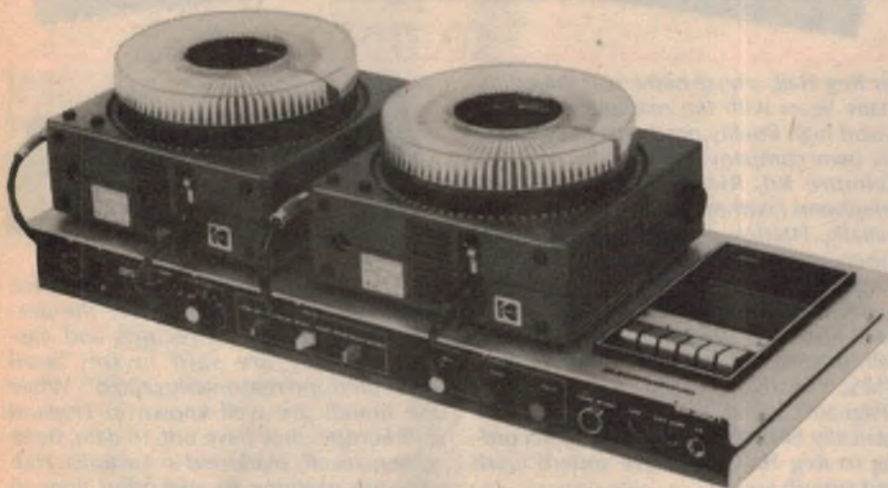

of-the-road stereo music, interspersed with community service features. While CBA in Sydney is heading up this proposed approach, groups in other capitals are thinking along similar lines. In fact, the concept has been taken up in New Zealand, where CBA (NZ) has commenced work on a studio complex in the Auckland suburb of Ellerslie.

In the meantime, CBA's Five Dock studios are doubling as the source point for programs radiated over Sydney's ethnic radio station 2EA. It is in this role that the new automated program system has become the first in Sydney to go direct to air on a day-to-day basis.

Commissioning the system proved to be far less a problem than was at first anticipated and listeners have commented on the noticeably smooth production.

According to Rev Vernon Turner, Director of CBA, this is due largely to the fact that all announcements, comments on music and the music itself are pre-recorded and there is opportunity to re-record if anyone makes a slip. Later, the equipment presents everything in the right order, working to cues on the tapes. There are no awkward pauses and no shuffling of papers if something goes wrong; everything happens precisely on cue. In the unlikely event of an item not

coming up, the equipment senses the break, waits a scarcely noticeable 8 seconds and then proceeds to the next "event" automatically.

In the studios, it is possible to operate much more efficiently because valuable people are not tied up waiting for each music track to finish before they read their next announcement. The announcements can be done in a block, separated only by appropriate cues on the tape. This done, the announcer is free to go, or to turn his/her attention to something else. It contributes significantly to efficiency in the studios and to the convenience of personnel.

### CONVOY INTERNATIONAL

In the short space of three months a remarkable change has been effected to an old building at the lower end of Dowling Street, Woolloomooloo, Sydney, where Convoy International have moved from their smaller premises a few hundred yards away in Maclean Street. A building on the corner of Dowling Street and Cowper Wharf Road near the southern approach to the Cahill expressway has been transformed into an efficient complex, providing three separate showrooms for demonstrating quality high fidelity equipment and colour TV Audio visual programming studios are also included, a theatre, administration offices and well equipped service facilities. In addition, ample space is available for Convoy's activities in the Wholesale distribution of TDK tape and other Hi-Fi equipment.

---

### CROSSOVER NETWORKS

ZEPHYR PRODUCTS of 70 Batesford Road, Chadstone, Victoria 3148, have announced a loud speaker crossover network design and manufacture service. In the past it has been difficult to obtain specific crossover requirements and the only alternatives have been to either compromise to some commercially available unit of "do it yourself".

A standard high quality unit with push button selection of separate left and right channel crossover frequencies of 150, 400, 750 or 1000Hz Bass to Mid at 18dB/Octave and 3500, 5000, 7500 or 10000Hz mid to high frequencies at 12dB/Octave is now available ex stock. Separate regulation is provided for left and right channel mid range and high frequency.

The standard unit is housed in a high quality brushed aluminium box with leatherette top and rubber feet. Alternatively a wooden housing can be supplied to order. The unit can be located adjacent to other equipment and offers complete crossover adjustment at the push of a switch and the turn of a knob.

## HIFI NEWS—continued

Clients contemplating the purchase of equipment, or involved in the encoding of an audio visual programme, or planning a multi-screen presentation, will find Convoy easy to identify with its distinctive "BIG C" exterior building decoration. Customer parking is available at a Shell service station immediately opposite, and in 2 hour parking spaces nearby.

Convoy was founded in March 1965 by its Chairman Malcolm Goldfinch, who maintains a close interest in the business and makes frequent trips overseas to keep in touch with manufacturers. Convoy represents in Australia.

The firm's Managing Director, Dennis Gowing, attributes the Company's growth largely to the careful acquisition of sole distribution rights for outstanding products—all market leaders in their respective fields. Dennis Gowing says: "Our technicians test all items of equipment sold prior to sale and, in many instances, we offer our own warranty which exceeds the manufacturer's warranty. For example, Convoy offers a 5-year warranty on some top quality amplifiers".

Convoy is organised into three autonomous yet complementary divisions: "Convoy Sound" headed by Andrew Goldfinch; the Wholesale Division, headed by Neville Rayner; Convoy Electrosonic, headed by Peter Freudenstein with Bob Stimson on temporary loan from Electrosonic London to



Above: The new Philips AM/FM-stereo car radio and cassette player, model RN 648. Below: The car cassette player NP 457.



assist with the pioneering of this new exciting market area. Convoy Service is headed by Geoff Matthews, who has recently visited Japan, spending time with Nakamichi and Accuphase. All are highly experienced in their respective areas.

Convoy are exclusive agents for Electrosonic Limited England, the world's leading designers and manufacturers of electronic control equipment for synchronised slide/sound audio visual presentations. Through Electrosonic's agents, Convoy can arrange for audio visual presentations throughout Europe, the U.S.A., South Africa, and, in fact,

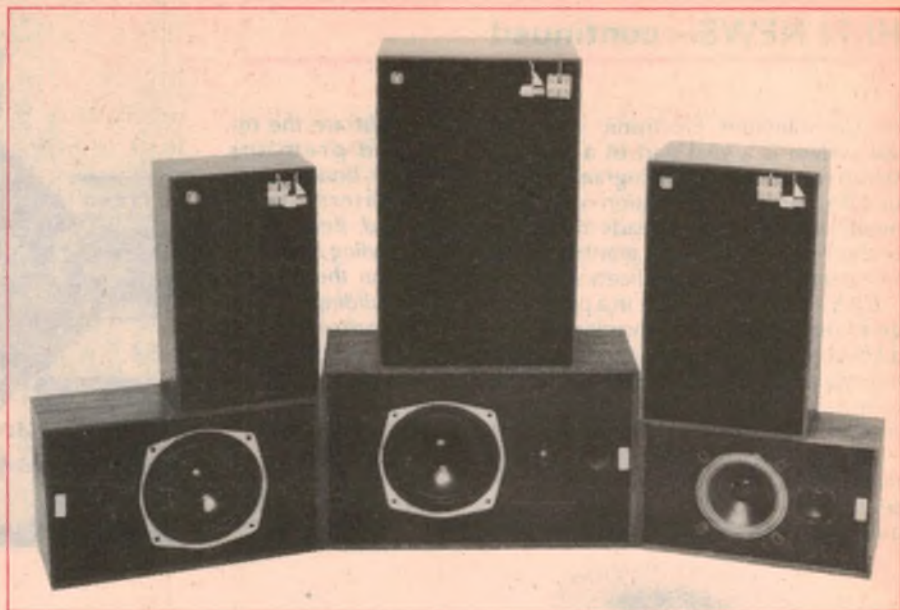

Mr Reg Hall, whose name was linked for many years with the marketing of Kenwood high fidelity products, has formed his own company: Halstov Pty Ltd, 268 Belmore Rd, Riverwood, NSW 2210, telephone (Sydney) 533 3652.

Initially, Halstov will introduce and distribute nationally, the well known British range of Mordaunt-Short loudspeaker systems. The models pictured above have just been introduced on to the British market: "Carnival" rated at 40W RMS; "Festival" rated at 45W RMS; "Pageant" rated at 50W RMS. All are basically bookshelf systems but, according to Reg Hall, they have superb finish and superb sound.

Halstov Pty Ltd are also bringing to Aus-



tralia Marsden Hall Record Care System products, intended to optimise the performance and life of records and cassettes. They are said to be "well presented and reasonably priced". While the brands are well known in England and Europe, they have not, to date, been systematically marketed in Australia. Halstov are planning to add other lines to their range in the not-too-distant future.

almost throughout the entire free world. Various designs of equipment for single or multiscreen synchronised slide/sound audio visual presentations are available, either on sale or rental. The Electrosonic Hire Department operates from its own area with its own loading and unloading dock at the rear of the building on McElhone Street.

Executive offices for Convoy Wholesale and wholesale trade displays are located on the first floor. This Division handles the Australia wide distribution of top quality Hi-Fi equipment including world renowned brands such as TDK tape, Bowers & Wilkins loudspeakers, Nakamichi tape decks and Accuphase amplifiers.

For further information contact: D. H. Gowing, Managing Director, Convoy International Pty. Limited, 4 Dowling Street, Woolloomooloo, N.S.W. 2011. Telephone: 358 2088, 357 2444.

Philips have released three new stereo car cassette units. Top of the range is the Philips RN 648 AM/FM MPX radio cassette system featuring I.A.C. (a unique interference absorption circuit for FM) latching fast forward and rewind, electronic tape speed control plus automatic

end of tape stop and switch back to radio. Philips 'Turnolock' tuner provides for automatic selection of six stations of your own choice. Output is six Watts RMS per channel. The recommended retail price of the unit is \$380.00. Speakers, aerial and suppression are available separately.

The Philips RN 348 is a powerful AM radio/cassette unit providing full stereo sound reproduction. It has stereo balance control, variable tone control and electronically controlled tape speed. The unit is simple to operate with push button tape fast forward and playback indicator light. Output is 5.5 watts RMS per channel. The recommended retail price of the RN 348 is \$155.00. Speakers and aerial are extra.

Philips Model NP 457 is a low cost stereo cassette player with automatic tape to radio switching facility, slide volume and tone controls and fast forward. This model also features electronic tape speed and automatic eject. The recommended retail price is \$95.00, speakers and aerial extra.

All three Philips car stereo units are covered by Philips' warranty and backed by more than 430 Car Radio Centres throughout Australia.

Ever wondered how a recording studio copes with the pressure level extremes between an orchestral fortissimo and the gentle whisper of an alto flute? They don't! A piece of equipment called a Peak Limiter generally does it for them, simply and efficiently, by flattening out the entire dynamic range being fed into it. Which results in a flattened out sort of sound. Listeners can usually sense the dynamic range deficiency, even though they may not be consciously aware of just what has happened. There are other forms of dynamic range control which include manual "Gain Riding" and compression. The magnetic tape itself also tends to round off the signal peaks, thereby acting as its own limiter by restricting high level peak signal excursions. The end result of these forms of dynamic range "tampering" is that, whilst the basic sounds produced by the orchestra are recorded on tape above the noise level and without severe distortion, the sounds are displaced from their original dynamic relationship. Crescendos and loudness variations containing vital musical information have been reduced in scale, compromising the presence and excitement of the performance. Same thing applies to pop-music and rock, for whilst generally requiring a narrower dynamic range, the actual sound levels at rock performances frequently exceed 115 db due to the use of amplified instruments. This, plus the wide-spread use of 16 or more tracks of tape in recording, contribute dynamic range problems just as great as those experienced in recording classical music. Now whilst no recorded perform-

ance can fully duplicate all the sensory impressions received at a concert hall or rock festival, dbx does restore a substantial portion of the dynamic range which has been sacrificed during the recording process. And, at the same time, reduces the noise level quite significantly.

The difference in playback of most recorded material is quite dramatic. Presence is increased, and the excitement and intense realism of a live performance is startlingly restored.

## Sound Un~Limited



Ask your dealer to give you a listening test of either the 117 or 119, and judge for yourself. You can't help

but be impressed. dbx 117 = For use in home music playback systems. dbx 119 = Features extended compression range for tape enthusiasts and for semi-professional studio use. For brochures and the name of your nearest dbxpert write to

Auriema (A'asia) Pty Ltd

PO Box 604

BROOKVALE 2100

Phone 939 1900

# dbx

## 117 & 119

### dynamic range enhancers

# Aerial Systems for FM-Stereo reception

Frequency modulation broadcasting is capable of producing very high quality, noise-free stereo sound—providing the signal at the receiver's aerial terminal is adequate and appropriate. This article will provide useful background on the general subject of FM receiving aerials.

by NEVILLE WILLIAMS

To the average AM radio listener in urban areas, an aerial is the least of his worries. If not in-built, it can be a few feet of wire attached to a terminal, or a rod of uncritical length, mounted on the family car. Unfortunately, this very casual approach is not good enough for FM radio, if its potential advantages are to be realised.

The aerial system matters!

For technical reasons, FM (frequency modulated) radio stations have to operate at much higher carrier frequencies than conventional AM (amplitude modulated) stations. FM stations operate in the VHF (very high frequency) region 88-108MHz (Megahertz), as compared with 0.5 to 1.6MHz used for AM. At these higher frequencies, makeshift or completely inbuilt aerials are inappropriate and a more deliberate provision has to be made to ensure adequate signal pickup.

In fact, FM radio stations share the VHF spectrum with television stations and, while aerial systems for each may differ in detail, the guidelines are similar.

Good, average television receiving sites might be defined as lying between 3 and 20 miles from the transmitter, with the intervening path uncluttered by prominent topographical features, or by large man-made structures. The appropriate aerial in such sites would be a fairly modest array with up to half-dozen "elements" or metal rods on a boom, typically supported a few feet above the roofline.

In more distant areas, or in cluttered sites, it is usually desirable to use a more complex (and more expensive) aerial array, as often as not supported on a taller (and again more expensive) mast.

Close to the television transmitters, a strong signal can be obtained with a compact (and hopefully decorative) aerial on top of the receiver, or from a couple of "rabbit ear" rods protruding from the rear of the set. Unfortunately, elementary aerials like these are wide

open to signal reflections from furniture, people and metal blinds in the room, and can produce weird ghosting and colour effects. In many ways, being too close to the transmitter(s) can be more of a problem than being in the outer service area.

While TV viewers often put up with such problems, there is an obvious reward in the way of better pictures (particularly better colour pictures) for those who go to the trouble of installing an aerial appropriate to their situation, whatever this may mean in practical terms.

And so it is with the reception of FM radio broadcasts. A modest outdoor aerial will ensure an adequate signal in the main service area between about 3 and 20 miles from the transmitter(s). Further out, a more elaborate array may be desirable; closer in, indoor aerials can be considered but always with the possibility that the signal strength at the receiver can be affected by who, or what, is in the listening room. As with television reception, there is an advantage in providing an aerial appropriate to the location.

And here a word of explanation is warranted. Proponents of FM broadcasting have often drawn attention to the "durability" of the FM sound signal radi-

ated by television stations, and to the fact that the sound can usually be heard clearly, even when the picture is barely discernible. One might conclude that the reception of FM sound requires no effort at all, and an aerial no more ambitious than the often quoted "piece of wet string"!

There are at least three things wrong with such an assumption. The first is that listeners expect far more from a hifi radio broadcast than the kind of TV sound tolerated under adverse conditions; rather than being "heard clearly", it should offer a signal well above the noise, with a signal/noise ratio of not less than 50dB.

A second point is that all the foregoing remarks apply to FM transmitted and/or received in mono mode. For stereo mode reception, the signal/noise ratio may deteriorate by as much as 20dB and, for good "noise-free" stereo sound it is generally desirable to ensure a signal input to the tuner of 50uV or more.

A third point is that, in stereo mode, FM tuners are adversely affected by gross mixtures of direct and reflected signals. Whereas in television, this so-called "multipath" reception causes ghosting in the picture, its effect on stereo sound reception is to raise the distortion level. It may be marginal and even pass unnoticed but, in worst-case localities—usually where television viewing is bad—stereo sound reception can become so distorted as to be unacceptable.

Taking all these matters into consideration it is reasonable to suggest that, for good quality, noise-free FM/stereo, one should expect to use an aerial of the same general order as for good TV pictures at the same site.

In some cases, it may be possible to operate an FM tuner satisfactorily from an existing TV aerial by means of a splitter, so that the signal is shared between the TV tuner and the FM tuner. Much depends on response of the TV aerial at a signal frequency for which it was not designed, whether or not it is pointing reasonably towards all the desired transmitters, and whether or not the attenuation due to the splitter will degrade all signals below what is subjectively acceptable. In many cases, the idea may be quite practical and it is obviously a very convenient one.

That possibility aside, it may be helpful

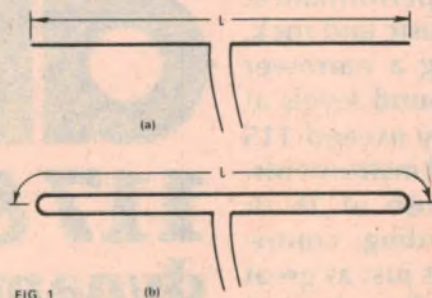

FIG 1  
Basic resonant aerials: a simple dipole (a) and a folded dipole (b). The dimension "L" should be 5% less than a half wavelength at the desired operating frequency.



to have a closer look at the basic requirements of an aerial specifically intended for VHF FM/stereo.

As with television, FM/stereo signals may be radiated with either horizontal or vertical polarisation—a definition which, by convention, describes the plane of the electric field of the radiated signal. Without necessarily understanding this piece of technical jargon, the polarisation of the signal as transmitted is determined by the design and orientation of the transmitting aerial.

At the receiving end, the aerial should be similarly polarised. In practical terms,

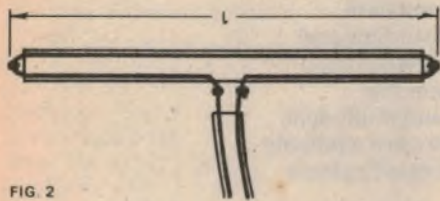

FIG 2

A simple folded dipole can be made up from 300ohm ribbon and supported vertically or horizontally clear of metal surfaces. If horizontal, mount broadside on to the direction of the station. See text regarding dimension "l".

most receiving aerials should be mounted with the active elements horizontal to receive a horizontally polarised transmission, or vertical for a vertically polarised transmission.

Initially, the Australian Broadcasting Control Board suggested that FM transmissions should adopt the polarisation which applied for television in each viewing area. Amongst other things, this would make it easier for the industry to design and instal a single aerial system to feed both television and FM receivers using a splitter in the feedline, as already mentioned.

With further consideration, thought is now being given to the idea of specifying "circular" or "mixed" or "cross" polarisation for all FM transmissions in Australia. Without trying to define precisely what these terms mean, the objective is to radiate a signal which will serve either horizontal or vertical receiving aerials. Advantages claimed for mixed polarisation include the following:

1. There is the possibility of using a common aerial for FM and television, irrespective of the polarisation of the latter.
2. The FM signal is suitable for situations where a vertical or near vertical aerial is almost mandatory, as in portable or car receivers.
3. In indoor situations, where a vertical "rabbit ear" aerial may suffer signal drop-out due to its immediate environment, or to movement in the listening room, a horizontal indoor aerial may be affected less seriously.
4. There is the possibility of using cross polarisation in difficult receiving sites as an extreme measure against multi-path

reception.

5. In practice, the polarisation of VHF signals tends to change and "spread" with increasing distance from the transmitter. A receiving aerial capable of responding to signals having various polarisation is therefore likely to have an advantage, even if the transmitted signals are given fixed vertical or horizontal polarisation.

During the present evolutionary period, listeners in the various areas where FM is available should keep themselves up to date on the siting, polarisation and power of their local transmitters. In Sydney, for example, special circumstances have led to the anomalous position where the community station 2MBS-FM is using vertical polarisation at relatively modest power, while the ABC is transmitting on high power with horizontal polarisation. 2MBS plans to change to horizontal and higher power within the next few weeks, with cross polarisation in the longer view.

Temporarily, the most obvious course in Sydney has been to use a vertically polarised aerial to favour the lower powered 2MBS, on the basis that it will still pick up enough signal from the ABC transmitter. If it does not work out quite this way, the aerial could be turned sufficiently off the vertical (as viewed from the transmitter) to equalise the signals.

Irrespective of polarisation, the efficiency of a VHF aerial depends largely on its being naturally resonant at the incoming signal frequency or, more broadly, across that part of the spectrum in which the wanted signal is being transmitted. In turn, the natural resonance of an aerial is related to its physical length.

Perhaps the most basic form of resonant aerial is the half-wave dipole, as illustrated in Fig. 1 — simply a length of wire or metal rod supported in space but broken electrically at the centre and with provision to connect a 2-conductor downlead. The diameter of the two aerial "elements" is not very significant within the broad definition "wire or rod" and the width of the break in the centre need be only great enough to mate naturally with the insulation and down lead.

What is important is the overall length "l" and, for a given signal frequency, this can be calculated by the formula:

$$l = 142.5 / f$$

where:

l is the required length in metres and f is the station frequency in MHz.

(Note that the figure 142.5 takes into account the "half" wavelength and also a reduction factor of 0.95 for so-called "end effect").

A dipole should be mounted at right angles to the path of the incoming signals. For horizontal polarisation it needs to be broadside on to the transmitter; for vertical polarisation, it is mounted vertically.

One of the problems of a simple dipole, as per Fig. 1, is that it is very sharp-

ly resonant and therefore less than ideal where it is desired to intercept signals from more than one station. Designers of television and FM aerials usually take steps to ensure a broader frequency response and this can become a quite tortuous design exercise where the objective is to cover a whole band of frequencies. We shall say more about this later.

The first step towards "broadbanding" is usually to substitute for the simple arrangement of Fig. 1 a "folded dipole" as per Fig. 1a. The folded dipole can be made up from aluminium alloy rod, as commonly seen in TV arrays, the rod diameter and spacing being not very critical within the limits of what is customary and convenient. It could equally be contrived from wire, providing it can be suitably supported on a non-metallic rod or surface.

Apart from providing a somewhat broader response, a folded dipole modifies another important characteristic which has not thus far been mentioned: the apparent impedance of the aerial at resonance, as evident at the output connections. With a simple dipole, the "source" impedance is about 75 ohms and it works most efficiently into a 75 ohm downlead. An ordinary folded dipole, on the other hand, exhibits a source impedance of about 300 ohms and works best into a 300 ohm cable.

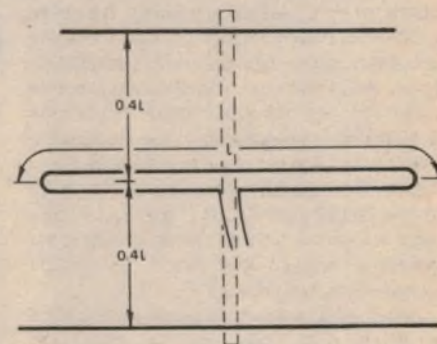

FIG 3

The configuration of a simple beam for a single station or stations on nearly adjacent frequencies. If mounted horizontally, the elements should be broadside on to the station with the shortest element in the front.

This latter fact makes it relatively easy to contrive a simple but effective indoor FM aerial from a length of standard 300 ohm down lead or "ribbon", so commonly used for TV aerial installations. As shown in Fig. 2, one piece of lead is cut to length "l" appropriate for the desired station(s), and the ends soldered across. One wire only is cut in the centre and the remainder of the ribbon used as a downlead to the 300 ohm terminals on the FM tuner or receiver. The "element" portion can be pinned to a non-metallic wall, horizontally or vertically as required, and preferably clear of adjacent metal and wiring.

Using the formula given previously,

# We've found a tape deck with the beauty of Hasselblad, the clarity of Minolta, and the precision of Bolex.

We searched high and low, reel to reel and deck to deck. For sound recording equipment that has the same high standard of manufacture as our leading camera brands. Top of our list came a brand named Dokorder. Dokorder's reel to reel tape decks are available in two and four channel stereo featuring three-motor and three-head facilities. Dokorder machines range in price from less than \$285 to around \$915. Advanced design features include electronic operation of tape transport, speed change and multi-sync facilities on the more expensive models. Cassette decks are available with amplifier options, the celebrated Dolby noise reduction system and many other special features.

Telephone or drop us a line. We'd be pleased to send you full specification and price details.

## The name is Dokorder.



Second reel (illustrated) extra.

### PHOTIMPORT

Melbourne Adelaide Brisbane Perth Sydney

For descriptive literature and specifications, send a 30 cent stamp to **Qualitron Industries Division** of Photimport (Australia) Pty. Ltd.

Head Office: 69 Nicholson Street, East Brunswick, Vic. 3057  
Australia, Telephone 38 6922

PA3/D

## AERIAL SYSTEMS FOR FM-STEREO

the required length (l) for 2MBS in Sydney (92.1MHz) would be 1.547 metres or 61 inches. For the ABC FM station (92.9MHz) "l" would work out at 1.534 metres or 60.4 inches. For these two stations, so close together in frequency, a length "l" anywhere between these two figures would be effective for both.

Because the frequencies are so close, it would be possible to make up a simple beam array covering both, as illustrated in Fig. 3. To act as a "director", the front element must be 5% shorter than the calculated "l" for the highest frequency to be handled; this being 92.9 the director would work out at 1.45m or 57in (erring on the short side in both cases). Conversely, the reflector must be at least 5% longer than "l" for the lowest signal frequency and, for 92.1MHz, this works out at 1.63m or 64in, this time erring on the long side.

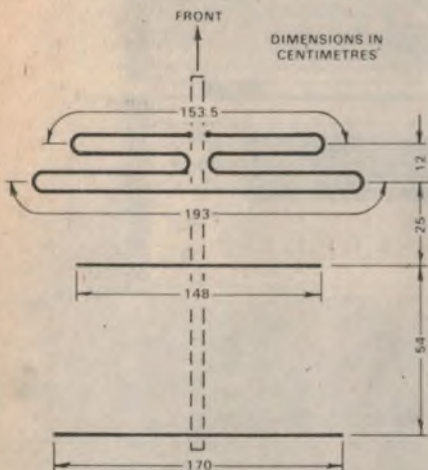

FIG 4

The configuration of the new broadband FM beam currently being marketed by Matchmaster. The role of the various elements is explained in the text.

The spacing between elements can conveniently be about 0.2 of a wavelength, or 0.4 of a half-wave. We show it on the diagram as  $0.4 \times (1)$ , which works out as 62cm or 24 inches for a 2MBS/ABC beam as above.

Because of the presence of the extra elements, the impedance of a typical "Yagi" beam such as in Fig. 3 falls well below that of a simple dipole and, where a folded dipole is used as in Fig. 3, the impedance is likely to be about 150 ohms. Having in mind that it is envisaged as a receiving (not transmitting) aerial, it is permissible to connect it to the receiver with either 300-ohm twin ribbon, or 75-ohm coaxial cable; in the latter case, the braid connects to one element and the centre conductor to the other. The validity of this option depends entirely on the ribbon or cable being terminated at the receiver in the proper

way: 300-ohm ribbon only to 300-ohm terminals; coaxial cable only to a 75-ohm coaxial inlet.

(A commercial example of a relatively narrow band FM beam was reviewed in our July 1975 issue. Designed primarily for the Sydney stations in the 92-93MHz segment, it is still available from Audiosound Electronic Services of 148 Pitt Rd, North Curl Curl NSW 2099. It is intended for use with 75ohm coaxial cable and can be mounted horizontally or vertically as desired.)

Against this background, it is not too difficult to appreciate the rather random nature of "rabbit ear" or single rod aerials protruding from the back of some FM tuners and some TV receivers.

Rabbit ears form a dipole which may or may not be resonant at the desired signal frequency, depending on how far they are extended. They may or may not be broadside on to the station, depending on how they are angled. They may favour vertical or horizontal polarisation, depending on their elevation. They may or may not get an unambiguous signal from the transmitter, depending on how much metal structure, metal furniture, metal blinds, etc, there is in the vicinity to distort the signal pattern. It is little wonder that the rods have to be "fiddled" for each separate station, or left in a compromise position which is optimum for none!

Single rod aerials suffer the same problems because they can be regarded as half a dipole working against the body of the tuner or receiver. They approach resonance when they are about one-quarter wavelength long at the desired signal frequency—a condition which may or may not be achieved as the user blindly extends or contracts them.

### WIDE-BAND AERIALS

While it is not unduly difficult to contrive an aerial system for a single VHF station, or for two or three stations on adjacent frequencies, it is very difficult indeed to produce one which has resonant and directional qualities over a wide range of frequencies. A lot of maths is involved and a lot of practical testing.

Television aerials, for example, have to cover discrete frequency bands within the range 45 to 222MHz and, in practice, there are different designs for different areas, depending on the channels in use. While some TV aerials may pick up some FM transmitters well enough, others may not, depending entirely on what their characteristics happen to be at the relevant FM station frequencies. Ideally, an aerial for FM reception should cover the entire FM band (88 to 108MHz) and therefore be suitable for use anywhere in Australia for any FM channel(s) likely to be used.

(Continued on page 95.)

## The new KEF Cadenza Loudspeaker

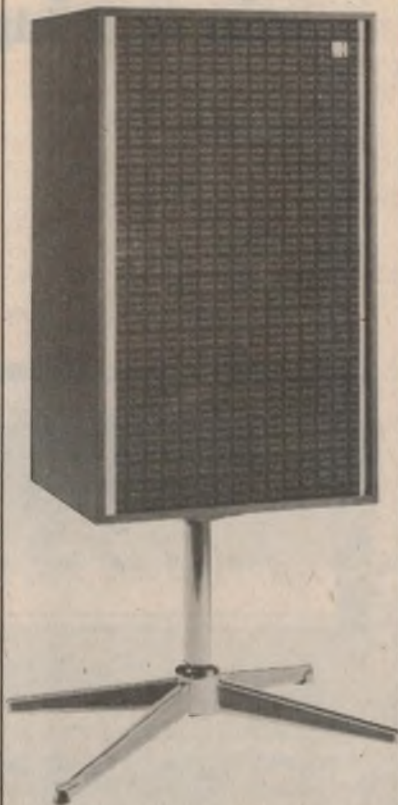

an above average high quality loudspeaker, that brings out the best sound of your stereo equipment. Hear this new attractively priced loudspeaker at leading Hi-Fi stores and sound centres.

Because KEF only make loudspeakers, they have to be good. Very good.



The Speaker  
Engineers.

# How to get two Hi-Fi units for the price of one...

**Sony's new Stereo Receivers (STR7025, 7035, 7055)  
(Component-quality Amplifier and FM-AM Tuner  
with  $1.7\mu\text{V}$  high sensitivity, 60dB selectivity)**



Now that FM high fidelity stereo broadcasting is finally here, most hi-fi fans are adding a quality FM tuner to their rigs.

But newcomers to high fidelity (and those who are upgrading) are in luck . . . with Sony's new STR Series FM-AM Receivers, they can get *both* a component-quality tuner and a powerful amplifier for no extra cost. Take the Sony STR7025, for instance. For under \$350 you get a highly sensitive and selective FM-AM tuner, beautifully integrated with a 24 watt per channel stereo amplifier.

For anyone starting or improving a stereo system, the STR7025 is a great place to begin.

With Sony-engineered quality throughout, it will make even a cheap turntable or speakers sound better.

You get

- All the input and output controls you'd expect from Sony, including MIC mixing and four speaker outlets.
- Direct coupling for tighter, cleaner bass.
- Reserve power: 24 watts per channel (4 ohms) continuous RMS at 1 kHz.
- Low noise. Low distortion. S/N Phono 60 dB I.M.D. less than 0.8% at rated output.
- Frequency response: 30-40 kHz.

The tuner section's specifications are equally impressive:

- High sensitivity:  $1.7\mu\text{V}$ .
- Minimum interference is assured by FETs in the front end.
- Selectivity is 60 dB with solid state filters to reject adjacent channels.
- Extra wide tuning dial.
- Capture ratio as low as 1.5 dB.

The STR Series reflects Sony's usual crisp, appearance design, integrated here into an impressive whole. The two functions are of course wholly independent: your enjoyment is only limited by your own interest in experimenting with sound—beautiful sound by Sony. Check out the STR Receiver Series at your Hi-Fi retailer soon. Sony STR7025, STR7035 and STR7055. One of them is the ideal source for your future stereo system.

# SONY®

Research makes the difference

GAC.S.7552

## Sansui SR-525 Direct Drive Turntable

Direct-drive is generally held to provide the most permanent way to minimise turntable rumble, wow and flutter, and Sansui is one manufacturer who agrees with this approach. Here we review the Sansui SR-525 direct-drive turntable system.

Like most other turntables these days the Sansui SR-525 is sold as a complete system with arm, cartridge, integral base and tinted perspex cover. RCA terminals on the rear of the base connect to the moulded cable which has phono connectors at either end. A 2-pin plug is fitted to the two-core mains flex. This should be changed to suit Australian conditions and other current Sansui equipment.

Styling of the unit is clean and simple, with the integral platform finished in satin-grey enamel rather than the more common wood-grain. The base has four large adjustable rubber feet which provide acoustic isolation from the table or shelf on which the unit is mounted.

Overall dimensions of the SR-525 are 469 x 150 x 375mm (W x H x D) and mass is 9.5kg. Clearance is required at the rear of the unit to allow the perspex cover to open fully.

Simple controls are provided for operation of the turntable. A toggle lever on the left-hand side selects the speed, 33 $\frac{1}{3}$  or 45rpm. Nearby are two small knobs for independent vernier adjustment of each speed. And on the right-hand side near the arm fulcrum is the hydraulically damped cueing lever. Since this is a manually controlled unit, there is no automatic stop or lift-off at end of record play.

The platter is a 310mm aluminium alloy balanced diecasting with a mass of 1.4kg. It is an essential part of the motor system since without it the motor runs quite erratically. The motor is described as a "20-pole brushless DC servo-type" but from the circuit it appears to be a form of AC induction motor with inbuilt tachometric feedback to its transistor drive circuitry.

Since the motor circuitry runs from a regulated DC supply the turntable is independent of mains voltage and frequency fluctuations. Semiconductor complement of the SR-525 circuitry is eleven transistors and twenty diodes.

The large flat motor is bolted directly to the baseboard. This cannot be done with a normal high revving motor because a great deal of motor vibration would be transmitted via the base board and turntable spindle to the disc and thence to the stylus.

An S-shaped tonearm is fitted with

removable headshell. Longitudinal balance and vertical tracking force setting is provided a rotatable counterweight with a smaller counterweight provided for lateral balance. Anti-skating force is applied by a hanging weight system.

A moving magnet cartridge, model SV-27A, is fitted. It has a 0.5mil conical diamond stylus and an optimum tracking force range of 1.5 to 2 grams.

The Sansui SR-525 has clean styling and simple controls. Direct drive assures low rumble, wow and flutter.

In use, we found the turntable operated smoothly and quietly at all times. We do have a few quibbles though. The cueing lever is not damped on the uplift which means that the loudspeakers produce a thump if the stylus is lifted smartly off the disc. It also seems strange to have a turntable which is virtually independent of the mains as a frequency standard using a mains-powered strobe-light to obtain correct speed settings. In our opinion the speed adjustment controls should have a marked setting which gives a correct speed as set by the manufacturer. The strobe-light could then be eliminated.

Vertical tracking forces were within 5% of calibrated settings and anti-skating compensation appeared to be close to optimum. The arm appears to have low

bearing friction and would be suitable for cartridges with tracking force recommendations down to 1 gram. At 2 gram, the cartridge fitted handled the +16dB drum test track on the W&G 25/2434 test disc with only slight mis-tracking, which is a fair result. Cartridge output was 4mV at 5cm/sec which is a little above the specification.

Frequency response of the cartridge was within  $\pm 3$ dB from 20Hz to 20kHz. Channel separation was greater than 20dB in both directions, over the range from 100Hz to 8kHz, and channel balance was within 1dB over the same range. Waveform of sine and square



waves good. Overall sound quality was good although not up to the standard of the top-of-the-line cartridges.

Wow and flutter was excellent at 0.1% (DIN 45507), the best measurement we have recorded to date. Rumble was also very low although we hesitate to quantify the result. Suffice to say that rumble is negligible compared to ordinary disc pressings.

In summary, the Sansui SR-525 is a fine performer which can fit well into any system. Recommended retail price including cartridge is \$299.00.

Further information may be obtained from high fidelity retailers or the Australian distributors for Sansui equipment, Rank Industries Australia Pty Ltd, 68 Queensbridge St, South Melbourne, Vic or interstate offices. (L.D.S.)

## Cerwin-Vega ads are nearly as rare as Cerwin-Vega speakers.

Up till now, only a handful of Cerwin-Vega speakers came into the country. And only those people with an ear to the ground and a fistful of dollars got their hands on a pair. But happily, the situation is changing. We can now offer a range of six living room systems. But unhappily, you'll still need a fistful of dollars. Prices range from \$424 to \$2500 a pair. Maybe a few consoling words would be appropriate. Cerwin-Vega speakers are built to take the absolute maximum power with the absolute minimum distortion. And they succeed. Like no other speakers you've ever heard before. The sound is always clean



**Cerwin-Vega**

Loud is beautiful...if it's clean.

and crisp, no matter what the volume. Which is why many of the world's leading rock groups use Cerwin-Vega. And why Cerwin-Vega won the contract to design and build the speaker systems for the movie 'Earthquake'. The result: an earth shattering realism, that won an Academy Award for the Sensurround System. An example, closer to home, are the Cerwin-Vega 2IIR living room speakers. An amp. with as little as 3 watts RMS will drive these speakers, and yet they will take as much as 100 watts RMS, and produce a sound level of 119db at 1 metre without distortion. The kind of performance that comes from putting our time and money into speaker development. Not into ads.

PKB88525

## Tests prove that Tracker cleans up the competition, as well as your records and tapes.

Various types of record cleaners have been available for decades. However, most of these products have failed to keep pace with modern advances in record materials and recording techniques. The Tracker RC-1 record cleaning solution was developed to meet these modern demands.

Tracker cleaning products went into stringent testing at the Chemistry Dept. at the University of Victoria, B. C., Canada in 1974 and as this chart shows, Tracker RC-1 dramatically reduced the records static charge.

Further information on the Canadian Tests is available by writing to us at Box No. 882, G. P.O. Sydney, 2001.

Tracker products are suited to all the new and advanced record materials, advanced sound techniques and delicate tape heads.

There's the RC-1 Record Care Kit, that not only thoroughly removes the static, but helps to resist further build-up of negative static charge. This protects the grooves from being ground away by new particles of dirt. This modern cleaning kit consists of an exclusive formulation together with handy screw-on spray, plus a fine velvet pad. Refills are available.

And for your tape collection, Tracker provides delicate professional care with the HC-1 Tape Recorder Care Kit. Tracker came through the tests, so give your old cleaners the brush off and go with the winner!

Look for the Tracker RC-1 and HC-1 under our label, or branded under your hi-fi shop's name.

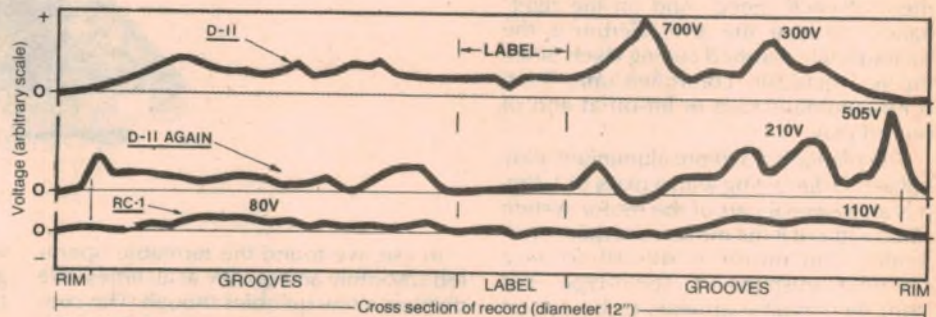

These 3 traces show static charge on a record after cleaning twice with competitive cleaning solution and then once with RC-1 solution.



**tracker**

Better than anything you've used before.

PKB88530

## Otari MX-5050 Professional Series Two-Speed Tape Recorder

Otari Electric Company Ltd of Japan manufacture a range of conservatively rated tape recorders for use in broadcast and recording studios. Here we review one of the Otari MX-5050 series, which is available in a variety of speed and track configurations.

As far as tape recorders are concerned there is generally a great deal of difference between those intended for the domestic high fidelity market and those intended for more demanding use in broadcast and recording studios. The latter machine is likely to be more ruggedly built, incorporate more preset adjustments for signal level, equalisation and bias (although not necessarily have more knobs and buttons) and be more conservatively rated.

The MX-5050 series recorders are two-speed machines using  $\frac{1}{4}$ in tape and are available in eight different model configurations as determined by the tape speeds and the recording and reproduction format, ie, the head arrangement. Tape speeds available are 15 ips and  $7\frac{1}{2}$  ips or  $7\frac{1}{2}$  and  $3\frac{3}{4}$  ips.

Recording and reproduction formats are  $\frac{1}{2}$ -track or  $\frac{1}{4}$ -track stereo, full track,  $\frac{1}{2}$ -track and  $\frac{1}{4}$ -track monaural and  $\frac{1}{4}$ -track four-channel. Naturally all these possibilities are not available together in the one machine. For example, the machine we had for review was designated MX-5050-2SHT, which indicates that it had tape speeds of 15 and  $7\frac{1}{2}$  ips and a head assembly with four separate heads; Erase,  $\frac{1}{2}$ -track Record,  $\frac{1}{2}$ -track Playback and  $\frac{1}{4}$ -track Playback. A head changeover switch allows selection of the playback head.

This combination of heads allows the 2SHT model to record in  $\frac{1}{2}$ -track monaural or stereo mode with simultaneous playback for monitoring purposes. The unit can also play  $\frac{1}{4}$ -track monaural or stereo tapes made on other machines.

An interesting feature of the four channel model is that it has staggered  $\frac{1}{4}$ -track 2-channel erase heads in order to be able to erase the four tracks simultaneously when recording in four-channel mode.

Each model is available in the standard walnut finish cabinet as pictured, or a portable case which actually weighs more. In addition, there is a rack mounting kit available. Anyway you look at it, the machines are heavy, ranging from 24kg in the standard cabinet to 34kg for the heaviest portable model. Both cabinets may be used horizontally or vertically, with best cooling obtained in the

vertical position.

All components of the tape transport assembly are mounted on a very thick aluminium plate which is attached to the polished dress plate to provide extreme rigidity. The two spooling motors are 6-pole induction types while a hysteresis-synchronous motor drives the large cap-

*A solenoid-controlled three-motor transport mechanism and a full range of preset adjustments for equalisation, signal and bias levels are features of the Otari MX-5050 series of recorders, which are intended for use in broadcast and recording studios.*

stan flywheel via a flat belt. The only other belt in the transport mechanism drives the reel revolution counter.

The transport accommodates reels from 12.7cm to 26.7cm (10 $\frac{1}{2}$ in) diameter in NAB or EIA hub configuration.

All functions of the transport mechanism are solenoid controlled with the exception of the adjustable cueing lever. This makes for fast, easy and foolproof operation and permits the use of an optional remote control unit.

Some of the other functions which are not often found on domestic machines include: tension selector for large or small reels, edit control which permits tape spilling and rocking, adjustable cueing control for audible monitoring during fast forward and rewind, built-in test and

cue-tone oscillator at 1kHz, adjustable bias and equalisation controls, standard reference level output calibration control and XLR connectors for line inputs and outputs.

Inside, the machine is surprisingly uncluttered and simple in concept. Most of the circuitry is accommodated on two large PC boards. One criticism we can make concerns ease of removal of these boards—it would be no easy task since there are so many soldered interconnections.

Accessories provided with the MX-5050 comprise two NAB locking hubs, one Otari 27.5cm take-up reel, one



reel adjusting shim, one fuse and a comprehensive manual in a looseleaf binder. The manual gives full details of specifications, installation, operation and maintenance and includes complete circuit diagrams.

We have not subjected the Otari to the comprehensive testing necessary to fully assess its performance, but we can state from our brief experience of the machine that it is well built and worthy of consideration for application in broadcast or recording studio.

Further information on price, performance and availability of Otari tape recorders can be obtained from the Australian distributors, Klarion Enterprises Pty Ltd, 63 Kingsway, South Melbourne, Victoria, 3205. (L.D.S.)

# Nakamichi 600 2-head cassette console

The new Nakamichi model 600 cassette deck has only 2 heads, in contrast with the 3 provided by models 1000 and 700. But its performance is quite outstanding—for example we found its frequency response easily met its spec of 40Hz-18kHz for limits of plus and minus 3dB.

While there are other cassette and tape decks with angled control panels we found that by comparison the presentation of the Nakamichi 600 the most satisfying and practical. Even if you dislike the style, you would have to agree that the finish is very good.

Overall dimensions of the console are 400 x 174 x 239mm (W x H x D) while the control panel itself is 400 x 235mm. Mass is approximately 6.5kg. Finish on the control panel can be loosely described as matt "scratch-grain" while the case of the unit is matt black plastic.

A removable tinted perspex cover fits over the whole control panel, which gives it a subdued but elegant appearance. However, we believe it would be more practical if it were hinged at the top. Otherwise, the tendency is for the

user to leave it off permanently so that dust and dirt can accumulate on the control panel and in the cassette well and mechanism. The cassette carrier does not have a transparent cover of its own.

Noticeable omissions from the 600 are facilities for microphones and a stereo headphone socket. These may be no great loss for people who merely wish to listen to recorded music via their hifi system, but those who wish to record live music will find it wanting. The answer from Nakamichi is the matching 610 Control Preamp, which has stereo mixing of any five of up to nineteen separate inputs including five low impedance microphone inputs. In addition it has pink noise and tone oscillators for signal level and bias optimisation.

There are nine small pushbuttons on

the control panel, from left to right: Tape Counter reset, Tape Counter Memory, Tape Bias (EX or SX), Equalisation (70 or 120uS), 400Hz tone, Multiplex filter, Dolby Noise reduction, Intermodulation Suppression and Power. The "EX" and "SX" designations on the tape bias switch refer to Nakamichi's high coercivity tapes. Nakamichi SX is similar to TDK Super Avilyn (SA) in that it requires the same bias, signal level and equalisation as CrO2 tape.

The Intermodulation Suppression switch is used during playback to reduce distortion introduced when recording at high signal levels, i.e., above 0dB reference level. The circuitry (of which we have no details) apparently uses the fact that recordings are distorted in a predictable fashion as the tape is driven into saturation. At any rate it certainly works, as we demonstrate later.

The multiplex filter button inserts a 19kHz notch filter into circuit when recording from FM transmissions.

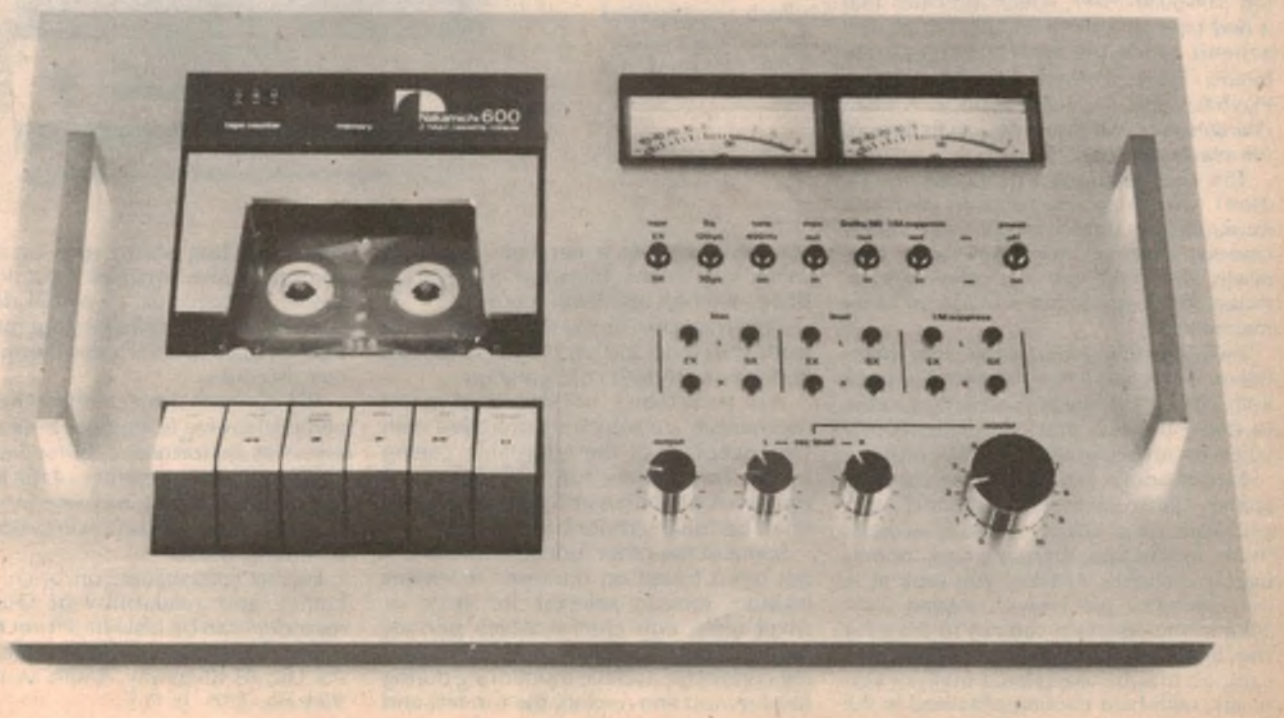



There are twelve individual preset potentiometers, each with its own neat dust cover, for adjustment of bias levels (for the SX and EX positions) tape playback level and intermodulation suppression.

In order to give a more precise indication of recording signal conditions, the two meters are "peak level" indicating and are accurately calibrated over the unusual range from -40 to +7dB. Frequency response of the meters is within 2dB from 20Hz to 20kHz. Our only complaint is that the meters are too deeply recessed to be clearly read from a sitting position.

All controls operated smoothly, with the transport rocker buttons having a particularly pleasant feel—almost the next best choice to a solenoid operated deck. It is possible to record programs with the machine unattended using a mains timer. The machine is set in the Recording mode and the Pause button pressed. When the timer connects the power to the machine there is a slight delay until all circuitry is operational and then the automatic stop solenoid releases the Pause button to allow recording to proceed.

One point we did appreciate was the three-core mains flex and three-pin plug. These were presumably fitted by the Australian distributor since the mains plug was the "piggy-back" type. This helps prevent the proliferation of power points which are otherwise necessary in a multi-unit system. At no time did we experience any problems with "earth-loops", or any interference for that matter.

Performance testing on cassette decks can often be an unrewarding chore since they often do not meet their specifications—especially those regarding frequency response. Often this is merely because the bias and signal level conditions have not been optimised to suit the particular tape (in spite of the fact that the tape used might be recommended by the manufacturer). However, in the case of the Nakamichi 600 we were impressed by its performance.

We used three types of tape: Nakamichi SX, TDK SA-C90 and BASF Cr02. The first two are listed in the owner's manual while Cr02 is not mentioned. It appears that Nakamichi do not recommend it because of the higher head wear.

Best performance was obtained with Nakamichi SX, for which the machine was optimised. Here we obtained an almost exact replica of the response curve shown in the owner's manual: 25Hz to 18kHz within  $\pm 2$ dB. Dolby Noise Reduction had negligible effect on the response apart from affecting the level slightly at 20kHz where it was -4dB without and -6dB with Dolby.

This is easily the best response result we have ever achieved from any cassette deck and is better than the results on any Nakamichi machine that we can recall being published in any overseas journal.

Results with the TDK SA-C90 tape were clearly not as good which would appear to be caused by more than optimum bias level in the SX position of the Tape switch. It seems likely that better results could have been obtained had we wished to adjust the bias levels. On BASF Cr02 results were again very good although not quite as linear as for the SX tape. Here the response was still only -2dB at 18kHz, so good results could be obtained from a Cr02 tape if that was all that was available in an emergency.

Other performance results obtained with Nakamichi SX were: Wow and flutter, 0.15% DIN weighted; THD at 1kHz 0dB, 1.3%; THD at 1kHz and +7dB, 5% and 3% with IM reduction; Separation, -30dB at 6kHz, -40dB at 1kHz and -38dB at 100Hz; Signal-to-noise ratio 48dB and 53dB with Dolby, both figures unweighted. All these results are very close to the specification. Marvellous!

Direct copies from high quality discs were indistinguishable when played back in synchronism—even the best ears were fooled!

Clearly the Nakamichi 600 is the best cassette deck we have ever tested and is almost a bargain at the price of \$599. Further information can be obtained from the Australian distributors, Convey International Pty Ltd, 4 Dowling St, Woolloomooloo, NSW 2011. (L.D.S.)

**This is the only  
tool needed  
to build  
the new**

**7BW  
Hi-Fi  
SPEAKERS**

(AND IT'S SUPPLIED)

Do it yourself and save! The new G.H.E./Philips 7BW Hi-Fi speaker kits are available now. Kits include pre-cut timber panels all hardware and require no soldering. The popular 7B, 3 way system offers 28-20,000 HZ response and optimises 10-40W R.M.S. Amplifiers.



Send coupon for specification brochure:

NAME: .....

ADDRESS: .....

**George Hawthorn  
Electronics**

966-968 HIGH ST, ARMADALE,  
MELBOURNE, VIC, 3143.  
TEL 509 0374, 509 9725



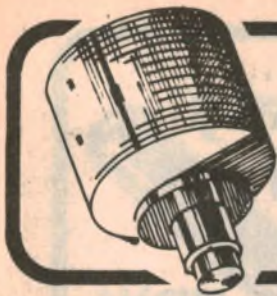

## News Highlights



### Compact colour camera shows microsurgery techniques

The use of closed circuit television has revolutionised teaching techniques in many of mankind's skills, but in no field has its impact been more dramatic than in the difficult art of microsurgery. This was demonstrated recently (March 29 to April 2) at an International Microsurgery Workshop in Sydney, attended by about 30 surgeons from Singapore, Israel, Germany, Japan, India, and all parts of Australia.

By means of a compact Hitachi 9015 colour TV camera, supplied by AWA Rediffusion and linked to a high powered microscope, microsurgical techniques were shown to the attending surgeons on colour TV monitors. They were then able to copy the methods shown on the screens.

Microsurgery is surgery performed under a specially designed, optically perfect, motorised operating microscope. Minute instruments and equipment are used and over a number of years highly sophisticated operating techniques have been developed.

From a basic start some 50 years ago in ear, nose and throat operations, microsurgery is now being applied to a wide range of surgery from replacements of severed parts such as fingers, hands and arms and transplants of nerves and ligaments to experimental operations within the womb. Recent advances have seen Australia leading the world in this field, particularly in digit and limb replacement, as well as in neonatal and prenatal research surgery.

The Microsearch Foundation, a voluntary organisation promoting microsurgery and research in Australia, together with the Australian Government and the Post Graduate Committee in Medical Education of the University of NSW, presented the international surgery workshop. It was conducted by Dr Earl Owen, staff specialist surgeon at the Prince of Wales and Prince Henry Hospitals and director of the Children's Surgical Research Unit.

Dr Owen and four other distinguished Australian surgeons—Dr Paul Landvay, Dr Ian G. Taylor, Dr Micheal Patkin and Dr David Vickers—demonstrated the latest microsurgical techniques, including knot tying, aorta dissection, foetal surgery, renal artery anastomosis, nerve repair and dissection, and other procedures.



*Dr Earl Owen, who conducted the International Microsurgery Workshop, is shown using the motorised operating microscope. The compact Hitachi colour TV camera is integrally fitted to the viewing optics.*

The demonstrators used a Carl Zeiss microscope with the Hitachi 9015 colour camera mounted integrally to the viewing optics. This was the first demonstration in Australia of this camera from AWA Rediffusion, recently appointed a distributor of Hitachi closed circuit television products in Australia.

The Hitachi 9015 is the smallest colour camera of its type yet used in Australia, and its compact size (about 10cm square and 23cm long) and light weight make it ideal for attaching to medical equipment. Conventional TV cameras have previously been too cumbersome to mount integrally with medical and optical equipment. The microscope gave a 2.8 magnification and the camera a 36 magnification to the image on the TV screens.

Four 43cm TV screens were placed facing the attending doctors, who carried out microsurgical operations simultaneously with the demonstrators, checking their work against that of the demonstrator, as shown on the screens.

A second colour camera, a Hitachi FP1500, was placed about 5 metres from the demonstrators, taking an overall view of the operations, including the demonstrators' hands. By throwing a switch the demonstrator could change from one camera to the other. A video cassette recorder was used to record the procedures for future showing.

Dr Owen says the use of closed circuit TV has revolutionised the teaching of microsurgery and looks to the day when doctors will be able to carry out delicate operations by looking at a three-dimensional screen, rather than through a microscope.

"Before TV the difficulty in teaching microsurgery was that students could not see what the doctor was doing," he says. "Now, by the use of small cameras attached to the microscopes, large numbers of students can be taught at a time. Master video tapes can be made of operations, and these can be circulated among teaching institutions which have the equipment to play them back."

## New research lab for laser fusion

A \$46.5 million Laboratory for Laser Energetics is being established at the University of Rochester's College of Engineering and Applied Science for research into the development of a clean, abundant future energy source using laser fusion.

This will be the first university-government-industry teaching and research center in laser and energy studies, and results will be available to scientists across the country.

Sponsors include Exxon Research and Engineering Company, General Electric Company, Northeast Utilities, Empire State Electric Energy Research Corporation (ESEERCO), and the New York State Energy Research and Development Authority (NYSERDA). In addition, the University is negotiating with the US Energy Research and Development Administration (ERDA).

Research in the new laboratory will be based on laser plasma interaction studies conducted at the University of Rochester since 1967, and will focus on eight major areas of study. They include design and fabrication of a 10 kilojoule laser system, termed Omega X; theoretical studies of laser fusion experiments; target development; laser fusion experiments; neutron application studies; development of new types of lasers; such as a laser to provide the efficiency and wavelength required in eventual laser fusion power generation systems; development of an X-ray laser; and research on fundamental physics of light interaction with matter.

Since early 1974, researchers at Rochester have been working with a 1.2 kilojoule laser system to "burn" or combine the nuclei of light atoms into a heavier helium atom. A key objective of

## Pilots see in dark with head up

A new British Head Up Display enables a pilot to literally see in the dark during night operations. The image, projected on the windscreen in the form of a TV like picture, is obtained from forward-looking infra-red or low-light television sensors mounted in the aircraft, and presents a view exactly as it would be seen through the windscreen in daylight.

The new system incorporates a TV-raster scan so that the night scene is overlaid with the normal stroke-written symbols used by the pilot, day and night, to control the aircraft safely, to navigate and to aim weapons. Showing constantly in light that is adjustable in intensity is information such as speed and height, engine instrument readings, direction of target and its distance from the plane.

The infra-red device will be used by combat aircraft of the RAF, enabling them to operate effectively for 24 hours a day. It is also attracting considerable



overseas interest and is at present being evaluated by the United States Navy. The system was developed by Marconi-Elliott Avionic Systems, Kent, England.

the estimated five-year program will be to expand the research capabilities of the laser system to an energy capability of six to 10 kilojoules.

## Omega base nearer

The Commonwealth Government has authorised investigation aimed at completing a draft agreement with the United States Government to establish an Omega navigation aid station in Australia.

The Minister for Transport, Mr Peter Nixon, said recently that the decision had been reached following the Government's consideration of the report by the

Joint Parliamentary Committee on Foreign Affairs and Defence which was tabled in Parliament on 27 May, 1975.

"The Committee's report confirms the benefits of Omega to commercial shipping and refutes the claims of critics who present Omega as a military-directed system", Mr Nixon said.

"Australian shipping and aviation interests will gain substantial benefits in safety and economy from an international navigation system that is world-wide in extent. The Australian station is necessary to complete world-wide coverage, and participation by Australia will be an important contribution to international co-operation in this area."

## Megavolt linear accelerator for cancer treatment

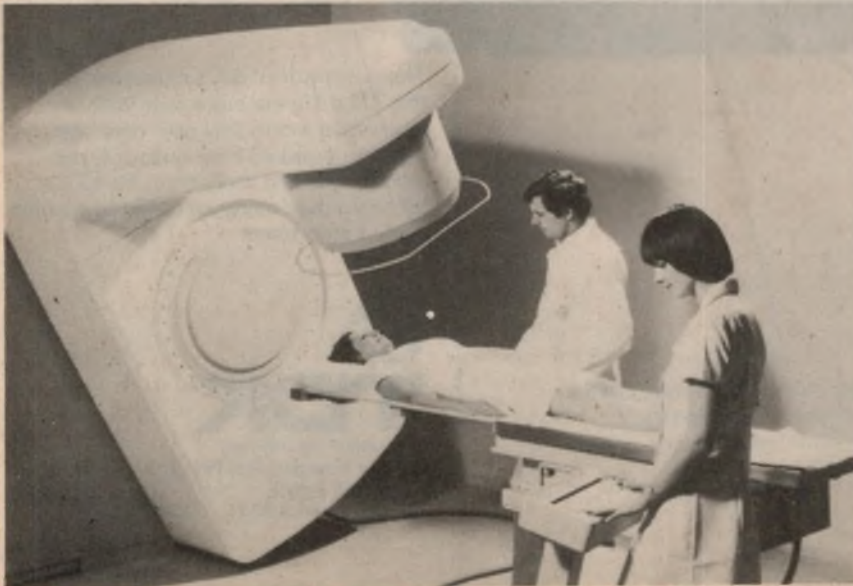

A British company, M.E.L. Equipment Co Ltd, has recently introduced a megavoltage linear accelerator which produces intense beams of high energy X-rays for the treatment of cancer conditions. The accelerator—designated the SL75/5—is the latest in the range of units for which the company is world famous.

The compact machine—suitable for the smaller clinic or to supplement the capacity of a larger accelerator—is simple to operate and easy to set up. It provides the benefits of better depth dose characteristics, a higher dose rate and greater precision due to the exceptionally narrow penumbra (the shadow area outside the main beam) at the beam edges. A simple patient positioning system and motorised movements make operations of this machine easy and the gantry rotates through a full 360 degrees, allowing treatment from any angle.

Extracts from an address by Mr. E. Nakamichi, President Nakamichi Research Inc. at a recent Seminar in Sydney for Nakamichi dealers.

"Chromium Dioxide tape is not recommended for use with any Nakamichi tape decks."

"The wear on recording heads is significantly reduced by using TDK Super Avilyn as compared with any Chromium Dioxide tape."

"TDK Super Avilyn Cassettes are recommended for use with all Nakamichi tape decks. Before leaving our factory, all Nakamichi equipment has bias voltages set for TDK SA to achieve optimum performance".



From the report by Louis A. Challis & Associates Pty Ltd. Consulting Acoustical & Vibration Engineers, NATA laboratory.

"TDK Super Avilyn Tape looks like being one of the most important advances in tape formulations in the mid-seventies"

# TDK SA breakthrough in tape technology

Super Avilyn's performance exceeds that of Chromium Dioxide formulation which previously was the best choice for linear high frequency response and high-end S/N, but CrO<sub>2</sub> suffered from reduced output in the middle and low frequencies (SA provides 1.5-2db more output than the best CrO<sub>2</sub> in those ranges, equal output at high frequency).

SA also outperforms the ferric oxide tapes (regular or cobalt energized) which are unable to take full advantage of the noise reduction benefits of the CrO<sub>2</sub> equalization because their high end saturation characteristics are not compatible with this standard (they require 1EC 120ms, normal or high EQ).

The net result of SA's characteristics and this EQ difference is a tape with an impressive 4-5db S/N gain over the latest top-ranked high output ferric oxide tapes and more than 10-12 db S/N gain over many so-called low noise ferric oxide tapes.



## TDK

Australian Distributor  
Convoy International Pty. Ltd.  
4 Dowling Street,  
Woolloomooloo 2011 358 2088

# NEWS HIGHLIGHTS

## Satellite system will warn of forest fires

Those who fight to prevent and control forest fires will get assistance from space this year as a new satellite-linked monitoring system begins a constant watch on thousands of square miles of precious Californian forests.

Some 23 NASA-designed ground stations will monitor forest conditions throughout California's important Region One forest area, providing data every three hours to foresters in Sacramento through a geostationary weather satellite.

NASA's Ames Research Centre in Mountain View, California, developed the compact, self-powered stations in co-operation with the State of California's Division of Forestry (CDF). Part of the network will be operating during the 1976 forest fire season; the remainder will

be completed in time for the 1977 season.

The 90kg ground stations, powered by solar and wind energy combined with storage batteries, will provide continuous reports on wind speed and direction, air temperature, net solar radiation, relative humidity and the moisture content of such flammable forest litter as pine needles and grass. Sensors to measure rainfall and air pollution—including particulate matter and ozone concentrations—may also be added to the forest monitors.

Once every three hours, data from the automatic stations will be relayed through Synchronous Meteorological Satellite-2 (SMS-2), which is in constant view of the area from its vantage point over the equator.

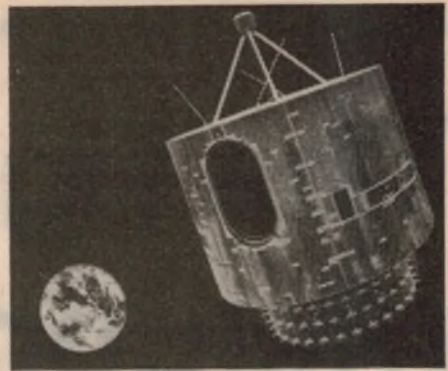

Once the system is in operation, the complex processing and relay of the data will require less than 90 minutes from the time the automatic monitors record information on conditions in remote forest areas until foresters receive the data in Sacramento.

Foresters will use the continuous data on weather conditions to identify areas where fire hazard is greatest, deploy firefighting teams to counteract the threat and plan strategy to battle any fires that do develop.

## Improved solar panel absorber coating

The heart of a solar hot water heater is the copper panel that absorbs the sun's rays. The surface of this panel is made black because, as anyone with a car knows, black absorbs heat better than any other colour.

Dr Alan Reid of the CSIRO Division of Mineral Chemistry has now found a simple, cheap way of making this black panel even blacker. At the same time, his treatment decreases the amount of heat that is lost through being radiated away from the absorber once it has heated up. Even existing panels can be given the treatment.

Copper absorbers are made black by

dipping them for a short time in an alkaline bath of sodium chlorite. After examining the 'copper black' surface with a scanning electron microscope and X-rays, Dr Reid and Mr Alan Wilson confirmed that the black coating is largely fine-grained cuprous oxide—something only guessed at before.

Dr Reid's aim was to make copper black coatings more durable, since sooner or later (especially if over-heated) they tend to turn brownish and become less efficient absorbers. This was found to be due to the film being slowly oxidized from cuprous oxide to cupric oxide.

In an attempt to make copper black



films more stable, Dr Reid tried, among other things, dipping them in a chromate solution. Instant success! The absorbers came out of the solution very much smoother and with a blue-brown iridescence, much like the bloom on a camera lens.

Presumably, some sort of copper-chromium compound—possibly the very stable cupric chromite—had formed over the cuprous oxide grains. The new surface was more durable and, even better, was found to absorb sunlight more efficiently.

Measurements by Mr Eric Christie of the Division of Mechanical Engineering showed that the absorption of sunlight in the visible and near infrared regions had been improved from 88% to 93%, while the radiation of heat from the absorber had been reduced from 8% to 6%.

The reason for the improvement of the copper black's absorption after chromate treatment is partly because chromium ions are strong absorbers of visible light. In addition, the smoother finer-grained surface with its iridescent bloom helps to reduce scattering of light.

A manufacturer of solar hot water heaters, Beasley Industries Pty Ltd, is planning to use the new process.

## Laser cuts quartz tubing—5,000 pieces an hour!

Shown in the accompanying photograph, an engineer keeps a watchful, but shielded, eye on a laser beam being used to cut quartz tubing in the manufacture of tungsten halogen lamps.

Traditional glass cutting methods are not suitable for quartz—it has a melting point approaching 2,000°C and practically no thermal expansion. Diamond impregnated cutting wheels are expensive, need frequent replacing, do not guarantee a clean cut and the quartz has to be washed after cutting.

In contrast, the laser beam cuts up to 5,000 pieces an hour, needs no replacing and eliminates the washing process while producing fewer losses during manufacture.

Tungsten halogen lamps are very small for their considerable output, give 50 percent more light and have twice the life of conventional tungsten lamps. They are extensively used for flood-lighting and

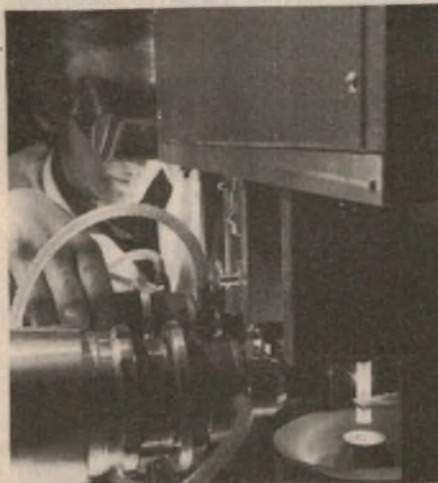

have virtually superseded conventional tungsten in projector, theatre and studio lighting.

*Do you know what made the hatter mad?*

# The fight against mercury poisoning

One of the most dangerous chemicals to which man can be exposed is mercury. Prolonged exposure can give rise to mercury poisoning, the symptoms of which include hallucinations, lack of control of limbs, and a marked deterioration in speech. The problem is of sufficient concern to cause the US Government to set strict standards on the levels of mercury to which industrial workers may be exposed, and the US National Bureau of Standards has developed a new mercury monitor so that the standards laid down may be policed.

by MADELEINE JACOBS

Remember the Mad Hatter—the funny looking man with the big hat in “Alice in Wonderland” who was always asking crazy riddles and talking nonsense? People today think of the Mad Hatter as a memorable character in a story, but to people in the 1800’s he was an unpleasant reminder of the times—a victim of mercury poisoning.

In fact, until recently hatters actually did go mad. The mercury compound used in curing felt and fur for hats was a common cause of mercury poisoning well into this century. Victims developed a tremor called “hatter’s shakes”, which affected their eyes and limbs and addled their speech. In advanced stages they developed hallucinations and other psychotic symptoms.

Although the use of mercury in the hat industry was outlawed in the 1940’s mercury poisoning is still an occupational hazard today. The “metal of a thousand uses”, as mercury has been called, is a prime component in the electrical apparatus industry, such as in the manufacture of dry cell batteries, switches, and other electrical components. Its single largest use is in the production of two industrially important chemicals, chlorine and caustic soda. Because of its versatile and unique properties, mercury and its compounds are also used widely in pharmacology, the paint industry, agriculture, and a myriad of other applications. Today, nearly 150,000 workers in the United States are routinely exposed to mercury on the job.

To protect these workers, the National Institute of Occupational Safety and Health (NIOSH) several years ago for-

mulated standards which limit the exposure of workers to mercury. The standard is designed to protect the health and safety of workers for an 8-hour day, 40-hour week over a working lifetime. According to the standard, workers are not to be exposed to concentrations of mercury greater than 0.05 milligrams per cubic meter determined as a time-weighted average exposure for an 8-hour workday. Employers are required to take steps to insure that the standard is met. This usually involves monitoring environmental levels of mercury in the “breathing zones” of workers, since most mercury poisoning is caused by inhalation of mercury vapours.

To assist in this monitoring, two scientists at the National Bureau of Standards have developed a new mercury monitor which will help public health officials determine if a worker has been unduly exposed to mercury. In addition to its extreme sensitivity and selectivity for mercury, the monitor is portable, easy and inexpensive to produce, and reusable. And, unlike other monitors currently in use, the NBS device gives the total accumulated dosage of mercury over a workday—called for by the NIOSH standard—rather than the concentration of mercury a worker is exposed to at a give time.

In developing the mercury monitor, or “dosimeter,” Dr. Eugene P. Scheide and Dr. John K. Taylor, chemists in the NBS Institute for Materials Research, employed several well known principles. In effect, the monitor is a “microbalance,” according to Scheide, whose research was supported by the NBS Office of Air and Water Measurement.



The key to the microbalance is a quartz crystal which vibrates at a certain, known frequency. This is called a piezoelectric crystal detector. Knowing that gold selectively adsorbs and amalgamates mercury, Scheide and Taylor evaporated a thin layer of gold onto the crystal. A mathematical formula developed by another scientist in 1959 relates the change in frequency of the crystal to the mass of mercury adsorbed.

After the frequency change is measured, the monitor can be restored for reuse by placing it in an oven at 150° C and passing clean hot air over the monitor. Using this method, more than 90 per cent of the adsorbed mercury is removed.

One of the most significant features of the NBS device is its portability. Many mercury monitors in use today are stationary and so do not necessarily measure accurately the worker’s real exposure to mercury. This is because the concentrations of mercury in the work site vary from place to place in a room and even around the vicinity of a worker.

The NBS dosimeter, on the other hand,



The mercury monitor at work. The sensing device of the monitor is worn on the lapel of a lab coat or shirt in the "breathing zone" of the worker. The miniature air pump attached to the sensor is worn in a pocket or around the worker's waist. This portability enables the device to measure accurately the worker's exposure to mercury.

is small and light—about 2 x 2 x 5cm in size and 10g in weight. The crystal itself is enclosed in a glass holder and is sealed to it at the base using epoxy cement. A restriction in the entrance of the holder focuses the air stream to about 2mm diameter at the centre of the crystal.

In the workplace the dosimeter would be worn on a worker's clothing in his breathing zone and would be used in conjunction with commercially available miniature air pumps (about 3 x 6 x 13cm in size and 200g in weight). At the end of the workday, the dosimeter is sent to a central lab where the change in frequency of the crystal is measured and the amount of mercury the worker has

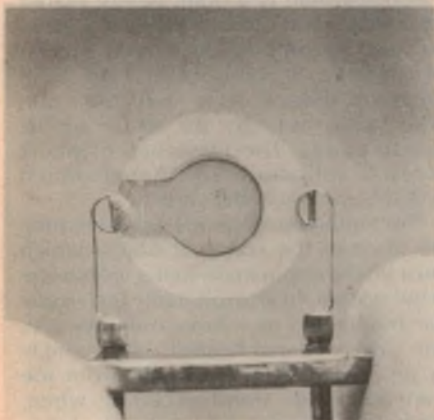

The key to the mercury monitor—a quartz crystal which vibrates at a known frequency. The crystal is coated with a thin layer of gold to adsorb mercury, and enclosed in a glass holder.

been exposed to is calculated. The dosimeter does not read out directly.

Another key feature of the mercury monitor is its extreme sensitivity and selectivity for mercury. In fact, the monitor is much more sensitive than most other techniques that are now employed, with an ability to measure mercury concentration levels at the parts-per-billion level.

The main drawback of the monitor at the present time is that each device must be calibrated individually. However, the cost of an individual mercury analysis using the piezoelectric sensor is relatively low since the sensor can be reused many times and the frequency measurement and data processing can be automated. The analytical instrumentation needed to read the frequency changes in the crystal is also relatively inexpensive compared to other equipment currently in use for mercury monitoring.

Scheide points out that although the dosimeter was developed for monitoring mercury in the industrial workplace, it has other possible uses in long term studies of mercury exposure. For example, it might be useful for dentists and dental hygienists who have long term exposure to extremely small concentrations of mercury. In addition, the principles employed in the dosimeter—the piezoelectric crystal detector and selective coating—might well be applicable to the measurement of other important pollutants.

Reprinted from "Dimensions" by arrangement with the US National Bureau of Standards.

# 451

## SOUND CENTRE

455 KING GEORGE'S RD.  
BEVERLY HILLS

### MAGNAVOX SPEAKERS

10.40	\$ 19.95
8.30	\$ 13.95
6.25	\$ 13.95
6J	\$ 6.50
XJ3	\$ 7.50

### PHILIPS SPEAKERS

AD12100	\$48.00
AD10100	\$45.00
AD8066	\$18.00
AD5060/SQ	\$19.00
AD0210	\$35.00
AD0160	\$11.00

Crossovers to suit new  
PLAYMASTER 3-41L  
PLAYMASTER 3-45L  
PHILIPS SYSTEMS

Timberwork kits  
available for  
Magnavox & Philips  
systems

455 KING GEORGE'S RD.  
BEVERLY HILLS  
TEL.: 57 8654  
BUS. HRS. 10 a.m.-6 p.m.

# X-ray astronomy and the black holes of gravity

At the forefront of modern scientific research today is a comparatively young science known as X-ray astronomy. Researchers are hopeful that a study of intergalactic X-ray sources, usually associated with the so-called black holes of gravity, will provide the missing link between modern quantum theory and the general theory of relativity. Several interesting discoveries have been made in recent years.

by DR JOHN GRIBBIN\*

\*University of Sussex, England

In the space of a few years X-ray astronomy has developed from an esoteric speciality into one of the most important branches of modern science. This has been entirely due to the building of satellites which carry X-ray telescopes above the Earth's atmosphere which, fortunately for us, screens out radiation at these short wavelengths and prevents it from reaching the ground. The first such satellite was the American Uhuru, which made early surveys of the X-ray sky five years ago.

More recently the focus of attention for X-ray work has shifted to Europe with the launch of the Dutch satellite ANS (now near the end of its operational life) and Britain's Ariel 5, now the prime instrument of the world's astronomical community for studying X-ray sources in space. The European emphasis of the new science is likely to continue with the launch of EXOSAT by the European Space Agency to succeed Ariel 5 at the end of the present decade.

Some idea of the importance of X-ray astronomy can be gained from the fact that in a period of economic restraint, with many areas of scientific research being cut back, the British Science Research Council is continuing to finance X-ray astronomy as one of the major research efforts. And the excellent scientific results which encourage the council's support are typified by the two most important discoveries made by Ariel 5 since it began operations late in 1974.

In December, 1974, detectors on board Ariel 5 recorded a sudden outburst of X-radiation from a seemingly new source in the sky—the counterpart in X-ray astronomy of an optical nova.

This transient source, officially Ariel 1118-61 but dubbed "Cen Xmas" because it lies in the constellation Centaurus and was found near Christmas, was detectable only for ten days and

showed a very unusual variation, with a period of 6.75 minutes.

Continuing observations of the sky throughout 1975 have shown that in one respect Cen Xmas is typical of a whole class of transient X-ray sources. According to the latest estimates, such X-ray nova may be occurring at the rate of one a week throughout our galaxy, although the detectors on one satellite cannot find them all. This is because many occur while the detectors are directed elsewhere and there is no way of knowing in advance just where an outburst will occur.

But in another way Ariel 1118-61 has provided a real puzzle for the theorists, who were beginning to think that all the X-ray sources found by Uhuru could be tidily categorised with the application of only two models. Most variable X-ray sources found previously showed periodic variations of either a few seconds or of at least a few hours, and often several days.

This fitted neatly with the standard "binary" model for such phenomena, in which one very small, dense star (the X-ray source) orbits round a larger star. X-ray emission can occur in such a situation because material from the large star is pulled by tidal effects on to the small star, where the rapidly infalling gas collides with the stellar surface to produce a hot spot of X-radiation.

A period of a few seconds in the X-ray emission could then arise easily by the rotation of the compact star—an object with mass as great as our Sun's but occupying a volume no bigger than a large mountain on Earth, spinning on its axis once every few seconds.

Alternatively, a periodic variation of hours or days ties in nicely with the time it would take for the tiny neutron star to orbit its larger companion, with regular eclipses. Our mountain sized star is like the Earth going around the Sun, but with

a "day" only a few seconds long and a "year" only a few hours or days long.

That all agrees well with the theories, but fitting in a period of 6.75 minutes, as found in the Cen Xmas source, is much harder. Is this a slowly spinning star, or one with a very short "year"? Either possibility could be correct, and the question is being discussed among the theorists. The one sure thing is that the final explanation of this phenomenon will tell us a lot more than we know at present about how stars evolve.

The other particularly dramatic achievement of Ariel 5 was the discovery in August 1975 of a much more spectacular transient source which was bright for more than a month and at its peak produced more X-ray energy than any other object in our galaxy.

In a collaborative venture typical of modern astronomy, Ariel 0620-00 was identified by optical and radio astronomers with a bright nova in a known star, and was studied by detectors aboard other satellites. Because the source was so bright, albeit briefly, and because evidence suggests that it may lie at least 3,000 kiloparsecs or  $9.78 \times 10^6$  light years away (1 parsec is roughly 3.26 light years), some astronomers believe that this object is very likely to contain a black hole. It is worth reflecting here that light from Ariel 0620-00 as observed by astronomers was emitted from the star nearly ten million years ago!

A black hole is a point where matter has collapsed in on itself through gravitation and become so dense that gravitational force prevents even light from escaping—hence it is invisible, and detectable only by its effect on its surroundings. The existence of black holes is still disputed, though much evidence points in this direction.

The argument depends on estimating the mass of the compact object which must be the companion to the visible star in the system. In all probability the visible star brightened as a nova only because one side of it was heated very strongly by an intense flood of X-rays from the companion, the flood occurring when, for some reason, an unusually large amount of material slopped over from one star to the other.

The amount of energy the companion can produce depends on its mass—the more massive it is the stronger is its gravi-



tational pull, and the harder the inflowing material falls the stronger is the X-radiation produced. Because this X-ray star has a visible companion it is possible to estimate how far away it is, and therefore to calculate how massive the compact must be in order for the X-radiation to be as bright as is "seen" by the Ariel 5 detectors.

The implication is that something as massive as four suns is compressed into a tiny volume of space. That would have to be a black hole—an object so dense that even light cannot escape from it. The X-rays we see would then be coming from a cloud of material surrounding the hole in space, heated by collisions among the atoms as the swirling material funnels through a tiny "throat" into the hole, like swirling water running out of a bath.

To many people such a bizarre discovery may seem of little account. But a second thought suggests that it is not so. Professor Ken Pounds, one of the team at Britain's Leicester University which discovered the object, says this find is tremendously exciting for physicists because the existence of objects such as this is a direct prediction of Einstein's theory of relativity, and to look at them and make measurements of their radiation will allow investigation of many details of that theory.

But in a mere speculative way, black holes could also be of direct importance to us on Earth. One possibility is that less massive black holes—mere pinpricks in space—may be quite common in interstellar space, and there may even be a good chance that we could find such an object within our solar system.

If that were so, says Professor Pounds, we could conceivably find one by its low energy soft X-ray emission; and if such an object were accessible to mankind there would be "all sorts of fantastic possibilities about getting energy out of it in the useful sense".

Few astronomers, even today, would go as far as Professor Pounds with such speculation. But it is probably fair to compare X-ray astronomy, and high energy astrophysics in general, with the study of atomic and nuclear physics of 40 years ago.

As science has advanced, further progress can best be made by looking beyond our laboratories and even beyond our home planet to the energetic events in the galaxy outside. Just as the nuclear physicists of 50 years ago could hardly have foreseen the development of their science today, so the modern astrophysicist can hardly be expected to predict what effect the latest discoveries will have on the society of the 21st century.

Perhaps, however, it is fair to invert Shakespeare's words and, in trying to discern how our scientifically based society can develop and find new sources of energy, say "not in ourselves but in our stars".



## -that's where the money is!

Stott's course is totally comprehensive — and includes both sophisticated electronic equipment and project materials you need to gain a thorough understanding of servicing techniques

Divided into three self-contained sections, the course covers:

Part 1 — Introduction to Electronics (theory and practice)

Part 2 — Monochrome Television Receivers

Part 3 — Colour Television, including processing circuitry, service techniques, fault tracing and trouble shooting techniques.

Like all Stott's courses, you work with your own instructor who is an expert in this exciting and rewarding field, at your own pace, in your own home.

If you are a beginner, Stott's will teach you everything you need to know concerning television principles and receiver circuitry.

If you are already working in the field, or have completed some studies in electronics, you may be eligible to enter the course at an advanced stage. Whether your aim is to enter the TV service industry or whether you wish to gain a thorough understanding of television theory and servicing as an aid to sales experience, this is the course which will help you make it!

Other electronics courses offered by Stott's include:  
Radio for Amateurs — Amateur Operator's Certificate  
For full information mail this coupon today:

**Stotts**

TECHNICAL CORRESPONDENCE COLLEGE  
The name to trust in correspondence education

Please send me, without obligation, full details of the following courses:

---

Stott's undertake that no sales counsellor will call.

Mr., Mrs., Miss	Age
Address	
Postcode	

159 Flinders Lane, Melbourne	66 King William St. Kent Town, S.A.	
383 George Street, Sydney	89 St. George's Terrace, Perth	
290 Adelaide Street, Brisbane	P.O. Box 3396, Singapore 1	

STC815 EA. 6. 76

# Flying spot scanner for super-8 colour films

Schemes to package TV material for direct sale to the public—a kind of video counterpart to the audio disc and tape scene—have been under development for several years by companies in America, Japan, and Europe. No one dominant system has yet emerged but, in the meantime, the German "NordMende" Company has come up with a scheme which, if not the ultimate, will certainly fill a very useful role in some areas of the market.

by PHILIP WATSON

Home video replay systems have had a brief but chequered history. Inspired by the success of the video tape at professional broadcasting level marketing people reasoned that a similar system, scaled down in size and price to suit the domestic market, would have a wide appeal.

In conjunction with a small TV camera it could be used as a substitute for the conventional home movie outfit, with the very real advantages that the end result could be seen immediately, and that running costs would be significantly reduced. More importantly, the hardware could also serve to replay pre-recorded tapes through the domestic TV set; tapes of feature length movies, classic sporting events, educational subjects, hobbies, etc, which, it was claimed, could readily be made available.

Unfortunately, that vision has not eventuated—at least, as yet. While considerable progress has been made in scaling down the size and cost of video recorders, these are still in a price bracket more suited to educational authorities and business organisations than the mass domestic market. On top of this would be the cost of a TV camera and ancillary equipment if the system was required to make recordings as well as replay them.

And, fairly obviously, until any one system "takes" with the general public it is unlikely that pre-recorded material will be made available in any substantial quantity.

But out of this idea came a modified concept. The major attraction seemed to be the idea of playing pre-recorded programs, rather than making instant home movies. If this assumption was correct the recording medium could be something other than magnetic tape, provided it was cheap to duplicate and used inexpensive and reliable replay hardware.

The result has been a host of ideas, including both disc and tape systems. In the disc systems there are currently at least four methods being exploited, including mechanical, capacitive, and optical systems, one of the last named employing hologram techniques.

Most of the tape systems have been magnetic or optical schemes in one form or another, but little has been heard about these recently. Apparently the disc systems are showing more promise, the main reason probably being that discs, as a class, lend themselves much more readily to mass reproduction—eg, by pressing in the manner of gramophone records—than do tapes which must be actually transported from reel to reel in order to duplicate.

But with all the effort being put into producing these systems some people

have been inclined to ask whether one obvious medium, photographic film, has not been overlooked, at least for certain specialised applications. In particular, the super-8 film system has much to commend it. While developed for home movies, it is now regarded as good enough for many commercial applications, including news coverage for TV stations.

There are a number of advantages in favour of film. A major one is that much of the material it is proposed to release for home entertainment and education is already in this form, while the means to reduce it to the super-8 format already exist world wide.

Furthermore, a lot of movie material has already been released in the super-8 format, so that a supply of program material already exists; it does not have to wait for the hardware to be proved and accepted.

Some may query the logic of converting film images to TV images, on the basis that a conventional optical projector is a good deal cheaper and should present a larger and better quality picture than is possible via a TV receiver.

This is perfectly true, but there are also a number of advantages to being able to present films on a TV screen. A major

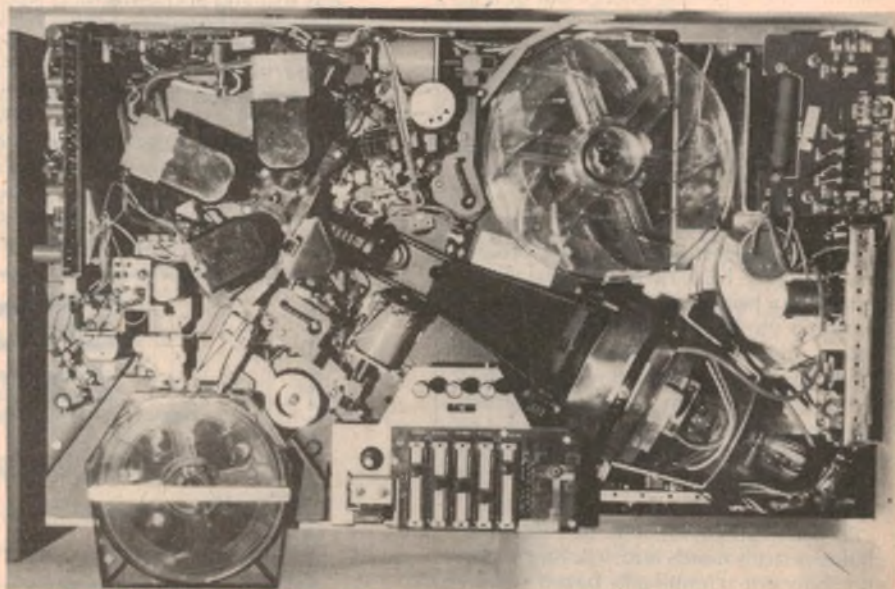

The operating deck of the Colorvision CCS 8mm flying spot scanner. The cassette is in the bottom left hand corner and the takeup spool at top right. The CRO and photomultiplier housings are clearly visible. See diagram on next page.

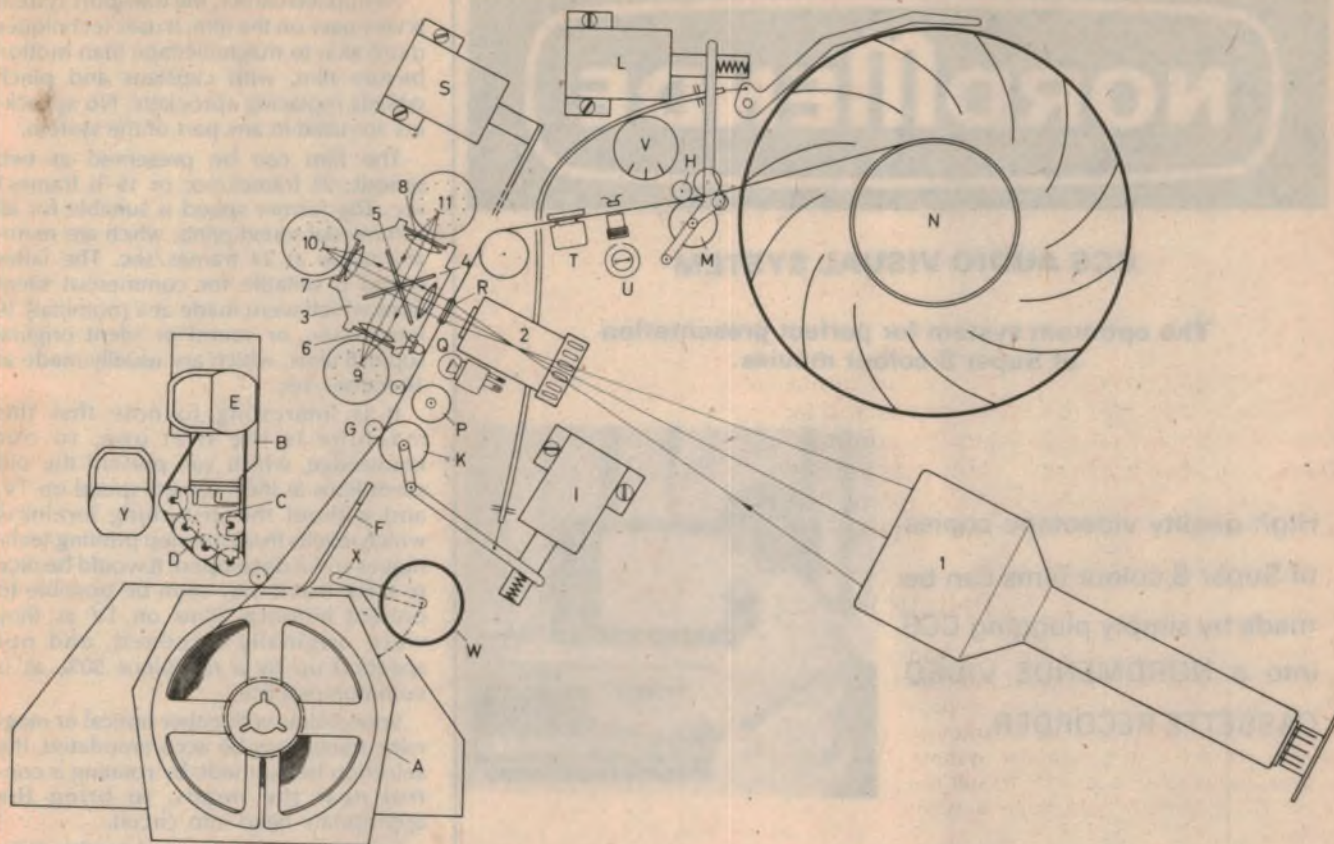

This diagram shows the optical and transport systems of the CCS Colorvision flying spot scanner. The optical path consists of the CRT (1) on which the raster is generated, the lens (2) which projects the raster onto the film gate (R), the mirror box (3) in which are two dichroic mirrors (4, 5) and three filters (red, green, and blue, 6, 7, 8), and three photo-multiplier tubes (red, green and blue, 9, 10, 11).

The major components of the transport system are the cassette (A), threading motor and associated drive wheels (D, E), film guide (F), rewind roller (W), first capstan and rubber roller (G, K), still picture roller (P), magnetic sound head (T), optical sound head (U), second capstan and rubber roller (H, M), and take-up spool (N).

To thread the film the rewind roller briefly spins the reel in the reverse direction, then the threading motor assembly moves forward and engages the reel. The film guide also moves forward and guides the leading edge of the film, as it comes off the reel, towards the first capstan. When it reaches the first capstan the associated roller presses it against the capstan and drives it along the film track towards the second capstan.

When the second capstan is reached the film is captured by the rubber roller and driven towards the take-up spool. At the same time the threading motor and the film guide withdraw and the first capstan roller releases. The film is captured by the take-up spool and transported by the second capstan only, during the "play" period.

one is that, in many circumstances, a TV screen already exists as the prime display device for other program material; off air, off tape, etc. In such cases it is often a good deal more convenient to convert film to suit this display, than to set up projector, screen, speakers, etc, with all the optical alignment which is involved, and the need to darken the room.

A TV image can normally be presented in fairly high ambient light without significant loss of quality, so the system functions as an effective light and contrast amplifier. It also permits adjustment of brightness, contrast, and colour balance, which is not possible with an optical projector, but which can often significantly improve a colour film which is of less than optimum quality.

Also, once the image is converted to a TV signal it can be distributed to any number of receivers, located in other classrooms, for example.

Again, the film receives much gentler handling in a flying spot TV scanner than it does in an optical projector. It is not subjected to heat, or to the intermittent film motion which can damage the sprocket holes. And, since there is no heat problem, single frame projection is permissible for an indefinite period.

And, if it is desired to create program material, the cost of a good film camera would be only a fraction of the cost of a colour TV camera. In practice, a suitable camera may already be available, due to the popularity of these among photographic enthusiasts.

It was this kind of reasoning which prompted the development of the NordMende Colorvision CCS super-8 flying spot camera. And, while its price at present puts it outside the mass domestic market, it would appear to fill a very useful role in educational and similar fields. Whether time will bring the price

for such devices within the range of the domestic market remains to be seen but, even if it does not, its future would seem to be assured in its present role.

By courtesy of Sun Electric Co Pty Ltd, 28 Queensbridge Rd, South Melbourne, the Australian agents for NordMende, we were recently given the opportunity of studying one of these machines at close quarters. The NSW office of Sun Electric delivered the machine to our laboratory, together with a NordMende 1800 (44cm) TV receiver and left it with us for several days while we put it through its paces.

The Colorvision CCS accepts super-8 film in Bell & Howell Auto 8 cassettes fitted with 15m, 30m, 60m and 120m reels. Loading is entirely automatic, the cassette being simply inserted in the machine and the threading key depressed. Should the film not thread correctly the machine switches itself off to permit investigation

# NORDMENDE

## CCS AUDIO VISUAL SYSTEM

The optimum system for perfect presentation of Super 8 colour movies.

High quality videotape copies of Super 8 colour films can be made by simply plugging CCS into a NORDMENDE VIDEO CASSETTE RECORDER.



Available from

your

# NORDMENDE

retailer

For details contact

### SUN ELECTRIC COMPANY PTY. LTD.

**VICTORIA:** 28-56 Queensbridge Street,  
SOUTH MELBOURNE 3205. Telephone 62 0691.

**N.S.W.:** 113 Wicks Road,  
NORTH RYDE 2113. Telephone 888 7222.

**A.C.T.:** 32 Barrier Street,  
FYSHWICK 2609. Telephone 95 0399.

**STH. AUSTRALIA:** 17 Anzac Street,  
KESWICK 5035. Telephone 297 5488.

**QUEENSLAND:** 84-88 Victoria Street,  
WEST END 4101. Telephone 44 7061.

**WEST AUSTRALIA:** 164-166 Railway Parade,  
LEEDERVILLE 6007. Telephone 81 4422.

**TASMANIA:** 10 Wignall Street,  
NORTH HOBART 7002. Telephone 34 5209.

as to the cause.

As implied earlier, the transport system is very easy on the film. It uses techniques more akin to magnetic tape than motion picture film, with capstans and pinch wheels replacing sprockets. No sprockets are used in any part of the system.

The film can be presented at two speeds; 25 frames/sec or 16- $\frac{2}{3}$  frames/sec. The former speed is suitable for all commercial sound prints, which are normally made at 24 frames/sec. The latter speed is suitable for commercial silent films which were made at a (nominal) 16 frames/sec, or sound or silent original super-8 films, which are usually made at 18 frames/sec.

It is interesting to note that this machine is the first one, to our knowledge, which can present the old silent films at their correct speed on TV, and without the disturbing jerkiness which results from the step printing techniques so far developed. It would be nice to think that it may soon be possible to present historical films on TV as they were originally screened, and not speeded up by a ridiculous 50%, as is common practice.

Sound films with either optical or magnetic tracks may be accommodated, the selection being made by rotating a control near the heads, to bring the appropriate head into circuit.

Sound may be recorded on the magnetic stripe as well as replayed. This facility would be particularly valuable where an original sound track was to be added to a film, particularly commentary and sound effects as for an instructional film. A "trick" or "voice over" circuit is provided whereby the commentary can be added after the sound effects or background music, or even over the existing track on a commercial film.

With the film running there are a number of controls which may be adjusted for optimum picture quality. There is an optical focus lever attached to the lens in the picture optical path, which may be adjusted to compensate for small variations in thickness from film to film.

There is an anti-jitter control which is used to neutralise any tendency for the picture to jitter, a frame control to centre the picture vertically within the screen area, red tint and blue tint controls to help compensate for film colour balance variations, and an aperture correction ("brilliance") control, which also contributes to picture sharpness.

The mechanical controls include the threading button, fast forward and fast reverse buttons, a stop and still picture button, and a restart button. The film can be stopped at any time by pressing the stop button. It may be moved forward manually a frame at a time.

In the event of a film break the machine shuts down automatically and, at the end of the reel, it rewinds automatically.

The flying spot scanner used in the Colorvision CCS is similar in principle to

those used in TV stations for 16mm movie film.

The raster which scans the image is presented on the face of a small cathode-ray tube (about 75mm dia.) and a reduced image of this raster is created on the film frame by means of a lens. This image is picked up by a lens in a mirror box and, by means of dichroic mirrors and filters, is split three ways into red, green and blue images. These are then focused onto three photo-multiplier tubes which produce the red, green, and blue output signals.

There are actually two scanning rasters on the CRO tube face (at 25 frames/sec.), one above the other (in terms of film movement) and each consisting of 312.5 lines. Together, they constitute a full 625-line interlaced scan.

Each scan is only half the height of the frame, but this is offset by the fact that

Second frame: 312.5 odd lines. Second frame: 312.5 even lines. And so on.

Fairly obviously, in any flying spot scanner, the speed of the film through the gate must be exactly synchronised with the scanning rate, and must also be in correct phase so as to centre the picture vertically on the screen.

In this scanner the film speed and phase are monitored by means of a lamp and photocell on opposite sides of the sprocketed edge of the film. The pulses from the sprocket holes, after processing, are compared with pulses from the frame deflection circuits in a phase and frequency comparator network. The output of this constitutes a correction voltage which is used to vary the speed of the film transport motor.

The phase of the pulses derived from the frame deflection circuit can be varied by means of a panel control—the framing

with by the automatic degaussing circuit after the next switch-off, switch-on cycle. After this the set put up a very good performance, the picture geometry being particularly commendable.

For testing we were fortunate in having access to a very representative range of super-8 films, in addition to those delivered with the machine. They included a reduction from a commercial 35mm monochrome sound print, with the sound converted to magnetic stripe; a similar copy of a colour cartoon; a reduction from a 16mm colour documentary, again using magnetic sound; a home-movie style colour film with magnetic sound (original film); and a print of the historical film of 1903, "The Great Train Robbery".

We were also able to obtain a couple of optical sound prints, both reductions from 16mm. These were by courtesy of Atlab Film Laboratory Service.

Of these, the best picture quality, as judged by direct projection, was the reduction from the 35mm monochrome print, and this quality was reflected in the TV image. It would be fair to say that the picture quality was virtually indistinguishable from the average TV presentation of a 16mm print. In short, without being told, it would have been difficult to pick it as anything other than a 16mm presentation.

A very close second was the cartoon, with the advantage of very good colour for a film of this class. Once again it would have been extremely difficult to pick this from a conventional 16mm presentation.

The documentary was marginally inferior, as might be expected from any film originating in the 16mm format, rather than 35mm. Nevertheless, it produced a perfectly acceptable picture which the average viewer would have accepted for its content without questioning its quality.

Below this again was the home movie film which, while good in its class, was beginning to show some of the limitations of this format. At the same time it was interesting to note that the sound, made at the conventional super 8 speed of 18 frames/sec. was not noticeably affected by the slower replay speed of 16-2/3 frames/sec., even though this represents a shift of around 8%. Family voices, well known to at least one observer, appeared perfectly natural.

There is little point in commenting on the image quality of the "Great Train Robbery", except that it appeared to be no worse than the extracts of this classic which have been screened on TV, from larger gauge films. What was immediately evident, and which added immeasurably to the enjoyment of the film, was the fact that it was being screened at the correct speed of 16 frames/sec., and without jerkiness.

From these observations our overall impression is that the results obtained (Continued on page 125)

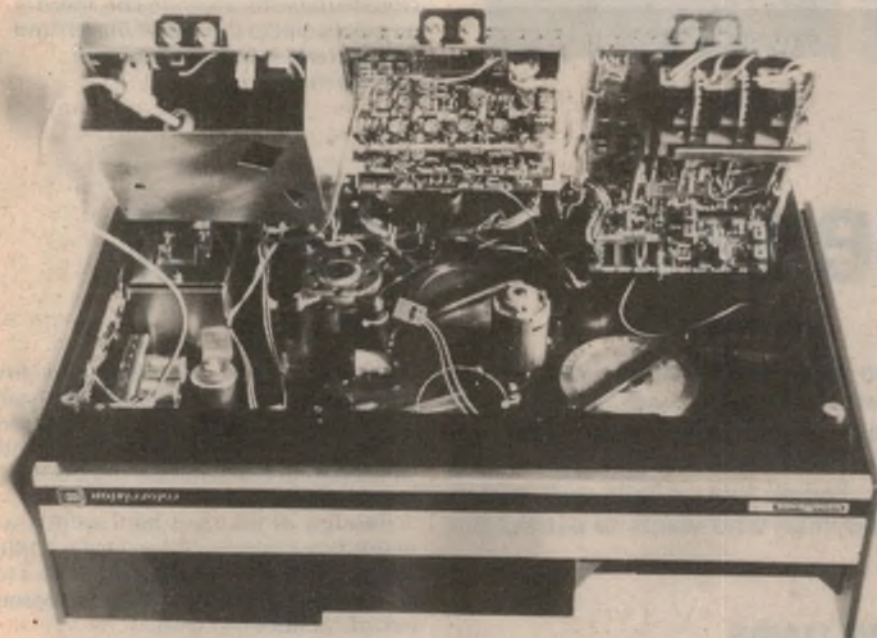

The underside of the Colorvision scanner, showing various sections swung out for easy service access. The main drive motor may be seen slightly left of centre, together with the capstan flywheels.

the frame moves by half its own height during the period of one 312.5 line scan. Thus the whole of the frame is scanned by the 312.5 lines. As this scan finishes at the bottom of the frame the top of the frame is moving into the area of the second scan where it is scanned 312.5 lines, interlaced with the first.

For the 16-2/3 frame rate each frame is scanned three times. Each raster is now two-thirds of a frame high, while the frame moves one-third its own height during the scan, thus providing a complete 312.5 line scan as before. This is repeated for the second 312.5 lines to complete the interlaced scan, after which the frame is scanned again with the first half of the interlaced scan and the next frame is scanned by the second half.

Thus the sequence would be as follows: First frame: 312.5 odd lines. First frame: 312.5 even lines. First frame: 312.5 odd lines. Second frame: 312.5 even lines.

control and the effect of this is to move

Output from the CCS Colorvision is an RF signal in the UHF band which may be fed directly into the aerial terminal of any TV receiver equipped with a UHF tuner. For sets not so equipped, a UHF/VHF converter is available.

The NordMende 1800 TV receiver supplied to us as a monitor is worthy of some mention. It uses a touch control

To ensure that our test of the scanner was not influenced by the set's behaviour, we arranged to have a normal installation check made on the set. This resulted in some minor adjustments to colour balance, convergence, etc., as would normally be carried out in a customer's home. There was also some suggestion at one stage that the set had been parked too close to some of the speakers in our audio room, resulting in a minor loss of purity. In any case, whatever the cause, it was effectively dealt

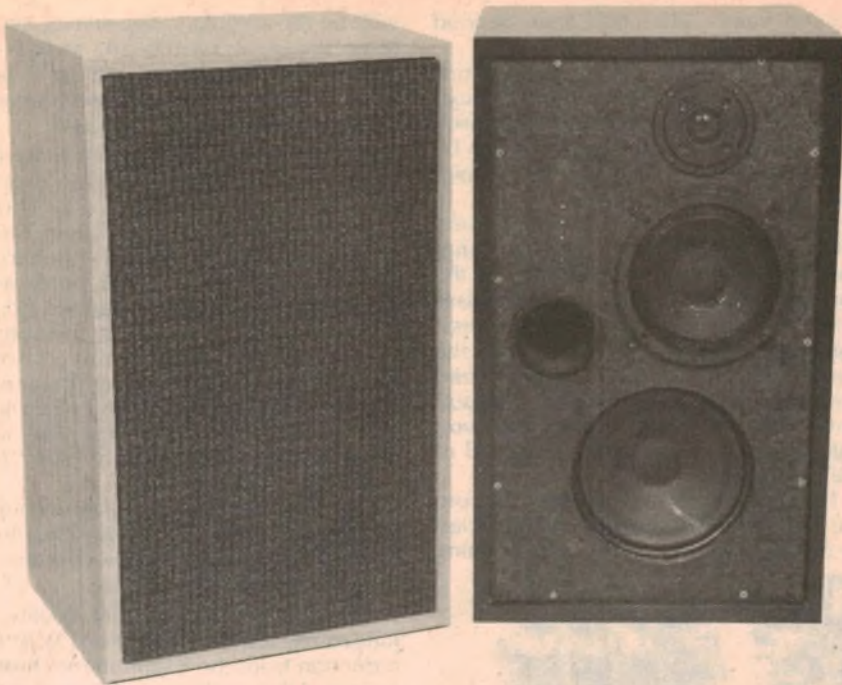

**The fidelity  
you want  
at a price  
you can afford**

*Externally, the Playmaster 3-41L system is very similar to the earlier 2-45L and 3-45L systems but it uses the new Magnavox 6-25 driver for the mid-range, operating in conjunction with a slightly more elaborate cross-over network. It so happens that the system shown is a mirror image of the baffle layout in the drawing but, because the drivers are close to the vertical centre line, there is no great point to this. Make the left and right systems identical if it is more convenient.*

# 3-41L Speaker System

Here's a loudspeaker project that we must rate as being one of the most-easy-to-live-with systems we have ever come up with. After several months of domestic listening, it has emerged as commendably neutral and notably free from those elusive peculiarities which sometimes become apparent in the longer term. For all that, it falls well within the means and skills of the home handyman who wants to extract the best value from his hifi dollar.

by **NEVILLE WILLIAMS**

The new system is a logical development from the earlier Playmaster 3-45L system which we described, with considerable enthusiasm, in our April 1975 issue. The 3-45L used a Magnavox 8-30 in a nominal 45-litre enclosure for the bass range, giving an effective response down to 40Hz or below. A Magnavox 6J, in a small sub-enclosure handled the midrange, while a Philips AD0160/T8 dome tweeter carried on beyond the limit of audibility. To interconnect the 3 drivers, we specified a relatively simple divider network involving capacitors, resistors and 2 air-cored inductors.

A large number of 3-45L systems were built by readers and the reports we had back fully justified our own enthusiasms. It remains a good basic design and excellent value for money, with the difference that a further option is now available.

The new system calls for a different type of mid-range loudspeaker, a more elaborate divider network, and with

thicker enclosure panels mandatory rather than optional. It will cost somewhat more but, in our opinion, is well worth the extra money. It's a system which will stand comparison, in the domestic scene, with commercial units having a much higher price tag.

As far as internal dimensions are concerned, the enclosure can be the same as specified for the earlier system, but it must be constructed from material not less than 18mm thick. In fact, all our initial work was done with the 3-45L enclosures originally supplied to us by 451 Sound Centre, 451 King Georges Road, Beverly Hills, NSW. The speakers were still in the original triangular pattern rather than in line, but we don't regard this as being very significant. What it does mean is that readers who have 3-45L systems with 18mm walls can easily up-date to the new design, without changing the baffle layout.

Reference to the accompanying diagram (Fig. 1) will show that the dimen-

sions have been reduced by a few millimetres—a change made necessary by the fact that panel sizes for enclosures of this general volume have to be slightly smaller to cut economically from the new metric sheets.

Because of this, and the fact that we needed to distinguish it from the earlier system, we have called it the 3-41L, indicating 3 drivers and an enclosure volume of about 41 litres.

The motivation to develop the system really flowed from our work with engineers from the Philips Elcoma Division to develop and present their "System 14" in our "Year Book" and their "System 16" in our February '76 issue. While the overall balance was very similar to the original Playmaster 3-45L, we felt that the Philips mid-range sound was somewhat cleaner, particularly in the case of the System 14 which used their special 2-inch mid-range dome driver. Could we make up the leeway and rival the performance of the larger systems without increasing cost too much or size at all?

Looking critically at the behaviour of the 6J mid-range we felt that it could be suffering resonance effects in the 200-300Hz region from being sealed tightly into the small sub-enclosure. This is a familiar problem with sealed-in or sealed-back mid-range drivers and is one reason why they are either avoided altogether or fed from a divider network which cuts off steeply above the troublesome region.

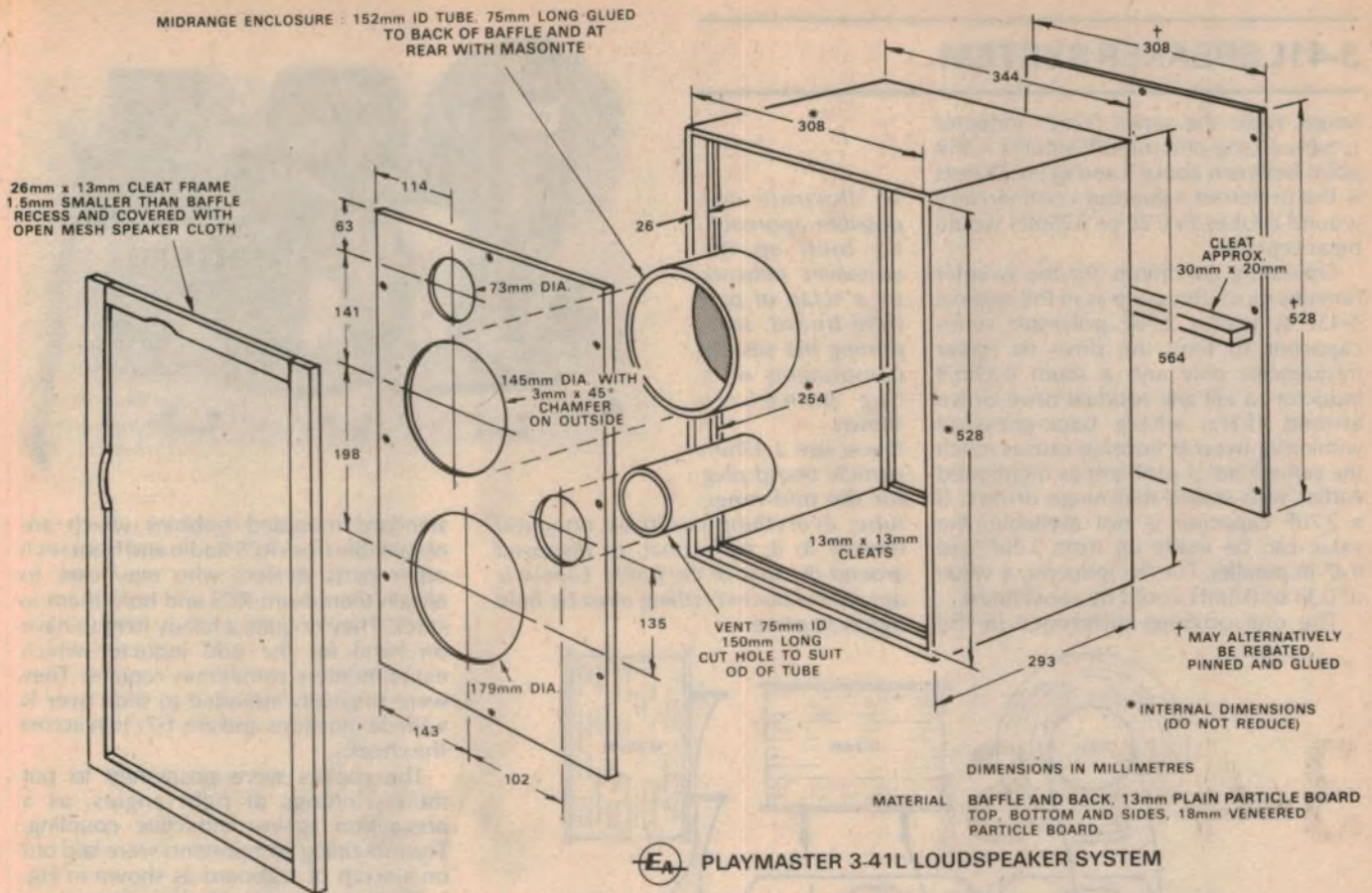

Because we wanted to retain a mid-range driver in the compact system, and because we also wanted to avoid too much complication in the cross-over network, we tried a very simple alternative with highly successful results: retain the Innerbond filling in the simple enclosure but raise the speaker from the baffle by about 5mm on brackets or spacers such as ordinary rubber grommets. By thus reducing the back loading on the cone, the modification eliminated any impedance and response kink in the 200-300Hz region and allowed the response to fall away smoothly below 900Hz (due to the series capacitor) as originally intended.

At the top end of the mid-range spectrum, we felt that matters could be improved by introducing a deliberate electrical roll-off above about 6kHz, rather than relying solely on the acoustic response characteristic of the driver itself. This would involve the provision of a second inductor—albeit one that would be amenable to home winding.

It was about this same time that Magnavox came to light with a new driver described as their 6-25. It uses basically the same magnet structure as the 8-30 and is intended primarily as a bass driver for compact systems. Looking at it, we felt that it held considerable promise for a quality mid-range role with at least as much power handling capacity as the 8-30 (mid-range only) and similar sensitivity.

And that's the way it turned out. In

Fig. 1: The revised dimensions of the enclosure suggested for the 3-40L system correspond to what manufacturers tell us are the largest practical for economical usage of metric size sheets. The internal volume could be increased to 45 litres or 1.6 cu ft but it must not be reduced below the above specifications. To avoid further inroads on internal volume, the back panel is specified as 13mm thick, but stiffened with a cleat. The baffle is also 13mm thick but cannot "drum" because of the way it is supported and because of the drivers and tubes attached to it. See text re sealing and lining.

association with a suitably re-arranged divider network, and mounted as indicated, the 6-25 gave the kind of uncluttered midrange definition that we had been seeking and the kind of overall balance that seemed to obviate any urge to fiddle further! Continued listening and A-B tests have only served to confirm this initial impression.

Fig. 2 shows the electrical circuit of the revised crossover network.

Operating conditions for the woofer remain unchanged. A 6.8 ohm resistor and 22uF non-polarised electrolytic in series across it offset its own natural reactance and give a net impedance of about 8 ohms, which remains substantially constant over a wide frequency range. So terminated, the 1mH series inductor gives a smooth 6dB/octave roll-off with the -3dB point between 800 and 900Hz.

While it is possible to argue for a different crossover frequency, the designated figure is adequate and convenient and the required 1mH inductance is an available value and is also manageable for hand winding. The 22uF capacitor should also be available as a standard

item but it could be replaced by two series 50uF electrolytics, 25VW or higher, connected back-to-back with their negative ends tied together. A lower wattage 6.8 ohms resistor would be adequate for normal program levels but the huskier wirewound type will save any apprehension about overload.

Since the 6-25 mid-range unit has a similar sensitivity to the 8-30 woofer, an 8-ohm version is required for an 8-ohm system.

To level out the impedance of the 6-25, it is shunted by a series network comprising an 8.2 ohms resistor and a 10uF non-polarised electrolytic. While this latter is the preferred value, not too much difference would be apparent within the range 8uF to 12uF, provided either by a single capacitor or by conventional electrolytics connected back-to-back to give the equivalent capacitance. The 22-ohm resistor shunted across it preserves some electrical damping at the cone resonance—about 50Hz as mounted—thereby minimising unwanted cone excitation.

A 22uF non-polarised electrolytic provides the necessary low-end roll-off to match the upper end of the woofer

## 3-41L SPEAKER SYSTEM

range, while the series 0.2mH inductor imposes a top-end roll-off with the -3dB point between about 5 and 6kHz. 0.2mH is the preferred value but commercially wound chokes to 0.22 or 0.25mH would be acceptable.

Operating conditions for the tweeter remains much the same as in the original 3-45L system—a 2.7 $\mu$ F polyester series capacitor to limit the drive to upper frequencies only and a shunt 0.35mH inductor to kill any residual drive down around 1kHz, where back-pressure within the tweeter housing causes much the same kind of problem as mentioned earlier with sealed mid-range drivers. If a 2.7 $\mu$ F capacitor is not available, the value can be made up from 2.2 $\mu$ F and 0.47 in parallel. For the inductor, a value of 0.33 or 0.3mH could be substituted.

The one obvious difference in the

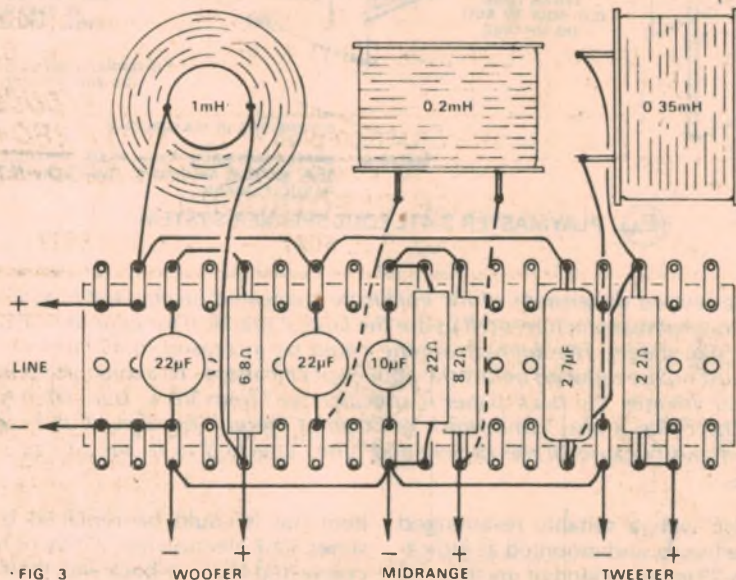

FIG 3

tweeter circuit is the inclusion of a 2.2 ohm resistor directly in series with the tweeter itself. It has the effect of bringing the tweeter drive voltage more into line with that of the other two and trims the overall balance to what we liked best. It could be omitted or shorted out if you particularly want extra "bite" at the top end.

Incidentally, all drivers are wired in phase, as shown in the circuit. This is normal procedure where they are fed, as here, from 6dB/octave filters.

We gave considerable thought to the construction of the divider network. The done thing, lately, seems to be to present these on a printed circuit board, with prefabricated inductors, with resistors and capacitors of a particular shape and size, and with switches to fiddle the overall balance. It makes it easy in the physical sense but we have heard frequent complaint about the cost of such networks. For this reason, we opted for the hard (and the economical) way.

For the sake of illustration, we put

*To illustrate one possible approach, we built up the crossover network on a scrap of particle board, supporting the smaller components on a tag panel as shown.*

*If you use a 13mm particle board plug for the mid-range tube, everything could be attached directly to it; either that, or disposed around the rear of the baffle. Layout is not critical but everything must be held rigidly in place.*

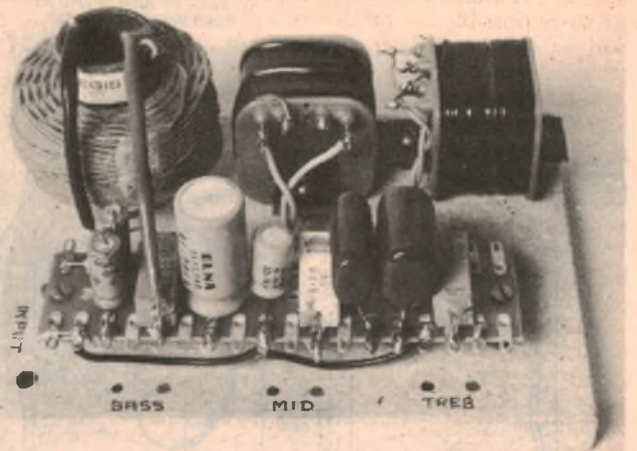

standard moulded bobbins which are obtainable from RCS Radio and from such other parts dealers who may care to obtain them from RCS and hold them in stock. They're quite a handy item to have on hand for the odd inductor which experimenters sometimes require. They were originally intended to slide over  $\frac{3}{4}$  x  $\frac{3}{4}$ in laminations and are 1-7/16in across the cheeks.

The chokes were positioned to put their windings at right angles, as a precaution against inductive coupling. The remaining components were laid out on a scrap of tagboard as shown in Fig. 2. The layout is not critical but it may save you having to work something out for yourself.

If you buy all the inductors, they can be mounted in the appropriate fashion. Alternatively, the inductors can be hand wound on bobbins made from a scrap of broom handle and scraps of plywood, masonite, or other non-metallic material. The cheeks can, in fact, be made very easily with a hole saw blade in an electric drill. Drill a centre hole also through the bobbin, smear the mating faces with

*The components shown dotted are optional and valid only for the recommended 0.2mH inductor. Two 16 $\mu$ F could be used back-to-back.*

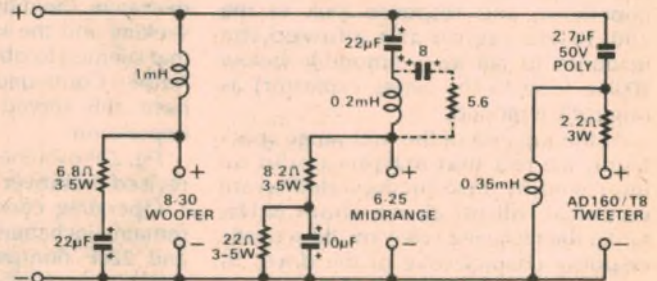

FIG 2

together a crossover network on a scrap of particle board, measuring 15cm x 11cm, with the inductors held down by screws and the remaining components on a scrap of tagboard. Input and outputs, coded red for active and black for earth, were marked on the board with felt pen.

The 1mH inductor seen in the photograph is a rather venerable unit, which we just happened to have on hand; it could as easily be hand wound. The other two were, in fact, hand wound using

PVC glue, clamp, and leave to set. The bobbin can then be handled and wound as a unit, and later fastened to the baseboard with a brass screw. Drill a couple of fine holes in one cheek, one adjacent to the bobbin to take the start of the winding, and another near the outer edge to take the finish.

For a 1mH choke, wind on 197 turns of 18B&S or 19SWG gauge enamelled copper wire, which will substantially fill the available space. The 0.35mH inductor will need 118 turns of the same wire, and



the 0.2mH inductor 90 turns. Layer wind as far as possible but be careful to avoid kinks or other circumstances which could damage the insulation and cause a shorted turn. When the inductors are complete, bind and protect the winding with adhesive plastic tape.

The moulded bobbins are too small to accommodate the 1mH choke but they will accommodate the smaller values. For the 0.2mH choke wind on 105 turns of the wire already specified. For the 0.35mH choke, we suggest 140 turns of a slightly lighter gauge, say 20B&S. The bobbins have wire lugs already moulded in; carefully scrape the enamelled wire where it comes out the cheek, twist it around the wire lug and spot solder it, avoiding the use of excess heat. Bind and protect the inductor as before.

Plotted in terms of drive voltage to the loudspeakers, the basic crossover network gives a virtually copybook set of 6dB/octave curves, with flat tops and with the 3dB crossover points at 900Hz and 6kHz.

The optional "fiddle" components shown dotted put a kink in the mid-range curve, corresponding to a slight prominence in the 6-25 response around 3600Hz ("calibrated" ears only!)

Turning now to the enclosure itself, it can be made up from raw materials to the dimensions shown in Fig. 1. Thicker—not thinner—materials may be substituted but it is essential to preserve the internal volume and therefore the internal dimensions. External finish can be a matter for individual choice and skill.

Incidentally, with suppliers and manufacturers caught temporarily in the no-man's-land between imperial and metric measurements, panel sizes may have to be rationalised somewhat to avoid excess wastage when cutting from sheets of one kind or the other. Small variations from the recommended dimensions would not affect performance, provided the internal volume remains unchanged and provided the enclosure is not narrowed to the point where it crowds the rear end of the port tube.

The construction may involve internal cleats, mitres, or any other method that you can cope with but certain requirements are paramount: the enclosure must be rigid and it must be absolutely airtight—rendered so by glue or a sealing compound. Butted but unsealed joints are not good enough, no matter how workmanlike. The back should be screwed and glued into place so that the main enclosure becomes an integral unit, permanently and predictably airtight.

No leaks must be permitted around the outgoing lead or plug and socket. Use caulking compound to seal off any possible air paths.

While some may want to build their own enclosure, many will prefer the simpler alternative of buying the pre-assembled woodwork and fitting the drivers, crossover components, and wiring. The prototype cabinets pictured

## Greyscale/Convergence Generator

Features ★ CROSSHATCH ★ DOTS ★ VERT. & HOR. LINES ★ VERT. BARS  
★ GREYSCALE (8 Step) ★ WHITE SCREEN ★ BLACK SCREEN ★ VHF  
OUTPUT (Tunable) ★ HOR. & VERT. SYNC. & BLKG. ★ PORTABLE MAINS/  
BATTERY OPERATION ★ HIGH STABILITY & RELIABILITY ★ LOW PRICE

~~ONLY \$110.00 plus 15% S.T.~~

**REDUCED TO  
\$90+S.T.**

## **PAL** COLOUR BAR GENERATOR PUSH BUTTON MODEL COLROSE PBC III

- ★ Provides the THREE COLOUR BAR STANDARDS as used in Australia (100% Amp 100% SAT., 100% Amp 95% SAT., 75% Amp 100% SAT.)
- ★ Provides the THREE ASSOCIATED GREYSCALE PATTERNS.
- ★ Accurately Centred CROSSHATCH pattern for easy adjustment of picture height, width and linearity.

Other features include ★ DOTS ★ VERT. & HOR. LINES ★ VERT. BARS  
★ RED SCREEN ★ WHITE SCREEN ★ PAL/NTSC COLOUR BARS ★ VARIABLE BURST AMPLITUDE ★ VARIABLE VIDEO OUTPUT — pos. or neg. polarity ★ VHF OUTPUT — tunable ★ SOUND CARRIER — mod. (1kHz) or unmod. ★ CANCEL Y(Luminance) U(B-Y) & V(R-Y) switches ★ C.R.O. Sync. Socket.

**PRE-TAX  
STOCK  
CLEARANCE**

~~STILL ONLY \$350.00 plus 15% S.T.~~

**REDUCED TO  
\$280+S.T.**

\* OTHER UNITS FROM \$200+S.T.

**COLROSE ELECTRONICS**

13 Freda Street, Netley, S.A. 5037 — Phone 293 5617

**New  
Low Price  
\$269  
FOR/FOA Sydney**



## **KENWOOD QR666**

**High performance Communications Receiver**  
For the short wave listener or amateur radio operator.

This high performance, solid state receiver covers the frequencies 170 KHz-30 MHz with 6 bands, receiving in the AM, SSB and CW modes.



\*Recommended retail price.

Three way power supply operates from 110/240V AC, internal or external 12V DC. The unit includes a 500 KHz marker oscillator.

**Available from your radio dealer  
or your Kenwood Amateur Radio  
Equipment dealer:**

MITCHELL RADIO COMPANY, Albion, QLD.  
TELAIR ELECTRONICS, Brisbane, QLD.  
DICK SMITH ELECTRONICS, Gore Hill, NSW.  
VICOM, Artarmon, NSW.  
DIGITRONICS, Newcastle West, NSW.  
VICOM INTERNATIONAL, Auburn, VIC.  
HAM RADIO SUPPLIERS, Melbourne, VIC.  
FARMERS RADIO, Adelaide, SA.  
INTERNATIONAL COMM. SYSTEM,  
Port Adelaide, SA.  
WILLIS TRADING COMPANY, Perth, WA.

Kenwood Amateur Radio Equipment is marketed in Australia by Weston Electronics Company, P.O. Box 71, Kingsgrove, NSW 2208.

WE502 R

## 3-41L SPEAKER SYSTEM

on this occasion were supplied to us by Messrs E.K.A. Manufacturing, of 28 Charles St, St Marys, NSW 2760 (Sydney tel. 623 6371). The company has supplied cabinets to the industry for some time but can be contacted direct if your normal supplier cannot assist. We understand also that complete kits (EKA cabinets, speakers and crossover components) will be available from Messrs 451 Sound Centre, mentioned at the beginning of this article.

The EKA cabinets are finished externally and are complete with fret. However, they have not been sealed beyond normal assembly techniques and need further treatment. The company manager, Mr Fred Newhouser, explained that this is a quite deliberate policy, because detailing work can be handled much more economically by the handyman than in the factory.

We first stripped out the absorbent lining and added a cleat to stiffen the rear panel, as shown in the drawing. The cabinet was then tilted back at 45 degrees and a line of PVC glue run internally into each of the upturned joints—the top of the cleat, the bottom of the rear panel and the front of the bottom baffle cleat. We did this four times, with a few hours lapse in between, so that there was ultimately a continuous line of glue completely sealing the back panel and the ring of cleats against which the baffle would ultimately rest.

This done, the padding was pinned back into place—firmly so that it could not droop away from the inner surfaces. For this you will need either a stapler or a handfull of long drawing pins or upholstery tacks. The same remarks would apply, of course, to a fully home-made enclosure.

While it is reasonable to use Innerbond if it is available recent work has verified that thick carpet underfelt (not underfoam) can also be used to clad the walls of a ported enclosure. It, too, would need to be firmly pinned into place.

While this work is in progress, attention can be turned to the baffle board. Depending on where you buy the cabinet, it may come with the port tube and the mid-range enclosure already fitted, or you may have to arrange these yourself.

If not provided, the mid-range enclosure tube and capping can be purchased from Magnavox, along with the 8-30 and 6-25 loudspeakers. The port tube should be less of a problem since 3-inch I.D. cardboard tubes are used as paper spools in commercial copying machines.

Pin and glue the mid-range tube and cap in place, then cut the port tube to length, apply glue, and push in into the matching hole in the baffle. Place the baffle face down, run a fillet of PVC glue around the base of both tubes and leave

to set. This done, the baffle can be fitted provisionally into the cabinet, checking or drilling the clearance and pilot holes for the fixing screws. Use at least three screws along each side and two at top and bottom.

Smooth the ends of the port tube and, if there is any sign of the cardboard feathering, smear the surface with glue so that there are no fragments to produce noise in the air moving in the port. Finally, paint the surface of the baffle and the inside of the port a flat black.

The drivers and divider network can now be mounted and wired.

The tweeter is intended to mount against the face of the baffle but do not assume that it will form an airtight seal,

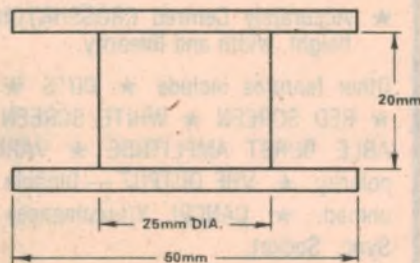
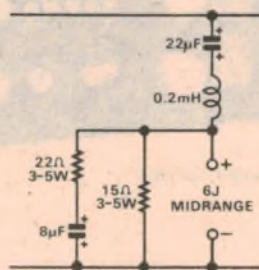

Fig. 4: The inductors can be wound up on bobbins made to these dimensions from plywood, masonite or other non-metallic material.

no matter how flush the surfaces appear. We put a ring of  $\frac{1}{8}$  inch thick adhesive backed foam around the face of the tweeter hole against which the tweeter can bed. The foam, identified as Engels No. 5C, is sold in hardware stores as a draught excluding material. Alternatively some prefer to use a ring of non-hardening caulking compound, EKA recommending the compound sold for caulking auto windscreen surrounds.

The 8-30 woofer can be mounted behind the baffle, using its own cork buffers as the gasket. However, make sure that it seats down snugly and firmly and plug any air spaces around the mounting screws with caulking compound. If, for any reason, you want to mount the bass driver in front of the baffle, this is in order, provided there is enough clearance behind the fret cloth for the housing and full cone travel. However,



For those who wish to up-date their existing 3-45L systems, without going to the expense of new 6-25 drivers, the original 6J (a 15-ohm type) can be wired as shown. It must be mounted off the baffle, as described for the 6-25.

it would be absolutely essential to bed the woofer into foam or caulking compound.

The mid-range driver must not be sealed into its enclosure but should be mounted proud of the surface, with about a 5mm air gap all round. If the mounting hole is made deliberately small and chamfered as in the drawing, all you need do is to slip a suitably small rubber grommet over each mounting screw between the housing and the baffle surface. If the cut out is too large to ensure a good grip for the screws, you can do as we did in our prototype: cut and drill four little brackets from 16g aluminium, measuring about 22 x 12mm, attach them to the speaker frame with  $\frac{1}{4}$  inch long bolts, bend them into a shallow step with pliers and screw to the baffle surface. Paint them flat black.

The baffle assembly should now be about ready to instal in the cabinet but, once again, don't rely on a surface-surface abutment to provide a seal. Carefully attach a complete ring of adhesive foam to the cleats, against which the baffle can seal. Make sure to pierce the foam where the screws go through, to avoid the risk of them screwing the foam into a knot.

As an alternative to foam, caulking compound carefully applied will serve the same purpose, although it is less pleasant to cope with if you later want to remove the baffle.

Blacken the heads of the screws and any other part of the speaker metalwork which is likely to show through the cloth.

If the fret frame is a tight fit, it may need only to be pushed into position. If not, scraps of velchrome tape on each corner face of the baffle, and on the rear faces of the frame, will hold the latter in position. Velchrome can usually be obtained from haberdashery stores.

And that should just about complete your new 3-41L systems. Having good average sensitivity, as hifi systems go, they can be used quite successfully with modest amplifiers of the order of 5 watts RMS per channel. But, equally, they are rated for 30W RMS and, driven harder, can produce as much level as you're ever likely to want in an ordinary domestic situation.

And, with response to below 40Hz, they will also sound fine with your domestic electronic organ—normally far better than the usual in-console speakers!

The impedance, by the way, remains very close to 8 ohms, except in the region of system resonance. Here it behaves exactly as intended, with impedance peaks at about 70 and 25Hz and a trough of 9 ohms right on 40Hz.

By a happy coincidence, we are currently describing a new high quality amplifier for home construction. Team it with a pair of 3-41Ls and you should end up with a really fine system—and enough change left over to spend on something else!

# some are more equalizer than others

## • MARK XVII octave equalizer

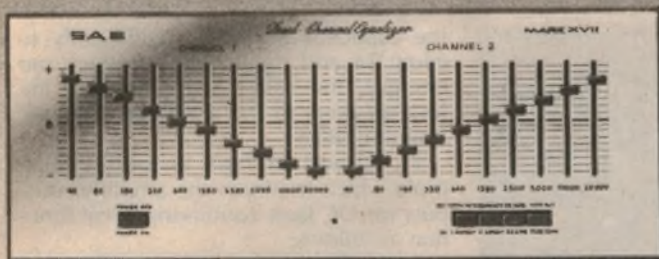

### specifications...

Your tone controls are just not designed to compensate for

- Room acoustics
- Speaker placement
- Old or bad recordings.

We built the Mark XVII Equalizer to solve these problems and more.

These are some of the ways:

- Individual Octave Control for each channel.
- Long throw, oil-damped linear slide pots for greater accuracy.
- Dual range operation (controls operate over either  $\pm 8\text{dB}$  or  $\pm 16\text{dB}$ )

#### Plus

- Capable of driving any system
- Low distortion—less than 0.03% THD and IM
- Low noise — greater than 90dB
- 5-year parts and labour service contract
- SAE's reputation as the finest manufacturer in the audio field.

You'd have to look a long time to find an EQ that delivers this much value. SAE innovation has done it.

price \$356.50

## • MARK 2700B half octave equalizer

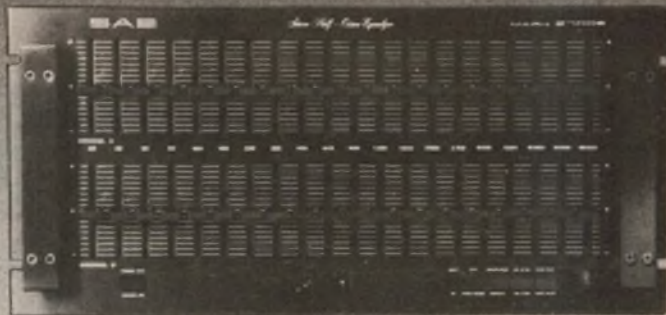

### specifications...

**Pink Noise Generator.** A built-in pink noise generator assures an accurate reference for proper equalization of wide band speaker response, speaker phasing, channel power balancing and frequency equalization.

**Low Distortion.** Fully complementary output drive circuits provide total harmonic and inter-modulation distortion levels of less than 0.02%.

**Low Noise.** High Q Toroid inductors in combination with low loss capacitors and low noise professional slide potentiometers result in circuitry offering greater than 100dB signal-to-noise ratio and accurate equalization curves.

**IC Power Supply.** Individual IC control for positive and negative power supplies further assures low noise circuitry and stability with changing line conditions.

The SAE 2700B Dual-Channel Half Octave Equalizer delivers +23dBm for recording applications, offers complete control, extremely low noise, accurate equalization, and the usual superb SAE quality.

price \$695.00

# SAE

components for the connoisseur.

Sole Australian Distributors.

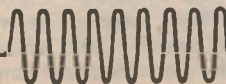

## LEROYA INDUSTRIES PTY LTD

Head Office, W.A.: 156 Railway Pde., Leederville 6007. Phone 81 2930.

N.S.W. Office: 100 Walker St., North Sydney 2060. Phone 922 4037

VICTORIA Office: 103 Pelham St., Carlton 3053. Phone 3477620

Add Loudspeaker Protection to your

# Playmaster Twin Twenty Five

—and read the useful trouble-shooting procedure



In this third article on the Playmaster Twin, Twenty Five we publish details of the optional loudspeaker protection and switch-on mute circuit, and also give a trouble-shooting procedure for fault-finding in the amplifier circuitry.

by LEO SIMPSON

As noted in the previous article in this series, there is space adjacent to the power transformer for the PC board for the optional loudspeaker protection and muting circuit. Many constructors may wish to complete the basic amplifier and make it operational before deciding to incorporate this feature.

Two separate facilities are provided by the circuit: protection of the loudspeakers in the event of an amplifier malfunction where the fuses do not blow, and elimination of switch-on transients. While the switch-on transient of the Playmaster Twin Twenty Five is certainly not excessive we regard its elimination as being a worthwhile operating refinement.

On the score of loudspeaker protection in the event of malfunction perhaps we should also point out that in most cases the fuses will provide adequate protection.

The circuit published here is a slight modification of the Loudspeaker Protector published in November 1975 (File

1/MS/13). It uses a PC board measuring 102 x 51mm and coded 75L11. For those who missed the first article we will repeat the description of the circuit.

Basically it consists of a relay which normally connects the loudspeakers to the amplifier a few seconds after switch-on. If a DC voltage is subsequently applied across the loudspeakers due to an amplifier malfunction, the relay subsequently disconnects them.

Five general purpose silicon transistors are employed in the circuit. T5 drives the relay direct. A diode in the collector circuit protects T5 against inductive kick-back from the relay when it is de-energised. T4 controls T5 via the 10k resistor. When T4 conducts, so does T5.

Base bias for T4 is provided by a network consisting of two 56k resistors, one 220k resistor and a 100uF capacitor. At initial switch-on of the amplifier the 100uF capacitor has zero charge, so no forward bias is applied to T4 and the relay is off. After about three seconds,

the capacitor is charged sufficiently to allow T4 and then T5 to conduct and energise the relay. This connects the loudspeakers to the amplifier, after the required delay.

T1, T2 and T3 form an odd-looking triple which monitors the amplifier outputs for DC fault conditions. They function as follows:

Both channels of the amplifier are monitored by T1, 2, 3 via a low-pass filter consisting of four 22k resistors and two 50uF capacitors. Typically, the DC offset voltage at the output of each amplifier channel may range from 20 to 150 millivolts. These normal offsets do not affect the monitoring network, due to the voltage division provided by the 22k resistors.

If one of the amplifier outputs goes positive by more than two volts, T3 is forward-biased and it conducts to remove the base bias from T4. Hence T4 and T5 turn off and the relay disconnects the loudspeakers. Similarly, if the amplifier output becomes negative by more than 2 volts, the emitter of T1 is made negative with respect to its base. T1 is thus forced to conduct as is T2, so removing the bias from T4 and turning off T4 and T5 as before.

So all the transistors function as simple switches which are only controlled by the presence of DC voltages at the amplifier outputs. AC signals have negligible effect due to the input low-pass filter.

The two 50uF capacitors in the input filter are non-polarised electrolytics. They have to be, since DC voltages of either polarity may be applied to them. The capacitors we used are made by Elna and are referred to by the manufacturer as being "bipolar"—a term normally applied to conventional transistors. We prefer the term "non-polarised".

The most convenient method of powering the Protector circuit in the Playmaster Twin Twenty Five was to run it from the positive 30V rail via a 15V zener diode, with adequate power rating to cope with the maximum current drain

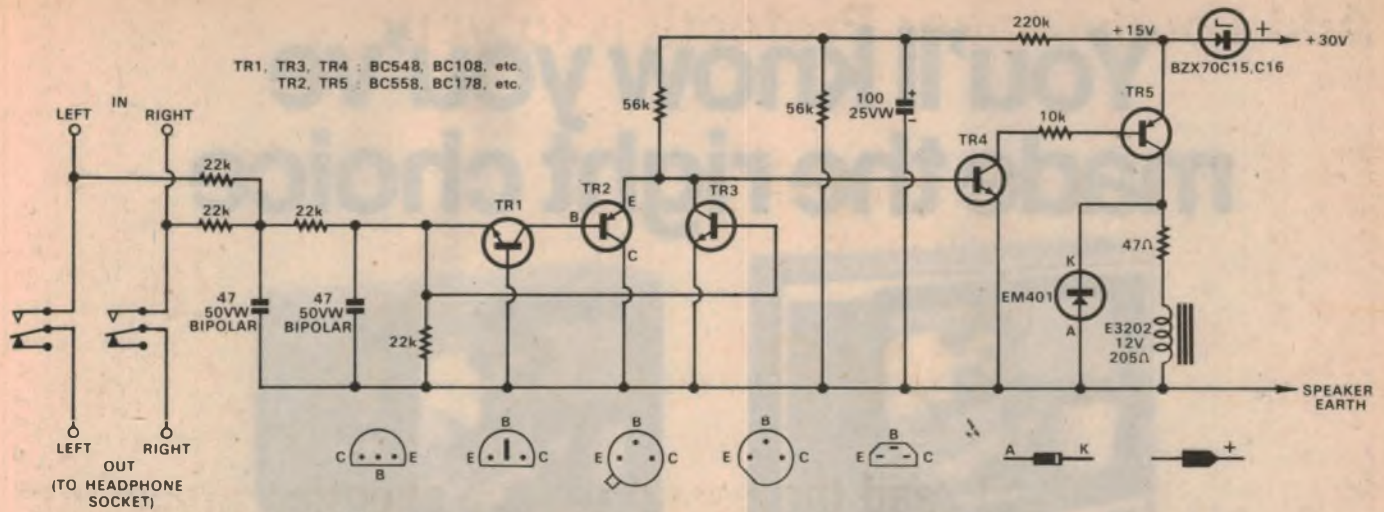

**EA** LOUDSPEAKER PROTECTOR (PLAYMASTER TWIN TWENTY FIVE)

1/5A/-

The loudspeaker protector circuitry is fed via a 15V zener diode from the positive 30V of the power amplifier.

of around 60 milliamps which occurs when the relay is energised. Current drain before the relay is energised is less than 100 microamps. This large variation in current drain means that the series zener diode is the simplest way of obtaining around 15V for the Protector circuit.

Assembly of the PC board is straightforward. The double-changeover relay is made by Varley, type E3202 and has contacts rated at 5 amps which should be adequate for the purpose. The relay is soldered directly to the PC board. The non-polarised capacitors can be soldered in either way, with no regard for polarity.

Use PC stakes to make connections to the PC board. These made it easy to make or break connections. The PC board is mounted on the amplifier chassis with the aid of two Richco CBS-6N plastic PC board supports.

When assembly is complete the Protector can be energised and checked for correct operation without connecting it to the amplifier loudspeaker outputs. The common connection on the Protector PC board connects to one of the loudspeaker earth return points at the rear of the main amplifier PC board. The 30V rail connection is taken from the solder lug connection to the collector of T13 in the righthand amplifier.

Switch the amplifier on and check that the relay closes after about three seconds. Drop-out time for the relay after switch-off is less than a second. A shorter delay before the relay closes will occur if the amplifier is switched on immediately after it has been switched off.

Fault conditions at the loudspeakers can now be simulated with the aid of a jumper lead. Simply connect each of the loudspeaker inputs on the Protector to the positive 30V rail and then to the negative 30V rail. Each time the relay should open almost immediately and then close

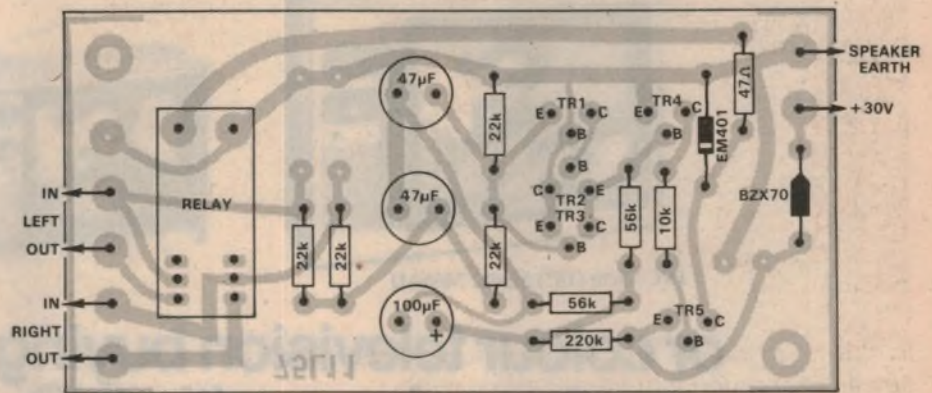

Below is the orientation of the Protector board with respect to the main PC board.

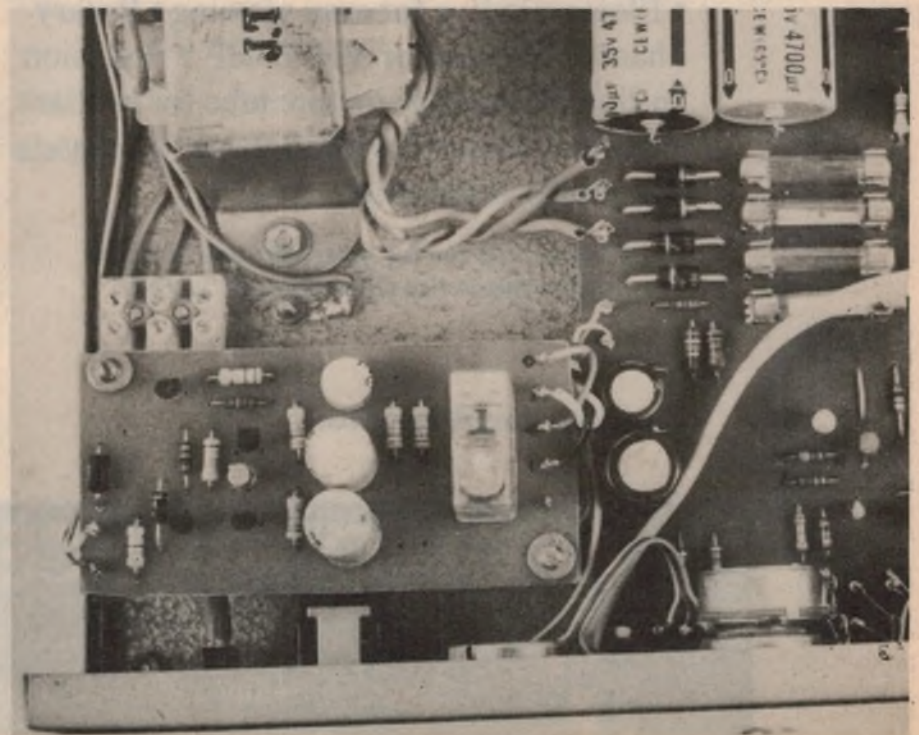

# You'll know you've made the right choice



JVC 48cm (20")  
Model 7765AU (with rotary tuning)



JVC 48cm (20")  
Model 7865AU (with electronic touch tuning)



JVC 43cm (18") Model 7465AU



JVC 33cm (14")  
Model 7165AU

## or colour television buying made easier... with JVC

- Electronic Eye for easy viewing
- Rotary channel selector for VHF/UHF
- Precision in-line black stripe picture tube for brilliant natural colours
- Revolutionary 'Y' chassis for greater reliability.

**Call in and see for yourself: you'll know you've made the right choice... JVC.**

*Available immediately from*



# JVC

the right choice

## APOLLO HI-FI CENTRE

283 Victoria Rd, Marrickville. Ph 560 9019.  
Open Thursday till 9PM, all day Saturday.



## PLAYMASTER TWIN TWENTY FIVE

again after the "simulated" fault is removed.

When operation of the circuit has been checked, the remainder of the connections can be made to the amplifier circuitry. The inputs to the Protector board are from each of the power amplifier outputs while the outputs of the Protector board connects to the stereo headphone socket and thence to the loudspeaker terminals. Check last month's article on the amplifier to see the correct wiring of the headphone socket.

Now let us move on to the trouble-shooting procedure. We will assume that the positive and negative supply rails are operational. If the negative or positive 15V rails are less than 1V, the likely cause is a short-circuited or reverse connected zener diode. On the other hand, if these supplies are substantially higher than they should be, then it is likely that the associated zener diode is open circuit.

Voltage measurements should be made using a meter with a sensitivity of at least 20,000 ohms per volt or alternatively, with a FET volt-ohmmeter which will usually have an input impedance of 10 megohms or more.

Trouble-shooting in the power amplifier circuitry should be performed with the 100 ohm 1W resistors wired across the fuse-holders in place of the 2 amp fuses. If a fault causes the 100 ohm resistors to burn up before the cause can be found, no great harm will be done. Just replace the resistors with 100 ohm units of 5W rating or higher, if easily available. These may also become very hot while fault finding progresses but at least they will prevent any further damage to the amplifier circuitry.

Voltages shown on the circuit are intended as a guide only. A normally operating amplifier may have variations which a novice will regard as unusual. The 30V supply rails can be expected to vary by at least plus or minus 5% due to mains voltage fluctuations, so the two voltages marked "+28.5V" and "-28.6V" can be expected to vary by a similar amount.

Similarly, the zener-stabilised 15V supplies can be expected to be anywhere within about 13.6 to 15.7V, partly due zener tolerance and partly to mains voltage fluctuation. Voltages in the preamplifier circuitry can be expected to vary proportionally. Add to these normal variations the inaccuracies inherent in the meter and you should see why we state that the voltage readings are only a guide.

A useful point to remember is that all correctly operating transistors will have a base-emitter voltage drop of 0.6 to 0.75V.

If the output offset voltage is grossly in excess of 150mV, eg  $\pm 30V$ , check first

that the input earth of the associated power amplifier is connected back to the appropriate balance control terminal at the front of the PC board. This connection is made via the shielded cable shown on the PC layout on page 61 of last month's issue. This check should be made with a multimeter switched to a low ohms range.

If the connection is good, check the base-emitter voltages of T6 and T7 (0.7V) and their collector voltages -

tor associated with the emitter of T8 should be 0.7V, and the collector voltage of T8 should be about -22V. If it is closer to -30V then T8 is short circuit.

If the output offset voltage is within the above limits and the 100 ohm protective resistors are dissipating excessive power then it is likely that the amplifier is unstable or is drawing excess quiescent current. If no variation in the current can be obtained by adjusting the 1k preset potentiometer, T15 is open circuit.

If the power amplifier is drawing excessive current then it may be unstable or T15 may be faulty. A check for

### LIST OF PARTS

- 1 PC board, 102 x 51mm, code 75L11
- 3 BC548 NPN silicon transistors
- 2 BC558 PNP silicon transistors
- 1 BZX70/C15 or C16 or equivalent zener diode
- 1 EM401 silicon power diode
- 1 Varley E3202 relay, 12V 205 ohm coil with double changeover contacts
- 1 100uF/25VW PC electrolytic capacitor
- 2 50uF/50VW PC non-polarised electrolytic capacitors
- 2 Richco CBS-6N PC board supports
- 6 PC stakes

### RESISTORS

- ( $\frac{1}{4}$  or  $\frac{1}{2}W$ , 10% tolerance)
- 1 x 220k, 2 x 56k, 4 x 22k, 1 x 10k, 1 x 47 ohms.

**NOTE:** Resistor wattage ratings and capacitor voltage ratings are those used for our prototype. Components with higher ratings may be used provided they are physically compatible. Lower rated components may also be used in some cases provided their ratings are not exceeded.

approximately +28.6V and equal. If no fault is evident here, check the base-emitter voltages of T9 and T10 and the voltage drop across each 39 ohm resistor. In each case the voltage should be about 0.7V. If these resistors have excessive voltage and/or are burning up, check to see that T9 and T10 are not transposed.

One voltage reading deliberately omitted from the circuit diagram is the DC voltage at the output of each amplifier—referred to as the "output offset voltage" above. While this is nominally zero it may range anywhere between  $\pm 150mV$  depending on the setting of the Balance control and component parameters. With the Balance control central the offset voltage will typically be about  $\pm 30mV$ . If the offset voltage is more than  $\pm 150mV$  then it is likely that T6 or T7 is faulty.

Voltage drop across the 150 ohm resis-

instability can be made using an oscilloscope or a multimeter switched to an appropriate (5 to 30V) AC range. If the amplifier is not unstable, as evidenced by no AC output signal, then try to adjust the quiescent current control, the 1k preset potentiometer. If no variation can be obtained, then T15 is open circuit. If no quiescent current can be obtained and the voltage drop across T15 is zero or less than 2 volts, then T15 is short circuit.

Incorrect value resistors associated with T15 will produce similar fault conditions.

Instability in the power amplifier may be due to the following causes: instability in the preamplifier, faulty RLC network in the output stage, faulty 0.1uF supply bypass capacitors, faulty 4700uF filter capacitors or open-circuit .0022uF capacitor associated with the collector of T10.

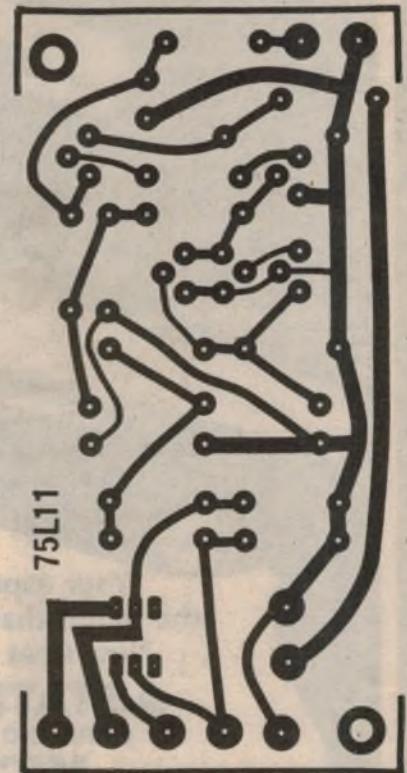

857

**UNIDIRECTIONAL**

Ideal for groups  
unique design  
eliminates  
'pop' noise

820

**PROBE DYNAMIC**

Perfect concentric  
pattern for choral  
and instrumental groups

810

**ULTRA CARDIOID**

Dynamic  
Lo or Hi Z

840

Lightweight  
miniature  
professional  
lavaliere  
dynamic



Your experience has taught you  
the things that make a **FINE** microphone.  
Now treat yourself to the **FINEST**.

**ASTATIC 800 SERIES**  
CARDIOID AND OMNIDIRECTIONAL  
**MICROPHONES**

Your experience has taught you the things  
that make a **FINE** microphone stand.  
Now treat yourself to the **FINEST**.

**NOMIS 900 Series MICROPHONE STANDS**

Satin and bright chrome durable finish. Based on proven field designs  
from one of Australia's oldest sound specialists. Professional quality at  
surprisingly low prices.

Australian Distributors  
"The Sound People"

**NOMIS**



903  
Floor

905  
Boom

904  
Banquet



Full details and specifications from the Australian Distributors

**NOMIS ELECTRONICS PTY. LTD.**

689 SOUTH ROAD, BLACK FOREST, S.A. 5035. (08) 293 4896

INTERSTATE DISTRIBUTION ENQUIRIES WELCOME



## PLAYMASTER TWIN TWENTY FIVE

Instability in the preamplifiers should not be a factor at this stage because they should be disconnected from the power amplifier inputs while trouble-shooting in this section progresses. The capacitors mentioned above may be checked merely by bridging with capacitors of equivalent value.

If only one channel is faulty, the operating channel can be used as a basis for comparison for voltage measurements.

Trouble-shooting in the preamplifier

amplifier PC board.

Some amplifiers using substitute plastic transistors have been found to "motorboat" when the Volume control is at zero setting due to a very high frequency oscillation in T3 and T103. This is a not uncommon fault with emitter-followers and is often evidenced by supposedly noisy Volume controls. In this case, it is cured by fitting a ferrite bead, type FX1115, to the base leads of T3 and T103. An alternative cure is to connect a

1k resistor in series with each Volume control wiper.

Another amplifier using metal encapsulated transistors (which we do not recommend) was found to be unstable with Volume and Treble controls fully advanced. In this case the cure was to increase the 47pF capacitor associated with T3 and T103 to .0033uF. This does not affect the measured frequency response.

Constructors may incorporate both of the above measures as a preventive measure to save the trouble of having to incorporate either of these changes should they later prove necessary. ☺

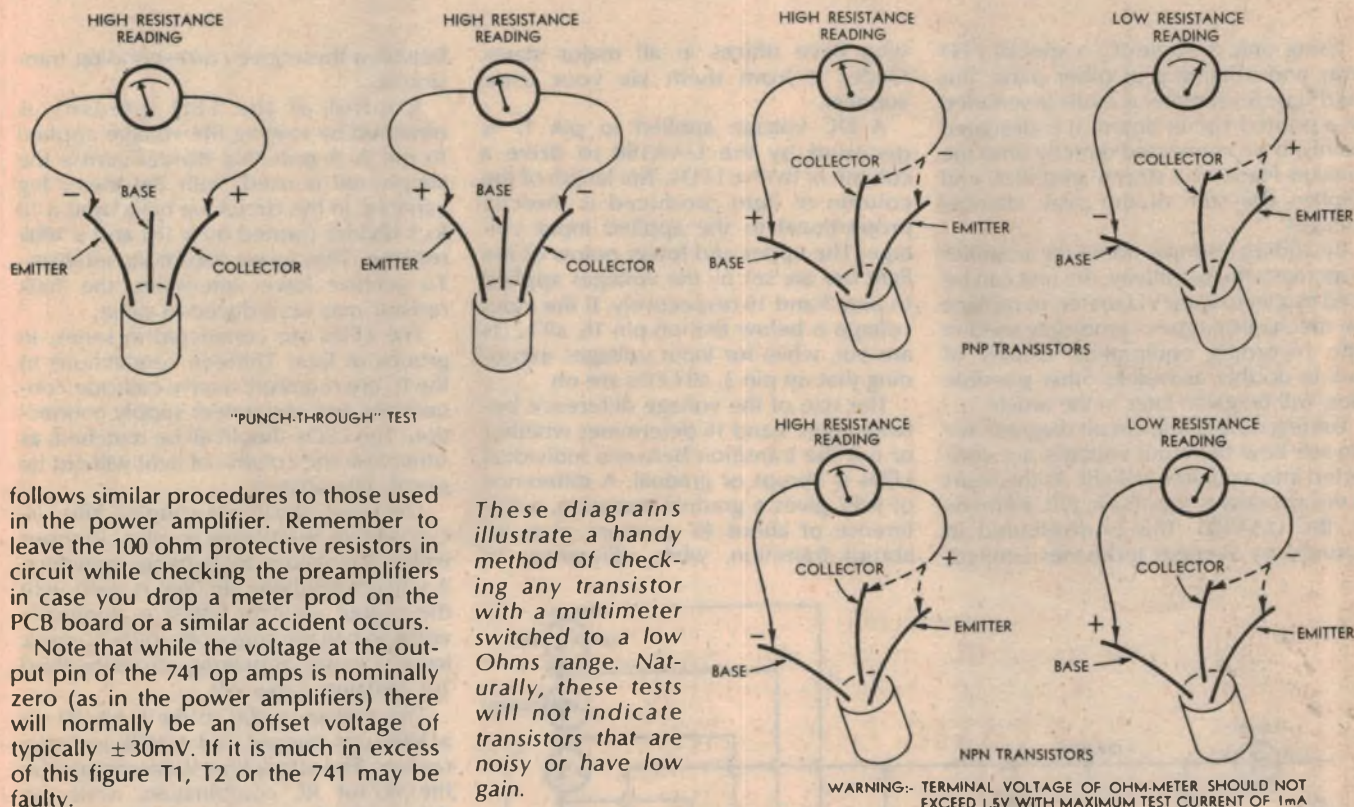

follows similar procedures to those used in the power amplifier. Remember to leave the 100 ohm protective resistors in circuit while checking the preamplifiers in case you drop a meter prod on the PCB board or a similar accident occurs.

Note that while the voltage at the output pin of the 741 op amps is nominally zero (as in the power amplifiers) there will normally be an offset voltage of typically  $\pm 30\text{mV}$ . If it is much in excess of this figure T1, T2 or the 741 may be faulty.

If any transistors are removed from the circuit as suspect, it is handy to be able to check them with the aid of a multimeter. The range which is usually appropriate is "R x 100 ohms". First check the transistor from collector to emitter in both directions. Each measurement should produce a high resistance reading. Similarly, check the base-emitter and base-collector junctions. These should give high readings in one direction and low readings in the other. The diagrams illustrate the method.

Hum in the amplifier may be a problem caused by some of the abnormal operating conditions already described, or by incorrect layout. But the latter should not occur if the wiring diagrams have been followed explicitly.

Hum may be noticeable only when the headphones are in use. In this case the likely cause is close proximity of the headphone socket leads to the transformer core. Move the leads away and tuck them under the edge of the

*These diagrams illustrate a handy method of checking any transistor switched to a low Ohms range. Naturally, these tests will not indicate transistors that are noisy or have low gain.*

## ERRATA—PLAYMASTER TWIN 25 AMPLIFIER

Readers may have noted two omissions in the parts list of the amplifier. The first is the power transformer, which has a centre-tapped 44 volt secondary. The transformer for our prototype was supplied by Jones Transformers, type number JT 180. The equivalent from Ferguson Transformers Pty Ltd is PF 3993.

The remaining omission from the parts list is "2 x .001uF metallised polyester of polystyrene" capacitors, which are used in the RIAA preamplifiers.

A further error in the parts list designates the main PC board as 76sa3 instead of 76sa4.

There are several inconsistencies between the main circuit diagram and the

PC board layout on page 61 of the May issue. The circuit diagram is correct. First, the RIAA equalisation network in the preamplifier is actually reversed on the PC board. This is inconsequential as it does not affect circuit operation in any way.

Four tantalum capacitors are shown reverse-polarised on the PC layout. These are the 0.47uF capacitors associated with the emitter circuit of T5 and T105 and the 10uF capacitor in the feedback networks of each RIAA preamplifier. Some constructors who have completed their amplifier may elect not to correct these errors since the DC voltage applied to the capacitors are so small that they are not likely to cause malfunction.

Build this simple

# LED Level Meter

This simple LED audio level indicator can be used to monitor the output from your amplifier. A column of twelve LEDs gives a "bar of light" display proportional to the output voltage, and lighting of the uppermost LED can be made to correspond to clipping level.

by DAVID EDWARDS

Using only a single IC, a special LED array and a handful of other parts, this solid state level meter is easily assembled on a printed circuit board. It is designed mainly to be connected directly onto the speaker leads of a stereo amplifier, and displays the sum of the peak channel voltages.

By adding a simple transistor amplifier to increase the sensitivity, the unit can be used as a solid state VU meter, to replace the mechanical types commonly used in tape recording equipment. Details of how to do this, as well as other possible uses, will be given later in the article.

Turning now to the circuit diagram, we can see how the input voltages are converted into a column of light. At the heart of this process is the 16 pin DIL Siemens IC, the UAA180. This is distributed in Australia by Siemens Industries Limited,

who have offices in all major states. Order it from them via your usual supplier.

A DC voltage applied to pin 17 is decoded by the UAA180 to drive a column of twelve LEDs. The length of the column of light produced is directly proportional to the applied input voltage. The upper and lower points of the light bar are set by the voltages applied to pins 3 and 16 respectively. If the input voltage is below that on pin 16, all LEDs are out, while for input voltages exceeding that on pin 3, all LEDs are on.

The size of the voltage difference between pins 3 and 16 determines whether or not the transition between individual LEDs is abrupt or gradual. A difference of 0.5V gives a gradual transition, a difference of about 4V or more gives an abrupt transition, while differences in

between these give corresponding transitions.

Control of the LED intensity is obtained by varying the voltage applied to pin 2. A potential divider across the supply rail is used, with the lower leg variable. In the circuit we have used a 10 to 1 divider formed by a 1M and a 100k resistor. This gives maximum intensity. To achieve lower intensities, the 100k resistor may be reduced in value.

The LEDs are connected in series, in groups of four. Thirteen connections to the IC are required, twelve cathode connections and one power supply connection. The LEDs should all be matched, as otherwise the column of light will not be evenly illuminated.

The input signals are coupled into circuit via two 1k isolating resistors in series with 1uF tantalum decoupling capacitors. A voltage doubling rectifier is used with the output voltage, which is nominally equal to half the sum of the peak to peak input voltages, appearing across the third 1uF tantalum capacitor.

This voltage is fed to the UAA180 via a 100k pot trimpot and a 100k isolating resistor. The attack time is determined by the 1k/1uF RC combination, while the decay time depends on the 100k/1uF RC combination.

The common terminal for both inputs is intended to be connected to the chassis of the amplifier. This will avoid any complications with DC offsets between the two amplifiers. If required for use with a four channel amplifier, two more input coupling networks can simply be added in parallel with the two already provided.

The reference voltage for the UAA180 is provided by the 4.7V 400mW zener diode. Pins 3 and 16 are simply connected directly to either side of the zener. Filtering of the supply rail is provided by the 470uF 16VW electrolytic capacitor. The unit will operate with a supply rail between 10 and 16V. The maximum current drawn is about 50mA.

Shown at left is the circuit diagram. The heart of the unit is the UAA180 integrated circuit.

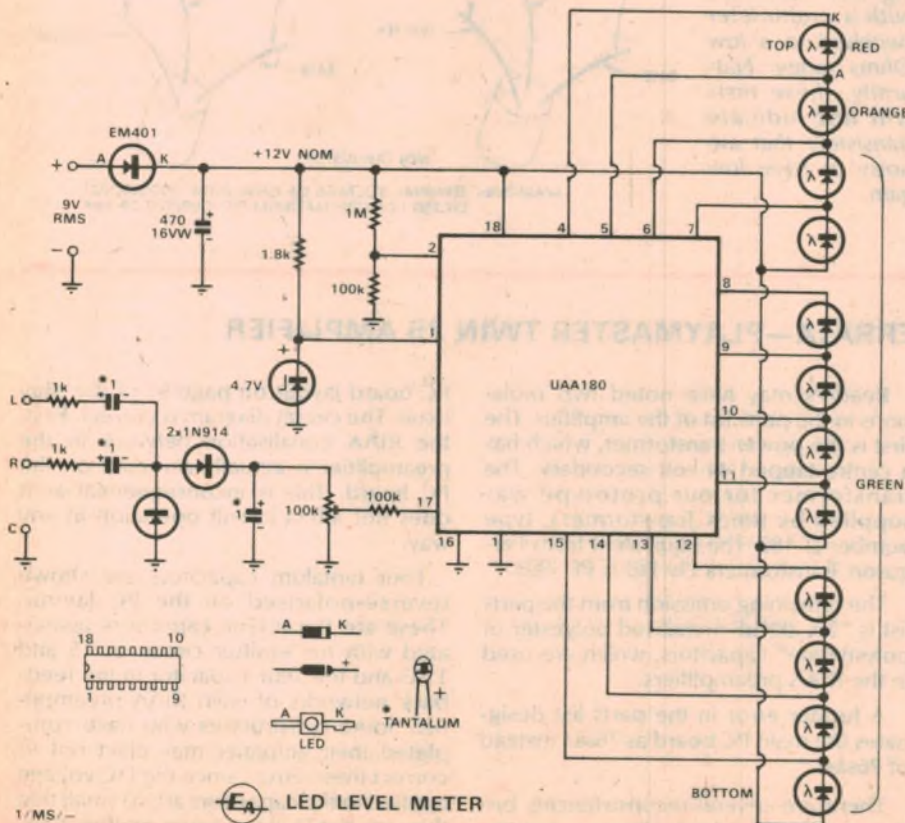

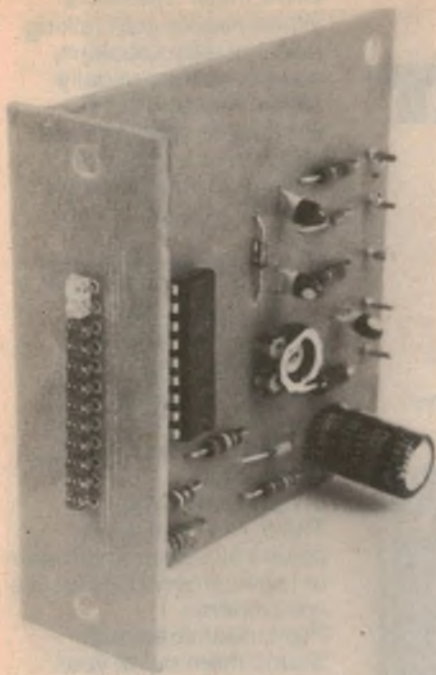

Here is a photograph of the finished unit, showing how the LEDs are mounted at right angles to the main board.

For operation on DC supplies, the diode in series with the + input is replaced with a link, and the appropriate voltage applied. If a well regulated supply is used, the 470uF electrolytic may be reduced in value.

The unit will also operate satisfactorily directly from an AC supply. The EM401 diode, in conjunction with the 470uF electrolytic capacitor, acts as a half-wave rectifier. A transformer with a secondary voltage of about 9VRMS, and capable of supplying the required current, should be used. Suitable types include the DSE M2840, from Dick Smith Electronics, the 6155 type from A & R, or the PL1.5 - 18/20VA type from Ferguson Transformers Pty Ltd.

The components are assembled on a small printed circuit board, coded 76lm5, measuring 96 x 69mm. This is designed for use with the Siemens miniature LED array, which consists of ten green LEDs in an array. Matching yellow and red LEDs complete the dozen. They are spaced on 2.54mm centres, and have leads on 2.54mm centres.

As you can see from the photographs, the LEDs are mounted on one end of the board. This end can be carefully separated from the main section of the board, and re-attached at right angles by soldering the pads provided together, so that the frontal area behind the LEDs is a minimum. Alternatively, the LEDs can simply be mounted on a suitable panel, and then connected directly to the pads on the board using a short length of rainbow cable.

Apart from the connections to the LEDs, only five other connections required, two power supply leads, and three connections to the amplifier. Once



## When his mini-computer, one day, refused to compute, Alvin was in strife... THEN he remembered!

Alvin's one of those self-styled electronic wizards, totally dedicated to his hobby—his array of expensive equipment assembled over the years is proof positive. He knows that electronic equipment requires dust and moisture-free atmospheric conditions for maximum efficiency, and so, when, one day, his pride-and-joy mini-computer refused to compute, he knew what to do... damp contacts, dusty computer heads, contaminated points... spray with CRC CO Contact Cleaner—lifts, dissolves, evaporates completely,



effectively, immediately, all residual contaminants and moisture. No disassembly of complicated units, no expensive parts to replace... just a simple application of an incredible product like CRC CO Contact Cleaner to "dissolve" the problem. If you're a dedicated "Alvin" too, you'll want to try CRC CO Contact Cleaner yourself. Ask for it at your nearest electrical/electronics retailer, or for more info about it write to: CRC Chemicals Australia Pty Ltd, Centre Court, Paul Street, North Ryde, NSW, 2113

THE SOLUTION SOLUTION

CRC CHEMICALS AUSTRALIA PTY. LTD.

Centrecourt, 25-27 Paul St., Nth. Ryde 2113. Phone: 888-3444

# BIG, FAT SOUND WITHOUT BIG, FAT PRICE TAGS

Model: EDS 3000  
12" Woofer 4 1/4" Midrange 3" Tweeter  
25-20,000 Hz 60 Watts RMS at 8 ohms

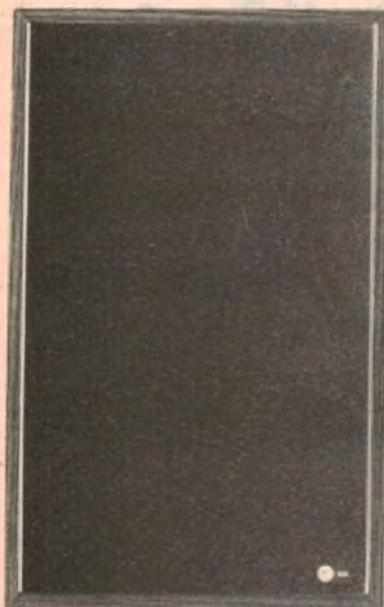

Model: EDS 2000  
10" Woofer 3" Tweeter  
35-20,000 Hz  
30 Watts RMS at 8 ohms

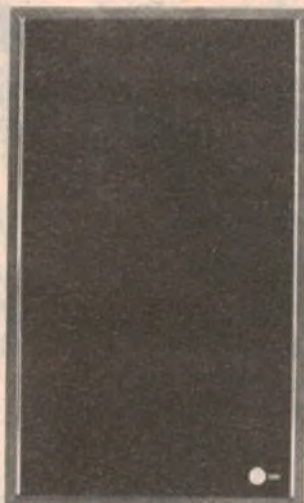

Model: EDS 1000  
8" Woofer 3" Tweeter  
35-20,000 Hz  
30 Watts RMS at 8 ohms

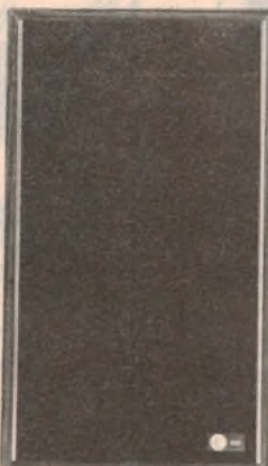

**Pro-Linear Speakers**  
When people start talking about quality speakers nowadays they usually start off around \$250.

Pro-Linear speakers are about to change all that. They give you the sound you like. At a price you'll love.

Pro-Linear speakers are made in Canada under rigid standards by Pro-Linear Acoustics. To give you some idea of our faith in their faithful reproduction, Pro-Linear speakers come with a big, fat warranty.

### 5 Year Warranty.

The 5 Year Warranty covers all labour and repair or replacement of defective components.

Pro-Linear speakers. Sound them out at your local hi fi shop.

**PRO-LINEAR**



From Canada with care

PKB885

How far has soldering tool technology advanced?

## CONTROLLED POWER at the touch of a button!



**DUOTEMP.** Slim, light, with dual thermal-power capacities. Idles all day on half wave power, at optimum PCB soldering temperature, without over heating.



For fast heat-up — For long sequences or heavy joints, a touch of the sensitive button converts it to full wave. Power is instantly doubled. Temperature is maintained while soldering.

This is made possible by the high thermal efficiency of the Adcola design. Fast heat-up and tip temperature recovery. Regulated temperature. Long element life.

**ADCOLA**

STILL SETTING THE PACE IN SOLDERING EQUIPMENT



**DUOTEMP**

Today's standard in soldering tools for printed circuits and sensitive micro-electronic components.

### OTHER MODELS

There's an even more advanced model, with sensitive in-handle electronic circuitry for feedback temperature control. It's called Thermatic.

**THERMATIC**

For occasional use, we recommend the high efficiency single temperature Adcola Standard.

**STANDARD**

3 SIZES IN EACH MODEL

MA753

*For professional slide presentation:*

# The Sync-a-Slide automatic slide advance

The Sync-a-Slide is a device used to synchronise a slide series with a recorded commentary on tape. It uses a low frequency tone recorded either on the second track of a stereo pair, or along with the commentary, to actuate the advancing mechanism of an automatic projector.

by M. E. HOOD\*

Some time ago the author felt the need for a tape-slide synchroniser to automate an audio-visual he was then producing. Like all such plans, that particular audio-visual came and went and the tape-slide synchroniser was not constructed. More recently, the necessity to produce a number of audio-visuals arose and the idea was resurrected.

An audio-visual commonly consists of a series of slides, together with a commentary, which may be either recorded or spoken at the time of presentation, plus some form of cueing signals to alert the operator to advance to the next slide. In the most basic case the one person both reads the commentary and operates the projector, using visual clues marked on the script to initiate slide changes.

The next stage of refinement occurs when the lecturer and projector operator are two different people. If the script has been planned, the projectionist can again read his cues from this—although this is not always easy in a darkened room—or alternatively the lecturer can say "next slide please" at each slide change.

There is great advantage in pre-recording the commentary. The presentation can be perfected, sound effects can be added and the lecturer is free to concentrate on operating the projector. But there is still the necessity for cues of some kind to tell him when to change the slide. Again, he can read a script, with its attendant difficulties, or some form of audible cue mark can be recorded on the tape; tones, dings, etc. The obvious disadvantage of audible cues is the fact that they are audible and as such become distracting at best, and positively annoying at worst.

The device described here was design-

ed to be used with a cassette recorder and records a virtually inaudible low frequency tone and the commentary on one channel. On replay the recorded tone is detected and saturates a transistor, which can be used to advance an automatic projector, or light a lamp to tell the operator of a manual projector to advance to the next slide.

The actual choice of the frequency for the tone is dictated by three considerations. Firstly, the tone should be low enough in frequency to lie on the lower

*Block diagram of the NE567 PLL tone decoder IC showing the external frequency determining components, R1 and C1. C2 and C3 determine the bandwidth of the PLL.*

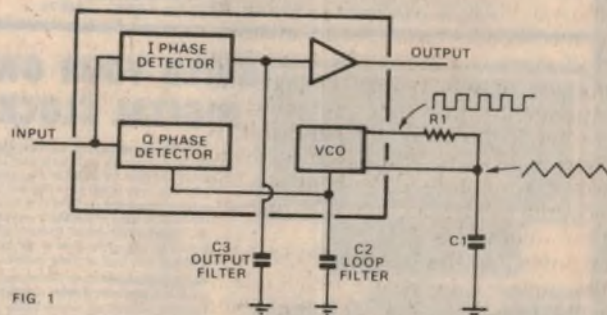

section of the ear sensitivity curve. The ear becomes progressively less sensitive with decreasing frequency and it is desirable to locate the tone where the ear is least able to hear it.

Secondly, the frequency should not be so low that low frequency response limitations of the recording equipment will unduly attenuate the cue signals. In the replay amplifier and loudspeakers low frequency roll off can be an advantage since it makes the tones less audible, but if the recorder cannot record and replay the cue tones at any adequate level, then the system cannot work.

Thirdly, the frequency should preferably not be a multiple of 50Hz to avoid spurious triggering by mains hum which may be present. The frequency used in

the prototype was 60Hz, but any frequency between 30Hz and 100Hz should be acceptable. The circuit as described is variable over this range. Higher audio frequencies can be used, which could be of advantage if audible cue tones are required, by merely altering the time constants of some of the components. (See appendix.)

The Sync-a-Slide uses an NE567 phase locked loop tone decoder IC; a device which has been available in America for some time but which has not been described much in Australia to date. The NE567 is used to both produce and detect the tone recorded on the tape.

The NE567 (see Fig. 1) consists of a voltage controlled oscillator whose rest frequency is determined by the value of R<sub>1</sub> and C<sub>1</sub>:

$$f = 1/R_1 C_1$$

When a signal is fed into the input,

provided it is sufficiently close in frequency to that of the Voltage Controlled Oscillator (VCO), the frequency and phase of the VCO will be pulled until it is running in exact synchronism with the incoming signal, but 90° out of phase. This condition of synchronism or lock is sensed in the IC and the output goes low.

Just how close the frequencies need to be is determined by C<sub>2</sub> and C<sub>3</sub>, the loop filter and output filter capacitors. These determine the bandwidth of the Phase Locked Loop (PLL), i.e. how far it will chase a frequency not identical to that of its own internal oscillator, and how far that frequency can drift once locked before the PLL lets go, and how many cycles of input on or near the correct

\*P.O. Box 572, Woden, ACT 2606



# "BUILD IT YOURSELF" THE PLAYMASTER 'TWIN 25' AMPLIFIER KIT

## \$89.50

You have seen the beautiful Front Panels on the \$500 imported amplifiers - the metal used for these panels is only available overseas. Now Dick Smith has paid to have made overseas the same quality panel for the Twin 25 amplifier. Only Dick has this one! He specially imports this EXCLUSIVE Bronzed Anodized Front Panel for use with the amazing Twin 25 amplifier. Normally costing \$3.50 extra. NOW INCLUDED FREE!

**EXCLUSIVE**  
Power Transistor Sockets  
At NO Extra Charge!

**EXCLUSIVE**  
LEVEL GRADUATIONS  
ON TREBLE & BASS CONTROLS

**EXCLUSIVE**  
Simplified complete instruction manual & assembly instructions.

"It is about half the price of an imported amplifier with the same power output - The overall performance of the new Playmaster is equal to that of many amplifiers costing up to three & four times the price - Says Leo Simpson in the Electronics Australia for April 1976."

**EXCLUSIVE**  
Special 'Professional' Knobs to match the fully imported Front Panel.

**SPECIAL**  
Silk Screened component overlay on the PC board for easy identification and assembly.  
Single Board Construction.

The Twin Twenty-five is the latest and the best in a long line of very popular Hi-Fi amplifier kits. You really have to hear this amp to believe that such quality is possible for such a low price. Even beginners can tackle the project! Dick has even arranged a special service offer for you. If the amp won't go - check the power transistors with a multimeter. If they are OK, return the completed circuit board together with \$8 and we will service, replace any faulty parts and return to you.

**SPEAKER PROTECTOR KIT FOR THE TWIN 25 PLAYMASTER AMPLIFIER**  
Extremely simple to fit to your Twin 25 amplifier. Cat. K-3425 ... \$10.75

## IT LOOKS SO GOOD YOUR FRIENDS WON'T BELIEVE YOU BUILT IT!

**SPECIFICATIONS**  
Power Output: 25W/channel into 8 ohm with one channel driven.  
Frequency Response: ±1dB from 25 Hz to 20 kHz with tone controls level.  
Compensation: RIAA to within ±1dB.  
Sensitivity: Phono 2mV into 56k for 25W output. Other inputs 150mV into 36k minimum.  
Overload: On phono 120mV.  
Sig/Noise: 10dB (on phono) @ 10mV and 25V 10dB (other inputs).  
Crosstalk: Better than -45dB over 100 - 10kHz.  
Distortion: Less than 0.05% at normal listening levels.  
Bass / Treble Controls: ±13dB nom. at 50 Hz & 10kHz.  
Stability: Unconditional.  
Cat. K-3410 ... \$89.50  
PACKING AND POSTAGE ... \$3.50

## BUILD YOUR OWN DIGITAL CLOCK

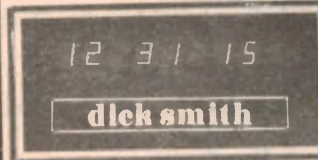

Dick has pioneered the low cost Digital Clock in Australia and this unit is the latest and best kit based on his experience of selling over 2,500 kits. This kit has a much simplified construction and even the beginner can successfully put this one together. Advanced constructors should be telling the time in less than an hour. Just look at these features:

- Well spaced components on silk screened and fully tinned board simplify construction.
- Full hours, minutes and seconds display using big (10mm) bright orange gas discharge display.
- Panel type display is pre-wired, just plug into socket on PC Board.
- Time is accurately derived from 50 Hz mains frequency 12/24 hour operation.
- Circuit uses MMS14 IC, 13 transistors and 5 diodes.
- Cat. K-3364 ... \$24.90
- Or Complete with Plastic Case Cat. K-3368 ... \$29.90

**NEW REVERBERATION UNIT KIT**  
Fantastic for Electronic Organs, Amplifiers, P.A. Systems, Car Stereo Systems etc. Complete kit includes all components and Reverb Spring Unit.  
SEE E.A. MAY 1976  
Cat. K-3424 ... \$14.75

## PROJECT 30 FANTASTIC DO-IT-YOURSELF BUDGET HI FI SYSTEM

REPLACES THE FAMOUS 'PROJECT 250' (OVER 2000 SOLD)

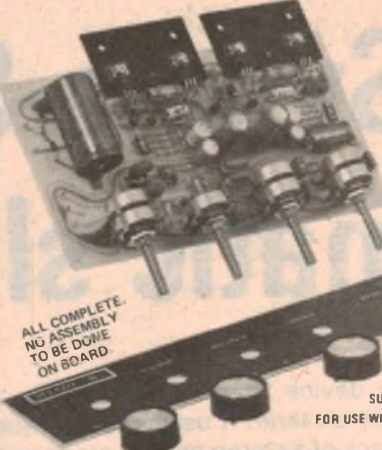

**FEATURES**  
14 watts R.M.S. per channel  
Full frequency response  
Low distortion  
12 transistors, 6 diodes  
No messy wiring, Only 8 connections to be made  
Suits crystal or ceramic pickups  
Can be used with stereo tape decks or tuners  
Complete with knobs, anodised front panel and heatsinks  
Controls: Volume, Bass, Treble, Balance  
Dimensions: 205mm x 132mm inc. sinks  
Requires external transformer approx 20-27 V. T.A. Our M-6672 is ideal.  
Cat. F-4120 ... \$29.50  
Cat. M-6672 Transformer to suit ... \$6.50

## STEREO AMP \$29.50

ALL COMPLETE. NO ASSEMBLY TO BE DONE ON BOARD

SUGGESTED ACCESSORIES FOR USE WITH THE PROJECT 30 AMPLIFIER

Famous Garrard Record Changer Model CC10, complete with ceramic stereo cartridge and casing device. We sold previously at \$32.50. Cat. A-3068 200 Only at a low \$19.75

Base to suit Garrard Record Changer (will take amplifier too) Cat. A-3430 ... \$9.50  
Acrylic Cover to suit above base. Cat. A-3420 ... \$11.00  
NOTE: The above 28 watt system costing now \$100 complete would be hard to purchase built up for under \$200, so why not build one and save yourself a mint.

## NOVICE TRANSVERTER KIT



## \$99.50

DICK SMITH "NOVICE TRANSVERTER" SEE E.A. 10 metres to 80 metres at up to 30W p.e.p. April '76

- Designed by Australia's top R.F. Engineer, exclusively for us.
- The cheapest and best way for a novice to get going on 80 metres.
- Put in any signal (AM/FM/SSB) on the 27MHz novice band and it is instantly "Transformed" down to 80 metres.
- Inbuilt receiver converter "Transverts" 80 meter signals up to 10 meter novice bands.
- Max power 10 watts and 30 watts p.e.p. SSB from as little as 100mw input (and suitable 100mw-3 Watts).
- Easy to build (takes about 3 hours) fibreglass boards, fully reverse voltage protection
- Input and output 50ohm
- 13.8 volt DC (max) operation - ideal for Mobile rigs.

Cat. K3134 ... Very Special Offer \$ 99.50

## TV GAME KIT

WAS \$89.50  
NOW \$39.50



SEE E.A. MAY '76  
SAVE \$50

T.V. games open up a whole new vista of fun and this project must be the best of any yet! On the screen you get a net and top & bottom to the court. You can select bot or hole in the wall. There is a separate control for each player plus an adjustable ball speed control. The ball bounces off the top and bottom edges. A special "interaction" control introduces a wobble on both sides for extra fun. We reckon there are 15 different games you can make up by adjusting the controls, some for 2 players and some you play against yourself. Circuit uses 13 IC's, 5 transistors and is battery powered with a separate modulator board and two control boxes. Highly recommended for the more advanced constructor.  
Cat. K-3415 Build Yourself and SAVE ... \$39.50

## 45 WATT 2 METER AMPLIFIER KIT

## \$27.50

YOU CAN BUILD THIS UNIT IN UNDER AN HOUR!  
A fantastic 2M c.t. amplifier kit of the simplest design. Uses the 2N6084 45W transistor. Requires 8-12W drive to give 35-45W output from 13.8V supply (to suit your mobiles). Fully solid state switching, double sided fibreglass PCB. Everything supplied including explicit instructions - there's even provision on the board to wire in a VSWR meter (not supplied).  
Cat. K-3132 ... \$27.50  
Eddystone Box to suit:  
Cat. H-2210 ... \$4.00

## BOOKS

World Radio TV Handbook 1976  
A complete directory of International Radio and Television. Over 500 pages. For every enthusiast.  
Cat. B-2080 ... \$10.90

RADIO AMATEURS HANDBOOK  
FAMOUS ARRL PUBLICATION. This is the latest edition of this widely used book. 25 chapters and over 600 pages cover everything. Textbook, Data book and Construction Manual.  
Cat. B-2218 ... \$8.90

TTL COOK BOOK  
A complete guide to the understanding and use of Transistor Transistor Logic (TTL) integrated circuits - the basics of TTL are given, what it is, how to power it and so on. Also contains a catalogue of TTL devices, giving physical and electrical specs on all devices mentioned in the book.  
Cat. B-1246 By D. Lancaster - 328 pages \$10.75

**DICK SMITH ELECTRONICS GROUP**  
N.S.W. Branches: CITY 125 York St tel:291126  
GORE HILL: 162 Pacific Hwy tel:439 5311  
BANKSTOWN: 361 Hume Hwy tel:709 6600

Head Office tel:439 5311 telex:AA 20036 cables:DKSMIT Sydney  
Shop hours: Mon-Fri 9-5:30 Sat 9-12  
Mail Orders P.O. Box 747, Crows Nest, 2065, N.S.W.

POSTAL CHARGES

Order Value	Charge
\$5 - \$9.99	\$1.00
\$10 - \$19.99	\$1.50
\$20 - \$49.99	\$2.00
\$50 - \$99.99	\$3.00
\$100 or more	\$3.99

By Cash Post: Minimum packing and handling charge \$1.00. See E.A. for freight and insurance charges you receive the goods.  
NEW MINIMUM MAIL ORDER AMOUNT \$5

# MIDLAND INTERNATIONAL 23 CHANNEL SSB TRANSCEIVER



\$39.75

\$239.50

## HAND HELD 2 CHANNEL 1 WATT TRANSCEIVER

THIS UNIT IS DESIGNED FOR THE AMATEUR OR NOVICE WHO WANTS THE ULTIMATE IN PERFORMANCE AND RANGE. A REAL BEAUTY!

**Specifications:**  
 Circuitry: 26 transistors, 2 FETs, 2 IC's 56 diodes  
 Channels: 23 channels - All crystals supplied  
 Modes of operation: AM, Lower and upper Sideband  
 Controls: On/off/volume, variable squelch, mode selector, SSB clarifier/AM delta tune, PA/CB channel selector and noise blanker switch  
 Jacks & Connections: Mic., antenna, external speaker, P.A. speaker and DC power  
 Power source: 9 volt to 15 volt DC, 13.8 volt DCIE (I.A.)  
 Receiver - Receiving System: Dual conversion superheterodyne with tuned RF ANL and AGC circuits  
 Sensitivity: AM - 0.5uV for 10 dB (S+N)/N SSB - 0.25 for 10 dB (S+N)/N  
 Selectivity: AM - 50 kHz @ -6 dB SSB - 2.1 kHz @ -6 dB  
 Clarifier: SSB clarifier +600 Hz  
 Audio Output: 5 watts maximum  
 SSB Transmitter - RF Input Power: 15 watts P.E.P.  
 SSB Generation: Balanced modulator, crystal lattice filter  
 Frequency Response: 300 to 2700 Hz @ 6 dB  
 Carrier Suppression: USB - 60 dB LSB - 64 dB  
 AM Transmitter - Modulation: High level  
 RF Input Power: 5 watts  
 Harmonic Suppression: 50 dB down  
 Cat. D-1100 ..... \$39.75

\*\*\* FULLY PMG APPROVED \*\*\*  
**FAMOUS MIDLAND 1 WATT TRANSCEIVER**  
 This is a rugged professional unit which is ideal for the boating enthusiast and sportsman. Sensitive superheterodyne receiver has tuned RF and 3 IF stages for increased reception power and sensitivity. AGC circuit reduces fading and distortion. Variable squelch cuts static and noise on standby. Has a range of up to 10 miles on land (depending on terrain) and 50 miles over water. Supplied with carrying strap, earphone and one set of crystals installed on 27.24 MHz or 27.88 MHz (please state preference). Has 11 transistors, 1 thermistor, 1 squelch transistor and 1 diode. Effectively converted into a high level push pull Class B system. Has 2 1/4" PM speaker and 56" telescoping antenna. Powered by 8 penlight cells (has AC adaptor & battery charger connections). Has a sensitivity of 1.4 uV for 10 dB (S+N)/N.  
 Cat. D-1100 ..... \$39.75

# MULTI-7 A MUST FOR ALL MOBILES



**MULTI-7 VHF 2 METRE 23 CHANNEL TRANSCEIVER**  
 Compare this unit - no others have all the features:  
 \* Exclusive receiver fine tuning for "off frequency" stations  
 \* Inbuilt centre zero discriminator meter for frequency adjustment  
 \* Exclusive "AFB" (audio feedback) squelch circuit opens on the weakest of signals.  
 \* Helical resonator and crystal filter  
 \* Speaker can be changed to top or bottom of cabinet  
 \* Special "instantaneous" channel button allows instant QSY to nominated channel.  
 Frequency Range 146.0 to 148.0 MHz. 23 Channel FM Transceiver  
 All solid state construction RF power output 10W or 1W with switch Receiver Sensitivity 1.0uV @ 30 dB S/N Power Requirements: 13.5V DC @ 2.3A max. Size: 134x58x216D mm Weight: 1.8 kg. Comes with microphone, mobile mount, manual and DC leads  
 Supplied complete with one set of crystals on channel 40 (146.00 MHz)  
 Cat. D-3007 ..... \$189.00

**ONLY \$189.00**

**SPECIAL**  
 Additional crystals available at \$6.00 per channel if purchased with the Multi-7. Yes this will give you 6 channels for only \$219.00 - a bargain!  
 Crystals normally available for the Multi-7 include repeater and anti repeater 1, 2, 3, 4, 5, 6 and simplex channels 40, 50 and 52.

## SPECIAL KIT PARTS

RE-4 Reverb Spring (See details below. Used in Reverbation Unit - Details opposite page)	Cat. X-1035	\$9.75
UB-5 Zipzap Box (Used in TV Game Kit - Details opposite page)	Cat. H-2755	\$1.10
76/VG5 Printed circuit board (Used in TV Game Kit - Details opposite page)	Cat. H-8308	\$5.50
76/M5 Printed circuit board (Used in TV Game Kit - Details opposite page)	Cat. H-8310	\$1.50
74C02 CMOS Integrated circuit (Used in TV Game Kit - Details opposite page)	Cat. Z-5410	\$0.50
74C02 CMOS Integrated circuit (Used in TV Game Kit - Details opposite page)	Cat. Z-5412	\$0.50
7512A Printed circuit board (Used in Reverbation Unit - Details opposite page)	Cat. H-8314	\$2.00
76/SA4 Printed circuit board (Used in Twin 25 Amplifier Kit - See opposite)	Cat. H-8302	\$3.95

## RESISTOR PACK SAVE OVER 300 RESISTORS



ALL USEFUL VALUES  
 \$6.00  
 LESS THAN 2c EA  
 \$5.90

WHAT A SENSATION! Now we have improved our already famous Computer Resistor Pack. 300 resistors, 60 values from 10 ohm to 1 Meg. No useless values. For example you get 2 x 560K and 20 x 1K. All resistors are 1/4 watt 5% tolerance carbon film high stability type.  
 Cat. R-7010 ..... \$5.90

## GREENCAP PACK



Tremendous Value! Get the values you really use and not a lot of weird rubbish. All brand new top quality greencaps. 125 V - 10%. Normal price over \$10.  
 Cat. R-7040 Save over \$4.00 ..... \$5.75

## ELECTROLYTIC CAP PACK



50 TOP QUALITY CAPACITORS! Values based on computer use listings - no useless values. Save over 70% on normal one-off purchasing. All single ended types.  
 Cat. R-7030 ..... \$5.00

## 12V NI-CAD Rechargeable PACK

Replace all those penlight cells with a rechargeable Ni-cad pack. This pack powers transceivers with 100 mW to 5 watt input as well as other portable equipment using 12 V DC power. Replaces 8 penlight cells.  
 Cat. S-3310 ..... \$18.75

## Professional Pliers

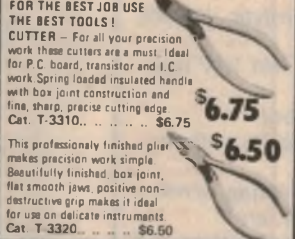

FOR THE BEST JOB USE THE BEST TOOLS!  
**CUTTER** - For all your precision work these cutters are a must. Ideal for P.C. board, transistor and I.C. work. Spring loaded insulated handle with box joint construction and fine, sharp, precise cutting edge.  
 Cat. T-3310 ..... \$6.75  
**PLIERS** - This professionally finished plier makes precision work simple. Beautifully finished, box joint, flat smooth jaws, positive non-destructive grip makes it ideal for use on delicate instruments.  
 Cat. T-3320 ..... \$6.50

## Heatsink Clip Set

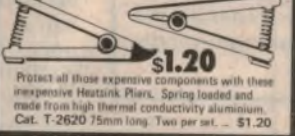

Protect all those expensive components with these inexpensive Heatsink Pliers. Spring loaded and made from high thermal conductivity aluminium.  
 Cat. T-2620 75mm long. Two per set. .... \$1.20

## MINIATURE SOLID STATE BUZZER

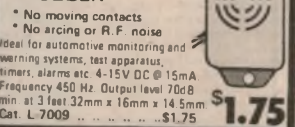

No moving contacts  
 No arcing or R.F. noise  
 Ideal for automotive monitoring and warning systems, test apparatus, timers, alarms etc. 4-15V DC @ 15mA Frequency 450 Hz. Output level 70dB min. at 3 feet. 32mm x 16mm x 14.5mm  
 Cat. L-7009 ..... \$1.75



\$49.50

## COLOUR YOUR MUSIC

See your sound in vibrant colours. These units can be used with almost any sound source equipped with external speakers. Simply connect to speaker terminals. The sound will not be affected as the music only switches the lights - it does not power them. Has 30 brilliant diamond pattern flashing lights with master sensitivity control. Colours are Red, Yellow, Green, Blue and Violet.  
 Cat. A-4950 ..... \$49.50  
 Professional version of the above unit. Has 32 diamond flashing lights and 4 individual colour mixing controls.  
 Cat. A-4952 ..... \$84.00

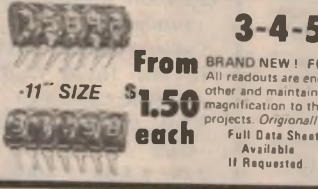

From \$1.50 each

## 3-4-5 DIGIT READOUTS

BRAND NEW! FULLY GUARANTEED! Hewlett Packard Readouts. All readouts are end stackable so that they may be mounted next to each other and maintain the same spacing. They include a lens which gives a magnification to the display. All types give a red display. Ideal for all projects. Originally were selling at over \$20.00 each. Now from \$1.50 ea.  
 Full Date Sheet 5082-7400-3 3 Digit ..... \$1.50  
 Available 5082-7400-4 4 Digit ..... \$1.75  
 If Requested 5082-7400-5 5 Digit ..... \$2.00

## SPRING REVERB UNIT

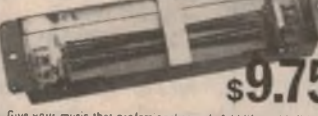

Give your music that professional sound. Add life and brilliance to otherwise flat sounds. The technique has been successfully used by many musicians and groups to give added impact to their performances. The natural string decay of guitars, for example, is greatly enhanced by reverbation. Specifications: Input current 350 mA. Driving coil imp. 15 ohm. Pickup coil imp. 10 Kohm. Frequency response 100 to 3000 Hz. Attenuation -30dB. Reverb. time 25 to 30 msec.  
 See article in E.A. May 76 for circuit details.  
 Cat. X-1035 ..... \$9.75

## MULTI BAND RADIO



\$29.90  
 \* AM Broadcast Band 535 - 1605 KHz.  
 \* New FM Broadcast Band 88 - 108 MHz  
 \* TV1 (channels 2 to 6) 56 - 108 MHz  
 \* TV2 (channels 7 to 13) 174 - 217 MHz  
 Covers Australian VHF Hi and Low band. Listen to all the mobiles. Circuit has 12 transistors, 9 diodes and 2 receivers. 300mW output. 240V AC and 6V DC. Available in Black, Beige, Green or Mustard colours. Please state colour.  
 Cat. D-2840 ..... \$29.90

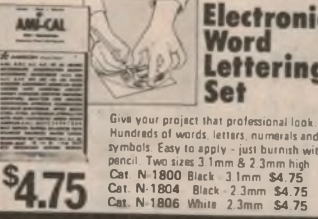

Give your project that professional look. Hundreds of words, letters, numerals and symbols. Easy to apply - just burnish with a pencil. Two sizes 3.1mm & 2.3mm high.  
 Cat. N-1800 Black - 3.1mm \$4.75  
 Cat. N-1804 Black - 2.3mm \$4.75  
 Cat. N-1806 White - 2.3mm \$4.75

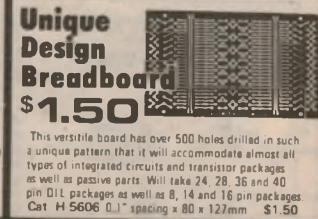

Unique Design Breadboard \$1.50  
 This versatile board has over 500 holes drilled in such a unique pattern that it will accommodate almost all types of integrated circuits and transistor packages as well as passive parts. Will take 24, 28, 36 and 40 pin DIL packages as well as 8, 14 and 16 pin packages.  
 Cat. H-5606 0.1" spacing x 80 x 127mm \$1.50

# DICK SMITH ELECTRONICS GROUP

Head Office tel:439 5311 telex:AA20036 cables:DKSMIT Sydney  
 Mail Orders P.O. Box 747, Crows Nest, 2065, N.S.W.

N.S.W. Branches  
 CITY 125 York St tel:291126

GORE HILL  
 162 Pacific Hwy tel:439 5311

BANKSTOWN  
 361 Hume Hwy tel:709 6600

Shop hours: Mon-Fri 9-5.30 Sat 9-12

POSTAL CHARGES

Order Value	Charge
\$9.99	\$1.00
\$19.99	\$1.50
\$29.99	\$2.00
\$39.99	\$2.50
\$49.99	\$3.00
\$59.99	\$3.50
\$69.99	\$4.00
\$79.99	\$4.50
\$89.99	\$5.00
\$99.99	\$5.50

By Credit Facility. Minimum packing and handling charge \$1.50. We reserve the right to add any price when you receive the goods.  
 NEW MINIMUM MAIL ORDER AMOUNT \$5

## LED Level Meter

again, these connections may be made with rainbow cable.

Construction should present no difficulties. The components are simply mounted on the circuit board sections, which are then carefully soldered together. To provide mechanical strength, the joint can be reinforced with a quick setting epoxy cement. Take care that the LEDs are oriented correctly, with

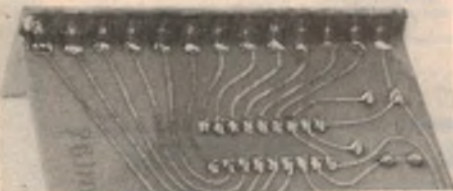

This view gives details of how the two sections of PCB are joined together. Note the reinforcing epoxy cement.

the ten green ones at the bottom (marked "B" on the PCB), and the red LED at the top (marked "T").

The completed assembly is then secured behind an appropriately shaped slot in the front panel, using the mounting holes provided. All that remains is to set the trimpot to the correct value.

There are two possible settings of the trimpot, giving two interpretations of the display. In the first mode, the trimpot is adjusted so that the uppermost red LED is illuminated when the amplifier is just clipping on both channels. The number of LEDs illuminated at any time is then related to the power output of the amplifier.

This mode, however, does not give a visually interesting display at normal listening levels. So if you want to impress visitors by making the display flash more, simply adjust the trimpot so that at your highest listening level a visually satisfying display is obtained.

Shown below is the PCB overlay. Pay particular attention to the polarity of the LEDs, diodes and capacitors.

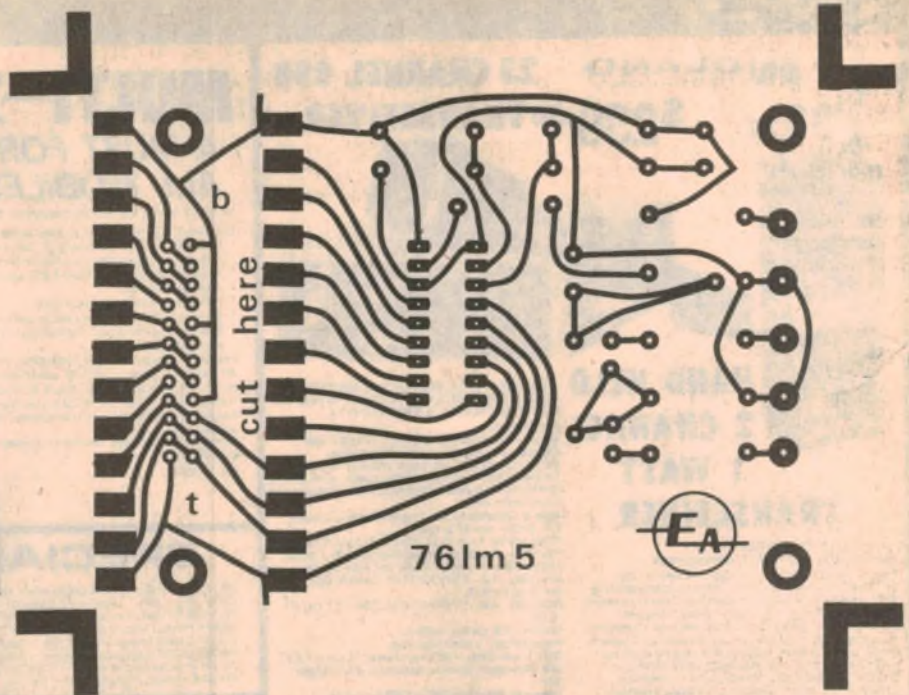
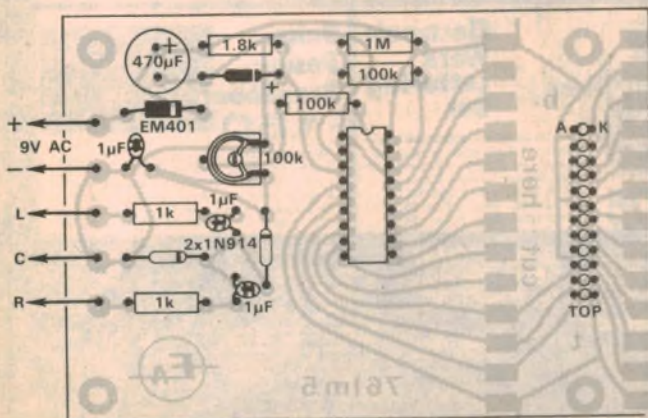

### PARTS LIST

- 1 UAA180 LED driver IC
- 12 miniature LEDs, matched (see text)
- 1 4.7V 400mW zener diode, 1N750, BZY88C4V7 or similar
- 2 silicon diodes, 1N914, 1N4148 or similar
- 1 silicon diode, EM401 or similar
- 1 470µF 16VW PCB mounting electrolytic capacitor
- 3 1µF tantalum electrolytic capacitors
- 2 1k, 1 1.8k, 2 100k, 1 1M ¼W resistors
- 1 100k miniature trimpot
- 1 printed circuit board, 96 x 69mm, coded 76lm5

PC board stakes, mounting screws, connecting wire, solder, etc.

NOTE: Resistor wattage ratings and capacitor voltage ratings are those used for our prototype. Components with high ratings may generally be used provided they are physically compatible.

Shown above is a full sized copy of the PCB pattern, suitable for tracing, while below is the circuit diagram for a small auxiliary amplifier, to increase the input sensitivity when required.

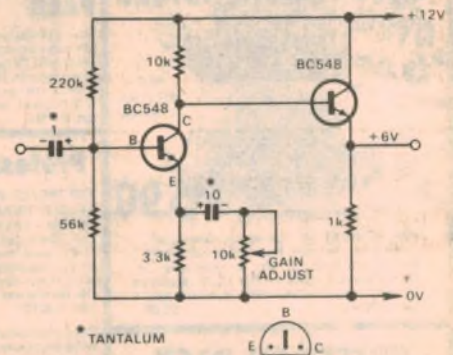

To set the uppermost LED to correspond to clipping level, simply insert a 100 ohm 5 watt resistor in series with each speaker, and apply a sine wave signal at about 1kHz to both channels at once. Advance the volume control till audible clipping can be heard, and then set the trimpot so that the top LED is only just emitting.

In case you are wondering whether or not this procedure will damage your equipment, we can assure you that with modern solid-state amplifiers it will not. The 100 ohm resistors will prevent excessive power dissipation in the amplifier output stages and in the speakers. But note that this does not apply with older valve-type amplifiers, which should not be set up using the 100 ohm resistors.

As mentioned earlier, the LED Level Meter can also be used to replace the mechanical VU meters commonly fitted to cassette recorders. However, the input sensitivity needs to be increased to allow



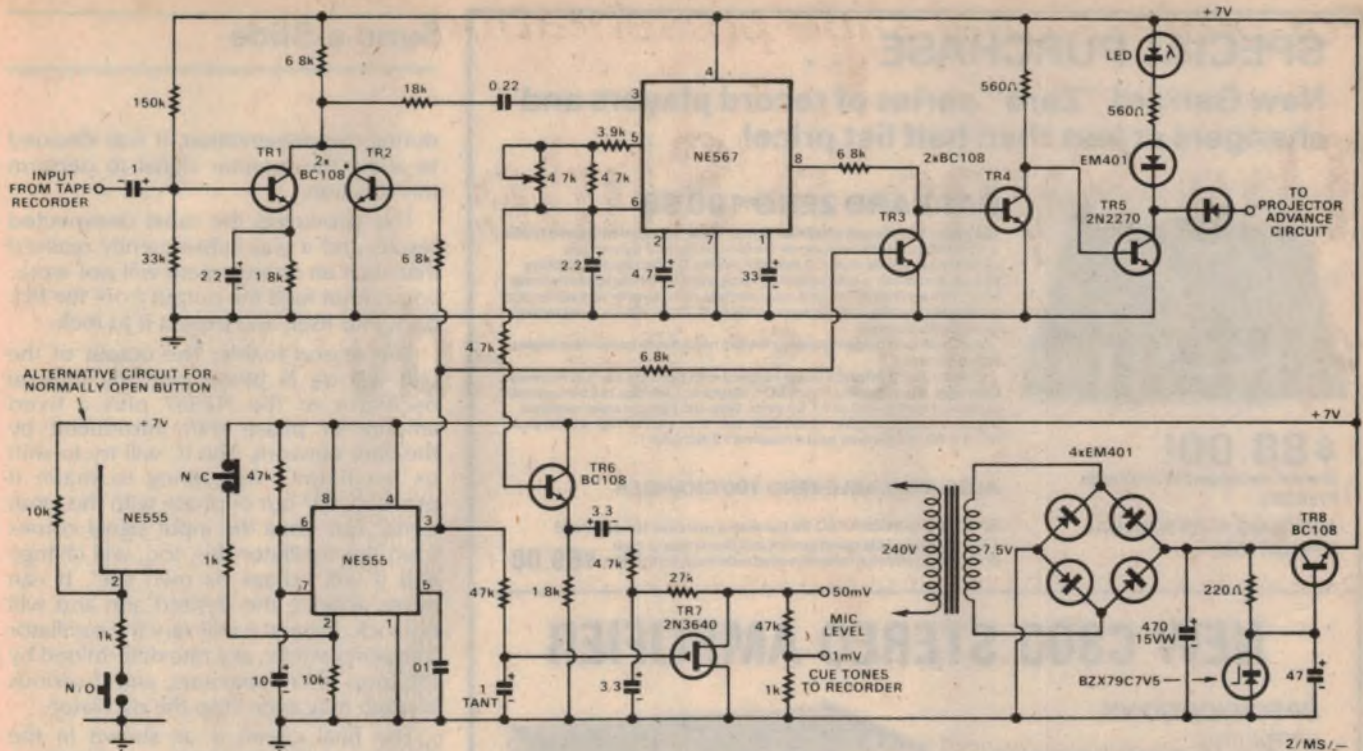

The complete circuit diagram for the Sync-a-Slide automatic slide advance.

frequency are required before the PLL will produce a low output.

How wide should the bandwidth of the PLL be set? Again there are conflicting requirements. Firstly the bandwidth should be as narrow as possible so that the PLL will ignore signals other than the required tone. But secondly the bandwidth should be as wide as possible to take into account tape speed variations, temperature changes and component aging, all of which may change the frequency of the tone detected or recorded. In this circuit the bandwidth is around  $\pm 10\%$ , i.e. 5Hz, which seems to present a suitable compromise. The bandwidth can be decreased by increasing the values of  $C_2$  &  $C_3$ .

In order that the frequency recorded is the same as the centre frequency of the PLL bandpass, the tone is derived from the internal VCO of the NE567. A roughly triangular wave at high impedance is available at pin 6. This is buffered by TR6, a BC108 emitter follower, and filtered to approximately 100mV of reasonably pure sine wave by a low pass filter.

A P-channel FET, Tr7, and a 27k resistor form a voltage divider which normally holds the tone level at less than about 1mV. When the gate voltage of Tr7 goes high, the FET is pinched off and assumes a very high resistance. With a 20k input impedance provided by the recorder, about 50mV of tone is available at the drain of the FET.

Tone bursts of a fixed length, here 0.5s, are produced by the NE555 timer IC. The NE555, unlike the NE567, has been dealt with extensively in this publication and

## LIST OF COMPONENT PARTS

1 Plastic or metal case	2 1.8k	1 27k
1 Power transformer, 7.5V secondary	1 3.9k	1 33k
4 Jack sockets	3 4.7k	3 47k
1 Press button, normally closed (See text)	1 4.7k pot	1 150k
1 Printed board		
3 Core power cable, cable clamp, 3 pin power plug, grommet, screws, nuts, solder, hookup wire, etc.		

**SEMICONDUCTORS**

- 1 NE555 IC
- 1 NE567 IC
- 6 BC108 transistors (or similar)
- 1 2N2270 transistor
- 1 2N3640 FET
- 6 EM401 diodes (or similar)
- 1 BZX55-C6V2 zener diode (or similar)
- 1 LED

**RESISTORS** ( $\frac{1}{2}W$  unless specified)

1 220 ohms	4 6.8k
2 560 ohms	1 10k
2 1k	1 18k

**CAPACITORS**  
(All electrolytics 10V rating or greater, unless specified.)

- 1 .01uF
- 1 .22uF
- 1 1uF tantalum electrolytic
- 1 1uF electrolytic
- 2 2.2uF electrolytics
- 2 3.3uF electrolytics
- 1 4.7uF electrolytic
- 1 10uF electrolytic
- 1 33uF electrolytic
- 1 47uF electrolytic
- 1 470uF 15V electrolytic

**NOTE:** Components with higher ratings may be used provided they are physically compatible. Lower rated components may also be used in some cases, provided their ratings are not exceeded.

elsewhere so the theory of its operation will not be detailed here.

When first tried in rough form the system suffered from a rather puzzling problem. It was connected to the tape recorder in the same general manner as depicted in the circuit diagram, although the circuit itself was somewhat simpler at that stage. Connection to the tape recorder was by means of suitable plugs and cables, with the intention that the

one configuration would serve for both recording the commentary and cue tones, and for playing back with the cue tones extracted to operate the projector.

The particular recorder is fitted with a monitoring facility, whereby what is being recorded appears in the output. Since it is desirable, when making a commentary, to advance each slide as the cue tone is generated, exactly as will happen

## SPECIAL PURCHASE . . .

New Garrard "Zero" series of record players and changers at less than half list price!



### GARRARD ZERO 100 SB

The heavy 12" diecast belt driven dynamically balanced two speed (33 1/3 & 45 RPM) turntable is driven by the famous Garrard Syncro-Lab synchronous 4-pole motor. It incorporates the Garrard parallel tracking pick-up arm which is internationally recognised for its negligible tracking error. This arm has an integral magnetic bias compensator and will accept cartridges requiring a stylus force as low as 0.75gm. Stylus force setting is simple & accurate.

A viscose fluid damping queuing system is used with convenient finger tip tab controls.

Garrard Zero 100 and 100SB supplied with Goldring ES-70S Magnetic Cartridge. If required the Shure M75 Magnetic Cartridge can be supplied in place of the ES-70S at \$7.50 extra. Base and perspex cover available. Post and Packing N.S.W. \$2.50 QLD. VIC. S.A. \$4.70. T.A.S. \$5.00 W.A. N.T. \$6.80 (Registered post if required \$2.00 extra).

**\$88.00!**

(Normal recommended retail price \$198.00)

**AUTOMATIC OR MANUAL OPERATION**

### ALSO AVAILABLE ZERO 100 CHANGER

Specifications as Zero 100 SB but with a rim drive turntable and is fitted with variable speed control and illuminator in built stroboscope. (Normal recommended retail price \$185.00) **\$69.00**

## NEW C800 STEREO AMPLIFIER

### SPECIFICATIONS

#### POWER OUTPUT:

25 watts per channel R.M.S. Total output 50

watts R.M.S. 8 Ohms

#### FREQUENCY RESPONSE:

20 cycles to 40,000 ± 1dB

#### HUM & NOISE

Aux 70dB Mag 60dB

#### INPUT SENSITIVITY

Mag 2mv Aux 250mv

#### EQUALISED

Mag RIAA

#### TONE CONTROLS

Bass 50cs ± 13dB Treble 10kcs 15dB

#### HARMONIC DISTORTION

Less than 0.1 per cent

#### LOUDNESS CONTROL

50cs 10dB

#### SCRATCH FILTER

(high filter) at 10kcs 5dB

#### RUMBLE FILTER

(low filter) at 50cs 5dB

#### PROVISION FOR TAPE RECORDER

Record or playback with din plug connector

#### SPEAKER SWITCHING

Two sets of speakers can be connected and

selected by switch on front panel, they can also

be drawn together.

#### HEADPHONES

Headphone jack is situated on front panel

#### DIMENSIONS

16 1/2 in x 11 in deep x 5 in high Weight 16lbs

#### POWER SUPPLY

Regulated power supply with switching protec-

tion for output transistors.

#### SEMICONDUCTORS

33 Silicon transistors plus 7 diodes.



### BY CLASSIC

- \* **Elegant and functional design**
- \* **Push-button controls**
- \* **Microphone input with separate control**
- \* **Provision for simulated 4 channel stereo**
- \* **Cabinet in teak or walnut oiled finish with matching metal trim**

**\$149**

(FREIGHT EXTRA)

### NEW MAGNAVOX—MV50—50 WATT SPEAKER SYSTEMS AS FEATURED IN FEB. 1976 ISSUE OF ELECTRONICS TODAY

Complete kit of parts (less cabinet) comprising magnavox 10-40 10" bass unit 625 mid range 6" two XJ3 dome tweeters, crossover network, innabond, speaker silk & plans of cabinet.

**\$75.00**

#### CABINETS AVAILABLE

Freight extra per rail or air freight

### MAGNAVOX 8-30 SPEAKER SYSTEM (4 WAY)

DRIVE UNITS: Magnavox 8-30 high performance 8" bass unit. Magnavox 6J 6" mid range speaker. Magnavox new high-fidelity dome tweeters (two supplied).

SPEAKER KIT (less cabinet) comprises above speakers, 1mH inductance, 1.8mfd. & 1.4 mfd. polyester capacitor, 1-3" & 1-6" tube, innabond, speaker silk & plans of cabinet.

**\$52.00**

per kit

#### CABINETS AVAILABLE

Post & pack (Reg. post) \$8.50 WA & NT \$6.50 NSW, VIC, QLD & SA

## Sync-a-Slide

during the presentation, it was decided to allow the monitor signal to perform this function.

This produced the most unexpected results and it was subsequently realised that such an arrangement will not work; you cannot feed the output from the PLL back into itself and expect it to lock.

The reason is this: The output of the unit will be in phase with the internal oscillator of the NE567 plus a fixed amount of phase shift introduced by the filter network. The IC will try to shift its oscillator's frequency to make it precisely 90° out of phase with the input signal, but since the input signal comes from the oscillator this, too, will change and it will "chase its own tail". It can never achieve the desired aim and will not lock. Instead it will vary the oscillator frequency wildly, at a rate determined by the loop filter capacitors, and if serious enough may even stop the oscillator.

The final circuit is as shown in the diagram and its operation is as follows:

A cueing tone is initiated by operating the switch in the divider network feeding pin 2 of the NE555. A normally closed push button was used, as a momentary break push button which did not make an objectionable amount of noise was easier to find than the alternative normally open push button. Also the amount of travel of the normally closed push button is considerably less. A normally open push button can be used, the triggering requirement being that the terminal 2 should drop below 1/3 Vcc.

The output (pin 3) of the NE555 goes high for a period determined by the value of R and C connected to pins 6 and 7. The values shown give an output pulse of about 0.5s. The transition time of the output is slowed by the 100k resistor and 0.1uF capacitor, to avoid recording audible transients with the tone. This voltage turns the FET on and off and hence the tone.

The projector is advanced at the same time by Tr3 turning on, which turns off Tr4, which in turn causes Tr5 to conduct. This lights the LED or a lamp and advances the projector. Diode D1 is to protect against negative voltages being applied to the collector of the transistor from the projector, which could happen if the projector connecting cable was wired incorrectly.

Transistor Tr5, together with Tr4 and Tr3, is necessary because the power needed for the projector advance mechanism exceeds the ratings of the NE567. The maximum voltage which can be applied to the output transistor of the NE567 is 15 volts. Kodak Carousel projectors run 22 volts in their advance mechanism. Also the peak current required is about 500ma, far greater than the 100ma the NE567 can safely handle.

**CLASSIC RADIO** 245 PARRAMATTA RD, HABERFIELD  
2045 PHONES 798 7145, 798 6507

Transistor Tr2 is used to cut off the audio input from the recorder's monitor circuit, while the tone is being recorded. If there is no monitor signal, Tr2 can be omitted.

Transistor Tr1 amplifies and limits the input signal and the small value of emitter capacitance rolls off the very low frequencies.

The power supply consists of a bridge rectifier which produces around 12 volts. This is controlled by Tr8 which regulates the voltage to 7V. In place of the bridge rectifier it would be feasible to use a centre tapped winding (7.5V a side) and two rectifiers in a full wave configuration.

Construction was on Veroboard and as with all prototypes, hotchpotch. A large amount of vacant board was left for the inclusion of an audio amplifier at a later date since the author's recorder is only a cassette deck and has no in-built power amplifier.

Subsequently, a second version was made, using a printed board, and the board pattern and component overlay pattern are reproduced. As usual, copies of the board pattern will be distributed to the various board manufacturers, and ready-made boards should be available shortly after this article appears.

As stated at the beginning of the article, the Sync-a-Slide is designed to record the commentary and cues on the one track, although it can be used with a stereo system using separate tracks for the commentary and cues. In the latter case, there are no problems regarding interaction between the commentary and cues.

When using a single track there is the reservation, at least in theory, that low frequency voice components could cause false triggering and, hence, unwanted advancing of the projector.

In practice, during extensive trials, no false triggering has been observed where the commentary has been voice only, since the amount of energy below 100Hz is relatively small, and of insufficient duration for the PLL to recognise it as a steady tone. Music is a different situation, for here frequencies of considerable amplitude around that of the cue tones

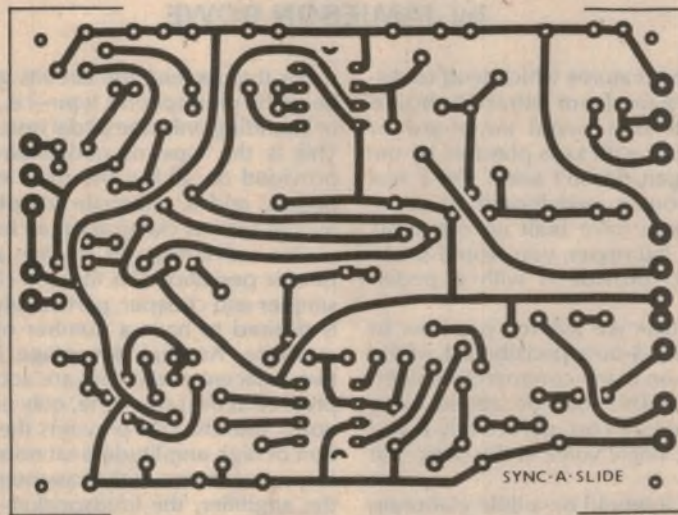
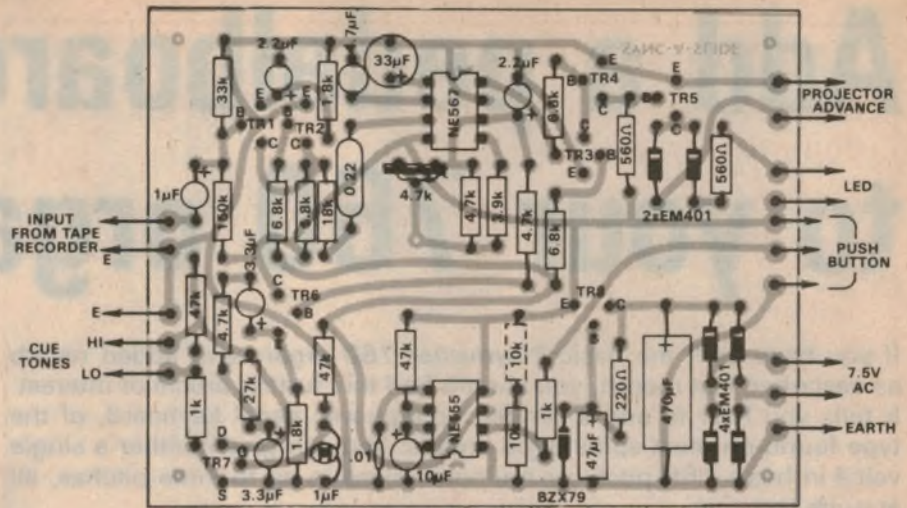

At top is the component overlay pattern on the PC board, viewed from the component side. Directly above is an actual size reproduction of the PC pattern.

are likely to be present for relatively long periods.

Again, in practice, most music fails to falsely trigger the Sync-a-Slide. Even a lot of pop music and organ music with heavy bass seems to cause no trouble. This appears to be because the bass content of much music is limited to a small number of notes and judicious choice of cue tone frequency can avoid these notes.

But some music makes the Sync-a-

Slide go crazy. The time of triggering doesn't seem in any way related to the music. This problem could be overcome by including a notch filter to remove all energy from the commentary track at the cue frequency. But the problem is not severe and since the author now uses the separate tracks of a stereo pair, the notch filter was not included in the prototype.

The Sync-a-Slide has been in use for some months now and even in the schoolroom situation—surely a test for any piece of equipment—it has performed faultlessly.

#### APPENDIX

To change the frequency of operation, the free running frequency of the VCO must be altered according to the following formula:

$$f = 1/R_1 C_1$$

At the same time the breakpoint of the filter should be changed:

$$R_x C = 1/f_0$$

The bandwidth of the IC may be found from the following formula:

$$BW = 2354/f_0 C_2$$

More information on the NE567 can be found in the National Linear Integrated Circuits Manual. 



The prototype unit, built into a plastic utility case. The cue control button is on the right, while at left is the PLL frequency adjustment control.

# Add a pedalboard to your 760 organ

If you have built the basic Playmaster 760 organ, and added reverb as described last month, you should find this further article of interest. It tells you how to add a simple monophonic pedal keyboard, of the type found on most spinet-type organs. You can give it either a single voice in basic 16ft pitch, or multiple voices in up to three pitches, all at quite low cost.

by JAMIESON ROWE

One of the features which tend to distinguish organs from other keyboard instruments is a pedal keyboard or "pedalboard", with keys playable by the feet. An organ doesn't seem like a real organ without a pedalboard of some sort, so if you have built up our basic Playmaster 760 organ, you would probably like to provide it with a pedalboard.

In this article we will tell you how to add a simple 13-note pedalboard, of the type found on many commercial spinet-style organs. This may be added quite easily and at low cost, particularly if you want only a single voice at the basic 16ft pitch.

Although it would be a little elaborate for use with the basic 760 organ, we will also tell you how to expand this basic pedalboard scheme to provide more voices and up to three pitches—again quite simply. And details will also be given for those who may want to use the same simple pedalboard circuitry for larger 25-note, 30-note or 32-note pedalboards, suitable for larger instruments.

For the present, the circuits given will be of the monophonic type—i.e., capable of sounding only one pedal note at once. This is the type of pedalboard circuit provided on all but the most elaborate organs, and is adequate for playing all except serious classical organ music.

One advantage of having a monophonic pedalboard is that the circuitry is simpler and cheaper, particularly when it is desired to have a number of pitches available. Another advantage is that if two adjacent pedal keys are accidentally pressed at the same time, only one of the notes sounds. This prevents the generation of high amplitude beat notes, which can cause severe embarrassment to both the amplifier, the loudspeaker—and the player.

For those who intend to build a full-scale instrument capable of playing serious classical music, details of polyphonic pedalboard circuitry will be given in a later article. We also hope to tell you how to add "sustain" to the pedal circuitry, which can give considerably improved realism. But this also will be in

a later article.

Just as the keyboard forms the most costly and crucial single item in the 760 organ itself, the most costly and crucial item involved in adding a pedalboard tends to be the pedal key assembly itself. In fact there is very little to the most basic pedalboard system, apart from the pedal key assembly with its switches.

You could make your own 13-note pedal key assembly, although this will call for a fair degree of skill in woodwork and metalwork. The diagram of Fig. 1 shows most of the appropriate basic dimensions, such as key length and spacing. The depth of touch of both natural and sharp keys should be approximately 16mm, as measured along the front of the sharps. Each key should be fitted with a return spring, and the force required to depress a key fully should be around 1350 gms wt., again as measured along the front of the sharps. The keys should preferably be made from well-seasoned hardwood.

If you haven't the facilities or the time to make a presentable pedal assembly yourself, don't despair. You can buy a ready-made assembly from two sources. They're not exactly cheap, but this is scarcely surprising in view of the labour involved in putting one together.

The two sources are Electronic Arts, of 126 Bombay Street, Lidcombe, NSW 2141, and Baber Nominees Pty Ltd of 2 Monomeeth Drive, Mitcham, Victoria 3132.

Electronic Arts very kindly made one of their pedal key assemblies available to us, and this is the one used for the prototype pedalboard unit shown in the photographs. It comes without switches, but we have evolved a very simple way of mounting readily available miniature push-button switches on the frame, using a strip of epoxy-fibreglass PC board. The push-buttons give very reliable switching, having gold contacts which are fully sealed against dust. The fibreglass strip provides a flexible mounting for the switches, to protect them from damage due to possible pedal over-travel.

The push-buttons must be of the SPDT type, to give the required monophonic keying. Those we used are from the C & K range, having the type number 8125. They are available from C & K Components (Aust.) Pty Ltd, of 2/6 McFarlane Street, Merrylands, NSW 2160, and if you buy the 13 required for the pedalboard



The prototype pedal unit, which includes a swell pedal. The article explains how to provide it with either a single stop or a number of stops.

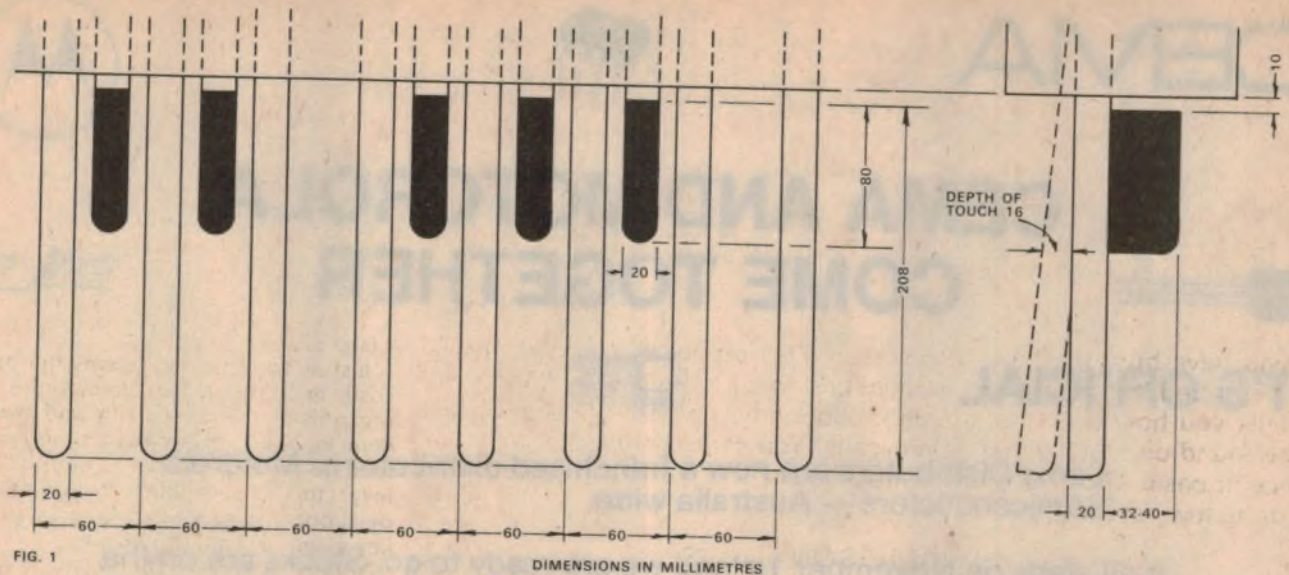

all at once, they will cost you around 89 cents each plus tax. The switches should also be available from normal suppliers.

The strip of epoxy-fibreglass PC board material used to mount the switches on the pedalboard frame measures 505 x 75mm. It is attached to the metal frame using seven small self-tapping ("P-K") screws, which use holes already in the metal frame as supplied. Matching 3mm holes are drilled along one side of the strip, with spacing as shown in the diagram of Fig. 2.

As you can also see from Fig. 2, the other side of the strip is formed into a series of "fingers", to provide flexible supports for the 13 switches. The fingers are made quite simply, by making a series of 50mm-long cuts with a hacksaw. Each finger has a 6mm hole to mount its switch, the switches being mounted "upside-down" so that when the strip is attached to the frame, the switch plungers are actuated by the ends of the pedal keys. This should be clear from the photographs.

Blank pieces of epoxy-fibreglass laminate measuring 505 x 75mm, suitable for making the switch mounting strip, will be available from at least two firms: RCS Radio Pty Ltd, and Watkin Wynne Pty Ltd. As both firms are wholesalers, the blanks should be ordered via your normal supplier.

The strip with its switches attached is screwed directly to the top of the pedalboard frame, without any spacers or washers. This gives correct operation of the switches just before the key heels hit the felted upper stop of the frame, with the fibreglass "fingers" required to flex only about 1.5mm to 2mm before the stop is effective.

As you can see from the photographs, we mounted the completed pedalboard assembly in a small free-standing box, to go beneath the table supporting the 760 organ itself. The box also supports the Electronic Arts swell pedal assembly, so that it becomes the complete "lower

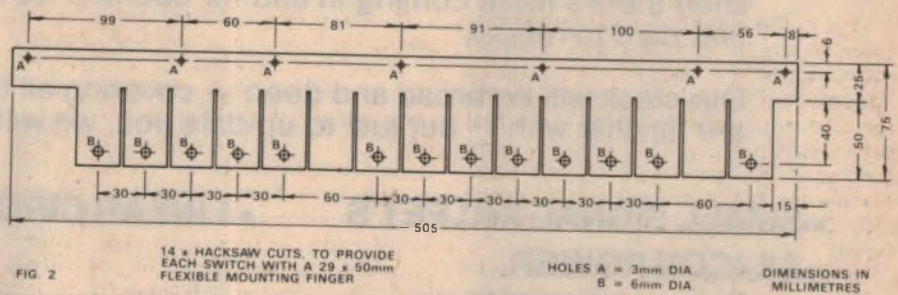
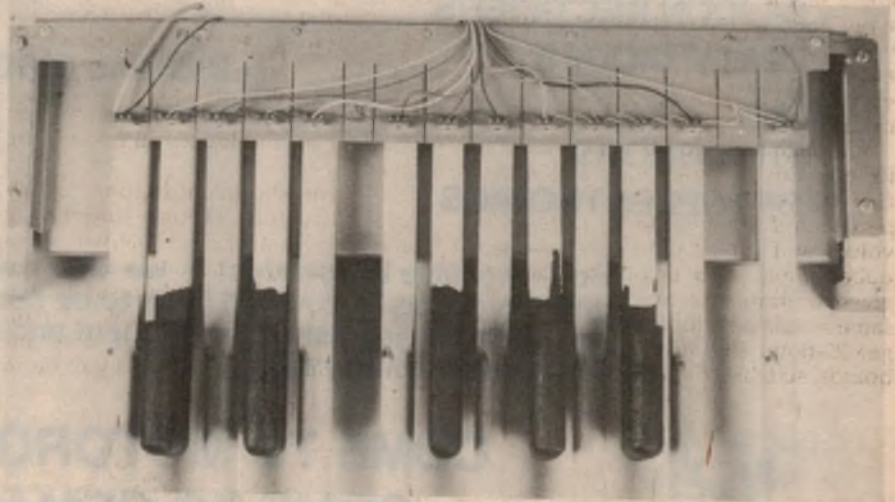

FIG. 2

14 x HACKSAW CUTS, TO PROVIDE EACH SWITCH WITH A 29 x 50mm FLEXIBLE MOUNTING FINGER

HOLES A = 3mm DIA.  
B = 6mm DIA.

DIMENSIONS IN MILLIMETRES



A close-up of the pedal assembly, showing the switches mounted on a slotted strip of epoxy fibreglass. Details of the strip are shown above.

half" of a basic spinet organ in component form. The box is made quite simply from particle board; if you wish to duplicate it, the basic dimensions and construction are shown in Fig. 3.

Of course this two-part spinet organ may not appeal to everyone, and there is no reason why you couldn't use another format if you prefer. Some may prefer to remove the basic 760 organ from its table-top case, and fit it together with the pedalboard assembly, the swell pedal and perhaps a loudspeaker into a conventional spinet-style cabinet. This may particularly appeal to you if you have plans to expand the organ still further.

Incidentally, for those who do want to build a spinet-style cabinet, but who are not confident about designing one from scratch, Electronics Arts are able to provide plans for a suitable cabinet. The same firm is also able to provide pre-fabricated cabinet kits, if you don't fancy all the work. Both the plans and the cabinet kits are designed to use the firm's pedalboard and swell pedal assemblies.

As you can see from the circuit diagram, the pedalboard switches and the swell pedal connect to the rest of the organ circuitry via an "umbilical" cable and a 16-way plug and socket. As ready-made cable having the appropriate number of conductors does not appear to be

# CEMA



## CEMA AND MOTOROLA COME TOGETHER



### IT'S OFFICIAL



Cema Distributors are now a franchised distributor of Motorola Semiconductors — Australia wide.

It all starts on November 1st and we are ready to go. Stocks are on the shelf there's more coming in and for openers we have an offer you will find hard to refuse.

Our stock will be broad and deep — covering all the product groups you are familiar with — but just to up-date you, we will list them . . .

- SMALL SIGNAL-INC.FET'S
- SILICON POWER
- SILICON RECTIFIERS
- ZENER DIODES
- R.F.
- THYRISTORS
- OPTOELECTRONICS
- LINEAR CIRCUITS: Op. amps  
Volt Regs  
Interface  
Communication
- DIGITAL CIRCUITS: CMOS  
HTL  
and M6800 MPU

So — we have the product — we also have the people and the outlets. If you still have to be convinced, why not call your nearest office or agent and ask about that super opening offer.



## COME TO MOTOROLA COME TO CEMA



**CEMA** (DISTRIBUTORS) PTY. LTD.

A FRANCHISED **MOTOROLA**   
SEMICONDUCTOR DISTRIBUTOR

OFFICES: SYDNEY 439-4655 MELBOURNE 329-7144

AGENTS:	Adelaide	Brisbane	Canberra	Wollongong
NAME:	Woollard & Crabbe	Electronic Components (Q'ld)	Custom Scientific	Macelec
PHONE:	51-4713	371-5677	47-6179	29-1276

# ORGAN PEDALBOARD

available, we made one up using a length of shielded microphone cable, a length of 12-way flat "rainbow" cable, and a 3-way cable made by splitting a 3-wire group from a second length of rainbow cable. These were all laced together to produce a reasonably neat result.

The shielded cable is used for the swell pedal connection, to prevent capacitive pickup from the pedal key wiring. The pedal key wiring does not require shielding, as the pedal note selected is filtered quite heavily by its tone colour filter.

The 16-way plug and socket used for the interconnections are low-cost moulded plastic items from the McMurdo range. They should be readily available, as they were used in the EDUC-8 computer project. The catalog numbers are 1338-12-02 and 1338-02-02.

The wiring of the pedal key switches is arranged so that regardless of the number of keys which may be depressed at once, only one note is passed to the tone colour filter; the lowest note pressed. With no keys pressed the output line is earthed, to prevent possible hum pickup.

Inside the organ itself, the connections to the individual pedal key switches are taken to the appropriate outputs of the note generator board. The swell pedal pot is connected to the reverb module board, in place of the original volume control which is now connected as a pedal volume control. The signal selected by the pedal key switches is fed

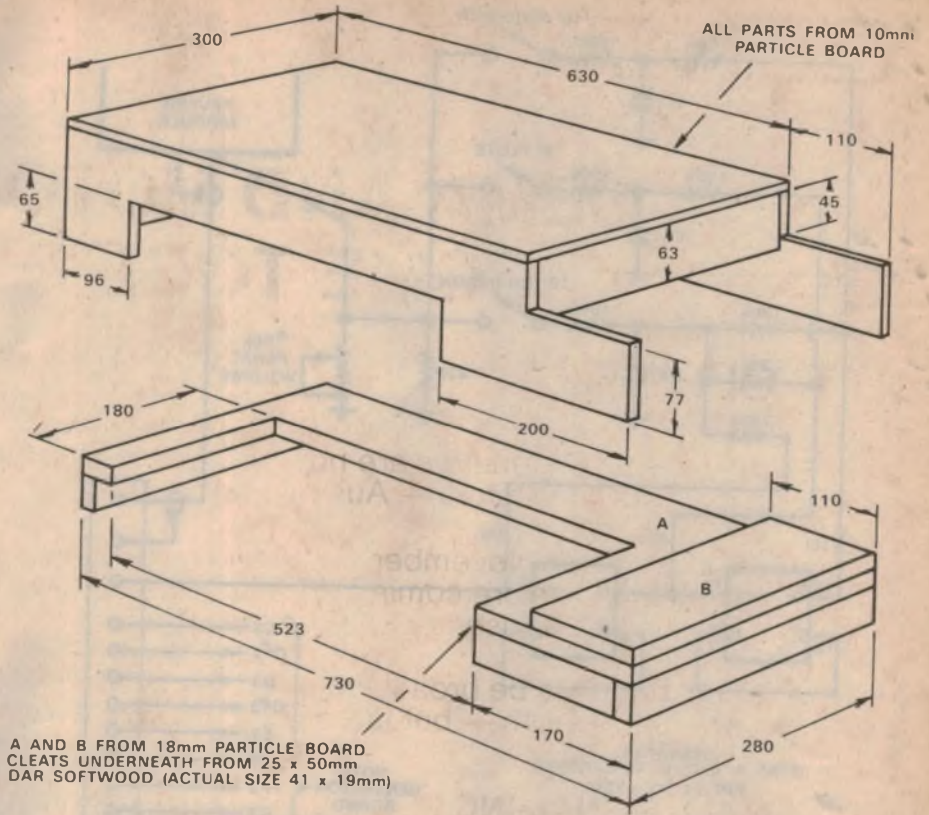

A AND B FROM 18mm PARTICLE BOARD  
CLEATS UNDERNEATH FROM 25 x 50mm  
DAR SOFTWOOD (ACTUAL SIZE 41 x 19mm)

DIMENSIONS IN MILLIMETRES

FIG. 3

to the pot via the tone colour filter, which is simply a low-pass RC network using two 100k resistors and a 0.1uF plastic capacitor. This gives a pleasant flute sound, with a moderate third harmonic component—rather like the well-known "Bourdon" stop on pipe organs.

The output from the pedal volume

control is fed back to the reverb module board, to the same terminal pad used for the swell pedal. The swell pedal is thus able to control the pedal volume, acting as a "master" volume control. This does not correspond to pipe organ practice, but it is a convenient arrangement for a domestic organ.

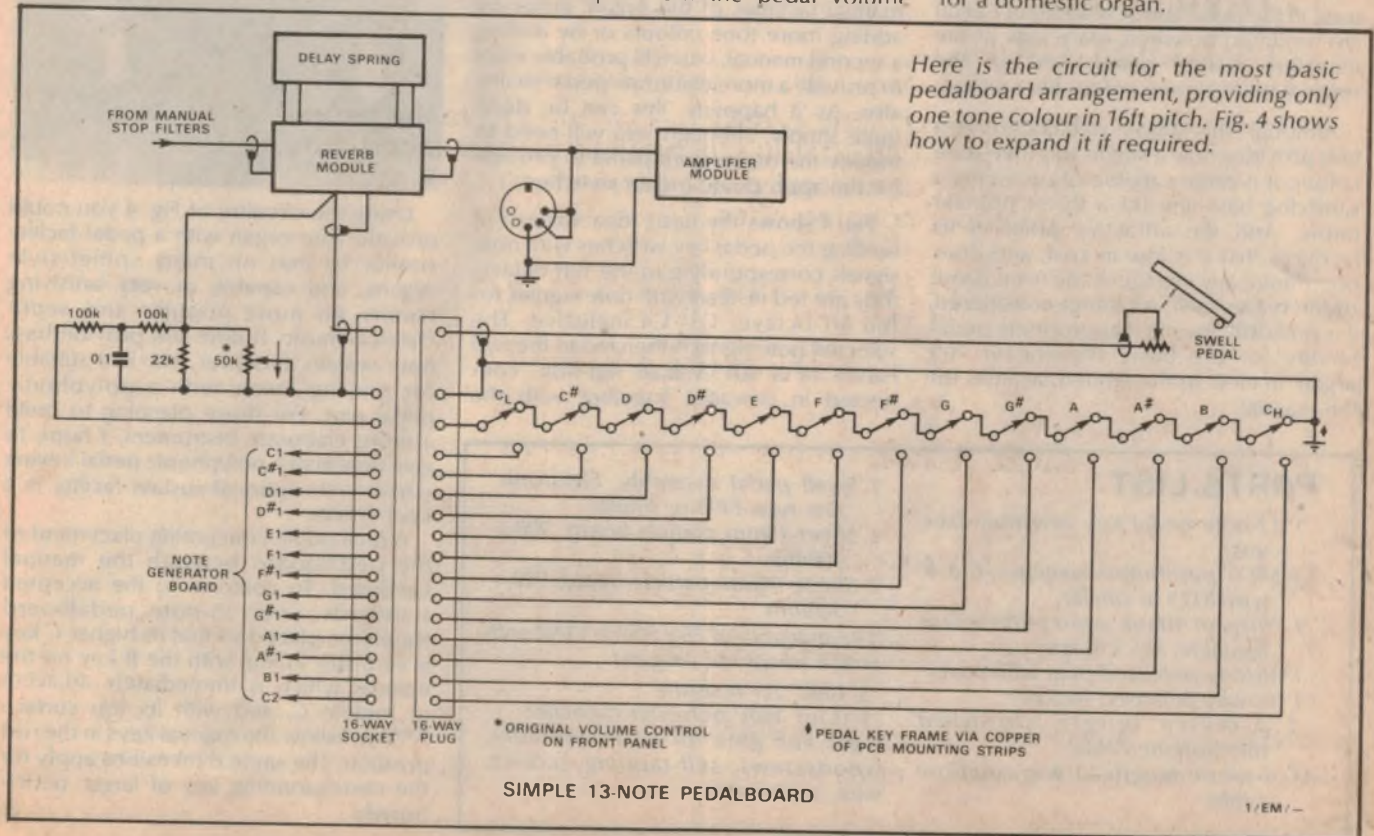

Here is the circuit for the most basic pedalboard arrangement, providing only one tone colour in 16ft pitch. Fig. 4 shows how to expand it if required.

SIMPLE 13-NOTE PEDALBOARD

1/EM/-

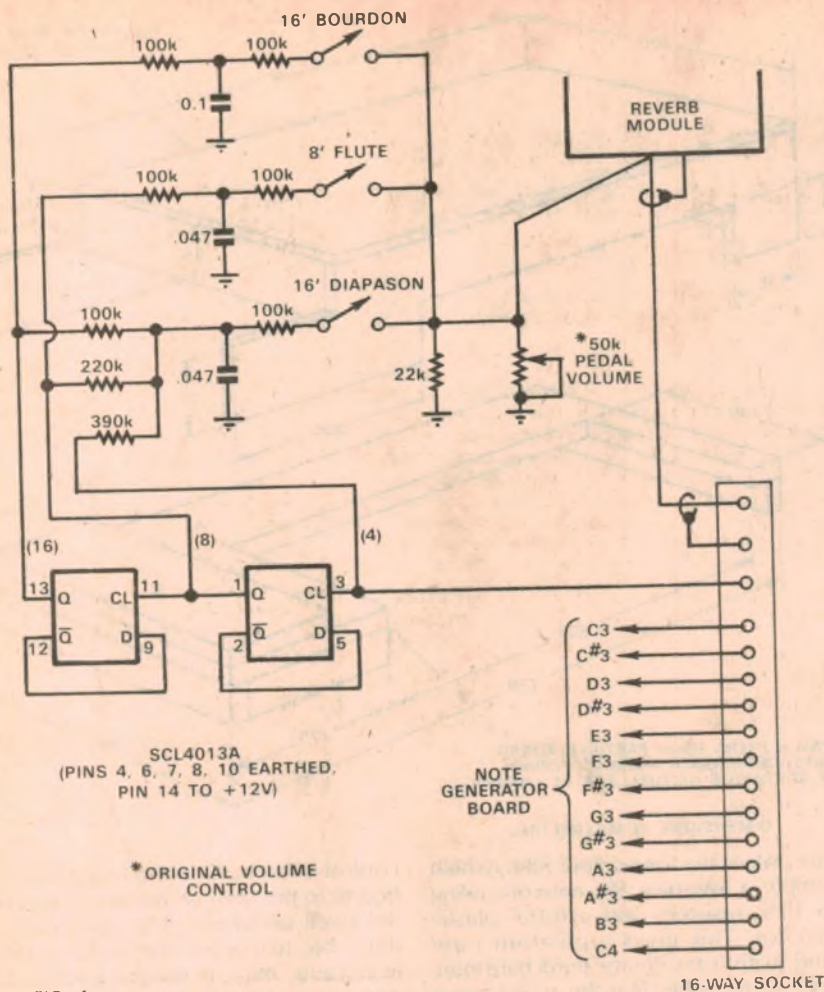

FIG. 4

The handful of passive components used in the pedal tone colour filter circuit are mounted between spare tags of the miniature resistor panel, used for the original manual tone colour filter wiring.

Although this simple pedalboard system provides only a single 16ft flute tone colour, it is quite capable of providing a satisfying bass line for a lot of popular music. And the attractive point in its favour is that it is low in cost, and does not require any change in the front panel of the organ itself. All things considered, it is probably the most appropriate pedal facility for the basic Playmaster 760 organ, in view of the limited facilities on the manual.

However if you plan to extend the manual facilities of the organ, either by adding more tone colours or by adding a second manual, you will probably want to provide a more elaborate pedal facility also. As it happens, this can be done quite simply, although you will need to modify the organ front panel to provide for the appropriate rocker switches.

Fig. 4 shows the basic idea. Instead of feeding the pedal key switches with note signals corresponding to the 16ft octave, they are fed instead with note signals for the 4ft octave: C3–C4 inclusive. The selected note signal is then fed to the two halves of a 4013A dual flip-flop, connected in cascade. Together with the

selected 4ft note, these give the 8ft and 16ft equivalent notes as well.

This simple arrangement thus gives three basic pedal note pitches: 16ft unison or fundamental, 8ft octave or 2nd harmonic, and 4ft superoctave or 4th harmonic. These may be used individually, to provide flute or reed tone colours of the three pitches, and/or combined to produce staircase signals for use in diapason or string tone colours. Both ways of using the signals are shown in Fig. 4, to illustrate this, but you could develop this further if you wish.

Incidentally, this circuit and the simple pedal circuit can both be extended easily to longer pedalboards if you wish. If you want a 25-note or a full 32-note pedalboard, and have the appropriate key assembly with SPDT switches, simply wire them up in the same fashion as shown. The additional notes required are all readily available on the note generator board. Needless to say, you will require additional conductors to connect up the pedalboard to the rest of the organ, and a larger plug and socket if the pedalboard is kept as a separate item.

Below is a close-up view showing how the pushbutton switches are mounted on the slotted strip of epoxy-fibreglass. The circuit at left shows how to provide the basic pedalboard circuit with three pitches.

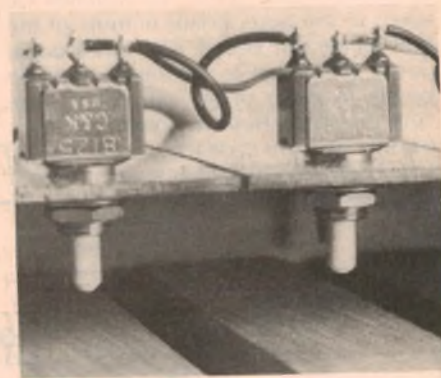

Using the circuitry of Fig. 4 you could provide your organ with a pedal facility similar to that on many spinet-style organs, and capable of very satisfying results on most popular and semi-classical music. It does not provide bass note sustain, however, nor is it suitable for playing music with a polyphonic pedal part. For those planning to build a more elaborate instrument, I hope to give details of a polyphonic pedal keying circuit with optional sustain facility in a later article.

A final point, concerning placement of the pedalboard beneath the manual keyboard. To conform to the accepted standards, your 13-note pedalboard should be placed so that its higher C key is vertically in line with the B key on the manual which is immediately adjacent to middle C, and with its top surface 777mm below the manual keys in the rest position. The same dimensions apply for the corresponding key of larger pedalboards.

## PARTS LIST

- 1 13-note pedal key assembly (see text)
- 13 SPDT pushbutton switches, C. & K type 8125 or similar.
- 1 Strip of blank epoxy-fibreglass laminate, 505 x 75mm
- 1 16-way polarised plug with cover
- 1 16-way polarised socket
- 1 2-metre length shielded microphone cable
- 1 4-metre length 12-way rainbow cable

- 1 Swell pedal assembly, Electronic Arts type EP-1 or similar
- 1 Sheet 18mm particle board, 900 x 300mm
- 2 Sheets 10mm particle board, 900 x 300mm
- 1 1.5m length of 25 x 50mm DAR soft-wood (maple or oregon).
- 3 100k ½W resistors
- 1 0.1µF 100V polyester capacitor
- Nails and glue for case assembly, woodscrews, self-tapping screws, wire, solder, etc.



CT71 Curve Tracer displays semi conductor characteristics of transistors, diodes and FETs, etc.



DM64  
10MHz dual trace  
10mV/cm, bi-stable  
storage. Up to  
250cm/ms writing  
speed.



D83  
Dual trace plug-in  
50MHz for Audio  
to RF applications,  
including logic.

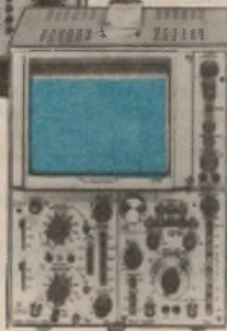

## This has got to be the best selection of low-cost oscilloscopes

The Telequipment line of Tektronix portable and bench oscilloscopes combine low price with a number of advanced features. These include storage CRT's, plug-in oscilloscopes, bandwidths to 50MHz, internal graticules and a wide choice of vertical, horizontal and triggering performance, making these instruments versatile and easy to use—and, we think you'll find them the best value on the market.

Get on the phone now to your Tektronix office for your price, spec sheets and a demonstration.



**TEKTRONIX**  
committed to  
technical excellence

SYDNEY 888 7066 MELBOURNE 81 0594  
ADELAIDE 223 2811 BRISBANE 31 2896  
PERTH 21 7885

D61  
10MHz dual trace,  
X - Y mode, TV line  
or frame triggering.



D67 Dual Trace  
25MHz at 10mV/div.  
FET inputs, delayed  
sweep time-base.



# ELECTROCRAFT PTY. LTD.

106A Hampden Rd.  
Artarmon, 2064  
Phone 411-2989

Distributors of Belling Lee, Channel Master, Ecraft, Hills, HI Q, Lab Gear, Kingray, Matchmaster. Largest range of aerial equipment in Sydney. One stop shop for all your equipment. Expert advice given.

## TELEVISION AERIALS, DISTRIBUTION AMPLIFIERS, EQUIPMENT AND ACCESSORIES WHOLESALE, TRADE AND RETAIL SUPPLIED.

### ECRAFT

	Price
Neosid Balun 75 / 300 uncased	\$0 65
O S A B Outside aerial balun	3 81
6 SB 6ft. Balun Fly Lead	3 65
P S B Plug and Terminal Balun	2 53
2 75 T / S 2-way 75 ohm Transformer Splitter box	7 79
3 75 T / S 3-way 75 ohm Transformer Splitter box	8 41
4 75 T / S 4-way 75 ohm Transformer Splitter box	8 94
5 75 T / S 5-way 75 ohm Transformer Splitter box	12 66
2 3T 2-way 300 ohm Splitter box	4 48
3 3T 2-way 300 ohm Splitter box	5 86
4 3T 2-way 300 ohm Splitter box	7 12
Adjustable Low Band Attenuator	6 31
10" diameter degaussing coil	24 00
L 735 / A outlet box	1 70

### TELEVISION AERIALS FOR COLOUR

	Price		Price
EFC 1	\$24 17	215 8 EL	\$19 26
EFC 2	\$32 06	216 9 EL	\$24 10
EFC 3 / 24	\$46 65	CY 7 Colinear	\$25 95
EFC 4 / 24	\$58 68	2010 Airways	\$42 50
		CA 16	\$31 73
		CA 16 Gain Lift extra	

### CHANNEL MASTER

3111 Super Colaray	\$36 50	638 8 EL	19 26
3110 2 EL Colaray	22 75	257 Colinear	26 07
		361A 17 EL Crossfire	54 95
		367A 29EL	102 18

### HI. Q SINGLE YAGI'S

CH 2 4EL	\$20 80	Gutter Clip Aerial 1 EL	8 90
CH 4 & 5 A B EL	27 74	Gutter Clip Aerial 2 EL	11 00

### COAXIAL CABLES

Attenuation per 100ft at 200 MHz  
Belden 9242) Double screened with  
Belden 924B) Duofoil and Braid  
TVM1A Concordia Copper Screened  
Hartland WH89 Copper Braid  
Hartland WH87 Copper Braid  
Hartland WH86 Copper Braid  
300 ohm Feeder Cable  
Open wire line 300 ohm  
Open wire line 300 ohm

### FILTERS

F75B Single Channel Low Band Filter	\$9 56
F75C Single Channel High Band Filter	\$19 12
F75D / A Low Band Filter	\$7 65
F75WN Filter for Chs. 3, 4, 5, 5A	\$10 91
F / Hi / Lo High-Low Twin Aerial Filter	\$14 53
F300A Single Channel Balanced Low Band Filter	\$5 58

### F. M. AERIALS

	Price
Matchmaster	\$21 30
Hills 3 EL	11 17
HI Q 4 EL	15 91
HI Q Gutter Clip 2 E 1	9 50

### TELESCOPIC MASTS

20 ft	\$19 30
30 ft	30 81
40 ft	42 06
50 ft	54 42
60 ft	58 00

	Reel Size	Price
4 0 dB	500 ft	\$42 28
3 1 dB	500 ft	58 61
4 4 dB	100 metre	30 15
3 3 dB	100 metre	36 92
6 0 dB	100 metre	26 56
6 5 dB	100 metre	19 25
1 8 dB	100 metre	8 80
1 5 dB	100 ft	9 90
1 5 dB	300 ft	29 80

### KINGRAY AMPLIFIERS

D15 / 500 m / V	\$48 80
D30 / 500 m / V	57 95
D40 / 600 m / V	79 30
D12 / 1500 m / V	67 10
MH 20 Mast Head	64 63

### LAB GEAR AMPLIFIERS

	Price
VHF UHF	
Mast Head 22 dB	\$72 43
CM 6014 / DA 20 dB	60 25
CM 6034 / DA 4 outlets 8 dB each	54 90
CM 6036 / DA VHF 30 dB UHF	
28 dB	84 63
Televarta (VHF to UHF frequency converter)	67 48
Channel Master Telstar 0023A	58 91

### ALL TYPES OF HARDWARE IN STOCK

Wall brackets, chimney mts., J Brackets, Turn-buckles, Guy Rings and Guy Wire. All types of masts, etc.

# Electronic Pigeon Guard

Keeping the peace between pigeon fanciers and cat lovers may seem to call for diplomacy rather than electronics. Nevertheless, this contribution to our Kitsets—EA competition tells how electronics saved the day. If you have a similar problem, this may be the answer.

\*by D. McILWRAITH

top of the platform and three aluminium plates arranged on top of this as shown in the diagram. The sensor wires were placed about  $\frac{1}{8}$ in apart and connected as shown. This layout was arrived at experimentally and proved to be the most successful. The device worked most effectively, particularly during the first seven or eight days after installation, before all the cats got the message. ☺

This is a simple device to protect pigeons from cats. A friend was having trouble with cats jumping onto the landing platform of his pigeon house, reaching in and clawing at the pigeons, and causing the death of a number of them.

This situation created a problem in domestic diplomacy. The pigeons belonged to the son of the house, whose interest in them was supported by his father. Left to himself, his father may well have taken quite drastic action to "discourage" the cats, but was restrained by his wife, who is just as ardent a cat lover as her son is a pigeon fancier.

My pigeon guard has made everybody happy; the son because he no longer worries about the pigeons; his mother because no harm has befallen the cats; and his father because he helped solve his son's problem without getting on the wrong side of his wife.

The device is so designed that, when a cat steps onto a sensor on the platform, it receives a nasty shock via an arrangement of aluminium plates.

The circuit shows how this is arranged. When the cat steps onto the sensor wires, moisture on its paws causes current to flow from the positive supply rail through the 10k resistor and the base emitter junction of TR1.

circuit through the primary of the ignition coil, producing a high voltage in its secondary.

When the cat leaves the platform TR1 stops conducting and, the next time the vibrator contacts B and C open, the SCR turns off.

The trigger network and the vibrator are mounted on a piece of Veroboard and the whole arrangement mounted in an aluminium box with the power supply. This box and the ignition coil were mounted underneath the landing platform.

A layer of polythene was glued to the

## PLEASE NOTE

This project is one contributed to our Kitsets-EA Competition. As such, it has not been through our laboratory and should not be regarded as a regular "Electronics Australia" project. We will therefore not be in a position to answer postal queries about its operation, or supply back-up information, diagrams, etc, beyond what is published. And while we may quote the contributors name and address, to authenticate the article, the contributor is under no obligation to answer letters about his project. That is entirely a matter of his own inclination and convenience.

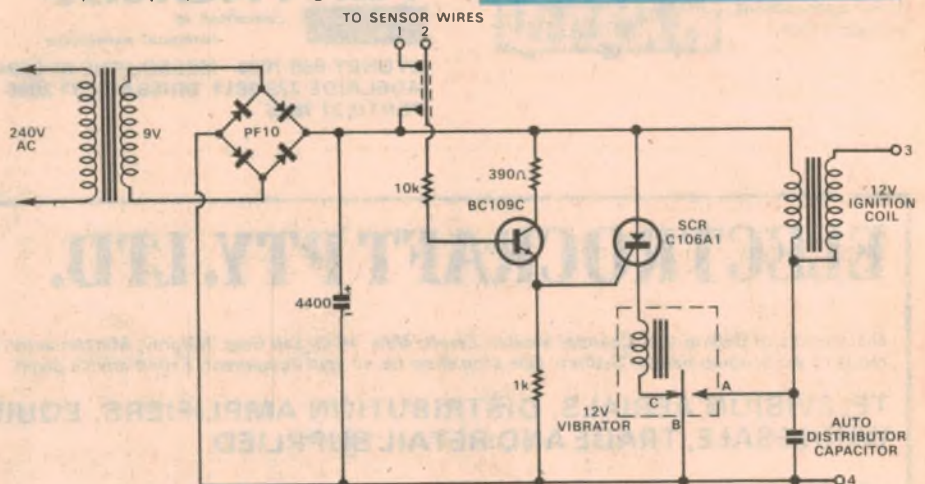

The circuit of the Pigeon Guard is quite simple and most parts should be readily available. The only doubtful item is the vibrator, but these should be available from discarded equipment. Even if not in first class condition, they should function in this role.

## PARTS LIST

- 1 Transformer, 240V/9V
- 1 12V ignition coil
- 1 Ignition capacitor
- 1 Bridge rectifier, MB4 or similar
- 1 4000µF electrolytic capacitor
- 1 C106A1 SCR
- 1 12V vibrator
- 1 10k  $\frac{1}{2}$ W resistor
- 1 1k  $\frac{1}{2}$ W resistor
- 1 390 ohm  $\frac{1}{2}$ W resistor
- 1 Piece Veroboard, 2in x 4in

This biases TR1 into conduction, effectively connecting the gate of the SCR to the positive rail via the 390 ohm resistor. This gates the SCR on. The SCR is in series with the energising coil and associated contacts (B and C) of a discarded vibrator.

This causes the reed to vibrate and a third contact (A) completes a pulsing cir-

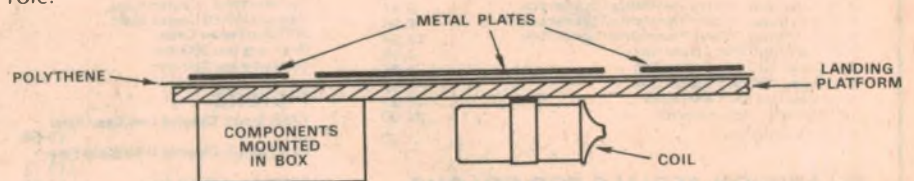

Above: Side view of the landing platform, showing the location of the major components. Right: Plan of the platform showing placement of, and connections to, the plates and sensing wires.

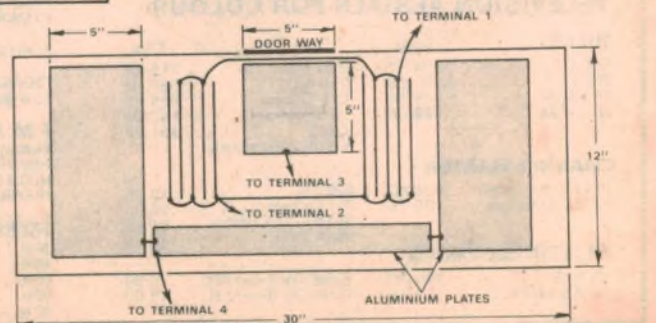

\*49 Wilton Crescent, Bishopdale, Christchurch, N.Z.

## These have got to be the best buys in 10MHz oscilloscopes.

These 'scopes offer you extensive performance and features for a realistic price. Dual Trace and 10MHz at 10mV/div sensitivity, with automatic selection of chopped or alternate mode. Trigger from internal, external or TV, with automatic selection of TV line or frame. This, plus the backing of Tektronix warranty and service. Get on the phone now to your Tektronix Office for price, details and a demonstration.



**TEKTRONIX®**

committed to  
technical excellence

SYDNEY 888 7066 MELBOURNE 81 0594  
ADELAIDE 223 2811 BRISBANE 31 2896  
PERTH 21 7885

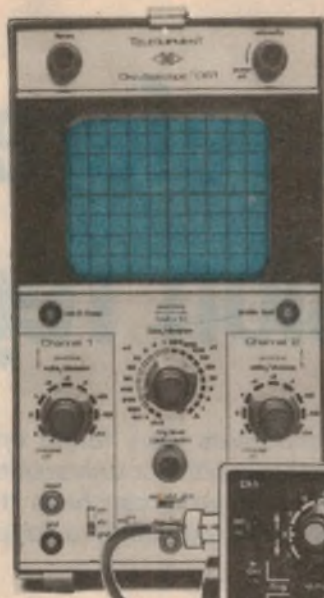

## Performance...

TELEQUIPMENT D61  
10MHz dual trace, X - Y mode,  
TV line or frame triggering.

## Portability...

TELEQUIPMENT D32  
Weights only 4.5kg. Includes  
internal rechargeable batteries  
and battery charger.

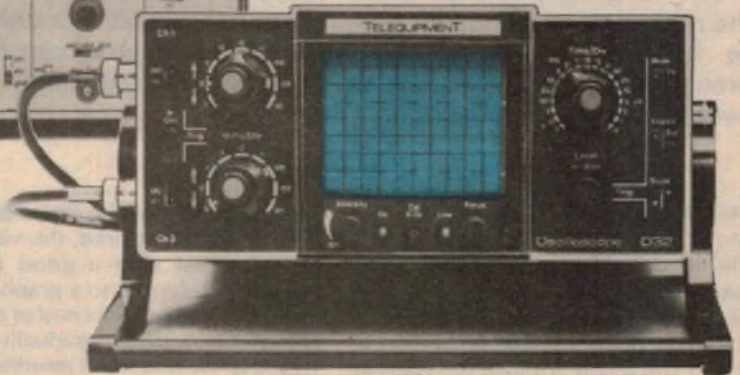

# Enjoy great Hi-Fi sound While on the Move...

## Fit a DOMINION Car Stereo

DOMINION Model 4100 \*\$61.20



Mini under-dash cassette stereo player. 5 watts per channel, fast forward, rewind, auto stop, with slider volume and tone and balance controls.  
Dimensions: 5 1/4" wide x 6 1/2" deep x 2" high.

**SPECIAL  
OFFER**

With each DOMINION Car Stereo purchased one pair 5", 5 watt car wedge speakers or one pair 7" x 5" speakers with black metal grilles at NO EXTRA CHARGE.

DOMINION Model 4511 \*\$99.45  
With stereo FM radio



High quality, in-dash mounting stereo cassette player. With a sensitive AM-FM stereo radio. A DX local-long distance reception switch, fast forward control. 5 watts output per channel. Dimensions: 7" wide x 5" deep x 2" high.

Distributed  
throughout  
Australia by:

**radioparts** GROUP

562 Spencer Street, North Melbourne. Phone: 329 7888.  
1097 Dandenong Rd., East Malvern. Vic. Phone: 211 8122.

\*Quantity discounts on application

# DC voltage reference uses precision regulator

Not very long ago, voltage references or standards were found only in the rarified air of standards labs, research institutions or universities. Now, thanks to a new precision regulator IC, anyone can have this reference featuring 0.1% accuracy. You can put it together in a couple of evenings, at very low cost.

by IAN POGSON

What is the precise voltage between points A and B? You immediately reach for the trusty old multimeter which has served you faithfully for the last umpteen years. The measurement is duly taken but this time, you really want an accurate reading and there is that nasty feeling that the old meter may not be as accurate as it used to be.

You could send your meter to one of the authorities who maintain very accurate sub-standard instruments, and have yours calibrated for a fee. This is satisfactory enough but it takes some time, and there is the fee. Both the time and cost would be incurred each time you required any calibrations in the future.

A mercury cell may be used as a voltage reference for calibration purposes. These cells are relatively inexpensive and provided the age of the cell is known,

along with the temperature at the time the voltage is required, the voltage may be estimated with a good degree of accuracy. Referring to a graph, given for 70°F, the voltage at the end of one month is given as 1.3566V, gradually falling to 1.3524 at the end of 12 months.

Although the graph only gives information for the first 12 months of storage, it should be reasonable to expect 2 to 3 years over which a cell may be used for reference purposes. For the greatest possible accuracy it would be necessary to have the information whereby the voltage can be reasonably accurately determined, according to the age of the cell.

The silver oxide cell may also be used as a voltage reference. These cells may not be as readily available as mercury cells but there seems to be evidence to support the idea that silver oxide cells are

somewhat superior. The nominal voltage of silver oxide cells is 1.6V.

You may be fortunate enough to have access to a Weston cell. These cells are a highly accurate source of voltage reference. The voltage of one of these cells is quoted as being 1.018636V at 20°C and with a temperature coefficient of .00004V/°C.

A typical Weston cell can be expected to be within plus or minus 0.05% of the nominal voltage and the long term drift should not exceed about 0.01% per year.

While it may be generally agreed that the Weston cell is a very satisfactory answer to the voltage reference question, it will also be conceded that they are rather delicate and call for careful handling, both mechanically and electrically.

Quite recently, our attention was drawn to a new device from National Semiconductor Corp. It comes in a number of variations but essentially it is an IC chip consisting of a temperature compensated zener diode driven by a current regulator and a buffer amplifier. The makers state that "the devices provide an accurate reference that is virtually independent of input voltage, load current, temperature and time". It is short circuit proof, and so is rugged both electrically and mechanically. Whereas most reference cells will tolerate little or no output current for long periods, this device will deliver up to 20mA continuously.

It appears that during manufacture, the output voltage is trimmed to within very fine tolerances. Two output voltages are available. Type LH0070 has a nominal output of 10V, while type LH0071 has a nominal output of 10.24V to provide equal step sizes in binary applications. Each type is divided into three tolerance classes, designated with suffixes -1, -2, -3, with -3 having the closest and -1, the widest tolerance figures.

We have built a voltage reference standard around the type LH0070-2, which gives a nominal 10V output with the middle tolerance figures. Conservatively, the output voltage from this device may be relied upon to be within  $\pm 0.1\%$  under normal temperature conditions. Compared with the figures given earlier for

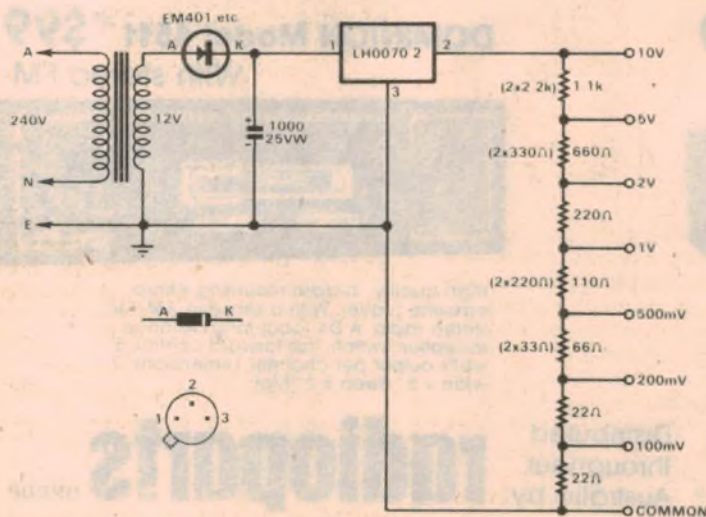

DC VOLTAGE REFERENCE

Heart of the circuit is the new LH0070-2 precision regulator IC.

the Weston cell, the 0.1% figure is only moderately less accurate. Given the other advantages of the new device, it compares overall very favourably with the Weston cell.

Let us have a look at the circuit to see how we have made use of the LH0070-2 voltage reference. Power supply is obtained from a small mains transformer, with a 12V secondary. The 12V AC is rectified with a single diode half-wave rectifier and filtered with a 1000uF 25VW electrolytic. This gives about 19V DC, which is fed to the input of the device, at the output of which is the 10V reference.

In order to make the reference more useful, we have strung a voltage divider across the output. The voltage divider has been tapped so as to give outputs on 5V, 2V, 1V, 500mV, 200mV and 100mV.

A voltage divider in this application

### PARTS LIST

- 1 Moulded case with aluminium lid (159mm x 96mm x 50mm)
- 1 Power transformer 240V primary, 2 x 6V at 200mA secondaries, PF2851 or similar
- 1 Reference IC, LH0070-2
- 1 100uF 25VW electrolytic
- 1 Mains terminal strip
- 1 Miniature tag board with 7prs tags
- 1 Miniature tag board with 13prs tags
- 8 Banana sockets, 1-black, 7-red
- Resistors (1/2 watt, high stability, 1% tolerance)
- 2 22 ohms
- 2 33 ohms
- 3 220 ohms
- 2 330 ohms
- 2 2.2k
- Miscellaneous
- Solder lugs, power flex, 3-pin plug, hookup wire, solder screws, nuts.

presents problems of its own. The close tolerance on the output voltage direct from the device is not affected by the voltage divider, but the accuracy of the voltages at the taps will not only depend upon the initial output voltage accuracy but also upon the accuracy of the respective resistances of the divider chain. Also, to allow current to be taken from the tap points, the resistor values must be kept low, consistent with output current considerations of the device. Another consideration is to be able to make up the divider, using readily available high stability resistors, of 1% tolerance and in the preferred range.

All of the above points have been met, and we believe a good compromise has been reached. The overall resistance of the divider is 2200 ohms, which results in a bleed current of a little more than 4.5mA. This amount of current and resistance combination was considered to be such that the current level would not cause undue heating of the device, and

## TECHNICIANS! Special Prices on Test Equipment



### YF-20K

#### High-Sensitivity Multitester

20,000 Ohms Per Volt DC  
10,000 Ohms Per Volt AC  
V DC 0-5-25-125-500 & 2.5K Volts  
V AC 0-10-50-250-1000 Volts  
DC Current: 0-50uA-250mA  
Resistance: 0-Rx10-Rx1K Ohms



### YF-330

#### High-Sensitivity Multitester

V DC 0.3V 3V 12V 30V 120V 300V 60V 1.2kV 6kV (20k V)  
V AC 6V 30V 120V 300V 1.2kV (8k /V)  
DC Current: 0.6mA 3mA 30mA 300mA 12A (300mV) Ohms  
Range — x 1 x 100 x 1k x 10k  
Midscale—25 2.5k 25k  
250k  
Maximum — 5k 500k  
5M 50M



- Replaces buzzer and bells and danger of inductive kickback
- Audio tone varies with resistance (0 to 50 OHM)
- Open circuit 9V at the probes
- Short circuit current 6mA
- Fits your hand and your tool box
- Safe for semiconductor
- Measures only 70mm x 35mm x 95mm

FOR INFORMATION AND PRICES TELEPHONE

**AUSTRALIAN TIME EQUIPMENT PTY LTD**

192 Princes Highway, Arncliffe, N.S.W. 2205

Phone: 59 0291

## For fine detail work — a hands free magnifier



The **Magna-Sighter** is a precision 3-D binocular magnifier that leaves your hands completely free for work. It has hundreds of applications, and is invaluable for scientists, technicians, craftsmen, toolmakers, hobbyists, etc. Slips easily over the head—over glasses, too. Proved and used by many U.S. universities, space research bureaux, government departments and major industrial organisations. Available in 3 different magnifications. Price \$21.00

## MAGNA-SIGHTER

For further information send this coupon today:

STOTT TECHNICAL SERVICES

MEA 6 76

(Division of Stott's  
Technical Correspondence College Pty. Ltd.)  
159 Flinders Lane, Melbourne, Vic., 3000

Please send me full information on the 3-D Magna-Sighter. I understand that no Sales Representative will call.

Name.....

Address.....

Postcode.....

STC 846



# HOBBY KITS

To-days Technology for Your Enjoyment

## SATURN 5

UNIVERSAL VIDEO GAME

Play SQUASH, FOOTBALL, TENNIS, PING PONG, HOLE IN THE WALL, TARGET PRACTISE - WITH OPTIONAL SOUND EFFECTS, ON-SCREEN SCORING.

Build your own Saturn 5 and experience hours of fun and excitement playing these fascinating TV games with your family and friends!

Saturn 5 is an entirely new approach to video games and consists of a master control unit with plug in game options. This together with the remote dual slider player controls offers an unlimited range of game possibilities, including double/singles (tennis) and horizontal/vertical player movement (football/squash). Play tennis, ping pong and hole in the wall with the basic Saturn 5 kit. Football and squash options now available.

Why not design your own games and play golf, baseball, billiards, moving target etc. etc.

Optional kits are available to add sound effects and on-screen scoring if required. Saturn 5 is easily built and features CMOS technology and battery operation. A pre-built modulator is included which plugs into any TV set (colour or black and white) at the aerial terminals.

With our exclusive assembly manual and technical support service, virtually anyone can construct this kit.

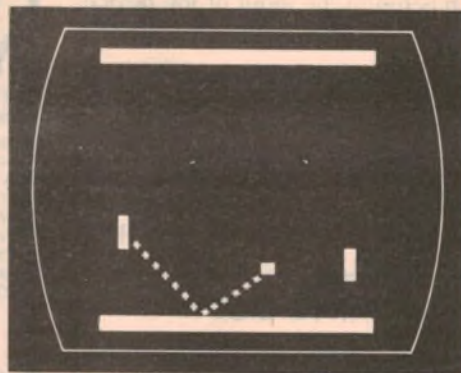

THE HOTTEST ELECTRONIC TV GAME KIT IN TOWN!

Complete SATURN 5 basic kit with ping pong, tennis, hole in the wall games **\$37.50\***

OPTIONS	Sound effects	\$3.50*
	On-Screen scoring	\$7.50*
	Football	\$7.50*
	Squash	\$7.50*

\* Including post and packaging

## Playmaster "TWIN 25" AMPLIFIER

\* Designer Approved Kit



**\$85.00** plus \$6.00 freight and packaging.

Upgrade your old Playmaster system with this exciting new Playmaster TWIN 25. This latest design features single board construction (eliminates old layout problems) and a new quasi complementary output stage that is low in cost yet has unconditional stability!!

With our exclusive step-by-step assembly manual and technical support service this is an ideal kit for beginners or professionals alike.

Complete kit including prepunched and plated metalwork, all components, fibreglass printed circuit board with 10 gauge front panel screened component overlay, hookup wire, hardware, solder and, of course, front panel with matching knobs at no extra charge.

### FULL TECHNICAL SUPPORT AND WARRANTY SERVICE

All Applied Technology HOBBY KITS are covered by our exclusive 90 days warranty against faulty components and packaging (full details with each kit).

Yet another exclusive is the full technical support service. If you are unable to make your HOBBY KIT operational, help is just a phone call or a letter away. If you do have to return any KIT for factory attention, it will be repaired for a nominal service fee.

All Kits on display at our factory showroom.

Hours: 9-5 weekdays, 9-12 Sat.  
Phone: 476-3759



109-111 Hunter Street,  
HORNSBY, N.S.W. 2077  
Phone (02) 476-4758  
Open Saturday morning

Please supply .....

Enclosed is my Cheque/Postal Note/Money Order for \$.....  
made out to APPLIED TECHNOLOGY PTY. LTD.  
(PLEASE PRINT CLEARLY)

NAME .....

ADDRESS .....

P/C .....

## DC voltage reference

the amount of resistance has been kept low enough so that very little voltage drop will be incurred when a meter of reasonably high resistance is connected across it. Combinations of preferred resistance values have been used and which are available in high stability 1% tolerance types.

Construction of our DC Voltage Reference is simple and straightforward and should be easily undertaken by all except raw beginners. Our unit is housed in an economy moulded case, 160mm long x 95mm wide and 50mm high, with an aluminium top panel. The voltage divider is wired on to a miniature tag strip with 13 pairs of tags. Except for the transformer, the power supply components and the voltage reference device are wired on to another miniature tag strip with 7 pairs of tags.

As may be seen from the picture, the tag strips, transformer, mains terminal strip and power cord clamp are screwed to the bottom of the case. A solder lug is fixed under one of the transformer mounting screws and the mains earth lead is terminated to this lug. Another short lead runs from the earth lug and has another solder lug at the other end. This lug is held under the metal panel mounting screw so that the panel will be effectively earthed.

Eight banana sockets are mounted on the panel to terminate the points along the voltage divider. We mounted these sockets on 20mm centres. We used Letraset to mark the panel, followed by a coat of clear enamel. When wiring the sockets from the voltage divider, we left

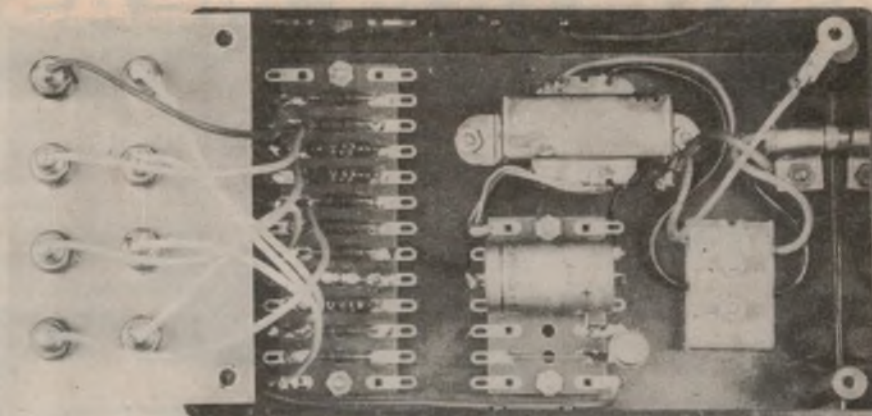

The above photograph, together with the two wiring diagrams given below, should make construction a straightforward process. Note that the front panel is earthed.

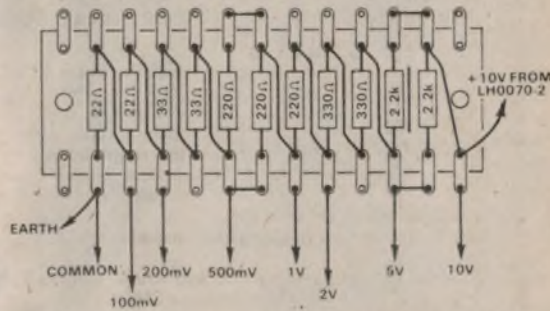
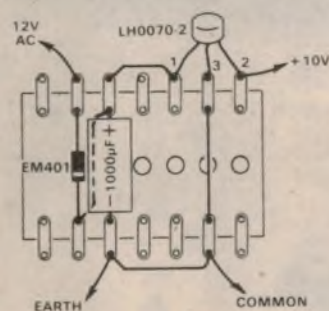

lead lengths long enough to be able to pull the panel away from the main case. This facilitates access when required.

Having done the wiring, it is a good idea to make a thorough check before switching on. Assuming that all is well, a couple of initial voltage checks would be in order. The voltage across the 1000µF electrolytic should be of the order of 18 to 19 volts. The output voltage from the top of the voltage divider should be 10 volts. This will naturally fall within the

close tolerance of the reference device.

To give some idea as to what you may expect in the way of accuracy from the tapping points along the divider, here are the readings which we obtained from the prototype when using a Solartron Digital Voltmeter LM1619 (this voltmeter has a very high input impedance and uses a Weston cell as its reference): 10.00V, 5.01V, 2.00V, 1.003V, 501mV, 201mV, 100mV.

In its present form it is only possible to make calibration checks up to a limit of 10V. However, by some external apparatus, it may be extended up to whatever may be desired. The items required are an accurate voltage divider to meet the particular situation, a variable high voltage DC power supply and a galvanometer or a sensitive centre reading meter.

The voltage divider may follow a similar pattern to the one in the voltage reference and extended in value to suit the maximum required voltage. The same bleed current, or even a higher value of bleed current may be used to advantage. The bottom tap on the voltage divider will be at 10V, with the galvanometer connected between it and the 10V output of the voltage reference. The DC variable voltage supply will be applied across the divider.

When set up, the voltage applied across the external voltage divider must be such that the galvanometer reads zero. All voltages above this point will then be in accordance with the taps on the divider and may be used for calibration purposes.

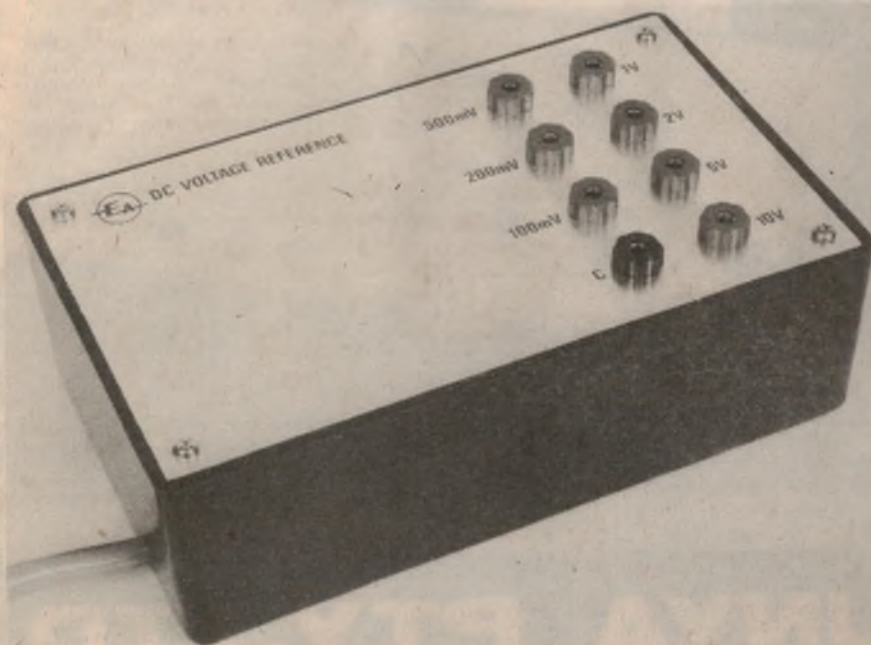

A standard case with an aluminium front panel was used to house the prototype.

# DISTORTION MEASUREMENT

## BROADCAST

### THE NEW SOUND TECHNOLOGY 1710A

- Balanced floating 600 ohm output oscillator from 10Hz to 110kHz, adjustable level from +26DBM to -90DBM in 0.1 DB steps.
- Balanced input to analyser measures floating or balanced sources, minimises ground loop and noise pick up.
- Measure distortion to 0.002%.
- Measure power -80DBM to +40DBM.
- Measure A.C. volts 100  $\mu$ V F.S. to 100V F.S. with 2% accuracy.
- Measure voltage or signal to noise ratios with 100DB dynamic range.
- Automatic set level and inter-modulation distortion measurement capability.
- Replica of input signal but isolated from input and referenced to ground always available via separate front panel socket.



## HI-FI

### SOUND TECHNOLOGY 1700B

- Oscillator range 10Hz to 110kHz.
- Balanced input to analyser measures floating or balanced sources, minimises ground loop and noise pick up.
- Measure distortion to 0.002%.
- Measure A.C. volts 30  $\mu$ V to 300V with 2% accuracy.
- Measure power (across external 8 ohms) from 1  $\mu$ W to 10KW.
- Measure voltage or signal to noise ratios with 100DB dynamic range.
- Automatic set level and inter-modulation distortion measurement capability.



The Sound Technology 1710A and 1700B will revise your thinking on distortion analysers. They measure total distortion down to 0.002% just by pushing the distortion button, no balancing or frequency control juggling, automatic set level capability lets you measure distortion versus frequency or distortion versus power/voltage or receiver sensitivity at given distortion level, etc. etc., all **without resetting level**. Fast, dependable, accurate measurement is today's need. Let us show you how Sound Technology gets it together.



# ARLUNYA PTY. LTD.

P.O. Box 113, Balwyn, Victoria, 3103, Australia. Telephone: (03) 836 6533.  
Telegrams and cables: "Arlunya" Melbourne, Australia.



# Circuit & Design Ideas

Conducted by Ian Pogson

Interesting circuit ideas and design notes selected from technical literature, reader contributions and staff jottings. As they have not necessarily been tested in our laboratory, responsibility cannot be accepted. Your contributions are welcome, and will be paid for if used.

## Wide range metronome

This metronome design employs a novel approach, in that it produces short bursts of an audio tone instead of single DC pulses. These bursts have a much higher energy level and can be more readily heard against ambient noise levels. At its lowest frequency the prototype produced one burst every eight seconds. Its highest frequency was well in excess of three bursts per second. The length of each burst is controllable.

The circuit employs a 555 IC timer in conjunction with a multivibrator. The multivibrator is turned on periodically by the 555 and it then oscillates at about 400Hz.

The 555 operates in a standard astable circuit, with its pin 2 (trigger) and pin 6 (threshold) connected together. Under these conditions, C1 charges via VR1, R1, VR2 and R2 until the voltage across it reaches  $\frac{2}{3}$  of the supply voltage. At this stage, the internal circuitry of the IC reverts to its previous state and the capacitor commences to charge once more. Since the capacitor discharge path is by way of VR2 and R2 only, whereas the charge path is by way of VR1 and R1 as well as VR2 and R2, the discharge period is shorter than the charge period. In the present design the multivibrator is turned on during the discharge period.

The output of the 555 at pin 3 goes low during the discharge period and is high during the charge period. Thus, during the charge period the lower ends of R3, R4 and R5 in the multivibrator are at a potential which is very close to the positive rail and the multivibrator cannot operate. During the discharge period the lower ends of these resistors are taken nearly to the negative rail, whereupon the multivibrator is able to oscillate in normal fashion.

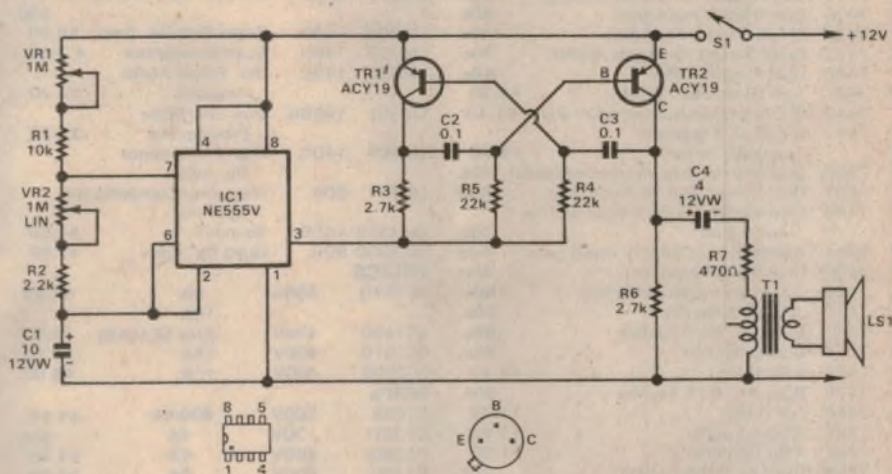

R7 is included in the circuit to prevent the inductance in T1 primary from upsetting multivibrator operation. Tr1 and Tr2 have a maximum reverse base-emitter voltage rating of 12V, which is just sufficient.

(Editorial note: Some difficulty may be experienced in obtaining the ACY19 transistors, or a suitable substitute. However, silicon types should be satisfactory provided some small changes are made. To protect the base-emitter junction against excess reverse voltage, a small signal silicon diode may be connected in series with each emitter, without upsetting the multivibrator operation. It may be necessary to alter the bias resistors to get reliable oscillation; this may also necessitate a change in the two coupling capacitors to maintain the frequency at 400Hz.)

VR1 is specified as a log component, since a log track enables adjustment at the higher frequency end to be opened

out as the spindle is rotated. The potentiometer is wired up such that the resistance it inserts into circuit increases as the spindle is turned clockwise. VR2 is wired in the same way, so that both controls operate in the same sense. It should also be noted that C1 should be a good quality electrolytic capacitor. Current consumption is reasonably low, being about 6mA, rising to about 10mA when a burst is produced.

Having completed the unit, first set up VR2 for the desired burst length and then adjust VR1 for frequency. If, however, it is desired to calibrate VR1 accurately in terms of frequency it would be better to make VR2 a pre-set pot which is mounted inside the unit. It may be set up for any burst length favoured and then left. Then VR1 may be calibrated by checking burst frequency against a watch with a sweep second hand.

(By M. G. Robertson, in "Radio & Electronics Constructor".)

## Low noise crystal oscillator

The importance of achieving high spectral purity (ie low-noise sidebands and low-harmonic output) in oscillators, particularly those used for frequency synthesisers or for frequency conversion (to avoid reciprocal mixing) is now well recognised as an important consideration in modern equipment design.

Ulrich Rohde, DJ2LR/W2, describes a

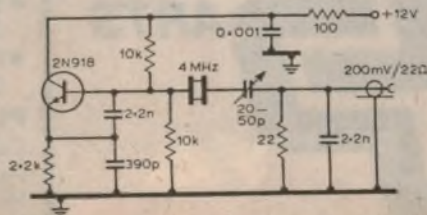

crystal oscillator arrangement in which the crystal not only forms the frequency-control device but also a low-pass filter to band-limit the noise output and suppress harmonics, without any substantial sacrifice of stability but at fairly low output.

It is pointed out that conventional crystal oscillators, despite the high Q of the

**DYNAMIC ELECTRONIC INDUSTRIES**  
**P.O. BOX, 162, SEAFORD, VICTORIA 3198 (PH. 786 6045)**

**T.T.L. DIGITAL**

I.C. No	Description (All Dual in-line packs)	
7400	Quad 2 input nand gate	40c.
7401	Quad 2 input nand gate open/collector	40c.
7402	Quad 2 input nor gate	40c.
7403	Quad 2 input nand gate open/collector	40c.
7404	Hex Inverter	40c.
7405	Hex Inverter open/collector	40c.
7408	Quad 2 input and gate	40c.
7409	Quad 2 input and gate open/collector	40c.
7410	Triple 4 input nand schmitt trigger	40c.
7413	Dual 4 input nand schmitt trigger	40c.
7420	Dual 4 input nand gate	40c.
7430	Single 8 input nand gate	40c.
7437	Quad 2 input nand gate/buffer	70c.
7440	Dual 4 input buffer	40c.
7441	1 of 10 decoder/driver	\$1.30
7442	B.C.D. to Decomal decoder/driver	\$1.10
7447	B.C.D. to 7 segment decoder/driver	\$1.70
7450	Dual and/or gate inverter/expander	40c.
7451	Dual 2 input and/or invert gate	40c.
7453	Expandable 4 wide 2 input and/or invert gate	40c.
7454	4 wide 2 input and/or invert gate	40c.
7460	Dual 4 input expander	40c.
7470	J K edge triggered flip flop	60c.
7472	J K M/S flip flop	70c.
7473	Dual J K M/S flip flop	95c.
7474	Dual D flip flop	95c.
7475	4 Bit Latch	\$1.10
7476	Dual J K M/S flip flop	90c.
7480	Full Adder	\$1.75
7482	2 Bit full adder	\$1.85
7483	4 Bit full adder	\$1.50
7486	Quad exclusive or gate	70c.
7490	Decade counter	90c.

7491	8 Bit shift register	\$1.30	
7492	Divide by 12 counter	90c.	
7493	Binary counter	90c.	
7495	4 Bit right/left shift register	\$2.10	
7496	5 Bit shift register	\$1.90	
74107	Dual J K M/S flip flop	95c.	
74121	One-shot Multivibrator	70c.	
74141	B.C.D. to decimal decoder/driver	\$3.10	
74192	Up/down decade counter	\$2.45	
74193	Up/down binary counter	\$3.80	
9001	J K M / S flip flop (74105)	\$1.30	
9368	5 Bit latch BCD to 7 seg decoder	\$3.10	
<b>LINEAR I.C.'s</b>			
LM301	8DIL General Purpose Op Amp	90c.	
LM308	14DIL Super Beta Op. Amp.	\$2.30	
LM339	14DIL Quad Comparator	\$3.20	
LM380	14DIL 5W Power Audio Amplifier	\$1.70	
LM381	14SDIL Dual Low Noise Pre-amplifier	\$3.30	
LM709	14DIL High Performance Op. Amp		
LM741	8DIL Frequency Compensated Op Amp		
LM1808	14DIL Sound IF	\$4.66	
LM3900	8DIL Quad Op Amp.	\$1.60	
<b>TRIACS</b>			
SC141D	400V 6A	\$1.90	
		10A	
SC146D	400V (Use SC151D)	\$2.00	
SC151D	400V 15A	\$2.20	
SC250D	400V 15A	\$8.00	
<b>SCR's</b>			
C103B	200V 800mA	\$1.65	
C106YI	30V 4A	95c.	
C106DI	400V 4A	\$1.40	
C122D	400V 8A	\$2.00	
C122E	500V 8A	\$2.50	

**SILICONE BRIDGE RECTIFIERS**

PD10	100	1.8A	\$1.30
PD40	400	1.8A	\$1.70
PD100	1KV	1.8A	\$4.10
PA40	400	8A	\$5.80
PA60	600	8A	\$6.60
PA100	1KV	8A	\$8.50
PB40	400	25A	\$7.00
PB100	1KV	25A	\$9.00

**SILICONE RECTIFIER DIODES**

A14A	100V	1A	20c
IN5059	200V	1A	25c
IN5060	400V	1A	28c
IN5062	800V	1A	40c
A14P	1KV	1A	40c
IN5624	200V	5A	\$1.50
IN5625	400V	5A	\$1.70
M25/400	400V	25A	\$3.20
M25/400R	400V	25A	\$3.20

**DIACS**

ST2			\$1.20
ST4			90c

**SPECIAL OPENING OFFER!**

**FREE** post and packaging  
 5% discount on orders over \$15.00.  
 5% discount on quantities of 100 and over.  
 Please send me the following items and/or your free catalogue

Enclosed is a cheque for .....

Name .....

Address .....

(EA6 76)

# Techniparts...

**Brisbane's newest self-serve retail electronic components centre**  
 (and at competitive prices!)

Woolworths Arcade,  
 95 Latrobe Terrace,  
 PADDINGTON. 4064.  
 P.O. Box 118,  
 PADDINGTON. 4064.  
 Phone: Brisbane (07) 36 1474.  
 Parking 200 Cars.  
 City Bus Stops Front Door.  
 Trading Hours  
 (8.30 am - 5.00 pm Mon.-Fri.  
 8.00 am - 11.15 am Sat.)



We possibly carry the largest range of semiconductors available anywhere in Australia to the enthusiast, including:

- Transistors, Power, General, FET, UJT. Over 150 types stocked.
- Diodes, Power, Signal, Zener.
- Integrated Circuits: Linear, Timers, Audio, Op Amps, FET Op Amps, Regulators.
- Integrated Circuits TTL, Standard TTL, Low Power, Schottky, High Speed.
- Integrated Circuits CMOS, 4000 series and 74C series.
- Integrated Circuits MOS, Shift Registers, ROM, RAM, Clock Circuits.
- Special I.C.'s, Temperature Transducers, Display Drivers.
- Optoelectronics; Displays, LED Lamps, Opto couplers.

**PLUS** A wide range of Resistors, Pots, Capacitors, Transformers, Hardware, Audio Connectors, Knobs, Tools, Cables, Heatsinks, Meters, Switches etc.

crystal, are still very noisy and produce many spurious signals, mainly because of the large-signal characteristics of the

### Versatile light alarm

This device turns itself on automatically at a certain light level, then produces an AF tone whose frequency varies with light intensity. The circuit uses a photoconductive cell type ORP12, the resistance of which changes according to the light incident on it. In total darkness the ORP12 resistance is 10M or more. When fully illuminated the resistance drops to between 75 and 300 ohms.

The ORP12 in series with R1, couples to the emitter of the unijunction transistor TR1. This acts as an audio oscillator. The repetition frequency of the pulses depends on the resistance of the ORP12 and R1 and on the capacitance of C1. Both R1 and C1 are fixed, whilst the resistance of the ORP12 changes with light intensity. And so the pulse frequency increases as the light on the ORP12 increases. Between pulses, a small standing current of about 1 to 2mA flows between base-2 and base-1 of the transistor.

Transistor TR2 is a silicon power transistor which conducts when its base becomes positive of its emitter by about 0.6V. Between the pulses from TR1, the base of TR2 is at a lower potential than 0.6V and so it passes no collector current. On the other hand, the pulses from TR1 take the base of TR2 up and it passes a heavy collector current when the pulses are present. If a 3 ohm speaker is connected to the speaker terminals, the amplified pulses from TR2 flow through

it, the series resistor R6 limiting their amplitude to about 0.6A. The speaker produces a tone of the same frequency as the pulses from TR1.

As TR2 passes no current between pulses, the average dissipation is low. A power transistor is specified to cope with the relatively high collector current pulses but it does not have to be mounted on a heat sink. Similarly, R6 is specified as a 3W type because of the high current pulses which it has to pass.

So far, functions have been considered on the assumption that R2 is not in circuit. With R2, considered, there is an added effect on circuit operation. The ORP12, R1 and R2 form a voltage divider and if the ORP12 presents a high resistance, the potential at the junction of R1 and R2 will be lower than the emitter triggering level of TR1 and so C1 cannot charge up to that level. Thus TR1 is not oscillating and TR2 is turned off. If the resistance of the ORP12 is reduced, the potential at R1, R2 will rise and TR1 will oscillate. And so, below a certain level of illumination of the ORP12 the circuit is quiescent.

With the circuit values shown, the circuit will be turned off in a fairly dark room. The tone from the speaker is at a high volume level. If the ORP12 is illuminated by a 100 watt lamp about 8 feet away, the frequency of oscillation is about 1kHz. At this frequency, current consumption is about 18mA. The con-

width is limited to less than 100Hz; secondly all higher harmonics are substantially suppressed (for example 60dB down for the third harmonic of a 4MHz fundamental). A photograph of the output on a sweep-frequency analyser shows that the circuit is capable of an impressive degree of spectral purity. (From "Radio Communication".)

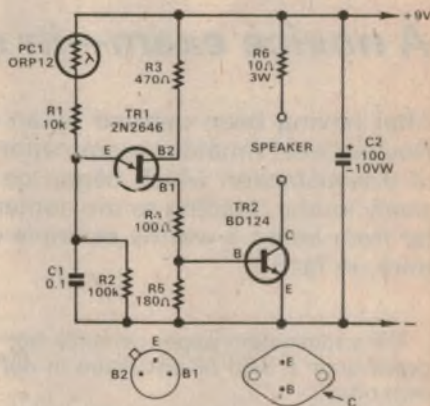

sumption reduces as frequency reduces and it increases to a maximum of about 23mA when the ORP12 is highly illuminated. Applications for this device will readily suggest themselves to the reader. (By J. R. Davies, in "Radio & Electronics Constructor".)

### Thermal overload cutout

Thyristors provide a simple and economical alternative to the older mechanical type of thermal overload cutout. Four-layer devices have a trigger threshold that is temperature dependent. By arranging that the gate current is just below the threshold, any increase in temperature will cause triggering. Potentiometer R2 sets the bias current to the "just untriggered" level. Once triggered the thyristor latches and can only be reset by opening S1. Circuit control can be via relays and/or transistors.

The heating element can be isolated from the thyristor case, or it can be a short resistive link, in the positive line or bolted to a heat sink, and connected to the thyristor anode as shown. In DC circuits, a 1/25 ohm will monitor a 25A circuit with ease. Thyristor packaging and mounting govern the thermal inertia of the system.

(By C. Woolf, in "Wireless World".)

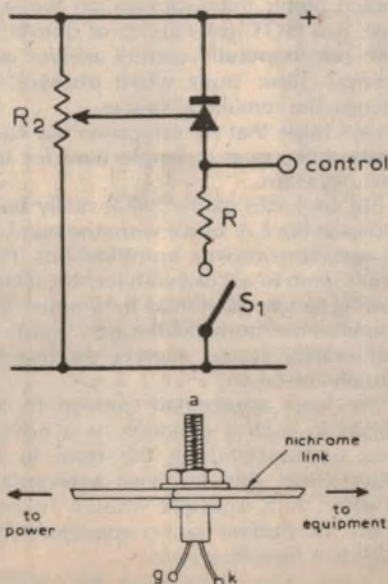

**FERGUSON**

Manufacturers of:  
Electrical / electronic  
equipment, wound  
components and  
lighting control  
equipment.

**BRANCHES  
IN  
ALL STATES**

**Ferguson Transformers  
Pty Ltd.**

Head Office  
331 High Street, Chatswood  
NSW 2067

PO Box 301 Chatswood,  
NSW, Australia 2067

Phone: 02-407-0261



## Forum

Conducted by Neville Williams

### *A novice exam—in more ways than one*

After having been delayed by an industrial dispute, the long awaited Novice Level Amateur examination was held on March 16. Rumbblings of dissatisfaction which began on the same day have grown progressively louder, leading to the contention that the novice exam was itself far from being a worthy example of the examiner's art; quite the contrary, in fact!

The examination paper certainly triggered quite a deal of discussion in our own office.

Phil Watson, an electronics tutor from way back, and currently the most active amateur in our ranks, had plenty to say about it, beginning with the multiple choice format and leading into criticisms of individual questions.

Jim Rowe, who has studied educational theory and psychology, tended to defend the form of examination on practical grounds. But he certainly wasn't happy with this particular effort. Apart from aspects that Phil Watson had drawn attention to, Jim felt that some of the questions were concerned with areas which a novice amateur would not need to know about to pursue the hobby in a perfectly normal way.

I personally felt that a few wide-ranging questions could indicate the breadth of the examinee's background reading, as distinct from what he actually needed to understand in detail. But what really bugged me were question/answer combinations which seemed to suggest either that the examiner(s) had set the papers in a hurry, or had failed completely to understand the implications of their own wording! We shall say more about that later.

Mr Rex Black, a long-time supporter of amateur, youth, club and novice movements, was critical of many aspects of the examination, but particularly of the Morse Code section. Some examinees were faced with a 5wpm signal obtained, presumably, by the simple expedient of playing a 10wpm tape at half speed. This is contrary to established tutorial procedures where character speed and sound is maintained and the spacing between them varied to obtain the desired word-per-minute rate.

But easily the first to lodge an official protest was Keith Howard, Director of the Westlakes Radio Club and a professional educator. On the afternoon of the

examination day, he despatched a telegram of protest destined ultimately for the Postmaster-General, following it with a letter of explanation, and indicating that he would be preparing a detailed report on the examination paper.

Amongst other things, this report supports observations by Rex Black and Jim Rowe to the effect that some of the questions would seem to go beyond what novice examinees would be expected to know. They were certainly well outside the limits implied by the Department's guidelines in the form of "Sample Ten Novice Questions".

Space does not permit us to reproduce in full the submissions by Keith Howard, Rex Black and others, but we include in the accompanying panel, Keith Howard's summary of the requirements for a multiple choice type of examination paper indicating, by implication, how the paper in question failed to measure up.

Clearly, there is far more to a multiple choice paper than appears on the surface. It is NOT just a series of questions with one hopefully correct answer and several other buzz word phrases to occupy the remaining spaces.

Let's hope that the educators will have made their point in ample time for the next occasion.

But, as I said earlier, what really bugged us at the E.A. office were the number of question/answer combinations that didn't seem to accord with technical fact, leading to speculation as to whether the examiner had been deliberately "subtle", deliberately casual, merely careless or actually mistaken!

The least appropriate person to be placed in such a quandary is a novice level examinee—using the term in its wider sense. And the least appropriate medium is a multiple choice format where the student has no opportunity to provide a flexible answer.

Faced with something he cannot

understand, the novice level examinee is likely to be disturbed by his own inadequacy, and forced into guessing, without realising that the lapse is on the part of the examiner.

Let's take question 7 to illustrate what I mean:

7. An audio amplifier will give the best response when operated:

- a. Class A
- b. Class AB
- c. Class B
- d. Class C

At first glance it looks like a perfectly routine question but, in fact, it is so loosely worded that it is utterly meaningless—and I am not "nit picking" in saying this.

Unqualified, the word "response" has no precise meaning and one can only speculate as to what the examiner had in mind. The most likely alternatives are:

1. He really meant "frequency response", a common term which is often casually shortened to "response"; or
2. He used the word in the collective sense to mean "fidelity", a usage that would be foreign to ordinary audio terminology.

Now look at the word "amplifier" and tell me which of two common usages is envisaged:

1. An audio amplifier as an entity with the output stage operating in class A, class B, etc; or
2. An audio amplifier stage operating in class A, class B etc.

But, having nominated possible interpretations of the question itself, we are still in as much trouble as ever.

If the examiner had in mind an audio amplifier as an entity, no single option can be nominated as the correct one, irrespective of whether he was thinking of frequency response or overall fidelity. The simple fact is that audio amplifiers exhibiting very wide frequency response and very good fidelity characteristics overall may use any of three modes of operation (A, AB, B) and there is no automatic "best". In fact, one of the most noteworthy present-day amplifiers is the QUAD "current dumping" design which uses a class A output stage supplemented by additional output transistors operating on the class C side of class B!

In short, this interpretation of the statement in no way accords with the options, which suggests either:

1. It was not what the examiner had in mind, or
2. The examiner was injecting into the novice amateur paper the much argued, highly emotional and totally irrelevant hifi fable that "the only good amplifier is a class A amplifier".

Yet, to consider the amplifier in question as a single stage wouldn't help much either. It would be pointless to question the examinee about frequency response because, unlikely as any mode would be other than class A, there is really no connection between mode and frequency

response, anyway!

Mode, of course, has everything to do with the distortion content but, in normal terminology, distortion content is never associated with the word "response". Either way, the red face would appear to belong to the examiner.

I imagine that, in practice, the majority of novice examinees would have circled class A because it seemed the right thing to do for an audio amplifier. A better informed but "smart" examinee would do likewise, not because it was right, but because he would work out that that was what the examiner expected, no matter how unfounded the reason.

Which brings me to Jim Rowe's reaction to this and other questions in the paper: questions on matters of fact may present problems to those with limited knowledge but they should become progressively easier to answer for those who have a better understanding of the

subject. If questions contain implications or ambiguities which become apparent—and confusing—to better informed people, then they are bad questions, per se.

As I've already said, question 7 is so ambiguous, so loosely expressed, that it is incapable of being properly satisfied by any one of the options. And, if one did deliberately mark an option, it would be in defiance of technical logic.

Another question, also on audio, stirred Jim Rowe to loud protest:

*29 Which method of coupling, when used in an audio amplifier, would have the best frequency response?*

- a. R.C. coupling
- b. Transformer coupling
- c. Direct coupling
- d. Choke coupling

Frankly, this question has about it the same aura of the 30's and 40's, as if it were copied from an old paper, or inspired by

## Guidelines: Multiple Choice Questions

There are certain well defined requirements for the formulation of a so called "multiple choice" question paper.

The multiple choice form question consists of an introductory question or statement (the stem) followed by a number of alternative responses (the options) one of which answers the question or completes the statement in the stem.

The correct response is called the key and the incorrect options are called distractors.

There are several forms of multiple choice question and five of them are used in the examination paper under consideration. They are:—

- a. The best answer type.  
Options are correct or appropriate in varying degrees and the student selects the best or most nearly correct.
- b. The correct answer type.  
The item stem is followed by several options one of which is absolutely correct while others are incorrect.
- c. The incomplete statement type.  
The item stem consists of part of a statement rather than a direct question and the student has to select the part of the statement from among the options which correctly concludes the statement.
- d. The negative type—used to handle questions which usually have several good answers. The options include several correct and one incorrect. The student selects the incorrect one.
- e. The external stimulus type.  
Stem stimulus material consists of a diagram and the questions centre around interpretation of this material.

The stem should:—

- a. pose a clearly defined problem
- b. contain necessary information
- c. be worded concisely.

The options should be:—

- a. reasonably parallel in structure
- b. able to fit logically and grammatically to the stem
- c. worded clearly
- d. not so inclusive as to logically eliminate another more restrictive option from being the unique one.

There should be no possible justification for considering one of the distractors as an acceptable response.

All options should be sufficiently plausible to attract examinees who are misinformed or inadequately prepared. They should not be irrelevant responses.

No distractor should unnecessarily call attention to the key.

The key must actually answer the question posed by the stem.

Taken as a whole, the item must test knowledge or skill worthwhile and appropriate for the test population. The item as well must be within the appropriate range of difficulty for the intended test population.

When an evaluation in the stem of an item asks for the "best" or "most" it must indeed require the examinee to identify the best or most of several options rather than to distinguish between the correct and the incorrect.

Items should be considered in the light of the premise that any given item usually turns out to be more difficult for the examinee than the examiner intended it to be.

With these general remarks in mind the March Novice examination stands condemned as a poor test in most respects.

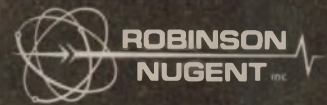

## IC Sockets

FOR ALL APPLICATIONS:

- Gold or tin plated
- Solder or wire-wrap
- Mil-spec or commercial
- D.I.L. or to-type
- E-Z entry or standard

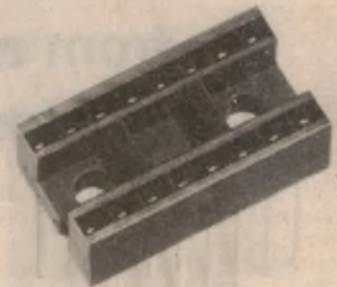

ICN-163-WB3

16 pin, commercial wire-wrap,  
gold plated standard entry

# EX-STOCK

Available from:

SYDNEY: Dick Smith, Radio Despatch, Pre-Pak  
ADELAIDE: Graphic Electronic Industries Pty Ltd  
PERTH: W. J. Moncrieff Pty Ltd  
BRISBANE: Fred Hoe & Sons Pty Ltd  
CANBERRA: The Electronic Shop  
NEWCASTLE: Digitronics Pty Ltd

or direct from:



99 ALEXANDER STREET  
CROWS NEST  
NEW SOUTH WALES

Telephone: 439 2488

# DON'T KEEP YOUR CUSTOMERS DANGLING



**Install a DORO electronic secretary  
and maintain instant communication  
from any telephone in the world  
for less than \$1 per day**

At your command Doro's Electronic Secretary gives and receives messages, reviews them, saves all or part, starts tape fresh. It takes dictation for an hour, permits review or change at will. It records and confirms new outgoing announcements at any time. **All by remote control.**

Available with remote dictation microphone and transcription foot control, and headset.

Doro is all quality. Built to last. See it to believe it.

Doro's Electronic Secretary meets the need of the busy executive and electronics technician.



APO PERMIT NO. C75-16-48

**SPECIAL this month only  
FREE DORO 701 portable standard cassette dictating  
machine with every purchase of a Doro Electronic Secretary.**

For more details and your nearest Doro dealer call:

MODERN DICTATING SYSTEMS PTY. LTD.

Telephone:	Brisbane	44 1591	Sydney	439 2712
	Melbourne	41 6068	Canberra	95 7721
	Perth	28 8888	Auckland, N.Z.	30299

Distribution enquiries welcome.

## FORUM: Novice exam— continued

an old text book. It reminds one of another classic old audio dogma that "direct coupling is best—if for no other reason that it is direct coupling!

But Jim Rowe's accusing finger was pointed less at the options than at the word "best". One might suppose that the examiner had in mind the word "widest" but, if so, that is what he should have said. One might then have reasoned that the "direct coupling" option should be circled, if only because it typically offers more sustained response below 20Hz.

But the word "best" does not simply mean "widest". It has broader connotations and could be paraphrased by "most appropriate".

In practice, designers of audio amplifiers do not necessarily strive for the widest frequency response. They usually impose a deliberate cut in low frequency response below about 25Hz to combat rumble, acoustic feedback and other non-musical effects.

So the "best" frequency response, meaning the "most appropriate" frequency response is not necessarily the widest. In practice, designers commonly use a mixture of direct and capacitive coupling in amplifier design: direct coupling to secure the widest frequency response inside the major feedback loop, and R.C. coupling elsewhere to secure the "best" or "most appropriate" overall response.

Where does that leave the examinee?

Once again, the novice would probably circle the direct coupling response because it seemed superficially appropriate. A discerning examinee would perhaps do the same thing, not because it was correct, but because he would reason that it was the response the examiner was expecting!

Here's another one which should delight the hearts of anyone who has ever had to think through the design of an audio amplifier. Here we can be fairly certain that the examiner is talking about an amplifier as an entity rather than a single stage, because of the phrases "single ended type" and "to construct":

30 A push pull audio amplifier has one of the following advantages over a single ended type.

- a. Cancels odd harmonics
- b. Cancels even harmonics
- c. Less power output
- d. Less expensive to construct

Just in passing, the question offers an example of a contradiction between the stem and one of the options. The stem is concerned with "advantages" but one of the options is "less power output", which would scarcely be seen as an advantage even by a non-technical person.

That point aside, if you want to get a mark for that one, simply circle (b). But I wonder how an examinee would have fared who circled (d)?

The trouble is that it is almost certainly as true as (b) and a good deal more relevant to the present design scene.

If you doubt that, consider the fact that audio amplifier designers set out to meet a certain set of parameters: power output, frequency response, linearity, reliability, etc. . . . and cost. Nowadays, from simple I.C. amplifiers to 100-watt (plus) monsters, they opt for push-pull output.

Why?

Because push-pull technology offers them the cheapest way to meet specifications.

The same objection applies to question 31 which offers the examinee option (b) "Improved fidelity" as the benefit of including negative feedback in an audio amplifier. But option (d) "Less expensive to construct" is also true. Imagine the cost penalty of having to achieve today's performance figures at any relative level without having resource to negative feedback!

In case we seem to be myopic about audio amplifiers, consider question 6:

6. The voltage across and the current through a resistor are known. What formula is used to determine the power dissipated?

- a.  $W = E/R$  c.  $W = E^2/R$
- b.  $W = I \cdot R$  d.  $W = R/E$

The simple fact is that none of the formula offered in the options "is used", having in mind the information available. Anyone in his right mind—novice or engineer—knowing the voltage across and current through a resistor, would use the direct formula:

$$W = E \times I$$

Surely, no one would follow the much more complicated path of working out the resistance and then use a second formula to calculate power dissipated.

Okay, so the examiner was being subtle in trying to discover the examinee's grasp of Ohm's Law; he deliberately withheld the obvious formula; he reasoned that someone needing to know the specifications of a resistor would need to work out its resistance anyway.

Perhaps that line could be argued but it would not be unreasonable to expect the examiner to be just a little more subtle in his choice of words in the stem. There could have been no argument had he said: "... Which of the following formulas could be used ...?"

That would make the stem technically logical but, unfortunately, the appropriate response contains a typographical error. It should read:

$$W = I \cdot R$$

It actually reads:

$$W = I \cdot R$$

On a completely different subject, question 24 says:

24. Which meter would be the cheapest and most suitable to measure a 50Hz alternating current at 15 amperes?

- a. Moving iron c. VTVM
- b. Moving coil d. Wattmeter

Here we strike another hassle about the meaning of words. We can assume that "cheapest" means what it says, but what does "and most suitable" signify? Most suitable in what respect?

I can recall handling, at various times, and even owning a few moving iron meters of a type which could conceivably have been used to measure alternating current. They would certainly have been the cheapest way to do it, but accuracy . . . that's another matter.

I also recall working in a factory where they would not think of using moving iron meters to measure alternating current, cheapness notwithstanding. All measurements were done with moving coil meters—not the conventional D'Arsonval type but meters in which the field is energised by the same current as the moving coil; in short dynamometer movements.

So what's the appropriate response to that one?

And if you fancy your knowledge of power supply design, consider this question:

48 It is required to filter the DC output of a 240VAC 50Hz power supply. What value filter capacitor would be the most suitable:

- a. 15uFd c. 50uFd
- b. 500uFd d. 1uFd

The first two options can be scrubbed without too much consideration but the "most suitable" of the remaining two would depend entirely on the nature of the circuit, which is not even hinted at. For a low/medium voltage, higher current circuit 50uF would be the natural choice but, for a low current, and particularly high voltage circuit, 1uF could easily be adequate and more practical.

One could go on, but I think the point has been made. In preparing a question (or stem) it is essential to provide adequate definition and to avoid ambiguity and even inaccuracy arising from second-level interpretation. If the intention is to provide one correct option only, then the others should be totally inadmissible. And, as Keith Howard has pointed out, all options should read on from the stem.

In going through the paper, I noticed such things as this:

27 It is required to increase the power output of a transmitter by 3dB. The power would then be increased by:

- a. 4 times c. 8 times
- b. 6 times d. doubled

The correct response is "doubled", but it happens to be the very one which doesn't read. A similar problem occurs with questions 10, 11, 20, 31, 32, 47.

But enough has been said. Let's just make the point that our objective has not been to "have a go" at the Department or its officers; rather has it been to emphasise that future Novice papers will have to be something more than a collection of old face-lifted AOCP questions! ☺

# 6 TV GAMES ON ONE IC

W.H.K. will distribute one of the most advanced TV Game, MOS Circuit, in Australia. This 24 Pin device has been designed to provide 6 different games using a standard television receiver. The MOS Circuit is intended to be battery powered and a minimum number of external components are required to complete the system.

**FEATURES:** 6 selectable games—Tennis, Football, Squash, Pelota or Rifle Shooting—two games; Automatic Scoring; Score display on TV Screen, 0-15; Selectable Bat Size; Selectable Angles; Selectable Ball Speed; Automatic or Manual Ball Service; Realism Sounds; Shooting Forwards in Football Game; Visually defined area for all Ball Games.



Fig. 1. Tennis Game

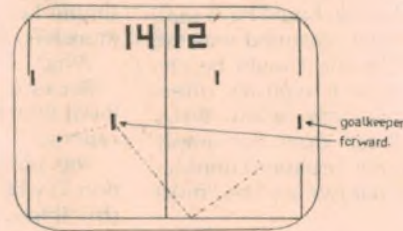

Fig. 2. Football Game

**OPERATING CHARACTERISTICS: TENNIS & FOOTBALL:** With the Tennis game the picture on the television screen would be similar to Fig. 1 with one 'bat' per side, a top and bottom boundary and a centre net, the individual scores are counted and displayed automatically in the position shown. The detail of the game will depend upon the selection of the options. Considering the situation where small bats are used and all angles, after reset has been applied, the scores will be 0, 0 and the ball will serve arbitrarily to one side at one of the angles. If the ball hits the top or bottom boundary it will assume the angle or reflection and continue in play. The player being served must control his bat to intersect the path of the ball. When a 'hit' is detected by the logic, the section of the bat which made the hit is used to determine the new angle of the ball. To expand on this, all 'bats' or 'players' are divided logically into four adjacent sections of equal length. When using the four angle option it is the quarter of the bat which actually hits which defines the new direction for the ball. The direction does not depend upon the previous angle of incidence. With the two angle option the top and bottom pairs of the bats are summed together and only the two shallower angles are used to programme the new direction of the ball. The ball will then traverse towards the other player, reflecting from the top as necessary until the other player makes their 'hit'. This action is repeated until one player misses the ball. The circuitry then detects a 'score' and automatically increments the correct score counter and updates the score display. The ball will then serve automatically from the centre line towards the side which had just missed. This sequence is repeated until a score of 15 is reached by one side, whereupon the game is stopped. The ball will still bounce around but no further 'hits' or 'scores' can be made. While the game is in progress, three audio tones are output by the circuit to indicate top and bottom reflections, bat hits and scores. The 'football' type is shown in Fig. 2, and with this game each participant has a 'goalkeeper' and a 'forward'. The layout is such that the 'goalkeeper' is in his normal position and the 'forward' is positioned in the opponent's half of playing area. When the game starts, the ball will appear travelling from one goal line towards the other side. If the opponent's forward can intercept the ball, he can 'shoot' it back towards the goal. If the ball is missed it will travel to the other half of the playing area and the first team's forward will have the opportunity of intercepting the ball and redirecting it forward at a new angle according to the 'player' section which is used. If the ball is 'saved' by the 'goalkeeper' or it reflects back from the end boundary, the same forward will have the opportunity to intercept the outcoming ball and divert it back towards the 'goals'. A 'score' is made in the 'football' game by 'shooting' the ball through the defined goal area. The scoring and game control is done automatically as for the tennis game. The same audio signals are used to add atmosphere to the game.

**SQUASH:** In this game (not illustrated) there are two players who alternately hit the ball into the court. The right hand player is the one that hits first, it is then the left hand player's turn. Each player is enabled alternately to insure that the proper sequence of play is followed.

**PELOTA:** This game is similar to squash except that there is only one player.

**RIFLE SHOOTING:** This game (not illustrated) has a large target which bounces randomly about the screen, a photocell in the rifle is aimed at the target. When the trigger is pulled the shot counter is incremented, if the rifle is on target the hit counter is incremented, a hit noise is generated and the target is blanked for a while. After 15 shots the score appears but the game can still continue.

**RIFLE GAME NO. 2:** In this game the ball traverses the screen from the right under control of the manual serve button. Otherwise the game is as above.

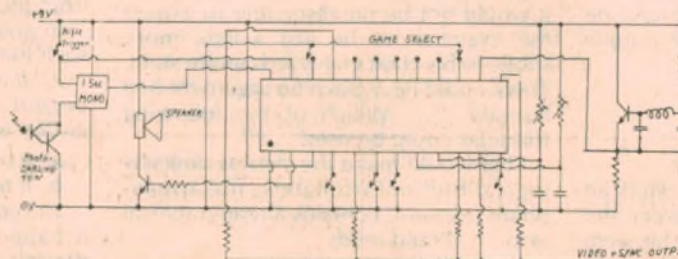

**PRICE & DELIVERY:** The manufacturer of this '6 in 1 TV Game IC' has received huge orders from Europe. The proposed delivery of our large order is scheduled for October '76. Due to the great demand for this outstanding IC we suggest to place your order now. Price each, \$28.00. Prepaid Orders received before August 15th, \$25.20 each. Discount: 1-4 nett, 5-9 less 5%, 10-24 less 10%, 25 onwards less 15%. Post, Pack & Insurance \$2.00 per order. With your Order Acknowledgement you receive full Circuit diagrams. We intend to manufacture a PC Board to suit at extra cost.

To Companies who wish to manufacture complete units on a commercial basis we offer this '6 in 1 TV Game IC' at a very special price. (Minimum quantity 500 off.)





# W.H.K. ELECTRONIC & SCIENTIFIC INSTRUMENTATION

MANUFACTURING, IMPORT, EXPORT, WHOLESALE & RETAIL

2 GUM ROAD, ST. ALBANS, 3021. VICTORIA. AUSTRALIA. PHONE: 396-3742 (STD area code 03)

POSTAL ADDRESS: P.O. BOX 147, ST. ALBANS, VICTORIA. AUSTRALIA. 3021.

## THE WORLD'S MOST ADVANCED SOLID-STATE MINIATURE WIRELESS MICROPHONE-TRANSMITTER



The Model WM.F1 is a new design offering excellent sensitivity and transmission. It is a self-contained unit operating on a 1.3 volt mercury battery. The microphone picks up the slightest sounds and transmits these sounds through your FM Radio. There is no wire connection between the microphone and the radio. Under ideal conditions you can hear anything that the microphone picks up through your FM Radio positioned up to 350 feet away, outdoors, and up to 100 feet indoors. The unit is tuneable to any blank spot on your FM Radio dial between 88 and 108 MHz.

SPARE BATTERY \$1.35 ea. **\$18.50 ea.**

### SPECIAL CLEARANCE SALE

Transformers 240 input, 12.6V, 1A output each \$2.90, 2.5 \$2.70 ea., 6 10 \$2.50 ea., 11 onwards \$2.30 ea.  
 5V, 1A Power Supply Kit, consisting of Transformer, Bridge Rectifier, Filter Capacitor, Voltage Regulator & Case \$9.60 ea.  
 400V, 6A TRIAC's, TO 48 with Nut & Washer, German made, each \$1.60, 2.5 \$1.50 ea., 6.24 \$1.40, 25 onwards \$1.30 ea.  
 309K Voltage Regulator 5V, 1A Metal Can each \$2.25, 10 onwards \$2.00 ea.  
 1N914 (1N4148) Signal Diodes per 10 \$0.60  
 2N3055 125 watt Power Transistor (Metal Can) each \$0.95, per 10 \$8.00. Post & Pack \$2.00 per order plus \$0.50 additional per Transformer.

## 72-PAGE TECHNICAL CATALOGUE

INCLUDING THE FOLLOWING:

- Anti-Reflective Filters for Displays
- Solar Batteries
- Fresnel Lenses
- Polarising Filters
- Diffraction Gratings
- Fibre Optics
- Digital Clock IC's with month and date alarm, etc.
- Construction plans from Windmill Generators to advanced Lasers
- Integrated Circuits: TTL, CMOS, ECL and Linear IC's
- Low cost LED Displays including red, green, yellow and orange
- Gauge Counters and Dosimeters
- Heat Pipes
- Magnano Resistors
- Hall Effect Devices for magnetic field measurements
- Solid-State linear temperature transducers for under \$8.00
- Liquid Crystal Displays
- Alpha-numeric Displays
- Printed Circuit Boards
- Drafting Templates
- 4-decade presettable up/down counter IC's ideal for batch counters
- Crystal Time Bases for Frequency Meters and Clocks
- 7-decade counter-latch decoder driver CMOS IC will count up to 9,999,999 ideal for frequency meters and time interval counters
- 8-digit stopwatch IC needs only crystal display and switches, can also be used as 24-hour crystal controlled clock
- 8-digit crystal controlled Stopwatch Kits
- Digital Voltmeter Kits
- Solderless Breadboard Kits, 20 different models
- Computer Kits: Printers, Terminals, Mass Storage up to 50 Mega Bits, Memories, Microprocessor IC's, TV Typewriters, 512 BIT electrically alterable ROM write, erase & read voltages are switched internally
- Technical Books from Lasers to Computers

WHK No. 7 catalogue \$2.00 plus \$0.50 p.p. with the catalogue you receive two \$1.00 vouchers which can be used towards the purchase of goods. Catalogue free to INDUSTRY & EDUCATION DEPARTMENTS

Please forward WHK No. 7 Catalogue  
Please Print

Name \_\_\_\_\_  
 Street \_\_\_\_\_  
 Town \_\_\_\_\_ Postcode \_\_\_\_\_  
 SR4148R \_\_\_\_\_ WHK

# MODEL SR4148R PORTABLE

A 48 KEY, 14-DIGIT RECHARGEABLE SCIENTIFIC NOTATION ELECTRONIC CALCULATOR



**\$52.50**

Sales Tax exempt

14 Digit Display

Dimensions  
1 1/4" H x 3" W x 5 3/4" L

-123456.7891 -99

The display capacity of this machine is able to show values ranging from  $1.0 \times 10^{-99}$  up to  $9.999999999 \times 10^{99}$ . This represents a precision capability which exceeds those known to most of the physical constants in the universe. There simply is no limit to the value of the angles you can enter for trigonometric functions.

**EE** The exponent key lets you make an entry in the exponent field of display.

### Logic

The logic of the SR4148R has been designed for practical, easy entry. The system is algebraic so that computations are indexed into the machine just as you would write them onto paper.

### Outstanding and Exclusive Features

For students, numerous fundamental math principles have been programmed into the logic of the machine. Among these tenets are:

- Any number raised to the zero power equals one
- Zero raised to any power equals zero
- All results are precise for immediate comprehension.

**EE↑** For professionals, such exclusives as the exponent integer increase and decrease keys **EE↑**, **EE↓** greatly facilitate complex calculations. Engineers, for example, commonly work with familiar values as  $10^{-6}$  for microseconds. If, after a computation an exponent reads:  $10^{-4}$  and the operator wishes to express this in microseconds, merely pressing the **EE↓** key permits him to step down the exponent accordingly.

### Performance Categories

Memories Two independent storage registers:

**STO 1 RCL 1**

**STO 2 RCL 2**

**Σ1** Sigma or automatic memory summation key

### Special Keys

**d/r** Degree/Radian Mode Key

**( )** Parenthesis Keys

**→P** Converts Rectangular Coordinates to Polar

**→R** Converts Polar Coordinates to Rectangular

Power Supply: Lifetime Ni-Cad Batteries & Adaptor/Recharger included.

### Log Keys

- e<sup>x</sup>** Calculates natural antilogarithm of x
- log** Calculates common logarithm of x
- Ln** Calculates natural logarithm of x
- 10<sup>x</sup>** Calculates common antilogarithm of x

### Statistical Keys

- x<sup>n</sup>** The distribution key is pressed after each numeric entry in a mean/standard deviation example
- x→σ** To find the average distribution **x̄** press the statistical key. Finally, to see the standard deviation **σ** press the exchange register key

### Trigonometric Keys

- arc** used when determining inverse trig calculations
- sin** Calculates the sine of x
- cos** Calculates the cosine of x
- tan** Calculates the tangent of x
- Power Keys**
- y<sup>x</sup>** Raises the base y to the x power
- x<sup>2</sup>** Squares x
- √x** Obtains the square root of x
- √y** Determines the x root of y
- π** Pi is an automatic constant which is recalled when this key is pressed

### Standard Keys

- x→y** Exchange register key
- +/-** Sign change key
- 1/x** Inverse or reciprocal key
- CE/C** Clear Entry and Clear all

**X - + - \* =** And last but not least the standard four function and arithmetic keys

W H K. ELECTRONIC & SCIENTIFIC INSTRUMENTATION  
 2 GUM ROAD, ST. ALBANS VICTORIA 3021—PHONE (03) 396 3742  
 POSTAL ADDRESS: P.O. BOX 147, ST. ALBANS, VICTORIA, 3021

SALES TAX (EXEMPTIONS AND CLASSIFICATIONS) ACT  
 TO:—THE COMMISSIONER OF TAXATION AND  
 THE COMMONWEALTH OF AUSTRALIA

Please send by return, ..... (quantity)

Model Electronic Calculators.

I have enclosed cheque/money order for \$ ..... including \$2.50 each for packaging and delivery.

Name ..... (Block Letters)

Address .....

(Postcode)

I hereby certify that the purchased by me from on ..... (date) is for use in ..... (Name of University or School) in or directly and essentially in connection with the production of facts, by means of observing, measuring, testing or otherwise experimenting with material phenomena, for the purpose of proving or illustrating natural principles or laws or in the study of pure or mixed mathematics. Exemption is accordingly claimed under item 63 (1) in the First Schedule to the Sales Tax (Exemptions and Classifications) Act.

Signature of official of University or School

Name of University or School

Date ..... Signature of Student

Address of Student .....

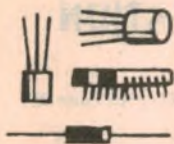

# What's new in Solid State

## Other uses for a LED flasher IC

I suppose most of us in the electronics game love to play around with an intriguing new integrated circuit—particularly if it's low in cost. This interest in new devices isn't just restricted to the hobbyist—engineers, technicians and college lecturers tend to be just as keen as anybody else. As soon as an IC maker comes out with a new device, a vast horde of individuals attack it with gusto.

There's no doubt that this interest and activity can result in the discovery of valuable information about the ICs concerned. Facts about what the IC will do, what it won't do, and often how to use it for all sorts of applications that the original designer probably didn't even dream of. A classic example of this occurred with the now almost ubiquitous "555" timer IC—whose applications are still being expanded, although by now they would surely fill a large book.

Well, it looks as if the same thing is happening to another recently released device: the LM3909, a low-cost 8 pin DIL chip announced in the middle of last year. It was originally designed for low power lamp flasher applications, using either LEDs or incandescents, and staff writer David Edwards discussed these applications in an article we published in the July, 1975 issue.

Apparently ever since the LM3909 was released, people have been discovering that it can be used for all sorts of uses other than lamp flashing. So many "way out" applications have been found that Peter Lefferts of the National Semicon-

ductor applications lab has brought out a new applications brochure, to describe them in detail. Some of them are so interesting that I have obtained permission to reprint them here this month and next, from the local NS people. So it's over to Peter Lefferts:

Experiments with simple audio oscillators led to development of the circuit in Fig 1. It is optimized to oscillate at any acoustic load frequency of resonance! With just a speaker, oscillation occurs at the speaker cone "free-air" resonance. If the speaker is in an enclosure with a higher resonant frequency . . . this becomes the frequency at which the circuit oscillates.

An educational audio demonstration device, or simply an enjoyable toy, has been fabricated as follows. A roughly cubical box of about 64 cubic inches was made with one end able to slide in and out like a piston. The box was stiffened with thin layers of pressed wood, etc. Minimum volume with the piston in was about 10 cubic inches. Speaker, circuit, battery and all were mounted on the sliding end with the speaker facing out through a 2 1/4 in. hole. A tube was provided (2 1/2 in long, 3/8 in ID) to bleed air in and out as the piston was moved while not affecting resonant frequency.

"Slide tones" can be generated, or a tune can be played by properly positioning the piston part and working the push button. Position and direction of the piston are rather intuitive, so it is not difficult to play a reasonable semblance of a tune

after a few tries.

The 12 ohm resistor in series with pin 2 (output transistor Q<sub>1</sub>'s collector) and the speaker, decouples voltages generated by the resonating speaker system from the low impedance switching action of Q<sub>1</sub>. The 100 uF feedback capacitor would normally set a low or even sub-audio oscillation frequency. Therefore, the major positive feedback voltage to pin 8 is the resonant motion generated voltage from the speaker voice coil. Therefore the LM3909 will continue to drive the speaker at the resonance with the highest combined amplitude and frequency.

It can be seen already that the LM3909, having direct speaker drive and resonance following capability, can do things that are a lot less practical with older timer and unijunction circuitry. Two further "sound effect" type of circuits are now given.

The siren of Fig 2 produces a rapidly rising wail upon pressing the button, and a slower "coasting down" upon release. If it is desirable to have the tone stop sometime after the button is released, an 18k resistor may be placed between pins 8 and 6 of the IC. The sound is then much like that of a motor driven siren.

In this circuit, the oscillation must not be influenced by acoustic resonances. The 1uF capacitor and 200ohm resistor determine a pulse to the speaker that is wider than that for flashing LEDs, but much narrower than is used in the tuned system of Fig 1. The repetition rate of speaker pulses is determined by the 2.7k resistor, and the charge on the 500uF capacitor. Discharging this capacitor with the pushbutton increases current in the 2.7k resistor causing a rapid upshift in tone.

The "whooper" of Fig. 3 sounds somewhat like the electronic sirens used on city police cars, ambulances, and airport "crash wagons". The rapid modulation makes the tone seem louder for the same amount of power input.

The tone generator is the same as in the previous siren. Instead of a push-button, a rapidly rising and falling modulating voltage is generated by a second

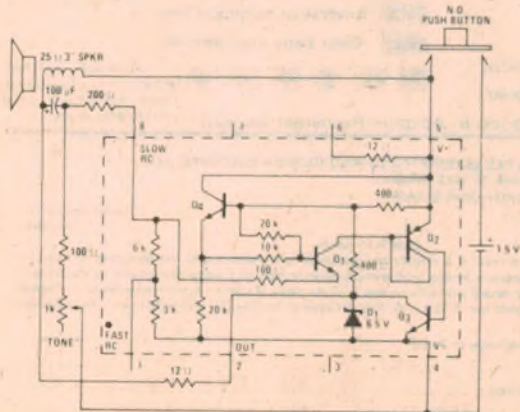

Fig. 1: An electronic "trombone" game.

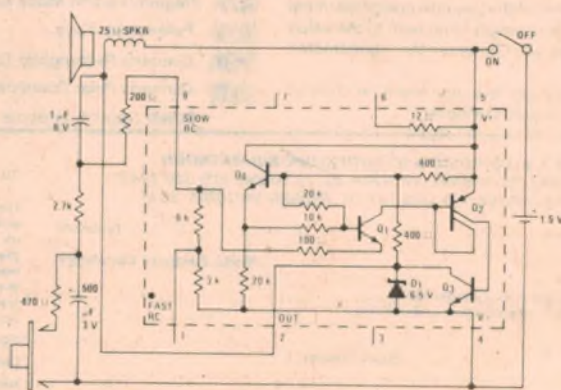

Fig. 2: A "fire siren" oscillator circuit.

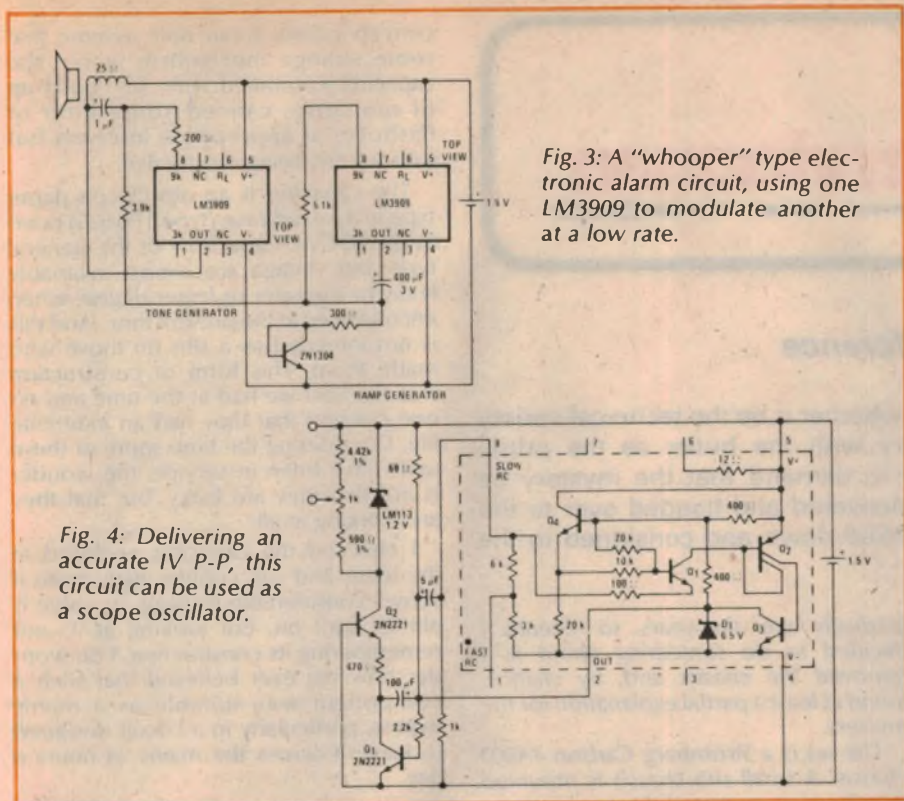

Fig. 3: A "whooper" type electronic alarm circuit, using one LM3909 to modulate another at a low rate.

Fig. 4: Delivering an accurate IV P-P, this circuit can be used as a scope oscillator.

LM3909 and its associated 400µF capacitor. The 2N1304 transistor is used as a low voltage (germanium) diode. This transistor along with the large feedback resistor (5.1k to pin 8) forces the ramp generator LM3909 into an unusual mode of operation having longer "on" periods than "off" periods. This raises the average tone of the tone generator and makes the modulations seem more even.

A useful electronic lab device is a precision square wave generator/calibrator. If the output is held within a few tenths percent of 1 V peak-to-peak, it is useful in calibrating oscilloscopes and adjusting 'scope probes. Many lower cost or battery-portable oscilloscopes do not have this feature built in. Also it is useful in checking gain and transient response of various amplifiers including "hi-fi" power amplifiers.

Battery powered equipment is free from both the inconvenience of a line cord, and from some of the noise and hum effects of equipment attached to the power line.

Operation for over five hundred hours from a single flashlight "D" cell is the bonus provided by the circuit of Fig 4. The lowest reference voltage regulator available, the LM113, is used in conjunction with a current source, and the voltage boost characteristic of the LM3909.

Output is a clean rectangular wave which can be adjusted to exactly a 1V amplitude. A rectangular wave of approximately 1.5ms "on" and 5.5ms "off" was chosen for circuit simplicity and low battery drain. Waveform clipping is virtually flat due to complete turn-off of the current switch Q<sub>2</sub> and the typical "on"

impedance of 0.2 ohms provided by the LM113. The 0.01% temperature coefficient of the LM113 at room temperature allows negligible drift of the waveform amplitude under laboratory conditions. Loading by a 'scope probe will also be insignificant.

The circuit will work properly down to battery voltages of 1.2V. This is because the 100µF electrolytic capacitor drives the emitter of Q<sub>2</sub> below the supply minus terminal. At a battery voltage of 1.2V, the collector of Q<sub>2</sub> can still swing more than 1.6V. Q<sub>1</sub> uses the "off" periods of the LM3909 to insure that the 100µF capacitor is charged to almost the entire battery voltage. Thus when the LM3909 turns on and pin 2 drives almost to the minus supply voltage, the negative side of the capacitor is driven 0.9 to 1.2V below this terminal. Low battery voltage cannot lead to an undetected error in the 1V squarewave. This is because the waveform becomes distorted rather than just decreasing in amplitude as battery voltage becomes too low.

Taking advantage of the versatility and the indestructibility of the LM3909 by a 1.5V battery, the IC can become an ideal teaching means, or experimental device for the young electronic hobbyist. As well as the circuits already presented, the LM3909 can be made to work in amplifier, radio, and even logic type circuits. (Examples of these will be given next month—J.R.)

For further data on devices mentioned above, write on company letterhead to the firms or agents quoted. But devices should be obtained or ordered through your usual parts stockist.

# Know Where You are Going

Choose a career in the field of Electronics — the Nation's most progressive and fastest expanding industry.

Advancement in this modern science demands technical ability, a sound knowledge of basic principles and applications. You can master the subject by training at the Marconi School, and be ready to grasp the opportunities that occur in the various branches of Radio Technology.

## BROADCASTING

A thorough grounding is available to students in the broadcasting field, leading up to the P.M.G. Broadcast Station Examination.

## COMMUNICATIONS (Marine)

An extension to the Broadcast Operators course and extending into the fields of Navigation Aids and Electronic Devices used in mobile communications as required by the P.M.G. Certificates of Proficiency.

## APPLIED SERVICING

Comprehensive training in the maintenance and repair of radio and television receivers offers substantial rewards to competent technicians. Marconi School training covers all aspects of radio and television receiver circuit applications, practical exercises in fault finding and alignment procedures.

The Marconi School Radio Servicing correspondence course is approved by the N.S.W. Apprenticeship Commission

Classes are conducted at:  
67 Lords Road, Leichhardt.

Day: 9 a.m. to 4 p.m.

Evenings: 6 p.m. to 8.30 p.m. or by Home-Study Courses (except practical instruction on equipment).

SEND FOR PROSPECTUS  
There is no obligation

NAME .....

ADDRESS .....

MARCONI SCHOOL OF WIRELESS  
Box 218, P.O., Leichhardt 2040  
A service of  
Amalgamated Wireless (Australia) Ltd.



## The Serviceman

### Mystery stories—with a difference

Most of us like a good mystery story, whether it be the technical variety or the more common detective story with the butler as the prime suspect. But in either case we tend to demand that the mystery be solved in the end; the guilty party uncovered and handed over to the law, or the offending component tracked down and consigned to the rubbish bin.

Unfortunately, I have two mystery stories this month for which I can offer no solution. From the clues so far available there is just no logical explanation which I, or others, can offer. Time may solve one of them; the other is likely to remain a permanent mystery.

While some may find the lack of a nice, neat solution annoying or frustrating, I have related the stories for a particular reason. It is to emphasise the scope for frustration, misunderstanding, and recrimination which either of these situations contain, had they involved a non-technical customer and a professional serviceman.

The first story is in the form of a letter, with the suspect component, from a regular reader of the magazine, and these notes, for the past 30 years. He writes.

Dear Sir,

You may be interested in an unusual incident concerning my TV set. About two years ago, while viewing one evening, there was a frightening bang inside the cabinet but strangely, the set continued to function without faltering. Nevertheless, it was hurriedly switched off.

I removed the chassis, expecting to find an electro with its "inside outside", but a careful inspection failed to reveal anything amiss. Nor could I detect any burning smells. So the chassis was re-installed in the cabinet and, after a few weeks, the incident was almost forgotten.

The set operated faultlessly for several months after this, but then another loud bang occurred from vicinity of the set, this time while it was switched off. Another examination of the chassis failed to reveal anything wrong.

Over the next 18 months about three or four similar incidents occurred, all while the set was switched off. By now I was almost convinced that the noise was not connected with the set, but was in the wall or under the floor.

The audio had been deteriorating

gradually over the years, so recently I decided to do something about it. I removed the chassis and, by chance, found at least a partial explanation for the mystery.

The set is a Stromberg Carlson 4A002 chassis. A small sub-chassis is mounted on a bracket on top of the power transformer, and this carries a fuse panel which also serves as primary voltage tap selector, by moving the fuse to different positions. The mains flex goes through this sub-chassis via a grommited hole. A terminal strip is mounted under the sub-chassis to terminate the mains lead. Two .01uF 600V bypass capacitors are also mounted on this strip, each connected between one of the mains leads and chassis.

It is difficult to see behind the sub-chassis, but on this occasion I happened to glance at it from the right angle when the light was right and saw one of the capacitors with its end popped off.

The circuit shows that one of these capacitors—the one connected to the active line—is connected across the 240V supply all the time the power supply is switched on, since they are connected to the termination of the mains lead. The switch on the volume control uses one pole as a "spot swallower" and the other to control the mains power to the transformer but, in any case, is fitted after the mains bypass capacitors. As the set was normally used, the power point was left switched on at all times and the set controlled with its own switch.

The exploded capacitor could be a logical explanation for the initial bang, but how does it explain the subsequent ones? Strangely enough, when I clipped the faulty capacitor out and checked it, it proved to be intact electrically, though leaky. I am enclosing the capacitor with this letter.

Yours etc  
P.D. (Wombat. NSW.)

Well, that's mystery number one. I am as much at a loss to explain it as is the

correspondent. I can only assume that some strange mechanism within the capacitor combined with, say, build up of moisture, caused some kind of flashover at appropriate intervals but without this being destructive.

The capacitor is an old Ducon paper type in a waxed case (type TP8 625) rated at 600VDCW. Capacitors of this general type and vintage are almost invariably leaky to a greater or lesser degree when encountered at the present time. And this is not intended as a slur on those who made them. This form of construction was the best we had at the time and no one claimed that they had an indefinite life. Considering the time some of these units have been in service, the wonder is not that they are leaky, but that they are working at all!

I checked the capacitor enclosed in the letter and can confirm that, while it shows considerable leakage, its value is almost spot on. But looking at it, and remembering its construction, I do wonder how we ever believed that such a component was suitable as a mains bypass, particularly in a circuit designed to leave it across the mains 24 hours a day.



The mystery capacitor, as submitted by the reader. It still shows normal capacitance, but high leakage.

The second story is also about a TV set and an explosion apparently involving the power mains, but there the similarity ends. Whereas the first story concerned a monochrome TV set of early vintage, this concerns a modern colour TV set. Also, the effect of the fault was far more disturbing than in the first case.

The story comes from a colleague who has been in the electronics game all his life (he's nearly as old as I am!) and is no newcomer to solving electronic mysteries. Yet he could offer no certain explanation for the events I am about to relate.

It happened one evening when his family had settled down for a session in front of the TV set. Not being particularly attracted to the selected program he decided to retire to the workshop and try to catch up on some long overdue odd jobs.

The workshop is supplied with light and power on separate circuits but, the workbench is wired with additional

power points and lights and, as a unit, is plugged into a power point. Thus the light in the vicinity of the bench operates from the power circuit rather than the light circuit. The bench lighting consists of a fluorescent light for general illumination, plus a couple of incandescent lamps on gooseneck fittings.

My friend was standing a little remote from the bench when it happened. There was a loud explosion which, as nearly as he could determine, came from the vicinity of the bench and, at the same time, a marked dimming of the lights. Unfortunately, he was not sure whether both lighting circuits were involved, or only those on the power circuit, but these latter certainly were.

At the same time there came an anguished cry from the lounge room, "Dad, the TV set's gone off."

"Well switch it off; I'll be up in a moment."

His impression was that the power factor capacitor in the fluorescent light had failed but was puzzled by the fact that there was no characteristic smell. Later examination revealed a black box which certainly contained the ballast inductor and may also have contained the capacitor, but there was no capacitor to be seen as a discrete component. More importantly, there were no distress signs of any kind; no smell, no melted insulation, no blackened fittings; everything seemed quite normal.

Putting first things first (naturally) he switched off the bench, went into the lounge room and inquired of his wife and daughter whether they had heard any explosion—he still wasn't sure exactly where the sound had originated. They assured him that they hadn't. (As he confided to me, it was really a pointless question, since neither was having hysterics, which they certainly would have been had there been an explosion in the lounge room loud enough to be heard in the workshop.)

An important part of the story is the fact that his daughter had set up an electric sewing machine and she was only really conscious of the TV picture and the local light on the sewing.

The TV set is a hybrid type, using valves in the horizontal and vertical deflection systems. It is also fitted with a circuit breaker, with a reset push button protruding from the back of the cabinet. He pushed the button in as a matter of course, but there was no way of telling whether the breaker had, in fact, tripped. Then he switched the set back on. The result was an immediate dimming of the sewing machine light, while the machine itself ground to a halt. He switched off hurriedly.

This was puzzling, to put it mildly. For one thing, it would have to be quite serious fault in the TV set to draw so much current as to dim the light and stop the machine. But, allowing that such a fault existed, why did it not trip or blow

# BRIGHT STAR CRYSTALS PTY LTD

35 EILEEN ROAD, CLAYTON, VICTORIA. 546 5076

## NOTICE

RE:— E.A. SEPT '75

QUARTZ DRIVE CRYSTAL CLOCK CONSTRUCTORS  
NEW C-MOS DIVIDER BOARD USING  
EXISTING CRYSTAL AVAILABLE

With more than 36 years experience BRIGHT STAR can supply ALL your Crystal needs.

### ALSO AVAILABLE

Crystal Clock  
and Decade Counter

Wideband Amplifier

- \* Wideband Amplifiers
- \* Crystal Oscillators.
- \* Crystal Clock and Decade Counters. C-MOS.TTL
- \* Send S A E. for new catalogue



COMMUNICATION SYSTEMS  
PERTH. PHONE 76-2566

ROGERS ELECTRONICS  
ADELAIDE. PHONE 64-3296, 42-6666

FRED HOE & SONS PTY. LTD  
BRISBANE. PHONE 47-4311

DILMOND INSTRUMENTS  
HOBART. PHONE 47-9077



## ARE YOU A MONO T.V. TECHNICIAN? DO YOU REQUIRE TRAINING FOR COLOUR?



Enrol in The Combined School of Advanced Electronics and be trained to the standard required by the N.S.W. Divisions of The Television and Electronic Technicians' Institute of Australia and Television and Electronic Services Associations of Australasia. This standard is accepted by the television service industry.

### TWO CONVERSION COURSES AVAILABLE

#### Course A

Requires attendance at a well-equipped school located at Riverwood, Sydney, one night per week for approximately six months. This course is recommended for Sydney metropolitan students.

Course Fee is \$200.00

#### Course B for Country and Interstate Students.

Students will be sent the theory lessons by post. Answers will be required and marked, as for a correspondence course. As colour T.V. cannot be taught by correspondence alone you will be required to attend the school in Riverwood, Sydney, for six full days. These six days will be split into two periods of three days and, to cause as little disruption to business as possible, will be held on Saturdays, Sundays and Mondays.

Course Fee is \$225.00

#### OTHER COURSES

In addition to Courses A and B, a Semi-Conductor Course and a Course on Colour T.V. Servicing Techniques using Instruments, are conducted. The School is approved by the Commonwealth Department of Employment and Industrial Relations. If you are eligible, your fees may be paid for you under the N.E.A.T. Scheme. The School has a wide range of colour T.V. receivers and instruments for practical training. Course B is similar to the popular course which has been operating for N.S.W. country students over the past two and a half years. Fees normally payable in advance may be paid by easy instalments, if required. Send for Enrolment Details and Syllabus to:

#### The Combined School of Advanced Electronics

(Conducted for the N.S.W. Divisions of T.E.T.I.A. & T.E.S.A.)

P.O. BOX 92, BELMORE, N.S.W. 2192 PHONE: (02) 759 1978



# Scope Cordless 60w Soldering Tool



60 watts of heat available right at the tip.

Replaceable heating element.

De luxe low thermal conductivity stainless steel barrel keeps tip hotter — body of iron cooler.

Tough impact resistant body.

Pistol grip handle gives natural ease of control.

Twin 1.2 volt Nickel Cadmium 4 amp/hr batteries give a full day's work before needing recharging.

## HEATS IN 6 SECONDS, COOLS RAPIDLY WHEN TRIGGER RELEASED

### SOLDERS 100-200\* TYPICAL JOINTS BEFORE RECHARGING

\*Light electrical connections. Capacity will vary for lighter or heavier joints.

**PISTOL GRIP DESIGN** balances weight of cells for comfort and tip control.

**FULLY RECHARGEABLE OVERNIGHT**, from car, power-point or Scope Transformer.

### ABSOLUTE SAFETY

No earth leakage currents. Solder anywhere with total personal and component protection.

**Kevin Ball, T.V. Technician.**

"In my job I work mainly on circuit boards and I'm rapt with Scope Cordless. I've never reached a point where the gun can't handle a day's soldering. I like the feel of it; tremendous balance."

**Basil Rogers & Co. Pty. Ltd., Radio & T.V. Repairs.**

"I'm delighted with its performance and sheer convenience in the workshop or in the field. It's light, fits easily in your hand and you can solder even with the set on."

# SCOPE

Distributors to the Electrical Trade:

**NATRONICS PTY. LTD.** The Crescent, Kingsgrove, N.S.W. 2208

Manufactured by: **SCOPE LABORATORIES, MELBOURNE.**

one of the several protective devices in the system as a whole.

In the TV set, directly in the mains lead to the transformer primary, is a 2A fuse and a cutout. On the secondary side, and scattered throughout the circuit, are light duty fuses and fusible resistors intended to protect individual sections of the set. On the other hand a fault in, say, the power plug or cable would have to contend with both a fuse and circuit breaker in the house wiring system.

But this aspect aside, it looked like a job for the serviceman, the set being still under warranty. Perhaps when he found the fault, the reason for the strange behaviour would be apparent. But more complications were on the way. My colleague is too long in the tooth to commit himself to a service call unless he can be sure of being able to demonstrate the fault to the serviceman. So, after the set had been lying idle for about 15 minutes, while he checked out the workshop, he pushed in the cutout button again and switched it on. And on came the sound, the valve heaters and, ultimately, the picture.

Determined to follow up the mystery, he left it running while he returned to the workshop to finish the job he had started. All went well for about half an hour, then the workshop lights dimmed and again came a call from the lounge room. All that was missing was the explosion.

By the time he reached the lounge room someone had switched the set off. Pushing in the cutout button he switched it on again. And down went the sewing machine light again. It was an exact repeat of the previous incident even to the point where, some time later, he was able to switch the set on again with no signs of distress and the set functioning normally.

That was several weeks ago and the set has not missed a beat since. As my colleague put it, "I could call the serviceman, but what would I have to show him? I can't even be sure that it is the set at fault—it could be in the house wiring."

In fact, we discussed the whole sequence of events at some length when he related the story, in an effort to make some sense of the symptoms. It wasn't a very profitable discussion. The only firm conclusion we reached was that the dimming lights could be caused by either one of two basic faults; excessive current drain, or a high resistance connection somewhere in the house wiring.

Inasmuch as there was none of the usual symptoms associated with a short circuit—smoke, smell, soot, etc.—plus the fact that neither the house fuses or circuit breaker was affected, we were both inclined to favour the high resistance connection. Beyond that, I'm afraid, the theories become more and more obscure.

Even assuming, for example, that the failure of the TV set was effect rather than cause; that the real fault was a high resistance joint which had developed in the

house wiring and that the TV set blacked out as result of the reduced voltage. Where does the explosion fit into the picture? Why, on both occasions, was it not possible to switch the TV set on immediately, but possible after about 15 minutes?

So the mystery remains. The one "consolation" is that, if it is a house wiring fault, it will probably show up again, particularly with the advent of winter and heavy current demands for radiators, etc.

As I said at the beginning, imagine the scope for frustration, misunderstanding, and recrimination which such situations contain, had a professional serviceman been called in to deal with them.

#### POSTSCRIPT

Since writing the above, a possible explanation for the last story seems to have emerged. While I could have rewritten the story, I thought it more convincing to leave it in the form I had written it—warts and all.



*One of the damaged contacts. This was assembled on a spare holder to enable the photograph to be taken.*

Light was shed on the mystery when my colleague had occasion to go near his fuse box and suddenly felt impelled to do what he had been promising himself he would do ever since the incident occurred—check all the fuses to see whether there was any evidence which would throw some light on the mystery.

In this installation the main domestic fuses—light and power—are housed in a two circuit, porcelain fitting which is a combined fuse holder and switch. A black plastic knob on the front is pulled to switch the power off, this causing the fuse holder proper to jump out about half an inch, breaking the circuit while still being held mechanically. The knob is then unscrewed to remove the fuse holder completely. It is a type which, I understand, is no longer being fitted.

The contacts in the fuse holder are made from light gauge spring brass, folded double to make a contact which is, in effect, about  $\frac{1}{8}$ in thick. These mate with a slit of similar width in solid brass blocks in the body of the holder, at which the cables are terminated.

In this case the two contacts on the power side were in a shocking condition,

one being so badly eroded that the rolled end which mates with the brass block was completely missing, leaving two jagged ends of light gauge brass to—hopefully—make some kind of contact with the brass block. There was no need to look any further for a faulty contact and a source of voltage drop.

Suddenly he recalled another event which might explain the reason for the damaged contacts. A few months previously he had engaged a builder to extend his garage and workshop, a job which entailed excavating a considerable amount of clay and shale.

The builder and his team turned up with an assortment of power tools, some quite heavy duty types, including an electric jackhammer. The builder mentioned that he would fit a heavier than normal fuse in the power circuit to minimise inconvenience to the household in the event that too many of these appliances were operated at the one time.

When the additions were finally completed, many weeks later, the builder removed his bodge fuse wire and replaced it with a more normal grade. And my colleague thought no more about it.

But he was thinking about it now. Could it be that the total current which the fuse holder had been called upon to handle was such that the contacts had heated? If so, then this could well have been the start of a cumulative fault. When contacts get hot they usually lose the springiness on which they depend to make good contact, and when they don't make good contact, they get hot. And when they get hot...

And was the mysterious explosion in the workshop the last straw; the surge that melted the last vestige of brass that was making reasonable contact? If so, it could explain why the circuit would no longer carry the load being imposed upon it, particularly the TV set. In fact, it now appears virtually certain that there was no fault in the TV set—all it did was pull enough additional current to show up the fault.

I am aware that the above explanation leaves a number of questions still unanswered. Why, for example, would the circuit not tolerate the TV set immediately after the drop in voltage but, on two occasions, accepted it after a break of some 15 to 20 minutes?

Also, why did no other household appliance, the washing machine, refrigerator, etc., or combinations of them, have a similar effect in the weeks that followed?

As before, one can only guess. But it does seem likely that temperature effects within the fuse holder may have accounted for the first observation. It is also possible that a subsequent surge may have created a tiny weld between the brass finger and the mating block, sufficient to keep the system running for the remaining weeks.

Unlikely? Well, if you've a better explanation...

# Logic design: practice

There are a number of practical considerations which can make it either unattractive or insufficient to produce a logic circuit by simply translating its minimalised logic function into hardware. In this chapter we take a look at the practical considerations, including those which arise from recent developments in IC technology.

by JAMIESON ROWE

As we noted in the previous chapter, designing a practical logic circuit is generally not just a matter of minimalising the logic function to be performed, and simply translating it into hardware. Usually, there are other considerations, of a more practical nature. At times these can make it either necessary or desirable to change the logic configuration from the minimal form, into a form which may seem superficially to be less elegant.

One of these practical considerations is that whereas logic theory treats each circuit element as a separate entity, practical logic elements usually come in packages containing multiple elements. Typical packages contain four 2-input gates (a "quad gate" package), or three 3-input gates, or six inverters (a "hex inverter" package).

Because of this, a logic configuration which is minimal from the theoretical point of view may turn out to be wasteful in practice. It may call for only a small number of elements, but these may have to be provided by quite a few different IC packages, each of which may end up with unused elements. It may therefore be better from a practical point of view to change the logic configuration, even adding elements if necessary, in order to use IC packages more efficiently.

Fig. 1 should help to make this clear. Both (a) and (b) show ways of implementing a logic circuit to produce the function

$$Z = A \cdot \bar{B} \cdot (C + D) + \bar{E}$$

The configuration in (a) uses only six logic elements in all, and is probably the minimal form. However it involves the use of three different IC packages, each of which is only partly used. Unless the unused elements could be used elsewhere in a logic system, this way of implementing the function would therefore be quite wasteful.

If the configuration is changed to that in (b), it becomes less minimal from the theoretical point of view. We are now using eight elements to produce the required function, instead of six. But by

implementing it in this way, we require only two IC packages, instead of three, and there are only two unused elements. This could well be a worthwhile saving.

This is not to say that the goal in logic circuit design is to always end up with the absolute minimum number of IC pack-

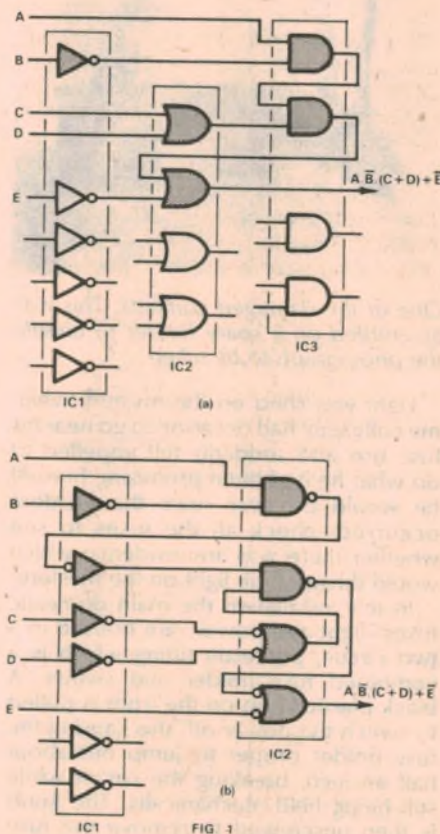

ages, or lowest "can count", regardless of anything else. There is more to it than that, as we shall see.

In passing, note that whereas the configuration in Fig. 1 (a) uses positive logic convention throughout, the configuration (b) takes advantage of the ability to change logic convention as desired. This allows two of the elements in IC2 to be used as AND gates, while the other two

are used as OR gates. Juggling logic conventions can be a very powerful tool in practical logic circuit design.

Another important consideration is component availability. Within a given family of logic ICs, there can be quite wide variations in device availability. Some device types may be readily available, while others may be in short supply. Some may be made by a number of different firms, or "multiple sourced", so that they may have a more assured availability than others which may be made by only one or two firms.

If a minimalised logic function would require the use of devices whose availability cannot be sufficiently assured, it would generally be desirable to change it to a configuration using more readily available devices. In other words, it may again be desirable to sacrifice some degree of logic elegance, in order to produce a circuit which uses readily available parts.

A closely related consideration is component inventory. As with most other parts, the price of logic element ICs tends to be inversely proportional to quantity. The more you buy, the lower the unit price. And while this can occur with "mixed orders"—i.e., orders involving a number of different parts—it tends to occur to an even greater extent with orders involving a single device type. This is not surprising, because the manufacturer's costs are lower when there is a large and uninterrupted production, testing and packaging run.

It can therefore be significantly cheaper to buy larger quantities of a relatively small number of different device types, than to buy smaller quantities of a larger number of different device types. And having bought the devices, the cost of controlling and maintaining the parts inventory may also be lower.

As a result, if the minimalised logic function would call for a relatively large number of different devices, it may well be desirable to change to a configuration using fewer different devices—even though it may have a higher "can count".

Another important practical consideration is logic element loading. Ideally, a logic gate or other element would be capable of performing its designated function regardless of the number of other elements connected to its inputs and outputs. However practical logic elements fall



somewhat short of this ideal, having quite well-defined loading limitations. If these limitations are exceeded, the performance of the element generally deteriorates in one of a number of ways.

With TTL, ECL, and the earlier RTL elements, the limitation is primarily a matter of the logic levels at the output of an element tending to converge as more and more succeeding inputs are connected to it. The "low" logic level tends to rise, while the "high" level tends to fall. Naturally enough the more the two levels approach one another, the less reliable circuit operation becomes due to noise, etc. There is thus a very definite limit on the number of succeeding inputs which should be connected to an output.

In the case of CMOS logic elements, there is no direct tendency for the static output levels of an element to converge as more inputs are applied, because CMOS inputs draw virtually no static current. However they do possess capacitance, which tends to impose dynamic loading on any output to which they are connected. As capacitive loading is applied to a CMOS output, its propagation delay and dynamic power dissipation both tend to increase. So again there tends to be a limit to the number of inputs which should be connected to an output.

MTL elements have as yet only been used in LSI applications, and it seems unlikely that they will be packaged as individual logic elements, suitable for custom design of logic circuits. However if this were to occur, there would be similar loading restrictions. Here it would be a matter of the number of outputs which could be connected to an input, though, because MTL uses elements with multiple outputs and single current-source inputs. This was explained in chapter 3. Due to leakage currents, each output connected to an input would tend to increase the static loading, so that the "high" logic level would drop with the number of outputs connected.

With early logic elements such as those of the RTL family, it was common to define the loading capability of element outputs in terms of "fan-out". This was simply the number of standard element inputs which it was capable of driving reliably. A gate output with a rated fan-out of 10 would therefore be capable of driving up to 10 standard inputs, with reliable operation.

As elements having different types of input circuit came into use, it became necessary to introduce a complementary term describing the loading of an individual input—its "fan-in". This was again expressed as a multiple of the so-called standard input, so that a standard input would have a fan-in rating of 1 while an input of a low-power element might have a fan-in of 0.3. Conversely the input of a high power element might have a fan-in of 5.

Fan-out and fan-in were useful concepts, making it quite easy to work out how many inputs of various types could

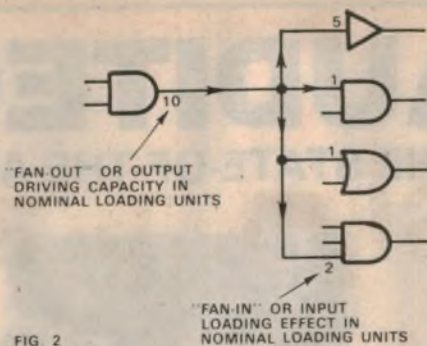

FIG. 2

be connected to a particular output. All that was necessary was to add up all the input fan-in ratings, and make sure they did not exceed the output's fan-out rating. This is illustrated in Fig. 2.

Unfortunately the concepts of fan-out and fan-in are less suitable for TTL and CMOS elements, for different reasons. With TTL devices, there can quite often be a significant difference between the loading capability of an element output in the "high" state and its loading capability in the "low" state. Similarly an element input can impose a loading in the "high" state which is quite different from that of another input with the same "low" state loading.

This makes it difficult to assign simple fan-out and fan-in figures to TTL devices, and manufacturers have tended to adopt an alternative approach. Outputs are rated in terms of their current sinking capability in the "low" state, and their current sourcing capability in the "high" state. Similarly inputs are rated in terms of their leakage current in the "high" state, and their operating current in the "low" state. With all of these values known, it is again possible to make sure that you are working within the loading limitations.

In the case of CMOS elements, a fixed fan-out and fan-in figure again cannot be applied because there is no static limitation. The permissible loading depends upon the speed you want to work at, and

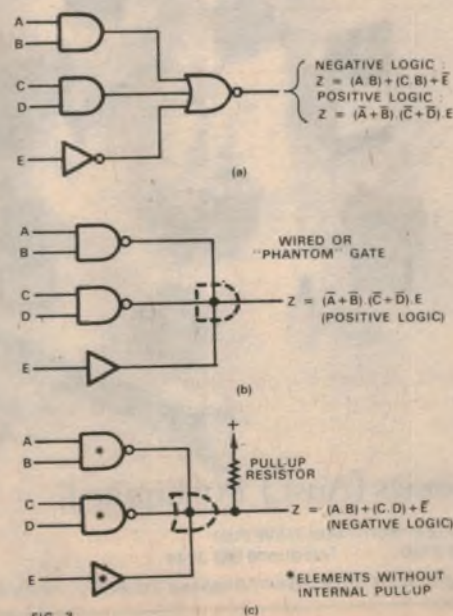

FIG. 3

the allowable power dissipation of the devices concerned. If you are designing a low speed circuit, more inputs can be connected to a given CMOS output than if the same device is used in a high speed circuit.

For CMOS elements, then, loading information is generally expressed in terms of graphs showing the relationship between output stage power dissipation and frequency, for various loading capacitances, and also the relationship between load capacitance and propagation delay for various supply voltages. The loading capacitance of each input is also given, together with the equivalent self-capacitance of each output, so that it again becomes possible to work out how many inputs may be connected to an output for a given operating speed.

The main point to grasp about loading is that there is a definite limit to the number of inputs which may be connected to the output of a logic element. This means that if we have a minimalised logic function which would involve exceeding the loading limits on one or more of the logic elements, it must be altered to produce a configuration which doesn't do so. Again this may well involve additional logic elements—but it is better to have a not-quite-minimal circuit which works reliably, than a minimal circuit which doesn't quite-work under all conditions.

A further practical consideration in logic design is the opportunity to use wired or "dot" logic, in place of IC logic elements. You may recall that this type of logic was mentioned briefly in chapter 3, when we were looking at MTL.

Fairly early in the development of logic circuits, designers found that it was sometimes possible to use a direct wiring connection (or a "dot" on the schematic circuit) to perform effectively the same job as an IC logic element. In effect, a direct connection can behave as if it were a "phantom" logic element, so that the desired logic function can be performed using fewer IC elements than otherwise.

The diagrams of Fig. 3 illustrate the idea. The configuration of (a) uses a total of 4 elements, with two 2-input AND gates and an inverter feeding a 3-input NOR gate. The output represents one or other of the two functions shown, depending upon whether the NOR gate output is interpreted according to the negative or positive logic conventions. (The inputs are all assumed to follow the positive logic convention, for simplicity.)

Now compare this with the configuration of (b). This actually performs the same logic function, although it uses only three elements: two 2-input NAND gates, and a non-inverting buffer. The outputs of the three elements are joined together, and their junction effectively behaves as a "phantom" gate. If all three outputs are high, the junction is also high; but if any output goes low, it pulls the junction low also.

If we think in terms of the positive logic convention, the wired junction of the

# AUDITEC

PRESENTS THE STATE-OF-THE-ART IN AUDIO:

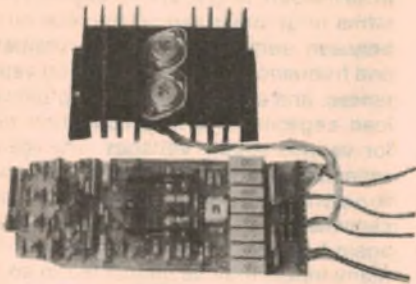

033

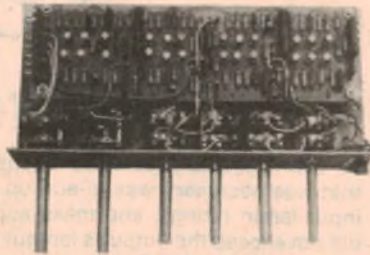

1036



035

*We believe the combination of these modules will build you the best quality audio amplifier currently available at any price! Send the coupon below for full details.*

**Auditec modules are available from:**

SYDNEY: ALAN OLIVER ELECTRONICS P/L, 188 Pacific Highway, St. Leonards 2065 Ph.: 43-6305

BRISBANE: DELSOUND PTY LTD, 35 Logan Road, Woolloongabba 4102 Ph.: 91-7048

MELBOURNE: ZEPHYR PRODUCTS, 70 Ratesford Road, Chadstone 3148 Ph.: 56-7231

BUNDABERG: BUNDABERG HI-FI, 244 George Street, Bundaberg 4670 Ph.: 71-3176

DUBBO: DUBBO HI-FI, 64 Talbragar Street, Dubbo 2830 Ph.: 82-3793

TAMWORTH: HI-FI GALLERY, 186 Bridge Street, Tamworth 2340 Ph.: 65-7788

ADELAIDE: KTRONICS, 12 Peel Street, Adelaide 5000 Ph.: 87-5505

And from: **AUDITEC AUSTRALIA**  
P.O. Box 228 Hornsby, N.S.W. 2077  
Phone (02) 47-4166

AUDITEC AUSTRALIA, PO BOX 228, HORNSBY, NSW 2077  
PLEASE SEND DETAILS OF THE NEW 033, 035 AND 1036 MODULES TO

NAME: .....

ADDRESS: .....

POSTCODE: .....

EA6/76

## REPUTATION

Reputation cannot be bought! A good reputation is earned with consistent quality and service

C & K OF AMERICA, has a sound International reputation for quality products — Switches perfected and produced almost entirely by automation.

C & K OF AUSTRALIA upholds this fine reputation as a Specialist Switch Marketing Company offering U.S.A. factory fresh products and service.

The extensive range offers a choice of more than ONE MILLION different switch styles and configurations. Toggle, Pushbutton, Slider, Rocker and Lever Handle actions, a variety of actuators and terminal styles to suit any application .... Snap-in bezels, LED adaptable types, dressy hardware .... All these and the recently introduced C & K Thumb-wheel Switches.

C & K really care, there's even a special spanner available to facilitate switch mounting.

C & K reputation .... Consider the advantages.

An obligation-free and comprehensive catalogue is yours for the asking.

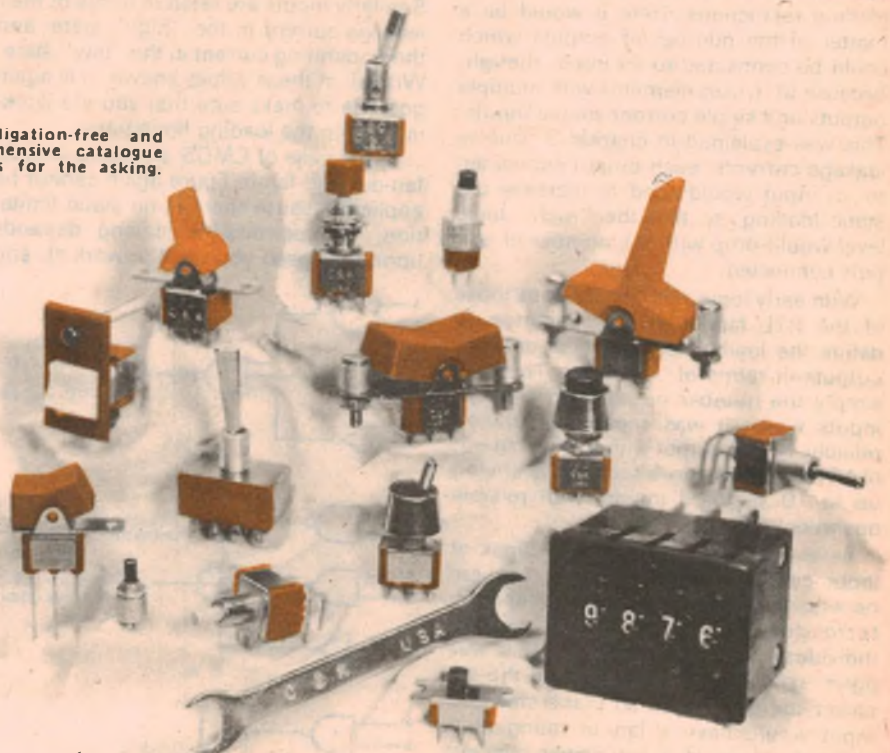

**C&K Electronics (Aust.) Pty Limited**

Office 2/6 McFarlane Street Merrylands NSW 2160  
PO Box 101 Merrylands 2160 Telephone 682 3144

Agents: Melb. 88 5282 / Adel. 269 2544 / Brisbane 70 8097 / Perth 68 7111

three outputs thus acts as an AND gate. Alternatively if we think in terms of negative logic, it is acting as an OR gate. Hence the terms "wired-AND" and "wired-OR", often used by designers to describe such phantom gates.

Note that although input term E no longer needs to be inverted with the configuration of (b), a buffer element is shown between the source of E and the wired junction. This is generally required to provide isolation, as a direct connection would force E to follow the junction, and prevent E from being used elsewhere. However if E is derived from another logic element, and is not required elsewhere, the buffer would not be required.

Astute readers may have already realised that if the logic elements used to drive a wired-logic junction have output stages with active pull-up devices, the operation of the wired junction involves conflict between output stages. This is because one element may have an output device attempting to keep the junction

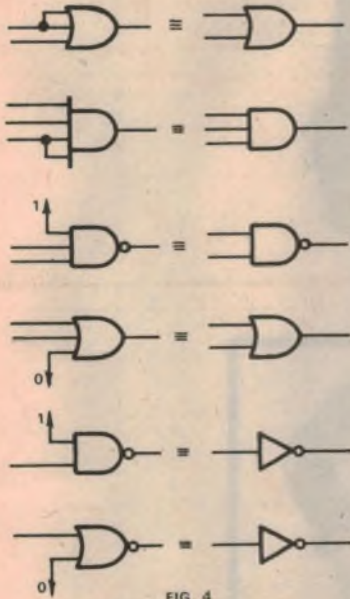

FIG. 4

"high", while another may have another output device attempting to drive the junction "low".

While this is nominally an infringement of loading rules, in practice it causes no trouble with many types of logic element. For example TTL element output stages are designed to be able to "sink" very much more current in the "low" state than they are able to "source" current in the "high" state, so that a "low" output can easily force a number of other "high" outputs into the low state without causing the low voltage level to rise unduly. Naturally enough this causes increased power dissipation in the outputs that are forced low, but generally this is acceptable providing only one element of any particular IC is forced low at any one time.

Of course it is not always possible to arrange that all of the logic elements involved in driving a wired-logic junction are part of different ICs. If a number of such

elements must be implemented using a single IC, and more than one may be forced low at the same time, this can still be done by using an IC whose elements have output stages without internal pull-up devices. These are often called "open-collector" or "uncommitted output" logic elements.

An external pull-up resistor is then used to provide logic "high" pull-up for the wired junction, as shown in Fig. 3(c). To emphasise that the wired junction may be interpreted as performing either a wired-AND or wired-OR function, this diagram shows a phantom OR symbol, and the negative logic version of the output function.

By the way, it may be worthwhile to point out that multi-input logic elements can almost always be used to perform the function of elements having fewer inputs. In other words, a 4-input gate can be used as a 3-input gate, or a 2-input gate, or even as a buffer or inverter. Usually this is done by either paralleling the redundant inputs with those that are used, or by tying them to an appropriate "true" or "false" logic rail, as shown in Fig. 4.

This trick can be very handy if one needs to implement a simple logic element, but to provide such an element directly would involve the addition of a complete new IC package. If there is a more complex element in an existing IC which would otherwise be "spare", this can be used to advantage.

Note that if a redundant input of a gate is not paralleled with a used input, it must be taken to the logic "true" level (1) in the case of an AND or NAND gate, or to the logic "false" level (0) in the case of an OR or NOR gate. This is because we are really making use of the Boolean Algebra "universe class" and "null class" laws, as defined in expressions (16), (17), (18) and (19) of chapter 4.

If nothing else, the points we've raised so far in this chapter should have driven

home the point that there is a lot more to logic design in practice than merely translating the minimalised logic function directly into hardware. In fact there are many things for the designer to bear in mind, so that the design of efficient custom logic circuits tends to involve a great deal of time and skill.

Naturally enough this tends to make custom designed logic circuits quite costly, and accordingly those involved in producing digital systems and equipment have long been keen to find an alternative approach. Until recently there was no such alternative, but the rapid advances in IC technology have now changed this position, and seem likely to change it even more in the future.

In fact two broad alternatives to custom logic circuit design are emerging. One involves the use of programmable logic arrays, or "PLA's", and the other involves the use of microprocessors or "μP's".

A PLA is basically a large-scale integrated (LSI) circuit which is capable of being programmed to perform one of a number of logic functions. At present there are two broad types, which work in rather different ways.

One type consists of a very complex logic circuit which has a "repertoire" of possible logic functions. Any one of the functions in its repertoire may be performed by applying appropriate control signals to a set of function input terminals. This is shown in Fig. 5 (a). The device may either be arranged to perform a single function in static fashion, by applying fixed control signals to the function inputs, or it may be made to perform various functions at different times, by changing the control signals as required.

This type of PLA is essentially a collection of standard logic circuits, each one of which is brought into operation as required under the control of additional logic connected to the function inputs. As such, it is most suitable for applications

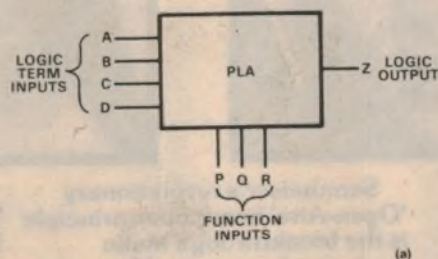

FUNCTION INPUT LEVELS			FUNCTION PERFORMED BY PLA
P	Q	R	
0	0	0	$Z = 0$
1	0	0	$Z = A + B + C + D$
0	1	0	$Z = \bar{A} + B + C + D$
1	1	0	$Z = A \bar{B} C D$
0	0	1	$Z = \bar{A} \bar{B} C \bar{D}$
1	0	1	$Z = A \oplus B \oplus C \oplus D$
0	1	1	$Z = \bar{A} \oplus B \oplus C \oplus D$
1	1	1	$Z = 1$

(a)

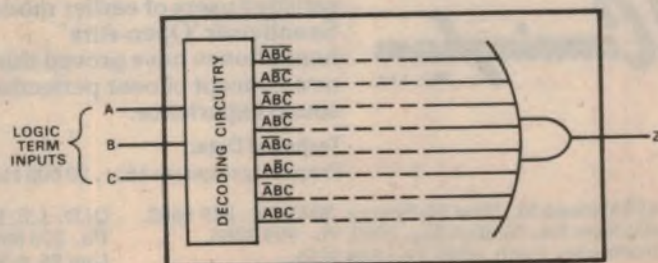

FIG. 5

(b)

# JOIN THE REVOLUTION

Get True Stereo with  
Sennheiser 'Open-Aire'  
Headphones



Sennheiser's revolutionary 'Open-Aire' headphone principle is the breakthrough audio engineers have waited for years.

Hundreds of thousands of satisfied users of earlier model Sennheiser 'Open-Aire' headphones have proved this new concept of near perfection sound experience.

Technical Data:

Frequency response 16... 20 000 Hz. Impedance 2 000  $\Omega$ . Weight 170 g. Cable length 3 m.

And now the Sennheiser 'Open-Aire' stereo headphone Model HD 424 achieves listening perfection with incomparable brilliance.

The Sennheiser stereo headphone HD 424 is extremely lightweight and so comfortable, you hardly know you have it on.

**R.H. Cunningham**  
Pty. Ltd.

VIC.: 493-499 Victoria St., West Melbourne, 3003. Ph.: 329 9633.  
N.S.W.: 4-8 Waters Rd., Neutral Bay, 2089. Ph.: 909 2388.  
W.A.: 256 Stirling St., Perth, 6000. Ph.: 288 3655.

QLD.: L.E. BOUGHEN & Co., 30 Grimes St., Auchenflower, 4066.  
Ph.: 370 8097. S.A.: Werner Electronic Industries Pty. Ltd.,  
Unit 25, 6-8 Gray St., Kilkeny, 5009. Ph.: 268 2801

Telex: Melbourne, 31447. Sydney, 21707. Brisbane, 41500. Perth, 93244.

where one mainly wants to implement one of a number of fairly standard logic functions.

Where more complex logic functions are required, the second type of PLA is more suitable. This type is basically not a logic circuit at all in the strict sense, but a "read-only memory" or "ROM". We will be looking at such devices in a later chapter, and it would not be appropriate to try and explain their operation here in any detail. However for the moment you can visualise this type of PLA as a device which is capable of separating out all of the possible truth value combinations of the input logic terms, and detecting when each combination occurs.

This allows virtually any logic function involving the input terms to be "synthesised", by arranging for the output of the PLA to be true for those truth value combinations which are appropriate, and false for the rest. The PLA is programmed internally to do this using the truth table of the required function as a guide.

If you find this hard to understand, the diagram of Fig. 5 (b) may help. It shows a simple and hypothetical PLA of this type, involving only three input terms. This is purely to illustrate the idea, as it would be rather wasteful to use a PLA for simple functions involving only three terms.

As you can see, the PLA consists of two basic sections—"decoding circuitry" which detects each of the possible truth value combinations of the input terms (here there are 8 possible combinations), and an output circuit which functions rather like a multi-input OR gate. Each output of the decoding circuitry is potentially capable of being connected to an input of the OR gate, with the PLA being programmed by making these connections as appropriate.

For example, if we wanted the PLA to perform the same function as a normal AND gate, we would arrange for only one of the decoding circuit outputs to be internally connected to the OR gate—the one corresponding to the combination (A.B.C). The output Z would thus go true only for that combination, and remain false for the rest.

Similarly, if we wanted the PLA to perform the NOR function, we would arrange again for only one internal connection—that corresponding to all three input terms being false.

If we wanted to be a little more adventurous, we could program the PLA to perform the exclusive-OR function. This would involve linking up internally three decoder outputs, to give the effective output function:

$$Z = A \bar{B} \bar{C} + \bar{A} B \bar{C} + \bar{A} \bar{B} C$$

Alternatively, we could make it perform an exclusive-NOR function, by linking up the other five internal decoder outputs instead. Then the output would be false only for the three truth value combinations just given, and true for all others.

Hopefully you can see from these exam-

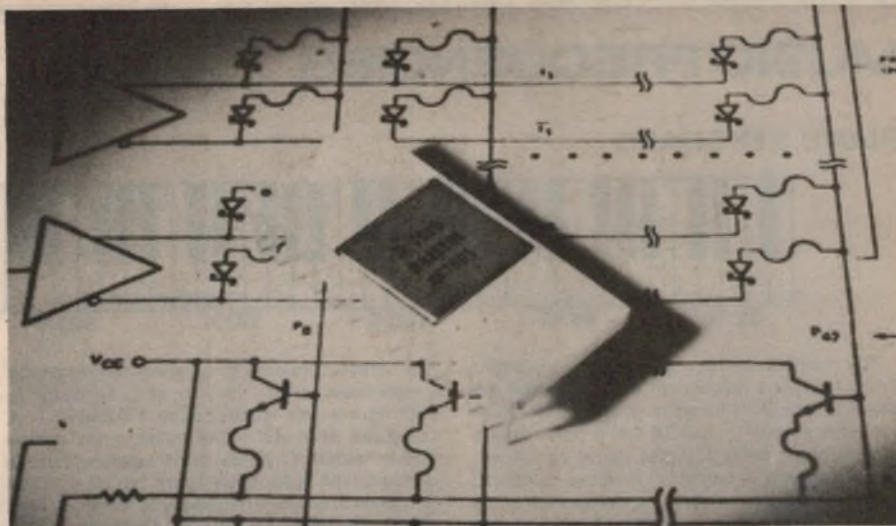

This user-programmable PLA device allow the synthesis of complex logic functions involving up to 48 truth value combinations of as many as 16 input terms. It also has eight independent outputs (Signetics).

ples how a PLA of this type may be "programmed" to perform virtually any required logic function, simply from a knowledge of the truth table of the function required.

Most practical PLAs are designed to accept many more than three input terms. In fact typical devices are capable of handling as many as 12 or 16 input terms, detecting as many as 48 different output truth-value combinations, and producing eight separate output terms.

Complex PLAs of this type do not use the exact arrangement shown in Fig. 5(b), however, because this would involve a very elaborate internal decoder—most of which would be wasted. For example with 16 input terms, a full decoder would involve no less than 65,536 output lines! Of these only a small number would tend to be used.

To avoid this complexity, the decoder itself is made programmable. In other words, each of the input terms and their logical complements are made available via buffer stages, and the PLA is programmed to decode only those truth value combinations which are actually required to produce the required function.

Like PLA's, microprocessors or "μP's" are recent developments of large-scale integration technology. A μP is basically

a miniature computer, compressed into one or more IC packages. Again we will be looking at μP's in some detail in a later chapter, and it would not be appropriate to try and explain their operation properly here. However for the sake of completeness, we should perhaps show in broad terms how a μP can be used to perform complex logic functions in place of a custom designed logic circuit.

A μP consists basically of a "processor", capable of performing any of a number of basic logical, arithmetic and manipulative tasks under the control of "instructions". Each instruction is a number, and by feeding the processor a series of numbers in turn, it may be made to perform a sequence of tasks. Such a series of instruction numbers is called a "program", and is usually stored in a memory device of some sort. A complete μP system thus tends to consist of the μP itself together with a memory to store the program, as shown in Fig. 6.

To use a μP to perform a complex logic function, it is programmed to behave rather like the PLA in Fig. 5.(b), only in a dynamic fashion. The sequence of instructions force it to continuously monitor the truth values of the various terms at its inputs, and compare them with a list of reference combinations stored in the memory. Then, according to the reference combination which matches the input combination each time, the μP is instructed to vary the truth value produced at one of its outputs.

The fact that the μP operates in a dynamic fashion means that there tends to be a slight delay between a change in the input terms and the appropriate change in the effective logic output. This can make the μP less attractive than the PLA where a complex logic function must be performed at very high speed. However the big advantage of the μP is that its effective logic function may be changed quite rapidly, merely by altering its stored program.

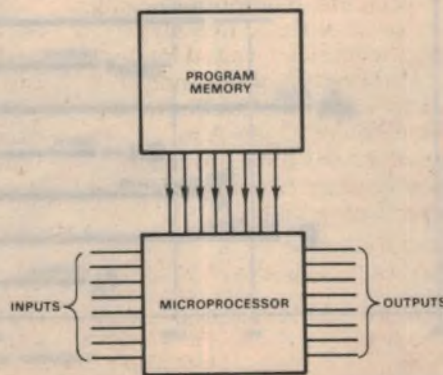

FIG. 6

# MUSIC FREQUENCIES

## PIANO KEYBOARD



The number of keys on a piano keyboard varies from one instrument to another but the above is typical. If tuned to present-day standard pitch middle C is at 261.6Hz (to 4 significant figures), other C notes being as shown. Standard pitch is based on A above middle C being 440Hz precisely. In tempered scale tuning, the octave (2 : 1) ratio is divided into 12 equal (ratio) steps so that each semitone in

any octave is related to adjacent semitones by a ratio equal to the 12th root of 2. To 8 significant figures this works out to 1.0594631. A computer print-out of the notes in the octave above middle C yields the frequency figures shown at the right. Each figure can be doubled or halved to give the frequency of the equivalent note in the adjacent octaves. Double or halve again for the octaves above or below those.

### The tempered musical scale

C	261.62556536Hz
C-sharp	277.18263104Hz
D	293.66476797Hz
D-sharp	311.12698377Hz
E	329.62755696Hz
F	349.22823147Hz
F-sharp	369.99442273Hz
G	391.99543600Hz
G-sharp	415.30469759Hz
A	440.00000000Hz
A-sharp	466.16376151Hz
B	493.88330123Hz
C	523.25113057Hz

## ORGAN KEYBOARD

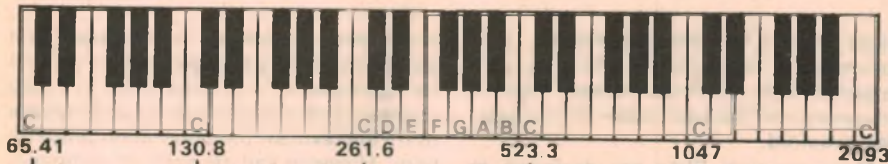

16'	(sub-harmonic)	32.70	65.41	130.8	261.6	523.3	1047
8'	fundamental	65.41	130.8	261.6	523.3	1047	2093
5-1/3'	(3rd harm of 16')	98.00	196.0	392.0	784.0	1568	3136
4'	(2nd harmonic)	130.8	261.6	523.3	1047	2093	4186
2-2/3'	(3rd harmonic)	196.0	392.0	784.0	1568	3136	6272
2'	(4th harmonic)	261.6	523.3	1047	2093	4186	8372
1-3/5'	(5th harmonic)	329.6	659.3	1319	2637	5274	10548
1-1/3'	(6th harmonic)	392.0	784.0	1568	3136	6272	12544
1'	(8th harmonic)	523.3	1047	2093	4186	8372	16744

## ORGAN PEDALBOARD



An organ pedalboard may have as few as 13 or as many as 32 notes but the bottom one is always the C equivalent to the bottom C on a 61-note manual. If played with an 8ft pedal stop, this key will produce the same frequency (65.41) but it is more commonly used with a 16ft stop or "voice" producing 32.7Hz. Other footages bear the same relationship to the 16ft and 8ft voices as indicated for the manual.

Organ keyboards are normally shorter than piano keyboards, 61 notes as above being one standard. Other common figures are 37, 44 and 49. When using a basic stop, normally designated as 8ft or 8', the fundamental frequency produced by the keys is the same as for a piano, assuming standard pitch and tem-

pered scale. If a 16ft stop is used instead, all frequencies are halved. Other stops give higher frequencies as indicated. While the 4ft, 2ft and 1ft are simple octave relationships, others represent sub-3rd, 3rd, 5th and 6th harmonics, readily calculable from the tempered scale print-out above.

## FREQUENCY SPECTRUM OF OTHER INSTRUMENTS & SOUND SOURCES

A large pipe organ or its electronic equivalent can produce fundamental note frequencies over virtually the entire frequency spectrum audible to humans. The fundamental note frequencies available from other instruments is much more limited but, because individual notes involve harmonics and overtones in addition to the fundamental, the actual frequency range involved extends much further upwards than the solid lines would suggest. Much the same remark apply to sources such as voice, drums and cymbals. It is for this reason that a high fidelity amplifier system needs to have a response at least equal to the frequency range of human listeners to do justice to the majority of sound sources.

**HUMAN HEARING:** People up to their mid twenties, with good ears can typically hear frequencies to 15-17kHz. Between 20 and 40, the limit diminishes gradually to 11-12kHz. In the group 40-60 the limit falls to 8kHz while people 70 and over cannot expect to hear much beyond 4 to 5kHz.

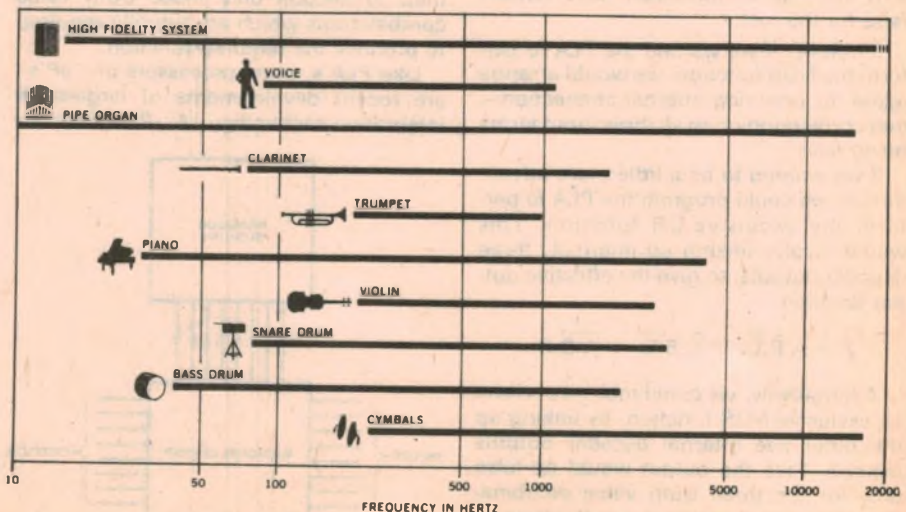

# MUSIC FREQUENCIES . . . 2

## NOTE FREQUENCIES IN ALL OCTAVES (TEMPERED SCALE, STANDARD PITCH)

Set out on the right are frequencies of all notes in all octaves likely to be generated directly in any musical instrument. The notes range from a sub-audible 8Hz to over 16,000Hz, the latter beyond the hearing limit of most people.

All frequencies are shown in Hertz, a term which means "cycles per second".

The figures were generated by a computer, rounding off to 8 decimal places, operating with the 12th root of 2 on whole numbers for "A"—110, 220, 440, 880, etc. Because the 12th root of 2 is an irrational number, and because a computer or calculator can only work to a certain number of decimal places, errors tend to accumulate. Therefore, by way of example, the figure for "C" obtained by working up from A-440 may differ from that obtained by working down from 880.

The differences are significant only in the mathematical sense. Musically, the frequencies could be rounded back to six significant figures and still be well beyond the most ambitious requirements for accurate tempered tuning.

8.17579892	C	16.35159784	C	32.70319567
8.66195722		17.32391444		34.64782888
9.17702400	D	18.35404800	D	36.70809600
9.72271825		19.44543649		38.89087298
10.30086116	E	20.60172231	E	41.20344462
10.91338224	F	21.82676447	F	43.65352894
11.56232572		23.12465143		46.24930285
12.24985738	G	24.49971475	G	48.99942950
12.97827180		25.95654360		51.91308720
13.75000000	A	27.50000000	A	55.00000000
14.56761755		29.13523510		58.27047019
15.43385317	B	30.86770633	B	61.73541266
16.35159784	C	32.70319567	C	65.40639133

Arrows indicate middle C

65.40639134	C	130.81278268	C	→ 261.62556536 ←	C	523.25113072
69.29565776		138.59131552		277.18263104		554.36526208
73.41619200	D	146.83238399	D	293.66476797	D	587.32953594
77.78174595		155.56349189		311.12698377		622.25396754
82.40688924	E	164.81377848	E	329.62755696	E	659.25511392
87.30705787	F	174.61411574	F	349.22823147	F	698.45646294
92.49860569		184.99721137		369.99442273		739.98884546
97.99885900	G	195.99771800	G	391.99543600	G	783.99087200
103.82617440		207.65234880		415.30469759		830.60939518
110.00000000	A	220.00000000	A	440.00000000	A	880.00000000
116.54094038		233.08188076		466.16376151		932.32752302
123.47082531	B	246.94165062	B	493.88330123	B	987.76660246
130.81278265	C	261.62556529	C	523.25113057	C	1,046.50226114

## IC FREQUENCY DIVIDERS

Modern integrated circuit dividers are designed to operate from an input signal at about 2MHz, provided either by a crystal locked oscillator or by an L/C oscillator which allows the overall pitch of the instrument to be varied while still preserving correct relationships within the octaves.

TOP OCTAVE NOTE	IC DIVISION RATIO	TOP OCTAVE FREQUENCY
C	239	8365.5230
B	253	7902.6086
A-sharp	268	7460.2985
A	284	7040.0000
G-sharp	301	6642.3920
G	319	6267.5862
F-sharp	338	5915.2662
F	358	5584.8044
E	379	5275.3562
D-sharp	402	4973.5323
D	426	4693.3333
C-sharp	451	4433.1707

Normal whole-number division ratios are set out in the table herewith, together with the top octave frequencies, assuming a master oscillator input of 1.999360MHz—the mathematically precise figure necessary to produce A = 440Hz.

To produce "C" notes to the computed frequencies, the master oscillator would, alternatively, have to be marginally above 2MHz. In practice, a 2MHz crystal is a logical choice, giving frequencies which are musically adequate for standard pitch tempered tuning.

## TUNING ACCURACY

When instruments are to be played in unison, they must be tuned to the same pitch — now normally A = 440 Hz. For purely solo work, few listeners would notice if an instrument varied from this by half a semitone either way, provided that intervals within the octaves were accurately maintained.

1,046.50226144	C	2,093.00452288	C	4,186.00904576	C	8,372.01809152
1,108.73052416		2,217.46104832		4,434.92209664		8,869.84419328
1,174.65907188	D	2,349.31814376	D	4,698.63628752	D	9,397.27257504
1,244.50793508		2,489.01587016		4,978.03174032		9,956.06348064
1,318.51022784	E	2,637.02045568	E	5,274.04091136	E	10,548.08182272
1,396.91292588	F	2,793.82585176	F	5,587.65170352	F	11,175.30340704
1,479.97769092		2,959.95538184		5,919.91076368		11,839.82152276
1,567.98174400	G	3,135.96348800	G	6,271.92697600	G	12,543.85395200
1,661.21879036		3,322.43758072		6,644.87516144		13,289.75032288
1,760.00000000	A	3,520.00000000	A	7,040.00000000	A	14,080.00000000
1,864.65504604		3,729.31009208		7,458.62018416		14,917.24036832
1,975.53320492	B	3,951.06640984	B	7,902.13281968	B	15,804.26563936
2,093.00452288	C	4,186.00904456	C	8,372.01808912	C	16,744.03617824

To define tuning accuracy within the octave, the octave is considered to be divided into parts based on the 1200th root of 2, with a hundred such parts (called "cents") to each semitone.

Assuming that listeners have come to accept the tempered scale, it has been stated that some highly perceptive listeners can pick a discrepancy of one cent, equal to about .06% of the note frequency. A figure more representative of the average musically aware listener is 5 cents, or about 0.3% of note frequency — an error tolerance approximating that of chromatic tuning forks.

The frequencies produced by dividing down from a master oscillator, as listed, exhibit an error ranging from well under .06% to a

maximum of 0.1%. On average the errors satisfy the criteria of being perceptible only to extremely discerning musicians, while being well below the 5 cents and 3% tolerance credited to the average musically involved listener.

For a crystal locked tuning standard see "Electronics Australia", August 1974.

## TUNING: BEAT METHOD

Tabulated below is the procedure for tuning an organ by the beat method, starting with a tuning fork, normally for C-523.

PLAY	PLAY, ADJUST	TUNE (10 secs)
Fork-523	C-523	Zero beat
C-523	C261	Zero beat
C-261	G	9 beats flat
G	D	13 beats flat
D	A	10 beats flat
A	E	15 beats flat
E	B	11 beats flat
B	F sharp	17 beats flat
F sharp	C sharp	12 beats flat
C sharp	G sharp	10 beats flat
G sharp	D sharp	14 beats flat
D sharp	A sharp	10 beats flat
A sharp	F	16 beats flat
F	C-523	Check: 12 beats

# High gain power IC with overload protection

National Semiconductor Corporation has developed a series of high gain power ICs which feature internal current limiting and thermal overload protection circuitry. Here the author describes the characteristics of the new devices, and examines some typical circuit applications.

by J. BRIAN DANCE, M.Sc

A relatively new series of devices manufactured by National Semiconductor Corporation look like ordinary power transistors, but are actually integrated circuits containing some 50 components on the silicon chip. They behave rather like fast npn power transistors with a current gain of about one million.

## Protection

The internal protective circuits incorporated into these devices prevent damage in almost all circumstances, provided that an excessive voltage is not applied to them. If the temperature of the silicon chip exceeds about 165°C, the power output stage is partially or fully shut down. This enables a much smaller heatsink to be used without any risk of damaging the device by thermal overloading; in other words, one does not have to include a margin of safety when selecting the heatsink.

Another protective circuit included on the chip limits the current flowing from the "collector" to the "emitter" to about 2A. This current carrying capacity can be effectively increased by connecting any number of devices in parallel. Since no one device will pass more than its limiting value of collector current, it cannot be damaged by excessive current. Current sharing resistors may be included in the emitter circuits.

## Types

The most economical device in the range, the LM395, costs about five times as much as the well-known 2N3055 power transistor. It is specified for use over the temperature range 0°C to +125°C, with a maximum applied voltage of 36V. The LM295 is a 42V device which will operate over the range -25°C to +150°C, whilst the LM195 is also a 42V device for use from -55°C to +150°C.

Each of these devices is available in a TO-3 case with connections as shown in Fig. 1(a). In this case, a 'K' is added to the device type, for example, LM395K. Electrically similar devices are available in the smaller TO-5 metal cases with the suffix 'H'.

Assuming adequate heatsinking, the thermal resistance of the TO-5 devices is about 12°C/W, whilst that of the TO-3 devices is only about 2.3°C/W. Without heatsinking, the thermal resistance of the TO-5 devices is about 150°C/W, whilst that of the TO-3 packages is about 35°C/W. Thus if one is applying a moderately high voltage and requires a current near to the maximum value, the TO-3 device should be selected.

Cost of the LM295 is about twice that of the LM395, while the LM195 costs more than three times as much. There is little difference in terms of cost between the TO-3 and TO-5 packages.

It should be noted that the case of the TO-3 devices is connected to the emitter (not to the collector as in most power transistors).

## Electrical properties

Unlike a conventional power transistor, if the base of an LM395 is open circuited, the device will fully conduct. When a current of typically 3uA (maximum 10uA for any device) is drawn from the base, the current falls to the quiescent value required for device operation (typically 2mA, maximum 10uA). If the base is connected to the emitter, current will flow out of the base and the collector current will fall to the quiescent value.

## Typical applications

Fig. 2 shows the LM395 employed as a current limiter, one of the simplest applications of the new devices. The internal circuit limits the collector current to about 2A (minimum 1A for any device) at an applied voltage of 15V in the case of the TO-3 LM395K, and 7V in the case of the TO-5 LM395H. A heatsink must normally be employed or the thermal protective circuit in the device will cause the collector current to fall as the chip becomes hot.

A circuit similar to that shown in Fig. 2 can be used to switch the collector current from the limiting value down to the quiescent current. This is achieved by switching the base connection between the collector and the emitter. Current through the switch will be of the order of only a few microamps.

The LM395 base to emitter voltage is typically 0.9V when the collector current

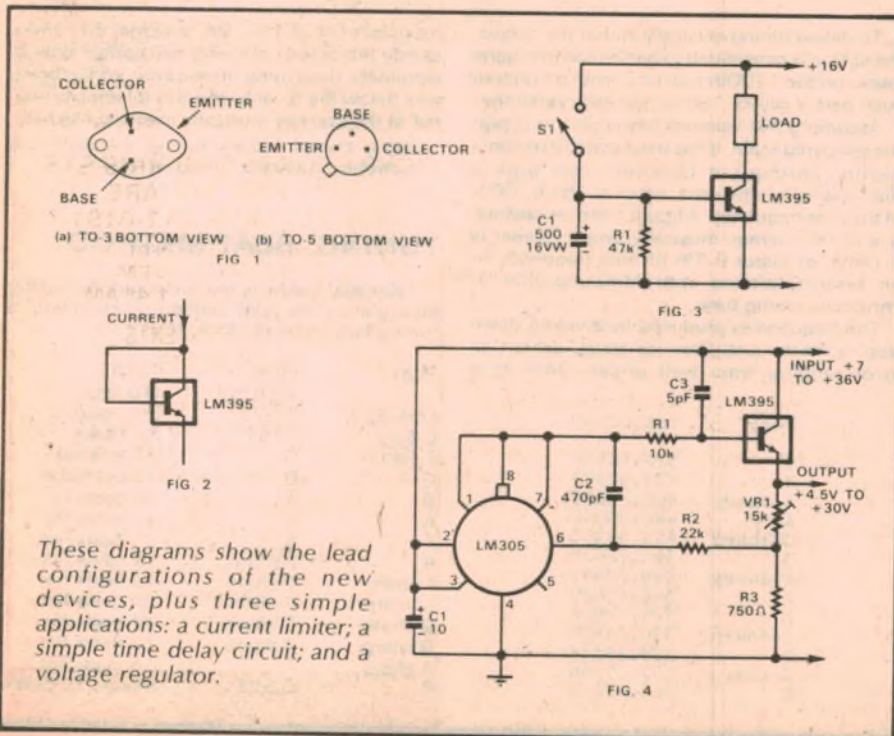

These diagrams show the lead configurations of the new devices, plus three simple applications: a current limiter; a simple time delay circuit; and a voltage regulator.



is 1A. Thus the output of a TTL or CMOS circuit can be fed to the base in order to control a collector current of over 1A.

A very simple time delay circuit is shown in Fig. 3. When S1 is closed, C1 charges and load current flows. The delay period occurs when S1 is opened and C1 commences to discharge through R1. The load current remains constant until the voltage between the base and emitter of the LM395 falls to less than about 0.9V. It then falls to the LM395 quiescent current. If the values shown are used, the current in the load falls after a delay of about 25 seconds.

The value of R1 must be chosen so that the voltage across it does not exceed about 0.6V when the maximum base current (10uA) flows through it. Thus it should not greatly exceed the value shown.

The output of the voltage regulator circuit of Fig. 4 can be set to any value between 4.5V and 30V by the adjustment of VR1. The output current can have any value up to at least 1A and is automatically limited by the protective circuits inside the device.

The LM305 accepts an unregulated

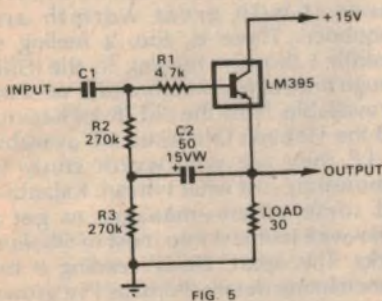

FIG 5  
An emitter follower with a very high input impedance.

input supply voltage at pins 2 and 3 and provides a control voltage at pin 8, which controls the LM395 output voltage. The LM305 feedback control signal is taken from a tapping on the output potential divider circuit.

An important advantage of using one of these devices in the output circuit of a voltage regulator is that accidental destruction of the device leaves it open circuit. The other devices in the circuit are thus protected.

An emitter follower with a very high input impedance is shown in Fig. 5. The output voltage from the LM395 emitter is fed back so that the potential across R2 remains almost constant. A base resistor (R1 in Fig. 5) should be included in all emitter follower circuits using these devices in order to prevent possible oscillation.

#### Conclusion

Although the devices are only available in the npn form, a circuit using an additional four components can be used as the pnp equivalent of the LM395. This circuit and others are given in the data sheet for the devices.

## AERIAL SYSTEMS FOR FM—continued

While aerial companies are planning towards a new market, there has thus far been very little in the way of marketing activity to date. The first specific FM aerial to be brought to our notice is one marketed by Matchmaster (TV Sales) Pty Ltd, whose Sydney address is 2 Mimosa St, Bexley 2207; Sydney phone number 587-4499. The aerial currently being offered has been designed by the well known authority on aerials and propagation, Dr. Rudolf Guertler.

Mechanically, the array is well made and well finished, using established TV aerial practice. The dimensions, however, are unique to its FM role and graphically illustrate the kind of measures that the designer has to adopt to achieve the desired characteristics in terms of working bandwidth, gain relative to a simple dipole, directivity, and impedance as seen by the downlead.

The "active" element—the one connected to the downlead—is fairly obviously a combination of two folded dipoles and, at first glance, one might assume that they have simply been chosen to resonate respectively above and below the high frequency and low frequency limits of the band. However, a quick check, using the formula given earlier, yields the unlikely figures of 93 and 74MHz.

But, of course, the dipoles are not isolated; they are coupled spatially and electrically and must have a mutual effect one upon the other. It is reasonable to assume that they finish up at two higher effective frequencies, to produce a broadband effect encompassing all FM broadcasting channels.

The thinking is reinforced by considering the dimensions of the larger "parasitic" element. It is a full electrical half-wave at 88MHz and can only be intended as a reflector for the lowest likely input frequency. Furthermore, it is spaced away from the lower frequency element by about 0.23 wavelength at 88MHz—a likely figure.

Having thus deduced the directivity of the beam, the shorter element nearer the centre can only be intended as a reflector for the higher frequencies. Regarded in this role, it would have this effect for frequencies above 101MHz, being spaced one-eighth wavelength behind the higher frequency dipole. In conventional beam design, this would not be an unusual option.

But why the particular choice of element spacing and why does the shorter element not tend to act as a director at frequencies below 100MHz? If the very close spacing to the longer dipole would prevent this, what effect does it have on the longer dipole by its very proximity? These questions are not asked with the idea of deducing an answer but simply to emphasise the considerations

and the complexities which lie behind the derivation of a typical broadband VHF beam.

Although the manufacturers made available a sample aerial to us for inspection and installation, we have not to date had the opportunity to put it to actual test. However, knowing the design expertise behind it, we have little doubt that it will do the job intended.

Apart from the basic beam assembly, the manufacturers have a range of the usual aerial hardware, including fittings which permit the FM beam to be mounted horizontally or vertically to an existing TV aerial mast.

One would assume that, if mounted vertically, it would need to be spaced away from the metal mast as far as practicable, in order to preserve its natural field pattern. Either that, or a non-metal support might be practical in some cases.

Also available is a "Balun" which is fully sealed and weatherproofed and intended to mount directly to the output terminals of the beam. From the Balun, standard 75 ohm coaxial cable can run down to the FM tuner or receiver. (Further information on the Matchmaster FM aerial can be obtained from representatives in the various state capitals or from the NSW address given earlier in the article.)

## RADIO DESPATCH SERVICE

869 GEORGE STREET  
SYDNEY

CNR GEORGE & HARRIS STS  
RAILWAY SQUARE  
TEL 211-0816, 211-0191

OPEN MON. TO FRI.  
8.15 AM TO 5.30 PM  
SAT. 8.00 AM TO 11.45 AM

### TEXAS INSTRUMENTS CALCULATORS

AT REDUCED PRICES  
SLIDE-RULE SR50A \$70.90 + 15% S.T.  
SUPER SLIDE-RULE SR51A \$102.42 + 15% S.T.  
CARD PROGRAMMABLE SR52 \$323.35 + 15% S.T.  
MICROLITH SCIENTIFIC CALCULATOR  
\$29.95 + 15% S.T.  
FULL RANGE OF NOVUS CALCULATORS  
WIDE RANGE OF ELECTRONIC COMPONENTS  
VARIETY OF ELECTRONIC TEST EQUIPMENT  
TV AERIALS B & W. COLOUR & ACCESSORIES

OPEN SATURDAY MORNINGS

# Classical Recordings

Reviewed by Julian Russell



## Mozart: Clarinet Concerto

**MOZART**—Clarinet Concerto. Donald Westlake (clarinet) with the Sydney Symphony Orchestra conducted by Robert Pikler.

Sinfonia Concertante, the Sydney Wind Soloists with the Sydney Symphony Orchestra conducted by Robert Pikler. RCA Red Seal Stereo VRL1-0073.

The very first bars alert the listener to the fact that he is going to hear some very stylish Mozart indeed. The orchestra's discipline is immaculate, its balance fine and its phrasing elegant. The clarinet soloist, Donald Westlake, has an attractive reedy tone, steady and quite without any soulful vibratos. One might be excused for thinking that here everything is lined up for a peerless recording. Well, the performance is excellent, one at which not even the most hypercritical could cavil. But one factor seriously interfered with my enjoyment of this lovely work. The clarinet is recorded consistently too close to the mike and receives too much prominence throughout. Indeed he often sounds as if he is playing in the listener's room with the orchestral part coming from the next. This also tends to coarsen Westlake's tone, something which never happens in the concert hall. This is all a great pity because the fault is too serious to overlook, especially when one speculates that everything could probably have been made all right by the simple adjustment of a knob. The superb quality of the orchestra's contribution under Pikler can thus be heard satisfactorily only when the clarinet is silent. A further pity. But all is not lost.

On the second side, in the Sinfonia Concertante, the balance has been adjusted and in this there is no doubting the classical elegance of all the players concerned. A special word of praise for the clean attack and release in both works. There is not a bar that isn't impeccably phrased and all the instruments blend to perfection. The eloquent silences are never overdone. They are just lovely moments of repose.

There has for many years been some doubt as to the authenticity of this work. But to my mind if it wasn't written by Wolfgang Amadeus Mozart it was composed by another composer of the same name. Just one more point, if a compar-

tively minor one—the whole production is most attractively got up. The record sleeve is printed a lovely warm green with a picture by Thomas Watling of a view of Sydney Cove in 1874. It is extraordinary how English the landscape is made to look despite the inclusion of some exotic looking trees in the foreground.

Both works, by the way, were recorded by the ABC in their Sydney Studio and the sleeve notes are from the same source. Except for the forwardness of the clarinet mentioned above, a most creditable achievement for all concerned.

★ ★ ★

**SIBELIUS**—Symphony No. 5 in E Flat.

Symphony No. 7 in C. Boston Symphony Orchestra conducted by Colin Davis. Philips Dolbysised Stereo Cassette 7300 415.

Much as I admire Colin Davis I don't think he quite gets the spirit of Sibelius' Fifth on this cassette. Apart from the opening being on the slow side there is

also a lack of tension. Indeed Davis often makes it sound almost dreamy. It emerges all too human. There is little to suggest the typical Sibelian stern, unpeopled landscape. There is also, here and there, some odd over-accentuation. The playing is never less than first class; it is the atmosphere that too often doesn't sound right. The sound is good, well balanced with plenty of presence. I enjoyed, too, Davis' uninhibited use of the brass, for which Sibelius always wrote so magnificently. The slow movement has many fine moments though at times it sounds almost matter of fact. The mysterious fairy tale atmosphere is missing despite—perhaps because of—the care with which it is phrased.

Just as he takes the opening too slowly—at least for my taste—the Finale goes much faster than usual so that much of its intended tension is dissipated. The engineering of both symphonies on this cassette presents to advantage Sibelius' marvellous scoring which looks so simple on paper and yet is so individual when played. How unlike some of the avant garde stuff knocking around nowadays!

I liked Davis' reading of the 7th Symphony much better than his Fifth. He opens it with great warmth and eloquence. There is, too, a feeling of breadth I thought missing in the Fifth, though here again even broader versions are available. Now the old 78s of Kajanus and the Helsinki Orchestra are available on LP they are well worth study to demonstrate just what I mean. Kajanus—and some others—manages to get a piano-wire tautness into most of Sibelius' works. This apart, Davis' reading is full of enchanting details. Perhaps I've grown too used to hearing Sibelius played otherwise, in a word more sternly with

## Ravel: Daphnis and Chloe Ballet

**RAVEL**—Daphnis and Chloe. Complete Ballet. New York Philharmonic Orchestra and Camarata Singers conducted by Pierre Boulez. CBS Stereo SBR235772.

The surface of my pressing of Side 1 is very prickly indeed, despite many attempts on my part to clean it. It is made all the more obtrusive by the very quiet, almost inaudible opening bars of the ballet. This issue has to confront many other fine performances—and recordings. My favourite is Monteux', though Munch and Ansermet have also made notable recordings. Some of Boulez' tempos are a little fast—Dorcon's Dance in 7/4 time is one, and the War Dance another. But, except for a sense of hurry, this does no great harm. After all Boulez is not playing for dancers, who would be in real trouble if he were. All through Boulez' reading is brilliant and sharp edged rather than romantically legen-

dary, as is Monteux'. And CBS engineering, usually a matter for unrestrained praise, is often not quite out of the top drawer. The orchestra gives a virtuoso account of the difficult score and chorus is fine, too.

The second side is cleaner though by no means free from pops and crackles. And here it is only occasionally that the engineering disappoints. I thought the warmth of the strings the best feature. There are some mighty climaxes; at times the brass is astonishingly clear, especially in solo passages for trumpet, and the woodwind in the Pantomime Scene is as delicious as one might expect from this fine combination. To me it doesn't matter if the finale is taken as fast as is humanly possible. I found it terrifically exciting with a quite ecstatic climax. However, despite its many good points, I still have my reservations about the product as a whole, though it may just be your cup of tea.

much of the music—even the scherzos—sounding something like a reprimand, sometimes whispered at others shouted. Dour is perhaps the best word to describe it.

But what a marvellous symphony this Seventh is. It was his last, though he lived for another 25 years after its composition. After its completion there was silence—for over a quarter of a century. Whatever he might have written was destroyed at his request after his death. Before we leave this splendidly engineered cassette I must add that Davis' ending to the Seventh makes much of what has gone before sound well worth while. I cannot imagine a better close.

★ ★ ★

**WALTON—Ariadne; A Song For The Lord Mayor's Table; and Three Other Songs.** Heather Harper (soprano) with Paul Hamburger (piano). Record Society Stereo S/6559.

Ms Maconchy's Ariadne, which takes up Side One, is in the form of old-fashioned monologue. A text of C. Day-Lewis describes Ariadne's despair and anger at having been abandoned by Theseus on the island of Naxos. A small orchestra describes her emotions in what might be termed eclectic style — or rather styles — while soprano Heather Harper uses her fine voice in the current fashion with wide, unmusical intervals. The work is very well performed by all concerned and the engineering is first rate. Ms Harper makes the best possible use of ungrateful material. I don't think the work comes off very well. The moods change so fast and so often that it would need the vocal eloquence of a Wagner or Strauss to reflect them all convincingly. However, perhaps the perfection of the production may win it enthusiastic supporters.

On the reverse side you will find William Walton in genial mood. A Song For The Lord Mayor's Table was commissioned by the Worshipful Guild of Goldsmiths in London and was first performed for their delight by Elisabeth Schwartzkopf and Gerald Moore at a banquet. What these worthy burghers thought of it is not recorded — no pun intended. But I enjoyed all six songs which vary greatly in atmosphere from a description of the smooth-flowing Thames to a caricature of the old nursery tune Oranges and Lemons. The only one I had reservations about was that in which Ms Harper's rather genteel accent was used to describe a cockney lass lamenting on Wapping Old Stairs her desertion by a sailor boyfriend whose trousers she had washed.

Of the three songs to Edith Sitwell's text I best enjoyed the deeply lyrical Daphne. The other two, which set a vocal line to Walton's earlier suite Facade, I thought far from an improvement on the original. Paul Hamburger accompanies all the items with great skill and sympathy.

**BEETHOVEN—Incidental Music to King Steven. Elegiac Song. Song of Sacrifice, Song of Fellowship, and Calm Sea and Prosperous Voyage.** London Symphony Orchestra with the Ambrosian Opera Chorus conducted by Michael Tilson Thomas. CBS Stereo 235764.

So you think you know pretty well everything Beethoven wrote? Well this disc is almost certain to contain music you've never heard before. Side 1 is taken up with the incidental music to the play King Steven. This is by no means my favourite in this recital. Although it dates from as late as Op. 117—the 9th Symphony is Op. 125, by way of comparison—some of it is reminiscent of a work as early as the Fifth Symphony and other parts sound like sketches for the 9th. But it is all genuine Beethoven, even if not at his greatest. One thinks all too often that one has heard some of it before without being able to place quite where. The singing and playing is peerless with engineering of matching excellence. Here and there you will hear music as radiant as any Beethoven ever wrote. I have only one quibble—the spoken words are omitted from the “melodrama” sequence leaving a little melo and no drama. Without consulting the accompanying notes and English-German texts one might well be excused for wondering what is going on. But to compensate for this there are some very exciting triumphant choruses.

### Rolf Bartik: a tribute

I am sad to announce the sudden death of Mr. Rolf Bartik of Phonograms Ltd. Rolf was the repertoire man and in that position which he filled so well he was also the contact man for record reviewers. He always received us with unflinching courtesy and was never at a loss to make a useful recommendation. He will be missed by all who had dealings with him. It is perhaps not well known that when he came to Australia from Vienna he intended to make a career for himself here as a bass-baritone. That he changed his plans was to the benefit, not only of his company, but also to the many who had business with it.

Side 2 opens with the Elegiac Song (Op. 118) which starts with a long introduction for strings as beautiful as anything Beethoven ever wrote. It is quite ravishing, and so is the vocal part which follows. This, too, is most expressively performed. The text, by an unnamed author, is in the form of a very lovely epitaph. Indeed the whole of this second side makes the production very worth while indeed. On it you will also find a Song Of Sacrifice (Op. 121b) which has a long legato vocal line, rapturous despite its slow tempo, and with highly original scoring in the accompaniment.

The Song Of Fellowship (Op. 122), a hearty students' song of five verses finds the composer in an unusually benevolent

mood. The last verse varies slightly in content and tempo with choir and orchestra changing its mood most effectively. To complete this interesting disc there are two pieces (Op. 112) Calm Sea and Prosperous Voyage, which resembles the Mendelssohn overture only in the title. The two pieces are played without a break, the first in an atmosphere of deeply lyrical tranquillity, interrupted by a brief story passage which subsides into an excitingly joyous acclamation at a safe arrival. Two beautiful pieces of which it should take you quite a long time to tire.

★ ★ ★

**MENDELSSOHN—Complete Piano Music, Vol. 3. Rena Kyriakou (piano) with Walter Klein in the 4-hands works. World Record Club Stereo S/6556-7-8. (Three Discs in Box.)**

This massive issue was first made in France in 1961. I have only this box, which I chose myself because it contained among other pieces the great Fantasia in F Sharp and the E Major Sonata, works that have long been absent from the concert repertoire of leading pianists, at any rate in Australia. Their study should be useful to all pianists, whatever their standard. True, in order to get these a potential buyer will also have to buy the accompanying works in this box, many of which do not reach the exalted inspiration of the two mentioned above. The unevenness of some of the composer's writing will be made all the more obvious by comparison. Although the sound is mediocre in terms of present day techniques the surfaces of my pressings are reasonably clean though the piano tone is, to say the least, disappointing.

But you can hear quite enough of Ms Kyriakou's playing to recognise her as a fine pianist, particularly well-suited to the presentation of Mendelssohn's music. She never fails to impart to everything she plays that limpid quality that the music demands in combination with elegant phrasing. Despite this, there are examples of poor balancing when one hand is given wrong emphasis over the other in quite a disturbing way. This is particularly noticeable where the left hand accompaniment often sounds blurred against the clarity of the right. But if you feel that you wish to complete your knowledge of this repertoire I am afraid that this issue is even today the only one you might find available.

In the box under review, Volume 3, you will find the Fantasy in F Sharp Minor, Op. 28, Perpetuum Mobile, Op. 119, Sonata in G Minor, Op. 105, Sonata in E Major, Op. 6, Six Kinderstucke, Op. 72. Seven Pieces, Op. 7, Variations in B Flat, Op. 83a, Allegro Brillante, Op. 72 for Four Hands, Scherzo in B Minor, Etudes, Op. 104, Vol. 1, Preludes, Op. 104, Vol 2, Etude in F Minor and Variations in E Flat Major, Op. 82.



## Next best thing to a sound proof booth.

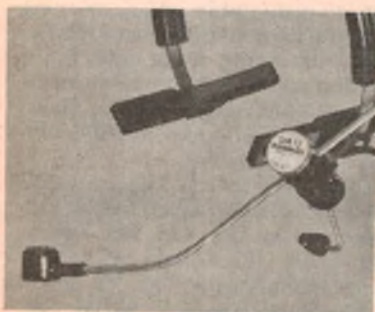

Shure's new headset microphones are coming through loud and clear. With their unique miniature dynamic element placed right at the end of the boom, Shure's broadcast team eliminates the harsh "telephone" sound and standing waves generated by hollow-tube microphones. The SM10 microphone and the SM12 microphone/receiver have a unidirectional pickup pattern that rejects unwanted background noise, too. In fact, this is the first practical headset microphone that offers a high quality frequency response, effective noise rejection, unobstructed vision design, and unobtrusive size.

Distributed in Australia by  
**AUDIO ENGINEERS PTY. LTD.**  
 342 Kent Street, Sydney. Write for catalogue.

**SHURE**®

**AUDIO ENGINEERS (Vic.)**  
 2A Hill Street  
 THORNBURY. 3071. Vic.

**RON JONES PTY. LTD.**  
 57 Castlemaine Street,  
 MILTON. 4064. Qld.

**ATHOL M. HILL PTY. LTD.**  
 1000 Hay Street  
 PERTH 6000 W.A.



# Lighter Side

Reviews of other recordings

## Devotional and organ

**THE LONGER I SERVE HIM.** George Beverly Shea. Stereo, Word WST-8671-LP. (From Sacred Productions Aust, 181 Clarence St, Sydney and other capitals.)

I was rather surprised to see this Bev Shea album turn up on the Word label rather than RCA, with whom he has been associated for so many years. And in place of the Nashville team is Kurt Kaiser and others from the Word Records organisation in Britain.

The most obvious difference is in the substitution of compositions and arrangements by Kaiser and other contemporaries for the hymns which have been over-exposed in the context of Billy Graham crusades: I Will Sing Of My Redeemer – Bring Back The Springtime – Until That Time – 'Tis The Blessed Hour Of Prayer – The Longer I Serve Him – Victory In Jesus – My Song For You – The Shadow Of The Cross – Would You – Oh, How He Loves You And Me.

While many of the titles may be strange to Bev Shea's admirers, they are completely in line with his theme "The Longer I Serve Him" and the diction is such as to let every word be understood.

There is generous orchestral and choral backing, appropriate for the voice of the veteran Gospel singer, but Bev Shea fans will see it for what it is – not just a performance but his own testimony in song. (W.N.W.)

★ ★ ★

**IN THE VOLUME OF THE BOOK.** The 2nd Chapter Of Acts. Stereo, Myrhh MSA-6542-LP. (From Sacred Productions Aust, 181 Clarence St, Sydney and other capitals.)

A fully imported album, recorded and processed in Hollywood, this is musically quite a mixed brew. "Start Every Day With a Smile" is a real "sweet music" effort but hard on its heels comes the hard rock number "Yaweh". After that, sweet music, hard rock and in-between sound is variously featured through the rest of the program:

Something Tells Me – The Grey Song – Now That I Belong To You – Ps. 63 – Prince Song – Morning Comes When

You Call – Borrowed Time – Last Day Of My Life – Hey, Whatcha Say – Keep On Shinin' – I Can't Get Near You.

I should make the point that, whatever the musical format, the 2nd Chapter Of Acts, as a group, maintain a very high performance standard and the recording itself is very clean, with a bass content that will really thump your speaker cones.

Whether you enjoy the album would depend on your musical tastes. If you belong to the "Sankey", "Alexander" or "Redemption" school you'd certainly choose something else. But, if a mixture of sound, traditional and mod, quickens your interest, then maybe you should sample a track or two of this new one by The 2nd Chapter Of Acts. (W.N.W.)

★ ★ ★

**E. POWER BIGGS plays the four Antiphonal Organs of the Cathedral of Freiburg.** Stereo, CBS, SBR-235761.

Where does one begin to comment briefly on a record like this? In case you don't know (I didn't) the Cathedral of Freiburg, in the Black Forest region of

Southern Germany, has four full-size organs disposed around its enormous interior—a building large enough to produce a reverberation time, by the sound of the record, of about 4 seconds. Each organ has its own console but E. Power Biggs uses a fifth central console from which all four organs can be played, bringing together the equivalent of 10 manuals and 4 pedal divisions. For the organ buff, the jacket carries pictures, a diagram of the layout and a stop list for all four instruments.

There are some 16 tracks on the two sides, some of them quite brief, drawing on the music of Handel, Mozart, Buxtehude, Purcell, Krebs, Banchieri, Soler and Campra. Biggs handles them all with commendable facility, which is at least a basic requirement but, in a situation like this, attention must inevitably focus on the resources rather than the music itself.

Technically, the sound is clean and, surprisingly, each new note seems to be clearly audible before it joins the huge reservoir of reverberant sound. But there is one frustrating aspect; the four organs have been "folded" into the stereo channels as two pairs and, while different sounds emerge from left and right, one cannot always be sure which organ is which.

Having listened to a few tracks in stereo, I ultimately opted for simulated quadraphonic. There is no way that it could relocate the organs accurately but it certainly split and spread the various ranks and helped create something of the atmosphere of what must surely be the surround sound experience to end all surround sound experiences.

Having said all that, I still haven't said much but, as you might gather, it's a record that the organ buff can hardly afford to pass up. (W.N.W.)

## Instrumental, Vocal and Humour

**BADEN POWELL.** Face au Public. Barclay L35742 Festival release.

I understand Baden Powell hails from Brazil and this fact is fairly obvious from the flavour of this interesting record of nine varied tracks, ranging from Bach's 'Jesu, Joy Of Man's Desiring' to 'The Girl From Ipanema'. Other titles are: A Lendo Do Abaete – Marche Ecossaise – Berimbeau – Tristeza – Samba Triste – Chanson De L'Adieu – Consolacao.

The recording is something of a cosmopolitan effort, being recorded in Japan, released by a French company initially, with titles in French and Spanish!

Normally, Baden Powell is heard as a solo guitarist but in this case leads an anon. quartet. Except for the first track on the second side, which has strange sounds as if it had been recorded in a parrot cage, the overall quality is superb and really enjoyable. (N.J.M.)

**MUSIC OF JOHANN STRAUSS Jnr.** Henry Krips conducting the Adelaide Symphony Orchestra. RCA Victrola stereo VVL1-0082.

For the fans of Johann Strauss Jnr here is a very pleasant album made all the more interesting for the fact that it was produced under the direction of Henry Krips who is now retired. He and Josef Krips were (and still are) noted conductors in the Australian scene. RCA and ABC are to be congratulated for releasing this album. There must be the making of many more within the libraries of the ABC.

Recording quality was good, although my copy was marred by surface noise at times.

Track titles are: Gypsy Baron Overture – Where The Lemons Bloom (waltz) – Czech Polka – Wine, Women And Song (waltz) – Morning Papers (waltz) – New Pizzicato Polka – Vienna Bonbons (waltz). (L.D.S.)

# E.D.&E. (SALES) PTY. LTD.

## EDUC-8 COMPUTER—COMPLETE KIT

(OCT-NOV-DEC 1974)

**\$368.75 (Plus Tax)**

OR INDIVIDUAL COMPONENTS  
AS REQUIRED

K  
I  
T  
S

K  
I  
T  
S

**MAJOR STOCKISTS OF ALL GENERAL RADIO & ELECTRONIC COMPONENT PARTS — YOU NAME IT — WE WILL QUOTE**

Valves — Transistors — Zener & Power Diodes — Semi-Conductors — Diacs — Triacs — S.C.R.'s — I/C's. Speakers — Microphones — Coils — IFT's. Transformers — Inst Cases — Metalwork. Players & Changers — Meters — Relays — Condensers — Resistors — Bezels — Styli — Cartridges — Recording Tape — Probes — Instruments — Potentiometers — Crystals — Ferrite Beads — Cores — Baluns — Terminals — Co-Axial Plugs & Sockets — Multi Connectors — Printed Circuit Boards — Copper Winding — Wire — Etc. — Etc.

## POPULAR KITS — TOP QUALITY — LOWEST PRICES

### AUDIO

- 1 Direct Reading A.F. Gen.
- 2 SQ Wave Gen-10Hz-1MHz.
- 3 Solid State A.F. Gen.
- 4 Additive Freq Meter
- 5 A.F. Tone Burst Gen.
- 6 Laboratory Solid State A.F. Gen.
- 7 Scaler/Divider Unit.
- 8 Crystal Freq Calibrator
- 9 Direct Reading A.F. Meter (0-200KHz — 10MV-2V)
- 10 High Performance A.F. Gen.
- 11 White Noise Gen.
- 12 —
- 13 —
- 14 —

### AUTOMOTIVE UNITS

- 15 Tacho & Dwell Angle for Service Stations
- 16 Dwell Extender Unit.
- 17 Solid State — CDI
- 18 All Electronic Ignition System.
- 19 Windscreen Vari-Wiper
- 20 Tacho & Dwell Unit
- 21 Brake Light Warning
- 22 Emergency Flasher
- 23 High Efficiency Flasher.
- 24 Solid State Volt Reg.
- 25 Car Theft Alarm System
- 26 Ignition Analyser & Tachometer Unit.
- 27 Strobe Adaptor for Ignition Analyser
- 28 Car Burglar Alarm
- 29 1975 C.D.I. Unit

### BATTERY CHARGERS

- 30 6 Volt — 1 Amp
- 31 12 Volt — 1 Amp
- 32 Automatic H/Duty
- 33 1-14 Volt — 4 Amp
- 34 1973 Automatic Unit
- 35 Constant Current Unit
- 36 —
- 37 —

### CONVERTERS — INVERTERS

- 38 12 VDC 300/600V 100W.
- 39 12 VDC 240 VAC 20W
- 40 12 VDC 240 VAC 50W.
- 41 24 VDC 300 VDC 140W
- 42 24 VDC 800 VDC 160W
- 43 —
- 44 —

### C.R.O. UNITS

- 45 1963 3" Calibrated.
- 46 1966 3" C.R.O.
- 47 1968 3" Audio C.R.O.
- 48 C.R.O. Electronic Switch.
- 49 C.R.O. Wideband P/Amp
- 50 C.R.O. Calibrator.
- 51 —
- 52 —

### INTRUDER WARNING SYSTEM

- 53 Electronic Thief Trap
- 54 Infrared Alarm System.
- 55 Simple Burglar Alarm
- 56 Light Beam Relay
- 57 Car Burglar Alarm.

### MULTIMETERS & V.O.M.

- 58 Protected D.C. Multimeter.
- 59 Meterless Voltmeter.
- 60 Wide Range Voltmeter.
- 61 F.E.T. D.C.
- 62 1966 V.T.V.M.
- 63 1968 Solid State V.O.M.
- 64 1973 Digital V.O.M. (1)
- 65 1973 Digital V.O.M. (2)
- 66 High Linearity A.C. Millivoltmeter
- 67 —
- 68 —

### PHOTOGRAPHIC UNITS

- 69 50 Day Delay Timer
- 70 Regulated Enlarger Line
- 71 Slave Flash Unit
- 72 Sound Triggered Flash
- 73 Solid State Timer.
- 74 Auto Trigger For Time Lapse Movies
- 75 —
- 76 —

### REGULATED POWER SUPPLIES

- 77 Laboratory Type 30/1 Unit.
- 78 Laboratory Type Dual Power Supply
- 79 Serviceman's Power Supply
- 80 Solid State H.V. Unit
- 81 IC Variable Supply Unit
- 82 1972(C) Unit (E.T.)
- 83 Simple 5V 1A Unit
- 84 Simple 3-6V 3.5A Unit
- 85 S/C Proof 0.30 VDC at 1A
- 86 Reg 0.30VDC at 3A O/L Protected
- 87 Variable Reg 12V-05A
- 88 Reg O/Load & S/C Protection 60 VDC at 2A (1973) — EA.
- 89 —
- 90 —

### R.F. INSTRUMENTS

- 91 Solid State Test Osc.
- 92 Signal Injector & R/C Bridge
- 93 Solid State Dip Osc
- 94 'Q' Meter
- 95 Laser Unit
- 96 Digital Freq Meter 200KHz
- 97 Digital Freq Meter 70MHz
- 98 IF Alignment Osc
- 99 27MHz Field Strength Meter
- 100 100KHz Crystal Cal.
- 101 1MHz Crystal Cal
- 102 Solid State Dip Osc.
- 103 V.H.F. Dip Osc
- 104 V.H.F. Powermatch

- 105 V.H.F. F/S Detector.
- 106 S.W.R. Reflectorometer.
- 107 R.F. Impedance Bridge
- 108 Signal Injector.
- 109 1972 FET Dipper.
- 110 Digital Freq Meter
- 111 Simple Logic Probe.
- 112 Frequency Counter & DVM Adaptor
- 113 Improved Logic Probe
- 114 Digital Logic Trainer.
- 115 Digital Scaler/Preamp
- 116 Digital Pulser Probe
- 117 Antenna Noise Bridge
- 118 Solid State Signal Tracer
- 119 1973 Signal Injector.
- 120 Silicon Diode Sweep Gen.

### TRAIN CONTROL UNITS

- 124 Model Control 1967
- 125 Model Control with Simulated Inertia
- 126 Hi-Power unit 1968
- 127 Power Supply Unit
- 128 SCR PUT Unit 1971
- 129 SCR-PUT Unit with Simulated Inertia 1971
- 130 Electronic Steam Whistle.
- 131 Electronic Chuffer.

### TV INSTRUMENTS

- 134 Silicon Diode Sweep Gen
- 135 Silicon Diode Noise Gen
- 136 Transistor Pattern Gen
- 137 TV Synch & Pattern Gen.
- 138 Cross Hatch & Bar-Gen

### VOLTAGE CURRENT CONTROL UNITS

- 142 Auto Light Control
- 143 Bright/Dim Unit 1971
- 144 S.C.R. Speed Controller
- 145 Fluorescent Light Dimmer.
- 146 Autodim-Triac 6 Amp
- 147 Vari-Light 1973
- 148 Stage. etc. Autodimmer 2KW.
- 149 Auto Dimmer 4 & 6KW

### RECEIVERS—TRANSMITTERS—

- CONVERTERS**
- 153 3 Band 2 Valve
  - 154 3 Band 3 Valve
  - 155 1967 All Wave 2
  - 156 1967 All Wave 3
  - 157 1967 All Wave 4
  - 158 1967 All Wave 5
  - 159 1967 All Wave 6
  - 160 1967 All Wave 7
  - 161 Solid State FET 3 B/C
  - 162 Solid State FET 3 S/W.
  - 163 240 Communications RX
  - 164 27 MHz Radio Control RX
  - 165 All Wave IC2
  - 166 Fremodyne 4-1970
  - 167 Fremodyne 4-1970
- R.F. Section Only**
- 168 110 Communications RX
  - 169 160 Communications RX

- 170 3 Band Preselector
- 171 Radio Control Line RX
- 172 Deltahat MK2 Solid State Communications RX
- 173 Interstate 1 Transistor Receiver
- 174 Crystal Locked H.F. RX
- 175 E/A 130 Receiver
- 176 E.A. 138 Tuner/Receiver
- 177 Ferranti IC Receiver
- 178 Ferranti IC Rec/Amp
- 179 7 Transistor Rec
- 180 —
- 181 —

### TRANSMITTERS

- 182 52MHz AM
- 183 52MHz Handset
- 184 144MHz Handset.

### CONVERTERS

- 187 MOSFET 52MHz
- 188 2-6MHz
- 189 6-19 MHz
- 190 V.H.F.
- 191 Crystal Locked HF & VHF /

### AMPLIFIERS PREAMPS & CONTROL UNITS MONAURAL.

- 194 Mullard 3-3.
- 195 Modular 5-10 & 25 Watt

### STEREO

- 196 1972 PM 129 3 Watt
- 197 Philips Twin 10-10W
- 198 PM 10 + 10W
- 199 PM 128-1970
- 200 PM 132-1971
- 201 ETI-425 Amp & Preamp
- 202 ETI-425 Complete System
- 203 ETI-416 Amp
- 204 PM 136 Amp 1972
- 205 PM 137 Amp 1973
- 205A PM 143

### GUITAR UNITS

- 209 P/M 125 50W
- 210 E/T 100 100W
- 211 P/M 134 21W
- 212 P/M 138 20W
- 213 Modular 200W
- 214 Reverb Unit
- 215 Waa-Waa Unit.
- 216 Fuzz Box
- 217 Sustain Unit

### PUBLIC ADDRESS UNITS

- 219 Loud Hailer Unit
- 220 P.A. Amp & Mixer.
- 221 P/M 135 12W
- 222 Modular 25W
- 223 Modular 50W

### CONTROL UNITS

- 225 P/M 112
- 226 P/M 120
- 227 P/M 127

### MIXER UNITS

- 229 FET 4 Channel
- 230 ETI Master Mixer.
- 231 Simple 3 Channel

### TUNER UNITS

- 232 P/M 122
- 233 P/M 123
- 234 P/M 138
- 235 Simple B/C
- 236 PM 146 AM-FM

### PREAMPLIFIERS

- 237 Silicon Mono.
- 238 Silicon Stereo
- 239 FET Mono
- 240 Dynamic Mic Mono.
- 241 Dynamic Mic Sterco
- 242 P/M 115 Stereo.
- 243 —

### MISCELLANEOUS KITS

- 244 Geiger Counter.
- 245 Direct Reading Impedance Meter
- 246 —
- 247 Electronic Anemometer
- 248 Simple Proximity Alarm
- 249 Pipe & Wiring Locator
- 250 Resonance Meter
- 251 Electric Fence
- 252 Metronome Ace Beat
- 253 Transistor Test Set
- 254 Electronic Thermometer.
- 255 Flasher Unit
- 256 Lie Detector
- 257 Metal Locator
- 258 Stroboscope Unit
- 259 Electronic Canary
- 260 240V Lamp Flasher.
- 261 Electronic Siren
- 262 Probe Capacitance Meter.
- 263 Moisture Alarm.
- 264 AC Line Filter
- 265 Proximity Switch
- 266 Silicon Probe Electronic Thermometer
- 267 Transistor/FET Tester
- 268 Touch Alarm
- 269 Intercom Unit
- 270 Light Operated Switch
- 271 Audio/Visual Metronome
- 272 Capacitance Leakage
- 273 Audio Continuity Checker.
- 274 Bongo Drums
- 275 Simple Metal Locator
- 276 Keyless Organ.
- 277 Musicolour
- 278 Stereo H/Phone Adaptor.
- 279 Attack Decay Unit
- 280 Tape Recorder Vox Relay
- 281 Tape Slide Synchroniser
- 282 Tape Actuated Relay
- 283 Auto Drums
- 284 IC Vol Compressor
- 285 Audio Attenuator.
- 286 Thermocouple Meter
- 287 Door Monitor.
- 288 Earth "R" Meter
- 289 Shorted Turns Tester.
- 290 Zenor Diode Tester
- 291 Morse Code Osc
- 292 Simple Electronic Organ.
- 293 Pollution & Gas Analyser
- 294 Universal H/Phone Adaptor.
- 295 Super Stereo ETI 410.
- 296 'O' Multiplier
- 297 Optomin

PHONE  
662-3506

**E. D. & E. (SALES) PTY. LTD.**  
118 LONSDALE STREET, MELBOURNE — 3000 — VIC.

PHONE  
662-3506

## LIGHTER SIDE—continued

**SINFONIA.** The light classics interpreted by birds of Brazil and orchestra under direction of Johan Dalgas Frisch. Intefusion stereo L35748.

The idea of light classics played against a background of exotic bird calls may seem corny to some but it can make quite a pleasant change. Not that the birds are in any way disciplined. They just sing away naturally and the orchestra plays in the foreground. Have a listen before you buy it to see if it appeals. Recording quality is good.

Track titles are: Blue Danube — La Paloma — Tico Tico — In Fuba — Sukiyaki — Santa Lucia — Humoresque — Fantasy Of The Air — Above The Waves — Reverie — The Roller Skaters — The Song Of The Red Mill — Loch Lomond. (L.D.S.)

★ ★ ★

**GREAT ACTION FILM THEMES.** United Artists L25250 Festival release.

For the dedicated movie buff we have another dozen film themes to demonstrate the capabilities of your 'Hi-Fi' to unsuspecting neighbours. The titles are: They Call Me Mister Tibbs — You Only Live Twice — In The Heat Of The Night — Z — Fist Of Fury — The Third Man — Shaft — The French Connection — Diamonds Are Forever — Topkapi — Enter The Dragon — The Man With The Golden Arm.

The quality varies from track to track as could be expected, considering the years covered. At the price of \$3.99 it would make a fair 'demo' disc but certainly not to be used as a background to dining! (N.J.M.)

★ ★ ★

**HOLLYWOOD THEMES.** Conducted by Leroy Holmes. United Artists stereo L 45625/6. 2-record set \$7.95.

It might be thought that a 2-record set of movie themes would be boring fare, but in fact, there are some memorable tunes included here. Unfortunately, most of the album is marred by the rather strident recording quality. So if you like the selection, listen carefully before buying.

In all, there are twenty tracks: Airport Love Theme — The VIPs — Women In Love — Of Human Bondage — Lenny — Thoroughly Modern Millie — The Night They Raided Minsky's — Bonnie & Clyde — Chitty Chitty Bang Bang — Star — The Lion In Winter — Zorba The Greek — Topkapi — For A Few Dollars More — The Good, The Bad & The Ugly — Pieces Of Dreams — Summer Of '42 — Romeo & Juliet — You & I (from "Goodbye Mr Chips) — We (Me Natalie). (L.D.S.)

★ ★ ★

**MARIA ELENA.** Los Indios Tabajaros. RCA Gold Seal stereo ANL1-1179.

Here is a re-issue of one of the first albums made by Los Indios Tabajaros. At the economy price of \$3.99 it makes very pleasant listening — romantic guitars with

an "exotic tropical" atmosphere. Some tape hiss evident but it is not obtrusive. A good buy.

Track titles are: Maria Elena — Maran Cariua — Los Indios Danzan — Baion Bon — A La Orilla Del Lago — Moonlight Serenade — Pajaro Campana — Ay Maria — Star Dust — Vais Criolla — Ternura — Jungle Dreami (L.D.S.)

★ ★ ★

**TIP OF THE ICEBERG.** Enoch Light Presents The Dynamic Sounds Of Jeff Hest. Project 3 L 35589. Festival Release.

This recording is of "Contemporary Jazz Rock", according to the cover notes. It is arranged and supervised by Jeff Hest, who also composed most of the tracks. Just where Enoch Light comes into it is not very clear. Twenty musicians and singers are featured, and the cover gives details of exactly who plays what and when.

Tracks featured are: Got A Hold On —

## MORE "EASY LISTENING" CASSETTES

**HAMMOND A LA BANANA.** Otto Weiss and his Ensemble. Stereo Dolby cassette, Contata A-124. (From Goldring Sales & Service in all states.)

A few weeks back I reviewed a companion tape "Hammond A La Melone" without any clue as to its source. This one, carrying a comparable title and cheesecake frontispiece, does identify the music with Otto Weiss, so he may as well collect the credit for both!

The music is typical early-style Hammond, with simple melody lines flowing against a lively percussion background provided (who can tell?) by a mix of synthetic and human percussionists.

On this occasion, anyway, Otto Weiss applies his up-tempo techniques to a mix of pop and slightly traditional fare: Narcissus — Roses In Tirol — Love Dream — Oh, Mary — Greensleeves — Danny Boy — Melody In F — I'm Sorry — Two Guitars — Dance Of Time — Alo Ahe — Cielito Lindo.

You will know whether you like a mix or percussion and old-style Hammond (with modern Leslie) but, if you do, here's another one. Recording quality is fine. (W.N.W.)

★ ★ ★

**THE MAGIC TRUMPET.** Stereo cassette, Dolbyised, Contata AA-121. (Distributed by Goldring Sales & Service.)

I can't tell you a thing about the solo trumpeter or the backing orchestra, except to say that he's good, and they're good, in the easy listening manner. Twelve tracks of trumpet lead could possibly be too much of a good thing for some, although Contata do their best to

Squawk Talk — La Guija (The Lizard) — Tip Of The Iceberg — Mercy, Mercy, Mercy — Where The Grass Is Green. To my view, the music leans more towards jazz than rock, but no doubt there will be those who disagree, and think the exact opposite. Such things aside, however, this record makes very pleasant listening.

Hi-Fi fanatics will be pleased to learn that this record was originally mastered on 35mm magnetic film — as were many Enoch Light records, a few years back. Certainly, the recording is very clean, with almost no background noise, and these qualities will show up on good equipment. (D.W.E.)

★ ★ ★

**THE BEST OF AL HIRT.** RCA Gold Seal stereo ANL1-1034.

Here is another bargain re-issue from RCA. Not only does it contain some phenomenal horn-blowing by Al Hirt but the recording quality on some of the tracks is unbelievably good. Other tracks are marred by recurring tape hiss but do not let that deter you. All round it's a

vary the mood; but then, of course, you can play one side at a time:

To Elise (Beethoven) — Love Dream (Liszt) — Virgin's Prayer — Down The Valley — Expression Of Your Sympathy — Danny Boy — Oh Happy Day — The Little Bell — Glory, Glory, Hallelujah — Stenka Rasin — Russian Lullaby — House Of The Rising Sun.

A mixed bag for sure, but they have this in common; they're tuneful and rhythmic and they won't distract you from the task in hand, be it driving or eating! Quality is excellent and playing time about 28 minutes. (W.N.W.)

★ ★ ★

**MOTORING MUSIC 3.** Stereo, Dolby cassette, Contata A-107. (Distributed by Goldring Sales & Service.)

The credits for this "happy sound" cassette mention the Gil Vermont and Albert Lizzio Orchestra with the Branjo Hronez Sound, the Cornely Singers and Henry Arland. With those resources, the producers manage to vary the nature of the sound from track to track, even if they have to avoid dynamic excursions, either up or down! The tracks:

African Beat — Love Story — Miracles Always Happen Again — It Is Not Too Late — Kiki — La Golondrina — Lara's Theme — Gangster March — Du — Clarissa — The Most Beautiful Day — Nobody Knows Why — Scotch Party — Adios.

Like all the other Contata cassettes, it is Dolbyised on TDK tape, and comes through a Dolbyised deck without a trace of noise or distortion. On a conventional deck, simply turn down the treble a whisker. Happy Motoring! (W.N.W.)

EDS 517007

# RADAR BURGLAR ALARM

FOR  
EVERYBODY

as published in  
E.A. March, 1976

HANDYMAN  
INSTALLATION

- CL8963/H Home Alarm. \$106.00
- CL3 Horn Speaker for CL8963/H. \$10.00.
- SPS8 Power Supply. \$12.00.
- SBC2 Trickle Battery Charger \$40.00.
- SH2 Antenna increases range of CL8963 three times. \$22.00.

All prices plus 15% S/T.  
P&P \$3.00 N.S.W.  
\$3.50 all other states.

## OTHER SERVICES

Design  
Industrial Repairs  
Production Works  
Wire Wrapping

Also:  
Speed Measurement  
Anti-collision Door Openers



**ELECTRONIC  
DEVELOPMENTS AND  
SERVICE PTY. LTD.**  
27 BUCKLEY ST.,  
MARRICKVILLE.  
N.S.W. 2204

EDS 517007

## LIGHTER SIDE—continued

beaut album as a stereo demo or just for the spectacular horn-blowing. And the tunes are all old favourites.

There are twelve tracks: Java – Stranger In Paradise – Bourbon Street Parade – the Best Man – Stella By Starlight – Holiday For Trumpet – I Love Paris – Sugar Lips – Poor Butterfly – Cotton Candy – Love Makes The World Go 'Round – When The Saints Go Marching In. (L.D.S.)

★ ★ ★

**MIDNIGHT RAINBOWS.** Joe South. Island Records stereo L 35752. Distributed by Festival Records Pty Ltd.

This is the first album Joe South has made in almost four years and I can assure readers that he has not lost his touch. Rather the opposite. There is at least one sure hit on the album: "To Have, To Hold And Let Go". His songs are easy to follow and generally have a message that the listener can identify with. The listener can also sing along as the lyrics to all but one of the songs are included on the album inner sleeve. Recording quality is very good.

Apart from the track already mentioned the others are: Midnight Rainbows – It Got Away – You Can Make It If You Try – God Forgave Me – My Fondest Memories – For Your Precious Love – Stranger In A Strange Land – Home And Homesick – Glad To Be Living On The Earth Today – Cosmos. (L.D.S.)

★ ★ ★

**THE ANITA KERR SINGERS.** Stereo, RCA APLI-1166.

This is a record I could happily play time and time again, for the sheer vocal beauty of the performance right through.

Known best as a backing group on a lot of RCA's 'Nashville' sound records, they appear here on their own in eleven tracks, I'll Play For You – At Seventeen – Love Won't Let Me Wait – I'm Not Lisa – Before The Next Teardrop Falls – Another Somebody Done Somebody Wrong Song – Every Time You Touch Me I Get High – I Love – Love Will Keep Us Together – The Masterpiece – Your Loves Return.

As usual with Nashville records, the quality is excellent; in short a record every ballad lover should have in their collection. Close 'miking' has given a personal touch to the sound that is very pleasant. (N.J.M.)

★ ★ ★

**THE BEST OF ABBA.** RCA Victor stereo VPL1-4020.

Abba is one of the many groups these days whose audience are mainly in the age-group from about 9 to 12. I suppose that makes a review of their album in these pages inappropriate (on the other hand, many may think otherwise). However, their music makes good

background for dancing at a party. My one gripe with the album concerns the recording quality. It is so poor that some tracks will be totally unacceptable to "hifi" ears. And on many tracks the voices are almost drowned out by the instrumental accompaniment. If this is the album of your choice, listen before you buy.

Track titles are: Waterloo – Ring Ring – Honey, Honey – Mama Mia – People Need Love – Nina, Pretty Ballerina – I Do, I Do (ad nauseam) – SOS – Dance While The Music Goes On – Bang-A-Boomerang – Hasta Manana – So Long. (L.D.S.)

★ ★ ★

**HOME.** Loretta Lynn. MCA Records MAPS 8089. Astor Release.

It seems only a short time since I last reviewed an album by this artist. Checking back, I find it was in September 1975. Once again, this album seems to mainly feature sad love songs: Home – Before The Next Teardrop Falls – The Window Up Above – (Hey, Won't You Play) Another Somebody Done Somebody Wrong Song – You Take Me To Heaven Every Night – Wrong Road Again – Always Wanting You – No Place Else To Go – He's Only Everything – Bring Some Of It Home.

In fact, my impression of this album is that it is a little unbalanced; there are no lighter songs included, as was done on the previous album. After listening to all the tracks, I found that I was in need of something a little flippant. This is not to criticise the songs included, however, they are all good songs sung well; it's just that they are all of the one style!

On the technical side, quality seems to have deteriorated a little, as I could detect some traces of background crackle. However, in other respects, the reproduction was extremely good, with some very effective stereo effects. (D.W.E.)

★ ★ ★

**PACO DE LUCIA.** Flamenco guitarist. Philips stereo 6328 171.

Paco De Lucia is acknowledged by many critics to be one of the world's leading flamenco guitarists but I feel he is not shown to best advantage on this album. Many of the tracks seem pedestrian by comparison with the lively nature of most flamenco music. Also contributing to the apparent lack of lustre is Paco's guitar which seems slightly flat – or was I reacting to a marginal speed error?

Recording quality is very good, however, and surface noise is low.

Track titles are: Panaderos Flamencos – Andalucia – Cepa Andaluzia – Impetu – Aires Choqueros – Entre Dos Aguas – Mantilla De Feria – Punta Umbria – Plazuela – Percusion Flamenca. (L.D.S.)



PSI-FI. Seventh Wave. Stereo. Gull GULP 1010. Astor Release.

Seventh Wave is a three man band who appear to go in for "glitter rock" and its derivatives. Aided by a large group of studio musicians, they have produced a moderately interesting record, laced with lots of synthesiser type musical effects. I cannot really compare their music with that from any other group that I know of.

To my ears, it sounds like a cross between hard rock, science fiction music, and nightmares! Even though most readers will not have heard of these songs before, some of the titles make quite interesting reading. In order, they are: Return To Foreverland - Roads To Rome - Manifestations - Loved By You - Only The Beginning - Aether Anthem - Astral Animal - El Tooto - Camera Obscura - Star Palace Of The Sombre Warrior.

After all that, you may be somewhat surprised to find that all of the tracks are listenable, and some of them are even musical! Definitely though, this record is really only for enthusiasts, so if I haven't put you off already, go ahead. Technically, the record is quite good, with some tracks having quite a wide dynamic range. (D.W.E.)

★ ★ ★

SEPTEMBER. Stud. BASF stereo 20 29054. Available from Sound & Film Enterprises of Australia Pty. Limited, 122 Chapel Street, St. Kilda, Victoria 3182.

Stud is a four man band, composed of former members of "Taste", "Blossom Toes" and "Family". They seem to favour slower numbers, because no real uptempo tracks are included, with the exception of the last track, which has a definite country and western flavour. It is difficult to pin a label to them; perhaps the best that can be done is to call them a "small 'r' rock and Roll' band, putting emphasis on the roll part rather than the rock!

Tracks featured are: Good Things - God Knows - Corner - Life Without Music 8 - Samurai - Five To Mid-Day - Prelude - Bad Handin' - Ocean - Boogie - Red Wine.

The first tracks on each side were the ones that appealed most to me, the lead vocals of Jim Cregan being particularly pleasant on these two tracks.

Recording quality is excellent, with very little background noise. The guitar work is particularly clean, and most of the vocals can be understood without too much difficulty.

## Ray Thornley: "most entertaining"

RAY THORNLEY ENTERTAINS. Vol 1. Stereo, Parker PKS-012. (Parker Recordings, P.O. Box 134, Toongabbie, NSW 2146.)

"Ray Thornley Entertains" is, indeed, one of the most entertaining records you'll come across in many a long day, whether or not you're an organ enthusiast. The endorsement "Vol 1" will almost certainly create a demand for more programs.

A local artist, Ray Thornley combines a flair for arrangement with outstanding ability at the keyboard. Over-recording is used freely in this production, with a grand piano supplementing the organ's own voices, but the jacket notes by Les Flanagan assure the listener that Ray Thornley plays every instrument on the disc, real or simulated.

In a program that varies widely in style and mood, Ray Thornley plays: That's Entertainment - Great Race Selection - Tara's Theme - In The Mood - Brother Sun, Sister Moon - The Old Piano Roll Blues - The Holy City - Duelling Banjos - Marche Militaire - Killing Me Softly - Anchors Aweigh.

While multi-track organs are nothing new, this one stands out as more than the merging of two solo efforts: Ray Thornley manages to create an overall orchestral effect that almost compels a mental image of a complete orchestra.

A couple of months back, I recommended enthusiastically Cliff Bingham and his solo Thomas. This one is different in concept but I must equally recommend Ray Thornley and his not-so-solo Lowrey Theatre model. They're a brace of albums by a couple of younger generation Australian organists, able to hold their own in any company! (W.N.W.)

# Why pay high prices for cermet?

The advantages of Cermet are well known. They are small, robust and totally enclosed. They have low thermal coefficients and high power-dissipation characteristics. They are very stable under wide variations in working conditions.

## Soanar-Noble Cermet Trim Potentiometers

Offer you the same advantages but at real down-to-earth prices.

Soanar-Noble VTP Cermet are available in a range of values from 100Ω to 1 meg and are designed for horizontal PCB mounting with vertical trim adjustment.

Terminations conform to the standard .1" grid spacing.

Ratings are .5 watts over the temperature Range — 30°C to +80°C.

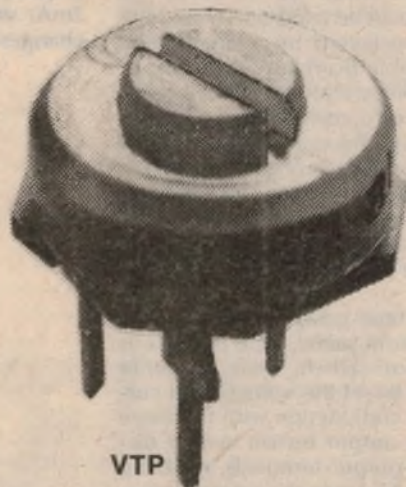

An enclosed, low cost cermet ideal for P.C.B. mounting.

TECHNICAL LITERATURE AVAILABLE ON REQUEST

**SOANAR ELECTRONICS PTY. LTD.**

SALES OFFICES VICTORIA: 89 0661  
N.S.W.: 78 0281  
S. AUST.: 51 6981  
QUEENSLAND: 52 5421  
W. AUST.: 81 5500

30 Lexton Road, Box Hill, Vic., 3128,  
Australia. Telex: 32286



# New Products

## Trio PR-652 lab-type supply

The Trio model PR-652 all solid state regulated DC power supply unit features two large size meters reading load voltage and current, continuously adjustable voltage and current levels, and provision for both remote sensing and remote programming.

As can be seen from the accompanying photograph, the unit is mounted in a large rectangular case, fitted with a carrying handle on top. The maximum external dimensions are 200mm (height) x 209mm (width) x 293mm (depth). All up weight is 8.5kg.

Access to the interior of the instrument is obtained by removing the top cover. Internal space is dominated by a massive transformer and a single large printed circuit board. The remaining components are mounted on the front and back panels. The back panel is formed by two massive heatsinks, each fitted with a single power transistor.

Accessories supplied with the unit are a comprehensive instruction manual, which included block and circuit diagrams, and spare fuses. The unit will operate with either 50 or 60Hz AC supplies, and can be used on 117 or 230V lines. This is selected by a small slider switch accessible from inside the case.

The unit will operate as either a constant voltage or a constant current supply. Changeover between the two modes is automatic. The output voltage is adjustable from zero volts to in excess of eighteen volts, while current is adjustable from zero to three amps. The voltage and current levels are indicated by the two large meters.

There are three push button switches fitted to the front panel. One of these is the main on/off switch, while the other two are used to set the voltage and current levels, in conjunction with the three controls. The output on/off switch disconnects the output terminals, enabling the voltage to be set to the correct value. This is easily done using the coarse and fine controls immediately underneath the right-hand meter.

The current check switch disconnects the positive output line while shorting the output of the supply. The left-hand meter then reads the current level, which can be adjusted using the current level control.

In use, the unit supplies power to the load in a constant voltage mode till the

preset current limit is reached. Then the unit switches over to the constant current mode. The particular operating mode in use is indicated by one of two appropriately labelled LED lamps.

In the constant voltage mode, output voltage variation due to line changes is specified to be within plus or minus 5mV, while the variation due to load changes is specified as less than 2mV. The output ripple (including noise), is specified as less than 1.5mV p-p. The unit submitted for review proved to be within these specifications, except for output ripple, which we measured as being less than 2mV p-p on both full and no load. This is of course only slightly higher, and still quite low.

In the constant current mode, the output current variation due to line changes is specified as being within plus or minus 2mA, while the variation due to load changes is specified to be less than 3mA.

The output ripple (including noise), is specified as less than 1mA p-p. Once again, the unit proved to be within these specifications.

We were unable to check the quoted transient response time (less than 3ms), or the temperature characteristics. Quoted operating temperature range is -10 to +50 degrees Celsius.

Three output terminals are provided, the centre one being chassis connection. This may be bridged to either the positive or negative terminal using the strap supplied.

At the rear of the case are ten screw terminals and a number of straps. These allow the unit to be connected as a remote sensing regulator. If an external potentiometer is available, the unit can also be used with remote programming. Furthermore, several similar units can be connected together in a master-slave arrangement to allow either increased voltage or current levels. Full details of the exact interconnections required are given in the instruction manual.

Summing up, the Trio PR-652 regulated DC power supply appears to be a well thought out and constructed unit, which would be equally at home in a commercial design lab. or on an experimentors bench. We found it to be easy to use, with the large meters being particularly handy.

The PR-652 is available from Parameters Pty Ltd, 68 Alexander Street, Crows Nest, NSW 2065. It is priced at \$165.00, plus 15% sales tax if applicable. It is one of a set of four similar units, the others being the PR-651 (1½A @ 18V, \$135.00 plus 15% tax), the PR-653 (1½A @ 35V, \$148.00 plus 15% tax), and the PR-654 (3A @ 35V, \$231.00 plus 15% tax). (D.W.E.)



Featuring two meters and dual constant current/constant voltage modes, the PR-652 is a versatile lab-type power supply.

# Commodore SR4148 Scientific Calculator

This small handheld calculator has full scientific notation, uses algebraic logic, has a large complement of special functions, and is fitted with nickel-cadmium rechargeable batteries. An adaptor/recharger unit is supplied, along with a vinyl protective case.

The Commodore SR 4148 calculator has 48 colour coded and labelled keys for entering numbers and operating instructions, as well as a small sliding on/off switch. Answers are displayed on a LED readout, capable of displaying numbers between  $1.0 \times 10^{-99}$  and  $9.999999999 \times 10^{99}$ . The display converts from normal to scientific notation and back again automatically. Numbers can also be entered directly in scientific notation.

All of the keys have a single function, allowing numbers and instructions to be entered quickly and easily. Eleven white keys are used to enter the digits 0 to 9, the remaining key being a decimal point (.). Five blue keys are used for the standard arithmetic operators,  $\times$ ,  $\div$ ,  $+$ ,  $-$  and  $=$ .

The remaining keys are used for various specialised operations. The red CLEAR key will delete an incorrect numerical entry, leaving all previous entries intact. When pressed a second time, the remainder of the calculator is cleared. The PI key generates this constant accurate to ten figures.

A key is provided to reverse the sign of the display, and also one to exchange the x and y registers. Numbers are normally entered into the x register, but can be entered into the y register using this key to enable various calculations to be made.

Keys are provided enabling direct calculation of the following functions:  $1/x$ ,  $x^2$ , square root of x,  $10^x$ ,  $\log x$ ,  $1n x$ ,  $e^x$ ,  $\sin x$ ,  $\cos x$ ,  $\tan x$ , arc  $\sin x$ , arc  $\cos x$ , arc  $\tan x$ ,  $y^x$  and the  $x^{\text{th}}$  root of y. First level parenthesis keys are also provided, enabling a second level of priority in arithmetic calculations.

A key is provided enabling direct conversion from degrees to radians and back again. The calculator is normally in the degree mode when first turned on. When this key is operated, any number on display is converted to radians, and a decimal point on the extreme right of the display is illuminated, to signify the radian mode.

Separate keys are provided for the conversion of rectangular coordinates to polar coordinates and back again. The pair of numbers to be converted is entered into the x and y registers, and the appropriate key operated. Polar coordinates can be in either degrees or radian mode, as desired.

Two memories are provided, apart from the x and y registers. Numbers are entered into the memories by use of the

appropriate STORE key, and can be recalled at will. Neither of the memories are cleared when the CLEAR key is operated. They are cleared on initial turn-on, and can be cleared during calculations by manually entering a zero. This is not normally necessary, as they can be "over-written", the previously stored number being lost.

Calculation of means and standard deviations are extremely simple with the SR4148. The series of numbers to be averaged is entered by the  $X_n$  key. After the last number has been entered, the "mean and standard deviation" key is pressed. The mean is then displayed, while the standard deviation is stored in the y register, and can be recalled by reversing the x and y registers.

A string of numbers can be summed using the summation key, simply by entering the numbers in sequence. The cumulative total is stored in memory 1, which should be cleared before commencing.

Using the EE key, numbers can be entered in scientific notation. Facilities are also provided for multiplying or dividing the number on display by multiples of ten. This feature is very handy, and enables the results of calculations to be converted to preferred values, such as microseconds or kilo-ohms very simply.

The calculator is supplied with an Owner's Manual, which can be carried in the protective case. This gives comprehensive instructions on the use of all keys, gives details of a few special calculations, and explains how errors and improper operations can occur. The operating accuracy of the various func-

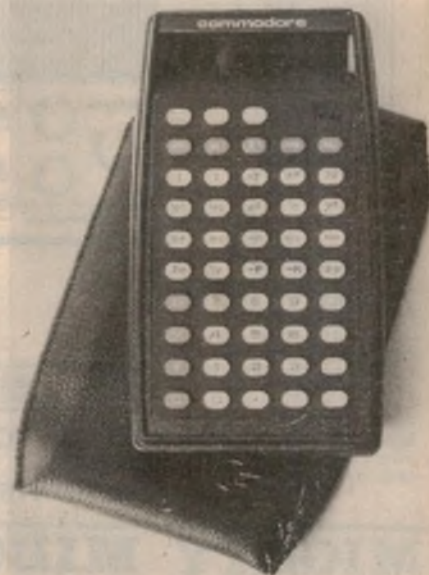

As you can see from the photograph above, the calculator is physically dominated by the keyboard.

tion keys is listed, as well as the basic machine accuracy. Tables of conversion factors and physical constants are also given.

In use, the calculator proved very impressive. Complex calculations were handled with ease. Provided the batteries are regularly recharged, available calculation time should exceed two hours or more. The SR4148 should prove a boon to advanced students and professionals alike.

A six months' guarantee is supplied. The price is \$59.50, plus 15% sales tax if applicable. The SR4148 is distributed in Australia by W.H.K. Electronic & Scientific Instrumentation, 2 Gum Road, St. Albans, Victoria 3021. Postage within Australia is \$2.00. (D.W.E.)

## THE VIDEO AND HI-FI CENTRE

Now in our spacious new showroom

2nd Floor, 79-85 Oxford St.,  
Bondi Junction, N.S.W. 2022. Tel.: 31 2555

To serve you better

- We specialise in video-recording and colour TVs • All brands for home and professional use • See us also for technical repairs and modifications.

# HAND PHONES

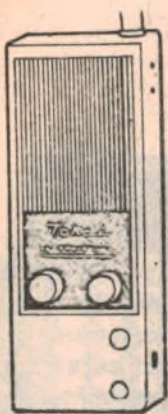

## TOKAI TC1607

This is possibly the most superb 1 watt phone available today. Used by many government departments incl. Maritime Services, Fisheries, C.S.I.R.O. Police, etc. 3 channel facility, bat meter rugged metal case, tone call, vinyl carry case

**\$97** p&p\$2

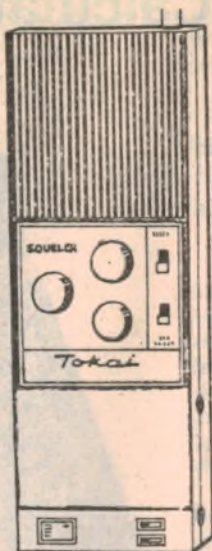

## TOKAI TC506 5WATT HAND HELD

## CONTACT 1 WATT WITH TONE CALL-EX STOCK

NEW SHIPMENT ARRIVED APRIL 14TH. This magnificent 1 watter has been modified to our requirements. The case is still all metal (ruggedness & shielding). We have added the tone call for extreme range and convenience. There is a variable squelch control to cut down on unwanted interference. Earpiece, handstrap as well as a full set of batteries are provided. Optional carrying case is available for \$7.00. This must surely be the best value available in a ONE WATTER. What makes it even better is our full warranty and spare parts service. Please state the frequency required. Sets are supplied on either 27.880 or 27.240. Extra channel \$6.50

**\$39.95**  
p&p\$2

This is a superb hand held unit for the boating man. It's ready to use just as it is—nothing extra is needed to put a good powerful signal in the air. If you wish an external 12V supply can be used, or rechargeables can be fitted, but wherever you go, your 5 Watter can go with you. Great value at

- 22 Semiconductors • Tone call • 6 Channel facility
- PA facility • 12 Volt • Modulation battery & RF meter
- All metal case.

**\$119** p&p\$2



## MIGHTY MIDGET

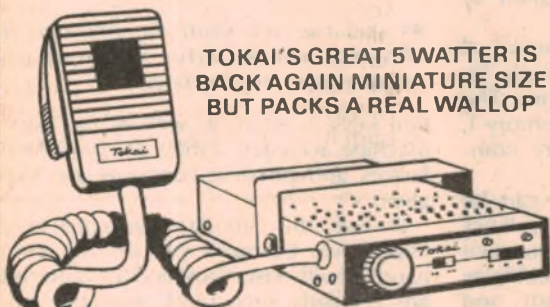

TOKAI'S GREAT 5 WATTER IS BACK AGAIN MINIATURE SIZE BUT PACKS A REAL WALLOP

TOKAI TC5038B All metal case (essential for proper shielding) 26 semiconductors incl. 1 FET. Three channel facility, squelch transmit and stand-by light, remote mike, etc. Measures only 1 1/8" x 3 1/2" x 7 1/4". We consider this the finest piece of equipment available on the 27Mc band. It is the unit we have chosen for installation on our Test Boat 'STORMBIRD'

**\$99** p&p\$2

## TV Monitor and Door Phone

SAVE OVER \$100 ON THIS C.C.T.V. MONITOR AND INTERCOM

Complete outfit consisting of:  
1 Camera on flexible mount with F1.6 lens and 30" flex  
2.5" TV monitor with intercom and 3 picture adjustments. Good for low light situations. Down to 20LUX monitor pool shop or front door.  
3 Intercom & alarm button for speech with picture. Used to be \$389

few only left at **\$199**

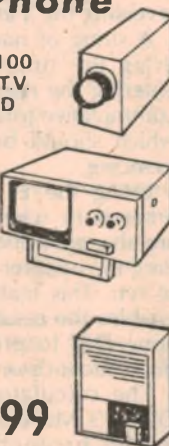

## Mobile Aerials for 27MC

GUTTER GRIP ABT 20"—mounts in a jiffy. Centre loaded. A terrific performer. Compl.

**\$19.95**  
P&P \$2

BASE LOADED SPRING—Heavy duty snap mount S/S whip complete with lead and plug Xtra range

**\$29.50**  
P&P \$2

Trunk mount centre loaded. Fibre glass aerial 48" with lead and plug

**\$27.50**  
P&P \$2

MARINE SPECIAL—No ground plate needed for glass boats. Centre loaded. Pricey but good

**\$49.95**  
P&P \$2

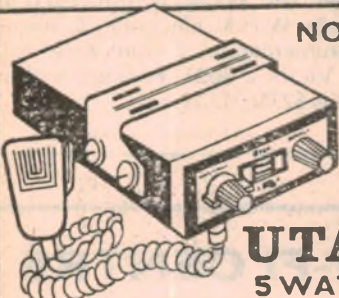

## NOVICES

**\$99**  
\$3.00 p.p.

## UTAC 18M 5WATT

This must be the best value around today. No expense has been spared with this 5 watter. It is built into a solid all metal case. Fully synthesized on the 23 U.S. C.B. channels. 19 transistors, 12 semiconductors. Squelch, P.A. illuminated channel selector. Heavy duty remote mike complete with all mounting hardwares circuit. Cannot be repeated.

## 12 VOLT REGULATED POWER SUPPLY

Made to OUR specs to suit YOUR rig. Why limit the performance of your gear with an old style 12 volt supply? The PS3N gives min 12 volt under 3 amp load (surge to 5 amp). Built in electronic circuit breaker.

Solid construction. On/off switch bezel light. Smoothed Ripple voltage 30 mV. Ready to wire into your system.

**\$29**

P.P. \$2.00

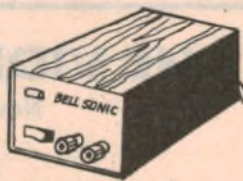

## Ground Plane Antennae

### 27MC

High Efficiency Ground Plane Antenna for CB base stations. All aluminum construction. Accepts PL 259 connector. Solid aluminum 108 inch heat treated radials and radiator. Elements supplied in two 54 inch lengths joined by threaded coupling nuts. Radial droop for 50 ohm match. Accepts 1/4 inch tubing and PL 259 connector. Frequency Range 27MHz impedance 50 ohms VSWR. Less than 151. Weight 45 lbs. Wave 14.

**\$39.50**

### 27MC GPV BASE LOADED

A ruggedly constructed low cost high performance vertically polarized omnidirectional base station antenna. It develops transmitting gain of 3dB through pattern compressions and a lowered angle of radiation along with improved signal to noise ratio. The matching stub places it at DC ground potential which substantially lowers the residual noise level and results in gains as high as 15dB in signal to noise ratio. Gain 3dB VSWR (At resonance) 1.25:1 Coaxial Feedline 52 ohms Omni-

Directional Pattern Overall Height 212 inch. Diameter of Radiator 112 inch to 1716 inch. Mast Bracket. Accepts Up to 158 inch. Weight 55 lbs. Full 12 Wave.

**\$49.50**

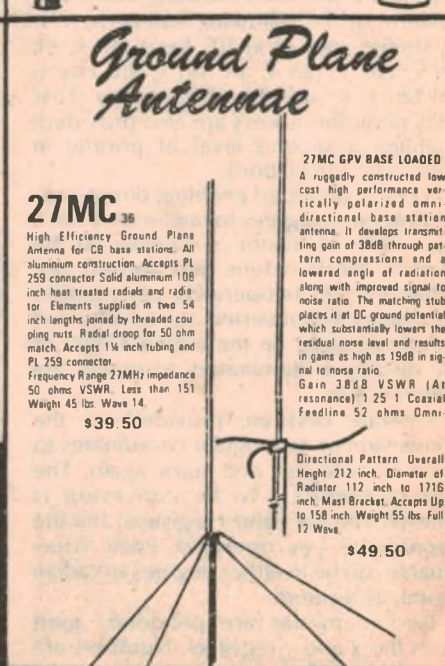

**PETER SHALLEY**  
554 Pacific Hwy. Killara NSW 2071  
Tel. 498-2611

## NEW PRODUCTS

### Toroids & Balun Kits

Of particular interest to amateurs, or others associated with HF and VHF communications, are two toroid kits currently being marketed by Dick Smith Electronics Pty Ltd. Both are from Amidon Associates, California, USA. One is designated as an RF Toroid Kit and the other as a Toroid Balun Kit.

The RF Toroid Kit consists of two small toroids, a hank of winding wire, and a



sheet of instructions. One core ("E", red) is for use below 30MHz and the other ("SF", yellow), for use above 10MHz, up to 60MHz.

The instruction sheet gives instructions for making a 1 to 1 balun and a 4 to 1 balun, a table of inductance values against number of turns for both toroids, and a nomograph covering inductance, capacitance, reactance, and frequency.

The Balun Kit consists of a much larger toroid, a hank of heavy gauge wire, and two instruction sheets. One is a reprint from the amateur magazine "73" describing how to make a toroidal multi-band tuner. The other sheet describes how to make a variety of antenna baluns, including 1 to 1, 4 to 1, matching 52 ohm coax to a 36 ohm vertical aerial, matching 72 ohm coax to a 600 ohm feeder, matching 52 ohm coax to 600 ohm feeder, plus general instructions on how to vary these specifications to suit other requirements. There is also a reprint from "QST" on the application of broadband balun transformers. These baluns are rated at 1kW.

The Toroid Kit is priced at \$2.50 and the Antenna Balun Kit at \$12.00.

### CCTV sync gen

Fully solid state, the Arlunya SPG200 is a monochrome sync pulse generator for use in TV studios and CCTV systems. It is fully compatible with the CCIR System B, and conforms to international instrument practice. Four outputs are provided: composite sync, composite blanking, horizontal and vertical drives.



The SPG200 has a number of operating modes: internal crystal lock, synchronisation from external 31.25kHz, gen-lock to external comp. video, sync or horiz, and mains lock.

In the gen-lock modes, four degrees of noise immunity are selectable. These allow the generator to be locked to non-standard or noisy signals, such as those from helical-scan VTR machines.

Further details from Arlunya Pty Ltd, P.O. Box 113, Balwyn, Victoria 3103.

### VXO controlled 144MHz SSB rig

The Icom IC202 144MHz transceiver is a compact portable unit which offers CW or SSB operation. An unusual feature is that it is VXO controlled: two crystals are used, each being "pulled" to cover a frequency range of 200kHz at the output frequency. This gives a total range of from 144.0 to 144.4MHz. Two extra crystal sockets are provided, to allow coverage up to 145MHz. Stability is plus/minus 200Hz per hour at 25C.

Operation is from either internal dry cells or external supply. Transmitter output is 3W PEP on USB, with a drain of 540mA approximately. The receiver uses single conversion with a 10.7MHz IF, and has a rated sensitivity of 0.5uV for 10dB (S + N/N) ratio. Selectivity is plus/minus

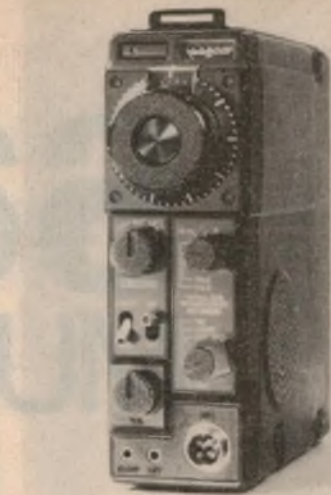

1.2kHz at -6dB points. The receive frequency may be offset by plus/minus 3kHz for clarification. A noise blanker is fitted.

Amateurs using the IC202 have reported superior performance to a 25W FM unit, over the same paths and with the same aerials.

Accessories include a 10W linear amplifier and a mobile mount.

Further information on the IC202 and other Icom equipment from the distributors, Vicom International Pty Ltd, 139 Auburn Road, Auburn, Victoria 3123.

## 6 DIGIT LED CLOCK KIT... \$13<sup>95</sup>

If you've been considering building a digital clock, but were discouraged by the high prices, we've solved your problem! SATISFACTION GUARANTEED.

#### KIT CONTAINS:

- 1 - National MM5314 Clock Chip 12/24 hour 50/60 Hz option
- 6 - Bright red common cathode displays. 0.27" character height
- 7 - NPN Segment driver transistors
- 6 - PNP Cathode driver transistors
- 9 - Carbon resistors
- 5 - Diodes
- 2 - Disc caps
- 1 - Electrolytic filter cap
- 3 - Switches for time setting
- 2 - Etched, drilled and plated p.c. boards
- 1 - Illustrated assembly instructions manual

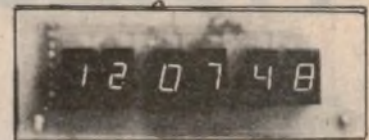

All you provide is a 9-12Vac transformer and a case of your choice.

Also available: Same kit as above, but with 0.5 inch jumbo displays . . . . . \$18.95

ORDERING INFORMATION: Goods will be shipped via airmail. We pay postage. All prices as listed are in AUSTRALIAN DOLLARS. Remittance by bank cheque or international money order. (Include receipt with order if the latter is used.)

**sabtronics**  
INTERNATIONAL

P.O. Box 64683, Dallas, Texas 75206, U.S.A.

# sanwa

## MULTITESTERS



±DCV 0-60mV  
0-0.3-1.2-3-12-30V  
(500k $\Omega$ /V)  
0-120-300-1.2k  
(50k $\Omega$ /V)  $\pm$ 2%  
0-30k (w/HV probe)

ACV 0-3-12-30-120-300-1.2k  
(1M $\Omega$ ) $\pm$ 2.5%  
Freq. 20Hz to 50kHz  
( $\pm$ 1dB)

\*DCA 0-2 $\mu$ A 0-0.03-0.3-1.2-  
3-12-30mA  
0-0.12-0.3-1.2-12  
(300mV)  $\pm$ 2%

ACA 0-1.2-12A  
 $\Omega$  x1 x10 x100 x1k x10k  
x100k (max. 200M)  
Batt. 1.5VX1 & 9VX1  
dB -20 to +63  
252x191x107mm 1.95kg

## Precise, Stable & Rugged

### Multitester N-501

The N-501 is unprecedented for its ultrahigh sensitivity equivalent to that of a v.t.v.m with no vacuum tubes or FET's used. This has been accomplished by the development of a meter movement with a full-scale sensitivity of 2 $\mu$ A and thorough development of the rectifying circuit resulting in a stable rugged instrument suited to the work bench or lab.

- 2 $\mu$ A suspension movement - 0.05mA/1mV resolution
- Constant 1M $\Omega$  input impedance (ACV) - RF-diode rectified current direct to movement
- Double protection - fuse & Si diode
- Revised scale marking - intermediate readings readily determined



**WARBURTON FRANKI**

ADELAIDE 356-7333 • BRISBANE 52-7255 • HOBART 23-1841  
MELBOURNE 69-0151 • PERTH 65-7000 • SYDNEY 648-1711  
• WELLINGTON N.Z. 698-272

## NEW PRODUCTS

### 6A slide switch

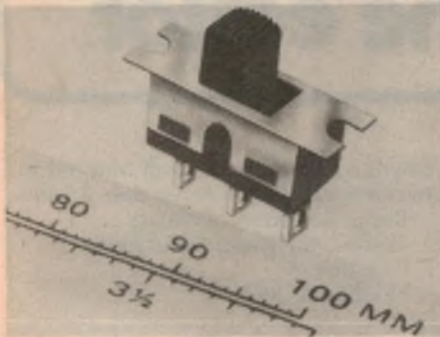

C & K Components has added a new SPDT subminiature slider switch to its range. The model 1101 switch is rated at 6A and is available in either PC or panel mount models. It measures 0.5 x 0.25 x 0.25in. Stan Trocki, C & K Director of Marketing, describes its development:

"We started out with the C & K basic toggle mechanism, retained the terminal and sealing options, and added a slide with a spring loaded Teflon contact follower. The result is an enclosed assembly with a proven internal mechanism, using standardised parts for economy."

For further information, contact C & K Electronics (Aust.) Pty Ltd, P.O. Box 101, Merrylands, NSW 2160.

# SALE

## Saturday 19th JUNE

Over \$5000 worth of discontinued Electronic Equipment — Both brand new and used.

Most below cost —  
Up to 80% off normal trade price.

ALL MUST GO — Highest offers accepted. Be early for best deals.

Car Radio's — Stereo's — Test Equipment — Transceivers — Receivers — Aerials — Amps — Cassette units — Semi conductors — Components and many more.

**9.00 AM TO 12 NOON**  
In Car Park  
(Next door to Dick Smith's)  
160 Pacific Hwy. Gore Hill.

**NOLAN ENERGY WORKS**

### Twin 15V supply

The TPS15 is a twin bench-type power supply with electrically independent 1A supplies variable from 0-15V, which may be used in series if required. For economy, meters have been dispensed with, and the knobs provided with calibrated dials. The supplies are short-



circuit proof, and maximum current is adjustable from 0 to 1A. Load regulation is 0.2% at 15V, with ripple less than 3mV P-P. Dimensions are 160mm x 140mm x 180mm, mass 2kg.

Enquiries to Electronic Dynamics Pty Ltd, P.O. Box 487, Dee Why, NSW 2099.

### Panels for organ



These matching panels for the Playmaster 760 organ project are available from Bespoke Metalwork, of 42c Sydenham Road, Brookvale, NSW. The dress panel has a very attractive brushed metal finish.

### FIDELITY SERVICE NEWSLETTER

Greetings. The pursuit of better sound reproduction has given birth to many excellent products in recent years. We hope by means of this occasional newsletter, to draw your attention to those products which, while advancing the state of the art, manage to stay within financial reach.



A case in point is the new SANSUI SR-525 direct drive turntable. A wow & flutter spec. of less than 0.03% and a weighted rumble figure of -72dB places it among the world's best. The integrated low mass, low friction tone arm is equal to almost any task and we can offer the turntable to you at the "belt drive class" price of \$275 plus \$4 p&p.



Another example is the PIONEER range of front loading cassette decks. The base model CT-F2121 will handle any type of tape manufactured, and provide 'Dolby' noise reduction together with ease of operation, fine general performance and Pioneer's undoubted quality. Available now at only \$249 plus \$4 p&p.



While not a new release, the AKAI AT 550 AM/FM stereo tuner has been frequently & favourably reviewed. An excellent fringe area performer with smooth flywheel assisted tuning it will be judged a worthy addition to most systems, and our special price of \$225 plus \$4 p&p represents a saving to you of \$35.

Finally, a 20c stamp will secure you a copy of our latest mail order catalogue.

#### BUDGET AMPLIFIERS (Limited Stock)

STANDARD PM 158 7 + 7 watts R.M.S. \$79  
DEITRON DSA 1010 10 + 10 watts R.M.S. \$89  
STANDARD PM 403 12 + 12 watts R.M.S. \$99

All plus \$3 p&p

#### FIDELITY SERVICE

19 Borman St., Slacks Creek, 4114 Qld.  
Ph. 208 2922

## DIGGERMAN ELECTRONICS

P.O. Box 33, Coramba, N.S.W. 2466

We offer a new realm in prices for hobbyists. Compare our prices. Return mail service.

#### QUALITY ELECTROLYTIC CAPACITORS:

Cap.	UPRIGHT		AXIAL LEAD	
	16V	25V	16V	25V
1 uF	7c	7c	8c	9c
4.7 uF	7c	7c	8c	9c
10 uF	7c	7c	9c	10c
22 uF	8c	8c	9c	11c
33 uF	8c	9c	10c	13c
47 uF	9c	11c	11c	14c
100 uF	11c	12c	13c	17c
220 uF	13c	17c	15c	20c
470 uF	18c	23c	21c	32c
1000 uF	24c	37c	31c	40c

#### POLYESTER FILM CAPACITORS: 100V 10% tolerance

001 — 7c	01 — 7c	1 — 10c
0015 — 7c	015 — 8c	15 — 13c
0022 — 7c	022 — 8c	22 — 15c
0033 — 7c	033 — 8c	33 — 16c
0047 — 7c	047 — 9c	47 — 19c
0056 — 7c	056 — 9c	082 — 7c
0068 — 7c	068 — 9c	0082 — 9c

RESISTORS: 1/4W carb. film 5% E12 values 2.2 Ohm-10M Record price of 2c each on single quantities.  
ZENER DIODES: 400mW 5% tolerance BZY88 values. 3V to 33V—15c each. 20 for \$2.60. May be mixed.

LEDs with mtg. clip, quality large red — 25c ea. Pots, trim pots & others — SAE for price lists. All goods top quality—satisfaction guaranteed or money back. No minimum order. One P & P charge of 40c regardless of quantity. Prices current for 3 months for benefit of late readers.

**HAM****RADIO ELECTRONICS  
BARGAIN CENTRE**390 Bridge Road, Richmond, Vic.  
42-5174Please allow for postage & packing  
when ordering by mailPlenty of BARGAINS for the  
Radio Amateur or the Hobbyist.NEW 4 TRACK STEREO CARTRIDGE  
PLAYERS. 5 watts output 12V D.C.  
operation. In sealed carton. \$15.  
P&P \$2.50."CAPITOL" 8 TRACK RECORDING  
CARTRIDGES \$2 each or 3 for  
\$5.25."B.A.S.F." C90 CR02 CHROM-  
DIOXIDE CASSETTES \$3 each P&P  
30c.6ft 240V AC POWER CORDS with  
moulded 3 pin plug 75c each or 10  
for \$6.50.STEREO TONE ARMS complete with  
ceramic cartridge \$5.90 each P&P  
30c.EDGEWISE 0-1 mA METERS 2 1/2" x 1/2"  
face 3" deep calibrated 0-5 \$3 P&P  
75c.PANEL METERS 5 1/8" x 4 1/4" face with  
0-1 mA movement. Various scales on  
meters (gas analyser, etc) \$5 P&P  
75c.NEW QCEO 6/40 CERAMIC VALVE  
SOCKETS \$2 P&P 40c.MORSE CODE PRACTICE KEYS \$1.50  
P&P 30c.BATTERY ELIMINATORS to suit trans-  
istor radios and cassette recorders  
AC-DC 6 volt 300 mA. PS6300  
\$7.50 P&P 75c.SPEAKER CABLE, colour codes twin  
flex 20c yd.CAR RADIO ANTENNA, 5 section lock  
down \$2.50 each P&P 75c.CAR EXTENSION SPEAKER CON-  
TROLS. Use both speakers together  
or separately. \$1.50 P&P 30c.JACKSON SLOW MOTION DRIVES 6:1  
ratio \$2.30 P&P 30c.**THIS MONTH'S SPECIAL**Brand new 2 track reel to reel tape  
decks. 3 speed (7/4-3 3/4-1 7/8) will  
accept 7" reels, fitted with counter  
and pause control 240V A.C. opera-  
tion. \$19.50 P&P \$3.15 kHz CRYSTAL FILTERS 10.7 MHz  
M.E.W. \$5 each P & P 75c.2N3055 TRANSISTORS \$1 each.  
58 ohm COAX CABLE 100 yd Rolls, 1/8"  
diam. \$12 roll P&P \$1.75.52 ohm COAX CABLE 1/4" diam. 45c yd.  
50c metre.DOW KEY COAXIAL RELAYS 48 volt  
D.C. operation \$15 P&P 75c.3 "N" TYPE CONNECTORS to suit  
above \$5.SPLIT STATOR CAPACITORS with  
screwdriver slot drive, 9 pF, 17 pF or  
25 pF. Brand new Eddystone type \$3  
each P&P 75c.3ft TWIN CABLE AUDIO LEADS with  
3.5 mm plug fitted 10 for \$2 P&P  
30c.2" SQUARE FACE 0-1 mA METERS  
calibrated 0-60 \$3 P&P 75c.*Prices correct at time of going to press.***MAIL ORDERS WELCOMED.**Please allow pack and post items  
listed on this page, if further infor-  
mation required send a stamped  
S.A.E. for immediate reply from  
the above address.

# Letters to the editor

## Harmour and Heath

One of the letters published in your January issue enquired about service and spare parts for Harmour and Heath sound projectors.

Mr Harmour has now retired from business, but the parts and servicing facilities for his sound equipment have been taken over by the firm Sonelec Pty Ltd, of Devonshire Street, Surry Hills, NSW. I hope this information is of interest.

James Randall  
Neutral Bay, NSW

**COMMENT:** Many thanks for the information, which will no doubt be of interest to those with Harmour and Heath equipment.

## Help appreciated

We'd like to thank you for publicising our need for volunteer technicians in a recent issue of "Electronics Australia"

Quite a lot of people contacted us after reading this issue, and some productive work has resulted. We are grateful to find publications that are willing to co-operate with community ventures such as ours.

We plan to start test transmissions on

Saturday, 1st May. We will transmit between 6 and 8 p.m., seven days a week.

Bevan Ramsden, Secretary  
Community Radio Federation  
P.O. Box 45  
Northcote, 3070

## Novice licence

Upon reading the March issue of EA, another argument against the two year limit of tenure for Novice licences came to mind.

Assuming only ten percent of unexperienced examinees pass the A.O.C.P. exam (as in a letter in the March, '76 issue), one can safely assume that only about fifty percent of Novices will pass the A.O.C.P. test after two years' experience.

What are the fifty percent who fail going to do? Some may be prepared to wait and try again at the next exam but a number of them will undoubtedly become "pirates". They have equipment within reach and have tasted the fruits of amateur radio.

This is defeating one of the main purposes for which the Novice licence was introduced.

I have noticed that most of the people writing to your magazine have only given reasons why there should not be a limit

# Cordless Soldering..

for electronic circuitry

With the Wahl  
**ISO-TIP**  
Rechargeable battery  
electric  
soldering  
tools

Complete freedom from cords, transformers, power points, plugs. The Wahl ISO-TIP soldering tool is light (170g), slim, powerful: suitable for tag soldering, printed circuits & miniature components.

- Heats in 5 seconds
- Up to 150 joints per charge
- Long life ni-cad batteries
- Choice of quick-change tips
- No leakage or induced current
- Exclusive 'lock-off' switch
- Spotlight illuminator
- Vehicle adaptor available

\* Approval No. V/74394/7578

From trade houses or

**ROYSTON ELECTRONICS**

22 Firth St., Doncaster, Vic., 3108.  
VIC.: 848 3777 QLD: 52 3166  
N.S.W.: 709 5293 S.A.: 42 6655  
RE757 W.A.: 81 5500

\* Automatically  
recharges when  
placed in stand.





of tenure; none has asked why there should.

I'm sure many readers would be interested in knowing the Radio Branch's motives in setting the limit.

T. Northey  
Farrer, A.C.T.

**COMMENT:** We certainly agree that the limited tenure of the Novice licence is likely to encourage piracy. Yet when the Editor suggested this a few months ago, he himself was accused of encouraging people to become pirates! It is also true that to date, no one has given a single cogent reason for the two year tenure. The motivation of the Department is likely to remain a mystery, as it apparently feels no need to explain or justify its actions.

## Reviews, colour TV

I buy Electronics Australia every month, and value it for its outspokenness and integrity. A good example of this was your attack on the poor quality of the AM section of the commercial FM-AM tuner which you reviewed in the March 1976 number.

In my opinion the strong point of your magazine is your technical knowledge. I buy it to read your reviews of equipment, and your technical discussions and projects.

I wish to suggest that if you find that you do not have enough space to include as many equipment reviews as you would like, you should drop or shorten your reviews of discs and cassettes. The latter, while valuable, are duplicated to some extent in less technical publications, but only Electronics Australia can give a penetrating, outspoken review of the equipment, often costing hundreds of dollars, that must be bought to reproduce these discs and cassettes on. That is your great strength, and I believe you should display it on more of your pages.

I would be interested to know when Philips are going to release colour sets having the new Philips picture tube that was released, or rather demonstrated to the trade in Sydney, in about July 1975. I have refused to buy a colour set until the initial rush of buyers is over and a second generation of receivers is released having very accurately converged pictures and high-fidelity sound free of

buzz and whistle. I hope that the new generation of European receivers will have these attributes.

I hired a Decca 26-inch colour receiver for a short while last year, but got tired of seeing pink snow in skiing scenes, white lettering with a green edge and a red edge, and hearing a 15 kiloHertz whistle which the service man could not get rid of. On channel 2 the picture often broke up into the most violent herringbone pattern, sometimes restricted to particular colours in the broadcast image. The serviceman apparently did not believe me when I told him this, and did not get rid of the fault. I suggested that since I live very close to the transmitting aerial of Channel 2, the problem might be partly caused by an excessively strong signal, and therefore the automatic gain control might have to be adjusted to make the signal from Channel 2 suit the receiver, but Trident did not send a serviceman a second time and I demanded that they take the set back, which they did.

A. C. Gyles  
Ferntree Gully, Vic.

**COMMENT:** Thanks for the bouquet. Regarding the content, our philosophy is to keep the journal broadly based but inevitably each individual reader group would like to see more space for their particular area of interest. You won't have to rely on European manufacturers to offer new technology receivers. You can expect to see Australian-made receivers using the 20AX system very shortly. Your experience with a Decca 26" receiver and with Trident would seem to be thoroughly untypical. We very favourably reviewed the same receiver from the same company about 12 months ago and nothing has happened since to change our opinion as published.

The views expressed by correspondents are their own and are not necessarily endorsed by the editorial staff of "Electronics Australia". The Editor reserves the right to select letters on the basis of their potential interest to readers and to abbreviate their contents where this appears to be appropriate.

# LANTHUR ELECTRONICS

69 Buchanan Avenue, North Balwyn.  
Vic. 3104 P.O. Box 162. Ph. 85 4061

## ELECTRIC DRILL SPEED CONTROLLER KITS

Will control speed down to stop of any ac/dc brush type motor. Contains triac, resistor, diodes, pot, knob, 3 pin base, plug & circuit.  
5 amp 1200 watt size \$8.75  
10 amp 2400 watt size \$9.75  
Price includes postage

## LAMP DIMMER KITS

Will control incandescent lamps down to out. Contains triac, diac, capacitors, resistors, pot, knob, ferrite rod, enamel wire & circuit.  
5 amp 1200 watt size \$6.95  
10 amp 2400 watt size \$7.95  
Price includes postage

## PLASTIC CABINETS

Suitable for above speed controller & lamp dimmer kits \$1.55  
Price includes postage

## BATTERY CHARGER KIT

Will charge wet batteries, 12 volt at 2 amps. Contains transformer, bridge rectifier, ballast resistor & circuit \$8.95  
Plus postage & pack \$1.30—Vic. \$2.15—NSW, Q., T. \$2.80—WA

## BATTERY SAVER KIT

For supplying dc voltages from 6 to 15. Contains transformer, bridge rectifier, filter capacitor & circuit.  
1 amp size \$7.95  
Plus post & pack \$1.20—Vic. \$1.80—NSW, Q., T. \$2.15—WA  
2 amp size \$14.50  
Plus post & pack, as for battery charger kit.

## METERS

AC/DC moving iron 10 amp f.s.d. Approx. size 55 x 55 mm. \$4.95

## SILICON DIODES

100 piv. 25 amp stud mount type. Forward or reverse avail. \$1.95

## ENAMEL WIRE

21 swg (20 b & s) 20 metres \$1.95  
Above three items post free

## BASIC ELECTRONICS

Basic Electronics, now in its fifth edition, is almost certainly the most widely used manual on electronic fundamentals in Australia. It is used by radio clubs, in secondary schools & colleges, and in WIA youth radio clubs. Begins with the electron, introduces and explains components and circuit concepts, and progresses through radio, audio techniques, servicing, test instruments etc.

\$3.00 plus 60c p & p

Electronics Australia,  
Box 163, Beaconsfield, NSW 2014.

## AEGIS PTY. LTD.

347 Darebin Rd, Thornbury,  
Vic. 3071. Phone 49-1017

Manufacturers of Wound Components for Electronic Applications

- ★ Miniature Aerial, RF, Oscillator Coils and IF Transformers for Transistor Receivers
- ★ Replacement Coils and IF Transformers for Valve Receivers
- ★ Radio Frequency Chokes and Video Peaking Chokes
- ★ Ceramic Insulators
- ★ Coil Formers, Bobbins, Cans, Cores, etc.
- ★ Interference Suppression Units:  
—Aerial Filters  
—Mains Filters
- ★ Crossover Network Inductances
- ★ Wide Range of Instrument Knobs

Stocked by all leading electronics suppliers



## SERVICEMEN



**SCRATCHING YOUR  
HEAD WON'T HELP!**

**THIS WILL!**



**PAL TELEVISION  
SERVICE HANDBOOK**

Manuals on:—  
Colour and Monochrome also  
Cassettes & Transistor Radios

**15 YEARS OF SERVICE**

Patchett's: Colour TV With  
Part Ref to PAL System.  
Bohlman's: PAL-D Colour  
Receivers Questions & Ans-  
wers. Bohlman's: Colour TV  
Picture Faults.

Send for your brochure:—

**J.R. PUBLICATIONS  
P.O. Box 29  
CHESTER HILL  
2162.**

or call

**53 Stanley St,  
Peakhurst.  
N.S.W.  
Phone 53 6295**

or

**VITAL BOOKS LTD.,  
AUCKLAND for  
N.Z. T.V. Handbook**



## Books & Literature

### Hi-fi reference

**ABC OF HI-FI** by John Earl. Published 1975 by Argus Books—Fountain Press, Kings Langley, Herts, England. Hard covers, 168pp 215 x 135mm, illustrated by pictures and diagrams. Recommended Australian retail price \$11.25.

From the title "The ABC of Hi-Fi" one might expect a book intended primarily for the newcomer to audio/hifi. However, a cursory glance through the pages reveals diagrams, curves and CRO pattern photos which are very much the stock-in-trade of enthusiast-level audio journals. Then why the alphabetical arrangement of subjects and the "ABC" presentation? Presumably because the author considered it a potentially interesting alternative to the option of normal chapters and a normal "microphone to loudspeaker" progression.

In fact, the book is divided into sections, the equivalent of chapters, as follows: Preface — Amplifiers — Loudspeakers — Program Sources and Signals — Quadraphony — Radio Tuners and Aerials — Recording and Replay — Sound Room and Sound Acoustics. Within each of these sections the author has arranged in alphabetical order words and phrases which he has found, by experience, to puzzle those still making their way up through the enthusiast ranks. Appropriate explanations are given, sometimes in 3 or 4 lines, sometimes involving a couple of pages.

John Earl is an experienced author and random sampling of the text gave no cause for raised eyebrows. If you're a hifi enthusiast and your grasp of terms and technology needs a little reinforcement,

you could find this book very useful, either for progressive study, or as a reference for when the terms turn up in other reading. Our review copy came from Thomas C. Lothian Pty Ltd, 4-12 Tattersall's Lane, Melbourne, 3000. (W.N.W.)

### Test instruments

**ELECTRONIC TEST EQUIPMENT**, by Harry T. Kitchen. Published by Argus Books Ltd (Fountain Press Imprint), Herts, England, 1975. Hard covers, 105 x 225mm, 199pp, many illustrations. Recommended retail price \$13.50.

This is a thorough and well-written introduction to basic test equipment, written for the student, beginning technician and serious hobbyist. The author is an experienced engineer, but one who has also been an enthusiast and magazine writer for many years.

It does not try to cover all of the wide variety of test and measuring equipment now encountered, but seeks instead to give a solid, practical understanding of the most basic and valuable instruments. There are chapters on passive meters, electronic meters, AF oscillators, RF oscillators, attenuators and oscilloscopes. These are the only ones covered—but they are covered quite thoroughly, both in terms of operation and use. Some home built instruments are also described, of fairly modern design.

A fairly detailed examination showed up only one error—the text refers to Fig. 2.18 as showing a 709 op amp in a basic AC voltmeter circuit, whereas in fact the circuit uses a 741.

Broadly speaking, though, it gives every evidence of being a well planned

### BASIC ELECTRONICS

Basic Electronics, now in its fifth edition, is almost certainly the most widely used manual on electronic fundamentals in Australia. It is used by radio clubs, in secondary schools & colleges, and in WIA youth radio clubs. Begins with the electron, introduces and explains components and circuit concepts, and progresses through radio, audio techniques, servicing, test instruments etc. If you've always wanted to become involved in Electronics, but have been scared off by the mysteries involved, let Basic Electronics explain them to you.

\$3.00 plus 60c p & p

Electronics Australia, Box 163, Beaconsfield, NSW 2014.

### EDUC-8 COMPUTER SYSTEM

The latest addition to our handbook series brings the published articles on our EDUC-8 do-it-yourself computer system together inside a single cover. It also provides additional information, including how to expand the memory, arithmetic and input-output facilities. If you haven't started building the system, it would make an ideal guide; if you are well advanced, you'll find it makes an attractive and convenient operating manual.

\$3.00 plus 60c p & p

and executed work. The text is written very clearly and concisely, and is well served by illustrations.

In short, then, an excellent basic introduction to test instruments.

## Colour servicing

**NEWNES COLOUR TV SERVICING MANUAL, Volume 2**, by Gordon J. King. Published by Newnes-Butterworths, London, 1975. Hard covers, 253 x 188mm, 238pp, many circuits and diagrams. Price in Australia \$12.00.

This is a companion book to volume 1 of the same name, reviewed in these pages in August, 1973. As with that volume, this one consists mainly of detailed circuit and service information on current British colour TV chassis. And, while the jacket notes specify only eight basic chassis, they also list 13 chassis type numbers and 15 brand names.

At the time volume 1 was reviewed we felt that, while the chassis were peculiar to the British and European market, descriptions of them and comments concerning service techniques would be beneficial to local technicians who, at that time, were studying colour and solid state TV techniques without the benefit of any local designs.

Since then the situation has changed markedly. Our local market now covers a vast array of designs, both local and imported, and local technicians have had ample opportunity to gain first hand experience at both distributor sponsored classes, and in the field. For this reason there would seem to be less call for this volume than there was for its predecessor.

On the other hand, any serviceman who is frequently called upon to deal with sets brought in by migrants or visitors returning from overseas, would doubtless find it invaluable.

As with volume 1, this book is well laid out with clear diagrams and ample text. For those who have a need for it, it would be a worthwhile investment.

The review copy came from Butterworths, 586 Pacific Highway, Chatswood, N.S.W. 2067. (P.G.W.)

## World Radio Handbook

**1976 WORLD RADIO AND TELEVISION HANDBOOK**, 30th Anniversary Edition. Editor J. M. Frost, Denmark. Published by Cardfront Publishers Ltd. Stiff paper cover, approx. 560pp 226 x 145mm.

This book was reviewed in our May 1976 issue by our regular DX correspondent, Arthur Cushen. The Technical Book and Magazine Company Pty Ltd have confirmed that they will be carrying stocks for Australian readers. Suggested retail price is \$10.80 over the counter, or plus \$1.50 p&p within Victoria, or \$2.20 p&p to other states. Their address: 289-299 Swanston St, Melbourne 3000.

# NEW BOOKS

JUST A FEW OF THE THOUSANDS ALWAYS IN STOCK CALL IN OR WRITE GIVING YOUR REQUIREMENTS. All books reviewed in "Electronics" can be ordered from us.

## 1976 ANNUALS

**WORLD RADIO & TV HANDBOOK INCLUDING HOW TO LISTEN TO THE WORLD**—Combined 1976 Ed. \$10.80  
**A R R L RADIO AMATEURS' HANDBOOK** 1976—American Radio Relay League \$9.95  
**RADIO AMATEUR CALL BOOKS 1976**  
 U.S. Listings \$17.50  
 Foreign (Ex U.S.A.) Listings \$16.50

## TV & TV SERVICING

**BASIC TELEVISION PRINCIPLES & SERVICING**—B. Grob New 1975 edition just received. \$14.45  
**COLOUR TV PICTURE FAULTS**—Bohman Quick location and repair by means of picture fault examples in colour \$9.30  
**COLOUR TV THEORY**—Hutson \$11.30  
**PAL COLOUR TELEVISION FOR SERVICEMEN**—W. C. Cook. A new book by an Australian \$15.00

**TELEVISION ENGINEERS' POCKET BOOK**—P. J. McGoldrick New 6th Ed. 372 Pages, illustrated \$7.50  
**TRANSISTOR TV SERVICING MADE EASY**—Darr \$6.35  
**TV SERVICING GUIDE** arranged by Trouble Symptoms—Deane & Young (Our best seller) \$4.75

**Howard W. Sams Publications**  
**TELEVISION BROADCASTING**—Tape and Disk Recording Systems—Harold E. Ennes \$20.35  
**TELEVISION BROADCASTING**—Equipment, Systems and Operating Fundamentals—Harold E. Ennes \$20.35  
**TELEVISION BROADCASTING**—Systems Maintenance—Harold E. Ennes \$20.35  
**TELEVISION BROADCASTING**—Camera Chains—Harold E. Ennes \$18.00

## SPECIAL OFFER!

~~\$18.40~~ \$12.00

**PAL RECEIVER SERVICING** by Seal  
 Scoop purchase of this outstanding Colour T.V. Service book enables us to make this offer  
 While Stocks Last!!!  
 Add Post & Pack  
 Vic \$1.00  
 Interstate  
 \$1.80



**COLOUR TV PICTURE FAULTS**—Bohman Quick location and repair by means of picture fault examples in colour \$9.30  
**COLOUR TV THEORY**—Hutson \$11.30  
**PAL COLOUR TELEVISION FOR SERVICEMEN**—W. C. Cook. A new book by an Australian \$15.00

## RADIO

**ANTENNA HANDBOOK**—A R R L \$5.10  
**RADIO AMATEURS VHF MANUAL**—A R R L \$5.10  
**REFERENCE DATA FOR RADIO ENGINEERS**, I.T.T. New 6th Edition \$36.05  
**BASIC RADIO**—Marvin Tepper Revised 2nd Ed. Encyclopedia of six paper cover Volumes. A course in communications and electronics. Profusely illustrated with easy to understand diagrams. Full Set \$27.50  
**BEAM ANTENNA HANDBOOK**—Orr \$7.00  
**CUBICAL QUAD ANTENNAS**—Orr \$5.70  
**FOUNDATIONS OF WIRELESS AND ELECTRONICS**—M. G. Scroggie \$9.50  
**HAM NOTEBOOK**—Volume 1 \$4.20  
**HAM HANDBOOK**—Volume 2 \$5.30  
**JAPANESE RADIO RECORDER TAPE PLAYER SCHEMATIC SERVICING MANUAL** \$7.25 From Ham Radio Magazine.  
**RADIO SERVICING POCKET BOOK**—Vivian Capel 3rd Ed. 225 Pages Illustrated \$5.10  
**RADIO & ELECTRONIC LABORATORY HANDBOOK**—Scroggie. New 8th edition \$15.70  
**RADIO HANDBOOK**. New 20th edition \$23.45  
**SIMPLE LOW COST WIRE ANTENNAS FOR RADIO AMATEURS**—Orr \$6.40  
**RADIO VALVE AND SEMICONDUCTOR DATA**—A. M. Ball 10 Ed. \$5.10

**TEST EQUIPMENT FOR THE RADIO AMATEUR**—Gibson—An RSGB publication \$6.65  
**73 VERTICAL BEAM & TRIANGLE ANTENNAS**—Noll \$6.35

**VERTICAL ANTENNA HANDBOOK**—Paul Lee, CQ. Series \$7.10

## VINTAGE RADIO FOR COLLECTORS

**RADIO COLLECTOR'S GUIDE 1921-1932**—Morgan E. McMahon \$6.35  
**RADIO ENCYCLOPEDIA 1927**—S. Gernsback \$12.80  
**RADIO DIAGRAMS AND SERVICING INFORMATION 1926-1938** \$9.00  
**VINTAGE RADIO—1887-1929**—Morgan E. McMahon \$7.60

## HI FI & SOUND

**HI FI DESIGNS (WIRELESS WORLD)**—tape, disc, radio, amplifiers, speakers, headphones \$3.00  
**HI FI LOUDSPEAKERS AND ENCLOSURES**—Revised 2nd Edition—Cohen \$6.10  
**HOW TO BUILD SPEAKER ENCLOSURES**—Badmaieff & Davis \$5.70  
**ELECTRIC GUITAR AMPLIFIER HANDBOOK** \$8.90  
**ELECTRONIC MUSIC SYNTHESIS**—Hubert S. Howe Jr. Lucid thorough guide to the use of these new instruments and techniques \$20.50

## ELECTRONIC

**DIODES EQUIVALENTS**—De Muiderkring European, American, Japanese types. A companion to Transistor Equivalents \$5.95  
**GETTING THE MOST OUT OF YOUR ELECTRONIC CALCULATOR**—William L. Hunter \$7.10  
**UNDERSTANDING AND USING THE OSCILLOSCOPE**—Hallmark \$6.40  
**TRANSISTOR EQUIVALENTS**—European, American and Japanese. 9000 types and 5600 substitutes. 8th edition \$5.95  
**TTL DIGITAL INTEGRATED CIRCUITS**—Part 1 7400-74132 with equivalents De Muiderkring \$8.95  
**HOW TO BUILD SIMPLE ELECTRICAL METERS & INDICATORS**—Charles Green \$5.10  
**INSTALLING & SERVICING ELECTRONIC PROTECTIVE SYSTEMS**—Harvey Swearer \$6.40  
**MAKING AND USING ELECTRONIC OSCILLATORS**—W. Oliver \$6.90  
**SECURITY ELECTRONICS**—Bunningham \$5.75  
**SEMICONDUCTOR HANDBOOK**—Part 1. TRANSISTORS—Characteristics, specifications & connections. Multinational coverage (De Muiderkring) \$8.95  
**SIMPLE TRANSISTOR PROJECTS FOR HOBBYISTS & STUDENTS**—Larry Steckler \$6.40  
**SOLID-STATE IGNITION SYSTEMS**—R. F. Graf & G. J. Whalen \$5.75  
**THE SEMICON INTERNATIONAL TRANSISTOR INDEX**. 6th edition. 1975-76 \$25.85  
**110 SEMICONDUCTOR PROJECTS FOR THE HOME CONSTRUCTOR**—R. M. Marston \$5.80  
**110 THYRISTOR PROJECTS USING SCRs AND TRIACS**—R. M. Marston \$5.40

## MANUFACTURERS' MANUALS

**FAIRCHILD SEMICONDUCTOR**—Full Line Condensed Catalog \$5.00  
**FAIRCHILD SEMICONDUCTOR CMOS DATA BOOK** \$5.00  
**GENERAL ELECTRIC SCR MANUAL INCLUDING TRIACS & OTHER THYRISTORS** \$5.40  
**GENERAL ELECTRIC SEMICONDUCTOR DATA handbook**—1482 pages \$8.00  
**GENERAL ELECTRIC TRANSISTOR MANUAL** \$4.00  
**VOLUME 6—LINEAR INTEGRATED CIRCUITS**  
 Series A \$6.70  
**MOTOROLA SEMICONDUCTOR PRODUCTS LIBRARY—3 VOLUMES & MASTER INDEX—DISCRETE PRODUCTS, Series A** \$20.00  
 Further volumes sold separately—  
 Series A \$6.70  
**VOLUME 5—MCMOS INTEGRATED CIRCUITS**  
 Series A \$5.85  
**National Data Books And Catalogues**  
**MOS INTEGRATED CIRCUITS** \$3.25  
**LINEAR INTEGRATED CIRCUITS** \$4.35  
**TRANSUCERS PRESSURE & TEMPERATURE** \$3.25  
**INTERFACE INTEGRATED CIRCUITS** \$4.35  
**DIGITAL INTEGRATED CIRCUITS** \$4.35  
**RCA SOLID-STATE DEVICES MANUAL (Replaces Transistor Manual)** \$7.95  
**RCA Solid-State Servicing** \$5.75  
**RCA LINEAR INTEGRATED CIRCUITS** \$3.75

MAIL ORDERS BY RETURN  
 per parcel interstate

PLEASE ADD 90c per parcel postage (Vic) \$1.70

## TECHNICAL BOOK & MAGAZINE CO.

295-299 Swanston St., MELBOURNE 3000 Ph. 663 3951

# THE SCHMITT TRIGGER

by A. J. LOWE

This Teach Yourself Board demonstrates the Schmitt trigger circuit. "Trigger" is a good name for this circuit. When the trigger of a gun is squeezed it goes off totally, at a particular point in the trigger motion. A gun cannot go off in a half hearted manner—it fires or it doesn't—no in-betweens. So with this circuit: we vary a voltage slowly (like squeezing a trigger) and suddenly at a certain value a lamp turns on full—not half on, or at some intermediate value, but full on.

This circuit is a little more complicated than some earlier ones so it is a good idea to lay out the components to see how they will fit in the space, before driving any nails. Note that the transistors are NOT in line with one another as they are on the multivibrator boards.

The value of R3 + R4 should be selected so that Q2 saturates fully. This circuit has been built for a 12V power supply so that the 6V lamp can be driven despite the resistor R5 in the emitter circuit of Q2. You can experiment with lower voltage lamps provided that they have a current rating within the limits of the transistor Q2—but such lamps are not easy to obtain.

As well as the experiment described opposite, try varying the value of R5. Its value determines the angle between the turn-on and turn-off points of the pot. This angle is called the hysteresis.

To reduce the hysteresis, reduce the supply voltage to six, otherwise excessive current may damage the lamp. Then parallel R5 with a 47 ohm resistor. This will bring the on and off points closer together.

## PARTS LIST

- 1 resistor 1000 ohms ¼W
- 1 resistor 5600 ohms ¼W
- 1 resistor 47 ohms ¼W
- 1 resistor 3300 ohms ¼W
- 1 potentiometer 5000 ohms
- 1 lamp 6V, 0.1 amp
- 2 transistors BC 209 or similar npn type
- 1 lampholder
- wire nails, etc.

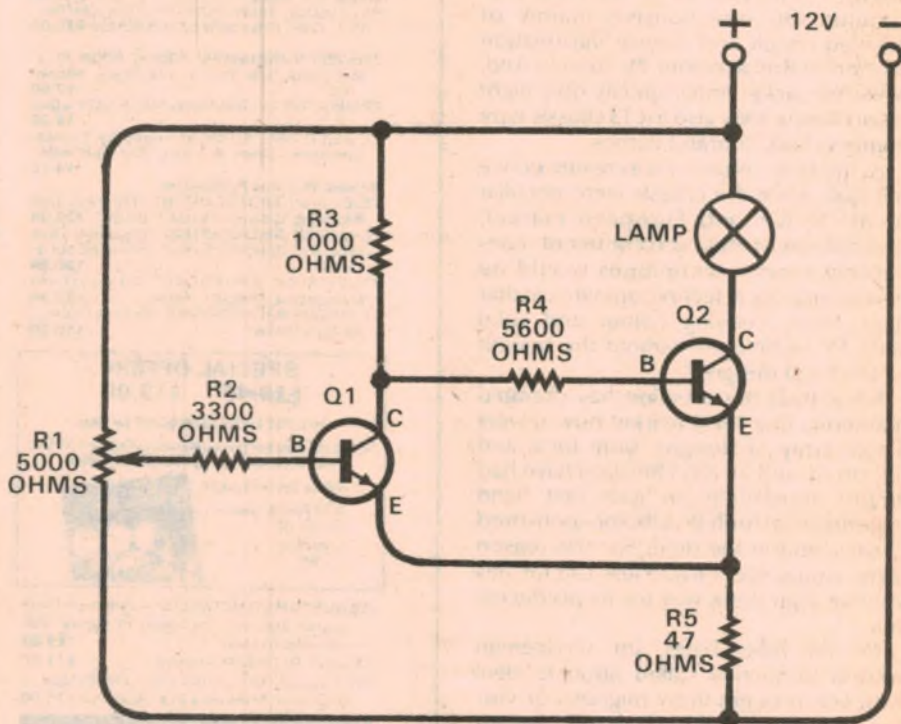
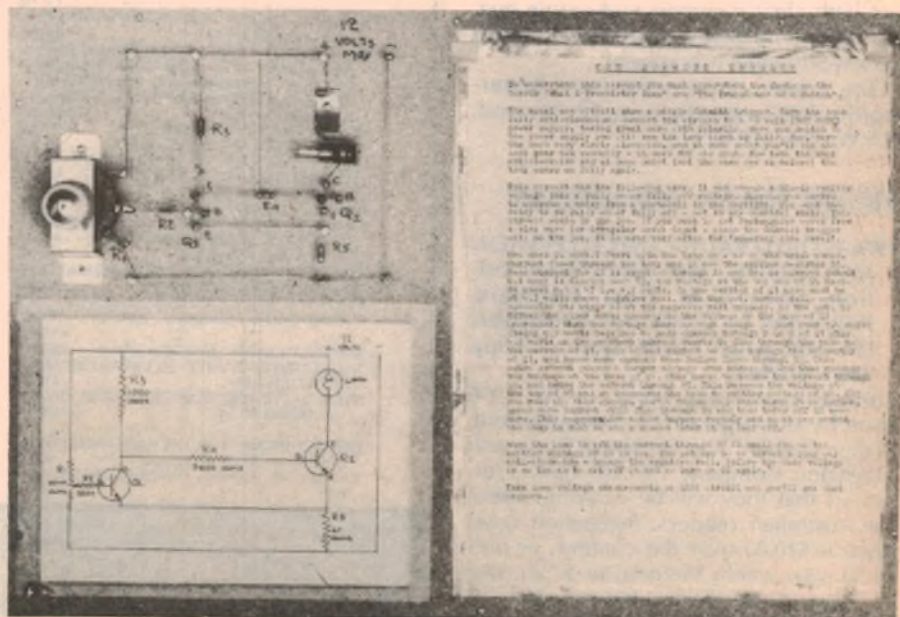

FIG. 2



# HOW THE SCHMITT TRIGGER WORKS

To understand this circuit it is essential to understand the circuits on the boards "What A Transistor Does" and "The Transistor As A Switch".

The model and circuit show a simple Schmitt trigger. Turn the knob anti-clockwise. Connect the circuit to a 12V (NOT MORE) power supply, taking great care with polarity. Switch on the power supply and the lamp will light up fully. Now, turn the knob very slowly clockwise and, at some point, the lamp will go out suddenly—it does NOT die down. Now turn the knob anticlockwise and at some point (not the same one as before) the lamp will come on fully again.

This circuit has the following uses. It can change a slowly varying voltage into a fully on or fully off voltage. Suppose we wanted to operate a relay from a photocell in the daylight. We want the relay to be fully on or fully off—not in any doubtful state. This circuit would do the job. If we want rectangular waves from sine wave (or irregular wave) input—again the Schmitt trigger will do the job. It is used very often for "squaring sine waves".

How does it work? Start with the lamp on—as in the trial above. Current flows through the lamp, through Q2, and the emitter resistor R5. Base current for Q2 is supplied through R3 and R4. As current (about 0.1 amp) is flowing through R5, the voltage across it must be about  $0.1 \times 47$ , i.e., 4.7 volts. So the emitter of Q1 also must be at 4.7 volts above the negative rail.

With the pot turned fully anticlockwise its wiper is at the negative rail voltage. As the pot is turned the wiper moves upward, so the voltage on the base of Q1 increases. When the voltage here is high enough—just over 5.4V (being 0.7V required to pass current through B to E of Q1 plus 4.7V on the emitter) current starts to flow through the base/emitter of Q1. This allows current to flow through the collector of Q1, and hence more current than before flows through R3.

This extra current causes a larger voltage drop across R3 and thus reduces the voltage at the base of Q2. This tends to reduce the current through Q2, and hence the current through R5. This reduces the voltage across R5 and so increases the base to emitter voltage of Q1. (Read all this again slowly.) This turns Q1 on harder, makes more current flow through R3 and thus turns off Q2 even more. This regenerative action happens rapidly and so at one moment the lamp is full on and a moment later it is full off.

When the lamp is off the current through R5 is small and so the emitter voltage of Q1 is low. The pot has to be turned a long way anticlockwise—toward the negative rail—before the base voltage is low enough to cut off Q1 and turn on Q2 again.

Take some voltage measurements on this circuit and see what happens.

## printed circuits

- Accurately machine printed / etched.
- Phenolic & fibreglass-gold / tin plated.
- Special manufacturers' packs of 10
- EA R & H. ET Philips. Mullard available
- Specials to your drawing
- POSTAGE small 60c. large \$1 00

76A3	2.50	78SA4	5.50	75PC12	2.50
ETS39	2.50	ET131	2.50	78S3	2.50
ET708	2.50	ET740A	4.50	ET740B	3.50
ET514	2.50	ET707A	2.50	ET707B	2.50
ET708	2.50	ET130	2.50	78RT3	3.00
78T2	2.50	78A03	2.50	78G3	2.50
76E02	5.50	75SWILA/Bpr	4.00	DMS-RC1	4.00
75PC12	2.50	EA78F1	2.80	ET534	2.50
ET514	2.50	ET129	2.50	ET28	2.50
ET439	3.00	ET420G	2.50	ET123B	2.50
ET123A	2.50	ET119	2.60	75F2	2.50
75L11	2.50	ET438	2.50	75V12	2.50
75F12	2.80	ET1124	2.50	ET122	3.00
75C19	2.50	75PC12	2.50	ET121	2.50
ET120	2.50	ET118	2.50	ET117A-B	2.80
ET704	2.50	ET500	2.50	75T19	2.50
75R7	3.00	75C07	2.50	75FM5	2.50
75TU10	3.50	75F55	2.50	75TU8	5.00
75TU9	3.50	ET533A-B	2.50	ET440	4.50
ET400	2.50	75W3	2.50	ET532	2.50
ET529B	3.30	ET529A	4.50	ET702	2.50
ET601R	2.80	ET601P	2.50	EBSRT	3.00
75EM6	2.50	75S04	2.50	75A01	2.50
ET414E	2.50	ET414D2	3.20	ET430	2.50
ET314	2.50	ET116	2.50	EBS	3.00
EBK14	3.00	ET528	2.50	ET312	3.00
75D1	2.50	74MX12D	3.50	74MX12C	2.80
74MX12B	3.20	74MX12A	2.80	ET701	2.50
ET527	2.50	ET428	2.80	ET313	2.50
ET530	2.50	ET427	2.50	ET428	2.50
74MX8	2.50	74EM9	2.50	74TU8	2.50
ET429	2.50	EBX	5.00	EB10T	5.00
EBP	5.00	EBM	5.00	EBD	5.00
EBA	5.00	EBT	5.00	EBF	6.00
EBG	6.00	74C9	4.20	7408	4.00
ET424	2.50	ET311	2.50	ET528	2.50
ET114	2.50	74SA5	4.00	ET601M	2.50
ET801L	2.50	ET422	3.30	74S3	2.50
ET801J	3.00	ET423	2.50	ET420F	3.30
ET521B	2.50	ET601H	2.50	ET602G	2.80
74A1	2.50	74HP1	2.50	7312T	2.80
ET601D	2.50	ET801C	2.80	ET420C	2.50
ET420D	2.50	ET420B	2.50	ET420A	2.50
ET524	2.80	ET801B	3.30	ET601A	3.90
ET801F	2.80	ET801E	3.30	ET801A	3.30
73TU11	2.80	73P11	2.80	ET520A-B	4.40
73C12	4.90	73BA9	2.80	ET113	3.10
73419	2.50	ET218	3.50	ET413	2.50
ET309	2.80	ET414D	2.50	73T17	2.80
73S6	2.50	ET521	3.90	ET213	2.50
ET415	3.30	73D1	2.50	ET518	2.50
733C	2.80	73T1	2.80	ET414C	2.80
ET414B	2.80	ET414A	2.80	72M12	2.80
72SASM	2.80	ET413	2.80	ET034A	3.10
72S11	2.80	72G7	2.80	7210	2.50
7211T	3.30	ET037-40	6.00	72SA10	3.10
72C8	2.80	ET029	2.50	72S10	2.80
72R9	2.80	72SA9	2.80	ET033	3.30
72MX8	3.10	72T3	3.30	ET026	2.80
721F8	2.50	71A8	2.50	72P3	2.80
72R2	2.80	72T2D	2.50	ET023	2.80
ET021	2.80	72T2A-B-C	4.40	73V18	3.30
73V1A	6.60	72SA1	3.30	71C12	4.40
ET019	2.80	ET018	2.80	ET017	2.80
ET014	2.80	ET007	2.50	71T12	3.30
ET011	2.50	71P8	2.80	72C2	3.90
ET012	2.50	72A6	2.50	72P56	2.50
ET034	2.90	71SA4C	3.30	71SA4B	2.80
71SA4A	2.80	ET025	2.80	71W7B	2.50
71W7A	2.20	ET003	2.80	71R1	2.50
71D3	2.50	ET005A	2.50	71TU2	2.50

### ALL SILICON 30/60w PA PORTABLE AMPLIFIER



6 1/2" W x 3 1/4" H x 8 1/2" D.  
12-16V two inputs. 5 & 100mV. 15 ohm output. No. 763D. Also 125. 250 500 ohm output No. 763A. All \$ 70 each. For 240V operation \$ 33 extra. Freight collect.

### COILS and IF's RF CHOKES Plus post 80c.

381 AIR 2.5mh 50ma—Pve 70c  
381 IRON 10uh to 1,000uh 25ma 70c

### FILTERS Plus Post \$1.50.

27 Line filter 2 amp \$14.  
29 Line filter 10/20 amp \$37.50  
30 Pulse filter 2 amp \$12.

MAIL cheque or money order (add postage) direct to:—

**RCS radio pty ltd**  
651 FOREST RD BEXLEY  
NSW 2207 587 3491

**BC221  
FREQUENCY METERS**

Brand new in original packing case—unopened complete with 240 volt power supply. Charts, etc. \$90 each—cartage by rail \$1. Freight payable at nearest attended railway station.

**P.M.G. TYPE TELEPHONES**

Standard desk type with magneto bell calling device. Range 30 miles. Uses standard batteries at each phone. Any number can be connected together on single line.

**\$35.00**  
(2 TELEPHONE SETS)

\$1 cartage to rail. Freight payable at nearest attended railway station.

**AUDIO BRAND U.S.A.  
TAPE CASSETTES**

Quadraphonic. High frequency. Professional quality, low noise.  
C60 \$1.30 EA. C90 \$1.95 EA. Postage for one 30c postage for five \$1.10.

**TEN CHANNELS  
VHF TRANSCEIVER**

TR 1936 125-150 MHz. 28 volt DC operated AM single crystal locks both TX and RX on same channel complete with generator.

**\$33.00**

**AERIAL CAMERAS**

Dallmeyer with 8" f/3.3" diam lens F24 mark IV 2.9 lens stops, 11, 8, 5.6, 4, 2.9. With wooden case \$45.00. \$1.00 cartage to rail. Freight payable at nearest attended railway station.

**FREQUENCY METERS**

AN URM 37 A 120 KHz to 1000 MHz, with two 40V power supply, \$125.00. \$1.00 cartage to rail. Freight payable at nearest attended railway station.

**ILFORD 17.5 mm  
SPROCKETED  
MAGNETIC TAPE**

1000 ft reels brand new original packing \$4.00 ea. quantity available.

Post A \$1.30 B \$2.00  
C \$2.30 D \$2.80

**No. 62 TRANSCEIVER**

With headphones, accessories etc. \$60

**TELEPHONE WIRE**

1 mile twin (2 miles) genuine ex-Army Don 8 perfect condition \$35 per drum \$1 cartage to rail freight payable at destination.

**PRISMATIC COMPASSES**

Genuine ex-army Mk 3, liquid damped, as new \$45.00 P & P \$1.70. B \$2.25, C \$2.40, D \$2.65.

**MORSE KEY** \$1.40 Post 40c  
**MORSE KEY BUZZERS** \$4.25 Post 60c

**DYNAMIC  
TRANSISTOR CHECKER**

Provides a visual indication of signal output. Tests electrode open circuits, short circuits, current gain. \$14.95 ea.  
P & P \$1.70 B \$2.25 C \$2.40 D \$2.65

**KAISE BATTERY TESTER**

Model SK-130. Wide coverage of measure ranges. 1.5 to 90 volts. \$25.00  
P & P \$1.70. B \$2.25. C \$2.40. D \$2.65

**ADLER FREQUENCY  
METER**

100KHz 20MHz \$95

**4 DIGIT RELAY COUNTERS**

50 volt DC, suit slot car Lap counters, etc.  
\$1.25 each. P & P 60c.

**NIBBLING TOOL**

Cuts sheet metal like a punch and die, trims, notches and cuts to any size or shape over 7/16 inch.

**ONLY \$9.95**  
Post \$1.10

**NIFE CELLS**

1.2 Volt, fully charged, 4in x 3in x 1in 4 AH.  
\$1.50 each. P & P 60c.

**MUIRHEAD**

Decade oscillator. Type DG 38A  
\$100.00

**HANDY SIGNAL INJECTOR**

Produces an Audio Signal in rich harmonics. Ideal for Sig Tracing in A.F., I.F., and R.F. circuits. Powered by 4 Penlight Batteries with On Off Switch and indicator lamp. Size 1 1/2" Diam 5" long Only  
\$8.50. Post \$1.10

**TELESCOPES**

25 x 30 \$5.95  
40 x 40 With Tripod \$8.95  
30 x 60 Prismatic With Tripod \$34.50  
P & P A \$1.70 B \$2.25, C \$2.40 D \$2.65

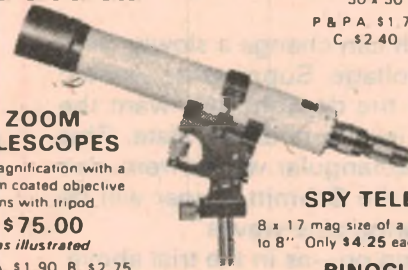

**ZOOM  
TELESCOPES**

60 magnification with a 60mm coated objective lens with tripod  
**\$75.00**  
as illustrated  
P & P A \$1.90 B \$2.75, C \$3.20 D \$3.95

**WALKIE TALKIES  
2-WAY RADIO,  
PMG APPROVED**

1 watt, 11 transistor \$130.00 set of 2.  
P & P A \$1.80 B \$2.50 C \$2.80 D \$3.20

**SMALL COMPUTER  
PANELS**

3in x 2in containing 2 valves, qty of resistors, etc.  
ONLY 75c. P & P 60c.

**ELECTRONIC FREQUENCY  
COUNTER**

Austronic type DFC 4 240V 50 cycle 0-100KHz  
**\$150**

**IMPELLER PUMPS**

New gunmetal body, Stainless Steel Shaft Neoprene Impeller. Up to 15ft Lift, suitable for almost any type of liquid. Self priming. Ideal boat bilge pump, siltage drains, etc. Approx size 8" x 5"

3/8" \$23.30  
1/2" \$31.95  
3/4" \$33.75  
P & P A \$1.90. B \$2.75. C \$3.20. D \$3.95

**RECEIVER No. 210**

2-16 M/cs \$85  
Transmitter No. 11 suits 210 \$35  
24 volt Power supply to suit above \$15.  
Or complete station with Headphones, Mic, Morse Key, Antenna \$110

**SIGNAL GENERATOR**

Patec Model SG1 150 Kc/s to 30 M/cs 240 VAC \$37.50  
\$1.00 cartage to rail.  
Freight payable at nearest attended railway station.

522 Transceivers 100 150M CS  
**\$35.00**

**5" CRO TUBE** 5 BPI \$6.50 each.  
Post A \$1.40. B \$2.25. C \$2.70. D \$3.45.

**POSTAGE KEY:**

A: NSW.  
B: Vic. Qld.  
C: SA, NT, Tas, New Guinea.  
D: WA.

**VALVES**

**BRAND NEW IN CARTONS**  
65N7GT 95c CV850 \$1.50  
5U4G 95c 1H4G 75c  
EF50 75c 832 \$5.00  
5Y3 \$2.25 6X4 \$2.25  
2x2 75c VR64 75c  
P & P 40c

**AIRCRAFT CLOCKS**

Genuine eight day jewelled movement sweep second hand. Dash mounting \$29.50 EA. P & P \$1.10

**PARABOLIC REFLECTORS  
PYREX MIRROR**

36" dia. Ideal solar radio optical experimenting also decorating purposes.  
\$60.00. Sorry shop sales only.

**TELESCOPES  
ZOOM FOCUSING**

30 x 30 \$19.95 — 45 x 40 \$28.95  
50 x 50 \$37.50  
P & P A \$1.70 B \$2.25, C \$2.40 D \$2.65

**SPY TELESCOPES**

8 x 17 mag size of a rifle cartridge extends to 8". Only \$4.25 each. post 60c.

**BINOCULARS**

PRISMATIC Coated Lenses. Brand new Complete with case.  
7 x 35 Wide Angle \$35.50  
8 x 40 Wide Angle \$39.50  
7 x 50 \$31.50  
10 x 50 \$32.50  
12 x 50 \$33.65  
20 x 50 \$37.95  
P & P A \$1.80 B \$2.50. C \$2.20. D \$3.20

**SOLENOIDS**

Plunger Type 12V 300MA. Suit electric camera control, miniature trains, radio, etc.  
\$2.50 P & P 20c  
200 MA 24 volt, 1/2in push movement.  
\$2.50 P & P 20c.

**SELSYN MOTORS  
MAGSLIP**

MK 11 \$5.25 ea.

**3000 TYPE RELAYS**

P.M.G. 200 Ohms — 1'500 Ohm  
Coils \$2.50 each. P & P 60c.

**P.M.G. TYPE KEY SWITCHES**  
**45c P & P 20c**

Cintel Oscillator and Electronic Counter, type 388.  
**\$250**

**SPECIAL lucky dip valve offer, 15 new valves in cartons for only \$2.95. We haven't got time to sort them, so you reap the benefit!**  
P & P A \$1.80. B \$2.50. C \$2.80. D

**RADAR TRANSCEIVER  
X BAND WITH KLYSTRON  
ETC. \$45.00**

**MULTIMETER**

A compact and handy tester for workshop or lab where quick circuit checks are required.  
DC Voltage 5-2.5K (20,000 OHMS per volt) AC Voltage 10 1000V (10,000 OHMS per volt) DC Current 0.50 UA, 0-2.5 MA, 0-250 MA. Resistance 0-6 Megohms. Capacitance 100 UUF to 1UF. Decibels — 20 to plus 22 DB. Complete with instructions.  
Only \$17.25 ea. Post \$1.05  
30,000 ohm per volt. \$23.75 P & P \$1.05

**EX ABC RECORDING  
TAPES TOP BRANDS**

1/4" x 2400' on 10 1/2" reels \$4.95  
P & P A \$1.70. B \$2.25, C \$2.40. D \$2.65

**Panoramic Adaptor**

E.M.I. type PRA-1 455 variable Kc Course 440-520 Kc  
Centre Freq 520-440 Kc  
Fine Centre Freq 20-0-20  
Filter band with 50, 100, 200 L.F.  
200 H.F. Sweep band width 0-200

**\$75.00.**

**CONDENSER LENS**

1 1/2" Diam 4 1/2" F.L. 75c 2 1/2" Diam 2" F.L. \$1.50 each. Or \$2.50 per pair. P & P 40c

**TRANSCEIVERS  
Ex Army**

No C42 set 36 to 60 MHz complete with 24V power supply, headphone, mic, leads etc \$65.00

No C45 set 23 to 38 MHz complete with mast, headphones, mic, 24V power supply etc. \$95.00

\$1.00 cartage to rail. freight payable at nearest railway station.

Harley double beam oscilloscope. Type 13A with probes.  
Working \$150.00

77D x RCA STUDIO RIBBON MICRO- PHONES Variable pattern & response music or speech \$80.00 ea. Post A \$3.30 B \$4.00 C \$4.30 D \$4.80

**TUNING UNITS**

T.U. Series Contains variable condenser suitable for aerial tuning, vernier, etc. 19" rack mounting, only \$9.50 EA. Post A \$2.30. B \$3.75. C \$4.80. D \$6.55.

**ANTENNA MASTS**

Telescopic 10ft extending to 27 ft. Complete with nylon rigging, stays pegs and base plate.  
**\$45.00**

**MARINE COMPASS**

3" floating dome. Gimbled, illuminated and compensated. In attractive strong chromed-brass housing \$27.50  
P & P A \$1.80 B \$2.50. C \$2.80. D \$3.30

**ANALYTICAL SCALES**

Brand new Griffin & George (London) Housed in timber & glass case 16" x 16" x 7". Weighs down to fractions of grams (No weights supplied.) Usual price \$187.50  
Special \$45.00 ea. Post A \$2.10. B \$3.25. C \$4.00. D \$5.25.

**REPERFERATOR**

Genuine Siemens Type 33c \$65.00

**Deitch Bros.**  
**70 OXFORD STREET, SYDNEY 2010**

SORRY NO COD

# The Amateur Bands

by Pierce Healy, VK2APQ



## Restructure of WIA—Report

Comments on the report; amateurs assist in an emergency; the novice licence scene; and items of overseas news are included in this month's notes.

A report for discussion among members was published in the WIA magazine "Amateur Radio" April, 1976. It deals with the organisation and management of the WIA. The need for the report arose from discussions at the 1975 WIA Federal Convention.

Federal Executive asked that members express their views on the report through their divisions.

The Federal Convention scheduled for the 7th-9th May, 1976 had two agenda items; one to formally receive the report, the other seeking its adoption.

It is doubtful if a true appraisal, by members, of a complex report of some 7000 words could be obtained in less than a month. Particularly as the report indicates that there was considerable apathy towards answering the questionnaire used to gather information for the report, which took nearly 12 months to compile.

It is a curious report from the viewpoint of one who, for more than a decade, was a member of the WIA Federal Council, and who met very strong opposition to the principle of proportional voting rights encompassing all members. Such a proposal is now being put forward in the report.

However, that proposal is tied in with the suggestion that all seven divisions (ACT; NSW; Vic; Qld; SA; WA and Tas) be wound up as corporate entities and be fragmented into possibly sixty or more radio clubs. Leaving the federal body as the only corporate body.

That is only one facet of the report. Another suggests the name, "Wireless Institute of Australia", is outdated because of the word "institute" and recommends a change to "The Amateur Radio Association of Australia". Maybe it was not realised that the WIA is just that, and recognised as such in administrative and amateur circles throughout the world. How this would assist financially and "attract more public relations appeal" is not clear.

It is understood that the report was prompted by the financial problems confronting the WIA. Yet this recommendation is given: "Consider the appointment of additional permanent staff to the federal office, preferably through the ranks of radio amateurs and adopt a more formal approach by the federal office".

The report covers many facets of amateur activities and the work of the federal body, and recommends setting up working parties to examine the implications associated with changes.

One facet not covered in the report is that the answer to the WIA problems may lie in the thoughts of the 50% of Australian amateurs who are not members, rather than in those that could be classified as a captive audience and who showed such apathy towards the questionnaire.

If not, it could be the lack of inspired leadership, combined with an over-centralised federal organisa-

tion, which has failed to stir enthusiasm among the amateur fraternity.

Whatever the causes, the problems are by no means peculiar to the WIA, or even to amateur bodies world-wide, most of whom are much larger than the WIA, yet are facing the same financial, administrative, and membership problems. In fact, most similar organisations, including learned societies of high standing, are facing these same problems.

The methods used and the way the current federal constitution was inaugurated could be a basic reason.

After all it is essential to diagnose the problem accurately then prescribe a remedy. Even if it is necessary to scrap recent innovations.

The report does not state whether these aspects were considered, but it does point out that an undue burden has, in the past, fallen on voluntary workers, particularly in VK3, and perhaps implies that, as a result, some matters may not have received the attention they deserved.

The decisions reached at the May conventions could preserve the status of the WIA organisation or hasten its fragmentation.

## AMATEURS ASSIST IN EMERGENCY

Recently amateur radio played a major part in getting assistance to the scene of a serious accident; again demonstrating the value amateurs can be in times of need.

The story was told in the Victorian Division WIA Sunday morning news broadcast on the 25th April, 1976.

"On Easter Monday, Victorian newspapers carried a news item headed 'Passengers Flee Bus Blaze'. But there was no mention of the part amateur radio played in getting ambulance and police to the scene in the quickest possible time.

"When Ned Rowse, VK3AEA, decided to borrow a KP202 (KEN, 2 metre, hand-held transceiver) to take with him during the Easter holidays he never imagined just how lucky that decision was. The Horn, Mount Buffalo, is 1697m high and 144MHz channel 40 was exceptionally good into Mansfield, Albury, Wangaratta and surrounding districts.

"Ned, being an enthusiastic bushwalker, found the KP202 very handy to stow in his backpack and take on hikes off the beaten track. One such trip was to the top of the rock formation called the Hump, about 137m above the road level.

"On Sunday afternoon, 18th April, 1976, while descending the Hump after a QSO with Bob Knaggs, VK3AJN, in Wangaratta, the roar of a powerful motor bike could be heard making haste up the mountain road. As the bike rounded a bend the engine was heard to cut and a frightening screech of brakes was followed by the awful metallic thump associated with

a smash.

"The next instant a thunderous boom followed by a mighty column of fire and smoke shot up to mark the impact scene for miles around. Spilt petrol had rapidly engulfed the front of the passenger coach in flames. The screams of the passengers told Ned that help had to be brought with all possible speed.

"The hump is 40 minutes' drive from Bright, which had the nearest ambulance and police. Quick thinking saved a lot of time. Ned called any stations in the surrounding district for help to get a message to the police.

"VK2ZIE, M. A. Jardine in Beechworth, replied and offered to assist. Several other stations stood by offering help, VK 2ZIE alerting the police in the meantime.

"Ned went on to assist passengers out of the blazing bus with the help of a fellow bushwalker who played an active role in comforting shocked passengers and fighting the blaze.

"Thirty-five minutes later the ambulance, followed by Sgt. Young of the Bright police, arrived at the scene. The police and National Park rangers then proceeded to get the situation under control.

"After all this happened, Tony Sweetman, VK2BOX, arranged for a replacement bus for the stranded passengers and other assistance necessary."

(As Tony told the story to VK2APQ, he was touring in his landrover around the Mount Buffalo area and was caught in the traffic holdup caused by the accident. He was able to ascertain, through a two metre contact with Ned, VK3AEA, what transport was required and go to the nearest telephone.)

"Mr J. B. Walker, of Pioneer Tours, asked Ned to pass on to all those amateurs who helped, and who offered to help, the most sincere thanks on behalf of his passengers and himself."

A footnote to the report was that Bill Lygon, VK3YBL, was one of the passengers on the bus and also passed on his thanks to all amateurs who took part in the emergency. It was said that Bill wanted to take his KP202 with him on the trip but was vetoed by his wife. Maybe the veto won't be exercised next trip.

## NOVICE LICENCE SCENE

Elsewhere in this issue the subject of the novice licence is discussed at length.

However, a further disquietening aspect arose just prior to these notes being prepared. Maybe the apparent objection will be clarified by now. It was all the more disquietening because of the opposition in the past to the novice licence by some WIA Federal Executive members, also to the recommendations of the committee set up to investigate the novice licensing in Australia.

Following reports by examinees and the review on the novice exam held in March, 1976, the chairman of the WIA Novice Licence Investigating Committee, Rex Black, VK2YA, after discussing a suggestion with committee members, offered the services of three members, Rex Black, VK2YA; Keith Howard, VK2AKX and Pierce Healy, VK2APQ, to prepare a report on the opinions of those who sat for the March examination and those who prepared students for it. The report was to be available for the WIA Federal Convention on the 7th-9th May, 1976.

The reply received from the Secretary Manager, WIA Federal Executive by Rex Black was:

"Motion: 'That the Novice Investigating Committee be wound up and disbanded'. Moved by Executive.

"Proposer's comments: ... Since the necessary investigations have now resulted in the introduction of the novice licence it appears desirable to discharge the committee set up for this purpose." (Agenda item 76.140 sheet 1/1).

The first section of the comment reviewed the historical background since the committee was set up in 1970.

If the committee is disbanded at a time when there is controversy about the novice licence then it is surely an exercise in poor public relations on the part of the WIA federal body. After all, the majority of those who sat for the examination or are interested in the novice licence are potential new members of the Institute.

Radio clubs and other organisations, as well as individual amateur operators, are cordially invited to submit news and notes of their activities for inclusion in these columns. Photographs will be published when of sufficient general interest, and where space permits. All material should be sent direct to Pierce Healy at 69 Taylor Street, Bankstown 2200.

# COMMUNICATIONS COMPONENTS AND KITS from AMATEUR COMMUNICATIONS ADVANCEMENTS

P.O. BOX 57, ROZELLE 2039, NSW

## 45W TWO METRE BOOSTER AMPLIFIER KIT

This kit was featured in the April issue of Electronics Today International page 86. It delivers 35-45W output from about 10W drive on a 13.6V supply. It features the 2N6084, diode changeover switching, simple construction.

ETI 710 kit..... \$26.50  
Heatsink to suit..... \$2.50  
Post and Packing Kit—60c  
Heatsink—60c

## RF POWER TRANSISTORS

We are proud to present these premium quality RF power transistors by C.T.C. They are rated to withstand infinite VSWR at all phase angles and are suitable for use in class AB or C circuits up to 220MHz from a 12.5V supply. The set of three is suitable for a three stage 1/2W to 40W power amplifier.

	1-4	5up
B3-12 5W out	\$5.70	\$4.80
B12-12 15W out	\$7.70	\$7.10
B40-12 40W out	\$17.50	\$17.20
	or \$30 the set	

BM70-12 typically 80W out at 146MHz from 9-12W drive at 65% collector efficiency ..... \$48.50

We also stock the popular 2N6084 made by both Motorola and SSS for only..... \$16.75 or for 10 or more ..... \$16.00

POST & PACKING is 20c for a single device, 40c for up to five, 60c for more.

## SPECIAL CAPACITORS FOR RF APPLICATIONS

These are suitable for RF tuned circuit, DC blocking and bypass applications to several gigahertz at power levels to many hundreds of watts. Silver-mica construction rated at 350V DCW. Extensively used in high power solid state RF power amplifiers.

	1-10	11up	Values stocked
22-62pF	\$1.85	\$1.75	33pF, 47pF
68-250pF	\$1.95	\$1.85	68, 82, 100, 150, 200
270-500pF	\$2.20	\$2.10	300, 470

## POST AND PACKING

30c for 10 or less, 60c for more than ten.

## AMATEUR BANDS

For the record, the concept of the novice licence, as recommended by the investigating committee, was somewhat different from that which eventuated from discussions between the WIA and departmental officers.

Maybe if the committee's recommendations had been more closely followed, the situation would now have been more satisfactory.

## AN OVERSEAS GUEST

A visitor to Sydney in April, 1976 was the vice-president of the Cyprus Amateur Radio Society, Totos Theodossiou (Theo) 5B4AP. Theo was the guest of the Sydney Chapter, Quarter Century Wireless Association, at their April dinner. Members were pleased to hear of the activities and aims of CARS and discuss many facets of amateur radio, both local and international.

It was interesting to learn that this small society, about 60 members, would be represented at the IARU meeting in Miami during April, 1976. Also that a reciprocal licensing agreement had been finalised between Cyprus and the United Kingdom, and similar agreements would be sought with Australia, Greece and South Africa.

The Sydney Chapter, QCWA, have requested the WIA to approach the appropriate authority for a reciprocal licensing agreement between Australia and Cyprus.

Operation on 144MHz is popular in Cyprus and a repeater about 1800 metres high in the Troodos mountains covers the whole of Cyprus.

The repeater has been put on tone access because it was being triggered by stations in Israel (4X4 and 5Z4) and Lebanon (OD5) inadvertently operating on the repeater input frequency. Direct contact on 144MHz with those call areas is commonplace.

During the weekend, 20th-21st March, 1976, for the first time, the Cyprus Amateur Emergency Net and other CARS members provided communications

*Fifteen Wagga Radio Club members took part in the John Moyle Memorial Field Day Contest. The photo shows the field location on Mt Granite with the 2 metre antenna and operating tent in the background and a 6 metre antenna being assembled.*



for an 800 km car rally. CAEN mobile units were stationed at the time control points along the route through the Troodos mountains. At Limassol and the rally headquarters in Nicosia CARS members provided base and control station facilities. In some cases the CAEN cars followed the rally cars along wet, unmade roads in the middle of the night.

The operation was coordinated by Theo 5B4AP and it was treated as a CAEN exercise. All communication was on 2 metres FM and the repeater proved invaluable.

## THE CYPRUS AWARD

The Cyprus Award was created in 1962 and is sponsored by the Cyprus Amateur Radio Society. Its purpose was to increase activity in that part of the world particularly on the less frequently used bands and on VHF.

The award is not easy to win, in fact only just over 200 stations have qualified for it during the past 14 years.

The first was issued in April, 1965 to G3FXB and the only one issued for contacts entirely on VHF was number 42 to Israeli station 4X4MH who made all contacts on 144MHz.

Only three Australian stations have gained the award but no New Zealand stations. Likewise only two USA stations have been successful but no Japanese.

Full details of the award will be given when they come to hand or they may be obtained from the Award's Manager, Cyprus Amateur Radio Society, PO Box 1267, Limassol, Cyprus.

This and other items from the CARS Newsletter, March, 1976, received from Theo 5B4AP.

## 1976 BICENTENNIAL AWARD

This is sponsored by the Northern California DX club to commemorate the bicentenary of the USA.

Any station outside the continental limits of the USA are eligible, also KL7 and KH6 call areas.

Requirements:

1. Work 76 stations in the USA sixth call area.
2. In addition, work 13 stations in the USA sixth call area which are members of the Northern California DX club.

Time limits: All stations must be worked during the calendar year of 1976, e.g. January 1st to December 31st, 1976.

Verification: Required information:

1. List 76 stations worked which are not members of NCDXC.
2. Give date, time, frequency and mode of each QSO.

Band and Modes: There is one basic award certificate for mixed bands and modes. Stickers will be issued for each additional band/mode applied for. Application may be made for the basic certificate by working 76 California stations and 13 NCDXC stations using mixed bands and modes. Special stickers will be issued for individual single bands, all different individual modes of operation; CW, SSB, OSCAR,

RTTY, ATV, etc., on each band.

The same station may be counted for different bands or modes. Example: A station worked on 20 metre CW may be counted for the basic mixed modes award and also for the single band CW award.

Cost of Award: Send 5 IRC's with application for the basic award. Send 2 IRC's for each additional individual band/mode sticker.

Award custodian: Send List and IRC's to:—

Jim M. Ruys, W6UZX, 3860 Pestana Way, Livermore, CA. 94550, USA.

## INTERNATIONAL AMATEUR RADIO UNION

The Guyana Amateur Radio Society has been accepted as a member of the International Amateur



Radio Union and an application is pending from the Radio Society of Swaziland.

An interesting fact is that of the 740,000 amateur stations in the world only about 3000 are in countries not represented by the 89 IARU member societies. Unfortunately, there are 148 member countries in the ITU, each having the same voting power and many of them are not sympathetic towards amateur radio.

### AUSTRIAN ANNIVERSARY

Celebrations will take place between the 17th and 20th June, 1976, at Krems an der Donau, near Wachau, Lower Austria to mark the foundation, 50 years ago, of the Austrian Amateur Radio Society. Amateurs from all countries will be welcome.

### QSL BUREAU

The NSW division WIA has advised members of a revised method of handling QSL cards. For non-members the following arrangements may be of interest.

"If you are not a member you may either receive or despatch cards at the cost of two cents per card handled. There is a minimum of 50 cents for each handling. Inwards cards may be mailed direct to you. Outwards cards may be sent direct to the QSL Officer-Outwards, WIA-Hunter Branch, C/- Post Office, Teralba, NSW 2284."

Further details from the Administrative Secretary, Wireless Institute Centre, 14 Atchison Street, Crows Nest, NSW 2065.

### SCOUTS' APPRECIATION

Delegates from 86 countries, representing the 14 million strong World Scout Organisation, have voted unanimously to support the amateur service to retain its frequency allocations. The 25th World Scout Conference, meeting in Copenhagen, noted that the Jamboree-on-the-Air annually involves some 6000 amateur stations in 70 countries, with participation by more than 100,000 members of the scout and guide movements.

The resolution, proposed by New Zealand and seconded by Jordan and many other delegations, is as follows:—

"Cooperation with Amateur Radio Services."

The 25th World Scout Conference request all member organisations:

1. To urge their governments to resist any attempt to reduce the number and size of frequencies presently allocated to the amateur radio service and
2. Cooperate with their national amateur radio organisation in any actions designed to this end.

### RADIO CLUB NEWS

**WAIT AMATEUR RADIO CLUB:** The inter-club committee of the Western Australian Institute of Technology Amateur Radio Club—VK6PD—would like to contact any tertiary institutions and arrange skeds to discuss the activities of other clubs run by students and staff.

There are at present 20 members in the club consisting of students and staff. The president Danny Robinson, VK6TZ, and secretary Danny Schofield, VK6ZVK, are technicians of the Institute. Vice-president Andrew Martin, VK6ZCN, has been carrying out moonbounce experiments. Other licensed members are VK6QI; VK6ZAC; VK6ZDA; VK6ZDU.

Meetings are held every Wednesday afternoon and evening in their own clubroom in the Student Guild Cultural Centre.

Activities are centred around amateur TV both colour and monochrome, OSCAR acquisition, construction projects, field operation and general social events. Further projects for 1976 are RTTY and hidden transmitter hunts on 432MHz.

The postal address is VK6PD, Western Australian Institute of Technology, C/- Box 55, Students Guild, Hayman Road, Bentley WA 6102.

**WAGGA DISTRICT RADIO CLUB:** Club meetings are held on the last Friday of each month at 8pm in the Wagga Rescue Club building, Morrow Street, Wagga.

Classes for the AOCF are being conducted at the club rooms and novice licence classes are held at the Wagga Police Boys Club. During a demonstration at

## IONOSPHERIC PREDICTIONS FOR JUNE

Reproduced below are radio propagation graphs based on information supplied by the Ionospheric Prediction Service Division of the Department of Science. The graphs are based on the limits set by the MUF (Maximum Usable Frequency) and the ALF (Absorption Limiting Frequency). Black bands indicate periods when circuit is open.

676

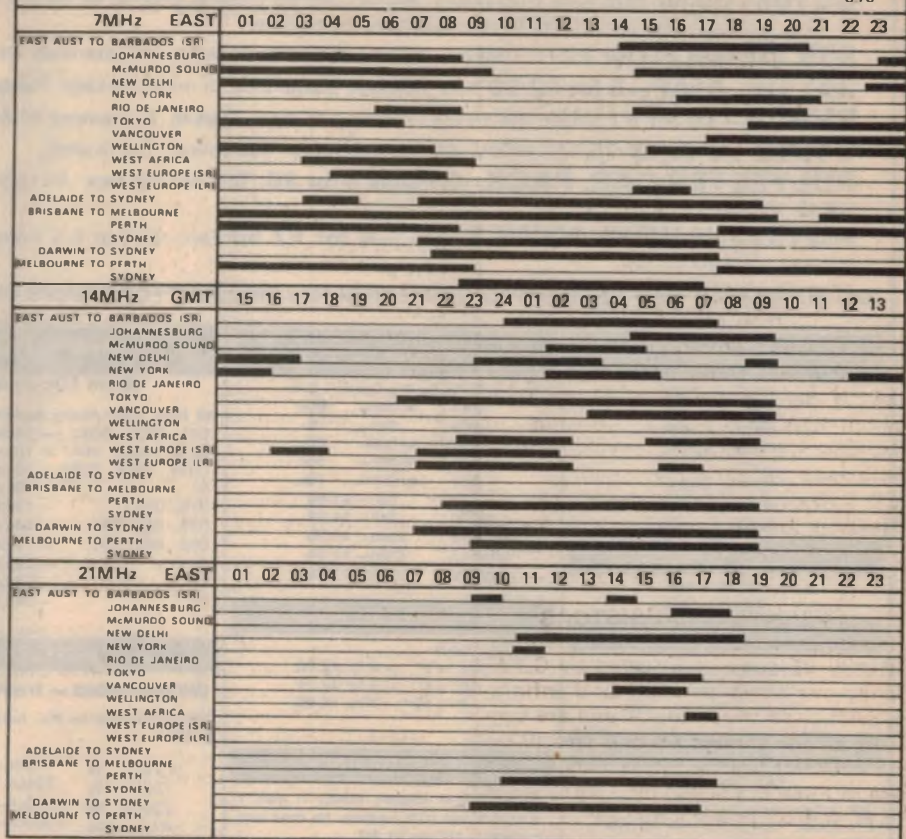

that club contact was made with the Griffith Police Boys Club.

A static display of amateur radio equipment was on show at the Wagga City Library for two weeks in April. The aim was to publicise amateur radio to the general public and encourage those interested to join the WDRC.

The call sign VK2RWG has been allocated for the WDRC repeater on channel 5 (146.15 in—146.75 out) and by now should be in operation from a site 16km south west of Wagga. Base stations as far away as Griffith, Wangaratta, Tumbarumba and Canberra can be worked through the repeater.

Fifteen WARC members took part in the John Moyle Memorial National Field Day Contest and operated on the 80; 40; 20; 15; 6; and 2 metre bands; from Mt Granite 32km from Tumbarumba. The modes used included FM on 6 metres and SSB and FM on 2 metres.

WDRC publicity officer Frank Sleep, VK2ZGB, reports that there is some activity in Wagga on 52.525MHz FM. However, this is subject to the inherent TVI problems.

Details of club activities and AOCF class arrangements may be obtained from the Secretary J. Brill, 20 Mahr Street, Tolland, Wagga Wagga 2650.

**GEELONG AMATEUR RADIO-TV CLUB:** Recently, members were guests of Dr Richard Maddever of the physics department, Geelong Grammar School. They were treated to an intriguing display of microcomputers, video terminals, examples of interfacing two types of computer terminals and several examples of games written in the easy to use "basic language".

Some members were successful in writing and running their own simple programs.

Another event was the visit of 30 budding amateurs from the Belmont Presbyterian Boys Club. They were given an informative address by Alan Bradley, VK3LW, followed by films of recent field days and GARC activities.

A demonstration of RTTY was given by Haydn

Chittock, VK3BFL, and David Mann, VK3ZMZ.

A report from the April, 1976 GARC newsletter is headed "Two metre Intrusion".

"It is noted with concern that TV channel 5A has commenced operation in the Eildon-Alexandra area. It is believed that the TV repeater has been changed from Channel 5 to Channel 5A because of interference received from the new FM station on 107.75MHz.

"This change appears to have been made with a minimum of publicity. Probably because the PMG assured the amateurs that there would be channel 5As introduced into Victoria.

"Footnote: TV channel 5A is 137MHz-144MHz, adjacent to the amateur two metre band, giving it the same relationship as TV channel 0 to the six metre band. Operation in an amateur band adjacent to an operating TV channel is impossible without severe interference."

### SO YOU WANT TO BE A RADIO AMATEUR?

To achieve this aim, why not undertake one of the Courses conducted by the Wireless Institute of Australia? Established in 1910 to further the interests of Amateur Radio, the Institute is well qualified to assist you to your goal. Correspondence Courses are available at any time. Personal classes commence in February each year.

For further information write to:

**THE COURSE SUPERVISOR,  
W.I.A.  
14 ATCHISON STREET,  
CROWS NEST, N.S.W. 2065**

# BC108-10 for 90c METAL CAN NEW, MARKED

**BC108-10 for 90c** New, Guaranteed, Marked. We are clearing these as we have a limited quantity left. GET yours NOW! (LIMIT of 10 to each customer.) This fantastic offer will never be repeated.

**555 TIMER-3 for \$2** I.C. TIMER in mDIP package. New, Marked, Guaranteed. Stock up NOW!

**741 OP. AMP-5 for \$2.50** New, Marked, Guaranteed, in mDIP package. Fantastic!

**EM410-10 for \$1** Silicon RECTIFIER (1000v, 1A) New, Marked, Guaranteed (LIMIT of 10 to each customer)

**C106D-3 for \$3.75** SCR (400V, 4A) New, Marked, Guaranteed Top Quality

**POLYESTER CAP. PACK-2 PACKS for \$6** 100 Caps per pack. All 10% Polyesters Post and Pack: Interstate \$1.50. N.S.W. \$1.30.

**HA1322. AUDIO POWER I.C.-4 for \$7.50** Each rated at 5.5 watts peak. Supply volt 13V. You get a total of 22 watts peak for \$7.50.

**GET YOURS NOW! DON'T BE DISAPPOINTED LATER! 10% DISCOUNT FOR ORDERS OVER \$20. MONEY BACK IF NOT SATISFIED!**

C-MOS	LINEAR I.C.'s	POLYESTER GREENCAPS	DIGITAL T.T.L. I.C.'s
4000 — 40c 4001 — 40c 4002 — 40c 4006 — \$2.75 4007 — 40c 4009 — \$1.25 4011 — 45c 4012 — 45c	The Best Prices for Top Quality I.C.'s: 741 m DIP — 60c 709 DIP — 70c 555 m DIP — 85c 301 m DIP — 70c 307 m DIP — 70c 723 DIP — \$1.00 3900 DIP — \$1.25 CA3012 (Can) — \$1.50 CA3013 (Can) — \$1.50 CA3018 (Can) — \$1.50	(from 10c each) All 10%, 100V Rating. Fantastic Value — 001, 0015, 0022 — 10c ea 0033, 0039, 0047 — 10c ea 0056, 0068, 0082 — 10c ea 01 — 10c ea 015, 022 — 12c ea 033, 039, 047 — 14c ea 056, 068, 082 — 17c ea 1 — 20c ea 15 — 23c ea 22 — 26c ea	New, Guaranteed, Low, Low Prices! 7400 35c 7430 35c 7401 35c 7440 35c 7402 35c 7441 \$1.20 7404 35c 7442 \$1.00 7408 35c 7447 \$1.50 7410 35c 7473 90c 7413 80c 7474 90c 7420 35c 7475 \$1.00
<b>74C SERIES</b> 74C00 — 45c 74C02 — 45c	<b>COPPER CLAD BOARD</b> Fantastic Value: 6 1/2" x 5" — 4 for \$2.00 10" x 6" — 3 for \$2.75 9" x 12" — 2 for \$3.50	<b>ELECTROLYTICS</b> (Single Ended — from 7c each) New, top quality for P.C. board mounting. All 25V 4.7uf — 7c 100uf — 19c 10uf — 7c 220uf — 25c 22uf — 9c 470uf — 30c 47uf — 14c 1000uf — 40c	<b>POLYESTER PACK</b> Super pack of polyester caps All 10% incl 160V, 270V, 400V types — 100 for \$3.50
<b>I.C. SOCKETS</b> 8 Pin mDIP socket — 40c 14 Pin DIP socket — 45c 16 Pin DIP socket — 50c	<b>RESISTOR PACK</b> Super pack of resistors. Mostly 1/2 watt, 1 watt, 5% and 10% resistors. No short lead rubbish — 100 for \$1.25.	<b>CERAMIC CAP. PACK</b> Super pack of ceramic caps incl low and high volt. types. Top quality — 50 for \$1.	<b>ELECTROLYTIC PACK</b> Super pack of electrolytics. Top quality pig-tails, low and high volt — 25 for \$2.50.

**DISCOUNT FOR VOLUME BUYERS IDEAL FOR ALL RADIO CLUBS, SERVICEMEN AND GROUP BUYERS, ETC.**

POPULAR SEMICONDUCTORS	FANTASTIC SPEAKER SPECIALS	STYROSEAL CAPACITORS
Transistors BC548 — 10 for \$1.80 BC549 — 10 for \$1.80 BC558 (178, 158) — 10 for \$1.80 BC559 (179, 159) — 10 for \$1.80 BC328 — 10 for \$2.00 BC338 — 10 for \$2.00 BC547 — 10 for \$1.80 BC635 — 70c ea BC636 — 70c ea BF198 — 60c ea 2SA353 (AF126) — 60c ea 2SB367 (AD162) — \$1.00 ea 2N6107 — \$1.00 ea 40250 — \$1.45 ea Silicon Rectifiers EM402 — 10 for \$1.00 1N5059 — 10 for \$1.00 Stick Rectifier TV18-2MT — \$2.00 ea	SCR C106D (400V, 4A) — \$1.40 ea RL4850 L.E.D. Red 1/4 with clips — 40c ea Diodes 1N914 — 10c ea 0A90 — 10c ea (Limited Quantity Only) M.S.P. 6WAC16 — 6 1/2 inch round WOOFER, 16 WATTS R.M.S. power output 15 OHMS IMP. FREQ. RESPONSE 35-6000 Hz. This high performance, high compliance, hi-flux, low Q, low resonance speaker with heavy duty ferrite magnet. Must be heard to be believed. A bargain at \$9.85 ea. or 2 for \$19 or 4 for \$36. Pack and Postage in N.S.W. is \$1.50 for up to 4 speakers. Pack and Postage INTERSTATE is \$2 for 1 or \$2.50 for up to 4 speakers. M.S.P. 64LC — 6" x 4" 15 OHM oval speaker. General purpose speaker. ideal for Car Radio, T.V. replacement, etc. etc. A BARGAIN at \$3.85 ea or 4 for \$14.50. (LIMITED QUANTITY ONLY)	680pf/1000V — 200 for \$12.00 100pf/125V — 200 for \$5.50 680pf/630V — 100 for \$3.50 680pf/125V — 100 for \$2.75 270pf/125V — 200 for \$5.50 220pf/125V — 100 for \$2.75
	<b>TANTALUMS (Miniature Type)</b> 4uf/6V — 100 for \$3.50 5uf/3V — 100 for \$3.00 7uf/3V — 100 for \$3.00	<b>TRIMPOTS</b> (Miniature 10mm vertical Mount. All 20c ea.) 100, 220, 470, 1k, 2.2k, 4.7k, 10k, 22k, 47k, 100k, 220k, 470k, 1M — All 20c ea.

Discounts on all orders: over \$20 — 10%  
over \$100 — 12%  
over \$200 — 15%

Basic post and pack 60 cents. Please assist by including extra postage for heavier parcels. Take advantage of these rockbottom prices as supplies are already limited. STOCK UP NOW!!! DON'T DELAY!!! POST YOUR ORDER TODAY!!!

POST AND PACK 60c OR EXTRA FOR HEAVY PACKAGES

# MICRONICS

P.O. BOX 175, RANDWICK, N.S.W. 2031

# Shortwave Scene

by Arthur Cushen, MBE



To find out more about broadcasting, many listeners these days are visiting radio stations and meeting staff in the country in which they have a special interest. This is particularly so of Indonesia, which was visited by two Melbourne listeners, who gained much information about new stations.

Interesting impressions of broadcasting in Indonesia are given by David Foster, who visited this area recently and uncovered many stations unknown to listeners outside of that country. From "Down Under" DX Circle these are some of the highlights:—

In Jakarta most of the time was spent at the Voice of Indonesia and the domestic Radio Republik Indonesian networks. The Voice of Indonesia uses a tiny cramped office, where a long chat was held with a very friendly head of Voice of Indonesia. Construction of two new buildings is planned, in fact one of 8 storeys is already under way. The other will be of 13 storeys, and will replace a couple of old buildings, including the one that Voice of Indonesia is currently housed in. They will be completed in about 18 months, and should give RRI a worthy broadcasting headquarters.

Plans had been mooted to move the whole station complex to the outskirts of Jakarta, with a more spacious site, but the President did not want it away from the city centre (possibly for security reasons).

An interesting sidelight was a humorous complaint that Radio Australia takes the cream of RRI's announcers. No wonder Radio Australia is so popular in Indonesia! In every hotel they stayed in, someone always had a radio tuned in to Radio Australia's Indonesian program, especially during the evening. The BBC ran a distant second, then the VOA. Radio Australia is liked particularly because of its lack of propaganda.

During the course of six weeks, David Foster and Michael Willis visited the main islands, as well as two weeks in Malaysia, and have returned with a practical knowledge and experience of broadcasting in these countries.

## COLOMBIAN SIGNALS

Two interesting new signals from Colombia have been heard by our readers. On 5962kHz a new 24 hour station has been heard around 0800GMT at good strength. It uses the slogan La Voz de Los Centauros, Vilavicencio and, though signals are good, there is some side-band from Radio Moscow on 5960kHz. Similar reception has been observed by Jack Buckley of Sydney.

Radio Nacional at Bogota is using the new frequency, 9682kHz, and heard around 2230GMT. The station's usual chimes are heard with plenty of identification, but at 2245GMT side-band from Melbourne is rather severe. John Mainland of Wellington notes this signal also at this time. This frequency has the call sign HJZK and is actually assigned to 9685kHz.

## RADIO PIONEER DIES

The death of Edward Startz will be grieved by many readers who remember him as the world's pioneer broadcaster with his Happy Station program broadcast from Holland for over 40 years. It was in 1928 that Eddie Startz joined the Philips experimental radio station at Eindhoven Holland and began broadcasting on short-wave to the world on the first station to be established on the European continent.

Notes from readers should be sent to Arthur Cushen, 212 Earn Street, Invercargill, NZ. All times are GMT. Add 8 hours for West, 10 hours for East and 12 hours for NZT.

Through the 1930's the Happy Station was heard by millions and using its call sign PCJ he created the slogan, Peace Cheer and Joy. After the war the private short-wave service was discontinued. On April 15, 1947 a foundation was set up to define and propagate Holland's voice in international broadcasting. This was known as the Dutch World Broadcasting system and used the slogan Radio Nederland. The Happy Station continued to be a feature every Sunday and was broadcast to all parts of the world.

When I interviewed Eddie Startz in the studios in Hilversum in June 1969 he was then broadcasting 14 transmissions every Sunday and this was made up of 3 different programs beamed to various parts of the world, and as well he had two transmissions in Spanish. In December 1969 he retired from Radio Nederland and the program has been continued by Tom Myer. After Eddie Startz retired from Radio Nederland he travelled to various DX Gatherings and visited the United States to attend one of their annual conventions.

In honor of his 40th anniversary on Radio Nederland a special verification card was issued, which will be treasured now by many short-wave listeners.

## MALTA'S GOSPEL SERVICE

Two Gospel organizations are now using the transmitters of Deutsche Welle for broadcasts beamed to Western and Eastern Europe.

The IBRA Radio has been heard on 6035kHz on Saturday with English 2030-2045GMT. The station announces that these broadcasts are being carried for IBRA Radio over Radio Mediterranean and are used daily at this time for broadcasts in various languages between 2015-2100GMT. IBRA Radio has a new address: IBRA Radio, Box 396, S-101 25 Stockholm, Sweden.

Broadcasts from the Voice of Hope over the Malta transmitter has been noted on Sundays 0700-0715GMT when the station is using 9635kHz. These programs of the Voice of Hope originate from their recording studios in London and reports can be addressed to P.O. Box 2590, Lisbon 2 Portugal.

## MADRID RETIMES SERVICE

Radio Nacional Espania at Madrid has retimed its Spanish transmission to Australia and the Philippines and the service now opens at 0800GMT instead of 0900GMT. Two frequencies are used, 11730kHz (excellent reception) and 15440kHz (fair strength).

The English transmission to North America is being received on 6065kHz and 11880kHz both at good strength with the station closing at 0400GMT and asking for reports.

## CANADA RETIMES SERVICE

Radio Canada International has again retimed its service to the South Pacific and this is now 1000-1100GMT. The frequencies, 9625 and 5970kHz, remain the same.

Radio Canada has introduced some new frequencies for its other services, including 9680kHz used to Africa 0600-0800GMT. This transmission has French for 20 minutes at 0600GMT and then English at 0620GMT, French 0640 and so the languages alternate up to 0800GMT. This transmitter is backed up by 6145 and 11915kHz from Sackville and 6125, 7155 and 11720kHz from Daventry.

## BERNE USES 11950KHz

The Swiss Broadcasting Corporation at Berne has introduced a new 25-metre frequency, 11950kHz for the Far East and Pacific. English is heard 0700-0730GMT and 0900-0930GMT on four frequencies, 9590, 11775, 11950 and 15305kHz in the 31, 25 and 19-metre bands. The balance is made up of Italian, at 0730GMT, French at 0800GMT and German at 0830GMT.

## RECEPTION CONDITIONS

During autumn short-wave conditions were below normal with severe sunspot activity. The southern latitudes also experienced severe aurora disturbances in late March and Early April. The aurora on March 27 in southern New Zealand was one of the most intense ever seen with the whole southern sky a blaze of light at 1030GMT. Some six hours earlier, one could detect the coming disturbance as many stations faded from the dial. The interference was so severe that even Radio Canada's transmissions to the South Pacific could not be heard. This is one of the very few occasions in their 30 years of broadcasting that their signals were not received.

We are now in the middle of winter and daylight listening is at its best. Signals are heard throughout the daylight hours on all bands and the lower frequencies in our location are providing good listening. It is only at this time of the year that signals on the 49 metre band can be received over a full 20 hour period. During darkness signals become restricted to the Pacific basin and Asia. Under suitable conditions transmissions from Europe can sometimes be heard.

## LISTENING BRIEFS EUROPE

**POLAND:** The home program of Radio Warsaw on 6035kHz continues to be heard in New Zealand, 0400-0505GMT. The transmission suffers some interference from Radio Moscow on the same frequency and according to John Mainland of Wellington the same program is being heard on 9750kHz. John Lewry of Newport, Vic. reports Radio Warsaw on 9675kHz with English 0630-0700GMT and then a program in Polish.

**SWEDEN:** Radio Sweden is continuing its test transmission to Australia and New Zealand with a relay of the Swedish home service 0630-0800GMT on 11705kHz. Radio Sweden has introduced its ninth English service to be broadcast in one day and this is a new transmission to North America. It is from 0300-0100GMT on 11955kHz.

**FINLAND:** The English transmissions from Helsinki, which are valid until September 5th, include a broadcast to Europe 0730-0800GMT on 6120kHz, 1830-1900 on 9550 and 11755, 2030-2100 on 6120, 11755 and to North America on 15185 and 15110kHz from 2300-2330GMT.

A new 250kW transmitter is being installed at Pori and is expected to be in operation by September. During last month Radio Finland celebrated its 50th year of broadcasting with special stamps and other commemorative features.

**BELGIUM:** A new name has been given to the overseas services of the Belgium Radio and Television, and this is now known as "BRT 4". The new address is: BRT Service, des O.C., B.P. 2020, 1040 Brussels. The old address of ORU P.O. Box 26 Brussels is still valid for listeners' requests.

**GREECE:** According to the BBC Monitoring Service the "Voice of Greece" broadcasts to the east and west coasts of North America in Greek, English and French between 0001-0350GMT are now transmitted on 9760kHz instead of 9620kHz.

**FRANCE:** John Mainland, Wellington N.Z., reports that Radio France has been heard on 9660kHz from 0556GMT to 0700GMT. This transmission, all in French, has been heard on this frequency, but towards sign-off suffers from VLQ9. Paris is also observed at the same time on 6015kHz at very good strength.

**GREAT BRITAIN:** The BBC World Service recently changed its Tebrau relay station frequencies and dropped 17880kHz in place of 9670kHz for the period 1100-1130GMT. Reception in this area is good and Craig Tyson of Wembley, W.A., also comments on good reception of 9670kHz.

# EDGE ELECTRIX

31 BURWOOD ROAD, BURWOOD, NSW 2134,  
PO BOX 1003 BURWOOD NORTH TELEPHONE 747 2931

## Country Customers Please Note

We are mail order specialists and would like to supply your requirements. For free quotation write or phone.

We now stock KEF for the person who wants the very best in speaker kits.

SK3 Concerto Kit  
B139 50w RMS Woofer  
B110 Midrange  
T27 Tweeter  
2-B139  
2-B110  
2-T27  
2-DN12 Crossover Networks  
\$279 Pr.

Pre-cut boxes to suit \$55 ea.  
Transmission Line Boxes \$89 ea.

Full Kef range available, write or phone for information and quote on any Kef speaker.

5 year warranty



P & P freight on

... Conclusion from stereo buyers guide speakers No. 4 on product report on Kef concerto speaker ...

"Among the finest speakers available today, obviously well designed, well made and giving excellent reproduction. They are not cheap but one must expect to pay for quality."

## HITACHI CASSETTES

PRICED LOWER THAN EVER

		1 to 11	12 to 23	24 plus
C60	Low Noise	1.50	1.35	1.25
C90	Low Noise	1.85	1.75	1.65
C120	Low Noise	2.45	2.30	2.20
C46	Ultra Dynamic	1.85	1.75	1.65
C60	Ultra Dynamic	2.05	1.95	1.85
C90	Ultra Dynamic	2.40	2.30	2.20
C120	Ultra Dynamic	3.20	3.10	2.90
C60	Ultra Dynamic Royal	2.40	2.30	2.20
C90	Ultra Dynamic Royal	3.00	2.85	2.70
C90SM	BASF	2.40	2.20	2.00
P & P 1-12		\$2.00	12-24 \$3.00	24+ \$3.50

Parts for ETI 740 FM Tuner available now

**EDGE ELECTRIX SPECIAL  
PLAYMASTER 146 AM/FM TUNER KIT  
\$135.00**

Including Front Panel but no Metal Work.

P & P \$3.00

## MAGNAVOX MV 50

The fabulous Magnavox MV 50 speaker kit now available.

This system uses  
2-10/40 40W RMS Woofer  
2-625 6" midrange  
4-XJ3 dome tweeter  
2-MV 50 crossover networks

Speakers available separate

10/40... \$21.50 ea.

625... \$15.95 ea.

XJ3... \$8.95 ea.

MV 50... Crossover \$19.95 ea.

Save on the complete kit.

Only \$145 Pr.

Boxes Available.

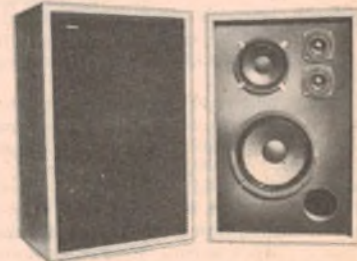

P & P FREIGHT ON

## MAGNAVOX

8/30... \$13.95 8" Woofer 30W

6J... \$7.50 6" midrange

8WR... \$11.50 8" twincone

6WR... \$10.50 6" twincone

## PHILIPS

AD0160/T8-1" dometweeter \$12.00 ea.

AD5060/Sq8-5" squawker \$22.50 ea.

AD0210/Sq8-2" dome squawker \$38.00 ea.

AD8066/W8-8" 40W Woofer \$18.50 ea.

AD12100/W8-12" 40W Woofer \$49.00 ea.

ADF500/4500/8-3 way crossover  
\$14.50 ea.

ADF 600/4000/8-3 way crossover  
\$29.00 ea.

## PHILIPS

7A System... 2-AD12100/W8

2-AD 5060/Sq 8

2-AD0160/T8

2-ADF 500/4500/8...

\$185 Pr.

P & P freight on

## PHILIPS

14 System 2-AD12100/W8

2-AD0210/Sq 8

2-AD0160/T8

2-ADF600/4000/8... \$245 Pr.

P & P freight on

PLEASE ADD SUFFICIENT PACK & POST

# INFORMATION CENTRE

**FLIP-FLOP?:** I'm making a display which needs a series of flashing lights in sequence similar to computers. I've found a flip-flop circuit but it only caters for two lights, so I imagine I want some type of flip-flop that can work with about ten lights. I am wondering if you have any projects that come near my need? (A.L., Vaucluse, NSW.)

• It appears from your description that what you require is some form of ring counter, using individual lights as readouts. Such counters may be constructed using flip-flops as basic building blocks. Details of suitable flip-flops, and different forms of ring counters that can be constructed using them are given in chapters 4 and 5 of our handbook "An Introduction To Digital Electronics". This is available from our Information Service for \$3.60, including postage.

**DOUBLE CASSETTE DECK:** I have recently built the Playmaster 144 cassette deck and I would like to add a playback deck to it for transferring tapes. Would it be possible to add a stereo P/R head from another Vortex mechanism straight into the existing replay preamplifier, to use as a replay unit? (W.G., Blacktown, NSW.)

• There seems to be no apparent objection to your scheme for adding a second deck to the existing electronics. You would have to modify the copper pattern of the printed board so that the relay does not short the input of the replay preamplifiers when the R/P deck is in the "record" mode. It may be necessary to add another relay interlocked with the first, so that the second deck does not add noise to the system when you are listening to tapes.

**CALCULATOR INSTRUCTIONS:** I have recently bought a calculator to help with my electronics calculations, but have had difficulty working out how to use it. Could you please publish an article on how to use a calculator. I did manage to work out the approach to one problem; calculating the value of several resistor in parallel. (The writer gives an example of how he tackled this problem.) (R.B., Risdon Vale, Tas.)

• We agree that the instructions which come with most calculators leave much to be desired, but an article to fill this gap is rather a tall order. As we see it, the problem is really twofold: (1) knowing the broad basis on which the calculator works and, therefore, what it will do and (2) knowing how to handle formulas, whether they are to be processed by hand or on a calculator.

Item (1) is the real problem because item (2) is necessary anyway. If this training is absent, then the calculator is of little or no value. A major problem in preparing an article is that not all calculators have the same facilities, or perform their functions in the same manner. Thus instructions which may be suitable for one would be quite unsuitable for another, while any attempt to cover all types would be a prohibitive task. We understand that some textbooks are likely to appear in due course but, until then, we suggest that experience is the best teacher. Your approach to the parallel resistors problem, for example, is quite correct, and other problems can be tackled in a like manner.

**AUDIO-VISUALS:** May I suggest a project? Could you design a control unit to fade the lamp of one automatic slide projector while a second projector is brought up to full brightness, thus effecting a dissolve. The slide would be changed in the darkened projector.

Assuming such a control system could be developed it should then be possible to encode the necessary signals onto one track of magnetic tape system to give a completely automatic presentation.

Commercial units along these lines are available, but they are expensive. If the enthusiast could take care of the electronics himself it would result in considerable saving. Much more elaborate systems are possible, limited mainly by the ingenuity and financial resources of the user.

What happened to the Ring-Prism

movie projector you described some years ago? Also, have you noticed that Kodak in the USA have introduced a system to play super-8 film through the TV set, using continuous film motion?

• Thank you for your letter and suggestions, which we have abridged somewhat. Yours is the first suggestion along these lines and we will certainly keep in mind. Much would depend on how much interest is shown by other readers. The Ring-Prism projector is apparently still being developed. We understand it has been delayed by practical production problems, but these are just about solved. We are well aware of the various schemes to replay movie film through the domestic TV set, but it remains to be seen whether this idea "takes" with the public. The use of continuous film motion in such schemes is almost universal, since this is the technique used commercially.

**SPEAKER POWER RATINGS:** Could you possibly tell me the power my speaker system (stereo) can handle as I am building my own. My system consists of a 7 cu ft bass reflex vented enclosure. It has an 80 watt 12" bass driver. The resonance as measured in Adelaide is 23Hz, the compliance measured by me being 750 newtons per meter. This measurement was made with an accurate drawing ruler, known weight and straight edge. Also included in the cabinet is an 8" mid-range 90 watt speaker and a horn tweeter. (J.M., Ridleyton, S.A.)

• Without going into a lot of theory, the practical answer is that providing the enclosure you use is correctly designed to suit the loudspeakers, the resulting system should be capable of handling the full power rating of the loudspeakers —i.e., around 80 watts RMS or the transient power output produced by an amplifier capable of delivering this continuous power. This assumes also that the

If you are unable to complete an "Electronics Australia" project because you missed out on your regular issue, we can usually provide emergency assistance on the following basis:

**PHOTOSTAT COPIES:** \$2 per project, or \$2 per part where a project spreads over multiple issues. Requests can be handled more speedily if projects are positively identified, and if not accompanied by technical queries.

**METALWORK DYELINES:** Available for most projects at \$2 each, showing dimensions, holes, cutouts, etc., but no wiring details.

**PRINTED BOARD PATTERNS:** Dye-line transparencies, actual size but of limited contrast: \$2. Specify positive or negative. We do not sell PC boards.

**REPLIES BY POST:** Limited to advice concerning projects published within the past 2 years. Charge \$2. We cannot provide lengthy answers, undertake special research or discuss design changes.

**BACK NUMBERS:** Only as available. Within last 6 months, face value. 7-12 months, add 5c surcharge; 13 months or older, add 10c surcharge. Post and packing for 60c per issue extra.

**OTHER QUERIES:** Technical queries outside the scope of "Replies by Post" may be submitted without fee, for reply in the magazine, at the discretion of the Editor.

**COMMERCIAL SURPLUS EQUIPMENT:** No information can be supplied.

**COMPONENTS:** We do not deal in electronic components. Prices, specifications, etc., should be sought from advertisers or agents.

**REMITTANCES:** Must be negotiable in Australia and made payable to "Electronics Australia". Where the exact charge may be in doubt, we recommend submitting an open cheque endorsed with a suitable limitation.

**ADDRESS:** All requests to the Assistant Editor, "Electronics Australia", Box 163, Beaconsfield, 2014.

# L.E. CHAPMAN

EST. 1940

103 ENMORE ROAD, ENMORE, N.S.W. 2042. PHONE 51-1011  
NEW Postage Rates Please Add Extra.

## TAPE RECORDER DECK



7 inch reel to reel, complete except head and face plate. **\$10**

## SUPER SPECIAL B.S.R. RECORD CHANGER



12 inch turntable balanced arm cueing device etc. **\$35**, pack and post \$1.50. Interstate \$2.50.

## LEVEL AND BALANCE METERS

1200 Ohm  
100 microamps

**\$2**



**GARRARD MINI-CHANGER Stereo \$19.00**  
Pack and post \$1.00  
Interstate \$2.50

## SPEAKER SPECIAL



6 1/2 inch Dual Cone  
4 ohm

**\$5**

## CRO EX LAB

**\$35.**



## BSR 4 SPEED 240V GRAM



Motor and Pickup **\$7.95**

## TV tuners valve type



**\$10.**

## WAFER SWITCH

4 pos 15 cents, 2 pos 50 cents

## BSR CERAMIC CARTRIDGE STEREO

**\$4**



**TRANSISTOR 7 RADIO**  
Complete with 3 1/2 inch speaker  
No cabinet **\$3.95**

## SPEAKER CABINET

Complete with  
6 x 4 speaker  
in 8 or 15 ohm.  
Size 7 1/4 x 10 x 4  
**\$5-50.**

## TRANSISTOR EAR PLUGS

3 for **\$1.00**



## MINIATURE TUNING CONDENSORS

**75 cents**



## VU METER

**\$3.00 pair**



## SPECIAL SOLID STATE STEREO AMPLIFIER AND TUNER

5 Watts RMS per channel,  
famous make **\$30**. Pack and  
post \$3 interstate, \$1.50 NSW.

## BARGAINS

Hook up wire 30 mixed colours \$1.  
250 mixed screws with self tappers, bolts, nuts, etc. \$1.25 + postage 50c.  
100 mixed radio TV knobs including fine tune & channel change \$5.00.  
1/2 meg. double pole switch pots 50c.  
100 mixed condensers, mic as polyester ceramic 50c.  
Mixed pots 30 including ganged & concentric \$5.  
Morganite & IRC 33 useful valves fresh stock \$2.00 + postage 50c.  
Slide switch 3 position 50 cents.  
50 ohm Pots ideal for ext. Speakers 50 cents. Transistor and Driver Speaker Transformers \$1.00 pair.  
Ferrite Rods 6 1/2 x 1/2 inch 50 cents.  
Pots 30 mixed values including ganged and concentric \$5.  
In Line Fuse Holders 20 cents  
Stereo Speaker Wire 12 cents yard.  
100 Mixed TV and Radio Knobs including Fine Tune and Channel Change \$5.  
Car radio suppressor condenser 30 cents.

## BARGAINS

100 mixed condensers micas polyester ceramic \$2 per pack and post 45c.  
Electros 3 in one 100-25-40, 24-250-300. 50-250-300 75 cents.  
Screw in 6 Volt Pilot Lights \$1.50 for 10. Plug-in type 10 for \$1.00.  
100 mixed condensers micas polyester ceramic \$2 per pack and post 45c.  
3.5 to 3.5 Jack Plugs 7ft Shielded Cable 75 cents; 6.5 to 3.5 Jack Plugs 7ft. Shielded Cable 75 cents.  
Mixed Tag Strips 50 cents for Dozen.  
Tape Recorder Heads Transistor — Top quality suit most recorders \$5.00.  
Jack Plug Sockets 6.5 mm 35 cents.  
Morganite and IRC resistors 33 values \$2 per 100 pack and post 45c.  
Philips Gramo Motor and Pickup 4 Speed 6 Volt \$7.75.  
Crossover Condensers 2 mfd 60 cents.  
Crystal Microphone Inserts \$1.00. Microphone Transformers 50 cents.

## BARGAINS

Switch Wafers: 11 position 20 cents.  
Perspex tops for record players size 12 x 8 1/2 x 3 3/4 \$1.50  
Pots: 50k 50 cents; 1M 50 cents.  
Tape Spools: 7 inch 75 cents. 1/2 Meg Double Pole Switch Pots 50 cents.  
Coaxial TV Feeder Cable 75 ohm 30 cents yard.  
Jack Plugs 6.5 mm 50 cents; 3.5 mm 25 cents. R.C.A. Plugs 25 cents.  
Battery Saver 240 to 6-7, 5-9 Volt, 6 Volt/300mA, 9V 200mA, \$10.  
Hook Up Wire 30 mixed colours lengths \$1 bag.  
Speaker 4 pin plugs 15 cents.  
25 mixed 5 and 10 Watt resistors \$2.00  
250 mixed screws, BSA, Whit self-tapper bolts, nuts, etc. \$1.25 bag plus 40c post.  
BSR Stereo Player Model P-128 \$52 pack and post \$1.50. Interstate \$2.00.  
TV Aerials Complete Range Hills Colour \$12 to \$60.  
Car radio aerials, lockdown, top quality extended 1600 mm \$4.50.  
Electros 3-in-one: 20, 400, 450; 10, 400, 450, 75, 50, 65 \$1.00.

## BARGAINS

AWA 11 inch P.I. TV EHT transformers \$5.00.  
Car Converters: 12 volt to 6-7, 5-9 volt 500 MA \$6.00.  
Microphones — Dynamic 10k \$3.50.  
Valve Sockets: 7 or 9 pin 10 cents. Octal 10 cents.  
Power transformers 60 mil 225v aside 6.3 winding \$5 small power transformer 240v, 220v and 22v windings \$3  
Ferrite Rods 6 inch 50, 9 x 1/2 75 cents.  
Pots: 10K ganged log 50 cents; 1 Meg ganged log \$1.25; 1/2 Meg ganged log \$1.25; 2 Meg ganged log \$1.25;  
2 Meg double pole switch \$1.50  
Sharp TV Flyback Transformers 8FT 604 \$7.00.  
Miniature Speaker Transformers, drive and output \$1.00 pair.  
Heat Sinks: 4 x 2 1/4 \$1.50.  
National 3 in one woofer mid range and tweeter 15 ohm 10 inch \$32.  
Picture tubes 17 inch 90 deg new \$19.  
Picture Tubes — New 110 Deg 17 inch \$15.

# SPEAKERS SPEAKERS SPEAKERS

6 1/2 inch Dual Cone 4 ohm	\$5.00	MSP 5 x 7 inch 3 1/2 ohm	\$4.00	MSP 6 x 2	\$3.50
4 x 2 8 ohm	\$1.50	Rola 5 x 4 inch 3 1/2 ohm	\$3.00	MSP 4 x 2 5 ohm	\$2.50
Special 12 inch dual cone MSP TACX 8 ohm	\$8.00	Rola custom kit 63G x Tweeter C60 Woofer crossover and pot	\$19.00	MSP 6 x 4 47 ohm	\$3.50
8 TACX 8 ohm	\$8.00	Magnavox 5 inch 15 ohm	\$4.00	ROLA 5 x 7 47 ohm	\$6.00
6 x 9 in 8 or 15 ohm	\$6.00	MSP 2 1/2 inch 8 ohm	\$2.00	ROLA 6 x 9 47 ohm	\$6.00
5 x 7 in 8 or 15 ohm	\$5.00	3 inch 8 ohm	\$1.50	Magnavox 5 inch 8 ohm	\$4.00
6 1/2 inch 8 or 15 ohm	\$4.50	Magnavox 5 inch 4 ohm 8 Watt	\$5.00	Magnavox 10 Watt	\$12.00
8 x 4 8 or 15 ohm	\$4.50	Magnavox 5 inch 15 ohm	\$4.00	Pioneer 3 1/2 inch 45 ohm	\$3.50
6 x 4 8 or 15 ohm	\$3.50	Pioneer 3 1/2 inch 8 ohm	\$1.50	MSP 3 inch 8W 15 ohm	\$5.00
5 x 4 15 ohm	\$2.50	Magnavox 5 inch Dual Cone Tweeter	\$6.00	Magnavox 6 x 9 inch 3 1/2 ohm	\$12.00
4 inch 8 ohm	\$2.75	Magnavox 10 inch 8 ohm	\$8.00	MSP 8 inch Woofers 8 ohm, 30 Watt	\$2.50
3 inch 3 5 ohm	\$2.50	Pioneer horn-type Tweeter 3 inch	\$9.50	Magnavox 6 x 9 inch 3 1/2 ohm	\$17.50
5 inch Tweeters 8 ohm	\$3.50	Magnavox 6 inch 3 1/2 ohm	\$5.00	MSP 12 inch 12 VAX x 8 ohm, 20 Watt RMS	\$3.50
6 inch Dual Cone Tweeters	\$6.00	Pioneer horn-type Tweeter	\$12.00	4 inch 120 ohm	\$4.50
5 x 3 80 ohm	\$3.00	Pioneer midrange 5 inch	\$9.50		
5 inch Magnavox Dual Cone 8 inch 27 ohm	\$6.00				

## INFORMATION CENTRE

tweeter is capable of handling a proportional level.

**RADIO STATIONS:** Your published information regarding Australian and New Zealand Radio Stations has several mistakes concerning stations in Queensland. Station 4QS is in Dalby—I can see it from my doorstep. Similarly 4AT is at Gwynne Ck, Yungaburra, on the Atherton Tableland; 4RK is at Gracemere,

Rockhampton, and 4QY is at Kamma, closer to Edmonton than Cairns. I do not know who is responsible for the information, and perhaps these errors are not serious. But when you strike some nut who insists that 4QS is in Toowoomba, when it is within sight here in Dalby, it can be rather irritating. (E.J., Dalby, Qld.)

• The information we publish regarding stations comes from the Australian Broadcasting Control Board, and presumably the locations given are the official business addresses of the station concerned.

## NOTES & ERRATA

**DIGITAL TACHOMETER** (Year Book 75/76, File No. 3/TM/12): The parts list specifies 3 x 570 ohm resistors. These should be marked 470 ohm. Fig. 7 shows a 0.1uF capacitor connected in parallel with C6. This was omitted from the circuit and the parts list.

**DSB TRANSMITTER** (March 1976, File No. 2/TR/58): Omitted from circuit: Value of HT line electrolytic bypass between EF86 and 12AU7; should be 50uF. A .01uF capacitor between centre tap L5 primary and chassis line. Heater of 6146

## TELECINE—from p.35

were dependent almost entirely on the quality of the film concerned; given good quality film the Nordmende Colorvision CCS can produce first class pictures; certainly more than adequate for its intended role.

The price of the unit is \$1644 retail. This is a little higher than the cheapest record and replay tape machines, but it would permit a large saving in overall cost if programs were to be recorded, due to

from heater string; should be between "A" and "B".

**LEDS AND LADDERS** (March 1976, File No. 3/MS/63): In the PCB overlay diagram on page 43, the labelling of the wiring to S1 is incorrect. The labels S1 and OFF should be interchanged.

**DRAKE RECEIVER:** The price of \$425 quoted for the Drake SSR1 synthesised communications receiver in the advertisement on page 46 of the April 1976 issue is incorrect. Elmeasco Instruments Pty Ltd wish to advise that the correct price is \$290.

the much lower cost of a film camera compared to a colour TV camera.

Summing up, the CCS Colorvision super-8 scanner is a very versatile machine which, in addition to its main role of direct replay, can be used for creating sound tracks, or for adding sound to an existing track. The picture quality obtained from it is excellent, and limited mainly by the film quality. It would be a most useful device in any educational or instructional situation, either in place of or in addition to a magnetic tape machine.

## LED LEVEL METER—from p.51

the unit to function with input signals of the order of tens of mV rather than volts.

The accompanying diagram gives details of a small variable gain amplifier, using two readily available transistors, which is quite suitable for this role. Normally, for a stereo deck, two of these amplifiers would be required, each driving a separate LED array. The 10k trippot is used to adjust the gain of the amplifier. The 100k trippot in the LED Level Meter should be adjusted for maximum sensitivity, allowing the gain of the amplifier to be set as low as possible.

The amplifier operates from a nominal 12V DC supply, the same as that produced by the 9VRMS transformer and rectifier combination in the LED Level Meter. As the current drain is only of the order of 10mA, the amplifier can be simply connected in parallel with the meter.

The amplifier gain should be adjusted so that 0VU corresponds to the red LED

just emitting. If you are replacing a mechanical movement, simply adjust the gain so that both the meters read the same on a sine wave signal with a frequency of about 1kHz.

## AUDIO MODULES

Professional quality

Balanced mic. preamp. Compression preamp 600 Ohm line amps. Active mixer & splitter Pickup preamp. Equalisers. Monitor amp. 4 input mic. module. Regulated power supply.

Write for data sheets and price list

**HARBUCH ELECTRONICS**

2 Yaralla Crescent, THORNLEIGH,  
N.S.W. 2120

Phone 02-84-7758

## LAFAYETTE

### 27MHz TWO-WAY RADIO

FOR INDUSTRY, FARM,  
BOATS, SPORTS, ETC.



#### MICRO 66

Only 1-15/16" H x 5-3/16" W x 6-13/16" D

5 WATTS

6 CHANNELS

\$139 50 (Crystals Extra)

The latest in the famous LAFAYETTE Micro series the MICRO 66 embodies the versatility, reliability and performance which have made LAFAYETTE famous throughout the world in 27MHz communications. With an extra sensitive receiver of better than 1uV for 10db S-10-N ratio. "Range-Boost" modulation circuitry, a built-in speaker plus push-button selected external speaker-microphone (supplied), the MICRO 66 is ideal for Boats or Base Station operation. Operates from 12V DC or 240V AC with optional Base Station Power Supply.



5 WATTS

12 CHANNELS

#### DYNA-COM 12A

\$139 50 (Crystals Extra)

A powerful 5-Watts input power in a hand-held transceiver! Excellent sensitivity and selectivity. Ruggedly designed for extra reliable performance. This high-power walkie-talkie operates from internal batteries (rechargeable Ni-cad batteries available) or an external 12V source.



1 WATT 3 CHANNELS

#### Model HA-310

\$73 50 (Incl. 27.240MHz)

1,000's of LAFAYETTE HA-310 walkie-talkies in use in Australia, 100,000's throughout the world attest to their superior qualities. A professionally designed, sturdily constructed, commercial quality unit for top performance and long term reliability. Rechargeable Ni-cad batteries are available to suit.

All above transceivers are P. M. G. Type Approved (Licence Required)

A LARGE RANGE OF ACCESSORIES IS AVAILABLE. ANTENNAS, CRYSTALS, CONNECTORS, ETC. PLEASE ENQUIRE FOR DETAILS

## LAFAYETTE ELECTRONICS

div. of Electron Tube Distributors P/L

94 ST. KILDA RD. ST. KILDA  
VIC., 3182 Phone 94 6036

## HE HAS INNER VISION



### The Ancients called it COSMIC CONSCIOUSNESS

There are no physical limitations to inner vision . . . the psychic faculties of man know no barriers of space or time. A world of marvelous phenomena awaits your command. Within the natural — but unused — functions of your mind are dormant powers which can bring about a transformation of your life.

Know the mysterious world within you and learn the secrets of a full and peaceful life!

The Rosicrucians (not a religion) are an age-old brotherhood of learning. For centuries they have shown men and women how to utilize the fullness of their being. This is an age of daring adventure . . . but the greatest of all is the exploration of self. Determine your purpose, function and powers as a human being.

Write for your FREE copy of "The Mastery of Life" — Today! No obligation. No salesmen. A nonprofit organization. Address: Scribe K.C.Z.

**The ROSICRUCIANS** (AMORC)  
San Jose, California 95191 U.S.A.

SEND THIS COUPON

Scribe K.C.Z.  
The ROSICRUCIANS (AMORC)  
San Jose, California 95191 U.S.A.

Please send me the free book, *The Mastery of Life*, which explains how I may learn to use my faculties and powers of mind.

Name \_\_\_\_\_  
Address \_\_\_\_\_  
City \_\_\_\_\_ State \_\_\_\_\_ Zip \_\_\_\_\_

"AMORC is the authentic Rosicrucian Order."

# Marketplace

## FOR SALE

**EM I. BTR2** tape rec. \$500 Tandberg \$100 Mic. R C A 77DX \$60 44BX \$60. S.T.C. 4021 \$30 Byer turntable \$90 Rec. Cutting Machine \$150 Cutting heads \$50 ea Cutting amp \$100 R C A. 40 watt speaker system \$500. 600 ohm line tranny. \$5 Computer tape. new. \$14 per reel. Mod. 15 teletype \$150 Creed \$60 Creed. no motor \$20. Reperforators \$70 New teletype parts All Studio equipment Studio 20 Recordings & Sales 313383 367 Bourke St. Darlinghurst. N S W 2010

**AUSTRALIAN RADIO DX CLUB**—Covering overseas and long distance radio reception, including shortwave and medium-wave. Monthly bulletin for all members. For full details, write enclosing 40c to ARDXC, 3 KADANA ST., OAK PARK, VICTORIA 3046

**MOBILE RADIO TEST SET.** AWA 412 with high & low band modules. Fitted with full range of IF crystals. (New price \$1728) selling for \$1,000 or nearest offer.  
Electronic Services, 6 Pirie St. Fyshwick ACT 95 2411

**SOLAR BATTERY CHARGERS.** Let the sunlight charge your batteries—12 volt 0.25A \$163. 12 volt 0.650 amp \$295. 12 volt 1.2A \$590. Add \$6 for post packing. Tel. 96 1974 or write to Solar Transmission 24 Windale St. Dandenong 3175.

**TECHNICAL HANDBOOKS**—IC's Equiv. & substitutes—Transistor equivs—Transistor manual—All \$3.50 P&P \$1.50—World Transistor Cross Reference \$9.50 P&P \$2.00—Transistor Specification Manual \$5.80 P&P \$1.50—Primo Microphones EMU 522-\$21.80—P.T.T. Desk Model, DM1487—\$34.00—Omnidirectional EM518—\$29.00 P&P \$2.00 LED Readouts—1 inch \$3.90—3/4 inch \$1.80 P&P 35c—Premium quality transistors BC147, 148, 149, 157, 158, 159—10 for \$1.80—AC127, 128, 187, 188—68c ea.—Diodes—BA222—10 for 90c P&P 40c—Coils, VPC Series—VPC—1—\$1.00—VPC 14G—\$2.00—VPC 470—\$1.00—P&P 40c—Electronic Concern, Box 733, Darlinghurst 2010, NSW

**OSCILLOSCOPES:** Heathkit IO-12 plus universal probe \$90 EMI type WMS \$40. Phone 498 6774.

**ELECTRONIC DIGITAL CLOCK** \$15 only. Write Hong Kong Electronic Bargain Centre, P.O. Box K2618 Hong Kong for 1976 free complete line catalogue

**TEST EQUIPMENT** Data Precision model 245 digital multimeter \$150. Wavetek model 30 function generator \$150. Hewlett Packard 10528A logic clip \$50. phone 55 01650. R. Sanderson, 14/32 Flinders St., Mentone, Vic 3194.

## ORGAN KEYBOARDS

For enlarged version "Electronics Australia" organ. U.S.A. made, 61 notes, gold contacts. \$110 incl. freight.

details from  
**ELECTRONIC ORGAN CO**  
(AUST),

**124 LIVINGSTONE AVE,**  
**PYMBLE, NSW 2073.**

(Mail only)

**NEW BARGAINS FROM MICRONICS . . . TRIMPOTS** (Miniature 10mm vertical mount) 100, 220, 470, 1k, 2.2k, 4.7k, 10k, 22k, 47k, 100k, 220k, 470k, 1M—All 20c ea.  
**ELECTROLYTICS**—SINGLE ENDED FOR P.C. BOARD MOUNTING, All 25v: 4.7uf—7c, 10uf—7c, 22uf—9c, 47uf—14c, 100uf—19c, 220uf—25c, 470uf—30c, 1000uf—40c. **POLYESTER GREENCAPS** All 10%, 100V Rating—001, 0015, 0022, 0033, 0039, 0047, 0056, 0068, 0082, 01—10c ea. 015, 022—12c ea., 033, 039, 047—14c ea. 056, 068, 082—17c ea., 1—20c, 15—23c, 22—26c. **CARBON FILM RESISTORS** All 5% Tol., 1/2 watt. High stability in range of E12 values. Your choice from 10 ohm to 1 meg—All 3c ea. **SUPER SPECIALS** BC108 Metal can—10 for 90c (limit of 10 per customer) 555 TIMER mDIP—3 for \$2.74 1 op amp mDIP—5 for \$2.50. C106D (400V, 4A)—3 for \$3.75. EM410—10 for \$1 (limit of 10 per customer) HA1322 AUDIO I.C. 5.5 watts peak (incl. cct. diagram) \$2.25 ea. or 4 for \$7.50. **SUPER BARGAIN PACKS: RESISTORS**—Mostly 1/2w, 1w, 5% and 10% Resistors—100 for \$1.25. **POLYESTER CAPS**—All 10% incl. 160v, 270v, 400v types—100 for \$3.50. **ELECTROLYTICS**—Pigtails, low and high volt.—25 for \$2.50. **CERAMIC CAPS** incl. low and high volt.—50 for \$1. Post and Pack 60c. Please add extra for heavy parcels. MICRONICS, P.O. Box 175, RANDWICK, N.S.W. 2031.

**TRANSFORMER BARGAINS**—All 240V pri., r.m.s. values quoted. 12V CT 1A, \$4.50; 18V 4A, \$10.50; 25V CT 1.2A, \$7; 40V CT 1.4A, \$10; 70V CT 1.7A, \$15.50; plus many others. Send S.A.E. for catalogue. Prices include postage. R.K.O. Electronics, 4 Shaw Street, Springvale South, Vic. 3172. Phone 546 6631.

**RESISTORS AND CAPACITORS** Packs of 285 resistors. Standard Pack contains 5 each of E12 values 10 ohm to 470k in 1 R.H. GL 1/2 metal glaze resistors (1/2 watt at 70°C, 5%), Computer Pack contains selected quantities, all values included. \$7 per pack. Individual resistors 3c each, 250 or more 2.5c each. Each value is individually packed so no sorting out required! Phillips 1/2 watt carbon film still available see E.A. November. **CAPACITORS** Ceramic 50 volt circular plate 10, 25, 47, 68, 120, 270, 470, 680 pf and 001 mf 5c each. 0022, 0033, 0047, 01, 02, 047 8c each. 1 mf 9c each. Ceramic pack contains 80 capacitors being 5 each of values listed. Due to high demand reduced to \$4.50 per pack. Polyester "Green Cap" 100 volt 001, 0022, 0033, 0047, 01, 7c each, 022, 033, 047, 068 mf 10c each, .1 and 22 13c each. Polyester pack contains 5 each of these values for \$5.00. **ELECTROLYTICS**, Uprights 1000, 16 volts, 40c. 35 volts 70c. 2200 mf 16 volts 55c. Pigtails 1000-10 volts 35c. 1000 35 volts 80c. 2200 mf 16 volts 80c. 2200 35 volts \$1.20. Transistors BC549 6 for \$1.00 or 18c each. BC557 6 for \$1.00 or 19c each. Diodes IN914A 10 for \$1.00 12c each. All components brand new from manufacturers or agents. Each value of component individually packed. Post and packing included in all orders over \$6.50. For orders less than \$6.50 add 40 cents for post and packing. 5% discount on orders over \$35.00. 10% discount on orders over \$75.00. Send orders to RAM ELECTRONICS, 575 Sydney Road, Seaford, NSW 2092. Please enclose cheque or money order.

**PC LAMINATES TO CLEAR**, 3 1/2 x 24" x 1/16", single-sided phenolic, 1 oz copper \$2.50 for a pack of 5. Please add postage. Weight 700gm. Hobby Hire, 16 Coveney St. Bexley 2207. Tel 50 4361.

**THE WHAT WHERE WHO HASSLES AND HOW MUCH BOOK**—is the only comprehensive compendium/ buyers guide ever produced for the electronics and communications hobbyist or small businessman in Australia. Over 250 companies are listed under 20 categories. A lovingly handmade production. ONLY \$2.50 + 30c p&p from AMATEUR COMMUNICATIONS ADV. P.O. BOX 57, ROZELLE 2039.

**FOR HIRE** All Test Instruments, free delivery (Sydney Metro Only), free technical advice. Design, repair services also available. Ring HOBBY HIRE any time, any day on (02) 50-4361.



**MEMORIES:** 1101, 256 BIT RAMS MOS \$3.00; 1103, 1024 BIT RAM MOS \$8.00; 7489, 64 BIT ROM TTL \$5.00; 8223 Programmable ROM \$7.00 POSITIVE VOLTAGE REGULATORS 305 up to 40 volts TO-5 \$2.00; 340 T series 5V, 6V, 12V, 15V & 24V (specify voltage wanted) TO-220 \$2.25; 376 up to 40 volts mDIP \$1.10 NEGATIVE VOLTAGE FOLLOWER 304 up to -30 volts TO-5 \$1.60 OPERATIONAL AMPLIFIERS; 301 TO-5 or mDIP 60c; 307 TO-5 or mDIP 90c; 709 TO-5 or mDIP 75c; 741 TO-5 mDIP 80c; 747 (dual 741) TO-5 of DIP \$2.45; 748 (freq. adj) mDIP \$1.25; 3900 QUAD DIP 80c VOLTAGE FOLLOWER: 302 TO-5 \$1.10 VOLTAGE COMPARATOR: 311 mDIP \$1.50 CALCULATOR CHIP: 5005 12 DIG 4 func w/mem \$5.95 DIGITAL CLOCK CHIPS MM5311 28 pin BCD 4 digit mux \$6.95; MM5312 24 pin 1 pps BCD 4 digit mux \$7.95; MM5314 24 pin 6 digit mux \$8.95; MM5313 28 pin 1 pps BCD 6 digit mux \$6.95; MM5316 40 pin alarm 6 digit \$9.95. All parts new & guaranteed; Data sheets supplied upon request with order WORLDWIDE ELECTRONICS P.O. Box 308, HORNSBY N.S.W. 2077

**TECHNICIAN  
TWO WAY RADIO—SYDNEY**

For a small expanding company with sound growth potential.

**EXPERIENCE PREFERRED**

Willing train suitable applicant  
Use of company vehicle  
Good salary by negotiation  
Half yearly bonus paid  
Unlimited overtime available.  
Written applications should include personal details, technical experience or training, accommodation requirements.  
Suitable location arranged for interview for non-Sydney residents.

Write to

**THE MANAGER,  
P.O. BOX 388, ARTARMON,  
N.S.W. 2064.**

**DISPLAY ADVERTISEMENTS IN  
MARKETPLACE** are available in sizes from a minimum of 6cm x 1 col rated at \$10 per col cm. Other sizes are at card rates. **CLASSIFIED RATES \$1.75 per line per insertion payable in advance. Minimum two lines.**

**CLOSING DATE is six weeks prior to the on-sale date. Issues are on sale the first Monday of each month. ADDRESS all classified orders, copy, enquiries, etc. to: The Advertising Manager, ELECTRONICS Australia, Box 162, Beaconsfield, 2014.**

**TIME CLOCKS  
SANGAMO**

**\$16.00  
WITH  
DAY OMIT  
DEVICE**



**240V 50 cs  
15A Contacts**

Used tested and guaranteed  
PACK & POST N.S.W. \$2.00  
Vic. & Qld. \$2.50, W.A. \$3.00

**CLOCK DISPOSAL CO.  
P.O. Box 147  
LINDFIELD, N.S.W. 2070**

**A.C.E. RADIO**

136 VICTORIA RD., MARRICKVILLE, NSW 2204  
PHONE 51-3845

**PLAYMASTER 25 + 25  
STEREO AMPLIFIER**

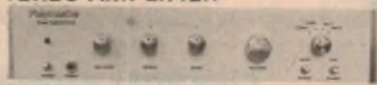

As per E.A. April, May 76. Complete kit of parts \$89.00.  
P.P. NSW \$3.00. Interstate \$4.50 Separate items available.



**PLAYMASTER 3-45L  
SYSTEM**

Features the mighty 8-30 woofer, 6J mid-range, the new 1" dome tweeter. This top quality low cost 3 way Hi Fi system can be supplied in either teak or beautiful walnut veneer. \$75.00 each plus freight.

**NEW MODEL MAGNAVOX SPEAKERS**

10-40 10" bass 8 ohms	\$22.95	Famous 8-30 8 ohms	\$14.95
625 6" mid range 8 ohms		P.P. NSW \$1.40 Interstate	\$2.20
	\$15.40	Magnavox 3 way cross-over for	
XJ3 dome tweeter	\$7.80	10-40, 625 and 2XJ3	\$20.95



**GARRARD MODEL 82**

A superb 3 speed transcription changer/player. Auto/manual operation 4 pole magnetically shielded syn. motor. Resiliently mounted. Counterbalanced. Elegant tone arm with slide-in cartridge carrier calibrated. Antiskate 265mm (10 1/2"). Aluminium platter. Cue and pause control. Cartridge tilting lever. Magnetic cartridge diamond stylus. Size 375 x 335 x 170mm (14 3/4" x 13 1/4" x 6 1/4") 4.5kg (10 lbs) P & P \$2.50 Interstate \$3.50.

Also available is the deluxe changer/player **SL95B**. Has all the above features plus the world-famous synch-RP-LAB motor, a tone arm of advanced design. A new record release mechanism, also a heavyweight non magnetic platter. With magnetic cartridge, diamond stylus. Each model is supplied with comprehensive instruction manual. Super price \$65.00 P & P \$2.50 Interstate \$3.50 Mounting base and perspex dust cover for either model \$28.50 Trade enquiries welcome. Send S A E.

**\$40**



**EXPO FM/AM/MPX  
STEREO RECEIVER  
2 GREAT MODELS**

For low cost top quality Hi Fi home entertainment. Model DX 2400 12+12 watts RMS \$156.00. Model DX 2200 6+6 watts RMS \$129.00. Freq. Resp. 30 Hz-2500 Hz Distortion better than 0.8% for magn. ceramic. Aux tape bass treble loudness controls. FM88-108MHz sensitivity 2-5UV P & P N.S.W. \$3.50.

**SOUND COLUMNS**

Black Vynex Covered Cabinets Rugged and Attractive. Innerboard Lined for Richer Sound  
Excellent Frequency Response 8 or 16 ohms Three Models

<b>15W RMS</b> 2 x 8" Speakers Size 19 1/2" H. 11" W. 7" D	<b>25W RMS</b> 4 x 6" Speakers 33" x 10" x 10"	<b>40W RMS</b> 4 x 8" Heavy Duty Speakers 37" x 11" x 10"
\$35.00	\$45.00	\$59.00

**CAR SPEAKER SPECIAL**

4 watts 8 ohm inch speaker. Indurable black plastic housing. Made for door or rack mounting. \$9.95 pair P.P. \$1.50 interstate \$1.90.

**TU-108 TUNING UNIT**

10-12 MHz Complete with ceramic coil formers. Var. Caps. Switches. etc. \$9.75

**MUSICOLOUR II**

Magical colour organ operates in conjunction with your home stereo or PA system—simple to connect and operate. 3 channels 1.500 watt max load per channel. \$69.50.

Constructed ready to use.  
Complete kit of parts with instructions and circuit \$59.50  
P.P. \$2.50 interstate \$3.50

**GOODMANS AUDIOM 18p**

100 watt, 18 inch dia. loudspeaker. This top of the range model has a heavy cast frame for extra stability. Can easily handle the massive response required by bass guitar or electronic organ.  
45-4.500 Hz 80 HMS \$139.95

**SANYO NI-CAD**

Rechargeable batteries

**KENWOOD TRIO QR 666  
COMMUNICATION RECEIVER**

New improved version. Send SAE for full tech. data.  
\$265.00 plus freight.

**PRECEDENT DOLBY CASSETTE DECK**

This famous brand deluxe unit features—tape counter. Auto shut-off, memory rewind. Headphone monitoring. Dolby indicator. Recording level meters. Slide volume controls. Record rewind, play, pause, FF, stop and eject keys. Mic inputs. Phono and DIN sockets. Specs. input sen. at 400 Hz. Mic 180 UV. IMP 10K Aux 60 MV 47K. DIN 30 MV 20K. freq. resp. CR 02 40 Hz—16 kHz.

\$149.00 P.P. \$2.50

**HI POWER BATTERY CHARGERS**

6 and 12 volts hi-lo charging rate for cars, trucks, motorcycles, boats, caravans, tractors. Protected against overloads, short circuits, reversed polarity. 8 amp \$48.95.  
12 amp \$52.95. 18 amp \$58.95.

**100 PF VAR T' MITTING CAPS**

Double spaced. Ceramic insulation. High volts 1/4" shaft.  
\$4.50 P.P. \$1.50.

**WE REGRET THAT PRICES ARE SUBJECT TO CHANGE  
WITHOUT NOTICE**

# WILLIS TRADING CO.

PERTH G.P.O. Box No. X2217, W.A. 6001

429 MURRAY ST.  
PERTH, W.A. 21 7609 21 7600

## BARLOW-WADLEY RECEIVERS



Model XCR-30 Mk II 500kHz to 31 MHz continuous coverage, crystal controlled reception of AM/USB/LSB/CW  
\$245.00 Plus P&P.



**Drake General Coverage Receiver**  
5mHz to 30mHz Battery & Mains  
\$299.00 Plus P&P



## DIGITAL WATCH

6 Function LED Stainless Steel Case & Band. Hours, Min., Seconds, Day & Date  
\$69.00 Plus P&P.

## Electronic Tool Kit \$19.75



Tweezers  
File  
40w Soldering Iron  
Solder  
Phillips S/Driver  
2 Screw Drivers  
Long Nose Pliers  
Flat Nose Pliers  
End Cutters  
Vinyl Zip Case

## ELECTRONIC HOBBY KITS. BUILD YOURSELF

A Crystal Radio Kit at only  
\$4.95



A 2 Transistor Radio Kit at only  
\$5.95



or a VHF Aircraft Band Radio.  
At only \$7.50



## Advertising Index

A & R Soanar Electronics Group	103
ACE Radio	127
Aegis Pty. Ltd.	111
Akai Electric Co. Ltd.	5
Amateur Communication Advancements	118
Apollo Hi-Fi Centre	44
Applied Technology Pty. Ltd.	68
Arlunya Pty. Ltd.	70
Auditec Australia	88
Audio Engineers	98
Auriema (A'asia) Pty. Ltd.	13
Australian Time Equipment Pty. Ltd.	67
Bright Star Crystals Pty. Ltd.	83
Cema (Distributors) Pty. Ltd.	60
Classic Radio	56
Clock Disposal Co.	127
Convoy International Pty. Ltd.	4, 26
C. R. C. Chemicals	49
C & K Electronics (Aust.) Pty. Ltd.	88
CQ Workshop	128
Colrose Electronics	39
Danish Hi-Fi	6
Deitch Bros	116
Dick Smith Electronics	52, 53, 109
Diggerman Electronics	109
Dynamic Electronic Industries	72
E. D. & E. Sales Pty. Ltd.	100
Edge Electrix	122
Electrocraft Pty. Ltd.	63
Electronic Developments & Service Pty. Ltd.	102
Electronic Organ Co. (Aust.)	126
Ferguson Transformers Pty. Ltd.	73
Fidelity Service	109
General Electronic Services Pty. Ltd.	75
George Hawthorn Electronics	23
Haco Distributing	OBC
Hagemeyer (Aust.)	IBC
Ham Radio Electronics	110
Harmon Australia Pty. Ltd.	10
Interson Pty. Ltd.	17
J. R. Publications	112
L. Chapman	124
Lafayette Electronics	125
Lanthur Electronics	111
Leroya Industries Pty. Ltd.	41
Magnecord International	20, 50
Marconi School Of Wireless	81
Micronics	120
Modern Dictating Systems Pty. Ltd.	76
Nomis	46
Peter Shalley	106
Philips "Elcoma"	2
Photimport Dokorder	16
451 Sound Centre	29
R. H. Cunningham Pty. Ltd.	90
RCS Radio Pty. Ltd.	115
Radio Despatch Service	95
Radio Parts Group	65
The Rosicrucians	126
Royston Electronics	50, 110
Sabtronic International	107
Scope Laboratories	84
Sony Kemtron Pty. Ltd.	IFC, 18
Stanton Pickering	8
Stott's Magna Sighter	67
Stott's Tech Correspondence College	31
Sun Electric Co. Pty. Ltd.	34
Techniparts	72
Technical Book & Magazine Co. Pty. Ltd.	113
Tektronix	63, 65
Tesla	83
Video Hi-Fi Centre	105
Warburton Franki (Sanwa)	108
W. H. K. Electronics	78, 79
Western Electrics	39
Willis Trading Co. Pty. Ltd.	128
Wireless Institute of Australia	119

# MORSE CODE

COMPLETE HOME COURSE TO 10 W.P.M. ON CASSETTE.

Four 60-minute cassettes, full course including plain language and test exams with printed check sheets. Electronically produced to Examination style.

POST FREE \$70.00.

ALSO, FULL A.O.C.P. & NOVICE MORSE, THEORY & REGULATIONS PERSONALISED COURSES AT OUR LECTURE WORKSHOP.

All enquiries to—

## CQ WORKSHOP

Shop 17, Embank Arcade  
325 Collins Street MELBOURNE 3000  
or  
G.P.O. Box 2534W MELBOURNE 3001  
PHONE (03) 62 5177

# SUBSCRIPTION SERVICE



## ELECTRONICS Australia

### Subscription Rates

\$A14.00 per year  
within Australia.  
\$A17.00 per year  
elsewhere.

Make sure you receive every copy of the magazine by ordering it from your newsagent or the publisher. For publisher subscriptions post this coupon, with your remittance, to Electronics Australia Subscription Dept., John Fairfax & Sons Ltd, GPO Box 506, Sydney 2001. Subscription will start with first available issue.

Name .....

Address .....

Postcode ..... Enclosed is ..... for ..... years



# Introducing the revolutionary UD-XL EPITAXIAL cassette



Developed by MAXELL this completely new EPITAXIAL magnetic material combines the advantages of the two materials (gamma-hematite and cobalt-ferrite): the high sensitivity and reliable output of the gamma-hematite in the low and mid-frequency ranges and the excellent performance of the cobalt-ferrite in the high-frequency range. The result is excellent high-frequency response plus wide dynamic range over the entire audio frequency spectrum.

Compared to chrome tape, sensitivity has been improved by more than 3.5dB. Because EPITAXIAL is non-abrasive, it extends to the life of the head. Consequently, the UD-XL delivers smooth, distortion-free performance during live recording with high input. When using UD-XL it is recommended that tape selector be in the NORMAL position.



Fidelity is also ensured by a precision-manufactured cassette shell with a special anti-jamming rib that provides smooth tape travel and helps eliminate wow and flutter.



Another good idea of the UD-XL cassette is a replaceable self-index label. Simply peel off the old label and put on a new one when you change the recording contents. No more mess on the label.

Magnetic material structure

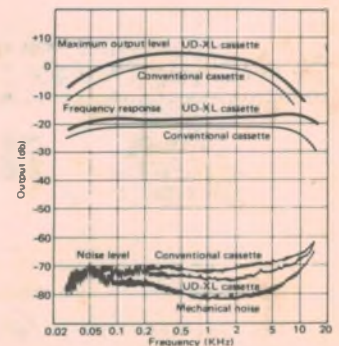
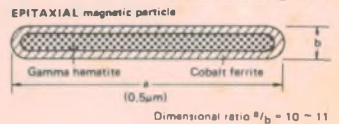
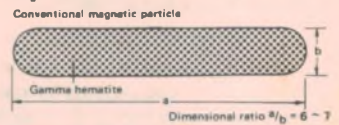

# maxell®

For further information please write to Maxell Advisory Service, P.O. Box 49, Kensington, N.S.W. 2033.

WT.GD. 76M



## A turntable with features you'd expect only on a more expensive unit

One feature you'll notice is the price; in fact we believe it to be 'the best buy' turntable available today.

With features only expected on more expensive units, such as wow and flutter of 0.5 WRMS thanks to the DC motor with FG (frequency generator) servo-controlled circuits.

How's this for a list of features. Practical, purposeful features like

- illuminated stroboscope
- elliptical stylus

- completely automatic tone arm return
  - viscous-damped cueing lever
  - anti-skating dial scale control
  - CD4 ready
  - audio insulated legs
- and the list just goes on.

Any way you want to look at it, you'll agree the Technics SL23 is a sound buy, with appearance and performance to match.

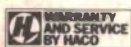

For a National Technics Catalogue please write to:  
National Technics Advisory Service, P.O. Box 49, Kensington, N.S.W. 2033



# Technics

by National

WT GD 105 T