

ELECTRONICS

Australia

with **CB and HIFI NEWS**

FEBRUARY, 1977

AUST \$1.00* NZ \$1.20



**REACTIONS TO CB RADIO • ELECTRONICS
IN SCHOOLS • LINEAR SCALE OHMMETER**

A whole new way to look at Hi-Fi:



Not just matched-wholly integrated!

Sony's new Leo II and Venus II. Fine Furniture Matched Systems.

If you love good music but have had reservations about all those Hi-Fi "bits and pieces" coming into your living room relax, the answer has arrived. Sony, who actually make many of the finest components around, have really put it all together. And in a shape that's as elegant as the finest decorator furniture. Naturally the sound's as rich and real as any hi-falutin' Hi-Fi rig. Naturally, it's a Sony.

The "bits and pieces" look is out
And the components are the very same top-end units selected by Hi-Fi buffs themselves for those room-dominating rigs. But without that do-it-yourself look that never quite makes it in a tasteful living room.

Instead, Sony started with a fine furniture piece that presents the very latest Hi-Fi components with the

smooth, uncluttered lines of a continental sports car. And with the controls and performance to match.

If you've been having trouble convincing someone around the home that you should both be enjoying good music, show her Sony's new living room Hi-Fi, soon. She'll like the looks. She'll love the sound. Choose from the Leo II (illustrated) or the Venus II.

What you get:

LEO II (illustrated)

Turntable PS2350 The new belt-drive model that turns the Hi-Fi buffs right on. 4 pole motor. Automatic arm return and shut off. Viscous damped cueing. Anti-skating compensator. magnetic cartridge. diamond stylus

Stereo Tuner ST2950S Tune in the beautiful new stereo FM music broadcasts or hear your favourite local programmes as they really sound. Or either of two Short Wave bands

Amplifier TA2650 Powerful output of 43 watts RMS per channel. With true stereo symmetry from direct-coupled circuits. Full range of impressive controls to master your home music system

Speakers Dynamic sound SS2250 3-way system with new "carbocon" woofer. 6cm range and horn-type tweeter. Decorator finished cabinets

Furniture Unit SU1700 Specially designed for a perfect integration. (Included in price)

Matched Options Shown:

Front Loading Cassette Deck TC186SD
Headphones DR11

VENUS II (same included furniture unit)
The same refined look at a more economical price
Turntable and Tuner Same as Leo II

Amplifier TA1630 Smooth power of 22 watts RMS per channel with true stereo quality. Loudness and presence switches for true Hi-Fi listening even at low volume levels

Speakers SS1250 Sony dynamic 2 way speakers with new third element passive radiator for better bass

SONY®

Research makes the difference.

GAC S 7909



ELECTRONICS Australia

Australia's largest-selling electronics & hi-fi magazine

VOLUME 38 No 11

CONTENTS—FEBRUARY, 1977



Operation Electronics: a new school electronics project designed specifically for NSW high schools is to be launched in March. Our article on p22 gives brief details on the course and outlines the part "Electronics Australia" plans to play.



Developed in our laboratory, this simple self zeroing, direct reading ohmmeter features a linear scale and can provide accurate resistance measurements from 0.5 ohm to 1 megohm. See page 38.

On the cover

Our cover this month is a montage of the Marisat 1 satellite at Cape Canaveral, showing the launch booster, the satellite, and control panel operators. Marisat satellites are revolutionising maritime communications, as our article on p28 explains. (Photo courtesy Hughes Aircraft Company).

world of electronics and hi-fi

- 3 Editorial: The winds of change . . .
- 7 Hi-Fi News:
 - Piezoelectric tweeters live again—Astatic microphones from Nomis—Yamaha CA410 stereo amplifier—AKG reverberation unit—A new cartridge from Pickering—Bozak sound equipment now sold in Australia*
- 14 Microphones Pt 5: Matching and matching transformers
- 17 Review: Sound Technology 1710A Distortion Measurement System
- 21 Review: Luxor 3-way vented loudspeaker system
- 22 Operation Electronics: new project for schools
- 24 The consumer comes face to face with the computer
- 28 Satellites are updating the world's shipping
- 40 The CB scene: 27MHz in wheatbelt . . . but in the city?
- 64 Forum: Noise, Dolby, dbx and all that . . .
- 80 Stone Soup: a modern parable

projects and technical

- 34 A full logic SQ decoder for your quadraphonic system
- 38 Direct reading ohmmeter features a linear scale
- 42 Video data terminal for microcomputers—2
- 48 Simple converter for University of NSW radio station
- 52 Suppressing radio frequency interference from electrical machinery
- 56 Heathkit Model TD-1089 electronic chimes unit
- 61 Restoring & upgrading the Wide Band CRO
- 68 The serviceman: Self-converging systems
- 73 Circuit and design ideas:
 - A simple noise blanker—Zener plus diode temperature coefficients—Stable Pierce oscillator as TTL clock—Programmable ratio frequency divider*
- 76 Op-amps without tears—2: a practical introduction to op-amps
- 95 Introduction to digital electronics—13: Multiplexing
- 100 New products:
 - B & K Precision Model 510 transistor tester—Colour module for video game—Portable soldering tool kit—Low profile keys with tactile feel—Accessories for CB radio*

regular features

- 30 News highlights
- 83 Record reviews—classical
- 87 Record reviews—devotional, popular, jazz
- 104 Book reviews
- 107 Letters to the Editor
- 109 The amateur bands
- 113 Shortwave scene
- 115 Information centre
- 118 Marketplace—classified
- 120 Index to advertisers
- 117 Notes and errata

CB RADIO
On p41 we look at CB radio in the country, and in the city. The contrast—one of responsibility versus irresponsibility. Also examined is the threat to the CB emergency channel 9 in the United States.

LOC MOS 4000B*

Think
Signetics
Think
PHILIPS

DESIGNER'S CHOICE

The locally oxidised CMOS alternative

- LOC MOS 4000 is the new high performance CMOS family from Philips. Costing no more than conventional CMOS it gives you:
 - higher speeds - lower static power - high noise immunity
 - buffered, standardised outputs
 - ideal transfer characteristics - high packaging densities
- LOC MOS 4000 is pin-for-pin compatible with the other popular 4000 ranges.
- LOC MOS 4000 is fully second sourced - no alternate source problems.

*LOC MOS 4000B Series fully meets new JEDEC Standard "B" Series CMOS specifications.

Philips Electronic Components and Materials

Sydney.....	42 1261, 42 0361
Melbourne.....	699 0300
Brisbane.....	277 4822
Adelaide.....	223 4022
Perth.....	654 199

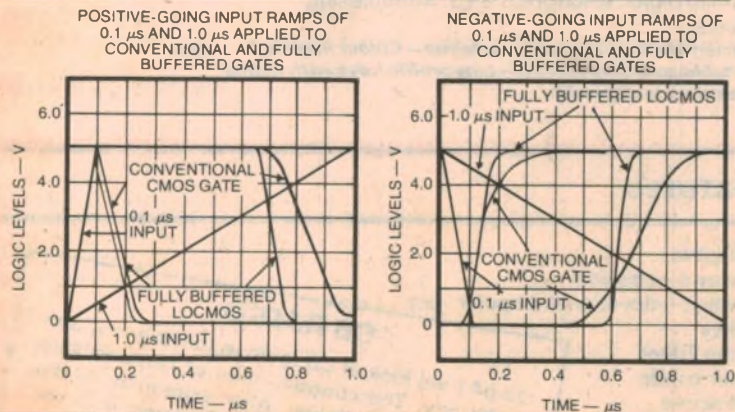

Philips Electronic Components and Materials
P.O. Box 50, LANE COVE, 2066 N.S.W.

I am interested in using your new LOC MOS integrated circuits HEF 4000 series.

Please send brochure.

Please arrange for your representative to call on me.

NAME

POSITION

Clip coupon to your letterhead



**Electronic
Components
and Materials**

PHILIPS

153-0173



Editorial Viewpoint

The winds of change . . .

To own a wireless set in the middle 1920s was sufficient to brand one as a person of some note in the community. It was accepted as tangible evidence of a person's means, initiative, and technical resource. Since then, of course, radios have become more common than spectacles but I'm still boggled by the present given to a couple of my tiny grandchildren during the past festive season: a 5-transistor superhet each, costing less than \$3, complete with instruction book, battery and earphone for personal listening.

A five transistor radio for less than the price of a toy!

In those distant '20s a mere handful of people operated amateur radio stations and every transmission was an event. My own connection with the hobby did not come until the late '40s, and it was with some pride that I built two 5-ft wooden racks and filled them with VHF transmitters and receivers constructed largely from wartime disposals "bits". Nowadays, I can communicate just as effectively with a single transceiver the size of a car radio—without any hint of the unusual. Thousands of others are doing likewise, legally and illegally, on 27MHz!

Without venturing too far back in time, I can recall the first news items about a marvellous new creation called a computer—a room full of racks, wires and valves capable of doing sums at unheard-of speeds. To be invited to inspect one was an experience; to actually use one was the province of a select few. Yet, today, there are computers everywhere. People build them and operate them as a hobby. And, for a few dollars, you can carry and use an electronic calculator that may well rival the capacity of some of those early marvels.

How times have changed.

A couple of years back, a whole generation of TV servicemen were preparing to cope with the flood of calls that must follow the introduction of colour. It was a matter of simple logic: sets with two or three times as many components would require to or three times as many calls! A few models did, for a while, but since then the "flood" has faded to a trickle and quite a few servicemen are now whistling for work. Who would have believed that the statistical failure rate of some TV sets now on the market would get down to an all-up figure of 0.3 calls per set per annum?

The curious thing about all this is that, while we may point up such enormous changes, we've grown so used to them in the electronic industry. 1976 came and went but we're already tending to forget it was the year of the microprocessor, the year of the reliable colour TV set, the year in which CB radio challenged the Australian communications scene.

What lies ahead for 1977?

Quite a lot, I imagine, if only because the projections of technological progress so indicate. We, as a magazine, will face new challenges—and so will you as readers and as followers of a vibrant, outgoing branch of technology.

Despite the economic climate, despite unpredictable marketing, despite the personal problems of coping and keeping up, I look forward to 1977 with anticipation and excitement.

— Neville Williams

EDITOR-IN-CHIEF

Neville Williams
M.I.R.E.E. (Aust.) (VK2XV)

EDITOR

Jamieson Rowe
B.A. (Sydney), B.Sc. (Technology, NSW)
M.I.R.E.E. (Aust.) (VK2ZLO/T)

ASSISTANT EDITOR

Philip Watson
A.M.I.R.E.E. (Aust.) (VK2ZPW)

SCIENCE FEATURES

Greg Swain, B.Sc. (Hons. Sydney)

PRODUCT REVIEWS

Leo Simpson

TECHNICAL PROJECTS

David Edwards, B.E. (Hons. Tasmania)
Ian Pogson (VK2AZN/T)

GRAPHICS

Robert Flynn

PRODUCTION

Daniel Hooper

ADVERTISING MANAGER

Selwyn Sayers

CIRCULATION MANAGER

Alan Parker

ON SALE THE FIRST MONDAY OF EACH MONTH

Registered for posting as a periodical—Category B

Printed by Dalley-Middleton-Moore Pty Ltd, of Wattle St, Sydney and Masterprint Pty Ltd of Dubbo, NSW, for Sungravure Pty Ltd, of Regent St, Sydney

*Recommended and maximum price only

Editorial Office
57-59 Regent St, Sydney 2008
Phone 699 3622.

Postal Address: PO Box 163, Beaconsfield 2014

Advertising Offices
Sydney—57-59 Regent St, Sydney 2008.
Phone: 699 3622.

Representative: Narcisco Pimentel.

Melbourne—392 Little Collins St, Melbourne 3000. Phone: 67 8131

Representative: Keith Watts

Adelaide—Charles F. Brown & Associates Ltd
168 Melbourne St., North Adelaide 5006.

Representative: Tom Duffy 267 4377.
Perth—454 Murray Street, Perth 6000
Representative: Jack Hansen 21 8217.

Subscriptions

Subscription Dept, John Fairfax & Sons Ltd,
GPO Box 506, Sydney 2001. Enquiries: Phone
(02) 498-3161.

Circulation Office

21 Morley Ave, Rosebery, Sydney 2018.
Phone 663 3911.

Distribution

Distributed in NSW by Sungravure Pty Ltd
57-59 Regent St, Sydney, in Victoria by Sun-
gravure Pty Ltd, 392 Little Collins Street, Mel-
bourne; in South Australia by Sungravure Pty
Ltd, 101-105 Weymouth St, Adelaide; in

Western Australia by Sungravure Pty Ltd, 454
Murray Street, Perth; in Queensland by Gordon
and Gotch (A'asia) Ltd; in Tasmania by Ingle
Distributors, 93 Macquarie St, Hobart; in New
Zealand by Gordon and Gotch (NZ) Ltd, Adel-
aide Rd, Wellington.

Copyright. All rights reserved

Devices or arrangements shown or described
herein may embody patents. Information is
furnished without responsibility for its use and
without prejudice to patent rights.

All manuscripts, photographs and other
material submitted to Electronics Australia for
publication must be accompanied by a stamped,
addressed envelope. Contributions are submit-
ted at the sender's risk, and responsibility for
loss cannot be accepted by Electronics Aust-
ralia.

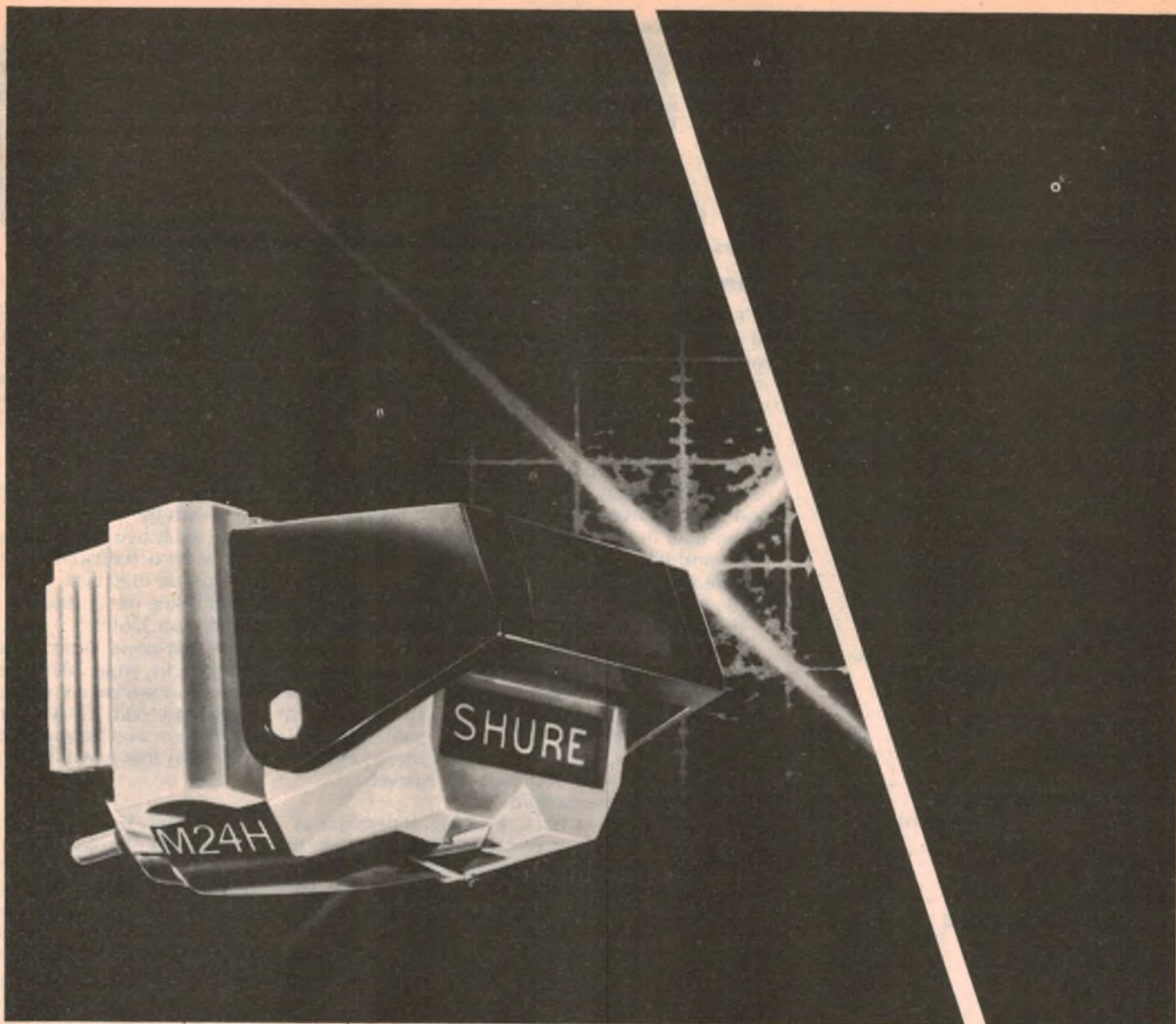

Uncompromised stereo/quadrphony —Undeniably Shure.

2+4

**MODEL M24H
STEREO +
QUADRIPHONIC
CARTRIDGE**

The new Shure M24H Cartridge offers audiophiles the best of both worlds: It is the only cartridge on the market that does not compromise stereo reproduction to add discreet quadriphonic capability. It eliminates the need to change cartridges every time you change record formats! This remarkable performance is achieved at only 1 to 1½ grams tracking force — comparable to that of the most expensive conventional stereo cartridges. Other M24H features include the lowest effective stylus mass (0.39 mg) in quadriphony, a hyperbolic stylus tip design, an exclusive "Dyneric® X" exotic high-energy magnetic assembly, and a rising frequency response in the supersonic carrier band frequencies that is optimized for both stereo and quadriphonic re-creation. If you are considering adding CD-4 capability, but intend to continue playing your stereo library, this is the ONE cartridge for you.

Distributed in Australia by
AUDIO ENGINEERS PTY. LTD.
342 Kent Street, Sydney. Write for catalogue.

SHURE®

AUDIO ENGINEERS (Vic.)
2A Hill Street,
THORNBURY. 3071. Vic.

AUDIO ENGINEERS (Qld.)
57 Castlemaine Street,
MILTON. 4064. Qld.

ATHOL M. HILL PTY. LTD.
33-35 Wittenoom Street,
EAST PERTH. 6000. W.A.



Peerless PMB6—remarkable realism equal to the best electrostatics

New Peerless Orthodynamic principle—this is really living

With Peerless PMB6 headphones everything you hear is true. Based on the newly developed and patented Peerless Orthodynamic principle, PMB6 headphones deliver reproduced sounds equal in quality to the most sophisticated electrostatics. Peerless bring it back alive—sounds so real, you feel you're actually there.

In one ear and in the other—in total comfort

There's nothing more annoying than headphones that clamp you in a head-lock. With Peerless featherweight construction, fine fit and pillow-soft ear pads, absolute comfort is certain over long time listening.

Until you've heard it through Peerless—you just haven't heard it!

Between two perforated ferrite magnet discs lies an ultra thin diaphragm/voice coil. This light and very elastic diaphragm, whose total surface is put into motion, makes crystal clear high frequency reproduction possible. Its construction also ensures uniform phase characteristics and low distortion. The diagram below details this novel new design.

In your favourite piece of recorded music, you'll hear notes and nuances you'd never have believed existed.

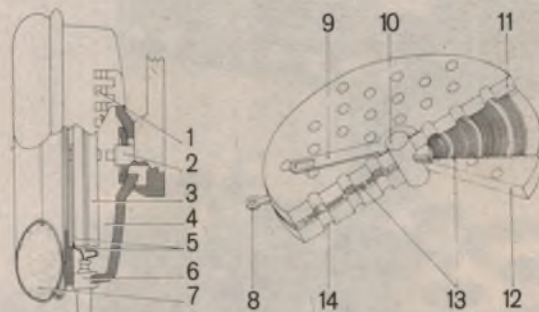

1. Air holes 2. Ball joint suspension 3. Drive unit 4. Damping material 5. Terminals 6. Cable grip 7. Ear pads 8. Terminal 9. Terminal 10. Centre axle 11. Magnet 12. Magnet 13. Diaphragm/voice coil 14. Hole in magnet.

Peerless PMB6 Technical Data

Frequency:	Range 16-20,000 Hz
Impedance:	140 Ohms
Max. Constant Load:	40 dB
Operating Power:	2.5 mW
Distortion:	1%
Rated Input:	2W (DIN)
Weight:	210 g
Colours:	Black, Red and Olive Green

Peerless PMB6 \$49

Electrostatic quality, superb comfort and a realistic price

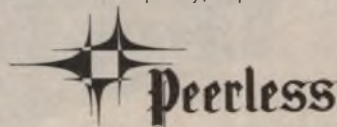

Danish Hi Fi Shop 9, Southern Cross Hotel, Melbourne. Telephone 63 8930. **Danish Hi Fi** 698 Burke Road, Camberwell, Victoria. Telephone 82 4839. **Convoy Sound** 1 Maclean Street, Woolloomooloo, N.S.W. Telephone 357 2444. **Convoy Sound** 387 George Street, Sydney. Telephone 29 4466. **Brisbane Agencies** 72 Wickham Street, Fortitude Valley, Queensland. Telephone 221 9944. **Danish Hi Fi** 308 Walcott Street, Mt. Lawley, Western Australia. Telephone 71 0100.

Dokorder.

A superb range that has sound quality taped.

Increasingly advanced recording techniques mean that near perfect sound is available to the music lover. To fully appreciate this sound, you need equally sophisticated reproduction equipment. And that's what Dokorder is all about!

A range of highly sophisticated tape recorders and decks . . . seven models to select from. One for every need and budget. For instance, the new 1140 . . . Dokorder's finest professional tape deck. Studio quality and a host of features. And the 8140 4-channel

tape deck with multi-sync, for fun, flexibility and fine sound. Then, there's the new MK550 stereo cassette deck featuring servo controlled drive system, built-in Dolby, Cue and Review system, Peak Level Indicators, Normal/Chrome equalization and a switched FM multiplex filter—features you should insist on in any first-class deck.

With Dokorder, there certainly is a unit to suit every need! And every Dokorder gives you superb sound quality.

Dokorder.

PHOTIMPORT

MELBOURNE ADELAIDE BRISBANE PERTH SYDNEY

For descriptive literature and specifications, send a 30 cent stamp to **Qualitron Industries Division** of Photimport (Australia) Pty. Ltd.

Head Office: 69 Nicholson Street, East Brunswick, Vic. 3057
Australia. Telephone: 38Q 6922



PA11D



Piezoelectric tweeters live again

At a time when nearly all hifi speaker systems use a dynamic tweeter, the re-appearance on the market of a horn type piezo tweeter has to be news. And, in this case, it is the Components Products Dept of Motorola who have made it so.

by NEVILLE WILLIAMS

Piezoelectric tweeters are not new, of course, being only a little younger in concept than piezoelectric phono pickups. They have had their problems, however:

Most of the early examples used a rochelle salt crystal and suffered the familiar fate of breakdown when exposed to excess heat or humidity. And, while ceramic wafers avoided this hazard, they only accentuated another problem: that of driving a voltage-sensitive element from the very limited signal present in ordinary voice coil circuitry. However, this was evidently not the final word.

Two papers in the subject were presented to the AES (Audio Engineering Society) Convention in 1972: Hugo Schafft—"A New Piezoelectric Direct Radiating Tweeter" and Ronald M. Schmetter—"The Piezoelectric Loudspeaker: Its Use In Audio Systems". Both were associated with Motorola Inc of Illinois, USA and the papers reflected current research into more sensitive and more robust ceramic wafers.

In the 1974 AES Convention, Jonathon R. Bost of the same Company presented:

"A New Type Of Horn Tweeter Employing A Piezoelectric Driver"—obviously, the prototype of those now on the market.

In the 1972 paper, Schmetter stated, that his Company had, for some time, been using a variety of piezoelectric loudspeakers in their audio products and had built up a considerable amount of expertise in the relevant technology.

The basis for their loudspeakers was a ceramic disc serving as the drive unit, normally a lead-zirconium-titanate compound, "fired to a high temperature, then cooled and permanently polarised with



When signal voltage is applied to the faces of two piezoelectric discs, as shown, they tend to distort at the centre, driving an attached cone.

a direct current field". A deposited nickel electrode on each face provided the necessary electrical connections. Where increased output was required, an option was to combine two discs in a layered bimorph sandwich.

Main emphasis in the Motorola program was on piezoelectric tweeters which took two forms: A cone type in a conventional 3½-inch basket (as for dynamic tweeters) and a hyperbolic horn type where higher sound pressures were required—typically in excess of 100dB for 4 volts input.

Schmetter claimed that the frequency response over the target range—5kHz to 20kHz or more—was comparable with "some of the better push-pull electrostatic tweeters", being notably smooth and with very good transient response. The polar diagram of the cone version was similar to that of other cone tweeters, but the horn offered a wider, smoother dispersion over the working range.

In terms of impedance, the piezoelectric tweeters looked like a resistor in series with a capacitor, but in fact were predominantly reactive, varying from about 600 ohms near the low end of the

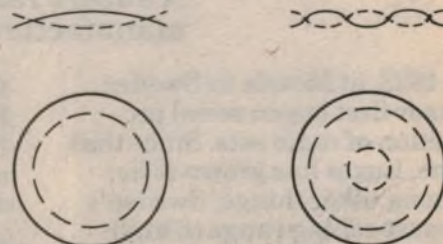

Faced with natural resonance effects in the piezoelectric drive, the designers have guided the fundamental mode (left) to provide the 5kHz turnover frequency and dampened other modes (right) to secure what they claim to be an appropriately flat response.

working range, to about 75 ohms at the top end.

Being reactive, the tweeters actually absorbed very little drive power making it difficult to quote a power rating. They did have a voltage rating (typically 55V peak) but, more importantly, their sensitivity was such that they could now be mated quite conveniently with typical low and mid-range dynamic drivers.

In his paper—virtually the case for piezoelectric tweeters—Schmetter set considerable store by their ease of application, particularly in 2-channel speaker systems. A piezoelectric tweeter of the kind under consideration could simply be connected across the speaker line at voice coil impedance. Because of its high reactance at low frequencies and its natural response, it needed no special protection against low frequency drive. And, if a high frequency level control was deemed necessary, it could either be a simple series resistor, or a fairly high value potentiometer across the audio line.

On the subject of amplifier loading, Schmetter pointed out that all practical,

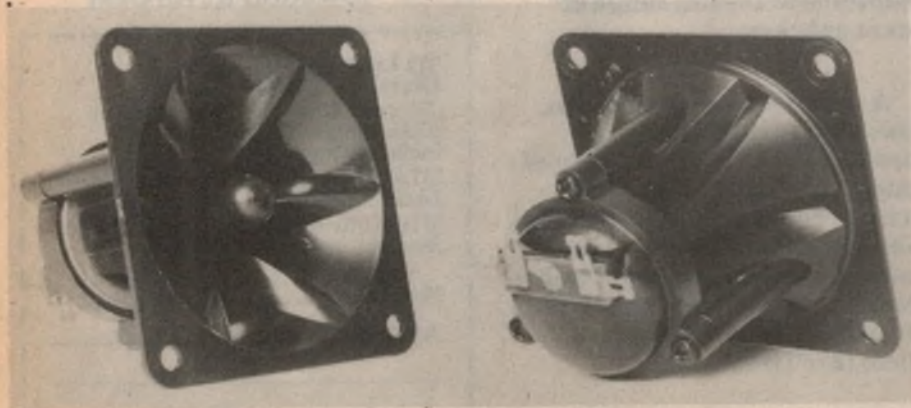

Motorola's KN 6005A piezoelectric tweeter is so designed that it can mount in a similar baffle cutout to that required by typical magnetic cone or dome tweeters. While it could be designed into a hifi loudspeaker system, its more obvious appeal will be as an add-on unit for public address or music speaker systems, characterised by high power levels and high acoustic efficiency.

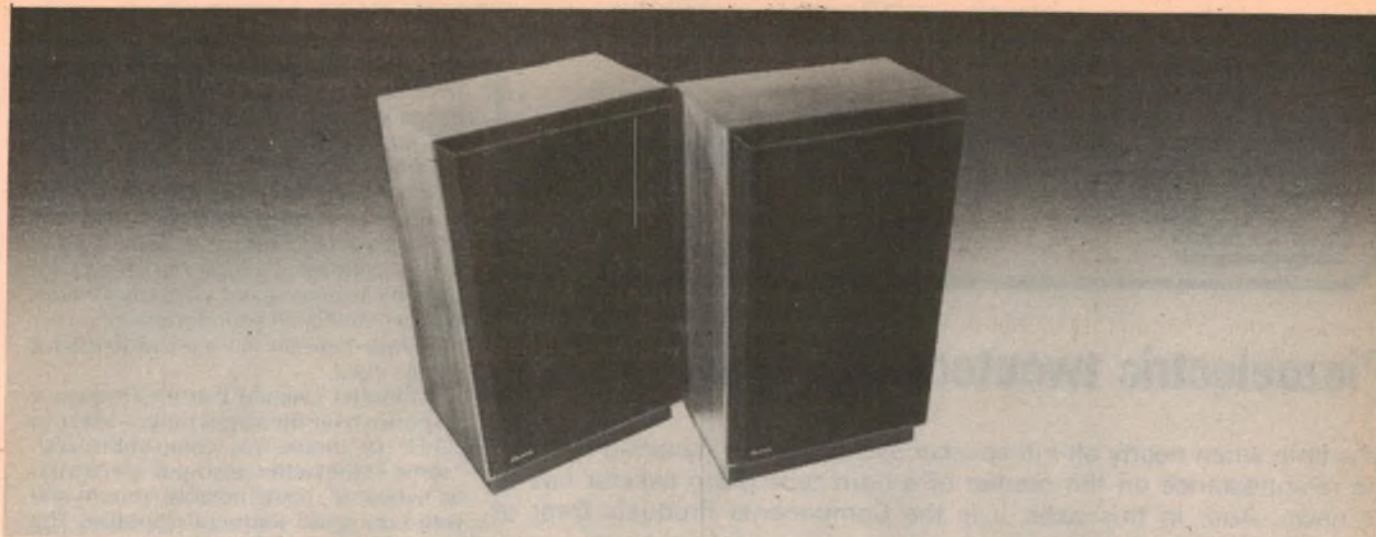

The Luxor Bass Reflex 50W loudspeaker

The Luxor 'Swedish Sound' Speakers

A superb range of speakers from Sweden's largest manufacturer of high-quality stereo systems.

In 1923, at Motala in Sweden, Luxor first began serial production of radio sets. Since that time, Luxor has grown to be, among other things, Sweden's largest-selling range of high-fidelity speakers.

The technically advanced Bass Reflex speaker. Based on the principles of the bass reflex.



Fully equipped for three systems. With a power handling capacity of 50W, a 25cm (10") bass speaker, dome tweeter and treble speaker. Available in specially finished cabinets of walnut, teak, jacaranda, matt black or matt white.

All-round ambiophonic sound. Luxor's own simulated 4-channel stereo system, to give

you an even better quality sound. Featuring all the technical features of a normal Luxor stereo unit, but with the depth of reproduction of a 4-channel unit.

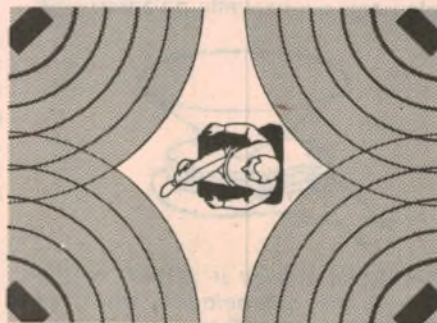

The Ambiophonic concept is adaptable to the full range of Luxor speakers.

A comprehensive range. Luxor have a large range of speakers to cater for a variety of tastes, standards and requirements. From the 50W Bass Reflex speaker with a 25cm (10") bass speaker, dome tweeter and treble speaker. To a 15W speaker with a 13cm (5") drive unit and a 6.5cm (2½") treble unit.

They look as good as they sound. Luxor speakers combine a careful attention to detail with an

unmistakable touch of design flair. Elegant and sleek. Available in a range of modern finishes.

The superb Swedish sound. As Sweden has developed in the world of music, so Luxor has developed in reproducing that sound. The more you know about Luxor speakers, the more impressive they become.

LUXOR
Sweden at its best

To: Luxor, P.O. Box 205,
Glen Iris, Victoria, 3146.

I would like to know more about Luxor range of stereo systems, including speakers.

I am interested in becoming a Luxor Distributor.

I am interested in becoming a Luxor Stockist.

Name _____

Address _____

Postcode _____

(Luxor, C/- 1396 Malvern Road,
Tooronga, 3146.)

LUX144

conventional loudspeaker systems present a complex load, often with quite an erratic reactive content across the frequency range. In practice, the smooth capacitive reactance of a piezoelectric tweeter, operating over the treble region, should not prove any great hazard to an amplifier in which normal stability precautions have been taken.

The 1974 paper by J. R Bost makes only brief reference to the bimorph driver element, although it does point out that it is so designed that it exhibits a fundamental resonance near the bottom end of its intended operating range. Presumably, this natural resonance provides the lower "corner" of the response curve at about 5kHz. A further resonance mode is evident at the second harmonic, presumably in the 10kHz region.

From that point on, Bost's paper is concerned almost exclusively with the design of the horn radiator which must dampen and suppress the natural resonance effects of the driver and cone assembly, as well as matching its impedance to that of the room. Merely to scan the paper is to realise that there is far more to the design of a horn radiator than producing a flare with eye appeal!

Bost begins with Olsen's classic formula relating to the design of conventional dynamic horn tweeters, eliminates or modifies the factors which do not apply to a piezoelectric driver and emerges with guidelines which are the mere beginning of what he refers to as an "Edisonian" engineering procedure—in another word "empirical".

This led to the adoption of a relatively large diameter 33mm cone, coupled at its apex to the piezoelectric driver, but fairly rigidly supported around the perimeter. The driver at the apex therefore works into a complex load—acoustic due to the horn, and physical by having to stress the cone.

The design also provides for a small, tapered air gap between the front face of the cone and the support housing. The various parameters combine, however, to yield a substantially flat output response from the very small areas of the cone which face into the throat of the actual horn. Bost quotes the total cone area as 85 sq mm, of which only 13.5 sq mm couples into the throat of the horn.

From this effective throat area, the horn expands to a mouth diameter of 3 inches, terminating in a plate which allows the unit to mount in the kind of cutout commonly provided for an ordinary 75 mm dynamic tweeter. At this diameter, the horn cuts off at around 2kHz, comfortably below its operating range.

While the moulded ribs and central plug give the tweeter a highly functional appearance, Bost stresses that they have a true functional role, in that each segment is really the development of a natural orifice which forms part of the

ASTATIC MICROPHONES FROM NOMIS



To old-timers in the electronics industry—if not to "young-timers"—the name "Astatic" will be well known, in association with piezo-electric or crystal microphones and pickups. In fact, the Astatic Corp, of Conneaut, Ohio, USA is still very active, although much more concerned these days with dynamic microphones.

Undoubtedly, the microphone with which Astatic was once most frequently associated was the famous old D-104 crystal, which was available either as hand model or supported in a ring for stand use. It was beloved by amateurs and others for its ruggedness and its tendency to favour those speech frequencies which mattered most in terms of sheer intelligibility!

Believe it or not, the old D-104 is still being manufactured, forty years or so after its original release!

But, if you want an Astatic communications microphone nowadays, you are much more likely to be offered the 337L-GS unit, pictured in the foreground, a tapered dynamic with push-on switch, mounted on a 13-in chrome flexible gooseneck. Normally of low impedance (38 ohms) it can be used with Astatic's LT-6 step-up transformer, where appropriate.

Rated frequency range is 100-12000Hz, and output -57dB relative to 1mW/10 microbars.

In the rear centre of the above group is the Astatic 810, a general purpose quality microphone which Astatic claim to be well suited for prestige public address, recording or broadcast work, and manufactured to specifications sufficiently rigid for them to be used in pairs for stereo. Normal finish is black and satin-chrome but it can be supplied in black and dull gold for special situations.

Internal structure and filtering give the 810 a cardioid pickup pattern with a

front-to-back ratio of 25dB. The response plot shows a typical "presence" lift of about 3.5dB between 2 and 4kHz, dropping gradually to 10dB-down points at 55Hz and 13kHz. Both electrostatic and electromagnetic shielding is incorporated, while the grille and filtering provide a significant safeguard against dust, wind noise and breath "pop".

The 810 has a built-in step-up transformer, interconnected internally to the broadcast type 5-pin connector socket. By suitably wiring the leads emerging from the 18ft shielded twin cable, the microphone can be used either at 150 ohms impedance or 40,000 ohms, in the latter case with one side grounded.

The 850 and 857 microphones are virtually identical in appearance, being characterised by a near-spherical ball filter, giving extra protection against wind and breath "pop". In other respects, the 850 would appear to be electrically identical to the 810, with the same suggested applications and the same connection arrangements.

The 857-H (or -HS, with switch) is high impedance only, with a substantially flat response from 200Hz to 7kHz, tapering to 10dB down at 100Hz and 12kHz. With a front-to-back ratio of 15dB, the 857-H is suggested as suitable for P.A., rock-n-roll, paging, recording, etc.

Astatic are represented in Australia by Nomis Electronics Pty Ltd, 689 South Road, Black Forest, S.A. 5035. Phone (08) 293 4896.

Think small.

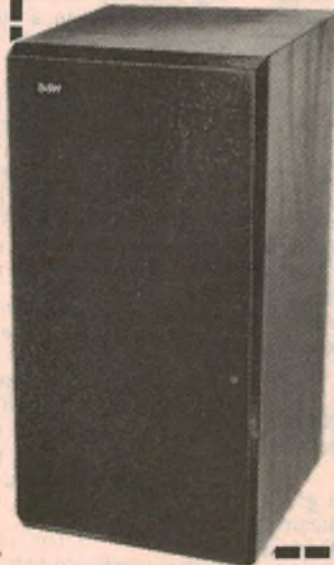

Is space your problem?
Think B&W DM5 loudspeakers. Only 18" x 9" x 9½"

Despite its compact size, B&W's DM5 speakers can be rated as a system of very high quality. This is what the experts say:

Electronics Australia, Oct. '76 . . . "Listening tests confirm the supplied frequency response curves. It is very smooth and well maintained up to the limit of audibility . . ." Stereo Buyers' Guide says . . . "The DM5 mid ranges are excellent, being smooth with a nice bite to them and the highs are well maintained and shimmering in quality . . ."

Stereo Magazine Issue 13 . . . "The DM5 is a fine, well crafted speaker of modest dimensions and price but with a standard of performance that belies both those parameters . . . the mid range response is clear and possessing a lifelike presence that left us most impressed.

Have your B&W dealer demonstrate to you the fine qualities of the DM5. Recommended retail price \$299.00

B&W  **LOUDSPEAKERS**

Sole Australian agent:

Convoy
INTERNATIONAL

4 Dowling Street Woolloomooloo 2011 357-2444

VICTORIA: Allans Music (Aust) Ltd. 63 0451 Ence Electronics Pty. Ltd. 42 3761 Instrol Hi-Fi (Vic) Pty. Ltd. 67 5831 Southern Sound 67 7869 Southern Sound, Moorabbin 97 7245 Tivoli Hi-Fi 81 2872 Buy-Rite Electrix 42 6000 E & B Wholesale (Geelong) 9 6616 The Sound Craftsman 509 2444. **N.S.W.:** Convoy Sound W'Loos showroom 357 2444 Convoy Sound City showroom 29 1364 The Gramophone Shop 633 2846 Instrol Hi-Fi Pty. Ltd. 290 1399 Milverson Pty. Ltd. Chatswood 412 2122 Milverson Pty. Ltd. Parramatta 635 3688 Riverina Hi-Fi 938 2663/4 United Radio Distributors P/L 232 3718 Wests (Rurwood) Pty. Ltd. 747 4444 Arrow Electronics Pty. Ltd. 29 8580 Jock Leate Camera & Hi-Fi Stores Pty. Ltd. 579 6399 Pitman's Radio & T.V. Wagga 25 2155 **QUEENSLAND:** John Gipps Sound 36 0080 Premier Sound Rockhampton 28 2701 **TASMANIA:** Bal Canto 34 2008 **WESTERN AUSTRALIA:** Audio Distributors 31 5455 **A.C.T.:** Pacific Stereo 95 0695 Durtone 82 1388 **SOUTH AUSTRALIA:** Sound Spectrum 223 2181 Blackwood Sound Centre 278 1281 Decibel 61 1865 Allans Music (Aust) Pty. Ltd. 223 5533.

HIFI NEWS—continued

throat. The particular configuration was chosen to minimise the number of components in the assembly, the horn being formed by injection moulding using rubber modified styrene.

It would appear from Motorola literature that the Company is manufacturing and marketing a variety of piezoelectric horn tweeters—a couple of conventional units such as the model pictured at the head of this article, a wide flare model with 50 x 125 mm mouth and a dual horn for 360-degree dispersion.

The model pictured is the KSN 6005A and is being brought into Australia by Freedman Electronics of 91-91a Liverpool Rd, Summer Hill, NSW—who advise

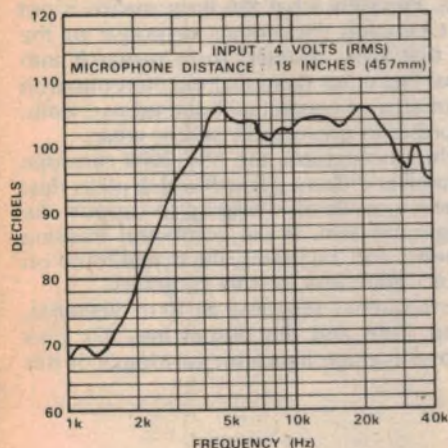

The natural frequency response curve of a typical piezoelectric horn tweeter, as given in the manufacturer's literature, and taken without any series reactance or resistance.

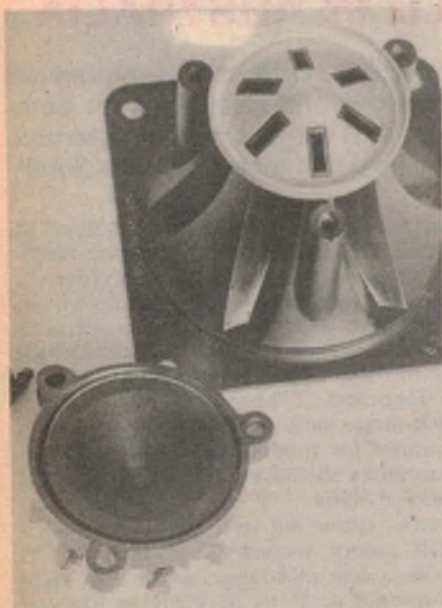

An internal view of the KN 6005A tweeter showing the driver and cone assembly in the foreground and the slots in the faceplate which form the throats of the multiple horn sections.

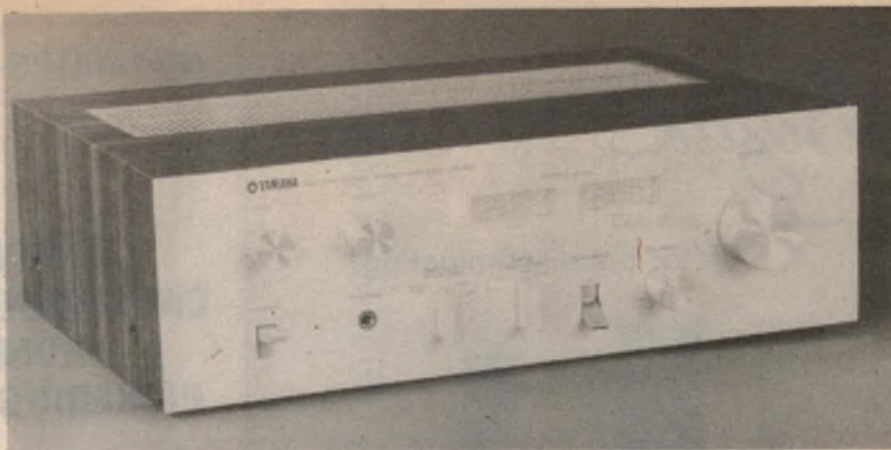

Concerned by the rising cost of quality hifi equipment, Yamaha have made a deliberate effort to include in their range equipment which, while built to high standards and carrying full guarantee, will still appeal to the limited-budget buyer. Pictured above is the CA410 integrated amplifier, finished in typical Yamaha style with "white face" and walnut grain cabinet. Power output is 27W RMS per channel, and all normal facilities are provided, including tape monitoring and dual output meters. Model CA610 offers additional features and 50W per channel. As a companion unit, Yamaha nominate the YP511 direct drive turntable using an 8-pole "24 throat" servo drive motor. For further details: Rose Music Pty Ltd, 17/33 Market St, South Melbourne 3205.

that they are sole agents in this country for Motorola's piezoelectric products. Retail price is "about \$18 each".

When substituted for a dynamic tweeter in a typical 2-way loudspeaker system in our laboratory, the most obvious characteristic of the KSN 6005A was its very high sensitivity. It was many dB up on a typical hifi 8-ohm woofer, leading to the conclusion that it could be used easily in a 4-ohm system, or in association with much more sensitive 8-ohm or 15-ohm drivers, as used for public address or music systems.

With the 2-way hifi system mentioned earlier, the tweeter output had to be cut back using series capacitance, series resistance or with a potentiometer, as suggested by the makers. It became evident that setting the level in this role would be a rather critical exercise, complicated by the fact that the tweeter tended to be over-prominent in the upper middle register.

This fact, coupled with the high sensitivity and high effective impedance suggested that by far their strongest attraction would be as supplementary units for public address and music systems. One or more could be wired directly to the voice coil line to increase the sonic "bite" in the upper middle register.

For conventional hifi applications, in competition with specially designed dynamic dome tweeters, the KSN 6005A would seem to have much less appeal, and one would certainly not expect simply to wire it across the voice coil line. It would have to be planned into the system with as many components as necessary to ensure appropriate output level, a flat response over the working range, and a deliberate rather than an accidental crossover characteristic.

AKG REVERB: Some years ago, AKG of Vienna announced and demonstrated their BX20 studio quality synthetic reverb unit—using the familiar spring transducer principle but considerably refined to produce a much smoother and flatter response curve than normal.

Now, AKG have announced a new, compact model for use by musicians, or in small or mobile studios, in OB vans, etc—in fact, for any application where there is a need for compactness, portability and robustness.

Two distinct signal channels are provided, with provision for different settings for decay times, reverb intensity and high and low frequency compensation.

Overall dimensions of the BX15 reverb unit are 17 x 12 x 19 cm. It is fitted with a carrying handle and may be placed on any surface within 8 degrees of the horizontal, without prejudice to its parameters. Decay times are selectable at 1.5, 2.0, 2.5, 3.0, and 3.5 seconds.

Handled in Australia by AWA, further information is available from Brian Carey, Commercial Public Relations Aust Pty Ltd, 157 Walker St, North Sydney 2060.

SOUND ON FILM: From the same source comes news of the Sondor "Libra" unit for coping with sound recordings in the context of film dubbing, as in film and television studios.

The "Libra" utilises standard 16mm sprocketed film stock but employs sprocketed drive in association with a capstan pinch wheel to ensure a minimum of wow and flutter, and the ability to maintain accurate synchronisation, even at greatly accelerated operating speeds.

Threading is simple: the film is simply dropped into a straight line path.



for the discriminating



BOZAK NOW AVAILABLE IN AUSTRALIA

For 25 years, the name Bozak has stood for uncompromising quality in sound.

And Bozak quality extends far beyond the living room. Professional musicians and audio engineers seeking to reinforce performances without colouration have consistently installed Bozak sound systems in concert halls, in theatres, in indoor and outdoor arenas—wherever sound matters. To name but a few, the Hollywood Bowl (Los Angeles Symphony), Tanglewood (Boston Symphony), and in Broadway theatres for the musicals 'Candide' and 'A Little Night Music'.

This same Bozak quality is now available to discerning audiophiles in Australia and throughout the South Pacific. From the supreme Bozak Concert Grand loudspeaker system, recognized by audio experts in the U.S., Japan and Europe as the standard by which all others are judged, to the Bozak Bard, a high fidelity speaker system designed to be used—AND INSTALLED—out of doors the year round, to the superlative Bozak electronics, every piece of Bozak equipment is designed to provide many years of musical enjoyment.

For informative literature on the complete Bozak range, contact the sole Australasian agents:—

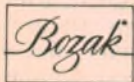

BOZAK Australia Pty. Ltd.

5 Birdum Street, Moorabbin, Victoria,
Australia, 3189.
Telephone: (03) 95-6447

HIFI NEWS—continued

A NEW CARTRIDGE FROM PICKERING

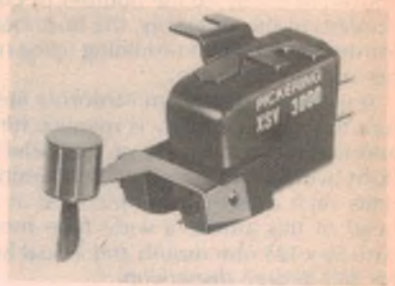

Pickering & Co Inc have just announced the release of a new high performance magnetic pickup cartridge, type XSV/3000, equipped with what they describe as their "Stereohedron" stylus. Precisely what the term means is not clear but it is almost certainly Pickering's response to the specialised contours that have resulted from research into CD-4 tracing problems. Pickering claim that the Stereohedron stylus ensures a greater area of contact with the groove walls, thereby reducing record (and presumably stylus) wear.

As apparent from the photograph, the XSV-3000 cartridge is equipped with the familiar Pickering brush which picks dust particles from the grooves, while also helping to support the weight of the cartridge and arm. If the combined tracking weight is set at between 2 and 2½ grams, the actual force on the stylus will be about 1 gram less, or 1 to 1½ grams.

Pickering quote the frequency response as 10 to 30,000Hz, the channel separation 35dB and the output into 47k plus 275pF as 5mV—an above-average figure for cartridges of this quality.

BOZAK SOUND EQUIPMENT NOW SOLD IN AUSTRALIA

Bozak Inc., of Connecticut, USA, manufacturers of high quality loudspeakers and electronics for both domestic and professional use, are now represented in Australia, New Zealand and throughout the South Pacific region.

A group of high quality Bozak loudspeakers is pictured at the right. Pride of the line, and largest in the domestic range is the "Concert Grand", shown in two styles: "Contemporary", with plain grille cloth, and "Classic" with mesh front. Built from 38mm high-density particle board, both are surfaced with genuine low-sheen walnut veneer and both are fitted with hidden castors to facilitate moving. Approximate dimensions are 945mm wide, 505mm deep and 1370mm high. The drivers—four woofers, two mid-range and eight tweeters—can be parallel wired or separated for multi-channel drive. Power handling capacity is quoted as 60-150W RMS, response 28 to 20,000Hz, and impedance 8 ohms.

The "Symphony" series (front left and right) are scaled down for homes which cannot accommodate the Concert Grands, with two woofers, one mid-range driver and eight tweeters. Response is quoted as 35 to 20,000Hz and power handling capacity 50-100W RMS. As with the Concert Grand, the contemporary "Symphony" systems can be supplied either with off-white grille cloth, as shown, or dark brown cloth.

Where space is a problem, Bozak suggest the "Rhapsody" (left) with one 12-inch woofer, one mid-range driver and two tweeters, with appropriate crossover network. It has a power



handling capacity in the range 15-60W RMS. Rated low frequency response is to 40Hz.

The smallest system pictured, the "Sonora" is a three-speaker combination—woofer, mid-range and tweeter—with a power rating of 12-60W RMS and a low frequency rating to 45Hz.

The small, round system in the front of the group is an interesting unit, designed to take good quality reproduction out of doors—on a patio or beside a swimming pool. Called the Bozak "Bard", it is a sealed system, with a frontal diameter of 460mm (18in) and a depth of 305mm (12in). Power handling capacity is quoted as 12-60W RMS, response 50-15000Hz, and impedance 8 ohms.

The makers say that it is completely resistant to rain, sleet or snow and it can be mounted anywhere—hung from rafters, attached to a wall or used as a free-standing system on patio or decking. The housing is of aluminium finished in eggshell white baked enamel and, if it starts to look grubby, the user is invited simply to hose it down—speaker and all!

In addition to these items, Bozak's "Professional Sound Reinforcement Equipment" catalog shows a variety of column speakers, ceiling speakers, monitors and bass reinforcement systems, along with unmounted drivers of various types.

There are mixer-preamplifiers, power amplifiers to 2 x 150W rating, microphone and line transformers, microphones and stands.

For further information: Bozak Australasia Pty Ltd, 5 Birdum St, Moorabbin, Vic 3189.

ELECTRONICS AUSTRALIA 1976/77 YEARBOOK.

Crammed with fascinating reading, do-it-yourself projects, hand picked record and book reviews, a full listing of Australian and New Zealand radio and TV stations, equipment reviews and a look at CB in Australia. \$1.20

FROM YOUR NEWSAGENT

Or for \$1.80 by mail order from "Electronics Australia", PO Box 163, BEACONSFIELD 2014

BROADCAST TECHNICIAN

B.O.C.P.

A CHALLENGING opportunity for a qualified man to take on an all solid-state plant, 3 studios, 2 booths, busy production, ethnic Station 2EA and ready-to-go FM-stereo. Fully automated Station.

Applications in strict confidence to Station Manager (Mr. Ben Whitnall), Christian Broadcasting Association Ltd., Five Dock, 2046. Phone 83 7321.

ASTATIC MICROPHONES

ULTRA-CARDIOID
Unsurpassed 25db
front-to-back
rejection for
critical use.



FOR ENTERTAINMENT

857



UNIDIRECTIONAL
Ideal for groups
unique design
eliminates
'pop' noise.

FOR COMMUNICATIONS

337
LG-3



Quality dynamics
at modest cost.
Excellent response
for paging and
Communications.

The ideal microphone for
quick installation—ready
wired with rugged switch
for relay operation.

Australian Distributors
"The Sound People"

NOMIS

NOMIS ELECTRONICS PTY. LTD.
689 SOUTH ROAD,
BLACK FOREST, S.A. (08) 293 4896

DISTRIBUTED BY:

N S W Martin de Launay, Sydney—29 5834;
Newcastle—2 4741; Wagga—21 4644; Wollongong—28 8020;
QLD Mann de Launay, Brisbane—52 8487; S.A. Neil Muller,
Adelaide—74 1162; Mt. Gambier, SESB Services—25 6970;
W.A. Atkins Carlyle, Perth—22 0191; N.T. Vaneman & Wyatt,
Darwin—81 3491; VIC. JES Electronic Components,
Melbourne—88 5282.

MICROPHONES

Part 5: Matching and matching transformers

Reproduced by courtesy of Sennheiser Electronics, this series of articles is intended to assist sub-professionals and amateurs who need to use microphones, but without the advantage of formal acoustic training. This article discusses matching requirements, matching transformers, and simple calculations.

by G. PRAETZEL and E. F. WARNKE*

Transformers are used to match microphones correctly to the equipment input. Such matching has to conform to several requirements, including those specified in Part 2 of this series (November 1976), if correct operation of the system—microphone, transformer, amplifier—is to be achieved. Information concerning the application of transformers, and the types available, can be obtained from "Mikrofon-Anschluss-Fibel". (Refer Part 4, January 1977.)

For those interested in tackling the calculation of matching transformer requirements, the following text deals with the matter in some detail. We have attempted to present this somewhat complex subject at a practical level with a minimum of mathematics.

Everybody is familiar with simple power transformers, such as a filament transformer, which steps down the mains supply at 240V to 6V or 12V, and the purpose of this transformation is immediately obvious.

What may not be appreciated is that voltage transformation also involved impedance transformation. In circuits such as we are considering, it is necessary to make sure that, in providing voltage transformation (usually voltage step-up) we do not transgress the load impedance requirements of the microphone.

The ratio of a transformer may be described in two ways; as the turns ratio, which may also be considered as the voltage ratio, or as the impedance ratio. While the voltage ratio is equal to the turns ratio, the impedance ratio is equal to the square of the turns ratio.

How, then, does one go about selecting a transformer to match a low impedance microphone to a high impedance input of an amplifier or tape recorder?

Let us take an example: An MD421 microphone with an impedance of 200 ohms is to be connected to a tape re-

recorder with an input impedance of 500,000 ohms (500k).

We have already learned (Part 2) that dynamic microphones should, ideally, operate in an unloaded condition or, in practice, into an impedance from 5 to 10 times higher than their own impedance.

On this basis the microphone impedance needs to be increased to a value

Microphones have come a long way since the day in 1920 when Dame Nellie Melba, famous Australian prima donna, used this model in an early British experimental broadcast. It was simply a telephone type carbon microphone, fitted with a horn. Dame Nellie's autograph can be seen on the side.

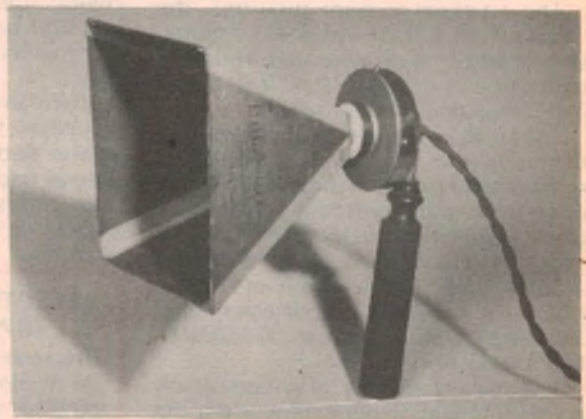

equal to one tenth of the amplifier input impedance, ie, 50,000 ohms. (50k). Thus we have to convert from 200 ohms to 50k, or an impedance ratio of 250 to 1.

From practical experience, and based on what is likely to be available, we may suggest a stock transformer with a turns ratio of 15 to 1, and check its suitability with the following simple calculation.

Microphone impedance x square of the turns ratio

$$200 \times 15^2$$

$$200 \times 15^2 = 200 \times 225 = 45,000 \text{ ohms. (45k)}$$

This figure is slightly lower than that previously suggested which, in terms of microphone loading is marginally to the good.

The voltage transformation provided by the transformer is even more important. A typical microphone, such as the MD421N, has a sensitivity of .2mV/ubar. At a sound pressure of 2ubar an audio signal of .4mV would be available from the microphone. The transformer would step this voltage up by 15 times, to a much more useful value of 6mV.

From this it can be seen why voltage transformation is even more important than impedance transformation. On the basis that the dynamic microphone should operate into the highest possible load it might appear that it could be connected directly to the 500k input impedance, and that this would constitute an ideal arrangement.

In terms of microphone loading this is correct, but such an arrangement would deliver only .4mV to the amplifier, instead of the 6mV obtained from the transformer. This would amount to a very substantial sensitivity loss (about 21dB) which would be quite unacceptable.

In the above calculations certain assumptions were made to simplify the presentation. For example, a convenient transformer ratio was assumed, which

"just happened" to provide the correct answer. A more realistic approach is to calculate the turns ratio required, then seek an available transformer which comes close to this figure.

Also, the calculations were based on a 10 to 1 ratio between load and microphone impedance, whereas a figure of 5 to 1 is quite acceptable and has the advantage that it provides the maximum permissible voltage step-up. On this basis the following formula is a very convenient one:

$$Re = 5Rq U^2$$

where Re is the lowest permissible input impedance, Rq is the impedance of the microphone, and U is the transformer turns ratio.

Using this formula we can take advantage of the fact that almost all dynamic microphones have an impedance of 200 ohms, so that 5Rq becomes almost a constant at 1000, making the formula

$$Rq = 1000 U^2$$

The formula can be further simplified by dividing both sides by 1000 and quo-

*Reproduced by arrangement with Sennheiser Electronic. Translated by T. M. Jaskolski and adapted for magazine publication by P. G. Watson.

ting R_e in kilo ohms (k):
 $R_e = U^2$

Using this formula we find that a transformer with a 20 to 1 turns ratio would need an amplifier input impedance of 400k.

To find the required transformer turns ratio when we know the input impedance of the amplifier, a simple transposition of the formula gives:

$$U = \sqrt{R_e} \text{ (} R_e \text{ in kilo ohms)}$$

As an example, assume an amplifier with a 900k input impedance. The square root of 900 is 30 so a transformer with a turns ratio of 30 to 1 would be ideal; it would provide the highest permissible voltage step-up of the microphone voltage, while ensuring that the microphone was not unduly loaded.

High impedance inputs of the order discussed above are usually associated with valve amplifiers. Transistor amplifiers normally have much lower input impedances, while retaining a similar order of sensitivity.

For this reason it is sometimes stated that input transformers are unnecessary with transistor amplifiers. However, there are exceptions to this. One is where it is desirable to provide a balanced input. Another is where certain amplifiers—typically in some non-European tape recorders—have insufficient sensitivity.

Transformers are available having 5 to 1 turns ratios, and these are usually satisfactory for this application. This gives a 25 to 1 impedance ratio, making the 200 ohm microphone impedance into 5k at the amplifier input. Even if the amplifier input itself is 5k—thus presenting a lower than optimum load—the frequency response should still be acceptable for many applications.

At the same time such an arrangement would give between 6 and 7dB of gain which, in the case of a low sensitivity amplifier, may mean the difference between an unacceptable situation and an acceptable one. If, in the process, there is some downgrading of the frequency response it may be necessary to accept this compromise.

The reason that a 5 to 1 voltage step-up gives only about 7dB in this case, rather than nearly 14dB as might be imagined, is that when the generator impedance and load impedance are equal, only half the voltage appears across the load, the other half appearing across the generator. As the load impedance is increased we come closer to achieving the theoretical maximum gain.

Thus, if the same transformer is used with a 10k amplifier impedance this step-up will give a 9dB gain and, into a 22k load, over 11dB.

On this basis the 5 to 1 transformer can cope with a wide range of situations and, while it may be possible to calculate turns ratios which are marginally more suitable for specific cases, there is probably little point in doing so if such a transformer is not available. 

**"So how does it all sound?
In brief, fantastic! In more detail, the outstanding feature is a complete lack of strain with even the most crashing crescendos coming over easily... particularly outstanding was the bass which can be characterised as having notable clarity, probably due to an almost total lack of confusing boom".**

— Popular Hi-Fi, 1975.

"The first impression one gets when listening to the MA3 is one of physical presence, and this quality seems to be independent of the closeness of the recording. This may be attributable to the exceptional smoothness of its mid-range unit, together with the use of a very analytical tweeter".

— Hi-Fi and Audio, May 1975.

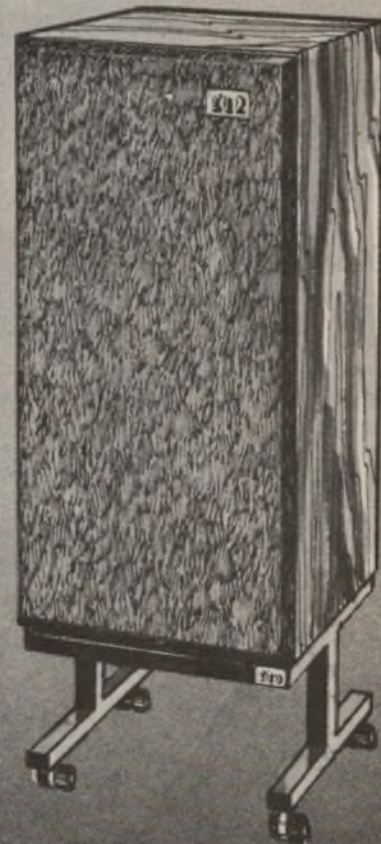

MONITOR AUDIO

MA 3

**The best sounding speaker
you can buy at any price!
They cost \$1300 a pair.**

*R R P (Stands extra).

Sole Australian Distributors:

 **LEROYA
INDUSTRIES PTY**

Head Office, W.A.: 156 Railway Pde., Leederville, Western Australia, 6007. Phone 81 2930.

N.S.W. Office: 100 Walker Street, North Sydney, N.S.W. 2060. Phone 922 4037.

VICTORIA Office: 103 Pelham Street, Carlton, 3053. Phone 347 7620.

QUAD-Quarter of a century of amplifier development



The Acoustical
Manufacturing Co. Ltd
have been designing and
producing amplifiers
since 1936 but it was not
until 1951 that the

Q U A D 1 was introduced,

the forerunner of the Quad series
of Amplifiers which have earned an
unrivalled reputation for originality of design,
excellence of performance and reliability in the
ensuing twenty-five years.

The introduction of the Quad 405 current dumping
amplifier represents yet another contribution to the
science of sound reproduction.

Current dumping successfully overcomes many of the
problems associated with high power amplifiers,
crossover, thermal tracking and matching of components,
added to which the complete absence of adjustments or
alignment requirements, ensures that performance will be
consistently maintained.

For further details on current dumping and other Quad
products write to Dept HFN

Distributed by Audioson International Pty Ltd
64 Winbourne Road,
Brookvale N S W 2100
Sydney Melbourne Adelaide Perth
938 1186 329 6066 337 7000 25 9993

**Design Council
Award 1976**

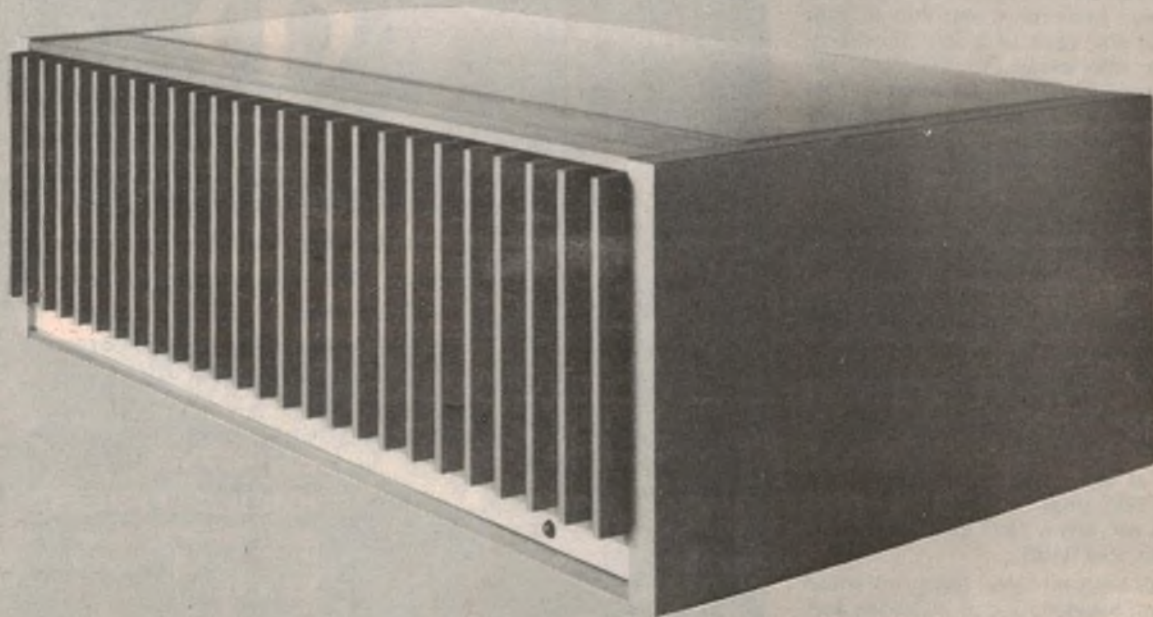

QUAD

**for the closest approach to the original sound
for twenty-five years.**

QUAD is a Registered Trade Mark

Sound Technology's 1710A measures THD & IMD down to .002% with automatic nulling

Distortion measuring test sets are a fairly specialised class of instrument and those with auto-nulling facilities even more so. But the Sound Technology 1710A with auto-null measurement of both THD and IMD is almost in a class by itself.

The Sound Technology 1710A is a far more advanced and complicated instrument than the 1700A unit which we reviewed in the October 1975 issue of "Electronics Australia". It is also larger. In fact, it must be the largest audio test instrument currently available. Dimensions are 437 x 280 x 368mm (W x H x D) and mass is 13.6kg.

Like the 1700A, the 1710A has an ultra low distortion generator and a tracking harmonic distortion analyser. It also has a three stage calibrated attenuator, balanced outputs from the generator and better input facilities. The sample we tested also had the optional Intermodulation distortion test facility and "Auto Set Level" for Total Harmonic distortion measurements.

For those used to using a conventional total harmonic distortion meter, the 1710A represents a radical change. Instead of having to manipulate a single range switch and the nulling controls plus an external audio generator there is a veritable multitude of rotary switches

and pushbuttons. Orientation takes quite some time before the unit's potential can be fully utilised.

Fortunately, most of the controls are arranged in related groups, so that superficial familiarity can be gained in a reasonable period. The audio generator section has four rows of pushbuttons, for selection of four thousand discrete frequencies between 10Hz and 110kHz. As well, there is a knob with a small tuning range so that the oscillator can be set exactly to any frequency in the above range.

Accuracy of the selected frequency is within $\pm 2\%$ of the setting, with the tuning control centred.

Four terminals are provided for the generator output which is direct-coupled and balanced and floating with respect to ground. Either side of the output or the centre-tap (this implies a transformer, but there is none) may be grounded without any level change.

Immediately above the bank of push-buttons is a calibrated three-range

attenuator which gives increments of 10dB, 1dB and 0.1dB. Total range of the attenuator is 90dB. Source impedance of the generator may be switched to 150 or 600 ohms except for the maximum output condition of the attenuator, in which case it is zero ohms. Since the attenuator is calibrated in terms of dBm (decibels relative to 1 milliwatt into 600 ohms) the generator impedance must be set to 600 ohms and terminated in 600 ohms for the calibrations to be accurate. The generator output can be monitored by the 1710A's millivoltmeter by pushing a circular button adjacent to the meter. Maximum output is 15.5V into 600 ohms.

The generator can also be switched off for signal-to-noise ratio measurements while still leaving the load terminated by the selected source impedance. This is achieved by a circular button adjacent to the attenuator just described. We thought this button confusing as its inbuilt iris, which conventionally shows an "on" condition, is used to show when the generator is off.

The THD analyser section contains a notch filter which is always tuned to the audio generator frequency. The analyser measures total harmonic distortion in nine ranges giving full-scale deflection

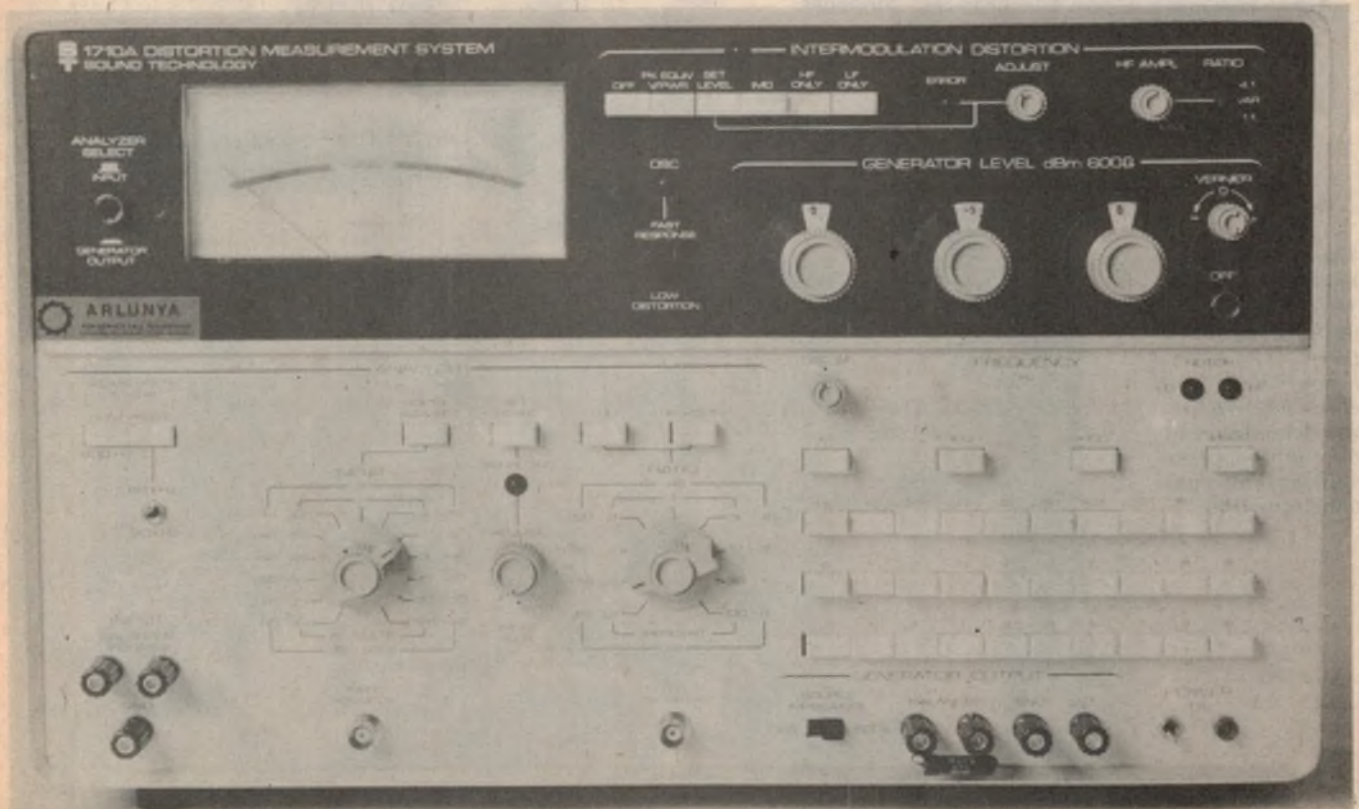

SOUND TECHNOLOGY 1710A

from 100% to .01%, with automatic nulling on all ranges.

An important difference between the 1710A and other imported automatic distortion analysers should be noted here. Typically, automatic THD analysers offer a limited choice of spot frequencies, typically two or ten. In contrast, the 1710A offers automatic nulling within 5 seconds on any frequency within the range 10Hz to 110kHz.

Operation of the millivoltmeter and analyser sections of the 1710A is controlled by two attenuator switches and four associated push-buttons marked "Volts/Power", "Set Level", "THD" and "dB Volts". Depressing the "Volts/Power" button gives a normal millivoltmeter function which is controlled by the thirteen range input attenuator. This provides AC voltage measurements from 0.3mV FSD to 100V FSD.

The "Set Level" switch is used for setting 100% FSD for THD and S/N ratio measurements. It is not necessary to switch up or down range on either attenuator for this function. In addition, our sample 1710A had the "Auto Set Level" facility which does this task automatically for THD measurements. It cannot be used for signal/ noise ratio measurements.

Pushing the "THD" or "dB VOLTS" buttons brings the ratio attenuator into play. In conjunction with the input attenuator this may be used to measure S/N ratios to 100dB and AC voltages with FSD sensitivity of 30uV!

Active high and low-pass filters can be

selected at 400Hz and 30kHz or 80kHz to remove hum and high frequency noise components from THD and S/N ratio measurements. Rate of attenuation beyond the breakpoint is 18db/octave.

A differential input stage with high common mode rejection ratio enables floating, balanced or grounded sources to be measured with minimal earth loop and noise pick-up. A BNC socket gives a replica of the input signal on input ranges below and including 0.3V FSD and a maximum of 316mV for FSD on higher ranges. This is particularly handy for monitoring the signal to low noise preamps or in situations when common mode conditions make measurement difficult. Another BNC socket provides the output of the THD or S/N function for oscilloscope viewing of residual products. Input impedance of the 1710A is 100k.

Intermodulation distortion measurement was the other optional facility provided on our sample 1710A. It enables measurement to the SMPTE (Society of Motion Picture & Television Engineers) or DIN methods (to be nominated when ordering by the purchaser). Our sample was fitted for the SMPTE method which gives test frequencies at 7kHz and 50 or 60Hz synchronised with the mains. Our sample was set to 50Hz but not synchronised to the mains. This can and did cause "beat" problems in some measurement situations. A typical example of this occurs when measuring IM at or near clipping point in an amplifier.

The ratio between high and low frequencies is variable with the aid of a three-position slide switch and potentiometer.

Measurement of IMD is straightforward and just as easy as THD with the 1710A. Residual IMD of the instrument is quoted as .0025% in contrast with the .002% figure for THD. In practise, we achieved .002% for both measurements.

At the time of writing the owner's manual was not yet available so we can make no comment on features of the circuitry. Readers can gain some idea of the complexity from the internal photo which only shows a part of the interior.

Reviewing an instrument of this sort is in some ways unsatisfactory. It is so large and complicated that even a long review can only give a brief introduction. In fact the few days for which we had the instrument was only enough to gain but a cursory familiarity. But even that gave some idea of the excellent performance of the machine.

In short, the Sound Technology 1710A is virtually a complete amplifier measurement system. It is fast and very precise. It is also very expensive, especially after the recent devaluation. But even at \$3000 plus it will be good value for money in many audio laboratories throughout Australia. This sort of measurement capability is mandatory nowadays if an audio laboratory is to be worthy of the name.

Further information on price, performance and availability can be obtained from the Australian distributors for Sound Technology equipment, Arlunya Pty Ltd, P.O. Box 113, Balwyn, Victoria. 3103. (L.D.S.)

The 1710A automatically nulls the THD analyser notch using phase detectors, floating integrators and photocouplers which control resistors in the phase shifting and summing networks.

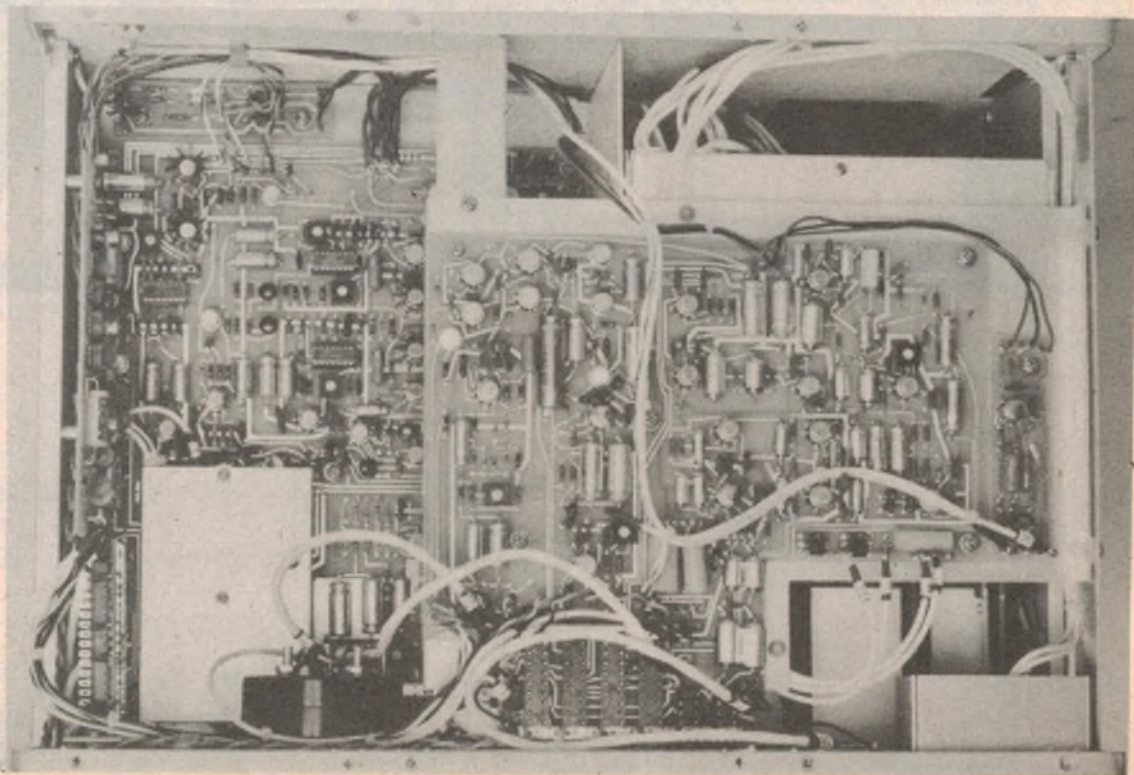

- - 80 dB rumble
- 0.04% wow and flutter
- continuously variable speed range through a servo controlled d.c. motor...
- push-button selection of 78, 45, 33 $\frac{1}{3}$ r.p.m.

**does this make
the ultimate
turntable?**

FONS
gives you that and
more.

At \$289 R.R.P. with base and cover, or only \$479 complete with base, cover, S.M.E. 3009 arm and Stanton 681eee, how can you resist.

P.S. If this isn't the ultimate turntable, we'd like to know why.

* Measurements taken from authoritative U.S. "F.M. Guide" May 1976.

Sole Australian Distributors:

ΛΛΛΛΛ **LEROYA**
VVVV **INDUSTRIES** PTY LTD

156 Railway Pde., Leederville,
Western Australia 6007.
Phone 81 2930.

N.S.W. Office:
100 Walker St., North Sydney.
2060. Phone 922 4037.

VICTORIA Office:
103 Pelham St., Carlton 3053.
Phone 347 7620.



Everyman should have his Castle...

KENDAL & RICHMOND.

The Kendal (left) and Richmond (right) are both bookshelf speakers and are of the new generation reflex systems based on recent scientific analysis of loud-speaker low frequency loading—and what a difference they make!

With a power handling capacity of up to 25 watts per channel RMS. The braced cabinet is constructed of 15 mm and 18 mm high density chipboard, hand-finished with selected wood veneers and protected with a final coat of tough polyurethane lacquer.

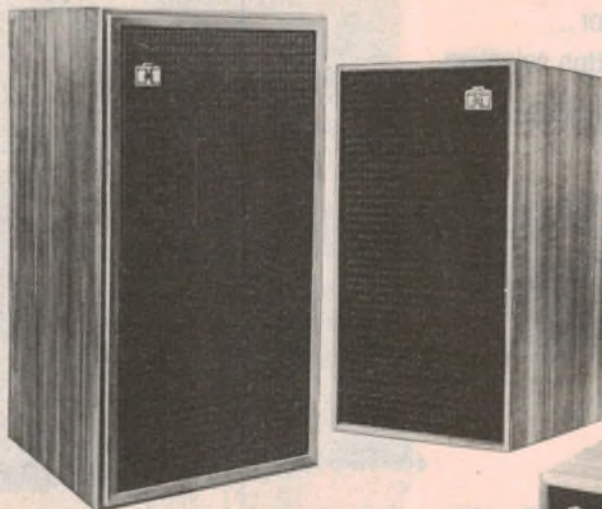

Castle Acoustics

SPEAKERS FOR CONNOISSEURS!

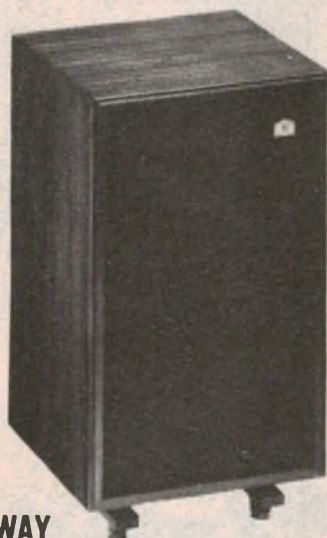

CONWAY.

A high quality, floor standing, three-speaker three-way system intended for the average room and for use with medium powered (25-50 Watts per channel) amplifiers.

Designed primarily as a loud-speaker of exceptionally good performance, the Conway is also a piece of high quality furniture.

The beautifully finished contemporary style cabinets are available in Walnut with and without stand.

HOWARD.

A five-speaker three-way system designed for the connoisseur of sound quality and craftsmanship.

The Howard has a power handling capacity of 50 watts per channel RMS. Size: 26" high x 19" wide x 15" deep and weighs 56 lbs.

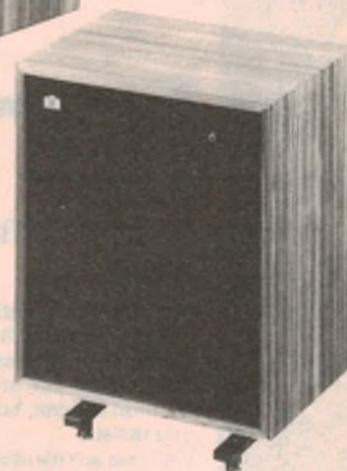

CASTLE 8RS DD.

The Castle 8RS DD is a highly sensitive eight inch unit covering the frequency range from about 50Hz (depending on cabinet size) to 20 kHz.

Suitable for use with good quality stereo systems, tape recorders, car radios, public address and background music systems.

Distributed by

PHOTIMPORT

MELBOURNE ADELAIDE BRISBANE PERTH SYDNEY

For descriptive literature and specifications, send a 30c stamp to
Qualitron Industries Division of Photimport (Australia) Pty. Ltd.

Head Office: 69 Nicholson Street, East Brunswick, Victoria, 3057, Australia. Telephone: 3806922. PA19/C

Luxor 3-way vented Loudspeaker system

European manufacturers are noted for unconventional loudspeaker designs but this three-way system from Luxor follows conventional principles. It has a power rating of 50 watts.

One of the most obvious features of this Luxor system is its irregular shape. The baffle is tilted slightly backwards to improve the radiation angle for the high frequencies and the top and bottom panels tilt to the rear—presumably to break up reflections inside the enclosure. It is a thoroughly commendable objective—even if you cannot put a tall vase of flowers on top!

Apparently this is a new model from Luxor since it was not listed in the 75/76 catalog. It is a departure from other Luxor designs, all of which employ sealed cabinets. The system under discussion has a 65mm I.D. port which is bent inside the enclosure to accommodate its length, being fabricated from PVC pipe similar to that used for plumbing fixtures.

For the size of enclosure and port, a relatively large woofer with a nominal diameter of 25cm is employed. It has a generous magnet and a roll surround and a viscous treated cone with an effective diameter of 17cm. The midrange unit is accommodated in its own isolated compartment. It too has a viscous treated cone with an effective diameter of 8cm. The tweeter is a woven fabric dome with a diameter of 25mm.

Black acoustic foam covers the three drivers mounted on the baffle. In several past reviews of other loudspeakers we have commented on the lack of protection offered by acoustic foam grilles. On this occasion we received a sample pair and both arrived in damaged condition. This was due to the fact that they had not been packed in cartons expressly designed for this model—presumably because the distributor cut corners to get them to us.

Both sample systems had in fact been carefully packed in separate cartons with plenty of shredded paper as cushioning. The trouble was that the shredded paper was packed up against the foam grilles. As a result, the tweeter on one enclosure was caved in and the woofer on the other enclosure was pushed in to the extent that its roll surround was distorted. After a few days the woofer reverted to its normal position and appeared none the worse for wear. Still, to be on the safe side, we swapped woofers to obtain a system with the drivers palpably undamaged. We also noted that the plinths of both enclosures had been split and chipped, apparently while in transit.

This does not show in our photograph. The cartons were not damaged at all!

Construction of the enclosure is quite rugged. It is made of 19mm particle board suitably braced and fastened with the aid of timber cleats. We were a little dubious about the lack of sealant around the baffle and the small number of screws securing the baffle to the enclosure, but tests indicated that they had the appropriate "Q" factor for a vented system. Internal surfaces are lined with an acoustic absorbent material which looks like bonded acetate fibre.

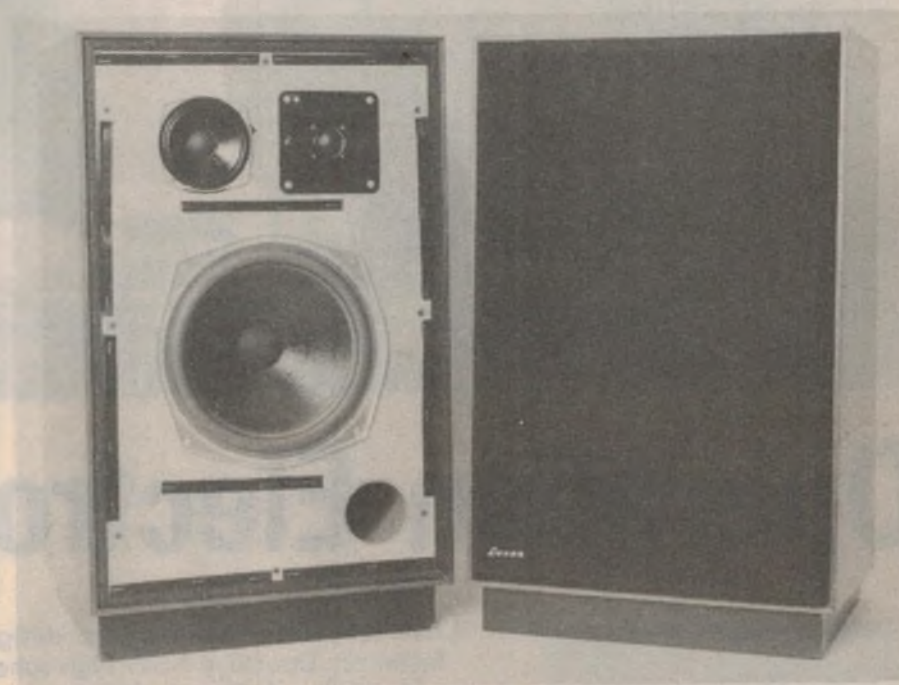

The panels of this Luxor system are angled slightly to reduce internal reflections.

Instead of the customary terminals, the Luxor loudspeaker systems are fitted with an adequate length of two-core flex terminated in a two-pin DIN plug. Power rating of the system is 50 watts.

Frequency response tests showed a prominent midrange characteristic around 3kHz and some peakiness in the treble around 10kHz. There was also some "reediness" in the sound at about 900Hz which appeared to be due to excitation of the tweeter resonance. The woofer appeared to be slightly lacking in sensitivity compared with the other drivers, although it was fairly prominent around 80 to 100Hz.

Overall we found the sound reproduction on most types of music disappointing, the midrange and treble units having a tendency to emphasise surface noise on discs. Some redesign of the crossover network appears necessary to smooth out the response of the system. We see no reason why this could not be accomplished fairly easily as the drivers themselves appear to be of good quality.

Efficiency of the system was high so that it could be effectively teamed with amplifiers of modest power rating—provided they are rated for 4 ohm loads. Impedance of the system was reasonably flat with a peak value of around 14 ohms at the upper bass resonance and a

minimum value of 3.4 ohms at about 8kHz. That should not present any problems for 4-ohm rated amplifiers.

With so much critical comment in this review, our summary can hardly be a eulogy. But our impression is that a little more effort could transform this system to obtain much better performance. The potential is certainly there.

Further information and demonstration of the Luxor 3-way vented loudspeaker system can be obtained from high fidelity retailers or from the Australian distributors for Luxor equipment, O.B.C. (Imports) Pty Ltd, 1396 Malvern Road, Tooronga, Victoria. (L.D.S.)



Operation Electronics

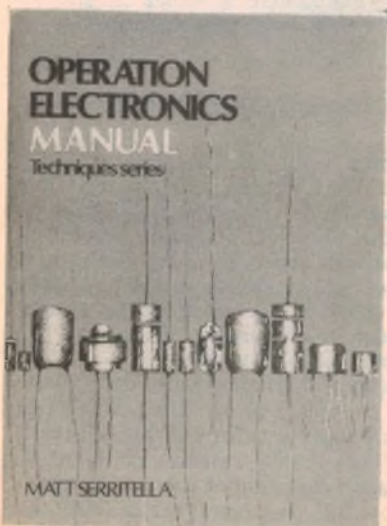

A new school electronics project designed specifically for the Electronics "Technics" Course in NSW high schools is being launched next month by Macmillan Australia, the well-known publishers. Written by Matt Serritella, a widely experienced industrial arts and electronics teacher, the project seems likely to become officially endorsed.

Called "Operation Electronics", the new Macmillan project is designed to provide a complete basis for an introductory school electronics course. Both theory and practical are covered, with a manual or textbook written for class work and an "ideas box" of construction projects for practical laboratory work.

Matt Serritella, the man behind the project, was formerly an industrial arts

teacher at Riverstone High School in NSW. While at the school he was directly involved in piloting the Electronics Technics course at the school for the NSW Education Department. At present he is back in California, where he has had wide experience in electronics teaching.

In planning and writing the project material, he has designed it specifically for the needs and facilities of Australian secondary schools. The practical projects require a minimum of construction and text equipment, and those which are needed are in the main standard items

The Operation Electronics manual provides both basic theory and a practical construction guide for students and teachers.

MW receiver

A recently developed integrated circuit (i.c.) greatly simplifies radio-receiver construction. Called a ZN414, this i.c. looks like a transistor, but actually contains ten transistors along with a score or more resistors.

Parts for MW receiver

CODE	QUANT	DESCRIPTION
I*	1	Ferrite rod antenna, with coil*
C ₁ *	1	Capacitor, 200-400 pF, variable*
C ₂	1	24 pF
C ₃	1	0-25 pF ceramic disc capacitor
C ₄	1	0-01 pF capacitor
C ₅	1	50 μF, 12 V working electrolytic capacitor
R ₁	1	39 kΩ, 0.25 W resistor
R ₂	1	100 kΩ, 0.25 W resistor
R ₃	1	470 Ω, 0.5 W resistor
X	1	ZN414, AM tuning i.c. (made by Ferranti)
P	1	Headphones, 2000 Ω impedance
B	1	Battery, 1.5 V, AA penlight cell
S	1	Switch, SPST toggle
Miscellaneous		
	1	Knob
	4	Fahnstock clips
	1	Battery holder, size AA
		Matrix board, 100 x 50 mm
		Wire Antenna wire Solder
		Stand offs Nuts and bolts
		Case materials

*Components I and C₁ form the tuning or tank circuit of the radio. Order together and specify to supplier that combinations of ferrite rod antenna with coil and tuning capacitor to suit AM broadcast band is required. Various values will tune this band satisfactorily, and will spread the supply of your order.

In operation, the ZN414 forms a very good tuned radio frequency (TRF) tuner. Only a very few extra parts are required to complete the circuit and it will operate a crystal earphone with no additional amplification. If, however, you would like to operate the ZN414 through an amplifier to drive a speaker, the one described in Project 17 would be suitable.

HOW IT WORKS

Radio stations broadcast at a certain frequency. For stations on the medium wave (MW) band the frequency of the radio carrier-wave can be anywhere from 540 kHz to 1600 kHz. When someone is talking, or music is playing, on the radio the sound is combined with the carrier in a process called modulation.

The modulated carrier is transmitted and picked up by your receiver. There are many stations on the MW band. Each one has a different carrier frequency and the radio receiver is able to select which carrier is wanted. Selection takes place at the very beginning of the circuit.

The tank circuit of I and C₁ determines the station being received. If one of these is made variable then the frequency to which the tank circuit will tune is also variable. (With the coil and capacitor used in this receiver you will be able to tune the entire MW band.)

The i.c. then amplifies the signal and demodulates it (removes the carrier). Automatic gain control (AGC) is also provided so that when tuning across a loud station your eardrums aren't blasted. The AGC makes sure that strong, nearby stations are amplified only slightly; distant, weak stations are amplified strongly. In this way, the output is kept at about the same level, no matter how strong or weak the carrier is. In chapter 13, page 76 in the *Manual*, is a more detailed version of how radio works.

CONSTRUCTION

- 1 Begin construction by cutting a 100 x 50 mm piece of matrix board.
- 2 Mount L, C₁, battery holder and four Fahnstock clips in the approximate location shown, using nuts and bolts.
- 3 Insert all other components according to figure P22.2.
- 4 Make all the inter-connections shown in the diagram. Section 18.2.1, page 109 in the *Manual*, shows the correct way of using matrix board. Especially see figure M18.20.
- 5 Check all the wiring for accuracy, then solder all connections.

Figure P22.1 Circuit of MW receiver

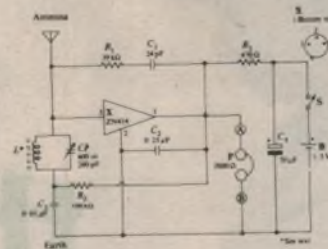

Figure P22.2 Wiring layout (top view). Wires are actually under the board.



Published by THE MACMILLAN COMPANY IN AUSTRALIA PTY LTD.
Printed in Hong Kong

Shown above are both sides of one of the project cards in the Ideas Box. This is one of the Level 2 projects, a simple one-IC radio receiver built up on matrix board.

in most science rooms and industrial arts workshops.

Other test instruments are actually designed in simple form as senior level practical projects, so that they may be acquired by schools with a minimum of outlay.

The Operation Electronics Manual is available separately from the Ideas Box, and may be used alone as an introductory textbook for science classes, trades course in electrical practice, electronics and communications classes. It consists of 128 pages measuring 190 x 265mm, and includes some 230 illustrations.

The manual is divided into two main sections, the first dealing with basic electronics theory and the second with electronics in practice.

The theory section has some 15 chapters, and its coverage is indicated fairly well by the chapter headings. These are 1—Basic Atomic Structure; 2—Basic DC Circuits; 3—Principles of AC; 4—Resistors; 5—Capacitors; 6—Inductors and Transformers; 7—Sound Waves and Sound Transducers; 8—Semiconductors; 9—Radio Waves; 10—Switches; 11—Power Supplies; 12—Amplifiers; 13—Radio Receivers; 14—Oscillators; 15—Special Semiconductors.

The level at which this section is written is very elementary, and emphasis is placed on broad familiarity rather than detailed understanding of basic concepts.

The second and practical section of the manual has a further eight chapters, and again the chapter headings give a good

idea of the scope. These are 16—Safety Precautions; 17—Tools and Instruments; 18—Circuit Layout and Construction; 19—Using a Multimeter; 20—The Morse Code; 21—Symbols, Tables and Formulas; 22—Components and Value Codes; 23—Order Lists and Suppliers. The book ends with two data appendices, dealing respectively with suggested power sources and recommended further reading.

The practical section is well written, and is full of down-to-earth practical guidance for both teacher and pupils. Clear descriptions are given of such matters as printed circuit board layout and etching, soldering, and mounting of power transistors.

Whereas the manual is intended mainly for classroom use, the Ideas Box is primarily intended for use in practical laboratory or workshop sessions. The box contains instruction cards for some 42 practical construction projects. Some of the cards are single sheets, while

others are double sheets folded to the same overall size of 190 x 265mm. The cards are printed in two colours on heavy laminated stock, treated to resist constant handling and grime.

The 42 projects are graded in difficulty, and are divided into four levels. Level One contains nine elementary projects, comprising: 1—Jumping Ring; 2—Electric Pencil; 3—Morse Code Buzzer; 4—Shock Box; 5—Simple Telephone; 6—Buzzer; 7—Night Light; 8—Crystal Radio; 9—Continuity Tester.

Lever Two then follows with fourteen further projects, of moderate complexity: 10—Metronome; 11—All-Purpose Oscillator; 12—Intercom; 13—Train Controller; 14—Pocket Organ; 15—Thermometer; 16—Siren; 17—Power Amplifier; 18—Do-Nothing Box; 19—Radio Microphone; 20—Two-Way Signaller; 21—Automatic Night Light; 22—MW Receiver; 23—Dampness Detector.

(Continued on page 117)

Electronics Australia & school electronics

As more and more schools become involved in teaching electronics, there are bound to be problems. Component supply problems, problems in finding enough simple projects to satisfy students as they become more enthusiastic, and perhaps problems in finding out why projects don't work as expected.

With our fairly extensive experience in project planning, building and presentation, it seems logical that Electronics Australia should play a part in helping smooth out these problems. So starting next month, we will be running a problem-solving service through the magazine.

We won't be able to answer your problems by direct mail or telephone, but whatever your problems to do with school electronics—whether you are a student or a teacher—we let us know and we'll try to publish an answer in the magazine as soon as we can.

The Consumer Comes Face to Face with the Computer



by ZANE THORNTON*

The wand automatically "reads" the price tag, and transmits the information to the point-of-sale (POS) terminal, where it is displayed and printed. The POS terminal can be connected directly to a computer or can store the data for later computer processing.

Up until now consumers have had little in the way of personal contact with computers. But, as computerised sales and accounting systems become more and more visible in the marketplace, consumers will have to come to terms with the machines. Indeed the individual is destined to come face to face with computers as part of his everyday activities.

The relationship between the consumer and the computer has never been an easy one. A few years ago, the computer was consigned to the backroom of business. There, behind the scenes, cloaked in mystery and anonymity, it was a perfect scapegoat—the foil for human errors in billing statements, lost orders, troubles at the bank, welfare overpayments, and misplaced records. The consumer, in other words, has been conditioned to mistrust the "machine."

Today, the computer is moving out of the backroom to meet the consumer at the point where money is exchanged for goods and services. Three new types of computer-based systems are on the way: the department store electronic point-of-sale terminal, the supermarket automated check-out counter, and the bank electronic funds transfer systems. This

journey has already produced some turbulent moments, and there may be more before the "bugs" are ironed out and shoppers gain enough understanding to be comfortable with this kind of automation.

In addition to consumers, the characters in the scenario include retailers, bankers, unions, legislators, regulatory agencies, merchandise manufacturers, and a variety of trade associations. New or continuing skirmishes are likely to concern such issues as price marketing, labour displacement, privacy, banking policy, and competition and antitrust.

The full impact of the large problems is yet to be felt. But less serious factors, such as "premature" use of computer-based systems in the retail environment, can also lead to consumer dissatisfaction. A relatively minor but still irritating example occurs daily in many department stores.

Customers queue up in the aisle as a cashier hovers over a computer based

console, laboriously punching buttons. This console is an electronic point-of-sale (POS) terminal, part of a larger computer system that has replaced the conventional electro-mechanical cash register. It is capable of speeding up the sale considerably; estimates indicate, in fact, that it can handle the transaction two or three times as fast as the conventional cash register. Why then, the bottleneck?

Actually the customer is experiencing the growing pains associated with the introduction of new technology. If shoppers queue up, it may mean that the terminal has been installed on the sales floor before there is any capability to use it in its intended fully automatic mode. In the manual mode, it is a clumsy replacement for the cash register. But once the merchandise is properly marked and the system fully automated, resemblance to the cash register diminishes and benefits become more apparent. Then labels can be read automatically by an optical character recognition (OCR) scanner/reader, called a wand, and the POS terminal can perform the two basic functions it is intended for:

- It can execute the sales transaction for the customer.
- It can automatically collect a wide

*Deputy Director of the NBS Institute for Computer Sciences and Technology.

variety of merchandising information and make it immediately available to management for use in such merchandise control functions as inventory control, re-order, credit billing, and sales analysis.

From the customer's point of view, shopping in a POS-equipped department store should not vary greatly from the past—except that the shopper may spend less time at the checkout counter and encounter fewer "out-of-stock" frustrations. Once merchandise selections have been made and taken to the cashier counter, the sales clerk will pass a handheld wand over the lines of print on the label, the data from the ticket will be stored in the POS system, and the terminal will print a sales ticket and automatically calculate taxes and discounts.

If the purchases are to be paid for by credit card, the clerk may insert the customer's card into the terminal at the start of the transaction and have the credit authorization verified while the rest of the transaction is being completed. Again, all this may take place two or three times as fast as with a conventional cash register.

What the customer sees at the cashier counter is only the tip of the iceberg. POS systems will be hard at work behind the scenes in a merchandise control chain that stretches from the department store to the plant where the merchandise is manufactured. The end effects of this new form of automation should be more effective management of retailing and better quality service to the consumer. The store manager can do a better job of serving the customer because he will have rapid access to more accurate and timely data from the sales floor.

The US National Bureau of Standards has played an important role in helping bring about this latest automation in the retail industry. The Bureau provided technical advice and assistance to the National Retail Merchants Association (NRMA), a trade association representing more than 30,000 department, specialty, and variety stores, in developing its Voluntary Retail Identification Standard for labelling merchandise in a way that can be read automatically by an OCR scanner/reader. In addition, the NRMA has made available to its members NBS-produced computer security guidelines and procedures for safeguarding individual privacy.

Industry-wide standards are crucial to the new breed of automated system; without such standards, the systems cannot be made to operate economically. The retail industry spent some 6 years developing its voluntary retail identification standard.

The grocery industry is another recent "convert" to the kind of automation technology that deals directly with the consumer. It spent 3 years in developing its standard labelling code, called the Universal Product Code (UPC). To the consumer there is a very obvious and



The supermarket industry expects to achieve maximum savings from computer-based systems by posting the price on the shelf under the product and eliminating individual pricing. Consumer groups believe that the elimination of item pricing will make it much more difficult for shoppers to compare prices of various products.

important difference between the retail industry's code and the UPC—price marking.

The machine-readable department store merchandise identification label displays the price of the items in human-readable, dollars-and-cents form. The department store customer should notice little difference between the new and old labels except that the numbers and letters on the machine-readable labels are in an Optical Character Recognition (OCR) type font. OCR markings are as easy to read as are the conventional printed or typed characters.

The "priceless" UPC symbol, in its basic form, is made up of a bar-code arrangement that represents 10 digits. The first five digits identify the manufacturer of the product on which the symbol appears. For example, 18000XXXXX identifies the Pillsbury Company, and 24000XXXXX identifies the Del Monte Corporation. The second five digits identify the product, for instance XXXXX18238 identifies an 8 ounce box of Rice Chex.

In addition to the UPC, the supermarket system has two other main components: the check stand with its automatic reader and point-of-sale terminal, and a small backroom computer that contains a directory of applicable UPC numbers, the prices associated with each number represented by the bar-code symbol on each item, and a memory for storing transaction data.

What can people expect in the automated supermarket? The shopper will select items much the same as she does now except that about 75 percent of the merchandise will be marked with the UPC symbol but not the price; instead, a label on the shelf will show the

unit price. At the checkout counter, the clerk will orient each item on the conveyor belt so that the UPC symbol passes directly over the scanner under the checkstand. The scanner will read the symbol and convert it to digits that are then transmitted to the backroom computer, where the incoming ten-digit is located in the computer's directory of UPC numbers and prices.

The computer will pick off the price corresponding to the incoming UPC number and transmit the price back to the checkstand where it will appear on a screen atop the terminal. Simultaneously, the price will trigger a printer within the terminal that prints an entry on the sales tape. When the last item has been scanned, the terminal will total the bill, compute applicable taxes, and figure the amount of change due the customer. Those responsible for the automated supermarket system estimate that the automated checkstand operates about two-thirds faster than the conventional manual checkstand.

When the grocery industry announced its plans to change to wide-spread use of automated checkstands and the priceless UPC, consumers drew the battle line. Some groups declared that they would boycott supermarkets that used the computerized system which would remove the dollars-and-cents label from grocery products. The Subcommittee for Consumers of the US Senate Commerce Committee held a symposium on December 11, 1974, to obtain information and advice about the UPC. At that symposium, an industry spokesman gave the following explanation:

"Item price marketing is estimated to cost approximately \$1 per thousand

PLAY SAFE

We hope you'll never need it!



There's a well known saying, that goes something like – "you shut the stable door after the horse has bolted". In the case of a handy fire extinguisher, not too many homes have them. Yet every year in homes, cars, caravans and even garden sheds, fires occur which could have been put out quickly and efficiently if a Chubb fire extinguisher had been handy. \$15.95 is not much to pay for a feeling of security all year through. The model we offer readers is well designed and easy to operate. The body and operating mechanism is compact and made from plastic, which makes it rust proof and almost indestructible. It comes complete with a fixing bracket – ready to use!

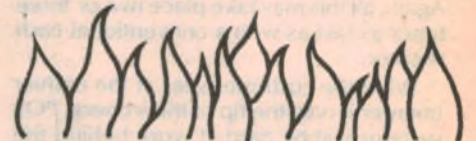

The Dry Powder content is completely non-damaging and non-toxic in confined spaces. Fires fueled from petrol, oils, fats, lacquers, tar, alcohol, wood, paper and straw can be contained. The Chubb unit weighs only 3 lb. 12 oz. (1.685 kgs.) and is 14.3/8" high (36.5 cm). Easy do-it-yourself refill kits are available. Each unit is carefully packaged and contains complete operating instructions.

\$15.95

POST FREE

CHUBB FIRE EXTINGUISHER

HOW TO ORDER: Fill in BOTH sections of the coupon. In each section print your name and full postal address in BLOCK letters. Cut the entire coupon out around the dotted line. Send it with your money order or crossed cheque to this Magazine's Reader Service Department (Chubb Fire Extinguisher), P.O. Box 93, Beaconsfield, N.S.W. 2014. Cheques should be endorsed on the back with sender's name and address and made payable to this magazine. Offer is open to readers in Australia only. Please allow four weeks for delivery.

THIS MAGAZINE'S "CHUBB FIRE EXTINGUISHER" OFFER NO. 60/75 EA FEB	
Name	Name
Address	Address
State	Post Code
Post Code	
Quantity	Please send me (state quantity) Chubb Fire Extinguisher/s.
	I enclose my cheque, postal/money order to the value of \$

Consumers and Computers

items marked and item repricing approximately \$3 per thousand items marked. Thus, current item pricing and repricing practices add between \$250 million and \$300 million annually to food distributions costs (for non-variable weight items). On an individual store basis, this works out to about \$8,000 per year in a \$60,000 per week supermarket (at 1973 wage rates). The total so-called 'hard' net benefits of an automated checkstand installation in such a store has been estimated at approximately \$35,000 annually. Duplicate item marking (UPC plus dollars and cents) would, therefore, reduce this to about \$27,000 annually."

The grocery industry has been fairly cautious in stating the benefits that will accrue to the consumer as a result of the UPC and the automated checkstand. The question of passthrough of cost savings to the customer in the form of lower prices has been particularly nebulous. For example, in the presentation to the Senate Subcommittee a spokesman provided a list of "possible benefits" one of which was "Lower prices (?)". The spokesman went on to say, "The question mark is that we know if our projections are right the cost of handling grocery products will be lower. There is no law, however, that says a retailer must reflect lower costs in lower prices. However, there is clearly the potential for lower prices to the extent that the retailer takes the lower costs and reflects them." More recently, the grocery industry has adopted the statement, "opportunity for lower prices."

Other "possible benefits" include greater accuracy in pricing, quicker checkout, more informative sales receipts, fewer out-of-stock items through better inventory control, and no need to separate multiple price items. (For example, three items priced at 3 for 37c can be separated and passed over the scanner interspersed with other items and the computer will keep track of them and tally them on the tape at the price of 37c.)

One of the perceived benefits to industry at the retail level is "improved labour productivity," as reported to the Subcommittee. This benefit is made up of several parts: (1) checker productivity is expected to increase because the automated system will reduce the amount of labour required per dollar of sales; (2) because items will be UPC source marked at the point of manufacture, the amount of labour required for in-store price marking or remarking will be reduced; (3) reorder labour will be reduced because the automated system will provide continuous, accurate inventory and item movement data; and (4) checker training will require less time.

In addition to expected labour



Computer sales systems in department stores as well as supermarkets can reduce labour costs by providing continuous inventory and sales data for each item.

productivity benefits, the industry also expects to benefit from a reduction in mis-rings or the number of mistakes made by the checker; shorter period of time for recapping transactions at the end of the day; and more timely and comprehensive information to assist the store manager in making decisions on price, inventory control, and space allocation.

Although the absence of dollars-and-cents price marking on individual items has been a large part of the UPC controversy, there are indications that other difficult issues remain. Ms. Ellen Zewel, President of the National Consumer Congress, alluded to some of these issues before the Subcommittee for Consumers when she said, "Do you realize

all the social impact questions that this system has raised have never been addressed by the people who are concerned about bringing this system into the market-place? . . . You have not dealt with it from the marketing level to the consumer, you haven't dealt with the implications of privacy, of having data consumption patterns, particularly in a world where you have food stamps."

Ms. Zewel has probably hit upon the single most important reason that detente between consumer and this area of automation and technology has not yet been reached—in spite of increasing supermarket check-out automation. Very simply, the new breed of computer systems for direct or unbuffered interaction with the consumer require special consideration in their design and implementation. System designers have to give a great deal more thought to consumer habit and behaviour and to the tradeoffs between what is technically satisfying to the system engineer and what degree of change the consumer will accept. In short, the system designer cannot afford to go about his job in splendid isolation. He would be well advised to invite the consumer into his laboratory early in the design process.

As Carol Foreman, Executive Director of the Consumer Federation of America, observed, "The source marking of the UPC is something perhaps the consumers and labour should have had an input to, but have not had, and that time is past."

Next month we will discuss another aspect of the consumer-computer encounter: the transfer of money by electronic means and the maze of financial, regulatory, and technological issues in a "less-cash, less-cheque society." ☺



The Universal Price Code symbol identifies the manufacturer and the product by a numerical code. The store computer has information on the price and inventory of each item in its memory, ready to be used by the POS terminal.

Reprinted from "Dimensions" by arrangement with the US National Bureau of Standards.

Satellites are updating the world's shipping

A significant step forward in normal marine communications has taken place with the launch last year of three dedicated maritime satellites. Called Marisat, the system introduces the first major advance in marine communications since the advent of radio telegraphy, providing high-quality ship-to-shore voice and data communications.

At this very moment more than 10,000 ships are under way on the high seas, many of them leading examples of the shipbuilding art. Town-sized tankers, nuclear-powered men-of-war, and mammoth merchantmen regularly ply the sea lanes—maritime marvels equipped with electronic navigation, detection and operating gear the equal of many space-rated systems in use today.

But they may as well be century-old schooners insofar as maritime communications are concerned, because most of them are still using a ship-to-shore technique that's more than 75 years old!

In 1899, Marconi used short-wave radio bands to send the world's first wireless signal across the English Chan-

nel. Seventy-seven years ago this was indeed an achievement; but in the context of this era's hurtling technology it seems as archaic a mode as the use of an antiquated ear trumpet by today's hard of hearing.

The analogy seems incongruous but current data supports it. According to the American Institute of Maritime Shipping more than 90 percent of the world's 65,000 seagoing vessels still rely on this time-worn anachronism for communication with shore stations and other ships—high-frequency radio bands whose average transmission capacity is only eight words per minute! And even this miserly rate can be achieved only if and when there are no ionospheric disturbances or storms at sea.

Couple these impediments with the fact that these very same frequencies are usually clogged with intercontinental radio traffic and it's little wonder that ships even 300 or so miles offshore seem to have literally sailed into a dead sea of silence.

Ship owners, for example, who want to alter ship courses, are often forced to sweat out delays up to 48 hours before captains can be contacted. In terms of lost time and wasted fuel these are lapses as unconscionable as they are unavoidable. But there's more. Add to that bleak scenario the spectre of 3000 new launchings every year and it's easy to see how quickly bad can get to worse if technology stands pat.

But space technology and the introduction last year of a new communications satellite, called Marisat, which has been specifically designed to answer the needs of the US Navy and maritime and offshore industries, will erase these problems in much the same manner that radio supplanted wire telegraph systems in the early 1900s. The Marisat system has been in commercial operation since last August, and is currently relaying high quality voice, telex, facsimile and data to

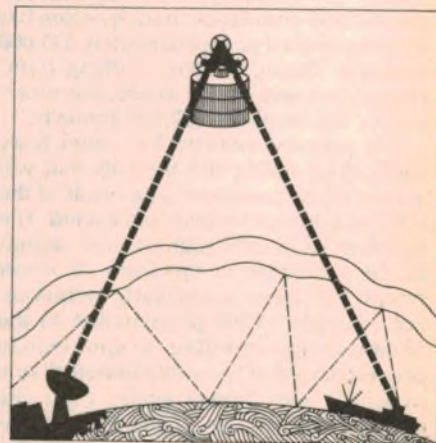

Marisat offers ships a clear voice by replacing short-wave radio, which is subject to fading and interference by poor weather and ionospheric disturbances.

and from ships at sea via two earth stations located on the east and west coasts of the United States.

Three spacecraft comprise the Marisat system, and provide around-the-clock communications capability. The first two launched are in geostationary orbit 35,800km over the Atlantic and Pacific Oceans respectively, whilst the third is stationed over the Indian Ocean and is used by the US Navy. The Indian Ocean satellite also serves as an in-orbit spare for commercial service, and could be repositioned over either the Atlantic or Pacific if required.

Design of the new Marisat satellite draws selectively on the flight-proven technology developed by the Hughes Aircraft Company (which built the satellites) for the Intelsat IV and IVA global satellites, TACSAT for the Department of Defense, and the series of national communications satellites built for Telesat Canada and Western Union Corporation in the US. Also, Marisat employs the time-proven spin stabilization technique which the Hughes/NASA Syncom satellite, the world's first synchronous orbit communications spacecraft, demonstrated so successfully in 1963.

Launch facilities were provided by NASA from Cape Canaveral, Florida, for Comsat General Corporation, the prin-

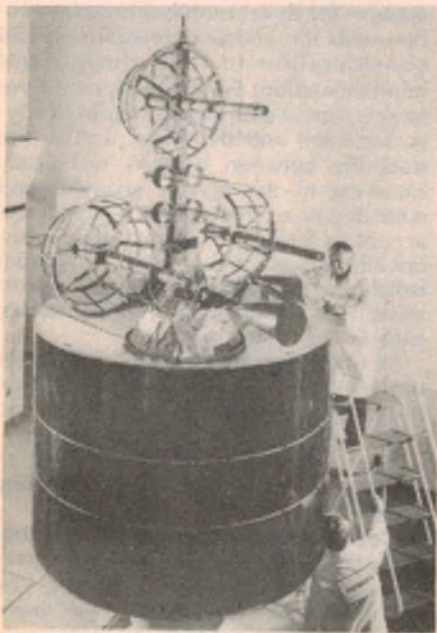

A Marisat satellite before launch. The unusual antenna design allows both US Navy and merchant marine vessels to communicate to shore bases.

principal owner and operator of the system. Sharing a limited interest in the system are RCA Global Communications, Western Union International, and ITT World Communications. In addition to the United States, vessels from 10 countries are so far represented in the Marisat fleet—Belgium, Canada, Denmark, Italy, Japan, Liberia, Norway, Panama, Sweden and the United Kingdom. A total of 26 commercial vessels now make up the Marisat fleet.

Operation of the satellites is directed by Comsat General from its system control centre in Washington, DC. Earth stations for the Marisat system are located in Santa Paula, California and Southbury, Connecticut. The earth stations are interconnected with terrestrial networks and linked by 24 hour voice/data lines with Comsat General's control centre.

The Marisat satellite contains three communications repeaters. One of these, the UHF repeater, contains a wideband and two narrowband channels to be used exclusively by the Navy, all of which can be turned on or off by ground command.

The remaining two repeaters provide ship-to-shore and shore-to-ship civil maritime communications. The repeater handling shore-to-ship communications translates C band signals at 6GHz from an earth station into the L band frequency of 1.5GHz for ship reception.

The ship-to-shore repeater translates transmissions received at 1.6GHz into 4GHz signals for the satellite-to-earth station downlink. The 6/4 GHz bands are also used for tracking, telemetry, and command signals to the satellites.

Earth-pointing capability of the antenna system is achieved through a noncontacting three-channel coaxial rotary joint which couples the despun antenna farm to the rotating platform containing satellite subsystems, including communications repeaters.

Dominating the antenna array are the UHF helices which surround smaller helices for L band frequencies mounted at the antenna mast. C band transmit and receive horns protrude from the foot of the mast. Command and telemetry antennas are mounted at the top of the entire array, which weighs approximately 12kg.

Electrical power for the satellite is generated by the fixed solar panels surrounding the cylindrical body of the spacecraft. The solar array contains approximately 7000 solar cells and provides about 330 watts DC power. The satellite design includes nickel-cadmium batteries with sufficient capacity to power the satellite subsystems during launch and through the biannual eclipse periods.

Comsat General has ordered 200 shipboard terminals for commercial users of the Marisat system. The terminals, which may be bought or leased by the user, include an antenna and the transmit-receive equipment necessary to com-



Top: Small dome-covered antennas aboard the ships are used for sending signals to and receiving signals from Marisat. Middle left: Marisat earth station in California. Middle right: A shipboard telephone service is one of the capabilities of Marisat. Bottom: map showing Marisat locations.

municate with ships or offshore facilities. A number of these terminals have already been installed aboard various ships, including tankers, passenger liners, cargo vessels, oil exploration vessels, and others.

Vessels conduct communications via an above-deck four-foot diameter antenna protected from weather by a radome. The antenna is linked to a below-deck unit consisting of a console with communications and control equip-

ment teleprinter and telephone.

The Marisat program is proving the operational and economic feasibility of providing fast, dependable 24-hour communication service to subscribing ships. Considering the growing need for such service and the reliability of other space communication systems, there is little doubt that satellite communication networks will be extended to service virtually all of the world's major shipping lanes.

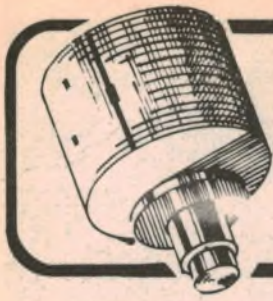

News Highlights



General Electric to design new electric vehicle

In response to the US Government's concern about reducing the nation's growing dependency upon oil imports, the General Electric Company—with Triad Services, Inc., ESB Incorporated, and Chrysler Corporation as consultants—is designing an experimental electric car with the possibility of twice the performance of commercially available electric vehicles.

Primary goal of the industry team is to design an electric automobile "from the ground up", rather than assemble a prototype vehicle from off-the-shelf components. The unique approach is in answer to the Energy Research and Development Administration (ERDA) exploration of alternative methods of transporting the nation's highly mobile population from place to place.

The six-month preliminary design project is funded under a \$265,000 contract from ERDA. The ERDA contract calls for the design of an experimental short-trip vehicle with a minimum top

***the goals . . . 0-50kph
in 10s; 90kph top
speed; 120km range***

speed of 90km per hour and an acceleration of 0 to 50kph in ten seconds.

Dr James Lafferty of GE stated that the first-generation experimental car will be designed as an evolutionary vehicle that

can be used as a test bed for the most modern technology available. For example, it will enable engineers to evaluate improved drive systems and components to determine which type offers the best performance.

ERDA's design goals for the experimental electric car call for a cost to the consumer of no more than \$5,000 in 1975 dollars if it went into mass production. They also specify a minimum life of 100,000 miles and an operating cost of no more than 15 cents per mile (1975 dollars)—figures comparable to conventional cars. In addition, the ERDA contract requires a stop-and-go range of at least 120km without a battery recharge, a maximum recharge time of six hours, and—as accessories—at least a heater and defroster.

British Ceefax service gets go-ahead



The British Government recently authorised the continued transmission of the BBC's latest form of broadcasting—its Ceefax service of news and information—at the end of a two year experimental period. Here, Ceefax sub-editor Peter Wheadon operates a VDT keyboard to insert a new page about a drugs theft. With him is research assistant Diane Needham who has checked the page for accuracy. Ceefax information is transmitted during the blanking periods of a normal TV transmission. By pressing a series of buttons on a decoder interfaced to his TV set, the viewer can choose from "over a hundred different pages". At least 50,000 sets will be capable of receiving Ceefax by the end of 1977.

RF energy could destroy cancer tissue

Research carried out by Dr Harry LeVein at the Veterans Administration Hospital in Brooklyn, US, indicates that RF energy could be used to reduce the size of malignant tumors and even to destroy cancerous tissue. In experiments so far, and using a frequency of 13.56MHz, Dr LeVein managed to reduce the size of tumors in some 21 cases of advanced cancer, and destroyed the cancerous tissue in some of them. None of the patients were permanently helped, however, as the cases were all too far advanced.

According to Dr LeVein, the destruction of the cancerous tissue is due to heat generated by the RF energy. The cancer tissue is heated to an average of 119°F, more than hot enough to kill both cancerous and normal tissue. Normal tissue in the area remains unaffected, however, because the blood circulation in this tissue is better and heat is carried away. The temperature of the normal tissue thus remains considerably lower than that of the cancerous tissue.

The attitude of the cancer authorities appears to be that, while the experiments are encouraging, carefully controlled clinical tests will be required to determine what role, if any, the new technique will play in cancer therapy.

Telecom installs cross-assemblers

Cross-Assemblers for four different microprocessors have recently been installed on the Telecom Australia (H6000) computer network. An emulator has also been implemented.

These software products are accessible to Telecom staff throughout Australia, thereby facilitating microprocessor usage in areas where the expense of acquiring elaborate development systems cannot be justified.

Telecom research laboratories have been using microprocessors for some time now; the most notable development in this area is probably the ACTION experimental domestic computer terminal. Another development is an object-tape loader PROM for the SC/MP Kitbug set.

DMM for the blind



Either spoken or Braille readings are given by this digital multimeter designed at Macquarie University's Electronics Laboratory. A Fluke 8000A multimeter, a Braille cell and a T.S.I. "Speech Plus" talking calculator are interfaced.

Aust. telephone service too expensive

"Due to very large increases in charges for telephone services, introduced in recent times, we now have one of the most expensive telephone services in the world."

This is stated by the Chairman of ATDA (Australian Telecommunications Development Association), Mr T. E. Hodgkinson, in his "ATDA Chairman's Report" contained in the ATDA's 1976 Annual Report—Telecommunications 1976'.

Later in his report Mr Hodgkinson states: "The high charge for new connections does not increase demand and, indeed, can only be considered to be a deterrent factor. Australia has approximately 35 telephones per hundred of population, a very low figure when compared with, say, the USA and Sweden,

GE wins patent war with IBM

The US Patent and Trademark Office has upheld the General Electric Company's right to one of the key semiconductor inventions of the past decade.

The GE invention, a structure that protects semiconductors and integrated circuits against failure, is finding use in today's multi-million-dollar market for hand-held calculators, electronic watches, and semiconductor memories for computers, according to Dr. Arthur M. Bueche, GE vice president for research and development.

After more than three years of legal proceedings between GE and International Business Machines Corporation, the US Patent and Trademark Office has upheld GE's claim to priority of the invention.

In one form of the GE invention, a thin film of silicon nitride is placed between the gate and silicon dioxide in metal-oxide-semiconductor field-effect transistors (mosfets). This structure virtually eliminates the contamination by alkali ions that previously caused widespread failure of the tiny devices.

In another application, these nitride-over-oxide layers are used in standard



GE scientist, Dr Dale M. Brown, examines a king-sized overlay used to check the fabrication process.

bipolar transistors as a surface and junction-sealing passivation layer. Both the manufacturing yield and reliability of modern integrated circuits and semiconductor devices are "substantially enhanced" by the GE invention.

International atomic second is too short!

Tests of the latest generation of National Bureau of Standards atomic clocks, NBS-6, demonstrate that it determines the length of the second to within 0.85 parts in 10^{13} (comparable to about one second in 370,000 years).

The determination of the second to this accuracy reveals that the international atomic second, maintained by the International Time Bureau (BIH) in Paris, is too short by about 11 parts in 10^{13} .

The new NBS-6 cesium beam clock is twice as accurate as its predecessor. NBS-6 achieves this improved perfor-

mance through the use of its beam reversal capability, improved magnetic field stability, and better techniques for directly evaluating systematic frequency offsets due to the electronic system and the microwave cavity structure.

These features enable the operators to measure the inevitable frequency biases which cause the output frequency to differ slightly from the undisturbed cesium atom's frequency. Once these biases are estimated, they can be allowed for, thus providing a better realization of the cesium frequency.

both of which have well over 60 telephones per 100 of population".

Reference is made in the Annual Report to the severe economic conditions to which the telecommunications manufacturing industry has been exposed for some time and particularly in the past year. In the section on Defence, an executive of an ATDA member-company is quoted as saying: "The year was one in which no meaningful tenders were let at all".

Examples are given of the ways in which individual companies have tackled the situation of curtailed orders from traditional domestic sources by seeking other markets inside and outside Australia.

One member-company of ATDA, for

example, secured an order from a Venezuelan airline for a call-handling system against competition from a major US telecommunications company, whose quote was more than twice the Australian figure, and a German firm, which did not offer technology as advanced as the Australian system. Another company sold highly-specialised loudspeaker columns to the Central American republic of Guatemala. The columns will be installed in a new opera house for Guatemala City.

Other companies sold equipment of many types in Asia and the Pacific Basin area, including special radio-telephone systems for isolated Hong Kong islands, new Australian-made telephone switchboards in Malaysia, and electronic switchboard equipment for the Parliament of Papua New Guinea.

New mini-floppy for Australian market

Shugart Associates, who claim to have the largest share of the OEM floppy disk drive market, have introduced a half-size unit—the SA400. The new mini-floppy is not only smaller, but is also priced at almost half the cost of existing floppies.

The SA400 is primarily aimed at the VDU market as a replacement for cassette equipment and also at the rapidly growing microprocessor area. It is claimed to give greatly improved access times over currently available cassettes and to be extremely competitive in applications not requiring the capacity of conventional floppies.

Measuring only 113mm square, the mini-floppy has a capacity of 110k bytes. The drive measures only 3½" x 5¾" x 8". Access time is around half a second with a transfer rate of 125k bits/second.

Shugart will provide the basic drive on its own or with an optional controller. The controller card is ideal for systems use since it will control up to 3 drives.



Dick Walker (centre) of Shugart Associates demonstrates the new mini-floppy to David Padden (left) and Collin Slaughter (right), both of Warburton Franki.

Further information on the Shugart SA400 is available from Shugart's agents, Data Products Division, Warburton Franki Pty Ltd, 199 Parramatta Road, Auburn 2144.

Automatic telephone pager/answering service

A breakthrough by Plessey Communication Systems Pty Limited has resulted in the development of a fast automatic telephone message relay system called TeleTRAK. The system combines the advantages of two currently available services with the newly developed TeleTRAK automatic dialler.

In use the TeleTRAK system automatically records telephone messages on the Plessey Ansafone Mark 7P telephone answering/recording machine. The TeleTRAK dialler then automatically dials the

user's personal paging receiver number operating through the Telecom Australia metropolitan wide paging service, or alternatively the telephone number where the user can be contacted.

Once alerted the user can immediately phone his or her office for an automatic replay of the recorded message. Alternatively, he or she can call from any other phone using a security controlled voice code to command the machine to play back recorded messages.

International convention and equipment exhibition

Organised by the Melbourne Division of the Institution of Radio and Electronics Engineers Australia, the IREECON International convention and equipment exhibition will be held in the Exhibition Building, Melbourne, from August 8 to 12, 1977.

Chairman of IREECON Convention Board, Mr. S. J. Rubenstein, said that although the convention was still some months away it had already aroused considerable interest, both locally and overseas. Overseas and local scientists and engineers will deliver papers on a wide range of subjects and manufacturers and distributors will show the latest technological advances in electronic equipment.

Companies and Government instrumentalities wishing to reserve space should contact the IREE at Clunies Ross



S. J. Rubenstein

House, 191 Royal Parade, Parkville, 3052, or 157 Gloucester Street, 2000. These information centres can also supply information regarding the call for and submission of technical papers, and on delegate registration.

BOGEN

LOUDSPEAKER AND HORNS
CAREFULLY SELECTED TO SUIT
ANY NEED



S.P. SERIES

15 & 30 Watt RMS

- High intelligibility wide frequency response.
- Weather proof
- All metal
- Omni Purpose Bracket
- Built in driver



W.A.H.

- High efficiency
- Wide dispersion angle
- Omni directional mounting bracket
- Use With 30 or 40 watt DR series driver units.



MH

- High efficiency directional trumpet
- Heavy duty U. Bracket & Horn castings
- Low frequency cut off excellent for speech
- Use with 30 or 40 watt DR series driver units.



HFS2

- All weather high fidelity coaxial protector
- Frequency response 150-15,000 Hz
- Equipped with woofer, tweeter and crossover network
- Supplied with mounting bracket
- 15 watts RMS output.

FOR FURTHER INFORMATION:

AUDIO TELEX COMMUNICATIONS
PTY. LTD.

SYDNEY
54-56 Alfred Street,
Milsons Point 2061
Telephone: 929-9848

MELBOURNE
828 Glenferrie Road,
Hawthorne 3122
Telephone: 819-2363

Update your quadraphonic system with this—

Full Logic SQ Decoder

In the three odd years since we developed the Playmaster 140 quadraphonic amplifier, a great deal of research has gone into the development of more ambitious decoding circuitry. This article describes a full logic SQ decoder built up by a New Zealand reader for his own 140 amplifier, using techniques and integrated circuits developed by CBS in collaboration with Motorola.

by HUGH McSHERRY*

Like many other E.A. readers I have thoroughly enjoyed the fine sound from discs provided by the simple SQ decoder described in Part 4 of the Playmaster 140 amplifier (EA March 1974). However, from my reading of overseas listeners with quadraphonic discs played through commercial SQ decoding systems I concluded that I was still missing something and got the itch to try out the full SQ logic system.

Playing stereo and quadraphonic discs through the simple SQ decoder resulted, to my ears, in an impressive form of stereo sound but it was not quadraphonic sound, as intended. The trouble at my place of domicile was that I had nowhere to turn to find out what this was, so I decided to be a guinea pig.

My aim therefore was to hook up the three integrated circuits prescribed by

the inventors of the SQ system in order to get the best results from SQ encoded discs. A subsidiary objective was to produce a printed circuit so that other home constructors would have an easy shot at this quad business.

But why SQ?

Well, the situation has not changed since that mentioned by Mr Williams in his article referred to above: namely SQ discs are relatively prolific whereas other systems software is less readily accessible. More potently, the possessor of the Playmaster 140 or a like amplifier is three-quarters on the way to a full logic system; the preamplifier and the power amplifiers remain as before and the logic system will not object to one more volt (the Playmaster 140 provides 21 volts).

As for the end result, the electronic reconstruction of encoded four channel

sound is very much an aural affair! Although the logic P.C. Board has been (to coin a phrase) subjected to objective tests, the audiophile will want to know what it sounded like. But, since there is no common ground where subjective tests are concerned, I can only give my own impressions:

The results were exactly what I had hoped for, that is, they paralleled those experienced by United Kingdom listeners.

With quadraphonic discs, to quote Robert Layton, "the sound image is, as it were, liberated from the immediate speaker areas and moves forward into the room while the timbre and quality of the sound itself is undoubtedly enriched". Remarkable is the more realistic separation of orchestral detail.

As for recent stereo discs, provided the ambience mode is chosen, the difference between a quad disc and a stereo disc played through the quad system is marginal. My thought on this is that the stereo discs have an appreciable amount of ambient sound trapped in the grooves.

But I must say that, with my four speakers roughly equalised for output, I was enthralled by the Vanguard SQ disc of the Petrushka ballet. I have been unable to locate a SQ test disc but, fortunately, I had to hand the CBS disc of Boulez with his four mikes right in the centre of the New York Philharmonic playing Bartok's Concerto for Orchestra (CBS disc). With the instrument placement chart provided with the disc I was relieved to find that all was well. Not a disc that I will play often as I am too old to enjoy string basses rear right and woodwinds rear left!

For those who like it, the full logic can be a fun thing; for example, I played a stereo disc of Sir Geraint Evans doing Mozart arias and had him singing singly out of each of the four speakers in turn. I have noticed that an advantage of the new outfit is that one can wander round the room with no apparent dislocation of sound source i.e., the stereo seat is

*Dept of Physics, Victoria University, Wellington, N.Z.

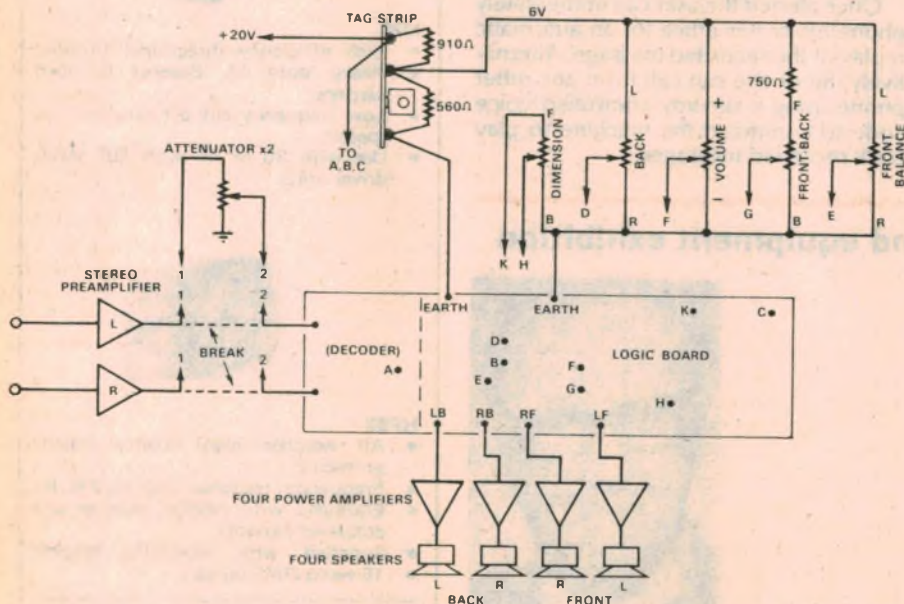

This block diagram indicates how the SQ decoder/logic module might be integrated into a 4-channel system. The writer chose to make all controls accessible but, for simplicity, all but Volume and Front/Back Balance could probably be made internal presets. One option seemingly open to Playmaster 140 owners would be to make all the controls miniature presets, attached to the board, so that it substitutes electrically for the simple SQ decoder, accepting the stereo input and delivering pre-adjusted outputs to the existing front and back volume controls. In this way, the double stereo facility and the Stereo-24 decoder would be retained.

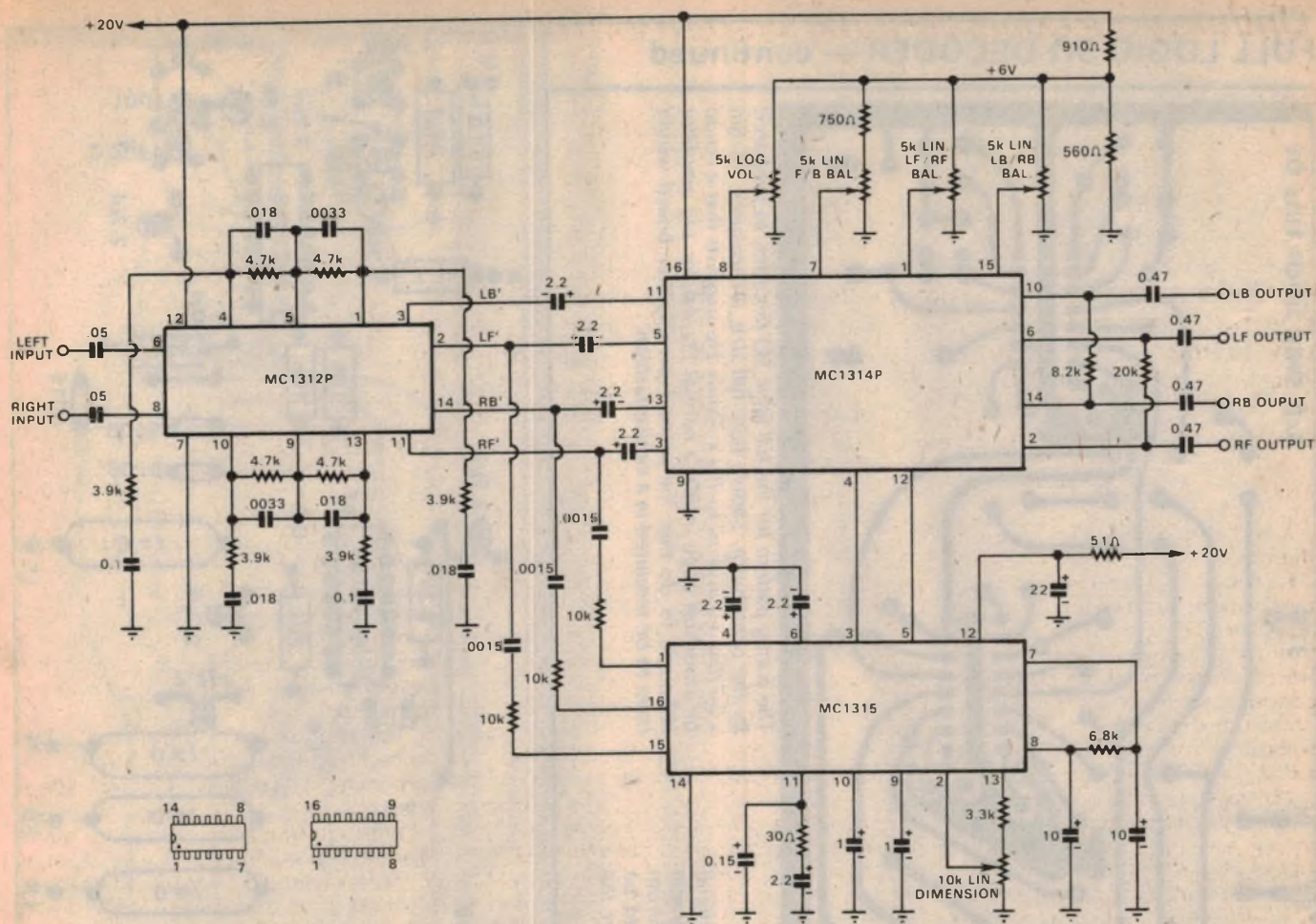

The circuit diagram of the basic decoder/logic system, issued by Motorola Semiconductor Products Inc, who manufacture the ICs under licence to CBS, owners of the SQ trademark. Limited stocks of the ICs are held in Australia by Motorola

and their distributors, sufficient for likely home-constructor needs. As explained in our March, 1974 issue, a royalty fee is payable to CBS by users of the particular ICs but suppliers should be able to meet the demand now, as then.

removed. This was with a solo violin playing.

On the subject of channel balance, with no yardstick to rely on (I deliberately refrained from voltage measurements) I adopted an American suggestion: A mono disc, preferably a male speaking voice, is played and each speaker adjusted for equal volume—as you hear it. This idea seems to work fine for all types of SQ discs.

In a sense, the decoder was double-checked in that I actually built up two versions. The first was the larger of the two, rendered so because I could not obtain, at the time, small 5% tolerance capacitors to use around the MC1312 chip; instead, I had to settle for the rather bulky Philips 1% type. The second board, which I completed later with smaller capacitors, is the one which will find more general application and is therefore the one depicted here.

All resistors can be ¼-watt types, 5%, or the smaller ½-watt types still capable of fitting the board. As for capacitors, the 1.0, 2.2 and 10µF units were 35V bead type tantalums, while the 20 or 22µF was a 35V pigtail type. Because no 0.15µF capacitor was available, I used a 0.22 and 0.47 in series. All the rest were 25V (or higher) polyester (or mylar which I

prefer) with the precaution that those around the decoder were checked to be within 5%.

With the wiring and layout diagrams to assist, construction of the actual decoder should not present too great a problem to anyone with reasonable do-it-yourself experience.

Planning the board into a Playmaster 140, or into another amplifier set-up will call for somewhat more thought and skill, however, since it will involve marrying the new circuitry to the old, as well as making the necessary arrangements to accommodate it in the physical sense. Again, this should not deter the experienced experimenter, although I certainly would not encourage the beginner to get involved who still needs step-by-step instructions for every component and wire.

The potentiometers may present a slight problem if your existing amplifier has little panel room to spare. For the purpose of the SQ logic I reshaped my amplifier to use slider pots. They do take up an awful lot of room but they have the virtue that one can see at a glance "the state of play".

There are two other options: (i) use rotary pots which occupy much less space (ii) use preset pots—preferably the

full size ones—inside the amplifier case; the idea being to set up the system for normal use and leave it at that. Of course the master volume pot would need to be at front.

This last alternative will appeal least to those who like tinkering. For those who used the published layout of the Playmaster 140, it would be convenient to mount the logic PCB edgewise (in the longitudinal direction) immediately in front of the power amplifiers and likewise mount the preamplifier PCB edgewise between the logic board and the front controls.

It will be noted that the SQ decoder pattern on the new board follows that used in the Playmaster 140 (EA March 1974 p. 73). As this had been in use for over a year or so and performed well, no useful purpose was seen in changing it. It will be seen that there are three variations, however:

- for the purpose of the three chip system it was convenient to bring the inputs to the left hand side of the board.
- Motorola in a revised version of the circuit surrounding the decoder chip (MC 1312P) changed the capacitors and resistors to the more easily obtained 'preferred' values. The new

FULL LOGIC SQ DECODER — continued

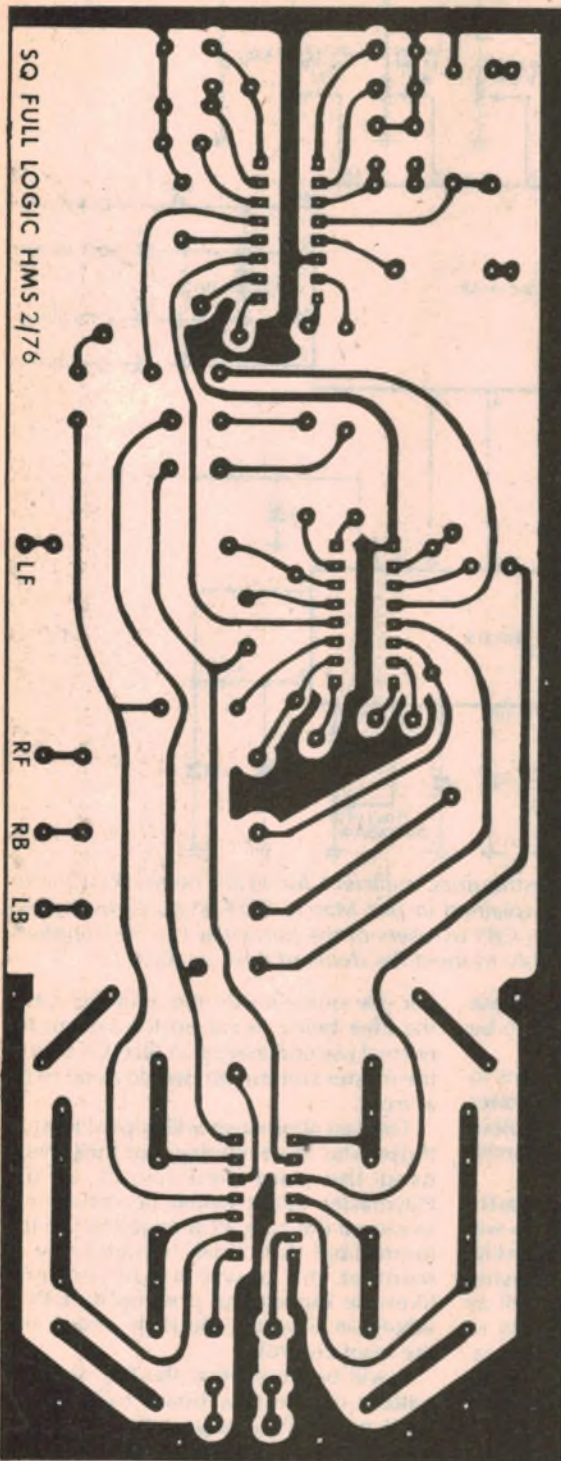

The wiring pattern for the full logic SQ decoder, as prepared by the contributor. Shown here full size, it measures 7-5/8in x 2-7/8in, equivalent to 194 x 73mm. He suggests that it could be stood on edge inside a normal Playmaster 140 amplifier although, to do this, the present preamplifier board would have to be mounted in a similar fashion.

Showing the layout of components on the printed circuit board. The left hand end virtually duplicates the original simple decoder so that, with care, the parts could be transferred from it to the new board. Alternatively, the new board could be cut about where indicated on the block diagram and the original board married to it.

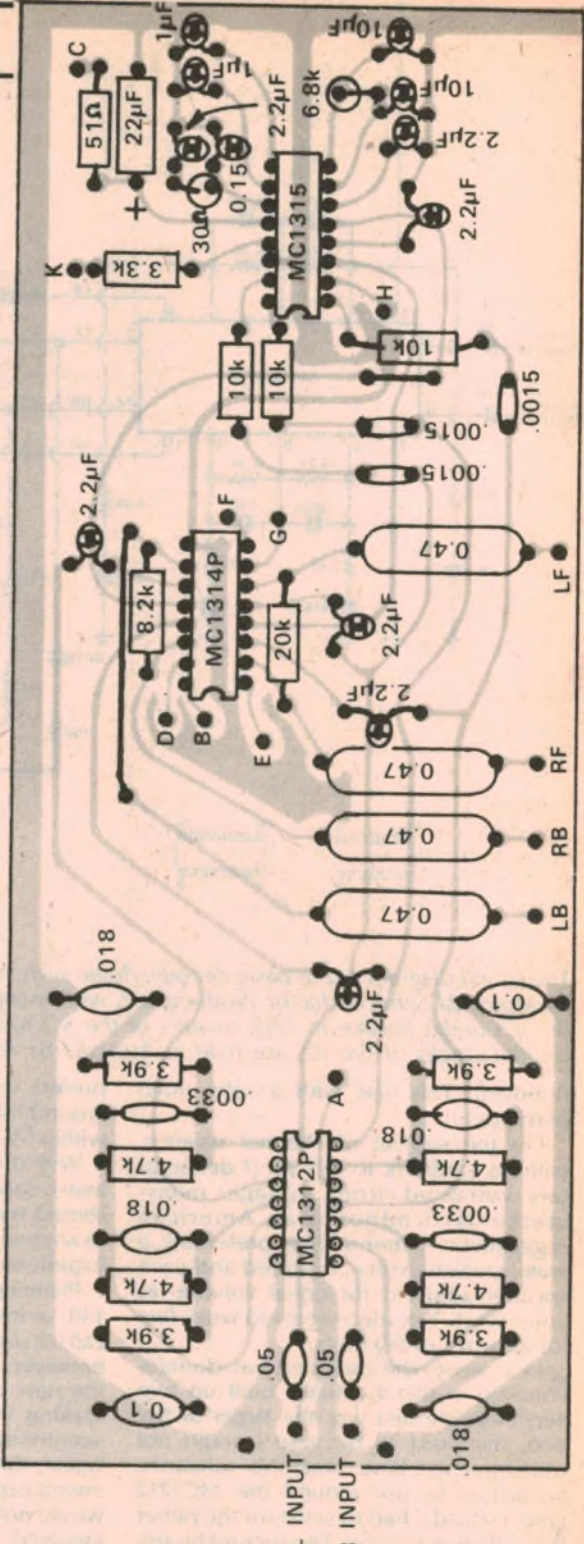

values are used in the complete system. I have had in use, singly, for some time both simple decoder boards and have noticed no audible difference. So constructors who wish to retain the Playmaster decoder could do so by chopping the new PCB pattern as indicated by dashed vertical line and drilling and inserting soldering pins as marked. I have not tried this but see no reason to believe that this arrangement will be other than compatible.

(c) However, the Playmaster coupling capacitors and resistors are no longer required and would require to be removed. Also, since separation is taken care of in the logic system, the blend resistors (7K5 and 47K) are no longer required. Jumping wires would be required to take the place of the four 0.47mfd capacitors removed. This done, the connections remain as before. Whatever arrangement is used it is important to stick to the earthing arrange-

ment set out in the December 1973 issue. The pros and cons of regulated supplies for power amplifiers seem to be still a matter of argument among audio enthusiasts. I favour (and use) unregulated supplies for the power amplifiers and use a regulator for the chips. But there seems to be general agreement that the arrangement propounded by Mr. Williams in the article just quoted is a must for the loudspeaker (and power amplifier) earths. One point should be mentioned here:

the 400uF decoupling capacitor used in the Playmaster 140 for the simple decoder is not adequate for the full logic version because of a clearly audible hum. I finished up with a 2200uF in parallel with the 400uF, the series resistor being manipulated to give the necessary 20V supply to the decoder. This done, it worked fine. At a measured supply voltage of 19.75, the current drain of my prototype measured 52.4mA, which compares with Motorola's figure of 60mA (typical).

A presumption has been made that the SQ logic board described here will be of primary interest to those who have made the Playmaster 140. However a number of inveterate do-it-yourselfers, me included, may have other four channel arrangements. For them the SQ logic board is a piece of cake! It has an input impedance of 2 megs, an output impedance of 2K and unity gain at quiescent—so it could go almost anywhere! One point however, it doesn't like an input voltage of more than 1.9 and I gain the impression that best results come from the recommended level of 500mV. Therefore it may be desirable—I find it necessary—to put pots in the block diagram; 10k log seemed OK.

Being a simple soul, the question is asked, "How do you work it? As shown in the circuit there are three chips in the system; the first one, MC 1312P, was fully described in the March 1974 EA.

The MC1315P (wave matching logic) chip is Motorola's answer to the criticism of not enough front to back separation. It motivates the dimension control and if you really want all the sound to come out of the back speakers this is the pot to turn. Normal use is 50% rotation.

The heart of the job is the MC1314P chip which is four voltage controlled amplifiers with the four pots giving all you want for the localisation of sound. Space will not permit giving all the permutations but the block diagram will be a guide.

For example, say sound is required from the left back speaker alone. The volume control is set to the required level of sound; Front Balance 50% rotation; Front/Back Balance hard on to Back; the Back Balance hard on to left and the Dimension Control hard on to Back—easing off the last control as necessary.

For normal use the balance pots are adjusted in accordance with the previous paragraph on balancing.

Perhaps the most important question is left to last. Is all this effort worthwhile? Frankly I don't know. But my answer you must put in my age group. I am rather an ancient and enjoy clear and smooth sound thru the decoder and an accurate pre-amp. If you want kicks out of your audio by all means go ahead. Me? I'm itching to get hold of the SQ Gurrelieder (CBS) after hearing which the London critic went round in a daze muttering a mixture of adjectives and obscenities, adding up to amazement!

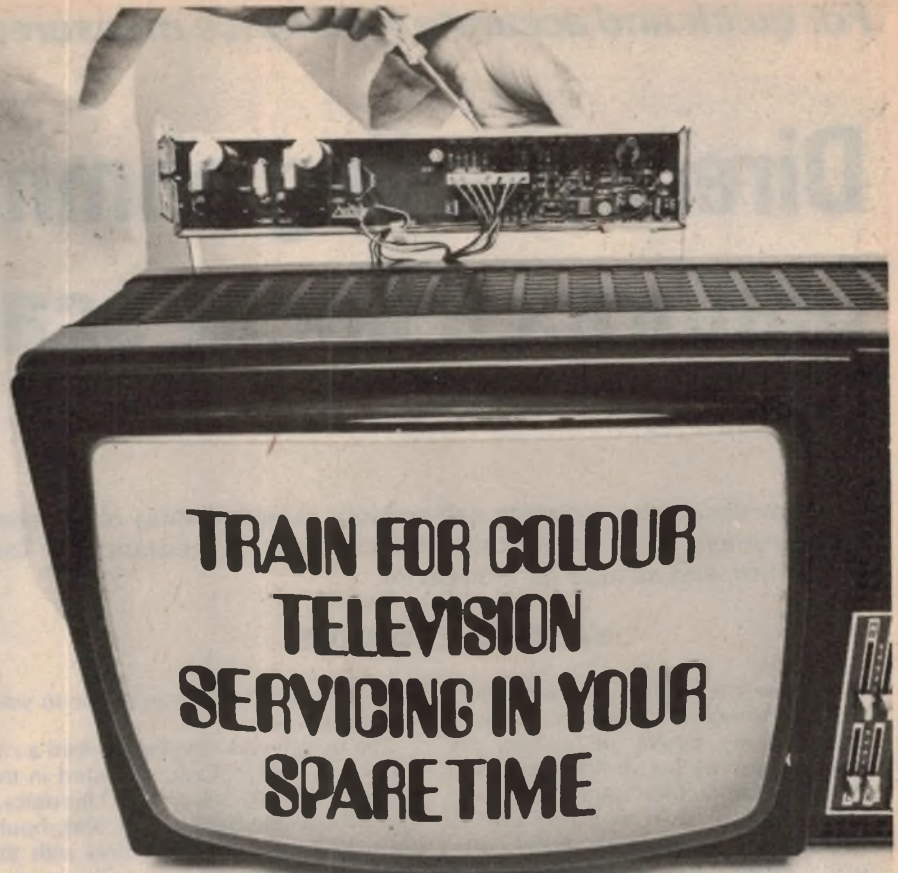

-that's where the money is!

Stott's course is totally comprehensive — and includes both sophisticated electronic equipment and project materials you need to gain a thorough understanding of servicing techniques.

Divided into three self-contained sections, the course covers:

Part 1 — Introduction to Electronics (theory and practice)

Part 2 — Monochrome Television Receivers

Part 3 — Colour Television, including processing circuitry, service techniques, fault tracing and trouble shooting techniques.

Like all Stott's courses, you work with your own instructor who is an expert in this exciting and rewarding field, at your own pace, in your own home.

If you are a beginner, Stott's will teach you everything you need to know concerning television principles and receiver circuitry.

If you are already working in the field, or have completed some studies in electronics, you may be eligible to enter the course at an advanced stage. Whether your aim is to enter the TV service industry or whether you wish to gain a thorough understanding of television theory and servicing as an aid to sales experience, this is the course which will help you make it!

Other electronics courses offered by Stott's include:
Radio for Amateurs — Amateur Operator's Certificate
For full information mail this coupon today:

STC941

EA.2.77

Stotts 

TECHNICAL CORRESPONDENCE COLLEGE
The name to trust in correspondence education.
Please send me, without obligation, full details of the following courses:

(please PRINT)

Stott's undertake that no sales counsellor will call.

Mr., Mrs., Miss _____ Age _____

Address _____ Postcode _____

159 Flinders Lane, Melbourne, 3000. Tel: 63 5583
383 George Street, Sydney, 2000. Tel: 29 2445
290 Adelaide Street, Brisbane, 4000. Tel: 31 1627

66 King William St., Kent Town, S.A., 5067. Tel: 42 5798
89 St. George's Terrace, Perth, 6000. Tel: 22 5481
P.O. Box 3396, Singapore 1

For quick and accurate resistance measurements . . .

Direct reading ohmmeter features a linear scale

Here is a design for a simple self-zeroing, direct reading ohmmeter. The instrument has a linear scale, and can measure resistances as low as 0.5 ohm, and as high as 1 megohm.

by DAVID EDWARDS

There are many times when an electronic constructor wishes to measure resistor values. Often, he can use the ohms ranges of his multimeter, and achieve a satisfactory result. However, the accuracy of such measurements is limited by the non-linear scale commonly employed, and the ease of measurement is limited because such instruments usually require calibration immediately before use.

The little instrument described in this article has a linear scale, and does not require calibration before use. It operates from a single 9V battery, and is capable of quite high accuracy. If you have available a suitable milliammeter then the complete instrument should cost very little to build. In fact, you may

have most of the parts available in your spare parts box.

The design was developed from a circuit by V. Ramprakash, reprinted in the November 1976 issue of "Electronics." Fig. 1 shows the basic circuit, and should be referred to in conjunction with the following discussion.

The unknown resistor R_x is connected between the output and inverting input of an operational amplifier, which is thus connected in the negative feedback mode. A reference resistor R_s is connected from the inverting input to ground, while a stable voltage source V_{ref} is connected to the non-inverting input.

A milliammeter and suitable series resistor R_m are connected between the op-amp output and the non-inverting input. We shall designate the meter current as I_m , and the current through the reference resistor as I_s .

The negative feedback around the op-amp forces the voltages at both inputs to be equal. This implies that $I_s = V_{ref}/R_s$. Neglecting the input bias currents, this current must also flow through R_x . This enables us to calculate the voltage drop across R_x , and hence the output voltage V_{out} .

$$\begin{aligned} \text{Hence } V_{out} &= V_{ref} + I_s R_x \\ &= V_{ref} + R_x V_{ref} / R_s. \end{aligned}$$

Now the meter current I_m is given by $(V_{out} - V_{ref})/R_m$, so that

$$\begin{aligned} I_m &= (V_{ref} + R_x V_{ref} / R_s - V_{ref}) / R_m \\ &= R_x V_{ref} / R_s R_m. \end{aligned}$$

Thus if $V_{ref}/R_m = I_{fsd}$, the current required for full scale deflection on the meter, then the meter reading will be proportional to R_x/R_s , and a full scale reading will occur when $R_x = R_s$.

By selecting different values for R_s , different full scale readings can be obtained. The accuracy of the final reading will depend only on the linearity of the meter, the precision to which $V_{ref}/R_m = I_{fsd}$, and the tolerances of

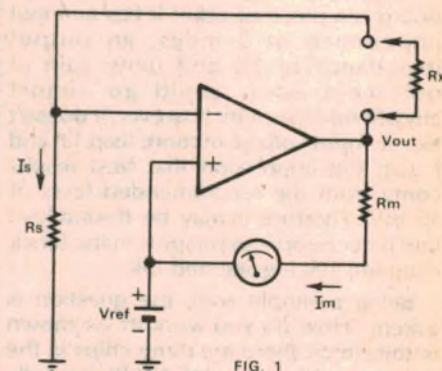

FIG. 1

the resistors used for R_s .

If R_x is short circuited, the meter will read exactly zero, because the feedback will adjust the output voltage to be the same as the reference voltage. With R_x open circuited, there will be no feedback, and the output voltage will rise to the positive supply rail, and hence the meter will be overdriven. In a practical circuit, this can be prevented.

The practical ohmmeter circuit is shown in Fig. 2. A 741 type op-amp has been used, with a general purpose NPN transistor to increase the output current drive capability. A second NPN transistor is used in the V_{be} multiplier mode as the reference voltage source. The 2.2k calibration control is used to adjust the collector voltage to 2V.

A four position rotary switch is used as a combined range and power switch. The basic ranges provided are 1M, 10k and 100 ohms FSD. A momentary contact push switch has been included in parallel with part of the meter resistance. This gives a FSD of 200mV, rather than the 2V normally obtained, giving an effective increase in the FSD of the meter of ten times. This provides three additional ranges of 100k, 1k and 10 ohms FSD.

We have chosen to obtain the extra ranges in this way, rather than by using additional reference resistors, because of the excessive current drains which would otherwise be required. To achieve an FSD of 10 ohms would require an R_s of 10 ohms and a current drain of 200mA, which is excessive for a battery powered device.

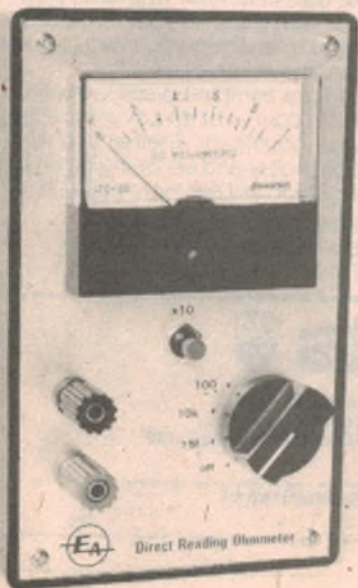

The completed instrument. Front panel lettering was done by Lettraset, finished with a protective coating of lacquer.

PARTS LIST

- 1 741 type operational amplifier
- 2 BC108, BC548 NPN transistors
- 1 OA90, OA91 germanium diode
- 1 0-1mA 100 ohm panel meter
- 1 4 position 2 pole rotary switch
- 1 knob to suit
- 1 miniature momentary contact push switch
- 2 terminals, 1 red, 1 black
- 1 Plastic case, 150 x 90 x 50mm
- 1 216 9V battery, and clip to suit
- 1 small piece Veroboard, DIP board or similar
- 1 2.2k trimpot
- 1 1M, 1 10k, 1 2.7k, 1 2.2k, 1 1.8k, 2 100 ohm 1/4W resistors

NOTE: Resistor wattage ratings and capacitor voltage ratings are those used for our prototype. Components with high ratings may generally be used provided they are physically compatible.

To provide protection for the meter when the test leads are open circuited, a germanium diode has been placed in parallel with the meter. This will limit the voltage across the meter to 300mV, and will prevent the meter needle from being "pinned" too severely.

To achieve maximum accuracy, the starred resistors should all be 1 or 2% tolerance types. An additional 10k low tolerance resistor is required to enable the meter to be initially calibrated.

With the test leads open circuited, current drain on all ranges is about 5mA. Maximum drain is achieved when using the 100 ohm range, and is about 25mA. Provided excessive use is not made of this range, the estimated life of the No. 216 battery specified in the parts list should be in excess of 150 hours.

Construction of the ohmmeter should be within the capabilities of most constructors. We used a small plastic case measuring 150 x 90 x 50mm to house the unit, with the meter, switches and output terminals mounted on the aluminium front panel supplied with the box.

The 741 and associated components were mounted on a small piece of DIP board. We used a section of the board coded 73d1, and mounted it directly on the rear of the terminal posts. Placement of the remainder of the components can be seen in the photographs. The three reference resistors are mounted on the switch wafer, and the battery is clamped under the DIP board.

The germanium diode is mounted directly across the meter terminals, with the meter dropping resistors connected to and from the DIP board. The negative lead of the battery is switched, to minimise the connections to the switch.

Once construction is complete, the meter can be calibrated. Switch to the

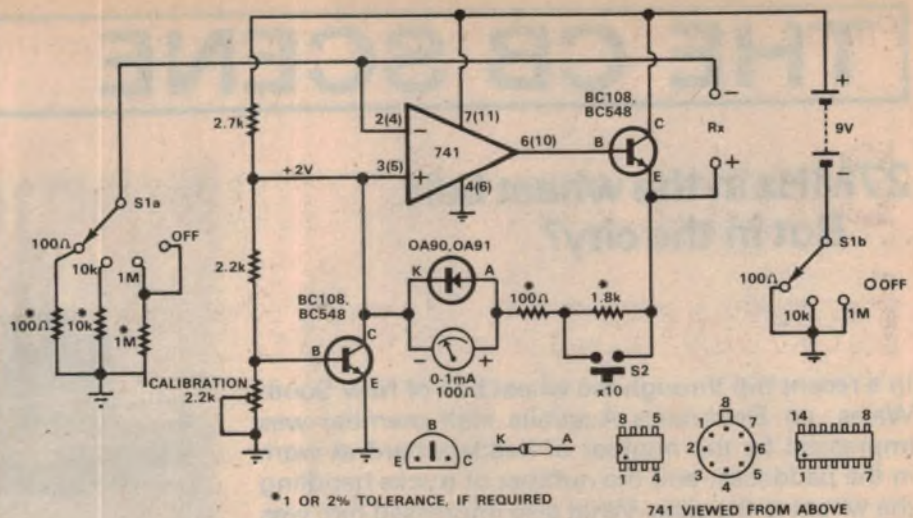
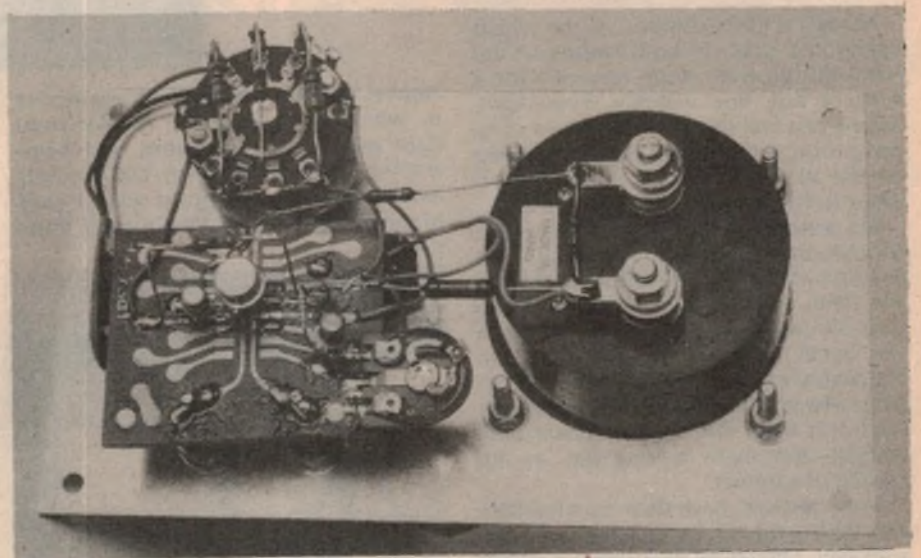

FIG. 2

EA DIRECT READING OHMMETER

7/M/-



This photograph clearly shows the internal construction of the ohmmeter. The 741 IC and associated components are mounted on the DIP board, with other components strung across the switch wafer and to the meter terminals.

10k range, and place a 10k resistor across the terminals. If you have used precision resistors for the reference resistors, this resistor should also be a precision one. Then simply adjust the calibration control so that the meter reads full scale. Then switch to the 1M range, and check that when the x10 switch is pressed, the meter reads 0.1.

So there you have it, a small, portable, direct-reading ohmmeter, which should give hours of trouble free service, and free your multimeter for other more important jobs. As a final point, do not forget that power is consumed whenever the unit is switched on. So to conserve the battery, switch it off when it is not in use.

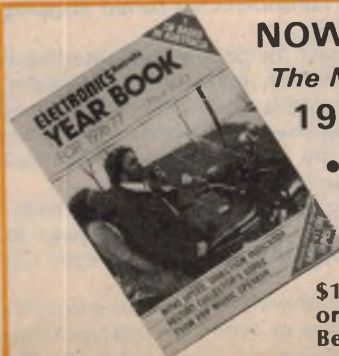

NOW ON SALE:

**The New "Electronics Australia"
1976/1977 YEAR BOOK**

- The big push for CB radio in Australia
- Build your own 250W music speaker
- 27 pages of valuable reference data
- Digital wind speed and direction indicator

\$1.20 from your newsagent; or \$1.80 by mail order from "Electronics Australia", PO Box 163, Beaconsfield 2014.

THE CB SCENE

27MHz in the wheat belt. ... But in the city?

In a recent trip through the wheat belt of New South Wales, an Electronics Australia staff member was impressed by the number of headers hard at work in the paddocks, and the number of trucks handling the wheat to the silos. What also impressed him was the way in which the exercise was being coordinated by CB radio!

Around mid-December, as the wheat ripens into gold—in both senses of the term—the growers hope fervently for a spell of hot, fine weather. Even light, patchy rain will delay or dampen a crop and produce the wrong kind of reading on the electronic grain monitor: too moist to harvest; too moist for the silo!

But, when the first stand is ready—ripe enough and dry enough—the rush is on to strip it, as fast as possible. It could rain any time, and there are other crops to strip all over the countryside. So, for a few hectic weeks, when urbanites are concentrating on their Christmas shopping, wheat growers and contractors are hard at it from the crack of dawn until twilight—and that's a long day in the middle of summer.

Many growers have their own headers and their own trucks, but few are self-sufficient. Most pool their resources with relatives or neighbours and strip their crops in rotation. If they're still short of equipment, a rough notice goes up on the property gate: "Contractors Wanted—Now".

The average communal operation involves from two to four "headers" working through a crop in formation, or else separately, depending on shape and contour of the land. Spinning blades in front of each header strip the ears from the crop, separate the grain and feed it into a hopper at the rear, at the rate of about ten to twelve tonnes per hour.

At this rate, it doesn't take long to fill the hopper but, before this happens, a pickup truck has to range alongside the header and take the wheat aboard—both vehicles still on the move.

This done, the pickup truck heads off to the edge of the property and, using its auger hoist, transfers the wheat to containers aboard a trailer. Somewhere out along the highway, a prime mover is hurrying back with an empty trailer, ready to exchange it for the one being filled.

Hopefully, there will be no delays, but there could be a hold-up at the silos, with



Above: Three vehicles which are the key to wheat harvesting: the header (left), light pickup truck (centre) and semi-trailer. Below: A semi-trailer cab, American style, equipped with a roof-mounted 23-channel Realistic CB transceiver.



the semi and driver imprisoned in a queue. Wanted: another prime mover.

Or truckers may make redundant journeys because a header has broken down, or a local rainshower has halted stripping for the day.

In the past, the people concerned have had to rely on habit, intuition, horns, flashing lights—everything short of smoke signals—to coordinate their activities. But the chances of frustration and delay have remained high.

This season, in particular, wheat-growers have discovered an answer to their communication problem: CB radio.

Compared with the price of a header, a semi-trailer or even a pickup truck, the cost of a piece of CB gear fitted into the

cab is chickenfeed—if it helps get the chickenfeed in faster!

The header operator can call for a pickup truck when he needs it. A pickup truck can be recalled early to top off a semi, to get it on its way sooner. The semi driver can find out whether he's needed back at the paddock, without having to drive the ten intervening miles. And if something goes wrong at the homestead—a scrub fire, say—the wife or children have some chance of summoning aid.

It's all so logical but the trouble is that it's quite illegal as the regulations now stand.

To be sure, a property owner may be given a licence and a frequency for a 5-watt base and a number of portables to use for his own purposes on his own property. But he can't legally communicate with neighbours using similar systems, nor is he free to change channels, either to make contact or to avoid interference.

What the wheatgrowers need is what they are now using—illegally:

Full 23-channel (often SSB) units properly installed in the cabs of headers and trucks, with properly mounted whip aerials, working against the body of the vehicle, and inductively loaded to resonance. With gear like this, they can coordinate activities over a radius of about 15 miles in hilly country—rather more on the open plains. They can talk back to homesteads, work with hand-held transceivers, and cooperate with other groups using other channels.

The largest single operation that we heard about was on a very large property involving an unspecified number of headers but no less than thirty trucks to handle the wheat they were stripping! An extra radio equipped utility was posted by the boundary gate to check each truck in and out and to ensure that a thirty-first vehicle didn't get into the act and shoot

THE CB SCENE

through with a couple of thousand dollars worth of wheat!

The problem is that the present "wireless telegraphy" regulations are just not flexible enough to accommodate this kind of free-wheeling operation, no matter how sympathetic the administrators may be. Wheatgrowers can cooperate in a communal way with equipment and vehicles and store their wheat in communal silos, but they can't operate a communal radio system!

Individual Radio Branch spokesmen understand the problem and are even sympathetic, but they have to administer the regulations as they exist. And the suggestions which they can offer are not very convincing:

Maybe the people concerned could do something like small boat owners—form themselves into a club of some kind and be given the right to talk to a common base on a particular frequency. (Small boat owners can use 27.88MHz.)

Or maybe they could be better served by applying for accommodation in the VHF band—at about four times the cost!

But wheatgrowers, and others on the land, couldn't use and wouldn't want a rigid base + portables system. Their "base" may be here today, somewhere else tomorrow! And, for some of the time, base will be in their own home, with the portable on their own tractor, while they plough or fight a fire on somebody else's property!

And they're certainly not interested in something that will cost them four times as much to install and a lot more to maintain in service.

In short, the man on the land needs CB radio in the current American sense of the term—easy to buy, easy to own, easy to install, easy to use, and easy to return for service.

And he needs it, not as a toy or as a diversion, but as an adjunct to productivity and to personal safety.

In fact, your E.A. observer returned from the wheat belt thoroughly convinced that a relaxed style of Citizens Band Radio could not come quickly enough, if only to legitimise the activities of those who were using it so sensibly!

The conviction lasted about three hours—long enough to have dinner, watch the news on television and then turn on the receiver to discover what was going on in the "big smoke" on 27MHz.

In fact, the most obvious activity was a vocal melee on Channel 9, presumably resulting from someone having attempted to suggest to someone else that they change frequency to keep channel 9 open for emergencies. He was being told, in no uncertain terms, where to go, and what to do with his equipment. As others got into the act, there

CB Emergency channel 9 under fire

One of the arguments which has been advanced locally in favour of the Citizens Band Radio is the option of setting aside CB channel 9 for emergency calls, as is the practice in the USA and elsewhere. In fact, would-be legal CBers in Australia have set up CREST (Citizens Radio Emergency Service) which has already been able to cooperate in a spontaneous manner with various civil services—without too many questions being asked!

The reason for selecting channel 9 is not merely to conform to overseas practice. Australian CB lobbyists felt that there was merit in keeping general traffic off the channel as far as possible, thereby minimising the risk of interfering with overseas emergency services under skip conditions.

As part of their self-appointed task, Australian monitor station operators have asked other users, from time to time, to QSY (shift to another frequency) and this has triggered more than its share of ill feeling and outright abuse. Some licensed amateurs understandably resent being so requested by people they regard as "pirates", but no less resentment seems to be evident from other "CBers" who flatly refuse to be "organised" by the "dogooders". What will emerge from this battle of wits and wills is anybody's guess but the on-air abuse certainly isn't doing the CB cause any good in the meantime—or the amateur cause either!

Some have expressed the hope that legalisation of CB radio and the use of proper call signs and names will bring with it a sense of responsibility and make for more orderly use of the facility—in particular channel 9. Recent reports from America suggest, however, that the emergency channel concept is under a cloud in that country also, to the extent that a writer in the CB Radio magazine "S9" is asking "Should we Dump Channel 9?"

The emergency channel 9 concept in America dates back to the late '50s, to a time when usage of the CB Band varied widely from state to state and when a

were threats of violence, challenges to turn up at such and such a place to "have it out", all expressed in quite uninhibited language. The only one who didn't have much to say was the "whistler", who did his usual and tedious "thing", adding to the emotions of both sides.

The next night appeared to be a virtual re-run, but on channel 8, with a changed cast, and with the whistler replaced by the "mumbler".

A few minutes of that proved a sure

motorist needed to carry a fistful of crystals if he was to have any chance of maintaining CB contact as his journey progressed. Gradually CBers came to see that there would be an advantage in settling upon one nation-wide channel for emergency communications and channel 9—somewhere near the middle of the band—seemed as good a choice as any.

But while the idea was variously pushed by individual CBers and magazine writers, it was not until 1965 that it was taken up by REACT—the voluntary group that had started up some years earlier with the idea of monitoring the CB channels and offering help where it was needed.

In 1970 the FCC stepped in and made it mandatory for CB operators to reserve channel 9 for emergencies and, over the next 4 to 5 years it became very firmly entrenched—perhaps too much so. American CBers began to grumble that what was once a voluntary "helping hand" channel was gradually turning into a private channel for members of REACT—the American CB emergency service. Allegedly, REACT would order others off the channel but were not above using it themselves to support what was beginning to look like a vigilante operation, right down to uniforms and cars dressed up in the manner of police vehicles.

With this kind of disenchantment building up, and with the enormous increase in CB traffic during the past couple of years, there has been a notable spillage into the temptingly open space of channel 9, and a progressive stretching of what constitutes an "emergency".

There is some hope that the availability of 17 new channels as of January 1 last may relieve the pressure on all channels and on 9 in particular, but it's going to take quite a while for enough users to install the new gear, or for it to make any real impact on the 23-channel population.

Whether channel 9 can withstand the tide in the meantime is the big question.

cure for the optimism generated out in the west. One could hardly blame members of the Radio Branch (including "bloody -----", mentioned by name during one of the melees) from doubting the maturity, responsibility and sincerity of at least some would-be legal CBers!

In fact, the two contrasting experiences seemed to epitomise the dilemma faced by the authorities who have to reach a decision about CB radio: Wheat bags or ratbags? 

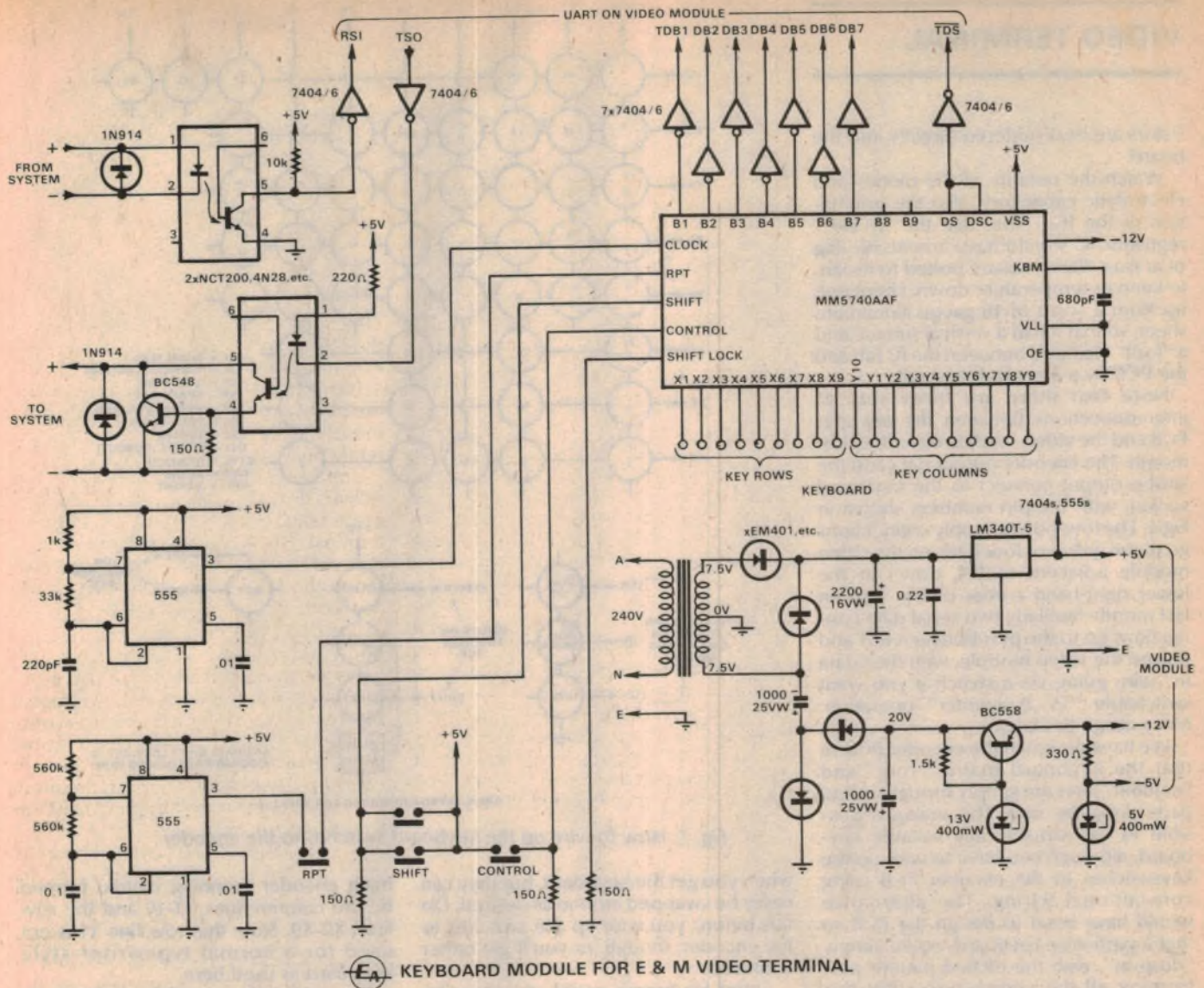

EA KEYBOARD MODULE FOR E & M VIDEO TERMINAL

Fig. 5: The circuit for the rest of the terminal, apart from the keyboard.

regardless of the DC potentials of the 20mA loops.

The 20mA line coming from the computer system is connected to the LED of one opto-coupler, whose phototransistor is coupled to the RSI (receiver serial input) pin of the UART via another 7404 inverter. The inverter gives the correct logic polarity, so that the RSI input of the UART is held at the correct positive logic level for the 20mA "mark" condition of the line.

The TSO (transmitter serial output) pin of the UART is connected to the LED of the other opto-coupler via a further 7404 inverter, so that when the TSO output is at the positive logic "mark" level, the LED is conducting. The phototransistor of the coupler is then connected in Darlington configuration with a BC548 or similar transistor across the line to the computer system, so that in the "mark" state the two are conducting and completing the loop.

Note that 1N914 or similar diodes are connected across the two 20mA line connections, to protect the opto-couplers

from damage in the event of reverse polarity.

The power supply requirements of the complete video terminal are quite modest. The EME-1 display module requires +5V at around 300mA, -5V at around 15mA, and -12V at around 15mA also. The keyboard encoder and its 555 clock generators and inverters also require +5V at a few tens of milliamps, and the encoder also requires -12V at a few milliamps.

These requirements are provided by the simple power supply circuitry shown. A single transformer is used, with a centre-tapped 15V secondary rated at 1 amp. A full-wave rectifier using the full winding and two 1A silicon diodes with a 2200µF reservoir capacitor is then used to feed an LM340-T three terminal IC regulator, to produce the +5V supply.

A half-wave voltage doubler rectifier using two further 1A silicon diodes and two 1000µF capacitors is used to derive the two negative supply voltages. The output from the rectifier is fed through a simple series-pass transistor regulator

using a 13V zener diode in the base of a BC558 or similar transistor, to produce a nominal -12V supply. A simple shunt regulator circuit fed from this supply is then used to produce the -5V supply.

Virtually all of the circuitry shown in Fig. 5 is mounted on a small PC board measuring a modest 132 x 80mm. The PCB pattern is coded 77ut2, and etched boards made to this pattern should be available shortly from board suppliers. They should be low in cost as the PCB is single-sided, small in size and does not involve a large number of holes.

Wiring of the PCB should be fairly straightforward, as we have prepared a wiring diagram with the etched pattern "ghosted" in light grey as if the board were held up to a light (Fig. 6).

When you wire up the board, I suggest that you fit the wire links first, then the resistors and capacitors, and finally the semiconductors. As the MM5740 encoder IC is fairly expensive, it might be wise to use a 40-pin socket rather than solder it directly into the board. But use a high grade socket, or you may get contact troubles. The remaining ICs and tran-

VIDEO TERMINAL

sistors are best soldered directly into the board.

Watch the polarity of the diodes and electrolytic capacitors, also the orientation of the ICs. Note that the LM340-T regulator IC should have a heatsink flag of at least 40mm square bolted to its tab, to keep its temperature down. I bent one up from a scrap of 16 gauge aluminium sheet, so that it had a vertical surface and a "foot" clamped between the IC tab and the PCB by a 3mm bolt and nut.

Note that there are three sets of interconnections between the encoder PCB and the video module described last month. The encoder output data and the strobe output connect to the keyboard socket, with the pin numbers shown in Fig.6. The four power supply connections go to the group of four pads on the video module adjacent to D4, down in the lower right-hand corner of Fig. 3 given last month. Similarly two serial data connections go to the pins between R31 and R32 on the video module, with the "data in" wire going via a switch if you want switchable "TV typewriter" operation. More about this later.

We have designed the encoder PCB so that the keyboard matrix "row" and "column" lines are simply brought out to pads along the side. This makes it possible to use virtually any suitable keyboard, although you have to wire up the keyswitches to the encoder PCB using conventional wiring. The alternative would have been to design the PCB so that a particular keyboard would simply "drop in", with the etched pattern performing all the connections. But this would have produced a large and costly PCB, as well as making it difficult for readers to use other keyboards.

For the prototype I used one of the keyboard assemblies currently being offered by Dick Smith Electronics Pty Ltd, as this firm was kind enough to provide a sample. The keyboard is a sturdy plastic moulding, with gold-plated contacts in the switches. It has most of the keytops required for an ASCII-encoded format, although there is no "carriage return" keytop. However, there are a couple of blank keytops on switches which are otherwise spare, and one of these can be used as the carriage return key. The keytops are not all in the usual positions

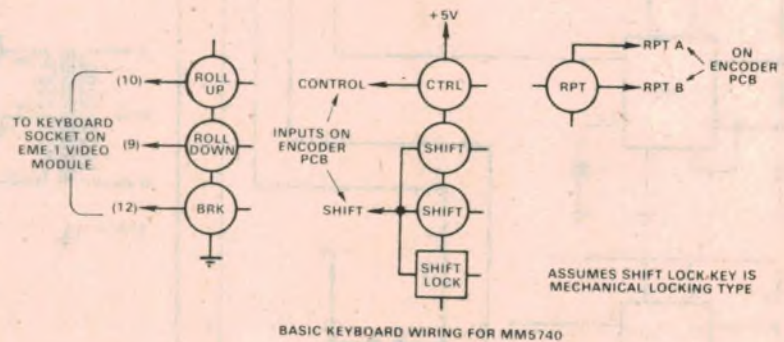
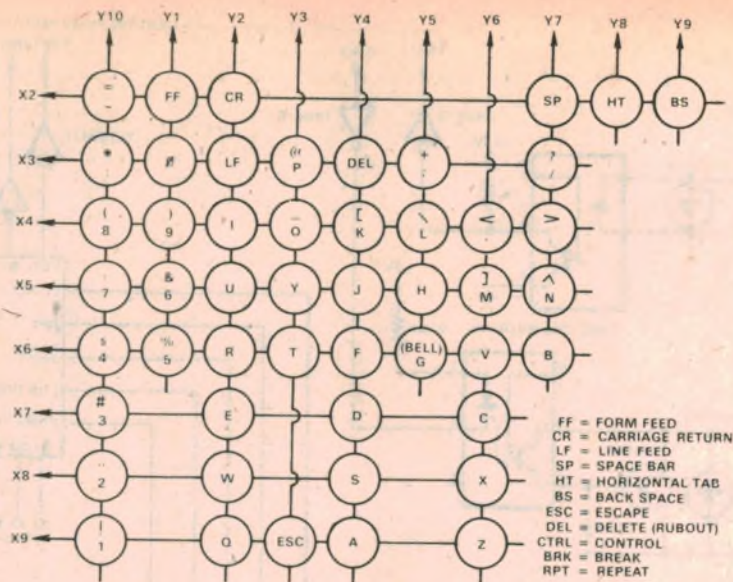

Fig. 7: How to wire up the keyboard switches to the encoder.

when you get the keyboard, but they can easily be swapped around as desired. Do this before you wire up the switches to the encoder, though, or you'll get rather confused!

Other keyboards could of course be used, including some of those from surplus keypunch equipment. But check that the keytops are suitable for ASCII encoding—some keyboards have the numerals as "upper case" symbols on the keytops, or keytops with strange combinations of characters which just "won't work" with the MM5740 encoder.

Even the keyboard from DSE has a few keytops which are not suitable for the MM5740. Two of these may be used for the "roll up" and "roll down" keys for the EME-1 module, but the others may simply be ignored.

Fig. 7 shows the way the various keyswitches are wired up to the encoder board. Most of the keys are wired in the

main encoder scanning matrix, formed by the column lines Y1-10 and the row lines X2-X9. Note that row line X1 is not used for a normal typewriter-style keyboard as used here.

The remaining switches connect to either the control inputs of the encoder PCB, or the keyboard socket of the video display module. Those that connect to the encoder board are the control key, the two shift keys (wired in parallel), the shift lock key, and the repeat key, while those that connect to the video module keyboard socket are the roll up, roll down and break keys. The last of these also performs UART resetting, if this is ever needed.

Of the keys that connect to control inputs on the encoder PCB, note that all but one have the +5V rail as their common connection. The exception is the "repeat" key, which has one side going to the 10Hz oscillator output and the other going to the encoder IC.

Note that the circuit of Fig. 7 assumes that the shift lock key on the keyboard is of the mechanically locking type. This is the case with the key on the DSE keyboard, and also on some others.

If you have a keyboard with a non-locking "shift lock" key, this can still be used because the MM5740 device has an internal shift-mode latch. The connection to it is via pin 20 of the IC, and is brought out to a pad on the encoder board as you

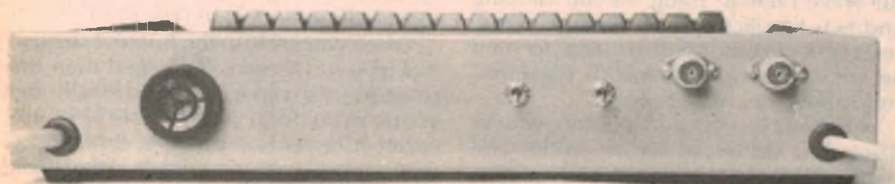

This view of the rear of the terminal shows the audio alarm, two small toggle switches for terminal-TV typewriter switching, and the output connectors.



You can see from this view of the inside of the terminal how easy it is to assemble, thanks to the two PCB modules. The second "R" key visible on the right was used on the prototype as the "CR" key.

can see in Fig. 6. The way to connect up a non-locking key to this pad is shown in Fig. 8. Note that the circuit provides for a 12V 40mA indicator lamp, to show when the MM5740 is in the shift mode. The lamp driver transistor may be a 2N2222, BC548 or other general-purpose NPN silicon type.

Using the two PCB modules we have described, you should be able to build up our video data terminal either as such or as a "TV typewriter". Some readers may elect to build it up as one or the other, knowing that they are never likely to want it to perform the other function. Similarly they may connect up the links for a particular serial communications rate, say 110 bauds, and leave it at that.

However as some readers may wish to have the device switchable in terms of function and data rate, we have indicated in Fig. 9 how this may be done.

As you can see, we have shown three switches. Switch S1 is used to control the hardware echo facility, so that its two

positions are marked "full duplex" and "half duplex". Switch S2 is then used to make or break the line from the opto-coupler to the UART serial input, so that it becomes a "normal-TV typewriter" switch.

Note that for normal full-duplex operation, both switches should be in the

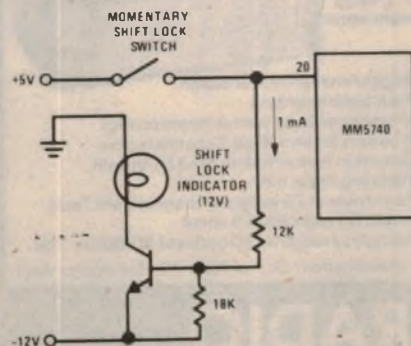

Fig. 8: How to wire up a shift-lock key which is not mechanically latching.

positions shown. For half-duplex data communications, S1 alone should be changed, while for "TV typewriter" operation both switches must be changed to the other positions.

The third switch shown, S3, illustrates how you can switch data rates if desired. Although only a two-position switch is shown switching between 110 and 300 bauds, there is no reason why you could not have a switch with further positions if you wish. However, if one of the speeds you want is 110 bauds, as shown, the switch must be a three-pole type in order to be able to control the links LK11 and LK12.

We have shown switching for only the 110 and 300 baud rates because these are the two speeds used on most of the smaller microcomputer systems.

Also shown in Fig. 9 are the connections for the audio alarm device, to allow the terminal to respond to the "bell" character. Any alarm device designed to operate from a nominal 6V supply and drawing up to 200mA may be used. We used a Bell Audiolarm from C & K Electronics, but a Sonalert could also be

SPECIAL PURCHASE NEW GARRARD RECORD CHANGERS AT A FRACTION OF LIST PRICE

GARRARD ZERO 100 TRANSCRIPTION CHANGER \$80.00

(Normal recommended retail price \$198.00).

Supplied with Pickering Magnetic Cartridges with Diamond Stylus. Post & Packing (Reg. post) N.S.W. \$5.50, Vic. S.A. & Qld. \$6.75, Tas. \$6.50, W.A. & N.T. \$8.75

GARRARD M.82 \$57.00 TRANSCRIPTION CHANGER

Recommended retail price \$120.00

Supplied with Pickering Magnetic Cartridge with Diamond Stylus. Post & packing (Reg. post) N.S.W. \$3.60, Vic. S.A. Qld. \$4.74, Tas. \$5.50, W.A. & N.T. \$6.75

GARRARD 6-400 CHANGER \$28.50

Recommended retail price \$48.00

Supplied with high quality Garrard/Sonatone Ceramic Cartridge with Diamond Stylus. (Post & Packing same as M82)

GARRARD CC10A RECORD CHANGER \$14.75

Fitted with a Sonatone Garrard Ceramic Cartridge Sapphire Stylus supplied with template & instructions. Post & packing N.S.W. \$2.50, Int. \$3.50

GARRARD SL 95B TRANSCRIPTION CHANGER \$69.00

Recommended retail price \$175.

Supplied with Pickering Magnetic Cartridge with Diamond Stylus. Post & packaging same as Zero 100

GARRARD—SRP20 RECORD PLAYER CARTRIDGE AND POST CHARGES AS.CC10A

\$9.50

BASE & PERSPEX COVERS AVAILABLE IN TEAK & WALNUT FINISH
FOR ILLUSTRATIONS & SPECIFICATIONS OF GARRARD CHANGERS SEE OCT. OR
NOV. ISSUE OF ELECTRONICS AUSTRALIA

PLAYMASTER — MAGNAVOX HI FI SPEAKER SYSTEMS 3 WAY

3-45-L

AS FEATURED IN ELECTRONICS AUST.
APRIL '75

Complete kit of parts for above system including speakers. Magnavox 8-30 Bass Unit, 6J Mid Range Philips ADO160/T8 Dome Tweeter, crossover components, 6" & 3" tubes, speaker silk & innabond (Less Cabinet).

\$53.00 PER KIT

3-41-L

AS FEATURED IN ELECTRONICS AUST.
JUNE '76

As above but using the new Magnavox 6-25 midrange in place of the 6J with additional crossover components

Freight & packing extra per pass. rail or air freight

\$62.00 PER KIT

NEW MAGNAVOX — MV50— 50 WATT SPEAKER SYSTEMS

As featured in Feb. 1976 issue
of Electronics Today

Complete kit of parts (less cabinet) comprising Magnavox 10-40 10" bass unit, 625 mid range 6" two XJ3 dome tweeters, crossover network, innabond, speaker silk and plans of cabinet.

\$72.00

Per Kit

freight extra
per rail or air freight
Cabinet available

New C800 STEREO AMPLIFIER BY CLASSIC

\$149
(freight extra)

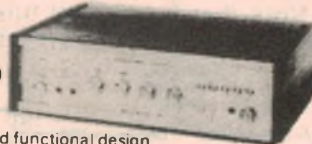

- Elegant and functional design
- Push-button controls
- Microphone input with separate control
- Provision for simulated 4-channel stereo
- Cabinet in teak or walnut oiled finish with matching metal trim
- Power output 25 watts per channel RMS Total output 50 watts RMS 8 ohms
- Frequency response 20 cycles to 30,000 = 1dB

Full specifications Oct. or Nov. 76 Electronics Aust.

VIDEO TERMINAL

used—or even a small bell or buzzer.

As you can see from the photographs, the prototype terminal was assembled in a low-profile case made from 20G mild steel sheet. The case measures 360mm wide by 400mm deep by 60mm high, with a sloping front cutout to allow the keyboard to mount in a convenient operating position. The case is designed so that a small portable TV receiver or monitor may be placed on top, to form a complete video terminal.

The prototype case was kindly supplied by Cowper Sheetmetal and Engineering, of 11 Cowper Street, Granville, NSW 2142. It was finished in chocolate lacquer, and looks very attractive.

Assembly of the circuitry inside the case is quite straightforward. The two PC

REMAINING PARTS:

- 1 PC board, 132 x 82mm, coded 77ut2
- 1 Keyboard encoder IC, MM5740AAF (National Semiconductor)
- 1 5V/1A three-terminal regulator, LM340T-5
- 2 555 time ICs
- 2 NCT200, 4N28 or similar opto-couplers
- 2 7404 hex inverter ICs
- 2 1N914, 1N4148 or similar diodes
- 4 1A silicon diodes, OA626 or similar
- 1 13V 400mW zener diode
- 1 5V 400mW zener diode
- 1 BC548 or similar NPN transistor
- 1 BC558 or similar PNP transistor

RESISTORS Half watt, 5%:

- 4 x 150ohms, 1 x 220ohms, 1 x 330ohms, 1 x 1k, 1 x 1.5k, 1 x 10k, 1 x 33k, 2 x 560k.

CAPACITORS

- 1 220pF polystyrene or NPO ceramic
- 1 680pF polystyrene or ceramic
- 2 .01uF greencap (polycarbonate)
- 1 .047uF greencap
- 2 0.1uF greencap
- 1 0.22uF greencap
- 2 1000uF 25VW PC-type electrolytic
- 1 2200uF 25VW PC-type electrolytic

MISCELLANEOUS

- 1 Case, 400 x 360 x 60mm with sloping-front (see text).
- 1 15V 1A stepdown transformer
- 1 ASCII-type keyboard assembly (see text)
- 1 Audio alarm, Sonalert or Bell Audiolarm
- 2 Co-axial sockets

Miniature toggle switches, as required
Mains cord and plug, section of B-B connector strip, cord clamp; length of 4-way cable for system cable, with suitable connector; rubber feet, assembly screws, etc.

CLASSIC RADIO

245 PARRAMATTA RD, HABERFIELD 2045 PHONES 798 7145, 798 6507

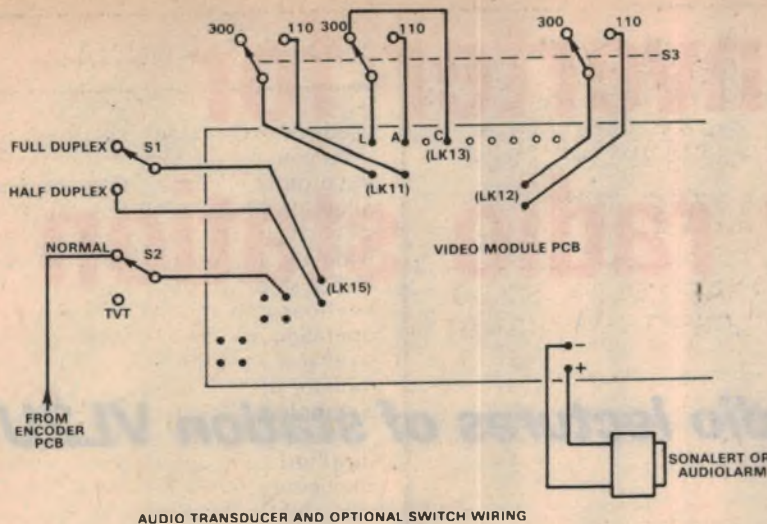

AUDIO TRANSDUCER AND OPTIONAL SWITCH WIRING

Fig. 9: Details of the wiring for the duplex and TVT switches S1 and S2, together with optional baud rate switching via S3.

boards are simply mounted on spacers or "Richco" plastic moulded PCB mounts, with the video module about 35mm from the rear of the case, and the smaller encoder module in front of it alongside the power transformer. Incidentally we used the Ferguson PF3597, a low-profile type which is now given the type number PL15/20VA. However, the case height has been designed to allow most of the available 15V/1A transformers to be used—including the A & R 2155A and the DSE 2155.

The mains cord enters through a grommetted hole in the case rear, is clamped and the active and neutral leads terminated in a B-B connector which also terminates the transformer primary leads. The mains cord earth conductor is looped around and soldered to a lug which is bolted to the metal case.

Also mounted on the rear of the case are the coaxial sockets for the video and modulated RF outputs (for the display), the optional function and communication rate switches, and the audio alarm device. The communication cable to the main computer system also leaves the case at the rear, via another grommetted hole.

The only remaining item is the keyboard assembly, which is mounted in the front of the case so that its keys protrude through the cutout in the removable top-front. If you use the DSE keyboard, as we did, the easiest way to mount it in position is to bend up a couple of shallow brackets out of strips of aluminium sheet, with a shape best described as a shallow inverted-U with unequal legs. The legs can be bent as required to obtain the correct height and slope for the keyboard in the case, and then mounting holes drilled in the feet and the bottom of the case, to screw it in position.

We also mounted rubber feet on the underside of the case, to prevent scratching the surface on which the terminal is placed. The case top is attached using small self-tapping screws.

When you have completed the assembly, it would be a good idea to check through all of the interconnections before applying power. Then when power is applied, the terminal should operate straight away.

There are only two adjustments, as noted in the first article, and both of these may be done without instruments. The first is to set the frequency of the VHF modulator, to allow clear display on a TV receiver tuned to a vacant high-band channel. This is done by simply tuning the receiver to a suitable channel, and then adjusting the trimmer capacitor CV1 on the video module until the image appears and is best displayed.

Don't forget to remove the normal

antenna while doing this, however, and don't forget to remove it subsequently whenever you are using the terminal with a normal TV receiver. Otherwise you'll get interference from TV transmissions, and the neighbours may also find themselves getting interference from your terminal!

If you do this adjustment when the terminal has just been powered up, you'll find that the display will show a lot of "garbage"—jumbled alphanumeric characters and symbols, in random order. This is merely the random turn-on contents of the display refresh RAMs, and is quite normal. To clear the display, simply type in a series of line feed characters. Then type the "form feed" key, which homes the display circuitry so that the next character to arrive will appear in the bottom left-hand corner of the screen.

Now type a full line of characters—32 if you have set up the display module for 32 x 32 format, or 64 if you have set it up for the 16 x 64 format. This will allow you to make the remaining setup adjustment, for line width. All you do is adjust RV1, on the display board, until the lines are of a suitable width on the screen.

In normal operation, the terminal operates in very similar fashion to an ASR-33 teleprinter. The only real difference is that the "print-out" is displayed on the TV screen, and that you are able to roll the display up and down as desired using the two special keys.

Of course there is no facility for dumping programs onto paper tape, and subsequently re-loading them. However we hope to provide a suitable low-cost alternative for this also, in the near future. ☺

Alternative keyboard with encoder:



Readers planning to build a video terminal may be interested in this keyboard assembly available from the Microswitch Division of Honeywell Pty Ltd, at 863 Burke Street, Waterloo NSW 2017. It is complete with a MOS keyboard encoder providing ASCII output, and features Hall-effect keyswitches which offer bounce-free, high reliability operation. Designated the 54SW5-3, the keyboard has a mechanically latching shift-lock key, but no CR or LF keys. A CR keytop is available, however, and the correct coding can apparently be generated. Price for the keyboard is \$110 plus 15% sales tax. The CR keytop is 20c extra.

Simple converter for University radio station

... listen into the radio lectures of station VL2UV

Since the original VL2UV converter was described some fifteen years ago, inevitably there have been many changes in components and availability and so we thought that the time was right to update the design. Here is a description of the new unit, together with information as to how an existing broadcast receiver may be modified to receive the University station.

by IAN POGSON

In January, 1962, we described a converter to be used for receiving the then new University of NSW Radio Station. Just recently we have had requests to update the design and so we decided to have another look at the possibilities. As the frequency of University Radio is on 1750kHz, it is outside the normal tuning range of the usual broadcast receiver, which covers from 530kHz to 1600kHz. To receive University Radio it is therefore necessary to either modify your broadcast receiver to tune to the higher frequency, or use a converter.

Before describing a converter for this special purpose, let us have a brief look at the possibility of modifying an existing receiver which happens to be on hand. This might range from an old locally made valve receiver, to a small pocket transistor radio finding its origin somewhere in the Far East.

Two questions immediately arise. Does the receiver in question lend itself to modification? Also, does the reader feel competent to make the necessary changes or adjustments? These are questions which only you can decide for your-

self. If the answer is in the negative, then the converter is for you. On the other hand, you may be in a position to approach the receiver modification in one of two ways.

If it can be done, by far the easiest way is to simply adjust the trimmers on the oscillator and aerial sections of the tuning gang. Before attempting any adjustments however, make sure that the transmitter is on the air. The oscillator trimmer should be reduced in capacitance until the signal is heard. The aerial trimmer should then be adjusted for maximum response. We are assuming at this stage that it is possible to tune up to 1750kHz by this method. If unfortunately this is not possible, then the trimmers should be reset to their former positions.

Should you be successful in this exercise, you will notice that when tuning across the dial that the normal broadcast stations have shifted along. This is a price that must be paid for being able to tune University Radio in this way.

The second method is rather more involved. Assuming that you cannot tune the oscillator high enough by adjusting the trimmer, an alternative is to set the oscillator on the low side of 1750kHz. With an IF of 455kHz, this means that the oscillator must be set to 1295kHz and this would normally correspond to tuning a station 455kHz lower again, on 840kHz. In short, the receiver will be tuned to 840kHz, between 2GB and 2EA. Now the lead from the aerial coil to the gang must be lifted and the gang section must be substituted with a variable trimmer across the aerial coil. The trimmer is adjusted so that the aerial coil resonates at 1750kHz.

If you have been successful in receiving the University Radio by means of one or other of the above methods, then you need not read any further. If not, then here is how to make up a very simple but effective converter which you can use in conjunction with an unmodified broadcast receiver.

The circuit uses the now well established junction FET mixer with a bipolar transistor as the local oscillator. A ferrite rod aerial tuned to 1750kHz is

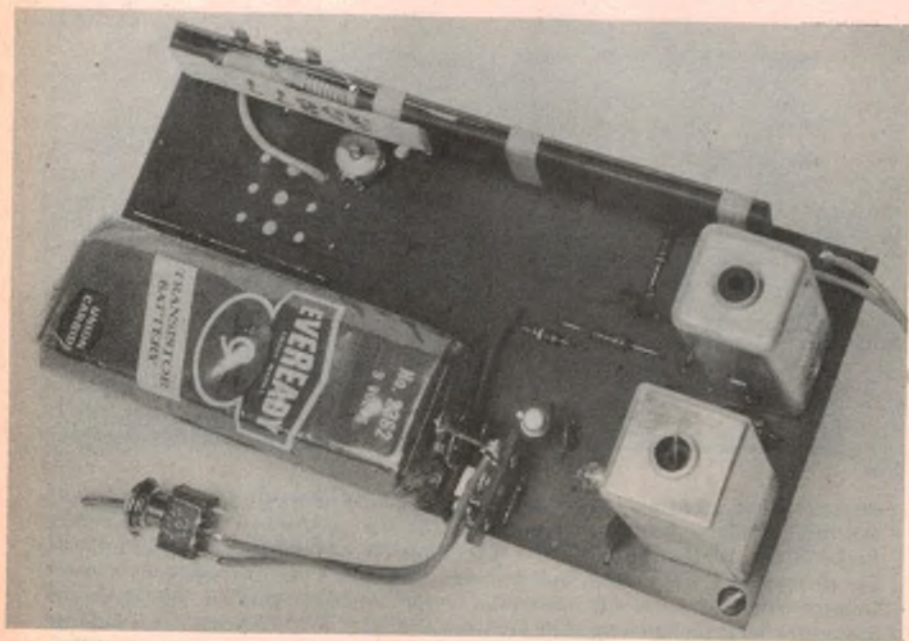

A single PC board accommodates all the circuitry. The unit should fit easily into a standard plastic case, and details of this are left to individual readers.

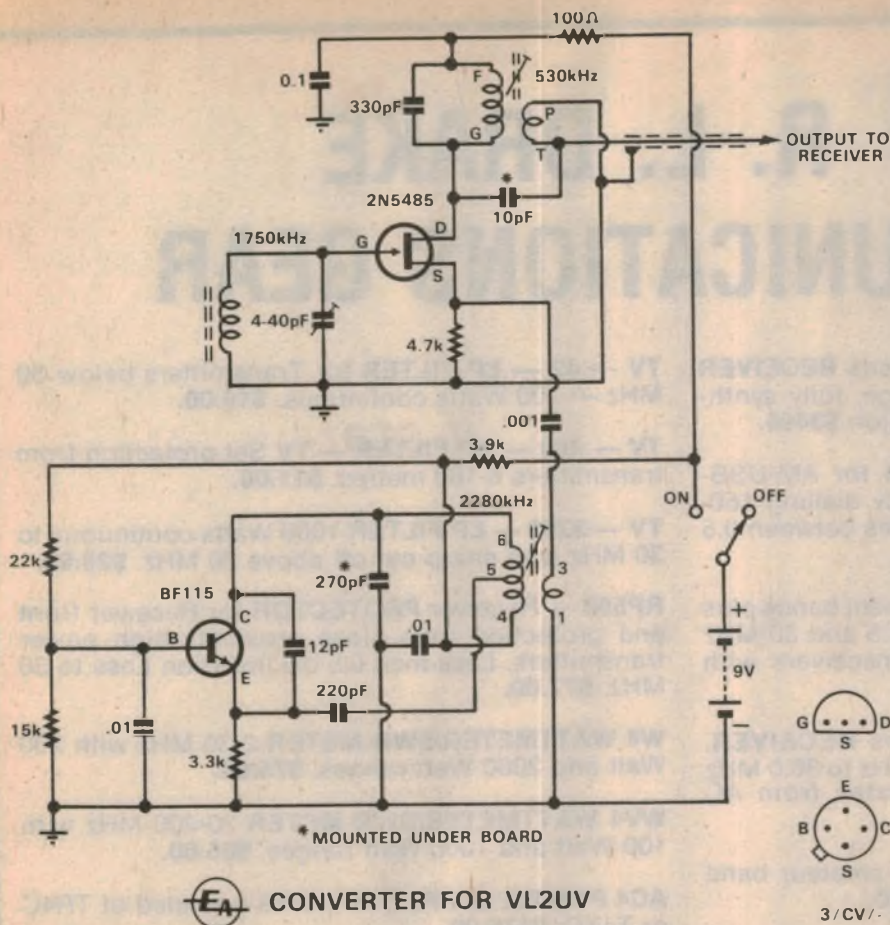

EA CONVERTER FOR VL2UV

3/CV/

used in the gate of the FET. The FET is self-biased well into its non-linear region with a 4.7k source resistor. The local oscillator is set to a frequency of about 2280kHz, with its output injected into the source of the mixer. This results in a difference frequency between 2280kHz and 1750kHz of about 530kHz. The output of the mixer is fed into a broadcast aerial coil connected in reverse and with the drain circuit resonated to the output frequency. The untuned winding becomes the output to feed into the normal broadcast receiver.

Most of the components are quite common and readily available. However, the coils in particular may require some clarification. We used a small flat ferrite rod aerial which we obtained from Radio Despatch Service. This rod fits nicely on to the board and you may be able to get a similar one. However, any of the normal broadcast ferrite rod aerials should be satisfactory. Fitting it to the board may require some mechanical changes with respect to the prototype.

The mixer output coil is actually an aerial coil, type 253 made by RCS Radio. This coil is readily available but any similar coil should be a satisfactory substitute where necessary. The oscillator coil is wound by the builder on a Neosid former which is also readily available. Winding details will be given a little later on.

The unit requires a power supply of 9V

at about 1.2 milliamps. We used a type 2362 battery for the prototype but other sizes of 9V battery should be also suitable if more convenient. On the other hand, if you have a source of well filtered 9V DC, then this may be used instead of a battery.

Before starting on the main assembly, there is the oscillator coil to be wound. This consists of 120 turns of 28B&S enamel wire, centre tapped and close wound on a Neosid 7.6mm x 58mm former. Care should be taken with this coil, making sure that the winding is reasonably tight and terminated so that there will be no movement of the winding, which in turn could cause erratic oscillator behaviour. The tap may be done in a number of ways. One way is to make a loop at the desired point, clean the enamel off, twist together and solder. A piece of insulation tape should be put under the tap.

A secondary winding consisting of 10 turns of the same gauge wire is wound over the earthy end of the primary winding. Care should be taken in terminating the windings so that they correspond with the appropriate points on the printed board.

Having finished the winding of the oscillator coil, it is a good idea to apply some quick drying adhesive to the ends of the windings, to make sure that the coil is mechanically stable. Now fit the coil into its can. Bend the lugs of the can over so that when the screws are used

PARTS LIST

- 1 Printed board, 152mm x 76mm, code 73/3C
- 1 Ferrite rod aerial coil (see text)
- 1 Aerial coil, RCS type 253 or similar
- 1 Coil former, Neosid 7.6mm x 58mm with can and grade 900 slug
- 1 Battery, 9V type 2362
- 1 3-tag miniature tag strip
- 1 SPDT miniature toggle switch
- 4 1/2in spacers tapped 1/8in Whitworth
- 1 Transistor, 2N5485, FE5485, BFW11
- 1 Transistor, BF115 or equivalent

RESISTORS (1/2 watt)

- 1 100 ohms
- 1 3.3k
- 1 3.9k
- 1 4.7k
- 1 15k
- 1 22k

CAPACITORS

- 1 10pF NPO ceramic
- 1 12pF NPO ceramic
- 1 220pF polystyrene
- 1 270pF polystyrene
- 1 330pF polystyrene
- 1 .001uF 100V greencap
- 2 .01uF 100V greencap
- 1 0.1uF 100V greencap
- 1 4-40pF Philips trimmer

MISCELLANEOUS

Hookup wire, solder, 28B&S enamel winding wire, battery clips, screws, nuts. Note: Resistor wattage ratings and capacitor voltage ratings are those used on the prototype. Components with higher ratings may generally be used, providing they are physically compatible. Components with lower ratings may generally be used, providing ratings are not exceeded.

for mounting, they will contact the side of each hole. This is to ensure that the can is connected to the earthed copper. The coil is fixed to the board with two 6BA screws. If 6BA screws are not readily available, the alternative is to re-tap the holes to 1/8in Whitworth.

You may notice when you have a close look at the picture of the main assembly that we have made use of what would have been open space on the board. In particular, the battery and the ferrite rod aerial take up quite a bit of the spare space. Before starting on the assembly of the board, it would be a good idea to decide just how you are going to fix these items to the board. You may find that you need an extra hole or so and it is easier to drill them before any components have been mounted.

You will find it necessary to drill two small holes to take the trimmer across the ferrite rod aerial. We made use of exist-

**DRAKE****R. L. DRAKE**

COMMUNICATIONS GEAR

DSR2 Digital readout communications **RECEIVER** 10 kHz-30 MHz continuous coverage, fully synthesised, for AM-USB-LSB-CW reception **\$3495.**

SPRA communications **RECEIVER** for AM-USB-LSB-CW reception. Direct frequency dialling 150-500 kHz plus any 23 x 500 kHz ranges between 0.5 and 30 MHz. **\$715.**

R4C Amateur **RECEIVER** covers HF ham bands plus any 15 x 500 kHz ranges between 1.5 and 30 MHz except 5.0 to 6.0 MHz. **\$685.** (Transceivers with T4XC).

SSRI Synthesised communications **RECEIVER.** Provides continuous coverage 500 kHz to 30.0 MHz for AM-USB-LSB reception. Operates from AC Mains or internal batteries. **\$290.**

TR4C sideband **TRANSCEIVER** full amateur band coverage 10 through 80 metres. **\$630.**

T4XC sideband **TRANSMITTER** full amateur band coverage 10 through 80 metres plus 160 metres accessory crystal plus 4 fixed frequency positions. **\$630.** (Transceivers with R4C).

MN4 and MN2000 MATCHING NETWORKS — enable Feedline SWRs of up to 5:1 to be matched to the Transmitter. Built-in Wattmeter. MN4 handles 200 Watts. MN2000 handles 1000 Watts continuous and 2000 Watts PEP. MN4 \$115, MN2000 \$230.

**R4C RECEIVER****ELMEASCO****Instruments Pty. Ltd.**

TV — 42 — LP FILTER for Transmitters below 30 MHz — 100 Watts continuous. **\$16.00.**

TV — 300 — HP FILTER — TV Set protection from transmitters 6-160 metres. **\$11.00.**

TV — 3300 — LP FILTER 1000 Watts continuous to 30 MHz with sharp cut off above 30 MHz. **\$28.00.**

RP500 — Receiver **PROTECTOR** for Receiver front end protection from close proximity high power transmitters. Less than 0.5 dB Insertion Loss to 30 MHz. **\$77.00.**

W4 WATTMETER/SWR METER 2-30 MHz with 200 Watt and 2000 Watt ranges. **\$75.00.**

WV4 WATTMETER/SWR METER 20-200 MHz with 100 Watt and 1000 Watt ranges. **\$85.00.**

AC4 POWER SUPPLY for mains operated of TR4C or T4XC. **\$175.00.**

DC4 POWER SUPPLY for battery operation of TR4C or T4XC. **\$187.00.**

NIPPAN FC3A FREQUENCY COUNTER — 15 Hz to 250 MHz, operates from mains or inbuilt batteries. **\$258.00.**

FLUKE 1900A FREQUENCY COUNTER — 5 Hz to over 80 MHz, operates from Mains or optional inbuilt batteries. From **\$608.**

FLUKE 8030A DIGITAL MULTIMETER — a complete handheld multimeter with optional RF, High Voltage and High Current Probes. From **\$284.**

TELIHAMVISION OM-7 SLOW SCAN TV CAMERA and monitor — complete. **\$995.00.**

MOSLEY ELECTRONICS — 3 Element **BEAMS** — arriving soon.

PRICES INCLUDE SALES TAX.

Write, phone or call for 1976/77 catalogue.

P.O. Box 30, Concord, N.S.W. 2137.

Telephone: 736-2888.

Melbourne: 233-4044; Adelaide: 42-6666.

Brisbane: 36-5061.

Perth: 25 3144; Wellington N.Z. 721-318.

Due to devaluation Drake prices will increase by approx. 15% when existing stocks have been sold.

VL2UV converter

ing holes to fix the ferrite rod, making use of some tinned copper wire and available lugs on the rod assembly. At the negative end of the battery, we ran a short piece of tinned copper wire from the adjacent earth part of the copper on the board, to the clip lug on the battery. At the positive end of the battery, you will see that we used a miniature 3-lug tagstrip. Again, we used a short piece of tinned copper wire from one of the lugs to the battery clip lug. The other floating lug was used for the switch and the supply lead to the board.

Having determined the above points, the components may now be assembled on the board, starting with small items, resistors, capacitors, etc. Remember that the 270pF and 10pF capacitors associated with the oscillator and output coils, respectively, are mounted under the board. Do not forget the link, which may be a scrap of resistor pigtail. When fixing the oscillator coil, make sure that you have it orientated correctly, so that the coil terminations correspond with the appropriate points on the printed board.

In some earlier converters we used an aerial coil made by RCS Radio as the output coil. These coils were originally designed for use in valve receivers and they are no longer made. The aerial coils made for use with transistor receivers are quite satisfactory, but some of the coil connections are different. This problem is solved by making a cross connection to the appropriate point on the copper.

As the board was made to accommodate Neosid coil formers, and we are using a coil made by RCS Radio in this instance, some care is needed in fitting this transformer. The following procedure is suggested.

Bend the tap pin over close to the moulding so that there is no chance of it becoming short circuited when fitted later on. Now bend each of the remaining four pins over so that they lie over the corners of the can. Then the pins are bent in dog-leg fashion such that they will enter the four holes in the printed board. The can mounting lugs must also be bent inwards and in a similar manner so that they will pass through the respective holes in the board.

Now solder a short length of insulated hookup wire to the bent tap pin, again making sure that no short circuit will be created later on. Mount the coil as described previously, but run the hookup wire through the centre slug adjusting hole in the board. Solder pins "G", "F" and "P" but do not solder "B" to the copper pads. Instead, run the lead of hookup wire to the pad adjacent to "B".

Having completed the assembly of the board, some leads must also be provided

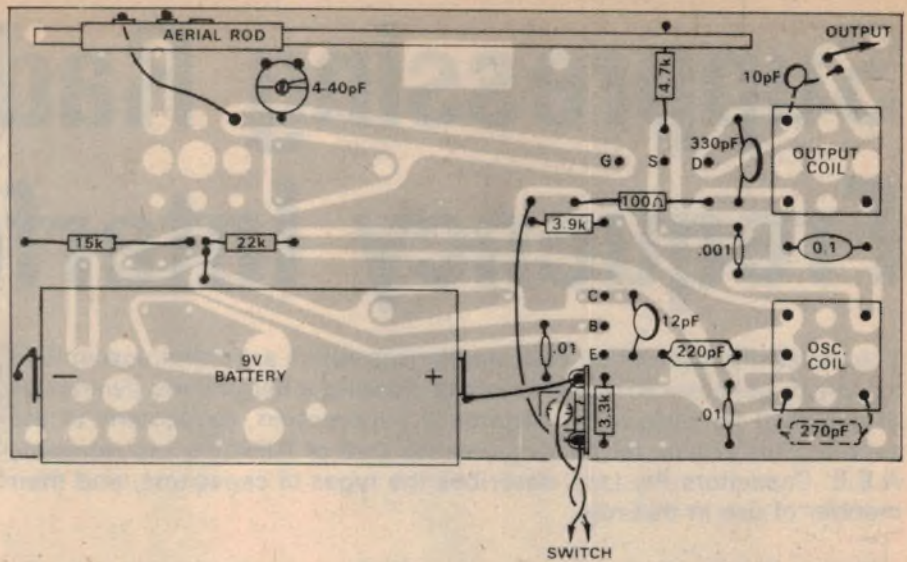

The component layout shows the PC board viewed from the component side. A full-size reproduction of the PC pattern was published in the January issue.

to go to external points. These do not amount to very much in this case. A pair of leads are needed to run to the battery on/off switch, and output leads will be required, depending upon the way you couple into your broadcast receiver. We will deal with this a little later on when we discuss adjustments.

From the pictures it will be obvious that we have not fitted the converter into any kind of enclosure. It may be used as it is or, if you prefer, you may fit it into some sort of box or cabinet of your choice.

At this stage, a careful check should be made to ensure that no errors have been made. Satisfied that all is well, the converter is ready to be put into operation. If you have an ordinary broadcast receiver with aerial and earth terminals and without a ferrite rod aerial, then you may use a piece of coax cable from the output of the converter to the terminals on the receiver. On the other hand, if you have a small transistor personal portable receiver, or a larger receiver with a ferrite rod aerial, then you may use this instead. However, some preparation is necessary before you can use this type of receiver.

The simplest way is to get a few yards of insulated hookup wire. After determining which way the ferrite rod aerial runs inside the receiver, wind from six to ten turns of hookup wire around the receiver so that the ferrite rod is parallel with the axis of your winding. The winding may be just bunch wound and the two insulated ends twisted together to hold the winding in place. Now bare the two ends and solder them to the two output points of the converter, instead of the coax cable mentioned before.

The above method is quite rough but it works very well. However, if you wish, you may devise a neater way of winding and arranging the turns around the receiver. On the other hand, if you wish you may be able to open up the set and

if space permits, wind six turns or so directly around the ferrite rod, again using insulated hookup wire and terminating it to a piece of cable from the output of the converter.

Switch on the receiver and tune almost to the extreme low frequency end of the dial. This will be about 530kHz on most receivers. The exact frequency will be determined later on and it should be chosen such that no interference will be had when listening to VL2UV. Now switch on the converter and with the receiver volume control set to a suitable level, adjust the slug in the converter output coil for maximum noise or hiss.

As mentioned earlier, and before proceeding with adjustments, it is important to establish that VL2UV is on the air. Now adjust the slug in the oscillator coil until VL2UV is heard. The trimmer across the ferrite rod aerial is now adjusted for maximum response. You will possibly find that this occurs with the trimmer set at minimum capacitance. If it is possible to slide the coil on the aerial rod, then it should be moved so that the short end is further reduced. The trimmer may then be peaked more definitely.

Having made these adjustments, happily all may be well and all that is left is to listen to the program material! On the other hand, and as mentioned before, there may be some interference and steps should now be taken to avoid it or at least to reduce it to a minimum. The converter should be rotated so that the maximum signal is obtained from VL2UV. Also, the receiver may be rotated so that any interference may be nulled out. Another idea is to stand the receiver on end to reduce pickup of unwanted signals. In addition to these steps, slight retuning of the receiver one way or the other should avoid interference. This means that the converter output coil and the oscillator coil must also be slightly retuned.

Suppressing Radio Frequency Interference

The increasing use of domestic appliances which are either susceptible to, or can generate RF interference is creating a heightened awareness of the need for adequate interference suppression, particularly at the source. This article, by the engineering staff of RIFA Pty Ltd (formerly A.E.E. Capacitors Pty Ltd), describes the types of capacitors, and their manner of use in this role.

Electrical devices which produce changes in current flowing therein are generally causes of electrical interference in radio and television receivers. Typical cases are: switches, thermostats, relays and other electromagnetic components, and rotating machinery, eg, vacuum cleaner, floor polisher, washing machine motors, etc.

An examination of these and similar devices shows that the current either is interrupted or changed rapidly. Under these conditions it can be shown that the resultant waveforms consist of a number of frequencies which may extend into the radio and TV spectrum.

In broadcast transmission a carrier wave of radio frequency, modulated by an audio frequency component, is used. If an appliance, even one working on DC, has its current interrupted or suddenly changed, then a wide band of frequencies may be generated which can energe the input circuit of nearby receivers, producing in their audio circuits the familiar crackles, clicks and other noises. In the case of TV the reception will be disturbed by spots of a pattern of lines on the screen.

There are four main forms of interference propagation:

1. Mains conductance
2. Mains inductance
3. Direct inductance or radiation
4. Re radiation or inductance from nearby conductors which do not carry mains current, eg gutter and water pipes, etc.

Generally, suppression should be at the source of interference as this is the most effective method. Suppression at receivers has limited effect, particularly when poor aerials are used giving a low signal to noise ratio.

Nevertheless, a number of TV set manufacturers are currently fitting suppression networks to the mains inlets of their receivers. While their usefulness is limited, they can be beneficial in some cases, particularly in reducing the effects of heavy surges caused by switching inductive loads, such as refrigerators, etc.

While some of the measures to be discussed may be implemented on existing appliances, it is far better if these procedures are undertaken by the manufacturer as part of the design of the equipment. As well as ensuring that the suppression is carried out in the safest and most effective manner, it ensures that the particular appliance should never cause interference.

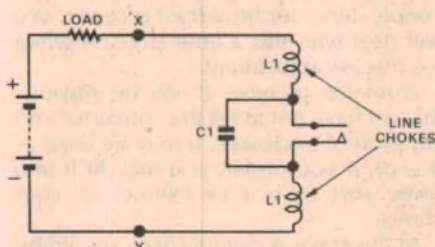

FIG. 1

Basic circuit showing how radio frequency interference, generated by a set of contacts, may be controlled.

An appliance which has to be suppressed in the field presents many problems. As well as the electrical and physical difficulties likely to be encountered, there is the problem of locating the offending device in the first place.

An electrical appliance responsible for interference cannot always be easily identified. It need not be located in the same room or even in the same building where the interference is experienced.

Methods of tracing the interference are also complicated when it originates in multi-storey apartment buildings. It is also hampered by the fact that many domestic appliances are not used continuously and thus tracing is made even more difficult.

A suppressor is usually a capacitor or inductor used singly or in combination, depending on the degree and type of suppression required. Capacitors are generally the most economical method of suppression, particularly in the medium frequency broadcast band, and are most effective when connected inside the appliance and as near as possible to the source of interference.

If a fairly simple case of a pair of contacts opening and closing is examined, it can be shown that a small arc follows the separating switch contacts and that across these contacts, due to the impedance of the arc, RF voltages at various frequencies will be generated and RF currents will oscillate around the circuit at its natural frequency. It is impor-

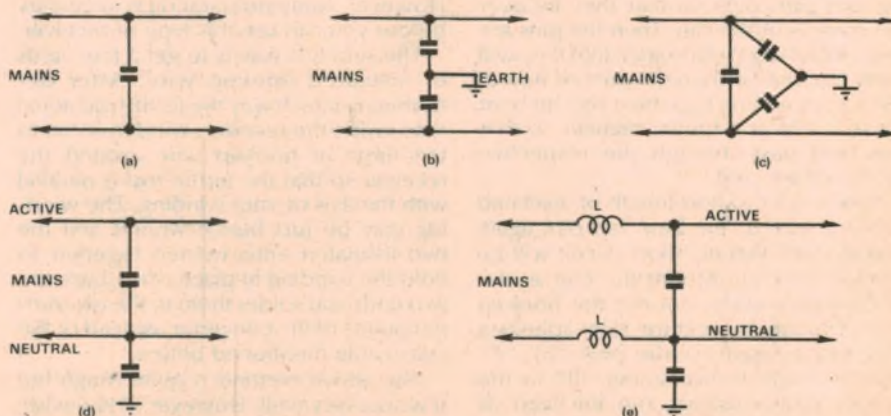

These diagrams illustrate a variety of possible suppression networks, ranging from a simple arrangement at (a) to a relatively complex one at (e). In general, the type chosen will depend on the severity of the interference.

tant to realise that interference is not entirely associated with induction from the arc as such, but also by the circulation of HF currents around the associated circuit. If the impedance of the circuit can be increased artificially, without greatly altering its DC resistance, then these spurious oscillatory currents will be reduced in value, and probably altered in frequency, and the amount of interference will be reduced. To achieve this chokes can be fitted.

Of interest is the method whereby a short circuit path is provided across the gap so that the oscillations will be confined to this circuit and will not circulate around the external circuit. A capacitor shunted across the switch will provide this circuit, with the capacitor impedance being high at DC or 50Hz, and low over the frequency range concerned. The RF currents which will pass through the capacitor are in inverse ratio to its impedance compared with the impedance of the external circuit. (Refer to Fig. 1 for the resultant circuit.) An

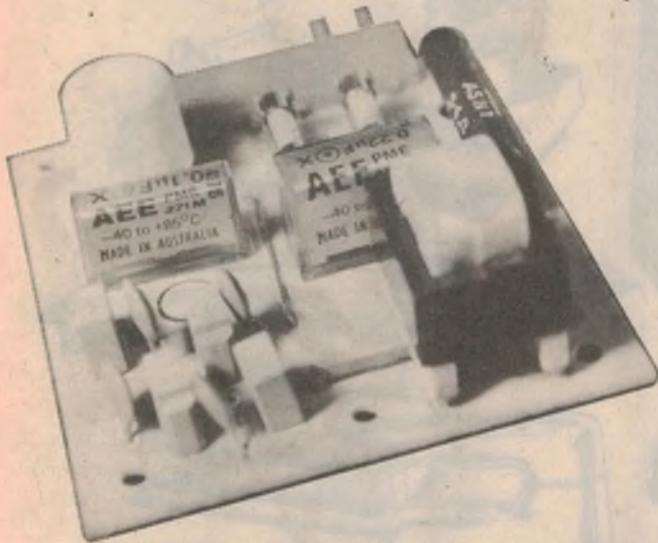

AEE type PME 271 epoxy encapsulated RF interference suppressors in a typical role. The board shown is part of a switched mode TV power supply in the EMI circuit C221. The role of the suppressors is mainly to prevent switched mode type interference from entering the supply mains. (Photo by courtesy of EMI.)

examination of this circuit will show that the voltage available for circulating HF currents around the external circuit now appears across X and Y. To reduce these currents still further the HF impedance across these points must be reduced and this can be achieved by a capacitor of low impedance to these circulating currents, across X and Y (shown dotted in Fig. 2).

The circuit made up of L1, C2 and L2 is actually a form of potentiometer across C1 and the switch contacts. The external circuit is across C2 so by suitably arranging the values of L1, L2 and C2 the residual HF voltage is mostly diverted around the external circuit. The interfering voltages need not be removed entirely. If they are reduced in value so that they are negligible under the operating conditions required, then the device can be deemed to have been suppressed.

As described earlier, a practical method is to confine the interference to "limited circuits" and this can be

achieved in the following way (see Fig. 3): The large capacitance value is .1uF, and because of its low impedance at HF the symmetrical interference currents will flow in a circuit consisting of the .1uF and interference source in parallel whilst the .0047uF capacitors provide a low impedance path to ground for HF currents.

Series motors are used in about 70% of household appliances which cause interference. Another 20% are contact mechanisms found in shavers, refrigerators, food mixers, and irons, etc. These devices cover a wide range of generated frequencies and are sometimes difficult to suppress. Food mixing machines often have a speed control consisting of a resistor which is varied centrifugally and operated by contacts. A capacitor of .047 to about .1uF can be connected across the contacts and a delta suppressor similar to Fig. 3 is put in the line at the motor terminations. The capacitors should, as in all suppressor applications, be suitable for the voltage peaks found

in these applications.

Smoothing irons have a capacitor connected across their contacts with the values being of the order of .0047 to about 0.1uF, depending upon conditions and particular manufacturer. Here thermal ambients will also have to be considered.

It is normally desirable to connect a low value resistor in series with a capacitor fitted across contacts, both to improve suppression and to protect the contacts. The value of such a resistor will be a compromise between several factors, including some determined by the individual circuit.

In some cases the resistor may be a discrete device, in others it may be fabricated as part of the capacitor. Metallised paper capacitors, in particular, lend themselves to a form of construction whereby the resistance of the metallised coating may be used for this purpose, and the amount of resistance introduced by this method can be quite easily controlled.

In some cases where suppression cannot be sufficiently achieved by the use of low impedance filter and bypass circuits then, as mentioned earlier, it is necessary to fit line chokes. These would vary in value, depending upon the suppression requirements, ie TV and/or broadcast band, etc. The chokes should be used with capacitors as described to give sufficient suppression and also to provide suitable earth connections.

In cases where the supply is discon-

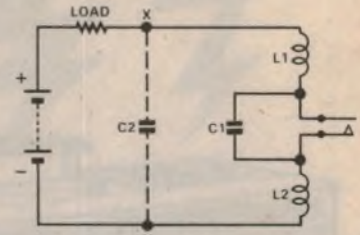

FIG. 2

Capacitor C2, between points "X" and "Y", is aimed at reducing circulating currents in the external circuit.

nected in an inductive or capacitive load a large transient 'reverse' voltage will appear across the switching contacts causing arcing. Where the switches are slow-acting or encounter contact-bounce, severe arcing will occur causing excessive wear of the contacts as well as a series of clicks in the radio receiver. The use of a suitable capacitor that can withstand large surge voltages is connected in series with a resistor across the contacts to reduce the arcing and also the amplitude of the reverse voltage.

Since nearly all interference suppression networks include at least one capacitor, it will be useful to examine the construction and parameters of capacitors which are suitable for suppression applications.

1. The capacitor must have adequate insulation both with respect to its dielec-

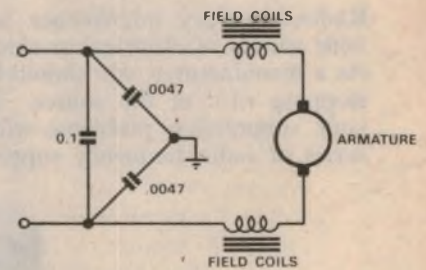

FIG. 3

A typical network as used to suppress a commutator type motor as commonly found in domestic appliances.

tric strength, ie across its terminations, and also between the capacitor element and its housing, ie terminations commoned and the case. This last, of course, does not apply where the metal case of the capacitor constitutes one of its terminations to earth.

Capacitors for suppression are divided into two classifications—Class X and Class Y.

Class X are used where a failure of the

The Problem

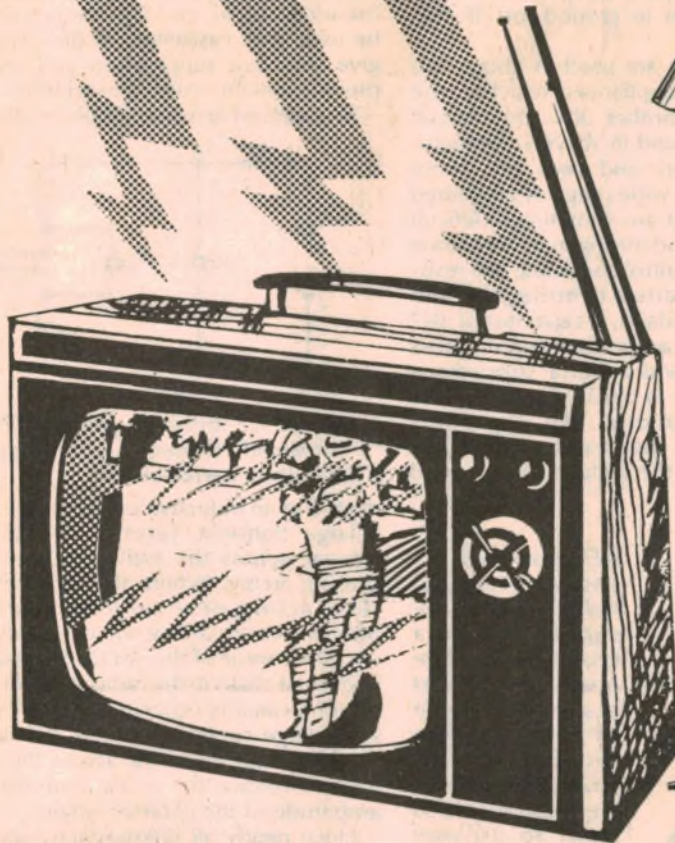

The Solution

Radio-frequency interference is generated by a wide variety of electrical or electronic equipment. As a manufacturer, you should be concerned with stopping r.f.i. at the source. Let A.E.E. solve your suppression problems with their PME271 series of radio frequency suppression capacitors.

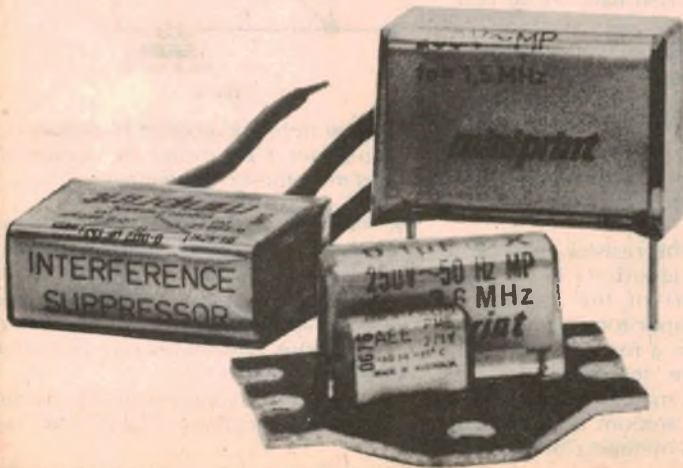

RIEFA

(AEE's NEW NAME)

202 BELL STREET, PRESTON, VIC. TEL. 480 1211
 23 SLOANE STREET, MARRICKVILLE, N.S.W. TEL. 516 3944

AGENTS:
Adelaide: Collett & Cant Pty. Ltd., Tel. 223 1971
Brisbane: Electronic Components, Tel. 371 5677
Perth: Ross Stevenson & Co., Tel. 81 6144
Hobart: W. P. Martin Pty. Ltd., Tel. 34 2811

capacitor could not result in danger to life, ie electrocution. Generally, class X capacitors are connected in shunt across mains voltage lines, etc.

Class Y are used where failure of the capacitor would result in danger, via electrocution, to life. Class Y capacitors are used where either or both mains lines are connected to frame or earth via a capacitor.

It follows that the dielectric strength of Class Y is higher than that of Class X. Additionally, the maximum capacitance of Class Y must be such that the current to frame is limited.

2. The capacitor should have very low self inductance. This means that the capacitor geometry is designed so that the winding itself has minimum inductance and also that the capacitor's internal wiring is of minimum length. It is also necessary that the capacitor can be connected electrically using the shortest possible length of external leads.

3. The capacitor dielectric should be suitable for the application. In the bulk of all requirements mains voltages or alternating voltages of significant magnitude will appear across the capacitor, together with surges of back EMF with spikes of considerable magnitude.

Over many years it has been established that the most reliable capacitor in this

Above: The AEE PME 271 metallised paper, epoxy encapsulated suppression capacitor. Below: Such a capacitor as part of the suppression network in an Electrolux cleaner. Note the confined space into which such a capacitor can be fitted.

itself as an identical impedance to that obtaining before the self-healing operation.

4. Safety: Capacitors connected in the appliance from the supply lead to earth should not exceed .005uF because of the possibility of electric shock to the user. Capacitors used in portable appliances or in appliances located in damp location should be able to withstand extreme environmental conditions (refer to PME271 environmental classification).

Typical capacitors of suitable construction will withstand test conditions of 90-95% relative humidity for 56 days with little or no effect upon the dielectric.

The awareness of the problem of radio frequency interference has increased

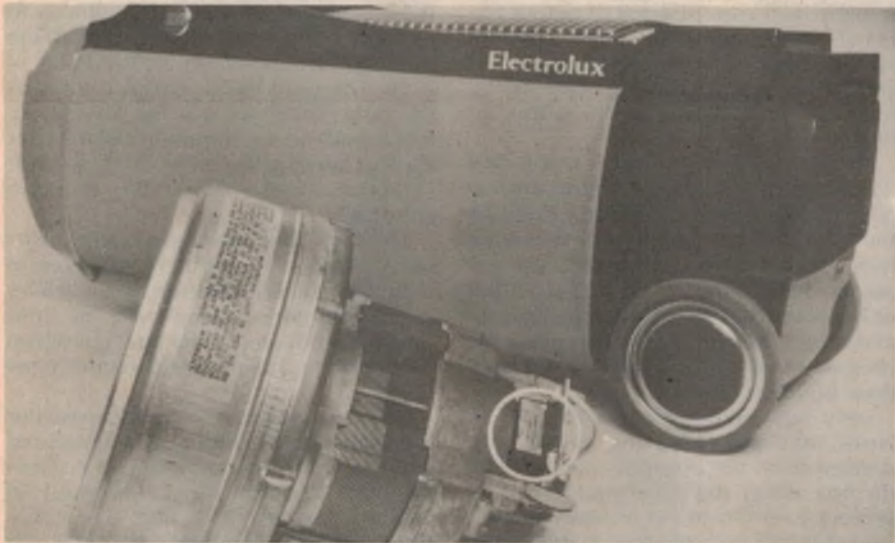

application is a vacuum impregnated paper dielectric tape. Plastic dielectrics, while superior in many respects, may tend to ionise in this rather arduous application and have a shorter working life. The modern approach favours the metallised paper capacitor.

Metallised paper capacitors can be wound to minimum inductance. Their physical size and weight are reduced and their self healing mechanism is better than that of other materials. Thus, in the event of accidental or unexpected overload, the metallised paper capacitor will self-heal immediately and re-present

markedly during the past few years as the average household makes use of an ever-increasing number of electrical and electronic products. Recommendations have been drafted and submitted to the Federal Government for a more stringent control of RF interference.

Many manufacturers of appliances and other electrical products are already fitting suppression units, be it a single capacitor or a more elaborate network, to their units. Several colour television manufacturers utilising the "switch mode" power supply incorporate suppression networks in their receivers.

R.H. Cunningham
Pty. Ltd.

**Why improvise?
There is a Bulgin
battery holder
for all regular
size batteries . . .**



List Nos.: B.3, B.2, B.1.
Three, Two and One 1035 Cell respectively.



List No. B.11
Range of three models accepting one, two or three 1015 size cells. Panel mounting with rear support bracket.



List No. B.1
Further three panel mounting models accepting one, two or three 1050 size cells.

BULGIN Products include:

- Fuse Holders
- Switches — Toggle, Micro, Key operated & Semi-Rotary
- Bezel Lampholders
- Plugs and Sockets

Available from Wholesalers
or the Australian Agents

R.H. Cunningham
Pty. Ltd.

VIC.: 493-499 Victoria St., West
Melbourne, 3003 Ph.: 329 9633
N.S.W.: 4-8 Waters Rd., Neutral
Bay, 2089 Ph.: 909 2388
W.A.: 256 Stirling St., Perth,
6000 Ph.: 28 3655
OLD: L. E. BOUGHEN & CO.,
Cnr. Milton & Baroona Rds.,
Milton 4064 Ph.: 36 1277
S.A.: Werner Electronic
Industries Pty. Ltd., Unit 25,
28 Gray St., Kilkenny, 5009.
Ph. 268 2801

Telex: Melbourne, 31447
Sydney, 21707 Brisbane,
41500 Perth, 93244.

We review a novel do-it-yourself kit

Heathkit Model TD-1089 electronic chimes unit

by GREG SWAIN

The jarring sound of a doorbell or buzzer is hardly a desirable way of announcing a visitor's arrival. A better alternative is the Heathkit TD-1089 Programmable Electronic Chimes unit which, at a touch of the door button, will announce your visitor with a short tune. We obtained the kit from the local Heath agents, Warburton Franki Pty Ltd, and assembled it to bring you this report.

This intriguing project from the Heath Company certainly generated a lot of interest in our office. There was no shortage of takers to "press the button" to set the unit off with its short tune, although some were pleased when the novelty began to wear off!

As with all Heath projects, the idea is that you get the fun of building up the kit, and on completion be rewarded with a worthwhile item. You're not just buying a specific item of electronic equipment—you're buying six or seven hours of experience and diversion as well. In fact, many Heath projects would make ideal beginners' kits, so detailed are the instructions.

Basically, the Model TD-1089 Programmable Electronic Chime can be considered as a novel replacement for the conventional doorbell, buzzer, or simple chime. It can be programmed to play a short tune, up to 16 beats in length, at the push of a button, and can play any tune that can be set within the full 13-note complement of a musical octave. The unit is housed in an attractive moulded housing measuring approx 220 x 145 x 70mm (W x H x D).

Quite a number of tunes can be programmed into Heath's Electronic Chimes (the assembly manual lists 25 examples), and changing the tune is easy. All one has to do is to rearrange the programming leads in the connectors of the C through C' "keyboard" located behind a front access panel. Controls for adjusting the tuning, volume, speed and decay characteristics are also located behind the front access panel.

Output from the unit is via a small

loudspeaker, and should be more than adequate for most average sized homes. An extension speaker may also be connected if required, and provision for this is made by means of a pair of output terminals at the back of the unit. The extension speaker is simply wired in parallel across the internal speaker, and should have an impedance of 16 ohms or higher.

An unusual feature of the unit is that it indicates whether a signal is originating from the front door or the back door, by the length of the tune played. When the front door button is pressed, for example, a full 16-beat tune is played. But only a portion of the tune—between four and nine tones in length depending on programming—is played when the back door button is pressed.

Let's now take a look at the circuit. Note that the following details are derived from the assembly manual, and do not affect the constructor during project assembly in the ordinary sense.

In all, there are 5 integrated circuits and 10 transistors employed in the circuit. Buffer circuit IC1 (SN7417N) is arranged as a pair of latching circuits, one for an input from the front door pushbutton and one for an input from the rear door pushbutton.

When the front door pushbutton is depressed, the input through diode D1 to IC1A is "low". This causes the output to also go low. This low condition is coupled through resistor R3 back to the input of IC1A, and latches this input to a low condition, where it is held (latched) regardless of the door pushbutton.

The low condition from IC1A is

applied to the input of IC1B and its output is also low. The third buffer, IC1C, receives its input from IC3; this input is normally "high". At the beginning of the 16th beat, this signal goes low, and the output of IC1C follows this and is also low. This output is capacitively coupled through C1 to the input of IC1A. At this time, the negative-going signal has no effect on the input to the latch circuit in its low condition.

At the end of the 16th beat, pin 17 of IC3 (SN74154) goes high. The input to IC1C is now high, causing its output to go high. This signal is coupled through capacitor C1, as a high on the input of IC1A. The reset high is coupled through the same circuit as was the low signal; that is back to the input through resistor R3, thus latching the circuit in a high-level condition. IC1B follows this and also goes high.

The back door latching circuit, consisting of IC1D, IC1E and IC1F, functions in a similar manner. However, it does differ in that the reset signal may be pre-selected from any of the beats between the fourth and ninth signal output from IC3.

The beat generator is an RC oscillator consisting of transistors Q1 and Q2 and their associated components. The effective "R" (resistance) is composed of resistors R9 and R11, and is variable within the limits of Speed control R9. The effective "C" of the circuit is obtained by the action of capacitor C3. The R and C values, along with the other component parameters in the circuit, determine the frequency of oscillation.

The operation of this circuit is initiated when the output of integrated circuit IC1B or IC1E goes low. This has the effect of allowing the supply voltage to be applied to the oscillator circuit. The output of this circuit is taken from the collector of transistor Q2. This collector is the midpoint of voltage divider R12-R14, which is within the oscillator circuit. When the voltage across capacitor C3

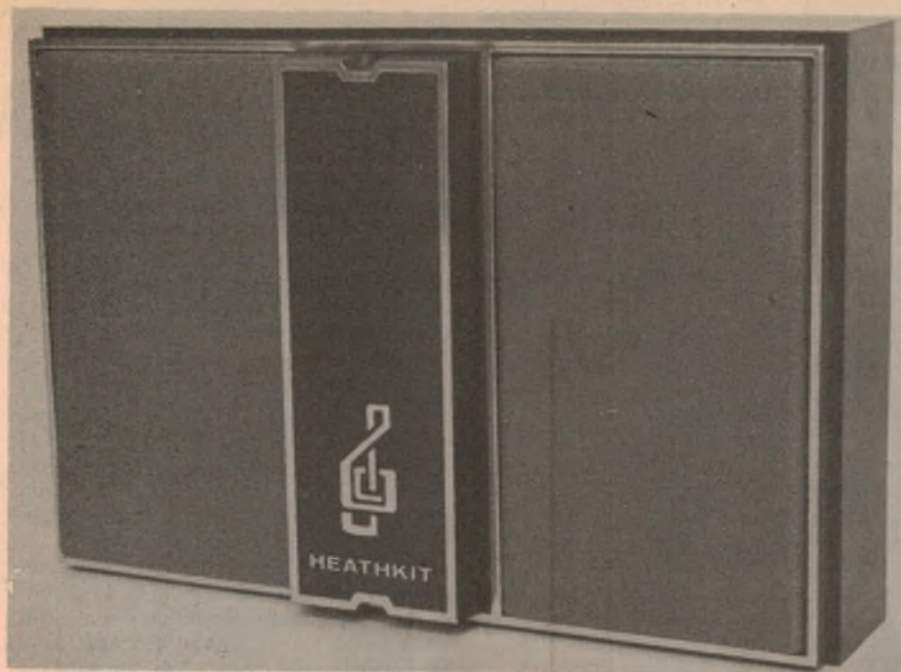

of IC3 make its following termination effective only when that specific output is "low". At all other times, diodes D3-D18 prevent feedback to the IC through other leads connected to the same tone point resistors.

The tone generator is an RC oscillator comprised of transistors Q7 and Q8 and their associated components. The low end of the frequency is determined by the combination of capacitor C8, resistor string R31-R44, and by the setting of variable resistor R45. Each resistor is connected for a tone output that is represented by the 13 notes, C through C'. (Note: These are representative notes or tones only, and may not correspond to the actual tones generated on a musical keyboard). Each note or tone has three connector pins to which one or more of the output leads from IC3 may be connected.

Tone generator transistors Q7 and Q8 are connected in a manner similar to those in the beat generator, although inverted. The output of the tone generator is at the collector of Q7, which is at a point on a voltage divider that consists of resistors R17, R18 and R19. When the current through the resistor string (R31-R44) charges capacitor C8 to a trigger level, Q7 and Q8 both turn on and saturate. Q7 momentarily shorts resistor R17 and the output voltage rises, producing a positive-going spike. Buffer inverter Q6 changes these to negative-going spikes.

The negative-going spikes from transistor Q6 in the tone generator drive subharmonic generator integrated circuit IC4. Pins 2 and 3 of the IC must be "low" to permit the frequency dividers to function. At each beat, all four outputs from IC4 go low, as pins 2 and 3 momentarily go high. This prevents audible clicks in

reaches a critical level, both Q1 and Q2 turn on and go to saturation. Transistor Q2 effectively shorts across resistor R14 momentarily and drops the output signal to near zero. This produces a sharp, negative-going spike.

Buffer transistor Q3 takes the negative-going signal spike from the oscillator circuit through resistor R13 and inverts it to create a positive-going spike. This positive spike serves several functions: it is the input signal for counter IC2 (SN7493AN); it is the blanking signal for decoder IC3 (SN74154); it is the reset signal for sub-harmonic generator IC4 (SN7493AN); and it is the driving signal for decay driver transistor Q4.

Integrated circuit IC2 is a counter that is enabled when a low pulse is applied to its pins 2 and 3. These lows originate as the outputs from IC1B or IC1E.

When IC2 is enabled, the positive-going spikes from buffer Q3 cause four different signals to be generated in IC2. At the first output pulse from Q3, a steady high level will be seen at IC2 output pins 1 and 12. On the second pulse, IC2 pin 9 will go high and pins 1 and 12 will go low. In succession, each output from IC2 is set or reset by the output of the preceding stage. Thus, every pulse will be seen, alternatively as a high or a low at pins 1 and 12. Every second pulse from pins 1 and 12 will set or reset the output at pin 9. Every fourth pulse from 1 and 12 will set or reset the output at pin 8, and every eighth pulse at 1 and 12 will set or reset the output from pin 11. What has been described is, simply, a 1-2-4-8 binary counter. These outputs represent a binary count of 16 beats.

The 4-to-16 line decoder, integrated circuit IC3, is enabled when pins 18 and 19 are both "low". One of these pins goes low when the output of either IC1B or IC1E goes low. The other pin is nor-

mally low, but momentarily goes high during each beat. This blanks the transition from one count to the next.

The binary output from IC2 determines the state of each of the 16 outputs from IC3. Thus, the signal from the beat generator, as counted by IC2, makes each of the 16 IC3 outputs change from high (no tone) to low (tone) for one beat, one after another.

Each output from IC3 is coupled through a diode to an unterminated lead. Each of these 16 leads may be plugged into a terminal pin on the resistor network consisting of R31 through R44 (note that there is no R40) in the tone generator circuit. Each of the diodes at the outputs

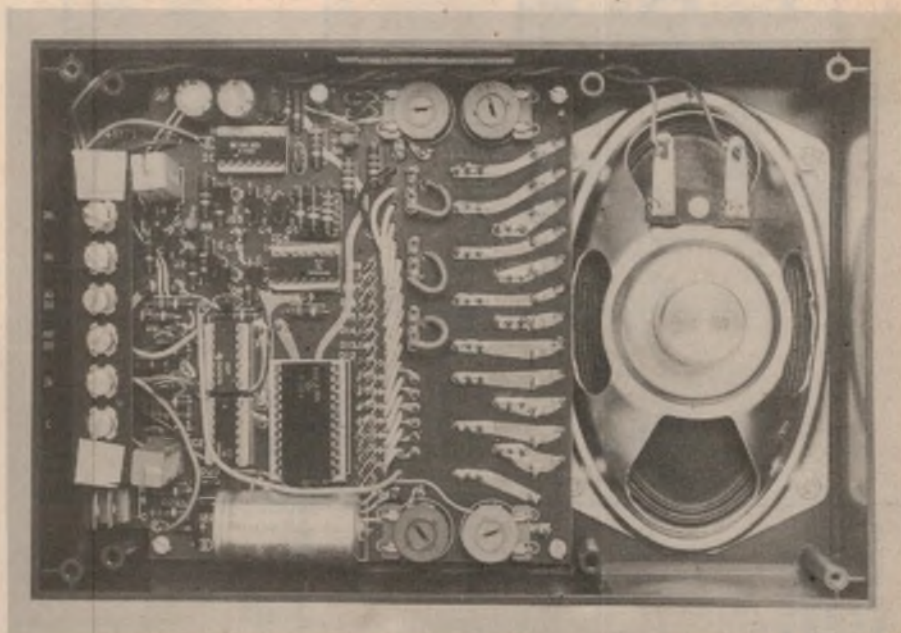

All components are accommodated on a single PC board. The four preset pots are for setting the volume, tuning, speed and decay characteristics.

Heathkit Programmable Electronic Chimes

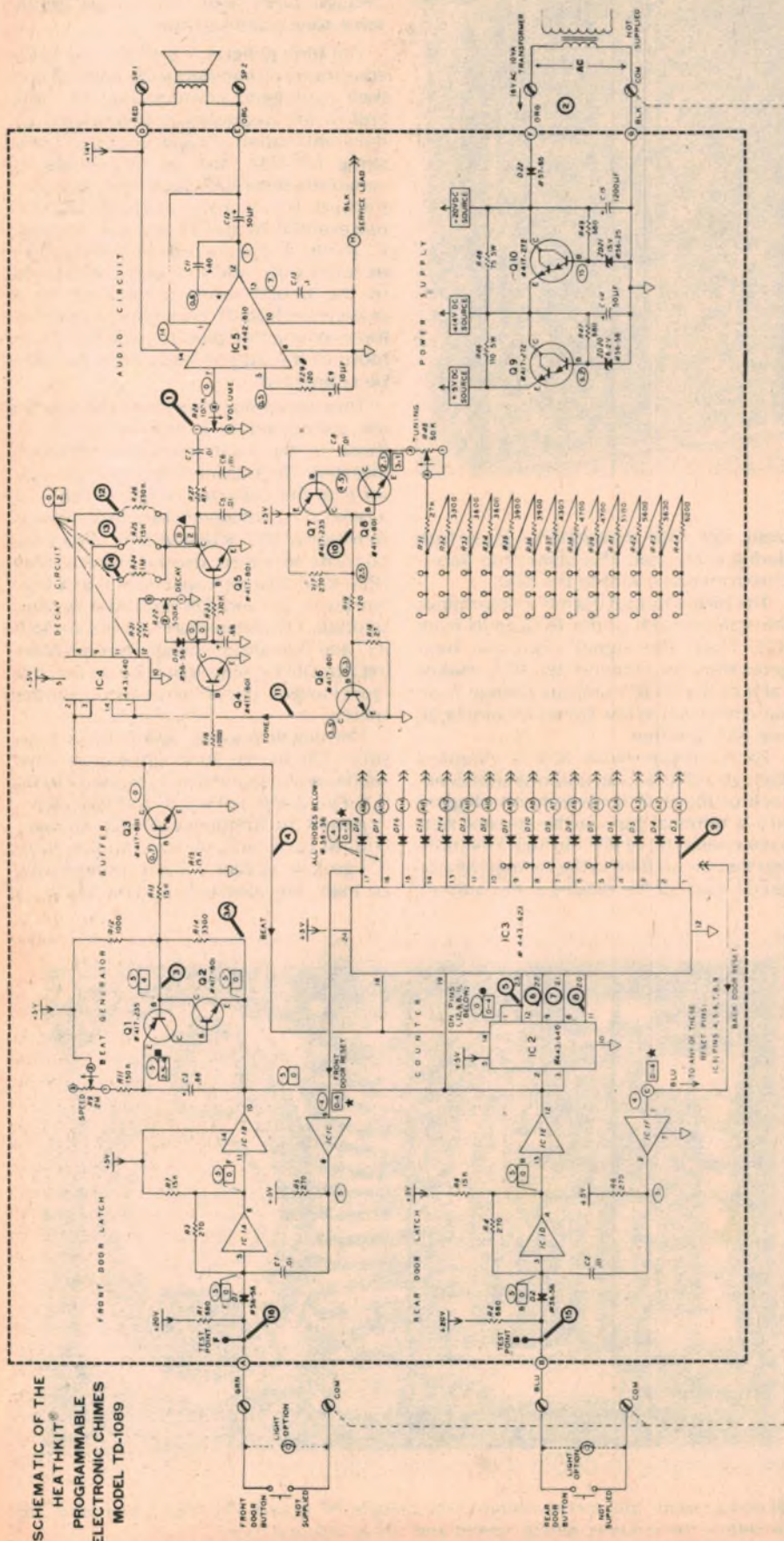

the speaker during "no-tone" beats (or rests) in the sound output.

Three of the frequency dividers in IC4 produce square-wave outputs of 1/2, 1/4, and 1/8 of the frequency produced by the tone generator. Plug-in resistors R24, R25 and R26 permit a choice of subharmonic content in the final audible tone. The fourth frequency divider in IC4 is an independent section. It operates from the same input signal, but its output, a square wave at 1/2 the input frequency, is used to drive the decay circuit.

Resistors R24, R25 and R26 are the upper portion of a voltage divider and transistor Q5 serves as the lower portion. As the base drive on the transistor increases, the collector-to-emitter path functions as a variable resistance that decreases in value. Thus, the signal output from the divider also decreases.

The drive for the decay circuit coming from IC4 is rectified by diode D19 and is used to charge capacitor C4. As the voltage on C4 increases, Q5 acts as a decreasing resistance. The amount of drive is adjusted by Decay control R22. At maximum drive a note is produced that rapidly decreases in loudness. Zero drive produces a note which remains at a constant loudness throughout the beat.

At each pulse of the beat generator, the decay drive from IC4 drops momentarily to zero. At the same time, transistor Q4 is turned on by the signal through R16 and its near-saturated condition discharges capacitor C4. The result is that each beat starts the tone at maximum loudness without regard to the end loudness of the preceding tone.

The variable-height square wave signal from the decay circuit is filtered by capacitors C5 and C6 and by resistor R27. The signal is then coupled through capacitor C7 and volume control R28 to audio amplifier IC5 (TBA820L), and thence to the loudspeaker.

Operating power for the unit is derived from an external bell transformer (not supplied) with secondary ratings of 16VAC, 10VA minimum. This AC is rectified by diode D22 and is filtered by capacitor C15. Two cascaded transistor regulators, Q9 and Q10, using zener diode references produce a 14V supply for the amplifier and a 5V supply for the remaining circuits. Shunt resistors R46 and R48 function to reduce the power dissipation in transistors Q9 and Q10.

The kit itself is typical Heathkit, carefully packaged, literally complete to the last nut and bolt, and accompanied by the usual detailed assembly manual. It uses top-grade components, went together with absolutely no hassles and, as with all our previous Heath projects, functioned right from switch-on. Top marks here.

The accompanying photographs clearly show how the unit is physically constructed. The electronics is all contained on a single double-sided PC board which is screwed down on plastic stand-

off pillars inside the case, next to the internal loudspeaker. All components, with the exception of a handful of resistors, are mounted on the topside (lettered) side of the board. IC sockets are used to mount the five integrated circuits.

The resistors on the underside of the board, thirteen in all, are mounted down one edge, nearest the speaker. Also on the underside of the PC board are some 54 connector pins. These accept the bared ends of the programming patch leads, and allow a number of tunes to be quickly and easily programmed into the unit.

The keyboard, by the way, forms part of the pattern on the underside of the PC board, and is laid out in piano keyboard style. It is lettered from C at one end to C' at the other end (C, D, E, F, G, A, B, C).

Assembly of the PC board, the major part of the job, is straightforward. The board is accurately etched and drilled, and all components fit easily into place. Component placement is further aided by the fact that the PC board is coded and pre-tinned.

Installation of the unit should pose no problems either. An accompanying illustration booklet gives installation diagrams, both for installing a system from scratch and for modifying an existing system employing a standard doorbell mechanism. The assembly manual also contains a section giving a detailed description of the installation procedure.

In all, the assembly manual lists some 25 tunes that may be programmed into the Electronic Chimes. A chart is presented with each tune, detailing the patching procedure, and allows a person with no musical experience whatsoever to program the unit. The musically inclined will be able to program in any other tune (preferably one with a regular beat) that falls within a 13-note octave.

Some of the tunes listed in the assembly manual include Westminster, "Chimes" Program, America, Yankee Doodle, Swanee River, Mary Had a Little Lamb, Jingle Bells and Holy, Holy. We recommend the "Chimes" Program. Believe me Yankee Doodle can wear a bit thin after the initial novelty has worn off, especially if you get a lot of visitors.

For those unlucky enough to encounter difficulties, the assembly manual contains the usual detailed troubleshooting procedure. The procedure in this case consists of a series of general tests, followed by a troubleshooting flowchart and voltage tests. By following the steps outlined, most constructors should experience little difficulty in isolating and correcting the majority of fault conditions.

And if you're unable to track down the fault? In this event, you may take advantage of the full technical back-up and factory repair service offered by the

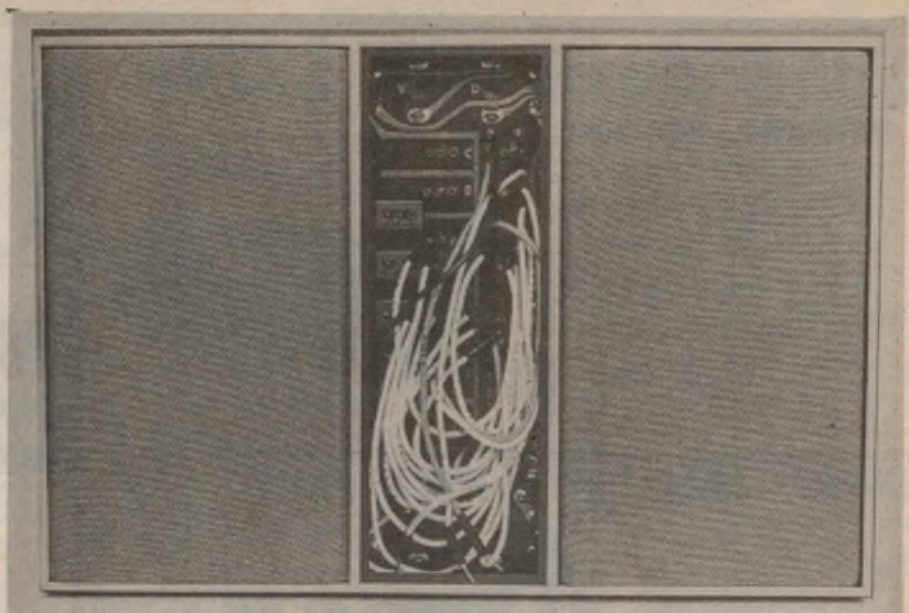

The removable front access panel enables the unit to be quickly and conveniently re-programmed, if desired. Pattern is laid out piano keyboard style.

company. The TD-1089 kit is covered by a 90-day warranty, during which time Heath will replace any defective parts, or service the project, free of charge. A service fee is applicable in the case of incorrect assembly.

Overall, our impression of Heath's Electronic Chimes project is very favourable. If we do have any specific criticisms to make, they concern the fact that a power transformer and the doorbell pushbuttons are not supplied as part of the kit. Still, the enthusiast should have no problem in purchasing either of these items separately.

Of course, in many cases the Electronic Chimes will be used to replace a standard doorbell mechanism, and a suitable power transformer and doorbell pushbuttons will already be available. Heath have simply adopted the philosophy that the customer should not be forced into purchasing these items with the kit, and thereby incur a resultant cost penalty.

A suitable power transformer for the project would be the Ferguson PF 2155. Equivalent transformers include the DSE 2155 from Dick Smith Electronics, and the A & R 2155 from A & R Soanar. These are all multi-tapped transformers capable of supplying up to 15VAC at 1A, which should be adequate. Other transformers could of course be used, provided they are capable of meeting voltage and current requirements.

A range of pushbutton switches is available, and these may be selected according to the constructor's whim. An option here is that illuminated pushbuttons may be used, as detailed in the assembly manual.

Cost of the Heathkit Model TD-1089 Programmable Electronic Chimes is around the \$60 mark. At that price it must be considered expensive, but you do get a well prepared, well thought out project that does not skimp on presentation or the standard of components. And there is factory backup if things go wrong.

The Heath Company is represented in Australia by Warburton Franki Pty Ltd, who have branch offices in all state capitals and in Wellington, NZ. Readers should either write to The Heath Centre, 220 Park St, South Melbourne, Vic 3205, or ring one of the following numbers: Sydney 648 1711, Melbourne 699 4999, Brisbane 52 7255, Adelaide 356 7333, Perth 65 7000, Hobart 23 1841, Wellington (NZ) 69 8272.

SPECIFICATIONS

Power Requirements: 16VAC from standard doorbell transformer rated at 10VA.

Tonal Range: One octave (13 notes).

Tune Length: 16 beats (notes or rests).

Tone Characteristic: Decaying, mellow.

Power Output: 1W minimum.

Speaker: 16-ohm impedance, 3" x 5".

Actuating Inputs: Two, for front and rear door pushbuttons.

Distinction Between Inputs: Tune length.

Controls (Internal Presets): Speed, decay, volume, tuning.

Programming Matrix: 13 notes x 16 beats, same note up to 9 beats.

Power Consumption: 6W idle; 12W maximum.

Dimensions: 8 $\frac{3}{8}$ " x 5 $\frac{3}{4}$ " x 2 $\frac{5}{8}$ " (W x H x D).

\$350 VALUE FOR \$279!!

INCREDIBLE... BUT TRUE!

You've probably heard someone who picked up a so-and-so in the States for so much - usually well under Australian selling prices.

Try that with one of these brand new Midland 13-893's you'll be in for a rude shock! Current advertised prices for the 13-893 is around \$350 each in the USA! Dick Smith's price in Australia: **ONLY \$279.50!!!!**

The 13-893 is considered to be a 'Rolls-Royce' model in the CB field. A true **DOUBLE CONVERSION** superhet receiver, and the transmitter has not only RF & audio gain controls, but a **MICROPHONE GAIN CONTROL** as well! That's a very handy control - lets you control your modulation so every man & his dog can't eavesdrop your QSO's.

While stocks last, the fantastic 13-893 is exactly the same price as the famous 13-892 (it should be much dearer if overseas ads are any guide!) At the time of going to press, stocks of the 893 were good - but we cannot guarantee how long this will last! If you want one, better grab one now - before they disappear!



Cat D-1701

- DOUBLE CONVERSION SUPERHET RECEIVER
- 3 MODES - AM, USB & LSB - ON 23 CHANNELS
- MICROPHONE GAIN CONTROL
- 0.5uV SENSITIVITY



\$279.50

WHILE STOCKS LAST

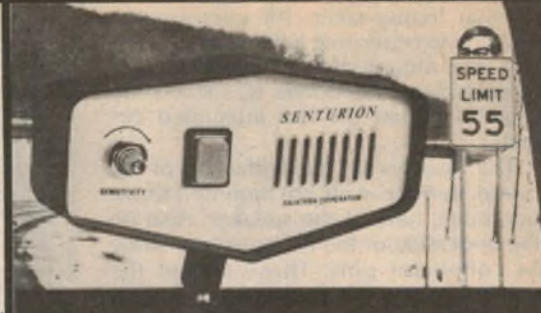

THE MOST SOPHISTICATED, SENSITIVE MICROWAVE DETECTOR AVAILABLE...

INSTALLING ONE OF THESE RADAR DETECTORS IN YOUR CAR WILL ACTUALLY MAKE YOU A SAFER DRIVER.

WHY PAY \$130 OR MORE FOR A LESS EFFECTIVE UNIT?

Everyone does it - you don't pay as much attention as you should; suddenly you find you are well over the speed limit. If you're lucky, you drop down to the limit (until you do it next time!) If you're not so lucky...

DICK'S PRICE:

\$115

Cat A 8507

A radar alarm in your car makes you a safer driver by keeping you aware of the speed limit. You find that just knowing the thing is there increases your attentiveness; you don't let your mind (and speed) wander so you become less prone to mental aberrations.

FEATURES: 2 alarms (1 audio & 1 visual) - external power from car cigarette lighter (not internally powered as earlier models were) with lighter plug and lead supplied - easy stick on attachment to dash (supplied) - sensitivity control - neat, unobtrusive appearance on car dashboard - low power consumption

DUMMY LOAD \$3.50

WATCH YOURSELF TALK!

This incredible little dummy load contains a light globe which lights up on transmit. The lamp changes brightness with modulation level. You can actually watch yourself talk!

Suitable for all CB transceivers, will handle peak powers of 5W. Mounted in a standard PL259 plug, which just screws into the antenna socket of your transceiver. Easily replaceable bulb. Cat D-7024 - \$3.50



WHITE FLASH

This BRAND NEW 27MHz helical antenna - EXCLUSIVE TO DICK SMITH - comes ABSOLUTELY COMPLETE with mounting base, lead-in & PL259 plug.

We predict this will be the most popular antenna ever!

'KNIGHT OF THE ROAD'S' \$29.00

brand new

Cat D-4076

SANYOYOYO!

This fantastic hand-held rig is now back in stock. Incidentally versatile high power transceiver, can accept crystals for any 6 of the 23 CB channels or the marine & boating channels. Full 5W input power, can be used as a normal hand held or as a base with its external power, external mic, external antenna, external speaker and external charger jacks!

NEW PRICE WILL BE OVER \$100.00 BECAUSE OF DEVALUATION!

SPECIAL ONLY \$79.50 INCLUDING 87.88MHz XTALS!



IN STOCK NOW \$79.50

Cat D-1142

FOR MICROPROCESSORS & VDTS

INCREDIBLE LITTLE CALCULATOR KEYBOARD. Ideal for conversing with a computer, mixing with a microprocessor. All have 4 functions & 10 digits, but some have different notations on other keys (5 x 4 matrix). Some are pre-used but as new condition.

few only 200

WATCH FOR DETAILS OF THE COMPUTER TERMINAL KIT'S



Cat X-1170

JUST THE THING FOR ALL THE VIDEO TERMINALS IN THE MAGS!

Full alpha-numeric keyboard with control keys, space & tab, everything you would find on a computer keyboard (funny, because that's what they are!). Individual key contacts (spst) for virtually any wiring up mode, or for any encoding system.

Cat X-1180

\$49.50



STUDENTS!

UNI & TECH COURSES ARE ON AGAIN! And you're a year older! Is last year's calculator good enough for your more advanced studies this year? Go on - give your marks a boost! Get an up-to-date programmable calculator. You won't be sorry!

TEXAS SR-52

- 224 step program memory
- 20 memory registers
- 10 user defined keys
- 10 con. branches
- 3 uncon. ...
- 5 flags
- 2 subrout.
- 72 labels etc etc etc!

22 pre-recorded program cards supp



Cat D-3724

\$299.98

ALARM THE BURGLAR

Protect your property with a professional alarm system. Install it yourself and save lots of money!

Contains all sensors, i.e. window, fire, etc, plus the master control centre. Bewdy, mate! Cat L-5105

\$37.50

YOU can do it with the Dick Smith 'How to Install Your Own Burglar Alarm' leaflet. Incredible value at 25c, or

FREE when you buy the above alarm. Cat B-4500

DON'T FORGET TO ASK FOR IT!



How to install your own burglar alarm 25c

FANTASTIC SPEAKER KIT

ANYONE can build a pair of these superb little speakers in just a couple of hours...

\$27.50 each

All instructions are supplied - if you can read, you can build these speaker boxes! All you need is a tube of glue & a screwdriver!

Cat C-2610 - \$27.50 ea.

Speakers to suit above boxes: You could use just about any 8-inch speaker in this box - but we recommend the CBMX which sells for just \$7.50 - that's a saving of over \$5.00 on our catalog price! Cat C-2012 - now \$7.50



INCREDIBLE VIDEO GAME

This kit gives you far, far more than the usual video game kits. 6 selectable games with automatic digital scoring on screen; with just about everything on screen selectable to your requirements & skill: bat size, ball speed, angles, etc. The kit is very easy to build - a single box contains all the 'works' with separate armchair controls for each player.

COMPLETELY COMPLETE KIT INCLUDES FRONT PANEL DECAL

This is the original 'Electronics Today' (Nov 76) kit; not a backyard design where you don't know what you're getting



Cat K-3432

COMPLETELY SAFE \$49.50

BRAND NEW MUSICOLOR \$49.50

WITH DICK SMITHS *** EXCLUSIVE *** CHAMPAGNE FRONT PANEL.

You can build this kit successfully - even if you've never seen a resistor in your life! With the new Musicolor 111, you get our brand new Musicolor 111 instruction manual - everything from 'this is a resistor' to 'Sit back and relax, and watch the pretty lights'. Everything. So you really can't go wrong, can you? Have a look at the kit today at your Dick Smith store or dealer. And the manual, too. Then you will see this is just the kit for you!

Also available. Special 'short form' kit which contains PCB, components, etc., but no case or 'hardware' Cat K-3141 - \$29.50



DICK SMITH ELECTRONICS GROUP

Head Office: Phone 439 5311. Telex AA20036. Cable Diksmi Sydney.

Mail Orders: P.O. Box 747, Crows Nest, N.S.W., 2065.

N.S.W. Branches: GORE HILL - 162 Pacific Highway, 439 5311.

SYDNEY - 125 York St., 29 1126. BANKSTOWN - 361 Hume Hwy., 709 6600.

QLD - 166 Logan Rd., Buranda, 391 6233.

Interstate Branches: VIC. - 656 Bridge Rd., Richmond, 42 1614.

DICK SMITH DEALERS:
 Sound Components, Tamworth, NSW 66-1363
 The Record Centre, Griffith, NSW 62-1577
 Hunts Electronics, Toowoomba, QLD 32-6944
 Electronic Hobby Centre, Palm Bch, QLD 34-1248
 Fosters Auto Spares, Cairns, QLD 51-1795
 Aero Electronics, Hobart, TAS, 34-8232
 Altronics Parts, Perth, WA 28-1599
 A E. Cooling, Elizabeth St, SA 255-2249
 Veneman & Wyatt, Stuart Pk, NT 81-3491
 Pacific Electronics, Honiara, Solomon Is 494
 DEALER PRICES MAY BE HIGHER TO COVER HIGH FREIGHT CHARGES

SHOP HOURS
 Mon - Fri: 9 to 5.30
 Sat: 9 to 12.

POSTAL CHARGES

ORDER VALUE	CHARGE
\$5 to \$9.99	\$1.00
\$10 to \$24.99	\$1.50
\$25 to \$49.99	\$2.50
\$50 to \$99.99	\$3.50
\$100 or more	\$5.00

FOR C.O.D. SEND \$2.40 EXTRA PLUS \$3.00 DEPOSIT. MINIMUM MAIL ORDER AMOUNT IS \$6.

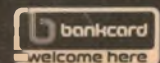



Why the cannon on your 1812 Overture sounds more like a popgun.

A rather unfortunate situation occurs during a recording session.

Because the dynamic range of most recording equipment doesn't equal the dynamic range of live performances, the loudest sounds end up being very much compressed, while the softer sounds have to be lifted above tape noise.

So no matter how good your equipment is, it will never ever give a true performance.

Introducing dbx.

Fortunately for the home hi-fi buff there's now an extremely effective solution available.

The dbx 117.

Basically it's a dynamic range enhancer that works on the signal's voltage level without changing the frequency response. (Unlike other systems that are designed merely to

filter out high frequencies.)

And attached to any good system it will noticeably increase the entire dynamic range of any signal put into it. While at the same time reducing surface noise.

So now your softs become even softer. While your lounds, especially your crescendo's, become much more dramatic when they finally reach the top.

Consequently giving the recorded performance both more body and definition.

dbx will also improve the sound of your older records. So there's less need for you to have to replace them. (The dbx 117 will also help reduce hiss from FM broadcasts as well as your tapes.)

In fact should you desire to test the dbx before purchase, we then

suggest you contact one of our dealers listed opposite and politely ask him to play you a copy of the 1812 Overture.

Should you still have a few reservations then all we have to say is that perhaps the 1812 Overture was recorded featuring a popgun.

Or your ears aren't as good as you thought they were.

dbx



Blueprint for Flat Frequency Response

In the graph below, frequency response was measured using the CBS 100 Test Record, which sweeps from 20-20,000 Hz. The vertical tracking force was set at one gram. Nominal system capacitance was calibrated to be 300 picofarads and the standard 47K ohm resistance was maintained throughout testing. The upper curves represent the frequency response of the right (red) and left (green) channels. The distance between the upper and lower curves represents separation between the channels in decibels. The inset oscilloscope photo exhibits the cartridge's response to a recorded 1000 Hz square wave indicating its resonant and transient response.

Smooth, flat response from 20-20,000 Hz is the most distinct advantage of Empire's new stereo cartridge, the 2000Z.

The extreme accuracy of its reproduction allows you the luxury of fine-tuning your audio system exactly the way you want it. With the 2000Z, you can exaggerate highs, accentuate lows or leave it flat. You can make your own adjustments without being tied to the dips and peaks characteristic of most other cartridges.

For a great many people, this alone is reason for owning the Z. However, we engineered this cartridge to give you more. And it does. Tight channel balance, wide separation, low tracking force and excellent tracking ability combine to give you total performance.

See for yourself in the specifications below, then go to your audio dealer for a demonstration you won't soon forget.

The Empire 2000Z.

Already your system sounds better.

Frequency Response—20 to 20KHz \pm 1 db using CBS 100 test record
Recommended Tracking Force— $\frac{1}{4}$ to $1\frac{1}{4}$ grams
 (specification given using 1 gram VTF)

Separation—20 db 20 Hz to 500 Hz
 30 db 500 Hz to 15K Hz
 25 db 15K Hz to 20K Hz

I.M. Distortion—(RCA 12-5-105) less than 08% 2KHz to 20KHz @ 3.54 cm/sec

Stylus—0.2 x 0.7 mil diamond

Effective Tip Mass—0.2 mg

Compliance—lateral 30×10^{-6} cm/dyne
 vertical 30×10^{-6} cm/dyne

Tracking Ability—0.9 grams for 38 cm per sec @ 1000 Hz
 0.8 grams for 30 cm per sec @ 400 Hz

Channel Balance—within $\frac{1}{4}$ db @ 1 kHz

Tracking Angle— 20°

Recommended Load—47 K Ohms

Nominal Total System Capacitance required 300 pF

Output—3mv @ 3.5 cm per sec using CBS 100 test record

D.C. Resistance—1100 Ohms

Inductance—675 mH

Number and Type of Poles—16 Laminations in a 4 pole configuration

Number of Coils—4 (1 pair/channel—hum cancelling)

Number of Magnets—3 positioned to eliminate microphonics

Type of Cartridge—Fully shielded, moving iron

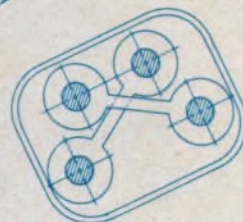
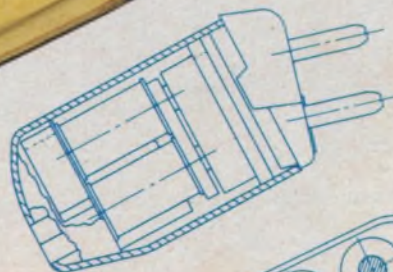
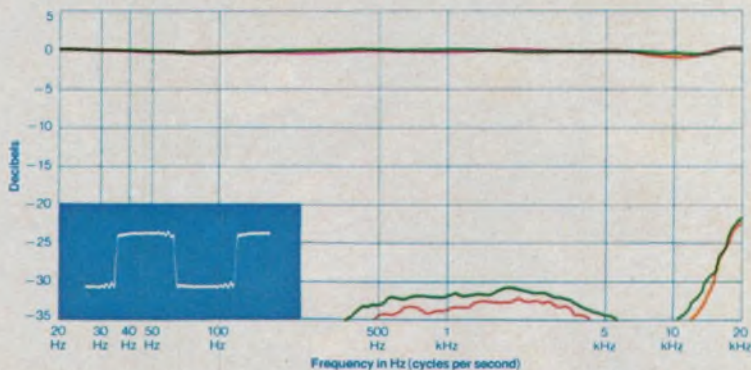



ST7200

SU7200

Matching Pair Performance and Appearance

What comes out of a tuner and amplifier is only as good as what goes into them.

And we've put a lot into both.

Both specially matched for the finest and most authentic music reproduction.

First the ST7200 Tuner allows you to enjoy FM/AM Radio that is second to none. Pin point accuracy is assured by the full sized dial and signal/Tuner meter.

As for our SU7200 amplifier, we list a full 22 watts RMS per channel, 41 click stop volume control, low distortion circuit, loudness switch, tape monitor switch, and a power bandwidth of 5-100 KHz.

Impressive features?

Any way you want to look at it, you'll agree this matched pair from Technics would be hard to beat.

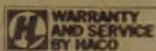

For a National Technics Catalogue please write to:
National Technics Advisory Service, P.O. Box 49, Kensington, NSW 2033
(Specifications subject to change without notice.)



Technics

hi-fi

WT.GD122T

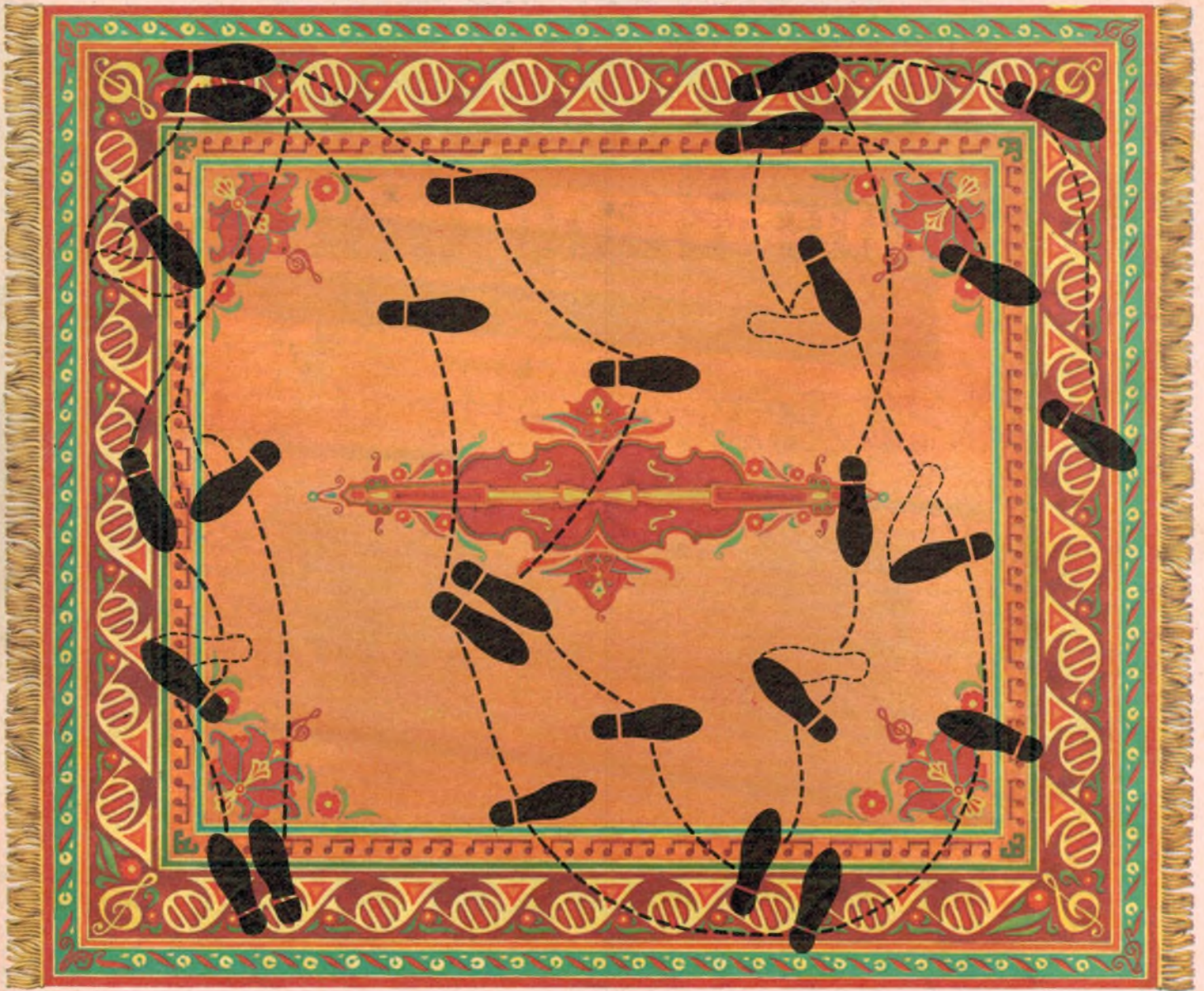

When you dance around the room can you hear all the music?

Some very heady stuff is bandied about when it comes to discussing the pro's and cons of various speakers.

All of it rather wonderful of course, but invariably there's one small catch.

Unless you stand practically right in front, the sound you get will never be all that clearly defined.

This of course brings us to our speakers. The Epicure Tens.

Not only can you hear them in just about any part of the room, but you can hear, very clearly, every instrument that's meant to be heard. Simply because they give near hemispherical dispersion.

You'll also find lower distortion in the mid-range, especially noticeable with voices.

(Due to a balanced, low-mass voice coil

assembly which is centred perfectly and automatically by the use of a unique space-age, ferro-fluidic liquid.)

While the concave air spring tweeter produces nearly hemispherical dispersion across most of the audible range.

The Epicure Tens also contain a rather unique low-mass woofer.

This gives a smoother, more accurate bass, enabling you to hear the individual bass instruments, and not just the bass.

In fact so proud are we of our speakers, we even go so far as to give them a ten year warranty.

And that's an awful lot of dancing around any room.

EPICURE

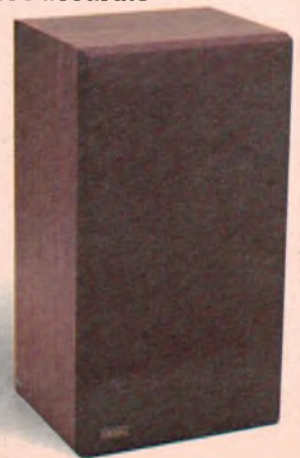

Restoring & upgrading the Wide Band CRO

Following our article in the current Year Book, "New Life for an Old CRO", we have another story along similar lines. Not only was an old CRO brought back to its original performance, but in some respects it was actually improved.

by PHILIP WATSON

One of our most popular projects in years gone by was the Wide Band CRO, described way back in 1957. (February, March, April, May, and September.) Subsequently, in September 1962, we described a Schmitt trigger sync circuit which could be added to the original design.

In its day, this CRO was of quite advanced design, particularly as one presented for the home constructor. By all accounts, a great many were built and, judging by our mail, many are still in use. We still get requests for circuit reprints from readers who wish to overhaul their unit, but have mislaid the relevant copies of the magazine over the years.

And even by today's standards, the performance figures are still good, and more than adequate for the average workshop or service department. The only snag is that, over the years, some of the vital components may have deteriorated, playing havoc with the performance. Which is what this story is really all about.

Recently, one of our staff had occasion to bring the original unit out of mothballs and give it a birthday. Several sections had failed over the years and it was in pretty poor shape.

Its immediately obvious faults were as follows:

- (1) The sync system had failed completely.
- (2) It suffered from slow vertical drift as it warmed up until, after a couple of hours, the image would be beyond the range of the vertical shift control.
- (3) For each setting of the sensitivity switch there would be a major change in vertical setting.
- (4) The time base oscillator would not oscillate spontaneously, on the lowest range, when the unit was switched on. It was necessary to switch to a higher range, then back again, in order to start it.
- (5) Marked non-linearity of the time base on the second lowest range, accompanied by reduced deflection.

Fault (1) was relatively easy. A 30k wire

wound decoupling resistor feeding the Schmitt trigger circuit had gone open circuit. A new resistor restored the excellent sync characteristics of this circuit.

Fault (2) was more of a challenge. Studying the vertical amplifier circuit, prime suspect was the coupling capacitor between the 12AU7 cathode follower and the 6BX6 amplifier. This latter valve is directly coupled to the two 6CK6 output valves which, in turn, are directly coupled to the CRO tube deflection plates.

The vertical shift control operates in the 6BX6 grid circuit and anything which upset this circuit would alter the vertical setting. If the coupling capacitor was leaky, it could easily upset this stage.

Second suspect was the 1M grid resistor in the same stage. If it had gone high, it could create all kinds of similar problems due to grid current.

On test the resistor measured spot on but the old paper capacitor showed a leakage of around 150M. While that may not seem like much leakage, it was enough. A new plastic capacitor cured the trouble and also cured fault (3), for reasons which are easy enough to follow. (It seems likely that the capacitor leakage increased with temperature.)

We also checked the .25uF coupling capacitor between the first 6BX6 and the 12AU7. While lot better than the previous one, it did show measurable leakage. We replaced it as a precaution.

Turning to the time base circuit, we considered fault (4). The most likely culprit seemed to be a .035uF timing capacitor in the lowest range. In practice it turned out to be two paper capacitors, a .02 and a .01, in parallel, plus a .005 mica.

The two paper capacitors turned out to have a combined leakage of 25M! They were replaced with a .033uF plastic type and cured that problem.

The non-linearity proved to be a real curly one and was eventually solved, not by any logical reasoning, but by a routine check of all components. The symptoms were confusing because they seemed to

indicate that the fault was confined to one range. This seemed to limit the possible culprits to the .005uF or 250pF capacitors in the timing circuits for this range. In fact, replacing both had no effect.

The form of non-linearity was rather unusual. Approximately the first quarter of the trace was stretched but, in itself, reasonably linear. Then the rate changed abruptly and remained linear for the rest of the trace.

More careful study of the other ranges showed that the lowest range also exhibited the symptom, but to a negligible degree. However, this did widen the choice of suspect components.

The fault was eventually traced to the .25uF coupling capacitor—another paper type—between the two sections of the 12AU7. The first section of this valve (pins 6, 7, 8) is part of the oscillator circuit and also drives one deflection plate from its cathode. The second section (pins 1, 2, 3) is driven from this same cathode line—via the .25 capacitor—and functions as a unity gain phase inverter to drive the second plate.

The .25 capacitor was open circuit so that only one plate was receiving any substantial drive. Why it produced the precise symptoms it did is difficult to explain. Possibly, over that range of frequencies, there was enough residual capacitance to produce a differentiated spike. A new capacitor restored what is virtually perfect linearity, and also increased deflection on all ranges.

By now the CRO was back to virtually new condition and putting up a really good performance. But it also reminded us that it did have one nasty habit; a basic fault which reflected the limited range of components available to the designer in those days.

The fault was a sensitivity to mains voltage pulses or surges. These would cause the image to kick up or down the screen; an effect which could be quite annoying when trying to measure the height of a pattern. It was worst in industrial situations where lift motors, etc., could create

PMI announces two new Op Amps that really work!

Op-02 High performance 741

If your design requires premium 741 performance the PMI OP-02 is for you. A high performance general purpose OP AMP that really fills the gap between standard 741's and precision 725's. The OP-02 fits all 741 sockets. It's even better than the PMI SSS 741! Input offset voltages are guaranteed better than the 725, but the speed of the 741 is retained. MIL STD 883 processing is available.

Prices run higher than standard 741's, of course, but well below standard 725's. For a little bit extra you get guaranteed better performance across the board, low noise, low drift, low TCvos, low TCios, and insensitivity to output load conditions. Check the table opposite. Phone CEMA for complete specifications.

	Input Offset Voltage mV MAX		Input Offset Current nA MAX		Input Bias Current nA MAX	
	MIL	Comm.	MIL	Comm.	MIL	Comm.
Industry Standard 741	6.0	7.5	500	300	1500	800
PMI SSS741	3.0	7.5	10	50	100	200
PMI OP-02	1.0	3.0	5	10	50	100
Industry Standard 725	1.5	3.5	40	50	200	250
PMI SSS725	0.18	1.6	4	25	120	180

New 108 A

Do you want to know the real inside story of our new 108A/308A precision low power op amp? PMI were approached by a large user of 108A's to supply 108A's that met 108A specifications. PMI tried but couldn't. PMI found out why nobody else could either, it was simply designed wrong.

PMI have redesigned the 108A. Corrected the unbalance which caused the high TCv_o. Gave it the PMI zener zap treatment. Plus ion implantation, and the kind of pricing high volume production parts deserve.

Check with CEMA for complete specification Up to MIL-M-38510/101B-04 specs. Processed to Mil-std-883A Level B Vos 0.5mV Max; TCv_o 0.5uV/°C Max.



CEMA DISTRIBUTORS PTY. LTD.

SYDNEY:
21 Chandos Street,
Crows Nest, N.S.W., 2065.
Tele: 439-4655

MELBOURNE:
208 Whitehorse Road,
Blackburn, Victoria,
3130. Tele: 877-5311

AGENTS:

BRISBANE: Electronic Components (QLD) — 371-5677. CANBERRA: Custom Scientific — 82-3581. ADELAIDE: Protronics Pty Ltd. — 51-4713.
PERTH: Reserve Electronics — 87-1026. WOLLONGONG: Macelec — 29-1276.

The modified circuit showing the simple changes to the plate and screen supply to the first 6BX6. Image stability is improved quite dramatically.

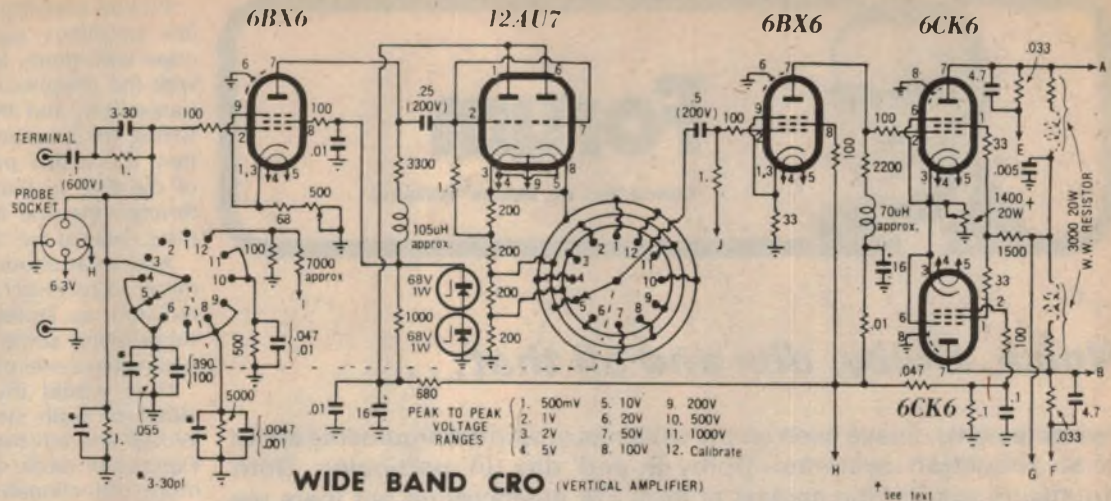

quite severe surges. It was much less of a problem in the average domestic situation.

Since we had thoroughly familiarised ourselves with the vertical amplifier circuit again, we considered the possibility that it might now be practical to minimise this problem.

Studying the circuit, we could not escape the conviction that the disturbances could only be getting in via the 150V HT line, ultimately appearing at the plate and screen of the first 6BX6. From there on the high amplification and extended low frequency response of the following stages would do the rest.

At first glance this theory may seem untenable because the 150V rail is pegged by a VR150 voltage regulator tube. The point to appreciate is that no such regulator device is perfect; it can significantly reduce voltage changes, but it cannot eliminate them. And it would need only a few millivolts change to produce a significant movement on the CRO tube.

Assuming this theory was correct, what could be done about it? These days zener diodes have taken over from VR tubes and have many advantages, not the least of which is low cost and availability in a wide range of voltages. As a result it is not unusual to find voltage regulator circuits involving two, or even three, stages.

In this case it seemed logical to take the already pegged voltage and feed it through a second regulator stage to supply the plate and screen of the first 6BX6. If the theory was right it would have to improve matters.

The highest voltage zener readily available is 75, but two (or more) units can be connected in series. It was decided to connect two 68V types in series to give 136V. It was reasoned that a drop of 14V would not seriously upset the performance of the stage.

Before trying the idea, we set up a reasonably repeatable pulse producing system. This was simply a 1kW radiator connected to the same power point as the CRO and which, at switch on, could kick the image up the screen by up to 25mm. Then we lashed up the circuit,

clipped in temporarily, and repeated the test.

We were most gratified to find that the kick had now been reduced to barely 1mm; in fact, hardly noticeable unless one was watching for it. While we hesitate to use the word "cured", we feel that the problem has at least been controlled.

Note: It should be appreciated that this problem can still occur if surges appear in the supply rail of the equipment under test and are fed to the CRO along with the signal. Such situations are relatively rare, but they are not the fault of the CRO.

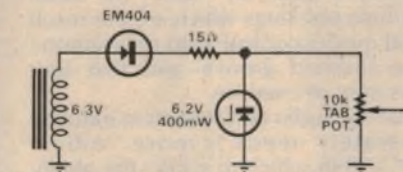

The modified voltage reference circuit.

In more permanent form we mounted the few components on a five terminal tag strip and mounted it above the chassis alongside the 12AU7 and 6BX6 sockets, just behind the front panel. There was even a spare hole in the chassis to take the necessary screw!

Another useful improvement, which is fairly easy to implement, concerns the calibrate function. In the original design the 6.3V heater line was used as a reference. This was fed to a voltage divider (7000 and 100 ohms) which delivered the correct voltage to provide full graticule deflection when the attenuator switch was set to "calibrate".

The main limitation of this arrangement is that it is at the mercy of line voltage variations. While these are not usually serious, the writer felt that would be nice to have a more stable reference, if this could be provided without much effort.

In fact, it is quite simple and two possible approaches were considered. The classic one is to use two zener diodes, with a voltage rating somewhat less than the peak voltage, connected in series back to back. These will then clip each half cycle at the zener voltage, plus the

voltage across the reversed zener, about 0.6V.

The second approach is to first rectify the AC with a single diode, producing half wave pulses, then to clip these pulses with a single zener.

There is not much to choose between the two arrangements, in terms either of cost or performance. Both will produce a crude attempt at a square wave but one which has essentially constant amplitude.

The easiest way to use such a pattern is to switch off the time base and produce a vertical line, the height of which becomes the reference.

If the wave shape is important the following points can be useful. The lower the clipping voltage the straighter will be the vertical component. On the other hand, at voltages below about six, zeners have a more rounded "knee" characteristic which gives a rounded characteristic to the clipping.

For a number of reasons, including what happened to be readily to hand, we used a rectifier and single diode arrangement. We tried several zener values, finally settling for 6.2V which gives a reasonably flat clip.

Fairly obviously, the reduced peak to peak voltage will call for a modification of the original 7000/100 ohm voltage divider network to produce exact full scale deflection in the calibrate position. This may be done by carefully selecting individual resistors, in parallel or series combinations, on a trial and error basis, or by substituting a tab pot, say 10k.

Either way, the final adjustment will need to be made against some kind of reliable voltage reference, such as the peak-to-peak voltage reference described in the January 1977 issue.

The result of these repairs and modifications is a particularly useful CRO, in spite of its age. It offers a perfectly linear time base, a response from a few Hz to 3MHz, a calibrated input attenuator and a rock steady image—to name just a few of its major features. So, if you have such an instrument lying idle, dig it out and give it an overhaul; you'll find it well worthwhile.



Forum

Conducted by Neville Williams

Noise, Dolby, dbx and all that...

Twice, recently, I have been on the sidelines of spirited arguments about noise reduction systems—Dolby-B and dbx in particular. Both arguments were in the context of local FM broadcasting but there are wider implications for the dedicated hifi enthusiast.

The starting point for many discussions about noise in an audio context is the ratio between the loudest and softest sounds we want to hear—or think we want to hear. We may typically accept that a full orchestra or a grand organ playing at its limit will produce a sound level greater by 100 decibels than that from a gentle solo string or a tiny remote pipe. So a “dynamic range” or 100dB becomes something of an ideal.

However, in practical audience situations, there is a tendency to settle for a considerably smaller dynamic range than this. While many in an audience may be exhilarated by the full power of an orchestra or organ, others may register extreme discomfort; knowing this, a conductor or organist may exercise some restraint. At the other extreme, ambient noise in an auditorium may mask very soft sounds, anyway, and musicians may quite deliberately raise their level so that they will be dependably audible. So the practical dynamic range of a live performance may be diminished to less than 80dB.

When such a performance has to be transported by radio or recording into a domestic listening room, there may be further modifying factors: the maximum loudness which can be tolerated in a domestic situation and, at the other extreme, the amount of system and domestic noise present and likely to mask the softest passages.

Under ideal conditions, the domestic environment may not add significantly to the constraints already imposed on the original performance. Under adverse conditions, too wide a dynamic range may be an embarrassment: when the softest passages are sufficiently above the local ambient, the loud passages are too loud! Accepting some kind of a mean between these extremes, most present-day hifi conscious listeners would probably be quite happy with a broadcast or recorded performance which offered a true 70dB of dynamic range—no overload distortion on peaks, and no obvious noise behind the softest passages.

In fact, even this much modified dynamic range is difficult to achieve at a domestic level—even assuming a good quality vinyl pressing (the quietest medium normally available in the home) and a good quality playback system. One overseas expert puts the practical dynamic range of the best European classical discs at 65dB maximum.

We may, in fact, be prepared to concede that the best disc records are satisfying and adequate in regard to dynamic range and inherent noise, but the inference is clear: by “best” we mean only those pressings which are the result of rigid quality control from microphone to the finished groove—and that isn't always easy to exercise.

What the audio entertainment industry desperately needs is more “elbow room” within which to work—the ability to give hifi conscious listeners the sound they want (by the best present-day standards) without nudging system overload at the top end or system noise level at the bottom end. At the same time, a wider tolerance aperture would make possible a greater dynamic range, if customer demand was so identified.

The discussions I referred to earlier both had to do with the problems of FM stations in getting premium quality recordings from cartridge or tapehead to the listeners' loudspeakers, without the intrusion of significant noise and the consequent need to further compress the dynamic range by manual or automatic methods.

Pickup cartridges, preamps, mixers, line amplifiers, transmitters—they could cope with them. But how do you cope with the telephone lines from studio to transmitter, and the things that can go wrong for a variety of reasons. Should they use a dbx processor at each end of the line to limit the dynamic range through the line and thus keep everything clear of the “mud”?

And what about the path from transmitter to receiver? Should the signals be radiated as Dolby-B, in the hope of suppressing some of the noise in the transmit/receive process?

How would the signal stand up to either or both systems of processing? Would any advantage gained be at the expense of subtle distortion, subjectively more objectionable than a bit of hiss behind the softer passages? While such questions are being argued locally, they have also been the subject of much debate and experiment overseas.

BASIC PRINCIPLE

The basic idea behind these and other methods of signal processing is well established and obvious in intent: The dynamic range of the signal is artificially and automatically compressed before the signal is fed into that part (or those parts) of the reproduction chain where the aperture between overload and noise is not wide enough. The dynamic range is later expanded—again automatically and by the same amount—before it is reproduced in the listening room.

But, while the basic intention is simple enough, its execution is quite difficult. The designer has to produce an automatic gain control system which will ensure a certain level of gain for low level signals and relatively less gain for high level signals. The output signals from the AGC controlled amplifier will therefore have a smaller dynamic range than did the original input signal. At a later point in the chain, another complementary stage must reverse the process and restore the signals to their original form.

A basic problem in all such signal processing has to do with the “time constant” of the gain control circuitry, or the rate at which it can change the amplifier gain to accommodate to the signals passing through. If the time constant is too short—if the gain changes too rapidly—individual notes may be distorted; if the



A typical 2-channel dbx noise reduction unit, intended to compress the dynamic range of signals by 2:1, and later to restore them to normal. For details of dbx equipment, contact Auriema (A/asia) Pty Ltd, P.O. Box 604, Brookvale, NSW 2100. Tel. (Sydney) 939-1900.

time constant is too long, its control action will be sluggish—audibly so!

A further major problem has to do with the assessment of how weak or strong a signal really is from one instant to the next. It is one thing to say in general terms that a gain control voltage should vary with the strength of the signal; it is quite another to ensure that there will be some mathematically predictable relationship between the two. But, unless such a relationship can be established and maintained for all compressors and all expanders, the final signal will differ from the original in its dynamic qualities—perhaps to a discernible and objectionable degree. In the jargon, this is referred to as a failure to “track”.

The many problems of processing audio signals have been eased in recent years by the availability of solid-state devices and the possibility of exploiting circuit approaches which would have been impossibly complicated a few years ago. Voltage controlled amplifiers and active bandpass and rejection filters are part of the everyday scene.

The Dolby-A system, if not the first, was certainly the most notable attempt to make things easier for professional recordists handling signals between the original masters and what finally reaches the consumer disc or tape.

In the Dolby-A system, loud signals are not subject to any processing; they are handled straight through and are free from any artificiality. Only signals below a certain level are modified, being raised by 10dB or more and giving them that order of advantage over any noise which may occur further along the amplifier/recorder chain. When the “Dolbyised” program material is ultimately “decoded”, the lower level signals are dropped back to the original amplitude and with them goes the intruding noise—down by about 10dB.

One of the points made for the Dolby-A system is that, if the processing is to generate any potentially discernible effects on particular classes of program material, they will relate only to the lowest level and therefore least obvious signal components.

Another feature of the system is that it splits the signal frequency spectrum into four bands, each processed separately. This ensures that, in each band, there will either be enough signal to mask the noise present in that band—or else the band will be “quietened” by 10dB or thereabouts.

These factors, plus modern circuit technology and a high degree of standardisation in regard to “tracking”, have ensured wide acceptance of the Dolby-A system in the professional audio field.

The Dolby-B system is much simpler and is the one which more directly concerns home recordists and FM listeners. It still operates on the low level signals, but mainly those at the upper end of the spectrum above about 2kHz. However, because top-end hiss is subjectively



CRONUS

Electronic stopwatch

Available for a wide range of applications from single function timers to the CRONUS eight digit, four function stopwatch with remote control.

Write or phone for full details to

INSTRUMENT TECHNOLOGY PTY LTD

192 PRINCE'S HIGHWAY ARNCLIFFE, SYDNEY, NSW. 2205
Phone 59 0291 Telex AA20940

NORTRONICS

AUDIO & DIGITAL TAPE HEADS

Long Life-Extended Response



Replacement heads for:

Domestic Recorders	Cassette decks. Cassette players. Reel to reel. Cartridge.
Professional Recorders	Broadcast recorders in reel to reel & cartridge or cassette. Studio recorders 1/4" to 2" multi track.
Duplicators	Reel to reel & cassette. Aircraft Recorders, cockpit & background.

To fit: AMPEX, SCULLY, TEAC, ATC, GATES, PENTAGON, INFONICS and many others.
ALIGNMENT TAPES — Reel to reel, Cartridge, Cassette.

EMAC INDUSTRIES PTY. LTD.
9 Meriton Place, Clayton South, Vic. 3169.
Ph: 544-5157



AUSTRALIA'S FIRST BYTE SHOP

Imesai 8080 Truly second generation Micro-processor Mini Computer. Complete range of memory and I/O modules available.

Cromemco TV dazzler • Byte saver • Cyclops camera • A-D, D-A • Cromemco Z80 mini computer.

Processor Technology The Sol System Intelligent Terminal.
Wide range of PROM; RAM; Parallel/Serial I/O; firmware; simulator, text editor; video display modules.

All the above are available in kit or assembled form. For further details send SAE to BYTE, P.O. Box 156, Carnegie 3163 Victoria, OR, for hands on experience phone Melbourne 560 0358 for appointment.

TRAINING COURSES COVERING MANY TYPES OF MICROPROCESSORS COMMENCING FEBRUARY '77.

BRIGHT STAR CRYSTALS PTY LTD

35 EILEEN ROAD, CLAYTON, VICTORIA 546 5076

MAY WE REMIND YOU

THAT BRIGHT STAR CRYSTALS
HAVE MORE THAN 36 YEARS
EXPERIENCE IN



MADE IN AUSTRALIA

HOSE & EQUIPMENT CO. PTY. LTD. SYDNEY. PHONE 666-8144

COMMUNICATION SYSTEMS
PERTH. PHONE 76 2566

FRED HOE & SONS PTY. LTD.
BRISBANE. PHONE 47 4311

ROGERS ELECTRONICS
ADELAIDE. PHONE 42 6666

DILMOND INSTRUMENTS
HOBART. PHONE 47 9077

FORUM—continued

more noticeable on hifi gear than noise lower down in the spectrum, the system can make a useful contribution in situations where hiss is a problem. The two most obvious situations involve cassette recorder/players, and FM/Stereo receivers operating in near-fringe conditions.

The phrase "can make a useful contribution" is deliberate because the full benefits of Dolby-B are often not realised in practical conditions, particularly in cassette decks. To be effective, and for precise tracking, decks need to be set up critically for a particular tape and thereafter operated at just the right signal throughput levels. If a different class of tape is used, the adjustments may or may not hold good. And if, for any reason, the pre-emphasised treble frequencies are "crushed" by head or tape saturation, the Dolby-B decoding will interpret the crushed highs as low level highs and attenuate them by a few dB more!

It is for such reasons, as well as patent implications that some manufacturers have sought to popularise other systems of automatic noise reduction which do not operate at all during recording. They simply sense whether or not signal energy is present in the upper register and, if not, reduce the treble response accordingly—and with it the hiss. They are, in fact, rather like a dynamic treble-cut tone control.

Getting back to Dolby-B, however, one of the reasons for its acceptance on the consumer market is undoubtedly its neo-compatibility. A Dolbyised recording can be played back on a non-Dolby deck without the listener necessarily being aware that there is anything unusual about the cassette. Or if he does notice that the highs are a trifle bright, a touch of treble cut will bring them reasonably into line.

The same is true of FM broadcasting. In the United States, a hundred or more FM stations are encoding all their outgoing programs in Dolby-B, at the same time reducing the treble pre-emphasis to 25uS. Stations in the U.K., West Germany and elsewhere have also operated along similar lines for trial periods to test audience reaction. Listeners equipped with receivers having in-built Dolby-B decoding stand to gain a few dB in signal/noise ratio, where noise is a problem. Other listeners with ordinary receivers having 50 or 75uS de-emphasis will hopefully not be discomforted by the mildy "doctored" signals from the transmitters.

By contrast to all this deference to compatibility, the dbx noise reduction system employs a brute force approach to achieve quite sensational figures—a lowering of the noise threshold by 30dB or more and therefore an increase in the

potential dynamic range by the same amount. Translated into practical terms, this has the following implications:

MASTER RECORDINGS: If adopted as standard for all signal handling ahead of the final consumer recording, it would provide a 30dB wider aperture than normal (Dolby-A offers about 10dB) making it possible to equal or exceed top present-day standards in more recordings.

PROGRAM LINES, ETC: Assuming the same head room for peak signals, low level signals could be raised above extraneous line noise by 30dB or more.

CONSUMER TAPE, CASSETTE DECKS: If it became practical to dbx-process signals going on to the tape and then dbx-decode as they were recovered, the 45-55dB signal/noise ratio commonly encountered on consumer decks would begin to look like 80dB, giving a lot more latitude for "good" recordings and the potential for quite superb recordings—at least in respect to dynamic range and S/N ratio.

DISC RECORDINGS: If discs were dbx encoded and then played back (of necessity) through dbx decoders, the spin-offs could be distributed to produce: discs with startling dynamic range and uncannily low noise; or a much larger proportion of all discs equal to or better than the present-day best in terms of the foregoing qualities; or longer play pressings with normal dynamic range.

As already mentioned, dbx is a no-holds-barred system which makes no attempt to produce a signal directly listenable in non-decoded form.

It operates by compressing the dynamic range of an input signal by exactly 2:1. Thus an "ideal" signal having a 100dB range from +20dB to -80dB might be compressed to new limits between +10 and -40dB. It would be handled and recorded in this modified

form but expanded back to its original range immediately prior to reproduction. In the compressed form, it could be kept comfortably below overload and comfortably above the system noise. Equally, a signal destined to have a more modest but still excellent 70dB of range would be seen by the mastering system as having only a non-demanding 35dB range.

Proponents of the dbx system point out that, since it operates as a linear compressor and expander, over the whole frequency range, it does not have to be set up to match any particular threshold. Provided compression and expansion are set up for a linear 2:1 relationship, tracking is automatic and universal.

The fact that the dbx system processes the full signal bandwidth and by such a large amount leaves it potentially open to some of the audible processing sounds mentioned earlier—"pulsing" as the gain changes at a discernible rate, and momentary wisps of noise exposed when the change in signal level is too abrupt for the quieting.

To combat this, the designers of the dbx system have resorted to complex pre-emphasis and de-emphasis of frequencies above 1600Hz in both the signal and sensing circuitry, aimed at reducing the audibility of the processing without making undue demands on the headroom of typical tape.

One other aspect of the dbx system is that the designers have been able to draw heavily on modern solid-state technology to continuously sample the RMS value of the signal envelope within specific time intervals. The samples are used to control compression and expansion and, being a fairly definable and precise procedure, good tracking is possible.

In view of all this, the dbx system should surely have swept into a dominant position; yet one of the engineers whose remarks prompted me to get involved in the foregoing was quite rude in his rejection of the whole idea! My impression was that he spoke for a lot of engineers, many of them in the inner sanctums of hifi, who regard dbx, Dolby and other processing systems as mere "bandages", or "pills" to which the industry can become addicted. "Let's get rid of the ailment", they say.

They are also quick to point out that dbx differs from Dolby in one vital respect: while dbx can do a lot of good if it is right, it can do proportionately as much harm if it is wrong. For example, if a recording or cartridge, or tapehead suffers from a peak or trough of, say, 3dB, a dbx expander will promptly and automatically turn it into 6dB!

And as for tapes and discs with their track and groove dynamics compressed by dbx, is the position really so desperate that we need yet another group of products and yet more circuitry in the chain ahead of our loudspeakers?

So run the arguments.

Dear Mr Williams,

I fully concur with your comments in the January "Forum" regarding CB emergency calls.

Channel 9 (27.065MHz) has not been without hoax calls but we have tried to adopt a responsible attitude considering that, when an emergency situation exists, we are within the law to operate. However, this has not precluded irresponsible persons from trying to discredit our operations by making hoax calls. If only they would realise that, whilst diverted by a hoax, the relevant authorities may one day be faced with a real emergency.

You observe that there is an irresponsible element in any group and I am convinced that there is such within the ranks of licensed amateurs. Indeed, some of the monitors for channel 9 are amateurs and they are aware of remarks to the effect: "it's fun to give CREST a run for their money".

I trust that by airing this situation, you will have helped bring about a more responsible attitude.

Bill Payne

(National Director, CREST Australia).

Lafayette))

27MHz two-way



**5 WATT 6 CHANNEL
'MICRO 66'**

From the Lafayette Radio Electronics Corporation of U.S.A. Lafayette transceivers embody features which have made them world famous. 1,000's in use throughout Australia, 100,000's world-wide. Government, industrial, marine, sports and farm applications testify to their versatility and rugged reliability.



All units Telecom Type Approved (Licence Required)

Lafayette are 2-way specialists. Full range 27MHz crystals, antennas, auxiliary equipment available!

Dealer enquiries invited

Lafayette))

the Communicators

LAFAYETTE ELECTRONICS

Div. of Electron Tube Distributors P/L
94 ST. KILDA RD., ST. KILDA
Victoria 3182. Tel. 94 6036



The Serviceman

Self-converging systems

Regular readers may remember that approximately 18 months ago (August 1975) I described a visit to a two-day colour service course sponsored by EMI. At the beginning of December 1976 I had the opportunity to attend another such course and I am sure readers will be interested in many of the points I learned.

The main purpose of the school was to provide an opportunity for servicemen to familiarise themselves with the current range of TV sets which the company is marketing, and to emphasise that the company's entire range is now using self-converging deflection systems of one kind or another.

Particular emphasis was placed on the company's two locally produced sets—22in and 26in—using the Philips 20AX display system; picture tube, self-converging yoke, and associated circuitry.

For those not familiar with it, the 20AX system consists of an in-line gun vertical stripe picture tube, a precision yoke—which is really the heart of the system—and a magnet assembly for purity and static convergence adjustment. It was described in more detail in the August 1975 issue of *Electronics Australia*, p25.

I first became acquainted with the 20AX system at a trade demonstration by Philips in June 1975 and, like everyone else, I was most impressed. At that stage most of us were still recovering from the trauma of learning convergence techniques for the conventional delta-gun picture tube. Having learned all the reasons why such a tube needed to be converged, the rumours then current about self-converging systems sounded far too good to be true. There just had to be a catch somewhere.

On the other hand, Philips were quite specific about their system. They claimed that any yoke could be fitted to any picture tube and, using static convergence only, would produce a convergence error no greater than 2mm on any part of the picture. And, as they pointed out, this was better than was being achieved by many systems with full dynamic convergence. With the addition of simple tolerance correction circuitry near perfect convergence was possible.

What was more, they proved their claims with some very effective demonstrations. Not only did the demonstration sets exhibit excellent convergence, they also had excellent picture geometry in general; a marked absence of barrel or

pincushion distortion, and first class linearity in both axes. What was more, they were achieving this with 26, 22 and 18in tubes and 110° deflection. As I said earlier, everyone was most impressed.

The only snag was that most of us had to go back to looking at and working on the old dynamic convergence type sets. No matter how enthusiastic the local manufacturers might have been, it takes time to re-design and re-organise for a change as drastic as this.

It was with considerable interest, therefore, that I learned, a few months back, that both Philips and EMI were about to release new ranges of sets employing the 20AX system. So when EMI invited me to the two day service school to see and actually work on their version I didn't hesitate.

For one thing, I was eager to see how a particular manufacturer had elected to use the 20AX system, since there are several options available, having varying degrees of refinement.

Also, I was anxious to see how the 20AX system compared with other self-converging systems. For, although the 20AX demonstration in June 1975 was the first self-converging system many of us had seen, it was not the only one in the field. RCA had already announced their cemented yoke system and there had been a number of reports of various schemes being developed in Japan.

The school was conducted by Mr. Don Wallace, EMI's Technical Sales Manager, and Mr. Leigh Downey, their National Service Adviser. Together, they presented a series of lectures and discussions during which the various receiver circuits were discussed in detail. This included typical faults as they had been encountered in the field, their symptoms, and the appropriate repairs. Circuit modifications, and the reasons for them, were also discussed.

Then we were let loose on a batch of 22in receivers, two students to a set, to get the feel of the convergence and other setting-up controls.

Purity and static convergence were

tackled first. The purity adjustment is roughly similar to what we have been used to, but is rather more convenient. The yoke proper is mounted inside a yoke housing, which is secured firmly to the picture tube. The yoke, in turn, is locked to the housing by two simple clips, one each side near the front of the housing.

These clips are released and the yoke moved backwards by rotating a large plastic control lever in front of the magnet assembly. The set is fed with a blank raster and the blue and green guns switched off. The gun switches, along with most of the other setting up controls, are readily accessible from the front of the set when the chassis is swung up and locked in a near vertical position.

Backing off the yoke produces the usual red blob. This is adjusted for a roughly central position, consistent with colour purity, by rotating the purity magnet. The yoke is then edged forward, and minor adjustments made as necessary to eliminate any impurity which might appear. Finally it is moved forward to give even screen coverage, and locked in place. As a final check the blue and green guns can be switched on individually.

So far, nothing very much had changed, except that the mechanics had made things somewhat simpler. For example, it can be done without using a mirror, since it is quite easy to reach behind the set and operate the rotary levers while watching the screen from one side.

Then came the all-important static convergence. A cross hatch pattern is used for this, although only that portion in the centre of the screen is required. The pattern generated at EMI has a dot in the centre square, which is quite helpful, but the centre square alone is perfectly adequate.

Convergence is actually a matter of shifting the red and blue images to match the green image, the green gun being the centre gun. The job is done in two steps; convergence of the red and blue images, then convergence of this combined (magenta) image with the green image.

Adjustment is by means of two pairs of magnet rings, referred to as the four pole system and the six pole system. The six pole system is at the front of the assembly, nearest the tube, and the four pole system behind it. Each lever is distinctively shaped, to assist in identifying them by touch. They are also colour coded, brown and white, to make instruction easier.

To converge the red and blue images the green gun is switched off and the four pole magnet adjusted. This job is easier to do than it is to describe. According to the instructions one should set the field strength lever (brown) to either one of its limit stops, and then adjust the field direction lever (white) to converge the blue and red images on either the horizontal or vertical axis, whichever occurs

first. Then the two levers are moved as one until the images converge on the other axis.

In practice we tended to take a few short cuts, but the basic plan, i.e., white lever first for one axis, then both levers together for the other axis, works well. The job can be done—in fact was done—without the aid of a mirror by looking at the image from the side of the set and reaching around the back to adjust the levers.

When red and blue images have been converged at the centre the green gun is switched on and the two six pole levers are adjusted in a similar manner to converge the now magenta image with the green image.

Finally, there is a raster shape magnet which is adjusted to give a straight horizontal centre line. The lever for this is at the rear of the assembly, near the purity lever, but has a scalloped end for easy identification.

This should—and did—result in a well converged image over most of the screen; one which would be as good as some delta-gun systems with full dynamic convergence. But that is not the end of the story. There are a number of auxiliary controls with which even the minor errors can be corrected to produce a near perfect result. These adjustments are best made with the green gun switched off.

There are six controls in all, four pots and two variable inductors. The two inductors are labelled "line balance coil" and "line sawtooth coil". The line balance coil is used to converge the red and blue images at the ends of the horizontal centre line. The line sawtooth coil is used to converge the red and blue vertical lines at the edges of the picture.

Two of the pots converge the red and blue images vertically, at the top and bottom of the screen respectively, and so are adjusted to remove any marginal error along the top and bottom horizontal lines.

The other two pots are labelled "parabola" and "sawtooth". The parabola pot is adjusted to minimise any fishtail effect between red and blue at the top and bottom of the centre vertical. The sawtooth pot provides some crossover of red and blue on the vertical axis and, ideally, these two pots should be adjusted one against the other for best overall effect.

And if all that sounds complicated, let me assure you that it isn't. Coming at the set cold—I had never touched a 20AX system before—and having to identify each control from the instruction sheet as I went along, I turned out a first class convergence job in less time than it would take an experienced operator to do a full dynamic convergence job. After that, having identified the controls, it was a snack.

Nor was I boasting when I said a first class convergence job. One of the other students summed it quite neatly: "You could put that set in my lounge room any time you like".

Equally impressive were the picture geometry controls which, incidentally, have no effect whatever on the convergence adjustments. There are six controls, five of them on the vertical oscillator board. These are: width, height, phasing, keystone, and pincushion. (The latter is marked parabola on the circuit, but should not be confused with the parabola control on the convergence board.) This sixth control is horizontal linearity, on the line output board.

The impressive characteristics of these controls are that they provide more adjustment than one is likely to need and

dynamic convergence systems, has been virtually eliminated.

And as if all these goodies were not enough, the 20AX system results in a power saving of some 20%, or close to 40W in these sets. Most of the power saved is what was previously required for the dynamic convergence circuits.

As I mentioned at the beginning, the entire EMI range of colour sets now use self-converging systems of one kind or another. The smaller models, below 22in, are imported and, while they obviously employ the broad principles which have now been established for self-converg-

The 20AX yoke and static correction assembly, showing the location of the adjustments. Purity is adjusted using the "Yoke Axial Position" lever and convergence by the brown and white 6-pole and 4-pole magnet levers. (From EMI service data, by courtesy of EMI.)

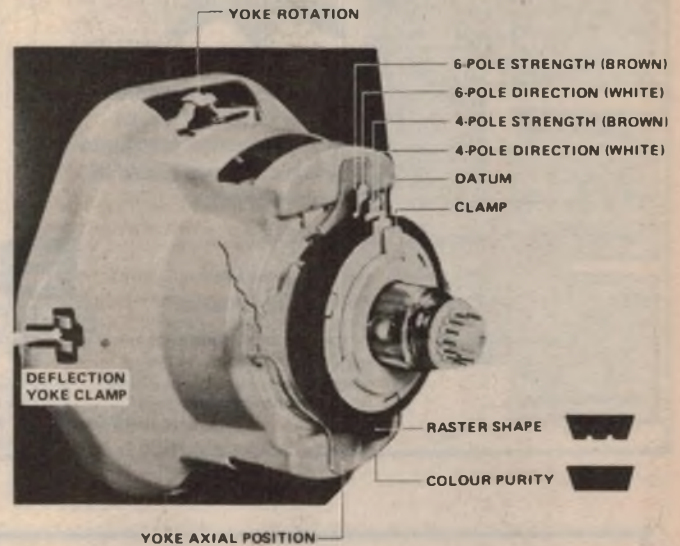

that they have negligible interaction. For example, the width control will vary the picture by several inches on each side, while the pincushion control will vary the shape from gross pincushion to gross barrel distortion.

The keystone control varies the picture width at the bottom of the picture and, again, has plenty of reserve. It makes it easy to straighten the verticals after the best pincushion adjustment has been found.

The phasing control is a horizontal shift control. Due to the nature of the horizontal hold control it does not move the picture horizontally, as did most older types, so a separate control has been provided.

The horizontal linearity control is a variable inductor incorporating a permanent magnet. Its effect is to compress or expand the left hand side of the picture more than the right and, as a side effect, to vary the overall width. This latter effect can then, if necessary, be corrected with the width control.

There is no vertical linearity control, the inherent linearity being so good that there is obviously no need for it.

With all these controls optimised, the geometry was first class, and a good deal better than many of the earlier colour sets, which left a lot to be desired. Furthermore, I am assured by the EMI personnel that the system is inherently stable; convergence drift, a problem with

ing systems, they differ mechanically.

Most employ a static convergence magnet assembly broadly similar to that used on the 20AX (though smaller) but there the similarity ends. The purity routine is more akin to that used in the old delta-gun system, with the yoke being manhandled directly. Also, some check purity on green and some on magenta.

The final convergence involves varying the angle of the yoke slightly, relative to the tube, in both axes. When the optimum position is found the yoke is secured in this position using plastic wedges which are glued to the bell of the tube.

While it is difficult to quibble with the end results, the procedure is not nearly as convenient as that provided by the 20AX system. Fortunately, these systems are inherently quite stable and adjustment would be a rare requirement.

Summing up, it is apparent that the self-converging systems are rapidly replacing the delta-gun dynamic convergence systems, and that they have many advantages to offer. These include generally better convergence, markedly simpler adjustment techniques, fewer components, lower power consumption and better convergence stability. These mean, in turn, reduced labour and material costs during manufacture, higher reliability in the field, and lower running costs.

And speaking as a serviceman, I would

Educational & Research Aids

Modern aids for the modern era



ELECTRONIC EXPERIMENT BOARDS

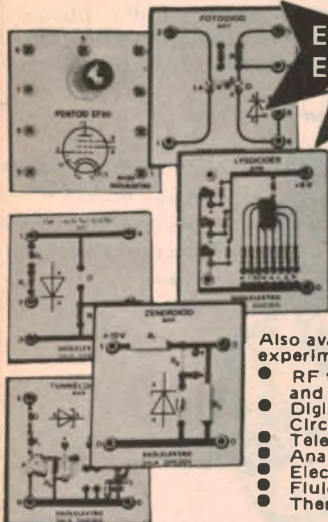

Used for characteristic evaluation of active components, complete with full documentation of experiments.

Also available for experiments in:

- RF transmission and reception
- Digital techniques & Circuit Control
- Telecommunications
- Analog Circuits
- Electric Power
- Fluid Mechanics
- Thermodynamics

W3

MINILAB Model bwd603A

- Function Generator, 0.01Hz to 1MHz
- Power Amplifier, DC to 80kHz
- Bi-Polar Power Supply, -15 to +15V, 1A
- Operational Amplifier, X1 to X100
- High Voltage Power Supply, 0 - 200V, 30mA
- Low Voltage Power Supply, 6.3 - 0 - 6.3V, 1A
- Low Voltage Power Supply, -15 to +15V, 1A

BWD ELECTRONICS PTY. LTD.

VIC.: Miles Street, Mulgrave, 3170.
Telephone 561 2888
N.S.W.: 182-186 Blues Point Road, North Sydney, 2060
Telephone 929 7452.

QLD.: Warburton Franki (Brisbane) Pty. Ltd.,
13 Chester St., Fortitude Valley, 4006.
Telephone 52 7255.

S.A.: A.J. Ferguson (Adelaide) Pty. Ltd.,
44 Prospect Road, Prospect, 5082.
Telephone 269 1244.

W.A.: Cairns Instrument Services,
32 Wickham Street, East Perth, 6000.
Telephone 25 3144.

TAS.: Associated Agencies Pty. Ltd.,
25 Barrack Street, Hobart, 7000.
Telephone 23 1843

zephyr products

70 BATESFORD ROAD, CHADSTONE,
VICTORIA, 3148, AUSTRALIA

CABLES: ZEPHPROD. TELEPHONE: (03) 568 2922



AGENCIES:-

ALTEC LANSING
AMPEC ENGINEERING
AUDITEC
BRIMAR VALVES
C.G.S. RESISTANCE
CAMBION
ELECTRONIC DEVELOPMENT SERVICES
E & L INSTRUMENTS
GARRARD
HARTLAND Mfg
J.B.L.
K.E.F.
L.P.S. RESEARCH
MANN COMPONENTS
PRIMO
PIHER
R.C.F.
RADFORD

PRODUCTS

- AMPLIFIERS
- AMPLIFIERS MODULES
- AMPLIFIERS POWER SUPPLIES
- ALARM DEVICES
- BREADBOARDING SYSTEMS
- CABLE
- CONNECTORS-AUDIO
- CONNECTORS-MULTIPIN
- DESIGN SYSTEMS
- DRIVER UNITS HI-FI & P.A.
- FUSEHOLDERS
- GUIDE STRIPS
- HARDWARE
- HORNS HI-FI & P.A.
- INHIBITORS
- INTEGRATED CIRCUIT PACKAGING
- INTERFACING HARDWARE
- INSTRUMENT MODULES
- INSTRUMENT POWER SUPPLIES
- JACKS
- LAMP HOLDERS
- KNOBS
- MATRIX BOARD
- MICROPHONES
- MICRO PROCESSOR SYSTEMS
- MIXER P.A.
- PLUGS
- RACKS (EQUIP)
- RACKS ACCESSORIES
- RESISTORS
- SPEAKERS
- STANDS P.A.
- SUBCONTRACT
- TURNTABLES
- TERMINAL PINS
- WIRE ENAMEL
- WIRING FACILITIES

SERVICEMAN

consider that the 20AX system has exploited these characteristics to the best advantage. It produces first class convergence, lends itself to really good geometry correction circuits and, most important of all, is delightfully simple and easy to adjust.

If I needed anything to bring home this last point it was provided by a tour of the EMI factory on the last afternoon of the school and, in particular, watching the sets go through the final test and adjustment stages as they came off the production line. The final testers, mostly women, seemed to take only minutes to put the sets through the full convergence and geometry routine—even when they were taking time off to explain the various steps to our group.

Altogether, it was a most profitable and enlightening couple of days.

As always when a group of servicemen get together, there is plenty of "shop talk" during the coffee and lunch breaks. From these discussions comes the following story, which raises a valid technical point, as well as having its lighter side.

Way back in the early days of radio, when large outdoor aerials were essential in all but the most favourable areas, handyman type installations often suffered from a simple error. They were not fitted with a drip loop in the lead-in configuration, designed to allow rain water to drip off the wire before it entered the house. As a result, water often found its way right into the set.

The problem was largely forgotten as radio aerials went out of fashion but more recently, particularly with the advent of coax feeder for TV aerials, it has re-appeared.

This was the background to the story related by one country serviceman. It seems that he was called in to repair a routine fault in a TV set, the aerial for which the owner had obviously installed himself, using good quality coax by reason of a fringe area situation.

While working behind the set in the customer's lounge room he became aware that the carpet under the set was damp, and that there were obvious stains which indicated that this had happened on previous occasions. A quick check of the installation confirmed that water was coming in via the feeder, and had even reached the receiver aerial terminals.

When he approached the owner, and pointed out what was happening, the reaction was one of incredulity, followed by slow comprehension.

"So it wasn't the poor bloody cat!"

As the storyteller put it, "I don't know how many kicks in the behind poor old puss had suffered, but at least I had saved him from any further punishment, and cleared his reputation as well".

Which is fair enough, I suppose, but how does one apologise to a cat? ☺

Variations on the Car Alarm

Following publication of the Car Burglar Alarm in the November 1976 issue the author, Mr Ian Robertson, advises that feedback from readers suggests some minor variations from the original circuit to suit particular situations.

The main modification is prompted by the difficulty some readers have experienced in obtaining a 12V relay with a coil resistance greater than 500 ohms. The majority of relays have a resistance of about 150 ohms.

Some readers have been supplied with low resistance relays and have fitted them, only to find that the unit will not work. In such cases the reason for failure may not be immediately obvious.

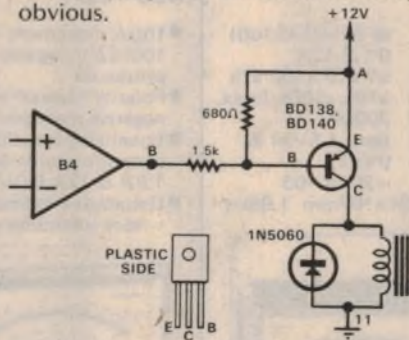

The addition of this simple driver stage will allow the more readily available low resistance relays, around 150 ohms, to be used.

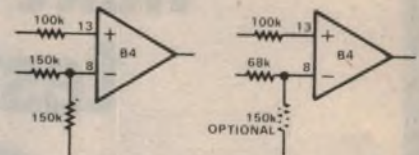

Warbler or multitone alarms are best fed with a continuous signal. The original circuit is on the left, the modified version on the right.

For this situation the driver stage shown in the circuit may be used. The components may be mounted on a small tag strip adjacent to the relay. The transistor should not need a heat-sink for 150 ohms relays, but one should be fitted for relay resistances below 100 ohms.

The other circuit variation is to provide continuous operation of the alarm, rather than pulsed, if the alarm is either an electronic warbler alarm or a multi-tone air horn. This can be provided by simply changing the value of the resistor between pin 10 of B3 and pin 8 of B4. Previously 150k, it should be reduced to 68k. The 150k to pin 10 of A3 need not be changed.

For fine detail work — a hands free magnifier



The **Magna-Sighter** is a precision 3-D binocular magnifier that leaves your hands completely free for work. It has hundreds of applications, and is invaluable for scientists, technicians, craftsmen, toolmakers, hobbyists, etc. Slips easily over the head—over glasses, too. Proved and used by many U.S. universities, space research bureaux, government departments and major industrial organisations. Available in 3 different magnifications. Price \$21.00

MAGNA-SIGHTER

For further information send this coupon today:

STOTT TECHNICAL SERVICES MEA 2 77

(Division of Stott's
Technical Correspondence College Pty. Ltd.)
159 Flinders Lane, Melbourne, 3000. Tel: 63 5583

Please send me full information on the 3-D Magna-Sighter.
I understand that no Sales Representative will call.

Name.....

Address.....

Postcode.....

STC 951

Your next electronic circuit tester should be a Sanwa

N-501

- 2μA suspension movement – 0.05mA/1mV resolution
 - Double protection – fuse & Si diode
 - Constant 1MΩ input impedance (ACV) – RF-diode rectified current direct to movement
 - Revised scale marking – intermediate readings readily determined
 - Multifarious application – as circuit analyser
- ±DCV 0-60mV 0-0.3-1.2-3-12-30V (500kΩ/V) 0-120-300-1.2k (50kΩ/V) ±2% 0-30k (w/HV probe)
- ±DCA 0-2μS 0-0.03-0.3-1.2-3-12-30mA 0-0.12-0.3-1.2-12 (300mV) ±2%
- ACV 0-3-12-30-120-300-1.2k (1MΩ) ±2.5% Freq. 20Hz

ACA Ω to 50kHz (±1dB) 0-1.2-12A x1 x10 x100 x1k x10k x100k (max. 200M) Batt. 1.5Vx1 & 9Vx1

dB -20 to +63 252x191x107mm 1.95kg



460-ED

- 10μA movement – 100kΩ/V, varistor protected
- Polarity reversal switch – negative measurements
- Equalizing transformer – common shunts & jacks for 1.2A & 12A DC/AC
- Detachable indicator block – easy maintenance

- Accurate DC reading – no HF current interference
- ±DCV 0-0.3-3-12-30-120-300 (100kΩ) 1.2k (16.6kΩ/V) ±2% 30k (w/HV probe)
- ±DCA 0-12μA 0-0.3-3-30-300mA 0-1.2-12A (300mV) ±2%
- ACV 0-3-12-30-120-300-1.2k (5kΩ/V) ±3% Freq. 20Hz to 1MHz at 3V
- ACA 0-1.2-12 (300mV) ±3%
- Ω x1 x10 x100 x10k (max. 50M) Batt. 1.5Vx1 & 9Vx1
- dB -20 to +63 184x134x88mm 1.3kg



U-60D

- Measurement ranges available.
- DCV 0.1 0.5 2.5 10 50 250 1000 (20kΩ/V) (25kV w/HV probe extra)
- ACV 2.5 10 50 250 1000 (8kΩ/V)
- DCmA 0.05 2.5 50 500 (500mV drop; 100mV for 0.05mA)
- Ω Range – X1 X10 X100 X1k Midscale –50Ω 500Ω 5kΩ 50kΩ Maximum – 5kΩ 50kΩ 500kΩ 5MΩ Batteries 1.5V dry cell (UM-3 or equivalent) X2
- LI 0.06mA 0.6mA
LV 3V 3V



LI 6mA 60mA
LV 3V 3V

- Allowance. Within ±3% f.s.d. for DCV & DCmA Within ±4% f.s.d. (±6% for 2.5V) for ACV Within ±3% of scale length for Ω
- Size & weight. 133X92X42 mm & 300 gr

P-2B

- The sturdy midget – quality quality instrument of functional design
 - Designed for rugged service – phenol-resin front panel & metal rear case
 - Positive range setting – special feature of a pinjack tester
 - Reserve instrument – for household or field service
- DCV 0-10-50-250-500-1k (2kΩ/V) ±3%
- DCA 0-0.5-10-250m (670mV) ±3%
- ACV 0-10-50-250-500-1k (2kΩ/V) ±4%
- Ω 0-5k 500k Batt. 1.5Vx1
- dB -20 to +36
- MΩ 0.1–50) using
μF 0.0002–0.6) external power
- 120x88x40mm 325gr



75WF

75 years of service to Australian industry.



WARBURTON FRANKI

- ADELAIDE 356-7333 ● BRISBANE 52-7255 ● HOBART 23-1841
- MELBOURNE 699-4999 ● PERTH 65-7000 ● SYDNEY 648-1711
- WELLINGTON N.Z. 698-272

Circuit & Design Ideas

Conducted by Ian Pogson

Interesting circuit ideas and design notes selected from technical literature, reader contributions and staff jottings. As they have not necessarily been tested in our laboratory, responsibility cannot be accepted. Your contributions are welcome, and will be paid for if used.

A simple noise blanker

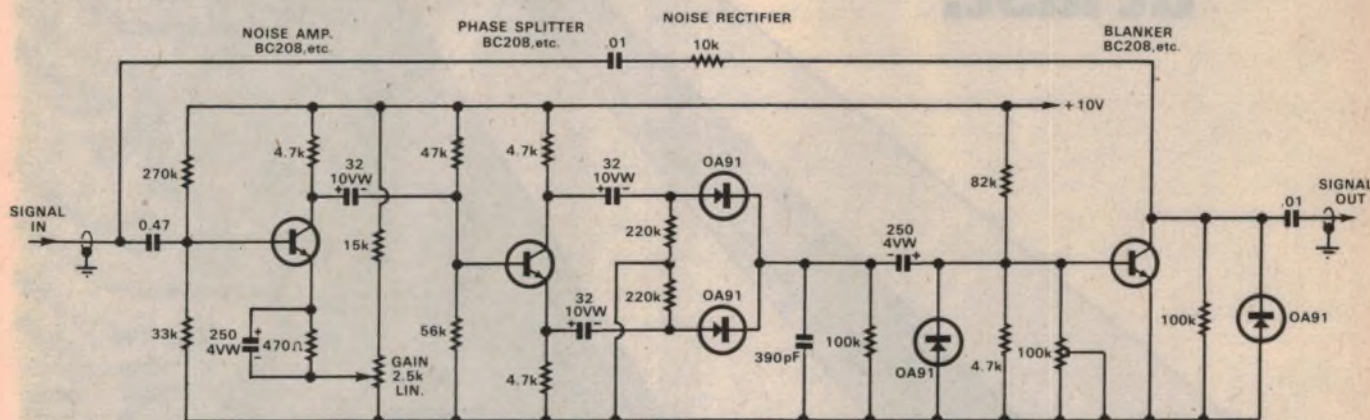

In *Circuit & Design Ideas* for March, 1976, I put forward the circuit for an IF noise limiter. This circuit is very effective but the application which I had in mind was rather demanding and although it was doing a good job, I felt that some sort of noise blanker would be even better. After some searching, I came up with a somewhat modified version of the blanker unit which I described in December, 1969.

If you check back on this former circuit, you will find that it follows the classical design originated by Lamb. However, one feature was the use of a symmetrical germanium transistor for gating. These are now difficult to obtain and so my thoughts turned to the idea of making what was the pulse amplifier function as a short-circuit across the signal path during noise pulses. The idea was tried and it worked really well. This meant quite a worthwhile simplification of the circuit and using readily available components.

The basic circuit is shown. Signal plus noise is fed into a noise amplifier, with a gain control so that the signal can be sliced off, and still able to amplify the noise pulses rising above the signal level. The amplified pulses are passed on to a phase splitter which in turn feeds a full wave rectifier. Positive-going noise pulses are now fed to the base of the blanker transistor. With forward bias set for optimum performance, the blanker looks like an open circuit with no pulses on the base and so it does not affect the signal passing through. When a pulse hits the base, the transistor looks like a short circuit across the signal path and causes a signal voltage drop across the 10k resistor in series. The result is that the signal is cut off for the duration of the noise pulse.

In my case, the noise blanker was fitted in an almost ideal position—between the collector of an untuned RF amplifier and the gate of a JFET mixer. The signal level happened to be high enough and the

lack of tuned circuits avoided the usual problem of ringing on large noise pulses. If you are able to fit the blanker in the same position, then so much the better. Normally, a blanker is fitted between the first mixer and the first IF amplifier and this means that there will be a tuned circuit between the mixer and the signal fed to the blanker and the next stage.

The blanker may be made as an out-board unit and fitted into a box with shielded leads for input and output. The supply of 10V DC may be obtained by whatever means is convenient, provided it is well filtered.

Setting up is best done with the aid of a CRO. The standing forward bias on the blanking transistor is set for best operation by means of the 100k trimpot. The 2.5k gain control is brought out to the panel and it is set to suit the conditions prevailing at any time.

(By Ian Pogson, "Electronics Australia".)

Zener plus diode temperature coefficients

Generally a silicon diode has a temperature coefficient of the order of $-2.5\text{mV}/^\circ\text{C}$, whereas the temperature coefficient of a zener diode varies with voltage type. For a BZY88, a 5.6V diode has a zero temperature coefficient, whereas a 3.3V diode has a negative temperature coefficient and a 6.8V device a positive one (-2.5 and $+2.5\text{mV}/^\circ\text{C}$ respectively).

Thus, adding a silicon diode in series

with a 6.8V zener, or two silicon diodes in series with a 8.2V zener will reduce the overall temperature coefficient to zero, as well as increasing the overall reference voltages. A silicon transistor base-emitter junction has the same coefficient as a silicon diode. Thus this method can also be used to provide an effective means of adjusting the temperature coefficient of a zener diode.

(From "Radio Communication".)

ELECTRONICS AUSTRALIA 1976/77 YEAR BOOK.

Crammed with fascinating reading do-it-yourself projects, hand picked record and book reviews, a full listing of Australian and New Zealand radio and TV stations, equipment reviews and a look at CB in Australia. \$1.20

FROM YOUR NEWSAGENT

Back on the rails at last.



Recognise this? The Swann Electronics Card Guide—the one you've been trying to get for months. Now it's back. You can order ex stock, no waiting, it's now made in Australia.

When you need guides, just cut to size from the convenient 3 or 6 foot lengths.

It's been hard to find a cheaper way. Now there's no need. Available with its own nuts and bolts for mounting.

Available from:
Swann Electronics
(Formerly McMurdo
Australia)

Head Office: Cnr. Forster
and Hardner Rds., Mt Waverley
P.O. Box 350, Mt Waverley,
Vic. 3149 Phone. 544 3033

Sydney (02) 807 1944
Brisbane (07) 262 2852
Adelaide (08) 42 6664,



SWANN ELECTRONICS PTY LTD

LBV 3304

Stable Pierce oscillator as TTL clock

The requirement for stable oscillators able to work from a few volts and suitable for interfacing with TTL devices arises more and more frequently. An

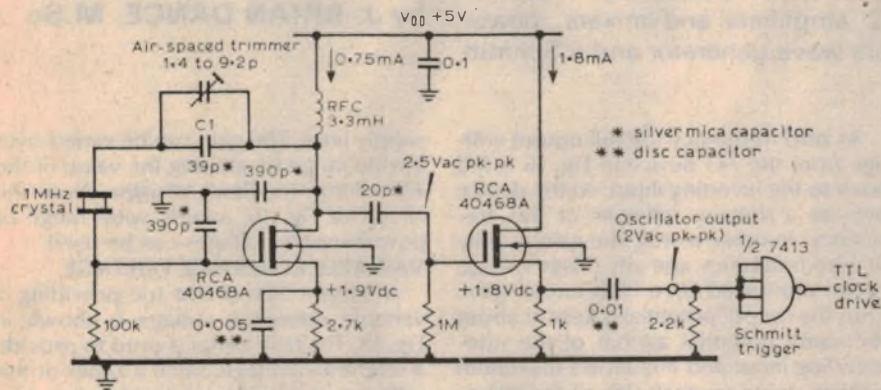

arrangement is shown that allows the supply voltage to vary all the way from 3 to 9V without the output from a 1MHz crystal changing by more than about 0.1Hz. This has a modified MOSFET Pierce oscillator followed by another MOSFET as a source-follower isolating stage. The extremely low susceptibility to voltage and temperature changes stems from the use of high-value source resistors in both stages and large-value fixed capacitors in the gate and drain loops of the oscillator stage. It is claimed that the overall performance of such an oscillator depends almost entirely on the crystal; if this has temperature stabilisation about one part in 10^6 is achievable.

A good interface with TTL is provided by a type 7413 Schmitt trigger IC and the output from this is rich in harmonics, allowing the oscillator to be accurately adjusted to zero beat against MSF, WWV, VNG, etc. Capacitor C1 governs the calibration range of the trimmer capacitor and may require selecting to suit the crystal.

(From "Radio Communication".)

Programmable ratio frequency divider

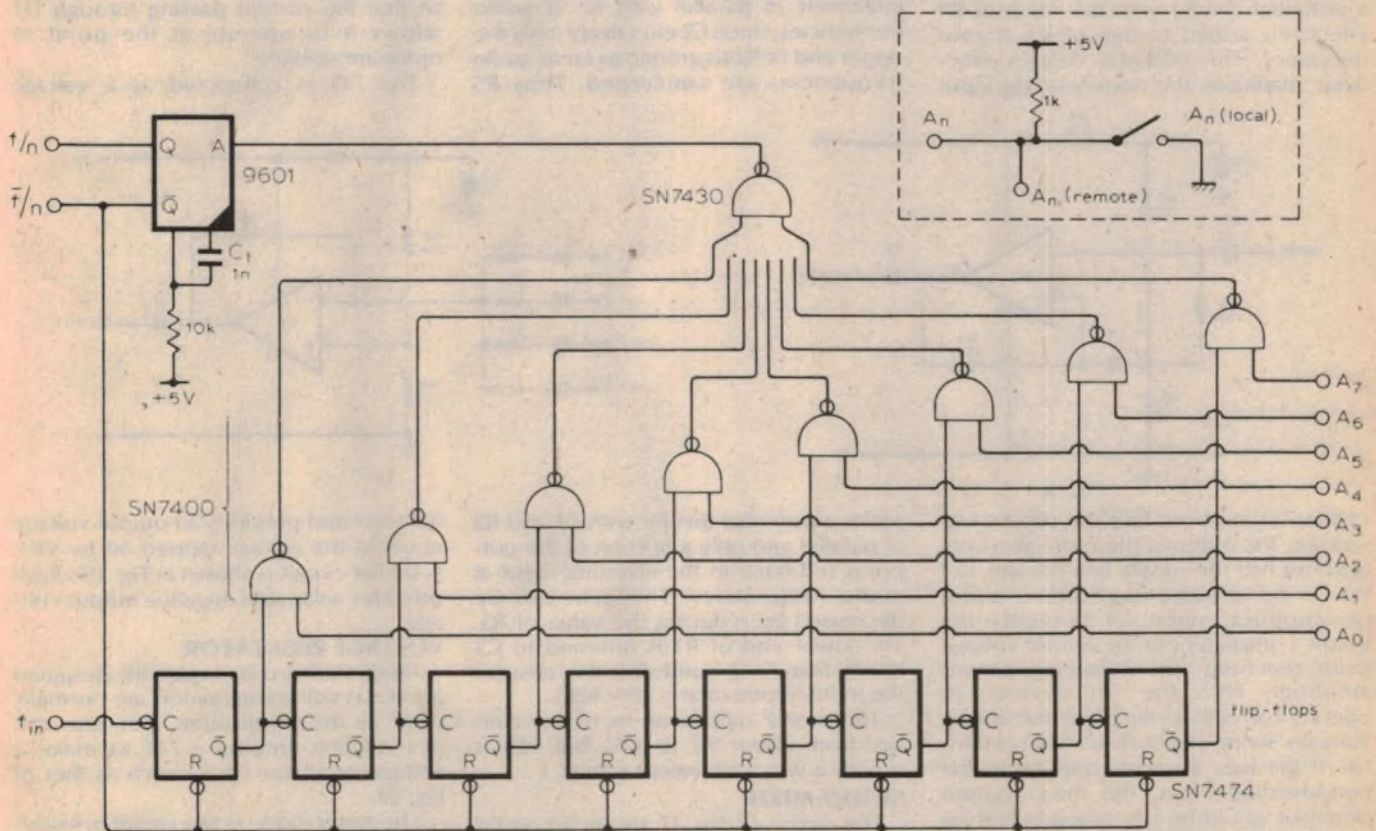

This programmable frequency divider has the advantage of low cost, simple design and expandability. The circuit is basically an eight-bit ripple counter with a programmable binary 1 detector. Whenever the programmed sequence appears at the counter outputs, it is reset by the monostable multivibrator which prevents latch up by only allowing a short

pulse to the reset line.

The desired division ratio is addressed to the inputs A_0 to A_7 , as a binary number. When all inputs are at 0V there is no output. When all inputs are at 5V the output is $1/255$ of the input frequency.

If both remote and local programming is required, the local switches must all be

set to 5V when remote is in use. Inputs and outputs should be buffered with inverters. The counter was tested from 10Hz to 100kHz and the limiting factor appeared to be the value of C1. With 1nF the counter should divide accurately up to about 200kHz.

(By M.F. Smith, in "Wireless World".)

Op-Amps without tears-3

Having looked last month at basic DC amplifier and microammeter circuits using the ubiquitous 741 op-amp, this month the author discusses other applications. These include AC amplifiers and mixers, power supplies, an AC millivoltmeter, a square-wave generator and a Schmitt trigger.

by J. BRIAN DANCE, M.Sc

AUDIO PREAMPLIFIER

The circuit of Fig. 16 is that of an audio preamplifier with a high input impedance which is suitable for use with a crystal pick-up, etc. The circuits discussed previously have all employed balanced positive and negative power supply lines so that the 741 can operate correctly when its input and output potentials have values on either side of the zero (earth) potential. In audio applications this is not usually very convenient, since one normally has only a single power supply line in the equipment.

In the circuit of Fig. 16, R2 and R3 form a potential divider with the value of R4 effectively added to that of R2 at zero frequency. This potential divider effectively maintains the non-inverting input

At zero frequency the full output voltage from the 741 device in Fig. 16 is fed back to the inverting input, so the device acts as a voltage follower at this frequency. In other words, the gain is unity at zero frequency and any offset voltage is not multiplied by a high circuit gain. Thus the output potential is kept at about the same potential as that of the non-inverting input and this allows maximum voltage swing on each side of the quiescent output potential.

At audio frequencies, however, the capacitor C3 effectively joins R5 to the junction of R2 and R3. In addition, R3 is effectively in parallel with R2 at audio frequencies, since C2 effectively joins the upper end of R2 to ground as far as audio frequencies are concerned. Thus R5

supply lines. The gain can be varied over a wide range by altering the value of the 470 kilohm feedback resistor. As in the circuit of Fig. 16, a fairly wide range of power supply voltages can be used.

VARIABLE REFERENCE VOLTAGE

A simple 741 circuit for providing a variable reference voltage is shown in Fig. 18. The 6.8V zener is used to provide a reference voltage, since a zener of this voltage can be obtained with a very low temperature coefficient. The current flowing through the zener is constant and is independent of the output load on the 741. The value of R1 should be chosen so that the current passing through D1 allows it to operate at the point of optimum stability.

The 741 is connected as a voltage

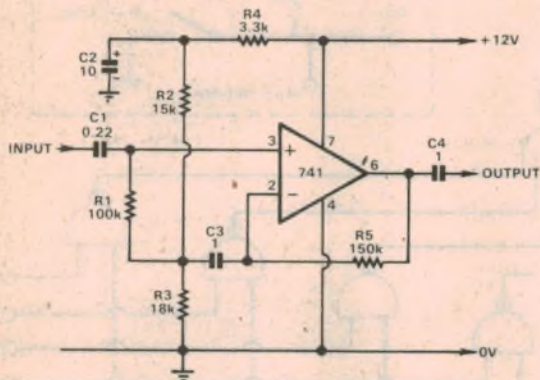

FIG. 16

of the 741 at about half the supply line voltage. The output is therefore also kept at about half the supply line voltage, but this is no disadvantage in an audio preamplifier, since C4 prevents the steady component of the output voltage from reaching the following power amplifier. Thus the 741 device can operate correctly as the input and output voltages swing about their mean potential. If the bias were not applied to the non-inverting input, the mean output potential would be low and it would be unable to become appreciably more negative, so the device would not be able to handle negative going signal peaks.

This method of biasing operational amplifiers is often used. Indeed, the next circuit to be discussed uses such bias and it is normally used with most small integrated circuit power amplifiers.

forms a potential divider with R3 and R2 in parallel and only a portion of the output is fed back to the inverting input at audio frequencies. The gain can be decreased by reducing the value of R5. The lower end of R1 is returned to C3 rather than to ground and this ensures the input impedance is very high.

The power supply can be of any voltage from about 9V to 30V, but 12V is usually a very convenient value.

AUDIO MIXER

The circuit of Fig. 17 shows an audio mixer unit which produces an output signal which is a combination of the three or more input signals. The 47 kilohm resistors in the input circuits prevent any signal from one input line from reaching any other input.

Biasing of the non-inverting input is again employed in this circuit so as to obviate the need for balanced power

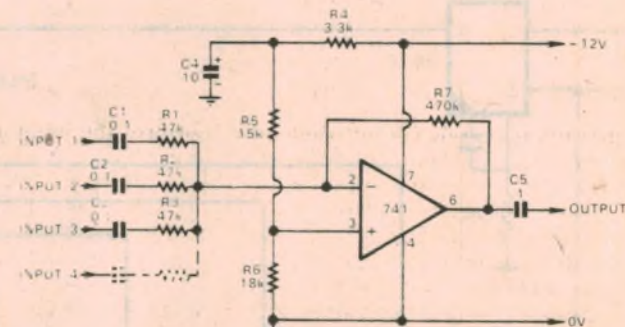

FIG. 17

follower and provides an output voltage equal to the voltage tapped off by VR1. A similar circuit is shown in Fig. 19 which provides a variable negative output voltage.

VOLTAGE REGULATOR

Integrated circuits especially designed for use as voltage regulators are normally used in this application, but one can nevertheless employ a 741 to make a voltage regulator circuit such as that of Fig. 20.

The zener diode in this circuit provides a reference voltage to the 741 device. If the inverting input is momentarily at a potential lower than that of this reference voltage, the output of the 741 will rise in voltage and cause TR1 to conduct more heavily; this will tend to raise the output voltage. After a short time the fraction of the output voltage tapped off by VR1 becomes equal to the reference voltage.

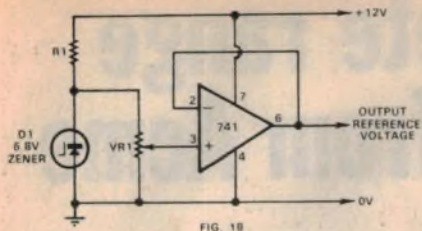

FIG. 18

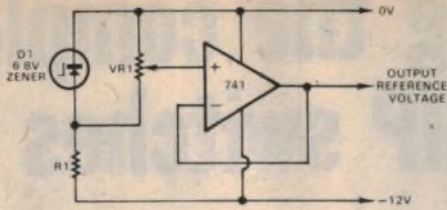

FIG. 19

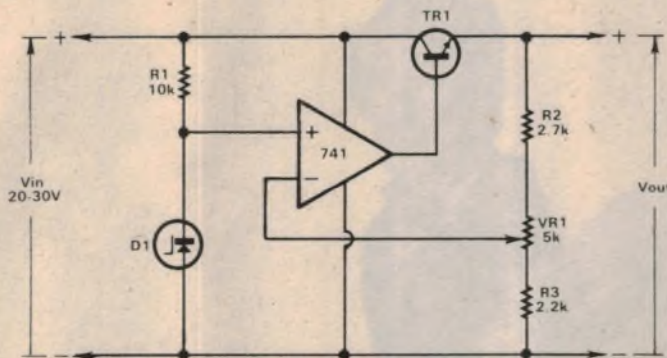

FIG. 20

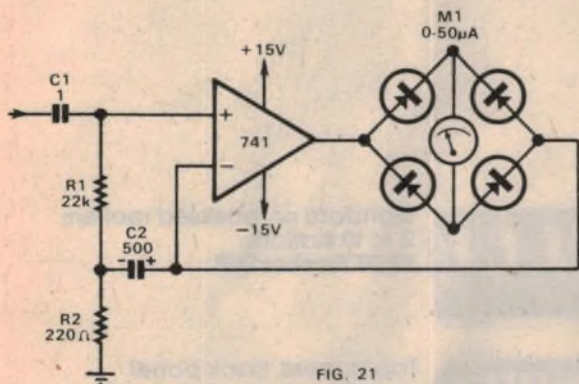

FIG. 21

The maximum output current depends upon the particular type of transistor used for TR1, but the typical output impedance is less than 0.1 ohm.

It should be noted that the 741 is used as a comparator in this circuit, to compare the reference voltage from the zener diode with that tapped off by VR1.

AC MILLIVOLTMETER

It is difficult to make a satisfactory millivoltmeter for alternating signals using a meter and diodes, since the non-linearity of the diode characteristic results in a non-linear scale.

In the circuit of Fig. 21 the input voltage to be measured is fed to a 741 device. The alternating voltage from the output of the 741 drives an alternating current through the diode bridge, through the blocking capacitor C2 and through R2. However, the diode bridge ensures that all current peaks pass through the meter in the same direction. The deflection of the meter is linearly proportional to the alternating input voltage. If the values shown are used, the full scale deflection is about 10mV.

The output voltage is fed back to the inverting input so as to stabilise the quiescent working point, whilst the alternating voltage developed across R2 is fed back to the non-inverting input and

ensures the input impedance exceeds 1 megohm.

ASTABLE CIRCUIT

The circuit of Fig. 22 can be employed to generate square waves with a mark to space ratio of unity. The frequency is dependent mainly on the values of R1 and C1. For example, if C is 1000pF and R is 100 kilohm, the frequency will be rather less than 10kHz. The maximum frequency is usually about 20kHz to 30kHz.

Although similar astable circuits can be constructed using two transistors, the 741 astable circuit is very simple and the high gain of the device produces an output waveform with very steep slopes.

The output voltage of a 741 device can swing to within about 80% of the supply voltage lines. Thus the output with $\pm 12V$ supplies is about $\pm 10V$ (20V peak-to-peak).

If a circuit is required which will produce an unsymmetrical square wave output, one must arrange that the charging and discharging times of the capacitor C1 are unequal. This can be done by replacing the resistor R1 with a parallel circuit, each arm of which contains a resistor in series with a diode, the two diodes pointing in opposite directions. The charging occurs through one diode and resistor, whereas the discharging of

FERGUSON

"DEVELOPMENTS"

Once Ferguson made a transformer like this:—



It was the Ferguson PF2155 and was an extremely useful and popular transformer.

IN THE INTERESTS OF SAFETY

The Ferguson Engineering Staff considered improvements to the terminations were necessary. It was decided to make a transformer which was designed to comply with Australian Standard C126. The result looks like this:—

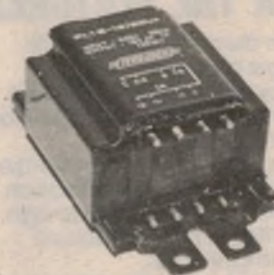

Advantages:

- 8 Secondary Terminals.
- Quick-connect pinlok type connections.
- 6 x 30 cm leads supplied with shrouded receptacles.
- Low-profile configuration with mounting holes as well as slots.

The range of output voltages is: 1.5V, 3V, 4.5V, 6V, 7.5V, 9V, 10.5V, 12V, 13.5V, 15V and 18V.

Additionally, centre tapped configurations also available, e.g. 9V-0-9V, 7.5V-0-7.5V, 6V-0-6V, 4.5V-0-4.5V, 3V-0-3V and 1.5V-0-1.5V.

Two types are available: PL 1.5-18/20VA at 1.11 AMP and PL 1.5-18/40VA at 2.2 AMPS.

Available from your
**ELECTRICAL
WHOLESALE**

Manufactured by:

FERGUSON TRANSFORMERS
P/L

Head Office: 331 High Street,
Chatswood, NSW 2067.

Phone (02) 407-0261 — Telex: AA25728.

Announcing the complete range of Grayhill DIP switches from Acme

ROCKER, PIANO & TOGGLE



CHECK THE FEATURES:

All these dual in-line Grayhill package benefits.
 Easy mounting to PC board by direct flow-soldering or insertion into a standard socket.
 Moulded-in terminals minimize contact system contamination.
 Compact, high density design: low profile; minimum above board height .270".
 Cost savings industry accepted package dimensions; multi-functional, programmable PC boards; elimination of mounting hardware or hard-wiring interconnections.
 Outstanding performance at no price premium 50 mA at 30 VDC/35,000 operations; 125 mA at 30 VDC/25,000 operations. Mechanical life: 50,000 operations.
 Spring loaded sliding ball contact system provides positive wiping contact, exceptional long life and immunity to normal shock and vibration . . . all essential in back panel logic applications.
 Protective cover reduces contamination during the cleaning and soldering operation — and can remain on the switch in the equipment to deter unauthorised actuation.
 Options include protective covers, .125" terminal length, black (instead of red) switch covers, switches without standoffs.



Standard or recessed rockers.
 2 to 10 stations.
SPDT Rocker DIP



Top access, back panel programming switches with your choice of circuitry.
SPST Rocker DIP



2, 3 or 4 stations.
DPDT Rocker DIP

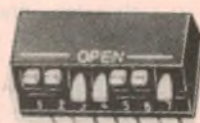

The double DIP. 1 or two stations. Back panel programming . . . without removing PC boards from their racks.
The Piano-DIP SPST side-actuated DIP switch.



DIP switch for front panel programming.
The Toggle-DIP . . . exceptional life rating makes this switch ideal for front panel usage.

For complete Grayhill literature, write or phone the ACME Engineering Agent or office in your State.



ACME Engineering Company Pty. Ltd. 2-18 Canterbury Road, Kilsyth, VICTORIA 3137 Telephone: 729 6211

OP-AMPS WITHOUT TEARS

C1 takes place by a current passing through the other diode in the opposite direction and through a resistor of different value.

Monostable circuits (e.g., for pulse stretching) and bistable circuits can also be made using a 741 device.

SCHMITT TRIGGER

A simple Schmitt trigger circuit using the 741 is shown in Fig. 23. When the input voltage increases, a point is reached at which the output voltage changes quite suddenly from its initial 'high' value to a 'low' value. The input voltage must then be reduced well below the point at which switching first occurred before the circuit again switches rapidly back to its original state with the output 'high'.

The resistors R2 and R1 form a potential divider and the potential of the non-inverting input will be held at $V_{out} \times R1 / (R1 + R2)$. Thus as the input voltage increases, switching will occur when it reaches the non-inverting input voltage. The output voltage will now be negative and of the same magnitude as it was previously positive. Thus the input voltage will have to fall to this value before switching back to the original state occurs.

POWER SUPPLIES

In operational amplifier circuits in which balanced positive and negative power supplies are required, two 9V bat-

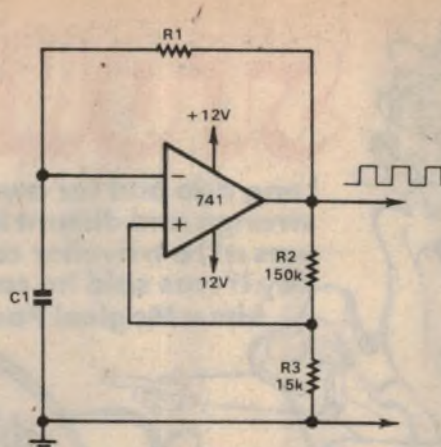

FIG. 22

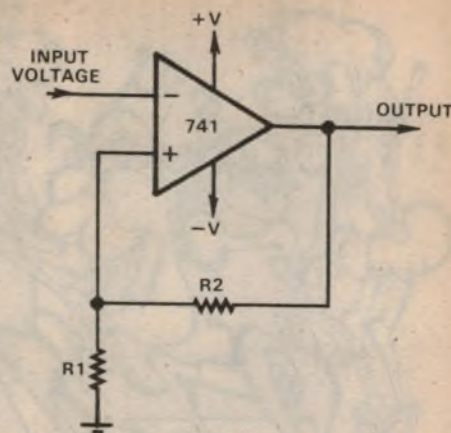

FIG. 23

teries have an appreciable effective inductance in series with their capacitance. Thus the extra decoupling is required to ensure one will not meet troubles through power line coupling.

Similarly, if a single power supply line is to be employed, a single decoupling capacitor (about 0.1uF) should be connected between this supply line and ground. Mains power supply circuits should preferably be stabilised if one requires long term stability. In addition, stabilisation normally reduces the hum level by a very large factor.

It is often advantageous—especially in experimental work—to use a power supply which cannot deliver a current exceeding some 50 to 150mA. If an accidental short is made or an incorrect connection during one's experiments, it is then unlikely that enough current will

operational amplifiers of the 741 type in a single 14 pin dual-in-line package with the connections of Fig. 24(a). The 1458 device also contains two 741 type devices in a single package, but as this package has 8 connections, there are not enough pins for offset nulling connections to be provided. The connections are shown in Fig. 24(b). The 1458 is also available in a 14 pin dual-in-line case, again without offset nulling connections. Offset nulling can be provided in such devices by applying a bias at an input, but this may not be convenient.

A new device from National Semiconductor, the LM348, has four operational amplifiers similar to the 741 in a single 14 pin dual-in-line package. No offset nulling facilities are provided owing to the limited number of pins available, but the input currents are lower than in the 741 and the supply current to all four amplifiers is less than that to a single conventional 741 device. Such multiple devices are very useful when one requires a circuit in which several operational amplifiers are employed together.

Another device with input currents several times lower than those of the 741 is the 307 device. The connections of the 8 pin dual-in-line package are the same as those of a similar 741 package, but no offset nulling facilities are incorporated.

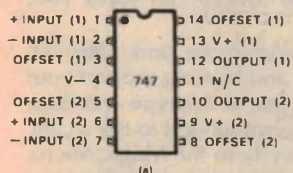

(a)

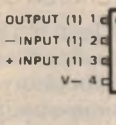

(b)

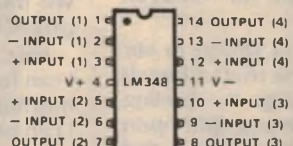

(c)

teries will normally be sufficient. However, instability can occur in some cases, especially if the supply leads from the batteries are not very short. It is wise to connect decoupling capacitors of about 0.1uF from each supply line to ground as near as possible to the integrated circuit; this provides good decoupling at high frequencies. One should avoid the use of batteries which are so old that their internal resistance is high, since this can also lead to instability.

If a mains power supply is to be used, the 0.1uF decoupling capacitors are still required to ensure stability unless the supply lead lengths between the reservoir capacitor in the power supply unit and the operational amplifier are quite short (less than about 5cm). Although these 0.1uF capacitors are in parallel with the much larger electrolytic capacitors in the power supply unit, they provide high frequency decoupling close to the device itself. The power lines are long enough to have an appreciable inductance, and electrolytic capacitors them-

flow from the power supply lines to damage any of the devices being fed with power.

SIMILAR DEVICES

The 741 device is made by most of the large semiconductor manufacturers under types numbers such as LM741 (National Semiconductor), CA741 (RCA), uA741 (Fairchild), MC1741 (Motorola), etc. Although all of these 741 devices should be satisfactory in all of the circuits we have discussed, similar integrated circuits of the same type number from different manufacturers can differ considerably in their electrical behaviour. Most of these differences are negligible with well designed circuits, but it should not be forgotten that they do exist. The manufacturer's data sheet should always be examined in detail, not forgetting the quantities which are not quoted on the data sheet.

There are a number of other operational amplifiers rather like the 741. For example, the 747 device contains two

FUNDAMENTALS OF SOLID STATE

Fundamentals of Solid State is in its second reprinting, showing how popular it has been. It provides a wealth of information on semiconductor theory and operation, delving much deeper than very elementary works, but without the maths and abstract theory which make many of the more specialised texts very heavy going. 'Solid State' has also been widely acclaimed in colleges as recommended reading—but it's not just for the student. It's for anyone who wants to know just a little bit more about the operation of semiconductor devices.

\$3.00 plus 60c p & p
Electronics Australia
Box 163, Beaconsfield, NSW 2014.



STONE SOUP

Long ago and far away, in a strange and distant land (or was it?) a traveller came one day. It was said he carried with him a Magical Package...

The King heard of the coming of the traveller, and sent his Ambassadors to greet him, and escort him to the palace. And lo, a great multitude followed, for they too wished to share the wonders of this Magical Package.

And the King gave a great reception, and when all the people were assembled, the traveller spoke. Sire, he said, drawing a beautiful box from beneath his robes, I bring you this Magical Package, and he took from the box a gleaming stone. This stone, he said in hushed and reverent tones, has wondrous powers—you need only boil this magic stone in water to make the thickest, the richest, the most mouthwatering soup you have ever tasted.

Sir, said the King, if what you say may be true, you may have anything you wish, for times are hard and many of the people cannot afford a square meal. Will you show us the magic of this stone?

So they gathered in the royal kitchen, and took a giant cauldron, and filled it with water and set it to boil on the fire. And when it was boiling, the traveller took the gleaming white stone from the package, caressed it gently, then dropped it into the cauldron. Now, he said we must wait; for not even a Magic Stone can make soup in an instant.

The traveller looked about the kitchen for a spoon to stir the water, but no spoon was big enough. So he tried a bunch of onions, but they slipped from his hand into the boiling water. And he tried a bag of potatoes, but the bag split open and the potatoes fell in. Next he tried a bunch of carrots and parsnips, but the tops came off and in they fell. No matter, said the traveller, for they cannot harm the magic of the stone, provided we add a little salt and seasoning. And then he spied the very thing—several large ox-bones with the meat still upon them, and he set several of the royal cooks to work, each stirring the cauldron with a bone.

After some days of stirring, and tasting, the traveller pronounced the soup to be ready. The royal taster tried the soup, the king tried the soup, all the court and the assembled multitude tried the soup, and they all agreed they had never tasted a soup which made the mouth water more.

And when they had all tried the soup and none was left, they found in the bottom of the cauldron the gleaming white stone, neither harmed nor changed in any way. And great was their rejoicing, for here truly was the answer to their dreams, and they would never go hungry again.

So the traveller journeyed from that strange and distant Land, burdened down by riches heaped upon him by the grateful King and people, and after many travels and adventures, he came to the shores of our fair land. And it was said he carried with him a Magical Package...

Now the leaders heard of the coming of the traveller, and sent their technologists to greet him, and escort him to them. And lo, a great multitude followed, for they had read the glossy handouts, and they too wished to share the wonders of this Magical Package.

And the leaders gave a great reception, and when all the

people were assembled the traveller spoke. Sirs, the traveller said, I bring you this Magical Package, and he took from his case a gleaming white stone with golden legs down each side. This, he said, in hushed and reverent tones, is called a Microprocessor. This Magic Micro has wondrous powers, for you can use this for the most complex, the most difficult, the most awe-inspiring logic tasks you can ever conceive. With this package you need never design another random logic circuit again. And furthermore, thanks to modern technology, it has been possible to make this Magic Package in large quantities, at such a low price, that even the humblest of your people can own one. And, said the traveller, all these wonders can be yours today.

Sir, said the leaders, if what you say be true, we will give you orders for so many of these packages, you will be rich beyond your wildest dreams—for times are hard, and we cannot afford to employ any more random logic designers. Will you show us the magic of this Package?

So they gathered in the laboratory, and the traveller took the gleaming white stone with golden legs from its box, and gently, caressingly, placed it in a circuit board. Now, he said, we must wait, for not even a Magic Micro can solve your problems in an instant.

First, he said, we must feed it a programme, and, although I can feed it by hand, this takes time, and looking around your magnificently equipped laboratory I see a Teletype—perhaps I can borrow that to become a peripheral servant to the Magic Micro. A Teletype may not speak directly to the Magic Micro, but I just happen to have with me a Universal Asynchronous Receiver/Transmitter called by some, a UART, which will interface between your Teletype and the Magic Micro—and perhaps, I can borrow those two power supplies—for the Magic Micro needs power to excite it and keep it running happily.

And, said the traveller, the Magic Micro does not speak the same language as people, for it is much too smart for that—it uses a special language of its own. Now I speak this special language, for am I not its Master, and you too could learn this language in time—but it is simpler to have a big computer translate for you—let us use the Time-Share Terminal I see in your magnificently equipped laboratory. So they set several programmers to work, and after some weeks of writing, and thinking, and talking to their Time-Share Terminal, they produced a programme and fed it to the Magic Micro through the Teletype.

But alas, the Magic Micro refused to digest the Programme. Aha, said the traveller, this often happens—the programme must have a bug—not I hasten to add a type that is unclean or verminous—but cunning bug, well versed in the ways of man and the Law of Murphy, and able to conceal itself in the most incredible ways in the simplest programme. Now doubtless your skilled programmers could unearth him in time, but I have another wondrous gift to offer—a Debug routine which is contained in this small package, and which you may have in exchange for a trifling sum.



And the crowd was greatly impressed by this munificence, and got ready to write even larger orders.

And so it came to pass after several days, that the bug had been found, caught, tried and executed, and the programme was ready to feed to the Magic Micro. But in these few days, the programme had grown at a prodigious rate, and it could no longer fit into the little memory of the Magic Micro.

There is no cause yet for alarm, and despondency, and gnashing of teeth, said the traveller, for this Magic Micro can address 64k bytes of memory. If you would just write out an official order.

And the crowd was mighty pleased, and pressed their orders upon him, and he went to his chariot, and returned with more gleaming white stones with golden legs, and placed them reverently in the circuit board.

The traveller fed the program to the Magic Micro which digested it and sat there full and quietly content. Now said the traveller, we will ask the Magic Micro your question, for I have spoken to it and it is ready. Who has a question to ask the Magic Micro?

Ask it, said one technologist, what is the sum of two plus two? So the traveller tip-toed to the Teletype—flexed his fingers like a concert pianist—raised his hands, and as his flashing fingers danced over the keys a message appeared "2 + 2 = ?".

The Magic Micro did not at first deign to answer, for this was a request from a humble servant—a peripheral—it was full from digesting the program. But at last, the Magic Micro sighed softly to itself, addressed its lowly servant, the borrowed teletype, and issued commands to print "2 + 2 = 4"—then went back to its peaceful cycling.

And the crowd broke their silence and went wild—their joy knew no bounds, for here truly was the answer to their dreams. Never again would they have to design a circuit that was logical—they need only write those magic symbols on the paper.

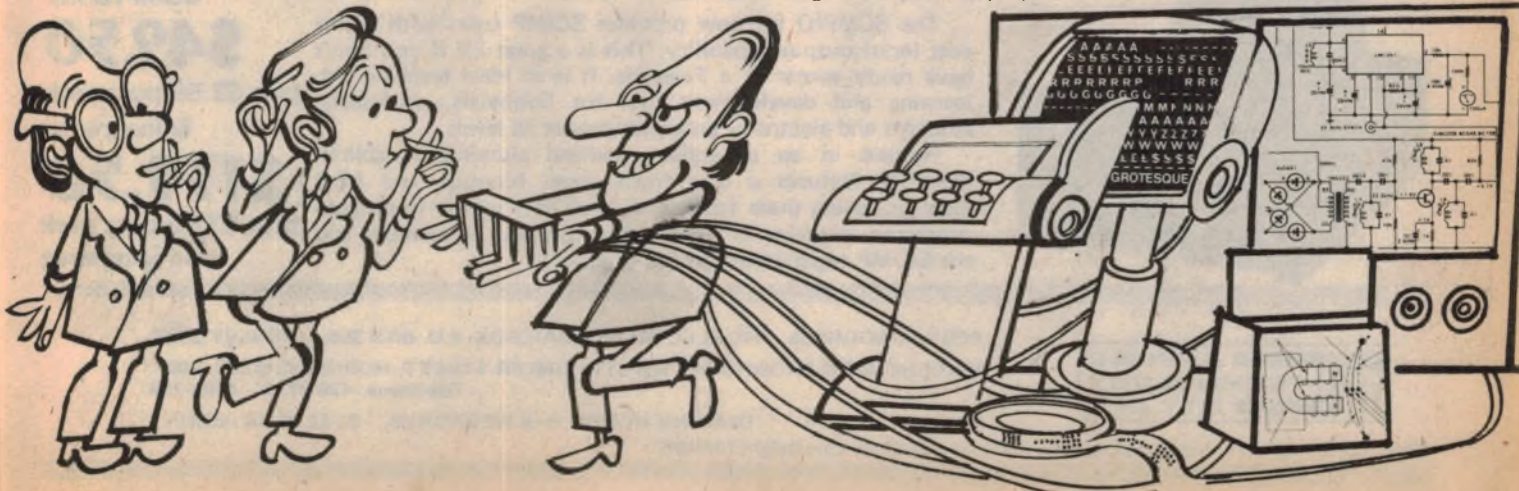

MICROPROCESSORS

In all the rush and excitement to learn and use this new technology, it's easy to confuse a microprocessor with a microcomputer. A microprocessor is a very powerful building block with many applications, but it needs a lot of extra hardware and software, and usually many thousands of manhours to turn it into a microcomputer.

The microprocessor's main application will be in logic circuits as a super integrated circuit, replacing a whole board full of IC's with a few packages.

If we are going to use them intelligently, we need to study them in detail, and we can do this without a lot of equipment. The simplest arrangement uses toggle switches to input data together with several seven segment LED's to read the output, and a few other IC's.

This approach has the advantage, apart from low cost, of forcing us to write simple short programmes, and to concentrate on learning the essentials.

Once we know enough about the microprocessor, we can use development sets and other aids to cut down the time needed to make bench models, and to develop software.

But, for the beginning, this is a MICROprocessor—so THINK SMALL.

Alan M. Fowler

So they pulled out their official order books and ordered Magic Micros, and circuit boards, and Universal Asynchronous Receiver/Transmitters, and Teletypes, and tapes in cassettes, and discs that were floppy, and universal PROM programmers, and blocks of random access memory, and power supplies to keep the Magic Micro excited, and clocks to keep it in time, and cases to keep it free from harm, and handbooks, and . . .

And in the midst of the tumult there sat quietly a lone designer of logic that was random, hoary with age, and he said, I am minded of a story I heard in my youth, of another gleaming white stone that made the most marvellous soup. Yet this new gleaming white stone with golden legs is not the same, it is more like the bottom of the carrots that fell into the cauldron in that strange and distant land. For is not this gleaming white stone with the legs of gold the thin end of the veg?

But they paid him no heed, for they were dreaming their impossible dreams, and their minds were full of the most marvellous things they would do.

And the traveller departed, weighed down with orders. And the crowd looked at their gleaming white stone in awe—and saw for the first time the maze of equipment needed to support it.

And a great coldness descended upon their hearts.

By Alan M. Fowler

(With apologies, and all due credit, to the Author of the original "Stone Soup".)

NEW FOR '77

MATCHING FM TUNER FOR TWIN 40 / TWIN 25

Based on the International 740 (ETI March 1976) the RX7400 has been redesigned to incorporate a really good looking 10 gauge front panel and a new LED tuning indicator. The unique LED "electronic dial" and precision tuning potentiometer have been retained. The AP2157 preassembled varicap front end means the RX7400 is easily constructed and aligned without special equipment. Optional AM module available.

RX7400 kit \$125.00 F.

Assembled & tested \$155.00 F.

AM 200A AM tuner module \$20.00.

Post & packing \$1.50.



\$125.00

\$155.00

Assembled and Tested

TWIN 40: REDESIGNED FRONT PANEL

Based on original design by Leo Simpson at Electronics Australia this superb amplifier delivers 40W RMS per channel equipment the TWIN FORTY features a fully imported matching knob set and a redesigned front panel. BY POPULAR DEMAND two additional switches are provided and these can be used for scratch/rumble filters, speaker switching, loudness controls (details on request). With our step by step preassembly manual construction is a real breeze.

TWIN 40 KIT \$105.00 F.

Assembled & tested \$135.00 F.

\$105.00

\$135.00

Assembled and Tested

TWIN 25: A VERY POPULAR KIT

We still have stocks of the POPULAR TWIN 25. Now design features improved thermal stability and higher rated current bias transistors.

TWIN 25 \$89.50 F.

Assembled & tested \$119.50 F.

\$89.50

\$119.50

Assembled and Tested

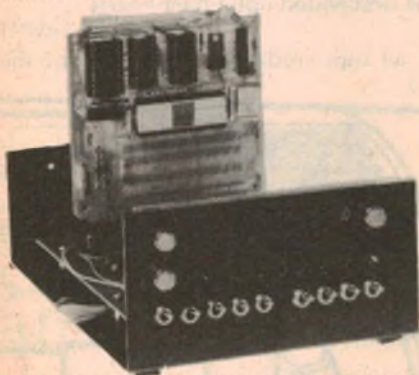

SCMPIO — LOW COST 1/0 KIT FOR SC/MP

The SCMPIO kit now provides SC/MP users with a low cost input output capability. This is a great kit if you don't have ready access to a Teletype. It is an ideal teaching aid, learning and development tool for hobbyists, professors, students and electronic entrepreneurs at all levels.

Housed in an attractive anodized aluminium cabinet, SCMPIO features a user front panel function and LED displays. Using these facilities it is an easy matter to execute programs, examine or modify the contents of memory and the SC/MP registers and to run programs.

SCMPIO kit

\$49.50

plus \$2.50 post pack & insurance

\$139.50

plus \$3.50 post pack and insurance



POSTAL ADDRESS: THE ELECTRONIC MAILBOX, P.O. BOX 355, HORNSBY 2077.

WAREHOUSE & SHOWROOM: 109-111 HUNTER STREET, HORNSBY, N.S.W. 2077.

Telephone: 476 3759 476 4758

TRADING HOURS: 9-5 WEEKDAYS, 9-12.30 SATURDAY

Note: Items marked F are not suitable for posting and will be sent freight forward.

Classical Recordings

Reviewed by Julian Russell



Mahler: *Das Lied*—“superb performance”

MAHLER—*Das Lied von der Erde*. Janet Baker (mezzo-soprano); James King (tenor); and the Concertgebouw Orchestra of Amsterdam conducted by Bernard Haitink. Philips Stereo 6500 831.

In recent years Bernard Haitink has built up an impressive reputation for his interpretations of Mahler works. You don't have to listen long to this magnificently recorded disc to realise he is again in top form for this popular Mahler work. There is a sense of real intoxication in the opening movement—intoxication with life, not alcohol, of course. Yet he achieves this without, so to speak, a single stagger in the tempo which thrusts its way implacably onwards throughout.

James King makes a brave effort to match this temperament and only just fails to do so. His Wagnerian training has fitted him admirably for the more forceful passages but true lyricism is missing from his range of expression.

After the hurly burly of much of the first movement you will hear the most delicious quiet playing in the second movement with lovely solos from the first desk orchestral players.

Then you have Janet Baker at her inspired best in all but so very few bars that it would be churlish to single them out. Unlike King her quiet lyrical singing is utterly enchanting and she has much of this to do in *Das Lied*. The fourth movement, “Of Beauty”, is flower fresh vocally and orchestrally rising to a fine passionate climax.

There are six movements in this great work, each with its own character, all orchestrated in wondrous fashion. This magical sound is caught to perfection by Philips engineers. The amount of orchestral detail audible at all times is quite wonderful and Haitink keeps his forces in perfect balance no matter what the tempo or dynamics.

I cannot find words to describe the beauty of the *Pianissimos*, both by Baker and the orchestra, in the final “Farewell” movement. They left me in a haze of delight with, at the end, Baker's lovely voice dwindling further and still further in volume until it seems actually to merge into the almost inaudible sound of the orchestra.

This version of *Das Lied* has many formidable recorded competitors but when

all is summed up, including my slight reservations about James King and momentary—and I stress only momentary—lapses by Janet Baker I can't see anything else preventing this superb performance from being the first choice among Mahler lovers. And don't forget that even the best of its competitors, no matter how good, has small imperfections, too.

Indeed it is as difficult to imagine a wholly perfect *Das Lied* as it is to come across a wholly perfect performance of Mozart's *Don Giovanni*. In the meantime, a very long meantime, I expect, this magnificent performance should satisfy all but the most hypercritical.

★ ★ ★

MENDELSSOHN—*Symphony No. 3 in A Minor (Scotch)*. Overture: *Calm Sea and Prosperous Voyage*. EMI Compatible Quadraphonic/Stereo OASD 3184.

So far as I can trace, this is the first recording made by the young Italian conductor, Riccardo Muti, and very impressive it is. It is difficult to understand why so talented a musician has not been recorded before. He has held some very important conducting posts in Europe, including opera conducting at the Florence May Festival, principal conductor in England of the New Philharmonia Orchestra, and many distinguished guest appearances with the best European and American orchestras.

Being Italian, both by birth and musical education, his first consideration is to make music sing in whatever form it may be presented. And this he does most beautifully. In addition—another Italian trait—he gets the very most out of a dramatic situation. Rhythmically, too, his performance is always full of interest. The whole of the symphony is most beautifully played and while reviewing it I enjoyed the delicate though spirited Scherzo so much that I treated myself to an encore of it, something I very rarely do.

The Overture, *Calm Sea and Prosperous Voyage*, makes a generous fill and, although in the early part the ensemble is momentarily not as clean as it might be, does nothing to dim the lustre of Muti's entrance into the world of recorded music.

PUCCHINI—*Tosca*. Complete Opera.

Galina Vishnevskaya (*Tosca*); Franco Bonisolli (Mario Cavaradossi); Matteo Manuguerra (Baron Scarpia) and others with the Chorus of Radio France, the Orchestra National de France conducted by Mstislav Rostropovich. DGG Stereo 2707 087 (Two discs).

Mstislav Rostropovich is probably the finest cellist in the world today. He is also a very good pianist and often displays this talent when accompanying his wife, soprano Galina Vishnevskaya. Lately he has taken to conducting and as far as I know his first recorded performance in this role is in this new issue of *Tosca*.

Now both husband and wife are, of course, Russian, and Mr. adapts to this Italian music rather better than Mrs. Her voice in the middle and lower registers is fine but when she gets above the stage she tends to develop many of the Eastern European characteristics of women singers—shrillness and a strong vibrato not approved by other schools of singing. She is a fine dramatic *Tosca* if not a very alluring one. Indeed there is more than a hint of the fishwife in the vehemence of her *parlando* passages, especially in her second act scene with Scarpia.

Rostropovich gives a sound reading of the score but seldom seems to abandon himself to the composer's revelling in lurid melodrama. He starts splendidly with the Scarpia motive, possibly one of the best villain's themes ever written. He then goes on with splendid urgency to Angelotti's entrance and feverish search for the key of the chapel where he, an escaped political prisoner, hopes to hide. There is an excellent conspiratorial atmosphere dominating his scene with the painter Cavaradossi, both on the stage and in the firmly directed orchestra.

During most the rest of the opera Rostropovich generates a good deal of excitement and on occasions some very real tenderness. Sometimes however he has a tendency to emphasise a subordinate theme in the orchestra to an extent that distorts the natural line of the main melody. He also takes the off-stage *Cantata* in Act 2 very much louder than I have ever heard it played before.

Not unexpectedly his orchestral interlude to Act 3, which describes dawn over Rome with the many church bells ringing in different pitches, is a beautiful bit of musical landscaping. But I can't avoid feeling that Puccini is not quite his line and he is more comfortable, indeed often incomparable, in his concert performances of the romantic and classical schools. A comparison between his conducting of *Tosca* and his solo cello part in the Dvorak Cello Concerto should at once make my meaning clear.

As to the rest of the cast I liked best Matteo Manuguerra's Scarpia, always an aristocrat though at the same time a brutal chief of police, his voice expres-

AUDITEC STUDIO MONITORS

No Gimmicks—just superlative performance

The 2033 and 1034 Studio Monitoring Amplifiers use the revolutionary Murray Circuit Design Technique which substantially eliminates transient intermodulation distortion, and gives performance figures which few (if any) amplifiers can match.



2033—2 Channel,
100 Watts (RMS) per
channel (illustrated).
1034—1 Channel,
200 Watts (RMS). ●
T.H.D. less than

0.01% ● S/N Ratio better than 100dB ●
Fully s/c protected, stable for all loads ●
Overload and peak clipping indicators ● Can-
non connectors in, out and auxiliary ● **100%**
Australian designed and manufactured.

AUDITEC AMPLIFIERS ARE AVAILABLE THROUGH:

Melbourne: Zephyr Products. Phone 568 2922
Brisbane: Eda-Delsound. Phone 52 8694
Adelaide: Neil Muller Pty Ltd. Phone 74 1162
Bundaberg: Bundaberg Hi-Fi. Phone 71 3176
Canberra: Musique Boutique. Phone 82 2553
Tamworth: Hi-Fi Gallery. Phone 65 7788
Maryborough (Qld): Keller Electronics. Phone 21 4559
Rockhampton (Qld): Premier Sound. Phone 28 2701
Surfers Paradise (Qld): Beno's Musical Supplies. Ph. 38 1668
Whyalla (S.A.): Audiocab Sales. Phone 45 7755

*For descriptive leaflets on these amplifiers,
call, phone or write to:*

AUDITEC AUSTRALIA PTY. LTD.
10 Waitara Avenue, Waitara,
N.S.W. 2077
Phone: 48 4116

enclosures for public address & sound reinforcement



We introduce our wide range of speaker enclosures, primarily designed for permanent installation. All are superbly constructed and attractively finished and each offers a flexibility of uses depending upon application.

The range includes small sound reinforcement enclosures, just to give a little lift, medium-sized, high performance enclosures, right through to our large, powerful heavy duty models.

You have a choice of finishes on some models to match the decor of your auditorium or hall; attractive, long-wearing padded vinyl or handsome timber veneer.

The enclosures are fitted with good quality speakers of proven performance and incorporate the most up-to-date acoustic features providing you with a product of extremely high efficiency and very good value.

Contact us for brochure and price list.

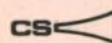

C. S. SERVICES PTY. LTD.
135 WENTWORTH RD., ENFIELD
N.S.W. 2136. PHONE: (02) 747 6363

*CONSTANTLY STRIVING TO MEET
THE DEMAND FOR QUALITY SOUND
REINFORCEMENT EQUIPMENT*

sive and of beguiling quality. Franco Bonisolti is an efficient Mario though some of his very top notes sound as if they are produced with considerable effort. The smaller roles are always well in character and though the chorus has little to do, what they do is always fine. I feel that whatever the manifest talents of the two Russians, interest in this issue will depend much on curiosity about how they deal with this altogether strange idiom. And on those grounds it is well worth owning.

The engineering is generally speaking very good, with a few exceptions. For instance the first statement of the "E Lucevan" theme sounds as if it has a different acoustic from the rest of the work and the cannon that signals the escape of the prisoner Angelotti sounds like a drummer hitting an instrument with a wet parchment.

★ ★ ★

SCHUBERT—Lieder.

MAHLER—Lieder. Jessye Norman (soprano) accompanied by Irwin Gage. Philips Stereo 6500 412.

Last year musical Sydney was both astounded and ravished by the singing of this black soprano from the United States—astounded by the maturity of style and versatility of so young a performer, and ravished by the sheer effortless beauty of her voice. She floated her voice out into the Sydney Opera House Concert Hall, in a manner that delighted but never cloyed, such was the variety of her vocal colour and the seemingly instinctive perfection of her phrasing.

She convinced equally in her softness as in her most forceful bars. Her diction in English, French and German was never less than faultless. And she delivered all her programs with warm, smiling generosity. Her Australian accompanist—in her solo recitals—was that splendid collaborator Geoffrey Parsons. On this disc she is equally lucky in her American accompanist, Irwin Gage.

Although this recital was recorded about three years ago it already displays all the features I have raved about in her Sydney performance, though during the interim she has matured ever so slightly in her inimitable control and deep musicianship.

Listening to this disc you may find this hard to believe. I could only detect one momentary lapse—in Schubert's "Raste, Krieger", though if you allow it to interfere with your enjoyment of this beautiful performance you are not worthy to own such an utterly delightful disc.

This recital is not all sweet lyricism. She has her grand dramatic moments too. She makes the Schubert group sound ridiculously easy to sing—and singers will know all about their many difficulties. Her Mahler is equally impressive. She settles into the mood of each song with intuitive accuracy.

The engineering is as perfect as anyone could desire.

Some of the songs by both composers will be well known to the average concertgoer but here and there she drops in a surprise item that you may never have heard before. A real treasure of a record!

★ ★ ★

FRANCK—Symphony in D Minor. Philadelphia Orchestra conducted by Eugene Ormandy. CBS Stereo low-price record. ODA 5070.

Here is the Philadelphia at its most luscious except for an occasional bar when the upper strings are a little harsh. The superb tone is nearly always there but not always the old unanimity. The whole of the opening has a cathedral-like solemnity—a much more opulent sound than could ever have been heard in the modest St. Clothilde church in Paris where Franck spent many years as organist. To me the whole of the first movement is a little heavy-handed for, after all, Franck was a French composer despite the fact that he was born in Belgium. Yet this has always been the Philadelphia style. Its patrons get plenty of tonal splendour for their money.

This is an old record remastered fairly satisfactorily though nowadays the sound would be still more glossy. To many modern ears the famous "cyclic" Finale sounds a bit patchy with its themes from previous movements dropped in without very much significance. But my mentioning this does not mean that I share the present day disparagement of this composer. You'd have to seek very far to find a better work for piano and orchestra than the Symphonic Variations. And if the Symphony sounds a bit treacly to our ears—well there are quite a lot of people who like treacle.

★ ★ ★

ORFF—Carmina Burana. Celestina Casapietra (soprano); Horst Hiester-mann (tenor); Karl-Heinz Stryczek (baritone) with the Leipzig Radio Chorus, the Dresden Chapel Singers and the Leipzig Radio Symphony Orchestra conducted by Herbert Kegel. Philips Stereo 9500 040.

After Previn's electrifying recording of this work reviewed recently in this column, the new Philips tends to disappoint. There is a formality about it that hides much of the fun and bawdiness that Previn and his company seemed to revel in. It might be remembered that Orff's own endorsed performance by Jochum had many of these features. Then again the East German soloists are not in the same class as those chosen by Previn.

The Philips engineering has good presence but lacks the depth of its rival. The many sudden changes of tempo and mood are here carried out with commendable simultaneity by both chorus and orchestra. Yet the feeling of elemental fun—and frequent tenderness—cannot

match that of Previn's version—and several others for that matter.

I have heard the Leipzigers play and sing impressively but I am afraid this is not one of their better days. A Latin/English text with a sprinkling of German accompanies the disc.

★ ★ ★

MOZART—The "Adelaide" Violin Concerto in D Major. K.Anh.294a. Violin Concerto in D Major, K. 271a. Yehudi Menuhin (violin) with the Menuhin Festival Orchestra conducted by Menuhin. EMI Stereo 3198.

Neither of these two concertos could be called top-drawer Mozart—but a lot of Mozart's second-class output is better than many other composers' best. The Adelaide is something of a rarity nowadays, snobbishly disregarded in many quarters. But as played and conducted by Menuhin, who here sounds right back to his best form, it is always delightful to listen to. Moreover he manages to get his orchestra to play with considerable sparkle and lively rhythm.

True there are some rare, but important blemishes, especially in Menuhin's playing of the Enesco cadenza in the K271a. This is especially odd since Menuhin was a pupil of Enesco in Paris and remained a close friend and admirer of his teacher all his life. But otherwise, presented as they are here, these concertos are a welcome addition to the catalog.

RADIO DESPATCH SERVICE

**869 GEORGE STREET
SYDNEY**

**CNR GEORGE & HARRIS STS
RAILWAY SQUARE
TEL 211-0816, 211-0191**

OPEN MON. TO FRI.
8.15 AM TO 5.30 PM
SAT. 8.00 AM TO 11.45 AM

*Our Comprehensive Stocks
include:—*

- T.V. AERIALS & ACCESSORIES**
- TRANSFORMERS**
- SPEAKERS**
- I.C. & SEMICONDUCTORS**
- POMONA SHIELDING BOXES**
- SOLDERING IRONS**
- ELECTRONIC HANDBOOKS-**
- CASSETTE TAPES**
- REPLACEMENT VALUES FOR**
- NATIONAL T.V.**
- P.C. BOARDS**

OPEN SATURDAY MORNINGS

NOW YOU CAN BUILD THE FABULOUS PLAYMASTER "FORTY FORTY" and the PLAYMASTER "TWIN 25"

FORTY FORTY

TWIN 25

\$105

\$89.50

Designed by Leo Simpson of Electronics Australia.

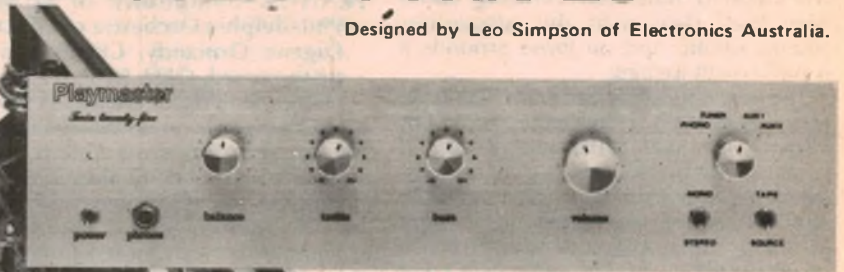
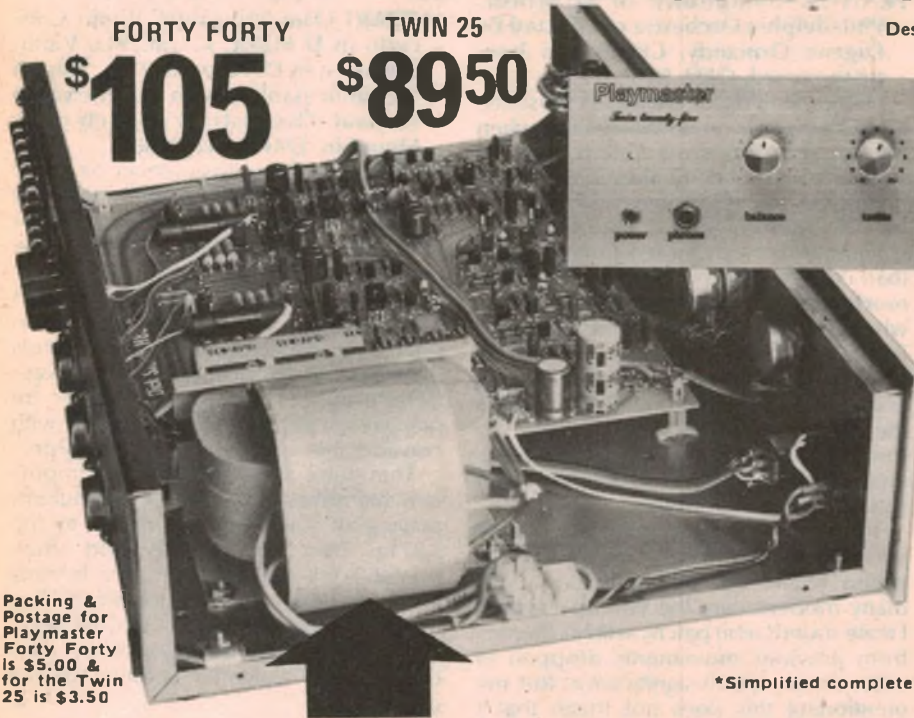

Packing & Postage for Playmaster Forty Forty is \$5.00 & for the Twin 25 is \$3.50

ATTENTION



This Playmaster Forty Forty has the low noise transformer. The Twin 40 is a cheaper amplifier with a normal iron core transformer. We do not supply the Tw'n 40 and do not intend to.

FEATURES

- *Exclusive Bronzed Anodized Front Panel
- *Professional Knobs to match the Front Panel
- *Level graduation on Treble and Bass controls
- *Simplified complete Instruction Manual and Assembly Instructions
- *Special silk screened fibreglass PC Board

THE "FORTY FORTY" HAS AN EXCLUSIVE 'C' CORE LOW NOISE (LH) TRANSFORMER

The "C" core transformer in the Dick Smith kit is EXCLUSIVE — and its one of the key components in this amplifier. Normal interleaved (laminated) transformers are alright — just — but for the optimum performance the "C" core, with its grain-oriented steel and better electrical characteristics is hard to beat. The result: a quieter more powerful amplifier. More power can be delivered by transformer with less "noise" being radiated to get in the sensitive front end of the amplifier.

ATTENTION: This amplifier is slightly more expensive because of the "C" core (LH) low noise transformer — however it is really worth the extra \$5 — on headphones alone the background noise level is lower.

Cat. K-3411 Playmaster Forty Forty Kit \$105.00

PLAYMASTER "TWIN 25"

For those who require a lower powered unit or who do not have the living area suitable for the higher powered Forty Forty, then the Twin 25 is the ideal amplifier. The 25 watts RMS per channel suits most available speaker systems. "It is about half the price of an imported amplifier with the same power output" says Leo Simpson in Electronics Australia for April 1976. Thousands of these units have already been built during the last few months.

Cat. K-3410 Playmaster Twin 25 Kit \$89.50

SPECIFICATIONS for BOTH AMPLIFIERS

Power Output:

Forty Forty — 40 W per channel into 8 ohms with 1 channel driven.

Twin 25 — 25 W per channel into 8 ohms with 1 channel driven.

Frequency Response: ± 1 dB from 25 Hz to 20 kHz with tone controls level.

Compensation: RIAA to within ± 1 dB.

Sensitivity: Phono 2mV into 56k for 25W or 40W output.

Other inputs 150mV into 36k minimum.

Overload: On phono 120mV.

Sig/Noise: 70dB (on phono) @ 10mV. 70dB (other inputs).

Crosstalk: Better than -45dB over 100 - 10 kHz.

Distortion: Less than 0.05% at normal listening levels.

Bass / Treble Controls: ± 13 dB nom. at 50 Hz and 10 kHz.

Stability: Unconditional.

CONVERT YOUR EXISTING TWIN 25 TO GIVE YOU 40 WATTS RMS PER CHANNEL.

With this conversion kit you can boost your Twin 25 to give 40 watts RMS per channel. Complete with full instructions and all necessary parts including "C" core transformer. Cat. K-3435 Conversion Kit Only \$25.00

FREE Power supply circuit included when you purchase the above kit to show you how to use your existing Twin 25 Transformer for a 13.8 volt 2.4 Amp Regulated Power Supply. A must for the hobbyist.



"C" CORE TRANSFORMER ONLY

Cat. M-0148 .. \$24.50

OPTIONAL CABINET

Dress up your amplifier with an attractive high quality simulated Teak timber cover. Will give it that \$500 look. Suits both the Playmaster Forty Forty and the Twin 25 amplifiers.

Cat. H-3113 \$7.50

SPEAKER PROTECTOR KIT

Suits both the Playmaster Forty Forty and the Twin 25. Get that extra protection for your speakers from damage by amplifier malfunction and switch on / switch off thump.

Cat. K-3425 \$10.75

DICK SMITH ELECTRONICS GROUP

HEAD OFFICE: Phone 439 5311. Telex AA20036. Cable 'Diksmit' Sydney

MAIL ORDERS: P.O. Box 747, Crows Nest, N.S.W. 2065

N.S.W. BRANCHES: GORE HILL—162 Pacific Hwy, 439 5311

SYDNEY—125 York St, 29 1126 BANKSTOWN—361 Hume Hwy., 709 6600

INTERSTATE BRANCHES: QLD—166 Logan Rd., Buranda 391 6233

VIC—656 Bridge Rd., Richmond 42 1614



DICK SMITH DEALERS:

Aero Electronics, Hobart (34 8232)

Veneman & Wyatt, Darwin (81 3491)

Wills & Co., Launceston (31 5688)

Hunts Electronics, Toowoomba (32 6944)

A.E. Cooling, Elizabeth South (255 2249)

The Record Centre, Griffith (621 577)

Altronics Parts, Perth (28 1599)

Bladen Brook Electronics, Tamworth (66 1363)

Dealer prices may be higher due to transport costs.



Lighter Side

Reviews of other recordings

GREAT PROTESTANT HYMNS. Virgil Fox playing the Organ at the Riverside Church. Stereo, RCA "Pure Gold" series ANL1-1582.

Perhaps I should begin by mentioning that this is a re-issue, although I cannot recall any details of the earlier version. But the jacket of another Virgil Fox disc served to remind of details of the organ used: 10,000 pipes, distributed in ten divisions, six of them around the front of the church and the remaining four above the rear gallery, almost a city block away in the huge auditorium.

And that's the way it sounds—a huge instrument in a huge auditorium, with any number of mixtures and effects, sometimes ponderous, sometimes heavy with tremulant, sometimes delicate in a remote kind of way.

Personally, I came to terms with the recording most effectively by accepting it for what it is, switching to simulated 4-channel and letting it envelop me.

The program itself lasts nearly an hour and involves eight medleys featuring hymns like "The Church Is One Foundation", "All Hail The Power", "Oh God Our Help", "Love Divine", "When I Survey" and many others—21 in all—played in traditional tempi and harmonies, with no more embellishment that one would expect from an accomplished church organist playing for a church audience.

The quality is clean and smooth even if lacking somewhat in "sparkle". But maybe that's the wrong thing to expect from such a vast environment, anyway. (W.N.W.)

Devotional Records

GOSPEL SING-A-LONG. The Dick Bolks Singers. "Stereo", 2-record set, Singcord ZLP-954S. (From S. John Bacon, 12-13 Windsor Ave, Mr Waverley, Vic 3149. Price \$8.95).

I put quotes around the word stereo because this is really double mono—instruments only on the left and voices only on the right. And I mean "only"; swinging the balance control to the extremes gives you the choice with the "ensemble" in the balance position, and both speakers operating.

On stereo phones the effect is quite odd, with each ear deaf to the opposite track. In fact, I made it sound right only by plugging the phones into the rear channels of a quadraphonic system, using the SQ decoder circuits to provide left-right blend.

Technical considerations aside, the songs on the two discs are taken from the Stamps Baxter C&W Gospel Hymnal and, if that doesn't mean a great deal to you, they will either be well known already to evangelicals or be readily assimilated. Among the 40 titles are songs like: Burdens Are Lifted At Calvary — When The Saints Go Marching — Each Step Of The Way — Mansion Over The Hilltop — On The Jericho Road — Love Lifted Me — Farther Along, etc.

Against a gently rhythmic instrumental background, the Dick Bolks Singers provide a very smooth blend of part singing, with excellent diction. Some will enjoy every moment of the four sides; others will prefer to interpose single sides in other music. But, if you like happy Gospel songs for relaxation—or to set a mood—you could regard as well spent the purchase price of this 2-record set. (W.N.W.)

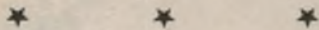

JOHN MICHAEL TALBOT. Stereo, Sparrow SPR-1003. (From Spotlight Music Pty Ltd, 5th Floor, 264 Pitt St, Sydney 2000.)

In his own jacket notes, John Michael Talbot introduces himself as a young man who, by his middle teens, had made it into a country rock band, only to find himself becoming progressively more disillusioned with the artificiality of the associated way of life. Conversion to Christianity put a temporary end to his

career but, in this new solo album, and in his own compositions, he bears testimony to a new faith and a new avenue of service:

He is Risen — Jerusalem — How Long — Would You Crucify Him? — Woman — Greenwood Suite (Appeal, Interlude, Proclamation of Victory) Hallelu. If these titles seem succinct, it is because each refers to specific scripture passages, as listed on the jacket.

I imagine that the album would have its strongest appeal to those who knew John Michael Talbot as a popular artist. At this remote distance, appreciation of his music and lyrics would involve generating an empathy with his background and paying close attention to his lyrics above a rather insistent guitar.

If you're a rock Gospel fan, you may react much more positively but, even so, I can't see it having any strong appeal outside that particular circle of listeners. (W.N.W.)

Instrumental, Vocal and Humour

AGE OF GOLD. Leonard Bernstein and the New York Philharmonic Orchestra. Stereo, CBS SBR-235796.

The title "Age of Gold" is borrowed from the ballet by that name by Shostakovich and refers to one track on side 2—the polka from "Age of Gold". But I would gather that it is also intended to be a collective title for the excerpts on the disc—a round dozen that must surely be among the best known from equally well known Russian composers:

Dance of the Tumblers (Rimsky-Korsakov) — Waltz From Eugen Onegin (Tchaikovsky) — Wedding From Lt Kije (Prokofiev) — Polonaise From Eugen Onegin (Tchaikovsky) — March From the Love Of Three Oranges (Prokofiev) — The Procession Of The Sardar (Ippolitov-Ivanov) — Dance Of The Polovtsian Maidens (Borodin) — Age Of Gold Polka (Shostakovich) — Waltz From The Sleeping Beauty (Tchaikovsky) — Troika From Lt Kije (Prokofiev) — In The Steppes Of Central Asia (Borodin) — Russian Sailors' Dance (Gliere).

If you don't already have these highly listenable items on disc, and you decide

to buy this collection you'll find yourself with a very clean recording — clean, I suspect, because CBS haven't tried to load up the groove too heavily. Stereo spread and separation are excellent, too. (W.N.W.)



Pure Gold Waltzes, Boston Pops Orchestra RCA 'Pure Gold' Series ANL 1-1440

This is one of a series of reissue albums from RCA featuring popular artists such as Al Hirt, Perry Como, Eddie Fisher and George Beverly Shea and this one with veteran conductor Arthur Fiedler at the helm is a promising sample.

I don't know how old the original recordings are but the quality is acceptable with nine favourite waltzes to enjoy, these being: Two Hearts In Three Quarter Time — Danube Waves — Girls Of Baden — Swanilda's Waltz (from Coppelia) — Gold And Silver Waltz — By The Beautiful Blue Danube — L'Estudiantina Waltz — Valse Bluettes — Waltz Scene From 'Faust'

The performance tends to be on the gentle side, ideal for that dreamy interlude or as a background for an evening with friends. (N.J.M.)

Reviews in this section are by Neville Williams (W.N.W.), Jamieson Rowe (J.R.), Leo Simpson (L.D.S.), Norman Marks (N.J.M.), David Edwards (D.W.E.) and Greg Swain (G.S.).

LIGHTER SIDE—continued

OKLAHOMA. Original Broadway Cast Album. MCA Records MAPS 1683

I really did not know whether to pan or praise this album. By every standard of 1976 it could be drubbed unmercifully. But it is the original Broadway cast album—so that's different. It is hard to imagine that Rodgers' & Hammerstein's "Oklahoma" is 25 years old. It is even harder to believe that it was hailed as a revolutionary musical at the time. It sounds absolutely ancient!

As is common with the cast of stage musicals, they cannot sing—it's more like caterwauling. And the recording quality sounds exactly like a 25 year old LP that has been played every Sunday for 25 years on the family clunker "radiogram". Yuk.

Having said all that I can still recommend this album. It has a lot of nostalgic charm especially to anyone in the 30 to 40 year old bracket who was regimented into performing "Oklahoma" excerpts at school concerts. By all means buy it but be prepared to disbelieve how corny it sounds! (L.D.S.)

COL NOLAN QUARTET, ARRANGEMENTS. M7 MLF 157

This record provides some very refreshing jazz from a local group, the Col Nolan Quartet, with Col Nolan on piano, electric piano, clavinet and organ, Dieter Vogt on acoustic and electric bass and trumpet, Laurie Bennett on drums, Bob Bertles on tenor and altosax, recorder, flute and soprano sax with special guest John Sangster on percussion. The tracks include two versions of the theme from 'Picnic At Hanging Rock' — You Are My Heart's Delight — Back At The Chicken Shack — Fixation — Theme From 'Samson and Delilah' — Take Five — Careless Love — Come Rain, Come Shine.

Some peculiarity in the review copy caused faulty tracking on my player on both sides for the first few seconds but, otherwise, the quality was superb, with very tight clean bass.

On one version of 'Picnic At Hanging Rock' on side one, Errol Buddle is featured on recorder. (N.J.M.)

CEYLON/BIRD OF PASSAGE. Karlheinz Stockhausen. Chrysalis stereo L35877. Distributed by Festival Records Pty Ltd.

Mention avant-garde music and in the same breath you're talking of Stockhausen. For the last twenty years or so he has been at the forefront of modern composers and at the frontier of musical composition. Trouble is, to my mind, the frontier has not moved by much in those twenty years. To most ears, avant-garde music still sounds alien and these two recent compositions from Stockhausen have little that is new. After patient listening I am not enthusiastic. I am sitting on my hands. (L.D.S.)

STEPPENWOLF GOLD. THEIR GREAT HITS. Steppenwolf. ABC Records DSX-50099. RCA release.

Older rock fans, and no doubt some younger ones, will appreciate this collection of Steppenwolf material. As with all collections of this sort, there is very little which can be meaningfully said about it, without becoming repetitive.

For the benefit of avid collectors, I will list the tracks in order: Born To Be Wild — It's Never Too Late — Rock Me — Hey Lawdy Mama — Move Over — Who Needs Ya — Magic Carpet Ride — The Pusher — Sookie, Sookie — Jupiter's Child — Screaming Night Hog.

Technically, I found my review copy to be about average. Some hiss and noise was evident, but not in excessive amounts. (D.W.E.)

CLASSICAL GUITAR DEBUT. Tim Kersten. M7 stereo MLF 139.

Tim Kersten is a gifted young Australian guitarist making his recording debut on this album. The selections played by Tim are mostly introspective in nature and are mostly Flamenco

pieces. This makes it more difficult to convince the listener of his talent since he cannot resort to a dazzling display of virtuosity. But after listening to the album on several occasions I am convinced that Tim Kersten is a performer with much potential. And I can recommend this disc for 45 minutes of relaxed listening. Recording quality is excellent. (L.D.S.)

THE CAERPHILLY MALE VOICE CHOIR. Astor Gold Star stereo GGS 1493.

The Caerphilly Male Choir is one of the foremost Welsh choirs with a reputation stretching back seventy years. But the standard shown on this album is more like a rehearsal than a concert performance. The voices are ragged, none too well co-ordinated and the tempo is raced. And to top it off, the recording quality is distinctly poor. The Caerphilly is certainly not well served by the release of this album. And the shame of it all is that it features traditional favourites.

Just so you know what you're missing, here are the track titles: Hyfrydol — The Bandit's Chorus — Peter Go Ring Dem Bells — The Battle Eve — Myfanwy — Conspirator's Chorus — Dwellers By The Sea — The Soldiers' Chorus — Tydi A Roddaist — The Long Day Closes — This Ol' Hammer — Go Down Moses — The Lord's Prayer. (L.D.S.)

ROBERT GOULET. After All Is Said And Done. M7 Records MLF-154.

The strong, powerful voice that characterises the Robert Goulet style must be now be well known to most readers. If, like me, you are an admirer of his style, this album should particularly appeal. In it, Robert Goulet sings a selection of popular songs that add up to a very enjoyable listening session indeed.

Track titles are: After All Is Said And Done — Something To Believe In — July You're A Woman — I Won't Send Roses — The Little Prince — Someone To Give My Love To — The Green Years Of Love — I Won't Last A Day Without You — You And Me Against The World — The Way We Were.

Recording quality is good, with negligible background noise. Recommended. (G.S.)

DECCA

Record Cleaner WORKS AS YOU PLAY...

This new DECCA Record Cleaner removes dust and grit as your record spins on the turntable. It consists of an arm carrying a brush made from a newly-developed man-made fibre. Its "bristles" are incredibly fine, incredibly soft yet strong, and are also electrically conductive to remove static as well as dust. The result — Improved sound quality, reduced record wear.

•\$13.95 at hi-fi stores and record bars.

Australian agent: **British Merchandising Pty. Ltd.,**
49-51 York Street, Sydney. Telephone 29 1571.

*Recommended retail price



While you listen to the music you can dance around our room.

N.S.W.

SYDNEY CITY:

Homesound, George St

EASTERN SUBURBS:

Woolloomooloo—Convoy Sound

WESTERN SUBURBS:

Parramatta—Riverina Hi-Fi.

Concord—Sonata Hi-Fi

SOUTH:

Roselands—Miranda Hi-Fi.

Miranda Fair—Miranda Hi-Fi.

Hurstville—Jock Leate.

LIVERPOOL: Miranda Hi-Fi.

GOSFORD: Miranda Hi-Fi.

SPRINGWOOD: Springwood Hi-Fi.

NEWCASTLE: Newcastle Hi-Fi.

HUNTER VALLEY: Hunter Valley Electronics.

TAREE: Godwins Hi-Fi.

WOLLONGONG: Sonata Hi-Fi.

ORANGE: Anno's Hi-Fi.

A.C.T.: Pacific Stereo.

VICTORIA

MELBOURNE CITY:

Image Audio

Southern Sound.

Allans Music.

MELBOURNE SUBURBS:

St. Kilda—Denman Audio.

Hawthorne—Tivoli Hi-Fi

Nth. Caulfield—The Soundcraftsman.

Mordialloc—Mordialloc Hi-Fi.

Moorabbin—Southern Sound.

Warnambool—A. G. Smith.

QUEENSLAND:

BRISBANE CITY:

Reg Mills Stereo.

BRISBANE SUBURBS:

Ashgrove—Living Sound

Maryborough—Keller Electronics

Tingalpa—Todds Hi-Fi.

SOUTH AUSTRALIA

ADELAIDE CITY:

Allans Music.

Hi-Fi Acoustics

ADELAIDE SUBURBS:

St. Peters—Sound Dynamics.

WEST AUSTRALIA

PERTH CITY:

Musgraves.

Clef Music

PERTH SUBURBS:

Nedlands—Audio Distributors.

Mosman Park—Audio Distributors.

TASMANIA

BURNIE: James Loughran Audio Services.

LAUNCESTON: Wills & Co.

EPICURE

Or write to Auriema (A/asia) Pty. Ltd.,
P.O. Box 604, Brookvale, N.S.W., 2100.
Telephone 939 1900

AUR21

LIGHTER SIDE—continued

LOVE, LIFE AND FEELINGS. Shirley Bassey. United Artists stereo L 35851.

Shirley Bassey is noted for performances full of verve and vitality but this album must have been recorded on one of her off days. Granted that many of the songs are blues but some lighter touches are needed. Even "You've made me so very happy" sounds like a lament. Be warned. If you put this record on when you're feeling blue you may end up thoroughly miserable. Pardon me while I pop an anti-depressant.

Recording quality is good.

Track titles are; What I Did For Love — The Hungry Years — Born To Lose — Everything That Touches You — Isn't It A Shame — Midnight Blue — The Way I Want To Touch You — Natali — You've Made Me So Very Happy — Alone Again (Naturally) Feelings — If I Never Sing Another Song. (L.D.S.)

NAT "KING" COLE SINGS SONGS FROM THE MOVIES. Capitol Records VMP-1032. EMI Release.

This record is a selection of motion picture hits of Nat "King" Cole, and features eleven numbers from nine different movies. Both sides are headed by the songs from Columbia Pictures' comedy western "Cat Ballou"—"The Ballad of Cat Ballou", in which Nat was joined by Stubby Kaye (they appeared in the movie as street singers), and "They Can't Make Her Cry", a romantic ballad.

Other tracks are: Blue Gardenia — St Louis Blues — The Song Of The Raintree Country — The Cool Of The Day — China Gate — Night Of The Quarter Moon — Never Let Me Go — Beale St Blues — Hajji Baba.

In summary, a nostalgic trip back over some of the well known and popular Nat "King" Cole movie themes. Recording quality is quite okay. (G.S.)

SEDAKA EMERGENCE. RCA Victor APL1-1789.

The title of this album seemingly suggests the emergence of Neil Sedaka as a classic romanticist after years of popular songwriting. But, for me, the new style is not all that inspiring, despite Sedaka's statement in the cover notes that "These twelve songs are the best I've written in eighteen years . . ."

About the only song that struck a responsive chord with the past was the first track on side 1: I'm a Song (Sing Me). Other track titles are: Gone with the Morning — Superbird — Silent Movies — Little Song — Cardboard California — One More Mountain to Climb — God Bless Joanna — Is Anybody Gonna Miss You — What Have They Done to the Moon — Rosemary Blue — Wish I Was a Carousel.

My advice is to listen before buying. You may like it or you may not. Recording quality is excellent. (G.S.)

A DECADE OF CHARLEY PRIDE. Charley Pride. RCA Victor SP-173-G. Also available on cassette and cartridge.

Charley Pride is one of the giants of country music, and is very popular in Australia. This record is crammed with twenty of his best known songs, and demonstrates to the full his unique talents. If you don't have one of his records in your collection, then I can thoroughly recommend this one.



LION

ELECTRONICS

Security Systems

POSTAL ADDRESS: 38 CENTRAL AVENUE, REDCLIFFE, W.A. 6104. TELEPHONE: 65 7515
SHOWROOM: STONEHAM ROAD, BELMONT, W.A. 6104.

INSTALL YOUR OWN BURGLAR ALARM

<p>L4</p>  <p>\$9.00</p>	<p>L76-002</p>  <p>\$22.00</p>	<p>L76-001</p>  <p>\$14.50</p>
<p>Instant Latch with built-in Siren Module Open and closed circuits can be connected. 12-volts DC. Up to three L4's can be used.</p>		
<p>5" Horn Speaker 8 (1)5W</p>	<p>L10</p>  <p>\$1.45</p>	<p>L33</p>  <p>\$4.28</p>
<p>Other available equipment:</p> <p>Pressure Mats 18" x 30" \$14.35 Car Door Switches (Alpha-type) \$1.30 Home Alarm Kit consisting 1 x L76-002 Latch, 1 x L4 Horn, 5 x L10 Reed Switches, 1 x L33 Key Switch \$39.50 Car Alarm Kit consisting 1 x L76-002 Latch, 1 x L4 Horn, 6 x Car Door Switches, 1 x L33 Key Switch \$36.00 Set of Instructions sent with all orders. P & P \$1.00</p>		



**When his mini-computer, one day,
refused to compute, Alvin was in
strife... THEN he remembered!**

Alvin's one of those self-styled electronic wizards, totally dedicated to his hobby—his array of expensive equipment assembled over the years is proof positive. He knows that electronic equipment requires dust and moisture-free atmospheric conditions for maximum efficiency, and so, when, one day, his pride-and-joy mini-computer refused to compute, he knew what to do... damp contacts, dusty computer heads, contaminated points... spray with CRC CO Contact Cleaner—lifts, dissolves, evaporates completely,



effectively, immediately, all residual contaminants and moisture. No disassembly of complicated units, no expensive parts to replace... just a simple application of an incredible product like CRC CO Contact Cleaner to "dissolve" the problem. If you're a dedicated "Alvin" too, you'll want to try CRC CO Contact Cleaner yourself. Ask for it at your nearest electrical/electronics retailer, or for more info about it write to: CRC Chemicals Australia Pty Ltd, Centre Court, Paul Street, North Ryde, NSW, 2113

THE SOLUTION SOLUTION

CRC CHEMICALS AUSTRALIA PTY. LTD.

Centrecourt, 25-27 Paul St., Nth. Ryde 2113. Phone: 888-3444

LIGHTER SIDE

Equally, it would complement an existing collection.

In order, the featured tracks are: Mississippi Cotton Pickin' Delta Town — Hello Darlin' — Distant Drums — A Brand New Bed Of Roses — I Ain't All Bad — She's Too Good To Be True — The Green, Green Grass Of Home — Busted — Hope You're Feelin' Me (Like I'm Feeling You) — Guess Things Happen That Way — It's Gonna Take A Little Bit Longer — Before The Next Teardrop Falls — Then Who Am I — Amazing Love — I'd Rather Love You — Let The Chips Fall — Comin' Down With Love — Mama Don't Cry For Me — Louisiana Man — Cotton Fields.

On the technical side, my review copy was a credit to the local RCA people. Surface noise was very low, and the overall sound very clean. In short, it was a pleasure to review. (D.W.E.)

★ ★ ★
FUTURISTIC DRAGON. T. Rex. Stereo.
EMI Records BLN 5004.

Marc Bolan's latest album is just what I expected. Marc's distinctive voice is always to the front, painting surreal pictures in your mind. The lyrics flow fairly smoothly, without at any times becoming exceptional, while the music tends to be a little stiff. However, one or two tracks do rise above the standard of most of the record.

I was most impressed with the following tracks, which I feel would be worth sampling if you are contemplating purchasing: Jupitar Liar — New York City — Dawn Storm. On the technical side the record was a little disappointing, as background noise was evident in some places. (D.W.E.)

★ ★ ★
SPITFIRE. Jefferson Starship. Stereo.
Grunt Records BFL1-1557 RCA release.

Grace Slick once (at Woodstock), introduced Jefferson Airplane as playing "morning maniac music". My first impression of the Jefferson Starship, which is formed from the hub of Jefferson Airplane, is that it is tired. The original vitality does not seem to be quite there, as it used to be.

While there are those who will no doubt disagree with me, I found the record to be just a pleasant aural experience, something which I did not object to hearing, but at the same time not something that I felt the need to immediately play again. As one would expect, the record is filled with technical expertise, and is of very good quality. The first track on side two I found to be quite impressive in this respect.

This record will affect different people in different ways, and I expect that I will probably grow to like it, given to time and a sufficient number of playings. So there it is; try it yourself. (D.W.E.)



EMI has announced that a contract has been concluded with Leonard Bernstein for a series of orchestral recordings. These will be made in Paris with the Orchestre National de France and will include a recording with Mstislav Rostropovitch of the Schumann 'Cello Concerto' and Bloch's 'Schlemmo'. The sessions will take place in the Salle Wagram where all EMI's major projects in Paris are recorded. Peter Andry, General Manager of EMI's International Classical Division, signed the contract on behalf of the company. He welcomed Maestro Bernstein to EMI and said that these recordings represented the fulfilment of a long-cherished plan and would be of considerable international significance.



CARA MIA. The Disco Sound of Paul Delicato. M7 stereo MLF 153

If you are a fan of Tom Jones, Engelbert Humperdinck or even Lovelace Watkins, then high voltage vocalist Paul Delicato is certain to have tremendous appeal. His is the sort of record you slap on the turntable to send you ripping through the chores or to get people on their feet and dancing at a party. Like those singers above Paul Delicato has the range and vitality to set up almost any song. And he is backed with some excellent arrangements.

Recording quality is not marvellous but the standard of performance makes up for that. A good buy.

Ten tunes are featured, two in medley form: Cara Mia — It's the Same Old Song — Happy Together — What Becomes Of The Brokenhearted — I Can't Make It All Alone — Lean On Me — I Couldn't Live Without Your Love — Just Enough To Keep Me Hangin' On — Baby Face — You Must Have Been A Beautiful Baby — Spirit Of America. (L.D.S.)



JOHN MEILLON. The Humorous Side of Henry Lawson and Banjo Paterson. M7, MLF 151.

Having become thoroughly accustomed to the deep voices and the intense style of readers like Leonard Teale, the more casual and conversational approach of John Meillon didn't seem quite "right". This impression persisted through most of side 1 and through the two stories "The Loaded Dog" and "Bill And Jim Nearly Got Taken Down".

By side 2, John Meillon had established his right to be heard and the remaining two stories fared better as a result; "At Dead Dingo" and "His Masterpiece".

As prose, all four items provide a contrast with the oft-repeated poems and provide a different facet of the two well known Australian writers. What place you have in your collection for these items of Australiana is something only you can decide, however.

If you are a potential buyer, there are no problems either with diction or technical quality. (W.N.W.)

YOU NEED NEVER BUY ANOTHER DRY BATTERY

ARLEC

BATTERY ELIMINATORS

POWER

- PORTABLE RADIOS
- CASSETTE PLAYERS
- ELECTRONIC CALCULATORS
- FLUORESCENT LANTERNS
- ELECTRIC TOYS, ETC.

AT NEGLIBLE COST.

INDOORS



PS309 PLUGPACK MULTI-VOLTAGE AC ADAPTOR

Switched output for 6V, 7.5V & 9V equipment at 300 mA DC. Plugs directly into power socket. Double insulated for maximum safety. SEC approved.

OUTDOORS



PS393 KARPAK

Plugs into the cigarette lighter socket of the car. Switch selector for 6V, 7.5V & 9V output at 300 mA DC. Solid state voltage regulation ensures top performance from the equipment. Negligible power drain from the car battery—even when stationary.



SEE THEM AT YOUR LOCAL ELECTRICAL OR HARDWARE STORES.

A+R SOANAR ELECTRONICS GROUP

SALES OFFICES VICTORIA: 89 0661
N.S.W.: 78 0281
S. AUST.: 51 6981
QUEENSLAND: 52 5421
W. AUST.: 81 5500

30 Lexton Road, Box Hill, Vic., 3128
Australia. Telex 32286.



"WITHOUT MY SCOPE IRONS I RECKON I'D NEED A 25 HR. DAY."



8.00am "Start the day with a heavy earth connection on the emergency power plant. Need a 130 watt iron. My Superspeed's got that and more. Just as well, the workshop's 400 yards away".

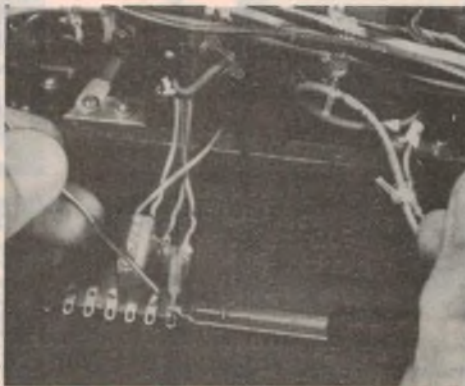

9.15am "Call from No. 2 Moulding Shop. Ran some temporary leads involving both tag joints and Printed Circuit Board (P.C.B.) connections. The Scope Minispeed handled the lot".

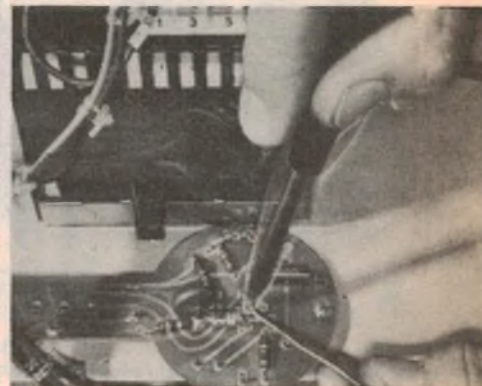

10.55am The V.D.U. in the process control room is playing up. Replacing miniature resistors on a P.C.B. is, ideally, the job for a temperature controlled 60w iron but my Scope Minispeed did the job and did it well.



11.15am "Fix the speaker leads in the canteen P.A. Need a 30-40 watt iron, but my Scope Minispeed did the job".

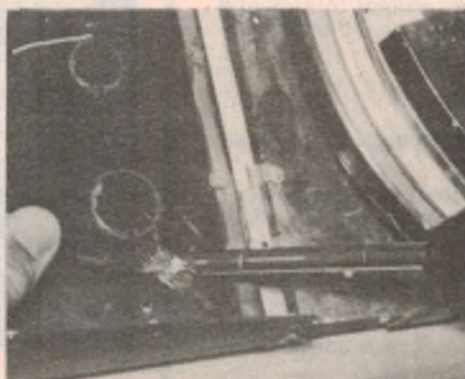

1.30pm "Resolder a 7/036 earth to sheet metal — LP gas flame would work, but too much risk of heat damage to PVC cable. The Superspeed iron produced its full 150 watts and did the job".

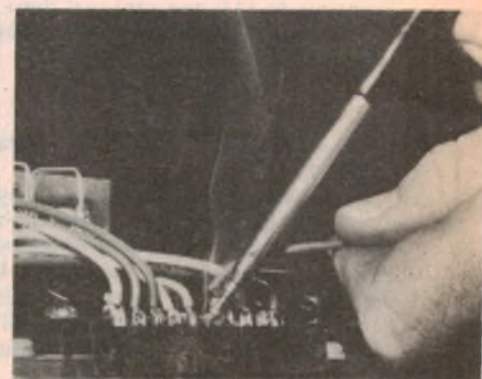

2.15pm "Fred borrowed my Minispeed to tackle an open circuit on the fork lift's headlights. He permanently soldered the wires to the terminal block, and used the Mini's 75 watts to do it".

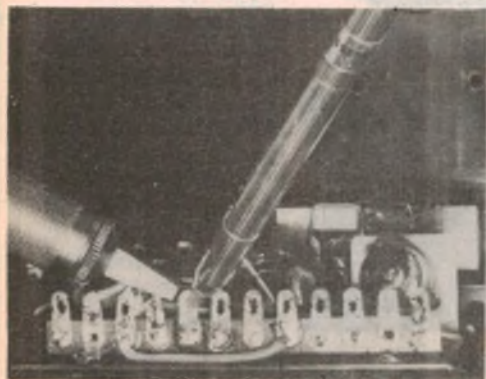

2.17pm "Tag soldering in the workshop and a desolder job on a P.C.B. Using the Minispeed saves swopping between conventional 60 watt and 25 watt irons".

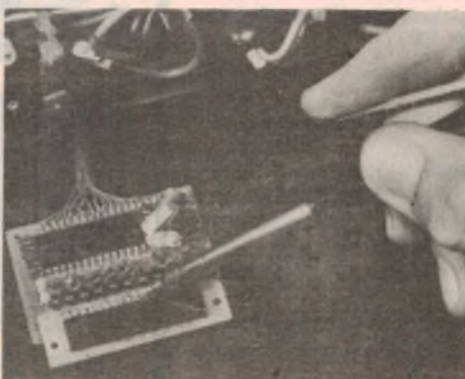

3.58pm "Emergency in shop six. I used my Minispeed to unsweat the leads of the main heater control circuit and then desolder the pyrometer circuit on the P.C.B. One iron, two different jobs".



4.18pm "This wiring's a real birds nest. Passed through the wires with the Minispeed stone cold, desoldered the three joints, let the iron cool down, then withdrew through the PVC insulation. The 5 second heat up and low tip mass let's me do this".

Scope soldering irons save time three important ways:

1. Versatility.

One Scope iron replaces several conventional irons because it can tackle a wide range of soldering problems, from integrated circuits and printed circuit boards to heavy earth and chassis connections.

You don't have to swap irons half-way through the job. Both the Minispeed and the Superspeed function as 20-30 watt irons, and then within seconds and a touch of the finger switch, you get increased heat output to increase the Minispeed to 75 watts, and the Superspeed to 150 watts.



2. Speed.

Five seconds gets both irons ready for work, and they cool down quickly as well. When you encounter a heat sink you want an iron that can make up the heat loss instantly and maintain good soldering temperature. Result, the job's done fast and you can move onto the next.

3. Safety.

Scope irons are isolated from the mains. The special isolation transformer lets you work on live equipment with a higher degree of safety than a conventional iron.

The Scope range of products is designed to deliver efficiency and convenience. Consider the advantages of these products.



(A) Scope Cordless. 60W.

Designed for working where no power is available or during temporary failure. It's powered by two rechargeable Nicad cells with the capacity to solder between 100 and 200 typical electronic connections before overnight recharging.

(B) Scope 12V Hobby Iron.

This versatile iron is designed to work within 6 metres of your car battery.

(C) Scope Vibroscope.

This electric pencil allows for permanent writing on all metals. Valuable in an engineering store identifying metal tools, dating and naming parts, inscribing trophies.

For enquiries and further information on the Scope range of products contact: Scope Laboratories, 93 Matthews Avenue, Airport West, Melbourne, 3042.

SCOPE

THE RIGHT IRON FOR THE RIGHT JOB.

No. 1 rated!

PLEASE NOTE—PRICE REDUCTION DESPITE DEVALUATION

In US by "Consumer Report"

CORVUS

Thoroughly recommended in Australia by a major electronics publication. Electronic Concepts Pty. Ltd. is proud to introduce the exclusive Corvus 500.

With MOSTEK* single chip technology, the new Corvus 500 is the first non-Hewlett-Packard calculator with Reverse Polish Notation. 10 addressable memories, 4 level roll down stack to be introduced. If you compare the Corvus 500 feature by feature with the HP45, you will find striking similarities. There are also some important differences.

*MOSTEK is one of America's advanced LSI (Large Scale Integration) chip manufacturers

	Corvus 500	HP 45
RPN (Reverse Polish Notation)	Yes	Yes
Memory Store and Recall 10 Registers	Yes	Yes
4 Level Stack Rotate Stack	Yes	Yes
10 MEMORY EXCHANGE WITH X	Yes	No
Log LN	Yes	Yes
Trig (Sine Cosine Tangent INV)	Yes	Yes
HYPERBOLIC (SINH COSINH TANH INV)	Yes	No
HYPERBOLIC RECTANGULAR	Yes	No
π CHS	Yes	Yes
Δ through INVERSE	Yes	No
GRADIANS	No	Yes
DEGREE RADIAN CONVERSION	Yes	No
Degree Radian Mode Selection	Yes	Yes
DEC DEG MIN SEC	No	Yes
Polar to Rectangular Conversion	Yes	Yes
Recall Last X	Yes	Yes
Scientific Notation Fixed and Floating	Yes	Yes
Fixed Decimal Point Option (0 9)	Yes	Yes
DIGIT ACCURACY	12	10
DISPLAY OF DIGITS	12	10
%	Yes	Yes
GROSS PROFIT MARGIN %	Yes	No
Mean and Standard Deviation	Yes	Yes
$\Sigma + \Sigma -$	Yes	Yes
Product Memories	Yes	Yes
C.F. DIRECT CONVERSION	Yes	No
F.C. DIRECT CONVERSION	Yes	No
LIT GAL DIRECT CONVERSION	Yes	No
KG LB DIRECT CONVERSION	Yes	No
GAL LIT DIRECT CONVERSION	Yes	No
LB KG DIRECT CONVERSION	Yes	No
CM INCH DIRECT CONVERSION	Yes	No
INCH CM DIRECT CONVERSION	Yes	No

As you can see, the Corvus 500 is a lot more calculator for \$79.95.

Price \$79.95

Mail charge \$2.50

Sales Tax exempt \$72.50

For sales tax exempt purchases, please supply number or certificate.

We have listed some of the many features, but let's amplify on some highlights:

1. RPN (Reverse Polish Notation) "COMPUTER LOGIC" and 4 LEVEL STACK

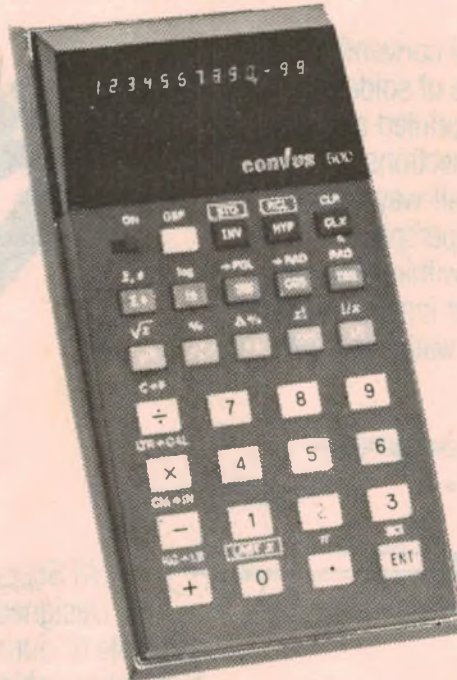

Your problem is solved the way it is written, left to right sequence, eliminating restructuring, unnecessary keystrokes, and the handicap of having to write down intermediate solutions. And all information is at your disposal — just roll the stack (R) to any intermediate information desired. You arrive at your solution faster, more simply and, therefore, more accurately.

Perhaps at this point we should address ourselves to the controversy between algebraic entry and RPN. One question we must ask is why proponents of algebraic entry always use an example of sum of products and never an example of product of sums: $(2+3) \times (4+5) =$ Algebraic $2+3 = MS 5+4 = X MR =$ TOTAL 12 keystrokes (SR5, 1, add 2 more keystrokes)

RPN: 2 Enter 3 + 4 Enter 5 + x TOTAL 9 keystrokes

2. THE CORVUS 500 and HP-45 HAVE 10 ADDRESSABLE MEMORY REGISTERS, 4 LEVEL OPERATIONAL STACK, and a "LAST X" REGISTER (10th Mem Reg). With 10 addressable memories, you have access to more entries, or intermediate solutions: less remembering, or writing down. YOU have to do. And less chance for error. The stack design also permits X and Y register exchange, and roll-down to any entry to the display for review or other operation. The "last x" register permits error correction or multiple operations when a function is performed, the last input argument of the calculation is automatically stored in the "last

x" register, which can be quickly recalled to correct an error, or to perform another operation using the same number.

3. DIRECT HYPERBOLIC and HYPERBOLIC RECTANGULAR to POLAR, and INVERSE. For those of you electronic and computer science engineers who require access to this specialised application, the Corvus 500 solves "your" problems.

4. A WORD ABOUT CORVUS 500 12-DIGIT DISPLAY AND ACCURACY. Finally you have displayed 12 digit accuracy in business format and $10 + 2$ in scientific notation. LED is manufactured by Hewlett Packard.

FOR THE FIRST TIME you can raise the number 10 to 199th power or calculate Factorial (x!) of up to 120. Unbelievable!

5. DIRECT FROM AND TO METRIC CONVERSION SAVES VALUABLE KEYSTROKES.

WHAT ABOUT CONSTRUCTION? With so many features, the next most obvious question must be in regard to the quality of the unit itself. We are proud to report the Corvus 500 to be double injected moulded, with "tactile" feedback keyboard. The compact, contoured case is $5\frac{1}{2}$ " long by 3" wide by $1\frac{1}{4}$ " high and weighs just 8 oz. The COMPLETE CORVUS 500 for \$79.95 includes:

- Rechargeable and replaceable Nickel Cadmium batteries. Optional 3AA batteries
- Adaptor/Charger.
- Owner's Handbook
- Soft carrying case

The Corvus 500 is warranted by the manufacturer against defects in materials and workmanship for one year from date of delivery.

For those of you who have the HP-21 or 45 or any other advanced calculator on order, aren't you glad you still have the opportunity to take advantage for the release of the Corvus 500 for \$79.95? Hurry! Order yours today.

AN INVITATION:

Electronic Concepts is proud to offer this exciting Corvus 500 as well as other Mostek based calculators and digital watches as exclusive importer of Corvus Brand products for Australia.

You, our discerning reader will no doubt recognise the tremendous price/performance value on offer. By mailing the order coupon today we can assure you of early delivery — and should you not be satisfied, you may return the unit to us with full money back guarantee within seven (7) days.

Or better, convince yourself of the real quality and value of our Corvus range, just visit our conveniently located showroom in Cambridge House, Clarence Street, just behind Wynyard exit (York Street), or phone 02-29-3755 for more information.

Other Corvus models on offer:
Corvus 600 Financial Genius \$69.95
Statistician \$19.95

Corvus 615 Business
Corvus Digital Watches — but more about these in our next advertisement.

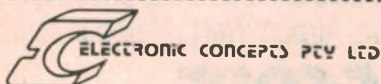

Ground floor, Cambridge House,
52-58 Clarence St., Sydney NSW 2000.
(02) 29 3753-4-5

Yes! I'd like to try the Corvus 500 for 7 days CASH payment: Cheque or money order enclosed. \$79.95 plus \$2.50 postage.

NAME

ADDRESS

POST CODE

bankcard 1st time offered for your convenience BANK CARD mail order facility. Please complete

Please charge my bankcard.

BANKCARD NO

EXPIRY DATE

SIGNATURE

Multiplexing

The technique of multiplexing is frequently used in digital electronics to minimise the number of circuits or communication channels required to handle multiple signals. In this chapter the author looks at the technique of multiplexing, at multiplexer and demultiplexer circuits, and at important applications of the technique.

by JAMIESON ROWE

Frequently a number of digital signals must be processed identically, or sent together over a significant distance. Where this must be done, it is generally desirable to minimise the number of processing circuits involved, or the number of cables or data channels required, in order to reduce the overall system costs and improve reliability.

One common and important way of doing this is multiplexing, which we will look at in this chapter. The word "multiplex" comes from two Latin words, "multi" meaning many, and "plecto" meaning to braid or interweave together. So literally, multiplexing is a technique where a number of signals may be interwoven so that they may be passed through a relatively small number of circuits or channels.

Strictly speaking there are two different types of multiplexing, one known as time-division multiplexing and the other as frequency division multiplexing. However

the latter is used almost solely in communications, and is largely an analog technique. It is time-division multiplexing which is used much more widely in digital electronics, and this is the type of multiplexing which we will look at here.

The basic principle of time-division multiplexing is quite simple, as shown in Fig. 1. Two commutating switches are used,

one at the input of the processing circuit or communications channel, and the other at the output. The rotors of the switches are rotated continuously at the same speed, and in phase synchronism.

The input switch cyclically samples the various input signals, so that each input signal is connected to the circuit or channel for a proportion of each revolution. Here there are six inputs and a six-segment commutating switch, so each signal is connected to the circuit or channel for one-sixth of the time.

The signal actually fed through the circuit or communications channel is thus not continuous, but an interleaved series of cyclic samples of the individual inputs.

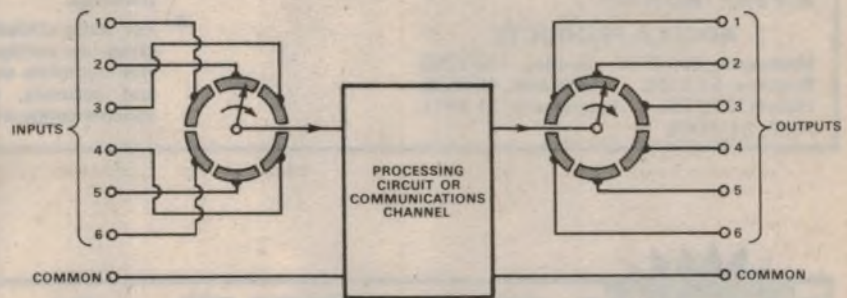

FIG. 1. BASIC PRINCIPLE OF MULTIPLEXING

At the output of the circuit or channel, the input multiplexing process is reversed by the second commutating switch, which acts as a distributor or demultiplexer. As the output corresponding to each input signal sample is produced by the circuit or channel, it is routed to its corresponding output line by the switch rotor.

Note that in order to convey signal changes faithfully the multiplex sampling must be done either at a much higher rate than signal changes, or synchronously with them.

In digital logic circuitry, the equivalent of the input sampling switch of Fig. 1 is the multiplexer circuit. An 8-line to 1-line multiplexer circuit is shown in Fig. 2, and as you can see it consists of a set of eight AND gates together with an 8-input OR gate and a 3-bit decoder.

Each AND gate controls one of the input lines, while the outputs from the AND gates are effectively combined by the OR gate to produce a common output line. The AND gates are enabled by the eight output lines of the 3-bit decoder, and as only one output of the decoder can be at the logic 1 level at any one time, only one AND gate can be enabled at any one time.

Which of the inputs of the multiplexer is connected to the output may therefore

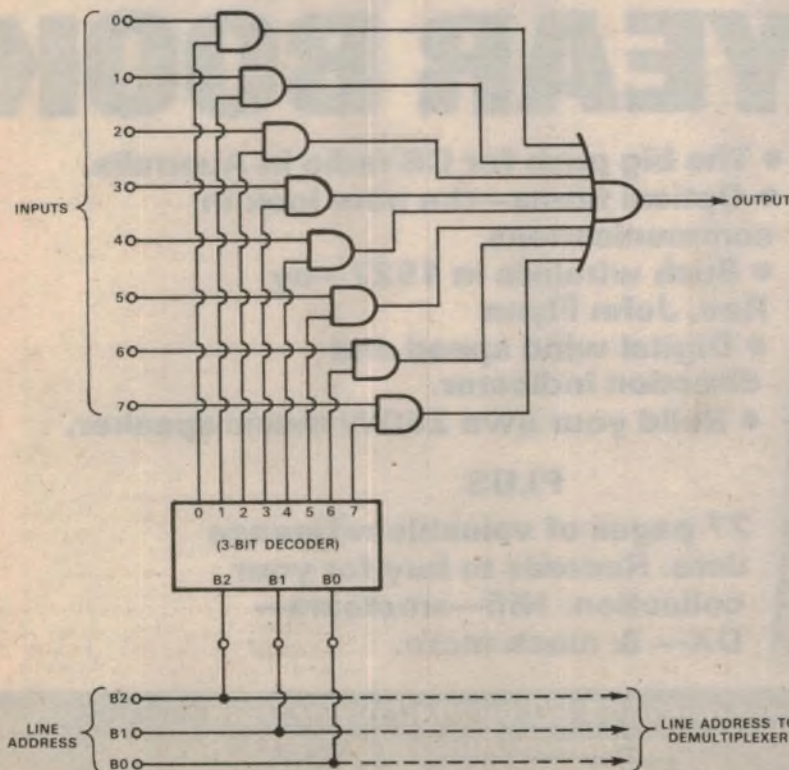
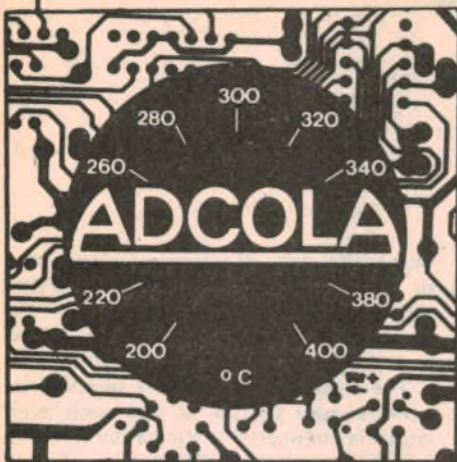

FIG. 2. 8-LINE TO 1-LINE MULTIPLEXER



Uncontrolled soldering temperatures may have been adequate in the valve and socket era, but today's solid-state devices and printed circuits are easily degraded by excess heat. This controlled-temperature soldering equipment protects your circuits . . . and your reputation.

ADCOLA PRODUCTS

Melbourne, 848 3777. Sydney, 709 5293.
 Brisbane, 52 3166. Adelaide, 42 6655.
 Hobart, 34 2233. Launceston, 31 2511.
 Perth, 81 5500

Non-destructive soldering



THERMATIC

Mains voltage. Variable, electronic feedback temperature control. Solid-state sensing and switching. Three times the heating power of conventional tools for fast heat-up and heavy duty soldering.

- For less critical applications, the DUOTEMP idles on half-wave AC at the recommended soldering temperature. Converts to full-wave, doubling power for long sequences or heavy duty soldering.
- For more critical applications, the ECT series low voltage soldering stations provide complete safety, zero tip potential, and accurate, dial-selected, infinitely variable temperature control.

K76

**NOW
ON
SALE**

THE NEW Electronics Australia YEAR BOOK



- The big push for CB radio in Australia.
- Optical fibres—the new look in communications.
- Bush wireless in 1927—by Rev. John Flynn
- Digital wind speed and direction indicator.
- Build your own 250W music speaker.

PLUS

27 pages of valuable reference data. Records to buy for your collection. Hifi—amateurs—DX— & much more.

\$1.20 from your local newsagent.

or for \$1.80 by mail order from "Electronics Australia", P.O. Box 163 BEACONSFIELD 2014.

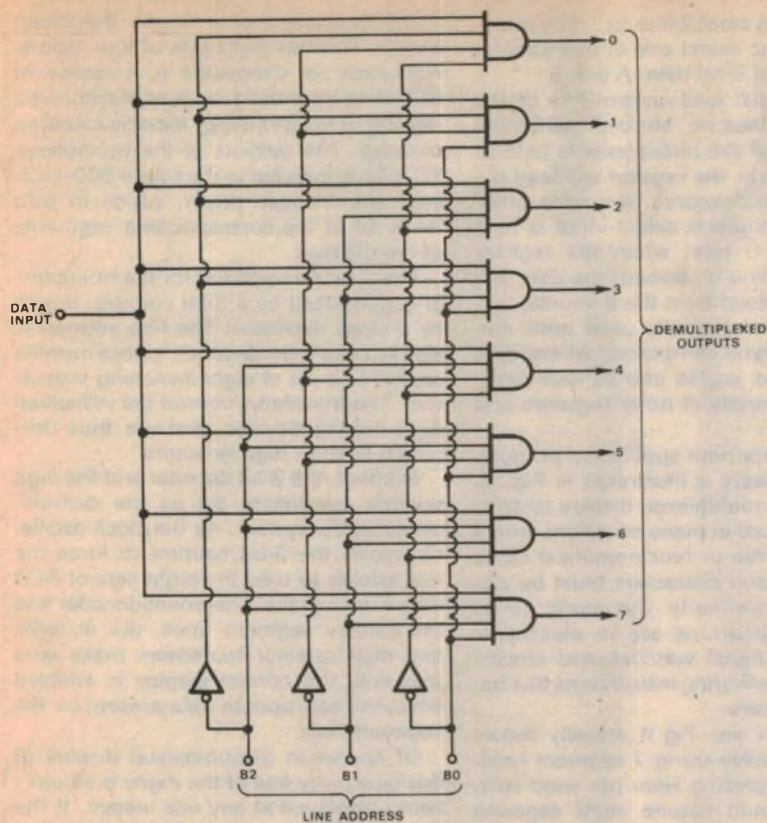

FIG. 3 : 1-LINE TO 8-LINE DEMULTIPLEXER

be controlled merely by changing the 3-bit binary code applied to the decoder inputs, B0, B1 and B2. The binary code applied to these inputs thus becomes a "line address". A line address of 000 causes input line 0 to be connected to the multiplexer output, while a line address of 101 causes input line 5 to be connected instead, and so on.

To produce cyclic sampling of the input lines for multiplexing, all that is necessary is to derive the line address codes from a 3-bit binary counter which is driven in turn by a clock pulse generator. The counter will then produce a continuous sequence of binary code numbers, causing the multiplexer to scan the eight input lines in cyclic order.

Ideally the counter used to produce the line addresses should be a synchronous type, to avoid "glitches" (see chapter 10).

Note that the line address code used to drive the multiplexer is normally also used to drive the demultiplexer at the other end of the system or communications channel, as indicated in Fig. 2. This is to ensure that the two ends remain in synchronism.

The digital logic equivalent of the output distributor switch of Fig. 1, is the demultiplexer circuit. A 1-line to 8-line demultiplexer circuit which complements the multiplexer of Fig. 2 is shown in Fig. 3. As you can see, it is actually quite similar to a 3-bit binary decoder (compare it with Fig. 5 of chapter 11). The only difference is that each of the AND gates has an additional input, and the additional inputs are all connected together to form

the common data input line.

As with a decoder, only one of the AND gates can be enabled at any one time, and the 3-bit line address again determines the enabled gate. Hence when the line address is 000, any signal appearing at the data input is routed automatically to output 0; when the line address is 011, it is routed to output 3; and so on.

Hence by driving the line address inputs of the demultiplexer from the same counter used to drive the multiplexer circuit, the multiplexed data is automatically "unravelling" back into its separate parts.

Note that a multiplexed data communications channel using the circuits of Figs. 2 and 3 would require a total of four lines connecting input and output: the single line carrying the multiplexed data, together with three lines to carry the line address information. However, the system would be capable of handling eight signals, twice the number normally carried by four lines. (Note that as in most logic circuits, all of the lines use a common "earth" return.)

We could double this capacity by using a 16-line to 1-line multiplexer circuit, together with the corresponding 1-line to 16-line demultiplexer. Yet this would involve only a single additional line, to

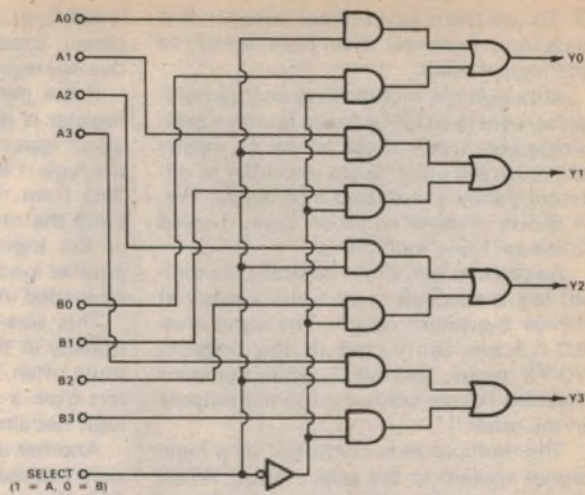

FIG. 4 : QUAD 2-LINE TO 1-LINE MULTIPLEXER OR "DATA SELECTOR"

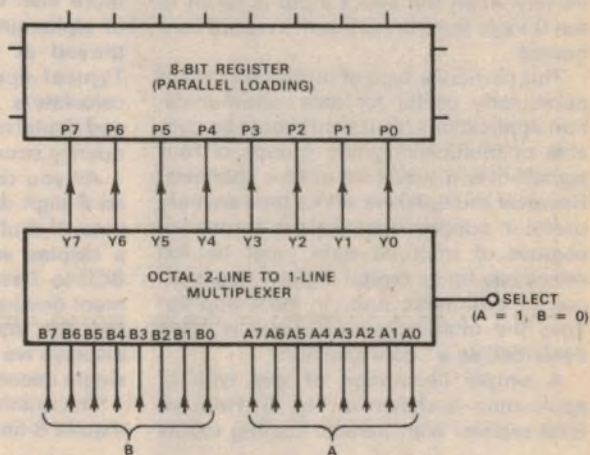

FIG. 5 : USE OF A MULTIPLEXER FOR SELECTION OF REGISTER INPUT DATA

carry the fourth address bit—a total of only five lines.

In general terms, multiplexing allows "N" communications channels to carry a number of signals given by the (N-1)th power of 2. So that 3 channels will carry 4 signals, 4 channels will carry 8 signals, 5 channels 16 signals, 6 channels 32 signals, 7 channels 64 signals, and so on.

You can see from this that where a small number of signals is involved, the advantages of multiplexing are quite small and may not be worth the effort. However, as the number of signals grows, the saving in channels rapidly becomes significant.

Although multiplexer and demultiplexer circuits may be built up from discrete logic elements using configurations like those shown in Figs. 2 and 3, many of the often-required circuits are in fact made available as single integrated circuits. Thus one can buy integrated 16-line to 1-line multiplexers in both TTL and CMOS varieties, for example, along with other types of multiplexer and demultiplexer.

Actually because of the similarity between decoders and demultiplexers some of the integrated devices are designed to be used as either. Known as decoder/demultiplexers, those devices are basically a full demultiplexer like that of Fig.

3. To use them as a normal decoder, the data input is merely taken permanently to the logic 1 level.

Although the multiplexers and demultiplexers we have looked at so far have been single-pole types, these are by no means the only type used. Quite a number of different varieties are used in practice; Fig. 4 shows another common type, a quad 2-line to 1-line multiplexer.

As you can see, this is basically the digital logic equivalent of a conventional 4-pole 2-position switch. The input lines A0-A3 are connected to the outputs Y0-Y3 in one "position", while the input lines B0-B3 are connected to the outputs in the other.

The multiplexer is controlled by a logic signal applied to the select input. When the select input is taken to the logic 1 level the A input lines are connected, and conversely when the select input is taken to the 0 logic level the B input lines are connected.

This particular type of multiplexer is not particularly useful for data communication applications, as it would only be capable of multiplexing two groups of four signals over a single set of four channels. However multiplexers of this type are very useful in applications where a number of sources of multi-bit data must be fed selectively into a digital register, logic circuit or arithmetic unit. In such applications the multi-pole multiplexer is often described as a "data selector."

A simple illustration of this type of application is shown in Fig. 5. Here an 8-bit register with parallel loading inputs

is fed from an octal 2-line to 1-line multiplexer, used to select one of two alternative sources of 8-bit data: A and B.

If the parallel load control line of the register is pulsed or "strobed" while the select input of the multiplexer is held at the logic 1 level, the register will load the data from the A source. If on the other hand the multiplexer select input is held at the logic 0 level when the register parallel load line is strobed, the data will be loaded instead from the B source.

This sort of circuit is used quite frequently in digital computers, where data must often be loaded into various registers from a variety of other registers and logic circuits.

Another important application of multipole multiplexers is illustrated in Fig. 6. This shows a multiplexed display system, of the type used in many situations where more than three or four numerical digits or alphanumeric characters must be displayed at nominally the same time. Typical applications are in electronic calculators, digital watches and clocks, and digital measuring instruments like frequency counters.

As you can see, Fig 6 actually shows an 8-digit display using 7-segment read-outs. If multiplexing were not used such a display would require eight separate BCD-to-7-segment "decoders", with segment drivers, one for each display. But as you can see, by multiplexing the eight displays we reduce this requirement to a single decoder-driver.

The multiplexing is done in this case by a quad 8-line to 1-line multiplexer, which

is the equivalent of a 4-pole 8-position switch. This has eight sets of four inputs, with each set connected to a source of BCD data from the calculator's arithmetic register or the frequency meter's counting decades. The outputs of the multiplexer Y0-Y3 are then fed to the single BCD-to-7-segment decoder/driver, which in turn feeds all of the corresponding segments of the displays.

The 3-bit line address for the multiplexer is generated by a 3-bit counter, driven by a clock oscillator. The line address is also fed to a 3-bit decoder, whose outputs are fed to a set of eight switching transistors. The transistors control the individual digit display devices, and are thus described as the "digit selectors".

In effect, the 3-bit decoder and the digit selector transistors act as the demultiplexer in the system. As the clock oscillator cycles the 3-bit counter to force the multiplexer to feed the eight sets of BCD data in turn to the 7-segment decoder and the display segment lines, the decoder and digit selector transistors make sure that only the correct display is enabled when the appropriate data present on the segment lines.

Of course in a multiplexed display of this type, only one of the digits is actually being displayed at any one instant. If the clock oscillator used in the multiplexing system were to be run at a very low frequency, this would become quite obvious: the various digits would be seen to be displayed one after the other, in cyclic fashion.

In practice the clock oscillator is run at

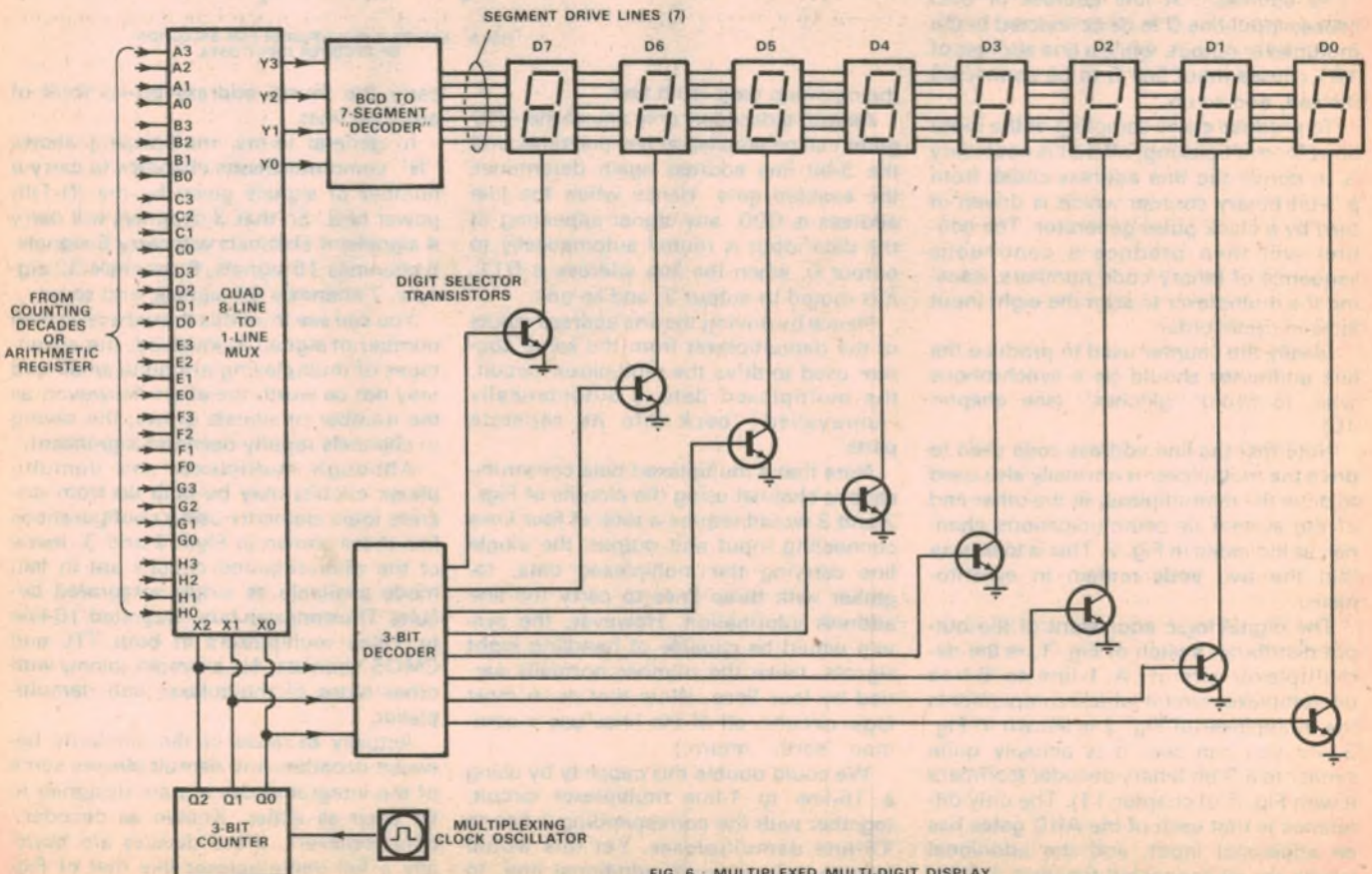

FIG. 6 : MULTIPLEXED MULTI-DIGIT DISPLAY

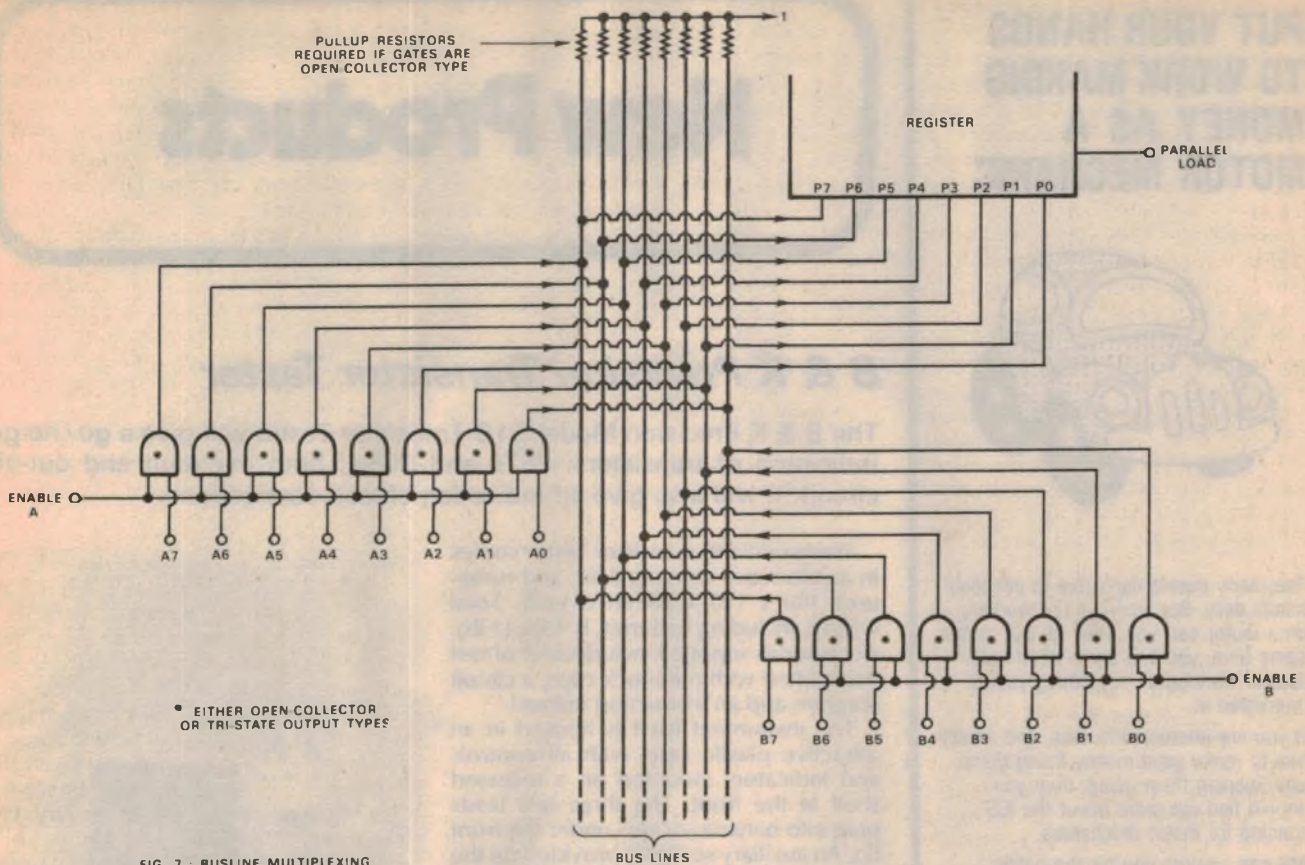

FIG. 7 - BUSLINE MULTIPLEXING

a frequency high enough to allow human persistence of vision to make it seem that all digits are being displayed continuously. Generally this means that each individual digit must be displayed no fewer than 50 times per second, so that the minimum multiplexing clock frequency is given by $50N$, where N is the number of digits in the display. Thus for an eight digit display the multiplexing clock should be run at 400Hz or higher.

Apart from saving decoding and display driving circuitry, this type of multiplexed display can also give a saving in display power consumption. This is because some types of display device are significantly more efficient when operated under low-duty-cycle pulsed conditions, than when operated under steady-state conditions.

For example, a LED display operated in a multiplexed 8-digit display (and hence with a $\frac{1}{8}$ duty cycle) at a segment drive current of 25mA is typically 75% more efficient than if the segments were operated at 5mA continuously. Hence the complete 8-digit display operating at an average segment current of 25mA will be 75% more efficient than if it were not multiplexed and operated at (8 times 5mA) or 40mA.

This means that to obtain the same brightness from a non-multiplexed

display, it would probably have to be operated at about 8mA per segment per device, giving a total of $(7 \times 8 \times 8\text{mA})$ or 450mA total, compared with $(7 \times 25\text{mA})$ or 175mA total for the multiplexed display.

Before we close this chapter, we should look briefly at a type of multiplexing which is now used quite extensively in computers and other data handling systems. This is the technique of "busline" multiplexing, illustrated in Fig. 7.

Basically this technique uses a "data bus" consisting of a set of signal lines which form virtually a data "highway" through the system. Data words are passed from one section of the system to another by feeding them onto the buslines from the source section, and picking them off at the destination section.

In essence, the buslines act as wired-OR gates (See chapter 6). The data words are multiplexed onto the lines by sets of gates, as shown in Fig. 7, while they are picked off and fed into registers by connecting the parallel load inputs onto the bus lines.

Hence to feed the data on lines A0-A7 into the register shown, the "enable A" line would be taken to logic 1 level and the parallel load input of the register pul-

sed. The "enable B" line would have to be kept at the logic 0 level during this operation, to ensure that the data on lines B0-B7 was not placed on the buslines as well.

Alternatively to load the data from B0-B7 into the register, instead, the "enable B" line would be taken to logic 1 level and the "enable A" line to logic 0 level, while the register's parallel load input was pulsed as before.

This type of multiplexing system may be expanded fairly easily to cope with virtually any number of input sources and output destinations. All that is necessary is to ensure that only one set of source gates is enabled at any one time, and that the parallel load inputs of the destination register(s) are enabled when the data they are to receive is present on the buslines.

Note that if the gates used to control the data sources are of the "open-collector" or uncommitted output type, the buslines must be fitted with pull-up resistors as shown. However the pull-up resistors are not required if the gates used are of the "Tri-state" type originated by National Semiconductor. These gates provide active pull-up as well as active pull-down, when enabled, quite apart from having a third state in which the output is "floating" at high impedance.

PUT YOUR HANDS TO WORK MAKING MONEY AS A MOTOR MECHANIC



Too many people don't like to get their hands dirty. But when you're working on a motor car, you have to. But at the same time, you can get a lot of satisfaction working on something you're interested in.

If you are interested in cars, and would like to make good money fixing them, and keeping them going, then you should find out more about the ICS training for motor mechanics.

ICS can prepare you for the public examinations that give you recognised qualifications — the first step in getting the best jobs in the motor industry. Send the coupon now, and ICS will return you a complete Career Program Guide, that tells you how the ICS method works, and what the training programs teach you.

You study at home, at your own pace. Almost from the first lesson, you can start putting your new knowledge to work. And the study program only asks for about an hour a day. Would you spend an hour a day to earn more money?

Mail the coupon — today!

International Correspondence Schools,
400 Pacific Hwy, Crows Nest, NSW 2065
Tel: 43-2121

ICS

International
Correspondence Schools
400 Pacific Hwy, Crows Nest
NSW 2065 Tel: 43-2121

Yes, I would like to put my hands to work to make money. Please send me, without cost or obligation, the Career Program guide on the subject I have ticked below.

Motor Mechanic 224700

Colour TV Technician

Electronics Technician

Mr./Mrs./Miss

Address

.....

Postcode

Occupation

PKB 54416

New Products

B & K Precision Transistor Tester

The B & K Precision Model 510 Transistor Tester will give a go/no-go indication of transistors, FETs and SCRs, both in-circuit and out-of-circuit. It will also give an indication of lead connections.

The model 510 Transistor Tester comes in an attractive carrying case, and measures 180 x 110 x 60mm overall. Total weight, including batteries, is 450g (1 lb). Accessories supplied include a set of test leads fitted with mini-lock clips, a circuit diagram and an instruction manual.

The instrument itself is housed in an attractive plastic case, with all controls and indicators mounted on a recessed shelf at the front. The three test leads plug into banana sockets under the front lip. An auxiliary socket is provided on the front panel for testing devices out of circuit.

A three position slide switch functions as a power switch, and also selects either the LO or HI test ranges. In the LO range, the base of the transistor under test is driven by a 1mA test current, with a 2% duty cycle, while in the HI range, a 250mA 2% duty cycle current is used. For both ranges, the collector is driven by a 125mA 2% duty cycle current.

A six position lever operated rotary switch is used to connect the transistor under test into the circuit in all possible lead configurations. Three red light emitting diodes are used to indicate the test results.

The centre LED, labelled "test", is used to indicate a no-go condition. It also serves as a pilot light. A transistor is tested by connecting the test leads to it, selecting the appropriate range, and then operating the rotary test switch through all six positions.

When the test switch is placed in a position where an OK transistor is correctly connected, one or other of the remaining two LEDs will illuminate, and indicate the polarity of the transistor, i.e., NPN or PNP. The lead configuration of the transistor will then be indicated by the position of the test switch, in conjunction with the colour coding of the test leads.

If the transistor under test is faulty, the test LED will remain flashing in all positions of the test switch. For out of circuit measurements, the LO position is normally used. For in-circuit tests, the HI position is used, and this will give a cor-



rect indication of polarity and lead identification for heavily shunted devices (down to 10 ohms shunt resistance, and up to 25uF shunt capacitance).

In the HI position, lightly shunted transistors may give a go indication in two adjacent test positions. This is because transistors have some gain when the collector and emitter are interchanged, and in fact will function in the reversed position. In this case only the polarity of the transistor and the base lead can be identified. However, switching to the LO range will normally eliminate one of the go indications, and enable the collector and emitter leads to be identified.

When FETs are tested, an indication can be obtained of the polarity (N or P channel), and of which lead is the gate. The drain and source leads cannot usually be identified, as most FETs are symmetrical devices.

(continued on p101)

Colour module for video games

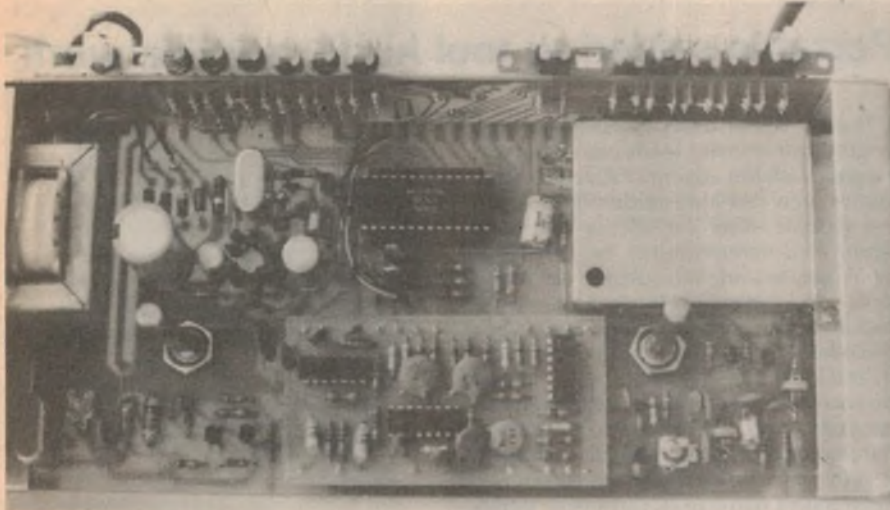

The Chromatec VG-04 colour video game features sound and automatic scoring.

Chrominance Technology Pty Ltd is now marketing a range of modules for home video games. Included are modules for adding colour to existing b & w games, b & w games boards, and VHF modulators. The range also includes a complete colour game with scoring and sound effects.

The name "Chromatec", which was initially associated with the manufacture in Australia of PAL TV signal generators, has recently widened its association with colour television to include colour home video games. The company is currently marketing a conversion module for colouring the background, bats and ball of most currently available b & w TV games. These include both designs using "discrete" integrated logic and those employing LSI chips.

This board, designated VGM-02, can also be used with other games boards available from the company (VGM-01 5.5MHz sound carrier and VHF modulator and VGM-03 b & w games board for GI AY-3-8500 LSI chip) to build a complete colour game from scratch.

In addition to these modules, a complete colour and sound game, VG-04, is available featuring five bat and ball games: football, tennis, squash, ice hockey and solo. Each has its own appro-

priate background colour—green for tennis, blue for ice hockey, etc. One bat is dark blue and the other red, while the ball is orange. Score numerals and field boundaries are white.

A switch is provided to select either monochrome or colour. When switched to the colour position and used with a b & w TV set, one bat appears black and the other white against a grey background.

The entire unit is housed in an attractive wooden case and comes complete with RF lead, game-aerial changeover switch and operating instructions. The unit has been carefully designed to conform to ABCB specifications.

In addition to TV games, Chromatec is still marketing the WFG range of PAL colour bar generators, modular SPGs and distribution amplifiers.

Readers should direct their enquiries to Chrominance Technology Pty Ltd, PO Box 274, Springvale, Vic. 3171.

Transistor tester ctd . . .

SCRs can also be tested, with the gate and cathode leads being identified, and the anode lead by inference. Note, however, that the model 510 cannot distinguish between an SCR and a PUT, which is in fact an anode gate SCR. (Normal SCRs have cathode gates). No mention of this is made in the instruction manual.

We were also a little disappointed to learn that diodes cannot be checked. It seems that the addition of a diode range to the unit would be quite simple, and

would make for a much more versatile unit.

In conclusion, the Model 510 Transistor Tester is a very well designed and made instrument, which would certainly be a welcome addition to any service centre working with modern solid state (discrete) circuitry. At a cost of \$90.00 plus 15% sales tax, however, it is a little out of the range of the average experimenter.

It is available in Australia from Parameters Pty Ltd. Their Sydney address is 68 Alexander Street, Crows Nest 2065, or in Melbourne at 53 Governor Road, Mordialloc 3195. (D.W.E.)

R.H. Cunningham
Pty. Ltd.

**THEY'RE EVERY
MICROPHONE
YOU EVER
WANTED.**



SENNHEISER

We have taken the latest advances in electret technology one step further. By combining them with advanced acoustic technology to make professional condenser microphones more portable.

One common powering module (K2U) serves three different compact heads: omnidirectional (ME20), cardioid (ME40) and mini-shotgun (ME80). Thus, for most studio and location situations, it's no longer necessary to carry three different microphones. Each head contains its own microphone capsule and "front-end" electronics, all exactly matched to its own precisely-controlled acoustical environment.

The Powering Module runs on a single 5.6V battery, or phantom-powered directly from your recorder, preamp or other auxiliary equipment. Best of all, of course, is the great versatility. In a matter of seconds, you screw on whichever head you need and go!

Powering module and heads are available separately.

Australian Agent

R.H. Cunningham
Pty. Ltd.

VIC.: 493-499 Victoria St. West
Melbourne. 3003 Ph. 329 9633
N.S.W.: 4-8 Waters Rd. Neutral
Bay 2089 Ph. 909 2388
W.A.: 256 Stirling St. Perth.
6000 Ph. 28 3655
QLD.: L. E. BOUGHEN & CO.,
Cnr. Milton & Baroona Rds.,
Milton 4064 Ph. 36 1277
S.A.: Werner Electronic
Industries Pty. Ltd., Unit 25,
28 Gray St., Kilkenny, 5009.
Ph. 268 2801.

Telex Melbourne 31447
Sydney 21707 Brisbane.
41500 Perth 93244

HMC 6566

Standardize on

CAMBION®

The Guaranteed Electronic Components
*Reg TM Gardner Denver Co

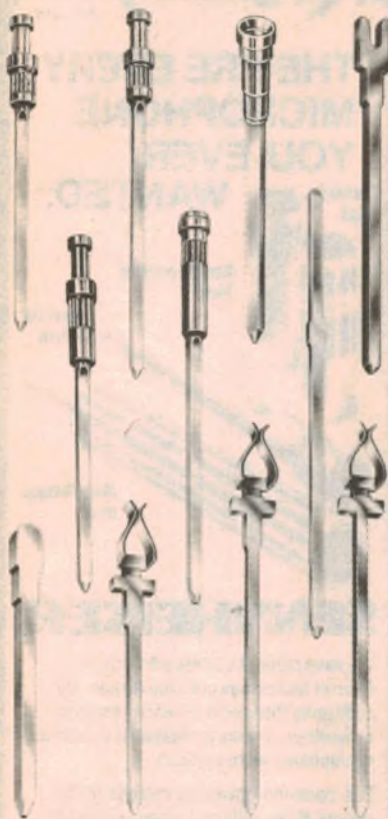

Wire-wrap* pins and terminals in variety and quantity.

Cambion knows what it takes to make all the connections in today's sophisticated circuits. That's why you'll find a wide range of CAMBION Wire-Wrap pins with terminals or jacks readily available. CAMBION pins assure mechanically strong, reliable, uniform, durable metal-to-metal and solder-to-metal connections. Write for our Integrated Packaging Catalog 119A.



ELECTRONIC DEVELOPMENT
SALES PTY. LTD.
27 BUCKLEY ST., MARRICKVILLE.
N.S.W. 2204

EDS 517007

NEW PRODUCTS

Portable soldering tool kit for service work

The hassles of bulky transformers and tangled transformer leads are a thing of the past with the advent of Royston Electronics' new portable soldering tool kit.

It accepts either the Adcola Thermatic (controlled temperature) or Duotemp (dual power) mains voltage soldering tools, and provides receptacles for a pack of solder, spare tips, and Soderwick desoldering braid. The tool holder pops up and locks when the lid is open, so that the tool is at the most convenient handling angle. It also protects the barrel from damage and provides free air around it to prevent overheating. Also, of course, it eliminates damage to carpets or tables when servicing home appliances.

The hot tool stows safely when the lid is closed, with complete protection for the flexible cord.

This kit, particularly with the Thermatic soldering tool, eliminates the hazards of excessive, uncontrolled tip temperatures and the very real risk of damage to printed circuits and heat sensitive components. This applies particularly to colour TV, where high density solid state components can be degraded without the damage being noticed at the time.



The new kit accepts either the Adcola Thermatic or the Duotemp mains voltage soldering tools.

Both the Adcola tools feature fast heat-up. However, on a service call the tool can be plugged in to a power point immediately on arrival, left idling until the job is completed, then safely stowed and carried.

Readers requiring further information should contact Royston Electronics, 22 Firth St, Doncaster, Victoria 3108.



VIDEO TECHNICS

2ND FLOOR, TELFORD TRUST BUILDING
79-85 OXFORD STREET, BONDI JUNCTION: PH. 387 2555

Now available MONITOR ADAPTOR KIT FOR COLOUR RECEIVER.



- CONVERTS RECEIVER INTO VIDEO MONITOR.
- ALLOWS OFF-AIR RECORDING OR RECORDING WITH VIDEO CAMERA.
- EASY TO INSTALL.
- ALL INSTRUCTIONS & CIRCUIT DIAGRAMS INCLUDED.

\$95.00 + P.P.

WANTED: FRANCHISE DEALERS

COLOUR TV TUNER

● Record one channel while watching another ● No modification required to existing television sets ● Will record while TV set is off ● Usable with any video recorder BW or Colour with an RF output which means this tuner allows video recording of TV programs and playback through aerial input of TV set. \$295.00 + P.P.



VIDEO TECHNICS
COLOUR TV TUNER
MODEL HD6709

WANTED: FRANCHISE DEALERS

Low profile keyboards with tactile feel

The Digitran Company of the USA has released two standard versions of its Minikey keyboard for general sale.

The Minikey keyboards are ideal for use in any digital entry application requiring the compactness of a miniature keyboard. They are available in either 12 key (4 rows of 3) or 16 key (4 rows of 4) arrangements. Both front and rear mounted keyboards are available in single pole, row and column, and 2 of 7 or 2 of 8 output codes.

The Minikey provides real tactile response in a miniature size keyboard. The top of the key extends only 1.78mm above the face of the keyboard, while key travel is approximately 1.27mm (including 30% overtravel).

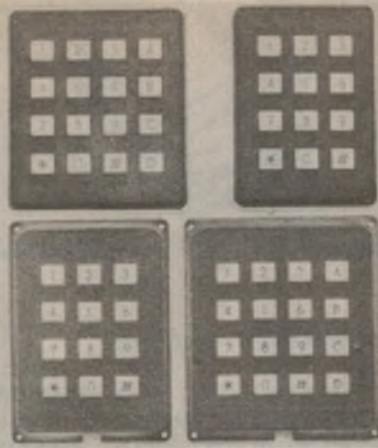

Readers should direct their enquiries to British Merchandising Pty Ltd, 49 York St, Sydney, NSW 2000.

Accessories for CB radio

The 83-2SW CB antenna switch from Amphenol Tyree is designed to switch either a transceiver between two antennas or one antenna between two transceivers. The unit is ideal for switching an antenna between a transceiver and a monitor or scanner.

The switch may also be used for switching between an antenna and a dummy load, such as the Amphenol 83-887 load.

The 83-2SW is designed to provide low reflection in both 52 and 75 ohm transmission lines. It will handle up to 1kW (2kW PEP, SSB), thus making it suitable for amateur work as well. The switch case is made of plated metal to ensure adequate shielding and rugged construction.



Also available from Amphenol Tyree, and also aimed at the CB market, is a new UHF coax connector. Designated type 83-58FCP, it can be installed on a cable by utilising only a pair of pliers.

Further information from Amphenol Tyree Pty Ltd, 176 Botany St, Waterloo, NSW 2017.

printed circuits

- Accurately machine printed / etched
- Phenolic & fibreglass-gold / tin plated
- Special manufacturers' packs of 10
- EA, R & H, ET, Philips, Mullard available
- Specials to your drawing
- POSTAGE small 60c, large \$1 00

76R12	3.00	77U72	3.00	ET833	6.00
ET632P	2.50	ET632M	7.50	ET482B	2.80
ET482A	6.50	76CL12	2.50	ET630	2.20
76B4	2.60	ET480PS	2.50	ET480	2.80
ET631	7.00	ET630	2.20	ET066	2.20
ET064	2.00	ET449	2.20	ET804	2.80
ET448A	2.20	ET448	2.80	ET711C	2.00
ET711B	2.20	ET068	2.00	ET061	2.00
ET044	2.00	ET043	2.00	76M19	3.50
ET711R	2.50	ET7110	6.00	ET447	2.80
ET544	2.50	76PC9	4.40	76EX10	2.80
ET602	6.50	ET446	2.50	ET533A/C	3.50
ET446	2.50	ET553C	2.00	ET533A	2.50
ET711	7.50	ET543B	2.50	ET543A	2.50
ET445	2.50	ET241	2.80	ET780B	2.50
ET780A	3.00	ET541	2.50	ET444	2.50
76SA7	2.50	76M17	2.50	76LM5	2.50
76SS6	3.00	76SW4	2.00	76R4	2.50
76M5	2.50	76VG5	5.00	76E04	3.00
76VG5	5.00	76M5	2.50	76R4	2.50
ET708	2.50	ET740A	4.50	ET740B	3.50
ET514	2.50	ET707A	2.50	ET707B	2.50
ET706	2.50	ET130	2.50	76RT3	3.00
78T2	2.50	76AD3	2.50	76C3	2.50
78E02	5.50	75SWILA/Bpr	4.00	DRS-BC1	4.00
75PC12	2.50	EA78F1	2.80	ET534	2.50
ET514	2.50	ET129	2.50	ET128	2.50
ET439	3.00	ET420G	2.50	ET123B	2.50
ET123A	2.50	ET119	2.80	75F2	2.50
75L11	2.50	ET438	2.50	75V12	2.50
75F12	2.80	ET1124	2.50	ET1122	3.00
75CL9	2.50	75PC12	2.50	ET121	2.50
ET120	2.50	ET118	2.50	ET117A/B	2.80
ET704	2.50	ET500	2.50	75T19	2.50
75R7	3.00	75CD7	2.50	75FM5	2.50
75TU10	3.50	75F5	2.50	75TU8	5.00
75TU9	3.50	ET533A-B	2.50	ET440	4.50
ET400	2.50	75W3	2.50	ET532	2.50
ET529B	3.30	ET529A	4.50	ET702	2.50
ET801R	2.80	ET801P	2.50	E85NT	3.00
75EM6	2.50	75SD4	2.50	75A01	2.50
ET414E	2.50	ET414D2	3.20	ET430	2.50
ET314	2.50	ET118	2.50	E85	3.00
E8K1	3.00	ET528	2.50	ET312	3.00
75D1	2.50	74MX12D	3.50	74MX12C	2.60
74MX12B	3.20	74MX12A	2.60	ET701	2.50
ET527	2.50	ET428	2.80	ET313	2.50
ET530	2.50	ET427	2.50	ET428	2.50
74MX8	2.50	74EM9	2.50	74TU8	2.50
ET429	2.50	E8X	5.00	E810T	5.00
E8P	5.00	E8M	5.00	E8D	5.00
E8A	5.00	E8T	5.00	E8F	6.00
E8C	6.00	74CS	4.20	7408	4.00
ET424	2.50	ET311	2.50	ET526	2.50
ET114	2.50	74SA5	4.00	ET801M	2.50
ET601L	2.50	ET422	3.30	74C3	2.50
ET801J	3.00	ET423	2.50	ET420E	3.30
ET521B	2.50	ET601M	2.50	ET601G	2.80
74A1	2.50	74HPL	2.50	7312T	2.80
ET601D	2.50	ET801C	2.80	ET420C	2.50
ET420D	2.50	ET420B	2.80	ET420A	2.50
ET524	2.80	ET801B	3.30	ET601N	3.90
ET601F	2.80	ET601E	3.90	ET601A	3.30
73TU11	2.80	73P11	2.80	ET520A-B	4.40
73C12	4.90	73BA9	2.80	ET113	3.10
ET419	2.50	ET218	3.50	ET417	2.50
ET309	2.80	ET414D	2.50	73TU7	2.80
73S6	2.50	ET521	3.90	ET213	2.50
ET418	3.30	73D1	2.50	ET518	2.50
733C	2.80	73T1	2.80	ET414C	2.80
ET414B	2.80	ET414A	2.80	72M12	2.80
72SA9M	2.80	ET413	2.80	ET034A	3.10
72S11	2.80	72G7	2.80	72110	2.50

ALL SILICON 30/60w PA PORTABLE AMPLIFIER

6 1/2" W x 3 1/4" H x 8 1/2" D 12-16V, two inputs 5 & 100mV, 15 ohm output No. 763D Also 125, 250, 500 ohm output No. 763A All \$70 each For 240V operation \$33 extra Freight collect

COILS and IF's All \$2.50 ea plus post 60c.

RF CHOKES Plus post 80c
3B1 AIR 2.5mh 50ma-Pye 70c
3B1 IRON 10uh to 1.000uh 25ma 70c

FILTERS 27 Line filter 2 amp \$14
29 Line filter 10 / 20 amp \$37 60
Plus Post \$1.50 30 Pulse filter 2 amp \$12.

MAIL cheque or money order (add postage) direct to:—

RCS radio pty ltd
651 FOREST RD BEXLEY
NSW 2207 587 3491

Preclene

THE INSTANT, SAFE, NON-CORROSIVE,
LOW TOXICITY, NON-EXPLOSIVE CONTACT CLEANER.

Removes grease,
dirt and dust with
a high pressure
cleaning action
while leaving no
residue . . .



Preclene FROM THE
ELECTROLUBE TROUBLE
REGD. SHOOTERS

IS AVAILABLE FROM ELECTRICAL
WHOLESALEERS.



Full technical information on PRECLENE
and other ELECTROLUBE products is
available from Australian agents:

RICHARD FOOT (AUSTRALIA) PTY. LTD.

63 HUME STREET, CROWS NEST, N.S.W. 2065. Telephone: 43-0326.

R.F. 2266A

PROJECTS

Projects

PROJECTS

MORE

Projects

Newnes Technical Books

The latest of the inexpensive project books by R.M. Marston, Technical Author and Design Consultant, built around internationally available components.

110 ELECTRONIC ALARM PROJECTS

Also Available:

- 110 COSMOS DIGITAL I.C. PROJECTS
- 110 OPERATIONAL AMPLIFIER PROJECTS
- 110 THYRISTOR PROJECTS
- 110 INTEGRATED CIRCUIT PROJECTS
- 110 SEMICONDUCTOR PROJECTS
- 20 SOLID STATE PROJECTS FOR THE HOME
- 20 SOLID STATE PROJECTS FOR THE CAR & GARAGE

Also available, the first of the new Newnes Constructors Guides.

This series under the general Editorship of Morris Colwell, provides clear and easily understood descriptions, advice and general help for amateur constructors, students and technicians aimed at breaking down the barriers that often deter beginners in electronics.

Just published —

ELECTRONIC COMPONENTS PRINTED CIRCUIT ASSEMBLY ELECTRONIC DIAGRAMS

SIMPLE CIRCUIT BUILDING PROJECT PLANNING & BUILDING PRACTICAL ELECTRONIC PROJECT BUILDING

*All paperbacks priced between \$4 and \$7.

Ask for them at your favourite book or component shop.

• In Melbourne

McGill's Newsagency
Technical Book & Magazine Co.

• In Sydney

Dick Smith Electronics
Thorburn's Technical Bookshop



Newnes Technical Books



Books & Literature

Booklet on Edison

THOMAS EDISON, PROFESSIONAL INVENTOR, by Thomas P. Hughes. Published by Her Majesty's Stationery Office, London, 1976. Soft Covers, 140 x 216mm, 48pp, with illustrations. Recommended Aust. retail price \$3.40.

This very readable little monograph is actually a Science Museum Booklet. The author is Professor of History and Sociology of Science at the University of Pennsylvania, and is thus well qualified to write on the subject.

The theme is Edison as an outstanding inventor-entrepreneur, and Professor Hughes analyses well the personality characteristics involved in this most fortuitous combination. It makes very enlightening reading.

If you're at all interested in the history of science and technology, I think you'll find it very interesting.

The review copy came from the local representative for HMSO, Thomas C. Lothian Pty Ltd of 4-12 Tattersall's Lane, Melbourne. (J.R.)

Basic television

FIRST STEPS IN TELEVISION, by Brian Sexton. Fountain Press, Argus Books Ltd, Hertfordshire, 1975. Hard covers, 138 x 223mm, 189pp, many diagrams. Recommended Aust. retail price \$13.50.

An introductory book on television, as the title suggests, and written in this case specifically for the non-technical reader seeking a broad idea of the principles rather than a detailed knowledge of cir-

cuit design. The author is a professional engineer turned technical writer.

In writing the book he has assumed that the reader has virtually no knowledge of electronics, just a basic idea of elementary school physics. He starts off with a look at waveforms and electromagnetic principles, and then works steadily through the basic concepts leading up to video generation and transmission and reception.

It's a very ambitious task to try tackling a subject like this at such a basic level, and inevitably one can find sections which seem less than ideal. I suspect that the type of reader for whom the book is intended may well find it quite heavy going at times, due to the difficulty in explaining every single conceptual jump.

But by and large, my impression is that the author has achieved considerable success in his aim. If the reader is prepared to persevere, it should give him quite a clear and sound insight into the basic operation of monochrome and colour TV.

The review copy came from Thomas C. Lothian Pty Ltd, who represent Fountain Press in Australia. Copies should be available in all major bookstores. (J.R.)

Microprocessors

MINICOMPUTERS AND MICRO-PROCESSORS, by Martin Healey. Hodder & Stoughton, London, 1976. Soft cover, 155 x 233mm, 353pp, with diagrams. Recommended Aust. retail price \$21.95.

An introductory book on mini and micro computers, written primarily for electronics designers and technicians

AEGIS PTY. LTD.

347 Darebin Rd, Thornbury,
Vic. 3071. Phone 49-1017

Manufacturers of Wound Components for Electronic Applications

- ★ Miniature Aerial, RF, Oscillator Coils and IF Transformers for Transistor Receivers
- ★ Replacement Coils and IF Transformers for Valve Receivers
- ★ Radio Frequency Chokes and Video Peaking Chokes
- ★ Ceramic Insulators
- ★ Coil Formers, Bobbins, Cans, Cores, etc.
- ★ Interference Suppression Units:
 - Aerial Filters
 - Mains Filters
- ★ Crossover Network Inductances
- ★ Wide Range of Instrument Knobs



Stocked by all leading electronics suppliers

who are familiar with conventional digital logic circuits, but need to make the transition to computer techniques. It may also be of use to programmers and systems analysts who wish to learn more about the hardware side of systems.

The author is a lecturer in the Department of Electrical and Electronic Engineering at the University College of Cardiff in Wales. He seems to have produced a very well planned and concisely written work.

The conceptual flow as well as the scope are both shown fairly well by the chapter headings. These are 1 - Digital Computers and Their Applications; 2 - A Rudimentary Digital Computer; 3 - Further CPU Features; 4 - Input/Output; 5 - Microprocessors; 6 - Peripheral Devices; 7 - Software; 8 - Advanced Features; 9 - Selecting a Computer System.

The text is served by a reasonable number of illustrations, although these could perhaps have been increased in number to advantage.

As it stands, however, a well written and highly informative introduction to mini and microcomputer systems.

The review copy came from Hodder & Stoughton Australia Pty Ltd, of Cnr. Bridge Rd and Jersey Street, Hornsby, NSW, but copies should be available via most technical bookstores. (J.R.)

Tape servicing

SERVICING CASSETTE & CARTRIDGE PLAYERS by Homer Davidson. Published 1975 by TAB Books. Stiff paper covers, 294pp 210 x 130mm, freely illustrated by photographs and drawings. Price in Australia \$8.50.

In his preface, the author mentions a survey which indicated that the average (?) American family owned about 4 tape players, predominantly of the cartridge and cassette variety. This being so, there has to be plenty of potential customers for those repairmen who choose to specialise in such equipment. Hence the motivation for producing this book.

The first six chapters deal with types of players, circuits, testing and adjusting procedures, lubrication, cleaning and speed problems. The following five chapters tend to be more specific in terms of brands, problems and cures, while chapter 12 is taken up mainly with case histories.

While the book contains a lot of general design information about cartridge and cassette players, one would have to be quite dedicated to the subject to want to read it merely for the sake of so doing. As the preface indicates, it is intended specifically for the repairman intending to specialise in tape equipment.

If that is your position and objective, you will be happy to work your way systematically through those 294 pages. Our review copy came from Technical Book Co, 294 Swanston St, Melbourne, 3000. (W.N.W.)

NEW BOOKS

JUST A FEW OF THE THOUSANDS ALWAYS IN STOCK. CALL IN OR WRITE. PRICES SUBJECT TO FLUCTUATION. CORRECT AT TIME OF GOING TO PRESS.

1977 ANNUALS

AMATEUR RADIO CALLBOOKS 1977	
USA Listings	\$18 95
Foreign Listings	\$18 50
ARRL RADIO AMATEURS' HANDBOOK 1977 edition due February. Order now. Will post your copy as soon as our shipment lands	
	\$11 95
WORLD RADIO & T.V. HANDBOOK INCLUDING HOW TO LISTEN TO THE WORLD—Combined 1976 Ed	
	\$10 80

TV & TV SERVICING

BASIC TELEVISION PRINCIPLES & SERVICING—B Grob New 1975 edition just received	
	\$14 45
COLOUR TV PICTURE FAULTS—Bohman Quick location and repair by means of picture fault examples in colour	
	\$9 30
COLOUR TV THEORY—Hutson	
	\$12 00
PAL COLOUR TELEVISION FOR SERVICEMEN—W C Cook A new book by an Australian	
	\$15 00
PIN POINT TV TROUBLES IN 10 MINUTES	
	\$7 70
TRANSISTOR-TV SERVICING GUIDE Middleton	
	\$6 20
TELEVISION BROADCASTING—Tape and Disk Recording Systems—Harold E. Ennes	
	\$20 35
TRANSISTOR TV SERVICING MADE EASY—Darr	
	\$6 35
TV SERVICING GUIDE arranged by Trouble Symptoms—Deane & Young (Our best seller)	
	\$4 75

SPECIAL OFFER!

~~\$18.40~~ \$12.00

PAL RECEIVER SERVICING by Seal

Scoop purchase of this outstanding Colour T.V. Service book enables us to make this offer.

While Stocks Last!!!

Add Post & Pack

Vic \$1 00

Interstate

\$1 80



RADIO

ANTENNA HANDBOOK—A R R L \$7.30

BEAM ANTENNA HANDBOOK—Orr	\$7 00
CUBICAL QUAD ANTENNAS—Orr	\$5 70
73 DIPOLE AND LONG-WIRE ANTENNAS Noll	\$6 20
FM & REPEATERS FOR THE RADIO AMATEUR ARRL	\$4 35
HAM & CB ANTENNA DIMENSION CHARTS Noll	\$2 95
HAM NOTEBOOK—Volume 1	\$4 20
HAM HANDBOOK—Volume 2	\$5 30
HAM RADIO OPERATING GUIDE ARRL	\$7 30
JAPANESE RADIO RECORDER TAPE PLAYER SCHEMATIC SERVICING MANUAL	\$7 25
From Ham Radio Magazine	
PIN-POINT TRANSISTOR TROUBLES IN 12 MINUTES	\$9 65
RADIO AMATEUR'S VHF MANUAL ARRL	\$7 30
RADIO & ELECTRONIC LABORATORY HANDBOOK—Scroggie New 8th edition	\$15 70
RADIO HANDBOOK New 20th edition	\$24 40
RADIO TRANSMITTER PRINCIPLES & PROJECTS Noll	\$8 90
RADIO VALVE AND SEMICONDUCTOR DATA—A M Ball 10 Ed	\$5 10
REFERENCE DATA FOR RADIO ENGINEERS	\$37 50
SIMPLE LOW COST WIRE ANTENNAS FOR RADIO AMATEURS—Orr	\$6 40
SINGLE SIDEBAND FOR THE RADIO AMATEUR ARRL	\$5 65
SPECIALIZED COMMUNICATIONS TECHNIQUES FOR THE RADIO AMATEUR ARRL	\$5 65
TELEPRINTER HANDBOOK An RSGB Publication	\$20 80
TEST EQUIPMENT FOR THE RADIO AMATEUR—Gibson—An RSGB publication	\$6 65
TRANSISTOR RADIO SERVICING COURSE Lemons	\$9 40

UNDERSTANDING AMATEUR RADIO. ARRL

	\$7 30
73 VERTICAL, BEAM & TRIANGLE ANTENNAS—Noll	\$6 90
VERTICAL ANTENNA HANDBOOK—Paul Lee CQ Series	\$7 10
VHF-UHF MANUAL Evans & Jessop An RSGB Publication Revised 3rd Ed. enlarged	\$18 20

HI FI & SOUND

EASY SPEAKER PROJECTS Buckwalter	\$4 95
HIGH FIDELITY AUDIO AMPLIFIER CIRCUITS A Texas Instruments Manual	\$3 00
ELECTRIC GUITAR AMPLIFIER HANDBOOK	\$9 95
HI FI DESIGNS (WIRELESS WORLD)—tape, disc, radio, amplifiers, speakers, headphones	\$3 00
HI FI LOUDSPEAKERS AND ENCLOSURES—Revised 2nd Edition—Cohen	\$8 25
HOW TO BUILD SPEAKER ENCLOSURES—Badmief & Davis	\$5 70

ELECTRONIC

110 COSMOS DIGITAL IC PROJECTS FOR THE HOME CONSTRUCTOR Marston	\$6 75
DIODES EQUIVALENTS—De Muiderkring European, American, Japanese types A companion to Transistor Equivalents	\$5 95
ELECTRONICS ENGINEER'S REFERENCE BOOK Turner Completely new undated 4th Ed. of this major reference work. should be in the library of every serious student and engineer	\$61 70
ELECTRONIC FLASH EQUIPMENT Mott	\$5 65
HOME TV-FM ANTENNAS Lawrence & Eloy	\$7 50
GUIDE TO VIDEO TAPE RECORDING by Editors of Photographic Magazine	\$3 30
HOW TO USE VIDEO TAPE RECORDERS Kibbett	\$8 75
IC OP-AMP COOKBOOK Jung	\$15 55
INTERNATIONAL TRANSISTOR SELECTOR Towers Over 10,000 U.S. Japanese British & European Transistors with substitutes TAB	\$5 95
IT'S EASY TO USE ELECTRONIC TEST EQUIPMENT Klein & Gilmore	\$6 75
PRACTICAL OSCILLOSCOPE HANDBOOK Vols 1 & 2 R.P. Turner	\$10 95
PRACTICAL PA GUIDE BOOK Crowhurst. How to Install, Operate & Service PA systems	\$6 75
PROJECTS IN SIGHT. SOUND & SENSATION Waite	\$6 20
SECURITY ELECTRONICS—Cunningham	\$5 75
SEMICONDUCTOR HANDBOOK—De Muiderkring Characteristics, Specifications etc.	
Part 1—Transistors	\$8 95
Part 2—Diodes & Thyristors	\$7 95
THE WORLD TRANSISTOR CROSS-REFERENCE GUIDE	\$10 85
TRANSISTOR ELECTRONIC ORGANS FOR THE AMATEUR 3rd edition, Douglas	\$15 00
TRANSISTOR EQUIVALENTS—European, American and Japanese 9000 types and 5600 substitutes. 8th and 10th edition	\$8 50
TRANSISTOR SUBSTITUTION HANDBOOK 15th edition just arrived	\$5 65
TTL COOKBOOK Lancaster	\$11 25
TTL DIGITAL INTEGRATED CIRCUITS— with equivalents, De Muiderkring	
Part 1—Series 7400-74132	\$8 95
Part 2—Series 74141-74298	\$10 95
National Data Books And Catalogues	
CMOS INTEGRATED CIRCUITS	\$5 70
DIGITAL INTEGRATED CIRCUITS	\$4 35
INTERFACE INTEGRATED CIRCUITS	\$7 60
LINEAR APPLICATIONS Vol. 1	\$7 60
LINEAR INTEGRATED CIRCUITS	\$7 60
MOS INTEGRATED CIRCUITS	\$5 70
TRANSISTORS SMALL SIGNAL FIELD EFFECT POWER	\$3 25
TTL DATA BOOK	\$7 60
RCA SOLID-STATE DEVICES MANUAL (Replaces Transistor Manual)	\$7 95
RCA SOLID-STATE SERVICING	\$5 75
RCA LINEAR INTEGRATED CIRCUITS	\$3 75
Texas Instruments	
THE POWER DATA BOOK	\$6 90
THE TRANSISTOR & DIODE DATA BOOK—Vol 1	\$6 90
THE TRANSISTOR & DIODE DATA BOOK—Vol 2	\$6 90
THE TTL DATA BOOK	\$6 90
SUPPLEMENT TO THE TTL DATA BOOK	\$6 90

MAIL ORDERS BY RETURN
per parcel interstate

PLEASE ADD 90c per parcel postage (Vic) \$1.70

TECHNICAL BOOK & MAGAZINE CO.

295-299 Swanston St. MELBOURNE 3000. Ph. 663 3951

BKX ELECTRONICS Supply Service

179 VICTORIA ST., KINGS CROSS N.S.W. 2011

MODULESsave time and money by using ready built and tested modules. Simple and reliable to use. Each unit is also available as a kit.

AM15 module...\$10.75 kit...\$8.75
15 Watt RMS amplifier module. Has low distortion, typically less than 0.1%, full frequency response of 30Hz to 50 kHz, has 9 transistors and two diodes a fibreglass PC board, and requires a dual power supply of +28 and -28 volt

AM30 module...\$13.75 kit...\$11.75
30 Watt RMS amplifier module. Same as above, but requires +35 and -35 volt

PA40 module...\$15.75 kit...\$12.75
Preamp and controls suitable for use with AM15 and AM30. Magnetic input is 3mV into 50k ohms. Other inputs 100mV into 100k ohms. Output 200mV into 10k Signal to noise better than 60dB, and distortion better than 0.1%. Controls +14dB and -18dB at 50Hz and 10kHz. PC board mounted pots for volume balance treble and bass. A fibreglass board.

SQ1 module...\$12.50 kit...\$10.50
Uses MC1312 IC, requires power supply of 18 to 22 volts.

SQ2 module...\$33.50 kit...\$29.50
Uses MC1312, MC1314 and MC1315. This unit has full decoding and wave match control. Ideal for building up a four channel system at low cost.

TU1 module only....\$8.50
AM tuner module, 9 or 12 volt supply, ferrite rod, superhet model.

TU2 module only....\$29.50
AM and FM stereo tuner. provision for stereo indicator and tuning meter. 12 volt supply, 3.5uV sensitivity. High quality unit at a new low price.

KITSjust five of the kits from our range.

ETI422 50 Watt stereo \$119.00
Comes complete with wooden sleeve.

ETI424 Reverberation unit \$49.50
With metal cover.

ETI427 Graphic equaliser \$99.50
Comes complete with wooden sleeve.

ETI440 25 Watt stereo \$89.50
With metal cover.

EADFC 200MHz counter \$115.00
Complete kit with metalwork, front panel and prescaler.

PM141 5 Watt stereo \$29.50
Comes with transformer, pots, power supply, but without knobs and front panel. Ideal for construction under a turntable. Suitable for high output ceramic, and crystal cartridges.

EA75CDI Updated system \$19.50
Complete with drilled metal case and prewound secondary coil. A reliable and easily constructed kit.

proportional radio control

TRANSMITTER-MODULATOR
TXM Module...\$13.50 Kit...\$11.50

27MHz. crystal controlled transmitter-modulator. Requires antenna, crystal and 12 volt supply. Typical range is 100 metre, output is 300mW. Input is suitable for Amplitude modulation.

RECEIVER
RX Module...\$13.50 Kit...\$11.50

27MHz. crystal controlled receiver. A 9 volt supply, antenna and crystal is required. This receiver uses a ZN414 integrated circuit chip, and an IF of 455kHz.

CRYSTALS
XT2 Pair...\$ 6.95

A matched pair with 455KHz separation

ENCODER
EN15 Module...\$13.50 Kit...\$11.50

15 channel proportional encoder. This is a pulse width modulation type with synchronisation. It requires a 5 volt supply, and can directly drive a TXM module. All channel positions are set by 10k potentiometers, these are not supplied with the module or kit. This encoder can easily be converted to a system with fewer channels.

DECODER
DC15 Module...\$13.50 Kit...\$11.50

15 channel proportional decoder with synchronisation. It requires a 5 volt supply and is driven directly by the receiver module. Servo and drive unit will be featured in a later issue.

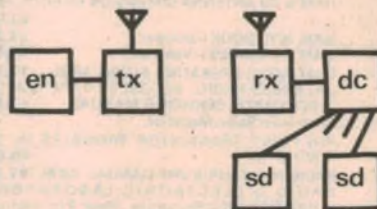

printed circuit boards

Boards required for building EA and ET projects will be available about one week from issue of the magazines. Also boards can be made to your artwork. In both cases the cost will be...

Single side laminate.. basic 80c
per square inch 5c

Double side laminate.. basic 90c
per square inch 9c

Single side fibreglass.. basic 80c
per square inch 9c

Double side fibreglass.. basic 90c
per square inch 13c

specials

.....only while present stocks last

7400	28c	74121	50c
7413	28c	74151	\$1.00
7440	28c	741D (linear)	40c
7442	60c	SC141D	\$1.20
7445	80c	2500uF 25V	49c
7446	80c	8.2V zener	14c
7448	80c	12V zener	14c
7460	35c	24V zener	14c
7479	40c	27V zener	14c
7483	95c	30V zener	14c
7492	70c	BC350 pnp	9c
7496	95c	4016 CMOS	60c
22K	Double gang linear pots		69c
47K	Double gang linear pots		69c
100K	Double gang linear pots		69c
47K	Double gang log pots		69c
BC350	PNP, similar to BC559		9c
500mW	Zeners, 8.2, 12, 30 volt		14c
LM309K	5 volt, TO3 regulators		\$1.25
LM741D	DIL 8 case IC		.40
1101	256 bit RAM, +5, -9 volt		\$1.95
2102	1024 bit RAM, +5 volt		\$3.50
ZM1000	Nixie readout tube		99c

LINEAR IC

LM301D	87c	LM741T	70c
LM301T	87c	LM749T	\$2.35
EM307	\$2.20	LM777T	\$1.78
LM308D	\$2.32	LM795	\$6.50
LM308T	\$2.32	LM1303	\$2.15
LM309K	\$1.25	LM3900	.83
LM339	\$3.20	LM3909	\$2.65
LM380	\$2.04	LM7805	\$2.36
LM381	\$3.20	LM7812	\$2.36
LM702T	\$3.20	LM7815	\$2.36
LM709	.64	MC717P	\$1.50
LM709T	.64	MC1312	\$4.34
LM710T	.82	MC1314	\$6.89
LM715T	\$3.20	MC1315	\$10.84
LM716T	\$2.90	NE555	.92
LM723	\$1.14	SN76023	\$1.90
LM723T	\$1.14	TAA840	\$2.95
LM730T	\$3.20	TCA220	\$1.95
LM734T	\$2.90	ZN414	\$3.25
LM739	\$2.15	8038	\$7.50
LM740T	\$3.50	CA3028	\$3.50
LM741	.70	CA3048	\$3.95
LM741D	.40	CA3130T	\$1.70

FUSEHOLDERS

FH1	3AG panel mount	90c
FH2	1AG panel mount	90c
FH3	3AG in line plastic	22c
FH4	3AG chassis mount	22c
FH5	3AG double chassis mount	39c
FH6	3AG chassis mount, cover	22c

showroom

ELECTRONIC SUPPLY SERVICE SHOP
179 Victoria St.

William street

Darlinghurst Rd.

mail order

Minimum order \$5.00
Pack and Post free in Australia
Catalogue 90c

BKX ELECTRONIC SUPPLY SERVICE,
PO BOX 787, POTTS POINT,
SYDNEY, NSW, 2011.



Letters to the editor

Transistor tester

On page 83 of your November 1976 issue of Electronics Australia is shown a circuit for a direct reading transistor tester, which appeared in the Wireless World in their August, 1976 issue on page 52.

It was contributed by Mr. A. Rigby and shown under the heading "Circuit Ideas".

You may be interested to know that Rigby might have got his ideas from a paper of mine in Electronic Engineering, April 1965. I enclose a reprint of this paper.

Murray M. Winn, Associate Professor
School of Physics, University of Sydney

A bouquet . . .

I write to congratulate your magazine and the effort of Greg Swain on your Year Book feature on CB.

Obviously, your editorial policy is top notch in that the progressive analytical approach is evident from start to finish. I must thank you also for the editorial reference to the N.C.R.A. and I can say we have had a very large volume of response and memberships. So much so that I take this opportunity to apologise to those people who have written to us, and not yet received a reply. We will reply as soon as possible.

A point of interest is the quality of the replies. With previous editorials in other publications the letters were very basic. However, we have had very interesting letters, all in support and from many amateurs at that. I think this only reinforces a widely shared view that the WIA is not totally representative of the majority. Some letters from amateurs offer active involvement to assist. Obviously we will take up their offers where possible.

For the interest of your interstate readers and yourselves, were you aware that on Sunday, December 12th the WIA (NSW) weekly broadcast was made on Channels 14 and 9? The obvious result was that the CREST monitors were unable to hear any emergency whatsoever on Channel 9. The minority radicalism of the WIA is becoming increasingly evident and it ties in with the comments of one supposedly "responsible" amateur---"I don't care if my activities on Channel 9 result in the death of any person relying on your services". This comment was made to me and others of CREST.

As a "responsible" organisation I also feel they should qualify their claims as made by Brian Warren in the Bulletin of December 18th, where it was stated that the FCC in the US had "blamed CB for 80% of interference complaints". This is a good solid statement. However, he failed to qualify this with the fact that there was only just over 14,000 complaints, which equals 0.1% of their CB population, and even less of the TV owning population.

It is incredible that CB radio is claimed to interfere with everything from the TV to the sex life of the armadillo. However, once a person achieves novice or amateur status or even obtains a licence for his boat radio, the "serious problems" expounded by the WIA are expected to disappear as if by magic.

Thank you again for a brilliant effort of journalism.

Bill Payne,
National Director,
National Citizens' Radio Association

. . . and a brickbat

May I take your magazine, and Mr. Rowe in particular, to task over two recent construction projects on micro-processor applications, the ASCII to Baudot translator and the Text Editor for SC/MP?

I think, and please correct me if I'm wrong, that your editorial policy is to present, along with construction details, some idea of how the projects are supposed to work. This gives both builders and non-builders a chance to keep up with the latest devices and techniques as they become available.

Since not all your readers are computer programmers, or up-to-date with microprocessor techniques, how about a flow chart for the program and some explanations of how SC/MP converts ASCII to Baudot, etc. The hex program listing is fine, but rather like including a parts list and PCB layout for an amplifier, but no circuit diagram.

So, in keeping with the editorial in December EA about the "elite" computer people, what about more "circuit

(Continued on page 117)

The views expressed by correspondents are their own and are not necessarily endorsed by the editorial staff of "Electronics Australia". The Editor reserves the right to select letters on the basis of their potential interest to readers and to abbreviate their contents where this appears to be appropriate.



THE NEW MICRO TROUBLE SHOOTER ADDS A LITTLE LENGTH TO OUR LINE

HOOKS ILLUSTRATED ACTUAL SIZE

X-100W

XL-1

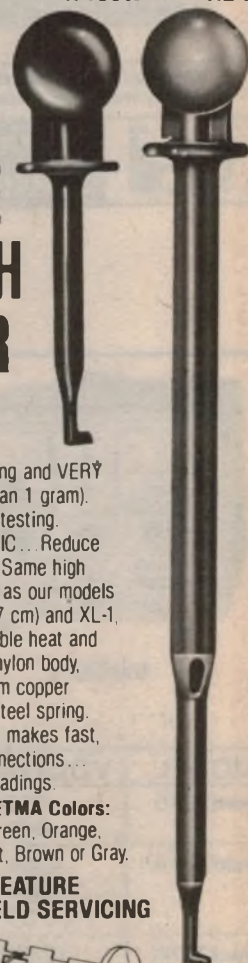

(1.75" - 4.45 cm) long and VERY little weight (less than 1 gram). Ideal for difficult IC testing. Connect DIRECT to IC... Reduce resistance build-up. Same high quality construction as our models X-100W, (2.25" - 5.7 cm) and XL-1, (5" - 12.7 cm): Durable heat and chemical resistant nylon body, Gold-plated Beryllium copper contact, Stainless steel spring. Single contact point makes fast, safe, short-free connections... assures accurate readings.

Available in 10 RETMA Colors: Red, Black, Blue, Green, Orange, Yellow, White, Violet, Brown or Gray.

ALL MODELS FEATURE EXCLUSIVE FIELD SERVICING

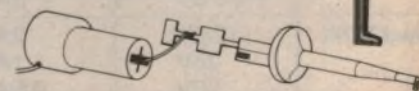

Damaged lead wire easily replaced.

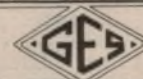

99 Alexander Street, Crows Nest, NSW
Telephone: 439 2488
38 Park Street, South Melbourne, Victoria
Telephone: 88 7782

27 MHz Novice, Amateur and Marine CB Transceivers

at a budget price from Bail Electronic Services

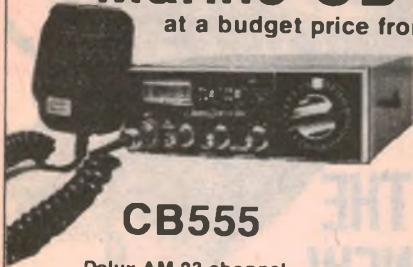

CB555

Delux AM 23 channel transceiver with N.B. Features RF gain control, AF gain, switchable automatic Noise Limiter/Noise Blanker, and Modulation/On Air indicator. **\$143.**



GTX-3325

Delux SSB/AM 23 channel transceiver featuring built-in Range Boost Modulation. FET RF amplifier for high receiver sensitivity, Noise Blanker. RF gain control and large S-meter. 15 watts PEP SSB, 5 watts AM. **\$263.**



CBR9000

In-Dash mounted 6 channel 27MHz 5 watt transceiver/AM broadcast/FM broadcast plus scanning. Features Tx, Scan and Rx indicators. Scan control allowing the set to monitor all 6-27MHz channels while you are listening to your favourite programme. **\$189.**



606CB
The Ultimate Communications/Entertainment Centre.

In-Dash combination, AM 23 channel 27MHz 5 watt transceiver/AM BC receiver/FM MPx receiver/stereo cassette player. Switch on the 606CB's unique Stand-By control while you play your favourite cassettes or

listen to regular AM or FM Stereo broadcasts. The 606CB will then monitor 27 MHz for you, interrupt your programme for 27 MHz transmissions, and resume programme play afterwards. **\$326.**

Also available from BAILS — a large range of Antennas and Accessories. Above prices include S.T. Freight and Insurance is extra. 90 day warranty. Prices and specifications subject to change.

Note all transmitting Equipment Requires a Licence.



ELECTRONIC SERVICES

60 Shannon St., Box Hill North, Vic., 3129. Phone 89 2213
Distributors in Qld., NSW, S.A., W.A.

JAS7677-14

Stabilised power supplies



bwd207B



bwd216A



bwd272A



bwd242A

bwd246A

MODEL	VOLTAGE	CURRENT
bwd207B	15V	12A
	30V	6A
bwd216A	400V	200mA
	200V	50mA
	2 x 6.3V	3A
bwd272A	12.5V	2A
	25V	1A
	50V	0.5A
bwd242A	2 x 36V	2A
	36V	4A
	72V	2A
bwd246A	2 x 36V	5A
	36V	10A
	72V	5A

Send for the Data Sheets

BWD
ELECTRONICS
PTY. LTD.

VIC.: Miles Street, Mulgrave, 3170. Telephone 561 2888
N.S.W.: 182-186 Blues Point Road, North Sydney, 2060. Telephone 929 7452

QLD.: Warburton Franki (Brisbane) Pty. Ltd., 13 Chester St., Fortitude Valley, 4006. Telephone 52 7255.
S.A.: A.J. Ferguson (Adelaide) Pty. Ltd., 44 Prospect Road, Prospect, 5082. Telephone 269 1244.
W.A.: Cairns Instrument Services, 32 Wickham Street, East Perth, 6000. Telephone 25 3144.
TAS.: Associated Agencies Pty. Ltd., 25 Barrack Street, Hobart, 7000. Telephone 23 1843.

W1

The Amateur Bands

by Pierce Healy, VK2APQ



Bushfires & floods—WICEN in action!

On the third and fourth of December, 1976, a section of New South Wales division of the Wireless Institute Civil Engineering Net (WICEN) became a major communication link during a serious bushfire emergency in Sydney's northern suburbs.

Extremely hot conditions and gusty winds caused serious bushfires in several areas of scrub around Sydney. The most serious threat to property was in the Hornsby area, north of the city.

Initial action was to provide point to point communication between the State Emergency Service field units and the Hornsby Council Chambers. This link was provided by members of the Hornsby District Radio Club, under the direction of Barry White, VK2AAB, the club president.

Later it developed into a net of about 30 mobile units attached to the various field canteens. At about 6.00pm on Friday the 3rd, it appeared that a more serious situation was likely to develop and the main WICEN body was alerted to provide links to the city and NSW Police Headquarters. Fortunately, these links were not required and the Hornsby District Radio Club station VK2APF, continued to provide local communication requirements.

As the situation developed, the channel 8 repeater at the NSW Division's station at Dural was declared an emergency communication link to handle WICEN traffic.

Throughout the night the communication net covered many aspects, with traffic being passed from SES field officers to headquarters in the Hornsby Council Chambers, from food canteens, to organise food to firefighters, and for fire spotting.

At about 11.00pm it was thought that a predicted wind change might endanger the repeater site at Dural. Several mobile stations went to the area with emergency power and alternative repeater equipment to maintain the service if necessary. However, the wind force was less than expected and the danger passed.

Operation from VK2APF continued until 3.00am when a standby period was declared until a canteen detail at 6.00am. After a relatively quiet Saturday morning the system went into full operation again in the afternoon when winds caused the fires to spring up once more. At one stage it was necessary to establish a relay station to handle traffic between Cowan and the Brooklyn areas. For a period of about fifteen minutes about sunset a total power failure occurred just north of Hornsby and a further communication link had to be provided.

Activity continued until 9.30pm when the WICEN station was placed on standby. The emergency officially ceased around 10.00am on Sunday, 5th December.

Well in excess of 50 amateurs were available during the emergency and WICEN worked directly with the Hornsby section of the SES.

It was in May, 1976, that the Hornsby District Radio Club contacted the Hornsby SES and offered their services as a part of the WICEN organisation. When this emergency arose there was no delay in establishing the base station and links where they were needed.

Congratulations have been extended to all associated with the WICEN activities during that state of emergency.

A WICEN service of a different nature was provided at Wagga from 18th to 21st October, 1976, when serious floods threatened to inundate the city of Wagga and the town of Narrandera. The regional WICEN co-ordinator Sid Ward, VK2SW, and deputy co-ordinator Doug Menneke, VK2ZMP, were in charge of the operations.

Three self contained two man teams were stationed at selected gauging stations upriver from Wagga and another team was stationed 24km downstream.

Regular hourly and, at flood peak, half hourly readings and other data were passed via the channel 3 Wagga repeater direct to the WICEN station in the Divisional Headquarters of the State Emergency Services, Wagga.

These continuously available data permitted accurate estimates of the maximum river height and were of great value to the work force constructing sandbag levees.

In addition, the Wagga WICEN group provided mobile two metre simplex communications for the police volunteer rescue group and from the flooded areas of the city to another WICEN station at SES Div. Hq.

Simultaneously, at Narrandera, some 105km downstream, Harry Cuthbert, VK2AEC, was monitoring the Wagga river heights via the Wagga repeater and relaying to the Narrandera SES authorities.

The Wagga WICEN group were supported by members of the Wagga District Radio Club in providing the 100% communication service. Congratulations and due thanks have been expressed for a job well done.

GOSFORD FIELD DAY

All amateurs, their families and friends, and all interested in amateur radio are invited to attend the CCARC 20th annual field day on Sunday, 20th February, 1977, at the Gosford Showground.

This is a family event with attractions for all and adequate shelter should the weather be inclement.

Program:

8.30am-10.30am. Registration: Gents—\$4.00; Ladies—\$2.00; Children—\$1.00. Includes morning tea, lunch, afternoon tea, outings and entry fee for field events.

8.45am-9.15am. Mobile scramble in three sections. (a) HF bands. (b) 6 metres. (c) 2 metres. No operation in showground or 1km radius. Contacts on VHF tunable count 3 points. Net channels 1 point. No operation through the Gosford repeater. Log extract to "name tag" table before 10.00am. Late entries will not be accepted.

Prior to 9.45am. All items for disposal must be handed to the officer in charge of the stall.

- 9.45am-10.30am. 2 metre fox hunt (channel 40 146MHz only, sniffers required).
- 10.00am-10.30am. Morning tea.
- 10.00am-10.15am. Junior 2 metre pedestrian fox hunt—16 years and under.
- 10am. Disposal stall open.
- 10.45am-11.30am. Children's events.
- 11.00am-11.10am. 2 metre AM pedestrian fox hunt.
- 11.00am. Quiz sheets available from "name tags" table. To be handed in by 1.30pm.
- 11.00am. Divisional broadcast from VK2AFY with O/B from Showground.
- 11.20am-11.40am. 2 metre pedestrian fox hunt (AM).
- 11.30am-1.30pm. Lunch—two sittings (included in registration fee).
- 12.00-12.10pm. 2 metre pedestrian fox hunt (AM).
- 1.00pm approx. Drawing of lucky numbers—numbers must be claimed by 1.15pm otherwise a re-draw will take place.
- Prior to 1.30pm. Return completed quiz sheets to "name tags" table. Late entries not accepted.
- 1.30pm. Bus leaves for Reptile park and tour of area, return at 4.00pm.
- 1.30pm. Talk-in fox hunt; frequencies 27.125MHz AM; 146.00MHz FM and Gosford repeater Channel 3. Two sections—(a) Full participation (licensed amateurs only). (b) Listener only (open to both licensed amateur and listeners).
- 2.00pm and 2.15pm. Junior 2 metre AM pedestrian fox hunt—16 years and under.
- 2.30pm-3.45pm. 2 metre FM fox hunt 146.00MHz FM only, sniffer required.
- 3.30pm-4.15pm. Afternoon tea
- 4.00pm-4.30pm. Prizes presented—if leaving early please advise the announcer on duty.

Other attractions: Artex exhibition, ladies' stall, jam, cakes, sweets, novelties, display of electronic musical equipment, children's events, lucky door prize, disposals store, amateur television, trade displays, 807's, soft drinks. Plenty of parking room in showground.

General information: The CCARC station VK2AFY will be operational on—Gosford repeater channel 3. Channel 40 and 7050kHz SSB.

Disposals: If you have items to be sold at the field day, contact Bill Smith, VK2TS, RMB 100A Mangrove Mountain, Gosford 2250. Telephone after hours (043) 741207, and advise him of the number of lots that you want sold and he will send you the necessary forms together with lot numbers and instructions. Do not put off requesting the forms and lot numbers. Late arrivals at the disposals stall with equipment improperly tagged or catalogued may be refused. A commission is charged on all sales.

NOVICE LICENCE NEWS

It is gratifying to hear the increasing number of novice call signs on the air—the three letter series commencing with "N" prefixed by VK and the usual call area figure.

To assist those wishing to obtain their novice licence, whether WIA members or not, the NSW division Youth Radio Scheme held a trial novice licence examination on 30th October, 1976. It is understood that similar trials are likely prior to future novice licence examinations.

Three highly qualified professional teachers, Ken Hargreaves, VK2AKH, Rex Black, VK2YA and Keith Howard, VK2AKX—who are also most experienced in YRS activities—planned the trial examination.

The examination was set up with four aims—

1. That opportunity be given to novice licence candidates to experience examination conditions, so that nervousness might be less likely to affect performance.

2. That the examination be used to point up weaknesses in knowledge and examination technique, and allow for informed and intelligent revision.

3. To try out certain streamlining methods of administration of the examination.

4. To advertise the WIA and its member clubs by offering a service to intending novice licensees.

During September, radio clubs in NSW and YRS supervisors of other states were advised of the examination plan and invited to participate. A resume of the examination procedure was included. The

Radio clubs and other organisations, as well as individual amateur operators, are cordially invited to submit news and notes of their activities for inclusion in these columns. Photographs will be published when of sufficient general interest, and where space permits. All material should be sent to Pierce Healy at 69 Taylor Street, Bankstown 2200

QUALITY CB GEAR

When you buy from VICOM you get only quality gear sold and serviced by the experts. All transceivers are given a thorough pre-delivery checkout supported by technical expertise and well equipped workshops. A wide range of spare parts is available and all new gear carries a 90 day warranty.

NEW *



synthesised \$289

PANTHER SSB DELUX TRANSCEIVER
 This superb rig is the ultimate in quality and sophistication! The Panther SSB is synthesised and requires no crystals. Frequency stability is within 0.001%! There are 69 available modes: 23AM, 23LSB, 23USB at 5w am and 15w pep input. Controls include squelch, effective noise blanker and transceiver PA system switch. Front panel meter indicates modulation, "S" points or relative RF output. The rig comes complete with mic, mobile mounting brackets, dc cable and VICOM 90 day warranty. A real bargain!



BUILT-IN SWR BRIDGE!

\$169 *

COUGAR 23 B AM DELUX TRANSCEIVER
 Delux mobile 23 channel (synthesised) for the quality conscious Novice. The Cougar features built-in swr meter, noise blanker, delta tune, rf gain control, mic gain control, built-in modulation meter, separate PA switch. Circuitry consists of 1 IC, 20 transistors, 18 diodes. RECEIVER: dual conversion, sensitivity 0.5 uV for 10 dB S/N/N, selectivity 8 dB bandwidth 5 kHz, PA audio power 5 watts. TRANSMITTER: 5w input, spurious harmonic suppression better than 55 dB. Comes complete with mic, mobile bracket, dc cable and manual *

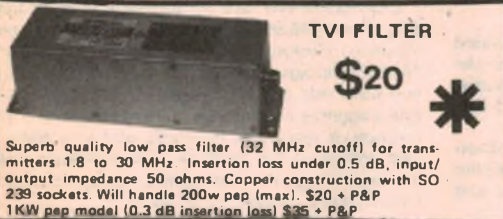

TVI FILTER

\$20 *

Superb quality low pass filter (32 MHz cutoff) for transmitters 1.8 to 30 MHz. Insertion loss under 0.5 dB, input/output impedance 50 ohms. Copper construction with SO-239 sockets. Will handle 200w pep (max). \$20 + P&P. 1KW pep model (0.3 dB insertion loss) \$35 + P&P *

GET THOSE EXTRA "S" POINTS!

QUALITY 27 MHz ANTENNA COUPLER

To match the transmitter final to the antenna line and ensure optimum power transfer. This quality coupler covers 27-30 MHz with an input impedance of 50 ohms unbalanced at 200w pep. Output impedance range 10 to 300 ohms unbalanced. Insertion loss better than 0.5 dB.

POPULAR VC2 SWR/PWR METER

The popular VC2 covers 3-150 MHz with power measurement 12/120 watts. Will handle up to 1000w. 50 ohms impedance, twin meters. This quality true-line instrument is ideal for the shack or for permanent mobile installation. \$36 + P&P

\$59 *

\$36 *

VICOM DEALERS WANTED

Vicom are seeking active Dealers to join our expanding Australian-wide CB retail outlets. We sell only quality gear and "get rich quick" outfits need not apply. Would-be Dealers should have technical facilities and personnel who are capable of handling and assisting with queries from our many customers. Written applications should be address to the attention of Managing Director.

A licence is required for all transmitting equipment.

VICOM

DEALERS

Perth: Netronics, 388 Huntriss Ave, Woodlands Phone 46 3232
 Adelaide: Graham Stallard, 27 White Ave, Lockleys Phone 43 7981
 Canberra: Daicom Electronics, 29 Colbee Court Phillip Phone 82 3581
 Brisbane: Elite Electronics, 69 Wardell St Dorrington, Phone 38 4480

Head Office & mail orders . . .
 139 Auburn Rd, Auburn, Vic. 3123 Ph: (03) 82-5398
 Sydney
 23 Whiting St, Artarmon, NSW 2064 Ph: (02) 439-1271

Prices include Sales Tax but exclude freight and insurance. For insurance allow \$1 per \$100, minimum \$1. Freight sent Kwikasair (freight "collected") unless otherwise specified. Prices and specifications are subject to change without notice.

ANTENNAS

BASE LOADED WHIP

Model M1 base loaded mobile whip, 40.5 inches long 50 ohm impedance, vswr less than 1.5. Includes roof top mount, optional boot lid mount, spring and coax with PL259 plug. \$27 + P&P

Model G2 as above with gutter clamp \$29.90 + P&P

27 MHz TRUCK ANTENNA

Twin centre loaded mirror mounted antennas especially designed for truck use. Comes complete with cables, plugs, connecting brackets, instructions. \$42 plus P&P \$3



\$79

27 MHz Helical Ground plane wound on light and strong fibreglass rod

CAR RADIO SPLITTER

Permits operation of your AM or AM/FM car radio from 27 MHz antenna. Can be used with any series fed (ungrounded) 27 MHz antenna. Finished with RG58/u and car radio high impedance lead, each 60 inches long. Excellent isolation between entertainment radio and 27 MHz transceiver. Includes adjustable 27 MHz match for optimising SWR. \$31 + P&P \$1.50.

PLUGS & SOCKETS

(Minimum mail order \$5)

PL259 plug incl reducer	\$1.30
PL259 without adapter	\$1.30
SO239 chassis socket	\$1.30
RCA/SO239 adapter	\$2.20
Rt angle connector PL259/SO239	\$2.20
"T" adapter SO239	\$2.20
"T" adapter (2 female 1 male)	\$2.50
Lighted 5w dummy load	\$2.90
1 1/2' coax jumper leads with PL259s	\$2.30
3' coax jumper leads with PL256s	\$2.50
3 & 4 pin transceiver mic plugs	\$2.30
3 & 4 pin transceiver mic sockets	\$2.30
Magnetic mix holder	.96
Lightning arrester	\$3.50
RG58AU 50 ohm coax 50c/m	
RG8 low loss coax \$1.35/m	

13.8V DC POWER SUPPLY

This is a fully regulated supply with an output of 13.8 vdc at 3 amps (5A peak). Includes an on-off switch and neon indicator and comes complete with mains flex and 3 pin plug. Ideal as a bench supply or for powering transceivers.

\$35 *

AMATEUR BANDS

examination was also publicised in the regular news bulletins broadcast over VK2WI, VK2AWI and VK2AWX/P. Applications were invited through radio clubs and from individual candidates, the latter being asked to nominate a radio amateur holding the AOCP to act as supervisor. Applications were to be forwarded with a fee of \$1.00 to the NSW YRS education officer, Ken Hargreaves.

The paper consisted of 50 carefully selected theory questions and 20 regulation questions, set in the multiple answer format used for the PMG examination. Test tapes were used for the Morse code section.

One feature of the procedure was that as soon as each paper was in progress the previous one was being marked and candidates were handed their results on leaving the centre, just three hours after arriving.

Of 59 papers analysed the percentage of passes for the individual papers were—Theory 58%; Regulations 74%; Morse code reception 62%; Sending 76%; Total Morse code 55%. Passed all three papers 45%.

In the full report on the exercise it is suggested that the marking procedures used be strongly recommended to the PMG as an entirely practical and timesaving procedure.

ACT CONVENTION ACCOMMODATION

Accommodation in Canberra can be critically short over Easter. If you intend visiting the WIA Australian Capital Territory Division annual convention from Friday, 8th April-Monday, 11th April, 1977, be advised to book now.

The convention committee has arranged accommodation at four locations in Canberra which should cater for most tastes. For information write to the—Canberra Easter Convention Committee, PO Box E338, Canberra, ACT, 2600.

Details of the program in next month's notes, but book accommodation now.

RADIO CLUB DIRECTORY

Here are additions to the radio club directory published in the December, 1976, issue of these notes.

Club name: SYDNEY CHAPTER QUARTER CENTURY WIRELESS ASSOCIATION.
 Membership: Holders of an amateur licence for 25 years or more.
 Meeting place: North Sydney Anzac Memorial Club, Anzac Street, Cammeray.
 Day and time: 2nd Wednesday of each month at 7.30pm.
 Affiliation: Quarter Century Wireless Association, USA.
 Net frequency: 147.2MHz.
 Contact: President—Brian Anderson, VK2AND; Secretary—Harry Caldecott, VK2DA; Bill McGowan, VK2MQ; at their call book addresses.

Club name: SUMMER AND RADIO CLUB.
 Club call sign: VK2AGH.
 Meeting place: St. Peter's Church of England Hall, Ballina Road, Goollellabah.
 Day and time: Each Friday at 7.30pm.
 Affiliation: WIA NSW division.
 Net frequency: Repeater channel 4, VK4R1C.
 Contact: Harold Wright, VK2AWH, PO Box 518, Lismore 2480. Telephone (066) 21 3664 (AH).

Club name: SACRED HEART COLLEGE RADIO CLUB.
 Club call sign: VK5FZ.
 Meeting place: Sacred Heart College, Brighton Road, Somerton Park.
 Day and time: Each Friday at 7.00pm.
 Affiliation: YRCS South Australia.
 Net frequency: 53.1MHz AM.
 Contact: L. Powning, VK5ZLO, 6 Oxford Street, Somerton Park.

It is proposed to include the Radio Club Directory in the 1977 issue of the "Electronics Australia Year Book". Club secretaries and publicity officers are advised to watch for details in future issues.

RADIO CLUB NEWS

WESTERN AUSTRALIA VHF GROUP: The Kalgoolie repeater is operational on Channel 8. It is located on top of the poppet head at the Hainault Tourist Mine. The range is 25km to the south and 40km in other directions: It is operating satisfactorily but a few modifications and additions will complete the installation. The majority of the work is being carried out by Lew Pannell, VK6ZGQ, and Doug Maley, VK6QR.

During the latter half of 1976 the group have acquired many excellent pieces of equipment from the Carnarvon satellite tracking station, NASA, the ABC, and government laboratories. These and many other historical wireless items are being restored, some to working order, to display in the Wireless Hill Communications Museum. In October, 1976, the Melville City Council resolved—

(i) That the City of Melville seek recognition from the trustees of the West Australian Museum for the Wireless Hill Communications Museum as a Municipal Museum pursuant to Section 37 of the Museum Act 1969-1973.

(ii) That an organising committee be established in accordance with Section 37 to establish, promote and maintain a Communications Museum at Wireless Hill.

The committee to report to Council's Wireless Hill Park Committee which in turn to commit recommendations to council on matters relative to the Park and the Museum.

The committee to consist of nine members—The director of the WA Museum or his deputy.

A person nominated by the Director-General of Education.

Four members nominated by the City of Melville.

Three members nominated by the WA VHF Group (Inc.).

(iii) That the council noted that funds for the Museum are not available in the 1976/77 Municipal Fund Budget and that the VHF Group be advised that upon submission of a program by the proposed organising committee due consideration will be given for inclusion in the Council's 1977/78 budget.

The Group are now confident that substantial progress will be made during the year. In the past the rate of development has been controlled by finance and voluntary effort available.

Historical items have been loaned by the Group to the ABC and Channel 7 television stations for use in their programs. It has already opened discussions with the West Australian Institute of Technology and Mount Lawley Technical College as to the possibility of certain museum working displays being developed through research projects by senior electronics students. This proposal has been well received.

Present indications are that future generations will, through the initiative of amateurs, be able to view the technical advances made in the field of radio communications in its many facets.

Also housed in the museum building is the group's transmitting and receiving equipment, the VHF repeater VK6RAH and workshop. The adjacent lecture room is used for VHF group meetings, the repeater group and the WIA, WA council.

The address of the Wireless Museum is Cnr. Alomondbury Road and McCallum Crescent, Ardross, Perth WA.

SOUTH AUSTRALIAN DIVISION WIA: The inaugural meeting of a Microprocessor Group was held on 19th October, 1976, at the Burley Griffin Building and attended by 19 members.

At the meeting members detailed their current activities in the microprocessor field and it appears that several are already working with microprocessors.

Future meetings of the group will be held on the second Friday of each month at the Burley Griffin Building, WIA headquarters, West Thebarton Road, Thebarton.

The committee elected are: Meeting organiser—Clive Pearson, VK5PE; secretary/treasurer—John Moffat, VK5MG; technical committee—Howard Harvey, VK5ZBE; Peter Christie, VK5EM; Terry

IONOSPHERIC PREDICTIONS FOR FEBRUARY

Reproduced below are radio propagation graphs based on information supplied by the Ionospheric Prediction Service Division of the Department of Science. The graphs are based on the limits set by the MUF (Maximum Usable Frequency) and the ALF (Absorption Limiting Frequency). Black bands indicate periods when circuit is open.

277

7MHz EAST		01	02	03	04	05	06	07	08	09	10	11	12	13	14	15	16	17	18	19	20	21	22	23
EAST AUST TO BARBADOS (SRI)																								
JOHANNESBURG																								
McMURDO SOUND																								
NEW DELHI																								
NEW YORK																								
RIO DE JANEIRO																								
TOKYO																								
VANCOUVER																								
WELLINGTON																								
WEST AFRICA																								
WEST EUROPE (SRI)																								
WEST EUROPE (LRI)																								
ADELAIDE TO SYDNEY																								
BRISBANE TO MELBOURNE																								
PERTH																								
SYDNEY																								
DARWIN TO SYDNEY																								
MELBOURNE TO PERTH																								
SYDNEY																								
14MHz GMT		15	16	17	18	19	20	21	22	23	24	01	02	03	04	05	06	07	08	09	10	11	12	13
EAST AUST TO BARBADOS (SRI)																								
JOHANNESBURG																								
McMURDO SOUND																								
NEW DELHI																								
NEW YORK																								
RIO DE JANEIRO																								
TOKYO																								
VANCOUVER																								
WELLINGTON																								
WEST AFRICA																								
WEST EUROPE (SRI)																								
WEST EUROPE (LRI)																								
ADELAIDE TO SYDNEY																								
BRISBANE TO MELBOURNE																								
PERTH																								
SYDNEY																								
DARWIN TO SYDNEY																								
MELBOURNE TO PERTH																								
SYDNEY																								
21MHz EAST		01	02	03	04	05	06	07	08	09	10	11	12	13	14	15	16	17	18	19	20	21	22	23
EAST AUST TO BARBADOS (SRI)																								
JOHANNESBURG																								
McMURDO SOUND																								
NEW DELHI																								
NEW YORK																								
RIO DE JANEIRO																								
TOKYO																								
VANCOUVER																								
WELLINGTON																								
WEST AFRICA																								
WEST EUROPE (SRI)																								
WEST EUROPE (LRI)																								
ADELAIDE TO SYDNEY																								
BRISBANE TO MELBOURNE																								
PERTH																								
SYDNEY																								
DARWIN TO SYDNEY																								
MELBOURNE TO PERTH																								
SYDNEY																								

McCarthy, VK5GU; Bill Verrall, VK5WV.

A demanding program of group projects has been established and the technical committee has been given unlimited scope and encouragement to co-opt group members to assist.

For all membership enquiries refer to John Moffat, VK5MG, telephone 47 3688 or Clive Pearson, VK5PE, telephone 47 4111.

GOLD COAST RADIO CLUB: Again the CCRC members were hosts for the WIA Queensland Division annual convention held on the weekend 30th-31st October, 1976, at the RSL Hall, Southport.

Introduced by the president of the Queensland Division WIA, Dave Laurie, VK4DT, Mr John Marshall, assistant Qld. General Manager of the ABC officially opened the convention. In doing so, Mr Marshall spoke of the part played by amateur radio in times of emergency when amateurs are called in to provide communication links and in doing so act in a most responsible way.

Another speaker was Newton Wade, VK4QW, who has held an amateur licence since 1912. Newton spoke about the early days of radio. He also had on display replicas of amateur wireless equipment used before 1914.

The CCRC held its 7th annual general meeting on Friday 8th October, 1976, when details of a very successful year was recalled in the president's report.

ILLAWARRA AMATEUR RADIO SOCIETY: Scheduled EME tests with SK6AB and LX1DB provided no signals on 14th November, 1976, although VK2AMW's own echoes were received to a maximum of 7dB above the noise.

A special test requested by K3PGP was made on the 27th November, 1976. The best signal report was "T" copy as his signals did not peak above 2dB over noise. K3PGP reported that VK2AMW was being received quite well.

It is reported that a mid South Coast Radio Club

has been formed with 15 foundation members. The club plans to establish a repeater in the Ulladulla area with coverage from Gerringong to Narooma.

SACRED HEART COLLEGE RADIO CLUB: There are an average of 15 members including students and non-school members who attend club meetings at Somerton Park, Adelaide SA. Six members sat for the recent novice licence examination and another six are preparing for the examination to be held in May 1977.

Practical work is an important aspect of the club's activity and is providing an invaluable aid to members. Projects vary in size and complexity.

On air activity is an integral part of the club activity under the call sign VK5FZ and is invaluable experience for prospective licensees.

Prospective members are welcome and are invited to attend the club on Friday evenings between 7.00pm and 9.00pm.

SO YOU WANT TO BE A RADIO AMATEUR?

To achieve this aim, why not undertake one of the Courses conducted by the Wireless Institute of Australia? Established in 1910 to further the interests of Amateur Radio, the Institute is well qualified to assist you to your goal. Personal Classes for 1977 will commence on Tuesday, February 8th, 1977. Applications which are accepted in order of priority, are now being received. Correspondence Courses may be commenced at any time.

For further information, write to
**THE COURSE SUPERVISOR,
W.I.A.
14 ATCHISON STREET,
CROWS NEST, N.S.W. 2065**

**BC221
FREQUENCY METERS**

Brand new in original packing cases—unopened complete with 240 volt power supply Charts etc \$90 each—cartage to rail \$2 Freight payable at nearest attended Railway Station.

P.M.G. TYPE TELEPHONES
Standard desk type with magneto bell calling device Range 30 miles. Uses standard batteries at each phone. Any number can be connected together on single line.

\$35.00
(2 TELEPHONE SETS)

\$2 Cartage to Rail Freight payable at nearest attended Railway Station

**TEN CHANNELS
VHF TRANSCEIVER**

TR1956 125-150 MHz 28 volt DC operated AM single crystal locks both TX and RX on same channel complete with generator

\$33.00

TUNING UNITS

T U Series. Contains variable condenser suitable for aerial tuning vernier 5" Ceramic Coil Former etc. 19" rack mounting, only \$9.50 ea. Post A \$2.30, B \$3.75, C \$4.80, D \$6.55

FREQUENCY METERS

AN URM 37 A 120 KHz to 1000 MHz, with 240V power supply \$125

\$2 Cartage to Rail. Freight payable at nearest attended Railway Station

**ILFORD 17.5 mm
SPROCKETED
MAGNETIC TAPE**

1000 ft reels brand new original packing \$4.00 ea. quantity available

Post A \$1.30 B \$2.00
C \$2.30 D \$2.80

No. 62 TRANSCEIVER

With headphones, accessories etc \$60

TELEPHONE WIRE

1 mile twin (2 miles) genuine ex Army Don 8 perfect condition \$35 per drum \$1 cartage to rail freight payable at destination

PRISMATIC COMPASSES

Genuine ex-army Mk 3 liquid damped as new \$45.00 P & PA \$1.70 B \$2.25, C \$2.40 D \$2.65

MORSE KEY | MORSE KEY BUZZERS

\$1.40 Post 40c | \$4.25 Post 60c

**DYNAMIC
TRANSISTOR CHECKER**

Provides a visual indication of signal output Tests electrode open circuits, short circuits, current gain \$14.95 ea. P & PA \$1.70 B \$2.25 C \$2.40 D \$2.65

MULTIMETER

A compact and handy tester for workshop or lab where quick circuit checks are required

DC Volts 2.5 to 1 000V (20 000 OHMS per volt) AC Volts 10 to 1 000V (10 000 OHMS per volt) DC Current 50 UA 25 MA 250 MA. Resistance 40 K OHM 4 MEG OHM Decibels minus 20 DB plus 62 DB complete with instructions only \$19.95 Ea. P.P. \$1.05. Multimeter similar to above 30 000 OHMS per volt \$23.75 P.P. \$1.05. Only \$17.25 ea Post \$1.05

BENDIX PIONEER

Drift Sight
Type B3
\$250.00

4 DIGIT RELAY COUNTERS

50 volt DC, suit siof car Lap counters, etc. \$1.25 each. P & P 60c

NIBBLING TOOL

Cuts sheet metal like a punch and die, trims, notches and cuts to any size or shape over 7/16inch

ONLY \$9.95
Post \$1.10

NIFE CELLS

1.2 Volt, fully charged, 4in x 3in x 1in 4 AH \$1.50 each P & P 80c

5" CRO TUBE 5 BPI \$5.50 each
Post A \$1.40 B \$2.25 C \$2.70 D \$3.45

HANDY SIGNAL INJECTOR

Produces an Audio Signal in rich harmonics. Ideal for Sig Tracing in A.F., I.F., and R.F. circuits. Powered by 4 Penlight Batteries with On/Off Switch and indicator lamp. Size 1 1/2" Diam 5" Long Only \$6.50 Post \$1.10

\$22 Transceivers 100 150M CS

\$35.00

POSTAGE KEY:

A: NSW
B: Vic, Qld
C: SA, NT, Tas, New Guinea,
D: WA

VALVES

BRAND NEW IN CARTONS
65N7GT 95c CV850 \$1.50
5U4G 95c 1H6G 75c
EF50 75c 837 \$5.00
5Y3 \$2.25 6X4 \$2.25
2 x 2 75c VR65 75c
P & P 40c

AIRCRAFT CLOCKS

Genuine eight day jewelled movement sweep second hand Dash mounting \$29.50 EA P & P \$1.10

CONDENSER LENS

1 1/2" Diam 4 1/2" F L 75c 2 1/2" Diam 2" F L \$1.50 each Or \$2.50 per pair P & P 40c

**ZOOM SPOTTING
SCOPES**

30 x 30
LENGTH 12 1/2", HEIGHT
10"
WEIGHT 1 1/4 lb.
\$23.95

45 x 40
LENGTH 16",
HEIGHT 10"
WEIGHT 2 lb.
\$36.50

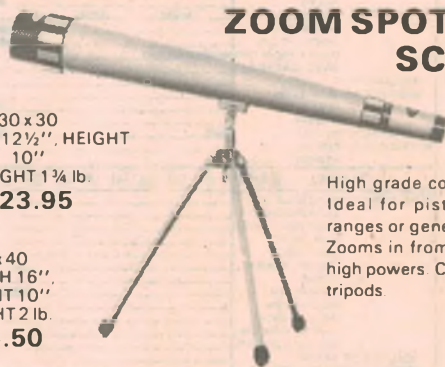

High grade coated lenses. Ideal for pistol and rifle ranges or general viewing. Zooms in from very low to high powers. Complete with tripods

POST: A \$1.70, B \$2.25,
C \$2.40, D \$2.65.

TELESCOPES

25 x 30 \$6.50
P & PA \$1.70, B \$2.25,
C \$2.40 D \$2.65

IMPELLER PUMPS

New gunmetal body. Stainless Steel Shaft. Neoprene Impeller Up to 15ft Lift, suitable for almost any type of liquid. Self priming. Ideal boat bilge pump, sullage drains, etc. Approx size 8" x 5"

3/8" \$23.30
1/2" \$31.95
3/4" \$35.95
P & PA \$1.90 B \$2.75 C \$3.20 D \$3.95

LAVOIE FREQUENCY METER

Fr- / 6U
100 to 500 M / HZ
240 Volt operated
PERFECT CONDITION
\$375.00

SPECIAL lucky dip valve offer. 15 new valves in cartons for only \$2.95. We haven't got time to sort them, so you reap the benefit. P & PA \$1.80 B \$2.50 C \$2.80

**SMALL COMPUTER
PANELS**

3in x 2in containing 2 valves, qty of resistors, etc. ONLY 75c P & P 60c

**ELECTRONIC FREQUENCY
COUNTER**

Austronic type DFC 4 240V 50 cycle 0 100K Hz \$150

SPY TELESCOPES

8 x 17 mag size of a rifle cartridge extends to 8". Only \$4.75 each, post 60c

BINOCULARS

PRISMATIC Coated Lenses Brand new Complete with case.
7 x 35 Wide Angle \$35.50
8 x 40 Wide Angle \$39.50
7 x 50 \$31.50
10 x 50 \$32.50
12 x 50 \$33.65
20 x 50 \$37.95
P & PA \$1.80 B \$2.50 C \$2.20 D \$3.20

**SMALL CLIP-ON
POCKET TELESCOPE**

15X \$3.95 Post 60c

RECEIVER No. 210

2 1/6 M/cs \$65
Transmitter No. 11 suits 210 \$35
24 volt Power supply to suit above \$15
Or complete station with Headphones, Mic, Morse Key, Antenna \$110.

SOLENOIDS

Plunger Type 12V 300MA Suit electric camera control, miniature trains, radio, etc. \$2.56 P & P 20c
200 MA 24 volt, 1/2in push movement \$2.50 P & P 20c

***SELSYN MOTORS
MAGSLIP**

RECEIVERS 2" MK2 \$5.50
TRANSMITTER 3" MK2 \$15.00
Post Packing A \$1.75 B \$2.75 C \$2.75 D \$3.65

3000 TYPE RELAYS

P M G 200Ohms — 1'5000hm
Coils \$2.50 each P & P 60c

P.M.G. TYPE KEYSWITCHES

75c P & P 20c

Cossor Double Beam Oscilloscope 1035 Tested

PANORAMIC ADAPTOR

E M I type PRA-1 455 variable Kc Course 440-520 Kc Centre Freq 520-440 Kc Fine Centre Freq 20-0-20 Filter band with 50 100 200 L F 200 H F Sweep band width 0-200

\$75.00

**TRANSCEIVERS
Ex Army**

No C42 set, 36 to 60 MHz complete with 24V power supply, headphone, mic, leads etc \$65.00.

No C45 set, 23 to 38 MHz complete with mast, headphones, mic, 24V power supply etc \$95.00.

\$1.00 cartage to rail, freight payable at nearest railway station.

Hartley double beam oscilloscope Type 13A with probes Working \$150.00

77D x RCA STUDIO RIBBON MICROPHONES Variable pattern & response music or speech \$80.00 ea Post A \$3.30 B \$4.00 C \$4.30 D \$4.80

**EX-ARMY TWO-WAY
FM RADIOS**



1 2 WATTS OUTPUT SUPERHET
PRC9 AND 9A 27 to 39 M / HZ
PRC10 AND 10A 38 to 55 M / HZ
WITH HANDSET
ANTENNA ONLY \$25 EA
\$2 Cartage to Rail Freight payable at nearest attended Railway Station

**16MM SOUND PROJECTORS
IN GOOD WORKING ORDER**

240 volts operated. Complete with Speaker and Amplifier.
CINEVOX \$150.00
BELL & HOWELL \$250.00
SIEMENS \$375.00

\$2 Cartage to Rail. Freight payable at nearest attended Railway Station

**WALKIE TALKIES
2-WAY RADIO,
PMG APPROVED**

7 TRANSISTOR \$55.00 Set of 2
1 watt, 11 transistor \$142 set of 2
P & PA \$1.80 B \$2.50 C \$2.80 D \$3.20

**MICROPHONES
OMNI DIRECTIONAL
50K OHMS**

FREQ RESPONSE 100-10 000Hz Sensitivity 56dB complete with 5ft cable Microphone Holder and Stand Base only \$7.95 ea
P & PA \$1.70 B \$2.25 C \$2.40 D \$2.65

REPERFORATOR

Genuine Siemens Type 33c \$65.00

Deitch Bros.
70 OXFORD STREET, SYDNEY 2010

SORRY NO C O D

Shortwave Scene

by Arthur Cushen, MBE



The increasing use of rotatable aerial systems is enabling short-wave stations to achieve greater ranges using existing transmitting equipment. This has been well illustrated by the Swiss Broadcasting Corporation which is now using a rotatable "curtain" antenna, and broadcasts daily to Australia and New Zealand.

The use of the rotatable aerial for international broadcasting goes back to the days of PCJ at Eindhoven in Holland which introduced this system in 1938. The principle, though crude in those days, did work, and the more sophisticated aeriels today are using the same principle.

The Swiss Broadcasting Corporation is using this system in a modern form in which the transmitter feeds into a rotatable "curtain" antenna, the largest of its kind in the world.

The antenna super-structure consists of two towers of tubular steel construction, each 56 metres high. Between the two towers are suspended two sets of 16 broadband, half-wave dipoles sharing a common reflector, thus forming the curtain array.

A system of two electric motors and a circular track measuring 57.5 metres in diameter, upon which the entire antenna super-structure is built, makes it possible to rotate the 135-ton antenna to any position within 15 minutes.

The SBC broadcasts in 7 languages with special programs in Esperanto and Romansh, the fourth national language of Switzerland. The SBC receives around 25,000 letters each year from listeners in every continent. The organisation employs a staff of 130, as well as many freelance broadcasters under contract.

The transmitters which are operated by the Swiss PTT include; Schwarzenburg, two 250kW and two 100kW; Beromunster, two 250kW and one 100kW; Sottens one 500kW; Lenk two 250kW; and Sarnen one 250kW.

The Swiss Broadcasting Corporation at Berne has two daily transmissions in English for Australia and New Zealand. The broadcasts are 0700-0730 and 0900-0930GMT on 9560, 11775, 11950 and 15305kHz. Each second Saturday the Swiss Merry-Go-Round is broadcast and this includes news for the short-wave listener, propagation information, and technical replies to listeners' questions. The mailing address is: The Swiss Broadcasting Corporation, CH-3000, Berne 16, Switzerland.

COLOMBO'S EXTERNAL SERVICE

The external service of the Sri Lanka Broadcasting Corporation has been well received on 11835kHz. The broadcast has been carried on three frequencies 1030-1130GMT, and the station's closing announcement is: "This is the External Service of the Sri Lanka Broadcasting Corporation. We have been broadcasting to listeners in South East Asia, Japan and Australia on 17850kHz in the 16 metre band, 15120kHz in the 19 metre band and 11835kHz in the 25 metre band. Time now is 20 seconds to 5pm and this transmission will go off the air till 4pm tomorrow. Till then this is your announcer saying goodbye."

Notes from readers should be sent to Arthur Cushen, 212 Earn Street, Invercargill, NZ. All times are GMT, add 9 hours for West Aust. Summertime, 11 hours for East Aust. Summer time and 13 hours for NZ Summer time

The transmissions on 15120 and 17850kHz are not received so strongly. Another SLBC program has been observed on 15280kHz and this is the all Asian service. The BBC news has been noted at 0700GMT.

WINB SCHEDULE

The International Broadcasting Station WINB at Red Lion Pa., in the United States has been heard on a new frequency of 15355kHz, closing at 2000GMT. This gospel broadcaster has English up to 1930GMT. From 1930-2000GMT they carry a foreign language gospel session, at which time they change frequency to 11775kHz.

The present schedule of the station is 1700-1830GMT on 15375kHz, 1830-2000 on 15355 and 2000-2200 on 11775. The programs are beamed to Europe and North Africa and the transmitter power is 50kW. The address of the station is Radio WINB, PO Box 88, Red Lion Pennsylvania, 17356, USA.

FEBC NEW TRANSMITTER

According to the Far East Broadcasting Company in Manila a new 100kW transmitter has been installed in Northern Luzon in the Philippines to broadcast Russian programs on short-wave. This new transmitter is at the site of the 250kW medium-wave station DWRF which operates on 1470kHz from Iba Zambales. The new transmitter is designed with a complimentary aerial system to beam programs into Eastern Siberia and is carrying 4½ hours of Russian language programs each day, as well as relaying other broadcasts beamed to the area.

ISRAEL ON 15330kHz

The Israel Broadcasting Authority has been heard on 15330kHz with its English and French programs to Europe 1200-1300GMT. This new frequency has been also heard by Peter Bunn of Melbourne with the channel also being used by the Far East Broadcasting Association in the Seychelles. The signals from FEBA are reported also by Robert Hanna of Melbourne opening at 1245GMT and mixed with Israel. The program lasts for 15 minutes and the frequency replaces 11870kHz.

ENGLISH FROM DACCA

Radio Bangladesh has been heard with English broadcasts 0445-0515GMT on 17889kHz at fair strength. The frequency is announced as 17890kHz, but has been as low as 17888. According to a schedule received by Peter Bunn of Melbourne, reporting in "Australian DXers Calling", and information from the BBC Monitoring Service, English is broadcast 0445-0515GMT on 15410, 17890 and 21685kHz. The same three frequencies are used 0515-0545GMT for a broadcast in Arabic. At 1115-1145GMT a service in Nepalese is on 7150 and 9740kHz. A further English session is broadcast 1230-1300GMT on 11910 and 15270kHz. From 1340-1630 and 1645-1915GMT the station uses 11890 and 15410kHz for a variety of language broadcasts.

MEDIUM WAVE NEWS

AUSTRALIA: Station 2ST Nowra on 1000kHz has recently increased power to 5kW, and since December has been operating 24 hours a day. Chris Martin of Sydney, reporting in "DXPost", states that 7FG Fingal Tasmania on 1160kHz is expected to open shortly, while another ABC repeater, 7SH St. Helens 1570kHz, is scheduled to open later this year. When Government funds are available a 2kW transmitter is to be installed on Thursday Island using 950kHz. 4MK Mackay is to move from 1380 to 1030kHz and use 5kW, while 2MG Mudgee is to increase power to 5kW.

NEW ZEALAND: The Auckland private radio station, 1XI, this month changes frequency from 1590 to 1330kHz. The station also plans to change its slogan when the frequency change takes place. According to the annual report of the Broadcasting Council the projected new National program station for the central North Island area has been deferred due to economic reasons. In the past year a new transmitter has been installed at 4ZB Dunedin, while 3ZB and 3YC Christchurch are also to have new equipment.

LISTENING BRIEFS EUROPE

ITALY: Rome Radio has been heard on the new frequency of 9735kHz opening at 1100GMT. This channel is used by Deutsche Welle for its relay from Antigua and carries broadcasts in Spanish. The signal from Rome is not very strong, as the transmission is intended for reception in Europe.

FINLAND: Helsinki has been noted on 15270kHz with English at 0700GMT when Radio Peking is not using the frequency. Jack Buckley of Sydney reports reception of Finland at 0957GMT during a pause in the broadcasts of Radio Peking.

PORTUGAL: The Voice of Hope, operated by Adventist World Radio, has been noted on 9670kHz at 2100GMT by Mark Fahey of Turramurra, NSW. The station uses this frequency daily except for Tuesdays and Thursdays.

AFRICA

ETHIOPIA: Radio Voice of the Gospel has been heard by Mark Fahey of Sydney on 11950kHz. The station has been heard daily with English to West Africa, closing at 2030GMT.

EGYPT: According to the BBC Monitoring Service, Radio Cairo's broadcasts to North America in French from 0100-0200 and in Arabic from 0200-0300 are once again heard on 9625kHz.

MOZAMBIQUE: Broadcasts from Maputo have been observed on the frequency of 11830kHz after being on 11819kHz for some weeks. According to Noel Green of Blackpool, UK, the station has Portuguese at 1800GMT followed by a news bulletin in English. According to Gerry Wood of Radio South Africa a program from Maputo has been heard on 4972kHz, having moved from 4855kHz.

SWAZILAND: The Swazi Commercial Radio is reported by Gerry Wood as operating on 2490kHz 1700-2200GMT; 3223kHz 0400-0700 (Sun 0730) 1530-2200GMT, 4980 0500-0945 (Mon-Sat), 1330-1530 (Mon-Fri), and 1100-1530 (Sat); 6155 0500-0945 (Mon-Sat), 1330-1530 (Mon-Fri), 1100-1530 (Sat), and 0730-1530 (Sun).

ASIA

NEPAL: According to the World Radio Handbook newsletter a new 100kW transmitter is now in operation and broadcasts are as follows: 0020-0350, 0720-1050 and 1150-1720GMT. The frequencies in use are 790kHz 10kW, 3424kHz 100kW, 5007kHz 5kW, and 7105kHz 100kW.

IRAQ: According to the BBC Monitoring Service, Radio Baghdad's domestic service main Arabic program is now heard throughout transmission time 0228-2320GMT on the new frequency 11700kHz in parallel with 11725kHz.

IRAN: Radio Tehran Iran is now broadcasting its domestic service on short-wave 15315kHz for the countries of the Persian Gulf region for the complete transmission; on 15084kHz for Europe and America from 0630GMT; 17730 and 9022kHz for America and North Africa from 0700-1700GMT; and 7215kHz for Iraq and Syria from 1930GMT.

A.C.E. RADIO

MUSICOLOUR III

For the disco, light show, party, nites, or just relaxing... enjoy your records and tapes more with the new magical Musicolour Organ. Simple to connect to the home stereo or P.A. system. 3 channels, 1500 watts max. load each.



\$69.95

Fully constructed, ready to operate. Complete kit of top quality parts and instructions, including 1-C sockets — **\$59.95. P.P. NSW \$3.50, interstate \$5.50**

30 WATTS OF EXCELLENT HI-FI WITH PLAYMASTER LOUDSPEAKER SYSTEMS

3-45L Features the mighty 8-30 woofer, 6J midrange and the incomparable Philips AD016/T8 tweeter. This top quality low cost 3 way hi fi system is available from stock in either walnut or teak veneer and complies with the specs. as per April '75. **\$84.00 each**

3-41L As described in June '76 E.A. Again features the mighty 8-30 woofer, with the advantage of the new Magnavox 6-25 midrange, and the more elaborate cross-over network. The dome tweeter is Philips AD016/T8 Beautiful teak, or the ever popular walnut veneer cabinets are available. Either system can be carefully packed and despatched per airfreight passenger rail or road. Packed weight approx. 40kl. pair. **\$96.00 each**



SPEAKER KIT SYSTEMS

E.A. 3-45L CONSISTS OF 8-30 WOOFER, 6J MIDRANGE, PHILIPS AD016/+8 TWEETER, AND CROSSOVER COMPONENTS, \$41.75. + P.P. E.A. 3-41L CONSISTS OF 8-30, 6-25 MID, AD016/T8, AND CROSSOVER COMPONENTS \$49.95 + P.P. MAGNAVOX MV-50, 10-40 WOOFER, 6-25, TWO x J3 1" DOME TWEETERS, AND CONSTRUCTED FREQUENCY DIVIDING NETWORK. \$71.00 + P.P. ALL KITS INCLUDE INSTRUCTIONS.

HI FI CABINET KITS

Do it yourself—big savings. Our kits are extra easy to finish. Top, bottom, each side and back are factory assembled, baffle is pre-cut. Veneered plyboard. Teak or walnut. Complete with innerbond and speaker grille cloth. 8-30 3-45L systems **\$55.00 pair.** MV-50 system **\$69.95 pair.**

FAMOUS MAGNAVOX AUST. MADE LOUDSPEAKERS

MODEL	Imp	Watts	Rms	Rezon.	Hz	Freq Hz	V.C. Dia	Price	P.P.
10-40	10"	8	40	45		30-8000	1 1/2"	\$20.95	\$2.50
8-30	8"	8	30	45		30-8000	1 1/2"	17.50	2.25
12WR	12"	8	16	45		30-16000	1"	14.95	2.00
10WR	10"	8	16	45		30-16000	1"	12.65	2.00
8WR	8"	8	16	45		30-16000	1"	10.75	2.00
6WR	6 1/2"	8	12	45		30-16000	1"	9.90	2.00
6-J	6 1/2"	15	8	85		80-7000	1"	7.50	1.50
6-25	6 1/2"	8	25	45		45-6000	1 1/2"	14.95	2.00
XJ3	Dome	8/15	25	1500		2000-20000	1	7.80	1.30

SOUND SYSTEMS—SLEEK AND SLENDER FOR COMMERCIAL OR HOME HI FI

Black Vinex Covered Cabinets Rugged and Attractive Inner-board Lined for Richer Sound. Excellent Frequency Response 8 or 16 ohms. Floor or Wall Mounting. 3 Models

15W RMS	25W RMS	40W RMS
2 SPEAKERS	4 x 6" SPEAKERS	4 x 8 HEAVY DUTY SPEAKERS
Size 19 1/2" H 11" W 7" D	33" x 10" x 8"	37" x 12" x 8"
\$35.00	\$49.00	\$65.00

SANYO CADNICA RECHARGEABLE BATTERIES

Sealed nickel cadmium batteries. Type A \$2.50 EA, 4 for \$9.00 Type C \$4.10 4 for \$14.75 Type D \$5.00 EA, 4 for \$18.00. P.P. \$1.00 INTERSTATE \$1.75

SANYO NI-CAD BATTERY CHARGER \$25.95 P.P. \$1.60

C-B 27MHZ COMMUNICATION EQUIPMENT

GEAR TO SUIT BUSHWALKER, FISHERMAN, CAR, TRUCK, BOAT OWNER

Model NC-310 Features 3 channels. Battery checker, squelch control, tone call switch, external aerial, speaker and power jacks, battery charger jack, spec. 13 transistors, RF input power, 1 watt TX freq. Tol $\pm 0.005\%$ Tone call freq. 2000 HZ, RX. Sen 0.7UV at 10dB SN, sel. 45dB at ± 10 KHZ. If freq. 455 KWZ

\$59.95 complete with book and circuit, p.p. \$1.60 interstate \$2.95

Model Z Mobile, 6 channel 5 watts, 14 transistors, 8 diodes, squelch control, sig. strength/RF meter, microphone, book and circuit, 12 volt operation. Size 4 3/4" WX 1 1/2" HX 6 3/4" D **\$118.00 p.p. \$2.50 interstate \$3.50**

WESTON 5 WATT C-B TRANSCEIVER

Great boat or mobile rig. Auto noise limiter, squelch, A.G.C. over-mod. limiter. Low pass filter for bandwidth. SPECS T-miter. Crystal locked. 5 watts input to RF stage. Freq. coverage Any 11 channels, in 27 MHz band. Receiver, crystal locked, double superhet, 6.5 MC and 455 Kc 1 1/2 3" speaker, dynamic mic. 50 ohm antenna, 20 resistors, 8 diodes, 12VDC operation. Sensitivity 0.5UV 10dB S/N. Size 6 1/2" x 2 1/2" x 7 1/4". Wt. 4 1/2 lbs.

PRICE \$159.95 p.p. N.S.W. \$4.50, Interstate \$5.50

GARRARD MODEL 82



\$57.00.

A superb 3 speed transcription changer/player. Auto manual operation. 4 pole magnetically shielded syn. motor. Resiliently mounted. Counterbalanced. Elegant tone arm with slide-in cartridge carrier calibrated Antiskate. 265mm (10 1/2") Aluminium platter. Cue and pause control. Cartridge tilting lever. Magnetic cartridge diamond stylus. Size 375 x 335 x 170mm (14 1/2" x 13 1/4" x 6 1/4") 4.5kg (10 lbs) P & P \$2.50 Interstate \$3.50

GARRARD CHANGER/PLAYER

MODEL-6400 3 speed auto manual changer—player. 2 spindles. Motor 2 pole 240V 50Hz 10 1/2" turntable cue and pause, tubular section pick up arm. Sonatone cartridge. Great value **\$28.50**

PRE-CUT MOUNTING BASE

And fully moulded tinted perspex cover, with hinges, to suit above Record Changers **\$28.50. P.P. \$4.50**

Separate Base or Cover \$14.50

SCOOP

AWA TV spares brand new—guaranteed 12" B/W picture tube 12 CP/110 310CFB4A **\$9.50, P.P. \$3.50.** Solid state Matsushita 13 CH tuner \$10.00, P.P. \$1.00. 13 CH valve tuner (6GK5, 6GS7) \$3.00, \$1.00. Power transistors 2SD200 10 for \$3.90, P.P. \$1.00. 6BM8 valves 4 for \$3.00, P.P. 70c. 6GV8 valves 4 for \$3.00, P.P. 70c. 4GK5 7GS7 valves 4 for \$3.00, P.P. 70c

PVC SPEAKER FLEX

Twin 14/0101 Grey with black trace **\$5.50** 100 metres P.P. \$2.50

MULTI CORE SOLDER

60/40 16 GAUGE WEIGHT 500g **\$4.50** P.P. 90c

CROSS-OVER CHOKES

1 MILLIHENRY \$2.50, p.p. 40c
5 MILLIHENRY \$2.20, p.p. 40c
35 MILLIHENRY \$1.90, p.p. 40c
2 MILLIHENRY \$1.80, p.p. 40c

PLAYMASTER FORTY/FORTY STEREO AMPLIFIER

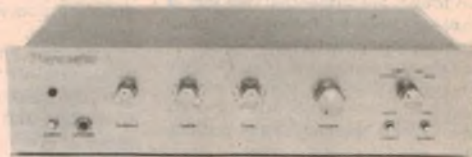

COMPLETE KIT OF TOP QUALITY COMPONENTS ALSO CIRCUIT AND INSTRUCTIONS

\$95.95. P.P. \$3.50. Interstate \$5.50. The 40/40 Kit is available with an assembled and tested printed circuit board at **\$107.95**

PLAYMASTER 25 + 25 STEREO AMPLIFIER

Complete kit of top quality parts with instructions **\$77.50**

P.P. N.S.W. \$3.50. Interstate \$5.50

AWA E-TONE 60 WATT RMS LOUDSPEAKER

30CM (12") B AND 150HMS VC DIA. 5.1CM BIG 3KG MAGNET. FREQ. 40-7000 HZ FOR BASS GUITAR, ORGAN, GUITAR. WEIGHT 4.5 KG **\$49.00. P.P. \$3.50**

DIODES

NEW—GUARANTEED
TYPE IN 4723R 600PIV 3AMP
12 FOR \$3.60 P.P. 40c
24 FOR \$6.00. P.P. 60c

1-C SOCKETS

16 DIL, 14 DIL, 8 DIL MIXED DOZEN **\$3.90. P.P. 60c**

SUB-MINIATURE TOGGLE SWITCH

DPDT 250VAC 2A **\$1.50. P.P. 30c**

PHILIPS AD016/T8

1" DOME TWEETER **\$26.95 PAIR. P.P. \$2.50**

CEILING FAN MOTORS

240VAC 50HZ 55 WATTS **\$9.00 F.O.R.**

FRG-7

YAESU—MUSEN RECEIVER **\$365.00**

SENSATIONAL SPECIAL—NAKAMICHI 500

STEREO CASSETTE DECK

BRANDED AWA—THORN DCR -1 **\$265.00**

EXPO—STEREO CASSETTE DOLBY DECK

TO CLEAR **\$165.00**

50 WATTS RMS GUITAR/P.A. AMPLIFIER



4 INPUTS, 2 HIGH, 2 LOW, 2 CHANNEL. EACH CHANNEL HAS SEPARATE VOLUME, BASS AND TREBLE CONTROLS. BOTTOM CH. HAS VIBRATO WITH SPEED AND INTENSITY CONTROLS. SENSITIVITY—25 AND 200 MILLIVOLTS FOR 50 WATTS OUTPUT AT 500HZ AT 8/16 OHMS REMOTE FOOTSWITCH WITH PLUG AND LEAD INCLUDED. ALSO CIRCUIT 240 VAC 50HZ **\$139.50**

12" 60WATT RMS E-TONE SPEAKERS **\$45.00**
HI-LO IMP. ELECTRET MICROPHONES **\$26.00**

WE REGRET THAT PRICES ARE SUBJECT TO CHANGE WITHOUT NOTICE.

INFORMATION CENTRE

VIDEO BALL GAME: I would like to extend my congratulations to you for such a great project. The kids that come to our club at the college each Saturday enjoy hours of fun with it. I recently added the sound effects too. I found that by putting in two 0.01uF capacitors instead of the 0.01uF's specified at G and H, a more realistic sound is produced, exactly like one hears on a tennis court as the ball is struck.

Thanks once again for a most interesting project, and I am looking forward to others. (Fr. M.J., Lysterfield 31 Vic.)

• We are pleased to hear of your success with the Video Ball Game. Other readers may care to try modifying the sounds in the way you have described. Finally, thank you for your kind comments concerning the project. We will try to keep to the same (or higher) standards in our future projects.

REEL TAPE DECK: I am interested in building a new stereo control unit for my reel to reel tape deck but found your last such control unit was a hybrid design as described in September 1967. Would it be possible for you to detail, in a future article, the necessary changes in the equalisation circuits of the popular Playmaster 144 Cassette Deck, to enable it to be used for a reel to reel control unit? (R.D., Heathmont, Vic.)

• Unfortunately there is very little interest in reel type tape decks these days, and even less interest in home construction of a major piece of equipment like this. So we regret to say that it is highly unlikely that we will be able to publish the article you request.

ULTRASONIC ALARM: I would like to construct the ultrasonic alarm as featured

in the February 1974 issue of "Electronics Australia" (File No 3/MS/44). Unfortunately, as I cannot find the next few issues of your magazine, I am not sure whether there were any notes and errata concerning the project. Would you please tell me if there were?

Also two new transducers became available after a while, designated 40T and 40R. Are these satisfactory and are any modifications needed? Thank you for an excellent and educational magazine. (M.D., East Bentleigh, Vic.)

• There were no Notes and Errata on this article. The new transducers are slightly more efficient and work in the circuits without any modifications necessary. Thank you for your favourable comments.

EXHAUST GAS ANALYSER: In your review of the Heathkit Model CI-1080 Exhaust Gas Analyser (EA September, 1976) you state that "it should not be used to adjust exhaust emission ... to meet ADR27" because, as I understand it, it is not accurate enough.

This doubt as to accuracy apparently arises because ADR27A requires a maximum CO content of 4.5%, and Heathkit claim an accuracy of 3% for their instrument.

Would not the claimed accuracy of 3% refer to "% of full scale reading", ie, 3% of 8% and therefore an accuracy of about $\pm 0.25\%$ CO? If this is so, the instrument would surely be OK for checking compliance with ADR27A. (A.D., Blakehurst, NSW.)

• The specifications panel in the Heathkit assembly manual gives the accuracy of the Model CI-1080 as "within 1 Air-Fuel Ratio depending on fuel used". This corresponds to an accuracy of about

If you are unable to complete an "Electronics Australia" project because you missed out on your regular issue, we can usually provide emergency assistance on the following basis:

PHOTOSTAT COPIES: \$2 per project, or \$2 per part where a project spreads over multiple issues. Requests can be handled more speedily if projects are positively identified, and if not accompanied by technical queries.

METALWORK DYELINES: Available for most projects at \$2 each, showing dimensions, holes, cutouts, etc., but no wiring details.

PRINTED BOARD PATTERNS: Dyeline transparencies, actual size but of limited contrast: \$2. Specify positive or negative. We do not sell PC boards.

REPLIES BY POST: Limited to advice concerning projects published within the past 2 years. Charge \$2. We cannot provide lengthy answers, undertake special

research or discuss design changes.

BACK NUMBERS: Only as available. Within last 6 months, face value. 7-12 months, add 5c surcharge; 13 months or older, add 10c surcharge. Post and packing for 60c per issue extra.

OTHER QUERIES: Technical queries outside the scope of "Replies by Post" may be submitted without fee, for reply in the magazine, at the discretion of the Editor.

COMMERCIAL SURPLUS EQUIPMENT: No information can be supplied.

COMPONENTS: We do not deal in electronic components. Prices, specifications, etc., should be sought from advertisers or agents.

REMITTANCES: Must be negotiable in Australia and made payable to "Electronics Australia".

ADDRESS: All requests to the Assistant Editor, "Electronics Australia", Box 163 Beaconsfield, 2014.

KNOW

Where you are going?

Choose a career in the field of Electronics — the Nation's most progressive and fastest expanding industry



**BROADCASTING
COMMUNICATIONS — marine
APPLIED SERVICING**

*Classes are conducted at
67 Lords Road,
Leichhardt*

Day 9.00 a.m. to 4.00 p.m.

*Evenings 6.00 p.m. to 8.30 p.m.
or by Home Study Courses
(except practical instruction on
equipment)*

SEND FOR PROSPECTUS

There is no obligation.

NAME.....

ADDRESS.....

MARCONI SCHOOL OF WIRELESS

Box 218, P.O. Leichhardt 2040.

A service of

Amalgamated Wireless (Australasia) Ltd.

ELECTRONICS courses at COLLINGWOOD

5 min. from the centre of Melbourne

- **INDUSTRIAL ELECTRONICS**
Post Apprenticeship level
Preliminary course available for people without prior experience
- **DIGITAL (part time)**
for experienced technicians
- **AMATEUR RADIO OPERATOR**
Certificate of Proficiency A.O.C.P.
Limited Certificate A.L.O.C.P.
Novice Certificate A.N.O.C.P.
- **CERTIFICATE of TECHNOLOGY**
Electrical Operating Testing
Distribution Communications
Electronics
Electrical Design Drafting

Further Information

**COLLINGWOOD TECHNICAL
COLLEGE**
35 Johnston St., Collingwood,
Vic. 3066

DIRECT FROM USA

'SUPER HORN'

- Piezo electric concept.
- 35v. rms. (100w. at 4ohms)
- Low cost
- High efficiency.
- Response 3.8 28KHz.
- No crossover required.
- As used by many major musical equipment manufacturers.

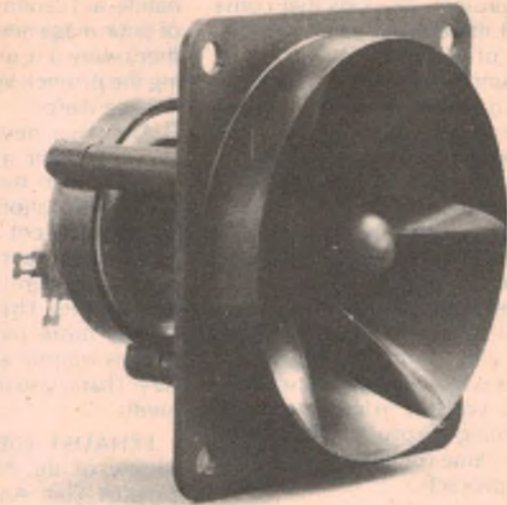

\$16

PLUS \$1.00
P&P

Sole Australian Distributors: Freedman Electronics Pty Ltd
Telephone: 797 9941—797 0986, 89-91A Liverpool Road, Summer Hill, NSW 2130

ELECTROCRAFT PTY. LTD.

106A Hampden Rd.
Artarmon, 2064
Phone 411-2989

Distributors of Belling Lee, Channel Master, Ecraft, Hills, Hi.Q, Lab Gear, Kingray, Matchmaster. Largest Television range of aerial equipment in Sydney

**TELEVISION AERIALS, DISTRIBUTION AMPLIFIERS, EQUIPMENT AND ACCESSORIES
WHOLESALE, TRADE AND RETAIL SUPPLIED.**

ESACRAFT

	Price
Neosid Balun 75 / 300 uncased	\$0.65
O S A B. Outside aerial balun (water proof)	3.81
6 SB 6ft. Balun Fly Lead	3.65
P S B. Plug and Terminal Balun	2.53
2 75 T/S 2-way 75 ohm Transformer Splitter	6.74
3 75 T/S 3-way 75 ohm Transformer Splitter	8.41
4 75 T/S 4-way 75 ohm Transformer Splitter	8.94
5 75 T/S 5-way 75ohm Transformer Splitter	12.66
2 3T 2-way 300 ohm Splitter box	4.48
3 3T 2-way 300 ohm Splitter box	5.86
4 3T 2-way 300 ohm Splitter box	7.12
Adjustable Low Band Attenuator Ch 2	5.33
10" diameter degaussing coil	24.00
Coaxial Plugs	46c

ALL TYPES OF COAXIAL CABLE IN STOCK FROM 30c PER YARD

TELEVISION AERIALS FOR COLOUR

CHANNELMASTER

9el Colour Crossfire 3615A	\$43.64
13el Colour Crossfire 3614A	54.69
17el Colour Crossfire 3613A	68.17
21el Colour Crossfire 3612A	78.54
24el Colour Crossfire 3617A	99.84
28el Super Crossfire 3617A	125.73
Super Coloray the 3111 Ghost Killing Aerial	41.98
2el Small Coloray 3110	27.96

HILLS E.F.C. RANGE 75 ohm

E.F.C. 1 75 ohm	31.43
E.F.C. 2 75 ohm	41.70
E.F.C. 3/24 75 ohm	60.64
E.F.C. 4/24 75 ohm	76.30

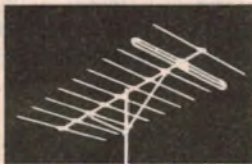

HILLS THE NEW TELRAY RANGE—

All Australia V.H.F. Channels & F.M.

6el	TL1	21.47
8el	TL2	29.52
9el	TL3	35.97
11el	TL4	43.67

HILLS AERIALS

2010 Airways	56.26
CA16 Phased Array	44.36
Extra Gain Lift els for CA16	5.01
8el 215	24.42

HILLS AMPLIFIERS

D5/26 Dist. 26dB gain	\$67.10
D4/16 Dist. 16dB gain	\$59.37
MH2/75 Mast Head 20dB gain 75 ohm	\$72.44
MH1/300 Mast Head 20dB gain 300 ohm	\$54.90

FM AERIALS

Hills	2EL FM1	9.39
HILLS	3EL 353	12.98
Hills	3EL FM3	18.27
Hi-Q	4EL	18.75
Hi-Q	Gutter clip	12.70
Matchmaster G2FM		19.29
Austenna	FM3F	21.95

27MHz High quality transceivers Range up to 20 miles. 5 watts output. Switched PA suitable for dash mounting
Model G M E 275 6 Ch's (Post Office Approved) \$156.00
Model G M E C 555 23 Ch's \$163.00.

LAB GEAR AMPLIFIERS

	Price
VHF	
Mast head 22 dB 75 ohm	\$72.43
CM 6014 / DA 20 dB	60.25
CM 6034 / DA 4 outlets 8 dB each	54.90
CM 6036 / DA VHF 30dB UHF 28dB	84.63
Televista (VHF to UHF frequency converter)	67.48

KINGRAY AMPLIFIERS

	Price
D15 / 500 m/V	\$48.80
D30 / 500 m/V	57.95
D40 / 600 m/V	79.30
D12 / 1500 m/V	67.10
MH 20 mast Head 300-75 ohm	64.63

TELESCOPIC MASTS

20ft	18g steel in	\$19.30
30ft	10R sections	\$30.81
40ft	must be guyed	42.00
50ft		54.42

CDE AR.22 Rotator \$79.00

Stolle Aerial Rotator with Thrust Bearing for heavier rigs \$115.56

ALL TYPES OF HARDWARE IN STOCK

Wall Brackets, Chimney Mounts, J Brackets, Guy Rings & Guy Wire, Masts from 8ft to 50ft.

INFORMATION CENTRE

3% in terms of CO content, as stated in the article. We used the words "in terms of CO content" quite deliberately—"of full scale reading" was neither referred to nor implied.

To give an example, if a reading of 5% CO is indicated on the meter, then the real value could lie anywhere between 2% and 8% CO. On this basis, the Model CI-1080 is NOT suitable for checking for compliance with ADR27A, and should be used purely as a diagnostic tool as explained in the text.

PLAYMASTER 132: I require some information on the PM 132. With regard to the power supply adjustments, mention is made of a 4 ohm resistor to set the current trip. This could give a current of just under 15 amps under some fault conditions. Is this correct? If so, please explain.

A 39 ohm 5W resistor shown on the circuit diagram and parts list is shown as a 68 ohm 3W resistor on the board layout. Which is correct? (K.H., Eaton, WA.)

• A 4 ohm resistor is correct for adjustment of the current trip setting. This could result in peak fault currents of up to 15A before tripping occurs, but lower settings will cause nuisance tripping.

The resistor should be as shown in the circuit diagram; 39 ohms 5W.

School Electronics—from p23

Level Three provides 11 intermediate projects: 24—Megaphone; 25—Directional Microphone; 26—Stereo Amplifier; 27—Headlight Reminder; 28—Ni-Cad Battery Charger; 29—Squarewave Generators; 30—Sinewave Generator; 31—Transistor Tester; 32—Intermittent-Wiper Control; 33—Tachometer; 34—Theremin.

Finally Level Four provides eight projects for the senior students: 35—Screamer Alarm; 36—Variable Power Supply; 37—Ignition Timing Light; 38—Automatic Battery Charger; 39—Colour Organ; 40—Transistor Ignition; 41—VHF Receiver; 42—Motor Speed Controller.

Each Ideas Box contains a copy of the

NOTES & ERRATA

AUTO RHYTHM UNIT FOR ELECTRONIC ORGANS (October 1976, File No. 1/EM/42). An erratum for this project, published in the January 1977 issue, was unfortunately mutilated due to a typographical error. The correct text should read as follows:

In the circuit diagram on page 41, and in the text on page 40, amplifier B1 was incorrectly described. The centre frequency of the amplifier should be 1kHz, not 2kHz as given in the article. Similarly, amplifier B3 was described as having a cutoff frequency of 2kHz. This should be 200Hz. For both amplifiers, the values shown on the circuit diagram, and on the PCB overlay are correct.

Operation Electronics Manual as well as the project cards. Macmillans suggest that for a class of 20 pupils, one Ideas Box and either 10 or 20 Manuals would be sufficient. The Ideas Box will cost approximately \$27.50, while separate Manuals will cost about \$3.75 each.

Macmillan Australia are planning to launch the Operation Electronics project next month, and they are inviting interested teachers to contact them at either their Melbourne or Sydney offices. The addresses are 107 Moray Street, South Melbourne, and 12 Berry Street, North Sydney. Telephone numbers are (03) 699-8922 and (02) 929-4278.

Macmillans are also looking for a boy and girl in the 11-13 age group, who are interested in and have some background in electronics, to demonstrate electronics construction at the launching. Interested students should write to Macmillans at the above addresses, giving details of themselves and their experience.

The girl and boy chosen will each receive a set of tools from Tandy Electronics, together with a one year's free subscription to Electronics Australia. In addition, their school will receive a free Operation Electronics kit.

LETTERS—from page 107

diagrams" for the software before we all become just assembly workers in our hobby, with no idea of what we are doing or why we're doing it?

J. Edwards

Oxley, Queensland.

COMMENT: Broadly speaking, our policy is as you propose. However the degree to which this aim may be achieved inevitably varies from project to project, if only from space considerations. If we had tried to give satisfactory explanations of the operation of the ASCII-Baudot translator and the Text Editor, the articles concerned would probably have grown so large that those readers who are not interested in microprocessors would have objected—or worse, simply not bought the issues concerned. We'll see what can be done, but it's not really possible to be all things to all people.

LANTHUR ELECTRONICS

69 Buchanan Avenue, North Balwyn,
Vic. 3104 P.O. Box 162. Ph. 85 4061

ELECTRIC DRILL

Speed controller kits. Will control speed down to stop of any ac/dc brush type motor. No loss of torque. Consists of triac, resistor, diodes, pot, knob, 3 pin base, plug & circuit.
5 amp size (1200 watt) \$8.95
10 amp size (2400 watt) \$9.95
Prices include postage

LAMP DIMMER KITS

Will control incandescent lamps down to out. Consists of triac, diac, capacitors, resistors, pot, knob, ferrite rod, wire & circuit.
5 amp size (1200 watt) \$6.95
10 amp size (2400 watt) \$7.95
Prices include postage

PLASTIC CABINET

Suitable for above speed controller & lamp dimmer kits \$1.55
Post free if with above kits otherwise plus postage 0.40.

ETCHING KITS

For printed circuit board. All you need to make your own printed circuits, including a piece of board 6 x 4 inches, and instructions \$4.95
Prices includes postage

BATTERY CHARGER KIT

Will charge 12 volt wet batteries at 2 amps. Consists of transformer, bridge rectifier, ballast resistor and circuit. \$9.75
Plus postage Vic \$1.10
Other \$2.00

BATTERY SAVER KIT

Will supply dc voltages from 6 to 15. Consists of transformer, bridge rectifier, filter capacitor and circuit. One amp size \$8.50
Plus Postage Vic \$1.10
Other \$2.00
Two amp size \$16.50
Plus postage Vic \$1.15
Other \$2.50

SPEAKERS

Australian made M.S.P. Good quality 4 inch 15 ohm \$3.95
Price includes postage.



FAST DESOLDERING

SAFE with Soder-Wick
EASY

1. Hold Soder-Wick on termination with hot soldering tip. Wicking action soaks up solder.

2. Remove tip and braid. Termination is left clean and free of solder.



Soder-Wick is a specially treated copper braid which soaks up molten solder like a sponge. Desolders a P.C. pad in a second or so: acts as a heat sink to protect circuits and components.

In a range of sizes from your wholesaler or 02-709 5293
03-848 3777

ROYSTON ELECTRONICS

RE475

STAR DELTA

CO. PTY. LIMITED

INCORPORATING
**P. A. HENDERSON & CO
TRANSFORMER
MANUFACTURERS**

- SINGLE & 3 PHASE TRANSFORMERS TO 20 KVA.
- MOTOR STARTING AUTOTRANSFORMERS TO 600 HP.
- NEUTRAL REACTORS

8 East St.,
Granville, N.S.W. 2142.
P.O. Box 31, Phone
637-7870.

"COWPER"

Cabinets and chassis for all projects featured in this magazine are available from

COWPER SHEETMETAL & ENGINEERING

- CASES PANELS
- CHASSIS BOXES
- GENERAL SHEET METAL WORK FOR THE ELECTRONICS INDUSTRY
- WELDING
- PRESS CAPACITY TO 75 TONS

11 Cowper Street,
Granville, N.S.W. 2142
Phone 637-8736

Marketplace

FOR SALE

RESISTORS AND CAPACITORS. Resistors all E12 values. 1/4 watt carbon film 10 ohm to 1 meg 2 cents each I.R.H. GL 1/2 or GLP 1/2 watt Metal glaze 10 ohm — 470k 3 cents each or 2.5 cents over 250 1 watt 1 ohm to 1k 6 cents each or 5 cents over 100 PACKS STANDARD PACK contains 5 each of E12 values in ranges shown COMPUTER PACK contains quantities based on general usage. 1/2 watt 285 resistors \$7.00. 1/4 watt 305 resistors \$5.90. CAPACITORS ELECTROLYTICS single ended uprights Mfd 35 v w 1. 2. 2. 3. 3. 4. 7. 10. 22. 10 cents each. 33 47. 15 cents 25 v w. 100 16 cents each 220 25 cents each 470 35 cents. Polyester Greencaps 100 v w .001. 0022. 0033. 0047. 0056. 0068. 7 cents each 01. 022. 033. 047. 056. 068. 082. 10 cents each .1. .22. 13 cents each. Poly Pack 5 cents of these values \$6.00. 75 capacitors. Other components see E.A. June, 1976 All components brand new from manufacturers or agents. Each value of component individually packed. Post and packing included in all orders over \$6.50 For orders less than \$6.50 add 40 cents for post and packing. 5% discount on orders over \$35.00. 10% discount on orders over \$75.00. Send orders to RAM ELECTRONICS, 575 Sydney Road, Seaforth, N.S.W. 2092. Please send cheque or money order.

TELETYPES repaired. Spare parts. Paper Rolls. Machines for Sale. NETWORK ENGINEERING Ph (02) 211 4630

COLOR PIX. TUBES. 90 degree, various sizes from \$35.00 Line O.P. transistors, type 1073, equiv. BU 126. \$1.95 each TELESERVICE, 842 Canning Hwy, Applecross 6153. WA. Send S.A.E. or postage with enquiries.

MAGNETS—We have a comprehensive range of bars, buttons, pots, horseshoes, etc. Small and large quantities—Alnico and ceramic ATTRACTION MINI-MAGNETS. Phone 913 3972. P.O. Box 149, Collaroy, NSW, 2097

AUSTRALIAN RADIO DX CLUB The premier DX club of Australia now in its 12th year of national operation. Catering for the interests of both S.W. listeners and DXers, the monthly bulletin covers the S.W. and M.W. spectrums. For full details enquire now to ARDXC, P.O. Box 67, Highett, Vic 3190

TIME CLOCKS SANGAMO



LESS
DAY OMIT
DEVICE
\$13.50

WITH
DAY OMIT
DEVICE
\$16.00

240V 50 cs
15A Contacts

Used tested and guaranteed
PACK & POST N.S.W. \$2.00
Vic. & Qld. \$2.50, W.A. \$3.00

CLOCK DISPOSAL CO.
P.O. Box 147
LINDFIELD, N.S.W. 2070

FAST 14 DAYS P.C. BOARD SERVICE for any project. 20 cents a sq. inch. Send in your magazine clipping of P.C.B. required (returned with your order) measure image area for example: 6 in. x 3 in. = 18 in. x 20 cents = \$3.60 P&P 60c.

Give a professional finish to your projects. Pressure-sensitive metal labels from your art work or magazine cut-outs. 18c. a sq. inch. P&P 60c.

P.E. JOANNA touch Sensitive Electronic Piano, May 75. Complete set of 14 P.C.B's. \$36.00. P&P \$2.50

P.E. RADIO CONTROL. June 76. Complete set of 8 P.C.B's. \$12.50. P&P 80c.

P.W. RHYTHM GENERATOR. June 76. A set of 3 P.C.B's. \$11.50. P&P 80c.

P.W. VIDEO-WRITER, August 76. Complete set of 5 P.C.B's. \$29.50. P&P \$2.10.

NOVELTY MART INC. P.O. BOX 390, MASCOT, N.S.W. 2020.

OSCILLOSCOPE BARGAINS. As new 3" University CRO \$120. Also Jayem 3" VGC \$50. 45 Lexton Rd. Box Hill 3128 (03) 893 3674

WANTED

WORKING CIRCUITS for a voice operated morse code transmitter, also circuit for a radio receiver frequency 02.5m and antenna. Write T. Farrell, P.O. Box 18, Thornbury, Victoria 3071, stating price and delivery date.

DISPLAY ADVERTISEMENTS IN MARKETPLACE are available in sizes from a minimum of 2cm x 1 col rated at \$11 per col cm.

CLASSIFIED RATES \$2 per line per insertion payable in advance. Minimum two lines.

CLOSING DATE is six weeks prior to the on-sale date. Issues are on sale the first Monday of each month.

ADDRESS all classified orders, copy, enquiries, etc., to: The Advertising Manager, ELECTRONICS Australia, Box 162, Beaconsfield 2014.

FUNDAMENTALS OF SOLID STATE

Fundamentals of Solid State is in its second reprinting, showing how popular it has been. It provides a wealth of information on semiconductor theory and operation, delving much deeper than very elementary works, but without the maths and abstract theory which make many of the more specialised texts very heavy going. 'Solid State' has also been widely acclaimed in colleges as recommended reading—but it's not just for the student. It's for anyone who wants to know just a little bit more about the operation of semiconductor devices.

\$3.00 plus 60c p & p
Electronics Australia
Box 163, Beaconsfield, NSW 2014

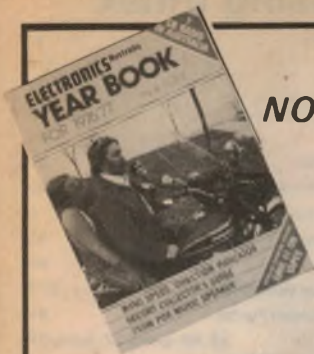

**NOW
ON
SALE**

ELECTRONICS AUSTRALIA YEAR BOOK

Crammed with fascinating reading, do-it-yourself projects, hand picked record and book reviews, a full listing of Australian and New Zealand radio and TV stations, equipment reviews and a look at CB in Australia.

\$1.20 from your local
newsagent

Or for \$1.80 by mail order from
"Electronics Australia", PO Box 163,
BEACONSFIELD 2014

Electronics Training

We're looking for people 17 to 34 to train in the highly specialized field of electronics. Training covers communications, computer principles, radar and many other areas associated with avionics. After training, you will earn \$9964 p.a. and be eligible for many other benefits. If after completing your initial service you decide to leave, you'll be set up for a career in this highly specialized field.

To join our team, you must be an Australian Citizen or meet our nationality requirements, and have good passes in Maths and Science or Physics. Contact the Air Force Careers Officer for more details. Write to Box XYZ in your State Capital or phone Adelaide 2232891, Brisbane 31 1031, Townsville 71 3191, Hobart 34 7007, Melbourne 613731, Perth 224355, Sydney 212 1011, Newcastle 25476 and Canberra 476530.

Air Force



Component and Electronic Equipment Specialists

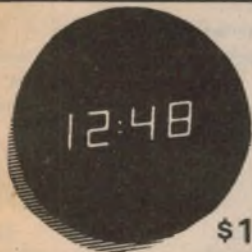

\$17

DIGITAL WATCH MODULE

Hours and mins LED display. Requires two 386 batteries



Communications Receiver

Quartz crystal controlled Receiver
Drake SSR1, 5 MHz to 30 MHz, 30 bands, continuous tuning also SSB, CW. \$299.



VHF Converter

Fantavox VHF Converter, 110 to 136 MHz—Just place near any AM or FM Radio receiver. Complete with battery and full instructions.

\$7.95



Kenwood
Transceiver

\$575

The TS520, a superb SSB Transceiver from Kenwood. Solid state throughout except for final and drive stages. Designed and built for the serious enthusiast



FRG-7 Synthesised Receiver

For amateurs and short wave listeners. Electronic band changing 0.5-29.9 MHz continuous coverage Uses Wadley loop

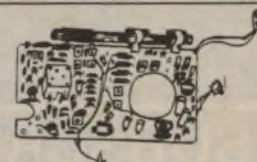

TRANSISTOR RADIO CHASSIS

Complete with all components except speakers. Some AM-FM types only

75¢

C.B. TRANSCEIVER

1 watt 3 channel, has call system, provision for external aerial, speaker and power supply Post 91 extra Others available

\$50

FM MONITOR



A 12-channel FM Monitor Receiver for low or high bands \$110 plus crystals.



KENWOOD Pacemaker T'ceiver.

Kenwood's new TS820 SSB, CW RTTY Transceiver. Features newly developed Digital Readout Dial Optional 1.9-28MHz; PLL system; IF Shift; RF Processor, RFNFB



MULTIMETER KIT

Build your own meter complete with PC board and full instructions 16 ranges.

\$16.95

PRICES DO NOT INCLUDE P&P.

WILLIS TRADING CO. PTY. LTD.

PERTH G.P.O. Box No X2217 W.A. 6001 429 MURRAY ST PERTH W.A. 21 7609 21 7600

IN STOCK NOW!



IBETA 23-Channel AM Mobile Citizensband Transceiver

STILL AT THE PRE-DEVALUATION
PRICE OF

\$89

+ P&P \$5.00

(NORMALLY \$139.00)

SPECIFICATIONS

1. **Semiconductors:** 19 Transistors and 15 Diodes
2. **Frequency Range:** 26.965MHz-27.255MHz
3. **Mode of Operation:** AM
4. **Controls:** Volume Control with Power On-Off Switch • Variable RF Gain Control • Variable Squelch Control • Delta Tune Switch • Channel Selector Switch • CB-PA Switch • ANL Switch
5. **Connectors and Jacks:** Microphone Connector • Coaxial Type Antenna Connector • Public Address Speaker Jack 3.5mm • External Speaker Jack 3.5mm
6. **Speaker:** 3½ inches, 8 ohms
7. **Microphone:** Dynamic Microphone (500 ohms)
8. **Power Supply:** 13.8 VDC Positive or Negative Ground

Call, write or phone to: **C. H. S. TAYLOR'S WAREHOUSE SALES**
169 JOHNSTON STREET, COLLINGWOOD, VIC. 3066 PHONE: 419 3862



SOUNDOUT SERIES III STEREO
INBUILT AMPLIFIERS IN ALL MODELS

DISCO SCENE '77

To make your Disco alive Call the experts at Cashmore Sound

- 3 professional discotheque portable units
- Series III mono (170 watts)
- Series VI mono (170 watts)
- Series III stereo (2 x 170 watts)
- Mirror balls
- Motors
- Light Units (coloured)
- Colourtron Amplifiers
- Rope lights
- Strobes
- Smoke genies
- Bubble machines
- Projectors
- Jingle machines
- Speaker enclosures—manufactured
- JBL-Altec-Etone
- Portable disco stands
- Microphones—SHURE—AKG etc.
- Amplifiers—CROWN—H/H—BOSE etc

DEMONSTRATION IF REQUIRED

Sales—Hire—Installation—Service—Top D.J.s Available.

CASHMORE SOUNDOUT DISCOS

149-151 Georges River Road, Croydon Park, N.S.W. 2133.

Telephone: Sydney, 798-6782 798-5647.

SUBSCRIPTION SERVICE



**ELECTRONICS
Australia**

Subscription Rates

\$A 14.00 per year
within Australia.
\$A 17.00 per year
elsewhere.

Make sure you receive every copy of the magazine by ordering it from your newsagent or the publisher. For publisher subscriptions post this coupon, with your remittance, to Electronics Australia Subscription Dept., John Fairfax & Sons Ltd, GPO Box 506, Sydney, 2001. Subscription will start with first available issue.

Name

Address

Postcode Enclosed is for years

Advertising Index

A & R Soanar Group	91
Ace Radio	114
AEE Capacitors	54
Acme Engineering Pty Ltd	78
Aegis Pty Ltd	104
Adcola Products Pty Ltd	96
Applied Technology Pty Ltd	82
Audio Engineers Pty Ltd	4
Audio Telex Communications Pty Ltd	33
Auditec Australia	84
Australian Government Recruiting	119
Australian Time Equipment Pty Ltd	65
Auriema (A asia) Pty Ltd	32, 89, facing 32, facing 89
BKX Electronics Supply Service	106
Bail Electronic Services	108
Bozak (A asia)	12
British Merchandising Pty Ltd	88
Butterworth Pty Ltd	104
Bright Star Crystals Pty Ltd	66
BWD Electronics	70, 108
Cema (Distributors) Pty Ltd	62
CS Services	84
CRC Chemicals	90
Cashmore Sound	120
Christian B/casting Association	13
Classic Radio	46
Collingwood Technical College	115
Convoy International Pty Ltd	10
Cunningham R.H. Pty Ltd	55, 101
Danish Hi Fi	5
Deitch Bros	112
Dick Smith Electronics Group	60, 86
Electrocraft Pty Ltd	116
Electronic Concepts	94
Electronic Development & Sales Pty Ltd	102
Eimeasco Instruments Pty Ltd	50
Emac Industries	65
Ferguson Transformers Pty Ltd	77
Freedman Electronics	116
General Electronic Services Pty Ltd	107
Haco Distributing Agencies	facing 88
Hagemeyer (Aust)	IBC, OBC
Harman Australia Pty Ltd	facing 33
International Correspondence Schools	100
Interson Pty Ltd	16
Lafayette Electronics	67
Lanthur Electronics	117
Leroya Industries Pty Ltd	15, 19
Marconi School of Wireless	115
Nomis Electronics Pty Ltd	13
Nova Sound Systems	89
OBC Imports Pty Ltd	8
Peter Broughton	118
Philips	2
Photimport	6, 20
RCS Radio	103
Radio Despatch Service	85
Richard Foot	103
Royston Electronics	117
Scope Laboratories	92, 93
Sontron Industries	66
Sony Kemtron Pty Ltd	IFS
Star Delta Co Pty Ltd	118
Stotts Magna Sighter	71
Stotts Technical College	37
Swann Electronics	74
Taylor's Warehouse Sales	120
Technical Book & Magazine Co Pty Ltd	105
Vicom International	110
Video Technics	102
Warburton Franki Ltd	72
Willis Trading Co Pty Ltd	119
Wireless Institute of Australia	111
Zephyr Products	70

WHY YOUR NEXT CASSETTE SHOULD BE A MAXELL UD



3 THE SHELL — Even the best tape can get mangled in a poorly constructed shell. That's why Maxell protects its tape with a precisely constructed shell, made of lasting heavy-duty plastic.

No fixed guide posts are used. Instead Maxell uses nylon rollers on stainless steel pins thus eliminating the major cause of skipping, jumping and unwinding.

A tough teflon (not waxed paper) slip sheet keeps the tape pack tight and flat. No more bent or nicked tape to ruin your recording.

Maxell doesn't use a welded seal, but puts the cassette together with precision screws. Result — Maxell doesn't jam.



1 THE RESEARCH — More than twenty years ago, Maxell produced their first reel of magnetic tape. At that time, Maxell made a commitment to produce and sell only the finest magnetic products their technology could create.

That commitment still stands today.

2 THE TAPE — This continuous research has led to the development of the Maxell UD (ultra dynamic) cassette. A tape that has a coating of super-fine PX gamma ferric oxide particles with an extra smooth mirror-finish surface.

All of this adds up to high output, low noise, distortion free performance and a dynamic range equaling that of open reel tapes.

4 THE LEADER — A leader tape that has a four function purpose.

- a) Non-abrasive head cleaning leader (cleans recording head for 5 secs.).
- b) 5 second cueing line (recording function starts 5 seconds after the line appears).
- c) Arrows indicating direction of tape travel.
- d) A/B side mark (indicates which side is ready for play).

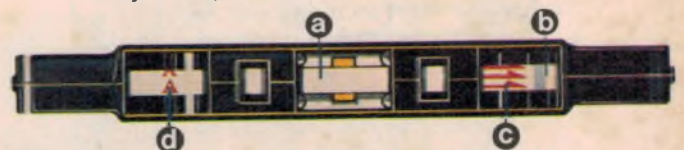

Now you know why your next cassette should be a Maxell UD (ultra dynamic).

maxell®

The sound expert's cassette. UD available in C60, C90 and C120.
Distributed by **Hagemeyer (Australasia) B.V.** Branches in all States.

Turning the tables on turntables.



JL-F45S

Spend some time inspecting the JVC turntable range. We doubt that anyone else has taken the amount of trouble to give you the faultless reproduction and durability that's built into every one of our models. The JVC automatic direct-drive turntable featured (JL-F45S) has a repeat knob for continuous or selected replays of discs (up to 6 times), and our DC direct-drive motor is far superior to AC servo-motors, and gives faultless high fidelity results every time. Wow and flutter is reduced even further to less than 0.03% WRMS. The concentricity and other critical factors of the 12" die-cast platter have been carefully determined for best results.

On all JVC turntables, the unique Tracing Hold tonearm system is another feature which means less record wear and less tracing error for you; it does this by lowering the centre of gravity of the tonearm counterweight assembly to a point below its pivot, providing ideal balance.

The introduction of a new gimbal support has been added to provide more precision, stability, sensitivity and durability. Whereas other gimbal systems may look like ours, most cannot supply the perfect JVC balance in horizontal and vertical planes. Belt-driven turntables also available: JL-F35 (fully automatic) JL-A15 (semi-automatic).

JVC

the right choice

For details on all JVC Hi Fi Equipment, write to: JVC Advisory Service, P.O. Box 49, Kensington, N.S.W. 2033