

# ELECTRONICS

## Australia

with **CB and HIFI NEWS**

APRIL, 1977

AUST \$ 1.00\* NZ \$ 1.20

**BONUS  
CATALOG  
INSIDE**



**SAVING OUR OLD RECORDINGS  
LUXURY CAR IS ELECTRIC  
MINI-SCAMP COMPUTER**

**Why TV repair—  
men can go  
broke!**





# Introducing ELCASET! World's newest tape format



## True open reel performance.

You want the highest quality sound. Right? You also want cassette convenience. Right?

Meet Sony Elcaset, the world's newest tape format and the first to give you both.

It's simply the nearest thing yet to sound perfection in an easy tape package. It's an entirely new type of cassette and player system which moves twice as much tape, twice as fast as a standard cassette for a performance that truly rivals the best in reel-to-reel.

### Always something new from Sony

Our restless search for something better has given the world some products that have truly revolutionised sound and sight.

And in the case of Elcaset, it's backed by a consortium of Japan's leading electronics manufacturers.

### Much more than a bigger cassette

In developing Elcaset we took the bugs out of the standard cassette system. To do so we utilised the superior tape transport system of videotape. The tape is actually removed from the case for better alignment and tape to head contact—3.3 times more per second!

The tape comes with three other dramatic improvements:

- Reel hub locks to prevent tape spill
- Permanent, in-place, anti-erase tabs
- Another most amazing of all—Elcaset tape comes with its own built-in detectors that automatically set bias and equalisation and Dolby noise reduction.

Tape is freely available, including Sony's famous double-coated FeCr.

Elcaset is sensational. Elcaset is a major step forward.

Elcaset is the future of Hi-Fi in tape.

As "*Hi-Fi Review*" said (November '76)

"The format as represented by the EL-7 is an ideal one for home use, with obvious performance superiority compared with even the best compact cassettes, yet without the fiddle of open reel . . .

. . . The Elcaset has enormous potential for listeners seeking both top quality sound and convenience."

And "*Electronics Today—International*" (December '76)

"The Sony EL-7 was judged to be a very good performer, and certainly convinced us that the Elcaset format is a welcome introduction to the Hi-Fi field . . . the Elcaset system is likely to have enormous appeal to critical Hi-Fi enthusiasts."

### Main Features: EL-5 Elcaset Deck \$795

- Front loading vertical cassette
- DC servo motor
- Feather touch logic controls with optional remote
- Dolby\* NR System
- 3 position bias and equalisation selectors
- Line mike mixing
- Soft eject cassette lid
- Punch in recording
- Optical auto shut-off
- Timer activator control.

### EL-7 Elcaset Deck \$1225

- Front loading vertical cassette
- DC servo motor for capstan
- Feather touch logic controls with optional remote
- Dolby\* NR System
- 3 position bias and equalisation selectors
- Three motors
- Three heads
- Line mike mixing
- Soft eject cassette lid
- Punch in recording
- Optical auto shut-off
- Timer activator control
- Closed loop dual capstan drive

### Performance:

	EL-5	EL-7
Signal to noise:	62db (FeCr) Dolby off	62db FeCr
Frequency response:	25Hz-20kHz (FeCr)	25Hz-22kHz (FeCr)
Wow and flutter:	.06% (WRMS)	0.04% (WRMS)
Total Harmonic Distortion:	.8%	.8%

When someone beats Sony it's always **SONY**

GAC S 7920 Research makes the difference.





# ELECTRONICS Australia

Australia's largest-selling electronics & hi-fi magazine

VOLUME 39 No 1

## CONTENTS—APRIL, 1977



On page 34 this month we describe an easy-to-build SWR meter for use up to 27MHz. The unit is particularly suited to checking out CB-type antennas, and will enable you to make the necessary adjustments for optimum performance.



Service charges have long been a contentious and often misunderstood issue. Just how much should a self-employed serviceman charge if he is to derive a reasonable standard of living, and how much should the public expect to pay? Our article on page 58 looks at this question in detail, and draws some surprising conclusions.

### On the cover

Taken against the background of the National Library of Australia building in Canberra, our cover shows Mr Peter Burgess, archivist in the Music and Sound Recording Section, with an historic Edison "Opera" model cylinder phonograph. Our story on page 12 this month tells of the work going on at the National Library to preserve our musical and recording heritage. (Photo by Bruce Moore, National Library, Canberra.)

### world of electronics and hi-fi

- 3 Editorial: Projects—Very much alive and well!
- 7 Hi-Fi News:
  - New quality label, new test record—The Lin-Track record cleaner—New test record—All you've ever wanted to know about hi-fi*
- 12 The National Library of Australia: Saving our musical and recording heritage
- 17 Review: AKG magnetic cartridges have "transversal suspension"
- 19 Review: JVC JL-F45 direct-drive automatic turntable
- 20 Microphones Pt 7: Two channel recording techniques
- 26 Electronic learning aid for handicapped children
- 28 Transformer 1: a full scale electric passenger car
- 55 Forum: Is the public "ripping off" servicemen?

### projects and technical

- 31 The 27MHz scene: Dummy loads, SWR meters and power measurement
- 34 Simple low-cost SWR meter checks HF antennas up to 27MHz
- 38 Build an in-circuit transistor tester
- 40 Cassette tape interface for microcomputers
- 46 Using the NRZ recording technique for program and data storage
- 48 Build a simple VOX relay and learn about voice controlled switches
- 50 Converter for low frequency weather beacons
- 58 The serviceman: How much should you charge?
- 63 Circuit and design ideas:
  - Versatile logic probe displays four modes—Clock power failure indicator—Thermistor controlled thermostat*
- 66 Mini Scamp—an ideal microcomputer for the beginner
- 73 Microcomputer news and products
- 74 Op-amps without tears—5: a practical introduction to op-amps
- 79 Introduction to digital electronics—15: Arithmetic circuits
- 92 New products:
  - JVC 48cm colour TV receiver—New, low-priced scientific calculator—New products from Dick Smith . . . safety fuse holder and a car radio—Pushbutton subminiature switch—Stratronics power supply modules—Siren-like "bell" extension for telephones*

### regular features

- 22 News highlights
- 84 Record reviews—classical
- 87 Record reviews—devotional, popular, jazz
- 97 Letters to the Editor
- 98 Book reviews
- 101 The amateur bands
- 105 Shortwave scene
- 109 Notes and errata
- 110 Marketplace—classified
- 112 Index to advertisers



# SIGNETICS 2650 MICROPROCESSOR



Remember this ad?  
(last year)

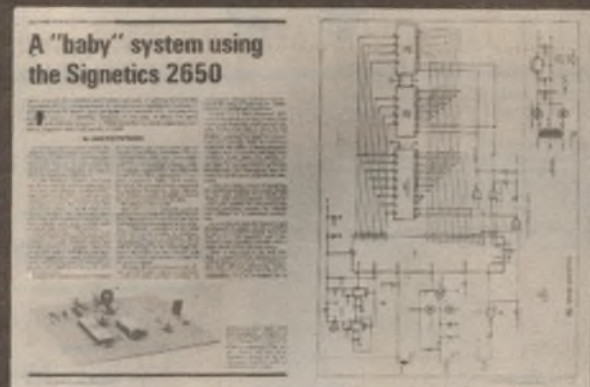

Recall this feature?  
(last month)

## NOW EASY TO TRY NOW EASY TO BUY

START WITH THE INCREDIBLY SIMPLE  
**2650-KT95EA**  
"BABY MICROPROCESSOR KIT"

NOW AVAILABLE FROM THESE  
PHILIPS SIGNETICS STOCKISTS

**NEW SOUTH WALES:** Applied  
Technology, CEMA, Electronic  
Enthusiasts, ICS, Tecnico (Sydney),  
Digitronics (Newcastle),  
Macelec (Wollongong)

**ACT:** Daicom

**QUEENSLAND:** Electronic  
Components, Fred Hoe,  
NS Electronics

**VICTORIA:** CEMA, ICS, Sontron,  
Sycom, Tecnico

**SOUTH AUSTRALIA:** Gerard &  
Goodman, ICS, K-tronics, Protronics,  
World Imports

**WESTERN AUSTRALIA:**  
Atkins Carlyle, Willis Trading

**TASMANIA:** W. G. Genders,  
NS Electronics



Electronic  
Components  
and Materials

# PHILIPS

153-0194



## HUGE RESPONSE TO CALCULATOR OFFER

In last month's article describing the Heathkit IC-2009 calculator kit, we warned that stocks wouldn't last long at the special offer price. They sure didn't—three days after the April issue was published, we were advised by Heathkit representatives Warburton Franki that their entire stock of 600 kits had been sold!

We're sorry for those who missed out, but no one could have predicted that the response would have been so great, and so fast . . .



# Editorial Viewpoint

## *Projects: very much alive and well!*

As a bonus in this month's issue, you will find in the centre a 24-page electronic components and kits catalog from Davred Electronics. The name of this firm may not be familiar to you yet, because as we noted in the news columns last month they have only just commenced operation in Australia. However, the parent company is the New Zealand firm David J. Reid (NZ) Pty Ltd, which has been established for some 25 years and has a current turnover running into millions of dollars.

I'm sure that their decision to extend operations to this country will be welcomed by those of our readers who are involved in electronics construction, whether professional or hobbyist. Now that the majority of our electronic components are imported from overseas, an additional "supply route" must inevitably make it easier to procure components on a continuing basis.

Quite apart from this purely practical consideration, the development is encouraging in a more general sense. With so much of our electronics industry in what is perhaps best described as a "depressed" state, it is good to see that a New Zealand firm is sufficiently confident in the future of the industry to make this investment.

I imagine that one of the things which has encouraged them to do this is the expanding hobby market. As we at EA can testify, the hobby side of electronics is continuing to grow in a very healthy manner, helped in no small measure by the semiconductor manufacturers with their continuous stream—some would say avalanche—of new integrated circuits.

When the first integrated circuits appeared on the market around 10 years ago, there were predictions that they represented the "beginning of the end" for electronics as a hobby. Yet as things have turned out, the reverse has happened. The whole scope and horizon of electronics as a hobby has expanded, and continues to expand at a rate which scarcely could have been envisaged by even the far-sighted back in the 60's. And this has been due almost entirely to IC's!

An excellent example of this is shown by microcomputer projects. Ten years ago, the idea of describing even a small digital computer for home construction was virtually an "impossible dream". Then about three years ago, we were able to make the dream come true; our EDUC-8 project showed how to build a complete microcomputer, involving some 100-odd ICs and costing around \$380. This was a big step forward—but just the start.

As it happens we are launching in this very issue a new microcomputer project: Mini-Scamp. Designed by Dr. John Kennewell of Newcastle University, Mini-scamp is virtually an updated version of EDUC-8 based on a modern microprocessor IC. It is very much more powerful than EDUC-8, yet it involves only 15 ICs on a single modest-sized printed circuit board, and can be built for less than \$100.

With developments like this, electronics as a hobby has never looked more buoyant. In fact here at EA we seem to have enough project possibilities already to last us through to about 1990!

—Jamieson Rowe

### EDITOR-IN-CHIEF

Neville Williams  
M.I.R.E.E. (Aust.) (VK2XV)

### EDITOR

Jamieson Rowe  
B.A. (Sydney), B.Sc. (Technology, NSW)  
M.I.R.E.E. (Aust.) (VK2ZLO/T)

### ASSISTANT EDITOR

Philip Watson  
A.M.I.R.E.E. (Aust.) (VK2ZPW)

### SCIENCE FEATURES

Greg Swain, B.Sc. (Hons, Sydney)

### PRODUCT REVIEWS

Leo Simpson

### TECHNICAL PROJECTS

David Edwards, B.E. (Hons, Tasmania)  
Ian Pogson (VK2AZN/T)

### GRAPHICS

Robert Flynn

### PRODUCTION

Daniel Hooper

### ADVERTISING MANAGER

Selwyn Sayers

### CIRCULATION MANAGER

Alan Parker

ON SALE THE FIRST MONDAY OF EACH MONTH

Registered for posting as a periodical—  
Category B.

Printed by Dalley-Middleton-Moore Pty Ltd, of  
Wattle St, Sydney and Masterprint Pty Ltd of  
Dubbo, NSW, for Sungravure Pty Ltd, of Regent  
St, Sydney.

\*Recommended and maximum price only.

**Editorial Office**  
57-59 Regent St, Sydney 2008

Phone 699 3622.  
Postal Address: PO Box 163, Beaconsfield 2014.

**Advertising Offices**  
Sydney—57-59 Regent St, Sydney 2008  
Phone: 699 3622

Representative: Narcisco Pimentel

Melbourne—392 Little Collins St, Melbourne  
3000. Phone: 67 8131.

Representative: Keith Watts

Adelaide—Charles F. Brown & Associates Ltd.  
168 Melbourne St., North Adelaide 5006.

Representative: Tom Duffy 267 4377

Perth—454 Murray Street, Perth 6000

Representative: Jack Hansen 21 8217.

### Subscriptions

Subscription Dept. John Fairfax & Sons Ltd,  
GPO Box 506, Sydney 2001. Enquiries: Phone  
(02) 498-3161.

### Circulation Office

21 Morley Ave, Rosebery, Sydney 2018.  
Phone 663 3911.

### Distribution

Distributed in NSW by Sungravure Pty Ltd,  
57-59 Regent St, Sydney, in Victoria by Sun-  
gravure Pty Ltd, 392 Little Collins Street, Mel-  
bourne; in South Australia by Sungravure Pty  
Ltd, 101-105 Weymouth St, Adelaide; in

Western Australia by Sungravure Pty Ltd, 454  
Murray Street, Perth; in Queensland by Gordon  
and Gotch (Asia) Ltd; in Tasmania by Ingle  
Distributors, 93 Macquarie St, Hobart; in New  
Zealand by Gordon and Gotch (NZ) Ltd, Adel-  
aide Rd, Wellington.

### Copyright. All rights reserved

Devices or arrangements shown or described  
herein may embody patents. Information is  
furnished without responsibility for its use and  
without prejudice to patent rights.

All manuscripts, photographs and other  
material submitted to Electronics Australia for  
publication must be accompanied by a stamped,  
addressed envelope. Contributions are submit-  
ted at the sender's risk, and responsibility for  
loss cannot be accepted by Electronics Aust-  
ralia.



# Creation of the new Calibration Standard filled a need...the acceptance of Stanton's 681 TRIPLE-E is unprecedented!



It was no accident!

The Recording Industry needed a new calibration standard because it had been cutting discs with higher accuracy to achieve greater definition and sound quality.

So, the engineers turned to Stanton for a cartridge of excellence to serve as a primary calibration standard in recording system check-outs.

The result: the new calibration standard, The Stanton 681 TRIPLE-E.

The rest is history!

Major recording studios adopted it... as did many of the smaller producers. Radio stations across the world put the 681 TRIPLE-E on all of their turntables, both for on-the-air broadcasting and for disc-to-tape transfer.

And, audiophiles by their purchases have voted it the outstanding stereo cartridge available.

The Stanton 681 TRIPLE-E offers improved tracking at all tre-

quencies. It achieves perfectly flat frequency response beyond 20 kHz. Its ultra miniaturized stylus assembly has substantially less mass than previously, yet it possesses even greater durability than had been previously thought possible to achieve.

Each 681 TRIPLE-E is guaranteed to meet its specifications within exacting limits and each one boasts the most meaningful warranty possible. An individually calibrated test result is packed with each unit.

As Julian D. Hirsch of Hirsch-Houck Labs wrote in Popular Electronics Magazine in April, 1975: "When we used the cartridge to play the best records we had through the best speaker systems at our disposal, the results were spectacular".

Whether your usage involves recording, broadcasting, or home entertainment, your choice should be the choice of the professionals... the STANTON 681 TRIPLE-E.



Sole Australian Distributors.

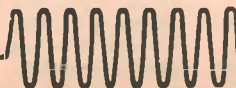

**LEROYA INDUSTRIES PTY LTD**

Head Office, W.A.: 156 Railway Pde., Leederville 6007. Phone 81 2930.

N.S.W. Office: 100 Walker St., North Sydney. 2060. Phone 922 4037

VICTORIA Office: 103 Pelham St., Carlton. 3053. Phone 3477620.

Available at quality conscious Hi-Fi dealers throughout Australia!



# TDK SUPER AVILYN! THE EXPERT'S CHOICE

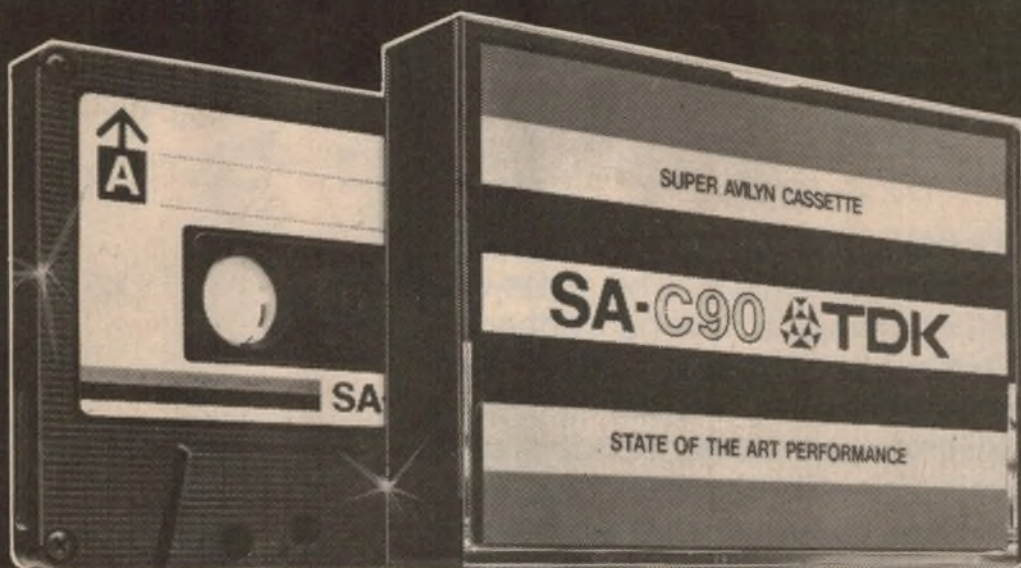

## This is what the experts say:

**MR. E. NAKAMICHI, PRESIDENT,  
NAKAMICHI RESEARCH INC.**

"TDK Super Avilyn cassettes are recommended for use with all Nakamichi tape decks. Before leaving our factory, all Nakamichi equipment has the bias set for TDK SA to achieve optimum performance."

**ELECTRONICS TODAY APRIL 1976**

"Listening tests proved that Super Avilyn tape sounds as good as its measured performance indicates. Background noise is substantially lower than other tapes and the dynamic range is unquestionably better. Frequency response is excellent."

**HI-FI REVIEW JULY 1976**

"TDK Super Avilyn lived up to its reputation in these tests. For the uncompromising tape enthusiast it is one of the best cassette tapes available. Its price is very competitive making this tape good value for money in the high performance range. For the perfectionist, TDK's hard to beat."

**LOUIS CHALLIS & ASSOCIATES, CONSULTING  
ACOUSTICAL AND VIBRATION ENGINEERS.  
NATA LABORATORY APPROVED.**

"TDK Super Avilyn looks like being one of the most important advances in tape formulation in the mid 70's."



SOLE AUSTRALIAN AGENTS:  
CONVOY INTERNATIONAL PTY. LTD.  
4 DOWLING STREET WOOLLOOMOOLOO 2011. TEL. 357 2444

*Wait till you hear what you've been missing.*

*Available at all good record bars and hi-fi stores.*





## JBL's new L166.

It's the most accurate loudspeaker JBL has ever made. The three-way L166 combines a new hemispherical high-frequency radiator with a new low-frequency transducer to deliver really impressive power-handling capability, super-wide dispersion and deep, tight bass. It has the most acoustically transparent grille ever developed. If you haven't heard the L166, you haven't heard nothing.

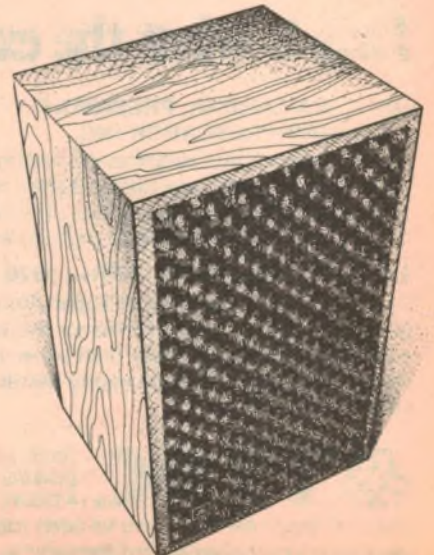

**JBL**





# Hi Fi News

## New quality label, new test record

With countless record albums filling the dealers' shelves, parading under a wide variety of labels, it might seem unlikely that the addition of a few titles and another label could make news. But it does, in hifi circles, when they are offered to enthusiasts, by enthusiasts, on the basis of technical quality.

The label is "ARK" and the source is the ARK Recording Company, a Division of Fulton Electronics, of 4428 Zane Ave. N., Minneapolis, MN 55422, USA.

Information on the records, together with three sample pressings were supplied to us by M.R. Acoustics, P.O. Box 110, Albion, Brisbane 4010. (Tel 48 7598, 284 6764, 265 1582). A covering letter from Mr C. H. Robertson, Director, explained that his company would be handling only direct retail and mail order sales for Australia. Trade inquiries should be directed to Audio Engineers Pty Ltd and their branches.

The promotional literature accompanying Mr. Robertson's letter took a quite different line from other record promotional and engineering material. In some, there is a clear preoccupation with the quality of the tape mastering, extending to the use of 35mm coated film, digitally encoded audio, the generous use of compander techniques—or no intermediate mastering at all! Some, like RCA, show more concern with the lacquer master and their Dynagroove approach—and so on.

In contrast, Fulton Electronics focus attention on the microphone as the key to all good recording and they don't spare the adjectives in making their point. We quote:

"As the 'eye' of the audio system, the conventional microphone has exhibited a tendency to cloud the recorded image with its own peculiar, non-musical sonic additions. Recognizing this and other problems in conventional microphones, the musician/engineers at ARK Recording Company determined to build a unique microphone system that would establish a new standard of excellence in performance.

"Using the sound of live music as a constant frame of reference, it was decided that this microphone should listen to sounds as the human ear without unnatural and unmusical additions or deletions, that it should not lose detail

by  
**NEVILLE  
WILLIAMS**

*The three sample albums discussed here were all recorded in Minneapolis, Minnesota, USA, hometown of ARK records. "Westminster" has no connection with the Cathedral of that name but the organ is nevertheless an impressive instrument.*

with distance from the source, and that it should not become acoustically overloaded by the dynamics of live music no matter how powerful or sibilant.

"In addition, it would possess natural airiness, clarity, and depth when capturing subtle and delicate sounds, and yet be capable of reproducing the most percussive, dissonant, random and complex information with equal fidelity. These characteristics would be accompanied by an extremely wide bandwidth, extending well above and below the audible range, as well as incredibly low distortion, hum and noise specifications.

"Years of experimentation and research have transformed these ideals into what may be the world's finest microphone. New electronics with the same high standards were designed and built to complement it. Special recording heads and new mastering techniques were employed to put the widest possible frequency and dynamic ranges on to the tape and then to the disc.

"The result of these efforts has been an expanding list of custom recordings that are being recognized internationally as the finest sounding records currently

available.

"All of them are 'on location' recordings, and some are live concerts. The natural sounds of the instruments and voices, as well as the acoustics of the hall, are recorded as the ear would hear them. The master tapes are not doctored with artificial reverbs, artificial limiting, equalizing, or multi-channel mono mix-downs. The sounds you hear are presented as you would have heard them had you been there.

"These records are released by special arrangement, and are made available as a service for the serious listener, and for the demonstration and testing of audio equipment. Some of the records available are a limited edition only, and new ones will be added from time to time.

"As you listen to these programs, we trust that barriers between you the lis-



tener and the music itself will be swept aside, and true aesthetic enjoyment will be yours."

Without any thought of ridicule, one might remark that this sounds very much like the voice of an audio purist, directed obliquely at a whole range of resources employed by recording engineers to produce the modern commercial recording. There's even the phrase "multi-channel mono mix-downs" reminiscent of the arguments that were running recently in this magazine's "Forum" pages.

Some seventeen ARK albums are listed in the literature supplied to us by M.R. Acoustics: ten choral, four band, two organ and one choral/orchestral. As distinct from a conventionally balanced catalog, the material probably reflects what was accessible to the recordists by way of recitals and performances in the better served American provincial centres.

While the music would undoubtedly please a similar cross-section of listeners as attended the original occasions, it explains Mr Robertson's observation to us: "Please keep in mind that the main purpose of these records is not so much



# NOW!

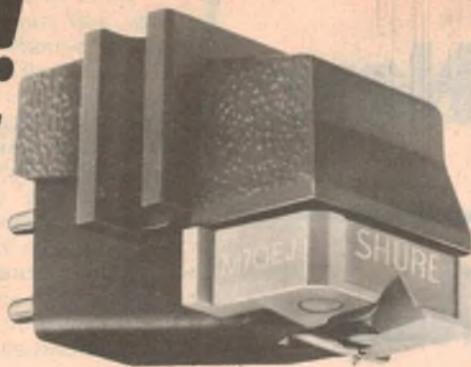

# seven ways to beat the odds...

## CARTRIDGE AND STYLI SPECIFICATIONS

Replacement Styli	Stylus Comp. Colour	Output (1 M $\Omega$ at 5 cm/sec. peak recording velocity)	Frequency Response	Channel Balance	Channel Separation (mm/μm)	Tracking Force	Trackability (Peak Recording Velocity)
M70EJ 10 x 18 $\mu$ (.0004 x .0007 in.) Bifurcated (Elliptical)	Light Green	6.2 mV	20 to 20,000 Hz	within 2 dB	20 dB at 1 kHz	1 1/2 to 3 grams	400 Hz - 20 cm/sec 1,000 Hz - 26 cm/sec 10,000 Hz - 11 cm/sec at 2 grams
M70B 15 $\mu$ (.0006") Spherical	Beige	6.2 mV	20 to 20,000 Hz	within 2 dB	20 dB at 1 kHz	1 1/2 to 3 grams	400 Hz - 20 cm/sec 1,000 Hz - 26 cm/sec 10,000 Hz - 11 cm/sec at 2 grams
M70-3* 64 $\mu$ (.0025") Spherical	Dark Green	6.2 mV	20 to 20,000 Hz	-	-	1 1/2 to 3 grams	-

\*Optional 78 rpm Stylus: Set amplifier to "MONO" or "A - B."

NET WEIGHT: 5.8 grams

INDUCTANCE: 720 millihenries

DC RESISTANCE: 630 ohms

OPTIMUM LOAD: 47,000 ohms resistance in parallel with 400 to 500 picofarads total capacitance per channel.

**FULL ONE YEAR WARRANTY:** Shure Brothers Incorporated ("Shure") warrants to the owner of this product that it will be free, in normal use, of any defects in workmanship and materials for a period of one year from date of purchase. You should retain proof of date of purchase. Shure is not liable for any consequential damages. If this Shure product has any defects as described above, carefully repack the unit and return it prepaid to your dealer, or the Shure Service Centre in Australia — Audio Engineers Pty. Ltd., 342 Kent St., Sydney, N.S.W., 2000, for repair. The unit will be repaired or replaced and returned to you promptly. This warranty does not include stylus wear.

**PATENT NOTICE:** Cartridge and stylus manufactured under one or more of the following U.S. patents: 3,055,988, 3,077,521, 3,077,522, and 3,463,889. Other patents pending.

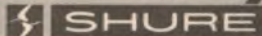

The response curve is basically flat within the audible spectrum. *Comparable with cartridges costing twice the price!*

Trackability is the measure of a cartridge's *total* performance. This cartridge has excellent full frequency trackability with an *exceptional* capability to track the highly modulated passages of most records.

The 1 1/2 to 3 gram tracking force range means the M70 cartridge series is suitable for the vast majority of stereo systems made today.

Besides backing our cartridge with a full one-year warranty, we also assure you that our genuine replacement styli will restore your cartridge assembly to the exact original specifications — no matter where in the world you buy the genuine Shure N70B (spherical tip stylus for the M70B cartridge model), the N70EJ (elliptical tip stylus for the M70EJ cartridge), or the N70-3 (optional 78 rpm stylus).

Only Shure can deliver this caliber of technology for high fidelity cartridges.

From the same engineering team that created the incomparable V-15 Type III cartridge. Our unbroken track record in 18 years of stereo high fidelity is your assurance of quality.

No other cartridge offers this much performance at such a low price.

# M70EJ & M70B cartridge series... the *better* bargain

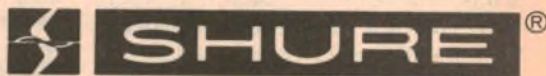

- Audio Engineers Pty. Ltd. 342 Kent Street, Sydney, N.S.W. 2000
- Audio Engineers (Vic.) Pty. Ltd. 2A Hill St., Thornbury, Vic. 3071
- Audio Engineers (Qld.) Pty. Ltd. 57 Castlemaine St., Milton, Qld. 4064
- Athol M. Hill Pty. Ltd. 33-35 Wittenoom St., East Perth, W.A. 6000

AE117/FP



## HI FI NEWS—continued

the musical content, but rather their sonic qualities”.

Or Fulton's own statement already quoted: “These records . . . are made available . . . for the demonstration and testing of audio equipment”.

Three sample records supplied to us, as pictured, are summarised below for your guidance:

### CHORAL MUSIC FROM WESTMINSTER. Ark 2123-S.

The choir at Westminster Presbyterian Church, Minneapolis, conducted by Edward D. Berryman, with Robert Vickery playing the 1927 Kimball pipe organ, rebuilt by Moller in 1958 and 1971. The tracks: Praise My Soul The King Of Heaven — Lord For Thy Tender Mercies' Sake — Let This Mind Be In You — Magnificat (Kelly) — Bread Of Heaven (Elmore) — Psalm 121 (Hanson) — Psalm 150 (Hanson) — Grieve Not The Holy Spirit (Noble) — Eternal Father (Holst).

### ORGAN MUSIC FROM WESTMINSTER. Ark 10151-S.

The same 4-manual Kimball/Moller as for the preceding album, but played by Edward D. Berryman S.M.D. Full instrument specifications on the jacket. The tracks: Fantasy In Echo Style (Sweelinck) — Adagio-Allegro-Adagio K594 (Mozart) — Finlandia (Sibelius) — Selections From Pastorale (Bach) — Scherzo from Symphony II (Vierne) — Clair De Lune (Vierne) — Selections From Sonata V (Mendelssohn) — Finale From Symphony VII (Widor).

### ORGAN SOUNDS FROM MOUNT OLIVET. Ark 1094-S.

Recorded at the Mount Olivet Church, Minneapolis. Moeller pipe organ 45 ranks installed 1956, rebuilt 1966. Played by Diana Lee Metzker. The tracks: Prelude and Fugue in B minor; Jesu, Joy Of Man's Desiring; Rejoice Now Christian Souls (Bach) — Beautiful Saviour (Metzker) — Sonatine For Pedals (Perersichetti) — From Heaven Above (Karg-Elert) — Shepherd's Prayer (Lindberg) — Fantasie Triompale (Nystedt).

In line with earlier remarks, all three of the above albums contain music which might typically be presented by professional musicians in well endowed American churches — not concerts in the international sense, but certainly to the liking of people who make up such congregations in America, Australia or elsewhere.

Technically, however, one thing certainly impresses: a sense of spaciousness about the recordings and a freedom from any sense of overload or distress. I am not suggesting that the albums are unique in this regard—simply that the results support Fulton's claim to have achieved an excellent basic sound by his

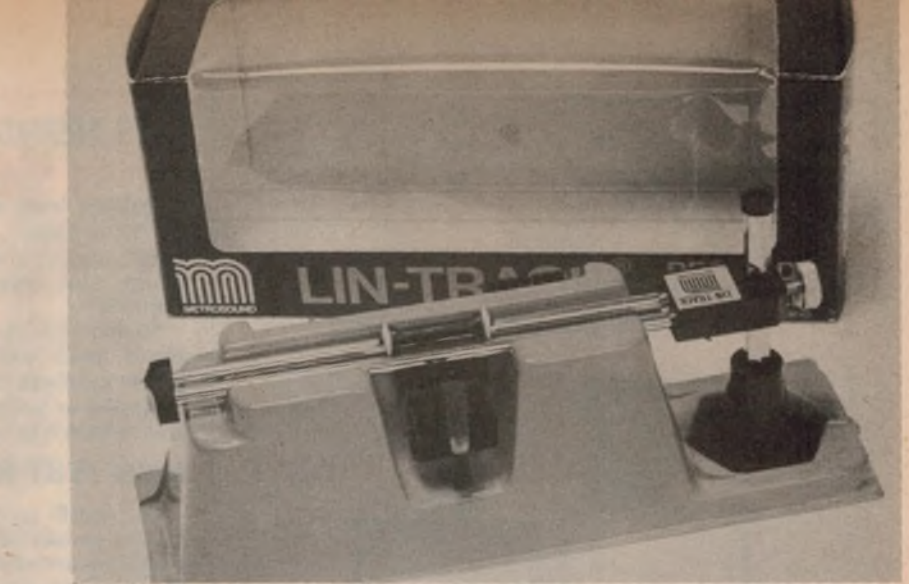

## THE LIN-TRAK RECORD CLEANER

Depending on your point of view and to some extent, it seems, on your country of birth, keeping your records free of dust can be either a ritual or an intolerable chore. The Lin-Trak is the latest anti-dust gadget for you to love or hate!

According to the local distributors, those responsible for its design decided that they didn't particularly like much of the record cleaning gadgetry that is currently available on the market.

- Some gadgets ride the playing head and may modify the tracking and tracing characteristics.
- Some are awkward to use because of the travel, the overhang and the support arrangements required by the radial arm.
- Some impose sufficient drag on the record to modify the speed of some turntables.

Lin-Trak seeks to overcome all these problems at one time by employing a very light brush with a linear rather than a radial traverse, therefore: independent of the playing arm; easier to position; negligible weight and drag.

Lin-Trak is supported on a base which is intended to attach to the playing deck by adhesive pad, in any clear space but usually in the rear left corner. Two parallel metal arms extend inwards towards the label, their height being adjustable to suit the height of individual turntables.

Riding the metal rails is a small assembly comprising a velvet pad and a brush. The two rest lightly on the record and, as it rotates, they follow the groove inwards at the same rate as the stylus, hopefully picking up any particles of dust and lint.

After each recording, the arm is swung

particular approach.

More critically, the top-end response is adequate without being anything out of the ordinary. The middle register is notably clean and uncluttered but it is the bass from the big pipes that really distinguishes these records—the Westminster

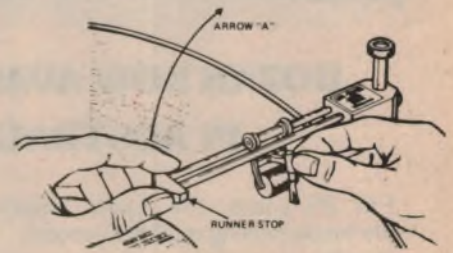

organ having a particularly smooth fundamental quality. If it doesn't sound that way, then your speaker systems don't have what it takes in the 40Hz region.

out of the way and any particles removed from the felt pad with a small hand brush provided in the kit. It is then ready for the next playing.

Lin-Trak is manufactured in England by Metrosound Audio Accessories Ltd. As shown in the photograph, it comes in a see-through carton, on a bright orange support moulding which, between them, dwarf the device itself.

Checked in our lab. it behaved in the way the manufacturers said it would, riding the grooves and ready to pick up elusive specks which cause those occasional clicks and plops. And there's no way it could affect record speed.

But, at the same time, as with a lot of other record cleaning gadgetry, Lin-Trak is a product for the dedicated audiophile. It's not designed for people who suffer from shaky hands, poor eyesight or lack of patience.

Lin-Trak is distributed in Australia by Leo Rogaly and Lewis Pty Ltd, 94/95 Cooper St, Surry Hills, NSW 2010. It will be available through selected retailers and hi fi dealers. The price: \$9.95.

As distinct from the music in the grooves, the imported pressings are good but not unique. Tape hiss is at that



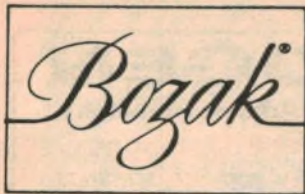

for the discriminating

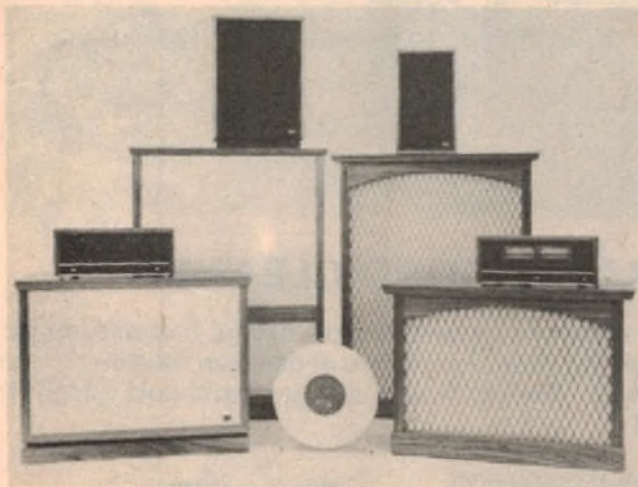

## BOZAK NOW AVAILABLE IN AUSTRALIA

For 25 years, the name Bozak has stood for uncompromising quality in sound.

And Bozak quality extends far beyond the living room. Professional musicians and audio engineers seeking to reinforce performances without colouration have consistently installed Bozak sound systems in concert halls, in theatres, in indoor and outdoor arenas—wherever sound matters. To name but a few, the Hollywood Bowl (Los Angeles Symphony), Tanglewood (Boston Symphony), and in Broadway theatres for the musicals 'Candide' and 'A Little Night Music'.

This same Bozak quality is now available to discerning audiophiles in Australia and throughout the South Pacific. From the supreme Bozak Concert Grand loudspeaker system, recognized by audio experts in the U.S., Japan and Europe as the standard by which all others are judged, to the Bozak Bard, a high fidelity speaker system designed to be used—AND INSTALLED—out of doors the year round, to the superlative Bozak electronics, every piece of Bozak equipment is designed to provide many years of musical enjoyment.

For informative literature on the complete Bozak range, contact the sole Australasian agents:—

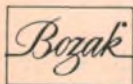

### BOZAK Australasia Pty. Ltd.

5 Birdum Street, Moorabbin, Victoria,  
Australia, 3189.

Telephone: (03) 95-6447

## HIFI NEWS—continued

tantalising level where various members of our staff rated it as "discernible", "not worth worrying about" or "insignificant", almost in direct relationship to their ages (and treble acuity. The same applied to the occasional bit of surface "prickle".

So there it is. If you want to judge ARK records for yourself, get in touch with M.R.Acoustics via the postal address or phone numbers given earlier. Retail price of the Fulton albums is quoted as \$10 plus an additional \$1.50 to cover packaging and despatch by certified mail.

### NEW TEST RECORD

The fourth record in the group pictured is the HFS75 test record, produced in England in association with Hi-Fi Sound magazine and distributed by Howland-West Ltd. M.R. Acoustics are offering this test record for \$8.50, plus \$1.50 for packing and despatch by certified mail.

The record offers the following test procedures, each with a distinct set of grooves, with no transfer track, and with appropriate notes on the rear of the jacket. Producers of the record point out that it should not be just "played through" like an ordinary record because casual playing of a test disc wears the grooves and marginally reduces their validity for genuine test situations. Particularly is this true of the high amplitude tracking test grooves with can readily be damaged by casual playing with pickups which can not possibly cope.

In brief, the tests are as follows:

1. CHANNEL RECOGNITION AND PHASING. Left and right channels identified, signals in and out of phase.
2. CHECK TRACKING PRESSURE AND BIAS. 300Hz at +11dB, +14dB, +18dB, lateral modulation.
3. CHECK TRACKING PRESSURE AND BIAS. 300Hz at +7dB, +11dB, vertical modulation.
4. PINK NOISE for observing balance and colouration of speakers, action of spectrum filters, etc.
5. RUMBLE. 1kHz reference tone followed by blank grooves.
6. BIAS AND TRACKING IN OUTER GROOVES. 300Hz lateral modulation +15dB.
7. WHITE NOISE. For subjective evaluation of pickups, loudspeakers, taping facilities, etc.
8. BIAS AND TRACKING IN MEDIAN GROOVES. 300Hz, lateral modulation, +15dB.
9. CHANNEL BALANCE AND SEPARATION. 45-degree modulation at 1kHz.
10. WOW AND FLUTTER. 3kHz for use with wow and flutter meters.
11. BIAS AND TRACKING IN INSIDE GROOVES. 300Hz, lateral modulation, +15dB.

The HFS75 would normally represent a handy addition to our own laboratory test records but for one reservation: in the particular pressing submitted for review, the spindle hole and grooves were not precisely concentric. While it did not prevent us from using the disc for subjective evaluation, as envisaged in the jacket notes, it would render the wow and flutter track useless for measurement by instruments.

Hopefully, not too many pressings will be so affected.

We gather that the HFS75 record is merely the first of the special purpose pressings which M.R. Acoustics plan ultimately to market. Says Mr. Robertson: "We are just completing arrangements to offer the Stereo Review (USA) range of test and demonstration discs/tapes, music appreciation sets, etc."

This is good news at both the enthusiast and the professional level, since the supply of special purpose recordings has always tended to be rather spasmodic in this country.

Due on sale shortly:

The new  
ELECTRONICS Australia LOG BOOK



# All that you've ever wanted to know about hifi. . .

If ever a book is to qualify as a hifi enthusiast's bible, the "Audio Cyclopaedia" by Howard M. Tremaine would surely have a strong claim to the distinction. You can browse through it, study it, or treat it as a cyclopedic reference, as the title implies.

For those with a long memory, the "Audio Cyclopaedia" is the outgrowth from a much older and smaller work "The Audio Engineer's Handbook". As material was added progressively to this early work, the publishers (Howard W. Sams Inc) felt that the "Handbook" title was no longer appropriate and suggested that it had taken on more the character of an encyclopaedia. This is the second edition in the revised form, and the fourth printing, dated 1975.

In fact, the format differs from what one would expect of either title, being based on the question-and-answer approach: literally thousands of questions picked out in bold face, each followed by an appropriate answer, freely illustrated in handbook style by photographs, circuits, graphs, tables and formulas.

One might reasonably suppose that the Author chose this method as the most practical way of tackling a book of such mammoth proportions—over 1750 pages, set double column in a clear but compact typeface. While each question and answer has to be complete in itself, at least they can be shuffled and modified as necessary during up-dating, and others can be added, with only the sequence numbers having to be changed. It would certainly be easier than coping with 1700 pages of continuous prose, broken only by chapters!

In fact, the book does have chapters as well, 25 in all, which are summarised briefly below:

Basic Principles—Acoustics & Studios — Motors & Generators — Microphones — Attenuators — Equalisers — Wave Filters — Transformers, &c — Sound Mixers — VU Indicators — Valves, Transistors & Diodes — Audio Amplifiers — Disc Recording — Cutting Heads — Styli — Pickups — Magnetic Recording — Optical Recording — Motion Picture Projection — Loudspeakers, Phones, &c — Power Supplies — Test Equipment — Measurements — Installations — Charts, Data, &c.

For someone who has spent long years in the audio/hifi business, browsing through the chapters is like visiting a large technological museum, where the old and the new are displayed side by side.

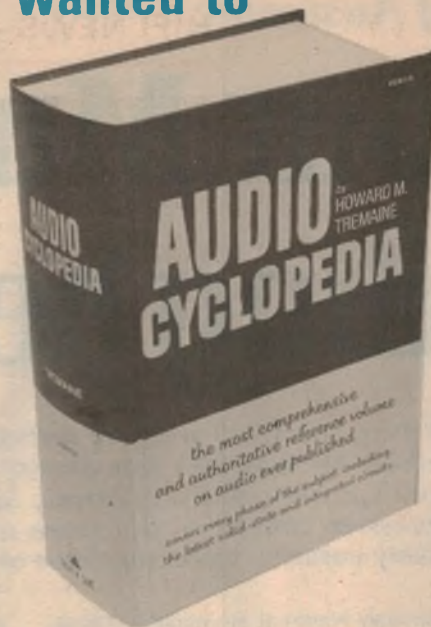

In Audio Cyclopaedia one constantly encounters pictures and diagrams that once heralded the very latest product release, or that created their own stir in the technical literature. Remember the tiny Miniconic pickup cartridge, the Karlson loudspeaker enclosure, the much-reproduced drawing of the RCA 6L6 beam power valve, or the test equipment that came in polished wooden cases?

Fortunately, not all the test equipment illustrated is of this vintage, as indicated by instruments from Tektronix and Hewlett-Packard.

But I'll stick by the analogy with a technological museum. Howard Tremaine's Audio Cyclopaedia has grown fat by accumulating, from dozens of sources, material which ranges from the now largely historical, through to what was current when this second edition was completed. Some of what is now significant is missing—the compact tape cassette, Dolby-B processing, quadraphonic discs, etc., while FM/stereo rates only the briefest mention. It's an allowance that the intending purchaser would have to make.

Comes the question: how does the reader possibly locate particular information in such a large volume? In such a huge array of questions and answers?

By using the detailed 50-page index at the back. Think of a key word in the subject that is puzzling you and there is an excellent chance that you'll find it listed, and followed by figures which indicate chapter, question number and page.

This must be the largest single volume we have ever reviewed, and it's one packed with information. If you expect it to be expensive, you'll not be disappointed: \$48.95, as distributed by Prentice-Hall of Australia Pty Ltd, P.O. Box 151, Brookvale NSW 2100. Stocks are limited but the company says that it can import more, as needed. (W.N.W.)

## BOGEN

Public Address Amplifiers

*Technical Superiority,  
Reliability and Performance  
at economical prices.*



### C SERIES

Available in 10, 20, 35, 60 and 100 watt RMS output

- Plug in optional low imp. mic transformers.
- Two amplifier outputs can be combined to double the power output.
- Music muting.
- Short circuit, overload including circuit breakers.
- Rack mounting optional.



### CT SERIES

Available in 35, 60 and 100 watt RMS output

- Built in five equalizer filters for anti feed-back control.
- Built in electronic compression for constant output.
- Remote volume control capability.
- Music muting.
- Two amplifiers can be bridged at the input or output.
- Special overload and short circuit protection.
- Rack mounting optional.



### MTB 250 WATT BOOSTER

- High quality system amplifiers.
- Available 60, 125, 250 watt.
- Frequency response 20 – 30,000 Hz  $\pm 2$  dB.
- Hum – 83 dB
- Rack mounting optional.

FOR FURTHER INFORMATION:

**AUDIO TELEX COMMUNICATIONS  
PTY. LTD.**

SYDNEY  
54-56 Alfred Street,  
Milsons Point 2061  
Telephone: 929-9848

MELBOURNE  
828 Glenferrie Road,  
Hawthorne 3122  
Telephone: 819-2363



*The National Library of Australia:*

# Saving our Musical & Recording heritage

*At the National Library in Canberra there is a small group of dedicated people quietly working to preserve a part of Australia's heritage that was almost ignored up until a few years ago: music and sound recordings. Despite the relatively late start, they have managed already to acquire an impressive collection. But there are probably many valuable items still tucked away in dusty corners—including those of EA readers.*

Like most modern libraries, the National Library of Australia is nowadays much more than a formalised collection of books, papers and periodicals. Within the neo-classical exterior of its main building on the shores of Lake Burley Griffin in Canberra, there are in fact a number of different information collection and service facilities.

One such facility is ANSTEL, the national library of scientific and technological information, which offers a number of computer-based information services. Another is ANSOL, the Australian National Social Sciences Library, which also provides computer-based information services.

A third major facility is ANHUL, the

Australian National Humanities Library, which was established in mid-1975 to provide a national focus for library-based information services in the humanities. The Music and Sound Recordings section of the Library is in fact part of ANHUL, along with a number of other sections devoted to pictures and photographs,

by **JAMIESON ROWE**

films, maps, newspapers and manuscripts.

Sound recordings haven't been around for as long as books, to be sure, but they've been around now for quite a while. In fact this very year is the centenary of Thomas Edison's invention of

the phonograph, in 1877. In view of this one might perhaps expect that an institution like the National Library would have been collecting recordings for a great many years.

Sad to relate, that's not the case. It is only in the last few years that people have become fully aware of the importance of preserving such things as recordings, photographs and films. As a result of this, the Library was really not in a position to establish the Music and Sound Recordings section until 1973.

A small amount of material had been acquired before then, but not much: about 500 recordings, collected over 30-odd years.



*Left: Mrs Prue Neidorf, Chief Librarian of the Music and Sound Recordings Section, with an Edison "Opera" model cylinder phonograph—the most expensive model made. Above is a rather intriguing poster for the cheaper "Standard" model.*





Above: Peter Dawson, with orchestra, in an acoustic recording studio in London around 1910. Right: Archivist Peter Burgis with an old Brunswick gramophone.

Happily since it was established in 1973, the section has done an impressive job of making up for lost time. The recording collection now amounts to nearly 250,000 recordings.

As you might expect, these include some really old recordings on Edison-type cylinders. They have around 4000 cylinders, dating from around 1902 when the original wax type were superseded by the moulded plastic variety. But they also have a few wax blanks for "home recording" use, and even some samples of Australian-made cylinders.

The bulk of the collection consists of 78rpm discs—some 120,000. These cover a wide range of subject matter, and include recordings of many famous artists. There are also recordings of special interest from a technical viewpoint, such as an Edison "microgroove" 78rpm long playing 10-inch disc which was made in 1926 and plays for no less than 12 minutes per side!

The Library has also been fortunate enough to acquire some 60,000 transcriptions of early Australian radio plays, serials and comedy shows. Old favourites like Dad and Dave, Mrs 'Obbs, The Search for the Golden Boomerang, and Crosbie Morrison's Nature Talk. As many of our older readers will be aware, these were recorded on 16-inch discs.

What may be less widely known is how





# “Let's make it at your place”

DYNACO DYNAKITS have an international reputation for value-for-money high fidelity quality in performance and musical excellence.

If you want giant results and savings too, “LET'S MAKE IT AT YOUR PLACE” with DYNACO DYNAKITS.

• Pat 4 Preamplifier • Pat 5 Preamplifier  
• Stereo 80 • Stereo 150 • Stereo 400 •  
Power Amplifiers • AF6 AM/FM Tuner •  
FM5 FM Tuner • QD.1 Quadaptor

*Dynaco*  
*dynakit*







Above: Some old cylinder recordings, including one of Australian make. Below: A 16-inch transcription disc and a tiny 3 1/2-inch sample disc. Right: How the Scientific American announced Edison's invention of the phonograph in 1877. All photographs in this article were taken by Bruce Moore, National Library.



these transcriptions came into being. When the first sound films appeared in the late 1920's, they used the Vitaphone sound-on-disc system. Equipment to produce the special 16-inch discs was brought to Australia, but soon after it had been set up the sound-on-disc system was superseded by optical sound-on-film.

As a result, the firms who had imported the equipment looked around for some other way to put it to work—and hit upon the idea of producing recorded programs for radio broadcasters.

In addition to the radio transcriptions, the Library also has an important collection of 16-inch discs made for the original use: film sound tracks.

They also have recordings of speeches by early politicians, and interviews with public figures.

The rest of the recording collection consists of more recent 45rpm and LP discs, and some tape recordings.

Apart from recordings, the section has a collection of music scores, concert

# SCIENTIFIC AMERICAN

A WEEKLY JOURNAL OF PRACTICAL INFORMATION, ART, SCIENCE, MECHANICS, CHEMISTRY, AND MANUFACTURES.

Scientific American. 304 [November 17, 1877]

**WINDMILLS OPERATE UNDER PRESSURE OF DISPERSED AERATION FROM ATMOSPHERIC AIR**

It is known that the air is never at rest, that it is constantly in motion, and that the pressure of the atmosphere is not uniform, but that it varies in different directions, and that it is constantly changing. The windmills of the world are not the only ones that are affected by these changes. The windmills of the sea are also affected by these changes, and they are also affected by the changes in the pressure of the atmosphere. The windmills of the sea are also affected by the changes in the pressure of the atmosphere. The windmills of the sea are also affected by the changes in the pressure of the atmosphere.

**THE TALKING PHONOGRAPH**

Mr. Thomas A. Edison announced to the world the invention of the phonograph, and the world has been ever since fascinated by it. The phonograph is a machine which is able to reproduce the sound of any voice or instrument, and it is able to do so with such fidelity that it is almost indistinguishable from the original. The phonograph is a machine which is able to reproduce the sound of any voice or instrument, and it is able to do so with such fidelity that it is almost indistinguishable from the original.

384 [DECEMBER 22, 1877]

**THE TALKING PHONOGRAPH**

Mr. Thomas A. Edison announced to the world the invention of the phonograph, and the world has been ever since fascinated by it. The phonograph is a machine which is able to reproduce the sound of any voice or instrument, and it is able to do so with such fidelity that it is almost indistinguishable from the original. The phonograph is a machine which is able to reproduce the sound of any voice or instrument, and it is able to do so with such fidelity that it is almost indistinguishable from the original.



A small illustration of a gramophone with a large horn.

Mr. Thomas A. Edison announced to the world the invention of the phonograph, and the world has been ever since fascinated by it.

Mr. Thomas A. Edison announced to the world the invention of the phonograph, and the world has been ever since fascinated by it.

Mr. Thomas A. Edison announced to the world the invention of the phonograph, and the world has been ever since fascinated by it.

Mr. Thomas A. Edison announced to the world the invention of the phonograph, and the world has been ever since fascinated by it.

Mr. Thomas A. Edison announced to the world the invention of the phonograph, and the world has been ever since fascinated by it.

Mr. Thomas A. Edison announced to the world the invention of the phonograph, and the world has been ever since fascinated by it.

Mr. Thomas A. Edison announced to the world the invention of the phonograph, and the world has been ever since fascinated by it.

Mr. Thomas A. Edison announced to the world the invention of the phonograph, and the world has been ever since fascinated by it.

Mr. Thomas A. Edison announced to the world the invention of the phonograph, and the world has been ever since fascinated by it.

Mr. Thomas A. Edison announced to the world the invention of the phonograph, and the world has been ever since fascinated by it.

Mr. Thomas A. Edison announced to the world the invention of the phonograph, and the world has been ever since fascinated by it.

Mr. Thomas A. Edison announced to the world the invention of the phonograph, and the world has been ever since fascinated by it.

Mr. Thomas A. Edison announced to the world the invention of the phonograph, and the world has been ever since fascinated by it.

Mr. Thomas A. Edison announced to the world the invention of the phonograph, and the world has been ever since fascinated by it.

Mr. Thomas A. Edison announced to the world the invention of the phonograph, and the world has been ever since fascinated by it.

Mr. Thomas A. Edison announced to the world the invention of the phonograph, and the world has been ever since fascinated by it.

Mr. Thomas A. Edison announced to the world the invention of the phonograph, and the world has been ever since fascinated by it.

Mr. Thomas A. Edison announced to the world the invention of the phonograph, and the world has been ever since fascinated by it.

Mr. Thomas A. Edison announced to the world the invention of the phonograph, and the world has been ever since fascinated by it.

Mr. Thomas A. Edison announced to the world the invention of the phonograph, and the world has been ever since fascinated by it.

Mr. Thomas A. Edison announced to the world the invention of the phonograph, and the world has been ever since fascinated by it.

Mr. Thomas A. Edison announced to the world the invention of the phonograph, and the world has been ever since fascinated by it.

Mr. Thomas A. Edison announced to the world the invention of the phonograph, and the world has been ever since fascinated by it.

Mr. Thomas A. Edison announced to the world the invention of the phonograph, and the world has been ever since fascinated by it.

Mr. Thomas A. Edison announced to the world the invention of the phonograph, and the world has been ever since fascinated by it.

Mr. Thomas A. Edison announced to the world the invention of the phonograph, and the world has been ever since fascinated by it.

Mr. Thomas A. Edison announced to the world the invention of the phonograph, and the world has been ever since fascinated by it.

Mr. Thomas A. Edison announced to the world the invention of the phonograph, and the world has been ever since fascinated by it.

Mr. Thomas A. Edison announced to the world the invention of the phonograph, and the world has been ever since fascinated by it.

Mr. Thomas A. Edison announced to the world the invention of the phonograph, and the world has been ever since fascinated by it.

Mr. Thomas A. Edison announced to the world the invention of the phonograph, and the world has been ever since fascinated by it.

Mr. Thomas A. Edison announced to the world the invention of the phonograph, and the world has been ever since fascinated by it.

Mr. Thomas A. Edison announced to the world the invention of the phonograph, and the world has been ever since fascinated by it.

Mr. Thomas A. Edison announced to the world the invention of the phonograph, and the world has been ever since fascinated by it.

Mr. Thomas A. Edison announced to the world the invention of the phonograph, and the world has been ever since fascinated by it.

Mr. Thomas A. Edison announced to the world the invention of the phonograph, and the world has been ever since fascinated by it.

Mr. Thomas A. Edison announced to the world the invention of the phonograph, and the world has been ever since fascinated by it.

Mr. Thomas A. Edison announced to the world the invention of the phonograph, and the world has been ever since fascinated by it.

Mr. Thomas A. Edison announced to the world the invention of the phonograph, and the world has been ever since fascinated by it.

Mr. Thomas A. Edison announced to the world the invention of the phonograph, and the world has been ever since fascinated by it.

Mr. Thomas A. Edison announced to the world the invention of the phonograph, and the world has been ever since fascinated by it.

Mr. Thomas A. Edison announced to the world the invention of the phonograph, and the world has been ever since fascinated by it.

Mr. Thomas A. Edison announced to the world the invention of the phonograph, and the world has been ever since fascinated by it.

Mr. Thomas A. Edison announced to the world the invention of the phonograph, and the world has been ever since fascinated by it.

Mr. Thomas A. Edison announced to the world the invention of the phonograph, and the world has been ever since fascinated by it.

Mr. Thomas A. Edison announced to the world the invention of the phonograph, and the world has been ever since fascinated by it.

Mr. Thomas A. Edison announced to the world the invention of the phonograph, and the world has been ever since fascinated by it.

Mr. Thomas A. Edison announced to the world the invention of the phonograph, and the world has been ever since fascinated by it.

Mr. Thomas A. Edison announced to the world the invention of the phonograph, and the world has been ever since fascinated by it.

Mr. Thomas A. Edison announced to the world the invention of the phonograph, and the world has been ever since fascinated by it.

Mr. Thomas A. Edison announced to the world the invention of the phonograph, and the world has been ever since fascinated by it.

Mr. Thomas A. Edison announced to the world the invention of the phonograph, and the world has been ever since fascinated by it.

Mr. Thomas A. Edison announced to the world the invention of the phonograph, and the world has been ever since fascinated by it.

Mr. Thomas A. Edison announced to the world the invention of the phonograph, and the world has been ever since fascinated by it.

Mr. Thomas A. Edison announced to the world the invention of the phonograph, and the world has been ever since fascinated by it.

Mr. Thomas A. Edison announced to the world the invention of the phonograph, and the world has been ever since fascinated by it.

Mr. Thomas A. Edison announced to the world the invention of the phonograph, and the world has been ever since fascinated by it.

Mr. Thomas A. Edison announced to the world the invention of the phonograph, and the world has been ever since fascinated by it.

Mr. Thomas A. Edison announced to the world the invention of the phonograph, and the world has been ever since fascinated by it.

Mr. Thomas A. Edison announced to the world the invention of the phonograph, and the world has been ever since fascinated by it.

Mr. Thomas A. Edison announced to the world the invention of the phonograph, and the world has been ever since fascinated by it.

Mr. Thomas A. Edison announced to the world the invention of the phonograph, and the world has been ever since fascinated by it.

Mr. Thomas A. Edison announced to the world the invention of the phonograph, and the world has been ever since fascinated by it.

Mr. Thomas A. Edison announced to the world the invention of the phonograph, and the world has been ever since fascinated by it.

programs and related material. Other sections of the Library also have the collected papers and memorabilia of such outstanding artists as Dame Nellie Melba and Peter Dawson.

Before writing this article, I was able to visit the Library and inspect the Music and Sound Recordings section at the invitation of Peter Burgis, who is the Sound Archivist.

It was very interesting indeed to see the activities of the section, in the company of Peter Burgis and Mrs Prue Neidorf, who is the section's Chief Librarian.

At present the section is quite small in terms of staff, and housed in rather inadequate facilities. As a result it has not been possible to fully catalog the collection, nor to provide proper listening facilities for researchers or the public. However, later in the year it is planned to move the section into a much more suitable facility, with high quality dubbing and listening equipment.

The impressive results which have

been achieved to date are basically due to the enthusiasm of the staff. After you talk with them for a while, there can be no doubt that they're dedicated people.

For example Peter Burgis has travelled widely tracking down numerous collections of recordings, taping interviews with early recording artists and their surviving relatives, and talking to pioneer recording engineers and technicians.

Thanks to the efforts of the section's staff, the National Library has been able to acquire many important examples of Australia's music and sound recording heritage. Despite the relatively late start, these at least have been saved for posterity. But there are probably many other valuable and rare items lying in dusty corners throughout Australia.

So if you have any rare old recordings or early sheet music, please contact Peter Burgis or Prue Neidorf at the Music and Sound Recordings section, National Library of Australia, Parkes Place, Canberra ACT. They'll be happy to hear from you.



# EDUCAL KIT SPECIALISTS

## DIGITAL AM-FM CLOCK RADIO KIT



### FEATURES

- ½" LED DISPLAY
- AM-FM RADIO
- ALARM
- SLEEP SETTING
- SNOOZE SETTING
- 500mW OUTPUT
- COMMERCIAL CASE

ONLY \$37.00 COMPLETE  
P & P \$2.00

### MODEL EDUCAL DCR-77

Why pay \$30.00 for just a clock in an instrument case? Only an extra \$7.00 gives you an AM-FM radio plus a moulded plastic case as sold in Europe. (We get English version).

We are trying to obtain the AM-FM modules pre-aligned for you!

## ONLY EDUCAL HAS THE DCR-77



## AM-FM STEREO TUNER KIT \$89

### FEATURES

- PRE-ALIGNED FM MODULES (3)
- MONO/STEREO
- LOCALLY PRODUCED—NOT IMPORTED
- 4 PRE-SET STATIONS ON FM
- FULL RANGE MANUAL TUNING AM-FM
- 75 or 300Ω INPUT
- A.F.C.
- STEREO BEACON
- PROFESSIONAL FINISH

### SPECIFICATIONS

TUNING 88-108MHz  
BANDWIDTH 300 KHz  
I.F. 10.7 MHz  
I.F. REJECTION 65dB  
IMAGE SUPPRESSION 40dB  
A.M. REJECTION 40dB  
CHANNEL SEPARATION 38dB (min.)  
DIMENSIONS 13.75" x 10.5" x 4.25"

### STEREO-AMP KIT

30 WATTS / CHANNEL RMS  
FREQUENCY RESPONSE 8Hz-30 kHz  
(3dB down) 20Hz-20kHz (FLAT)  
DISTORTION 0.1% INTO 8Ω  
FULL BASS & TREBLE CONTROLS  
LOUDNESS CONTROL  
DIN SOCKET PHONES SOCKET  
TEAK VENEER CASE  
MAG. CARTRIDGE INPUT  
AUX. INPUT TAPE INPUT

ALLOW  
P & P + INS.  
\$3.50

## \$79

EDUCAL, P.O. BOX, CARLTON SOUTH, VIC. 3053.  
OR—21 WELLS AVENUE BORONIA, VIC 3155



## AKG magnetic cartridges have "transversal suspension"

Previously renowned for their microphones, stereo headphones and other transducers, the Austrian manufacturers AKG have now released a range of five magnetic cartridges. These have "transversal suspension", a feature claimed to be a major advance in cartridge design.

As with the majority of magnetic cartridges on the market today, the AKG cartridges use the "induced magnet" principle. They have 12.7mm mounting centres, standard colour coded output terminals and an output signal similar in magnitude to equivalent cartridges made by competing manufacturers.

That is where the similarity ends. In a conventional induced magnet cartridge the stylus cantilever has a wire pivot which is fixed to the end of the carrier tube. A synthetic rubber grommet around the cantilever provides damping. According to AKG, this system results in a "wandering" effective pivot point for the cantilever, dependent on the signal frequency. This is claimed to contribute to uneven frequency response, inadequate channel separation, unstable stereo image and poor tracking ability. By contrast, the AKG suspension is a virtual knife-edge with fulcrum and damping at the same point on the cantilever.

Designated P8ES, P8E, P7E, P6E and P6R, the AKG cartridges all have the same body shape and the stylus assemblies are interchangeable. This means that it is possible to upgrade the performance of the cheaper models by installing a more expensive stylus assembly. However, AKG will only guarantee the specifications when a cartridge body is used with its designated stylus assembly. Each stylus assembly has an integral flip-down stylus protector.

By comparison with the removable stylus assemblies on other cartridges, those on the AKG models are a very tight and precise fit. This must help in assuring consistent performance. On the other hand, the AKG stylus assembly is such a tight fit that it is very difficult to remove, and a fumble-fingered user might damage it in attempting to do so.

Mounting an AKG cartridge in a typical headshell is not as easy as it should be. The mounting screws exert, at best, a very tenuous grip on the unnecessarily foreshortened slotted mounting feet. This, combined with the irregular shape of the cartridge body, makes it difficult to obtain correct alignment and stylus overhang setting. A small change in the body moulding would correct this drawback.

Recommended load for each cartridge is 47k shunted by 470pF. As most tone arms have cable capacitances considerably below this figure, typically 100pF, shunt capacitors should be added to the tonearm wiring to obtain the optimum capacitance.

First to be tested was the top-of-the-line P8ES, which has a tracking force range of 0.75 to 1.25 grams and an optimum tracking force of one gram. We used the maximum figure of 1.25 grams to enable it to track the +12dB test on the W&G 25/2434 disc. Frequency response was within  $\pm 2$ dB from 20Hz to 18kHz and 4dB down at 20kHz. Square wave response was almost ideal. Cross-

*Housed in plastic cubes, the five AKG cartridges are each supplied with small screwdriver and mounting hardware.*



talk was better than 27dB at 1kHz and better than 20dB at 10kHz.

The most notable feature of this and all the other cartridges in the AKG range was the very clean waveform throughout the audible spectrum. They are the best cartridges we have seen, as far as this aspect is concerned. This confirms the low figures quoted by AKG for inter-modulation distortion.

Sound quality of the AKG P8ES is very clean and well balanced with extended treble and bass to match. Clearly, it can be compared with the premium models from competing manufacturers.

Just below P8ES in specification is the P8E. As might be guessed, the "E" stands for an elliptical stylus. Tracking performance of this model is very similar to the P8ES as was the frequency response and crosstalk. Sound quality was also very similar.

Median cartridge in the range is the P7E. This has a tracking range of 1.25 to 2.5 grams and an optimum tracking force of 1.5 grams. At 2 grams, it tracked the +16dB test of the W&G 25/2434 disc. For the rest of the test though, we used the optimum figure of 1.5 grams.

Frequency response was within  $\pm 2$ dB from 20Hz to 16kHz and 9dB down at 20kHz. Crosstalk was -28dB at 1kHz and -11dB at 10kHz. Square wave response was very good. Again, there were only slight audible differences between this, and the more expensive units in the range.

The next model down from the P7E is the P6E, which has a tracking range of 1.5 to 3 grams and an optimum tracking force of 2.5 grams. This we regard as being too heavy with an elliptical stylus. We tested it at 2 grams, at which it tracked the +16dB test of the W&G reference disc. Frequency response was within  $\pm 2$ dB from 20Hz to 20kHz.

Crosstalk was 36dB at 1kHz in one direction and 25dB in the other. At 10kHz it was 16 and 13dB respectively. Sound quality of this cartridge was clean and bright although it has a tendency to sound a little overbright with some loudspeaker systems which are themselves bright.

The P6R is the bottom of the range, the only unit with a spherical stylus. Tracking range is 2 to 4 grams. We used it at 2

grams at which it tracked the +16dB test of the W&G reference disc. Frequency response was within  $\pm 2$ dB from 20Hz to 18kHz and 6dB down at 20kHz. Crosstalk was 28dB at 1kHz in one direction and 22dB in the other direction. At 10kHz, the respective figures were 15 and 10dB.

Sound quality was clean and pleasant without any tendency to be overbright. For the buyer on budget, this would be the one to go for.

These tests certainly demonstrate the potential of the new AKG range. There are sure to be many AKG cartridge fans before too long.

Further information can be obtained from high fidelity retailers or from the Australian distributors, Amalgamated Wireless (Australasia) Ltd, Ashfield division, 554 Parramatta Road, Ashfield, NSW 2131. (L.D.S.)





# METROSOUND\* LIN-TRACK a new concept

For turntables with low mass arms, the \*Lin-track linear cleaning arm employs a new concept—simple but effective.

It is compact, with low mass (below 0.5 grams) and has a negligible effect on speed.

The independently pivoted brush tracks in the record groove at precisely the correct angle to clean out damaging grit and dust while the velvet pad picks up surface grime.

With minimum height and overhang, it will fit most turntables.

\*World patents applied for

SOLE AUSTRALIAN AGENT:

## LEO ROGALY & LEWIS PTY. LTD.

Sydney: 94/96 Cooper St., Surry Hills. Tel. 212 4266.  
Melbourne: 407 Highett Rd., Highett. Tel. 95 9203.

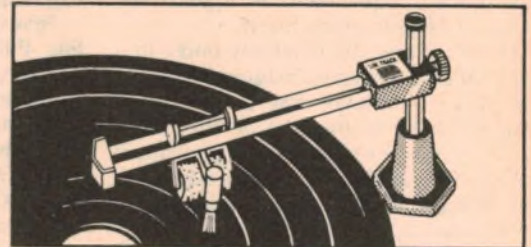

## AUDITEC STUDIO MONITORS

### No Gimmicks—just superlative performance

The 2033 and 1034 Studio Monitoring Amplifiers use the revolutionary Murray Circuit Design Technique which substantially eliminates transient intermodulation distortion, and gives performance figures which few (if any) amplifiers can match.

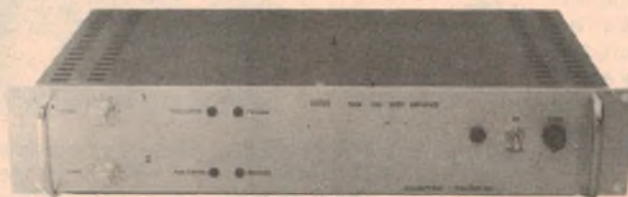

2033—2 Channel, 100 Watts (RMS) per channel (illustrated).  
1034—1 Channel, 200 Watts (RMS). ● T.H.D. less than

0.01% ● S/N Ratio better than 100dB ● Fully s/c protected, stable for all loads ● Overload and peak clipping indicators ● Cannon connectors in, out and auxiliary ● 100% Australian designed and manufactured.

AUDITEC AMPLIFIERS ARE AVAILABLE THROUGH:

Melbourne: Zephyr Products. Phone 568 2922  
Brisbane: Eda-Delsound. Phone 52 8694  
Adelaide: Neil Muller Pty Ltd. Phone 74 1162  
Bundaberg: Bundaberg Hi-Fi. Phone 71 3176  
Canberra: Musique Boutique. Phone 82 2553  
Tamworth: Hi-Fi Gallery. Phone 65 7788  
Maryborough (Qld): Keller Electronics. Phone 21 4559  
Rockhampton (Qld): Premier Sound. Phone 28 2701  
Surfers Paradise (Qld): Beno's Musical Supplies. Ph. 38 1568  
Whyalla (S.A.): Audio Lab Sales. Phone 45 7755

For descriptive leaflets on these amplifiers,  
call, phone or write to:

AUDITEC AUSTRALIA PTY. LTD.  
10 Waitara Avenue, Waitara,  
N.S.W. 2077  
Phone: 48 4116



# JVC JL-F45 direct-drive automatic turntable

Fully automatic operation, selectable repeat and a direct drive motor are some of the desirable features of the top-of-the-line JVC JL-F45 turntable. Two speeds are provided and wow and flutter is quoted at 0.03% RMS.

The JVC JL-F45 comes complete with tone arm, integral base and cover. A cartridge is not provided, the reason probably being that buyers in this price range prefer to choose their own, rather than settle for the manufacturer's selection.

The styling of the JL-F45 is aimed to produce a sleek, low profile. Whereas other designs might emphasise the mass of the platter and produce an air of ruggedness, the JVC is less obtrusive—the heavy platter is recessed into the chassis.

Overall dimensions of the JVC JL-F45 are 460 x 130 x 368mm (W x H x D), and mass is quite hefty at 11kg. Clearance is required at the rear to allow the perspex cover to swing open.

Spring-loaded hinges allow the tinted perspex cover to stay open at almost any angle and to close gently. The cover can also be unclipped from the hinges, as shown in our photograph.

The major operating controls of this fully automatic turntable are delightfully light in operation, but the speed select and adjust knobs are too small. The turntable can be used as a manually controlled player, and the damped cueing system allows those with uncertain co-ordination to safely manipulate the tonearm.

An interesting feature is the "repeat" knob which allows a record to be played up to six times in succession or repeated continuously.

Effective length of the tonearm is 220mm. It is statically balanced with a rotatable counterweight which also provides the tracking force settings. We noted that the owner's manual states that the tone arm has a "tracking force dial of 0.1 gram steps". In fact, it is continuously adjustable and the calibrations are in ½-gram steps. Tracking force range is from 0 to 3 grams.

The accuracy of the tracking force calibrations is within 5% while the antiskating settings appear to be about optimum for cartridges with elliptical styli. Presumably the setting would have to be varied slightly to suit cartridges with conical styli. The removable headshell

has the standard EIA locking collar, standard colour-coded leads and slotted mounting holes for stylus overhang adjustment. Antiskating is provided via a small knob near the tonearm fulcrum. The platter is a 310mm aluminium alloy diecasting with a mass of approximately 1.8kg. Like other direct drive turntables, the platter is an essential part of the motor system, for without it the motor spindle runs jerkily at low speed. JVC described the motor as a DC servo type; it takes the form of a multipole outer-

capacitance for ideal operation, shunt capacitors may need to be added.

Wow and flutter was excellent at 0.1% (DIN 45507) which is equal to the best measurement we have recorded to date. However, heavy floor vibrations tend to show up as audible wow so the turntable suspension could be improved. Rumble is very low and negligible to that inherent on most disc pressings.

In use, the turntable is always very quiet and the automatic start and stop facility is very gentle in lifting and lowering the arm. It can safely handle the best quality cartridges without fear of damage.

Summarising, the JVC JL-F45 is a highly desirable unit combining the best features of a high performance direct drive turntable with automatic operation.



The heavy platter is recessed into the chassis to reduce its apparent mass.

rotor induction motor with transistor drive circuitry.

We noted that the two-core mains cord has a moulded two-pin plug, similar to those fitted to electric shavers, which can be inserted into a standard 240V mains power point. We would prefer to see a three-core flex and three-pin plug fitted, since this is not a double-insulated appliance.

The length of the shielded signal cable is 1.2 metres and cable capacitance is 100pF in each channel. This makes the turntable suitable for CD-4 operation, but for some premium stereo cartridges which require as much as 470pF shunt

Recommended retail price is \$379.

Further information can be obtained from high fidelity retailers or from the Australian distributors, Hagemeyer (Australia) B.V., 59 Anzac Parade, Kensington, NSW 2033. (L.D.S.)

## BASIC ELECTRONICS

Basic Electronics begins with the electron, introduces and explains components and circuit concepts, and progresses through radio, audio techniques, servicing, test instruments, etc.

\$3.00 plus 60c p & p

Electronics Australia,  
Box 163, Beaconsfield, NSW 2014.



# MICROPHONES

## Part 7 Two channel recording techniques

Reproduced by courtesy of Sennheiser Electronics, this series of articles is intended to assist sub-professionals and amateurs who need to use microphones, but without the advantage of formal acoustic training. This article discusses various forms of two-channel recording.

by G. PRAETZEL and E. F. WARNKE\*

The recording of a piece of music cannot be considered as a purely abstract, physical process. Sound and tone structures are influenced by space. The frequency and loudness of a sound need to be augmented by a spatial component in order to appear natural.

Human hearing has the ability to perceive the spatial component of a sound. Not only does it have a directional ability, which can locate the position of the original sound, but it can also assess the intensity and direction of reflected sounds. (Refer Part 1. October, 1976.)

To obtain a true reproduction of a sound it is obvious that, at the very least, we must provide two channels in order that we can, in some measure, capture the directional information which is missing in a single channel system. It is in this way that stereo recording techniques provide a significant improvement over mono systems.

Superficially, the principle appears very simple. Two microphones, suitably placed in the room, convert the sound waves into electrical impulses and these are recorded as two separate tracks on any suitable recording device. As a rule, at least at amateur level, this will be a two track tape recorder. The signal may be played back via two loudspeakers, suitably placed, or a pair of headphones. How to locate the microphones for best results will be the subject of this and subsequent articles.

Professionals use a technique called "polymicrophony"; the use of multiple microphones with elaborate mixing facilities. Often more than 20 microphones may be used in a recording studio, each one close to an individual instrument, and fed via a mixer to a stereo recorder.

In what proportions these multiple sounds are mixed before being fed to the stereo tracks is determined almost entirely by the recording engineer who, because of the close proximity of each microphone to one instrument, can manipulate the balance over a very wide

range, by purely electronic means.

He can introduce filters into any channel to boost or attenuate a particular part of the audio spectrum, he can add reverberation to any or all channels, in any desired degree, or even shift an individual instrument along the stereo base, i.e., from left to right, by means of a panorama potentiometer ("panpot").

(Editorial note: The latest commercial techniques use wide tapes carrying, typically, 16 tracks for the first recording. Most of the balancing is done subsequent to this, during the mix-down to the final two-track or four-track recording.)

Fairly obviously, equipment of this complexity is beyond the financial scope of most amateurs. Nevertheless, there are several recording techniques available to the amateur which will give satisfactory results.

The simplest approach uses two identical microphones fed directly to the two recording tracks. For simple musical combinations it may be quite adequate and will almost always be better than a similar type of mono recording.

If a simple mixer can be employed

then additional microphones can be used to simplify the job of balancing the level between instruments or groups of instruments. Another possibility is to use additional microphones placed to favour reverberation only, using the mixer to provide the best balance between direct and reflected sound. By this means the conflicting requirements of intelligibility, reverberation, and presence can be adjusted for the best overall result.

In order to better appreciate the problems of microphone placement it is worthwhile to consider a number of fundamental approaches to stereo recording, with their advantages and limitations.

The first is the dummy head technique. In many ways the promise implied by the development of stereo recording has not been fulfilled. While a vast improvement over the mono technique it fell far short of the anticipated "perfect" reproduction. It did not achieve a true spatial effect; the best it could do was to expand the sound source from that of a single speaker to the space between two speakers. It did little to create a spatial effect which would involve the listener.

It was this limitation which inspired the development of the four channel (quadraphonic) approach. But even the best quadraphonic system provides only a two dimensional effect along the lines connecting all four speakers; it cannot provide a true three dimensional effect involving distance perception or sound perception above or below the speaker line.

*The dummy head used by Sennheiser for binaural recording experiments. Sounds recorded in this way can produce quite startling results when played back through headphones. The model is wearing a pair of light weight headphones suitable for such listening.*



\*Reproduced by arrangement with Sennheiser Electronic. Translated by T. M. Jaskolski and adapted for magazine publication by P. G. Watson.



As a step towards solving this problem a number of workers have experimented with the dummy head technique. Typical of these was a group of acoustic engineers at the Heinrich-Hertz Institute in Berlin-Charlottenberg.

They built a dummy head similar in appearance to the upper half of a shop window dummy, the head being made as accurately as possible. In particular, the shape and texture of the outer ear was very carefully imitated, as was the auditory canal. High quality capacitor microphones were located at the inner ends of these auditory canals.

Signals from these microphones are recorded or transmitted by any two channel (stereo) system and reproduced by a pair of high quality headphones. A person wearing these headphones receives a sound impression which is a very close copy of the sound pattern he would have observed had he occupied the position of the dummy head.

Unfortunately, signals recorded in this way do not retain their realism when reproduced through loudspeakers, although the workers at the Heinrich-Hertz Institute are working on a technique which they claim may make this possible.

The amateur who wishes to try this technique does not need to use a dummy head. The Sennheiser MKE 2002 stereo head microphone has been specially developed for this purpose. It looks like a stethoscope type earphone but is actually fitted with two miniature capacitor microphones which rest in the middle of the outer auditory canal.

Signals recorded from such a microphone will be a very accurate copy of the sound heard by the person wearing the microphone.

(Editorial note: Impressive—even startling—though the results can be from recordings of this type, there are some reservations about the system. In particular, it cannot make provision for the small but important head movements which are part of normal auditory direction finding techniques. Refer Electronics Australia, October 1975, pp12-15.)

Since the dummy head technique is suitable only for headphone listening, other methods must be used to make more conventional stereo recordings. The two to be described are called, respectively, the AB-technique and the XY-technique.

In the AB-technique two identical microphones are placed between three and five metres apart in front of the group to be recorded. This technique is also useful for recording large organs.

In setting up, particular attention should be paid to obtaining a good centre image. This can best be done by making a test recording of voice or other sound source in the centre of the recording area.

This recording method gives good stereo reproduction but, at least in theory, may be less suitable for produc-

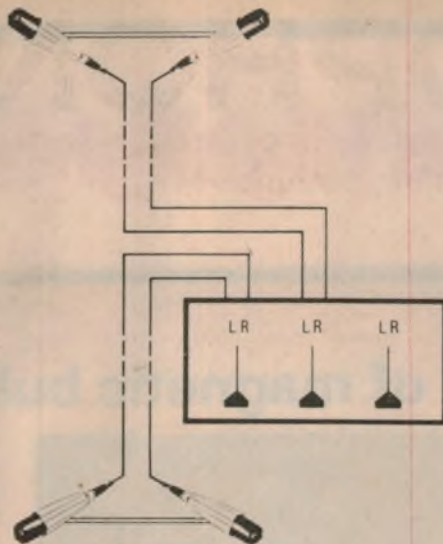

*Additional microphones and a simple mixer can solve a lot of recording problems. The diagram shows how to use a second set of microphones to add a suitable amount of reverberation to the main signal.*

ing a mono version. The reasoning is that sounds with considerable difference in level and having certain orders of time delay can interfere with or cancel one another. How serious this is likely to be in practice depends a lot on individual circumstances.

The type of microphones used for AB recordings is not critical, directional or

omnidirectional being equally suitable. The AB technique is mainly suitable for rooms with good natural acoustics, in which case the omnidirectional type may be preferable.

The XY-technique appears to be more favoured by amateurs. It uses two identical microphones mounted close together with an angle between them of between 90 and 120°. The 90° angle is preferable for super cardioid types and 120° for cardioid types. Alternatively, the microphones can be mounted one above the other, to reduce the distance between the diaphragms as much as possible.

This latter configuration is recommended if it is known that monophonic copies are likely to be made, since it minimises the phase differences, etc., already mentioned in regard to the AB technique.

Additional microphones for soloists, reverberation, etc., can be used with this technique, via appropriate mixers.

It is particularly important that XY microphone pairs be connected in correct phase. This can be established by talking into the pair while they are monitored in a monophonic connection. If severe attenuation of low frequencies is observed, the polarity of one microphone should be reversed.

The next article will deal with larger musical groups, choirs, small orchestras, etc., and the problems of achieving a balanced recording.



## VIDEO TECHNICS

2ND FLOOR, TELFORD TRUST BUILDING, 79-85 OXFORD STREET, BOND JUNCTION, NSW 2022 PH. 387 2555  
3RD FLOOR, EQUITABLE LIFE BUILDING, 301 CORONATION DRIVE, BRISBANE 4064 PH. 378 8919

### MONITOR ADAPTOR KIT FOR COLOUR RECEIVER.



- Converts Receiver into Video Monitor.
- Allows off-air recording or recording with Video Camera
- Easy to install.
- All instructions & circuit diagrams included



**\$95.00 + P.P.**

### COLOUR TV TUNER



VIDEO TECHNICS COLOUR TV TUNER MODEL H06709

- Record one channel while watching another
- No modification required to existing television sets
- Will record while TV set is off
- Usable with any video recorder BW or Colour with an RF output which means this tuner allows video recording of TV programs and playback through aerial input of TV set. **\$295.00 + P.P.**



### VIDEO FOCUS INTENSIFIER

Announcing our video focus intensifier to improve the playback quality of all VCR system video recorders. This consists of a small circuit board which fits inside the VCR (Philips etc.) This circuit detects a change in picture contrast and inserts a transient—in effect an extra—signal at this point, which crispens the image. The effect, if the size of this transient is adequate is to recover lost sharpness, and the principle is indeed very effective. Full fitting instructions included. **€39 00 + P&P.**

**VIDEO EQUIPMENT**—Sony, Akai, Portopacks. Also agents for J.V.C. and National. All formats and brands. Colour and B.W. RECORDERS, EDITORS, GENERATORS, AND BLANK VIDEO TAPE AVAILABLE. New and used equipment. Trade and terms. **SPECIALS.** We have several B.W. Portopacks traded on colour sets

## WANTED FRANCHISE DEALERS





## News Highlights



### First practical use of magnetic bubble memories

Using a unique technology invented at Bell Laboratories, engineers in Detroit, Michigan, have put into trial a recorded-message machine, without moving parts, that stores recorded messages such as: "We're sorry. You have reached a non-working number."

The new machine, a little larger than a bread box, is the first of its kind that operates with magnetic bubble memory, and is believed to be the first application of this technology. Magnetic bubbles are tiny magnetized areas in a thin film of material such as garnet crystal. These areas can be moved about electronically to store and access data.

Now being tested in one of Michigan Bell Telephone Company's Detroit switching offices, the machine—called the 13A announcement system—is being used to record and announce standard, repetitive 12- or 24-second "call assist" messages. Each message can be played back to as many as 500 telephone lines simultaneously.

The new machine stores messages in digital format—that is, in a code represented by the presence or absence of the tiny bubbles in the machine's memory. On the machine that the 13A replaces, a message is recorded on a magnetic drum turned by an electric motor. Messages on the latter eventually degrade and must be re-recorded. Mes-



*Bell Labs supervisor Ron Trupp inspects a message board from the Bell System's new recorded message machine. The machine is the first to make practical use of magnetic bubble memory devices.*

sages processed by the 13A, however, don't lose quality with repeated playing.

A single 13A machine can record and announce up to eight different messages. Its predecessor, about the same size, could handle only one message.

In operation, the 13A stores each message on a separate printed circuit board. On each board there is a maximum of two magnetic bubble packages. The bubble package, about half the size of a cigarette pack, contains four bubble chips, each able to store up to 68,121 bits of information. The storage capacity of each package is 12 seconds of digitized speech.

The machine electronically encodes speech into digital information before it is stored in the magnetic bubbles. A special electronic decoder reconstructs the voice signals when needed.

Magnetic bubbles are said to offer several operational advantages over other memory devices. These include no moving parts (as with tape and disc memories), and moderately fast data retrieval without losing information when circuit power is interrupted.

For example, a bubble memory can access stored information in less than two thousandths of a second—slow by semiconductor standards, but ten times faster than high-performance disc memories.

Bubbles also offer system designers high storage capacity (engineers at Bell Labs have already fabricated a 250,000-bit memory). In addition, bubble memories use very little power and require few processing steps.

### British study examines energy alternatives

Conservation, coal and nuclear power will be the mainstays of Britain's future energy system when the North Sea's oil and gas resources begin to run out; and any British energy research and development (R and D) program must be shaped with this in mind.

These are key conclusions from a study of Britain's energy R and D strategy carried out at the request of Dr Walter Marshall, Fellow of the Royal Society, chief scientist at the Department of Energy and deputy chairman of the United Kingdom Atomic Energy Authority (UKAEA).

The study was carried out for the Advisory Council on Research and Development for Fuel and Power (ACORD), which advises the government on energy R and D. Dr Marshall is

the chairman of ACORD.

The importance of coal, nuclear power and energy conservation comes from the report's analysis of a series of possible future energy scenarios for Britain. The scenarios were based on various assumptions about the growth of the economy, the price of fuels on the world market and so on.

The scenarios led inescapably to the conclusion that nuclear power must play a large role in the United Kingdom's energy future. One scenario analysed the impact of an embargo on nuclear power and this showed that economic growth would suffer significantly.

The report says that fusion power and wave power are the most important alternative energy technologies. Fusion is important because it offers such tremen-

dous rewards—but the technical difficulties make international collaboration essential.

Wave energy also offers large rewards and probably long before fusion. The report gives this a high priority and the Department of Energy has already started a £1 million wave energy R and D program to assess this new energy source.

According to the report, of the primary energy consumed in Britain 30 percent is lost in converting that fuel into a useful form—electricity or refined petroleum products, for example—and distributing it to the customer. A further 30 percent is lost by the user because of inefficient appliances. In all only 40 percent of primary energy becomes "useful energy". This is why the report puts conservation at the top of the strategy's list of "priority" technologies.



## If the Sun stopped shining

What would happen to the Earth's atmosphere if the Sun stopped shining? That's hardly the most pressing question facing the world; the Sun has thousands of millions of active years ahead of it.

But for scientists trying to find out why the atmosphere behaves as it does, it's a very interesting question. If they could watch what happened when the Sun went cold, they would learn much about the links between the energy input from the Sun and the processes that produce climate and weather around the world.

They can't make these observations of course, but at the Australian Numerical Meteorology Research Centre in Melbourne one scientist, Mr Barrie Hunt, has done the next best thing. Recently he simulated the demise of the Sun in a mathematical model of the atmosphere, and came up with some very interesting findings.

Mr Hunt used a model put together by researchers in America for his experiment with the Sun. It is simpler than some general circulation models, dealing with only half the earth—from the equator to either pole—and not taking account of mountains or the pattern of

land and sea. But it has proved itself a good model.

Mr Hunt first ran the model until it settled down into a fair representation of the real atmosphere's motion. Then he 'turned off' the Sun and ran it for a further 50 simulated days.

One unexpected result was that north-south air movement slowed much more rapidly than the east-west circulation. Mr Hunt says this indicates that scientists are more likely to find explanations for changes in the Earth's climate in north-south activity than in the much more stable east-west flow.

One of the fears about Man's pollution of the atmosphere has been that it may destroy a delicate natural balance maintaining the atmosphere's main circulation patterns. The results of the experiment make this now seem less likely; the surprising persistence of these patterns after the Sun's demise suggests that they are very stable. This does not mean pollution won't cause any climate changes—rather that it is unlikely to produce a basic circulation shift that would change climates everywhere.

Incidentally, the model's temperature

### If the Sun stopped shining

Earth's average surface temperature (°C)

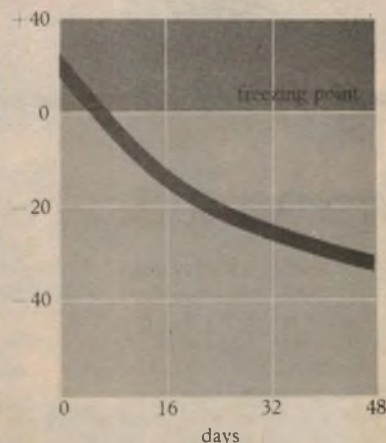

output shows that the Earth would very soon become uninhabitable if the Sun went out, despite the persistence of atmospheric activity. The average temperature at the equator fell to freezing point within 12 days of the onset of darkness and to about -60°C within 48 days.

## Floppy disc module for typesetting

Electronics is playing an ever increasing role in the field of printing. Probably the area most affected can be found in the composition of type, taking the form of phototypesetting.

Since its inception, phototypesetting has been basically controlled by computers and gradually the power of these has increased with a corresponding reduction in physical size.

With the high labour intensity created by the keyboarding side of typesetting, certain manufacturers have concentrated on methods to reduce keystrokes and simplify keyboard operation. With this in mind, Addressograph Multigraph, who manufacture the very successful Comp/Set range of phototypesetters, have now released a floppy disc module. This is basically designed to capture keystrokes and act as a random access memory device. This diskette can hold



up to 288,000 command codes or characters, equal to 57,600 words, and allows the operator to automatically search and retrieve at very high speed and, more importantly, at random access. Prior to this, storage was on paper or magnetic tape with their inherent unwinding or rewinding problems, particularly when the area to be recalled was in the middle sections.

Addressograph Multigraph Australia Pty Ltd is located at 636-666 Wellington Rd, Mulgrave, Vic 3170.

## Professor Ratcliffe re-elected IREE president

Professor John S. Ratcliffe, Professor of Chemical Engineering at the University of New South Wales, has been re-elected President of the Institution of Radio and Electronics Engineers Australia for a second term.

A member of the Institution for more than 26 years, Professor Ratcliffe was a member of the Newcastle Division from 1948 to 1965, when he joined the Sydney division. He was Deputy President of IREE from 1974 until last year.



## 85% growth forecast for home video games

The newest and fastest growing sector of the US consumer electronics industry, electronic video games, is forecast to grow in factory sales at a compound annual rate of 46 percent through 1980. Underlying this will be the impressive 85 percent compound annual growth of home video games and the modest 14 percent compound annual growth of arcade video games.

These projections are the result of a recently published study conducted by Creative Strategies, Inc, San Jose, California, which comprehensively examined the two major segments of the electronic video games market—arcade and home video games.

In 1975 arcade video games sales totalled 54,000 units for total factory sales of \$68 million. By 1980 CSI forecasts arcade game sales of 89,000 units or \$133 million and semiconductor content of \$12 million.

Home video game sales in 1975 totalled 310,000 units for factory sales of \$22 million. By 1980 CSI forecasts home game sales at 17 million units for factory sales of \$454 million.

Home game sales outside the United States in 1976 will be limited to about 250,000 games. By 1980, however, CSI projects that foreign sales will account for 40 percent of total sales. The major foreign markets will be Western Europe including Great Britain, Japan and Canada.





**top  
forte**

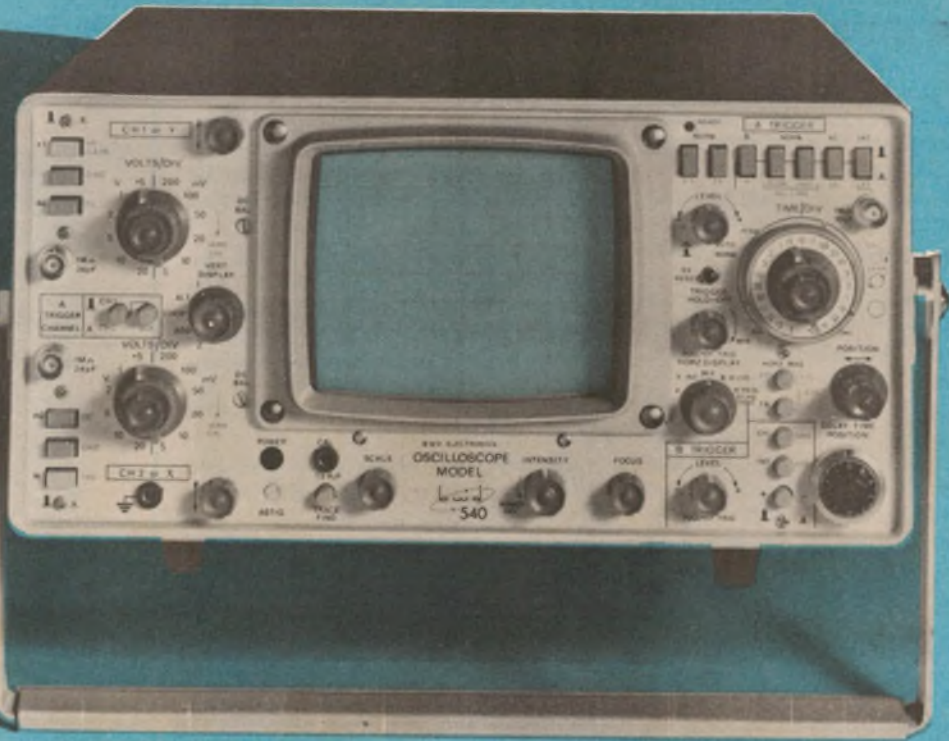

**BWD540**  
Dual Trace  
DC-100MHz -3db  
5mV sensitivity  
5nSec. sweep speed

*Computers,  $\mu$ -Processors,  
Research and development,  
Field service*



**BWD539D**  
Dual Trace  
DC-20MHz -3db  
5mV sensitivity

*Colour TV,  
C.B. Radio,  
 $\mu$ -Processors,  
Video & audio  
recording.*



**BWD504**  
DC-6MHz  
10mV sensitivity

*Education,  
Hobbyists,  
X-Y monitor*

**BWD**  
ELECTRONICS  
PTY. LTD.

Miles Street, Mulgrave, Victoria, 3170  
Telephone 561 2888. Telex 35115

- N.S.W. Amalgamated Wireless (A'asia) Ltd., Sydney. Phone 888 8111
- QLD. Warburton Franki (Brisbane) Pty. Ltd., Phone 52 7255
- S.A. Protronics Pty. Ltd., Adelaide. Phone 51 4713  
Rogers Electronics, Adelaide. Phone 42 6666
- W.A. Cairns Instrument Services, Perth. Phone 25 3144
- TAS. Associated Agencies Pty. Ltd., Hobart. Phone 23 1843





the right choice

**How to turn this  
black and white page  
into a 28 page,  
full colour,  
JVC Hi Fi catalogue.**

Write your name and  
address in the space below  
and send this page to us.  
To help you make the right  
choice, we'll send you our  
very lavish and very free  
hi fi catalogue by return.

Name \_\_\_\_\_

Address \_\_\_\_\_

\_\_\_\_\_ Postcode \_\_\_\_\_

Address your envelope to:  
JVC Advisory Service,  
Hagemeyer (Australasia) B.V.,  
P.O. Box 49,  
Kensington.  
N.S.W. 2033.





## When you dance around the room can you hear all the music?

Some very heady stuff is bandied about when it comes to discussing the pro's and cons of various speakers.

All of it rather wonderful of course, but invariably there's one small catch.

Unless you stand practically right in front, the sound you get will never be all that clearly defined.

This of course brings us to our speakers. The Epicure Tens.

Not only can you hear them in just about any part of the room, but you can hear, very clearly, every instrument that's meant to be heard. Simply because they give near hemispherical dispersion.

You'll also find lower distortion in the mid-range, especially noticeable with voices. (Due to a balanced, low-mass voice coil

assembly which is centred perfectly and automatically by the use of a unique space-age, ferro-fluidic liquid.)

While the concave air spring tweeter produces nearly hemispherical dispersion across most of the audible range.

The Epicure Tens also contain a rather unique low-mass woofer.

This gives a smoother, more accurate bass, enabling you to hear the individual bass instruments, and not just the bass.

In fact so proud are we of our speakers, we even go so far as to give them a ten year warranty.

And that's an awful lot of dancing around any room.

## EPICURE





While you listen to the music you can dance around our room.

**N.S.W.**

- SYDNEY CITY: Homesound, George St.  
 EASTERN SUBURBS: Woolloomooloo—Convoy Sound.  
 WESTERN SUBURBS: Parramatta—Riverina Hi-Fi. Concord—Sonata Hi-Fi.  
 SOUTH: Roselands—Miranda Hi-Fi. Miranda Fair—Miranda Hi-Fi. Hurstville—Jock Leate.  
 LIVERPOOL: Miranda Hi-Fi.  
 GOSFORD: Miranda Hi-Fi.  
 SPRINGWOOD: Springwood Hi-Fi.  
 NEWCASTLE: Newcastle Hi-Fi.  
 HUNTER VALLEY: Hunter Valley Electronics.  
 TAREE: Godwins Hi-Fi.  
 WOLLONGONG: Sonata Hi-Fi.  
 ORANGE: Anno's Hi-Fi.  
 A.C.T.: Pacific Stereo

**VICTORIA**

- MELBOURNE CITY: Image Audio. Southern Sound. Allans Music.  
 MELBOURNE SUBURBS: St. Kilda—Denman Audio. Hawthorne—Tivoli Hi-Fi. Nth. Caulfield—The Soundcraftsman. Mordialloc—Mordialloc Hi-Fi. Moorabbin—Southern Sound. Warnambool—A. G. Smith.

**QUEENSLAND:**

- BRISBANE CITY: Reg Mills Stereo.  
 BRISBANE SUBURBS: Ashgrove—Living Sound. Maryborough—Keller Electronics. Tingalpa—Todds Hi-Fi.

**SOUTH AUSTRALIA**

- ADELAIDE CITY: Allans Music. Hi-Fi Acoustics.  
 ADELAIDE SUBURBS: St. Peters—Sound Dynamics.

**WEST. AUSTRALIA**

- PERTH CITY: Musgraves. Clef Music.  
 PERTH SUBURBS: Nedlands—Audio Distributors. Mosman Park—Audio Distributors.

**TASMANIA**

- BURNIE: James Loughran Audio Services.

LAUNCESTON: Wills & Co.

**EPICURE**

Or write to Auriema (A/asia) Pty. Ltd., P.O. Box 604, Brookvale, N.S.W., 2100. Telephone 939.1900

AUR21

**NEWS HIGHLIGHTS**

**Electronic supervision of hospital patients**

The way in which electronics can now provide direct computer-control of hospital patients, especially post-surgical patients, was recently outlined to members of Australia's medical and electronics engineering professions by an Australian, Professor Bruce Sayers.

Professor of Electrical Engineering Applied to Medicine at the Imperial College of Science and Technology, London, Professor Sayers is now back in London, after spending three weeks in Australia. He presented public lectures in Canberra and in the five mainland state capitals. With Dr. Colin Vickery, Senior Lecturer in Electrical Engineering at the Imperial College, he also conducted summer school courses in Sydney and in Melbourne.

Professor Sayers said direct computer-control provided a "smoother ride" for the patient, particularly a cardiac patient, through the difficult time immediately



Professor B. Sayers (left) and Dr C. Vickory.

following major surgery.

When drugs, such as those to control blood-pressure, were given continuously to reduce excess load on the heart, the infusion rate could be modulated under computer-control according to pre-specified patterns and the pressure response analysed automatically.

**Gold medal award to CSIRO radio astronomer**

Britain's Royal Astronomical Society has awarded its prestigious Gold Medal to a CSIRO scientist.

Mr John Bolton, 55, a Chief Research Scientist with CSIRO's Division of Radiophysics at Parkes, NSW, received the medal for outstanding contributions to both radio and optical astronomy, particularly for his studies of radio sources in space.

Announcing the award recently, the Minister for Science, Senator J. J. Webster, said Mr Bolton had been one of the first to link a radio source in space to a known astronomical feature. In 1948 he had discovered a number of isolated radio sources and shortly after linked them to visible objects. Two of these were nearby galaxies and the third was

the Crab Nebula, the remnants of a star which Chinese astronomers had seen blow up in 1054 AD.

The Royal Astronomical Society's citation also paid tribute to Mr Bolton's work in investigating radio emissions from the Sun, and cited his role in the development of two major radio astronomy observatories.

In 1955, after being appointed Professor of Astronomy and Physics at the Californian Institute of Technology, Mr Bolton established the Owens Valley Observatory, still one of the world's leading radio astronomical centres. He returned to Australia in 1961 to help establish what was then the world's most powerful radio telescope, the 64-metre instrument at Parkes.

**DICK SMITH SUPERCATALOG**

**FREE\*** with the May 1977 issue of **ELECTRONICS AUSTRALIA.**



**YOU'VE SEEN THE REST — NOW HERE'S THE BEST!**

Most catalogs are just that — lists of products with prices. Not so Dick Smith's — it's got data, information, suggestions, ideas, circuits — and fully illustrated products with some of the best prices around. And it's free with the next issue of E.A.

\* Normally 75c per copy. **ORDER YOUR E.A. NOW!**



# Electronic learning aid for handicapped children

A portable communication unit, developed by the Division of Electrical Engineering of the National Research Council of Canada, is the latest example of the application of electronics technology to the rehabilitation of the handicapped. The unit has been specifically designed for the verbally disabled, and is based on a set of visual symbols developed by an Australian inventor.

by JOAN RICKERD

A suitcase sits on a crowded laboratory workbench. In appearance, it looks like any other—same size, shape, colour. But there the similarity ends, for when it is opened it holds not the usual paraphernalia of the traveller, but a passport to learning for hundreds of handicapped children.

Conceived and developed by the Division of Electrical Engineering of the National Research Council of Canada, this portable communication unit is designed to promote language and educational development for the non-verbal, severely disabled child.

"Our hope," says Mr O. Z. Roy, research officer in the Medical Engineering Section of the Division, "is that the unit will help to ease the frustration that these children encounter when they try to communicate with others."

The unit's basic system consists of a visual symbol display, a subject-machine interface and an optional speech synthesizer. Each side of the case contains the visual display, 128 "squares" or

addresses, for a total of 256 in all. Each address contains a symbol and the written word representing that symbol. Selection of a particular symbol is indicated by a small red light within the square. These Bliss symbols (called after their Australian inventor) are capable of conveying both subjective or objective life experiences that a child may wish to communicate to someone.

The total capacity of the display can be varied from 32 symbols, during the initial stages of learning, to 512 as a subject's vocabulary and comprehension increases. (The 512 is achieved by dividing each address into two segments and indicating which of the two is desired by either having the light on continuously or blinking.)

The subject-machine interface allows the child to control the display by means of a single switch or by any number and combination of switches. This flexibility enables the subject to use his or her abilities fully while utilizing the machine. A variety of interfaces can be used, from



*This child is able to point to the symbol he wants, whereas children who are more handicapped require an electronics system of pointing.*

a mechanical switch to a light-activated joystick, thus allowing the display to be scanned in an up-down position, from left to right, or diagonally. A subject with a certain amount of dexterity could use the joystick while those with lesser dexterities could use an arrangement of large push buttons.

The display also has a memory which stores sequences of symbols and allows complete idea development. The memory can be read out on the display by selecting an assigned address in the single switch mode, or by pressing a separate "memory read" switch. In its most automatic form, a single switch is used to activate the device.

A scan pattern has been developed which first scans vertical columns, then horizontal rows and finally writes into the memory. With this method of operation, a time-based error correction feature has been incorporated. If, for example, the subject overshoots a column, by waiting a predetermined length of time, say one to ten seconds, the system automatically resets to "home" (top left) or to the first column first row address. If on the other hand an error is made in selecting a row, then the system resets to either the top of that particular column or to home.



*Charles Bliss, Australian inventor of the Bliss symbols now widely used in educating verbally handicapped children. Bliss claims that his "international symbol language" would also be of use to migrants as a means of communication.*



Two addresses have been assigned for "memory read" and "memory erase"; upon activation of one or the other, the system reads out automatically or erases the contents of the memory at the designated address. For subjects with greater control, the scanning pattern is unlocked and individual functions such as read, write and erase are added.

Audio reinforcement is utilized during the process of learning the Bliss symbols, providing a multisensory learning experience. When this is desired, the display can be coupled to a computer and a speech synthesizer. The computer and the synthesizer form the speech production subsystem.

"At the present time," says Mr Roy, "a remote computer is used to control the production of speech, but in the near future, it is expected that the computer will be built into the speech synthesizer."

The synthesizer is one that is commercially available and produces speech artificially from internal electronic circuits. When a symbol is specified, a digital code which identifies it is sent to the computer. The computer recognizes the code and sends information to the synthesizer to speak out the associated word.

The spoken word provides immediate positive reinforcement for the choice of symbol and emphasizes the relationship between the symbol, the concept and the spoken word for the concept. A sequence of symbols can be specified. Upon receiving a precise command from the subject, either activating a special switch or referencing a special display position, the computer will speak out the whole sequence of selected concepts. This allows the subject to formulate whole thoughts or "sentences" by combining symbols as is normally done with words in written or spoken speech.

The unit has been used with both children and adults at the Ottawa Crippled Children's Treatment Center and at the Rideau Regional Hospital in Smiths Falls.

"I saw the first child use the original communication system (COMHANDI) we developed in the basement of a school in 1971," says Mr. J. R. Charbonneau of the Medical Engineering Section. "The Center then had no centralized facilities. Now it is celebrating its 25th anniversary in new quarters on Smyth Road. We have been assigned a training laboratory there and a member of their staff acts as coordinator of projects. The Center also acts as liaison and coordinator of projects for the Ottawa Centennial School and the Rideau Regional Hospital. Established by the Bliss Symbolics Foundation as a resource center for Eastern Ontario, the Ottawa Center will disseminate information and instruct other centers in the use of Bliss symbology."

The Medical Engineering Section is working in close collaboration with the Information Science Section of the



*This preschooler increases her vocabulary through the use of pictures. When the teacher asks her to point out the word shoe, for example, she pushes on the joystick to scan to the picture of the shoe which will then light up. A Votrax system speaks out the word, thus reinforcing it in the child's mind.*

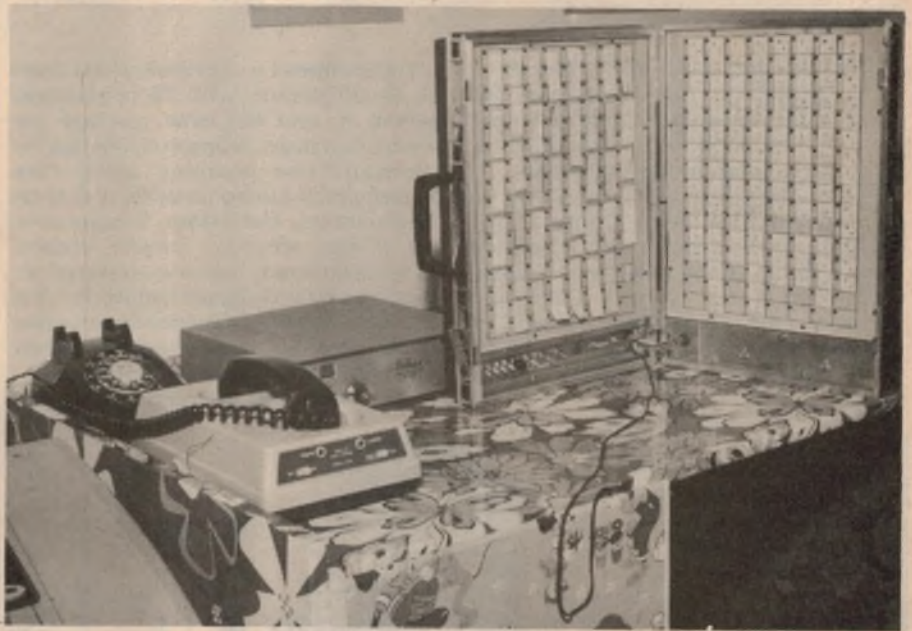

*The portable communication unit was conceived and developed by NRC's Division of Electrical Engineering. The symbols are capable of conveying both subjective and objective life experiences.*

Division, which has been involved in a speech synthesis project for some time. The artificial production of speech by computers has been studied for its possible applications in the field of education.

"Although this artificial speech has a noticeable accent," says Mr. J. Cossalter of the Information Science Section, "it contains the natural stress, intonation and rhythm patterns of human speech, and people quickly adapt to its particular machine accent and soon find it easy to understand."

A software system has been developed which translates written text directly into speech. Text can be read from a computer resident file or typed in from the terminal; the system automatically translates the text into its phonetic representation and then speaks it out. Translation into speech is achieved by applying about 200 pronunciation rules to letter combinations found in the text.

"The text-to-speech system," points out Mr Cossalter, "could be further developed and integrated into a reading

*(continued on p. 109)*



*Design includes power windows and air conditioning*

# Transformer 1: full scale electric passenger car

Until recently, electric vehicles have been little more than "bare-bones" designs for utility applications. Performance requirements meant that weight had to be kept to an absolute minimum, meaning compact vehicles that offered little in the way of accessories or luxuries. Now, an American company has turned this concept upside down by offering power brakes, power windows, air-conditioning and a heater in a big-car design.

It's here!—the world's first luxury electric passenger car. But with a price tag of \$28,000 for the deluxe model, the new car, called Transformer 1, will be beyond the financial reach of most motorists.

Robert Aronson, inventor-President of Electric Fuel Propulsion Corporation, Michigan, the developers of Transformer 1, gave details of the new car at a press conference in Los Angeles, California, last year. The conference included a demonstration ride for pressmen in the model just delivered to actor Lloyd Bridges.

Transformer 1 is the result of ten years of development, with 78 prototypes behind it, and has now reached the production stage. Aronson claims that his company can produce 5,000 cars annually, with a 6-month delivery date on special orders. The 2-door, 5-seater auto has power steering, power brakes, power windows, battery-operated air conditioning unit, liquid fuel heater and defroster. The luxury interior features fine wood panelling, leather-covered seats and a beautifully engineered sun roof.

The Electric Fuel Propulsion Corpora-

tion was established in 1966, and within two years powered the winning car in The Great Transcontinental Electric Car Race. In 1970, two of its vehicles defeated all competition in the Clean Air Race, travelling over 7,000 miles in eight days to win 1st and 2nd place. Aronson is now linking up with both US and European dealers to handle his electric cars, which will come in various models, from a low \$7,000 up to the pricey Transformer 1.

Whilst in Los Angeles, Robert Aronson was also finalising his plans for a network of 100 fast re-charging stations in the Los Angeles area. The stations would buy the necessary rig and make it available to a number of AA service stations in their district.

Inventor Aronson has taken the Transformer 1 cross country to prove its ability to operate easily between 50 and 55mph under its own power source, with a mobile trailer, to permit the electric power source to be fully charged while making the trip. Normally the car would have to be recharged every 45 minutes to make 100 miles due to the driving conditions of the highway traffic. With its mobile power plant in tow, the car can travel over 1,000 miles in 24 hours.

The powerful 180-volt tri-polar lead cobalt battery system is an advanced electro-chemical device delivering more than twice the energy per pound as ordinary lead-acid batteries, and capable of being recharged six times faster. Aronson claims that his batteries can be recharged 800 times, which would be equivalent to driving between 56,000 to 90,000 miles. The batteries will accept a high recharge rate without damage to the cells. The Transformer 1 model carries 2,000 pounds of cobalt batteries.

Other motorists are not normally aware that Transformer 1 is anything but conventional—not unless they notice the absence of engine noise or that the exhaust system is missing. Transformer 1 is pollution free and virtually noiseless in operation, giving it an important edge over conventional vehicles from an environmental viewpoint.



Robert Aronson, President of Electric Fuel Propulsion Corporation, stands beside Transformer 1 for the camera. The production model costs around \$28,000.





*Transformer 1 is the world's first full-size luxury electric vehicle. Standard features include power windows, power brakes,*

*power steering, air-conditioning, a heater, stereo sound, and a luxury interior of leather seats and wood panelling.*



*Above: a surprise for most mechanics. Powerful 180V tri-polar lead-cobalt battery system delivers more than twice the energy per pound of lead-acid batteries. Above right: Aronson and Transformer 1 at a recharging station. Bottom right: Transformer 1 in traffic. Vehicle has a similar appearance to conventional cars.*



Another advantage is that very little maintenance is required. All that is required is that the motor brushes be inspected once a year, and the tyres checked before a long trip. There is no radiator to fill, no engine oil or air filter to change, and no need for engine tune-ups.

Aronson expects to sell 500 cars in Los Angeles in the next 12 months. He now has two distributors for his electric cars, one in Beverley Hills, California, and the other in London. Life expectancy of the new car is put at 20 years with normal driving service. ☺







## YOUR WAREHOUSE OF COMPONENTS

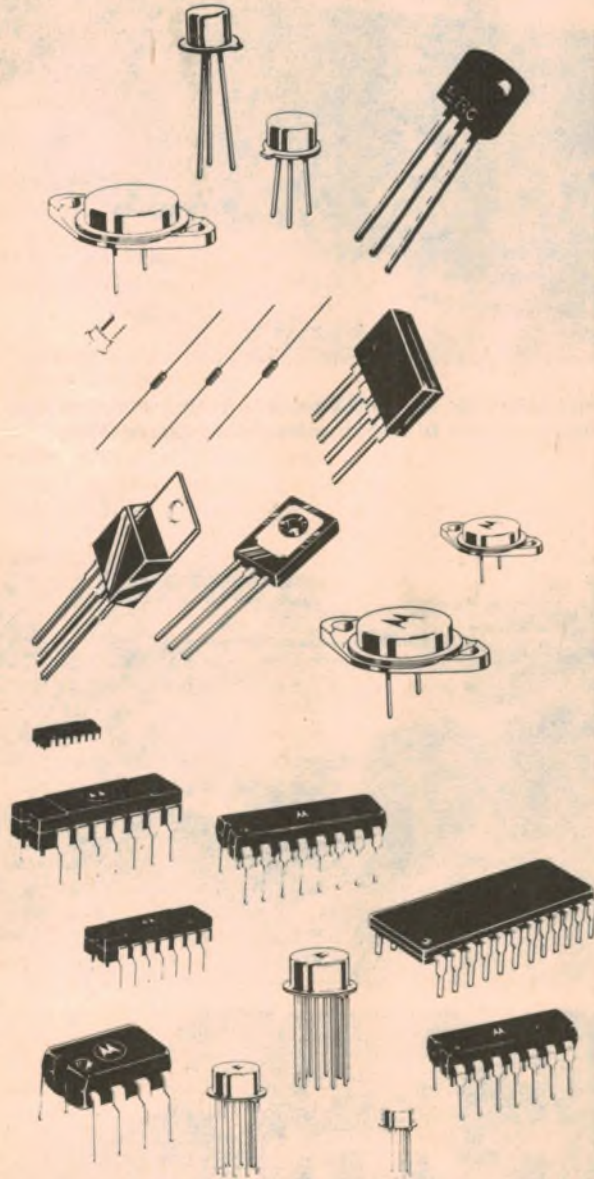

### TRANSISTORS

Small Signal — TO.5; TO.18; TO.92  
Silicon Power — Plastic and Metal  
complimentary pairs 2 Amp through 20  
Amp — including Darlington.  
Field Effect — N and P Channel J FETS and  
MOS FETS.

### DIODES

1 Amp — 3 Amp — 6 Amp Rectifiers  
500m Watt — 1 Watt — 5 Watt Zener  
Diodes.  
BRIDGE RECTIFIERS — 1 Amp — 2 Amp  
and the Super MDA 3500, 35 Amp

### THYRISTORS

SCR: 800m Amp MCR103; 4 Amp C106;  
8 Amp C122; 35 Amp C228  
TRIAC: 4 Amp SC141; 10 Amp SC146; 35  
Amp SC260

### DIGITAL I.C.'s

Standard and Low Power Schottky TTC.  
CMOS — 4000 Series from four major  
suppliers.  
Microprocessors — 6800 — 2650 — 6100  
and 6502  
Memory — NMOS and CMOS Shift  
Registers, RAM and ROM

### LINEAR I.C.'s

Operational Amplifiers  
Voltage Regulators  
Interface  
D/A — A/D Converters

*All these parts at competitive prices —  
from all the leading manufacturers.*

### CEMA DISTRIBUTORS PTY. LTD.

SYDNEY  
21 Chandos Street,  
Crows Nest N.S.W. 2065  
Tele 439-4655

MELBOURNE  
208 Whitehorse Road,  
Blackburn, Victoria,  
3130 Tele. 877-5311

AGENTS  
BRISBANE Electronic Components (OLD) — 371-5677  
CANBERRA Custom Scientific — 82-3581  
ADELAIDE Protronics Pty Ltd — 51-4713  
PERTH Reserve Electronics — 87-1026  
WOLLONGONG Macelec — 29-1276



PHILIPS

SOLID STATE SCIENTIFIC INC.

Signetics



AMI

litronix



# THE 27MHz SCENE

## DUMMY LOADS, SWR METERS AND POWER MEASUREMENT

Activity on the 27MHz band has focused attention, not only on transceivers but on ancillary equipment. In this article we talk about dummy antenna loads, SWR and Power meters and a couple of other interesting items.

by NEVILLE WILLIAMS

A 27MHz operator who becomes involved in any kind of instrumentation rapidly finds the need for a suitable dummy load to connect in place of the antenna. There are various reasons for this:

If the measurements or procedures involve operating the transmitter into a load, it is most inconsiderate to other channel users to use a live antenna as the load and to be radiating a signal unnecessarily while the tests are proceeding. A dummy antenna will keep the RF energy on the bench, where it belongs, and will dissipate it harmlessly in the form of a few watts of heat in the dummy load resistor(s).

Again, if one is concerned with SWR (Standing Wave Ratio), it is highly desirable first to check the readings of the SWR meter at the output of the transmitter (and perhaps of the cable as well) with a proper dummy load connected in place of the antenna. If the SWR meter gives a unity reading under these conditions, subsequent adjustments to the actual antenna can proceed on the safe assumption that the SWR reading will approach unity as the aerial is trimmed towards optimum.

R.F. power output is another measurement of interest to 27MHz operators—often as a second function of an SWR meter. Because a power reading depends on the measurement of RF voltage across a certain load, the reading will be inaccurate if the load is not what it is supposed to be: purely resistive in character and within the range 50-52 ohms for the usual CB-style 27MHz commercial equipment.

In fact, one cannot rely on the average 27MHz antenna to exhibit these precise characteristics and the only logical way to check the power output from a transmitter is to do so when it is operating into a dummy antenna presenting the specified order of load resistance.

If the reading so obtained checks with the transmitter specifications, all would seem to be well. If it doesn't, there may



be a problem to solve: something amiss in the transmitter, supply voltage too low or too high, or inaccuracy in the power meter itself.

The power reading when operating into an actual antenna may differ quite markedly from that into a resistive load and may also vary progressively across the 27MHz band. But, while the readings may not have any absolute value, they can indicate that the transmitter and aerial are still doing their thing!

As already mentioned, most commercial CB style transceivers are designed to operate through nominal 50-ohm coaxial cable into nominal 50-ohm antenna systems. Dummy antenna loads, therefore, need to present this order of resistance—typically within the range 50-52 ohms.

Possibly the simplest dummy antenna currently on the market is the one pictured. Advertised by Tandy, it sells for \$2.95 and is described as a "non-inductive 52-ohm load for testing up to 5 watts".

A very simple device, it is essentially a standard Amphenol plug, with an appropriate resistor wired from pin to shell and tucked down inside the rear end. A slide-on moulded cover affords additional protection. Tandy apparently see it as suitable for use with typical CB style transceivers of up to 5W AM or 15W P-E-P, although we imagine that a prolonged run would cause the resistor to heat quite markedly.

An enthusiast should be able to contrive something similar easily enough, provided they can obtain a suitable 50-52 ohm resistor. Note that it should be non-

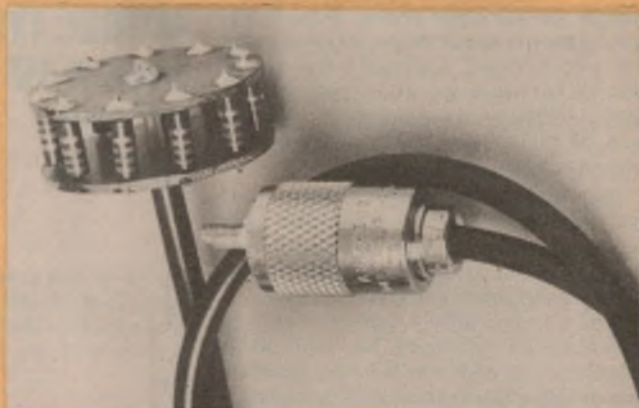

A commercial dummy load (left) as sold by Tandy Electronics, is adequate for 4W 27MHz transceivers but the home-made unit above should handle at least double the power.

inductive, therefore not wirewound, unless it is to a special non-inductive configuration. Options include good quality moulded, carbon film or metal film resistors, with the further option of connecting two or more in parallel to yield a resistance within the desired range.

In fact, a rather better dummy load, as pictured, is well within the capabilities of the average electronic handyman. It uses eleven 1-watt 560-ohm resistors in parallel, to give a resistance of 50.9 ohms and a nominal power dissipation of 11 watts. While quite an array of non-wirewound resistors might be suitable, we used—and would recommend—the metal glaze type made in Australia by IRH.

To mount the resistors as shown, you will need two rings of copper, brass or tinplate, thick enough to ensure a rigid assembly but not so thick as to necessitate wholesale heating when soldering. We chose to use two circles of PC board, with the copper facing outwards and accessible for soldering. This way, rigidity is ensured and soldering is no problem at all.

The size of the cheeks is not critical but we chose to finish them to a diameter of 40mm. Having marked the centre of one of them, scribe a 35mm circle and then divide it into 10 equal parts to accommodate the 11 resistors. Clamp the cheeks together, copper side out, and drill fine holes right through each. This done, the resistors can be threaded through, spot soldered, and the leads clipped off.

Finally, cut back the outer sheath of a piece of RG58 or other 50-ohm cable (length not critical) and spread the braid so that it can solder to one copper cheek. Pass the centre insulated conductor through and trim its insulation so that the centre conductor passes through to the



# THE 27MHz SCENE

copper on the other cheek. If the holes are made no larger than necessary and the job is done carefully, the result should be mechanically quite strong. Add an Amphenol type plug to the other end of the cable and your dummy antenna load is complete.

And while it is intended here primarily for use with 27MHz equipment, past experience with this type of construction suggests that it would be suitable for use on any band up to 400MHz or more.

While it is entirely practical for an enthusiast to construct his own SWR meter to use with the dummy antenna (see article elsewhere in this issue) commercial SWR meters are readily available at modest cost from radio stores distributing CB type equipment.

Typical of such units is the model 110 meter pictured, and sold locally in Dick Smith Electronics stores for \$19.75 (catalog no. Q-1352). It combines three functions: an SWR meter, a power meter



A "Vanco" low-pass filter for 27MHz transceivers, as sold by Dick Smith Electronics. (Catalog D-7082, \$10.50.)

and a field strength indicator—suitable for use within the frequency range 1.5 to 144MHz.

The SWR function involves a segment of open line between two SO-239 UHF connectors, with pickup wires feeding the rectifiers and metering circuit in the traditional way for such instruments. It requires a progressively higher power through-put to produce full-scale deflection at the lower frequencies, typically 15W at 7MHz, 25W at 3.5MHz and so on. At 27MHz, there is sensitivity to spare with a typical 5W input transceiver. The meter face is directly calibrated in SWR from 1 to 3, the apparent assumption being that ratios greater than 3 need to be corrected rather than measured!

Assumed system impedance, by the way, is 52 ohms and the rated accuracy as an SWR meter is 5%, which is ample for non-professional applications.

As an RF power meter, the 110 has two switch positions giving full-scale readings of 10W and 100W. Ideally, the meter should be used with a resistive dummy antenna but the manufacturers state that reasonably accurate power indications will be obtained working into a live antenna, provided that the SWR has been shown not to exceed 1.5.

## MODEL 110 SWR & RF POWER METER

*An SWR and power meter is invaluable as an indication that all is normal in the "rig".*

Rated accuracy of the 110 on power measurements is 10%. The higher figure is due to the fact that power is proportional to the square of the voltage across the load, so that any inaccuracy in reacting to volts is compounded when translated into a power reading.

Common practice with a meter like the 110 is to leave it connected permanently in the antenna feedline so that, at a flick of a switch, it can show either SWR or the power being fed to the aerial. Alternatively, the instruction leaflet suggests that it be set for half-scale reading in the SWR Forward mode, any variations in the behaviour of the system thereafter being fairly obvious.

This would, in fact, be an option with any SWR meter, including the do-it-yourself instrument described elsewhere.

A further option is to use the 110 as a field strength indicator, quite separate from the transceiver and relying on its own pickup spike or other independent antenna. In this mode, its reading will be dependent more on the actual radiated field rather than on what is being fed to the antenna.

Under test, the 110 SWR & Power meter performed very well indeed and appealed as an instrument that would be

very useful in any transmitting situation within its power limits (0-10-100W) and frequency limits (1.5-144MHz). And at \$19.75 it is certainly not expensive.

Another small instrument which has recently made its appearance on the Australian market is the Kopek International "RF Signalizer". The unit pictured is the RP-10, intended primarily for the 28MHz amateur band but often used on 27MHz. However, Dick Smith Electronics are planning to market the RP-27, intended expressly for the 27MHz band. Designated by the catalog number D-3828, it is priced at \$47.50.

The Signalizer connects directly into the antenna coax, and is powered by the same supply as the transceiver, typically 13.5V at about 35mA.

In transmit mode, the signal passes straight through to the antenna but, in the absence of signal from the transmitter, the Signalizer reverts automatically to receive mode, and introduces a variable gain preamplifier into the line. The gain is continuously variable between about -20dB and +15dB.

The contribution which a Signalizer can make to 27MHz communication depends almost entirely on the performance of the main transceiver. If the trans-

*(Continued overleaf)*

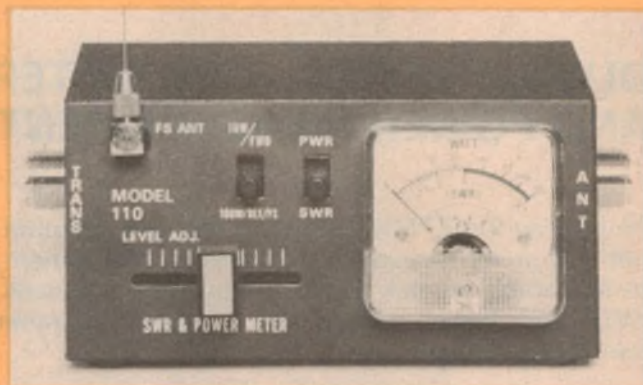

## 27MHz PREAMP

*Under the title "RF Signalizer", Kopek International Ltd market a range of RF preamplifiers. The RP-10 shown is really intended for the 28MHz amateur band, although frequently used for 27MHz. RP-27 is the preferred type for this frequency.*





# THE 27MHz SCENE

## REALISTIC TRC124 TRANSCEIVER FROM TANDY

Up-to-the minute in its design, the new Realistic TRC-124 solid-state CB-style transceiver has made an immediate impact on the Australian market. And little wonder; appearance is good and, on test, its performance was quite outstanding.

An AM-only unit, it covers the usual 23 channels of the American class-D citizens band, but does so using the phase lock loop (PLL) principle, instead of a multiplicity of individual crystals.

Physically, the TRC-124 is very similar in appearance to its earlier stablemates, being housed in a black vinyl surfaced case measuring 165mm wide x 55mm high x 215mm deep. Two knurled studs on the sides can secure it into a cradle bracket, either to hang beneath the fascia of a car or boat or to stand propped up on a tabletop or shelf. The in-built loudspeaker radiates through a grille in the bottom of the case.

This much is conventional.

The most striking variation in the front panel design is a channel selector knob devoid of channel numbers. When the transceiver is switched on, however, an inscrutable dark window is revealed as the filter over a LED readout, which displays the channel number in use far more clearly than is normally possible with the more usual calibrations. The switch itself has a very light, smooth feel, partly because of its design and partly because it would appear to involve only two wafers.

Alongside the channel window is an edgewise meter which serves a triple function. In "receive" mode it is fully illuminated and acts as a calibrated S-meter. In "transmit" mode it indicates the relative power output of the unit. At the same time, the illumination level is reduced but pulses with speech to indicate that the output signal is being modulated.

On the opposite side of the panel, a "Delta Tune" switch provides a plus and minus shift in the tuning, to accommodate better to an off-frequency signal, or possibly to dodge interference on one or other sideband.

Other controls on the front panel



include volume, off/on; squelch; RF gain; noise blanker; P.A. switch. The press-to-talk button is in its usual position on the microphone and the modulation gain is preset on the assumption of an average close-talking situation. The rear panel accommodates the antenna socket and miniature jacks for an extension speaker and P.A. speaker—the latter being essential if the P.A. facility is to be used, usually for boating situations.

Access to the TRC-124 is very easy: remove four screws and the break-apart case opens to expose both sides of the large printed board which accommodates virtually the whole of the circuitry. According to the manufacturer's handbook, there are 28 transistors involved, 1 FET, one LSI integrated circuit, 3 ordinary ICs, 25 diodes and 1 thermistor. Three crystals provide the necessary frequency references, with the phase locked loop doing the rest. Good selectivity is ensured by two ceramic filters.

Specifications credit the receiver with a sensitivity of 0.18 $\mu$ V for 10dB signal/noise ratio; selectivity  $\pm$  3kHz at -6dB; adjacent channel rejection 60dB; audio output 3.5W at 100Hz for 10% distortion.

For the transmitter, power output is quoted as 4W maximum with modulation from +90% to -100%—this into a 50-ohm load; frequency tolerance better than .005%.

Normal supply voltage is 12, negative ground.

Most of our observations, covering the behaviour of the transceiver on air, were made in a home situation using the power supply described in the January issue and the 5/8-wave antenna described in March. Reception reports on transmission quality were uniformly good and the power output at the particular supply voltage read as 3.2W into a dummy load and 4.0W with the antenna connected.

Sensitivity of the receiver was confirmed when it readily resolved the modulation from a signal generator in the "shack" with the RF output turned down to minimum (a small fraction of a micro-volt) and with the modulation cut back to 10%! And, under ordinary receiving conditions it did all the right things in this often congested and noisy band.

Independent checks under vehicle mobile conditions confirmed the effectiveness of the noise blanker in dealing with pulsed interference.

If the TRC-124 was to be criticised at all, it would be because it lacks SSB facilities. But then, at a post-devaluation price of \$169.95, it is \$100 or so below the price of its AM/SSB counterparts.

The Realistic TRC-124 is sold through all Tandy Electronics stores, although we have been warned that supplies are currently lagging behind the demand. It carries a 90-day warranty and back-up service is provided by Tandy. (W.N.W.)

### DUMMY LOADS, etc.

*(Continued from previous page)*

ceiver has high intrinsic sensitivity and high signal/noise ratio, a preamplifier will not add to the number or readability of available signals. Conversely, if the transceiver has limited performance, or you are listening with an all-band receiver (which are commonly poor in the 27-30MHz region) a high performance wide-band preamplifier like the Signalizer could make a lot of difference.

Curiously, reports about the Signalizer indicate that it is often just as useful in the alternative role of attenuating signals which might otherwise block a receiver having limited AGC or overload performance.

So who needs a Signalizer?

Presumably those whose receivers cannot properly cope with very weak and/or very strong signals.



# Simple low-cost SWR meter

*... checks HF antennas up to 27MHz*

Having completed the installation of some new 27MHz gear in your home station or car, there may be a lurking suspicion that it is not working at its maximum possible efficiency. With the standing-wave-ratio or SWR meter described in this article, you will be able to check on your antenna and feeder and make adjustments as necessary.

by IAN POGSON

If a radio transmitter is to operate efficiently, certain important requirements must be met. An antenna must be provided which is suited to the general situation and, in order to get the energy to it from the transmitter, some kind of feedline is required. In particular, it is the relationship between the feedline and the antenna which concerns us in the present article.

We have mentioned a "standing-wave-ratio meter", but what is its purpose? It is a device intended to show the presence or otherwise of "standing waves" and hence the "standing wave ratio" on the transmission line between the antenna and transmitter.

What are standing waves and what is their significance? This is quite a curly question and much has been written and said about it over the years. Without digging too deeply, we will take a look at the subject and see what we come up with.

As a generator of RF energy, a transmitter needs to work into a certain order of load resistance—either a specified value or within a range of values to which the transmitter can accommodate by adjustment. Most CB-type 27MHz commercial transmitters are designed to work into a nominal 50-ohm load and we will confine our remarks to this figure.

Working on this assumption, if we connect a resistor of 50 ohms across the output of such a transmitter, it will deliver its rated power into the resistor. One rather obvious point is that the resistor must be capable of dissipating the output from the transmitter—typically up to 5 watts for CB style equipment.

Although the above exercise might satisfy the transmitter from the point of view of loading, it is of little use when we want to radiate the energy and use it for communication. So let's envisage a couple more steps.

Instead of a resistor, consider the hypothetical case where we connect a transmission line of infinite length across the output, instead. Assume also that the line is designed so that its distributed inductance and capacitance per unit length gives it a "characteristic impedance" of 50 ohms. As such, it will appear to the transmitter the same as the 50 ohm resistor and the transmitter will

deliver the same amount of energy into the line.

Remember that we said that the hypothetical line was of infinite length, so that the energy fed into it always had a place to go!

Now suppose that we substitute a practical 50-ohm transmission line of finite and random length, and we connect a resistor of 50 ohms across the far end of the line. The situation, as far as the transmitter is concerned, will be the same as with a line of infinite length: the transmitter will deliver the same amount of energy, which would travel down the line and be dissipated as heat in the resistor.

But, of course, we are still not meeting the ultimate objective of radiating the energy from the transmitter by means of an antenna.

So, instead of the resistor at the far end of our transmission line, we now connect the line to an actual antenna. Assuming that the antenna is resonant at the frequency of interest and that it is so arranged that the feed point "looks like" 50 ohms, then all of the energy arriving via the feedline will be accepted by the antenna and most of it should be radiated as desired.

Under these conditions, there will be a continuous flow of current along the line, with the values of current and voltage along the line being uniform.

The line is then said to be "flat"—nothing to do with its physical appearance but indicating that it is terminated by a load equal to its own characteristic impedance.

Now consider the situation where the load presented by the aerial to the feedline is something other than 50 ohms. This could be due to the aerial not being resonant at the frequency of interest, or the provisions at the feed-point are not correct.

When the feed point resistance looks to be other than the required 50 ohms, we have a situation called a "mismatch". When the transmitter power is fed into

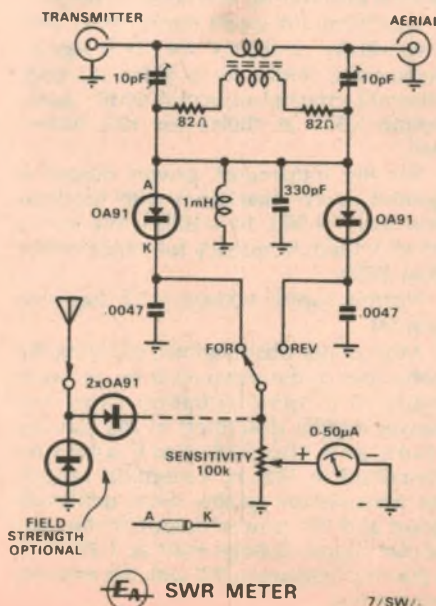



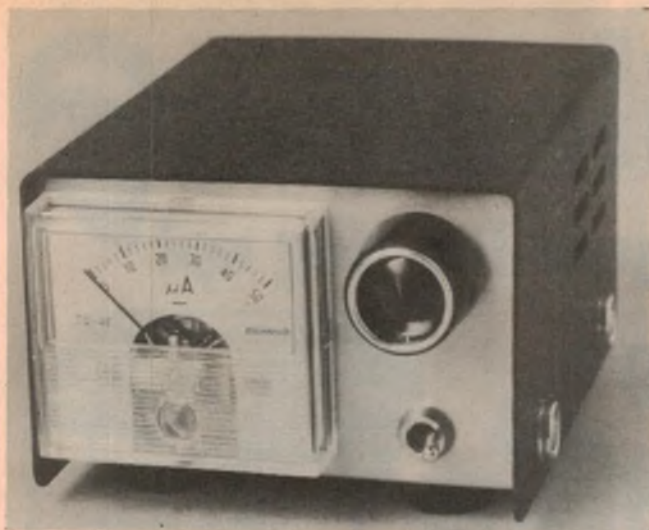

*Our prototype SWR meter, housed in a standard commercial case. Meter calibrations are shown on the following page.*

the system, some of the energy is absorbed by the load but a certain amount (depending upon the extent of the mismatch) is reflected back along the transmission line. The voltage and current associated with the reflected energy adds algebraically with the forward current and voltage, which results in a variation of current and voltage along the length of the transmission line.

If one were to measure and plot the voltage or current along the length of the cable, the resulting graph would show a cyclic variation in amplitude related to the wavelength of the particular frequency within the cable. This is referred to as a "standing wave".

The ratio between the maximum value of voltage or current at any point in the cable to the minimum value elsewhere is referred to as the "standing wave ratio" or "SWR".

The SWR for a properly matched or "flat" line is 1. With a small mismatch, the figure may rise to 1.1 or 1.2, increasing for a serious mismatch to 3 or beyond.

As the SWR rises above 1, and the line becomes less "flat", its apparent impedance as seen by the transmitter, can no longer be relied upon to be 50 ohms. In turn, this may inhibit the transmitter from delivering the anticipated amount of power to the line.

In addition to the inconvenience of not being able to load the transmitter up to its normal power capability, the presence of standing waves on the transmission line leads to a certain amount of extra energy wastage in the line, due to resistive and dielectric losses.

In short, the presence of standing waves on a transmission line is to be avoided, or at least reduced to a level where they are of little consequence. This is where the Standing Wave Meter comes into the picture. With it, we are able to determine the magnitude of standing waves on a transmission line, and hopefully make appropriate adjustments to eliminate or minimise them.

A detailed explanation as to how a standing wave meter works can become

quite involved and so we will content ourselves with a somewhat simplified treatment.

If we consider the case where the feedline is terminated in a purely resistive load, any outgoing power on the line will have its current and voltage in phase. On the other hand, if the terminating resistance is not the correct one, as we have already found, there will be some reflected power on the line and in this case the current will normally be out of phase with the voltage. The standing wave meter is so designed that it can discern between an in-phase and out-of-phase condition and give readings accordingly.

Construction of a standing wave meter is quite simple and, provided a little care is taken, it should be possible to come up with a unit which will do the job just as well as commercially available units. It should be stressed that the instrument should be constructed as described. If there are significant deviations, they could lead to a situation where it may not be possible to adjust it properly, with consequent unsatisfactory performance.

We housed our meter in a commercially available box, measuring 83mm wide, 56mm high and 102mm deep. This box is available from Dick Smith Electronics; it is modestly priced and well suited for our purpose. If you are unable to get one for any reason, or you wish to use some other box, there is no reason why you should not do so, provided that you keep the layout similar to the original and keep leads to the input and output sockets very short. In fact, we soldered the lugs of the board assembly directly to the corresponding lug of each of the sockets.

To keep costs down, we avoided the use of a printed board. As there are only a few components to be mounted into the main assembly, we elected to use a piece of miniature tag board instead. The diagram shows the location of all the components on the board and it is important that this should be closely followed.

Before starting on the general assembly, the secondary winding should be put on the balun core. The winding consists of four turns of 20 B&S enamel wire through one hole of the core. There will be four passes through the hole with three across the outside. Leave leads about 2cm long.

For the board assembly you will need a piece of miniature tag board with six pairs of tags. Only five pairs are actually used. Mount the transformer which you have just wound first. Keep the leads short and position the transformer in a central position with respect to the three pairs of tags at one end. The primary "winding" consists of a short piece of hookup wire passed through the unused hole in the core and each end soldered to the end pair of lugs. Do not forget the two ties under the board. The RF choke and the 330pF capacitor are connected in parallel, also under the board and between the ties. Fix both items so that they are close together and as near as possible to the centre of each tie.

The two trimmers should be carefully mounted at each end of the transformer. Make sure that they are mounted as symmetrically as possible, also taking care not to burn the body of the trimmer. The rest of the items may now be mounted on the board, still making sure that all leads are as short as possible and maintaining symmetry.

With the wiring of the board completed, the meter, switch and potentiometer can be fitted to the front panel and the two coaxial sockets can also be fitted to the back panel. The main board is held at one end by soldering the appropriate lugs directly to the lugs of the coaxial sockets. At the other end, we used a 1in long, 1/8in Whitworth screw, with three nuts as a standoff mounting.

## PARTS LIST

- 1 Box, 83mm wide x 56mm high x 102mm deep (see text)
- 1 Miniature switch, SPDT
- 1 Potentiometer, 100k linear
- 1 Knob
- 2 Coax sockets, S0-239
- 1 Meter, 0-50uA, 48mm wide x 42mm high
- 1 Miniature tag board with 6 pairs of tags
- 1 TV balun core, Neosid type 1050/1/F14
- 2 0A91 diodes
- 2 0A91 diodes (for field strength)
- 1 Terminal (for field strength)
- 1 RF choke, 1mH
- 2 82 ohm 1/2W resistors
- 2 10pF Philips trimmers
- 1 330pF polystyrene capacitor
- 2 .0047uF greencap capacitors

Miscellaneous  
Hookup wire, solder, solder lugs, screws, nuts.



# Ahoy, Me Hearties



look at the pirate treasure I've dug up!



125<sup>00</sup>

**BUDGET MIDLAND**  
CB without tears — and without parting with too much loot! Full 5W input, 23 channel operation. AM. Comes with mic & mtg. brackets, etc. Cat D-1430



159<sup>50</sup>

**WORKHORSE MIDLAND**  
Australia's most popular AM transceiver. ANL & NB make noise almost disappear! High quality receiver, rugged transmitter. A beauty! Cat D-1436

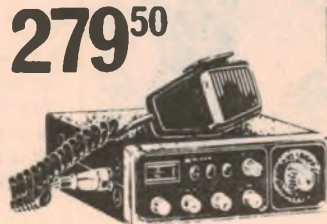

279<sup>50</sup>

**SUPERB SSB MIDLAND**  
One of the most-used SSB rigs around. Incredible range — much more efficient than DSB (AM) units. 69 available modes, 23 channels. 5W input. Has RF gain control, too! Cat D-1700

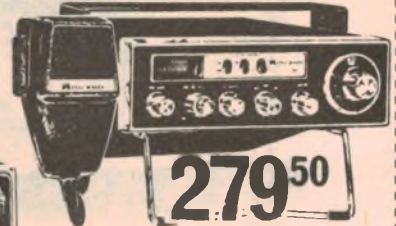

279<sup>50</sup>

**BASE/MOBILE SSB MIDLAND**  
Very similar rig to the 892 — but has an inbuilt 115 volt power supply. To go base, all you need is a 240/115V transformer — which Dick sells! (Cat M-1158) So you have the option with this rig of base or mobile! Cat D-1710



79<sup>50</sup>

**SANYO 5 WATT  
6 CHANNELS!**

**AUSTRALIA'S MOST SOUGHT AFTER MARINE TRANSCEIVERS.** Both hand held and mini marine are full 5W input, with 6 channels (1 supp. on 27.88MHz). Both are ideal for the weekend yachtsman or fisherman — or with the correct crystals, on any 6 CB channels. Very versatile units!

**HAND HELD:** Very heavy duty units, can also be used as base (6 different output functions allowed). Optional carrying case available. Cat D-1142 .. . \$79.50

**MINI MARINE:** Tiny size allows installation anywhere! Supplied with hardware & mic, etc. You cant go past this one! Cat D-1152 .. \$89.50

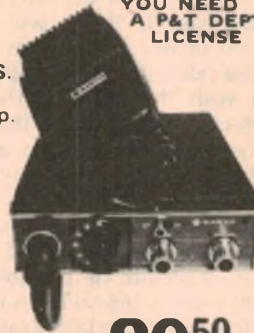

TO OPERATE THESE UNITS IN AUST. YOU NEED A P&T DEPT LICENSE

89<sup>50</sup>

**WHITE FLASH 29<sup>00</sup>  
HELICAL**

YOU'VE SEEN WHAT YOU GET ELSEWHERE FOR THE PRICE: That's right — just the helical! You then have to buy the base, the co-ax lead, the PL259 plug, etc. Not with the 'White Flash'. That's all included in the one low price. And what's more, it's all pre-assembled. You only have to connect the plug to the rig, mount the antenna, and away you go! What could be simpler? Cat D-4076.

## HANS THOLSTRUP USES MIDLAND

In his recent marathon journey, Hans Tholstrup used Midland 27MHz gear exclusively. Even he was amazed at the range and performance he obtained — even in the middle of Bass Straight! If it's good enough for Hans Tholstrup to stake his life on, surely Midland is good enough for you?

Hans used a Midland 13-854 marine unit, a Midland 23 channel CB & two 'White Flash' helical antennas.



## ARE YOU READY?

MY GREAT, MAMMOTH, STUPENDOUS, EXCITING, FANTASTIC, INCREDIBLE, SUPERB, AMAZING, NEW 1977-78 SUPERCATALOG WILL BE RELEASED IN THE NEXT ISSUE (MAY 1977) OF



**ELECTRONICS  
Australia**

(SUPERLATIVES COULD NOT DESCRIBE IT!)

### DICK SMITH ELECTRONICS GROUP

Mail Orders: P.O. Box 747, Crows Nest, N. S. W., 2065.

N.S.W. Branches: GORE HILL - 162 Pacific Highway, 439 5311.

SYDNEY - 125 York St., 29 1126. BANKSTOWN - 361 Hume Hwy., 709 6600.

Interstate Branches: QLD - 166 Logan Rd., Buranda, 391 6233.

VIC - 656 Bridge Rd., Richmond 42 1614.



**DICK SMITH DEALERS**  
Sound Components, Tamworth NSW 66 1363  
The Record Centre, Griffith NSW 62 1677  
M&W Electronics, Orange NSW 62 0401  
Electronic Hobby Centre, Palm Bch, QLD 34 1248  
Aero Electronics, Hobart, TAS, 34 8232  
Altronics Parts, Perth, WA 28 1599  
A.E. Cooling, Elizabeth St, SA 255 2249  
Vaneman & Wyatt, Stuart Pk, NT 81 3491  
Pacific Electronics, Honiara, Solomon Is 494  
DEALER PRICES MAY BE HIGHER TO COVER HIGH TRANSPORT CHARGES

**SHOP HOURS**  
Mon - Fri: 9 to 5.30  
Sat: 9 to 12

MINIMUM AMOUNT FOR BANKCARD IS \$5.00

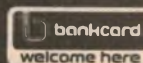

### NEW POSTAL CHARGES

Order Value	Charge
\$5 - 9.99	\$1.00
\$10 - \$24.99	\$2.00
\$25 - \$49.99	\$3.00
\$50 - \$99.99	\$4.00
\$100 or more	\$5.50

By Courier Freight. Minimum packing and handling charge \$1.00. We despatch 'brightly' and you pay when you receive the goods.  
FOR C.O.D. SEND \$2.40 EXTRA PLUS \$3.00 DEPOSIT  
MINIMUM MAIL ORDER AMOUNT IS \$5.00



## SWR Meter

With all the components fitted to the box, there is some interwiring to be done. Most of it may be seen from the inside picture. While these leads are not vital, they should all be kept reasonably direct. The earth lead from the potentiometer goes to the negative meter lug and then to the nearest earth lug on the board. You will also notice that there are two lugs fitted under the socket mounting screws. A piece of 16-gauge tinned copper wire should be soldered across these lugs and another piece of the same wire taken from each lug out to the two earth lugs on the board.

The standing wave meter is now complete and it remains to adjust the two trimmers before it can be used. To make this adjustment, you will need a 50 ohm dummy antenna capable of dissipating the power output of your transmitter. If you do not already have one, a suitable unit is described elsewhere in this issue.

You will need a piece of 50 ohm coaxial cable, about 50cm long and with a suitable coaxial plug at each end. Connect one end of this lead to the transmitter output and the other end to the input side of the standing wave meter. Looking towards the front panel, and if you have wired the unit the same as the prototype, the input socket will be at the left. Now connect the dummy antenna to the output socket of the standing wave meter. Set the two trimmers to mid position. Throw the switch to the right, which should be the "forward" position. Set the potentiometer to about mid position.

Switch on the transmitter. The meter should give a reading. Reverse the switch and the reading should be less. If not, the switch is operating in the opposite mode and this should be taken into account. With the meter in the forward position, adjust the potentiometer for a full scale reading on the meter. Set the switch to "reverse". With an insulated aligning tool, adjust the trimmer nearest the transmitter for a dip in the meter reading. Switch off the transmitter.

Now reverse the leads at the back of the standing wave meter and repeat the process. With the switch in the opposite position for "forward", adjust the potentiometer for full scale reading on the meter. Reverse the switch and adjust the other trimmer now nearest the transmitter, for a dip in meter reading. The above process should be repeated until you get the situation where a full scale forward reading is reduced to zero when the switch is thrown to the reverse position. The standing wave meter is then ready for use.

There is still one problem to solve. The meter as purchased will have a scale calibrated 0-50 and the readings on this scale must be converted to SWR.

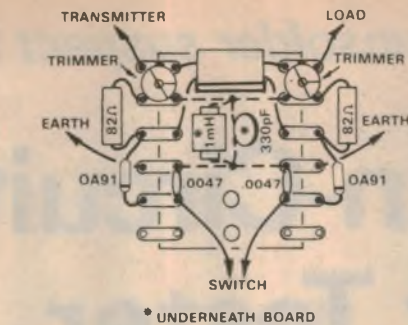

This wiring diagram should make assembly of the tagboard a straightforward process. The input and output lugs are soldered directly to their respective sockets.

Right: internal view of the prototype. Follow the symmetrical earthing arrangement detailed in the text.

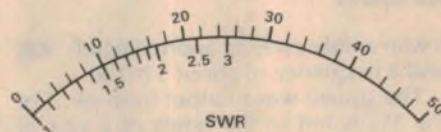

The relationship between the calibrations of a 0-50 scale meter and SWR values can be seen at a glance from this diagram.

The table at right is presented for those who may wish to fit a calibrated scale directly to the meter, or mark the SWR points on the existing scale.

Regardless of the meter scale calibrations, provided that they are linear, the SWR may be readily calculated by the formula. Assuming the 0-50 scale,  $SWR = (50 + x)/(50 - x)$ , where  $x$  is the actual "reverse power" scale reading.

To avoid having to calculate the SWR each time, we have provided a table giving readings up to 3. It is then an easy matter to check the scale reading and read off the SWR from the table.

To make the process even easier, we have drawn a meter scale, calibrated 0-50, with the corresponding SWR readings marked on the scale. Instead of using the table, you may check the readings from your meter scale, against the calibrated scale. Also, if you have the facilities to copy the calibrated scale, you may make up a scale and fit it directly to your meter. A further thought. You may see fit to take the original scale off the meter, fill in the SWR points and then refit.

How to use the SWR meter and make adjustments to antennas is a subject in its own right and we will content ourselves at this stage with just a few remarks. Possibly at a later date we will go into the subject more fully.

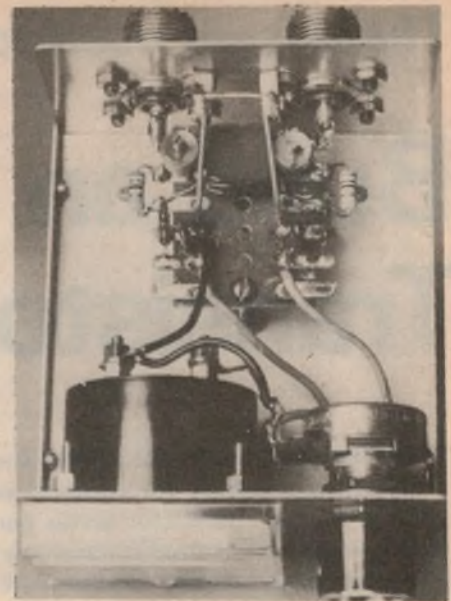

METER TABLE	
SWR	SCALE
1.0	0
1.1	2.38
1.2	4.55
1.3	6.52
1.4	8.33
1.5	10
1.6	11.54
1.7	12.96
1.8	14.28
1.9	15.5
2.0	16.67
2.5	21.4
3.0	25

If you have a commercially made antenna system, more than likely, all you will use the SWR meter for is to confirm that all is working as the makers intended. On the other hand, if you are involved in the installation of an antenna on a car, due to the many variables encountered, the performance may not be as predictable as one would hope. Under these conditions, adjustments may have to be made to the length of the antenna and possibly to the feed system, to get the optimum performance.

An optional extra which you may add to your SWR meter, is the facility for measuring field strength. This may be done by adding two 0A91 diodes and a terminal, as shown in the circuit. An "antenna", which will be determined experimentally, is added to the terminal. It may typically consist of a piece of 16 gauge tinned copper wire, about 25cm long. The unit, with its antenna will then have to be placed close to the output of the transmitter, or rather the transmitting antenna to get sufficient pickup to be indicated on the meter. The sensitivity control will normally be set full on. The field strength meter will then serve as an indicator when the transmitter is on. ☺



*There is no need to unsolder suspect transistors!*

# Build an In-Circuit Transistor Tester

Servicing solid-state equipment can present problems because of the difficulty in checking components without removing them from circuit. An "in-circuit" transistor tester can be a great help in this regard as it can pinpoint most malfunctioning transistors. Servicemen and hobbyists are sure to find the simple tester presented here a most useful aid.

by LEO SIMPSON

This device was originally published in the English magazine "Television" in October 1976. Their version was assembled on Veroboard and housed in a diecast case. Our version is assembled on a PC board and housed in a low-cost plastic case. In other respects, the design is virtually identical.

Until recently, in-circuit transistor testers have not been readily available nor cheap to buy in Australia. So servicemen and hobbyists have had to rely on voltage measurements to locate faulty transistors. Even so, there are many circuit applications where voltage measurements may not give a clear indication of faulty devices. Flip-flops are just one example.

Another reason why voltage measurements may not be useful is that power applied to a faulty circuit may cause further damage. And while ohmmeter measurements can be helpful, they do not always give clear cut results.

So a strong case can be made for an in-circuit transistor tester of the type described here. Indeed, we suspect that once a serviceman or hobbyist has used such a device he may wonder how he ever managed without it.

Both NPN and PNP transistors can be tested without operating switches or controls.

There are two LED indicators. When a good NPN device is tested, one LED flashes. If a good PNP device is tested, the other LED flashes. If the device is faulty, either both LEDs flash or both are extinguished.

All that the tester is supposed to indicate is that transistor action is taking place—i.e., base current causes the collector-emitter path to become a low resistance in one direction. The tester does not give any indication of beta or high leakage in a transistor.

The nucleus of the circuit is a 555 timer integrated circuit working in the astable mode. It produces a square wave at pin

3 with a duty cycle of approximately 50% and a frequency of about 3 hertz.

The square wave output from pin 3 of the 555 is fed to the bases of a pair of complementary transistors with their collectors tied together. The transistors produce an inverted version of the square wave input. So the circuit described this far is a low frequency generator with complementary outputs, which have been designated the x line and the y line.

The total output derived from the x and y lines is a square wave with amplitude approximately equal to twice the battery voltage. This 3Hz square wave is applied, via a 330 ohm resistor, to a pair

Similarly, when a good PNP transistor is under test, it will conduct when line y is positive with respect to line x. This will extinguish LED2 and allow LED1 to flash the "PNP OK" signal.

Any transistor under test with an open circuit junction will extinguish neither LED, so both continue to flash. Transistors with a short circuit between collector and emitter will extinguish both LEDs.

The circuit also has to distinguish between functional transistors and those devices with short-circuit collector-base or base-emitter junctions. This is where diodes D1 and D2 come into the picture. The voltage drop across a functional transistor, when conducting, is typically 0.2V or less, in this circuit. By contrast, a device with a short circuit c-b or b-e junction will have a voltage drop of about 0.7V.

Thus, when a functional NPN device is being tested, the forward voltage drop across LED1, due to D1 and the transistor under test, will be small enough to extin-

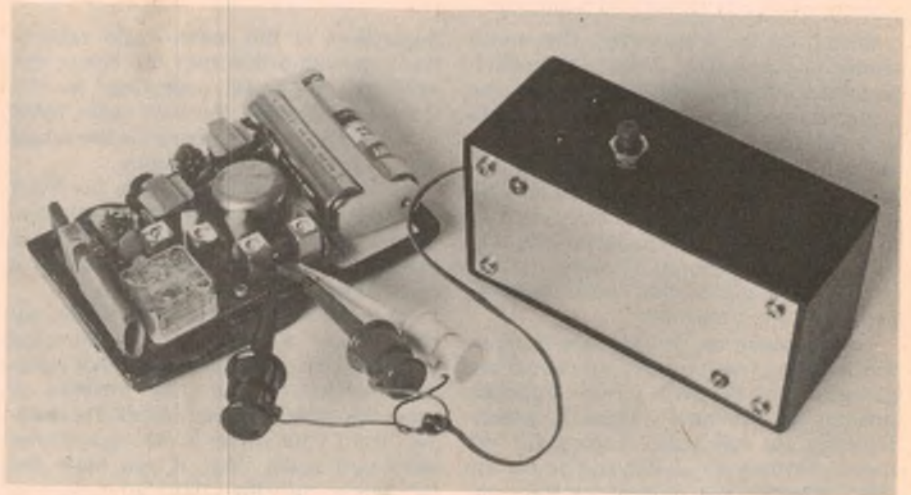

Checking suspect transistors in a circuit is easy with this In-Circuit Tester.

of light emitting diodes connected in inverse parallel. With no transistor under test, this results in the LEDs flashing alternately at the 3Hz rate.

When the transistor under test is a "good" NPN type, it will conduct when line x is positive with respect to line y. This will extinguish LED1. LED 2 will continue to flash at the 3Hz rate to indicate "NPN OK".

guish it. But when a device with a short-circuit junction is tested, its forward voltage drop combined with that of D1 (or D2), is enough to allow the associated LED to continue flashing. So both LEDs continue to flash for a device with a short-circuit junction.

Since the current drain is quite low and the likely use is intermittent, the power requirement can be met by a small 9V



battery such as the Eveready 216.

We assembled the circuit on a small PC board measuring 76 x 45mm, code 77tt4. The transistors used may be BC548 and BC558 or any of their multitudinous equivalents. The diodes are 1N4148 or equivalent.

Space has been provided on the PC board for additional diodes in series with D1 and D2. These may have to be added to suit particular LEDs. This is because some LEDs have a wider or narrower voltage range over which they will emit light. So it may be necessary to add more diodes or use a combination of silicon and germanium diodes to obtain satisfactory LED indications. The criteria are: One LED must be extinguished by a functional transistor under test; both LEDs must continue to flash when a transistor with a shorted junction is under test.

A small plastic box with a light-gauge aluminium lid houses the prototype tester. Measuring 102 x 53 x 41mm, these plastic boxes are available at low cost from Dick Smith Electronics Pty Ltd.

There is no special wiring layout required for the tester. Use a small low powered iron when soldering.

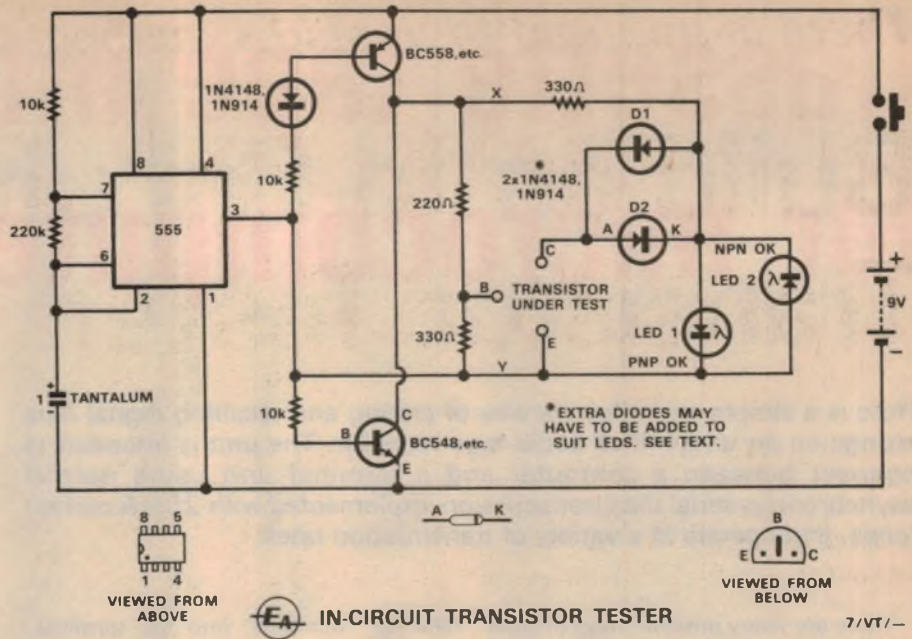

The circuit is basically a 3Hz oscillator with complementary outputs.

## PARTS LIST

- 1 plastic box, 102 x 54 x 41mm, with aluminium lid
- 1 PC board, 76 x 45mm, code 77tt4
- 1 555 timer integrated circuit
- 1 BC548 NPN transistor
- 1 BC558 PNP transistor
- 3 1N4148 silicon diodes
- 2 red LEDs
- 3 small E-Z hooks, red, black, grey
- 1 9V battery, Eveready 216, plus connector
- 1 push-button switch with "normally open" contacts
- 1 1μF tantalum capacitor

### RESISTORS

- ( $\frac{1}{2}$  or  $\frac{1}{4}$ W, 10% tolerance)
- 1 x 220k, 3 x 10k, 2 x 330 ohms, 1 x 220 ohms.
- Battery clamp, connecting wire, screws, nuts, washers, solder.

Two schemes could be used for making connections to transistors in circuit. The method used in "Television" was to have a pair of probes, one containing the circuitry and the other with a double prod. This would work well for testing from the underside of PCBs, but might be inconvenient when testing transistors with the less common leadout arrangements. It would also be less practical when working from the component side of a PCB.

Our method, which is easier to implement, uses three miniature clips of the E-Z hook type. The type we actually used was the Pomona "grabber". In practice though, these are a little large

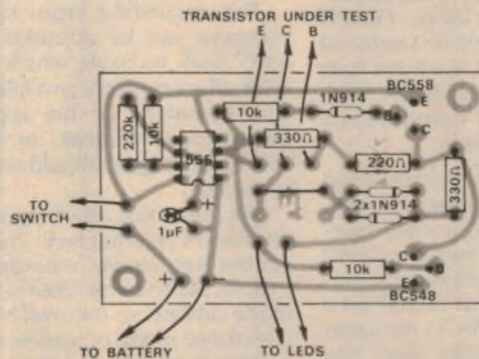
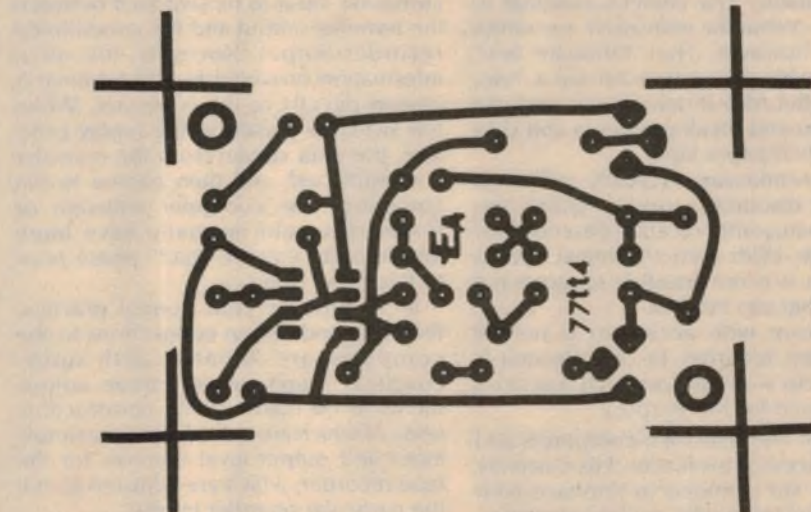

Above is the PC pattern, actual size. At left is the component layout.

and a smaller type is better suited to crowded PCBs.

We used a red hook for the collector connection, a black hook for the emitter connection (corresponding to positive and negative) and a grey hook for the base connection. This works quite well and is easy to remember.

While our system of E-Z hooks or similar is more practical when working from the component side of a PCB, it may not be usable on the copper side.

So readers have to make the decision as to which method is more suitable to their applications. Either way, the in-circuit tester can be a handy device.

In use, the tester will give clear indications where the surrounding circuit resistances are 40 ohms or more. It tends to give ambiguous indications when testing the output stages of audio amplifiers, where the circuit resistances are lower than this.



# Cassette tape interface for microcomputers

Here is a simple and effective way of storing and recalling digital data strings on an unmodified audio tape recorder. The unit is intended to connect between a computer and a terminal unit using normal asynchronous serial data transmission implemented with 20mA current loops, and operate at a variety of transmission rates.

by DAVID EDWARDS

There are many possible ways of storing digital data and computer programs that will provide ready access, flexibility and reliability. The choices available to a home computer enthusiast are rather limited, however. The "fortunate few" interact with their computer via a Teletype model ASR-33 teleprinter, and can thus store and recall programs and data on punched paper tape.

Other enthusiasts (usually with less financial resources), use a "glass" terminal, such as that recently described by Jim Rowe. With such a terminal device, however, it is not possible to store and recall programs or data.

For those with access to a normal audio tape recorder (a cassette unit is ideal), help is at hand, as such machines can be used for this purpose.

Most of the small mini-computers and microprocessor evaluation kits currently available are intended to interface with a teleprinter or similar device using standard 20mA serial current loops. Data is transmitted and received in standard asynchronous serial form. Each bit lasts for a little over nine milliseconds, with the stop bit transmitted continuously during breaks in transmission.

Data in this form cannot be recorded directly on a normal audio tape recorder, but must be suitably conditioned. Normal practice is to use "frequency-shift keying" or FSK, recording digital one signals as a 2400Hz tone, and digital zero signals as 1200Hz tones. This is consistent with the standard resulting from the "Kansas City" symposium, sponsored in the USA by BYTE Magazine.

The unit described in this article is designed to connect between the computer and the terminal unit, without affecting the operation of either. The output data stream from the computer is passed directly to the terminal as normal, and at the same time is processed and made available at the recorder input.

To record a program or data listing, all that is required is that the program or

data be "dumped" into the terminal, while the recorder is recording.

A switch is provided to enable the computer input to be switched between the terminal output and the conditioned recorder output. Normally, the serial information provided by the terminal is passed directly to the computer. When the switch is placed in the replay position, the data stream from the recorder is conditioned, and then passed to the computer. The computer software or firmware would normally have been instructed to enter a "load" phase prior to this being done.

In accordance with normal practice, the input and output connections to the computer are isolated with optocouplers. There are only three adjustments to be made during construction, none of which are critical. Two are simply input and output level controls for the tape recorder, which are adjusted to suit the particular recorder in use.

The recording input signal for the recorder can be adjusted from 0 to 4 volts peak to peak, which should cope with all commonly available recorders. The sensitivity of the replay input is 400mV peak to peak, or about 140mV RMS, which again should cope with most recorders.

The remaining adjustment is that of the interface's system clock. This is mainly to set the frequencies recorded on tape at exactly 2400Hz and 1200Hz, so that tapes made on one system will be compatible with those made on another system. This setting is not at all critical if the unit is only ever used to replay its own recordings, however, as the inherent design of the unit ensures that within limits it will always be compatible with itself.

This is because the two frequencies recorded on tape are separated on replay by a digital filter which is in effect tuned by the system clock frequency. Since the tones on the tapes are derived from the clock also, the filter will always cope with recorder speed variations of

up to 30% without error, although naturally enough, the data stream will be stretched or compressed in time.

Recapping, then, the purpose of the clock adjustment is only to make tapes made on one system compatible with those made on another, and also compatible with the Kansas City standard.

We have arranged that the data switching between the two tones recorded on tape occurs synchronously, so that no harmonics are generated which could possibly interfere with the operation of the recorder, by interaction with the bias oscillator. This does mean that the data pulses are altered in length by a small amount, but this does not prove serious in practice.

By now you may be wondering what the cost of all these features is going to be. Well, rest assured. Even though there are twelve integrated circuits (ICs), they are all low cost, readily available linear and digital TTL parts. Only a single 5V power supply rail is required, and this is provided by a three terminal regulator.

The component parts are assembled on a single printed circuit board (PCB), measuring 142 x 132mm. Apart from a case, two switches and the input and output connectors, all that is required is a transformer. We will leave these details up to the individual constructor, as we feel that for this sort of project, this is the most flexible approach.

We are indebted to Ed Monsour of E & M Electronics for much helpful advice with the initial design of the circuit. In fact, our system was developed from an initial design of his.

Turning now to the circuit diagram, we can discuss the circuit operation in some detail. The clock is formed by a 555 timer, connected in the astable mode. T1, a BC337 transistor is used to buffer the output, to maintain a reliably low "0" logic level when two TTL loads are driven. The clock frequency is a nominal 24kHz.

A 7490 decade counter is used to divide the clock frequency by ten, and provides the 2400Hz signal required by











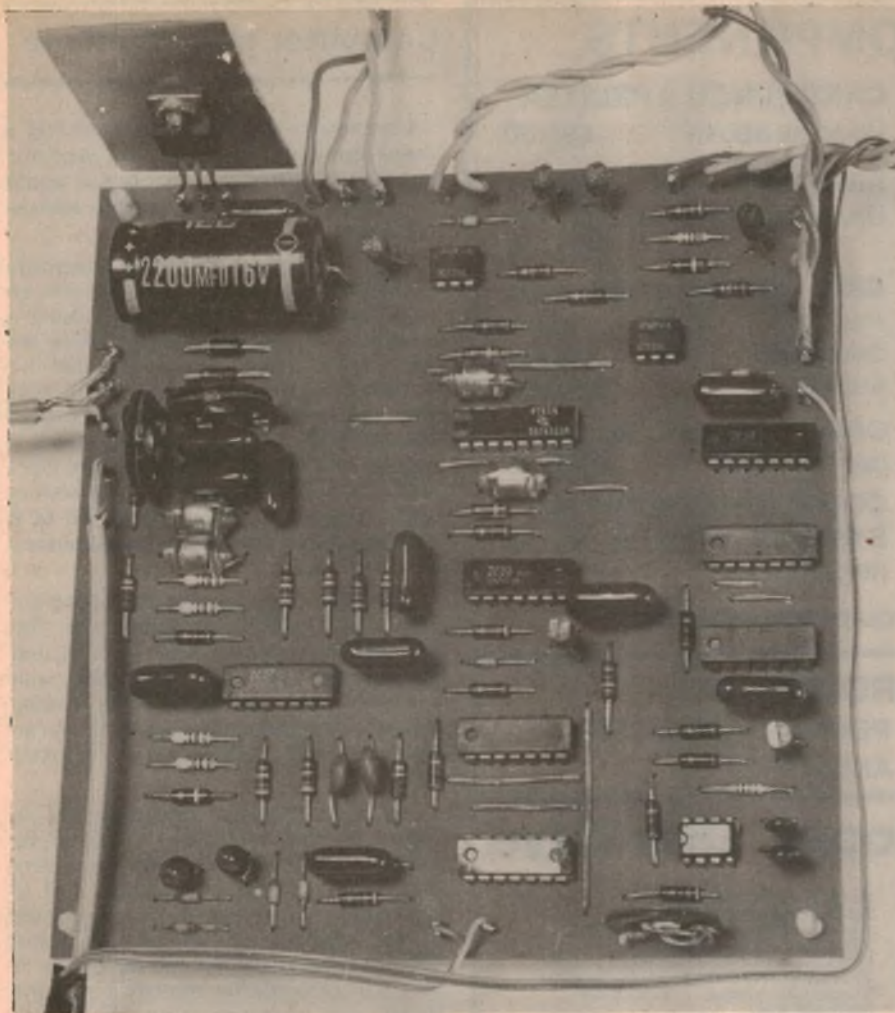

All components are accommodated on a single printed circuit board.

The filtered replay tones are then clipped by the remaining LM3900 amplifier, which has four diodes connected in the feedback loop. The output from this amplifier is a 2.4V peak-to-peak square-wave with relatively steep transitions between levels. This waveform is squared up even more by a transistor switch (T6), and then inverted and buffered by a gate, G5.

The output from the gate is then passed to two monostables formed from a 74123 device. One monostable triggers on positive going edges, and the other on negative going edges. Each monostable is set to give an output pulse width of 1 $\mu$ s. The negative going pulses from the monostables are summed in a gate, G6.

The output of this gate is a train of positive going pulses, synchronised to the zero crossings of the input tones. This signal forms one of the two inputs to the digital filter. The second input is simply the same signal, slightly delayed in time by the propagation delay of two further gates, G7 and G8.

The digital filter itself is formed by a 7493 binary counter and a D type flip-flop, FF3. The input of the counter is driven continuously by the 24kHz system

clock signal, while the counter is reset at every zero crossing of the input tones by the delayed 1 $\mu$ s pulses.

The clock frequency has been chosen so that when the input tone has a frequency of 2400Hz, with a half period of 208.3 $\mu$ s, five clock cycles each 41.7 $\mu$ s long will be counted between each reset. Under these conditions, the most significant bit of the counter will always remain low.

When the input tone has a frequency of 1200Hz, the half period will be 416.7 $\mu$ s, and ten 41.7 $\mu$ s clock pulses will be counted. This means that the most significant bit of the counter will go high for some time at the end of each half period of the recorded tone, as shown in Fig. 2.

Thus we can tell the frequency of the incoming replay tone by looking at the most significant bit of the counter: if this bit stays low, the input is 2400Hz, and if it goes high for some time, the input tone is 1200Hz. The higher frequency tone can be 30% lower in frequency, and the lower tone 30% higher in frequency, before the most significant bit will give an erroneous indication.

The most significant bit of the counter is connected to the D input of the flip-flop, which is clocked by the non-

## PARTS LIST

### SEMICONDUCTORS

- 1 555 timer IC
- 2 4N28, NCT200 or similar optocouplers
- 2 7400 quad gates
- 2 7474 dual D type flip-flops
- 1 7490 decade counter
- 1 7493 4 bit binary counter
- 1 74123 dual monostable
- 1 LM3900 quad op-amp
- 1 LM309,  $\mu$ A7805 or similar 5V 1A regulator
- 5 BC337 NPN silicon switching transistors
- 1 BC327 PNP silicon switching transistor
- 7 1N914A silicon diodes
- 2 EM401 silicon diodes

### RESISTORS (all $\frac{1}{4}$ W)

- 2 150 ohm, 1 220 ohm, 8 1k, 1 1.8k, 2 3.9k, 4 4.7k, 2 6.8k, 2 10k, 1 47k, 4 220k, 4 470k, 4 1M
- 1 4.7k trimpot (0.2in lead spacing)
- 2 10k trimpots (0.2in lead spacing)

### CAPACITORS

- 2 390pF polystyrene
- 4 470pF polystyrene
- 1 0.0022 $\mu$ F polyester
- 1 0.01 $\mu$ F polyester
- 11 0.1 $\mu$ F polyester
- 2 10 $\mu$ F tantalum electrolytics
- 1 2500 $\mu$ F 16VW electrolytic, pigtail type

### MISCELLANEOUS

- 1 printed circuit board, coded 77cc4, 142 x 132mm
  - 1 transformer, 240V to 15VCT @ 1A, A&R 2155, PF 2155, DSE 2155 or similar
  - 1 SPST switch
  - 1 DPDT switch
  - Solder, tinned copper wire, hookup wire, shielded cable, scrap aluminium (for heatsink), PCB pins
- NOTE: Resistor wattage ratings and capacitor voltage ratings are those used for our prototype. Components with high ratings may generally be used provided they are physically compatible.

delayed zero crossing pulses. This means that the flip-flop samples the counter output just before it is reset, and stores this output till the counter is next reset.

This has the effect of shortening the "low" output pulse by 208 $\mu$ s, and lengthening the "high" output pulse by 208 $\mu$ s. Since one output pulse is stretched, and one is shortened, the errors tend to cancel. In any case, 208 $\mu$ s is short compared to the shortest pulse normally found in the system (9.09ms long), and we have not found this error to cause any problems with either computers or terminals.

The power supply is simply a rectifier-



# COMPUTER COMPONENTS

## MAGNETIC TAPE DRIVES

7 & 9 track complete with vacuum cols, alpha numeric keyboard, uses standard computer tapes. \$160.00

**CARD PUNCHES** — 80 column card punches complete with keyboard. \$50

**CARD VERIFIERS** — 80 column card verifiers complete with keyboard. \$40

**NEW CARD PUNCHES AS ABOVE.** \$150.00

## CARD PUNCH & PRINTER

Used as above \$95.00

**PRINTERS** 132 column Drum, tractor feed, 300 1pm \$200.00

**DISC DRIVES**, single disc, multiple fixed heads, complete with power supply \$200.00

**CARD READERS.** 80 column card readers. \$150.00

**COMPLETE COMPUTER SYSTEMS** — price to be negotiated.

Many other items of equipment available.

## FRASER PRODUCTS

425H PENNANT HILLS RD PENNANT HILLS 2120  
848 9133 AH654 1127

## The SA400 minifloppy Disk Drive

### Performance Specifications

#### Capacity Unformatted

Per Disk: 109.4 kbytes; Per Track: 3125 bytes.

#### Formatted

Per Disk: 80.6 Kbytes, 89.6 Kbytes;  
Per Track: 2304 bytes, 2560 bytes;  
Per Sector: 128 bytes, 256 bytes;  
Sectors/Track: 18, 10; Transfer Rate: 125 kilobits/sec; Latency (avg): 100 ms.

#### Access Time

Track to Track: 40 ms; Average: 463 ms; Settling Time: 10 ms; Head Load Time: 75 ms.

### Functional Specifications

Rotational Speed: 300 rpm;  
Recording Density (inside track): 2581 bpl (103 bp mm); Flux Density: 5162 fcl (206 fcp mm);  
Track Density: 48 tpi (1.89 tp mm);  
Tracks: 35; Index: 1; Encoding Method: FM.  
**Media Requirements**  
SA104 (soft sectored); SA105 (16 sectors hard sectored); Industry standard flexible diskette Oxide on 0.003 in (0.0008 mm); Mylar 5.25 in (133.4 mm) square jacket.



**IMSAI**  
AUSTRALIAN AGENTS  
PROFESSIONAL MICROCOMPUTERS  
FULLY ASSEMBLED OR KITS

The IMSAI 8080 computer is powerful, accommodating up to 64K bytes of MOS write protect memory, it's fast with 500 nSec total memory access time and 2 μSec minimum instruction time. Complete systems including programming available for small business at low cost — suitable for: stock control, invoicing, quotations, patient records, type-setting.



**PR-40 PRINTER KIT**  
40 character line, 75 line/min, 64 character ASCII, parallel data.



**ASCII ENCODED KEYBOARD KIT**



**CASSETTE TAPE DRIVES**  
Digital or analogue heads, fixed or variable speeds (1-10 ips). Read/write and motion control electronics available. Motion control, head engage software controlled.

Send \$1.00 for complete catalogue and price list of microprocessor kits, peripherals etc., stating your application

## DYNETICS PTY LTD

425 Pennant Hills Road, Pennant Hills, NSW 2120. Bus. 848-9055 A/H 654-1127

## Computer tape interface

filter capacitor combination driving a three terminal 5V 1A regulator. Six 0.1μF bypass capacitors are distributed about the circuit, to eliminate possible switching spikes.

Construction of the PCB assembly should be relatively easy. All ICs can be soldered directly to the board, using a minimum of heat and solder. There are nine wire links, which should be insulated. All resistors should be 5% ½ or ¼W types. The three trimpots required should have 0.2" pin spacings. Care is required with the orientation of the electrolytic capacitors, diodes, transistors and integrated circuits. Use the PCB overlay diagram as a guide to placement of components.

External connections to the board are best made with circuit board pins. The connections to the recorder sockets, and to S1a1 and S1a3 are best made with shielded cable, as shown on the overlay diagram. The remaining connections can be made with colour coded hookup wire.

Do not forget that a heatsink will be required for the regulator IC. This can be either a scrap piece of aluminium bent up into an "L" shape, mounted next to the board, or the case itself. If the leads to the regulator are more than about 100mm in length, it may be necessary to wire a 0.1μF capacitor directly across the input and common pins, to ensure stability.

Once construction is completed, the board can be tested and adjusted. Monitor the +5V rail on initial switch on, and switch off immediately if it does not go to 5V ±0.25V. Assuming all is well, the clock can be adjusted. If you have access to a frequency meter, simply monitor the collector of the buffer transistor, and adjust for 24kHz.

If you do not have access to a frequency meter, connect a computer and terminal, and while keying the terminal, adjust the clock frequency so that the 1200Hz and 2400Hz waveforms at the recorder input are equal in amplitude. To achieve even better alignment, connect the recorder input terminal to the recorder output terminal, and adjust the clock for equal amplitude signals at pin 5 of the LM3900.

This adjustment procedure will not set the clock at exactly 24kHz, but it will put it in the ball park, and will provide optimum performance if used alone. If you are attempting to read tapes made on another system, with possibly a slightly different clock frequency, then the clock can be adjusted during playback for minimum errors.

The preset level controls are adjusted so that the appropriate levels are supplied to and obtained from the re-



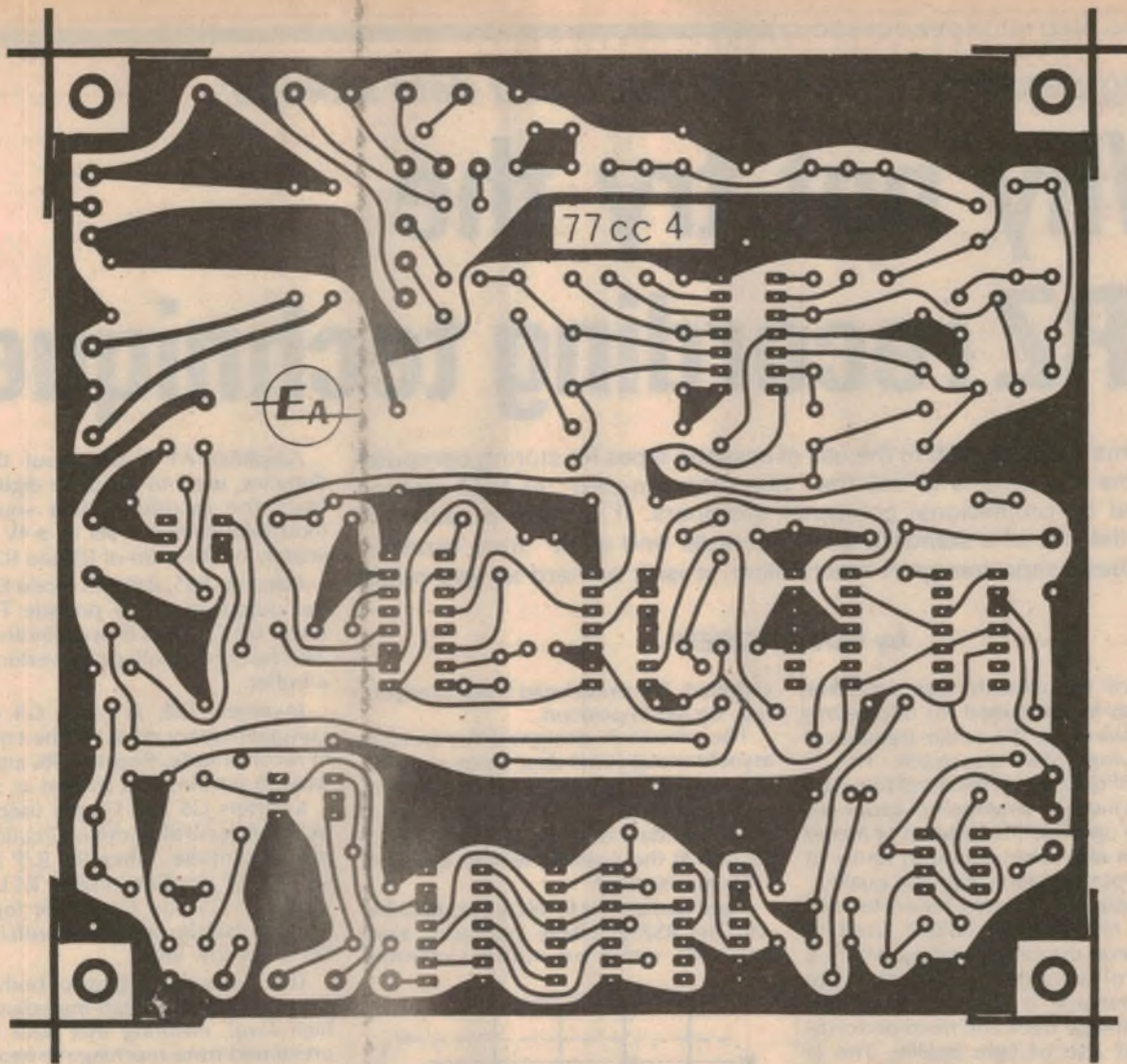

Here is a full-size reproduction on the PC pattern.

recorder. During playback, it is better to have the input amplifier clipping rather than have too small a signal, so that sudden drops in level will not cause errors.

In use, the interface unit is simply interposed between the computer and the terminal. With the switch in the record position, the computer and terminal will interact as normal, and any data and programs can be recorded simply by switching on the recorder (in its record mode, of course).

To replay programs back into the computer, send the appropriate load commands from the terminal to the computer, then switch to replay, and finally put the recorder in the replay mode. During replay, the terminal keyboard is disabled, but the terminal will still display the computer output, which will usually allow indication that the load has been completed.

After the load is completed, switch the interface back to "record" to resume normal operations.

At this point a few words regarding the type of recorder which can be used are in order. In general, any machine which

is capable of recording and replaying 2000Hz and 2400Hz sinewaves without causing appreciable distortion and level changes will be adequate. Machines which use an AC bias system, rather than a DC bias system, are to be preferred, as these usually give more consistent results.

While reel to reel machines can be used, we feel that a cassette recorder is better, mainly because of the ease of tape handling. While a tape counter is not vital, it does give a convenient means of indexing and finding particular programs or data groups.

Units with automatic level controls can be used, as well as manual models, although the former is a little more convenient to use. Be warned that some portable recorders do not like working into a high impedance, such as that provided by the interface unit, and it may be necessary to provide a nominal load (e.g. 22 ohms) for the output stage.

The unit is also capable of working with cassette decks, as used in hi-fi systems. Simply adjust the level presets to suit the lower signal levels commonly

found in such machines.

Finally, some discussion of accuracy is warranted. We have dumped and loaded 200 bytes of memory a good many times with recording and replaying done on different machines without error. This suggests that substantially error free operation should be obtainable with most types of recorders.

There may be occasional errors due to tape dropouts, momentary loss of tape-head contact and so on, however. To minimise these, only good quality tapes should be used. We recommend that a tape be replayed immediately after recording, to check for errors. If the tape gives errors, replay it again as a second check, as errors will sometimes occur in playback.

If the tape still refuses to replay without errors, make another attempt at recording. We suggest that you keep a hard copy of all programs so that if the worst comes to the worst, you can always feed them in by hand again. With a good recording, performance during replay largely depends on the setting of the output level.



Using cassette tape for program and data storage:

# Why not try the NRZ recording technique?

An alternative approach to the use of cassette tapes for storing computer programs and data is to use the "non-return-to-zero" or NRZ method favoured by professional computer designers. If you are prepared to forego the use of a standard audio recorder and work "from scratch" with a basic tape transport mechanism, it isn't as hard as you might think.

by IAN CROSER\*

Most of the cassette tape interface designs so far described for microcomputers have used the audio frequency-shift keying (FSK) approach. This is capable of quite good results at low data rates, but involves a number of problems if reliable operation is required at higher rates. It is also fairly critical in terms of recorder performance and tape quality.

In comparison, the non-return-to-zero or NRZ recording technique used in commercial digital recording offers a number of advantages. Probably the main advantage is that it is relatively tolerant of tape deck and head performance, and also of tape quality. This is because it uses saturation-level recording, where the tape is always saturated in one magnetic direction or the other.

Another advantage of NRZ recording is that it is more efficient, allowing you to record higher bit densities and hence store more information on a given length of tape. At the same time it is essentially somewhat simpler than the FSK approach, requiring neither recording bias or the need to erase. As the recorded levels are relatively high there is also very little problem with hum and noise.

To be sure, you can't use a normal audio tape recorder for NRZ recording. It is necessary to start with a bare tape mechanism, and provide the rather different type of electronics required for NRZ recording and playback. But this turns out to be rather simpler than you'd think.

The circuit shown has been developed for use with one of the "Vortex" cassette tape deck mechanisms which have been available for some time. It does not require the deck to be modified significantly, using the record/play head as

supplied. The erase head is not used, but may be left in position.

The circuit is designed for normal asynchronous serial data input and output, as used by most small microcomputer systems. It will operate quite reliably at data rates up to 1000 bits per second at the normal cassette speed of 1.75in per second.

Input and output levels are compatible with the RS232 voltage interfacing standard, as used by many systems.

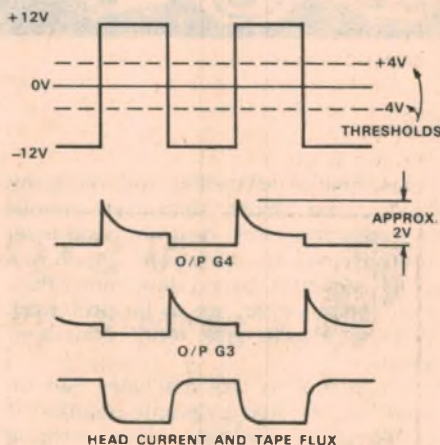

FIG. 1 RECORD MODE

However, it would be relatively simple to adapt the system for 20mA current-loop interfacing if desired. As shown the input impedance is approximately 10k, with thresholds at  $\pm 4V$ ; output levels are  $\pm 11V$  with current limiting at 40mA.

As you can see from the circuit diagram, the complete interface uses only two ICs apart from the power supply. Analog functions are performed by three amplifiers of an LM324 quad op-amp device, while the digital functions are performed by the elements of a 7407 hex inverter.

Amplifier A1 is the input threshold detector, used to produce digital levels from the incoming data signals. Its threshold levels are set at  $\pm 4V$  approximately by the ratio of R1 and R2.

Resistors R15, R16 and diode D1 clamp the output of A1 to provide TTL logic levels for G1. This is one element of the 7407 hex open-collector inverter, used as a buffer.

Inverters G2, G3 and G4 provide complementary drive for the tape head, in record mode. Resistors R6 and R7 are used to set the head current at  $\pm 5mA$ .

Inverters G5 and G6 are used to disable the recording drive circuitry in the playback mode. When the R/P switch is set to the P position, resistor R3 takes the inputs of G5 and G6 to the logic high level, so that the outputs of both inverters fall to the low level.

This forces the outputs of both G3 and G4 to rise to their high-impedance logic high level, ensuring that data input is prevented from reaching the head. Note that a 7407 device has been chosen to reduce leakage currents in G3 and G4 in replay mode.

As you can see, this recording circuit simply converts the incoming digital data into bipolar current levels through the recording head. This is shown in Fig. 1. Note that although the inductance of the recording head produces "spikes" in the voltage waveforms fed to it from G3 and G4, the head current and hence the magnetic flux recorded on the tape are sub-

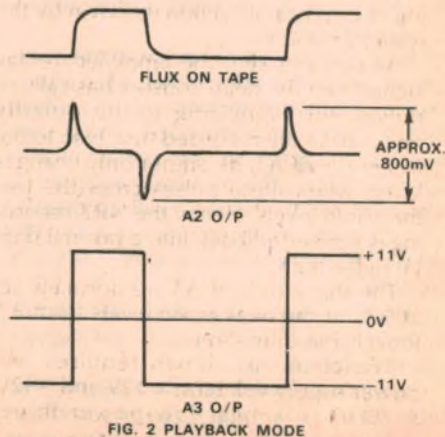
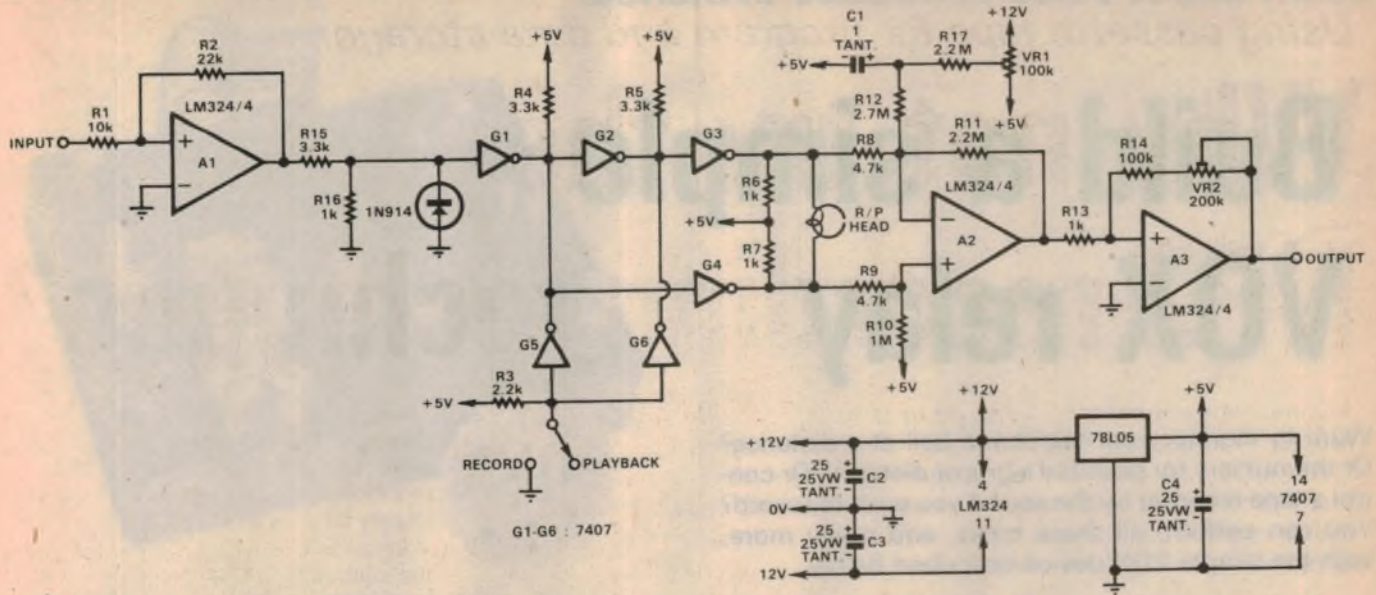

FIG. 2 PLAYBACK MODE

\*c/o P.O., Stirling, S.A. 5152





The complete circuit for the author's NRZ digital recording unit, which apart from the power supply uses only two ICs—an LM324 quad op-amp, and a 7407 hex inverter. No erase head is required, as the recordings are at saturation level.

automatically erases anything previously on the tape.

The type of cassette used is not critical, although "wide dynamic range" tape will probably give the best results. Also as the speed tolerance is entirely a function of the data format, it would probably be desirable to use C30 cassettes rather than longer-play types with a thinner and less stable base.

The second channel of the tape head may be either used separately, or wired in series or parallel with the first, for more reliable operation.

I have not described the physical construction of the tape interface, as this is best left to the individual constructor. As few parts are involved, the complete circuit could be built underneath the Vortex mechanism if desired.

stantially the same as the incoming data.

A logic 1 in the data is recorded as a saturation flux level in one direction, and a logic 0 as a similar flux level in the opposite direction.

If a 1 is followed by another 1, or a 0 by another 0, the recorded flux does not change in either level or direction. Hence the description of this type of recording as non-return-to-zero.

For replay, A2 is used as a high gain differential-input amplifier to boost the head signal to detectable threshold levels. R8, R9, R10 and R11 set the differential voltage gain at approximately 500 while VR1 is used to adjust the output offset voltage to zero.

The offset adjustment circuit is filtered by C1, which is tied back to the +5V rail because this is the amplifier's input reference.

Amplifier A3 is used as the replay threshold detector. Its hysteresis levels are adjusted by VR2 for reliable decoding of the data. Its action is shown by the waveforms in Fig. 2.

As you can see, the amplified replay signal from the head consists basically of pulses corresponding to the polarity reversals of the recorded flux. Due to the hysteresis of A3, its output only changes levels when these pulses cross the two threshold levels. Hence the NRZ recording is converted back into a normal digital pulse train.

The thresholds of A3 are normally set at 50% of the peak pulse levels from A2, for reliable operation.

The circuit as shown requires two power supply voltages, +12V and -12V. A 78L05 or similar low-power three-

terminal 5V regulator is used to derive the +5V supply for the 7407 from the +12V rail. The supply voltages are not particularly critical, although the +12V rail should be within  $\pm 1V$  and well filtered.

Typical current drain is less than 60mA from the +12V rail and less than 50mA from the -12V rail, but the exact drain depends upon output loading.

The tape mechanism was not modified except for the record switch, which was set to close contacts when the record button is pushed. As noted earlier, the erase head is not used as a new recording

## IN STOCK NOW!

### IBETA 23-Channel AM Mobile Citizensband Transceiver

**STILL AT THE PRE-DEVALUATION PRICE OF \$89** + P&P \$5.00 (NORMALLY \$139.00)



**SPECIFICATIONS**

<p>1 Semiconductors: 19 Transistors and 15 Diodes</p> <p>2 Frequency Range: 26.965MHz-27.255MHz</p> <p>3 Mode of Operation: AM</p> <p>4 Controls: Volume Control with Power On-Off Switch Variable RF Gain Control · Variable Squelch Control Delta Tune Switch · Channel Selector Switch · CB-PA Switch · ANL Switch</p>	<p>5 Connectors and Jacks: Microphone Connector · Coaxial Type Antenna Connector · Public Address Speaker Jack 3.5mm · External Speaker Jack 3.5mm</p> <p>6 Speaker: 3½ inches, 8 ohms</p> <p>7 Microphone: Dynamic Microphone (500 ohms)</p> <p>8 Power Supply: 13.8 VDC Positive or Negative Ground</p>
---	---

**Also in Stock**

Mobile Antenna to suit Ibeta CB Transceiver \$15 plus p&p \$2.

Overall length: 47"

Cable: 17 feet RG-58U (52 ohms) coaxial cable w/ PL-259 Connector

Mounting: a. Trunk Mounting b. Rooftop Mounting

**TRADE ENQUIRIES WELCOME**

Call, write or phone to: **C. H. S. TAYLOR'S WAREHOUSE SALES**  
169 JOHNSTON STREET, COLLINGWOOD, VIC. 3066 PHONE: 419 3862



Learn about voice controlled switches:

# Build a simple VOX relay



Want to monitor your telephone bell at a distance? Or the nursery for possible signs of distress? Or control a tape recorder by the sound you wish to record? You can perform all these tricks, and many more, with the simple VOX device described below.

by WALTER NEVILLE

A more descriptive name for a VOX is a voice operated switch, although sound operated switch would be rather more accurate. But, finer points aside, the names give a pretty good idea of what the device does; it responds to sound by operating a relay and, through this, almost any electrical device we like to nominate.

The VOX idea is not new. Both amateurs and professionals have been using them for years in association with radio telephone circuits; to switch on the transmitter when the operator starts to speak. This avoids the need to provide and use a press-to-talk button on the microphone. In fact, the word VOX is made up from the initials of Voice Operated Xmitter—"Xmitter" being a common abbreviation for transmitter. By coincidence, "VOX" is also Latin for "voice".

But, as we have already suggested, the idea does not have to be confined to transmitters. A popular application is where the user of a radio telephone channel wishes to keep a record of the daily traffic.

A tape recorder will make an accurate record but will waste vast quantities of tape if left running during idle periods. Similarly, a great deal of time will be wasted searching for a wanted item in the midst of large lengths of blank tape.

By fitting a VOX, the tape recorder will be activated only when there is something to be recorded—and it will do it automatically, without someone having to remember to switch it on. As a result, at the end of the day, all the traffic will have been recorded in one compact presentation, requiring no longer to play than the total traffic time.

At less serious levels there are all kinds of novel tricks which it makes possible. Electrically operated toys, such as slot cars, model trains, etc. can be made to

stop or start at a word of command. In a similar manner lights can be turned on, a record player started, or any similar function performed by waving a "magic" wand and shouting "Abracadabra". (It doesn't have to be "Abracadabra" of course, but one might as well make it look right.)

This VOX consists of a microphone, a transistor amplifier and detection circuit, and a relay. When a sound of sufficient amplitude reaches the microphone, the relay is activated and its contacts perform the required operation. The circuit incorporates a delay of about three seconds, which means that the relay remains activated for this time after the sound ceases. The sensitivity, or the level of sound needed to activate the device, can be varied with a simple pot control.

The relay is fitted with a "change-over" type set of contacts. This means that there are three connections to the contacts; the wiper or moving arm, the normally closed contact, and the normally open contact.

As the name implies, the normally closed contact is the one that completes the circuit to the moving arm when the

relay is at rest, i.e., the coil is not energised. When the coil is energised, the moving arm completes the circuit, instead, to the normally open contact.

This adds to the versatility of the device. For example, a light wired via the moving arm and the normally closed contact would remain on until a sound reaching the microphone activated the relay and turned it off. Conversely, if it was wired via the normally open contact it would remain off until a sound activated the relay.

There are two approaches to building this project. It is available as a Science Fair kit (No. 28-131) and this is certainly the easiest way to obtain all the components. The price (\$7.00 approx.) is quite modest. On the other hand, those who already have some parts on hand may prefer to buy the remaining items separately. This should not present any problems, since none is in any way special and should be available from any well stocked electronics parts supplier. We will discuss the parts in greater detail later.

As with the previous Science Fair kits, this one comes complete with all the components, instructions, etc., neatly

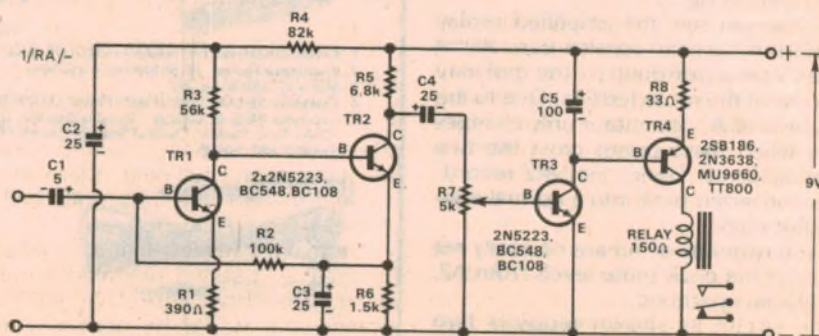

The operation of the circuit is explained in the text. TR1 and TR2 form a simple amplifier from which signals are fed to TR3 via the potentiometer R7. TR3 is not biased and functions as a detector, turning on TR4 and activating the relay.



packed in a plastic box. The box becomes the chassis on which the project is built.

The building instructions are, as usual, very comprehensive, and even the beginner should have no difficulty making it work. Pressure of time forced us to construct it in several short periods spread over several days, with the last part being completed by another party. In spite of this fits-and-starts approach, it worked immediately it was switched on.

As with our previous kit projects, we chose not to trim the component leads in most cases, even though this makes the underside view a little untidy. Our reason is to preserve the components in a conditions which will allow them to be salvaged and used for other projects when the novelty of this one wears off.

The operation of the circuit itself is not hard to follow. It is best thought of as two separate parts; the first two transistors, TR1 and TR2 as one section, and TR3 and TR4 as the other section.

Transistors TR1 and TR2 are both NPN silicon types connected as a direct coupled amplifier. This lifts the signal level from a few millivolts as it comes from the microphone to several volts by the time it reaches the gain control pot R7.

Transistor TR3 is also an NPN silicon type and is operated without any bias. It is directly coupled to TR4, which is a germanium PNP type, in the collector circuit of which is the relay. (Note TR4's upside down presentation.)

As can be seen from the circuit the base of the TR4 is connected to the collector of TR3 in such a way that, while ever TR3 is deprived of forward bias, and is not conducting, TR4 is similarly deprived and cannot conduct.

If a positive voltage is applied to TR3 base, TR3 will conduct. Current will flow from the positive rail through R8, the emitter/base junction of TR4, and the collector/base junction of TR3, to the negative rail. In the process, the current through the emitter/base junction of TR4 will turn this transistor on and allow current to flow in its collector circuit and through the relay, activating the latter.

The really interesting point is how we provide the positive voltage for the base of TR3. As we pointed out earlier, TR3 operates without any bias. This means that it cannot respond to the negative half cycles of the audio signals fed to it. If it were biased normally, negative half cycles would tend to reduce the forward bias, and the collector current. Since these are already at zero, they cannot be reduced further.

But the positive half cycles do have an effect. Each positive half cycle pulse turns TR3 on, which also turns on TR4. At the same time, the voltage at the TR3 collector causes capacitor C5 to charge and this charge will hold TR4 on between positive pulses.

In fact, C5 does more than this. It stores enough charge to hold TR4 on for about

three seconds after the signals feeding TR3 cease. Eventually, it discharges through the base/emitter junction of TR4 and R8. When this happens TR4 turns off and the relay drops out.

We have already suggested a number of applications for the VOX, but without much detail as to how the various devices may be connected to it. For a start we would strongly advise against trying to control mains operated appliances. Unless you are very sure of what you are doing it is all too easy to create a very dangerous situation. In the interest of safety, stick to battery-operated devices.

One component supplied with the kit is called a battery disconnect insert. This is a rather elaborate name for nothing more than a couple of square centimetres of double sided copper board, but it makes possible a very neat trick.

The two wires from the relay contacts are connected to this, one wire soldered to each copper face. If this is now inserted between any two cells of, say, a tape recorder battery, or between one cell and its contact, the battery will be rendered open circuit and the recorder will not operate, unless the relay contacts are closed.

In this way the tape recorder, or any other battery operated device, can be controlled. In practice, however, such a simple set-up does have some limitations. For example, the tape recorder is rendered inoperative in all modes, such as rewind, replay etc, as well as recording. For serious use a switch should be fitted in parallel with the relay contacts.

If used to control a model train or slot car, there are two possible options. It may be wired to either start the model, or stop it, at a word of command. Since the relay will hold in for only about three seconds, the more effective arrangement might be the stopping mode.

The model could be set to run continuously, but to stop when commanded to do so. It would remain stationary while the relay held in, then start up again automatically.

For any of these tricks it should be possible to discriminate between ordinary conversation, and the word of command, by careful setting of the sensitivity control and by deliberately delivering the word of command at a somewhat higher level.

By connecting a buzzer circuit across the relay contacts, the VOX can be used in a number of monitoring modes. Placed near the phone, with the buzzer taken to a remote point, it would operate when the phone bell rang. Alternatively, it could monitor the front door bell or chimes.

The makers suggest that it could also be used as a sound operated intruder alarm. Just how effective such an arrangement would be depends on a number of factors, including how sure one can be that quite innocent sounds will not cause false alarms.

Earlier we suggested that the parts for this project could be bought in other than kit form. The only items requiring special mention are the transistors and the relay.

The relay used in the original had a coil resistance of about 130 ohms and we imagine that a 150 ohm coil could be used in its place. Relays with such coil resistance are readily available from most suppliers.

Transistors TR1, TR2, and TR3 are all the same type, 2N5223 in the original. TR4 was a 2SB186. In place of TR1, 2 and 3 we suggest either a BC548 or its older counterpart, the BC108. For the 2SB186 we suggest the 2N3638, MU9660, or TT800. These are not direct equivalents, but should be close enough to work in a simple circuit like this.

Which is about all we need to tell you. It is an intriguing little novelty, and one with which you can impress your non-technical friends. Alternatively, you may find a genuine practical use for it. Either way, you'll have a lot of fun and learn something while you build it. ☺

## BASIC ELECTRONICS



If you've always wanted to become involved in Electronics, but have been scared off by the mysteries involved, let Basic Electronics explain them to you. Begins with the electron, introduces and explains components and circuit concepts, and progresses through radio, audio techniques, servicing, test instruments, etc.

\$3.00 plus 60c p & p  
Electronics Australia  
Box 163, Beaconsfield, NSW, 2014

## KNOW

### Where you are going?

Choose a career in the field of Electronics — the Nation's most progressive and fastest expanding industry

BROADCASTING    
COMMUNICATIONS — marine  
APPLIED SERVICING

Classes are conducted at  
67 Lords Road,  
Leichhardt

Day 9.00 a.m. to 4.00 p.m.  
Evenings 6.00 p.m. to 8.30 p.m.  
or by Home Study Courses  
(except practical instruction on equipment)

### SEND FOR PROSPECTUS

There is no obligation.

NAME.....

ADDRESS.....

MARCONI SCHOOL OF WIRELESS  
Box 218, P.O. Leichhardt 2040.

A service of  
Amalgamated Wireless (Australasia) Ltd.



# Converter for LF weather beacons

Here is a little converter which should be of use particularly to boating enthusiasts. When used with a broadcast receiver, such as a transistor personal portable, it enables one to listen to the weather reports broadcast for use by aircraft. This information could be very valuable, particularly when the weather is changeable.

by IAN POGSON

Converters can be very useful things, in that they make it possible to tune in signals on a specific frequency or frequency range, which is not covered by any receiver on hand. The converter then converts the wanted signal from its transmitted frequency to a frequency which is tunable by an existing receiver.

Last month we described a converter which enables us to tune the University of NSW Radio on 1750kHz and on previous occasions we have described very similar converters to cover other frequencies. On this occasion, we present a converter which enables us to tune in one of the "non-directional beacons" used for aviation and which give details of prevailing weather conditions.

These NDBs are located at numerous airports throughout the whole of the country, and their frequencies range from the low to medium frequencies—below the broadcast band. Although

there are many of these signals on the air, most of them only identify themselves by Morse code. On the other hand, beacons associated with large airports constantly give updated voice reports of weather conditions within a certain radius. These reports could be of considerable value to boating enthusiasts who could make use of the information simply by using the converter to be described, along with a small transistor portable receiver.

Just how useful these transmissions could be to boating was very well demonstrated at the time when I was carrying out checks on the new converter. Early in the day here in Sydney, it was rather hot but the sky was reasonably clear, without a hint of any serious change in the foreseeable future. However, the Sydney Airport beacon started to mention storm development around the mountains to the west of Sydney. This continued, with the information

being constantly updated and giving the position and direction of movement of the storms. Later on, the Sydney area was enveloped in quite severe storms and the information which was made available could have given ample warning to small boats.

The circuit is substantially the same as that for the converter described last month for the University station. Changes have been made to circuit values to meet the needs of the different functions. For readers who are not already familiar with this circuit, here is a brief description.

A junction FET mixer is used together with a bipolar transistor for the local oscillator. A ferrite rod aerial is tuned to the frequency of the wanted signal and which is connected to the gate of the FET mixer. The mixer is self-biased well into the non-linear region with a 4.7k source resistor. The local oscillator is set to a frequency about 1610kHz above that of the frequency of the wanted signal. The output of the mixer is fed into a broadcast aerial coil connected in reverse and with the drain circuit resonated to the output frequency. The untuned winding becomes the output, to feed into the normal broadcast receiver.

Most of the components are quite common and readily available. However, the coils in particular may need some clarification. We used a flat ferrite rod aerial which we obtained from Radio Despatch Service. This rod fits nicely on the board and you may be able to get a similar one. However, any of the normal broadcast ferrite rod aeriels should be satisfactory. Fitting it to the board may require some mechanical and electrical changes with respect to the prototype.

The mixer output coil is actually an aerial coil, type 253 made by RCS Radio. This coil is readily available but any similar coil should be a satisfactory substitute. The oscillator coil is wound by the builder on a Neosid former which is also readily available. Winding details will be given a little later on.

The unit requires a power supply of 9V at about 1.2 milliamps. We used a type 2362 battery for the prototype, but other sizes of 9V battery should also be suitable. On the other hand, if you have a power supply with a well filtered 9V DC output, then this may be used instead of a battery.

Before starting on the main assembly, it would be a good idea to wind the

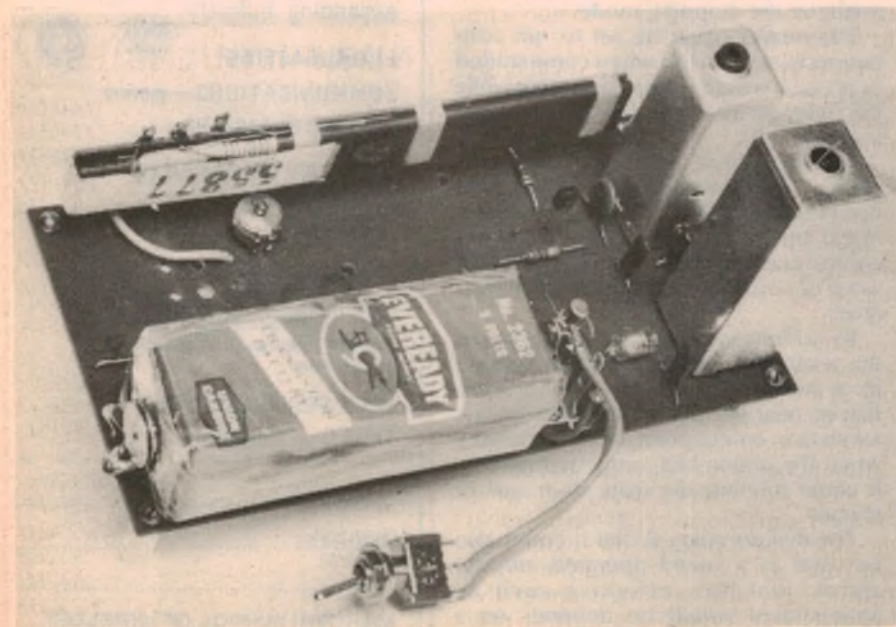

Built on the same PCB as many of our other recent converters, the new converter is compact and easy to build. It's low in cost, too!



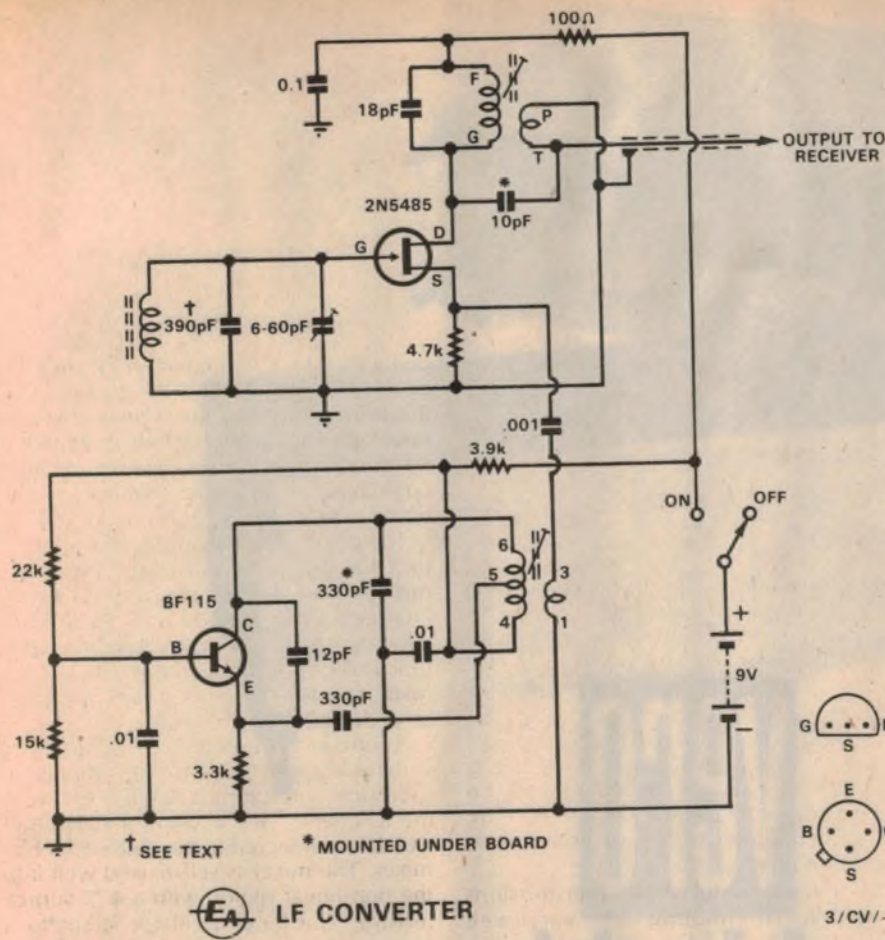

**EA LF CONVERTER**

The circuit of the converter. As you can see, it uses only two transistors and a handful of other parts.

coil terminations correspond with the appropriate points on the printed board.

In some of our earlier converters we also used an aerial coil made by RCS Radio as the output coil. However, these coils were originally designed for use in valve receivers and they are no longer made. The aerial coils made for use with transistor receivers are quite satisfactory, but some of the coil connections are different. The problem is solved by making a cross connection to the appropriate point on the copper.

As the board was made to accommodate Neosid coil formers, and we are using a coil made by RCS Radio in this instance, some care is needed in fitting this transformer. The following procedure is suggested.

Bend the tap pin over close to the moulding so that there is no chance of it becoming short circuited when fitted later on. Now bend each of the remaining four pins over so that they lie over the corners of the can. Then the pins are bent in dog-leg fashion such that they will enter the four holes in the printed board. The can mounting lugs must also be bent inwards and in a similar manner so that they will pass through the respective holes in the board.

Now solder a short length of insulated hookup wire to the bent tap pin, again making sure that no short circuit will be created later on. Mount the coil as described previously, but run the hookup wire through the centre slug adjusting hole in the board. Solder pins "G", "F" and "P" but do not solder "B" to the copper pads. Instead, run the lead of hookup wire to the "B" pad.

oscillator coil. This consists of 120 turns of 28B&S enamel wire, centre tapped and close wound on a Neosid 7.6mm x 58mm former. Care should be taken with this coil, making sure that the winding is reasonably tight and terminated so that there will be no movement of the winding, which in turn could cause erratic oscillator behaviour. The tap may be done in a number of ways. One way is to make a loop at the desired point, clean the enamel off, twist together and solder. A piece of insulation tape should be put under the tap.

A secondary winding consisting of 10 turns of the same gauge wire is wound over the earthy end of the primary winding. Care should be taken in terminating the windings so that they correspond with the appropriate points on the printed board.

Having finished the winding of the oscillator coil, it is a good idea to apply some quick drying adhesive to the ends of the windings, to make sure that the coil is mechanically stable. Now fit the coil into its can. Bend the lugs of the can over so that when the screws of the can are used for mounting, they will contact the side of each hole. This is to ensure that the can is connected to the earthed copper. The coil is fixed to the board with two 6BA screws. If 6BA screws are not readily available, the alternative is to re-tap the holes to 1/8in Whitworth.

You may notice when you have a close look at the picture of the main assembly

that we have made use of what would have been open space on the board. In particular, the battery and the ferrite rod aerial take up quite a bit of the spare space. Before starting on the assembly of the board, it would be a good idea to decide just how you are going to fix these items to the board. You may find that you need an extra hole or so and it is easier to drill them before any components have been mounted.

It is necessary to drill two small holes to take the trimmer across the ferrite rod aerial. We made use of existing holes to fix the ferrite rod, making use of some tinned copper wire and available lugs on the rod assembly. At the negative end of the battery, we ran a short piece of tinned copper wire from the adjacent earth part of the copper on the board, to the clip lug on the battery. At the positive end of the battery, you will see that we used a miniature 3-lug tagstrip. Again, we used a short piece of tinned copper wire from one of the lugs to the battery clip lug. The other floating lug was used for the switch and the supply lead to the board.

Components may now be assembled on the board, starting with small items, resistors, capacitors, etc. Remember that the 330pF and 10pF capacitors associated with the oscillator and output coils, respectively, are mounted under the board. Do not forget the link, which may be a scrap of resistor pigtail. When fixing the oscillator coil, make sure that you have it orientated correctly, so that the

## NDB FREQUENCIES

Alice Springs	224kHz
Wellington (NZ)	234kHz
Launceston	242kHz
Oakey	254kHz
Avalon	260kHz
Canberra	263kHz
Perth	272kHz
Christchurch (NZ)	274kHz
Coolangatta	278kHz
Devonport	281kHz
Brisbane	302kHz
Wynyard	302kHz
Mackay	308kHz
Sydney	317kHz
Bundaberg	320kHz
Rockhampton	335kHz
Tamworth	341kHz
Essendon	356kHz
Adelaide	362kHz
Cairns	364kHz
Auckland (NZ)	374kHz
Melbourne	377kHz
Lae (PNG)	388kHz
Moorabbin	398kHz





## Assemble this new VERO case/frame system in a matter of minutes

**Vero case/frame systems are easy to assemble.** In a matter of minutes you can make your own cases and frames designed to hold 100 mm x 160 mm Eurocards and international cards 4.5" x 6.5".

**Vero comes packed flat,** facilitating delivery and storage. All you have to do is assemble the pre-constructed components using the 16 self-tapping screws supplied.

**Vero case/frame systems look great!** Stylishly fashioned from anodised aluminium extrusions, black PVC clad sheet, and high quality plastic, they are attractive and robust.

**Vero comes in 2 convenient sizes** — 3U high x 482 mm wide x 240 mm deep and the larger 3U x 482 mm x 300 mm to accommodate additional items such as power supplies.

**Vero stacks up well too!** Case/frame units are fitted with individually moulded feet which allow easy stacking. The front feet incorporate an integral hinge-down leg, providing a tilt facility.

**Find out more about Vero case/frame systems.** Call Warburton Franki at any of the following numbers today.

**75WF**

Seventy-five years of service to  
Australian industry and science.



**WARBURTON FRANKI**

• ADELAIDE 356-7333 • BRISBANE 52-7255 • HOBART 23-1841  
• MELBOURNE 699-4999 • PERTH 65-7000 • SYDNEY 648-1711  
• AUCKLAND N.Z. 360-154 • WELLINGTON N.Z. 698-272



## NDB converter

With the board assembly now complete, some leads must be provided to go to external points. Two leads are needed to run to the battery on/off switch, and output leads will be required, depending upon the way you couple into your broadcast receiver. We will deal with this a little later on when we discuss adjustments.

From the picture it will be obvious that we have not fitted the converter into any kind of enclosure. It may be used as it is or, if you prefer, you may fit it into some sort of box or cabinet of your choice.

A careful check should be made to ensure that no errors have been made. Satisfied that all is well, the converter is ready to be put into operation. If you have an ordinary broadcast receiver with aerial and earth terminals and without a ferrite rod aerial, then you may use a piece of coax cable from the output of the converter to the terminals on the receiver. On the other hand, if you have a small transistor personal portable receiver, or a larger receiver with a ferrite rod aerial, then you may use this instead. However, some preparation is necessary before you can use this type of receiver.

One way is to get a few yards of insulated hookup wire. After determining which way the ferrite rod aerial runs inside the receiver, wind from six to ten turns of hookup around the receiver so that the ferrite rod is parallel with the axis of the winding. The winding may be bunch wound and the two insulated ends twisted together to hold the winding in place. Now bare the two ends and solder them to the two output points of the converter, instead of the coax cable mentioned before.

The above method is quite rough but it works very well. However, if you wish,

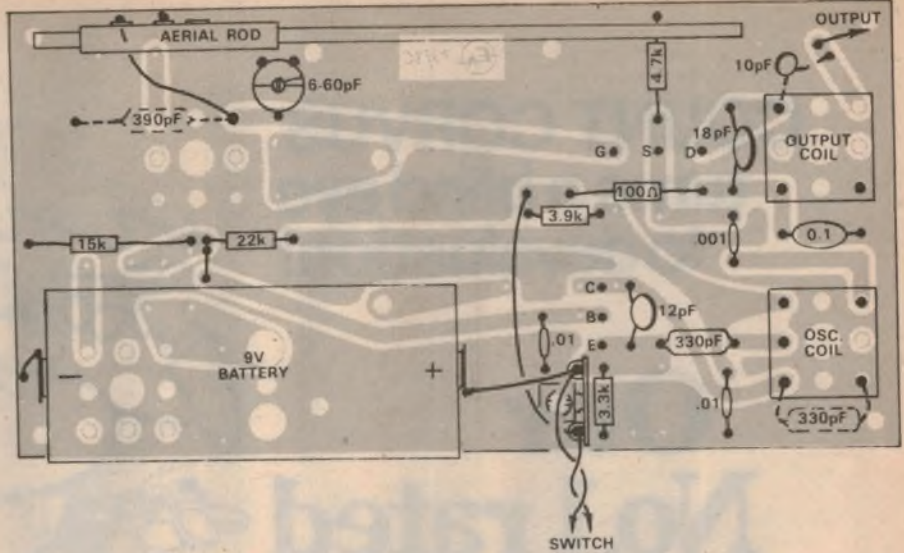

Use this diagram to guide you in wiring up the converter on the PC board. Note that a small 3-lug tagstrip is used near the battery.

you may devise a neater way of winding and arranging the turns around the receiver. On the other hand, if you wish you may be able to open up the set and if space permits, wind six turns or so directly around the ferrite rod, again using insulated hookup wire and terminating it to a piece of cable from the output of the converter.

Switch on the receiver and tune right down to the high frequency end of the dial, so that you have just tuned past station 3NE, or 1600kHz. This will ensure a clear spot as your first intermediate frequency. The receiver should be left tuned to this position. Switch on the converter and with the volume control on the receiver set to a suitable level, adjust the slug in the converter output coil for maximum noise or hiss. You may find that the slug will protrude somewhat above the top of the can. If this is excessive, then the 18pF capacitor should be reduced to 15pF.

As an alternative to setting the receiver tuning just outside the broadcast band, you may wish to choose a lower frequency. However, this has problems of broadcast stations breaking through, particularly at night. To reduce this possibility, you may be able to rotate the receiver to null out the interfering station, or perhaps even stand the receiver on end to reduce pickup of the ferrite rod.

So far, so good. Now we come to the point where it must be decided which transmission is to be used. A table is provided giving all the suitable stations in the Australia and New Zealand area, not forgetting PNG. It is now up to you to select the station closest to you and this will give the frequency to which the converter must respond. The ferrite rod aerial must be made to tune to the wanted frequency and the local oscillator must also be adjusted to tune to the wanted frequency plus 1610kHz.

You will notice that the lowest frequency is 224kHz and the highest 398kHz, with Sydney on 317kHz, which is roughly in the middle. You will find that the local oscillator can be adjusted to tune stations from 398kHz to below 317kHz, with the values given on the circuit. However, if you need to tune more towards the lower end, then it will be necessary to add some few tens of pF across the coil. Alternatively, you may add a second slug in the coil. In the prototype, I connected a Philips 4-40pF trimmer across the coil, in parallel with the existing 330pF capacitor.

Unfortunately, tuning the aerial loopstick is not as easy as for the oscillator. However, there are a number of ways of making this adjustment. I will give some pointers as to how this adjustment may be done and then it is "over to you".

If you are using the same ferrite rod as used on the prototype, then here is a pointer as to how much capacitance is

### PARTS LIST

- 1 Printed board, 152mm x 76mm, code 73/3C
- 1 Ferrite rod aerial coil (see text)
- 1 Aerial coil, RCS type 253 or similar
- 1 Coil former, Neosid 7.6mm x 58mm with can and grade 900 slug
- 1 Battery, 9V type 2362
- 1 3-tag miniature toggle switch
- 4 1/2in spacers tapped 1/8in Whitworth
- 1 FET, 2N5485, FE5485, BFW11
- 1 Transistor, BF115 or equivalent

#### RESISTORS (1/2 watt)

- 1 100 ohms
- 1 3.3k
- 1 3.9k
- 1 4.7k
- 1 15k
- 1 22k

#### CAPACITORS

- 1 10pF NPO ceramic
- 1 12pF NPO ceramic
- 1 18pF NPO ceramic
- 2 330pF polystyrene
- 1 .001uF 100V greencap
- 2 .01uF 100V greencap
- 1 0.1uF 100V greencap
- 1 6-60pF Philips trimmer

#### MISCELLANEOUS

Hookup wire, solder, 28B&S enamel winding wire, battery clips, screws, nuts. Note: Resistor wattage ratings and capacitor voltage ratings are those used on the prototype. Components with higher ratings may generally be used, providing they are physically compatible. Components with lower ratings may generally be used, providing ratings are not exceeded.

(Continued on page 109)



**COUNT CORVUS**  
turns a blind eye  
to devaluation!

**Our**  
**No.1 rated**  
**scientific**

# CORVUS CALCULATOR

is only \$79.95



*Believe it — despite devaluation this magnificent instrument is at a lower price than before. It will solve the most complex scientific and business calculations. You can just imagine what worlds we might have conquered if it had been invented 100 years ago!*

**THE MANY OUTSTANDING CORVUS FEATURES INCLUDE:**

- 14 digit display
- 12 digit business mode plus sign
- 10 x 2 Scientific mode plus sign Mant + Exp
- 12 digit accuracy
- Reverse Polish Notation (4 stack)
- 10 addressable memories (incl. Last X) with memory to X exchange on all memories
- Radian mode
- To and from Radian Conversion
- Sigma plus standard deviation and mean
- Trig functions plus inverse and hyperbolic
- Range up to  $\pm 200$  exponential value
- Fixed, floating and scientific decimal point mode

- Percent — percentage difference
- $\pi$  constant (11 digit accuracy)
- Natural and base 10 log and anti-log
- To polar — to rectangular conversion
- Vector additions
- All functions of X from and to
- 8 decimal conversions
- Ni-cad batteries
- AC/DC adapter charger
- Soft carrying case
- 1 year full warranty

Other Corvus Calculators available  
804D for business, home and school \$14  
615 Business Statistician \$19.95  
610 Financial GENIUS \$74.95



Corvus Calculators are also available at all Sydney Wide Stores. For Victorian readers at The Calculator Supermarket, 274 Lonsdale Street.

Please send me by return mail the No. 1 Rated Scientific CORVUS CALCULATOR for only \$79.95 plus \$2.50 postage and handling. I am enclosing  cheque  money order  postal note for  calculator(s).

Bankcard Mail Order facility — please complete. Please charge my Bankcard.



**bankcard**

Bank \_\_\_\_\_

Bankcard No. \_\_\_\_\_

Expiry Date \_\_\_\_\_

Signature \_\_\_\_\_

NAME .....

ADDRESS .....

..... Postcode .....



**ELECTRONIC CONCEPTS PTY LTD**

Ground Floor, Cambridge House,  
52-58 Clarence St., Sydney 2000.  
Tel: (02) 29 3753

*Money back guarantee if returned in original condition within 14 days.*





## Is the public "ripping off" servicemen?

Elsewhere in this issue, our "Serviceman" contributor examines the charges which a typical self-employed serviceman should allegedly make if he is to enjoy a standard of living and of personal welfare protection comparable with other people in the community with trade skills. Before it is even in print, ordinary conversation about the article has brought to light a variety of reactions.

The subject of radio and TV service charges has been covered at other times in this magazine, being usually prompted by a complaint that some serviceman charged X pounds or X dollars for a 5c resistor!

Or more recently: "just to put his finger in and free a little lever in my cassette player".

When examining such a statement, one really has to go back to basics. Do we, as a community, concede the need for electronic servicemen? If so, do we concede their right to earn a reasonable tradesman-level wage for a nominal 40 hours of work per week?

Concede we surely must.

Should they also share the privilege of public holidays, annual holidays, sick leave and the occasional "compassionate" day off—on full pay like everyone else? Yes again, surely.

If they are to clear a certain amount per week, shouldn't they also be able to recoup enough to subsidise their phone bill, their car expenses, their accommodation costs, etc., beyond what would be involved in private usage?

Granted—even if rather grudgingly!

Well then, if we divide their wages plus expenses by their effective working hours (30-35 would be common throughout the community), we arrive at a figure representing the rate at which they must sell their effective time. Not surprisingly, it comes out at quite a few dollars per hour. It bears comparison, in fact, with what it costs a company to sustain a productive employee—a figure well in excess of his/her weekly pay packet.

When we call a serviceman, we acknowledge personally the community need for his existence. It becomes our responsibility to pay for his time when he lifts his phone to listen to our complaint, while he drives to our address, fixes the fault, returns to his starting point and

completes the book-keeping flowing from the call.

The cost of the 5c resistor is quite incidental, merely adding a few cents to the basic cost of making the service available.

While an abbreviated dissertation along these lines can establish the principle readily enough, it is far from being an adequate basis for a serviceman to work out how he should organise his business.

It ignores the supplementary part his family may play in his business; it ignores involvements with test equipment; it ignores the implications of ordering and holding stocks of replacement components; the hours somebody will certainly have to spend maintaining business records; provision for possible loss of earning capacity through accident; re-



Radio/TV servicemen in Australia have long had to put up with the "bushranger" image. But it would appear that some, at least, are themselves being robbed by having to work longer hours for no more money and a lot less security than the average wage-earner.

tirement provisions—and other possible aspects of good personal and business management.

The problem is that, in real life, too many aspiring servicemen do ignore these factors. They start with a keen technical interest and with a conviction that they would like to run their own business; be their own boss. They work long hours; they charge what they feel that their customers will pay without too much resentment; they manage their component buying and charges by intuition—and then wonder why they seem to be getting nowhere for all their work and worry.

The article by "The Serviceman", reflecting the findings of a professional business consultant, could explain why. It draws attention to a lot of factors which a self-employed serviceman may all too easily overlook; at least until he's learned the hard way.

You may debate their relative importance and their relative magnitude but the simple fact is that they are no different from those that operate, largely unnoticed, in the case of the average company employee who does have sick leave, compassionate leave, annual leave, long service leave, tea breaks, other non-productive periods, overtime for extra hours worked, petty cash for incidental expenses, car expenses perhaps and, in the long term, superannuation.

In a normal company/employee situation, matters like this are looked after in the staff and wages office, and their costs are buried deep in overheads and mark-ups.

But, if a serviceman wants equivalent privileges, he has to arrange them for himself and distribute their costs over his service charges. My guess is that many—perhaps most—self-employed servicemen fail to do so, or are denied the opportunity by us, their customers!

In voicing these sentiments, it may appear that we are angling for a wholesale rise in service charges at a time when it would seem more helpful to hold the present line. In fact, we have no vested interest in the matter at all; and while our serviceman contributor may appear to be an interested party, he wrote the article only after we set up a meeting between him and a representative of the consulting firm.

What he reports is not a matter of sentiment or emotion. It is simply what came out of the computer as a result of commonsense inputs.

At the same time, we would hope that the article does not become an incentive to the "rip-off" merchants—if they still exist in a falling market for TV servicing. And by rip-off merchants, we are not talking about the serviceman who charges several dollars to instal a 5c resistor. The fallacy of that reasoning has already been explained. A rip-off merchant would have to be someone whose charges are clearly disproportionate to the actual costs of time and





TRIMMER POTENTIOMETERS

# SERIE PT

## PT 10



PT 10 h (2'5)



PT 10 v

## PT 15



PT 15 h (2'5)



PT 15 v (12,5)

Piher Trimpots are available  
Interstate from: —

### VICTORIA

Zephyr Products Pty. Ltd.  
PH. 568 2922.

### SOUTH AUSTRALIA

Graphic Electronic Industries  
Pty. Ltd. PH. 42 6655

### QUEENSLAND

Fred Hoe & Sons Pty. Ltd.  
PH. 277 4311.

### NEWCASTLE

Digitronics, PH. 69 2040.



**ELECTRONIC  
DEVELOPMENT  
SALES PTY. LTD.  
27 BUCKLEY ST.,  
MARRICKVILLE.  
N.S.W. 2204**

**EDS 517007**

materials.

But, as I said earlier, I suspect that the tendency amongst servicemen these days is to rip-off themselves, rather than the customer, often without realising they are doing it.

Take the case of a country TV serviceman we contacted, who was quite incredulous when we mentioned the figure to him of \$18.75 an hour.

He was even more incredulous when we repeated the prediction that, with inflation, the figure would rise to over \$20 per hour by this time next year. (And this was before the 6% rise in the consumer price index on February 22). Said he:

"I charge \$12 an hour and, even then, my customers grizzle. \$480 for a 40-hour week, they say!"

But it didn't take long to establish in conversation that the same customers, in their friendly way, would think nothing of taking up hours of his time every week simply "maggging" on the job, at the counter, or over the phone. He had to be "on the job" for long periods to get in enough productive hours—the ones he got paid for! And he had to do his books after that, or pay someone else to help out.

Yes, he was making a living but he seemed to have little time for away-from-the-job leisure. He took holidays when he could, he tried not to be sick, and he had no real provision for accident, long service leave or retirement.

The question follows: is there scope for an equitable life style on a nominal charge of \$12 an hour?

Again, I could mention a country serviceman, charging at about the same level, and for the same reasons, employing a local technician to help him at the bench and occasionally on the road. It's a casual, friendly arrangement but neither seems to have given it much thought beyond the fact that it's a job and the wages are there regularly every week.

I suspect that a proper business analysis of this situation would reveal that both employer and employee are in a vulnerable position and that their respective rights and expectations could not possibly be raised to ordinary community standards without a substantial increase in the hourly rate.

And should I add: without loud grizzles from the customers and protests about rip-off merchants!

Turning from the country, discussion around the serviceman's article brought to light the story of someone elsewhere in our Company, who was seeking certain replacement parts. Shocked by their cost through normal channels, he got the tip that they could be obtained cheaply at a Sydney suburban address.

He called there during the next Sunday afternoon and was served from the rear of a private home, from a confusion of spare parts and family possessions.

When he observed that the vendor could not be making much at the price quoted, it turned out that the margin was

# So you need electronic components?



And you've missed out on the Short Form Catalogue



supplement. Then fill in the coupon below right now or call in at our "pick your own" warehouse at

104-106 King Street, Newtown, Sydney, and you'll see the most comprehensive in-depth range of electronic components at

low, low, prices, like you've never seen before.

Also watch for our "Super Specials" advertised in "Electronics Australia".

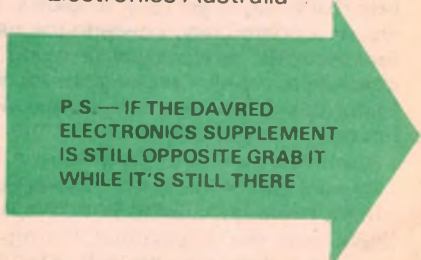

**P.S. — IF THE DAVRED ELECTRONICS SUPPLEMENT IS STILL OPPOSITE GRAB IT WHILE IT'S STILL THERE**

## DAVRED ELECTRONICS PTY. LTD.

104-106 King St., Newtown, Sydney, Australia  
P.O. Box 317, Newtown, Sydney, Australia 2042

### THE NEW BREED IN ELECTRONICS SERVICE

Mail to, Davred Electronics Pty Ltd,  
P.O. Box 317, Newtown, Sydney 2042

Please hurry my copy of your super Short Form Catalogue for which I enclose 50 cents to help defray post and packaging.

NAME .....

ADDRESS .....



## FORUM—continued

just a few percent. The vendor's philosophy seemed to be that he'd rather work seven days a week for himself "for a crust" than 5 days a week for a boss!

It's his choice, but what worries me is that we—the public—tend to think it rather smart to locate a source or a service which is a bargain. Yet it's a bargain because someone else has settled for a standard of living lower than we expect for ourselves as a right.

Someone else raised the question of a serviceman's efficiency—or the luck of the game in picking a fault quickly or otherwise. A 5-minute job in one situation may take an hour in another.

As far as skill is concerned, a learner may have to be prepared to work harder and longer for his money than a skilled man, and the customer should certainly not be penalised for his lack of skill.

As for the luck factor, most servicemen tend to average it out, weighting the lucky jobs to ease the charge on those that are less fortuitous. But, in so doing, they have to get their sums right to keep their overall hourly average on target.

Much more could be said about self-employed servicemen or other small service operations but I leave the matter there, and open for further comment.

Another whole area of discussion had to do with relatively large service organisations, of the kind attached to marketing organisations. Typically, these provide "free" service during the warranty period for electronic products, and thereafter charge around \$12 to \$15 per hour for out-of-warranty work. Whatever you may have thought about such arrangements, they may make your local serviceman look rather hungry. But there's more in them than meets the eye.

Your friendly neighbourhood emporium does not hand out warranties because they love their customers; they do it because they are obliged to by competition, by marketing pressures and by consumer protection legislation.

Nor is the service during the warranty period really "free". Built into the purchase price of every article so affected is a margin to cover the likely average cost of service or replacement.

In fact, with companies operating their own service facilities, the surcharge tends to be higher than strictly necessary to cover the warranty period, flowing on to subsidise the general operation of the service department. Thus, the figure charged for out-of-warranty service may cover the cost per hour of employing a technician, but may contribute little or nothing towards the premises, stock, equipment, and administration.

So, if your friendly local emporium offers back-up service on their lines for \$12 an hour or less, grab the chance but don't feel too elated: you subsidised it anyway, when you paid for the goods in

the first place! Even at \$15, these days, they're probably only trying the break even. And, remember, in most cases, you brought the product to them!

Just one more quip, which rather amused me, this time from a local serviceman who does a bit of lighting and public address on the side. It helps put a little fruit on the sideboard but it also creates a problem with organisations which consider that their worthy cause qualifies them for special consideration. Hence the quandary:

If I charge nothing, I'm a fool.

If I charge full commercial rates, I'm a robber.

If I charge something in between, I'm merely quibbling!

To change the subject, the reference in Jim Rowe's editorial, last month, to CB type P.A. systems in cars was put in at my instigation. Let me explain a little further.

Driving to work, recently, I paused at a "y" intersection, yielding to traffic merging from my right. Apart from the legal obligation, it was the decent thing to do, since drivers in the merging traffic stream had been trapped in a half-mile queue.

But those were not sufficient reasons for the driver behind who promptly began bipping his horn—a gesture that most of us have learned to ignore.

But the next moment the intersection re-echoed to a loud metallic voice, not all that clear, but plainly directed at the

bloke ahead—me, in this case—who was hesitating to barge in. And, as the traffic moved and the car in question stormed past, there was a fibreglass CB-style antenna waving in the breeze!

As I said earlier, I've learned to ignore the occasional rudeness that one encounters on the road—we're all guilty of it at times—and I don't think that I'm particularly sensitive or emotional. But the idea of being harangued through the P.A. facility on a CB installation was more than I could swallow. I was so furious for the next ten minutes that I could only have been what the traffic authorities choose to refer to as an emotionally disturbed driver.

A great many CB-style equipments have a public address option built in, ostensibly to extend their usefulness when installed on boats. Boatowners can speak for themselves but of this I am certain: there is no room on the road for equipment which will allow drivers to extend their potential rudeness to public slanging matches.

I am not debating, at this point, whether CB-style equipment should be legalised as such, or restricted to certain classes of users; those are matters for the Federal Government

What I am saying here concerns the state traffic authorities. If they want to keep tempers cool on the road, they should move immediately to ban the installation of public address facilities on all normal road vehicles.

## Electronics in the classroom

Could you please help with a problem concerning the "Electric Pencil" project in the Macmillan Operation Electronics course (Level 1, Project 2). I cannot follow the explanation given as to how the pencil works. It talks about transformer action, with a high current induced in the armature—but in fact the armature is connected directly in series with the main coil. Perhaps I've missed something somewhere, but surely the current flowing in the two must be the same?

As far as we can see you're quite right. The reference to transformer action in the "how it works" part of this project seems to be both wrong and misleading. The armature is directly in series with the main coil winding, as you point out, so that the current in the two must be the same.

The reference to an electric buzzer given later in the explanation seems to be much more helpful. In fact the pencil seems to operate exactly like a buzzer, except that the breaker contacts are formed by the stylus and the metal work. The energy for the sparks which heat the metal comes from the inductance of the main coil, which produces a pulse of high-voltage back EMF each time the

armature pulls away from the work and breaks the circuit.

In chapter 13 of the Operation Electronics manual, the author says that when the electromagnetic waves cross the antenna wire, they generate a small EMF in it. How is this EMF fed into the tuned circuit, when the antenna wire is simply connected to one end of the coil and capacitor?

The circuits given in the chapter concerned are over-simplified, and require explanation. You are right in assuming that if the situation were as they show, the EMF induced in the antenna wire couldn't be coupled into the tuned circuit, because there is no complete path shown.

In fact there is a path, because with an antenna of this type, the "bottom" end of the tuned circuit must be grounded. The antenna circuit path is then completed by the small capacitance which exists between the antenna and ground.

The aim of this column is to help both students and teachers with any problems arising in school electronics courses. If you have a problem, write to us and we'll try to publish an answer as soon as we can. We cannot reply by mail.





# The Serviceman

## How much should you charge?

The charge a serviceman should put upon his services has always been a contentious subject and is all the more so today, with rising cost on the one hand, and increased consumer sensitivity on the other. This article discusses the basis on which charges should be assessed and cites typical figures.

Just how should a self employed serviceman assess his service charges? Is it possible to pluck a figure out of the air, based on experience, common practice, and a certain amount of "gut feeling"?

Or is it possible to calculate an accurate hourly rate based on the cost of running the business and an acceptable wage for the proprietor?

The "gut feeling" approach is risky at best. If the figure is set too high, custom may be lost; if it is set too low it is all too easy to go broke!

That may sound like an obvious statement but more than one serviceman has finished up in the red because, fearing that he might charge too much, and lose customers, he charged too little.

On the other hand, a charge based on an accurate calculation—and "accurate" is the operative word—leaves little to chance. It protects both ways; against undercharging or overcharging.

It also has an important psychological benefit. Some people are diffident about charging an adequate fee because they fear it will appear excessive. But if the fee is based on an accurate calculation they will feel much more confident about it. They know that, if challenged, they could substantiate the figure.

In both the preceding paragraphs I used—and emphasised—the word "accurate". Again, it may appear to be stating the obvious, but an inaccurate figure can be worse than no figure at all. At least, with no figure, there is no pretence at anything but guesswork. But once the figure is calculated, it tends to be accepted as gospel.

Which brings me to the next point. While it is easy to justify seeking such a figure, just how easy is it to calculate? Is it within the scope of the average serviceman, using paper, pencil and pocket calculator?

Most of us can allocate ourselves a salary and tot up our obvious expenses such as light bill, phone bill, cost of run-

ning a vehicle, shop rent etc, but is this good enough?

The truth is that most of us are better servicemen than we are accountants. It is all too easy to overlook the less obvious but very real, and very important, costs which are part of running every business. The result, at best, is that we work long hours, for less money than if we were working for another employer, take foolish financial risks, probably undermine our health, and finish up at retirement age with little to show for our effort.

At worst, we go bankrupt.

Just how many hidden costs there are was brought home to me very forcibly recently when I had the opportunity to discuss this whole subject with a professional organisation which, in association with an accountant, has established a computer program designed, first, to ensure that all relevant data are taken into account and, second, from these data, produce a realistic assessment of what an individual should charge for his services.

The organisation is the Concord West Executive Computer Service\* and during a long discussion with them they pointed out a number of important factors which many self-employed people either ignore completely or for which they make inadequate allowance.

The basis for virtually all labour costing is the hourly rate. It may not be perfect,

inasmuch as no two people are likely to achieve the same productivity per hour, but it is about the best we have.

We can look at an hourly rate in two ways. An employee, working for wages, sees it as so many dollars per (say) 40 hour week. The employer sees it as a quite different figure. To the actual pay packet amount he has to add such things as sick pay, workers' compensation, holiday pay, long service leave and superannuation, to name just some of the more obvious additional costs. In many cases there are other employee benefits, such as subsidised canteens, free medical service, etc.

When all these factors are taken into account it is not unusual for the employer to be looking at a figure about 50% higher than the pay packet figure which the employee sees. In some cases it can be well in excess of this.

When we come to consider the self-employed person we can appreciate that he is really both employer and employee. As an employer he operates a business which, hopefully, will show a profit. As an employee he has a right to expect a reasonable weekly wage plus all those benefits which he would receive as a matter of course, under an industrial award, were he really employed by a separate employer.

To provide a better understanding of all the factors involved the Computer Service organisation ran a program based on a hypothetical self-employed serviceman, using figures supplied partly by myself, such as typical day to day running costs, capital outlay on equipment, etc, and partly by the organisation, covering such things as depreciation rates, allowance for inflation, etc. We came up with the following list.

**SALARY:** These days a competent serviceman would expect to earn between \$180 and \$220 per week. For the purpose of the exercise we settled for a round figure of \$200.

This is on the assumption of an eight hour day and a five day week (40 hours). If he worked additional hours he would expect the business to pay additional salary at appropriate penalty rates. No such additional hours were included in this exercise.

**OTHER EMPLOYEES:** We did not consider another full time employee for this

## Not just for servicemen . . .

Although this article has been written by our regular contributor, primarily for the benefit of his fellow servicemen, the business principles involved are just as valid for any self-employed person; the electrician, the plumber, the refrigerator mechanic, the motor mechanic, or anyone who sells their time and skills to the public.

Some people who read this article may interpret it as an attempt on the part of "Electronics Australia" to encourage an increase in service charges. In fact, this magazine has no vested interests which justify such an attitude. We have published it to demonstrate the simple fact that, if a serviceman is to enjoy a standard of living, protection, and retirement expectations equal to that of most skilled persons in industry, then price structures along the lines suggested are inevitable.

\*Concord West Executive Computer Service, P.O. Box 96, Concord West, 2138. Phone (02) 73-0658.



exercise, but it is quite usual for a self-employed person to employ his wife on a part-time basis to answer the telephone, take care of some of the short-term bookwork, etc. Salary? Say \$50 per week.

**VEHICLE:** Day-to-day running costs, registration, insurance, etc, \$50 per week.

**DEPRECIATION:** This is a very complex subject, particularly as it involves taxation. It is one of the areas where the professional accountant usually needs to be consulted. The Computer Service adviser put great stress on the need to calculate depreciation on the current replacement cost of the equipment; not its purchase cost several years ago. Further, the figure should be upgraded annually as replacement costs rise with inflation.

We entered two figures under this heading: the vehicle, which would cost \$6500 to replace, at \$1485 p.a.; and test equipment, replacement value \$2900, at \$725 p.a.

**GENERAL OVERHEAD:** Telephone, electricity, postage; \$312. Printing and stationery; \$108.

**SHOP RENT:** This is a very variable figure, depending on the size and location of the shop. For the exercise we selected a nominal figure of \$100 per week. If the proprietor owns the shop then it is not unreasonable to expect the business to pay a sum equal to the market rental value of the shop.

**INSURANCE:** This is a very important factor, with several sub-divisions. The most obvious are fire, theft, and loss of profit. A conventional employee is automatically covered by workers' compensation insurance and most awards carry a certain amount of sickness and accident coverage. The self-employed person is entitled to no less than this and should have a personal sickness and accident policy. (Medibank may take care of your medical expenses, but it doesn't put tucker on the table!)

Another essential form of insurance is public risk, covering injury to customers while on the serviceman's premises, or as a result of negligence on his part.

The total allowed in this case was \$281 p.a.

**SICK LEAVE:** If based on most awards, typically 5 days p.a.

**PUBLIC HOLIDAYS:** May vary from state to state, but typically 11 days p.a.

**ANNUAL LEAVE:** Typically, 4 weeks. Some awards now provide an annual leave loading, but this would be optional for the self-employed person. Not included in this exercise.

**GRATUITOUSLY GRANTED DAYS:** This rather impressive phrase refers simply to the fact that many awards provide a certain number of days off per year for the employee to attend funerals, doctors, dentists, opticians, blood bank etc. Three days p.a. is a typical figure.

**LONG SERVICE LEAVE:** Again, the self-employed person is entitled to no

less than his counterpart under an award. A typical figure is 13 weeks after 10 years. The business should be able to pay for this by reason of an adequate cash surplus taken out of the business annually and invested in a suitable interest bearing deposit, building society, or similar.

**SUPERANNUATION:** The self-employed person has a right to look forward to a retirement security which is no less than that of a conventionally employed person. Unfortunately, self-superannuation is a very complex subject and, by all accounts, one which a great many self-employed persons elect not to provide for. The main reasons appear to be the fear of inflation.



*If you enjoy the atmosphere of the service bench, then your own service business may seem a logical choice. But be aware that you will need as much business ability as technical skill if you are to achieve an acceptable living standard.*

It may be provided for by what is virtually a life assurance policy or by other suitable investment. Typical of the latter is the Bank of NSW Superannuation Nominee Fund. This is virtually a fixed deposit which earns a form of compound interest. Payments to such funds or life assurance policies, are tax deductible.

However, there are limitations on the various taxation concessions so that the benefits of tax concession plus interest earned must be balanced against likely inflation.

The advice we received was that it is a personal decision, that there are many factors, and the individual would be well advised to seek the advice of his accountant as to what he can do, what tax rebates can be claimed, and to make up his own mind as to what is the best proposition.

It was not allowed for in this exercise, but could have been included quite readily.

**NON-SALEABLE HOURS:** This simply recognises the fact that, out of a nominal 40 hour week, it will not be possible to

sell 40 hours to the public. Even assuming there is no shortage of customers, there are inevitable routine jobs and interruptions which are counter-productive. For this exercise we assumed 30 saleable hours per week.

**GROSS PROFIT:** This is a figure which generally has to be estimated—possibly by the accountant—on the basis of experience and which is designed to ensure that the business makes a NETT PROFIT (do not confuse the two) after all expenses have been met. For the purpose of this exercise it was set at 35%.

**INFLATION:** A budget such as that just discussed is accurate for costs and other factors only as they apply at the time of calculation. Prices are rising for nearly

every item we need to run the business, from actual service components to printing and stationery. A frequent cause of financial embarrassment, according to the advisor, is that adjustments for these rises are left too late.

The Computer Service can help in this regard since it can run a subsidiary program taking into account an inflation rate of (say) 12%, and from which it will calculate the increase in hourly rate necessary, on a month by month basis, to continue covering all the business costs and maintain the purchasing power of the salary and profit.

And having waded through that lot, how many readers can honestly say that they would have taken all those factors into account had they been assessing their hourly charge rate? Or how many who are servicemen, have actually considered them all in assessing their current figure?

My tip is that very few, if any have gone this far, if only for the reason that the very size of the list, and the obvious complexity of converting all of them to hourly



# coaxial cables

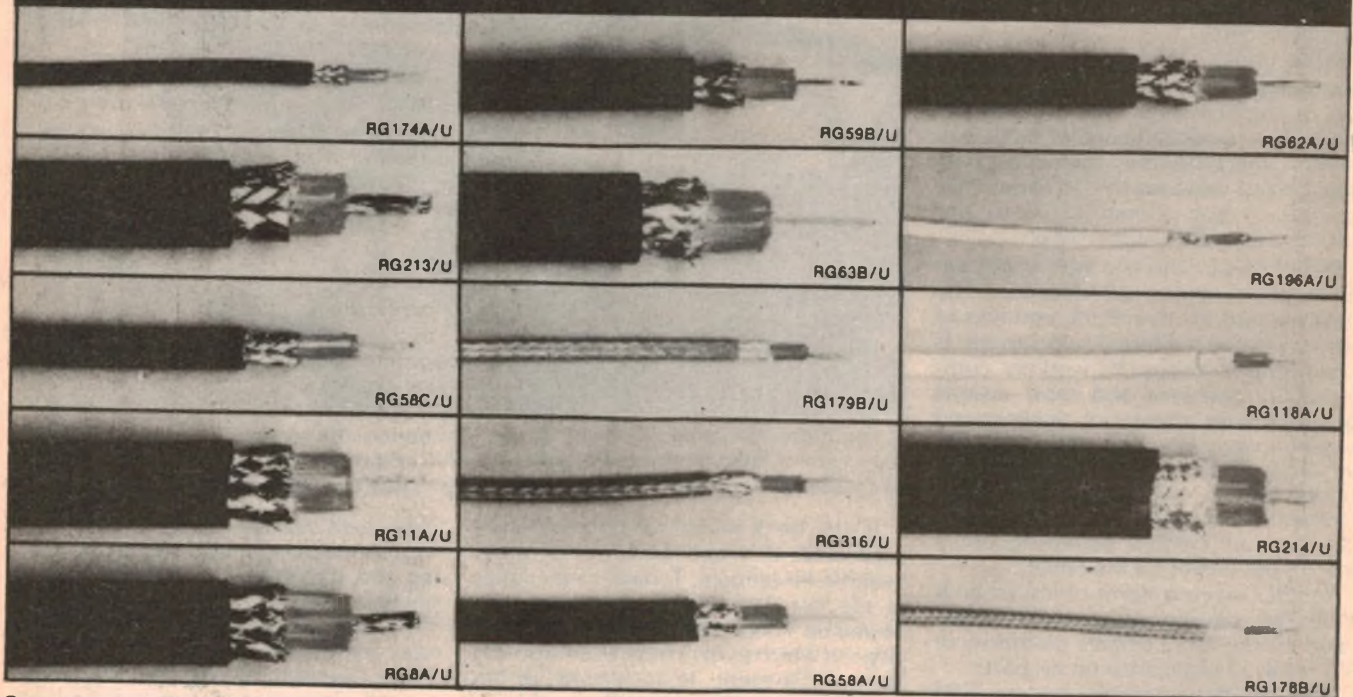

Coaxial Cables. All the popular grades of Coaxial Cables to U.S. Military specifications in stock for immediate delivery. Not to mention our ranges of tri-axial cables, aircraft cables, multi conductor cables, retractile cords, stereo and language lab cables, CB antenna cable, microphone

cable TV antenna cable, even computer and marine cables, . . . all from ACME Engineering.

For additional information phone or write the ACME office or agent in your State.



**VICTORIA:** ACME Engineering Co. Pty. Ltd., 2-18 Canterbury Rd., Kilsyth. Tel: 729 6211. **QUEENSLAND:** P. H. Phillips Pty. Ltd., 458 Brunswick St., Fortitude Valley, Brisbane, 4006. Tel: 58 2011. P. H. Phillips Pty. Ltd., 203 Ingham Rd., Townsville, 4810. Tel: 71 4131. P. H. Phillips Pty. Ltd., 4 Warrego St., Parramatta Park, Cairns, 4870. Tel: 51 4422. **NEW SOUTH WALES:** Acme Engineering Co. Pty. Ltd., 16 Newton St., Auburn, 2144. Tel: 648 4638. **TASMANIA:** W. P. Martin Pty. Ltd., 202 Argyle St., Hobart, Tas. 7000. Tel: 34 2811. W. P. Martin Pty. Ltd., 32 Canning St., Launceston, 7250. Tel: 31 5545. **A.C.T.:** Electronic Components Pty. Ltd., 29 Wollongong St. (P.O. Box 510), Fyshwick, 2609. Tel: 95 9138. **SOUTH AUSTRALIA:** Neil Muller Pty. Ltd., 8 Arthur St., Unley, 5061. Tel: 74 1162. **WESTERN AUSTRALIA:** J. G. Thomas & Associates, 71-73 Lake St., Perth, 6000. Tel: 28 1022.



costs, is clearly beyond the capabilities of most of us, even aided by a pocket calculator.

Which is where an organisation like Concord West Executive Computer Service comes in. They have a program geared to take all these factors, whether submitted as time, money, or percentages and, in a few minutes, produce an appropriate hourly rate figure.

Taking the figures we have just enumerated, the computer took only a few minutes to tell us—among a lot of other things—that this particular self-employed serviceman would need to charge \$18.87 per hour to cover all the listed expenses.

Also that, at this rate, the business itself would be making a nett profit of 20 cents per hour or, in more tangible figures, a mere 251 dollars a year.

More realistically, the business is just about breaking even, its main contribution being to provide all the award benefits for the employee, over and above his salary.

Is such a nominal profit acceptable? This is a personal decision. Some may be quite content if the business makes only a nominal profit; others may feel that the worry and financial risks associated with running a business justify a more substantial return:

One of these risks is a factor we have already mentioned; inflation. The Computer Service ran their subsidiary program on these figures on a projected .12% inflation. It showed that the hourly rate of \$18.87 should, in 12 months increase to the rather deterring figure of \$21.15!

Which brings one to the point where a serviceman may easily say: "That's too much. I'll settle for \$20 per hour".

What he's really saying is: "That's more than I have the heart to charge my customers. I'll settle for \$20 and compromise the viability of my business"!

One point which must be considered is that the order of profit is that from the service side of the business only. To it can be added whatever profit—genuine profit—that can be made on components sold in the process of servicing.

But remember, again: the mark-up on components is not all profit. Components in stock represent money lying idle. The interest not earned by such money must be taken into account when assessing the true profit.

Also, there is invariably a percentage of waste, caused by overstocking of parts which do not move as rapidly as anticipated, and which eventually have to be written off. There is also usually a small percentage of components purchased in error due to wrong diagnosis and which, at best, tie up money until a genuine use can be found for them; at worst, they may have to be written off.

Ordering parts, providing a place to keep them, keeping track of them for stock record purposes, etc, all takes time; time you are not selling to the public as

## A sample of the print-out

	PA EST	WEEKS	DAY	HOURLY
TABLE B B/F	16050	361.48	72.30	12.06
WCR/PAS/CL/PR	281	6.33	1.27	0.21
PAYROLL TAX	0	0.00	0.00	0.00
OTHER ONCOST	0	0.00	0.00	0.00
OWHDS CASH PD	0	0.00	0.00	0.00
OWHDS PROVSNS	0	0.00	0.00	0.00
GROSS PROFIT	8794	198.06	39.61	6.60
SALES VALUES	25124	565.87	113.18	18.87
LESS				
ONCOST	-16331	-367.82	-73.56	-12.26
GEN OWHDS PD	-5025	-113.18	-22.64	-3.77
PROVSNS OWHDS	-3517	-79.21	-15.84	-2.64
NET PROFIT	251	5.66	1.14	0.20

Reproduced above is a very small portion of the computer print-out. In the right hand (hour) column, opposite "Net Profit", will be found the 20c referred to in the text. Opposite "Sales Values" is the \$18.87 hourly charge rate.

a serviceman. It has to be paid for out of the profit margin on the components.

So, while component mark-up may improve the profit figure marginally, it is not likely to have a major effect.

Whether the final profit figure is acceptable or not, there is no point in arguing about it. It is completely factual. If such an order of profit is unacceptable, then possible alternatives must be considered.

For example:

(1) Increase the hourly charge rate. The acceptability of this would have to be considered in the light of possible effect on custom, particularly as it would be influenced by opposition organisations and the reputation of the business.

(2) Seek lower rental premises. Even assuming their availability, the likely adverse effect on custom would have to be considered. Also, if such a change significantly increases distances to be travelled, there may be no real saving.

(3) Possible cuts in overhead. One should always be on the alert for waste, but it is unlikely that any significant cuts could be made. In fact, the Computer Service adviser claims that most people are remarkably efficient in holding down their overhead.

(4) Business expansion; increased sales of appliances, etc. In fact, most organisations of this kind already conduct some measure of sales business and it may well be that this will contribute the main

source of real profit.

However, as with the sale of components, there is a significant difference between the mark-up figure and the real profit. Also, sales take time, just as does service. While ever this time can be taken from non-saleable hours, or slack periods of service, its use in this role is logical.

But a serviceman cannot be in two places at once. While he is on the road, doing a round of service calls, he cannot be in the shop ready to demonstrate the latest colour TV set to a prospective customer. About the best he can do is to be on the lookout for possible sales avenues among his service clients.

It would be foolish to deny that some of the figures from a budget like this are unpalatable. The hourly charge rate is higher than we would like, if only because it creates a customer relations problem. The business profit figure represents only a nominal profit which could quickly become a loss if due regard was not given to inflation and similar factors.

And the prospect of having to increase our hourly charge rate, at the very least on a quarterly basis, but preferably on a monthly basis, is equally unpalatable.

But it would be just as foolish to ignore these figures. If we cannot accept them, or find a way to beat them, then—frankly—we shouldn't be in business. We would be better advised to shut up shop and seek a job working for wages for another organisation.



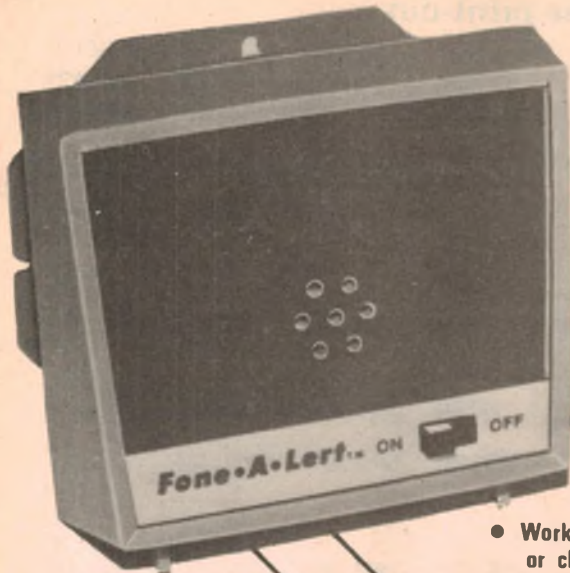

## Don't miss calls —

when you're away  
from the phone or  
door — at Home,  
Work or Play!



Just press suction cup to surface of phone or chime . . . that's all!

# Fone•A•Lert

**Penetrating  
Audible Signal —**

- Works on any phone or chime box.
- Size: 4¼" w x 3¾" h x 2½" d; integral wire reel.
- Uses standard 9-volt transistor battery; lasts for months.
- Attractive plastic housing; stands alone or hangs on a nail or hook.
- Durable, solid state design; no mechanical parts to get out of order.
- Saves rental and installation costs of remote phone signals.

At last, an amazing new device lets you hear your phone or doorbell *wherever you are on your premises!* Fone•A•Lert is a miracle of electronic technology that produces a piercing audible signal synchronized to the ringing of your phone or doorbell. There are no electrical connections to make, no dismantling of your phone, no drain of electricity, not even anything to plug in!

Fone•A•Lert is so simple to install, even a child could do it. Just apply the suction cup end of the shielded wire to the surface of a telephone or electrical doorbell chime box that emits a signal. Unreel the wire (comes with 40 feet; more wire can be added) and carry the unit with you — outside, upstairs, downstairs — wherever you know you'll be out of hearing range of the phone or bell or where environmental noises might make it difficult to hear. The pocket-size device can be carried, stood on its own integral feet or hung on any convenient nail or hook. From an open window, Fone•A•Lert will easily reach your ears across the yard.

Then just flick the switch on the face of the unit to "on" — and that's it! Fone•A•Lert is ready to signal you every time your phone or doorbell rings. When you don't need its penetrating signal any longer, just flick the switch to "off". When you want to move the device from one phone to another, or from a phone to your doorbell, simply release the suction cup and attach to its new location. If you desire, additional length of 24 AWG, 2-conductor speaker wire can easily be spliced into the wire that comes on the integral rear wire reel. And Fone•A•Lert requires so little current that a standard 9-volt transistor battery will last for months — and you automatically know the battery is good by the short "beep" when the unit is switched to "on".

Fone•A•Lert is the long-needed answer for active people who can't miss phone calls but don't want to sit next to the phone waiting. Don't miss another phone call or caller . . . let Fone•A•Lert do the listening for you. You've got better things to do.

**\$17.95** plus \$1.00  
postage

### MONEY BACK IF NOT DELIGHTED.

\*Refunds will only be payable if the goods are returned within 21 days of delivery, subject to any overriding State or Federal law.

**HOW TO ORDER:** Fill in BOTH sections of the coupon. In each section print your name and full postal address in BLOCK letters. Cut the entire coupon out around the dotted line. Send it with your money order or crossed cheque to Reader Service (Fone-A-Lert), P.O. Box 93, Beaconsfield, N.S.W. 2014. Cheques should be endorsed on the back with the sender's name and address and made payable to this magazine. This offer is open to readers in Australia only. Please allow four weeks for delivery.

Name .....

Address .....

State ..... Postcode .....

This magazine's Fone-A-Lert offer No. 101/77  
EA 4.77

Name .....

Address .....

State ..... Postcode .....

Please send . . . (state quantity) Fone-A-Lert/s.

I enclose my cheque, postal/money order to the  
value of \$ . . .



# Circuit & Design Ideas

Conducted by Ian Pogson

Interesting circuit ideas and design notes selected from technical literature, reader contributions and staff jottings. As they have not necessarily been tested in our laboratory, responsibility cannot be accepted. Your contributions are welcome, and will be paid for if used.

## Versatile logic probe displays four modes

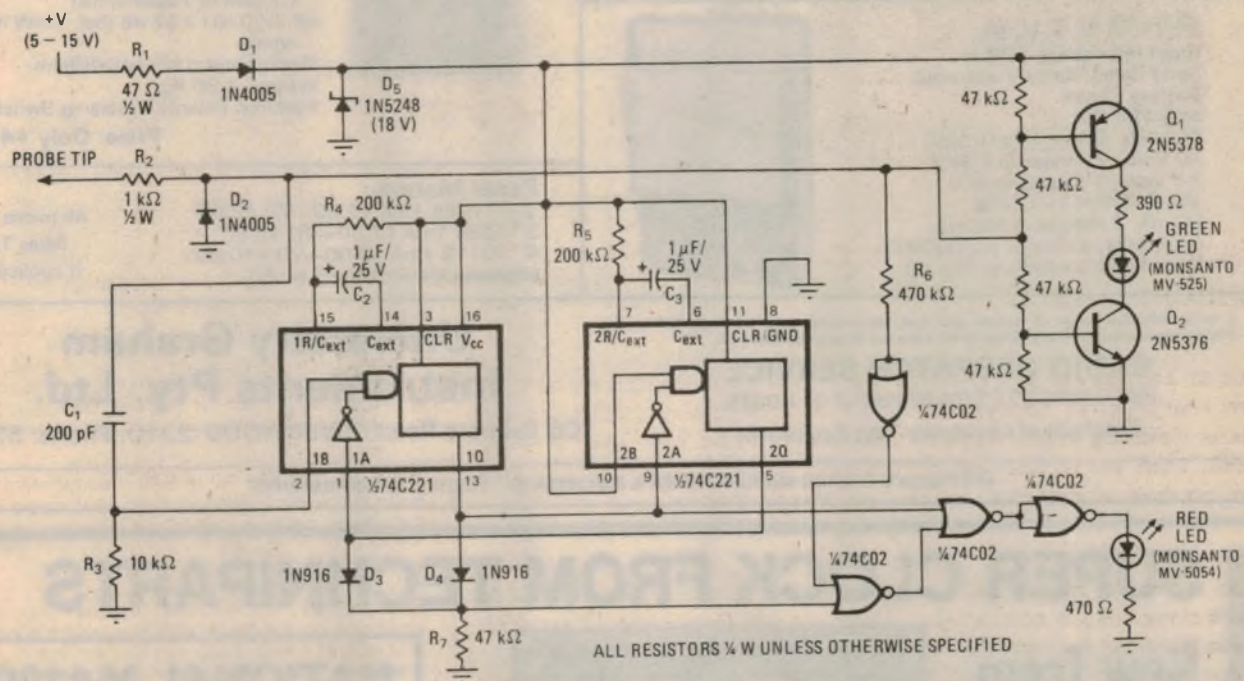

In addition to indicating static states—high and low logic levels as well as open circuited nodes—an inexpensive logic probe can be built to indicate a pulse train by flashing. Packaged in a pen-type flashlight or similar enclosure, the probe performs as well as commercial models at a fraction of their cost, and it is compatible with both CMOS and TTL voltage levels.

A pair of LEDs, red and green indicates the various states in accordance with the truth table. The green LED glows only when the input is connected to a high impedance or open-circuited logic node; because neither situation affects the quiescent on state of Q1 or Q2, current flows through the LED. Application of a logic-1 or logic-0 level to the probe input turns off Q1 or Q2 respectively, and in either event, the green LED goes off. The NOR gates turn on the red LED when a logic-1 input is applied through current limiting resistor R6. Note that the red LED will also glow when the 1Q output of the dual monostable multivibrator goes high. The monostable is employed solely for the fourth condition in the truth table—the dynamic input of a pulse train to the probe.

The 74C221 CMOS dual monostable

has both positive- and negative-transition-triggering inputs, either of which can be used to inhibit the other—the output Q remains low whenever input A is high or input B is low. Firing the monostable generates a positive pulse at Q that has its duration determined by an external RC time constant. A pulse train input to the probe is AC coupled and shaped through C1 and R3 to the positive-transition input of the first monostable, 1B. The 1Q output then goes high for  $T = R_4 \times C_2 = 200\text{k} \times 1\mu\text{F} = 200\text{mS}$ . On returning to the low state, the 1Q output triggers the second monostable through negative-transition input 2A, and its 2Q output goes high, inhibiting the first monostable through input 1A for an additional  $T = R_5 \times C_3 = 200\text{k} \times 1\mu\text{F} = 200\text{mS}$ . After the 400mS period, the monostables are ready for triggering by the next positive transition at 1B, and hence the system exhibits a characteristic frequency of 2.5Hz or  $(400\text{mS})^{-1}$ , regardless of the input pulse frequency. The 2.5Hz signal at 1Q is coupled through the NOR gates to flash the red LED at this rate.

The OR gate consisting of D3, D4 and R7 ensures positive indication of pulse

train inputs, irrespective of symmetry or duty cycle. Waveforms with very low or very high duty cycles, which could not otherwise be distinguished from constant DC levels, will therefore flash the red LED at the 2.5Hz rate.

The probe input is protected from negative polarity signals by R2 and D2. The unit, which will operate from any 5V to 15V source, is protected against over-voltage by D5 and R1 and against the wrong supply voltage polarity by D1. The logic level thresholds are about 20% and 80% of the supply voltage, and the probe draws only about 10mA from a 5V source.

(By Gordon W. Martin, in "Electronics".)

## Clock power failure indicator

The circuit shown is actually a latch which will indicate a brief mains power failure. Such a device can be of particular use with small computers, and with practically all types of electric clocks which are operated from the mains. Apart from the many other types of mains operated



# University

## MULTIMETERS TEST INSTRUMENTS

A model designed to suit every purpose



### "Popular Model" CTN500MP

(20k ohms per Volt D.C.)  
DCV: 2.5/10/50/250/500/5kV  
ACV: 10/50/250/500/1kV  
dB: -20/0/+62dB (5 ranges)  
DCA: 50uA/5mA/50mA/500mA  
Res: Rx1, Rx10, Rx100, Rx1k ohms  
(1 ohm to 10M ohms)  
Size: 150x110x50mm  
Weight: 450 gm **Price: Only \$22.50**

NB Also available in Kit Form.

PRICE: ... HIGHEST QUALITY at the LOWEST PRICE  
GUARANTEE: 90-day, backed by University after sales service  
SERVICE: ... 24-hour efficient repair service

### "De Luxe" MVA-100CN



(100k ohms per volt D.C.)  
DCV: 0.5/2.5/10/50/250/1000V  
ACV: 2.5/10/50/250/1000V  
DCA: 10uA/500uA/5mA/50mA/  
500mA/10A  
ACA: 10A  
Res: Rx1, Rx10, Rx1k, Rx10k, Rx100k  
(.1 ohm to 100M ohms)  
dB: -20/0/+62 dB (Ref. 1mW in 600  
ohms)  
Dimensions: 180x140x80mm  
Weight: 1.36 Kg.  
Features: Polarity Reversing Switch  
**Price: Only \$45.00**

### FET-74 V.T.V.M.

Input impedance 12MΩ  
Solid State, Battery operated,  
Battery Check  
only \$80.00

DC Volts: 8 Ranges to 1.5KV  
AC Volts: 7 Ranges to 1.5KV  
P-P Volts: 7 Ranges to 4KV  
dB, 6 Ranges to +66dB  
DC mA, 8 Ranges to 500mA  
Resistance, 4 Ranges to 1000MΩ  
30kV Probe available at \$25.00



### Panel Meters

2½" TD66 1mA \$7.60—VU \$8.60  
3" TD86 1mA \$7.80—VU \$8.80  
4" TD118 1mA \$9.00—VU \$10.00  
Edgewise Meters HK.35 \$4.00

\*All prices plus  
Sales Tax  
if applicable.

A comprehensive range of meters and test instruments may be inspected at our Showroom and are available either direct from our Riverwood office or

### RADIO DESPATCH SERVICE

869 GEORGE ST SYDNEY PHONE 211 0816

Stockists of University Test Equipment

## University Graham Instruments Pty. Ltd.

106 Belmore Road, RIVERWOOD 2210. Phone: 53 0644

AUSTRALIA'S LEADING MANUFACTURER & IMPORTER OF ELECTRICAL INSTRUMENTS

# SUPER CLOCK FROM TECHNIPARTS

New from  
National



### MA1010A

- ★ Same as Popular MA1002B except with .84" Digits
- ★ 50/60HZ Operation
- ★ Price \$23.50 Post Free
- ★ Transformer JT197 \$6.50 Post Free

## TECHNIPARTS LOW COST CRYSTAL TIMEBASE KIT

- ★ Using National MM5369 3.58 MHZ to 60HZ Divider
- ★ Includes PCB, Crystal, Divider, Trimmer etc.
- ★ PCB has allowance for ÷ 6 and ÷ 10 Counters also TTL buffered output = 3 IC'S.
- ★ Great to use with Clock Modules, Timers etc.
- ★ Power Supply 3—15VDC

PRICE: \$6.75 Post Free

1HZ + 10HZ + TTL Out Option \$3.20 extra

## NATIONAL MA1003 CAR CLOCK MODULE

- ★ 12VDC operation
- ★ Maintains Timekeeping Down to 5VDC
- ★ Display Blanking with Ignition off Draws 5mA.
- ★ Draws 100MA with Ignition on.
- ★ Just add 3 switches + DC 12V.
- ★ On board 2MHZ crystal.

PRICE \$32.00 Post Free.

# TECHNI PARTS

Woolworths Arcade,  
95 Latrobe Terrace,  
PADDINGTON. 4064  
P.O. Box 118,  
PADDINGTON. 4064

Ph: Brisbane (07) 36 1474

Trading Hours (8.30am — 5.00pm  
Mon. - Fri., 8.00am — 11.15am Sat.)



## CIRCUIT & DESIGN IDEAS

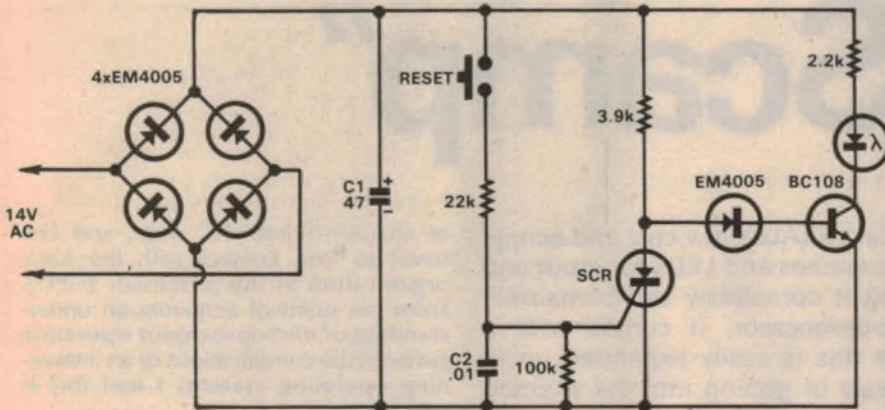

electric clocks, some of the seven segment digital clocks can eventually display a readable but completely wrong time after a momentary power failure. Even with some clocks using a standby battery, the indicator is still useful to warn that battery power has been used, and that the time may also be wrong. In all cases where a clock has been shown to sustain a momentary power failure, the indica-

ted time should be checked against a known accurate time source.

The operation of the circuit is as follows: When the power is switched on, the transistor conducts, turning on the LED (or other suitable indicator). Pressing the reset switch fires the SCR, which turns the transistor off. The diode in the base of the transistor is necessary to make the transistor turn off, to compen-

sate for the voltage drop across the SCR. The time constant resulting from the 47µF capacitor and its resistive load, will determine the "hold on" time which will ignore very short power interruptions. The value of the capacitor may be varied and the best value determined experimentally to suit the particular purpose.

The types of the main components are shown on the diagram, with the exception of the LED and the SCR. No problem should be experienced in getting a suitable LED or other indicator. The SCR which I used was a small one, in a TO-18 case and which was unmarked. However, again no trouble should be had in getting a suitable low power SCR suitable for the application.

I fitted this arrangement to the clock which I built and which was described in "Electronics Australia" for April, 1975. The 14V AC supply was readily available in this case. In some cases, it may be necessary to provide a separate miniature transformer to provide the 14V AC. Although it is not normally recommended, experienced constructors may be able to power the circuit via a small high voltage capacitor directly from the mains.

(By Mr R. A. Vickers, 14 Simmonds Street, Oakleigh, Victoria 3166.)

## Thermistor controlled thermostat

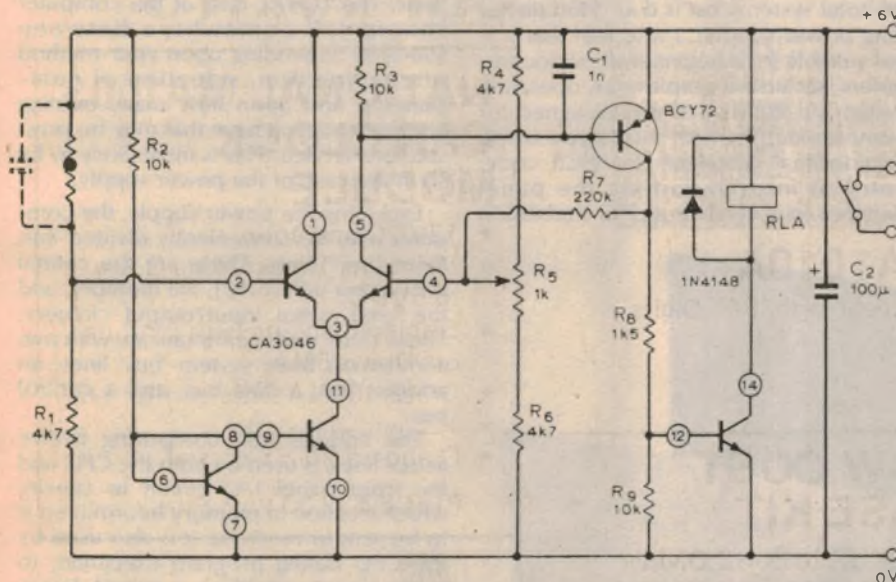

Essentially the circuit is a bridge formed by the thermistor, R1, R4, R5 and R6 with an amplifier for sensing the unbalance. The circuit switches a relay on when the temperature is below a chosen level, and by altering R1 the operating temperature can be changed. If the opposite function is required the positions of the thermistor and R1 are reversed. The sensing circuit uses a CA3046 which supplies two matched pairs of transistors in addition to the output transistor. Tr1 and Tr2 act as a voltage com-

parator, the tail current being provided by the current mirror Tr3 and Tr4. The base voltage of Tr2 can be adjusted using R5 which allows the switching temperature to be set precisely. Positive feedback via R7 prevents chatter when the switching point is reached. If the thermistor is separate from the amplifier, a 0.1µF capacitor should be connected across R1 to minimize pickup effects.

(By D. E. O'N Waddington, in "Wireless World".)

## RADIO DESPATCH SERVICE

869 GEORGE STREET  
SYDNEY

JABEL alignment tools. Sizes No. 2, No. 4 & No. 6  
Radio & electronic pliers and side cutters HKL  
screw drivers

MK100 wire strippers  
C.R.C. aprays for electronic equipment  
N1 cad cells

commander Eveready torch  
rear deck mounted car speakers  
Ferguson PF2851 transformer  
Dip test clips

Shure cartridges and styli, spherical and elliptical  
models B & W or colour television aeriels 406/10  
or 215. TL2, TL3, EFC1, EFC2 & EFC3 colour.

Large range of TV aerial installations.  
Texas calculators. Novus calculators.  
R.C.S. type 253 aerial coil as used in E/A converter  
for YL2UV & CB 27 MHz CONVERTER  
P.C. BOARDS

CNR GEORGE & HARRIS STS  
RAILWAY SQUARE  
TEL 211-0816, 211-0191

OPEN MON. TO FRI.  
8.15 AM TO 5.30 PM  
SAT. 8.00 AM TO 11.45 AM



*An ideal microcomputer for the beginner:*

# "Mini Scamp"

Forget about expensive terminals: here's a REALLY low cost and simple microcomputer. It uses front-panel bit switches and LEDs for input and output, in normal binary code, making it completely self contained. Based on the National SC/MP microprocessor, it comes with a minimum of 256 words of RAM—but this is easily expanded up to 1024 words. We think it's the ideal way of getting into the exciting world of microcomputers at low cost.

by **DR. JOHN KENNEWELL** Physics Dept., Newcastle University

The design of this microcomputer started around October of last year with the formation of the Newcastle Microcomputer Club. It became obvious at the inaugural meeting that there were many people who would like to play with their own microcomputer, developing programming skills, yet who were unable to afford even the lowest cost kits available on the market. The problem becomes even more acute when considering the cost of a terminal to interface with these kits.

Various solutions to the terminal problem have now been presented in this magazine. Jim Rowe has described an ASCII-Baudot translator for use with surplus Baudot teleprinter machines (EA, October 1976) and also a video data terminal (EA, January and February 1977). However, either of these alternatives

means an outlay of at least about \$200, not including the microcomputer itself, which brings the total cost to around \$300 using a small system such as the SC/MP evaluation kit.

Recently Applied Technology have released a SC/MP I/O kit, which interfaces with the SC/MP evaluation kit and permits program and data entry via panel switches. While this unit undoubtedly fills a gap in available I/O hardware and seems to be enjoying great popularity, the total system cost is over \$150 (including power supply). I also feel that it is not suitable for a beginner to microcomputers because it employs an operating system (in ROM) that was designed for communication with a teletype using hexadecimal characters in ASCII code. Entry of information via the panel switches thus involves a prior translation

of characters into this code, and one tends to lose contact with the basic organisation of the processor (CPU). From the point of acquiring an understanding of microprocessor operation (without the complications of an intervening operating system) I feel this is undesirable.

In searching for a suitable design, and to overcome the problems mentioned above, it became apparent to me that the idea of using an available evaluation kit together with an I/O interface was not the way to go. As an operating system was not desirable, there was no need for read only memory (ROM). Building a system from scratch meant that costs could be kept down as only those features necessary were included. At the same time, I personally wished to build a much larger system than that shown here, and ease of system expansion was well to the fore in my design considerations. The TOTAL cost of the computer should fall somewhere between \$50-\$100 depending upon your method of construction, selection of components, and upon how many existing components you have that may be pressed into service. This is most likely to be so in the case of the power supply.

Excluding the power supply, the computer may be conveniently divided into three basic units. These are the central processing unit (CPU), the memory, and the front panel input/output circuitry. These three units communicate with one another via three system 'bus' lines: an address bus, a data bus, and a control bus.

The address bus, comprising twelve actual lines, is used by both the CPU and the front panel I/O circuit to specify which location in memory information is to be sent or received. It is also used by the CPU during program execution, to select a particular input or output device for communication with the outside world.

The data bus, of 8 lines, enables the passage of information between any two of the three units in either direction. The unit that does not participate in a given

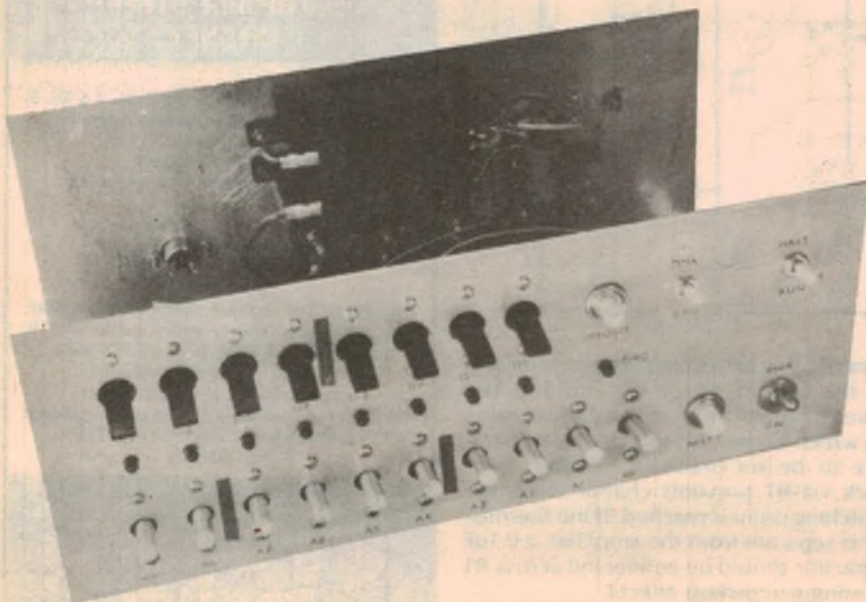

*At left is the author's prototype of his Mini Scamp, with the full circuit shown on the page opposite.*







data transfer is disabled (i.e. put in a high impedance state) so that it does not affect the transfer.

The control bus, of only 3 lines, is used to specify whether information is to be read from the memory, or is to be written into the memory, and to place the CPU in a 'hold' condition while it waits for information to be given it via the front panel or other slow peripheral device.

Twelve address lines enable a total of 4096 words of memory and/or peripheral devices to be addressed independently by the CPU. The concept of the bus system described here makes possible the easy expansion of the computer up to this limit, if so desired, by the addition of more memory and more I/O devices. The SC/MP CPU is actually capable of directly addressing up to 65k of memory and/or peripherals. Although this may be readily accomplished with a latch and some buffer IC's it will not be discussed here further.

Of the three sections making up the system the CPU is the heart, or rather the brain, of the system. It comprises the SC/MP integrated circuit microprocessor chip, which requires two voltages for correct operation, +5V and -7V. The -7V (actually -6.2V) is provided from a nominal -12V line by means of a series dropping resistor (56 ohms, 1W) and a zener diode regulator. The other resistors in the circuit are pull-up resistors, to ensure that the appropriate pins on the SC/MP have the correct potential for normal operation.

Some of these potentials can be modified by switches on the front panel. For instance, the DMA/CPU switch can disable the CPU by placing zero potential on the ENIN terminal of SC/MP. This is necessary when data is being entered into memory via a direct memory access (DMA) from other front panel switches, as described later. The RUN/HALT switch controls the potential of the CONTINUE terminal, and enables suspension of program execution at any time. The RESET pushbutton must be pressed before initial execution of each program. This ensures that all internal registers of the SC/MP are set to zero, and that the first instruction fetched from the memory will be from location one.

The capacitors on each of these switched lines are crude debounce devices, but have been found to be quite adequate. A quick or snap action when using the switches will always help in this respect.

The 470pF capacitor connected between the X1 and X2 pins determines the speed at which the processor will run. Unlike many other microprocessors, the SC/MP has all the required timing generation circuitry built in, with the exception of this one external component. The value of capacitance shown here will run the SC/MP at near its

maximum speed with a 'microcycle' time of 2 $\mu$ s. Typical program instructions in the SC/MP take from 5 to 22 microcycles to execute.

The memory section of the circuit uses two low-cost 2112 static MOS memory chips which together provide 256 words of memory, each word of 8 bits in length. These words occupy address locations starting at 0 and extended to 255 (decimal) inclusive (0-FF hexadecimal). The eight address pins on the devices are fed from the eight least significant address lines (AD0-AD7 inclusive).

To ensure that the devices only occupy address locations 0-255, the remaining lines of the address bus are fed to a 74LS138 one-of-eight decoder. The "0" output of the decoder is then fed to the

It has two fundamentally different modes of operation. When the DMA/CPU switch is in the DMA position, then the address switches have control of the address bus. The contents of the memory address indicated by these switches will be displayed by the LED's (L0 to L7) on the front panel.

If it is desired to change the contents of any particular memory location, the address of that location is set up on the address switches, and the data to be inserted is set up on the data switches (DS0 to DS7). If the DEPOSIT pushbutton is then depressed and released, the LED's will confirm that the data has indeed been stored in memory at that location. In this way a program may be loaded into memory. This is described in more detail

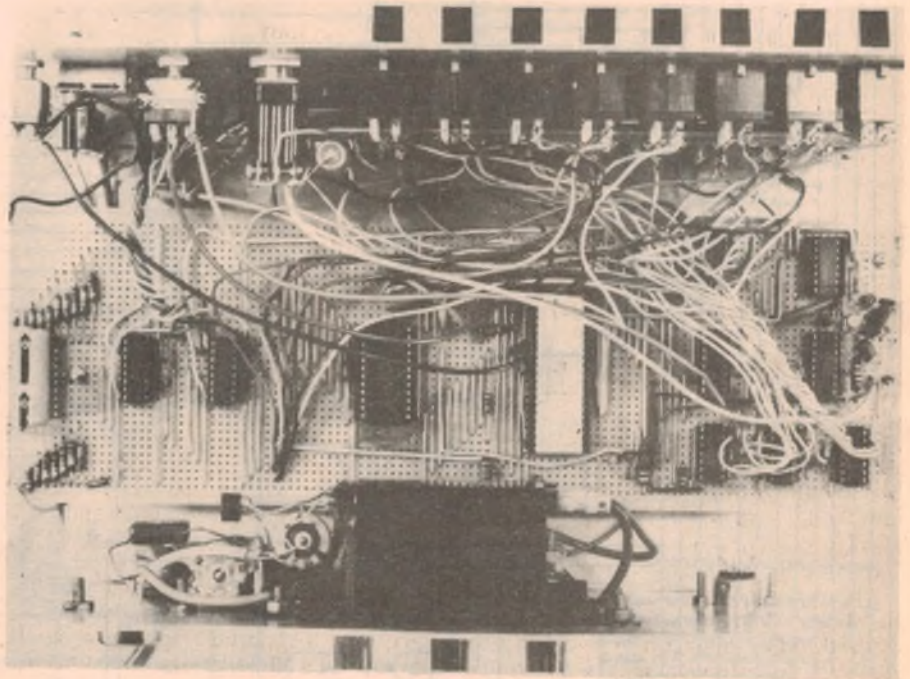

The inside of the author's prototype, which was built up using Veroboard. To help readers we are producing a PCB pattern — see box at lower right.

chip select (CS) inputs of the memory chips, so that the latter are only enabled or "selected" when the four address lines AD8 through AD11 are in the zero state.

Note that the 74LS138 is basically a 3-bit decoder, and has only three nominal code inputs. The most significant address line AD11 is therefore fed to one of the decoder's own chip select inputs, to achieve the desired result.

Note also that the remaining outputs available on the 74LS138 (1-7 inclusive) may be used to provide selection signals for additional memory devices. The memory of the system can thus be expanded very simply, merely by adding further pairs of 2112 devices.

The front panel I/O section actually has the greatest circuit complexity of the three parts of the system—neglecting, of course, the tremendous internal complexity of the CPU and memory LSI chips.

a little later, using a sample program.

As it is more convenient to represent both data and addresses in hexadecimal rather than binary notation, it will be found convenient to group or delineate these switches into fours. PVC marking tape was used on the front panel of the prototype computer as can be seen in the accompanying photograph.

In the second mode of operation, the DMA/CPU switch is set to the CPU position. In this mode, the address switches are disabled, and have no control over the address bus. The RUN/HALT may then be set to RUN and the CPU will begin to execute whatever program instructions are in memory at this time. Also in this mode, the data switches function as an input device at the hexadecimal address 0801 (hex). Thus, under program control, data can be read into the CPU from the data switches. The



instruction to do this has the form

### LD SWITCHES

where SWITCHES has a hex value of 0801. The LD instruction loads whatever data is found at the address of the operand (in this case address 0801) into the accumulator register of the CPU.

To indicate to the external world that it requires data (i.e., that the above instruction has been executed), the CPU, via signals on address lines ADO and AD11, and on the read data strobe control line (NRDS) is used to turn on a data request LED (DRQ). This is done via G3 which detects a coincidence of the above three signals and toggles the flip-flop which turns on the DRQ LED and also pulls the NHOLD control line to zero. This will cause the CPU to remain in a 'wait' condition until the line returns to a 'one' state. This will occur when the deposit button is pushed, triggering the monos, which after a small delay from the 390-ohm and 0.0033uF RC network, reset the flip-flop.

In this second mode the LED's act as an output device with an address 0802 (hex), which is selected by G2 and activated by an instruction of the form

### ST LEDS

where LEDS represents the hex address 0802.

The astable multivibrator comprised of the two BC108's is disabled in the CPU mode, but in the DMA mode provides a continuous string of latching pulses to the 74C175's so that the LED's will always display the contents of the address as indicated by the address switches.

The two diodes in the circuit are used as cheap 'OR' gates for simplification. They could be replaced by another IC if desired, but they have proved quite adequate, and help to keep the cost and total package count down. For similar reasons the 7401 has been used as a "poor-man's tri-state buffer", instead of the more expensive buffer IC's manufactured especially for tri-state applications. There is no reason, however, why these latter chips, such as the 81LS97, should

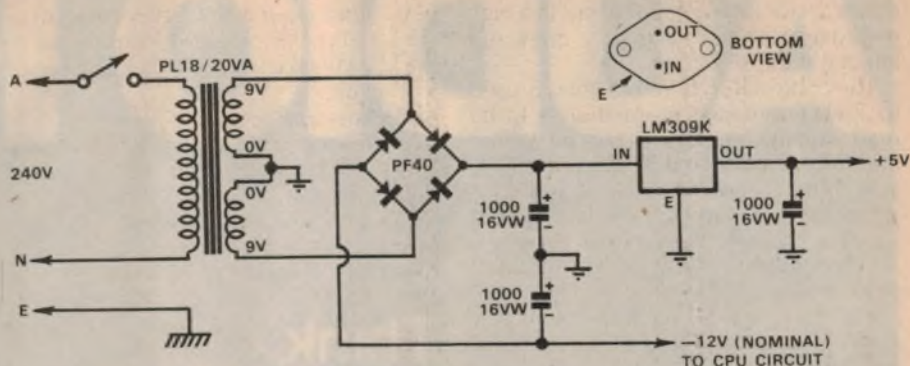

Fig. 2: A simple power supply circuit for Mini Scamp. Any other supply capable of delivering 5V at 500mA and -12V at 150mA could be used instead.

not be used if available.

If the system is to be run with only the minimum amount of memory, (i.e., 256 words) then only 8 address switches are required ( $2^8 = 256$ ). The remaining switch lines (AS8 to AS11) may simply be left floating. This is equivalent to placing a zero on these lines. Thus, depending upon the amount of memory you have available, anywhere from 8 to 12 address switches will be required on the front panel.

It should be noted however, that no more than 2K of memory can be accommodated on this system without modification. This is because addresses above hexadecimal 0800 (or decimal 2048) are used to reference the data switches and LED's.

Those of you who have closely followed the circuit will have realised that in fact the addresses 0801 and 0802 (hex) are not unique in their ability to reference the switches and LED's respectively. All twelve address lines instead of only two, as used at present, would be necessary to uniquely specify a single device. Thus all addresses which have a one in bit positions 0 and 11 will refer to the data switches. These all lie at locations greater than 0800 (e.g. 0803, 0805, 08A9, etc.) and so will not conflict with memory addresses less than this value.

Various techniques and methods may be used in the construction of the microcomputer. Veroboard was used to

build the prototype as shown in the photograph, and probably provides the lowest cost way to go. Layout and component placement is not critical. A single length of Veroboard could be used, or the three main sections could each be constructed on smaller separate boards. This latter approach allows one to more easily interchange units if desired. (e.g. to try an 8080 CPU, or to substitute a larger memory unit).

Printed circuit boards for each section make for simpler construction and greater flexibility, and several members of our microcomputer club will probably employ this approach. However, it should be borne in mind that the cost of PCB's and their respective sockets will

## Mini Scamp: a PCB is coming

Dr. Kennewell's "Mini Scamp" microcomputer design seems to us to be just what many of our readers have been waiting for: a really simple way of becoming familiar with microprocessors and their operation. Because of its low cost, its ease of expansion, and the fact that it needs no expensive terminal, we believe it could become an extremely popular project and a worthy successor to our own EDUC-8 design. To help ensure this well-deserved popularity, we are producing a low-cost PCB pattern for the project. All going well we hope to publish details next month.

## It's CB City at Hawthorn Communications Centre



### AM 23 CHANNEL TRANSCEIVERS

XTAL 2 channel auto scan \$145.00  
COUGAR DE LUXE. Built in SWR, power and S meter, with adjustable modulation noise blander that works! \$159.00

NATIONAL. Famous make with all the wanted features for the connoisseurs \$195.00  
PACE Low cost, compact, reliable \$79.00  
SEIKI Low cost, big performance \$99.00  
GRANADA. 240 AC and 12V DC Base STN \$169.00

### SSB AM TRANSCEIVERS

XTAL XSSB-10 \$245.00  
PANTHER (Arriving Soon) Lock down CB/AM Antennas c/with splitter. Fantastic output from top loading coil \$35.00  
Base loaded roof boot mount with cable and plug \$25.00

**HAWTHORN COMMUNICATIONS CENTRE**  
549 BURWOOD ROAD  
HAWTHORN, VIC 3122  
Tel: 81 7330



# AUDIO ICs

Think  
**Signetics**  
Think  
**PHILIPS**

## DESIGNER'S CHOICE

Here are the audio ICs you'll need to build up FM tuners, Pre-amps or Power amplifiers. Whether you are a manufacturer, serious hi-fi buff or simply a hobbyist you'll find the best of European and American designs in this range from Philips and Signetics.

- **FM AMPLIFIER/MIXER**  
SD6000
- **AM/FM CHANNEL RECEIVERS**  
TBA570, TBA700
- **AM RECEIVERS**  
NE546, TCA440\*
- **FM DETECTOR/LIMITERS**  
ULN2111, TBA750A TCA420A,  
TCA770
- **FM GAIN BLOCKS**  
ULN2208, ULN2209
- **FM IF SYSTEM**  
CA3089
- **STEREO DECODERS (PLL)**  
TDA1005, UA758 (MC1310E)
- **DUAL LOW NOISE PREAMPS**  
LM381, LM382, LM387, NE542,  
PA239, TCA490 (UA739)

- **DC CONTROL CIRCUITS**  
TCA730, TCA750
- **ELECTRONIC TUNING STABILISERS**  
TAA550, TCA530, TCA750
- **POWER DRIVERS**  
NE540, SE540, NE541\*
- **POWER AMPLIFIERS**  
TBA810,\* TCA760B, TDA1004,  
TDA1010,\* TDA2611\*

When buying audio ICs from your local component supplier be adamant that you will only accept Philips/Signetics. You want the best. If he can't supply from stock ask him to order in for you. And if at the same time you need semi-conductors, ask for Philips transistors, Darlington transistors, diodes and rectifiers. They're Australian made - and by supporting the Australian industry you help them support you. Good business - good sense.

Philips Electronic Components and Materials,  
P.O. Box 50, LANE COVE, 2066.  
Sydney 421261, 420361; Melbourne 6990300;  
Adelaide 2234022; Brisbane 2274822;  
Perth 654199.

\*(available soon)



**Electronic  
Components  
and Materials**

# PHILIPS



## \*BINARY COUNT AND DISPLAY

```

0000 08      NOP
0001 C408    LDI  8
0003 35      XPAH 1
0004 C400    LDI  0
0006 31      XPAL 1
0007 C902    LOOP ST  2<1>
0009 8FFF    DLY  255
000B A803    ILD  COUNT
000D 90FB    JMP  LOOP
000F 00      COUNT . BYTE 0
0010

```

Here are two sample programs to help you get going with Mini Scamp. In both cases the hexadecimal numbers in the first column are memory addresses, and those in the next column are the actual code. Each pair of hex digits is an 8-bit byte.

greatly increase the cost of the overall unit, and may not be justified, particularly if further expansion is not desired.

The LED's and their transistor drivers were soldered onto a long narrow strip of Veroboard and then the LED's were glued through holes in the front panel.

The power supply requirements are quite small, and any supply giving +5V at say 0.5A and about -12V at 150mA should prove adequate. Fig. 2 gives a typical circuit for those wishing to build the power supply using new components.

It will be found that the cost of the switches can be a considerable fraction of the total computer cost. Those used for the prototype were lever switches (DPDT) from Tandy Electronics. Similar switches at a much lower cost from Electronic Disposals in Little Lonsdale Street in Melbourne have also been tried. Although satisfactory to date, only time will allow us to determine how many repeated switchings may be made before the contact resistance becomes too large for correct operation. In this regard, it is most desirable to wire both poles of the above type of switches in parallel.

Although this microcomputer was conceived mainly as an educational instrument through which an understanding of the engineering and programming concepts involved could be learnt, there is no reason why it could not be put to work in the role of a simple controller. Detection of off/on states of various devices, and the activation of relays, etc., is most easily accomplished using the sense inputs and flag outputs available on the SC/MP chip. Anyone wishing to make good use of the computer should obtain a copy of the SC/MP Technical Description from NS Electronics Pty. Ltd., in Bayswater, Victoria, or from their distributors. This manual describes all of the program instructions available on the SC/MP, and details what each of these actually does.

On the programming side, you might like to try your hand at writing a multiplication routine, a BCD to binary conversion program, the converse, i.e. binary to BCD, or even a simple program to demonstrate the function of the logical operations, AND, OR and EXCLUSIVE OR.

Although it uses a different instruction set than does the SC/MP, the advice on programming contained in the EDUC-8 handbook provides valuable information for those with little prior knowledge in this field. I have also found the hexadecimal conversion table printed in the E.A. Yearbook (1976/77) to be of great assistance when manually assembling small programs.

In order to get you started along the road in programming your microcomputer, I will describe two short demonstration programs.

The first program simply counts in binary, displaying each number on the LED's with a fixed delay between numbers. The delay is necessary to slow the computer down sufficiently for you to observe what is happening. The program listing is shown in Fig. 3.

Ignoring the first two columns for the moment, what we have is a list of instructions to the computer in 'Assembly' language. The first instruction (NOP) does nothing, and is ignored by the CPU, as the first instruction actually executed is at address one. The next four instructions load the hex address 0800 into pointer register 1. The following instruction (ST 2(1)) outputs whatever number is presently in the accumulator to the LED's. Note that the operand 2(1) means the address stored in pointer register 1 plus 2 (i.e., 0802) which is, of course, the address of the LED's.

The next instruction (DLY 255) creates the delay, while the ILD COUNT instruction adds one to the location called COUNT (which has address 000F) and then loads this number into the

## \*MOVING LIGHTS WITH INPUT

```

0000 08      NOP
0001 C408    LDI  8
0003 35      XPAH 1
0004 C400    LDI  0
0006 31      XPAL 1
0007 C101    LOAD LD  1<1>
0009 C810    LOOP ST  BITS
000B C00E    LD  BITS
000D C902    ST  2<1>
000F 1E      RR
0010 C809    ST  BITS
0012 8FFF    DLY  255
0014 B806    DLD  COUNT
0016 9CF3    JNZ  LOOP
0018 90ED    JMP  LOAD
001A 00      BITS . BYTE 0
001B 00      COUNT . BYTE 0

```

accumulator, ready for display on the LED's when the CPU jumps back (via the JMP LOOP instruction) to the ST 2(1) instruction.

The information in the second column is the translation of the assembly language instructions detailed above into machine language form. These hexadecimal numbers may be loaded into the memory at their respective addresses shown alongside in column 1.

First, set the RUN/HALT switch to HALT, and the DMA/CPU switch to DMA. Then set all the address switches to zero, and set the hexadecimal number 08 on the data switches. Now press DEPOSIT, and the LED's should also display 08. Continue by setting the address switches to 01 and the data switches to C4. Depress DEPOSIT again. As the LDI 8 instruction is a double-byte instruction, the number 08 must now be set into address 02 followed by 35 into 03, and so on, using the above procedure. When all locations up to and including 0F have been loaded, the program is ready to be executed or run.

Set the DMA/CPU switch to CPU, depress and release the RESET button, and then set the RUN/HALT switch to RUN, and the LED's should then be counting. If not, return the appropriate switches to HALT and DMA, in that order, and check the contents of each address by successively incrementing the address switches from 00 to 0F hex.

The second program shown in Fig. 4 demonstrates both the data input facility of the computer and also the rotate instruction (RR). When run, the program will request (via DRQ) any number from the data switches. For example, when DRQ comes on, set hex 80 on the switches, then press DEPOSIT. The single light on the left will then be successively moved to the right and finally 'rotated' back to its initial position. After 256 rotations, the program will then request a new bit pattern to rotate. ☺



# Study in a classroom with only one student.

## The great way to learn.

We all tend to think of learning as something done in a classroom. With a teacher at a blackboard. And many students competing for his attention. Because this is the way we learnt at school.

But experience has shown that the value of this kind of teaching decreases as we get older. Because each of us learns best at our own pace.

In a big class, you are tied to the average pace. It may be too fast or too slow. And you don't always have the chance to ask your questions — or get the answers you want.

ICS offers you the great way to learn: *supervised independent study*. A program of learning that is supervised by your tutor, a person expert in the field you have chosen. And your study is independent of any other student — so you don't compete for attention.

Every course offered by ICS has been constructed in sections. You begin at the beginning, and work your way steadily through more and more complex material.

At every step of the way, you test yourself to be sure you have absorbed the subject. At regular intervals, you complete test papers which your tutor grades and returns to you with his comments. These tests are an integral part of your learning progress. And they ask you not only what you have learnt, but also how you can apply what you have learnt. You move on to the next section only when you, and your tutor, are satisfied you have completely understood the previous section. Your tutor guides you all the time.

In the years since ICS was founded, almost 9 million men and women have received tuition, in hundreds of different subjects.

They come to ICS simply because, like you, they had a desire for knowledge in a specific field of endeavour. Some wanted to increase their ability to earn money. Others wanted to achieve greater job satisfaction, or a better understanding of subjects away from their regular line of work.



# You.

Read through the list of courses offered by ICS. Select the one that interests you, then mail the coupon below. We will send you a FREE career guide that explains what ICS will teach you, and how ICS will teach you.

**International Correspondence Schools,  
400 Pacific Highway, Crows Nest, 2065.**

**Advertising and Public Relations**  
Advertising Institute of Australia Diploma  
Public Relations  
Copywriting  
Advertising Layout and Illustration

**Hotel/Motel Management**  
Hotel/Motel Management  
Restaurant and Catering Management  
Financial Management for Hotels and Motels  
Club Management  
Hotel/Motel Owners

**Accountancy**  
Institute of Chartered Secretaries and Administrators — A.C.I.S. Degree  
Commercial Education Society of Australia — Associate Degree  
Practical Accounting  
CES Bookkeeping and Office Practice Certificate  
Costing  
Elementary Bookkeeping  
**Colour TV Servicing Technician**  
TV Service Technician  
TV Principles  
TV Engineering  
TV Servicing

**Building and Architecture**  
Building Contractor  
Building Sciences  
Quantity Surveyor  
Building Supervisor  
Clerk of Works  
Architectural Assistant  
Carpentry and Joinery  
Basic Building  
Plumber  
Builder's Draftsman and Plan  
Drawing  
Carpenter  
Bricklayer

**Computer Programming and Data Processing**  
Computer Programming and Data Processing  
General Computer Programming  
Computer Systems Analysis  
Cobol Programming  
Computer Servicing Specialist

**Institution of Fire Engineers**  
Membership  
Graduateship

**Writing**  
All Media Professional Writing  
Professional Writing  
Freelance Journalism  
Short Story Writing  
Script Writing — TV, Radio, Film  
Copywriting  
Technical Writing

**Art**  
Commercial Art  
Recreational Art  
Watercolour and Oil Painting  
Cartooning  
Showcard and Sign Production  
Basic Art  
Watercolour Painting  
Oil Painting  
Showcard and Ticket-writing  
Sign Painting and Designing  
Advertising Layout and Illustration

**Secretarial**  
Pitman's Stenography  
Gregg Stenography  
Clerk-Typist  
Gregg Shorthand with Speed Building  
Gregg Speed Building  
Pitman's Shorthand  
Elementary Bookkeeping  
Typewriting

**Interior Decorating**  
Interior Decoration Program

**Photography**  
Photography Program

**Creative Leisure**  
Dressmaking  
Dressmaking and Pattern Cutting  
Typewriting  
Guitar

**Electronics**  
Electronics Technician  
Audio, Radio and Hi-Fi Sound Systems Specialist  
Communications  
Broadcasting Specialist  
Electronic Computer Servicing Specialist  
Industrial Electronics Specialist  
Basic Electronics  
Electronic Instrumentation and Control Systems  
Electronic Technology  
Electronics Maintenance  
Radio-Electronic Telemetry  
Electric Motor Repair and Servicing

**Sales and Marketing**  
Australian Marketing Institute Diploma  
Sales Representative  
Sales Management  
Retail Merchandising  
Modern Marketing Management

**Air Conditioning and Refrigeration**  
Air Conditioning and Refrigeration Technology  
Drafting for Air Conditioning  
Basic Air Conditioning and Refrigeration Technology  
Commercial and Domestic Refrigeration and Air Conditioning Servicing  
Domestic Appliance and Refrigeration Servicing  
Air Conditioning Technology  
Air Conditioning for Automobiles

**Business Management**  
Institute of Business Administration Diploma in Management  
Commercial Education Society of Australia — Diploma in Management  
Industrial Management  
Works Management  
Personnel Management  
Office Management  
Small Business Owners  
Modern Marketing Management  
Modern Management Stores Supervision  
Purchasing and Supply Management  
Club Management

**Automotive Servicing**  
Automotive Mechanic  
Institute of Automotive Mechanical Engineers — Member & Associate Member  
Queensland 'A' Grade Motor Mechanic  
Queensland 'B' Grade Motor Mechanic  
Senior Motor Mechanic or 'A' Grade Certificate of Victorian Automobile Chamber of Commerce  
Basic Motor Engineering  
Automatic Transmission Specialist  
Automobile Engine Tune-up  
Automobile Electrician  
Do-It-Yourself Servicing  
Panel Beating and Spray Painting  
Diesel Mechanic  
Air Conditioning for Automobiles

**Civil and Structural Engineering**  
Civil Engineering  
Surveying and Mapping  
Basic Structural and Concrete Engineering  
Basic Structural Engineering  
Overseer of Works

**Mechanical Engineering**  
Mechanical Engineering Technology  
Works Management  
Hydraulic and Pneumatic Power  
Boiler Inspector  
Boiler Attendant  
Complete Steam

**Electrical Engineering**  
Basic Electrical Engineering  
Electric Motor Repair and Servicing  
Industrial Electrician  
Electrical Mechanic

**Drafting**  
Drafting  
Mechanical Drawing and Tool Design  
Electrical and Electronic Drafting  
Structural and Architectural Drafting  
Drafting for Air Conditioning  
Builder's Draftsman and Plan Drafting

# ICS

International Correspondence Schools  
400 Pacific Hwy. Crows Nest NSW 2065. Tel: 43-2121  
18-20 Collins St. Melbourne 3000. Tel: 63-7327  
New Zealand: 182 Wakefield St. Wellington.

**Mail the coupon today** and you will receive a career guidance kit, without cost or obligation, that will tell you how the ICS study method works, and what the particular course teaches you.

Please provide me with Career information on

NAME

ADDRESS

POSTCODE

OCCUPATION

AGE

PKB 54372

274200

This list is correct at the time of submission for publication, and may vary.



# Microcomputer News & Products

## Shugart "minifloppy"

Floppy discs are now well established as an efficient and reliable storage medium for computer programs and data. Unfortunately the cost of conventional floppy disc drives and controllers has tended to price them out of the microcomputer area.

Happily this situation should now improve, thanks to the SA400 Minifloppy disc drive released in the US late last year by Shugart Associates. Virtually a scaled-down version of the well proven Shugart SA800 drive, the new unit takes discs only 133mm in diameter (5.25in), stores up to 109.4 kilobytes, and sells for only 2/3 the price of its larger brother: around \$460 plus tax.

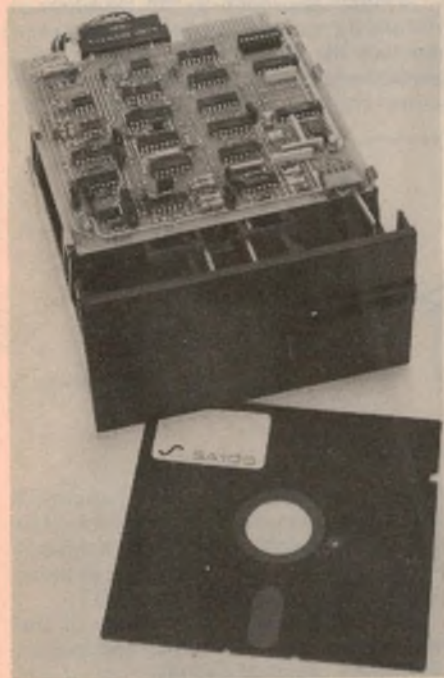

The performance is still very high, largely because the head and other key parts are identical with those used in the larger devices. Data transfer rate is 125 kilobytes/second, with a recording density of 2600 BPI maximum. Average access time is 550 milliseconds. Soft error rate is  $1/10^6$ , hard error rate is  $1/10^{11}$ , and seek error rate  $1/10^6$ .

Track spacing is 48 per inch, and there are 35 tracks. Both hard and soft sectored discs are available.

Size of the SA400 is 83 x 146 x 203mm, with a mass of 1.36kg. Total power dissipation is only 15W. No AC power is

required, as the drive motor, track stepping motor and read-write electronics all operate from +5v and +12V DC.

Shugart also makes a matching controller module, the SA4400 Ministreaker. This can control up to three SA400 drives, but costs more than a basic SA400 drive.

Stocks of both the SA400 and SA4400 are now available from the Australian agent for Shugart, Warburton Franki Pty Ltd of 199 Parramatta Rd, Auburn NSW 2144.

The SA400 minifloppy drive would seem ideal for use by serious microcomputer hobbyists and other small users. However, in view of the relatively high cost of the SA4400 controller, here at EA we are currently working on the design of a low cost controller to allow the SA400 to be interfaced to small systems. We hope to present the design in the near future.

## SC/MP Tiny BASIC

Back in the December 1976 issue, we announced that National Semiconductor was coming out with a Tiny-BASIC interpreter for their SC/MP, called NIBL. At that stage only a 3k bytes preliminary version was available, with an improved 4k version still to come.

Well, the 4k version of NIBL has now arrived, and it's even better than was predicted. It is now very much an extended Tiny-BASIC, with many powerful features which should make it of great interest and value to professional and hobby computer users alike.

As predicted, it now offers an RND function to generate 16-bit random numbers, and a LINK statement to allow calling machine language subroutines. The hoped-for DO...UNTIL statements are also provided, too.

In addition, there is now the ability to perform FOR...NEXT loops as in many full BASICs. There is also the ability to handle character strings, and to handle hexadecimal constants. There is also a REM statement for remarks, a MOD function for absolute values, a STAT function to return the current value of SC/MP's status register (allowing the program to manipulate flag and sense lines), and paging functions.

NIBL's formal grammar is now somewhat more flexible, too, allowing greater programming efficiency. Multiple statements per line are now allowed, while LET is no longer mandatory in assignment statements.

And you can now buy NIBL in punched

paper-tape form, as an alternative to buying a set of PROMs. A tape costs \$15, and may be ordered direct from NS Electronics, Cnr Stud Road and Mountain Highway, Bayswater, Victoria 3153.

## Faster SC/MP chip, too

National Semiconductor has also announced a new N-channel version of the SC/MP chip itself. It offers three main features over the existing P-channel chip: Twice the speed, one quarter the power, and only a single +5V supply.

Designated SC/MP-II, the new chip will be available in Australia shortly, from NS Electronics and their various distributors in each state.

## ROM emulator



The Sunrise Electronics KPRAM is a ROM and PROM emulator, to facilitate rapid and efficient development of dedicated microcomputer systems. It contains RAM, a hexadecimal data entry keyboard, toggle switches for addressing, and a set of LEDs for data checking. A program can thus be fed into the RAM or modified at any time, while at the same time connected into a system emulating a ROM.

Further information from Warsash Pty Ltd, PO Box 217, Double Bay, NSW 2028.

## New MC6800 kit

Motorola Semiconductor Products has released a new evaluation kit for their well-known MC6800 microprocessor. Called the MEK6800D2, the new kit has its own 24-key keyboard and 6-digit hex display, obviating the need for an expensive data terminal. It also features an inbuilt audio cassette interface, for convenient program storage at low cost.

The kit comes with 256 bytes of RAM for user programs, a 1k byte ROM with a debug/monitor called JBUG, and 16 lines of parallel I/O via a PIA. Provision is made for easy expansion.

By the time you read this, the new kits should be available from local Motorola distributors for around \$240.

By courtesy of Motorola, EA has one of the new kits and we are currently putting it through its paces. We hope to publish the results next month, all going well.



# Op-Amps without tears-5

Following on from the discussion of higher-performance bipolar op-amps given last month, the author now looks at FET-input devices and their various advantages. A number of useful practical circuits are also described.

by J. BRIAN DANCE, M.SC.

Last month we discussed how improvements in the internal circuitry of operational amplifiers has enabled much lower input currents to be obtained. However, all of the devices discussed previously employ bipolar transistors in their input stages. We will now consider the various types of device which employ field effect transistors in their input stages so that even lower input currents—down to about 1pA (one millionth of a microamp)—can be obtained.

## INPUT CURRENT

The input current of "input bias current" of an operational amplifier is defined as the average of the two input currents. The "input offset current" is the difference between the two input currents. The input bias current is often of the order of ten times the input offset current, but this factor can vary widely.

The input current produces a voltage drop across the input resistance (and in the internal impedance of any signal source feeding the amplifier) and this causes errors. If the amplifier is operated with equal resistances in each input circuit, the error is minimised, since it is then proportional to the difference between the input currents, that is, to the input offset current.

If an input current of 10nA is required for the operation of an amplifier and the external resistance in the input circuit is 200 megohms, a voltage drop of 2V will appear across the resistor and the voltage at the amplifier input will be 2V less than expected. Thus the output voltage error will be 2V times the amplifier gain.

The importance of reducing the input bias current cannot be emphasised too strongly. Indeed, it affects the design of almost all operational amplifier circuits. For the correct operation of amplifier devices it is necessary to supply a direct current to each input, this current being in the range of picoamps to microamps depending on the device type. Great efforts have been made to reduce input currents and this has led to the development of new techniques.

## FET TECHNIQUES

The technique of using "super gain" input transistors (as used in the LM108 series) represents the best which can be achieved with bipolar transistors at the present time. If we wish to make a further

substantial reduction of the input current, we must turn to amplifier devices which employ field effect transistors or FETs in their input stages.

One can use discrete FETs which drive a monolithic operational amplifier, but this is generally rather inconvenient when compared with the use of a single integrated device. In addition, the FETs must be specially selected for close matching if a high performance is required; this matching is both troublesome and expensive.

In order to make a device containing the input FETs together with the main amplifier in a single convenient package, the FETs of some devices are integrated on the same silicon chip as the remainder of the amplifier. Unfortunately it has proved most difficult to fabricate well matched, moderately high voltage junc-

and the offset voltage drift is guaranteed not to exceed 5uV/degree C in the case of the "A" devices. In addition, these devices show very low noise.

Another way of achieving the desired characteristics is by the use of the hybrid technique in which an input chip containing two matched FETs is placed in the same package as the main amplifier chip. The latter is a conventional operational amplifier without the input transistors. An excellent performance can be obtained from such devices, but one of the main disadvantages is the relatively high cost of incorporating the two dice in a single package.

Another approach to the problem of obtaining very high input impedance involves the use of MOS (Metal Oxide Semiconductor) FETs integrated onto the same chip as bipolar transistors. The

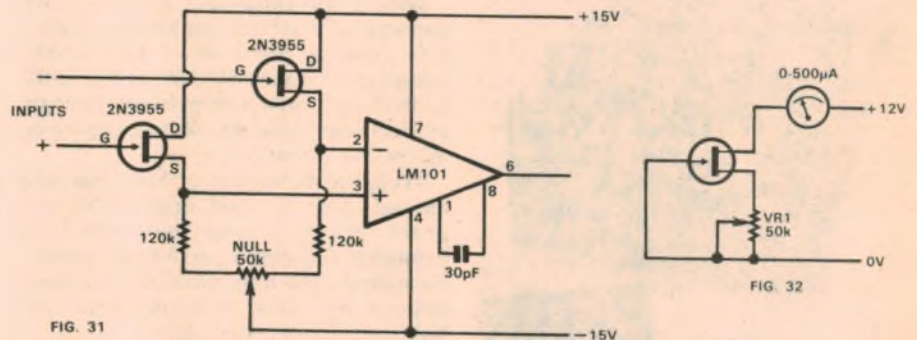

tion FETs on the same chip as bipolar transistors; such techniques generally result in a low yield of satisfactory devices and hence to a high unit cost.

The resulting devices have typical input offset voltages of 25 to 50mV, whilst the drift in this offset voltage is of the order of 30 to 50uV/degree C. If these figures are compared with those for the LM108 (2mV and 6uV/degree C) or for the LM108A (0.3mV and 1uV/degree C), it is obvious that devices with FETs integrated on the chip have a performance which leaves much to be desired.

Recently, however, this position has been changed with the release of the National Semiconductor LF155, LF156 and LF157 "Bi-FET" devices; these are the first monolithic operational amplifiers with well matched, high voltage junction FETs in the input stage. The input offset voltage has been reduced to about 3mV

resulting devices are very economical and the input currents are very low, but their noise performance and temperature drift figures are not so good as those of devices employing junction FETs.

We will now consider some of the devices fabricated by these techniques with some practical circuits.

## DISCRETE FET INPUT

The input impedance of an operational amplifier can be greatly increased if a pair of discrete junction FETs are used as the input to feed a conventional monolithic device, as illustrated in Fig. 31. The two FETs should be a matched pair and are shown connected as source followers; they therefore give a voltage gain of just under unity and the overall gain is almost equal to that of the monolithic device. The FETs act as impedance transformers. No feedback is shown in Fig. 31.

N-channel junction FETs may be selected for matched characteristics



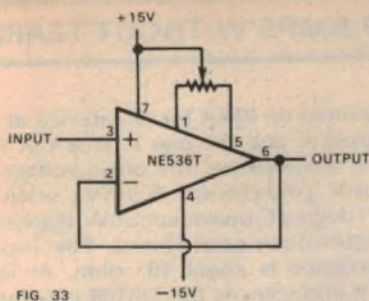

FIG. 33

using the simple circuit of Fig. 32. The variable resistor VR1 is reduced in value until the meter indicates a drain current of 200-300uA. Another FET is now substituted for the original one without altering the setting of the potentiometer. If the drain currents of the two devices are within about 20% of one another, the match is satisfactory for most purposes. The 12V supply used should have a short circuit current limited to about 50mA to avoid possible damage to the device being tested. Cheap plastic encapsulated FETs may not have the low input current required for this application.

All types of amplifier employing junction FETs in the input stage can operate with extremely low input currents (a few pA) provided that the temperature is not too high (not more than about 65 degrees C). The input currents are the reverse leakage currents of the gate-channel junction diodes and it is a basic property of such diodes that the reverse current rises exponentially with temperature, roughly doubling in value for each 10 degree C rise. At high temperatures (above about 60 degrees C) lower input currents can be obtained by using the LM108 device.

### MONOLITHIC FET DEVICES

Devices which have junction FETs for the input circuit integrated onto the silicon chip are available with very high input impedances. Their output characteristics are very similar to those of other conventional operational amplifiers.

One example of such a monolithic device is the Fairchild uA740C which has a typical input current of 0.1nA (maximum 2nA) at 25 degrees C and an input offset current of about 60pA (maximum 300pA) at the same temperature. The input resistance is about  $10^{12}$  ohm (one million megohms). However, the input offset voltage is typically 30mV with a maximum of 110mV.

The uA740 includes internal frequency compensation, has offset nulling facilities, will not latch up and includes input and output protective circuits. It is produced in an 8 pin circular metal package. The supply current is fairly high at 4.2mA (maximum 8mA), whilst the voltage gain is about one million and the slew rate 6V/us. Conventional  $\pm 15$ V supplies may be used (maximum  $\pm 22$ V).

Another FET input monolithic operational amplifier is the Signetics NE536T which has a differential input resistance

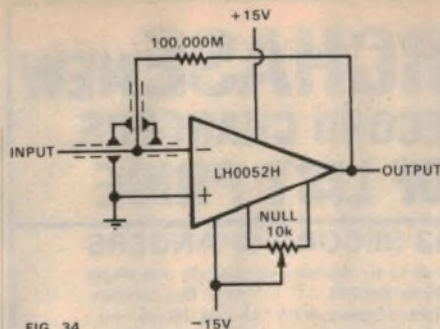

FIG. 34

of about  $10^{14}$  ohm (one hundred million megohms) at 25 degrees C, the input current being about 30pA (maximum 100pA) and the input offset current 5pA. The input offset voltage is 30mV (maximum 90mV) with a typical drift of 30uV/degrees C. The NE536T is similar to a conventional operational amplifier in a circular metal case with 8 leads. It has input and output protection, offset nulling facilities and internal compensation. The price is of the order of ten times that of the early bipolar types.

The NE536T may be used in the simple circuit of Fig. 33 as a voltage follower in which it accepts an input of extremely high resistance and provides an output of much lower resistance which can, for example, easily deflect a 1mA meter. If full advantage is to be taken of the extremely high input impedance of this device, great care must be taken in the construction of the input circuit. The

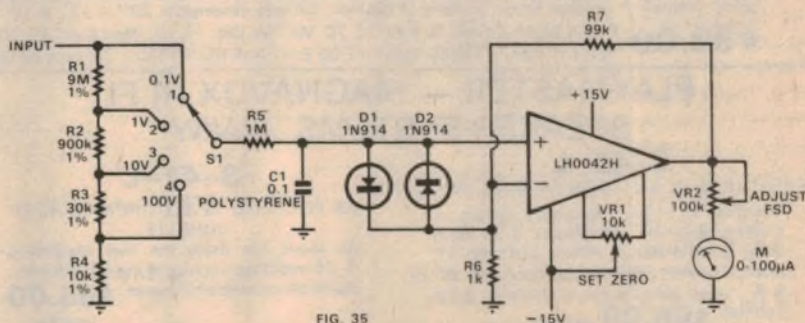

FIG. 35

input lead should be soldered onto a stand off insulator employing Teflon (polytetrafluorethylene) as the insulating material and any input terminal must be mounted in a material such as polystyrene—never in metal. Any finger grease near the input terminal may lower the input impedance; the surfaces surrounding the input lead should be washed with industrial ethanol to remove grease without leaving any other deposits. The use of sockets should be avoided in high resistance circuits. Guarding of the input connections on any printed circuit board (which must be of high quality glass fibre) by means of a metal guard foil kept at the same potential as the input is very desirable at the highest impedances.

What adverse effects are caused by an offset of 30mV and a drift of 30uV/degrees C? The offset voltage can be nulled out, but the drift cannot; indeed, offset nulling increases drift. If

one uses a device to measure a steady voltage of 1mV, a drift of 30uV/degrees C over a 20 degree C range will produce an input error of  $30 \times 20 = 600$ uV or 60%. Any amplifier gain will leave the percentage error unchanged. In amplifiers for alternating signals drift may not be quite so serious, but can cause the operating point in the output stage to move into the cut off region; such amplifiers often have a higher gain than those for zero frequency signals.

### HYBRID AMPLIFIERS

The hybrid or "monobrid" FET input operational amplifiers we will consider are produced in similar types of package to those used for integrated circuits, namely dual-in-line, flatpacks and circular metal packages. The hybrid technique is used to produce a device with a performance which cannot be equalled with purely monolithic devices at the present time. The prices of some hybrid types are little more than that of some monolithic FET types, but precision hybrids are considerably more expensive. The internal circuits of hybrid devices can employ close tolerance components which cannot be fabricated on monolithic chips. Active laser trimming systems are available which enable the hybrid manufacturer to adjust the device parameters under computer control—at a price.

We will consider some of the National Semiconductor hybrid devices, since

they offer a wide range. The type numbers commence with LH (linear hybrid) as opposed to their LM (linear monolithic) devices. One of the most economical hybrids is the LH0042 which consists of a monolithic dual FET input stage internally connected to a compensated monolithic amplifier rather like a 307 device without the input transistors. The input offset current is about 2pA (maximum 10pA) at 25 degrees C, whilst the input bias is 15pA (maximum 50pA), but these quantities roughly double for each 10 degree C rise. The input offset voltage is 6mV (maximum 20mV) with a 10uV/degree C temperature coefficient—appreciably lower than that for monolithic devices. The input impedance is  $10^{12}$  ohm.

The more expensive LH0052 precision FET input operational amplifier is made by laser trimming of the offset. The typical input offset current is thus reduced to 10fA (0.01pA) with a



# SPECIAL PURCHASE NEW

## B.S.R. & GARRARD RECORD CHANGERS

### AT A FRACTION OF LIST PRICE

#### NEW STANDARD B.S.R. C123 RECORD CHANGERS



Fully automatic turntable plays up to six records automatically and single records automatically or manually as required. 11" turntable. Bias compensation. Cue & pause control. Record speeds 33 $\frac{1}{3}$ , 45 and 78 rev/min. Finished in black with silver trim. Player and changer spindles supplied. Fitted with ceramic cartridge. Post & Packing extra. N.S.W. \$2.70, Vic. Qld. SA. \$4.70 W.A. \$5.70 (registered post \$2 extra if required). **\$20.00**

#### GARRARD 6-400 CHANGER

### \$28.50

Recommended retail price \$48.00  
Supplied with high quality Garrard/Sonotone Ceramic Cartridge with Diamond Stylus. (Post & Packing same as M82)

#### GARRARD CC10A RECORD CHANGER

### \$14.75

Fitted with a Sonotone Garrard Ceramic Cartridge Sapphire Stylus supplied with template & instructions. Post & packing N.S.W. \$2.50. Int \$3.50.

#### GARRARD SL 95B TRANSCRIPTION CHANGER

### \$69.00

Recommended retail price \$175.  
Supplied with Pickering Magnetic Cartridge with Diamond Stylus. Post & packaging same as Zero 100

#### GARRARD M.82 \$57.00 TRANSCRIPTION CHANGER

Recommended retail price \$120.00  
Supplied with Pickering Magnetic Cartridge with Diamond Stylus. Post & packing (Reg. post) N.S.W. \$3.60, Vic., S.A., Qld. \$4.74, Tas. \$5.50, W.A. & N.T. \$6.75.

BASE & PERSPEX COVERS AVAILABLE IN TEAK & WALNUT FINISH

#### NEW GOODMAN—FOSTER 3 WAY 4 SPEAKER. HI-FI SYSTEM

Frequency Range 45 to 22,000 cycles. Power rating 25 watts  
Supplied in kit form (less cabinet) each kit comprises Two English Goodman 8" bass units, Foster 5" mid range, Foster 1" dome tweeter, crossover components (condensers & inductance) innabond, speaker fabric & plans of cabinet. Cabinet dimensions 23" x 13" x 10".

**\$39.00** Post & packing extra. N.S.W. \$2.70. Vic. SA, Qld. \$4.70. West Aust. \$5.70. PER KIT (REGISTERED POST \$2.00 EXTRA IF REQUIRED.) Cabinets Available.

#### PLAYMASTER — MAGNAVOX HI FI SPEAKER SYSTEMS 3 WAY

3-45-L

AS FEATURED IN ELECTRONICS AUST. APRIL '75

Complete kit of parts for above system including speakers Magnavox 8-30 Bass Unit, 6J Mid Range Philips ADO160/T8 Dome Tweeter, crossover components, 6" & 3" tubes, speaker silk & innabond (Less Cabinet)

**\$66.00** PER KIT

Freight & packing extra per pass. rail or air freight

3-41-L

AS FEATURED IN ELECTRONICS AUST. JUNE '76

As above but using the new Magnavox 6-25 midrange in place of the 6J with additional crossover components

**\$56.00**

PER KIT

#### NEW MAGNAVOX — MV50— 50 WATT SPEAKER SYSTEMS

As featured in Feb. 1976 issue of Electronics Today

Complete kit of parts (less cabinet) comprising Magnavox 10-40 10" bass unit, 625 mid range 6" two XJ3 dome tweeters, crossover network, innabond, speaker silk and plans of cabinet.

**\$76.00**

Per Kit

freight extra per rail or air freight. Cabinet available.

#### New C800 STEREO AMPLIFIER BY CLASSIC

**\$149**  
(freight extra)

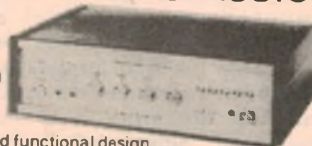

- Elegant and functional design
- Push-button controls
- Microphone input with separate control
- Provision for simulated 4-channel stereo
- Cabinet in teak or walnut oiled finish with matching metal trim
- Power output 25 watts per channel RMS Total output 50 watts RMS 8 ohms
- Frequency response 20 cycles to 30,000 = 1 dB

Full specifications Oct. or Nov. 76. Electronics Aust.

## CLASSIC RADIO

245 PARRAMATTA RD, HABERFIELD 2045 PHONES 798 7145, 798 6507

## OP-AMPS WITHOUT TEARS

maximum of 100fA for any device at 25 degrees C and the bias to 0.5pA at the same temperature. The offset voltage is 0.1mV (maximum 0.5mV) with a 2uV/degree C (maximum 5uV/degree C) temperature coefficient. The input impedance is about 10<sup>12</sup> ohm. At low input impedances the LM108 generates less noise than the LH0052, but when the impedance rises about 150 kilohms, the reverse is true.

Other hybrids use a FET input feeding a fast operational amplifier like the LM318. For example, the LH0062 high speed FET amplifier has a 70V/us slew rate and a 15MHz bandwidth combined with a 0.2pA input offset current at 25 degrees C. The LH0063 is even faster with a 6000V/us slew rate and a bandwidth of 100MHz; the manufacturers call it a "damn fast buffer amplifier". It has a gain of unity, an input impedance of 10<sup>10</sup> ohm and can provide 250mA output current.

Hybrid devices are also used in other fields than operational amplifiers, but as monolithic manufacturing techniques improve, many hybrids will be displaced by more economical monolithic devices.

### HYBRID CIRCUITS

An amplifier which will provide meter readings from inputs in the picoamp region is shown in Fig. 34. The input current flows through R1 to the output, very little current flowing into the input of the device itself. An input current of 10pA will produce 1V across R1 with the value shown and hence a 1V change at the output.

The resistor R1 should be a high quality type sealed in glass and should not be handled before use or finger grease may reduce its value. The input circuit should be guarded and insulated with teflon. The circuit may be converted into a charge sensitive pre-amplifier by connecting a capacitor across R1.

### VOLTMETER

The circuit of Fig. 35 shows how a multi-range voltmeter with an input resistance of 10 megohms can be made using the relatively economical LH0042 hybrid device. No guarding of the input circuit is required, as the resistance is about 10,000 times lower than in Fig. 34. However, it is important that C1 should have a very low leakage current and a polystyrene type should be suitable. D1 and D2 protect the device from excessive input voltages.

When S1 is in position 1, the full input voltage will be applied to the non-inverting input. The gain is (1 + R7/R6) or 100 with the values shown. Thus 0.1V at the input will produce 10V at the output. The value of VR2 may be set for the correct full scale deflection and then all of the other ranges will have been calibrated, since 1% tolerance resistors are used



in the input circuits. If R6 and R7 are 1% components and a 1% 100 kilohm fixed resistor is substituted for VR2, no calibration is required.

### WIDEBAND AC VOLTMETER

The circuit of Fig. 36 shows how a high speed FET hybrid device, the LH0062, can be used in a millivoltmeter having ranges from 15mV upwards which can operate accurately at frequencies from 100Hz to 500kHz. The input resistance is 10 megohms.

The bridge rectifier may consist of four 1N4148 diodes and ensures that the output current always passes through the meter in the same direction. If S1 is set to the 5V range and a signal with 5V peaks is applied at the input, the output voltage will rise until the two inputs of the device reach the same potential at any instant. There is a negligible voltage drop across R3, so the current through R9 will be  $5/40\text{mA} = 125\mu\text{A}$ . The calibration control VR2 is adjusted so that 100 $\mu\text{A}$  passes through the meter when the input is 5V RMS.

### Bi-FET DEVICES

The National Semiconductor LF155 series (LF=Linear FET) was released in 1975 and represents a great development. These devices are made by ion implantation to achieve very uniform doping across the water. These can replace the more expensive hybrid and modular FET operational amplifiers in most applications and have internal compensation. The series comprises a total of 15 devices, The LF155, 155A, 255, 355 and 355A are for low supply current (2mA), the LF157 series for wide band uses (slew rate 50V/ $\mu\text{s}$ , gain bandwidth product 20MHz) and the LF156 series where a compensated device of moderate speed is required.

When compared with the 741, the LF156 input bias current is 1000 times lower, the slew rate about 100 times greater, the gain-bandwidth product 25 times greater, whilst noise and drift are far lower. The input impedance of  $10^{12}$  ohm is about a million times greater than that of a 741, but the price of the cheapest Bi-FET device is about 6 times that of the cheapest 741.

### NOTCH FILTER

A use of the LF155 may be illustrated

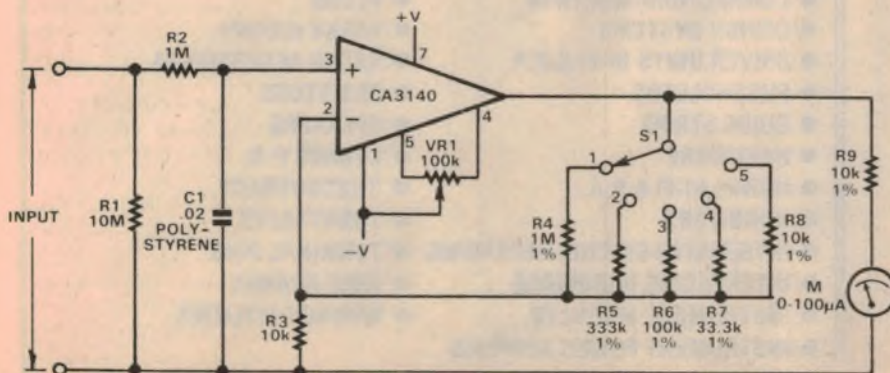

FIG. 38

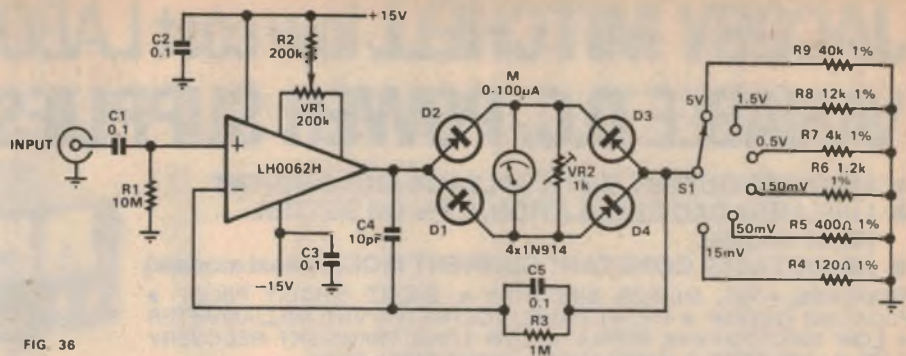

FIG. 36

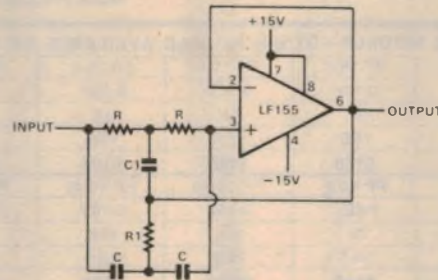

FIG. 37

by the notch filter circuit of Fig. 37 where the high input resistance of the device enables high value resistors and therefore low value capacitors to be used in the "twin T" networks. This is important, since close tolerance capacitors of large value are expensive. The gain of this circuit is constant at unity for all frequencies except those very close to the narrow notch where it falls by about 70dB. This frequency is equal to  $1/2\pi RC$  where  $2R1=R$  and  $2C=C1$ . If, for example,  $R=10$  megohms and  $C=320\text{pF}$ , the notch will be at the power supply frequency of 50Hz and unwanted power hum will be rejected by the circuit whilst other frequencies are unaffected. However, hum harmonics are not attenuated.

### MOS DEVICES

The RCA Company produce two operational amplifiers in which MOS transistors are fabricated on the same chip as bipolar transistors. One of these devices, the CA3130, has already been reviewed (Electronics Australia, Oct. 1976), whilst the other is the new CA3140. In both devices the MOS input transistors are used to obtain an input impedance of  $1.5 \times 10^{12}$  ohm.

Both devices are available only in circular metal packages, some of the main differences between them being the  $\pm 8\text{V}$  power supply rating of the CA3130 as opposed to the  $\pm 18\text{V}$  of the CA3140 and the internal frequency compensation of the latter. The CA3140 can replace the 741 in all circuits. Both of these devices are very cheap (only about twice the price of a 741) and are considerably more economical than any other type of FET input amplifier.

### ECONOMICAL METER

The CA3140 may be used in the type of circuit shown in Fig. 38 to measure steady voltages or currents. When S1 is in position 1, the gain is 100, so an input of 10mV will produce 1V at the output and this will give a full scale deflection of M. The other scales shown are 30mV, 100mV, 300mV and 1V, the input impedance on all ranges being 10 megohms (corresponding to  $10^9$  to  $10^7$  ohms/volt). C1R2 filter any high frequencies from the input, whilst VR1 sets the zero.

This circuit may also be used to measure small currents. For example, with S1 in position 1, the full scale deflection with 10mV at the input will be obtained when 1nA flows through R1, the other ranges being 3nA, 10nA, 30nA and 100nA. If R1 is shunted by a 100 kilohm resistor, the current ranges will be 100nA to 10 $\mu\text{A}$ .

The CA3140 input current is typically 5pA (maximum 50pA for any CA3140) and this will flow through R2 producing 5 $\mu\text{V}$  (maximum 50 $\mu\text{V}$ ) across it. Thus the error on the 10mV range due to this is 0.05% typical or 0.5% maximum. However, if one is measuring current, the current passing through R1 differs from the input current by the input bias current of the CA3140. At an input current of 1nA, the error due to this is 0.5% typical (5% maximum). Nevertheless, this economical circuit is most useful. It may be used (without M and R9) with any standard moving coil multimeter set to the 1V range to greatly increase the sensitivity of the multimeter.

We have been a little in the clouds this month discussing sophisticated devices, but next month we shall return to ground with a discussion of audio devices.



# JACOBY MITCHELL low cost LABORATORY VARIABLE D.C. POWER SUPPLIES

- METERED OUTPUT, BOTH VOLTAGE AND CURRENT
- LINE AND LOAD REGULATION, 0.2% OR BETTER (Most models)
- ADJUSTABLE CONSTANT CURRENT MODE (Most models)

FEATURES: ● ALL SILICON CIRCUITRY ● SHORT CIRCUIT PROOF ● FLOATING OUTPUT ● FRONT PANEL VOLTMETER AND MILLIAMMETER ● LOW PEAK-TO-PEAK RIPPLE ● LOW LOAD TRANSIENT RECOVERY TIME ● LOW OUTPUT IMPEDANCE ● INPUT 240V—50Hz.



Model PP-30-2-2 Power Supply



Model PP-30-2 Power Supply

STOCK MODELS—OTHER MODELS AVAILABLE ON INDENT								
MODEL	PP-18-2	PP-18-3	PP-18-5	PP-30-1	PP-30-2	PP-30-5	PP-30-10	PP-30-20
OUTPUT VOLTAGE	0-18V	0-18V	0-18V	0-30V	0-30V	0-30V	0-30V	0-30V
OUTPUT CURRENT MAXIMUM	2A	3A	5A	1A	2A	5A	10A	20A
CONSTANT CURRENT	YES	YES	YES	YES	YES	YES	YES	YES
PRICE	\$99	\$130	\$198	\$101	\$137	\$276	\$316	\$374
MODEL	PP-60-2	PP-60-3	PP-15-10	PP-10-40	PP-100-1	PP-30-1-2	PP-30-2-2	
OUTPUT VOLTAGE	0-60V	0-60V	0-15V	0-10V	0-100V	2x (0-30V)	2x (0-30V)	
OUTPUT CURRENT MAXIMUM	2A	3A	10A	40A	1A	2x (1A)	2x (2A)	
CONSTANT CURRENT	YES	YES	YES	YES	YES	YES	YES	
PRICE	\$291	\$374	\$221	\$368	\$291	\$222	\$267	
MODEL	PAD-260-60	PP-100-2A						
OUTPUT VOLTAGE	0-130V AC 0-60V AC 0-260V AC	0-100V						
OUTPUT CURRENT	1A AC 1A DC	2A						
CONSTANT CURRENT	YES DC ONLY	YES						
PRICE	\$328	\$347						

Specifications quoted are for general guidance only, are subject to verification and change without notice.

For full information contact Australian Representatives:  
The Crescent, Kingsgrove, N.S.W. 2208. Phone 50 0111  
OFFICES: Melbourne 44 5021 • Adelaide 293 6117  
Brisbane 52 8266 • Perth 72 2696



\* PLUS SALES TAX AND FREIGHT IF APPLICABLE

31/77

## zephyr products

70 BATESFORD ROAD, CHADSTONE,  
VICTORIA, 3148, AUSTRALIA

CABLES: ZEPHPROD. TELEPHONE: (03) 568 2922



### AGENCIES:-

ALTEC LANSING  
AMPEC ENGINEERING  
AUDITEC  
BRIMAR VALVES  
C.G.S. RESISTANCE  
CAMBION  
ELECTRONIC DEVELOPMENT SERVICES  
E & L INSTRUMENTS  
GARRARD  
HARTLAND Mfg  
J.B.L.  
K.E.F.  
L.P.S. RESEARCH  
MANN COMPONENTS  
PRIMO  
PIHER  
R.C.F.  
RADFORD

### PRODUCTS

- AMPLIFIERS
- AMPLIFIERS MODULES
- AMPLIFIERS POWER SUPPLIES
- ALARM DEVICES
- BREADBOARDING SYSTEMS
- CABLE
- CONNECTORS-AUDIO
- CONNECTORS-MULTIPIN
- DESIGN SYSTEMS
- DRIVER UNITS HI-FI & P.A.
- FUSEHOLDERS
- GUIDE STRIPS
- HARDWARE
- HORNS HI-FI & P.A.
- INHIBITORS
- INTEGRATED CIRCUIT PACKAGING
- INTERFACING HARDWARE
- INSTRUMENT MODULES
- INSTRUMENT POWER SUPPLIES
- JACKS
- LAMP HOLDERS
- KNOBS
- MATRIX BOARD
- MICROPHONES
- MICRO PROCESSOR SYSTEMS
- MIXER P.A.
- PLUGS
- RACKS (EQUIP)
- RACKS ACCESSORIES
- RESISTORS
- SPEAKERS
- STANDS P.A.
- SUBCONTRACT
- TURNTABLES
- TERMINAL PINS
- WIRE ENAMEL
- WIRING FACILITIES



# Arithmetic circuits

Following on from the discussion of binary arithmetic given in the previous chapter, we are now in a position to look at the actual circuit configurations used to perform arithmetic in practice. The main type of circuit discussed is the binary adder, widely used to perform not just addition, but most of the other basic arithmetic as well.

by JAMIESON ROWE

As we saw in the last chapter, the adoption of two's complement notation allows binary subtraction to be performed in exactly the same way as addition. It is also possible to perform binary multiplication by repetitive addition, and division by repetitive subtraction. Hence a circuit designed to perform binary addition may be used to perform virtually all of the basic arithmetic functions, and this is very often done.

From a practical point of view, this means that binary "adder" circuits tend to form the backbone of digital arithmetic hardware. So that if you have a basic understanding of adders and the way they are used, you should find it fairly easy to find your way through most arithmetic systems.

This being the case, we will confine ourselves almost completely in this chapter to a discussion of binary adders and the "arithmetic-logic units" or ALUs which have been developed from them.

You may recall from the previous chapter that there are only four basic possibilities when two digits or "bits" are added together. We described these as the "four rules of binary addition".

To produce a binary adder circuit, we must basically produce a circuit which responds to two input bits according to these rules. In other words, we must produce a circuit whose behaviour corresponds to the truth table shown in Table 1. If you compare this table with the "four

INPUTS		OUTPUTS	
ADDEND A	AUGEND B	SUM $\Sigma$	CARRY C
0	0	0	0
0	1	1	0
1	0	1	0
1	1	0	1

rules" given in the previous chapter, you'll see that it simply presents the same information in slightly different form.

As you can see there are two outputs, one the SUM output (usually symbolised as shown by the Greek sigma) and the other the CARRY output.

In short, then, a basic binary adder is a circuit with two inputs and two outputs,

which functions so that the outputs have the truth-values shown for the various truth-value combinations of the two inputs.

If you look at Table 1 fairly closely, it should become clear that in fact the SUM output corresponds to a logic exclusive-OR or EX-OR function between the two inputs, while the CARRY output corresponds to a simple AND function.

There are quite a few different logic configurations which will perform these functions. A fairly simple example is shown in Fig. 1, using 3 AND gates, two inverters and an OR gate.

You have probably noticed already that this is actually labelled a "half-adder" circuit. This is because in considering binary addition so far, we have in fact only been looking at a special case: where we are adding the least significant bits (LSBs) of two numbers. It is really only when LSBs are added together that the addition involves only two bits.

More generally, there are in fact three bits to be added together: the addend bit, the augend bit, and a carry-over bit from the addition of the next less significant bit pair.

In other words a full binary adder circuit must be able to cope with three inputs, and have a truth table corresponding to that shown below in Table 2.

Again, there are quite a few different logic configurations which will perform these functions. An example is shown in Fig. 2. As you can see it is rather more complex than the half-adder of Fig. 1, using seven 3-input AND gates, three inverters and two 4-input OR gates.

There are two broad ways in which

INPUTS			OUTPUTS	
CARRY C	ADDEND A	AUGEND B	SUM $\Sigma$	CARRY C
0	0	0	0	0
0	0	1	1	0
0	1	0	1	0
0	1	1	0	1
1	0	0	1	0
1	0	1	0	1
1	1	0	0	1
1	1	1	1	1

binary adders are used to perform addition of complete binary numbers, one using the serial or "bit-by-bit" approach and the other the parallel or "all bits at once" approach. The serial approach is relatively low in cost, but rather slow; the parallel approach is fast but tends to be much more costly.

Typically, serial binary addition involves a single full-binary adder, through which the addend and augend numbers are passed bit-by-bit and corresponding bits together—starting with the LSBs. Usually the two numbers are shifted into the adder from a pair of shift registers, with the sum output of the adder fed to either a third shift register or back into one of the original registers (usually the addend register). A single flip-flop is used to store the carry-over.

The basic configuration for an adder of this type is shown in Fig. 3. Here the adder is designed to handle 8-bit numbers, and the addend and augend registers are 8 bits wide (i.e., they each consist

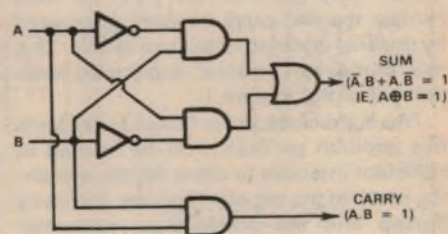

FIG. 1: HALF ADDER CIRCUIT

of 8 flipflops). The addend register is also used to receive the sum, this being done by connecting the sum output of the adder back to the D input of the most significant bit (MSB) flipflop.

The carry flipflop is basically a D-type device, with its D input fed from the carry output of the adder, and its Q output connected to the carry input of the adder. The shift clock lines of both the addend and augend registers are connected together, and to the CLK input of the carry FF, to form a master clock pulse line.

In operation, the two numbers to be added together are first loaded into the addend and augend registers. The loading may be done either by parallel loading or serial shifting, as convenient, although the circuitry to do either has been omitted from Fig. 3 in the interests of clarity.

The carry flipflop is then cleared, to make sure that it does not inject a spurious carry-over from some previous addition, or from its random content after power-up.



At this stage, the A and B inputs of the adder will already have presented to them the LSBs of the two numbers, from the two register outputs. Hence the sum output of the adder will already represent the LSB sum of the two numbers, and the carry output any carry-over which should be generated.

Hence if a single clock pulse is applied to the clock line, three things will happen:

1. The carry FF will store the carry-over of this first bit-pair addition, ready for the next bit-pair addition.
2. The LSBs of both addend and augend will be shifted out of their respective registers, and lost, leaving the next significant bits applied to the adder inputs.
3. The LSB of the sum, produced by the adder, will be shifted into the MSB bit position of the addend register.

A second clock pulse causes this sequence of events to be repeated, except that in this case the sum of the second pair of bits is shifted into the MSB bit position of the addend register, and the LSB sum bit is shifted one place to the right. The second bits of the original addend and augend are lost as before, while the carry FF stores the new carry bit.

The complete addition of the two 8-bit numbers requires a total of 8 clock pulses. At the end of the eighth clock pulse, the addend register will contain the 8-bit sum of the two. The augend register will be cleared, as the augend will have been shifted fully out. The carry FF will also contain the end-carry, or carry generated by the final addition of the two MSBs. This may or may not be used, depending upon the rest of the system.

The eight clock pulses used to perform this addition process must be spaced at sufficient intervals to allow for the switching times of the register flipflops, the carry flipflop and the adder logic elements. Hence serial addition tends to take an appreciable time—and a time directly proportional to the bit length of the numbers involved, for a given type of logic. So that adding two 16-bit numbers will take twice as long as adding two 8-bit numbers, and so on.

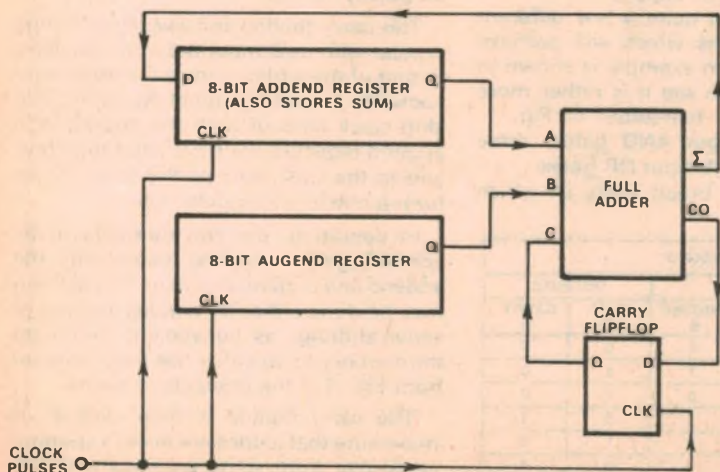

FIG. 3: 8-BIT SERIAL ADDER

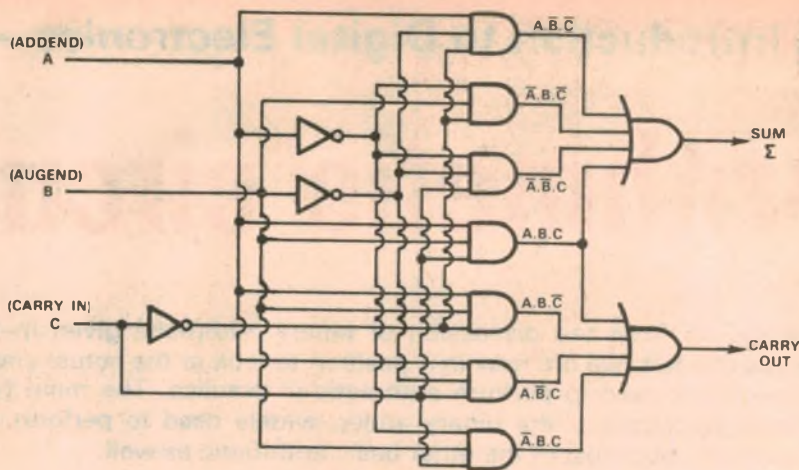

FIG. 2: FULL ADDER

Considerably faster addition can be performed using the parallel approach, because all bit pairs are added virtually simultaneously. This also makes the addition time largely independent of number size, although adders for large numbers can require special carry logic if high speed operation is to be achieved.

Basically, parallel addition involves a set of full adders working in parallel, one for each bit pair. This is illustrated in the diagram of Fig. 4.

Shown in this diagram is a 4-bit parallel adder, using four full adder circuits. The lowest adder takes the two LSBs of the two input numbers, A0 and B0, and produces the appropriate sum sigma-0 and carry C0. The latter is then used by the second adder, together with bits A1 and B1 of the two input numbers, to produce the second sum sigma-1 and carry C1. The third and fourth adders work in the same fashion.

If a 4-bit parallel adder like that shown in Fig. 4 is used in a system dealing solely with 4-bit numbers, the carry input of the LSB adder would be disabled by connecting it to the logic 0 level as shown. Similarly the carry output of the MSB adder

(C3) would probably be left unused. However the existence of this input and output does allow a number of such circuits to be used together, to handle larger numbers.

To form an 8-bit adder, for example, two such circuits would be connected together with the C3 output of the circuit handling the four least significant bits fed to the LSB carry input of the circuit handling the four most significant bits. To handle 16-bit number four circuits would be cascaded in the same way.

The circuit of Fig. 4 could thus be described as effectively providing a 4-bit "slice" of parallel adder circuitry, as it is really a building-block suitable for building a parallel adder of almost any desired size.

At this stage it might be worthwhile to point out that the addition of two numbers is by no means the only task that can be performed by adder circuits like those shown in Figs. 3 and 4. As you might expect, they can be used for two's complement subtraction, by forming the subtrahend number into its two's complement before an otherwise normal binary addition.

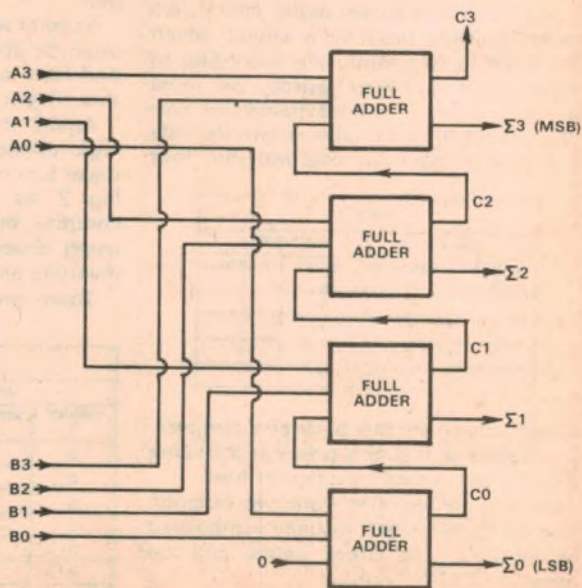

FIG. 4: 4-BIT PARALLEL ADDER



# Lafayette ))

## 27MHz two-way



**5 WATT 6 CHANNEL  
'MICRO 66'**

From the Lafayette Radio Electronics Corporation of U.S.A. Lafayette transceivers embody features which have made them world famous. 1,000's in use throughout Australia, 100,000's world-wide. Government, industrial, marine, sports and farm applications testify to their versatility and rugged reliability.



**5 WATT 12 CHANNEL  
DYNA-COM 12A**

**1 WATT 3 CHANNEL  
LAFAYETTE HA-310**

All units Telecom Type Approved (Licence Required)

**Lafayette are 2-way specialists. Full range 27MHz crystals, antennas, auxiliary equipment available!**

Dealer enquiries invited

# Lafayette ))

**the Communicators**  
**LAFAYETTE ELECTRONICS**  
Div. of Electron Tube Distributors P/L  
94 ST. KILDA RD., ST. KILDA  
Victoria 3182. Tel. 94 6036



## -that's where the money is!

Stott's course is totally comprehensive — and includes both sophisticated electronic equipment and project materials you need to gain a thorough understanding of servicing techniques.

Divided into three self-contained sections, the course covers:

Part 1 — Introduction to Electronics (theory and practice)

Part 2 — Monochrome Television Receivers

Part 3 — Colour Television, including processing circuitry, service techniques, fault tracing and trouble shooting techniques.

Like all Stott's courses, you work with your own instructor who is an expert in this exciting and rewarding field, at your own pace, in your own home.

If you are a beginner, Stott's will teach you everything you need to know concerning television principles and receiver circuitry.

If you are already working in the field, or have completed some studies in electronics, you may be eligible to enter the course at an advanced stage. Whether your aim is to enter the TV service industry or whether you wish to gain a thorough understanding of television theory and servicing as an aid to sales experience, this is the course which will help you make it!

Other electronics courses offered by Stott's include:

Radio for Amateurs — Amateur Operator's Certificate

For full information mail this coupon today:

STC941

EA 4 77

# Stotts



TECHNICAL CORRESPONDENCE COLLEGE

The name to trust in correspondence education

Please send me, without obligation, full details of the following courses:

(please PRINT)

Stott's undertake that no sales counsellor will call

Mr., Mrs., Miss

Age

Address

Postcode

159 Flinders Lane, Melbourne, 3000. Tel: 635583  
383 George Street, Sydney, 2000. Tel: 292445  
290 Adelaide Street, Brisbane, 4000. Tel: 311627

66 King William St., Kent Town, S.A., 5067. Tel: 425798  
89 St. George's Terrace, Perth, 6000. Tel: 225481  
P.O. Box 3396, Singapore 1



**A.C.E.****RADIO****MUSICOLOUR**

For the disco, light show, party, nites, or just relaxing enjoy your records and tapes more with the new magical Musicolour Organ. Simple to connect to the home stereo or P.A. system. 3 channels, 1500 watts max. load each.

**\$69.95**

Fully constructed, ready to operate

Complete kit of top quality parts and instructions for the models 11 or 111 **\$49.95**  
P.P. NSW \$3.50, interstate \$5.50

**30 WATTS OF EXCELLENT HI-FI WITH PLAYMASTER LOUDSPEAKER SYSTEMS**

**3-45L.** Features the mighty 8-30 woofer, 6J midrange and the incomparable Philips AD016/TB tweeter. This top quality low cost 3 way hi fi system is available from stock in either walnut or teak veneer and complies with the specs., as per April '75.

**\$84.00 each**

**3-41L.** As described in June '76 E.A. Again features the mighty 8-30 woofer, with the advantage of the new Magnavox 6-25 midrange, and the more elaborate cross-over network. The dome tweeter is Philips AD0160/TB. Beautiful teak, or the ever popular walnut veneer cabinets are available. Either system can be carefully packed and despatched per airfreight passenger rail or road. Packed weight approx. 40kl. pair.

**\$96.00 each****HI FI CABINET KITS**

Do it yourself—big savings. Our kits are extra easy to finish. Top, bottom, each side and back are factory assembled, baffle is pre-cut. Veneered plyboard. Teak or walnut. Complete with innerbond and speaker grille cloth. 8-30 3-45L systems **\$55.00** pair. MV-50 system **\$69.95** pair.

**FAMOUS MAGNAVOX AUST. MADE LOUDSPEAKERS**

MODEL	Imp	Watts	Rms	Reson	Hz	Freq Hz	V.C. Dia.	Price	P.P.
10-40 10"	8	40	45	45	30-8000	1 1/2"		\$23.00	\$2.50
8-30 8"	8	30	45	45	30-8000	1 1/2"		\$19.00	2.25
12WR 12"	8	16	45	45	30-16000	1"		\$16.50	2.00
10WR 10"	8	16	45	45	30-16000	1"		\$13.90	2.00
8WR 8"	8	16	45	45	30-16000	1"		\$11.80	2.00
6WR 6 1/2"	8	12	45	45	30-16000	1"		\$10.90	22.00
6 J 6 1/2"	15	8	85		80-7000	1"		\$8.50	1.50
6-25 6 1/2"	8	25	45	45	45-6000	1 1/2"		\$16.50	2.00
XJ3 Dome	8/15	25	1500		2000-20000	1"		\$8.95	1.30

**20WATT STEREO AMPLIFIER CHASSIS.**

Update your stereo system with a hi-fi 10 watt RMS per channel amplifier. Small and compact, 85 x 145 x 45 mm h. Fully assembled—ready to operate. Easy to install in radiogram cabinet, recordplayer base, etc. 240V 50Hz power transformer included. Circuit supplied individual heatsinks for power transistors.



**SPECIFICATIONS.** Power Output 10 + 10 WRMS, at 8 ohms. Output Imp 8-16 ohms. Distortion, Better than 0.5% Freq. Response 35-18000Hz. Sig. To noise Better than 50dB. CH separation Better than 50dB. Input sensitivity 500mV. Bass control + -10dB at 40Hz. Treble control + -10dB at 12000Hz. Power supply, 28-0-28V, 1amp. Dim. 185 x 145 x 60M/M. **\$33.95** P&P \$3.50.

**P.A. PROJECTION FLARES**

Dimensions 18" dia. x 14" complete with mt. bracket. Weatherproof 8" heavy duty speakers.



10 watts RMS 15 ohms **\$24.95**  
20 watts RMS 8 ohms **\$28.95**

**COBRA****CB 2-WAY RADIOS**

Model 21 23CH 5W **\$149.00**  
Model 26 23CH 5W **\$189.00**  
Model 138 23CH. AM SSB 5W AM, 15W SSB **\$290.00**  
Send S.A.E. for full tech. data

**NEW TRANSISTORS****DIODES, 1-Cs****GUARANTEED**

2N 4248 10 for	\$1.50
8C 108 10 for	\$2.00
2N 4250 10 for	\$2.00
KM 903G 10 for	\$1.00
8C 548 10 for	\$2.00
2SD 200 10 for	\$4.00
IN4723R 600PIV 3A 10 for	\$2.50
309, 723, 709, metal can 10 for	\$4.50
LM377N 10 for	\$6.00
LM270H 10 for	\$4.50

P.P. 60c

**FM WIRELESS****CARDIOID MICROPHONE**

Electret condenser type, emitting freq. range 88-106MHz.  
Freq. dev. ± 75KHz FS 504/VM at 50 ft. **\$24.95**, p.p. 80c.

**WESTON 5 WATT C-B TRANSCEIVER**

Great boat or mobile rig. Auto noise limiter, squelch, A.G.C. over-mod. limiter. Low pass filter for bandwidth. SPECS T-mixer. Crystal locked, 5 watts input to RF stage. Freq. coverage, Any 11 channels, in 27 MHz band. Receiver crystal locked, double superhet. 6.5 MC and 455 Kc. 1 1/2" 3" speaker, dynamic mic. 50 ohm antenna. 20 transistors, 8 diodes. 12VDC operation. Sensitivity 0.5UV 10dB. S/N. Size 8 1/2" x 2 1/2" x 7 1/4". Wt. 4 1/2 lbs.

**PRICE \$159.95** p.p. NSW \$4.50, Interstate \$5.50**GARRARD MODEL 82****\$57.00.**

A superb 3 speed transcription changer player. Auto manual operation. 4 pole magnetically shielded syn motor. Resiliently mounted Counterbalanced. Elegant tone arm with slide-in cartridge carrier calibrated. Antiskate 265mm (10 1/2"). Aluminium platter. Cue and pause control. Cartridge tilting lever. Magnetic cartridge diamond stylus. Size 375 x 335 x 170mm (14 1/4" x 13 1/4" x 6 1/4"). 4.5kg (10 lbs) P & P \$2.50. Interstate \$3.50.

**GARRARD CHANGER/PLAYER**

MODEL—6400 3 speed auto manual changer—player. 2 spindles. Motor 2 pole 240V 50Hz 10 1/2" turntable cue and pause, tubular section pick up arm, Sonatone cartridge. Great value **28.50.**

**PLAYMASTER FORTY/FORTY STEREO AMPLIFIER**

KIT OF TOP QUALITY COMPONENTS. ALSO CIRCUIT AND INSTRUCTIONS.

**\$95.95.** P.P. \$3.50 Interstate \$5.50. The 40/40 Kit is available with an assembled and tested printed circuit board at **\$107.95**

**PLAYMASTER 25 + 25 STEREO AMPLIFIER**Complete kit of top quality parts with instructions **\$77.50**

P.P. N.S.W. \$3.50, Interstate \$5.50

**SANYO CADNICA RECHARGEABLE BATTERIES**

Type A \$2.50EA 4 for \$9.00  
Type C \$4.10EA 4 for \$14.75  
Type D \$5.00EA 4 for \$18.00  
P&P \$1.00 Interstate \$1.75.  
**SANYO NICAD BATTERY CHARGER**  
**\$25.95.** P&P \$1.60

**PLESSEY ROLA SPEAKER SPECIALS**

CBM X / 17 20 watts, 8 ohms. Resonance 35Hz. Freq. 35-20000Hz. \$11.00 P&P \$1.00 CBMX00, 10 watts 15 ohms, reson 45Hz. Freq. 35-20000Hz. \$8.50 P&P \$1.00 8" x 4", 15 ohms. Oval car radio speaker, \$3.95 P&P 80c

**CHEAPER BY THE DOZEN**

12 FOR \$ c  
3.5mm plug, large body 1.80  
6.5mm plug, metal 4.65  
6.5mm plug, right angle 2.90  
6.5mm plug stereo 4.00  
3.5mm panel jack 1.70  
6.5mm panel jack mono 2.80  
6.5mm panel jack stereo 2.80  
RCA plug, Red and black, large body 1.80

RCA panel socket 1.80  
RCA inline socket 1.80  
DIN 2 pin speaker plug 2.80  
DIN 2 pin speaker socket 2.00  
DIN 3 pin plug 3.40  
DIN 3 pin panel socket 2.50  
DIN 5 pin plug 3.90  
DIN 5 pin panel socket 2.50  
Coax plug, Colour TV cable 2.90  
Coax panel socket 1.90  
Coax car antenna plug 1.80  
Banana plug 2.80  
Banana socket 2.50  
Alligator clip Plastic handles 1.00  
Plug adaptor, 3.5mm plug to 6.5 mono socket 4.60  
Adaptor plug 3.5mm plug to 6.5 stereo socket 6.90  
Neon bezel Red Dia 10 max 42mm 15mm Sq Face 7.40  
Standard panel mounting fuse holder 7.30  
AOD P.P. 90c.

**MULTI CELLULAR HORN TWEETER**

Freq. 2000-20,000 Hz. sen. 105dB. 30 watts. 8ohms **\$12.95**  
P.P. \$1.30.

**TEXAS RF POWER TRANSISTORS**

Type TI-1133 Silicon NPN  
7-5 amps **\$3.25** p.p. 60c

**PEAK 5" MID-RANGE**

Solid Back 300-6000 Hz  
8 ohms 30 Watts  
**\$10.95** p.p. \$1.50

**TO CLEAR NEW SPEAKERS**

**\$2.95** ea. p.p. \$1.30  
8" 15 ohms 10" 15 ohms 10" 8 ohms  
6" 15 ohms 6" 8 ohms 8" 27 ohms  
**\$1.95** ea. p.p. \$1.00  
8" x 4" 15 ohms 5" x 4" 15 ohms  
6" x 4" 15 ohms 6" x 4" 3.5 ohms  
**95c** ea. p.p. 75c  
4" x 3.5, 8, 15 ohms 5" x 3" 8 ohms  
5" x 3" 33 ohms 6" x 4" 33 ohms

**ELECTROLYTICS**

New and Fresh. P.C. board types

2500 UF 16VW 10 for **\$2.80**  
1000 UF 25VW 10 for **\$2.80**  
470 UF 35VW 10 for **\$2.50**  
220 UF 16VW 10 for **\$1.50**

P &amp; P \$1.00

**AWA E-TONE 60 WATT RMS LOUDSPEAKER**

30CM (12") 8 AND 15OHMS VC DIA. 5.1CM BIG 3KG MAGNET FREQ. 40-7000 Hz FOR BASS GUITAR, ORGAN, GUITAR. WEIGHT 4.5 KG. **\$49.00** P.P. \$3.50

**38 cm (15")**

Power 100W rms freq. 40-5000 **\$107.00**  
160 rms freq. 30-4000 **\$160.00**  
200W rms freq. 30-3500 **\$170.00**  
Send S.A.E. for full details

**AUTOMATIC WIRE STRIPPER**

5 sizes. 1-3.2mm dia. **\$10.50**  
P.P. 80c.

**PERSPEX COVERS**

Fully moulded. Tinted. With Cheney hinges. 16" x 13 1/2". **\$7.50** p.p. \$2.50

**REFLEX HORNS**

Rugged—attractive

Suitable for indoor

or outdoor.

Size 8" x 5", 8 or 15 ohms, 15 watts

**\$18.50** p.p. \$2.506" 8 ohms, 10 watts **\$10.95** p.p.

\$1.50

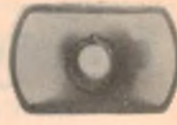

WE REGRET THAT PRICES ARE SUBJECT TO CHANGE WITHOUT NOTICE



Apart from this, they can also be used for incrementing a single binary number. To do this with the serial adder of Fig. 3, for example, it is merely necessary to load the number to be incremented into the addend register, clear the augend register (or load it with zero), and preset the carry FF—rather than clear it—before applying the usual train of 8 clock pulses.

The initial "1" in the carry FF will thus be added to the number in the addend register, and the result returned as before to the same register.

This ability to serve as an incrementer may also be used to convert numbers into their two's complement, prior to performing subtraction.

As you may recall from the previous chapter, the most convenient way of generating the two's complement of a number is to complement each of the bits individually, and then add 1 to the resulting number. This is the method used here.

With a serial adder like that in Fig. 3, this would be most easily done by providing additional logic at the output of the addend register, so that by the application of a control signal the A input of the adder could be derived from the Q-bar output of the LSB addend flip-flop, instead of the Q output. This would then mean that when a number is shifted out of the addend register into the adder, it comes out in bit-complemented form—also known as the "one's complement".

So that by loading the number to be complemented into the addend register, clearing the augend register, and presetting the carry FF before we apply the usual 8 clock pulses, we can form the two's complement of the number in a single operation. The logic at the output of the addend register causes the number to be fed to the adder in one's complement form, while the initial "1" in the carry FF causes it to be incremented into the two's complement.

Having formed the two's complement in this way, it would then be a relatively simple matter to complete a full subtraction operation. The minuend number would be loaded into the "augend" register, and the logic at the output of the "addend" register changed to reconnect the normal Q output to the adder A input. Performing a normal binary addition will then result in the two's complement remainder being left in the "addend" register.

Note the sequence of events: the sub-

trahend is dealt with first, loading it into the "addend" register and then using the adder to turn it into the two's complement. Then the minuend number is loaded into the "augend" register, and the adder used to perform the actual subtraction.

As you can see, a binary adder can be used for other things apart from straightforward binary addition. In fact by adding a bit of additional circuitry here and there,

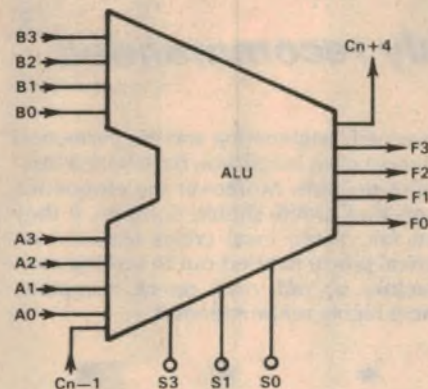

SELECT CODE			FUNCTION PERFORMED BY ALU
S3	S1	S0	
0	0	0	$F_n = 0$
0	0	1	$F_n = A_n \text{ OR } B_n$
0	1	0	$F_n = A_n \cdot B_n$
0	1	1	$F_n = A_n \oplus B_n$
1	0	0	$F_n = (\bar{A}_n) + 1$
1	0	1	$F_n = (\bar{B}_n) + 1$
1	1	0	$F_n = (A_n) + 1$
1	1	1	$F_n = A_n + B_n + C_{n-1}$

FIG. 5: 4-BIT PROGRAMMABLE ARITHMETIC-LOGIC UNIT (ALU)

it becomes possible to perform quite a number of different logical and arithmetic operations.

When this is done the circuit tends to turn from an adder into a general-purpose programmable arithmetic-logic unit, or "ALU".

Such ALU circuits are widely used in modern digital systems; they are made as single LSI integrated circuits, and thus become important system building blocks.

Virtually every computer has such an ALU element forming the central part of its CPU, or central processing unit. Similarly an ALU forms an integral part of every microprocessor and calculator IC.

The logic symbol used to represent a 4-bit parallel ALU is shown in Fig. 5, together with a table illustrating the

variety of logic and arithmetic functions which may be available in the repertoire of a typical device. The functions performed are selected by control logic signals applied to three "function select" inputs, S0, S1 and S2. As the device thus accepts three bits of control information, it follows there are eight different functions available ( $2^3 = 8$  selection possibilities).

As you can see, one of the eight possibilities is shown here as being a "device inactive" or "disabled" mode: when the select code is 000, the outputs of the device are all held at the zero logic level.

All of the remaining seven possibilities are used to provide useful logic and arithmetic operations. There are three logic functions, with the code 001 producing the OR function, the code 010 producing the AND function and the code 011 producing the exclusive-OR function.

The remaining four codes produce arithmetic functions. Code 100 results in two's complementing of the input number A, and code 101 produces the same effect on number B. Code 110 results in number A being incremented, while the final code 111 produces full binary addition of the two numbers complete with any lower-order carry via the input  $C_{n-1}$ .

As with the parallel adder of Fig. 4, the ALU of Fig. 5 is designed to be suitable for use in multiples to handle larger numbers. It could thus be described as a "4-bit slice" of an ALU, or as a "4-bit ALU slice". Two such slices could be used to handle 8-bit numbers, or four to handle 16-bit numbers, etc.

In this discussion of binary arithmetic circuits we have looked mainly at adder circuits, and we have also considered only pure-binary arithmetic. Hopefully this simplification has made it easier for you to grasp the basic concepts involved, so that you should now be in a position to understand other types of arithmetic circuits when you come across them.

Pure binary arithmetic based almost entirely on adders or ALU elements is now used in a majority of digital computers—certainly in all microprocessors, and in most minicomputers. Some of the larger computers perform arithmetic in a BCD code instead of pure binary, and this is also done in most digital calculators. Larger computers also tend to use additional types of arithmetic circuitry to supplement adders: circuits like fast multipliers and dividers.

Unfortunately these circuits and those for BCD arithmetic are too specialised for this introductory course.



# Classical Recordings

Reviewed by Julian Russell



## Verdi—*Il Corsaro*: highly recommended

**VERDI—*Il Corsaro*. Complete Opera.** Jose Carreras (Corrado); Jessye Norman (Medora); Montserrat Caballe (Gulnara); Gian-Piero Mastronomel (Seid) and others with the Ambrosian Singers and the New Philharmonic Orchestra conducted by Lamberto Gardelli. Philips Stereo 6700 098. (Two Boxed Discs with libretto in English, French, German and Italian.)

Another "early" and seldom played opera indispensable to any collector of Verdi's works. Its composer had during its creation—and after—many tiresome disputes with publishers and librettists with which I won't bore you here. I will content myself by saying it receives a very fine recording on this two disc set.

As to the music itself, it has many a really grand moment, some very original harmonies when one considers its fairly early 19th century origin, and from beginning to end is full of that unquenchable flow of lovely melodies so characteristic of the composer. Indeed much of the score shows refinement well ahead of its position in Verdi's vast output.

The very first bars of the splendid, short overture should do much to convince you of the truth of this statement. And they are representative too of the mettlesome way in which the conductor, Gardelli, treats the whole opera. Early in the first act you will also note, I hope with approval, the high standard of the choral singing and orchestral playing.

Like so many of Verdi's early operas, the libretto cannot be considered as any great work of art. But it is magnificently suited as a vehicle to carry the composer's musical inspirations. Anyway how many librettos will stand up to performance without their accompanying music? I don't think you will recall many.

It is generously cast. Tenor Jose Carreras has a fine ringing voice managed as well in the expansive passages as in the more tender scenes. Then you have Jessye Norman, utterly enchanting in her role of Medora and Montserrat Caballe at her mature best as Gulnara, strong in characterisation and alluring in vocal quality. Gian-Piero Mastronomel is a little uneven in the middle parts of the opera, starting magnificently and finishing in the same manner, but a trifle disappointing here and there in between.

*Il Corsaro* is not a long opera, but in

its superb engineering and the perfection of most of its length you have here a boxful of delights. Moreover the eloquence won by Gardelli should dampen, if they are fair, some local critics almost hysterical praise handed out to visiting conductors of our own opera company. Most highly recommended.

★ ★ ★

**BRAHMS—Piano Concerto No. 1 in D Minor. (New recording.) Arthur Rubinstein (piano) with the Israel Philharmonic Orchestra conducted by Zubin Mehta. Decca Stereo SXLA 6797.**

Rubinstein was 90 last year. The merciless photograph on the disc sleeve confirms his age; his playing does not. It is still miraculously youthful. Rubinstein, while still very young, had the benefit of knowing the composer's preferences for the tempos and dynamics of this concerto. Brahms himself explained them to Joachim who in turn passed them on to Rubinstein. We must therefore accept, albeit reluctantly, Rubinstein's first entry in the first movement at a slower tempo than Mehta's orchestral introduction. Otherwise there are no outstanding eccentricities in Rubinstein's performance. My main disagreement with the production is that the piano is often recorded so forwardly that some of Mehta's excellently played orchestral part is almost inaudible. Despite my admiration for both the old man and the young one (Mehta), I think this issue will appeal more to collectors than the general record buying public who can obtain many alternative performances.

★ ★ ★

**BRAHMS—Concerto for Violin, Cello and Orchestra. Wolfgang Schneiderhahn (violin) and Janos Starker with the Berlin Radio Symphony Orchestra conducted by Ferenc Fricsay. Tragic Overture. Berlin Philharmonic Orchestra conducted by Lorin Maazel. DGG Dolbyised Stereo Cassette 3335 140.**

This performance, first issued on disc some 25 years ago, has now transferred with surprising success to a Dolbyised cassette. The sound is quite respectable,

though for obvious reasons not up to more modern standards. Schneiderhahn's tone sounds a little thin after Grumiaux's in the Beethoven sonata reviewed later. However his playing is always supremely musical.

By the way I don't attribute the quality of Schneiderhahn's tone to the cassette. To me it was always a bit on the thin side both on disc and in live performances. Starker's cello is expressive and always romantic. But he doesn't, at least on this cassette, match the richness of tone of such contemporary players as Rostropovich or Gendron.

The orchestra sounds reasonable, though with a tendency to congestion in the middle register during fortissimo passages. But this can be a characteristic of Brahms' scoring unless it is carefully avoided by careful balancing of the instruments. However with all its shortcomings—in terms mostly of more modern techniques—the performance was well worth preserving in convenient cassette form, though whether buyers will consider it worth cassette price remains to be seen. The Berlin Radio Symphony Orchestra is conducted sympathetically by the late Ferenc Fricsay.

The fill, Brahms' Tragic Overture, is well enough played by the Berlin Philharmonic under Maazel and the sound is better. But at the risk of offending Brahms' many admirers, the work has always been a bore to me and remained so during this performance.

★ ★ ★

**BEETHOVEN—Piano Concerto No. 3 in C Minor. Fantasia for Piano, Chorus and Orchestra. Daniel Barenboim (piano), Vienna Academy Chamber Choir and the Vienna State Opera Orchestra conducted by Laszlo Somogy. Westminster Stereo WGS-8112.**

The concerto starts well with its long orchestral introduction, but when the piano enters it is so closely recorded that it seems to have an acoustic of its own. Otherwise Barenboim gives a good conventional performance using much more orthodox tempos than he did when he later recorded the piece with Klemperer. But I must repeat that Barenboim's acoustic is so close that it often has the effect of coarsening his tone. I found the first movement particularly difficult to listen to for that reason.

Things improve in the slow movement with soloist and orchestra in poetic mood, especially when they deliver the long Italianate melody. But later the balance again puts the pianist so far to the fore here and there that at times it sounds quite embarrassing.

This is one of Barenboim's first recordings, made in 1964 when the young pianist was only 20 years old. It was seven years later that he recorded all five piano concertos with Klemperer who must have had a considerable influence on the



younger musician. To sum up this earlier effort, Barenboim's playing is excellent, his interpretation mature but conventional and the orchestral playing better than satisfactory. But, oh, that balance between the two.

The record sleeve is not an advertisement for good taste for this kind of work. It features a close-up photograph of an apparently naked woman holding copies of the well-known plaster casts of Beethoven's head over each breast. It would be much more suitable as a cover for a girlie magazine.

The fill is the Fantasia for piano, chorus and orchestra in which the Vienna Academy Chamber Choir joins the concerto forces. Here Barenboim is most impressive in the piano solo opening. It is an example of beautiful choice of tempo, sensitive phrasing and dynamic variations. There is, however, no text of the choral part—at least in my review pressing. The chorus is good in their contribution, so like the "joy" theme from the composer's 9th Symphony. I found the overall balance much better in this than in the concerto. And it has a really exciting finish.

★ ★ ★

**BEETHOVEN—Sonatas for Violin and Piano, No. 5 in F (Spring) and No. 1 in D.** Arthur Grumiaux (violin) and Claudio Arrau (piano). Philips Dolbysed Stereo Cassette 7300 473.

When Grumiaux first recorded on LP the complete set of Beethoven's Violin and Piano sonatas, his partner was the illustrious Clara Haskell. In this new cassette his still more illustrious collaborator is Claudio Arrau. The Grumiaux-Haskell performance was given the warmest approval when it was first issued—and deservedly so. The engineering now sounds a little primitive but still eminently acceptable.

Now, with the benefit of modern cassette techniques, this first of a promised complete series can be given the same warm welcome. Grumiaux's tone is as pure as ever, his instinct for finding the exact cusp of a phrase just as impeccable. Both players sound so much at ease that they make even the most difficult passages sound within the capabilities of a couple of talented students. This is, of course, the simplicity that hides great art. The players, except in a couple of minor exceptions, are in perfect rapport and the Dolby sound is absolutely faithful.

Another important point: whenever the violin has only figurative accompaniment to the transference of the melody to the piano, Grumiaux, though never giving them too much emphasis, makes them still sound interesting in their own right. The general effect, if a little relaxed—and shouldn't it be?—is quite seraphic.

Grumiaux coupled his earlier recording with the Kreutzer. Here he uses the

Sonata in G with as happy a result as the preceding Spring performance. The absence of reverberation may make the engineering sound a little too dry for some ears. For me it had the effect of bringing both players right into my large music room. Also the players' whole approach confirms the description of chamber music as "the music made by friends".

I found it difficult to imagine that either sonata could be made to sound better on disc. Just out of curiosity I played one of the first cassettes ever issued before Dolby improved the system. The difference in the quality of the sound of the new process is almost unbelievable. I look forward eagerly to the rest of the sonata series played by the same two artists.

★ ★ ★

**BARTOK—The Miraculous Mandarin.** (Last episode only.) BBC Orchestra conducted by Antal Dorati.

**PROKOFIEFF—Suite from The Love For Three Oranges. Scythian Suite.** London Symphony Orchestra conducted by Antal Dorati. Philips Universo Stereo Series 6583 011.

Dorati recorded The Miraculous Mandarin way back in 1954 with the Chicago Symphony Orchestra. In those days it was regarded as a masterpiece of engineering. It was one of those diamond hard Mercury recordings that made a great deal of a highly complex orchestral score astonishingly audible.

At that time many American recordings had the same sharply brilliant sound as opposed to their then softer grained European counterparts. He recorded it again for Philips in 1966 with the BBC Orchestra in which much of the glassiness of the Mercury disc was mercifully absent. This is the one that has been reprocessed for the performance under review.

The Miraculous Mandarin is far from being one of my favourite Bartok works. As a stage spectacle in ballet form the story was obscene, even in these present days of permissive theatre, and musically

its harshness and undisguised brutality matches the story. Altogether its effect on me was as repugnant as the hideous German expressionistic period in art.

This reissue, though still brilliant, happily misses the carborundum effect of the first Mercury. The disc represents excellent value since it includes, together with the Mandarin, four items from Prokofieff's Scythian Suite and all six of the excerpts from his Love for Three Oranges, both admirably played by the London Symphony Orchestra. The originals of these also date from 1966. Nowadays the three performances have all the distinction of present day stereo engineering.

Dorati changes his style perceptively in his delivery of the three very different works. Indeed he comes very close to making the Mandarin sound bearable. The six-item suite from The Love for Three Oranges seems to me to contain all that is worth preserving from the opera from which they are taken. I make this personal statement based on the fact that I heard the opera some three years ago in Madrid and found little to enjoy in the rest of the score. The production was by a Balkan company presented rather in the manner of a commedia dell'arte which had the merit of ingenuity if little else.

The Madrid opera is perhaps the least attractive in any European capital that I have attended. It is tucked away in a back street behind the Cortez (parliament) and my most attractive memory of any performance that I attended there was the German restaurant-bar opposite that one attended after the shows.

By the way, the justifiably popular March, still often played alone nowadays, runs through the whole work. Dorati's reading of the suite is fine, sometimes elegantly crisp, at others lyrical and always characteristically nervous. The rather dry acoustic robs the Prince and Princess episode of a little of the warmth it deserves, but otherwise the performance is completely satisfactory. The Scythian Suite is as expertly played as the other two pieces. All three, display the unmistakable influence of the Stravinsky of the Sacre period. ☺

**DICK SMITH SUPERCATALOG**

**FREE\***

with the May 1977 issue of  
**ELECTRONICS AUSTRALIA.**



**YOU'VE SEEN THE REST — NOW HERE'S THE BEST!**

Most catalogs are just that — lists of products with prices.  
Not so Dick Smith's — it's got data, information, suggestions,  
ideas, circuits — and fully illustrated products with some of  
the best prices around. And it's free with the next issue of E.A.

\* Normally 75c per copy. **ORDER YOUR E.A. NOW!**



# SOMEBODY'S ERROR HAS BECOME YOUR OPPORTUNITY!

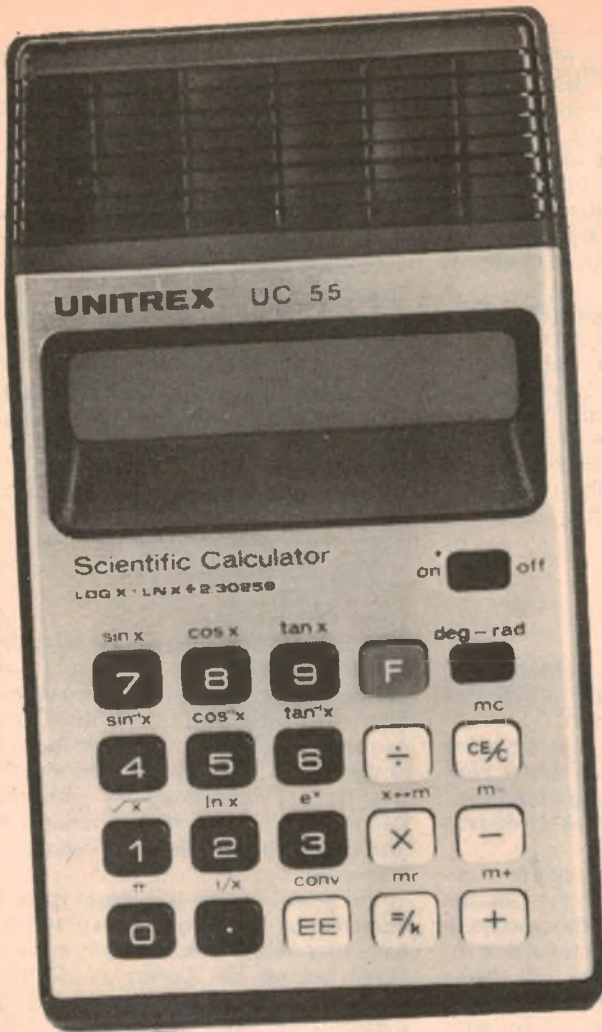

The Unitrex UC55 (actual size) breaks new price barriers for a scientific calculator.

Yes, these attractive Unitrex UC55 scientific calculators were intended for a big Canadian retail chain—but they were shipped to Australia by mistake!

Instead of returning them, Unitrex are offering them to "Electronics Australia" readers at a clearance price.

**STUDENTS**  
**\$12.99**  
**\$14.90**  
**FOR OTHERS**  
 plus \$2.99 for postage and handling.  
 Battery 85c extra

- Positive, click-action buttons.
- Operates from internal 9-volt battery, with provision for external supply.
- Nine-digit red LED display, including error, sign and "F" indication.
- Chain calculations.
- Alternative floating point algebraic or scientific notation with 5-digit mantissa, 2-digit exponent and two signs. ( $10^{99}$  to  $10^{-99}$ ). Auto shift.

- 5-function accumulating memory.
- Trig functions in radians or degrees. Sin, Cos, Tan,  $\text{Sin}^{-1}$ ,  $\text{Cos}^{-1}$ ,  $\text{Tan}^{-1}$ .
- Root X, 1/X functions, pi key.
- Automatic constant on all four arithmetic functions.
- MOS/LSI solid-state circuitry
- Handy, compact size: 140×78×26mm. Weight, with battery, 170 grams.
- 90 days' warranty.

**HOW TO ORDER:** Fill in both sections of the coupon. In each section print your name and full postal address in block letters. Cut the entire coupon out around the dotted line. Send it with your money order or crossed cheque to this Magazine's Special Offer (Calculator), P.O. Box 93, Beaconsfield, N.S.W. 2014. Cheque should be endorsed on the back with sender's name and address and made payable to this Magazine. This offer is open to readers in Australia only. Please allow four weeks for delivery.

<p style="text-align: center;"><b>SALES TAX (EXEMPTIONS AND CLASSIFICATIONS) ACT</b></p> <p>To: The Commissioner of Taxation and the Commonwealth of Australia</p> <p>I hereby certify that the Calculator/s purchased by me from _____ on _____ (date) is for use in _____ (Name of University or School) in or directly and essentially in connection with the production of facts, by means of observing, measuring, testing or otherwise experimenting with material phenomena, for the purpose of proving or illustrating natural principles or laws or in the study of pure or mixed mathematics. Exemption is accordingly claimed under item 63 (1) in the First Schedule to the Sales Tax (Exemptions and Classifications) Act.</p> <p>Signature of official of University or School _____          Designation _____          Name of University or School _____          Date _____ Signature of Student _____          Address of Student _____</p>	<p style="text-align: center;"><b>EA 4 This Magazine's Unitrex Calculator Offer 115/77</b></p> <p>Name _____          Address _____          State _____ Postcode _____</p> <p>Please send me <input type="checkbox"/> Calculator/s UC 55 + <input type="checkbox"/> Battery/s (state quantity)</p> <p>I enclose cheque. Postal/Money order to the value of \$ _____</p> <hr/> <p>Name _____          Address _____          State _____ Postcode _____</p>
--	---





## Lighter Side

Reviews of other recordings

### Devotional Records

**WHERE ELSE WOULD I GO... Children of the Day.** Stereo, Maranatha HS-777-15. (From S. John Bacon Pty Ltd, 12-13 Windsor Av, Mt Waverley, Vic. \$6.95)

One would gather from the jacket notes and pictures that "Children Of The Day" is predominantly a family group, who write most of their own music and do most of their own arrangements, all aimed at a Gospel witness. Certainly the family theme is strong in the tracks on this album:

Face In The Crowd — Silver Packages  
— Wings Of Morning — Can You Feel Him — Goodbye — Wind Blowing Softly — The Holy Spirit Song — Tried In The Fire — Where Else Would I Go?

The titles may not mean much as they stand, but the inner sleeve carries the lyrics in full, and the scripture themes on which they are based. The actual arrangements are modern, ranging from quite sparse backing to soft rock—strongly reminiscent of the themes in present-day Christian musicals. But they're easy on the ear, thought provoking in their lyrics and of potential interest to anyone looking for new Gospel music.

Technically the quality is about average. Critical hi-fi buffs may note some suggestion of fuzz in the crowded passages, but there is no background noise and diction is okay. (W.N.W.)

★ ★ ★

**JAN: WHERE WOULD I BE WITHOUT HIS LOVE.** With the Laurie Lewis Orchestra and Voices. Stereo, Art Records AST-505. (From Advent Radio-Television Productions, 150 Fox Valley Rd, Wahroonga NSW 2076).

As Jan Martin, the artiste featured on this album has appeared frequently on radio, television and the Gospel platform. Now married, as Jan Judd, and the mother of two children, Jan tells of her Christian faith in this new album.

There are twelve tracks in all: Where Would I Be Without His Love — O King Of My Life — Take The Time — Some thing Beautiful — When The Lord Is With You — Turn Your Life Over To Jesus — Through It All — I Can't Help But Wonder Why — There's Enough Of God's Love

— When I Survey The Wondrous Cross  
— All About Love — Jesus Is The Answer.

Many of the numbers may be unknown to you but don't worry: Jan's intimate style and near faultless diction leaves never a word in doubt. She has the backing of a full orchestra, albeit rather muted, in a gently rhythmic style and the album should have an automatic appeal to those with middle-of-the-road tastes in Gospel music.

Recorded in Sydney, the quality is very clean—no noise, and free from any apparent distortion. Well worth a hearing. (W.N.W.)

### Instrumental, Vocal and Humour

**SIBELIUS—Symphony No 2 in D. Stockholm Philharmonic Orchestra conducted by Antal Dorati.** RCA Victorola stereo VICS 1318.

Composed in 1901 and first performed in Helsinki in 1902, the "No 2" is the most often performed of the Sibelius symphonies. The piece has a distinctly heroic flavour. Some would say it is downright jingoistic. It was closely identified with the patriotic struggle for independence of the Finnish people against their Russian overlords. For my part, I cannot understand its continued popularity. Apart from historic associations it seems to have little to offer, but that is a highly personal reaction.

For those who wish to add the Sibelius second symphony to their collections, the performance on this disc can be recommended. Recording quality is very good. (L.D.S.)

★ ★ ★

**TELEMANN: Sonatas and Trios.** Jacques Vandeville, oboe, William Christie, clavecin, Marijke Verberne, cello, and Jean-Louis Charbonnier, bassoon. Societe Francaise Productions, SFP-91049. Distributed in Australia by Sound & Film Enterprises, 122 Chapel Street, St Kilda 3182.

For lovers of baroque chamber music, and Telemann in particular, this disc should be very interesting. To the best

**MOMENTS OF JOY.** Stereo, M7, MLX-142.

Call this album a sampler, if you like, but it's probably intended by M7 more as a mixed Gospel program compiled from their stock of master tapes.

The Liberty group contribute "Philippians 4:8" and "I Am With You". Another group, Family, add "Jesus, The Son Of Man", and "Amazing Grace". Judy Stone contributes a restrained "The Lord's Prayer" and an up-tempo "Day By Day". Contrasting vocals come from Ray Acuff with his C&W style "Somebody Touched Me", followed immediately by boy soprano Richard Bonsall, with his amazingly pure voice and "How Beautiful Are The Feet".

The remaining tracks include Eric Smith, organ, "When I Survey The Wondrous Cross"; The Bankstown Police Citizen Boy's Club Choir, "Psalm 127"; Peter Wright, "In The Eyes Of The Lord" and Don Gibson/Sue Thompson, "Fly The Friendly Skies With Jesus".

Overall, the performances are average, the quality is average and the price is average at \$4.98 but, if you want to add to your collection one of those rare items, nowadays—a mixed program album—here is your chance to do so. (W.N.W.)

of my knowledge the pieces performed have not been recorded often, nor are they perhaps the most outstanding of Telemann's works. Yet they are interesting as examples of this facet of his prodigious output.

There are 3 sonatas and one trio. The sonatas are the No. 5 for oboe, the No. 11 for oboe and continuo, and the sonata in A minor for oboe, bassoon and continuo. The trio is the No. 12 in E flat major for oboe, clavecin and bassoon continuo.

The playing here is of a high standard, although scholarly rather than with warmth. The recording is excellent. (J.R.)

★ ★ ★

**JON SANTO PLAYS BACH.** Synthesised Electrons. Stereo, Astor MCA-2220.

Jon Santo, physicist, musician, arranger and composer, used four synthesisers and an electronic piano, coupled to an extensive array of digital and audio equipment to produce this solo album of Bach compositions as listed briefly below. The jacket also shows K numbers:

Bardinerie — Courante — Jesu, Joy Of Man's Desiring — Gavotte — Corrente — Rondeau — Sarabande — Prelude — Prelude In G-Major — Prelude In C-Minor — Chorale Prelude "Wachet Auf" — Fugue In A-Minor — Willst Du Dein Herz Mir Schenken — Adagio In A-Minor — Gigue.

Reviews in this section are by Neville Williams (W.N.W.), Jamieson Rowe (J.R.), Leo Simpson (L.D.S.), Norman Marks (N.J.M.) and David Edwards (D.W.E.)



## LIGHTER SIDE REVIEWS—continued

The treatments vary from pure (but not way-out) electronic performances to a neo-instrumental sound; from solo voice and choral to simulated orchestral.

As with all synthesised classics, the question arises as to where such an album will find its appeal. Most likely to those with an ear for the classics combined with an interest in electronic methods of music making. But even if your interest in both facets is modest, let me assure you that Jon Santo's album makes very easy listening and a not unwelcome alternative to the more traditional sounds in a record library.

Recorded in Germany, the sound is clean and the surface is good. Playing time, about 30 minutes. (W.N.W.)

★ ★ ★

**SAINT-SAENS—Concerto No 1 in A minor for violoncello and orchestra, Opus 33.**

**LALO—Concerto in D major for violoncello and orchestra. Lamoureux Concert Orchestra conducted by Charles Munch. Andre Navarra, violoncello. Erato stereo STU 7055. Distributed by RCA Limited.**

These two concertos are quite similar in nature, although that by Edward Lalo is split into four movements while that by Saint-Saens is just the one movement. Both are bright and easy to listen to. Navarra's playing is sensitive and skilful while Munch as director controls it all with a firm hand. Recording quality is

very good. I hope RCA finds it possible to release more Erato discs here. (L.D.S.)

★ ★ ★

**HANDEL—Music for the Royal Fireworks suite. Water Music suite. RCA Victor Symphony Orchestra conducted by Leopold Stokowski. RCA Victrola stereo VICS 1388.**

Originally recorded in 1962 by the famous Leopold Stokowski this re-issued disc with two popular Handel suites is a good addition to anyone's collection. No doubt most people will play the Water Music suite more frequently than the Fireworks music but they are both enjoyable. Recording quality is very good. (L.D.S.)

★ ★ ★

**THE VERY BEST OF MANUEL and the Music of the Mountains. Studio 2 stereo TWOX 1051.**

Manuel and his mountain music are in no way a bunch of hillbillies but a large polished string orchestra with easy-on-the-ear arrangements. But they are not as easy on the ear as they should be here, because those strings do tend to sound rather strident. That's a pity because there is some good music on this disc.

There are twenty tracks in all: Brazil — Rodrigo's Guitar Concerto De Aranjuez — Eso Beso — Eye Level — The Carioca — Lisboa Antigua — The Twelfth Of Never — El Bimbo — Beyond The Moun-

## Allen 620 computer theatre organ

**Dwight Beacham Plays the Allen System 620 Computer Theatre Organ. Recorded at the Fountain Street Church, Grand Rapids, Michigan. Stereo (no brand) DLW1019A-B.**

In December, 1965, I reviewed a record by Dwight Beacham playing the Allen "Music Scene". In this latest recording, he plays a more ambitious theatre model, designated the System 620, which uses a dual digital tone generator. The two generators are offset very slightly in tuning with respect to each other, adding a subtle randomness which is more characteristic of a pipe instrument.

The sound which results is certainly reminiscent of the "good old days" of the theatre organ. In fact, the organ was located in a church auditorium for the recording and the reverberation serves to round things out nicely.

So much for the instrument. In his previous recording, I felt that the youthful soloist did not quite capture the theatre atmosphere of years gone by but, in this new recording, he plays each of

the items in a manner which befits them. The pieces are known to most of us and I enjoyed them all. If you are a lover of the theatre organ, then I can thoroughly commend this recording to you. On the other hand, if you are just interested, it should readily appeal as music for easy listening.

The twelve items are: I Won't Dance—Answer Me, O My Love—Rainbow on the River—Junk Man Rag—The Thrill Is Gone—Hooray for Hollywood—Love Me or Leave Me—Time in a Bottle—Our Director March—Sapphire—Choo-Choo Ch'Boogie—Shadow of the Cross.

The recording quality is very good, bringing out all the separate voices cleanly and crisply and the stereo spread adds authenticity to the theatre organ sound.

The review copy came from Allen Digital Computer Organs. Copies may be obtained from the above company for \$5.60 posted. There are two addresses: 32 Woodhouse Road, Doncaster East, Vic 3109; or 39 Roland Avenue, Wahroonga, NSW 2076. (I.L.P.)

## Where to hear the 1812 Overture with cannon, not corks.

### N.S.W.

**SYDNEY CITY**  
Douglas Hi Fi Kent Hi Fi  
D.M.E. Hi Fi Instrol Hi Fi.

**EASTERN SUBURBS**  
Woolloomooloo—Convoy Sound

**NORTH SHORE**  
Chatswood—Autel Systems.  
Crows Nest—Allied Hi Fi.  
Gladesville—Hi Fi H.t.  
Chatswood—Milversons  
Brookvale—Riverina Hi Fi.

**WESTERN SUBURBS**  
Fairfield—Bing Lee Electronics.  
Summer Hill—Fidela Sound  
Parramatta & Westfield—Grammophone Shop  
Parramatta—Milversons  
Parramatta & Bankstown—Miranda Hi Fi.  
Concord—Sonata Music.

**SOUTH**  
St. Peters—Dyna Stereo.  
Miranda Fair—Miranda Hi Fi.

**LIVERPOOL**: Miranda Hi Fi.  
**WOLLONGONG**: Sonata Hi Fi.

**GOSFORD**: Miranda Hi Fi.  
**NEWCASTLE**: Ron Chapman Hi Fi.  
Newcastle Hi Fi.

**MAITLAND**: Hunter Valley Electronics.

**TAREE**: Godwins Hi Fi  
**LISMORE**: Lismore Hi Fi.

**A C T**  
Pacific Stereo. Duratone Hi Fi.

### VICTORIA:

**MELBOURNE CITY**  
Douglas Trading. Nat. Sound.  
Allens Music. Southern Sound.  
Instrol Hi Fi.

**MELBOURNE SUBURBS**  
Hawthorn—Tivoli Hi Fi  
Nth. Caulfield—Soundcraftsman  
Moorabbin—Southern Sound  
Mordialloc—Mordialloc Hi Fi  
—Denman Audio.

Belmont—Belmont Stereo  
Warnambool—A. G. Smith

### QUEENSLAND:

**BRISBANE CITY**  
Reg Mills Stereo Tel Air Electronics  
Stereo Supplies.

**BRISBANE SUBURBS**  
Redcliffe—Hi Fi Sales (Q'ld.) Pty. Ltd.  
Ashgrove—Living Sound Centre.  
Tingalpa—Todd Hi Fi  
Ipswich—Ipswich Hi Fi

### SOUTH AUSTRALIA:

**ADELAIDE CITY**  
Allans Music. Hi Fi Acoustics.  
Challenge Hi Fi.

**ADELAIDE SUBURBS**  
Blackwood—Blackwood Sound.  
St. Peters—Sound Dynamics.

### TASMANIA:

**HOBART**  
Quantum. United Electronics.

**SUBURBS**  
Burnie—Audio Services

### WEST AUSTRALIA:

**PERTH**  
Alberts Hi Fi  
Leslie Leonards.  
Audio Centre.  
Japan Hi Fi.



Or write to Auriema (A/asia) Pty. Ltd  
P.O. Box 604, Brookvale, N.S.W. 2100  
Telephone 939 1900



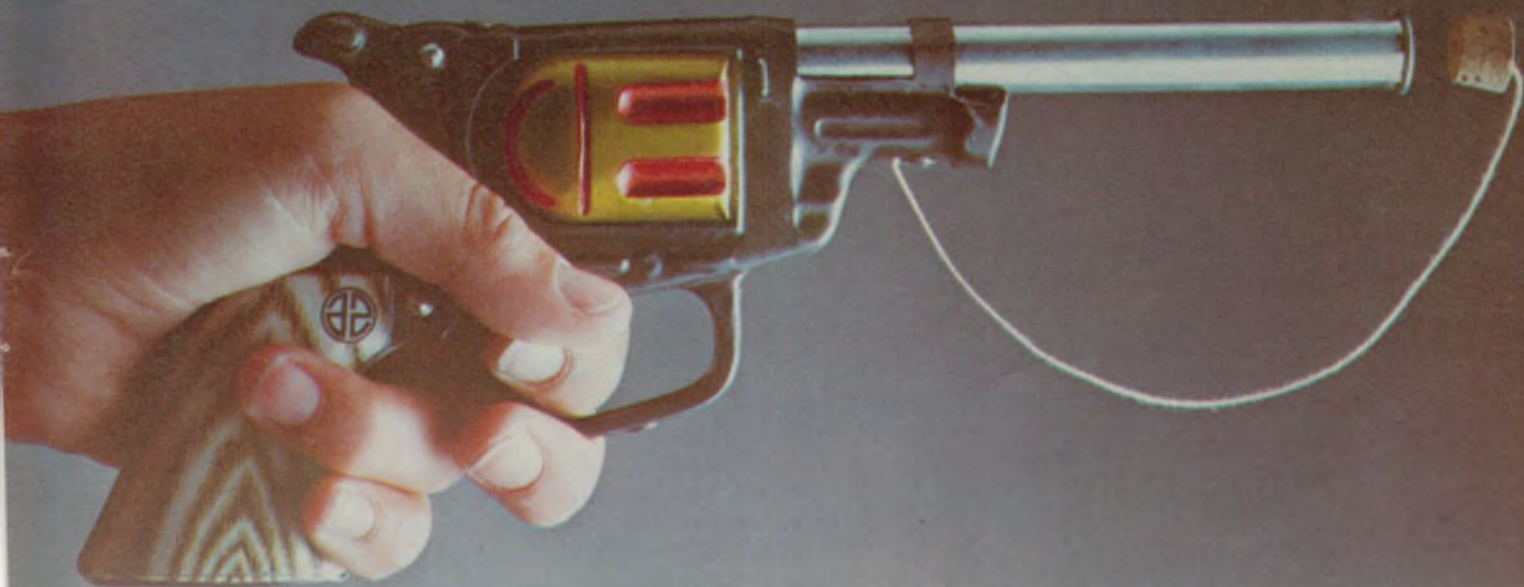

## Why the cannon on your 1812 Overture sounds more like a popgun.

A rather unfortunate situation occurs during a recording session.

Because the dynamic range of most recording equipment doesn't equal the dynamic range of live performances, the loudest sounds end up being very much compressed, while the softer sounds have to be lifted above tape noise.

So no matter how good your equipment is, it will never ever give a true performance.

### Introducing dbx.

Fortunately for the home hi-fi buff there's now an extremely effective solution available.

The dbx 117.

Basically it's a dynamic range enhancer that works on the signal's voltage level without changing the frequency response. (Unlike other systems that are designed merely to

filter out high frequencies.)

And attached to any good system it will noticeably increase the entire dynamic range of any signal put into it. While at the same time reducing surface noise.

So now your softs become even softer. While your louds, especially your crescendo's, become much more dramatic when they finally reach the top.

Consequently giving the recorded performance both more body and definition.

dbx will also improve the sound of your older records. So there's less need for you to have to replace them. (The dbx 117 will also help reduce hiss from FM broadcasts as well as your tapes.)

In fact should you desire to test the dbx before purchase, we then

suggest you contact one of our dealers listed opposite and politely ask him to play you a copy of the 1812 Overture.

Should you still have a few reservations then all we have to say is that perhaps the 1812 Overture was recorded featuring a popgun.

Or your ears aren't as good as you thought they were.

**dbx**



AUR19



# Now at the same price!\*

Now you can enjoy the benefits of Memorex Chromium Dioxide cassettes for no extra cost!

As a special offer Memorex CrO<sub>2</sub> C90 cassettes are available for the same price as MrX<sub>2</sub> C90 cassettes.

Buy now and save \$2.00 a cassette on R.R.P.  
Available wherever good tapes are sold.

Try Memorex CrO<sub>2</sub> Cassettes for

- Better frequency response.
- Less distortion of high frequencies.
- Lower head wear compared to some cobalt modified iron oxides.
- Cleaner heads and pressure rollers.
- Less Modulation Noise.



\* C90 size only. Limited offer.



Sole Australian Distributors—

**LEROYA INDUSTRIES** PTY LTD

Head Office, W.A.: 156 Railway Pde., Leederville 6007. Phone 81 2930.  
N.S.W. Office: 100 Walker St., North Sydney 2060. Phone 922 4037.  
Victoria Office: 103 Pelham St., Carlton 3053. Phone 347 7620.



## LIGHTER SIDE REVIEWS—continued

tains—Peanut Vendor—Y Viva Espana—Love Theme from Spartacus—The Way We Were—Spanish Flea—Island In The Sun—Honeymoon Song—Theme from "A Summer Place"—Magic Mountains—Moon River—La Bamba. (L.D.S.)

★ ★ ★

**TOP OF THE POPS.** The Gene Harrison Chorus & Orchestra with the Branjo Hronez Sound, Henry Arland. Stereo Dolby cassette, Contata A-112. (Distributed by Goldring Sales & Service).

I happened to be doing a spot of odd-jobbing when this cassette was playing, much to the surprise of another member of the household who caught me "listening to rock", apparently by choice. I guess some of the tracks do have a rock sound but very "soft" and quite effective by way of a bright background. The tunes:

Chirpy, Chirpy, Cheep, Cheep—Did What I Did—I'm Gonna Run Away From You—Lady Rose—Don't Let It Die—Co Co—Knock Three Times—When You Are A King—Black And White—Banner Man—I Am, I Said—Amarillo—Borreguito—Sweet Caroline.

The quality is okay, particularly if played in Dolby mode and, as I said earlier, it can provide a bright background for those odd jobs, or for driving. (W.N.W.)

★ ★ ★

**DINING AND DANCING Vol 1.** Reubert Hayes playing the Conn 544 Electronic Organ. Stereo, M7, MLX-148.

This is the first of two companion albums recorded recently by Reubert Hayes at the Salamander Hotel/Motel, at Port Stephens on the NSW north coast. In fact, the album reflects Reubert Hayes' present role as resident organist—a mix of music appropriate for the two activities forming the title.

Side 1 is the dancing side: five strict tempo medleys including such numbers as: Rock Me—Mame—Chloe—I Only Have Eyes For You—Lara's Theme—The Anniversary Theme and many others. Like most strict tempo organ, it's fine if you want to dance, okay as pure background, but strictly routine if you want to listen more deliberately.

The listening is much better on side 2 where the organist is not so tied to the tempo and he can give you numbers like: A Lovely Way To Spend An Evening—Love Walked In—Secret Love—Autumn Leaves—Fernando, etc. I wonder whether the better mix would not have been to intersperse a couple of strict tempo numbers with a "listening" track?

But, maybe, instead of sitting it out in the manner of a staid reviewer, I should have treated it the way it is clearly intended: dinner and then a spot of relaxation and dancing with the lights turned low! (W.N.W.)

★ ★ ★

**TAKE IT TO THE LIMIT.** Lenny Dee, organ with orchestra. Stereo, Astor, 8434.

Lenny Dee has come a long way since his early albums of solo or near solo organ. Here, he fronts a complete ensemble of named musicians, although his personal role in the recording is not even mentioned on the jacket—just his name with the multi-voices of a modern electronic organ, merged into a full instrumental backing of piano, guitars, flute, bass, drums and strings.

The program: Only Love Is Real—Tangerine—The Homecoming—Deep Purple—Do You Know Where You're Going To—Take It To The Limit—Breaking Up Is Hard To Do—Baby Face—I Write The Songs—Lonely Night (Angel Face).

Recorded at Bradley's Barn, the quality, balance and stereo spread is excellent and "Take It To The Limit" must rate as an album that is highly listenable middle of the road sound—either as background or turned up to give your system a workout. (W.N.W.)

# SOANAR SOANAR SOANAR

The only name you need to know when buying electronic components.

● WE MAINTAIN HUGE STOCKS OF CAPACITORS, RESISTORS, RECTIFIERS, SUPPRESSORS, POTENTIOMETERS, SEMI-CONDUCTORS & ELECTRONIC HARDWARE.

● IMMEDIATE DELIVERY SERVICE.

● NO INVOICE SURCHARGE.

● FREE INTO STORE. AUSTRALIAN CAPITAL CITIES.

Catalogue available on request

SOANAR ELECTRONICS PTY. LTD.

SALES OFFICES

30 Lexton Road, Box Hill, Vic., 3128  
Australia. Telex 32286.

VICTORIA: 89 0561  
N.S.W.: 78 0281  
S. AUST.: 51 6981  
QUEENSLAND: 52 5421  
W. AUST.: 81 5500

AD  
SOANAR  
GROUP





**When his mini-computer, one day,  
refused to compute, Alvin was in  
strife... THEN he remembered!**

Alvin's one of those self-styled electronic wizards, totally dedicated to his hobby—his array of expensive equipment assembled over the years is proof positive. He knows that electronic equipment requires dust and moisture-free atmospheric conditions for maximum efficiency, and so, when, one day, his pride-and-joy mini-computer refused to compute, he knew what to do... damp contacts, dusty computer heads, contaminated points... spray with CRC CO Contact Cleaner—lifts, dissolves, evaporates completely,



effectively, immediately, all residual contaminants and moisture. No disassembly of complicated units, no expensive parts to replace... just a simple application of an incredible product like CRC CO Contact Cleaner to "dissolve" the problem. If you're a dedicated "Alvin" too, you'll want to try CRC CO Contact Cleaner yourself. Ask for it at your nearest electrical/electronics retailer, or for more info about it write to: CRC Chemicals Australia Pty Ltd, Centre Court, Paul Street, North Ryde, NSW, 2113

THE SOLUTION SOLUTION

**CRC CHEMICALS AUSTRALIA PTY. LTD.**  
Centrecourt, 25-27 Paul St., Nth. Ryde 2113. Phone: 888-3444

**LIGHTER SIDE—cont'd**

**BILL COLLINS' FAVOURITE MOVIE THEMES. 7 MLF 160 Stereo.**

Sven Libaek's Orchestra does a first class job of presenting a dozen of TV movie buff, Bill Collins', favourite themes.

Together with a comment from Bill at the end of each side, the tracks are: As Time Goes By (from 'Casablanca')—Love Is A Many Splendored Thing—Romeo And Juliet—On Green Dolphin Street—Spellbound—Emanuelle II—Picnic At Hanging Rock—Way To The Gold—Friendly Persuasion—Now Voyager—For Fairbanks—The Way We Were.

The style of playing is fairly relaxed, in keeping with a quiet evening at home and the centre fold of the jacket gives a brief run-down on the movies represented. The sound quality is good. (N.J.M.)



**YOU BETTER KNOW IT. Lionel Hampton Impulse AS78. RCA release.**

Six of the legendary names of Jazz get together on this disc, recorded in 1964. Lionel Hampton on vibraphone, piano and vocals, is joined by Clark Terry on trumpet, Ben Webster, tenor saxophone, Hank Jones, piano, Milt Hinto, string bass and Osie Johnson on drums.

There are nine titles all told: Ring Dem Bells — Vibraphone Blues — Tempo's Birthday — Sweethearts On Parade — Pick A Rib — Trick Or Treat — Cute — Swingle Jingle — Taste Of Honey.

Apart from a faint rumble in the quiet passages, the overall quality does not betray the age of the original recording, making an enjoyable disc for those who can still remember the styles of the musical Thirties and Forties. (N.J.M.)



**MAMAS AND PAPAS. 20 GOLDEN HITS.**

**The Mamas And Papas. ABC Records two record set DSX-50145. RCA Release.**

Do you remember all those magical tunes from the late sixties that made the whole world smile and tap its feet? You do, well here is a record that will bring it all back to you. The group that was the essence of those times has long since faded away, but their magic music still lives on. Of course I'm talking about the Mamas and Papas, who have been favorites of mine for quite a long time (since the late sixties, in fact!)

All their great hits, such as California Dreamin', Twelve-thirty, Dancing In The Street, Creeque Alley and many more are included. I can thoroughly recommend this record, both for the enjoyable music it contains, and in the technical sense. My review copy was very clean, and a pleasure to listen to. (D.W.E.)



ONCE IN A LIFETIME. Shirley Bassey. EMI stereo EMC 2543.

Here is a good buy for fans of Shirley Bassey, who gives a consistent performance on both sides of this disc. The arrangements and musical backing complement Shirley Bassey's talents well and the recording standard is also up to par. What more can you ask?

A total of sixteen tracks are presented: Once In A Lifetime—A House Is Not A Home—He Loves Me—I'll Get By (As Long As I Have You)—Everything's Coming Up Roses—In The Still Of The Night—Tonight—The Lady Is A Tramp—Don't Rain On My Parade—Ev'rytime We Say Goodbye—People—Fools Rush In—With These Hands—Moon River—A Lot Of Livin' To Do—You'll Never Know. (L.D.S.)

★ ★ ★

UNITED TALENT. Conway Twitty and Loretta Lynn. MCA Records MCA-2209. Astor Release.

Conway Twitty and Loretta Lynn are relative giants in the field of country music, and they have pooled their talents on this record. Both sing on each track, sometimes together, and sometimes separately. The songs themselves are the usual types that can be found on their own records.

On the whole, I found them to be quite pleasant, but never rising to any great heights of excellence. Technically, however, I found my review copy disappointing, as distortion was audible on some tracks. (D.W.E.)

★ ★ ★

NEVER GONNA LET YOU GO. Vicki Sue Robinson. RCA Victor APL1-1256.

"It seems that all the new stars: (1) come from (2) come through or (3) now live in Philadelphia. Vicki (1) comes from. At the age of 10 she moved to New York (a large provincial city in the upper U.S.), now known as Disco City. Born into an artistic family (Father into Drama, and Mother, a much acclaimed photographer), Vicki soon learned the tricks of survival in New York; i.e.: ducking under subway turnstiles; beating taxi drivers for fares; and conning money from her very

sensitive and sometimes naive producer.

Vicki, now 21, has appeared in the original Broadway productions of "Hair," "Jesus Christ Superstar", and "Soon". Her other experiences include a successful following in New York's coffee houses and a lot of studio session work. Personally I think that she is moody, overly sensitive, self indulgent, and a perfectionist—all the things that make a star, and all the things that make a record producer rich."

I have quoted Warren Schatz, Vicki's producer, simply because I can't think of a better introduction to this record. And all I will add is that I agree with him. So rush out and sample this record, I'm sure you'll like it; I did. Technically, it is very good. (D.W.E.)

★ ★ ★

WONDER WOMAN. Reg Livermore. Festival Records L 45711/2.

I deliberately waited to review this record until after I had seen the show, knowing how closely connected show and movie albums can be. This set of two records is no exception, and much of the visual humour of Livermore's characterizations and costumes (an example is the outrageous "heroine" on the cover) cannot really be translated into sound.

But the album must be judged on its own merits of course. Reg's comedy sketches come across well and the music, while not always widely recognised, is an interesting collection of varied themes and rhythms. One track in particular—Surabaya Johnny—was quite haunting and worth several replays. However, his rendition of "Lay Lady Lay" may not please all tastes. "It Should Have Been Me" is a good example of that exuberant quality of style which has made Livermore such a popular success.

If you're already converted, this album won't need selling, but if you've never seen Reg on stage perhaps a quick listen to Record 2 Side 1 will give you an idea of what you're missing. The album was recorded live, and is technically quite good. (D.W.E.)

## M.R. Acoustics

P.O. BOX 110, ALBION, BRISBANE 4010

(Manufacturers of high quality loudspeakers)

are proud to announce their appointment as sole Australian Importers of the HFS75 test record.

This record, made in the U.K., is used by many equipment reviewers in that country to test and evaluate pick-up cartridges. As well it performs the invaluable task of allowing YOU to optimise tracking weight and anti-skating for your arm/cartridge combination. Expensive test equipment not needed, only evaluation by your ears of a series of test tones.

Full instructions included. Price **\$8.50** each R.R.P.

We are also agents for high quality recordings by FULTON of the U.S.A. These discs are used by Audiophiles around the world for subjective evaluation of Hi-Fi systems.

The Organ records, for example, present a tremendous challenge to any loudspeakers yet made—

- (1) Organ music from Westminster
- (2) Organ music from Mt Olivet; other titles also available include the brilliant brass of the Anoka Concert Band (2144-S) and the Robbinsdale Concert Band (5136-S). Lovers of good voice recordings take note of The Armstrong Choirs (41872-S). Price **\$10.00** each R.R.P.

Available from your favourite Hi-Fi/Record Store or direct from M.R. Acoustics—Add \$1 pack & post per record. Extra 50c gives certified mail insurance cover.

Trade enquiries through State Branches of Audio Engineers.

# DECCA

## Record Cleaner WORKS AS YOU PLAY...

This new DECCA Record Cleaner removes dust and grit as your record spins on the turntable. It consists of an arm carrying a brush made from a newly-developed man-made fibre. Its "bristles" are incredibly fine, incredibly soft yet strong, and are also electrically conductive to remove static as well as dust. The result - improved sound quality, reduced record wear.

\*\$13.95 at hi-fi stores and record bars.

Australian agent: **British Merchandising Pty. Ltd.,**  
49-51 York Street, Sydney. Telephone 29 1571.

\*Recommended retail price





# New Products

## JVC 48cm colour TV receiver

The new screen size of 48cm is an ideal compromise for many potential colour TV receiver buyers. Here we review the JVC 48cm set which has a "self-converging" yoke and "black-stripe" tube. It conforms to Australian standards in all respects and includes a UHF tuner.

Prior to the introduction of the 48cm screen size there was quite a large jump from the largest of the "small sets", with a 43cm screen, to the 53cm screen size. Now the 48cm sets provide an obviously larger screen size than the 43cm models with only a slight increase in cabinet size. Size of this JVC model 7765AU is 648 x 472 x 462cm (W x H x D) while the mass is a manageable 30kg.

Styling of the JVC 48cm model is simple though not austere. Some people might regard the apparently slim cabinet as an attempt to stretch the illusion of compactness too far. The overall depth of 472cm is a fact which still has to be faced at installation.

Semiconductor complement of the solid state circuit is 5 integrated circuits, 43 transistors and 33 diodes which is a relatively large total when the lack of dynamic convergence circuitry is considered. This factor does show to advantage however, in the favourable power consumption of 98 watts. Audio power output is quoted as a maximum of 1.5 watts, feeding an oval loudspeaker measuring 10x15cm.

As with a majority of sets originating from Japan, the JVC receiver uses a conventional double-wound power transformer and bridge rectifier in the power supply. And a conventional regulator is employed instead of the switch-mode regulator found in some locally manufactured sets.

The modular approach is not employed in the JVC 7765AU. Instead, it has a rudimentary chassis which accommodates two large PC boards. These in turn contain most of the circuitry. While this tends to give the impression of a relatively simple circuit, especially in comparison to earlier colour TV receivers, it does not result in good accessibility.

VHF coverage is channel 0 to 10 inclusive, with channel 11 being the selector position to energise the UHF tuner. If reception of channel 11 is required, the dealer can make a small modification to provide it, at the expense of one of the

unused channels. UHF channel coverage is from 21 to 69.

Antenna connections are either via 75-ohm coax socket or 300-ohm ribbon terminals for VHF, and 300-ohm ribbon terminals for UHF. In addition, the antenna terminal panel has an attenuator which can be switched in for local VHF channel reception or switched out for DX reception.

On the control panel, only three knobs are visible. They are the 14-position rotary control for the VHF tuner, the con-



tinuously variable knob for the UHF tuner and the combine volume control and On/Off switch. The remainder of the controls are hidden behind a tall narrow door between the screen and control panel. This is a good idea as it tends to discourage young children and fiddlesome adults from tinkering with the controls.

Also on the control panel is the "electronic eye", which is actually a CdS cell. This monitors the room lighting and automatically adjusts Colour saturation, Brightness and Contrast. Below the loudspeaker panel are two 3.5mm jacks which provide for connection of a tape recorder and earphones.

Hidden behind the door are knobs for Brightness, Colour, Tint and Vertical Hold. As well, there are screwdriver controls for Sub-brightness and Sub-contrast. There are also switches to

disengage the AFC (during fine tuning) and the electronic eye facility.

At switch-on, the program sound is present almost immediately, followed by the picture some 15 or so seconds later. It was evident right from the start that the set produced a very good picture. Good colour reception was obtained from the four Sydney channels and acceptable colour was also obtained from Newcastle stations, although at times the picture from these does become "snowy".

Purity and convergence were first class. There is no question that the combination of the "self-converging" yoke and the "Blackstripe" vertical slot tube produce a picture which is considerably improved over conventional sets with delta-gun tube and dynamic convergence circuitry.

With a standard test pattern displayed, the picture geometry was quite acceptable although we would have liked to obtain a slight improvement in the vertical linearity. As with all sets, overscan was present to a degree, but a reduction in width would have been desirable. We attempted to adjust the width coil but found its position underneath the EHT module hazardous and virtually inaccessible.

Our reference white-point source showed that the three guns were set close to optimum. If anything the picture white was slightly blue, which gives the impression of being "whiter than white". Besides being preferred by many people this is to the advantage of commercials for laundry detergents!

Sound quality is passable, but with a modest class-A amplifier, transformer-coupled output and a small loudspeaker, nothing to get excited about.

There is one feature of this JVC colour set which is likely to cause controversy amongst technical users. This is the restricted range available from the Colour, Tint and Brightness controls and the lack of a readily accessible contrast control. To quote the JVC manual, the "Tint, Colour and Brightness knobs are provided for fine tuning adjustment only. These controls have click centre position for the standard setting. They don't change remarkably even if fully rotated".

As it happens, the standard settings of these controls give a close-to-optimum picture. Our only complaint was that the brightness was a little high for rooms with subdued lighting. This could also be interpreted as a lack of control range in the electronic facility. Manual adjustment of the Brightness control will correct the situation, but then the contrast is not quite optimum. Nor were we able to correct this with the Sub/contrast control.

While some users may be irritated with the lack of control facility, it must be admitted that the user controls on most colour TV receivers are maladjusted, often seriously so. In comparison, the JVC approach with the "electronic eye",

(continued on page 95)



## New, low-priced scientific calculator

With basic calculators seemingly down to little more than the cost of the hardware, the most obvious trend now is to produce more advanced calculators selling at prices at or below those of the earlier 4-function units. A good illustration of this is the new Unitrex UC 55 pictured.

Curiously, the UC 55 was never intended for release on the Australian market, having been produced in Hong Kong for Unitrex of Canada, presumably for ultimate supply to a large U.S. retail chain. By mistake, a bulk shipment was sent to Unitrex Australia who were then faced with the problem of what to do with them—either re-freight them at considerable expense, or sell them locally. Since they did not want to inject them into their normal Australian range, marketed through retail outlets, Unitrex decided to make them available direct to consumers by way of a magazine special offer.

In fact, the UC 55 is not only a scientific calculator in name, but it also has the "scientific" look, with black, white and red buttons set in a brushed metal panel and housed in a moulded black case. All press buttons are of the click action type, giving a positive feel to the user. Two slide switches on the panel provide for on-off and the degrees-radians facility.

The red LED display is viewed through a filter window which magnifies the digits to an apparent 4mm or thereabouts—but which does limit the viewing angle, as is common with such lenses. The display differs from most we have seen in that digits are entered from left to right, instead of the other way round. In all other respects the number entry and display follows the usual 4-function floating decimal algebraic convention.

The display provides for 8 discrete numerals plus a ninth position for sign, error, shift indication, etc.

Used in straightforward non-shift mode, the UC 55 provides normal 4-function facilities, with sign change, plus a "constant" facility for all four arithmetic functions, plus automatic transfer into and out of scientific notation in the event of overload in algebraic mode; this for both negative and positive qualities.

By utilising shift, the memory facility

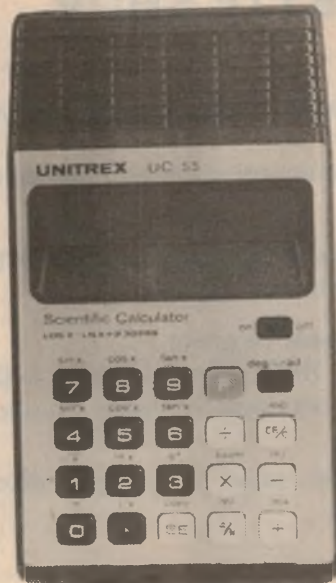

can be invoked involving 5 buttons: plus, minus, read, cancel, interchange.

Also available in shift mode is a variety of trigonometrical functions, power, root, reciprocal, and pi, plus the deg-radians option mentioned earlier.

The UC 55 operates from a 9-volt transistor type battery, drawing typically 20 to 35mA, depending on the nature of the display.

It is accompanied by a small instruction booklet, printed in English and French, appropriate for its originally intended destination on the North American continent. The instrument itself is covered by a 90-day warranty, backed by Unitrex of Australia Pty Ltd, 105 Queen St, Melbourne 3000.

The UC 55 is not available through Unitrex but is being handled by the Offers Dept of our parent company (see advert elsewhere). The price is \$12.99 to those who can legitimately claim tax exemption. Otherwise \$14.90, plus handling charges in each case. (W.N.W.)

### AEGIS PTY. LTD.

347 Darebin Rd, Thornbury,  
Vic. 3071. Phone 49-1017

Manufacturers of Wound Components for Electronic Applications

- ★ Miniature Aerial, RF, Oscillator Coils and IF Transformers for Transistor Receivers
- ★ Replacement Coils and IF Transformers for Valve Receivers
- ★ Radio Frequency Chokes and Video Peaking Chokes
- ★ Ceramic Insulators
- ★ Coil Formers, Bobbins, Cans, Cores, etc.
- ★ Interference Suppression Units:
  - Aerial Filters
  - Mains Filters
- ★ Crossover Network Inductances
- ★ Wide Range of Instrument Knobs



Stocked by all leading electronics suppliers

R.H. Cunningham  
Pty. Ltd.

## THEY'RE EVERY MICROPHONE YOU EVER WANTED.

Cardioid Head

Omnidirectional Head

Powering Module

Mini-Shotgun Head.

## SENNHEISER

We have taken the latest advances in electret technology one step further. By combining them with advanced acoustic technology to make professional condenser microphones more portable.

One common powering module (K2U) serves three different compact heads: omnidirectional (ME20), cardioid (ME40) and mini-shotgun (ME80). Thus, for most studio and location situations, it's no longer necessary to carry three different microphones. Each head contains its own microphone capsule and "front-end" electronics, all exactly matched to its own precisely-controlled acoustical environment.

The Powering Module runs on a single 5.6V battery, or phantom-powered directly from your recorder, preamp or other auxiliary equipment. Best of all, of course, is the great versatility. In a matter of seconds, you screw on whichever head you need and go!

Powering module and heads are available separately.

Australian Agent

R.H. Cunningham  
Pty. Ltd.

VIC.: 493-499 Victoria St. West  
Melbourne. 3003 Ph. 329 9633  
N.S.W.: 4-8 Waters Rd. Neutral  
Bay 2089 Ph. 909 2388  
W.A.: 256 Stirling St. Perth,  
6000 Ph. 28 3655  
QLD.: L. E. BOUGHEN & CO.  
Chr. Milton & Baroona Rds.,  
Milton 4064 Ph. 36 1277  
S.A.: Werner Electronic  
Industries Pty. Ltd., Unit 25,  
28 Gray St., Kilkenny. 5009  
Ph. 268 2801

Telex Melbourne. 31447  
Sydney. 21707 Brisbane.  
41500 Perth. 93244

RHC 6566





## AUSTRALIA'S FIRST BYTE SHOP

**8080** Truly second generation Microprocessor Mini Computer.  
Complete range of memory and I/O modules available.

**Cromemco** TV dazzler • Byte saver • Cyclops camera • A-D, D-A • Cromemco Z80 mini computer.

**Processor Technology** The Sol System Intelligent Terminal.  
Wide range of PROM; RAM; Parallel/Serial I/O; firmware; simulator, text editor; video display modules.

**North Star Inc.** Floating point arithmetic unit. Mini floppy disc, controller and software.

**Oliver Audio** Paper tape reader.

All the above are available in kit or assembled form. For further details send SAE to BYTE, P.O. Box 156, Carnegie 3163 Victoria, OR, for hands on experience phone Melbourne 560 0358 between 2 p.m. and 8 p.m. for appointment.

## NEW PRODUCTS

### New products from Dick Smith

#### Safety fuse holder

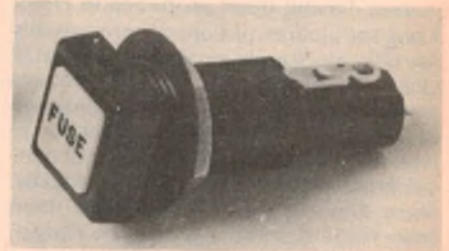

Instead of the usual screw-in fuse holder that can shake loose, Dick Smith Electronics now has a push-in variety. The unit, the S-4204 has a push-in bright yellow square that is spring loaded. Replacement of blown fuses is at least as quick as with the old style of holder. Price is 65c each.

#### . . . and a car radio



Costing around the \$49 mark, this pushbutton AM car radio comes complete with a 100mm speaker, a wiring harness, and ignition suppressors. The unit is claimed to offer good all-round performance together with compact size.

Enquiries on the above items to Dick Smith stores in Sydney, Brisbane and Melbourne.

#### Pushbutton switch

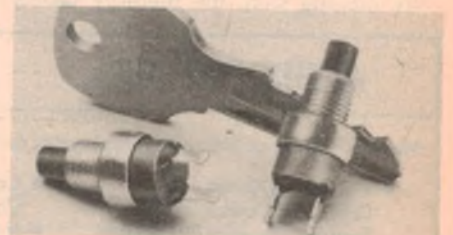

C & K's Model 8534 pushbutton switch is designed to complete one million make-and-break trips with a short overall travel distance of just .04in. It fits a 0.25in diameter panel opening and measures less than 1in in length.

Enquiries to C & K Electronics, Office 2, 6 McFarlane St, Merrylands, NSW 2160.



## CRONUS

### Electronic stopwatch

Available for a wide range of applications from single function timers to the CRONUS eight digit, four function stopwatch with remote control.

Prices from \$45.10 plus sales tax where applicable.

Write or phone for full details to

# INSTRUMENT TECHNOLOGY PTY LTD

192 PRINCE'S HIGHWAY ARNCLIFFE, SYDNEY, NSW, 2205  
Phone 59 0291 Telex AA20940



## Statronics power supply modules

A new range of low cost modular power supplies has been introduced by Statronics Pty Ltd. There are four different models, each available in either bench or open module versions. All feature constant current limiting and crowbar over-voltage protection.

Four different supplies are available in the new Statronics STA53 series, each available in either an open modular version for incorporation into other equipment, or a free-standing bench version. All models feature constant current limiting with dissipation override, and crowbar over-voltage protection.

The four models offer ratings of 5V at 3A, 12V at 2A, 15V at 1A and 24V at 1A. All have a quoted line regulation of 1% for  $\pm 10\%$  input variation, load regulation of 2%, and ripple and noise of 0.5mV/V.

Size of the open modules is 160 x 103 x 66mm, with the bench type 165 x 103 x 70mm. The bench versions come with an enamelled case, 6ft lead and 3-pin plug.

All of the supplies are based on a bridge rectifier circuit with 3-terminal IC regulator. A zener diode, resistive divider and SCR are used in the over-voltage crowbar circuit, designed to protect expensive load circuit ICs in the event of an accidental short.

The construction of the supplies is simple but effective, using a U-shaped chassis from heavy-gauge aluminium.

The supply pictured is a 5V/3A open unit, which Statronics supplied for us to inspect and put through its paces.

The performance of the sample was well within specs. Output voltage was within 1% of nominal on open-circuit, with load and line regulation both around 1%. Ripple and noise were 0.9mV RMS at full load, well within the manufacturer's specification.

The crowbar over-voltage protection facility seems very worthwhile. Its main job is to protect the load circuitry from the accidental application of excessive voltage due to the slippage of a test prod, although it would also serve the same function in the unlikely event that the regulator IC should develop a short.

A fusible link is incorporated into the

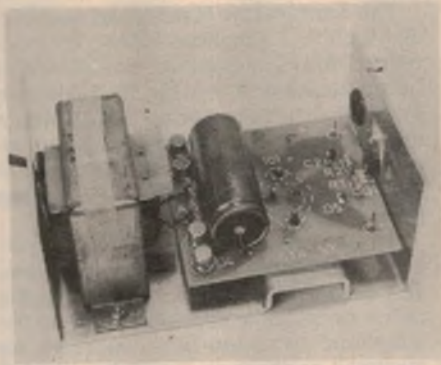

PC board pattern, to protect the transformer in this last situation. At first we were a little dubious about such a "PCB fuse", as it would be messy to replace when blown. However the supply is designed primarily for OEM use, and the fuse is really only there to provide "last-ditch" protection when all else has failed. As such it seems reasonable enough.

We liked the physical construction of the supply, which is surprisingly sturdy.

In short, the STA53 series of supply modules would seem ideally suited for microcomputer systems, terminals and any other equipment with fairly standard power requirements. As the prices start at \$28.50 plus tax for the 5V/3A unit, they are excellent value for money, too.

In fact even hobbyists should find it more attractive to buy one or more of these Statronics modules, rather than build up their own supplies.

Statronics tell us that they are also coming out with a pair of dual supplies, to be added to the STA53 range shortly. One is a  $\pm 12V$ , the other a  $\pm 15V$ , but both offer switchable operating modes: positive master/negative slave or vice-versa, or fully symmetrical, or both independent.

For further information contact Statronics Pty Ltd at 103 Hunter Street, Hornsby, NSW2077. (J.R.)

## JVC colour TV receiver—from page 92

automatic fine tuning and automatic frequency control will result in a near optimum picture, regardless of the lack of skill of the user.

JVC obviously have faith in their approach and product reliability. Warranty is for two years, free of labour or transport charges. This is very favourable.

For those requiring a medium size set, the JVC 7765AU with its favourable price and warranty and good performance must come under consideration. Further information can be obtained from dealers. Trade enquiries should be directed to the Australian distributors, Hagemeyer (Australasia) B.V., 59 Anzac Parade, Kensington, NSW 2033. (L.D.S.)

# STAR DELTA

## CO. PTY. LIMITED

INCORPORATING  
P. A. HENDERSON & CO  
TRANSFORMER  
MANUFACTURERS

- SINGLE & 3 PHASE TRANSFORMERS TO 20 KVA.
- MOTOR STARTING AUTOTRANSFORMERS TO 600 HP.
- NEUTRAL REACTORS

8 East St.,  
Granville, N.S.W. 2142.  
P.O. Box 31, Phone  
637-7870.

## "B & M"

Cabinets and chassis for all projects featured in this magazine are available from B & M.

### EARLY PROJECTS AT REDUCED PRICE

*(Until finish of stock)*

- Cases ● Panels
- Chassis
- General Sheet Metal
- Welding

B. & M. SHEET METAL  
11 Cowper Street,  
Granville, N.S.W. 2142  
Phone 637-8736



# CB

**Fantastic Bargain!**



**NOVICE LICENCE HOLDERS! Want a Second Rig?**

**FREE AERIAL OFFER worth \$24 with the UNIVERSE 23 CHANNEL AM TRANSCEIVER**

**SPECIFICATIONS: (E. & O.E.)**

- 23 Channels
- 26.965MHz to 27.255MHz
- Power to final 5W
- Dual Conversion
- 31 Semiconductors
- Metal Case
- P.A. Facility
- Squelch
- Illuminated Meter & Channels
- Red T/mit Light

**\$88.50** *plus \$5.50 p+p*

For a limited period only we will include a centre loaded tuneable whip, so rush in now. Don't miss out on this special deal. Mail inquiries answered if S.A.E. enclosed. Selected dealers may purchase this special. Minimum quantities of 50.

**PETER SHALLEY**  
**CB SPECIALIST 12 YEARS**  
554 PACIFIC HWY.  
KILLARA NSW 2071  
TEL-4982611

## NEW PRODUCTS

### Siren-like "bell" extension for telephones

Designed to attach easily to any telephone or chimes unit, the Fone-A-Lert announces a caller by emitting a piercing audible signal. The unit is ideal for workshop, factory or home.

The Fone-A-Lert is designed specifically for those situations where environmental noises or distance would make it otherwise difficult to hear the telephone or doorbell. It comes housed in an attractive plastic case, complete with an integral wire reel and 40ft of lead. Dimensions are a compact 4¼ x 3¾ x 2½in (W x H x D).

An attractive feature of the Fone-A-Lert is its simple installation procedure. The suction cup end of the lead to the unit is simply attached to the case of the telephone or chime box. There are no electrical connections to make, making it easy to transfer the Fone-A-Lert from one telephone to another.

Power for the Fone-A-Lert comes from a standard 9-volt transistor battery that will last for several months. Battery con-



dition is indicated by a short "beep" when the unit is first switched on. An on-off switch allows the battery to be conserved when the device is not in use.

The Fone-A-Lert is on sale through the Reader Service Department of our parent company, cost \$17.95 plus \$1.00 p&p. Interested readers are referred to the advertisement on p62 of this issue.

## RADIO YOUR SPECIAL INTEREST?

### Get the skills and knowledge you need from Stott's courses

A Stott's Radio Course can start you off on a new career or let you get the most from your hobby. Stott's Radio Courses include theory and practical work on interesting projects.

Radio subjects range from AM Radio Receiver Servicing through Amateur Radio and Amateur Operators Certificates. And for those who want to advance to television servicing, Stott's provide excellent courses.

Choose the course that's right for you and send for a prospectus now!

- AM Radio Receiver Servicing
- Amateur Radio
- Amateur Operator's Certificate
- Introduction to Electronics
- Complete Radio & TV Servicing
- Monochrome
- TV Receivers
- Colour TV Receivers



**Stotts**

159 Flinders Lane, Melbourne, 3000. Tel: 63 5543  
383 George Street, Sydney, 2000. Tel: 29 2445  
290 Adelaide Street, Brisbane, 4000. Tel: 31 1627  
66 King William St., Kent Town, S.A. 5067.  
Tel: 42 5798 89 St. George's Terrace, Perth, 6000  
Tel: 225481 P.O. Box 3396, Singapore 1

EA.2.77

TECHNICAL CORRESPONDENCE COLLEGE

The name to trust in correspondence education

Please send me, without obligation, full details of the following courses:

(PLEASE PRINT)Stott's undertake that no sales counsellor will call.

Mr., Mrs., Miss..... Age.....

Address.....

Postcode.....

STC 934





# Letters to the editor

## Musicolour hint

Recently I constructed a MKIII musicolour from kit form. After switching on, I discovered the only fault to be the "low" light which did not illuminate with programme feed in.

After some considerable time, I discovered the FET in the compressor was faulty—the result however is large attenuation of 1 kHz and under—otherwise the system works.

I am sure other builders would have had this problem and I suggest they short circuit the field effect transistor while mounting and soldering. A quick test for the faulty FET is to substitute a 330 ohm resistor in its place—the musicolour should then operate as normal.

Kent Bayley  
Radio Station 2GO,  
Gosford, NSW

## CB suggestion

The Postal and Telecommunications Department is unable to cope with detecting, tracking down and prosecuting unlicensed operators. While there are about 7000 amateur radio licensees in Australia research indicates a figure of between 20,000 and 200,000 unlicensed operators on the 27MHz (11 metre) band. The equipment is arriving into this country at an ever-increasing rate, and I believe the time to act is now.

The following is my proposal to solve the inevitable fiasco. Legislation should be introduced to accommodate CB radio on the 27MHz band, using channels 1 to 23 as used in America—i.e., 26.965 to 27.255MHz with 10kHz separation. The P & T Department would then issue licences, together with call signs (say

VC3AA, etc), at a cost of \$5.00 per licence. Licences would be available only for commercial equipment meeting certain minimum specifications.

I truly believe that this will be required eventually, so why not take advantage of the \$100,000 plus revenue already available? All unlicensed users would surely welcome the chance of "going legal" for \$5, particularly as they would then get an official call sign instead of the "home made" call signs they use at present.

Ivor Morgan, VK3DH (since 1930)  
East Hawthorn, Victoria.

## CB vs amateurs?

Reference your article in the EA Year book 76/77 on CB Radio, "Consumer Pressure could make it happen" by Greg Swain or was it really titled "America Does so Australia Should"? In the rules of debate you now invite a member of the negative team to write opposing CB and publish a list of Amateur Operators who have contributed to public safety. I am neither Ham or CBER.

Mark Wittaker  
Murrumbateman, NSW

**COMMENT:** Over the years, we have published quite a lot about the role of amateurs in emergency situations. In any case, it's not a question of CBers V amateurs, but whether or not a CB facility is appropriate for Australia.

The views expressed by correspondents are their own and are not necessarily endorsed by the editorial staff of "Electronics Australia". The Editor reserves the right to select letters on the basis of their potential interest to readers and to abbreviate their contents where this appears to be appropriate.

**RN ROBINSON  
NUGENT, INC**

## TEST/BURN-IN SOCKETS

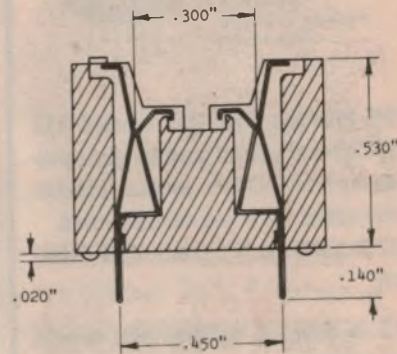
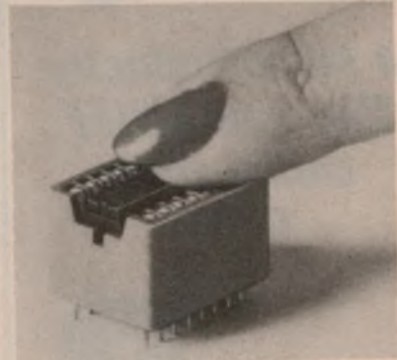

Designed to provide a low-cost alternative to complex, costly "Zero" insertion force units in production testing and burn-in applications. Excellent for working with PROMs.

Available with 14 to 40 pins.

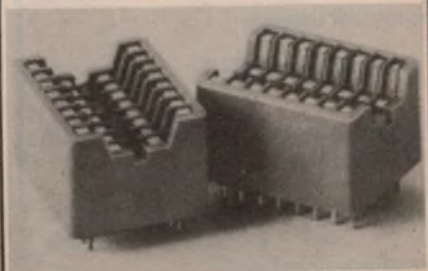

99 Alexander St., Crows Nest Telephone 439 2488

Adelaide 42 6655  
Brisbane 277 4311  
Canberra 47 6179  
Newcastle 61 4991  
Perth 25 5722



## FAST DESOLDERING

**SAFE with Soder-Wick**

**EASY**

1. Hold Soder-Wick on termination with hot soldering tip. Wicking action soaks up solder.

2. Remove tip and braid. Termination is left clean and free of solder.



Soder-Wick is a specially treated copper braid which soaks up molten solder like a sponge. Desolders a P.C. pad in a second or so: acts as a heat sink to protect circuits and components.

In a range of sizes from your wholesaler or

02-709 5293  
03-848 3777

## ROYSTON ELECTRONICS

RE476



# No kidding!

**a semiconductor that can SNIFF combustible gases**



Actual size  
Fit 7-pin miniature  
valve socket

**THE FIGARO TGS** gas sensors 812 and 813 are general purpose gas sensitive semiconductors whose conductivity varies with gas concentration. 812 is particularly suited to CO detection.

813 is ideal for methane and natural gas detection.

Applications include:

- Gas leak alarm for Town Gas, LPG, natural gas, car exhaust, etc.
- Automatic ventilation
- Carbon monoxide detector
- Fire alarm
- Alcohol detector
- Air pollution monitor

Single unit price is \$9.78 (or \$8.50 + 15% sales tax)

Characteristics and suggested circuits supplied with each order or available separately on request.

**DIGITRON  
ENGINEERING**

16 COVENEY ST. BEXLEY.  
P.O. Box 177. Bexley. 2207.  
Phone (02) 50-4361



## Books & Literature

### Video recorders

**VIDEO TAPE RECORDERS** by Harry Kybett. Published by Howard Sams Inc, first edition, second printing 1976. Stiff paper covers, 352 pages 215 x 135mm, freely illustrated by photographs and diagrams. Price in Australia \$12.90.

According to recent reports, 1977/8 will be the year of the big push in home video recording, with at least two major Japanese systems competing for supremacy, apart from others that may have to be reckoned with. This may be a good book, therefore, for the enterprising engineer, technician and serviceman who wants to be a jump ahead of the event.

The author, Harry Kybett, would appear to have had extensive practical experience as well as academic training and is in a good position to expound his chosen subject. From an original background in British television with the

BBC and ABC, he is now a consultant in the USA, so that the emphasis now is on the NTSC system. But while Australian readers will have to appreciate the differences between NTSC and PAL, the principles of video equipment and recording are valid for both.

Contrary to the impression that may have been created by my opening remark, the author has quite a lot to say about professional quadrature machines and could provide a valuable introduction or refresher at that level. From that base, he goes on to talk about the principles of sub-professional equipment as expressed in the commercial, educational and home video field. There are 15 chapters altogether, beginning with audio recording, covering the early attempts at video recording by high lineal speeds and leading into the development of rotating head systems. There are chapters on servos, control functions and ancillary equipment, editing and mention of current developments. In short, a

## For fine detail work — a hands free magnifier



The **Magna-Sighter** is a precision 3-D binocular magnifier that leaves your hands completely free for work. It has hundreds of applications, and is invaluable for scientists, technicians, craftsmen, toolmakers, hobbyists, etc. Slips easily over the head—over glasses, too. Proved and used by many U.S. universities, space research bureaux, government departments and major industrial organisations. Available in 3 different magnifications. Price \$21.00

## MAGNA-SIGHTER

For further information send this coupon today:

STOTT TECHNICAL SERVICES (Division of Stott's Technical Correspondence College Pty. Ltd.) 159 Flinders Lane, Melbourne, 3000. Tel: 63 5583	MEA 4 77
Please send me full information on the 3-D Magna-Sighter. I understand that no Sales Representative will call.	
Name .....	
Address .....	
Postcode .....	

STC 951



promising looking volume.

The review copy came from Prentice-Hall of Australia Pty Ltd, P.O. Box 151, Brookvale, NSW 2100. (W.N.W.)

## Amateur radio

**ARRL HAM RADIO GUIDE.** Editorial coordinator W7YL. Published by the American Radio Relay League. Stiff paper cover, 128 pages 275x208mm, freely illustrated by pictures and diagrams. Price in Australia \$7.30.

Stated purpose of this new ARRL publication is to introduce readers—most likely prospective or novice amateurs—to the challenging world of amateur radio. Unfortunately, if they're at all timid, it might just have the reverse effect and prove rather daunting; such is the vast scope of the hobby today!

The early chapters do indeed start at the beginning, the first being devoted to Novice Licences. Then follow chapters on Message Handling—Contests—The Basic Intrigue of DX—Logging, QSLing and Awards—Repeaters—The Flea Power Challenge.

But, interspersed in these pages are pictures of elaborate equipment, elaborate stations and antenna systems that look like major engineering achievements!

The book climaxes in this vein with chapters on radioteletype, moon-bounce communication and amateur satellites. Read the book and you'll at least know where you could end up in the hobby, if the bug really bites!

But there is one word of warning: while the concepts are widely applicable, procedural and administrative details are those which apply in the USA. Australian readers would need to keep in mind local "regs", some more liberal, others more restrictive than those in America.

Our review copy came from the Technical Book & Magazine Co Pty Ltd, 289-299 Swanston St, Melbourne, 3000. (W.N.W.)

## Data transmission

**PRINCIPLES OF DIGITAL DATA TRANSMISSION**, by A. P. Clark. Pentech Press, London, 1976. Hard covers, 222 x 143mm, 256pp, with 80 illustrations. Prices in UK £7.50 clothbound, £4.25 paperback.

A fairly advanced text, written for the senior undergraduate and practising engineer. It is designed to give a sound introduction to the use of digital techniques for reliable data transmission.

There are 16 chapters, of which the first 11 provide a non-mathematical look at the basic properties of telephone lines and HF circuits. The remaining 5 chapters then provide a theoretical analysis of digital signals and modulation techniques.

The text is very concise, but should be found quite readable by those with the appropriate background.

The review copy came from the publisher, who gave no indication of local price or availability. (J.R.)

# NEW BOOKS

JUST A FEW OF THE THOUSANDS ALWAYS IN STOCK CALL IN OR WRITE PRICES SUBJECT TO FLUCTUATION CORRECT AT TIME OF GOING TO PRESS

## 1977 ANNUALS

<b>AMATEUR RADIO CALLBOOKS 1977</b>	
USA Listings	\$18.95
Foreign Listings	\$18.50
<b>ARRL RADIO AMATEURS' HANDBOOK 1977</b> edition due February Order now Will post your copy as soon as our shipment lands	
	\$11.95
<b>WORLD RADIO TV HANDBOOK 1977</b> edition due April. Order now	
	\$11.95

## TV & TV SERVICING

<b>BASIC TELEVISION PRINCIPLES &amp; SERVICING—B. Grob</b> New 1975 edition just received	
	\$15.75
<b>COLOUR TV PICTURE FAULTS—Bohman</b> Quick location and repair by means of picture fault examples in colour	
	\$9.30
<b>COLOUR TV THEORY—Hutson</b>	
	\$12.00
<b>PAL COLOUR TELEVISION FOR SERVICEMEN—W. C. Cook.</b> A new book by an Australian	
	\$15.00
<b>PIN POINT TV TROUBLES IN 10 MINUTES</b> \$7.70	
<b>TRANSISTOR-TV SERVICING GUIDE</b> Middleton	
	\$6.20
<b>TELEVISION BROADCASTING—Tape and Disk Recording Systems—Harold E. Ennes</b>	
	\$21.20
<b>TV SERVICING GUIDE</b> arranged by Trouble Symptoms—Deane & Young (Our best seller)	
	\$4.75

## RADIO

<b>ANTENNA HANDBOOK—A. R. R. L.</b>	
	\$7.30
<b>AMATEUR RADIO TECHNIQUES—Hawker.</b> RSGB	
	\$7.40
<b>AMATEUR RADIO THEORY COURSE—Ameco</b>	
	\$7.00
<b>BEAM ANTENNA HANDBOOK—Orr</b>	
	\$7.80
<b>CUBICAL QUAD ANTENNAS—Orr</b>	
	\$7.50
<b>CB—THE BEST BOOK ON CB—includes all 40 channels and 1977 regulations, choosing equipment, installation, and use</b>	
	\$6.25
<b>73 DIPOLE AND LONG-WIRE ANTENNAS.</b> Noll	
	\$6.20
<b>FM &amp; REPEATERS FOR THE RADIO AMATEUR.</b> ARRL	
	\$7.30
<b>HAM &amp; CB ANTENNA DIMENSION CHARTS.</b> Noll	
	\$2.95
<b>HAM RADIO OPERATING GUIDE.</b> ARRL	
	\$7.30
<b>JAPANESE RADIO RECORDER TAPE PLAYER SCHEMATIC SERVICING MANUAL</b>	
	\$9.90
From Ham Radio Magazine.	
<b>PIN-POINT TRANSISTOR TROUBLES IN 12 MINUTES</b>	
	\$9.65
<b>RADIO AMATEUR'S VHF MANUAL.</b> ARRL	
	\$7.30
<b>RADIO &amp; ELECTRONIC LABORATORY HANDBOOK—Scroggie</b> New 8th edition	
	\$15.70
<b>RADIO HANDBOOK.</b> New 20th edition	
	\$24.40
<b>RADIO TRANSMITTER PRINCIPLES &amp; PROJECTS.</b> Noll	
	\$8.90
<b>RADIO VALVE AND SEMICONDUCTOR DATA—A. M. Ball</b> 10 Ed	
	\$5.10
<b>REFERENCE DATA FOR RADIO ENGINEERS</b>	
	\$37.50
<b>SIMPLE LOW COST WIRE ANTENNAS FOR RADIO AMATEURS—Orr</b>	
	\$7.80
<b>SINGLE SIDEBAND FOR THE RADIO AMATEUR.</b> ARRL	
	\$5.65
<b>SPECIALIZED COMMUNICATIONS TECHNIQUES FOR THE RADIO AMATEUR.</b> ARRL	
	\$5.65
<b>TEST EQUIPMENT FOR THE RADIO AMATEUR—Gibson—An RSGB publication</b>	
	\$6.65
<b>TRANSISTOR RADIO SERVICING COURSE.</b> Lemons	
	\$9.40
<b>UNDERSTANDING AMATEUR RADIO.</b> ARRL	
	\$7.30
<b>73 VERTICAL BEAM &amp; TRIANGLE ANTENNAS—Noll</b>	
	\$6.90
<b>VHF-UHF MANUAL</b> Evans & Jessop An HSGB Publication Revised 3rd Ed enlarged.	
	\$15.50

## HI FI & SOUND

<b>EASY SPEAKER PROJECTS.</b> Buckwalter	
	\$4.95
<b>HIGH FIDELITY AUDIO AMPLIFIER CIRCUITS A Texas Instruments Manual</b>	
	\$3.00
<b>ELECTRIC GUITAR AMPLIFIER HANDBOOK</b>	
	\$9.95

<b>HI FI DESIGNS (WIRELESS WORLD)—tape, disc, radio, amplifiers, speakers, headphones</b>	
	\$3.00
<b>HI FI LOUDSPEAKERS AND ENCLOSURES—Revised 2nd Edition—Cohen</b>	
	\$8.25
<b>MODERN RECORDING TECHNIQUES.</b> Runstein A new book from Howard Sams	
	\$12.45

## ELECTRONIC

<b>DIODES EQUIVALENTS—De Muiderkring</b> European, American, Japanese types A companion to Transistor Equivalents	
	\$5.95
<b>ELECTRONICS ENGINEER'S REFERENCE BOOK.</b> Turner Completely new undated 4th Ed. of this major reference work, should be in the library of every serious student and engineer	
	\$61.70
<b>ELECTRONIC FLASH EQUIPMENT.</b> Mott	
	\$5.65
<b>GUIDE TO VIDEO TAPE RECORDING.</b> by Editors of Photographic Magazine	
	\$3.30
<b>HOME TV-FM ANTENNAS.</b> Lawrence & Elroy	
<b>ELECTRONIC CALCULATOR USERS HANDBOOK</b> Babani The cheapest and most comprehensive book on calculators	
	\$2.75
<b>HOW TO USE VIDEO TAPE RECORDERS.</b> Kybett	
	\$8.75
<b>HOW TO BUILD AND USE ELECTRONIC DEVICES WITHOUT FRUSTRATION, PANIC, MOUNTAINS OF MONEY, OR AN ENGINEERING DEGREE</b>	
	\$14.20
<b>IC OP-AMP COOKBOOK.</b> Jung	
	\$16.25
<b>IT'S EASY TO USE ELECTRONIC TEST EQUIPMENT.</b> Klein & Gilmore	
	\$6.75
<b>PRACTICAL PA GUIDE BOOK.</b> Crowhurst. How to Install, Operate & Service PA systems	
	\$6.75
<b>PROJECTS IN SIGHT, SOUND &amp; SENSATION.</b> Waite	
	\$6.20
<b>SECURITY ELECTRONICS—Cunningham</b>	
	\$6.20
<b>SEMICONDUCTOR HANDBOOK—De Muiderkring</b> Characteristics, Specifications, etc	
	\$8.95
Part 1—Transistors	
	\$7.95
Part 2—Diodes & Thyristors	
<b>TRANSISTOR EQUIVALENTS—European, American and Japanese, 9000 types and 5600 substitutes, 8th and 10th edition</b>	
	\$8.50
<b>TRANSISTOR SUBSTITUTION HANDBOOK</b> 15th edition just arrived	
	\$5.65
<b>TTL COOKBOOK.</b> Lancaster	
	\$11.25
<b>TTL DIGITAL INTEGRATED CIRCUITS—</b> with equivalents, De Muiderkring	
	\$7.95
Part 1—Serie 7400-74132	
	\$8.95
Part 2—Serie 74141-74298	
	\$10.95
<b>VIDEO TAPE RECORDERS.</b> Kybett	
	\$11.25
<b>WORKING WITH THE OSCILLOSCOPE.</b> Saunders	
	\$5.95

## MANUFACTURERS' MANUALS

<b>FAIRCHILD SEMICONDUCTOR—Full Line Condensed Catalog</b>	
	\$5.00
<b>FAIRCHILD SEMICONDUCTOR CMOS DATA BOOK</b>	
	\$5.00
<b>GENERAL ELECTRIC SCR MANUAL INCLUDING TRIACS &amp; OTHER THYRISTORS</b>	
	\$5.40
<b>GENERAL ELECTRIC SEMICONDUCTOR DATA handbook—1482 pages</b>	
	\$8.00
<b>RCA SOLID STATE DATA BOOKS</b> New 2-volume set	
	\$7.95
Integrated Circuits SSD-210	
	\$7.95
Power Devices SSD-220	
<b>RCA SOLID-STATE DEVICES MANUAL (Replaces Transistor Manual)</b>	
	\$7.95
<b>RCA SOLID-STATE SERVICING</b>	
	\$5.75
<b>RCA LINEAR INTEGRATED CIRCUITS</b>	
	\$3.75
<b>National Data Books And Catalogues</b>	
	\$5.70
<b>CMOS INTEGRATED CIRCUITS</b>	
	\$4.35
<b>DIGITAL INTEGRATED CIRCUITS</b>	
	\$7.60
<b>INTERFACE INTEGRATED CIRCUITS</b>	
	\$7.60
<b>LINEAR APPLICATIONS, Vol. 1</b>	
	\$7.60
<b>LINEAR INTEGRATED CIRCUITS</b>	
	\$5.70
<b>MOS INTEGRATED CIRCUITS</b>	
	\$5.70
<b>TRANSISTORS SMALL SIGNAL FIELD EFFECT POWER</b>	
	\$3.25
<b>TTL DATA BOOK</b>	
	\$7.60
<b>Texas Instruments</b>	
	\$6.90
<b>THE POWER DATA BOOK</b>	
	\$6.90
<b>THE TRANSISTOR &amp; DIODE DATA BOOK—Vol. 1</b>	
	\$6.90
<b>THE TRANSISTOR &amp; DIODE DATA BOOK—Vol. 2</b>	
	\$6.90
<b>THE TTL DATA BOOK</b>	
	\$6.90

MAIL ORDERS BY RETURN  
per parcel interstate

PLEASE ADD 90c per parcel postage (Vic) \$1.70

**TECHNICAL BOOK & MAGAZINE CO.**  
295-299 Swanston St., MELBOURNE 3000. Ph. 663 3951



# QUALITY CB GEAR

When you buy from VICOM you get only quality gear sold and serviced by the experts. All transceivers are given a thorough pre-delivery checkout supported by technical expertise and well equipped workshops. A wide range of spare parts is available and all new gear carries a 90 day warranty.

HAM AND NOVICE USE

## PANTHER



synthesised \$279

### PANTHER SSB DELUX TRANSCEIVER

This superb rig is the ultimate in quality and sophistication! The Panther SSB is synthesised and requires no crystals. Frequency stability is within 0.001%! There are 69 available modes: 23AM, 23LSB, 23USB at 5w am and 15w pep input. Controls include squelch, effective noise blanker and transceiver PA system switch. Front panel meter indicates modulation. "s" points or relative RF output. The rig comes complete with mic, mobile mounting brackets, dc cable and VICOM 90 day warranty. A real bargain!

HAM AND NOVICE USE

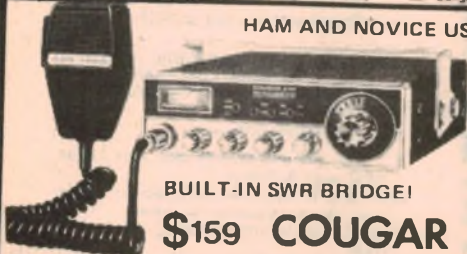

BUILT-IN SWR BRIDGE!  
\$159 COUGAR

### COUGAR 23 B AM DELUX TRANSCEIVER

Delux mobile 23 channel (synthesised) for the quality conscious Novice. The Cougar features built-in swr meter, noise blanker, delta tune, rf gain control, mic gain control, built-in modulation meter, separate PA switch. Circuitry consists of 11C, 20 transistors, 18 diodes. RECEIVER: dual conversion, sensitivity 0.5 uV for 10 dB S+N/N, selectivity 6 dB bandwidth 5 kHz, PA audio power 5 watts. TRANSMITTER: 5w input, spurious harmonic suppression better than 55 dB. Comes complete with mic, mobile bracket, dc cable and manual. \*

### TVI FILTER



\$20

Superb quality low pass filter (32MHz cut-off) for transmitters 1.8 thru 30MHz. Insertion loss under 0.5dB, input/output impedance 50 ohms. Complete with SO239 sockets. Will handle 200w pep (max) \$20 + P&P \$2. 1Kw pep model (0.3dB insertion loss) \$34 + P&P \$3

### POPULAR VC2 SWR/PWR METER

The popular VC2 covers 3-150 MHz with power measurement 12/120 watts. Will handle up to 1000w, 50 ohms impedance, twin meters. This quality true line instrument is ideal for the shack or for permanent mobile installation. \$36 + P&P



\$36 SWR/PWR METER

### VICOM DEALERS WANTED

Vicom are seeking active Dealers to join our expanding Australian-wide CB retail outlets. We sell only quality gear and "get rich quick" outfits need not apply. Would-be Dealers should have technical facilities and personnel who are capable of handling and assisting with queries from our many customers. Written applications should be addressed to the attention of Managing Director.

A licence is required for all transmitting equipment.

## ANTENNAS

### BASE LOADED WHIP

Model M1 quality base loaded mobile whip, 40.5 inches long, 50 ohm impedance, vswr less than 1.5. Includes roof mount and optional boot lid mount, spring and coax with PL259 plug. \$27 + P&P  
Model G2 as above with gutter clamp \$29.90 + P&P

### HELICAL WHIP

Model HW-11S-6 6ft helical whip, covered in tough plastic, this top loaded (helical) is designed to give a perfect 52 ohm match. \$22 + P&P  
- spring base \$13  
- roof base \$17.50

### MARINE WHIP

Model HW-11-GM requires no ground plane and can be operated on fibreglass, wood surface or on mast. Comes complete with matcher, coax, PL259 plug. \$65

### HUSTLER CENTRE LOADED WHIP

Ideal mobile whip, mounts on bumper bar.

Whip	\$19
Mast	\$26
Bumper Mount	\$19
Spring	\$11.50



27MHz ground plane, superb quality, wound on strong fibreglass rod with teflon protection. \$79

1/2 wave high efficiency ground plane, solid 108 inch heat treated radials and radiator. Radials droop for 50 ohm match. Complete with SO239 socket. \$35 + P&P \$3

### LIGHTED DUMMY LOAD

5w dummy load built-in to a PL259 plug. Glows and indicates modulation, power output etc. \$2.90

\$2.90



### JUMPER LEADS

Handy 3ft jumper leads,



RG58 coax with fitted PL259's \$2.50  
18" version \$2.30

FOR THE SERIOUS SWL!



SWLs

### BARLOW WADLEY

The famous portable Barlow Wadley Communications Receiver with crystal controlled reception of am/lb/usb/cw:

Standard model	\$319
With FM	\$339

### ANTENNAS

Listener-1 "V" type covers 3-30MHz with special trap for DX reception \$22  
Listener-3 long range wire dipole antenna 3-30MHz complete with balun, feed wax, VHF plug, insulators. Ideal for the serious SWL \$49

### SWL ANTENNA COUPLER

For matching receiver to the antenna line, this quality product handles signals from 2-30MHz with an output impedance from 50 to 600 ohms

### RECEIVER BOOSTER

This preselector improves the selectivity and sensitivity of your short wave communications receiver. It covers four bands from 2-30MHz with a gain of 15dB! \$35 + P&P

### CAR RADIO SPLITTER

Permits operation of your AM or AM/FM car radio from 27MHz antenna. Can be used with any series fed (ungrounded) 27MHz antenna. Finished with RG58/u and car radio high impedance lead, each 60 inches long. Excellent isolation between entertainment radio and 27MHz transceiver. Includes adjustable 27MHz match for optimising SWR. \$31 + P&P \$1.50



## SPECIAL!

### 27MHz TEST SET

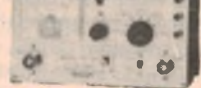

\$45

Model FS-117 has built-in wattmeter and 5 watt dummy load, measures swr, modulation, field strength, crystal activity. Ideal for home repairs and "tweaking". PRICE THIS MONTH ONLY \$45 + P&P \$3

SAVE \$10

### PLUGS & SOCKETS FOR THE COMMUNICATOR

4 pin mic plugs and sockets (ea) \$2.30  
1 1/2" coax jumper leads with PL259's \$2.30  
3" coax jumper leads with PL259's \$2.50  
PL259 plugs \$1.30  
SO239 chassis sockets \$1.30  
SO239/RCA adapter \$2.20  
"T" connector \$2.50  
Lightning arrester \$3.50



## the COMMUNICATIONS SPECIALISTS

### Mic Compressors

for those extra "s" points

\$65



Model MC33A ac/dc includes two tone generator and built-in compression level meter. Handles low and high impedance mics with distortion better than 0.5%. Compression level -3 dB to -35 dB. \$65 + P&P  
Model MC22 as above (extl compression level meter) \$54 + P&P

### COAXIAL SWITCH

\$22



CS201 quality 2 position coax switch. Will handle up to 2.5Kw pep, 50 ohms impedance with insertion loss better than 0.2dB! VSWR better than 1.2 up to 1GHz. Position not selected is automatically grounded.

# VICOM

Head Office & mail orders . . .  
139 Auburn Rd, Auburn, Vic. 3123 Ph: (03) 82-5398

### CONDITIONS OF SALE

Prices include sales tax but exclude freight and insurance. For insurance allow \$1 per \$100, min \$1. Freight sent Kwika air (freight "collect") unless otherwise specified. Prices and specifications subject to change without notice. The law requires that a licence must be held for all transmitting equipment.

Vicom CB gear also available at -

Sydney: Jack Gillham, 23 Whiting St, Artarmon. Ph: 439 1271  
Canberra: Daicom Electronics, 29 Colbee Crt, Phillip Ph: 82 3581  
Adelaide: Graham Stallard, 27 White Ave, Lockleys Ph: 43 7981  
and a network of Dealers throughout Australia. Dealer enquiries welcome.



# The Amateur Bands

by Pierce Healy, VK2APQ



## Central Coast Amateur Radio Club's Field Day

The Central Coast Amateur Radio Club's annual field day is always a very popular event, but this year the attendance figure broke all previous records. There were many new Novice licencees in evidence, as well as the faces seen in previous years.

The registration figures for amateurs, their families and friends at the Gosford Showground for the CCARC field day far exceeded all previous attendance figures, the total being 702. In addition, more than 50 local residents who heard a news item about the field day from broadcast station 2GO Gosford came to the showground to see what was taking place—and even Ireland!

The event was held on Sunday the 20th February, 1977 and drew visitors from places as far afield as Lismore, Kempsey, Port Macquarie, Narrabri, Young, Bathurst, Canberra, Illawarra area, Sydney and Newcastle.

A guest visitor was the federal president of the Wireless Institute of Australia, Dr. David Wardlaw, VK3ADW. David expressed his pleasure of having the opportunity to meet many of those present and to discuss various aspects of institute activities. Also matters concerning the future wellbeing and status of amateur radio.

Cool fine weather made conditions very pleasant for those taking part. One could compete in the field contests, inspect the trade displays of the latest types of amateur equipment, look for bargains in the disposals section or just enjoy a chat with old friends or new acquaintances.

Trade displays by Sideband Electronic Sales, Dick Smith Electronics, Vicom, Amateur Communication Advancements, Cirtex and VK2GL QSL Cards, were well patronised and a good quantity of equipment was sold.

There was a trend towards better quality of equipment in the disposal trading section. The total value for the 140 lots offered was approximately \$4000, most of which was sold.

A demonstration of amateur television provided direct outside broadcasts of the hidden transmitter hunts and video tapes were made of several of the finishes.

The Youth Radio Scheme information centre and display of simple electronic projects created a lot of interest among both the young and not so young. The display was organised and manned by Rex Black, NSW YRS state supervisor; Ken Hargreaves, NSW YRS education officer and Gordon Proctor, Gosford Youth Radio Club instructor.

YRS literature on club activities was available, also YRS instructional manuals. These and Keith Howard's "Manual of Questions and Answers for the Novice Licence" were eagerly sought after.

The teaching kit on display at the Youth Radio Scheme stand was part of the extensive teaching equipment in use at the Westlakes Radio Club at Teralba, much of which is produced by the Swedish educational company Gumperts Sholmateriel A.B. of Stockholm.

The kits comprise units representing various electrical and electronic components, and with these it is possible to perform hundreds of demonstrations and experiments.

Besides showing the functions of transformers, motors, generators, diodes, transistors and valves, the equipment may be used to construct transmitters and receivers. These can be used to demonstrate receiver and amplifier principles as well as to demonstrate effects such as standing waves.

Purchase of this equipment was made possible through a grant received from the New South Wales Department of Community Services.

The ladies' stall was stocked with donations of various types of home made jams, biscuits, cakes, knitted and crocheted articles, plants and other items for sale, and did a good trade. For the musically inclined there was a display of electronic organs by the Gosford Branch of the Nova Castrian Piano Company.

A coach tour of scenic spots around the Central Coast was very popular among the visitors. A visit to the Reptile Park was an added attraction for those interested in wildlife.

A number of contests were conducted throughout the day: HF and VHF scrambles, hidden transmitter hunts for mobile operators and pedestrians. All were keenly contested. The winners and place-getters received valuable prizes donated by several trade houses. In addition there were prizes for ladies' and gents' quizzes and lucky registration numbers.

Throughout the day groups could be observed discussing the pros and cons of the latest pieces of equipment on display, problems associated with equipment, WIA matters. Also discussed was illegal operation on 27MHz, and the report to the Minister for Post and Telecommunication on the introduction of a Citizen Band Radio Service in Australia, and the many other aspects of amateur radio.

Appreciation was expressed among the visitors attending for the work done by CCARC members for organising an event which draws so many amateurs together. Most agreed that should this event be allowed to fade away, it would be a serious blow to the growth of amateur radio. The number of the younger generation of amateurs who have been encouraged and assisted with their hobby through the competitions, discussions and demonstration of equipment is certainly large. This was evident this year in the number of new Novice licencees who attended.

Congratulations to CCARC members who worked hard to allow fellow amateurs to have such an enjoyable field day.

To the trade houses and others who made donations to the prize list and the ladies' stall the CCARC

have expressed their sincere thanks. Also to all who went along to their 20th annual field day and helped to make it a record success.

## RSGB CERTIFICATES

The council of the Radio Society of Great Britain has approved the extension of three awards to allow endorsements for five band operation. These are: British Commonwealth Radio Transmission Award.

British Commonwealth Radio Reception Award.  
DX Listeners' Century Award.

A revised edition of the Society's HF Certificate and Awards leaflet is now available together with a new countries list designed to facilitate claims for five band awards.

This list can be used to claim single band awards and later returned with a five band claim. All claims must be accompanied by proof of membership or appropriate remittance.

Copies of the awards leaflet may be obtained from the Society's HF awards manager by sending a large self addressed envelope to G5GH, Westbury End, Finmere, Buckingham, Bucks. An IRC for postage would not be amiss.

## RADIO CLUB NEWS

**GEELONG AMATEUR RADIO CLUB:** Harold Selman, VK3CM, club treasurer reported details of an interesting contact in the February issue of the GARC Newsletter. The contact was with KC4AAA located near the south pole. The frequency 14.230MHz.

This is an American Base named "Amundsen—Scott South Pole Station" which is manned by scientists and others from many nations. There are 100 personnel at the base, situated 100 metres from the geographic position of the south pole, on a plateau 2804 metres above sea level consisting of 2740 metres of ice and snow.

The temperature varies from -17.8C to -80C. The air is very dry as the nearest point to the sea is 1290km, but they do not have the fierce gales which suddenly erupt at the Mawson Base.

The accommodation is within a huge aluminium dome, which houses separate buildings for scientific work, communications and a cook house. These are heated by water and glycol piped from the diesel power units.

Total darkness is experienced from March until September, and they are completely isolated until the base is again open to aircraft in November.

The GARC reports that enrolments for the 12 week intensive lecture and tutorial course for the amateur certificate examination has been quite satisfactory. This is the result of two feature articles and classified advertisements in the local newspaper, the Geelong Advertiser and also from WIA news broadcasts.

A two hour lecture is given on Tuesday nights and a one hour tutorial plus one hour Morse code practice each Thursday night.

**SOUTH EAST RADIO GROUP:** The monthly meetings of the group for April, May and June will be mainly concerned with planning the annual SERG convention set down for the weekend 11th and 12th June, 1977.

The annual meeting will be held on the 22nd July, 1977. All meetings will be held in Room 16, South East College of Further Education, Mount Gambier, commencing at 8.00pm.

The group also proposes to commence a class for those wishing to gain a Novice licence. A syllabus will be available when details are finalised.

**ILLAWARRA AMATEUR RADIO SOCIETY:** The moonbounce report for February, 1977 includes details of first time E-M-E contacts with Japan, Europe and America during December 1976 and January 1977, from VK2AMW located at Dapto.

December 12th 1976—first contact with JA1ATL, 'O' signal reports exchanged both ways. Contact was also made with JA1VDV, signal report—'O' both ways. First contact with F2TU and 'M' reports each way.

January 8th 1977—first contact with K3PGP exchanging 'M' reports. Also, WB5LUA but signals faded out after a few minutes; however a 'T' report was sent.

January 23rd 1977—FY7AS, French Guiana: the first Australia—South America contact on 70cm. 'M'

Radio clubs and other organisations, as well as individual amateur operators, are cordially invited to submit news and notes of their activities for inclusion in these columns. Photographs will be published when of sufficient general interest, and where space permits. All material should be sent to Pierce Healy at 69 Taylor Street, Bankstown 2200.



# BRIGHT STAR CRYSTALS PTY LTD

35 EILEEN ROAD, CLAYTON, VICTORIA 546 5076

## MAY WE REMIND YOU

THAT BRIGHT STAR CRYSTALS  
HAVE MORE THAN 36 YEARS  
EXPERIENCE IN



MADE IN AUSTRALIA

HOSE & EQUIPMENT CO. PTY. LTD. SYDNEY. PHONE 666-8144

COMMUNICATION SYSTEMS  
PERTH. PHONE 76 2566

FRED HOE & SONS PTY LTD  
BRISBANE. PHONE 47 4311

ROGERS ELECTRONICS  
ADELAIDE. PHONE 42 6666

DILMOND INSTRUMENTS  
HOBART. PHONE 47 9077

## AMATEUR BANDS

reports being exchanged each way. The contact was the result of a "CQ" call during the known EME common window, rather than a scheduled test.

Located at the Guiana Space Centre, FY7AS used circular polarisation and had a consistent signal though only 1dB to 3dB above noise for most of the time.

Lyle Patison, VK2ALU, moonbounce project co-ordinator reports that it seems that the supremacy of bipolar transistors for very low noise 70cm preamplifiers is over. The MT4575 bipolars used by VK2AMW and others give a measured noise figure of 1.2dB on 432MHz. Now JA1VDV has come up with a design for a 432MHz preamplifier having a gain of 15dB and the incredibly low noise figure of less than 0.8dB, according to his report in the "432 EME News", January, 1977. The transistor used is a V244 GASFET which costs about \$200 in the USA and Japan. It is apparently a standard type of GASFET for use in the 4GHz to 8GHz range.

Lyle comments that the price may seem very high for such a device, but if they were to use it at VK2AMW in place of the present front-end transistor the receiving system would be upgraded to the same extent as an increase in the antenna dish diameter from the present 9.2 metres to 12.1 metres. This would cost considerably more.

**SUMMERLAND RADIO CLUB:** The 1976-77 annual report of the president, Fred Herron, VK2BHE contains interesting details of the club's progress.

The committee has met regularly on Tuesday each week throughout the year. Due to geographical proximity, a policy of close cooperation with the WIA Queensland division has been maintained. A representative body of SRC members attended a special WIA meeting in Brisbane and the Central Queensland WIA convention in Rockhampton. Communication on two metres with VK4 stations has been quite active.

## GEMTRONICS CB Transceivers from BAIL novice, CB and marine



### GTX-3323

Delux AM 23 Channel transceiver featuring built-in range boost modulation, switchable Automatic Noise Limiter, Modulation indicator and front panel CB/PA switch. \$89

### GTX-3325

Delux SSB/AM 23 channel transceiver featuring built-in Range Boost Modulation, FET RF amplifier for high receiver sensitivity, Noise Blanker, RF gain control and large S-meter. 15 watts PEP SSB, 5 watts AM. \$279

## also available from BAIL ELECTRONICS



### 606CB

#### The Ultimate Communications/Entertainment Centre.

In-Dash combination, AM 23 channel 27MHz 5 watt transceiver/AM BC receiver/FM MPx receiver/stereo cassette player. Switch on the 606CB's unique Stand-By control while you play your favourite cassettes or listen to regular AM or FM Stereo broadcasts. The 606CB will then monitor 27 MHz for you, interrupt your programme for 27 MHz transmissions, and resume programme play afterwards. \$368



### CBR9000

In-Dash mounted 6 channel 27MHz 5 watt transceiver/AM broadcast/FM broadcast plus scanning. Features Tx, Scan and Rx indicators. Scan control allowing the set to monitor 27MHz channel while you are listening to your favourite programme. \$184

Also available from BAILS — a large range of Antennas and Accessories. Above prices include S.T. Freight and Insurance is extra. 90 day warranty. Prices and specifications subject to change.

Note all transmitting Equipment Requires a Licence.

**ELECTRONIC SERVICES**

60 Shannon St., Box Hill North, Vic., 3129. Phone 89 2213

Distributors in all states and N.T.

JAS677-19



A licence has been obtained for the repeater under construction as a club project and it is planned to relay WIA divisional news broadcasts as soon as it is operational.

Two members represented the SRC at the special WIA regional conference at Newcastle in January, 1977 and motions submitted on behalf of the club dealing with regional representation on WIA council and the policy of the WIA in regards to CB radio were adopted. Friday night practical project meetings continue to hold the interest of members and many worthwhile projects are in hand.

Club membership continues to grow and club finances are in a healthy state, and it is believed that the club now occupies a position of prominence in the WIA.

Fred also expresses his appreciation for the assistance given him by members of the committee and sees the club firmly established and ready to meet any challenge that may arise in the future.

**WAGGA DISTRICT RADIO CLUB:** The accompanying photograph shows club member Basil Broderick, VK2HI in Wagga Base Hospital recuperating after a serious operation. Much to some frustration on the part of some nursing staff, the WDRC set up VHF equipment so that Basil could keep in touch with his many friends throughout the Riverina area. Many contacts were made through the Wagga channel 3 repeater, VK2RWG.

The antenna consisted of a vertical halfwave dipole stuck to the wall with sticking plaster. The transceiver was loaned by club member Bruce Dicker. Included in the photograph are WDRC president Jeff Brill and vice-president John Eyles.

**MOORABBIN AND DISTRICT RADIO CLUB:** Officers elected for 1977 are president—Harold Hepburn, VK3AFQ; vice-president—Glen Percy, VK3ZQP; secretary—John Kerr, VK3BAF; treasurer—Roger Thomas, VK3RC.

General meetings will continue to be held on the third Friday of each month. A "natter night" on the first Friday and hidden transmitter hunt on the second Friday are also held. The meeting place is the club rooms, Turner Road Reserve at the rear of the Moorabbin City swimming pool.

**WEST AUSTRALIAN VHF GROUP (INC):** Reports are that the group is off to a good start for 1977. Participation in the John Moyle Memorial National Field Day in February and a demonstration contact via mode B of OSCAR 7 satellite i.e., 432MHz uplink and 145MHz downlink had been planned for the January meeting.

Two way ATV contact had been established, with noise free pictures over a six kilometre path between Rod Henderson, VK6RH and Ron Fisher, VK6PR.

## NOVICE LICENCE CLASSES

Publicity given to novice amateur radio classes in the 19th and 20th January, 1977 editions of the NSW mid north coast newspaper—The Manning River



Wagga club member Basil Broderick, VK2HI, continued his amateur activities whilst recuperating in Wagga Base Hospital after an operation.

## IONOSPHERIC PREDICTIONS FOR APRIL

Reproduced below are radio propagation graphs based on information supplied by the Ionospheric Prediction Service Division of the Department of Science. The graphs are based on the limits set by the MUF (Maximum Usable Frequency) and the ALF (Absorption Limiting Frequency). Black bands indicate periods when circuit is open.

477

7MHz EAST		01	02	03	04	05	06	07	08	09	10	11	12	13	14	15	16	17	18	19	20	21	22	23
EAST AUST TO BARBADOS (SR)																								
JOHANNESBURG																								
McMURDO SOUND																								
NEW DELHI																								
NEW YORK																								
RIO DE JANEIRO																								
TOKYO																								
VANCOUVER																								
WELLINGTON																								
WEST AFRICA																								
WEST EUROPE (SR)																								
WEST EUROPE (LR)																								
ADELAIDE TO SYDNEY																								
BRISBANE TO MELBOURNE																								
PERTH																								
SYDNEY																								
DARWIN TO SYDNEY																								
MELBOURNE TO PERTH																								
SYDNEY																								
14MHz GMT		15	16	17	18	19	20	21	22	23	24	01	02	03	04	05	06	07	08	09	10	11	12	13
EAST AUST TO BARBADOS (SR)																								
JOHANNESBURG																								
McMURDO SOUND																								
NEW DELHI																								
NEW YORK																								
RIO DE JANEIRO																								
TOKYO																								
VANCOUVER																								
WELLINGTON																								
WEST AFRICA																								
WEST EUROPE (SR)																								
WEST EUROPE (LR)																								
ADELAIDE TO SYDNEY																								
BRISBANE TO MELBOURNE																								
PERTH																								
SYDNEY																								
DARWIN TO SYDNEY																								
MELBOURNE TO PERTH																								
SYDNEY																								
21MHz EAST		01	02	03	04	05	06	07	08	09	10	11	12	13	14	15	16	17	18	19	20	21	22	23
EAST AUST TO BARBADOS (SR)																								
JOHANNESBURG																								
McMURDO SOUND																								
NEW DELHI																								
NEW YORK																								
RIO DE JANEIRO																								
TOKYO																								
VANCOUVER																								
WELLINGTON																								
WEST AFRICA																								
WEST EUROPE (SR)																								
WEST EUROPE (LR)																								
ADELAIDE TO SYDNEY																								
BRISBANE TO MELBOURNE																								
PERTH																								
SYDNEY																								
DARWIN TO SYDNEY																								
MELBOURNE TO PERTH																								
SYDNEY																								

Times—has helped to virtually eliminate the operation of illegal 27MHz transmitters in the Taree, Tuncurry, Wingham and Old Bar areas. This was confirmed in the 16th February edition.

The classes commenced on the 2nd February, 1977 at 7.00pm in the State Emergency Service Headquarters, Victoria Street, Taree under the direction of Geoff Hunziker, VK2BGF assisted by Cliff Coverdale, VK2VK.

Those attending are given instructions in radio theory, regulations and Morse code practice in preparation for the Post and Telecommunications examination in November, 1977.

The response to the invitation to enrol in the class was so large that it could not be accommodated and it is planned to repeat the course at a future date.

It is expected that similar courses will soon commence in Kempsey and Port Macquarie.

The NSW Youth Radio Scheme will be conducting a novice licence trial examination on Saturday 16th April, 1977. The procedures will be similar to the previous test as reported in these notes, being designed to duplicate exam conditions for novice candidates, so that initial nervous reaction is overcome.

Those wishing to avail themselves of this facility should contact Ken Hargreaves, YRS Education officer, 52 Merlin Avenue Florville, 2280.

It is understood that one of the examination centres for the trial test will be the Wireless Institute Centre, 14 Atchison Street, Crows Nest.

## SO YOU WANT TO BE A RADIO AMATEUR?

To achieve this aim, why not undertake one of the Courses conducted by the Wireless Institute of Australia? Established in 1910 to further the interests of Amateur Radio, the Institute is well qualified to assist you to your goal. Correspondence Courses are available at any time. Personal classes commence in February each year.

For further information write to

**THE COURSE SUPERVISOR,  
W.I.A.  
14 ATCHISON STREET,  
CROWS NEST, N.S.W. 2065**



# New 'LORLIN' supa-switches from C&K

## TYPE MS

Rotary action DPDT mains switch suitable for inductive circuits 4A at 250V, 80A surge.

## TYPE CK

Inexpensive, totally enclosed, single bank, 12 position rotary wafer switch in 1,2,3 & 4 pole.

## TYPE PT

Printed track switch of outstanding cost saving design.

## TYPE PBMS

Pushbutton mains switch push on/push off. Ideal for T.V. industry, 4A at 250V, 80A surge.

## TYPE KRA

Key operated rotary for maximum security.

## TYPE RA

1" diameter miniature rotary, 22 clip, 12 position.

## TYPE MR

Single pole rotary, PCB mounting, 2 or 3 position.

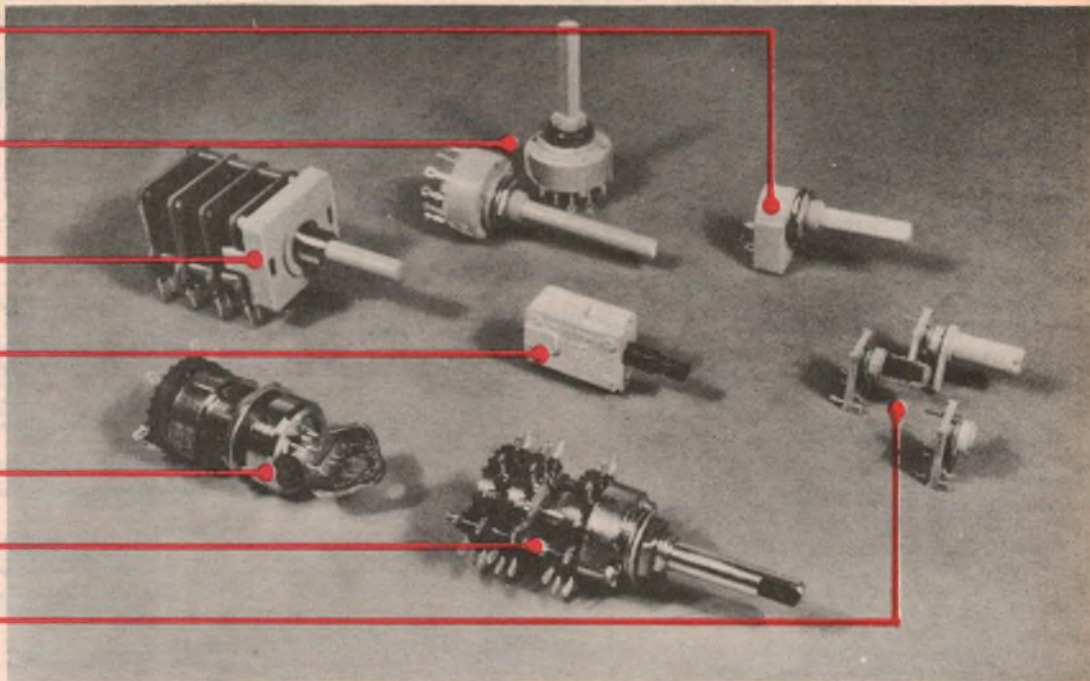

## C&K Electronics (Aust.) Pty Limited

Office 2/6 McFarlane Street Merrylands NSW 2160  
PO Box 101 Merrylands 2160 Telephone 682 3144

Agents: Melbourne 88 5282 / Adelaide 269 2544 / Brisbane 36 1277 / Perth 68 7111

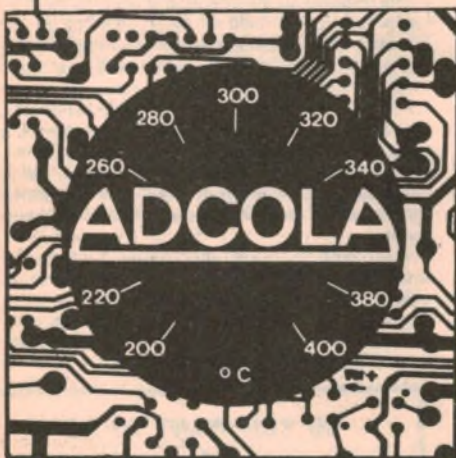

Uncontrolled soldering temperatures may have been adequate in the valve and socket era, but today's solid-state devices and printed circuits are easily degraded by excess heat. This controlled-temperature soldering equipment protects your circuits . . . and your reputation.

### ADCOLA PRODUCTS

Melbourne, 848 3777. Sydney, 709 5293.  
Brisbane, 52 3166. Adelaide, 42 6655.  
Hobart, 34 2233. Launceston, 31 2511.  
Perth, 81 5500

# Non-destructive soldering



## THERMATIC

Mains voltage. Variable, electronic feedback temperature control. Solid-state sensing and switching. Three times the heating power of conventional tools for fast heat-up and heavy duty soldering.

- For less critical applications, the DUOTEMP idles on half-wave AC at the recommended soldering temperature. Converts to full-wave, doubling power for long sequences or heavy duty soldering.
- For more critical applications, the ECT series low voltage soldering stations provide complete safety, zero tip potential, and accurate, dial-selected, infinitely variable temperature control.



# Shortwave Scene

by Arthur Cushen, MBE



Verification from a small radio station in the tiny country of Bhutan adds another country in Asia to the short-wave listener's collection of interesting stations.

A new country for short-wave listeners is Bhutan which has now been heard in both Australia and New Zealand during its regular transmission each Wednesday 1230-1330GMT on 7040kHz. Bhutan is a small state in the Eastern Himalayas bounded by Tibet, Bengal and Sikkim. The station verified John Durham, Meremere, NZ, with a letter in English. The Broadcasting organization is that of the National Youth Association of Bhutan and the verification is signed by Mrs Brigitte Dorji.

Last September the ARDC arranged a special program from this station and the success was such that broadcasting was put on a weekly basis. The verification letter indicated that the power was 300W and that signals are now being received over a wider area with reports coming from Japan and New Zealand. The address of the station is Radio N.Y.A.B., PO Box 1, Thimphu, Bhutan.

## RECENT VERIFICATIONS

**PERU:** Radio Inca del Peru at Lima has verified Stephen Greenyer of Invercargill NZ with a card and a letter, confirming his reception on 4762kHz. The verification was signed by the Director General, Augusto S. Ireis. The address of the station is Corporación Electronica Peruiana, Ave. Nicolas, Pierola 533, Lima, Peru.

**INDONESIA:** RRI Banjarmasin has confirmed our reception with a letter in English. The station operates: 2200-0100GMT on 3250kHz, 0400-0700 on 5970, and 0900-1500 on 3250. The letter expressed a wish for further reception reports.

**ANDORRA:** A verification card has been received, confirming our reception on 6230kHz at 0610GMT during October. The card shows a group in native dress, with the mountains in the background. The address is PO Box 1, Andorra.

**INDONESIA:** Radio Pekanbaru, using 5885kHz and heard at 1500GMT, has confirmed reception of a report from Paul Edwards of Wellington, NZ with a letter in Indonesian. According to the Finland DX Club, Radio Pekanbaru has a new station manager, Mr Azil Azwar, who verifies letters with an English reply. He earlier signed verification letters at Radio Djambi.

**AUSTRIA:** The Austrian Army Radio has confirmed our reception with an oblong card received after four months by seemail. The station now operates on 6221kHz using 1kW and was heard around 1900GMT. According to the card the schedule is 1400-1900GMT.

## NEW ENGLISH SERVICE

Announcements in English from stations in Central America are not very common, but one of the latest to introduce English announcements is Radio Reloj in San Jose, Costa Rica.

According to the announcement heard at 0700GMT on Sunday they are requesting reception

reports. The full announcement is "You are listening to Aque Costa Rica, a weekly program that comes to you on Sundays at 0700GMT and on Tuesdays at 0300GMT over Radio Reloj on 6006 and 4832kHz. If you wish to receive our souvenir QSL card simply request it by writing to Aque Costa Rica, PO Box 3936, San Jose, Costa Rica".

These two transmitters operate 24 hours a day and are frequently heard around 0700GMT with the signal on 6006kHz being the stronger of the two. The only other station in Costa Rica which has English announcements is TIFC, which has gospel programs.

## PHILIPPINES SIGNALS

The Far East Broadcasting Company in Manila has made a frequency change for the service to Australia and New Zealand and now operates on 11765kHz instead of 11890kHz. The English transmission is 0800-1000GMT, followed by a 30 minute session in Russian. Another frequency which is carrying the same program is 11850kHz, but this channel is mixed with Paris during the time of the transmission.

The Philippines Broadcasting Service, which is operated by the Government, now has an External Service 0700-1855GMT on 9580kHz. The transmission is now in English. The portion of the broadcast previously beamed to South Asia and carried in the languages of that area has been discontinued.

## INDONESIAN MW SIGNALS

The gradual move to medium wave by stations in Indonesia is apparent when listening in the mornings. Signals have been heard on many split frequencies.

Our reception has included Jember on 963kHz, which has light orchestral music with a female announcer up to 1558GMT when the station closes with the usual RRI announcement and a good-night melody. Jogjakarta on 1107kHz has also been heard, and this station relays the news from Jakarta at 1500GMT. Another strong signal, RRI Sumenep using 10kW, has been heard on 1097kHz with news from Jakarta at 1500GMT and local announcements interspersed with portions of March Militaire at 1515GMT.

Other signals were heard and noted, including: 540, Bandung; 585, Surabaya; 756, Purwokerto; 864, Cirebon; 972, Surakarta; and 1008 Maduin. All these signals have been noted around 1500GMT by members of the Australian Radio DX Club and in New Zealand.

## NEW FREQUENCIES

On March 6, several stations made frequency changes. Radio Canada, for their transmission to the South Pacific 2000-2100GMT, are now using 11865kHz in place of 15290kHz. The frequency of 11865kHz was tested for a week in January and the frequency found to be satisfactory. The new channel is being used along with 15325 and 17820kHz.

Radio Nederland, which has been reported testing on 9895kHz, has also been using this frequency on a regular basis from March 6. The frequency is used 0930-1050GMT in English, 1230-1350 in Spanish, 1400-1520 in English and 1530-1645 in Dutch. The transmitter is located in Lopik, Holland.

Radio Budapest is using the new channel of 6040kHz for its external service broadcasts in Greek,

Turkish, German, Hungarian, English and Italian in the period 0700-1300. This has replaced the scheduled 6150kHz, according to the BBC Monitoring Service.

The Deutsche Welle relay station in Antigua has introduced some new frequencies on a regular basis, as well as three additional programs carried on the 250kW transmitters. The Spanish broadcast is heard 1000-1130GMT on 9735kHz, Portuguese 1000-1035 on 6145kHz, and English 1300-1320 on 9605. These new transmitters bring the number of transmitters now used by Deutsche Welle from sites in Germany and relay bases overseas to 27.

## LISTENING BRIEFS EUROPE

**BULGARIA:** Radio Sofia has been heard in a new transmission in Spanish on 5915kHz from 0430 to 0500GMT. This is a new transmission to Central America, but reception is spoilt by severe interference. Radio Sofia has retimed its program to North America and this is now broadcast 0430-0500GMT. Only one frequency is used, 7115kHz, which gives good reception.

**HOLLAND:** Radio Nederland has been noted on the out of band frequency of 9895kHz from 0930-1050GMT in a transmission in English for Europe. The frequency is given as a test. Robert Chester of Adelaide reports the same frequency in use for a test 1400-1520GMT.

**MONACO:** Trans World Radio at Monte Carlo is using 7125kHz on Sunday 0725-0900GMT, according to John Mainland of Wellington, NZ. This frequency replaces 7105kHz which is still used on weekdays.

## AFRICA

**SOUTH AFRICA:** Radio South Africa is using a new frequency of 11800kHz and opens at 1758GMT with a program in French. The program is switched to Portuguese at 1856GMT, with French again observed at 2000GMT.

**SEYCHELLES:** FEBA in the Seychelles has been heard on 9700kHz opening at 0311GMT, followed by a program in Swahili from 0315GMT. At 0330GMT an English announcement is given. Then follows a 30 minute program in English mainly directed to younger listeners. Some interference from AFRS is noted on the frequency at 0400GMT.

**SOMALIA:** Radio Hargeisa has been heard on 11646kHz with a music program and news in Somalia at 1530GMT, according to Dene Lynneberg of Wellington.

## ASIA

**INDONESIA:** Craig Tyson of Wembley, WA, reports a new Indonesian station on 6011kHz. The identification is Radio Khusus Pemintah Bandung and it has been heard from 1015-1150GMT. The station broadcasts English popular music and has frequent announcements in Indonesian. Reception has been observed as early as 0945GMT, but after 1000GMT there is some sideband interference from VOA Okinawa using 6010kHz.

**TURKEY:** The Turkish Police Radio has been observed by John Mainland of Wellington, NZ, on 6340kHz. The reception was at 0645GMT and the station has Turkish announcements and music. The broadcasts are carried on a 1kW transmitter and originate from studios in Ankara.

**SRI LANKA:** A new frequency for the All Asian Service of the Sri Lanka Broadcasting Corporation has been observed at 1245GMT. Our reception was on 6015kHz which carried the English program up to this time and left the air without any closing announcement. It is presumed that this frequency has replaced 6010kHz.

**SAUDI ARABIA:** According to the BBC Monitoring Service the "Holy Qu'ran Station" at Riyadh now transmits on 17875 instead of 17755kHz.

**IRAN:** According to announcements, the short-wave transmissions of Radio Teheran in Persian are from 0430GMT on 15315kHz; 0600 on 15084; 0630-1630 on 17730; and from 1900 on 7215. This domestic service relay is reported by the BBC Monitoring Service.

**IRAQ:** Radio Baghdad's domestic service, "Main Program", in Arabic is now heard on the new frequency of 7115kHz from approximately 1145GMT until the end of the transmission at 2320GMT. ☉

Notes from readers should be sent to Arthur Cushen, 212 Earn Street, Invercargill, NZ. All times are GMT. Add 8 hours for WAST, 10 hours for EAST and 12 hours for NZT.



# L.E. CHAPMAN

EST. 1940

103 ENMORE ROAD, ENMORE, N.S.W. 2042. PHONE 51-1011  
NEW Postage Rates Please Add Extra.

## ELECTROS

1000 MFD	10volt	10 for \$1
47uF	35v	10 for \$1
47uF	16v	10 for \$1
47uF	200v	5 for \$1
47uF	25v	5 for \$1
220uF	10v	10 for \$1
0.39uF	160v	10 for \$1
500 MFD	12v	5 for \$1
70 MFD	45vac	5 for \$1
47uF	160v	5 for \$1
6.8uF	1500v	10 for \$1
15uF	400v	5 for \$1

**SUPER QUALITY CROSS OVER CONDENSERS FOR 8/OHM SPEAKERS 50 CENTS.**

## POWER TRANSFORMERS

60 MIL 240V 245 ASIDE 6.3 \$5.  
80 MIL 240V 245 ASIDE 6.3 \$6



## SPEAKER TRANSFORMERS

7000 to 15/OHMS \$1.75  
1200 to 15/OHMS \$1.75  
7000 to 3.5 OHMS \$2.50

## TRANSISTOR 7 RADIO

Complete with 3 1/2 inch speaker  
No cabinet \$3.95

## T.V. TUNERS

Pye Eaf 002  
Complete with  
valves \$5



## B.S.R. CERAMIC STEREO

\$5

Pick up Cartridges  
Universal Type

## SPECIAL COLOUR TV CHASSIS & BOARDS

Some complete \$1 to \$20  
Counter sales only on these items



## SUPER SPECIAL OUTPUT TRANSISTORS

AD 161  
162 K5 \$2.50 A PAIR

## SLIDE POTS 50k 4 for \$2

Mixed Transistors  
10 Different Values \$2

## CASSETTE TAPE DECKS COMPLETE EXCEPT HEADS

\$10.



## SPEAKER SPECIAL

2 1/2 INCH 8/Ohm 2 for \$1.

## VALVES

SASA 11.50	66J6 11.50	88N8 11.50	1723 11.50
6AN7 11.50	12AN7 11.50	PCF80 11.50	8W6 11.50
6BL8 11.00	60B5 11.50	9U8 11.50	21H85 11.50
6BM8 11.20	6B75 11.50	6AB4 11.50	6BX7 11.50
6D7A 11.00	6AL8 11.50	6E8 11.50	6BX9 11.50
6CM5 11.50	6BJ5 11.50	6BW8 11.50	11AR11 11.50
6D06 11.50	6CK6 11.50	12AX7 11.50	17BF11 12.00
6AL3 11.50	ECC81 11.50	12AZ7 11.50	8BF6 11.50
1S2 11.20	6A28 11.50	1X2B 11.50	6BA8 11.50
6S2 11.20	60C8 11.50	6V4 11.00	6CT7 11.50
6AC1 12.00	6B15 11.50	6V9 11.50	ECC89 11.50
6C25 11.50	12AT6 11.00	6V9 12.00	6CH6 11.50
354 11.00	15CW5 11.50	6U9 12.00	12AX4 11.50
6AT6 11.00	19V3 11.50	6A08 12.50	EV51 11.50
6AM8 11.50	80A4 11.50	6AH4 11.50	PCC85 11.50
6AB8 11.50	60B5 11.50	50E5 11.50	1654 11.50
6BR8 11.50	6BF8 11.50	RC15 11.50	6A24 11.50
6BCC 11.50	60C8 11.50	6AK5 11.50	EV88 11.50
50E5 11.50	30AE3 11.50	1T4 11.00	6AM6 11.50
UCL82 11.50	12AX4 11.50	6C07 11.50	9AR8 11.50
6AM6 11.50	EF39 11.50	PCL83 11.50	60C8 11.50
6S47 12.50	EF9 11.50	12AD5 11.50	UBC81 11.50
6R06 12.00	15CW5 11.50	6BK7 11.50	6BW8 11.50
1B3 11.50	6AU5 11.50	6JN8 11.50	PCC84 11.50
6BC8 11.50	6BF5 11.50	16A5 11.50	7AN7 11.50
6B84 11.50	50E5 11.50	6BN4 11.50	9JW8 11.50
12AU7 11.00	8E36 11.50	60B5 11.50	PCF80 11.50
6EAB 11.50	U141 11.50	60N6 11.50	6CUB 11.50
155 11.50	35W4 11.50	60J8 11.50	70J8 11.50

## PICK UP ARM BALANCED COMPLETE WITH CARTRIDGE \$9.00

Fuses 3/4 amp 10 for \$1  
500MA ..... 10 for \$1  
10 amp pigtail 10 for \$1

## MEGOhMETER EX LAB \$25

B.S.R. record changer  
C142 magnetic cartridge  
balanced arm etc

\$46

## WAFER SWITCH

4 pos 15 cents,  
2 pos 50 cents



T.V. Tuner \$10

**SPEAKER CABINET** including 2 dual cone speakers, 6 1/2 inch 10 watts RMS \$16. Size 16 1/2 x 10 1/4 x 8. Pack & post Interstate \$5 a pair, NSW \$3.00.

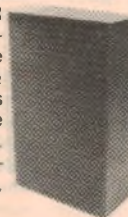

**STEREO AMPLIFIER** tuner 5watts per channel, complete ready to use, shop soiled \$25.00. Pack & post \$1.50. Interstate \$2.50.

## Super Special

B.S.R. Record Changer 12 inch turntable Balanced Arm cueing device etc \$35 pack and post \$2 interstate \$2.50



VU METER \$3.00 pair

Gramophone Motor & Pickup B.S.R. 4 Speed \$7.95



## LEVEL AND BALANCE METERS

12.000 ohm 100 Microamps \$2

# BARGAINS BARGAINS BARGAINS BARGAINS

Hook up wire 30 mixed colours \$1  
250 mixed screws with self tappers, bolts, nuts, etc \$1.25 + postage 50c  
100 mixed radio TV knobs including fine tune & channel change \$5.00  
1/2 meg double pole switch pots 50c  
Speaker Cabinets, Size 16x10x8 including 2 6 1/2 inch dual conespeakers \$18 each  
Mixed pots 30 including ganged & concentric \$5  
Morganite & IRC 33 useful valves fresh stock \$2.00 + postage 50c  
Slide switch 3 position 50 cents  
50 ohm Pots ideal for ext. Speakers 50 cents  
Transistor and Driver Speaker Transformers \$1.00 pair. Ferrite Rods 6 1/2 x 1/2 inch 50 cents  
Pots 30 mixed values including ganged and concentric \$5  
In Line Fuse Holders 20 cents  
Stereo Speaker Wire 12 cents yard  
100 Mixed TV and Radio Knobs including Fine Tune and Channel Change \$5  
Car radio suppressor condenser 30 cents  
Special—Stereo Amplifier 3 watts per channel RMS 240 volt bass & treble

boost controls. Includes fancy chrome face plate \$10  
Electros 3 in one 100-25-40, 24-250-300 50-250-300 75 cents.  
Screw in 6 Volt Pilot Lights \$1.50 for 10. Plug-in type 10 for \$1.00.  
100 mixed condensers micas polyester ceramic \$2 per pack and post 45c  
3.5 to 3.5 Jack Plugs 7ft Shielded Cable 75 cents, 6.5 to 3.5 Jack Plugs 7ft. Shielded Cable 75 cents  
Mixed Tag Strips 50 cents for Dozen.  
Special Fancy chrome knobs Ideal for amplifiers, 5 for \$1.  
Tape Recorder Heads Transistor—Top quality suit most recorders \$5.00  
Jack Plug Sockets 6.5 mm 35 cents  
Morganite and IRC resistors 33 values \$2 per 100 pack and post 45c  
Philips Gramo Motor and Pickup 4 Speed 6 Volt \$7.75.  
Crossover Condensers 2 mfd 60 cents  
Crystal Microphone Inserts \$1.00.  
Microphone Transformers 50 cents  
Switch Wafers: 11 position 20 cents  
Perspex tops for record players size 12x8 1/2 x 3 1/4 \$1.50  
Pots: 50k 50 cents, 1M 50 cents

Tape Spools: 7 inch 75 cents 1/2 Meg Double Pole Switch Pots 50 cents  
Coaxial TV Feeder Cable 75 ohm 30 cents yard.  
Jack Plugs 6.5 mm 50 cents; 3.5 mm 25 cents R.C.A. Plugs 25 cents.  
Speaker Special 2 1/4 inch MSP \$1.6 x 4 3/8 ohm \$3.50 Magnavox 5 inch 8 ohm 4 MSP 4 inch 3 ohm \$2.50  
Hook Up Wire 30 mixed colours lengths \$1 bag  
Speaker 4 pin plugs 15 cents 25 mixed and 5 and 10 Watt resistors \$2.00  
250 mixed screws, BSA, Whit self-tapper bolts, nuts, etc. \$1.25 bag plus 40c post  
BSR Stereo Player Model P-12B \$52 pack and post \$1.50 Interstate \$2.00  
TV Aerials Complete Range Hills Color \$12 to \$60  
Car radio aerials, lockdown, top quality extended 1600 mm \$4.50  
Electros 3-in-one: 20, 400, 450, 10, 400, 450, 75, 50, 65 \$1.00  
AWA 11 inch P.I. TV EHT transformers \$5.00  
Power Transformer 60 mil 240 volt 36 volt Centre tap 6.3 winding \$5

Mics Dynamic 10k \$3.50  
Valve Sockets: 7 or 9 pin 10 cents Octal 10 cents.  
Power transformers 60 mil 225v aside 6.3 winding \$5 small power transformer 240v, 220v and 22v windings \$3  
Pilot Lights: 24 volt screw-in, 10 for \$1.50  
Ferrite Rods 6 inch 50, 9 x 1/2 75 cents  
Pots: 10K ganged log 50 cents; 1 Meg ganged log \$1.25, 1/2 Meg ganged log \$1.25, 2 Meg ganged log \$1.25;  
2 Meg double pole switch \$1.50  
Sharp TV Flyback Transformers 8 FT 604 \$7.00  
Miniature Speaker Transformers, drive and output \$1.00 pair  
Heat Sinks: 4 x 2 1/4 \$1.50  
Speaker Transformers 7000 to 15 ohm \$1.75  
National 3 in one woofer mid range and tweeter 15 ohm 10 inch \$32  
Picture tubes 17 inch 90 deg new \$19.  
Speaker Cabinets 7 cu. ft. 32 watts RMS 8 ohm including speakers \$37 each  
Picture Tubes—New 110 Deg 17 inch \$15

# SPEAKERS SPEAKERS SPEAKERS

6 1/2 Inch Dual Cone 4 ohm \$5.00  
4 x 2 8 ohm \$1.50  
Special 12 inch dual cone MSP TACX 8 ohm \$8.00  
8 TACX 8 ohm \$8.00  
6 x 9 in 8 or 15 ohm \$6.00  
5 x 7 in 8 or 15 ohm \$5.00  
6 1/2 inch 8 or 15 ohm \$4.50  
6 x 4 8 or 15 ohm \$3.50  
5 x 4 15 ohm \$2.50  
4 inch 8 ohm \$2.75  
5 inch Tweeters 8 ohm \$3.50  
6 inch Dual Cone Tweeters \$6.00  
5 inch Magnavox Dual Cone 8 inch 27 ohm \$6.00

Magnevox midrange 5 inch dual cone \$8.00  
MSP 6 x 7 inch 3 1/2 ohm \$1.50  
Rola 5 x 4 inch 3 1/2 ohm \$8.00  
Magnevox 5 inch 15 ohm \$6.00  
MSP 2 1/4 inch 8 ohm \$5.00  
Magnevox 5 inch 4 ohm 8 Watt \$4.50  
Magnevox 5 inch 15 ohm \$4.50  
Philips Gramophone Motor & Pickup 6 volt \$9.50  
Pioneer horn-type Tweeter 3 inch \$2.50  
Magnevox 6 inch 3 1/2 ohm \$2.75  
Pioneer horn-type Tweeter \$3.50  
Pioneer midrange 5 inch \$6.00  
MSP 6 x 2 \$6.00  
MSP 4 x 2 5 ohm \$6.00

MSP 6 x 4 47 ohm \$8.00  
ROLA 6 x 7 47 ohm \$6.00  
ROLA 6 x 9 47 ohm \$6.00  
Magnevox 5 inch 8 ohm \$4.00  
Magnevox 10 Watt \$12.00  
Pioneer 3 1/2 inch 45 ohm \$3.50  
Magnevox 6 x 8 inch 3 1/2 ohm \$5.00  
Magnevox 5 inch mid range 8 ohm \$6.00  
MSP 8 inch dual cone 8 inch \$5.00  
Magnevox 10 inch dual cone 15 ohm \$10.00  
MSP 8 or 5 inch 3 1/2 ohm \$3.50  
MSP 4 inch 120 ohm \$3.50  
4 inch 120 ohm \$4.50  
2 1/4 inch 33 ohm \$2.00



# INFORMATION CENTRE

**LM317K REGULATED POWER SUPPLY:** I have constructed the Regulated Power Supply as outlined in the August 1976 issue. After checking over the circuit and finding it in order, I tried out the supply, and found the voltage could be regulated from 0 to 30 volts, and the current from 0 to 1-7/8 amps.

However, after about ten minutes use powering a 12V car radio the output of the regulator dropped to 1V. A new LM317K IC was installed, and the supply was again found to be normal. The same loss of regulation occurred when attempting to power the car radio, however.

The load was well within the capabilities of the power supply as the car radio was rated at 12V and 2A, and had no shorts in the input. I am now in a quandary as to the possible cause of the trouble, and would appreciate some advice. (L.K., Wyalkatchem, WA).

• You state that your regulator was only able to supply 1-7/8 amps and that you attempted to supply a 12V 2 amp load with it. From your description of the resulting "failure" of the LM317K devices, it appears that they are simply current limiting to prevent excessive power dissipation. The LM317K is essentially blow-out proof, so we suggest that you check the operation of both devices again with a more suitable load. They are probably quite normal.

**PLAYMASTER 760 ORGAN:** I have just completed your organ project according to the instructions given in the relevant issues. I find, however, that I can get little response (in terms of volume) from the flute and horn voices. Also there is no effect at all from the vibrato control potentiometer. While the latter may be

due to a bad connection, it seems odd that the flute and horn voices should give feeble signals. I should be grateful if you could give me some advice as to what might be incorrect. (K.C.B., South Yarra, Vic.)

• The vibrato control should certainly work, while the two voices you quote should give anything but a feeble signal. In fact the flute voice tends to be the loudest of the four, if the circuit is working correctly. It sounds as if you may have either a wiring error or a component fault in the keying line or stop filter sections of the circuit—and also a fault in either the vibrato pot or the wiring to it.

**CALCULATOR KEYBOARDS:** I am writing to warn other readers so that they will not fall into the same trap as myself. Recently I bought a cheap calculator, with the idea of using its keyboard and display as a low-cost terminal for my microprocessor. Unfortunately the way in which the keyswitches were made as an integral part of the PC board, and the way the PCB wiring interconnected them, made it much more difficult than one would expect. The PCB connections did not lend themselves at all to a straightforward encoding scheme, and when I tried to disassemble the keyboard, I had to damage the adhesive plastic membrane which holds all the spring-metal switch slivers in place. Rewiring was long and difficult, and the overall result was not a success. So the moral is don't buy any old low-cost calculator with the idea of using it for this purpose. If any other readers know of a calculator which does have a suitable keyboard, I would be grateful to hear from them. (J. P., Canberra ACT.)

• Thanks for the warning, J.P.—it may

If you are unable to complete an "Electronics Australia" project because you missed out on your regular issue, we can usually provide emergency assistance on the following basis:

**PHOTOSTAT COPIES:** \$2 per project, or \$2 per part where a project spreads over multiple issues. Requests can be handled more speedily if projects are positively identified, and if not accompanied by technical queries.

**METALWORK DYELINES:** Available for most projects at \$2 each, showing dimensions, holes, cutouts, etc., but no wiring details.

**PRINTED BOARD PATTERNS:** Dye-line transparencies, actual size but of limited contrast: \$2. Specify positive or negative. We do not sell PC boards.

**REPLIES BY POST:** Limited to advice concerning projects published within the past 2 years. Charge \$2. We cannot provide lengthy answers, undertake special

research or discuss design changes.

**BACK NUMBERS:** Only as available. Within last 6 months, face value. 7-12 months, add 5c surcharge; 13 months or older, add 10c surcharge. Post and packing for 60c per issue extra.

**OTHER QUERIES:** Technical queries outside the scope of "Replies by Post" may be submitted without fee, for reply in the magazine, at the discretion of the Editor.

**COMMERCIAL SURPLUS EQUIPMENT:** No information can be supplied.

**COMPONENTS:** We do not deal in electronic components. Prices, specifications, etc., should be sought from advertisers or agents.

**REMITTANCES:** Must be negotiable in Australia and made payable to "Electronics Australia".

**ADDRESS:** All requests to the Assistant Editor, "Electronics Australia", Box 163, Beaconsfield, 2014.

## printed circuits

- Accurately machine printed / etched
- Phenolic & fibreglass-gold / tin plated
- Special manufacturers packs of 10
- EA, R & H, ET, Philips, Mullard available
- Specials to your drawing
- POSTAGE small 60c, large \$1.00

ET632C	8.00	ET632B	6.50	ET132	2.50
77UT2	3.00	77F1B	2.50	ET632A	6.50
ET633FR	6.00	77UT2	3.00	77F1A	3.20
ET632P	2.50	ET632M	7.50	ET633	6.00
ET482A	6.50	76CL12	2.50	ET482B	2.80
76B4	2.60	ET480PS	2.50	ET630	2.20
ET631	7.00	ET630	2.20	ET480	2.80
ET064	2.00	ET449	2.20	ET066	2.20
ET448A	2.20	ET448	2.80	ET804	2.80
ET711B	2.20	ET068	2.00	ET711C	2.00
ET044	2.00	ET043	2.00	ET061	2.00
ET711R	2.50	ET7110	6.00	76M19	3.50
ET544	2.50	76PC9	4.40	ET447	2.80
ET602	6.50	ET446	2.50	76EX10	2.80
ET711A	7.50	ET543B	2.50	ET533A/C	3.50
ET445	2.50	ET241	2.50	ET543A	2.50
ET780A	3.00	ET541	2.50	ET780B	2.50
76S7	2.50	76M17	2.50	ET444	2.50
76SS6	3.00	76SW4	2.00	76LM5	2.50
76M5	2.50	76VG5	5.00	76R4	2.50
76VG5	5.00	76M5	2.50	76E04	3.00
ET708	2.50	ET740A	4.50	76R4	2.50
ET514	2.50	ET707A	2.50	ET740B	3.50
ET706	2.50	ET130	2.50	ET707B	2.50
76T2	2.50	76A03	2.50	76RT3	3.00
78E02	5.50	75SWILA/8pr	4.00	76G3	2.50
75PC12	2.50	EA76F1	2.80	DRS-RC1	4.00
ET514	2.50	ET129	2.50	ET534	2.50
ET439	3.00	ET420G	2.50	ET729	2.50
ET123A	2.50	ET119	2.60	ET123B	2.50
75L11	2.50	ET438	2.50	75F2	2.50
75F12	2.80	ET1124	2.50	75V12	2.50
75CL9	2.50	75PC12	2.50	ET122	3.00
ET120	2.50	ET118	2.50	ET121	2.50
ET704	2.50	ET500	2.50	ET117A-B	2.80
75R7	3.00	75CD7	2.50	75T19	2.50
75TU10	3.50	75FE5	2.50	75FM5	2.50
75TU9	3.50	ET533A-B	2.50	75TU8	5.00
ET400	2.50	75W3	2.50	ET440	4.50
ET529B	3.30	ET529A	4.50	ET532	2.50
ET801R	2.60	ET801P	2.50	ET702	2.50
75EM6	2.50	75SD4	2.50	EBST	3.00
ET414E	2.50	ET41402	3.20	75A01	2.50
ET314	2.50	ET118	2.50	ET430	2.50
EBK1	3.00	ET528	2.50	EBS	3.00
75D1	2.50	74MX12D	3.50	ET312	3.00
74MX12B	3.20	74MX12A	2.80	74MX12C	2.60
ET527	2.50	ET428	2.80	ET701	2.50
ET530	2.50	ET427	2.50	ET313	2.50
74MX8	2.50	74EM9	2.50	ET428	2.50
ET429	2.50	EBX	5.00	74TU8	2.50
EBP	5.00	EBM	5.00	EB10T	5.00
EBA	5.00	EBT	5.00	EBD	5.00
EBC	6.00	74C9	4.20	EBF	6.00
ET424	2.50	ET311	2.50	7408	4.00
ET114	2.50	74SA5	4.00	ET528	2.50
ET601L	2.50	ET422	3.30	ET601M	2.50
ET601J	3.00	ET423	2.50	74S3	2.50
ET521B	2.50	ET601H	2.50	ET420E	3.30
74A1	2.50	74HPL	2.50	ET601G	2.80
ET601D	2.50	ET601C	2.80	7312T	2.80
ET420D	2.50	ET420B	2.80	ET420C	2.50
ET524	2.80	ET601B	3.30	ET420A	2.50
ET601F	2.80	ET601E	3.90	ET601N	3.90
73TU11	2.80	73P11	2.80	ET601A	3.30
73C12	4.90	73BA9	2.80	ET520A-B	4.40
ET419	2.50	ET218	3.50	ET113	3.10
ET309	2.80	ET414D	2.50	ET417	2.50
73S6	2.50	ET521	3.90	73TU7	2.80
ET416	3.30	73D1	2.50	ET213	2.50
733C	2.80	73T1	2.80	ET518	2.50
				ET414C	2.80

### ALL SILICON 30/60w PA PORTABLE AMPLIFIER

6 1/2"W x 3 1/4"H x 8 1/2"D 12-16V two inputs 5 & 100mV 15 ohm output No 763D Also 125 250 500 ohm output No 763A All \$70 each. For 240V operation \$33 extra. Freight collect.

**COILS and IF's** 3/4" x 1/4" x 2" H. All \$2.50 ea plus post 60c.  
**RF CHOKES** Plus post 80c.

381 AIR 2.5mh 50ma—Pye 70c.  
381 IRON 10uh to 1,000uh 25ma 70c.

**FILTERS** 27 Line filter 2 amp \$14  
29 Line filter 10/20 amp \$37.50  
Plus Post \$1.50 30 Pulse filter 2 amp \$14

MAIL cheque or money order (add postage) direct to:—

**RCS radio pty ltd**  
651 FOREST RD BEXLEY  
NSW 2207 587 3491



# Sanwa precision circuit testers— Big on features. Bigger on selection.



1

2

3



4

5

6

7



**WARBURTON FRANKI**  
ADELAIDE 356 7333 BRISBANE 52-7255 HOBART 23-1841  
MELBOURNE 69-0151 PERTH 65-7000 SYDNEY 648-1711  
WELLINGTON, N.Z. 698-272

**Sanwa**  
MULTITESTERS

1. **BX-505**
  - Fast-response, 24 $\mu$ A movement — fuse & diode protected with high resolution factor (0.4 $\mu$ A/scale division)
  - Revised scale marking — intermediate readings readily determined
2. **U-60D**
  - 44 $\mu$ A movement — quality performance, diode protected
  - Stable ACV measurement — solid-state rectifier & enlarged frequency coverage
3. **SP-10D**
  - Easy operation — multiposition rotary selector switch & well-lighted scale
  - Stable ACV measurement — durable diode rectifier
4. **N-501**
  - 2 $\mu$ A suspension movement — 0.05mA/1mV resolution
  - Double protection — fuse & Si diode
5. **CX-505**
  - 16.5 $\mu$ A movement — varistor protected & 50k $\Omega$ /V for DC
  - Capacitor tester — push-button operation with solid-state oscillator built in
6. **PDM-500 (Insulation Tester)**
  - Battery operated — 3 small-size 1.5V batteries built in
  - Push-button operation — pointer calibration & insulation test
7. **CAM-201S (Clamp Meter)**
  - Measuring ranges 15-60-300A — 500V — 50k $\Omega$
  - Meter protection diode provided

# ELECTROCRAFT PTY. LTD.

106A Hampden Rd.  
Artarmon, 2064  
Phone 411-2989

Distributors of Belling Lee, Channel Master, Ecraft, Hills, HI.Q, Lab Gear, Kingray, Matchmaster. Largest Television range of aerial equipment in Sydney

**TELEVISION AERIALS, DISTRIBUTION AMPLIFIERS, EQUIPMENT AND ACCESSORIES  
WHOLESALE, TRADE AND RETAIL SUPPLIED.**

## ECRAFT

	Price
Neosid Balun 75/300 uncased	\$0 65
O.S.A.B. Outside aerial balun (water proof)	3 81
6 SB 6ft Balun Fly Lead	3 65
P.S.B. Plug and Terminal Balun	2 53
2 75 T/S 2-way 75 ohm Transformer Splitter	6 74
3 75 T/S 3-way 75 ohm Transformer Splitter	8 41
4 75 T/S 4-way 75 ohm Transformer Splitter	8 94
5 75 T/S 5-way 75ohm Transformer Splitter	12 66
2 3T 2-way 300 ohm Splitter box	4 48
3 3T 2-way 300 ohm Splitter box	5 86
4 3T 2-way 300 ohm Splitter box	7 12
Adjustable Low Band Attenuator Ch 2	5 33
10" diameter degaussing coil	24 00
Coaxial Plugs	46c

ALL TYPES OF COAXIAL CABLE IN STOCK FROM 30c PER YARD

## TELEVISION AERIALS FOR COLOUR

### CHANNELMASTER

9el Colour Crossfire 3615A	\$43 64
13el Colour Crossfire 3614A	54 69
17el Colour Crossfire 3613A	68 17
21el Colour Crossfire 3612A	78 54
24el Colour Crossfire 3617A	99 84
28el Super Crossfire 3617A	125 73
Super Coloray the 3111 Ghost Killing Aerial	41 98
2el Small Coloray 3110	27 96

### HILLS E.F.C. RANGE 75 ohm

E.F.C. 1 75 ohm	31 43
E.F.C. 2 75 ohm	41 70
E.F.C. 3/24 75 ohm	60 64
E.F.C. 4/24 75 ohm	76 30

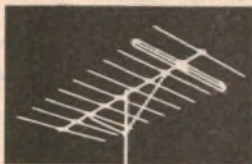

## HILLS THE NEW TELRAY RANGE— All Australia V.H.F. Channels & F.M.

6el	TL1	21 47
8el	TL2	29 52
9el	TL3	35 97
11el	TL4	43 67

## HILLS AERIALS

2010 Airways	56 26
CA16 Phased Array	44 36
Extra Gain Lift els for CA16	5 01
8el 215	24 42

## HILLS AMPLIFIERS

D5/26 Dist. 26dB gain	\$67 10
D4/16 Dist. 16dB gain	\$59 37
MH2/75 Mast Head 20dB gain 75 ohm	\$72 44
MH1/300 Mast Head 20dB gain 300 ohm	\$54 90

## FM AERIALS

Hills	2EL FM1	9 39
HILLS	3EL 353	12 98
Hills	3EL FM3	18 27
HI-Q	4EL	18 75
HI-Q	Gutter clip	12 70
Matchmaster	G2FM	19 29
Austenna	FM3F	21 95

## CB RADIO

27MHz High quality transceivers. Range up to 20 miles, 5 watts output. Switched PA. suitable for dash mounting.  
Model G.M.E. 275 6 Ch's (Post Office Approved) \$156 00  
Model G.M.E. C 555 23 Ch's \$163 00

## LAB GEAR AMPLIFIERS

### VHF

	Price
Mast head 22 dB 75 ohm	\$72 43
CM 6014/DA 20 dB	60 25
CM 6034/DA 4 outlets 8 dB each	54 90
CM 6036/DA VHF 30dB UHF 28dB	84 63
Televerta (VHF to UHF frequency converter)	67 48

## KINGRAY AMPLIFIERS

	Price
D15/500 m/V	\$48 80
D30/500 m/V	57 95
D40/600 m/V	79 30
D12/1500 m/V	67 10
MH 20 mast Head 300-75 ohm	64 63

## TELESCOPIC MASTS

20ft	\$19 30
30ft	\$30 81
40ft	42 00
50ft	54 42

18g steel in 10ft sections must be guyed.

**CDE AR.22 Rotator \$86.00**

**Stolle Aerial Rotator with Thrust Bearing for heavier rigs \$135.82**

## ALL TYPES OF HARDWARE IN STOCK

Wall Brackets, Chimney Mounts, J Brackets, Guy Rings & Guy Wire. Masts from 8ft to 50ft ETC



## INFORMATION CENTRE

save a few headaches. If any reader does know of a calculator which lends itself to a more convenient conversion, they could let us know and we will be happy to spread the good news.

**MOVIE SOUND:** I found an article in the December 1973 issue on synchronising tape with movies. I had been looking for such an article for a long time, and it was with great excitement that I read this article. Unfortunately my knowledge of electronics is very basic and the article did not describe the construction of the circuit in the detail normally provided with your projects. On behalf of the many movie buffs like myself, then, I would ask you to please consider a new and fully described project along these lines. It would find wide appeal, I am sure, especially if it used some of the new ICs which have been available. (S.G., Ermington, NSW.)

• The suggestion seems a good one, S.G., and we will see what can be done.

**741 OP-AMP:** I have tried three 8-pin dual-in-line 741 devices in the circuit shown in Fig. 5 of your article "Op-Amps Without Tears" in the December 1976 issue, without success. With all of the devices the output pin 6 stays at -6.4V regardless of the variations to the voltage on pins 1, 2, 3 and 5. I have followed the circuit exactly. What gives? I hope you can help as I am "floored". (R.H.P.-R., Killarney Heights, NSW.)

• The circuit is correct. From your letter we can only suggest one possibility: that you have mistaken the 741 connections. Connection diagrams for ICs show the device as viewed from the top, not the bottom or pin side. Hope this helps!

## NOTES & ERRATA

**RTTY TERMINAL** (March 1977, File No. 2/MS/43): In the parts list on page 48, two extra 10k resistors were specified, instead of two 1k resistors, which are shown correctly on the circuit diagram and printed circuit board overlay.

**BABY 2650 COMPUTER** (March 1977, File No. 2/CC/18): The parts list specifies only one 1N914 or similar diode, whereas two are required as shown correctly in the circuit and wiring diagrams. The quoted price of \$70 for the kit does not include sales tax; when this is included the price is approximately \$85. Note also that to allow better for component tolerance variations in the clock circuit, the 330pF capacitor should be changed to 270pF and the 10k resistor in series with the tab pot should be changed to 6.8k. These changes should ensure that all clocks may be set to the correct frequency of 1MHz. To improve ease of adjustment, the tab pot may also be reduced in value to 10k, or even 4.7k if desired.

## Learning Aid . . . from p.27

machine for the blind." The display and synthesizer are also being used to teach the alphabet, numbers, basic arithmetic and phonetics to severely handicapped pre-school children. The devices provide non-verbal children with a "voice", allowing them to answer questions in the classroom and, in addition, serve as a means by which the teacher can determine whether the child understands.

As well as being a further step forward in the Council's project to develop and evaluate computer-aided learning systems, these aids to communication form part of the application of technology to the rehabilitation of the handicapped, giving them the opportunity to live more productive lives—another example of how science is serving the citizen.

Reprinted from "Science Dimension", courtesy of the Public Information Branch of the National Research Council of Canada.

## LF converter . . . from p.53

required to resonate it at three frequencies. 840pF for 224kHz, 425pF for 317kHz and 270pF for 398kHz. If you are using a different aerial rod, then there may be some variation on these values.

If you are fortunate enough to have some test equipment at your disposal, such as a Q meter, then you only have to remove the rod and determine the amount of capacitance required for the frequency of interest.

Another method is to connect say two sections of a tuning gang across the loopstick coil and adjust it to resonance. Then remove the gang without disturbing the setting and measure the capacitance. A fixed value of capacitance, together with the 6-60pF trimmer, equal to the measured figure may then be connected across the loopstick.

With the value of capacitance determined at least approximately, adjust the slug in the oscillator coil until the signal is heard. Now the aerial rod circuit has to be adjusted for maximum response. Make sure that you have the aerial rod running at right angles to the direction of the transmitter from your location.

# LANTHUR ELECTRONICS

69 Buchanan Avenue, North Balwyn.  
Vic. 3104 P.O. Box 162. Ph. 85 4061

### ELECTRIC MOTOR

Speed controller kits. Will control any ac/dc brush type motor down to stop with no loss of torque.  
Ten amp. capacity \$10.95  
Five amp. capacity \$10.25

### LAMP DIMMER

Kits. Will control incandescent lamps down to out.  
Five amp. (1200 watt) \$7.25  
Ten amp. (2400 watt) \$8.50

### PLASTIC CABINET

Suitable for above speed controller & lamp dimmer  
\$1.75

### BATTERY SAVER KITS

Will supply dc voltages from 6 to 15.  
One amp. size \$8.95  
Two amp. size \$16.95  
Plus postage \$2.50—Balance will be refunded.

### BATTERY CHARGER KITS

Will charge 12 volt wet batteries at 2 amps \$10.25  
Plus postage \$2.00—Balance will be refunded.

### PRINTED CIRCUIT BOARD

Etching kits including piece of board, chemicals & instructions \$4.95

### SPEAKERS

Aust. made MSP High quality. Four inch 15 ohm.  
\$3.95

### CAPACITORS

Vertical can type. 2500mfd. 35vw. Three for \$4.00  
Single ended pcb mount. 2500mfd. 16vw. Four for \$2.00

### CERAMIC DISCS

• 1 mfd. 50vw. Eight for \$1.00

### AUDIO ALARM

Bell type VL-150-RM. Continuous or intermittent 2900hz tone. 5/16 volts at 18/70 ma. Diode protected \$13.95

### HYBRID AUDIO

MODULES. Sanken 10 watt. 20hz to 100khz. \$8.50

### SLIDER SWITCHES

DPDT 6 terminals. Five for \$2.00

### MAGNETIC EARPIECES

With cord and 3.5mm plug. Five for \$2.00  
PRICES include postage unless otherwise stated.  
MINIMUM ORDER VALUE \$2.00



## MOS-ENCODED, INTERACTIVE VDU KEYBOARDS

- Ideal for microprocessor and terminal use.
- Two mode USASCII coding.
- 14 keys with Control codes.
- Half Effect solid-state switch elements.
- Two key rollover.
- +5, -12V operation.

Order No: 67SW5-17EA

**\$135.00** ex tax

HM3 (\$155.25 inc. tax)

**MICRO SWITCH**

A DIVISION OF HONEYWELL

Honeywell Pty Ltd  
863-871 Bourke Street  
Waterloo NSW 2017

TEL: 69 0355



**R.H. Cunningham**  
Pty. Ltd.

Protect your instruments and equipment with

# ALERT cartridge fuses



ALERT fuses are "on guard" against electrical overloads in Electronic, Industrial and Telecommunications installations. Manufactured by Kenneth R. Beswick Ltd., U.K., the ALERT range include British Military Standards, British P.O. Standards, and many of the international specifications.

### Popular Sizes EX-STOCK

- TDC 10:** 1 1/4" x 1/4" Quick acting 100 ma to 25 amp.
- TDC 11:** 1 1/4" x 1/4" Slow blow (or delay) 60 ma to 10 amp.
- TDC 13:** 20mm x 5 mm Quick acting 63 ma to 3 amp
- TDC 69:** 5/8" x 3/16" Quick acting 25ma to 10 amp.
- TDC 123:** 20mm x 5mm Slow blow 100 ma to 2.5 amp.

Available from Wholesalers or the Australian Agents

**R.H. Cunningham**  
Pty. Ltd.

VIC.: 493-499 Victoria St., West Melbourne 3003 Ph. 329 9633  
N.S.W.: 4-B Waters Rd., Neutral Bay 2089 Ph. 909 2388  
W.A.: 256 Stirling St., Perth 6000 Ph. 28 3655  
QLD.: L. E. BOUGHEN & CO., Corner Milton & Baroona Rds., Milton 4064 Ph. 36 1277  
S.A.: Werner Electronic Industries Pty. Ltd., Unit 25, 28 Gray St., Kilkenny 5009 Ph. 268 2801

Telex: Melbourne, 31447  
Sydney, 21707 Brisbane, 41500 Perth, 93244

# Marketplace

## FOR SALE

**RESISTORS AND CAPACITORS.** Resistors all E12 values 1/4 watt carbon film 10 ohm to 1 meg 2 cents each I.R.H. GL 1/2 or GLP 1/2 watt Metal glaze 10 ohm — 470k 3 cents each or 2 5 cents over 250 1 watt 1 ohm to 1k 6 cents each or 5 cents over 100 PACKS STANDARD PACK contains 5 each of E12 values in ranges shown. COMPUTER PACK contains quantities based on general usage 1/2 watt 285 resistors \$7.00. 1/4 watt 305 resistors \$5.90 CAPACITORS ELECTROLYTICS single ended uprights Mfd 35 v w. 1, 2, 2, 3, 3, 4, 7, 10, 22, 10 cents each 33 47, 15 cents 25 v w. 100 16 cents each 220 25 cents each 470 35 cents. Polyester Greencaps 100 v w. 001, 0022, 0033, 0047, 0056, 0068, 7 cents each 01, 022, 033, 047, 056, 068, 082, 10 cents each 1, 22, 13 cents each. Poly Pack 5 cents of these values \$6.00 75 capacitors Other components see E.A. June, 1976. All components brand new from manufacturers or agents Each value of component individually packed Post and packing included in all orders over \$6.50 For orders less than \$6.50 add 40 cents for post and packing 5% discount on orders over \$35.00 10% discount on orders over \$75.00. Send orders to RAM ELECTRONICS, 575 Sydney Road, Seaford, N.S.W. 2092. Please send cheque or money order

**GOLD COAST T.V. BUSINESS** Long established, suit hand/wife team. Modern home also available if required further enquires P.O. Box. 1058 Southport, QLD 4215

**SHORTWAVE LISTENERS & DXERS:** The "Southern Cross DX Club" is for you! Members in all States. Details for 18 cent stamp to—GPO Box 336, Adelaide, South Australia 5001

**OIL HEATER** Installation Repair Business SCONE including 3 bedroom home \$38,000 stock and equipment extra. Serving Northern Hunter Valley. Great potential. Phone 065 45 2136

**COMPONENTS** and equipment for professional, industrial and consumer uses. Security, sound and control system specialists. Free Quotes. Nalco Industries, 73-5131.

**AUSTRALIAN RADIO DX CLUB** The premier DX club of Australia now in its 12th year of national operation. Catering for the interests of both S.W. listeners and DXers, the monthly bulletin covers the S.W. and M.W. spectrums. For full details enquire now to ARDXC, P.O. Box 67, Highett, Vic. 3190

**SUB-CONTRACT T.V. WORK** available to service shop in North Shore (Sydney) area. High standard of workmanship and integrity expected. Phone Beattie Electronics 456 1377.

**TELEPRINTERS** Creed 7B Teletype 15 Reperl 14. Reader 14 T D Paper, Spares, etc. 16" Transcript turntable \$80.00 B.T.R. 2 E.M.I. tape rec. \$500 Studio mon. Speaker \$40.00. Mic. \$40.00. Oscillator \$40.00 Comput Tape \$1.00 Lab. amp \$15.00. 240 D.C. Fan \$5.00. Typewriter \$5.00 A.C. D.C. Meter \$5.00 Jack field 28 panel \$10. Voltohmyst \$40.00 P.M.G. Time clock \$3.00. Studio 20 Sales 313383 367 Bourke St. Darlinghurst 2010

**SALE** of surplus, soled and ex-equipment T.V. and electronic parts. Saturday mornings until sold out. Nalco Industries 73-5131, 107 Queen St., North Strathfield.

**TELETYPES** repaired. Spare parts. Paper Rolls. Machines for Sale. NETWORK ENGINEERING, Ph (02) 211 4630.

## WANTED

**QUAD FM TUNER** valve type contact David 27A Dalton Road, Mosman 2088, N.S.W. phone 969 9286

**CIRCUIT** for 1929-30 Stromberg-Carlson "T.R.F." wireless. Australian built. Reply P.O. Box 99 Windsor 2756.

## STEREO LPS

**99 cents, 75 cents and less!**

New American 12in records. Rock & Roll and Popular artists. Agents and resellers wanted. S.A.E. for information and prices. AUDAX, 133 North Street, Toowoomba QLD 4350

## TIME CLOCKS



SANGAMO \$16.00 DAY OMIT DEVICE	HORSTMANN \$12 TYPE "K"	SANGAMO \$13.50 LESS DAY OMIT DEVICE
--	-------------------------------	--

240V 50 cs 15A Contacts

Used tested and guaranteed  
PACK & POST N.S.W. \$2.00  
Vic. & Qld. \$2.50, W.A. \$3.00

**CLOCK DISPOSAL CO.**  
P.O. Box 147  
LINDFIELD, N.S.W. 2070

## TELEGRAPH TUTOR

Applications are invited for the above position to teach telegraphy in the Telegraph Technicians Certificate and Supplementary Certificate to students attending fulltime nine-week courses

This position would suit an experienced Telegraph Technician with experience in codes, distortion measuring techniques, teleprinter logic, signalling network standards, telex switching and data transmission.

Previous teaching experience, although desirable, is not essential. Salary is in the range \$8,878—\$11,467 depending upon age, experience and qualifications. A higher salary level could be negotiated for a particularly well qualified applicant. Twelve weeks' annual leave. Government superannuation available.

For further information write to or ring:

Head of the Department of Electronic Engineering,  
(Mr K. D. Corner),

Central Institute of Technology,  
Private Bag,  
Trentham Camp Post Office,  
WELLINGTON, NEW ZEALAND



# BURGLAR ALARMS

## WE STOCK

Alarm Modules, Electronic Eyes, Photo Sensitive Cells, Microwave, Ultra Sonics, Gas/Heat/Smoke Sensors, Sirens, Bells, Pressure Mats, Door Monitors, Car/Caravan/Home/Office Hold Up Factory Alarms, Key Switches, Reed Switches, Relays, Shock Recorders, Aluminium Tape. You Name It We Have It.

## DO IT YOURSELF SYSTEMS

Pre Wired for Easy Installation, of microwave—ultrasonic, infra-red, magnetic reed contact, press mats, etc.

## PORTABLE ALARMS

## EXECUTIVE DESK ALARMS

Send 80c in Stamps for Illustrated Catalogue

N.S.W. AGENT FOR NIDAC SOLID STATE SECURITY SYSTEMS

WHOLESALE SECURITY FROM

# PROTECTOR R.C. ALARMS

119-121 Pittwater Rd, MANLY  
N.S.W. 2095 PH: 977-6433



\$17

## DIGITAL WATCH MODULE

Hours and mins. LED display Requires two 386 batteries. Make into a pendant or brooch

## ELECTRONIC TOOL KIT



\$19.75

- Tweezers
- File
- Soldering Iron
- Solder
- Philips s/driver
- 2 screw drivers
- Long nose pliers
- Flat nose pliers
- End cutters
- Vinyl Zip Case

## TS-520



The TS-520 is the final word in SSB transceivers, a superb creation from Kenwood, designed and built for serious enthusiasts around the world. It features solid state circuit throughout except for the final and drive stages.

## FM MONITOR



A 12-channel FM Monitor Receiver for low or high bands  
8110 plus crystals



## FRG-7 SYNTHESISED RECEIVER

For amateurs and short wave listeners. Electronic band changing 0.5-29.9 MHz continuous coverage. Uses Wadley loop

## Drake General Coverage Receiver

5MHz to 30MHz Battery & Mains



\$279



\$18.95

## MULTIMETER KIT

Build your own meter complete with PC board and full instructions. 16 ranges

## J.I.L. 606CB

\$310.00

The ultimate in mobile entertainment & communication.



AM/FM multiplex receiver—stereo cassette player plus 23 channel 27 MHz transceiver

PRICES DO NOT INCLUDE P&P

# WILLIS TRADING CO.

PERTH G.P.O. BOX NO. X2217, W.A. 6001

429 MURRAY ST.  
PERTH, W.A.  
21 7609 21 7600

# ELECTRONICS Supply Service

179 VICTORIA ST., KINGS CROSS N.S.W. 2011

mail order

BKX ELECTRONIC SUPPLY SERVICE,  
PO BOX 787, POTTS POINT,  
SYDNEY, NSW, 2011.

Minimum order ..... \$5.00  
Pack and Post ..... free in Australia  
Catalogue ..... 90c

## 25V and 50V PC ELECTROS

	1	10	100
1.0, 2.2, 3.3,			
4.7, 10, 22 uF	12c	\$1.00	\$8.00

47, 100 uF	19c	\$1.50	\$12.00
------------	-----	--------	---------

220, 330, 470 uF	42c	\$3.50	\$30.00
------------------	-----	--------	---------

## 25V and 50V PIGTAIL ELECTROS

1.0, 2.2, 3.3,			
4.7, 22 uF	12c	\$1.00	\$8.00

100, 220 uF	25c	\$2.00	\$18.00
-------------	-----	--------	---------

470 uF, 63 V.	30c	\$2.50	\$20.00
---------------	-----	--------	---------

1000 uF, 50 V.	50c	\$4.50	\$40.00
----------------	-----	--------	---------

2500 uF, 25 V.	50c	\$4.50	\$40.00
----------------	-----	--------	---------

2500 uF, 35 V.	75c	\$6.50	\$60.00
----------------	-----	--------	---------

## POLYSTYRENE CAPACITORS

120, 270, 470,			
820, 4700 pF	15c	\$1.00	\$8.00

## POLYCARBONATE CAPACITORS

.047, .082, 100V	15c	\$1.00	\$8.00
------------------	-----	--------	--------

.1, .33, .47,			
.56, 250V	15c	\$1.00	\$8.00

## TRANSISTORS and DIODES

BC309 (BC179)	11c	\$1.00	\$8.00
BC350 (BC177)	11c	\$1.00	\$8.00
BFY50	60c	\$5.00	\$45.00
TIP31A	80c	\$7.00	\$65.00
TIP32A	80c	\$7.00	\$65.00
TIP33A	\$1.40	\$12.00	\$95.00

	1	10	100
TIP34A	\$1.40	\$12.00	\$95.00
TIP3055	90c	\$7.00	\$60.00
2N2904	75c	\$6.00	\$50.00
2N3566	55c	\$4.50	\$40.00
PN3568	65c	\$5.50	\$50.00
PN4355	65c	\$5.50	\$50.00
2N3638	45c	\$4.00	\$35.00
40411	\$2.00	\$17.00	-

5 Amp, 100 Volt	30c	\$2.70	\$25.00
1 Amp, 1000 Volt	18c	\$1.50	\$12.00

400V, 1A bridge	95c	\$9.00	\$80.00
800V, 2A bridge	\$1.30	\$12.00	\$105.00

8.2, 12, 22, 24,			
27, 30 volt,			
400mW Zener.	14c	\$1.20	\$10.00

8.2, 16, 36, 39,			
43, 47, 56, 68,			
1.7 Watt Zener.	75c	\$6.00	\$50.00

SC141D triac	\$1.20	\$11.00	\$100.00
--------------	--------	---------	----------

## DIGITAL ICs

7400, 7413, 7440	28c	\$2.50	\$22.00
7442	55c	\$4.50	\$40.00
7445	75c	\$6.50	\$60.00
7446-7	\$1.20	\$10.00	\$90.00
7448	90c	\$8.00	\$70.00
7460, 7479	28c	\$2.50	\$22.00
7480, 7483, 7491	75c	\$6.50	\$60.00
7492, 7496,	85c	\$7.50	\$70.00
74121, 74151,	65c	\$5.00	\$45.00
74154.	\$1.20	\$10.00	\$90.00

1101 memory	\$1.20	\$11.00	\$95.00
-------------	--------	---------	---------

.25" readout common cathode	45c	\$4.00	\$35.00
--------------------------------	-----	--------	---------

## EXTRA SPECIAL

	1	10	100
Trimmers			
12 - 120 pF	30c	\$2.50	\$22.00

Reverb springs			
Plessey type	\$5.95	\$52.00	\$450.00

Valves			
6BL8, 12AU7	75c	\$5.00	\$40.00

Garrard Turntables			
3 speed, 8" platter,			
9 volt, no cartridge	\$5.50	each.	

Stereo ceramic cartridge,			
suitable for above	\$3.00	each	

3 Watt stereo amp module,			
bass, treble, balance and			
volume controls. For use			
with above cartridge. 12			
volt transformer supplied.	\$17.00	each	

5 Watt stereo amp module,			
similar to above.	\$23.00	each	

4", 3 Watt speaker	\$3.60	each	
--------------------	--------	------	--

8", 6 watt speaker	\$6.00	each	
--------------------	--------	------	--

AM Tuner module, 12 volt	\$8.50	each	
--------------------------	--------	------	--

FM stereo, AM tuner	\$27.50	each	
---------------------	---------	------	--

## LINEAR ICs

739	\$1.20	\$10.00	\$95.00
741D	45c	\$3.59	\$30.00
741T	55c	\$4.50	\$40.00
777T	90c	\$8.00	\$75.00
MC1312	\$3.95	\$35.00	-
MC1314	\$4.95	\$45.00	-
MC1315	\$8.95	\$85.00	-

## CROSS HATCH and GREY SCALE GENERATOR

Crosshatch, blank raster, and grey scale generator. Both video and VHF outputs. Suitable for connection to antenna. Runs on 9 volt battery. Complete kit with box battery and instructions....

\$23.50

Built unit, aligned and tested..

\$32.50

## SQ DECODER

Full logic SQ Decoder kit. EA Feb 1977 Complete kit with pots.

\$29.50

Similar module to above, smaller board

\$32.50

## OHMMETER

Direct reading ohmmeter kit. Complete with case and front panel. EA Feb 77.

\$16.00

## KEYBOARD KIT

Keyboard kit. EA Feb 1977. Only components on board supplied.

\$32.50

## UNIVERSITY CONVERTER

University Converter kit. Battery not supplied.

\$10.50



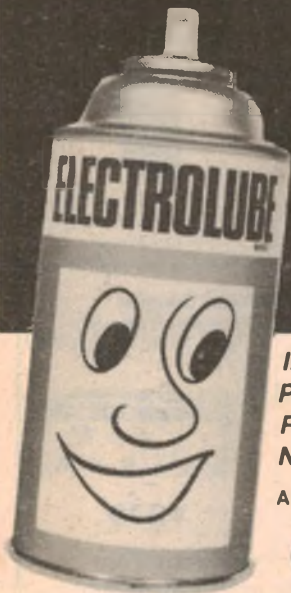

# ELECTROLUBE

REGD.

## 2A-X THE UNIVERSAL MECHANICAL AND ELECTRICAL CONTACT CLEANER AND LUBRICANT

**INCREASES CONDUCTIVITY, LOOSENS AND PREVENTS TARNISH AND CORROSION, REDUCES ARCING, REPELS MOISTURE, NON-TOXIC**

AVAILABLE FROM LEADING ELECTRICAL WHOLESALERS.



Information on 2 A-X and other Electrolube Products is available from Australian Agents:

**RICHARD FOOT (AUSTRALIA) PTY. LTD**

63 HUME STREET, CROWS NEST, N.S.W. 2065. Telephone: 43-0326.

R.F.2264B

### TRANSFORMERS:

#### 12 or 24 Volt Range: Primaries 200-240 volts

Ref. No.	Amps	Wt. Gms.	Secondary Windings	\$
242	300MA	150MA	198 0-12V at 150 MA x 2	4.93
111	0.5	0.25	283 0-12V at 0.25A x 2	5.08
213	1.0	0.5	425 0-12V at 0.5A x 2	6.38
71	2	1	793 0-12V at 1A x 2	8.13
18	4	2	1020 0-12V at 2A x 2	9.80
70	6	3	1538 0-12V at 3A x 2	11.18
108	8	4	2268 0-12V at 4A x 2	13.19
116	12	6	2722 0-12V at 6A x 2	14.13
115	20	10	0-12V at 10A x 2	21.25

#### 30 Volt Range:

Voltages obtainable: 3, 4, 5, 6, 8, 9, 10, 12, 15, 18, 20, 24, 30, or 12-0-12 or 15-0-15.

Ref.	Amps	Wt. Gms.	Secondary Taps	\$
112	0.5	623	0-12-15-20-24-30	6.73
79	1	737	" "	8.25
3	2	1361	" "	10.02
21	4	2600	" "	13.85
89	10	5670	" "	23.75

#### 50 Volt Range:

Voltages obtainable: 6, 7, 8, 10, 14, 15, 17, 19, 21, 25, 31, 33, 40, 50, or 25-0-25.

Ref.	Amps	Wt.	Secondary Taps	\$
102	0.5	737	0-19-25-33-40-50 V	8.78
103	1	1304	" "	11.40
104	2	2495	" "	12.87
105	3	3176	" "	14.88
106	4	4100	" "	18.13
107	6	5444	" "	29.40

#### 60 Volt Range:

Voltages obtainable: 6, 8, 10, 12, 16, 18, 20, 24, 30, 36, 40, 48, 60, or 24-0-24, or 30-0-30.

Ref.	Amps	Wt.	Secondary Taps	\$
124	0.5	737	0-24-30-40-48-60V	8.35
126	1	1361	" "	9.38
127	2	2495	" "	13.06
125	3	4083	" "	17.97
40	5	5670	" "	23.22

Prices do not include postage or packing. Assess postage to your address using weights given and add 5% of postage rate for packing. Trade enquiries welcome—quantity discounts on request.

**DOUGLAS TRANSFORMERS, BOX 23, COORANBONG, NSW. 2265.**

Personal Callers: 477 Freemans Drive, Cooranbong Telephone (049) 77 1431.

## SUBSCRIPTION SERVICE



**ELECTRONICS Australia**

#### Subscription Rates

\$A 14.00 per year within Australia.

\$A 17.00 per year elsewhere.

Make sure you receive every copy of the magazine by ordering it from your newsagent or the publisher. For publisher subscriptions post this coupon, with your remittance, to Electronics Australia Subscription Dept., John Fairfax & Sons Ltd, GPO Box 506, Sydney, 2001. Subscription will start with first available issue.

Name .....

Address .....

Postcode ..... Enclosed is ..... for ..... years

## Advertising Index

A & R Sonar Group	89
Ace Radio	82
Acme	60
Aegis Pty Ltd	93
Adcola Products Pty Ltd	104
Audax	110
Audio Engineers Pty Ltd	8
Audio Telex Communications Pty Ltd	11
Auditec Australia	18
Australian Time Equipment Pty Ltd	94
Auriema (A'Asia) Pty Ltd	25, 88, facing 25, facing 88
Bail Electronic Services	102
Bozark Australia Pty Ltd	10
British Merchandising Pty Ltd	91
Bright Star Crystals Pty Ltd	102
BWD Electronics Pty Ltd	24
BKX Electronics Supply Service	111
Cema (Distributors) Pty Ltd	30
Central Institute of Technology	110
CRC Chemicals	90
Chapman L. E.	106
Classic Radio	76
Clock Disposal Co	110
Convoy International Pty Ltd	5
Cunningham R. H. Pty Ltd	93, 110
C. H. S. Taylor's Warehouse Sales	47
C & K Electronics (Aust) Pty Ltd	104
Douglas Transformers	112
Dick Smith Electronics Group	36
Digiton Engineering	98
Dynetics Pty Ltd	44
Educal	16
Electrocraft Pty Ltd	108
Electronic Concepts Pty Ltd	54
Electronic Development & Sales Pty Ltd	56
General Electronic Services Pty Ltd	97
Haco Distributing Agencies	IBC
Hagemeyer (Aust)	OBC, facing 24
Harman Australia Pty Ltd	6, 14
Hawthorne Communications Centre	69
Honeywell	109
International Correspondence Schools	72
Jacoby Mitchell	78
Lafayette Electronics	81
Lanthur Electronics	109
Leo Regaly & Lewis Pty Ltd	18
Leroya Industries Pty Ltd	facing 89
Marconi School of Wireless	49
M R Acoustics	91
Peter Shalley	96
Philips	2, 70
Protector RC Alarm Systems	111
RCS Radio	107
Radio Despatch Service	65
Richard Foot (Aust) Pty Ltd	112
Royston Electronics	97
Sanwa Electric Instruments	108
Sontron Instruments	94
Sony Kemtron Pty Ltd	IFC
Stanton Magnetics	4
Star Delta Co Pty Ltd	95
Stotts Magna Sighter	98
Stotts Technical College	81, 96
Sungrature Pty Ltd	62, 86
Technical Book & Magazine Co Pty Ltd	99
Techniparts	64
University Graham	64
Vicom International	100
Video Technics	21
Warburton Franki Ltd	52
Willis Trading Co Pty Ltd	111
Wireless Institute of Australia	103
Zephyr Products	78



# Technics presents its credentials

## Linear Phase speakers



SB5000

SB6000

An excellent example of Technics continuous research policy is these two linear phase speakers. The SB6000 and the SB5000.

Linear phase speakers, in general terms, means reproduction of the original incoming signal faithfully and without "brightness" or "colour." In other words, sound that is pure, clear and with

all the "zing" and "punch" of the original sound track.

After all the better your speaker, the greater your listening pleasure.

And that's why, for the very discriminating and knowing audio enthusiast, Technics presents the SB6000 and the SB5000.

 **Technics**



### SB6000 Linear Phase 2-Way 2-Speaker System

- The 30 cm woofer gives low distortion through the low to midrange frequencies.
- The 3.2 cm dome tweeter gives high efficiency and low distortion.
- 100 watts peak power input.
- 92 dB/W (1m) sound pressure level.
- Dimensions (WxHxD): 425 x 846 x 340 mm
- Weight: 28kg

### SB5000 Linear Phase 2-Way 2-Speaker System

- A popular version of the linear phase speaker system series.
- The woofer is wide-range 25 cm.
- The 6 cm wide-range edgeless cone tweeter delivers crisp high frequencies.
- 75 watts peak power input.
- 93.5 dB/W (1m) sound pressure level.
- Dimensions (WxHxD): 350 x 717 x 323 mm
- Weight: 16kg.



For a National Technics Catalogue please write to:  
National Technics Advisory Service, P.O. Box 49, Kensington, NSW 2033  
(Specifications subject to change without notice.)



# WHY YOUR NEXT CASSETTE SHOULD BE A MAXELL UD



**1 THE RESEARCH** — More than twenty years ago, Maxell produced their first reel of magnetic tape. At that time, Maxell made a commitment to produce and sell only the finest magnetic products their technology could create. That commitment still stands today.

**2 THE TAPE** — This continuous research has led to the development of the Maxell UD (ultra dynamic) cassette. A tape that has a coating of super-fine PX gamma ferric oxide particles with an extra smooth mirror-finish surface. All of this adds up to high output, low noise, distortion free performance and a dynamic range equaling that of open reel tapes.

**3 THE SHELL** — Even the best tape can get mangled in a poorly constructed shell. That's why Maxell protects its tape with a precisely constructed shell, made of lasting heavy-duty plastic.

No fixed guide posts are used. Instead Maxell uses nylon rollers on stainless steel pins thus eliminating the major cause of skipping, jumping and unwinding.

A tough teflon (not waxed paper) slip sheet keeps the tape pack tight and flat. No more bent or nicked tape to ruin your recording.

Maxell doesn't use a welded seal, but puts the cassette together with precision screws. Result — Maxell doesn't jam.



**4 THE LEADER** — A leader tape that has a four function purpose.

- a) Non-abrasive head cleaning leader (cleans recording head for 5 secs.).
- b) 5 second cueing line (recording function starts 5 seconds after the line appears).
- c) Arrows indicating direction of tape travel.
- d) A/B side mark (indicates which side is ready for play).

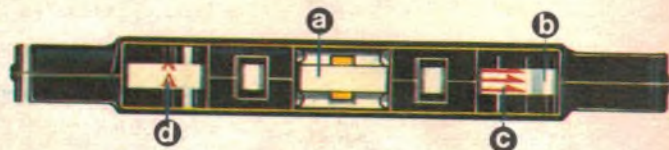

Now you know why your next cassette should be a Maxell UD (ultra dynamic).

**maxell**®

The sound expert's cassette UD available in C60, C90 and C120  
Distributed by Hagemeyer (Australasia) B.V. Branches in all States