

ELECTRONICS

Australia

with CB and HIFI NEWS

SEPTEMBER, 1977

AUST \$1.25* NZ \$1.25

**BODY
SCANNER
USES
RADIO-
ISOTOPES**

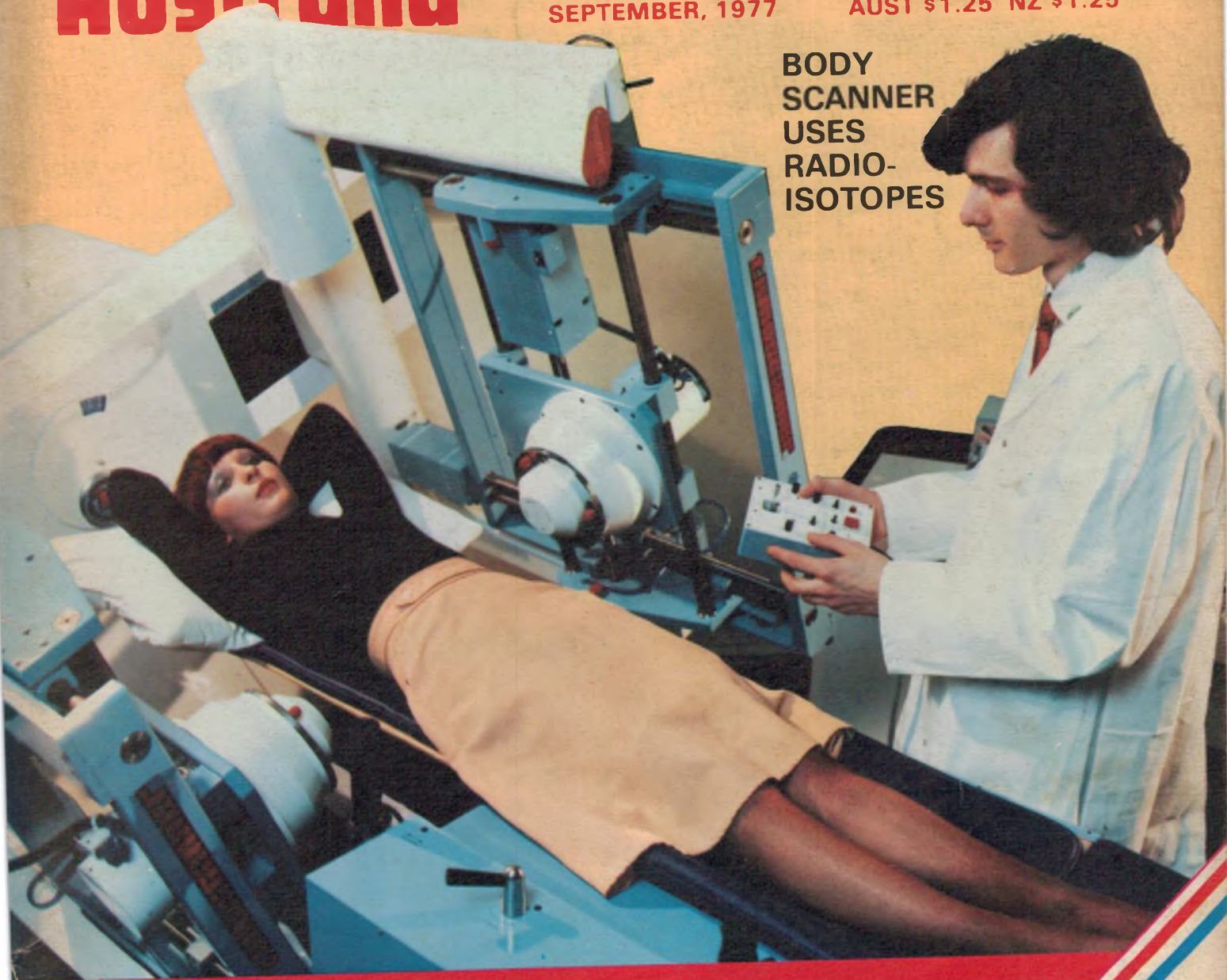

TELETEXT BEING TESTED
IN SYDNEY—SEE INSIDE

**HOW THE USA & JAPAN
ARE WAGING A TV WAR
BEGINNER'S METER
RELAY UNIT FOR
TRAILER LAMPS**

**NEW CONTEST:
WIN A CB
RIG!**

Drive Direct to the Best Sound.

The Audio Perfectionist's Direct Drive. PS4750.

Introducing another triumph of Sony research...the PS4750 that puts a new meaning on "state of the art".

In one elegant design Sony has reduced rumble, feedback, wow and flutter to levels so minute they are far below hearing and virtually beyond measurement. How did we do it?

First, we used today's most advanced direct drive system with none of the noisy belts, pulleys and idler wheels used in normal turntables.

Second, we used a new material, "B.M.C." instead of metal for both the base and platter because it's acoustically "dead". Result: far less vibration and feedback.

Third, those rubber discs are our exclusive air-damped cushions to overcome record warp and vibration.

Our speed control employs an electronic detective system that any road patrol would envy. It totally monitors, controls and compensates through a multi-gap coating inside the platter rim.

Sony innovation didn't stop there. The precision 'S' tone arm is so sensitive it's nearly neurotic, with all the advanced features you need for perfect control. All this adds up to probably the quietest turntable ever made.

PS4750. It's the direct approach to pure sound.

An Automatic Direct Drive at a Belt-Drive price. PS3300.

High performance direct driving now comes at a price that's as easy to handle as its well-placed controls.

And our PS3300 outperforms today's better belt drives with ease - automatically. So if you prefer enjoying Hi-Fi relaxed, this is your turntable.

Performance is astonishingly good with wow and flutter only 0.04% WRMS and signal/noise of 65dB (DIN-B).

In keeping with its high performance image the PS3300 looks ultra, too. Its super slim shape and low slung lines will do wonders for any Hi-Fi rig.

Features galore include • brushless and slotless direct drive motor for precise even speed • DC servo control for total monitoring/compensation of speed • Automatic system for arm return, cut and repeat • Highly sensitive "S" tone arm and Sony's magnetic cartridge VL32G included • Illuminated stroboscope and electronic pitch control.

Direct drive is where it's at, so when you're ready, drive on over to Sony.



SONY
Research makes the difference.



ELECTRONICS Australia

Australia's largest selling electronics & hi-fi magazine



Developed in our laboratory this new digital volt-ohm meter can measure DC and AC volts from 10mV to 199V and resistance from 10 ohms to 1.99 megohms. It's easy to build too, on a specially designed PC board, and should cost you less than \$60.00. The details are on p50.



Now retailing through Dick Smith stores, the Hy-gain AM/SSB transceiver is one CB rig that any enthusiast would be proud to own. You could win the unit pictured above—provided you've got a sense of humour—in the EA/Dick Smith CB Cartoon Contest. Refer to p44.

CONTENTS—SEPTEMBER, 1977

V39 No 6

Editorial: Solar Energy—a lobby required	3
News highlights	4
Teletext—a new dimension for TV broadcasting	8
Telecom: leading the way with solar power.....	14
The dramatic battle for the US TV market.....	16
Forum: Is AM to remain the "poor relation"?	22
HiFi News:	
<i>M-C cartridge, twin-pivot arm and an all valve amplifier—Percy Wilson: 1893-1977—Ampex appointment</i>	33
HiFi Product Review: JBL 4301 Broadcast Monitor	35
The Australian CB Scene:	
<i>Philips: We'll be into UHF CB by January—Chiba Communications Industries Inc. to set up in Australia—Gemtronix GTX-3325 AM/SSB transceiver—Earphone/microphone headsets for CBers—EA-Dick Smith CB Cartoon Contest—Antenna eliminator—Mains power supply for CB sets</i>	37
A 2½-digit volt-ohm meter that's easy to build	50
Novel lamp flasher for incandescent lamps	55
An elementary 1-transistor radio—for boys aged 8 to 88	56
Trafficator repeater for trailers and caravans	58
Circuit and Design Ideas:	
<i>Car battery monitor—In-circuit current tester—Model train signal system—Protection for CB mobile equipment</i>	61
The Serviceman: Old faults in modern equipment	65
Using the new digital logic trainer—some basic logic configurations	68
A practical approach to electronics—1: Demonstration meter	74
Introduction to digital electronics—17: Memory—RAMs	81
Microcomputer news and products	88
Getting into Microprocessors: How to make music with your Mini Scamp	91
Getting into Microprocessors: We review a low-cost hex terminal	94
Record Reviews—Classical	96
Record Reviews—devotional, popular, jazz	99
New Products	104
Books and Literature	108
The Amateur Bands	110
Shortwave Scene	115
Information Centre	116
Marketplace—classified advertising	118
Index to Advertisers.....	120
Notes and Errata	117

Projects to build:

- Especially for beginners: an elementary 1-transistor radio/p56
- Solid state trafficator repeater for caravans and trailers/p58
- The theory and practice of building a multimeter/p74

On the cover

Called the "Tomoscanner", this new British scanning system uses an integral computer to construct colour pictures of thin sections (slices) through the brain or body. The scans are based on radiation patterns emitted by tissues after the injection of a radioactive isotope into the bloodstream, absence of radiation showing black and graduated to red at maximum. Clinical trials have shown that the new system can increase information from brain scans by up to 50 percent.

LOCMOS 4000 B

Think
Signetics
Think
Philips

DESIGNER'S CHOICE

Locmos 4000
series has
always met
the new Jedec
CMOS
specifications.

The LOCMOS 4000 Series is our high performance CMOS family, and sets the standard for CMOS capability. Costing no more than conventional CMOS, it offers you these benefits.

- BUFFERED OUTPUTS (EXCEPT 4007/4069) FOR MORE DRIVE
- LOW GATE PROPAGATION DELAYS FOR FASTER OPERATION
- LOW POWER CONSUMPTION
- VERY LOW POWER - SPEED PRODUCT - SUPERIOR
- CHOICE OF PLASTIC OR Cerdip PACKAGES
- MORE THAN 100 TYPES ALREADY IN A RAPIDLY EXPANDING RANGE

So don't accept any old CMOS. Ask your local IC stockist for one of the LOCMOS 4000 Series from Philips-Signetics.

It's the IC range supported by Australia's largest IC production plant and engineering team.

Philips Electronic Components and Materials,
P.O. Box 50, Lane Cove, 2066, N.S.W.

Sydney, 427 0888; Melbourne, 699 0300; Perth, 65 4199.
Brisbane, 277 3332, 277 4822; Adelaide, 223 4022;



Electronic
Components
and Materials

PHILIPS



Editorial Viewpoint

Solar energy: a lobby required

When the Senate Standing Committee on National Resources presented its report on solar energy early in May this year, one of the recommendations it made was that the establishment of an energy policy for Australia is an important priority. It further recommended that there should be no action taken to increase the level of funding or accelerate the development of solar energy, until such an overall energy policy is established.

In themselves, these recommendations seem reasonable enough. In fact I endorsed them myself, in the leader printed in the June issue. A national energy policy seems long overdue, and in "normal" circumstances it would be unwise to commit significant funds to accelerate the development of any one energy resource, until its place in our overall and long-term energy strategy has been determined. What worries me, though, is that taken together these recommendations provide an almost perfect scenario for indefinite deferment of action.

Here it is early August as I write this, four months since the report was presented. As yet there is not even the vaguest suggestion of any action regarding its proposals, such as the setting up of an Australian Energy Commission to develop an energy policy.

The problem is, I guess, that an energy commission and a national energy policy are likely to benefit Australians as a whole, not just a particular industry or interest group. As a result, while everyone thinks the idea is a good one, no-one is motivated enough to actually do anything about its realisation. Groups like the uranium miners and industries like the petroleum developers, with self-interest to motivate them, can mount powerful lobbies and enlist the support of all sorts of other people. But those trying to get action on an energy policy (and solar energy, for that matter) are in the main motivated by altruism—something not renowned for its effectiveness in gathering financial or political support.

Yet can we really afford to let the matter drag on indefinitely, or worse still die altogether due to lack of support? It seems inevitable that sooner or later, we are going to have to rely quite heavily on solar energy. In view of this it is surely very foolish to keep on deferring serious development of this resource beyond the present pitiful and purely token effort.

In its report, the Senate Committee made the prediction that "solar energy will not make any significant contribution to Australia's energy needs before the end of the century." If we succumb to a fatalistic acceptance of the situation, this will very likely be true.

Yet as Margaret Mead and others have pointed out, it is surprising what can be achieved in a short time when people are really motivated. Where there's a will, a way is soon discovered.

In this case, we need not only the will but for it to be expressed in the right quarters. If enough Australians write to our MPs urging action on an energy commission, things might start to happen.

—Jamieson Rowe

EDITOR-IN-CHIEF

Neville Williams
M I R E E. (Aust.) (VK2XV)

EDITOR

Jamieson Rowe
B.A. (Sydney). B.Sc. (Technology. NSW)
M I R E E. (Aust.) (VK2ZLO/T)

ASSISTANT EDITOR

Philip Watson
M I R E E. (Aust.) (VK2ZPW)

SCIENCE FEATURES

Greg Swain, B.Sc. (Hons. Sydney)

PRODUCT REVIEWS

Leo Simpson

TECHNICAL PROJECTS

David Edwards, B.E. (Hons. Tasmania)
Ian Pogson (VK2AZN/T)

GRAPHICS

Robert Flynn

PRODUCTION

Danny Hooper

ADVERTISING MANAGER

Selwyn Sayers

CIRCULATION MANAGER

Alan Parker

ON SALE THE FIRST MONDAY OF EACH MONTH

Registered for posting as a periodical—
Category B

Printed by Dalley-Middleton-Moore Pty Ltd. of
Wattle St. Sydney and Masterprint Pty Ltd of
Dubbo. NSW. for Sungravure Pty Ltd. of Regent
St. Sydney.

*Recommended and maximum price only.

Editorial Office
57-59 Regent St. Sydney 2008

Phone 699 3622.
Postal Address: PO Box 163, Beaconsfield 2014.

Advertising Offices
Sydney—57-59 Regent St. Sydney 2008.

Phone: 699 3622.
Representative: Narcisco Pimentel.

Melbourne—392 Little Collins St. Melbourne
3000. Phone: 67 8131.

Representative: Keith Watts

Adelaide—Charles F. Brown & Associates Ltd.
168 Melbourne St., North Adelaide 5006.

Representative: Tom Duffy 267 4377
Perth—454 Murray Street, Perth 6000

Representative: Jack Hansen 21 8217

Subscriptions

Subscription Dept. John Fairfax & Sons Ltd.
GPO Box 506, Sydney 2001 Enquiries: Phone
(02) 498-3161.

Circulation Office
21 Morley Ave. Rosebery, Sydney 2018.

Phone 663 3911.

Distribution

Distributed in NSW by Sungravure Pty Ltd.
57-59 Regent St. Sydney, in Victoria by Sun-
gravure Pty Ltd. 392 Little Collins Street, Mel-
bourne, in South Australia by Sungravure Pty
Ltd. 101-105 Weymouth St. Adelaide; in

Western Australia by Sungravure Pty Ltd. 454
Murray Street, Perth; in Queensland by Gordon
and Gotch (A'asia) Ltd; in Tasmania by Ingle
Distributors. 93 Macquarie St, Hobart; in New
Zealand by Gordon and Gotch (NZ) Ltd. Adel-
aide Rd. Wellington.

Copyright. All rights reserved

Devices or arrangements shown or described
herein may embody patents. Information is
furnished without responsibility for its use and
without prejudice to patent rights.

All manuscripts, photographs and other
material submitted to Electronics Australia for
publication must be accompanied by a stamped,
addressed envelope. Contributions are submit-
ted at the sender's risk, and responsibility for
loss cannot be accepted by Electronics Aus-
tralia.

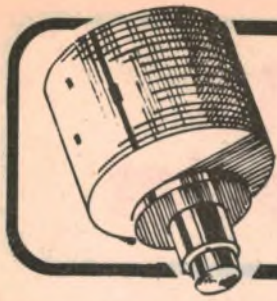

News Highlights



AMI announces first commercial VMOS device

The S4015-3 1024 x 1 bit static RAM, recently introduced by American Microsystems, Inc. (AMI), is the first commercial RAM product of AMI's promising new VMOS technology. Directly competitive at 45 nanoseconds with the bipolar Fairchild 93415/25 and the NMOS Intel 2115/25 RAMs, the new VMOS device has a price tag which is lower than both these devices.

VMOS is the acronym for V-groove Metal-Oxide-Silicon large scale integrated circuits. It refers to an N-channel MOS logic structure integrated on a three-dimensional surface rather than in the two dimensions of the older planar NMOS technology.

Three main advantages are derived from the VMOS design: high speed, increased LSI circuit density, and lower manufacturing cost (because smaller die size means a major increase in the number of dice per wafer).

In a cutaway view of a VMOS transistor

(see photograph) the transistor elements can be seen arranged vertically up the sides of the V. The heavily doped n+ substrate serves as both the source and common ground for all the V-groove cells on a chip. Between the source and the n+ drain is a p-layer channel, forming the effective MOS substrate. The "pi" layer is a lightly doped p-type silicon epitaxial layer serving as a space-charge region to lower the capacitance and increase the breakdown voltage of the drain-substrate junction.

Device speed is critically affected by the channel length: the shorter the channel length and the greater its width, the better. VMOS solves the problem neatly. Channel length is simply the thickness of the p-layer, but channel width winds around the entire circumference of the V-groove, so that each transistor can transconduct several times more current per given unit of die surface area than a planar NMOS transistor can. VMOS cell size can be the same width as the con-

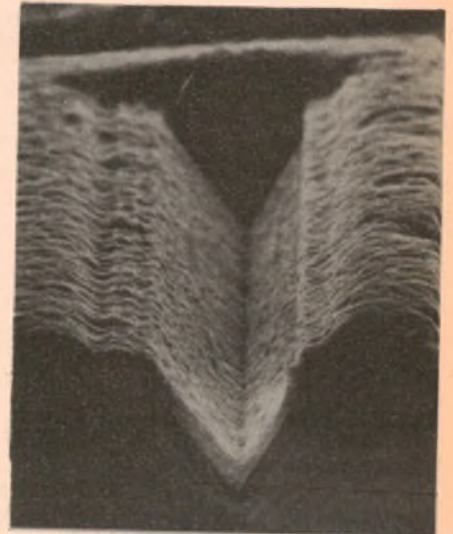

Scanning electron microscope photograph of a VMOS transistor.

ductor lines to it, rather than larger, as in NMOS.

The net result is a considerable increase in VMOS circuit density over both standard NMOS and bipolar technologies.

Solar powered cigarette lighter!

After marketing a Sun-powered barbecue last year with tremendous success, a Swiss firm, G. Ray SA, is now launching a Sun-powered cigarette lighter. The neat parabolic lighter folds up into a compact package that is easily slipped into a pocket. In use, it is simply placed facing the Sun and in no time at all lights a cigarette inserted in its centre. According to a press release from Swiss Office for the Development of Trade, the new lighter "is bound to be a sensation among smokers living in countries with perpetual sunshine."

Banks install Plessey fire warning system

Early warning communication and alarm systems to aid customer and staff evacuation of multi-storey buildings during fire are being installed by Plessey Communication Systems Pty Ltd in three Commonwealth Bank buildings in Sydney. The Bank plans the progressive installation of similar systems in buildings of more than four floors in other capital cities.

The system provides direct communication between nominated fire wardens on each floor and central control stations under the control of each building's chief warden. It permits the chief warden to sound fire alarms on each floor independently for orderly evacuation.

In the event of a major alarm, this flexibility allows the chief warden to exercise control over the flow of people along evacuation routes at any given time. An emergency battery system keeps communication lines open in the event of power failure during a crisis.

National chip obsoletes horizontal and vertical hold controls

A technique for TV receivers that should make both horizontal and vertical hold controls, as well as factory presets, obsolete has been developed by National Semiconductor Corporation. It is a simple linear integrated-injection-logic countdown chip that for less than \$1 delivers a phase-locked horizontal scanning frequency and counts down from it to get an injection-locked vertical output pulse.

The key to the synchronisation system is a new 503kHz ceramic resonator, made by MuRata Corp. of America, Rockmart, Georgia. This provides a more accurate initial frequency reference than the LC and RC voltage controlled oscillators now used. Another advantage is that it does not require shielding from the set's yoke as LC circuits do, and it exhibits more stability over temperature changes, including warm-up, than RC oscillators.

GE develops new semiconductor fabrication technique

The General Electric Company recently announced what it termed "one of the most significant advances in the production of semiconductor components in the past decade".

GE's new technique, called thermomigration, reduces the time required to fabricate a semiconductor device by as much as a thousandfold. In addition, the new technique—which relies on a temperature gradient to drive a liquid dopant through a silicon wafer—promises to reduce fabrication temperatures and increase processing yields.

The technology, invented by scientists at the GE Research and Development Center in Schenectady, New York, has already enabled the company's Semiconductor Products Department to market new solid state power devices

To manufacture a semiconductor device, a crystal of silicon is first grown

at the highest possible purity and then sliced into thin wafers. Next, precise amounts of an impurity—called a "dopant"—are introduced into the wafer to change its electrical properties.

In the new GE process, invented by Dr. Thomas R. Anthony and Dr. Harvey E. Cline, one side of the silicon wafer is heated while the opposite side is cooled. The temperature difference forces the dopant—in the form of a liquid—to migrate through the wafer, from the cooler side to the hotter side.

GE's thermomigration technique can be accomplished in only minutes. By contrast, the best previous commercial method for equivalent doping of wafers required nearly a week of processing time. In addition, the new process can be performed at a temperature several hundred degrees (fahrenheit) below that required by the previous method.



GE researchers Dr Thomas Anthony (left) and Dr Harvey Cline show new wafers made by thermomigration technique. The new technique promises to reduce fabrication temperatures and increase yields.

Lightwave communications

The US Bell System recently began evaluating the world's first lightwave communications system to provide a wide range of telecommunications services.

The new system is carrying customers' voice, data and video signals on pulses of light over a 1½-mile underground cable containing hair-thin glass fibres. Signals are travelling through these fibres between two Illinois Bell switching offices, and between one of the facilities and a downtown Chicago office building housing a number of customers.

"This is a major step forward in our exploration and development of lightwave communications," said Morris Tanenbaum, AT&T's vice president of engineering and network services. He

described the technology of transmitting communications signals by light as "one that could lead to significant service and cost benefits in both local and long distance telecommunications".

The lightguide cable, recently installed beneath Chicago's streets, contains 24 fibre lightguides manufactured by Western Electric Co. Only one-half inch in diameter, the cable is a fraction the size of cables for lower-capacity systems now used to interconnect telephone switching offices in cities. A single pair of lightguides in the cable can carry 672 simultaneous conversations (at a 44.7 megabit per second rate), or an equivalent mix of voice and various types of data signals.

Bell System research in lightwave communications has been under way for more than 15 years. In that time, Bell Labs scientists and engineers did fundamental work on all the major components now at work in the Chicago system. Among these are: light sources (lasers and light-emitting diodes) smaller than grains of salt; hair-thin glass fibre lightguides of extremely high transparency; and tiny photodetectors that convert light pulses back to electrical signals compatible with the rest of the telecommunications network.

Research on improved lightweight communications components is continuing at Bell Labs, and at a number of other R&D laboratories. Scientists and engineers at Bell Labs have demonstrated, for example, materials and processes resulting in lightguides that are stronger than steel—potentially valuable for improving reliability of lightguides.



Western Electric Engineer Tom Karloff checks fibre lightguide production.

Quartz watch uses solar cells



Electronic watches are fine, except for those exasperating trips to the jewellers to get the batteries replaced. To reduce these trips to a minimum, Citizen Watch Co of Tokyo turned to a space-age solution—silicon solar cells. The result: Citizen's quartz solar-cell watch, now selling well in most major cities of the world.

Retailing in Australia for around the \$240 mark, the watch features the familiar analog readout. It comes in white face and black face, with the eight solar cells on the face resembling shuttered windows. Accuracy is guaranteed at ± 15 seconds and battery life is said to be 5 years.

NEWS HIGHLIGHTS

TV "study carrel" for visually handicapped

A "Television Study Carrel" which enables visually impaired students to read books has been developed by Mr D. T. Harrison, a Senior Resource Teacher at the R.V.I.B. School for Blind Children, Burwood, Victoria. The system uses both optical and TV techniques to provide an enlarged TV display of book type.

The book to be read is placed face down on a glass plate let into a desk top. A television camera with zoom lens and close up attachments is mounted under the desk and views the book via a 45° mirror. The resultant display is seen on a 15" monitor, conveniently located over the desk. Negative/positive switching is provided for use where glare is a problem, and the size of the print is

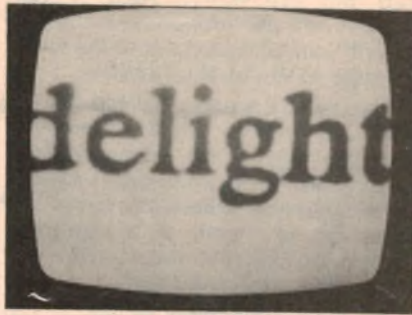

Text appears on the screen in big, bold letters.

controlled by the zoom lens.

An advantage of the method is that no re-focusing is required for books of different thickness because the focal plane is the top of the desk. There is sufficient space on the top of the desk to accommodate such items as a typewriter and a tape recorder while the book is being read. Seven of the units are now in use at the school, and cost is now down to around \$1,200.

Amateur television repeater station

The South Australian Amateur TV Group has been granted a licence by the P & T Department to install and operate an unattended amateur television repeater station. The station, which will operate under the call sign VK5RTV, will be situated at O'Halloran Hill south of Adelaide, and have a service area covering the city and suburbs.

As the repeater will transmit in the 576MHz amateur band, owners of TV sets fitted with a UHF tuner will be able to receive the station just above channel 34. The only extra equipment required for reception will be a small UHF antenna. A channel in the 420-450MHz band will be used in the "up-link".

The repeater is scheduled for operation early in 1978—the first such licenced amateur television repeater in Australia. Anyone interested in fast-scan ATV is invited to join in the ATV net each Sunday morning at 7085kHz immediately following the VK3 WIA broadcast.

—John Ingham VK5K6

Business Briefs:

MASTER INSTRUMENTS IS AGENT FOR TADIRAN

Master Instruments Pty Ltd has announced an agreement with Tadiran (Israel Electronics Ltd) giving Master sole Australian representation of Tadiran Energy Systems. Master has already successfully launched part of the large range of Energy Systems, including lithium high energy long life cells and nickel cadmium batteries. Military and aircraft batteries, special purpose silver zinc and several other batteries are in the range due to be marketed.

Master Instruments Pty Ltd is located at Cnr. Sloane & Saywell Streets, Marrickville, NSW. Telephone 519 6173.

US SOLAR POWER EXPORT TO LUCAS INDUSTRIES

Mr Myer M. Goldstone, Group General Manager of Lucas Australia and New Zealand, and Mr Robert W. Willis, President of Solar Power Corporation, have announced the temporary assignment of William Brusseau of Solar Power Corporation, Boston, Mass., USA, to Lucas Australia to evaluate the market potential of solar electric devices in Australia and New Zealand. Mr Brusseau will be located at Lucas Industries Australia Limited, Cheltenham, Victoria.

British waveguide goes commercial

The world's first commercial waveguide phone system—a super communications "highway" capable of carrying half-a-million calls at once—has been given the go-ahead by the British Post Office.

A waveguide tube about the diameter of a car exhaust pipe will link Bristol and Reading in a £7 million project due to become operational by 1983.

The new waveguide—a spiral of copper wire round the inside of a glass-reinforced plastic tube—is a design unique to Britain. Its main features are low cost, light weight and simple construction, making it easy to handle and install.

With its capacity of 500,000 phone calls, or some 300 television pictures, waveguide outstrips anything that can be provided by conventional telephone cable. At present, the largest inter-city cable in service can carry just over 16,000 phone calls at once.

50 and 100 watt wind generators

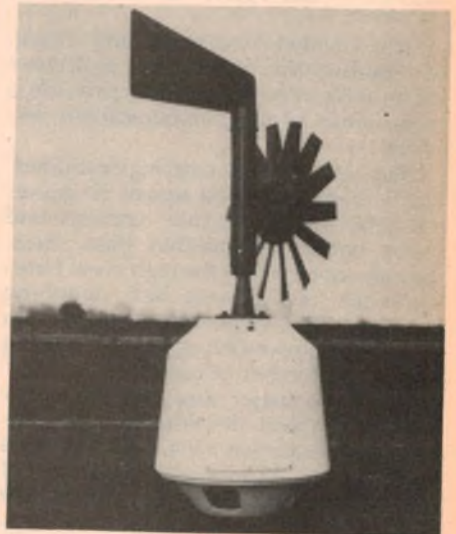

A fifty watt and a one hundred watt generator have been added to the 5 watt and 10 watt range of wind-driven generators manufactured by Selectromarine Ltd.

These units, which are available in 12 and 24 volt versions, employ slip rings, can be left totally unattended, will withstand all recorded wind speeds, and have been constructed to operate in hostile marine environments from the arctic to the equator.

Typical installations include the powering of remotely sighted radio transmitters, radar transponders, tide and water level indicators, telemetry equipment, and navigational aids.

The new generators are marketed by Ralph Howe Marketing Ltd, New Orchard and High St, Poole, Dorset, England.

How to crack a highly paid job as an electronics technician.



We'll give you excellent training - as good as you'll get anywhere in Australia.

We'll give you free medical, dental and hospital treatment.

We'll provide plenty of good tucker and a comfortable place to stay.

We'll give you substantial leave, and on top of all that, we'll pay you well while you're training.

On your side, you'll give us a period of hard, but interesting and rewarding work. And, when eventually you leave us, you'll find yourself a fully qualified and experienced Electronics Technician. Not a bad thing to be, these days.

So, if electronics is your idea of a great career and you are (at time of entry) approx. 15 to 17 for apprenticeship

and over 17 for an Adult Trainee, join the Navy, Army or Air Force.

Phone us at:

Adelaide 223 2891. Brisbane 226 2626.

Canberra (Navy) 65 3318.

Canberra (Army or Air Force) 47 6530.

Hobart 34 7077. Melbourne 61 3731.

Perth 22 4355. Sydney 212 1011.

Write to either the Navy, Army or Air Force Electronics Technician Counsellor, GPO Box XYZ in your

nearest State Capital City (please include your date of birth).

**Learn
Electronics
with us.**



Authorised by Director-General of Recruiting, Dept. Defence
TSAP2.FP.67

Teletext—new dimension for TV broadcasting

It is now confidently expected that at least one Sydney TV station will be operating a teletext service before the end of the year. This article gives a brief run-down on what this new system is all about, and considers some of its implications regarding both the TV industry and the viewing public.

by PHILIP WATSON

Teletext experiments are currently being conducted by Television Corporation Ltd, who operate TCN 9 in Sydney. These transmissions commenced in April of this year and are currently limited to test transmissions. Channel 9 expects to start an actual service by the end of this year, after additional equipment has been installed.

To start at the beginning, though, just what is teletext? Teletext is a system whereby a modified television receiver may receive and display pages of text broadcast by the television station. The text is effectively transmitted "in parallel" with the normal TV program, so that either is available to the viewer; although in reality the teletext material is transmitted during presently unused portions of the television signal.

The system was developed in the UK, using standards agreed to between the British Broadcasting Corporation, the Independent Broadcasting Authority, and the British Radio Equipment Manufacturers' Association. Although the British transmissions are presently approved on an experimental basis only, two services, from the BBC (called CEEFAX) and from the IBA (called ORACLE) have been broadcast now for over two years, and are gaining popularity.

A teletext page can have 24 rows of information with forty characters in each row. In broadcast teletext the first row, at the top of the page, can have only 32 characters and has a formalised layout which includes page number, the date and the time in hours, minutes and seconds.

A station presenting a teletext service will usually broadcast a magazine of about 100 pages, which are transmitted in rotation. Each page requires one quarter of a second for transmission, so the entire magazine recycles every 25 seconds (for 100 pages).

At the receiver a decoder device, which has been set by the viewer to receive a certain page, waits for that page to come around in the cycle, then stores its contents in a small memory. Thus, the

viewer may have to wait for a maximum of 25 seconds for the wanted page to be transmitted.

The stored page is then displayed on the TV screen as 24 lines of 40 characters each instead of the normal picture. It may be held as long as the viewer desires.

These teletext services carry a wide range of information—news stories, sports results, a weather map, financial news, travel and entertainment information and much more. They can use six colours as well as white and, to highlight important changes, words can be made to flash on and off. There is a system of graphics which teletext journalists use to draw colourful graphs and diagrams and to construct large headings and titles.

The information is actually transmitted during the vertical blanking period; the time between the finish of one normal TV frame and the commencement of the next. This period is necessary in the normal TV system to allow time for the electron (writing) beam to return from the bottom of the screen to the top. The period is not very long, but it does amount to some 25 lines.

The data are carried on only two lines in each field-blanking period. Thus four television lines in every 625 carry teletext information. The data rate during each teletext line period is 6.937Mbit/sec. This is sufficiently fast to accommodate the

codes for the forty characters in a row of Teletext information. Thus four rows of each Teletext page are transmitted in every 625 lines.

As well as a complete set of letters and numerals (in ASCII code), there is a set of 64 "graphic" characters, which enable maps, diagrams and rough pictures to be drawn. It is possible for a page to be transmitted and displayed only when changed, as for news flashes. Text may be superimposed on the normal program to make subtitles, or for news flashes, sports results, etc.

A typical British transmitted teletext magazine contains the following items:

- 15 pages general news
- 2 pages weather forecasts
- 5 pages travel news
- 10 pages financial and company news
- 10 pages sports news
- 10 pages consumer news, shopping guide, farm news, gardening, science news
- 5 pages radio & TV program guide
- 5 pages film & theatre information
- 5 test pages
- 5 pages index to magazine.

Each group of 100 pages is called a magazine. Broadcast teletext can provide up to eight of these magazines but a sequence of eight hundred pages transmitted row by row on just two lines in each field-blanking period would take

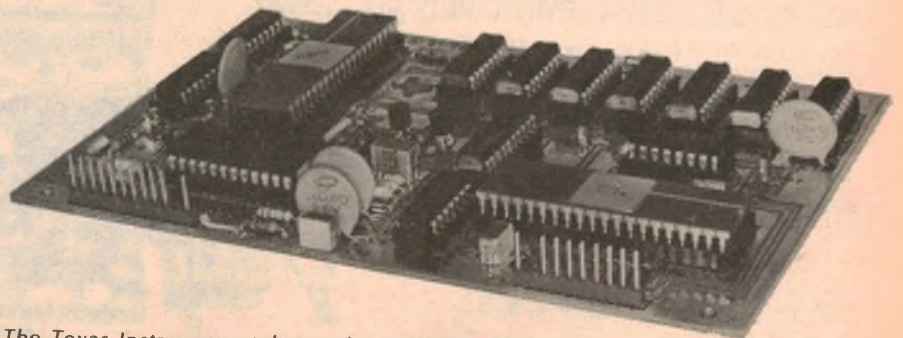

The Texas Instruments teletext decoder board which is likely to be the basis of the first generation teletext receivers in Australia. Measuring only 100mm x 160mm it is probably the most compact commercially available unit to date.



A typical scene at the editorial end of a teletext chain. This picture was taken in the BBC's editorial department where sub-editor Peter Wheadon uses a VDT to insert a new page into the news section. Research assistant Dianne Needham checks the page for accuracy. Scenes like this will soon be repeated in Australia.

more than three minutes to transmit and viewers will not want to wait up to three minutes for any page they may wish to see.

For this reason the total number of pages broadcast in one teletext sequence must be considerably less than eight hundred until such time as there are cheap multi-page stores for the decoder or teletext is broadcast on more than two of the lines in the field-blanking period. Currently broadcast teletext magazines in Britain have between 100 and 120 differently numbered pages.

One way of increasing the number of pages in a magazine without increasing the maximum access time is to transmit one version of a particular page and then after one or more complete transmission sequences change the information. In that way the viewer can read through a sequence of several pages which will "turn over" automatically before him.

Other uses have been suggested for the teletext technique. One is to add dialogue sub-titles to foreign language programs, allowing these to be presented in countries or to ethnic groups which might otherwise be denied them. The BBC has already experimented with this idea, presenting a Latin opera in its original form, with English sub-titles.

Another use is to provide sub-titles to assist the hard of hearing; an idea which is being enthusiastically investigated by the United States FCC.

A major advantage of these ideas is their flexibility. They need not intrude on the program unless the viewer specifically requires them, and they can be varied as required according to the audi-

ence involved.

Another suggestion was advanced by the now disbanded Australian Broadcasting Control Board. This was that signals could be inserted in the vertical blanking period, at the beginning and end of advertising periods, to automatically activate advertising monitors. (Doubtless other uses could be found for this idea!)

The teletext test transmissions from TCN 9 have up to date been restricted to daytime transmission of four test pages, repeated to form a magazine of 60 pages total. These transmissions have been received with good results by several receiver manufacturers in Sydney, and have been re-broadcast in Melbourne.

The end of 1977 should see a full teletext generating system installed, controlled by a computer and allowing operators to add, edit or delete pages as necessary. The total capacity of the machine will be 1900 pages, comprising eight full magazines, transmitted as required, and space for editing new pages. This system should be on the air in the new year, with full magazines, as source material becomes available.

Channel 9 is planning to investigate the use of more than two transmission lines—possibly up to eight—which would permit many more pages of information to be made available to the viewer without any increase in waiting time.

According to Mr Les Free, chief engineer for Channel 9, their introduction of the service will be in three stages. The first, experimental transmissions, is already under way and, at present, is all that is possible under the terms of their experimental permit.

This stage will be used to evaluate the technology, provide test signals for set manufacturers, and allow time for any problems, such as upsets in the behaviour of older TV sets, to become apparent and to be corrected. At some stage towards the end of this period the industry will have to establish a set of technical standards, either voluntarily within the industry, or as set down by the Australian Broadcasting Tribunal or its technical advisers.

Stage two, subject to the approval of the Australian Broadcasting Tribunal, will provide actual service transmissions—news, weather, sports results, and similar information. This period will be used to gauge public reaction, assess staff and operational requirements, and generally establish the service in a form which will have maximum public appeal. This stage should commence towards the end of this year.

Stage three will involve incorporating advertising into the system. This also will require action by the Broadcasting Tribunal. Not only will it be necessary for them to approve this step, it will be necessary for them to provide regula-

tions, similar to those already covering conventional TV transmissions, setting out the manner in which advertisements may be presented, restrictions on the type of material, ratio of advertising material to information material and so on.

In this respect Australia is unique; no other country has yet established such a service on this basis, and there are no guidelines for those who must draft such regulations. Britain's IBA is about to introduce advertising into their system, but their situation differs considerably from Australia's, in that the IBA is still a government sponsored organisation.

Other TV stations are in various stages of investigating teletext. The Australian Broadcasting Commission is preparing for tests. Equipment has been ordered and initial tests could commence in late July or early August.

Channel 7 in Sydney is investigating available equipment and has been quoted for \$120,000 worth of equipment by a British manufacturer, but has placed no order as yet. Channel 10 in Sydney is "interested" but has reservations about the likely audience until receiver costs come down.

As already implied, the TV set requires a suitable decoder to make the teletext information available. This can take two forms; an outboard adaptor which is simply interposed in the TV set's aerial line, or it can be built into the receiver as an added feature. In either case there is a small panel of numerical keys, similar to those on a pocket calculator, with which the viewer feeds in the page number he requires.

Outboard adaptors are fitted with a standard TV tuner and "front end" which selects the required station. The signals are then fed to the decoder circuit proper and, after decoding, to a small TV transmitter. This operates on a blank TV channel and is fed into the TV set's aerial terminal, the TV set's tuner being set to the blank channel. When normal TV operation is required a switch on the adaptor feeds the aerial straight through to the TV set.

A typical example of this approach is an external adaptor made by the British company, Labgear Ltd, and being handled in Australia by Tecnico Electronics. Tecnico have imported a number of sample units for demonstration to the trade; one of the most successful demonstrations being at their "Expo Tecnico" in Sydney during May of this year. For many members of the trade it was the first time they had seen teletext in operation.

At the moment, cost appears to be the main snag in the viability of the system. Currently available outboard units carry a price tag of around \$600; a figure which all sections of the industry agree will have to be reduced considerably if the system is to attract a large number of users. Many feel that it will need to come below the \$100 mark.

Building the decoder into the set

A typical teletext index, in this case for the "Ceefax" system as used by the BBC. This, and the "ORACLE" system used by the ITA have achieved a modest degree of popularity. Both systems are the same technically.



appears to be a much better proposition. This avoids the need for a separate tuner, power supply and transmitter, which represents a significant proportion of the cost. It is hoped that this approach, together with the development of suitable ICs, plus mass production, will eventually achieve the necessary price reduction.

The eventual fate of the teletext venture—whether it "takes" with the general public—appears to depend almost entirely on the ability of set manufacturers to produce decoders, either outboard or built-in, at an attractive price.

Unless or until this happens, any station which elects to present such a service will have to carry the cost with very little return. They will naturally seek advertising revenue, but advertisers are not likely to respond with much enthusiasm unless they are assured of a significant viewing audience.

Channel 9 is well aware of this situation, but they are quietly confident that the next twelve months will see a major breakthrough by the TV receiver industry which will reduce costs and create a rapid increase in the potential audience.

Present hopes are being pinned on a complete decoder board being introduced to the receiver industry by Texas Instruments. Called the TIFAX XM11 module, it is a single board measuring 100mm x 160mm and employing a number of ICs. It operates from a 5V rail and draws approximately 750mA. (1A max.)

Interfacing it with a TV circuit requires that it be fed with video signal and line flyback pulses at suitable levels, and that it be connected so as to intercept the red, green, blue, and monochrome drives to the picture tube. It also needs access to the blanking circuits. Connection to the keyboard involves a nine core cable.

The board can decode a complete range of upper and lower case alphanumeric symbols, plus graphics for diagrams, etc. It features "character rounding" which improves the appearance and recognition of characters which employ diagonal lines, such as "K" and "W". It can generate six colours, plus white, and provides for flashing displays and boxed displays; the latter for newsflashes, subtitles, etc., to be superimposed on the normal picture.

It is also designed to accommodate a

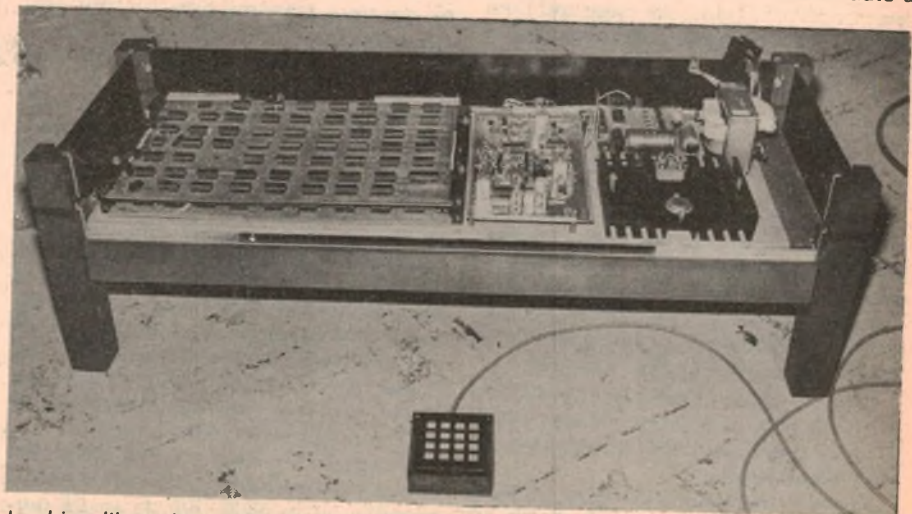

Looking like a low slung coffee table, and taking up about as much space, this is an early version of a teletext decoder. Now outmoded by the Texas Instruments' board, it played a useful part in early Australian experiments.

Electronics is going digital. This book can help YOU go right along with it:

Electronic equipment now plays an important role in almost every field of human endeavour. And every day, more and more electronic equipment is "going digital". Even professional engineers and technicians find it hard to keep pace. In order to understand new developments, you need a good grounding in basic digital concepts, and *An Introduction to Digital Electronics* can give you that grounding. Tens of thousands of people—engineers, technicians, students and hobbyists—have used the first two editions of this book to find out what the digital revolution is all about. The new third edition has been fully rewritten and updated, to make it of even greater value. The author is Jamieson Rowe, Editor of "Electronics Australia" magazine, a qualified engineer and experienced technical writer.

You don't need any previous knowledge of digital electronics—the book starts you right from scratch, and covers all of the basic concepts you need.

PRICE \$3.00

Available from newsagents, bookstores, electronic suppliers and also from "Electronics Australia", Box 163, P.O. Beaconsfield 2014. (Post and packing 60c).



Here are the chapter headings:

1. Signals, circuits and logic
 2. Basic logic elements
 3. Logic circuit "families"
 4. Logic convention and laws
 5. Logic design: theory
 6. Logic design: practice
 7. Numbers, data & codes
 8. The flipflop family
 9. Flipflops in registers
 10. Flipflops in counters
 11. Encoding and decoding
 12. Basic readout devices
 13. Multiplexing
 14. Binary arithmetic
 15. Arithmetic circuits
 16. Timing & control
- Glossary of terms

QUALITY TESTED TAPE

FROM \$2.00

I've had these tapes fully tested by a laboratory. I'm convinced that they are as good, if not better than TDK SD or Hitachi UD!



All tapes come packed in plastic library box with tape data & care ideas.

Most tape used by hi-fi buffs in Australia has been imported. Until now, this was the only quality tape readily available.

Dick Smith decided to change all this. He searched Australia for a manufacturer who could not only manufacture large quantities of tapes for the retail market, but who could meet and maintain the very high standards of the imported tapes.

This is it — the new Dick Smith cassette tape. Australian made, with a quality you'll find very hard to beat.

We asked a laboratory to fully test the Dick Smith tapes alongside the other UD tapes available. The Dick Smith UD was at least the equal of the others — and in some of the tests exceeded them!

All we ask is that you try a couple of these superb tapes yourself. We're sure we won't have to ask you again — you'll be asking us for them!

and just look at the prices....

C60 LN	Cat C-3350	Each: \$2.00	Eleven or more: \$1.50
C90 LN	Cat C-3352	Each: \$2.50	Eleven or more: \$1.99
C90 UD	Cat C3354	Each: \$3.00	Eleven or more: \$2.50

IT'S LOGIC!

SAVE \$36

EA's brand new digital logic trainer...

It's new, it's bigger, it's better AND IT'S CHEAPER!!!! Everything you've ever wanted to know about logic, but were afraid to ask — you can now try for yourself! See this month's EA for all details.

- * 4 bit binary up/down counter (presettable)
- * 4 bit BCD — decimal decoder.
- * 2 Schmitt triggers
- * Transistor, resistors & capacitors
- * CMOS circuitry (battery operated)

Easy to build — instructions supplied.
IDEAL TEACHING AID!

Mk III

Cat. K-3010

Looks fantastic! Wooden case and white panel with black screened lettering give this a real professional appearance! Case & panel supplied!



\$69

Separate components also available:
 Combined PCB/front panel (Cat H-8325) \$9.75
 74C14 IC (Cat Z-5413) \$1.60
 4009 CMOS IC (Cat Z-5609) \$1.30
 4023 CMOS IC (Cat Z-5623) \$0.46
 4027 CMOS IC (Cat Z-5627) \$1.22
 4028 CMOS IC (Cat Z-5628) \$2.31
 4029 CMOS IC (Cat Z-5629) \$3.10

SPECIAL OFFER TO SCHOOLS, ETC.
 Buy three or more of these educational aids on official order with tax exemption and we will give them to you for just \$52.18 each! Incredible saving!

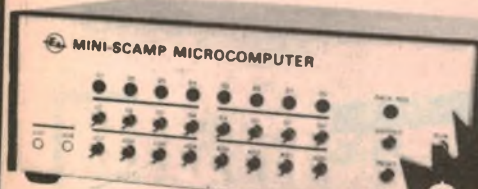

Fantastic Miniscamp Computer

\$105

And when you're through playing games — build yourself a computer! That's right, a real live working one. 256 word memory (easily expandable) will teach you about programming, how computers 'think' etc. It could be the start of a career for you! See EA May & June for full details — see us for full kits! Cat K-3446 .. \$105.00

 Why not enter the microcomputer competition? See this month's Electronics Aust. for details!

SPECIAL OFFER TO SCHOOLS, ETC.
 Buy five or more of these educational aids on official order with tax exemption and we will give them to you for just \$87.65 each! That's value!

BIG MEMORY NOW AVAILABLE:
 Parts necessary —
 PCB (cat H-8326) \$3.75
 2112 Memory (cat Z-9304).. ..ea \$5.20

Just 33% of Educ-8 price!

DICK SMITH ELECTRONICS GROUP

VISIT YOUR NEAREST BRANCH:

- SYDNEY — 125 York St, Ph. 29 1126
- BANKSTOWN — 361 Hume Hwy. Ph. 709 6600
- GORE HILL — 162 Pacific Hwy. Ph. 439 5311
- MELBOURNE — 656 Bridge Rd, Richmond Ph. 42 1614
- BRISBANE — 166 Logan Rd, Buranda. Ph. 391 6233

AND NOW OUR NEW STORE AT PARRAMATTA: 30 GROSE ST — Ph. 683-1133

MAIL ORDERS:

Box 747, Crows Nest.
 NSW. 2065. Ph. 439-5311
 SHOP HOURS:
 Mon to Fri: 9AM — 5.30PM
 Sat: 9AM — 12 noon
 (Bris. Sat: 8.30AM—11.30AM)

POSTAGE/PACKING CHARGES

ORDER VALUE	CHARGE
\$5 — \$9.99	\$1.00
\$10 — \$24.99	\$2.00
\$25 — \$49.99	\$3.00
\$50 — \$99.99	\$4.00
\$100 or more	\$5.50



greater number of teletext lines, should the standards provide for this.

The price tag for this board has been quoted at various levels. A figure of \$400 has been quoted for "one off", and \$300 for "10 off". Beyond this the price should fall substantially for larger orders, though exact figures are hard to come by. No doubt any manufacturer who was willing to place an order for several thousand could command a very attractive price but, understandably, few, if any, firms are willing to stick their necks out this far, at this time.

On the other hand, several local manufacturers have purchased or ordered small quantities with which to experiment and produce prototype receivers. Some are already at the prototype stage.

A spokesman for EMI indicated that they are carrying out developmental work, based on the Texas Instruments decoder. Initially, they will be modifying some of their current receivers for teletext reception, as a part of a technical testing program.

EMI have offered to conduct this testing program in collaboration with the TV stations, to provide a basis on which the performance of both the transmitters and the receivers can be evaluated. Such a program should be of considerable value to the TV stations since, so far, there have been only a few receivers operating in the field; too few to provide an accurate indication of coverage, reliability, or any problems which might arise.

This program is only at the discussion stage at the time of writing; no firm timetable has been set down for its implementation. In any case, EMI has indicated that any data collected from the program will be made available to the industry in general. The receivers used for this survey will not be offered for sale.

The second phase, after the testing program is completed, is to produce a teletext compatible receiver. This means that the set will be designed so that the teletext facility can be added to it.

The main benefit of this is that, at any time during a production run, it could be switched from standard receivers to teletext type, with minimum effort. There is also the possibility that they may produce adaptors which could be plugged into such chassis after they had been bought.

As to the likely price structure, EMI envisage that, with quantity production, the cost of decoder boards could well drop to around the \$50 mark. If so, they feel that a receiver price increase of \$100 to \$150 would seem to be feasible, and that the market would support such a price.

A spokesman for Philips confirmed that they are also conducting research into teletext receiver design. In fact they have already supplied some modified receivers to Channel 9, to assist the channel with its investigations.

A number of experimental receivers

were under construction at the time of writing, and it was hoped that at least one of these would be on display at the IREE International Convention held in Melbourne in August.

Rank Arena is another organisation which has indicated that they intend to "be in it" when teletext is an established fact. For the moment, however, they feel that the situation is not sufficiently predictable to justify setting up a production line.

They are therefore concentrating on a development program designed to investigate the technical and economic aspects of various approaches to the teletext receiver. As with other manufacturers, most of the work is around the Texas Instruments decoder board.

In fact, if there is sufficient consumer interest, Pye will be prepared to initiate

One way to receive teletext signals is to fit an external adaptor, such as the Labgear model 7026 shown here on top of a small TV set. Some Australian manufacturers are considering a similar approach, at least for the transitional period.

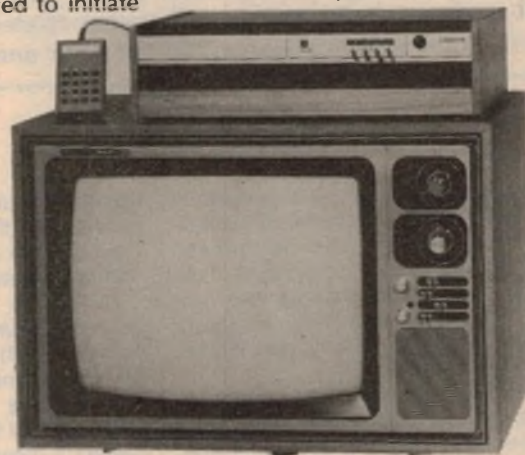

Several approaches have been considered so far. The most obvious one is the complete receiver which, regardless of other possible approaches, is the one which most manufacturers will regard as their ultimate target.

Some of the other approaches would be more appropriate to the transitional period. One of these is a basically conventional set, without the teletext feature, but which has been designed to accept an add-on teletext unit, either on a simple plug-in basis, or as could be fitted by a service mechanic.

Yet another is a completely self-contained add-on unit which connects between the aerial and the aerial terminal of the receiver, similar in broad concept to the Labgear unit already described.

Rank emphasise that no decision has been made at the time of writing, and that a good deal of investigative work remains to be done before such a decision can be made. For the same reasons, no estimate of likely cost structures could be made at this time.

According to a spokesman for Pye Industries, they are planning a small production run of sets for distribution throughout the trade. These will be used initially to demonstrate teletext and to allow the makers to investigate consumer and trade reaction. If the teletext programs create sufficient demand, these sets would be available for sale to the public.

larger production runs and maintain them for as long as is justified by the demand. These sets are expected to be on demonstration by Christmas 1977.

The company was not in a position to comment on the likely price of such a set, but they did indicate that, in larger production quantities, the price of the decoder board was "... between \$100 and \$200".

To this they would have to add a keyboard and cable, a couple of interface printed boards and, of course, the labour. We would make a rough guess that, by the time the set reached the customer, and taking into account mark-ups, sales tax etc, the increase would be nudging the \$400 mark.

Assuming that the sale of these sets, and the development of teletext trans-

missions indicates an assured future for teletext, Pye will move on to their next phase; the development of a more advanced receiver which will probably feature, among other things, a remote control type keyboard unit, using a radio link rather than a cable. Such a set is likely to be planned for the 1979 market.

According to Mr Peter Carroll, engineering manager for Pye, remote control is the way manufacturers are thinking in Britain. However, such a set would involve a lot of additional design work, and a significant amount of tooling-up. Naturally such costs would have to be recovered in a reasonable time and would be reflected in the price structure.

On the other hand, a full scale production run would involve large orders for decoder boards, and permit a much more attractive price to be negotiated. With all these variables, plus inflation, it is obviously difficult to estimate a price structure so far ahead, but about \$200 over the base price of the receiver would be a likely figure.

And that just about sums up the teletext situation at the time of writing. There seems little doubt now that Australia will have a teletext system in one form or another. The question is when, in what form, and how well it will be patronised. But, whatever the outcome, it will have been a worthy effort on the part of all concerned.

Telecom: leading the way with solar power

Telecom Australia is to employ a large capacity solar cell power installation to supply energy for a new microwave trunk telephone system between Alice Springs and Tennant Creek. The installation will be the first of its type in the world, and demonstrates the lead achieved by Telecom in the practical application of solar energy.

The decision to employ solar power on the new 580km microwave trunk system crowns three years of solid development work by Telecom power engineers. This work has shown that solar power can now be justified economically, for loads up to 200 watts, for many specialised remote applications.

Announcing the solar energy application, Managing Director Mr Jack Curtis said Telecom experts were currently evaluating tenders for the supply and

installation of solar systems to provide power for the new microwave radio trunk system which is scheduled to commence operation in 1979.

Mr Curtis said that the new solar powered trunk system, which will be linked into the Darwin/Tennant Creek/Mr. Isa/Townsville microwave trunk system and the national broadband grid, would have three bearers—with total capacity equivalent to nearly 3,000 telephone circuits. One bearer will cater

for telephone and telegraph demands, a second will be reserved as an emergency for the first in case of breakdown, and the third will be used for TV program relays.

There will be 13 repeater stations along the new trunk system and each will obtain electrical power from its own solar unit. The estimated overall cost for solar power for this trunk system is about \$500,000.

The radio equipment power consumption for the 13 isolated stations on the Alice Springs/Tennant Creek system (set at intervals of about 45km) is about 125 watts continuous at 24 volts DC.

Telecom is hopeful that the combination of solar power with low energy use equipment will make a significant contribution to the extension of communication facilities in to the outback of Australia. Telecom has been pursuing the development of solar power systems for over 4 years, starting with the design and installation of small (less than 20 watt load) solar power supplies. There are now about 40 of these small systems in operation throughout Australia powering small capacity telephone services in isolated outback areas.

Telecom has spent about \$100,000 to date on solar power system development and installations. This includes a program to design and build a large prototype solar module recently completed and undergoing tests at Telecom's experimental field station at Maidstone (Vic).

The Maidstone module consists of a 650 watt peak silicon solar array mounted on the roof of a standard shipping container which is being used as the power plant shelter. A large battery of 1,500 ampere-hours capacity provides 10 to 15 days reserve and is installed inside the container along with control gear and some on-site staff facilities.



STO 3 Lyle Perkins displays a module of the 650 watt solar energy array mounted atop a standard shipping container. The container serves a dual role by also housing the recording instruments and storage batteries.

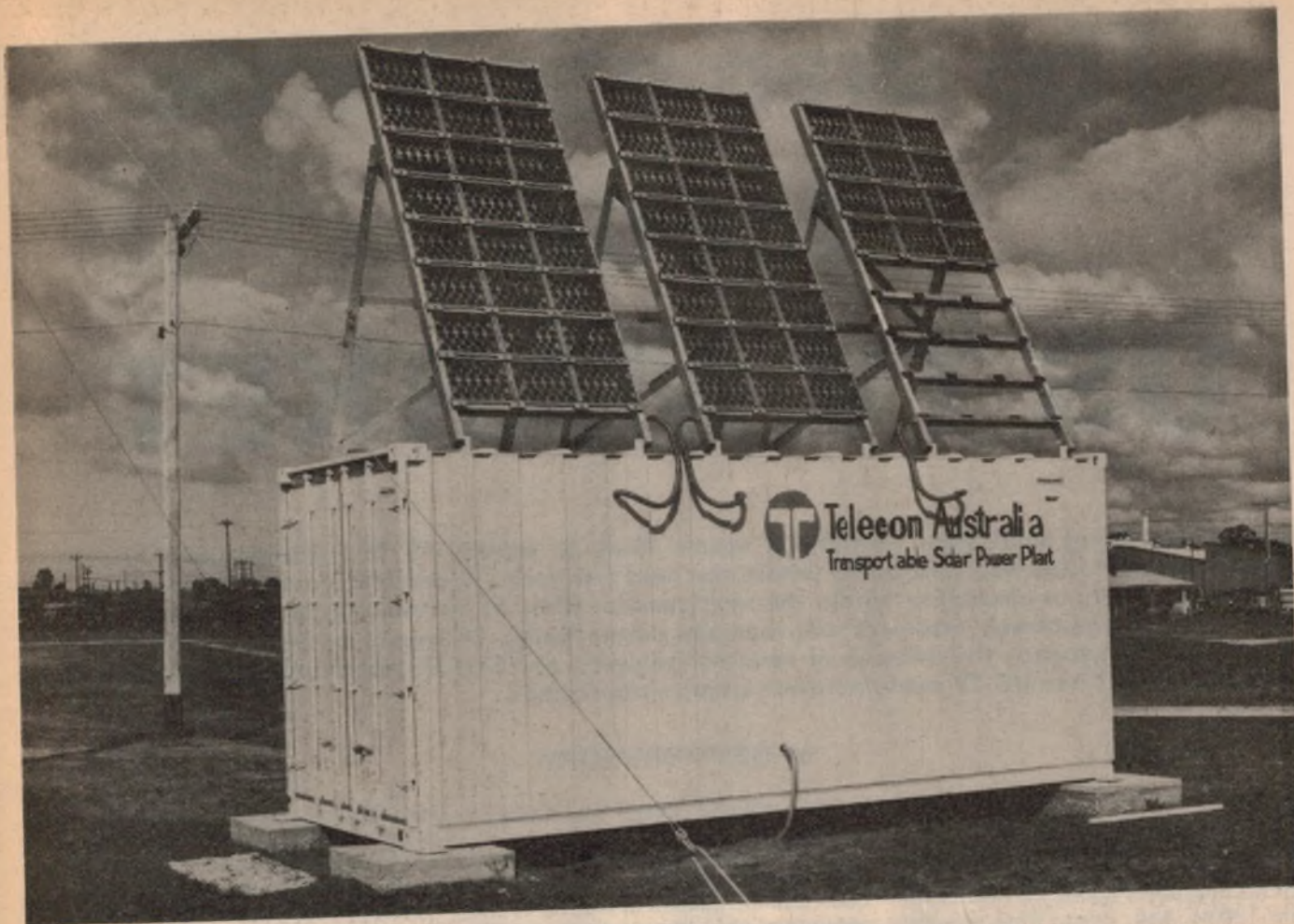

Photo shows how a standard shipping container is used for mounting the solar panel arrays.

The unit provides 125 watts of continuous power in high sunlight areas of Australia.

Telecom's engineering development program for solar energy applications has included:

- Development of small and large solar

power supplies.

- Accelerated environmental life testing of solar panels.
- Development of computer aided system sizing techniques.
- Investigation into the preferred type and life testing of lead acid batteries for

solar applications.

- Investigations of the accumulation and effect of dust on the output of the solar array.

Reprinted from "Telecom", House Journal of Telecom Australia, by permission.



Above: Engineer Michael Mack (left) and STO Perkins check the recording instruments. At right is a view inside the container showing the battery racks.



The dramatic battle for the US TV MARKET

Rapidly advancing solid state technology seems likely to enable US TV manufacturers to regain supremacy over Japanese companies within the next few years. A one-chip, small screen colour TV receiver is a distinct possibility within the next decade, while at the same time the capabilities and functions of large-screen receivers will increase dramatically. Observers predict a major industry shakeout to accompany the infusion of new technologies, and that US supremacy in semiconductor manufacture will see US TV manufacturers emerge triumphant.

by GENE GREGORY

Can US television manufacturers regain their former prowess in a massive restructuring of the industry following the phenomenal example of US calculator manufacturers during the first half of the 1970s? And, if so, what are the implications for the Asian electronics industry? These are the muted, and yet largely unmooted, questions that ultimately must be answered once the smokescreen of legal gobbledegook and diplomatic doubletalk clears the battlefield in which the electronics industries of three continents are locked in mortal contest.

On the surface, the recent decision of the US Customs court of New York to over-rule the US Treasury Department's refusal to impose countervailing duties on Japanese television sets benefiting from consumption tax exemptions, and the almost simultaneous recommendation of the US International Trade Commission (ITC) that relief in the form of increased custom tariffs be given an "injured" US television industry, have the appearance of nothing other than an ominous resurgence of protectionism sponsored by a new and powerful coalition of industry and labour, a union forged at the brink of alleged disaster during the halycon days of the recent recession.

It is true that both the decision of the Customs Court and the recommendations of the ITC were based upon the inherently protectionist 1974 Trade Act, which considerably strengthened the main provisions of law under which imports into the United States can be restricted, either because they are regarded as unfairly competitive or simply because

of their adverse impact on American industry.

But the action brought by Zenith Radio Corporation in the New York Customs Court and the petition of the ITC by the consortium of 11 labour unions and five firms from the industry, the so-called Committee to Preserve American Color Television (COMPACT), must be seen in the context of a much broader legal counter-offensive mounted against imports of television sets from Japan, Taiwan, Korea and Mexico. In January 1976, GTE Sylvania Incorporated, also a member of COMPACT and a petitioner in the latest Escape Clause action, had already filed a complaint with the ITC alleging that 13 Japanese television companies have engaged in unfair methods of competition and unfair acts in the importation of colour television receivers in violation of Section 337 of the Tariff Act of 1930, a highly protectionist piece of legislation born of the hysteria following the 1929 crash.

GTE Sylvania was joined in this petition by the Philco Corporation, whose trademark GTE Sylvania purchased in 1974 when Philco discontinued television receiver production. Subsequent to the Sylvania/Philco complaint, the ITC initiated its own investigation of Japanese television marketing business practices which cover 14 areas of alleged unfair acts.

While both of these proceedings were suspended during the Commission's consideration of the COMPACT Escape Clause petition, made in September 1976 after a phenomenal 3-fold increase in colour TV imports boosted the share of Japanese imports to 30% of the market,

they remained on the docket and were taken up again as soon as the Commission's recommendations for the relief of the industry had been acted upon by the President. After several rounds of negotiations, the Carter Administration's peripatetic special trade representative, Robert Strauss, concluded an agreement in May with the Japanese to restrict imports of TV sets. Under a proposed consent order, the ITC may drop its investigations of unfair pricing practices in return for agreement by Japanese manufacturers to submit to detailed surveillance of their exports to the US over a 5-year period.

**American manufacturers
have launched
technological
and tariff warfare
against their
Japanese counterparts**

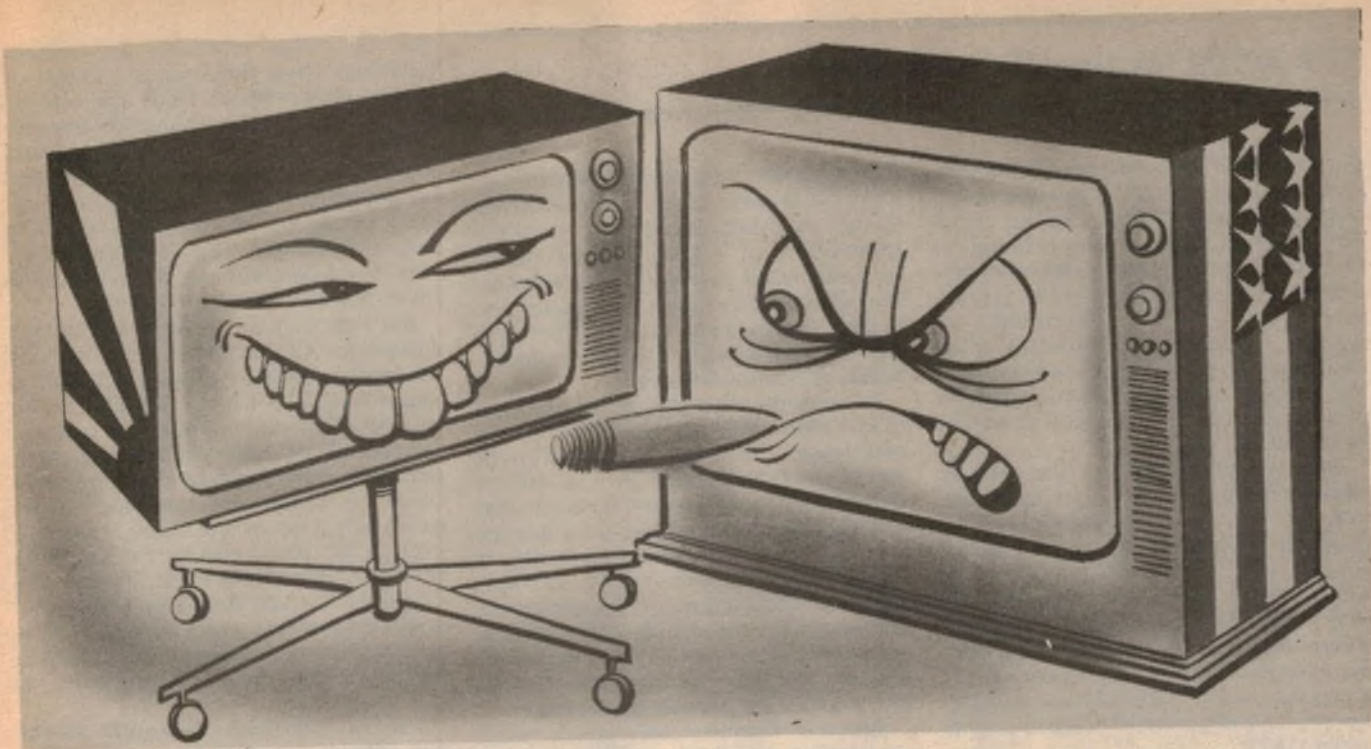

In addition to these proceedings before the ITC and the US Customs Court, there is continuing anti-dumping surveillance at the Treasury Department and a major antitrust suit pending in the US District Court for the Eastern District of Pennsylvania, brought by Zenith in 1974 against 21 Japanese manufacturers and their US marketing subsidiaries. Seeking almost \$1,000 million in trebled damages as well as an injunction against continuing alleged violations of the law, Zenith has charged that Japanese producers have engaged in a variety of antitrust violations, including an unlawful combination, conspiracy in restraint of

US foreign and interstate commerce, and conspiracy to monopolise such trade in violation of the Sherman Act. As of this writing, no date has been set for the trial.

Apart from the enormous payments of legal fees, and the public-expenditure of multiple and sometimes lengthy investigations and court actions, what specific impact this protean resort to legal action will have on imports of finished or unfinished television sets and sub-assemblies from Japan, Taiwan and Korea is by no means clear. If the US Customs Court ruling is upheld and a 15% countervailing duty is imposed on

Japanese colour TV imports at some future date, this, combined with the "voluntary restraints" which the Japanese industry has accepted, would force down imports of colour TV receivers by as much as 50% from current levels. The US industry has sought to cut back Japanese colour TV imports to 1.2 million sets a year from the 2.96 million record level of 1976.

Prices have already begun to reflect these changing supply conditions. Anticipating possible extension of countervailing duties to other electronic products as well, US importers of radios, hi-fi equipment and television sets from Japan have been forced to raise prices to cover eventual retroactive duty payments. No one can possibly estimate the cost of these measures to the American consumer, but they are enormous. Had the ITC recommendations been accepted by the Carter Administration, the added cost at retail would have been an estimated \$131 million in the first year as a result of an assumed 50% pass-through of the increased import duties and an increase in retail prices of 75% of the higher tariff rate.

Under the "imaginative" orderly marketing agreement which Mr. Strauss negotiated in its stead, some 4 million US consumers will have to pay more for their colour TV sets during the next three years. Added to the price rises already provoked by the Customs Court decision, this gives a conservative measure of the cost to the US economy of protectionist measures already taken.

But this is just the tip of the iceberg. As former US trade negotiator Harold B. Malngren pointed out at a recent Lon-



The battle for the US TV market . . .

don session of the Conference Board, the real danger in the US is not the direct costs of these measures, but the chaos derived from excessive harassment of foreigners by US industry and the random reaction of the government to pressure groups. "In my judgement," he warned, "this shotgun approach is more dangerous or potentially disruptive than the import quotas legislation which periodically sprang forward in Congress in the last ten years or so."

Clearly, recognition of the danger represented by the Zenith countervailing duty case is by now universal. Making it clear that the issue could trigger a global trade war, the GATT (General Agreement on Tariffs and Trade) Council took exceptionally expeditious action at a June 16 special session in Geneva, condemning the Customs Court's decision as a violation of international trade law and a prima facie impairment of Japan's rights under GATT.

Given the seriousness of the situation, the Treasury Department has indicated it will appeal the Customs Court ruling all the way to the Supreme Court if necessary, and hearings have already been scheduled by appellate courts to speed what will, at best, be a lengthy process. Chances of reversing the Customs Court decision, Special Trade Representative Robert Strauss emphatically stated to newsmen in Washington recently, cannot be considered to be better than 50-50. The Court's decision was carefully reasoned, taking into consideration not only existing US statutes, including recent provisions of the 1974 Trade Act, but also the so-called "grandfather clause" of the GATT protocols under which signatories accepted the GATT provisions insofar as they were not inconsistent with existing domestic legislation over the years.

The Treasury Department will have difficulty in sustaining its position that exemptions from, or remission of, indirect taxes on exported products do not constitute bestowing bounties or grants as defined under the GATT agreement. In the meantime, Japanese companies will have to post bond covering the full amount of increased duties on imported sets, or deposit letters of credit with the US Treasury. While in itself not a costly requirement, it introduces an element of uncertainty and risk which will serve in some measure as a deterrent to imports from Japan. Not surprisingly, in the ensuing confusion, many importers are cancelling contracts and others raising their prices to cover themselves in the event that duties are ultimately levied.

The agreement which Special Trade Representative Strauss hammered out with the Japanese Government in May

for "voluntary" restrictions of exports for a period of three years has enabled the Carter Administration to reject the imposition of higher import duties recommended by the ITC. Even within the administration there are those who believe that the Japanese were forced to pay too high a price to fend off protectionist pressures, however.

To provide what Strauss has termed "short-term relief to some short-term problems" the Japanese Government agreed to limit exports to 1.56 million complete colour television receivers and 190,000 unassembled units—or a total of 1.75 million sets. In return, to head off Congressional pressures to have Japanese acquisitions of US electronic companies reviewed and disallowed, the agreement struck with Tokyo expressly encourages further Japanese investments in US colour TV production facilities.

Japanese manufacturers which have, or establish, production facilities in the United States will have no limitation imposed on imports of components for television sets or on kits which lack nine basic parts, including picture tubes. Anything more complete than this will be treated for the purpose of the restraint agreement as a finished TV set. Since Sony makes its own Trinitron colour tubes in San Diego and both Matsushita and Sanyo buy tubes from US manufacturers already, this aspect of the agreement fits the existing economic exigencies of rational TV manufacture.

Neither is the exclusion of other components, selected to assure a minimal 40 percent US input into the final product, likely to impose any serious problems for Japanese manufacturers already producing sets in the US. For other Japanese TV manufacturers this aspect of the agreement will likely hasten the decision to invest in US manufacturing plants.

While this will relieve somewhat the competitive pressures on US TV producers, with an opportunity to regain lost market-share, it poses a threat to major private label mass merchandisers such as Sears, Roebuck. Sears, which sells approximately nine percent of all colour TVs sold in the US, and depends heavily on Sanyo and Toshiba as prime contractors, appears to be in danger of losing temporarily, or even permanently, what it thought was a secure long-term source of supply.

Certainly, if the US industry gets its way, the links between US mass merchandisers and Asian suppliers will be considerably weakened. The COMPACT labour-industry group has launched its campaign to override the President's rejection of ITC-recommended tariff imposition, claiming that the agreement completely disregards the seriousness of the damage

that US colour television and related industries have suffered as a result of foreign competition. Since the agreed level of imports would still allow imports at 60% above the 1971-75 average, which the US industry has suggested as a suitable limit, the COMPACT group will pressure Congress to sustain the ITC's recommendations. Few informed observers in Washington rate the chances of their success very high, however.

But with such an "orderly marketing" agreement fully in force, settlement of the legal problems confronting Japanese imports will only have just begun. Some industry observers consider the pending Sylvania-Philco complaint alleging unfair practices in the importation of portable colour television sets from Japan to be potentially one of the most important ever to be considered by the Commission. It is conceivable that through this case the ITC could develop a wholly new method whereby protectionist interests could attack imports and obtain remedies equivalent to embargoes on specific products.

The Sylvania-Philco complaint alleges that Japanese manufacturers are selling their products for export to the US at below-cost prices and further are receiving subsidies from the public treasury. On the face of it, the complaint would appear to be subject to the Anti-dumping Act and the Countervailing Duty Law, but the US television industry has lost cases previously brought under both statutes.

The industry now argues that practices complained against in the present case fall within the purview of the ITC under Section 337 of the Tariff Act of 1930. If the ITC accepts this logic, the US industry will have a broad new device with which to attack Japanese and other import competition. Quite apart from the ultimate decision on such cases, a problem arises from the procedures under Section 337. Unlike other ITC proceedings, they fall under the Administrative Procedures Act, and therefore have all the complexities, expense and delay of court litigation along with the few touches unique to ITC proceedings.

GTE Sylvania Inc. and four of the Japanese manufacturers concerned—Tokyo Shibaura Electric Co., Hitachi Ltd., Sharp Corp., Sanyo Electric Inc.—have agreed to propose consent orders to the ITC to settle GTE Sylvania's charges. Under the consent order, the Japanese companies would agree they would not violate US law in future and would provide the ITC with details about their exports to the US.

While the proposed orders did not establish that the Japanese had engaged in the past in what Sylvania alleged were predatory pricing and other unfair practices, they would bar such practices in the future and preclude any agreement to fix prices or restrict sales. Each Japanese company would have to report annually, by screen size, its unit volume



Sony assembly line of Trinitron colour TV sets—hard times ahead for Sony on the US market?

of production, revenue, and costs for all colour sets sold in the US or exported to the US for resale. The orders further provide for inspection and audits to assure compliance. The ITC could hold hearings to determine any violations of the consent orders and could impose penalties that would include exclusion of a violator's products from imports into the US.

Whether the Japanese have simply agreed not to do something which they were already not doing is a question this procedure would, in fact, beg. The danger is that the public may be misled by such action to believe that the consent order is tantamount to admission of past guilt. The consent action may be the best way to avoid the high cost of long litigation, but it is important that it be described clearly for what it is and not allowed to fuel runaway protectionism or to serve as another means of continued harassment of importers by excessive and almost random intervention by the government agencies.

As in all such matters of law, the pyrotechnics of public confrontation and the debate of fine points of jurisprudence are likely to mask the fundamental questions. The recent investigations and decision of the ITC demonstrate the extent to which rhetoric can obfuscate reality and politicize the processes of industrial and trade policy decision-making.

Attention was focused on two points

of law involved. All that had to be shown is that imports of television sets had increased and that this increase was a substantial cause of serious injury, or a threat of such injury, to the US industry. Since the Commission took as its time frame the period 1968-1976, its decision was a foregone conclusion. Imports during that period, mainly from Japan and Taiwan, had increased by 188 percent, and rose even more sharply in 1976; during this period the number of US television manufactureres had fallen from 18 to 11. Three other manufacturers had been acquired by foreign multinationals: Magnavox by Philips, Motorola's TV production facility by Matsushita, and majority interest in Warwick by Sanyo. Moreover, during the recession years of 1974 and 1975, a significant number of firms, as many as eight of the eleven manufacturers in 1974, were operating at a net loss.

Investigations also confirmed the obvious fact that there has been a significant decline in the average number of persons employed in the television receiver assembly operation in recent years and that there had been significant underemployment of remaining workers as a result of temporary layoffs and shortened work weeks. The Commission acknowledged that in the short span of five years 1971-1976, the US television industry underwent a major structural reorganisation.

The entire US industry shifted from

relatively labour-intensive tube technology to the manufacture of solid-state sets which makes possible the introduction of intensive automation in production lines. This, in turn, raised cost efficiencies, increased yields, upgraded quality and reduced maintenance problems. Labour became a relatively less important factor in the total cost of production.

But in their judgement, the ITC Commissioners found that imports were a more important cause of the decline in employment from 36,654 production workers in 1971 to 23,388 in 1975, despite the fact that the latter number of workers produced approximately the same number of receivers in 1975 as with 57 percent more workers in 1971.

The Commission was also apparently not obliged to include in its calculus either the amount of production US firms shifted to offshore manufacturing facilities during the period 1968-1976, or the effects of such transfers on corporate profitability. The fact that Zenith and RCA, which between them share 43% of the US television market and supply a considerable portion of television imports from off-shore facilities, continue to show healthy profits, and in 1976 reported earnings at all-time highs, was dismissed, as was the general improvement in television operations in GE and the record earnings for 1976 of Magnavox under the aegis of the new management skills, technology and capi-

ل.ن.ب.ط

top
forte

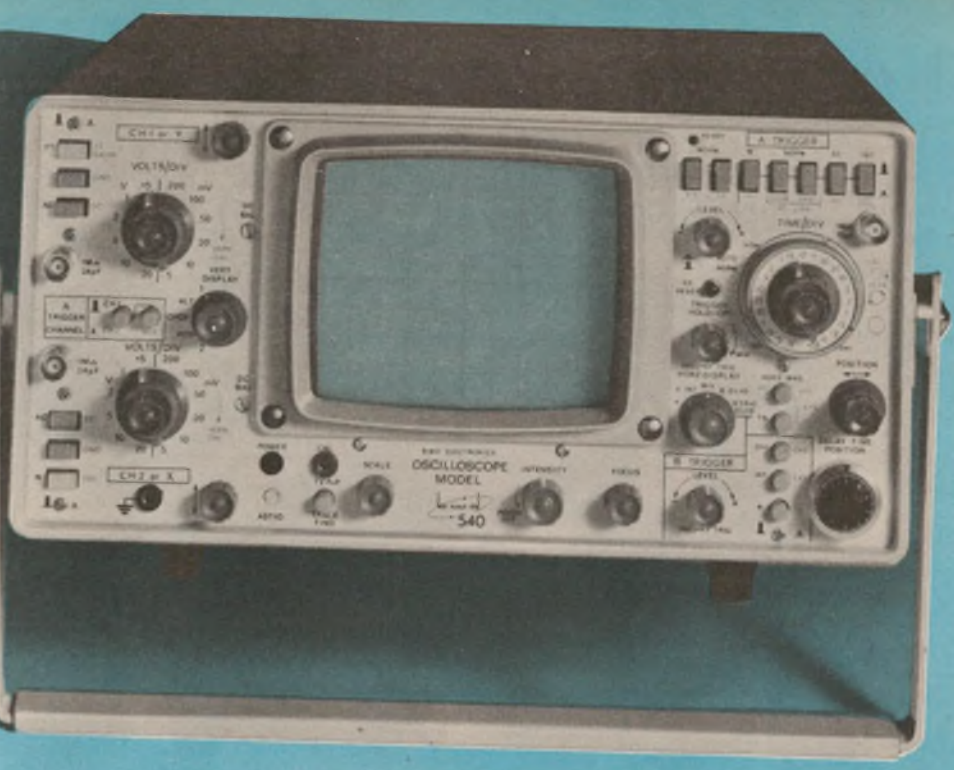

BWD540
Dual Trace
DC-100MHz -3db
5mV sensitivity
5nSec. sweep speed

*Computers, μ -Processors,
Research and development,
Field service*



BWD539D
Dual Trace
DC-25MHz -3db
5mV sensitivity

*Colour TV,
C.B. Radio,
 μ -Processors,
Video & audio
recording.*



BWD504
DC-6MHz
10mV sensitivity

*Education,
Hobbyists,
X-Y monitor*

BWD
ELECTRONICS
PTY. LTD.

Miles Street, Mulgrave, Victoria, 3170
Telephone 561 2888. Telex 35115

- N.S.W. Amalgamated Wireless (A'asia) Ltd., Sydney. Phone 888 8111
- QLD. Warburton Franki (Brisbane) Pty. Ltd., Phone 52 7255
- S.A. Protronics Pty. Ltd., Adelaide. Phone 51 4713
Rogers Electronics, Adelaide. Phone 42 6666
- W.A. Cairns Instrument Services, Perth. Phone 25 3144
- TAS. Associated Agencies Pty. Ltd., Hobart. Phone 23 1843

FP376B

The battle for the US TV market . . .

tal infusions of North American Philips.

Wall Street analysts had begun turning more positive toward television maker's prospects, especially those of RCA and Zenith, well before the ITC's recommendation. While any relief from Japanese competition would be of help to US industry, stock market analysts agree, latest bullishness about TV stocks is based on more than tariff relief. Analysts believe, the Wall Street Journal reports, the outlook has improved for the major US companies for other reasons.

"RCA represents a potential major turnaround," Otis Bradley of Spencer Trask & Company said in his March recommendations to purchase RCA shares. Bradley's prediction was based upon what he described as "great strength in the company's basic business." In the case of Zenith, which Bradley added to his list or recommended stock in February, he finds strength both in the basic television business of the Company and its recent agreement with Sony to market Sony's Betamax video-tape recording systems in the United States. In the case of both RCA and Zenith, Bradley said, his estimates didn't include any help the companies might get from government actions that might dampen import pressures.

The state of the US industry leaders was also reflected by GE Vice Chairman W. D. Dance who recently expressed his company's satisfaction with its television operations, stating "Our VIR sets were in scarce supply all Fall (1976). We're very satisfied—we gained share in consoles, held our own in portables. I think we're here to stay, and the Japanese are here to stay.

"Significantly, the ITC chose to ignore the salubrity of the US industries' leaders, which had kept pace with competition through heavy investment in technology, automation and quality control. Instead, the Commission focused its attention on small, non-integrated assemblers whose days were inevitably numbered, regardless of imports, by basic changes in technology which require increasingly large volume production to sustain heavy investments in highly automated production facilities.

Several other factors suggest that the US television industry is not the invalid which the ITC investigations suggests. It is remarkable that no major US television manufacturer was associated in the claim of injury under the Escape Clause provisions of the 1974 Trade Act.

Reliable sources in Washington report that COMPACT was initially bank-rolled to the tune of \$300,000 by Corning Glass, which has recently introduced a unique 19-inch colour picture tube, developed jointly with Zenith over a 5-year period,

featuring improved manufacturing processes, lower glare content, and reduced picture tube costs. While Owens' Illinois-Ford, a second picture tube manufacturer, joined with Corning, along with eleven trade unions in the electrical field, the only two television receiver manufacturers to associate themselves with the petition to the ITC were GTE Sylvania and Wells-Gardner Electronics, a small private-label assembler located in Chicago. And, in part because no major TV manufacturers were associated in the petition, the Electronics Industry Association, the industry's official spokesman, did not appear as a witness in the course of the ITC's investigations.

Far from being infirm, or faced with the threat of extinction, as recent rhetoric claims and the ITC recommendations appear to confirm, there is substantial evidence that US television manufacture is on the verge of a comeback which promises to be even more significant than that of the calculator industry. Television blankets a broader range of potential applications, unlike the zero-based comeback of US calculator manufacturing. What's more, the US television industry still has close to 70 percent of the colour TV market and accounts for a substantial share of monochrome sales.

The dramatic US comeback in calculators is instructive, for it clearly demonstrates how the US lead in technology can impact the industry and markets in a very short time span. In 1970, it will be recalled, US calculator imports from Japan accounted for 40 percent of a \$224 million market, a share which had been acquired in the span of just four years. A year later, Japanese calculator imports represented almost 60 percent of units sold in the United States, and approximately 45 percent of the total market value.

But this was their peak year, in terms of market share. By 1974, Japanese calculator imports had dropped to just 21 percent of the value of US calculator consumption (an estimated 750 million market); the number of electronic calculators shipped by integrated US manufacturers was estimated at over 8 million, with a value of approximately \$500 million, a dramatic recovery from zero-base in the same amount of time it had taken Japanese imports to take a commanding lead.

In 1971, several developments converged to produce a radical change in the competitive advantage of the US industry vis-à-vis Japanese and other Asian production. The vigorous price and performance improvement in US MOS/IC technology, along with innovative Japanese marketing strategies, had



Home colour video replay system developed by Hitachi Ltd—US companies could win out here too.

already established clearly that the electronic calculator was a product with a high elasticity of demand, its market broadening substantially as prices declined. Then in 1971, several US IC makers introduced single-chip four-function calculators. Labour costs as a percentage of total production cost dropped further, and Japanese firms lost the advantage previously obtained in the assembly of transistorized and multi-chip IC calculators.

This change was intensified and accelerated by the entrance into the US and world markets in mid-1972 of the first US semiconductor manufacturers with their own lines of pocket calculators. This action restored to the US calculator industry the vertical integration lost with the disappearance of the electro-mechanical calculator and added a further dimension to the competition between US and Japanese firms for US market shares.

While this radical structural change was produced by the introduction of new MOS/IC technology by the US semiconductor industry, the new US entrants into the calculator market had an important windfall advantage in the import surcharges and the revaluation of the yen in relation to the dollar after the Nixon shocks of 1971. These measures had the effect of making Japanese exports to the US more expensive and, provided a timely protection for the massive entry of US semiconductor manufacturers into the market.

US firms then proceeded quickly to reverse the Japanese industry's advantage, using large-scale production and aggressive pricing policies.

(to be continued)

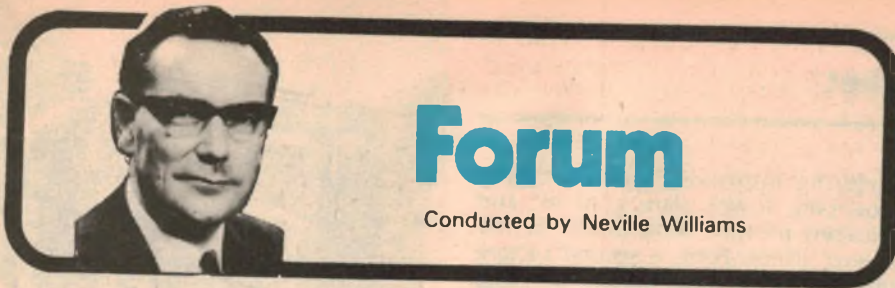

Forum

Conducted by Neville Williams

Is AM to remain the "poor relation"?

For an industry and a journal that grew off the back of the domestic "wireless", or radio if your prefer it, a subject that is remarkably neglected is ordinary AM broadcasting. Most of us just take it for granted but, every now and again, someone reminds us about the frustrations of those who take it more seriously.

To indicate what I am getting at, I can do no better than quote a letter to hand from a Victorian reader. Here is what he has to say:

Dear Sir,

Reading your note on the changed bandwidth of AM stations had prompted me to ask whether you could devote some space, perhaps in "Forum", to medium-wave AM reception.

I believe that AM has become the "poor relation" of radio now that FM is firmly established. Granted the better quality of FM, it is still a fact that many of us want to listen to programs on particular AM stations.

In my case, I want to listen to the newer Melbourne stations: 3CR, 3EA, 3ZZ, 3MP and occasionally to the Geelong station 3GL.

I have used four different receivers in my admittedly difficult listening location (in direct sight of the commercial transmitting aerials) and have been troubled to a greater or lesser extent by whistles and breakthrough of the commercial stations at harmonic, sub-harmonic and even apparently non-harmonic frequencies. As far as I have been able to ascertain, Japanese built equipment seems to suffer more from this kind of interference than my old Australian-made AWA Radiola Super-8 transistor portable.

The point is that I, and I think many others would appreciate a discussion of problems of MW AM reception, including the causes of various whistles and break-throughs and what, if anything, can be done about them.

I understand that the balance between sensitivity and selectivity is very important but, although manufacturers often quote AM sensitivity figures, they do not seem to quote selectivity. I believe there are IHF and DIN standards and possibly BS standards covering this and I think it would be of general interest if you could publish relevant excerpts from these standards.

I have gained the impression that the -6dB and -40dB frequencies, and amount of cut at 10kHz are important quantities. If this is so, could you specify these quantities in your product reviews?

In the matter of product reviews, could you devote a little more space to the evaluation of the AM section of tuners and receivers? I think that many people would be interested, particularly listeners to the "new" and less powerful stations.

Further, perhaps you could give consideration to two add-on projects to use with existing tuners and receivers.

Firstly, a preselector stage to feed into the external aerial terminal. I suppose the in-built ferrite rod aerial would have to be disabled by, say, shielding with an earthed aluminium foil. I am not sure how much a tuned RF stage contributes to selectivity, as distinct from sensitivity, but anything is a help when in trouble. I suppose some kind of variable sensitivity or antenna attenuation control could be built into the preselector.

Secondly, a whistle filter unit to go



Whistles and "cat-squawks" in a radio receiver are not a new problem, as is revealed from this advertisement clipped from "Radio News" December 1925. In those days, the troubled reader was exhorted to re-equip his set with Ambassador transformers—hardly appropriate in this present case.

onto the output of a tuner or in the tape monitor loop of a receiver. Is it possible, in this age of ICs, to home construct a filter with a switched notch for a range of frequencies? I have seen mention of filters for 4kHz, 4.5kHz, 5kHz, 9kHz and 10kHz. Some of these frequencies may apply only to Europe, the UK or the USA. Also, I believe there is a whistle produced with stations close to multiples of the intermediate frequency of a receiver.

L.J. (Lower Templestowe, Vic).

As I hinted at the outset, the present very casual attitude to radio in Australia is in stark contrast to what some of us can remember of the early days, when the ambition of most households was to save up to buy a wireless set. We can think back to the days when we would study the radio programs more carefully than we now read the TV guide: to the evenings when most homes re-echoed the voices of Jack Davey, Mo, Bob Dyer and others.

Now radio earns sparse mention in the popular press, rare mention in conversation and very limited attention in technical journals like "Electronics Australia".

And, in mentioning "radio, we virtually have to include FM broadcasting as well.

A couple of years back, when those who wanted FM broadcasting were campaigning vigorously for it, there was no end of letters, arguments, news items in the press, requests for information about tuners, etc. Now that the stations are operating, mainly with culturally based programs, the subject is rarely mentioned outside the circle of regular listeners, and with only a brief program summary in the daily papers.

But there is an essential difference between the future of FM and of AM.

FM in Australia is still in its infancy and has yet to go through the stage where more stations will be commissioned, a wider variety of programs will be offered, and a larger share of the listening audience acquired—with an emphasis on noise-free high quality stereo sound.

AM, on the other hand, has had its "day of glory" and is now filling mainly a utility role: news, current affairs, sport, talkback, pop music and background music, with a relatively small number of culturally based programs.

By and large, AM receivers have become as utilitarian as the programs themselves. They could be designed to higher performance standards, with AM/stereo a possibility, but there is very little pressure for such initiatives from the consumers who would have to meet the costs involved. They accept what they have and give the matter little further thought.

While L.J. is not primarily concerned about quality of sound reproduction, his problem flows from the same worldwide "utility" attitude to medium-wave AM receiver design.

Behind all the frills, the average receiver is made selective enough to separate out the stations serving typical receiving situations, but not so selective as to impose a prohibitive degree of sideband cutting. The front-end tuning system is likewise designed to cope with the main role of the receiver, but stops short of more exotic and expensive techniques.

Medium-wave AM receivers and tuners vary, of course, from the very cheap to the very expensive but, by and large, they are variations of this one theme: the listener expects them to receive reliably those stations intended to serve his/her particular area—with a signal that sounds like radio has always sounded! In between the strong stations will be others that are listenable, some that are not, plus, perhaps, various stray whistles and heterodynes. The casual listener accepts this as an indication that there are other stations out there that he could listen to if he wanted to, but in practice, he couldn't care less about them.

Station frequency allocations have also tended to reflect this line of thinking: allocate licences and frequencies to an ever-increasing number of stations intended to serve local communities. The fact that stations have to share channels, making it difficult to receive them outside their respective local areas, is a price that is increasingly being expected—and paid.

While, in the past, enthusiasts of DX (long distance) reception have complained bitterly about this trend, L. J. may well object that he is not a DXer at all; he merely wants to listen to a few stations that are not all that far away, but he is being frustrated in even that objective.

Without being au fait with listening conditions in his area, it would appear that his real problem has less to do with frequency allocations than with his location "in sight of commercial transmitting aeri-als". But, given that very high local signal strength is causing trouble, why is it that he can't seem to find a receiver that will cope? Why don't manufacturers produce better quality receivers? Why don't they give more detailed specifications? Why are they so off-handed about MW AM anyway?

While it would be easy to launch into a recital about what receiver and tuner manufacturers should do, the simple commercial fact is that they tend to produce what their customers want. And customers want a certain range of facilities; they want a certain style and finish; they want a certain order of performance from disc, tape and FM/stereo; but AM...? Its mere presence is enough—as a utility.

In fact, in their impressive tuner/pre-amplifier reviewed in the June issue, Nakamichi didn't bother to provide AM at all. Presumably, if a customer wants the news, weather or cricket, he can always pick it up on his "tranny"!

And Armstrong, the well known British Company, have found it worthwhile to promote a new version of their 626 receiver which saves £34 by eliminating the AM coverage because: "for many, AM on a receiver is an unused facility—and hence, an unnecessary expense."

It so happened that, as these parts were being written, Pioneer's top-of-the-line TX9500 II tuner was in our lab and I checked on the AM section. Built around a single complex integrated circuit, it involves a ferrite rod antenna, a 3-gang tuning capacitor (one tuned RF stage) and three IF transformers—a highly conventional configuration.

The specifications in the owner's manual are neither very complete nor very illuminating:

Sensitivity	
IHF, ferrite antenna	300uV/m
IHF, external antenna	15uV
Selectivity.....	30dB
Signal-to-noise ratio.....	55dB
Image response ratio.....	70dB
IF response ratio.....	65dB

In the manual, Pioneer express themselves as being very happy with the performance of the AM tuner circuitry but their contentment has to be measured against what is normal and conventional, rather than what could be achieved if they had put as much money and effort into AM as has gone into FM/stereo.

And this is part of the problem which L.J. faces. No matter how stylish the face on a hifi tuner or receiver, or no matter how elaborate the frills on a conventional consumer market portable, there is very little chance that the "works" will go beyond the conventional formula: ferrite rod antenna/coil, one RF stage and a couple of conventionally peaked IF stages, and a few rather sketchy specifications.

To be able to form any real judgement as to how a tuner or receiver will perform in terms of selectivity, enough data have to be presented or derived to indicate the shape of the selectivity curve at the top, bottom and centre of the band (thereby including the effects of both the RF and IF tuned circuits).

If the curve dips only a few dB out to 7 or 8kHz either side of centre, then plunges very steeply downwards, it should offer a good audio modulation passband: fine for the hifi enthusiast listening mainly to local stations.

If the nose of the curve is much narrower, say 3 to 4kHz on either side, with a steep vertical slope beyond that, the audio response would be short of upper treble but the ability to pick signals out of the background would be good.

Of course, if the nose of the selectivity curve is sharp but the sides or "skirts" trail outwards, the user would tend to get the worst of both worlds: noticeable sideband cutting, with poor discrimination against interfering signals and noise, as well.

But rarely is this kind of information available, and I can't see us plotting

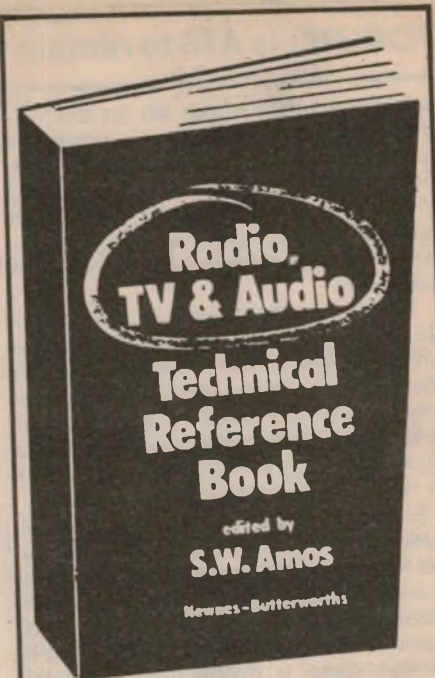

* The only book available containing all the facts and data spanning the whole spectrum of Radio, TV and Audio.

* Brings together 31 contributors, each one expert in his subject.

* The book is aimed mainly at the technician who has to operate and maintain electronic equipment. It is suitable for the technical operator, the technical assistant, the service man, and the amateur radio and audio enthusiast.

* Extensive work containing:—

1172 pages In metric
94 photographs S.I. UNITS
1150 drawings

* Also available

**ELECTRONICS ENGINEERS
REFERENCE BOOK
4th Edn. Turner (1976)**

Ask for them at your local bookshop

In Melbourne:

● TECHNICAL BOOK COMPANY
● MCGILLS NEWSAGENCY

In Sydney:

● THORBURN'S TECHNICAL
BOOK CO.

Butterworths
Pty Limited

FORUM: Is AM to remain the "poor relation"?

selectivity curves in our lab for the purpose of reviews. We can only devote so much time and so much space to each product and the effort has to be devoted to deriving or verifying the data which potential buyers most want to know—and that doesn't normally include AM selectivity.

There's another angle to this rather depressing recital of negatives: the problems which may be encountered in the presence of one or more powerful local stations are not simply a matter of selectivity and sensitivity. They have to do with the more subtle ways a receiver or tuner reacts to large RF input levels.

For example, strong signals from local stations can overload and be rectified by the RF amplifier stage—a problem which is encountered more frequently with transistors than with valves. The rectified signal only becomes audible when another signal is deliberately tuned in, the process being referred to as "cross modulation" or "intermodulation". It leads to the frustrating situation where local station signals appear on top of weaker signals but not between them!

Harmonics from the local oscillator are another subtle source of trouble. When the oscillator generates a single frequency at any one time, only two signals are able to combine with it to produce a resultant at the intermediate frequency: the wanted signal, to which the RF circuits are tuned, and the "image" which the RF circuits should reject (70dB down in the Pioneer specifications above).

But if a whole range of harmonics is present from the local oscillator, they may well heterodyne (or beat with) a variety of incoming carriers, with locally generated harmonics of those carriers, with harmonics actually radiated from strong local transmitters, or with harmonics of the receiver's own IF system, to produce signals, whistles or "joeys" capable of sneaking through the IF channel.

And it is true, as L.J. suggests, that troubles can concentrate at harmonics of the intermediate frequency, particularly at around $2 \times 455\text{kHz}$.

I happen to live fairly close to just one local broadcast station—not several—and while it does not normally cause any trouble, its signal may be heard in dozens of spots across the dial of simple receivers, or even car radio receivers which have presumably been designed on the assumption of a small rod aerial and no strong local signal.

Effective selectivity ahead of the mixer is the best all-round precaution against such problems. I have painful memories of the early 455kHz domestic superhets (circa 1935) where, for economy reasons, we had to get by with one tuned aerial coil of not very high "Q". The use of an

RF stage, the appearance of iron-cored coils and of very high "Q" ferrite rod antennas improved this position dramatically.

These provisions are now common to all but the simplest tuners and receivers. What we are really saying, therefore, is that AM tuner design needs still further refinement if it is to cope with growing congestion in the medium-wave AM band. But buyer pressure to do so is so low that advanced technology is seen in only a very few exotic and expensive examples.

Why not add a tuneable RF preamplifier, asks L.J. and this is legitimate thinking. However, he has also put his finger on the number 1 problem: most of the tuners and receivers involved have ferrite rods serving in the dual role of antenna and first tuned circuit. They certainly could not be wrapped in foil to stop direct signal pickup—that would wreck their resonance and the "Q"—and I don't like the chances of shielding them effectively inside the receiver as a whole.

I imagine that the necessary approach would be to modify the input circuitry of the main receiver, isolating the ferrite antenna and giving access, when required to the input element of the first RF amplifier. The external RF preamplifier would then have to provide for the antenna and input tuning, as well as the tuned coupling into the receiver. It could be done, I guess, but there would be more to it than a simple external fitment.

L.J. also asks about tuned filters to help cope with the whistles. A 10kHz (or 9kHz) filter to cope with interstation beats is common enough, although it normally multiplies into a complete circuit segment by the time one includes circuitry around the filter to cope with level and impedance considerations.

But to cope with the random whistles which can occur in a situation like that described by L.J., something more than a switchable filter would be required. Maybe a compound tuneable filter, capable of dealing with more than one whistle frequency at a time.

Frankly, it all sounds rather tedious and, if there's one positive thing I could say, it would be to suggest to L.J. that he may have to look beyond the normal range of receivers and tuners to genuine communications-standard designs where, hopefully, special attention will have been given to a multiplicity of tuned circuits, to oscillator harmonics and to internal shielding. A communications-style receiver may cost more, but that may well be the price that one has to pay for the facility that L.J. says he wants.

Maybe some other readers will be able to offer to him the benefit of their experience in a similar situation.

One final thought: perhaps L. J. should also consider the use of a frame aerial. ☺

AVAILABLE

FROM:

I.C.S.
16 GERTRUDE STREET
ARNCLIFFE 597 1444

DISTRIBUTORS:

NORTH

PARAMOUNT
ELECTRONIC
SERVICES
47-51 JERSEY ST
HORNSBY 476 5911

SOUTH

BRYAN CATT
INDUSTRIES
105 MIRANDA ROAD
MIRANDA 524 4425

EAST

RADIO DESPATCH
869 GEORGE STREET
SYDNEY 211 0191

WEST

ELECTRONIC
ENTHUSIASTS
EMPORIUM
7-10 JOYCE STREET
PENDLE HILL 636 6222

INDUSTRIAL

J.A. SEVERN
50 BAMBARA
CRESCENT
BEECROFT 869 1058

DISTRIBUTORS FOR THE ELECTRONIC INDUSTRY

Are you aware??

We offer Top Brand Products at market prices with one of the largest product ranges available from a single source of supply.

PRODUCTS AVAILABLE AS LISTED:

Semi-conductors

DELCO
ELCOMA
GENERAL ELECTRIC
INTERMETAL
ITT
NATIONAL (NS)
NEC (RECTIFIERS)
R.C.A.
SANYO
SIGNETICS
T.I.

Passives

A.E.E.
BEYSCHLAG
BOURNES
ELCOMA
ERIE
ITT
SOANAR
SPRAGUE

NEW ICS CATALOGUE
AVAILABLE IN JULY

Electro-Mechanic

ALCO
AUGAT
CANNON
ITT
J.A.E.
JEAN REGAUD
NATIONAL (RELAY)
POMONA
ROTRON
SWITCHCRAFT
T.I. (IC SOCKETS)
THERMALLOY

Instant Component Service

16 GERTRUDE STREET, ARNCLIFFE

At last. Dynavector.

A moving coil cartridge that doesn't need a transformer — and won't cost you the earth.

It's often said that the cartridge and the speakers are the most essential elements in any hi-fi system. What you put in between is of secondary importance. The aim, always, is linear performance across the audible frequency spectrum. And here's a little number that makes it infinitely more achievable — the Dynavector moving coil cartridge.

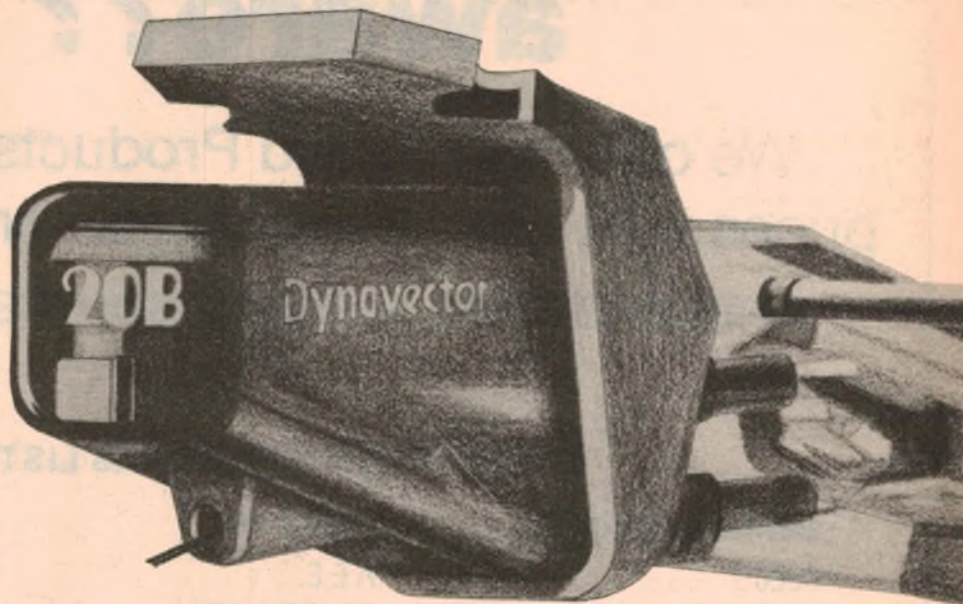

The concept of moving coil cartridges is by no means new. Many a mature audiophile will remember them as being "the best" in the good old days of valve amplifiers. Dynavector is entirely new in what is unquestionably the most significant area of development in moving coil cartridges; the elimination of the need for a step-up transformer. Dynavector output is 2mV at 1kHz, 5cm/sec and is fed directly to the magnetic cartridge inputs of amplifiers. This high output value is made possible by the development, through Onlife Research (Dynavector's Japanese manufacturer), of a winding device that enables an extra thin (0.115mm in diameter) copper alloy wire to be wound 200 times into a single coil.



The black dot in the box at left is the actual size of the coil former used — around which two separate coils are wound at right angles to each other. A further benefit of this micro coil technology is Dynavector's low inductance, rendering it insensitive to load impedance.

But what does Dynavector give you in the sound department? We borrow from **Hi-Fi Answers, August 1976** where Dynavector (called Ultimo in the UK) was appraised.

"Listening tests on the cartridge told us what we could do with our theories. Immediately noticeable was the deep rich bass character, a gain claimed to be the consequence of the moving coil design. The top end possessed a sweet, silky quality and the bass was well controlled and extended."

Dynavector also gives you an indication of what it will do before you use it. Each cartridge is individually performance recorded as a final process of manufacture, and is packaged with its very own B & K frequency response graph. A photo-reduction of a typical graph can be seen below.



Dynavector uses the Shibata diamond stylus with an option of either a tapered aluminium or rigid beryllium cantilever — models 20A and 20B respectively.



The Shibata diamond stylus shape permits greater surface contact with the groove, which not only provides CD-4 capability but reduces record wear.

The illustration above is a detailed impression of the degree of surface contact the Shibata stylus provides.

So, it's up to you. Take in a Dynavector versus moving magnet cartridge demonstration at one of the better hi-fi dealers in your area. Or write to Sonab (enclosing a stamped self-addressed envelope) for a copy of the Dynavector colour brochure. But if you possibly can, HEAR the Dynavector difference. It's really quite amazing.



Dynavector 20A.20B

Distributed by Sonab of Sweden Pty Ltd 13 Rickard Road, Narrabeen North N.S.W. 2101 Telephone: 913-2455

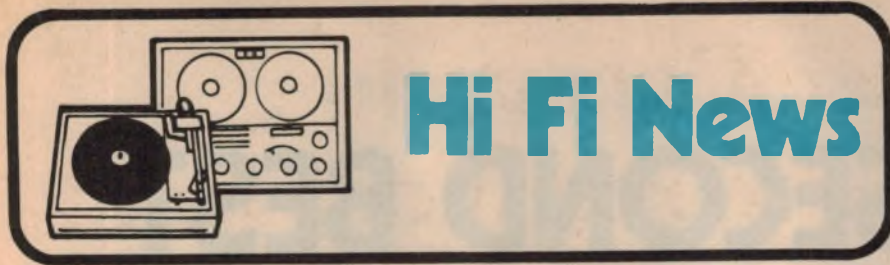

Hi Fi News

M-C CARTRIDGE, TWIN-PIVOT ARM AND AN ALL VALVE AMPLIFIER

At a recent meeting in Sydney, Dr N. Tominari, President of Onlife Research, Inc, Tokyo explained and demonstrated a range of highly individualistic high fidelity equipment, including a moving coil cartridge, an unusual playing arm designed to complement it, and a new all-valve preamplifier/power amplifier combination.

by NEVILLE WILLIAMS

Hosted by Derek Pugh of Sonab of Sweden Pty Ltd, the occasion provided an opportunity for people from the technical press and from hifi establishments around Sydney to see and hear Dynavector products for the first time.

Revealing something of his background, Dr Tominari said that, until a few years ago, he had been quite happily involved as Professor of mechanical engineering at the University of Tokyo, with high fidelity sound as a hobby interest—one shared, in fact, by some of his students.

He would normally have continued in that situation had it not been for the rise of the "student power" movement and the upheavals which it caused in Japanese universities. Much against his inclinations, he found himself in the position of chairman of the university's "punishment committee"—a position that became so untenable that he decided to resign and to turn to his hobby as the basis for a new career.

Three years ago he formed a company to research and manufacture high quality audio components and, during the subsequent period, was joined by some half-dozen of his "brightest" students. The company now operates from its own Onlife Building, at 3-8-6 Ginza Chuoku, Tokyo 104.

Curiously, Dr Tominari sees its derivation from mechanical engineering as contributing a unique quality to his company. To paraphrase his explanation:

Most electronics engineers start out from an electrical background and they are not always well equipped to cope with the many mechanical problems which are involved in designing and producing high fidelity sound equip-



Above, the new Dynavector moving coil cartridge by Onlife Research Inc. and, on the right, the Dynavector arm which has been developed to go with it. Note the separate pivot for vertical movement.

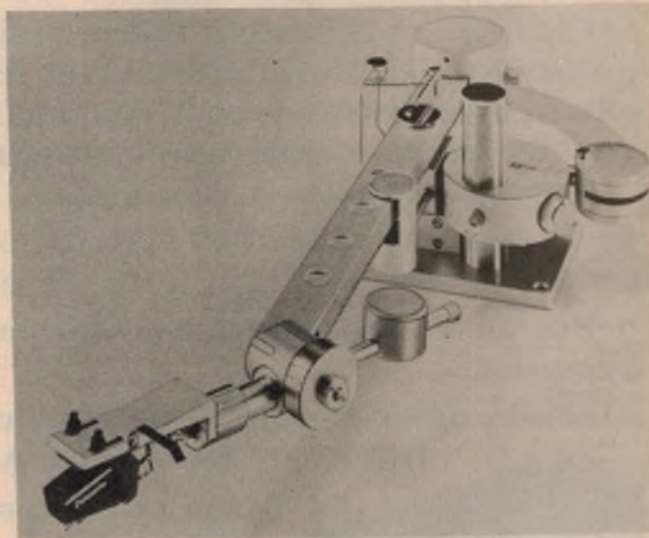

ment. They tend to translate mechanical problems to electrical analogs and to solve them in this form—not appreciating that they might have introduced errors and omissions in the process. At Onlife, mechanical problems are seen, analysed and solved in their original form.

Dr. Tominari said that, originally, he had been very much a tape enthusiast but had become intrigued by the quality from premium discs, particularly when traced by a premium grade moving coil cartridge. These cartridges appeared to impart a clarity and transparency to the reproduction which could not be explained simply in terms of their measured frequency response or other such characteristics.

He suggested that the difference may well have something to do with phase, the structure of a moving coil cartridge

being such that there is less phase modulation of the signal than with a moving iron design. (Designers of competitive cartridges might conceivably want to debate this point. Ed.)

The main problem about moving coil cartridges was the very low output from the tiny coil, and the necessity for either a very high grade step-up transformer or a very low noise pre-preamplifier. There was the further problem that moving coil cartridges tended to exhibit somewhat higher mass and lower compliance than the high trackability moving iron types, necessitating the use of a greater tracking weight.

Onlife research Inc solved the first of these problems by learning how to wind coils with many more turns (in excess of 200) than had previously been considered practical, using a wire of 11 microns diameter—so fine that the job has to be done under a binocular microscope. But the result is a cartridge that delivers a nominal 2mV output direct from the moving coils and sufficient to drive a typical modern high-gain low-noise preamplifier stage. The actual rating, by the way, is 2mV at 1kHz, 5cm/sec.

On the subject of compliance, Dr

Tominari said that the Dynavector moving coil cartridge is fully equal to hifi requirements at 8.17 microcentimetres per dyne but that compliance figures could easily become a fetish, to the detriment of other qualities. With a weight of 10gms, the Dynavector moving coil cartridge is rated to track at 1.5 grams. However, it is fitted as standard with a Shibata stylus which spreads the tracking weight up the groove walls and removes any possible apprehension about groove or stylus wear.

There are two models of the cartridge, the 20A with tapered aluminium cantilever, and 20B with the further refinement of a straight beryllium cantilever. The rated frequency response is within ± 2 dB from 20Hz to 30kHz, but each cartridge is packaged with its own Bruel & Kjaer calibration curve.

OUR SECOND BEST IS BETTER THAN MOST OTHERS' FIRST BEST.

TDK's AD (Acoustic Dynamic) is one of the world's finest cassette tapes but not the best cassette tape made by TDK.

Our SA (Super Avilyn) has the edge but that's only if you're using the special bias/equalisation setting on your tape deck.

However, if you're using the normal or standard setting, you'll have to settle for AD – second best.

Chances are you won't find anything better or with more consistent sound quality for decks with normal tape selector settings (or no selector switch at all). In other words, even if you don't own extravagant equipment, with AD you can still hear extravagant sound reproduction.

You see, because of AD's superior dynamic range at the critical high end, you'll hear any music that features exciting "highs", with amazing brilliance and clarity you won't get from any other tape.

But there is something else you should hear before you try TDK's AD. The price.

Unlike other so-called "super premium" cassettes, AD's price is down-to-earth (that should make AD sound even better).

There's just no comparison between ours and what others consider to be their best. So try the second best cassette we've ever made – AD.

Available in: C45
C60
C90
C120

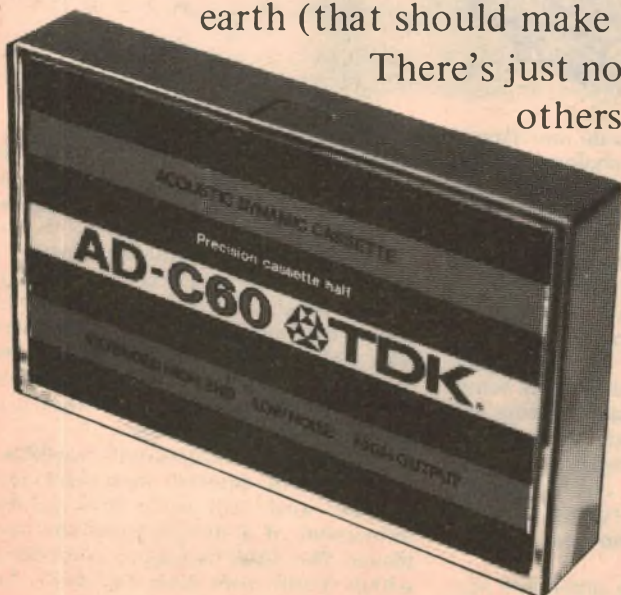

 **TDK**® AD
(Acoustic Dynamic)

SOLE AUSTRALIAN AGENTS:
CONVOY INTERNATIONAL PTY LTD
4 DOWLING ST WOOLLOOMOOLOO 2011
TEL 357 2444 TELEX AA23111

Interestingly enough, the frequency response actually extends to 50kHz (-3dB +2dB) and this, together with the Shibata stylus and the very low coil impedance, makes the Dynavector cartridge eminently suitable for CD-4 quadraphonic replay, so that it is completely compatible in this respect. It is also non-critical in regard to its terminating load and is largely unaffected by shunt resistance and capacitance.

While the Dynavector (or "Ultimo") moving coil cartridge can be used with any high-quality lightweight arm (defined typically as 17-30gm) the combination is not optimum because of a likely system resonance running to a 6-7dB peak around 8-10Hz.

Considering the problem, Dr Tominari decided that a much heavier arm is really desirable, to hold the cartridge (or any cartridge) steady in a lateral direction, so that side/side groove modulation would vibrate only the stylus, not the complete head assembly. Such increased lateral inertia should not produce any difficulties because, apart from eccentric grooves, which would cause a record to be rejected anyway, lateral movement of a cartridge is very small and very slow.

Vertical movement is quite a different matter because up/down movement due to warp is commonly encountered, and produces greater movement and acceleration. Yet it need not compromise the sound of a disc, provided the arm and cartridge can still track the groove. This latter requirement makes it essential to minimise vertical inertia, leading to a conflict in the design of a conventional arm, where vertical and lateral inertia cannot be separated. Designers therefore tend to settle for a figure which is a compromise: below optimum inertia for lateral and above optimum for vertical.

Onlife Research's answer is the



Reminiscent of some of the hifi styling by Nakamichi and Yamaha, this clock/radio from Toshiba-EMI (Australia) is both functional and eye-catching. Designated as model CR1100, it employs the very latest solid-state technology with all the normal radio and clock functions incorporated in a single integrated circuit. Push-button controls allow for rapid setting of alarm and indicated time, the latter to within one second of the radio "pips". A touch plate gives the option of a few more minutes of snooze, or silencing the radio altogether at sleeptime. Details from Toshiba-EMI (Australia) Pty Ltd, 16 Mars Rd, Lane Cove, NSW 2066.

Dynavector DV-505 arm, incorporating two distinct pivot systems. The main base pivot provides for lateral movement of the arm assembly and, in fact, supports it completely, so that it is rigid in the vertical plane. A second pivot allows for vertical movement of the head section only, so that two distinct moving masses are obtained—effectively 100gm for lateral movement and only 12gms for vertical movement.

Dr Tominari pointed out that the general idea is not new, having been exploited for a time by other manufacturers, including Pickering. While it may be mechanically more complicated and somewhat less convenient for some applications he felt that this was a small price to pay for optimised performance.

There is a possible objection that the foreshortened vertical radius exaggerates any change in stylus angle with up and down movement of the head. But Onlife literature makes the point that excessive vertical inertia in a conventional arm causes the stylus shank to change its attitude to the head and that this radius is effectively only one tenth the radius built into the Dynavector arm!

Given the concept, the arm itself has many refinements. A weight, coupled by compliance to the rear of the arm, is tuned to the natural resonance of the arm and produces a double humped response instead of a single strong peak, much as happens in a ported enclosure. This, together with damping provided by a vane which travels between two magnets, gives an amplitude response which peaks by no more than 2dB at about 12Hz.

The arm also has adjustments for height, dynamic balance, groove bias, stylus overhang and playing weight. In terms of appearance, it is just the reverse of the very slim arms that are offered by most other manufacturers.

Last, but not least, the audience was invited to hear the combination of Dynavector cartridge and arm played through—not a top quality transistor amplifier—but a new valve amplifier! When I posed the question to him: "You mean valve power amplifier?" Dr Tominari was quick to put me straight: "All valve, right from the preamplifier!"

When asked about power fets, I was told in no uncertain terms that, when transistors are as good as valves, Onlife will start to use them; not before!

And I had to admit that, when the amplifier was working from a 2mV cartridge, there were none of the hisses or

(Continued on page 33)



The new Dynavector "3000 GOLD" preamplifier represents a wide departure from popular present-day hifi practice. First and foremost the designers have preferred valves in all stages, as well as in the associated separate power amplifier. Secondly, the two channels are kept entirely separate, with their own individual power supplies and with their own controls: left channel, top row; right channel bottom row. The controls themselves provide the usual facilities, but with the addition of a separate phono knob, which allows the instant choice of up to three cartridges. The meters indicate the level of signal passing through the preamplifier.

PERCY WILSON: 1893-1977

A letter to hand from well known hifi writer George Tillett says: I have to report the death of my old friend Percy Wilson, one of the real pioneers and formerly Editor of *The Gramophone*. By courtesy of another British hifi pioneer Gilbert A. Briggs, we reproduce a segment of Percy Wilson's biography covering his early association with the gramophone (phonograph ?).

My first real interest in the gramophone came when I bought a record as a Christmas present for my mother-in-law, in 1919: Caruso, Galli Curci and the others singing *Chi mi frena* from "Lucia" and *Bella figlia dell' amore* from "Rigoletto".

My wife and I were setting up house at the time and I couldn't afford a gramophone myself. But in 1923 I had saved enough to buy one, though its price (about £40) bent my banking account not a little!

It was then that I saw a copy of the third issue of *The Gramophone* which I promptly bought and wrote off for numbers 1 and 2. The latter was already out of print but I managed to secure a copy by going to the editorial offices and meeting Christopher Stone, the London Editor. We made friends at once and I used to spend some of my lunch hours with him.

On one occasion, I told him that I had worked out the conditions for minimum tracking error for the transit of a soundbox across a record. This problem had been exciting interest in the early issues of *The Gramophone*, so Christopher invited me to clinch the argument by publishing a mathematical explanation. This we did in September and October, 1924.

The articles created something of a stir amongst "gramophiles", and I was invited to go along to several gramophone societies and give a demonstration. It was then that I met my old colleagues H. F. V. Little, an expert on opera as well as a chemist and mathematician of no mean standing, and G. W. Webb, who had specialised in historical research on sound reproduction. And the circle of gramophone friends soon grew and included all sorts of folk, scientific, musical, and others who just had uncanny hearing faculties.

These friends made me realise that I had wasted my £40 in buying an internal-horn gramophone. I was persuaded to buy an H.M.V. Schools Model which had an external flared horn, and the 4-spring motor which, they asserted, was the best in the world. They even showed me how to stop the horn from rattling by running melted cobbler's wax down the seams!

Born at Halifax, Yorkshire, in March 1893, Percy Wilson lived through the evolution of sound reproduction in Britain, from the early gramophones to current technology. He is pictured here, around 1960 with an E.M.G. Mark X gramophone, which was still in use at the time, side by side with a British Ferroglyph tape recorder.



They were right. This model was easily the best gramophone I heard in those days, particularly after they had taught me how to "tune" the H.M.V. Exhibition soundbox. This was an empirical business involving adjustment of masses of stylus holder, stylus bar, and diaphragm, compliance of bar and springs, and depth of air chamber, etc.

I then started to investigate the acoustic properties of horns. I got out my Rayleigh's "Sound" and looked up the basic mathematics, but only found the case of a conical horn worked out in any detail. What I wanted was a flared horn but had no clue as to what was the best shape. So I asked George Webb and he told me he had seen a reference somewhere to an exponential horn. That set me going and by the end of 1925 I had all the formulae for an exponential horn worked out. (The method of deriving the modified shape I explained in *Modern Gramophones*, published by G. W. Webb and myself in 1929.)

I was so pleased with this investigation that I had a wooden former made for an exponential horn some 5 feet long. The first horn made from this was built up by sticking layer after layer of parcel tape and pasting with flour paste. It took hours and hours. Then one had to leave it to dry thoroughly before giving a coat of varnish.

During this period another significant step had been taken by Christopher Stone. He conceived the idea that *The Gramophone* should have an Expert Committee who could command authority in the trade, and he asked me to suggest people to be invited as members.

I named a few (Webb, Little, Gilman, Wild) and Mackenzie himself added Balmain whom I had not then met. Later a number of others were added, including

4 enthusiasts who worked at the National Physical Laboratory (N.P.L.) at Teddington. As a result, we had facilities at our disposal for accurate measurements without the necessity of paying for them!

Balmain abominated bends in horns and had invented a method of floating a straight horn (his was conical in shape) on two baths of mercury. Compton Mackenzie had one of Balmain's machines and positively asserted that it was much superior to any gramophone he had ever heard.

So when my straight exponential horn was ready, we decided to rig up a portable Balmain carriage to support the horn on Mackenzie's mercury baths; and to convey it to Jethou in the Channel Islands where Mackenzie lived at the time. We went down in force in the late summer of 1926, just after Mackenzie had received a new H.M.V. gramophone with No. 4 soundbox and had reluctantly decided that it was superior to his old Balmain. The passage from Guernsey to Jethou was in a small boat so I had to sit in the sternsheets with the horn supported between my knees!

We had the contraption rigged up within a couple of hours. For the first trial, Mackenzie chose one of the then quite new electrical recordings which had thrilled him on the new H.M.V. machine, and we used the No. 4 soundbox for the purpose. There was no question at all about the verdict. The exponential horn walked away with it on both old and new recordings.

When we returned home, flushed with success, I proceeded to adapt the Exhibition soundboxes and to modify the pattern maker's former so that horns could be made, with a specially cast elbow, to fit the H.M.V. Schools Model; and I made



JBL's new L166.

It's the most accurate loudspeaker JBL has ever made. The three-way L166 combines a new hemispherical high-frequency radiator with a new low-frequency transducer to deliver really impressive power-handling capability, super-wide dispersion and deep, tight bass. It has the most acoustically transparent grille ever developed. If you haven't heard the L166, you haven't heard nothing.

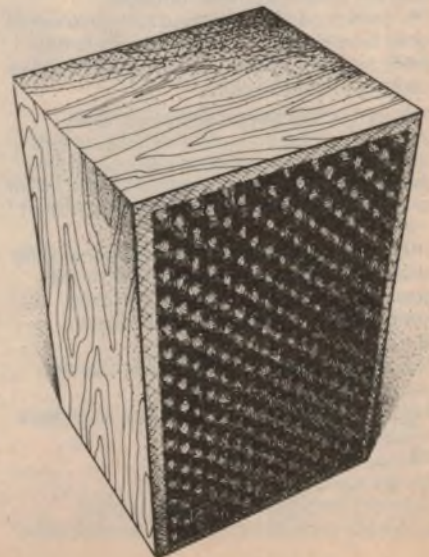

JBL

This is the safest place in the world to play your records.

We believe you should have as little as possible to do with the ADC Accutrac 4000.

So once you've placed your record on the turntable, and pressed a few buttons, you can leave the rest to the world's first computerised turntable.

The human errors that do a lot of damage to records are a thing of the past.

You get more out of it, because we put less into it.

It's a fact that when you compare the ADC Accutrac to other expensive turntables, the rest are made to look clumsy, complex and old-fashioned.

Truly superb sound reproduction can now be achieved in a much simpler way.

The turntable with a memory.

We started by replacing a lot of noisy mechanics with a neat little computer.

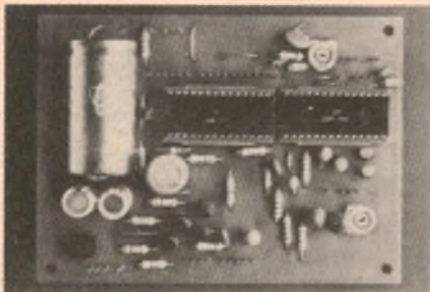

Out came standard components. In went the latest breakthrough in MOS computer circuitry.

So all Accutrac's operations are controlled and programmed far more quickly and efficiently than any other automatic turntable.

The control panel is designed for you to select up to 13 tracks in any order you want to hear them, and a 24 selection memory bank allows for programmed repeats.

The motor that keeps an eye on itself.

We replaced the conventional belts, wheels and pulleys with an electronically controlled direct drive system that keeps wow and flutter to a completely inaudible .03% and rumble at -70dB.

The motor contains electronic speed-sensing circuits, which keep a constant eye on the accuracy of the massive 12 inch diecast turntable's speed, and instantly corrects any error.

There's also a speed tuning circuit that lets you vary the speed over 5%.

A glance through the stroboscope provides a reliable speed check.

The tonearm you never touch.

We did some more eliminating.

Out went the noisy linkages that power automatic arms from the main turntable drive



motor.

Out went velocity-sensing mechanical arm-trip mechanisms.

Out went all the clumsy cams and gears.

Instead, Accutrac's tonearm is moved by its own electro-optically controlled servo-motor. It responds instantly and silently to your programme in the turntable's memory bank. Tracking error is minimised by the arm's 9 1/3 inch (237mm) effective length, and horizontal and vertical bearing friction has been reduced to the negligible level of 5-7mg, due to Accutrac's new ball race and pivot system. From the instant the stylus touches the record, the arm is totally decoupled from the servo-motor and controls, so it always tracks the groove with perfect freedom.

The cartridge that knows where it's going. Accutrac has the most advanced cartridge in the world.

The ADC LMA-1.

It scans the surface of the record with a tiny beam of light from a solid-state infra-red generator.

When the beam is focused on the record, closely spaced grooves scatter the light, while the smooth surface between the tracks reflects the light back to a detector which triggers the arm mechanism.

This system ensures that the tonearm selects the right track quickly and smoothly, while accurately gauging where it begins and ends. The low mass cartridge with its elliptical stylus, features the *Induced Magnet* system on which ADC built its enviable reputation.

It combines a strong, accurate, signal output with a 3/4 to 1 1/2 gram tracking ability.

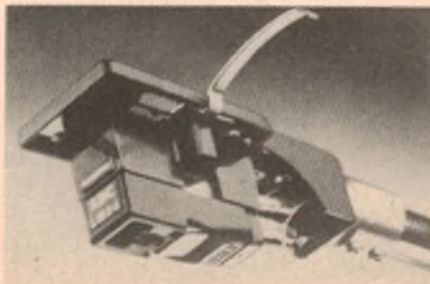

The integrated design of the tonearm and cartridge results in minimal arm mass and an ideal tonearm resonance between 8-10Hz.

It's all at your command.

As you see, Accutrac has some very intriguing features, quite apart from the turntable.



What looks like a pocket calculator is actually a cordless command module. So you have remote control.

The sculptured space-age object is the receiver for the turntable's memory bank. It's 'winking eye' tells you that your commands have been received.

Then you just sit back and enjoy what we hope you'll agree is the main attraction: the sheer excellence of the sound reproduction.

ADC

Distributed by
BSR (A'asia) Pty. Ltd.,
Anne Street, St. Mary's,
NSW 2760
Phone 6230375, 6235410

Accutrac 4000
Guaranteed for 2 years.

HIFI NEWS—Continued

arrangements with a papier mâché firm to put the horns on the market. These, too, were an unqualified success, but like a fool I did not ask for, and did not get, any commission.

Later, I also adapted the horn for use as a loudspeaker. At the time there were no really satisfactory speakers on the market and this horn arrangement easily outmatched them all.

I even went so far as to have an 8ft. straight horn suspended by pulleys from the ceiling in my hall, and arranged in such a way that, when lowered, the open end, which was square, exactly fitted the upper part of the doorway of our drawing room. What my poor wife must have suffered in stooping underneath with trays of coffee, etc., for our admiring guests in the drawing room! But it was only when moving coil loudspeakers became available that we abandoned it (for in her heart she was as proud of it as I was).

In the end, I gave it to the N.P.L. for use in their new wind tunnel!

That was not my last adventure with horns, for I was soon invited to design a huge one for exhibition in the Science Museum, and smaller ones for E. M. Ginn and other firms for their new ranges of gramophones. But none of these experiences had the same excitement as the earlier ones.

M-C CARTRIDGE—Cont.

the scratchings that one came to expect from the old EF86 valve preamplifiers. And the KT88s in the output stages quite happily pushed the built-in power output meters to 50 watts per channel peaking to 100 watts without any obvious sound of overload.

Mind you, I would not have wanted to carry the preamplifier and main amplifier up to Sydney central station, one under each arm. Nor would I have wanted to pay for them out of a week's wages!

How did it all sound, when fed through four Sonab loudspeaker systems?

Here I must begin to equivocate.

No argument: the system sounded very good, but also did the Shure V15 III with which the Dynavector cartridge was compared.

The Dynavector arm also behaved very well, but if there were any problems with the alternative SME arm, they weren't obvious, either.

And I'm not at all sure that we would have noticed the difference if someone had surreptitiously substituted Cyril Murray's pet solid state Australian-designed amplifier for the all-valve job.

When one is expected to express an opinion about equipment at this level of excellence, it pays to be somewhat cautious. On the occasion, it is easy, as some did, to make throwaway remarks like "anyone who can't hear the difference

has wooden ears". Expressed in print, however, any opinions have a much more lasting impact and need to be adequately authenticated before they are offered.

Personally, before expressing too loud an opinion about the differences in sound texture between two cartridges, I would want to hear them playing the same grooves simultaneously, with facilities for a phrase-by-phrase comparison.

Before saying too much about arm resonance, I would want to explore the situation using discs which might excite any low frequency resonance, or to set up one of those marginal situations where arm resonance becomes a factor in acoustic feedback.

As for the argument about valves v. transistors, I am certainly not prepared to wrap them all up into two rival packages. There have been poor transistor amplifiers, and poor valve amplifiers. And there are the better examples of both. I feel sure that, if a valid difference is to be discovered between the best of both, it would have to be demonstrated by very carefully controlled listening tests in which observers were required to express opinions without knowing what they were listening to at any one time.

What we heard on the occasion were not tests of this nature. We simply heard a demonstration of equipment which had been the subject of a lecture, and it looked like "in the flesh". We heard it playing a range of music, and this it did very well indeed. And one came away with the impression that, if planning to re-equip with new hifi gear, the theories and the hardware of Dr Tomonari's company, Onlife Inc, should be taken firmly into consideration, along with the excellent reviews it is enjoying overseas.

And, if one is to borrow that very outworn television commercial "Where do yer git it?" the answer is: inquire from Sonab of Sweden Pty Ltd, 13 Rickard Rd, Narrabeen, NSW 2101.

Ampex appointment



Mr Richard Blackett has been appointed by Ampex Australia Pty Ltd as the manager of a new manufacturing facility which the Company will be setting up here.

FERGUSON

AUDIO COMPONENTS

TRD223 Transistor Driver Transformer. Ratio 2.5 1 + 1 (50 ohms: 12 + 12 ohms).

MT552 Line matching Transformer for Mixers and other professional audio applications with selection ratios 1:1 (75 ohm:75 ohm) 1:2 (75 ohm:300 ohm) and 1:3 (75 ohm:600 ohm).

OP590 Audio line output Transformer rated 100 watts with auto winding tapped 2, 4, 8, 16, 50 and 100 ohms (70 volts and 100 volts line).

OP592 Audio line output Transformer rated 30 watts tapped 2, 4, 8, 16, 163 and 333 ohms (70 volts and 100 volts line).

TYPES MT Multi tapped speaker to line matching Transformers.

TYPES EK Single ratio speaker to line matching Transformers.



**TYPES
MT586
MT587
EK**



**TYPE
OP590**



**TYPE
MT581**

Available from Electrical wholesalers—prices and availability on request

Manufactured by:

FERGUSON TRANSFORMERS

P/L

Head Office: 331 High Street,
Chatswood, NSW 2067.

Phone (02) 407-0261 — Telex: AA25728.

Branches & Agents in other states



VIDEO TECHNICS

2ND FLOOR, TELFORD TRUST BUILDING, 79-85 OXFORD STREET, BONDI JUNCTION, NSW 2022. PH. 387 2555.
3RD FLOOR, EQUITABLE LIFE BUILDING, 301 CORONATION DRIVE, BRISBANE 4064. PH. 381 257.

FOCUS INTENSIFIER



Announcing our video focus intensifier to improve the playback quality of all VCR system video recorders. This consists of a small circuit board which fits inside the VCR (Philips etc.) This circuit detects a change in picture contrast and inserts a transient—in effect an extra—signal at this point, which crispens the image. The effect if the size of this transient is adequate is to recover lost sharpness, and the principle is indeed very effective. Full fitting instructions included. **\$39.00 + P.P.**

VIDEO EQUIPMENT—Sony, Akai, Portopacks. Also agents for J.V.C. and National. All formats and brands Colour and BW RECORDERS, EDITORS, GENERATORS AND BLANK VIDEO TAPE AVAILABLE. New and used equipment Trade and terms. Specials. We have several BW Portopacks traded on colour sets.



COLOUR TV TUNER

VIDEO TECHNICS
COLOUR TV TUNER MODEL HD6709

- Record one channel while watching another ●
- No modification required to existing television sets
- Will record while TV set is off ● Usable with any video recorder BW or Colour with an RF output which means this tuner allows video recording of TV programs and playback through aerial input of TV set. **\$295.00 + P.P.**

MONITOR ADAPTOR KIT for 26" Rank—Philips, 14", 18" & 20" General—Healing.



- Converts Receiver into Video Monitor.
- Allows off-air recording or recording with Video Camera.
- Easy to install.
- All instructions & circuit diagrams included.

\$95.00 + P.P.

You'll never have to miss a favourite TV programme —whatever you're doing



PHILIPS N 1502 TV Recorder

Will receive and record all Aust. channels Stocks now available. \$1,195 incl. S.T. Shipped anywhere in Australia freight on.

FRANCHISEES REQUIRED FOR S.A., W.A., VICTORIA AND TASMANIA

PARAMOUNT ELECTRONIC SERVICES

47-51 JERSEY ST., HORNSBY. N.S.W. 2077 PHONE (02) 476 5911
COMPONENT WHOLESALEERS AND DIRECT IMPORTERS

Quality Components at Backyard Prices— No Tricky Advertising

CHECK THESE FOR VALUE

2N3055 TO-3 \$1.20, BC 107, BC 108, BC109 25c; BC 177, BC 178, BC179 30c; 2N3638 35c; 2N3638A 38c; 1N4004 14c; 1N914 10c or \$6 per 100. LM555 71c; LM741 69c; LM340T reg. \$2.25; LM320T reg. \$3.50 7400 39c; 7402 39c; 7408 46c; 7410 44c; 7420 44c; 7430 44c; 74C00 48c; 74C02 48c; 74C04 48c; 4000 46c; 4001 46c; 4011 46c.

AY-3-8550 2 Axis Video Game Ic \$15
Joystick Controls for AY-3-8550 \$3.50 each
Convert your existing Video Game Using AY -3-8500 to 2 Axis for only \$22.00 Appollo Video Games, assembled. B/W \$55.00—Colour \$85.00
MA1003 12 volt Car Clock Module \$26.50.

NATIONAL SEMICONDUCTOR DATA BOOKS
FULL RANGE IN STOCK.

WE CARRY AN EXCELLENT RANGE OF SEMICONDUCTORS, RESISTORS & CAPACITORS, SWITCHES, PLUGS CONNECTORS ETC. SELECTED RANGE OF E.A. & E.T.I. KITS.

CB RADIO

*MAY CHANGE DUE TO IMPORT DUTY INCREASE.
GET A LOAD OF THESE PRICES



**SIDEWINDER
111 AM \$95***

**KRACO AM-SSB
MODEL 2340
OUR PRICE
\$185***

ACCESSORIES GALORE AT TRADE PRICES

- RUBBER DUCKIE ANTENNA \$7.50
- MODEL 110 SWR / POWER / FS METER \$16.50
- MODEL 175 SWR / FS / ANT. / MATCHER \$22.50
- MODEL 176 SWR / PWR / FS / MATCHER \$27.50
- MODEL 140 ANT. MATCHER \$10.50
- TV 1 FILTER \$1.20 PL259-FROM 99c

RIGHT ANGLE CONNECTORS, T SPLITS IN LINE JOINERS, 4 PIN MIC. PLUGS/SOCS, DUMMY LOADS, LIGHTNING ARRESTORS etc. etc. etc.

PACKAGE DEAL For less than \$200 Kraco AM-SSB2340 27 MHz CB Transceiver Centre Loaded A41C Antenna with Base, Antenna Cable with PL 259, 45cm, Jumper Lead with 2 x PL259, Model 140 Antenna Matcher Normally \$289 our price \$199. P & P \$9.00 save \$90.

Catalogue Price List now available, Free to Personal Callers or send S.A.E. 16cm x 10cm approx.

MAIL ORDER TO P.O. BOX 301, HORNSBY, N.S.W. 2077.
Please add \$1 to cover P&P on components—No minimum order

JBL 4301 Broadcast Monitor

The JBL model 4301 Broadcast Monitor is a modestly sized bass reflex loudspeaker system with a 25cm woofer and a 3.5cm tweeter. The system has fairly high efficiency and is suited to amplifiers with rated power up to 60 watts per channel.

Let us state, at the outset, that we will ignore the fact that the 4301 is termed a "Broadcast Monitor". Instead we will review it as a conventional high fidelity loudspeaker. The reason for this approach will become apparent at the end of the review.

In appearance, the JBL 4301 looks much like other loudspeaker systems. It is sensibly sized, at 483 x 291 x 306mm (W x H x D) and weighs 12kg. It is finished on four sides in oiled walnut veneer and has a removable grille covered in a dark blue fabric.

The woofer is a nominal 25cm unit with a large alnico magnet and a 50mm diameter voice coil. It has a generous roll surround, a rugged diecast chassis and a heavily ribbed cone. Effective cone diameter is about 15cm. The small cone tweeter has an effective diameter of 35mm which should make it a virtual point source and result in good treble dispersion.

By comparison with some other recent designs, the 133mm long tunnel seems to have a rather small diameter at 50mm but in practice this does not seem to result in the common problems of "frequency doubling" and "chuffing".

Nominal impedance of the system is 8 ohms. Measurements indicate that there are impedance peaks of 25 ohms at 15Hz and 60Hz which correspond to the expected resonances of the bass reflex system. There is also a peak at about 1.2kHz, which is probably the resonance of the tweeter.

Minimum impedance of the system was about 5.8 ohms so the 4301 will not present any loading problems for amplifiers designed for nominal 8 ohm loudspeakers.

A multi-element crossover network with iron-cored inductors and paper capacitors is employed. There is also a tweeter attenuator which can be adjusted when the front grille is removed.

The enclosure volume is 28 litres. It appears to be well constructed and is very well finished. It is lined with an acoustic absorbent material. Spring loaded terminals are mounted on a recessed panel at the rear of the enclosure.

Since wave tests revealed a frequency response which appears to largely con-

firm the published 1/3-octave band pink noise response. Over the greater part of the audio range the system is quite smooth, with a slight prominence in the region around 3kHz and a rising response above 10kHz. Bass response is quite smooth and well controlled, with little of the lumpiness that used to be associated with bass reflex systems.

Efficiency of the system is fairly high, so that the 4301 will give a good account

very satisfying system to listen to.

We have just one complaint. This concerns the literature supplied with the 4301, which indicates that the system is intended particularly for monitoring the program quality broadcast by AM, FM or TV stations. The 4301 is said to be "of particular importance for monitoring the quality of the transmitted signal in order to detect and control spurious noise, ie, turntable rumble, air conditioning ... tape hiss or cue tone leakage".

JBL also envisage the 4301 being used in the far from ideal conditions of a "typical broadcast booth of 6' x 10' x 8'". On the face of it, these are not hifi applications. Any loudspeaker which is designed to emphasise program defici-



of itself with amplifiers having ratings of 20 to 30 watts per channel. JBL state that the 4301 may be safely used with amplifiers rated up to 60 watts per channel.

For those used to the sound quality of other JBL systems the 4301's will probably be a surprise. It has a wide range sound with no apparent boosting of the mid range as seems so common with many loudspeakers. However the rising response above 10kHz tends to emphasise tape hiss and surface noise on discs. This can be modified to produce a more comfortable result by turning down the treble attenuator.

Bass response is very good and challenges that of much larger systems. It is clean and well maintained down to about 40Hz. Overall, provided the treble attenuator is adjusted as above, it is a

ences such as record clicks and tape noise would tend to be a bane rather than a boon to the hifi listener.

There is also a note in the literature stating that "JBL Professional Products are not intended for household use".

So where does that leave the prospective hifi buyer? It seems almost certain that in reality JBL does want him or her to buy, so why go on with all this nonsense about "professional applications"? Clearly it's a good loudspeaker, and can be suitable for BOTH domestic and "broadcast monitor" use.

Recommended retail price of the JBL 4301 is \$598 for a pair. Further information can be obtained from high fidelity retailers or from the Australian distributors for JBL products, Harman Australia Pty Ltd, 271 Harbord Road, Brookvale, NSW 2100. (L.D.S.)

**LOUD AND CLEAR MESSAGES
FOR YOUR OWN PROTECTION**

OVER AND OUT TO AN AUSTRALIAN MADE, AUSTRALIAN STANDARD ELECTRICITY AUTHORITY APPROVED POWER SUPPLY WITH NON APPROVED, NON STANDARD LOW QUALITY EQUIPMENT.



R Reliable Regulated **CB POWER SUPPLY**

O Over load protected—no fuses. Output 13.8 volts, 2 amps continuous.

G Guaranteed to safety standards. Good quality Ferguson equipment.

E Extra power—35 watts intermittent. Electricity Authority approved.

R Ripple and noise free. Reasonably priced.



13.8 volts 2 amps Regulated

Yours for only **\$45.00** including sales tax, packaging and post from **JOHN KNOX ELECTRONICS P/L**
P.O. Box 240, Willoughby, NSW 2068

Trade Enquiries Welcome. Other ratings made to order.

Send SAE to obtain specifications. Wood grain finish extra \$1.25.

Manufactured and Guaranteed by: Ferguson Transformers Pty Ltd

CITIZENS BAND ANTENNAS

QUALITY **SCALAR** ANTENNAS ARE
DESIGNED AND MANUFACTURED IN AUSTRALIA

MOBILE MARINE BASE STATION

Scalar Citizen Band Whip Antennas are designed to provide efficient performance with reduced length. Either helical, centre or top loading on fibreglass rods. They are available for vehicle or marine installations on standard, or marine base, or for gutter or for trunk lid mounting

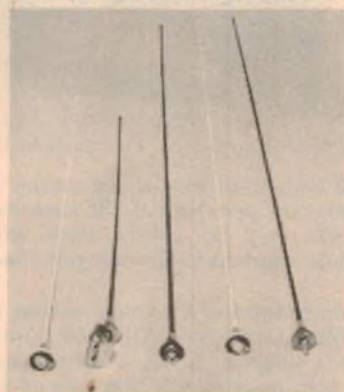

TYPES ILLUSTRATED

CB 1220 42" Centre Loaded.

M27R (CB 1120) 30" Centre Loaded.

GA28 (CB 1420) 60" Helical.

GA30 (CB 1520) 60" Helical / Sector / Top Loaded.

M27R60 (CB 1320) 60" Centre Loaded.

A WIDE RANGE OF SCALAR CB ANTENNAS (FROM 30" TO 108" LONG) AND ACCESSORIES ARE AVAILABLE FROM LEADING WHOLESALERS AND DISTRIBUTORS THROUGHOUT AUSTRALIA.

TRADE ENQUIRIES WELCOME

SCALAR INDUSTRIES PTY. LTD.

COMMUNICATION ANTENNA ENGINEERS.

18 SHELLEY AVENUE, KILSYTH, VICTORIA, 3137.

TELEPHONE: 725-9677. Cables: Welkin. Telex: AA 34341

N.S.W. 20 THE STRAND, PENSHURST, 2222. Telephone: 570-1392
QLD (STD 07) 371-5677 WA. (STD 092) 57-1555 SA. (STD 08) 42-6666



The Australian CB SCENE

PHILIPS: WE'LL BE INTO UHF CB BY JANUARY

Welcoming the decision that the Australian Citizen Band Radio Service would ultimately be concentrated in the UHF portion of the spectrum, spokesmen for Philips Industries Holdings said that the Company would have an Australian specification UHF CB transceiver on the market by January next and that they were looking at a price of around \$300.

Mr Huyer, Chairman and Managing Director of Philips Industries Holdings Ltd said: "Philips development laboratories in Melbourne have been working on an Australian prototype UHF CB radio.

"Using the specifications referred to in the Minister's statement we will now prepare for production. We will have an Australian specification UHF CB transceiver on sale by next January.

"With the expected long production runs, we are confident that we can be competitive with overseas manufacturers who may produce CB units to Australian specifications. We expect that the Philips unit will sell for about \$300, including aerial."

Mr Huyer pointed out that Philips Australia had, for many years, successfully designed and manufactured UHF two-way mobile radios and sold them in large quantities, against world competition, in South-East Asia.

"Two-way mobile radios made by Philips Australia are used by transport companies, commercial operators, police, taxi fleets and emergency services," Mr Huyer said.

"The proposed Philips CB UHF radio is in many ways similar to the two-way units sold to industrial users. But the combination of significantly longer standard production runs, lower power output and simpler specifications will make our CB radios about fifty percent cheaper to produce."

Mr. Ian McKenzie, General Manager of the Philips-TMC Radio Division stressed that a UHF Citizen Band Radio Service had a number of advantages over conventional 27MHz equipment which, in any case, had to be regarded as an interim system, due to be phased down within five years.

Referring to UHF, Mr McKenzie said:

"It is not affected by sun spot cycles and is not subject to interference from general electrical noise. In fact, back-



Not the real thing, say Philips, but the kind of unit currently in production for a number of mobile services, which could be re-designed for CB use. Power would be lower, specifications less tight and production runs higher—important factors in getting the price down.

ground noise at 470MHz is about 1000 times lower than at 27MHz.

"A larger number of operators can be active within a city—three to four times more operators can use the same frequency. CB transmission on UHF does not create TV interference experienced with 27MHz."

Mr McKenzie confirmed that Philips in Australia had the capacity to design and manufacture an Australian specification UHF CB transceiver and to have units available for sale next January. The Philips unit would sell for about \$300, including aerial.

The fact that Philips Australia are able to compete successfully in the existing local and overseas market for UHF mobile services certainly lends credibility to the claim that they can carry right on into the UHF CB market.

On their side is the fact that the huge potential USA market for UHF CB is currently dormant and there is no immediate prospect of orders large

enough to spark a major reaction among the Asian manufacturers—with resulting rivalry and price cutting.

There is, of course, the wry possibility that the Australian initiative will stir the situation in America and trigger off this very kind of reaction.

Curiously enough, the UHF allocation was the first CB service to be authorised in the USA, in the early 1950's, and designated as "class A". Now known as the General Mobile Radio Service (GMRS) it uses eight pairs of frequencies with each pair separated by 5MHz to permit two-frequency systems:

Base & mobile (MHz)	Mobile only (MHz)
462.550	467.550
462.575	467.575
462.600	467.600
462.625	467.625
462.650	467.650
462.675	467.675
462.700	467.700
462.725	467.725

VICOM

Head Office & Mail orders (03) 82 5398
139 AUBURN RD AUBURN VIC 3123 Ph (03) 813 2355

VICOM gear also available from a network of dealers throughout Australia Dealer enquiries welcome

Prices and specifications subject to change without notice



BENGAL SSB DELUXE BASE STATION

The fabulous rig which includes station controls for mike gain, rf gain, squelch, slide-o-tune, noise blanker, PA, CB signal strength, modulation and RF output. Also includes headphone monitoring jack which also can be used for tape recording. Works on 12v dc or 240vac. Comes complete with mic, manual and VICOM 90 day warranty. Price \$339 + P&P

MODEL FS-177 CB CHECKER

Includes facilities for testing 9 different functions, incl RF power, swr, modulation, relative field strength, oscillator output, crystal activity, audio modulation. Ideal for home repairs and "tweeking". Price \$55 + P&P.



\$36



The popular VICOM VC2 swr and power meter is specially designed for the serious communicator looking for accurate readings. The bridge operates from 3 thru 150MHz with power measurement either 12 or 120 watts. Will handle up to 1000 watts. Individually calibrated power chart for all Australian Amateur bands and 27MHz CB. A real bargain at this price!

COAXIAL SWITCH

\$22



CS201 quality 2 position coax switch. Will handle up to 2.5Kw pep. 50 ohms impedance with insertion loss better than 0.2dB VSWR better than 1.2 up to 1GHz. Position not selected is automatically grounded.



FIELD STRENGTH METER

Covers a frequency range 2-200MHz, this handy little meter enables each checking of antenna radiation. \$8 + P&P \$1

PROFESSIONAL SWR/PWR METER

The new Oskerblock SWR 200B Deluxe is a professional swr bridge using the thru-line principle, covers 3-200MHz, 52/75 ohms. Each unit is individually calibrated. Four power ranges, 2/20/200/2000 watts. \$79 + P&P

ICOM



ICOM Transceiver 2M FM IC 22S

\$269

IT'S CRYSTAL CLEAR!

The IC22S from VICOM is a p11 synthesised rig with programmable ROM for any frequency multiple of 25KHz from 146 thru 148MHz. Simplex, duplex or duplex reverse is achieved by a flick of a switch on the front panel. This fabulous new rig features ceramic discriminator, IDC, electronic tx/rx relay, full swr protection and VICOM 90 day warranty. Circuitry includes 34 transistors, 7 FET, 13 ICs, and up to 128 diodes. Receiver sensitivity better than 0.4uV for 20dB quieting. Your new IC22S comes complete with mic, mobile mounting bracket, plugs, cables, spare diodes and English instruction manual. Programmable matrix is pre-wired for R1-8, 40, 50, 51. A real bargain at \$269 plus freight and insurance.

PLUGS & SOCKETS FOR THE COMMUNICATOR

4 pin mic plugs and sockets (ea)	\$2.30
1 1/2' coax jumper leads with PL259's	\$2.30
3' coax jumper leads with PL259's	\$2.50
PL259 plug	\$1.30
S0239 chassis sockets	\$1.30
S0239/RCA adapter	\$2.20
"T" connector	\$2.50
Lightning arrester	\$3.50



JUMPER LEADS

Handy 3ft jumper leads.



RG58 coax with fitted PL259's	\$2.50
18" version	\$2.30

UNIDEN the best value



The fabulous UNIDEN 2020 p11 transceiver offers separate usb, 1sb and cw 8-pole filters as STANDARD and 6146Bs in the final with screen grid voltage stabilisation for minimum distortion products. Features pcbs and even the front panel can be swung out for easy servicing! A comprehensive range of spare parts is available together with back-up service support. Overseas this rig sells for at least \$65 more than the FT10E1. Compare the features of the UNIDEN 2020 with other HF transceivers and you'll quickly be convinced that it offers the best value!

HAM GEAR

AUSTRALIA'S BEST EQUIPPED CB SERVICE FACILITY

Vicom have the technical expertise and back-up support to handle the most complex communications gear. Test equipment includes the new Singer \$10,000 FM10CS Communications Service Monitor which gives spectrum analysis and high precision frequency generation and measurement to 600MHz. Reasonable rates for all service work. Why not give us a try!

Model 150 Solid State FET VOM

Super sensitivity makes it suitable for any application in the field or on the bench.

- * 11 megohm input resistance on all dc volt ranges
- * 1 megohm input resistance on all ac volt ranges
- * temperature compensated for high accuracy
- * built-in overload protection
- DC volts: 7 ranges, 0.25 thru 1000 volts
- AV volts: 4 ranges, 2.5 thru 1000 volts
- DC amps: 5 ranges, 0.025 thru 250mA
- Resistance: 5 ranges to 5000megohms
- Decibels: 4 ranges

Complete with comprehensive instructions, test leads and batteries

20,000 ohms/volt General Purpose Model TP 55N

Accurate and dependable, 6 dc ranges, 5 ac ranges, 4 current ranges, 4 resistance ranges, capacitance and decibel ranges also. Price of \$29 includes instructions and test leads

DELUXE MIRROR SCALE MODEL 200

20,000 ohms/volt on 6 dc volt ranges, 10,000 ohms/volt on 5 ac volt ranges. Readings for capacity, resistance, decibels. An advanced multimeter for the professional, serious hobbyist or for the school lab. Price of \$29 is a real bargain for this quality instrument! Includes comprehensive instructions and test leads

Model 117 FET PROFESSIONAL METER

Designed for the professional, the FET high input resistance assures voltage measurement without effecting the circuit operation. Includes 7 dc ranges (to 1200v), 4 ac ranges (to 300v), 3 dc current ranges, 4 resistance ranges (to 2000meg) and 4 decibel ranges. Price \$52 includes test leads and instructions

CB ANTENNAS

BASE LOADED WHIP

Model M1 quality base loaded mobile whip, 40.5 inches, 50 ohm impedance, vswr less than 1.5. Includes roof mount and optional boot lid mount, spring and coax with PL259 plug. \$19.90 + P&P

27MHz MARINE WHIP

Model HW 11 GM requires no ground plane and can be operated on fibreglass, wood surface or on mast. Comes complete with matcher coax, PL259 plug. \$65 + P&P

RINGO

Model V1 half-wave ground plane, gain 3.75dB, overall length 5.5m, mounting on mast tubing up to 1 1/2" diameter. \$49 + P&P

GROUND PLANE

27MHz 1/4 wave ground plane, superb quality, solid 108 inch heat treated radials and radiator. Radials droop for 50 ohm match. Complete with S0239 socket. \$35 + P&P

Locally made HELICAL - 5ft -

excluding base \$19 + P&P
base for above \$6 + P&P



SWLs



BARLOW WADLEY

The famous portable Barlow Wadley Communications Receiver with crystal controlled reception of am/usb/cw/cw

Standard model	\$319
With FM	\$339

ANTENNAS

Listener 1 "V" type covers 3 30MHz with special trap for DX reception \$22
Listener 3 long range wire dipole antenna 3 30MHz complete with balun, feed wax VHF plug, insulators. Ideal for the serious SWL \$49



Direction: Russell J. Kelly
Peter D. Williams



SERVICE

IMPORTERS - WHOLESALERS - RETAILERS of CB

The Australian CB SCENE

The class-B CB service for low-power mobile transceivers was authorised in the same portion of the spectrum but neither made much headway because of the lack of suitable equipment at the time. In fact, the class-B service was abandoned altogether.

This position is now changing, with technology being accelerated by the new US Police two-way equipment operating on assigned frequencies very close to 460MHz.

Adoption of UHF equipment by the services has served to prove that it can be mass-produced, and a downward price spiral is inevitable. Already, things are looking up for UHF CB in the USA and their General Mobile Radio Service is emerging as a high quality and practical system for person-person communication.

Users of the GMRS frequencies can operate with up to 50 watts of input power, and antennas elevated by up to 200 feet, with FM as the most commonly used form of modulation. While the direct unit-range is limited in poor locations, repeaters and auto-patchers are currently permitted.

In major centres like Cleveland, Dallas and Chicago, GMRS type CBers have taken a leaf out of the 2-metre amateur book and set up community repeaters at strategic points. They can access such repeaters with hand-held or low power mobile equipments, and can contact families or offices by these means over considerable distances.

Better than that, touch-tone pads on the back of the microphone in some units can activate patching circuits or the squelch in selected receivers, giving a degree of selective calling.

Facilities of this kind don't come cheaply, of course, and the outlay on a system may run from two to eight times what one may pay for an ordinary VHF installation. But for the person who wants deliberate communication, as distinct

from the ability to talk in a crowd, the price penalty is well worth paying.

With new CBers crowding into the expanded 40-channel 27MHz band at the rate of about one half-million per month, it is inevitable that pressure will mount to open up the class-A allocation in the same way, with channel switched transceivers no more elaborate and no more costly than necessary, at least for short-haul communication.

The Australian plan for 40 channels, later 80 channels, distributed throughout a 1MHz band would seem a very logical pattern to follow. If it does happen, transceivers will surely be developed to meet the demand, with competition forcing prices down towards the levels which obtain for 27MHz gear.

Anticipating such a development, Australian manufacturers will obviously have to move quickly and positively to establish themselves in the local market.

Even if the American and Australian channels do not exactly coincide, the problems of adaptation from one to the other aren't likely to be prohibitive. A phase-locked-loop synthesiser can easily be rearranged to produce a modified group of frequencies and a broad-banded front end can readily be re-tweaked by a megacycle or so.

Be that as it may, Philips have "stuck their neck out" and stated positively that they would be into UHF CB by January. It is to be hoped that others will follow suit who, at the moment, are merely making interested noises.

And, it may well be that their first customers will not be CBers at all, in the usual sense of the term, but business people and professionals who need mobile communications but who are not operating on a scale to warrant a fully commercial 2-way radio system.

CHIBA COMMUNICATIONS IND. INC. TO SET UP IN AUSTRALIA

A highly innovative personal communications company will soon market its range of Citizens Band Radio equipment in Australia under its own name. The company is Chiba Communications Industries, Inc. of Japan, which employs over 1000 people. It has sales in excess of \$85,000,000 per year, and exports its current production to the United States of America under the Royce brand.

Chiba claims to have pioneered the PLL developments in CB and through its innovative research and development departments intends to strengthen its position as a world leader dedicated to continuous progress in the field of personal communications.

Chiba will market its high quality products in Australia under the Chiba brand and logo. The first products to be released will be an 18 channel AM/SSB unit manufactured to the new Australian regulations.

Daniel Presser, the 32 year old advanced consumer electronic marketing expert already responsible for the successful marketing strategy of Unitrex in



Mr. I.
Yamamoto

Australia, has accepted the position of Chiba's Managing Director for Australia. He said:

"I believe that continuity of supply of high quality, technologically innovative product, backed with full service facility is a basic requirement for any consumer electronic company to be successful in the long term.

"Chiba will undertake to do this for the Australian retailer and consumer, and is far better equipped to do so than those small importers who are motivated solely by monetary reward and are not dedicated to the continued untarnished growth of an Australian consumer electronics industry."

For further information: Janet McFarlane, Caldor Corporation Pty Ltd, 105 Queen Street, Melbourne, Vic. 3000.

ELECTO-PHONE

"The best in 18 channel"

AUSTRALIAN
STANDARD
18 CHANNEL CB's
IN STOCK NOW!



Controls for:—
Volume, squelch, channel selector, s/r power meter.



Volume, squelch, LED channel selector, swr / rf / signal meter, dimmer, rf gain, delta tune, noise blanker



Volume, squelch, mode selector, rf gain, swr / rf / signal meter, clarifier, and LED channel selector.



RADIO PARTS GROUP

562, SPENCER STREET, WEST MELBOURNE, VIC.
PHONE: 329 7888
1103, DANDENONG ROAD, EAST MALVERN, VIC.
PHONE: 211 8122

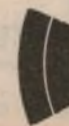

MELBOURNE'S
CB
CENTRE



CB TEST EQUIPMENT



CB Servicemaster

MODEL 1040

- Greatly simplified CB transceiver servicing
- Checks complete CB transceiver performance in minutes
- Checks AM and SSB transceivers
- No complex hookups or calculations required
- Test results displayed on direct reading meters
- Only one hookup required for all tests
- Eliminates need for special equipment

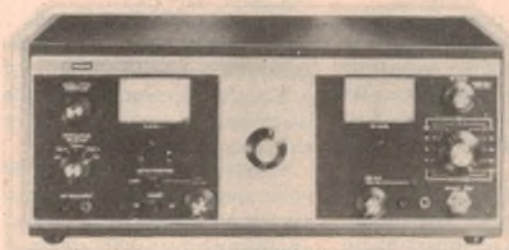

MODEL 2040 PLL CB SIGNAL GENERATOR

- Designed for use with all class D CB transceivers . . . AM and SSB.
- Covers all 23 channels plus provision for additional channels for future expansion.
- ± 5 parts per million (.0005%) accuracy or better.

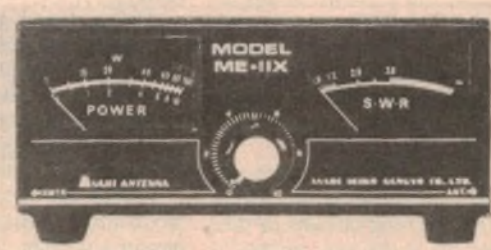

MODEL ME-11X SWR & POWER METER

Measuring method	Directional Coupler
Maximum handling power	100 watts
SWR indication	1:1 ~ 3:1
Frequency Range	3.5-150 MHz
Circuit Impedance	50 ohm

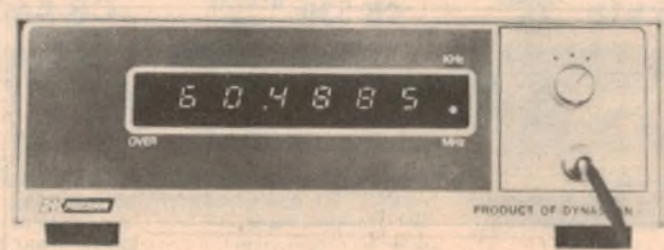

MODEL 1801 40 MHz AUTORANGING COUNTER

- Automatic ranging 20 Hz-40 MHz guaranteed.
- 1 Hz resolution.
- Six-digit solid-state readout with discrete reliable TTL logic.

For general and specific information:

TECNICO ELECTRONICS



Premier Street, Marrickville,
N.S.W. 2204. Tel. 55 0411.

2 High Street, Northcote,
Vic. 3070. Tel. 489 9322.

GEMTRONIX GTX-3325: "PERFORMED WELL"

After having reviewed a string of AM-only transceivers, it was a pleasant change to be faced with a full AM-SSB unit, the GemTronics GTX-3325. While such a unit can be expected to cost roughly double the price of an AM-only transceiver, it obviates the frustration of not being able to copy the signals from otherwise strong stations.

However, while a full AM-SSB transceiver can give the operator access to all other stations within range, the reality of the situation is not quite as ambitious as the "mathematics" in the booklet which comes with the GemTronics transceiver: 23 AM channels, plus 23 upper sideband, plus 23 lower sideband, equals 69 "effective" operating channels.

For sure, the operator may have 69 options in respect to operating mode, and the GemTronics SSB filters are very effective, but it would be nothing short of remarkable to find 69 interference-free contacts in progress at the one time in the one area!

That piece of nit-picking aside, the GemTronics GTX-3325 is a very neatly presented unit, intended normally to hang beneath the fascia panel of a car or power boat, supported by the cradle which is supplied with it as a standard fitting. Overall dimensions of the actual case are 202mm wide, 60mm high and 250mm deep.

Whereas some transceivers have a notably small panel meter, or none at all, and subdued panel lighting, the GemTronic has an open, well lit meter with two simple scales: an upper green scale showing incoming signal strength in "S" points, and a white scale with red over-run to indicate normal (or abnormal) transmitting conditions. Both scales are very easy to see.

The channel select switch is also clearly marked and illuminated and has a smooth, light action. No problems here at all.

Other controls are: volume, off-on; squelch; fine tune; RF gain; mode switch (AM, USB, LSB). While they are smooth in operation and match the styling of the larger channel selector knob, I personally found them less pleasant to use than ordinary small round knobs would have been in the same role. One either has to position the fingers beforehand to fit the flats—which might be at any inclination—or else cope with the corners!

Separate LED indicator lights are provided: green for on/receive and red for transmit. Lever switches in the bottom right-hand corner select the CB or PA

(Public Address) function, noise blanker on-off, internal/external loudspeaker (for CB).

At the rear of the transceiver, are miniature sockets for connection to an external (CB) speaker, a PA speaker, 12-14V supply (either positive or negative ground) and, of course, the usual PL-259 antenna socket. The microphone socket is on the left-hand side.



The GemTronics GTX-3325 is notable for its clean styling and clearly marked controls.

Access to the internal "works" is readily available in the event of service being required, removable lids exposing both sides of the wiring board. Internal construction is normal and open.

In terms of circuitry, the GTX-3325 uses quite an array of crystals in a synthesiser system to provide the necessary frequency control, with a rated stability of $\pm 50\text{Hz}$ for normal room temperature variations and $\pm 500\text{Hz}$ for temperature extremes of -20C and $+50\text{C}$. Spurious and harmonic radiations are quoted as more than 50dB below the carrier level, with carrier suppression on SSB better than 40dB.

On SSB mode the receiver operates as a single-conversion superhet with a 7.8MHz filter giving a selectivity of $\pm 1.2\text{kHz}$ at 6dB down, and $\pm 2.3\text{kHz}$ at 50dB down. On AM, a double frequency change is used giving a broader bandwidth: $\pm 3\text{kHz}$ at 6dB and $\pm 10\text{kHz}$ at 50dB. Audio power output is 2 watts at 10% distortion—perhaps a little on the sparse side for a noisy vehicle.

In checking through the receiver

specifications, etc., we note that the "fine tune" control "permits slight adjustment of receiver tuning", with no mention of the transmitter frequency. In fact, it does not appear to relate in any way to the transmitter, as is often the case with SSB "clarifiers" so that there is no way it can be merged into a slightly off-frequency net. There is possibly room for argument here, whether it should or should not be so.

Tested in typical suburban location with fixed outdoor antenna, the GemTronix receiver performed well in all modes and although the sensitivity (curiously) is not quoted in the manual, it appeared to reach well down into the now considerable noise on the 27MHz

band. Coupled to a signal generator, it readily resolved the minimum available signal: considerably less than 1uV, 30% modulated.

Low frequency response from the in-built loudspeaker appeared to have been cut back a little harder than most other transceivers we have tested recently but, while it makes voices sound a little thinner from the unit itself, it would probably give a better than average balance when used with an external speaker, as clearly envisaged.

On transmit, power into a dummy load was well up on the rated 4W on AM, and performance on SSB also appeared to be in line with ratings: 25W PEP input, 15W PEP output. Reports on the transmissions were all along the lines: "good, clean modulation".

The GemTronix GTX-3325 was submitted for review by Bail Electronics Services of 60 Shannon St, Box Hill, North Melbourne, 3129. Phone (03) 89-2213. Price quoted was \$269 and this includes a 90-day warranty on workmanship and on components other than semiconductors. (W.N.W.)

WHY TAKE RISKS ? Buy from DICK SMITH The CB EXPERT !



Who is Dick Smith? He's Australia's CB expert! He's been selling CB longer than most of the 'backyarders' put together. He started a highly successful car radio business 8 years ago, which was the foundation of the famous electronics business which bears his name. He's sold more CB than anyone else and really is a name you can trust when you buy your CB radio!!!

Dick backs all his sets with service & spare parts.

We also stock a full range of MIDLAND CB rigs.

This set is fully licensable- you can obtain your license RIGHT NOW from the P&T Dept.

**SCOOP
PURCHASE
HY-GAIN
SSB
CB RIGS**

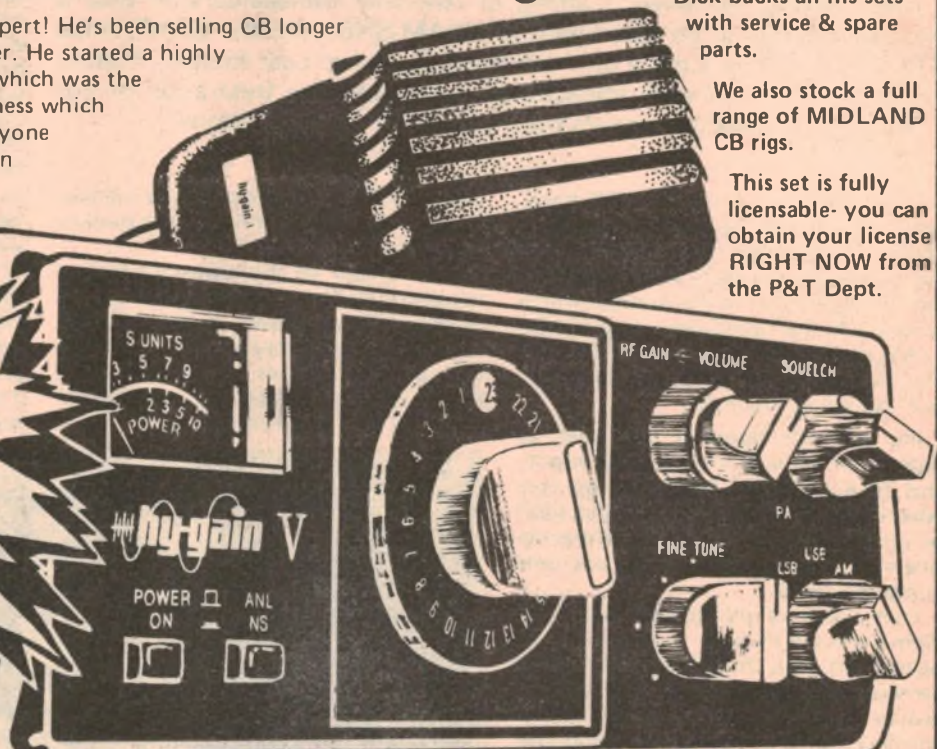

Of the 10 SSB CB transceivers reviewed in "CB Australia" magazine, June '77, only two stood out. Here's what the reviewer, Roger Harrison, said about the Hy-Gain V... "outstanding in functional design & operation... the controls had the best feel of all the units... good, clear sound... handbook is very informative..." In fact he didn't have one point of criticism on this unit!
Cat. D-1704..... \$279.50

This unit was selling for ~~\$310.00~~
DICK'S PRICE ONLY

\$279⁵⁰

156cm

**SUPER
POWER
PUSHER**

MOBILE ANTENNAS

WHITE KNIGHT HELICAL SECOND GENERATION HELICALS:

Everyone knows the original isn't always the best... The right time to buy is when the second version is out - time for all the bugs to have been ironed out! Our D-4076 helical has all the bugs ironed out. You'll go a long way to get a better one. Super power pusher!
Cat D-4076 \$29.00

\$29⁰⁰

DEFINITELY NOT
MADE BY GREG
ACKMAN!!!!

WHITE KNIGHT - TOP LOADED

TOP LOADED - they work as effectively as they look: FANTASTIC! Ask an expert - he'll tell you how efficient top loading is. And they look good, too - white f'glass with stainless steel matching stub. The ideal antenna for all mobiles.

Cat. D-4452 \$29.50
ALSO AVAILABLE IN TWIN TRUCKERS VERSION - complete with mirror mount & co-phase harness. Cat D-4454 only \$49.50

\$29⁵⁰

**DICK SMITH
ELECTRONICS
GROUP**

VISIT YOUR NEAREST STORE:
SYDNEY - 125 York St, Ph. 29 1126
BANKSTOWN - 361 Hume Hwy. Ph. 709 6600
GORE HILL - 162 Pacific Hwy. Ph. 439 5311
MELBOURNE - 656 Bridge Rd, Richmond. Ph. 42 1614
BRISBANE - 166 Logan Rd, Buranda. Ph. 391 6233
MAIL ORDERS: P.O. Box 747, Crows Nest, N.S.W. 2065.



WE HAVE DEALERS ACROSS AUSTRALIA. PHONE YOUR NEAREST STORE FOR THE DEALER CLOSEST TO YOU.

ORDER VALUE	CHARGE
\$5 - \$9.99	\$1.00
\$10 - \$24.99	\$2.00
\$25 - \$49.99	\$3.00
\$50 - \$99.99	\$4.00
\$100 or more	\$5.50

AND NOW OUR NEW STORE AT PARRAMATTA: 30 GROSE ST - Ph. 683-1133

The Australian CB SCENE

Earphone/microphone headsets for CBers

One of the obvious problems of mobile radio operation is to find enough hands to attend simultaneously to the demands of driving a vehicle, while operating a 2-way radio without awkward pauses. Telex Communications Inc. have an answer to this dilemma in the way of a lightweight earphone/microphone headset.

The usual mobile radio microphone hangs on a hook under the dash, or rests on the seat mixed with other things, or falls to the floor of the car, whence it has to be retrieved by fumbling. If noise level inside the vehicle is subject to wide variation, due to speed and traffic conditions, there is the further problem that the receiver volume has to be altered constantly to suit.

The answer provided by Telex Inc. is obvious enough to anyone at all familiar with the aircraft industry: equip the driver—or the person operating the CB unit—with a headset combining an earphone, a microphone and a pendant push-to-talk switch which can be clipped to their clothing, where it will be most accessible.

The Telex CB-1200 headset has a single cushioned earphone, which the operator can wear on the preferred side of the head. The cushioned headphone limits the noise from external sources reaching the particular ear, while also minimising the audibility of the incoming voice to other people in the vehicle. The other ear remains uncovered to ensure that the driver or operator is fully aware of traffic situations. A small ceramic microphone is attached to the headset by a boom, fully adjustable so that it can be positioned close to the lips, irrespective of whether the headphone is worn on the right or left-hand side. By so positioning the microphone, the best possible ratio is maintained between the level of the speaker's voice and the ambient noise.

While most CB transceivers assume the use of a dynamic microphone, the ceramic unit in the CB-1200 is associated with a battery powered FET amplifier, which ensures the appropriate signal and impedance levels.

Frequency response of the headphone is rated as 100-8000Hz and, while this is adequate for quite high quality speech reproduction, the frequency range would normally be limited to a narrower bandwidth than this by the transceiver's own internal circuitry. Rated frequency response of the ceramic microphone is 100-5000Hz.

An alternative headset, specially suited for noisy situations, is the Telex CB-88

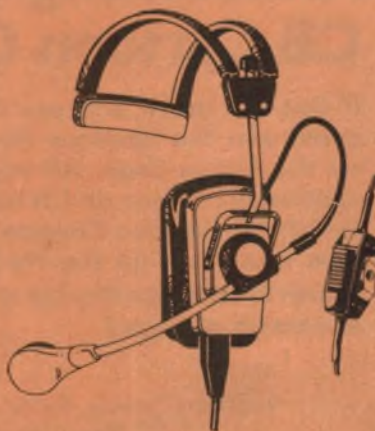

Telex CB-1200 headset with push-to-talk switch. Design resembles pilots' headsets.

lightweight unit. One essential component is a boom-mounted magnetic microphone which has noise cancelling qualities—maximum sensitivity to close-up voice at the front, minimum sensitivity to noise arriving from a greater distance.

Pendant from the base of the microphone boom is a soft earpiece intended to be inserted into the ear, with a cord running away to the normal transceiver microphone socket.

The microphone/earphone combination can be supported by a lightweight headband or it can be attached to one wing of a pair of spectacles.

Another unit in the Telex range, of potential interest to Australian CB operators, is the CB-73 power microphone.

Styled to resemble an ordinary transceiver hand microphone, it has an in-built 3-stage preamplifier intended to "maximise talk-power" by maintaining a substantially constant output signal level, more or less independent of the operator's voice level. An extra button on the microphone allows it to operate in noise-cancelling mode in particularly noisy environments.

The three units described above are handled in Australia by Audio Telex Communications Pty Ltd, of 54 Alfred St, Milson's Point (Syd); telephone (02) 929 9848. In Melbourne, 828 Glenferrie Rd, Hawthorn; telephone (03) 819 2363.

Lafayette)) 27MHz two-way



5 WATT 6 CHANNEL
'MICRO 66'

From the Lafayette Radio Electronics Corporation of U.S.A. Lafayette transceivers embody features which have made them world famous. 1,000's in use throughout Australia, 100,000's world-wide Government, industrial, marine, sports and farm applications testify to their versatility and rugged reliability.



All units Telecom
Type Approved (Licence
Required)

Lafayette are 2-way specialists. Full range 27MHz crystals, antennas, auxiliary equipment available!

Dealer enquiries invited

Lafayette))

the Communicators
LAFAYETTE ELECTRONICS
Div. of Electron Tube Distributors P/L
94 ST. KILDA RD., ST. KILDA
Victoria 3182. Tel. 94 6036

CB! RADIO



- Xtal XCB 12 AM with 2 channel scan \$129.00
- Xtal XCB 7 AM 23 channel with delta tune \$89.90
- Pace CB 143 AM 23 channel Compact, reliable \$69.95
- Granada 240V AC Base Station With SWR meter \$169.00
- Royce AM—Here at last—A top seller in U.S.A. Limited supply \$129.00
- Cougar Deluxe AM. Everybody's favourite With built in SWR bridge. \$136.00

SSB TRANSCEIVERS 23 CHANNEL

- Gemtronis 2325 \$195.00
- Kraco—At our price they won't last \$219.00
- Super Panther. With digital readout. \$245.00
- Pearce Simpson Cheatah Top line SSB \$295.00
- Bengal Base Station 240V AC \$325.00

BASE STATION ANTENNAS

- 1/4 Wave Ground Plane \$35.00
- 1/2 Wave 3.8 DB Gain Vertical \$48.00

MOBILE ANTENNAS

CB AM/FM Motorized C/w/with rear ext. cables, splitter & switch Top loaded for maximum radiation yet looks like car antenna \$55.00

Lock down type also available \$35.00
Large range of Helicals, Gutter Grips, Magnetic Base, Twin Trucker and Boot Mount Antennas, SWR Meter, Co-ax Plugs, etc.

MAIL ORDERS WELCOME

**HAWTHORN
COMMUNICATIONS CENTRE**
549 BURWOOD ROAD, HAWTHORN, VIC. 3122.
TEL: 818-7330

You could win 23-channel

Announcing the EA-Dick Smith CB Cartoon Contest . . .

If you can draw, and you've got a sense of humour, then you could win the fabulous Hy-gain V 23-channel CB rig pictured on the facing page. All you have to do is send in an original captioned cartoon on CB radio to the Electronics Australia-Dick Smith CB Cartoon Contest. To the individual who sends in the best entry will go the Hy-gain rig, specially donated by Dick Smith Electronics Pty Ltd and valued at \$279.50. (Contest rules at bottom of page.)

Here's an example . . .



"If there was a really bad fire I guess the CB would have to wait!"

About the Hy-gain V SSB rig

Marketed by Dick Smith Electronics Pty Ltd, the Hy-gain V is a full 23-channel AM / SSB transceiver that has established an enviable reputation on the Australian scene. The unit features excellent finish coupled with impressive on-air performance.

Front panel layout is equally impressive. Featured are controls for volume, RF gain, squelch/PA, fine tuning, mode (AM, USB, LSB), and channel selection, together with power on/off and noise limiter / noise silencer switches.

All accessories are supplied with the unit, including a microphone and mounting bracket.

Rules and Conditions:

- (1) The cartoon must be related to CB radio. It must be original, although not necessarily drawn by the entrant, and must not have been previously published.
- (2) All entries will remain the property of "Electronics Australia". The best entries will be published and an appropriate fee paid to the entrant.
- (3) EA Editor Jim Rowe will judge the

contest. His decision will be regarded as final and no correspondence will be entered into.

(4) Employees of Sungravure Pty Ltd, Dick Smith Electronics Pty Ltd or any associated companies are not eligible to enter. Entries postmarked or delivered by hand later than October 30, 1977, will not be eligible. The winner of the Hy-gain CB will be announced as soon as possible after the closing date.



FRG-7 SYNTHESIZED RECEIVER

for
Amateurs,
Novices,
and
Short-Wave
Listeners.

TECHNICAL DATA

- Electronic Band Changing.
- 0.5 — 29.9 MHz. Continuous Coverage.
- Uses Wadley Loop (drift cancellation circuit) to derive synthesized heterodyne oscillator signal.
- LSB, USB, AM and CW.
- Frequency Readout better than 10 KHz (readable to 5 KHz).
- Stability within 500 Hz during any 30 minute period after warmup.
- Better than 0.7 μ V for 10 dB S + N/NSSB and CW.
Better than 2 μ V for 10 dB S + N/N AM
- Selectivity \pm 3 KHz at -6 dB, \pm 7 KHz at -50 dB
- Input Impedance, high 0.5 — 1.6 M Ω .
50-75 Ohm 1.6 — 29.9 M Ω .
- 234V AC 50-60Hz or 12V DC (external/Internal 8 dry cell).
- Size 340 mm x 153 mm x 285 mm.

FRG-7 \$328

Above prices include S.T Prices and specifications subject to change.

60 Shannon St., Box Hill North
Electronic SERVICES Vic., 3129
Ph 89 2213

this fabulous SSB CB rig

DONATED BY DICK SMITH: *TOTAL VALUE \$279.50



Outstanding front panel design and excellent finish are features of the Hy-gain V 23-channel SSB/AM transceiver. It normally sells through Dick Smith stores for \$279.50.

Specifications:

Receiver

Sensitivity (AM) 1uV
Sensitivity (SSB) 0.25uV
Selectivity (AM) 7kHz, 6dB down
Selectivity (SSB) 7kHz, 6dB down
Fine tune range ± 800kHz
Audio output power 3W
Squelch range (AM) 1uV—10mV
Squelch range (SSB) ... 0.7uV—20uV

SSB Transmitter

Frequency response.. 400Hz—2.6kHz
RF output power 12W PEP

Carrier suppression 40dB
Unwanted sideband suppression 40dB
Harmonic suppression 50dB

AM Transmitter

Modulation high level class B
Power input 5W
RF power output 4W
Harmonic suppression 50dB

General

Frequency control.. synthesizer crystal controlled
No of channels 23

ENTRY FORM Electronics Australia-Dick Smith CB Cartoon Contest

Complete this form and attach it to your entry, posting them not later than 30th October, 1977, to CB Cartoon Contest, c/o Electronics Australia, Box 163, Beaconsfield, NSW 2014. A letter may be used instead of the form in states where this requirement is illegal.

NAME:

ADDRESS:

POSTCODE

DELTA BASE CB RADIO

697 CENTRE RD.
EAST BENTLEIGH
VIC.

579-4758

**EXTRA SPECIAL
OFFER!**

**½ WAVE RINGO
ANTENNAS**

50 ft. of ¼" Co-Ax.
2 PL 259's

\$46

THIS OFFER SEPTEMBER ONLY

WHEN PHONING ASK FOR
BRENDA (VCE 179)
OR RAY (VCE 256).

OPEN 7 DAYS

KNOW

Where you are going?

Choose a career in the field of Electronics — the Nation's most progressive and fastest expanding industry

BROADCASTING
COMMUNICATIONS — marine
APPLIED SERVICING



Classes are conducted at
67 Lords Road,
Leichhardt

Day 9.00 a.m. to 4.00 p.m.

Evenings 6.00 p.m. to 8.30 p.m.
or by Home Study Courses
(except practical instruction on equipment)

SEND FOR PROSPECTUS

There is no obligation.

NAME

ADDRESS

MARCONI SCHOOL OF WIRELESS
Box 218, P.O. Leichhardt 2040.
A service of
Amalgamated Wireless (Australasia) Ltd.

The Australian CB SCENE

Antenna eliminator

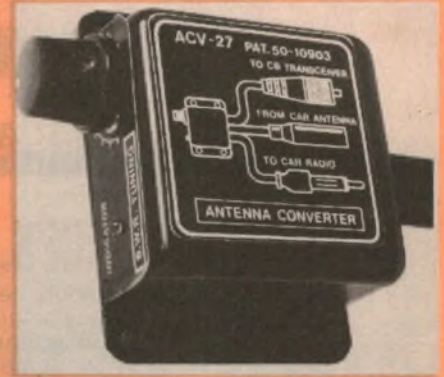

You don't have to drill another hole and mount another antenna on your car with this antenna converter. Designated the ACV-27, it allows you to use a CB rig with your existing car radio antenna, although admittedly with some compromise to effective CB range.

Installation is dead easy—just follow the diagram provided. SWR can be adjusted to less than 1.5:1, and both radio and CB can be used simultaneously without switching.

The ACV-27 is imported into Australia by Paradio Electronics, 7a Burton St, Darlinghurst, 2010. It is available in Sydney from Radio Despatch Service and Pre-Pak Electronics, and in Brisbane from Delsound Pty Ltd. Price is about \$15.00.

Mains power for CBs



Released under the Arlec brand name, the Electropak is designed specifically to power CB radios direct from the mains. It provides a 13.8V DC regulated output and has a continuous rating of 1A, with 1.8A peak capability—adequate for the majority of CB mobiles.

The Electropak is fully approved by Electricity Supply Authorities. It is manufactured by A & R Electronic Equipment Co Pty Ltd, 30-32 Lexton Rd, Box Hill, 3128—branches and agents throughout Australia.

From out of the blue comes a dramatic improvement in CB from Telex, the aviation communications experts.

Exclusive Double-Header feature allows use as a conventional power mike or a superior, noise-cancelling power mike.

Patented design fits every hand—the same style used by pilots around the world.

Unique aircraft-type front mount eliminates mike tumbling. Mike comes off the bracket in the talk position.

Built-in variable gain power amplifier.

Made in U.S.A.

The first "loud and clear" CB mike.

Unique Telex CB-73 Double-Header—power mike with switchable noise-cancelling mode.

Puts you through loud—thanks to the power mike—and clear—thanks to the special noise-cancelling mode. Built-in integrated circuit amplifier maximizes "talk power" without distortion. In high noise environment, switch to unique noise-cancelling mode. Try it. You'll get the message—loud and clear.

The Pilot People
TELEX
COMMUNICATIONS INC.

AUDIO TELEX COMMUNICATIONS PTY. LTD.

SYDNEY
54-56 Alfred Street,
Milsons Point 2061
Telephone: 929-9848

MELBOURNE
828 Glenferrie Road,
Hawthorne 3122
Telephone: 819-2363

Televue CB

THIS MONTH'S SPECIALS



WE STOCK A WIDE RANGE OF AM AND SSB RIGS SUCH AS

- KRACO. Both Base and Mobile units.
- SUPER PANTHER
- STINGRAY
- TELSAT 75 SSB
- COM-PHONE
- 723 LAFAYETTE MICRO
- SHIGMA
- PACE
- BENGAL
- X-TAL CB 12
- PEARCE SIMPSON RIGS
- X-TAL SSB 10

PHONE FOR EXTRA CRASH HOT PRICE!

PHONE, WRITE, OR DROP IN AND SEE US AT . . .

Televue 218, CHAPEL STREET, PRAHRAN, VIC. 3181.
MELBOURNE. PHONE 03-51-6743.

We also do confined area 2-way installations eg farms, race clubs etc . . .

Prices subject to change
Correct at press time.

PMG LICENCE REQUIRED

Coaxial Cable
P/N RG 58 C/U

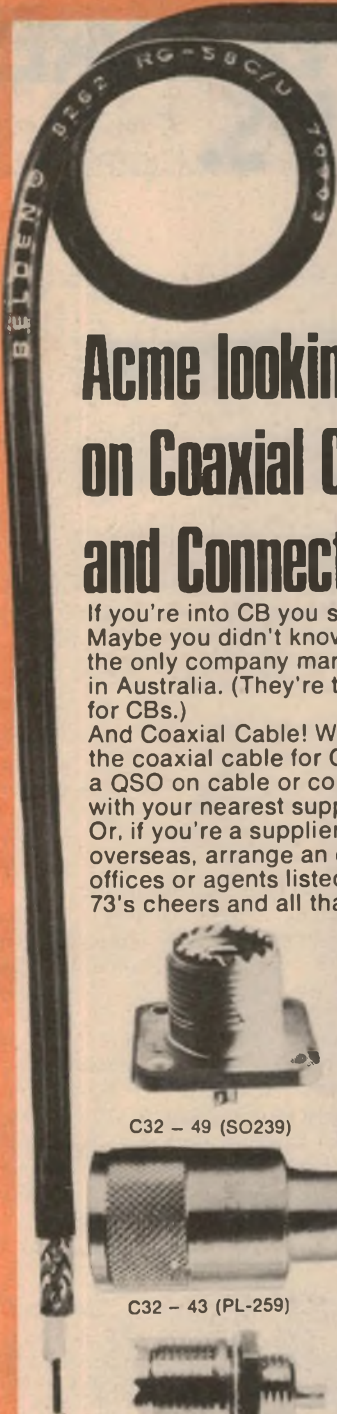

CQ.. CQ

Acme looking for a copy on Coaxial Cables and Connectors.

If you're into CB you should be into ACME! Maybe you didn't know it before, but ACME are the only company manufacturing UHF connectors in Australia. (They're the same connectors used for CBs.)

And Coaxial Cable! Who else but ACME have all the coaxial cable for CB? Miles of it! If you want a QSO on cable or connectors, arrange an eyeball with your nearest supplier.

Or, if you're a supplier suffering headaches buying overseas, arrange an eyeball with any of our State offices or agents listed below.

73's cheers and all that from ACME!

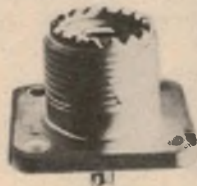

C32 - 49 (SO239)

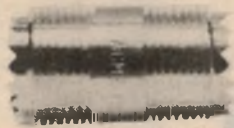

C32 - 13 (PL258)

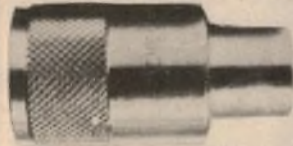

C32 - 43 (PL-259)

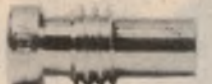

C32 - 24 (UG-174/U)

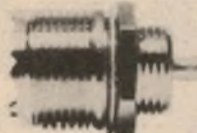

C32 - 28

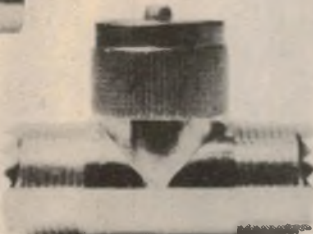

C32 - 32 (M358)



ACME ENGINEERING CO. PTY. LTD.,
2-18 Canterbury Rd., Kilsyth, VIC. 3137.
Ph. 729 6211

N.S.W. Ph. 648 4638 **QLD.** Ph. 58 2011 (Brisbane)
S.A. Ph. 74 1162 Ph. 71 4131 (Townsville)
W.A. Ph. 28 1022 Ph. 51 4422 (Cairns)
TAS. Ph. 34 2811 (Hobart) Ph. 31 5545 (Launceston)
A.C.T. Ph. 95 9138

Convert your CB into a base station



Power your rig direct from mains electricity with an SEC approved power supply.

These small portable units provide a factory-set 13.8V DC regulated output for maximum transmitting power.

High performance integrated circuitry guarantees clean, hum-free reception. Quick-connect terminals facilitate rapid changeover from static-mobile-static operation.

ARLEC CB radio power supplies

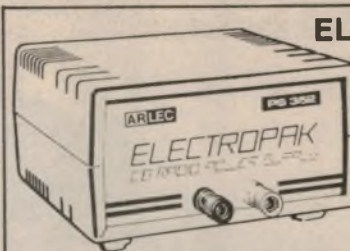

**ELECTROPAK
PS352**

For
CB Radios
up to 5 Watts
Rating

1.8 Amp peak capability. Automatic overload protection.
1.0 Amp continuous output. Size: 140 x 80 x 133mm



**SIDE 4 BAND
PS353**

For CB
Radios up
to 15 Watts
Rating

4 Amp peak capability. Automatic overload protection.
2 Amp continuous output. Size: 140 x 80 x 133mm

See them at your local CB Store or write to
A&R Electronic Equipment Co. Pty. Ltd. for further details

A+R ELECTRONIC EQUIPMENT CO. PTY. LTD.

A MEMBER OF THE A+R-SOANAR ELECTRONICS GROUP
SALES OFFICES VICTORIA 89 0661
N.S.W. 78 0281
S. AUST. 51 6981
QUEENSLAND 52 5421
W. AUST. 81 5500

30 Lexton Road, Box Hill, Vic. 3128
Australia. Telex 32286.



NOW YOU CAN CHANGE TEMPERATURES WITHOUT CHANGING TIPS.

THE NEW SCOPE TEMPERATURE CONTROLLED 60W IRON.



(Model TC60 240v 60w actual size).

Heathkit Continuing Education Series—

the fast, easy, low-cost way to learn electronics!

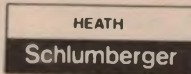

These three basic programmes provide an excellent overview of contemporary electronics—they'll provide you with the fundamentals you need to follow your interests wherever they may lead you. The programmed learning text is clearly written, with technical material fully explained as it is introduced. Built-in quizzes let you test your knowledge at each step. The records give you a "personal" outline of text material and additional information, and electronic parts are included for use in the experiments. Each course leads logically into the next, and when you complete all three, you'll have a thorough knowledge of basic electronics.

Part 1: DC Electronics— electrical fundamentals, theory and practice—

- | | |
|---------------------------|--------------------------------------|
| 1. <i>Electron Theory</i> | 6. <i>Electrical Measurements</i> |
| 2. <i>Voltage</i> | 7. <i>Network Theorems</i> |
| 3. <i>Resistance</i> | 8. <i>Inductance and Capacitance</i> |
| 4. <i>Ohm's Law</i> | |
| 5. <i>Magnetism</i> | |

Includes all texts, records, 56 parts for 20 experiments. Average completion time, 20 hours.

Programme EE-3101 \$61-00

Part 2: AC Electronics— sine waves, inductive and capacitive reactance, impedance, phase shift, transformers and filters

1. *AC Fundamentals*
2. *AC Measurements*
3. *Capacitive Circuits*
4. *Inductive Circuits*
5. *Transformers*
6. *Tuned Circuits*

Includes all texts, records, 16 parts for 8 experiments. Average completion time, 15 hours.

Programme EE-3102 \$61-00

Part 3: Semiconductor Devices— transistors, zeners, SCR's, FET's, digital and linear IC's, LED's, opto-electronics

- | | |
|--|------------------------------------|
| 1. <i>Fundamentals</i> | 7. <i>FET's</i> |
| 2. <i>Diodes</i> | 8. <i>Thyristors</i> |
| 3. <i>Zener Diodes</i> | 9. <i>IC's</i> |
| 4. <i>Special Diodes</i> | 10. <i>Opto-electronic Devices</i> |
| 5. <i>Bipolar Transistor Operation</i> | |
| 6. <i>Bipolar Characteristics</i> | |

Includes all texts, records and 27 parts for 11 experiments. Average completion time, 30 hours.

Programme EE-3103 \$61-00

Heathkit Experimenter/Trainer

For the Heathkit DC, AC and Semiconductor programs—helps you perform each project quickly and easily. And after you finish the programs, it's ideal for "breadboarding" your own design projects. Has solderless breadboarding sockets, 2-range variable sine and square wave signal source, dual-variable power supplies for positive and negative voltages (both variable over 1.2 to 16 volts, 120 mA, both regulated and short-circuit protected). Built-in 1k and 100k linear potentiometers. Center tapped power transformer secondary provides 30 V rms, 50 Hz for line experiments

Kit ET-3100 \$92-00

Digital Techniques Program—For the advanced experimenter, technician, hobbyist or engineer.

Learn digital fundamentals, circuit design, TTL, ECL, CMOS, PMOS, NMOS integrated circuits; SSI, MSI and LSI; ROM's, PLA's; microprocessor theory

1. *Introduction: techniques and uses, binary numbers, digital codes.*
2. *Semiconductor Devices for Digital Circuits.*
3. *Digital Logic Circuits: AND gates, OR gates, NAND / NOR logic, etc.*
4. *Digital Integrated Circuits: TTL, ECL, CMOS, nMOS, pMOS, how to choose.*
5. *Boolean Algebra.*
6. *Flip-Flops and Registers: latches, D & JK flip-flops, storage registers, applications.*
7. *Sequential Logic Circuits: binary, BCD, modulo N, up / down counters, dividers, shift registers.*
8. *Combinational Logic Circuits: encoders, decoders, exclusive OR, comparators, multiplexers, ROM's, PLA's.*
9. *Digital Design: combinational and sequential circuits, procedures.*

10. Digital Applications: counters, computers, microprocessors.

Update your knowledge of electronics with this program in digital fundamentals. Provides a solid background with particular emphasis on circuit design. Covers the latest integrated circuits; ROM's and PLA's; even microprocessors. Helps you learn to design digital circuits for virtually any application.

The program assumes a prior knowledge of electronics fundamentals, either completion of the Heathkit basic electronics programs or equivalent knowledge. It can be successfully completed by technically-oriented people with a math or science background.

The program includes all texts, records and 44 parts for 24 experiments. Av. completion time: 40 hours.

Programme EE-3201 \$76.00

Heathkit Digital Design Experimenter/ Trainer

Use it to perform all the experiments in the Heathkit Digital Techniques Programme, also to develop projects, build and test prototypes, verify circuit operation, check digital IC's. Has solderless breadboard sockets, four binary data switches, 2 "no-bounce" switches to pulse logic circuits, 3-frequency pulse clock generator, 4 LED's for visual indication of logic states. Three regulated power supplies: +12V, 100 mA current limited; -12V, 100 mA current limited; +5V, 500 mA, overload protected. Accommodates up to eight, 14 or 16-pin dual-in-line IC's, also 24, 28 and 40-pin DIP's.

Kit ET-3200 \$107-00

ORDER BY COUPON NOW OR COME TO OUR SHOWROOM

Please rush me the programme of my choice. My cheque for \$ _____ is enclosed plus \$2.50 for package & post.

Name

Address

.....P/Code.....

- Programme EE-3101
- Programme EE-3102
- Programme EE-3103
- Kit ET-3100
- Kit ET-3200
- Programme EE-3201

Send to: W. F. Heathkit Centre,
220 Park St., South Melb. 3205. Phone: 699-4999

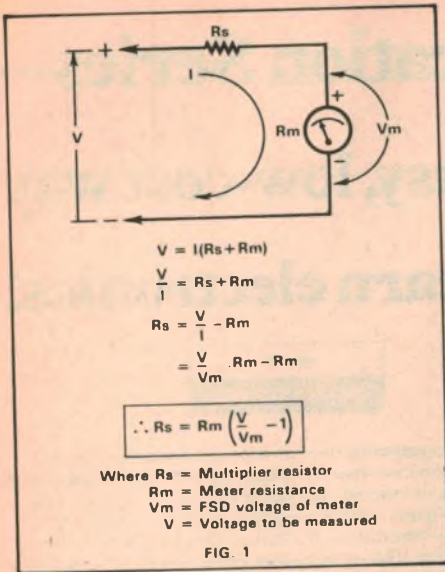

in a 1, 3, 10 sequence. This is a most practical arrangement for a multimeter, as it simplifies meter scales and makes readings easier. It also minimises the necessity for switching from range to range as measurements are in progress.

Most AC millivoltmeters on the other hand follow a very similar sequence, which gives an exact 10dB step between each range. This gives a fixed ratio of 3.16 between each range. Since we intend to adapt this instrument for AC measurement at a later stage, let us incorporate this feature now. Accordingly, new values need to be substituted into the above formula. Results are again tabulated below.

1V	900 ohms	1.8k // 1.8k
3.16V	3,060 ohms	+ 2.2k // 120k
10V	9,900 ohms	+ 6.8k
31.6V	31,500 ohms	+ 22k // 1.2M
100V	99,900 ohms	+ 68k
316V	315,900 ohms	+ 220k

In the above table, it is assumed that the resistors for the ranges are all connected in series. Fig. 2 shows the method of connection. The rotary switch progres-

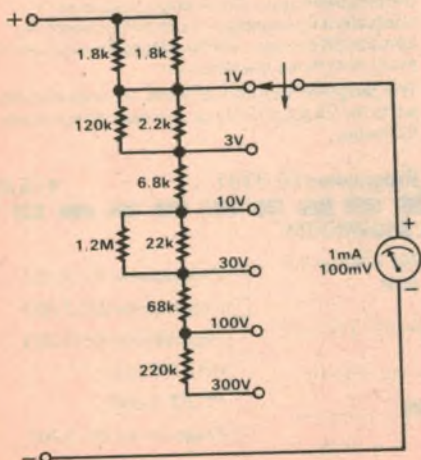

FIG. 2

sively adds in more resistance for the higher ranges. This is the method used by most multimeters, as it simplifies the wiring and does not require resistors with high voltage ratings to be used on the higher ranges.

Even so, we have limited the voltage ranges to a maximum of 316V, a figure which can safely be tolerated by typical rotary switches.

Fig. 2 could be used as the basis for a simple voltmeter, but we wish to add current ranges as well. This means that calculations are necessary to select the value of suitable current "shunt" resistors.

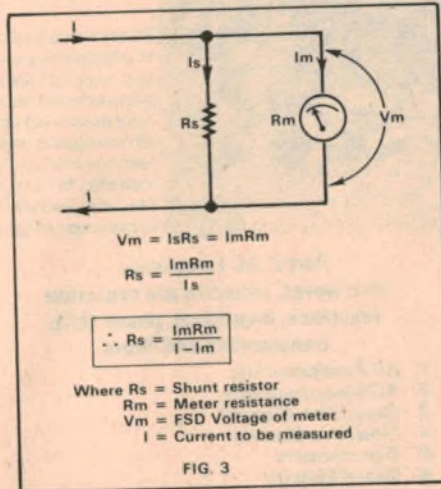

Fig. 3 shows the basic circuit of an ammeter. Also shown is the derivation, using Ohm's and Kirchoff's laws of the formula:

$$R_s = \frac{I_m R_m}{I - I_m}$$

where R_s = shunt resistor
 R_m = meter resistance
 I_m = FSD current of meter
 I = desired FSD current range

Tabulated below are the shunt resistor values worked out for six useful current ranges suitable for our instrument:

1mA	no shunt required	
3.16mA	46.3 ohms	47 ohms // 330 ohms
10mA	11.1 ohms	22 ohms // 22 ohms
31.6mA	3.27 ohms	3.3 ohms
100mA	1.01 ohms	1 ohm
316mA	0.317 ohms	0.33 ohms // 8.2 ohms

Notice that these current ranges have

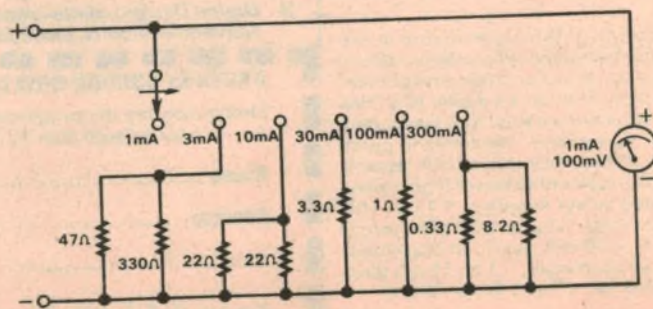

FIG. 4

the same ratio of 3.16 between ranges. If this were not the case we would have to provide additional current scales on the meter face. We have not provided current ranges above 316mA FSD, since contact resistance of the switches becomes appreciable. Commercial multimeters use a more complicated switching arrangement and tapped shunts which are not so easy to calculate, to avoid this problem. For economy we have taken the simple approach.

Fig. 4 shows how the shunt resistors are connected to provide the current ranges. Fig. 5 shows how the voltmeter and ammeter circuits are combined with the aid of an additional switch.

The voltage and current ranges are selected by separate poles of the same two-pole, six-position switch. The additional switch, a two-pole, three-position type, acts as a Function switch with settings for DC volts, Off and DC milliamps. In the Off position, the meter is shorted out to provide electrical "damping" of the movement when it is not in use.

The idea behind this electrical damping is that the meter coil and magnet system constitute a simple generator, which is harder to turn when the output is shorted. Thus, the pointer swings about less when subjected to external movement, provided the meter is shorted.

We have also added a refinement which is not found on many cheaper multimeters, diode protection. Two diodes connected in inverse-parallel across the meter protect it against voltages in excess of about 700 millivolts, in both directions.

Since the voltage across the meter is normally no more than 100 millivolts, the diodes do not have any effect on accuracy of readings.

The diodes protect the meter movement only. The shunts, multipliers and indeed the diodes themselves can still be burnt out by serious overloads. Some multimeters incorporate limiting resistors to protect the diodes, and an additional capacitor in parallel with the meter to eliminate spurious rectification effects which can occur with some waveforms.

Note that even with the diodes in circuit, the meter can still be subjected to overloads of up to about ten times the normal FSD current. This means that the pointer will really "whang" across the scale (with this order of overload) which will make the user tremble for the sake of the instrument. Fortunately, most well

Beginner's Test Meter

Most people with a few years' experience in electronics take their multimeter for granted. But to the beginner, a multimeter can be a box of mysteries. The best way to learn about multimeters is to build one, like the simple voltmeter presented here. It is a useful piece of equipment as presented, but it can also form the basis for a more refined instrument at a later stage.

by LEO SIMPSON

Anyone familiar with the prices of imported multimeters and component parts will quickly recognise that "building your own" is not a cheap way of obtaining a good multimeter. Far from it! The components used in run-of-the-mill commercial multimeters are made to high tolerances and if purchased separately over the counter would be very expensive.

With this in mind, we have not attempted to produce a full multimeter. It's just not practical. Instead, we have produced a meter with useful DC voltage and current ranges.

We start with a basic moving coil meter. This is also known as a d'Arsonval meter, after the inventor. The meter we have selected is a one-milliamp movement, which means that it requires one milliamp of direct current to drive the point to full scale deflection (FSD).

Customarily, moving coil meters are

manufactured so that the voltage required for full scale deflection is 100 millivolts. This convention makes the design of metering circuits easier and more predictable than if this parameter was not controlled.

Plugging the values of 100mV (FSD) and 1mA (FSD) into the appropriate Ohm's Law equation ($R = V/I$) enables us to calculate the resistance of the meter at 100 ohms.

Knowing two of these three parameters, (i.e., resistance, full-scale voltage and full scale current) is all that is required to be able to calculate resistor values for the ranges of a simple DC voltmeter. The resistor for each voltage range is connected in series with the meter and is called a "multiplier" resistor.

Fig. 1 shows the basic circuit of a simple voltmeter. Below it is the derivation of a formula, using Ohm's and

Kirchoff's Laws, which may be used to calculate multiplier resistor values. For those who are flummoxed by algebra, forget the derivation and just use the formula:

$$R_s = R_m \left(\frac{V}{V_m} - 1 \right) \text{ ohms}$$

where R_s = multiplier resistor

R_m = meter resistance

V_m = FSD voltage of meter

V = desired FSD voltage range

From here on, it's just a matter of substituting values into the formula and using a calculator ("plastic brain" to those who still prefer longhand arithmetic) to do the hack work. As noted above, meter resistance for our example is 100 ohms and FSD voltage drop is 100 millivolts.

To help you, the table below shows the resistor value calculated for each of six typical voltage ranges. It also gives the actual resistor or parallel combination of resistor values which would be selected, if a separate resistor was used for each voltage range.

1V	900 ohms	1.8k/1.8k
3V	2,900 ohms	3.3k/27k
10V	9,900 ohms	10k
30V	29,900 ohms	47k/82k
100V	99,900 ohms	100k
300V	299,900 ohms	330k/3.3M

Notice that the voltage ranges increase

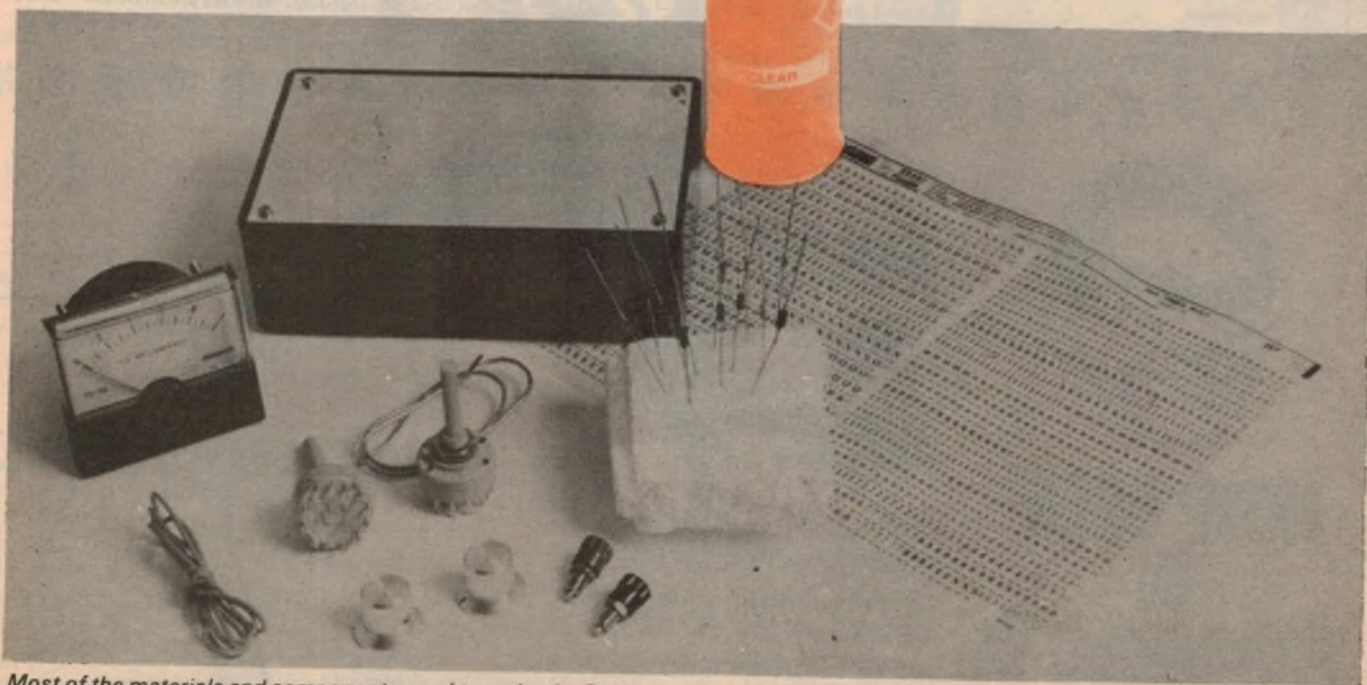

Most of the materials and components used to make the Beginner's Test Meter are shown here.

WATTMASTER DOLBY STEREO

\$139

Features of this great cassette deck include: *Fast forward, *Rewind, *Stop, *Pause, *Eject, *CrO₂ switching, *Twin VU

meters, *Mic inputs, *Headph - one output, * new improved autostop incorporating a micro drag reed sensor system to prevent tape damage.

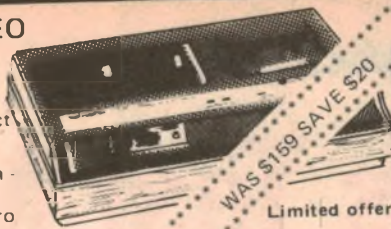

Cat. A-3681... ..\$139

WAS \$159 SAVE \$20
Limited offer

13-861 MIDLAND

Total versatility - the new 23 channel Midland portable/mobile CB. One, it's a portable, with shoulder strap & telescopic whip antenna & two, it's a mobile, which is connected to your car antenna & supply. 4 watt output, plus many other extras!!!!!!!!!!!!
Cat. D-1432... ..\$189.50

\$189.50



SUPERB HI-FI CABINET

This beautifully produced audio cabinet comes in a pack that you simply put together! It has many superb features!!!!!!!!!!!!!! Dimensions: (mm)605wx 680hx 380d(od).
Cat. A-0100... ..\$45.00



British made Garrard Turntable. Upgrade your old Hi-Fi! It's mini design enables you to put it where others won't go.

*balanced arm has crystal stereo cartridge. *plus many other extras!!!
Cat. A-3068... .. WAS \$32.00 ..\$22.50



SANYO

5 watt 6 channel

* Separate mic & speaker 5Watt input, full jack facilities for base or mobile. Battery meter and centre loaded whip.
BIG VALUE!!!!!!!!!!!!!!!!!!!!
Cat D-1142\$89.50

\$89.50



SUPER SPEAKERS

WE'RE SO SURE OF THESE SPEAKERS WE'VE GIVEN THEM A TWO YEAR WARRANTY! You'll

be as happy as we were with them. You get rich, quality sound from these 3 way speakers. They feature a 12" woofer and will handle up to 80Watt peak power. Finished in a beautiful walnut veneer - type cabinet with deluxe foam grilles. Similar imported systems cost up to 50% more!
Cat. A-2360... ..\$199 a pair

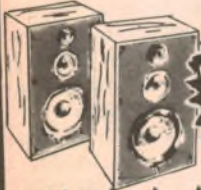

\$199

The era of personal programming is here.

The SR-52. Adds a vital, powerful new dimension to your work. Wherever it may be.

Run TI's pre-recorded programs or your own, in just a few hours you could be writing your own programs. With it's 224-step program memory, the SR-52 can take programs you may have thought required a computer. It has 20 data memories you can access directly or indirectly, the facility for editing & debugging your program & is also a powerful slide rule calculator. It is supplied with 22 pre-recorded program cards a 96 page Basic Library manual and a supply of blank program cards. A head cleaning card is also provided.
Cat. Q-3724... .. INCLUDES TAX... ..\$299.98
Optimization. Projections. Forecasting. Probability. Data reduction. What-if matrices. Iteration. Risk analysis. Mathematical modeling. Worst case analysis
Optional pre-recorded libraries are available. \$32.50 eg. Statistics, Maths, Finance, etc. all Cat. Q-3725
Blank Card Libraries. Cat. Q-3726... ..\$19.50

ONLY **\$299.98**

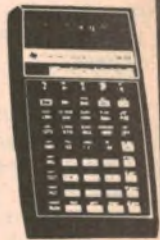

45 WATT 2M AMPLIFIER KIT. Simple & Reliable Design! Now with up to 45 Watts out output. Yes, a fantastic 2M r.f. amplifier of the simplest possible design. You can build it in an hour! Uses 2N6084 45W transistor. Requires 8 - 12W to give 35 - 45W output from 13.8V supply. Every thing supplied, including explicit instructions.
Cat. K-3132... ..\$27.50

AM/FM POCKET RADIO

\$12.50

Good looking and great sounding personal portable brings you your favorite AM and FM programs! Easy to read tuning dial. Large dynamic speaker, built in ferrite aerial for AM and a telescopic aerial for FM. Complete with battery and earphone.
Cat. A-4364... ..\$12.50



GREAT VALUE

POWER

GREAT VALUE!!!

Put power in your car stereo! Model PA99 Power Stereo Amp. This will give you a great 10W into each channel. It has a universal impedance & works off your car battery (12V negative earth). Fit it anywhere you like - under dash - in your boot - glove box -
Cat. A-6612... ..\$32.50



WAS \$59

now **\$32.50**

NOW OPEN IN PARRAMATTA



HERE WE ARE!

DICK SMITH WHOLESALE PARRAMATTA STORE.
30 Grose Street - 1st Floor.
Telephone No. 683-1133
Come and meet our manager - BILL EDGE

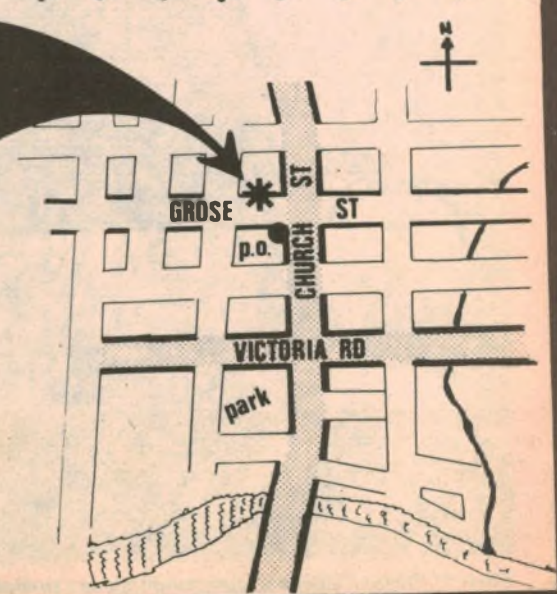

AN INTRODUCTION TO DIGITAL ELECT.

Quick! Already a collector's item, just a few copies left from this best-ever edition. Buy now or miss out! Cat B-3622 .. \$3.00



8080 PROGRAMMING FOR LOGIC DESIGN

Here is one book no microprocessor or computer student should be without. Incredible amount of material crammed into its pages. Value! Cat B-2344.. \$12.00

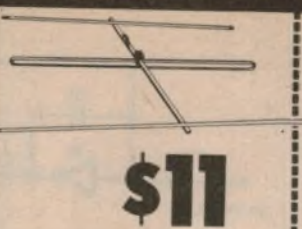
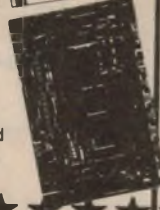

\$11

FM CAN MEAN FINE MUSIC

If you have a good antenna, that is! Don't try to cheat with a TV antenna — use the correct one and your music will reward you! Cat L-4064 .. \$11



L.J. SILVER DETECTOR

FIND A FORTUNE!

You could with our L.J. Silver metal detector. You might even find it's name-sakes loot! Very sensitive, gives audio and visual indication. Easy-to-use, balanced for control. Suited to professional beachcombers, etc. Cat X-1064.. \$49.50

4950 FINDS ALL METAL



\$13.50

Incredible little tie-clasp microphone — TINY! Easily secreted, ideal for demonstrators, etc. Electret mic, 600 Ohms impedance. Also — use on CB radios. Just make a foot switch for tx! Cat C-1060.. \$13.50

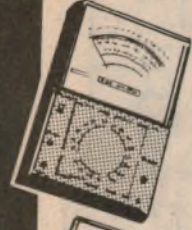
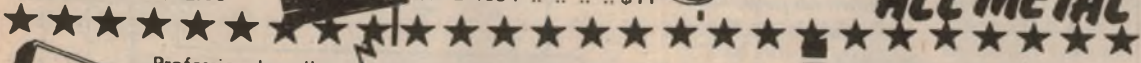

Professional quality, 100k ohms/volt. Real value, very useful scales (not like some meters!) 1kV DC & AC, 10A DC, 10k ohms. Cat Q-1100 .. \$39.75



Our most popular meter! Diode protected, banana plugs for sure contact. 20k/V DC, useful ranges. Cat Q-1024 \$22.50

HI-VOLT PROBE

Measure up to 50kV with the Q-1024 meter. 980M probe — ideal for EHT checking! Cat Q-1025. \$17.50

RAINBOW CABLE PACK Ideal for wiring looms, project building, etc. 12 colour coded strands, 2 metres of sets menus you get 24 metres of wire for only Cat W-4012. .. \$1.50

Figure 8 wire pack: Handy pack for speakers, etc. 25 feet of fig. 8, complete with 4 insulated wire nuts for easy termination. Real value! Cat W-4015.. \$1.50

SPEAKERS HAVE TO DO MORE THAN SPEAK [they have to look pretty, too ..] Revive your tired old speakers with our brilliant acoustic speaker grille cloth. You'll be surprised the difference it can make to your surroundings. We're not saying it will make them sound better, but ..

- Black weave Cat C-2650 .. \$4.50
- Cream weave Cat C-2652 .. \$5.25
- Brown weave Cat C-2654 .. \$5.90
- Navy weave Cat C-2656 .. \$5.90

ALL CLOTHS ARE 52 x 80 CM IN SIZE.

INTERCOM/PHONE PICK-UP

Easily fitted to an intercom, etc for magnetic pick-up. Suction pad, Record, amplifier, etc. Comes complete with lead & plug. Cat C-7300.. \$1.20

only 1.20

1.95 C-1160

MIC INSERTS —

Great for experimenters or servicemen, etc. Two styles, Cat C-1160 is electret, 1-3V operation. Other is ceramic (Cat C-1164) suits most mic cases. Both one price C-1164

1.95

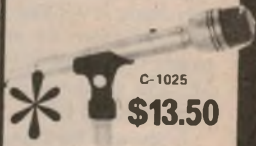

C-1025

\$13.50

DYNAMIC OMNI MIC. Excellent value at this price — ideal for tape recorders, amateurs, etc. 50k impedance. Cat C-1025.. \$13.50



C-1010

\$2.25

CRYSTAL LAPEL MIC. Popular type — high imp. for general purpose use. One meter of cable, plus plug. Chrome finish. Cat C-1010 .. \$2.25 Only \$2.25? Has someone made a mistake?

Weller

Controlled temperature Soldering Iron

ONLY \$49.90

Cat. T-1000



If you want to do a good job, you choose a good tool — and the Weller Controlled Temperature Soldering Iron is such a tool. It's important to have the correct heat at the bit of the iron. Most irons have too high a bit temperature so when soldering is done the iron doesn't cool down too much. As well as wasting power and bits, this is dangerous for many components. Other irons have around the right temperature at the bit, but cannot cope when called upon to use some of their stored heat to solder.

The Weller TCP-1 monitors the temperature at the bit. If more heat is needed, it supplies it — but never too much to waste energy, waste the bit or damage components. It makes sense, doesn't it?

Spare tips available

DICK SMITH ELECTRONICS GROUP

VISIT YOUR NEAREST BRANCH:
 SYDNEY — 125 York St. Ph 29 1126
 BANKSTOWN — 361 Hume Hwy. Ph 709 6600
 GORE HILL — 162 Pacific Hwy. Ph 439 5311
 MELBOURNE — 656 Bridge Rd, Richmond. Ph 42 1614
 BRISBANE — 166 Logan Rd, Buranda. Ph 391 6233

MAIL ORDERS:
 Box 747, Crows Nest.
 NSW. 2065. Ph 439-5311
 SHOP HOURS:
 Mon - Fri 9AM to 5.30PM
 Saturday 9AM to 12 noon
 (Brisbane Sat. 8.30 to 11.30)

POSTAGE/PACKING CHARGES:
 ORDER VALUE CHARGE
 \$5 - \$9.99 \$1.00
 \$10 - \$24.99 \$2.00
 \$25 - \$49.99 \$3.00
 \$50 - \$99.99 \$4.00
 \$100 or more \$5.50

AND NOW OUR NEW STORE AT PARRAMATTA: 30 GROSE ST - Ph. 683-1133

YES!
AVAILABLE
OCTOBER
E.T.I.
NEW

DAVRED ELECTRONICS CATALOGUE

**DAVRED
PRE-NEW CATALOGUE
PROMOTIONS**

Fathers Day SUPER OFFER

THE ULTIMATE IN
AN ORIGINAL
GIFT TO AN
ELECTRONIC
FRIEND



NEVER BEFORE
SEEN OR
OFFERED
IN AUSTRALIA
\$4.99

'ELECTRONIC' ASHTRAY

(NOTE: Limited stocks available of this Special and unusual item)

SEPTEMBER SPECIAL PROMOTION PRICES
Davred Speakers Magnetic Pre-Amplifier

Type	Size	Watts	Ohms	Price
PFS Ceramic	5" x 3"	5	3.5 or 8	\$4.20
EPF35 Ceramic	5" x 3"	5	3.5, 8 or 15	\$4.15
EPF48 Ceramic	6" x 4"	5	3.5 or 8	\$4.15
PF585 Ceramic	6"	6	3.5 or 8	\$6.10
EPF575 Ceramic	7" x 5"	6	3 or 8	\$5.99
EPH60HE Ceramic	9" x 6"	15	3.5 or 8	\$7.99

Type	Size	Ohms	Price
TW82 Speaker	3 1/2"	8	\$7.80
TWF200A Ceramic	3"	8	\$4.99
MSD80 Ceramic	3"	8	\$10.60
HM23 Ceramic	8 1/2"	8	\$12.90
MF80 Ceramic	8"	8	\$9.70
MF80T Ceramic	8"	3 or 8	\$9.85
MF100 Ceramic	10"	8	\$11.50
MF100T Ceramic	10"	8	\$11.70

(Electrokit 15)

This Electronic Kitset is designed to convert the low signal of a stereo magnetic cartridge to operate into a ceramic/XTAL Amplifier input. Supplied with discrete semiconductors, silk screened printed circuit board and all components for total assembly.
Input sensitivity 3-5 millivolt
Output adjustable for ceramic or Xtal. Approx. 110 millivolts — 300 millivolts
Standing current 1.5 milliamps.
Operating voltage 15 volts DC
Comprehensive assembly instructions are supplied.
Approximate size of PC board when assembled 4 1/4" long, 3" side and 1/2" high
\$5.90

EL1. Solder Extractor Engineers **\$5.99**
Spare Nozzles for above **99c**
Spare Washers for above **16c**

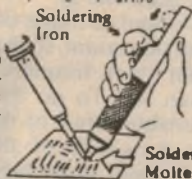

Solder Molten

Disc Ceramic — 50 volt

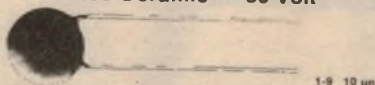

1-9 10 up
2.2, 3.3, 4.7, 6.8, 8.2, 10, 15, 22, 33, 47, 68, 82, 100, 150, 220, 330, 470, 1K, 2K2, 3K3, 4K7, 10K, 22K, 47K pfd
11c 9c

SLIDER POTENTIOMETER

Single Log 10K, 25K, 50K, 100K.

1-9 10 up
85c 45c

Single Lin 10K, 22K, 50K, 100K, 250K, 500K.

1-9 10 up
85c 45c

Ganged for Stereo Log 100K + 100K.

1-9 10 up
90c 75c

Ganged for Stereo Lin 50K + 50K, 100K + 100K.

1-9 10 up
89c 79c

Light Emitting Diodes

	Colour	Vf	Max. Cont. Fwd. Cur.	Vr.	Size	1-9	10-49	50 up
TIL209	Red	1.6 at 20mA	40mA	3	12" D	20c	18c	15c
TIL211	Green	2.3 at 25mA	50mA	3	12" D	50c	48c	46c
TIL220	Red	1.6 at 20mA	50mA	3	2" D	28c	26c	19c
TIL222	Green	2.5 at 25mA	50mA	3	2" D	38c	36c	28c
TIL312P	Red	—	7 seg —	—	3" L	\$1.50	\$1.30	\$1.27

instructions for the do-it-yourself buyer

1. Print your name and complete address
2. Give the part number and description of all goods required
3. Add up amounts and total. If applicable add extra postal charges. (Calculate postal charges on scale opposite.)
4. Total all the above items and forward cheque or postal order to address below.

POSTAL CHARGES

Order value	Charge
\$5 — \$9.99	Nil
\$10 — \$24.99	\$0.50
\$25 — \$49.99	\$1.50
\$50 — \$99.99	\$2.50
\$100 or more	\$4.00

DAVRED Please Note: Minimum P&P \$1.00
ELECTRONICS PTY. LTD.

104-106 King Street Newtown Sydney Australia P.O. Box 317 Newtown, N.S.W. 2042
THE NEW BREED IN ELECTRONICS SERVICE Telephone 516-3544

YES!
AVAILABLE
OCTOBER
E.T.I.
NEW

DAVRED ELECTRONICS CATALOGUE

the clock rate control. Adjust this so that you can easily count the individual clock pulses, and then compare the clock rate with the flash rate of L1, L2, L3 and L4. These should be flashing at 1/2, 1/4, 1/8 and 1/16th of the clock rate.

This shows how a counter can be used to divide the frequency of an incoming signal by a multiple of two. Other division ratios can also be obtained, as we will see later in the article.

A more general form of counter is provided in the upper right hand corner of the trainer. To try this counter connect the indicating LEDs up to the outputs, and the clock signal to the clock input. Now check that the counter operates in the same manner as the circuit of Fig.1.

Now connect the UP/DOWN input of the counter to S6. With S6 in the H position, the counter should function as before, but when it is placed in L position, it should count down. Then connect S5 to the BINARY/DECODE input. With S5 high, check that the counter will count both up and down in binary. Then place S5 low, and check that the counter now counts in BCD code, rather than in pure binary.

This counter can also be set independently of the clock, using the PRESET ENABLE input and the four inputs A, B, C, & D. Connect S3, S4, S5 & S6 to these inputs, and S1 (NL) to the preset enable input. When S1 is not pressed, the counter should count up in binary.

When S1 is pressed, the counter should stop counting, and the data present on S3, S4, S5 & S6 should be transferred to the outputs, and indicated on the LEDs. When S1 is released, the count should commence from the number set on the four data switches.

The CARRY IN and CARRY OUT pins are intended for use when several counters of this form are cascaded. Carry out is normally high, and goes low when the maximum count is reached (15 or 1111 in binary, 9 or 1001 in decimal). When

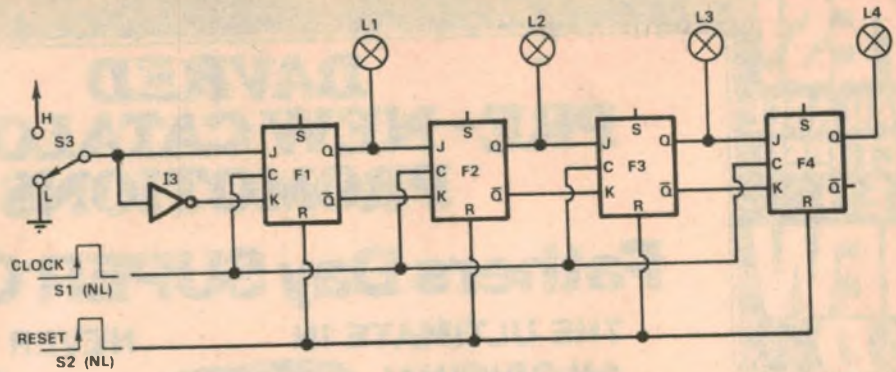

FIG. 2 - 4-BIT SHIFT REGISTER

carry in is taken high, the clock input is disabled.

To follow the operation of the 4-Bit Decoder, connect S1 (NL) to the counter clock, and S2 (NL) to the preset enable input. Also connect the binary/decode input to the L line. Then connect the outputs of the counter to the decoder inputs, and decoder outputs 0, 1, 2 & 3 to the LEDs. After S2 is pressed, only L1 should be on.

Disconnect L4 from the 3 output, and connect it in turn to the remaining outputs of the decoder not already connected to LEDs. None of them should be on, thus indicating that the inputs to the decoder are at zero (0000).

Now press S1 once, and then check that only L2 is emitting. This corresponds to an input to the decoder (from the counter) of 0001. In similar fashion, you can check that the correct outputs are obtained from the decoder for inputs up to and including 1001 (decimal 9).

The decoder can be used to make the counter reset at a particular count, so that it will divide the input clock frequency by a number less than ten. To do this, connect the preset enable input of the counter up to the 4 output of the decoder. When this output goes high, the counter will be reset, so that the clock

pulses will be divided by 4.

The second major use of flipflops is to form shift registers. Fig. 2 shows how this is done. As before, the Q outputs are connected to the indicating LEDs. The clock inputs of all the flipflops are connected together, and the resulting "clock line" is connected to the normally low (NL) output of S1. The "reset line", formed by connecting all the reset inputs together, is connected to the NL output of S2.

The output of S3 connects to the J input of F1, and to the K input via an inverter. The remaining flipflops have their J and K inputs connected to the Q and Q-bar outputs of the preceding flipflops.

When power is first applied, the LEDs should show a random pattern. Depressing the reset switch (S2) should make all the LEDs go out, indicating that the flipflops have all been cleared, or had their outputs set to a low logic level.

Now set S3 to the H position, and then depress S1 once. L1 should now be emitting, showing that the logic level provided by S3 has been shifted into the register. After setting S3 to the L position, depress S1 again. This will shift a low logic level into F1, and at the same time transfer the previous contents of F1 into F2.

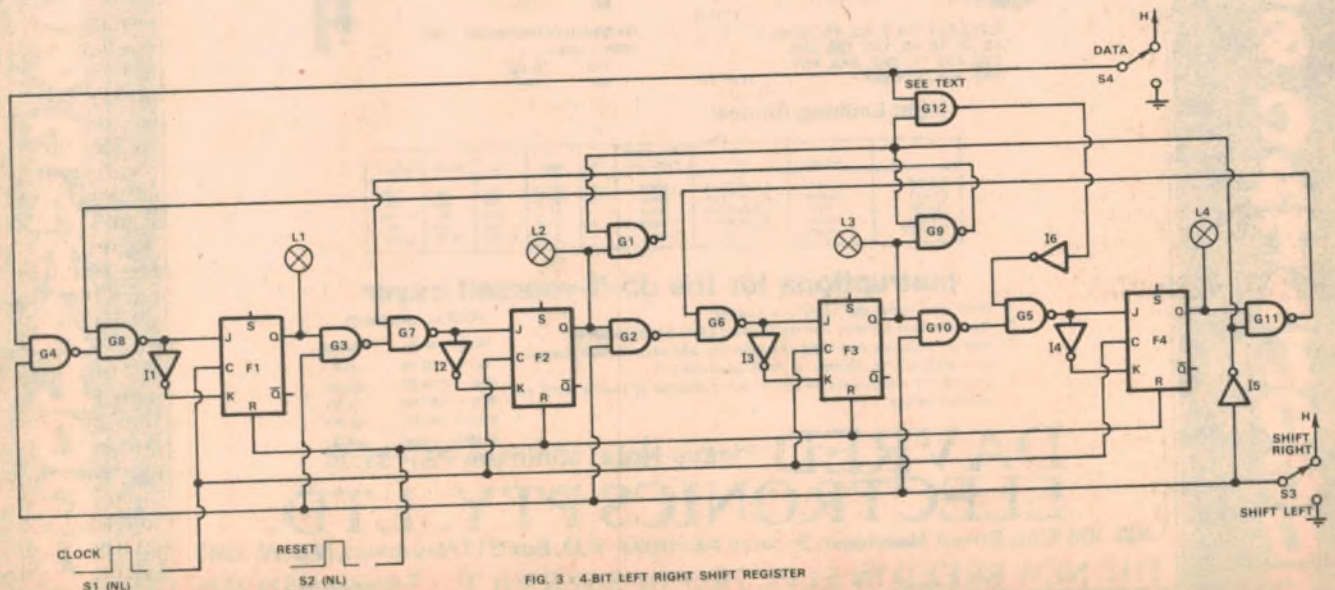

FIG. 3 - 4-BIT LEFT RIGHT SHIFT REGISTER

Digital Logic Trainer

In this article the author gives details of how to use our new Digital Trainer, as described in the July issue. Circuit details and wiring information are given so as to enable the reader to examine the operation of many basic logic configurations.

by DAVID EDWARDS

With any logic trainer of this type, the number of logic configurations into which it may be wired is enormous, being mainly limited by the imagination of the user. In the present article I can therefore provide only a brief introduction to this subject. However this should be sufficient to enable the reader to advance further under his own steam.

Before commencing to use the trainer to try out the logic circuits about to be described, you should have a thorough understanding of the operation of basic logic functions. If you are at all hazy on this subject, I would recommend that you try reading our editor Jim Rowe's book "An Introduction to Digital Electronics".

The new edition of this book should

be available by the time you read this article. The book gives the uninitiated a good grounding in basic digital electronics, covering this topic right from the beginning.

Perhaps the first thing you can do with the trainer is experiment with the various elements, connecting their inputs up to switches S3, S4 and S5, and using the LEDs to monitor conditions at the outputs. In this way, you should be able to work out empirically the operation of the LED indicators, the inverters, and the two and three input gates.

You should be able to see, for example, that by using different logic conventions at the inputs and the outputs of the gates, these will function as NAND gates, NOR gates, AND gates or OR gates.

The truth table for the JK flipflops can be worked out in a similar manner, but the process may tend to confuse you if you do not already have a grasp of the basic principles of a flipflop.

The resistors and capacitors can be used to form RC time delay networks, and also to form simple oscillators using the Schmitt triggers. To make an oscillator, connect a resistor from input to output of the Schmitt gate, and then connect a capacitor from the input to the L line. The oscillator frequency is then given by $0.67/RC$.

Assuming now that the reader understands the operation of the principle building blocks provided on the trainer, we can now proceed to discuss some examples of typical logic circuits. Fig. 1 shows the circuit schematic and the wiring diagram used to implement a 4-bit ripple carry counter, using the four JK flipflops.

Study Fig. 1, and familiarise yourself with the circuit diagram. See how the connection from the Qbar output of F1 to the C (clock) input of F2 is shown on both the circuit diagram and the wiring diagram. Then, using the wiring diagram as a guide, make the connections shown on the circuit diagram.

After checking that all connections are correct, turn on the power switch. LEDs L1 to L4 should show some random pattern, with some emitting and some not. Taking L1 as the least significant bit (LSB), and L4 as the most significant bit (MSB), work out the number represented in binary by the LEDs, where an emitting LED is taken as indicating a high logic level, and a non-emitting LED as a low logic level.

Now depress S1 once, and observe the new pattern produced on the LEDs. You should be able to see that the binary count has increased by one. By pressing S1 repeatedly, you should be able to observe 16 different binary counts, before the patterns start to repeat again.

Now disconnect the lead from S1, and connect it to the clock output. The flipflops should now count at a rate set by

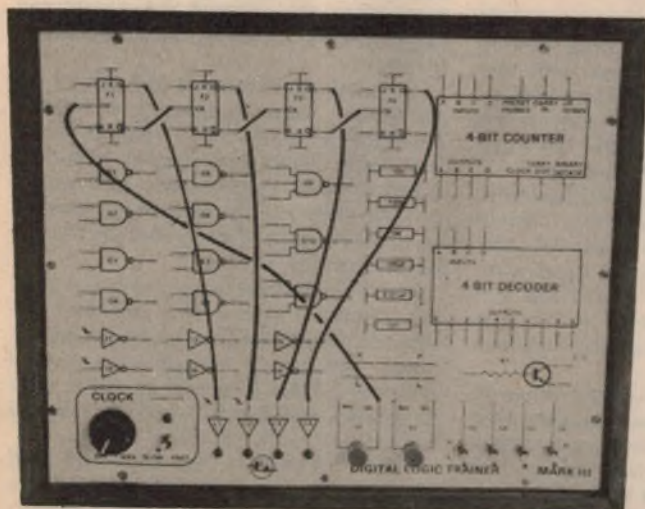

These two diagrams show the circuit representation of a simple logic configuration, and also how it is wired on the Trainer.

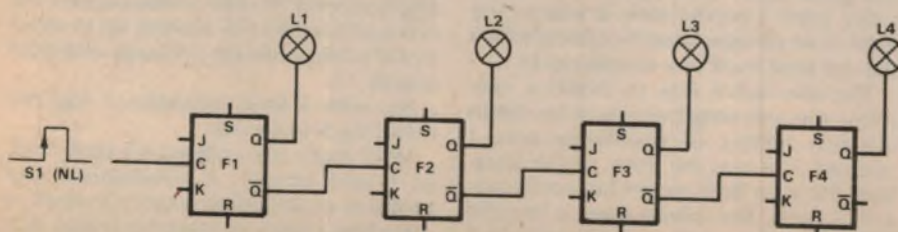

FIG. 1: BASIC 4-BIT RIPPLE CARRY COUNTER



NLS LEADS AGAIN!!

THE NEW MS-15 MINISCOPE

- 15 megahertz bandwidth.
- External and internal trigger.
- Time Base—0.1 microseconds to 0.5 Sec/div—21 settings.
- Battery or line operation.
- Automatic and line sync modes
- Power consumption less than 15 W.
- Vertical Gain—0.01 to 50 volts/div —12 settings.
- Weight is only 3 pounds.



With Rechargeable Batteries & Charger Unit

\$299

15% sales tax if applicable.



Non-Linear Systems, (Australia) Pty. Ltd.

60 Lothian Street, North Melbourne, Victoria, 3051, Australia.
Telephones: (03) 329-9951 — (03) 329-9377 Telex: 34082.

Soldering printed circuits?

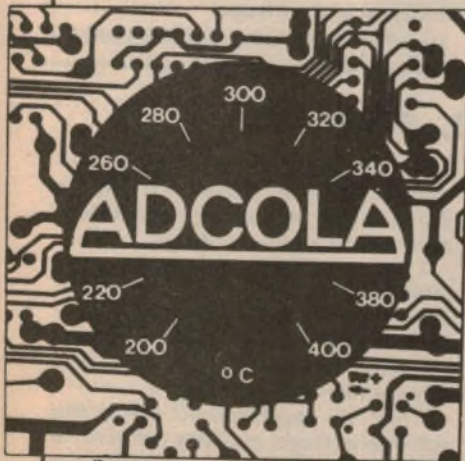

The Duotemp protects circuits and components at a cost far lower than soldering tools with automatic temperature control.

- Correct soldering temperature for printed circuits.
- Fast heat-up and heat recovery.
- Power boost for long sequences or heavy joints.



THE PUSH BUTTON . . .

The Duotemp soldering tool will idle all day on half-wave AC without overheating. A touch of the button converts it to full wave, instantly doubling the thermal capacity.

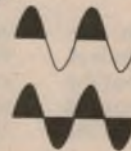

DUOTEMP

AVAILABLE IN 240V AC & 24V AC

MODEL D30	3mm tip
MODEL D50	5mm tip
MODEL D65	6.5mm tip

From your electronic parts supplier or enquire from
ADCOLA PRODUCTS

Melbourne, 848 3777. Sydney, 709 5293.
Brisbane, 52 3166. Adelaide, 42 6655.
Hobart, 34 2233. Launceston, 31 2511.
Perth, 81 5500

A77



The Serviceman

Old Faults in Modern Equipment

It is an unfortunate fact that we often condition ourselves to look for certain faults in certain types of equipment, yet can be deceived when similar symptoms occur in relatively unfamiliar equipment. A typical example this month was a fault in a solid state TV set which, had it occurred in a valve set, would have been immediately recognised.

To kick off this month I have a reader's letter on which I would like to comment. It concerns the story in the July issue about the double image on the Kriesler model 49-6, and is reproduced elsewhere. I suggest you study it before reading any further.

The letter is gratifying for several reasons. In the first place both my colleague and I were pleased to learn that we were not the only ones to have encountered this fault. Being in the "unbelievable" class, it is nice to have confirmation that it was not a figment of an over-active imagination.

It also tends to confirm that failure of C116A is the primary cause of the fault. Readers may remember that I suggested that this may be only part of the story, probably in conjunction with power supply fault.

Finally there are M.I.'s comments about the electrical condition of the capacitor and its effect on DC current in the yoke. At that point, however, I sense the M.I. ran into the same kind of brick wall as did both my colleague and I: by what mechanism would this have such a weird effect on the picture? I am afraid we are none the wiser.

Nevertheless, many thanks for your letter M.I. At least you have confirmed our sanity and integrity!

Appropriately enough, my main story this month concerns a couple of monochrome TV sets from the same stable and of a similar vintage, both being Kriesler chassis types 49-7.

Both sets had the same symptoms—sound but no picture—and, at least initially, I discovered a similar fault pattern. In the final analysis, however, the prime cause was different.

In greater detail the symptom was complete lack of raster, rather than lack of video information, suggesting that the fault was most likely in the line output stage and/or the supply voltages to the picture tube.

My first check was the collector voltage of the line output transistor, a BU105 (TR33). While the peaky waveform in this part of the circuit makes it virtually impossible to get an accurate reading

with conventional voltmeters, I knew from experience with similar circuits that my particular voltmeter should give a reading of about 130V. While having little meaning in absolute terms, it was a handy figure for comparison. In fact, it proved to be scarcely necessary at this stage, since the reading on the collector was zero.

The supply to the line output transformer is about 35V, via the boost diode (D19) and an 8.2 ohm, 5W, resistor (R162). A multimeter check showed the diode to be OK, but the 8.2 ohm resistor was open circuit. This was some help, but I wasn't naive enough to imagine that this would be the end of the story. The resistor was of reliable make, not prone to spontaneous failure.

Before switching on again I connected the meter to the line output transistor collector. This proved to be a wise move because the voltage rose to only 50 and both the transistor and the 8.2 resistor commenced to overheat. I switched off hurriedly.

My first suspect was a faulty line output transistor and, as it is fairly easy to remove in this set, I pulled it out and checked it for a collector-emitter short

with the multimeter. When this checked OK I checked it in the transistor tester, just in case, but again it checked out OK.

Before replacing the transistor I switched on again and checked the 8.2 ohm resistor. It was quite cool, thus ruling out any ideas of short circuits in various associated components.

I re-fitted the line output transistor and used the CRO to make a quick check on the drive to its base. Once again, everything was normal. Following this I went over the line output stage checking other likely components, including the resistors, several diodes, and the 0.18uF capacitor feeding the horizontal yoke circuit. None of these provided any clues.

By now I was beginning to suspect either the line output transformer or the horizontal yoke coils, but I did not have any replacements on hand with which to confirm this. And, as it was just on closing time, I decided to give it away and make a fresh start in the morning.

At that moment a colleague walked in and I took the opportunity to ask him whether he had any suggestions to fit the symptoms. He did, as it happened, having had a similar fault some time ago in a set of a different make. In that case it had turned out to be short between the second and final anodes of the picture tube.

This seemed a reasonable suggestion—and one that hadn't occurred to me—so we made a quick resistance check between these two points. But again I drew a blank. I closed the shop, bid my colleague goodnight, and went home.

Next morning, I tackled the job anew and mentally reviewed all that I had checked and found so far. This brought me back to my colleague's experience with the internally shorted picture tube. Could this picture tube have a voltage sensitive breakdown; one that would not show up on the ohmmeter, but became effective at high voltage?

To prove the point I disconnected the

It wasn't imagination, after all!

Dear Sir,

I read with interest your article in the July issue, as a 49-6 chassis was delivered to me by a friend with the request that I try to get it going properly. He didn't mind the double picture so much, but the double advertisements were intolerable!

I am not a full-time serviceman, but an electrical fitter who has completed both black and white and colour TV courses. I am therefore prevailed upon by friends and workmates for spare time repairs.

In this case I noticed that the horizontal shift referred to by your colleague was effected by the horizontal hold, as well as by the brightness.

In my case the capacitor in ques-

tion, C116A, had decided that its contents were better outside than inside the container. As a result, the fault was quickly and easily rectified.

I too was intrigued as to how this fault caused such peculiar symptoms. A resistance check on the dud capacitor revealed it to be almost a calibrated short. This would allow DC to flow through the yoke winding.

This DC appeared to upset the whole line stage, and also the vertical stage via the boost line. Increasing the brightness, and therefore the final anode current, appeared to drown the effect. In any case, DC through the horizontal yoke coil causes heating and it not recommended.

Yours faithfully,
M.I., Ipswich, Qld.

Electronics is where it's all happening

...if you're into it you've got it made!

It's the world's fastest growing industry... with new discoveries...new products every day. And, every day, there are more jobs...bigger salaries...better opportunities...for people who are trained.

You can be part of this boom now by training with International Correspondence Schools. Learn to design, build, install, test, control and maintain modern electronic equipment...from your own colour TV or hi-fi set to a digital computer.

Your career opportunities are limitless...in broadcasting, industry, the military, aerospace programs, medical science and communications. With your enthusiasm and ICS tuition, a well paid job and a secure future in electronics is well within your grasp.

How do I get into it? ICS have put together a FREE Electronics Career Folder. It tells you all about the many courses open to you including Communications and Broadcasting, Industrial Electronics, Computer Servicing and Audio/Radio Servicing...courses endorsed by the Television and Electronics Technicians Institute of Australia. Post the coupon and the career folder will be on its way to you without obligation. Don't wait another minute...progress won't. The big developments in electronics are happening now and the demand for skilled people is growing all the time.

Special Colour TV repair course. Colour TV is booming all over Australia, beyond the expectations of all the manufacturers, resulting in a shortage of qualified people to fill the service gap.

You could make a successful career in this growing field with the help of the ICS School of TV Servicing. You can benefit by this course - all you need is the enthusiasm to learn and enjoy rewarding work.

Your ICS course could be a start of an exciting new career or you can use your new-found knowledge to earn extra money in your spare time.

This special course is endorsed by the Television and Electronics Technicians Institute of Australia.

Send the coupon today. It could be the first step in an exciting new future for you.



Find out how you can be where it's all happening - in Electronics. Fill in the coupon and post today!

ICS Home Study
...your passport
to success in life!

Your invitation to join the thousands of successful ICS graduates.

To: International Correspondence Schools
400 Pacific Highway, Crows Nest, NSW. 2065
18-20 Collins Street, Melbourne VIC. 3000
182 Wakefield Street, Wellington, N.Z.

274450

YES!

Please send me, entirely without obligation, a copy of the:

- ICS Electronics Career Guidance Kit
- ICS Colour TV Servicing Career Guidance Kit.

MR/MRS/MISS _____

ADDRESS _____

POST CODE _____

PRESENT OCCUPATION _____

AGE _____

Take the first step -
Fill in and mail this coupon today!

ICS

PKB 54430

rent, and if the magnitude of the current is within specifications.

The circuit as shown uses a low level (0-1V) DC voltmeter. Operation is based on the fact that at room temperatures, all conductors have some resistance (albeit small) and, when current flows through the semiconductor, there is a slight voltage drop between any two points along the conductor. Typically, such voltage drops are in the uV range, but with a voltage amplifier having a gain of 1000 or more, the minute voltage can be brought up to a reasonably measurable value.

The circuit uses an 8-pin DIL 741, with the DC voltmeter already mentioned. This circuit takes advantage of the high

common-mode rejection ratio (CMRR) of the op-amp to reject any noise pickup voltages that are common to both input terminals.

To keep the value of the feedback resistor R6 to a reasonable value, the output of the op-amp (pin 6) drives the combination of R4 and R5 with the feedback taken from the junction of these two resistors. This voltage divider action in the feedback voltage multiplies the conventional gain $(1 + R6/R1)$ by the voltage divider ratio $(R4 + R5)/R5$ to produce a theoretical voltage gain of approximately 1400×5.5 , which equals 7700.

Since any residual offset voltage

generated within the op-amp is also multiplied by this factor, two offset (coarse and fine) potentiometers (R7 and R8) are provided to trim the offset close to zero with the input probes shorted.

In experiments with this circuit, probing a current carrying conductor produced a "ball-park" figure of 12mV per inch, for each milliampere of current flow. In general, it would be too much to expect either precision or close calibration results from such a general purpose circuit as opposed to a specialised and expensive instrumentation amplifier. Nevertheless, the circuit does indicate current flow in a conductor and can be reasonably calibrated. Where currents greater than about 1.5mA are concerned, the sensitivity of the circuit can be reduced by lowering the value of feedback resistor R6.

(By Sol D. Prenskey, in "Popular Electronics".)

Model train signal system

The circuit shows the basics of a system which I devised to provide control of a two-colour signal system for a model railway. I have used light dependent resistors instead of the often used combination of magnets and reed relays. I feel that the LDR is more reliable and so would reduce the likelihood of failure which is often associated with mechanical systems.

To sense the passing of a train, I have used an LDR at each signal. LDRs have the property whereby they have a high resistance in low light levels, changing to much lower resistance when the light becomes brighter. In this application, when a train passes over the LDR, it increases in resistance and therefore the voltage at the junction of the LDR and R1 will increase. This voltage is then sufficient to forward bias the transistors at the junction and they in turn will switch over the flip-flop.

Each section can be considered as a module and any number can be connected in a chain or closed loop. The

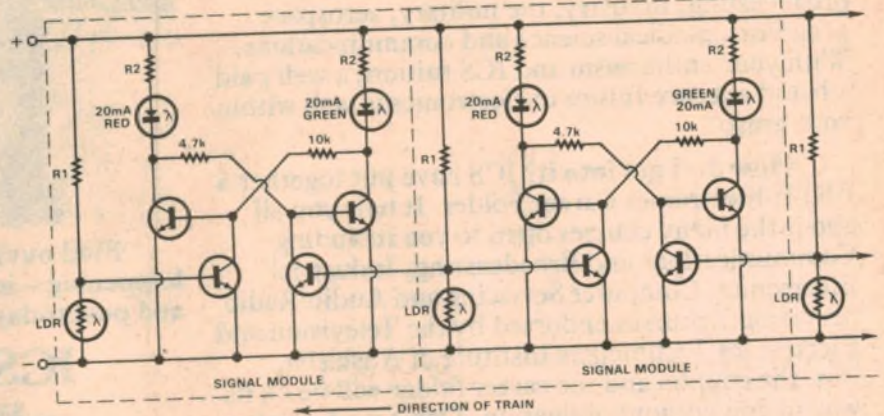

layout of components is not critical but separate modules are to be preferred. The transistors can be virtually any general purpose small signal silicon types. Almost any type of LDR and suitably coloured LEDs should be satisfactory. The resistors in the base circuits have been made unequal (10k and 4.7k) to ensure that all green LEDs start up

when the system is first switched on.

The circuit may be operated from a supply ranging from 3V to 12V DC. R1 should be 68k, 150k, or 270k, for operation on 3V, 6V, or 12V, respectively. Also, R2 should be 47 ohms, 220 ohms or 470 ohms, for 3V, 6V, or 12V, respectively.

(By Mr. R. Dodd, 2 Quintus Terrace, Dover Gardens, SA 5048.)

Protection for CB mobile equipment

SCR trigger circuits for possible use in protecting CB and other electronic equipment have been described in the past and some of these can be further simplified when applied to CB transceivers. This is particularly true in the case where the rig has a three prong plug for the 12V line and one of the prongs is not used.

In my circuit as shown, the relay has been eliminated. Wire No. 3 goes to the unused prong on the plug, while the unused contact in the mating female connector goes to ground. Removal of the

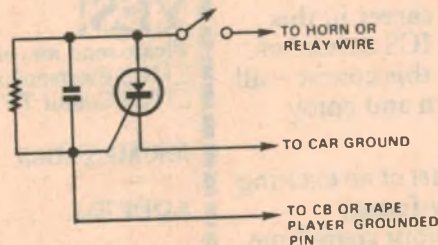

power cable or physical removal of the CB rig or tape recorder from the vehicle will trigger the vehicle's horn. From actual experience, I can attest that the circuit has paid for itself in value of equipment protected.

(By Robert B. McKinley, Jr., in "Popular Electronics".)

Electronics is going digital. This book can help YOU go right along with it.

Tens of thousands of people—engineers, technicians, students and hobbyists—have used *An Introduction to Digital Electronics* to find out what the digital revolution is all about. The new edition has been fully rewritten and updated, to make it of even greater value.

Available from newsagents, bookstores, electronic suppliers and also "Electronics Australia", 57 Regent St. Sydney. PRICE \$3.00. OR by mail order from "Electronics Australia", P.O. Box 163, Beaconsfield, 2014. PRICE \$3.60.

BUILD IT YOURSELF & SAVE

It's as simple as ABC*

(BECAUSE YOU ARE THE LABOUR CONTENT)

WHAT ARE THE ADVANTAGES OF PLAYMASTER SPEAKERS OVER OTHER COMPARABLE 12" SPEAKER KIT DESIGNS?

Playmaster

3 WAY 75 LITRE SPEAKER SYSTEM

Designed by
Neville Williams
Editor in Chief
Electronics Australia



SPEAKER KIT
Cat. C-2042
BOX KIT
Cat. C-2622

PHILIPS AD12K12		PLAYMASTER
720 x 460 x 261	ENCLOSURE DIMENSIONS	717 x 475 x 293
62 LITRES	CUBIC CAPACITY	75 LITRES
40watts RMS	POWER HANDLING	40watt RMS
CLOTH STRETCHED OVER WOODEN FRAME	GRILLE	DELUX ACOUSTIC FOAM
NOT INCLUDED	FADERS	INCLUDED
\$269 per pair	PRICE	\$254 per pair
1" DIAMETER	TWEETER	2 1/2" DIAMETER

We regard the Playmaster 3 way 75L systems as the best value for money speakers in Australia today.

ALSO ASK FOR THE DETAILS OF the 10"53L system.

Only \$189.25 per pair

Speaker kit (pair) Cat C-2042 ... \$130.00
Enclosure kit (pair) Cat C-2622 ... \$124.00
TOTAL SYSTEM PRICE (PAIR) ... \$254.00

\$254

PER PAIR

(OUR PRICE LEAVES THE OTHERS WONDERING HOW WE SELL THEM AT THIS LOW PRICE)



A: Glue and 'fold' the box sides around the front baffle. The box sides are pre-grooved to make the job child's play.



B: Screw in the speakers and wire them as shown in the detailed instructions. A pre-assembled 'loom' is supplied -- no soldering required.



C: Insert the acoustic filling material and place the rear panel in position. Lay the acoustic grille on the front baffle and press home.

DICK SMITH ELECTRONICS GROUP

VISIT YOUR NEAREST STORE:

SYDNEY - 125 York St. Ph. 29 1126

BANKSTOWN - 361 Hume Hwy. Ph. 709 6600

GORE HILL - 162 Pacific Hwy. Ph. 439 5311

MELBOURNE - 656 Bridge Rd, Richmond. Ph. 42 1614

BRISBANE - 166 Logan Rd, Buranda. Ph. 391 6233

MAIL ORDERS: P.O. Box 747 Crows Nest, N.S.W. 2065.

AND NOW OUR NEW STORE AT PARRAMATTA: 30 GROSE ST - Ph. 683 1133



WE HAVE DEALERS ACROSS AUSTRALIA. PHONE YOUR NEAREST STORE FOR THE DEALER CLOSEST TO YOU.

ORDER VALUE	POSTAGE/PACKING CHARGES
\$5 - \$4.99	\$1.00
\$10 - \$24.99	\$2.00
\$25 - \$49.99	\$3.00
\$50 - \$99.99	\$4.00
\$100 or more	\$5.50

Circuit & Design Ideas

Conducted by Ian Pogson

Interesting circuit ideas and design notes selected from technical literature, reader contributions and staff jottings. As they have not necessarily been tested in our laboratory, responsibility cannot be accepted. Your contributions are welcome, and will be paid for if used.

Car battery monitor

To get some idea as to how the circuit functions it will be helpful to look upon the battery voltage as being initially very low, well below 10V, and then observe what happens as it is increased.

As soon as the battery voltage is raised above some 3V the red LED starts to glow, and it continues to glow as the battery voltage increases. When the voltage comes close to 10V the potential at the slider of VR2 with respect to the negative rail rises to that needed (about 1.2V) for current to flow in the base-emitter junctions of transistors TR3 and TR4. TR4 starts to draw collector current through R4 and the yellow LED. As the battery voltage further increases TR4 becomes turned on fully with only a low voltage, of about 0.2V or less, between its collector and emitter. The yellow LED glows at full brightness. Part of TR4 collector current flows through the now forward biased diode D2, whereupon the voltage across the red LED falls to 0.8V or less and it extinguishes.

The battery voltage continues to increase, with the yellow LED alight on its own. When the voltage reaches 13V, current flows into the base of TR1 and TR4 takes action to that given with TR3 and TR4 takes place. At about 13V TR2 turns on fully, causing the green LED to light. At the same time D1 is now forward-biased and the voltage across the yellow LED becomes too low and it is extinguished. The green LED stays on for all voltages above 13V.

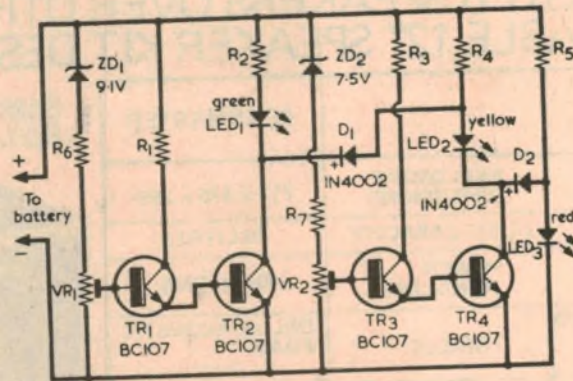

The battery voltages at which the two pairs of transistors become turned on are controlled by the settings of VR1 and VR2. It will be seen that there are two small areas of overlap, at which two LEDs are alight at the same time. This is an advantage, since two fairly precise indications of battery voltage are then given.

The three LEDs can be any types having maximum forward current ratings in the region of 30mA to 60mA. In the circuit, they are operated at about 10mA or more.

The circuit is set up by applying the requisite voltages to the unit and adjusting VR1 and VR2. Initially, the sliders of both these potentiometers are set to the negative ends. If the discharge and charge voltages to be chosen are 10V and 13V respectively, a 10V supply is first

applied. VR1 is adjusted so that both the yellow and red LEDs are illuminated. 13V is next applied and VR1 is adjusted to cause both the green and yellow LEDs to light up. The unit is then set up. VR1 and VR2 can be set to other voltages if required.

Input voltages for setting up may be obtained from batteries or any suitable power supply. The voltages used should be checked with an accurate voltmeter. The current drawn from the battery is about 10mA when the red LED is alight, rising to about 23mA when the yellow LED is on and to about 37mA when the green LED is lit up. Such values are negligibly low in an electrical system where current levels are normally defined in amps.

(By F. T. Jones, in "Radio & Electronics Constructor".)

In-circuit current tester

Since an op-amp is basically a differential amplifier, it can be used in a unique metering circuit to determine the presence of current flow in a conductor, and approximately the amount of current, whether the conductor is a copper wire or a printed board foil trace. This can be done without breaking the conductor.

Such a metering device can come in handy if you have a crowded PC board and you suspect one of the active elements is not working. Instead of risking damage due to the heat required to remove the suspect semiconductor, or having to cut a trace to insert a meter, all you have to do is press a couple of sharp probe tips to the copper trace at (for example) the supply bus and see if that particular element is drawing cur-

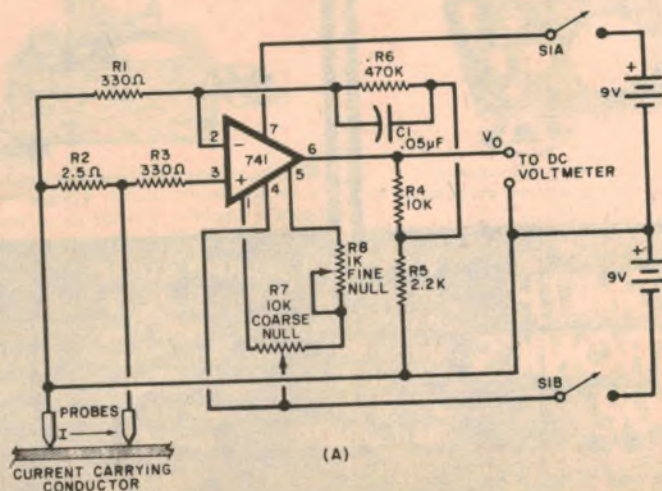

WHY YOUR NEXT CASSETTE SHOULD BE A MAXELL UD



1 THE RESEARCH — More than twenty years ago, Maxell produced their first reel of magnetic tape. At that time, Maxell made a commitment to produce and sell only the finest magnetic products their technology could create. That commitment still stands today.

2 THE TAPE — This continuous research has led to the development of the Maxell UD (ultra dynamic) cassette. A tape that has a coating of super-fine PX gamma ferric oxide particles with an extra smooth mirror-finish surface. All of this adds up to high output, low noise, distortion free performance and a dynamic range equaling that of open reel tapes.

3 THE SHELL — Even the best tape can get mangled in a poorly constructed shell. That's why Maxell protects its tape with a precisely constructed shell, made of lasting heavy-duty plastic.

No fixed guide posts are used. Instead Maxell uses nylon rollers on stainless steel pins thus eliminating the major cause of skipping, jumping and unwinding.

A tough teflon (not waxed paper) slip sheet keeps the tape pack tight and flat. No more bent or nicked tape to ruin your recording.

Maxell doesn't use a welded seal, but puts the cassette together with precision screws. Result — Maxell doesn't jam.



4 THE LEADER — A leader tape that has a four function purpose.

- a) Non-abrasive head cleaning leader (cleans recording head for 5 secs.).
- b) 5 second cueing line (recording function starts 5 seconds after the line appears).
- c) Arrows indicating direction of tape travel.
- d) A/B side mark (indicates which side is ready for play).



Now you know why your next cassette should be a Maxell UD (ultra dynamic).

maxell®

The sound expert's cassette UD available in C60, C90 and C120. Distributed by Hagemeyer (Australasia) B.V. Branches in all States

The complete range.

"E" Cell

The "E" Cell device suitable for a number of applications such as repetitive timing and control, pulse counting and memory, timing, current-time integration, use-time measurement.



Capacitors and resistors

Capacitors for a wide variety of applications, ranging from tantalum, electrolytic, chip ceramic, variable ceramic, precision piston trimmers. And resistors metal glazed 1/16 Watt, 30 to 1000M.

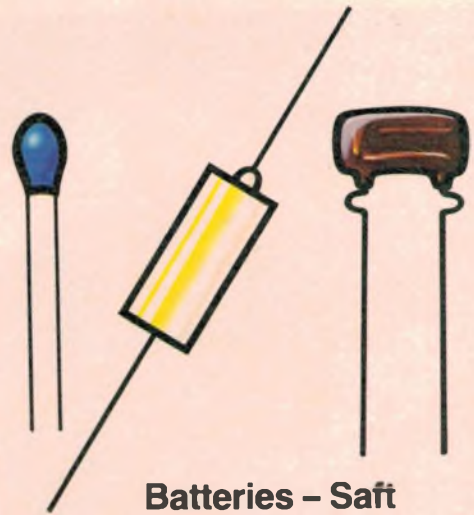

Batteries - Saft

Nickel cadmium (rechargeable) cells and batteries, for domestic, heavy industrial, emergency power, military and aviation.



Connectors

A multitude of connectors including the Multicon range consisting of 2, 4, 6, 8, 10, 12, 18, 24 and 33 pole. Also the 159 range of plugs and sockets ranging from 7 to 71 poles. Gold flash on contacts and solder tags for long term protection against tarnishing.

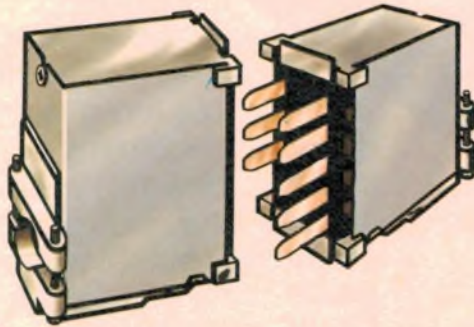

Semiconductors

Digital and linear devices using MOS technology for Communications, Radio, Power control.

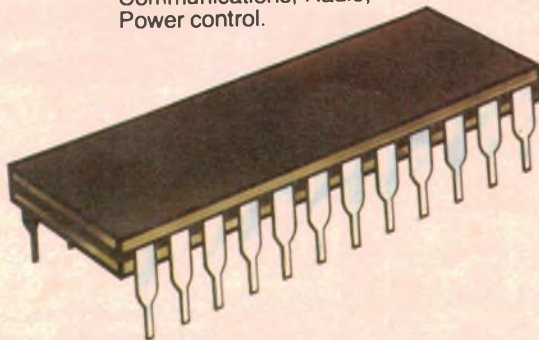

Dry reed inserts and relays

Suitable for most switching functions the inserts have proven extreme reliability, long life, and the ability to operate in grossly unfavourable environments.



Cable and wire

OKI cable and wire for electronic applications ranging from switchboard cable, various plastic insulated wire to high frequency coaxial cable.

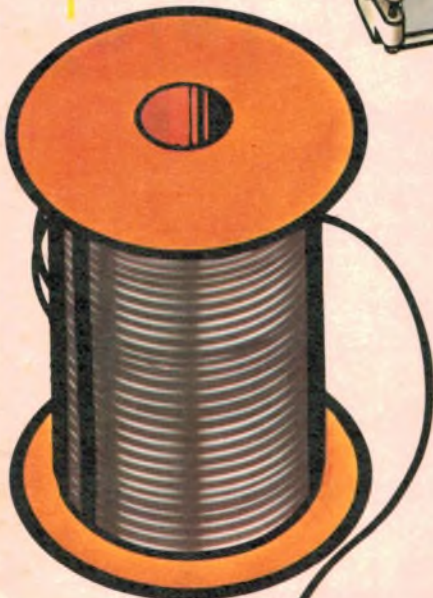

PLESSEY



**Plessey Australia Pty Limited
Components Division**
Christina Road,
Villawood NSW 2163
Telephone 720133 Telex 20384

NSW: Kitsets, Dee Why 9827500; Edge Electrix, Burwood 7474576; Electronics Supply Service, Kings Cross 3582420; Selectro Parts, Yagoona 7083639; CQ Electronics, Blacktown 6215809.

VIC: Plessey Australia Pty Ltd, North Melbourne 3290044; Zephyr Products, Chadstone 5682922.
QLD: L. E. Boughen, Milton 361277; C. A. Pearce, Brisbane 2214944; C. A. Pearce, Townsville 723620; Audiotronics, Brisbane 447566; Kitsets, Fortitude Valley 528391.
SA: K. D. Fisher, Prospect 2692544. **WA:** H. J. McQuillan, Welshpool 687111.

Plessey components.

Switches

Rotary, lever key, toggle, thumb wheel, touch activated including illuminated.

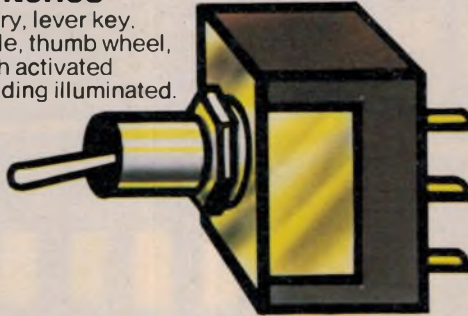

Lamps and indicators

Consisting of filamentary, neon and LED styles designed for all general illumination applications.

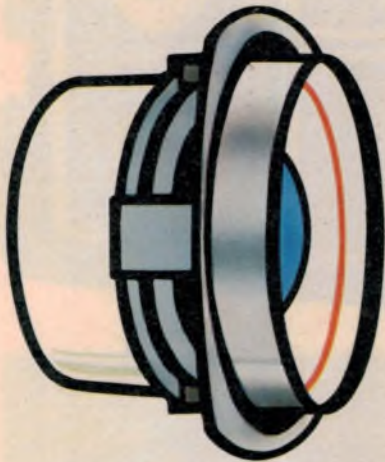

Speakers - Foster

Speakers ranging from guitar, woofers, mid range, tweeters, horns, full range and elliptical, all are available.

MPP capacitors

The Plessey 427 Metallised Polypropylene capacitor a progression in technological development, to the fluorescent lighting manufacturer. The units are small, leakproof, lightweight and satisfy the requirements of S.C.C., B.S., I.E.C. and Australian standard specifications.

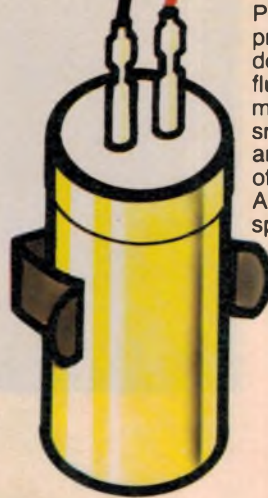

Sonalerts - Mallory

Electronic audible signals providing a startling innovation in warning devices, producing a penetrating sound by purely electronic means. Circuitry is all solid state for maximum efficiency, lowest current requirements, and highest reliability.

Optoelectronic devices

Including LDR's, LED's photodiodes, phototransistors, photocouplers and 7 segment, alphanumeric and cold cathode displays.

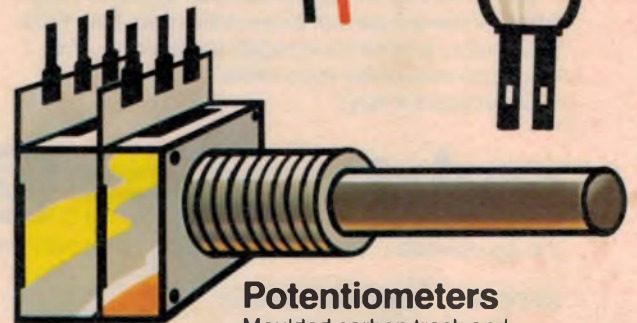

Potentiometers

Moulded carbon track and wire-wound of both commercial and professional standard.



We've just made the impossible...

a professional 3½ digit DMM Kit for less than \$60.



The Sabtronics Model 2000 is an impossible \$59.95! And that price still includes phenomenal accuracy, range and professional features.

This all-new bench/portable multimeter, reading to ± 1999, has a basic accuracy of 0.1% ± 1 digit, and has five functions giving 28 ranges, 100% overrange and overload protection. So you know it's no toy!

Besides, what toys are as automatic as the 2000? With automatic overrange indication, automatic polarity, even automatic zeroing!

Yet the 2000 is easy to assemble. We send you all the parts you need, even the high-impact case. We also send you clear, step-by-step assembly instructions.

So you end up with a professional quality 3½ digit DMM for the unheard-of price of less than \$60. From Sabtronics, specialists in digital technology. And manufacturers of the impossible.

Order yours today!



Made in U.S.A.

sabtronics

INTERNATIONAL LTD.

P.O. Box 64683 Dallas, Texas 75206 (214) 369-7310

SPECIFICATIONS: (condensed)

DC volts in 5 ranges: 100µV to 1000V.
 AC volts in 5 ranges: 100µV to 1000V.
 DC current in 6 ranges: 10nA to 2A.
 AC current in 6 ranges: 10nA to 2A.
 Resistance in 6 ranges: 1Ω to 20MΩ
 Input Impedance: 10MΩ
 Display: 9mm (.36") LED
 Power requirements: 4.5 VDC to 6.5 VDC
 (4 "C" cells - not included).
 Size: 8"W x 6.5"D x 3.0"H.
 (203W x 165D x 76H mm).

ORDERING INFORMATION

The prices as listed are in Australian dollars and do not include any tax or duty which may be levied upon receipt of the goods. Please send remittance in the form of a Bank Draft for an equivalent amount in U.S. dollars. If an International Postal Money Order is used, include original receipt with order to insure prompt shipment.

TO: Sabtronics International, Ltd.
P.O. Box 64683, Dallas, TX 75206, U.S.A.

Please send via insured airmail:—

_____ (qty) Model 2000 DMM kit(s)

@ A\$59.95 each _____ subtotal.

Insurance, postage and handling:

A\$9.00 per unit _____ subtotal

Amount enclosed A\$ _____ *TOTAL

Please print or typewrite

Name _____

Address _____

City _____

*I have enclosed the U.S. dollar equivalent of the A\$ total.

Trafficator Repeater Unit

power transistors can be fastened to the side of the box. They must be insulated from the box, using mica washers, but should be thermally bonded to the case using silicone heatsink compound. It might also be a good idea to use nylon bolts and nuts to bolt them to the case, to make insulation more reliable.

The PCB must be mounted close to the case, to allow clearance for the trailer socket. To prevent accidental short circuits, place a piece of cardboard or similar insulating material underneath the board.

The circuit as drawn is intended for use with negative earth cars. It can be adapted for positive earth cars simply by using opposite polarity transistors. Replace the TIP2955 with a TIP3055, and

the BC337 with a BC327. The EM401s and the zener diode will have to be fitted in the reverse polarity to that shown in the PCB overlay diagram.

When mounting the 5W and 1W resistors, set them up a little from the board, to allow air circulation for cooling. This will also prevent the PCB from being damaged. We recommend that PCB pins be used to make the connections to the PCB, as these make construction easier.

Wiring details for the Utilux connector are normally supplied with it, and to ensure uniformity they should be followed exactly. The centre pin is the trailer earth return, and it should be reliably connected to the diecast box, which in turn should be earthed solidly to the car chassis. This can normally be

accomplished by the mounting screws.

The unit when completed is best tested by actually trying it with a trailer. If a trailer is not available, it can be tested by wiring up an electrical equivalent of a trailer. The tail and brake light circuits can be checked out with a multimeter, while to test the indicator circuits, it will be necessary to use two 12V 21W globes.

Connect the bulbs between the pass transistor collectors and the car chassis, and check that they operate as and when required. If the unit fails to operate correctly, check first for faulty joints, and then for incorrectly oriented transistors. The lead configurations we have shown may not be correct for transistors other than those specified.

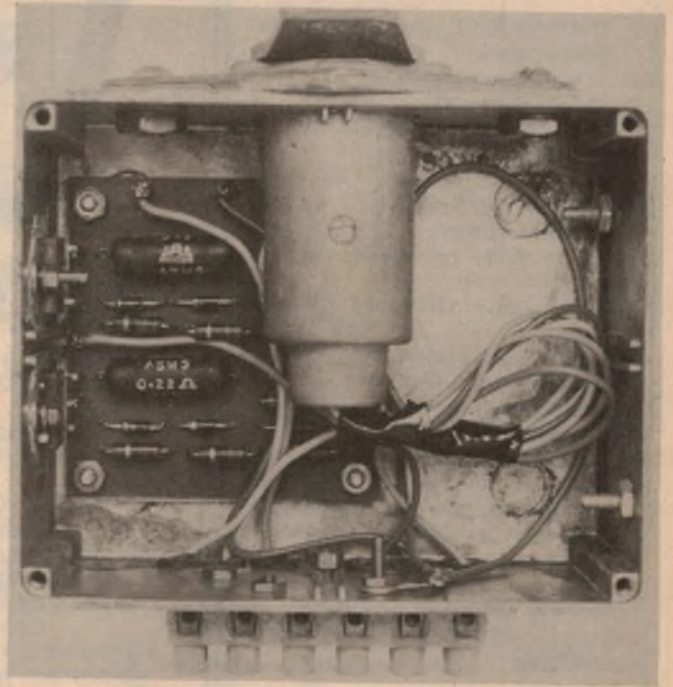
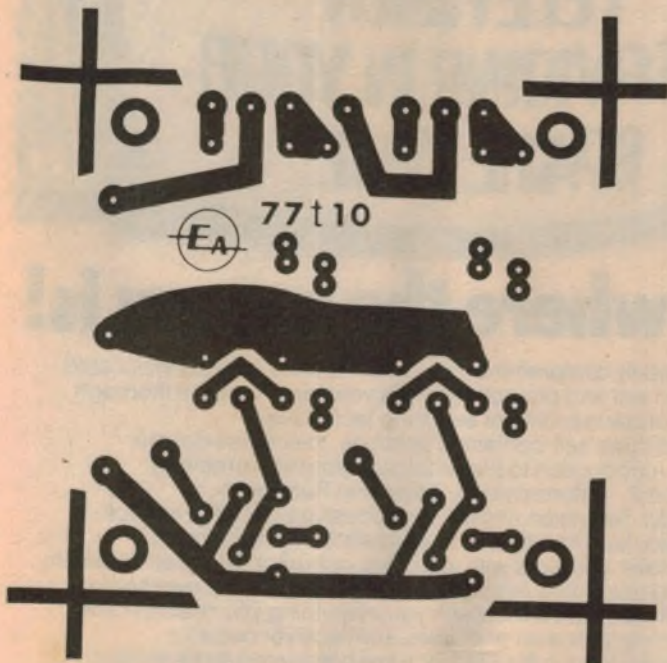

ABOVE LEFT: This full size duplicate of the PCB pattern can be traced if desired.

LEFT: Use this diagram as a guide to the placement of components.

ABOVE & BELOW: Use these photographs to aid in the assembly of the unit.

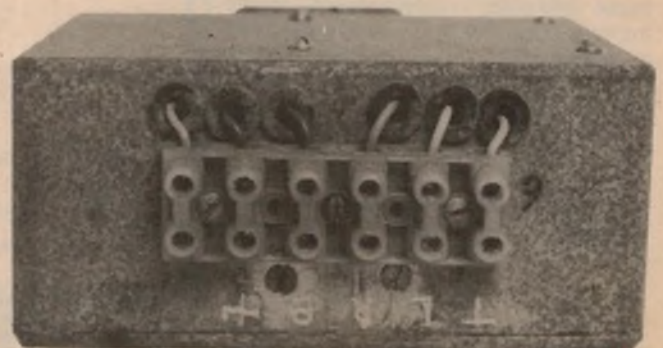
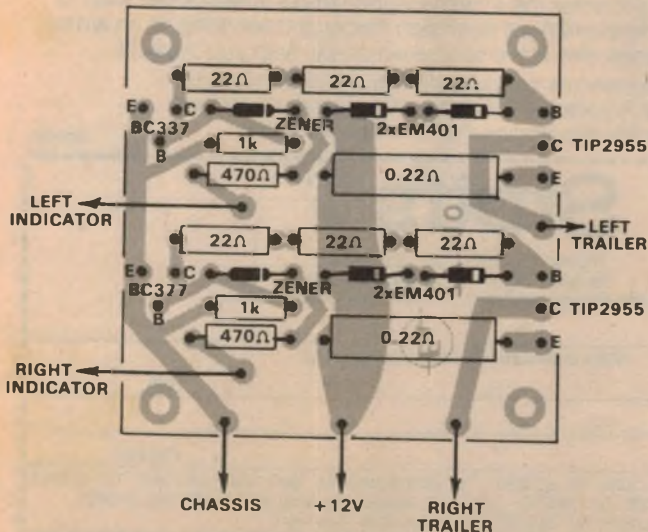

board, although the two power transistors must also be bolted to a suitable heatsink.

We mounted the PCB in a standard diecast box, with the commonly used Utilux trailer connector fitted to the side of the box. A small terminal block is mounted on the outside of the box, as a termination point for the wiring to the car circuits. A number of small grommets are used to lead the wires from the terminal block into the box. The box itself forms the heatsink for the power transistors.

The box is best mounted upside down at some convenient point next to the towbar, with the connector for the trailer socket facing the rear.

Five wires are required to the unit, two

PARTS LIST

- 2 TIP2955 PNP power transistor (plastic pack)
 - 2 BC337 NPN transistors
 - 4 EM401 silicon diodes
 - 2 5.6V 400mW zener diodes
 - 2 0.22 ohm 5W resistors
 - 6 22 ohm 1W resistors
 - 2 470 ohm 1/4W resistors
 - 2 1k 1/4W resistors
 - 1 Utilux trailer connector, cat. No. H1115
 - 1 die cast box, 114 x 89 x 51mm or similar
 - 1 printed circuit board, coded 77t10, measuring 66 x 66mm
 - 5 small grommets
 - 1 5-way terminal block
- Solder, hook wire, machine screws and nuts, mica washers, heatsink compound, PCB pins, solder lugs.
- NOTE: Resistor wattage ratings and capacitor voltage ratings are those used for our prototype. Components with high ratings may generally be used provided they are physically compatible.

for the indicators, one for the tail light, one for the brake light, and the positive supply line. The leads from the indicators connect to the PCB, while the tail and brake light leads connect directly to the trailer socket. The +12V supply lead can be obtained from the boot light circuit, thus avoiding the need to run a cable from the front of the car.

A fuse should be present in this lead, so one must be fitted if the boot light circuit is not already fitted with one. There is no need to switch the supply line with the ignition switch, as when the ignition is off, the current consumption is negligible.

Construction of the unit is very straightforward. The PCB mounts on the bottom of the case, orientated so that the

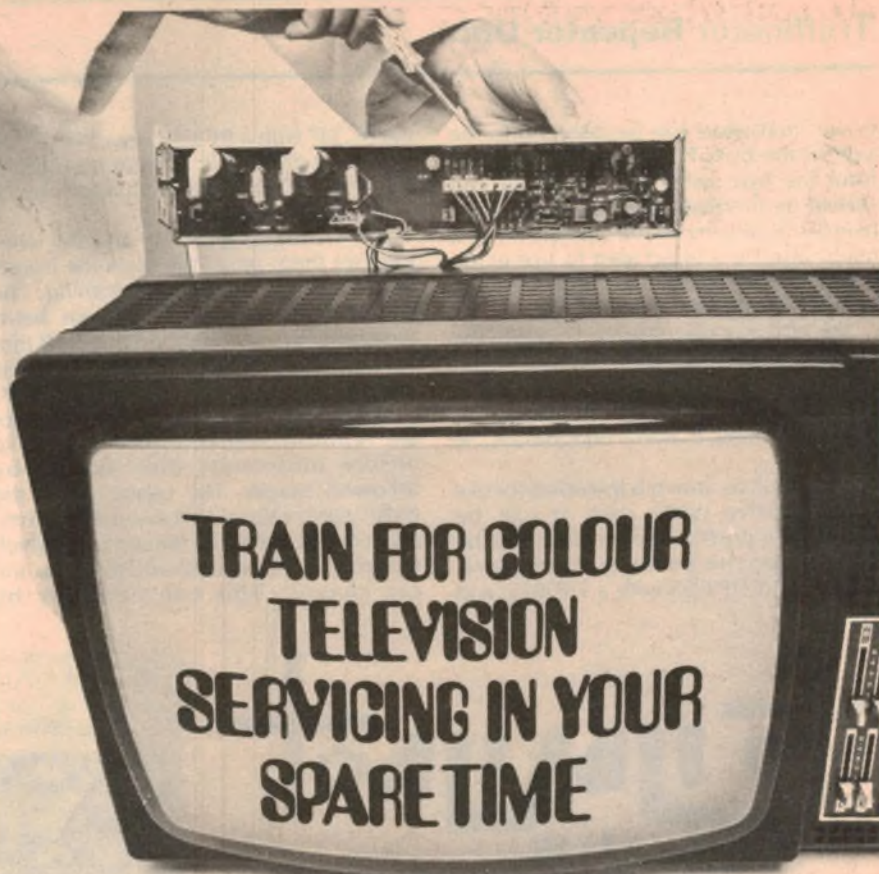

-that's where the money is!

Stott's course is totally comprehensive — and includes both sophisticated electronic equipment and project materials you need to gain a thorough understanding of servicing techniques.

Divided into three self-contained sections, the course covers:

Part 1 — Introduction to Electronics (theory and practice)

Part 2 — Monochrome Television Receivers

Part 3 — Colour Television, including processing circuitry, service techniques, fault tracing and trouble shooting techniques.

Like all Stott's courses, you work with your own instructor who is an expert in this exciting and rewarding field, at your own pace, in your own home.

If you are a beginner, Stott's will teach you everything you need to know concerning television principles and receiver circuitry.

If you are already working in the field, or have completed some studies in electronics, you may be eligible to enter the course at an advanced stage. Whether your aim is to enter the TV service industry or whether you wish to gain a thorough understanding of television theory and servicing as an aid to sales experience, this is the course which will help you make it!

Other electronics courses offered by Stott's include:
Radio for Amateurs — Amateur Operator's Certificate
For full information mail this coupon today:

STC941

EA 9 77

Stotts



TECHNICAL CORRESPONDENCE COLLEGE

The name to trust in correspondence education

Please send me, without obligation, full details of the following courses:

(please PRINT)

Stott's undertake that no sales counsellor will call.

Mr., Mrs., Miss

Age

Address

Postcode

159 Flinders Lane, Melbourne, 3000. Tel: 63 5583
383 George Street, Sydney, 2000. Tel: 29 2445
290 Adelaide Street, Brisbane, 4000. Tel: 31 1627

66 King William St., Kent Town, S.A., 5067. Tel: 42 5798
89 St. George's Terrace, Perth, 6000. Tel: 22 5481
P.O. Box 3396, Singapore 1

A Trafficator Repeater

In this article we present the design and constructional details of a solid state relay unit, intended to drive the indicator lights of trailers and caravans without upsetting the flashrate of the car. It is short circuit proof, and requires a minimum of wiring to be added to the car.

by DAVID EDWARDS

The incentive for this project arose out of the author's experiences with an earlier electromechanical (relay) unit. This unit had the virtues of reliability and simplicity, and gave good service for about two years on a Mini-Moke.

The relays were mounted in a diecast box, along with the standard trailer connector. The relay coils were connected in parallel with the car's indicator lights, with the normally open relay contacts used to switch the trailer indicators. Power for these lights was obtained directly from the battery (via the accessories fuse), and required a single wire to be run from the front to the rear of the car.

The unit was recently transferred to a less "spartan" car, and I was quite surprised to find that it would not operate when the car engine was running. A quick investigation showed the cause of the trouble, and started me on

the path leading to this article.

Many modern cars are fitted with warm-up resistors for the trafficator lights, so that they are not switched completely off between flashes. This has a twofold effect: it increases the life of the lamps, by reducing the inrush current, and it prolongs the life of the trafficator unit, by reducing the maximum current which has to be switched.

This means that the voltage across the lamps does not fall completely to zero between flashes, as it did on my previous car. The relays used had a rather low dropout voltage, and with the new car they were remaining energised all the time when the indicators were in use.

Rather than cure this by increasing the dropout voltage, I elected to design a transistorised unit instead. The final circuit is as shown in the diagram. A PNP power transistor is used to switch the lamps on and off, and is controlled by

a smaller NPN transistor. The base of this transistor is driven by a resistor/zener diode network connected to the car indicator circuit.

This network ensures that the lamps will remain off for all input voltages less than 6V, and will come on for voltages exceeding 6V. The actual switch action occurs over a very small voltage range, giving a very definite transition between the on and off states.

The power transistor is connected as a constant current generator. Two series diodes are used as a voltage reference, and the transistor action tries to keep a constant voltage across the 0.22 ohm current sensing resistor. The value of this resistor has been chosen to provide a collector current of 3A.

The normal indicator bulb is a 12V 21W unit, and draws a current of about 2A. Thus it draws insufficient current from the pass transistor, which therefore remains saturated. The total voltage drop across the transistor and current sensing resistor is then about 1V, so that the lamp brilliance is not reduced significantly.

Power dissipation in the pass transistor is thus negligible under normal conditions. If the indicator lamp is short circuited, the current rises, but to the 3A level. The transistor starts to dissipate a significant amount of power, but the device we have specified has a 90 watt rating, which means that with an adequate heatsink, it should be able to withstand a short circuit indefinitely.

A second advantage of the circuit is that any inrush current to the lamp is also limited to 3A. This should act to prolong the life of the bulb.

Actually two of the circuits shown are required, one for each indicator circuit. We have designed a small printed circuit board, coded 77t10, and measuring 66 x 66mm, which has provision for the two circuits. All components mount on the

This is the circuit diagram of the basic relay. Two of these circuits are required, one for each indicator circuit.

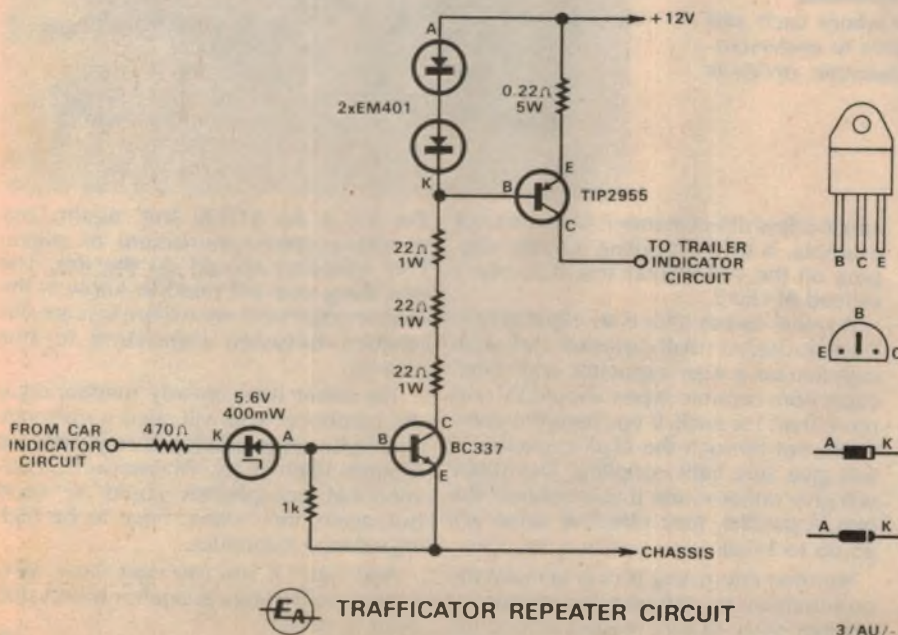
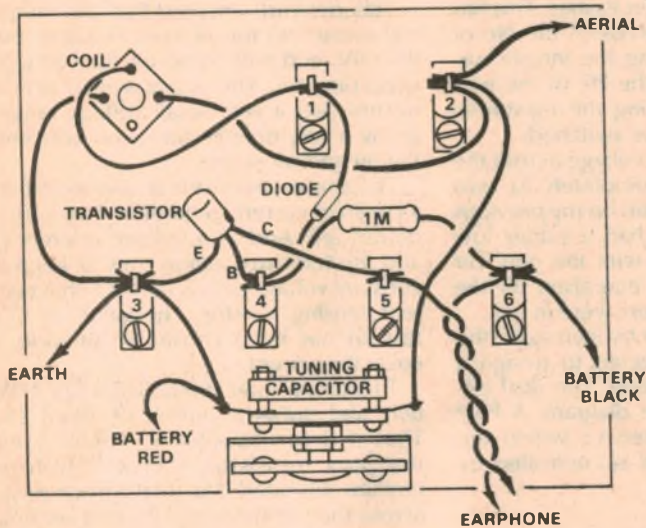

diagram and held securely in place by means of the self-tapping screws, also provided.

The variable capacitor should be bolted to the small aluminium angle bracket, which can then also be screwed in position. Finally, the dial can be slipped on to the shaft and held firm by the decorative centre screw supplied for the purpose.

If you mount the tuning capacitor exactly as shown in the Davred diagram and in our own version of it, the dial scale will have to be read side-on. To make it read correctly at the top, simply mount the capacitor with the lugs pointing to the right instead of upwards, as in our photograph. The leads attached to the capacitor are long enough to make this possible, but be careful that none of the metal work of the capacitor or its mounting bracket touch any of the clips or bare wire leads.

The tuning coil simply pushes into a hole drilled in the wooden baseboard, with the connecting lugs and wires orientated as shown.



The wiring diagram above will show you where each and every connection is made but when it comes to understanding how the radio really works, the schematic circuit is easier to follow.

This done, the various components and leads can be arranged and pushed under the clips as per the diagram, making sure that there is a firm metal-metal contact in each case. If the leads are loose in any of the clips, remove them, spring the clip open and try again.

The connections are the same as suggested in the Davred kit but we pride ourselves that our printed diagram will be easier to follow than the original duplicated plan.

Battery powered receivers normally have an off-on switch to conserve the battery when the receiver is not being used. No such provision is made in this kit and the battery will need to be disconnected physically. You may find, however, that it is adequate just to swivel the connector on one lug, allowing the other lugs to touch when you want to listen.

Current drain from the battery, by the way, is very low—typically less than 1 milliamp.

When you come to use the receiver, you will find that its sensitivity and selectivity are quite limited: it will be only sensitive enough to pick up the stronger signals in a typical suburban location, and it may not be selective enough to separate them all cleanly one from the other.

In fact, you will find it necessary to experiment with the aerial to get the best results in your area. If you connect an aerial wire directly to the tuned circuit, as in the circuit and pictorial diagram, it would have to be quite short, say from 1 to 3 metres in length, typically suspended from a picture rail and clear of other metal objects. A longer aerial would tend to give louder signals but at the expense of selectivity, although it may be a proposition further out from the stations.

If you do want to experiment with a longer aerial in an effort to optimise results, it is best coupled to the tuned cir-

wires act as a capacitor and have much the same effect as an actual physical component.

As mentioned earlier, the set can work without an earth wire, but an earth becomes progressively more important as you get further away from the stations. It's just a matter of trying it to see.

One final matter: what if you want to build the set from oddment components not in a kit?

Well, the coil can be any transistor type aerial or RF coil with a tapping for the transistor base. The appearance and connections may be quite different from one illustrated but it should work.

A wide choice of tuning capacitors is also open, ranging from a miniature type like the one in the kit to the very large varieties common in the early days of radio. The important thing is to get one with a maximum value of capacitance not less than about 350pF.

The 1-megohm resistor is a standard component, while any serviceable germanium small-signal diode will serve as the detector. The amplifier transistor in

This is how your completed receiver will look, requiring only the connection of an aerial for it to operate. Note that the tuning capacitor has been mounted with the lugs to the right so that the dial calibrations can be read correctly.

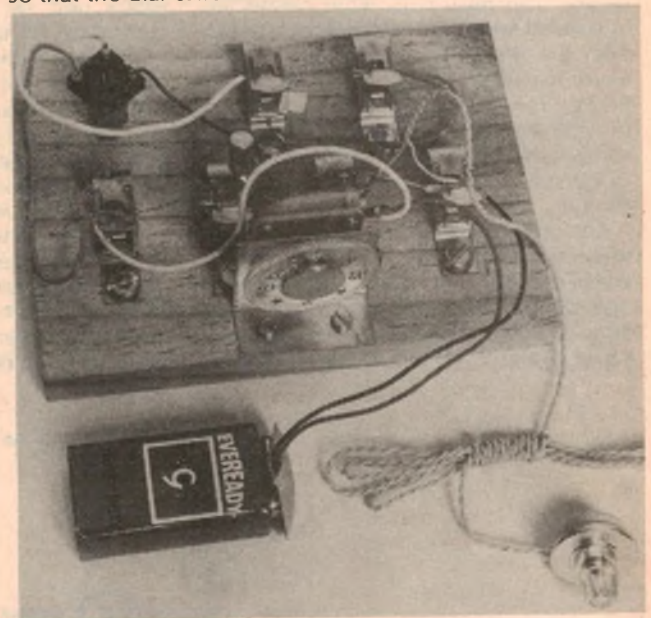

cuit in a less direct manner. One idea, for example, is to try coupling it to the tapping on the coil, connecting it to clip 1 instead of clip 2.

A rather better idea is to clip it to pin 2 but through a small capacitor. Ask your supplier for a 47pF capacitor and 100pF capacitor—ceramic types shouldn't cost more than 15c each. If you feed the aerial to the set through the 47pF capacitor, it will give very light coupling. The 100pF will give rather more. If you connect the two in parallel, their effective value will go up to 147pF.

Another interesting trick is to make the connection to the set by means of another piece of wire twisted around the aerial lead for a few inches. The twisted

the kit is an AC126 but, again, any general-purpose germanium or silicon PNP transistor should do the job. The one thing you will need to know is the lead arrangement since there is some difference between transistors in this respect.

The other item already mentioned is the earphone: you will need a magnetic type with an impedance or resistance up around 1000 ohms. Alternatively, conventional headphones could be used but, again, they would have to be high impedance magnetics.

And clips? If you can't get those, why not use solder lugs as anchor points and learn to solder?

Have fun!

DAVRED KIT: "For boys aged 8 to 88!"

AN ELEMENTARY 1-TRANSISTOR RADIO

by WALTER NEVILLE

Do-it-yourself radio receivers don't come much simpler than the little 1-transistor set pictured here and built around a kit sold by David J. Reid (N.Z.) Ltd for the princely sum of \$5.95. For the sake of beginners, we explain how it works and provide diagrams which are considerably more detailed than those supplied with the kit itself.

A couple of points should be made, right at the outset, about this or any other similar beginner's kit:

Firstly, they are intended primarily as an educational exercise, to help get you started in electronics. They should not be regarded as a way to equip yourself with a cheap personal radio. If that were the objective, you could buy a far more efficient miniature 6-transistor superhet, for about the same outlay; but you wouldn't learn much from it!

Secondly, this particular kit uses clip connections and does not call for the use of a soldering iron. When you have gained from it the knowledge and experience that it can offer, the parts can be reclaimed and become the nucleus of a spare parts box, beloved of all electronics enthusiasts.

Let's talk first about the circuit diagram on this page, which is intended to show how the various components interconnect. If you haven't, learnt to follow schematic circuits, now is a good time to start.

Circuit diagrams do not seek to represent components in a pictorial way, nor do they have them arranged in the same physical layout as in the piece of equipment involved. Instead, they show components in a fairly standard and stylised form, but one which is often suggestive of their electrical function. Thus the symbol for a coil looks rather like multiple turns of wire; the symbol for a capacitor looks like a couple of adjacent plates, while that for a resistor suggests something other than a simple path for the flow of current.

Schematic circuit diagrams, as a general rule, are laid out in a way which most easily allows a reader to follow the signal path and to identify various circuit functions. For this kind of analysis and understanding, a schematic circuit is far easier to follow than a pictorial diagram which may be provided as an aid to construction.

Here is the schematic circuit diagram. How to understand it is explained in the text. Note also what is said about the aerial and earth connections.

Let's have a look at it then:

The desired stations are selected (or tuned in) by means of variable tuning capacitor, connected across a coil. With the plates of the capacitor out of mesh, the capacitor and coil tune to about 1600kHz (16 on the dial); with the plates fully meshed, the capacitor and coil tune to about 530kHz (5.3 on the dial). Most of the broadcasting stations you will want to hear transmit on frequencies between these limits.

The aerial is shown connected to one end of the tuned circuit; we shall say more about this later. The other end can connect to earth, usually to a water tap or waterpipe, or to a metal pipe driven into moist ground. In fact, the receiver will work without an earth connection.

A signal picked up by the aerial and selected by the tuned circuit is fed from a tapping on the coil to one connection of a germanium diode. This diode acts as a "detector", picking out the audio or sound signal which is impressed on the incoming station carrier wave.

This audio signal is fed from the other end of the detector diode to the "base" electrode of general purpose germanium transistor, which is intended to act as an amplifier of the signals, enlarging them before they are applied to the single earphone.

For the transistor to do its job, it has to be supplied with voltage and current from a battery—hence the 9V battery specified in the circuit diagram.

Because the transistor involved is a general purpose germanium "PNP" type, the transistor collector is connected via the headphone to the negative side of the

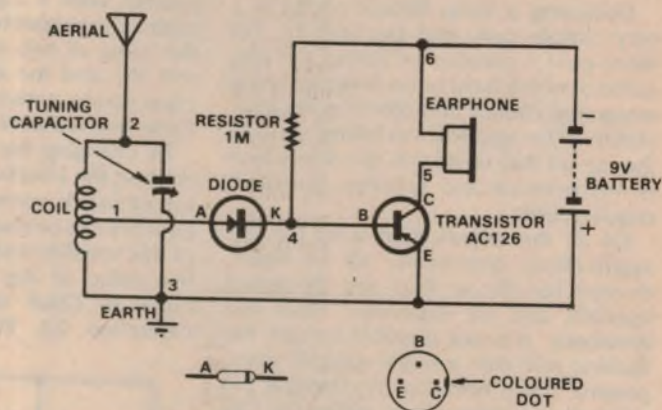

battery. Also, because the collector current has to flow through the headphone, it (the headphone) must be a high impedance magnetic type. A crystal headphone will not work directly in this simple circuit because it would not provide a DC path for the collector current.

The transistor "emitter" connects to the positive side of the battery and also to the "earth" side of the tuning capacitor.

A point to note is that, if a transistor is merely connected across a battery in this way, little or no collector current will flow and the transistor consequently will not be able to amplify effectively. To correct this situation, a selected value of resistor, as shown, causes a small amount of current to flow from the battery to the base and this promotes a flow of current in the collector circuit. In transistor jargon, the resistor provides a "forward bias" for the base and "turns on" the transistor.

Signal coming from the detector is superimposed on the base bias, causing it to fluctuate at an audio rate. This causes the collector current to fluctuate in sympathy and agitates the tiny diaphragm in the earphone. Because the fluctuation in collector current is normally greater than the fluctuation in base current, the transistor is said to "amplify" the incoming signal, making it louder than it would be if the earphone were connected simply in the detector circuit.

In the original kit, it is envisaged that the little radio will be built on the piece of board provided, measuring 127mm x 90mm x 12mm. Six clips are arranged on the board, as shown in the pictorial

Novel lamp flasher

Here is a simple incandescent lamp or LED flasher circuit using discrete components. Its frequency can be varied over a range of more than 12 to 1 using a single potentiometer. The author also describes a higher power version capable of driving a large number of lamps.

by VIJAY PRADHAN

Designing a lamp flasher circuit is a very simple task and because of this there exist a number of flasher circuits, some of which have been designed using integrated circuits and others using transistors. The application being simple, the circuit that is ideal is the one which is inexpensive and satisfies the main requirements.

Of all the circuits that exist for this application, practically all of them, except for those that are designed specially and are expensive, have one drawback. It is not possible to vary the flashing rate with a single variable component. This is because, by changing the value of one component, either the ON time or the OFF time of the lamp changes. Therefore to change the flashing rate, keeping ON to OFF ratio constant, such circuits require changing of two components simultaneously.

The circuit described here was developed for use in a solid state fault annunciator system where it was necessary to provide a facility of changing the flashing frequency simply by varying a single component. The circuit is inexpensive, self starting and could be produced in quantity on a production line. The flashing frequency can be varied continuously from one flash every 2.5 seconds to five flashes per second, which is normally the maximum flashing rate for an incandescent lamp, by varying a single resistance potentiometer.

Basically the oscillator is a simple emitter-coupled astable multivibrator, modified as shown in Fig. 1. It differs from a normal emitter-coupled astable multivibrator in two ways. The resistor in the collector of transistor Q2 is eliminated and in its place is the emitter resistance of a transistor, Q3, as reflected in the base circuit. This also gives an advantage that now full current demanded by the collector of transistor Q2 is supplied by the base of transistor Q3. The main reason for adding transistor Q3 is to convert the collector output of transistor Q2 which is switching between +10V and +12V to the output required by a lamp which is from 0V to +12V.

Another deviation of this astable from the standard astable is in the capacitor network connected between the two emitters of transistors Q1 and Q2. One capacitor is replaced by two capacitors in series, with a variable resistor in

parallel with a capacitor C1 of lower value. The output frequency depends on the value of two emitter resistances R4 and R5; and the effective value of the capacitance network connected across these two resistors.

By changing the value of the variable resistor, the effective value of the capacitor network connected between two emitters can be changed. When the value of this variable resistor is zero, the effective value of the capacitor network is equal to 125uF which is the value of capacitor C2. When the resistor is

and gives equal ON to OFF ratio of lamp over the entire range indicated above. To reduce cost, cheaper transistors BC107 and BC177 could be used in place of 2N2222 and 2N2907 respectively.

Recently there was another application where 80 lamps had to be driven with this

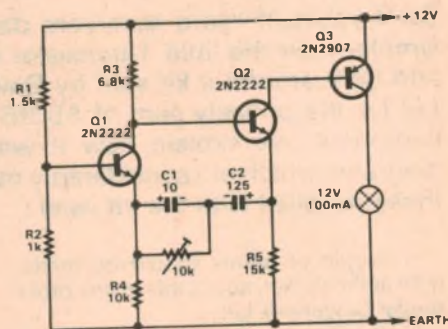

FIG. 1

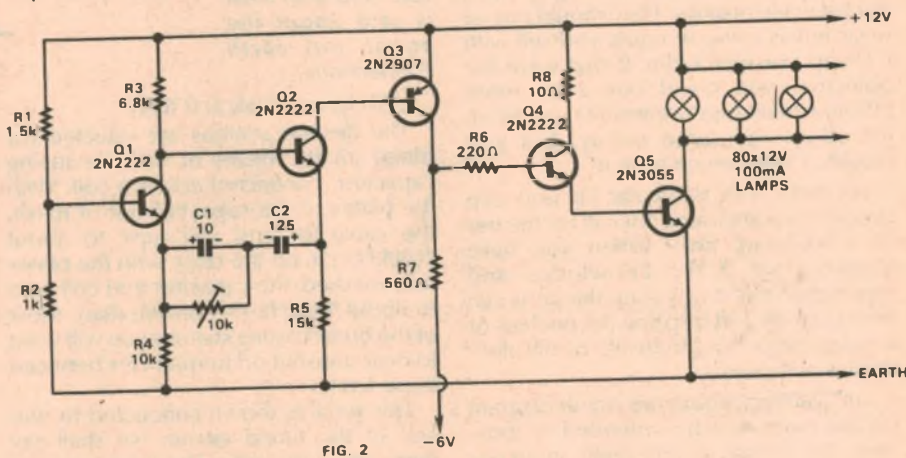

FIG. 2

increased slowly, the reactance of the capacitor C1 starts coming in series with capacitor C2 with the effect that the capacitance of the network now decreases. The range over which the frequency can be varied is approximately given by the ratio of the two capacitors, C2/C1. In this case the ratio of capacitors is

$$\frac{125\mu\text{F}}{10\mu\text{F}} = 12.5$$

which is also the actual range obtained of the flasher given by

$$\frac{5 \text{ flasher/sec.}}{1 \text{ flash/2.5 sec.}} = 12.5$$

The lamp used was +12V, 100 mA. If this lamp is to be replaced by a LED then the appropriate resistor (approx. 620 ohms) should be placed in series with the LED to limit the current for the protection of LED.

The circuit was assembled and tested a number of times, and has been working continuously for the last five years without any problem. It is self-starting

astable multivibrator, for which slight modification had to be made. The new circuit shown in Fig. 2. To get higher current required, power transistor Q5 was used for which the transistor Q4 was needed as current driver. Resistor R6 was taken to negative supply to ensure proper turnoff of transistor Q5 at higher temperatures. For even higher currents, a relay could be added in place of lamps in the collector of transistor Q5, with a diode in parallel with the relay coil to suppress inductive switching spikes.

REFERENCES

1. Walston J.A. and Miller J.R., Transistor Circuit Design Texas Instruments Inc., pp423-426 McGraw Hill, 1963
2. Millman J. and Taub H. Pulse Digital and Switching Waveforms, pp 445-451, McGraw Hill, Inc., 1965
3. Clayton G.B., Emitter Coupled Emitter Timed Multivibrators, Wireless World, 634-637, January 1968.



**Here is up to
175 professional
edge connections.
Cheap.**

This is the Swann Electronics Professional Edge Connector Kit: the kit that saves you the considerable expense of having prototypes or small orders made up to your specs. Fit only the contacts you actually require! Fool proof to assemble.

The Ferranti-designed base can be used single-sided for 62-way connections, or double-sided for 124-way connections.

The Standard kit comprises two bases, 175 gold-plated phosphor-bronze contacts coined for maximum spring, 6 open end brackets, 6 closed end brackets and 4 polarising keys.

The Single base kit contains 85 contacts, 2 open end brackets, 2 closed end brackets and 2 polarising keys.

Use this coupon to order now.

To: Swann Electronics, P.O. Box 350, Mt. Waverley, Vic. 3149. Ph. 544 3033. Please send me:

- () Standard Edge Connector Kits \$10 ea.
- () Single Base Edge Connector Kits \$6.60 ea.

Name

Address

..... Postcode.....



Swann Electronics Pty. Ltd.

Enquiries — Swann Electronics (Formerly McMurdo Australia) Sydney: (02) 807 1944 Adelaide: (08) 42 6664 Brisbane: (07) 262 2852

LBV 3301

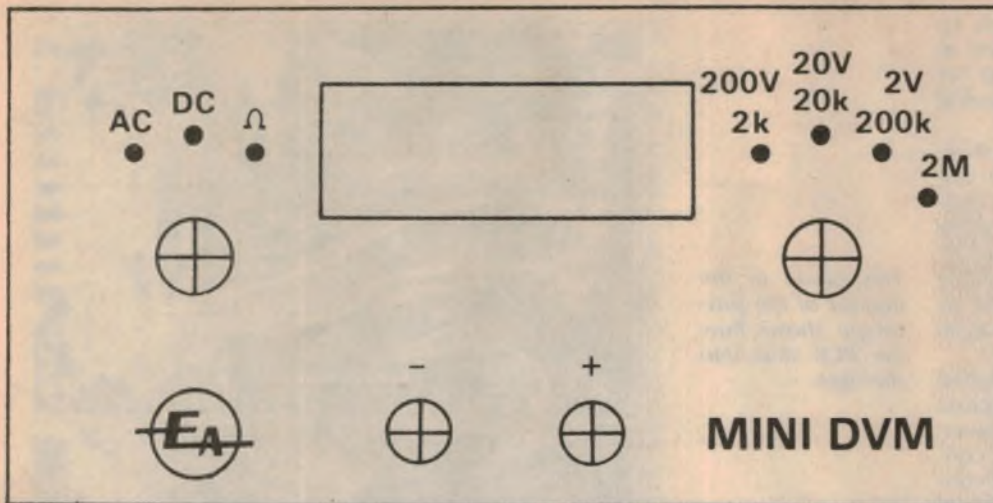

This reproduction of the front panel artwork is actual size, and may be used directly or copied as required.

This actual size copy of the PCB artwork can be used to make your own board, if you have the facilities to do so.

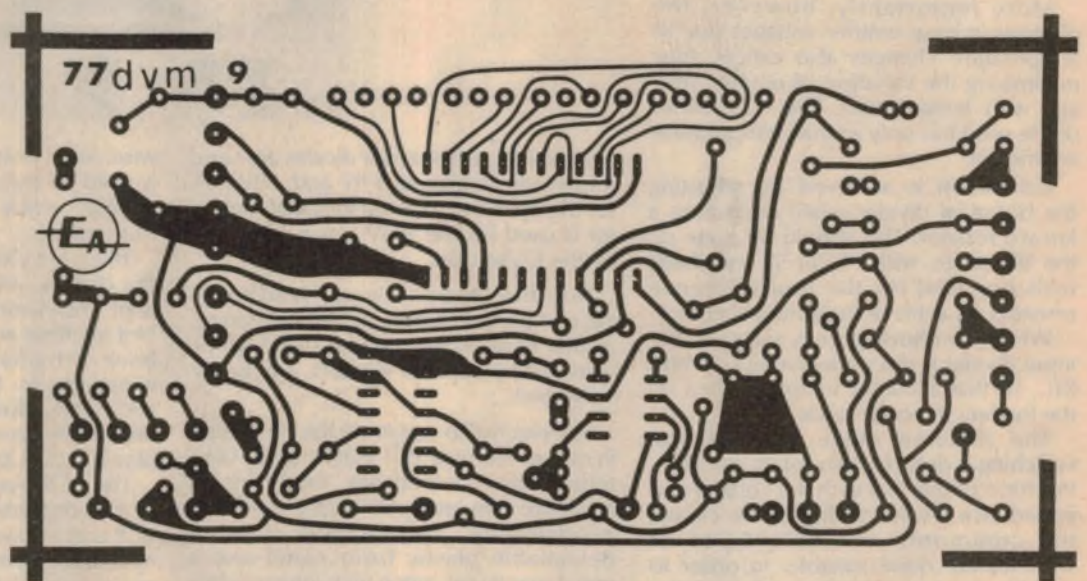

LIST OF COMPONENTS:

SEMICONDUCTORS

- 1 DM7700 (ADD 2500) DVM chip
- 1 NSB 5881 common cathode 4 digit LED display
- 1 CA3130 FET operational amplifier
- 1 741 operational amplifier (fourteen or eight pin package)
- 2 9.1V 400mW zener diodes
- 1 6.2V 400mW zener diode
- 2 3.3V 400mW zener diodes
- 1 7805 or LM340T-5 5V three terminal regulator
- 1 red LED
- 2 1N914 silicon diodes
- 2 EM401 silicon diodes
- 2 BC548 NPN transistors
- 1 BC558 PNP transistor

CAPACITORS

- 2 2500uF 25VW pigtaile electrolytics
- 1 47uF 16VW PCB mounting electrolytic
- 2 10uF tantalum electrolytics

- 1 1uF tantalum electrolytic

- 1 0.68uF polyester

- 5 0.1uF polyester

- 3 0.01uF ceramics

- 1 0.001uF ceramic

- 1 680pF ceramic

- 1 220pF ceramic

- 1 100pF ceramic

- 1 56pF polystyrene

- 1 10pF ceramic

RESISTORS (all 1/4W)

- 1 5.6M, 2 3.9M, 1 2.2M, 1 1.5M, 1 1M, 1 560k, 2 470k, 1 390k, 1 220k, 1 120k, 1 100k, 2 56k, 1 27k, 1 10k, 1 5.6k, 2 4.7k, 1 2.2k, 4 1k, 1 470 ohm, 1 270 ohm, 2 220 ohm, 1 47 ohm

TRIMPOTS (all 0.2" lead spacing)

- 1 100k, 1 22k, 1 1k

MISCELLANEOUS

- 1 PCB, coded 77dvm9, measuring 132 x 66mm

- 1 plastic case, 150mm x 180mm x 80mm

- 1 transformer, 240V to 12V @ 150mA

- 1 mains plug, cord, grommet, clamp and 2 way terminal block

- 2 7 lug tag strips, with mounting feet

- 2 terminals, 1 red, 1 black

- 1 3 position 4 pole rotary switch

- 1 4 position 3 pole rotary switch

- 2 knobs to suit

Scrap aluminium, machine screws and nuts, solder, solder lug, hookup wire, rainbow cable, insulation tape

NOTE: Resistor wattage ratings and capacitor voltage ratings are those used for our prototype. Components with high ratings may generally be used provided they are physically compatible.

was down 30%. This corresponds to -3dB. These values were measured at maximum signal amplitude (2V at the 741 output). At lower voltages, an extended response will be obtained.

Four ohms ranges are provided, 0-2k, 0-20k, 0-200k and 0-2M. These are implemented by passing a known constant current through the resistor under test. The current is generated using a 6.2V zener diode as reference. An adjustable divider across the zener is buffered by a BC548 NPN transistor connected as an emitter follower.

A BC558 PNP transistor is connected as an additional emitter follower across the 27k load resistor for the first follower, but with four switched resistors connected in its emitter circuit. In this configuration, the base-emitter voltages of the two transistors cancel.

More importantly, however, the changes in base-emitter voltages due to temperature changes also cancel, thus minimising the variation of emitter voltage with temperature. The 6.2V zener diode used has only a small temperature coefficient.

Calibration is achieved by adjusting the potential divider while measuring a known resistor. This should be done on the 20k range, with 1% (or 5% matched) resistors used for the four reference resistors, to achieve maximum accuracy.

When the ohms range is selected, the input divider is disconnected by S1A and S1C, so that accuracy is not affected by the loading it would cause.

The required range and function switching is done by two rotary switches. We have found that with the voltage and impedance levels existing in the circuit, the commonly available types of switches are quite suitable. In order to simplify the decimal point switching, the ohms ranges have been reversed with respect to the AC and DC voltage ranges.

The power supply requirements of the complete circuit are quite modest. A small 12V/150mA transformer has been used, with two half wave rectifiers. The constant current source to bias the substrate is supplied directly from the nega-

This photo of the interior of the prototype shows how the PCB slots into the case.

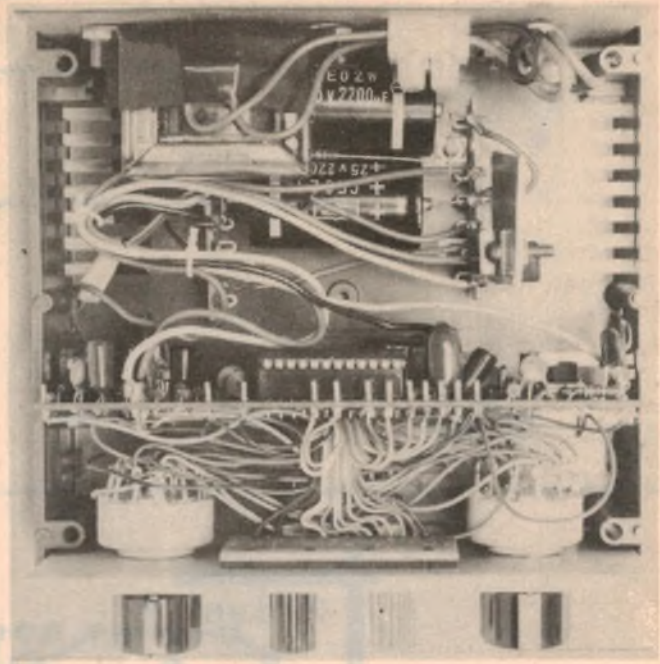

tive rectifier, while zener diodes are used to provide stabilized +9V and -9V rails for the op-amps. A three terminal regulator is used for the +5V supply required by the DVM chip.

Note that the power supply, and hence the complete instrument, is fully floating, so that earth loops will not cause problems when earthed circuits are being measured.

We elected to construct the prototype in one of the type PC1 plastic cases contributed by A & R Soanar. The PC1 is an attractive moulded plastic case featuring a "clamshell" construction. It has a detachable plastic front panel and a metal rear panel, along with internal slots to accept PCBs.

All of the circuitry apart from the power supply is contained on a single PCB, coded 77dvm9 and measuring 132 x 66mm. Connections to the two rotary switches and the input terminals, which are mounted on the front panel, are made using PCB pins and light hookup

wire. An 11-way section of rainbow cable is used to make the connections to the display, which is also mounted on the front panel.

There are sixteen connection points on the display, and we have provided sixteen corresponding points on the PCB. Not all these are required, but they have been provided to make the display wiring easier. Simply start at pin No 1, and work down through the pins in order. No connections are required to pins 2, 4, 5, 6 and 9.

The PCB overlay diagram shows most of the connections required between the PCB and the switches. Note that the connections between the two switches are not shown. Refer to the circuit diagram for details of these.

Keep the connections to the switches as short as possible, while at the same time allowing sufficient length so that the front panel and PCB can be removed from the case. Do not use shielded cable, or lace the wires into bundles, as this will increase the capacitive loading on the input divider, and upset the AC performance.

The transformer and associated mains components are mounted on the rear panel, with the power supply components supported on two short lengths of tagstrip mounted on the bottom of the case. Once again, connections to the PCB are made with hookup wire and PCB pins.

A wiring diagram has been provided to aid in the assembly of these components. As shown in the photographs, a small piece of aluminium should be fastened to the three terminal regulator, to act as a heatsink.

The display is mounted by filing a rect-

Use this overlay diagram to aid the placement of components on the PCB. PCB pins should be used for all external connections.

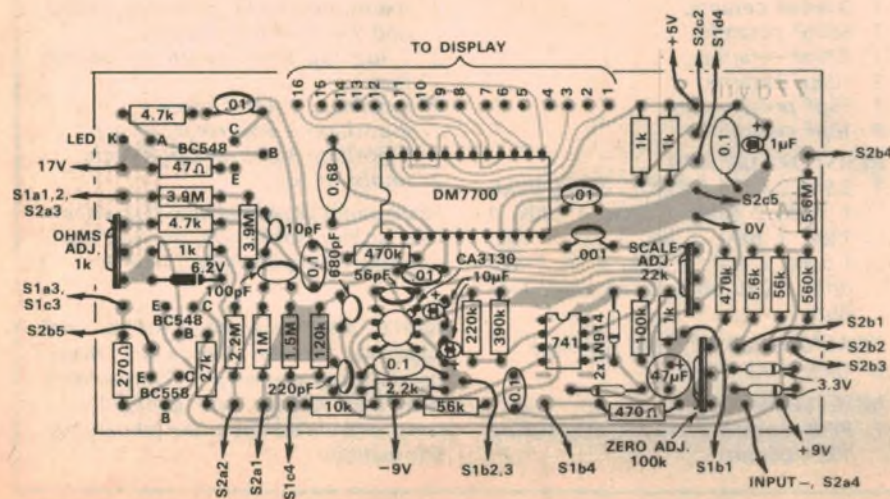

2½ digit volt-ohm meter

This new Digital Volt-Ohm Meter has ten ranges and a big, bright 2½-digit LED readout. It can measure DC and AC volts from 10mV to 199V, and resistance from 10 ohms to 1.99 megohms. It has an input impedance of better than 10 megohms in parallel with 10pF, and needs a minimum of calibration. Best of all though, it should cost you less than \$60.00!

by DAVID EDWARDS

At the heart of this new low cost digital volt-ohm meter is a single LSI chip, the DM7700, manufactured by National Semiconductor. This chip is in fact a complete digital voltmeter in its own right. Only a handful of passive components, and a common cathode LED display are required to implement a 2½-digit DC voltmeter.

The actual voltage conversion is achieved by a dual voltage-to-frequency conversion technique. Included on the chip is an internal temperature compensated voltage reference, and also segment and digit drivers for the multiplexed common cathode display.

The chip can cope with both positive and negative inputs, and has automatic overrange and underrange indications. An internal clock is provided for the conversion process, as well as a multiplexing clock for the display.

Only two power supply voltages are required, +5V and a negative substrate bias voltage. The readout is updated three times a second, and is accurate to plus or minus 1%. There are only two adjustments to be made to achieve this accuracy, a scale adjustment and a zero adjustment.

Turning now to the main circuit diagram, we can discuss the operation of the new unit in more detail. The input voltage to be measured is applied to pin 7, through the scale adjust pot. Pins 3, 4, 5 and 6 are connected as shown to the scale adjust pot, and to the 470k/0.68uF reference R/C combination.

A light emitting diode (LED) is used as a voltage reference for a BC548 NPN transistor, connected as a constant current source. This is used to supply the required substrate bias. A LED has been used as the voltage reference because it is a cheap, easily obtainable low voltage unit. The forward voltage drop of a red LED is about 1.6V, and does not vary appreciably with current.

The display is connected directly to the DVM chip. No current limit resistors are required, as the DM7700 incorporates constant current segment drivers. The

decimal point is multiplexed along with the rest of the display. Pins 9 and 10 are used to select which of the three decimal points are to be turned on, and are controlled by sections of the function and range switches.

Two back to back zener diodes and a 470 ohm resistor are used to limit the input voltage to the DM7700 to plus or minus 4V. We found this to be necessary to prevent ambiguous readings from being displayed when large input voltages were applied. The DM7700 normally gives an over or under range indication when the input voltage exceeds plus or minus 1.99V.

The input voltage to be measured by the DV0M is passed by S1A to a voltage divider chain. This has a total impedance of 11M in parallel with 9pF. The three taps on the divider give attenuations of 1, 10:1 and 100:1. The frequency response of the divider is flat up to at least 20kHz, which is above the upper frequency limit of the precision rectifier used on the AC ranges.

The input divider is formed from preferred value components, and to achieve greatest accuracy, these should all be 1%

values. Alternatively, selected 5 or 10% values could be used. The required output of the divider is selected by S2A, and buffered by a CA3130 FET input op-amp connected as a voltage follower. This has an input impedance of about 1.5×10^{12} ohms, so it does not load the divider at all.

The output from the CA3130 is passed to a 741 type op amp connected as a precision rectifier. The input resistor, formed by two preferred values in parallel, has been chosen to give an overall gain of 0.707, so that with sine wave inputs, the output represents the RMS value of the AC component of the input voltage.

The lower frequency limit is determined by the value of the input coupling capacitor. This is formed by two tantalum electrolytics, connected back to back. With the values we have chosen, the response is only down about 1% at 50Hz, and 5% at 5Hz.

The upper frequency limit is determined by the slew rate limit of the 741, and will vary from device to device. Our prototype had a response which was down 1% at 4kHz (with respect to 1kHz), and 5% at 10kHz. At 45kHz, the response

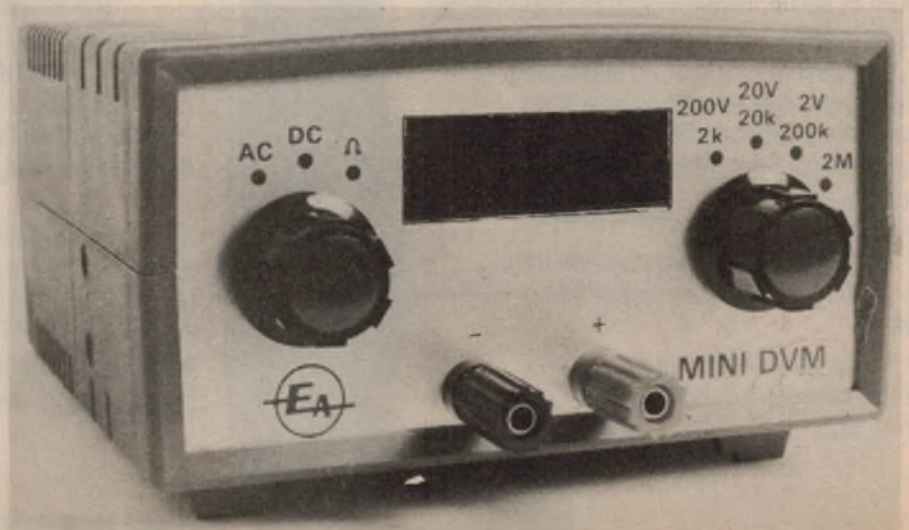

The new Scope temperature controlled iron introduces new convenience to high reliability soldering.

1. Faster temperature selection.

You can select any temperature with the control key without the delay of unscrewing a hot tip and then heating up a cold one. This also saves the cost of buying tips for various temperatures.

2. Change temperature while soldering. Then hold $\pm 2\%$.

The operator can change temperatures between 200° and 400°C whilst soldering. This convenience makes it more likely that the operator will solder at the correct temperature for any job. Selected temperature will always be within 2% accuracy.

3. No separate control box.

The temperature control selector is in the handle of the iron. This saves money and space.

4. 60 watt element.

This ensures more stable temperature control with heavy soldering jobs.

The Scope temperature controlled iron explained.

1. Tips need only be changed to alter weights or shapes. Thirteen different tips are available. See chart.

2. Earth leakage currents are kept below 6 μ A. Design checked by an independent consulting engineer.

3. 60 watt element is about 3 times the heat required. Greater temperature stability and faster recovery on heavy joints.

4. Heat is kept away from handle by using low conductivity s.s. barrel alloy, plus black aluminium heat sink. Removable hook provided.

5. Handle shaped for easy, light control. Whole iron weighs only 70 gms.

6. Temperature sensing probe extends to front of barrel. Ensures prompt response to heat drain.

7. Removable temperature setting key. Supervisor can set precise soldering conditions without changing tips. And, can then take key away to ensure conditions are not altered.

8. Neon indicator indicates when iron is heating and reduces risk of being left on.

9. Plugs direct into mains. Other voltages available: 24V, 50V.

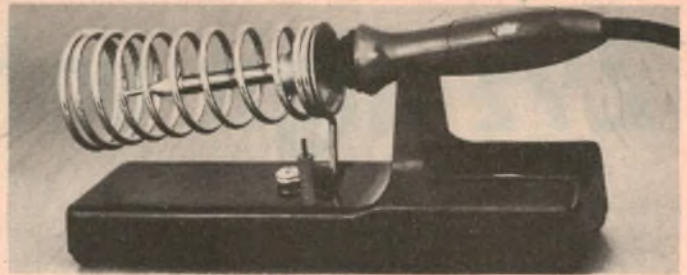

Accessories:

Safety stand. Model STS. Designed for bench top use when operator is seated. Comes with sponge pad for tip cleaning.



Desoldering tool. Model SR3A. Comes with plunger safety guard and replaceable temperature resistant Teflon tip.

Long life tips for Scope TC60 iron.

TYPE	SINGLE FLAT	WIDTH	TYPE	DOUBLE FLAT	WIDTH
LL/SF/16		1/16" = 1.6mm	LL/DF/08		1/32" = 0.8mm
LL/SF/24		3/32" = 2.4mm	LL/DF/16		1/16" = 1.6mm
*LL/SF/32		1/8" = 3.2mm	LL/DF/24		3/32" = 2.4mm
LL/SF/48		3/16" = 4.8mm	LL/DF/32		1/8" = 3.2mm
LL/SF/64		1/4" = 6.4mm	LL/DF/48		3/16" = 4.8mm
LL/CONCORDE		23mm	LL/DF/64		1/4" = 6.4mm
* THIS TIP IS FITTED AS STANDARD			LL/DF/SPECIAL		2.6mm 20mm

Other Scope products.

(A) Scope Cordless. 60W.

Designed for working where no power is available or during temporary failure. It's powered by two rechargeable Nicad cells with the capacity to solder between 100 and 200 typical electronic connections before overnight recharging.



(B) Scope 12V Hobby Iron. This versatile iron is designed to work within 6 metres of your car battery.

(C) Scope Vibroscope. This electric pencil allows for permanent writing on all metals. Valuable in an engineering store identifying metal tools, dating and naming parts, inscribing trophies.

(D) Scope Superspeed Iron. Extreme soldering versatility. 20-150 watts of manually controlled heat output. Heats in 5 seconds.

(E) Scope Mini Iron. Similar benefits of soldering versatility, speed and safety as for Superspeed but 20-75 watt controlled output.

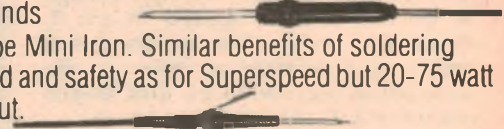

For enquiries and further information on the Scope range of products contact: Sydney, Ampec Engineering Co. 747 2731. Hobart, W. P. Martin Pty. Ltd. 34 2811. Adelaide, Protronics. 51 4713. Brisbane, K. H. Dore & Sons. 21 1933. Perth, Simon Holman & Co. Pty. Ltd. 81 4155. Melbourne, Scope Laboratories. 338 1566.

SCOPE

THE RIGHT IRON FOR THE RIGHT JOB.

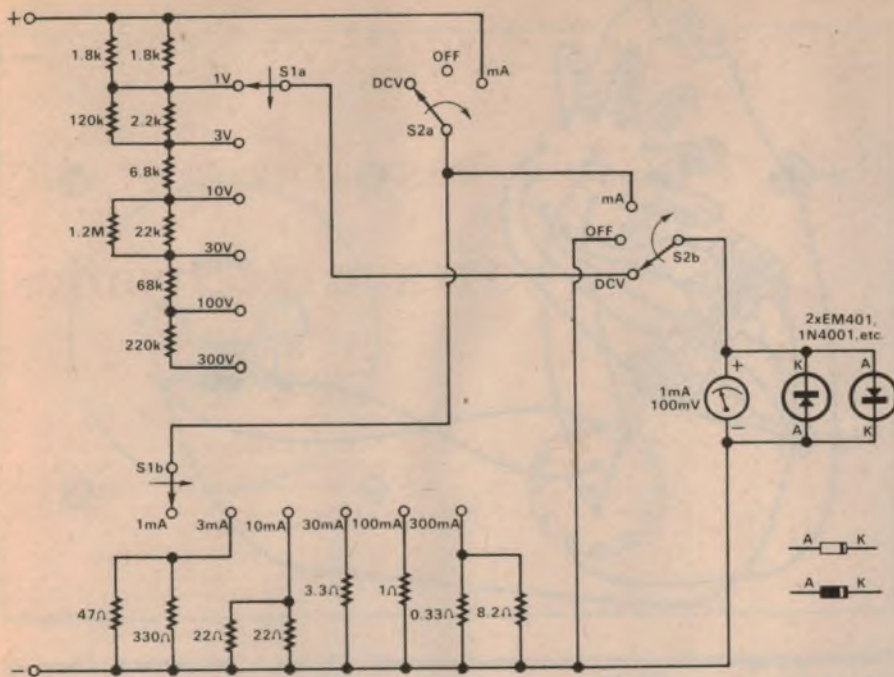

EA BEGINNER'S TEST METER

FIG 5

made meter movements can withstand repeated 10-times overloads with no effect on accuracy.

That completes the theory behind the simple instrument. Now for the practice. We decided to build the unit into a low cost compact plastic box, fitted with a blank aluminium lid. Available from most electronic parts retailers, the box we used has dimensions 158 x 96 x 50 mm.

We used a meter with frontal dimensions 65 x 60 mm and requiring a circular cutout 55 mm in diameter. Smaller meters could be used, but they will not look the part and they will be harder to read. Larger meters may require a larger box. Check this when you purchase.

Our meter was supplied with a scale having calibrations from zero to 1 milliamp. The calibrations had to be changed and another scale added. No great skill is required for this task, just a little care.

To provide the additional lettering required we purchased a 1/2-sheet of Letraset rub-on type, in 12 point Times Bold. This is available from most stationery stores, particularly those near technical colleges. At over \$2 for a 1/2-sheet, Letraset is expensive—but it enables you to do a neat job.

Most currently available panel meters are easily dis-assembled. Just carefully unclip the front cover, undo two small screws and the white panel carrying the

meter scale can be slid out. Take care not to damage the meter movement itself.

While the meter is in its dis-assembled state, its insides can be examined. Check it out. The meter has a multi-turn coil of very fine copper wire, suspended and free to rotate about its axis between the poles of a permanent magnet. The magnet is arranged so that the coil moves in a radial field, i.e., one that is constant and always at right angles to the plane of the coil.

Fitted to the coil are two spiral springs which apply a restoring torque which is proportional to the distance moved by the coil from its rest or "zero" position. The action of the springs is to bring the coil to rest in a new position with a displacement from zero which is directly proportional to the magnitude of the current flowing through the coil. Thus it is the springs which determine the linearity and accuracy of the meter.

Some meters may appear to contain either a low-value series resistor or a high-value shunt which is usually in the form of a coil of resistance wire. This is actually a trimming resistor which is used to compensate for manufacturing tolerances and adjust the movement for the desired nominal sensitivity. Do not fiddle with it.

Having finished the reconnaissance, the meter panel still awaits facial surgery. Use adhesive tape to affix the meter panel to a bench surface. Remove the "milliamps" legend and the decimal points with the aid of a typewriter eraser or a new razor blade (or trimming knife). Take care not to scratch the painted surface.

Now take a spring-bow compass and use drawing ink to make an arc underneath the existing scale. This step may not be necessary with some meters.

The additional scale is to read 3.16 at full-scale deflection. To simplify matters, we calibrate the new scale only up to 3.0, at 95% of FSD. This gives the key to the other scale calibrations. Use the existing scales to mark in the additional calibrations. Use of the calculator now gives the equivalent scale markings:

- 3.0 coincides with 9.5
- 2.5 coincides with 7.9
- 2.0 coincides with 6.3
- 1.5 coincides with 4.7
- 1.0 coincides with 3.16
- 0.5 coincides with 1.6

Now for the Letraset. Add a zero to the "1" at the end of the existing scale. Letter in the additional scale, as shown in the photograph of the final unit. Follow the Letraset instructions to the letter.

If you find that you have made a batch of the job, clean the whole mess off and start again. Take care not to damage the paint or the original scale. When finished, reassemble the meter and check that the zero adjusting screw works okay.

(Note: Because of the diversity of meters, we cannot make a special printed scale available. Would-be constructors are encouraged to "have a go". Care and patience are necessary but that's all.)

Perhaps the most difficult stage in con-

Shown below is the meter movement, disassembled, and with the sheet of rub-on lettering ready to add the new letters to the meter scale.

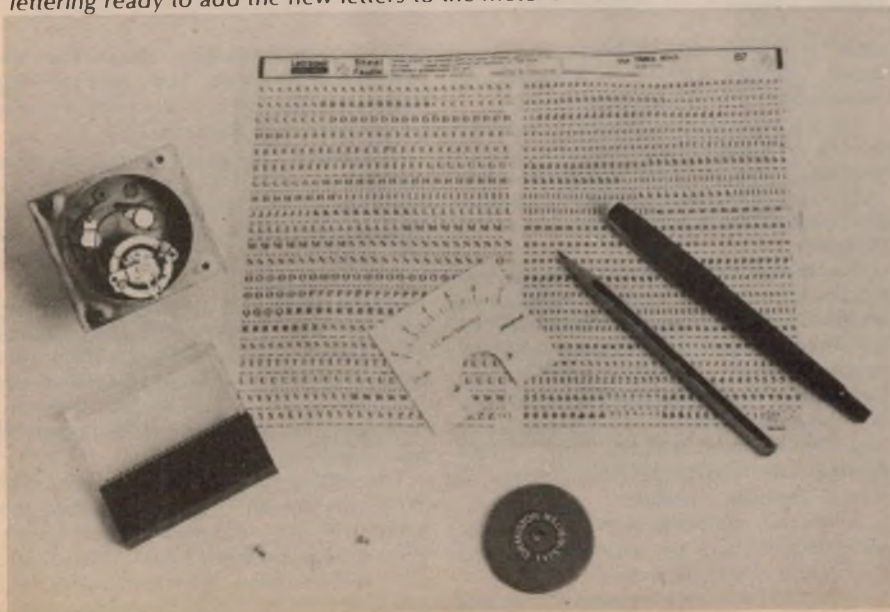

struction will be drilling and making the cutout for the meter in the light-gauge aluminium panel supplied with the plastic box. We can recommend two tools to do the job. Purchase these now and you will find them a boon for this and future projects.

The first is a tapered reamer. This is the only satisfactory way to make round holes in thin metal. Drill a pilot hole large enough to take the tip of the tool and then ream out to the required diameter, by turning it clockwise and pushing steadily.

The other tool recommended is a "nibbler". This is fine for cutting any shaped hole in thin metal up to 16-gauge aluminium or 22-gauge steel.

Both tools are available from Dick Smith Electronics, or from the larger tool retailers.

First step in drilling and cutting the panel is marking up. Decide how the meter, switches and terminals are to be positioned and then mark in the positions using a metric rule and suitable scribing tool such as a compass, trimming knife, etc. If you do not wish to scratch the panel use a fine nylon-tipped pen. Punch the hole positions and then drill pilot holes. Use the reamer and nibbler to finish the job.

Clean the panel with solvent and then remove all scratches by rubbing in one direction with steel wool. This will give a "scratch grain" finish. It is important at this stage not to touch the panel with your fingers. This will leave finger marks which are difficult to remove.

Now mark in the switch positions. This can be done with Letraset. Use lower-case letter "o" and fill in with ink to obtain uniform circular blobs. Now finish lettering the panel. Finally, still without laying a finger on the panel, spray it with clear lacquer. Do not attempt heavy coats of lacquer, otherwise it will be necessary to



Marking the panel with Letraset is simple.

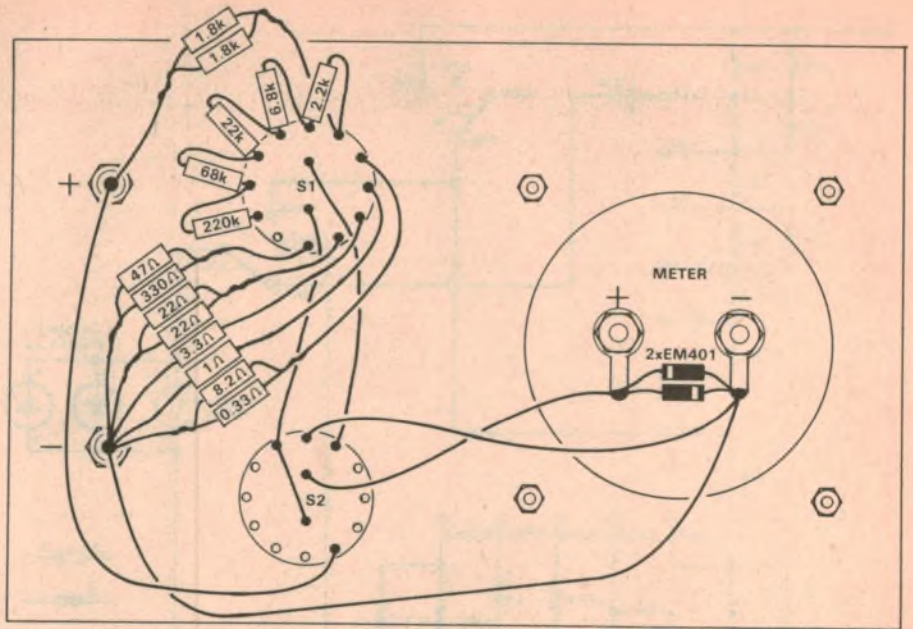

The wiring diagram above has two resistors omitted (120k and 1.2M) for clarity. Compare this with the photograph below.

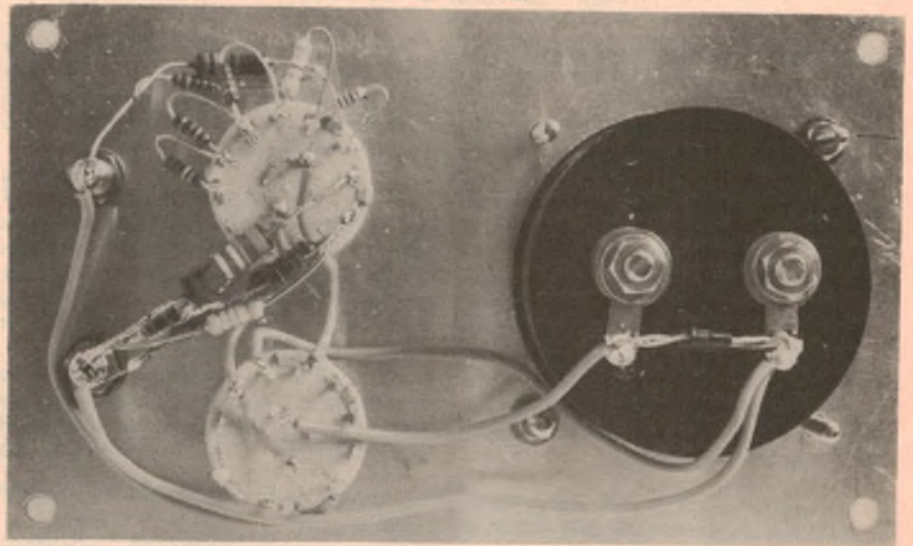

clean it all off with thinners and start again. Use two light coats, if necessary, with at least 4 hours between coats.

Let the clear lacquer dry for at least 12 hours and then final assembly can proceed. This is quite straightforward. Just follow the wiring diagram. Most of the resistors are strung across one of the switches.

A note about the switches. We used two Lorlin 2-pole, six-position switches supplied by C&K. These can be converted to provide less switch positions by a cunning adjustment. Just remove the nut and lockwasher from the threaded bush, lever out the small circlip with a screwdriver and then re-insert with its "key" in the appropriate numbered hole. Presto, a 2-pole, 3-position switch!

Take care in soldering the small components and check the wiring against the wiring and circuit diagrams.

Now you have a meter with six voltage

and six current ranges. Notice that the lowest current range, 1mA, also provides what is effectively a seventh voltage range, with 100 millivolts FSD.

The meter can be calibrated by comparison with a multimeter of known accuracy, if you have one available. For voltage measurements just connect the two meters in parallel with a suitable DC voltage source. For current measurements, connect the two meters in series, together with a suitable voltage source and current limiting resistor(s). For calibration we found we had to remove the 8.2 ohms, 120k and 1.2M resistors. Otherwise the accuracy of the prototype was surprisingly good.

The voltage ranges have a sensitivity of 1000 ohms/volt. This means that the loading of the voltmeter is equal to the FSD voltage multiplied by 1000 ohms. For example, when switched to the 10V range, the resistance of the instrument is

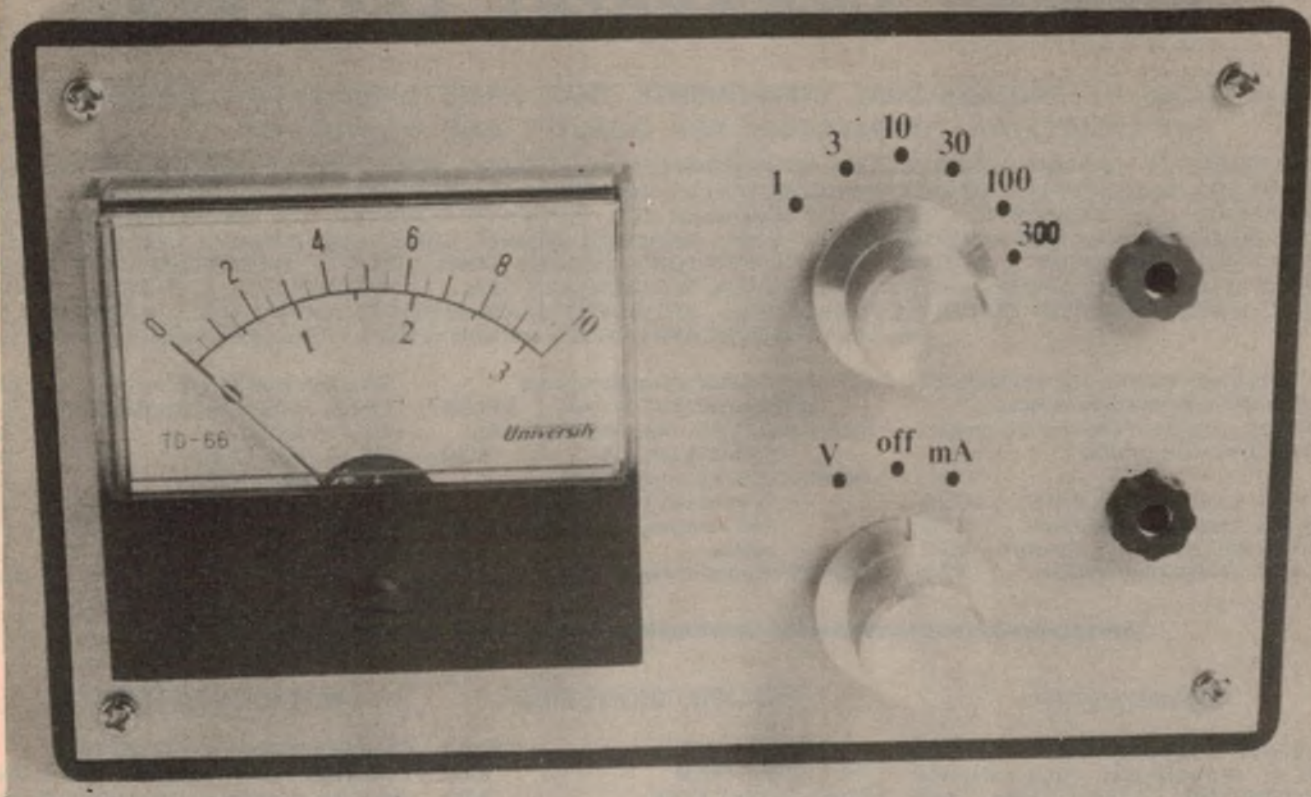

Here is the prototype Beginner's Test Meter a little larger than actual size, warts and all.

PARTS LIST

- 1 plastic case with aluminium lid, 158 x 50 x 96mm
- 1 meter movement, 1mA FSD, to suit plastic case
- 1 2-pole, 6-position rotary switch
- 1 2-pole, 3-position rotary switch (see text)
- 2 1N4001, EM401 silicon power diodes
- 2 knobs
- 2 banana jack sockets, one red, one black

RESISTORS

(5% tolerance, $\frac{1}{4}$ or $\frac{1}{2}$ W)

- 1 x 1.2M, 1 x 220k, 1 x 120k, 1 x 68k,
- 1 x 22k, 1 x 6.8k, 1 x 2.2k, 2 x 1.8k,
- 1 x 330 ohms, 1 x 47 ohms, 2 x 22 ohms,
- 1 x 8.2 ohms, 1 x 3.3 ohms,
- 1 x 1 ohm, 1 x 0.33 ohms.

MISCELLANEOUS

Letraset (12pt. Times Bold), spray can of clear enamel, drawing instruments, hookup wire, screws, nuts, solder.



A tapered reamer and a sheet-metal nibber are useful tools for this project.

10k. The appropriate figure for each range is found by adding the meter resistance 100 ohms to the multiplier resistance.

1000 ohms/volt is a fairly low sensitivity for a voltmeter and can often limit its application. Any circuit section which is being measured by the voltmeter (any voltmeter, for that matter) must have an

inherent resistance which is one-tenth the voltmeter resistance, otherwise the reading will be inaccurate due to the loading effect of the voltmeter.

This problem is largely overcome in electronic voltmeters which have a resistance of 10 megohms or more, on every DC voltage range. But that is the subject of a subsequent article.

SIEMENS COMPONENT CATALOGUE

615 PAGES OF PROFESSIONAL COMPONENTS THAT HAVE EARNED FOR SIEMENS AN INTERNATIONAL REPUTATION FOR QUALITY AND RELIABILITY.

THE RANGE OF COMPONENTS COVERS:- MICROPROCESSORS's, PROM's, RAM's, EDGE CONNECTORS, MAGNETO RESISTORS, HALL EFFECT DEVICES, MAGNETICALLY CONTROLLED SWITCHES, TOUCH CONTROL IC's, OPTO-ANALOGUE LED DRIVER IC's, SPEED CONTROLLER IC's, 4-DECADE COUNTER IC's, PHOTOVOLTAIC CELLS, PHOTODIODES, PHOTOTRANSISTORS, red- green, yellow and infra-red LED's, LED ARRAY's, OPTO-COUPLER's, DISPLAY's, ANALOGUE & DIGITAL IC's, TRANSISTOR's, DIODES, SCR's, TRIAC's, MICROWAVE COMPONENTS, PTC & NTC THERMISTOR's, POT CORES, POWER SEMICONDUCTOR's, TRANSFORMER's & CHOKES, RELAY's, HEAT SINKS, PRINTED CIRCUIT CONNECTOR's, RFI SUPPRESSION DEVICES, CAPACITORS, RESISTORS, etc.
only 500 SIEMENS CATALOGUES available ex stock, Price \$5.00 including post & pack.

The following devices are available ex stock at low introductory prices: Application notes (up to 23 pages) supplied free with devices.

UAA170 analogue LED driver \$3.20
UAA180 analogue LED driver 3.20
SAJ 205 staircase volt. generator 8.90
SAJ 410 7-stage freq. divider 1.70

SAJ 341 4-decade programmable counter/clock IC w. reset \$14.50
SAS 201,211,221 magnetically contr. switch(4 pin IC) 3.50
INFRA-RED Kit consisting of 6 infra-red LED's, infra-red receiver plus 23 page notes 9.50
TCA 955 Speed controller IC 2.80

SBV 566 Hall effect device \$3.50
FP30L 100E magneto-Resistor 2.80
LD 41 red LED 0.22
LD 57 green LED 0.32
LD 55 yellow LED 0.32
LD 460 red LED array (10 LED's) 2.10
LD 470 green " " " 2.80
LD 480 yellow " " " 2.80
LD 260 infrared " " " 10.60

COMMODORE

SR-4148R CALCULATOR

This is an advanced, fully scientific calculator with 14 digit display, two memories and parenthesis: 32 functions, including rectangular-polar & degree - radian conversions, logarithms, exponentials, trig. & inverse functions etc.

Sales Tax ex. \$32.50
Sales Tax paid \$35.38

This price includes 6 month warranty, rechargeable batteries & charger

SR4190R CALCULATOR

This sophisticated new 108 function calculator has trig. & hyperbolic trig. functions, rectangular to polar & deg-rad. conversions, single key complex number operations, all statistical funct., metric conversions, deg. to deg.-min.-sec., addition & subtraction of hours-minutes-seconds and conversion to decimal hours.

Sales Tax exempt \$79.95
Sales Tax paid \$87.45

This price includes 6 month warranty, rechargeable batteries & charger.

Write for literature describing these and other programmable scientific calculators.

COMMODORE COMPUTER SYSTEM

Called PET 2001, the system comprises:- microcomputer with 4k bytes of RAM, 12k bytes of ROM containing BASIC and operating system, Video display (25 lines of 40 characters), 73 key, keyboard, cassette memory. Input/Output via Hewlett-Packard Interface bus, so plotters, printers and floppy disc may be added to the system. The projected american price is under \$500.00.

Australian price and delivery date are not determined. Please send S.A.E. marked PET 2001 for further details.

PHILIPS / SIGNETICS

2650 Microprocessor \$30.50
2101 256x4 RAM 6.47
2102 1024x1 RAM 3.50
1702A 256x8 EPROM \$17.45
send S.A.E. marked IC's for full TTL, CMOS & LINEAR IC price list.

DATA BOOKS:

Signetics data manual, 1200 pages appr. listing: microprocessors, etc. \$10.00
Signetics Analogue manual 6.95
Signetics Design with microcomputers, price to be advised

Signetics 2650 Microprocessor manual price to be advised

Microcomputer Design by Martin Research \$30.00
PCC's first book of computer games \$10.00

due to heavy weight of books, please add \$2.50 for p/p.

PHOTO SENSITIVE PRODUCTS

For the first time you can manufacture professional P/C boards, plastic & aluminium labels from your artwork with minimum effort and without a dark-room.

---- we stock ----

Photosensitized single and double sided P/C boards, Exposure Film, to be used to manufacture quality P/C boards and labels. Self adhesive aluminium & plastic labels (available in various colours). These labels give your equipment a professional appearance. Only two extremely simple steps required to produce labels.

For more details & price list on all materials & chemicals send S.A.E. marked:- photo-sensitive products.

W.H.K. ELECTRONICS

300 MHz FREQUENCY METER

Five types of module plug into a back plane to provide a customized system to measure frequency (with variable gating period, display rate, leading zero suppression, and non-blinking latched display) and period (to a resolution of 100ns, separate TTL compatible START, STOP, RESET, SPLIT, DISPLAY UNLATCH inputs).

Modularity enables optimal choice of sophistication or economy. BCD data is available for interfacing to a microprocessor or data logger.

The modules may be purchased separately:

- 1) Counting & display decade with latch & leading zero suppression.
- 2) 0.002% or better crystal time base with decade outputs from 0.1Hz to 10MHz.
- 3) Control module.
- 4) 40MHz preamplifier module
- 5) 300MHz preamplifier/prescaler module.

For descriptive literature and prices list send S.A.E. marked 300MHz DFM

ADVANCED VIDEO GAMES

We have available ex stock a 78 page catalogue listing advanced video game IC's and circuits.

See EA June 1977 for details.

Price \$6.50 plus \$0.50 p/p

TO CLEAR thousands of components. send S.A.E. for clearance list.

W.H.K. ELECTRONIC & SCIENTIFIC INSTRUMENTATION
2 Gum Road, St. Albans 3021 Vic.
Tel. (03)3963742 Telex AA33321

Memory: RAMs

Memory devices form an important part of many digital systems, the most obvious example being in computers. This chapter discusses random-access memories or RAMs, in particular semiconductor RAMs. It deals with both bipolar and MOS devices, static and dynamic RAMs, non-volatile RAMs and specialised devices like the FIFO and the content-addressable memory.

by JAMIESON ROWE

In many digital systems there is a need to store significant amounts of information, usually in the form of multi-bit binary numbers. A good example of this is in computers, where a sequence of numbers must be stored to provide the computer with its "program". It is often also necessary to store the actual data which the computer is to process, and the results of calculations.

Another example of the need for storage is in video display terminals, where a storage "buffer" must be used to hold the information to be displayed, so that the video scanning circuitry can continuously refresh the screen. A similar need exists in many mechanical printers, where it is often necessary to store incoming information temporarily, until the printing mechanism can deal with it.

Still another need for storage arises in systems which must perform code conversion, or generate numbers related to others by relatively complex mathematical functions. In many such applications it is easier and more efficient to have a stored "lookup table" of numbers, than to try calculating them. The table of stored numbers is used in a very similar way to the tables of logarithms or trigonometric functions which were at the elbows of mathematicians and students, before the era of pocket calculators!

Organised storage or "memory" facilities thus form an important part of many digital systems. They come in many different forms, each of which tends to offer a particular combination of such characteristics as cost, storage capacity, and the ease and speed with which information can be stored and retrieved.

The various types of memory system and device tend to fall into two broad groups. There are those which store information in serial fashion, so that in order to gain access to a particular storage location or "cell", it is necessary to perform some sort of serial scanning operation. These types of memory are known as serial-access memories.

Examples of serial-access memories are those using magnetic tapes or discs, and those using new technologies such as

charge-coupled devices (CCDs) and magnetic "bubble" devices.

Historically serial-access memories were the first to be developed, in the form of punched paper tape and cards, mercury delay lines and magnetic drums. They still tend to be used for very high capacity or "bulk" storage, and for storage of information which does not have to be accessed frequently, because they tend to offer the lowest cost per unit of storage.

Serial-access memories will be discussed in more detail in a later chapter.

The other main group of memory devices and systems are those which store

This is an enlarged view of a 1024-bit static RAM device using bipolar technology. The actual chip is less than 2.5mm square. The array of storage cells is clearly visible.

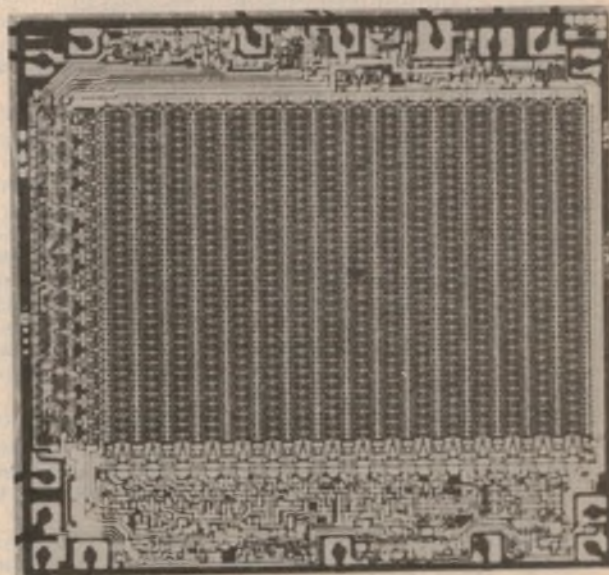

information effectively in parallel, so that any particular storage location or cell is just as accessible as any other, and can be reached directly. These types of memory are known as random-access memories, or "RAMs".

A useful way of visualising random-access memories is to think of them as an array of "pigeon-hole" cells, rather like the letter rack which used to be behind the reception desk in hotels. Information may be stored or "written" into any cell at random, with equal ease, and retrieved or "read" just as easily.

The first type of random-access memory to be used extensively was the magnetic core memory. This consisted of an array of tiny toroid cores or "doughnuts", moulded from magnetic ferrite material. Each core could be magnetised in one direction or the other, and so used to store one bit of information. Sets of wires threaded through the cores were used to write information into them, and also to read it from them.

Magnetic core memories of this type were capable of quite rapid access: in the order of 1 microsecond. Like most serial-access memories they were also non-volatile, in that the stored information does not "evaporate" when power is removed from the memory. However they were also relatively costly, as the arrays of cores had to be threaded on the wires almost entirely by hand.

Other types of magnetic random-access memory were developed in an effort to reduce the cost, including memories in which thin films of magnetic ferrite

material were plated onto the various magnetising and sensing wires. However, this approach to random-access memory has been almost completely superseded by integrated circuit memories, based on various types of semiconductor technology. One of the main factors behind the growth of IC memories has been their very much lower cost per stored bit of information, together with the dramatic reduction in memory size.

There are quite a number of different types of random-access IC memory, but most of them fit into two broad categories.



DICK SMITH AND DEALERS... PROUD TO BE AUSTRALIAN!

DICK SMITH ELECTRONICS DEALERS (Dealers who carry most of our catalog lines, or will obtain them for you)

NSW: Armidale: Armidale Electronics, 123 Faulkner Street. 72-1895. **Griffith:** The Record Centre, 222 Banna Ave. 62-1577. **Newcastle:** DGE Systems, 103 Broadmeadow Rd, Broadmeadow. 69-1222. **Orange:** M&W Electronics, 48 McNamara St. 62-6491. **Tamworth:** Sound Components, 78 Brisbane St. 66-1363. **VICTORIA:** Bendigo: Sumner Electronics, 97 Mitchell St. 43-1977. **Geelong:** Corio TV Services, 52 Little Ryrie St. 94-408. **QUEENSLAND:** Palm Beach: The Electronic Hobby Centre, 1168 Gold Coast Hwy. 34-1248. **Maryborough:** Keller Electronics, 94 Ellena St. 21-4559. **SOUTH AUSTRALIA:** Elizabeth Sth: A.E. Cooling, 6 Trimmer Rd. 255-2249. **Port Adelaide:** International Communication Systems, 75 Dale St. 47-3688. **Prospect:** Watson Communications, Shop 5, 77 Prospect Rd. 44-5835. **WESTERN AUST:** Perth: Altronics, 105 Stirling St. 328-1599. **TASMANIA:** Devonport: Devon Electronic Supplies, 45 Ashburner St. 24-4216. **Hobart:** Aero Electronics, 123a Bathurst St. 34-8232. **Wivenhoe:** Robbies Teletician, 35 Main St. 31-2560. **NORTHERN TERRITORY:** Alice Springs: Ascom Electronics, 66 Hartley St. 52-1713. **Darwin:** Ventronics, 24 Stuart Hwy, Stuart Pk. 81-3491.

DICK SMITH CB DEALERS (Dealers who specialise in CB & Marine Radio, but who carry some test equipment, etc, if required).

NSW — Adelong: T Reckman, 'Running Waters' 46-4258. **Albury:** Midstates Radio, 638 Dean St. 21-3888 **Ballina:** Carthew's Marine, 337 River St. 86-2669 **Bateman's Bay:** Vigden Motors, Orient St. 72-4555 **Bathurst:** Bathurst Bargain Centre, 79 Keppel St. 31-1200. **Bega:** South Coast Communications, 226 Carp St. 22-090. **Bourke:** Trev Randall, 20 Oxley St. 72-2129. **Bowral:** Comserve, 28 station St. 61-1861. **Condobolin:** Riverview Service Stn, 20 Lachlan St. 95-2625. **Coolah:** Gary Connelly, Binnia St. 84. **Cooma Nth:** RF Daniels, 6 Nadoo St. 32-709. **Coonamble:** West Auto, 55 Aberford St. 22-1877. **Cootamundra:** Halls Cycle Spot, 119 Parker St. 42-1682. **Dubbo:** Western Hi-Fi, 85 Talbragar St. 82-3793. **Cheshires,** 36 Victoria St. 82-2377. **Finley:** Con Carr & Co. 117 Murray St. 83-1611. **Forbes:** Scotty Wallace, 103 Rankin St. 52-2300. **Forster:** Cape Hawke Electrics, Head & Bch St. 561. **Glen Innes:** Glen Innes Electrical Centre, 266 Grey St. 1219. **Gloucester:** Gloucester Radio & TV, 81 Church St. 571-1152. **Gosford:** Chrysler Marine, 339 Mann St. 24-4644. **Goulburn:** Double Diamond Electronics, 18 Russell St. 21-5440. **Grenfell:** Grenfell Auto Electronics, 160 Main St. 43-1733. **Gunnedah:** Geddes Radio & TV, 205 Conadilly St. 42-0222. **Inverell:** Ben Bates, 281 Byron St. 22-2443. **Jindabyne:** Oberlecher, Shop 4 Kosciusko Rd. 62-112. **Kurri Kurri:** Kurri Electronics, 163 Lang St. 37-2141. **Laurieton:** R.N. Deards, The Parade, North Haven. 599-060. **Lavington:** CB Sales, 5/521 Margaret St. 21-6058. **Leeton:** Leeton Record Centre, 121 Pine Ave. 53-2081. **Lismore:** Chateau Sounds, 64 Magellan St. 21-3741. **Arthur Baines,** 17 Budge St. 21-3189. **Lithgow:** R&K Coomber, 153 Main St. 51-2563. **Milparinka:** Allan Garland, Albert Hotel.4. **Mudgee:** Mudgee Auto Electrical Service, 73 Church St. 72-1413. **Nowra:** John Arberry, 91 Illaroo Rd. 23-628. **Peak Hill:** Bionics Australia. 80 Caswell St. 31. **Rylstone:** Kunos TV, 4 Ilford St. 77. **Shell Harbour:** J&V Mills, 26b Mary St. 95-1175. **Sth Grafton:** Allan Norris, Pacific Hwy. 42-3400. **Sydney:** A.W. Barrs Accessories, 99 Crown St. 31-0673. **Taree:** Taree Photographics, 105 Victoria St. 52-3488. **Tullamore:** P.J. Ferrari, Oakleigh. 75. **Wagga:** Rivercom, 9 Copland St. 21-2125. **Walgett:** R.F. Pearson Electronics, 62 Wee Waa St. 243. **Wellington:** Wellington Service Centre, Lee St. 1002. **West Gosford:** Dunglell Electric Agencies, unit 2, the Viking Centre. 24-1768. **West Wyalong:** G&L McLachlan. 134 Main St. 424. **Wollongong:** Vortell TV Services, 10 Victoria St. 29-2254. **East Coast Communications,** 29 Bulwarra St, Keiraville. 29-5876. **VICTORIA — Drouin:** T.A. Williamson CB Centre, 151 Princes Hwy. 25-1342. **Horsham:** Civic Centre TV, 34 Fire Brace St. 82-3724. **Mildura:** Duraserve, 72 Lime Ave. 23-2438. **Norco Electronics,** 17 Mimosa Ave, 23-4432. **Sale:** W.D. Leslie, 363 Raymond St. 44-2677. **Shepparton:** Shepparton HiFi Centre, 51 High St. 21-9006. **Wangaratta:** B.H. Riley Photographics, 9/33 Evans St. 21-5907. **Warrnambool:** Western Electronics, 54 Kepler St. 62-4070. **QUEENSLAND— Biloela:** Audio Video Service, 26 Callide St. 26-126. **Bundaberg:** Bergman Electronic Engineering, 3 Chapman St, Booloolah. 72-4263. **Cairns:** GCG Communications, 385 Mulgrave Rd. 54-1035. **Dalby:** Dalby Radio & TV, 36 Patrick St. 62-2389. **Edmonton:** B.A. Foster, 61 Bruce Hwy. 55-4235. **Gladstone:** Electronics Unlimited, 9 Ferguson Cres. Marine Onboard Service, 54 Yaroan St. 72-3949. **Gympie:** City Ampol Service Stn, 48 Monkland St. 82-1327. **Lota:** L. Woods Electrical. 38 Armytage St. 396-9010 **Margate:** Margate Motors, 277 Oxley Ave. 284-2341. **Mackay:** J. Mitchellmore & Co. Victoria St, 511-211. **Miles:** Miles Engineering and Hardware, Murilla St. 118. **Nambour:** Ian Jones, 101 Currie St. 411-100. **Proserpine:** Fuller's Radio & TV, 72 Main St. 45-1071. **Rockhampton:** Premier Sound, 239 Musgrave St. 27-4004. **Toowoomba:** Arnolds TV & Radio, 566 Ruthven St. 32-3766. **Townsville:** Rylands Warehouses, 133 Charter's Towers Rd. 79-8844. **Victoria Pt:** Redlands TV Service, 18 Yeo St. 207-7308. **SOUTH AUSTRALIA — Adelaide:** World Imports. 232 Rundle St, 223-6539. **Cleve:** Cleve Furniture Store. 25 Fourth St 99. **Mt Gambier:** Hutchesson's Communications Centre, 5 Elizabeth St. 256-404. **Narrung:** David McNicholl, Main St. 11. **Peterborough:** J.M. Wills, 169 Main St. 307. **Port Lincoln:** Retrex Services, Lewis St. 82-1981. **Renmark:** Lawton Electrical, 7-9 Renmark Ave. 86-6682. **Wallaroo:** Kadina Radio Sales, 211-017. **Whyalla-Norrie:** Northern HiFi Centre, 41 Westlands Centre, Nicholson Ave. 45-5766. **Yorketown:** Bishop's Traders, 9 Warooka Rd. 29. **WESTERN AUSTRALIA:** **Bunbury:** Aabel Music Coy, 130 Victoria St. 212-777 **Carnarvon:** Western Telecommunications, 33 West St. 411-362. **Claremont:** Claremont Marine, 160 Stirling Hwy. 862-433. **Kalgoorlie:** Hocks TV Rentals, 87 Hannan St. 21-1906. **Paraburdoo:** CB Supplies, 496 Ashburton St 89-5200 x368 **Port Headland:** Asahi Electronics, 28 Anderson St. 732-504. **South Fremantle:** Coastal Electronics & TV. 366-370 South Terrace. 355-875. **Tom Price:** R.M. Dodson, 681 Caringal St. **Waroona:** Golden Electronics, 1 Coronation Rd, 331-595. **TASMANIA:** **Avoca:** Freeman's TV & Electrical, Falmouth St. 842-166. **Launceston:** Wills & Co, 7-11 Quadrant, 31-5688. **Tas HiFi,** 87a Brisbane St. 31-5815. **New Norfolk:** S.L. Plunkett, 25 Burnett St. 612-553. **Triabunna:** Spring Bay Electrical, 25 Vicary St. 57-3135. **NORTHERN TERRITORY:** **Darwin:** Integrated Technical Services, 2 Carey St. 81-5411.

WOULD YOU LIKE TO JOIN THESE DEALERS? *And sell reliable, known brands with full parts and service back-up? We still have a number of areas not covered adequately by dealers — particularly full dealers. If you have the drive and determination necessary to become a successful dealer, we'd like to hear from you. Drop us a line to Gary Johnston, 24 Carlotta St Artarmon — or ring Gary on 439-5311. It could be the best few minutes you'll ever spend!*

DICK SMITH ELECTRONICS GROUP

SYDNEY
125 York St
SYDNEY.
Ph 29-1126

SYDNEY
361 Hume Hwy,
BANKSTOWN
Ph 709-6600

SYDNEY
162 Pacific Hwy,
GORE HILL
Ph 439-5311

SYDNEY
30 Grose St,
PARRAMATTA
Ph 683-1133

MELBOURNE
656 Bridge Rd,
RICHMOND
Ph 42-1614

BRISBANE
166 Logan Rd,
BURANDA
Ph 391-6233

MAIL ORDERS
PO Box 747,
CROWS NEST
Ph 439-5311

One of these includes those memories which permit information to be written into storage cells with as much ease as it may be read out, so that they may be used in any situation requiring frequent and random writing and reading. Memories of this type should strictly be called "read/write random-access memories" or "R/W RAMs"; but it has become common to refer to them simply as "random-access memories" or RAMs.

The other main type of IC random-access memories includes those devices which either do not permit repeated writing of information into the storage cells, or do not allow repeated writing with the same ease that they allow repeated reading. Compared with the first type of memories, these devices are more suitable for use in applications where information needs to be written in either only

once, or infrequently, most of the time being read out. As a result, memories of this type are given the general title of "read-only memories", or ROMs.

There are various types of ROM, some of which have the stored information effectively written into them permanently during manufacture, and others designed so that they may be written into or "programmed" by the user, either permanently or semi-permanently. The latter types are generally known as programmable ROMs, or "PROMs".

ROMs and PROMs are very important devices, and deserve a discussion in their own right. For this reason, let us leave them now until the next chapter, and spend the remainder of the present chapter looking more closely at the first type of IC memories: RAMs.

RAMs are divided into two different types. In one type, the information is stored in what is basically an array of many flipflop latches, each storing one bit of information, and storing it stably until either the latch is reset, or the power is turned off from the RAM as a whole. RAMs of this type are known as STATIC RAMs.

In contrast with this approach, the other types of RAM store their information in an inherently less stable fashion—typically as charges in an array of capacitors. Each capacitor stores a charge corresponding to a single bit of informa-

tion, but unlike the latches of a static RAM the capacitors tend to lose the stored information due to charge leakage. To retain the stored information, the charges therefore have to be sensed and "refreshed" repetitively. These types of memory are thus known as DYNAMIC RAMs, to indicate that they need attention on a continual or dynamic basis.

Looking first at static RAM devices, these are again divided into two broad types: those using bipolar technology, and those using MOS technology. Fig. 1 shows the basic memory cells used in each type, and as you can see they are both essentially simple latch flipflops.

The bipolar cell shown in (a) uses only two transistors, as you can see, each with a collector load resistor R. The base of each is connected to the collector of the other, so that whichever is conducting

of Fig. 1(a) is connected to an X-address line, which in fact forms the main common emitter return path to the supply. A typical array will have quite a number of these X-address lines, each controlling a row of cells. The additional emitter of each transistor is individually connected to a separate Y or bit line, as shown. There will again be quite a number of pairs of these lines in a typical array, each pair associated with a column of cells, and used to write into and read from them.

The MOS memory cell of Fig. 1(b) is connected into its array in a similar manner, although here the X-address line does not control the storage latch itself, but two transistor switches T5 and T6 which connect the latch collectors to the vertical bit lines.

In each case, the basic idea is that the X-address lines of the array are used to select a particular row of memory cells, while the pairs of bit lines are then used to write into or read from the various cells in the selected row.

With the bipolar RAM cell, the X-address lines are normally held near the negative supply rail. The bit lines are held at a slightly higher voltage, so that the output coupling emitters of all cells in the column are slightly reverse biased. Under these conditions, the cells are quiescent, and will store information as long as power is applied.

To write into a cell, its X-address line is raised to within about a volt of the positive supply rail. While it is high, either the 0 or 1 bit line is also taken high, depending upon the data bit to be written into the cell. Then the X-address line is allowed to return to its quiescent level, followed by the bit line.

As the address line falls, the output coupling emitter connected to the high bit line is reverse biased, whereas that on the other side of the cell is forward biased and able to conduct. The cell is therefore "steered" in the appropriate direction, aided by its own inherent regeneration. By the time the address line reaches its quiescent level, allowing the two coupled emitters to assume control, the cell has stabilised with its new stored bit value; the transistor whose coupling emitter was taken high will be cut off, while the other transistor will be conducting.

To read from a cell, only the X-address line is taken high, while the bit lines are allowed to "float" and their potential sensed. When the address line rises, the coupled emitters become reverse biased, and the current of the conducting transistor transfers to its output coupling emitter. The voltage on that bit line therefore rises, indicating the value of the bit stored in the cell.

The readout is non-destructive, as the cell returns undisturbed to its quiescent state when the address line is returned to its low level.

To write into the MOS cell of Fig. 1(b), the X-address line is first taken high to turn on the two switch transistors T5 and T6. Then one of the two bit lines is taken

holds the other off and vice-versa. The resistors R are generally formed by diffusion from the same silicon as the transistors, with a value as high as possible in order to make the current drain and power dissipation of the cell extremely low.

The MOS cell shown in (b) is very similar, with the lower pair of transistors T1 and T2 in the same cross-coupled configuration. However, in place of the load resistors there is usually a further pair of MOS transistors as shown (T3 and T4), connected as constant-current devices. As with the bipolar cell, these are designed to minimise the cell's current drain and power dissipation, so that it stores information as efficiently as possible.

In place of the constant-current load transistors T3 and T4, some recent static MOS RAM cells use very high value ion-implanted polysilicon resistors. These have a value as high as 5000 megohms, bringing the average dissipation of a storage cell down to around 20 microwatts.

Basically a static RAM consists of a large number of cells like those in Fig. 1(a) or (b), connected in a two-dimensional array or matrix. Each cell in the array is accessible by means of "address lines" in the two main axes of the array, usually designated the "X" and "Y" axes for convenience, or sometimes the "word" and "bit" axes respectively.

As you can see, the bipolar memory cell

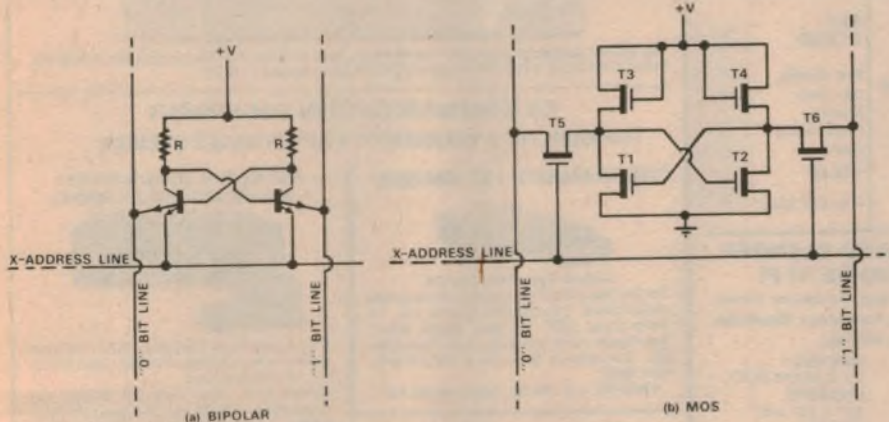

FIG. 1: STATIC RAM MEMORY CELLS

A.C.E. RADIO

MUSICOLOUR

For the disco, light show, party, nites, or just relaxing - enjoy your records and tapes more with the new magical Musicolour Organ. Simple to connect to the home stereo or P.A. system. 3 channels, 1500 watts max. load each.



Fully constructed, ready to operate **\$75.00**

Complete kit of top quality parts and instructions for the models 11 or 111 **\$55.00**
P.P. NSW \$3.50, interstate \$5.50.

PLAYMASTER 3-4IL Loudspeaker System.

30 watts of excellent hi-fi. Beautiful teak or walnut veneered cabinets. Driven by the mighty 8-30 Woofer. Smooth 6-25 mid-range. Super sensitive Philips AD0160/T8 Tweeter. Specially designed frequency divider network.

\$98.00 EA - \$199.00 PAIR Weight 40Kg. Despatch Aust wide



PLAYMASTER SPEAKER KITS

All complete with cross-over components, speaker grille cloth, innerbond and tubes

3-45L	3-4IL	MV-50
Magnavox 8-30 Bass	8-30 Bass	Magnavox 10/40 Bass
Magnavox 6J Midrange	Magnavox 6-25 Midrange	6-25 Midrange
Philips AD0160/T8 Dome Tweeter	AD0160/T8 Tweeter	2xMagnavox XJ3 Dometweeters
Weight 4.5 Kg	Wt 5Kg	Wt 5.5 Kg
\$57.00 each Kit.	\$67.00 ea Kit	\$78.00 ea Kit

Despatch by post, rail, road, sea, or airfreight

MIC STAND

Pro Quality
6ft Floor
Model
Heavyweight
base
\$25.00

F on Rail Road

SOUND SYSTEMS—SLEEK AND SLENDER FOR COMMERCIAL OR HOME HI FI

Black Vinex Covered Cabinets Rugged and Attractive Inner-board Lined for Richer Sound. Excellent Frequency Response 8 or 16 ohms. Floor or Wall Mounting. 3 Models.

15W RMS 2 SPEAKERS Size 19 1/2" H 11" W 7" D \$39.95	25W RMS 4 x 6" SPEAKERS 33" x 10" x 8" \$55.00	40W RMS 4 x 8 HEAVY DUTY SPEAKERS 37" x 12" x 8" \$65.00
---	--	---

WE ARE DISTRIBUTORS FOR THE PLESSEY FOSTER Range of Speakers. Send S.A.E. for data and price list.

Car Speakers

Top Sound Dual
imp. 4-8 ohms.
\$9.00 pair
P.P. \$1.50



BSR Record Changer



New Model C129 240V 50Hz 3 speeds
2 spindles Auto/Manual operation Cue
lever Stereo Ceramic cartridge. **\$20.00**
p.p. \$2.50

FM WIRELESS MICROPHONE

Cardioid Electret condenser type Transmitting freq. range 88-106MHz freq. dev. +75KHz Field S. 50uV/MAT 50ft. **\$24.95** p.p. 80c



SERVICE

Moderate Charges - Repairs Guaranteed
Radios Taperecorders Cassettes C-B Rigs, Etc.

PLESSEY ROLA

12" SPEAKER SPECIALS
C12PX 8 & 15 ohms 30w RMS Freq.
35-13000Hz
\$12.50 P & P \$1.50

Resistors 1/2W. 5%

Carbon Film 8.5 x 3 mm Preferred
values from 2.2 ohms to 4.7 megohms
one value per pack 50 for **\$1.90.** p.p. 50c

Ferrite Rod 4 1/2" x 3/8" dia. **75c**

MAGNOVOX SPEAKERS

Model 10/40 8 ohms 40w rms 30-8000Hz	\$25.95
Model 8/30 8 ohms 30w rms 30-8000Hz	\$19.00
Model 6wr 8 ohms 16w rms 30-16000Hz	\$12.95
Model 6wr 8 ohms 16w rms 30-16000Hz	\$12.40
Model 6.25 8 ohms 25w rms 45-6000Hz	\$16.95
Dome XJ3 8/15 ohms 25w rms 2.20kHz	\$9.35
p.p. \$2.50 Interstate \$3.50	

Mobile Trolley Stand



Ex-Pye. Brand new in cartons. On 4 heavy duty castors. 101 uses sq section mat black steel finish 23 3/4" H 23" L 16" W **\$23.50** F on Road Rail Air

Reflex Horns



Rugged Indoor or Outdoor
Weatherproof

Great for car or truck C-B size 8" x 5" with mounting bracket. 8 or 15 ohms. 15 watts **\$22.95** P.P. \$2.50

Polyester 100V

Greencap Capacitors
Radial N.B. each size in pack of 50
001 to 01 **\$4.60** pp 50c
012 to 018 **\$4.95** pp 50c
022 to 033 **\$5.25** pp 50c
039 to 056 **\$5.95** pp 50c
068 to 1 **\$8.95** pp 50c

Micro Switches

Normally open/closed contacts. Ex-Pye. 4 or 8 amp 240 V **\$1.25** ea. Mini Cherry 1A **60c** ea.

GARRARD MODEL 82



A superb 3 speed transcription changer/player. Auto/manual operation 4 pole magnetically shielded syn motor. Resiliently mounted Counterbalanced. Elegant tone arm with slide-in cartridge carrier calibrated Antiskate. 265mm (10 1/2") Aluminium platter. Cue and pause control. Cartridge tilting lever. Magnetic cartridge diamond stylus. Size 375 x 335 x 170mm (14 1/4" x 13 1/4" x 6 1/4") 4.5kg (10 lbs) P & P **\$2.50** Interstate **\$3.50**

Base and Perspex Cover with hinges. Teak or walnut **\$29.95**. Freight NSW **\$4.50** Interstate **\$6.50**

\$57.00.

PLAYMASTER FORTY/FORTY STEREO AMPLIFIER

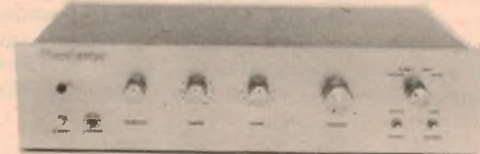

Top quality components. C-Core Transformer. Easy to Build. Full Instructions Kit **\$109.95**. Fully Constructed **\$135.00**. Freight NSW **\$3.50**. Interstate **\$5.50**.

CB COMMUNICATION EQUIPMENT

TOP QUALITY • WARRANTY • AFTER SALES SERVICE

COBRA MODEL 132 AM-SSB



Cobras Top-of-the-line CB Transceiver with all the features of maximum performance. 23 channels 4 watts am 12 watts p.p. SSB. Six pole crystal filters. Switchable noise blanking. Anl. Dynamike Mic. Gain control. Send S.A.E. for full technical data.

\$345.00. p.p. \$4.50 Interstate **\$6.50**

ROYCE C-B TRANSCEIVER + AM-FM MULTIPLEX RADIO



Phase Lock Loop Oscillator. 23Ch. RF Output 4 watts complete with Mic. send S.A.E. for full technical data.

Model-612 Gyro Lock CB Mobile AM Transceiver 23 CH. Local-Distant RF Gain Switch. Large S/RF Meter. Variable Tone Control. Twin Led TX RX indicator. Automatic Noise Eliminator Switch. 4 watts output. **\$119.95.** p.p. **\$3.50**

CB ANTENNAS 27MHZ. MARINE MOBILE.

1.55 mtrs (5 ft) stagger wound Helical **\$16.95** Base **\$5.50** Base with 12ft 52ohm coax cable and PL-259 plug **\$8.50**. F on Road. Rail. Air.

YAESU MUSEN FRG-7 Communication Receiver

These are the very latest model. Send S.A.E. for specs. and our low, low quote

Power Transformers

S.E.C. approved, 240 V 50Hz Primary.
1 0-tapped 6.3, 7.5, 8.5, 9.5, 12.6, 15 1A **\$6.50**
2 0-tapped 15, 17.5, 20, 24, 27.5, 30V 1A **\$7.20**
3 0-15V 2A **\$8.30**
4 28-0-28 2A **\$6.50**
5 26-0-26 2A C-Core **\$22.50**
6 12.6-0-12.6 150 MA **\$5.75**
7 0-12V 150MA **\$2.50**
8 0-24V, 150MA **\$2.50**
P.P. 1 to 5 **\$2.50** 6 to 8 **75c**

JUMBO NEON BEZELS

240 Vac. Red and Clear. Hole Dia. 7/8" max. Panel Thickness 7/16" Length O.A. - 2 1/2" **\$1.25** p.p. 40c

FAIRCHILD TRANSISTORS

Type 2N 3054 10 for **\$5.00** p.p. 50c

TV GAMES CHIP

6 games. type aY-3-8500-7647 14 Pin Dil **\$10.00** p.p. 40c

POTENTIOMETERS

To Clear Tandems 2 Meg. A 2 Meg. c. 1 Meg. A 5m + 2.5 mega. with Dpot switch. 500 KC 500 KA. 10 for **\$3.50** p.p. \$1.50 Single 1 megc 500 KC 250 KA 250 KC 150 KC 25 KA 50 KC 1 KA 5 KA Spst switch 10 for **\$2.50** p.p. 90c

TELESPORTS

SUPER 6 TV GAMES

The one with the gun. 2 target shooting games. 4 bat and ball games. 2 bat/ball sizes. 2 angles. 2 ball speeds guaranteed. Only **\$49.50** p.p. **\$2.50** plus freight

SWR.300-S.W.R. METER

Compact and rugged unit for CB and amateur radio antenna installations - also for field strength measurements (mobile or base) - V.S.W.R.: 1:1 to 10:1 Power: 0-20 Watt - F.S. Scale 0-10 **\$14.50** P.P. **\$1.00**



LEEDS AND NORTHRUP CO. NULL VOLTAGE TEST SET.

No. D74219-10-0-10+ DIAL READING 0-100. 3 MULTIPLIERS - x 100 x 1000 x 10000 **\$125.00** Plus Freight

HI VOLTAGE CERAMIC CAPACITORS

Ducon 001 12 KV 10 for **\$2.50** 10 pF. 47pF. 140 pF. 200 pF. 10 for **\$15** p.p. 60c

ROTARY SWITCHES

3 pos. x 4 pole. 2 x 4. 4 x 3. 12 x 1. 2" x 1/4" dia shaft **\$1.40** ea. p.p. 40c

AUDIO LEADS

1 RCA plug to 2 RCA inline sockets 5 pin din plug to 5 pin din inline sockets 5 pin din plug to 2 6.5 m stereo inline sockets 3.5 M plug each end 2 3.5 M plugs to 2 RCA plugs 1 RCA plug to 1 RCA inline socket 2 pin din speaker plug to 2 pin din inline spk socket. 5 pin din plug to 4 RCA plugs 4 3.5 M plugs to 4 3.5 M inline sockets 2 3.5 M plugs each end 1 RCA inline socket to 2 RCA inline sockets 1 3.5 M plug to 2 alligator clips **95c** each p.p. 40c

HAMMOND REVERBERATION UNIT

Latest Design Folded Line Model. Input 180-1475 ohms. Delay 31 secs 28v at 1000Hz 19MA Freq. 60-6000Hz **\$13.50.** p.p. **\$1.50**

WE REGRET THAT PRICES ARE SUBJECT TO CHANGE WITHOUT NOTICE.

briefly to the negative supply rail, depending upon the value of the bit to be stored. This drags down the corresponding side of the cell, forcing it to switch to the desired state (or to remain in that state if it is already there). The address line is then returned to its normal low level, turning off T5 and T6, and isolating the cell once more.

Reading the MOS cell is done in much the same way as with the bipolar cell. The address line is taken high, turning on T5 and T6 and allowing the "off" or high side of the cell to raise the potential of the corresponding bit line. The bit line potentials can thus be sensed to discover the value of the stored bit.

Naturally enough, because all of the cells in a particular row of the memory share a common X-address line, they are all potentially read whenever any cell in the row is either written into or read from. This happens with both the bipolar and MOS cells, but it causes no problems because further logic is used to select the desired bit line pair (or pairs, if a number of cells are being accessed at the same time). As readout is non-destructive, the unselected cells in the same row are only temporarily disturbed.

For convenience, the cells in a typical RAM are generally arranged in a roughly square array, or a number of such arrays in the case of a large RAM. Each array has approximately the same number of X-address lines and pairs of bit lines, so that a RAM with say 1024 cells would very likely have them arranged in a 32x32 array—with 32 X-address lines and 32 pairs of bit lines.

This internal geometric arrangement within a RAM is quite distinct from the way it may be designed to appear "organised" from the functional point of view, as seen by external circuitry. For example the same 1024-bit RAM may be arranged so that only one cell is selected at any one time, in which case it is said to be organised as a 1024 x 1 RAM. On the other hand, if it is arranged so that say four cells are selected together and written and read in parallel, it would then be said to be organised as a "256 x 4" RAM.

It could even be arranged so that eight cells are selected together, thus having an organisation of "128 x 8".

Fig. 2 shows how this sort of organisation is achieved. It shows a 256-bit RAM, with the storage cells arranged physically in a 16 x 16 array. However, it is functionally arranged so that four cells are selected at a time—i.e., it is organised as a 64 x 4 RAM.

Functionally it therefore has 64 effective storage "addresses", each of which can store 4 bits of information. To select these 64 addresses, the RAM must be provided with a 6-bit address code (6 bits have a total of 64 truth-value combinations). The address is applied to the six inputs on the lower left of the diagram. The four data bits read out from the address specified appear at the four data

terminals at the lower right, while the same four terminals are used as inputs if data is to be written into the address.

As you can see, four of the address inputs are taken to a decoder, whose 16 outputs are fed through drivers to control the X-address lines of the storage array. The remaining two address inputs are fed to a second decoder whose four inputs are used by the driving and sensing circuitry associated with the array's bit lines. In this case, each output line of the Y-decoder would be used to select a group of four bit-line pairs, effectively connecting them to the data terminals.

There is also a timing and control section within the RAM, as shown, whose function is to co-ordinate read and write operations. This section is provided with a logic input, so that external circuits can direct whether a write or read operation is to be performed. The label "READ/WRITE-BAR" indicates that a logic high corresponds to read, while a logic low corresponds to write.

The same section of the RAM is also often provided with one or more "chip select" logic inputs, as shown. These are to allow overall access to the RAM to be controlled conveniently—a feature which becomes very useful where a number of such RAMs are to be used together, to

while MOS devices have an access time of around 220ns.

Where high memory capacity is required, both of these main types of static RAM tend to have disadvantages. One is that their power consumption is still quite significant, as power is continuously dissipated by the storage cells.

If low power consumption is essential, an alternative type of static RAM tends to be used. The most common such device uses CMOS (complementary MOS) technology, with a silicon-on-sapphire construction. Although it is about five times more costly than a normal NMOS static RAM, the power consumption is very much less for the same capacity and access time. For example a 1024-bit/150ns device typically dissipates only 4mW (milliwatts), compared with around 300mW for a comparable NMOS device.

The other main disadvantage of static RAMs where large memories are concerned is cost. Even for the lower cost MOS type, the cost at the time of writing (mid 1977) is around 0.25 cents per bit. This may not seem high, but it soon adds up where large memories are concerned. As a result, large memories tend to be made using not static RAMs, but the dynamic type mentioned earlier.

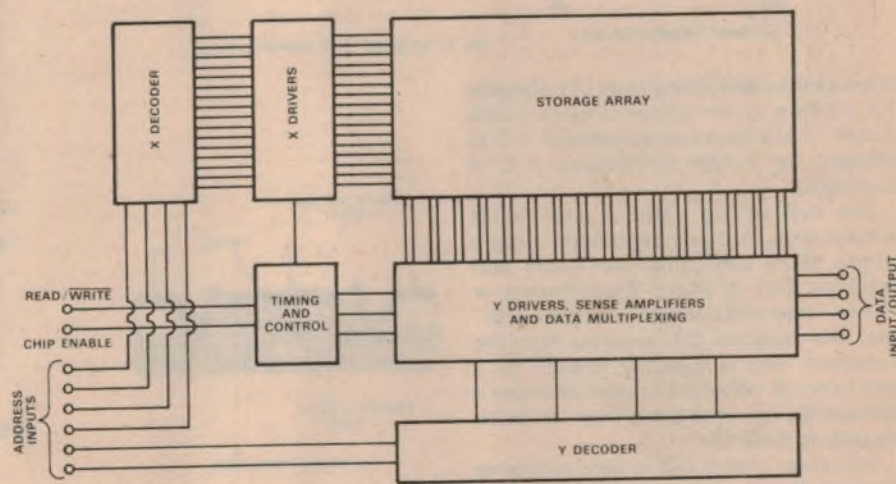

FIG. 2: BASIC READ/WRITE OR "RAM" MEMORY ORGANISATION

form a large memory. Each RAM's chip enable input can be controlled by one of the higher-order address bits, or from an output of a decoder driven by the higher address bits.

Static RAMs of the type we have considered so far are very widely used in modern digital systems. They are easy to use, and provide fairly fast memory facilities at a moderate cost—far less than that of core memories.

At the time of writing, the largest static RAMs being made have a capacity of 4096 bits, and both bipolar and MOS devices are made with this capacity. The bipolar devices tend to be faster—i.e., to offer a shorter access time—but they tend to have higher power consumption. Typical bipolar devices have an access time of around 100ns (nanoseconds),

In terms of basic organisation and function, dynamic RAMs are not greatly different from the static type we have discussed so far. The main difference lies in the actual memory cells themselves. As mentioned earlier, instead of flipflop latches like those of Fig. 1, the cells of dynamic RAMs are based on a capacitor. Two fairly common types of dynamic RAM cell are shown in Fig. 3.

As you can see the cell in (a) uses three MOS transistors together with the storage capacitor, shown as "C". Actually the capacitor is generally not a separate physical component, but in fact the gate-channel capacitance of transistor T2. Although only a few hundredths of a picofarad, it can store charge for around 2ms because of the high leakage resistance present.

With this cell there are two X-address lines as well as two data bit lines. One X-address line and data bit line are used for writing, and the other X-address line and bit line for reading. To write data into the cell, the X-write line is taken to the high level to turn on switch transistor T1. At the same time the write data bit line is taken high or low, depending upon the data bit to be stored. Capacitor C thus acquires the appropriate charge, which remains when the X-write line is returned to its low quiescent level.

To read data from the cell, the X-read line is taken high. This turns on switch transistor T3, allowing the read data line

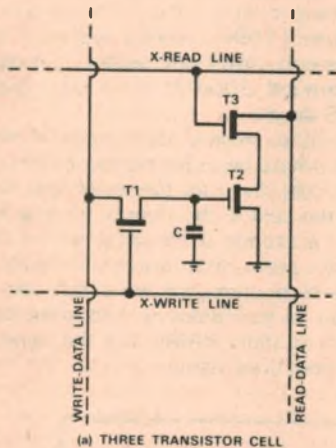

(a) THREE TRANSISTOR CELL

take long, as it is only necessary to perform as many read operations as there are X-address lines in the RAM's cell array. The internal circuitry automatically ensures that all row cells are refreshed.

At the time of writing, dynamic MOS RAMs are made with capacities up to 16,384 bits, and offering a cost of .08 cents per bit. As you can see, this is considerably lower than the figure for static RAMs. The access time is around 250ns, comparable with NMOS static RAMs.

It is predicted that dynamic RAMs with capacities of 65,536 bits will be in production by 1979, with a significantly lower cost again.

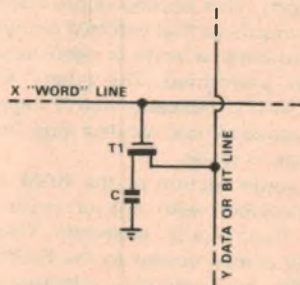

(b) ONE TRANSISTOR CELL

FIG. 3 DYNAMIC RAM MEMORY CELLS

to sense the conducting state of transistor T2. If this is an enhancement-mode device, it will be a low impedance if C is charged, or a high impedance if C is uncharged.

The cell of Fig. 3(b) is somewhat simpler than that just described, using a single MOS switching transistor and requiring only a single X-addressing or "word" line and a single Y-data or "bit" line. The capacitor C is separate from the transistor, and is typically formed by a small area of polysilicon material above a diffused bit line, with a thin layer of silicon dioxide as dielectric.

Operation of this cell is very similar to that just described, except that both read and write data are transferred via T1 to the single bit line.

Actually because the stored charge tends to leak away in the cell capacitors, dynamic RAMs are usually arranged so that every read operation is automatically followed by a write operation, to restore the charge. This is done by the sensing and driver circuitry connected to the bit lines, so that all of the cells in a particular X row are automatically refreshed whenever any cell in the row is either written into, or read from.

As the effective storage time of typical cells is around 2ms, all cells in a dynamic RAM must be refreshed at least every 2ms. Special circuitry is usually required to perform this refresh servicing, on an automatic basis. The circuitry effectively "commandeers" the dynamic RAM every so often, and refreshes it by performing read operations. However this doesn't

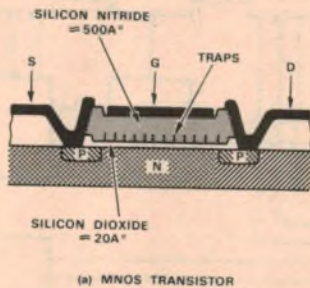

(a) MNOS TRANSISTOR

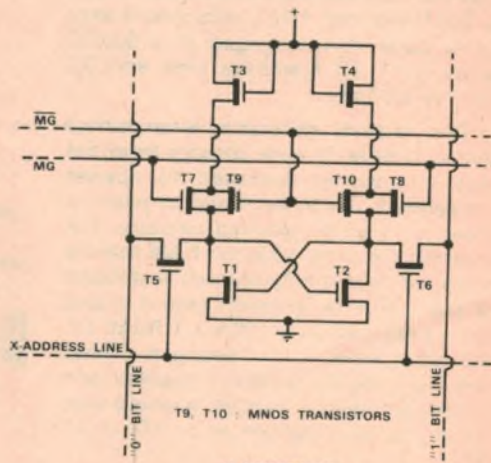

(b) MEMORY CELL

FIG. 4 NON-VOLATILE MNOS RAM

One of the disadvantages shared by all normal semiconductor RAMs, whether static or dynamic, is that they provide only "volatile" storage. The storage is dependent upon power being applied, so that if power is removed from the RAM, its stored information is lost.

Not surprisingly, there are situations where this volatility can be inconvenient to say the least. As a result, a number of alternative memory devices have been developed to provide non-volatile storage. These include the ROM and PROM devices to be discussed in the next chapter, bubble memories and magnetic discs and tapes (also to be discussed, in later chapters).

Just recently, non-volatile semiconductor static RAMs have begun to appear,

and these seem likely to provide a further useful alternative to standard devices.

One device of this type has been developed by the Tokyo Shibaura company in Japan. It uses metal-nitride-oxide-semiconductor (MNOS) transistors to provide the non-volatile storage. These do not take part in the normal write-read operation of the RAM cells, however, being used only to retain the stored information when power is removed.

The structure of an MNOS transistor is shown in Fig. 4(a). As you can see, it is not too different from a normal MOS transistor. The main difference is that there are two dielectric layers between the semiconductor channel and the insulated metal gate (G). Only one layer is silicon dioxide, and this is very thin—approximately 20 angstroms (2 nanometres). Above this is a layer of silicon nitride which is somewhat thicker, around 500 angstroms (50nm).

The idea of the two dielectric layers is that where the two layers join, crystalline defects are formed which can act as "traps". Under certain conditions, these traps can capture carriers. The trapped carriers effectively form a charged second gate of the transistor, and can control the transistor's channel conductivity independently of the main gate. And because of the high resistivity of the oxide and nitride layers, the trapped charge leaks away

extremely slowly. Typically it can be retained for more than a year, which is long enough to be regarded as non-volatile for most purposes.

Fig. 4(b) shows how a pair of MNOS transistors are incorporated into what is basically a standard MOS RAM cell. If you compare the diagram with that of Fig. 1(b), you will see that it is basically the same cell with four additional transistors. T7 and T8 are two normal MOS transistors, while T9 and T10 are two MNOS devices.

In normal operation, the logic levels on the additional gating lines MG and MG-bar are arranged so that T7 and T8 are continuously conducting, with T9 and T10 continuously held off by their metal gates. The cell is thus able to operate as

a completely normal MOS memory latch, and can be written into and read from exactly as described earlier. The MNOS transistors play no part in this normal operation.

However when power is to be removed, normal operation of the RAM is stopped. The logic levels on the MG and MG-bar lines are then reversed, switching off T7 and T8 and switching on T9 and T10. This causes the trap layers of these transistors to acquire charges, the size of the charges mirroring the current state of the latch—and hence effectively capturing the stored bit. The power may then be removed, leaving the stored charges trapped in the MNOS devices.

When the power is eventually re-applied, the logic levels on the MG and MG-bar lines are arranged so that T9 and T10 are simultaneously turned on, while T7 and T8 are held off. This allows the charges stored in the MNOS devices to "steer" the latch as it turns on, so that the saved bit of information is effectively fed back into the latch. Then the logic levels on the MG and MG-bar lines are reversed once more, changing the cells back into standard RAM cells.

In effect, the MNOS static RAM is really two separate memories integrated together: a standard MOS RAM and a non-volatile memory using charge storage, with the ability to pass stored information between the cells of each.

Before we end this chapter, there are two further memory devices which should perhaps be mentioned. One is the "first-in-first-out buffer", or "FIFO", which at first sight may seem quite different from the devices we have been talking about. Yet it is basically a static RAM, in disguised and augmented form.

From a functional point of view, a FIFO appears like a number of parallel shift registers, but with a difference: information can be fed in at one end and out at the other, at different rates. In effect, information fed in at the "input" end of the FIFO appears to "trickle" down to the other, whereupon it can be taken from the "output" end at a different rate altogether, without losing its sequence.

Such a device can be very handy where information must be fed from a system working at one rate, into another working at a different rate.

Although the FIFO seems rather like a strange sort of "flexible" shift register, it is in fact a static RAM provided with some additional circuitry. The main additions are a pair of address counters, multiplexed so that either can control the RAM addressing circuits.

One counter is used to control the address into which the FIFO's data input is written; the other controls the address from which the output data is read. The counters are automatically incremented each time a write or read operation is performed, respectively. Thus what happens inside the FIFO is that input data is stored in consecutive RAM locations at one rate, and independently read from those locations at a different rate.

There is additional circuitry which compares the contents of the two address counters, and provides two "housekeeping" logic signals: one to indicate when the FIFO is "full", and cannot currently accept any further input, and the other to indicate when the FIFO is "empty" and cannot currently deliver any output data. There may also be circuitry to allow both counters to be reset, so that it may be effectively "emptied" when power is first applied.

The other memory device which should be mentioned here is the so-called "content-addressable" memory, or CAM, also called the "associative" memory.

There are a number of different types of CAM, but from a functional point of view they all tend to have one thing in common. Stored data is not identified in terms of its absolute address in the memory, but by some characteristic of the data itself.

Writing into a CAM may be either a random operation, where new data is simply stored in any location not currently occupied, or it may be arranged so that data with certain common aspects—say some bits of a particular value—are stored together.

Reading from a CAM is done not by specifying a particular address, as with a RAM, but by specifying a data "key"—some necessary characteristic of the data that is sought, such as a certain bit pattern. The CAM then produces any of its contents which meet the criterion.

One type of CAM is basically a static RAM with an internal address counter, a clock, and a comparator which can examine memory contents and compare them with the "key" data supplied by the external circuit. When data is to be written into the CAM, the address counter is incremented until the comparator indicates an empty address. To read data out, the address counter is incremented until the comparator indicates a match between the stored data and the "key". The stored data thus found is presented at a set of output data terminals.

The content-addressable memory is a rather esoteric device, but finds use in code conversion applications and in systems designed to perform "associative reasoning".

VIDEO DATA TERMINAL FOR MICROCOMPUTERS

EME-1

- Teleprinter compatible
- 64 chars × 16lines OR 32 chars × 32lines
- On board modulator for direct TV antenna connection
- 75ohm composite video
- Crystal stabilised speeds selectable 75, 110, 150 . . . up to 9600baud
- TTL output to microcomputer serial in/out
- Low power

Phone or write for details:

E. & M. ELECTRONICS PTY. LTD.
136 Marrickville Road, MARRICKVILLE, NSW 2204
Telephone 51-5880



**FULLY ASSEMBLED
AND
TESTED**

\$295.00

Plus tax (15%)
and \$5 post
and ins.



**KIT OF PARTS CURSOR
PARTS KIT**

\$199.00 \$14.35

Plus tax (15%)
and \$5 post
and ins.

Microcomputer News & Products

Cassette interface

The CDB-159 audio cassette interface pictured at right is a high-performance unit designed specifically for use with microprocessor systems. It has just been released by Pennywise Peripherals, a new company started in Victoria by Dr. David Boulton, a lecturer in computer science at Monash University.

Dr. Boulton has used a special 3-frequency FM recording scheme in the unit, to make it capable of high transfer rates even with low cost cassette recorders. The standard transfer rate is 150 bytes per second, or 1200 baud, and this requires a recorder response of only 3.6kHz. With a hifi recorder having 12kHz bandwidth, rates up to 4500 baud can be achieved.

The recording format is self-clocking and uses no start or stop bits. Demodulation is via a phase-locked loop (PLL). The interface has a synchronous



serial organisation, and is easily interfaced via a parallel port. Standard handshaking signals are provided and used, and the unit has provision for remote control of two cassette recorders.

A software driver of around 256 bytes is available for the common microprocessors. Cost of the CDB-150 as an assembled PCB module is \$153 plus tax, with the completely packaged version shown priced at \$173 plus tax.

Enquiries to Pennywise Peripherals, 19 Suemar St, Mulgrave, 3170 (Tel 546-0308).

writing to P.O. Box 81, Albion, Qld, 4010, or by telephoning him on 262-1351 during the day. Enquiries are welcomed.

Zilog-SGS tie-up

SGS-Ates, the Milan-based IC and semi-conductor maker, is to become the European second source supplier of the Zilog Z-80 microprocessor component family. The agreement between the two companies gives Zilog effective access to SGS-Ates' strategically-deployed European applications network, and seems likely to give the Z-80 a healthy share of the European microprocessor market.

Dual-6800 systems



Pictured above are two of the PCB modules from the Qasar family of microprocessor products being manufactured by Fairlight Instruments in Sydney. Available as OEM boards or complete systems, the range features a dual-6800 CPU board. The two processors operate simultaneously on a common bus system, using opposite phases of the clock. Both run at full speed (1MHz).

The use of two processors results in simplified software, increased throughput and powerful debugging facilities in many applications. The system costs less than many comparable single-processor systems.

A full range of software support is available, including text editor, assembler, disc operating system, BASIC interpreter and FORTRAN compiler. Also available are packages which have been developed specifically for the Qasar system.

Brisbane micro club

A Microprocessor Interest Group has been formed in Brisbane. Its inaugural meeting was held on Friday 10th June, when some 50 people attended and elected a pro team executive.

The Group is interested in establishing links with other groups, with a view towards compatibility of aims and interchange of information.

The Group is also looking to expand its membership, and those interested should contact Mr Norman Wilson by

PP PENNYWISE PERIPHERALS



Australian Made

STACKABLE 4K x 8 BIT RAM PLANE

PCB only **\$15.75** (P&P free in Australia)

- Contains all interconnections for 32 2102's (1k x 1 BIT) organised as 4K bytes.
 - PCB's can be stacked for increased capacity without the added cost of edge connectors. Illustration shows two assembled boards stacked to obtain 8K bytes (or 4K x 16 bit words). Four RAM PLANES can be stacked for 16K bytes etc.
 - PCB is double sided 4.75" x 5.875".
 - No jumpers are required yet holes are not plated through.
 - Earth and Vcc are laid out in a full grid pattern to minimise current loops.
- External Connections: 10 address lines, R/W, 4 CE's each selecting 1K. +5V, E, 8 data inputs, 8 data outputs.

ALSO AVAILABLE

CDB-150 HIGH PERFORMANCE AUDIO CASSETTE INTERFACE 150 BYTES/SECOND TRANSMISSION RATE.

Send for free data sheet

Mail orders to:—

PENNYWISE PERIPHERALS
19, Suemar Street, Mulgrave, Vic. 3170.
(Phone:—546 0308.)

Prices correct at press time. Subject to change.

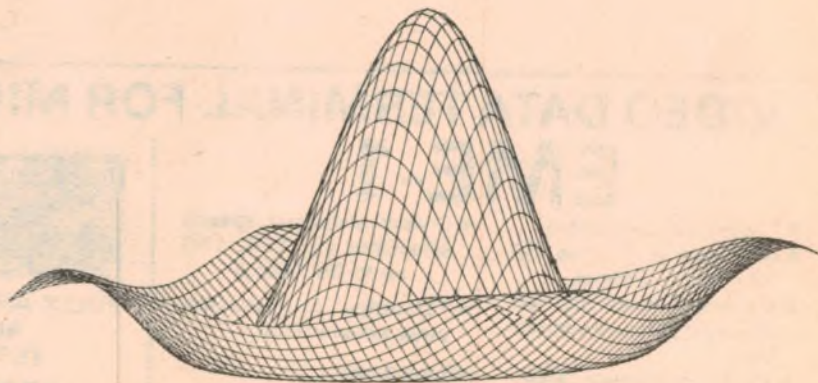

Looks a bit like a Robin Hood's hat, doesn't it? In fact it's a piece of computer graphic art, produced by reader Mr. P. W. Green, of Ascot Vale, Victoria. Mr Green explains that it is a projection of a 3-dimensional Cartesian co-ordinate plot of the mathematical "Sinc" function. His system (based on an H-P-programmable calculator) took about 24 hours to produce it on a plotter.

FREQUENCY METER AND CRYSTAL CALIBRATOR

TS-323/UR with spares Ex U.S. Navy. Bureau of Aeronautics brand new. 20 to 450 m/HZ. Accuracy of 0.01 per cent. Battery operated. Two a. batteries 6 volts three b. batteries 45V (135V) not supplied. AC power requirements 240 VAC to 150 volt stabilised DC and 6 3 volt AC. AC Power pack not included.

PRICE \$90.

\$2 Cartage to rail. Freight payable at nearest attended railway station.

P.M.G. TYPE TELEPHONES

Standard desk type with magneto bell calling device. Range 30 miles. Uses standard batteries at each phone. Any number can be connected together on single line.

\$35.00

(2 TELEPHONE SETS)

\$2 Cartage to Rail. Freight payable at nearest attended Railway Station

FOUR CHANNEL VHF TRANSCEIVER

125 to 140 M/hz. 28 volt DC operated AM single crystal locks both TX and RX on same channel complete with generator.

\$33.00

EX ABC MAGNETIC RECORDING TAPES 1/4" PROFESSIONAL QUALITY

5" x 600' \$1.50
7" x 1200' \$2.75
10 1/2" x 2400' \$5.95
P & P A \$1.10, B \$2.00, C \$2.25, D \$2.25

ILFORD 17.5 mm SPROCKETED MAGNETIC TAPE

1000 ft reels brand new original packing \$4.00 ea quantity available

Post A \$1.30 B \$2.00 C \$2.30 D \$2.80

No. 62 TRANSCEIVER

With headphones, accessories etc. \$60

TELEPHONE WIRE

1 mile twin (2 miles) genuine ex-Army Don B perfect condition \$35 per drum \$2.00 cartage to rail freight payable at destination.

RCA 77DX MICROPHONES

PROFESSIONAL QUALITY #75
P & P A \$1.80 B \$3.50 C \$4.55 D \$4.55

MORSE KEY | MORSE KEY BUZZERS
\$1.75 | \$4.25
Post 40c | Post 60c

KAISE MULTIMETERS

A compact and handy tester for workshop or lab where quick circuit checks are required.

DC Volts 2.5 to 1000V (20,000 OHMS per volt) AC Volts 10 to 1000V (10,000 OHMS per volt) DC Current 50 UA 25 MA 250 MA. Resistance 40 K OHM, 4 MEG OHM Decibels minus 20 DB plus 62 DB complete with instructions only \$24.20 Ea. P.P. \$1.05. Multimeter similar to above 30,000 OHMS per volt \$29.50 P.P. \$1.05.

Only \$17.25 ea Post \$1.05

BENDIX PIONEER

Drift Sight
Type B3
\$250.00

4 DIGIT RELAY COUNTERS

50 volt DC, suit slot car Lap counters, etc.
\$1.25 each P & P 60c

NIBBLING TOOL

Cuts sheet metal like a punch and die, trims, notches and cuts to any size or shape over 7.16inch

ONLY \$12.50

Post \$1.10

NIFE CELLS

1.2 Volt, fully charged. 4in x 3in x 1in 4 AH
\$1.60 each P & P 80c

5" CRO TUBE 5 BPI \$6.50 each

Post A \$1.40, B \$2.25, C \$2.70, D \$3.45

HANDY SIGNAL INJECTOR

Produces an Audio Signal in rich harmonics ideal for Sig Tracing in A.F., F., and R.F. circuits. Powered by 4 Penlight Batteries with On Off Switch and indicator lamp. Size 1 1/2" Diam 5" Long Only

\$6.95 Post \$1.10

POSTAGE KEY:

A: NSW
B: Vic. Qld, SA
C: NT, Tas.
D: WA

VALVES

BRAND NEW	6BM8	\$1.80
	6GV8	\$1.50
65N7GT	95c CV850	\$1.50
5U4G	95c 1H6G	75c
EF50	75c 832	\$5.00
5Y1	\$2.25 6X4	\$1.80
2 x 2	75c VR65	75c

P & P 40c

ARTILLERY DIAL SIGHTS MK2

Can also be adapted as a Dumpty Level or as base for a telescope has full 360° 5 1/4" diam. gunmetal rotating circle. Adjustable elevation and depression. Has top grade 3/4" diam. object lens. F.L. 10" with cross hairs, eyepiece, 1/2" right angle prism.—height 10"—weight 3 1/2 kgs. With leather carrying case. Original cost \$300. Our Special only \$27.50. P & P A \$1.95, B \$4.25, C \$5.90, D \$5.90

ZOOM SPOTTING SCOPES



30x30
LENGTH 12 1/2", HEIGHT 10"
WEIGHT 1 1/4 lb.
\$27.50

45x40
LENGTH 16", HEIGHT 10"
WEIGHT 2 lb.
\$39.75

High grade coated lenses. Ideal for pistol and rifle ranges or general viewing. Zooms in from very low to high powers. Complete with tripods.

POST: A \$1.70, B \$2.25, C \$2.40, D \$2.65.

TELESCOPES

25 x 30 \$7.95
P & P A \$1.70, B \$2.25 C \$2.40 D \$2.65.

CONDENSER LENS

1 1/2" Diam 4 1/2" F.L. 75c 2 1/2" Diam 2" F.L. \$1.50 each. Or \$2.50 per pair. P & P 40c

IMPELLER PUMPS

New gunmetal body. Stainless Steel Shaft Neoprene Impeller Up to 15ft. Lift, suitable for almost any type c. liquid. Self priming. Ideal boat bilge pump, sullage drains, etc. Approx size 8" x 5"

3/8" \$25.95 1/2" \$34.95 3/4" \$39.95
P & P A \$1.90, B \$2.75 C \$3.20 D \$3.95

MEGGER Battery Operated

No cranking—in vinyl case. Ranges: Meg Ohm 0-1000 Megs. Centre 20 meg. Rated voltage 500 volts. Low ohm 0-1000 ohm OH 1 range 0-1 meg ohm on 1k range. AC voltage 0-250 volts \$85.00
Post A \$1.60, B \$2.50 C \$2.75 D \$2.75.

SPECIAL NEW HAND DRILLS

German Ixion Double Pinion usually \$13.25 Special Only \$4.95 each
P & P A \$1.70, B \$2.25 C \$2.40 D \$2.65.

TURN AND SLIP INDICATORS

Useful for parachutists glider, aircraft pilots tractors for indicating angle of sway \$100 value only \$17.50
P & P A \$1.60, B \$2.20, C \$2.50, D \$2.50

MAGNESIUM DRY CELL BATTERIES

Suits PRC 25 and dozens of other uses. 15 volts long life only \$1.50 ea
P & P A \$1.65 B \$2.75 C \$3.20 D \$3.20

SPY TELESCOPES

B x 17 mag size of a rifle cartridge extends to B" Only \$5.95 each, post 60c

BINOCULARS

PRISMATIC Coated Lenses Brand new. Complete with case

8 x 30	\$32.50	P & P	
7 x 50	\$43.95	A	\$1.65
10 x 50	\$44.95	B	\$2.75
12 x 50	\$46.00	C	\$3.20
20 x 50	\$47.50	D	\$3.20

SMALL CLIP-ON POCKET TELESCOPE

15X \$6.20 Post 60c

RECEIVER No. 210

2.16 M/cs \$65.
Transmitter No. 11 suits 210 \$35
24 volt Power supply to suit above \$15
Or complete station with Headphones, Mic. Morse Key, Antenna \$110

SOLENOIDS

Plunger Type 24V 300MA. Suit electric camera control, miniature trains, radio, etc.
\$2.30 P & P 20c
200 MA 24 volt, 1/2 in push movement, \$2.30 P & P 20c.

SELSYN MOTORS MAGSLIP

RECEIVERS 2" MK2 \$5.50

TRANSMITTER 3" MK2 \$15.00

Post Packing A. \$1.75 B. \$2.75 C. \$2.75 D. \$3.65

3000 TYPE RELAYS

P.M.G. 200 Ohms — 1'500 Ohm
Coils \$2.50 each P & P 60c

P.M.G. TYPE KEY SWITCHES.
75c P & P 20c

Cosson Double Beam Oscilloscope 1035.
Tested \$150.00

AIRCRAFT INSTRUMENTS

Directional Gyros AN5735-1 \$35
Artificial Horizon Sperry #45
P & P A \$1.60 B \$2.50 C \$2.75 D \$2.75.

TRANSCEIVERS Ex Army

No C42 set. 36 to 60 MHz with 24V power supply, headphone, mic, leads etc \$65.00

No C45 set 23 to 38 MHz with headphones, mic. 24V power supply etc \$95.00

\$100 cartage to rail, freight payable at nearest railway station

Hartley double beam oscilloscope Type 13A with probes
Working \$150.00

200M FOCUSING MICROSCOPES

Battery & Mirror Illuminated
900X Magnification \$23.95
1200X Magnification \$35.00
P & P A \$1.70, B \$2.25, C \$2.40, D \$2.65

EX-ARMY TWO-WAY FM RADIOS



1.2 WATTS OUTPUT SUPERHET
PRC9 AND 9A 27 to 39 M/HZ
PRC10 AND 10A 38 to 55 M/HZ
WITH HANDSET ANTENNA \$25 EA
Battery \$3.50 extra. Harness \$4.50 extra
\$2 Cartage to Rail. Freight payable at nearest attended Railway Station

16MM SOUND PROJECTORS IN GOOD WORKING ORDER

240 volts operated. Complete with Speaker and Amplifier.
CINEVOX \$150.00
BELL & HOWELL \$250.00
SIEMENS \$375.00

\$1 Cartage to Rail. Freight payable at nearest attended Railway Station.

CB RADIOS

PMG Approved. Famous Pony Brand on 27 Meg.
7 transistor model \$55 per set of two (hand held).
11 transistor model 1 watt (hand held) \$72 ea.
5 watt 6 channel \$89 ea.
Post A \$1.65, B \$2.75 C. \$3.20 D \$3.20.

"KAISE"

Trans-Match Ham Tester SWR, RF Power, Modulation Percentage, Relative Field Strength. \$45.00 P & P A \$1.65, B \$2.75, C \$3.20, D \$3.20

"KAISE"

SK-100 Multimeter 100,000 ohms per volt, 12 Amps AC or DC \$55
P & P A \$1.65, B \$2.75, C \$3.20, D \$3.20

Deitch Bros.
70 OXFORD STREET, SYDNEY 2010

SORRY NO COD

How to make music with your Mini Scamp

One of the interesting and challenging things you can do with your Mini Scamp microcomputer is play music—perhaps not Beethoven symphonies or even soft rock, but certainly recognisable tunes. You can even use it to compose music. The interfacing hardware you need is not elaborate—would you believe one half-watt resistor?

by **DR JOHN KENNEWELL**
Physics Department, Newcastle University

A computer may be used to generate music by a variety of means. Some systems employ a relatively large amount of hardware, external to the computer, to generate the required tones and modulate their amplitude and/or duration. In consequence, the software or program required to control such a device is fairly straightforward. An example of such an instrument is the EDUC-8 Music Player Unit, described in the June 1975 issue of EA.

At the other end of the scale (!) is the program developed by Intel for their 8080 system. Those who have been fortunate enough to see and hear the demonstration of this program by Warburton Franki may remember that the only 'hardware' involved between the computer and the audio amplifier was a simple digital-to-analog (D/A) converter. In this case the software contains many routines for generating the complex waveforms required. When all the appropriate fundamental tones and their respective harmonics have been synthesized by the program instructions, they are added together and presented as a time sequence of digital words to the D/A converter. This converter is the interface required to change the discrete sequence of digital numbers into a relatively smoothed analog signal to which we are accustomed. The development of this program is said to have taken two to three man-years, and is thus not a venture to be undertaken lightly.

Fortunately, it is possible to generate simple tones with Mini Scamp relatively easily. While the results may not approach the ultimate in counterpoint and fugue, the programming is vastly simpler.

The basic idea behind the method employed here is to simply change one of the flag outputs (F0) from a zero level to

a one level and back again at a predetermined rate. The DELAY instruction is used to set this rate. By varying the amount of the delay, the frequency of the note can be altered. The note, of course, will be a square wave, or a rectangular wave (i.e., a square wave with unequal mark and space intervals).

To the ear, a square wave is not so unpalatable as might first be imagined. In fact, after experimenting with a program for some time in my office, the gentle-

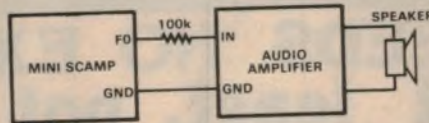

Fig. 1: The interfacing hardware you need. It could hardly be simpler!

man in the neighbouring room, Mr. Davis, came in with some comment on my ability to play the recorder! It is possible to change the tonal qualities of the sounds to some extent by varying the ratio of the time off to time on of the wave. A narrow pulse, for example, has considerably different harmonics than does a square wave, and has a more raucous sound.

The hardware required for your venture into music generation with the Mini Scamp computer is quite minimal, as may be seen from Fig. 1. The resistor shown is to limit the current into the audio amplifier. The output from flag 0 may be from 3 to 4 volts peak-to-peak, and will thus need some form of reduction with most sensitive amplifiers. The amplifier that I used was a simple transistor amplifier with a relatively low input impedance. If a high input impedance amplifier is employed, a voltage divider may be necessary to reduce the applied signal to less than 0.5 V p-p.

The first program shown here (Fig. 2) is a test program. This program requests a digital word input from the switches and then produces a short tone whose pitch is dependent on the value of the word you have just deposited. In this way one is able to build up a scale for future programs.

In operation, the first four 'active' instructions (excluding NOP) set up the base address for the switches (X'0800). A word is then loaded from the switches into the accumulator (LD 1 (1)) and stored for later reference in a location called NOTE. The next two instructions (LDI 0 and CAS) effectively put 0 at the flag 0 output. This will remain latched until the next CAS instruction. This will not occur for a time determined principally by the delay instruction at address X'10.

Reference to the SC/MP Technical Description shows that the actual delay is given by:

$$\text{delay in microcycles} = 13 + 2x(\text{accumulator}) + 514x(\text{displacement}).$$

This means the delay is affected by what is in the accumulator at the time of the

*MUSIC-TEST			
0000	08		NOP
0001	C408		LDI 0
0003	35		XPRH 1
0004	C400		LDI 0
0006	31		XPRL 1
0007	C101	NEW	LD 1(1)
0009	C815		ST NOTE
000B	C400	N1	LDI 0
000D	07		CAS
000E	C010		LD NOTE
0010	8F00		DLY 0
0012	C401		LDI 1
0014	07		CAS
0015	C009		LD NOTE
0017	8F00		DLY 0
0019	8B06		ILD TIME1
001B	9CEE		JNZ N1
001D	90E8		JMP NEW
001F	00	NOTE	.BYTE 0
0020	00	TIME1	.BYTE 0

Fig. 2: A simple test program used to find the data numbers required by your Mini Scamp for each musical note.

MICRO TERMINAL—Low Cost Alternative to Teletype

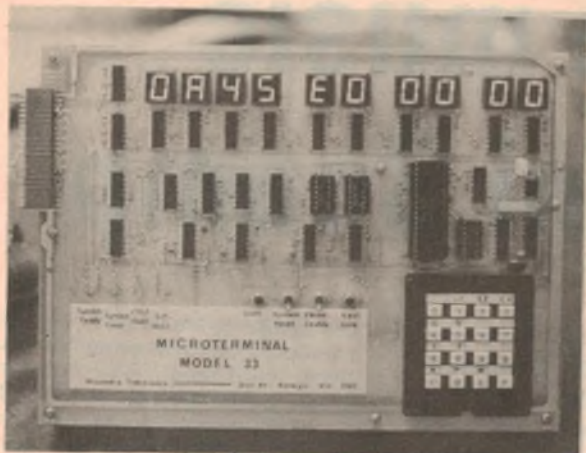

Why spend \$1,000 on a teletype? With our Micro Terminal your microprocessor kit thinks it is connected to a teletype. Suitable for 2650, SCAMP, 6800, F8, 8080. Displays 10 digits of data on 7 segment displays.

*Add your own power supply 5v dc at 2 amps and
—12v dc at 30mA. Fully Assembled Micro Terminal*

\$159
plus \$2.50
p&p.

SYSTEMS RELIABILITY (AUST.) PTY. LTD.

122 MORAY STREET, SOUTH MELBOURNE, VIC. 3205. Phone: 699 8433.

SUCCESS NEEDS NO EXPLANATION or at least, not much.

We keep a sharp eye on developments within the Electronics field, and adjust our product range accordingly.

To our already extensive component stocks, passive and active:- test gear, calculators, digital radios, switches and connectors etc, we have added speaker kits by

CORAL

a name synonymous with high fidelity.

Available are 6", 2 way - 8", 3 way (or 2 way) "bookshelf" - 10", 3 way - 12", 4 speaker, 3 way; including all leads, crossover networks, mounting hardware and assembly instructions.

(Cabinets not included - may be bought or built to your own specifications)

OPEN
MON-FRI
8.15 am
till
5.30 pm

RADIO DESPATCH SERVICE
869 GEORGE STREET, SYDNEY
(near Harris Street)
211-0816

OPEN
SATURDAY
8.00 am
till
11.45 am

211-0191

```

* MUSIC-TUNE
0000 00
0001 8FFF START DLY 255
0003 8FFF DLY 255
0005 C400 LDI 0
0007 36 XPAH 2
0008 C430 LDI X'30
000A 32 XPRAL 2
000B C601 NEW LD 1(2)@
000D 9BF2 JZ START
000F CB15 ST TIME
0011 C400 LOOP LDI 0
0013 07 CAS
0014 C2FF LD -1(2)
0016 8F00 DLY 0
0018 C401 LDI 1
001A 07 CAS
001B C2FF LD -1(2)
001D 8F00 DLY 0
001F 8005 ILD TIME
0021 9CEE JNZ LOOP
0023 90E6 JMP NEW
0025 00 TIME BYTE 0

* START DATA AT X'30
* TERMINATE WITH X'00
    
```

Fig. 3 (left): The author's simple tune-playing program.

Fig. 4 (right): The note listing for the author's tune "Hexadecilude".

```

* ELIMINATE ZEROES IN MEMORY
0000 00 NOP
0001 C501 NEXT LD 1(1)@
0003 9CFC JNZ NEXT
0005 C440 LDI X'40
0007 C9FF ST -1(1)
0009 9BF6 JMP NEXT
    
```

0030	BC	A4	99	A4	BC	73	84	99
0038	84	99	A4	BC	BC	BC	6B	73
0040	84	73	84	99	A4	99	84	73
0048	73	73	6B	73	84	73	84	99
0050	73	63	55	4E	4E	4E	3C	42
0058	4E	3C	42	4E	55	4E	42	29
0060	29	29	3C	42	4E	3C	42	4E
0068	73	63	55	4E	4E	4E	4E	00

Fig. 5: A simple program to eliminate zeroes from the memory, so you can use the random content as a "tune".

delay instruction, as well as the displacement or operand of the delay instruction itself. In the program here, the displacement is set to zero, and thus only the accumulator contents will determine the delay. By loading the contents of the location NOTE into the accumulator before the delay instruction, we obtain a delay proportional to the number we loaded from the switches. The larger this number, the greater will be the delay, and the lower the frequency of the note produced.

Following the delay, the second half of the 'square' wave is generated by placing a one in flag 0 (LDI 1 and CAS), and allowing another delay as before (LD NOTE and DLY 0). The remaining instructions repeat the square wave for 256 cycles (ILD TIME1 and JNZ N1) and then go back and request a 'new note' (JMP NEW).

When running this program you may generate a short note, of 256 cycles duration, by depressing and releasing the DEPOSIT button quickly. Alternatively, you may take advantage of the multideposit ability of Mini Scamp by keeping the DEPOSIT push button depressed. In this case, an almost continuous note will be produced, broken only briefly when the computer executes the JMP NEW, LD 1(1) and ST NOTE instructions each 256 cycles.

An important point to note at this stage is that the lower frequency notes last longer than the higher frequency notes. This is to be expected as 256 cycles of the note are output irrespective of the frequency. This fact must be kept in mind when writing a program to play different notes of equivalent duration.

As mentioned before, this test program may be used to set up a scale. If you have access to a piano, or other musical instrument, you can do this by playing a note on the instrument and

then finding what 8-bit word, when deposited from the switches, gives rise to the same tone. Thus, you can compile a list of notes over say, two octaves, and alongside these, the corresponding work as a two digit hexadecimal number. You are now ready to move to the second program listed here (Fig. 3).

This program takes a sequence of numbers starting at address X'30 and uses them to generate a tune. These numbers must be deposited along with the program before it can be run. Any short piece of music can be translated into the appropriate set of numbers using the table compiled with the first program. The tune is terminated by placing 00 at the end of this data sequence.

The first two active operations in this program create a delay of about 1/2 second. This is necessary as the program will repeat the tune endlessly unless HALTed. The delay thus places a pause between the end and beginning of the tune. The next four instructions set up the data address for the start of the tune (i.e., X'0030). The first "note" is then loaded into the accumulator and also stored in the location called TIME. If this "note" is zero, the end of the tune has been reached, and the program will start all over again (JZ START). Otherwise, a square wave will be generated by the method described for the first program. As pointer register 2 has been incremented by the load instruction at X'000B, it is now pointing to the next 'note', and the accumulator for both delay instructions must be loaded from the original note specified by the contents of register 2 minus 1 (LD -1(2)).

The variable TIME is incremented, and tested for zero (ILD TIME and JNZ LOOP) to see how many cycles of the note are to be generated. But, if you remember, TIME was previously set to the value of the note, and this gives us a crude way to make the different pitched notes more equal in length. That is, the larger the value of the note, the lower will be the frequency, but fewer

cycles of this frequency will be produced, as the word TIME is counted from its initial high value to 256 or zero. This method appears to work fairly well except for values close to either end of the scale (i.e., 00 and FF). When TIME has been incremented to zero a new note will then be fetched (JMP NEW).

A short musical piece to try out this program is listed in Fig. 4. The data shown here is loaded sequentially into addresses starting at X'0030. It is even possible to 'play' a tune without loading any data, by making use of the random information that the memory contains whenever the computer is switched on. However, before this can be done, any random zeroes in memory must be eliminated as these terminate the 'tune'.

A simple program to eliminate zeroes is shown in Fig. 5. This program should be run (until the DRQ LED comes on), then address X'00FF should be set to zero, and finally the MUSIC-TUNE program should be loaded and run, whereon your Mini Scamp will then entertain you to about 20 seconds of Mini Sculthorpe.

After experimenting with the material presented here for a while, many deficiencies will soon become apparent. It has not been my intention to present a fully-fledged synthesis program in this space, but rather to point out several ideas that may be built upon to produce ever-more interesting results. I believe that there is tremendous scope for experimentation in the field of computer music.

The use of the previously described random number generator opens up the whole field of computer music composition. For instance, a random number might be generated and used to indicate the pitch and/or duration of the note. Various tests can be then applied to see whether this note conforms to any number of musical rules you have specified. If it does, then it is accepted; if not, then it is rejected and a new random number is tossed up to try again.

Simple Hex Terminal

The Micro-Terminal Model 33 is a low cost alternative to a teletype or video display terminal, for use with microprocessor systems. The terminal allows the user to fully utilize the monitor/debug program usually supplied with a microprocessor evaluation or development system.

The terminal unit uses a small calculator-type keyboard for data entry purposes, and a row of seven segment displays to allow the microprocessor to "talk to the operator. The full range of hex characters can be displayed, with special functions such as carriage return, line feed, space, system ready (* or -) and syntax error (?) indicated by single LED displays.

A system reset switch is provided, with two complimentary reset lines available, so that the terminal unit and the microprocessor can be reset simultaneously. The two units communicate via fairly standard 20mA current loop circuitry, although no isolation has been provided on the terminal unit, as is customary.

Hex data is entered directly into the keyboard, with command characters and terminators entered using the shift key,

which operates in an analogous fashion to that on a typewriter. The signals from the keyboard are converted into serial 7-bit ASCII by a UART, and transmitted to the microprocessor.

Returning data from the microprocessor is accepted by the receiver section of the UART, and made available in parallel form. The special function characters are decoded, and used to drive the appropriate LEDs. Hex data is displayed sequentially in the display, with spaces automatically deleted. This gives an effective increase in the amount of data which can be displayed at any one time.

As you can see in the photograph, the displays have been spaced so as to effectively reinsert the spaces for the normal hex output formats of most microprocessors.

A carriage return/line feed combina-

tion from the microprocessor will reset the counter used to drive the display, giving a "new line" effect.

The basic model of the terminal has only eight displays, which should be sufficient for most systems. A second model is available with ten displays, which also has a "pause" facility for dumping out large slabs of memory. In this mode, the microprocessor is halted after ten characters have been displayed, by driving the pause, hold or halt line.

After the data has been copied, the "next line" switch can be used to display the next ten characters on the display. The process is repeated as often as required.

Physically, the unit contains about 30 ICs, as well as the displays and the keyboard. All components are assembled on a large double sided PCB, measuring 280 x 202mm. Connections to the board are made via a standard 0.1" spacing edge connector in the upper left hand corner of the board.

Only one adjustment is required. This is the clock frequency for the UART, which must be set to 1760Hz, to give the required 110 baud data rate. The terminal comes with a set of instructions for its use, and also details of the interfacing arrangements required for most commonly available systems.

We were able to try out the unit with the "baby" 2650 system, as described by Editor Jim Rowe in the March 1977 issue. We were able to enter and debug a small program, using the resident PIPBUG monitor. The terminal unit can be used to enter and display data under program control, although the type of data which can be displayed is limited by the seven segment displays.

The terminal units are only available fully assembled and tested, with the base model available for \$149.00 inc. tax, and the full feature model for \$159.00 inc. tax. They are made and distributed in Australia by Systems Reliability (Aust) Pty. Ltd., of 122 Moray Street, South Melbourne 3205. (D.W.E.)

The single board construction of the Model 33 terminal can be clearly seen in this photograph. Note the four indicator LEDs in the lower left hand corner of the board.

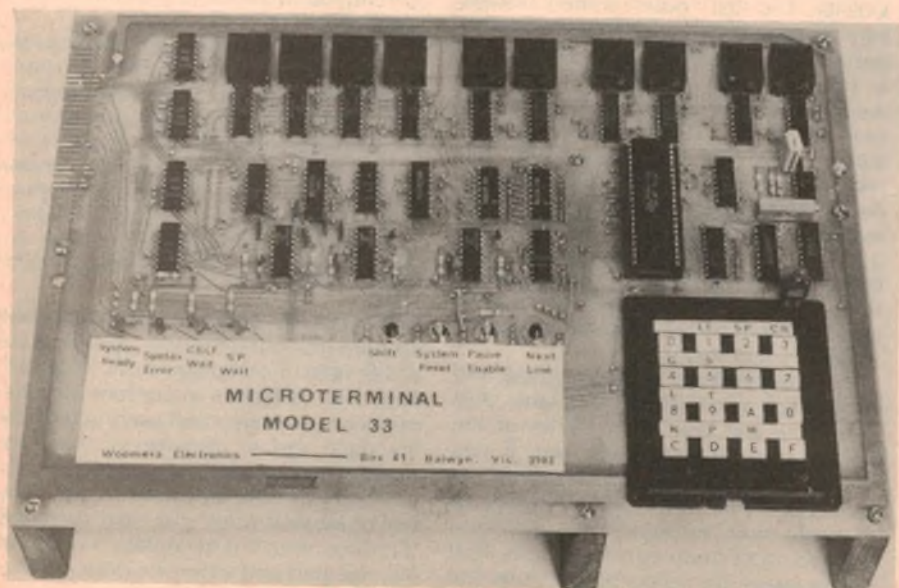



The Dick Smith—Electronics Australia Microcomputer Contest:

Started on your entry yet?

As announced in the July issue, Dick Smith Electronics and Electronics Australia are running an exciting microcomputer contest. The idea is simple—to the individual enthusiast, student or hobby club who can come up with the most intriguing and imaginative application for the Mini Scamp microcomputer, Dick Smith Electronics is awarding an outstanding prize: a complete “big brother” system valued at more than \$2000, shown above. It consists of a National Semiconductor SC/MP development system complete with Tiny BASIC interpreter, an E & M Electronics video terminal complete with 12-inch TV receiver, and two Statronics modular power supplies.

We're not looking for way-out academic applications, but down-to-earth practical ways of using microprocessors in the home, office or school. Like controlling a model train layout, or running a home movie show.

The system you develop must use Mini Scamp, and its software must fit in less than 1280 bytes of RAM and/or ROM/PROM. It should preferably have been tried out in practice, to make sure there are no hidden bugs. Your entry should include a detailed description of system operation, a complete program listing with comments, and details of any custom interfacing you have used.

Judges for the contest winner will be Mini Scamp's designer Dr John Kennewell, entrepreneur Dick Smith and EA editor Jim Rowe. Their decision will be regarded as final.

Entries must be accompanied by the official entry form below (except in states where this requirement is illegal). Entries should be postmarked no later than September 30th, 1977. The winner will be announced in EA as soon as possible after that date.

CONDITIONS OF ENTRY: Entries should represent the entrant's original work. Employees of Sungravure Pty Ltd, Dick Smith Electronics Pty Ltd or any associated companies are not eligible to enter. Entries postmarked or delivered by hand later than September 30, 1977, will not be eligible.

ENTRY FORM

THE DICK SMITH—ELECTRONICS AUSTRALIA MINI SCAMP \$2000 MICROCOMPUTER CONTEST

Complete this form and attach it to your entry, posting them not later than 30th September, 1977, to Microcomputer Contest, c/o Electronics Australia, Box 163, Beaconsfield, NSW 2014. A letter may be used instead of the form in States where this requirement is illegal.

NAME

ADDRESS

POSTCODE.....

Classical Recordings

Reviewed by Julian Russell



Ibert, Damase, Arma: recommended

IBERT—Concerto for flute and Orchestra. Jean-Pierre Rampal (flute) with the Lamoureux Orchestra conducted by Louis de Froment.

DAMASE—Serenade for Flute and String Orchestra. Rampal with the French Radio Orchestra conducted by Andre Girard.

ARMA—Divertimento de Concerto No. 1. Rampal and the French Radio Orchestra (strings and piano) conducted by Andre Girard. RCA Erato Stereo STU71022.

Here is some real refreshment for lovers of French music who are satiated with numberless recordings and reissues of Debussy's *La Mer* and Ravel's *Daphnis and Chloe*, great works though they are. Ibert will be known to most listeners by his witty *Divertissement*, as elegant a piece as ever came out of the post-Debussy school. His *Flute Concerto* reviewed here was first performed over 40 years ago by that masterly flautist Marcel Moyse. I wonder how many readers will remember his outstanding performance of Honegger's unaccompanied solo "The Goat" which so eloquently described the animal's alternations of skipping and meditation? It was, of course, first recorded on a 78.

The concerto starts with a *moto perpetuo* type of first movement which takes an invigorating grip on your attention. In this, Rampal makes his instrument sound almost garish in spots, though I think he is at his best in more lyrical passages. His playing and tone differs from that of his most distinguished pupil, James Galway. He (Rampal) is a bit fluttery in the slow movement, though beautifully fluent in the fast sections of the work. Perhaps he hasn't all Galway's glitter or his faculty for entertainment.

But he is a superb flautist for all that. Rampal doesn't try to stand out from the orchestra but prefers to blend into the ensemble as a first among equals. In this concerto he is supported by a small orchestra consisting of strings in five parts, woodwind and a single trumpet. The work is consistently pleasing, though to compare the music to that of Debussy's and Ravel's at their best would be asking just a little too much. Ibert has true French fastidiousness and is always refreshingly original and, above all, good humoured. I enjoyed it immensely.

The first movement is followed by a *Serenade for Flute and Orchestra* by Jean-Michel Damase. Damase, although born in 1928, takes us back to the atmosphere of *Les Six* who dominated so much of the French music produced during that decade. Perhaps, as the sleeve notes point out, he pays more allegiance to Poulenc than the other five composers of the group.

By the way, the late Peter Warlock wrote a wickedly funny limerick about these composers. Warlock (Philip Heseltine to give him the right name) had a whole bookful of the brilliant little verses and I sometimes wonder what became of

VERDI—*Requiem*. Joyce Barker (soprano); Mignon Dunn (alto); Ermanno Mauro (tenor); and Paul Plishka (bass) with the Slovak Philharmonic Choir and the Philharmonic Orchestra of Strasburg conducted by Alain Lombard. RCA Erato, Stereo STU70965/966.

Here is a fine recording of the *Verdi Requiem*, a work I love so much that I ration the times I listen to it in case I should wear out my reaction to its many beauties. In this performance, the dynamic range is so wide that you will have to be careful about the way you adjust your gain if the whispered opening is to be audible without the fortissimos blowing you out of the room. Lombard's interpretation is a very theatrical one—not that this matters, because Verdi was essentially an operatic composer.

The orchestral tone sounds much richer here than it did when I heard it under Barbirolli in Strasburg a few years ago. The soloists are fine in quality and immediately responsive to the conductor's direction. And the Slovak Philharmonic Choir is surprisingly good in the very Italianate music.

An important feature of Lombard's performance is the use he makes of significant silences, always perfectly judged. I have only two minor criticisms to make of the whole production. I found the diction often a little difficult to follow although there is an English and a French translation of the Latin text, in which it is sung. But then I am no Latin scholar so that the fault may be entirely mine.

them. It was a highly amusing and perceptive collection all in limerick form. The rude words would nowadays pass without comment and, if they could be found, would be well worthwhile publishing!

Damase's music is sometimes smooth and occasionally mischievous. The recording all through is a little hard but always beautifully clear. This too, is played with masterly technique and good taste by Rampal.

The third work on this disc is a *Divertimento de Concerto No. 1* by Paul Arma, born in 1905. Bad luck has followed Arma for most of his life. Three times he lost all his manuscripts when, because of his hatred of Fascism, he left Hungary, Germany and Occupied France. He was also left penniless after all three moves.

But he continued to bob up resiliently, though I think the program notes exaggerate a little when they compare his music to Bartok's. True there is some resemblance here and there to the early Bartok of the Hungarian period but that's about as far as it goes. Rampal plays the *Divertimento* deliciously and introduces some truly golden toned sound in the slow section of the second movement. The disc will make a welcome addition to anyone's record library.

Also the text of the very last section has been omitted altogether. It looks like the designer of the short brochure ran out of space when they got there. And if you are unfamiliar with the words you are likely to miss the marvellous dramatic impact of the final pianissimo *Libera Me*. I wish I had more space in which to praise this two disc boxed set, but I can recommend the entire production with great enthusiasm.



OFFENBACH arranged Rosenthal—*Gaite Parisienne*. Overture to *La Fille du Tabour-Major*. Monte Carlo Orchestra conducted by Manuel Rosenthal. EMI stereo/quadrasonic OASD 3311.

SULLIVAN arranged Mackerras—*Pineapple Poll*. Royal Philharmonic Orchestra conducted by Charles Mackerras. HMV Greensleeve stereo ESD 7028.

It seemed to me natural to group these two discs together because both are arrangements for ballet of music by 20th century musicians of 19th century composers' pieces. Both arrangements are excellent, with Rosenthal sticking closer to Offenbach's originals than does Mackerras with Sullivan's. No voices are used, and both versions are nothing like the selections one used to hear in cafes or played by military bands.

Though on the surface both works, being arrangements, would be expected to be very much alike, they are in fact

very different. Whereas Rosenthal uses complete short excerpts brilliantly scored and arranged, but with little difference from the original except in the orchestration, Mackerras gets up to all kinds of clever tricks while still preserving the spirit of the original—and I don't mean the word clever to be taken pejoratively. He often leaves one guessing about the origin of some of the tunes and doesn't make his puzzle any easier by combining themes from different operas, occasionally using exemplary counterpoint. And while Rosenthal sometimes introduces short bits of his own composition, Mackerras' music is always echt Sullivan.

To me, the sound is better in Pineapple Poll than in Gaité Parisienne which is sometimes a trifle thick through the middle, perhaps the latter is compatible quadraphonic/stereo while Pineapple Poll is straight stereo. But I must stress that the difference is so slight that it need not prevent prospective buyers from acquiring the Rosenthal disc. His performance is truly brilliant. But then for that matter so is Mackerras'.

I can think of no better way of finishing this review than by stating that while Rosenthal faces some pretty formidable competition on other labels, I doubt if Mackerras' performance and engineering is ever likely to be improved on.



MASSENET—Ballet Music from Le Cid. Lamento d' Ariane.
MEYERBEER—arranged by Lambert—Les Patineurs (ballet). Decca Stereo SXLA 6812.

Except in France where he is still revered as a member of the old school, Massenet is pretty well neglected by the rest of the world. But though performances of his opera *Le Cid* are rare indeed, the ballet music is still pretty well known by those who still remember Palm Court combinations and the kind of music that was used to accompany silent films. Others will probably never have heard of it or much else of Massenet's attractive music except perhaps *Manon*—not to be confused with Puccini's *Manon Lescaut*.

Richard Bonyngé handles this score so well that one could dare hope that, instead of more of less concentrating on the revision of early 19th opera, he might give us some Massenet in Sydney while he is still the musical director of the Australian Opera Company. He is, I believe, at present quite immersed in the music of this composer.

Bonyngé uses the National Philharmonic orchestra which, I believe, is the "property" of a Mr. Sidney Six, whatever that might mean. At any rate under Bonyngé's direction it can be rated quite high. The orchestra has good soloists and ensemble and a general tone not without bloom. I never suspected Bonyngé of having the really vigorous sense of rhythm he shows in the *Madrilène*. But

Vivaldi—The Four Seasons: "incredible virtuosity"

VIVALDI—The Four Seasons. James Galway playing the solo violin part on his flute at the same time conducting the Zagreb Soloists in support. RCA Red Seal Stereo VRL1-7125.

James Galway is much more extroverted than his ex-master Rampal. To a technique of astounding brilliance he adds a natural ease to entertain. He obviously finds deep enjoyment in making music whether it's of the most serious nature or merely a jig. Those who had the pleasure of hearing him live in the Sydney Opera House Concert Hall during his recent visit will recall his mischievous look when, for an encore, he produced a tin whistle, almost like a conjurer, and with it sent streams of pearly notes floating into the auditorium.

The solo part he plays in Vivaldi's *Four Seasons* was, of course, originally written for violin. But that doesn't matter to Galway who is quite at home transferring it to his flute. Not that transcriptions were rare during the baroque period. Then, they were often the rule rather than the exception. Even the great J. S. Bach found the time to transcribe pieces by other composers to instruments other than those for which they were originally intended. I even heard Galway, on radio, play the violin part of Cesar Franck's *Violin Sonata* on the flute with the happiest results. He himself admits that many of his interpretations come from listening to great players on other instruments such as Heifetz and Horowitz. Since no autograph score of the *Four Seasons* exists nowadays, it may

be of interest to musicologists to learn that Galway's transcription was made from the earliest known edition published by Leclerc in Paris in 1830.

Perhaps the engineering of the disc or the natural tone of Galway's instrument makes his tone sound a bit fuller than Rampal's. Galway's account of the work offers an example of almost incredible virtuosity interspersed with deeply felt musicianship. Indeed there were many sections of the *Four Seasons* that I liked better on the flute than on the violin.

Galway adds more colour to the score and, despite his instrument's rather forward recording, is never annoyingly prominent. His changes from one register to another are made so seamlessly as to pass unnoticed, even in the lowest reedy notes. His fast repeated notes are such as I've never heard produced on the instrument before. The whole exercise might well be described as another novelty to charm jaded listeners. The Zagreb Soloists conducted by Galway's himself offer splendid support.

I must add that anyone who had the unique experience of attending one of his live performances in Sydney must recognise that, in addition to his other mighty talents, he is as great an entertainer as was Paganini on the violin. Indeed "the Paganini of the flute" would be a good description with a special exception—one of Paganini's favourite tricks was to break a string during the progress of a work and finish it on the remaining three strings after having practised this in secret before the performance.

I am reluctant to pick one of the items when all are really so good.

By the way, it might be pertinent to mention here that the late Willie Redstone, a former musical editor of the ABC and a very dear friend of mine, was a pupil of Massenet. I am sure he would have been delighted with Bonyngé's performance.

Lamento d' Ariane also originated in one of Massenet's still less known operas which was first performed in Paris in 1906 and was repeated no fewer than 50 times in the following eight months. Now this is quite a good record for many operas which only too often receive one or two performances and are then forgotten. It will, I think, be unfamiliar to most present day non-French listeners.

The *Lament* features a long string cantilena beautifully phrased and played with beguilingly warm tone. The second part is decorated by some lovely lyrical flute playing. The sound throughout both works is especially good whether fully enriched or delicate.

The *Ballet Les Patineurs* based on

music by Meyerbeer and arranged by Congtant Lambert, is just as excitingly recorded. If your tastes are similar to mine the double basses at the very opening will amaze you. The work is another very skilful arrangement for ballet and the whole disc should appeal to lovers of classical ballet popular before flat chested dancers started wriggling all over stage when not assuming plastic poses. It has genuine sparkle when not going its deliciously lyrical way. ☺

THE "ELECTRONICS AUSTRALIA"

LOG BOOK

FOR: RADIO AMATEURS,
DX LISTENERS,
CB OPERATORS. \$2.95

From booksellers & radio stores OR direct from "Electronics Australia" 57-59 Regent St. Sydney.

Save on top quality European speakers

- assemble your own system with this - complete Philips kit.



All you need is a couple of hours, a pair of scissors and a screwdriver.



1 Screw the crossover networks to the baffle boards.

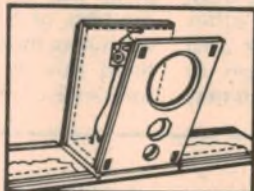

2 Apply glue to the case and fit baffle boards in grooves.



3 Wrap sides of case around baffle board.

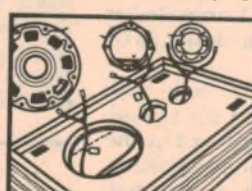

4 Insert speakers in holes and screw into position.



5 Clip fascia panel in place.



By assembling these Philips speaker kits yourself you can either save yourself a packet on what you were expecting to pay - or achieve a much higher quality system for the same money.

No need to make excuses about not being an electrician. These kits are complete. All components are genuine Philips units. Every part is ready to install. Every step is covered in simple illustrated stages. It's as easy as assembling a simple model kit from a hobby shop.

Now simply connect up to your amplifier and turntable and you're in business. For information about your nearest dealer contact your state office or send in this coupon.

Sydney 42 1261, 42 0361, Melbourne 699 0300
Brisbane 44 2471, Adelaide 223 4022
Perth 65 4199

Philips
Electronic Components and Materials,
P.O. Box 50, Lane Cove, N.S.W. 2066.
Please send me details on your High Fidelity Loudspeaker kits.

Name _____

Address _____

Postcode _____



Electronic Components and Materials

PHILIPS

153.0193



Lighter Side

Reviews of other recordings

Devotional Records

SAIL ON SAILOR. Mustard Seed Faith. Stereo, Maranatha H S-777/18. (From S. John Bacon Publishing Co, 13 Windsor Avenue, Mount Waverley, Vic. 3149.)

The designer of the jacket and sleeve for this album has concentrated on being different, to the point where one has to work at it to discover what its all about. All the information about those responsible for the recording, plus the lyrics, are in a script face which is more different than readable!

When you do read the lyrics, however, the ideas expressed are precisely those that one would find in traditional church hymnals and Gospel song books. The titles: The Question – Let go – Can't Work Your Way To Heaven – Once I Had A Dream – Dried Up Well – Sail On Sailor – Lighter Side Of Darkness – Sweet Jesus Morning – More Than The Sunlight – Back Home.

While the words and themes may be conventional, however, the vocals, the instrument line-up and the arrangements are strictly in the modern idiom, ranging from the somewhat sentimental, through a touch of bluegrass, to rhythm and soft rock. As such, its appeal will be mainly to the 'teen audience through to the early twenties. The sound quality is to normal standards. (W.N.W.)

TELL IT TO JESUS. Larnelle Harris. Stereo Word WST-8669. (From Sacred Productions Aust, 181 Clarence St; Sydney and other capitals.)

According to the jacket notes by Thurlow Spurr, a tremendous amount of work went into the preparation of this album, beginning with the choice of eleven numbers from the very large repertoire that the young negro Gospel singer Larnelle Harris has built up in many hundreds of appearances in public concerts and in appearances in high school auditoria.

Then came the arrangements by Bergen White, the job of laying down the rhythm, keyboard, string and vocal backing, followed by the vocal lead. The end result reflects all this planning, in a generous 35.5 minute program of 11 songs: Tell It To Jesus – Someone Who



Can – Lord Listen To Your Children Praying – Lord Send That Morning – Somebody Bigger Than You And I – Freedom Prayer – All The Time In The World – You Are The One – Praise The Lord, He Never Changes – I Am Ready For Jesus – He Touched Me.

I imagine that you will not know too many of the songs but Larnelle Harris' diction is such that you won't have any problem in following the lyrics. Whether you will want to or not will depend heavily on whether you do or don't

Instrumental, Vocal and Humour

ANOKA HIGH SCHOOL CONCERT BAND, 1974. Conducted by Charles B. Olson. Ark stereo 2144-S. (From M.R.Acoustics, P.O. Box 110, Albion, Brisbane 4010).

There are two points of special interest about this imported recording. A product of the Ark Recording Co, a division of Fulton Electronics, it was presumably made using their special microphone and recorded with a minimum of intervention at the mixing console. Whatever the reason, the sound is clean and spacious and the dynamic range is very wide.

Secondly, it features a local high school concert band and, as such, should appeal to those who are interested in "orchestral" band music, particularly involving non-professional players.

Unfortunately, the jacket is completely devoid of other details but the titles, taken from the label are: Emblem of Unity (J.J. Richards) – Roman Carnival (Berlioz) – Concertpiece No. 2 (Mendelssohn) – Pentagon (B. Green) –

belong to the now generation, with its love for the rock sound and the driving beat. If you like that sound, you'll regard this 35-minute album as a bargain. If you don't . . . enough said! (W.N.W.)



I'LL SING THIS SONG FOR YOU. The Hawaiians. Stereo, Word WST-8739. (From Sacred Productions Aust, 181 Clarence St. Sydney and other capitals.)

I had rather mixed feelings about an earlier album of the Hawaiians, reviewed recently in these columns. Perhaps it was that the whole of the sleeve presentation conditioned one to expect an Hawaiian program, whereas it turned out to be a very mixed recital reflecting the stage presentations of Hawaiians Mark and Diane, and ranging from neo-classical to contemporary.

On this album, the program is much more cohesive—tuneful, happy Gospel songs, selected for their message and a middle-of-the-road sound, rather than as a demonstration of the artists' versatility: Walkin' In The Light Of His Love – I'll Sing This Song For You – All The Time In The World – Give Them All To Jesus – Through It All – Lookin' All Around – Touch My Friend, Lord Jesus – It Matters To Him About You – My God And I – Friend Of The Father.

Whereas most of the Gospel records that seem to come my way these days are aimed at youth, this is one that will suit those with more conservative tastes. An imported album, the sound and surface are quite okay. (W.N.W.)

Jericho (Gould) – Music Makers (A. Reed) – Concertino For Tuba (F. Bencriscutto).

The Anoka High School Concert Band is a large and accomplished group who performed to the complete satisfaction of the local audience – an audience that gave no hint of its presence until the applause at the end of the each side. I have some reservations, however, as to whether the program would appeal overmuch to those outside the specific interest groups mentioned at the outset. (W.N.W.)

HAPPY HOURS. Honky Tonk Herman. Project 3 stereo L 36147. Distributed by Festival Records Pty Ltd.

If ever a record was destined to get a thrashing, this is it. Since I took it home it has been played to death at the demand of all the household. Honky Tonk Herman sounds as if he has ten fingers on each hand and is backed with frenetic fingering on banjo, bass and galloping drums. The only way you could stop from prancing about while this disc

Reviews in this section are by Neville Williams (W.N.W.), Jamieson Rowe (J.R.), Leo Simpson (L.D.S.), Norman Marks (N.J.M.), David Edwards (D.W.E.) and Greg Swain (G.S.).

RADIO DESPATCH SERVICES

869 GEORGE STREET, SYDNEY 2000
NEAR RAILWAY SQUARE



KEYBOARD AND ENCODER KBD-5

Full 8 bit parallel ASC 11. Outputs with parity bit for error detection, positive or negative output strobe 88 characters ASC 11 upper & lower case or upper case only if required.

All parts including keyboard \$89.95

Have the SWTPC 6800 Computer System available model MP-68

TERMINAL CT-1024

wide range of electronic components

OPEN MON-FRIDAY

PHONE 211-0816 211-0195

OPEN SATURDAY MORNING

LIGHTER SIDE

is playing is if you were in an iron lung. Recording quality is very good.

No less than twenty five tunes are featured, most in medley form. Here is a sample: Those Were The Days - Paper Doll - California Here I Come - What Have They Done To My Song - Cabaret - Waiting For The Robert E Lee - Tie A Yellow Ribbon 'Round The Ole Oak Tree - Somebody Stole My Gal - When I'm Sixty Four - Baby Face - Happy Days Are Here Again.

Thoroughly recommended. (L.D.S.)



THE SHIRLEY BASSEY COLLECTION. Volume II. United Artists stereo L 45631/2. 2-record set.

Not so long ago I reviewed Volume 1 of this collection and had some good words for it. I am less enthusiastic about Volume 2. Shirley is inclined to shout here, and is backed by some less-than-impressive orchestras. Nor is she helped by the recording quality, which tends to be on the harsh side at times.

Some of the 24 track titles are as follows: The Shadow Of Your Smile - Kiss Me, Honey Honey, Kiss Me - That's Life - Summer Wind - I Who Have Nothing. (L.D.S.)

ORGAN MAGIC. The Magic Organ, played by Jerry Smith. Stereo, Interfusion, (Festival) L-25279.



I'm sure that I haven't reviewed all twelve of the Magic Organ albums that have preceded this one but, after listening to those that did come my way, I offered the opinion that the sound had been created by a talented musician, copying the style of traditional fairground organs, but using a modern electronic, possibly a Hammond.

On this album, the background is given for the first time and it is as I had guessed. The musician is Jerry Smith, who started out as (and is still) a church organist but who has also done a lot of professional accompaniment work on organ and piano for big-name Nashville artists. And the instruments pictured on the jacket are indeed modern electronics, among them a Lowrey and a Hammond.

The style of this thirteenth album is still

AUDITEC POWER 25-250 WATTS

001 Mk. 2 30/50 Watts R.M.S. Power Amplifier Module. Load 8/4 ohms. Less than 0.05% T.H.D. Fully short-circuit protected. New lower recommended price. \$22.71



018 60 Watts R.M.S. @ less than 0.1% T.H.D. Fully short-circuit protected. \$37.51

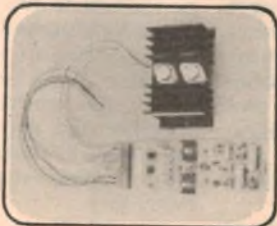

009 120 Watts R.M.S. @ less than 0.1% T.H.D. Fully short-circuit protected. \$60.38



033 Very high quality 100 Watts R.M.S. Power Amplifier for Studio work, etc. Distortion almost unmeasurable. T.I. distortion almost nil. Produces a subtle difference in sound which has to be heard to be appreciated. \$75.38

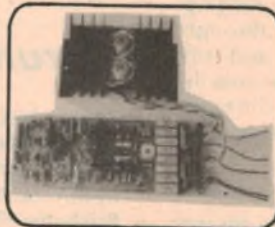

027 250 Watts R.M.S. power amplifier module @ less than 0.2% T.H.D. Fully short-circuit protected 8 OHM balanced output. \$113.28

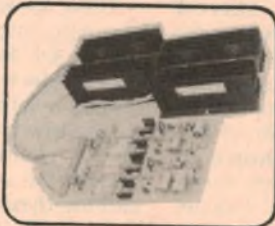

019 25 Watts R.M.S. power amplifier @ less than 0.1% T.H.D. powered directly from 12 volt car battery. \$51.69

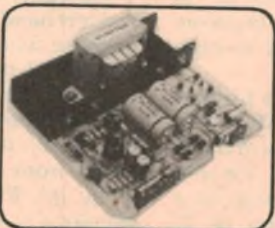

AGENTS:
MELBOURNE: Zephyr Products. Phone 568 2922
BRISBANE: Delsound Pty Ltd. Phone 229 6155
ADELAIDE: Neil Muller Pty Ltd. Phone 74 1162
BUNDBERG: Bundaberg Hi-Fi. Phone 71 3176
CANNBERRA: Musique Boutique. Phone 82 2553
TAMWORTH: Hi-Fi Gallery. Phone 65 7788
MARYBOROUGH (QLD): Keller Electronics. Phone 21 4559
ROCKHAMPTON (QLD): Premier Sound. Phone 28 2701
SURFERS PARADISE (QLD): Beno's Musical Supplies. Phone 38 1568
WHYALLA (S.A.): Audiolab Sales. Phone 45 7755
PERTH: Willis Trading Co. Phone 21 7609

FOR DESCRIPTIVE LEAFLETS ON THESE MODULES CALL, PHONE OR WRITE TO:

AUDITEC AUSTRALIA PTY LTD
10 WAITARA AVENUE
WAITARA, N.S.W. 2077
PHONE: 48 4116

(PACIFIC HIGHWAY SIDE OF WAITARA STATION)

A FULL RANGE OF PREAMPLIFIERS IS ALSO AVAILABLE

Prices quoted are recommended only, and include sales tax. Prices may be slightly higher interstate

recognisably Magic Organ but with a fuller sound and I judge that Jerry Smith is developing a revised approach for future albums. Here he plays: Sail Along Silvery Moon – The Inn Crowd – Alley Cat – Shine On Harvest Moon – Greensleeves – Just Because – Orange Blossom Special – Cream 'N Sugar – El Rancho Grande – The Touch Of Love – Indian Love Call – Speakeasy.

Technically, the sound is very clean and, what if the tempo is still strict, you'll find yourself toe-tapping to it. Anyway with twelve successful albums under his belt, Jerry Smith has to have a lot going for him! (W.N.W.)

★ ★ ★

THE LAST COWBOY. Gallagher and Lyle. A & M Records L 36093 Festival Release.



Gallagher and Lyle have established for themselves a sizeable niche in the country-rock music world, and this album can only help cement this position for them. Their music varies from slow ballads to bouncy light-rock, but always retains a well balanced sound. The instrumental backing is always delightful, providing the perfect complement to the vocals.

All the tracks are self composed, and are as follows: Keep The Candle Burning – Song And Dance Man – Acne Blues – I'm Amazed – King Of The Silents – Rain – We – Mhairu – Villain Of The Peace – The Last Cowboy.

If country-rock sounds appeal to you, this album is strongly recommended. Technically, the sound was quite clean, with no evidence of surface noise. (D.W.E.)

★ ★ ★

THE BEST OF THE TWO RONNIES; Ronnie Corbett, Ronnie Barker. Stereo, M7, MLF-179.

The two Ronnies will scarcely need introduction to anyone who owns a television set. Nor will you need to be convinced about their talents, whether expressed in monologue, dialogue, sketch, or in a musical setting.

On this album, their act is keyed almost completely to music, provided by a substantial orchestra and choir, but cleverly spoofed out front by the two Ronnies: Moira McKeller and Kenneth

The New Decca Cartridge joins the team that ensures Hi-Fi excellence

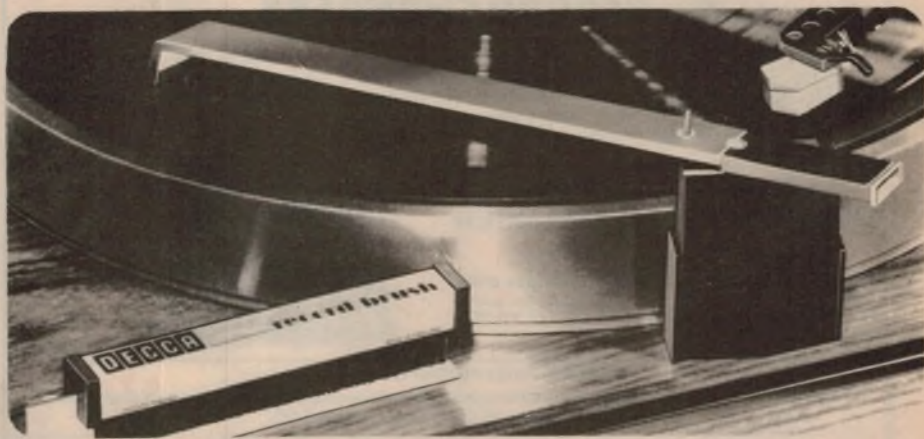

The new Decca London Elliptical Cartridge sets new standards by which other cartridges will be judged. And since the London Cartridge was first introduced, there have been some dramatic improvements in ways of maintaining record groove cleanliness. Decca Record Brushes and Decca Record Cleaners reach right down into the groove searching out really fine dust, and enable the London Elliptical to be used without "Crackle and Pop" problems previously found in other lightweight cartridges.

With an elliptical stylus, the area of impact with the groove is smaller than a spherical stylus. Since both the area of contact and the tip mass are important factors in determining the upper frequency resonance point, to maintain the wide frequency response Decca have reduced the metal thickness of the armature to a little over one thousandth of an inch. This reduction in both thickness and tip mass, combined with raising the upper frequency limits automatically increases the compliance of the cartridge and extends the bass response for a given tone arm.



Decca London Elliptical Cartridge
*\$125 at leading Hi-Fi Stores
Decca Record Brush and Decca Record Cleaner *\$13.95 each at Hi-Fi stores and Record Bars

*Recommended retail price

AUDIOANALYSIS

by Andrew Marshall

"It is still a cartridge that, for reasons best known to the engineers at Decca, sounds better than it measures, and in the case of the new elliptical model, that sound is simply superb." Reprinted by courtesy of the FM Guide, February, '76.
Frequency Range: 20Hz-20 KHz
Playing Weight: Recommended 1.5 grams

DECCA

Australian Agents:

British Merchandising Pty. Ltd.,
49-51 York Street,
SYDNEY. *Phone 291571

BM 3001

Anderson – The Brass Band – The Plimstead Ladies Male Voice Choir – Gilbert and Sullivan – The Scouts Jamboree – The Russian Choir – The Boys In The Ballet – The Short & Fat Minstrels.

In terms of quality, the recording, made at the Majestic Sound Studios, London, is extremely good and, to those with an ear for hifi, will compete strongly for attention with the voices. One other point: I wouldn't particularly recommend playing it to the Vicar because, unlike their TV shows, the humour in the lyrics depends rather heavily on double

entendre. Or, to repeat an Australianism that somebody used: "it's a bit close to the knuckle!" (W.N.W.)

TARNEY AND SPENCER. Tarney and Spencer. M7 Records MLF 163.

This album is a real surprise packet. The information provided on the cover is minimal, and Tarney and Spencer are previously unknown to me. Yet, from the opening bass of "I Can Hear Love", this record is a delight, and slots nicely into the category of light rock.

SPECIAL PURCHASE

NEW B.S.R. & GARRARD RECORD CHANGERS-ROLA & GOODMAN SPEAKERS AT A FRACTION OF LIST PRICE

NEW STANDARD B.S.R. C123 RECORD CHANGERS



Fully automatic turntable plays up to six records automatically and single records automatically or manually as required. 11" turntable. Bias compensation Cue & pause control. Record speeds 33 1/3, 45 and 78 rev / min. Finished in black with silver trim. Player and changer spindles supplied. Fitted with ceramic cartridge. Post & packing extra. N.S.W. \$3.70; Vic., Qld., S.A. \$5.70; W.A. \$6.70 (registered post \$2 extra if required)

\$20.00

GARRARD M.82 \$57.00 TRANSCRIPTION CHANGER

Recommended retail price \$120.00

Supplied with Goldring Magnetic Cartridge with Diamond Stylus. Post & packing (Reg post) N.S.W. \$3.60, Vic., S.A., Qld. \$4.74, Tas. \$5.50, W.A. & N.T. \$6.75.



GARRARD CC10A RECORD CHANGER \$14.75

Fitted with a Sonatone Garrard Ceramic Cartridge Sapphire Stylus supplied with template & instructions. Post & Packing: N.S.W. \$2.50 Inter \$3.50

BASE & PERSPEX COVERS AVAILABLE IN TEAK & WALNUT FINISH

NEW ROLA C12PX 12" HI-FI SPEAKERS

Rola twin cone Hi-Fi speakers. Freq. range 40 to 13,000 cycles power rating 30 watts 1mp-8ohms. Post & packing N.S.W. \$2.50. Interstate \$3.50

\$16.50

ROLA-FOSTER HI-FI 3-WAY \$45 PER KIT SPEAKER SYSTEM

Frequency range 40 to 20,000 cycles. Power rating 30 watts R.M.S. 1mp-8ohms. Supplied in kit form (less cabinet) each kit comprises Rola C12PX 12" bass unit, Foster 5" mid range, Foster 1" dome tweeter, crossover components (inductances & condensers) innabond, speaker fabric & cabinet plans (cabinet volume 60 litre). Post & packing N.S.W. \$4.00; Vic., S.A., Qld. \$5.50; Tas. \$6.00; W.A. \$7.50

NEW GOODMAN'S-FOSTER 3-WAY 4 SPEAKER HI-FI SYSTEM.

Frequency Range 45 to 22,000 cycles. Power rating 25 watts. 1mp-8 ohms. Supplied in kit form (less cabinet) each kit comprises two English Goodman's B" bass units, Foster 5" mid range, Foster 1" dome tweeter, crossover components (condensers & inductance) innabond, speaker fabric & plans of cabinet. Cabinet dimensions 23" x 13" x 10"

Post & packing extra N.S.W. \$2.70; Vic., S.A., Qld. \$4.70; W.A. \$5.70
\$39.00 PER KIT (REGISTERED POST \$2.00 EXTRA IF REQUIRED) cabinets available.

PLAYMASTER—MAGNAVOX HI FI SPEAKER SYSTEMS 3 WAY

3-45-L

AS FEATURED IN ELECTRONICS AUST. APRIL '75
Complete kit of parts for above system including speakers, Magnavox 8-30 Bass Unit, 6J Mid Range Philips AD0160/TB Dome Tweeter, crossover components 6" & 3" tubes, speaker silk & innabond (Less Cabinet). **\$57.00 PER KIT**

Freight & packing extra per pass. rail or air freight.

3-41-L

AS FEATURED IN ELECTRONICS AUST. JUNE '76
As above but using the new Magnavox 6-25 Mid Range in place of the 6J with additional crossover components **\$65.00 PER KIT**

CLASSIC RADIO IS A DISTRIBUTOR FOR FOSTER LOUDSPEAKERS

NEW MAGNAVOX — MV50— 50 WATT SPEAKER SYSTEMS

As featured in Feb. 1976 issue of Electronics Today

Complete kit of parts (less cabinet) comprising Magnavox 10-40 10" bass unit, 625 mid range 6" two XJ3 dome tweeters, crossover network, innabond, speaker silk and plans of cabinet.

\$78.00

Per Kit

freight extra per rail or air freight Cabinet available

New C800 STEREO AMPLIFIER BY CLASSIC

\$149 (freight extra)



- Elegant and functional design
- Push-button controls
- Microphone input with separate control
- Provision for simulated 4-channel stereo
- Cabinet in teak or walnut oiled finish with matching metal trim
- Power output 25 watts per channel RMS Total output 50 watts RMS 8 ohms
- Frequency response 20 cycles to 30,000 = 1dB

Full specifications Oct. or Nov. '76. Electronics Aust.

LIGHTER SIDE

Alan Tarney's vocals are very clear, and he possesses an exuberance that is clearly audible. This is particularly evident in "It's Really You". The instrumental backing is equally good, with particularly crisp guitar work, an authoritative drum section, and on "Need Your Lovin'", a good harmonica solo.

Most of the tracks are written either by Alan Tarney, or by Tarney and Spencer in conjunction. One familiar tune, given a refreshing treatment, is the Don Gibson hit of yesteryear "Sea of Heartbreak". Technically, the recording was reasonable, although the copy submitted for review was scratched on side 2. (D.W.E.).

★ ★ ★

SLEEPWALKER. The Kinks. Stereo. Arista records AL-4106. EMI release.



This is the Kinks first album on their new label, and it shows a marked change in musical direction as well. Unlike their previous album ("The Kinks Present Schoolboys In Disgrace"), it is not a concept album. Instead, they have gone back to their origins, and presented straight rock and roll.

From start to finish, this album is very professional, with Dave Davies' lyrics coming through very clearly in typical Kinks style. I was particularly impressed with the title track "Sleepwalker", and also with "Juke Box Music" and "Full Moon". This latter track is typical Davies humour.

In conclusion, a thoroughly recommended album. Technically, my review copy was very good, with little surface noise and a very clean sound. (D.W.E.)

★ ★ ★

THE VERY BEST OF ENGELBERT HUMPERDINCK. EMI Stereo EMC 062 98387.

Just in case you've been doing a Rip Van Winkle for the past ten years, Englebert Humperdinck as referred to on this album is not the late nineteenth century composer. Instead he's the very successfully renamed Tommy Dorsey, and English pop singer.

CLASSIC RADIO

245 PARRAMATTA RD, HABERFIELD 2045 PHONES 798 7145, 798 6507

Unfortunately for Englebert, this album does not show him to best advantage. With a few exceptions, the arrangements and orchestration are stereotyped and lacklustre. Nor is the recording quality anything to write about.

That is unfortunate because the track selection is good: Another Time, Another Place – Something – Day After Day – Quando, Quando, Quando – Leaving On A Jet Plane – Forever And Ever – Put Your Hand In The Hand – Help Me Make It Through The Night – Love With All Your Heart – plus nine others (L.D.S.)

★ ★ ★

GOLD & SILVER. Barry Bailey at the Console of the Rodgers Trio organ. Stereo, Harlequin (Festival) L-25284.

My reaction to this recording by Brisbane organist Barry Bailey was much warmer than to the last album which I reviewed in the May issue.

The organ here is his own three-manual theatre style Rogers, somewhat augmented, and supplemented by solo passages on a grand piano standing alongside. The whole performance sounds far more spontaneous and relaxed and, while the instrument sounds a trifle brighter than the average popular pipe organ in a cinema situation, I'm not sure that it isn't all to the good. And there's certainly no lack of deep bass to balance it.

The track titles: My Fair Lady Selection – And I Love You So – Heyken's Second Serenade – Someday My Heart Will Awake – The Impossible Dream – Maid Of The Mountains Selection – Schon Rosmarin – Button Up Your Overcoat – You're The Cream In My Coffee – Meditation – Gold & Silver Waltz – Estrellita – Let 'Er Go March.

Technically the acoustics are good for an in-home recording and the only shortcoming in terms of quality was an occasional "prickle" on the surface of the sample pressing. Certainly one that could interest popular organ enthusiasts. (W.N.W.)

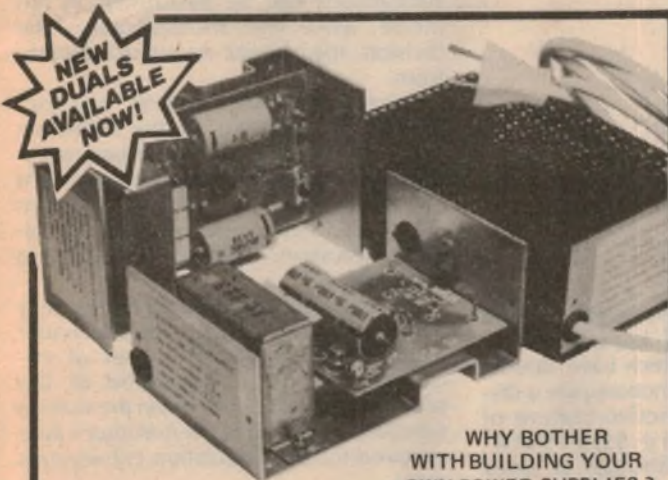

WHY BOTHER WITH BUILDING YOUR OWN POWER SUPPLIES ?

3A at 5V for \$28.50

- Is it really worth all the trouble making your own supplies, when you can get them ready made at low cost with all these features:
- Regulation 0.2% line, 1% load
- Ripple and noise 2mV p-p
- Meets C126 • Current limiting
- Crow bar overvoltage
- Operation to 80° C ambient
- 160x66x100mm (165x70x103mm Bench).

TYPE	RATING	OPEN	BENCH
53/5(B)*	5V 3A	\$28.50	\$32.00
53/12(B)	12V 1.8A	\$32.00	\$35.50
53/15(B)	15V 1A	\$32.00	\$35.50
53/24(B)	24V 1A	\$32.00	\$35.50
53/212(B)	+/- 12V 1A	\$38.50	\$42.00
53/215(B)	+/- 15V 1A	\$38.50	\$42.00
53/312(B)	12V 3A	\$38.50	\$42.50
53/313(B)	13.8V 3A	\$38.50	\$42.50
53/351(B)	13.8V 5A	\$42.50	-

*Suffix (B) denotes Bench version in enamelled case. Prices plus Sales Tax if applicable. Orders under 10 off sent Freight On.

Just check your requirements alongside and order direct or send for data sheet.
97 Hunter Street, Hornsby 2077
Telephone: 476-3607

STATRONICS

ELECTRONIC ENTHUSIASTS EMPORIUM

POPULAR INTEGRATED CIRCUITS AND SEMI-CONDUCTORS STOCKED

CA3017	4.80	CD4026	3.10	CD4724	3.85	LM3800	2.75	MC1496X	2.75	TOA1005	5.50
CA3013	5.80	CD4027	1.05	CD40057	1.80	LM3811	3.20	MC1590G	6.75	UAA170	3.25
CA3018	3.50	CD4028	1.80	CD40098	1.80	LM3827	2.60	MC14553	12.50	UAA180	3.25
CA3023	6.80	CD4029	2.85	CD40174	2.90	LM3871	2.75	MC1688P	4.90	UA723C	LM723
CA3028A	2.60	CD4030	.85	CD40175	2.90	LM395K	6.90	MC4044P	4.90	UA757	3.80
CA3035	5.20	CD4031	4.70	CD40182	2.90	LM555CN	1.20	MM5740	20.70	ULN2208	2.45
CA3039	2.10	CD4035	2.35	CD40194	2.90	LM555H	1.95	OM807	3.20	ULN2209	2.45
CA3046	LM3046	CD4040	2.50	CD40195	2.90	LM556B	2.95	SAJ110	2.50	ULN2211	2.10
CA3053	1.70	CD4041	2.50	DM8097	1.80	LM567B	10.90	SAR140	2.50	74C00	55
CA3059	8.40	CD4042	1.95	HEF 4001	7.00	LM567N	1.50	SC3050E	1.35	74C02	80
CA3062	4.40	CD4043	2.75	LM0070	6.90	LM568CN	3.50	SD306DE	1.50	74C04	55
CA3079	4.40	CD4044	2.25	LM114H	4.90	LM567CN	3.50	SL145A	2.70	74C10	85
CA3080	2.10	CD4045	3.20	LM301AN	4.95	LM709N	.85	SD425A	1.80	74C14	2.80
CA3081	2.70	CD4046	3.20	LM301CN	95	LM710CN	1.25	SL437D	3.60	74C20	75
CA3082	2.70	CD4047	1.95	LM304H	3.80	LM710CH	1.40	SL440		74C85	3.80
CA3083	2.90	CD4049	90	LM305AM	3.80	LM723H	1.70	SL442	2.90	74C86	2.00
CA3086	LM3086	CD4050	90	LM307N	1.80	LM723N	1.75	SL447	4.90	74C90	2.50
CA3089E	2.90	CD4051	2.25	LM308V	2.20	LM725N	5.80	SL449	1.60	74C154	5.50
CA3090	6.80	CD4052	2.25	LM309K	2.60	LM733CH	2.70	SL810C	7.25	74C160	3.60
CA3091	18.00	CD4053	2.25	LM310N	3.80	LM733N	2.50	SL812C	7.75	74C187	4.50
CA3120E	4.50	CD4066	1.45	LM311A	3.80	LM741CH	3.20	SL813C	12.50	74C174	2.50
CA3127E	4.50	CD4068	1.45	LM311H	3.80	LM741CN	3.20	SL820C	8.50	74C197	2.80
CA3128E	9.90	CD4069	90	LM312H	4.90	LM747CH	2.10	SL821C	9.50	74C201	1.95
CA3130T	2.25	CD4070	55	LM317K	8.90	LM747CN	2.50	SL823C	17.40	74C2975	16.70
CA3140T	2.25	CD4071	55	LM318N	5.90	LM749CN	1.20	SL827C	26.90	80C95	2.20
CA3600	3.30	CD4072	55	LM319H	7.25	LM1303N	2.80	SL624C	8.80	MY3C	
CD4000	55	CD4075	55	LM319N	5.90	LM1310N	3.50	SL630C	8.80	AL5352	1.50
CD4001	55	CD4076	1.25	LM320K	8.90	LM1458N	2.50	SL640C	10.60	GL448A	1.80
CD4002	55	CD4078	.55	LM320T	4.50	LM1488N	6.90	SL641C	10.60	GL5253	80
CD4006	2.30	CD4081	55	LM322N	4.50	LM1489N	5.75	SL645C	12.60	DL31	90
CD4007	55	CD4082	55	LM323K	7.90	LM1496N	1.90	SL901B	3.90	LM448A	38
CD4008	2.35	CD4085	1.65	LM324H	4.50	LM1808N	3.90	SL917B	6.50	LM5023	35
CD4009	1.50	CD4086	1.65	LM325N	4.50	LM3028	CA3028	SL1310	1.60	FN0357	3.50
CD4010	1.50	CD4087	1.80	LM328H	4.50	LM3046	2.80	SL3046	1.20	FN0500	3.50
CD4011	55	CD4092	2.70	LM340K	4.95	LM3098	3.35	SP8505	8.80	90C1	1.80
CD4012	55	CD4093	1.40	LM340K	4.95	LM3900	1.75	SP8515	12.90	R368	3.85
CD4013	90	CD4510	3.20	LM340T	2.70	LM3905	3.90	TA4300	2.90	9601	2.90
CD4014	2.40	CD4511	3.30	LM349N	4.50	LM3909	1.50	TBA570	2.90	NSN71	2.90
CD4015	2.40	CD4514	8.50	LM358N	3.20	MC1035P	2.80	TBA651	3.90	NSN74	2.90
CD4016	80	CD4515	8.50	LM370H	4.95	MC1312P	4.90	TBA700	4.90	TL1306A	13.80
CD4017	2.25	CD4516	3.20	LM371N	3.90	MC1314P	6.90	TBA810A	4.90	ULN190	18.50
CD4018	2.25	CD4518	2.85	LM372H	7.50	MC1315P	10.75	TB1750A	3.90	95H90	14.50
CD4019	2.25	CD4519	1.35	LM372N	4.50	MC1350P	1.95	TCA270	2.25	2107.2	3.75
CD4020	2.50	CD4520	2.55	LM373H	4.70	MC1351P	2.80	TCA290A	4.90	2K320	1.75
CD4021	2.25	CD4528	1.80	LM374H	4.80	MC1454E	5.40	TCA700A	4.90	SI883	11.50
CD4022	2.15	CD4539	1.98	LM375N	4.90	MC1458	LM1458	TCA580	8.50	SS0242	15.00
CD4023	55	CD4555	1.80	LM377N	3.50	MC1468L	8.50	TCA730	6.90	MA1007	15.50
CD4024	1.75	CD4556	1.80	LM379	7.50	MC1488	LM1488	TCA740	8.80	7805CP	2.90
CD4025	55	CD4720	12.80							7824CP	2.90

In some cases pin for pin substitutes will be supplied.

THIS IS NOT OUR COMPLETE RANGE. PLEASE ENQUIRE.

7400	48	7483	2.30	74S258	4.75	74LS174	2.70	80437	2.80	2N3589	50
7401	48	7485	2.95	74S196	7.50	74LS175	2.70	BD438	2.20	2N3638	55
7402	48	7486	85	82S23	8.95	74LS181	8.50	BF173	1.25	2N3638A	60
7403	48	7489	4.50	82B1A	3.90	74LS191	4.50	BF180	1.10	2N3647	55
7404	48	7490	90	82S80	7.50	74LS192	4.50	BF194	85	2N3643	55
7405	48	7481	1.90	74LS90	55	74LS194	2.60	BFY50	1.20	2N3694	65
7406	1.09	7482	1.20	74LS02	55	74LS195	2.60	BFY51	1.50	2N3819	1.35
7407	1.09	7483	1.20	74LS03	55	74LS196	2.60	BPX25	4.90	2N3866	2.75
7408	48	7485	1.65	74LS04	65	74LS221	2.50	BSX19	75	2N4037	1.25
7410	48	7496	2.15	74LS08	55	74LS253	2.75	BU128	3.85	2N4249	65
7411	54	74100	3.85	74LS06	55	SEMICONDS		MFE131	1.95	2N4250	65
7413	1.15	74107	95	74LS10	60	AC125	1.80	MJ802	8.90	2N4355	65
7414	2.70	74121	1.20	74LS11	55	AC126	1.80	MAJ955	2.60	2N4356	65
7418	1.00	74122	1.20	74LS13	1.20	AC127	1.80	MAJ502	8.90	2N4360	95
7417	1.15	74123	1.40	74LS14	2.95	AC128	1.80	MPF102	85	2N4362	55
7420	48	74132	1.90	74LS20	55	AC132	1.50	MPF103	85	2N4363	55
7422	1.95	74141	2.75	74LS21	55	AC187	1.50	MPF104	1.10	2N4368	MPF103
7425	95	74145	2.95	74LS22	60	AD188	1.50	MPF105	1.10	2N4369	MPF104
7428	70	74150	3.75	74LS27	60	AD189	2.80	MPF106	1.15	2N4370	MPF105
7427	88	74151	2.20	74LS28	60	AD189/82	4.50	MPF121	1.10	2N4375	MPF106
7430	48	74152	1.95	74LS30	55	AS322	1.80	MPF603	6.90	2N4591	11.30
7432	86	74154	3.20	74LS32	70	AT1138	2N301	TIP31C	1.20	2N6027	1.35
7437	90	74157	2.20	74LS37	70	ASY17	2.65	TIP32C	1.30	2N6084	21.00
7438	90	74160	2.75	74LS38	70	BC107	35	TIP120	3.20	2SC199	5.50
7440	48	74164	2.90	74LS40	65	BC108	35	TIP125	3.30	2SC1306	5.50
7441	2.80	74165	2.90	74LS42	2.20	BC109	35	TIP141	4.70	2SC1307	5.50
7442	2.60	74174	2.90	74LS73	75	BC177	40	TIP295	1.70	BA12U	80
7445	2.80	74180	2.90	74LS74	80	BC178	40	TIP305S	1.70	0A47	60
7446	2.60	74181	5.95	74LS75	1.20	BC179	40	TTR00	2N4037	0A80	35
7447	2.60	74185	4.90	74LS78	75	BC182	40	TTR01	1.20	0A81	35
7448	2.80	74190	3.20	74LS86	95	BC212	50	2N301	2N2869	5082 2800	3.20
7450	48	74177	2.90	74LS90	1.85	BC327	55	2N706A	1.20	40440	2N3731
7451	48	74191	2.90	74LS92	1.95	BC337	55	2N918	1.60	40637A	2.85
7453	48	74192	2.75	74LS93	1.80	BC547	55	2N2222A	1.20	40673	1.85
7454	48	74193	2.75	74LS95	2.80	BC548	55	2N2646	2.50	40872	2.80
7460	48	74194	2.50	74LS108	85	BC549C	55	2N2605	8.70	40874	1.90
7470	85	74195	1.90	74LS113	85	BC559	55	2N2904A	1.50	82B1B	45
7472	75	74196	2.90	74LS114	85	BC639	1.20	2N2905</			

New Products

New scientific calculator

The Commodore SR419OR calculator offers no less than 106 functions, and is aimed directly at the scientific, mathematical and statistical markets. It is fitted with internal nickel-cadmium rechargeable batteries, and is supplied complete with a recharging unit and vinyl protective carrying case.

The unit features a 14 digit LED display and 49 keys, 42 of which have dual functions. A comprehensive instruction manual is supplied, giving the user clear instructions on how to use the calculator.

In its most basic mode, the calculator can perform the normal arithmetic func-

tions, coping with numbers in the range 1×10^{99} to $9.999999999 \times 10^{99}$, both positive and negative. The display converts to scientific notation automatically.

Numbers can be entered directly in scientific mode, and it is also possible to increment or decrement the exponent, moving the decimal point accordingly.



The large number of keys, most of which have double functions, are a distinctive feature of the SR419OR. Although it does not show in this photograph, the keytops are also colour coded.

This means that the results of calculations can be displayed in standard units, such as microseconds or picafarads.

Standard mathematical functions, such as sines, squares, and logarithms can all be achieved with a single keystroke. The inverse of these functions can all be achieved using two keystrokes.

A range of metric conversions are provided, including feet to metres, pounds to kilograms and miles to kilometres. A gallons to litres conversion is provided, but this is not of much use in Australia, as it is based on the US gallon, rather than the imperial gallon.

Two memory locations are provided, enabling constants and intermediate results to be stored. A "clear all" function is provided to enable these to be cleared, as well as the usual clear entry and clear registers key.

Calculations involving angles can be handled in either degrees or radians, with the facility to convert from one to the other at will. Pi is provided as a constant, to facilitate its use in calculations.

Calculations can be carried out using complex numbers, and the results can be converted to polar form if required. An interesting feature of the unit is its ability to calculate directly in hours, minutes and seconds.

Using the hms key, a time can be entered as x hours, y minutes and z seconds. If more than 60 minutes or seconds are entered, the display will show the corrected sum. Additions and subtractions can be performed in this mode, while with multiplication and division, the answer reverts to decimal form.

Among the more esoteric functions the unit can perform are the following: It can calculate mean and standard deviations, do a linear regression (fit a straight line to a set of x,y co-ordinates, and then interpolate them along the line), and calculate gaussian, binomial and poisson distributions.

A numerical integration process may also be carried out, to give the area under a curve represented by a set of co-ordinates. A list is provided of the accuracy to be expected from the various functions, along with the maximum time required for any calculation (12 seconds max).

All told, there are 106 direct entry functions, and as readers will notice, in the space available for this review we have not been able to give descriptions of them all. Suffice it to say that the unit is very versatile, and certainly presents a different approach to calculations than the more common programmable units. It should be of considerable interest to college and university students, in particular.

Recommended price of the unit is \$79.95 sales tax exempt, or \$91.94 sales tax paid. It is distributed in Australia by W.H.K. Electronics & Scientific Instrumentation, of 2 Gum Road, St Albans Vic 3021. (D.W.E.)

CB power supply from Ferguson

A new 13.8V/2A regulated power supply specifically designed to power CB transceivers has been released by Ferguson Transformers Pty Ltd. Locally manufactured, it is short-circuit protected and approved by the Electricity Authority of NSW.

As the picture at right shows, the Ferguson ECA140 CB power supply comes in a neat metal case measuring 178 x 126 x 80mm. The case has a matt black finish, with white lettering. Controls have been kept to a minimum: an on-off switch, an LED pilot lamp, and the two output terminals.

One of the things about a CB power supply is that it is likely to be used by people with very little technical background, and Ferguson have obviously been at pains to make the ECA140 as safe as possible in such situations. Not only is it fully short-circuit protected, but it also conforms fully to the relevant SAA specifications, and has been approved by the Electricity Authority of NSW (approval number N158).

The short-circuit protection employs fold-back current limiting, so that if necessary the supply will operate virtually indefinitely under short-circuit conditions, without damage or overheating. The limiting knee is at approximately 2.5 amps, well above the normal drain of both AM and SSB rigs, so that it does not reduce transmitter power.



Rated output of the ECA140 is 13.8 volts at 2 amps, more than enough to give full output with virtually all AM or SSB transceivers. The unit we tested met this rating easily, being only 0.3% down in output voltage for 2A loading and 240V input. Ripple regulation was adequate down to 225V input, at 2A rated load, so that the performance should be more than adequate for all CB applications.

In short, the ECA140 seems a very safe and foolproof supply, with more than enough output to run even SSB rigs to full power. At \$37.50 plus tax it represents good value for money.

Temperature controlled soldering iron

The Scope model TC60 is a new temperature controlled soldering iron from Scope Laboratories, of Victoria. The element is rated at 60 watts, and is available in 24, 50 and 240V ratings.

The iron features a shaped plastic handle, and has an overall length (excluding cord) of 210mm. It is fitted with a black heatsink at the handle end of the barrel, which is intended to prevent the handle from becoming hot. A support hook is supplied which attaches to the heatsink.

When the iron is first turned on, it takes approximately 60 seconds for the tip to reach operating temperature. A small neon lamp is incorporated into the handle, and this indicates when the element is energised. Temperature control appears to be based on differences in the thermal expansion coefficients of the barrel and a rod inside the barrel. The differential expansion operates a micro-switch, which controls the voltage applied to the element.

The temperature of the tip is adjustable. This is achieved by inserting a special key (provided) into an aperture in the side of the barrel. No calibrations or scales are provided, the instructions simply stating that the iron is set at the factory to about 320 degrees C, and that



a half turn of the key changes the temperature by about 80 degrees C. The temperature can be increased by turning the key anti-clockwise, while a clockwise rotation will decrease the temperature.

Maximum earth leakage current of the design is stated to be less than 6uA. This means that it is quite suitable for soldering CMOS devices, although it would be wise to ensure that the barrel is earthed to the circuit earth.

An assortment of different tips are available, in both single and double flat models. The tips screw into the end of the barrel, and details are given of how they should be replaced. It is recom-

LANTHUR ELECTRONICS

69 Buchanan Avenue, North Balwyn,
(P.O. Box 162), Vic. 3104. Ph. 859 4061.

SPEED CONTROLLER KITS

For all brush type AC/DC 240 volt motors. Regulates down to stop with no loss of torque. Especially hand tools, lathes, potters wheels etc.
Five amp (1200 watt) size **\$10.25**
Ten amp (2400 watt) size **\$10.95**
Price includes postage.

LAMP DIMMER KITS

Will control incandescent lamps from full to out.
Five amp (1200 watt) size **\$7.50**
Ten amp (2400 watt) size **\$8.50**
Available with rotary or slider type control. Price inc. postage.

PLASTIC CABINET

Suitable for above speed controller or lamp dimmer
\$1.75

ALUMINIUM CABINET

As above **\$2.95**

BATTERY CHARGER KITS

For charging 12 volt wet batteries at 2 amps. Contains transformer, bridge rectifier, ballast resistor and circuit
\$10.25
Plus postage \$2 (Surplus refunded)
Aluminium cabinet to suit **\$3.95**

BATTERY SAVER KITS

Will supply DC voltages from 6 to 15. Contains tapped transformer, bridge rectifier, filter cap and circuit.
One amp size **\$8.95**
Two amp size **\$16.95**
Plus postage \$2.50 (Surplus refunded)
Aluminium cabinet to suit. One amp **\$3.95**
Aluminium cabinet to suit. Two amp **\$4.75**

CAPACITORS

Polyester film—1uf 100vw
Pack of 100 **\$15.50** Pack of 10 **\$2.00**
Pack of 25 **4.50**
CERAMIC DISC—English "Eria" .1 uf 50vw
Pack of 100 **\$11.00** Pack of 10 **\$1.35**
Pack of 25 **3.00**
ELECTROLYTIC—2500uf 35vw
Vertical can type **\$1.95** Three for **\$5.50**
1000uf 16vw S E pcb type
Three for **\$1.75** Ten for **\$5.50**

SILICON DIODES—Sub-min.

1 amp 400 piv. Ten for **\$1.50**
Stud mount type—25 amp 200 piv. Forward or reverse
\$1.95
Ten for **\$18.50**

P.C.B. Etching kits

Includes board, chemicals and instructions **\$4.95**

Prices include postage unless otherwise stated.

mended that special "Anti-Seize Lubricant" is used regularly on the tip thread, although none is supplied with the iron.

Replacement elements are available, should they be required. A safety stand is available as an accessory. This includes a sponge pad for tip cleaning.

In use, we found the iron to be quite comfortable in the hand, with the standard tip being suited to general electronic soldering. The controlled temperature facility is effective and quite welcome, especially when doing delicate electronic work.

The Scope model TC60 is distributed by Ampec Engineering, 42 The Strand, Croydon, NSW 2132. Recommended retail price is \$29.93. (D.W.E.)



AUSTRALIA'S FIRST BYTE SHOP

Inmsai 8080 Truly second generation Microprocessor Mini Computer.
Complete range of memory and I/O modules available.

Cromemco TV dazzler • Byte saver • Cyclops camera • A-D, D-A • Cromemco Z80 mini computer.

Processor Technology The Sol System Intelligent Terminal.
Wide range of PROM; RAM; Parallel/Serial I/O; firmware; simulator, text editor; video display modules.

North Star Inc. Floating point arithmetic unit. Mini floppy disc, controller and software.

Oliver Audio Paper tape reader.

All the above are available in kit form or assembled form. For further details send S.A.E. to: **BYTE, P.O. BOX 156, CARNEGIE, VIC. 3163. OR, for hands on experience phone: Melbourne 568-0648 or 569-7867.**

SONTRON INSTRUMENTS & THE BYTE SHOP
17, ARAWATTA STREET, CARNEGIE, VIC. 3163.

NEW PRODUCTS

Paradio distributes SWTP computers

Computer hobbyists and other small system users will no doubt be interested to learn that Paradio Electronics has been appointed sole Australasian distributor for Southwest Technical Products Corporation, of Texas.



The name Southwest Technical Products is probably well known to those readers who are interested in microcomputers, as they have become well established in the US market. One of their most popular products is pictured above—the MP-68 microcomputer, based on the Motorola MC6800 microprocessor. The MP-68 comes as a kit complete with 4k bytes of memory, serial interface, a standard Motorola MIKBUG monitor in ROM, and a power supply. The latter is adequate to cope with a fully expanded system, with up to 24k bytes of memory. The kit sells for \$713 retail, including tax.

A selection of software is available, including both 4k and 8k BASIC.

Also in the SWTP range is the PR-40 line printer, pictured below, and the new CT-64 video terminal kit, featuring upper and lower case, scrolling or page mode, and reverse video highlighting.

Enquiries for SWTP systems should be directed to Radio Despatch Service or Pre-Pak Electronics in Sydney, Magraths in Melbourne, and Delsound Pty Ltd in Brisbane.



EA'S NEW DIGITAL LOGIC TRAINER

\$72.00

Ideal as a teaching aid.



Electronic Tool Kit

\$22.95



Tweezers
File
Soldering Iron
Solder
Philip S/Driver
2 Screw Drivers
Long Nose Pliers
Flat Nose Pliers
Vinyl Zip Case



\$13.95
or 6 for
\$72.00

DIGITAL WATCH MODULE

Hours and mins. LED display. Requires two 386 batteries. Make into a pendant or brooch.

TRANSISTOR RADIO CHASSIS



Some AM-FM types complete with components except speaker. Most in working order **75c**

GRAPHIC EQUALISER

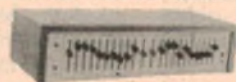

Complete with cabinet **\$99**

Drake General Coverage Receiver SSR1

.5mHz to 30mHz Battery & Mains



\$269.00



VHF Converter

Fantavox VHF Converter. 110 to 136 MHz—Just place near any AM or FM Radio receiver. Complete with battery and full instructions.

\$9.75



YAESU FRG-7 SYNTHESISED RECEIVER

For amateurs and short wave listeners. Electronic band changing 0.5-29 MHz continuous coverage. Uses Wadley loop.

SIGNETICS 2650 MICROPROCESSOR— BABY SYSTEM



A complete Microprocessor system, on a single P.C. board—Add a power supply and terminal.

\$72.00 + S/TAX

PRICES DO NOT INCLUDE P&P

WILLIS TRADING CO.

PERTH G.P.O. BOX NO. X2217, W.A. 6001

429 MURRAY ST.,
PERTH, W.A.
21 7609 21 7600

Australian designed paging system

An Australian company, Intercept Communications Pty Ltd, is manufacturing an electronic paging system claimed to be equal to or better than anything produced overseas.

Designated the "Intercept 180", the system uses a two-tone encoded sequence to contact any receiver. Any number of separate receivers up to a maximum of 180 can be called from one base unit. In addition, automatic group calls can be made to up to 20 groups of 9 receivers.

The paging encoder unit is housed in an attractive semi-transparent, smoky brown plastic case through which the 7-segment LED indicators are visible. When the operator keys the number to be called, it is automatically displayed on a 3-digit readout for verification before the call button is pressed.

The call button sends out a coded signal to the desired receiver. One-way voice transmission may then be sent by



the operator. A special "speak" light tells the operator when to start speaking.

A rotary index to hold 50 names is built into each encoder unit for easy operator access.

Reader enquiries to Intercept Communications Pty Ltd, Suite 6, Morr Arcade, 600 Burke Rd, Camberwell, Vic. 3124. Telephone 82 4359.

High sensitivity metal locator

Metrotech Corporation, California, has added a high-sensitivity metal locator to its line of products. The unit, called the Ferromagnetic Locator Model 880, is designed for rapid location of iron or steel, buried well casings, valve boxes, manhole covers and property markers, etc.

Features of the Model 880 include high noise immunity, a waterproof sensor tip, and audible and visual indication of targets. The Australian agents for Metrotech are Lordco Pty Ltd, 16 Alleyne St, Chatswood, NSW, 2067.

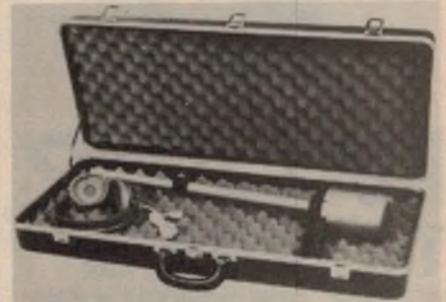

Automatic LCR meter has 0.2% accuracy

This new 3½-digit microprocessor-based LCR meter is fully automatic in operation. Designated the HP 4262A Digital LCR Meter, it measures capacitance from .01pF to 19,990uF, inductance from .01uH to 1999 henries, and resistance from .001 ohms to 19.99 megohms.

D and Q (loss) can also be measured and, a deviation measurement capability is provided. Accuracy of readings is typically 0.2%. Measurement frequencies are 120Hz, 1kHz and 10kHz, while test signal level is 1V.

Further information is available from



Hewlett-Packard Australia Pty Ltd, 31-41 Joseph St, Blackburn, Victoria 3130.

LOW COST ICs

ONLY TOP BRANDS

TTL

7400	36	7437	45	7491	1 20
7401	36	7438	45	7492	80
7402	36	7440	36	7493	80
7403	36	7442	1 00	7494	1 45
7404	36	7446	1 40	7495	1 45
7405	36	7447	1 30	7496	1 45
7406	45	7448	1 30	74100	2 40
7407	45	7450	36	74107	60
7408	36	7451	36	74109	60
7409	36	7453	36	74121	65
7410	36	7454	36	74122	65
7411	36	7460	36	74123	1 00
7412	36	7470	60	74125	70
7413	40	7472	50	74126	70
7414	1 80	7473	60	74132	1 40
7416	70	7474	60	74141	1 60
7417	70	7475	90	74145	1 40
7420	36	7476	65	74154	2 10
7421	40	7480	1 10	74174	2 00
7423	55	7482	1 10	74176	1 80
7425	55	7483	1 10	74177	1 80
7426	45	7485	1 80	74184	3 00
7427	55	7486	60	74185	3 00
7430	36	7489	3 00	74192	1 80
7432	45	7490	70	74251	2 00

CMOS

4000	35	4021	2 20	4052	2 15
4001	35	4022	2 10	4053	2 15
4002	35	4023	35	4060	2 50
4006	2 05	4024	1 50	4066	1 10
4007	35	4025	35	4071	35
4008	1 80	4027	90	4072	35
4009	1 00	4028	1 60	4073	35
4010	1 00	4029	2 10	4075	35
4011	35	4030	90	4081	35
4012	35	4035	2 15	4082	35
4013	80	4040	2 10	4510	2 20
4014	2 10	4042	1 70	4511	2 20
4015	1 85	4043	1 40	4516	2 20
4016	85	4044	1 40	4518	2 20
4017	1 90	4046	2 40	4520	2 20
4018	2 10	4049	85	4528	1 50
4019	95	4050	85		
4020	2 20	4051	2 15		

Also—IC Sockets, Resistors, Capacitors, etc. Just send SAE for illustrated catalogue. Pack & Post 50c min.

LINEAR ELECTRONICS

P.O. Box 254 Punchbowl 2196

EMI

Recording Engineer Trainee

EMI has a vacancy for a trainee at its studios in Sydney. The studios are undergoing a major programme of rebuilding that will put them in the forefront of world music studios, and this is an opportunity to receive the finest training available.

The person we seek would have a love of music, play an instrument and would have a knowledge of Hi-Fi and electronics. We would expect an education equivalent to Higher School Certificate.

If you are early 20's (or just under) and think this is your scene, then write in confidence to Roger Hope

E.M.I. AUSTRALIA LIMITED
P.O. Box 352, Haymarket 2000.

8028

E-Z-HOOK NAILCLIPS

THE QUICK WAY TO
BREADBOARDS
HARNESSEBOARDS
PRETEST BOARDS
BURN-IN BOARDS



NAILCLIP™

THE FINGER-TIP TEST TERMINALS

Finger operated clips drive into wood like a nail using the T-20 tool, or press into perf board with the PE-93 Perf-eze insert. Metal hook holds firmly against body. Won't damage lead wires. Solderable below board for connection of check out systems.

AVAILABLE IN FOUR STYLES (hook illustrated actual size)

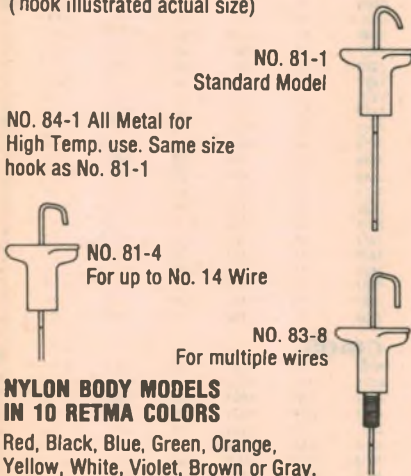

NYLON BODY MODELS IN 10 RETMA COLORS

Red, Black, Blue, Green, Orange,
Yellow, White, Violet, Brown or Gray.

AVAILABLE FROM



GENERAL ELECTRONIC SERVICES PTY. LTD.

99 ALEXANDER STREET
CROWS NEST, NEW SOUTH WALES
AUSTRALIA 2065
TELEPHONE: 439 2488

Adelaide 42-6655 Canberra 95-6811
Brisbane 277-4311 82-3581
Newcastle 69-1222 Melbourne 598-9207
Perth 25-5722

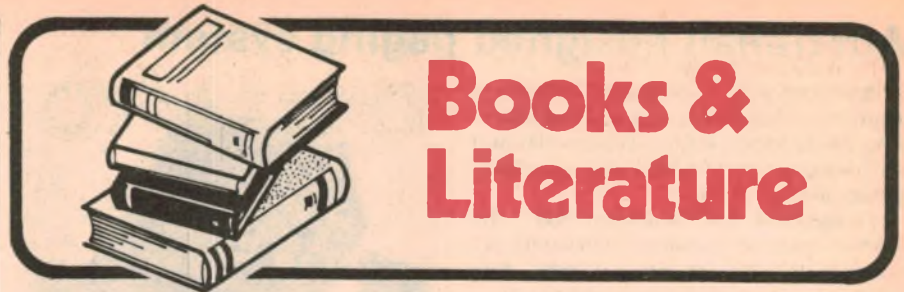

Books & Literature

Audio basics

BEGINNER'S GUIDE TO AUDIO by Ian R. Sinclair. Published 1977 by Newnes Books. Stiff paper covers, 184 pages 186mm x 118mm, illustrated mainly by diagrams. Price in Australian \$6.00.

This new book by Ian Sinclair is one of at least nine in the Newnes series "Beginner's Guide To", ranging from audio to domestic plumbing!

Under this present title, one could easily envisage a book written mainly from the hobbyist and consumer viewpoint discussing the external features, the interconnections and the uses of various items of audio equipment. Ian Sinclair has taken just the opposite tack, diving right inside to give the reader some idea of bias and compensation in tape systems, the circuit concepts of tone controls and filters, the configuration of voltage amplifying and output stages, the basic operation of FM/stereo and quadraphonics, and so on.

None of it is very profound, in keeping with the title of the book but, at the same time, the target "beginner" would need to assume the role of a student, rather than a casual reader, to benefit most by it.

Sample reading turned up only one questionable area, where the author appears to have missed the essential

resonance effect in a vented enclosure (a) by showing it filled with acoustic wadding and (b) by attributing its bass reinforcement qualities to the path length of the rear wave.

But that point aside, it adds up to a promising book for the hifi enthusiast who wants to gain some understanding of what goes on behind those brushed chrome panels. Our review copy came from Butterworths, 586 Pacific Highway, Chatswood, NSW, 2067. (W.N.W.)

Servicing data

JAPANESE CONSUMER ELECTRONICS SCHEMATIC SERVICING MANUAL. First edition, published 1974 by TAB books. Stiff paper covers, 196 pages 278mm x 215mm, illustrated by photos, charts, circuits and foldouts. Price in Australia \$7.25.

A follow-up to TAB's earlier "How To Repair Solid-State Imports", this book opens with three chapters giving a broad refresher on "Radio Principles" and "Radio, Recorder, & Stereo Servicing", plus a cross-reference to aid US servicemen to locate substitute transistors and ICs. I must confess, however, to being put off by the opening parts, which go right back to Edison, Fleming and DeForest; but after the first rather pointless page, it settles down to more

MICROCOMPUTERS & COMPONENTS (FULLY ASSEMBLED AND TESTED OR KITS)

MICROCOMPUTERS

- Imsai 8080
- Poly 88
- TDL Xitan Z80
- SWTP MP6800

M / COMPUTER BOARDS

- CPU
- Video Display
- Ram 4K, 8K, 16K
- I/O P, S, Cassette
- Indust. Control 240V
- Prototype
- S100 Motherboard
- Prom 4K, 8K

PERIPHERALS (C/W INTERFACE)

- NEW**
- Large F / Disc Drives
 - Mini F / Disc Drives
 - Printers
 - Cassette Decks
 - Cartridge Decks
 - Video Terminals

- USED**
- ASR33 Teletypes
 - IBM Selectric I/O
 - Paper Tape Punches
 - Tape Drives (Vac. Col)
 - Printers (Drum, Chain)

COMPONENTS USED

- Capacitors 11K μ F to 90K μ F

Send \$2 for catalogue and price list—
refundable against purchases—Govt &
Industry free.

DYNETICS PTY LTD
425E PENNANT HILLS RD
PENNANT HILLS 2120

B. 848-9055
A.H. 654-9050
Telex 22928

relevant and current material.

This is all preliminary, however, to the main section of the book, which contains some 77 schematics of AM radios, AM/FM radios, clock radios, cassette and cartridge recorders and players, phono players and portable receivers. There are also foldout schematics for a dozen black and white TV receivers. Many of them will probably be of limited value in Australia but I guess that amongst the various lines—the Sanyos, the Sonys, the Panasonics, the Toshiba's and the Sharps, there will be some which would have made their appearance on the Australian market—or in Australian servicing workshops.

But remember that we are talking about an American book published in mid 1974. Only a practising serviceman would be able to guess as to its potential reference value in Australia in late 1977.

Our review copy came from the Technical Book Company, 295 Swanston St, Melbourne, 3000. (W.N.W.)

Disappointing

MODEL SAIL & POWER BOATING ...

BY REMOTE CONTROL, by George Siposs. First edition Published by Tab Books USA. Soft covers, 192 pages, 216mm x 135mm, with photographs and drawings. Price in Australia, \$6.95.

RC MODELLER'S HANDBOOK OF GLIDERS AND SAILPLANES, by George Siposs. First edition. Published by Tab Books, USA. Soft covers, 195 pages, 208mm x 125mm, with photographs and drawings. Price in Australia, \$6.95.

While these titles would undoubtedly attract the attention of anyone interested in radio control of models, both books are likely to prove disappointing in this respect.

The first book has a total of 10 chapters but chapter 1, How Radio Control Works, is the only one which deals with radio control to any extent at all. Even then it confines itself to a very superficial discussion of commercial equipment and some of the technical terms employed. The remaining nine chapters are devoted to boat construction, sailing, types of motive power, boat design, etc.

Much the same comment applies to the second book. Chapter 1 carries the same title and is almost a copy of the same text. Most of the remainder is devoted to model aircraft construction and flying. However, there is one chapter covering the installation of the radio equipment, mainly covering the connection of servo motors to the control surfaces.

To sum up: These may be useful books for those interested in model making but if you are interested in radio control, we suggest you look elsewhere.

Our copies from Technical Book and Magazine Co, 289 Swanston St, Melbourne, Victoria. (P.G.W.)

BOOKS

Just some of the titles from the biggest range of radio and electronics books in Australia.

If the book you require is not listed below it can be ordered from us.

NEW—NEW—NEW

Latest editions of some of the most popular books on the subject:

R S G B. Handbook (New Edition) Volume 1 (Volume 2 expected any day—no price as yet)	\$21.10
A R R L Handbook 1977 (Amer. Radio Relay League)	\$11.95
A R R L Ham Radio Operating Guide	\$7.20
A R R L Electronics Data Book	\$7.20
Reference Data for Radio Engineers (New Edition) I. T. T.	\$37.50
Radio Handbook (William I. Orr) 20th Edition	\$24.40
World Radio TV Handbook 1977	\$11.95
Weather Satellite Handbook (Dr. R. E. Taggart)	\$4.95
Radio Amateur Callbook Magazine (U.S. Listings) (55th Anniversary Edition for use 1977)	\$18.50
Nonlinear Circuits Handbook (Analog Devices)	\$10.00
Building Hi-Fi Speaker Systems (Philips)	\$3.95
Electronic Musical Instruments (N. Crowhurst)	\$6.95
How to Build Proximity Detectors and Metal Locators (John Potter Shields)	\$6.35
Building and Installing Electronic Intrusion Alarms (John E. Cunningham)	\$6.35

New Books:

Solid-State QRP Projects (Edward M. Noll)	\$6.10
RF & Digital Test Equipment You can Build (Ed. Wayne Green)	\$8.50
Advanced Applications for Pocket Calculators (Jack Gilbert)	\$8.50
Build-it Book of Miniature Test & Measurement Instruments (Robert P. Haviland)	\$6.95
Microelectronics (Clayton L. Hallmark)	\$8.50
Master Handbook of Digital Logic Applications (William L. Hunter)	\$10.95
111 Digital and Linear IC Projects (Don Turte)	\$8.50
"Miniwatt" Technical Data—Valves, Picture Tubes, Semiconductor Devices (7th Edition)	\$7.50
Unique IC OP-AMP Applications (Walter C. Jung)	\$7.00
IC OP-AMP Cookbook (Walter C. Jung)	\$17.80
TTL Cookbook (Lancaster)	\$12.70
TV Typewriter Cookbook (Lancaster)	\$14.20
RTL Cookbook (Lancaster)	\$6.60
CMOS Cookbook (Lancaster) 1st Edition, 1977	\$14.20
Active Filter Cookbook (Lancaster)	\$19.00
FM From Antenna to Audio (Leonard Feldman)	\$7.00
Transistor Specifications Manual, 8th Edition	\$9.50
Transistor Substitution Handbook, New Edition	\$6.75
International Transistor Selector (T. D. Towers)	\$6.95
Shortwave Listener's Guide (H. Charles Woodruff)	\$5.60
Intermodulation and Harmonic Distortion Handbook (Howard M. Tremaine)	\$5.45
Master Tube Substitution Handbook (Tab Books)	\$7.00
Modern Crystal Sets—Fully Illustrated Step by Step (R. H. Warring) See and Make Series	\$4.95
Electronic Organs (Norman H. Crowhurst) Volume 3	\$9.35

CB Radio Books:

CBer's How-To Book (Leo G. Sands)	\$6.95
Citizen's Band Radio (Allan Lytel) Revised 2nd Ed.	\$6.95
Eas-Guide to CB Radio for Truckers (Forest H. Belt) Pictorial Guide to CB Radio Installation & Repair (Forest Belt)	\$8.50
CB Radio Operating Procedures (D. HICKS)	\$5.75
CB Radio Servicing Guide (Leo G. Sands)	\$7.00
How To Protect your CB Rig (F. Mims)	\$5.05
Easi-Guide to Citizen's Band Radio (Forest H. Belt)	\$4.95
CB Radio Construction Projects (Len Buckwalter)	\$5.60
Citizen's Band Radio Handbook (David E. Hicks)	\$8.50
Questions & Answers About CB Operations (Leo G. Sands)	\$5.30
CB Radio Operator's Guide (2nd Edition) (Robert M. Brown & Paul L. Dorweiler)	\$8.50
From CB to Ham Beginner (J. S. Stanley)	\$6.95
CBer's Handybook of Simple Hobby Projects—114 Tested Performance Improvers (Robert M. Brown)	\$5.50
Practical CB Radio Troubleshooting & Repair (David F. Norman)	\$8.50
The Big Dummies Guide to CB Radio	\$2.95
The Best Book on CB—Includes all 40 channels & 1977 Regulations (Evan Herbert)	\$6.25
CB Bible—The Complete Guide to Citizen's Band 2-Way Radio	\$6.95
The Wonderful Wacky World of CB Radio	\$5.95
IC Timer Cookbook	\$13.50

Microcomputers / Microprocessors Books:

Programming Microprocessors (M. W. Mcmurrin)	\$9.75
Microprocessors: Technology, Architecture & Applications (Daniel R. McGlynn)	\$18.80
Microprocessors (Electronics Book Series)	\$17.65
Microcomputers / Microprocessing: Hardware, Software & Application (Hilburn & Julich)	\$29.50

Prices subject to alteration. Correct at Press time.

Minicomputer Systems: Organization and Programming (PDP 11) (Eckhouse)	\$25.80
Minicomputer Systems: Structure, Implementation & Application (C. Weitzman)	\$29.55
Microcomputer Primer (Waite & Pardee)	\$11.30
Minicomputers for Engineers & Scientists (G. Korn)	\$33.15
SC / MP Microprocessor Applications Handbook (National)	\$7.20
How to Buy and Use Minicomputers and Microcomputers (W. Barden, Jr.)	\$14.20
Microprocessing / Microprogramming Handbook (B. Ward)	\$9.75

American Radio Relay League

Publications:

Hints and Kinks for the Radio Amateur	\$4.25
The Radio Amateur's VHF Manual	\$7.20
A R R L Antenna Handbook	\$7.20
Understanding Amateur Radio	\$7.20
The Radio Amateur's Licence Manual	\$2.55
How To Become a Radio Amateur	\$2.55
A Course in Radio Fundamentals	\$5.60
Special Communications Techniques for the Radio Amateur	\$5.60
FM & Repeater for the Radio Amateur	\$7.20
Single Sideband for the Radio Amateur	\$7.20
Ham Radio Operating Guide	\$7.20
Electronics Data Book	\$7.20

Howard W. Sams Publications:

Understanding IC Operational Amplifiers (Melen & Garland)	\$5.60
Know Your Oscilloscope (P. Smith)	\$7.00
TV Servicing Guide—Arranged by Trouble Symptoms (Leslie D. Deane & Calvin C. Young, Jr.)	\$6.50
Security Electronics (John L. Cunningham)	\$8.50
Electric Guitar Amplifier Handbook (Jack Darr)	\$10.20
Transistor Fundamentals—A Programmed Learning Course Volume 1—Basic Semiconductor & Circuit Principles (Robert J. Britte)	\$7.15
Transistor Fundamentals—A Programmed Learning Course Volume 2—Basic Transistor Circuits (Charles A. Pike)	\$7.15
Transistor Fundamentals—A Programmed Learning Course Volume 3—Electronic Equipment Circuits (Martin Gersten)	\$7.15
Transistor Fundamentals—A Programmed Learning Course Volume 4—Digital & Special Circuits (Louis Schweitzer & Reginald H. Peniston)	\$7.15

RCA Publications:

Electro-Optics Handbook	\$8.30
Linear Integrated Circuits	\$3.75
Understanding CMOS	\$2.85
Solid State Servicing—Hi-Fi, Tape, Records, AM / FM Mono, Stereo, TV B. & W., Colour	\$5.95
Designer's Handbook—Solid State Power Circuits	\$11.25
RC 30—Receiving Tube Manual	\$4.50
SC 16—Solid State Devices Manual (New Edition of RCA Transistor Manual)	\$7.50
RCA Power Devices (RCA Solid State)	\$7.95
RCA Integrated Circuits (RCA Solid State)	\$7.95

Other Titles:

73 Dipole and Long-Wire Antennas (Edward M. Noll)	\$7.15
73 Vertical, Beam & Triangle Antennas (Edward M. Noll)	\$7.15
Basic Television—Principles & Servicing—4th Edition (Bernard Grob) New Edition—Soft Cover	\$15.75
Basic Electronics—4th Edition (Bernard Grob) New Edition	\$20.05
Newnes Colour Television Servicing Manual (Gordon J. King) Volume 3	\$20.20
Colour Television Theory—PAL Systems Principles & Receiver Circuitry—SI Units (Hutson)	\$11.30
PAL Colour Television for Servicemen (W. C. Cook)	\$15.00
Pin-Point TV Troubles in 10 Minutes—Check Charts—New TV Trouble Shooting Techniques	\$8.50
The Oscilloscope (George Zwick)	\$6.75
Pin-Point Transistor Troubles in 12 Minutes—Check Charts—New Transistor Trouble-Shooting Techniques	\$9.65
Transistor Pocket Book (R. G. Hibbard)	\$9.00
Radio, Valve and Semiconductor Data—10th Edition Compiled by A. M. Bell	\$4.25
Pickups and Loudspeakers—How to Choose and Use (John Earl)	\$8.25
Audio Technicians and Bench Manual (John Earl)	\$9.00
Manual of Sound Recording—Second Edition (John Aldred)	\$10.25
Electronic Calculators (H. Edward Roberts)	\$7.60
Getting The Most Out Of Your Electronic Calculator (William L. Hunter)	\$6.95

For Mail Orders please add: 80c Local \$1.50 Interstate
McGILL'S AUTHORISED NEWSAGENCY PTY. LTD.
 187 Elizabeth Street, Melbourne. Phone: 60 1475-6-7

The Amateur Bands

by Pierce Healy, VK2APQ



The need to seek progress

If amateur radio is to maintain its place in the community it must adopt a more progressive attitude than it has in the past. Everyone, both in office and the rank and file, must not only be willing to accept changing standards, they must actively seek to upgrade the amateur regulations to enable experiments to keep pace with the state of the art.

In the past decade amateur radio in Australia has been confronted with more changes, both technological and social, than it ever has before. Many feel that it has not faced up to these changes as well, or made as much progress, as it might have done.

There have been two main factors which have tended to retard progress on the Australian amateur scene. One has been an apathy, or even open hostility, towards suggestions that regulations should be updated to cope with changing conditions and changing technology.

Advancing technology, for example, presents the opportunity for amateurs to experiment with new modes of transmission, not envisaged when the regulations were drafted. To permit such experiments, the appropriate regulations may have to be updated, something which may be done only through the Posts and Telegraph Department.

This department, in turn, needs to be approached by the amateurs' representative body, the WIA, before such changes are even likely to be considered. If, in such circumstances, individuals or particular executive groups are too conservative to appreciate the need for progress, the request may never reach the Department or, if it does, it may be in such a form that its rejection is almost automatically assured. Such situations have happened in the past and, when they did, it was often the Department which was blamed, unfairly, for the rejection.

The other factor is that some individual amateurs have been so obsessed with their personal ambitions and point of view that they were unable to accept any changes in standards which others felt were not only desirable, but essential, if the amateur movement was to maintain its position in the community.

A glaring example was the objection to the recently introduced novice licence. There is now little doubt that the foresight of those who advocated this move has been completely vindicated. The hundreds of candidates sitting for the twice yearly exam provide tangible proof of this. The point of view has been expressed that much of the unpleasantness accompanying the introduction of CB radio could have been avoided had the novice licence been introduced several years earlier, and with less opposition, than it was.

At the same time it is necessary for those who advocate changes to appreciate the difference between those which are within the powers of the P & T Department to grant on a purely domestic basis, and those which it can only grant in accordance with international regulations.

While compiling these notes a lot is being said about extending the privileges of limited and novice licences; for example that limited licencees should

be allowed to use the 28MHz band. This would be in direct contravention of the International Telecommunication Union regulation, to which Australia is a signatory. Australia has already been criticised for allowing limited licencees to use the 52MHz band, which is contrary to these regulations.

The following is an extract from the "The Geneva Story 1959", page 20, published by the WIA.

"Radio Regulation 41-04 reads: 'Any person operating the apparatus of an amateur station shall have proved that he is able to send correctly by hand and to receive correctly by ear, texts in Morse code signals. Administrations concerned may, however, waive this requirement in the case of stations making use exclusively of frequencies above 144MHz'."

"RR 41-04 is one regulation that was amended as a result of WIA proposals which advocated reducing the Atlantic City frequency of 1000MHz to 30MHz. A compromise was reached on the figure of 144MHz after both the UK and USA had been only in favour of reduction to 250MHz."

The correct approach, if this and similar changes are felt to be desirable, is to urge the local administration (P & T Department) to include such changes in official brief for WARC 79. As it happens, the International Amateur Radio Union, representing all amateur radio societies, had the whole of article RR 41 on the agenda for discussion at a recent meeting in Geneva, preparing the case for the amateur service at WARC 79. It is believed that changes to the article are being put forward by WIA representatives at meetings with administrative officers preparing the official Australian brief for WARC 79.

Another essential precaution when planning changes is to ensure that they do not conflict, or appear to conflict, with existing amateur interests. It should be possible to introduce new ideas without threat to current practice. New ideas should be in addition to, not instead of, the privileges we already enjoy.

A typical example is the current suggestion that novices be allowed to use VFO's while, at the same time, it has been suggested that a band plan be introduced for the 28MHz band, allocating spot frequencies with, say, 5kHz spacing.

Some amateurs have seen this as representing a conflict, either between the two modes of operation, or between one of these modes and its opposite, which they happen to prefer. While it might be argued that, with proper planning, all interests can be catered for, failure to clarify this point can lead to unnecessary antagonism within the amateur ranks.

There is no doubt that arguments can be made for and against the introduction of a 28MHz band plan. Those who object to it claim, among other things,

that fixed frequencies deprive the amateur of the flexibility which has characterised the HF scene for so many years; a flexibility which permitted an experienced amateur to find a channel where, superficially, none existed.

They also express the fear that a band plan, adopted initially as something to be administered by the amateurs themselves, may eventually become a regulation enforceable by the P & T Department. They point out that this has happened in other parts of the world.

Another risk, as they see it, is that, if the order of channel spacing is not as efficient as it might be, it will merely serve to demonstrate to the authorities that the amateurs are not making the best use of the band.

Those who advocate a band plan argue that it represents the kind of progress discussed earlier, and which the amateur should be ready and willing to take advantage of. They also argue that the need to search for vacant spots in the spectrum, on odd frequencies, would be largely eliminated if specific channels are allocated. Further, that planned spacing will reduce the kind of interference created by the random "fit-in-where-you-can" approach.

Also, they argue, there would seem to be no reason why the conflicting interests cannot be shared; that portion of the band can be used for fixed channel allocations, and portion left for the "tunable" advocates who enjoy this mode of operation.

But, whatever the outcome of this, or similar arguments, one thing is certain; no matter how much we disagree as individuals, or as individual groups, when decisions are made we must present a united front to the government's administering body and, through them, to WARC 79 at Geneva.

OVERSEAS NEWS

Arising from the Amateur Radio Convention in Madras, India, medicine banks will be up with the cooperation of amateur radio operators.

With Dr Mukesh Chandra as convenor, a Medical Amateur Radio Council has been set up to achieve the objectives laid down at the convention.

The aims of the council are to secure international cooperation, through amateurs, in the field of bio-medical electronics, establish medicine banks for rare drugs, nets for the exchange of information on latest developments and seek affiliation with the Federated Amateur Radio Society of India and MARC organisation.

Steps will also be taken to establish stations to serve village hospitals. Later the scheme will be expanded to link village hospitals with main hospitals, so that effective medical relief can be provided.

The council will comprise both medical and non-medical radio amateurs.

COMING EVENTS

The Annual Boy Scouts Jamboree-on-the-Air will be held on the weekend 15th-16th October, 1977. This is the event, each year, when scouts and amateurs world-wide combine in a unique international communication exercise.

A story and details of the 1977 JOTA in next month's notes.

OSCAR 8, the next amateur communication satellite, is now scheduled for launch on November 15th, 1977. The transponders will be 145MHz to 28MHz and 145MHz to 435MHz.

It will be easier to acquire access than OSCAR's 6 and 7 because of its 800km orbit but the access time will be shorter.

The South West Zone Convention is to be held at Griffith, NSW, on 1st and 2nd October. A wide range of events, including the 25th anniversary dinner, is being arranged.

The venue is the Griffiths Ex-serviceman's Oval Pavilion. Visitors are reminded that the Griffith Amateur Radio Club repeater is available on channel 5. (146.25MHz in, 146.85MHz out.)

YRS NEWS

A novice licence instructor's kit is now available through the NSW Youth Radio Scheme. The cost is \$12 per kit, posted, and is available from:—

David Wilson, VK2ZCA, Whalan High School, Mimika Avenue, Whalan, 2770.

The kit includes: The Manual of Questions and

Radio clubs and other organisations, as well as individual amateur operators, are cordially invited to submit news and notes of their activities for inclusion in these columns. Photographs will be published when of sufficient general interest, and where space permits. All material should be sent to Pierce Healy at 69 Taylor Street, Bankstown 2200.

AMATEUR BANDS

Answers for the Novice Licence, by Keith Howard, VK2AKX.

YRS notes for Elementary Stage 1.

YRS notes for Elementary Stage 2.

Learning the Morse code, by Rex Black, VK2YA.

A cassette tape with 5 Morse code receiving tests.

A 15-unit course plan with teaching notes for each unit.

Two sets of 100 questions at elementary level.

A readiness test for the start of the course.

A mid-course progress test.

50 questions and answers on regulations.

50 questions and answers on novice receivers.

50 questions and answers on novice transmitters.

A 50-question trial novice test in radio theory.

A 20-question test on regulations.

Any of the above (with the exception of the Manual of Questions and Answers) are available as extra items for your class. If you want a test paper for each member of your class, write in for them.

The manuals are available from:— Westlakes Radio Club, PO Box 1 Teralba, 2284, for \$3 a copy, posted to anywhere in Australia. There are more than 2000 copies of these manuals around Australia.

A better way to order the manuals is to pool the money from class members and order in bulk. Westlakes Radio Club will rail or post them as directed.

WICEN EXERCISE

On Saturday 23rd July, 1977 the NSW Police Department staged "Exercise Condor" which simulated a Boeing 707 crash near Dubbo, NSW.

The NSW Wireless Institute Civil Emergency Net provided additional communication links between the crash site and Sydney to cope with the heavy volume of traffic resulting from the crash and the involvement of 115 passengers and crew.

The object was to test the reliability of WICEN's VHF systems, the accuracy of relay traffic handling, and the ability to operate in the field without reliance on mains power.

The crash site was some 8km north of Dubbo and some 300km from Sydney, across the Blue Mountains. The original intention was to use the Orange repeater to provide the primary link from the crash site to Sydney. A secondary link was also planned, in the form of an SSB 2 metre circuit via Mt Canobolas to the Blue Mts, then via an FM 2 metre link to Sydney.

Test transmissions through the repeater proved this circuit but, when the exercise commenced, "Murphy's Law" prevailed and the input circuit from Dubbo deteriorated to an unreadable level.

This unlikely possibility having been catered for, the two metre SSB link immediately became the primary circuit and functioned perfectly at strength 9 plus throughout.

WICEN had been requested to use VHF only for the emergency traffic but an 80 metre SSB link was established between Dubbo and Sydney for WICEN unregistered traffic which would have provided a reliable back-up link had it been required.

SO YOU WANT TO BE A RADIO AMATEUR?

To achieve this aim, why not undertake one of the Courses conducted by the Wireless Institute of Australia? Established in 1910 to further the interests of Amateur Radio, the Institute is well qualified to assist you to your goal. Correspondence Courses are available at any time. Personal classes commence in February each year.

For further information write to

**THE COURSE SUPERVISOR,
W.I.A.
14 ATCHISON STREET,
CROWS NEST, N.S.W. 2065**

The exercise convincingly demonstrated the NSW WICEN's ability to provide the personnel and equipment to operate in the field with several different modes simultaneously.

Howard Freeman, VK2NL, the NSW WICEN coordinator was the observer at the Sydney terminal. He was well satisfied with WICEN's performance and congratulates those who participated, in particular those who braved the early morning chills of Mount Canobolas and the Blue Mountains.

The WICEN personnel participating were:—

Dubbo terminal: VK2ZRJ—Bob Alford, NSW Region 7 WICEN coordinator; VK2ZNV/VK2NCU—Wally Watkins; VK2BEO—Eric Brodrick; VK2AKC—Cec Kearines.

Mount Cabobolas two metre SSB relay:— VK2TK—Peter Carter and son Leon; VK2FD—Bruce Thomas; VK2ZIC/VK2NGG—Bruce Carroll.

Blue Mountains two metre SSB/FM relay:— VK2ZMR/VK2NER—Terry Ryefield; VK2NCN—Jeff Cullanan; VK2LM—Len Brennan and wife; VK2BNA—Allan Nutley and wife; VK2NFM—Stephen Chivers; VK2NIX John Green; VK2NIZ—Paul Robertson and wife; Robert Thompson.

VK2BR—Ray Gill, WICEN committee liaison officer was also in attendance as an observer and active participant.

Sydney terminal:— VK2DI—Mark Salmon; VK2ANF—Gareth Davey; VK2BMM—Mike Richter; VK2AAB—Barry White; VK2NL—Howard Freeman.

WIA NEWS

The federal executive WIA, reports that Bill Roper, VK3ARZ, because of changed business commitments, has resigned his position on the executive. His place has been taken by Surgeon Rear Admiral S. J. (Jim) Lloyd, VK3CDR.

Retirement: The retirement, for health reasons, of Mr. H. S. Young from the central office of the Post and Telegraph Department is recorded. Throughout this decade Horrie, as he is known to everyone, has been a tower of strength and advice for the amateur service under conditions of change as has been seldom seen in amateur circles. Everybody associated with amateur radio will join together in wishing him

a speedy recovery and a long and happy retirement.

The WIA has voted in favour of admitting the amateur radio societies of Turkey, Papua New Guinea, Jordan and Oman to the IARU. In regard to Turkey the TARC reported that, although amateur radio licences are not presently being issued by the government, it is hoped that their parliament will resolve this shortly.

The Jordanian application stated that, since the society (RJRAS) is officially sponsored by the King of Jordan, the society acts as the licensing authority and is therefore inclined very favourably toward amateur radio in Jordan.

RADIO CLUB NEWS

GEE LONG AMATEUR RADIO & TV CLUB: The novice licence course is co-ordinated by Trevor Kelly, VK3ZNX who will be pleased to answer enquiries from prospective students. The enrolment fee is \$27.50. This includes printed material, regulations handbook, and a well known reference book on the subject, plus expert tuition in all relevant subjects.

For further information, call at the club rooms Storrier Street, East Geelong on a Friday evening or write to GARC, PO Box 520, Geelong 3220.

DARWIN AMATEUR RADIO CLUB: A friendly and growing part of the community in Darwin today is that of amateur radio. The centre of this activity is the DARC incorporated, established in 1965.

The aims are to foster an interest in amateur radio as a hobby; to publicise the ideals of the hobby as a healthy and useful outlet for energy, initiative and knowledge so that these qualities may be used for the good of the community.

An amateur radio course is available through the Darwin Community College, telephone 27 1233. Assistance with studying for the exam is available from members of DARC Inc.

The club's monthly bulletin "Ground Wave" is an interesting publication containing news of club and members' activities, technical notes, and ideas to try.

BRIGHT STAR CRYSTALS PTY LTD

35 EILEEN ROAD, CLAYTON, VICTORIA 3168
(ALL MAIL TO: PO BOX 42, SPRINGVALE, VIC 3171)

MAY WE REMIND YOU

THAT BRIGHT STAR CRYSTALS
HAVE MORE THAN 36 YEARS

EXPERIENCE IN

CRYSTALS

MADE IN AUSTRALIA

HOSE & EQUIPMENT CO. PTY. LTD. SYDNEY. PHONE 666-8144

COMMUNICATION SYSTEMS
PERTH. PHONE 76 2566

ROGERS ELECTRONICS
ADELAIDE. PHONE 42 6666

FRED HOE & SONS PTY. LTD.
BRISBANE. PHONE 47 4311

DILMOND INSTRUMENTS
HOBART. PHONE 47 9077

TTL - low schottky

74LS00	Quad 2-input NAND	45c
74LS01	Quad 2-input NAND (Open collector)	45c
74LS02	Quad 2-input NOR	45c
74LS03	Quad 2-input NOR (Open collector)	45c
74LS04	Hex inverter	45c
74LS05	Hex inverter (Open collector)	45c
74LS08	Quad 2-input AND	45c
74LS09	Quad 2-input AND (Open collector)	45c
74LS10	Triple 3-input NAND	45c
74LS11	Triple 3-input NAND (Open collector)	45c
74LS12	Quad 3-input NAND	45c
74LS13	Quad 3-input NAND (Open collector)	45c
74LS14	Hex Schmitt trigger	\$1.75
74LS15	Triple 3-input NAND (Open collector)	\$2.35
74LS20	Quad 2-input NAND	64c
74LS21	Quad 2-input NAND	45c
74LS22	Quad 2-input NAND (Open collector)	64c
74LS26	Quad 2-input NAND driver (TV)	96c
74LS27	Triple 3-input NAND	52c
74LS28	Quad 2-input NAND buffer	52c
74LS30	Single 5-input NAND	45c
74LS32	Quad 2-input OR	52c
74LS33	Quad 2-input OR (Open collector)	96c
74LS37	Quad 2-input NAND buffer	52c
74LS38	Quad 2-input NAND buffer	52c
74LS40	Quad 2-input NAND buffer	52c
74LS42	Hex 3-to-2 bit decoder	\$1.85
74LS47	Hex 3-to-7 segment decoder (TV)	\$2.75
74LS48	Hex 3-to-7 segment decoder	\$2.75
74LS49	Hex 3-to-7 segment (Open collector)	\$2.75
74LS51	3-to-2 bit decoder	64c
74LS54	4-to-2 bit decoder	64c
74LS55	4-to-2 bit decoder	64c
74LS73	Quad JK edge trigger flip flop	60c
74LS74	Quad JK edge trigger flip flop	64c
74LS75	4-bit latch	\$1.00
74LS76	Quad JK edge trigger flip flop	\$1.24
74LS78	Quad JK edge trigger flip flop	65c
74LS83	4-bit binary full adder	\$3.72
74LS85	4-bit magnitude comparator	\$2.64
74LS86	Quad 2-input exclusive OR	72c
74LS90	Decade counter	\$1.84
74LS91	8-bit shift register	\$2.84
74LS92	Decade to 10 counter	\$1.64
74LS93	4-bit binary counter	\$1.64
74LS95	4-bit right shift register	\$3.96
74LS107	Quad JK edge trigger flip flop	\$1.24
74LS109	Quad JK edge trigger flip flop	76c
74LS112	Quad JK edge trigger flip flop	\$1.24
74LS113	Quad JK edge trigger flip flop	72c
74LS114	Monostable multivibrator	72c
74LS122	Monostable multivibrator	\$2.34
74LS123	Monostable multivibrator	\$2.72
74LS124	Quad voltage controlled oscillator	\$1.88
74LS125	Quad tri-state buffer drivers (emitter)	\$1.88
74LS132	Quad 2-input NAND Schmitt	\$2.24



74LS136	Quad exclusive OR (Open collector)	\$1.36
74LS138	3 line to 8 line demultiplexer	\$2.16
74LS139	Quad 2 line to 4 line demultiplexer	\$2.28
74LS145	BCD to decimal driver 15V	\$3.16
74LS151	8 channel multiplexer	\$2.00
74LS153	Quad 4 line to 1 line demultiplexer	\$3.16
74LS155	Quad 2 line to 4 line demultiplexer	\$2.64
74LS156	Quad 2 line to 4 line demultiplexer	\$3.64
74LS157	Quad 2 line to 1 line multiplexer	\$2.20
74LS158	Quad 2 line to 1 line multiplexer	\$2.96
74LS162	Decade counter asynchronous clear	\$3.48
74LS163	Decade counter asynchronous clear	\$2.72
74LS164	8 bit parallel in shift register	\$2.32
74LS174	Hex D flip flop with clear	\$2.32
74LS175	Quad D flip flop with clear	\$2.32
74LS181	Arithmetic logic unit	\$2.32
74LS192	Up down decade counter	\$2.96
74LS193	Up down binary counter	\$2.96
74LS194	4 bit left right shift register	\$2.40
74LS195	4 bit parallel in shift register	\$2.40
74LS196	4010 decade counter	\$2.40
74LS197	1010 binary counter	\$3.64
74LS221	Quad monostable multivibrator	\$2.20
74LS247	BCD to 7 segment driver 15V	\$3.24
74LS248	BCD to 7 segment driver	\$3.24
74LS249	BCD to 7 segment driver	\$3.24
74LS251	Tri-state 4 line to 1 line multiplexer	\$3.88
74LS253	Tri-state 4 line to 1 line multiplexer	\$2.20
74LS257	Tri-state quad 2 line to 1 line	\$3.96
74LS258	Tri-state quad 2 line to 1 line	\$2.76
74LS260	Quad 3-input NOR	\$1.40
74LS266	Quad exclusive OR (Open collector)	\$1.48
74LS279	Quad 82 latch	\$1.88
74LS283	4 bit binary full adder	\$3.48
74LS290	Decade counter	\$3.40
74LS293	4 bit binary counter	\$3.40
74LS365	Tri-state bus driver	\$1.88
74LS366	Tri-state bus driver	\$1.88
74LS367	Tri-state 2-to-1 driver	\$1.76
74LS368	Tri-state 2-to-1 driver	\$1.76
74LS386	Quad 2-input exclusive OR	\$1.48

OPTO - electronics

LED200	Large red led	17c
TTL209	Small red led with mount	20c
TTL211	Small green led with mount	48c
TTL220	Large red led with mount	24c
TTL222	Large green led with mount	48c
TTL312	.3" common anode readout	\$1.64
PND500	.5" common cathode readout	\$1.95
PND507	.5" common anode readout	\$1.95
TTL68	NPN silicon photo transistor	\$1.48
TTL112	Optocoupler 1-5KV isolation	\$1.64
ORP12	Photoreistor	\$1.20

CMOS -74C

74C00	Quad 2-input NAND	44c
74C02	Quad 2-input NOR	44c
74C04	Hex inverter	44c
74C06	Quad 2-input NAND	44c
74C10	Single 5-input NAND	44c
74C14	Hex Schmitt trigger	\$2.16
74C20	Quad 2-input AND	72c
74C30	Quad 2-input AND	72c
74C48	Hex 3-to-7 segment decoder	\$3.32
74C73	Quad D flip flop	\$1.12
74C74	Quad D flip flop	\$1.12
74C75	4 bit latch	\$1.12
74C76	Quad JK flip flop	\$2.36
74C85	4 bit magnitude comparator	\$2.96
74C90	Decade counter	\$2.36
74C93	4 bit binary counter	\$2.36
74C107	Quad JK flip flop	\$2.84
74C160	Decade counter asynchronous clear	\$3.12
74C161	Binary counter asynchronous clear	\$3.12
74C162	Decade counter asynchronous clear	\$3.12
74C163	Binary counter asynchronous clear	\$3.12
74C174	Quad D flip flop	\$2.60
74C175	Quad D flip flop	\$3.12
74C192	Up down decade counter	\$3.12
74C193	Up down binary counter	\$3.12
74C194	4 bit right left shift register	\$3.12
74C195	4 bit right left shift register	\$3.12
74C221	Quad monostable multivibrator	\$2.35

CMOS -4000

4000	Quad 2-input NAND	32c
4001	Quad 2-input NAND	32c
4002	Quad 2-input NOR	32c
4006	18 stage shift register	\$1.92
4007	Quad static CMOS inverter	32c
4008	4 bit full adder	\$1.96
4009	Hex inverter buffer	92c
4010	Hex buffer	96c
4011	Quad 2-input NAND	32c
4012	Quad 2-input NOR	32c
4013	Quad D flip flop	72c
4014	8 stage shift register	\$1.96
4015	Quad 3 stage shift register	\$1.64
4016	Quad 4010 latch	72c
4017	Hexadecimal decoder	\$1.64
4018	Hexadecimal decoder	\$1.84
4019	Quad static CMOS inverter	45c
4020	18 stage binary counter	\$2.56
4021	8 stage shift register	\$2.24
4022	Hexadecimal decoder	\$1.56
4023	Tri-state 2-input NAND	32c
4024	7 stage binary counter	\$1.12
4025	Tri-state 2-input NAND	32c
4026	Decade counter	\$3.64



4027	Quad JK Master slave flip flop	92c
4028	Hex 3-to-8 decoder	\$1.48
4029	Up down counter	\$1.84
4030	Quad decoder	40c
4033	Decade counter	\$3.76
4035	4 stage parallel shift register	\$2.48
4040	11 stage binary counter	\$2.48
4041	Quad static CMOS buffer	\$1.74
4042	Quad 3 latch	\$1.48
4043	Quad static CMOS hex 8 latch	\$1.24
4044	Quad static CMOS hex 8 latch	\$1.24
4046	Hex 3-to-8 decoder	\$2.76
4049	Hex Schmitt trigger	84c
4050	Hex buffer	84c
4051	4 channel multiplexer	\$1.56
4052	16 channel 4 channel multiplexer	\$2.24
4053	Tri-state 4 channel multiplexer	\$2.24
4055	Hex 3-to-7 segment driver	\$3.36
4056	Hex 3-to-7 segment driver	\$2.48
4058	18 stage binary counter plus oscillator	\$2.24
4060	Decade counter	\$2.24
4066	Quad 2-input NAND	\$1.20
4068	Single 3-input NAND	44c
4069	Hex Schmitt trigger	44c
4070	Quad 2-input OR	64c
4071	Quad 2-input OR	32c
4072	Quad 2-input NAND	44c
4073	Tri-state 2-input NAND	44c
4075	Hex static CMOS D flip flop	\$1.72
4077	Quad 2-input NAND	48c
4078	Quad 2-input NAND	48c
4081	Quad 2-input NAND	32c
4082	Quad 2-input NAND	44c
4085	3-to-2 bit decoder	\$1.88
4086	Quad 2-input NAND	\$1.88
4093	Quad 2-input NAND	\$1.40
4416	UPN output	\$1.32
4426	Decade counter 7 segment driver	\$3.76
4449	Hexadecimal decoder	44c
4502	Hexadecimal decoder	\$1.96
4507	Quad 2-input NAND	\$1.20
4510	Up down decade counter	\$2.76
4511	Hex 3-to-7 segment driver	\$2.32
4512	4 channel data selector	\$1.48
4516	Up down binary counter	\$2.00
4518	Quad decade counter	\$2.00
4519	4 bit and or latch	\$2.29
4520	Hex binary counter	\$2.00
4522	Hexadecimal decoder	\$3.20
4528	Quad 2-input NAND	\$1.52
4531	12 bit parity tree	\$3.12
4539	Hex 3-to-8 decoder	\$3.00
4555	Quad 2-input NAND	\$2.20
4556	Hex 3-to-8 decoder	\$2.20
4553	Three stage NAND counter	\$7.75

Electronics Supply Service

PHONE 358 2420

179 VICTORIA ST., KINGS CROSS N.S.W. 2011

POSTAL ADDRESS :
 BXK ELECTRONICS SUPPLY SERVICE,
 PO BOX 787, POTTS POINT,
 SYDNEY, 2011.
 MAIL ORDER.....MINIMUM.....\$8.00.
 PACK AND POST.....FREE IN AUSTRALIA.
 TELEPHONE ENQUIRIES.....(02) 358 2420.

LEADER TEST INSTRUMENTS

Monitor the faithfulness of any audio system



LMV-181A

LAG-120

LDM-170

LDM-170 DISTORTION METER

Range 0.3%, 1%, 3% 10%, 30% and 100%, F.S.
 Frequency Range 20Hz to 20kHz
 Level Range 1mV to 300Vrms, F.S.

LAG-120 AUDIO GENERATOR

Frequency Range 10Hz to 1MHz in 5 ranges
 Output Voltage Over 3Vrms into 600Ω
 Distortion 0.05% TYPICAL

LMV-181A AC MILLIVOLTMETER

Voltage range 100μV to 300V (181A)
 150μV to 500V (181B)
 Band Width 5Hz to 1MHz
 Amplifier Output 1 Vrms at F.S.

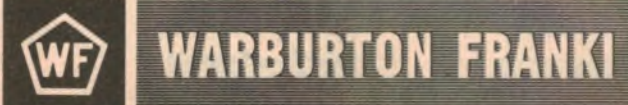

WARBURTON FRANKI

• ADELAIDE 356-7333 • BRISBANE 52-7255 • HOBART 23-1841
 • MELBOURNE 699-4999 • PERTH 65-7000 • SYDNEY 648-1711
 • AUCKLAND N.Z. 360-154 • WELLINGTON N.Z. 698-272

FRESH 1977 STOCK

ELECTROS		
1000 MFD	10volt	10 for \$1
47uF	35v	10 for \$1
47uF	16v	10 for \$1
47uF	200v	5 for \$1
47uF	25v	5 for \$1
220uF	10v	10 for \$1
0.39uF	160v	10 for \$1
500 MFD	12v	5 for \$1
70 MFD	45vac	5 for \$1
47uF	160v	5 for \$1
6.8uF	1500v	10 for \$1
15uF	400v	5 for \$1

PHILIPS MONO PICK-UP CARTRIDGES \$3.50

POWER TRANSFORMERS

60 MIL 240V 245 ASIDE 6.3 \$5
80 MIL 240V 245 ASIDE 6.3 \$6



SPEAKER TRANSFORMERS

7000 to 15/OHMS \$1.75
1200 to 15/OHMS \$1.75
7000 to 3.5 OHMS \$2.50

TRANSISTOR 7 RADIO

Complete with 3 1/2 inch speaker
No cabinet \$3.95

Speaker Systems
2CFT 40 Watts RMS \$70.00 pair.

B.S.R. CERAMIC STEREO \$5

Pick up Cartridges Universal Type

LEVEL AND BALANCE METERS



12,000 ohm 100 Microamps \$2

SLIDE POTS 50k 4 for \$2

Special miniature transistor pots
10k 4 for \$1

Special miniature tuning condensers for transistor radio 2 for \$1

Philips Tuners TV NT 3014 \$10.00
B S R Record Players Super Special \$12.
Pack & post N S W \$2.00
Interstate \$3.00

POTS

1/2 Meg switch 50 cents
10K switch 50 cents. 1 Meg 50 cents.
1/2 Meg 50 cents. 100K switch 50 cents. 250K 50 cents. 7500K 50 cents. 25K 50 cents. Dual concentric 500K 1 Meg \$1. Dual concentric 50K 25K \$1. 1 Meg Dual ganged log \$1. 1/2 Meg dual ganged double pole switch \$1. 2 Meg dual ganged Lin \$1. 1 Meg dual concentric \$1. 500K min 4 for \$1. 10K min 4 for \$1.

SPECIAL

25 mixed transistors and diodes \$2



SUPER SPECIAL OUTPUT TRANSISTORS

AD 161
162 K5 \$2.50 A PAIR

SLIDE SWITCHES

4 mixed types 4 for \$1

SLIDE POTS 250K 4 for \$1
1 Meg 4 for \$1

MICROPHONES

plug and lead \$2.50

Fuses 1/4 amp 10 for \$1
500MA 10 for \$1
10 amp pigtail 10 for \$1

GRAMOPHONE MOTOR and Turntable 3 speed \$3

SPECIAL PICTURE TUBES

17 inch 90° new
\$10.00

POWER DIODES

OA636 1000 v 50 cents



VU METER

\$3.00 pair

Gramophone Motor & Pickup B S R. 4 Speed \$7.95



BASE AND PERSPEX TOP

for record player
Size 17 1/4 x 13 1/2 x 6 1/4 \$10
Pack & post \$2.50 Interstate \$3.50

CONVERGENCE BOARDS

for Colour T.V. Complete \$4

PICK UP ARM

balanced complete with ceramic cartridge \$9



SPEAKER CABINET

including 2 dual cone speakers, 6 1/2 inch 10 watts RMS \$16. Size 16 1/2 x 10 1/4 x 8. Pack & post Interstate \$5 a pair. NSW \$3.00.



Super Special Record Player \$12



T.V. Tuner \$10

SPEAKER SPECIAL 2 1/4 INCH 8/Ohm 2 for \$1.

SPEAKER AND CABINET
Size 10 x 7 1/4 x 4 \$4
incl 6 x 4 speaker

SPEAKER SPECIALS TOP QUALITY

5 x 3 3/5 or 8/ohms \$2.50
6 x 4 8 or 15/ohms \$2.50
6 inch dual cone 8/ohms \$6
9 x 6 3/5 or 8 ohms \$6
5 x 4 3.5 ohms \$3.50

POWER TRANSFORMER 300 mil 240 volt; 115; 110; 6.3 \$5

POWER LEADS

for tape recorders, etc. 75 cents



CAR RADIO

push button tuner \$3



TELESCOPIC AERIALS

\$1.50

3 position push button switch 50 cents

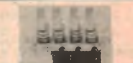

POWER TRANSFORMER 240 volt, 180 volt, 6.3 V 40/ mil \$2.50

BARGAINS BARGAINS BARGAINS BARGAINS

Hook up wire 30 mixed colours \$1
250 mixed screws with self tappers, bolts, nuts, etc. \$1.25 + postage 50c
100 mixed radio TV knobs including fine tune & channel change \$5.00
1/2 meg double pole switch pots 50c
Speaker Cabinets. Size 16 x 10 x 8 including 2 6 1/2 inch dual conespeakers \$18 each
Mixed pots 30 including ganged & concentric \$5
Morganite & IRC 33 useful valves fresh stock \$2.00 + postage 50c
Slide switch 3 position 50 cents
50 ohm Pots ideal for ext Speakers 50 cents
Transistor and Driver Speaker Transformers \$1.00 pair
Ferrite Rods 6 1/2 x 1/2 inch 50 cents
Pots 30 mixed values including ganged and concentric \$5
In Line Fuse Holders 20 cents
Stereo Speaker Wire 12 cents yard
100 Mixed TV and Radio Knobs including Fine Tune and Channel Change \$5

Car radio suppressor condenser 30 cents
Special—Stereo Amplifier. 3 watts per channel RMS. 240 volt bass & treble boost controls. Includes fancy chrome face plate \$10
Electros 3 in one 100-25-40, 24-250-300, 50-250-300 75 cents.
Screw in 6 Volt Pilot Lights \$1.50 for 10, Plug-in type 10 for \$1.00
3.5 to 3.5 Jack Plugs 7ft Shielded Cable 75 cents. 6.5 to 3.5 Jack Plugs 7ft Shielded Cable 75 cents
Mixed Tag Strips 50 cents for Dozen
Special Fancy chrome knobs. Ideal for amplifiers. 5 for \$1.
Tape Recorder Heads Transistor—Top quality suit most recorders \$5.00
Jack Plug Sockets 6.5 mm 35 cents.
Morganite and IRC resistors 33 values \$2 per 100 pack and post 45c
Philips Gramo Motor and Pickup 4 Speed 6 Volt \$7.75
Crossover Condensers 2 mfd 60 cents.

Crystal Microphone Inserts \$1.00
Microphone Transformers 50 cents.
Switch Wafers 11 position 20 cents
Perspex tops for record players size 12 x 8 1/2 x 3 3/4 \$1.50
Pots: 50k 50 cents, 1M 50 cents.
Tape Spools: 7 inch 75 cents 1/2 Meg Double Pole Switch Pots 50 cents
Coaxial TV Feeder Cable 75 ohm 30 cents yard
Jack Plugs 6.5 mm 50 cents. 3.5 mm 25 cents. R.C.A. Plugs 25 cents.
Hook Up Wire 30 mixed colours lengths \$1 bag.
Speaker 4 pin plugs 15 cents. 25 mixed and 5 and 10 Watt resistors \$2.00.
250 mixed screws. BSA. Whit self-tapper bolts, nuts, etc \$1.25 bag plus 40c post.
TV Aerials Complete Range Hills Color \$12 to \$60.
Car radio aerials, lockdown, top quality extended 1600 mm \$4.50.
Electros 3-in-one. 20, 400, 450, 10.

400 450, 75, 50, 65 \$1.00
Power Transformer 60 mil 240 volt 36 volt Centre tap 6.3 winding \$5.
Mics Dynamic 10k \$3.50
Valve Sockets: 7 or 9 pin 10 cents. Octal 10 cents.
6.3 winding \$5 small power transformer 240v. 220v and 22v windings \$3.
Pilot Lights. 24 volt screw-in, 10 for \$1.50
Ferrite Rods 6 inch 50, 9 x 1/2 75 cents.
Pots: 10K ganged log 50 cents: 1 Meg ganged log \$1.25. 1/2 Meg ganged log \$1.25. 2 Meg double pole switch \$1.50
Sharp TV Flyback Transformers 8 FT 604 \$7.00
Miniature Speaker Transformers, drive and output \$1.00 pair
Heat Sinks: 4 x 2 1/4 \$1.50
Speaker Transformers 7000 to 15 ohm \$1.75
Slide Pots 250 K 4 for \$1.

SPEAKERS SPEAKERS SPEAKERS

6 1/2 inch Dual Cone 4 ohm	\$5.00	6 inch Dual Cone Tweeters	\$6.00	MSP 4 x 2.5 ohm	\$2.50
4 x 2 8 ohm	\$1.60	5 inch Magnavox Dual Cone 8 inch 27 ohm	\$6.00	MSP 6 x 4.47 ohm	\$3.60
Special 12 inch dual cone MSP TACX 8 ohm	\$8.00	Magnavox midrange 5 inch dual cone	\$8.00	ROLA 5 x 7.47 ohm	\$6.00
8 TACX 8 ohm	\$8.00	MSP 5 x 7 inch 3 1/2 ohm	\$4.00	ROLA 6 x 9.47 ohm	\$6.00
6 x 9 in 8 or 15 ohm	\$6.00	Magnavox 5 inch 15 ohm	\$4.00	Magnavox 5 inch 8 ohm	\$4.00
6 x 7 in 8 or 15 ohm	\$6.00	MSP 2 1/2 inch 8 ohm	\$2.00	Magnavox 6 x 9 inch 3 1/2 ohm	\$6.00
8 1/2 inch 8 or 15 ohm	\$4.60	Magnavox 5 inch 4 ohm 8 Watt	\$5.00	Magnavox 5 inch mid range 8 ohm	\$6.00
8 x 4 8 or 15 ohm	\$4.60	Magnavox 6 inch 15 ohm	\$4.00	Magnavox 10 inch dual cone 15 ohm	\$10.00
6 x 4 8 or 15 ohm	\$3.60	Philips Gramophone Motor & Pickup 6 volt	\$6.75	MSP 4 or 5 inch 3 1/2 ohm	\$3.50
5 x 4 15 ohm	\$2.60	Magnavox 6 inch 3 1/2 ohm	\$5.00	2 1/2 inch 33 ohm	\$2.00
4 inch 8 ohm	\$2.75	Magnavox 6 x 3 8 ohm	\$2.60		
5 inch Tweeters 8 ohm	\$3.60	Magnavox 4 ohm 5 x 3	\$2.60		

Shortwave Scene

by Arthur Cushen, MBE



A devastating hurricane recently hit Marshara Island in the Red Sea and put the BBC relay station out of action, as well as setting back progress on the installation of two 200kW transmitters.

The devastation caused by the hurricane to the BBC transmitting site should be partially repaired by the time you read this and broadcasts resumed. The south-eastern tip of the Arabian Peninsula suffered widespread damage from a hurricane force storm which lasted from 13th-17th June. The southern regions of the State of Oman, and Masira Island in particular were the hardest hit, and storm damage was extensive with some loss of life, the destruction of hundreds of homes, and severe damage to local agriculture, government buildings and installations. The Eastern Relay Station was closed due to the effects of the storm as from 0200GMT on June 13th.

Fortunately there was no loss of life among the staff of 70 (including some 22 Europeans) at the Relay Base. The transmitter buildings escaped relatively lightly and the transmitter equipment suffered only superficial damage.

The transmitter building houses two medium wave transmitters of 750kW which operate on 701 or 700kHz and on 1410 or 1412kHz. As well, two transmitters for short-wave broadcasting are being installed. An initial report from the BBC states that, as might be expected, the aerial systems were hit hard. The 700/701kHz towers are down and though the 1410/1412kHz towers still stand the feeders to both aerial systems are badly damaged.

Two rhombic receiving aerials out of three still stand although both are damaged. 95 percent of the power house roof was blown off, but the engines appear to be intact under the debris. Nevertheless the job of restoring the station to full operational capacity will be a major task and will take some time.

The damage has also had other repercussions as the BBC were well advanced in their plans to re-site two transmitters from their Far East relay base to Masira during the enforced move from Tebrau, Malaysia, to Kranji in Singapore.

MEBO 2 TESTING

The well known ship Mebo 2, which for some years broadcast off the coast of Holland using the slogan Radio Nordsea, is now back testing off the coast of Lybia. The station is operating on medium-wave 773kHz, short-wave 6210 and 9810kHz, and on FM, according to the English announcement given every 30 minutes. The signal has been widely reported in both Australia and New Zealand on 6210kHz from around 1900GMT to closing at 2300GMT.

The station, in its announcements, states that it operates till 0100 local time or 2300GMT. The announcement is the same as used when operating Radio Nordsea, and is backed by the recording "Men of Action". The transmission is best received on 6210kHz, but reception of 9810kHz has also been noted. The program format is popular music, with recorded announcements every 30 minutes.

This ship joins another operating in the Mediterranean sea: the Voice of Peace has been operating

Notes from readers should be sent to Arthur Cushen, 212 Earn Street, Invercargill, NZ. All times are GMT. Add 8 hours for WAST, 10 hours for EAST and 12 hours for NZT.

for some months off the coast of Israel and broadcasting on 1540kHz medium-wave.

The use to which the Mebo 2 is to be put is not yet known, but the test period has resulted in surprising reception considering that the power on 6210kHz is only 10kW.

RADIO NEW ZEALAND

The short-wave service of Radio New Zealand has announced a tentative schedule which comes into operation on November 5, 1977, and remains in force up to March 5, 1978.

The schedule is: to the Pacific 1800-2200 on 11960, 1800-0700 on 15130, 2230-0245 on 17710, 0300-0700 on 11705, and 0730-1030GMT on 11780kHz.

The transmission to Australia is broadcast 0730-1030 on 11780kHz also. The DX World Program is heard on the first Sunday of each month at 1015GMT and the Mail Box Session on the third Sunday at the same time. These programs are also re-broadcast by the national stations of Radio New Zealand on medium wave.

TWR GUAM ON AIR

The long awaited tests by Trans World Radio on Guam were first observed by John Mainland of Wellington NZ, when broadcasts were heard in June on 9505kHz. The transmitter is one of a 100kW and, according to the World Radio Handbook Newsletter, several frequencies are to be used for the gospel broadcasts to Asia.

The address of the station is, Trans World Radio, PO Box 3518, Agana, Guam, 96910. The station will use two transmitters of 100kW with a special aerial system beamed towards Asia, but even though we are on the reverse side of the transmission reception is possible.

Another reader who heard the initial tests was Percy Smith of Enoggera, Qld, who heard the broadcasts on 9505kHz and verified the station by letter from Rodger Groff, Field Director. The call sign is KTWR and our reader was one of the first ten to report reception. According to the New Zealand DX Times the tentative schedule reads: 0930-1000GMT on 11780 and 11900kHz, in English with "Back to the Bible" Tuesdays-Saturdays, "Unshackled" Sundays, and "Night Sounds" on Mondays. The same frequencies are also scheduled 1000-1100GMT, beamed to Japan and Indonesia. 11780 and 9575kHz are listed for China 1100-1300 and south East Asia 1300-1330GMT.

ENGLISH FROM LISBON

The latest schedule from Radiodifusao Portuguesa indicates that broadcasts in English are 0300-0330GMT on 6025 and 11935kHz; 0500-0530 on 6025 and 11935; 1400-1430 on 17895; 1600-1630 on 17895; 1800-1830 on 15340 and 17880; 1700-1730 on 15340; and 1800-1830 on 6025 and 9740. This transmission has five minutes of English with the balance of the broadcast made up of French, Italian and Spanish. The broadcasts at 0300 and 0500 are to North America, but give good reception in the Pacific area, while the transmission at 1400GMT is beamed to the Far East.

The station is now issuing a new card showing a

map of Portugal. The station address is Radiodifusao Portuguesa, Lisbon 2, Portugal.

MEDIUM WAVE NEWS

AUSTRALIA: The latest repeater of the ABC is 75H St. Helens, Tasmania, which is operating on 1570kHz. The power is understood to be 100W and despite this the station has been heard at 0910GMT with Tasmanian news. Signals suffer considerable interference from the four other ABC stations on the frequency.

The Sydney Ethnic Radio Station 2EA on 800kHz is heard at 2000GMT when commencing a transmission in Greek. Our reception is best on Saturday, when 5RM does not open at this time. 2EA has a full station announcement at 1958GMT and gives the address as 420 Lyons Road, Five Dock, 2046, NSW.

NEW ZEALAND: The latest Radio New Zealand station to commence operation is 3YR Reefton, broadcasting from the West coast of the South Island on 1510kHz using 100W. Station 3YR carries both national and community programs and operates 24 hours a day, relaying the output of either of the two Greymouth stations 3YZ or 3ZA. The same program is also being carried by 3YW Westpoint on 1460kHz.

MALTA: The Deutsche Welle relay station on Malta, using 1570kHz, is often heard around dawn in Australia and New Zealand, with the distinctive interval signal. Latest information is that due to close co-operation between Malta and Lybia, the transmitters are also being used for relays of the Lybian Broadcasting Service. According to Victor Goonetilleke of Sri Lanka, the transmissions have been noted with Arabic programs as well as popular music.

LISTENING BRIEFS EUROPE

AUSTRIA: The Austrian Radio has moved to two out-of-band channels for their broadcasts to Europe. The frequency of 5925kHz is now used 1900-2200GMT in place of 6115kHz, while a new frequency of 12015kHz replaces 11855kHz for the period 1400-1600GMT.

HUNGARY: According to the BBC Monitoring Service, Radio Budapest has made a frequency change for its transmission in Greek, Italian, German, Hungarian, English and Spanish to Europe 2000-2230GMT, and is now using 7215kHz instead of 7200kHz. In the transmission at 0200-0230GMT the frequency of 17720 replaces 17710kHz.

AFRICA

SWAZILAND: The Swazi Commercial Radio has been heard on 3223kHz at 1900GMT with English programs. Before this time, a Gospel program has been heard or popular music. At 1900 GMT the announcement was heard "This is Swazi Radio, the International Sound". According to Dene Lynneburg reporting in the New Zealand DX Times, there is an Indian program after 1900 GMT.

NIGERIA: The Nigerian Broadcasting Corporation station in Ibadan has been noted at 0630GMT on 6050kHz under the BBC transmission. Another Nigerian station, this one at Jos on 5965kHz, has been heard on Sundays up to 0600GMT according to Paul Edwards of Wellington NZ.

ETHIOPIA: The former Voice of the Gospel, now broadcasting as the Voice of Revolutionary Ethiopia, has been heard on 6015kHz at 1630GMT with a news bulletin in English. A French program followed at 1700GMT according to John Durham, Meremere NZ.

AMERICAS

COLOMBIA: La Voz de los Centauros has appeared again on 5962kHz and in New Zealand has been heard from around 0500GMT onwards. Another Colombian, Radio Super at Bogota, has been noted by Robert Hanner of Melbourne, reporting in Australian DX-ers Calling, on 6067kHz around 0800GMT. Another Colombian, La Voz de la Selva on 6170kHz, which has been operating all night, has been heard at our location closing 0355GMT.

BOLIVIA: Radio Nacional Huanuni on 5965kHz is often heard with an extended schedule broadcasting to past 0600GMT. The power is listed as 1kW. A call-sign for this station has not been allocated.

INFORMATION CENTRE

DEAD LETTER: We are holding a letter returned to us by the Postal Commission, which they cannot deliver. It was addressed to Mr I. Humphrey, 18 Forfar Rd, Beaconsfield, 2014. If Mr Humphrey will contact us with the necessary address details we will forward the letter to him.

MODULAR DIGITAL CLOCK: In reference to the Modular Digital Clock (December 1976, File No. 7/CL/25), I have encountered two problems which may be of interest to other readers. On the clock module, there are two resistors above the minutes digits, the junction of which protrudes through the back of the board and may touch the heat sink of the power transistor, thus causing an unusual display. No permanent harm seems to result from this, however.

My module arrived with the red lens cover and lens detached from the board. It would seem that this is no cause for immediate alarm, so long as the LED junctions themselves have not been damaged. The clock will still work if you replace the lens and its red cover, and then glue the cover to the board. Don't apply glue to the lens itself, as this may affect the transmission of light through it. (J.M., Carisbrook, Vic.)

• Thank you for your comments about the clock, J.M. As you can see, we have published them in full for the benefit of other readers.

MOTORCYCLE CDI: I have a Yamaha RD350 twin cylinder, two-stroke motor-bike and I want to fit a CDI system to it. CDI seems to answer a lot of problems in two-strokes, especially plug fouling and high rpm misfiring (9000rpm). Would you simply use two trigger circuits and a common inverter? The bike has two sets of points and two coils. (R.C., Willoughby, NSW.)

• Since the inverter stops oscillating when the SCR is conducting, it will be necessary to use two separate CDI circuits.

DIGITAL WALL CLOCK: I constructed the digital wall clock featured in the July 1976 issue and have one query and a few comments which may be of interest: (a) How do you hold the count for accurate time setting to the nearest second? (b) I found your comments on the mains transformer incorrect in my case. The transformer will bolt to the base of the case but it is about 1/8" too thick, necessitating some modification to the case.

(c) Some constructors may not be familiar with the interconnection of segments "b" and "c", and this may be worthy of comment.

(d) If anyone did wish to connect the alarm, there is no information on how to set and cancel this function.

(e) Finally, a standby battery with a crystal drive would be a useful addition. (R.G., Dolans Bay, NSW).

• As you can see R.G. we have condensed your letter somewhat, but retained its essential content. It is not practicable to hold the count on the digital wall clock, this due to the internal circuitry of the CT7001 clock chip. You can, however, still set the time accurately by making use of the fact that the clock begins counting from 00 seconds when switched from the minute set position.

Regarding the transformer, we can only assume that the unit supplied to you differs from the one we received. Yes, the "b" and "c" segments are unconventional, and intending constructors should take note. This has been done to round off the corners of the digits, with the result that the "b" and "c" segments are not continuous.

We agree that insufficient information is supplied with the kit regarding the optional alarm circuitry. As for crystal backup, a 50Hz drive unit was described in the same issue (July 1976) and you may care to experiment with this.

Thank you for your photograph of the PC board holder. This will be considered for use in "Circuit and Design Ideas".

ELECTROCRAFT PTY. LTD.

Distributors of Belling Lee, Channel Master, Ecraft, Hills, HI. Q, Lab Gear, Kingray, Matchmaster. Largest Television range of aerial equipment in Sydney

106A Hampden Rd.
Artarmon, 2064
Phone 411-2989

TELEVISION AERIALS, DISTRIBUTION AMPLIFIERS, EQUIPMENT AND ACCESSORIES WHOLESALE, TRADE AND RETAIL SUPPLIED.

NEW FROM ECRAFT A range of Medium & High gain R.F. DISTRIBUTION Amplifiers, suitable for all TV & FM Radio transmissions within the VHF & UHF Bands 1 to V

APPLICATION Suitable for small home unit, showroom or household type installations. D16 & D25 amplifiers have good signal to noise ratio. As such this makes them suitable as a booster in semi-fringe or fringe areas

1.75 D16 16 dB gain \$45.90 1.75 D25 25 dB gain \$53.55

All type coaxial cables in stock from 30c per yd. 50 ohm - 75 ohm

HILLS	ANTENNAS	CH's	s
CA16	High gain phased array	Multi	44 36
215/2710	8 EL	Multi	24 42
2010/2710	Airways	Multi	56 26
E.F.C.1	75 ohm for colour	Multi	31 43
E.F.C.2	75 ohm for colour	Multi	41 70
E.F.C.3/24	75 ohm for colour	Multi	60 64
E.F.C.4/24	75 ohm for colour	Multi	76 30
207/45A		4 & 5A	31 47

CHANNEL MASTER

3110	2 EL Coloray	t2 to 11	27 96
3111	6 EL Super Coloray	Multi	41 98
315	2 EL City VEE	0 to 11	15 68
3615A	9 EL Crossfire	Multi	43 64
3614A	13 EL Crossfire	Multi	54 69
3613A	17 EL Crossfire	Multi	68 17
3612A	21 EL Crossfire	Multi	78 54
3610A	24 EL Crossfire	Multi	99 84
3617A	28 EL Crossfire	Multi	125 73

HILLS FM ANTENNAS

FM1	300 ohm	9 39
FM3	75 ohm	18 27

CHANNEL MASTER FM ANTENNAS

700 FM 8 EL	300 ohm	19 68
200 FM 2 EL	300 ohm	8 31

MATCHMASTER FM ANTENNAS

FMG	300 ohm	11 95
FMG/2	300 ohm	18 30
FMG/6	Fringe area 300 ohm	40 93

COBRA 132 \$350.00 AM/SSB

Delta Tune P A Extension Speaker Facility Illuminated Channel Indicator and Metre. R F MIC Gain Control. N B Switch. Auto Noise Limiter. **Sensitivity:** AM 0.5uV or better, SSB 0.25uV or better. **Selectivity:** 6dB at 4kHz, 50dB at 20kHz, 6dB at 2 kHz, 60dB at 5kHz. **Audio Output:** 3.5 watts typical.



THE COBRA 26 \$120.00

The Cobra 26 is called "The Performance Radio" because professional drivers prefer the 26's top rated features and performance. Just check this list: Switchable noise limiting (ANL), RF gain control, Delta Tune, illuminated Power/S meter, adjustable squelch, PA output, detachable dynamic mike and much more.

The Cobra 26 operates at maximum legal power and critical sensitivities. What it really means to you is more enjoyable use of your CB operation. See for yourself why the Cobra 26 is the standard of comparison in the Citizens Band two-way radio industry. *No matter what the conditions, the Cobra 26 punches through loud and clear.*

A big voice in a small package. The Cobra 19M \$110.00.

If you've ever heard a Cobra 26, you'll know it's hard to believe all that talk-power is legal. Cobra found the way to make their radios really talk and still obey the rules. Now you can talk just as loud and far with a smaller package. Cobra 19M is thin and narrow enough to mount conveniently in any car, even the latest subcompacts. And the 19M has other features you'd expect from a Cobra such as a plug-in dynamic mike, external speaker jack, and now, even an illuminated RF/signals metre. The Cobra 19M has the same receiver sensitivity and selectivity as its big brother, Cobra 26. It has an efficient automatic noise limiter too; you'll hear clearly in the heart of heavy traffic. Dimensions: 1 1/2" H x 5 1/2" W x 8" D. Power Output: Factory adjusted to 4 watts legal maximum. Modulation: 100%. Sensitivity: Less than 1.0uV for 10dB (S+N)/N. Selectivity dB—6dB at 4kHz, 40dB at 20kHz. Image Rejection:—30dB. IF Rejection:—80dB. Audio Output: 2.5 watts into 8 ohms.

CB AERIALS

ASIC. 5ft Fibreglass vertical helical whip aerial with base (Guard Mount) complete with 12ft cable & plug \$26.73.

5ft Helical home base aerial for mast mounting \$33.

CB2600 Gutter Clamp aerial complete with lead & plug \$20.70.

ALL TYPES OF HARDWARE IN STOCK Wall Brackets, Chimney Mounts, J Brackets, Guy Rings & Guy Wire. Masts from 8ft to 50ft. ETC.

If you are unable to complete an "Electronics Australia" project because you missed out on your regular issue, we can usually provide emergency assistance on the following basis:

PHOTOSTAT COPIES: \$2 per project, or \$2 per part where a project spreads over multiple issues. Requests can be handled more speedily if projects are positively identified, and if not accompanied by technical queries.

METALWORK DYELINES: Available for most projects at \$2 each, showing dimensions, holes, cutouts, etc., but no wiring details.

PRINTED BOARD PATTERNS: Dyeline transparencies, actual size but of limited contrast: \$2. Specify positive or negative. We do not sell PC boards.

REPLIES BY POST: Limited to advice concerning projects published within the past 2 years. Charge \$2. We cannot provide lengthy answers, undertake special research or discuss design changes.

DEPTH SOUNDER: I am sure a project describing a depth sounder, or echo sounder would be of immense value to many readers. Commercial units cost from \$300 to \$700, which is out of the reach of many small boat owners. If a design could be worked out for about \$100, I am sure many people would be delighted to construct one. (L.T., Duffy, ACT.)

● Your suggestion is an understandable one L.T., and we have considered such a project many times. Unfortunately these devices require several specific pieces of hardware, which are not normally available as separate items. In particular, there is the transducer, which both radiates the research signal and responds to the echo. This needs to be mechanically robust, as well as electrically reliable. Most systems also use a mechanical readout arrangement which, while not essential, appears to have several advantages.

We will keep the idea in mind in case suitable hardware should become available.

VARIABLE DELAY WIPER: I have built up the unit as described in the May 1975

BACK NUMBERS: Available only until our stocks are exhausted. Within 3 months of publication, face value. 4 months and older, if available, \$2. Post and packing 60c per issue extra.

OTHER QUERIES: Technical queries outside the scope of "Replies by Post" may be submitted without fee, for reply in the magazine, at the discretion of the Editor.

COMMERCIAL SURPLUS EQUIPMENT: No information can be supplied.

COMPONENTS: We do not deal in electronic components. Prices, specifications, etc., should be sought from advertisers or agents.

REMITTANCES: Must be negotiable in Australia and made payable to "Electronics Australia". Where the exact charge may be in doubt, we recommend submitting an open cheque endorsed with a suitable limitation.

ADDRESS: All requests to the Assistant Editor, "Electronics Australia", Box 163, Beaconsfield, 2014.

issue (File No. 3/AU/12), and am hoping that you can help me with two problems. The first one is in regard to connecting up the car wipers. I have a 1972 V.H. Valiant, with the wipers as per the enclosed diagram.

Could you tell me which wires to connect to the relay? The second problem is that the timer works OK off the battery, but when the motor is running the timer goes mad, and mistriggers. I have been unable to prevent this. (G.O.S., Claremont, Tas.)

● You have not stated whether the car has a single or dual speed wipers. Depending on this, either case 3 or case 4, as described in the May article, should be followed. If this does not give the correct results, we suggest that you experiment with the various wires at the switch. From your diagram, it appears that the wire marked "H" controls the high speed operation, the one marked "L" controls low speed, and "P" controls the parking facility.

To prevent mistriggering of the timer, connect a 0.01uF capacitor between pin 5 and pin 1 of the 555. This was covered by a note in the June 1975 issue.

Notes & Errata

RSGB HANDBOOK: Technical Book and Magazine Company has advised that the price quoted for Volume 1, reviewed in the July issue, was incorrect. The correct price is \$21.10.

MOS ORGAN KEYSER (June 1977, File No.1/EM/45): The keying busline outputs shown in Fig. 2 and Fig. 3 are in reverse order. From the adjacent end of the PCB edge connector they should read E, 16, 8L, 8U, 4L, 4U, 2 and E.

DIGITAL LOGIC TRAINER MARK III (July 1977, File No. 2/MS/44): In the overlay diagram on page 48, the polarity of the battery leads and the 100uF capacitor were incorrectly marked. The leads

marked + should be marked -, and the leads marked- should be marked +. Also, the unmarked IC near S1 is a 4011 device.

MODULAR DIGITAL CLOCK (December 1976, File No. 7/CL/25). In the parts list on page 53, 1 BC548 and 2 BC558 transistors were erroneously specified. The list should read 2 BC548 and 1 BC558 transistors. Also, on page 54, the fourth line in the first column should read "wiring on the clock PCB, so that . . ." Pad E8 and pad 2 are connected together on the clock PCB, but this connection is not shown in the circuit diagram. Both the circuit diagram and the component overlay diagram on page 55 are correct, and should be followed exactly.

COWPER SHEETMETAL WORK FOR THE ELECTRONICS INDUSTRY

E.A. Video Data Terminal Cases
Musicolor II & III
C.S. 108 & 216 Hobby Boxes
108 x 108 x 50 + + 216 x 108 x 50

Inquiries welcome on
Cases and Panels

Rack Mounting Chassis

Chassis & Covers

Vented Transformer Cases

General Sheetmetal & Welding

COWPER SHEETMETAL & ENG.

11 COWPER STREET
GRANVILLE N.S.W. 2142

PHONE 637 8736 (S.T.D. 02)
(A Division of The Star Delta Co. P/L)

DISCOVER the exciting world of EXPLORATION!



See our spectacular display of telescopes, binoculars, microscopes, weather equipment, build-it-yourself kits, books, charts and atlases

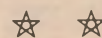

Send 45c to Dept. C, Box 568,

Crows Nest, 2065

for a complete informative catalogue.

Astro-Optical Supplies Pty. Ltd.

11 CLARKE STREET CROWS NEST SYDNEY N.S.W. 2065 PH. 43 4360
200 BOURKE STREET MID CITY ARCADE MELBOURNE VIC PH. 663 2761

HI-FI ENTHUSIASTS!

Want to get the best
out of your system
in 2 easy steps?

STEP 1. BUY A COPY OF THE FAMOUS HFS75 TEST RECORD.

Made in the U.K., this record is an invaluable aid as it allows YOU to optimise tracking weight and anti-skating for your arm/cartridge combination by simple evaluation of a series of test tones. You couldn't spend \$8.50* more wisely!

STEP 2. LET YOUR NEWLY OPTIMISED CAR- TRIDGE SHOW-OFF BY REPRODUCING SOME REAL QUALITY RECORDINGS.

Try the excellent ARK discs by Fulton of the U.S.A. for high fidelity and natural sound. Consider—(a) Organ Music from Westminster, (b) Organ Sounds from Mt. Olivet, (c) The Anoka Concert Band. These records will show you what stuff your system is made of, and it will only cost \$11 per title to find out! Other titles also available

Contact your favourite Hi-Fi/Record store,
or direct from

M.R. ACOUSTICS

P.O. BOX 110, ALBION,
BRISBANE 4010

Add \$1 per record for pack & post.
Extra 50c gives certified mail insurance cover

*Recommended Retail Prices

POTS

1/2 MEG TAB POTS	10 FOR \$1.28
1.5 K TAB POTS	10 FOR \$1.28
DUCON SWITCH POTS	\$1.75 ea.
220 K SLIDE POTS	3 FOR \$1.28
5 K SLIDE POTS	3 FOR \$1.28

ADRIAN MICHELL'S

TELEVISION REPLACEMENTS

REAR 139 UNION ROAD, SURREY HILLS,
VIC. 3127. PHONE 89-1019

Where the T.V. Technicians meet.



Marketplace

FOR SALE

DRAKE R-4C RECEIVER with extra 160 and 10 metre xtals
Little used, mint condition. \$635 cash Phone (S.A.)
Eudunda 252

8K STATIC RAM memory kits. \$100, low power. 450ns, top
quality imported boards, plated through holes, silk screened,
sockets for all IC's. \$220 ea. Ring Brian (02) 807 4376

COLOUR TV Why pay \$8.00 for a horiz output or high freq
power supply transistor? \$1.95 or \$1.75 each for 10, \$1.65
each for 50, excellent quality, suitable all makes VHF or UHF
push button tuning unit \$4.50, UHF tuners \$5.00. Add
postage or stamped S.A.E. for queries. Teleservice B42, Can-
ning Hwy, Applecross, W.A. 6153

RADIO MAST Deeco self-supporting 12' sections hvy duty
triang const., built-in ladder, hot dip gal. \$360 Phone
(02) 635-1320, P.O. Box 954, Parramatta 2150

HIGH QUALITY CASSETTE TAPES Wholesale price min ten
C60. A\$9.50 postpaid. Free sample La Salle Co., Saiying-
pun, P.O. Box 20359, Hong Kong

SHORTWAVE LISTENERS & DXERS: The "Southern Cross
DX Club" (G.P.O. Box 336, Adelaide, South Australia 5001)
is for you! Members in all States. Details for 18 cent stamp
Victorian enquiries to P.O. Box 396, Mt Waverley 3149

HEWLETT PACKARD 1740A CRO DC-100MHZ Dual Chan-
nel DC AC. 50ohm inputs, trigger view. 5mV sens and X5
sweep 5s/div to 5ns/div plus delayed sweep. 6 months old,
mint condition with probes, manuals, original packing
Surplus to requirements \$2,200 cash plus sales tax. Phone
(S.A.) Eudunda 252

AUSTRALIAN RADIO DX CLUB. The premier DX Club of Aus-
tralia now in its 13th year of national operation. Catering
for the interests of both S.W. listeners and DXers, the
monthly bulletin covers the S.W. and M.W. spectrums. For
full details, write enclosing a 20c stamp to ARDXC, P.O. Box
67, Highbury, Vic. 3190

BUSINESS FOR SALE

This business would suit an enterprising Radio & TV tech-
nician. Workshop is fully equipped, regular customers &
plenty of work available. For further details please write
or telephone:

Focus TV Service, P.O. Box 584
Esperance, W.A. 6450. 71 1202. A.H. 71 1992

**NEW ZEALAND
READERS!
PRINTED CIRCUIT
BOARDS**
for projects appearing in
this magazine are available
from

MINI TECH

Mfg. Co. Ltd.,
Box 9194, AUCKLAND
Phone 542-598

We will also make boards to
your own design — quotations
free.

DON'T READ THIS if you've got no cents. So you're a big
game bargain hunter, off alone into the jungle of electronics,
armed only with a soldering iron. Don't be taken for a ride
— send for our free guide. S.S.A.E. appreciated (small okay).
Take along our wild stock list as a guide which includes
choice game such as 2c resistors, 6c electrocaps, 6c
1N4148 (\$4.50/100, \$38/K), 15c zeners, 35c SCRs, 65c
triacs, 35c diacs, and many others worth bagging. We'll bag
'em for you — as many as you like for only 40c postage
allowance. No minimum quota either. We operate a genuine
same day turnaround service.

DIGGERMAN ELECTRONICS, Box 33, Coramba 2466

TELEPRINTING SPECIALS: Mod 15 Mint cond. \$90. Very
good \$70. Good \$50. Mod 15 Keyboard Perforator \$40.
Mod 14 T.D. \$30. FRXD4 Reperf. Trans. Dist. \$30. Paper
Rolls 12 for \$18. 11/16 Tape 20 for \$18. Creed 78 Tele-
printer \$80. Send for price list. Ex Gov. Goods. Photo,
Medical, Electrical, Scientific gear. All goods sent freight on
anywhere plus packing. Studio 20 Sales, 367 Bourke St.,
Darlinghurst 2010. Phone 31 3383

KITS & COMPONENT SPECIALS Digital Tacho Kits 4 digit
7 seg led \$48.50, Digital Dice Kit 7 seg led Sing \$16.25
Double \$32.50, Car burglar alarm E.A. Nov. 76 \$30.50,
W. Wiper Delay Kit \$18.75, Tran. Ignition Kit ETI May 77
\$28.00, McMurdo rocker sw. \$1 ea. 30 Amp relay \$6.50,
1m/A meter \$6.50, Neons 6/\$2, 1000 MFD 16V pc elec-
tros 6/\$1.50, 100K pots 6/\$1.50, FND500 6/\$1.1,
DL507 \$1.50, 555 IC 10/\$7, Slide switch 4/\$2, Trim Pots
10/\$3, 1N914 10/\$1, LEDs 10/\$3. See advert EA Aug.
Min. Order \$10. All post free S.M. Electronics Box 19, Don-
caster East 3109

RESISTORS AND CAPACITORS. Resistors all E12 values.
1/4 watt carbon film 10 ohm to 1 meg 2 cents each I.R.H.
GL 1/2 or GLP 1/2 watt Metal glaze 10 ohm — 470k 3 cents
each or 2.5 cents over 250, 1 watt 1 ohm to 1k 6 cents
each or 5 cents over 100 PACKS STANDARD PACK contains
5 each of E12 values in ranges shown. COMPUTER PACK
contains quantities based on general usage. 1/2 watt 285
resistors \$7.00. 1/4 watt 305 resistors \$5.90. CAPACITORS
ELECTROLYTICS single ended uprights, Mfd 35 v w. 1, 2, 2,
3, 3, 4, 7, 10, 22, 10 cents each. 33, 47, 15 cents, 25 v w.
100 16 cents each. 220 25 cents each. 470 35 cents
Polyester Greencaps 100 v w. 001, 0022, 0033, 0047,
0056, 0068, 7 cents each. 01, 022, 033, 047, 056,
068, 082, 10 cents each. 1, 22, 13 cents each. Poly
Pack 5 cents of these values \$6.00. 75 capacitors. Other
components see E.A. June, 1976. All components brand
new from manufacturers or agents. Each value of component
individually packed. Post and packing included in all orders
over \$6.50. For orders less than \$6.50 add 40 cents for
post and packing. 5% discount on orders over \$35.00. 10%
discount on orders over \$75.00. Send orders to RAM ELEC-
TRONICS, 575 Sydney Road, Seaforth, N.S.W. 2092.
Please send cheque or money order.

**REPAIRS TO JAPANESE RADIOS, CAR RADIOS,
CASSETTE RECORDERS, CAR CASSETTES,
8 TRACK PLAYERS**
PETER G. BROUGHTON,
99 Sussex Street, Sydney
Phone 29 3845

FIGARO TGS GAS SENSORS

TYPES 812 and 813

Check EA May issue for details or
contact us for free data.

DIGITRON ENGINEERING
16 Coveney Street, Bexley, 2207
Phone: (02) 50-4361

Sanwa precision circuit testers— Big on features. Bigger on selection.



1



2



3



4



5



6



7

1. BX-505

- Fast-response, 24 μ A movement — fuse & diode protected with high resolution factor (0.4 μ A/ scale division)
- Revised scale marking — intermediate readings readily determined

2. U-60D

- 44 μ A movement — quality performance, diode protected
- Stable ACV measurement — solid-state rectifier & enlarged frequency coverage

3. SP-10D

- Easy operation — multiposition rotary selector switch & well-lighted scale
- Stable ACV measurement — durable diode rectifier

4. N-501

- 2 μ A suspension movement — 0.05mA/1mV resolution
- Double protection — fuse & Si diode

5. CX-505

- 16.5 μ A movement — varistor protected & 50k Ω /V for DC
- Capacitor tester — push-button operation with solid-state oscillator built in

6. PDM-500 (Insulation Tester)

- Battery operated — 3 small-size 1.5V batteries built in
- Push-button operation — pointer calibration & insulation test

7. CAM-201S (Clamp Meter)

- Measuring ranges 15-60-300A — 500V — 50k Ω
- Meter protection diode provided



WARBURTON FRANKI

ADELAIDE 356-7333 BRISBANE 52-7255 HOBART 23-1841
MELBOURNE 699-4999 PERTH 65-7000 SYDNEY 648-1711
WELLINGTON, N.Z. 698-272

sanwa
MULTITESTERS



EMONA
enterprises

**MAIL ORDERS: Box 188,
COOGEE, NSW, 2034**



EMONA
ELECTRONICS

SALES Room 208, 661 George St., Sydney. Phone: 212-4815 — C.B.C. Bank Bldg., Haymarket.
REG. OFFICE 21 Judge St., Randwick. Phone: 399-9061.

AMATEUR RADIO EQUIPMENT!



- YAESU FRG-7 GENERAL COVERAGE RECEIVER-WADLEY LOOP SYSTEM
- YAESU FT-101E TRANSCEIVER
- YAESU FT — 301 TRANSCEIVER

- KENWOOD TS-820 H.F. TRANSCEIVER
- KENWOOD TS-520 H.F. TRANSCEIVER
- KENWOOD TR-7400A 2M DIG. TRANSCEIVER
- CHECK OUR STOCK ON OTHER YAESU AND KENWOOD AMATEUR RADIO EQUIPMENT

AMATEUR SOLID STATE BROADBAND BI-LINEAR AMPLIFIERS 1.6—30 Hz 200B BASE STATION



SPECIAL FEATURES

1. Automatic Keying
2. Relative power meter
3. Bypass feature
4. Harmonic filter
5. 20 dB RX Pre-amp
6. Dual mode — AM/SSB
7. Over temp. protection
8. Harmonics greater than 50 dB below output

Output: 150W RMS (AM) — 200W P.E.P. (SSB)
(SSB)
Drive: 5W RMS (AM) — 10W PEP (SSB)
Impedance — Input & Output: 50 Ω

ALSO: 80w, 144 — 148 MHz, FM, SSB
LINEAR AMPLIFIER 2M10 — 80L

SEE E.T.I. MAY & JUNE ISSUES FOR OUR RANGE OF:

- ELCON CALCULATORS ● MINI RECORDER
- CAR STEREO CASSETTES ● CAR RADIOS
- HAM-WORLD TIME CLOCK
- EMONA DIG. CLOCK RADIOS ETC.

C.B.

● THE DE-LUXE 23 CHANNEL 5 WATT SEIKI, HA-23C

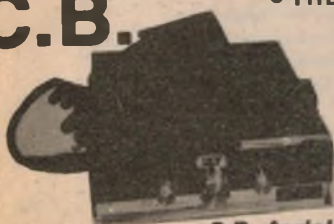

C.B. Aerials & accessories available.

CHECK EMONA'S MOST COMPETITIVE PRICES!

Sound move..

Get 2 free catalogues before you spend a cent on audio equipment.

The 100 page Sennheiser catalogue covers microphones, headphones, and accessories. Top professionals use Sennheiser in radio, TV and recording studios world wide: and there are models for paging and public address; conference and communications; pop groups and preachers. Don't make a move until you know about them. You should also know Millbank. PAC system. An inexpensive basic amplifier accepts plug-in pre-amps and combiners for any inputs: mic, tape deck, radio, chimes, signals, alarms, recorded messages etc. etc. You only pay for what you need.



Sole Australian distributors

R.H. Cunningham
Pty. Ltd.

Excellence in Electronics

Melbourne: 329 9633
Sydney: 909 2388
Brisbane: 36 1277
Adelaide: 268 2801
Perth: 28 3655

Sennheiser
ITE Millbank

TRANSFORMERS:

12 or 24 Volt Range: Primaries 220-240 volts

Ref	Amps	Wt	Secondary	
242	300MA	150MA	198 0-12V at 150 MA x 2	5.42
111	0.5	0.25	283 0-12V at 0.25A x 2	5.58
213	1.0	0.5	425 0-12V at 0.5A x 2	7.02
71	2	1	783 0-12V at 1A x 2	8.94
18	4	2	1020 0-12V at 2A x 2	10.78
70	6	3	1538 0-12V at 3A x 2	12.30
108	8	4	2266 0-12V at 4A x 2	14.50
118	12	6	2722 0-12V at 6A x 2	15.54
115	20	10	5300 0-12V at 10A x 2	23.37

30 Volt Range: Primaries 220-240 volts
Voltages obtainable: 3, 4, 5, 6, 8, 9, 10, 12, 15, 18, 20, 24, 30, or 12-0-12 or 15-0-15

Ref	Amps	Wt Gms	Secondary Taps	
112	0.5	823	0-12-15-20-24-30	7.40
18	1	737	0-12-15-20-24-30	8.07
3	2	1381	0-12-15-20-24-30	11.62
21	4	2600	0-12-15-20-24-30	15.24
89	10	5870	0-12-15-20-24-30	28.12

50 Volt Range: Primaries 220-240 volts
Voltages obtainable: 6, 7, 8, 10, 14, 16, 17, 19, 21, 25, 31, 33, 40, 50, or 25-0-25

Ref	Amps	Wt	Secondary Taps	
102	0.5	737	0-19-25-33-40-50 V	9.85
103	1	1304	0-19-25-33-40-50 V	12.54
104	2	2495	0-19-25-33-40-50 V	14.15
105	3	3178	0-19-25-33-40-50 V	16.38
108	4	4100	0-19-25-33-40-50 V	19.94
107	6	5444	0-19-25-33-40-50 V	26.40

80 Volt Range: Primaries 220-240 volts
Voltages obtainable: 8, 8, 10, 12, 18, 18, 20, 24, 30, 38, 40, 48, 60, or 24-0-24 or 30-0-30

Ref	Amps	Wt	Secondary Taps	
124	0.5	737	0-24-30-40-48-60 V	9.18
128	1	1361	0-24-30-40-48-60 V	10.31
127	2	2495	0-24-30-40-48-60 V	14.38
125	3	4083	0-24-30-40-48-60 V	18.78
40	5	5870	0-24-30-40-48-60 V	25.54

Miniature transformers with screens: Primaries 220-240 volts

Ref	MA	Wt Gms	Volts	
238	200	85	3-0-3	5.50
212	1A, 1A	595	0-8-0-8	7.85
13	100	113	8-0-8	5.50
238	330 330	188	0-8-0-8	7.22
207	500 500	586	0-8-0-8-8	5.50
205	500 800	1077	0-15-20, 0-15-20	9.02
214	300 300	823	0-20, 0-20	7.15
221	700 (DC)	737	20-12-0-12-20	9.54
206	1A, 1A	1304	0-15-20, 0-15-20	12.82
203	500 500	822	0-15-27, 0-15-27	11.28
204	1A, 1A	1417	0-15-27, 0-15-27	14.45

Battery Charger Types: Primaries 220-240 volts. Secondary 2v, 6v, 12v DC (Rectified)

Ref	AMPS	Wt Gms		
45	1.5	737	Please note: these units do not include rectifiers	11.57
5	4.10	1474		14.98
86	6.0	2608		18.50
146	8.0	3175		19.80
147	10	4082		

Prices do not include postage or packing. Assess postage to your address using weights given and add 10% of postage rate for packing. Sales tax is included in price

DOUGLAS TRANSFORMERS, BOX 23, COORANBONG, NSW. 2265.

Personal Callers: 477 Freemans Drive, Coorabong. Telephone (049) 77 1431

SUBSCRIPTION SERVICE



ELECTRONICS Australia

Subscription Rates

\$A 17.00 per year within Australia.
\$A 20.00 per year elsewhere.

Make sure you receive every copy of the magazine by ordering it from your newsagent or the publisher. For publisher subscriptions post this coupon, with your remittance, to Electronics Australia Subscription Dept., John Fairfax & Sons Ltd, GPO Box 506, Sydney, 2001. Subscription will start with first available issue.

Name
Address
Postcode Enclosed is for years

Advertising Index

A & R Soanar Group	47
Ace Radio	84
Acme Engineering	47
Adcola Products Pty Ltd	66
Astro-Optical Supplies Pty Ltd	117
Audio Telex Communications Pty Ltd	46
Auditec Australia	100
Australian Government Recruiting	7
BKX Electronics Supply Service	112
Broughton P. G.	118
Bail Electronic Services	44
B S R (A/asia) Pty Ltd	32
British Merchandising Pty Ltd	101
Butterworths Pty Ltd	23
Bright Star Crystals Pty Ltd	111
B W D. Electronics Pty Ltd	20
Chapman L. E.	114
Classic Radio	102
Concept Computer Educational Services	89
Convoy International Pty Ltd	28
Cowper Sheetmetal & Engineering	117
Cunningham R. H. Pty Ltd	120
Deitch Bros	90
Delta Base CB Radio	45
Dick Smith Electronics Group	12, 42, 62, 72, 73, 82
Digitron Engineering	118
Dynetics Pty Ltd	108
Douglas Transformers	120
E & M Electronics Pty Ltd	87
E.M.I. Australia	107
Electrocraft Pty Ltd	116
Electronic Enthusiasts Emporium	103
Electronics Australia	11, 89, 95
Emona Electronics	119
Ferguson Transformers Pty Ltd	33, 36
General Electronic Services Pty Ltd	108
Haco Distributing Agencies	IBC
Hagemeyer (Aust)	OBC, facing 61
Harman Australia Pty Ltd	31
Hawthorn Communications Centre	44
Instant Component Service	24, 25
International Correspondence Schools	64
Lafayette Electronics	43
Lanthur Electronics	105
Linear Electronics	107
Marconi School of Wireless	45
Mr. Acoustics	118
Mini Tech Manufacturing Co Ltd	118
McGills Newsagency Pty Ltd	109
Non-Linear Systems (A/asia) Pty Ltd	66
Paramount Rentals	34
Pennywise Peripherals	88
Philips	2, 98
Plessey Australia Pty Ltd	centre spread
RCS Radio	113
Radio Despatch Service	92, 100
Radio Parts Group	39
Reid D J.	70
Sabtronics International	facing 60
Sanwa Electric Instruments	119
Scalar Industries Pty Ltd	36
Scope Laboratories	48, 49
Sonab of Sweden Pty Ltd	26
Sony Kemtron Pty Ltd	IFC
Sontron Instruments	106
Statronics Pty Ltd	103
Stotts Technical College	59
Swann Electronics Pty Ltd	54
Systems Reliability (Aust) Pty Ltd	92
Technico Electronics Pty	40
Television	46
Television Replacement	118
Vicom International	38
Video Technics	34
Warburton Franki Ltd	76, 112
WHK Electronics	80
Willis Trading Co Pty Ltd	106
Wireless Institute of Australia	111

Pro. Series



Technics MK2 Series turntables. Built by perfectionists for perfectionists.

In 1970 Technics introduced the ultimate turntable drive method... the direct-drive principle.

In developing phases our first direct-drive turntable was succeeded by a whole family of them. A major innovation was the quartz phase-locked servo electronics featured in the SP10 MK2, enabling great speed accuracy to be attained ($\pm 0.002\%$). Its enormous torque and super fast start/stop action make it the choice of top broadcasting stations both in Australia and the rest of the world.

Two newly released Technics models—the SL1300 MK2 and SL1400 MK2 (automatic and semi-automatic respectively)—are totally quartz controlled drive turntables. You won't find any belts, gears or idlers in these. But

you will find our lowest wow and flutter ever (0.025% WRMS) and inaudible rumble (-73dB DIN B).

Both feature a pitch control of $\pm 9.9\%$ on normal turntable speeds that can be obtained simply by the push of a button.

The pitch chosen is displayed in digital form by a LED readout. All controls are located on the front panel of the turntables and can be operated even with the dust cover down.

Technics MK2 series of turntables are just a few components in the new Pro. Series from Technics. Reliable as they are precise.



Technics
hi-fi

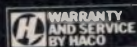

For a National Technics catalogue, please write to:
National Technics Advisory Service, P.O. Box 49, Kensington, N.S.W. 2033

Well stacked in front



The new range of JVC front-loading cassettes is here. And if you think that's the only change, you're highly mistaken. Because, as usual, JVC brings in the range with a few unique additions which are going to make you think twice about any other brand.

For a start, the JVC ANRS sound reduction system is incorporated throughout, to make hi fi recording and playback as free of hiss as possible. And in some cases, even improving the dynamic range of normal cassettes.

Another exclusive is the JVC Sen-alloy head, and believe it or not, it offers you the clearest sound and longest wearing lifespan of any head available; originally designed solely for

professional use, this head is now incorporated in JVC cassette decks CD-S200 and CD-1970.

And yet another first: JVC is the only manufacturer to provide decks with 5 LED peak-level indicators so that your recordings are perfect at all times. These are featured on models CD-1920 and CD-S200.

Loading is, of course, simplified. The special compartment is air-damped and removable for uncramped head maintenance.

The JVC famous range of top-loaders is still available, offering you the very highest quality. All things considered, there is no other consideration.



the right choice

For details on JVC Hi Fi Equipment, write to: JVC Advisory Service, P.O. Box 49, Kensington, N.S.W. 2033.