

# ELECTRONICS

## Australia

HiFi, Radio & Computers

NOVEMBER 1979

AUST \$1.40\* NZ \$1.50

MICROWAVES IN  
THE CLASSROOM  
— story inside



NOT REAL GOLD — BUT SOME  
PEOPLE HAVE STRUCK IT RICH!

**SPECIAL FEATURE: LATEST  
HOME MOVIE CAMERAS  
SAVE MONEY — BUILD OUR  
NEW METAL LOCATOR PROJECT**



# ULTIMATE.

## Philips High Fidelity Laboratories.

In any range of equipment there is a leader. One which sets the standard by which the others are measured.

With Philips Hi-Fi Stereo, the Hi-Fi Laboratories range stands at the very top.

These state-of-the-art Hi-Fi components, which were developed in America, offer precision craftsmanship, technical perfection and outstanding performance.

### High-Fidelity Pre-Amplifier

The AH 572 High-Fidelity Stereo Pre-Amplifier is an ultra-low distortion (0.008%) two-channel unit featuring high-accuracy step detent controls,

illuminated function readouts and touch switches with LED indicators for smooth, silent, sophisticated programming. It also includes adjustable phono input levels and a tape selector that provides five separate tape modes.

### High-Fidelity Stereo AM/FM Tuner

The AH 673 High-Fidelity Stereo AM/FM Tuner incorporates touch switches with LED indicators and illuminated function readouts. Other features include ASNC (Automatic Stereo Noise Cancelling). Separate level controls for AM and FM. An FM interstation disturbance mute. And an exclusive AM centre-tuned meter for wide-band full fidelity AM reproduction.

### High-Fidelity Stereo Power Amplifier

The 210 watts RMS per channel high-performance AH 578 High-Fidelity Stereo Power Amplifier completes the Philips Hi-Fi Laboratories range. It comprises high-accuracy step detent controls, touch switches with LED indicators and illuminated power meters and protection indicators. Also incorporated in the AH 578 are a sub-sonic filter, thermal and overload protection, and provision for connecting two pairs of loudspeaker systems.

**Philips Hi-Fi  
Laboratories Range.  
A step closer  
to sound perfection.**



# PHILIPS

We want you  
to have the best





# ELECTRONICS

## Australia

Volume 41 No. 8

November, 1979

Australia's largest selling electronics magazine



Sungravure staffer Lisa Wilkinson shows off our new "Prospector" metal locator which can be built for a fraction of the cost of commercial designs. Turn to p54 for the details.

### SPECIAL FEATURE

**HOME MOVIES '79** — a rundown on the current state of the home movie art, including the latest cameras, projectors and editing gear. Part 1 starts on p12.

**COMING NEXT MONTH!** — find out what's coming by turning to p127.

### On the cover

**TEACHER** Anne Lupton and students Chris Harris and Brad Garnham set up experimental microwave equipment for a class demonstration. For the full story on the microwave gear, turn to p.24. (Photo by staff photographer Warren Webb.)

**INSET:** well, it's not real gold — we faked it for the photograph. But if you build our "Prospector" metal locator on p54, you could really strike it rich!

## FEATURES

- EXOTIC NEW LITHIUM-AIR BATTERIES** *Greater range for electric vehicles* ..... 10
- SPECIAL FEATURE STORY: HOME MOVIES '79 — A WHOLE NEW BREED**  
*The latest cameras, projectors and editing gear, Part 1* ..... 12
- MICROWAVES IN THE CLASSROOM** *Demonstrating optics and electromagnetic waves* ..... 24

## HIFI TOPICS AND REVIEWS

- ZAPP, CRACKLE AND POP!** *The problem of static charges on discs* ..... 36
- HIFI REVIEW** *Kenwood KA-801 stereo amplifier* ..... 43
- AUDIO TALK** *Strewth it's loud — must be hifil* ..... 47

## PROJECTS AND CIRCUITS

- INTERSIL ICM7226 UNIVERSAL COUNTER KIT** *10MHz, 8-digit LED display* ..... 50
- THE 'PROSPECTOR' METAL LOCATOR** *Build it and join the gold rush!* ..... 54
- A HIGH QUALITY PULSE GENERATOR** *For checking amplifiers, digital circuits &c* ..... 62

## SPECIALLY FOR THE NEWCOMER

- EXPERIMENTER'S POWER SUPPLY** *1.5-12V 500mA output, short-circuit protected* ..... 95
- PRACTICAL ELECTRONICS: BOXES AND CASES** *A look at what's available* ..... 102
- COMPONENTS AND RATINGS** *Some common questions and the answers* ..... 108

## MICROCOMPUTERS

- UNDERSTANDING BASIC, PART 2** *How to program your home computer* ..... 77
- A SERIAL INTERFACE FOR THE ULTRA-LOW COST VDU** *19 ICs and less than \$50* ..... 83
- MICROCOMPUTER NEWS & PRODUCTS** ..... 90

## AMATEUR RADIO, CB SCENE, DX

- AMATEUR RADIO** *An expedition across the Kimberleys* ..... 117
- CB SCENE** *UHF CB helps Commodores to win 1-2-3* ..... 121
- SHORTWAVE SCENE** *BBC expands World Service — new Aust. & NZ schedules* ..... 123

## COLUMNS

- FORUM** *An incredible coincidence — or something else?* ..... 32
- THE SERVICEMAN** *When is an earth not an earth?* ..... 70
- RECORD REVIEWS** *Classical, popular and special interest* ..... 110

## DEPARTMENTS

- EDITORIAL 3 — NEWS HIGHLIGHTS 4 — CIRCUIT & DESIGN IDEAS 75 — LETTERS TO THE EDITOR 108 — NEW PRODUCTS 126 — BOOKS & LITERATURE 130 — INFORMATION CENTRE 132 — MARKETPLACE 134 — INDEX TO ADVERTISERS 136 — NOTES & ERRATA 133**



# Heatsinks

## off-the-shelf.

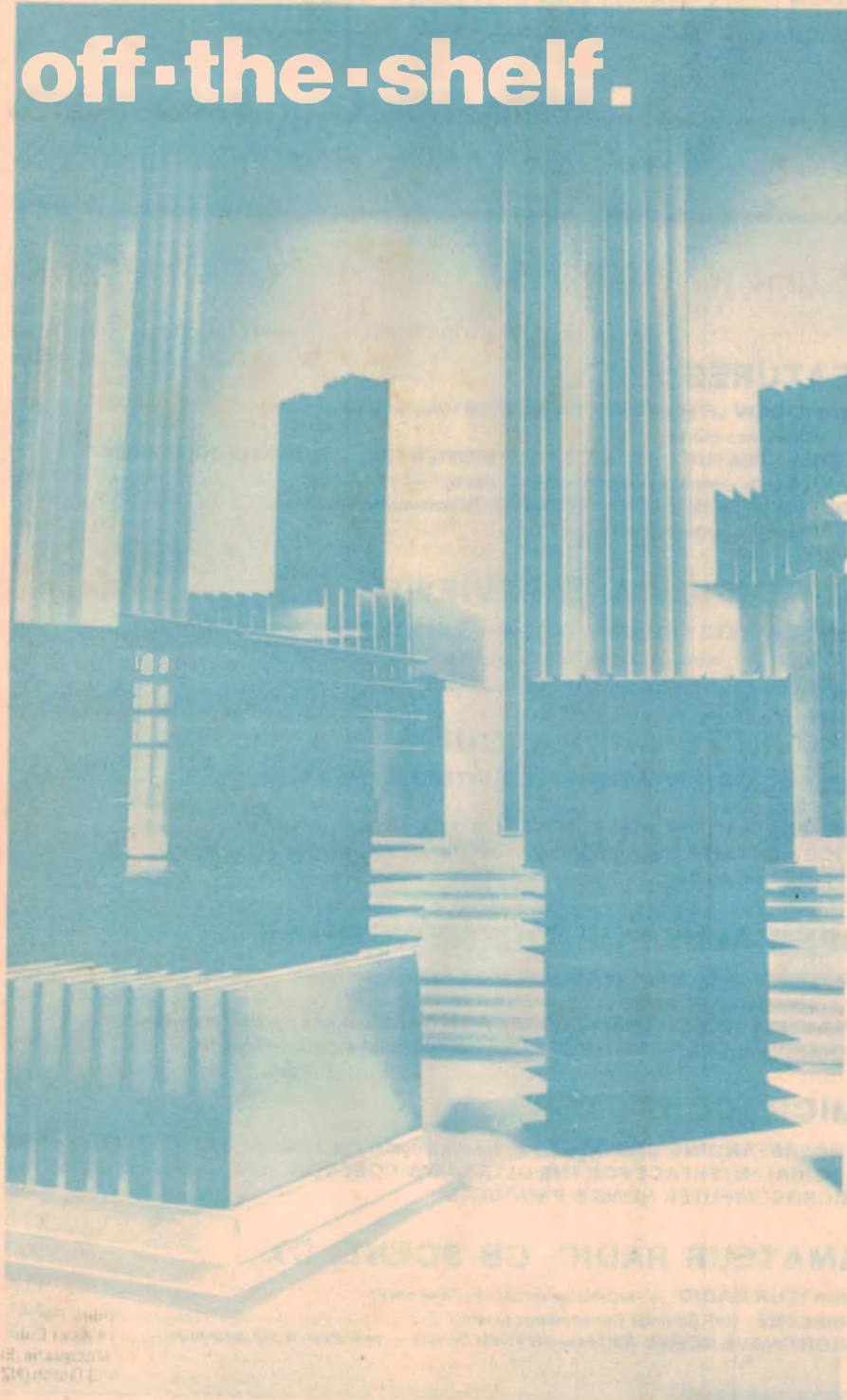

Electronic  
Components  
and Materials,



Circuit designers with power semiconductor applications need a standard heatsink range on which to base their designs and eliminate the need for time-consuming mechanical investigations and decisions.

The Philips range of off-the-shelf Australian made aluminium heatsink extrusions provides this standard. The table below lists the types and lengths available as standard stock-items. Bulk lengths can also be made available for reasonable sized orders with reasonable leadtimes.

36 and 72 inch lengths, bulk lengths, and the 65D series come in mill finish; the others are black anodised.

TYPE	2"	3"	4"	6"	8"	36"	72"
35D	*	*	*	*	*	*	*
40D	—	*	*	*	—	*	*
45D	—	*	*	*	—	*	*
55D	*	—	*	*	*	*	*
65	—	—	*	*	*	*	*

### SAMPLE EXTRUSION PROFILES

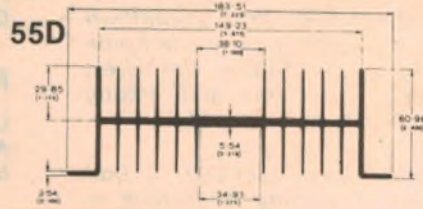
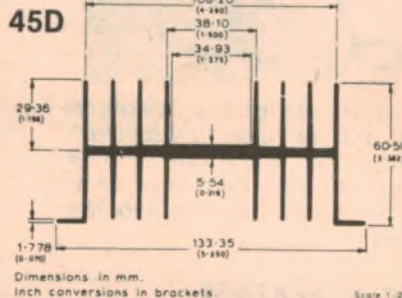

For further information, contact Philips Electronic Components and Materials, or their Distributors. **Philips Electronic Components and Materials**, P.O. Box 50, Lane Cove, N.S.W. 2066. Ph: (02) 427 0888.

# PHILIPS

We want you to have the best

HRME 153-0243

AVAILABLE THROUGHOUT AUSTRALIA FROM

**CEMA**

AND

**SOANAR**





# Editorial Viewpoint

## A time for change . . .

### EDITOR-IN-CHIEF

Neville Williams  
M.I.R.E.E. (Aust.) (VK2XV)

### EDITOR

Jamieson Rowe  
B.A. (Sydney), B.Sc (Technology, NSW)  
M.I.R.E.E. (Aust.) (VK2ZLO/T)

### TECHNICAL EDITOR

Leo Simpson

### ASSISTANT EDITOR

Greg Swain, B.Sc. (Hons. Sydney)

### TECHNICAL PROJECTS

Ron de Jong, B.E. (Hons. NSW), B.Sc.  
Ian Pogson (VK2AZN/T)  
John Clarke  
Gerald Cohn

### GRAPHICS

Robert Flynn

### PRODUCTION

Danny Hooper

### ADVERTISING MANAGER

Selwyn Sayers

### CIRCULATION MANAGER

Alan Parker

Although I have been writing these editorials or "leaders" for nearly nine years now, I still haven't found them very easy. Each month one must come up with a topic which not only seems likely to interest readers sufficiently, but can also be commented upon meaningfully in a few brief paragraphs. (I certainly don't envy those who write the leaders for daily papers — once a month is plenty!)

Actually this month's leader is even harder to write than usual, because it is likely to be the last I ever write. After almost 20 years with the magazine, I am leaving to try my hand at other things. I feel I need the challenge of something new.

Although I am leaving entirely of my own volition, it is with a good deal of regret. One cannot work this long for any worthwhile enterprise without becoming strongly identified and involved with it and its aims. At "Electronics Australia" there has been the special satisfaction of being part of a continuing tradition of responsibility, accuracy and service to readers.

Publishing a monthly magazine is not without its tedium and hard work — that's true of any worthwhile job. But working with Neville Williams and the rest of the EA team has generally been a most stimulating and rewarding experience. I've learnt a lot, and in return I hope I've played a worthwhile role in helping to make EA the outstanding electronics magazine it is today.

Needless to say the magazine itself will be continuing on, disturbed as little as possible by either my own departure or the recent retirement of Assistant Editor Phil Watson (which is noted further in this month's news columns). In fact you probably won't notice a great deal of difference, thanks to the talents of the remaining staff and the continuing guidance of the Editor-in-Chief.

Greg Swain is becoming Assistant Editor and Leo Simpson is to be Technical Editor. Both men bring a great deal of skill and initiative to these positions, and I am sure they will perform their new roles very capably.

Incidentally you will probably see articles carrying my own byline in the magazine for another month or two. We work a fair way ahead, and it will take a while for my last few articles to be published.

In closing, I would like to wish Neville Williams and the reorganised EA team every success for the future. I would also like to thank the readers, advertisers and contributors for the help and support they have given me during my stay here.

Thank you all, and goodbye.

— Jamieson Rowe

### Registered for posting as a publication — Category B.

Printed by Magazine Printers Pty Ltd. of Regent Street, Sydney and Masterprint Pty Ltd of Dubbo, NSW. for Sungravure Pty Ltd. of Regent St, Sydney.

### Editorial Office

57 Regent St, Sydney 2008.  
Phone (02) 699 3622  
Postal Address: PO Box 163, Beaconsfield 2014.

### Advertising Offices

Sydney — 57 Regent St, Sydney 2008.  
Phone (02) 699 3622  
Representative: Narciso Pimentel.  
Melbourne — 392 Little Collins St, Melbourne  
3000 Phone (03) 602 3033  
Representative: Keith Watts

Adelaide — Charles F. Brown & Associates Ltd.  
254 Melbourne St, North Adelaide 5006  
Representative: Sandy Shaw, (08) 267 4433.  
Perth — 454 Murray Street, Perth 6000  
Representative: Ashley Croft, (09) 21 8217

### Subscriptions

Subscription Dept, John Fairfax & Sons Ltd. GPO  
Box 506, Sydney 2001  
Enquiries: Phone (02) 20944, ext 2589

### Circulation Office

21 Morley Ave. Rosebery, Sydney 2018  
Phone (02) 663 3911.

### Distribution

Distributed in NSW by Sungravure Pty Ltd. 57  
Regent St, Sydney; in Victoria by Sungravure Pty  
Ltd. 392 Little Collins Street, Melbourne; in South  
Australia by Sungravure Pty Ltd. 101-105  
Weymouth St, Adelaide; in Western Australia by

Sungravure Pty Ltd, 454 Murray Street, Perth; in  
Queensland by Gordon and Gotch (A'asia) Ltd; in  
Tasmania by Ingle Distributors, 93 Macquarie St,  
Hobart; in New Zealand by Gordon and Gotch (NZ)  
Ltd, Adelaide Rd, Wellington.

### Copyright. All rights reserved

Devices or arrangements shown or described  
herein may embody patents. Information is fur-  
nished without responsibility for its use and  
without prejudice for patent rights. All  
manuscripts, photographs and other material sub-  
mitted to Electronics Australia for publication must  
be accompanied by a stamped, addressed  
envelope. Contributions are submitted at the  
sender's risk, and responsibility for loss cannot be  
accepted by Electronics Australia.

\*Recommended and maximum price only.





# News Highlights

## Australia selected for viewdata market trials

Australia has been selected as one of seven countries for a market trial of an international information network using the British Prestel viewdata system.

by Ian Reinecke

Financial Times

It is the most ambitious international use attempted for viewdata technology, which employs telephone lines linked to television sets to receive and transmit information. If the trial is successful, a computer will be located in Sydney. This could be accessed for the price of a local call and would connect with an international data base of business information.

Backer of the project is the British Post Office, which developed Prestel and has sold it to a number of other countries. The market trial will be conducted by the computer and communications consultancy, Logica. Target users are the multi-nationals,

particularly those with operations in most or all of the countries involved in the trial — Australia, Britain, the US, Netherlands, Sweden, West Germany and Switzerland.

Technical difficulties of establishing an international system are outweighed by political considerations which include the national jealousies of Prestel's rivals, particularly from France, Japan and Canada, none of them trial countries. All three have developed alternative viewdata systems but the rivalry is particularly intense between Prestel and the French Antiope system, which France is expected to market internationally in direct competition with Britain.

The French telephone authority, the PTT, announced recently that it would trial Antiope using 2000 households in a town near Paris and both countries are jockeying for international technical standards which favour their system.

All countries selected for the viewdata trial have connections either with

Logica, through local offices, or have, like the Netherlands and Switzerland, already purchased Prestel systems.

Many of the services provided on Prestel's 160,000 pages of information in London are possible candidates for the international network, which will direct its efforts at three main areas: international business information services, syndicated information, and retrieval, collection and dissemination systems.

Business users are the target of the service both because of the cost of accessing information and because optimistic forecasts of demand for the domestic market for viewdata have not held up. Initial predictions for the number of television sets modified for Prestel put the British market at 50,000 for this year but that figure has now been revised to 20,000, which may still prove too high.

## ... and France shows Antiope

IRECON '79 was the site of the first demonstration of "Antiope", the French developed Teletext and Viewdata system. France is pushing the system as a possible alternative to the British-developed viewdata system, which now goes under the commercial name of Prestel.

Antiope is available in both broadcast and interactive versions and, like viewdata, is based on an ordinary colour TV receiver equipped with a special receiver. Data may either be multiplexed onto a video signal and broadcast, or transmitted via modems through telephone links just like any other computer data. The same decoder is used for both versions.

The information itself is stored in computer data bases, and may be called up and displayed by means of a keypad. In the interactive version, the viewer can request any page among the thousands stored in the data base. Pages for the broadcast version offer all sorts of information, including

(Continued on page 5)

Viewdata: information is called up for display from a computer data base.





## Single chip speech synthesiser

The Musashino Electrical Communication Laboratory of Nippon Telegraph and Telephone Public Corp. (NTT) has developed a single-chip speech synthesiser. The new LSI synthesiser is designed to work with the lab's Parcor technique — a technique which analyses human speech and codes it into sound-source (the vocal chords) and filter (the roof of the mouth) parameters.

The synthesiser contains some 3500 logic circuits, a 350-bit RAM, and a 2240-bit ROM on a 3.65 x 3.7mm chip. Speech is synthesised every 125µs in pulse-code-modulated form by operating the sound source and filter parameters in a digital filter constructed with a 16-bit parallel multiplier and a 16-bit adder-subtractor.

## . .Antiope viewdata system-ctd from p4

newsflashes, weather information, civil defense warnings and stock market reports, and are constantly updated.

The interactive version also allows the user to establish two-way communication with another user, and exchange information.

# NASA plans giant computer!

A recent report in the British magazine "New Scientist" says that NASA is planning to build the world's biggest computer, some 40 times bigger than anything that exists today. The machine will solve the complex equations needed for designing aircraft and save design engineers from having to run laborious tests in wind tunnels. Scientists at NASA's Ames Research Center, Palo Alto, California are now deciding which of two large computer manufacturers should build the new machine: Control Data Corporation (CDC) or Burroughs.

The computer, to be called the numerical aerodynamic simulation facility (NASF), will cost more than \$US50 million by the time it is in operation sometime after 1985. The large sum is justified in two ways. First, the computer will mean that NASA does not have to build expensive wind tunnels. Secondly, large fuel savings should result from having better designed aircraft.

According to one NASA engineer, the computer will pay for itself in the fuel savings arising from just one airliner design.

## Laser process tailors magnetic bubbles

A new technique for tailoring the properties of magnetic bubble materials by laser annealing, followed by rapid cooling to freeze in the annealed structure, has been developed by IBM scientists in the US.

It is based on the fact that a laser beam can heat a small region of material to a high temperature so rapidly that the surrounding material remains cool. As the laser is scanned across the material, the regions that have been heated cool so rapidly that their high temperature structure is

frozen in.

In magnetic bubble films of gallium-substituted yttrium-iron-garnet, the technique can produce a redistribution of the sites occupied by gallium and iron atoms. The redistribution of atoms results in a film in which the bubble domains are smaller and in which the bubble collapse field and the saturation magnetization are increased.

The film is undamaged in the process, as shown by the fact that it returns to its original state when annealed in a furnace.

## Phil Watson retires

After 29 years of faithful service on the staff of what is now "Electronics Australia" Phil Watson has reached age 65 and will have retired at about the time you get to read this issue. I am sure that readers will join us in wishing for Phil and his wife the very best for their leisure years.



Leisure years? Whether that is the appropriate term to apply to "PGW" is a moot point. Phil has one of those inquiring minds which make it difficult for a person to remain aloof from technicalia, even in retirement. I suspect that his name may bob up from time to time as a contributor, when his typing finger begins again to itch!

Phil joined our staff in 1950, in the wake of World War II. Like many others in that era, he had behind him a varied background in local radio factories, troubleshooting and servicework, in hobbying, and even as a film projectionist in country halls. But, more importantly, he had worked for a time in the Australian Radio College and the associated

University Graham Instruments group. In that environment, his background knowledge was sorted and formalised to the point where he had emerged as a very capable demonstrator and lecturer.

So, when Phil joined us in 1950, he had an ordered grasp of basic radio theory, backed up by practical experience and the ability to communicate-three vital ingredients for success in technical journalism. As a member of the technical staff, he made an invaluable contribution to each issue, right through the fifties.

In May 1960, Phil became Technical Editor, little realising that for the next three or four months he would have to carry most of the load, while I was confined to a

hospital bed, as the result of an accident. But that seems a long time ago.

Then, and subsequently as Assistant Editor, Phil has made a vital contribution to EA. Amongst other things, he has been largely responsible for the general administration of our reader services. It is not for nothing that, for almost two decades, technical inquiries, requests for plans, circuits and backnumbers, &c, have all been routed to "The Technical Editor" and later to "The Assistant Editor".

And, of course, he has spent an enormous amount of time knocking articles into shape before publication — a job that must be done, if a magazine is to read smoothly and without too many errors and inconsistencies. That era has now come to an end.

Perhaps characteristically, Phil has requested no fuss and no formalities — and we respect that wish. So we simply say: "Thanks Phil for 29 years of support to our staff, our magazine and to successive generations of readers."

As the amateurs put it: "73s OM, best of luck and see you further down the log!"





— Neville Williams



# SERVICE TECHNICIANS!

## Specialised Soldering Tools from...

# SCOPE

SERVICE SITUATION	TAKE THIS TOOL	GET THIS USER ADVANTAGE
<ul style="list-style-type: none"> <li>● No power</li> <li>● No time to get power</li> <li>● Must work on live gear</li> </ul>	<p>SCOPE "CORDLESS"</p> 	<ol style="list-style-type: none"> <li>1. 40-200 Terminations depending on conductor size.</li> <li>2. Recharges overnight.</li> <li>3. Heats in 6 seconds.</li> <li>4. 60 watts - Controllable temperature.</li> </ol>
<ul style="list-style-type: none"> <li>● 12 volt. Battery power available only.</li> <li>● Outdoor and bad weather expected.</li> <li>● Service vehicle can get within 6 metres.</li> </ul>	 <p>SCOPE "12VOLT SUPERSPEED"</p>	<ol style="list-style-type: none"> <li>1. 5 Second heating.</li> <li>2. 200 watts if needed.</li> <li>3. Controllable temperature.</li> <li>4. You can replace tip or element anywhere in minutes.</li> </ol>
<ul style="list-style-type: none"> <li>● Modern sophisticated PCB equipment.</li> <li>● Accurate &amp; automatic temp. control wanted.</li> <li>● Components are heat critical.</li> </ul>	<p>SCOPE "TC60"</p> 	<ol style="list-style-type: none"> <li>1. Heats in 45 seconds.</li> <li>2. Dial any temp. 200°-400°.</li> <li>3. Plugs direct to mains. No transformer needed.</li> <li>4. Accept iron plated tips from 0.8mm to 6.4mm.</li> </ol>
<ul style="list-style-type: none"> <li>● Unpredictable soldering situation.</li> <li>● Maybe electrical or electronic or mechanical.</li> <li>● You can't come back to base for a bigger or smaller iron.</li> </ul>	<p>SCOPE SUPERSPEED 150w</p>  <p>SCOPE "MINI" 75w</p>	<ol style="list-style-type: none"> <li>1. 5 second heat up.</li> <li>2. Controllable temperature.</li> <li>3. Reserve heat for any normal job.</li> <li>4. 4 volt safety in the hand.</li> </ol>

Available from your normal trade suppliers in Australia and New Zealand.

### SCOPE LABORATORIES

Box 63 Niddrie Vic., 3042.  
Phone: (03) 338 1566. TLX 34382.



## Business Briefs:

**Sanyo Australia** has moved into new headquarters at 225 Miller St, North Sydney 2060. The new head office telephone number is 436 1122; the telex number remains 24339.

**Amalgamated Wireless (Australasia) Limited** has been awarded a contract by the Singapore Government for the turnkey installation of a dual Doppler VOR (very high frequency omnirange) aircraft navigational beacon to service the northern approach to the new Changi International Airport. The choice of the AWA Doppler VOR follows the successful installation by AWA of a Doppler VOR at Lazarus Island serving the southern approach to the existing Paya Lebar International Airport.

In addition to the Doppler VOR, the contract calls for the supply, installation and commissioning of a dual DME, remote control and monitoring (to Changi Air Traffic Control via a VHF link) and power and monitoring cabling to the power house provided near the shoreline by the Singapore Government.

VOR is an international standard medium range guidance system providing bearing information for aircraft. It is particularly suited to locations where radio signals are affected by reflections from mountains, buildings and other obstacles.

**Tandy Electronics** has announced the opening of its first three stores in Western Australia. The stores, all in Perth are located at 208 Beaufort St, City; Grove Plaza, Cottesloe; and Park Shopping Centre, East Victoria Park. The company says it plans to open nine more stores in Western Australia before the end of the current financial year.

**R&D Electronics** has been appointed sole Australian agent for Ladcor liquid crystal displays. Products to be stocked locally include 3½, 4, 4½ and 6 digit displays, all 12mm high, together with 25mm and 50mm displays for specialised applications. R&D Electronics is also Australian agent for Intersil Incorporated, a Californian-based semiconductor manufacturer. Intersil recently released a 1000-page catalogue containing detailed data sheets, application notes, and information on a range of CMOS ICs, microprocessor development systems, and linear devices. The catalogue is priced at \$10, and is available from R&D Electronics, 257 Burwood Highway, Burwood 3125.

**Dick Smith Electronics** has announced the opening of a new store at 263 Keira St, Wollongong (telephone 28 3800). Manager of the new store, the 11th in the Dick Smith Electronics Group, is Peter Harding. The store carries the full range of Dick Smith products — over 3000 lines in all!

**Multi-Contact Australia Pty Ltd** has been appointed sole Australian and New Zealand agent for Tschudin & Heid, AG, Reinach, Switzerland. Tschudin & Heid manufactures a comprehensive range of miniature pushbutton switches, key switches and control lamps. Further information from Multi-Contact Australia Pty Ltd, 58 Whiting St, Artarmon, NSW 2064; or from 9 Duckett St, Brunswick, Victoria 3056.

**Cema Electronics** has announced the opening of a second Silicon Valley retail store in Melbourne and the opening of a new branch office in Perth. The store in Melbourne is located at 208 Whitehorse Road, Blackburn, and handles the Cema range of semiconductors from Motorola, Texas Instruments, Hewlett-Packard, Philips, Signetics, Harris and Solid State Scientific. Passive components from Philips are also stocked.

The Perth store handles a similar range of products, and completes the chain of Cema stores in each mainland capital city. The address is 25 Brisbane St, East Perth, Western Australia.



## New range of rechargeable batteries

Chloride Batteries Australia Limited, Australia's only manufacturer of both lead and nickel cadmium batteries, has announced the release of a new range of Yuasa sealed rechargeable button cells designed for memory backup use.

Designated Series FT, these Yuasa cells are capable of continuous trickle charging, a facility that is not recommended for conventional button cells.

Especially designed for PCB mounting, the cells have application as a back-up power source for CMOS-RAM, office machines, measuring instruments, wireless telegraphy equipment and electric appliances using solar cells.

The Yuasa Series FT cells are available in 30, 50, 100 and 150mA hour ratings.

For further information, contact Chloride Batteries Australia Limited, 55 Bryant St, Padstow, NSW 2211.

## A car radio that tunes itself!

NV Philips Gloeilampenfabrieken, Netherlands, and its West German subsidiary, Philips GmbH in Hamburg, have developed a microcomputer-controlled car radio that automatically picks out the optimum frequency for an FM program selected by the driver.

The unit, called the MCC auto radio (for microcomputer control), eliminates the need for the driver to retune the radio whenever the car moves outside the range of one FM transmitter and comes within range of another broadcasting the same program. The microcomputer features a ROM that stores up to 60 FM frequencies, 10 each per FM program. When a button on the radio is pushed, the microcomputer continuously searches for the frequency with the strongest signal, locks the set onto that frequency, and shows it on a liquid crystal display!



# A NEW TRIO from TRIO

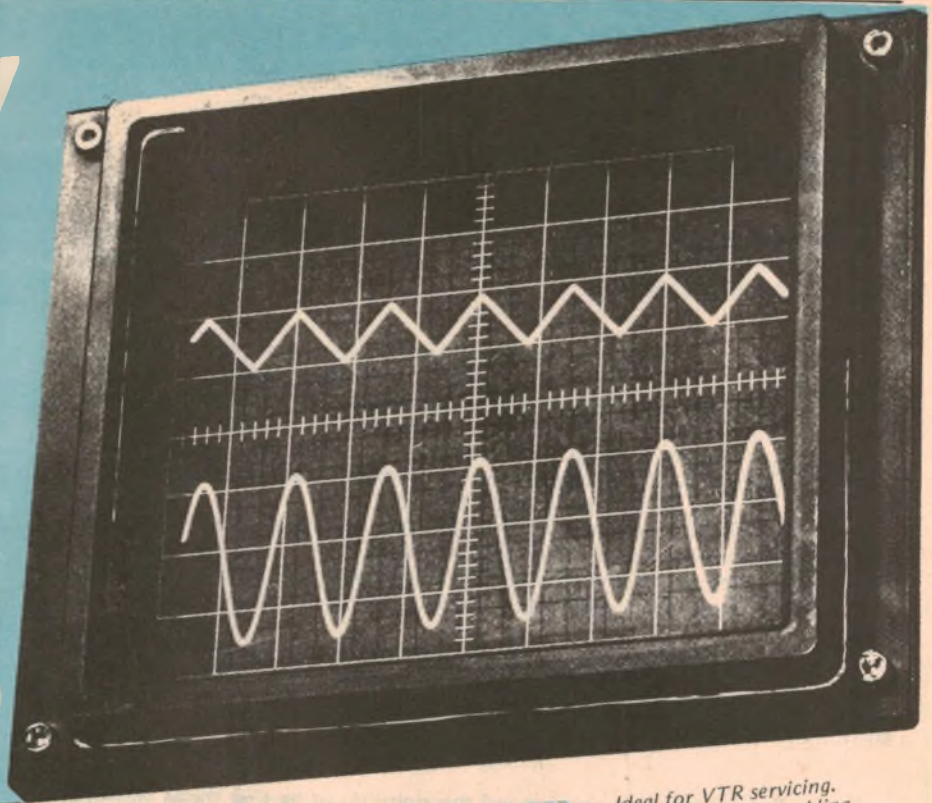

**CS1352** — Ideal for field use. Completely portable, AC, DC and battery operation. Dual trace 75mm display. DC-15MHz bandwidth and 2mV/div sensitivity plus triggered sweep. Features auto free-run for convenient voltage measurements and wide bandwidth for Lissajous phase measurements.

**CS1577** — A laboratory instrument with widest 30MHz bandwidth. Dual trace with a sensitivity of 2mV/div — ideal for low level signals. Max. sweep time is 0.1µs/div for measurement of fast rise time pulses. Auto-level (FIX) eliminates time consuming sync adjustments, plus auto free-run.

**CS1572** — Ideal for VTR servicing. Features video delayed trigger enabling sweep to start at any point on any single video frame. Plus expansion of intricate signals for easier analysis. And a capability to separate odd and even video fields. 5mV/div sensitivity and DC to 30MHz bandwidth. Has FIX and auto free-run. The scope for video pulse and digital work.



## PLUS AN UPDATE FOR THE POPULAR CS1560A

**CS1560A MK II** — has improved IC circuitry and a new CRT with electronic trace rotation and provision for a camera. Still provides 10mV/div sensitivity with 15MHz bandwidth and sweep times to 0.5µs/div. Auto free-run for making voltage measurements and wide bandwidth for accurate Lissajous phase measurements. The most popular scope for TV, lab, educational and general use.

Check the full Trio range from . . .

NSW SYDNEY

George Brown & Co  
Martin de Launay  
Radio Despatch  
Dick Smith Stores  
Standard Comps  
Brian Bambach  
D.G.E. Systems  
Electron 2000  
Electronic Comps  
Audiotronics  
L. E. Boughen

519 5855  
29 5834  
211 0191  
439 5311  
660 6066  
24 7246  
69 1625  
69 1222  
95 6811  
44 7566  
36 1277

GOSFORD  
N'CASTLE  
ACT. CANBERRA  
QLD. BRISBANE

## PARAMETERS PTY LTD

VIC. MELBOURNE

GEELONG  
S.A. ADELAIDE

W.A. PERTH

TAS. HOBART

Sydney  
Melbourne

Browntronic  
Douglas Radio  
J.H. Magrath  
Radio Parts  
Tech-Rentals  
G.B. Telespares  
Teleparts  
K.D. Fisher & Co.  
Gerard & Goodman  
Trio Electric  
Henderson Inst.  
W.J. Moncrieff  
Willis Trading Co  
Imbros Scientific

439 3288  
90 7444

419 3986  
211 1698  
663 3731  
329 7888  
267 5877  
328 4301  
21 7288  
269 2544  
223 2222  
51 6718  
381 4477  
325 5722  
321 7609  
28 5997



## NEWS HIGHLIGHTS

### Telephone information system responds with computer speech

Communications engineers at Siemens AG in West Germany have developed a computerised phone information system that responds by voice to dialled inputs.

Called "Ramses", the system is based on a Siemens model 7.750 computer which stores the phone numbers of all subscribers in a particular region. In addition, the computer contains data on the subscriber's town of residence, his last and first names, the street on which the subscriber lives, and the house number.

Accessing the computer to obtain a certain number is simple and requires no special handset — both dial and pushbutton types can be used. Each digit between 0 and 9 has two or three letters assigned to it, so that all the letters in the alphabet are available to the user.

To obtain the wanted number, the user simply dials (or keys) the first three letters of the subscriber's town, his last and first names, and the street, plus the digits for the house number. The computer then looks up the phone number

and gives it to the caller in synthetic speech implemented by a Siemens voice encoder. If it cannot find the party, the computer connects the caller to a regular operator.

Bell Labs in the US is reported to be working on a similar system which will both recognise human speech and respond in synthesised speech.

### Super-low loss glass fibres

"Super-low loss" glass fibres for optical fibre communications have been successfully test manufactured by Nippon Telegraph and Telephone Public Corporation (NTT), according to a recent Japanese report. The newly developed glass fibre has losses of just 0.2dB per km at a light wavelength of 1.55µm, meaning that the light intensity will only drop by half after 15km of travel.

NTT says that losses this low make possible long distance optical fibre communications with repeaters installed at 100-150km intervals.

### TV captioning for the deaf — US networks show the way

A government-sponsored "closed-captioning" project is to be introduced on several US TV networks for deaf viewers. The system, approved by the FCC (Federal Communications Commission), uses one line of the vertical blanking interval and superimposes a caption on the screen of a TV set equipped with a special decoder.

It doesn't affect the picture displayed on those sets not equipped with decoders.

Initially, the Public Broadcasting System will supply 10 hours of programming weekly and ABC and NBC five hours each to a new non-profit National Captioning Institute that will encode the broadcast material with captions. The captioning decoders, based on a Texas Instruments IC and manufactured by Sanyo Manufacturing Co., will sell next year at \$225 to \$250, and 48cm sets with built-in decoding capability will retail at about \$500.

CBS has declined to join the other networks, arguing that a captioning system should be one of the features of a broader-based teletext system. The number of US citizens with hearing impairments is estimated at 14 million.

## COME TO OUR PET SHOP



PET PERSONAL COMPUTERS AND COMMODORE BUSINESS SYSTEMS ARE NOW AVAILABLE

FROM

**AE** ADAPTIVE  
ELECTRONICS P/L

77 Beach Road, Sandringham, Vic 3191  
Telex: AA35666; Tel: (03) 598 4422

**We Won't Byte You**



# Exotic new lithium-air batteries

Greater range  
for  
electric vehicles



Imagine an electric vehicle (EV) that could be refuelled as quickly as a petrol-engined automobile, could run at least 500km at normal highway speeds, and was cheap to own and operate. Impossible, you say? Not according to Lockheed Missiles and Space Company.

by GREG SWAIN

To be a serious prospect, an electric vehicle must have an order of performance similar to today's petrol-engined cars. That demands a battery that will somehow squeeze the energy equivalent of a tank full of petrol into a light, compact, quickly rechargeable package. It's a goal that's becoming increasingly important as petroleum resources get scarcer and petrol costs rise.

Batteries that will meet the above goals are currently the subject of intensive design efforts in America and Western Europe. One of the most exciting prospects is being developed by Lockheed Missiles and Space Company, Palo Alto, California. Lockheed is working under contract to the US Energy Research and Development Administration (ERDA), and has begun a program to develop a new version of the company's patented lithium power cell.

The objective according to Dr Ernest L. Littauer, manager of Lockheed's Palo Alto Chemistry Laboratory, is a lithium-water-air battery of high energy capacity, moderate weight, and adaptable to the stop-start-standby needs of automotive propulsion.

Lockheed's studies of the high energy potential of lithium began several years ago. The company announced in 1972 that it had discovered a lithium cell that could

produce levels of energy storage far greater than could be produced by conventional lead-acid batteries. That cell was fuelled with lithium and water, and was developed for a number of specialised defence applications.

The experimental cell now being investigated under the ERDA contract will be fuelled with lithium and air, operating in a water-based solution. The concept has been proven in the laboratory and tests have shown that it will produce even greater power than the earlier lithium-water cell.

The lithium-air battery is radically different from the secondary lead-acid batteries now used in automotive applications in that it is mechanically rechargeable rather than electrically rechargeable. During discharge, the lithium, water and atmospheric oxygen react to produce electricity and lithium hydroxide as the reaction product. Recharging is carried out by the addition of electromechanical fuel and, in a properly designed battery, the total refuelling time should be comparable to that of petrol-powered cars.

The basic scheme is this: the car would initially be stocked with sufficient metal fuel (lithium; aluminium is another candidate) for a nominal range of 1500km. Then, at more frequent intervals (500-700km, depending on convenience), the vehicle would stop at a roadside station

to take on water and discharge the reaction product. At the end of the 1500km a set of new metal plates would be dropped into the fuel cell, and the cycle repeated.

The reaction product, lithium carbonate, a dry powder precipitated by flowing carbon dioxide through the residue in the battery, would be collected and recycled to produce new metal anodes.

Lockheed is also working on aluminium-air batteries, and these now seem an attractive alternative to the lithium-air cells. Both have extremely high power densities — around 6700-7700 Whr/kg when fully recharged. Compare this with the dismally low 38-40 Whr/kg of conventional lead acid batteries and you will appreciate just how dramatic this figure is.

In use, the aluminium plates of the cell are totally consumed before new plates are installed. The reaction byproduct is an air-dried powder, tri-hydrated alumina hydrargillite, which can be recycled back to aluminium metal.

Beside helping to solve the energy crisis, electrochemical batteries would have other advantages. The absence of vehicular emissions would be an attractive consideration in urban areas, for example. And the cost of ownership should compare favourably with that of petrol-engined cars.



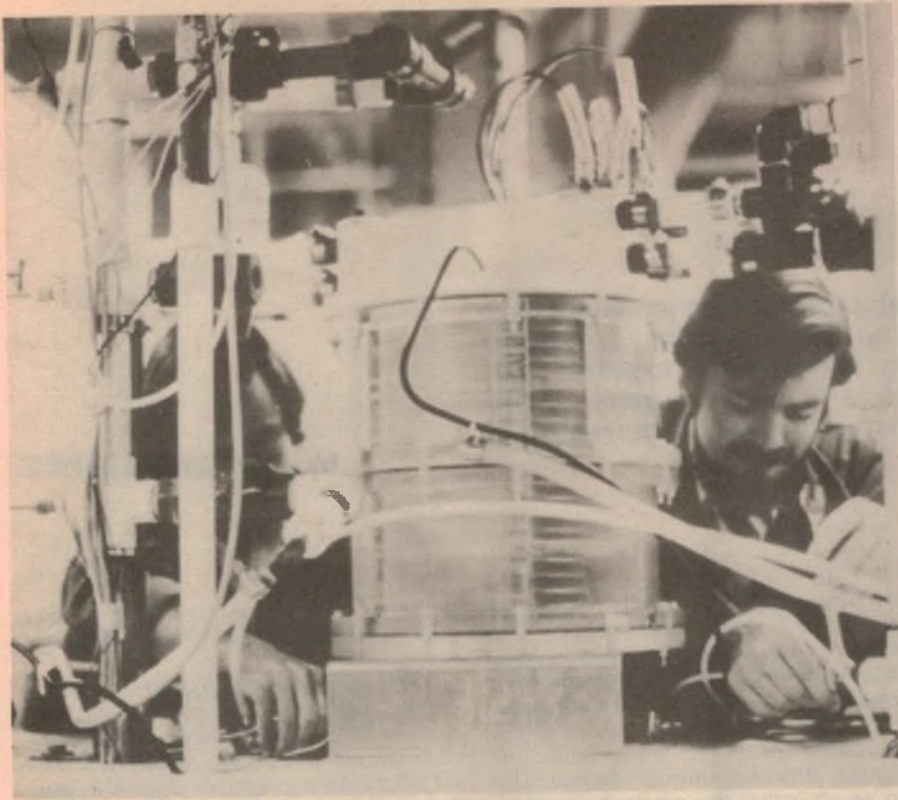

Researchers at Lockheed Missiles and Space Company, Calif., at work on one of the company's new lithium-air batteries. Lithium-air batteries may give future electric vehicles a range of around 500km and fast refuelling capability.

However, there are still many technical problems to overcome before electric vehicles powered by fuel cells become a reality. Although it sees the development of a suitable power source as an essential first step, Lockheed says that a full examination of the feasibility of an electric car will

require a multi-year effort. Such a program would include consideration of reliability, refuelling, safety, ease of operation, and overall energy utilisation.

But, as Dr Littauer says, "We must start looking at the year 2000 now; in 1990 it will be too late."

## Alcohol as a fuel option

The doubling of oil prices in less than two years and the prospect of further rises is making some other liquid fuels look economically attractive. Topping the list are the alcohols, methanol and ethanol.

Blended with petrol to give a fuel containing up to 20% alcohol, they offer a number of advantages. Only minor modifications need to be made to present day car engines for them to run well.

The blend (gasohol as it is called in North America — perhaps petrohol here?) gives good performance without tetraethyl

lead, a major cause of urban air pollution. And emissions of other pollutants are lower than with straight petrol.

As petrol extends these alcohols would enable Australia to reduce its dependence on foreign oil. A recent CSIRO study has indicated that fuel alcohol equivalent to more than half of Australia's current transport requirements could be obtained using existing technology.



## Socket to the Bugs for Life.

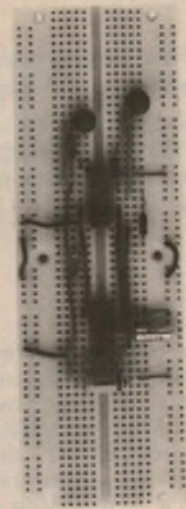

The highest quality socket in the industry now carries a new low price and a new lifetime guarantee. E&L guarantees the SK-10 socket against all failures. Should it ever break, be damaged or fail to perform as described, return it to us postpaid for a free replacement.

We can offer such a guarantee because the SK-10 is a top quality socket built tough for years of use. Integrated circuits and discrete components insert directly without adapters. No patch cords needed. And, of course, no soldering.

For the life of your bugs, pick up an SK-10 today. They're available at your local computer store.



AVAILABLE NOW FROM

**ELECTRONIC DEVELOPMENT SALES PTY. LTD.**

92 Chandos St.  
St. Leonards  
2065.

Phone: 438 2500  
438 2412  
Telex AA 25963

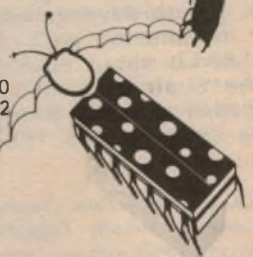



# Home Movies '79:

In the last few years some remarkable developments have taken place in home movie equipment. The latest cameras, projectors and editing gear offer outstanding performance together with operating facilities which were formerly only available to the professional. Here's the first part of a rundown on the current state of the home movie art.

by JAMIESON ROWE

In case you haven't noticed, home movie equipment has really undergone some impressive development in the last few years. After decades of treatment as the poor relations of motion picture professionals, amateurs are now being offered a bewildering array of mouth-watering equipment — some of it offering facilities not found even on professional gear.

Even if you're a keen home movie enthusiast, you may not be aware of all the recent developments and current trends. Some of the developments have been fairly obvious, while others have been more subtle. In these articles we will look briefly at most of the features offered by the latest equipment, and how they are likely to affect both the average family movie-maker and the more dedicated or serious hobbyist.

Perhaps the most dramatic development of all has been the advent of direct or "lip sync" sound movie making, as you may have heard. This was introduced by Kodak in 1974, and made a big impact because it finally allowed the amateur to make true "talkies" with a minimum of fuss. Previously you had to be content with adding music and/or narration to your silent films, unless you were prepared to go to all sorts of trouble and complexity.

Since its introduction, direct sound has been warmly embraced by the majority of home movie makers. Virtually every equipment manufacturer now produces sound cameras and projectors, and there is a growing range of sound editing equipment as well. More about sound shortly, though; let's look at general developments first.

Incidentally, we'll be talking exclusively about equipment made for the "Super-8mm" film gauge — the upgraded version of 8mm film introduced by Kodak in 1965. This is basically the

only film gauge now used by the vast majority of home movie makers. The old 9.5mm gauge has become obsolete, while 16mm is now far too expensive for hobby use — except by millionaires.

First, let's look at the cameras. In the last couple of years, these have undergone almost continual change. The nett result is that the modern sound or silent camera is almost a different

product altogether from its predecessors, despite the superficial resemblance.

The most dramatic changes have occurred inside the cameras, rather than outside. Most of the latest models are now largely electronics inside, and based on a microcomputer chip. This performs a lot of the functions which formerly required complex cams, levers



*RIGHT: The new Bauer S715XL sound camera, which features an internal microcomputer and an impressive 15:1 zoom lens.*



# a whole new breed

Right at the top of the market, the new Beaulieu model 6008 S sound camera offers a variable shutter, backwinding, mirror reflex viewfinder and 60 metre film cartridge capability.

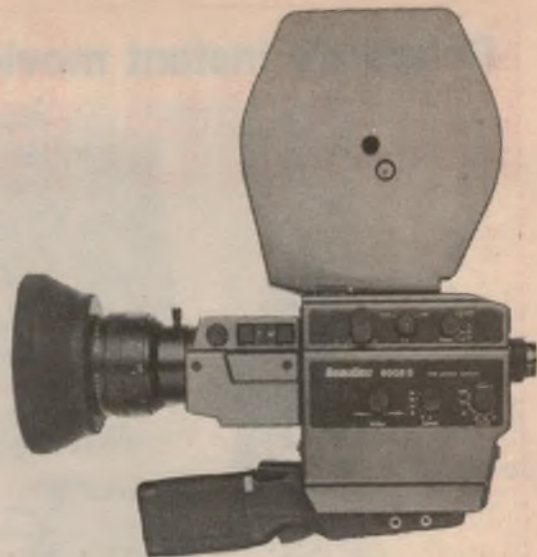

and mechanical governors. This has not only made the cameras mechanically simpler and more reliable, but also made it possible to achieve higher performance and provide additional features.

For example one of the things the microcomputer can do is control the speed of the main drive motor, replacing the electromagnetic governor formerly used. This gives greater reliability, improved speed regulation, and a greater range of speeds. Some of the new models offer not only the standard 18fps and 24fps (frames per second), but also 12fps ("fast motion"), 36fps and perhaps 54fps ("slow motion") and single frame as well. One or two even offer the TV shooting speed of 25fps, as well as 24fps.

Another thing the microcomputer can do is look after the automatic exposure system — now a standard feature on virtually all Super-8 cameras. Here the main advantages of microcomputer control are speed and accuracy of response, improved reliability and the ability to provide a variety of useful control functions: things like a button for back lighting compensation, a "hold" or "lock" button to allow special effects, a manual over-ride control, controlled automatic fades and lap dissolves, and a vernier adjust to allow the user to produce consistently "brighter" or "richer" exposures. Not all modern cameras provide all of these features, but some models come close.

A number of the newer models have taken advantage of the change to microcomputer control of the exposure system, by replacing the earlier "scissors" type lens diaphragm with a 5-bladed iris type. This gives more symmetrical stop control, and results in sharper images at all settings.

Along with the changeover to microcomputer electronics, most current cameras have changed from the conventional rotating mechanical shutter to a reciprocating elec-

tromagnetic shutter. This has made it much easier to provide the cameras with a reliable single-frame facility, and with a fully functional electrical remote control facility.

By again taking advantage of the internal microcomputer, the change to electromagnetic shutters has also allowed many models to be provided with an inbuilt "intervalometer", or



Made for those who want to take movies with the minimum of fuss: The Eumig Mini 3 camera, featuring "Servofocus".

single-frame timer. This allows the amateur to produce those dramatic and highly speeded-up scenes of plants growing, flowers opening, clouds gathering and swirling, and trains or cars travelling at thousands of kilometres per hour — without any additional equipment.

Another advantage of the microcomputer/electromagnetic shutter combination is that it allows the designer to provide a number of shutter speeds for normal shooting. This means that the user is not forced to accept the compromises involved in a conventional fixed shutter speed, but can adjust the shutter speed for optimum results in any situation.

What do I mean by compromises? Well, the traditional movie camera shutter has an opening of 180 degrees, giving an exposure time of 1/36th of a

second (about 28ms) at the normal Super-8 shooting speed of 18fps. This gives reasonably good "freezing" of subject motion, with most moving subjects, but is a little too short when you want to shoot in relatively low light levels.

Over the last few years, camera designers have found it possible to increase the shutter opening to 220 or even 225 degrees. This enabled them to produce so-called "XL" versions of some of their camera models, with the larger shutter opening giving a longer exposure time of around 1/29th of a second (34ms). In conjunction with a wide aperture lens, this produces a camera which is more suitable for shooting in low light levels — but at the same time it tends to produce more blurring of moving subjects, due to the longer exposures.

Fairly obviously, the best way of getting around this dilemma is to have a variable shutter; but until recently this has been a feature available only on very expensive professional cameras. This is where the microcomputer/electromagnetic shutter combination has come in, by allowing designers to provide either a full variable shutter or a number of fixed shutter settings, or both.

For example the new Beaulieu model 6008-S provides a full variable shutter, together with an "LL" (low light) setting of the control in addition to the normal setting. In this case the normal setting gives an exposure time of 1/72nd of a second (14ms), which is capable of freezing almost any subject motion, while the LL setting doubles this exposure time to allow working at lower light levels.

A full variable shutter together with a choice of "regular" or "XL" shutter settings is also offered by the new Canon models 814XL-S and 1014XL-S. Here the regular setting actually gives a shutter opening of "150 degrees", or 1/43rd of a second (23ms), making it quite good at freezing subject motion. The XL posi-



## Polaroid's instant movies: yes, but . . .



One of the developments you've probably heard about is "instant movies" — the Polavision system, introduced by Polaroid in 1977. This brought to home movies the self-processing feature pioneered so successfully by Polaroid in the area of still photography.

From a technological point of view, Polavision is most impressive; little short of a miracle, in fact. It allows you to take full colour movies, then view them only 90 seconds later. And this is all done with a minimum of fuss.

The camera is cartridge loading, is provided with automatic exposure control and a minimum of gadgetry to confuse the non-technical user. You simply set the focus for "near" or "far", point the camera at the subject using the through-the-lens or "reflex" viewfinder, and press the button. There is a simple 2:1 manual zoom facility on the lens to allow close-ups and creative composition.

The cartridge takes two minutes and 35 seconds of filming. When it is exhausted, you simply remove it from the camera and push it into a slot in the Polavision player unit. This is a small box similar to a portable TV set, with a 30cm diagonal screen, which automatically performs both processing of the film and its display. Ninety seconds after you push the cartridge into the player's slot, the pictures you have taken appear on the screen in full colour. And they can be shown subsequently any number of times.

In view of the huge success of instant still photography, one might have expected Polavision to revolutionise home movies. Particularly as it has obviously been packaged with the non-technical user in mind. But as yet, it does not seem to have had much impact.

Perhaps one reason for the lack of success is that as yet, Polavision is mute. This inevitably causes unfavourable comparison with conventional home movies, television and the cinema. Polaroid has announced that it is working on an experimental high-quality stereo sound version, based on an interleaved magnetic tape, but as yet there is no indication as to when this will reach the market.

The other possible reason is that as it stands, Polavision is virtually restricted to "animated snapshot" applications. The camera and player are restricted to the two minute-35 seconds cartridge, with the film permanently fixed inside the cartridge. Editing is virtually impossible, as is the assembly of long programs. And it is not really possible to display the films on a normal movie projector, due to their limitations when it comes to image brightness, contrast range and colour resolution.

The limitations are largely due to the fact that Polavision is an "additive" colour system. The images on the film are made up from alternating stripes of the three primary colours, rather like the phosphor stripes in modern colour TV tubes, but in transparency form. This is in contrast with the continuous areas of colour provided by the "subtractive" colour systems used by most other colour films.

By its very nature, an additive colour system tends to produce rather dark images — passing only around one-third of the light passed by a subtractive system transparency. This is because each primary colour is available on only one-third of the total area.

With Polavision this basic darkness is increased by a weak negative image which remains on the film along with the final positive — a shortcoming of the "instant" developing process. The weak negative not only reduces the overall brightness, but also reduces the available contrast range.

The limited colour resolution stems from the fact that the image is made up from tiny stripes of colour. Polaroid has achieved a very high density for the colour stripes: 1500 triplets per inch, much greater than earlier additive systems. But for the super-8mm picture used by current Polavision, even this density gives only 315 triplets for the full picture width — comparable with a normal colour TV picture.

The design of the Polavision player with its 30cm diagonal screen is such that these limitations are effectively overcome. But presumably the potential market for instant movies is still a little diffident about a system that as yet can only provide silent movies, 2½ minutes long and unedited, and displayed on a screen no larger than a portable TV.

## HOME MOVIES '79

tion gives a full "220 degrees" exposure of 1/29th (34ms), which when coupled with the f/1.4 lenses gives good low-light capability.

Not too many other cameras offer this degree of shutter flexibility as yet, but other manufacturers will almost certainly follow suit.

Along with the electromagnetic shutter, an increasing number of cameras are now provided with an output socket to allow triggering an electronic flash unit — for frame-by-frame shooting inside dark buildings and caves, etc. Often either the same socket or a second socket may be used to generate synchronising pulses or tone bursts, for double-system sound shooting. Even some of the direct-sound cameras provide one of the latter sockets, to give the user a choice of single-system or double-system sound.

When it comes to the main picture-taking lens, just about every Super-8 movie camera for the last decade or so has been provided with a variable-focal-length or "zoom" lens. Over the last few years the manufacturers of these lenses have been able to take advantage of computer-aided design techniques, to improve their performance considerably.

The two main benefits of this development have been in terms of improved picture sharpness at intermediate focal lengths, and longer



*The Sanyo model XL-620 "Super-tronic" sound camera, one of the new models with a built-in microcomputer.*

zoom ratio — the ratio of maximum to minimum focal length, which determines the degree of "zoom" which it can provide. So that the zoom lens on most modern cameras is not only capable of giving an impressive zoom effect, but is also capable of giving consistent results when used for the more important job of providing a wide choice of different focal length settings. Which is just as well, because in most



# Eumig 824 Sonomatic.<sup>®</sup>

## Dual track sound recording

There are other projectors that permit dual-track recording. But the Eumig 824 Sonomatic is unique in offering not only dual-track recording but also Sonomatic recording control.

Dual-track recording permits separate recording and separate or combined playback on the main and balancing stripes. This means easier adding, correcting, over-recording, attenuation, amplifying any sound effect—with the absolute reliability that the amateur movie maker can expect.



**More light.  
More picture.  
More brilliance.**

Utmost image quality with the multicoated 10-element 12.5—25 mm Eumig Suprogon Zoom f/1.2 projection lens. This yields 22% more light than the previous Suprogon—which already brought 35% more light to the screen than traditional projection lenses. The new Eumig Suprogon meets the highest demands in terms of speed, brilliance and definition. With a wide-angle setting down to 12.5 mm it offers a most convenient focal length range for large-screen projection even in small rooms.

### Technical data

Film gauge:	Super-8, Single-8, Standard-8
Reel capacity:	Up to 180 metres (600 feet) of acetate film
Lens:	Eumig Suprogon-zoom f 1,2/12,5-25 mm multicoated
Lighting system:	12 volt 100 watt tungsten-halogen lamp with diathermic reflector; burning life approx. 50 hours, preheating to extend lamp life, lamp economy switch with signal light.
Rotary selector switch positions:	Stop, automatic threading, forward and reverse projection, forward and reverse running without lamp, high speed motorised rewind
Framing speeds:	Continuously variable from 18 to 24 fps
Amplifier:	Combined recording and playback amplifier with integrated circuit; tone control
Output:	10 watts rms, 15 watts music
Sound recording modes:	Recording via audio or microphone input. Mixing into a first recording via audio or microphone input. Sonomatic key ensures precision programming to the exact frame for all recording and mixing operations. Twin track sound recording for separate recording and separate or combined playback on main and balancing stripe.
Signals:	Recording: by scale lighting of recording level indicator. Recording level: by meter needle on recording level indicator. Mixing: yellow signal lamp. Lamp economy switching: blue signal lamp.
Loudspeaker	Built-in, loadable up to 10 watts rms
Monitoring during recording:	Via built-in speaker
Inputs:	Microphone, audio
Outputs:	External speaker, line output
Frequency range:	75—10,000 Hz at 18 fps; 75—12,000 Hz at 24 fps
Recording level:	Automatic and manual with VU meter
Automatic sound start:	Activates sound section before sonomatic fade-in: „flying start“.
Size:	335 x 190 x 241 mm (13.2 x 7.5 x 9.5 in.) with handle
Weight:	Approx. 8.5 kg (18¾ lbs.)
Accessories supplied:	Microphone with remote control switch, mains lead, universal 120 metre (400 foot) reel, prerecorded film with main stripe and balancing stripe, instruction book, guarantee card, fuse, frequency response certificate.

**eumig**<sup>®</sup>  
makes filming easy

Distributed and Guaranteed for 3 years in Australia by

R. GUNZ (PHOTOGRAPHIC) PTY. LTD.  
P.O. BOX 690  
DARLINGHURST. NSW 2010

PH: 211.3155

ELECTRONICS Australia, November, 1979

15



# HUGE PRICE/TECHNOLOGY BREAKTHROUGH!



## find GOLD and hidden treasure with T.R. DISCRIMINATOR treasure detector

The computerised transmit/receive metal detector  
that can actually discriminate treasure  
from rubbish - and at an incredibly low price!

**JUST IMAGINE!  
A FULL T-R  
(transmit/receive)  
DISCRIMINATOR  
METAL DETECTOR  
FOR UNDER  
\$300<sup>00</sup>!!!**

★ Most metal detectors can't tell treasure from rubbish - this one can, as the discriminator microprocessor can compare ferrous and non-ferrous metals.

★ Uses an integrated circuit discriminator designed by a brilliant U.S. ex-military engineer.

★ Other discriminator-type metal detectors sell on the Australian market for \$300 - \$480!!

### IN AUSTRALIA TODAY

literally millions of dollars simply lies in the ground, waiting to be found

Not just gold nuggets, but also old coins, artifacts and other treasure!



Make money while you're paying for it - ask about our TERMS

**ONLY  
\$125<sup>00</sup>**  
P&P \$3 anywhere in Australia  
Cat. X-1065

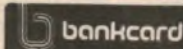

★ The system uses a microprocessor circuit which replaces all the conventional complicated knobs.

★ No this is not a "Toy" type B.F.O. metal detector - it's one of the most sophisticated electronic devices ever offered for the price.

\*\*\*\*\*  
**MADE IN THE USA**  
by the world's largest  
metal detector company  
\*\*\*\*\*



## DICK SMITH ELECTRONICS

<b>NSW</b> 125 York Street, 147 Hume Highway, 182 Pacific Highway, 30 Grass Street, 283 Keira Street,	<b>SYDNEY</b> Phone 280 3377 <b>CHULLORA</b> Phone 642 8922 <b>GORE HILL</b> Phone 439 6311 <b>PARRAMATTA</b> Phone 883 1133 <b>WOLLONGONG</b> Phone 28 3800	<b>ACT</b> 88-88 Gladstone Street, <b>VIC</b> 399 Lansdale Street, 858 Bridge Road, <b>QLD</b> 186 Logan Road, <b>SA</b> 203 Wright Street, <b>WA</b> 414 William Street,	<b>FYSHWICK</b> Phone 80 4844 <b>MELBOURNE</b> Phone 87 8834 <b>RICHMOND</b> Phone 428 1814 <b>BURANDA</b> Phone 391 8233 <b>ADELAIDE</b> Phone 212 1982 <b>PERTH</b> Phone 328 6944
---	--	--	---

EXCEPT WHERE NOTED, ALL ITEMS SHOWN IN STOCK AT PRICES GIVEN AT TIME OF GOING TO PRESS

MAIL ORDER CENTRE: PO Box 321, NORTH RYDE NSW 2113. Ph 888 3200. PACK & POST EXTRA.



SHOPS OPEN 9AM to 5:30PM  
(Saturday: 9am till 12 noon)  
BRISBANE: Half hour earlier.  
ANY TERMS OFFERED ARE TO  
APPROVED APPLICANTS ONLY  
RE-SELLERS OF DICK SMITH  
PRODUCTS IN MOST AREAS OF AUSTRALIA.





## HOME MOVIES '79 — A WHOLE NEW BREED OF EQUIPMENT



Two of the new models which offer automatic focusing. Above is the Bolex 564 XLAF, while at right is the Chinon 60 AFSL. Both are direct sound cameras.

cameras the lens is an integral part of the camera, and not interchangeable!

Most currently available cameras offer a lens with a zoom ratio of somewhere between 2.5:1 and 10:1, with the cost tending to rise proportionally. A few models near the top of the market offer an impressive 12:1 zoom ratio, while one camera — the new Bauer S715XL — offers a whopping 15:1 zoom ratio on a lens made by the renowned French firm Angenieux. Needless to say it isn't cheap.

For some time now, all except the cheapest models have offered optional power zooming — largely a gimmick feature, but it can be handy at times. Some of the latest models now offer either a choice of fixed power zooming speeds, or a continuous adjustment. This is yet another benefit of the changeover to microcomputer electronics.

To a lesser extent, the use of computer-aided lens design has also produced an improvement in terms of maximum aperture. The maximum aperture available on most current cameras is between  $f/1.8$  and  $f/1.4$ , with a few of the higher-priced models offering a maximum aperture of  $f/1.2$ . Again the larger the maximum aperture, the higher tends to be the price.

Most of the latest cameras are also provided with a handy feature known as macro-focussing, or simply "macro". This is simply an arrangement whereby turning a small knob or an additional ring on the lens lets you focus down to extremely close distances — in some

cases, right down to the front glass of the lens itself! This lets you get huge closeups of eyes, mouths, insects or anything else that takes your fancy.

Generally the macro feature involves either a shifting of one of the element groups inside the zoom lens, or the swinging-in of an additional element. In most cases the zoom feature of the lens is lost when you engage the macro feature, with the zooming ring becoming a second focusing ring.

Another feature you'll find on some of the latest models is automatic focusing. You can easily spot the cameras with this feature, because they have an unmistakable addition to the front of the case: a housing, usually either above or below the lens, with two small windows about 5cm apart.



A simple, easy to drive sound camera, the Hanimex model 440XL features a 4:1 zoom lens with macro focusing facility.

Automatic focusing operates in a manner very similar to that of the familiar split-image rangefinder. Behind the two small windows are a pair of mirrors, which operate in conjunction with lenses and prisms to produce images on a pair of matched photo-diode arrays. One of the mirrors is fixed, while the other is moved back and forth in an arc to scan the scene in front of the camera. The images on the two photo-diode arrays are continually compared — another job which can be done by the camera's inbuilt microcomputer. When the images coincide, the position of the scanning mirror is used to deduce the distance to the subject. Then a small servo-motor is used to set the focus ring of the main camera lens, for this distance.

As you might imagine, the effectiveness of this sort of system depends very much on the contrast between the subject you want to be in focus, and the background or surrounding objects. If there isn't much contrast between the two, it won't work very well.

Similarly because the scanning mirror moves only in the horizontal plane, the photo-diode arrays can really only respond to image differences produced by strong verticals. So if the scene consists mainly of horizontal lines, the auto-focus again won't be much good.

Needless to say because the two mirrors are only a few cm apart, the accuracy is also rather poor when the subject is more than about eight or 10 metres from the camera. So in most cases the circuit is arranged to



# LEADER TEST INSTRUMENTS

## LBO 508A OSCILLOSCOPE



Bandwidth DC-20 MHz.  
Sensitivity 10mV/cm.  
130mm highly C.R.T.

**\$899**

## LDM 170 DISTORTION METER

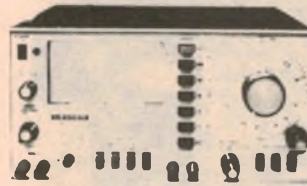

20Hz-20kHz 0.3% F.S.  
Measures distortion,  
signal-to-noise ratio,  
signal levels.

**\$490**

## LAC 895 ANTENNA TUNER



Built-in SWR and in-line  
Watt meter. 5 bands  
from 3.5 to 28 MHz.  
500W pep transmitter  
input.

**\$182**

## LBO 510A OSCILLOSCOPE



20 mV/4MHz.  
FET'S input

BUDGET PRICED  
**\$399**

## LSG 16 RF SIGNAL GENERATOR

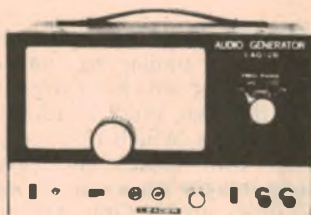

100KHz-100MHz  
Solidstate RF signal  
generator. Suited for  
aligning the IF circuits  
in AM, FM and TV sets.

**\$119**

## LAG 26 AF SIGNAL GENERATOR

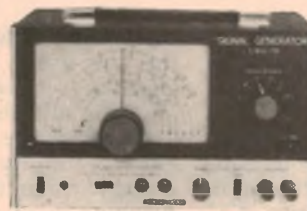

20Hz-200kHz  
Stable generator for all  
types of audio circuit.

**\$166**

## LFM 39A WOW AND FLUTTER METER

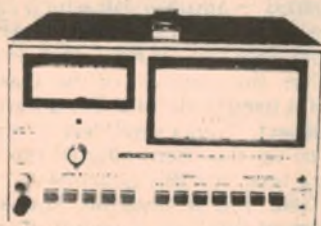

For accurate and easy  
determination of the  
wow and flutter charac-  
teristics of tape  
recorders to JIS, CCIR  
and DIN standards.

**\$699**

## LMV 181A AC MILLIVOLT METER



AC Voltages from  
100yV up to 300V. 5Hz-  
1MHz.

**\$189**

# YICOM

### SOUTH AUSTRALIA

Electronic Components and  
Equipment  
110 Tynte Street,  
North Adelaide  
(08) 267 2246  
International Communication  
System  
Dale Street,  
Port Adelaide.

### NEW SOUTH WALES

Radio Despatch Service  
869 George Street,  
Sydney.  
(02) 211 0816  
Custom Communications  
Shop 11,  
Parramatta Arcade,  
Darcy Street,  
635 6399  
Elektron 2000  
44 Brown Road,  
Broadmeadow  
NEWCASTLE, 2292  
(049) 69 1222  
Macelec  
99 Kenny Street,  
Wollongong  
(042) 29 1455

### QUEENSLAND

Delsound  
1 Wickham Terrace,  
Brisbane, Queensland  
(07) 229 6155  
Fred Hoe & Sons  
246 Evans St,  
Salisbury North,  
(07) 277 4311

### WESTERN AUSTRALIA

Atkins Carlyle  
1-9 Milligan Street  
Perth  
(09) 321 0101  
**A.C.T.**  
George Brown & Co.  
23-25 Whyalla Street,  
Canberra.  
(062) 95 0455

### VICTORIA

Radio Parts Group  
Spencer Street,  
West Melbourne and  
Dandenong Road,  
Malvern  
329 7888  
Browntronics  
93 Sackville Street,  
Collingwood  
(03) 419 3992



## HOME MOVIES '79 — A WHOLE NEW BREED OF EQUIPMENT

automatically set the focus to "infinity" if no distinct subject is found closer than about 10m. This is generally quite acceptable when you are working at short focal lengths (because of the depth of field), but it can be a problem when you are at the "telephoto" end of the zoom range.

Because of these shortcomings, most of the cameras which provide the auto-focus facility also have a control which allows it to be disabled. The lens can then be focused manually, in the usual way.

Incidentally the auto-focus feature should not be confused with the "no focusing" or "universal focusing" feature found on some of the simpler cameras. The latter is basically a very simple scheme, relying on the fact that when you are working at relatively short focal lengths and with the lens set for small to medium apertures, its depth of focus is quite large. So by setting the focus ring to a medium distance (say 5m), you can get quite well focussed pictures of a subject at almost any likely distance.

It's simply a way of setting the lens to behave like a fixed-focus lens, as used in the old box cameras. And needless to say, it doesn't give good results at either large apertures or when the lens is set for "telephoto" operation. However one camera (the Eumig Mini 3) produces quite acceptable results by taking the idea a little further: the "compromise" focus setting is automatically varied with the focal length, as you zoom. To help ensure reasonable results from this "Servofocus" system Eumig have also

limited the lens to a maximum focal length of 30mm and an aperture of  $f/1.9$ .

So much for the general features you'll find on the latest breed of home movie cameras. Now let's look at the particular area of sound camera developments.

The first Super-8 direct sound cameras which appeared around 1974-75 were pretty basic. They let you record sound along with the pictures, but the facilities for controlling both picture and sound were very limited

even compared with contemporary silent models. And the recorded sound quality was fairly modest, with noticeable wow and flutter.

Since then, things have changed quite a bit. The latest models provide just as many features and facilities as the silent models, for control over picture taking, together with almost as many again for the control of sound.

One of the most obvious features offered by many of the new models is the ability to take 60 metre (200ft) film cartridges, as well as the standard 15 metre (50ft) size. This lets you film continuously for nearly  $13\frac{1}{2}$  minutes at 18fps — ideal for sports filming or interviews, etc.

Kodak makes available two types of pre-stripped Super-8 colour film in the 60 metre cartridge: Kodachrome 40 (40/25ASA) and Ektachrome 160 (160/100ASA). The former is sold with processing pre-paid, while the latter is sold without. Kodak do provide a processing service for the Ektachrome, but it is available separately.

Most of the early sound cameras were fitted with automatic level control (ALC) circuitry for the sound section. But the only control available to the user was a high/low gain switch; there was no way of disabling the ALC circuit. This could be an embarrassment, as the ALC tends to wind up the gain and accentuate background noises (or camera noise) during pauses in speech, etc.

The latest cameras avoid this problem by allowing you to disable the ALC, and set the gain manually. They also allow you to fade the sound up or down at a



The new Canon model 1014XL-S, a microcomputer-controlled sound camera featuring 10:1 zoom lens, variable shutter, lap dissolve, inbuilt interval timer and macro focusing facility. Note also the offset handgrip, which folds up alongside the lens.

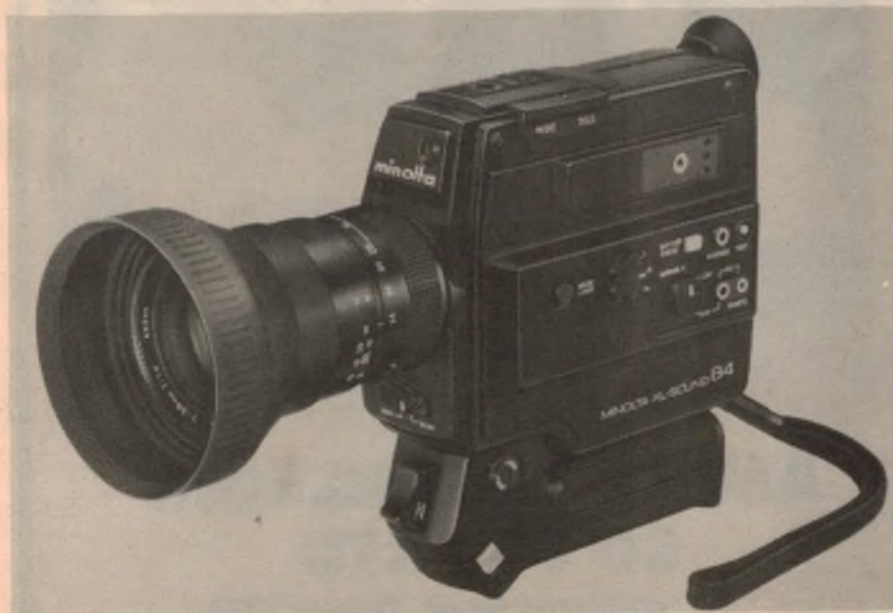

The Minolta XL-sound 84, a compact sound camera which provides an 8:1 two-speed zoom lens, a choice of 18 or 24 frames per second or single shot, and either automatic or manual control over sound recording level.



**NEW...**

**DIGITAL HANDHELD  
MULTIMETER ...  
USHERS IN A DYNAMIC  
GENERATION OF  
MULTIMETERS**



**SPECIFICATION**

**ME-501A**

- VOLTS: DC — 200MV 1000V ,
- ACCURACY 0.8%
- AC — 1000V
- ACCURACY 1%
- DCMA — 200NA 10%
- ACCURACY 1.2%
- RESISTANCE: 2K 2M
- TRANSISTOR HSE CHECKER: 10%

**ME-501A** FR. **\$70** TAX PAID

**ME-501B**

Same as ME 501A plus continuity checker.

Available From:

- NSW:** RADIO DESPATCH;  
M. DE LAUNAY;  
DAVID REID.
- VIC:** ELLISTRONICS;  
ARLIN; TECH SCIENTIFIC.

- SA:** PROTRONICS;
- WA:** RESERVE
- QLD:** WILBER

Also Available:

- ME-521 DX-3.5 DIGIT LED
- ME-522 3.5 DIGIT LED
- ME-523-3.5 DIGIT LED
- \* NEW
- MC-545-4.5 DIGIT LED

**DOT MATRIX IMPACT PRINTER  
MODEL 8300**

The model 8300 serial dot matrix printer features 125 characters per second print speed and one line buffer memory.

- 1 Print speed : 125 CPS (50Hz/60Hz)  
60 LPM (50Hz/60Hz)
- 2 Interface : 8-bit parallel-standard  
RS-232C/TTY-option
- 3 Data buffer : 1 line
- 4 Code : ASCII (96 characters)
- 5 Character font : 7 x 5 dot matrix (7x9 option)
- 6 Number of columns : 80 column
- 7 Character spacing : 10 CPI (Enlarged character  
printing is available)
- 8 Line spacing : 6 LPI
- 9 Paper width : Width: from 4.5 inch to 9.5  
inch (including sprocket  
margin)
- 10 Number of Copies : Original+3 copies nominal  
(max total thickness 0.013  
inch)
- 11 Paper feed method : Pin feed
- 12 Ribbon : 13mm width, purple color
- 13 Operating temperature : 10°C — 35°C (50°F —  
95°F)
- 14 Operating humidity : 10% — 80. (Non  
condensed)
- 15 Power input : 115VAC ± 10%/60HZ  
220 or 240 VAC ±  
10%/50Hz available
- 16 Power Consumption : Printing 100W  
Non printing 7W
- 17 Dimension : approx 449 (W) x 375(D)  
x 185(H) mm
- 18 Weight : approx 10Kg

—The above specifications may be changed without prior notice.—



**AMPEC ENGINEERING  
CO PTY LTD**

1 Wellington Street, Rozelle 2039  
PO Box 132, Rozelle 2039. Phone (02) 818 1166



## HOME MOVIES '79 — A WHOLE NEW BREED

controlled rate, either in tandem with picture fades or independently.

To allow monitoring of the sound level and quality during recording, the early cameras usually provided a flickering green LED (light emitting diode) in the viewfinder. In some cases this was supplemented by an output jack, which allowed you to plug in either a cheap earpiece or a pair of earphones for aural monitoring.

Nowadays the LED and the monitoring jack are both standard, while many cameras also provide a small VU-type level meter as well. In some cases there is also a mixing control, which allows you to mix the outputs of two separate microphones.

It is also fairly standard nowadays for the camera to be provided with a threaded hole on the top of the case, for the attachment of an optional telescopic boom microphone. This allows you to use both hands to hold the camera, instead of one hand being required to hold the microphone at arm's reach (Most amateur movie makers don't have access to a boom operator!).

The microphone fitted to these optional telescopic boom attachments is usually a directional electret capacitor type, of somewhat better quality than the small dynamic microphone supplied with most cameras. Although the telescopic boom is often quite short, most are provided with a compliant coupling at either the microphone or camera ends of the boom, so that the microphone picks up very little noise from the camera.

Most of the modern sound cameras are quieter in operation than the early models, which also helps.

It is also possible to obtain FM wireless microphones for use with some of the current sound cameras. However some of these use frequencies inside the 88-108MHz FM broadcasting band, and are frowned upon by the authorities. They may also be subject to unwanted interference from FM stations.

The remaining advantages of modern sound cameras are in terms of performance.

Right from the start, most sound cameras have had two main drive motors: one for the sound capstan and the other for the normal film advance mechanism. The capstan motor is the "master" drive motor, to ensure that the sound is recorded at constant speed. The other motor is operated as its "slave", with its speed controlled by some sort of servo system to keep it in step.

In the early sound cameras, the servo system used a small feeler arm which sensed the size of the film loop



*The Elmo 10125-XL sound camera, top model in the Elmo range. It offers a 10:1 zoom lens with macro facility, the ability to take 60 metre film cartridges, multiple speeds and a built-in interval timer.*



*The Eumig 881 PMA, a fairly elaborate silent camera with 8:1 zoom which can also accept the larger sound cartridges.*



## HOME MOVIES '79

between the picture gate and the sound recording head. The feeler arm operated a set of mechanical contacts connected in series with the picture drive motor, so that power was applied when ever the loop became smaller than a certain size, and removed when it became larger than that size.

This arrangement is capable of quite reasonable performance, but the mechanical loading applied by the feeler arm on the film loop tends to stiffen it, and reduce its effectiveness in isolating the recording head from the film's jerky motion in the picture gate. This tends to produce rather more flutter than one would wish. The simple on-off nature of the servo system also tends to introduce wow, particularly when the camera starts up at the beginning of a scene.

Most of the newer models still use this basic system, but in a refined form which gives improved results. The capstan motor is arranged to bring the capstan and flywheel up to speed before the film is engaged, which reduces the wow significantly. In some

## The firms who distribute them . . .

Listed below are the importers or distributors of the home movie equipment which is mentioned in this article or shown in the illustrations. In most cases the firms listed will not sell directly to the public; however should you have any difficulty in obtaining a piece of equipment, they will generally be able to advise you of the nearest dealer.

**BAUER, MINOLTA:** Photimport (Australia) Pty Ltd, 149 Milton Street, Ashfield NSW 2131.

**BEAULIEU:** Cinema Beaulieu division of International Dynamics, 23 Elma Road Cheltenham, Victoria 3192.

**BELL & HOWELL, CHINON, RICOH:** Maxwell Photo-Optics Pty Ltd, 55 Murray Street, Pyrmont, NSW 2009.

**BOLEX:** Wild Leitz (Australia) Pty Ltd, 45 Epping Road, North Ryde NSW 2113.

**BRAUN NIZO:** George's Camera Store Pty Ltd, 263 Elizabeth Street, Sydney NSW 2000.

**CANON:** Canon Australia Pty Ltd, 22 Lambs Road, Artarmon, NSW 2064.

**COSINA:** Tasmanex Pty Ltd, 374-376 Pittwater Road, Harbord, NSW 2096.

**ELMO:** C.R. Kennedy (Australia) Pty Ltd, 29 Mountain Street, Ultimo NSW 2007.

**EUMIG:** R. Gunz (Photographic) Pty Ltd, 63-73 Ann Street, Darlinghurst, NSW 2010.

**GOKO:** Camera Houses of Australia Ltd, 4/2 Harbord Road, Harbord, NSW 2096.

**HANIMEX:** Hanimex Pty Ltd, 108 Old Pittwater Road, Brookvale, NSW 2100.

**POLAVISION:** Polaroid Australia Pty Ltd, PO Box 163 North Ryde, NSW 2113.

**SANKYO:** Camera Distributors Pty Ltd, 108 Old Pittwater Road, Brookvale NSW 2100.

of the microcomputer-controlled cameras the picture drive motor is not simply turned on and off by the loop feeler arm contacts, but is controlled by the microcomputer to give a smoother "proportional" type speed regulation.

But because there still tends to be a flutter problem with mechanical contacts attached to the loop feeler arm, some of the new models incorporate

alternative ways of sensing the size of the film loop. These are designed to reduce or remove altogether any mechanical damping.

For example in the new Beaulieu model 6008-S, a small magnet is attached to the feeler arm. This passes over a Hall effect sensor, to convey the loop size information with much less loading than is imposed by mechanical contacts.

The latest Chinon cameras go one better, and do away with the loop feeler arm altogether. In its place they use a narrow beam of infra-red light (from an LED), which is detected by a silicon photo-diode sensor. The beam is angled so that as the film loop changes in size, it varies the amount of infra-red light reaching the sensor. Needless to say this system imposes no loading on the film loop at all.

(continued next month)

Two of the new Chinon sound cameras which use an infra-red light beam for loop sensing: the 200/8XL (left) and the 80 SMR (right). Both have an 8:1 zoom lens and lap dissolve.







## Your ears didn't believe us in the 50s. Will your eyes believe us now?

In the fifties, Aiwa made such technological breakthroughs with their microphones, people just couldn't believe their ears. People again doubted their senses after Aiwa developed the world's first portable stereo cassette recorder.

Now, when anyone hears our hifi mini-components they find it hard to believe that such big, full sound can come from something that looks so small.

We can believe it because we also believe size is not compromise.

However, will we stretch our credibility too far when we tell you our hifi mini-components are compatible with conventional equipment?

That means you don't have to buy all Aiwa hifi mini-components at once.

In truth, you don't have to buy them all, ever.

Aiwa make a lot of other unbelievable hifi equipment that you might prefer to mix with our mini-components.

There are 40 pieces in all. And compared with what you have to pay for them, their sound is amazing. But true.

**AIWA**<sup>®</sup>  
for Craftsmanship

MEMBER OF  
**hifi**  
INDUSTRY  
ASSOCIATION

From selected hifi specialists. For the one nearest you please phone Sydney 597 2388, Melbourne 328 1343, Brisbane 229 6817.

JACKA 1711



# Microwaves in the classroom

by GREG SWAIN



In the past, it's been quite difficult to demonstrate basic optical and electromagnetic wave phenomena in the high school science laboratory. Solid state microwaves have now made group demonstrations of these effects much more effective, easier and cheaper!

A basic course on wave theory, optics, and the nature of light has long been part of the senior high school science curriculum. But there has been a problem — students have not had a great deal of opportunity to perform practical experiments on these topics. Light is composed of very short wavelengths, and this tends to make experimental equipment complex and expensive, and not really suited to group demonstrations.

That problem is now easier to solve, thanks to modern technology and to the initiative of Sydney engineer Des Clift. Des has come up with a kit using a solid state microwave oscillator, which makes low cost experiments a practical proposition. The apparatus operates at the relatively long wavelength of 3cm,

so that the students can, for example, measure wavelength using a school ruler!

The idea is not new by any means — microwave kits have been used in some NSW schools for years now. However, these kits have used the old-fashioned klystron tube to generate microwave radiation. The kit developed by Des Clift, on the other hand, employs a modern solid state Gunn diode oscillator in a tuned microwave cavity, has a greater range, and is much lower in cost.

In fact, Des sells the entire kit for \$175 (plus interstate packaging and postage, plus sales tax where applicable). Considering what goes into the kit, that's extremely good value for money. An eight-page instruction manual is

available for \$2.50, and this details a number of experiments.

Basically, the kit can be used for highly effective class demonstrations of optical analogies and basic electromagnetic phenomena. The following are typical of the demonstrations which can be performed: transmission, reflection, polarisation, refraction, diffraction at a straight edge, diffraction from single slits and gratings, interference at a thin film, interference by Lloyd's mirrors, Michelson's interferometer, Newton's rings, and the Doppler effect. That's quite a list! It certainly illustrates the versatility of the kit.

For Des Clift, the project all started when he tendered for a contract advertised by the NSW Department of Education. He got the contract, but when I talked to him in mid-June he was still waiting for firm orders for his equipment. "They're waiting until the end of the financial year," he explained.

Des, by the way, runs a one-man company called Microwave Developments from the comfort of his French's Forest home in Sydney's northern sub-



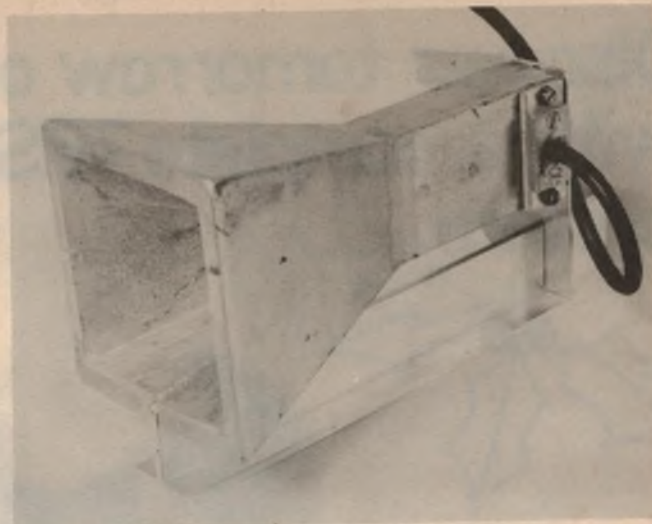

The microwave transmitter (left) can be set for either FM, CW or AM modulation. At right is the receiving antenna.

urbs. He is well qualified in microwave technology and, as I quickly discovered, has a most interesting and varied background.

Des is English-born, having emigrated to Australia back in 1965. During World War II, he served an apprenticeship with the Admiralty Signal & Radar Establishment and subsequently worked on airborne radar and communications equipment. He continued his education at various technical colleges on a part-time basis after the war, and studied electronics, pure and applied physics, and mathematics to degree level.

Des left the Admiralty in 1954 to work for GEC and, subsequently, for A.V. Roe Ltd and W.H. Sanders (Electronics) Ltd. During this time, he developed microwave test gear for two UK missile systems, an airborne radar system, and worked on telemetry and antenna systems for the Blue Steel missile.

Blue Steel, by the way, was a nuclear strike missile carried by the British Vulcan bomber.

For most of his working life in Australia, Des has been employed as a professional engineer by Hawker Siddeley Electronics Ltd, and has been involved mostly with defence contract work. He left Hawker Siddeley in 1976 to start Microwave Developments.

The microwave kit developed by Des for the Education Department includes the following items:

- 3cm (9.975GHz) microwave source, type HSK1A;
- 3cm microwave detector unit, type HSK2A, and stand;
- 2 300mm square aluminium plates;
- 1 60" wax prism and wax lens;
- 1 300mm square wire grating;
- 1 variable diffraction grating.

In addition, the following items are required in order to use the kit: 2 12V AC power supplies (0.2A), an audio amplifier, a galvanometer (optional), three or four wood blocks 100-150mm high (optional), and absorbing wood

screens (also optional). The first three items are standard school laboratory items, and should be readily available in most schools.

Let's take a closer look at some of the items in the kit.

The 3cm microwave source is a self-contained unit which operates from a 12V AC power supply. Heart of the unit is a cast waveguide assembly which contains a Gunn effect diode oscillator operating at a nominal frequency of 9.975GHz. A small range of frequency adjustment is provided by means of a screw inserted into the microwave cavity adjacent to the Gunn diode. This adjustment is set during manufacture, and should not be tampered with.

The output from the Gunn oscillator is coupled to a transmitting antenna in the form of a straight-sided flared horn. This provides a small amount of gain

and a modest amount of directionality. The aperture of the horn forms one end of the box, and is plugged with polystyrene foam to prevent ingress of foreign bodies.

Surprisingly, Des makes up the transmitting (and receiving) modules himself, albeit with a little outside help. The waveguides are cast by a local foundry although, as Des receives them, they're a bit rough. He attacks them with a file and a linearizer to make them more presentable before fitting the necessary components and hardware.

The metalwork, anodising and printing operations are also done by outside companies.

Included in the transmitter box is a printed circuit board assembly. This board performs power supply rectification and regulation, produces CW and

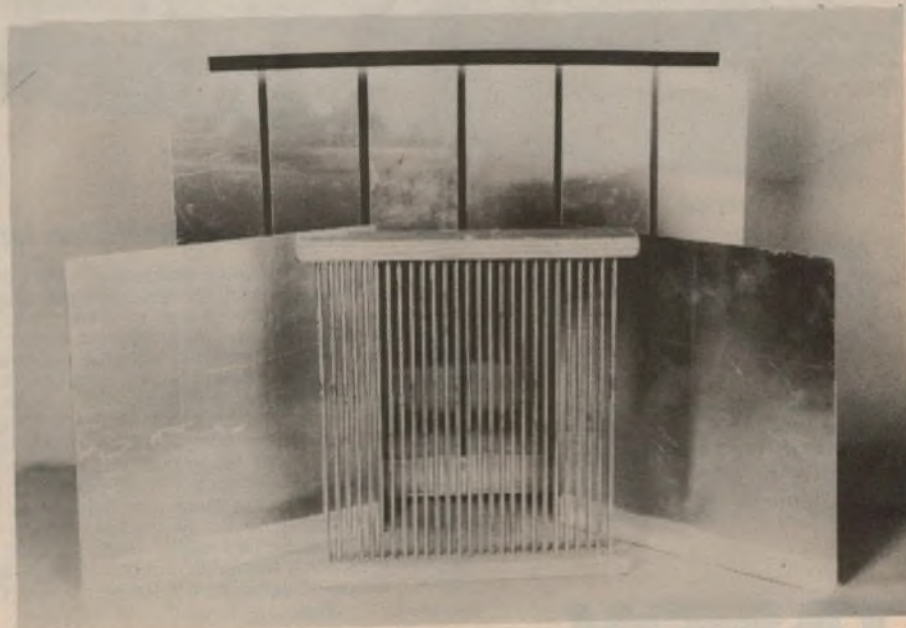

Some of the accessories supplied with the kit. Included are a wire grating, a variable diffraction grating, and two aluminium screens.



# Discover tomorrow on Christmas morning with a complete TRS-80 system .....



New Low Price

# 699

*Finally — the perfect whole-family gift — a solid investment that can educate, save countless hours of work, even entertain. Come in and try out the one gift that could pay off beyond your fondest dreams!*

## **The new microcomputer system for school, home office or hobbyist**

Tomorrow is an electronic world, based on computers — and it's already here! Your entire family can be pleausurably elevated into this brave new world. The priceless gift of tomorrow now has a price: \$699 ... and a name: The Tandy/Radio Shack TRS-80 Microcomputer. Tandy/Radio Shack's computer system surely ought to be on the gift list of every family. Despite that \$699 — though less than a video recorder — is costlier than an electric train. Or two! A proud father writes to tell us "this investment is one of the most significant in value to our family and to the future education of our child, that we have ever seen."

A youngster, aged 12, writes to tell us he's "Too young to go to work for Tandy ... but maybe we could work a deal where I would write some programs for you." An educator thanks us for "making possible the tapping of human innovation and creativity on an unprecedented scale." Tandy/Radio Shack's TRS-80 computer is the ideal "family Christmas gift," and one which has only become more affordable in recent months. A computer? That can teach? Remember? Display on its own screen? Keep the family budget? Catalogue recipes? Play games? Be programmed easily from its own typewriter keyboard? Now, the Tomorrow Machine is not only thinkable, but practical, affordable, and available. The Tandy/Radio Shack TRS-80 microcomputer system is for *your* family. Discover Tomorrow on Christmas morning ..... *this year!* 26-9051

# TANDY ELECTRONICS

Available at all Tandy Stores, Tandy Computer Stores and Participating Dealers around Australia or Mail Order Department, P.O. Box 229, Rydalmere, N.S.W. 2116



## Microwaves in the classroom

FM modulation (CW = continuous wave; FM = frequency modulation) of the Gunn diode, and contains a square wave oscillator. The latter can operate at either 1kHz or 100Hz and provides pulse amplitude modulation of the Gunn oscillator.

Power output from the Gunn diode is a miniscule 10mW, so there is no danger of injury from exposure to the microwave energy. The only proviso is that one should not look directly into the transmitter horn from a distance under two metres — microwave radiation can cause damage to the eyes. An appropriate warning is printed on the side of the box, adjacent to the horn aperture.

The only operating control is on the front panel and provides selection for the mode of operation, which generally will be amplitude modulation at 1kHz. An externally generated audio tone or voice signal must be fed into the two front panel 4mm sockets to produce frequency modulation.

Amplitude modulation of the Gunn oscillator by voice frequencies is not possible.

The box can be mounted either on its base or its back, thus giving radiation which is either vertically polarised (box on base) or horizontally polarised (box on back).

The microwave detector unit consists of a cast waveguide and horn similar in dimensions to the transmitter module. A high frequency, high sensitivity detector diode, mounted across the waveguide cavity, is used to receive the incident microwave radiation. The output from the detector is brought out via coaxial cable to two 4mm plugs.

Provision is made to mount the detector module on its stand in either of two planes, again to demonstrate polarisation effects.

The most useful mode of operation is



Student Chris Harris and teacher Anne Lupton setting up the transmitter.

with the transmitter set for amplitude modulation. This produces a slightly distorted square wave at the receiver output which, when fed to an audio amplifier, will produce either a 100Hz or a 1kHz tone from the loudspeaker.

A look at just three of the experiments that can be performed will quickly demonstrate the educational value of this kit.

**Reflection:** One of the easiest experiments involves a demonstration of the law of reflection — that is, the angle of incidence of a wavefront to a reflecting surface is equal to the angle of reflection away from the surface. This law is best demonstrated by setting the transmitter and receiver modules up at right angles to each other, and using

one of the metal plates to deflect the microwave beam from the transmitter through 90° to the receiver.

By setting the transmitter in the 1kHz AM mode, a tone will be heard in the speaker when the plate is set at the correct angle. The angle between the deflecting plate and each of the microwave units can then be checked by the students, and the experiment repeated for other transmitter/receiver angles.

**Interference:** A basic demonstration of interference can be made by using the microwave equivalent of thin film interference. Optical thin film interference typically occurs when an oil film forms on water, the interference being visible as bands of colouration.

Fig. 1 shows the basic scheme of a microwave thin film experiment. The microwave "thin film" can be several centimetres thick, and its width can easily be measured as it is adjusted to provide maxima and minima. These will occur every one half wavelength (1.5cm).

The thin film consists of the equivalent of a half silvered mirror placed in front of a 300mm square plate. Thus the receiver picks up a maximum signal when the reflections from the mirror and the square metal reflector are in phase. Similarly, cancellation takes place when the signals are out of phase, and the pronounced null which takes place allows the measurement of wavelength.

The microwave half silvered mirror can be the 300mm wire grating or,



Brad Garnham aims the receiving antenna to receive microwave energy reflected from an aluminium screen.



# Microwaves in the classroom

better still, a thin fibreglass sheet or srpb (synthetic resin bonded paper). The latter will produce less stray reflections than the wire grating, and thus give more pronounced nulls.

The Doppler shift experiment is similar to the above set-up, except that the transmitter is set to CW, and the amplifier is replaced by a high sensitivity oscilloscope. Stray reflections are used to produce the reference signal, while the moving plate produces the Doppler signal. The two signals are heterodyned in the detector to produce a low frequency AC signal which can be displayed on the oscilloscope.

**Michelson's Interferometer:** This remarkable optical experiment was invented by A. A. Michelson (1852-1931) as the basis of the renowned Michelson-Morley experiment, which established the constancy of the speed of light. It provided the first experimental evidence of the validity of the theory of special relativity, and showed that electromagnetic waves do not travel in a unique reference frame, or "ether".

The Michelson interferometer may be very effectively demonstrated by using the microwave kit as shown in Fig. 2. Of course, you will not be able to verify the constancy of the speed of light with this simple set-up — your measurements will not be accurate enough for that. What can be shown, however, is the way in which the device works by demonstrating that an interference pattern will be received at the detector.

As in the previous experiment, the half silvered mirror can be the wire grating, although a thin sheet of fibreglass will be somewhat more effective. Once again, the wavelength of the microwave radiation can be determined simply by measuring the position of the moveable plate at pronounced nulls. These nulls will occur every one half wavelength, or 1.5cm.

Since the frequency of the radiation is known, you can use this result to calculate the speed of light using the relation  $c = f\lambda$ , where  $c$  is the speed of light,  $f$  is the frequency, and  $\lambda$  is the wavelength.

Those are just some of the experiments that Des Clift's microwave kit can perform. In summary, it should prove invaluable for demonstrating a range of basic physical and optical phenomena to high school science students. The instruction notes are well written, and the equipment is straightforward and simple to use.

For further information, contact Microwave Developments, 12 Romford Rd, Frenchs Forest, NSW 2086. Telephone (02) 451 8429.

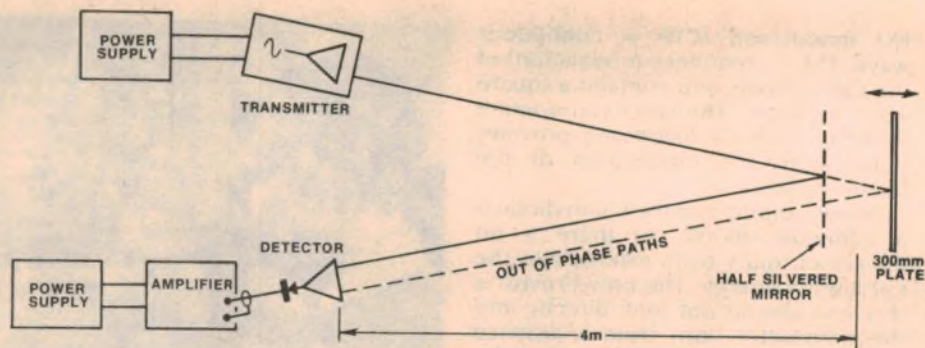

FIG. 1

Fig. 1: microwave thin film experiment. A thin fibreglass sheet can be used for the half silvered mirror.

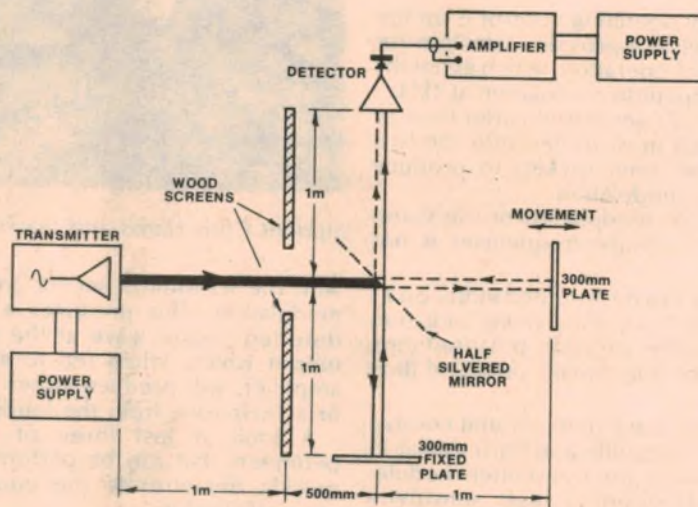
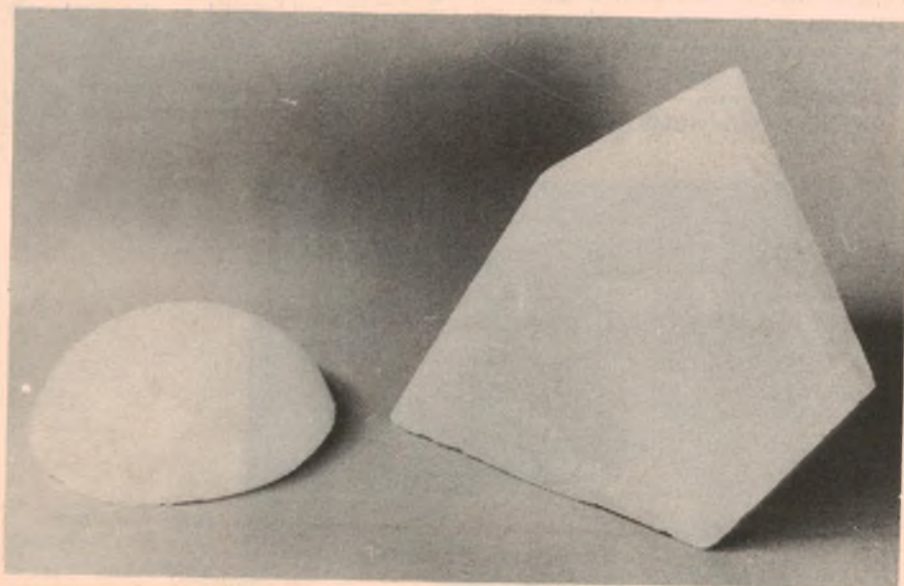

FIG. 2

Fig. 2: Michelson's interferometer. This experiment can be used to calculate the speed of light.



The paraffin lens and wax prism supplied with the microwave kit. They can be used to demonstrate some of the basic laws of optics.



# AMPEX

## PROFESSIONAL SERIES

# BLANK CASSETTES

# \$1.39

down to  
\$1.20 for  
bulk buy

+ POST & PACK.

### LIMITED OFFER PRICES

Quantity	1-100	100-200	200-400	400+
C45	1.39	1.35	1.30	1.20
C60	1.49	1.45	1.40	1.30

Now is your opportunity to purchase professional grade, world famous Ampex cassettes at unbelievable prices. . . but only while stocks last.

Made to professional standards, the low noise, high output oxide tape is polished by the exclusive Ampex ferro-sheen (t.m.) process, thus producing a wide dynamic range. Superior quality shell and components are used. The box is screwed type with a hard plastic window. Each cassette is complete with transparent library box and insert card.

Post or phone your order now and we'll deliver within 14 days, covered by our 14 day money back undertaking. Delivery is only \$2.00 per order (any size) - you can't lose!

For urgent Sydney Metropolitan (north to Gosford, south to Wollongong, and west to Katoomba) delivery, Phone (02) 33-5293 and we'll deliver within four days. You may pay either by Bankcard or C.O.D.



## No Risk Order Form

Post to:  
Dindy Marketing (Aust.) Pty. Ltd.,  
PO Box 55  
5th floor, 15 Boundary Street,  
Rushcutters Bay, 2011.

Yes, please rush my order within 14 days. I enclose cheque for \$..... including \$2.00 post.

	QTY.	PRICE	TOTALS
C45			\$
C60			\$
			& \$2.00 Delivery, and Insurance \$

Name .....

Address .....

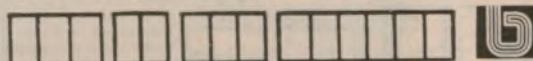

Or debit my Bankcard

Signed .....



# COMPUTER CORNER

**OWN A TRS-80? READ THIS AND SAVE!**

The Dick Smith Mini Disk Drive is 40% cheaper than the Tandy Disk Drive, and has 14% larger capacity. See our advert on page 24 of September's Electronics Australia for more exciting details!

**\$379.00**

Cat X-3230



**SCOOP PURCHASE**

**SAVE \$20.00 ON TAPE READERS!**

Do quick! Easy-to-build paper tape reader kit for all computer enthusiasts. **VALUE! \$75.00!**

**VALUE! \$75.00!**



Cat X-3486



**UPGRADE YOUR TRS-80, APPLE OR SORCERER**

So they've reduced the price of their 18k expansion kit it's still double the price of ours! Upgrade your TRS-80, Apple or Sorcerer to 18k (or 32k from 18k) with our easy-to-fit expansion kit. Full instructions provided. Don't be conned into paying \$300 for a \$150 conversion! Cat X-1185 (TRS-80 conv. Cat X-1188)

(NB Extra switches required for both TRS-80 & Apple. See our store sign)

**\$149.50**

## TREASURE HUNTERS

Dick Smith Electronics has treasure hunters at all budgets - from simple toys under \$30.00 to the finest available, the mighty Fisher 555D - the 'Rolls Royce' of treasure hunters. Find the treasure hunter you want from our outstanding range. **Budget Model: Ideal for the beachcomber.** You won't need to find a gold mine to pay for this one! Self contained, uses single 9-volt battery. Fingertip adjustable controls. Cat X-1082 **\$29.50**

**Techus Tracker TR Discriminator** (the only detector with a microprocessor IC). This unit feels the experts: it looks so simple, but it is a true T/R (transmit/receive) type with incredible sensitivity. Cat X-1085 **\$125.00**

(See our advert elsewhere in this issue).

**D-tex Treasure Hunter:** for when you're serious about treasure finding!

- Four versions of this world famous detector:
  - (1) With single 200mm search coil Cat X-1073 **\$395.00**
  - (2) With 200mm AND quest 355 search coils OR (3) with 200mm coil and GROUND REJECTION circuitry instead of large coil Cat X-1074 (specify type) **\$450.00**
  - (4) With both 200 & 355mm coils AND ground rejection Cat X-1075 **\$480.00**

NOTE: a budget Q tone model with 200mm coil only is available in limited quantities only. D-tex model Case King 1 Cat X-1073 **\$395.00**

**AND THE BEST OF THEM ALL!**

**THE FABULOUS FISHER 555D** - a VLF (very low frequency) T/R discriminator with ground rejection - acknowledged by experts to be the state-of-the-art in treasure hunters. It sells for \$100 less than its nearest rival, the Whites 6000D! Fisher 555D (may be in limited supply for a few weeks) Cat X-1078 **\$549.00**

NOTE: We strongly recommend that beginners in treasure hunting do not purchase the Fisher 555D. It is so incredibly sensitive it is quite difficult to use and master unless you have an expert to show you how!

## NEW!

Dick Smith cassettes have been upgraded. Brilliant new packaging tells you they're different - tied out for yourself just how good they really are! Try a couple of these quality tapes, better still, try ten (types can be mixed) to obtain the bonus book below!



**C60 LN: \$1.50 ea (Cat C-3350)**

**C90 LN: \$2.00 ea (Cat C-3352)**

**C90 EDR: \$2.75 ea (Cat C-3354)**

## BONUS:

Buy any ten Dick Smith cassettes, or any Dick Smith cassette deck or recorder and receiver FREE a copy of our new book 'The inside story on cassettes'. Tells you all about this incredibly versatile recording medium, and how to get the best from your tapes and tape recording equipment. Also available separately. Cat B-8035 @ 60c

The inside story on cassettes...

**AT LAST! Wollongong Now Open**

**WE ARE HERE**



The new Dick Smith Wollongong store is now open. Call in and say hi to the manager, Peter Harding, and his friendly staff. For everything you want in electronics - 263 Keira Street, Wollongong. Phone 28 3800

## UNUSUAL

**GIFT IDEAS**



Novelty radios make ideal gifts! One is disguised as a pig - male chameleon model to be exact. The other a big screw (around 300mm long, that's how big!) incredible what these Orientals will get up to! Big Screw Cat A-4305 was \$59.50 NOW **\$5.95**  
Male chameleon pig Cat A-4310. Was \$9.95; now only **\$5.95**

**SUPER SPECIAL:** 2114 Memory IC's at almost half price - 4k static RAM's. Ideal for the experimenter, was \$14.50 NOW **\$7.30**. Be quick for this bargain! Cat Z-9306

## LOW COST MONITOR

Suits Exidy Sorcerer, Tandy TRS-80, Apple, etc. Why pay over \$200 for a monitor when this one suits them all? Brand new & guaranteed 12V DC/240V AC operation. Cat X-1196



**\$149.50**



Incredible value! Quality EMU 630 cassette at a fraction of the price you'd expect. Ideal for letters, lectures, computer use, music, etc etc etc. And look at the price again!

(SORRY - This special is for mail order customers only. Personal shoppers: watch your store for in-store bargains.)

**75c**

Cat C-3030

## SUMMER TIME IS BARBIE TIME!

But it's also fun for him too! Don't let fire bans ruin your picnic plans. With a Solar Grill from Dick Smith you can have that outdoor barbecue anytime the sun is out - fire bans or not! This marvelous space age cooker will do your steaks perfectly - also chops, whangs, mince, tomatoes, etc etc. And you don't pay a cent for fuel! It will even boil the water to wash up! (A litre of water boils in approximately 9 minutes in sunlight!)



**\$95.00**

**A go-anywhere TV antenna - for car, house, boat, etc etc.** You can mount this in vertical or horizontal mode for either polarity transmission - so it's ideal for use on a caravan. Double folded dipole with reflector for maximum gain and minimum ghosting on all channels. Comes with mounting bracket. Cat L-4028



**\$23.95**

**BALUN:** Want to use co-ax? You'll need a balun. This one is weatherproof, strong. Cat L-4452 **\$2.50**

# DON'T FORGET! XMAS IS NEXT MONTH!

## 1/2 PRICE TRANSISTOR PACK!

We still have a few experimental transistor packs left (you may remember them from February Electronics Australia). These transistors are ideal for the hobbyist, and at the price we are offering them for offer exceptional value for money. There are twenty transistors in all, equivalent to BC108's, BC107's, BC157's and BC158's. **PACK OF TWENTY TRANSISTORS: \$2.50 (plus 50c P&P)** (normal price for twenty transistors of this type approx. \$6.80!).

These transistors are guaranteed brand new, and are all within manufacturer's specifications. They are NOT second or surplus rejects. Available through all Dick Smith stores, and any Dick Smith re-sellers and the Dick Smith Mail Order Centre.

## YOU ASKED FOR THEM

So we got them! You've asked us for 9 volt alkaline cells - here they are. Duracell alkaline batteries which outlast carbon cells by up to 8 to 1. So for those projects which need long battery life. Cat S-3286 **\$2.50**

## FIBRE OPTIC

Light your way in dark corners with this handy fibre optic torch. Shaft bands & twists into the work, great for the handyman & hobbyist. Cat X-1085 **\$3.95**

## DEAR CUSTOMERS

Quite often, products we advertise are completely sold out withing a few days. Or perhaps they may hold up delivery of promised goods so they are not in the stores when the advert appears. Please don't blame the store manager or staff, they are powerless to do anything about it! What we are trying to say is that, if you are about to drive across town to pick up a particular line, give the store a ring first - just in case!

**Dick Smith and Staff**

## IT'S ABOUT TIME ...

### STOPWATCH/TORCH

Incredible! A stopwatch that can do splits, lap timing, etc down to 1/100 second, in a tiny case that also includes a torch. LCD readout for long battery life, highly accurate.

Stocks may be low until mid month! Cat X-1043 **\$39.50**



### VALUE FOR THE MOTORIST:

Quartz chronometer accuracy, large easy to read fluorescent digits. Operates from 12 volts, takes less power than your dash lights. Easy to install bracket supplied. As shown, with case Cat X-1047 **\$24.50**

Unit without case (for installation in dash) Cat X-1045 **\$19.50**



## 150 PROJECTS TO BUILD...

That's right, a whole 150 of them! Radios, amplifiers, solar projects, etc etc. No soldering required, and it is battery operated - so it is completely safe!

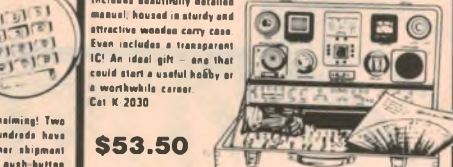

**\$53.50**

## COMING SOON!

**The new Yaesu FT-207R CPU controlled, synthesised 2m hand-held**

800 channels across 144-148MHz, with keyboard entry of all frequencies! Or you can scan manually, or automatically for a busy or a clear channel. With four channels of frequency memory, memory back-up when power is 'off', 600kHz repeater splits (or odd splits if you wish) - it's got the lot! Don't buy a 2 metre rig until you see this superb technological breakthrough. If a due in our stores in just a few weeks - and it will be well worth the wait! Cat D-2888 **\$388.00**



## AMATEURS

DON'T FORGET! Dick Smith will match or better ANY GENUINE ADVERTISED PRICE on Yaesu or Hy Gain amateur equipment!

## RECTANGULAR LEDS!

Give your projects that real pro look with these smart rectangular LEDs. Available in red or green. Cat Z-4040 Cat Z-4042 **65c each** (\$5c each for 10 or more)



## HUGE STOCKS NOW IN! The WIA Amateur Radio Callbook (1979 EDITION)

Yes! We now have large stocks of the all new, up-dated 1979 edition of the Wireless Institute's Australian Amateur Radio Callbook. Contains the call signs, names and addresses of almost all the amateur operators and SWLs in Australia & PNG, plus loads of data & information. Every amateur & SWL should have a copy. Cat B-2317 **\$2.95**

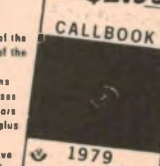

## BUYING BY MAIL?

It's so easy! Simply list the items you want with their catalogue numbers and post it off with your cheque to our mail order centre (address at right). Don't forget to include post & packing charges apply to total order value as per table at right. Then watch your letterbox!

ORDER VALUE:	P&P
\$4.00 to \$9.99	\$1.00
\$10.00 to \$24.99	\$2.00
\$25.00 to \$49.99	\$3.00
\$50.00 to \$99.99	\$4.00
\$100.00 or more	\$5.50

NOTE: These charges apply to goods sent by post in Australia only. Large and bulky items cannot be sent by post. If you prefer, we will dispatch your order by Comet Road Freight to anywhere in Australia for only \$8.00 that's below what it costs us! Large and bulky items are normally sent by Comet unless you specify differently (eg by rail or air - you pay freight on delivery).



## MINI HI-FI SPEAKERS

Top performance from such a tiny speaker. If space is a problem, or if you don't want your speakers to look obtrusive, try these. They're only 120 x 120 x 180mm, and performance is equal to many speakers costing two and three times as much! Try them, you'll be pleasantly surprised! Cat A-2375



- Car
- Boat
- Caravan
- Home Units & Flats

**\$99.50 pair**

## IN A WORD: BRILLIANT!

3 way light, floor, spot and flexor for campers, in the car, home; wherever you need a portable lamp. Hand held or use shoulder strap supplied. Cat X-1084

**\$14.95**



## FERRIC CHLORIDE IS NOW IN EASY-MIX PACK

Yea! No more messing about with powders waiting for them to dissolve. Now Dick has handy packs of ferric chloride in concentrated liquid form: just pour into water and you have instant solution! Makes 800ml of etchant. Cat H-5852



**20% MORE ETCHANT FOR THE SAME PRICE!**

**\$1.90**

## VALUE!

For computer enthusiasts, experimenters. This calculator keyboard kit with a host of uses: comes complete with screws, PC board, all keys and spring pad. Ideal for combination locks, alarm systems, etc. Cat K-2010

**\$3.75**

Four different colours available. Great value. Cat S-1200

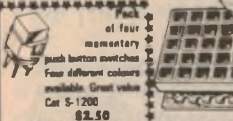

## BONZA BULK BUY BARGAINS - BEWDY!

Interested in buying (or selling) big quantities of bonza bulk buy items such as we show here? Talk to our marketing manager. Phone (02) 888 3200

## SAVE 20% FANTASTIC SAVING...

Famous 'Weller' cordless soldering iron

For soldering games wherever you go this handy Weller iron has built-in rechargeable cells; comes with mains charger. Bulk in and lights the way in dark corners. Incredible value: compare our price

WAY UNDER RECOMMENDED RETAIL PRICE!

INCLUDES MAINS CHARGER AND TIP - 12 MONTH GUARANTEE RANGE OF SPARE TIPS IN STOCK!



**\$26.00** value! Cat T-1050

## CALLING BIG CONSTRUCTORS

The answer to space problems. This huge rack mounting case. Quality construction, measures a huge 425x250x140mm. Comes as shown with handles & pre-punched ventilation holes. Professional quality.



**\$49.50**

## IT'S THE TIME OF THE BURGLAR AGAIN - AND IT'S TIME YOU DID SOMETHING ABOUT THEM!

### GLASS BREAKAGE DETECTOR

Incredible! Up-to-the-minute technology gives protection for shops, offices, homes, etc. Simply glues on window; if glass breaks, it actuates alarm system. Is not affected by tapping or other sounds; sensor reacts only to sound of glass actually breaking. Approx. 25mm cube.



Cat L-5230 **\$29.50**

Door switches handy for car alarms, home alarms, etc. normally open with door closed, close when door opens (if that's not double Dutch). Cat L-5258 **\$1.65 pr.**

### ALARM COMPONENTS

SIREN SPEAKER: Highly efficient. Warns the most determined felon. Operates from 12 volts. Cat L-7026 **\$22.50**

### FULLY INTEGRATED RELIABLE CAR PROTECTION

At least a reliable auto alarm that is easy to use. Installs in minutes, senses voltage drops in system to sound alarm. Even has a special loop for CB & cassette, etc. protection. 12 volt, suits all negative earth cars. Does not use vehicle horn - built-in siren for top protection.

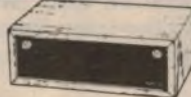

### GUARD YOUR HOME!

A lot of burglaries occur when you are at home! Guard your house with this portable ultrasonic alarm. If anyone crosses the invisible beam, the alarm sounds! Ideal for when you're watching TV, leaving the rest of the house unguarded. Battery operated, mains operation via optional power pack. Covers up to 300 square feet. Outstanding value; cheap insurance!



Cat L-5108 **\$99.00**

**\$49.50**

**Budget Car Sound**

Slider pots take a tumble... Top quality slider pots, made by Sosen. 50k resistance, probably the most used value going. Compare our price with others! Cat R-1982 **60c ea!**

### TOP VALUE! SPST MICROSWITCH FOR JUST 60c!

Yes, that's right - a microswitch for only 60 cents! These brand new, highly reliable switches were bought as a bulk purchase - and the huge saving is passed on to you. Micro switches normally sell for around \$2 - \$3 or so! Think of the uses: alarms, control circuits, models, service work, etc. Save now!

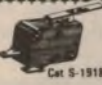

### IC SOCKETS LEAP DOWN IN PRICE!

Save with Dick Smith bulk buying power: we've slashed the price of our most popular IC sockets by up to 25%! Don't miss out... 8 pin mini dip. Cat P-4080 was 40c each. Save 25% - NOW ONLY 30c ea! 14 pin DIL. Cat P-4140. Were selling for 40c - NOW ONLY 35c EACH!



## FABULOUS COLOUR TV GAMES GREAT FUN FOR CHILDREN AND ADULTS.

Great for when the TV programs are crook (and isn't that a lot of the time?). These colour TV games feature plug-in cartridges which give you greater choice; you simply buy the cartridges you want. Simple to operate, will not damage the TV set in any way, hours of fun and enjoyment for the whole family. Price includes basic 6 game program.

- OTHER CARTRIDGES AVAILABLE:
- 10 game super sports (Cat X-1182) ..... \$20.00
  - Motorcycle - four games of skill (Cat X-1183) ..... \$29.00
  - Car race - play a friend or the clock (Cat X-1185) ..... \$25.00
  - Wipeout - Six fascinating games (Cat X-1188) ..... \$25.00



Other TV games available from a low \$19.95!!!

# DICK SMITH ELECTRONICS

**NSW** 125 York Street, SYDNEY Ph 290 3377  
147 Hume Hwy, CHULLORA Ph 642 8922  
162 Pacific Hwy, GORE HILL Ph 439 5311  
30 Grossa Street, PARRAMATTA Ph 683 1133  
263 Keira Street, WOLLONGONG Ph 28 3800  
**ACT** 96 Gladstone St, Fyshwick Ph 80 4944

**VIC** 399 Lonsdale St, MELBOURNE Ph 67 9834  
656 Bridge Road, RICHMOND Ph 428 1614  
**QLD** 166 Logan Road, BURANDA Ph 391 6233  
**SA** 203 Wright St, ADELAIDE Ph 212 1962  
**WA** 414 William St, PERTH Ph 328 6944

EXCEPT WHERE NOTED, ALL ITEMS SHOWN IN STOCK AT PRICES GIVEN AT TIME OF GOING TO PRESS. MAIL ORDER CENTRE: PO Box 321, NORTH RYOE NSW 2113 Ph 888 3200, PACK & POST EXTRA.

## NEW KITS (and new kit components)

Remember parts for most kits in most of the electronic magazines are normal stock lines. So even if a kit isn't listed, we may be able to help you anyway. Call in and ask us!

- PROCESS TIMER (see ETI Oct 79)  
Printed circuit board ..... Cat H-8623 \$3.95
- INFRA-RED REMOTE CONTROLLER (See Oct. EA)  
COY89A Infra-red diodes ..... Cat Z-3235 \$1.50  
BPW34 Photo transistors ..... Cat Z-1954 \$3.50  
Printed circuit boards (pair) ..... Cat H-8365 \$5.95
- DISCO STROBE (similar to ETI September)  
Complete kit ..... Cat K-3150 \$29.50  
Printed Circuit Board ..... Cat H-8572 \$1.95  
Flashtube ..... Cat S-3882 \$2.95  
Trigger transformer ..... Cat M-0104 90c  
Discharge Capacitors (each) ..... Cat R-2855 \$3.75  
Reflector ..... Cat K-8016 \$4.50
- WINDSCREEN WIPER DELAY (See September EA)  
Printed circuit board ..... Cat H-8364 \$2.50  
Other components for this project are normal stock lines
- AUTO CHIME (See September EA)  
Complete kit including instructions ..... Cat K-3502 \$29.75  
Printed Circuit Board ..... Cat Z-6105 \$1.88  
TMS-1000 Integrated Circuit ..... Cat Z-6825 \$16.50
- INDUCTION BALANCE METAL DETECTOR (See ETI)  
Short form kit (not including former or dowel for rod) ..... Cat K-3100 \$36.50  
Printed circuit board only ..... Cat H-8578 \$1.50
- PLAYMASTER STEREO EQUALIZER (See May EA)  
Complete kit including instructions ..... Cat K-3500 \$99.50  
UA4138 Quad Op Amps ..... Cat Z-6105 \$1.88  
PC Boards (set of 3 high quality boards) ..... Cat H-8360 \$12.95  
Slider pots ..... Cat R-1980 85c  
Knobs to suit slider pots ..... Cat H-3782 50c
- 9KHZ WHISTLE FILTER FOR TUNER (See Feb EA)  
Complete kit, including instructions ..... Cat K-3496 \$19.75
- INTERSIL LCD EVALUATION KIT (See Feb EA)  
(As used in EA digital voltmeter) ..... Cat K-3450 \$39.50

## MAJOR DICK SMITH RESELLERS

Listed below are re-sellers who stock a large range of our products. However, we cannot guarantee that they will have all items in stock or at the prices we advertise.

- A&M Electronics**  
78 High Street, Wodonga, Vic. Ph 244 588
- Advanced Electronics**  
5a The Quadrant, Launceston Tas. Ph 317 075
- Aero Electronics,**  
123a Bathurst Street, Hobart Tas. Ph 348 232
- Peter Brown Electronics**  
9 Doveton Street North, Ballarat Vic. Ph 323 0356
- Coastal Electronics**  
43 Vulcan Street, Moruya NSW Ph 742 545
- Crystal TV Rentals Pty Ltd**  
66 Crystal Street, Broken Hill NSW Ph 6897
- Delta Electrix**  
67 Queen Street, Ayr, Nth Qld Ph 831 357
- Elektron 2000**  
44 Brown Road, Broadmeadow, Newcastle NSW Ph 691 222
- Fred R Hayes Electrical**  
28 Station Street, Bowral NSW Ph 811 861
- D & M Harrington,**  
6/1 Machinery Drive, Tweed Heads South, NSW Ph 364 589
- Hutchesson's Communications**  
5 Elizabeth Street, Mt Gambier SA Ph 256 404
- Keller Electronics**  
218 Adelaide Street, Maryborough, Qld Ph 214 559
- Liamore Kironics**  
Cnr Magellan St & Brunner Hwy, Lismore NSW Ph 214 137
- M&W Electronics**  
48 McNamara Street, Orange NSW Ph 826 491
- Neill Enterprises**  
Shop 2/15 Forsythe St, Whyalla Norrie, SA Ph 454 131
- Power & Sound**  
147 Argyle Street, Traralgon, Vic Ph 743 638
- Stevens Electrical**  
42 Victoria Street, Mackay, Qld Ph 511 723
- Summer Electronics**  
95 Mitchell Street, Bendigo, Vic Ph 431 977
- Sound Components**  
78 Brisbane Street, Tamworth NSW Ph 661 363
- Trilogy Wholesale Electronics**  
40 Princes Hwy, Fairy Meadow, Wollongong, NSW Ph 831 219
- Tropical TV Services**  
249 Fulham Rd, Vincent, Townsville Qld Ph 791 421
- Variety Discounts**  
113 Horton Street, Port Macquarie NSW Ph 835 486
- Wellington Electrical Services**  
110 Lee Street, Wellington NSW Ph 325



SHOPS OPEN 9AM to 5:30PM (Saturday 9am till 12 noon)  
BRISBANE Half hour earlier  
ANY TERMS OFFERED ARE TO APPROVED APPLICANTS ONLY  
RE-SELLERS OF DICK SMITH PRODUCTS IN MOST AREAS OF AUSTRALIA





# FORUM

Conducted by Neville Williams

## AN INCREDIBLE COINCIDENCE — OR SOMETHING ELSE?

At the risk of being tedious, I want to add a few more remarks about the need for computer users to rationalise and "humanise" their relationships with the general public. At the very least, if the content of these columns helps to bring that about, the effort (and the tedium) will have been worthwhile.

The discussion was triggered by the July "Forum", where we outlined a problem facing one of our own staff members. The owner of a Torana 6 automatic sedan, he found that he had been issued with an insurance renewal notice which listed the vehicle as a Torana 4 manual — a less expensive vehicle.

Realising that he would be inadequately covered in the event of damage or loss, he rang the insurance office to advise them of the error. In due course, he received a substitute renewal notice, which was duly paid. That was in May 1977.

But in May 1978 and May 1979 the hassle was repeated, with slight variations. The computer system persisted in valuing and charging on the basis of a Torana 4 manual sedan, showing no evidence that the staff had made any attempt to correct the faulty information which had somehow penetrated its data bank.

What will happen in May 1980 remains to be seen.

We published the story as an illustration of what can happen when the inter-relationship between staff and computer is suspect; but, in so doing, we were prepared to accept it as an isolated example. Imagine our surprise when we received a phone call from a former staff member indicating that he was faced with a very similar problem involving the same insurance company.

It seems that, in 1972, he bought a Ford Cortina and took out a normal comprehensive insurance cover. In May 1978 he traded it on a new Toyota Corolla and had the insurance policy adjusted accordingly. Everything seemed in order when the policy came up for renewal in the following

September; all relevant details on the form were correct.

When our July issue appeared on sale, he had a long chortle at the expense of his former workmate, whom he was able to identify easily enough. But then came September 1979 and, out of curiosity, he looked over the details on his own renewal notice. Would you believe it:

The registered number was correct. The engine number was correct. But his 1978 Toyota Corolla had changed mysteriously into a much more expensive 1977 Ford Cortina Ghia with air conditioning. The premium had also been up-graded by about \$30!

He got on to the phone immediately and was treated with formal courtesy. He was told to ignore the original notice and await receipt of a new one. In the meantime, his vehicle would be held insured by cover note number so and so.

In due course, the replacement renewal notice arrival. Once again, he found himself the owner of a 1978

Toyota Corolla — but it was air conditioned!

When he rang once again to protest, there was a pause, presumably while some buttons were pressed. Back came the reply: "But, sir, our computer says that air conditioning was fitted in January this year."

Strange! He hadn't ordered it, he hadn't paid for it and he hadn't even noticed it!

"Well, there must be some mistake. Cross out the air conditioning and I'll give you the figure you should be paying . . ."

And the figure?

Precisely (and mysteriously) the same as already on the form!

The problem has now allegedly been sorted out but this much I know: there are now two present or former staff members who are waiting for their 1980 insurance renewals to see what kind of vehicles they currently own — in the opinion of a certain computer!

As the heading asks: "An incredible coincidence, or something else?"

If it's "something else", it may be a good idea for us all to check whether the vehicle we've insured is the one we are driving!

## STATIC INVERTERS

At this point, I could carry right on to outline the problems of yet another staff member who is trying to sort out a mix-up in a life insurance payment — occasioned because he dared to change his address. But let's forget it, and pass on to some other topics.

In the August issue, I discussed a suggestion from a reader that the power requirements for individual homes might be met, at least in part, by individual wind-driven generators operating through batteries and a DC/AC inverter system. Having considered the amount of power required in a typical suburban home, I pointed out the inadequacy of practical backyard windchargers and battery systems; this led on to the further observation:



"It's a riot. We got a couple of the wires crossed!"  
(Adapted from "PF Reporter")





PERSONAL ELECTRONICS

# The TI Programmable 59 has it all!

## Solid State Software modules. Magnetic card storage capability. Printer/plotter. Professional Program Exchange. Quality. Value. And much more.

Evaluate programmable calculator systems on the basis of power, flexibility, total software support and price/performance. You'll find there's one clearcut answer: The TI Programmable 59.

Leading the field in performance, quality and value, the Programmable 59 can get you into the power of programming now at a price you can afford. Then, you can add capability as you need it.

With up to 960 program steps, or up to 100 memories, the computer-like TI Programmable 59 can access an additional 5,000-step library of pre-written programs just by dropping in a tiny interchangeable *Solid State Software* module. And, with twelve different library modules available now, whole new worlds are open to you through the power of programming — even if you've never programmed before. *Magnetic card* read/write capability means you can also record your own programs and make them part of your library. A *Professional Program Exchange* makes hundreds of additional

programs available to you and TI's new *Specialty Pakettes* offer programs of interest to groups of specialists in a variety of fields. The TI Programmable 59 is only \$350.00\*. The non-card programmable TI-58C is also available at \$165.00\*. Add the optional *PC-100C printer/plotter*, for an additional \$285.00\*, and you can print, list, or trace your programs; plot curves and histograms, and print out alpha headings.

This enormous capability at your fingertips can help you maximize your problem-solving abilities. TI believed this strongly enough to invest millions in a program to provide 59's to our own professional employees worldwide. 8,000 calculators were distributed by the end of 1977. Results over the first 6 months of the program show time devoted to creative work increased 25%, with a corresponding reduction in fact gathering and repetitive tasks!

We want to tell you more about the TI Programmable 59 and our other programmable calculators. And, about our

software and the PC-100C printer/plotter. You'll discover how easily and economically you can increase your own personal productivity ... with a little help from Texas Instruments.



\*Recommended retail price only.

TEXAS INSTRUMENTS  
... INNOVATORS IN  
PERSONAL ELECTRONICS



TEXAS  
INSTRUMENTS  
AUSTRALIA LIMITED

N.S.W. : A.J.F. Systems & Components, 29 Devlin St. Ryde, 808-2555. Email Limited (Metering Division), Joynton Ave. Waterloo, 699-0033. Silicon Valley, 23 Chandos St. St. Leonards, 439-2965. Dick Smith Electronics, 24 Carotta St. Artarmon, 439-5311.

VIC. : A.J.F. Systems & Components, 310 Queen St. Melbourne, 67-9702. Delta Scientific Product Distribution, Red Bank Court, St Albans, 366-3742. Email Limited, 30 Clairmont Ave. West Bentleigh, 557-2944. Silicon Valley, 380 Bridge St. Richmond, 429-4780. Silicon Valley, 308 Whitehorse Rd. Blackburn, 877-5311. Dick Smith Electronics, 399 Lonsdale St. Melbourne, 67-9834.

S.A. : A.J.F. Systems & Components, 44 Prospect Rd. Prospect, 269-1244. Email Limited, 279 Grote St. Adelaide, 51-0411. Silicon Valley, 170 Sturt St. Adelaide, 51-4080. Dick Smith Electronics, 203 Wright St. Adelaide, 212-1962.

W.A. : Esdailes of Cloisters, 863 Hay Street. Perth, 321-9232. Silicon Valley, 25 Brisbane St. Perth, 328-8091. Dick Smith Electronics, 414 William Street. Perth, 328-6944.

QLD. : Email Limited, 407 Stanley St. Brisbane, 44-0281. Silicon Valley, 22 Ross St. Newstead, 52-1339. Dick Smith Electronics, 166 Logan Rd. Buranda, 391-6233.

TAS. : J. Welch & Sons, 130 Macquarie St. Hobart, 34-7511.

N.Z. : David Reid Data Products, 17 Huron St. Takapuna, Auckland, 49-9197.



# AMPEX



Noel Summerville and Ampex at Paradise Studios, Sydney.

## Noel Summerville tapes Australia's top music on AMPEX... naturally.

At Paradise Studios in Sydney, recording engineer Noel Summerville puts original music down on the tape that gives it all back: Ampex Grand Master. He's a professional.

Like recording pros the world over, Noel tapes on Ampex Grand Master, naturally.

The same professional quality is available to you in open reel and cassette formats from leading hi-fi stores.

**If it's worth taping, it's worth Ampex.**



OFFICIAL SUPPLIERS  
VIDEO RECORDERS  
AND MAGNETIC TAPE  
XXII OLYMPIAD

# AMPEX

**AMPEX AUSTRALIA PTY. LIMITED**  
4 Carlotta Street, Artarmon, N.S.W. 2064. (02) 439 4077  
541 King Street, West Melbourne, Vic. 3003. (03) 329 0388



"But supply . . . notwithstanding, the mind boggles at the idea of an inverter rated to deliver 5kW. The modest 0.3kW inverter in our February issue was big enough; multiply that by a factor of 17!"

This prompted a call from a reader associated with TELECOM who suggested that, for a really mind-boggling experience, I should know about the 60kW static inverters which were currently being installed by Telecom to forestall interruptions to the mains supply to exchanges, etc. They are taking over from the large rotary machines which have hitherto filled this role.

The idea is that critical equipment in the exchange should operate at all times from a static inverter system which delivers 415V 3-phase AC. In the normal way, the inverter is powered by DC obtained from the mains via a rectifier system. In the event of a mains failure, the inverter switches instantly to a bank of storage batteries, which are under constant float charge. The batteries should maintain normal power for, say, 15 minutes — sufficient to bridge a temporary mains drop-out and/or give time to fire up a diesel-driven generator.

The inverters in question are manufactured by STC at Moorebank, NSW. When I checked later with the company, I was told that 60kW is by no means an upper limit in terms of power rating. What about 80 or 100kW units?

Okay, I confess to an appropriate order of mental boggle. I must also confess to thinking in terms of something built up from over-the-counter components — a concept that is obviously much too limited.

In talking around the subject, I gain-

ed the impression that, while multi-kilowatt inverters may be specialised and expensive at present, the economics could change drastically if solar and/or windpower could be harnessed to provide an adequate DC source in remote, scattered areas. As someone pointed out:

"It's also very expensive to install and maintain supply mains to isolated properties. The supply authorities may well choose, in future, to invest in on-the-spot equipment rather than in sprawling reticulation systems."

By chance, while in the process of committing these thoughts to paper, I came across some remarks by Professor S. Kaneff, physical engineer with the Australian National University. They appeared in the August Journal of the Royal Australian Planning Institute and were reported by Susan Woods in "Financial Review" of September 11.

Professor Kaneff was stressing the increasing problem of providing electric power for off-grid users. He said that the cost of supplying and transporting conventional fossil fuels for on-the-spot generation was sky-rocketing to the point where the end cost in worst-case areas may reach \$1 per kilowatt-hour. Relief could hardly be expected from nuclear sources since, by their nature, they would be associated with even greater centralisation. For dispersed needs, it will become progressively more necessary and more economical to exploit solar energy as a primary source.

The one problem with the foregoing sentence is the seeming implication that the requisite technology is to hand, needing only the circumstances and the will to do it. In fact, we need more than that: a major technological

## Wide-band tuners of other days . . .

Dear Sir,

The April article on wideband AM tuners of the 1930s prompts me to remind you and readers that there were any number of enthusiasts in Australia and elsewhere at the time who were willing and able to tinker towards the same end, but without the 25-valve elaboration of some of the American sets of the time. Incidentally, many of these giant radios used a certain amount of subterfuge to raise their "valve count": separate local oscillator, amplified AVC, "image eye" indicator, AFC and so on.

Most local efforts were based on TRF tuners, and I remember one fine receiver (was it the "1939 Senior Radiogram"?) presented by the late John Moyle in the then "Radio & Hobbies", using a three tuned circuit TRF tuner with infinite impedance detector, and a class A push-pull audio end. Even with the rough and ready speaker transformers of those days it sounded marvellous with a Rola G12 speaker.

Later on in the 50s, there was the Playmaster wide band superhet tuner, with two tuned circuits at the antenna input and a 1900kHz IF. I did not make one myself, but I heard several of them working and was most impressed.

Then, in the 60s, Mullard Australia produced an unusual design with a pair of capacitively coupled series tuned IF's between mixer and IF amp; the amount of coupling determines the bandwidth. I made two of these valve tuners and they are still in service: one built in to my stereo system for broadcast listening, and the other coupled to a hifi mono amplifier in my outside workshop. Both have been quite reliable and are a pleasure to listen to, compared to ordinary AM radios.

D.B. (Mt Waverley, Vic.)

# PLESSEY COMPONENTS

For stocks of



## RECTANGULAR CONNECTORS

1. Multicon range of 2, 4, 6, 8, 10, 12, 18, 24 and 33-way plugs and sockets with silver-plated contacts.
2. 159 Series plugs and sockets with from 7 to 71 ways with Gold Flash-on contacts and solder tags.

## GENERAL COMPONENTS

Stocks held of

- Connectors
- Rotary Switches
- Lever Keys
- Reed Relays
- Neon Lamps
- Panel Lamps
- Switches
- Potentiometers
- Integrated Circuits
- Sonalert Devices
- Indicator Tubes
- Photodiodes
- Photo Voltaic Cells
- Nickel Cadmium Batteries
- Loudspeakers

Try us for hard-to-get components such as:-

- Silver Mica
- Transmission Mica
- Transmission Ceramics
- Computer Grade Electrolytics



## PLESSEY COMPONENTS

PO Box 2 Villawood, NSW 2163.  
Telephone 72-0133

Adelaide 269-2544 ● Melbourne 329-0044  
Brisbane 36-1277 ● Perth 458-7111



## FORUM: Solar and wind power — continued

breakthrough which will yield the amount of power needed, from installations of practical size and practical cost. Even assuming that the breakthrough must come, the problem remains of when! Nor are other possible alternative sources without their own hassles.

Out of the same series of conversations came an interesting observation about mechanical problems that have been encountered with wind driven generators in some remote areas of Australia. I had not heard about it before but pass it on for what it is worth.

I gather that the problem has to do with stresses set up in the mechanism under heavy gusting conditions. When the propeller is spinning at speed, it takes on the characteristics of a gyroscope, with a strong inclination to resist any change in the plane of rotation.

But a gusting wind, operating against the tail, may try to swing the whole system quite erratically to and fro. The blades tend to precess, leading to mental fatigue and ultimate failure. In some cases, they may distort sufficiently to strike the tower frame, with rather disastrous results!

The message seems to be that, while

wind-charger mechanisms commonly have in-built protection measures, further refinement may be necessary if they are to combine maximum efficiency with long-term reliability, particularly in unattended and unsympathetic situations.

It may just be that better damping is required — a suggestion that invoked a characteristic remark from one of our office wits:

"Impossible! How can you damp anything in the middle of the Nullarbor?"

### N.Z. EXPERIENCE

As it happens, a recent issue of "Engineers Australia" carries an article by R. W. Hubbard, Chief Engineer of the Waitemata Power Board in the North Island. They have been operating two large wind-mills, a Darrieus type which has been disabled twice by violent winds and a Savonius type which has suffered the same fate. R.W. Hubbard concludes that the strength parameters required for large industrial windmills just about rules them out, economically!

Turning to a quite different subject, we reproduce a letter from D.B. of Mt Waverley, Vic — obviously one of our long-standing readers. He reminisces

about the wide-band tuners of an earlier era.

In those days, radio was the dominant medium of home entertainment. There was no television, no FM broadcasting (in Australia), no tapes, no LP's — just the old 78rpm shellac discs. It was only natural that a proportion of the then huge army of radio listeners should be interested in better than average fidelity and it was this minority which provided the interest in wide-band tuners.

They divided broadly into two camps: one supported the TRF (tuned radio frequency) approach involving, usually, two RF stages and a detector, with the coupling circuits tuning directly to the wanted carrier. It was seen as the simpler system, free from subtle distortion which might arise from the frequency changing process in a superhet. It was also reasoned that a TRF, being intrinsically less selective, would produce less sideband cutting and therefore yield better treble response.

I don't know that the first point ever got much beyond the stage of argument. Selectivity, on the other hand, depended a great deal on the design and layout of the tuner. Especially with a reflex detector, and with possibly a trace of accidental regeneration, the "nose" of a TRF selectivity curve could sharpen up quite surprisingly, largely defeating the whole objective of the exercise.

On the other hand, champions of the superhet approach reasoned that the selectivity curve of an IF channel could be manipulated into a near-ideal square shape for minimum sideband cutting and effective adjacent-channel selectivity. It wasn't easy but, curiously, their efforts were often nullified in part by the selectivity of the front-end tuned circuits. Which led to the bandpass tuners mentioned by D.B.

As Maurice Chevalier often said, per medium of disc: "Ah yes ... I remember eet well!" I should. I was directly involved in a lot of that early work.

But, as pointed out more recently, interest in wide-range higher fidelity AM radio remains at a very low level. In November last, Australia changed over to a new AM broadcast band plan which reduced the separation between stations to 9kHz, thereby nullifying the effectiveness of those 10kHz whistle filters that remained in service. We can recall no letters of protest, and no laments for the potential erosion of broadcast band fidelity; just a couple of matter-of-fact queries about readjusting 10kHz filters.

In the USA, talk still continues about the introduction of stereo AM and this could re-focus attention on the band as a source of something other than merely utility programs. But we've been suggesting this for a long time and the reader may be excused for saying, "we'll believe it when we see it".

The video cassette you buy today...  
can only be as good  
as the service you get tomorrow.

It's not like purchasing a simple television set, which requires little or no intricate adjustments on installation. When you buy a video cassette recorder, the expert service that comes immediately with it is absolutely essential for good performance. And it is equally self-assuring to know the service will always be there when you need it. That's why people come to VIDEO TECHNICS. Because we're more than just a store for video cassette recorders and a range of electronic equipment. We're service experts, too.

### SPECIAL

Universal TV Video Monitor. Ideal as display unit for dream 6800, Sorcerer, TRS-80, Apple, CCTV, or any composite video signal. Features 240v AC or 12v DC. Video input via quality BNC socket. Can be switched over as TV receiver. Priced at \$149. See our complete range of video equipment and other special items such as clock timers, full length features and many more.



BUY FROM THE  
SERVICE EXPERT



## VIDEO TECHNICS

The Carousel Centre, Shop 17-18, 530 Oxford Street, Bondi Junction  
P.O. Box 50, Bondi Road, Bondi, 2026 NSW 2022 Telephone 3872555  
Third floor, Equitable Life Building, 301 Coronation Drive, Brisbane  
4064 Telephone 36 1257



# How to crack a highly paid job as an electronics technician.



We'll give you excellent training - as good as you'll get anywhere in Australia.

We'll give you free medical, dental and hospital treatment.

We'll provide plenty of good tucker and a comfortable place to stay.

We'll give you substantial leave, and on top of all that, we'll pay you well while you're training.

On your side, you'll give us a period of hard, but interesting and rewarding work. And, when eventually you leave us, you'll find yourself a fully qualified and experienced Electronics Technician. Not a bad thing to be, these days.

So, if electronics is your idea of a great career and you are (at time of entry) approx. 15 to 17 for apprenticeship

and over 17 for an Adult Trainee, join the Navy, Army or Air Force.

Phone us at:

Adelaide 223 2891. Brisbane 226 2626.

Canberra 822 333 Hobart 34 7077.

Melbourne 61 3731. Perth 325 6222.

Sydney 212 1011.

Write to either the Navy, Army or Air Force Electronics Technician Counsellor, GPO Box XYZ in your nearest State Capital City (please

include your date of birth).

**Learn  
Electronics  
with us.**

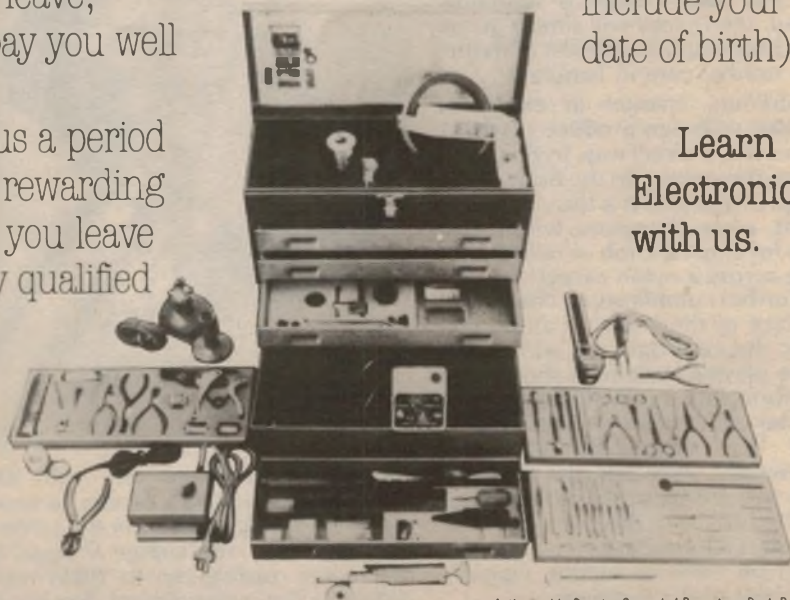

Authorised by Director-General of Recruiting, Dept. Defence  
TSAP15.FP.48





# Hi Fi Topics

## ZAPP, CRACKLE AND POP! THE PROBLEM(?) OF STATIC CHARGES ON DISCS

The very act of withdrawing a vinyl phono disc from its polythene sleeve may produce a substantial static electrical charge on the surface of the disc. Many audiophiles go to great lengths to combat the effect but how important is it — really — to the average home music enthusiast?

by NEVILLE WILLIAMS

To read about the possible deleterious effects of static charges on phono record reproduction, one does not need to search too far in popular hifi literature. It receives frequent mention in articles and advertisements devoted to record care.

One discovers, for example, that the static charge on the surface of a phono disc can be either positive or negative — although usually the latter — and that it can build up to many thousands of volts in certain circumstances.

Such a charge will provide a strong attraction for any particles of dust or lint in the vicinity, which may lodge in the grooves and become a source of background noise during replay. Unless the static charge is somehow dispelled, the record will simply go on accumulating dust for the rest of its life, despite normal care in handling.

In addition, charges in excess of about 4000 volts can produce playback noise in a more direct way, by discharging along the stylus into the body of the cartridge as it passes. It is the equivalent of what often happens when one reaches for a metal knob or railing after walking across a nylon carpet!

As a further complication, charges on the surface of the vinyl can attract the body of the cartridge and add to the effective playing weight. If the charge was uniform, and it proved necessary to do so, the effect could conceivably be offset by re-adjusting the counterweight. However, the charge is likely to vary from disc to disc and even across the surface of the same disc. The end result is a frequent and even cyclic variation on tracking weight, typically of the order of 0.3 to 0.4gm.

Some of these effects have been in-

vestigated recently by Stanton Magnetics Inc. Amongst other things, they set up a "dust" chamber, in which discs could be exposed to a swirling mist of oppositely charged pigment particles. How the particles settled on the disc provided a visual display of the charge patterns, making it easy to observe the effectiveness of various anti-static treatments.

While the existence of static charges on vinyl phono discs has not been in much doubt, actual measurement of the potentials involved has been

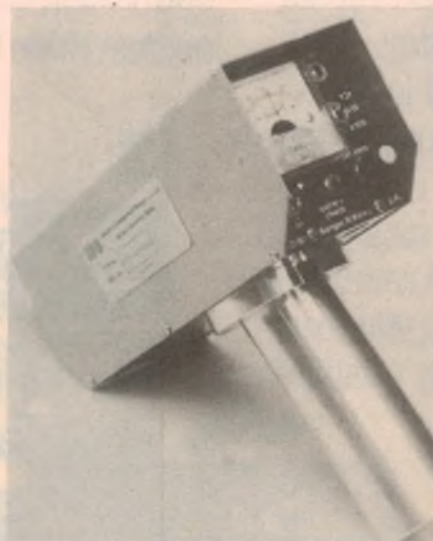

*Completely self-contained, the IDB Field Mill makes it very easy to measure the electrostatic charges on the surface of a vinyl disc. The charge is equal to the meter reading (up to 10kV) multiplied by the measurement distance in cm.*

something of a problem. Not only do the charges occur in random patterns on both surfaces of a disc, but they can also be disturbed and falsified by the very act of measurement.

One instrument that does give easy and credible answers is the Hand Held Field Mill Model 107, designed by Professor Secker of "ZeroStat" fame, and a recognised authority on static electrical effects. It is manufactured by Industrial Development Bangor (UCNW) Ltd, of Dean St, Bangor, Gwynedd, North Wales, U.K. It was a couple of days spent with this instrument, as pictured, that focused our attention on the whole subject. The instrument was loaned to us by Concept Audio Pty Ltd, of 22 Wattle St, Brookvale, NSW 2100.

Near the front of the instrument, which is normally held about 4cm from the surface to be measured, is an electrode which senses the presence of an electrostatic field. In front of the electrode is a motor-driven rotor plate which acts as a "chopper", transforming the electric field into a pulsed signal. This is amplified and processed within the instrument to give a meter readout, which indicates the average charge voltage over a few square centimetres directly in front of the sensing electrode.

At the rear of the instrument, and facing the operator, is a centre-scale meter calibrated to plus and minus 100V. A range switch extends this to plus and minus 1000 and 10,000 volts. The instrument is self-contained, with rechargeable batteries in the handle and it is supplied in a carrying case, with charger and instruction book.

At a cost of a thousand dollars or so, it is obviously beyond the means of the average audiophile. However, it could be a useful investment for anyone concerned with electrostatic problems generally, and with the effectiveness of anti-static measures.

Sufficient to say that, armed with the Field Mill, we attacked the rather random assortment of records that seems to have collected on the shelf in our



audio room over a period of years. But, alas, we were disappointed (?) to find nothing very spectacular in the way of static voltages. Instead of "up to 15,000 volts" we had heard about, most of the discs were hard put to it to do better than about 500-800 volts, irrespective of how withdrawn from their sleeves. Nor did it seem to matter much whether they were laid on their sleeves, or put on the turntable, or played or not played.

At this voltage level, the attraction for dust particles would be much reduced, the effect on tracking weight would be negligible and the chance of voltage flashovers virtually nil.

Somewhat disillusioned, we did a canvass of our staff and asked them how concerned they were about electrostatic problems in their home record-playing systems. Yes, they took reasonable care with their discs, they variously used anti-static mats, records brushes, dust-bugs, etc, but none were up-tight about static electricity, as such.

It was hard to reconcile this lack of evidence and concern with the almost crusading zeal of some (particularly overseas) audiophiles. There had to be some modifying factors which affected the severity of the problem, as seen by different individuals.

Seeking a second opinion, we called up Harry Mauger, a long-time acquaintance and pressing plant engineer in the Philips/Astor record factory in Melbourne. Some of his remarks proved to be quite enlightening:

"Yes", said Harry, "as they come out of the presses, our discs have a very high surface charge.

"If you try to play them on the spot, the charges will flash over so vigorously that it is difficult to judge whether you're listening to electrostatic zapps, or to crackles and pops due to surface faults.

"But the charges tend to dissipate fairly rapidly and spontaneously, and become less apparent as the pressing ages."

Bound up in this remark was one possible explanation for our own observations. None of the records we had tested were in any sense new. They had spent their days ageing, or curing, (or whatever) in a modestly conditioned Sydney atmosphere.

Our next question concerned disc formulations — a query raised by the fact that, of the discs on hand, a couple of imported pressings tended to have a somewhat higher charge than average.

No, we were told, disc formulations were not necessarily uniform. The PVA/PVC ratio may vary from one source to another, as may also the content of lubricant and carbon black. In fact, some manufacturers eliminated the carbon black altogether, using a dye, instead. Most Australian pressings would use a similar formulation but some overseas pressings may well use a different mix, possibly with a different behaviour pattern in terms of static

## NEW SONY DIGITAL AUDIO SYSTEM



At a recent function in Sydney, Sony (Australia) Pty Ltd officially introduced their range of PCM digital audio equipment.

At the heart of the range are two "Digital Audio Processors" which can virtually transform audio signals into a TV signal format capable of being recorded on hard video recorders, with all the performance potential of a modern digital system. The PCM-100 is intended for use with the Sony Betamax or U-matic video cassette recorders, while the PCM-1600 can take advantage of professional level machines. Another interesting unit is the PCM-3224, a fully self-contained 24-channel digital audio recorder.

Other ancillary items include a Digital Editing Controller, a Digital Sampling Rate Converter, and a Digital Reverberator, as pictured above. With this equipment and other back-up facilities which may be available to video equipment operators, a highly sophisticated approach to audio recording and processing becomes available, combined with state of the art specifications.

Included in the literature, also, was a leaflet on the Sony DAD-1X Digital Audio Disc System. While still in prototype form, it indicates the way in which Sony can move when the time for launch is considered appropriate.

For further details: Mr Gary Beauchamp, Sony (Australia) Pty Ltd, 453 Kent St, Sydney, 2000. Phone (02) 2 0221, Ext 314.

charges. Add to this differences in packaging materials and there is obvious scope for variation from one brand of disc to another.

But Harry Mauger went on: "Static charges don't just involve records.

"They involve the weather, the en-

vironment, people (including) our operators, their clothing — and even how they wriggle their bottoms on the stools!"

He went on to outline a case where a customer returned a record to the Astor factory with a bitter complaint that it was "a brand new record, subject to awful crackles". Tested in the factory, there was no sign of untoward noise but, when returned to the customer's home, it behaved as alleged. Perhaps, significantly, the listening room was heavily carpeted, generously heated and probably very dry.

Which brings us to another important consideration:

A large proportion of the Australian population (including audiophiles) live along the coastal fringe where, on average, the humidity level is reasonably high, even allowing for a modest degree of heating or air conditioning at various times during the year. It is in this environment that records are stored and used.

Add a fairly high proportion of natural fibres in carpets, furnishings and clothing and the overall environment is not all that provocative in terms of static electricity. These remarks would certainly hold for the writer's home and those of the staff members whom we questioned. Ordinary care is



The Permastat "anti-static record preservative kit". It contains the liquid, a spray fitting and a pad which is used to buff the record surface.



# ARLEC

## Why Build Your Own Power Supply?

When we can supply you with an approved plugpack ready to connect to your equipment.



# plug pack

### AC ADAPTORS

Plugpacks are a convenient means of powering extra-low-voltage, and battery-operated, equipment from AC mains. Self contained they plug directly into the mains power socket.

Available in 6 different sizes, plugpacks can be custom-built for a wide variety of applications including:





**Battery chargers** for nickel-cadmium & lead acid batteries etc.

**Battery eliminators** for calculators, tape recorders, cassette players, radios, flash guns, electric tools and other battery operated equipment.

**Power supplies** for amplifiers, tuners, electric shavers, digital clocks, electric toys etc.

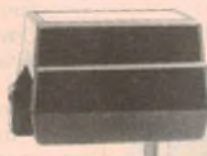
Whatever your requirement we can design a plugpack to suit you, including your own brand name.



62 x 42 x 42mm  MICRO	67 x 51 x 42mm  MINI	75 x 48 x 44mm  MIDI
70 x 48 x 45mm  MULTI	95 x 52 x 50mm  MAXI	95 x 52 x 60mm  MAXI PLUS

Each plugpack is supplied with a 3 metre lead and connecting plug of your choice.

#### Stock models include:

4, 6, 8 & 12V AC  
3, 4.5, 6, 7.5, 9 & 12V DC  
with outputs up to 18VA

**Custom-built models** to your own specification:

- Manufactured to Australian Standard C126.
- Models to Telecom specifications.
- S.E.C. approved.
- Really low prices.
- 12 month guarantee.

TECHNICAL SPECIFICATIONS AVAILABLE ON REQUEST.

## A READY-MADE AND APPROVED POWER SUPPLY COULD SAVE YOU A LOT OF TIME, TROUBLE AND EXPENSE.

# ARLEC

QUALITY PRODUCTS

## A+R ELECTRONICS PTY. LTD.

A MEMBER OF THE A+R-SOANAR ELECTRONICS GROUP  
30 Lexton Road, Box Hill, Vic., 3128, Australia. Telex: 32286.

VICTORIA: 89 0661  
N.S.W.: 789 6733  
S.H. AUST.: 51 6981  
QUEENSLAND: 52 5421  
WEST AUST.: 381 9522  
HONG KONG: (3) 89 1271



## THANKS TO TEAC, MUSICIANS CAN NOW "DO THEIR OWN THING!"

sufficient to ensure substantially noise-free sound reproduction.

But such conditions are not universal. In many parts of Europe and America, the prevailing humidity is notably low and premises are continuously heated for many months of the year. Even in Australia, where premises are permanently air-conditioned and dehumidified, the whole environment will be drier and more conducive to electrostatic effects.

In short, there is a number of reasons why some audiophiles are really bugged by static charges and dust on their discs, while others are scarcely aware of the problem.

As we have already suggested, the latter group can generally manage quite well with dry cloths, brushes, dust-bugs etc — plus care and commonsense. It is as the problem mounts that the inadequacy of some of these measures may become evident — and are criticised as a result!

This situation has led to the release of various fluids and "goos" which can be applied to record surfaces with the idea of counteracting static charges and maybe lubricating and preserving the surface as well. However, while it would be inappropriate to group and to damn all these products in one sentence, there is also a tendency on the part of audiophiles to suspect any "Wet" treatment which leaves a discernable residue in the grooves.

If I might quote Harry Mauger again: "We apply these things to a sheet of glass and let them dry. If you can write your name in what's left, we tend not to like it!"

Availability of the Field Mill makes it possible to check on the validity of claims for all anti-static treatments — whether they neutralise static effects completely, partially temporarily, or not at all. Or whether there is justification in the claims of some who contend that sweeping the surface of a disc with some so-called "anti-static" products actually increases the surface charge!

While preparing this article, we were given a copy of a lengthy report from the Leonard Feldman Laboratories (in Great Neck NY, USA) commissioned by Milty Products of Cheshire, UK. The report parallels material which was published subsequently by Feldman in "Radio-Electronics" magazine, and concerns tests carried out with the Milty Company's "Permostat" anti-static record preservative.

Feldman confirmed that treatment with Permostat lowered the average static charge on a typical disc from 2000V to 0V, and that it remained consistently at 0V after 100 playings and after normal storage in its jacket for 10 days, and subsequent removal. Further

(Continued overleaf)



Professional musicians, wishing to "jot down" a tune or experiment with arrangements can do so, on the spot, with the aid of TEAC's new "Portastudio". With full mix, record, mix-down and playback facilities in-built, it can turn any apartment into an instant recording studio.

Although heavily involved in their TASCAM professional recording equipment, TEAC engineers have recently turned their attention to the needs of creative musicians. As a company engineer explained to a press gathering at the Sydney Hilton, musicians often want to jot down tunes or experiment with arrangements at odd times and odd places — whenever an idea grabs them! They need adequate facilities, but in a portable and inexpensive form, and with a minimum of external patching and cabling.

TEAC'S response has been to develop the M-144 "Portastudio". The "Porta" part of the name is explained by its modest dimensions (460 x 117 x 370mm) and by its modest weight (9kg). Yet, within that size, it manages to combine a 4-channel mixer with full metering, bass and treble controls for each channel, and multiple input/output resources. A 4-track tape recorder is also in-built, with the potential to record, play back, dub and mix up to ten takes for the final ensemble sound.

The mixer will handle any combination of mic, line and instrument inputs, with provision for track-track dubbing, pan and mix-down for 2-track stereo, multi-role headphone monitoring and outputs for external devices such as an extra tape recorder and an echo generator. Performance specifications are entirely adequate for the role envisaged.

The in-built recorder is based on the compact cassette format but with two important modifications: traverse speed is doubled to 9.5cm/sec and the special head assemblies trace four tracks simultaneously across the full width of the tape. With the increased speed and with Dolby-B operating for all functions, the S/N ratio is quoted as 50dB (weighted), response 30Hz to 15kHz, and crosstalk 50dB at 1kHz; with an adjacent track in record mode, it is 15dB. Wow and flutter is quoted as less than .05% weighted, overall (record and playback).

Other facilities mentioned on the leaflet include: pause; punch-in recording; tape counter/memory; Simul Sync monitoring circuit. The whole idea, according to TEAC, is to provide musicians with a facility which will allow them to compose, rehearse and experiment at their leisure. They can end up with a tape which will adequately present their ideas to a promoter, or record producer.

"Why not metal tape and full playing time?" we asked.

"Because metal tapes are expensive and, for experimenting with single numbers, musicians don't need long playing time. It's more appropriate to keep items separate on conventional, quality tapes."

"And why Dolby, when dbx might have offered better S/N ratio for multi-tracking?"

"Because with six active channels involved, the cost of dbx processing would have distorted the price structure of the unit. In practice, Dolby-B is adequate."

For further information: TEAC Aust Pty Ltd, 165 Gladstone St, South Melbourne 3205. Tel (03) 699 6000.



# Don't miss this

## PROJECTS and CIRCUITS No. 2

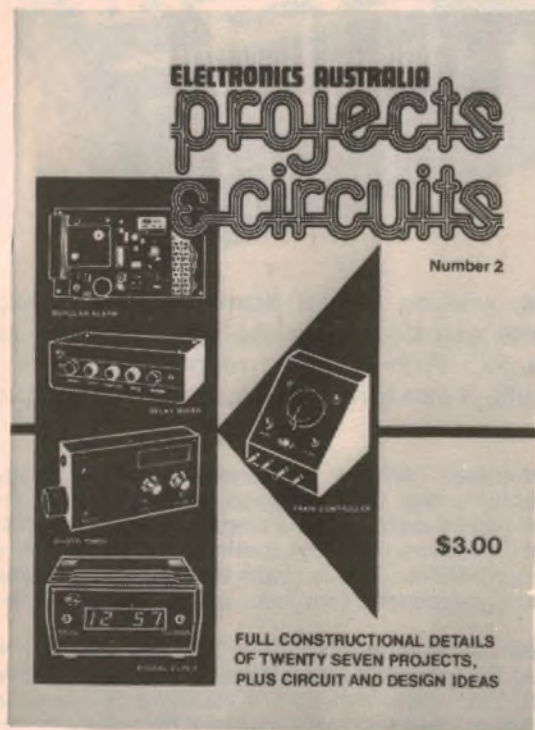

### 27 DO-IT-YOURSELF PROJECTS FROM "ELECTRONICS AUSTRALIA"

*You can't afford to miss out on this exciting new book from "Electronics Australia". Here are just a few of the projects it contains: remote TV headphones, multi-band vertical aerial, roulette wheel, radar burglar alarm, model train control, voice-operated relay, transistor tester, water level alarm ... plus many more. Get your copy now!*

Available from:  
"Electronics Australia", 57 Regent St, Sydney.  
**PRICE \$3.00** OR by mail order from "Electronics Australia", PO Box 163, Beaconsfield 2014. **PRICE \$3.60.**

## HIFI TOPICS — continued

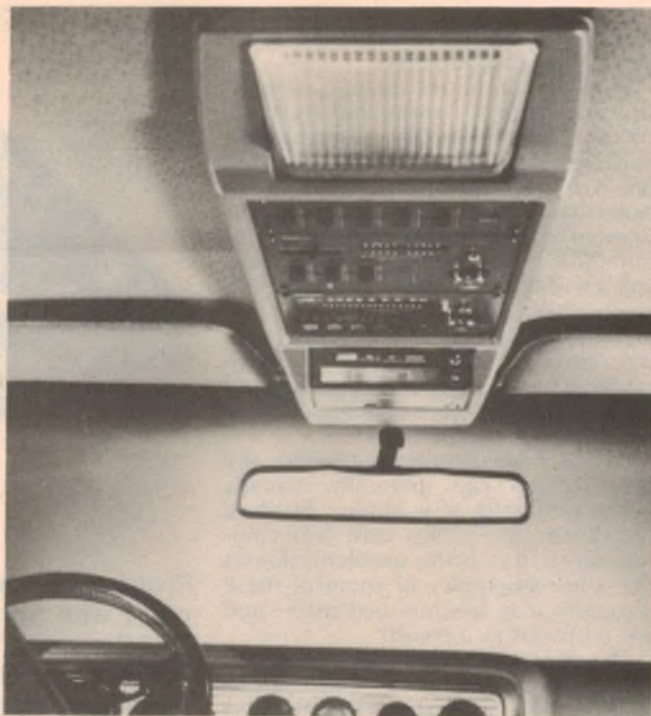

*With his parcel of copy and pictures for last month's show report, George Tillett enclosed these two photographs endorsed simply "How's this for your Rolls?" (My Rolls!) They show Panasonic's new RM-610 "Cockpit" overhead stereo console.*



### Zapp, crackle and pop — continued

observation, up to the time the report was delivered gave no hint of any new charge build-up.

No less important, extensive comparisons of treated and untreated discs, up to 100 playings, showed no loss of playback quality, in either objective or subjective assessment, as a result of treatment with Permostat. On the contrary, the treated disc emerged from the 100 playings in better shape than its counterpart, with less burnishing of the very high frequency components and with certainly less noise due to airborne dust particles.

Stanton Magnetics Inc have also conducted their own tests with Permostat and are now marketing it in the United States. In Australia it is being marketed by Concept Audio Pty Ltd.



Permostat comes in a kit containing a 3oz bottle of a clear, slightly greasy liquid, a spray attachment, a hand buff and adhesive labels to distinguish treated discs. When the liquid is used up, a "refill" provides a new bottle at somewhat less cost than the original kit.

In use, a new or freshly cleaned disc should be laid on a clean surface and sprayed, as evenly as possible, with about eight squirts of Permostat. It is then buffed for about 30-40 seconds to distribute the liquid and until all visual trace of it has disappeared. The other side is treated similarly. The disc should then remain static-free for a lengthy period and should not spontaneously attract or retain dust particles.

Yes, there is a catch: at the moment, Permostat is not a cheap product.

In December, last, the UK price was quoted as £4.65 for the kit and £3.15 for a refill — with one bottle providing sufficient liquid to treat 25-30 discs, both sides.

The current price in the U.S. is \$19.95 and \$15.96, which runs out at about 67c per disc from the kit and 53c per disc using refills.

Which lends point to our earlier remarks: if you're not one of those troubled by static and noise, you won't be lining up for Permostat at its present price.

But, if your record playing is punctuated by lots of Zapp, crackle and pop, you probably won't begrudge the 60 odd cents necessary to buy some silence!

And where do you get it? Try your local hifi dealer but, failing that, get in touch with Concept Audio Pty Ltd, of 22 Wattle St, Brookvale, NSW. Telephone (02) 938 3700. Recommended retail price for the complete kit is \$15.95 and \$9.95 for the refill.

## IN BRIEF . . .



**SANSUI ELECTRIC Co Ltd** have added a receiver to their range, model G-7700, which features what they describe as the "World's first digitally quartz-locked tuning system". While the tuning system uses a conventional knob and dial, it references to an internal quartz-locked signal, such that it remains locked on the precise frequency displayed on a digital readout. With the G-7700, tuning error and drift should be things of the past. The power amplifier features DC coupling and state of the art facilities and specifications. Power output is 120W RMS per channel (both driven) with harmonic and intermodulation distortion

below 0.025%. Hum and noise from phono input is -78dB (IHF) and RIAA compensation within +&- 0.2dB. For further information: Vanfi (Aust) Pty Ltd, 162 Albert Rd, South Melbourne 3205. Tel. (03) 699 5473.

**HARMAN AUSTRALIA** Managing Director, Mr Bill Martin, has advised from Chicago that Harman Kardon Inc has been sold by Beatrice Foods Co to the Shin-Shirasuna Electric Corp of Japan. In fact, Shin Shirasuna manufacture the present Harman Kardon range and now plan to expand it with additional products, including a new Citation range. The same design team, with Dr Matti Otolu, will design the new products.

Harman Australia will continue to distribute Harman Kardon.

**AUDIO TELEX COMMUNICATIONS** Pty Ltd have purchased new premises and are now located at 1 Little St, Parramatta, near Sydney. Their telephone number is (02) 633 4344.



They began operations in Milsons Point, NSW, in January 1976 marketing the Telex (USA) range of broadcast, educational and industrial products and the Bogen (USA) range of public address and professional audio. During the past three years, the company has established branches in Melbourne and Brisbane, and added to their range Telex compact cassettes and DI series public address amplifiers, both manufactured in New Zealand. Telex general Manager Rod Craig says that the new premises should meet their needs for the next 10 years, their trade service counter already having proved very popular. Audio Telex also represents Switchcraft components, Hy-Gain antennas, Astatic microphones and Nortronic heads.

**ETONE PTY LTD** have a new range of high power speakers for professional P.A. and musical instruments. Model 801 is a 38cm super high efficiency type for use in horn loaded cabinets, while the 805 is for use in vented systems requiring high efficiency and extended bass. The 807, also 38cm, has an aluminium voice coil and extended response to suit musical instruments. All the above use ceramic magnets and 100mm voice coils. Other drivers in the range include the 38cm model 484 for bass guitar and the 40W 15cm model 601 for use in multiple driver arrays. (53 Stanley St, Peakhurst 2210).

# Rapar

## PUBLIC ADDRESS AMPLIFIERS YOU CAN DEPEND ON



### TPA 50

Specs.  
**RMS power, 25 watts.** Frequency response: 50Hz to 15kHz (+3dB at 8 ohms). Multiple outputs: 4, 8 and 16 ohms. 70 and 100 volt lines. Inputs: Mic. 1, 47k ohms. Mic. 2, 600 ohms. Aux. 300mV, Phono 2.5mV.  
Size: 310mm (width), 230mm (depth), 80mm (height). Weight 3.8 kilos. Finish: Durable two-tone baked enamel.

**\*\$146.97**



### MODEL TPA 70

Specs.  
**RMS power, 50 watts.** Frequency response: 50Hz to 15kHz (+3dB at 8 ohms). Multiple outputs: 4, 8, 16 ohms, 70 and 100 volt lines. Inputs: Mic. 1, 47k ohms. Mic. 2, 600 ohms. Aux. 300mV, Phono 2.5mV.  
Size: 310mm (width), 230mm (depth), 80mm (height). Weight: 4.3 kilos. Finish: Durable two-tone baked enamel.

**\$183.60**

**TRADE AND DISTRIBUTOR ENQUIRIES WELCOME**

MANUFACTURED BY:



# RADIO PARTS GROUP

562 SPENCER STREET,  
WEST MELBOURNE, VIC. 3003.  
TEL. (03) 329-7888.

1103 DANDENONG ROAD,  
EAST MALVERN, VIC. 3145.  
TEL. (03) 211-8122.



# ELECTRONIC HARDWARE



Silicon Valley announces the Waldom Electronics range of electronic hardware now available in Australia for the professional and hobbyist. Nearly everything you need.

Solderless terminals — solder lugs, snap button hole plugs — solder lugs (locking type) — rubber bumpers — vinyl grommets — wire



connectors — metal cable clamps — nylon flat washers — butyrate cable clamps — round fibre spacers — quick disconnect devices — knife type quick disconnects — snap plugs — nylon speedy tys.™ A wide variety of connector packages and designer kits and tooling switches and much more.

**Ex. stock**

## silicon valley

**Silicon Valley Mail Order:** PO Box 898, Crows Nest 2065, N.S.W., Australia. Telephone: (02) 439 4655. Telex: AA 22846.

**Sydney:** 23 Chandos Street, St. Leonards.  
Telephone: (02) 439 2965.

**Melbourne:** 208 Whitehorse Road, Blackburn.  
Telephone: (03) 877 5311.

**Adelaide:** 170 Sturt Street, Adelaide.  
Telephone: (08) 51 4080.

**Brisbane:** 22 Ross Street, Newstead.  
Telephone: (07) 52 1339.

380 Bridge Road, Richmond.  
Telephone: (03) 429 4780.

**Auckland:** 7-9 Kirk Street, Grey Lynn.  
Telephone: 76 1169.



# Kenwood KA-801 stereo amplifier

Integrated stereo amplifiers with power outputs in excess of 100 watts per channel are now an everyday reality, although they are still impressively large and rugged. One of Kenwood's latest amplifiers is the KA-801, which has a power output of 110 watts per channel with no more than .015% distortion over the range from 20Hz to 20kHz.

There is no doubt that Japan continues to produce really well finished high fidelity equipment. This latest Kenwood is a classic example. From its immaculately finished satin-aluminium panel to the large multi-detented volume control knob; from the delightfully light and positive action of the toggle switches to the discrete and unobtrusive illumination of the meters — it all speaks of a refined product.

The Kenwood KA-801 is also a fairly large and heavy product, with overall dimensions of 440 x 153 x 407mm (W x H x D) including knobs, feet and rear projections. Mass is a hefty 17.5kg.

Rotary controls are provided for input selector, tape monitor, mode, bass, treble and balance controls, the speaker selector and of course, the volume control. As well, there are five toggle switches for Power, Attenuator (-20dB muting), Loudness, Tone control defeat and DC Coupling (on/off).

There are two power meters, which are calibrated over the range from .001 (one milliwatt) to 200 watts into assumed eight-ohm loads. However, our tests indicated that they are not particularly accurate or fast responding, which means that they are little more than panel decoration.

On the rear panel, there is the usual array of RCA output sockets together with a DIN socket for tape deck connection. But separate preamplifier outputs and power amplifier inputs have

been omitted from the KA-801, which is a little surprising for an amplifier in this price range.

Loudspeaker connections are made via shrouded binding post terminals, which are a good safety feature. They minimise the chance of shorted connections and also isolate the user from the relatively high output voltages (potentially 30 volts RMS or more).

One feature which we would prefer to see omitted from the rear panel is the two-pin mains sockets. These may be satisfactory for 110V systems in the USA, but are not recommended by local authorities for 240VAC mains.

We noted that the service manual for the KA-801 indicates that Kenwood produce a version of this amplifier for the UK market which does not have these sockets. In our opinion, this model would be more suitable for Australia (when fitted with three-core plug to suit) than the model presently marketed here. We have made a suggestion along these lines to Trio-Kenwood (Australia) Pty Ltd and they have indicated that "they will look into it".

As a final comment on the rear panel features, we liked the mounting feet-cum-stops which allow you to "up-end" the amplifier without damaging any of the connections. The stops should also prevent plugs and sockets from being damaged when the amplifier is pushed against the wall behind it.

Removing the cover of the amplifier reveals a neat interior with quite a few engineering innovations — all of which appear to be aimed at reducing the wiring (and hence labour content) in the unit. The only PCB actually visible in the interior photograph is that for the power supplies and power output stages.

This large PCB accommodates four large (10000uF/63VW) filter capacitors for the dual power supplies. The weight of the capacitors is actually supported by mounting brackets. Also on this PCB is the amplifier protection relay, controlled by an IC which monitors for DC offset in the amplifier outputs and line voltage. The same IC also has inputs for monitoring thermal overload and signal overload, although these are not used in the KA-801.

Massive heatsinks on either side of the amplifier chassis accommodate the four parallel-connected output transistors in each channel. These demonstrably rugged transistors are interesting in that they are large plastic encapsulated units with a mounting base roughly equivalent in area to the conventional TO-3 power transistor.

The prior stages of the power amplifiers, plus circuitry for the tone controls and power meters, is accommodated on a large PCB mounted immediately behind the front panel. All the circuitry for the phono inputs and other inputs is on a third PCB mounted off the RCA sockets on the back panel. The Input Selector and Tape Selector switches are actually on this rear PCB and are operated via flat cables.

In the same way, the Speaker Selector switch is actually operated via an extension shaft which runs right through to another back panel PCB accommodating all the speaker terminals —

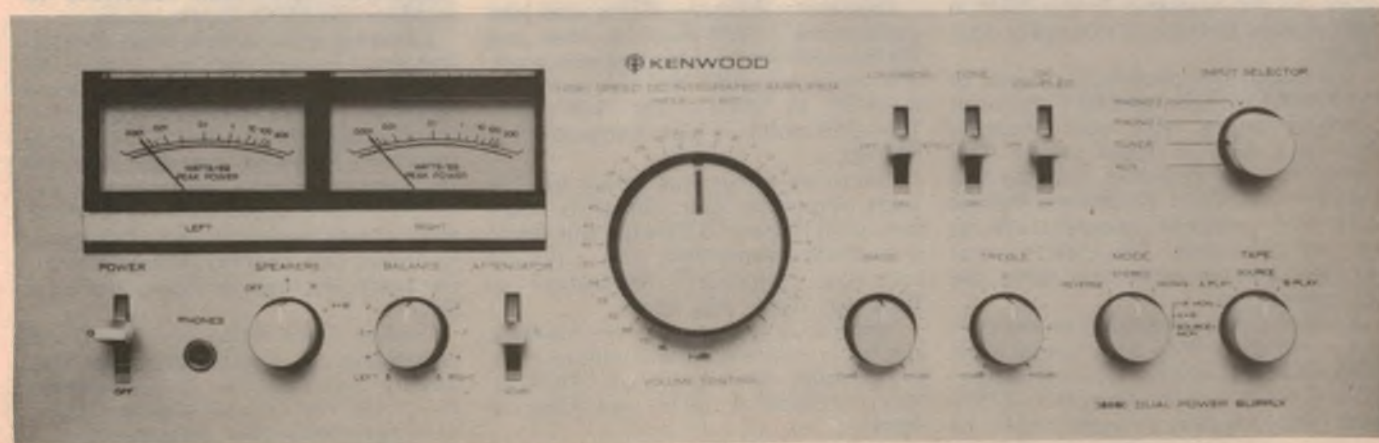



## KENWOOD KA-801 STEREO AMPLIFIER

there is no speaker wiring as such.

A general comment which can make about the KA-801 is that it has perhaps the most complicated circuit we have seen. For example, the discrete phono preamplifier uses no less than 14 transistors in each channel. By contrast, the complicated (in principle) tone control circuit, which uses a combination feedback and passive RC network, employs only one IC in each channel.

The power amplifier circuit is very complicated and uses no less than 20 transistors in each channel. This includes the dual FET input stage, accompanying cascode dual NPN stages and following differential pair. The output stages are fully complementary.

Kenwood boast that their KA-801 has DC response from the Auxiliary inputs to the outputs. This is true if the tone controls are switched out of circuit by the Defeat switch. The phono preamplifier is also DC coupled from the input, but has a capacitor at the output. We cannot really see the reason for this but Kenwood justify it, in the owner's manual by stating that "The phono input employs one AC coupling device (a capacitor) but this does not affect the operation of the DC coupled equaliser and power amplifiers that follow, since magnetic phono cartridges do not respond to static stylus pressure". We agree with this entirely but it seems that, with this one sentence, Kenwood have demolished their own arguments in favour of DC amplifiers.

Whatever the arguments in favour of DC amplifiers it is apparent to us that the KA-801 (like other similar amplifiers) needs a sharp cut-off filter for frequencies below, say, 20Hz. We agree that this would tend to make nonsense of DC coupling (so be it) but as it is, the amplifier responds to every ripple in the record surface and the loudspeaker cones can dance about alarmingly as a result.

We admit that the DC coupling switch on the front panel (which inserts one capacitor in each channel) does taper off the response below 18Hz at 6dB/octave, but this is not really adequate.

We began our performance tests of the KA-801 with the standard one-hour preconditioning, with both channels delivering 40% of rated power. This resulted in the heatsinks rising to and stabilising at about 70 degrees Celsius with the ambient temperature at around 20 degrees. This indicates that the heatsinks are more than adequate for normal use.

Kenwood rate the KA-801 power output at 110 watts RMS per channel, with both channels driven into eight-ohm loads for a distortion of less than .015% over the frequency range 20Hz to

20kHz.

We measured 128 watts per channel with both driven into eight-ohm loads, at the onset of clipping. With four-ohm loads, the power was 160 watts per channel with both driven. With 16-ohm loads, the power output was 81 watts.

At 20kHz, the harmonic distortion at rated power was 0.05%, being above the specification of 0.015%. The harmonic distortion reduced at lower frequencies until at 100Hz the figure matched that of specification. At half power, the harmonic distortion was

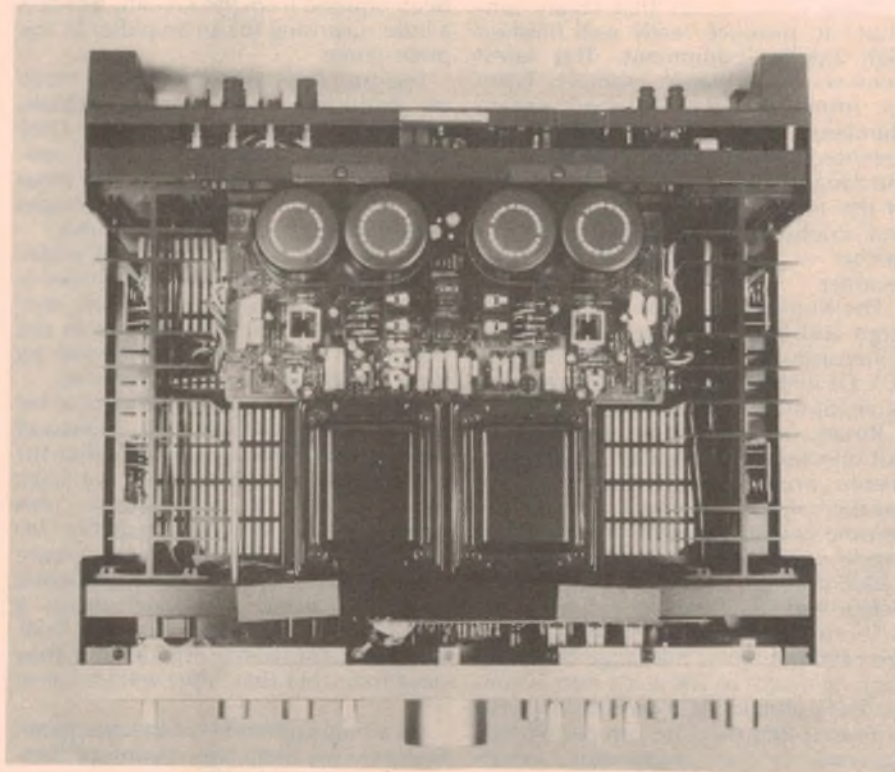

typically 0.03%.

Intermodulation distortion measured with 50Hz/7kHz signals in a 4:1 ratio was 0.03% into eight-ohms, much higher than the specification but still very acceptable.

Frequency response at one watt into eight ohms is -1dB down at 30Hz and 70kHz, with the DC coupling switch off. The response with the DC switch is from DC to 70kHz at the -1dB point. The -3dB point at high frequencies is 400kHz.

Phono sensitivity was 2.8mV for 100 watts output at 1kHz. Signal to noise ratio with respect to 10 watts and 10mV with 69dB unweighted, with a typical cartridge connected. Separation at 1kHz was 70dB. Very good.

Signal to noise ratio for the auxiliary and tuner inputs was 80dB with respect to 10 watts. Separation was 47dB at 10kHz, 65.5dB at 1kHz, and 73dB at 100Hz.

The tone controls provide  $\pm 7.5$ dB of boost and cut at 10kHz and 100Hz, which agrees with the specifications but does not agree with the calibrations on the front panel. The amount of boost and cut is fairly modest when compared to most amplifiers, but Kenwood have modified the contours from those of conventional circuits so the tone controls appear to be quite effective in practice. In any case, it is probably wise to restrict the amount of boost and cut available in a powerful amplifier.

RIAA equalisation is rated at within  $\pm 0.2$ dB from 20Hz to 20kHz and we measured the limits as  $\pm 0.2$ dB from 50Hz to 20kHz, which is still a very tight specification.

Slew rate of the amplifier exceeded the specification of  $\pm 150$ V/ $\mu$ second. The rise time was also less than the specification of 0.8 microseconds. The performance is therefore more than sufficient to produce excellent square waves.

Listening tests confirm what the performance figures indicate — that the KA-801 is a really high performance amplifier. In fact, many of the performance parameters, such as frequency response, rise-time and slew rate, are far beyond what is required for excellent audio reproduction. For those who are prepared to pay the price, Kenwood can certainly deliver the performance. Recommended retail price is \$759.

Further information on Kenwood equipment can be obtained from high fidelity retailers or Trio-Kenwood (Australia) Pty Ltd, 30 Whiting Street, Artarmon, NSW 2064. (LDS and JC).



# WE'LL GET YOU INTO ELECTRONICS. ONE WAY OR ANOTHER.

At International Correspondence Schools, we have at least 15 career courses you can take in electronics and other inter-related fields, like computers and television. These are the fields of the future that you *should*

progress in now. And they are all ideally suited to home study. And ICS, being the largest institution of its kind in the world, has access to the latest world-wide developments and among the best teachers Australia has to

offer. So, if you're interested in one or more of the courses below, mail the coupon to ICS, and we'll send back everything you need to begin a more successful career.

**1 Basic Electronics** course for a sound knowledge of radio theory and the industrial applications of electronics.

**2 Electronic Technician** course, with specialist courses in Audio, Radio, Hi-Fi; Communications/Broadcasting; Electronic Computer Servicing; Industrial Electronics.

**3 Electronic Instrumentation and Control Systems** course for electronics technicians interested in industrial instrumentation and control.

**4 Electronic Technology**, a program that will fit the ambitious technician for wide variety of jobs.

**5 Electronics Maintenance** for basic principles and electronic theory, followed by a practical section of maintenance procedures and techniques.

**6 Radio Electronic Telemetry** covers electrical and electronic aspects of telemetering. Employment opportunities abound in this very modern field.

**7 Amateur Radio Operator's Certificate of Proficiency** prepares you for the examination



leading to the Certificate of Proficiency issued by the Postal and Telecommunications Department.

**8 Data Processing**, various courses including Electronic Computer Servicing.

**9 TV Servicing** courses, in black and white, and PAL colour.

**10 TV Principles** course for basic television technology. And TV engineering course for complete practical coverage of television engineering.

**11 Basic Electrical Engineering** is especially for those who want to make a start in the industry or want a broad technical knowledge.

**12 Electrical and Electronic Drafting** is designed for experienced draftsmen wishing to enter this specialised field.

**13 Automobile Electrician** gives you the basics of servicing the automobile's electrical system.

**14 Industrial Electrician** course gives comprehensive training on all aspects of the electrician's work.

**15 Electrical Mechanic** course prepares you for external examinations.

Please send me, without cost or obligation, information about the ICS courses in Electronics.

Mr/Ms.....

Address..... Phone.....

Postcode..... Occupation..... Age..... Tick here if currently full time student

Write to your nearest ICS city:

# ICS

**International Correspondence Schools**

**Sydney:** 400 Pacific Highway, Crows Nest, N.S.W. 2065. Tel.: (02) 43 2121.

**Melbourne:** 18-20 Collins Street, Melbourne, Vic. 3000. Tel.: (03) 63 7327.

**Perth:** G.P.O. Box D157, Perth, W.A. 6001. Tel.: (09) 321 8530.

**New Zealand:** 182 Wakefield Street, Wellington.



244106

Bankcard



# Electronics: the FUN WAY!

At last, there's a book that treats electronics as the really enjoyable hobby it is!

It's called 'Dick Smith's Fun Way Into Electronics' – and it's the ideal introduction to electronics for all ages – from 5 to 95.

Dick Smith's Fun Way uses a unique 'breadboard' wiring system that needs no soldering – so it is safe and each project has easy, step-by-step instructions that anyone can follow.

There are twenty exciting projects to build, from continuity checkers to radio transmitters – even a beer-powered radio receiver!

Electronics is fun. Have fun with Dick Smith's Fun Way into Electronics.

- **SAFE**
- **SIMPLE**
- **ECONOMICAL**
- **FUN!**
- **ONLY \$4.95**
- **NOW AVAILABLE**

**SCHOOLS, COLLEGES, BOOK SHOPS, NEWSAGENTS, ETC.** Ask about our incredible discounts for bulk orders (10 copies or more) of this book. You'll be pleasantly surprised!

## And to help you get started:

**Save money with 'Fun Way' kits!** The components used in the Fun Way book are all common, easy-to-get types. But you can save by buying the kits from Dick Smith: We have assembled two kits which contain brand new, guaranteed components. You save up to 1/3 on the cost of individual components!

**SAVE MONEY – BUY THE KIT!**

### KIT 1: FOR PROJECTS 1 – 10

Build the first ten projects with these components – even includes the baseboard to assemble them on. You can make light flashers, Morse communicators, transistor checkers, continuity indicators, etc etc.

Contains: One particle board, 28 self tapping screws & washers, 1.7m wire, speaker, battery clip, 23 resistors, light dependent resistor, one diode, two LEDs, two transistors, 7 capacitors.

**\$6 90**

Cat K-2600

### KIT 2: FOR PROJECTS 11 – 20

This kit contains slightly more specialised components which, with the components in kit 1, will enable you to make the last ten projects, including radio receivers & transmitters, audio amplifiers, etc.

Contains: 10 capacitors, one variable capacitor, one potentiometer, one resistor, one signal diode, one integrated circuit, one ferrite rod aerial, one crystal earphone, one audio transformer and 70cm hook-up wire.

**\$7 50**

Cat K-2610

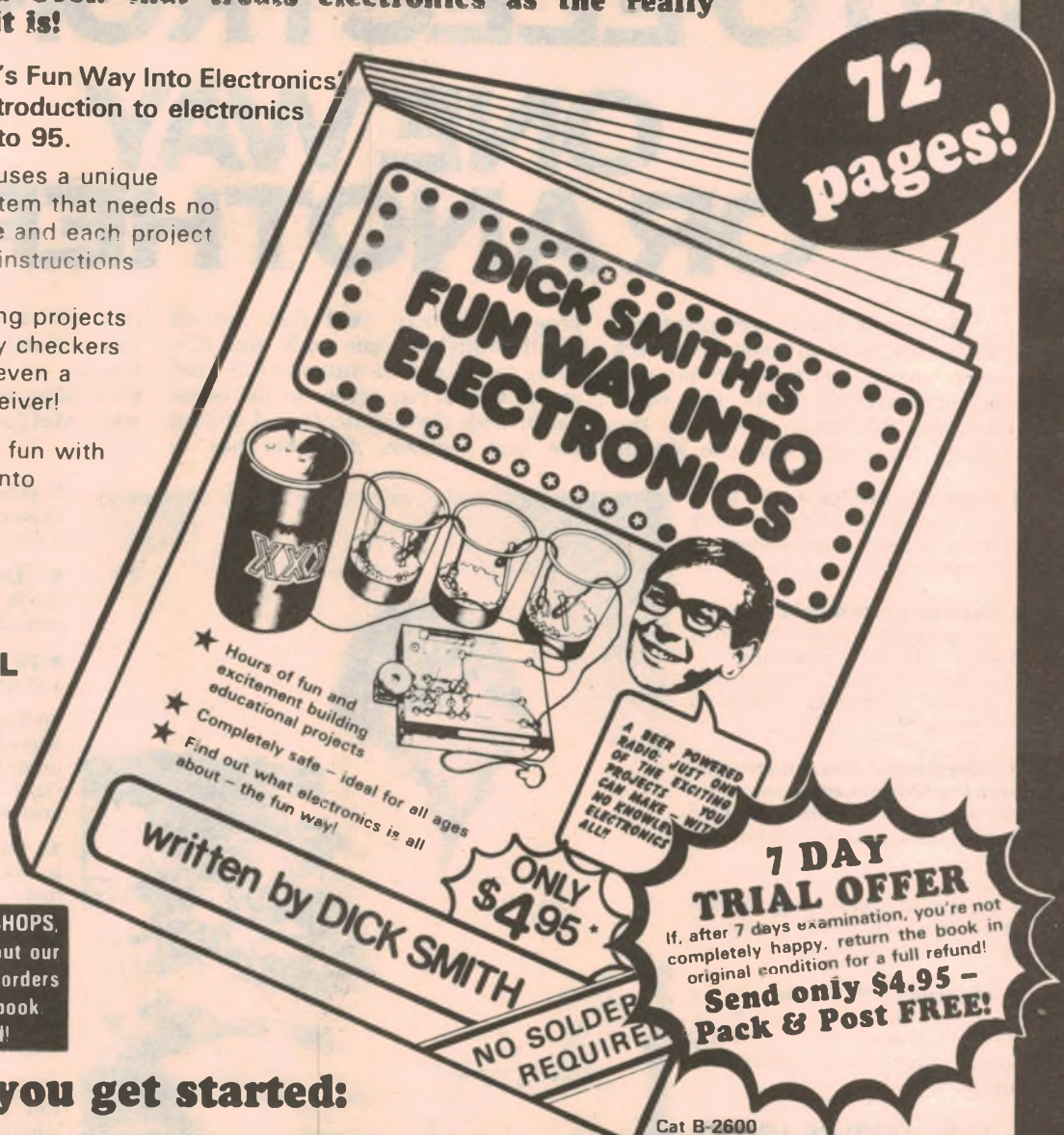

Cat B-2600

# DICK SMITH ELECTRONICS

**NSW** 125 York Street,  
147 Hume Highway,  
182 Pacific Highway,  
30 Grose Street,

**SYDNEY** Phone 290 3377  
**CHULLORA** Phone 642 8922  
**GORE HILL** Phone 439 5311  
**PARRAMATTA** Phone 883 1133

**ACT** 96-98 Gladstone Street,  
**VIC** 399 Lenahole Street,  
856 Bridge Road,

**FYSHWICK** Phone 80 4944  
**MELBOURNE** Phone 67 9834  
**RICHMOND** Phone 428 1814  
**BURANOA** Phone 391 8233  
**ADELAIDE** Phone 212 1962  
**PERTH** Phone 328 6944

263 Keira Street, WOLLONGONG Phone 28 3800

EXCEPT WHERE NOTED, ALL ITEMS SHOWN IN STOCK AT PRICES GIVEN AT TIME OF GOING TO PRESS

**MAIL ORDER CENTRE:** PO Box 321, NORTH RYDE NSW 2113. Ph 888 3200. PACK & POST EXTRA.

**bankcard**  
welcome here

**SHOPS OPEN 9AM to 5:30PM**  
(Saturday: 9am till 12 noon)  
**BRISBANE:** Half hour earlier  
**ANY TERMS OFFERED ARE TO APPROVED APPLICANTS ONLY**  
**RE-SELLERS OF DICK SMITH PRODUCTS IN MOST AREAS OF AUSTRALIA.**







# AUDIO TALK

by LEO SIMPSON

## Strewth it's loud — must be hi-fi!

As I write I have just returned from another press demonstration of the latest in audio technology. These functions are a welcome break from the office routine as they enable us to meet a lot of new people as well as learning about the gear in question.

On this occasion, the demonstration involved the latest Pulse Code Modulation system developed by Sony; it promised to be a really interesting and worthwhile demo. Sony are rightly proud of their pioneer work in this field — they billed it the “most significant technological advance in the 100 year history of sound reproduction.” With a billing like that, how could anybody possibly resist an invitation?

Besides, there was the promise of refreshments and luncheon to be served. This is not to say that I would go just for the opportunity of a “nosh up”.

The first part of the presentation was given by a Japanese audio engineer who apparently is a media personality of some note in Japan. He was a very personable character, who explained that he was not really at home with the English language. Fair enough — My Japanese is lousy. (Ed: Non-existent!)

But then this gentleman proceeded to regale us with a lively sales talk on the benefits of Sony's PCM, for about 15 minutes. All in Japanese. An interpreter would butt in after every few sentences and gives us the English version of the spiel — reading from a prepared translation!

In between trying to ignore the lively Japanese spiel and the fragmented English translation, I did not learn much except that Sony's standard video recorders were used as the basis for the PCM system.

Next came a video tape played on Sony's colour projection system. This purported to explain the idea behind Pulse Code Modulation but instead, it said nothing that the audience would not have known anyway.

Next (it went on and on), one of the

local Sony bods got up and gave a talk which described the various pieces of PCM gear made by Sony. This was alright in itself, but it was supported by a slide demonstration in which some of the slides were flashed onto the screen faster than the shots for a speed reading course. “the Sony PCM-100 . . . flash . . . is compatible with . . .” Duration 15 nanoseconds.

Worse still, every slide was blurred.

Then they came to the Sony PCM disc which is apparently still at the prototype stage. Rather than give a quick technical run-down with a slide or two, the Sony people elected to use an American TV newsreel. This was ghastly, from the smeared colours to the flashy, superficial pizzazz of US TV.

First, a burly all-American male talking through clenched teeth introduced the subject. Then his female cohort, who was an American version of one of our garrulous TV weather girls, took over the demonstration.

She described how the rapidly revolving disc was read by a laser on the underside, which picked up the recorded magnetic pulses. . . . What was that, again? Magnetic pulses read by a laser? Hmm.

While she continued on with her patter, the all-American type is pondering over a sample of the highly polished disc which he is holding. (Thinks: “I wonder how this'd go as a Frisbee. . . .”)

Then they come to the best part. Female turns to a high, wide and handsome Sony stereo receiver to give the audience a sample of the new high wide and handsome stereo sound . . . which presumably the audience hears through the little oval speaker in their TV set.

Now all the foregoing I can tolerate. But the worst had yet to come.

Finally, the demonstration. The first demo used the Sony PCM-100, which is intended to be teamed with the Sony Betamax video cassette recorder.

This used a recording made by the

Sony engineers with the Sydney Symphony Orchestra in the Opera House. The passage we heard was the 4th movement of Beethoven's Ninth Symphony. This was loud, much louder than an actual performance in the Opera House, but I still enjoyed it.

The sound quality was impressive and it was obvious to all that the dynamic range was very wide. But it really was not possible to make an objective assessment of the quality of reproduction. For a start, the room had air-conditioning which makes an inevitable noise contribution; there was a transformer or fluorescent light ballast somewhere which was making its obtrusive contribution during the quiet passages; and they left the projection TV set idling, with screen blanked.

But the main reason why I could not assess the sound quality was that it was just too loud. I was sitting at the front of the audience, with a pair of loudspeaker systems which were almost the size of your average four-drawer filing cabinet only a couple of strides away.

The most intriguing part of the demonstration was the performance of the peak level displays on the PCM-100. These columnar displays appear to be a liquid crystal type. Not only does the height of the column indicate the peak level, but the column itself pushes up a little horizontal bar which “holds” the peak level for a few seconds, before falling down. Very clever.

From observation of these displays during the demonstration it appeared that the program had a dynamic range approaching 70dB. Sony claim that the PCM-100 system has a total range of 85dB. When you consider that the room had an ambient noise level of 45 to 50dB at best, then the peak sound pressure levels must have been quite high.

The silly part of the PCM-100 demo was the fact that the Sony engineers kept fiddling with the volume levels. This makes nonsense of a demonstration which is supposed to display the dynamic range potential to best advantage.

At the end of the musical passage, the Sony engineers apologised for the fact that it was such a long recording and the impossibility of letting us hear the whole performance. So that was the PCM-100 and the Betamax system. And quite impressive too, even if the demonstration was spoiled by a number of factors.

Then they announced that they would next demonstrate the Sony PCM-1600 professional digital recorder, which is teamed with their professional video recorder. This system is superior in several respects to the PCM-100 and has a dynamic range of greater than 90dB. Yes, greater than 90dB.

One of the Japanese gentlemen calmly walked over to the machine, lightly touched a button and then . . .



**OPENING  
NOV, 13, 1979**

# **DWELL ELECTRONICS**

**NEW STORE IN**

**NORTHGATE — HORNSBY**



## **ROCKWELL AIM 65**

AIM 65 is fully assembled, tested and warranted. With the addition of a power supply, it's ready to start working for you. AIM 65 features on-board thermal printer and alphanumeric display, and a terminal-style keyboard. It has an addressing capability up to 65K bytes, and comes with a user-dedicated 1K or 4K RAM. Two installed 4K ROMs hold a powerful Advanced Interactive Monitor program, and three spare sockets are included to expand on-board ROM or PROM up to 20K bytes. (4K assembler, 8K basic optional). An Application Connector provides for attaching a TTY and one or two audio cassette recorders, and gives external access to the user-dedicated general purpose I/O lines. Also included as standard are a comprehensive AIM 65 User's Guide, a handy pocket reference card, an R6500 Hardware Manual, an R6500 Programming Manual and an AIM 65 schematic.

**AIM 65 1K RAM \$525 TAX PAID**

**AIM 65 4K RAM \$570 TAX PAID**

**4K ASSEMBLER IN ROM \$105**

**8K MICROSOFT BASIC IN ROM \$125**

## **OHIO SCIENTIFIC SUPERBOARD II**

**\$392**

Superboard II microcomputer features 8K Microsoft Basic in ROM. Cassette interface. Video interface. Ultra fast 6502 CPU. 256 character set including upper/lower case and 160 graphics elements. 4K RAM on board as standard can be economically expanded.

Requires 5V power supply. RF modulator for TV hook-up, cassette recorder.

### **CHALLENGER IP**

This same microcomputer supplied with a metal case and power supply.

**\$499**

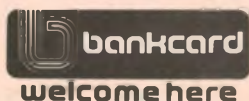

## **DWELL ELECTRONICS**

77 EDGEWORTH-DAVID AVENUE, HORNSBY, NSW 2077

TELEPHONE: (02) 487 3111

SHOP M17 LEVEL 3, NORTHGATE HORNSBY



## AUDIO TALK

the room fell in. Some maniac of a musician started belting hell out of his instruments, while in the left channel, a chorus with acid-etched metre-long vocal chords gave vent to something awful. Pure bedlam.

I clapped my hands over my ears to stop my head imploding and waited for one of the Japanese gentlemen on the other side of these loudspeakers to turn the volume down to something approaching sanity. Nothing happened. At that point I had a decision: either I lunge for the machine to do the job myself, or I leave — quickly.

I shot to my feet, did a rapid about-turn and charged full-tilt for the door. Woe betide anyone who was unfortunate enough to be in the way. Luckily, no-one was. Shortly after, my two colleagues also left, although with not quite such a dramatic exit.

Some time later I understand that the message finally dawned and the volume was turned down. But the damage had been done and the demonstration had failed.

Why is it that so many people think that if equipment has superior performance then it has to be played much louder, to demonstrate the difference? Why is it that such people think loud is beautiful?

Loud is not beautiful and loud is not high-fidelity. Loud is moronic. In fact, in factories today, loud is illegal and cause for a stopwork and Department of Labour and Industry inspection.

I suppose it is understandable that music (?) should be played very loudly in discotheques and similar places. There, the clients don't know any better. But a high-fidelity demonstration should be something different. The loudness should be realistic.

When I sit down to listen to a piano concerto I do not expect to be

assaulted by the sound of a 20-metre long piano played by a team of well muscled athletes wielding rubber mallets. I expect to hear a standard 88-note grand piano played at a realistic level.

Many years ago, before the advent of high power amplifiers and programs with super-dynamic range, a term called "scale distortion" was familiar to high-fidelity proponents. The idea behind this was that if a recording was not reproduced with a sound pressure level similar to that of the original performance, then there would be a problem of perceived tonal balance. This was the justification for "Loudness compensation".

In those days, the problem was insufficient sound pressure level. These days, it seems, the problem is excessive sound pressure level. The result is not incorrect perceived tonal balance, just straight aural overload.

Well, I hope that this account does not mean that I will never receive another invitation to a press demonstration again — particularly from Sony! I am always keen to go to these events. I have been to many worthwhile demonstrations — and more than a few memorable disasters.

The Sony PCM event is by no means unique in that it failed to present the equipment properly. That is a great pity, because there is no doubt that digital PCM techniques will enable great improvements in audio technology particularly because it enables the many steps in the recording process to be performed (such as taping, mixing, editing, etc) without degradation of the signal quality.

None of these advantages became apparent during the demonstration — nor could they, when you come to think about it. But there is no doubt at all that PCM techniques will ultimately displace analog methods of recording.



"I got it cheap. It was only used for a couple of press demonstrations."

## PROJECT BUILDERS

# DON'T RISK IT!

For safety's sake use transformers designed to Australian Standard Codes like Ferguson Transformers

### TWO POPULAR RANGES

#### 20/40/60VA Low Profile

A compact range with ratings from 6 to 40V and a 20VA multi-tap.

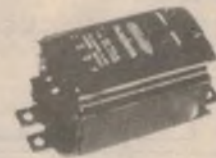

#### 5VA PCB Mounting

Designed to standard 0.1" grid. Double insulated, very compact with ratings from 4.5V, 1.11A upto 40V at 0.13A.



MADE IN AUSTRALIA TO AUSTRALIAN STANDARDS

Available from Electrical and Electronic Stores or write to;

## FERGUSON

FERGUSON TRANSFORMERS PTY LTD  
331 High Street, Chatswood N.S.W. 2067



Now you can build a "no-holds barred" counter

# Intersil ICM 7226 Universal Counter kit

Intersil Incorporated have released a range of universal counter integrated circuits. These ICs contain just about all the circuitry required for a full frequency counter. As promotion for the new devices, Intersil have introduced an evaluation kit which contains most of the components for a frequency counter, including eight LED readouts.

by JOHN CLARKE

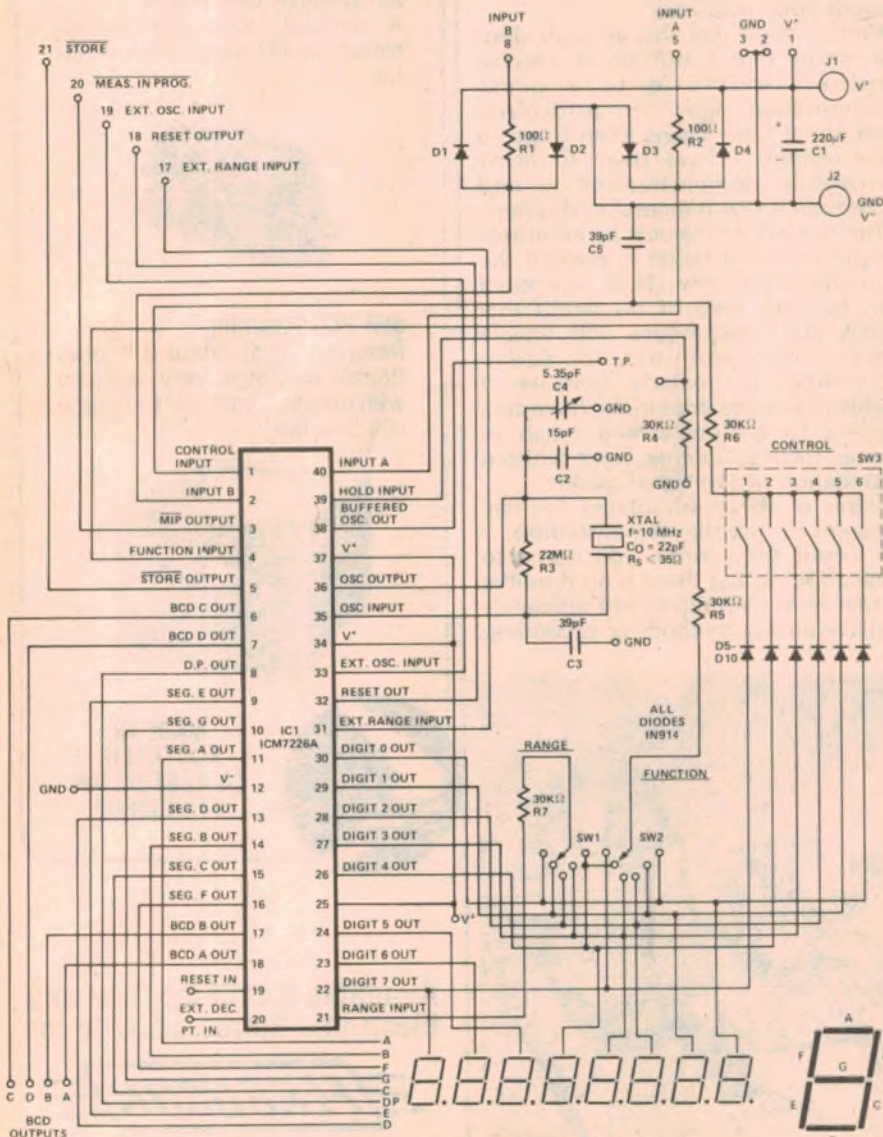

This is the circuit on the Intersil ICM 7226 evaluation kit PCB.

Recognising that it could take some time for designers to become fully familiar with this range of highly complex counter IC's, Intersil decided to give them a boost by producing an evaluation kit, based on the ICM 7226A. This is an eight digit, 10MHz counter IC with leading zero blanking and its own internal timebase circuitry.

Let's discuss the 7226 chip first and find out what it contains and what it can do. Then we will go on to discuss the 7226 evaluation kit and how it can be made up to produce a high performance frequency counter.

The 40-pin 7226 can perform the functions of frequency counter, period counter, unit counter, frequency ratio or time interval counter. As well as measuring frequencies up to 10MHz or more, the 7226 will measure periods from 0.5 microseconds to 10 seconds.

With an eight-digit display, high resolution measurements are possible. In the period and time interval modes, the resolution is a minimum of 0.1 microsecond (ie, the highest resolution) while in frequency mode, the resolution is 0.1Hz, for a gating time of 10 seconds. Gating times can be switched to 0.01, 0.1, 1.0 and 10 seconds.

The 7226 drives the segments and anodes of the LED displays directly, without the need for buffer transistors. The displays are multiplexed, which reduces the number of display output lines required from 72 to 16 (includes decimal point). The multiplex frequency is 500Hz and each display has a duty cycle of close to 12½%. There is also an interdigit blanking period of six microseconds to prevent display ghosting.

The timebase oscillator uses a 10MHz crystal. It is also possible to use an external timebase oscillator which must be 100kHz or higher.

There are two inputs to the ICM7226. The A input is for measurement of frequency, period, unit counting, frequency ratios and time interval modes. The B input is for frequency ratio and time interval. Both inputs require a signal swing of at least 50% of the supply voltage, peak-to-peak, and centred about 2.0 Volts for a 5 Volt supply. Any input 0.3 Volts above the supply will damage the circuit.



# Intersil ICM 7226

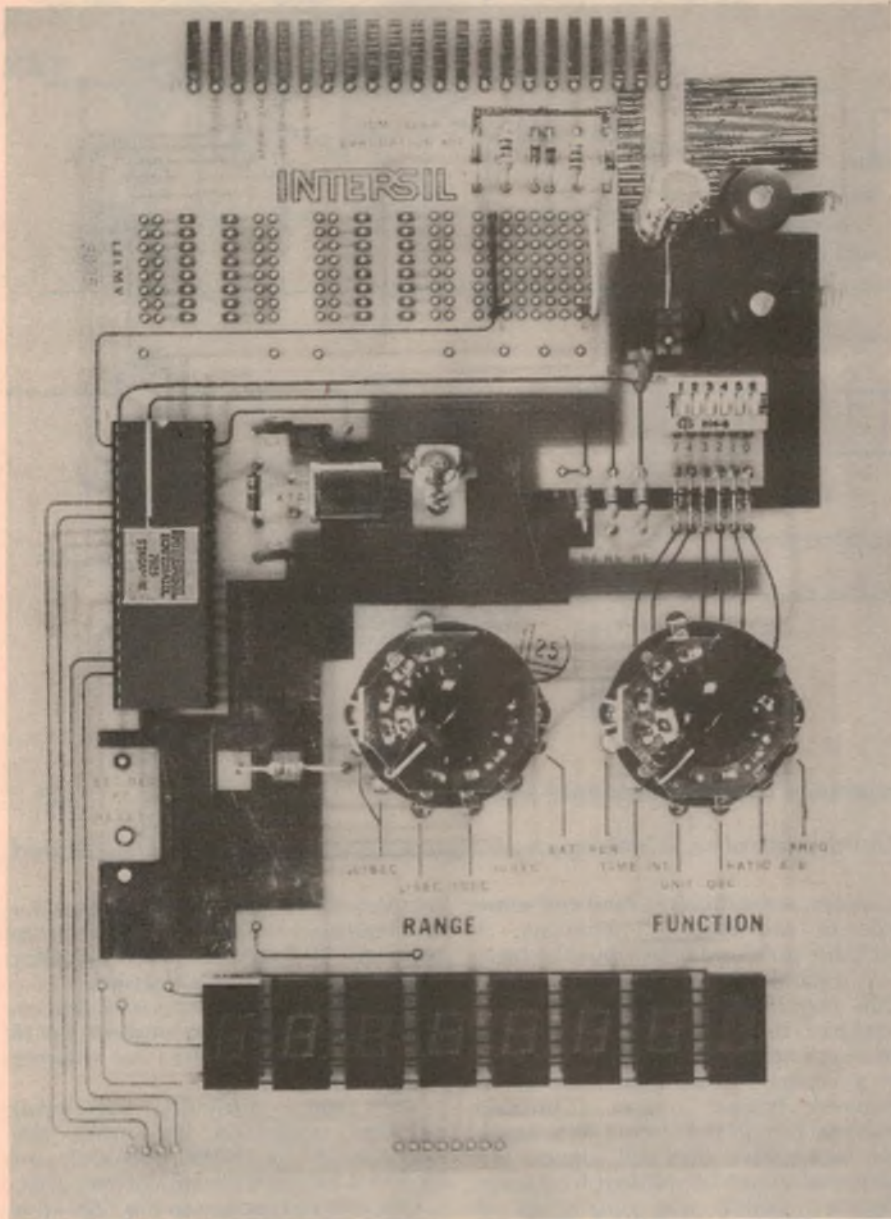

When assembled the PCB looks like this, with a breadboarding area at the top of the PCB.

As well as driving the LED displays, the multiplexed output lines also play a part in the control functions of the chip. Specifically, five input pins are controlled by being connected to a respective digit driver output. For example, by connecting the Function input, pin 4, to one of six designated digit driver outputs, the functions of Frequency, Period, Frequency Ratio, Time Interval, Unit Counter and Oscillator frequency are selected.

The last-mentioned function, "Oscillator frequency" is a checking mode which reads the crystal oscillator — the readout is 10MHz, regardless of the actual crystal frequency.

Another of these five multiplexed

inputs is pin 1, designated the control input. This allows the display to be blanked, tested (displays all eights), 1MHz select (instead of a 10MHz oscillator frequency), and three other specialised modes.

Other inputs controlled in this fashion are the Range input, pin 21, External Range input, pin 31 and the External Decimal Point input, pin 20.

Some of the other outputs provided by the 7226 are BCD outputs (four), a buffered oscillator output, a "measurement in progress" output and a reset output.

Well, that should serve as a brief introduction to the functions of the ICM 7226 universal counter IC.

- SYN-1 Single Board Computer . . . \$210.00
- KTM-2 CRT/TV Keyboard terminal module . . . . . \$349.00
- BAS-1 8K BASIC ROM for SYN-1 . . . . . \$149.00
- BUFFERED MOTHERBOARD for SYN-1, KIM-1 or AIM-65 systems . . . . . \$179.00



- 16K-8 fully tested memory board WRITE PROTECT and BANK switching for SYN-1, KIM-1 or AIM-65 systems . . . . . \$360.00
- EPROM Programmer and EPROM ROM Board MEMORY mapped EPROM programming will program up to 16K per command firmware in PROM included. For SYN-1, KIM-1 or AIM-65 systems . . . . . \$345.00



- AUTOMATIC TELEPHONE DIALER PROM dialling 32 numbers plus other options . . . . . \$180.00



- PRESETTABLE COUNTER 5 digits suitable for counting, batching and numerical control . . . . . \$150.00



- DIGITAL TACHOMETER . . . . . \$120.00



- STEPPING MOTORS wide range for N.C. Control, Plotters, Variable speed, Servo Control etc. From . . . . . \$49.50



- STEPPING MOTOR DRIVING CIRCUITS for 3 or 4 phase in Mode 1 phase 2 phase 1-2 phase excitation. From . . . . . \$12.00

- THUMB WHEEL SWITCHES — \$2.20ea.
- TROXINITY TRANSDUCERS — \$15.00ea.

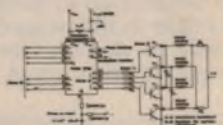

Mail orders add \$3.50 for postage and packaging

**G.C.S.**

67 Blackshaw Avenue, MORTDALE 2223.

Telephone: 570 1225

(Trade enquiries invited)



# INTERSIL ICM 7226 COUNTER KIT

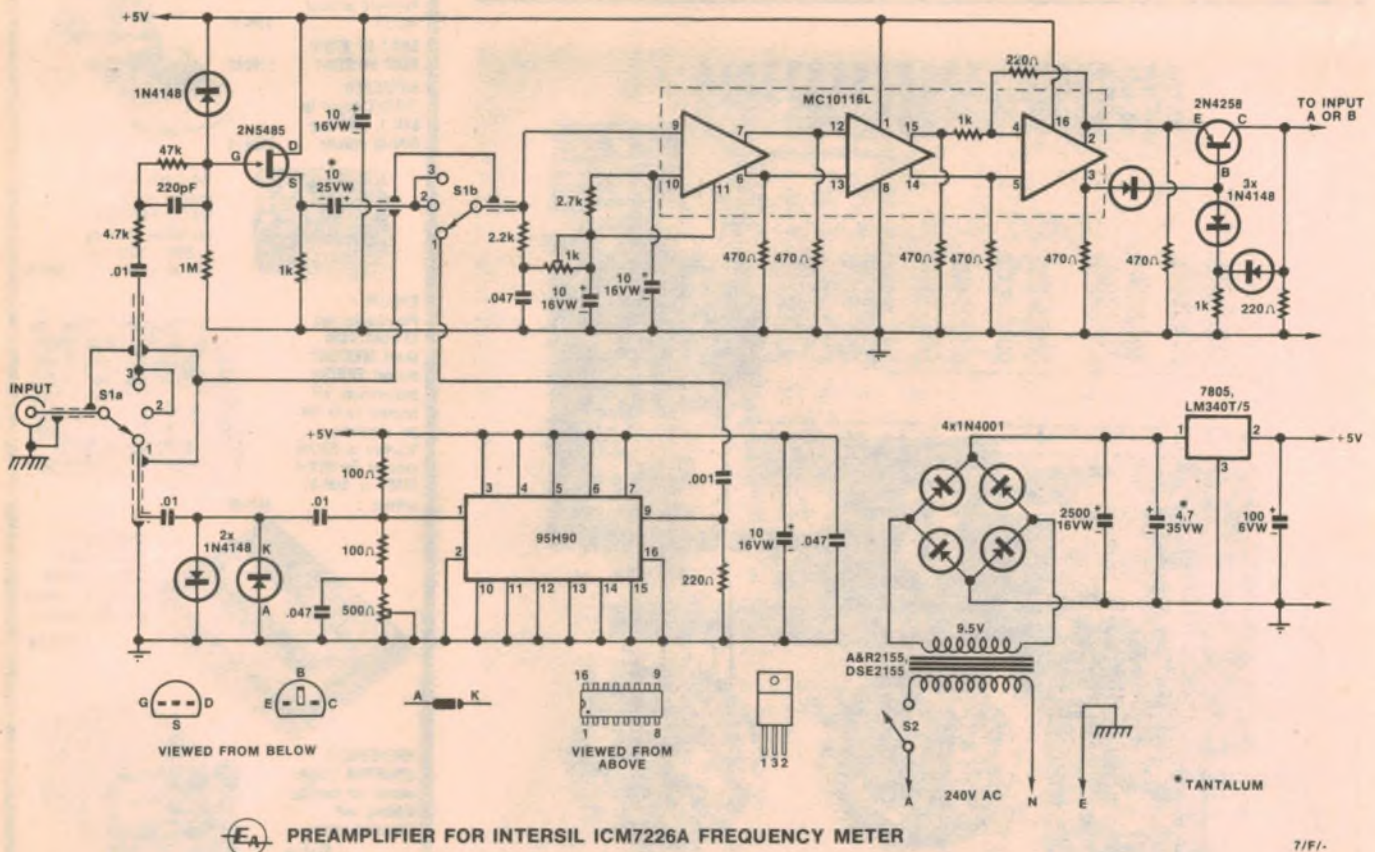

Suggested input circuitry and power supply for the Intersil kit. If both inputs are required, the preamps must be duplicated.

Comprehensive information is provided in the 7226 evaluation kit which also provides a PCB, the 7226 chip itself in a ceramic dual in-line package, a 10MHz crystal, eight seven-segment LED displays plus switches, diodes, resistors, capacitors and a few other bits and pieces.

The kit is quite simple to construct and takes only about one hour to put together. The range and function switches are mounted directly on the double-sided PCB which also carries the switch labelling. A miniature DIP switch provides the control functions, which were briefly mentioned above.

Power supply requirements for the 7226 evaluation kit PCB are 5 volts at 300 milliamps or more. Before connecting the power, the 7226 should be checked for correct orientation in its socket. If a mistake is made in this regard, it is the one sure way to destroy the chip. In other respects the chip is well protected.

The input pins are protected against static discharge and inputs A and B are each protected by an on-board resistor-diode network.

With power applied to our evaluation PCB we were able to run through the test modes to confirm that the circuit was operating correctly. All the displays were functional as well as the function operations. The displays,

however, are difficult to read and some type of red filter is necessary. A circularly polarised filter would be best.

As it stands, the counter inputs of the 7226 require signals that are TTL-compatible. This is the one shortcoming of all these counter chips — a separate preamplifier circuit is required. Intersil suggest a preamp based on the 10116 ECL chip. We can go one better than that and suggest the front-end of our seven-digit frequency counter, which was published in August 1978 (File No 7/F/24, 25).

The front end comprises a FET source-follower and the ECL 10116L. The 10116L is a triple differential amplifier with complementary outputs. As connected, the device amplifies and squares the signal. The ECL to TTL interface is done with the PNP transistor, 2N4258.

As an option, you could use the 95H90 divide-by-ten prescaler, which is also shown on the front-end circuit. Since the 7226 will count up to 14MHz (typically) by itself, the addition of the 95H90 would produce a counter capable of operation up to 140MHz (again, typically).

Finally, shown on the same circuit is a suggestion for a suitable power supply using a commonly available multi-tap transformer driving a bridge rectifier from a 9.5V tap. The output of the

rectifier is filtered by a 2500µF capacitor and fed to a three-terminal regulator to produce 5 volts DC. The regulator should have a suitable heatsink.

A breadboarding area is provided on the PCB. There are two locations for 16 pin IC's and a pad area for discrete components.

With some difficulty, the input circuitry suggested here with the exception of the 95H90 prescaler, can be wired into this breadboarding area.

Our overall reaction to the 7226 kit is a little mixed. As a vehicle for introducing the capabilities of the 7226 chip it is fine. But the PCB itself seems to have been almost deliberately designed to be as inflexible as possible. This means that the kit is less attractive as a basis for a practical instrument than it otherwise would have been.

Nevertheless, as an approach to obtaining a highly flexible frequency counter which provides variable gating times, period, interval and the other functions, it must be regarded as very good value.

Our sample of the Intersil ICM 7226 evaluation kit came from Radio Despatch Service, 869 George Street, Sydney, NSW 2000. The kit is priced to sell at \$84.00. Radio Despatch Service can also supply all the parts for the suggested input circuitry and power supply.



# ARLEC



**NEW**

## LOW PROFILE TRANSFORMERS

with 40% Extra Power

AL 7VA/6	6V C.T. or 3V
AL 7VA/9	9V C.T. or 4.5V
AL 7VA/12	12V C.T. or 6V
AL 7VA/15	15V C.T. or 7.5V
AL 7VA/18	18V C.T. or 9V
AL 7VA/24	24V C.T. or 12V
AL 7VA/30	30V C.T. or 15V

All Models Rated At 7 VA.

### Features:

- Insulated to AS C126
- PCB Mounting Pins
- Pin Compatible with other Current Models
- Mounting Clamps available for non PCB applications
- Modern Welded Stack
- Fully enclosed windings
- S.E.C. Approved
- Size L.49mm, W.35mm, H.34mm.
- Weight 0.23 Kg

Also available in 10VA with similar dimensions for O.E.M. Quantities.

**ARLEC**

**A+R Electronics Pty Ltd**

30-32 Lexton Road, Box Hill, Vic. 3128, Australia. Telex 32286

A MEMBER OF  
THE A+R SOANAR  
ELECTRONICS  
GROUP

VICTORIA: 89 0661  
NSW: 789 6733  
Sth. AUST: 51 6981

QUEENSLAND: 52 5421  
WEST AUST: 381 9522  
HONG KONG: (3) 89 1271

**(02) 439 4211**

We're not in the 'phone book yet, but we intend to be this time next year, so until then hang this up so you know where to call us for rapid answers to your PCB supply requirements!

**Circuits International**

"The Printed Circuit People"

Unit 4/375 Pacific Highway, Artarmon, N.S.W. 2064





Australia is caught in the grip of gold fever and now you can join the rush with our new "Prospector" metal locator. With a price which is a mere fraction of some of the more pretentious commercial designs, the "Prospector" is easy to build and has a performance which is sure to upset those who have paid the big money for the expensive import. In a word, its a bargain.

by **RON DE JONG**



Over the past few months we have had an unbelievable number of enquiries and requests for a metal locator. With gold fever at an all time high and new reports of gold finds almost daily, people are itching to join the search and are willing to pay outrageous prices for metal locators.

In fact, we have been bemused by all the fuss. On the one hand, we have been amazed by the prices of some of these metal locators and the vast array of knobs they have and on the other hand, we have been struck by the apparent success of these locators in helping people find nuggets.

Is it all a hoax? Is there a firm in the phone directory with a "rent a nugget" service for metal locator distributors? Is there gold to be found in the suburbs of Melbourne and Sydney? Who really knows? And for that matter, who cares? We have stopped wondering and have produced a cheap and very effective metal locator instead. We called it the "Prospector".

Metal locator designs can be classified into three broad groups, viz the IB or TR type (induction balance or transmit/receive), the BFO type (beat frequency oscillator) and the PI type

(pulse induction). Compared with the better IB or PI designs, the older BFO circuits are not really in the race. But our Prospector circuit is a new BFO design which uses a nifty digital mixing circuit which greatly increases the sensitivity.

In fact, the sensitivity of the Prospector BFO design compares quite favourably with some commercial induction balance designs which have the "ground-exclusion balance" feature although we admit that the GEB feature may give a performance advantage when searching for objects in heavily mineralised ground.

Apart from resulting in a simpler circuit, the BFO principle used in the Prospector also results in a unit which is easier to construct, in that it has only one search coil. By contrast, induction-balance metal locators usually require at least two search coils which often have a complex shape and which have to be accurately aligned with respect to each other.

Ease of operation is a feature of the "Prospector". It has just two controls, pitch and volume. The user listens to the audio output via a pair of stereo headphones. Besides being more com-

fortable than the cheap earpiece provided with some metal locators, stereo headphones have the advantage of reducing the effects of ambient noise.

Now have a look at the circuit of our new metal locator. While the Prospector is a good deal more sensitive than the average run-of-the-mill metal locator, the circuit is not at all complicated. Only three CMOS IC's are involved, two 4011 quad NAND gates and a 4013 dual-D flipflop.

The 4011 quad NAND gates are wired to provide two LC oscillators. One is the search coil oscillator while the others is the reference oscillator. These oscillator circuits are based on a design featured in the July 1978 issue of "Wireless World". With the advantage of low cost and the ability to interface directly with digital circuitry, the oscillator circuits enable a high Q to be realised because of the negligible loading of the CMOS inputs.

Identical circuits are used for the search coil oscillator and the reference oscillator so that any changes in ambient temperature or battery voltage cause both oscillators to drift by the same percentage, with the result that





Operation of each oscillator is quite straightforward. Looking at the search coil oscillator first, IC1a and IC1b act as a simple non-inverting amplifier, providing high gain with negligible input loading and low output resistance. The 220k resistor doesn't effect normal operation of the circuit but it does ensure that the oscillator starts properly when power is first applied. Feedback is applied from the output of gate IC1b via a 680pF capacitor to the parallel tun-

quency is unimportant and need only be in the range of 80kHz to 140kHz. When metal is brought near to the search coil the frequency of the search coil oscillator will change slightly. Theoretically, ferrous metals such as iron and steel will increase the frequency of the search coil oscillator while metals such as gold, silver, brass and aluminium will decrease the frequency of the oscillator. In practice though most pieces of iron and steel will be in-

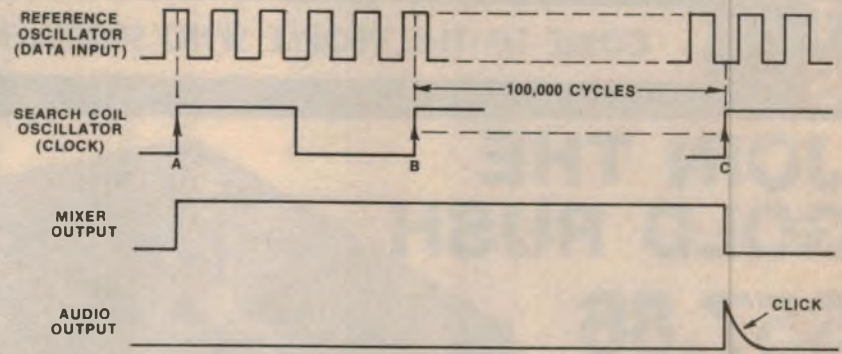

FIG. 1

We estimate that the cost of the "Prospector" metal locator is about

**\$20**

This price includes tax but does not include the cost of handle and coil former.

ed LC circuit comprised of the search coil inductance and the .001uF and two 330pF capacitors.

The reference oscillator works in the same fashion but a 455kHz IF transformer is used instead of the search coil. The reference oscillator runs at about 6 six times the frequency of the search coil oscillator, and is set by tuning the slug in the transformer — the actual tuning procedure is discussed later.

The operating frequency of the search coil oscillator is dependent on the inductance of the search coil, according to the usual formula:

$$f = 1 / 2 \pi (LC)^{1/2}$$

In our case the operating frequency is about 100kHz though the exact fre-

distinguishable from gold, etc because their ferromagnetic properties are completely swamped out by "eddy current" losses.

Each of the two oscillators is buffered by two of the remaining NAND gates, to reduce coupling and loading effects in the digital "mixing" circuit which consists of one section of the dual-D flipflop. The other half is not used.

To understand the operation of the mixer it is important to know how a D-type flipflop works, or rather, what it does: The logic level at the D (data) input is transferred to the Q output during the positive transition of the clock pulse.

In our circuit, the reference oscillator output is applied to the D-input of the

the beat frequency remains fairly constant. This stability is desirable in any metal locator, but especially so in this design because of the high sensitivity involved.

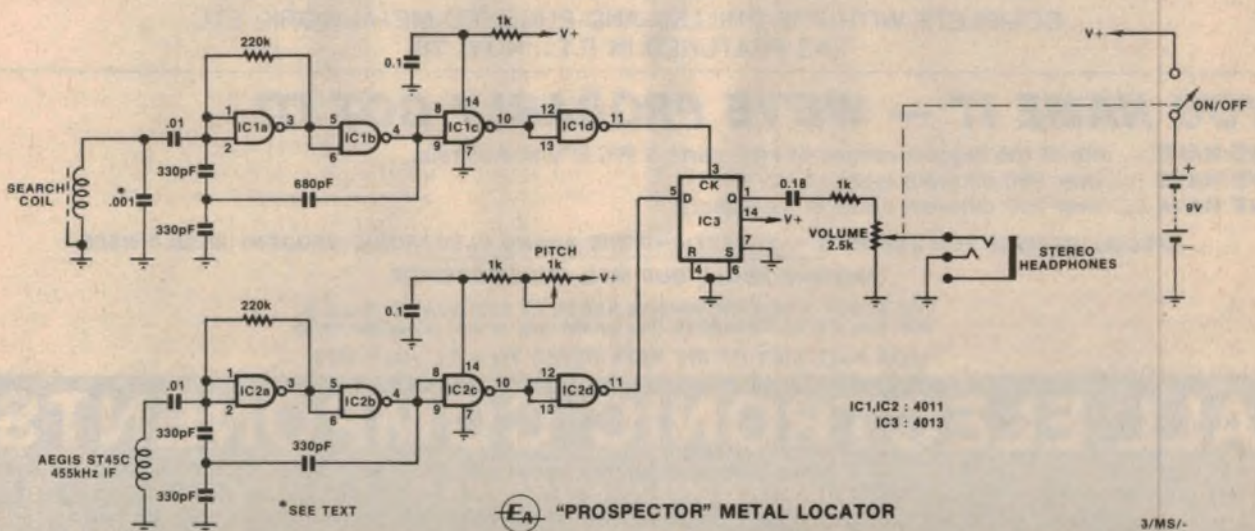

**"PROSPECTOR" METAL LOCATOR**

The circuit of the metal locator uses only three CMOS ICs.



FOR THE PAST 20 YEARS WE HAVE CATERED  
FOR TOMORROW'S ELECTRONICS ENGINEERS.

# ALL ELECTRONIC COMPONENTS

formerly

E.D. & E. (SALES) PTY LTD

K  
I  
T  
S

K  
I  
T  
S

COME TO THE PEOPLE WHO SPECIALISE IN KIT SETS

**JOIN THE  
GOLD RUSH  
\$57.86**

*(Includes wire and  
cable but not  
woodwork)  
+P&P \$5.00*

Compares with  
locaters  
10 times  
the price!

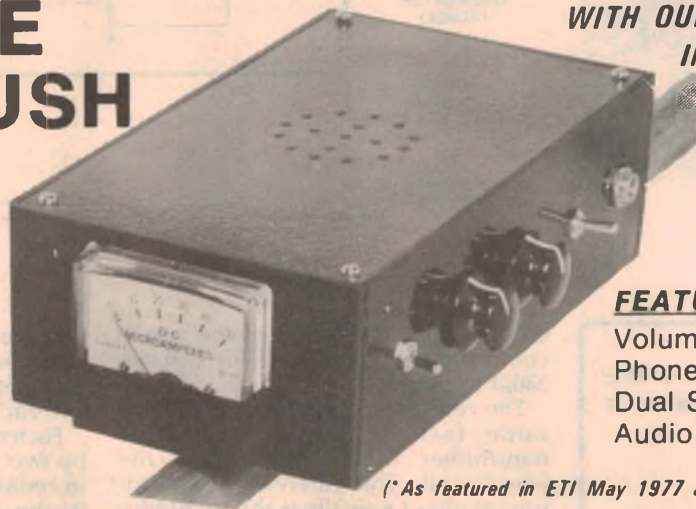

WITH OUR ETI 549  
INDUCTION BALANCE  
METAL LOCATER  
KITSET\*

**FEATURES INCLUDE:**

Volume & Level controls  
Phone Jack  
Dual Sensitivity Range  
Audio & Meter Indication

(\*As featured in ETI May 1977 and ETI Simple Projects No. 2)

Other metal locater projects available soon. Inquire for further details.

## You asked for it — here it is!

**Fantastic new inverter from E.A.**

Ideally suited for remote locations, outback areas, boats, yachts, vehicles, etc, where regular AC power supply is unavailable or unreliable.

EA 12-230V inverter kitset (See EA Feb '79)

Input 12V DC, Output 230V at 50Hz 300VA — \$195.50 inc. tax.

**E.T.I. 650 STAC TIMER KITSET — \$113.50 (incl. tax)**

COMPLETE WITH PRE-DRILLED AND PUNCHED METALWORK, ETC.  
(AS FEATURED IN E.T.I. NOV. '78)

## YOU NAME IT — WE'VE PROBABLY GOT IT!

**WE HAVE...** one of the biggest ranges of kits, parts & P.C.B.'s in Australia.

**WE HAVE...** over 300 different types of I.C.'s

**WE HAVE...** over 250 different types of transistors.

**SPECIAL SERVICE FOR SCHOOLS — EVERYTHING THE YOUNG ELECTRONIC STUDENT WOULD NEED  
INQUIRE ABOUT OUR MAIL ORDER SERVICE**

**WE STOCK A COMPREHENSIVE RANGE OF TOP QUALITY P.C.B.'S  
FOR E.A. & E.T.I. PROJECTS (For full list refer to E.A. November 1978)**

**FOR FULL LIST OF KIT SETS REFER TO E.T.I. JULY 1979**

# ALL ELECTRONIC COMPONENTS

**THE FAMILY BUSINESS**

TELEPHONE  
662-3506

**118 LONSDALE STREET, MELBOURNE 3000**

TELEPHONE  
662-3506



## METAL LOCATOR

flipflop while the search coil oscillator output is fed to the clock input. Both oscillator outputs are square waves and the reference oscillator is running at about six times the search coil oscillator frequency. The timing diagram of Fig. 1 helps illustrate the operation.

Starting from the leading edge of the first clock cycle, we see that at point A the data input of the flipflop is high and will be transferred to the output of the

## PARTS LIST

- 1 Plastic zippy box, 158 x 96 x 50mm
- 1 PC board coded 79md9, 74 x 58mm
- 1 2.5k linear rotary switch potentiometer
- 1 1k linear rotary potentiometer
- 1 Stereo headphone jack
- 1 Nine volt transistor battery, Eveready 216 or similar
- 1 Aegis ST45C 455kHz transistor IF transformer or similar
- 25 metres of 26 SWG enameled copper wire
- 1.5 Metres of shielded audio cable
- 1 Battery clip to suit Eveready 216
- 1 Stereo headphone set

### INTEGRATED CIRCUITS

- 2 4011 CMOS
- 1 4013 CMOS

### CAPACITORS

- 1 0.18uF metallised polyester (greencap)
- 2 0.1uF metallised polyester
- 2 .01uF metallised polyester
- 1 .001uF metallised polyester (see text)
- 1 680pF polystyrene or ceramic
- 5 330pF polystyrene or ceramic

### RESISTORS

- ( $\frac{1}{4}$ W, 10% tolerance)
- 2 x 220k, 3 x 1k.

### MISCELLANEOUS

Plywood, dowel, aluminium tubing, rubber handle grip, insulation tape, hook-up wire, four tapped spacers (12mm), screws, nuts, washers, saddle clamp.

flipflop. The next clock cycle at point B also coincides with a high at the data input so the output of the flipflop remains high. In fact, while ever the reference oscillator frequency is an exact even multiple of the search coil frequency this state of affairs will continue indefinitely and the output of the flipflop will remain unchanged.

If, however, the search coil frequency differs by as little as 1/12th of a hertz then about 100,000 cycles after point A

(ie, after one second) the clock signal will not coincide with the data input and a low logic level will be transferred to the output of the flipflop. This produces a click in the headphones which are connected to the output of the flipflop.

When the beat frequency is set to say 10Hz, ie 10 clicks per second, then a change of one click or one hertz in the beat frequency still corresponds to a change of 1/12th of a hertz in the search coil frequency.

Note that for proper operation of the mixer the reference oscillator must be set for the sixth harmonic, or the fourth or eighth — as long as it is an even harmonic because otherwise a low and a high would be alternately clocked by the flipflop. This would give a beat frequency of 100kHz which is inaudible.

Output from the mixer circuit is used to drive a pair of stereo headphones via a 0.18uF capacitor and an amplitude control consisting of a 1k resistor and 2.5k potentiometer. We have used a capacitor to differentiate the output



from the flipflop so that whenever the output changes, either from a high to a low or low to high a brief click is produced in the headphones.

A 1k potentiometer in series with the supply to the reference oscillator functions as the pitch control. Its operation relies on the fact that the frequency of the reference oscillator is dependent on the supply voltage. Using the 1k potentiometer provides a modest change in supply voltage and results in

a change in frequency. The resulting difference in frequency between the two oscillators is then multiplied by the mixer circuit.

There are several advantages in this pitch control circuit. It eliminates the need for a trimmer capacitor and simplifies layout because there are no signal voltages on the leads to the potentiometer.

Current consumption of the "Prospector" is typically about 2.5mA



# PROSPECTOR

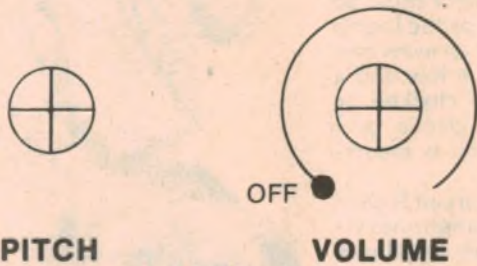

For maximum sensitivity  
set pitch to a low growl.

LEFT: Here is an actual size reproduction of the front panel artwork. RIGHT: an actual size copy of the artwork for the side panels.

# PROSPECTOR

by "ELECTRONICS AUSTRALIA"

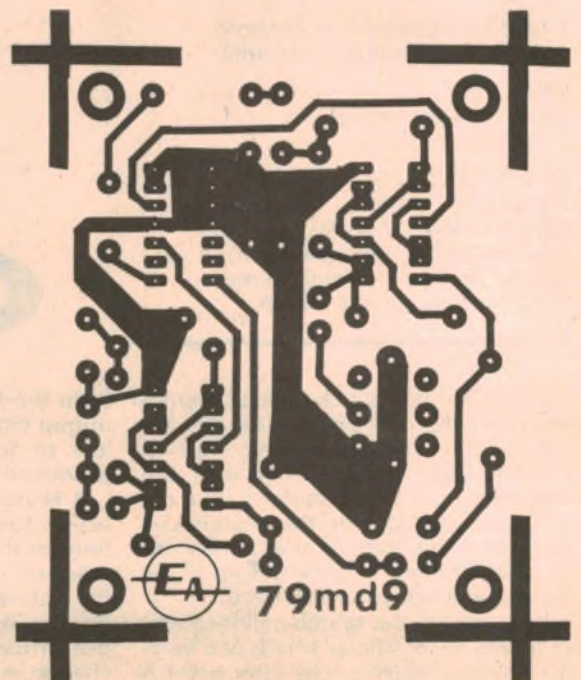
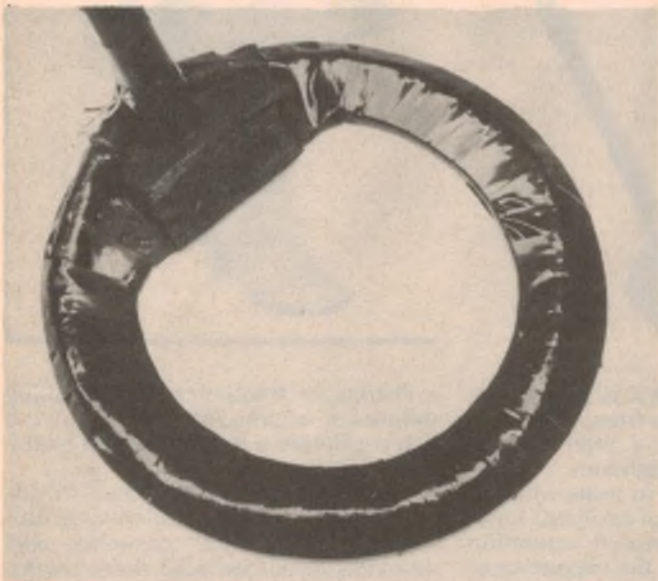

ABOVE: Close-up of the coil carrier. Note how the coil has been attached to the top of the carrier and wrapped with insulation tape. RIGHT: An actual size copy of the PC pattern.



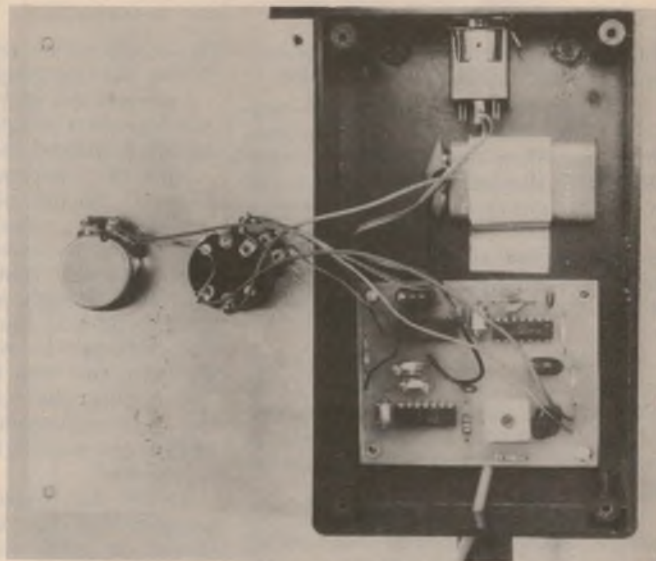
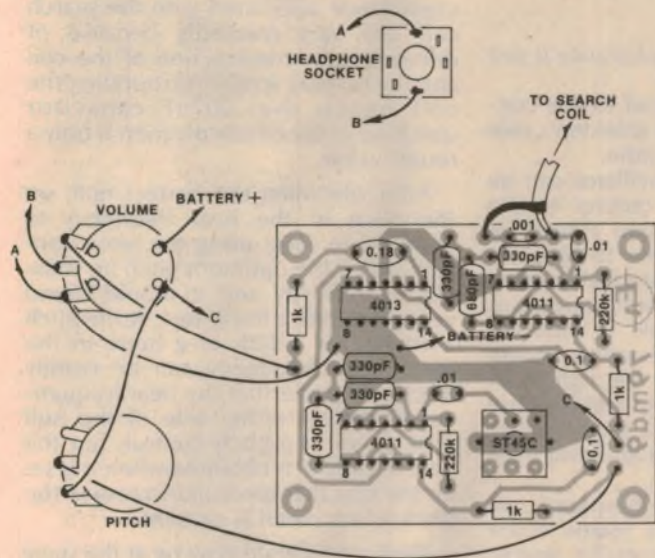

Use this wiring diagram and inside shot of the prototype to guide construction.

rising upto 3.5mA with the amplitude control set to maximum. The low current drain is due to the CMOS circuitry used and it leads to an expected life of about 150 hours for the specified battery — that's a lot of prospecting time.

Well that covers the circuit description: construction of the "Prospector" should present no difficulty. The circuitry is housed in a small inexpensive plastic zippy box with most of the components mounted on a small PC board coded 79md9 and measuring 74mm x 58mm. Mount the resistors and capacitors on the PC board first then the three CMOS ICs taking the usual precautions — handle the ICs without touching the pins and solder the two power supply pins first.

Next drill all the mounting holes for the PC board, headphone socket, amplitude and pitch controls and the battery clamp. Use the basic layout shown in the accompanying wiring diagram and use the front panel artwork also included in this article to position the holes for the amplitude and pitch controls. If you so desire you can make an attractive front panel for

the metal locator using the artwork already mentioned and some Scotchcal photosensitive aluminium. On the other hand, we anticipate that kitset suppliers will make suitable panels available.

With the main controls and the headphone socket mounted you can now complete the wiring to the PC board. The only remaining steps are to construct the search coil and make a simple alignment to the reference oscillator.

The coil should be made from 50 turns of 26SWG enamelled copper wire. Wind the turns close to each other around a 180mm circular former. Just about anything will do for this purpose such as an empty plastic ice cream container or you can wrap it around a square former such as cardboard box and then bend the coil to a roughly circular shape.

After completing the coil winding, wrap the coil in at least three layers of insulation tape bringing the two output leads out close to each other. Then wrap the coil in a tight layer of aluminium foil. The foil acts as a "Faraday screen" and reduces the effects of

ground capacitance on the search coil frequency — but it won't effect the sensitivity of the metal locator. Cut the foil into 20mm wide strips and wind it around the coil making sure that the two ends don't connect. This is very important because otherwise the shield would form a shorted turn and markedly reduce sensitivity.

Wind a couple of turns of 18 gauge (or similar) tinned copper wire around that part of the shield which is closest to the coil leadouts. Twist the ends of tinned copper wire several times to form a robust connection which can be soldered to later.

Then wrap the coil again in another two layers of tape which should preferably match the colour of the handle and control box. Now you should be ready to proceed with the timber coil carrier.

We made our coil carrier from thin plywood cut into a circle with an inside diameter of 150mm and an outside diameter of 220mm. Alternatively, tempered hardboard or some other non-metallic material such as plastic would be suitable. You could even consider using a Frisbee for the purpose.

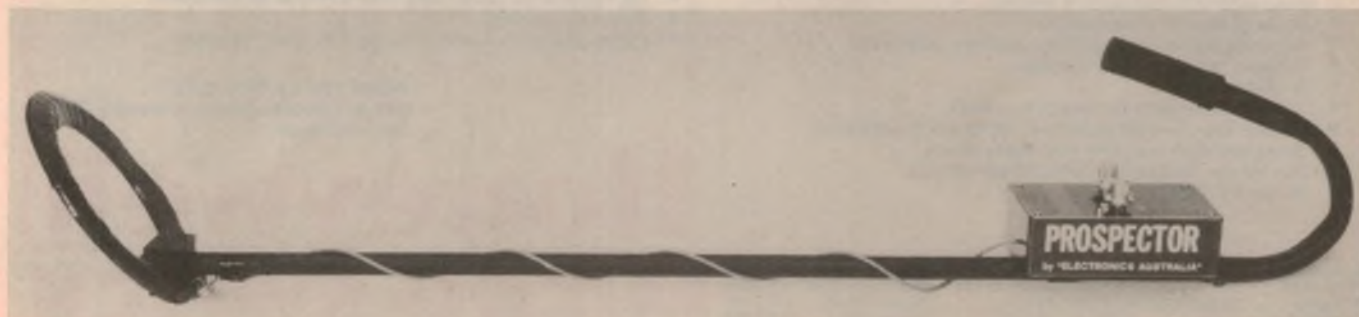



## METAL LOCATOR

Commercial metal locators use a waterproof plastic housing for the coil(s).

Attaching the coil carrier to the handle is a little tricky. We made the handle from a 90cm length of 18mm dowel attached to the coil carrier by means of an angled gluing block made from a scrap of timber. The handle is angled to the coil carrier at 135 degrees. Don't use screws or nails to do this job as they will reduce the effective sensitivity of the coil.

The coil is fixed to the carrier assembly using a couple of layers of insulation tape. We suggest you attach the coil to the topside of the carrier as this will help protect it from damage or abrasion.

Mount the control box on the handle using a saddle clamp which can either be purchased from a hardware store or made from a scrap of aluminium.

Rather than simply fix a rubber handgrip to the handle rod we made a curved extension piece from aluminium tubing which slips over the end of the dowel. The rubber handgrip is then fitted over the end of the aluminium tubing. The resulting handle assembly makes the Prospector easier

to use since the centre of gravity is just below the handgrip.

Connect the search coil to the control box via a length of shielded cable spiralled around the handle.

Now the reference oscillator can be aligned. Set the pitch control to the middle of its rotation and adjust the slug in the IF transformer to obtain a null frequency. Make sure that it isn't a false null though, ie a null corresponding to an odd harmonic — wind the slug through its whole range before deciding that you have the right null. This is quite easy to do in fact because the right null results in a much louder output and sounds quite different from a false null.

To set the reference frequency we suggest that you use a plastic screw driver or other non metallic instrument, but be sure not to damage the slug and don't wind the slug more than a millimetre or so above the top of the can. After making a course adjustment of the pitch of the beat frequency it can then be fine-tuned by using the pitch control.

If you can not obtain the correct null then the search coil frequency is not in the right range, ie. between 80 and

140kHz. The frequency can be corrected by either increasing or reducing the value of the .001uF capacitor which is shown across the search coil. The capacitance associated with the search coil can vary markedly because of differences in construction of the coil and the Faraday screen surrounding the coil hence the .001uF capacitor specified in the circuit diagram is only a rough value.

After obtaining the correct null, set the pitch of the beat frequency to about 10 to 20Hz using the pitch control. This is the optimum pitch for maximum sensitivity and it should sound very much like a low growl. At this pitch a change of 1/12th of a hertz in the search coil frequency can be readily discerned. Note that the beat frequency can be set either side of the null position on the pitch control, but the best sensitivity is obtained when it is set on the side that gives an increase in the pitch when metal is present.

Well, you should now be at the stage to actually try your metal locator with some real "paydirt". Just a few suggestions for possible locations: — try public beaches, parks, old ghost towns and the old gold mining districts such as the areas around Bathurst and Bendigo, but don't forget your own backyard because gold has been recently found in some Melbourne suburbs!

# KEYBOARDS



### Microcomputer-based Intelligent Keyboard 103SD24-2

- Solid state Hall Effect keys with single chip microcomputer.
- 8-bit CPU, ROM, RAM, I/O and time/event counter with 8-bit USASCII coding in 4 modes.
- Serial & Parallel data outputs.
- 14 relegendable keytops for customer assignment.
- 8 deep FIFO character storage.
- N-key rollover.
- Timed auto repeat for designated keys.
- Repeat key controls repeat for other designated keys.
- Secretary shift and audio feedback drive.
- Pin for pin compatible EPROM capability.
- Single 5V supply.

### MOS Encoded Communication Keyboard 53SD5-2

- Hall Effect solid state keys coupled to MOS encoding.
- Familiar Model 33 array.
- USASCII code assignment with 4 modes of operation.
- Two key rollover.
- Quiet operation — only moving part is key plunger.

HONEYWELL PTY. LTD.  
863-871 Bourke Street, Waterloo, 2017  
Tel: 699 0155

# Honeywell MICRO SWITCH

Available from:	MELBOURNE	Silicon Valley	52 1339		
ADELAIDE:	NEWCASTLE	DGE Electronics	69 1625		
BRISBANE:	PERTH	Micro Controls	325 2444		
CANBERRA:	Ortex	82 4994	SYDNEY	Silicon Valley	439 2965



# sanwa

## ... the long term reliable multimeter.

### N501 Multimeter The executive choice!

- Measurements similar to a VTVM can be taken as the N501 has a constant  $1M\Omega$  input impedance on the ACV ranges.
- Widespread coverage of the principal measurements is available as the N501 has AC + DC Volts to 1.2kV, AC and DC Amps to 12 Amps and 6 resistance ranges to 200 M $\Omega$ s.
- Attractive, 9mm thick walnut sideboards protect the multimeter from accidental damage.

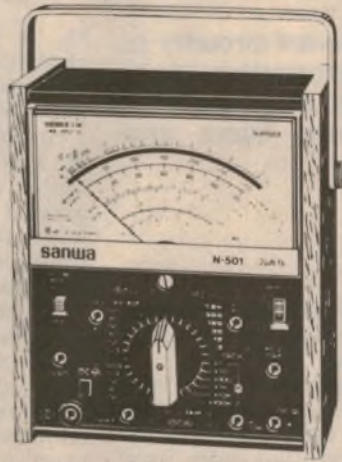

### T-55 THD Multimeter (T-55D c/w optional temperature probe)

The latest lightweight with heavyweight features!

- Adds a temperature capability (-50°C to 200°C) to the newest thin-dimension multimeter. Lets you measure the temperature of industrial and commercial appliances or individual component heat.
- Offers a multi-role multimeter to cover normal requirements plus AC Amps, battery test, LED test and temperature selections.

**NEW**



### U-60D UNIVERSAL MULTITESTER

- 44 $\mu$ A movement - quality performance, diode protected
- Stable ACV measurement - solid-state rectifier & enlarged frequency coverage.
- Linear scale characteristic - common scale reading for DCV and ACV
- Semiconductor test - simultaneous reading of load current & voltage with  $\Omega$
- Temperature measurement of -30°C to +150°C with extra probe



### PDM500C INSULATION TESTER

- Easy push button operation.
- Large easily read scale.
- No wearing parts (transistorized for long trouble-free life).
- One-man operation - no handle to crank.

**Specifications**  
Rated Voltage 500V.  
Resistance 100 Megohm.  
Effective scale reading: 0.1 - 100 - 200 Megohm.  
Continuity Scale: 0 - 100 ohms.  
Including vinyl-leather case with lead pouch, shoulder strap and insulated test leads.



### 460-ED MULTITESTER THE BEST BUY IN MULTIMETERS

100,000 ohms per volt with  $\pm 2\%$  accuracy for DC ranges with only 10 microamperes loss at full scale. H.F. current blocking when making DC measurements.

- 10 $\mu$ A movement - 100k $\Omega$ /V, varistor protected
- Polarity reversal switch - negative measurements
- Equalising transformer - common shunts & jacks for 1.2A & 12A DC/AC



### BX-505 MULTITESTER

- Fast-response, 24 $\mu$ A movement - fuse & diode protected with high resolution factor (0.4 $\mu$ A/scale division)
  - Revised scale marking - intermediate readings readily determined
  - Polarity reversal switching - negative measurements
  - Series capacitor terminal (OUTPUT+) - AF output level check
- RANGES: AC & DCV to 1.2kV (30kVDC with optional probe). AC & DCA to 12 amps



**WARBURTON FRANKI**

- ADELAIDE 356-7333 • BRISBANE 52-7255 • HOBART 23-1841
- MELBOURNE 699-4999 • PERTH 277-7000 • SYDNEY 648-1711
- AUCKLAND N.Z. 77-0924 • WELLINGTON N.Z. 698-272



For checking amplifiers, digital circuits, etc —

# A low cost, high quality pulse generator

This new pulse generator design uses state-of-the-art circuitry to provide a standard of performance out of all proportion to its modest cost and parts count. You'll find it an ideal instrument for testing digital circuits and evaluating amplifiers, filters and attenuators.

by **RON de JONG**

Considering the simplicity of this new pulse generator design, its performance is most impressive. It provides pulses with a variable amplitude of between 1 and 10 volts peak to peak, at a low 50 ohms source impedance, and with rise and fall times of only 40 nanoseconds. The repetition rate is variable between 1Hz and 100kHz, and the pulse width from a nominal 1 second down to 1 microsecond. Similarly there is an adjustable delay for the main output relative to a 'scope triggering output, again variable from 1 second down to 1 microsecond.

In short, the performance is fully comparable with expensive professional instruments — yet you can build it for a fraction of the price.

This is largely because we have been able to take advantage of the latest state-of-the-art components: modern CMOS pulse generating circuitry, driving an output stage which is designed around one of the new VMOS power transistors. It is the VMOS device which produces the exceptionally good rise and fall times, and allows the new generator to provide 10V P-P pulses at 50 ohms impedance.

What can you do with a pulse generator? Well, it is just the thing for testing digital circuits. The ability to vary both the pulse rate and width makes it very flexible as a source of clock signals. And with an adjustable delay between the main pulse output and the oscilloscope trigger output, you can look at any part of the pulse waveform as the pulses progress through gates, shift registers and other parts of the circuit — even with a 'scope which lacks fancy delayed trigger facilities.

Needless to say, it can make it much

easier to track down subtle timing errors, "race" conditions and the causes of mysterious "glitches".

Another important application of a pulse generator is in testing the transient response and stability of amplifiers, filters and attenuators. Since a pulse waveform is effectively a whole set of different frequencies spanning a broad range, it provides concise information on a variety of response parameters — some of which would be much harder to obtain by any other means.

A typical pulse waveform is shown in

Fig. 1, with most of the important characteristics marked. The rise and fall times can give important information as to the frequency and phase response of a circuit, along with its "slew rate" or the maximum rate at which the circuit's output voltage can change (usually expressed in volts/microsecond). Similarly the tilt can reveal the circuit's low-frequency performance, while the overshoot and/or ringing can give a good idea of its stability.

Incidentally, if the risetime of a pulse fed to an amplifier or attenuator is very short compared to the risetime of the pulse when it emerges from the amplifier, the output risetime can be used to find the amplifier's high-frequency response quite simply. The two are related by the formula

$$F_t = 0.35/T_r$$

where  $F_t$  is the amplifier's upper turnover frequency, where its response has fallen by 3dB, and  $T_r$  is the risetime.

But enough of the theory. Let's have a look at the circuit of the



The finished instrument is housed in a neat plastic box and the "Scotchcal" label gives it a professional appearance. Note that the switches and pots for each function are grouped together for ease of operation. The socket in the right hand end is the 12V AC inlet from the plug-pack.



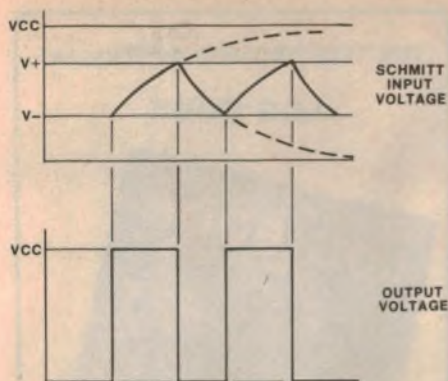

Fig. 2. Showing how a triangular wave at the input of the Schmitt trigger produces a square wave at the output.

new generator and see how it works. As you can see, it consists of four distinct parts: the pulse repetition oscillator, the delay circuit, the width circuit and the output stage.

The oscillator section is a simple relaxation circuit using an RC feedback circuit around a CMOS Schmitt trigger element. The Schmitt element is 1/6th of a 74C14 device, of which a second element is used as a buffer for the "scope output".

A Schmitt trigger element is similar to a normal inverter, except that it exhibits "hysteresis" in its switching characteristic. This simply means that its switching threshold for increasing input voltages is different from that for decreasing input voltages. In fact the threshold voltage for increasing input voltages ( $V+$ ) is higher than that for decreasing voltages ( $V-$ ).

The operation of the oscillator circuit takes advantage of this hysteresis effect. By connecting the output of the element back to its input via an R-C circuit as shown, the element is made to switch itself on and off alternately.

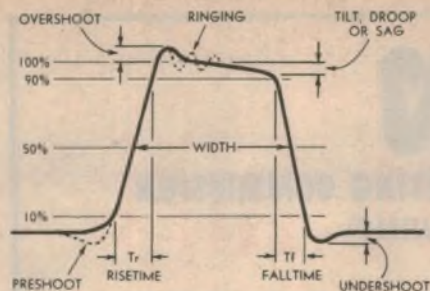

Fig. 1. No "square" wave is ever perfect, and this drawing shows the various faults and their manner of measurement.

The output (pin 2) of the 74C14 is taken back to the input (pin 1) via the 50k frequency pot and a 4.7k resistor, while the input is also connected to ground by one of a number of capacitors selected by S1b.

When power is first applied, the capacitor has no charge and holds the input at ground potential. Due to the inversion in the Schmitt element this makes its output go high; as a result the capacitor begins to charge up via the 50k pot and 4.7k resistor.

The charging continues until the capacitor voltage reaches the upper switching threshold of the Schmitt element,  $V+$ . When it reaches this voltage, the Schmitt element switches, and its output suddenly falls to ground potential. As a result the capacitor stops charging and begins to discharge, again via the 50K pot and 4.7k resistor.

The discharging continues until the capacitor voltage falls to the lower switching threshold of the Schmitt element,  $V-$ . Then the element switches again, its output goes high and the capacitor begins charging again. And this sequence repeats itself continuously, with the output of the element producing a series of pulses as shown,

in Fig. 2.

Fairly obviously the pulse repetition rate or frequency is determined both by the R-C timeconstant and by the hysteresis range of the Schmitt trigger — i.e., the voltage difference between  $V+$  and  $V-$ . The hysteresis does vary from IC to IC, but is substantially constant for a particular IC. Hence we vary the R and C values to adjust the frequency.

Switch S1b is used to select capacitors, to provide decade ranges in frequency. The 50k pot then provides continuous adjustment within each range. The maximum frequency for each of the five main ranges is 100kHz, 10kHz, 1kHz, 100Hz and 10Hz respectively, while the 50k pot allows interpolation within these figures and also extends the lower limit down to 1Hz.

Notice that S1b has a sixth position, in which the input is switched to a .01uF capacitor shunted by a pushbutton. In the same position, S1a of the same switch breaks the resistive feedback path, and connects the input instead via a 100k resistor to the +12V line. This produces a "single shot" facility, where a single output pulse is produced each time the button is pressed.

What happens in the single shot mode is that the pushbutton pulls the input of the Schmitt element low, forcing its output high as long as the button is held depressed. When the button is released the .01uF capacitor charges up via the 100k resistor, taking the Schmitt input above the  $V+$  level and causing the output to go low. The time taken for the .01uF capacitor to charge provides suppression for contact bounce in the button, and prevents multiple pulses.

Although the pulse from pin 2 lasts as long as the button is depressed, this does not affect the output pulse width as the following circuitry is triggered only by the positive-going edge.

The output from the oscillator is buffered by another Schmitt element which drives the "SYNC" output. Since the trigger levels of CMOS Schmitt elements are fairly equally spaced about  $\frac{1}{2}V_{CC}$ , the duty cycle of the "SYNC" signal is close to 50%. The regenerative nature of the gates also provides a clean signal which is free from spurious oscillations.

The output from the oscillator is also used to trigger the delay monostable, which uses one half of a 74C221 dual mono device. The monostable is connected in standard fashion, and is triggered from the positive-going edges of the clock output pulses. Switch S2 selects one of six capacitors to provide six decade ranges for delay, while the 100k pot provides a continuous adjustment within each range. The overall delay range is from one second down to 1us.

Actually the monostable itself simply produces variable width pulses, but these are used to produce a variable time delay by arranging for the follow-

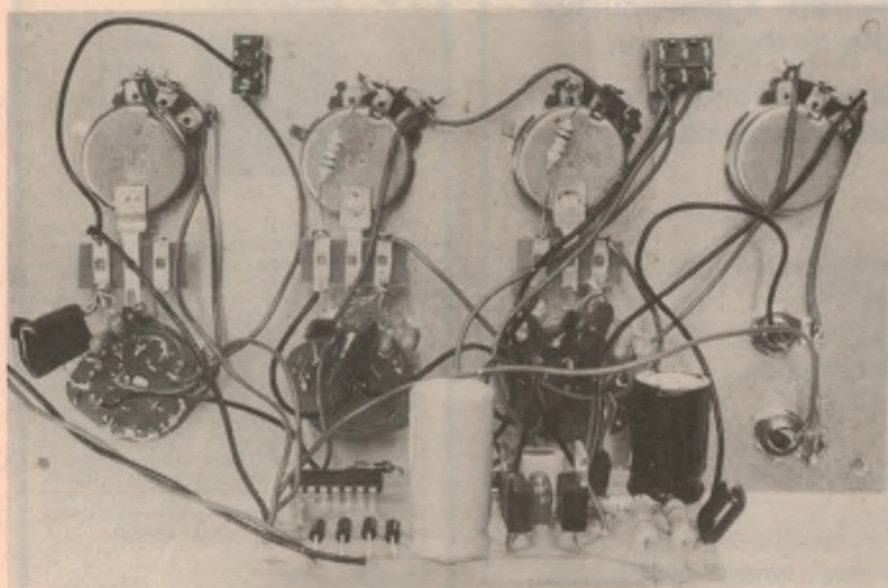

Rear view of the front panel (turned upside down) with the printed board assembly. Note the terminal strips soldered to the pot covers, and used to terminate the capacitors from the switches and resistors from the pots.





**AUSTRALIAN BROADCASTING COMMISSION  
(MELBOURNE)**

## **OPERATIONS OFFICER**

**\$10189 — \$12293 Per Annum.**

(This is the basic adult salary. Actual income would include generous penalty rates for Shift, Weekend and Public Holiday work, and Overtime).

Applications are invited from people qualified in, and preferably experienced in, the operation of technical equipment associated with Radio Broadcasting. Applicants must possess the BOCP, TVOCP, 1st Class COCP, or the Certificate of Technology (Electronics). Alternative qualifications will be considered.

The successful applicant would be responsible for the operation of equipment used by a team of A.B.C. staff involved in the preparation of A.B.C. Radio Programs in a variety of fields such as Music, Talks, Documentaries, Sporting, Drama, Current Events etc. If you have a demonstrated interest in these areas you are the person we want.

Annual leave of up to five weeks, an annual leave loading, cumulative sick leave, long service leave and membership of the Commonwealth Superannuation Scheme are benefits applicable to the position.

Removal expenses and settling-in allowance would be payable should the successful applicant not be resident in Melbourne.

Applications are to be in writing and addressed in an envelope marked "Application — Confidential" to:—

**Recruitment Officer,  
Australian Broadcasting Commission,  
G.P.O. Box 1686,  
MELBOURNE. 3001**

*(If you need further information phone 6098775).*

Applications must include copies of qualification certificates, all personal details — educational level, employment history, operational experience, address, telephone number — and a copy of two testimonials.

THE "ELECTRONICS AUSTRALIA"

### **LOG BOOK**



**FOR: RADIO AMATEURS  
DX LISTENERS  
CB OPERATORS  
\$2.95 (Includes postage)**

From "Electronics Australia", 57-59  
Regent St, Sydney, or P.O. Box 163,  
Beaconsfield 2014.

**NEW EDITION**

## **FUNDAMENTALS OF SOLID STATE**

Fundamentals of  
**SOLID STATE**



**ONLY  
\$3.50  
+ 60c  
p&p**

Fundamentals of Solid State has been reprinted, revised and updated showing how popular it has been. It provides a wealth of information on semiconductor theory and operation, delving much deeper than very elementary works but without the maths and abstract theory which make many of the more specialised texts very heavy going. It begins with atomic theory, diode types, uni-junction, field effect and bipolar transistors, thyristor devices, device fabrication and microcircuits. A glossary of terms and an index complete the book. Fundamentals of Solid State has also been widely adopted in colleges as recommended reading — but it's not just for the student, it's for anyone who wants to know just a little bit more about the operation of semiconductor devices.

Available from:  
"Electronics Australia", 57 Regent St,  
Sydney. **PRICE \$3.50 OR** by mail order  
from "Electronics Australia", PO Box  
163, Beaconsfield 2014. **PRICE \$4.10.**



# PULSE GENERATOR

ing circuitry to again respond only to an edge of the monostable's output pulse. In fact the following circuitry is another monostable, using the second half of the 74C221, and is arranged to trigger from the trailing edges of the first mono's output pulses. The effective delay is thus equal to the width of the pulses produced by the first mono.

The second mono is connected in almost identical fashion to the first, except that its output pulses are used in their entirety to drive the output stage. So that the second mono's time-constant determines the width of the generator's output pulses, rather than their delay relative to the sync output. Again the mono is provided with a switch S3 to select one of a series of capacitors for decade ranges, together with a 100k pot for continuous adjustment.

Note that the variable controls for both delay and width strictly have an 11:1 control range, due to the need to use standard preferred component values. However this is a little academic

as the pots have a tolerance of  $\pm 20\%$  anyway. This means that the scale calibrations can only be nominal; if accurate setting of pulse delay and width is required, it is best set using an oscilloscope.

Note also that the capacitor selected for the minimum pulse width and delay, ie 1 $\mu$ s, is 82pF rather than the expected value of 100pF. This is mainly due to the parasitic capacitance of the monostable, which is 15pF; also some additional wiring capacitance.

We estimate that the current cost of parts for this project is approximately

**\$50**

This includes sales tax.

As the width monostable provides both positive-going and negative-going output signals, switch S4 is used to select either one or the other to provide a choice of output pulse polarity. From S4 the selected signal then passes to the output stage, which uses

one of the new VMOS power transistors, a VN88AF.

The VMOS device is used as a simple switch, with a 50-ohm resistive load formed by two 100ohm/1W resistors in parallel. The advantage of the VMOS device is that it can be driven directly from CMOS logic, and also that it is capable of very fast switching. It is a majority-carrier device, and does not suffer from the carrier-storage effects present in bipolar devices.

In a generator of this type, it is desirable to have the output impedance remain constant at 50-ohms, while still being able to adjust the pulse amplitude over a reasonable range. The conventional way of doing this to use a dual ganged 50-ohm pot, but the pot required must be of the non-inductive carbon type and must also have a suitably high dissipation rating. Such pots are both expensive and difficult to obtain.

To avoid the need for a such a pot while still meeting the constant output impedance requirement, we have used an alternative approach. The output pulse amplitude is varied by adjusting the output stage supply voltage, using an LM317 adjustable 3-terminal

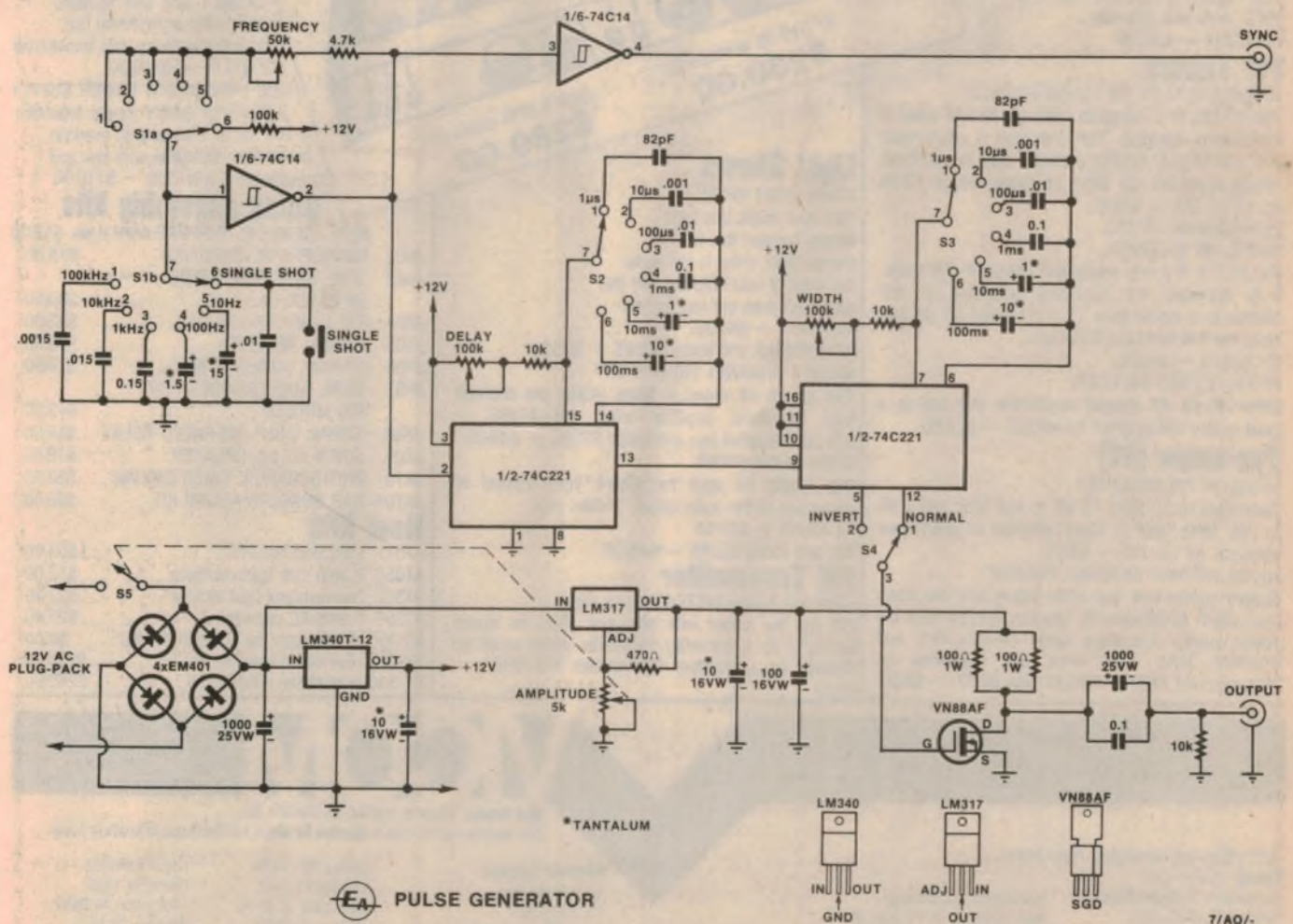

At the top left is the Schmitt trigger oscillator, followed by the delay circuit and the width circuit. At the lower right is the VMOS output stage which is largely responsible for the generator's high performance.



# Check out these sophisticated kits from Denmark

JostyKits... Denmark's finest, offer the kind of innovative design inside and outside that you'd expect from Scandinavia. Created by qualified electronic engineers, they feature solid-state space age technology advanced enough for the most

demanding kit builder. Each comes with a comprehensive instruction booklet. Whether you're a novice or experienced builder — JostyKits will give you hours of satisfaction in construction and performance!

## Audio

### AF300 AUDIO AMPLIFIER

A real work-horse, this universal power amp has a wide range of applications such as car radio, record players and small receivers.

Due to its well designed electronic circuit, the AF300 can be used over wide voltage ranges without deterioration of the specification parameters.

Kit AF300 — \$25.00

### AF340 40 WATT AUDIO AMPLIFIER MODULE

High quality 20-20,000 Hz, 37w RMS with low distortion.

Kit AG340 — \$35.00

## FM Tuners

### HF325-2 QUALITY FM TUNER MODULE

The HF325 is a complete high quality FM tuner of professional standing. The tuner unit is ready-made and pretrimmed, making it child's play to assemble. Tuning range 88-108 MHz, operating voltage 12-55 ac. Kit HF325 — \$79.00

Stereo decoder HF 310

### HF310 FM RECEIVER

The HF310 is a very reasonable priced HF FM tuner. Fully trimmed, the sensitivity according to IHF standards is better than 10uV. Features 60 dB S/N radio and low harmonic distortion.

Kit HF310 — \$49.00

### HF330 STEREO DECODER

Gives 40-45 dB channel separation, just add to a good quality FM receiver. Kit HF330 — \$24.00

## Pre-amps (RF)

### HF395 RF PREAMPLIFIER

Gain 30dB to 20 MHz, 10 dB to 100 MHz and 5 dB to 226 MHz. Ideal to boost reception on short-wave receivers. Kit HF 395 — \$6.00

### HF385 VHF/UHF ANTENNA PREAMP

Superb quality with two aerial inputs and one down lead which simultaneously supplies current from the power supply. Frequency range 40-250 MHz and 400-820 MHz. Gain 9-18 dB, depending on frequency. Kit 385 — \$30.00. Box B850 — \$6.00.

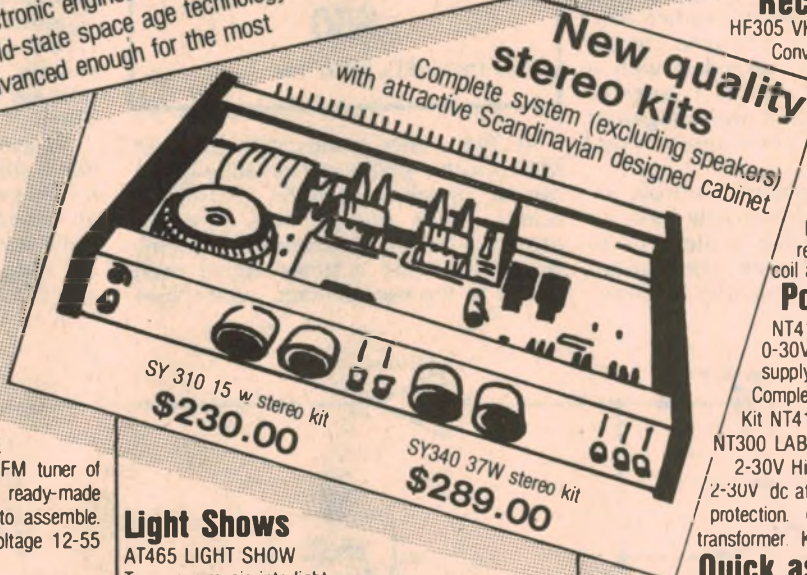

## Light Shows

### AT465 LIGHT SHOW

Turn your music into light. Simply connect this 3 channel light show to the audio terminals of your amplifier and this quality kit does the rest for you!

Kit AT465 — \$64.00

Attractive box and knobs B6065 — \$25.00

### AT468 4 CHANNEL LIGHT SHOW

This superb kit drives 4 lights (400w per channel) from the audio amplifier output. Kit AT468 — \$75.00. Attractive box and knobs B3265 — \$48.00

### AT365 LIGHT SHOW

This quality kit uses microphone input instead of connection to the audio output. 1599w max.

Kit AT365 — \$69.00

Box and knobs B3265 — \$48.00

## FM Transmitter

### HF65 FM TRANSMITTER 60-148 MHz

Will run 5w output with heat sink. Ideal for signal testing of for a miniature transmitter which could be received on a standard FM receiver. Kit HF65 — \$9.00.

## Receiver Converter

### HF305 VHF CONVERTER

Converts FM 105-148 MHz to

105 MHz

Kit HF305 — \$28.00

Box B3405 attractive

chassis kit — \$24.00

## AM Receiver

### HF61 MEDIUM WAVE

RECEIVER 540-1600 KHz receiver complete with ferrite coil antenna. Kit HF61 — \$9.00

## Power Supplies

### NT415 LAB POWER SUPPLY

0-30V 1 amp well-regulated supply for professional use.

Complete with box and transformer. Kit NT415 — \$128.00

### NT300 LABORATORY POWER SUPPLY

2-30V High quality supply, regulated

2-30V dc at 2 amps with overload

protection. Complete with box and

transformer. Kit NT300 — \$110.00

## Quick assembly kits

JK01 GENERAL PURPOSE AMP 0.5w \$18.00

JK02 MICROPHONE AMPLIFIER \$18.00

JK03 SIRE WAVE GENERATOR

20-20,000 Hz \$30.00

JK04 FM TUNER 88-108 MHz \$30.00

JK05 27 MHz RECEIVER \$33.00

JK06 27 MHz TRANSMITTER \$29.00

JK07 DUAL TONE DECODER FOR

R/C MODELS \$43.00

JK08 330Vac LIGHT OPERATED RELAY \$19.00

JK09 SIREN KIT inc. SPEAKER \$19.00

JK10 PHOTOGRAPHIC TIMER 240 Vac \$23.00

JK101 CAR BURGLAR ALARM KIT \$55.00

## New Kits

AT347 Electronic Roulette \$54.00

AT350 2 amp triac light controller \$12.00

AT357 Touch-control light dimmer \$33.00

AT356 6 amp AC regulator \$27.00

M1-360 Multivibrator, sq. wave to 10MHz \$6.00

SY-310 15w stereo amplifier kit \$230.00

SY-340 37W stereo amplifier kit \$289.00

JostyKits are available now from:

**Sydney:** Custom Communications, 6 Orchardleigh St. Yennora. Ph 631-3544.

Radio Despatch Service  
869 George St  
Sydney Ph 211 0816

**Adelaide:** Hamtronics,  
Goodwood Rd, Kingspark,  
Ph 272-8417. Port Adelaide.

International Communications Systems, 75-77 Dale St, Port Adelaide. Ph: 47-3688  
**Melbourne:** Eastern Communications, 898 Riversdale Rd Camberwell Ph 836 8635.

Tasman Electronics,  
12 Victoria St, Coburg  
Ph 354 5062.  
J.H. McGraths & Co. P/L,  
.208 Little Lonsdale St,  
Ph 663 3736.

**Brisbane:** Delsound,  
1 Wickham Tce  
Ph 229 6155  
**Launceston:** Advanced Electronics, 5A Quadrant,  
Ph 31 7075, Tasmanian Hi-Fi Company, 87A Brisbane St, Ph 31 5815.

Sydney 681 3544  
Adelaide 43 7981  
Gold Coast 32 2644  
Canberra 31 6685  
Melbourne 836 8635-  
Perth 321 3047  
Geelong 78 9660  
Rockhampton 28 2843  
Wagga 21 2125

Hobart 43 6337  
Cairns 54 1035  
Launceston 44 3882  
Brisbane 38 4480  
Wellington (N.Z) 28 7946

**Mall Orders:** Direct to VICOM, 68 Eastern Rd, Sth. Melbourne, Vic. 3205. **Enclose \$1 extra** for handling and postage costs

# VICOM



# High performance pulse generator

regulator IC.

Because the VMOS transistor has a significant saturation voltage, the LM317 is arranged to vary the supply voltage over a wider range than the desired range in output pulse amplitude. In fact it varies the supply voltage between 1.2V and 12V, for a pulse amplitude range of 1V — 10V peak to peak.

Note that this amplitude range corresponds to the no-load situation, ie,

open circuit output. Due to the fact that the generator has an output impedance of 50-ohms, the output amplitude will fall by 6dB if the output is fed into a matching 50-ohm load.

The output of the generator is taken from the drain of the VMOS device, via a DC blocking capacitor combination and a bleed resistor. These components

could be omitted if DC-coupled output were required, or alternatively you could fit a shorting switch across the blocking capacitors to provide a choice of AC or DC output coupling. This is a matter of individual preference.

There is a separate 12V regulator IC for the rest of the generator circuitry. Both regulators are fed with unregulated DC from a conventional bridge rectifier, fed in turn with 12V AC from an "AC plug-pack" or plug-in transformer. This keeps down the cost of the pulse generator itself, while at

## PARTS LIST

- 1 12V 500mA AC plug-pack transformer
- 1 utility box, 196mm x 113mm x 60mm
- 1 SPST momentary action push-button
- 1 SPDT miniature toggle switch
- 2 single pole 6-position rotary switches
- 1 Double pole 6-position rotary switch
- 2 100k linear rotary potentiometers
- 1 5k linear switch potentiometer
- 1 50k linear rotary potentiometer
- 1 PC board coded 79PG9, 59 x 91mm
- 2 RCA-type panel mounting sockets

### SEMICONDUCTORS

- 1 74C221 CMOS IC
- 1 74C14 CMOS IC
- 1 VN88AF VMOS FET
- 4 4 IN4001 or similar power diodes
- 1 LM340T-12 three-terminal regulator
- 1 LM317 three-terminal regulator

RESISTORS 1/4 watt: 100k, 3 x 10k, 4.7k, 470ohm 470ohm 5 watt.

### CAPACITORS

- 2 82pF polystyrene
- 2 .001uF greencaps
- 1 .0015uF greencap
- 3 .01uF greencap
- 1 .015uF greencap
- 3 0.1uF greencaps
- 1 0.15uF greencap
- 2 1.0uF 16VW tantalum
- 1 1.5uF 16VW tantalum
- 4 10uF 16VW tantalum
- 1 15uF 16VW tantalum
- 1 100uF 16VW tantalum
- 2 1000uF 25VW electrolytic

NOTE: Resistor wattage ratings and capacitor voltage ratings are those used on the prototype. Components with higher ratings may generally be used providing they are physically compatible. Components with lower ratings may also be used in some cases, provided the ratings are not exceeded.

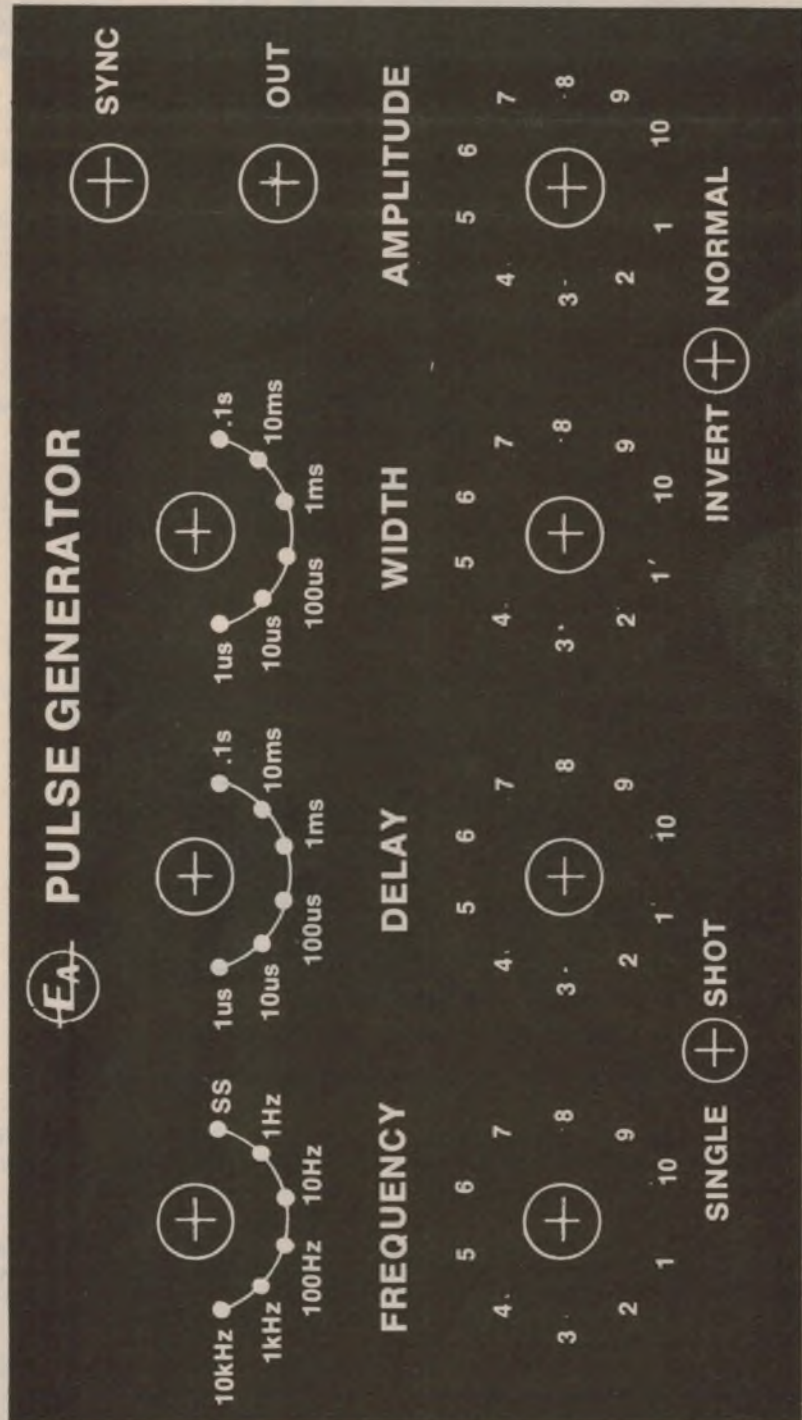

The front panel, reproduced full size. It may be cut out and used under a transparent sheet, and can also serve as a drilling template. Copies of artwork are available, and have also been distributed to label manufacturers.



## High performance pulse generator

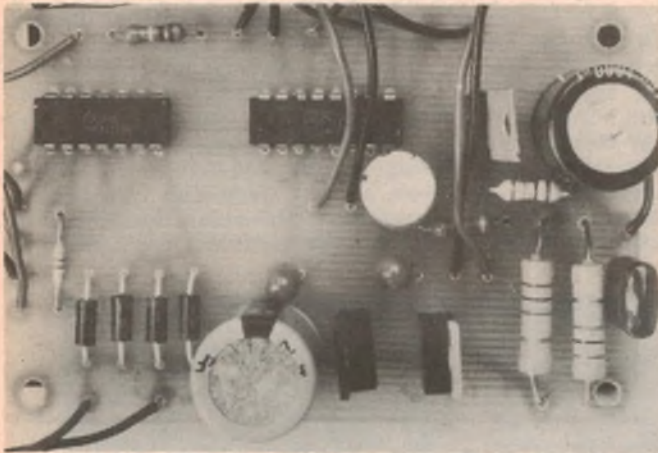

The component side of the printed board, showing the general layout. Compare this picture with the overlay pattern below.

Overlay pattern showing placement of all components on the printed board, and identifying the leads to the panel switches and pots. Watch carefully the orientation and polarity of all components.

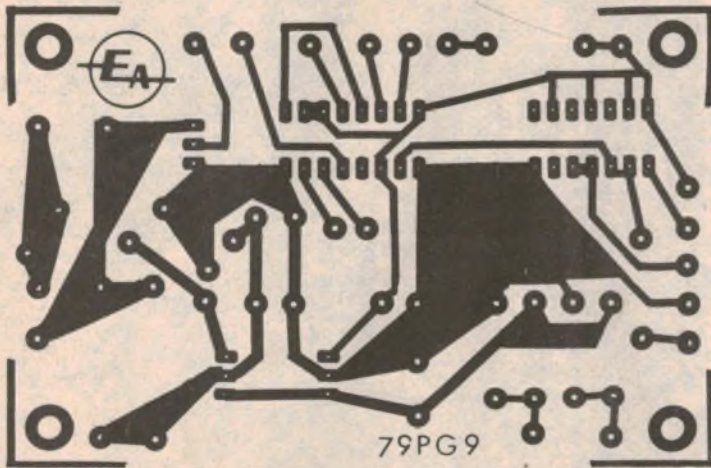
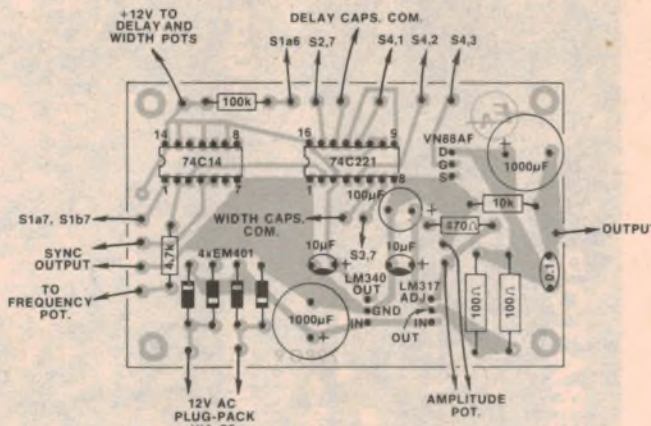

The printed board pattern shown exact size. Artwork has been distributed to the board manufacturers, and ready-made boards should be available by the time this article appears. Artwork is also available through our Information Service.

the same time allowing the plug-pack to be used to power a number of other instruments if desired. The AC plug-pack used with the prototype was a Ferguson type PPA12/500.

As you can see from the photographs, the prototype generator is housed in one of the low-cost plastic utility "zippy" boxes. The box we used measured 196 x 113 x 60mm. The front panel was given a professional look by

means of a "Scotchcal" photosensitised sheet, and the artwork used for this is reproduced here actual size for the benefit of readers who may care to do the same.

All of the components except the various timing capacitors, the range switches and the pots are mounted on a PC board measuring 93 x 60mm and coded 79PG9. The pattern for the PCB is reproduced here again actual size, for

those who may wish to trace or otherwise use it to make their own board. Patterns are also being sent to the various board manufacturers, so that ready-made boards should be available shortly.

Wiring up the PC board should be a relatively simple job, as we have produced an overlay diagram showing the parts placement and orientation. When you are wiring the board make sure that you insert the ICs and electrolytic capacitors the correct way around, and remember to observe the usual precautions when handling and soldering in the CMOS devices (including the VMOS output transistor). Make sure that the barrel and bit of your iron is connected to the "earthy" side of the PCB, and preferably solder the MOS devices into the PCB last of all.

The timing capacitors are mounted between the appropriate lugs of their respective switches and small tagstrips soldered to the backs of the pots, as you can see from the photograph. Lugs on the same tagstrips are also used to support the series resistors.

The output lead of the AC plug-pack is not provided with a plug, so we used a 2-pin DIN plug and socket of the type used for loudspeaker connections. Unfortunately while there is a cord-type socket, there is no panel-mounting plug, so we had to use a socket on the pulse generator and a plug on the input cable. This is not the best arrangement, but is probably acceptable as only low voltage is involved.

RCA phono-type sockets are used for the sync and main pulse outputs, to reduce cost. While not perhaps quite as suitable for an instrument of this type as higher-cost coaxial connectors, they are still quite satisfactory.

After completing the assembly of the generator, it is a good idea to check all components of the PCB for any errors. Similarly check the connections to the various controls, before applying the power. Having done this, the generator should spring to life as soon as power is applied.

No setting up is required, so that at this stage your new pulse generator should be ready for business.

## BASIC ELECTRONICS

Basic Electronics begins with the electron, introduces and explains components and circuit concepts, and progresses through radio, audio techniques, servicing, test instruments, etc.

Available from:  
"Electronics Australia", 57 Regent St,  
Sydney. **PRICE** \$3.50 OR by mail order  
from "Electronics Australia", PO Box  
163, Beaconsfield 2014. **PRICE** \$4.10.



# DISCO

Yes! Your next party can be just as exciting, vibrant and colourful as the best disco... splashes of colour and light to make any party really swing! Dick Smith has some fantastic disco gear and it won't cost you big money either...

## Musicolor Mk III

### STROBE

Turn out the lights, switch on your strobe light and 'freeze' the action - turns your party into a light show of distinction. Everything in this kit has been made to make its construction easy - even for the beginner. Kit includes photographic type reflector with perspex safety screen plus all electronic parts and case, to make a superb strobe with a variable flash rate of 1 to 20 seconds. Easy to follow but comprehensive instructions are included with each kit.

**'FREEZE' THE ACTION WITH A STROBE**

**\$29.50**



**UV TUBE**

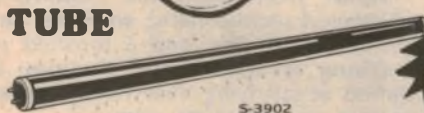

**\$29.95**

Not just a 'blued' tube - this is a true UV tube that will give fantastic effects when the normal room lighting is turned off. Clothes washed in certain brands of detergent will 'fluoresce' under this light to give weird and wonderful effects. The tube is rated at a standard 40 watts and has the normal two pin fitting.

**Also available and handy for disco installations:**

AC mains plugs Cat. P-5400 only 55c each; 3 core mains cable Cat. W-2055 @ 40c/m or if you buy a 100 metres or more pay only 35c/m; Heavy duty speaker cable Cat. W-2012 @ 18c/m or for 100 metres or more pay only 15c/m; Cordless soldering iron (has in-built rechargeable battery) complete with tip and charger for only \$26.00 Cat. T-1050 - plus many other 'bits and pieces' for your disco installation - Dick Smith Electronics the name behind successful consumer electronics.

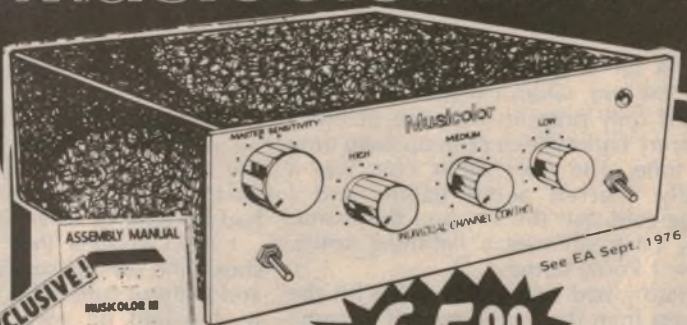

**EXCLUSIVE!**

**\$65.00**

Music into light! Audio information from your amplifier is used to control 3 channels of coloured lights - as the frequency changes the lights beat to the music using different levels of sound to give different light levels. Easy to construct by using the exclusive 16 page assembly manual. (For coloured lights see below).

See DPS for all P&P details



### DISCO COLOURED LIGHTS

**The Holder:** wall, floor or ceiling mount with swivelling base so you can 'place' your light.

**P-5620 \$3.50 each**

**THE FLOODS:** Screw into the above holder for use with Musicolor system

**YELLOW RED BLUE GREEN ONLY \$7.95 each**  
 S-3850 S-3852 S-3854 S-3856

### The Complete DISCO light system

A completely integrated unit with 30 lights in 5 different colours covering frequencies from very low to ultra high. Connect to your Hi Fi, plug into the AC, play your music and see the light show come to life! Presented in a wooden cabinet with multi-dimensional diamond pattern front for a colour show in depth. Size: 460(h) x 290(w) x 185(d)mm.

**\$79.00**

A-4950



# DICK SMITH ELECTRONICS



SEE OUR OTHER ADVERTS IN THIS MAGAZINE FOR OUR STORE ADDRESSES AND RESELLERS



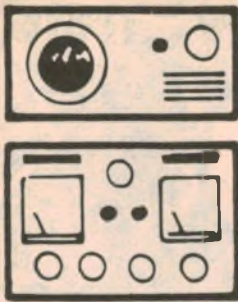

# The Serviceman

## When is an earth not an earth? A mystery solved?

Remember my story in the August issue about a colour set which suffered a vapourised copper track and burnt out picture tube heaters? Apparently this hit a raw nerve among fellow servicemen, who were only too eager to relate several similar experiences.

The set in question was a National TC-86A and, when I wrote the story, I could only present it as one of those mystery faults which crop up from time to time. The only other clue was a badly charred aerial balun, and I suspected that the set, and the mains, may have suffered a lightning strike. Now I know better.

Hardly had the August issue hit the streets than the stories started to come in. The first one was a phone call, taken by a member of the "Electronics Australia" staff, from a Mr E.W., of Nowra on the NSW south coast. The staff member made as many notes as possible, and passed them on to me.

Next came a letter from Mr M.W. of Surfers Paradise, in Queensland, and then another phone call, also taken by an "EA" staff member, from Mr I.R., of Brookvale, a northern Sydney suburb. All reported several cases of the same fault, but in differing circumstances, and offering different explanations.

Mr E.W. claimed that "... we have had, I suppose, 20 or 30 of these things." That statement was a bit of a shaker in itself but, even allowing for some unintentional exaggeration in casual conversation, it still sounds like a lot of sets — and a lot of picture tubes!

(Although there is no record of Mr E.W. having said so, I have an idea that he may be involved in installing and maintaining TV sets in a motel. He did say that they had a lot of these sets under contract, and I know they are a popular set in motels. This may be significant, in the light of the other reports.)

Mr E.W. went on to say that, while a detailed explanation was not feasible via a long distance telephone circuit, he offered the following suggestion. He feels that the particular section of copper foil is not heavy enough to carry the total earth current, under certain conditions of line voltage, and that it fails as a result. When it does, it leaves

the picture tube heaters as the earth return.

His cure for the problem was simple; he put "... a great lump of wire across the top of the printed board." (ie, in parallel with the copper foil) "We have had no failures whatever since."

I must confess that this suggestion shook me somewhat. In the first place, and without ruling the idea out entirely, I would be very surprised if the copper pattern in any set would be cut so fine that it would fail simply because of line voltage increases. Most power lines are pretty well regulated these days and, if they do vary, it is far more often down than up.

But I had to assume that he might be right, so I dug out the service manual and took a long hard look at the circuit. Unfortunately, I drew a blank here also. Study it as I might, I could find no way that such a set of conditions could be satisfied. I finally concluded that, if Mr E.W.'s theory was correct, it was because of something not obvious on either the circuit or the drawing of the board (designated board "G"). Maybe if I had a chassis in front of me it would be apparent, but I didn't have one immediately available.

Next came Mr M.W.'s letter from Surfers Paradise. (Fancy living in Surfers Paradise and having to spend your time repairing TV sets for a living!) Anyway, this letter was a real shaker. I would like to reproduce it in full, since he obviously has a keen sense of humour, but space does not permit.

In summary, it amounts to this: he was called to a motel where no less than three of these sets had failed at the same time in and exactly the same manner; a blown fuse, a vapourised copper track on the "G" board, and burnt out picture tube heaters. And, he adds, the same problem has occurred on several other occasions.

His theory, after much head scratching, is this; it is possible that

there was an arc-over in the picture tube with the strong possibility that it would involve the filaments, since these were closest to chassis potential.

Electrically, this makes sense: it could happen and the explanation is easy to follow. But three picture tubes developing internal arc-covers at the same place and at the same time? Surely that would have to be pushing coincidence a bit far; surely there would have to be a common factor.

But what?

I passed.

Then the "EA" office passed on to me the gist of Mr I.R.'s phone call. His explanation was, as nearly as I can gather, much more detailed than either of the other two. What is more, there appears to be no doubt in his mind as to the cause; the only difficulty is that, on his own admission, it is a quite complex explanation involving hardware and chassis connections not immediately evident from the circuit and service manual.

According to his theory the problem involves, among other things, the aerial system, at least insofar as the earthy side of the aerial is concerned. (An earthed aerial is not unusual and, in fact, is good policy in regard to lightning protection. A folded dipole can be mounted directly on a metal boom/mast combination which is solidly grounded, yet perform perfectly at signal frequencies.)

Apart from that, his comments, presented second hand, were not easy to follow. In the end I finished up evolving several original theories, all aimed at satisfying everybody's observations, including my own.

Finally, aided by access to another model of the same set which came in for service, I settled for one which I feel confident is the answer. It is also, I believe, what Mr I.R. was trying to get across. It fits his observations, those of the other two servicemen, and my own. This is the explanation as I see it.

This set really consists of three sections; the power transformer, the main chassis, and the tuner. The power transformer is mounted on its own bracket alongside, but separate from,



the main chassis, and the tuner is similarly mounted, on the cabinet, separate from the main chassis. The "G" board is mounted on the transformer bracket.

The crux of the problem is the manner in which these three sections, or chassis, are connected together, and to external earths. The mains cable is anchored on the transformer bracket and the active and neutral wires run to the respective ends of the primary. The mains earth wire connects directly to the transformer bracket, in accordance with the wiring regulations.

From this same chassis point a lead runs to point "G9" on the "G" board. Also, the earthy end of the 6.3V heater winding connects to "G9". The active side of the winding goes to the heaters, and the other side of the heaters to the main chassis.

The tuner chassis connects to the

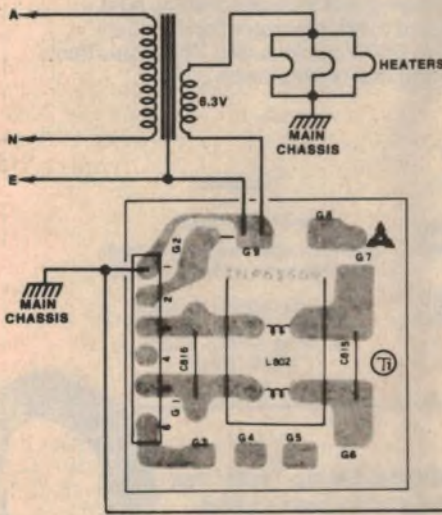

Simplified diagram showing the connections around the "G" board involving the mains earth, the chassis, and the earthed aerial. The length of copper foil between "G9" and pin 1 is the one which vapourises when the fault occurs.

main chassis via various cables and plugs, and the main chassis then connects to the transformer bracket via pin 1 of a 6-pin plug and socket assembly on the "G" board. Pin 1 is at the opposite end of the foil pattern from "G9". (It is this piece of foil which is destroyed.)

Now consider what happens if a fault occurs in an electrical appliance such as, say, a refrigerator, whereby the mains breaks down to the frame, which is earthed via the mains earth wire. For a few milliseconds, before the house fuse blows, the mains earth wire will be lifted above earth and towards 240V. (There are lot of variables here, such as the effectiveness of the mains earth, the length of run, whether the fuses might have been "strengthened," etc.)

While this condition exists the transformer bracket, "G9", and the earthy end of the heater winding will all be at this elevated voltage. But the main chassis, connected to the other end of this thin strip of copper foil, is separately earthed via the tuner and the aerial system. This puts the spurious earth wire voltage across this strip of foil, and vaporises it, which then leaves the picture tube heaters also between this

elevated voltage and the antenna earth, and it destroys these also.

On the basis of this theory a lot of previously unexplained facts suddenly make sense. For example; Mr M.W.'s three sets in the Surfers Paradise motel, all working from the same (earthed) aerial system and the same power supply. It would be "London to a brick" that there was a major appliance failure somewhere in the vicinity just before the sets were found to be faulty.

And if, as I suspect, Mr E.W.'s (Nowra) sets are in a motel, then exactly the same situation could exist. Which is rather frightening, when one considers that there might be a dozen or more sets in the one motel, all on the same aerial system and power wiring.

The choice of a refrigerator as the failed appliance in the above explanation was no accident, although it could just as easily be any other appliance. It

was, in fact, a refrigerator which caused one of the failures experienced by Mr I.R., the other point of the story being that the set was connected to a community aerial system, which was well and truly earthed.

The other incident he related was even more way out. In this case the handyman of the house had been working on the aerial mast, presumably strengthening it by welding some brackets to it — with an electric welder. When he went back inside he found he had no picture and, subsequently, that the copper foil, and the heaters, were both open.

Fortunately, that should be a rare one.

In summing up the problem Mr I.R. emphasised the need for all aerial systems, particularly community systems in motels, blocks of flats etc, to be DC isolated from the receivers. Unfortunately, according to him, it was difficult (at that time) to convince those concerned of the need for this.

Since then the Standards Association of Australia have issued standards covering the aerial connections within TV sets (Australian Standard AS3159) which specify that both aerial connec-

## printed circuits

- Accurately machine printed etched
- Phenolic & fibreglass-gold tin plated
- EA R & H ET Philips Mullard available
- Specials to your drawing
- POSTAGE small 80c large \$1.10.

ET573	2.80	ET577	2.80	ET473	3.50
790M9	3.00	79PS10	2.80	79R18	2.80
79RR8	4.20	79SF10	2.50	79AL9abc	4.20
79BT9	2.60	79TT7	2.60	79W9	2.80
79AC9	3.50	79SF9	2.60	ET731	3.00
ET576	4.20	ET574	2.80	ET575	3.00
ET730	3.50	ET814	2.80	ET725	3.50
ET252	3.00	79SR8	2.80	79TRF5	2.50
79WFB	3.20	79UT8	3.00	79M8	2.80
79PS6	2.80	79FR6	3.50	ET148	2.50
ET 451	2.50	ET472	3.00	ET724	2.20
6.800	8.50	79CL7	4.80	79KB7	2.80
79UPS6	2.50	79SAS	8.00	ET651	4.50
ET144	3.50	ET254	2.50	ET471	5.50
79R05	3.00	79EQ2C	2.50	79EQ2B	4.00
7EQ2A	3.50	ET249			2.50
		ET249		ET594	2.50
ET320	2.20	ET253		ET470	3.20
ET595	2.80	7905		79A3	3.00
491	4.50	559	3.80	721	3.00
79PS3	2.60	79SE3	4.00	79PB2	3.20
79PIB	2.80	79PIA	2.80	79C1B	2.80
79C1A	3.00	558	2.50	557	3.00
142B	4.00	142A	8.00	79UP1	5.00
79S1	4.50	79W3	2.60	79CL1	2.60
791T2	5.00	79SB12	3.00	79S12B	2.20
79S12A	5.50	791M12	3.00	79UP10	7.00
79N10	2.60	79C11	3.10	79DT10D	2.00
79DT10C	2.50	79DT10B	2.80	79DT10A	6.50
ET813	3.50	ET143	2.80	ET141	4.20
ET812	2.80	ET593	3.20	ET490	2.80
ET556	6.00	79DB11	2.80	79UP9	6.00
79BBd9	3.50	555	4.00	650C	2.60
650B	2.60	650A	4.00	138	3.80
718	2.60	553	3.00	811	3.30
590B	8.00	590A	8.00	79MC10	4.00
79E09	2.50	ET605	7.00	ET391B	2.50
ET391A	2.50	ET551	3.00	ET641	4.50
ET591C	2.20	ET550	2.80	ET592	4.50
79UT9	16.00	79MX9	3.30	79T9	2.30
79UM8	2.60	79CL8	3.00	ET638B	3.00
ET638A	4.00	ET248	2.30	ET318	7.00
ET591	4.00	ET810	2.60	79TM8	2.80
79TSC7	2.50	79PT7	2.50	79VBG7	3.50
ET137B	2.80	ET137A	3.50	ET139	2.50
ET717	3.50	ET587	7.00	ET640	16.50
79F6B	3.50	79N	2.80	79A06	2.80
246	4.00	489B	2.50	489A	2.80
79CD4	2.60	79PS5	2.50	79C5	3.20
79UP5	5.00	ET140D	4.00	ET140A	14.00
ET1140P	5.50	ET136	2.50	ET487B	7.50
ET487A	7.50	ET588 20	10.00	79NG4	3.00
79UT4	4.00	79EK3	3.30	79T3	3.60
79B2	3.00	791A2	2.60	ET450B	2.60
ET450A	2.80	ET716	4.00	ET715	3.00
ET486	3.20	ET245	2.50	79C2	3.00
79AF2	3.00	79S3	2.60	79CF1	2.80
77CB12	2.60	77PH12	2.60	77PM12	3.50
ET135	3.00	ET586	2.80	77MX11	2.50
775C11	3.80	77PS11	2.50	77UP6A	3.00
77MX11	2.50			77PS11	2.50
ET604	2.50	ET585 R	3.00	ET635	2.80
ET713	3.00	ASC11	2.80	77UP11	6.50
77TS9	3.00	ET603	3.00	ET583	2.50
ET134	2.60	77AL8	2.50	77T10	2.50
77DVM9	2.80	ET065			2.20
ET067	2.20	ET063	2.50	ET083	2.20
ET072	2.50	ET085	2.50	ET084	2.50
ET485	2.80	ET484	3.00	ET581	3.00
ET481M	2.50	ET582B	2.60	ET582A	2.50
ET547	2.50	ET317	2.50	ET712	2.50
77D7	2.50	7787	2.80	77DL77	6.00
77UP6	3.50	77TY7	2.80	77QB77	3.20
ET631/2	4.50	ET481PS	3.00	ET444M	2.50
ET444S	3.00	ET316	2.50	ET549A	2.50
ET548	3.20	77TY6	2.50	HMS276	6.00
77PTY7	2.80	77TY6	2.50	ET133	2.60
77E05	3.50	77PRE5	2.50	77UP5	8.50

### ALL SILICON 30/60w PA PORT AMP

6 1/2" W x 8 1/2" D x 3 1/4" H 12 — 16V two inputs 5 & 100mV. 125. 250 500ohm output only. No. 763A \$70 ea. 240V operation \$33 extra. Freight collect.

COILS and IF's All \$2.60 ea plus post 60c  
3/4" W x 1/2" D x 2" H

MAIL cheque or money order  
(add postage) direct to —

**RCS radio pty ltd**  
651 FOREST RD BEXLEY  
NSW 2207 587 3491





# PUTS YOU YEARS AHEAD!

On the job, in the lab, or the classroom you want the most advanced equipment you can get. Anything else is time-wasting and cumbersome. So have a look at the Hioki range — particularly these new multitesters.

They have such advanced features, are so sensitive and accurate, that they make the testing jobs easy. Let us demonstrate the advantages.

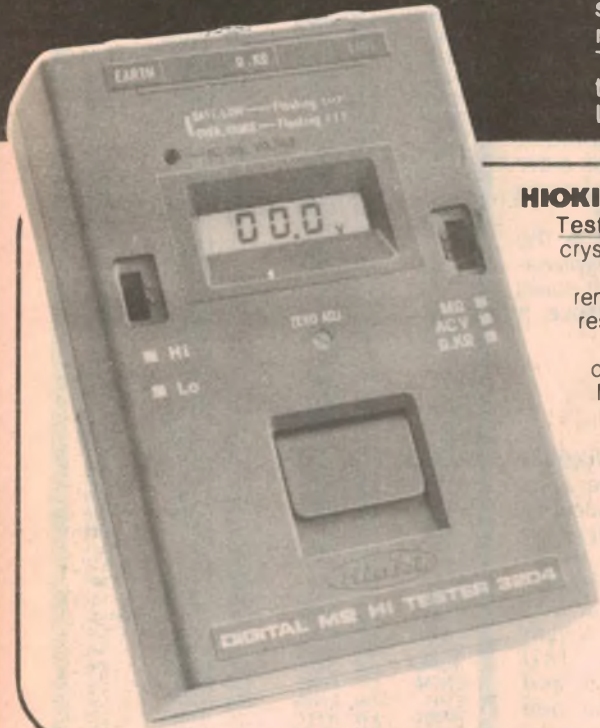

**HIOKI 3204 B** Believed to be the world's first production Digital Insulation Tester, the Hioki 3204B offers wide test ranges, high accuracy and a FE liquid crystal display.

Designed to meet Australian requirements, this 500 Volt instrument remains within specified lower terminal voltage limits when connected to low resistance loads. Output voltage is typically 495 Volts into 2 Megohms.

The model 3204B is Semi-Auto Ranging and includes display hold, overreading indication, battery check and overload protection facilities. Measurements facility for AC voltage to 500 Volts included. The instrument is supplied with one lead with probe and one red lead with clip.

### Specifications

#### Reading Ranges and Tolerances

Function	Range	Lo	Hi	Tolerance
M $\Omega$		1.999M $\Omega$	199.9M $\Omega$	$\pm 2\%$ rdg $\pm 3$ dgt
		19.99M $\Omega$	1999M $\Omega$	500M $\Omega$ under: $\pm 4\%$ rdg $\pm 2$ dgt 501M $\Omega$ over: $\pm 5\%$ rdg $\pm 2$ dgt
$\Omega$ -k $\Omega$		199.9 $\Omega$	19.99k $\Omega$	$\pm 1\%$ rdg $\pm 0.5\%$ f.s $\pm 1$ dgt
		1999 $\Omega$	199.9k $\Omega$	
ACV		199.9V - 500 V (Hi or Lo)		$\pm 1\%$ rdg $\pm 1\%$ f.s $\pm 1$ dgt (40Hz-70Hz)

**HIOKI 3205** Digital Multi Tester Compact multimeter featuring Semi-Auto Ranging, electronic and fuse protection and approximately 40 hours continuous operation with alkaline batteries. Among the many advantages are overrange indication, auto polarity and automatic battery condition indicator.

### Specifications

- DC V 0-200mV/2000mV/20V/200V/1000V 10M $\Omega$
- AC V 0-200mV/2000mV/20V/200V/1000V 10M $\Omega$
- $\Omega$  0-200/2000/20k/200k/2M/20M
- DC A 0-200 $\mu$  A/2000 $\mu$  A/20mA/200mA
- AC A 0-200 $\mu$  A/2000 $\mu$  A/20mA/200mA



**HIOKI 3206** Digital Clamp Tester has FE liquid crystal display, reading hold facility and surge hold for motor start readings. A special 0-20A range provides 0.01A resolution. This Auto Ranging instrument enables current measurements to be made without breaking the circuit. In addition, voltage and resistance measurements can also be made.

The circuit design ensures low battery power consumption providing approximately 100 hours continuous use with alkaline batteries. Overrange indication and battery exhausted warning are among the many features of this instrument.

### Specifications

- AC A 0-19.99 (Push Button)  
0-199.9/1000A (Auto)  
Surge Current 0-1000A
- AC V 0-199.9V/1000V (Auto)  
Surge Voltage 0-1000V  
0-199.9/1999 $\Omega$  (Auto)

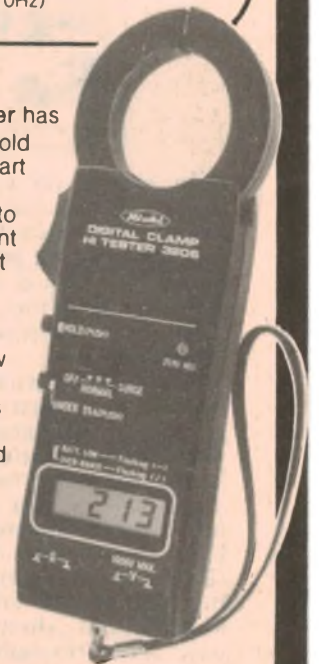

## A wide range of optional accessories also available

Hioki Multitesters are available through your favourite stockist or electrical wholesaler. If he does not have the model of your choice ask him to order it for you. For further information contact:—

SYDNEY 6016600

MELBOURNE 3296511

ADELAIDE 466411

BRISBANE 525231

PERTH 4466622

## H. ROWE

& CO. PTY. LTD.





## THE SERVICEMAN

tions be effectively isolated for both DC and low frequency (ie, mains) AC. This is primarily a safety measure to prevent the aerial becoming live in the event of a catastrophic failure within the set — but it also obviates the problem I have just outlined.

In regard to aerial distribution systems it seems that there are no requirements in regard to DC isolation as yet, although the SAA are considering the situation.

This theory also fits my own experience, including the charred balun. The balun is supplied with the set, as an accessory, and constitutes a DC path. The only point not covered so far concerns the aerial, and if, and how, it was earthed. The answer is simple; the customer lives in a home unit fitted with a communal aerial, though I must confess that the significance of this eluded me until now.

One other important point should be considered here. All of the incidents related, with the exception of my own, occurred some four or more years ago, not long after these sets first appeared on the market.

Which brings me logically to the next point. What do the makers, National, have to say about this problem? I had a long talk with the service department in Sydney, who gave me their side of the story.

They recalled that they encountered one or two such cases shortly after these sets went on the market and, as can be imagined, there was no immediately obvious reason for the failure. As a result, they put the problem to the National engineers in Japan, where the sets were then being made.

On the basis of only one or two incidents, and without knowing what other circumstances might have prevailed, the Japanese engineers suggested that it was due to internal arc-over in the picture tube; the same explanation as that offered by M.W. of Surfers Paradise.

(My own thoughts here suggest that there may have been two other factors to cloud the issue; possible communication problems, and a failure on the part of the Japanese engineers to appreciate fully the nature of our three wire mains system, which is not customary in Japan.)

Anyway, whatever the reasons, that was the verdict. And they further suggested, presumably to at least protect the board, that the relevant length of copper foil be bridged with a length of hookup wire.

From then on all sets made in Japan were modified in this way, as were all the sets which were subsequently made in Australia. Which left a small, but

significant, quantity of sets still in the field with this potential fault.

It was one such which I encountered, and undoubtedly there are others still around. It would be a good thing to watch out for whenever you handle this model set. If it has not been modified you can do your customer a good turn by doing it for him. He may never fully appreciate, or even know, how much money you might save him, but at least you will know you have done the right thing.

Having established the mechanism by which this trouble can occur, one is inclined to wonder how far away the appliance fault could be and still be dangerous. Would the set still be at risk if the fault was in house next door? Or several doors away?

For what it's worth, I recall an incident involving a colleague and a succession of blown fuses. It happened one night while he was in his workshop, and the power fuses suddenly blew. Not knowing what caused it he unplugged his workbench, plus the TV set, etc in the house, and replaced the fuse, which held.

He reconnected the TV set and other domestic appliances without incident, then went back to the workshop and plugged in the workbench. Bang! Out went the fuses again. Well, at least he knew it was something on the bench.

He unplugged all the equipment on the bench, replaced the fuse, then plugged in each piece of gear one at a time. And, of course he found the faulty item by the simple process of blowing the fuses yet again!

So what's the point of the story? Simply that, a couple of days later, while mowing his lawn, he was chatting to a neighbour from three doors away. The neighbour was worried that there was something wrong with his house wiring because, he explained, a couple of nights ago his circuit breaker tripped out three times in about half an hour, for no apparent reason!

Nuff said!

I also wonder whether this kind of fault is confined to the particular set. Right now a colleague has another set of well known brand on his bench in which every board has a section of copper track destroyed, along with several solid state devices on each board.

Replacing the boards cost the best part of \$400, and the owner might have been better off to heed my colleague's advice to cut his losses. As it was, my colleague nearly had a nervous breakdown trying to find the cause before he fitted the new boards. He found nothing and was eventually forced to fit the boards, close his eyes, put his fingers in his ears, and switch on.

In fact, the set ran perfectly, so he may never find the cause. But, having heard my story he has gone back to have another look at the whole situation to see if something similar might have happened to this set.

## ROD IRVING ELECTRONICS

499 HIGH STREET,  
NORTHCOTE 3070  
MELBOURNE,  
VICTORIA.

Ph. (03) 489 8131.

### SUPER SPECIALS

#### COMPONENTS

2114 s	\$6.25
2708	11.00
741 s	10 up 2.50
555 s	10 up 2.90
BD139 s	10 up 4.50
BD140 s	10 up 4.50
SC141D	10 up 1.10
SC151D	10 up 2.10
Red Leds	10 up 1.40
Red Leds	100 up 11.00
Yellow Leds	10 up 2.90
8 Pin I/C Skts	10 up 2.00
BC 547	10 up 1.00
BC 548	0.15 ea
BC 549	0.19 ea
MJ802	3.60 ea
6800 50V Caps (Lug)	4.50 ea
5600 40V Caps (PCB)	1.90 ea
Pots Single Gang Carbon	
All Values Except 100 ohm	0.50 ea
Quality Single Turn	
Cermet Pots Most Values	0.99 ea
Quality 10 Turn Pots	
Most Values	7.50 ea
Computer Cooling Fans	
4.68in Square	27.50 ea

### KITS & PRINTED BOARDS

(KITS OF PARTS INCLUDE QUALITY FIBREGLASS BOARDS)

SERIES 4000 AMP	
Front Panel	7.99 ea
ETI 470 60W	19.90 ea
ETI 480 100W	19.75 ea
ETI 480 50W	16.50 ea
(BOTH INCLUDE HEAT SINK BRACKET)	
ETI 470PS	18.50 ea
(INCLUDES RELAY NOT TRANSFORMER)	
Transformer to suit	22.90 ea
ETI 471 Preamp	45.50 ea
EA 79 SF9 Sound Trigger	15.00 ea
All Parts and Board available for	
Dream Computer	
ETI 574 PCB Disco Strobe	2.80 ea
ETI 549A Metal Detector	2.75 ea

We are also stockists of audio products, mics, mixers, speakers (Phillips, Magnavox) Neutrik Audio Connectors (Cannon Compatible) Solder, Irons, Car Speakers, etc. Phillips 12" 3 Way Speaker Kits (AD12K12) \$295.00 pr.

HEAVIER ITEMS ADD ADDITIONAL POSTAGE. EXTRA HEAVY ITEMS SENT COMET FREIGHT ON. PRICES SUBJECT TO CHANGE WITHOUT NOTICE SEND 40c & S.A.E. FOR FREE CATALOGUE.

MAIL ORDERS: PO BOX 135  
NORTHCOTE, VIC 3070  
MIN PACK & POST \$1.00



**in the time it takes for  
shot to travel the  
length of this  
barrel . . .**

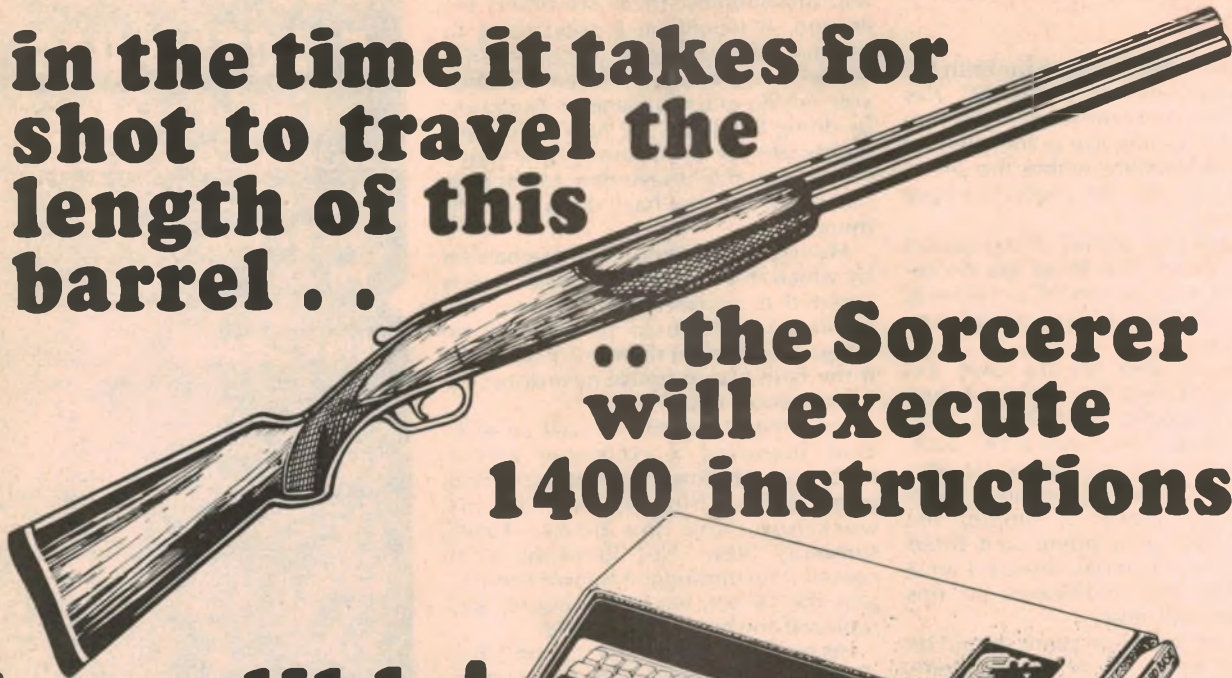

**.. the Sorcerer  
will execute  
1400 instructions**

**incredible!**

The Sorcerer is the personal computer with the speed, the features, the flexibility and the right price. This speed, power and flexibility is all standard with the Sorcerer.

The only other things you need to be up and running are a video monitor (Cat. X-1196) and a cassette recorder (Cat. A-4092).

No other computer can compare at the price of the Sorcerer. Come in to any of our stores and see the Sorcerer in action. You'll be convinced.



**8k \$1095**

Cat. X-1190

**16k \$1250**

Cat. X-1192

**ROM PAC™s**

Simply plug in to the Sorcerer — replacing the Standard BASIC PAC included. The following are now available — and there are more on the way!

- Word Processor PAC™ (inc data) . . . Cat X-3085 . . . **\$249.50**
- Development PAC™ (inc data) . . . . . Cat X-3090 . . . **\$139.50**
- EPROM PAC™ . . . . . Cat X-3095 . . . . . **\$75.00**

**Software tapes**

Three exciting games programs — pre-recorded on cassette for use with the Sorcerer.

- Cat. X-3600 Yahtzee **\$9.95ea**
- Cat. X-3602 Blackjack
- Cat. X-3604 Wumpus **More on the way!!**



**Upgrade to 16 or 32k**

Two 16k memory expansion kits — one to suit Apple and TRS-80 owners, and another for the Sorcerer. All ICs are Prime Spec. and fully guaranteed. Full instructions included.

- Cat. X-1185 Suits Sorcerer **\$149.50**
- Cat. X-1186 Suits Apple & TRS-80

**S-100 Expansion**

Adapts the Sorcerer to the popular S-100 bus — so you can use hundreds of different peripherals.



Cat. X-3010 **\$399.00**

TERMS AVAILABLE TO APPROVED CUSTOMERS MAIL ORDERS WELCOME — SEE OUR OTHER ADS FOR DETAILS

**COMPARE THE SAVINGS!**

If you're buying a computer, you'll want to know how much extra memory will cost . . . The Sorcerer can be as little as 1/2 the TRS-80 cost in \$\$\$ per kilobyte — the real cost!

SORCERER: 143k byte \$1274.00 (\$8.91/kbyte) 77.5k byte \$1178.00 (\$15.20/kbyte)

If you want even more memory: 615k byte \$2349.00 (\$3.82/kbyte) 315k byte \$3215.00 (\$10.21/kbyte)

Make the right choice NOW — buy the Sorcerer. Then when you need storage, it won't cost you an arm & a leg. Even if you're stuck with a TRS-80 — see Dick for storage anyway. You'll save 27% over Tandy's price & get 14% extra capacity too with our X-3230 Dick Smith Mini Disk Drive!

**Micropolis**

Dual density disk drive

143k capacity

**\$875.00** Cat X-3200



PRICES CORRECT AND STOCK AVAILABLE AT TIME OF GOING TO PRESS

**DICK SMITH ELECTRONICS**



SEE OUR OTHER ADVERTS IN THIS MAGAZINE FOR OUR STORE ADDRESSES

Ask for our comparison of the Sorcerer, Apple and Tandy computers. The Sorcerer is actually 20% cheaper than a comparable Tandy TRS-80 and over 50% less than a similar Apple II!



# Circuit & Design Ideas

Conducted by Ian Pogson

Interesting circuit ideas and design notes selected from technical literature, reader contributions and staff jottings. As they have not necessarily been tested in our laboratory, responsibility cannot be accepted. Your contributions are welcome, and will be paid for if used.

## Six digit facility for four digit clocks

Most of the digital clocks on the market today are of the four digit variety. I have a method which may interest readers who have a four digit clock and who may wish to add seconds to the already existing hours and minutes display. A simple and straightforward multiplexing method is used with a minimum number of components to reduce cost and complexity.

As shown in the diagram an MM5387 clock chip is used. The circuit is for common cathode LED display. Common anode LED display may be used with the necessary alterations. The tens of hours and hours outputs from the IC are connected as usual. The tens of minutes and minutes are connected in parallel with the tens of seconds and seconds segments, respectively. Two gates IC1 and IC2 of a quad NAND gate SN7400 were made into an oscillator, switching IC3, IC4 and Q3. IC3 and IC4 switch Q1 and Q2, respectively. Q1 and Q2 control the displaying and blanking of seconds and minutes displays. Q3

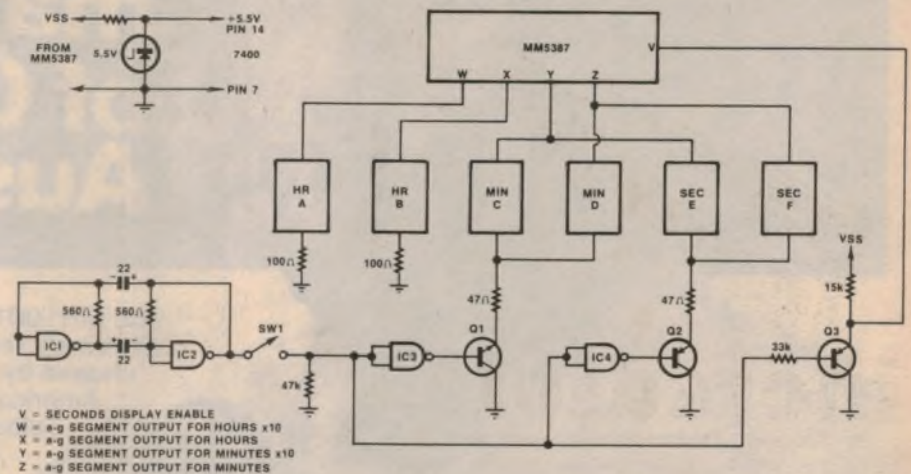

switches the seconds display.

As the oscillator operates at about 200Hz, the multiplexed displays of minutes and seconds appear to be continuous. The circuit has been fully tested and works very well. The only

problem was in setting the time. SW1 has been included to cut off the six digit function, the time being set with SW1 in the Off position.

(By Mr Ratman, 154 Permatang Tengah, Balik Pulau, Penang, Malaysia.)

## Autodim for fluorescent clock displays

This circuit will automatically adjust the brightness of a fluorescent clock to track the ambient light while maintaining equal output from digit to digit. The details shown apply specifically to a "Micronta" clock but the general principle should suit most fluorescent clocks.

The circuit controls the average current through all digits by rapidly turning the display on and off. This is interpreted by our eyes as a steady glow with the brightness determined by the ratio of on to off. IC1 is an oscillator with a frequency and duty cycle controlled by the level of illumination falling on RX, a light dependent resistor. Transistor TR1, and hence the display, is turned on for a period set by R2, C1 and off for a period determined by RX, C1. Since the resistance of RX is a function of the illumination falling on it, then so is the average current through the display.

R1 prevents the display from becoming too dim at night. A value of 10M

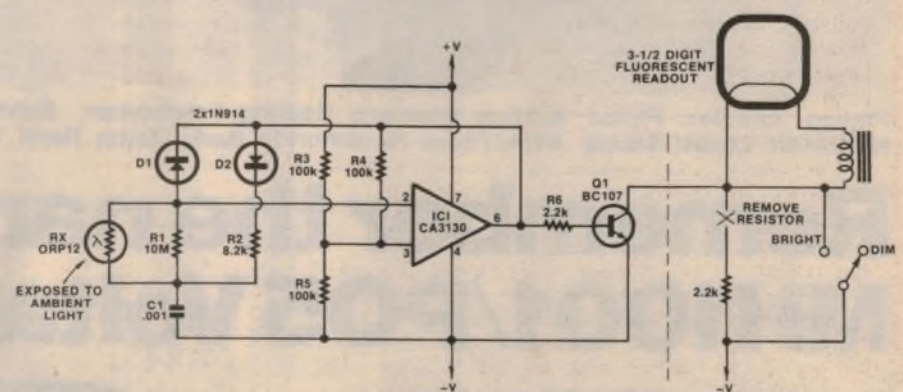

was ideal in the prototype but this may be changed to suit individual preference.

Some clock integrated circuits provide for a control voltage (pin 23 on the MM5316) and this pin requires a positive-going pulse. To make use of this input a few changes should be made to Autodim circuit as follows:

(1) Reverse the polarity of diodes D1

and D2.

(2) Replace TR2 with a PNP type (such as a BC177) and connect the emitter to Vss.

(3) Wire the TR1 collector to the control voltage input pin in lieu of the filament.

(By Mr W. Gummerson, 13 Hindmarsh Road, Liverpool, NSW 2170.)





# Stock one TRIPLER and you can service the majority of CTV's in Australia

The MH1001/PO5 manufactured by Varo is the extremely reliable 32KV Silicon Voltage Tripler chosen by many leading TV manufacturers in America, Europe and Australia for their colour TV production.

Soanar Electronics Pty. Ltd. now have substantial stocks of this Tripler available for use as direct replacements or substitutes in the repair or servicing of television sets.

The Varo MH1001/PO5 replaces Philips, Ero, Roederstein, Procon, AEG, Siemens and Origin Triplers and can be used in the following brands of CTV receivers:

Philips Kriesler Philco Korting Siemens Healing Telefunken Schaub Lorenz Norge Blaupunkt ITC  
HMV/EMI Luxor Graetz AWA/Thorn Nordmende Barko Saba Rank Pye Luxor Grundig Decca Autovox

## Remember the name! VARO MH1001/PO5 Voltage Tripler

By stocking one 'universal' type Tripler, you can reduce your inventory and save time, space and costs.

What is more, Soanar can provide circuits for utilising the MH1001/PO5 in those earlier model CTVs, as well.

**Available in every state.  
Just phone us.**



### SOANAR

**Soanar Electronics Pty Ltd**

A member of the A & R Soanar Electronics Group  
30 Lexton Road, Box Hill, Vic., 3128. Australia

SALES OFFICES  
VICTORIA: 89 0661  
N.S.W.: 789 6733

STH. AUST.: 51 6981  
QUEENSLAND: 52 5421  
WEST. AUST.: 381 9522



# Understanding BASIC

Here is part 2 of the author's easy to read introduction to the Basic programming language, used on just about all of the new personal computers. He shows you how to get your computer to do things a controlled number of times, and how to get it to make decisions.

by PETER A. STARK

The tremendous power of the computer comes from the fact that programs, or portions of them, can be repeated over and over. Suppose we add one more line to the last program we tried in part 1:

```
# 10 PRINT "WHAT IS YOUR NAME?"
# 20 INPUT N$
# 30 PRINT N$, "IS A NICE NAME"
# 40 GO TO 30
```

and run it again:

```
# RUN
```

```
WHAT IS YOUR NAME?
```

```
? PETE
```

```
PETE IS A NICE NAME
```

```
PETE IS A NICE NAME
```

```
PETE IS A NICE NAME
```

```
PETE IS A NICE NAME
```

```
PETE IS A NICE NAME
```

```
PETE IS A NICE NAME
```

```
PETE IS A NICE NAME
```

```
PETE IS A NICE NAME
```

```
PETE IS A NICE NAME
```

and so on . . .

Computer experts would now say the computer is *stuck in a loop*. It would keep on printing out the same line over and over if we didn't stop it by pushing a button on the control panel. Our last line, line 40, is the culprit. It told the computer to go back to line 30 and repeat from there. Thus the computer does the printout in line 30, and the very next line sends it right back to do another printout, and so on. This is an *infinite loop*, since it never stops — unless we push a button to stop it, that is.

A better way of controlling a GO TO is with an IF instruction. For example, we can say IF X=3 GO TO 30, and the GO TO will only be done by the computer if the value of the variable X happens to be 3.

Let's change the above program so it will ask for a name, and will only print out "IS A NICE NAME" if the name happens to be PETE; otherwise, the computer will answer that the name is a poor one:

```
# 10 PRINT "WHAT IS YOUR NAME?"
# 20 INPUT N$
# 30 IF N$ = "PETE" GO TO 60
# 40 PRINT N$, "IS A POOR NAME"
# 50 GO TO 10
# 60 PRINT N$, "IS A NICE NAME"
# 70 GO TO 10
```

As before, the computer asks WHAT IS YOUR NAME. If you answer PETE, then line 30 tells the computer to go to line 60, so that it will print the name again, followed by the words IS A NICE NAME. For any other name, the computer will not go to line 60, but will instead continue to line 40 and print IS A POOR NAME. Either way, a GO TO 10 returns to the top, so the computer asks for another name. Let's run it to see what happens:

```
# RUN
```

```
WHAT IS YOUR NAME?
```

```
? SAM
```

```
SAM IS A POOR NAME
```

```
WHAT IS YOUR NAME?
```

```
? GEORGE
```

```
GEORGE IS A POOR NAME
```

```
WHAT IS YOUR NAME?
```

```
? PETE
```

```
PETE IS A NICE NAME
```

```
WHAT IS YOUR NAME?
```

```
?
```

As before, the computer is stuck in a loop since it keeps returning to step 10. This is usually not quite what we want.

A good loop is one which has an end to it. In some way, we like to tell the computer when to get out of the loop. One common way is to count the repetitions of the loop, and stop at some predetermined number of them. For example, the following program prints out the numbers from 1 to 12 and their squares:

```
# NEW
READY
# 10 LET N = 1
# 20 LET S = N*N
# 30 PRINT N, S
# 40 LET N = N + 1
# 50 IF N < 13 GO TO 20
```

Line 10 starts the number N at 1; line 20 squares it by multiplying it by itself; line 30 then prints the number N and its square S. Now, line 40 says something a bit different from what a mathematician would expect from  $N = N + 1$  (which is not really a good equation after all.) What it means is that the computer should take the value of N, add 1 to it, and then place the result back as a new N. In other words, line 40 adds 1 to N. Since N started at 1, it is now 2. But since this is in a loop, in a little while N will go to 3, and then 4, and so on, all the way up to 12.

The symbol < in line 50 means *less than*, so this line says "if N is less than 13, go back to line 20." But eventually N will go from 12 to 13, and when that



BASIC is also used to program many small microcomputer development systems, like this one from the Italian firm SGS-Ates.



# NDK

## SERIAL PRINTER

# S-2000



- 8085 Microprocessor controlled single board electronics
- Quiet operation
- Simplified mechanism with minimal moving parts
- Front or back paper feed
- 170 cps bidirectional printing, 42 ips automatic space skipping
- 4in - 15in paper
- AC voltage selector, 100-240 volts AC
- 10 CPI 11.7 CPI, 5 CPI
- 9 x 7 Dot Matrix
- 6 months warranty
- Stand and interface included in price.

*Sole Australian distributor*

**JOHN F. ROSE**  
COMPUTER SERVICES PTY LTD

*OEM enquiries welcome*

AMA HOUSE  
33-35 Atchison Street  
ST LEONARDS 2065

Tel. (02) 439 1220  
AH (02) 328 6683  
Telex: AA 27901

*For the enthusiast looking for value — a stock clearance sale of items in an as-is condition without warranty. All items inclusive of sales tax.*

21L02 RAMS	\$0.90	ITHICA AUDIO S-100		PRINCESS B/W	
1602-B UARTS	\$4.25	Z-80 CPU CARDS	\$100.00	12in PORTABLE TV	\$50.00
C-8251 USARTS	\$4.50	ITHICA AUDIO S-100 VIDEO		1 ONLY EXIDY SORCERER 32K	
N8T26	\$1.60	BOARD (NO DOC)	\$80.00	CASSETTE AND EXPANSION	
6502 CPU CHIP	\$8.00	SOLID STATE MUSIC VIDEO		INTERFACE	\$1500
2513 CHR GEN	\$5.00	board s-100 64 x 16	\$140.00	1 ONLY OHIO	
44 PIN PCB EDGE		16K STATIC MEMORY		SCIENTIFIC C2-4P	
CONNECTORS	\$2.70	S-100 BOARDS	\$200.00	COMPUTER IN PIECES	\$300.00
63 KEY UNCODED		MPI DISK DRIVES		MATCHING TIMBER	
KEYBOARDS	\$46.00	5 1/4in WORKING CONDITION	\$260.00	DRIVE AND CPU	
GEORGE RISK KEYBOARD				CASES (NEEDS WORK)	\$800.00
CASES	\$60.00				





Many of the small computer systems now starting to be used in business are programmed in BASIC, like the one shown here. (Courtesy Computerland)

happens, line 50 no longer sends the computer back to line 20. So we have here a loop which is repeated exactly 12 times.

The IF statement is very useful, since it allows checking whether two things are equal or not. In addition to the less than or < symbol, we also use > which means greater than. The combination <>, means less than or greater than, which is the same as saying not equal, so IF X <> 5 GO TO 300 means that if X is not equal to 5 the computer should go to line 300. Moreover, instead of ending the IF with a GO TO, we can also end with the word THEN followed by any other valid Basic instruction. Our program to judge whether a name is nice or not could have been written with these two IFs:

```
# 40 IF N$ = "PETE" THEN PRINT N$,
"IS A NICE NAME"
# 50 IF N$ <> "PETE" THEN PRINT N$,
"IS A POOR NAME"
```

Two other combinations are <= which means less than or equal, and >= which means greater than or equal.

The idea of using a variable to count the repetitions of a loop is so common and useful that Basic has a special pair of instructions just for that purpose — the FOR and NEXT pair. These always go together, the FOR at the start of the loop and the NEXT at the end. To see how they work, let's rewrite the program to square the numbers from 1 to 12:

```
# NEW
READY
# 10 FOR N = 1 TO 12
# 20 LET S = N * N
# 30 PRINT N, S
# 40 NEXT N
```

Line 10 tells the computer that N is the counter, and it is supposed to vary from 1 to 12. Initially, N starts at 1, and the computer continues down through the following steps until it gets to NEXT N. Now it adds 1 to N, and goes back to the first statement inside the loop, which is line 20. It will repeat the loop, adding 1 to N each time, until N reaches 12. When N tries to go to 13, the loop ends.

There is a variation on the FOR which lets N change in different ways; this is done by adding one more word to the line:

```
# 10 FOR N = 1 TO 12 STEP 1
```

This specifies that N is supposed to go from 1 to 12 in steps of 1. If we said

```
# 10 FOR N = 1 TO 12 STEP 3
```

then N would go up in steps of 3. Or if we said

```
# 10 FOR N = 12 TO 1 STEP -1
```

it would go from 12 back to 1 in steps of -1. That is, N would go 12, 11, 10, 9, 8, and so on, all the way to 1. Just to see what happens, let's try running the program:

```
RUN
12 144
11 121
10 100
9 81
8 64
7 49
6 36
5 25
4 16
3 9
2 4
1 1
READY
#
```

Basic has several more possible instruction types. Some, like REM (remark) and STOP, are useful to the beginner and we will see them later in some of the demonstration programs. Others are for more advanced users and we will skip them here.

In addition to the various instruction types, Basic also has functions which perform specific maths calculations or some other operations. For example, a mathematician or engineer might use the SIN or COS functions when working with angles. The functions likely to be used by the beginner, out of the dozen or more most computers have, are these:

- INT ( ) converts whatever is placed inside the parenthesis into the next lower integer (whole number). For example, saying

```
# 10 LET J = INT(3.14)
```

would make J equal to 3.

- RND (0) makes the computer invent a random number between 0 and 1. This is usually used in games, for coming up with random moves or random numbers. For instance,

```
# 10 LET J = RND(0)
```

would result in J becoming equal to some unknown value between 0 and 1.

Sometimes we combine the RND and INT functions to generate other random numbers. For instance, suppose we are writing a game where the computer is supposed to pick a card from a deck of cards and print out what it is. Since there are 13 cards in a suit, we need a random number which is a whole number between 1 and 13.

If we use RND to make a number from 0 to 1, and then multiply it by 13, the result will be a number from 0 to 13. Add 1 to this, and you have a random number between 1 and 14, but always just a bit smaller than 14. Convert it to an integer with INT, and you have a whole number ranging from 1 to 13 (and never equal to 14.) The result of putting all this into one line is

```
# 100 LET C=INT (RND(0) * 13+1)
```

One more function useful to beginners is the TAB ( ); which makes the terminal's printer or display move over to the right to the position indicated by whatever is inside the parenthesis. For example

```
# 50 PRINT TAB(15); I
```

would print the value of I fifteen places from the left end of a line on the printer. Note that the TAB is used in a PRINT statement, and that it is usually followed by a semicolon.

Finally we are ready to put all this together into several simple programs. How about a program to pick five cards at random and print out what they are? We will program it as a loop which is repeated five times, use the RND func-





## SYSTEMS — SOLUTIONS

IF YOU HAVE A PROBLEM THAT CAN BE SOLVED BY A COMPUTER — WE HAVE A SYSTEMS SOLUTION.

- Two central processors with maximum RAM capacities of 56K and 384K bytes
- Three types of disk drives with capacities of 175K, 1.2M and 16M bytes
- Two dot matrix printers with 80 and 132 line capacity

Match these to your exact need, add one or more of our intelligent terminals and put together a system from one source with guaranteed compatibility in both software and hardware.

Soutwest Technical Products systems give you unmatched power, speed and versatility.



**Intelligent Terminal**



**6809 Central Processor**



**Disc System**

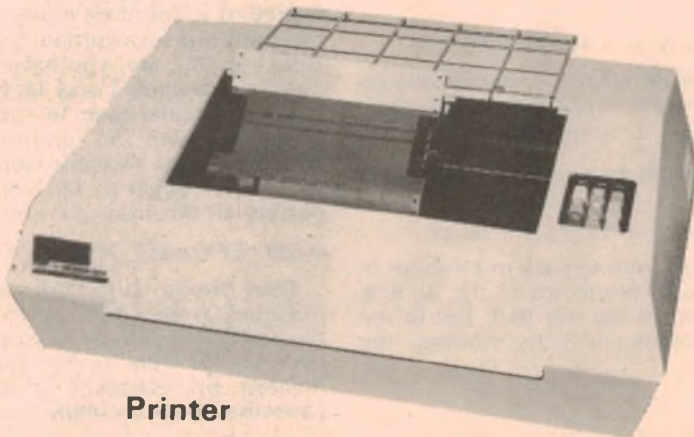

**Printer**

*AVAILABLE FROM:*

*CAN BE PROGRAMMED TO PRODUCE*

- DOCUMENTS
- LETTERS
- INVENTORY LIST
- FORM LETTERS
- LEDGER
- JOURNAL
- CONTRACTS
- SALES REPORTS
- STATEMENTS
- INVOICES



**SOUTH WEST TECHNICAL PRODUCT CORPORATION**  
(COVERING AUSTRALASIA)

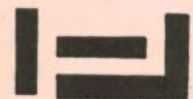

7<sup>a</sup> BURTON STREET, DARLINGHURST, N.S.W. 2010  
P. O. BOX 380 DARLINGHURST N.S.W. 2010

CABLE: "PARADIO" TELEX: AA 22579 PHONE: 02-313273.



# UNDERSTANDING BASIC — THE LANGUAGE OF YOUR COMPUTER

tion to pick a random number, and use IF statements to print out words like JACK or KING:

```
# NEW
READY
# 10 FOR I=1 TO 5
# 20 LET C=INT(RND(0)*13+1)
# 30 IF C<11 THEN PRINT C
# 40 IF C=11 THEN PRINT "JACK"
# 50 IF C=12 THEN PRINT "QUEEN"
# 60 IF C=13 THEN PRINT "KING"
# 70 NEXT I
```

Let's see how this runs:

```
# RUN
1
7
QUEEN
7
2
READY
#
```

Now let's add a few more steps to add the suit. We will use RND again to pick a number between 1 and 4, and use it to print out the suit. Add the following steps:

```
# 25 LET S=INT(RND(0)*4+1)
# 62 IF S=1 THEN PRINT TAB(6); "OF HEARTS"
# 63 IF S=2 THEN PRINT TAB(6); "OF DIAMONDS."
# 64 IF S=3 THEN PRINT TAB(6); "OF CLUBS"
# 65 IF S=4 THEN PRINT TAB(6); "OF SPADES"
```

To see what the program now is, we list it:

```
# LIST
0010 FOR I=1 TO 5
0020 LET C=INT(RND(0)*13+1)
0025 LET S=INT (RND(0)*4+1)
0030 IF C<11 THEN PRINT C
0040 IF C=11 THEN PRINT "JACK"
0050 IF C=12 THEN PRINT "QUEEN"
0060 IF C=13 THEN PRINT "KING"
0062 IF S=1 THEN PRINT TAB(6); "OF HEARTS"
0063 IF S=2 THEN PRINT TAB(6); "OF DIAMONDS"
0064 IF S=3 THEN PRINT TAB(6); "OF CLUBS"
0065 IF S=4 THEN PRINT TAB(6); "OF SPADES"
0070 NEXT I
```

READY

OK, let's run this:

```
# RUN
KING
5 OF HEARTS
6 OF DIAMONDS
JACK OF DIAMONDS
6 OF CLUBS
JACK OF DIAMONDS
JACK OF CLUBS
READY
#
```

Fig. 1: By using the PRINT TAB command, you can get your computer to plot a simple graph, like this parabola.



We could neaten the output so each card is printed on one line, but that's more complicated. Let's do another example. How about a program to input the names of two people and print them out in alphabetical order?

```
# NEW
READY
# 10 PRINT "ENTER TWO NAMES"
# 20 INPUT A$, B$
# 30 IF A$<B$ THEN PRINT A$, B$
# 40 IF B$<A$ THEN PRINT B$, A$
# RUN
ENTER TWO NAMES
? SMITH, JONES
JONES SMITH
READY
#
```

Notice how we are comparing two strings of letters as if they were two numbers; whichever is less is printed first. Although this example only sorts two names, we could do it for more names with a more complicated program.

Suppose a math student needs to plot an equation for his homework. The equation is  $y=x^2-10x+26$ , and he is supposed to find  $y$  for  $x$  going from 0 to 10. This program would do it:

```
# NEW
READY
# 5 REM THIS IS A REMARK
# 7 REM LET X GO FROM 0 TO 10
# 10 FOR X=0 TO 10
# 20 LET Y=X*X -10*X+26
# 25 REM PRINT BOTH X AND Y
# 30 PRINT X, Y
# 35 REM END OF LOOP
# 40 NEXT X
# 50 REM WHEN LOOP IS DONE, STOP
# 60 STOP
```

Note the remark (REM) lines. These are purely for our own convenience — the computer ignores them when it actually runs the program. Now let's see

Reprinted from the March 1979 issue of "CQ" magazine, by kind permission of the author and Cowan Publishing Corporation.

the program run:

```
RUN
0 26
1 17
2 10
3 5
4 2
5 1
6 2
7 5
8 10
9 17
10 26
READY
#
```

Better yet, why not have the computer plot a graph? Change line 30 to 30 PRINT TAB(Y); "\*"

Now when we run the program, we get the result shown in Fig. 1. Not bad for a simple little program, is it?

The graph may be sideways and a little coarse, but it certainly gives the picture.

Well, I hope this introduction has given you an idea of how easy it is to program a computer in Basic. It's really not hard at all when you get the hang of it. Now why don't you try writing a few programs of your own?

Don't worry if a program doesn't work first time you try it. Just keep trying — before long, you'll be making your computer jump through hoops with the best of them!

## SUGGESTED FURTHER READING

If you want to go a bit further into Basic language programming, there are two books which can be thoroughly recommended. Both are written by Dr David Lien, of San Diego:

BASIC COMPUTER LANGUAGE (TRS-80 Level 1 User Manual), published by Tandy Corporation. Available from all Tandy stores for \$5.95

THE BASIC HANDBOOK, published by Compusoft Publishing, San Diego. Available from Dick Smith Electronics stores, also the Technical Book and Magazine Company. Price \$15.95.



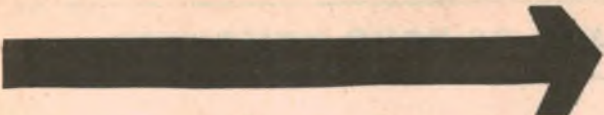

# THE SELECTRIC\* APPROACH TO HIGH QUALITY PRINTING

Any model IBM SELECTRIC typewriter can be interfaced as a computer output printer operating at 13.5 cps. The interface comprises a precision solenoid assembly which fits to the underside of the typewriter without drilling, tapping or permanent modification. Installation takes approximately 4 hours and is extensively documented. If you prefer, ASP or interstate agents will install the solenoids for \$75.00 (subject to inspection of your typewriter). Use as a typewriter is unaffected, the keyboard does not feel heavy, or in any way altered.

The electronics provided convert ASCII code into the proper bail select code for the typewriter, control the operation of the typewriter and allow the host computer to communicate on a variety of different interface standards. Available are S100, TRS80 (without Expansion Interface) and Universal Interfaces.

Prices: (including Sales Tax)	S100	\$599.00
(10% off for multiple orders)	TRS80	\$699.00
	RS232/Parallel	\$729.00
	IEEE	\$759.00

Dear Ali, I'm convinced I should be more Selectric.<sup>®</sup> Please reserve the conversion noted below and send me your Order Form.

Type of Interface	Quantity	My computer is a

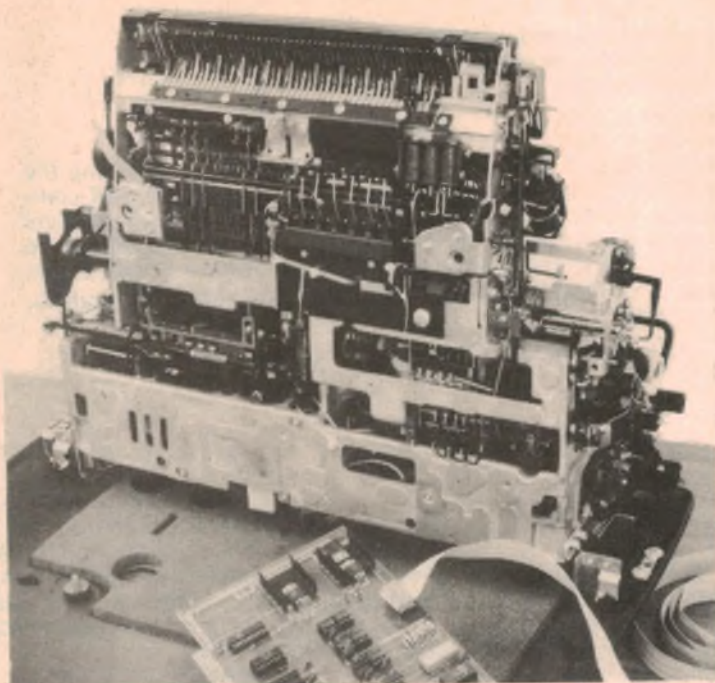

NAME: \_\_\_\_\_  
 ADDRESS: \_\_\_\_\_  
 PHONE: \_\_\_\_\_

\* SELECTRIC is a Trade Mark of IBM

**ASP MICROCOMPUTERS**  
 799 DANDENONG ROAD,  
 EAST MALVERN 3145.  
 Telephone 211 8855 211 8344

## FULLY EXPANDABLE DREAM 6802 KITS

**COMPLETE KITS \$135.00 including Cabinet**  
**COMPLETE KITS \$149.00 including Cabinet and Keyboard.**  
**ASSEMBLED and TESTED \$199.00 inc. Cabinet, Keyboard and Modulator.**

*Modulator for kits \$3 extra. Insured post \$2.50. C.O.D. \$2.00 extra. PHONE C.O.D. ORDER'S ACCEPTED*

- The high quality "Digitran" keyboard has an "over-centre" action to give positive contact and excellent tactile response. This greatly reduces keying errors, which will be especially appreciated towards the end of a long programme! Since the keyboard strongly influences operator enjoyment we believe that anything less is false economy
- Perspex Cabinet: The computer is assembled on a hardboard base, (similar to EA's prototype but more compact), and is then FULLY ENCLOSED with a CLEAR perspex cover. This protects the unit, and acts as a Display Case.
- Fully expandable: Space has been left for later expansion of the memory. The heavy duty power supply has the current capability recommended by the designer for this purpose.
- Pre-tinned fibreglass PC board with COMPONENT OVERLAY for easy assembly ● Programmed 2708.
- The PCB has been modified to accept a 6802 chip, which includes a clock, thereby eliminating the hard-to-get 6875. The 6802 was not yet available when the DREAM was designed, and the modification has been approved by the designer.
- When comparing prices, it should be noted that our kits are guaranteed to contain only prime quality guaranteed components
- Service is available ● Assembled units are guaranteed for three months.

**POWER SUPPLY KITS (1 AMP) \$29.** Contains all components, a heavy gauge aluminium chassis (undrilled) and a "Marvplate" cover. Compact size — 171 x 125 x 70mm.

**HEAVY DUTY POWER SUPPLY KITS (2.5 AMP) \$45.** Complete kit, with cabinet as above. Power supply kits are post free with Dream kits and are not available separately.

*Money-Back Guarantee: Examine your purchase for 7 days (without removing the I.C.'s from their packing) and if not satisfied return it for a full refund. The copy deadline prevented inclusion of a photograph. Due to the guarantee, you can examine it personally without risk. Please mention "Electronics Australia" on your order.*

MAIL ORDERS AND ALL ENQUIRIES TO:

### J. R. COMPONENTS

P.O. Box 128, EASTWOOD,  
N.S.W. 2122. Phone (02) 85 3976.

OUR COUNTER SALES AGENTS ARE:

PRE-PAK ELECTRONICS, 718 PARRAMATTA RD, CROYDON. PHONE 797 6144.



# Serial Interface for the Ultra-low Cost VDU

Here is a serial interface circuit which can be used to convert the Ultra-Low Cost VDU (August-September 1978) into a complete self-contained terminal, able to work with any small system. It uses only 19 integrated circuits, and you should be able to build it for around \$50.

by **JAN van HARMELEN**

Western Australian Institute of Technology  
Bentley, WA 6102.

To start off in the microprocessor field, one needs a microprocessor system and a terminal to communicate with it. The Ultra Low Cost VDU described in the August and September 1978 issues of this magazine is software driven, which means that the microprocessor system is used to do all the housekeeping functions. All facilities which a good VDU should have are implemented in software; a special program is written in such a way that the microprocessor produces functions like backspace, scrolling, cursor, cursor control, editing of displayed text, graphics display, etc.

Because it only contains the hardware which is necessary to display the contents of 512 memory locations on a TV screen, a software driven VDU is very cheap. Beginners in the microprocessor field cannot use it though, because the monitor program resident in most microprocessor kits only allows serial input and output. The software needed to control the Ultra Low Cost VDU can then only be produced using a serial type VDU!

This article describes a serial input interface which makes it possible to use the Ultra Low Cost VDU as a serial input VDU. Later, when a program for software control of the VDU has been developed, the major parts of the interface can be used to expand the microprocessor system.

To keep costs down, the serial interface does not have scroll, cursor or other facilities. It only provides the bare minimum required to communicate with a microprocessor. It only recognises two control characters: Form Feed (FF) and Carriage Return (CR). On receipt of FF the screen is erased, and the next character will appear in the top left hand corner of the screen. Upon reaching the 32nd character on a line, or when CR is received, the next line is erased, and

the next character will appear as the first on that line. When the last character on the screen, the 512th, has been received, the top line of the display is erased and the next character is displayed on the top line.

It is this last feature which makes this unit different from other VDU's, and on some occasions it is slightly awkward. However the simplifications result in a circuit that only contains 1k of RAM,

mixed with the low power versions. Standard and LS chips are pin-for-pin equivalent, and a low power output can drive at least three standard inputs. Even though a 7493 A-input equals two standard loads, there will be no problems in this circuit.

If you are thinking of using standard TTL throughout, remember that the 74LS112 does not have a standard series equivalent. Do not attempt to use the 74L series, as they have different pinouts.

The heart of the interface is the memory. It consists of two 2114 1k x 4 bit RAM chips. As only six bits are required to store the ASCII characters which can be displayed by the 2513 character generator used in the VDU, one of these chips is only half used. It would have been cheaper to use six 2102 RAMs, but the 2114 seems to be

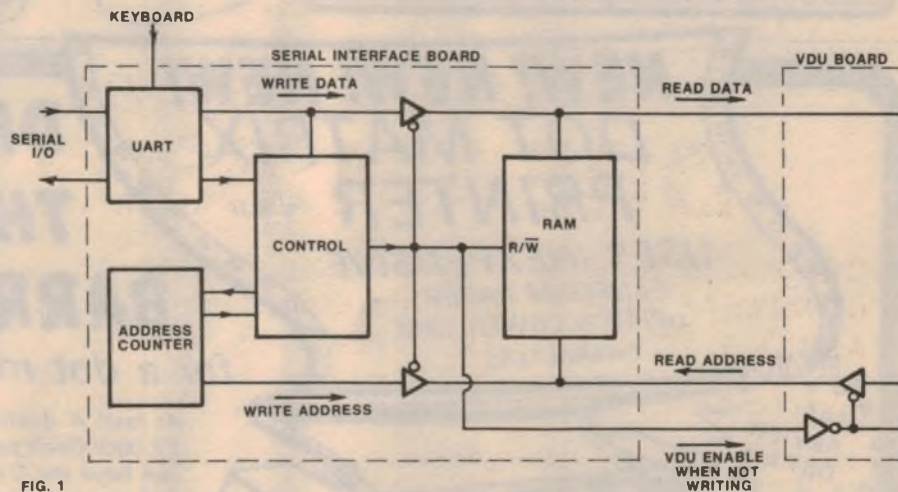

FIG. 1

which can be used for memory expansion once software control has been implemented; a UART, which is needed to convert the keyboard output to serial format anyway, and 15 low cost TTL ICs. Standard TTL would be the cheapest, but the supply current can be reduced considerably if the 74LS series IC's are used.

The monostables used in this design are not low power versions, because no 74LS equivalent of a 74121 exists, and a 74LS123 is more than double the price of a 74123.

The cost of the TTL IC's is around \$10. If you happen to have some standard TTL chips available, you can use them

the better choice, because most memory expansion of microprocessor systems is now done with this type.

As can be seen from the simplified block diagram of Fig. 1, the VDU is enabled as long as there is no serial input. When a character has been received, the VDU is momentarily disabled, the write address counter and the UART parallel output are enabled, and the data is written into the memory location designated by the write ad-

**On the facing page is the complete circuit schematic. Together with the original board it forms a complete serial VDU.**



# TRS-80 OWNERS: READ THIS AND SAVE A FORTUNE

**14%  
LARGER  
CAPACITY  
TOO!**

## introducing Dick Smith's MINI DISK DRIVE

- 133 4mm minifloppy diskette
- 40 tracks
- Soft Sectored
- Dual sensors for recording on both sides
- Recording density (inside track) 2768bpi
- 1 million bits/side/disk
- Drive no. is switch selectable
- Use as first drive or add-on drives with TRS-80
- Faster drive than TRS-80 (track to track access is 25ms instead of 40ms on TRS-80)
- Power supply will run two drives!
- Cable harness will run four drives!
- 90 day warranty
- Dick Smith Service Back-up



**MORE FEATURES  
FOR YOUR  
DOLLAR!**

### HERE'S WHAT YOU CAN SAVE:

NUMBER OF DRIVES	FIRST DRIVE	2ND DRIVE	3RD DRIVE	4TH DRIVE
MINI DISK DRIVE (Cat X-3230)	\$379.00	\$379.00	\$379.00	\$379.00
POWER SUPPLY UNIT (Cat X-3234) (Powers one or two drives)	\$60.00	N/A	\$60.00	N/A
WIRING HARNESS (Cat X-3232) (Connects up to 4 disk drives) (Or do it yourself!)	\$49.50	N/A	N/A	N/A
DDS DISKETTE (available from Tandy)	\$19.95	N/A	N/A	N/A
<b>TOTAL COST OF DICK SMITH SYSTEM</b>	<b>\$508.45</b>	<b>\$379.00</b>	<b>\$439.00</b>	<b>\$379.00</b>
TOTAL COST OF TANDY SYSTEM	\$699.00	\$689.00	\$689.00	\$689.00
<b>YOU SAVE:</b>	<b>\$190.55</b>	<b>\$310.00</b>	<b>\$250.00</b>	<b>\$310.00</b>

So if you buy a 4 drive system from Dick Smith you save a massive \$1080.55 plus you get 49k extra memory!

### DON'T PAY

~~\$689<sup>00</sup>~~

*You reap the benefit when you buy your computer accessories from Dick Smith!*



### SPECIAL INTRODUCTORY PRICE

**\$379<sup>00</sup>**

INC TAX

POWER SUPPLY **\$60<sup>00</sup>**

INC TAX

## NEW! NEW! NEW! DOT MATRIX PRINTER

USES INEXPENSIVE  
FANFORM PAPER  
UPPER & LOWER CASE  
CHARACTERS

## DICK BREAKS THE \$1000 BARRIER

for a dot matrix printer!

At last! A quality Dot Matrix Printer for less than \$1,000! Don't pay \$1,500 or even \$2,000 when you can have the C.ITOH Model 8300 for a lot less and still get performance.

Obtain a print speed of 125 characters per second through the standard parallel interface PLUS a one line data buffer. Character font is a 7x5 dot matrix with 96 characters (ASCII) and 80 column width. Suits the Sorcerer and any computer with a standard 'centronics' type parallel interface. Size: 449(w)x375 (d)x185(h)mm and weighs 10kg.

SEE  
REVIEW  
OCT E.A.

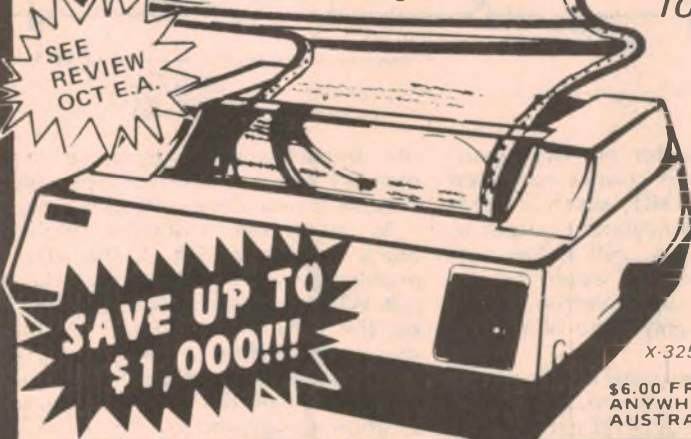

SAVE UP TO  
**\$1,000!!!**

X-3255

\$6.00 FREIGHT  
ANYWHERE IN  
AUSTRALIA.

Terms are available on the C.ITOH Model 8300 Dot Matrix Printer from a low 10% deposit and low monthly repayments. To approved applicants only

**\$970**

INC. TAX

# DICK SMITH ELECTRONICS



SEE OUR OTHER ADVERTS IN THIS MAGAZINE FOR OUR STORE ADDRESSES AND RESELLERS



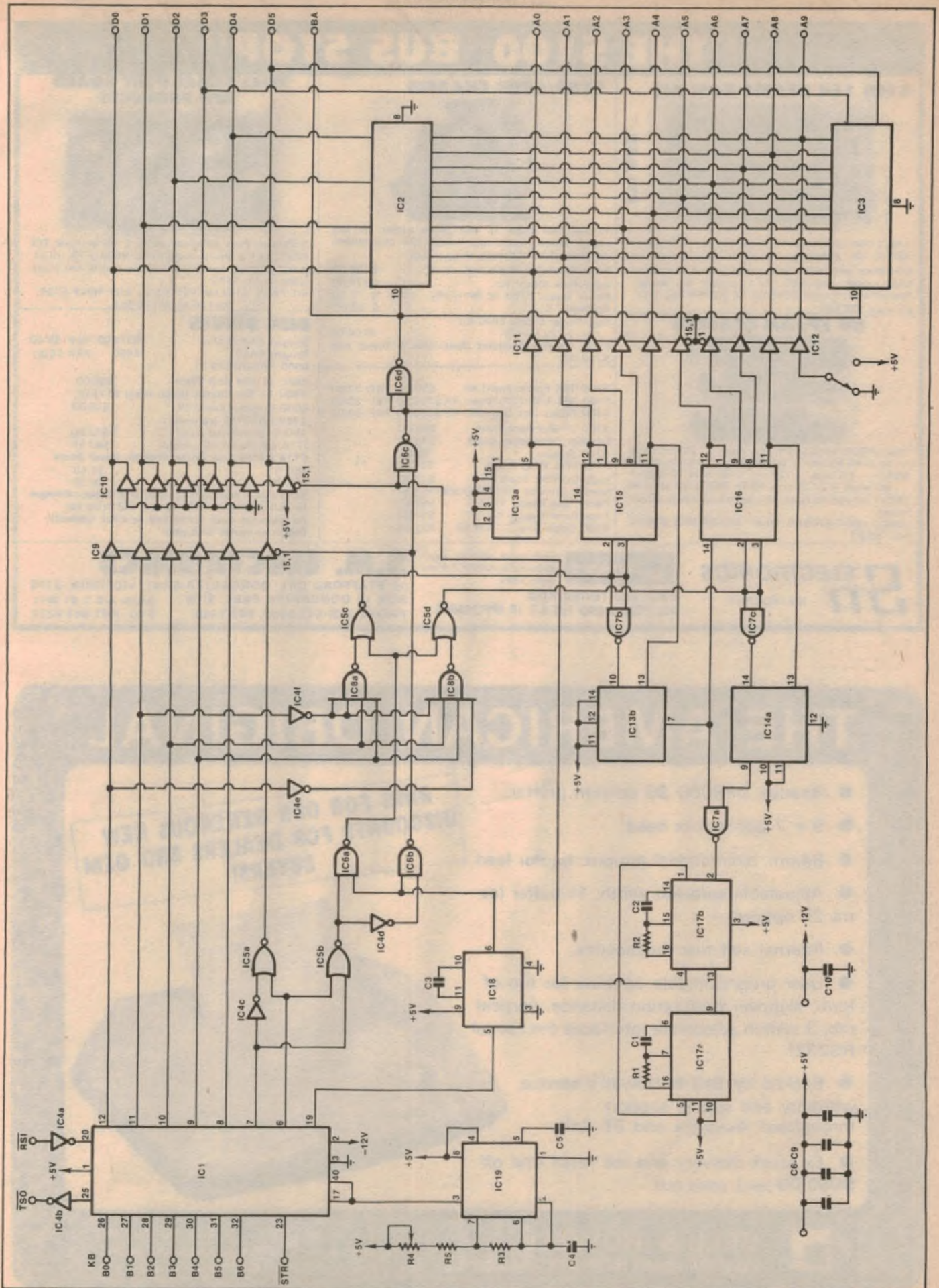



# "THE S100 BUS STOP"™

## S100 16K STATIC RAM KIT



ETI 642

16K, 2114, Low Power 1.2 Amps Typ for 16K, 300 or 450nS, 4K addressing, 4K write protect switches. Cromemco bank select, wait states, plated thru holes solder mask. See FEB ETI project for details. Assembled and tested \$366.00. \$5.00 P&P Reg. mail Kit Price \$299.00

## UV EPROM ERASERS



New product range, LEE/T 15W tube — 120 min timer — up to 40 eproms — will erase in 10/15 min. Model MEE/T — 8W tube — 120 min timer up to 10 eproms — will erase in 20/30 min. Model MEE is the same as MEE/T but with no timer. All erasers have safety cut out switch. PRICE: LEE/T \$105.00, MEE/T \$93.50, MEE \$74.00 P&P \$3.00

## S100/6800 CHASSIS



11 Slot back plane, 15 amp power supply, fan, key switch, bench mount, rack mount, fully card guided, anodised alum. 5 sockets in basic unit.

Basic Bench Mount Kit (incl. cover) \$196.00  
Basic Rack Mount Kit \$175.00  
Power Supply S100 Kit 8V +16V —16V \$79.00  
Accessory Kit \$52.00

Reg. Power Supply 6800 Kit \$104.00  
5v, +12V, —12V  
F.O.B. Overnight Transport (Assembled & Tested add \$100.00)

S100 16K Eprom Board Kit \$90.00 P&P \$3.00  
S100 Z80 4 MHz CPU Board Kit \$155.00 P&P \$3.00  
S100 Floppy Disc Controller Kit \$168.00 P&P \$3.00  
S100 11 Slot Back Plane \$36.00  
Extender Termination Board \$70.00  
S100 Sockets \$8.00  
S100 Wire Wrap Board \$28.50  
S100 Extender Board Kit \$33.00  
Number Cruncher Kit (MM57109) \$49.50  
Paper Tape Reader Kit \$69.50  
Front Panel Display Kit \$87.50  
8080 Single Step Control Kit \$21.65

## DUAL SERIAL PORT BOARD NEW PRODUCTS



9 Parallel Ports (programmable) 2 Serial Ports TTY RS232 or TTL Baud rate generator 9600 to 75, full address decoded, low power buffers, plated thru holes, solder mask \$189.  
KIT PRICE \$164.00 P&P \$3.00 ASS PRICE \$225  
Dual serial port version.

## DISC DRIVES

Shugart SA400 Mini \$375.00 P&P \$5.00  
Shugart SA801 \$650 P&P \$5.00

## 6800 PRODUCTS

6800 11 Slot Back Plane \$36.00  
6800 11 Slot Chassis (Basic Rack) \$175.00  
6800 Extender Board Kit \$33.00  
2708 EPROMS (ceramic) \$12.00  
450nS, guaranteed quality \$47.50  
2716 Eproms (single supply) \$7.50  
2114 RAMS Low Power Hitachi, Super Rams \$8.50  
450 NS \$7.50  
300 NS \$8.50

Send 60c in stamps for computer printout catalogue for full production information and price list. All products Aust. made and ex-stock (almost). Dealer enquiries welcome.

**S.M. ELECTRONICS**  
MELBOURNE

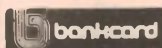

Give name, number, expiry date and signature. For mail order sales.

**BUILT AND TESTED P.O.A.**  
ALL PRICES ADD 15% S.T. IF APPLICABLE

**S.M. ELECTRONICS**

10 STAFFORD CRT. DONCASTER EAST, VICTORIA, 3109  
BOX 19 DONCASTER EAST, 3109. Dealer A.C.T. 81 5011  
PHONE (03) 842 3666, 842 3950. SYD. (02) 661 9237.

# THE AMERICAN ORIGINAL

- Anadex DP8000 80 column printer.
- 9 x 7 dot matrix head.
- 84lpm, bidirectional thruput, tractor feed.
- Adjustable sprocket width, 1k buffer (extra 2k option).
- Internal self test diagnostics.
- User programmable controls for top of form, skipover perforation distance, vertical tab, 3 switch selectable interfaces (incl serial RS232).
- Backed by Bell & Howell's service, warranty and spares support throughout Australia and SE Asia.
- Ex stock delivery and rec retail one off **\$950.00** (excl. sales tax)

**RING FOR OUR GENEROUS NEW DISCOUNTS FOR DEALERS AND OEM BUYERS!**

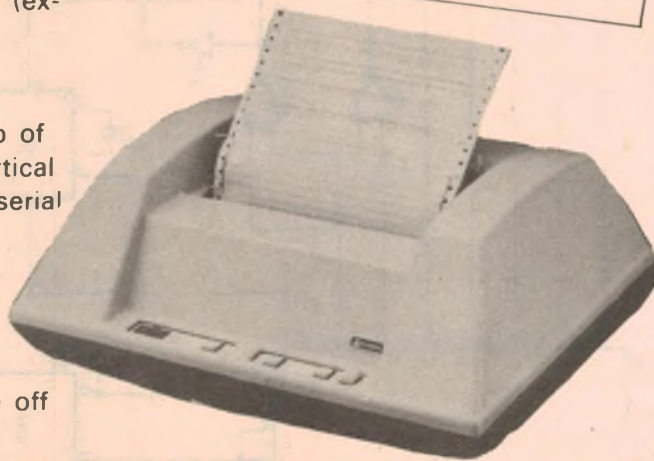

**BELL & HOWELL**  
ELECTRONICS AND INSTRUMENTATION DIVISION

Sydney 660 5366  
Melbourne 61 2551  
Brisbane 52 8633

Adelaide 46 5861  
Perth 381 4999  
Tasmania 34 2862



## SERIAL INTERFACE

dress counter. Then the VDU is again enabled, and the contents of the address counter are increased by one, to be ready for the next input. This sequence only takes microseconds, and does not disturb the display on the VDU screen because it is blanked for this unnoticeably short period.

Not included in the block diagram is the space buffer, a tri-state buffer, wired up to input 20H, that is the ASCII code for "space", into the memory when a line or page has to be erased.

A more detailed explanation of the unit's operation can be obtained by studying the circuit diagram, Fig. 2. The UART (IC1) and its clock generator (IC19) convert the parallel keyboard input (B0-B6) to a serial output (TSO), every time a negative going pulse is received on the STR input.

The output from the microprocessor is connected to the input of the serial interface (RSI). The output of the UART goes to the tri-state data buffer (IC9). IC4c and 5a convert the code for lower case letters to that for upper case. Monostable IC18 produces a short pulse every time a character is received. This pulse drives the control character decoding circuit consisting of IC4d, e, f, 5b, c, d, 6a, b and 8.

The address counter is divided into a character counter (IC13a and 15) and a line counter (IC16). The output of IC6b goes low if a printing character has been received. This pulse enables the data buffer (IC9), and through IC6c and d enables the address buffers (IC11 and

### LIST OF PARTS

IC1 MM5303, AY-5-1012, S1883, or 2536 UART  
IC2, 3 2114 1k x 4 bit RAM  
IC4 74LS04 hex inverters  
IC5 74LS02 quad 2-input gates  
IC6, 7 74LS00 quad 2-input gates  
IC8 74LS20 dual 4-input gates  
IC9-12 74LS367 hex tri-state buffers  
IC13-14 74LS112 dual negative edge triggered flip-flops  
IC15-16 74LS93 binary counters  
IC17 74123 dual one-shots  
IC18 74121 one-shots  
IC19 555 timer  
R1, 2, 3 10k 1/8W  
R4 50k trimpot  
R5 100k 1/8W  
C1, 2 680pF ceramic capacitor  
C3 1800pF ceramic capacitor  
C4 6800pF ceramic capacitor  
C5 0.01uF polyester capacitor  
C6-10 0.1uF polyester capacitor  
Utility PCB or wire-wrap board (see text), hookup wire, rainbow cable, solder, mounting hardware, etc.  
2 18 pin DIL IC sockets  
1 40 pin DIL IC socket

# Can you afford not to know about microprocessors?

Six years ago, microprocessors and microcomputers were little more than dreams in the minds of research engineers and science fiction writers. Now they are changing the whole face of electronics. The change is happening so fast that overseas it is being called an explosion, a revolution. What are these new devices, and why are they having such a dramatic impact? Whether you're a professional or a hobbyist, you really need to know.

This book will help you find out what the revolution is all about:

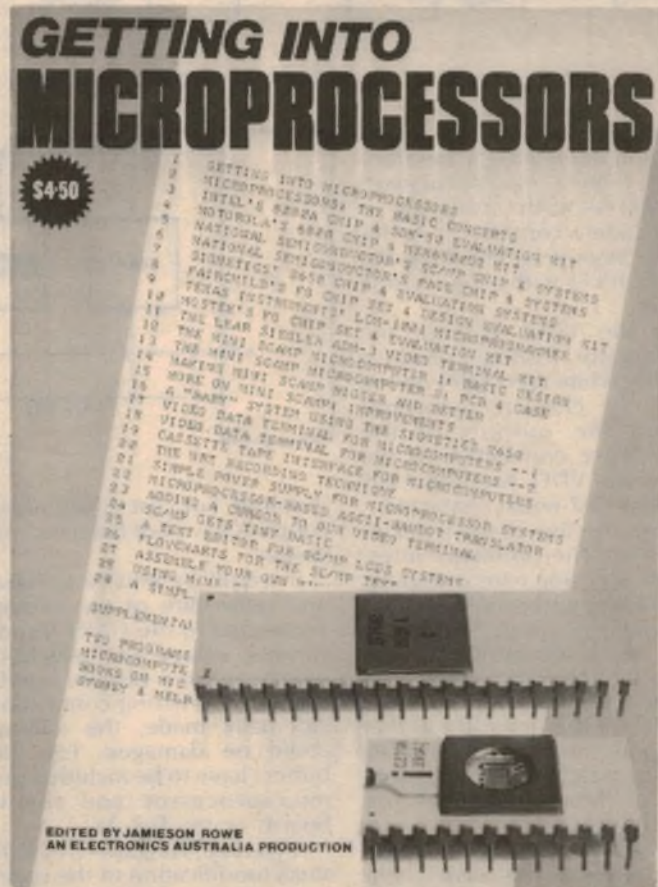

Available from "Electronics Australia", 57 Regent St, Sydney.  
**PRICE \$4.50** OR by mail order from "Electronics Australia",  
PO Box 163, Beaconsfield 2014. **PRICE \$5.10.**



## SERIAL INTERFACE FOR THE ULTRA-LOW COST VDU

12), disables the VDU board, switches to memory write, and its trailing edge advances the address counter.

IC5c produces a positive pulse if either an FF or CR is received, to reset the character counter. The output of IC5d resets the line counter on receipt of FF. When part of, or the whole address counter has been reset on receipt of CR or FF, or when the 32nd character has been entered on a line, the outputs of IC13b and/or 14a go low, starting the space pulse oscillator IC17. Its output repeatedly enables the space buffer (IC10), so entering "spaces" into successive memory locations, until a line or a whole page has been erased. The end of this operation is detected by IC13b and IC14a respectively.

It is my opinion that it gives a constructor a feeling of satisfaction if each

stage of construction can be tested before going on to the next. I therefore recommend that a microprocessor hobbyist starts with building a keyboard encoder, connects it to his keyboard and tests it by checking the outputs for each key with a logic probe or multimeter.

Second is the VDU. Without the character generator, it should produce a pattern of 512 white rectangles on the screen. With the character generator inserted and the outputs of the keyboard encoder connected to the data inputs of the VDU, pressing a key should produce 512 equal characters.

Now the construction of the serial interface can start. The prototype interface was built up using wire wrapping, which readers may also care to use. An alternative would be to use one of the utility PCBs which are available, with hookup wire for the logic wiring. The more adventurous may wish to design their own PCB, of the same size as that for the original Ultra-Low Cost VDU board and with matching edge connectors. Which of these alternatives you adopt is up to you.

I suggest that you wire up the interface initially without the UART chip (IC1) or clock (IC19) in place, and with the keyboard encoder outputs temporarily connected to pins 6-12 of the UART socket. With the interface connected up to the VDU board, the two should then work as a television typewriter, according to the descrip-

tion given earlier. Finally the UART can be inserted, and IC19 and its associated components soldered in. With TSO-bar and RSI-bar temporarily interconnected, the system should again perform as in the previous test. The UART clock oscillator should be adjusted to 1760Hz for 110 Baud operation. If a frequency counter is not available, R4 should be set to the middle of the range over which satisfactory operation with a microprocessor can be obtained.

Usually the input and output of a microprocessor board are in the form of 20mA current loops. They require a pair of opto-couplers for isolation from the VDU. If the cable between microprocessor and VDU is short, both have a common ground and are TTL compatible logic, this isolation is not

**TABLE 1: Power supply pin connections to IC's**

	+5V	GND	-12V
IC1	1	3	2
IC2, 3	18	9	
IC4-8, 18	14	7	
IC9-14, 17	16	8	
IC15, 16	5	10	
IC19	8	1	

On IC1 the following pins are also connected to GND = 4, 16, 21, 38  
+5V = 34-37, 39

modifications might be necessary. In cases where no simple solution can be found, you can add a 74LS04 to wire up the circuit of Fig. 3a to replace the existing circuit.

Once you have developed the software to direct the output of your programs to a section of memory instead of to the serial output port, it is time to convert the terminal to software control. This is straightforward, as described in the original articles. Then work out a scheme for parallel interfacing of the keyboard encoder via the I/O ports of the microprocessor system, and you can get rid of the serial interface board.

If you object to Direct Memory Access because it approximately halves

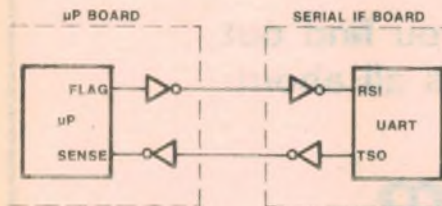

FIG. 3a

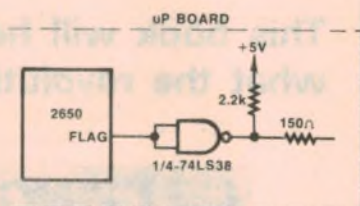

FIG. 3b

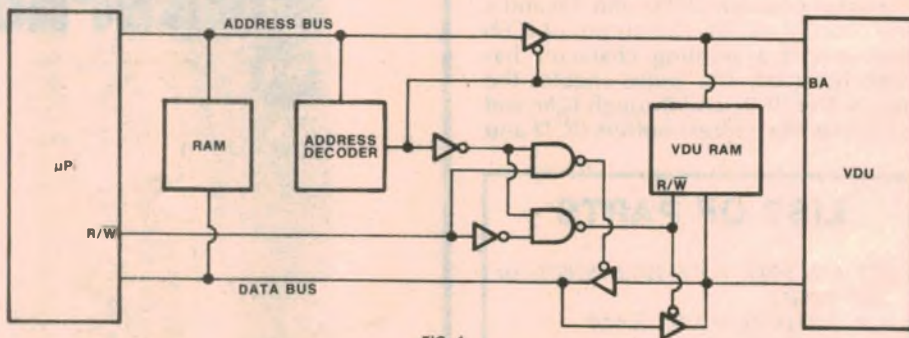

FIG. 4

required. For cost saving reasons opto-couplers have not been included in this design.

It would be unwise to have the flag and sense pins of the microprocessor connected to the UART through plugs, sockets, cables and switches (in case switchover to a cassette interface is required). If a wrong connection was accidentally made, the microprocessor could be damaged. For this reason buffers have to be included on both the microprocessor and the interface boards — see Fig. 3a.

If you are using the EA 2650 system, a small modification of the output circuit is necessary. Connect pin 3 of the 74LS38 to +5V through a 2.2k resistor. (See Fig. 3b). The 150 ohm resistor can be left in case you ever want to use a current loop. The input is already TTL compatible.

If using other systems, similar

the apparent speed of the processor and disturbs software timer loops, you might be interested in Restricted Memory Access. Instead of the processor being stopped when the VDU requires part of the memory, the memory which can be accessed by the VDU is limited, and this memory can be used without disturbing the processor. When the processor needs access to this memory space, for output, the address decoder disables the VDU (Fig. 4). Note that microprocessor access to the VDU memory is not necessarily for output only. The 512 memory locations of the 1k RAM which are not used by the VDU can be used for any purpose. As the tri-state buffers and RAM are available on the serial interface board, it should be possible to modify it to suit this scheme. But I leave the details of this to you. By the time you reach this stage, it should be no problem!



# BOOKS AND COMPONENTS

## S100 EPROM PROGRAMMER

After programming a 2708 or 2716 EPROM you won't need a screwdriver to pry it out of SSM's new PB1 board equipped with Textool sockets. Just flip the lever and lift it out. And on the same board there are 4 sockets waiting for 2708 or 2716 EPROMs that can be independently addressed to any 4k or 8k boundary above 8000 hex. Two boards in one.

PB1 has two separate programming circuits so 2708 or 2716 (5v) type of EPROMs can be programmed without modifying the board. Programming voltage is generated on-board by a DC-DC converter; no need for an external power supply. Programming sockets are Dip Switch addressable to any 4k boundary. And complete software is provided for programming verifying EPROMs.

With our Magic Mapping feature, unused EPROM sockets don't take memory space, so you are never committed to the full 4k or 8k of memory. The board can be configured for 0 to 4 wait states. Use fast or slow EPROMs. All lines are buffered.

SSM manufactures a full line of S-100 boards, including CPU, Video, I/O, RAM, EPROM, Music, Prototyping, Terminator, Extender and Mother boards. For complete details just send for our new, free brochure.

### PB1 2708/2716 Programmer & 4k/8k EPROM Board

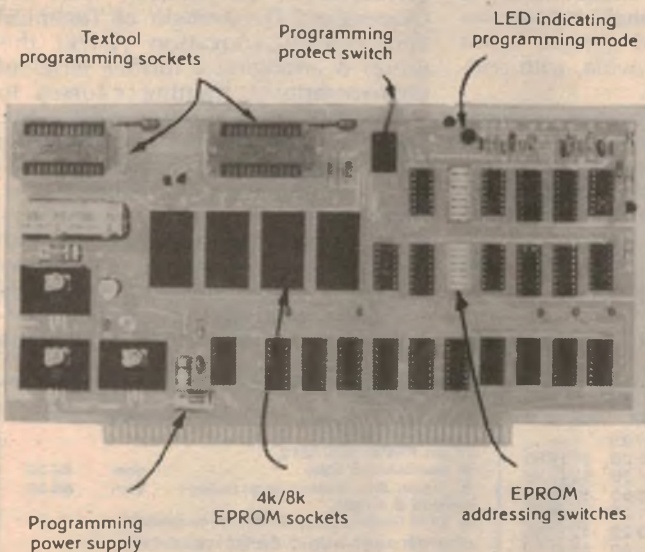

We used to be Solid Music. We still make the blue boards.

PB1 2708/2716 EPROM programmer kit with textool sockets \$155.00

Kit without textool sockets \$145.00

Manual only (refundable with kit purchase) \$5.00.

2708 EPROMS \$11.50

All plus 15% tax if app.

*We also carry a large range of data books from all the leading semiconductor manufacturers — RCA — GE — NATIONAL — MOTOROLA — TI — ANALOG — DEVICES — FAIRCHILD — INTEL — SIGNETICS — PHILIPS — SILICONIX — ALSO THE COMPLETE RANGE OF E AND L BUGBOOKS.*

*Please send a SASE for complete book catalogue and price list*

All items plus 15% sales tax unless otherwise marked. Prices subject to change without notice.  
All orders plus packing and freight \$2 small items \$5 large and heavy parts.  
Registration and insurance extra.

ALL BOOKS TAX EXEMPT POSTAGE \$2.00 EACH

**OSBORNE & ASSOCIATES, INC.**

## The World Leaders in Micro-processor Books

An Introduction to Microcomputers

Volume 0 — The Beginner's Book

If you're not familiar with computers, but would like to be, then this is the book for you. Computer logic and terminology are introduced in a language the beginner can understand. Computer software, hardware and component parts are described and simple explanations given for how they work. Text is supplemented with creative illustrations and numerous photographs. 300 pages.  
08-X \$8.95

Volume 1 — Basic Concepts

A must for anyone in the computer field, this best selling text explains hardware and programming concepts common to all microprocessors. Its universal appeal is reflected by its having the greatest yearly sales volume of any computer text.  
350 pages 02-2 \$10.95

Volume 2 — Some Real Microprocessors\*

New enlarged 1978 edition  
loose leaf format \$25.00

Provides objective, commercial-free descriptions of virtually every microprocessor on the market today. Lets you know what's available, how they work (or sometimes don't work), and how to use them. More detailed user/designer information than provided by most manufacturers.

Volume 3 — Some real Support Devices

Same objective, in-depth coverage as Volume 2, but applied to support devices that might be used in any microprocessor system: memory, data communication devices, data converters, direct memory access controllers, buses, and much more.

New enlarged 1978 edition  
loose leaf format \$15.00

8080 programming for logic design \$10.50

6800 programming for logic design \$10.50

Z80 programming for logic design \$10.50

8080A/8085 assembly language programming \$10.50

6800 assembly language programming \$10.50

Z80 assembly language programming \$10.50

6502 assembly language programming \$10.50

These books describe how to program a microcomputer using assembly language. They discuss classical programming techniques, and contain simplified programming examples relevant to today's microcomputer applications. 400 pages each.

Some Common BASIC Programs

76 short practical programs, most of which can be used on any microcomputer with any version of BASIC.

Complete with program descriptions, listings, remarks and examples. 200 pages. 06-3 \$10.50

**SYBEX**

## LEADER IN MICROCOMPUTER EDUCATION

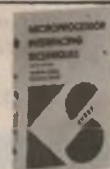

● **6502 APPLICATIONS BOOK** (For SYM and KIM), ref D302

A series of practical (hardware and software) applications for a 6502 board (SYM preferred or KIM) which can be used as experiments, or implemented at minimal cost. Examples are: Morse generator, electronic piano, digital clock, home alarm system, traffic controller. \$13.95

● **MICROCOMPUTER PROGRAMMING: 6502** By Rodney Zaks, ref C202

This text will teach you how to program with the 6502, from ground zero if necessary: arithmetic, input-output, including polling and interrupts, addressing techniques. Complete self-contained, it can be used by the novice to learn programming or by anyone who wants to learn about basic techniques, using the 6502. \$11.95

**MICROPROCESSORS: from Chips to Systems** By Rodney Zaks

An educational text, used worldwide at universities and in industry designed to teach all the fundamentals of microprocessors, the assembly of a system, and its use. 420 pp, ref C201 \$11.95

**PROGRAMMING The Z80**, 330 pp, ref C280

The basic introductory text on programming the Z80. Similar contents as C202. \$11.95

**MICROPROCESSOR INTERFACING TECHNIQUES** Austin Lesea and Rodney Zaks

All the basic interfacing techniques, from keyboard to floppy disk, including the standard buses (S100 to IEEE488). 416 pp, ref C207 \$14.95

## STEWART ELECTRONICS

33 SUNHILL ROAD, MT WAVERLEY 3149

Phone (03) 277 0622

Telex AA36908

Mon.-Fri. 9am-6pm

Bank Card Accepted.

Sat. 9am-12noon



# Microcomputer News & Products



## What next?

How do you tell the difference between a programmable calculator and a computer? It's getting harder and harder. This was demonstrated to us the other day by a brochure on the latest Casio model FX-502P/FA-1, which came from Electronic Calculator Discounts.

Superficially it looks like a fairly standard "scientific" pocket calculator, with a 10-digit-plus-exponent LCD display and the usual array of buttons. But when you look closely and read the brochure, it soon becomes clear that the FX-502P is a lot more than the usual scientific calculator. For a start it provides a total of 51 functions, including things like absolute value (ABS), integer (INT) and random number generation (RND).

Then comes a list of additional features, which sound more like a computer than a calculator: a 256-step non-volatile program memory; 22 memory data registers (also nonvolatile); three kinds of jump commands: unconditional, conditional and indirect; two loop control commands: increment and skip if zero (ISZ) and decrement and skip if zero (DSZ); and the ability to have up to nine subroutines, which may be nested to nine levels!

As if this wasn't enough, it also has an optional cassette interface (FA-1), which lets you store programs on any normal tape recorder. You can also use the calculator as a digital music synthesiser, recording the output on tape.

Apart from the cassette interface, all this comes in a slim little case the size of a wallet, which runs for 1300 hours from two tiny silver oxide cells!

One can't help wondering how long it will be before we see similar units with a full alphanumeric keyboard and display, and programmed in BASIC or PASCAL . . .

In the meantime, for those who want to know more about the Casio FX-502P, further information is available from Electronic Calculator Discounts, PO Box 106, Baulkham Hills, NSW 2153. Telephone (02) 624 8849.

## 132-column printer

Southwest Technical Products is now marketing the Decision Data model 6540 serial printer, both separately and as a part of its microcomputer systems.

The 6540 is a 132-column printer which uses a 9 x 7 dot matrix format and offers a printing speed of 120 characters per second (bidirectional). It is an impact type printer and accepts forms from 64mm to 380mm wide, with continuous sprocket feed.

Other features of the 6540 include horizontal and vertical tabs, full character set of 96, forward and reverse line feeding, line feeding in increments of 1/6, 1/2 and full line, and double character set. The machine has an internal line buffer of 512 characters, and can print charts and graphs as well as alphanumerics.

Serial interfacing is standard,

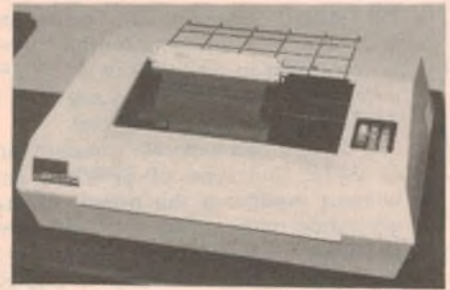

with either RS-232C or 20mA current loop formats and a choice of 110, 300 or 1200 baud.

Price of the printer is \$2395. Further details are available from SWTP distributors Paris Radio Electronics, PO Box 380, Darlinghurst, NSW 2010. Telephone (02) 31 3273.

## From the clubs . . .

IREE Microcomputer Interest Group of Brisbane: In conjunction with the Queensland Department of Technical and Further Education (TAFE) this group is arranging a further series of microcomputer training courses to commence in February next year. There are five courses in all, dealing with Digital Electronics and Logic Circuits, Introduction to Microcomputers, Microcomputer Systems, Understanding Computer Programming and Microcomputer Software. All courses are of 10 weeks duration. Intending students should apply by phone or personal call to TAFE office, Old South

## EXPAND YOUR M6800, AIM 65, SYM-1

OR OTHER MICROCOMPUTER

With PP

Motorola Exorcisor Compatible Modules

M4-16 16K STATIC RAM CARD Using 2114L Kit	Ass. & T
● PCB & Support ICs	\$ 97 20
● 4K 450nS Low Power	\$153 20 \$179 80
● 8K 450nS Low Power	\$207 20 \$241 35
● 16K 450nS Low Power	\$312 60 \$359 70
● 4K 300nS Low Power	\$161 20 \$187 80
● 8K 300nS Low Power	\$223 20 \$257 35
● 16K 300nS Low Power	\$344 60 \$391 70
<b>R18-2 16K PROM CARD WITH ON-BOARD PROGRAMMER For Single +5V Supply 2716</b>	
● Ass & tested with Low Insertion Force Sockets	\$197 30
● Ass & Tested with Zero Insertion Force Sockets	\$243 80
● D2 Kit Driver Program (listing + instructions)	\$10 00
<b>2708 PROM PROGRAMMING CARD</b>	\$139 70
● Ass & tested	
● D2 Kit driver program (listing + instructions)	\$10 00
● D2 Kit driver program in 2708 Specify base address	\$24 00
● Driver program for M6800 and VDU type Monitor (list + instr)	\$10 00
<b>RM-32 16K/32K/64K PROM CARD WITH BANK SELECT</b>	
● For mixtures of different Proms Assembled & tested	\$169 70
<b>PB-1 WIRE WRAP BOARD</b>	
● Plated through holes with ground plane	\$42 50

### AD-2 ADAPTER

- Allows R2 to plug into Exorcisor type edge connector. Available shortly.

### 24 pin PROM SOCKETS

- Low Insertion Force each \$4 20
- Textool Zero Insertion Force Socket each \$9 50

### PROMS & RAMS

- 2716 (single supply). 2708. 2114L available

### CDB-150 FAST AUDIO CASSETTE INTERFACE

- Complete in Case (Software driver included) \$185 60

### D2 KIT BUFFER ICs

- 2 x 8T26 3 x 8T97 7430 \$12 00

### BACKPLANES AND EDGE CONNECTORS

- 5 Slot Backplane (has ground plane) \$26 50
- 11 Slot Backplane (has ground plane) \$36 00
- Edge Connectors (PCB mounting or solder eyelet) each \$8 30
- 5 for \$38 70
- 11 for \$82 20

For Data sheets send stamped SAE

Add 15% if Sales Tax Applicable

Postage & Packings: \$1 00 cost under \$50, \$2 00 from \$50 to \$150, \$3 50 cost over \$150

Products Designed & Manufactured in Australia by

**PP Pennywise Peripherals**  
**Pennywise Peripherals**

19 Suemar St, Mulgrave, Vic 3170  
Ph (03) 546 0308



Brisbane Town Hall, cnr Vulture and Graham Streets, South Brisbane. Phone 224 7847 or 224 7839.

An Exidy Sorcerer Users' Club has been formed in South Australia. Meetings are being held on the second Wednesday of each month in the Psychology department of the University of Adelaide. Further information from club secretary Jeremy Webber, 22 Delange Avenue, Banksia Park, SA 5091.

The Microprocessor Special Interest Group (MICSIG) in Canberra advises that its meeting place is no longer the venue listed in our August 1979 listing. It is now the Oliphant Building, Research School of Physical Sciences, ANU.

A computer club has been formed in Darth, Tasmania. Meetings are held weekly, generally on Saturday. Secretary of the Darth Amateur Computer Society (DACs) is J. Stephenson, 4 Melinga Place, Tarooona 7006.

A local chapter of the PPC Club has been formed in Melbourne. Formerly the HP-65 Users' Club, the PPC Club was founded in California in 1974 and now has 2400 members world wide. It caters for all users of programmable calculators.

The new Melbourne chapter meets in Room 903 of the Menzies Building, Monash University. Further enquiries from Assoc Professor J. E. McGechie, Philosophy Dept, Monash University.

## Apples to Tasmania . . .

The University of Tasmania has ordered 20 Apple-II Plus microcomputer systems, with a total value of around \$60,000. The systems will each have 48K of main memory and a mini-floppy drive, and will run the UCSD Pascal operating system. One system will have a printer as well, and will be connected to the University's Burroughs B6700 mainframe machine.

The 20 systems will be used to establish a first year computing laboratory in the Department of Information Science. The selection of multiple self-contained microprocessor-based

# LOOKY VIDEO

**MONITOR TV's SWITCHABLE B/W \$149 COLOUR \$380 TRADE SUPPLIED**

**WHILE STOCKS LAST OHIO SCIENTIFIC COMPUTERS FROM \$367.**

**OHIO POWER KITS, EXPANSION KITS, SOFTWARE.**

**NATIONAL PORTA PACK VIDEO RECORDER WITH ELECTRONIC VIEWER COLOUR CAMERA \$2449 THE LOT.**

**B/W CAMERAS — PISTOL TYPE TRIPOD TYPE WITH RF \$345**

**TRENDCOM PRINTER — MANY INTERFACES TANDY DIRECT INTERFACE — SAVE \$100's \$296**

**BRUCE FISHER VK3YRF/ATV DUBBING and EDITING from \$10 per hour**

**CASH — CARDS — TERMS — LEASING**

LOOKY VIDEO

The home TV recorder experts with 10 years experience.

Write to  
PO Box 347, Richmond, Vic 3121  
418 Bridge Rd, Richmond, Vic 3121  
Tel (03) 429 5674

## LANTHUR ELECTRONICS

69 Buchanan Ave, North Balwyn, Vic 3104, Box 162. Phone: 859 4061

<p><b>ELECTRIC MOTOR SPEED CONTROLLER KITS.</b> Controls down to stop with no loss of torque. Suitable for all 240V AC/DC brush type motors. Electric hand tools, potters wheels, etc. 10 amp 2400 watt basic kit <b>\$10.95</b> Plain aluminium box <b>\$2.95</b> Cut to suit aluminium box <b>\$4.95</b></p>	<p><b>LAMP DIMMER KITS</b> Controls incandescent lamps from full to out. 10 amp 2400 watt basic kit <b>\$8.95</b> Rotary or slider control available. Plastic cabinet with alum lid <b>\$1.95</b></p>
<p><b>ELECTRIC FAN SPEED CONTROLLER</b> Complete ready to use. Mounted on open board 89 x 55mm. 600 watt, 2.5 amp capacity. Suitable for use with shaded pole, perm. split cap. or universal motors <b>\$8.95</b></p>	<p><b>BATTERY CHARGER KITS</b> Will charge 12 volt batteries @ 2 amps. Basic kit <b>\$10.50</b> Plus post. Vic <b>\$1.00</b></p>
<p style="text-align: center;"><b>DIODES</b></p> <p>Silicon heavy duty. Stud mount. 25 amp 200 piv. Each <b>\$1.95</b> 4 for <b>\$7.25</b></p>	<p style="text-align: center;"><b>OTHER</b></p> <p>(Surplus Refunded) Plain alum box <b>\$3.25</b></p>

ALL ABOVE ITEMS POST FREE



The COMMODORE PET is a completely self contained personal computer. Just plug in, and within a few short hours even the complete novice will be amazed at what can be done. The 8K model shown, 16K & 32K models (with typewriter-style keyboard) are available for \$1499, \$1829 and \$2199 respectively. External Cassette Deck, Dual Drive intelligent Minifloppy and Printers are now available. The 8K, 16K & 32K models are all expandable up to 40K via plug-in memory boards. For a review of the PET see May 1979 ETI.  
PET FOOD A large range of programs including games, business applications and even a program to teach yourself basic are now available.  
**SPECIAL \$200 worth of free software with every 8K PET**



We also handle the full range of top value TRIO test equipment. Pictured is the popular CS-1560All dual trace, DC-15 MHz 10 mV/cm, 0.5S to 0.5uS/cm Oscilloscope. Our price **\$580**. Probes to suit the CS-1560 (PC-27) are available for **\$42**.

**SPECIAL**  
GE PAR 38 100W COLOURED FLOODS  
MDe in U.S.A. ES Mount  
1-11 **\$5.50ea**  
12 + **\$5.00ea**  
Red Blue, Green Yellow, Clear —  
Please specify colour.

All prices include Sales Tax and Road or Rail delivery to your door/nearest railway station. Extra Information is available and we invite your enquiries. Please note that all prices, details and predicted availability were correct at time of going to press.

# EDIBLE ELECTRONICS

P.O. BOX 1053, RICHMOND NORTH, 3121. PH. (03) 415708





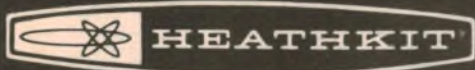

# Build your own Weather Station

## Fully Computerised Five-Function Digital Weather Station

The Heathkit ID-4001 Weather Station is microprocessor controlled and computes and displays weather data on easy-reading LED's—stores data in memory for instantaneous retrieval! Monitors indoor and outdoor temperatures and wind chill, barometric pressure, wind speed and direction, and time/data—all with electronic accuracy and reliability. It's ideal for home or office, boat clubs etc. anywhere accurate and instant weather information is needed.

**1. Wind Speed.** Two significant digits are displayed with your choice of average or instantaneous readings. Indicators show whether display is in miles-per-hour, knots or kilometres-per-hour. Date, time and magnitude of maximum wind gusts are retained in the memory and recalled whenever needed. Accuracy  $\pm 5\%$  or better.

**2. Wind Direction.** Current wind direction is displayed by one of 16 indicators arranged in a circular compass configuration, and identified by both compass points and radial degrees.

**3. Temperature & Wind Chill.** Displays include a 2½-digit readout with + and - signs, alternately displayed indoor/outdoor readings and switch-selected Fahrenheit and Celsius readouts. Temperature range extends from -40° to +70°C and from -40° to +158°F. Computes wind chill reading automatically at the touch of a button. Date and time of maximum and minimum temperatures are stored in memory for future retrieval. Accuracy  $\pm 1^\circ\text{C}$ .

**4. Barometric Pressure.** A 4-digit readout is displayed, with indicators to show whether pressure is rising or falling, and whether display is in inches of mercury or millibars. Range of pressure is 28.00 to 32.00 in Hg (981.9 to 1050 millibars). Date, time and magnitude of maximum and minimum pressure are stored in memory and instantly recalled. Compensated temperature range is 0°C to 50°C (32°F to 122°F).



**5. Time.** 6-digit display with 12 or 24-hour format time readout, 4-digit date readout and AM/PM indicator in 12-hour format. Includes outdoor transducer assembly. Optional cable below. For 120/240 VAC.

- Kit ID-4001 \$680.00 inc. tax
- Assembled IDW-4001 \$800.00 inc. tax
- IDA-1290-1, 50 ft. cable \$16.00
- IDA-1290-2, 100 ft. cable \$28.00
- IDA-1290-3, 150 ft. cable \$37.50

## Digital Indoor/Outdoor Thermometer



You'll never have to "gauge-guess" again! This fun-to-build kit monitors indoor/outdoor (or any two temperatures) with a big, bright ½" high digital readout. The readout includes plus and minus signs as well as indoor and outdoor indicator lights, so you know at a glance which temperature is being monitored.

**ID-1390AE SPECIFICATIONS:** Temperature Range Fahrenheit -40 to +120°, Celsius -40 to +50°

**KIT ID-1390AE \$103.50**

## Digital Wind Speed and Direction Indicator



Outstanding accuracy and easy-to-read digital display make this kit a "must" for pilots, boaters, and anyone whose activities are affected by the wind.

**ID-1590E SPECIFICATIONS:**

Wind Speed 0-99 in miles per hour, knots or kilometres per hour.

**KIT ID-1590E \$125.50**

### ORDER BY COUPON NOW OR COME TO OUR SHOWROOM

Please rush me the Heathkit of my choice. My cheque for \$ . . . . . is enclosed plus \$7.00 for package and post.

- Kit ID-1590E     Kit ID-4001     Assembled IDW-4001
- Kit ID-1390 AE    For Kits ID-1590E, ID-4001 & IDW-4001 indicate either:—
- IDA-1290-1, 50ft cable
- IDA-1290-2, 100ft cable     IDA-1290-3, 150ft cable

Name .....

Address .....

..... P/Code.....

Send to: W. F. Heathkit Centre  
220 Park St., South Melb. 3205. Phone: 699-4999



## Microcomputer News & Products

systems for the laboratory reflects the belief of Professor Arthur Sale that this type of system represents the future for general-purpose computing.

### Cromemco user group

Adaptive Electronics has announced the formation of the Cromemco Australia Users Group, a non-profit organisation which is planned to serve as a clearinghouse for user programs and information. The initial membership fee has been set at \$20, for which you will get a demonstration floppy disc and regular updates of Cromemco product releases.

Initial enquiries and subscriptions should be addressed to Stephen Pat-  
tinson of Adaptive Electronics, 77 Beach Road, Sandringham, Victoria 3191.

### Versatile 4 systems

Microprocessor Applications, of Selby, Victoria announce that they have been appointed Australian dealers for the "Versatile 4" range of systems produced by Computer Data Systems of Wilmington, Delaware USA. The basic Versatile 4 system features an 8085

processor, 32K RAM memory and dual Micropolis disc drives with a total of 630K bytes of formatted storage. The disc controller allows addition of a further two disc drives for a total of 1.2M bytes. The system comes complete in a fully enclosed cabinet with keyboard and 24 x 80 character display. Standard software included with the unit is the Micropolis disc operating system with powerful line editor, 8085 assembler and program development utilities, and the new Micropolis extended disc BASIC interpreter. The total retail price for this package is \$5900 before tax.

Further information is available from Microprocessor Applications at Maskell's Hill Road, Selby, Victoria 3159. Telephone (03) 754 5108.

Adaptive Electronics has announced that it is now marketing the Commodore PET personal computer range. A full range of systems is carried, including the CBM small business computer with 74-key keyboard. Further details from Adaptive Electronics Pty Ltd, 77 Beach Road, Sandringham, Victoria 3191. Telephone (03) 598 4422.

Paris Radio Electronics is distributing the publication "68 Micro Journal" in Australia. A monthly magazine for users of microprocessors systems based on the Motorola 6800, it carries a lot of useful software and applications information. Stocks of the magazine are currently being carried by J. H. McGrath in Melbourne, Radio Dispatch Service in Sydney, and the various Silicon Valley stores.



## Cottage Computers

1 RAMSDEN ST, CLIFTON HILL 3068

Tel: (03) 486636

\*\*\*End of Model Clearance\*\*\*

NPC CRT-2000 Video Interface Card only

\$148.50!!!

See us for 3M SCOTCHFLEX Rainbow Cable & Connectors; DIL, PCB headers, D 25/37...

Arriving soon : Science of Cambridge (UK)  
(under \$100!) Mkl4 Microcomputer Kit

\*\*Send 20¢ stamp for latest product list\*\*

##STOP PRESS: UART Adaptor Board for  
NPC Video Cards (All Models)  
Available JAN. 1980 (\$70)



## micro COMPUTER TRAINING

For the home computing enthusiasts and those in industry or commerce, a correspondence computer training course is now available. The training is based on 24 lessons arranged into 4 separate units.

Unit 1 - Introduction and BASIC language.

Unit 2 - Micro computer hardware.

Unit 3 - Programming technique.

Unit 4 - Computing and FORTRAN.

The cost is \$38 for each unit, with a special rate of \$130 for all 4 units.

ELECTRONIC & COMPUTER SERVICES,  
Box 108, P O DEE WHY, NSW 2099, AUST.

Enclosed is \_\_\_\_\_ dollars for units -

1  2  3  4  Info. only

name \_\_\_\_\_

address \_\_\_\_\_

## SOFTWARE FOR

APPLE, PET, TRS80 AND 6800

PIE (PROGRAMMA IMPROVED EDITOR) is a two-dimensional cursor-based editor designed specially for use with memory-mapped and cursor-based CRTs. It is totally different from the usual line-based editors which were originally designed for Teletypes. The keys of the system input keyboard are assigned specific PIE Editor function commands. Some of the features included in the PIE system are: Blinking Cursor; Cursor movement up, down, right, left, plus tabs; Character insert and delete; String search forwards and backwards; Page scrolling; GOTO line number, plus top or bottom of file; Line insert and delete anywhere on screen; Move and copy (single and multiple lines); Append and clear to end of line; Efficient memory usage. The following commands are available in the PIE Text Editor and each is executed by depressing the systems argument key simultaneously with the command key desired.

ALL PROGRAMMA INTERNATIONAL SOFTWARE  
AVAILABLE FROM:

Paris Radio Electronics  
(02) 313273

J. H. Macgrath & Co Pty Ltd  
(03) 6633731

PROGRAMMA Software Products



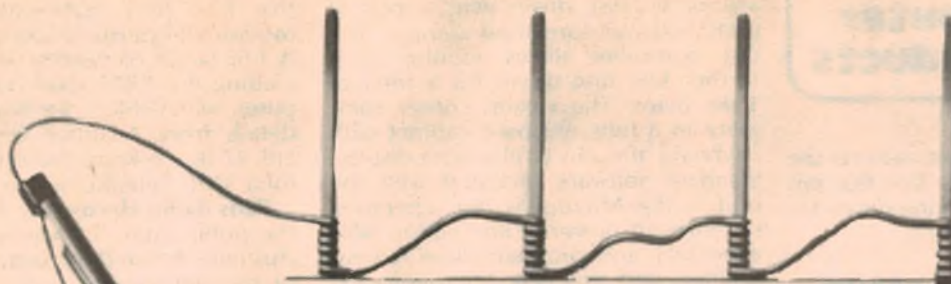

WHY CUT? WHY STRIP? WHY SLIT?  
WHY NOT...

**NEW**

# JUST WRAP™

WIRE WRAPPING TOOL

- AWG 30 Wire
  - .025" Square Posts
  - Daisy Chain or Point To Point
  - No Stripping or Slitting Required
- ...JUST WRAP™...
- Built In Cut Off
  - Easy Loading of Wire
  - Available Wire Colors:  
Blue, White, Red & Yellow

traditional Wire-Wrapping





JUST WRAP Wire-Wrapping

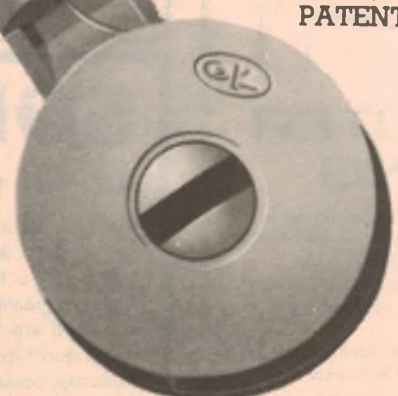

U.S.A. FOREIGN PATENTS PENDING

JUST WRAP TOOL WITH ONE 50 FT. ROLL OF WIRE		
COLOR	PART NO.	LIST PRICE
BLUE	JW-1-B	\$19.30
WHITE	JW-1-W	19.30
YELLOW	JW-1-Y	19.30
RED	JW-1-R	19.30
REPLACEMENT ROLL OF WIRE 50 FT.		
BLUE	R-JW-B	\$3.84
WHITE	R-JW-W	3.84
YELLOW	R-JW-Y	3.84
RED	R-JW-R	3.84
JUST WRAP-UNWRAPPING TOOL		
	JW-1	\$4.50





**AMPEC ENGINEERING CO PTY LTD**  
1 WELLINGTON ST, ROZELLE

Available from:  
NSW: RADIO DESPATCH; G. BROWN; M. DE LAUNAY; DAVID REID. ELECTRONIC DISTRIBUTORS  
VIC: ELLISTRONICS; ARLIN; TECH SCIENTIFIC.

SA: PROTRONICS.  
 WA: RESERVE  
 QLD: WILBER.





# Experimenter's power supply

Here is an ideal power supply for the hobbyist who is new to electronics. The output is switch adjustable to give seven different voltages at up to 500mA which means that it will drive most circuits of interest to the beginner. As a bonus, the power supply is completely safe because it has no mains wiring.

Over the past few months we have presented a variety of beginner's projects, all of which require batteries of one voltage or another. But batteries are fairly expensive these days so we decided to produce a power supply for the beginner. One of the main criteria for this project was that it had to be easy to build and as safe as possible.

The best way of making such a power supply safe is to completely eliminate mains wiring. With the introduction of 12V AC plugpacks from Ferguson Transformers Pty Ltd, this is a practical proposition. We used a Ferguson PPA12/500/2 plugpack which can supply up to 500 milliamps continuous. These are made to meet high insulation standards and are available at a reasonable price.

Using the Ferguson AC plugpack means that all mains wiring, switch and mains transformer can be eliminated from the power supply case. So the power supply really comes in two parts, plugpack and power supply proper.

In spite of the fact that this power supply is so easy to build, it has quite a high performance. It features excellent load regulation and hum and noise on

the output are very low, less than one millivolt. It is stable under all load conditions and will withstand short-circuits for short periods (this overloads the plugpack transformer rather than the regulator circuitry).

Our circuit uses the National Semiconductor LM317 three-terminal regulator. This regulator is different from conventional three-terminal regulators in that it can be used in an adjustable circuit which will give low output voltages. "Well, how is that different from a conventional regulator?" you may ask. Good question.

Three-terminal regulators normally provide a fixed output voltage such as 5V or 12V but they can be made adjustable, using the circuit shown in Fig. 1. What this circuit does is to apply the fixed regulator output voltage,  $V_{reg}$ , across resistor  $R_a$ . Assuming that no current is drawn by the adjustment terminal, then all the current flowing in  $R_a$  must flow in  $R_b$ .

The result of the current flowing in resistor  $R_b$  is to "jack up" the adjustment terminal so that the total voltage output of the circuit of Fig. 1 is  $V_{reg}$

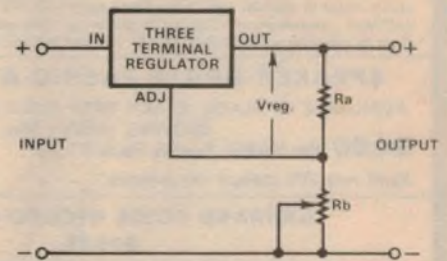

FIG. 1

This diagram shows how a three terminal regulator can be used as an adjustable power supply.

plus the voltage across  $R_b$ . As we have seen, the voltage across  $R_b$  is defined by the current through  $R_a$  which, in turn, is set by the regulator output voltage  $V_{reg}$ .

For example, if the desired output of Fig. 1 is twice the nominal regulator voltage,  $R_a$  and  $R_b$  should be equal. If the desired output is three times the nominal regulator voltage, then  $R_b$  should be twice  $R_a$ . Get it?

So we can define the output voltage of Fig. 1 merely by selection the ratio of the two resistors,  $R_a$  and  $R_b$ .

The formula to express this relationship is

$$V_{out} = V_{reg} + (V_{reg} \times R_b) / R_a$$

There are two problems with the circuit of Fig. 1 as far as conventional voltage regulators are concerned. First, the current flowing out of the adjustment terminal is not negligible and it tends to vary with the input voltage and temperature. This means that the regulation of the circuit is not particularly good.

Second, the minimum output voltage of the circuit is equal to the regulator



Here is the completed prototype together with the 12V AC plugpack. The unit is totally isolated from the mains in the interests of safety.

We estimate that the current cost of parts for this project is approximately

**\$28.00**

This includes sales tax.



# SPECIAL PURCHASES

## NEW B.S.R. RECORD CHANGERS-PLAYERS



**MODEL C197**  
**\$47.50**

This is a new model just released and is fitted with a ceramic cartridge & diamond stylus. Auto or manual operation. Three speed 33, 45 & 78rpm. Cueing control and bias compensation. Changer & player spindles supplied. 11" turntable. Post & packing extra, NSW \$2.75; Vic. Qld \$3.75; WA, NT & Tas \$4.75.

### SPEAKER GRILLE FABRIC AT 1/2 PRICE

AVAILABLE IN BLACK, BLACK WITH GOLD FLECK, LIGHT & MID BROWNS. WIDTH 60in.  
**\$4.80** Per YARD. Post & Pack \$1.75.

Send two 20c stamps for samples.

### GARRARD CC10A RECORD CHANGER

**\$15.75**

Fitted with a Sonatone Garrard Ceramic Cartridge Sapphire Stylus supplied with template & instructions. Posts & Packing: NSW \$2.50. Inter \$3.50.

### MODEL C142R

HI-FI UNIT WITH ADC MAGNETIC CART & DIAMOND STYLES

**\$55.00**



A precision automatic and manual record-playing unit fitted with 4 pole motor to provide constant speed conditions for the 1 1/2 inch turntable. The low resonance tubular pickup arm is counter-balanced with a resiliently mounted weight to permit light sensitive tracking, and the slide-in cartridge carrier enables styles inspection and the interchange of replacement of cartridges to be carried out simply and quickly. Fine stylus force adjustment and bias compensation are both calibrated for accurately setting the arm to given optimum playing conditions for the chosen cartridge.

The fluid-damped level-type cue and pause control ensures gentle lowering of the pickup to the surface of the record. A short spindle is supplied for single record play records. Precision engineering is reflected in the styling of the 142R, which is elegantly finished in black and silver.

POST AND PACKING EXTRA  
NSW \$3.75  
Tas. WA & NT \$7.00

Vic. SA & Qld \$5.75  
(Reg post \$2.00 extra)

### NEW RANK-ARENA F.M.-A.M. TUNER AMPLIFIER

MODEL RA402. Output 24 watts RMS (12+12). Response 50HZ to 50KHZ. Mag or ceramic inputs. High & low filters. Loudness control. Provision for 4 speakers.

Freight Extra

**\$147.00**

### NEW AWA HI-FI SPEAKER KITS 8" 2 WAY 3 SPEAKER SYSTEMS

AT LESS THAN 1/2 LIST PRICE

POWER RATING 20 WATTS R.M.S.  
IMPEDANCE 8 OHMS  
FREQUENCY RANGE 46 TO 18000 CYCLES

Supplied in kit form (less cabinet) each kit comprises One AWA 8WAC 8in. bass unit, two AWA 4MBC 4in tweeters with ceramic magnets & curve-linear cones, crossover components, grille cloth, innabond lining and cabinet plans

CABINETS AVAILABLE  
Post & packing extra, NSW  
\$2.50. Interstate \$3.50

**\$18.50**

Per Kit

### NEW E.M.I. AND HITACHI RECORDING TAPE AT BARGAIN PRICES

HI-DYNAMIC EMITAPE — HIGH OUTPUT — LOW NOISE — HI-FIDELITY

HLP18 7" reel 1800ft. long play \$5.95 P & P — \$1.00  
HDP12 5" reel 1200ft. double play \$3.95

Hitachi LN 8-track 90 minute cartridge. 5 for \$10. P & pack \$1.50



### NEW GOODMAN-FOSTER 3-WAY 4-SPEAKER HI-FI SYSTEM \$39.00 PER KIT

Frequency Range 45 to 22 000 cycles. Power rating 25 watts RMS Imp-Bohms. Supplied in kit form (less cabinet) each kit comprises two English Goodman 8" bass units. Foster 5" mid range. Foster 1" dome tweeter crossover components. Ocodensers and inductance innabond, speaker fabric and plans of cabinet. Cabinet dimensions 23" x 13" x 10". CABINETS AVAILABLE

Post & packing extra: NSW \$2.70; VIC, SA, QLD \$4.70; WA \$5.70 (REGISTERED POST \$2.00 EXTRA IF REQUIRED) cabinets available.

### RANK-ARENA 2 WAY SPEAKER

- 10 Watts RMS
- 8 ohm impedance
- 8" woofer with tweeter
- Supplied with lead and plug
- Teak finish

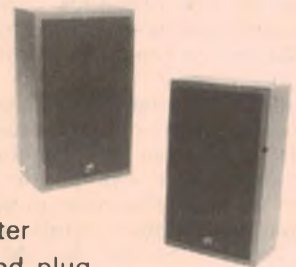

**\$42.00**  
PER PAIR

Dimensions 18"H, 11"W, 9 1/2"D  
Freight extra per rail air or road transport

### NEW HOKUTONE HI-FI SPEAKER KITS AT A FRACTION OF LIST PRICE

NEW THREE WAY HIGH FIDELITY SPEAKER SYSTEM WITH A FREQUENCY RANGE OF 35 TO 20,000 CYCLES. POWER RATING 50 WATTS.

Supplied in Kit form (less cabinet) Woofer HFW-302. 12" Mid range HM-24 dome. Tweeter HT-60 dome. Three way crossover with separate controls for mid range & tweeter. Innabond lining, grill fabric & cabinet plans supplied. Cabinet dimensions 668 high, 435 wide, 310 deep.

**\$69.00 per kit**

Freight extra by rail, air or road transport

### NEW GARRARD 6-200 CP RECORD PLAYERS

Fully automatic turntable automatically or manually as required. 11" turntable Cue & pause control. Record speeds 33 1/3, 45 and 78 rev/min. Finished in black with silver trim. Fitted with ceramic cartridge. Post & packaging extra. NSW \$2.70. Vic. Qld. SA \$3.70. WA \$4.70 (registered post \$2 extra if required).



**\$34.00**

### NEW MAGNAVOX — MV50 — 50 WATT SPEAKER SYSTEMS

COMPLETE KIT OF PARTS (LESS CABINET) COMPRISING MAGNAVOX 10240 IN 10" BASE UNIT. 625 MID RANGE 6" TWO XJ3 DOME TWEETERS. CROSS OVER NETWORK. INNABOND. SPEAKER SILS AND PLANS OF CABINET. ALSO 6 1/2" AND 4 1/2" TUBES.

**\$89.50 PER KIT**

Freight extra per rail or air freight.  
Cabinet available 830 System also available  
Range of Magnavox Speakers stocked.

# CLASSIC RADIO

245 PARRAMATTA RD, HABERFIELD 2045. PHONES 798-7145, 798-6507.



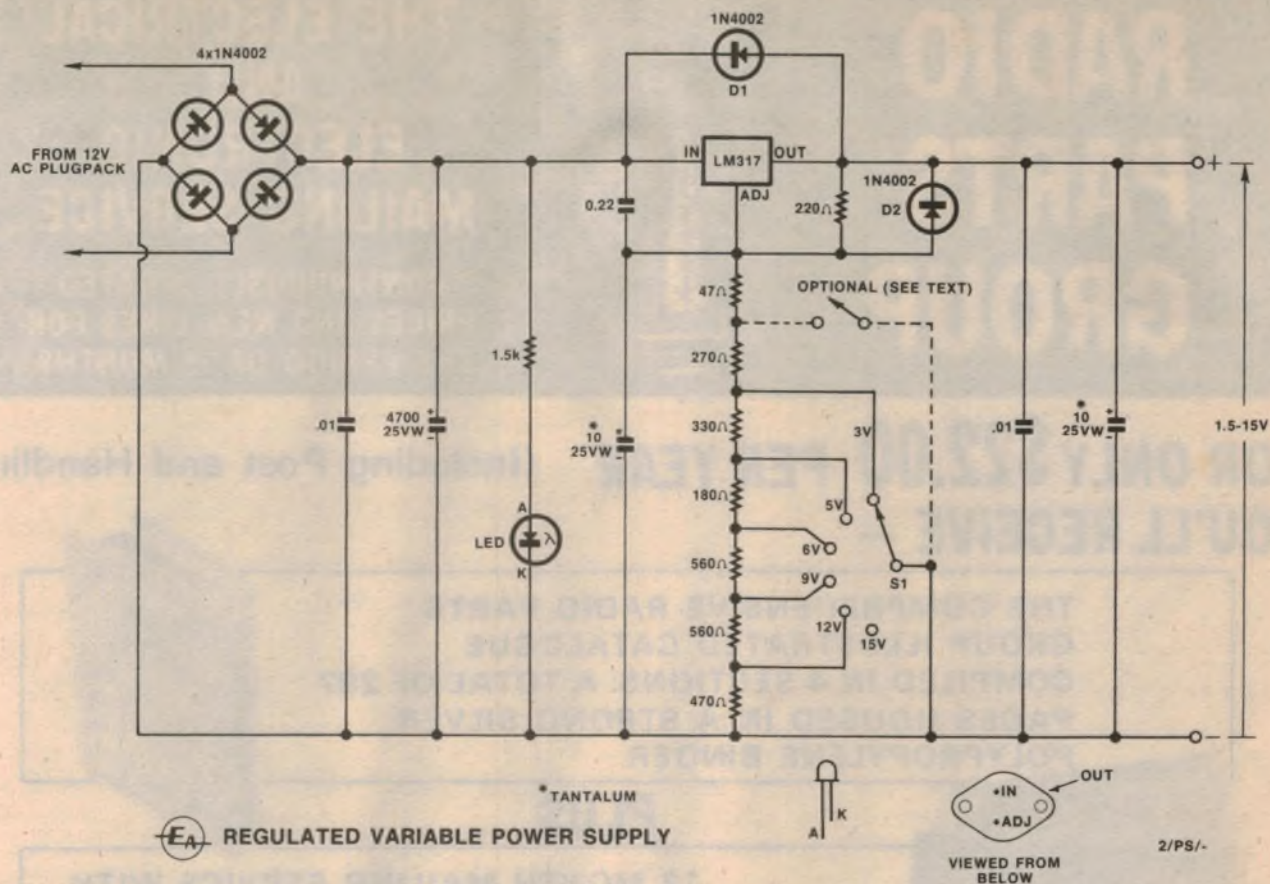

The schematic diagram of the power supply unit. The part of the circuit that appears in dotted lines is the 1.5V option which is explained in the text. The diodes around the regulator IC are to protect it from damage when the supply is connected to charged capacitors.

voltage,  $V_{reg}$ . That stands to reason, when you think about it, because it would be the result if  $R_b$  was reduced to zero. So if a 5V regulator was used in the circuit, then five volts would be the minimum output voltage. And five volts is occasionally not low enough.

The LM317 overcomes these problems. Firstly, it has a very low current flowing out of the adjustment terminal — less than 50 microamps. Provided we select the resistors in the voltage divider of Fig. 1 so that the current flowing "swamps" this 50 microamp current, we can ignore it. Second, the nominal regulator voltage of the LM317 is 1.25V (typically).

Now have a look at the complete circuit of the Experimenter's Supply. The plugpack transformer feeds a bridge rectifier and a 4700µF filter capacitor to produce about 18 to 20 volts DC. There is however a small 100Hz AC component which is superimposed on the DC voltage. This is referred to as "ripple". This DC voltage, with its small "ripple" content, is fed to the input of the LM317 regulator.

In the complete circuit,  $R_a$  has become 220 ohms while  $R_b$  is a "ladder" consisting of seven resistors. The output voltage of the circuit is

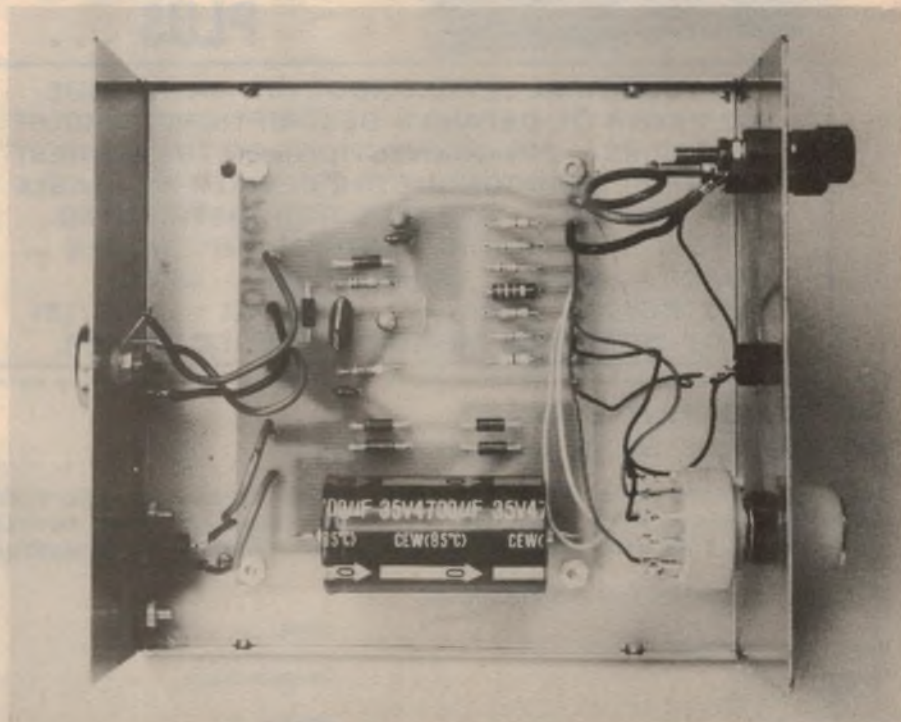

Inside the completed prototype. Note the heavier wiring between the PCB and the AC input socket, the regulator IC and the terminal posts on the front panel.



# RADIO PARTS GROUP



## THE ELECTRICAL AND ELECTRONIC MAILING SERVICE

CONTINUOUSLY UPDATED PRICES AND NEW LINES FOR THE PERIOD OF 12 MONTHS.

**FOR ONLY \$22.00 PER YEAR** (Including Post and Handling)  
**YOU'LL RECEIVE —**

THE COMPREHENSIVE RADIO PARTS GROUP ILLUSTRATED CATALOGUE COMPILED IN 4 SECTIONS. A TOTAL OF 287 PAGES HOUSED IN A STRONG SILVER POLYPROPYLENE BINDER.



**PLUS ...**

12 MONTH MAILING SERVICE WITH COMPUTERISED PRICE BOOKS (OVER 80 PAGES) WITH COSTS ON OVER 15,000 LINES, CIRCULARS, MANUFACTURERS' SPECIALS AND SEASONAL CATALOGUES.



**PLUS ...**

THE TECHNICAL SEMICONDUCTOR CATALOGUE. 153 PAGES OF DETAILED DESCRIPTIONS. CIRCUIT DIAGRAMS — PIN CONNECTIONS ON THE LARGEST RANGE OF SEMICONDUCTOR DEVICES AVAILABLE IN AUSTRALIA — STOCKED AND DISTRIBUTED THROUGH THE RADIO PARTS GROUP. DIODES — TRIACS — SCRs — TRANSISTORS — OPTO ELECTRONICS — LINEAR — DIGITAL — MOS/LSI CMOS INTERFACE MEMORY MICROCOMPUTER.



To RADIO PARTS Group  
 PO Box 124, North Melbourne 3051

I WOULD LIKE TO JOIN THE RADIO PARTS GROUP ELECTRICAL AND ELECTRONIC MAILING SERVICE. I AM ENCLOSING \$20.00 PLUS \$2.00 FOR POST AND HANDLING. THIS ENTITLES ME TO THE COMPREHENSIVE CATALOGUE, 12 MONTHS MAILING SERVICE AND A COPY OF THE SEMICONDUCTOR CATALOGUE.

Enclosed is my Cheque/Money Order/Order No.

(if Account Customer) .....  
 or please debit  
 my Bankcard No. ....

Name .....

Company Name .....

Address .....

for ..... copies at \$20.00 each.  
 Plus \$2.00 Post & Handling









# Basic Electronics

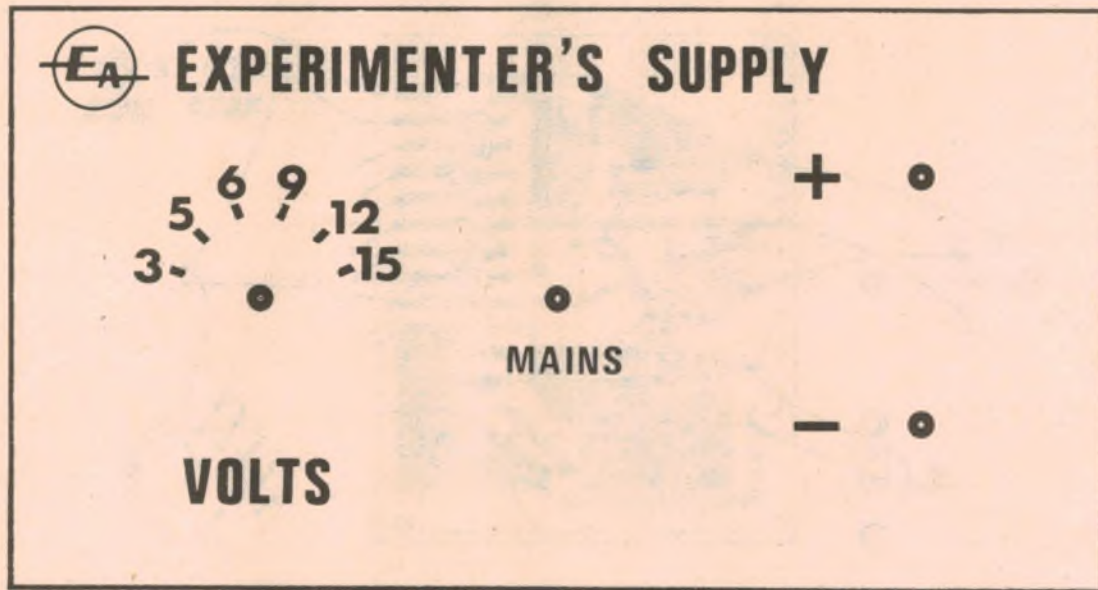

The full size artwork of the front panel. Scotchcal panels will be available from Radio Despatch Service, 869 George St, Sydney.

steel cover, and measures 70 x 134 x 150mm. It is very reasonably priced at \$4.95, and is supplied complete with rubber feet and cover fixing screws.

The front panel of the box was

"dressed up" using a Scotchcal panel. The artwork for the panel has been reproduced here and can be used as a guide for those that wish to make their own. The artwork can also be used as a

guide for the placement of the terminal posts, the indicator LED and the rotary switch.

The LM317 IC is mounted in the centre of the rear of the chassis and insulated from the case using a mica washer and plastic insulating bushes for the screws. Heatsink compound should be used to provide a good thermal path between the IC case and the back panel of the box.

The PCB is mounted on the base panel of the chassis using four screws together with lockwashers and nuts. Space the PCB off the base panel by the thickness of two nuts. Alternatively, you can use four Richco PCB mounts.

The wiring between the printed circuit board and the regulator IC should be reasonably heavy wire (23/019mm would be ideal) and should also be as short as possible. The same wire should be used between the PCB and the output terminals. The wiring between the PCB and the rotary switch can be done using ordinary hookup wire.

When all the wiring has been completed, go back and do a final check. This should cover the PCB, the wiring to the regulator, the LED and the switch. If you are satisfied that all is well apply power to the circuit. Using a multimeter, check the output voltages and make sure that they are reasonably close to the nominal voltages specified. The 1.5 volt setting can be tested by temporarily grounding the junction of the 47 ohm and the 270 ohm resistors.

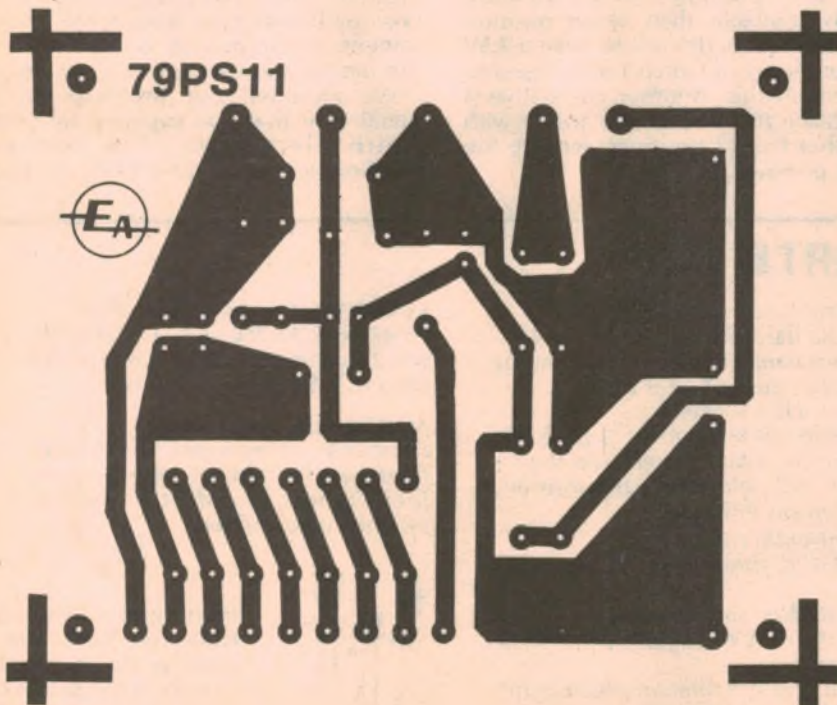

A full size reproduction of the PCB artwork. Use this to make your own or purchase a complete board from the usual suppliers.



# L. E. CHAPMAN

122 PITT RD, NTH CURL CURL  
MAIL ORDERS BOX 156, DEE WHY, NSW 2099  
TEL.: 93 1848

## SPECIAL TRANSISTORS

AD161-162 \$2.50 pair  
2SC901A \$1.50 each  
BC548B 10 for \$1  
Diodes OA636 50 cents each

**Speakers:** 8 ohm, 3 inch \$2.50  
5 x 4 47 ohm \$4.50

**Speakers:** 5 x 4 1500 ohm CT \$4.50

**Power Leads:** 240 volt, suit most tape recorders, radios, etc \$1 each

**TV Stick Rectifiers** 20SC \$1.00

**Philips TV Colour TV Convergence Boards** \$3 each

**TV Demodulator Units, complete with TCA IC** \$1 each



**465KC IF Transformers** for valve radios. \$1 each, also aerial and OSC coils, 75 cents each.

**Transistor Miniature Speaker and Drive Transformers.** \$1 pair.

**Car Radio Suppressors** 3 for \$1

**Philips TV Yokes AT10721-00** \$5 each

**Test Prods** suit most meters \$1 pair

**Tape Recorder Motors, 240v, heavy duty, reel-to-reel** \$6 each

**Slide Pots, 250K-50K** 3 for \$1  
**Dual 500K** 3 for \$1  
**1 Meg** 3 for \$1  
**2 Meg** 3 for \$1

Including Fancy Gold Knobs

## RESISTORS

150 ohm, 5W, 20c  
10 ohm, 5W, 20c  
47 ohm, 5W, 20c  
12 ohm, 3W, 20c  
2.5 ohm, 3W, 20c  
33 ohm, 3W, 20c  
8 ohm, 10W, 25c  
4000 ohm, 10W, 25c  
1000 ohm, 5W, 20c  
330 ohm, 10W, 25c  
220 ohm, 5W, 20c  
5 ohm, 5W, 20c  
220 ohm, 10W, 25c  
950 ohm, 3W, 20c  
115 ohm, 5W, 20c  
10 ohm, 5W, 20c  
1k ohm, 5W, 20c  
5000 ohm, 5W, 20c  
6.8k ohm, 3W, 20c  
330 ohm, 10W, 25c  
6800 ohm, 10W, 25c  
1500 ohm DUAL, 21W 50c  
50 ohm, 5W, 20c  
330 ohm, 5W, 20c  
1k ohm, 5W, 20c  
820 ohm, 5W, 20c  
12 ohm, 10W, 25c  
470 ohm, 7W, 20c  
4700 ohm, 4.5W, 20c  
5000 ohm, 10W, 25c

## ELECTROS

470uF 25V 5 for \$1  
400uF 10V 5 for \$1  
47uF 63V 5 for \$1  
350uF 16V 2 for \$1  
27uF 160V 5 for \$1  
25uF 63V 10 for \$1  
22uF 160V 10 for \$1  
47uF 16V 5 for \$1  
47uF 200V 5 for \$1  
2200uF 10V 10 for \$1  
68uF 16V 10 for \$1  
1000uF 25V 5 for \$1

## CAPACITORS

0.0039uF 1500V 20c ea  
6N8 1500V 20c ea  
0.0068uF 1500V 20c ea  
1200PF 400V 10 for \$1  
0.068uF 400V 5 for \$1  
2200PF 630V 10 for \$1  
0.47uF 250V 10 for \$1  
0.10uF 400V 5 for \$1  
0.082uF 160V 10 for \$1  
26k 250V 10 for \$1  
0.041uF 400V 10 for \$1  
0.033uF 250V 5 for \$1  
0.027uF 100V 20 for \$1  
220uF 10V 10 for \$1

## SPEAKERS

MSP 9 x 6 15 ohm \$6.00  
9 x 6 8 ohm 6.00  
12 watt 8 inch dual cone 8 ohm 9.00  
7 x 5. 15 ohm 5.50  
7 x 5. 8 ohm 5.50  
6inch dual cone, 8 ohm 5.00  
6 inch single cone, 15 ohm 5.00  
6 inch dual cone, 27 ohm 8.50  
5 inch dual cone, 27 ohm 5.00  
5 inch single cone, 3.5 ohm 3.50  
5 inch single cone, 8 ohm 3.50  
5 inch single cone, 15 ohm 3.50  
4 inch dual cone, 4 ohm 6.00  
6 inch dual cone, 3.5 ohm 6.00  
4 inch single cone, 15 ohm 3.00  
4 inch single cone, 27 ohm 4.50  
5 x 3. 27 ohm 3.50  
5 x 3 47 ohm 3.50  
7 x 5. 3.5 ohm 5.50  
12 watt 8 inch dual cone, 3.5 ohm 8.50  
5 x 7 single cone, 27 ohm 5.50  
3 inch, 8 ohm 2.50  
6 x 4. 8 ohm 2.50  
6 x 4. 15 ohm 2.50  
6 x 9. 27 ohm 6.50  
6 x 9 47 ohm 6.50  
3 inch, 8 ohm 2.50

## SPEAKERS SPECIAL

\$1 pair 2 1/4 inch  
5 x 3. 8 ohm  
2 for \$3  
**SPECIAL**  
8 x 4. 15 ohm, \$4  
8 x 4. 8 ohm, \$4  
2 3/4 inch, 8 ohm, \$1.50  
6 x 9. 3.5 ohm, \$6  
2 inch, 8 ohm, 2 for \$1  
6 inch dual cone, 4 ohm, \$5

## SPECIAL

100 mixed resistors, all useful, \$2  
100 Mixed capacitors, fresh stock, \$2

## AUDIO LEADS

3.5m to 3.5m, 7ft, 75c  
3.5m to 6.5m, 7ft, 75c  
6.5m, 7ft, 50c

## MICRO SWITCH

5A, 250V AC, 75c each

## TUNING CAPS

2 and 3 gang, \$1 each  
min 2 gang, 50c

## FUSES

0.5A, 2A, 3.25, 10 for \$1  
In line fuse holders, 30c  
RCA jack plugs and sockets, 40c pair

## PILOT LIGHTS

Screw in 6.3V, 10 for \$10.50  
12V, 10 for \$1  
24V, 10 for \$1

100 Mixed Resistors, \$2.00  
all useful

Transistor Specials AD149 \$3.50 pair

Special! 100 mixed capacitors — fresh stock, all useful.

\$2.00

**Stereo Gramophone Motor and Pick-Up, 3 speed, \$8.50 pp NSW \$1.50. Interstate \$2.50. WA \$3.50.**

**Amplifier Fancy Chrome Knobs, recommended retail price 50 cents each 6 for \$1**

**Power Transformers, 240 volt to 18 volt AC 1/2 amp \$3.50**

**Philips 4-speed Gramophone motor and pick-up, 4 speed, 6 volt, \$6 PP NSW \$1.50 Interstate \$2.50.**

ICS TBA 760, TBA 540, 7400, TDA 1005, TCA 750, TCA 420K, TBA 720, \$2.50 each.

**6 Position Push Button Switch, \$1.**

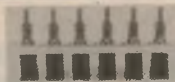

**SPEAKER SYSTEMS INCLUDING TWO 6x4 SPEAKERS**  
5 Watts RMS \$7 each  
Pack & Post NSW \$1.50  
Interstate \$2.50



## SPEAKER SYSTEMS

15 watt RMS including 2 6in dual cone, each cabinet \$16 each P&P  
NSW \$2.50; Interstate \$3.50, WA \$4.50



**TRANSISTOR EAR PIECES PLUGS AND LEADS, 3 FOR \$1 PICK UP ARMS MONO COMPLETE WITH CARTRIDGE, \$4.50 PICK UP ARMS STEREO COMPLETE WITH STEREO CARTRIDGE, \$6.50**



## TV TUNER VALVE TYPE

\$2.50  
Including valves  
P&P \$1.00  
Interstate \$2.50

## SUPER SPECIALS

**FM STEREO TUNER KITS**  
SETS OF 3 MODULES INCLUDE FM TUNER, DECODER & IF/DETECTOR CIRCUIT DIAG SUPPLIED; CAN BE USED WITH AMP MODULES  
**ONLY \$18!** PP \$1

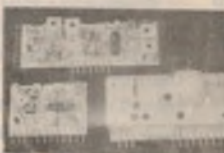

## VORTEX DECKS

COMPLETE WITH HEADS & CIRCUIT FOR AMPLIFIERS FOR THE DECK  
**ONLY \$25!**  
SPARE ERASE HEADS for above \$2 ea  
PP NSW \$2.50 INTERSTATE \$3.50  
WA \$4.50



## 24V MOTORS

REVERSIBLE  
only \$2.50 each

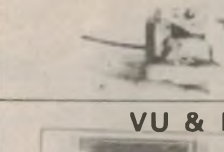

## VU & BALANCE METERS

**STEREO VU \$3**

**12 Kn 100uA \$2**



PHILIPS TV TUNER Transistor NT3030 NT3032 Colour—PP \$1  
**\$10 ea**



# Boxes and cases to house your projects

*No electronic project can be considered really complete until it is housed in a suitable case and fitted out with various controls and switches. Here we take a look at some of the ready-made cases that are available to the hobbyist, and tell you how to select the right case for the project on hand.*

by **GREG SWAIN**

As we've seen, the first step in building an electronic project is to solder the electronic components onto a circuit board of some sort. Having done this, the completed board assembly must usually be housed in a suitable metal or plastic case, and the wiring to the various external components completed.

A case serves several purposes:

- it protects the electronic circuitry from damage;
- it provides mechanical support for the circuit board and various other components, including front panel controls, input and output connectors,

power transformers, and meters etc;

- it helps give the completed project a professional finish; and
- in some projects, it isolates the user from dangerous voltages.

Basically, you've got two choices in obtaining a suitable case to house a project — you can either make your own or you can choose from the large range of ready-made cases and boxes now sold by the various electronics parts stores. The latter are available in all shapes and sizes and with a variety of finishes.

Of course, if you are assembling an electronic project from a complete kit,

the decision as to which case to use will have been made for you. This is because many of the projects described in electronics magazines are designed to go into a specific case. Generally speaking, unless you know what you are doing it's best to use the case specified by the project designer.

The designer might, for example, specify a metal case for a high gain amplifier circuit in order to shield it from various sources of RF (radio frequency) interference. Using a plastic case in this situation would almost certainly compromise circuit performance.

## Making your own

You will need a fairly well equipped workshop with a metal bender if you intend to make your own cases. Aluminium is the material most often used, and this is available in sheet form from various components stores and hardware outlets. The main advantages of aluminium are that it combines light weight with high strength, and yet is easy to work.

It's important that you choose the correct gauge of aluminium sheet in order to make the case sufficiently rigid. 18-gauge is adequate for most hobby work, although heavier gauges will have to be used if surface areas are large.

In addition to the aluminium sheet, you can also buy a range of useful hardware to aid your construction. Included here are such items as angle aluminium strip and right-angle brackets, metal and plastic spacers,

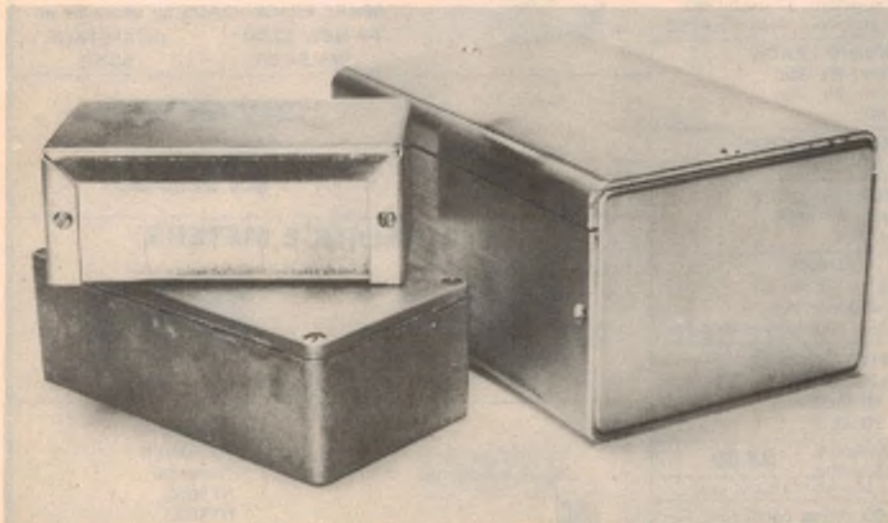

*Clockwise from bottom left: heavy-gauge metal diecast case, folded aluminium box, and aluminium instrument case. The cases are available in a range of sizes.*



## Cases and typical projects . . .

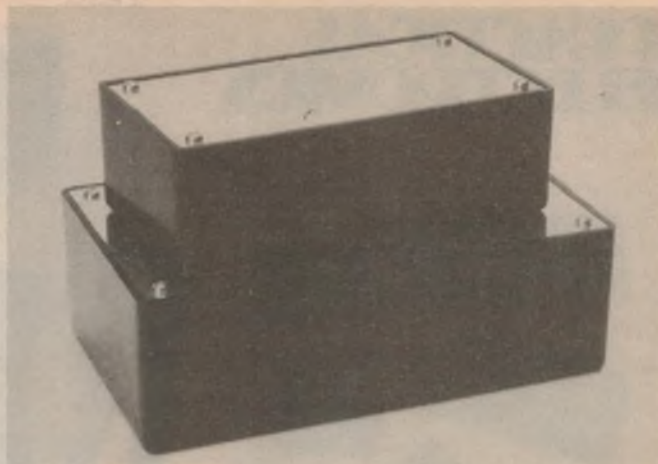

Left: A plastic zippy box was used to house this windscreen wiper control. View at right shows just two of the box sizes available.

rubber feet, and a variety of self-tapping screws and steel nuts and bolts. So provided you're reasonably proficient at metal work, you should have little difficulty in contriving a case to suit almost any project.

### Ready-made cases

These days, however, it usually doesn't pay to try to make your own cases — not with such a wide assortment of ready-made cases to choose from. Ready-mades enable the hobbyist to build really professional-looking projects inexpensively, and with a minimum of fuss. In fact, it's almost impossible not to be able to find a ready-made case to suit a particular project, both in terms of cost and appearance.

The photographs on these pages show just some of the ready-made cases that are available. They range all the way from low-cost plastic boxes up to professionally-finished instrument cases with metal handles. Each line is available in a range of different shapes and sizes, and some even come fitted with integral rubber feet.

The cases invariably come with lid-fixing screws, and are undrilled. Prices vary considerably, according to the size and style.

But how do you choose the best case for a particular project? Let's take a look at some of the things that should be considered.

What you generally have to try to do is satisfy a number of (sometimes conflicting) requirements. Basically, it all boils down to the job the circuit has to do, case size, heatsinking and shielding requirements, cost, appearance, the degree of ruggedness and, to some extent, personal preference. The case should obviously be large enough to house all the electronic circuitry, while the front panel area must be able to carry the various switches, controls and meters without obvious overcrowding.

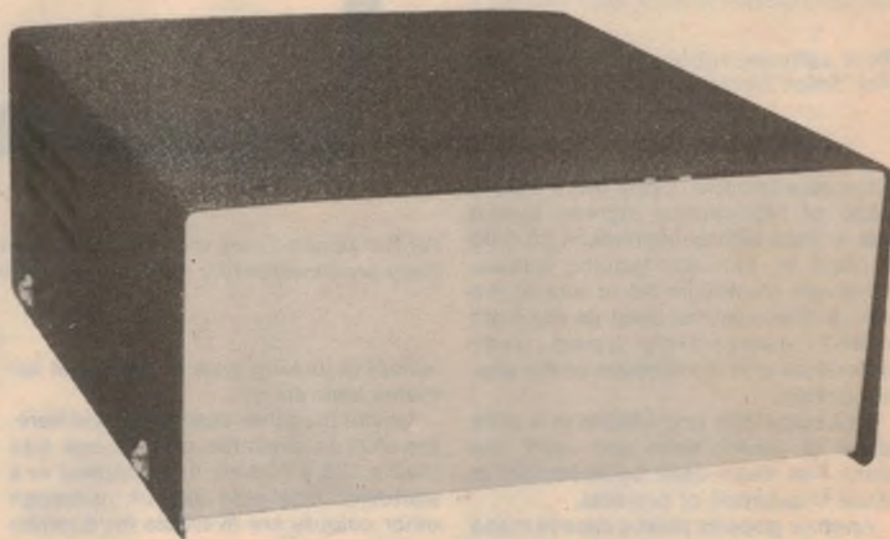

Above: The "deluxe metal cabinet" as sold by Dick Smith Electronics. It makes an ideal case for the 30V 2A regulated power supply shown below.

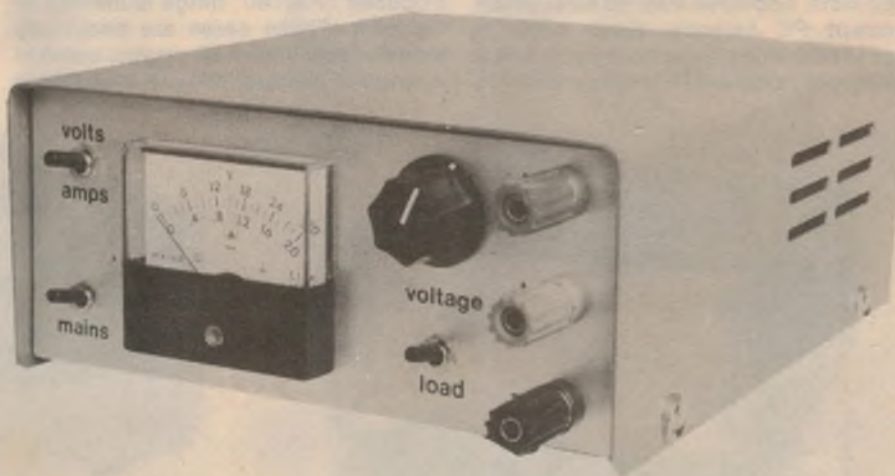

### Plastic cases

Plastic cases are often used to house small utility projects, particularly those powered from batteries or via a mains plug-pack. The big advantage of plastic cases is that they are extremely easy to work — drilling and reaming holes in

plastic is no problem. As a bonus, plastic cases are lightweight and generally cost much less than metal cases.

Many plastic cases cost less than \$2.00, for example.

Perhaps the best known plastic case



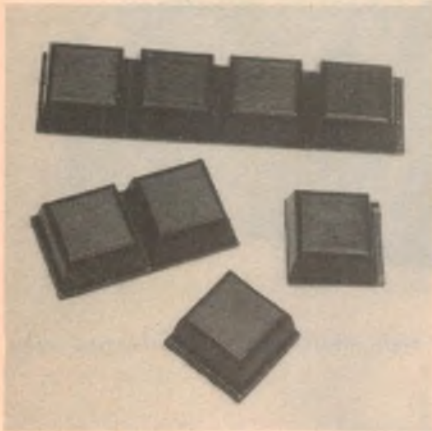

These adhesive rubber feet are sold by Dick Smith Electronics.

is the now famous "zippy box". This is made of high-impact styrene plastic and is fitted with an aluminium lid held in place by four self tapping screws. Either the aluminium lid or one of the plastic sides can be used as the front panel, depending upon user preference and the dictates of the project design.

The zippy box is available in a wide range of useful sizes and, over the years, has been used by hobbyists to house thousands of projects.

Another popular plastic case is made by A & R Soanar. Called the PC1, this versatile case splits into two halves and features integral moulded feet, ventilation slots, and three internal slots which accept PC boards. Each case is supplied with a plastic front panel and a steel rear panel which is prepunched to

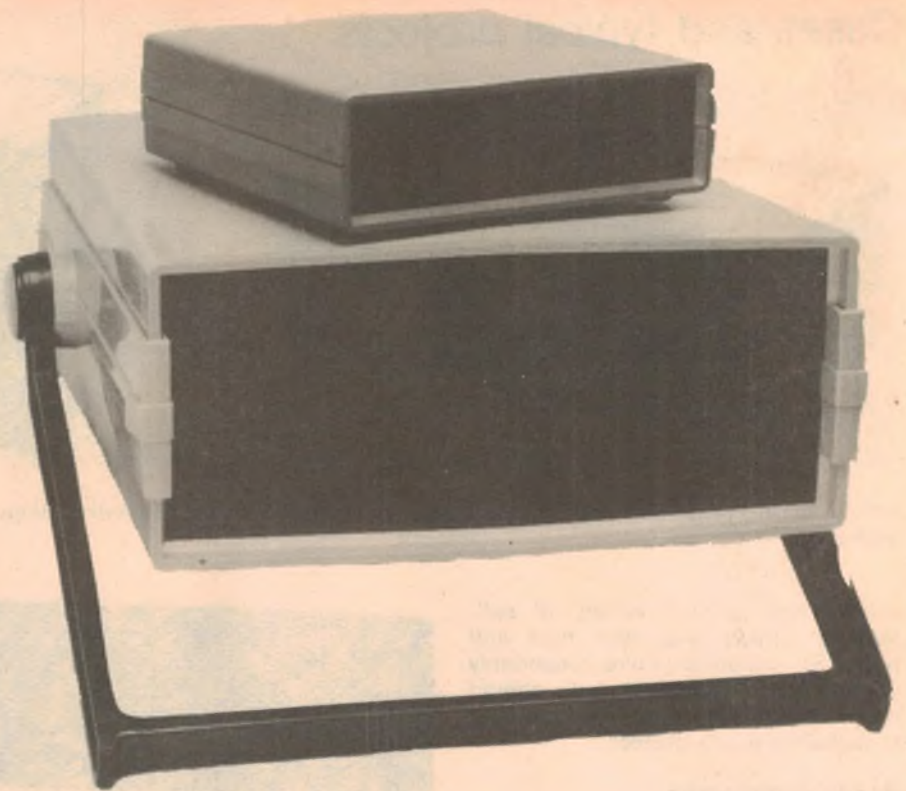

PacTec plastic cases are not cheap, but will really dress up that special project. They are imported by Associated Controls Pty Ltd, 55 Fairford Rd, Padstow 2211.

accept a locking type of grommet for mains lead entry.

Unlike the other cases featured here, the PC1 is available only in one size (140 x 130 x 70mm). It is supplied in a standard blue-grey colour, although other colours are available for quantity orders.

But if you really want something to dress up a project, then the recently introduced "PacTec" range is the one to consider. These cases are beautifully made of moulded ABS plastic, come in a range of colours, and are available in

over 50 models from stock. Some models even include an integral tilt stand and multi-position mounting rails for PC boards, while plastic mounting bosses are a feature of all models.

The main drawback of the PacTec cases is their rather high cost.

### Metal cases

The decision as to whether to use a plastic case or a metal case is usually automatic. As a rule, you should use a metal case whenever heatsinking is required, whenever sensitive audio or



Above: The PC1 from A. & R. Soanar makes a handy case for this electronic digital clock. At left are two metal cases from the Horwood range. Horwood cases are particularly well-finished, and are often supplied complete with metal handles.





# If he were around today we know he would use it.

Throughout his career as a composer and performer, there is no doubt that Franz Liszt went first class all the way. So it's logical to suppose, if he was around today, he would choose a chromium dioxide tape for recording and playback.

If you want to go first class too, choose Agfa Stereo Chrom and get unsurpassed recording characteristics, high frequency replay response, outstanding H.F. output and dynamic range, clearer tone with enhanced presence. Even the cassette features a special mechanism for better tape transport.

Agfa Stereo Chrom C60 and C90 cassettes are available at hi-fi specialists, music stores and photo dealers.

*\*Registered  
trademark of  
AGFA-GEVAERT  
Antwerp/  
Leverkusen.*







INTERNATIONAL



BY APPOINTMENT TO HER MAJESTY THE QUEEN  
SUPPLIERS OF SMOKERS REQUISITES ALFRED DUNHILL LTD. LONDON

**DUNHILL**

The name Dunhill is the registered trade mark  
of Alfred Dunhill Ltd. London

*London · Paris · New York*

20

WARNING - SMOKING IS A HEALTH HAZARD

*Dunhill*

Internationally acknowledged to be the finest cigarette in the world



**dunhill** The most distinguished tobacco house in the world

PATON 7685  
CC15/78



RF circuitry must be shielded, and for most (but not all) mains-powered projects. A heavy-gauge metal case will also be more rugged than its plastic counterpart, and this is an important consideration when heavy items such as mains transformers have to be accommodated.

Note that, for mains powered projects, the metalwork of the case should be earthed back through the mains wiring.

The range of metal cases includes simple folded aluminium boxes, diecast metal cases, steel and aluminium cases, and instrument cases made of heavy gauge aluminium. Each has its own advantages in terms of cost, appearance and function.

The metal diecast case, for example, is a particularly rugged case with thick metal walls and a close fitting lid. It provides quite effective screening against stray RF fields, and is often used to protect sensitive audio and RF circuits.

A fairly popular metal case is the "deluxe metal cabinet" sold by Dick Smith Electronics. It is available in four standard sizes, and consists of a light-gauge aluminium base fitted with a steel lid. The lid is louvred to aid ventilation and rubber feet are included as standard.

If appearance is important, then one of the instrument cases from the Horwood or similar ranges may be used. These attractive cases are made of heavy gauge aluminium, and are finished in vinyl except for the front and rear panels. They tend to be rather more expensive than other metal cases, though.

### Metal chassis

In addition to their ranges of standard cases, some electronics stores also stock pre-punched metal chassis for special projects. The chassis might be for a hifi stereo amplifier, or a radio tuner, for example, and may be sold separately or as part of a complete kit.

As far as the average hobbyist is concerned, it's usually a good idea to spend the extra few dollars for a commercial chassis. Making your own chassis is an incredibly time consuming business and, unless you're very good at metalwork, the end result will not be as professional as a commercial product.

So you can see that whatever your project, you should have little difficulty in finding a suitable case. Before making a final choice, though, make sure that you have considered all the relevant factors. There's nothing worse than buying a case, taking it home, and finding that it's not high enough to accommodate the power transformer! 🐼



This AM-FM stereo tuner kit from Dick Smith Electronics comes complete with a pre-punched steel chassis and an anodised scratch-grain-finished front panel.

## Front panels for projects . . .

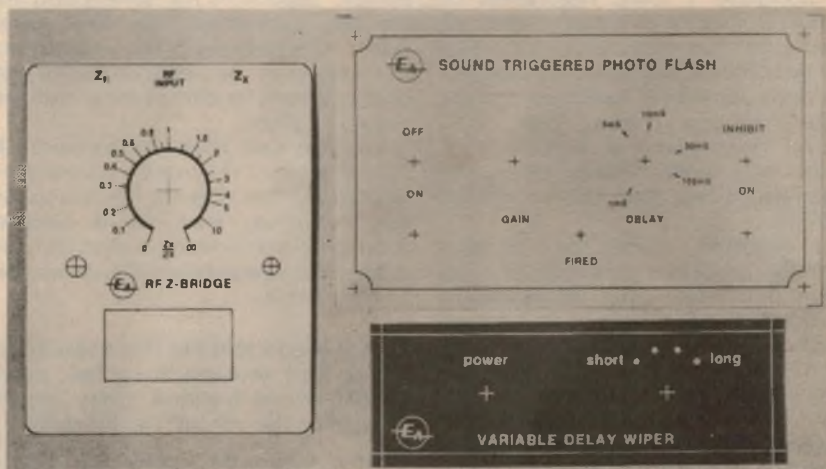

MANY of the projects described in the various electronics magazines are provided with "Scotchcal" type labels. Scotchcal is a photo-sensitive aluminium material with an adhesive backing. The label is produced by exposing the aluminium to ultra-violet light through a photographic negative and wiping over with developing/fixing chemical. By removing the backing paper, the resultant label can be glued to the front panel of the project to provide a neat, professional-looking finish.

At least one firm, Radio Despatch Service, sells ready-made Scotchcal panels for projects described in the magazines. These labels can be supplied in either blue or black, and with either a positive or negative image as requested by the customer. For popular projects, labels should be available ex stock, but any label for which artwork is available can be supplied within 24 hours. The labels are supplied rough trimmed, undrilled, and sprayed with a protective coating of clear lacquer. Enquiries to Radio Despatch Service, 869 George St, Sydney 2000.



## Common Questions and the answers on

# Components and Ratings

Many readers write to us with queries about component ratings and possibilities for substitution. This article brings together some of the common questions and provides helpful answers.

by LEO SIMPSON

**Q: I have a circuit with a number of resistors which get hot. Can I reduce the power dissipation by using higher rated resistors?**

You cannot reduce the power dissipation of a circuit merely by upgrading the ratings of components. A given circuit will, under the same operating conditions, always have the same power dissipation, regardless of whether the devices used are light-duty or heavy-duty.

To illustrate, let us consider the resistor problem posed by our reader. A 100ohm resistor passing 100 milliamps will dissipate 1 watt, regardless of whether it is rated at 1 watt, 5 watts or 20 watts. So changing the device rating does not change the power dissipated.

Perhaps our reader really wanted the resistors to run cooler. Well, as a general rule, using a higher rated device will allow lower operating temperatures but even this should be qualified.

For example, metal film resistors generally run cooler to the touch than carbon film types when dissipating a given amount of power. This is because the metal-film resistor is able to conduct more of its heat away via the leads to the PCB pattern or solder lugs.

So it is possible that if a carbon film resistor of 2 watt rating is substituted for a lower rated metal film resistor, it may actually run with a higher surface temperature.

A general rule to follow is that provided the resistors are run in ambient temperature of 70 degrees Celsius or less, the resistor may be used at up to its maximum power dissipation. Above 70 degrees Celsius, the resistor should be derated, according to the derating charts of the manufacturer.

**Q: I have a power supply which has a 5 watt resistor in the circuit. This resistor gets stinking hot but it is actually dissipating less than 5 watts, according to my measurements. What can I do about it?**

Wirewound resistors do run at high surface temperatures. For example, a 5 watt resistor dissipating 5 watts will typically have a surface temperature 120 degrees above the ambient temperature. 10 Watt resistors are worse. When dissipating 100% of rating, ie, 10 watts, they have a surface temperature of 200 degrees Celsius above ambient. Higher rated resistors are even worse again.

In fact, resistors with ratings of 10 watts or more get so hot that they can char the surface of printed circuit boards. They can also cause problems if they are wired to lugs to which electrolytic capacitors or semiconductors are also connected. The heat travels down the leads from the resistor, into the capacitor or semiconductor and thus can lead to overheating and subsequent failure.

You can gain some improvement by substantially derating wirewound resistors so that they do not run so hot. But even so, wirewound resistors should be positioned so that they are unlikely to cause damage to other parts of the circuit.

**Q: My friend told me that I should not use 1 watt resistors in a low power CMOS circuit because "they are too strong for the circuit". Is he right?**

No, provided the resistors are physically compatible with the PCB or whatever, there is no reason why you should not use 1 watt resistors. Resistors are resistors, after all, whether they be rated at 1/4W or 50W.

**Q: Is it permissible to use an electrolytic capacitor with a rating of 25 volts in a circuit where the voltage supplied to it will be only 5 volts?**

Years ago, it was desirable to use electrolytic capacitors at or reasonably near to their rated voltage, otherwise their capacitance and power factor was degraded. With modern electrolytics there are no problems. They can be used at a small fraction of their rated

voltage, which no reduction in performance.

As a general rule, you can use modern electrolytics at any voltage from just a couple of volts right up to their maximum rating, with no degradation in performance.

**Q: What is the shelf life of electrolytics? I have a bunch of electrolytic capacitors which I purchased a few years ago. Should I re-form them before using them in circuit?**

Many of our younger readers would probably wonder at the term "form". This term applies to the growth of the oxide coating on the aluminium foil inside an electrolytic capacitor. The oxide coat is actually the dielectric — the aluminium electrode is the anode, while the electrolyte, which is usually in paste form is the negative connection, or cathode.

In former years, the oxide dielectric of aluminium electrolytic capacitors was not particularly stable and tended to break down while the capacitor was on the shelf. If such a capacitor was placed into circuit and voltage applied, not only would the capacitance be low and power factor high, but the leakage current might be so high that the capacitor might overheat and destroy itself.

Consequently, it was prudent to "reform" or repair the oxide dielectric of electrolytic capacitors before putting them into circuit. The usual procedure was to connect the capacitor to a suitable high voltage supply via a limiting resistor. The resistor would limit the leakage current of the capacitor to a safe value, while the oxide coating reformed. For most capacitors this process would be complete after say, ten minutes. By this time, the leakage would have dropped to a safe and minimum value and the capacitor could be safely placed in circuit. Thereafter, provided the circuit was used reasonably frequently (say once every few months at a minimum), the capacitor would function reliably.

Well, so much for ancient history. All the above applies only to capacitors which were made more than about ten years ago.

Modern electrolytic capacitors have been improved to the point where their shelf life is practically indefinite. In other words, no one really knows



## COMPONENTS

just how good they are, except the manufacturers. This means that there is little point in going through the "re-forming" procedure. Provided the capacitors you refer to are only a few years old, you can place them directly into circuit.

**Q: I have built a regulated power supply and wish to upgrade it from 5 amps to 8 amps capacity. The modification involves substituting two parallel-connected-2N3055s for an existing single 2N3055. The existing driver transistor for the 2N3055 is a plastic TIP32, rated at 3 amps. Is there any point in substituting a TIP33 which is rated at 10 amps?**

If the transistor is presently running well within its ratings, there is no point in changing to a higher rated transistor. Even if the transistor was becoming hot (which it should not, in your circuit) the answer would be to improve the heat-sinking of the transistor, not substitute another transistor. In fact, in some cases you could prejudice the circuit operation by going to a higher current transistor because it would, more than likely, have a lower current gain.

**Q: What is the purpose of heatsink compound and how is it used? I understand it is used for transistor heat dissipation.**

Heatsink compound is used to improve heat transfer between the case of the transistor (or other power semiconductor) and the heatsink. It does this by displacing the air which is inevitably trapped in small pockets between the transistor mounting surface and the heatsink surface.

We must add that heatsink compound is, of itself, not a particularly good heat conductor. But it is considerably better than air, which is a very good insulator.

Heatsink compound should be **lightly** smeared over the transistor mounting surface and the mating surface of the heatsink. Heatsink compound is not a substitute for mica washers, which are still required when the transistor must be electrically insulated from the heatsink. When such a washer is used, it too should be lightly smeared with compound.

### LATEST EDITION OF BASIC ELECTRONICS

Order your copy now!

Available from "Electronics Australia,"  
57 Regent St, Sydney. **PRICE \$3.50.**  
OR by mail order from "Electronics  
Australia", PO Box 163, Beaconsfield  
2014. **PRICE \$4.10.**

# IF YOU WANT TO UNDERSTAND MORE ABOUT MICROPROCESSORS

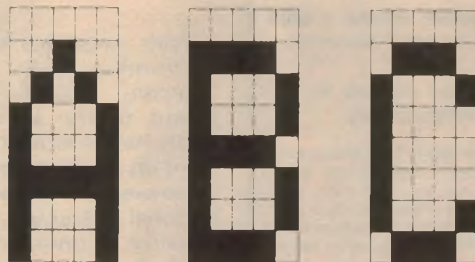

## APPLY HERE...

One of the fastest growing sections of the electronics industry is microprocessing and its associated technology. A sound basic knowledge and a constant up-dating of that knowledge is necessary to stay informed of the developments within this exciting new technology.

Stott's Technical Correspondence College has produced an up-to-the-minute home study course specifically designed for people interested in this subject.

This Stott's home study course has been meticulously prepared by experts in this field and takes you through the stages necessary to reach a basic understanding of micro-computers and the processing techniques needed for their application, whether for consumer or industrial use. To this basic training you can add further knowledge and gain more experience.

The course is prepared in three stages. It begins with initial training in basic electronics, goes on to digital electronics and then proceeds to an in-depth study of microprocessors.

For further information on Stott's Microprocessors Course or other courses which interest you, mail the coupon below.

# Stotts



TECHNICAL CORRESPONDENCE COLLEGE

The name to trust in correspondence education.

Melbourne, 159 Flinders Lane, 3000 Tel: 63 6212  
Sydney, 383 George Street, 2000 Tel: 29 2445  
Brisbane, 290 Adelaide Street, 4000 Tel: 31 1627  
Kent Town, 66 King William Street, S.A. 5067 Tel: 42 5798  
Perth, 140 St. Georges Terrace, 6000 Tel: 322 5481  
Hobart, 1st Fl. 29 Argyle Street, 7000 Tel: 34 2399  
Singapore, P.O. Box 3396, Singapore 1

Please send me free and without obligation full details of the following courses:

(PLEASE PRINT) \_\_\_\_\_

MR MRS MISS \_\_\_\_\_

AGE \_\_\_\_\_

ADDRESS \_\_\_\_\_

POSTCODE \_\_\_\_\_

Stott's undertake that no sales counsellor will visit you

The Stott's range of courses in  
Electronics are:

Radio for Amateurs  
Introduction to Electronics  
Digital Electronics  
AM Radio Receivers  
Radio/TV Servicing  
Colour Television  
Amateur Radio Operators'  
Certificate  
A full range of Hobby and  
Business courses also  
available.

ALA/ST1170/EA1179



# BILL EDGE'S ELECTRONIC AGENCIES

115-117 PARRAMATTA ROAD,  
CONCORD 2137. PHONE 747 6472

(Corner Lloyd George Ave. and Parramatta Rd., Concord)

OPEN SUNDAYS (10am - 2pm),  
MON - FRI (9am - 5.30pm), SAT (9am - NOON)

Some DICK SMITH products available at DICK  
SMITH, prices. All stock new & Guaranteed.

## Capture spectacular action shots with this Sound triggered photo flash

How would you like to be able to take photographs like those spectacular shots of breaking light bulbs and splashing liquids? You can take them with almost any normal camera and electronic flash unit, by using this low cost trigger unit. It's easy to build and offers facilities not found on any other design that we've seen

This fantastic project is now available as one of our economy kits only

**\$17.44**



Full instructions included

### — WHAT YOU GET —

Absolutely everything as per parts list on P 58 EA Sept 79 except for batt. clamp, flashgun lead, wire, solder, nut & bolts. All you need electronically to get it working

## INDUCTION BALANCE METAL DETECTOR

A really sensitive design operating on a different principle from that of other published circuits. This "Induction Balance" metal locator will really sniff out those buried coins and other items of interest at great depths (depending on the size of the object).

Here's real value -- why pay a fortune to find a fortune -- this kit will only cost you a mere \$32.50 -- absolutely everything supplied except for a broom handle for shaft and former for coil. (Full instructions included)

Other kits in our fantastic range include:  
(see Ad EA Sept 79)

- Fully protected dual power supply \$60.45
- Masthead amplifier for TV & FM \$26.47
- Square wave oscillator \$7.90
- Impedance bridge \$35.94
- Antenna tuning unit (all bands) \$28.95
- Quartz multiple frequency reference \$59.58
- High performance model train controller \$45.35
- Sound effects for model trains \$35.73
- "The minicolor" \$49.90
- Windscreen wiper delay kit only \$16.00 (see details Sept 79 EA)

### ALL DICK SMITH KITS AVAILABLE

MAIL ORDER \$1.00 packing/post plus 5% of order value additional pack/post up to \$80 thence a flat \$4. Heavy items sent freight or through carrier



# Letters to the editor

## Touchtone keyboard

With reference to the letter in the September issue of EA regarding Telecom Australia's Touchtone, the layout of the keyboard could quite easily have followed the same layout as used on modern electronic calculators.

However, it follows the CCITT (International Telegraph & Telephone Consultative Committee) recommended keyboard layout for push-button phones. This was adopted by most telephone administrations throughout the world, many years before modern electronic calculators became a commonly available item.

The CCITT keyboard layout is used in the USA, where push-button dialling has been in use for something in the region of 20 years. So in fact the question should really be: why doesn't the modern electronic calculator use the same keyboard layout as the Touchtone?

John Bae, Lindfield, NSW.

## Weather Satellites

Satellite Tracking Stations built by enthusiasts with small budgets are not new. Usually surplus equipment is acquired to allow the station to actually produce meaningful data such as weather pictures.

The recent article in EA is one example of the surplus station. Other private or institutional stations have been built in Australia since the mid sixties. The builders have usually made use of surplus facsimile receivers modified to run at the appropriate scan rate. Surplus weather satellite receiving gear is never going to be available to the amateur electronics enthusiast.

The undergraduate members of the Monash University Astronautical Society embarked on a Tracking Station Project in 1973. The first orbiting target was to be the manned Skylab but the lack of technical knowledge and inadequate surplus receiving equipment for 2287.5MHz caused the project to be abandoned in 1974. After relocating and redesigning the equipment a new project goal was specified. The NOAA weather satellites were selected as available targets. By October 1977 a "homemade" 10 element crossed Yagi antenna feeding a "homemade" 137MHz pre-amplifier was being

steered by a "homemade" fully controllable alt-azimuth mount/solid-state DC motor controller. The "homemade" receiver delivered the 2.4kHz signal to a "homemade" CRO controller/processor which delivered recognizable cloud/surface images by timelapse photography.

Progressive development of the Monash Tracking Station ceased in January 1978 due to immature club politics. However the new technology of home computers has made the circuits developed during 1976/77 very attractive as add-on facilities to produce computer enhanced weather pictures presented on conventional TV screens.

I hope these comments are of interest.

John Sved, VK3ZVZ  
St Kilda, Vic.

## Marconi School closes

It is possible by now that members of your staff may have heard that the Marconi School is ceasing its operations and in view of our long term association, we feel that we should let you know officially that this is the case.

We have ceased enrolling personal and correspondence students but will meet our obligations to trainees already under contract.

The reason for our closure is that a Nautical College for the training of Radio Officers and other skills associated with the industry has been set up by the Australian Government in Launceston, Tasmania. As this has been one of our main occupations it has been decided that we should withdraw from this field.

The Nautical College anticipates that they will be in full operation by 1981 but in the interim have asked us to undertake the training of Radio Officers for Year One of the Two Year Course, commencing in February, 1980, at the expiry of which the Marconi School will close.

Our association from the point of view of your magazine, as being our principle advertising medium, goes back to the days of possibly your first issues wherein we occupied the inside front cover for many years. Some four years ago we withdrew from this position and went to the bulk of the paper but even now we still receive coupons from the inside cover advertisement, proving that your magazine has a wide



and lasting circulation and to us from the correspondence point of view, was a highly valuable medium.

We thank you for your help in the past and should any further details be required regarding our closure please do not hesitate to contact the writer.

C. E. Bardwell, Manager  
Marconi School of Wireless  
AWA Marine & Aviation Division  
Leichhardt, NSW.

### Availability problem

It has been noted that in previous issues where component availability was uncertain that you have not hesitated in advising readers of the matter, even publishing alternative circuits.

Regrettably this has not been the case with the masthead amplifier project. To compound your carelessness, your article gives the reader the clear impression that the integrated circuit of interest (Philips OM350) is cheap and readily available; whereas in fact the IC appearing in your photos is a "pre-release" item for review. Philips have advised me that the IC will not be available until November (October at their distributors), this information at the cost of one phone call.

In the August Editorial you question the ethics of access to servicing information and I support your claim that this appears to be an area of restrictive trade practices. I also question the ethics of publishing constructional articles, knowing full well that components are not freely available.

I will look forward to your publishing of an appropriate explanation.

F. Bell,  
Asquith, NSW.

**COMMENT:** Your criticism would be more valid had you not substituted supposition for fact. When we prepared the project for publication, we were assured that there were adequate stocks of the OM350 available. However, just before the issue went on sale, we learned that a single supplier had purchased the entire existing local stock — and was only going to sell them in their own kits. Unfortunately it was too late for us to change the article, or delay its publication. So the problem was caused by a factor entirely outside our control — hardly a case of "carelessness" or misrepresentation, at least on our part.

#### THE "ELECTRONICS AUSTRALIA"

### LOG BOOK

FOR: RADIO AMATEURS  
DX LISTENERS  
CB OPERATORS

**\$2.95**

From "Electronics Australia", 57-59 Regent St, Sydney OR by mail order from PO Box 163, Beaconsfield 2014. Price includes postage.

## RADCOM QUALITY COMPONENT

105 ELDRIDGE ST., BANKSTOWN  
PHONE: 709-4706

### Air spaced variable capacitors

10pF-25pF-50pF-100pF  
250pF ALL AT \$2.50  
500pF at \$5.00

All preferred values of capacitors

All preferred values of resistors

### PLUGS CONNECTORS AND ACCESSORIES IN STOCK

High voltage fixed capacitors, all types of toggle and wafer switches.

### Multi-tapped transformers

0-15v 1 AMP \$5.00  
0-15v 2 AMP \$9.30

TRY US FOR THE HARD TO GET COMPONENTS

STOCKIST FOR

# silicon valley

## BRISBANE HOBBYISTS

Contact us for the parts you need from Alligator Clips to Zilogmicros.

We specialise in National Semiconductor. Any EA or ETI PCB'S — Stock to one week (or make your own with on precoated board and artwork).

Expert advice available

### TECHNIPARTS

95 Latrobe Tce. Paddington. Qld. 4064 PH: 36 1474.

## RADIO DESPATCH SERVICE

### THE SPECIALIST STORE

869 GEORGE STREET, SYDNEY, NSW 2000. (NEAR HARRIS STREET)  
PHONES: 211 0816, 211 0191

#### ATTENTION:

Front panels for EA projects now made up under order. Available on black or silver background. All panels made by the Scotchcal system. For prices contact R.D.S. —

MAIL ORDER Post \$1 + 5% of order value up to \$80 and thence a flat \$4.00.

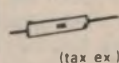

WIRE WRAP TOOL WSU-30  
WRAP • STRIP • UNWRAP  
\$7.80

#### LOGIC PROBES

LP2	1.5 MHz max input	\$24.95
LP1	10 MHz max input	\$44.95
LP3	50 MHz max input	\$69.95
DP1	Digital pulser with autopolarity pulse sensing	\$74.95

#### CONTINENTAL SPECIALISTS

### TEXAS INSTRUMENTS

TI 59 CALCULATOR  
TI PC100 PRINTER

### CANNON AUDIO CONNECTORS

November is Calculator Month at R.D.S. Write to us for our special prices.



We are distributors for Cannon Plugs and Sockets. Check our prices.



Distributors For

## XCELITE Tools

OPEN: MON-FRI 8.00 am-5.30 pm

Thursday late night shopping until 8.30 pm, Saturday 8.00 am-11.45 am.





REVIEWS OF RECENT

# Records & Tapes

CLASSICAL • POPULAR • SPECIAL INTEREST

## Avant-garde music: "superbly recorded"

**VICTORIAN TIME MACHINE — Dufay: Nuper Rosarum Flores (1436); Hames: Nuper Rosarum Flores — monody after Dufay for instrumental ensemble and early music consort (1977); Conyngham: To Be Alone — simultaneous solos for four performers and pre-recorded tape (1978); Fulkerson: Music for Brass Instruments III (1978).** The Victorian College of the Arts Renaissance Ensemble; Victorian Time Machine with Gerald English, tenor; James Fulkerson, trombone; Jochen Schubert, guitar; John Hopkins, conductor. MOVE stereo disc MS 3028 (Move Records, Box 266 Carlton South, Vic 3053)

This really is a major occasion: a superbly recorded and engineered disc of avant-garde music, performed at a high standard of professionalism. Since I am neither an electronics expert nor a musicologist, I will report on this record purely as music.

The Motet by Guillaume Dufay, composed for the occasion of the dedication of Brunelleschi's cathedral in Florence is musically as foreign to conventional listeners as anything the current avant-garde can think of; it was revolutionary in its day and remains both beautiful and daunting. The voices of the Renaissance Ensemble, directed by Gerald English, do it full justice. The work Richard David Hames has based on it relies, principally, on winds, cello, marimba and guitar, it is fairly sparse, certainly not unattractive and, if a trifle long, does hold one's attention throughout. The composer is an Englishman in his early thirties, currently working at the Victorian College of the Arts. Although the music seems to lose touch with Dufay at times, this in no way diminishes its impact.

James Fulkerson, an American trombonist and composer who spent some teaching time in Melbourne recently, is the author of the brass piece which requires twelve players and is conducted by John Hopkins. The music is

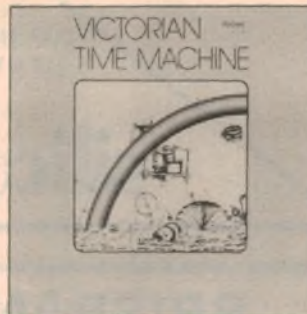

open-textured — varying single strands with more complex effects — typical of brass choirs; it does not offer anything of great originality, but is competently assembled and, once again, quite good enough to hold one's interest.

To my listening ear, Barry Conyngham's piece is by far the most important on the disc; it is, also, probably the best thing he has written so far except for the recently heard stage work "Bony Anderson", performed by the Seymour Group and Lyndon Terrachini. In the work on this disc, Conyngham has created an idiom

ideally suited to the gramophone record. The music depends on the closest collaboration between performers and composer; they create many varied sounds on instruments and vocally, and the things that have to be done to achieve the desired results might well prove distracting when observed live.

Barry Conyngham has, as a composer, shared Peter Sculthorpe's and Anne Boyd's preoccupation with loneliness and isolation — a theme also pursued by some of our finest artists in fields other than music. In this piece he has found new means of expressing what he describes as "a comment on the isolating nature of the modern world". This music will repay the listener's repeated hearing with unexpected details; it is recorded with great delicacy and the sound, throughout the disc, is clean and faithful, a compliment to the staff at Melbourne University's Electronic Music Studios. As a special bonus, the sleeve is decorated with bits and pieces from Leonardo da Vinci's doodlings. (P.F.)

## Bartok Sonata: "marvellous performance"

**BARTOK: The Three Piano Concertos: Stephen Bishop-Kovacevich, piano; London Symphony Orchestra (Nos. 1 & 3); BBC Symphony Orchestra (No. 2); conducted by Colin Davis. Sonata for Two Pianos and Percussion: Martha Argerich and Stephen Bishop-Kovacevich, pianos; Willy Goudswaard and Michael de Roo, percussion. Philips 6768 053 (two stereo discs, boxed).**

Although these performances of the Bartok concerti have been known for a few years (No. 2 was, I think, first issued about 1971), their excellence has been undisputed and it was a good idea to bring them together in a boxed set.

Comparisons, in these instances, are not easily made. I confess to an attachment to Katchen's reading of No. 3, probably due to greater familiarity;

also, I recently heard a stunning performance of No. 2 by Roger Woodward which I would love to have on disc but, taken in all, I think that anyone might be well satisfied by Bishop-Kovacevich. Not only are his interpretations authoritative and forceful, but they are quite splendidly accompanied by Colin Davis; there is, I think, some slight bias in favour of the piano, but this is not sufficient to disturb overall balance and the recorded sound is much to my liking.

The most exciting thing about this set is the inclusion of the Sonata; this is a very recent recording which I had not heard before. It is a simply marvellous performance and at least the equal of any I've previously known. As an interpretation, and for quality of the recorded sound (the percussion as much as the pianos) this is a truly great event and it is one that every music lover should try to hear. (P.F.)

Reviews in this section are by Paul Frolich (P.F.), Neville Williams (W.N.W.), Jamieson Rowe (J.R.), Leo Simpson (L.D.S.), Norman Marks (N.J.M.), Greg Swain (G.S.), and Danny Hooper (D.H.).



**GIULIANI:** *Variations on a Theme of Handel, op.107; "Gran Sonata Eroica" in A; Variations on "I bin a Kohlbaurn Bub", op.49; "La Melanconia"; Grande Overture, op.61. Pepe Romero, guitar. Philips Stereo disc 9500 513.*

Mauro Giuliani, born in 1781, was the leading guitarist of his time, working at the Austrian Court and in many of the main cities of Italy; apart from his virtuosity, he also had quite an enormous output of guitar music, of which this record is a very adequate sampler. Clearly, there was nothing Giuliani did not think his instrument capable of and the musical range of the works included here is truly impressive.

If Giuliani's status as the world's No. 1 guitarist was beyond doubt, things are less simple in Mr Romero's day! Not being a specialist, I am not in a position to make any comparisons between him and other contemporary guitarists such as, for instance, John Williams or Alirio Diaz, who have recorded from the same repertoire. All I can affirm is that Mr Romero's fingers are as nimble as is required and that his musical perception is at least equal to the music which, after all, is rather light-weight. The recorded sound is excellent. (P.F.)

☆ ☆ ☆

**ORFF:** *Trionfo di Afrodite. Soloists; Radio Chorus, Leipzig; Radio Chorus, Berlin; Radio Symphony Orchestra, Leipzig; conductor Herbert Kegel. Philips Stereo disc 9500 150.*

The Leipzig orchestra, under its conductor Herbert Kegel, has made quite a speciality of performing Carl Orff's works; it may seem an odd choice for one of the leading ensembles in the German Democratic Republic, but so be it. They really are doing the job well, they seem to enjoy doing it and it enables them to appear artistically progressive without having to play contemporary compositions from Eastern Europe. Although some excellent things are being written in Poland, Rumania and Bulgaria, nothing of much interest seems to emerge in East Germany.

The "Triumphs of Aphrodite" is easily recognised as coming from the same stable as Orff's best-known work, the "Carmina Burana". Written in 1951, described by the composer as a "Concerto Scenico", it shows the 15 years between the first of the series and this third work to have wrought some minor refinements; Orff certainly shows greater subtlety, has become less obsessively repetitive and takes more considerate note of the texts — mostly verses by Catullus and Sappho. In general terms, the work is concerned with pagan wedding rites and Orff provides, as usual, excellent vocal lines.

As is the case with most of Orff's works, one would not want to hear this music too frequently; as a rare event, it

sounds fresh and lively, the rhythms are complex enough to hold one's interest and the melodic material is quite catchy. The singing from all involved (lots of them!) is uniformly very good, the orchestral sound is fine and recording quality all one could wish for. I suspect that it would have been possible to make some parts of the score sound much more exciting, but this probably would have necessitated a more erotic interpretation and might have caused waves. An enjoyable issue if taken in its context. (P.F.)

☆ ☆ ☆

**ARIE AMOROSE:** *Arias by Giordani, Caccini, Stradella, Sarri, Cesti, Lotti, A. Scarlatti, Caldara, Bononcini, Durante, Pergolesi, Martini, Piccini, Paisiello. Janet Baker, mezzo-soprano; Academy of St Martin-in-the-Fields; conducted by Neville Marriner. Philips Stereo disc 9500 557.*

Dame Janet Baker's status as Britain's most celebrated singer of the 'seventies is so much taken for granted that each occasion on which she attempts something entirely new or different

comes as quite a surprise. This wholly delightful issue proves her great artistry once again.

The variety and range of the "amorous" arias included are great; the music, brilliantly arranged by Simon Preston, covers the period of late 16th to early 19th centuries and although a look at the enclosed texts suggests the prevalence of a gentle melancholy, there really is more than sufficient variety even in this; in fact, even humour is not entirely missing from some of the 18 arias included.

Janet Baker's singing, finely attuned to each separate piece, is well matched by Neville Marriner and the excellent orchestra — including continuo contributions from lutenist James Tyler and Nicholas Kraemer at the harpsichord. The recorded sound is clean and agreeably reverberant; lovers of this musical genre will be delighted to hear a great many unfamiliar arias, as well as a few old favourites — "Caro mio ben" by Giordani, Caccini's "Amarilli mia bella" and Martini's "Plaisir d'amour" among them. A great recording, in every respect! (P.F.)

## DEVOTIONAL

— 1979 style!

**"HEY DOC".** Mike Warnke. Stereo, Myrrh MSA-6599. (From Word Records Aust., 18-26 Canterbury Rd, Heathmont, Vic. 3135).

In the realm of itinerant evangelists, Mike Warnke has a style which is as close as you're ever likely to get that of the well known comedian Bill Cosby. At the other extreme, he can be heavily emotional.

In this recorded testimony, he tells of his early hippy background and his involvement with hard drugs. But, mainly, this address is about his subsequent service in Vietnam as a medical orderly with the US marine corps — hence the "Hey Doc!" It's told with Cosby-like quips and asides, plus equally characteristic and spontaneous sound effects.

Only towards the end, where the audience might believe that they are to escape without "religion", does Mike Warnke make a final, powerful application of what has gone before.

If you enjoy the Bill Cosby style, you're certain to enjoy Mike Warnke. If you're more interested in sermon material, you'll tend to concentrate on side 2. Over to you! (W.N.W.)

☆ ☆ ☆

**THE MASTER AND THE MUSICIAN.** Phil Keaggy. Stereo, New Song NS-006. (From Word Records Aust., 18-26 Canterbury Rd, Heathmont, Vic.) Phil Keaggy is introduced in the



jacket notes as a young man accomplished on a whole range of guitars, keyboards and drums — plus an interest in music from traditional folk to rock and roll.

He gives expression to this wide-ranging interest in this album of original orchestral music under the track titles: Pilgrim's Flight — Agora (The Marketplace) — The Castle's Call — Wedding In The Country Manor — Suite (of reflections) — Golden Halls — Mouthpiece — Follow Me Up — Jungle Pleasures — Deep Calls Unto Deep — Medley (Evensong, Twilight, Forever Joy) — The Exalted One.

The titles, fitting in with a highly fanciful narrative, would seem to relate to Phil Keaggy's own emergence as a dedicated Christian musician but the testimony is implicit rather than overtly expressed. If you want to share Phil Keaggy's message, you'll have to identify with the theme and the music, either spontaneously or by way of deliberate effort. Otherwise, the album will pass as modern, thematic instrumental with implied devotional connotations.

Technically, the sound quality is fine. (W.N.W.)



**STRAVINSKY: Pulcinella.** Teresa Berganza, mezzo-soprano; Ryland Davies, tenor; John Shirtley-Quirk, bass; London Symphony Orchestra, conductor Claudio Abbado. DG stereo disc 2531 087.

This is the first complete Pulcinella, with vocal soloists, I've heard for some years and I am delighted; it really is much more satisfactory than the usually heard Suites which offer only the orchestral music, sometimes not even all of it. In addition, the editors of this set enlisted the help of musical researchers to discover the provenance of the music used by Stravinsky. At one time, all of it used to be ascribed to Pergolesi; then came a period of "mostly by Pergolesi"; now we discover that of the eighteen sections, only eight were written by Pergolesi.

The fact remains that this is utterly delightful music, one of Stravinsky's most entertaining compositions and it is not diminished by the multiple authorship of the bits and pieces he used, leaving Diaghilev to believe in "Pergolesi". The singing, orchestral playing and Mr Abbado's swinging direction are of a standard worthy of the score, each band on the well-made disc is clearly timed and it remains to welcome this set and to congratulate the recording team. (P.F.)

## Full marks for quality

**VIOLA AND JAMES CARTER CHAMBER ENSEMBLE.** Stereo, Classic Series, RR Reference Recordings RR-4. (From MR Acoustics, PO Box 165, Annerley, Qld 4103).

I've had this recording on hand for some time, for no other reason than it seems to have been pushed aside by the succession of other audiophile discs, direct cut and digital. This one is neither, having been recorded on tape and then transferred to disc at half speed, with a maximum of care at all points. And, in terms of quality, I must give it full marks for sound that is intimate and clean, as befits a chamber ensemble.

The ensemble for this performance includes James Carter, a highly qualified American concert violinist; Philip Fath, principal clarinetist of the San Francisco Symphony Orchestra; Sharon Mann Polk, who performs and teaches piano in California and Switzerland; William Smith, pianist and Associate Conductor of the Philadelphia Orchestra; Deborah Carter, flautist, recitalist, and wife of William Smith.

The program: W. A. Mozart — Trio in

E-flat, Andante, Menuetto, Allegretto; F. A. Hoffmeister — Duo Concertante in F; J. B. Loeillet — Trio Sonata in E minor. An inner sheet introduces the artists and gives the background to the music and the recording sessions. It seems to have been quite a fun occasion.

I enjoyed it too, the more so because it was a complete change from my usual fare for these columns. (W.N.W.)

☆ ☆ ☆

**SYDNEY SYMPHONY ORCHESTRA** conducted by Willem van Otterloo, playing music by Alfred Hill, Nigel Butterley, Don Banks and Robert Hughes. Stereo, RCA Red Seal VRL10191.

A record for lovers of contemporary Australian music. The works played are Hill's "The Sea" and "Linthorpe — An Impression", Butterfly's "Fire In The Heavens" (all recorded in the concert



**"one of the best buys, if not the best buy, on the market at the moment . . ."**

Electronics Today International  
September, 1979 issue

## Australia's best value in a Dolby™ deck:

### The Dick Smith A-3500 Front loading deck

and no wonder ETI were so enthusiastic - check some of these features:

- DOLBY™ system electronically eliminates annoying tape hiss
- Bias and equalisation controls for Ferrichrome, normal and Chromium Dioxide tapes.
- Split recording controls enable balancing of stereo recordings
- Auto stop plus damped eject system
- Produced in Japan by renowned manufacturer.
- And you buy direct from the importer so you Save! Save! Save!

Due to the huge success of this cassette deck we have sold out BUT new stocks due early December

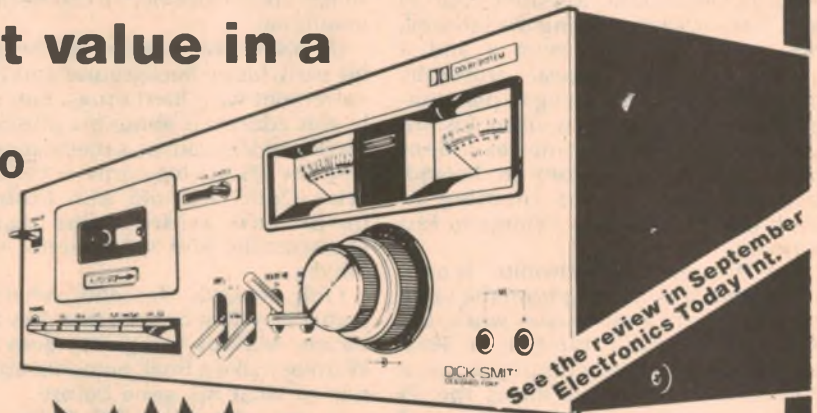

**\$159**

**SAVE \$40!  
WAS SELLING  
FOR \$199  
NOW QUALITY  
AT A LOWER  
PRICE. . .**

Cat. A-3500  
P&P \$5.50

Terms are available on this cassette deck to approved applicants: from a low 10% deposit and low monthly payments.

\* SEE OUR DOUBLE PAGE AD FOR FULL LIST OF STORES AND DEALERS

# DICK SMITH ELECTRONICS





hall of Sydney Opera House), Banks' "Prospects" and Hughes' "Sea Spell" (both recorded in the ABC Music Studios).

The recording is fine, and the SSO provides masterly performances under the late Willem van Otterloo. (J.R.)

☆ ☆ ☆

**VIVALDI: FIVE ORGAN CONCERTOS.** Marie-Claire Alain with I Solisti Veneti, conducted by Claudio Scimone. Stereo, World Record Club R 05300.

A relatively specialised record, which will mainly interest devoted Vivaldi enthusiasts and students of the various types of organ concerto. For those who have a fondness for the Handelian type of organ concerto (and I must confess to being one), it will not have the same appeal. The organ part is rather less substantial, and the structure more rigid.

Still, the performance here is spirited, and the recording of a high standard. If you like the works, you'll find a lot to enjoy. (J.R.)

☆ ☆ ☆

**MUNDHARMONICA IN GOLD.** Johnny Muller with the Rudi Bohn Orchestra. Stereo, Europa 111 735 (Astor release).



A very happy sound, this, with strong overtones of central Europe. Johnny Muller's harmonica work is superb, particularly for its variety of sound and the way in which it blends as an integral part of the orchestra. And the titles:

Moon River — Ich Mochte Mit Dir Verreisen — La Paloma — Das Lied Vom Tod — Dreaming of Mary-Lou — house of the Rising Sun — Ghostriders In The Sky — Shanandoah — Im Blauen Tal — Wenn Das Glück Es Will — True Love — Tennessee Waltz.

You don't have to read German to enjoy this one. The sound quality is very clean. (W.N.W.)

☆ ☆ ☆

**FERRANTE & TEICHER.** You Light Up My Life. United Artists L 36786 Festival release.

It looks as though Liberace has some competition in the fancy clothes stakes, judging by the cover of this latest offering from Ferrante & Teicher.

There are the usual twelve tracks: The Last Waltz — Nobody Does It

# D.C. Servo Drive Runs Smooth Steady Cool

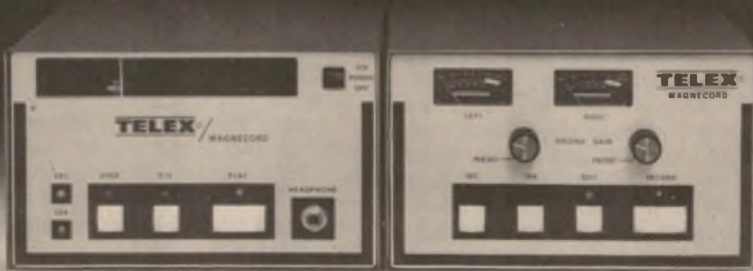

## Of course, it's Telex/Magnecord

Telex Magnecord broadcast cart machines run cool and steady. So cool no ventilation is required, so steady not even voltage or frequency fluctuations will alter their speed. Thanks to our dc servo flutter-filter drive. Completely immune to RFI and EMI, it meets or exceeds all NAB standards and is suited for local or remote/automated operation.

### Standard features at no extra cost.

- An edit pushbutton to add stop cues in playback and omit stop cues in record
- LED indicators show end of tape, status and secondary/tertiary cue tones
- Front panel headphone jack
- VU meters for each channel

### Convenient, Flexible

MC-Series is field convertible from mono to stereo, or play to record. Optional remote controls simply plug in.

Four broadcast cart machines to choose from in the Telex/Magnecord

MC-Series - all made in U.S.A. and affordable. Write for detailed information.

### Quality products for the audio professional



## AUDIO TELEX COMMUNICATIONS PTY. LTD.

Head Office: 1 Little Street, Parramatta, P.O. Box 421, 2150 N S W Tel 633 4344, Telex AA 22251

Regional Offices: 7 Essex Rd., Mt. Waverley, P.O. Box 468, 3149 Vic. Tel 277 5311, 394 Montague Rd., West End, P.O. Box 44, 4101 Qld. Tel: 44 6328



## RECORDS & TAPES — continued

Better — Stayin' Alive — After The Lovin' — Just The Way You Are — Finger Painting — Theme from 'Oh God' — How Deep Is Your Love — Hopelessly Devoted To You — Here You Come Again — You Light Up My Life — Lotus Blossom.

The quality is good although at times the tune tends to be somewhat submerged by a fair amount of over production or orchestration. Apart from this the disc is most enjoyable, ideal as a dining background. (NJM).

☆ ☆ ☆

### THE ALEXANDER BROTHERS. Scotland The Brave. Stereo, Astor, AGS-1024.

I don't know whether the Alexander Brothers are always as cheerful as they are pictured on the jacket, but their program on this album is certainly in keeping. With champion accordionist Tom Alexander featured in the backing, they sing the title song, of course, plus "My Ain Folk", "Ye Banks And Braes", "Skye Boat Song" and other sentimental Scottish titles to make up the round dozen.

The quality is good and my overall reaction was to remark how those old songs really "got at you!" A good one. (W.N.W.)

☆ ☆ ☆

### SYDNEY THOMPSON, DANCING GUITARS. IMAGE ILP 4993 Astor release.

This collection of sixteen tracks, all with a strong Latin flavour, should find favour with ballroom dancing enthusiasts, with its strict tempo rendition of old favourites like: Amor —

Cuban Love Song — El Cumbanchero — Tzena Tzena Tzena — Besame Mucho — Two Guitars — Sway — Glory Of Love — You Belong To My Heart Poinciana — Patricia — In A Little Spanish Town — Sucu Sucu — Cuanto Le Gusta — Frenesi — Perfidia.

The sound is very clean with good exploitation of the stereo image, but I cannot work out what the cover photo is, with its collection of feathers, sequins and fruit; it must be a hat! (NJM)

☆ ☆ ☆

### NUNZIO, Sound Track Recording. MCA 2374 Astor release.

The story of this film is that of a man in his early 20s with the intellect of a 13-year-old and some of the hassles he faces in Brooklyn. Most of the tracks have a "disco" flavour, a characteristic that seems to be impossible to escape these days.

The recording quality is quite brilliant and would put the disc into the "Demo" class, particularly the last few seconds on the second side. This has some of the heaviest bass notes I have ever heard on a record, finishing with an explosive sound that can literally rattle the house if your speakers can handle the signal. The composer was Lalo Schifrin who has quite a few movie scores to his credit. (NJM)

☆ ☆ ☆

### WELL, WELL SAID THE ROCKING CHAIR. Dean Friedman. Lifesong Records LS 6019. RCA release.

This latest album from Dean Friedman contains his recent National Top 10 hit "Lucky Stars". The other eight tracks on the album are: Rocking Chair (It's Gonna Be All Right) — I've Had Enough — Shopping Bag Ladies — Don't You Ever Dare — The Deli Song (Corned Beef On Wry) — Lydia — S & M — Let Down Your Hair.

"Lucky Stars" is the most listenable track. High-pitched vocals in the others make for hectic listening. (D.H.)

## "A tremendous challenge"

### THE POWER AND THE GLORY, Volume 1. Lloyd Holzgraf of the First Congregational Church of Los Angeles. Direct to disc, M&K Realtime RT-114. (From MR Acoustics, PO Box 165, Annerley, Qld)

With a title like that, a gold jacket, and a frontispiece featuring a huge classical organ, one is hardly surprised at the contents or the sound on this direct-cut disc. In fact, the notes refer to three organs (the two largest being



198 feet apart in the huge building), 11,-848 pipes and multiple ranks of 32ft bass.

With these resources at his disposal, and under his complete control, Lloyd Holzgraf opens on side 1 with a massive Toccata and Fugue in D-minor (Bach), followed by a much gentler Largo, D-minor Concerto (Vivaldi).

But the Toccata and Fugue pales into sonic insignificance compared with the opening track on side 2: "Grand March from Tannhauser" (Richard Wagner). The high pressure trumpets blare and the bass rolls and thunders in a sonic display which is awe inspiring, even if you don't particularly like it that way. What a poor amplifier system would make of the recording, I can't imagine.

The final track "The Bells of St Anne de Beaupre" (Alexander Russell) is much quieter but set against a deep bass accompaniment that might easily be overlooked.

Technically, the recording copes well with this tremendous challenge and, if your system will cope with the recording, you've got it made. But there will be no half-hearted reactions to it: it will either turn you right on — or right off! (W.N.W.)

## NEW from etone

380mm (15") loudspeakers, 100mm (4") voice coils, 9.5kg ceramic magnet structure, edgewound aluminium ribbon, high efficiency.

150mm (6") loudspeakers, 40 watts RMS, multiple driver array.

Details from **ETONE**

53 STANLEY STREET,  
PEAKHURST. N.S.W. 2210



**WHO'S HAPPY NOW? Connie Francis.**  
United Artists stereo L 36693.

Connie Francis has been a successful entertainer for over 20 years now and must be still doing well out of it. She still has a good voice and loads of personality. On this record, Connie uses a well-tried formula which her fans are sure to like. However, the big noisy orchestra with pounding rhythm section does tend to drown her out at times.

Recording quality is about par for the course and surface noise was low.



There are 12 tracks: Where The Boys Are — Number One With A Heartache — Til I Kissed Ya — Whisperin' — Lovin' Man — Far And Near And Always — Cryin' In The Rain — You Bring Out The Best Of The Woman In Me — A-Ba-Ni-Bi — Talk Back Trembling Lips — What Have I Got, I've Got You Babe — My Mother's Eyes. (L.D.S.)

☆ ☆ ☆

**MEMORY WALTZES. Myron Floren.**  
Stereo, Interfusion (Festival) L-25318.

When it comes to the romantic accordion sound, Myron Floren has few equals. But, lest you are put off by the thought of 10 tracks of straight accordion, let me hasten to add that he is associated with an orchestra that is not too far removed from the Lawrence Welk sound, of which he is a part.

The program here is of traditional waltzes to which you can dance, or just dream: Moon River — Let Me Call You Sweetheart — Fascination — Somewhere My Love — The Waltz You Saved For Me — Danube Waves — Always — I Love You Truly — My Heart Still Remembers — My Hero.

The quality is well up to normal standards. Real turn-back-the-clock music. (W.N.W.)

☆ ☆ ☆

**FANCY MEETING YOU HERE. Bing Crosby-Rosemary Clooney. RCA VAL 10183.**

There is no obvious recording date on this album but I'd guess that it is of fairly recent origin, judging by the overall quality, and the arrangements

For information on World Record Club albums, contact the club at 605 Camberwell Road, Hartwell, Victoria, 3124. Tel. 29 3636.

## Not direct-cut . . . but a "Super Sampler"

**SUPER SAMPLER. Cut From 11 REALTIME direct-cut discs. (From M. R. Acoustics, PO Box 165, Annerley, Qld 4103).**

"Super Sampler" it is called and a super sampler it is, hand picked for the hifi demonstration room or for the enthusiast who wants to show off his system with a minimum of effort. The 11 tracks contain quite a range of music:

Orchestral, choral: snippets from Beethoven's Ninth. Grand organ: Excerpts from Bach's "Tocatta and fugue in D minor" and from "Nun Danckt Alle Gott". Male basso: from "Marriage of Figaro". Jazz: from Duke Ellington's All Stars, from Earl Hines (piano), and from The Yeti Chasers ("thirties" band). Add a track each of latin rhythm, of percussion and of drums, and you have a real ear-tickling procession of sound.



All of the tracks come from the M&K Real time direct-cut discs and are intended to whet your appetite for the real thing. Maybe they will, but the main impact of this disc is to impress with the superb job RealTime have done working from their stand-by master tapes. When time permits, I must compare some of these tracks with the direct cuts.

M. R. Acoustics advise that the recommended retail price is \$5.00 and, at this figure, it is a bargain indeed as a demonstrator. (W.N.W.)

used by Billy May's Orchestra in the Backing.

The tracks are: Fancy Meeting You Here — On A Slow Boat to China — I Can't Get Started — Hindustan — It Happened In Monterey — Medley, You Came A Long Way from St Louis — You Can Take The Boy Out Of The Country — Love Won't Let You Get

Away — How About You — Medley Brazil, Here We Are — Isle of Capri — Say 'Si Si' — Calcutta.

These two troupers could certainly swing together on a song and the whole album really bounces along. If you can remember these two in their heyday you will enjoy this record. (NJM)

## LAND, SEA and AIR SCANNER



**BUY DIRECT FROM THE IMPORTER!**

**\$495.00**

(Includes Sales Tax)

**Bearcat® 220**  
VHF/UHF Scanning Type

Radio Broadcast Receiver, includes Aircraft Band. The Bearcat 220 is an advanced scanning receiver with digital frequency readout and push-button programming — no crystals required.

- 20 Channels. Frequency Coverage: 30-50 MHz, 118-136 MHz, 144-174 MHz, UHF 421-512 MHz.
- Push-Button Keyboard for easy frequency selection.
- Automatic track tuning for optimum performance on all channels.
- Channel Lock-Out and Delay facilities.
- Automatic Search facility. Will electronically tune between selected frequencies, lock-on and display frequency of received signals.
- Priority Channel facility.

An advanced technology receiver providing manual or scanning type operation on up to 20 channels without the need for extra crystals. Ideal for professional, commercial or amateur use, or for Government agencies. Also covers UHF CB.

Easy to use. Select the 20 frequencies you wish to scan and punch them in on the keyboard. The decimal display shows each frequency selected. To change frequencies, just enter the new ones.

Automatic search lets you scan any given range of frequencies within a band. When the receiver locks-on to an active channel the decimal display shows the frequency. Automatic track-tuning ensures circuits are always peaked for any broadcast.

Also available: Bearcat 210 (10 channels), Bearcat 250 (50 channels)

**Lafayette))**

the Communicators  
**LAFAYETTE ELECTRONICS**

Div. of E.T.D. Electronics P/L

94 ST. KILDA RD., ST. KILDA Victoria 3182. Tel. 534 6036





# Listen to the World FRG-7

## 20,000 km RANGE!

### Bonus!

FREIGHT  
ANYWHERE IN  
AUSTRALIA \$6.00  
BELOW COST!

ONLY  
**\$395<sup>00</sup>**

Cat. D-2850

- Covers all international shortwave broadcast bands 0.5MHz to 30MHz
- Extremely sensitive circuitry-picks up even the weakest signals
- Runs from power point or batteries-use it anywhere
- Fully solid state-contains 2 IC's, 22 transistors and 16 diodes
- Easy to use-full instructions supplied
- There are more expensive units with no better performance-don't be fooled

EXCLUSIVE: Dick Smith's Guide to the FRG-7 Receiver. Written by world authority Art Cushen MBE Explains in detail how to listen to the world with your FRG-7. It's a BONUS with every FRG-7 from Dick Smith. Also comes free with the FRG-7000 Receiver.

## THE ULTIMATE DIGITAL TUNER FRG-7000 EVEN INCLUDES CLOCK!

ONLY  
**\$625<sup>00</sup>**

All the features of the FRG-7 PLUS MORE!

- Full HF band coverage (0.25MHz to 29.9MHz)
  - Digital frequency display for ACCURATE tuning every time
  - Digital GMT/Local clock
  - CPU clock timer which enables you to record selected programs while you are away. It actually turns your set and tape recorder on and off at desired times
- Plus MUCH MUCH MORE!

Cat. D-2848



CREDIT TERMS TO APPROVED APPLICANTS. PRICES CORRECT & STOCK AVAILABLE AT PRESS TIME

# DICK SMITH ELECTRONICS



SEE OUR OTHER ADVERTS IN THIS MAGAZINE FOR OUR STORE ADDRESSES AND RESELLERS

DSE638

## The All New RUSTLER

designed with the serious treasure hunter in mind. This is a VLF/TR discriminator with an automatic tuning mode with Variable Speed Retuning (VSR). VSR is Bounty Hunter's advanced Automatic Tuning system which regulates the retuning speed to maintain the "thresh-hold" while the operator still has time to pinpoint. No "falsing" on trash. VSR also increases the stability of the discriminate mode in mineralized ground. By controlling the retune speed, the operator can adjust precisely for his searching conditions from normal ground all the way through highly conductive wet salt beach hunting



PRICE \$326.00  
PLUS FREIGHT \$3.00

Lifetime Warranty  
Batteries Included

### Additional Features:

- Combined On-Off/Volume control
- Primary Tuning Control
- Ground adjustment control
- Discrimination Level Selector
- 1/4" Stereo-style headphone jack
- 3" meter with battery test
- Weighs less than 4lbs with 8" coil

SPECIAL on earphones, model No EC6, Half Watts  
— 30-15KH, 2 metre cord & plug \$9.95. Post \$2

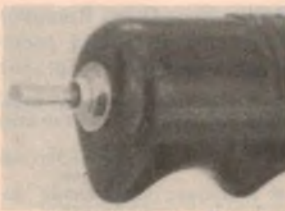

ALL METAL/DISCRIMINATE  
MODE SWITCH & RETUNE  
BUTTON.

COMPLETE SINGLE-HANDED  
OPERATION. The All-  
Metal/Discriminate mode switch  
and retuning button have been  
combined into one control in the  
handle

## D2 MEMORY BOARD



## 2KD2 MEMORY BOARD

2K of plug in on board memory for the MEK6800D2 assembled and tested \$39.95

## D2C1 GAME CASSETTE

Cassette of games and useful routines for MEK6800D2 \$9.95

7 GAMES  
2 Lunar Land Hex Calculator, 4 Digital  
Decimal Calculator, Electronic Organ,  
Clock/Stop watch, Word Demonstration

10 ROUTINES  
2 Display Routines, 2 Keyboard Routines,  
Random Number Generator, Memory Test, 2  
Byte Decimal Add, 2 Byte Decimal Subtract,  
2 Byte Decimal Multiply, 2 Byte Decimal  
Divide

## RAM

2114 1k x 4 Bit Prime 450ns \$6.50

Trade Enquiries Invited  
All Prices Include Return Mail Post &  
Packaging

# ELECTROCRAFT PTY. LTD.

68 WHITING ST, ARTARMON 2064. PHONE: 438 3266, Ext 6

PLEASE INCLUDE POSTAGE WITH ALL ORDERS. TRADE ENQUIRIES WELCOME. WE ARE SPECIALISTS 30 years in the antenna business. Hours — 8 am to 5 pm Sat 11-12 am.

# RAYDATA

P.O. BOX 477,  
GOSFORD 2250



# AMATEUR RADIO



by Pierce Healy, VK2APQ

## Amateur radio accompanies historic expedition across the Kimberleys

This year marks both the sesqui-centenary of the founding of Western Australia, and the centenary of the first crossing of the Kimberleys by Alexander Forrest. An expedition, retracing Forrest's historic journey, was undertaken as part of the sesqui-centenary celebrations, and a radio amateur was one of the team.

Forrest's original expedition used horses and lasted for six months. The re-enactment used four wheel drive vehicles and took four weeks. It was organised through the initiative of Dr W. G. Peasley, of City Beach, WA and consisted of three FWD vehicles and six men. The vehicles were owned by the Geraldton Historical Society and the party included Laurie Peasley, VK2BLP, of Eleebana, NSW. The following are extracts from Laurie's report.

The expedition started from De Grey Station north of Port Hedland on August 5, and, travelling mostly off the highway, journeyed up the coast to Beagle Bay Mission and Native Settlement, north of Broome.

From here the party travelled across to King Sound; along the Fitzroy — both south and north — to Fitzroy Crossing; Halls Creek, via the Margaret River area, and then to the Upper Ord River and Negri River. A detour was made into the Northern Territory to Mistake Creek and Waterloo Stations, followed by a civilized trip via the Duncan and Victoria Highways to Timber Creek, then down through Jasper Gorge to Victoria River Downs Station — a private township with its own air fleet — and west to the Upper Humbert River area.

The route continued down to the Buchanan Highway with a detour to the lonely dry river stock route on Birimba Station, before rejoining the highway and arriving at the Stuart Highway south of Daly Waters.

Survey maps, compass and Forrest's daily journal were used to fix the approximate point where Forrest and a companion Hicks reached the overland telegraph line on August 31, 1879 after a

dash of three days and nights across 160km of very dry, rough country inhabited solely by Aborigines. This point is now at a bend of the highway and a roadside parking area has been cleared near the clayhole where Forrest first found water after reaching the OT line. This is about 5km north of the point where Forrest reached the line and

often in a dry creek bed. This resulted in a small number of contacts being made with all states and overseas; reception was disappointing in the south-east of Australia even with multi-band dipoles laboriously strung up on many occasions. Twenty metres was the only useful band during daytime, but 80 metres was fair at night except as stated. Forty metres was of no use.

As the party usually moved off just after sunrise and did not camp till almost dusk, the two-hour time difference in WA and the artificial change of 1½ hours when reaching the NT had quite an effect on eastern state contacts. However, the FT-7, and the whips, adjusted for 3640kHz and

*L. to R.: Dr W. Peasley, K. Teakel, L. Peasley (VK2BLP), L. Teakel, H. Leaver. Plaque reads: Alexander Forrest reached the overland telegraph line near this spot on the night of August 31st, 1879 after he and his party had made an epic journey from De Grey on the WA coast. Erected by WA Historic Society.*



about 56km north of Daly Waters. A stone cairn was erected on August 31, 1979 by members of the expedition and the Katherine Historical Society, with Dr Peasley affixing a plaque on behalf of the WA Historic Society.

While the historical nature of the trip was the prime consideration, the author took the opportunity to use an FT-7 and two small walkie-talkies — the latter for use when hunting for marked trees — when time and conditions allowed. Since much of the travelling was through scrub, the whip antenna was installed only after camp was made,

14.25Mhz respectively, gave results equal to that of the dipoles (no antenna tuner used) with far less trouble in installation. In addition to this facility, another vehicle carried a Flying Doctor Service transceiver. This vehicle broke a main spring near Victoria River Downs and limped back to the bitumen, heading for Katherine for repairs. The two members turned up at the cairn-building finalising the main trip, before returning to Geraldton.

There were many interesting incidents, including finding two trees marked by Forrest: F69 near King



# 7 DAY TRIAL OFFER



**POST & PACKING IS FREE!**  
Huge 192 pages packed with up to date information for the Australian amateur.

If you're an old timer or new to the scene, this is the book for you! Has valuable data too; including frequency reference, band usage, operating procedures and **MUCH MUCH MORE!** If you are not satisfied, return it to us in original condition and we'll refund your money in full!

**VALUE AT \$6.95** B-2320

**SEND IN THIS COUPON TODAY!**

**DICK,**  
Please send me a copy of the Australian Amateur Hand Book. I enclose \$6.95 (post and packing is free).

NAME .....

ADDRESS .....

P. CODE .....

**DICK SMITH ELECTRONICS**



P.O. BOX 321, NORTH RYDE, N.S.W. 2113.

PERSONAL SHOPPER? then telephone (02) 888 3200 for your nearest Dick Smith store location

## AMATEUR RADIO

Sound, on a large double boob tree, and F197 on a coolabah tree at the depot waterhole on Forrest Creek where the main party camped during Forrest's dash for the OT line. The existence of the marked coolabah does not appear to be known locally.

Three members of the party, including the author, continued on to Darwin via Southport — now abandoned — where Forrest had taken a steamer to Palmerston (now Darwin). Letters from the Premier of WA, the Lord Mayor of Perth and the President of the WA Historical Society were conveyed personally to Dr E. Stack, Mayor of Darwin, by Dr Peasley and party, who were in turn presented with mementos of the occasion by Dr Stack.

Lasting impressions are of the general hospitality, spinifex and sand, cattle, aerial mustering by both planes and helicopters, anthills of all shapes (some giant size and some similar to a Field of Mars cemetery), boob trees (one 40ft in girth), and wrecked and stripped cars by the roadside.

Thanks to the people of north-west WA and the Northern Territory. It's a great part of Australia.

### CAREERS MARKET DAY

An interesting and rewarding way to publicise amateur radio is at a high school careers market day. Final year students meet and inquire from representatives of industry, commerce and professions, details which may assist them in deciding what career to choose for their working life.

Such a day was spent at the Fairfield Showground in the outer western suburbs of Sydney, NSW, on August 22, 1979, when I (VK2APQ) was invited by the organiser from Ashcroft High School to demonstrate amateur radio.

A large display board with a map of the world surrounded by QSL cards provided a backdrop, a Kenwood TS820S transceiver into a Scalar SC22DX trap vertical tri-band antenna provided the demonstration. It attracted much attention from a large number of the 2500 students, from some 20 high schools, who visited the ground.

The aim of displaying amateur radio was to demonstrate how a worthwhile hobby could be coupled with careers in today's electronic orientated society. Also how amateur radio could be a medium for increasing one's knowledge of cultural and living conditions throughout the world.

A number of overseas contacts were made and a few migrant students were able to hear a contact with their home country.

A number of teachers and several representatives from the 150 other

## BRIGHT STAR CRYSTALS PTY LTD

35 EILEEN ROAD, CLAYTON, VICTORIA, 546 5076  
(ALL MAIL TO:— P.O. BOX 42, SPRINGVALE, VIC. 3171)

### INTERSTATE AGENTS

\* ROGERS ELECTRONICS  
ADELAIDE Phone 42 6666  
\* HOSE & EQUIPMENT  
SYDNEY 666 8144

B.S.C. TELEX AA36004

\* DILMOND INSTRUMENTS  
HOBART 47 9077

\* WESTEST ELECTRONICS  
PERTH 337 6393  
\* FRED HOE & SONS PTY. LTD  
BRISBANE 277 4311

## C-MOS CLOCK FREQUENCY GENERATORS

**Supply Requirements**  
5 - 12 V Dc at 6 MA. No load.

**Output Drive:**  
50 MA Model - 6 & 22  
5 MA Model - 13

**Stability:**  
Better than 1-PP/M

**Operating Temperature Range:**  
0-60°C  
Supply voltage to be nominated by user

**Output frequency:**  
Nominated by user

**Maximum Crystal Frequency:**  
5 Volt Supply - 5MHz max 12 Volt - 9MHz max

**Crystal Frequency:**  
Required frequency X number counters  
Frequency X 2x

**NUMBER OF COUNTERS**  
Model BSC 6 - 14  
BSC 13 - 16  
BSC 22 - 28 Stages  
BSC 11 - 14

BSC 11 has varicap  
Fine and Course trimming for higher setting accuracy.

**Crystal Locked**  
for maximum stability

**Output Options:**  
2<sup>1</sup> through 2<sup>28</sup>

**FORMULAR** for crystals frequency -  
(Required output frequency X 2x to give a crystal frequency of 2 to 8MHz ie 100Hz X 2<sup>14</sup> = 6553.6)

**Output:** Square wave 0 - .99 supply volts I - 20 MA Max  
Supply voltage 5 - 12 Volts Dc

**Stability** ± 003% / 0-60°C

**P.C.B. Dimensions**

	length	width	height
BSC 6	43 mm	27 mm	20 mm
BSC 13	52 mm	40 mm	26 mm
BSC 22/11	54 mm	48 mm	26 mm

If the module you require is not listed then please inquire.

We have many others.

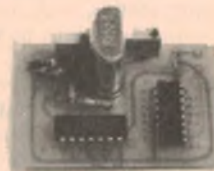

Model BSC 11



Model BSC 6

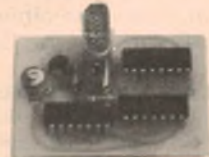

Model BSC 13/22



# AMATEUR RADIO

organisations also showed keen interest and indicated that they now had a much better appreciation of amateur radio.

My thanks to Mike Killpatrick, VK2NMO of Scalar Industries Pty Ltd for the loan of the SC22DX antenna, which was mounted in the centre of a 100m x 100m flat metal roof. It left little to be desired in performance.

## JAMBOREE RADIO STATION

The 4th Asia-Pacific—12th Australian Jamboree organised by the Scout Association of Australia, will be held from December 29, 1979 to January 7, 1980. The venue is the Perry Lakes Stadium and associated grasslands—an international track and field site established for the Empire Games in Perth, WA. The radio station is to be on the top floor of the stadium.

The purpose is to enable scouts to make new friends, visit new places and try new skills. Amateur radio amply assists in all these aspects. It is anticipated that there will be 12,000 participants, 2500 from 40 overseas countries and 8000 from eastern Australian states.

Western Australian amateurs will assist, and upwards of 100 will operate the station and radio workshop.

Facilities will include a station on 20 and 15 metres (around the clock) beaming around the world, a station on 10 or 15 metres (all day) beaming to eastern Australian capital cities, and stations on 40 and 80 metres operating as required with dipole antennas favouring north and south. An RTTY station is also planned.

Radio clubs and other organisations, as well as individual amateur operators, are cordially invited to submit news and notes of their activities for inclusion in these columns. Photographs will be published when of sufficient general interest, and where space permits. All material should be sent to Pierce Healy at 69 Taylor Street, Bankstown 2200.

## IONOSPHERIC PREDICTIONS FOR NOVEMBER

Reproduced below are radio propagation graphs based on information supplied by the Ionospheric Prediction Service Division of the Department of Science. The graphs are based on the limits set by the MUF (Maximum Usable Frequency) and the ALF (Absorption Limiting Frequency). Black bands indicate periods when circuit is open. 11.79

14MHz EAST		01	02	03	04	05	06	07	08	09	10	11	12	13	14	15	16	17	18	19	20	21	22	23	
EAST AUST TO BARBADOS (SR)																									
JOHANNESBURG																									
McMURDO SOUND																									
NEW DELHI																									
NEW YORK																									
RIO DE JANEIRO																									
TOKYO																									
VANCOUVER																									
WELLINGTON																									
WEST AFRICA																									
WEST EUROPE (SR)																									
WEST EUROPE (LR)																									
ADELAIDE TO SYDNEY																									
BRISBANE TO MELBOURNE																									
PERTH																									
SYDNEY																									
DARWIN TO SYDNEY																									
MELBOURNE TO PERTH																									
SYDNEY																									
21MHz GMT		15	16	17	18	19	20	21	22	23	24	01	02	03	04	05	06	07	08	09	10	11	12	13	
EAST AUST TO BARBADOS (SR)																									
JOHANNESBURG																									
McMURDO SOUND																									
NEW DELHI																									
NEW YORK																									
RIO DE JANEIRO																									
TOKYO																									
VANCOUVER																									
WELLINGTON																									
WEST AFRICA																									
WEST EUROPE (SR)																									
WEST EUROPE (LR)																									
ADELAIDE TO SYDNEY																									
BRISBANE TO MELBOURNE																									
PERTH																									
SYDNEY																									
DARWIN TO SYDNEY																									
MELBOURNE TO PERTH																									
SYDNEY																									
28MHz EAST		01	02	03	04	05	06	07	08	09	10	11	12	13	14	15	16	17	18	19	20	21	22	23	
EAST AUST TO BARBADOS (SR)																									
JOHANNESBURG																									
McMURDO SOUND																									
NEW DELHI																									
NEW YORK																									
RIO DE JANEIRO																									
TOKYO																									
VANCOUVER																									
WELLINGTON																									
WEST AFRICA																									
WEST EUROPE (SR)																									
WEST EUROPE (LR)																									
ADELAIDE TO SYDNEY																									
BRISBANE TO MELBOURNE																									
PERTH																									
SYDNEY																									
DARWIN TO SYDNEY																									
MELBOURNE TO PERTH																									
SYDNEY																									

Amateur TV on UHF will be provided with special receivers located in sub-camp fraternity areas, plus VHF stations on two and six metres for local contacts.

A workshop will be set up where, under amateur supervision, the scouts will be able to build simple electronic projects.

In addition a broadcast band radio station will provide news, instruction,

and music.

A special QSL card will confirm contacts made with the Scout Amateur Radio station VK6SH. To assist overseas or Australian scout groups with amateur radio facilities schedules may be arranged by writing to Scout Amateur Radio Station VK6SH, 12th Australian Jamboree, PO Box 7, West Perth, Western Australia 6005, stating day, time and frequency.

To check propagation conditions, all schedules will be acknowledged by a VK6 amateur four weeks prior to the day and hour the contact is asked for. A further check will be made three weeks prior to the date and time.

## TASMAN ELECTRONICS

12 Victoria St. Coburg, Vic. 3058. Phone (03) 354 5062

ELECTRONIC COMPONENTS  
TRANSISTORS  
IC's  
RESISTORS  
CAPACITORS

PLUGS & SOCKETS  
TRANSFORMERS  
SANKEN MODULES  
ILP MODULES  
POTENTIOMETERS  
DIODES. ETC

WIRE & CABLE  
AUDIO LEADS  
MULTIMETERS  
CALCULATORS  
INSTRUMENT CASES  
POWER SUPPLIES

MUSICAL INSTRUMENTS  
RECORDS, CASSETTES  
SPEAKERS AND  
SPEAKER KITS  
STYLII, BATTERIES,  
VALVES

T.V. AERIALS  
AND ACCESSORIES  
HI-FI PRODUCTS  
JOSTY KITS  
PROJECT PC BOARDS  
BOOKS, PLUG PACKS

MAIL ORDERS  
WELCOME—  
COME AND SEE  
US — our  
prices are the  
"BEST IN TOWN"

## SO YOU WANT TO BE A RADIO AMATEUR?

To achieve this aim, why not undertake one of the Courses conducted by the Wireless Institute of Australia? Established in 1910 to further the interests of Amateur Radio, the Institute is well qualified to assist you to your goal. Correspondence Courses are available at any time. Personal classes commence in February each year.

For further information write to  
**THE COURSE SUPERVISOR,  
W.I.A.**  
14 ATCHISON STREET,  
CROWS NEST, NSW 3065



# GET VICOM'S INTERNATIONAL LINE-UP

## AIRCRAFT RECEIVER Model 747

- \* 16 Channels
- \* AC/DC Operation
- \* 4 crystals supplied
- New Shipment just arrived!



**\$199**

## All the big names in international communications gear right here!

Like Icom, Leader, Kenwood — to drop only a few of our top names. At Vicom, you'll find not only Australia's largest range of communications gear — but all the best-known names in this field from around the world. Check out our international Line-up today!

## NEW! KENWOOD R-1000 COMMUNICATIONS RECEIVER

- \* AM/SSB/CW
- \* 200 KHz-30MHz



Introductory Price **\$498**

## VHF & UHF POCKET RECEIVERS

- \* 10 channel scanners
- \* 12 channel units
- \* prices from \$78 & ST

## TR DIP METRE SCOOP PURCHASE — \$89

Normally \$132  
Freq 1.5-250 MHz  
Modulation 2KHz  
Sine  
Power 9 volts  
2mA Max

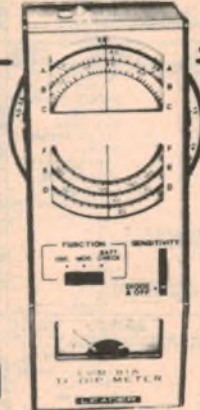

100 WATTS ON 6 METRES  
New IC551D 100W Model

**\$850**



## LSG 16 RF SIGNAL GENERATOR

100KHz-100MHz Solidstate RF signal generator. Suited for aligning the IF circuits in AM, FM and TV sets.

**\$119**

## LEADER

## DA 100

Wide band active receiver antenna.

Features:

1. Masthead pre-amp
2. FET antenna tuner
3. 50KHz — 3MHz

RRP **\$318.47**



**DR22**  
The DR22 is a high performance general coverage receiver.

Features:

1. Digital synthesizer
2. Bright LED display
3. Multi mode reception

RRP **\$1687**



## 27MHz Marine Transceivers

AC516 ANA incl. one channel — \$126.00  
MARINE ANTENNAS ALSO AVAILABLE!

## Coax Relays

CX-2L 1.8-170 MHz, 100 w pep — \$45.00  
CX-2H 1.8-450 MHz, 200 w pep — \$69.00

## SWR/PWR Meters

VC2 Popular twin meters, 3-150 MHz — \$35.00  
SWR200 Oskerblock, 3-200 MHz — \$86.00  
CN620 Daiwa, cross-needle type, 1.8-150 MHz — \$99.00  
CN630 Daiwa, 140-450 MHz, direct read — \$135.00

## Cameras

EX-803 B&W, handheld with 4:1 300m — \$414.00

## Plugs & Sockets

BNC Plugs \$2.80

BNC Jumper leads \$6.20  
BNC Chassis Sockets \$2.80  
BNC "T" adaptor \$5.60

## 2m Bi-Linears

MR900E Tono, 80-90w incl. Rx preamp — \$289.00  
MR1300E Tono, 120-B&W incl. Rx preamp — \$350.00

## Kenwood Transceivers

TS520S HF transceiver — \$635  
TS120S Solid state 100w — \$735.00  
TS120V Solid state 10W — \$600.00  
TS180S Solid state 10w — \$1240.00

Call us today for a good deal

## Microphones

VM-1 Noise cancelling, hand ptt, low 7 — \$10.00

## Coaxial Cable

RG58AU mil spec. 30m reels — \$13.00  
RG213/U mil spec. per metre — \$1.40

## ICOM Gear

IC701 transceiver NOW — \$1199.00  
IC22S 2m transceiver — \$299.00  
IC551 6m transceiver — \$799.00  
IC280 2m fm remotable — \$450.00  
IC502 6m ssb portable — \$239.00  
IC202S 2m, ssb portable — \$318.00  
IC211 2m all mode — \$847.00

## Morse Keys

HK702 Deluxe Key with marble base — \$41.00  
HK708 Economy Key — \$23.00  
HK706 Operator's Key — \$25.00  
MK701 Manipulator (side-swiper) — \$45.00  
PALOMAR 1C Keyer — \$149.00

## Baluns

AS-BL Asahi 50 ohm for beams — \$34.00  
BL50A 50 ohm, 4 KW, 1:1 for dipoles — \$32.00

## Radio Teletype Terminal

0-7000 Tono RTTY CW/Baudot/ASCII — \$839

Duncan Baxter VK3LZ Perth 321 3047  
Customer Service Manager Newcastle 69 1222

Sydney 635 6399 Gold Coast 32 2644  
Adelaide 43 7981 Geelong 78 9660 Brisbane 341 2332  
Rockhampton 28 2843 Melbourne 836 8635 Townsville 72 2633

Vicom

68 Eastern Road,  
South Melbourne,  
Victoria, 3205.  
(03) 699 6700

Launceston 44 3882  
Brisbane 38 4480  
Adelaide 272 8417  
Goolgoolie 21 1906  
Wellington(NZ)287 946  
Wagga 21 2125



# The Australian CB SCENE

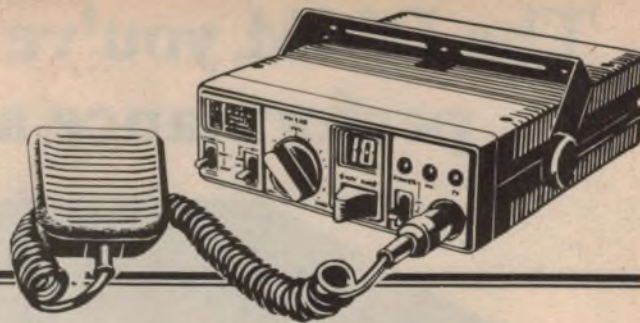

## UHF CB HELPS COMMODORES TO WIN 1-2-3

When the Holden team Commodores crossed the finish line 1-2-3 in the recent Round Australia Rally, they owed their victory in part to effective 2-way radio communication. It was provided not by expensive professional equipment but by Philips FM-320's — ordinary UHF CB transceivers.

The Repco Reliability Trial's route between Adelaide and Broken Hill had some unique hazards for the leaders.

Some 100km was over sandy station access tracks which had partly grassed over through disuse. Sheep had obliterated the tracks completely for up to a kilometre in some places, right where guidance was needed most ... around the numerous dams.

But an extra hazard faced the Marlboro Holden Dealer Team Commodore of Peter Brock — one which could have deprived him of his Repco Trial win. The car was running out of fuel.

The service van was waiting at a rendezvous 40km on the other side of the control at Yunta. The car would only make it to Yunta.

Fortunately, the team plane had been

specially fitted with a Philips UHF 320 CB Radio as part of an eight-station network. A call for help from Brock was instantly relayed to the service vehicle which raced in and fuelled the Commodore at Yunta control.

"We were very happy with the way UHF CB and the Philips sets, kept the team together," said the Marlboro Holden Dealer team manager, George Shephard.

"I was spending an average of 90 minutes a day talking to the three competing Commodores and the three service vehicles."

"The clear communications we got by going UHF helped us achieve the 1-2-3."

"The range, car to car, was up to about 50km in the flat outback country," George Shephard said.

The cars contacted the plane in the

air up to 400km (260 miles) away. The team plane would land ahead of the vehicles and a portable base station set up at the checkpoint.

Communications with the incoming cars meant service teams were totally prepared. There was time to select replacement light bulbs and other bits and pieces to keep the cars roadworthy, and even time to put the kettle on for Brock's favourite brew — tea.

As the team made their way around the country, they were delighted with the way outsiders chatting on the channel the team selected were prepared to switch away or stand by.

"We were pleased to find that there were no dills on the UHF waveband," said George Shephard. "I have a couple of 27MHz sets myself, and I know that we couldn't have got the same clear run on that frequency."

A Marlboro/Castrol press plane was similarly equipped with a UHF 320 Philips transceiver. The drivers would call up the plane on another channel to chat to the press, and George Shephard relayed news regularly as he co-ordinated from his aircraft.

The UHF 320 system was also a bonus for the crews in the three service vans following the team day and night throughout the sleepless fortnight.

"Whenever a driver started to feel disorientated, or weary, he could spark himself with a chat to another service vehicle driver.

"The good thing about the Philips sets were that you could leave them switched on 24 hours a day without being subjected to constant hiss, crackle and howl," George Shephard said.

The rally team hoped to reap further benefits from its purchase of the network, by using the radios at the Southern Cross Rally and in future Australian Rally Championship events.



Repco Reliability Trial winner Peter Brock with one of the Philips UHF 320 CB radios which provided the Marlboro-Holden Dealer Team with communications car-to-car and car-to-plane. Drivers were assured of on-the-spot availability of spare parts and fuel.

The third printing of the Dick Smith CB Handbook is now available. It covers locally available transceivers, antennas, and accessories, plus a list of over 200 clubs around Australia, CB jargon, etc. Comprising 122 pages the book retails for \$3.95.



# The DMM you've wanted: Quality and performance at a low, low cost



## Don't let our low price fool you!

Because Sabtronics sells factory-direct — we can offer the superior 2010A DMM kit for a surprisingly low \$69.95. Surprising because you get the accuracy, features and performance you'd expect from the high priced units.

The 2010A offers you the long-term accuracy of a laser-trimmed resistor network, an ultra-stable band-gap reference element and single chip LSI circuitry — all in a compact, rugged, human-engineered housing. With 31 ranges and 6 functions, you can measure AC and DC volts from 100  $\mu$ V to 1000V; AC and DC current from 0.1  $\mu$ A to a surprisingly high 10A; resistance from 0.1 $\Omega$  to 20 M $\Omega$ . Typical DCV and Ohms accuracy is 0.1%  $\pm$  1 digit. And you see these precise readings on a bright, 3 $\frac{1}{2}$ -digit LED display with automatic decimal placement and large, 9mm numerals.

Of course, that's what you'd expect from a quality DMM. But we've even added more features for extra convenience, flexibility and reduction of human error.

- Unique X10 Multiplier Switch — gives you convenient push-button selection to the next higher decade range. Hi-Lo Power Ohms capability gives you three high-ohms ranges that supply enough voltage to turn on a

silicon junction for diode and transistor testing. For in-circuit resistance measurement without turning on a semiconductor junction, you use the three low-ohms ranges.

- Wide Frequency Response — 40kHz to 40kHz bandwidth lets you measure audio through ultra-sonic AC signals.
- Touch and Hold Capability — with optional probe, retains readings for as long as you wish. You can make measurements in hard-to-reach places without taking your eyes off the probe tip or stopping to record data.
- Plus More — Auto Polarity, Auto Zero, Overrange indication and fully overload protected on all ranges.

And, although designed for benchtop use, the sleek, compact 2010A is powered by 4 "C" cells

(not included), bringing wide-range lab performance to the field when you need it.

## Easy, one-evening assembly

Your 2010A DMM kit comes complete with easy-to-follow, step-by-step instructions, all necessary parts (including the high-impact case), and test leads. You can complete assembly in a single evening. Whether you're a professional or hobbyist, if quality, performance and accuracy are important — and padded prices aren't — you should order the 2010A.

## Ordering Information

Prices and shipping charges listed are in Australian dollars and do not include any tax or duty which may be levied upon delivery of the goods.

Ordering your 2010A kit directly from our U.S.A. factory is easy:

Simply send us your order with a bank draft for an equivalent amount in U.S. dollars and we'll ship your kit via Insured Airmail. Please allow 4-6 weeks for delivery.

## Making Performance Affordable

**sabtronics**  
INTERNATIONAL

13426 Floyd Circle • Dallas, Texas 75243  
Telephone 214/783-0994

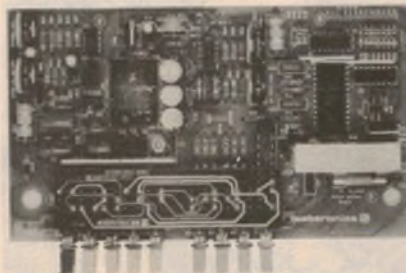

## Brief Specifications

**DC Volts:** 100 $\mu$ V to 1000V in 5 ranges

**AC Volts:** 100 $\mu$ V to 1000V in 5 ranges

**DC Current:** 0.1 $\mu$ A to 10 A in 6 ranges

**AC Current:** 0.1 $\mu$ A to 10 A in 6 ranges

**Resistance:** 0.1 $\Omega$  to 20 M $\Omega$  in 6 ranges

**Diode Test Current:** 0.1 $\mu$ A, 10 $\mu$ A, 1mA

**ACV Frequency Response:** 40Hz to 40kHz

**Input Impedance:** 10 M $\Omega$  on ACV and DCV

**Overload Protection:** 1200 VDC or RMS on all voltage ranges except 250 VDC or RMS on 200mV and 2V AC ranges. Fuse protected on ohms and mA ranges

**Power Requirement:** 4.5 to 6.5 VDC (4 "C" cells) optional NiCd batteries or AC adapter/charger

**Display:** 0.36" (9.2mm) Digits reading to  $\pm$ 1999

**Size:** 8"W x 6.5"D x 3"H (203 x 165 x 76 mm)

**Weight:** 1.5 lbs. (0.68kg) excl. battery

## To: Sabtronics International, 13426 Floyd Circle, Dallas, TX 75243, U.S.A.

Please send me

\_\_\_\_\_ (Qty.) Model 2010A Digital Multimeter kit(s) @ \$69.95 ea

\_\_\_\_\_ (Qty.) Airmail postage and insurance @ \$11.00 per kit

\_\_\_\_\_ (Qty.) Model THP-20 Touch and Hold Probe(s) @ \$18.00 ea

\_\_\_\_\_ (Qty.) #NB-120 Rechargeable NiCd Battery @ \$17.00/set

TOTAL AS \_\_\_\_\_

I have enclosed a bank draft in U.S. dollars equivalent to the AS total, payable to SABTRONICS INTERNATIONAL.

Name \_\_\_\_\_

Address \_\_\_\_\_

(Postcode & Country) \_\_\_\_\_



# SHORTWAVE SCENE



by Arthur Cushen, MBE

## BBC expands World Service: new schedules for Australia & NZ

Ever since the days of the old "General Overseas Services" of the BBC in London, Australia and New Zealand have been covered by a common Australasian Schedule of frequencies. These have, in the past, provided good reception in both countries. Now, however, the BBC World Service has moved into two separate schedules — one for Australia and one for New Zealand and the South Pacific.

The New Zealand schedule shows an increase of seven hours for the World Service. The broadcast now commences at 0300GMT and continues to 1130, while for morning reception transmissions are from 1600-2245GMT. In the past the service was 0600-1130 and 2000-2200GMT. The frequencies used are basically the same as for the World Service in the past, except that the earlier transmission is carried on 11910kHz and the 1600GMT transmission on 15070kHz is backed up at 1800GMT.

The main evening frequencies for both Australia and New Zealand remain the same with the transmission from 0600-0915GMT being available on 9510, 9640 and 11955kHz. The morning broadcast at 2000GMT continues to be received on 15070 and 21710kHz.

### NEW SAN JOSE CHANNEL

San Jose has been heard on the new frequency of 9490kHz around 0300GMT. The frequency is also used by Radio Moscow, but in New Zealand the Costa Rican station is the stronger of the two on the channel.

The transmission ends at 0530GMT and resumes soon after on 9615kHz, the frequency on which the station first operated during its early days of broadcasting. Radio Noticias del Continente is verifying reception reports with a post card of Costa Rica and one of

these coloured post cards was received by Stephen Greenyer of Invercargill, NZ following his report to Radio Noticias del Continente, Apartado 162, San Jose, Costa Rica.

The full transmission schedule is 2300-0500GMT on 9490kHz and 0500-1130 on 9615kHz. According to the BBC Monitoring Service the power of the transmitter is 50kW and it is located near Alajuela.

The station is understood to have been built with the idea of carrying commercial programs to Latin America, but its major role so far has been to carry news on the fighting in Nicaragua. There has already been concern among some South American governments regarding the station's newscasts and commentaries about their respective countries. There have also been complaints from the inhabitants of Grecia about interference from the transmitter to television programs.

### WORLD RADIO CLUB

The BBC World Radio Club program had been retimed for one of its broadcasts and is now heard on Sunday at 2100GMT instead of on Tuesday at the same time. The transmissions best suited for listeners in Australia are on Sunday at 0745GMT and Monday at 1115GMT. Another transmission takes place on Wednesday at 2315GMT.

This 15 minute program includes information on the latest short-wave news from the BBC Monitoring station at Caversham Park and from Noel Green in Preston in the north of England. Membership is free to any radio listener who writes to BBC World Radio Club, Bush House, London WC2B 4PH, England. Each month a

competition for members is held in which BBC pennants are awarded to the successful entrants.

### RELAYS OF RADIO JAPAN

Last year, Radio Japan used the facilities at Sines, Portugal, to relay its European Service in an attempt to improve European reception of the broadcasts from Tokyo. These test transmissions were carried out during June, July and October, 1978, and have been so successful that the transmitter has been leased on a permanent basis until March, 1980.

Radio Japan has announced the schedule for this relay to be 0700-0730GMT on 17815kHz, with English at 0700 and Japanese at 0715 for reception in the Middle East. The other transmission for reception in Europe is 2200-2230GMT on 15305kHz, with English at 2200 and Japanese at 2215. During the tests last year Radio Japan issued a special verification card and it is presumed that the new broadcasts from Sines will also be acknowledged in this manner.

### NEW ISLAND STATIONS

Wallis Island and Thursday Island have both commenced broadcasting on medium-wave for the first time. Wallis Island, located in the South Pacific north-east of Fiji, is using 1188kHz and closes at 1000GMT with the French national Anthem. The broadcast was first noted by Brian Clark of Auckland, NZ and signals have been heard around dusk.

Thursday Island broadcasts on 1062kHz, with a relay of programs from the Australian Broadcasting Commission. The station uses the call sign 4TI, has a power of 2kW, and has been heard by listeners in Australia and New Zealand till close down at 1400GMT.

### RADIO MONITORS PROGRAM

The Radio Monitors International Program, which is compiled in Poona, India and broadcast by the Sri Lanka Broadcasting Corporation, has an in-

Notes from readers should be sent to Arthur Cushen, 212 Earn Street, Invercargill, NZ. All times are GMT. Add eight hours for WAST, 10 hours for EAST and 12 hours for NZT. In areas observing Daylight Saving Time add a further hour.



**BRASS SHIPS CLOCKS  
SMITHS 8 DAY 7 INCH  
DIAMETER \$110**

Post A \$1.75; B \$3.00; C \$3.60

**GENUINE EX ARMY WRIST  
WATCHES**

Complete with nylon band \$19.50  
Post \$1.10

**P.M.G. TYPE TELEPHONES**

Standard desk type with magneto bell calling device. Range 30 miles. Uses standard batteries at each phone. Any number can be connected together on single line. **\$39.50**

(2 TELEPHONE SETS)

\$2 Cartage to Rail. Freight payable at nearest attended Railway Station.

**RECEIVER No. 210**

2-16 M/cs \$65  
Transmitter No. 11 suits 210 \$36.  
24 volt Power supply to suit above \$15  
Or complete station with Headphones. Mic. **\$110.**

**EX ABC  
MAGNETIC RECORDING  
TAPES 1/4"**

PROFESSIONAL QUALITY

5" x 600' **\$1.50**  
7" x 1200' **\$2.75**  
P + P \$1.30  
10 1/2" x 2400' \$7.95  
P + P A \$1.65 B \$2.75 C \$3.10

**COLLINS INDEPENDENT  
SIDEBAND TRANSCEIVER  
TRC/75**

Fully synthesised transceiver with am. upper, lower and independent sideband operation. 1KHz steps from 2MHz to 29.999MHz. 1 microvolt sensitivity. 2.5KHz bandwidth ssb. 6KHz bandwidth AM. 1 RW. PEP max output. Fully automatic tuning of both transmitter and receiver from remote control unit. Complete with automatic aerial coupling unit, mic, headset, etc. 400Hz supply. *Ideal for amateur use*  
**PRICE \$750**

**COLLINS SYNTHESISED 1  
SB RECEIVER**

TRC/75 receiver section of transceiver specification as above  
**PRICE \$400**

**TELEPHONE WIRE**

1 mile twin (2 miles) genuine ex-Army Don 8 perfect condition **\$45.00** per drum. \$2.00 cartage to rail freight payable at destination

**20X to 60X  
ZOOM TELESCOPE**

With Tripod **\$115.50**  
Post **A\$2.25, B\$4.10, C\$6.10**

**RCA 44BX MICROPHONES**

PROFESSIONAL QUALITY \$75  
P&P A \$1.80 B \$3.50 C \$4.55,  
D \$4.55

**AERIAL CAMERAS**

WITH 8" FL 3" DIAM. LENS F24 MARK IV 2.9 LENS STOPS 11, 8, 5.6, 4, 2.9 — **\$85**

\$2 cartage to rail freight. Payable to nearest attended railway station.

**PENTAC LENSES**

3" DIAM 8" FL WITH DIAPHRAGM STOPS 11, 8, 5.6, 4, 2.9 MOUNTED IN METAL HOUSING — **\$65**  
POST A \$1.85 B \$3.25, C \$4.10

**PRISMS**

4" SQUARE FACED RIGHT ANGLE PRISMS TOP QUALITY EX AIR FORCE — **\$65**; OR LENS & PRISM FOR **\$120.**  
POST A \$1.75, B \$3.00, C \$3.60

**SOLENOIDS**

200 MA 24 volt 1/8in push movement. **\$2.50 P+P 80c**

**NIFE CELLS**

1.2 volt, fully charged. 4in x 3in x 1in 4 AH **\$1.50 each P&P 80c**

**ROLA 66 MK 2  
TAPE RECORDERS**

Good condition **\$275.00**

**ARTILLERY DIAL SIGHTS MK2**

Can also be adapted as a Dumpy Level or as base for a telescope has full 360° 5 1/2" diam. gunmetal rotating circle. Adjustable elevation and depression. Has top grade 3/4" diam. object lens. FL 10" with cross hairs, eyepiece, 1/2" right angle prism — height 10" — weight 3 1/2 kgs. With leather carrying case. Original cost \$300.

Our Special only **\$27.50**  
P&P A \$2.25 B \$4.00 C \$6.00

**POSTAGE KEY:**

A: NSW  
B: Vic. Qld. SA  
C: NT Tas  
D: WA

**VALVES**

BRAND NEW  
6SN7 **\$1.95** 6B8 **\$1.95**  
6X4 **\$1.95** 6GVR **\$1.95**  
EF50 **\$1.50** 6AK5 **\$1.95**  
1H6 **\$1.50**  
2x2 **\$1.50** 832 **\$5.00**  
P+P 80c  
6x4 **\$1.95**  
VR65 **\$1.50**

**STC HIGH IMPEDANCE  
HEADPHONES**

3400 ohms, brand new, only **\$4.95** pair  
P&P A \$1.65 B \$2.75, C \$3.10.

**ZOOM SPOTTING  
SCOPES**



30 x 30  
LENGTH 12 1/2". HEIGHT  
10"  
WEIGHT 1 3/4 lb  
**\$32.50**

High grade coated lenses  
Ideal for pistol and rifle ranges or general viewing. Zooms in from very low to high powers. Complete with tripods.  
POST A \$1.75 B \$3.00, C \$3.60

**TELESCOPES**

25 x 30 **\$13.50**  
P&P A \$1.30

**SPY TELESCOPES**

8 x 17 mag size of a rifle cartridge extends to 8". Only **\$8.95** each, post 60c.

**BINOCULARS**

PRISMATIC Coated Lenses. Brand new Complete with case

8 x 30 **\$42.00**  
7 x 50 **\$48.95** P&P  
10 x 50 **\$1.00** A **\$1.75**  
12 x 50 **\$3.00** B **\$3.00**  
20 x 50 **\$5.00** C **\$3.10**

**SMALL CLIP-ON  
POCKET TELESCOPE**

15X **\$7.00**. P+P 80c

**3" ASTRONOMICAL  
REFLECTOR TELESCOPE**

117X magnification FL 700mm with 5x24mm finder scope and two section hardwood tripod **\$169.25**  
Post **A\$2.25, B\$4.10, C\$6.10.**

C42 set 36 to 60M/Hz with 24 volt power supply headphone mic leads etc **\$95.**  
Or 42 set separate **\$65.**

**AIRCRAFT INSTRUMENTS**

Directional Gyros  
AN5735 1 Air Operated. **\$35**

Sperry Artificial Horizon  
AN5736-1 Air Operated. **\$45**

Slip and Turn Indicators **\$17.50.**

P&P  
A \$1.65 B \$2.75 C \$3.10

**MAGNESIUM DRY CELL  
BATTERIES.** Suits PRC25 and dozens of other uses. 15 volts long life.

Only **\$1.50** each. P & P A **\$1.35** B **\$2.75** C **\$3.60.**

**ANEROID BAROMETERS**

In brass case, made in London **\$49.50**  
P&P A **\$1.65**  
B **\$2.75**  
C **\$3.10**

**CONDENSER LENS**

2 1/2" diam 2" FL **\$1.50** each or **\$2.50** per pair. P&P 80c.

**IMPELLER PUMPS**

New gunmetal body. Stainless Steel Shaft. Neoprene Impeller. Up to 15ft. Lift, suitable for almost any type of liquid. Self priming. Ideal boat bilge pump, sillage drains, etc. Approx size 8" x 5" 1/2" **\$35.75**, 1/2" **\$61.00**, 3/4" **\$66.50**  
P+P A **\$1.95** B **\$3.50** C **\$4.60**

**Liquid filled  
compass**



With magnified lens sight and degree reader.  
Only **\$7.95** each. Post **\$1.30**

**POLARITY & CURRENT  
CHECKER**

3 volt to 400 volt. Simple leads and prods quickly determines positive or negative with illuminated indicators, also checks AC current and intensity, fully insulated only **\$4.95**, pp **\$1.30**

**COLLINS COMMUNICATIONS  
RECEIVER**

Type SIJ.4  
500kHz to 30mHz  
**\$350.00**

**WRIST WATCHES  
SWISS JAEGER**

Le Coultre ex RAAF rated one of the world's best in smart chrome case with black dial. Original cost **\$250**

**SPECIAL \$49.50**  
Post **\$1.30**

**THEODOLITES**

Made by Wilds Microptic, with tripod Model T1, reads down to one minute of ARC **\$750.**

(Usual Price **\$1750**)  
Model T2 reads down to one second of ARC **\$1000** (Usual Price **\$3200**)

Freight payable at nearest attended R'way Stn

**ZOOM FOCUSING  
MICROSCOPES**

Zoom focusing microscopes 750X battery and mirror illuminated **\$31.75**  
Zoom 1200X similar to above **\$47.95**  
P&P A **\$1.65** B **\$2.75** C **\$3.10**

**DIRECTOR LEVELS**

Ex Army No 9 with azimuth horizontal circle and vertical adjustment suits all types of levelling. In leather case **\$90.**

P + P A **\$1.75** B **\$3** C **\$3.60.**



**EX-ARMY  
TWO-WAY  
FM RADIOS**

**1.2 WATTS OUTPUT  
SUPERHET**

PRC9 AND 9A 27 to 39M/Hz  
PRC10 AND 10A 38 to 55M/Hz  
WITH HANDSET ANTENNA **\$25 EA.** UNTESTED

Battery **\$3.95** extra. Harness **\$4.50** extra  
\$2 Cartage to Rail. Freight payable nearest attended Railway Station

**16MM SOUND PROJECTORS  
IN GOOD WORKING ORDER**

240 volts operated complete with Speaker and Amplifier

SIEMENS **\$3.75**  
BELL & HOWELL **\$195**  
\$1 Cartage to Rail. Freight payable at nearest attended Railway Station

**SELSYN MOTORS  
MAGSLIP  
RECEIVERS 2" MK2 \$8.50  
TRANSMITTER 3" MK2 \$20.00**

Post Packing A **\$1.75** B **\$3.00**, C **\$3.10**

**COMMUNICATIONS  
RECEIVER**

COLLINS R — 391/URR  
Continuous tuning of range 500 KHz — 32MHz in 32 bands. Receive frequency indicated directly on digital counter type readout to within 300Hz. Selectivity adjustable in six steps. From 100Hz to 16KHz bandwidth. Sensitivity 1 microvolt or better. 240 VAC operation — 10 inch rack mount — autotone on eight preset channels available complete with instructions and service manual and tested.  
**PRICE \$500.**

**Deitch Bros.**  
**70 OXFORD STREET, SYDNEY 2010**

SORRY NO COD



# SHORTWAVE SCENE

teresting series of features to be released in the next two months. These include: Radio Broadcasting on Gibraltar (11th Nov); Radio Broadcasting on the Andaman Islands (18th Nov); Radio Canada International DX Digest and Sunspot Information (2nd Dec); Broadcasting from Mt. Everest (9th Dec); Radio Australia 40th Anniversary (16th Dec); and The Story of Gospel Broadcasters (23rd Dec).

Adrian Peterson advises that Radio Monitors International is broadcast at 1100GMT on Sunday on 11835, 15120 and 17850kHz. The program is repeated at 1400GMT on 6075, 9720 and 15425kHz.

## LISTENING BRIEFS EUROPE

**AUSTRIA:** Vienna recently made a frequency change for its service to Australia 0900-1300GMT and replaced 21630 with 21670kHz. This change has not been a success due to the fact that AFRTVS programs from the Philippines are on the same frequency.

**MONACO:** Trans World Radio at Monte Carlo is using the outlet of 11795kHz at 1830GMT for a broadcast in Armenian. At 1845GMT a gospel program continues in Arabic. This new frequency replaces 11790kHz.

**USSR:** Radio Kiev in the Ukraine is using some new frequencies for its English broadcast. The transmission 0300-0330GMT is now on 9610, 9655, 11735, 15180, 17760 and 17870kHz. An earlier transmission 0030-0100GMT is on 11735, 12060, 15180, 17845 and 17870kHz.

## ASIA

**AFGHANISTAN:** Radio Afghanistan's domestic service, First Program, continues to be heard on two new shortwave channels — 11900kHz and 15280kHz — from sign-on at 0130 ap-

proximately to the now regular signoff time of 1930GMT. Programs are now broadcast continuously throughout this period. According to the BBC Monitoring Service two other channels, 4775 and 6230kHz, continue to be used at times for this service.

**ISRAEL:** According to a schedule from the Israel Broadcasting Authority, the English transmission at 0500GMT to Australia is now on 11655kHz but coverage is also provided on 11960, 15105, 15485, 17685, 17815, 21500, 21575kHz. These same frequencies are also used for a broadcast in French at 0515GMT. A further broadcast in English at 1200GMT to this area is carried on 11655, 17565, 17685, 21495, 21575, 21675 and 25640kHz. The broadcast 2000-2030GMT is on 9009, 9425, 11655, 15105, 15415, 17645, 17685 and 21575kHz. The final broadcast is 2230-2300GMT on 9815, 11655, 11985 and 15105kHz.

**PAKISTAN:** Radio Pakistan broadcasts in English with a slow speed news bulletin 02300-0245GMT on 17830 and 21590kHz. A further slow speed bulletin at 1100GMT is broadcast on 17662 and 21655kHz. The broadcast to the United Kingdom 1700-1930GMT is on 11675 and 15470kHz.

**INDONESIA:** Radio Republik Indonesia, Samarinda, has been noted on 3295kHz by James Niven, Mt Gambier reporting in "DX Time" on Radio Australia. The reception was at 1200GMT when a news bulletin in Indonesian was broadcast.

**TIBET:** The regional transmitters at Lhasa on 4750 and 5935kHz carries a relay of a program from Peking from 1300-1400GMT. The Lhasa channels were noted in parallel with many other China frequencies. Peter Bunn of Melbourne says that with the recent change in Radio Peking's verification policy, DXers should be aware that many new possibilities for QSLs from China now exist. All reports for regional stations broadcasting Peking programs should be sent to Peking, as the originator of the program. ☺

## JUST ARRIVED! NEW AIR SHIPMENT — SENSATIONAL



### 1070 DYNAMIC 'SPECTRUM'

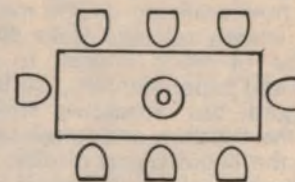
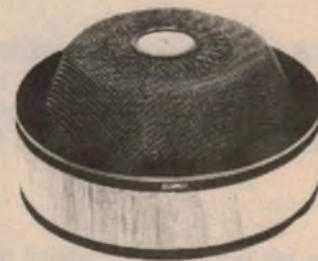

The Sound Man's "Dream" — as used by Universities, Radio Stations, People Groups, Talk Sessions, Committee Meetings etc.

- Low Profile Cardioid Dynamic Microphone.
- Special Tailored frequency response.
- A Humbucking coil to minimize hum indicator pick-up.
- Superior Mechanical shock-mounting system.
- It is revolutionary and it really performs.

## NOMIS ELECTRONICS PTY LTD

689 SOUTH RD. BLACK FOREST.  
ADELAIDE 5035 Phone (08) 293 4896



## CALCULATOR WATCH WITH ALARM AND CHRONOGRAPH

Your chance to own a precision digital watch/calculator combination at a realistic price. This multifunctional quartz digital watch features a calculator with 8 digit L.C.D. display, square root, percentage and memory, stopwatch (1/10 sec. to 10hrs)/lap. Alarm, date, day, AM-PM, hours/min /sec. Stainless steel case.

**\$169** INCLUDING REGISTERED MAIL  
WITHIN AUSTRALIA.

12 MONTH INTERNATIONAL GUARANTEE.

## MAIL COUPON TODAY

TO: TRIANGLE I.D. PTY LTD,  
465 Burwood Rd, Hawthorn, Vic 3122.

Please accept my order for calculator/watch/s.  
I enclose my cheque/money order for \$169 00  
OR I prefer to pay \$169 00 by Bankcard

BANKCARD NUMBER  
□ □ □ □ □ □ □ □ □ □

CARDHOLDERS SIGNATURE

PRINT NAME

ADDRESS

P/CODE

Allow 21 days for delivery.



# New Products

## Fluke 8022A 4-digit LCD multimeter

Fluke is a name well respected in the field of voltage measurement and this will continue with the release of their 8022A handheld digital multimeter. With a high-contrast four-digit liquid crystal display and excellent accuracy, the Fluke 8022A is sure to find acceptance.

There are quite a lot of digital multimeters now available on the market but the recently released Fluke 8022A should be of much interest to servicemen and experimenters. We liked the rugged but attractive styling, notably the function and range selectors and the liquid crystal display. The LC display has a high degree of contrast, more so than other DMMs we have used.

The function and range selectors consist of eight push switches along the left side of the case. Two switches select the function while the remaining six select the range. This is quite convenient because you only have to set the function desired, and then range up or down with the range switches until the desired reading is produced.

The 8022A measures 85mm wide x 180mm high x 33mm deep and weighs 369 grams and is just the right size for one-handed operation. It also has a tilting bail for bench use. Additional features are an easily accessible battery compartment, low battery voltage indication, shrouded connectors and probe sockets and a rugged flame retardant case.

The voltage ranges for both AC and DC measurements are from 200mV up to 2000V although the maximum permissible input voltage is 1000VDC 750VAC. There are four AC and DC current ranges, viz 2, 20, 200, 2000mA with what is termed a "burden voltage" or voltage drop of 0.25V on all ranges except the 2A range which has a burden voltage of 0.75V. The resistance range is from 200 ohm up to 20M ohm with a specified accuracy varying from  $\pm 0.2\% + 1$  digit on some ranges up to  $\pm 2\% + 1$  digit on the 20M ohm range.

We checked the accuracy of the resistance measurements against various resistance standards and found them to be right on the value and certainly within the specified accuracy.

The DC voltage readings were also checked. For example, with a 10.00 voltage reference we obtained a reading of 10.01 on the DMM, well within the specified accuracy of  $\pm 0.25\% + 1$  digit.

AC voltage accuracy is  $\pm 1\% + 3$  digits from 45Hz to 450Hz. While we did not attempt to establish the absolute accuracy of the AC voltage

rejection ratio of the DC voltage measurement ranges. This term is a measure of the rejection ratio of AC voltages superimposed on DC and the quoted figure is 60dB at 50 and 60Hz. It was a simple procedure to verify this figure, by using a transformer in series with a voltage reference. We noted no change in the DC reading of the DMM with the AC voltage impressed on the DC voltage, even though the peak AC voltage was greater than the DC voltage!

In summary, the 8022A is a rugged DMM with quite a few features that make it eminently suited to "trouble shooting". It also comes with a good range of accessories including 15kV and



measurements we did establish that the response was indeed flat within the specified frequency range and that outside the range the reading dropped 5% at 10kHz. This is about average performance for a DMM. The reason the response of most DMMs actually drops off at high frequencies is because of the op amp circuitry that is normally employed.

We also checked the "normal mode"

40kV high voltage probes, 200MHz high frequency probes useful up to 1GHz, temperature probes, a 600A clamp-on current transformer and an inexpensive 10-amp current shunt.

The price of the 8022A is \$144 plus 15% sales tax where applicable. Trade inquiries should be addressed to Elmeasco Instruments Pty Ltd, 15 McDonald St, Mortlake, NSW, Tel (02) 736 2888. (R. de J.)



## Variable regulated power supplies

Ferguson Transformers Pty Ltd have released a range of three new regulated DC power supplies, the ECA160 Series. We reviewed the middle-of-the-range 24V/1.5A version. Other models give 12V at 3 amps and 35V at 1 amp. All three units have approval from the electricity authorities.



Ferguson supplied us with a sample of the ECA160/24-1.5 model for evaluation. The supply is housed in a metal case with dimensions 225 x 100 x 180mm (W x H x D). Mass is 3.1kg.

The front panel accommodates a small meter movement, an amp-to-volt switch for the meter, a 10-turn knob for voltage adjustment, two output terminals a power switch and a red LED indicator.

The specifications for the supply are quite impressive. The linear series regulator circuit boasts short-circuit protection, fast transient response, low voltage drift and excellent regulation.

Line regulation for a  $\pm 10\%$  change in the 240VAC mains is quoted as  $\pm .04\%$  or 10mV, whichever is the least. Similarly, load regulation is quoted as  $\pm 10\%$  or 10mV whichever is the least, for a load of 1.5 amps. Our tests indicated that the ECA160 easily surpasses these figures.

The output voltage is adjustable via the 10-turn potentiometer and is resolvable to 5mV. The meter on the panel cannot match this however, since its resolution is only 0.5V or  $\frac{1}{2}$  the smallest graduation on the scale. A digital voltmeter with 5mV resolution or better is required to match the ability of the 10-turn pot.

The current scale on the panel meter gives a full-scale reading of 1.5 amps but the maximum output of the supply can actually go as high as 2.4 amps, depending on the output voltage setting. Graduations on the ammeter scale are at 100mA intervals.

Ferguson quote a 130% rated supply current capability and this was confirmed for voltages under 15V. With a

24V output setting the ECA160 could supply 2.4A, 160% of the rated supply current.

The power supply is fully protected against short circuits and has a diode and fuse incorporated for protection against external voltages. Two 3A fuses are supplied as spares.

Temperature stability of the supply is very good. There was a 12mV drift at a 1V output setting over a period of 3 hours from switch on and no discernible drift at higher output setting. The quoted figures after a 30 minute warm up period are  $\pm 0.1\%$  or  $\pm 20\text{mV}$  over 8 hours.

The temperature coefficient is claimed to be  $\pm 0.01\% + 500\mu\text{V}$  per degree celsius and our tests revealed a 0.006% change in voltage per degree. Over the operating temperature of 0 to 45 degrees the change in output voltage would be expected to vary by only 0.5%.

The output of the ECA160 is fully floating, up to  $\pm 300\text{VDC}$  above mains earth. While we appreciate this capability we think an earth terminal on the front panel would also be a handy feature.

Overall, the new series of Ferguson ECA160 power supplies are very good. They live up to their specifications which are of a very high standard and would certainly be suitable for laboratory, factory test and hobbyist use.

Recommended retail price of the Ferguson ECA160 power supply is \$88.90 plus sales tax where applicable. Trade enquiries should be addressed to Ferguson Transformers Pty Ltd, 331 High Street, Chatswood, NSW, 2067 or 181-183 Hawke Street, West Melbourne, Victoria, 3003. (J.C.)

## Next Month



### LARGE-SCREEN TELEVISION:

Large-screen television gives you a theatre size image in relation to your living room. We report on some of the latest developments.

### HOME MOVIES '79:

The second part of our comprehensive survey deals with projectors and editors and brings you right up to date.

### ELECTRONIC IGNITION:

Electronic ignition is in but CDI systems are out! Our new transistor assisted system used dwell-extension to give a hotter spark without the drawbacks of CDI.

### FAN-SPEED CONTROL:

Summer is with us and these hot sticky nights keep you awake. Our fan speed control helps you sleep by slowing your fan to a whisper-quiet zephyr. Zzzz...

### PLUS MUCH MORE

As usual, this issue is chock-a-block with interesting articles. Don't miss out!

Our planning for this issue is well advanced but circumstances may change the final content. However, we will make every attempt to include the articles mentioned here.



AUTHORISED DEALER  
**commodore**

2001-16/32



CBM™ with built-in VDU and full size typewriter keyboard.

16K 2001.16	\$1829
32K 2001.32	\$2199
Dual drive floppy disk, huge 340K 2040	\$2099
Tractor feed printer, 2022	\$1699
Friction feed printer, 2023	\$1499
External cassette	\$149

**Dual Drive Floppy Disk**

2040



**Tractor Feed Printer**

2022



**The CBM™ Computer Business System**

**PET BUSINESS SOFTWARE**

<b>THE WORD PROCESSOR —</b>	
standard 8K vers	\$24.95
ext 16K disk ver	\$99.95
<b>CREDITORS/GENERAL LEDGER</b>	
	t.b.a.

**TRS-80 SOFTWARE**

RSM-1S	\$23.95	RSM-2	\$26.95
RSM-2D	\$29.95	ESP-1	\$29.95
MICROCHESS 1.5	\$19.95		
AIR RAID	\$14.95		

S/T INCL (062) 815011 ADD P&P

**THE BYTE SHOP**

PO BOX 118, MAWSON, ACT 2607  
29 COLBEE CRT, PHILLIP

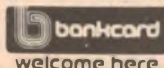

Give name, number, expiry date and signature. For mail order sales

**New Products**

**Soar ME-501 digital multimeter with LCD**

Just introduced by Ampec Engineering Co, the Soar ME-501 features a 3½-digit liquid crystal display (LCD), has automatic zeroing and polarity indication, and can check both NPN and PNP transistors for gain. Recommended retail price will be quite low for a digital multimeter — just \$70 tax paid.

The ME-501 features a comprehensive set of measuring ranges. It can measure DC and AC volts, DC current, resistance, and perform a diode test. The unit is easily held in one hand, and the various measuring ranges are selected by means of pushbutton switches arranged down the left side of the case.

Specifications are as follows: DC voltage 200mV, 2V, 20V, 200V and 1000V; AC voltage 200mV, 2V, 20V, 200V and 1000V; direct current 200µA, 20mA, 200mA and 10A; resistance 2k, 20k 200k, 2M and diode test. Accuracy is quoted as +/- (0.8% of rdg + 1 digit) for DC voltage ranges, +/- (1% of reading + 5 digits) for AC voltage ranges, +/- (1.2% of reading + 2 digits) for direct current ranges, and +/- (1% of reading + 2 digits) for resistance readings.

Transistor gain can be checked in the range 0-1000 (1b = 10µA). The accuracy for this test is +/- (10% of reading + 2 digits).

Input impedance is 10M for both DC and AC voltage ranges. Overload indication is by blanking of all digits, except for the MSD (most significant digit) "1" sign and the decimal point.

Further enquiries to Ampec Engineering Co Pty Ltd, PO Box 132, Rozelle, NSW, 2039. Telephone (02) 818 1166.

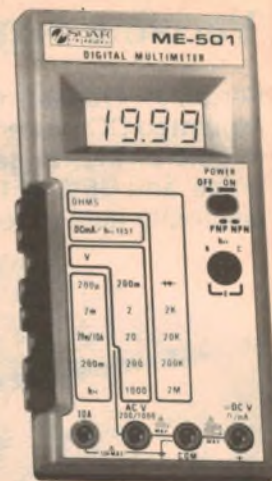

3, 6, 9V  
200mA  
Plugpack  
from  
Dick  
Smith.



Dick Smith Electronics have a new plugpack supply featuring switchable output. The output lead has a polarity changeover plug and a universal "cruciform" connector.

**For precision soldering.  
Light weight. High power.**



**ADCOLA STANDARD**

No frills.  
Just high performance.  
3mm S 30  
5mm S 50

Fitted with non-seize tips

Fully automatic 'THERMATIC' also available.



**ADCOLA DUOTEMP**

Temperature control at your fingertips.  
3mm D 30  
5mm D 50

FROM YOUR RADIO PARTS SUPPLIER OR:

(02)	709 5293
(03)	543 5122
(002)	34 2233
(07)	44 0131
(08)	42 6655
(09)	381 5500

SD2A





# FREEDMAN ELECTRONICS PTY LTD

## THE PROFESSIONALS

### 12 YEARS

of  
**Supplying the Entertainment Industry  
 in Australia**

**"Dynacord"**  
 PA Amplifiers  
 Echo Units

**"Freedman" Speaker Enclosures**  
 containing:  
 RCF — JBL — Etone — Celestion  
 speakers

**"Carlsbro"**  
 PA Amplifiers  
 Bass Amplifiers  
 Guitar Amplifier  
 Echo & Effect Pedals

MOTOROLA  
 Piezo Tweeters & Horns

**"Citronic"**  
 Disco Equipment

**"Microphones"**  
 SHURE — AKG — Prefer  
 — Audio Technica —

Microphone Stands &  
 Accessories  
 Parametric Equalizers  
 Reverb Systems  
 Cannon Plugs etc.

*All equipment on display in our showroom*

### FREEDMAN ELECTRONICS Pty Ltd

89-91A Liverpool Rd, Summer Hill, NSW 2130.

Telephone 797 0986 — 797 9941

## WE HAVE A SYSTEM FOR YOUR NEEDS AT A PRICE YOU CAN AFFORD

### The CBM™ Computer Business System



The CBM™, incorporated with the Floppy Disk and Printer makes an ideal business system for most professional and specialised fields. The CBM™ Business System as a management tool, delivers information to all levels of Business, previously attainable only with equipment many times more expensive, the CBM Business System is one of the most cost efficient business tools today.

*Write or phone today for your coloured brochure and our unbeatable prices.*

### Hewlett-Packard

NEW L.C.D.  
**PROGRAMMABLE SYSTEM**  
 HP41C \$315 (\$352)  
 Card Reader \$209 (\$234)  
 Printer \$375 (\$420)  
 Modules \$ 48 (\$53.76)

*(Details and Sales Tax forms available)*  
**REGISTERED POST \$3 NSW, \$4 Elsewhere.**  
**COUNT ON QUALITY — USE H.P.'s**

*Free advisory service to all EA readers — let us know your needs and we will tailor a system and supply software, etc. for you with the best deal you could ever have!*

### SPECIALS

**NATIONAL SEMICONDUCTOR**  
 4650 Scientific/Rechargeable \$29 (\$33)  
 4660 Functions, 3 Memories \$39 (\$45)  
 4640 Same 4660 with R.P.N. \$39 (\$45)  
 HP29C ~~\$192.50~~ \$162 (\$181)  
 HP97 ~~\$893.50~~ \$750 (\$835)  
 Texas Ti59 ~~\$235~~ \$245 (\$278)  
 Texas Business Analyst II LCD \$39.50 (\$43)

**FULL RANGE OF TEXAS AND CASIO**  
*(Price including sales tax shown in brackets)*

*End of year calculator sale price list available*

### TEXAS PROGRAMMABLE SYSTEMS

**STILL ON  
 GREATEST PACKAGE OFFER EVER!!**

**A Ti59 and PC100A printer ~~\$686~~ only \$450**

**(\$509 with s/tax)**

See June EA for details and software modules and pakettes  
 Reg. Post \$3.80 for NSW,  
 \$5 elsewhere



## ELECTRONIC CALCULATOR DISCOUNTS

Phone (02) 624-8849 (8am till 3pm) PO Box 106, Baulkham Hills, NSW 2153.





## Books & Literature

### Computer games

**MORE BASIC COMPUTER GAMES**, edited by David H. Ahl. Published by Creative Computing Press, Morristown New Jersey, 1979. Soft covers, 210 x 278mm, 185pp, with illustrations. Price \$11.75.

A further volume of "food" for the swelling ranks of computer games addicts, from the founder of the US computer hobby magazine Creative Computing. Many of the 84 games it provides have already been published in that magazine, but I doubt if this will worry anyone — most addicts will find the book irresistible anyway!

There are simple games and complex games, some of them quite unique while others are basically just variations on an existing theme. All of them have been translated into "standard" Microsoft BASIC, so they should run without trouble on machines like the Level-II TRS-80, Commodore PET, Apple II with Applesoft BASIC, Exidy Sorcerer and so on. The front of the book gives some suggestions for modifying the programs so that they would be capable of running on systems with other dialects of BASIC.

One thing to note: none of the programs is in the public domain. This means that you can use them for

private use, but they cannot be legally distributed to other parties. Some of the larger programs are available on cassette or floppy disc, from the publisher.

What more can I say? With the current popularity of computer games and the number of small systems now around which speak Microsoft BASIC, the book should sell like hot cakes.

The review copy came from McGills Newsagency Pty Ltd, 187 Elizabeth Street, Melbourne 3000, who can supply it by mail for an additional 80c (Victoria) or \$1.50 (interstate). (J.R.)

### Building a CRO

**HOW TO BUILD YOUR OWN SOLID STATE OSCILLOSCOPE**. By F. G. Rayer. Published 1979 by Bernard Babani (Publishing) Ltd. Stiff paper covers, 95 pages, 180mm x 106mm, illustrated by circuits and diagrams. Suggested retail price \$4.30.

From our correspondence, it is evident that quite a few hobbyists still aspire to build their own cathode-ray oscilloscope — as often as not, one with quite ambitious specifications. The project described in considerable detail in this new book may well interest those who are prepared to settle for a modest 2 to 3-inch "audio" style instru-

ment of the traditional kind. I base the description "audio" on an inspection of the circuitry; in checking through the book, I failed to find any actual technical specifications.

Based on the reputation of the author, I have no reason to doubt that the project would work out as expected, but would suggest that the availability and cost of the necessity components be explored before a commitment is made. It can be most frustrating to end up with a project lacking some vital component or costing more than its commercial off-the-shelf counterpart.

We received two review copies, one direct from the publishers and the other from Technical Book & Magazine Co Pty Ltd, 289-299 Swanston St, Melbourne 3000. (W.N.W.)

### Good, but dated . . .

**FM TRANSMITTERS AND RECEIVERS**. Published 1978 by Coles Publishing Co Ltd, Toronto, Canada. Stiff paper covers, 204 pages 203mm x 155mm, illustrated by circuits and graphs. Price in Australia \$7.50.

A surprising book, this. First, having been prepared by the Department of the Army, Canada, the basic text is verified as completely accurate and is apparently public property, free from the usual author's copyright.

A second point is that, for such a matter-of-fact title, the text turns out to be a very thorough coverage of frequency and phase modulation, theory and practice, with generous reference to amplitude modulation, by way of contrast. To this extent, it is a useful basic textbook.

The third aspect is a disappointment. Despite the 1978 dateline by Coles Publishing, the practical technology is confined to valves and the L/C components of the equivalent era. Transistors, ICs, resonant filters, &c, are missing.

And the fourth aspect? The price, which is modest by today's standards. It's an appropriate figure, if you want a slab of solid theory to underpin what you may have picked up elsewhere about modern solid-state FM technology.

Our review copy came from Thomas C. Lothian Pty Ltd, 4-12 Tattersall's Lane, Melbourne, 3000. (W.N.W.)

### Primer on BASIC

**BASIC AND THE PERSONAL COMPUTER**, by Thomas Dwyer and Margot Critchfield. Published by Addison-Wesley Publishing Co, Reading, Massachusetts, 1978. Soft covers, 213 x 278mm, 438pp, many illustrations. Price \$14.95.

An introduction to the programming language BASIC, and written especially for the newcomer with a personal computer. The authors are both

# CENTRONICS PRINTERS

## SAVE NOW!

MODEL 703 180cps - \$2,575

Call Karen on

# (02) 922 3100

ext.249

# CENTRONICS Simply Better



professional educators at the University of Pittsburgh, Thomas Dwyer being Professor of Computer Science and Margot Critchfield a doctoral student in education.

A look through the book shows that they have produced an excellent beginner's introduction to BASIC. It starts right at the beginning, is carefully graduated, and explains the various concepts in a very clear and easily understood fashion. There are plenty of examples and illustrations, too — including some humorous drawings which lighten the atmosphere.

There's a strong emphasis on applying BASIC to real-life problem-solving, as well. Chapter 4 deals with word processing and the use of string variables and arrays, while chapter 8 deals with data bases and files, along with other business applications. There is even a chapter on computer simulation.

In short, a very worthwhile book. It should be of value to anyone looking for a sound and readable BASIC primer and reference.

The review copy came from Dick Smith Electronics Pty Ltd, who apparently stock it in their stores under the catalog number B-2330. (J.R.)

## Audio projects

**PRACTICAL CONSTRUCTION OF PRE-AMPS, TONE CONTROLS, FILTERS AND ATTENUATORS.** By A. D. M. Smith. Published 1979 by Bernard Babani (Publishing) Ltd. Stiff paper covers, 112 pages 180mm x 106mm, illustrated by circuits and diagrams. Suggested retail price \$4.15.

The title of this new book, intended for the audio-oriented home constructor, just about spells out its contents. There are three tape playback preamplifiers, two microphone preamplifiers, and two preamplifiers each for ceramic and magnetic phono cartridges. A section on tone controls culminates in active and passive bass/treble cut/boost circuits and a "presence" stage. Other sections cover simple filters and an attenuator pad.

The author explains and discusses the designs, complete with typical response curves and, of course, circuits. PC board layouts are suggested for those who want to pursue this method of assembly. It looks to be a promising small book for those whose interests lie in this general direction.

Two copies were received for review, one direct from the publisher and the other from Technical Book & Magazine Co Pty Ltd, 289-299 Swanston, St, Melbourne 3000. (W.N.W.)

### "ELECTRONICS AUSTRALIA" PROJECTS & CIRCUITS NO. 2

Available from "Electronics Australia", 57 Regent St. Sydney PRICE \$3.00. OR by mail order from "Electronics Australia", P.O. Box 163 Beaconsfield. 2014. PRICE \$3.60.

# BOOKS

Just some of the books from the biggest range of radio and electronics books in Australia.

If the book you require is not listed below, it can be ordered from us.

## NEW — NEW — NEW

Latest editions of some of the most popular books on the subject

Australian Radio Amateur Callbook 1979	\$2 95
ARRL Handbook 1979 edition	\$13 95
World Radio TV Handbook 1979	\$15 95
RSGB Handbook (New edition) Volume 1	\$21 85
RSGB Handbook (New edition) Volume 2	\$18 90
RSGB Test Equipment for the Radio Amateur	\$19 55
Reference Data for Radio Engineers (New edition) ITT	\$39 95
Radio Handbook (William Orr) 21st Edition	\$26 50

## New Books:

Manual of Questions & Answers for the Novice Licence (Howard) 6th Edition	\$6 00
Tower's International Transistor Selector (T. D. Towers) 2nd Edition	\$9 80
Transistor Specifications Manual (Sams) 9th Edition	\$11 95
Master OP-AMP Applications Handbook (Harry W. Fox)	\$14 00
TV Antennas and Signal Distribution Systems (Salvati)	\$14 20
How to Repair Musical Instrument Amplifiers (Byron Wels)	\$8 50
Security Electronics (John E. Cunningham)	\$7 95
IC OP-AMP Cookbook (Walter C. Jung)	\$17 50
TTL Cookbook (Lancaster)	\$12 95
IC Converter Cookbook (Jung)	\$18 95
TV Typewriter Cookbook (Lancaster)	\$13 50
The Cheap Video Cookbook (Lancaster)	\$7 95
CMOS Cookbook (Lancaster) 1st Edition 1977	\$14 25
Active Filter Cookbook (Lancaster)	\$19 95
IC Timer Cookbook (Jung)	\$13 50
Master Tube Substitution Handbook (Tab Books)	\$7 00
Australian Electrical Wiring Theory and Practice (Pethebridge & Williams)	\$12 75

## Microcomputers/ Microprocessors Books:

Programming Microprocessors (M. W. McMurran)	\$9 25
Microcomputer Primer (Waite & Pardee)	\$10 75
The Z-80 Microcomputer Handbook (William Barden Jr)	\$11 95
Getting Acquainted with Microcomputers (Lou Frenzel)	\$11 95
The 8080A Bugbook Microcomputer Interfacing and Programming	\$14 25
Microcomputers for Business Applications (W. Barden)	\$12 70
Microprocessors (R. Zaks) (Sybex)	\$16 60
Microprocessor Interfacing Techniques (Lesea & Zaks) (Sybex)	\$17 60
Z80 Instruction Handbook (Scelbi)	\$7 60
Illustrating Basic (A Simple Programme Language) (Donald Alcock)	\$6 25
Understanding Microcomputers and Small Computer Systems (Scelbi)	\$15 40
Basic Primer (Waite & Pardee)	\$11 95
Basic Microprocessors and the 6800 (Ron Bishop)	\$15 00
The S-100 and Other Micro Buses (Poe & Goodwin)	\$7 95
Microcomputer Analog Converter Software and Hardware Interfacing (Sams)	\$12 95
Scelbi "6800" Software Gourmet Guide and Cookbook	\$14 20
Scelbi "8080" Software Gourmet Guide and Cookbook	\$14 20

Programming the 6502 (Zaks) (Sybex)	\$17 60
Scelbi's 8080 Galaxy Game	\$13 50
More Basic Computer Games (Ed. David H. Ahl)	\$11 75
Introduction to Microprocessors Software Hardware Programming (Lance A. Leventhal)	\$30 95
Mini/Microcomputer Hardware Design (Kraft & Toy)	\$26 95
Microprocessors Theory and Applications (Streitmatter & Fiore)	\$22 95
Microcomputer Board Data Manual (Ed. Dave Bursky)	\$10 00

## American Radio Relay League Publications:

Hints and Kinks for the Radio Amateur	\$7 20
The Radio Amateur's VHF Manual	\$7 20
ARRL Antenna Handbook	\$8 80
Understanding Amateur Radio	\$8 80
The Radio Amateur's License Manual	\$7 20
A Course in Radio Fundamentals	\$7 20
Specialised Communication Techniques for the Radio Amateur	\$7 20
FM & Repeater for the Radio Amateur	\$8 80
Single Sideband for the Radio Amateur	\$7 20
Ham Radio Operating Guide	\$7 20
Electronic Data Book	\$7 20
Solid State Design for the Radio Amateur	\$12 80
Learning to Work with Integrated Circuits	\$4 00
Getting to Know Oscar from the Ground Up	\$6 20
The ARRL Antenna Anthology	\$8 00

## Other Titles:

Video Tape Recorders (Harry Kybett)	\$13 50
Modern Recording Techniques (Robert E. Runstein)	\$14 25
How to Use Videotape Recorders (H. Kybett)	\$8 95
Electric Guitar Amplifier Handbook (Jack Darr) (Sams)	\$14 25
Linear IC Applications Handbook (George B. Clayton)	\$9 80
Linear IC Principles Experiments and Projects (Edward M. Noll)	\$14 20
Getting Acquainted with the IC (Rufus P. Turner)	\$7 00
World DX Guide — 1st Edition (Ed. Jens M. Frost)	\$9 95
Sound System Engineering (Don & Carolyn Davis)	\$26 95
73 Dipole and Long-wire Antennas (Edward M. Noll)	\$7 50
73 Vertical, Beam and Triangle Antennas (Noll)	\$7 50
Basic Television — Principles and Servicing — 4th Edn (Bernard Grob) New Edition — Soft Cover	\$18 75
Basic Electronics — 4th Edition (Bernard Grob)	\$19 35
VHF Handbook for Radio Amateurs (Herbert S. Brier & William I. Orr)	\$9 40
Building Hi-Fi Speaker Systems (Philips)	\$3 95
The Truth About CB Antennas (William I. Orr & Stuart D. Cowan)	\$9 40
Simple Low-cost Wire Antennas for Radio Amateurs (William I. Orr & Stuart D. Cowan)	\$9 40
Beam Antenna Handbook — New 5th Edition (William I. Orr & Stuart D. Cowan)	\$7 80
Better Shortwave Reception — New 4th Edition (William I. Orr & Stuart D. Cowan)	\$5 85
All About Cubical Quad Antennas — 2nd Edition (William I. Orr)	\$7 00
The Radio Amateur Antenna Handbook (William I. Orr & Stuart D. Cowan)	\$11 30
COS-MOS Integrated Circuits Manual (RCA)	\$7 95

For Mail Orders please add: 80c Local, \$1.50 Interstate,

**McGILL'S AUTHORISED NEWSAGENCY PTY. LTD.**

187 Elizabeth Street, Melbourne. Phone: 60 1475-6-7, 60 1505-6-7-8

PRICES SUBJECT TO ALTERATION





## INFORMATION CENTRE

**VDU TROUBLE:** I have recently constructed the VDU and Keyboard as described in the February and April 1978 issues. The VDU board itself appears to function correctly, with random characters appearing at switch-on and then a clear screen after I press the "clear" key. The keyboard has troubles, however; when used in the TV typewriter mode you rarely get what you type. Both the UART and keyboard encoder chips have been replaced, but to no avail. I can detect no obvious pattern in the character errors, but I enclose a table showing the character obtained when each key is pressed. (R. W., Mt Isa, Qld).

● From an analysis of the bit patterns of your transposed letters, it seems very likely that your trouble is due to a "twist" in the 7-way ribbon cable between the UART on the keyboard encoder PCB and the VDU PCB. In other words, you have connected D1 to D7, D2 to D6 and so on. This will effec-

tively reverse all of the codes, giving the transpositions you are getting: "I" for "B", "Q" for "E" and so on. The characters which were still OK are those with symmetrical bit patterns: "A", "I" and "U".

So try reversing the connections on one end of the cable — we're tipping that everything will suddenly come good.

**MK14 MICROCOMPUTER:** I have been reading the October 1978 issue of your magazine and came across the review by Greg Swain of the MK14 microcomputer. I would like some more information on this unit please, including prices. Also would it be possible to get it through you people, if I wanted it? The other information I wanted is as follows: could I add a video display? Could I add a keyboard for the display? Could I add an external memory, and if so, what type? What about a tape or floppy disk? I would appreciate some further information along these lines. (E. G., Hamilton, New Zealand).

● We're not too sure about the current price and availability of the Science of Cambridge MK14 kit; we can only suggest that you try contacting the firm listed in the review, and see if they still keep it. Failing that, you could

try writing to the manufacturer in England; their full name and address is Science of Cambridge Ltd, 6 Kings Parade, Cambridge, Cambs, CB2 1SN. As for expansion, the MK14 kit is basically a low cost teaching system and not really very suitable for serious expansion. It can be done, but the result will never be as satisfactory as with a system designed for more convenient expansion.

**PLAYMASTER SPEAKERS:** I have an amplifier with a rated output of 16W per channel and I need a new set of speakers. Will this amplifier drive a pair of Playmaster 3-75L 30cm speaker systems (rated 80W) satisfactorily or would it be better to try the 3-53L 25cm systems (rated 60W)? (C. C., Home Hill, Qld).

● Your 16W amplifier should drive either system satisfactorily for domestic listening, but the 3-75L is marginally more sensitive. We suspect that you have been deceived by confusing the wattage ratings with sensitivity, whereas, in fact, they are not related. While it may be possible to use your existing cabinets we could not guarantee that they would give the same results as we obtained from the recommended dimensions.

### ELECTRONIC ORGANS

Quality Wersi Organ Kits from Germany  
Technical knowledge not required  
Comprehensive instruction books to last detail (also available in German)

7 full organ models

Extensive voicing 16ft to beyond 11ft  
24 rhythm unit using 16 instruments  
Auto features:- reverb, sustain, percussion, wah-wah, transposer, piano, string orchestra, plus others.  
Electronic tremolo 70 watts RMS output per channel.

Approx. half cost of equal shop models  
Catalogue \$2.00. 104 pages in colour. (Refundable on \$60 order)  
Klaus Wunderlich demo record. Music only with jacket notes \$6.50 incl. postage



**WERSI** electronics



For more information on the entire WERSI line of fine musical instruments and kits contact:

### DEFI AGENCY

9 Florence Street, Burwood, Vic. 3125  
Phone (03) 288 7899

## CENTRONICS PRINTERS SAVE NOW!

MODEL 779 - \$975

MODEL 779 (incl. tractors) - \$1,195

Call Karen on

**(02) 922 3100**

ext.249

## CENTRONICS Simply Better



If you are unable to complete an "Electronics Australia" project because you missed out on your regular issue, we can usually provide emergency assistance on the following basis:

**PHOTOSTAT COPIES:** \$2 per project, or \$2 per part where a project spreads over multiple issues. Requests can be handled more speedily if projects are positively identified, and if not accompanied by technical queries.

**METALWORK DYELINES:** Available for most projects at \$2 each, showing dimensions, holes, cutouts, etc., but no wiring details.

**PRINTED BOARD PATTERNS:** Dye-line transparencies, actual size but of limited contrast: \$2. Specify positive or negative. We do not sell PC boards.

**PROJECT QUERIES:** Members of our technical staff are NOT available to discuss individual projects, either in person at our office or by telephone.

**REPLIES BY POST:** Limited to advice concerning projects published within the past two years. Charge \$2. We cannot provide lengthy

answers, undertake special research or discuss design changes.

**BACK NUMBERS:** Available only until our stocks are exhausted. Within three months of publication, face value. Four months and older, if available, \$2. Post and packing 60c per issue extra.

**OTHER QUERIES:** Technical queries outside the scope of "Replies by Post" may be submitted without fee, for reply in the magazine, at the discretion of the Editor.

**COMMERCIAL, SURPLUS EQUIPMENT:** No information can be supplied.

**COMPONENTS:** We do not deal in electronic components. Prices, specifications, etc., should be sought from advertisers or agents.

**REMITTANCES:** Must be negotiable in Australia and made payable to "Electronics Australia". Where the exact charge may be in doubt, we recommend submitting an open cheque endorsed with a suitable limitation.

**ADDRESS:** All requests to the Assistant Editor, "Electronics Australia", Box 163, Beaconsfield, 2014.

**VK POWERMATE:** I have built a 3-amp and an 8-amp version of the VK Powermate described in May 1978 (File No 2/PS44). The performance is excellent with the line and output voltage regulation being close to that specified by the author. I now require an 18 to 20-amp unit and propose to use four 2N3055s as the series-pass transistors and a JT253A transformer with secondaries parallel-

The heavy current-carrying sections of the PCB and other wiring and connections will be upgraded accordingly. The query I have relates to the TIP32 circuitry. Can the TIP32 handle the increased base currents for the 2N3055s? The paragraph on page 49 of the article states "Do not substitute a less rugged transistor for the TIP32, which has a collector current rating of 4 amps..."

Following similar reasoning, is it not likely that the TIP32 will "punch

through" should an overload occur on the 8-amp version? (R.C., Marara, NSW).

● As the current rating of this circuit is increased, there is increased likelihood of damage to the TIP32, in the event of a short circuit of the output. However, we felt that the TIP32 would have an adequate safety margin in the case of short-circuit to the 8-amp version.

As far as an 18 to 20-amp version is concerned, a TIP32 could certainly handle the normal base-current load for the four 2N3055s. But a short-circuit could again cause "punch-through" to occur. We recommend substitution of an MJ2955 or similar TO-3 type PNP transistor for the TIP32. We also suggest that it be mounted on a heat-sink. Note that while this modification will prevent damage occurring to the transistors in the case of a short-circuit, there is still the possibility of damage to the 732 regulator IC.

## Notes & Errata:

**2½ DIGIT DVOM** (September 1977, File No. 7/M/52): The DM7700 chip used in this project has been given a new type number and is now designated ADD2500BCN. There appear to be ample stocks available.

**ELECTRONIC SEASHELL:** (December 1978, File No. 3/MS/76): The circuit shows R24 connected directly to the 12V rail, whereas the printed board overlay shows it connected to the collector of Q2. The board overlay is correct, although the arrangement shown in the circuit will most probably work just as well.

**PELTIER DEVICES** (August 1979): The price of \$15.50 given for these devices from Stewart Electronics does not include sales tax of 15%. The price including sales tax is \$17.82, plus packaging and postage if applicable.

**UNDERSTANDING BASIC** (October 1979): Due to a printer's error, six lines of text were omitted from the end of the third column of page 70, after the word "READY". The missing lines were:

and returns to the beginning of the next line. Sometimes the computer will print a #, > or ? on the next line. This is the prompting character, and its purpose is to tell you it's your turn to type something and the computer is waiting.

**INTRODUCTION TO DIGITAL ELECTRONICS:** On page 25, three of the examples given at the top of the first column for the binary equivalents to decimal numbers are in error. They should read:

decimal 16 = 10000  
decimal 50 = 110010  
decimal 99 = 1100011

join our

# Gold Rush

with the

## RED BARON

... not only the best - but the **EASIEST!**



2 Coils  
8" & 12"

Lifetime  
Warranty

The RB 7 handles all types of soil — mineralized or non-mineralized in ALL-METAL OR DISCRIMINATE. big 12" head for deeper treasure

revolutionary new S.P.D. (Synchronous Phase Discrimination) circuitry enables Discrimination at VLF depths!

the professionals

This is the unit that WILL DISCRIMINATE AND CANCEL GROUND MINERALIZATION AT THE SAME TIME! \$660 + freight

**ORDER NOW BY MAIL OR CALL AT SHOWROOMS**

# ELECTRON 2000

44 Brown Road,  
Broadmeadow.  
N.S.W. 2292  
Or Phone 69 1222 (049)



# MARKETPLACE

## FOR SALE

**ELECTRONIC ORGANS** Build your own! Send 45c stamp for fullest details of the SCHOBER (USA) organ kits Schober Organs (Aust), PO Box 22, Guildford NSW 2161. (Established 21 years)

**CRITICS' SELECTIONS OF BEST MIND** — stimulating games from USA for Commodore PET and TRS-80 Send SAE for list Softronics Micro Systems, Box 238, Lindfield, NSW 2070. PET Sales & Programs.

**VALVE SELLOUT** — Metals, octals, loctals, WWII and earlier types, some XMIT types. Examples 6AB7, 6AC7, 6L7, 6BB, 25L6, 1K7G, IC7G, IM5G, 1A3, 3A5, 1T4, 6J7G, 6K7GT, 7A8, 7C5, VT52, CV1091, KTW62, 47, 2A5, 58, 801A, 802, 807, 100TH and many more. Some as low as 4 for \$1. Most new in original packets. SAE for list or state needs. O'Brien, 5 Edgar Rd, San Remo, 3925, Ph (056) 78 5317.

**KEYBOARD KITS** — Popular ASR-33 Format, ASCII output 53 keys and ASCII logic IC's all mount on same PCB. Three user definable keys, easy to follow instructions. Keyboard kit \$59.60, or assembled and tested \$68.00, optional mounting frame \$8.20. PCB edge contour \$2.00 post and pack free in Aust. For more info contact CANNY COMPUTING, PO Box 65, Nth Carlton, Vic. Ph 347 5513.

**TRANSFORMERS** — 115V Step-down, 150 to 1000W from \$15. Wide range of LT and HT Power Trans from \$1. SAE for list. O'Brien, 5 Edgar Rd, San Remo 3925 Ph (056) 785317.

## EPROM PROGRAMMING

**Mail Order Programming Service**  
Forward hex listing, receive EPROM with written certification of contents  
2708 1K bytes \$25, with EPROM supplied  
\$38. Others on request. Copying only \$7.50.

PACER IND P/L  
PO Box 169 RYDE NSW 2112

## TIME CLOCKS



SANGAMO \$16.00 DAY OMIT DEVICE	HORSTMANN \$12 TYPE "K"	SANGAMO \$13.50 LESS DAY OMIT DEVICE
--	-------------------------------	--

240V 50 cs      15A Contacts  
Used tested and guaranteed  
PACK & POST N.S.W. \$2.00  
Vic. & Qld., S.A. \$2.90, W.A. \$3.40

**CLOCK DISPOSAL CO.**  
P.O. Box 147  
LINDFIELD, N.S.W. 2070

**BOOMERANG TAPE RECORDING CLUB** full details, 9 x 4 SAE PO Box 118, Wellington, NSW 2820.

**TRS-80** — 16K Memory upgrade for sale — 8 4116's plus two DIP switches for \$100 — P. Stephenson 34 Maple Street Blackburn 3130 (03) 878-2628.

**AUSTRALIAN RADIO DX CLUB** — The largest DX club Australia with branches in Adelaide, Perth, Sydney, Melbourne and Canberra. Published over 360 pages of DX notes during 1978. The Official news source for Radio Australia's DX program for over 14 years. 1979 is world DX youth year with a special introductory membership fee for people under 18 years old. For full details write to PO Box 67 Highbett Victoria 3190 or PO Box 79 Narrabeen NSW 2101 enclosing a 30 cent stamp.

**ALL IN GOOD WORKING CONDITION:** Playmaster 136 amplifier with several improvements \$60; Realistic TM-101 AM-FM tuner \$35; Realistic SCP-1 stereo tape player \$30; Connoisseur BD1 belt drive turntable \$35; SAU-2 Pick-up arm & ADC 220XE cartridge \$35; Heathkit AA-15 amplifier \$100; Realistic TR-700 cartridge tape deck \$35; Realistic cartridge tape player \$20; Realistic DX 160 radio \$125; Frequency meter for DX160 \$80; AC/DC reel-to-reel tape recorder \$20; IMSAI main frame, front panel & 11 sockets, built and tested, in excellent condition \$850; Z-80 microprocessor board, built & tested \$180; Expander Black Box Printer, 80 column 110 baud \$550; Power supply, cabinet and mother board for a six slot S-100 computer. Space and Power for two shugart 801R floppy disk drives. Cabinet professionally built & thoroughly tested. One new at \$600; One demo model at \$400; Phone (02) 848-0452.

**METAL DETECTOR.** A unique single-transistor circuit with full construction details. \$5. A. Mack, PO BOX 17, Smithfield, 5114.

**HI-VOLTAGE XTRS** — Equiv BU205, 1500V 2.5Amp NPN Suit HV Regs, inverters etc \$1.20 ea with full data. Add \$0.80 P&P. P&D Instruments, Box C321, Clarence St PO Sydney 2000.

**GLASS INSULATORS** (standoff/feedthrough) Approx 200, 64mm Circular base, 47mm high. Brass centre post 100mm long with terminal ends. \$10 dozen plus post. Send \$1.50 for sample (incl post) or SAE for letter. O'Brien, 5 Edgar Rd, San Remo 3925.

**DISPLAY ADVERTS IN MARKETPLACE** are available in sizes from a minimum of 2cm x 1 col rated at \$11 per col cm.

**CLASSIFIED RATES** \$2 per line per insertion payable in advance. Minimum two lines.

**CLOSING DATE** is six weeks prior to the on-sale date. Issues are on sale the first Monday of each month.

**ADDRESS** all classified orders, copy, enquiries, etc, to: The Advertising Manager, **ELECTRONICS AUSTRALIA**, Box 162, Beaconsfield 2014.

**MODEL 15 TELETYPE.** Reconditioned, 240/110v trans plus extras. \$60 ONO (02) 513 812.

**PRINTER (OKADATA 110)** Serial or parallel demo model one only clearance \$950. new condition Ph: (02) 313 273.

## READER SERVICE

**FRONT PANELS.** Repeater and Mimic panels, Labels, Nameplates, Scales etc. Machine engraved to your specifications in metals or plastics. Front Commercial & Industrial Engraving 9 Napier St, Westmead 2145. Phone (02) 635-8537.

**E-PROM 2708-2716-5204 and 1702** Programming Service. Your listing either Typed or neat hand printed in Hex or Octal into your E-Prom. 2708 — \$22, 2716 — \$35, MM5204 — \$20, 1702 — \$16. E-Proms modified to your requirements, up to 20 bytes — \$6, up to 100 bytes — \$10, up to 200 bytes — \$15. Copies Etc. Also Software and Hardware assistance with your Z80-8080 and SC/MP Developments. Enquiries welcome. Send to Micro-Assistance PO Box 49, Sandy Bay, 7005, Tasmania.

**DATA &** lead connections supplied for any type of transistor or diode. Send \$0.90 per device, SAE & type numbers P&D Instruments, Box C321, Clarence St PO Sydney, 2000.

## POSITION VACANT

**IMAGINATIVE DESIGNER** — Engineer required as partner for promising electronics project. Contact AH (03) 328 3021 or AH (03) 497 3859.

## THE ULTIMATE IN LOW COST STORAGE

Software controllable read/write cassette system. (Test tape and system details provided). Stores and reads data in excess of 800 bits per second.

8 bit parallel or serial format. Your computer controls all read/write cycles. Crystal clock. (110 Baud clock output provided).

Pre-assembled and tested. Includes built in power supply. Using cassette recorder. (All signals direct to head).

**ALL THIS FOR ONLY \$138.00**

(2 Track transport available for \$55).

O. D. Products, PO Box 9, Hope Valley, SA 5090.

Tel. (08) 296 7384 All Hours.



## ELECTRONICS CENTRE

**BARGAIN PRICES • PERSONAL ATTENTION • SLICK MAIL ORDER SERVICE • SATISFACTION •**

### NEW BSR STEREO CHANGER/PLAYERS MODELS

C198 (ILLUSTRATED)  
S SHAPE TONE ARM  
4 POLE MOTOR  
WITH CERAMIC CART

**\$55.00**

WITH MAGNETIC CART

**\$65.00**



C197  
STRAIGHT TONE ARM  
2 POLE MOTOR  
CERAMIC CART

**\$47.50**

PACK & POST NSW \$2.75, V/SA/Q \$3.75, TAS/WA/NT \$4.75

With all the wanted facilities • Auto or manual operation • Cueing lever • Bias compensator • Adjustable stylus pressure • 33 45 78rpm • Plays 7", 10", 12" records • Separate changer and player spindles • Operating instructions • Ten plate for cut-out • Big 28cm turntable • Diamond stylus • 240V AC 50Hz.

### • BSR BELT DRIVE RECORD PLAYER •

**ABSOLUTE  
LATEST MODEL P-200**

**\$95.00**

P&P NSW \$3.50  
INTERSTATE \$4.50



STYLISH S SHAPE  
PICK-UP ARM •  
ADC MAGNETIC  
CARTRIDGE.  
DIAMOND STYLUS  
INCLUDED •

ALSO AVAILABLE WITH WALNUT BASE AND  
PERSPEX COVER WITH HINGES

**\$119**

P&P NSW \$5.00  
INTERSTATE \$7.50

Specs. 240VAC 50Hz. auto or manual operation • Plays 17, 25, 30cm (7, 10, 12in) records • 33 and 45 rpm, adjustable counter weight and stylus pressure • cueing lever • Bias compensator and anti-skate control • Die-cast platter with mat • RCA audio plugs and cable, 3-core power cable and plug •

## FREE ELECTRONICS AUSTRALIA MAGAZINE

ALL CUSTOMERS WHO SPEND \$21.00 OR MORE WILL RECEIVE NEXT MONTH'S ISSUE ABSOLUTELY FREE.

### C-CORE TRANSFORMERS



**LOW NOISE, HI EFFICIENCY**  
PRIMARY 240V 50Hz  
MODEL JT266 0-18V 8A **\$22.95**  
MODEL JT235 26.0-26V4A **\$21.95**  
MODEL JT248 10V, 10A **\$22.95**  
MODEL JT249 15VCT **\$23.95**  
750MA 8.5V-0-8.5V 7.5A  
FOR MICRO PROCESSOR **\$23.95**  
MODEL JT274 10V 10A  
2 x 12V 1A **\$22.95**  
MODEL JT 253A **\$41.95**  
0-18V 30A PEAK  
P.P. MODEL 253A NSW \$3.50 V.Q.T.  
**\$5.50 SA WA NT \$7.00**  
P.P. ALL OTHER MODELS  
NSW \$2.95 V.Q.T. \$3.75  
WA SA NT \$5.50

**GEARED  
MOTOR**  
240VAC 50Hz 3W  
**\$2.50**

P&P 50c

5 RPM. Plenty of torque With Cam and  
N/O N/C microswitch 15 switch contacts  
per min. OA size 65 x 60 x 35mm



**HEAVY DUTY  
NI-CAD RECHARGEABLE  
BATTERIES**



Top quality guaranteed  
Used by many Govt Depts.

**SIZE D. 1.2V, 4AH, \$6.25 ea.**  
P&P 75c.

**4 for \$23.00** P&P NSW \$1.60  
INTERSTATE \$2.50

**SIZE AA. 10 for \$13.95**

P.P. NSW \$1.00, INTERSTATE \$1.50

**PLAYMASTER STEREO GRAPHIC EQUALIZER  
COMPLETE KIT \$97.50 FULLY CONSTRUCTED \$125.00**

• **HITACHI STEREO CASSETTE TAPE DECK •**

Model D-230 Front Load Dolby system, 6 mth warranty

**DISCOUNT PRICE \$165.00**

P&P NSW \$2.75  
INTERSTATE \$3.75

• **VERY LAST OFFER •**  
**GEL-CELL RECHARGEABLE  
BATTERIES**



6 VOLT 1.2AH **\$4.95 EA** PP NSW 80c  
INTERSTATE \$1.20

**ALSO**

12V 1.2AH (Two 6V batteries supplied)  
complete with 240V plug-pak charger **\$10.95** PP NSW \$1.75  
INTERSTATE \$2.50

Batteries are in fully sealed high impact, moulded case 3" x 7/8" x 2"

**FOUND A FEW  
MORE CARTONS**

### • PUBLIC ADDRESS AMPLIFIERS •

**3 NEW  
MODELS  
MOBILE OR  
FIXED  
INSTALLATION**



**12VDC OR  
240VAC  
OPERATION**

EXCELLENT QUALITY. PERFORMANCE. REPRODUCTION GUARANTEED

**MODEL A-30.** Power output 30 watts High/low miC input 200 ohms — 50k ohms Sens 3MV Input for tape — tuner — aux. 10k ohms/50MV Phono 100k ohms/1V Output 4-16 ohms With inbuilt automatic electronic siren Size: 150 W x 145 D x 60 H MM.

**\$85.** PACK AND POST. NSW \$2.50  
INTERSTATE \$3.50

**MODEL A-50.** Power output 50 watts 2 high/low miC inputs 200 ohms — 50k ohms Sens 3MV Input specs. Same as model A-30 Output 4, 8, 16 ohms, 25, 70, 100V line inbuilt automatic electronic siren Fog-horn 4 tone chime Size 180 W x 220 D x 75 H MM.

**\$189** P&P. NSW \$3.00  
INTERSTATE \$4.00

**MODEL A-100.** 100 watts power output Same specs. As model A-50 **\$245.**  
All amplifiers supplied with mounting brackets, power cables. Available from stock PA microphones, table and floor miC stands, sound columns, flares, goosenecks, speaker cable, etc.

### WALL MOUNT SPEAKER CABINET



Ex-AWA for 8" Speaker. Modern style 2  
tone beige, heavy duty plastic. Excellent  
condition.

**\$7.50**

Pack and Post. NSW ..... \$1.50  
Interstate ..... \$2.50

### TELEPHONE CABLE

1/2 MILE REEL (Ex Army assault wire). 6  
strands s. steel. 1 copper. Rubber  
covered

**\$9.50**

Pack and Post NSW ..... \$2.00  
Interstate ..... \$4.00

### SERVICE

Moderate charges — Repairs  
guaranteed. Radios, Tape  
Recorders, Cassettes, Amps.



**PLESSEY  
ROLA  
SPEAKER  
SPECIALS**

**GUARANTEED TOP QUALITY  
BRAND NEW BARGAINS**

Model C12PX 15 ohms, 31cm (12in),  
twin cone Specs: 30W rms Reson  
Freq. 40Hz Freq. respon. 35-13,000Hz

**\$19.95 ea.** P&P. NSW \$2.00  
INTERSTATE \$2.75

**2 for \$37.00** P&P. NSW \$2.75  
INTERSTATE \$3.75

Model C8MX 8" Twin Cone Specs — 8  
ohms 7W rms. Reson. Freq. 35Hz Freq.  
Respon. 35-20,000Hz

**\$8.75 ea.** P&P. NSW \$1.00  
INTERSTATE \$1.50

**or 2 for \$15** P&P. NSW \$1.50  
INTERSTATE \$2.50

Model C80 8" Woofer. Specs — 8  
ohms, 20W rms. Reson. Freq. 45Hz,  
Freq. Respon. 35-8000Hz.

**\$12.95 ea.** P&P. NSW \$1.75  
INTERSTATE \$2.75

**or 2 for \$23** P&P. NSW \$2.50  
INTERSTATE \$3.50

### AMPHENOL

Fully Shielded, Chrome 6 pin Plug and  
Chassis Mt Socket. Type 91-MC6M.  
**\$2.50** P&P 50c

### WATT MASTER CEILING FAN MOTORS

200/250VAC 50Hz. Supplied with  
speed controller. 3 types. 55 watt for  
36" blades. 75W/48" 90W/56"

**\$12.50**

P&P. NSW \$3.50  
INTERSTATE \$5.50

### 1 MA. FSD PANEL METER



38 M/M SQ V-U SCALE. **\$1.35 EA.** 2  
FOR **\$2.00**, P.P. NSW 80c,  
INTERSTATE \$1.25.



**Don't let your valuable issues go astray**

# ELECTRONICS AUSTRALIA BINDERS

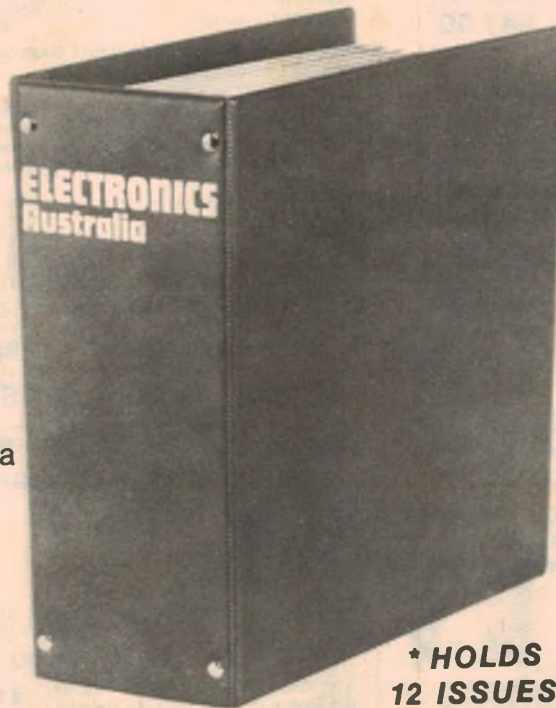

These attractive binders finished in brown plastic with gold lettering will keep your back issues of Electronics Australia neat and tidy.

**\* HOLDS 12 ISSUES**

Available from **Electronics Australia**, 57 Regent St, Sydney. **PRICE: \$4.50** or by mail order from Electronics Australia, P.O. Box 163, Beaconsfield 2014. **PRICE \$5.50 NSW; \$6.50 other states; or 6 for: \$28.00 NSW; \$30 other states.**

\*Magazines prior to April 1971 will need to be trimmed to fit binder

## ADVERTISING INDEX

ADVERTISER	PAGE
A & R Soanar	38, 53, 76
ASP Microcomputers	82
Ace Radio	135
Adaptive Electronics Pty Ltd	9
Adcola Products	128
Agfa-Gevaert Ltd	facing 104
Aiwa Australia Pty Ltd	23
Alfred Dunhill International Ltd	facing 105
All Electronic Components	56
Ampec Engineering Co Pty Ltd	20, 94
Ampex Australia Pty Ltd	facing 33
Audio Telex Communications Pty Ltd	113
Australian Broadcasting Commission	64
Australian Government Recruiting	35
Bell & Howell Aust Pty Ltd	86
Bright Star Crystals	118
Byte Shop, The	128
Cema (Distributors) Pty Ltd	42
Chapman L. E.	101
Classic Radio	96
Clock Disposal Co	134
Coates, H. F. & Co Pty Ltd	51
Defi Agency	132
Deitch Bros	124
Dick Smith Electronic Group	16, 30, 31, 46, 69
Dick Smith Electronic Group	74, 84, 112, 116, 118
Dindy Marketing (Aust) Pty Ltd	29
Dwell Pty Ltd	48
Edible Electronics	91
Electrocraft Pty Ltd	116
Electron 2000	133
Electronic Agencies	108
Electronic & Computer Services	93
Electronic Calculator Discounts	129
Electronic Development Sales Pty Ltd	11
Embryonic Systems Pty Ltd	93
Etone Pty Ltd	114
Ferguson Transformers Pty Ltd	49
Freedman Electronics Pty Ltd	129
Hagemeyer (Aust)	OBC
Honeywell	60
International Correspondence Schools	45
JR Components	82
Lafayette Electronics	115
Lanthur Electronics	91
Looky Video	91
McGills Newsagency Ltd	131
National Panasonic (Aust) P/L	IBC
Nomis Electronics	125
O D Products	134
Parameters Pty Ltd	8
Paris Radio Electronics	80, 93
Pennywise Peripherals	90
Philips	2, 1FC
Plessey Components	33
RCS Radio	71
Radcom Pty Ltd	109
Radio Dispatch Service	109
Radio Parts Group	41, 98
Raydata	116
Rod Irving Electronics	73
Rose, J. E.	78
Rowe H. & Co	72
Rudolf Gunz & Co Pty Ltd	15
S.M. Electronics	86
Sabtronics International	122
Scope Laboratories	6
Sigma Data Corporation	130, 132
Southmark Pty Ltd	53
Stewart Electronics	89
Stotts Technical College	107
Tandy International Electronics	26
Tasman Electronics	119
Techniparts	109
Texas Instruments Australia Ltd	facing 32
Triangle I.D. Pty Ltd	125
Vicom International	18, 66, 120
Video Technics	34
Warburton Franki	61, 92
Wireless Institute of Australia	119

## SUBSCRIPTION SERVICE



**ELECTRONICS Australia**

**Subscription Rates**  
*\$18.00 per year within Australia.*  
*\$A21.00 per year elsewhere.*

Make sure you receive every copy of the magazine by ordering it from your newsagent or the publisher. For publisher subscriptions post this coupon, with your remittance, to Electronics Australia Subscription Dept., John Fairfax & Sons Ltd, GPO Box 506, Sydney, 2001. Subscription will start with first available issue.

Name .....  
 Address .....  
 Postcode ..... Enclosed is ..... for ..... years



# THE DIFFERENCE IS STAGGERING.



Technics Linear Phase speaker systems were designed to reproduce music that sounds as close as possible to the original. Through exhaustive research Technics engineers designed and built equipment to find out exactly how sound travels at different frequencies. Then oscilloscopes were used to shape the revolutionary "staggered" design of the separate wide-range speaker units, so the sound from each reaches you simultaneously. So far as listening pleasure is concerned linear phasing means pure musical reproduction with brilliance when

brilliance is needed and clarity in the softest as well as the loudest musical passages. Shown above is the SB-7000, Technic's best selling linear phase speaker, and the SB-007 system. This is an exact image of its famous big brother in terms of performance capabilities as much as appearance. But around half the size . . . and cost. So now true linear phase response can be enjoyed in a convenient, compact format. Technics linear phase speakers. A new experience in realism.

For a National Technics catalogue, please write to:  
National Technics Advisory Service, P.O. Box 49, Kensington, N.S.W. 2033.



**Technics**  
hi-fi

T78.19



# REAL HI-FI

## AND IT'S ALL IN OUR COLOUR CATALOGUE

The truth is, JVC have always produced real hi-fi components and we believe this current range represents JVC's finest range ever. Here are some real innovations and performance features to whet your appetite:— Quartz locked turntables with uncanny accuracy; Receivers/Amplifiers, some with built-in SEA Graphic Equaliser and DC, class A/B amplification; Cassette deck with JVC automatic computerised tape tuning; Computer designed

speaker systems; Separate but matching JVC components designed to compliment one another; perfectly. And all this real hi-fi know-how is yours ...merely for the asking.



**If you think they look different,  
wait till you've heard them!**

### FREE OFFER COLOUR HI-FI CATALOGUE

Just fill out this coupon and we'll fill you in on what's available and new in terms of JVC hi-fi entertainment...and it's all FREE!

Name \_\_\_\_\_

Address \_\_\_\_\_

\_\_\_\_\_ Postcode \_\_\_\_\_

WT1323/EA/79

I am especially interested in...

- Cassette Decks
- Matching Systems     Amplifiers
- Speakers
- Turntables
- Receivers

Just address your envelope to...  
JVC Hi-Fi Advisory  
Service,  
Post Office Box 307,  
North Ryde,  
N.S.W. 2113

# JVC

the right choice