

# ELECTRONICS

**AUSTRALIA**

VIDEO, HI-FI & COMPUTERS

APRIL 1981

AUST \$1.80\* NZ \$1.90



## ***Infrared relay for wildlife photography***

**ALSO IN THIS ISSUE:**

- Build a Heart-rate Monitor
- Robots that See and Think
- Touch-sensitive Burglar Alarm
- COSMAC VIP Computer Reviewed
- High-impedance DC Voltmeter
- Bi-directional Computer Interface
- Robots that See and Think

**BONUS  
DICK SMITH  
CATALOG!**

# The year of the bioelectronic tonearm.

Fully automatic and electronically controlled  
for the ultimate in high fidelity sound reproduction.

Turntable technology is at its peak. Motors, platters and cabinets have almost all reached their performance limits. Only the tonearm remains as the last great challenge to turntable perfection. And Sony has revolutionized that with the Biotracer Tonearm.

Biotracer has dismissed tonearm resonance. Those wayward harmonics that used to break up the romance between the listener and his music. By combining a microcomputer,



velocity sensors and three linear motors in the tonearm to control every movement. All unnecessary tonearm movement caused by its own resonance or eccentricities in a record, like warping, are immediately detected by horizontal and vertical sensors. A microcomputer responds to the slightest variation and directs Biotracer's linear motors to compensate.

Sound reproduction is clear. Rich bass is richer. And high frequencies more brilliant.

All other turntable functions are also automatically orchestrated by the microcomputer. Record selection is automatic. So is repeat, lead in and out, and even stylus muting whenever it is lifted up or down.

A linear torque BSL motor, together with a quartz crystal lock and Magnedisc servo system, assures stable speed and precise platter rotation.



And Sony has paid attention to the little things. Like convenient total front panel operation including stylus force adjustment when the dust cover is down.

All of your music will live up to your wildest expectations. Because Sony has now perfected the entire turntable system. Even the tonearm.

The new PS-X75 turntable with Biotracer. A new year for your music.



PS-X75

The PS-X75's cabinet is made of SBMC (Sony Bulk Molding Compound) to stifle howl. And gel filled insulators absorb acoustical energy and prevent feedback between turntable and speakers.

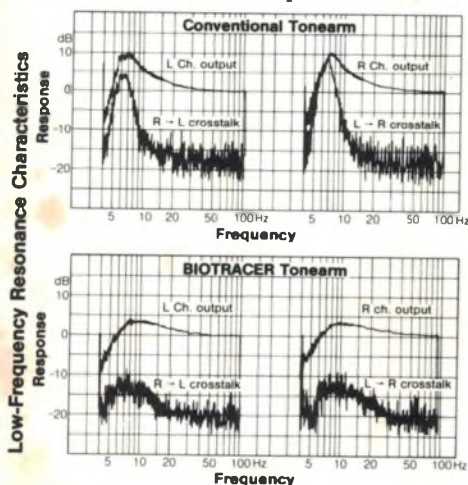

# ELECTRONICS

## AUSTRALIA

Volume 43, No. 4  
April, 1981

**AUSTRALIA'S HIGHEST SELLING ELECTRONICS MAGAZINE**

### Heart Rate Monitor



Based on an EPROM, this Heart Rate Monitor gives a digital display of heart rate from 30 to 240 beats per minute. Find out how to build it on p52.



While some companies have made big money out of electronic games, others have gone bankrupt. Our story on p18 looks at the winners, the losers and the technology.

COMING NEXT MONTH! — Find out what's coming by turning to p107.

### On the cover

A rainbow lorikeet captured at touchdown by Sungravure photographer Bob Donaldson. Bob took the shot using our new Infrared Light Beam Relay to trip a motor-driven camera. Full details p40.

### FEATURES

- HERE COME THE ROBOTS** *New generation robots think and see* ..... 10  
**THE BIRTH OF ELECTRONIC GAMES** *Space-age leisure activity* ..... 18  
**EA/R. H. CUNNINGHAM HEADPHONE CONTEST** *The winners* ..... 32

### HIFI TOPICS AND REVIEWS

- AUDIO/VIDEO ELECTRONICS** *Phono cartridges and styli* ..... 28  
**VIDEO BREAKTHROUGH BY TECHNICOLOUR** *Ultra-compact VCR* ..... 33  
**AUDIO TALK** *A second look at the Marantz St-8 Tuner* ..... 36

### PROJECTS AND CIRCUITS

- INFRARED LIGHT-BEAM RELAY** *Shop monitor, burglar alarm, photography* ..... 40  
**BUILD A HEART RATE MONITOR** *And check your fitness* ..... 52  
**SIMPLE TOUCH-SENSITIVE ALARM** *Uses a single integrated circuit* ..... 66  
**HIGH IMPEDANCE DC VOLTMETER** *Has automatic polarity indication* ..... 70  
**BIDIRECTIONAL SERIAL INTERFACE** *For TRS-80 and System 80 computers* ..... 82

### MICROCOMPUTERS

- COLUMN 80** *Assembly language and assemblers* ..... 119  
**COSMAC VIP COMPUTER REVIEW** *Low-cost, graphics oriented* ..... 120  
**MICROCOMPUTER NEWS AND PRODUCTS** ..... 122

### AMATEUR RADIO, CB SCENE, DX

- AMATEUR RADIO** *Tribute to Gil Miles — a true pioneer* ..... 97  
**CB SCENE** *Handsome prizes for 250 well-chosen words* ..... 100  
**SHORTWAVE SCENE** *New gospel radio station* ..... 102

### COLUMNS

- THE OFFICIAL LINE** *From the Department of Communications* ..... 9  
**FORUM** *The 1905 WT Act may be retired at last* ..... 24  
**THE SERVICEMAN** *In-home servicing is not all beer and skittles!* ..... 76  
**RECORD REVIEWS** *Classical, popular and special interest* ..... 112

### DEPARTMENTS

- EDITORIAL 3 — NEWS HIGHLIGHTS 4 — CIRCUIT AND DESIGN IDEAS 80 — LETTERS TO THE EDITOR 94 — BOOKS AND LITERATURE 104 — NEW PRODUCTS 106 — INFORMATION CENTRE 132 — MARKETPLACE 134 — READER SERVICE 136 — NOTES AND ERRATA 133**

# We know small computers.

You can know them, too. Small, personal computers you don't have to be an expert to use. Or a big company to afford. Small computers that could change the way you live, the way you work, the way your children learn. Small computers that could expand your world.

Small businesses can use small computers the same way big businesses use big computers. To manage more effectively, more productively, more profitably. Systems for the independent business or professional person can handle general accounting, process payrolls, bill customers, manage data, make reports. And more.

And a computer for the home may be the most useful appliance in it. To manage the family budget, balance bank accounts, keep tax records, stimulate your children's learning.

For business, home or education, the uses for a small computer are as boundless as your imagination.



ComputerLand has the widest selection of personal computing equipment and programs you'll find anywhere. Plus an expert and professional staff. They'll give you a "hands on" introduction to small computers.

## Let us introduce you.

And help you find the right solution to your individual computing needs.

With every solution, you also get the resources of ComputerLand. Not only for add-on accessories and software. But for expert advice, maintenance, and service — for all you need to make the most of your computer now and in the future.

If you'd like to know what a small computer can do for you, get to know the people at ComputerLand.

## ComputerLand

**Adelaide** — 125 PIRIE STREET PHONE 223-5083  
**Brisbane** — 127 CREEK STREET PHONE 221-9777  
**Canberra** — 22 COLBEE COURT PHONE 822-342  
**Chatswood** — CHATSWOOD PLAZA GROUND FLOOR  
**Gold Coast** — OPENING SOON PHONE (07) 221-9777

**Melbourne** — 555 COLLINS STREET PHONE 625-581  
**Perth** — 197 ST GEORGES TERRACE PHONE 321-4671  
**Sydney** — 31 MARKET STREET PHONE 267-5055  
**Sydney (East)** — OPENING SOON  
**Wollongong** — OPENING SOON

For other locations opening soon.  
Ring (02) 278-959



# Editorial Viewpoint

## Also needed: the means and the will!

Elsewhere in this issue, there is an announcement and discussion of legislation to replace the obsolete Wireless Telegraphy Act of 1905. When it comes into force, it should obviate many problems, including those specifically examined in "Forum" for February. Few people relish having to pick their way through out-dated laws and regulations which are, at best, ambiguous and, at worst, contradictory.

Some of the statements in this month's "Forum" were prompted by readers' comments which flowed from the February issue. In particular, the opinion was commonly expressed that attitudes and procedures to do with government approval of equipment and installations were biased in favour of traditional suppliers. True or not, the conviction has served in the past to persuade many to import, sell or install without official sanction.

One company representative, involved in the security business, was caustic about the unwillingness and/or the inability of Telecom to cope with urgent but legitimate situations. For example, he said, a client may have to change premises in the shortest possible time but may require continuity of communications and intrusion protection for insurance purposes. If a legitimate connection service is not available at the time it is needed, there is a powerful incentive to have the job done on a "moonlighting" basis.

If properly executed, the irregularity will normally pass unnoticed — provided a regular Telecom mechanic doesn't arrive belatedly, to find the installation complete. "The obvious answer," says the correspondent, "is never to apply for official connection"!

It may well be that Telecom's difficulties are being compounded by the problem mentioned in our February editorial — the critical shortage of people with adequate technical skills. But whatever the cause, the end result is the same: If a government instrumentality cannot provide a reasonable service, particularly in a monopoly situation, the community will cooperate to discover alternatives, legal or otherwise!

Which brings us back to the proposed new legislation covering the electromagnetic spectrum. Such legislation is certainly necessary and one would hope that it will be framed with the greatest possible care. But the Vice-regal signature will not be the end of the matter.

The departments charged with the responsibility of providing and administering technical services must have sufficient people and facilities to cope, and a willingness to tackle each task with promptness and goodwill. Otherwise the community will once again find it necessary and "respectable" to dodge the regulations.

**Neville Williams.**

**EDITOR-IN-CHIEF**  
Neville Williams  
M.I.R.E.E. (Aust.) (VK2XV)

**TECHNICAL EDITOR**  
Leo Simpson

**ASSISTANT EDITOR**  
Greg Swain, B.Sc. (Hons, Sydney)

**TECHNICAL PROJECTS**  
Ron de Jong, B.E. (Hons, NSW), B.Sc.  
John Clarke, B.E. (Elect., NSWIT)  
Gerald Cohn  
Paul de Noskowski

**GRAPHICS**  
Robert Flynn

**PRODUCTION**  
Danny Hooper

**SECRETARIAL**  
Pam Hilliar

**ADVERTISING MANAGER**  
Selwyn Sayers

**CIRCULATION MANAGER**  
Alan Parker

Registered for posting as a publication — Category B.

Printed by Magazine Printers Pty Ltd, of Regent Street, Sydney and Masterprint Pty Ltd of Dubbo NSW, for Sungravure Pty Ltd, of Regent St, Sydney.

**Editorial Office**

57 Regent St, Sydney 2008  
Phone (02) 699 3622 Telex 25027  
Postal Address: PO Box 163, Beaconsfield 2014

**Advertising Offices**

Sydney — 57 Regent St, Sydney 2008  
Phone (02) 699 3622 Telex 25027  
Representative: Narciso (Chit) Pimentel  
Melbourne — 392 Little Collins St, Melbourne 3000  
Phone (03) 602 3033  
Representative: Janis Wallace

Adelaide — Charles F Brown & Associates Ltd, 254 Melbourne St, North Adelaide 5006  
Representative: Sandy Shaw (08) 267 4433  
Perth — 454 Murray Street, Perth 6000  
Representative: Ashley Croft (09) 21 8217

**Subscriptions**

Subscription Dept, John Fairfax & Sons Ltd, GPO Box 506, Sydney 2001  
Enquiries: Phone (02) 20944, ext 2589

**Circulation Office**

21 Morley Ave, Rosebery, Sydney 2018.  
Phone (02) 663 3911

**Distribution**

Distributed in NSW by Sungravure Pty Ltd, 57 Regent St, Sydney; in Victoria by Sungravure Pty Ltd, 392 Little Collins Street, Melbourne; in South Australia by Sungravure Pty Ltd, 101-105 Weymouth St, Adelaide; in Western Australia by

Sungravure Pty Ltd, 454 Murray Street, Perth; in Queensland by Gordon and Gotch (A'asia) Ltd; in Tasmania by Ingle Distributors, 93 Macquarie St, Hobart; in New Zealand by Gordon and Gotch (NZ) Ltd, Adelaide Rd, Wellington

**Copyright. All rights reserved.**

Devices or arrangements shown in this magazine may embody patents. Information is furnished without responsibility for its ultimate use, or for failure of equipment to operate as expected, or for any damage, loss or injury which may be sustained. Material intended for publication is submitted at the sender's risk and, while care will be taken, responsibility for any possible loss will not be accepted by "Electronics Australia".

\* Recommended and maximum price only.



# News Highlights

## Auto electronics — big business by 1985

Vehicle manufacturers in the United States will be using more than \$1.5 billion worth of microprocessors, sensors and other electronic components and systems a year by 1985, according to a recent report by International Resource Development Inc, a US market research firm. This is more than three times the current level of use, and much of the expected increase is already reflected in manufacturers plans for the early 1980s.

IRD predicts that the major application of the new automobile electronics will be new types of safety systems, rather than fuel saving and pollution control as at present.

The most important long term trend in

the area is likely to be the replacement of the car's wiring with a single multiplexed signal bus, probably using optical fibres. Replacement of copper wires with fibre optics will result in considerable cost savings, and fibre optics have the added advantage of immunity to electromagnetic interference.

Many electronics companies have tried to enter the automotive market, but only a few have been successful. The major reason seems to be the stringent economics practiced by the car makers. One small firm manufacturing industrial pressure transducers in the \$300 price range found that General Motors was not prepared to pay more than \$5 per transducer. The larger electronics com-

panies seem better adapted to this type of cost control, and Motorola and National Semiconductor in particular now have strong positions in the market.

The advantages of extensive use of electronics in cars will be improved engine performance and greater safety, but disadvantages are predicted too. The new cars could be more difficult to service, requiring highly trained technicians, and because of the modular nature of the electronic subsystems it is likely that the failure of even a small component will require the replacement of an entire module. It appears there will be major opportunities for manufacturers of electronic test equipment for diagnosing the troubles of the electronic cars.

### Prestel trials held in Australia



A trial business Prestel system has been operating in Australia since March last year, involving twenty of the country's biggest companies and about 140 firms in the US, UK, West Germany, the Netherlands, Switzerland and Sweden, linked to a central computer database in the UK. The trial will continue through to June this year when it will become a fully operational service to the business community. Plans for a public access Prestel system for Australia are a bit more hazy.

Telecom Australia has made two submissions to the Minister for Communications, Mr Ian Sinclair, supporting Prestel, but the Australian Government is still uncommitted to any particular viewdata system. The Canadians, with their

### New electronic anti-skid braking system

One example of what can be done with electronics in automotive applications is a new Antilock Braking System (ABS) recently demonstrated by Mercedes Benz, and now offered as an option on its new generation trucks of 16 tonnes and above.

The system uses four single chip microcomputers — the first time, according to the company, that microcomputers have been used in a braking control system. The ABC uses a toothed wheel and sensor on each of the truck's wheels to detect the speed of rotation of the wheel. Information from the sensors is analysed by a microcomputer and used to con-

trol a solenoid valve which varies the pressure of the fluid in the brake cylinder. When wheel locking is imminent, as indicated by the speed of the wheel, pressure in the brake cylinder is reduced, preventing locking.

Mercedes demonstrated the effectiveness of the system by fitting it to a 26 tonne semi-trailer which was then driven at speeds of up to 100kph over icy roads and brought to a sudden stop. The truck was able to stop without jack-knifing or skidding, and the driver retained full control over the vehicle at all times.

Telidon service, are the other main contenders for an Australian viewdata system, and a team of experts is currently demonstrating the system here.

The Canadians claim that their system, being a later development, is more flexible and versatile than Prestel. Against this is the argument that Prestel has been in use since 1979, and is consequently a proven system, available without delay.

While no official decision has been made, Telecom has made tentative arrangements with British Post for the supply of hardware and software for a Prestel system, and is currently

negotiating with GEC Australia for maintenance of the equipment. In the UK, Prestel has been operating since September 1979, and currently has a total of 6500 users, who can dial up more than 16,000 pages of information supplied by 350 organisations and stored in 14 computer centres around Britain.

Unlike Teletext, which is transmitted in conjunction with a television signal, Viewdata systems are interactive, allowing the user to reply to the information on the screen. The various systems link an adapted television set to a central computer by telephone line.

## Altronics — the new force from the west!

Good news for Western Australian readers — Altronic Distributors Pty Ltd has announced a dramatic expansion program, concentrating on meeting the needs of the electronics hobbyist.

Altronics commenced business as the Perth outlet for Dick Smith products in 1976, but in the past 12 months the firm has expanded its activities considerably to become a fully independent, Australian owned electronics supply house. The company now operates an importing department and warehouse in Subiaco, just two kilometres from Perth, and a highly successful "One Stop Electronics Shop" in Stirling Street, Perth.

The products and components handled are chosen primarily with the interests of the electronics enthusiasts in mind, although an increasing number of professional lines are being developed and imported. Altronics also supply a number of resellers in all states and offer an attractive discount to large users and resellers. Part of the service provided is a monthly stock price list with information on new products etc.

Marketing assistance will be provided on request.

The man behind Altronics is Jack O'Donnell, who sold his highly successful audio communications business Ampac Industries, to concentrate solely on developing Altronics. One reason Jack gives for leaving the audio business was his desire to keep up to date with new technologies, particularly microprocessors.

According to Jack, one of the key reasons for Altronic's success so far is that his staff are selected for their



knowledge and enthusiasm for electronics. They are able to personally evaluate the technical performance of all the products they sell, as well as handle imports directly, by-passing the usual chain of importers and wholesalers. This results in significant cost savings which can be passed on to customers.

Altronics also offer a "red hot" mail order service, with speed and efficiency the strong points. Customer's orders are despatched within six hours of receipt, claims Jack. Only items in stock will be advertised, and in the event of a line being temporarily sold out the customer will receive an air mail advice of the expected delivery date. Jack promises "speed and efficiency second to none".

Personal shoppers should call at Altronics, 105 Stirling Street, Perth,



WA, Telephone 328 1599. Mail orders can be sent to Altronics, Box 8280, Stirling Street, Perth, WA 6000. The wholesale department is at 151 York St, Subiaco, WA 6008, Telex 94186 Altron.

## New products will speak!

Author Ray Bradbury, in a science fiction novel published in 1950, predicted talking clocks and other household appliances would be common by the year 2026. Recent developments suggest that the date should be put forward to 1981. A number of companies have now announced inexpensive chip sets which synthesise speech from a pre-programmed vocabulary, and work is proceeding on speech recognition devices as well.

The implications for the design of all types of products from toys to cars is immense. According to Pat Brocket, European Marketing Director for National Semiconductor, the market for speech synthesis alone is likely to reach \$10 billion in 10 years time.

Most of the speech chip sets are priced to allow their use in relatively inexpensive consumer products, and it is felt that

it is this area where speech technology will have the biggest impact. Whether the idea can be extended to professional electronic equipment is another matter. Lights, dials and digital displays are more familiar to the professional, and seem unlikely to be replaced.

On the other hand the talking vendor machine, fire alarm, car dashboard, and talking clock are either just around the corner, or already with us.

## Inflation lifts satellite cost

The cost of Australia's proposed domestic satellite has risen \$46 million in just over a year, mainly due to inflation. Cost of the satellite is now estimated at \$256 million, while related equipment and facilities are expected to cost \$26 million.

Among other things, the satellite will broadcast TV signals direct to remote homesteads and communities.

## WATCHING THE WOMBATS!

The latest CSIRO news release contains an intriguing little item. It seems that Landsat, the 900km high eye in the sky over Australia, has "spied patterns indicating large population of hairy-nosed wombats along the southern fringes of the Nullabor plain".

There's no need to worry about "Big Brother". He's too busy watching hairy-nosed wombats!

# NEWS HIGHLIGHTS

## New television cameras monitor bridge traffic

Motorists driving over the Sydney Harbour Bridge should remember that they're on television. High resolution TV cameras survey virtually every metre of the bridge and its approaches — more than five square kilometres of potential traffic jams.

The latest closed circuit TV system, designed and installed by AWA Rediffusion Ltd, incorporates 12 remotely controlled TV cameras all with high power zoom lenses and full tilt and pan facilities. The low light capability of the cameras provides excellent quality pictures day and night for 24 hour coverage. Pictures from the cameras are fed to the Bridge Tollmaster's office and to the Police Traffic Control Centre in Brisbane Street, East Sydney.

The new monitoring system has two purposes. Firstly it will quickly identify traffic problems and potential jams so that corrective action can be taken, and secondly, in conjunction with a new set of traffic signals it will significantly speed up the reversal of traffic flow in the centre four lanes of the bridge, effectively increasing the traffic capacity of the bridge at peak hours.



AWA Rediffusion engineers make an adjustment to one of the principle Harbour Bridge surveillance cameras.

## New trends in battery power

The familiar carbon-zinc battery is on the way out, according to a report by SRI International, a US business research organisation. The report predicts that batteries using lithium rather than zinc as the negative electrode will appear on the consumer market in the mid-1980s.

Lithium batteries have higher energy densities than zinc batteries, and each lithium cell produces twice the voltage of a carbon-zinc cell. In addition the lithium batteries have two to 10 times the shelf life of most zinc batteries and better performance at extreme temperatures. It is expected that lithium battery production in the United States and Japan will grow faster than production of any other types of primary (non-rechargeable) batteries.

One of the most important applications for the new batteries will be in specialised health care. The batteries will power implantable devices such as cardiac pacemakers, brain pacemakers which control epilepsy, bone growth stimulators and micropump drug infusion systems.

## CORRECTION:

Due to a printing error, the mail order price of "An Introduction to Digital Electronics" was incorrectly listed in the March issue (p16) as \$4.20. The correct price is \$5.20.

Orders enclosing the incorrect amount have been honoured for the currency of the March issue.

## Watching the rain by computer

Weathermen and forecasters can "watch" approaching rain on a television like display using a new system being developed by researchers at the Royal Signals and Radar Establishment (RSRE) in Britain.

The system, called "Frontier", gathers information from a countrywide weather radar network that plots the progress and position of rainfall. The information is transmitted to the Establishment's computing centre where it is collated and presented as a video display of the country showing rainfall represented by areas of colour — with different colours for different rates of rainfall.

RSRE researchers plan eventually to supplement the radar input with cloud data from weather satellites and add information from more traditional meteorological sources, enabling them to present an accurate and continually updated chart of the weather.



Subscribers to the British Prestel service will be able to call up the map on their own television screen.

## RCA launches "SelectaVision"!

By the time this issue goes on sale, RCA will have launched its SelectaVision video disc system onto the US market. According to a recent report in *Radio-Electronics*, on-sale date was March 22 in 5000 stores coast-to-coast, backed by a record advertising campaign on television and in newspapers and magazines. The players carry a suggested list price of \$499.95 and the initial disc catalogue contains 100 titles selling between \$14.98 and \$27.98, although most discs will sell for less than \$20.

Movies are the mainstay of RCA's first offerings, although there are also classic TV shows, sports, music and educational selections. The company will add 25 new titles in May; 25 in September; and 10 monthly thereafter.



# We're viewing the 80's on a greater scope.

BWD have combined the expertise of highly qualified personnel with a dynamic management team to forge ahead stronger than ever before. The strength of our future is reflected in the ever increasing demand for our high quality instruments. A policy of continuous development assures a constant output of original and innovative designs for both general and specialised needs.

BWD manufacture first class instruments, widely accepted for their simple, functional designs that can out-perform far more complex competitive products.

In the fields of research, design, education and servicing, BWD provide a wide range of instruments from pure electronics to power line systems - and this range will be rapidly expanded throughout the 80's.

- 1 BWD 880 POWERSCOPE 4 independent differential channels for measurement of phase voltage and current across non-isolated power line equipment
- 2 BWD 845 Variable persistence storage dual trace delayed sweep oscilloscope 30MHz bandwidth 1mV/div sensitivity with  $\approx 1\text{cm}/\mu\text{Sec}$  writing speed, autoerase and store. Mains or battery operation
- 3 BWD 820 Versatile portable oscilloscope Dual trace or differential 25MHz bandwidth 2mV/div sensitivity DC coupled X-Y-Z operation

- 4 BWD 603B MINI-LAB A portable laboratory instrument combining 5 power supplies 2 amplifiers a wide range function generator and sweep ramp in a single unit
- 5 A range of power supplies with fully adjustable outputs up to 72 Volts 5 Amps and 18 Volts 12 Amps
- 6 BWD 804 single beam with isolated ground 10MHz oscilloscope Internal or External trigger with auto or level select
- 7 BWD 540 portable dual trace 100MHz oscilloscope 5mV/div sensitivity with delayed trigger or sweep Mains or battery operation



#### DISTRIBUTORS

Victoria BWD Instruments Pty. Ltd. Melbourne  
 Victoria Browntronics Pty. Ltd. Melbourne  
 New South Wales Amalgamated Wireless (A. sia) Ltd. Sydney  
 New South Wales George Brown & Co. Pty. Ltd. Sydney  
 South Australia Protronics Pty. Ltd. Adelaide  
 Queensland LE Boughen & Co. Brisbane  
 Western Australia Warburton Frankl. Perth  
 Tasmania D & I Agencies Hobart  
 New Zealand P.H. Rothschild & Co. Limited Lower Hutt  
 New Zealand W. Arthur Fisher Limited Auckland

Ph 561 2888  
 Ph 419 3355  
 Ph 888 8111  
 Ph 519 5855  
 Ph 242 3111  
 Ph 36 1277  
 Ph 277 7000  
 Ph 23 2842  
 Ph 66 3581  
 Ph 59 2629

**BWD INSTRUMENTS Pty. Ltd.**  
 Miles Street, Mulgrave, Victoria, 3170. Phone (03) 561 2888

# ATTENTION!!

All TRS-80 and SORCERER owners/users

**PRICES SLASHED  
ON  
PRINTERS AND DISK DRIVES**

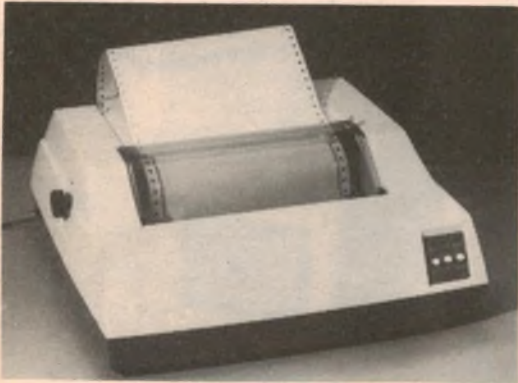

***DIRECT FROM FACTORY TO YOU. COMPARE THESE PRICES . . .***

ITOH 8300 R or P-80 column printer — \$895.00  
ITOH 1541 R or P-136 column printer — \$975.00  
MICROPOLIS 1043 5¼" Disk Drive \$995.00  
(Factory sealed carton)

## AMPEC ELECTRONICS

PH (02) 818-1166

**AVAILABLE FROM:**

DISTRIBUTORS: N.S.W. — Applied Technology — 1A Pattison Ave., WAITARA 487-2711; C.Q. Electronics — 95 Regent St., SYDNEY 698-8079; A.E.D. — 123 Military Rd., GUILDFORD 632-6301; C.I.S.A. — 159 Kent St., SYDNEY 241-1831. VIC — Ritronics — 425 High St., NORTHCOLE 489-8131; Ellistronics — 289 La Trobe St., SOUTH MELBOURNE 602-3836. QLD — N.S. Electronics — 95 Latrobe Tce., PADDINGTON 36-5061; Bob McKnight (Trading) — 23 G'Connell Tce., BOWEN HILLS 52-7600. W.A. — Reserve Electronics — 5 Bookham St., MORLEY 275-2377; Taimac Video Corp. — 323 William St., PERTH 328-1988.



# The Official Line

— from the Department of Communications

## A new Wireless Telegraphy Act

The Wireless Telegraphy Act which governs the allocation of space in the radio frequency spectrum has been in force since 1905.

Given technological changes in the past decade, let alone the past 75 years, this pre-television Act is now obsolete, despite amendments over the years.

Replacement of the Act has been discussed since 1940, but at last this is to become a reality.

Draft principles for the new Radiocommunications Bill 1981 have been circulated for comment to organisations representing users and manufacturers, and is available to interested groups and individuals. The Government aims to have a new Act in force by the end of this year.

Some of the difficulties with the old Act have come to the fore during the past year, with the advent of cordless telephones and wireless microphones. Readers of "Electronics Australia" would have seen details of how to make the latter, outlined in the December issue.

While no permission is required under the 1905 Act to sell or build such microphones, cordless telephones or similar radio transmitting devices, it is illegal to operate them without a licence. With the present legislation, many hapless buyers are likely to be caught

unawares and find they are not able to licence their equipment and legally operate it.

This is one of the anomalies in the present legislation which the new Bill will try to overcome.

Under the new Bill, unlicensed reception of radio messages will no longer be an offence. Instead, restrictions will be imposed on the manufacture, importation and sale of radio equipment which does not meet specified technical standards, and newly manufactured or imported transmission equipment will have to be of a kind authorised by the Minister. These provisions should correct the situation where equipment which is not suitable for operating in the radio frequency spectrum in Australia, because it may cause interference, can be legally sold.

Equipment used illegally will no longer be automatically forfeited, but where equipment is seized, it may be condemned if a court order is granted to that effect.

The new Bill will also limit the powers of search and seizure of unlicensed equipment which presently apply to "any person", and will instead give these powers to police officers and specially appointed inspectors.

Like the previous Act, the Bill will not relate to broadcasting and television ser-

vices which are covered by the Broadcasting and Television Act. The area it covers will be specified as applying to the transmission of electromagnetic energy for communications purposes, including radio-navigation, telemetry and remote control. This will help sort out any lack of clarity over the scope of the present Act.

One omission in the 1905 Act which has led to difficulties has been the fact that interference control is not covered. This has meant that the Department has been powerless to act in cases where, for example, interference has been caused from non-communications sources such as power lines or radio frequency heaters. The new Bill will aim to legislate for control of interference coming from a variety of sources.

The proposed legislation aims to simplify management of the radio frequency spectrum so that it is used in the best interests of all Australians. To ensure that it will be legislation which truly reflects the needs of users and manufacturers, a principles paper has been widely disseminated for public comment, and is still available.

At the time this article goes to press, we anticipate that legislation will be introduced into Parliament during the autumn session and debated in the Budget Session, subject to the priorities of the Government and Parliament. This will allow public comment on the detailed legislation.

Copies of the principles paper can be obtained by writing to: Mr C. Oliver, Radio Frequency Management Division, Department of Communications, PO Box 84, O'Connor, ACT 2607. Telephone (062) 644 625.

R. B. Lansdown, Secretary,  
Department of Communications.

## NEWS

### Satellite or cable? — British consider options

The British Home Office is currently exploring the options available for expanding the country's television services. The most important choice to be made is between a Direct Broadcast Satellite (DBS) system or the installation of a cable network to carry the extra channels.

Proponents of the satellite system argue that other European countries are going ahead with such a scheme (West Germany and France are jointly planning the launch of a domestic television satellite for 1984), and say that Britain should not be left behind.

The Direct Broadcast Satellite system would consist of a small dish antenna (perhaps a metre in diameter), mounted on a tripod or fixed to the side of the

house, and a suitable receiver and down converter to feed the signals to the domestic television set. The equipment could be developed and sold reasonably cheaply, but the total cost of a five channel DBS over its seven year life span has been estimated by the European Space Agency (ESA) as £234 million, including £48 million for two satellites — and such costs would recur every seven years.

Direct Broadcast Satellites will also raise some interesting legal questions. Each satellite projects a beam just a few degrees wide at its designated country, but particularly in Europe there will be some overspill into neighbouring countries. This is causing concern in Britain, especially because the country's island shape will result in much more overspill into the southern UK than any UK craft would project into Europe. Critics of the satellite scheme fear that cross-channel advertising is a possibility, with little gain to Britain.

Against these factors, the provision of a wideband cable network is becoming an increasingly attractive proposition. The

technology already exists to allow the transmission of several television signals simultaneously over fibre optic cables, and British Telecom is testing them for use in the phone system. The cables offer several advantages.

First, optical fibre cables could be used for many years before physical wear and tear became a problem. They could be laid in sufficient quantities to ensure that each house connected to the network had the capacity required for any future communications needs, electronic mail and videophones included. Optical fibre cables are also immune to electromagnetic interference — a problem which is likely to become more and more severe for satellites as the suitable orbital positions are filled up.

The task of wiring Britain for the information services envisaged for the future would be immense, and is certainly a longer term prospect than a Direct Broadcast Satellite. However once the network was installed it would be virtually permanent, with few of the problems associated with the DBS.

# Move aside mate!

# Here come the robots

by JIM SCHEFTER

Intelligent robots are set for rapid expansion onto the industrial scene, taking over in ways few companies could have imagined a few years ago. No longer mere automations of the past, the new generation robots can see, touch, and make decisions.

The hulk of a car body moves slowly into position, riding the automatic assembly line through an empty, workerless area. Suddenly hordes of sleek, smoothly articulated arms swing out, surrounding the car. They dip forward with noisy whines, pneumatic air bursts, and sharp explosions from fiery welders. Bright hot sparks arc out from a half dozen points as the sizzling welders burn metal to metal.

In moments, the swarming machines fall back. There is a last sigh of escaping

air, then only the sound of the car moving forward to another assembly station. Still there are no people; the team of sensitive robots waits silently for the next car.

That eerie scene, intelligent machines going independently about their business, is repeated thousands of times each day at Ford, General Motors, and Chrysler. It's even more common in Japan, where sharp increases in productivity at Datsun are the direct result of applying advanced robotics to assembly-

line operations. Toyota is not far behind.

The fact is that a new generation of robots is exploding onto the industrial scene, taking over in ways few companies imagined short years ago.

"Industrial robots used to be more like automation," said GM's Ed Kavetsky. "The machines just repeated the same motions. But now we're using general-purpose digital computers to get true robotics."

A robot is a device that can be programmed to perform a variety of mechanical tasks — unlike a piece of automated equipment, which is designed to do only one kind of job.

The oldest industrial robots are basically bulky, limited-motion devices controlled by very simple, non-computer software — a series of wires plugged into a circuit board.

More modern robots are controlled by sophisticated computers, with the capacity to memorize a lengthy, complex sequence of motions — those needed to spot-weld, for example.

These robots can perform only the programmed sequence. If a part isn't in the right place at the right time, the robot ignores it, or maybe crushes it by mistake. And reprogramming these robots is a laborious process: an operator must literally lead the robot step by step through the new job.

But the newest robots have moved far beyond earlier automatons. No longer confined to lockstep tasks, the best of them can see, touch, and make intelligent decisions.

## Capitalist tools

Robotics has become big business in recent years, both in terms of research and in commercial applications.

● Matsushita Electric Co in Japan

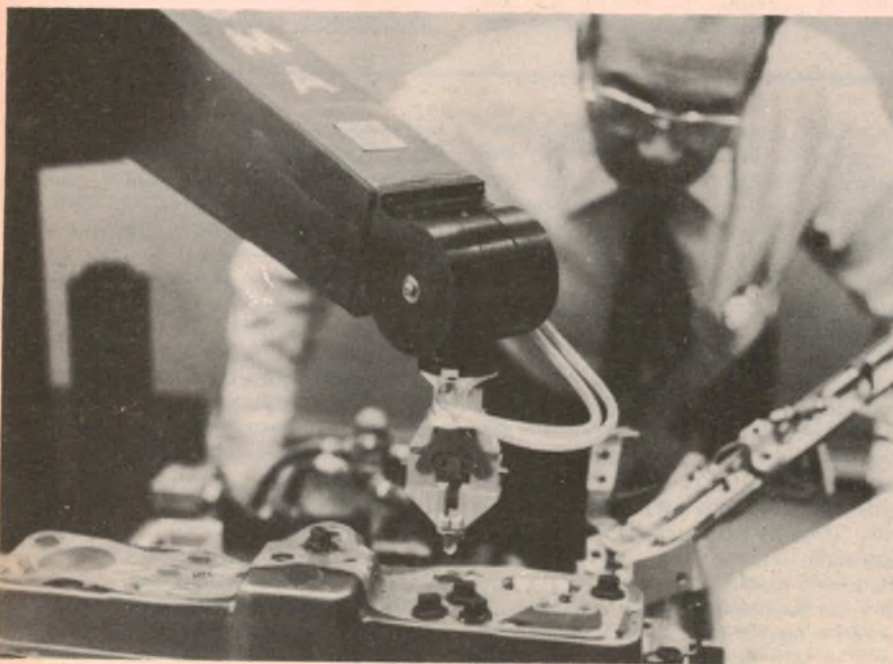
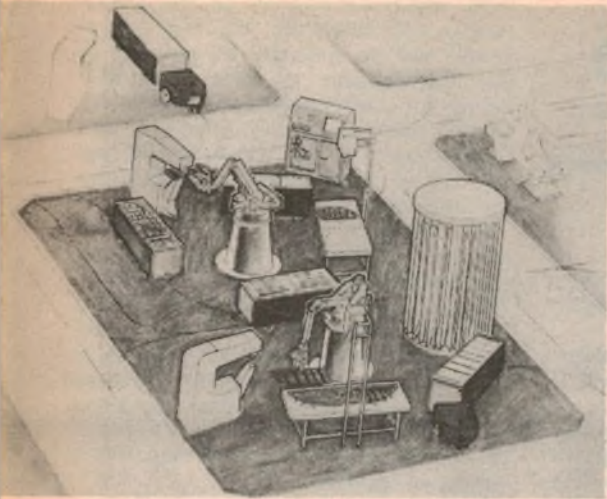

Inserting a light bulb into the back of a dashboard instrument panel, an advanced PUMA robot first positions the bulb precisely, then spins it into place. This lab demonstration illustrates a valuable attribute of the Unimate robot: positioning accuracy. Today's best industrial robots have a positioning accuracy of about 1.27mm. PUMA is 25 times more accurate.

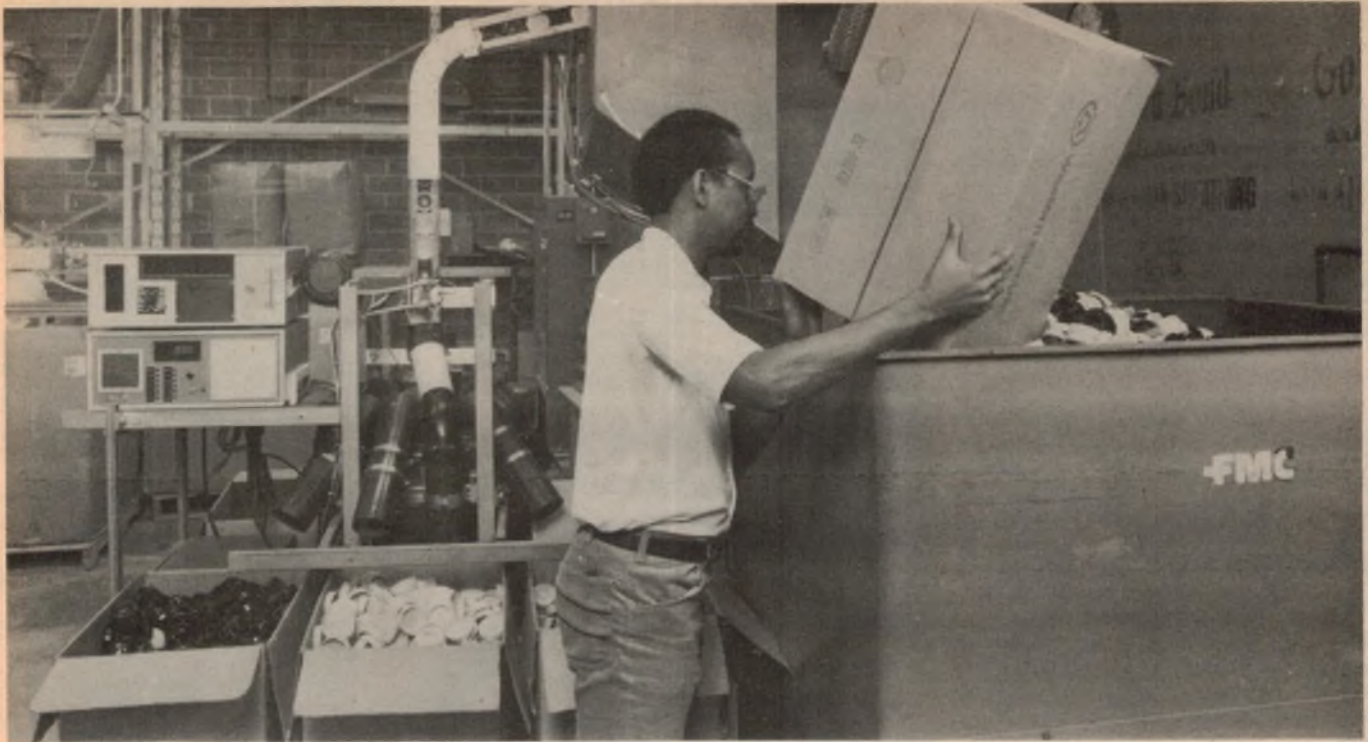

reported a 2900% improvement in productivity when it substituted a computer, a robot team, and four human monitors for 120 workers manufacturing vacuum cleaners.

- Western Electric developed an intelligent machine to sort telephone parts by colour. First of the units went into operation recently at the company's Atlanta service centre. Sorting speeds more than tripled, while accuracy improved nearly 15%.

- Texas Instruments has designed and built "seeing" robots that work on the company's calculator assembly lines in Lubbock, Texas. IBM uses similar vision-assisted robots for making printed circuit boards and testing components.

- Lockheed-Georgia has a pilot program with two robots working off a single computerised control unit to assemble an internal part of the C-130 Hercules cargo aircraft. That part contains 11 separate components and 154 rivets, all brought together and fastened without human aid.

- Battelle's Pacific Northwest Laboratories has demonstrated a micromouse, a little robot using infrared detectors for eyes, four microprocessors for intelligence and memory, and two more storage chips for permanent programming. The "mouse" learns a maze by trial and error, mastering it completely by the third run. Battelle thinks the robot could run shuttles in underground mines or control irrigation systems.

One of the most advanced research efforts under way is one-third complete at Westinghouse Electric's R&D facility in Pittsburgh. The company, working under a National Science Foundation grant, is developing a robotic batch-manufacturing assembly line that will

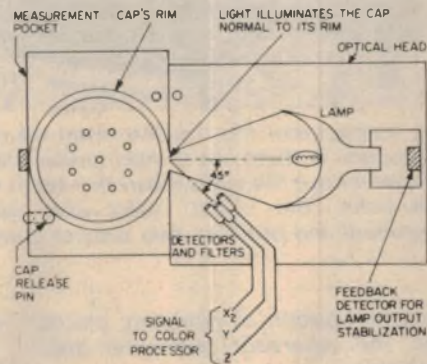

produce fractional-horsepower electric motors.

Batch manufacturing — assembling components to make a relatively small number of finished products — makes up about 75% of US manufacturing. Automated assembly lines are impractical for batch manufacturing because many products have a variety of styles that require slight but frequent changes in the assembly process. If Westinghouse can develop a robot-populated line adaptable to a variety of products, manufacturing efficiencies will soar.

While such research programs and one-by-one industrial applications advance future robotic technology, a number of companies are selling today's robots as fast as they can build them. Heavy industrial robots are produced by Cincinnati Milacron, Prab Conveyors, and others. But the clear leader in sales and technology is Unimation, based in Danbury, Connecticut.

More than half of all industrial robots sold in the US and most sold in Japan are Unimation machines: either large Unimates or the sleek new PUMA

*Colour-sorting robot (above) sorts 6500 telephone receiver caps an hour into proper bins. Robot's optical head (left) has three photodiodes capped with primary filters to simulate human colour reception. A microprocessor analyses the colour signals, then directs the robot to swing its rotating chute into line with one of 12 different colour bins. The Western Electric robot is 99.9% accurate (note the white cap in the wrong bin at lower left).*

(Programmable Universal Machine for Assembly).

The large Unimate robots handle heavy-duty tasks — automotive welding, spray painting, lifting and moving objects weighing hundreds of kilograms. Such machines have been around for about 20 years, evolving from simple units controlled by paper-tape instructional drives into more sophisticated modern electronic systems.

But the real advance is PUMA. "PUMA is a whole new breed of robot," said Brian Carlisle at Unimations research laboratory. "It's a computer-controlled smart robot."

It looks much like a human arm mounted on a pedestal; the smaller of two versions is of about human size. The upper arm tapers from the shoulder to the elbow. The forearm tapers further to the wrist. At the end, there's a hand, which can be a gripper, a built-in tool, or almost anything else needed where the work is to be done.

An early PUMA model went to the General Motors Technical Center in Warren, Michigan, for vision-development work.

# Robots: New Workers on the Assembly Line

(Continued)

Ed Kavetsky and the GM robotics team have devised a system that makes their PUMA one of the most advanced robots in the world. It has vision and decision-making abilities — both provided by three small DEC computers. One sorts out input from a video "eye," one controls PUMA's motion, and one serves as a supervisor, remembering everything needed for automatic operation.

## Seeing-eye arm

To develop this advanced system, the GM team analysed the demands of the automotive assembly line. They started with the fact that automotive components often move down conveyor lines in a mixture. Human workers can pick out the part they need. But that was too complex for a machine. Until now.

The first job was to teach a robot — actually its computer — to recognise specific parts. That meant designing a complex software package to interpret video data. (Cincinnati Milacron did this job.)

"We designed a unique lighting system to help the computer," Kavetsky said. "It doesn't require colour contrast, but it sees height so it can pick out a gray part moving on a gray background."

The system uses two bright lights angled down through lenses to form a brilliant line across the conveyor belt. A video camera looks straight down at that line (see photo).

As a random mixture of parts crosses the line, the video camera transmits 128 slices of data to the computer. Stored in the computer memory are the exact shapes of five parts — a brake drum, a connecting rod, a wheel, and two sizes of identically shaped universal joints. The video computer sorts through the data and identifies the parts. (If a part is not one of the five in memory, the computer ignores it.)

Five new pieces of data are then transferred to the supervisor computer: part identification, x and y coordinate, angle or orientation, and position on the belt at the moment of crossing the band of light.

To teach PUMA what to do with each part, the team had to stop the conveyor after a part was "videotronically" identified. Using a pushbutton controller, the GM engineers moved PUMA's "hand," one of several that can be attached, to the part and picked the part up. Each point or change of direction along the way went into the supervisory computer's memory. Finally, they used the "teach" controller to move the part to its desired location.

"The supervisory computer remembers all this for the 'auto' mode of operation," Kavetsky explained. Once the months of programming were completed, the robot's pickup and delivery motions became infinitely variable, precisely mat-

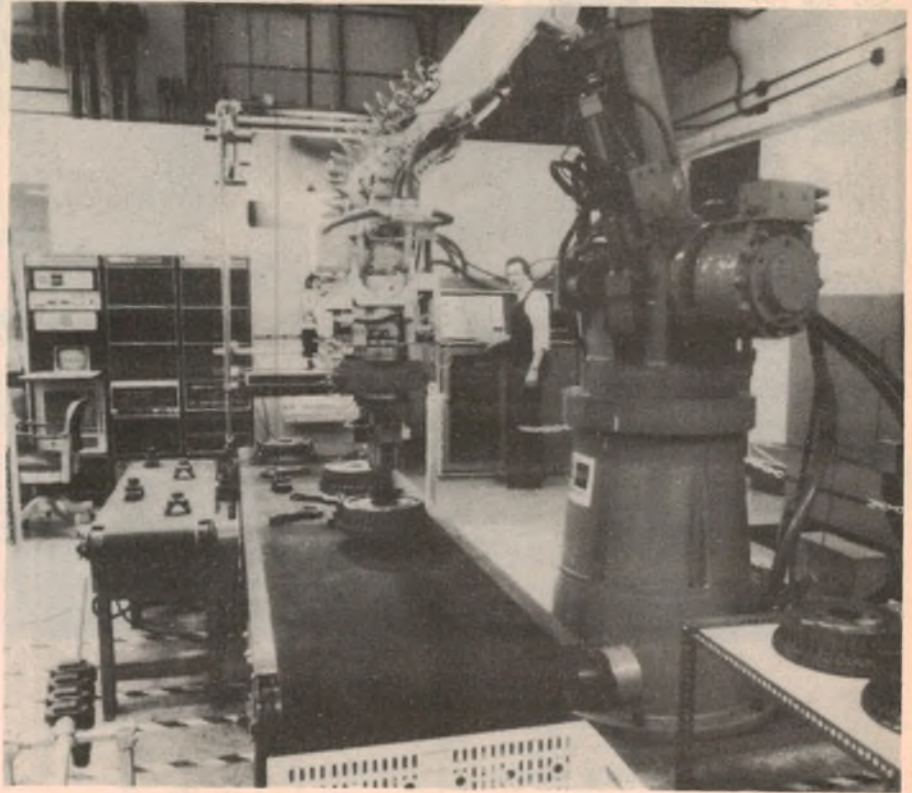

GM's seeing robot lifts a brake drum off conveyor for stacking with others (right foreground). A sharp line of light (visible slicing across another brake drum at rear) aids camera eye (on vertical bar) that feeds shape and position data to robot's computer brain. The "smart" robot also slides connecting rods onto racks (left foreground) and positions two sizes of universal joint on adjacent conveyor.

ching the position of randomly placed parts. The supervisory computer does the thinking.

"The robot is instantly retaught to take a new path, maybe one it has never taken before," Kavetsky said.

To prove his point, he dumped a box of mixed parts onto the conveyor. Lights came on. PUMA whirred in anticipation. Suddenly it acted, moving far faster than any human.

PUMA snatched brake drums, stacking them neatly on a pallet. It threaded connecting rods onto storage shafts. It placed the universal joints on an adjoining conveyor belt, positioning the two sizes at 90-degree orientations. And finally it stacked wheels on the floor.

In an assembly-plant setting, PUMA could take over similar tasks now performed by people. It would work three shifts a day, have no absentee problems, and probably improve production efficiency. GM and other manufacturers are cooperating with unions to protect jobs while still getting such benefits into plants.

Already GM has installed dozens of PUMA's without the vision system in several of its plants. In those applications, precise and consistent placement of parts is required. But the robots are

working out well.

According to senior engineer Walter Cwycyshyn, PUMA's are ready to take over a task at a Delco plant in Rochester, New York. There the robot will reach into a hot furnace, pull out an electric-motor armature, snap on a commutator ring, apply resin, and put it back for heat curing. Up to now, this tiring and potentially dangerous job has been done by humans using asbestos gloves and tongs.

"Robots are ideal for light assembly operations," Cwycyshyn added. GM also plans to use robots for installing and spinning light bulbs in dashboard panels, stacking and palletising speaker magnets, and installing screw fasteners. The PUMA robots could work up to three times faster than humans, but GM is holding them back to get more experience.

"If something goes wrong, I want to pull out the robot and put in a human," Cwycyshyn explained. "We couldn't do that if the line moved at triple speed." He added: "Ideally we'd like to see our parts come in a pan, have the robot pick the right part of that jumbled mess, then do something with it."

This may come soon, GM plans to try out the advanced "seeing" PUMA in a plant late this year.

# GIANT EASTER SHOW BAG



## E.A. GRAPHIC ANALYSER KIT

See E.A. March '81

A complete kit of parts. Includes: quality glass PCB., all LSI, RF modulator, power transformer, crystals etc.

**ONLY \$89.00**

+ \$4.00 P&P  
Horwood case to suit \$14.50 + \$2.00 P&P

## E.T.I. 477 MOSFET AMP

See E.T.I. JAN/FEB/MARCH '81

Complete kit includes: Quality glass PCB, Genuine Hitachi 2SK134/2SJ49 MOSFETS (watch out for inferior lower voltage types!) Predrilled Heatsink bracket, **PREWOUND** coil & all other quality components.

**ONLY \$59.50**

+ \$4.00 P&P  
Power Transformer to suit \$39.50 each + \$3.00P&P

## UNBELIEVABLE SAMPLE BAG OFFER!

A huge 20" x 10" bag FILLED with goodies

**ONLY \$4.50** (P&P \$1.00)

Yes! This bag is **jam-packed** with electronic components. All useful items — no rubbish. It even contains a "PHANTOM" comic and an all-day sucker!!

It makes an ideal addition to your junk box. Normally we could not afford to sell this much componentry at this fantastic price. It is **below cost price**.

Several famous manufacturers have provided components to help us. It's a get-to-know you special so **our loss is your gain!!** No, you don't have to go to the Royal Easter Show — simply call in at the address below or mail order (\$1.00 P&P).

WE WOULD LIKE TO THANK . . . I.C.S. (Instant Component Service), SOANAR, Texas Instruments, and many others for contributing to the bag.

### THE BAG CONTAINS:

Pack No.

1. 15 Assorted Instrument & Metal Knobs: Value \$6.50.
2. Binding Posts (2); AC Plugs (2); Screw Terminals (2); Test Sockets (2); Dial Drums (2): Value \$8.60.
3. 8-10 PCS Polyester & Electrolytic Capacitors: Value \$3.00.
4. 15 Assorted High Quality Grommets & Knockouts: Value \$3.50.
5. 30 Assorted Lengths/Colours High Quality Spaghetti Sleeving: Value \$2.50.
6. P.V.C. Sleeving. An assortment of sizes & colours: Value \$4.00.
7. MYSTERY KIT??? We won't say what it is!! Value (AT LEAST) \$4.00.
8. Professional grade D.I.L. Reed Relay with Coil: Pro. Grade Push Button Switch: Value \$7.00.
9. TMS.4030 TEXAS 4K Dynamic Ram. Value \$10.00.
10. An assortment of SOANAR Electronic components. Value: Over \$2.00.

**WOW!! TOTAL VALUE OVER \$50!!**

# Jaycar

**Shop Hours:**  
Mon - Sun -  
9AM - 5.30PM



**380 Sussex St Sydney 2000. Ph 264 6688**

### P & P CHARGES

ORDER VALUE	CHARGES	ORDER VALUE	CHARGES
\$ 5-\$9.99	.....\$1.00	\$25-\$49.00	.....\$3.00
\$10-\$24.99	.....\$2.00	\$50-\$99.99	.....\$4.00
		\$100 OR MORE	.....\$5.50



# Australia's Resistor House

## **"BIG SAVINGS!"**

**Carbon Film Resistors**  
1/4 watt 5% tol.

**50¢**

100  
in 100 lots\*

**40¢**

100  
in 1000 lots\*

**Metal Film Resistors**  
1/4 watt 1% tol. 50 P.P.M.

**\$2**

100 in lots of  
1000\*

**\$2.50**

100 in  
lots of 100\*

\*Plus sales tax if applicable.



**VSI  
ELECTRONICS  
(AUSTRALIA)  
PTY LTD**

**VSI, the distributor offering something unique – Service.**

**Adelaide 51 6483; Brisbane 52 4261; Melbourne 877 5311; Perth 328 8091; Sydney 439 8622**



# Robots: New Workers on the Assembly Line

(Continued)

While GM was teaching PUMA to see, the Unimation team was working on an improved version of the basic advanced model.

The robot took more than two years to develop. Much of the difficulty came in programming its LSI-11 computer to handle everything a good robot arm should do, Unimation's Carlisle said.

"The software is extremely complex," Carlisle explained. "Each joint goes through a coordinate transformation ending up with six four-by-four matrices to be solved. The LSI-11 outputs a new point every 29 microseconds, and at the same time, internal microprocessors are doing 32 recomputes on the motion."

Such high-speed computer control means that the robot's electric control motors receive new movement instructions faster than they can turn off and on again. The result is a superbly efficient robot that can move its arm with pinpoint accuracy to almost anywhere within a one metre sphere. Motion is absolutely smooth and can be extremely fast — up to three metres a second at the tip of the hand.

And this advanced robot doesn't have to be shown how to do each new task — it can now be told.

PUMA's developers came up with a special computer language called "Val." It includes about 100 English commands that make it easy to teach a PUMA new tricks. The commands include "here," "approach," "move," "depart," and other words.

"It lets us define points along the path we want PUMA to move," Carlisle said. "Point 'B', for example, can be at the centre of the hand, or define a special tool, or be at the end of the tool. PUMA will remember where 'B' is."

The number of points PUMA can learn is limited only by computer memory. "It could have hundreds and hundreds of points," Carlisle said. "We taught one to draw a picture of itself. It had to learn 150 points."

"We're building robots that are so accurate that we know more about where the tip of the hand is than we do about where the tool or component is," Carlisle said with some pride.

Now Carlisle and the Unimation research team are concentrating on developing sensors to make PUMA even more versatile. Sensors fitted into robot hands, for instance, can let PUMA pick up an egg or a brick with just the right force.

Carlisle is excited by the future. "We've built the tool," he said. "Now we'll see what we can do with it."

At the main production plant in Danbury the robots are assembled and tested under strictly controlled conditions. Inside the main door one day last winter, two PUMA's stood corralled behind a yellow fence. The noise was

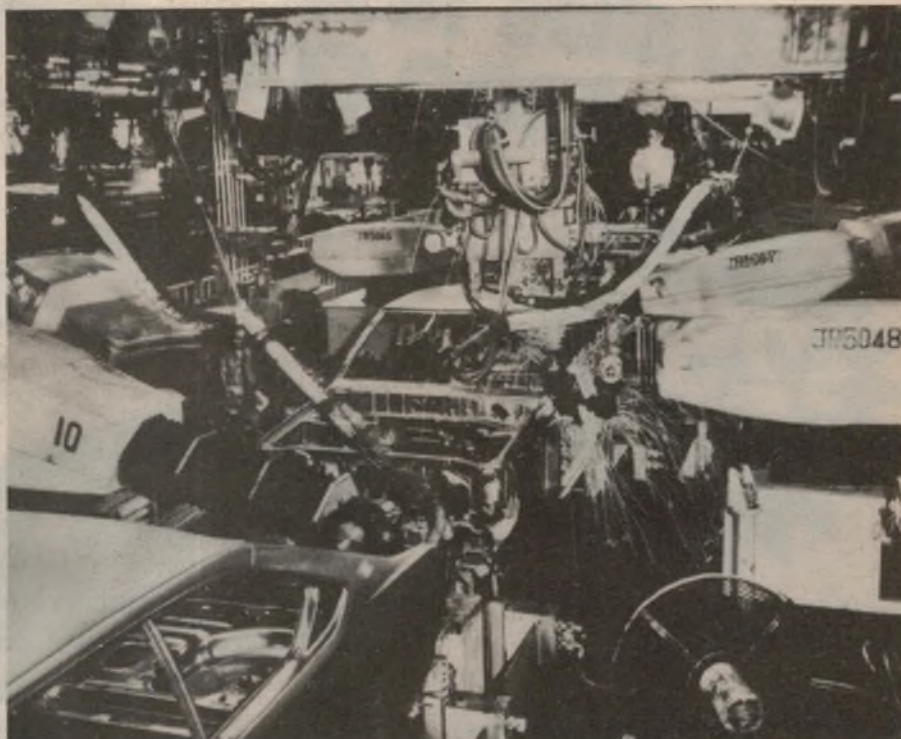

Medusa-like arms swing out in a shower of sparks, spot-welding a Datsun frame. Though swift, these older robots can't vary routine — even if car is out of place.

like that from caged animals, a low, throaty growl of gears and rumbling whine of small motors. The PUMA's stood there waving their arms up, down, sideways, and around — again and again going through the motions.

Each robot goes through a precise calibration exercise that ends with installation of a customised memory chip that knows exactly how this robot moves. If a control motor is changed during later maintenance, a new calibration is needed.

Once calibrated, each PUMA spends 80 to 100 hours in a cage waving its arm

through precise motions — a test that guarantees accuracy.

But once in a while, something goes wrong. A single PUMA stood in another cage, technicians working on its interior. And on its arm were painted two human figures.

"We don't know what's wrong with him yet, but he whacked a couple of guys who got too close," a worker said. "We call him 'killer.'" 

Reprinted from "Popular Science" with permission. Copyright © 1980 Times Mirror Magazines, Inc.

## EA Magazine Holders



The binders and magazine holders are available over the counter from Electronics Australia, 57 Regent Street, Sydney, NSW — Price: \$5.10 binders, \$4.50 holders.

Mail orders should be sent to Electronics Australia, PO Box 163, Beaconsfield, NSW 2014.

Prices including postage are:

Holders: \$5.40 NSW; \$5.50 other states; or six for \$28.30 NSW, \$30.40 other states, A\$32NZ.

Binders: \$6.20 NSW; \$7.90 other states; or six for \$32 NSW, \$34 other states, A\$36.60 NZ.

# Australia's first under \$300 COMPUTER...

**\$295**  
INCL. ZX80 BASIC  
MANUAL

Remember — all prices shown include sales tax, postage and packing.  
N.B. Your Sinclair ZX80 may qualify as a business expense.

## Sinclair ZX80 -British made.

Until now, building your own computer could cost you around \$600 — and still leave you with only a bare board for your trouble. The Sinclair ZX80 changes all that. For just \$295 you get **everything** you need including leads for direct connection to your own cassette recorder and television. The ZX80 really is a complete, powerful full-facility computer matching or surpassing other personal computers costing much more. The ZX80 is programmed in BASIC and you could use it for anything from chess to running a power station.

Two unique and valuable components of the Sinclair ZX80: the Sinclair BASIC interpreter and the Sinclair teach-yourself BASIC manual. The unique Sinclair BASIC interpreter: offers remarkable programming advantages — unique 'one touch' key word entry. The ZX80 eliminates a great deal of tiresome typing. Key words (RUN, PRINT, LIST etc) have their own

single key entry. Unique syntax check. Only lines with correct syntax are accepted into programs. A cursor identifies errors immediately, preventing entry of long and complicated programs with faults only to discover them when you run.

Excellent string handling capability — takes up to 26 string variables of any length. All strings can undergo all rational tests (e.g. comparison). The ZX80 also has string input to request a line of text; strings do **not** need to be dimensioned. Up to 26 single dimension arrays. FOR/NEXT loops nested up to 26. Variable names of any length. BASIC language also handles full Boolean arithmetic, conditional expressions, etc.

Exceptionally powerful edit facilities, allows modification of existing program lines. **Randomise function**, useful for games and secret codes. **Timer under program control**. PEEK and

POKE: enable entry of machine code instructions. USR causes jump to a user's machine language sub-routine. **High resolution graphics** with 22 standard graphic symbols. **The Sinclair teach-yourself-BASIC manual** 96 page book free with every kit.

**Fewer chips, compact design, volume production means MORE POWER FOR YOUR DOLLAR!** The ZX80 owes its low price to its remarkable design; the whole system is packed onto fewer, newer more powerful and advanced LSI chips. A single SUPER ROM, for instance, contains the BASIC interpreter, the character set, operating system and monitor. And the ZX80's 1K byte RAM is roughly equivalent to 4K bytes in a conventional computer because the ZX80's brilliant design packs the RAM so much more tightly. (Key words occupy just a single byte). You can add to the memory via the expansion port, giving a maximum potential of 16K.

**ORDER FORM:** SINCLAIR EQUIPMENT (AUSTRALASIA), PTY. LTD.  
86-88 Nicholson St, Abbotsford 3067. Tel 419 3033.

Quantity	Item	Item Price	Total
	Ready-assembled Sinclair ZX80 Personal Computer(s). Price incl. ZX80 BASIC manual, excel. mains adaptor.	\$295.00	
	Mains Adaptor(s) (600Ma at 9V DC nominal unregulated).	\$16.00	
	Memory Expansion Board(s) takes up to 3K bytes.	\$ 28.50	
	RAM Memory chips — standard 1/2K bytes capacity.	\$ 10.00	
	Sinclair ZX80 Manual(s) free with every ZX80 computer.	\$ 15.00	
I enclose cheque/Bankcard/Diners Club/Amex		TOTAL	
Name _____ E.A.I.			
Address _____ Postcode _____			

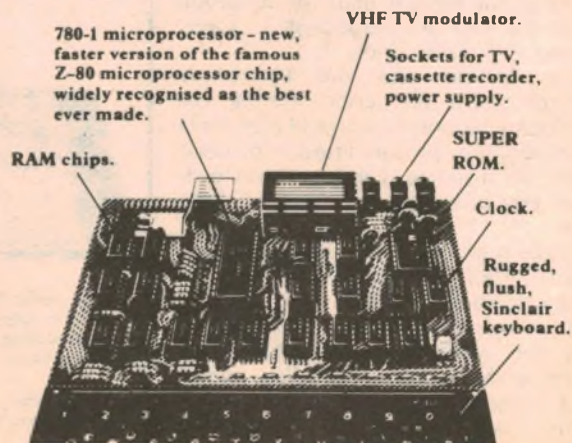



**SENSATIONAL** *sinclair*  
**ZX80**

**COMPUTER NEWS FOR 1981!**

**SINCLAIR EQUIPMENT (AUSTRALASIA) PTY. LTD.**

86-88 Nicholson St., Abbotsford, Vic. 3067. Tel. 419 3033.

**DYNAMIC 16K RAM PACK**  
**HERE NOW!**  
ACTUAL 16K RAM

**\$150** complete  
inc. S/T  
& post/pack



**ORDER FORM:** To SINCLAIR EQUIPMENT (AUSTRALASIA) PTY. LTD.  
Please forward **DYNAMIC 16K RAM PACK.** I enclose \$ .....

Name .....

Address ..... Postcode .....

I enclose cheque/Bankcard/Diners Club/Amex

**STOP PRESS:** **FLICKER FREE, REAL TIME MOVING GRAPHICS**  
•BREAKOUT•LUNA LANDER•SPACE BATTLE•PING PONG•GRAPHICS  
•MUSIC•HEXADECIMAL•ACTIVE DISPLAY•MOVIES•

No modifications to hardware whatsoever. All software is thoroughly tested and claimed to be the most advanced developed so far. Games are written in machine code to make maximum use of memory and provide continuous live action without loss of TV synchronisation. All programs run in 1K memory unless otherwise stated

CMCT

# electronic games

**SPACE-AGE  
LEISURE  
ACTIVITY**

BY JERRY AND ERIC EIMBINDER

*Electronic games have arrived. Thanks to the latest IC technology we can play chess with a talking computer, indulge in a game of space invaders, or test our skill at any number of hand-held games.*

Checkers was invented by a Greek during the Trojan War. Chess originated in India. The Romans gambled with dice. Board games were played in ancient Crete. The advent of the electronic game, however, brought a whole new dimension to the art and science of games. For the first time, the opponent could be a computer program and the game could be played at a pre-selected level of difficulty. Integrated circuits made it economically possible to create new concepts in visual and sound effects, and microprocessors permitted continuous change and advancement.

There were many pioneers in electronic games. Let's look back to see how it all started.

In 1962, a graduate student at the Massachusetts Institute of Technology named Steve Russell wrote a computer program for a game called "Spacewar". Research buffs estimate that Russell's ingenuity cost companies possessing computers several million dollars during the following four or five years because many employees, enthralled by the game, used computer time to guide rocket ships across computer displays.

"Spacewar" continued to be popular through the late 1960s. At this time, two students who learned the game on college campuses were Nolan Bushnell at the University of Utah and Bill Pitts at Stanford University's Artificial Intelligence Center.

Both Bushnell and Pitts set out independently to develop commercial versions of "Spacewar". Bushnell's model, "Computer Space," was finished first, in 1970. It used the raster monitor from a 48cm GE television set and 185 commercially available integrated circuits, mostly transistor-transistor logic (TTL) devices.

Although Bushnell didn't actually produce the game (the rights were sold to

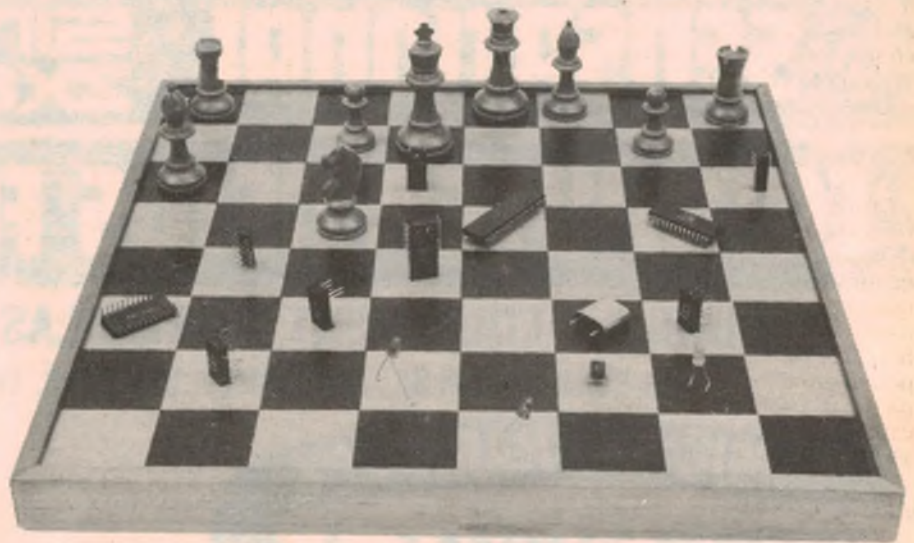

another company), he learned much about user interest from studying reactions to "Computer Space" in the marketplace. The game wasn't a successful financial venture, though, because it was too complicated for most players. Not giving up, Bushnell developed an easy-to-play electronic game for the company he founded in 1972—Atari.

Bushnell installed a coin-operated table-tennis game, "Pong," in a bar in Sunnyvale, CA, called Andy Capp's. The machine ceased working after two days and he stopped by to see what was wrong. A complete check of its TTL logic circuitry uncovered nothing wrong and, finally, Bushnell checked the coin box. It was jammed to capacity! Bushnell then knew that he had a winner.

Meanwhile, Pitts completed a prototype unit in 1971 and followed with a second model called "Galaxy Game" a

year later. He placed it in the Tressider Union Coffeehouse at Stanford, a few kilometres from where Bushnell's "Pong" game was under evaluation at Andy Capp's. Pitt's game, employing a Digital Equipment Corp PDP-11 computer, challenged some and discouraged many. The machine still stands there today. No more have ever been built.

The score in electronic game evolution at this time was one successful idea ("Pong") and two failures ("Computer Space" and "Galaxy Game"). The "Pong" paddle game survived and prospered. (Eventually, space war games, in simplified versions, would also capture the public's fancy.) Nolan Bushnell went on to build Atari into a major factor in the electronic games industry. Besides producing coin-operated machines, he moved Atari into the home video game business in 1975, marketing "Pong" through Sears and Roebuck stores. By

the end of 1976, there were some 70 companies in the TV-game business. Atari was then sold to Warner Communications for a reported price of \$US28 million.

The Thomas Edison of the home TV game was Ralph Baer. In 1966, as manager of the equipment design division of Sanders Associates, Manchester, NH, supervising a staff of up to 500 engineers and technicians, Baer was in a position to authorise work on TV games. He built a couple of symbol generators and soon had two spots chasing each other around the screen of a black-and-white TV set. Having convinced himself that the concept was feasible, he hired Bill Harrison to begin full-time work on TV-game development. Shortly afterwards, he also added engineer Bill Rusch to the project.

A 43cm RCA colour-TV set was purchased and, by early 1967, Baer, Harrison and Rusch were playing table tennis against a green background and hockey against a background of blue ice. Colour signal generation was handled very simply. The parts used were a 6½c transistor, two diodes, a few resistors and capacitors, a 3.58MHz chroma crystal, and a 15c oscillator tank coil. With these parts, they built the chroma oscillator and, through the use of the centre-tapped secondary on the tank coil, they obtained two 3.58MHz signals 180° out of phase with each other.

Taking an output from one side of the secondary and gating it into video with horizontal sync pulses produced an adequate approximation of a colour burst reference signal. Next, an RC phase-shift network was connected across the outer terminals of the secondary, using a potentiometer as a resistor, so that the phase at the junction of the resistor and capacitor could be varied from 0 to 180° with respect to the colour burst reference phase. Horizontal sync was used to gate out the new phase signal via one of the 3c diodes, again into video, and background colour was produced.

The project was a closely guarded secret. Harrison and Rusch worked in an enclosed 3x5-metre office containing two desks, a workbench and support electronic equipment. The door was kept locked at all times; only Baer, Harrison and Rusch had keys. Despite the secrecy of these measures, the area was referred to as "The Game Room". Because Harrison and Rusch had a habit of playing recorded guitar music while working, most of their fellow employees assumed that the room was being used to develop an electronic guitar.

A working multi-game model was completed in mid-1967 and Sanders Associates began looking for licensees. Demonstrations for potential customers continued through 1969, when, after a deal with RCA fell through at the last minute, an agreement with Magnavox was arranged. Magnavox modified the design for high-volume production and demonstrated the game to the press in



Atari's CX2600 video computer game system Plug-in cartridges and different hand controllers combine to offer a range of challenging full-colour games.

May 1972. By summer, the game, called "Odyssey," was on the production line. Nearly 100,000 Odyssey games were sold that year!

The original Odyssey contained approximately 305 discrete parts in its master control unit and hand controls. Overlays for the television screens were supplied with Odyssey to simulate field backgrounds. The Odyssey package also included dice, play money, card decks and game boards. Twelve games, some very similar, were offered.

The first version of Odyssey was manufactured until 1975, when large-scale-integration (LSI) parts became available. Nine complex integrated circuits were designed for use in Odyssey. The use of these chips cut the total number of parts needed to approximately 200 and reduced both cost and assembly time. Several advanced technologies were employed in the nine chips, including newly developed integrated injection logic (I<sup>2</sup>L). Electronics also produced the TV-screen backgrounds, so overlays were no longer needed.

Not all nine chips were necessarily used in a particular model of Odyssey. By appropriate selection from the master set of nine chips, 18 possible combina-

tions of chips were possible.

Subsequently, in 1976, Magnavox further cut the number of components needed to build a video game to 75 by introducing a single-chip LSI system. The chip contained all of the spot generator, logic, sync, multitone sound and digital scoring circuitry, but offered less flexibility than provided by the multi-chip system.

**GI's 6-in-1 TV-Game Chip.** Prior to the development of one-chip game systems, a number of companies were testing the marketplace for TV games with models using TTL circuitry. One of these companies was First Dimension Corp, founded in mid-1975 in Nashville by Norvell L. Olive. First Dimension manufactured 7000 games in time to ship for the Christmas 1975 season. Next, preparing for mass-volume production of its \$129 game in 1976, it purchased \$1.5 million worth of parts.

But in early 1976, General Instrument introduced the product that changed the nature of the video games industry. General Instrument put most of the circuitry needed for designing a video game on a single chip, the AY38500. The game designer was provided with one chip that provided four paddle games and two different rifle games. In addi-

The Gammonmaster II, a microprocessor-controlled backgammon game from Tryon Inc., Ohio, USA. You play the computer!

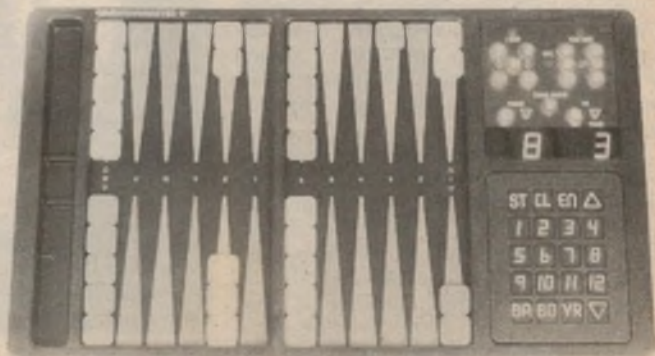

# electronic games

tion, capability for fast ball and slow ball, steep angle and shallow angle, and long paddle and short paddle operation was offered.

For companies thinking about going into the TV-game business, the GI chip was the convincer. For First Dimension, sitting with a huge inventory of discrete parts, it was a crushing blow.

The cost of the GI chip ranged from \$5 to \$6, depending on the volume involved. It promised total system costs of \$25 to \$30 and retail prices in the \$60 to \$75 range. Development of the chip had been initiated for Salora OY in Finland for use in a television set; subsequently, Telefunken GmbH and Loew-Opta GmbH in West Germany and Vanguard SA in Spain had also ordered the device. In order to market the IC in the US, General Instrument's Hicksville, NY plant developed a 525-line, 60 half-frames-per-second NTSC system version of the original chip, designed for 625-line, 50 half-frames-per-second PAL systems in GI's Glenrothes, Scotland plant.

The GI chip made it possible for companies to establish simplified production lines and build lower-cost games.

Hard times loomed ahead for many video game builders, however. Many small-games companies found they couldn't get parts unless they paid in advance. Delays were encountered in getting FCC Class-I-device approval. Others learned, sometimes belatedly, that the demand for the GI chip far exceeded the supply and other integrated-circuit suppliers weren't ready to fill the void. For example, Lloyd's Electronics said it received only 20% of the chips it had ordered from General Instrument for games planned for the Christmas 1976 season. As readers might recall, the supply of games ran out during the Christmas 1976 season in many parts of the United States.

Coleco was the first major customer for General Instrument's industry-revolutionising game chip and, as a result, received early delivery of the part. Approval for its game also came early from the FCC and, by May 1976, many stores had sufficient stock to meet Father's Day demands. Reorders poured in, encouraging Coleco to build up heavy production capability. Coleco president Arnold Greenberg estimated that his company's 1976 game sales exceeded \$110 million. Sales for TV games during the Christmas 1976 season lifted the industry into the big business category.

The first home TV-game system to accommodate replaceable cartridges was introduced by Fairchild Camera and Instrument in August 1976. The unit had hockey and tennis built-in. The key to its versatility, of course, was its capability to accept a never-ending number of new cartridges as they were developed — blackjack, baseball, tank battle, etc.

Each Videocart cartridge contained a semiconductor memory programmed to reproduce specific games on the television screen in full colour. The game console used a Fairchild F8 microprocessor and four semiconductor random-access memories to provide the basic game system electronics. For sports, the score and elapsed time were displayed continuously at the bottom of the screen.

As 1977 began, RCA followed Fairchild into the plug-in-game business using its 1802 integrated circuit in a microprocessor-based, black-and-white video-game system. The RCA unit combined keyboard console control with read-only-memory cartridge game inputs. Bowling was among the games offered by RCA.

The outlook for video games was never brighter. National Semiconductor had sold over 200,000 Adversary video games in 1976, containing built-in hockey, tennis and handball. A newer model adding soccer, pinball and a game called "Wipeout" was being readied for June delivery. Fairchild had been back-ordered since it started delivering limited quantities of its Video Entertainment System the previous August. Although delays in getting approval for its system from the FCC had set back its timetable, in January 1977, it doubled the cartridges in its line from three to six and announced that it would bring out a new cartridge every month.

Also in January 1977, General Instrument shipped its seven-millionth 6-in-1 TV-game chip (the AY38500) and announced that a series of new chips, providing racing and combat games, would soon be available.

Magnavox, planning to use the new GI chips, announced that it would supply a

24-game, four-player video system in September priced under \$100. A backgammon game, in pilot production by Allied Leisure, was heralded as the beginning of the next evolution of electronic games. At least as impressive was a chess-playing game designed by Mostek that not only permitted playing against the computer, but let the player select the skill level at which the computer would operate. Mostek offered to provide the software for the game to any manufacturer who would build the game with Mostek microprocessors. Connected to a TV set, the control unit was used for entering moves. The board and the pieces were displayed on the screen. It was an exciting time. Few realised that the Camelot era of video games was about to end.

Despite the shortage of TV games during the Christmas 1976 season, the market collapsed in 1977. Allied Leisure went bankrupt before it could deliver its backgammon games. National Semiconductor stopped development of its improved version of Adversary; Magnavox cancelled its top-of-the-line 24-game system. Atari, thanks to a fresh infusion of money by Warner Communications, hung in. So did Coleco, somehow surviving losses of \$30 million for 1977. One by one, most of the video game manufacturers dropped out. The casualties included the three semiconductor companies who were building games with their own chips: Fairchild, National Semiconductor, and RCA.

But as one electronic game industry suffered, another was being born.

**Hand-Held Games.** Until Texas Instruments introduced the hand-held learning aid called "Little Professor" in 1976, all of the activity in electronic games in-

*(Continued on p23)*

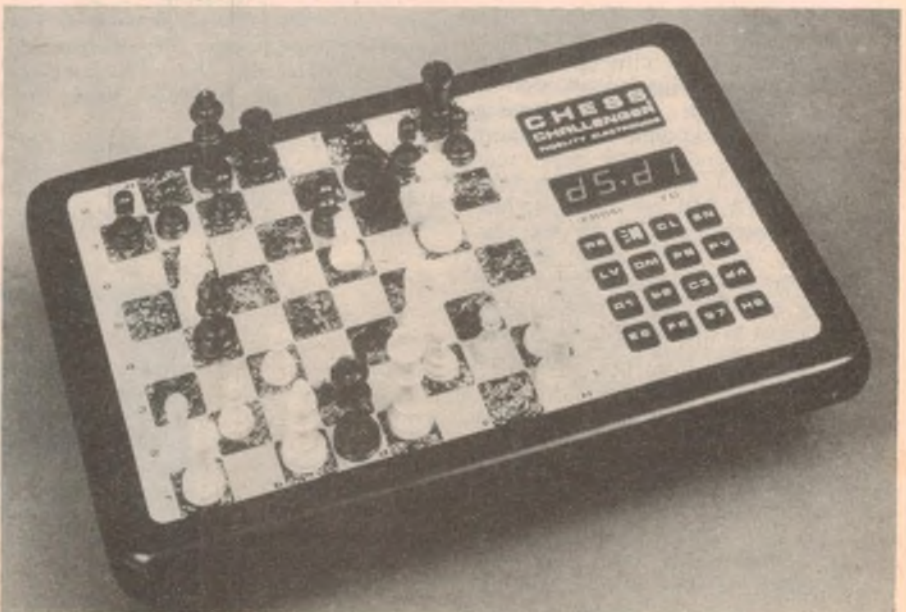

*Fidelity Electronics' Voice Chess Challenger — plays chess and talks!*

# Texas Instruments' Talking-Chip Set

Texas Instruments based its speech synthesis system on a voice-compression technique called linear predictive coding (LPC). LPC is based on a linear equation which formulates a mathematical model of the human vocal tract in order to predict a speech sample based on previous ones. TI combined a pipeline multiplier, an adder/subtractor and delay circuits on a chip to simulate a 10-stage filter. Codes for 12 synthesis parameters (10 filter coefficients, pitch and energy) serve as inputs to the synthesiser chip.

Processing of signals by the chip is depicted in Fig. 1. The input signal may be either periodic impulses or pseudorandom noise. The periodic inputs are used to reproduce voiced sounds that have a definite pitch such as vowel sounds or voiced consonants such as Z, B or D. A random input models unvoiced sounds such as S, F, T and SH.

A separate read-only memory (ROM) chip stores the coded digital data needed to specify the type of input signal, degree of amplification, and a set of filter coefficients. Pitch bits vary the frequency of the periodic impulses being supplied or, if all are zero, select random data to excite the multi-stage filter.

The rate at which the memory delivers updated filter coefficient data determines the quality of the created speech. However, while increasing the rate improves the quality of the speech, it also adds to the amount of memory needed to store this data. For its system, TI decided that updating the filter coefficients every 20 milliseconds would provide good speech quality without requiring heavy storage.

Each stage of the 10-stage filter (except the last one) carries out two multiplications and two additions on its two digital inputs before moving the results back and forth to adjoining stages. The operations of the 10 stages take place sequentially, as do the four operations within each stage.

The pipeline multiplier carries out all 20 of the multiplications required by the lattice filter. A different multiplication operation starts every five microseconds. There are eight stages in the multiplier and, thus, eight multiplications, in various stages of completion, are taking place at any one time. The output from the multiplier is one of two inputs fed to the adder/subtractor circuit. The other input is controlled by digital switches and, at various times, arrives from the adder, multiplier or latch memory. The output from the adder/subtractor is delayed one time period and stored in one of 13 shift registers, each of which has eight stages. See Fig. 2.

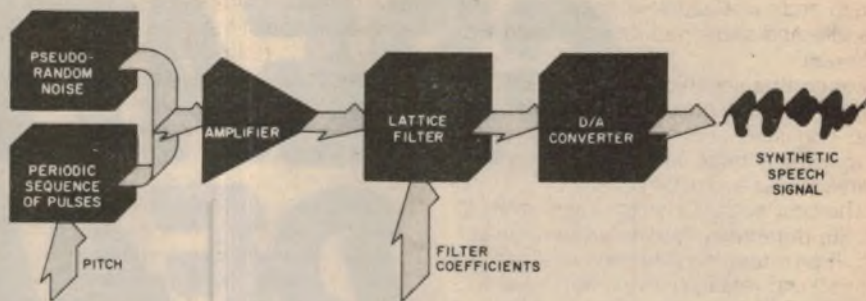

Fig 1: The excitation signal for Texas Instruments speech synthesiser system can be periodic impulses for voiced sounds or pseudorandom white noise for unvoiced sounds. Data needed to select type of excitation, determine degree of amplification, and specify filter coefficients is stored in ROM.

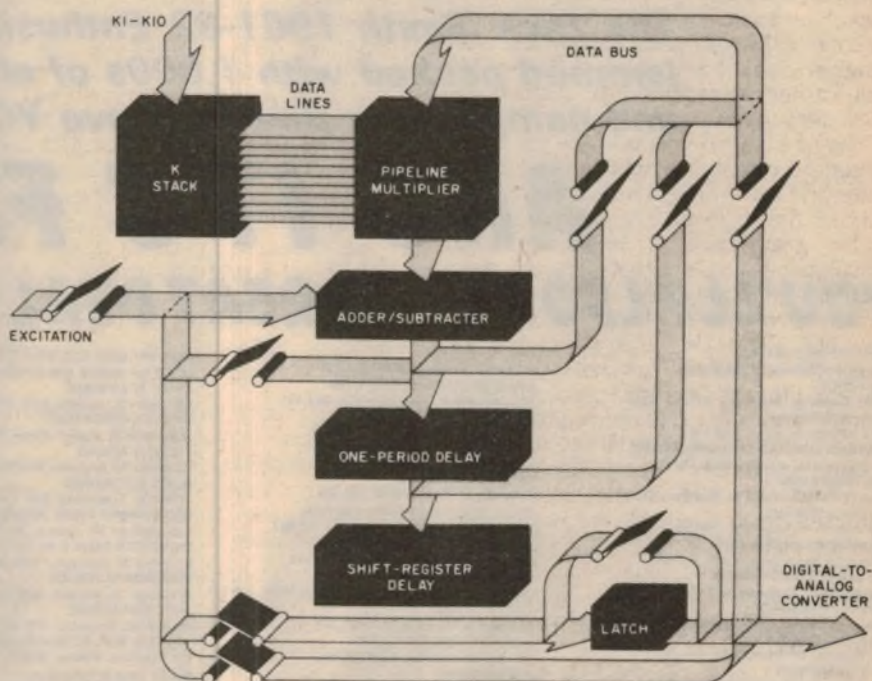

Fig. 2: In the 10-stage filter on TI's speech synthesiser chip, the pipeline multiplier performs all 20 of the multiplications required. It receives data and coefficients from the K stack of shift registers through the data lines and initiates a different multiplication operation every 5 microseconds. The multiplier's output consists of 13 data and one sign bits in parallel. Output of the adder/subtractor is also 14 parallel bits, but is delayed one time period before being stored in the shift register.

The chip contains an 8-bit digital-to-analog converter that transforms the digital information processed through the filter into synthetic speech. The converter has an accuracy of one-half of the least-significant bit and the ability to drive a 200-milliwatt speaker.

The speech synthesiser is teamed with a read-only memory (a 131,072-bit, p-channel metal-oxide-semiconductor memory) and a controller chip, the TMC0270 (actually it is

a custom TMS1000) in Speak & Spell (see next page). The TMC0350 ROM can accommodate approximately 165 words or 115 seconds of speech plus pitch, amplitude and filter parameter data.

In April 1980, Texas Instruments announced the availability of the TMS5000 single-chip synthesiser and the TMS6100 ROM, updated versions of the Speak & Spell chips, at \$13 a set in production quantities.

# THE GREATEST DEAL

## IN ELECTRONICS!

*The Dick Smith 1981-82 Enthusiasts Catalogue is jammed packed with 1,000s of electronic products and components that will save YOU money!!*

## AND IT'S FREE

**YOU'LL ALSO GET A GREAT DEAL FROM:**

AABEL MUSIC COMPANY  
130 Victoria St. Bunbury. WA 212 777  
ROBTRONICS  
2-305 Thomas St. Dandenong VIC 792 1386  
AERO ELECTRONICS  
123A Bathurst St. Hobart. TAS 348 232  
ARMIDALE ELECTRONIC & AUDIO SYSTEMS  
33 Bowman Ave. Armidale NSW 724 955  
AMATEURS PARADISE  
Shop 5 144 Scarborough St. Southport QLD  
A & M ELECTRONICS  
78A High St. Wadonga VIC 244 588  
BALLARAT ELECTRONIC SUPPLIES  
5 Ripon St. North Ballarat VIC 311 947  
KEL BARTLETT ELECTRONICS  
45A Walker St. Bundaberg QLD 724 757  
BEARUP'S PHARMACY  
Oxton St. Oxton NSW 381 488  
A.A.B. EQUIPMENT PTY LTD  
310 Mulgrave Rd. Cairns QLD 511 785  
ALLIED HARDWARE  
107 Barrack St. Merredin WA 411 282  
O & M BEARUP  
114 Bradley St. Guyra NSW 781 108  
PETER BROWN ELECTRONICS  
9 Davoren St. North Ballarat VIC 311 251  
BASSEYS MUSIC  
Shop 11 Belmont Centroway 188 High St. Belmont Vic.  
COFFS HARBOUR ELECTRONICS  
Shop 3 Coffs Harbour Plaza Park Ave. Coffs Harbour NSW  
ARTHUR BAINES  
17 Dudge St. Lismore NSW 213 189  
MELLOR ENTERPRISES  
Shop 2/15 Forsythe St. Whyalla SA 454 784  
W COCHRANE  
78 Fortescue Cres. Dampier WA 831 442  
A.E. COOLING  
8 Trimmer St. Elizabeth South SA 255 9196  
CIVIC CENTRE TELEVISION  
34 Fire Brace St. Marabon VIC 823 724  
ASCOM ELECTRONICS  
88 Hartley St. Alice Springs NT 521 713  
M & W ELECTRONICS  
48 McNamara St. Orange NSW 826 491  
BUCKARINGA HOLDINGS PTY LTD  
2 Seven St. Queero SA 487 171  
VARIETY DISCOUNTS  
113 Harton St. Port Macquarie NSW 835 488  
H.S. COOMBE & ASSOCIATES  
Denny St. Barri SA 821 511  
COOMA ELECTRONICS PTY LTD  
58 Sharp St. Cooma NSW 822 888

F.R.H. ELECTRICAL  
28 Station St. Bowral NSW 811 881  
CONQUEST ELECTRONICS PTY LTD  
212 Katoomba St. Katoomba NSW 822 491  
CRYSTAL TV RENTALS PTY LTD  
188 Argont St. Broken Hill NSW 8897  
H.O. HAYNES  
Binara St. Castlak NSW 771 005  
COASTAL ELECTRONICS  
43 Vulcan St. Moruya NSW 742 545  
COLLIS SOUND ELECTRONIC COMPANY  
28 Rutherglen Rd. Newborough VIC 273 017  
CURLLEWIS FARMERS CO-OPERATIVE  
22 Casadilly St. Gunnedah NSW 420 544  
OCEANO ELECTRIC  
Cor. Magellan St. & Brunner Hwy. Lismore NSW 214 137  
DELTA ELECTRIX  
87 Queen St. Ayr. NTH QLD 831 357  
CAMDEN HAVEN ELECTRONICS  
101 Bald St. Lauriaton NSW 599 044  
ELEKTRON 2000  
181 Wharf Rd. Newcastle NSW 282 844  
CRONAU'S TV & MUSIC CENTRE  
16 Turquay Rd. Piamba QLD 281 466  
CHAPMAN'S CUMPIE MUSIC  
50 Mary St. Gympie QLD 823 228  
R.B. COOK SALES  
53 Heasting St. Wauchope NSW 553  
DISCUS OF GLENBROOK  
5 Rona St. Glenbrook NSW 392 219  
EDWARDS ELECTRONIC ENGINEERS  
35 Carganter Cres. Casuarina NT 271 289  
DOUBLE DIAMOND ELECTRONICS  
18 Russell St. Goulburn NSW 215 440  
KEITH DONGES ELECTRONICS  
188 Barrowa St. Young NSW 821 279  
D.E.S. ELECTRONICS  
157 Brisbane St. Dubbo NSW 829 355  
ELECTRONIC DEVICES  
61 Princeps Hwy. Milton NSW 551 516  
COLAC ELECTRONICS  
215 Murray St. Colac VIC 312 847  
DERBY DISCOUNTS  
Lot 332, Clarendon St. Derby WA 911 510  
RAY CROSS ELECTRONICS PTY LTD  
151 Boronia Rd. Boronia VIC 782 2422  
FEENEY'S RADIO HOUSE  
54 Wyndham St. Roma QLD  
J.W. & R.K. EVANS  
1045 Gold Coast Hwy. Palm Beach QLD 341 248  
ESPERANCE ELECTRONICS  
Lot 8 McGloden Way. Esperance WA

EAST MAITLAND ELECTRONICS PTY LTD  
Shop 7 Cnr Lawson & High St. East Maitland NSW 337 327  
GONNY OF BOMBALA  
120 Mayha St. Bombala NSW 83 035  
EGGHELL HOBBYSPOITS  
273A Pappa St. Egohill. Cairns QLD 532 810  
HOCKS TV RENTALS  
87 Nansen St. Kalgoorlie WA 211 908  
HUNTS ELECTRONICS  
18 Nail St. Toowoomba QLD 328 944  
HUTCHESON'S COMM CENTRE  
5 Elizabeth St. Mt. Gambier SA 258 404  
GLOUCESTER RADIO & TV PTY LTD  
81 Church St. Gloucester NSW 571 1152  
GOLDBURN TV SERVICE  
195 Auburn St. Goulburn NSW 214 001  
M & E ENGINEERING  
Emundi Rd. Neesavilla QLD 487 818  
HAWKESBURY ELECTRONICS CENTRE  
111 George St. Windsor NSW 773 411  
BARRY GASH ELECTRONICS  
370 Bong Bong St. Bowral NSW 812 577  
INGHAM MUSIC SHOPPE  
High Park Shopping Centre, Shop 5 Herbert St. Ingham QLD  
POWER 'N' SOUND  
15 Franklin St. Traralgon VIC 743 838  
OUTBACK ELECTRONICS  
71 Barkly Hwy. Mt. Isa QLD 433 331  
HOOPERS MUSIC CENTRE  
38 Mary St. Gympie QLD 823 409  
K.B. ELECTRONICS & MARINE  
381 Marine Terrace Geraldton WA 212 176  
KENT ELECTRONICS  
42 Stuart Hwy. Darwin NT 814 749  
KALEXTRONICS  
Shop 4 Burgundy St. Plaza 101 Burgundy St. Heidelberg VIC  
KELLER ELECTRONICS  
218 Adelaide St. Maryborough QLD 214 559  
KURRI ELECTRONICS  
183 Lang St. Kurri Kurri NSW 372 141  
KINGSTON ELECTRONICS & RECORDS  
Channon Court. Kingston TAS 296 807  
KENTRONICS  
37 Pinjarra Rd. Mandurah WA 353 227  
J & J MOONEY ELECTRONICS  
Shop 3 Lawson St. South Maitland WA 721 339  
LETON RECORD CENTRE  
110 Pine Ave. Lenton NSW 532 081  
MUDGE AUTO ELECTRICAL SERVICE  
73 Church St. Mudgee NSW  
WAGGA WHOLESALE ELECTRONICS SALES  
87 Forsyth St. Wagga NSW

ALLAN NORRIS PTY LTD  
Pacific Hwy. South Grafton NSW 423 400  
NEWTONS OF SALE  
South Giffordland Hwy. Sale VIC 441 244  
NABLES SPRINGWOOD ELECTRONICS  
228 Macquarie Rd. Springwood NSW 511 884  
NAMBOUR ELECTRONICS SHOP  
Shop 4 Lawson House Ann St. Nambour QLD 411 604  
PURELY ELECTRONICS  
15 East St. Rockhampton QLD 21 058  
ONE STOP ELECTRONICS  
62 Aerodrome Rd. Maroochydore QLD 431 611  
P.J. O'BRIEN ELECTRONICS  
270 Corp St. Bega NSW 21 598  
PETER PHILLIPS ELECTRICAL  
77 Marsh St. Nowra NSW 20 722  
THE RECORD CENTRE  
222 Bona Ave. Griffith NSW 621 577  
SUMMER ELECTRONIC SERVICES & SALES  
95 Mitchell St. Bendigo VIC 431 917  
SONAR SHIP SUPPLIES  
130 Spence St. Cairns QLD 511 912  
SILICON CHIP ELECTRONICS  
Suite 3 98 Bridge St. Muswellbrook NSW 431 096  
SOUND COMPONENTS  
78 Brisbane St. Tamworth NSW 681 363  
ADVANCED ELECTRONICS  
5A The Quadrant. Lonsdownen TAS 317 075  
STEVENS ELECTRONICS  
42 Victoria St. Macchay QLD 511 723  
TOMORROW'S ELECTRONICS & HI FI  
68 William St. Gasford NSW 247 246  
TROPICAL TV  
249 Fulham Rd. Vincent QLD 791 421  
TABLELAND RADIO SERVICE  
2 Jack St. Atherton QLD 912 017  
TAYLOR ENTERPRISES  
Duncan Hwy. Halls Ch. WA 52  
TELE CLINIC — ALBURY  
538 David St. Albury NSW 215 883  
THOMPSON INSTRUMENT SERVICES  
79.81 McLeod St. Cairns QLD 512 404  
V.K. ELECTRONICS  
57 West Park Grove. Burnie TAS 311 708  
WELLINGTON ELECTRICAL SERVICES  
110 Leo St. Wellington NSW 8325  
VENTRONICS  
Japa Shopping Centre 24-28 Cavanagh St. Darwin NT  
LYN WILLING TV  
22A Evans St. Inverell NSW 721 821  
WEBSTER ELECTRIX  
101 Mara St. Echuca VIC 827 956

## YOUR COPY'S MISSING?

Please send 75c to Dick Smith Mail Order Centre P O Box 321, North Ryde, N S W



# electronic games

volved TV games. Another indication of what was soon to come took place late the same year when Mattel brought out two hand-held games, "Football" and "Auto Race," both controlled by Rockwell PPS-4 4-bit microprocessors. The Mattel games retailed in the \$25 to \$35 range.

At least 20 semiconductor companies had the technology in 1977 for massive penetration of the toy industry, but Texas Instruments moved the quickest. It explained to toy manufacturers that the same chip used in the "Little Professor," through appropriate programming, could play many other roles.

In designing the "Little Professor" as a learning aid for children five years or older, TI had combined electronics with an old educational practice, flash cards. The game generated a sequence of pre-programmed problems in addition, subtraction, multiplication and division; more than 16,000 individual problems could be presented. After the child selected one of four levels of difficulty, the "Little Professor" asked questions and the child replied. Answers were "graded" and a score was displayed.

According to a TI spokesman, the "Little Professor" may have been the best semiconductor salesman in the industry's history. TI's 4-bit microcomputer caught on fast and in the three-year period which followed, it won over toy company after toy company.

As the TMS1000 began to catch on in 1977, TI's own consumer products operation and the company's customers conveniently moved in different directions. TI continued to develop educational aids, while its customers concentrated on games of fun, chance, and skill. But TI's next learning aid, like the "Little Professor," also demonstrated features that the toy industry could appreciate.

The product was called "Data Man". It introduced a "beat-the-clock" timing feature and rewarded winners with "whiz-bang," a highly visual action-packed display styled after the "home run" antics provided by some stadium scoreboards. It also provided suitable commentary for errors (although Fairchild's "You lose, turkey," was probably the best of all display messages to losers). "Data Man" was a calculator-based learning aid like the "Little Professor," but it was more sophisticated and it included math strategy problems.

**First of the "Talkies".** Encouraged by the success of the "Little Professor" and "Data Man," in late 1977, Texas Instruments decided to build a learning aid that could speak electronically, but with human inflection and fidelity. A massive research study was made to see if a market for such a product existed.

The conclusions reached were that the concept was viable, that a neutral, masculine voice was more acceptable than an unusual or artificial voice, and



Speak and Spell from Texas Instruments — its release stunned TI's competitors.

that the public would accept a \$55 retail selling price.

TI, after deciding that the talking aid would have to speak at least 200 words, consulted educators and selected words commonly misspelled for the product's vocabulary. At this point responsibility for development of the product was assigned to Paul Breedlove.

Breedlove found that he could generate audible speech from coded digital information for the desired 200 words through the use of four chips. One of these chips, obviously, would be the TMS1000, which was assigned to handle all of the control functions. Two of the chips were 128K-bit TMC0280 read-only memories, already designed by TI. The fourth chip, however, a speech synthesis integrated circuit, would have to be developed.

The job of designing the speech chip, designated the TMC0350, went to Larry Brantingham and Richard Whiggins. They decided, in effect, to develop an electronic model of the vocal tract. Just as human speech is created by air impelled through the vocal tract, synthetic speech would be generated by processing pulses through a rapidly changing electronic filter.

The concept was based on converting speech into frames of 12 digital codes, each at the rate of 40 frames per second. As each frame of a motion picture stops the action for that instant of time, each frame of speech "stops the action" of the vocal tract for 1/40th of a second. This action is then converted into 12 codes that represent the pitch for that instant. Thus, to artificially produce speech, the microcomputer recalls speech frames from the memory. The pitch characteristic for each frame determines

if the electronic impulse will be a vowel or a hard consonant sound.

The sound is combined with a loudness level characteristic to determine how loud it should be, and it is then processed through a 10-stage lattice filter where it is combined with the 10 vocal tract characteristics. In effect, this filter acts on the electronic signal to accomplish what the vocal tract does to the air signals from the lungs. Next, the signal is passed through a digital-to-analog converter to a small loudspeaker.

**"Speak and Spell".** The new product was named "Speak and Spell". It was introduced in June 1978 and was an instant success.

Operation of Speak & Spell is simple. A child presses a button and is asked to spell a word. As the child presses each letter, the machine announces the letter. When the child has finished spelling the word, he presses "Enter," and the machine replies "That is correct," or "Wrong. Try again." After ten words, the learning aid plays a tune, and says, "Here is your score".

"Speak & Spell" was joined by two more TI learning products in 1979, "Spelling B" and "Mr Challenger". Recently TI added an ear phone, an AC adapter plug and automatic powerdown (after five minutes of non-use) to "Speak and Spell". It also brought out a plug-in module that converts the unit into a Japanese-speaking model. And, for Christmas 1980, TI brought out two advanced versions, "Speak & Read," and "Speak & Math".

Reprinted from "Popular Electronics" magazine.  
Copyright © 1980 Ziff Davis Publishing Company, USA.



# FORUM

Conducted by Neville Williams

## The 1905 W.T. Act may be retired at last — Departmental officers tackle a big job

In times past, I have made some rather disparaging remarks about the Wireless Telegraphy Act of 1905, and the patchwork of rules and regulations which has since been pasted over it. Such being the case, it is only fair that I should record the determination of the present administration to substitute order for chaos in this troubled area.

One aspect of the overall problem was raised in these columns in the February issue — that to do with the ready availability in the shops of transceivers and cordless telephones which have not received (and perhaps could not receive) type approval by the Department of Communications.

It provides the most recent example of an anomalous (and long-standing) situation, whereby it is legal to produce, or import, or buy from Government disposals — and then sell to the public — equipment which the public is forbidden to use. How to act in the face of what we described as an “administrative mess” has long posed a neo-moral problem for all concerned: importers, retailers, advertising executives, publishers, and the public.

Indeed, Australia is not alone with this problem, as is evident from an editorial in the February issue of the English magazine “Practical Electronics”. They find themselves in a no-win situation, because the British Home Office is also trying to administer space-age communications with procedures and attitudes flowing from a steam-age act. The present dilemma has to do with the “Open Band” — their contrived term for CB.

It should be acknowledged that officers of Australia’s Department of Communications (formerly the Radio Branch of the PMG or P&T Departments) have been acutely aware for a long time of the unsatisfactory legal situation. On many occasions, individuals have shared with me their concern and their hope that something would be done by this government or that.

But increasingly, and especially following the appearance of CB radio, they

have succumbed to the conviction that nothing was likely to eventuate in their time!

For some, however, it could indeed be starting to happen, although it might be a bit early to hold one’s breath. The proposal to update the 1905 Act has been in the too-hard basket for so long that considerable time might elapse before the present good intention is transformed into effective legislation.

The encouraging thing, right now, is a letter expressing the Government’s intention to move, over the signature of Mr Ross Ramsay, First Assistant Secretary, Radio Frequency Management Division, Department of Com-

munications. Problem areas are listed and, with them, the proposed corrective measures. By and large, I would heartily endorse them, although quite a few “ifs” and “buts” are likely to emerge from debate.

One major shortcoming in existing legislation is that the Department of Communications has no real power to control electromagnetic radiation from devices which are not transmitters within the meaning of the original Act. Inspectors have traditionally managed to “persuade” manufacturers and others to curtail potential radio frequency interference — but always at the risk of being told to go jump in the lake.

For example, their hands were tied in the case of a deliberate jamming device offered for sale in Queensland (“Australian CB Scene”, June ‘80). They can only request interference suppression in the case of electronic dimmers and speed controls (“Forum”, October ‘80). There have even been times when the PMG Dept has had to put up with interference to their own microwave links from industrial RF welders.

The proposed legislation would correct this situation and give them control over all electromagnetic emissions, including incidental emissions from “non communication” sources.

The intention is commendable but how to put it into practice is going to pose many problems. It would seem necessary to specify in legal terms all devices, products and installations which may be capable of producing significant electromagnetic radiation, and then require that they be subject to spectral analysis, as is currently done with transmitters.

In short, it will seemingly involve a two-tier system of type approval to ensure that all electrical equipment conforms to safety standards (as at present) and to interference limits (as projected).

It will cost money and complicate the manufacture, import and sale of electrical equipment, but how else are we going to restrain the rising tide of electrical interference in our homes, on our



roads, and in our environment generally?

And don't forget: the rising tide of electrical interference is one of the factors which is forcing a progressive increase in the power of radio, and TV and other transmitters — something that people are beginning to worry about for health reasons, although such worry lacks a foundation in most cases.

One other thing should not be forgotten, namely that, in the past, the Radio Branch has had a rather mixed reputation with those who have sought — or should have sought — type approval of transmitting equipment.

With "on side" suppliers, they have been co-operative enough but, on occasions over the years, representatives of those suppliers have mentioned to me their anxiety to stay on side with the Department. There was an obvious nervousness about following any course that might ruffle official feathers, no matter how logical that course might have seemed.

As for those outside the mainstream of communications, there has been loud (and unreasonable) objection to the testing fee, apprehension about delays in obtaining approval, and an often-voiced suspicion that non-mainstream equipment wouldn't get through anyway!

Without seeking to debate such allegations, one thing is obvious: if the Department's role and power in the matter of type approval is to be expanded, it must be seen to operate in an automatic, efficient and impartial manner. There must be no hint of preference for pals.

Otherwise, expanded activities will generate only massive resentment.

## RECEIVER LICENCES

Another problem area, referred to in our last month's editorial, has to do with the licensing in Australia of all wireless receiving equipment — a firm requirement, under the Wireless Telegraphy Act, and one which probably seemed appropriate at the time.

Framed long before there was any idea of public broadcasting, the provision had its roots in the thought that the secrecy of wireless messages — like telephone messages — needed to be protected by legislation. What better way to do this than to licence all receivers?

But, just in case a message should be overheard by someone else within earshot, or inadvertently intercepted, the Act also made it an offence to reveal the contents of a wireless message, or even the fact that a message existed!

Subsequently, with the evolution of public broadcasting, listener's licences were seen primarily as a means of raising revenue to meet the cost of it. Then, a few years ago, in a somewhat political decision, broadcast listener's and TV viewer's licences were abolished. As a result, a multitude of receivers, which would seemingly require a licence under the WT Act, are excused therefrom under Broadcasting and Television

legislation.

What further confuses the issue is tacit acceptance of the principle that any tuneable receiver which covers the broadcast band IS a broadcast receiver. That lets in a vast assortment of multi-band receivers, which are further legitimised by the fact that the Government provides broadcast services for listeners within their extended coverage.

And now, of course, the Government also permits and provides still further broadcast services in the form of VHF FM, VHF TV and UHF TV. One is prompted to remark that "broadcast" receivers now come in more shapes and sizes than UFOs!

And, far from involving any element of secrecy, broadcast services on medium-wave, shortwave, VHF and UHF are aimed at the widest possible audience, with the further hope that the "message" will be discussed publicly and favourably.

Essentially, amateur radio and CB radio are also communal activities, as are out-back, boating and other group services.

So plentiful and so varied is the receiving equipment available to listeners, these days, that the notion of preserving secrecy by legislation is a very hollow one. In any case, a resourceful person wanting to intercept and misuse confidential transmissions is not likely to be deterred by a licencing regulation.

In short, the whole realm of "wireless" communication has become so much a public domain that the responsibility for restricting access to confidential material must now logically rest with the sender and receiver. Technology for encoding or "scrambling" messages is readily accessible for those who may deem it necessary.

Recognising all this, the Department is proposing to abandon the regulation of receiving equipment, except in respect to harmful emissions — presumably radiation from oscillators, TV deflection systems, etc.

## FROM THE USA

By coincidence, in the very week that the correspondence arrived from the Department of Communications, a copy of the American publication "73 Magazine" landed on the table. In it, Editor Wayne Green draws attention to the fact that US newspapers had recently published a transcript of tape-recorded conversations between US Air Force personnel. The conversations related to the search for a missing (presumably nuclear) warhead, following an explosion and fire in a missile silo in Arkansas.

Said Wayne Green: "If ever there was a case where the FCC rules in section 605 regarding the privacy of radio transmissions was being broken, it is here. If the FCC lets this go untouched . . ." etc.

His challenge to the FCC is interesting, in that it confirms the continued existence of secrecy provisions in US legislation.

## Every printed circuit ever published in EA & ETI

- Accurate machine printed etched circuits
- Send \$5.00 for Computer Printout listing every project in stock
- Specials to your artwork
- Postage on PCB's add \$1.00

598A	2.80	ETI 329	2.80	598B	2.80
81DC2	2.80	80IF12	2.80	81SP1	3.00
477	4.00	81SW1	3.50	80FB12	3.00
80SA10	7.00	328	2.80	80RM12	3.00
ETI 1500	9.00	80AD12	3.00	ETI 1500	9.00
80MV11	2.80	ETI 572	3.50	80RAM12	5.50
ETI 476	4.00	80LS12	3.20	ETI476	4.00
255	2.80	247	2.80	80TRS11	2.80
80LBRI2	2.80	80DC10	4.80	80AW10	3.00
80TC12	2.80	80BM10	2.80	80ST10B	2.80
80ST10A	4.50	80TM8B	2.80	EA80TM8A	5.00
568	2.80	327	2.80	ETI147	3.00
ETI475	4.00	ETI457	3.00	ETI326	2.80
80LPG9	3.50	80B7	2.50	80DM9	4.50
80TR9	3.50	250	2.50	564	10.50
ET1324	3.50	80LL7	2.80	80M07	3.00
80PC7	3.00	80LL7	2.80	80M07	3.00
563	2.80	80CH7	4.80	565	3.50
80PP7B	2.50	467	4.00	149	2.80
80G6	4.00	80PP7A	5.00	80RF5	2.80
80D6	3.00	578	2.50	636	16.00
80PA6	12.00	78AF2	3.00	ET58820	10.00
80BB3	2.80	77CB12	2.60	78EK3	3.30
454	3.00	ET135	3.00	781A2	2.60
80AW4	4.00	ET135	2.80	ET716	4.00
80C14	2.80	80HHS6	2.50	ET245	2.50
466	6.00	325	2.50	78S3	2.60
80AU3	3.00	80PC4	3.00	77PH12	2.60
264	2.50	562	3.30	80PG6	5.00
322	2.80	453	2.80	80HLA5	2.50
80S1	2.50	566A	2.50	80TV8	3.30
ET560	2.80	80GPS3	2.80	566B	3.00
ET151	2.50	496	5.00	80F3	2.80
79D10	2.80	496G	6.50	80F3	2.80
79T11	2.80	80CM3A	3.20	ET152	2.80
ET262	2.50	561	2.80	726	8.00
ET150	2.80	80GA3B	3.20	80CM3B	2.80
79P9G	3.00	79SB10	2.80	455	3.00
ET573	2.80	ET452	4.50	80GA3A	5.00
79M9R	3.00	80SA3	4.50	ET474	2.80
79RT9	2.60	79EB12	2.80	ET321	3.50
79AC9	3.50	ET270	2.80	79FE11	2.80
ET576	4.20	ET261	2.50	79PC12	2.50
ET730	3.50	ET146	2.50	ET263	2.50
ET252	3.00	79MD9	2.80	ET260	2.50
79WF8	3.20	ET577	2.80	79PS11	2.50
79PS6	2.80	79PS10	2.80	ET606	3.00
6800	8.50	79SF10	2.50	ET473	3.50
79UPS6	2.50	79T7	2.60	79R18	2.80
ET144	3.50	79SF9	2.60	79A19abc	4.20
79R05	3.00	ET574	2.80	79W9	2.80
77E02A	3.50	ET814	2.80	ET731	3.00
ET320	2.50	79SR8	2.80	ET575	2.50
ET595	2.80	79UT8	3.00	ET725	3.50
491	4.50	79FR6	3.50	79TRF5	2.50
79PS3	2.60	ET472	3.00	79M8	2.80
79P18	2.80	79C17	4.80	ET148	2.50
79C1A	3.00	79SA5	8.00	ET724	2.50
142B	4.00	491	4.50	79KB7	2.80
79S1	4.50	79E02C	2.50	ET651	4.50
79IT2	5.00	ET249	2.80	ET471	5.50
78S12A	5.50	ET253	4.20	79E02B	4.00
78N10	2.60	559	3.80	ET594	2.50
78DT10C	2.50	78Se3	4.00	ET470	3.20
ET813	3.50	79P1A	2.80	79A3	3.00
ET812	2.80	558	2.50	721	3.00
ET556	6.00	142A	8.00	79PB2	3.20
78BB09	3.50	79W3	2.60	78C1B	2.80
650B	2.60	80SB12	3.00	557	3.00
718	2.60	781M12	3.00	79UP1	5.00
		78C11	3.10	79C11	2.60
		78DT10B	2.80	78S12B	2.50
		ET143	2.80	78UP10	7.00
		ET593	3.20	78OT10D	2.50

## HOURS OF TRADING

Mon to Fri: 9am to 5pm. Sat: 10am to 3pm.

Special 24 hr prototype service now available. Ask for our FREE quotation.

MAIL cheque or money order (add postage) direct to —

## RCS radio pty ltd

651 FOREST RD BEXLEY  
NSW 2207 587 3491

**IT'S HERE!**

# sinclair ZX80 MICRO COMPUTER

## PICK IT UP! TAKE IT HOME! PLUG IT IN!

### Bridge the gap into the future.

Now available — the incredible Sinclair ZX80 Home Computer. Small, fast, and very powerful — the Sinclair ZX80 is excellent as an introduction to tomorrow's world of computers. Superb educational value — children (and parents of course!) can now learn computer programming and operation at home.

**ZX80 PLUGS INTO MOST B&W OR COLOUR T.V.'s**



The Sinclair ZX80 comes complete with VHF modulator — so it simply plugs into your television aerial socket — and you're ready to go!

**RUN AND STORE PROGRAMMES USING YOUR OWN CASSETTE RECORDER.**

Sinclair's cassette interface allows you to run or store programmes with your own cassette recorder — see the introductory range of Linsac programmes available.



**ZX80 COMES COMPLETE WITH A 128 PAGE MANUAL — A FULLY ILLUSTRATED COURSE IN BASIC PROGRAMMING.**

An ideal introduction to BASIC. The operating manual is easy to understand, and written for the beginner. The Sinclair ZX80 will not only provide hours of entertainment while you're learning BASIC programming, it will also provide an excellent insight into a possible future career.



**ZX80 IS PROGRAMMED IN BASIC — THE MOST POPULAR COMPUTER LANGUAGE.**



sinclair  
ZX80

#### TECHNICAL INFORMATION

- Full screen contains 32 characters by 24 lines.
  - 1K RAM expandable to 16K BYTES.
  - One 'SUPER ROM' houses the BASIC interpreter, operating system, monitor and character set.
  - Single touch 'KEY WORD' entry.
  - SYNTAX errors identified at programming stage — not after you've tried to run your programme.
- \*Power required: 9V 600 mA DC (Not Supplied).....\$16.00

**LINSAC**  
**ZX80**  
**PROGRAMMES**

The following programmes are also available on cassette.

- Games Pack One
- Games Pack Two
- Games Pack Three
- Education Pack One
- Education Pack Two
- Utility Pack One

**ONLY \$12.00 EACH**

PICK IT UP FROM

**DAVID REID ELECTRONICS LTD.**

**SYDNEY**  
127 York Street  
PO Box Q103, Sydney 2000  
NSW, Australia  
Phone (02) 296 601

**MELBOURNE**  
356 Lonsdale Street  
GPO Box 1417 M  
Melbourne 3000 Aust  
Phone (03) 602 4673

B'card No. ....

Expiry Date .....

Name .....

Signature .....

NORRIE 1200

But what really intrigued me is that, in this day and age, the USAF should presumably still be using plain language transmissions in such a sensitive context — the search for a missing warhead!

If the use of receivers by the Australian public is re-regulated, one wonders what will happen to the secrecy provisions in the original Act. I did not notice any mention of them in the documents to hand. If a secrecy provision is to be retained in new legislation, it would presumably have to relate to certain classes of communication only, and their definition might pose quite a problem.

It may well be that this whole matter may gravitate towards the observance of copyright, rather than a wishful effort to impose secrecy by legislation.

**BROADCASTING, TV**

On another aspect, a statement in the Department of Communications release is to the effect that: "The new legislation is not intended to deal with broadcasting and television services, except to enable control of interference to them."

To the outsider — if not the insider — there has always been a sense of confusion between the responsibilities of the traditional PMG Radio Branch and the Broadcasting Control Board, or Tribunal. If further compounding is necessary, it is provided by the ABC, which has its own technical officers and areas of responsibility.

More than once, station engineers have complained to me that, if they want to change anything, they are answerable to about a dozen different bosses!

The de-regulation of receivers may obviate some of the hassles at a citizen level but the legislators will still have plenty to keep them busy in trying to erect fences between the various statutory authorities, to keep them apart, while still requiring them to co-operate in certain areas.

Incidentally, the de-regulation of receivers will not mean the automatic disappearance of all licences. The Department of Communications proposes to retain the present practice of licencing specific radio services, allocating specific frequencies or channels, requiring the use of type approved equipment, conducting examinations for operator qualifications where these are appropriate, and revoking licences in the event of serious offences.

In this context, amateur station operators may be excused for a slight tremor of alarm. They are currently permitted to build or modify transmitting equipment, and experiment in other ways, provided they do not step outside certain constraints on frequency, power level, spurious radiation, etc. It would be a sad day for amateur radio if ever they were saddled with formal type approval.

One interesting variation has to do with powers of search where a breach of the regulations is suspected. Under the 1905 Act, authority to search may be granted to "any person". In the proposed new legislation, authority to search and seize equipment will be granted only to police officers or specially appointed inspectors. Forfeiture of equipment may not be automatic, as it is at present, but may require a court order.

Also, in the context of licences, present intention is that "broadcast" receivers will be licence-free and/or outside the jurisdiction of the Department of Communications, except in respect to undesirable electromagnetic emissions.

But that presumably does not mean that a future government could not, if it saw fit, impose a licence or tax on broadcast radio and TV receivers for revenue purposes!

**TECHNICAL STANDARDS**

On the subject of technical standards of communication equipment, the Minister would be empowered to adopt and proclaim such standards — a power that is not implicit in the existing Act.

In addition, the legislation would seek to empower the Minister, to the limits of the Constitution, to control the manufacture, the importation and the sale of equipment which fails to meet those standards.

This should obviate the embarrassment of those with a tender conscience and/or a sense of communal responsibility, and curb the activities of those who are not so afflicted!

But what about the Government itself? Will it also "control" the disposal of surplus transmitting equipment which could not gain civilian type approval?

**EMERGENCY POWERS**

One other proposition is noteworthy in that the Governor-General should be given power to impose restrictions on the use of radio in specified areas at specified times. This is intended primarily to cover emergency situations but may cover special circumstances (eg restrictions on use on scientific sites or in defence areas).

The document adds the comment: "The present Act does not address these matters."

Well, that's for starters. Departmental officers are obviously open to suggestions as they try to spell out what is needed.

Says M. R. Ramsay, First Assistant Secretary: "Should a Bill be introduced in Parliament, it is anticipated that a period would be allowed for public comment before it is debated."

Hopefully, there will be a lot of useful public, trade and industry input before the words are frozen into a draft bill. ☺

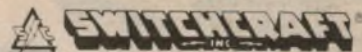

**CONNECTORS & ELECTRONIC COMPONENTS**

**Superb quality and reliability from one of the oldest and most experienced manufacturers in the USA.**

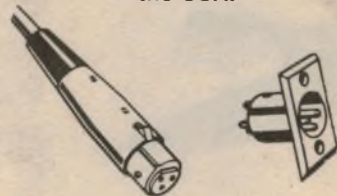

*QG Audio Connectors  
Die Cast Shell, PA & General Applications  
Available Nickel or Mat Black*



*QGP Professional Audio, Non-Reflective Vel-Tone Finish, Positive Ground, Die Cast Zinc Shell*

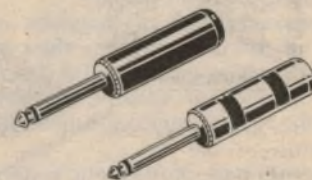

*Phono Plugs, Available Plastic or Brass Handle, Wide Range of Configurations*



*JP Series — Modular Jack Panels, Black Anodised Up to 40 Configurations*

**AUSTRALIAN DISTRIBUTORS**

**AUDIO TELEX COMMUNICATIONS PTY LTD**

<b>SYDNEY</b> 1 Little Street Parramatta, 2150 Tel: 633 4344	<b>MELBOURNE</b> 7 Essex Road Mt Waverley, 3149 Tel: 277 5311
---	--

**BRISBANE**  
394 Montague Road  
West End, 4101  
Tel: 44 6328

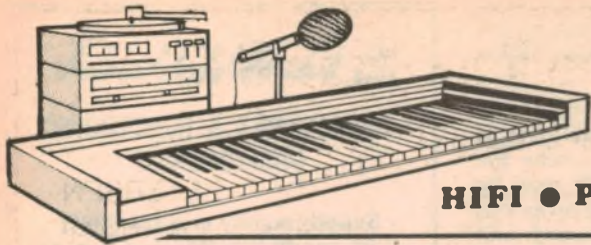

# AUDIO - VIDEO ELECTRONICS

HIFI • PROFESSIONAL AUDIO • ENTERTAINMENT



## PHONO CARTRIDGES AND STYLI — SOME BASIC PRINCIPLES REVISITED

These days, the vast majority of hifi enthusiasts use magnetic phono cartridges with diamond styli. This article, sourced from Ortofon of Denmark, may assist newcomers who have not yet sorted out some of the relevant terms which occur in hifi literature.

In broad terms, a magnetic cartridge is one in which movement of the stylus mechanism in a magnetic field causes a signal current to be generated in associated coils. This produces a signal voltage which is fed to the amplifier system.

As distinct from "magnetic" cartridges, types using the so-called "piezoelectric" principle have been very popular, but mainly in lower priced record playing equipment. The two best known variants are "crystal" cartridges, now largely superseded in popularity, and "ceramic" cartridges, as fitted to many budget priced players.

The manufacturers of magnetic cartridges have coined a variety of terms to describe their product but most fall into one of the three groups to be described: moving magnet, induced magnet, or variable magnetic shunt (VMS). In all of these, the magnetic circuit is manipulated, the coils remaining stationary.

In another type of magnetic system, the magnetic circuit remains stationary but the coils move, thereby generating the signal current and voltage.

**MOVING MAGNET:** The most common magnetic cartridge is the moving magnet. Here, the magnetic field emanates from a tiny, fixed magnet that is fastened to the remote end of the cantilever.

When the magnet is set into motion, which occurs when the stylus follows the modulations of the record groove, the magnetic field through the coils changes, and electrical voltages are generated in the coils. Although a moving magnet cartridge uses a tiny, powerful magnet on the cantilever, the weight of the magnet can still constitute something

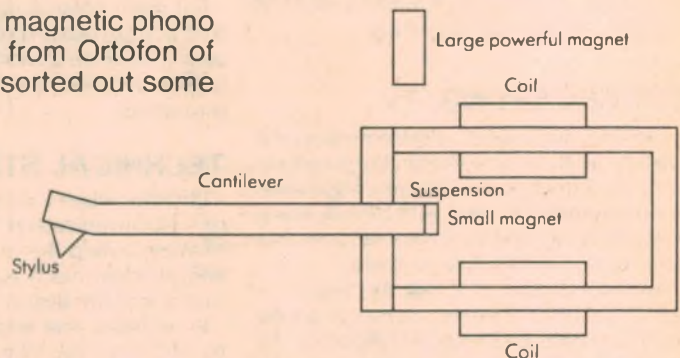

Fig. 2: By using a very small moving magnet and a large fixed magnet, the induced magnet cartridge achieves lower tip mass at the expense of extra weight in the cartridge itself.

of a restraint on the cantilever, increasing its mass and reducing its ability to react precisely to transients in the music. (See Fig. 1)

**INDUCED MAGNET:** This type of cartridge must be considered a further development of the moving magnet type. With the induced magnet cartridge, it is possible to use a smaller and lighter armature on the cantilever because a larger, powerful, fixed magnet increases the moving element's magnetic strength.

Compared to a moving magnet cartridge, the total mass of the cantilever can be reduced, thus improving transient reproduction. On the other hand, the cartridge's weight is increased by the fixed magnet, which may render this type of cartridge unsuitable for use with tonearms which already have a high mass. (Fig. 2).

**VARIABLE MAGNETIC SHUNT (VMS):** This represents the latest development of the magnetic cartridge principle.

The cantilever in a VMS cartridge can be made extremely

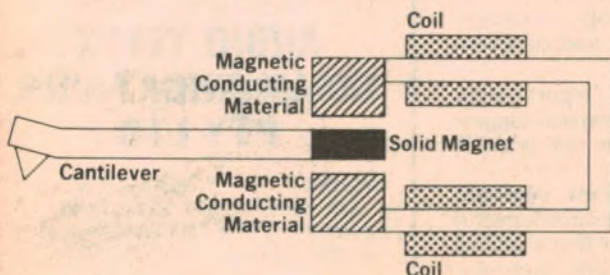

Fig. 1: The moving magnet system, the one most commonly used. Movements of the magnet produce currents in the coils. For simplicity, only one pair of coils, for one channel, is shown.

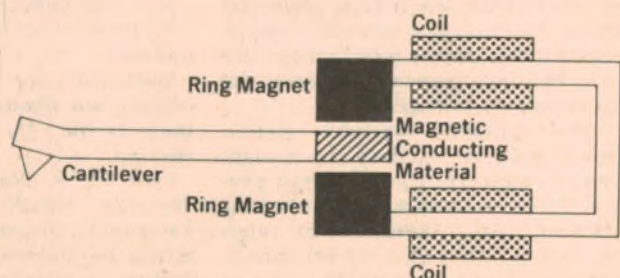

Fig. 3: The VMS or Variable Magnetic Shunt principle used in Ortofon's Low Mass cartridges. A tiny armature modulates the field between a ring magnet and the tips of four coils.

light because it is not weighed down by a magnet.

Here, the magnetic field emanates from a fixed ring magnet that encircles the cantilever, the rearmost part of which consists of a thin-walled armature of magnetic conducting material. When the cantilever is set in motion, the armature short-circuits part of the magnetic field, and a voltage is generated in the coils.

The VMS principle not only makes it possible to reduce the mass of the cantilever to an absolute minimum, but the construction is such that the weight of the entire cartridge can be reduced, making the VMS cartridge suitable for use with a large number of tonearms.

The special construction of the VMS principle means that the magnetic operating point in the cartridge may be placed at the origin of the induction curve, where there is no risk of non-linearity that can lead to distortion. The VMS principle has made it possible to produce low mass cartridges with a weight of only 1.5 grams. (Fig. 3).

**MOVING COIL CARTRIDGES:** The first cartridges with true hifi specifications were developed in the mid-forties and were of the moving coil design.

In general, moving coil cartridges are more expensive than magnetic cartridges and they do not, therefore, enjoy the same popularity. However, the most demanding hifi enthusiasts remain loyal to the moving coil design, because of its greater linearity and lower distortion.

Compared with a moving magnet cartridge, the reverse principle is applied in the moving coil cartridge. Here, a powerful fixed magnet is used and the coils are mounted on the cantilever itself. When the coils move in the field of the magnet, they cut the flux lines of the magnet and voltages are generated in the coils. (Fig. 4).

Fig. 4: In a moving coil cartridge, a nest of tiny coils attached to the cantilever, move within a powerful magnetic field, generating signal voltages and currents.

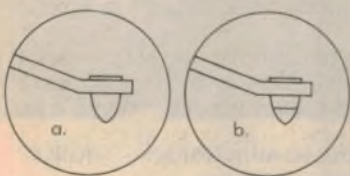
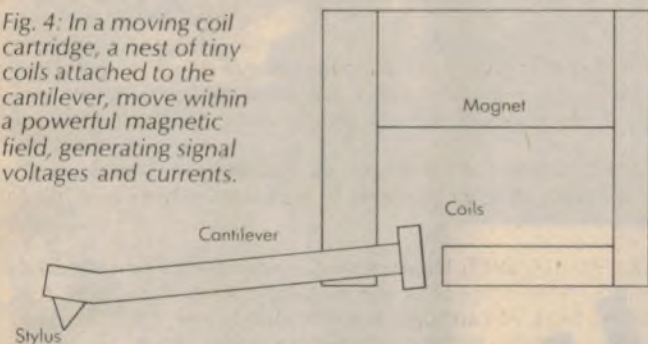

Fig. 5: (a) shows a whole or "nude" diamond stylus. (b) shows a diamond chip on a metal shank.

Once again, with a moving coil cartridge, it is important that the moving parts be as light as possible. Therefore, there are normally only relatively few turns of wire in the coils, and the output voltage from a moving coil is generally so low that it cannot feed a conventional amplifier without special steps being taken.

Nowadays, it is becoming more common to equip amplifiers in the higher price range with a special input stage for moving coil cartridges, but otherwise it will be necessary to purchase a transformer or pre-preamplifier before a moving coil cartridge can be connected to the phono inputs of a normal amplifier or receiver.

**OTHER CARTRIDGE TYPES:** The cartridge types mentioned in the preceding paragraphs are the most common and by far the majority of cartridges on the market today belong to one of these groups.

Many attempts have been made to use other electrical transformation principles, and some of the prototypes have —

## The importance of cartridge mass

by Ib PETERSEN

Technical Director, Ortofon Mfg A/S

*How significant is the total mass of a cartridge in relation to ultimate playback quality?*

It is very significant because, if the mass of the playback system is high, the moving mass will also be high. This remains true, even if the tonearm is properly counterbalanced and the tracking force is set, say, to a low one gram.

For example, if the moving mass is of the order of 20 grams, and the cartridge has a high stylus compliance,

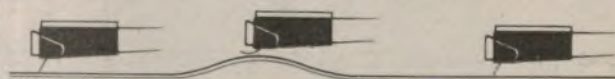

*A high-mass cartridge/toner tracking a warp.*

acceleration caused by warps in the record will not produce corresponding movement of the arm and cartridge. What tends to happen is illustrated above. Most of the upwards (or sideways) thrust is absorbed by the stylus and not — as it should be — by movement of the cartridge as a whole.

Because of unnatural pressures on the stylus mechanism, a high mass combination can produce or accentuate problems such as wow, sound colouration and acoustic feedback.



*A low-mass cartridge/toner tracking a warp.*

So if you want to use a truly high compliance cartridge — and this is important for accurate tracking ability at low frequencies — it is essential to ensure that the effective mass of the moving system be as small as possible. In practice it should be around 10 grams or less. But there is more to it.

All normal tonearms exhibit some natural low frequency resonance, of which the moving mass forms a vital parameter. Most modern quality tonearms have a moving mass of around 20 grams and, combined with a modern high compliance cartridge (15 $\mu$ m/mN to 35 $\mu$ m/mN) exhibit a natural resonance in the region 9.2Hz to 6.0Hz. This is too low, being in the range excited by record warps and acoustic feedback.

At the other extreme, a resonance at too high a frequency can be excited by bass notes on the record and result in a highly coloured bass end reproduction. Ideally, the resonance of the moving system should be guided into the 10-15Hz region and this underscores the desirability of selecting a cartridge which will combine the required high compliance with reduced mass.

*A typical Ortofon low-mass cartridge intended for use with a standard arm.*



These were the kind of factors which were taken into account by Ortofon during our LM — Low Mass — development program.

# A pro doesn't fiddle on stage.

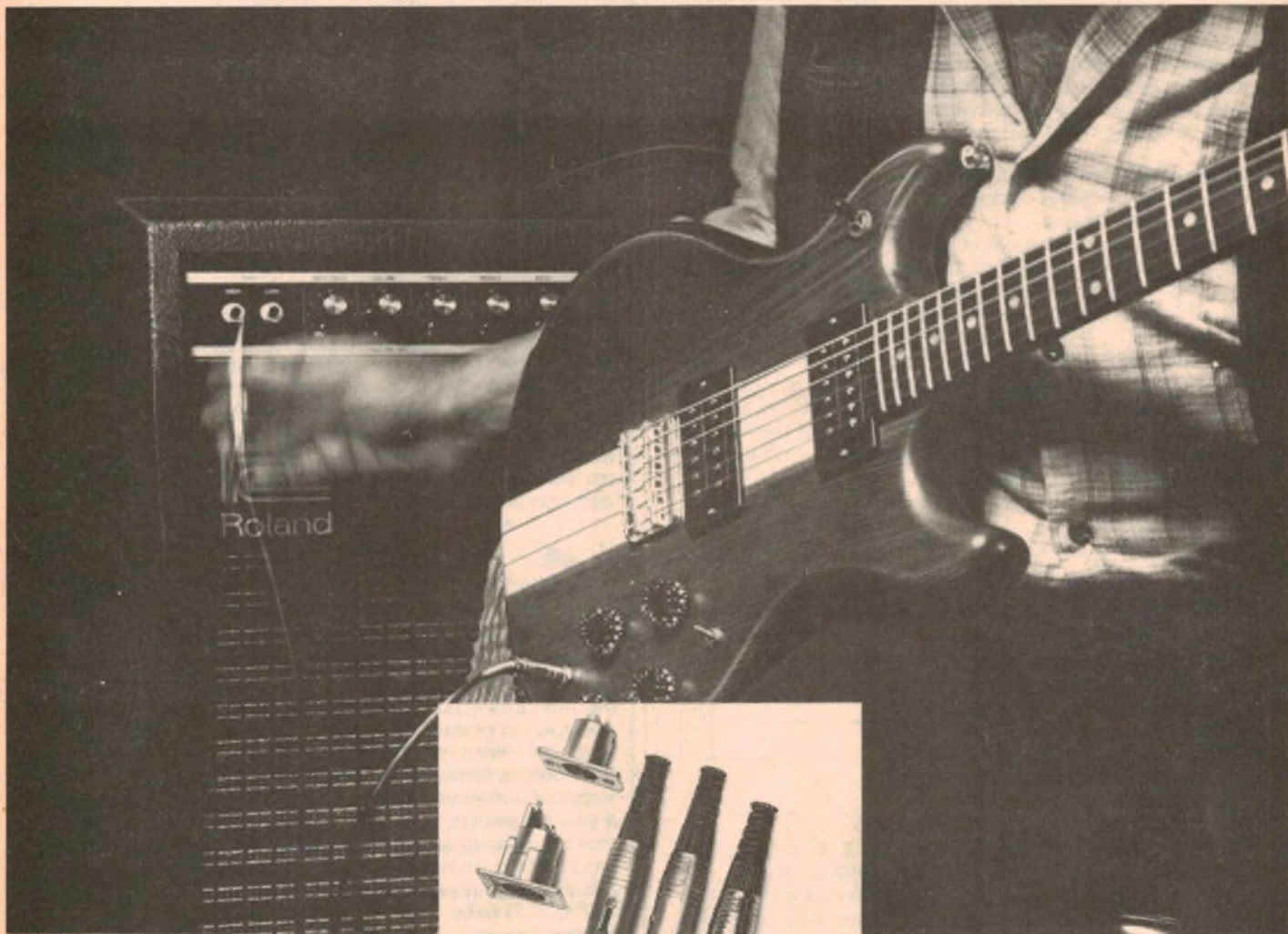

The crackle and hum of a loose audio connector is a pain for any performer. Especially when he's up on stage trying to give his best — and he has to keep running back to his amp to wiggle and fiddle a loose-fitting plug.

The Swiss attacked this problem and produced the superb range of connectors from Neutrik (pronounced NOY-TRICK).

They're built as solidly as a bank vault, as precisely as a Swiss watch.

The pins are anchored in high-temperature-resistant materials.

Once they're plugged in, they stay in. They are completely

isolated, to substantially reduce microphone noise.

The cable is tightly gripped, to withstand 100 lbs. of stress. Yet they're simply made and quick to assemble.

Yes, they do cost more than other connectors. But when you're up on stage and totally reliant on your equipment — the few extra cents won't matter a crotchet.

## NEUTRIK AUDIO CONNECTORS

Compatible with all XLR-type connectors in 3-, 4- and 5- pins.

R. H. Cunningham import some of the world's finest audio products — like Sennheiser microphones and headphones; radio mikes; voice synthesiser; loudspeakers — and more. Post this coupon for our Professional Audio Products Catalogue — free.

Name .....

Address .....

Are you a Musician/Engineer/Educator/  
Broadcaster/ Hi Fi Enthusiast/Other:

B&B RH136 AM

**R.H. Cunningham**  
PTY.LTD.

Audio equipment for professionals  
146 Roden Street, West Melbourne, 3003.  
4-8 Waters Road, Neutral Bay, N.S.W., 2089.



albeit to a limited extent — found their way into the hifi specialist shops. These are electret, condenser, and strain gauge cartridges, which require a special preamplifier section. They have so far not enjoyed much popularity on that account.

**THE STYLUS:** It goes, almost without saying, that the stylus is an extremely important component in a hifi cartridge. (Fig. 5).

It is usually made of diamond — the hardest material known — to give it maximum durability. However, the fact that it is of diamond is not sufficient in itself, for its construction and shape are also crucial factors in sound quality.

Many less expensive hifi cartridges use a so-called "tipped" diamond, where the diamond tip is mounted on a metal shank. However, such a shank may increase the stylus tip mass and thus impair the cartridge's transient reproduction, in comparison with a cartridge that uses a nude, untipped diamond.

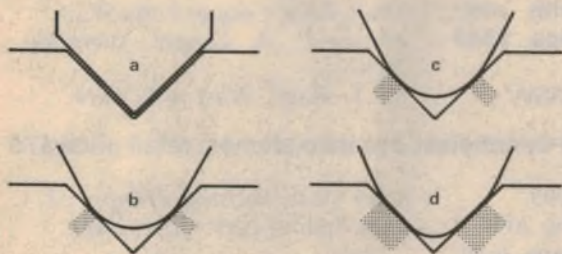

Fig. 6: A triangular stylus cutting a groove (a) and the contact area, shown shaded, for three popular types of stylus: (b) standard spherical; (c) elliptical and (d) Shibata or similar.

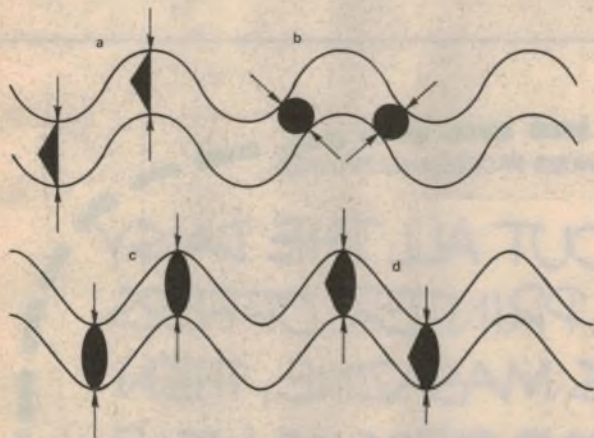

Fig. 7: Viewed from above, this is how the respective styli fit a typical groove. A spherical stylus (b) tends to be "pinched" where the groove is sharply angled, causing distortion.

There are several different diamond shapes to be found and the most important are described in the following paragraphs. (Fig. 6).

**THE SPHERICAL STYLUS** (b in Figs. 6 and 7) is the simplest and cheapest to produce and it is, therefore, the most common. Spherical styli can be recommended in all cases where robustness and economy are to be taken into consideration in the purchase of a cartridge.

**THE ELLIPTICAL STYLUS** (c in Figs. 6 and 7) comes just a little closer in contour to the triangular shaped cutting stylus that is used when cutting master records.

The elliptical stylus is able to follow the groove oscillations more accurately than the spherical type, and its distortion and phase error will, therefore, be less.

In the outer turns of the record groove where the diameter is greatest, it may be difficult to hear the difference between a spherical and an elliptical diamond, as there is relatively good space in the groove for the highest frequencies.

However, in the innermost turns of the record groove, the wider radius of the spherical diamond makes it difficult for this shape to track the finer groove undulations. This can muffle the treble, and lead to audible distortion in difficult passages.

There was a time when the experts disagreed about the choice between spherical and elliptical cartridge styli. However, this debate can now be considered resolved and today, very few, if any, elite cartridges are supplied with spherical styli.

**OTHER STYLUS TYPES:** The introduction, in 1971 of quadraphonic music reproduction from disc records, based on the CD-4 system, triggered a completely new development in the hifi cartridge field.

Cartridges for CD-4 records must be capable of reproducing frequencies as high as 45,000Hz.

This was more than the models in existence at that time could manage, as even the contact surface of the elliptical diamond is too wide for a 45,000Hz oscillation to be tracked accurately.

A solution to the problem might have been a sharper grinding of the elliptical diamond to obtain a reduced horizontal contact surface. This would, however, increase wear on the record groove considerably. The Japanese scientist — Shibata — went in an entirely new direction and invented the special stylus shape that now bears his name.

The Shibata shape distinguishes itself by having the necessary small contact surface at the horizontal level for playback of the ultra-high frequencies found on CD-4 records. At the vertical level, the special shape of the stylus gives a wider contact surface than is the case with either spherical or elliptical styli.

This means that a Shibata shaped stylus, in spite of its high frequency capabilities, gives less record wear than traditional stylus shapes.

Various cartridge manufacturers have been inspired by the Shibata shape and now produce cartridges with stylus shapes that give the same advantages as the Shibata. These have names such as bi-elliptical, pramanic, quadrahedral, hyperbolic, pathemax, and Fine Line.

Although CD-4 and other quadraphonic systems never really caught on with consumers, they have helped to speed up development of stylus types that improve playback of stereo records in the form of a more precise treble reproduction, lower distortion, and less record wear. 

## PORTABLE STEREO PLAYER FROM SANYO

Sanyo's new M 5550 "go-anywhere" stereo cassette player can bring high quality stereo sound to people on the move. It measures 80 x 132 x 25mm, weighs 340g and offers a response 63Hz to 10kHz. It is powered by two AA cells and can drive two sets of phones. RRP is \$229.



Congratulations! Here are

# THE WINNERS

In the R. H. Cunningham/Sennheiser headphone competition announced in Electronics Australia, December 1980:



In fact, it proved to be the most keenly supported competition we have ever sponsored. The winning entries were drawn personally by Mr Jim Cunningham, Managing Director of R. H. Cunningham Pty Ltd, while visiting the editorial office of "Electronics Australia". The successful entrants have already been notified by mail but their names are listed on the right.

● **FIRST PRIZE:** A pair of magnificent Sennheiser Unipolar 2002 stereo headphones, complete with matching unit, retail price \$349 goes to . . .

*Mr O. Carapet, Belrose NSW.*

● **Five pairs of HD400 Sennheiser dynamic phones, retail price \$79 to:**

*Steven Jenkins, Manly 2095.*

*Dale Anderson, Dee Why 2099.*

*J. M. Fetherston, Macquarie 2614.*

● **Three pairs of HD430 Sennheiser dynamic phones, retail price \$99 to:**

*Mrs J. Riha, Cooper Pedy 5723.*

*Master C. A. Gospel, Werribee 3030.*

*Mr T. Snape, West ryde 2114.*

*Peter Stork, Padstow Heights 2211.*

*John Adams, Lane Cove 2066.*

The management of R. H. Cunningham Pty Ltd would like to thank readers of "Electronics Australia" for their interest and support in this most successful competition.

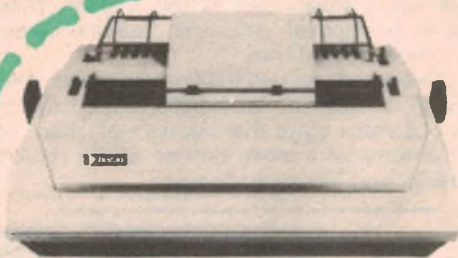

DIABLO QUALITY WORD PROCESSING PRINTER.

TEAR OUT ALL THE DAISY WHEEL PRINTER OFFERS IN THIS MAGAZINE, THEN 'PHONE MITSUI, SYD(02) 929 9921, OR MELB (03) 690 6722 FOR OUR SPECIAL PRICE ON A **DIABLO** 1345 OR 1355 HIGH SPEED. IF WE CAN'T EASILY BEAT ANY OFFER YOU'VE SEEN, WE'LL GIVE YOU **FREE**, **2 DAISY WHEELS!**



**MITSUI**  
**COMPUTER SYSTEMS**  
(Australasia) Pty. Ltd.  
7 West Street, North Sydney  
131 Sturt Street, 5th Melbourne.

# Video breakthrough by Technicolor

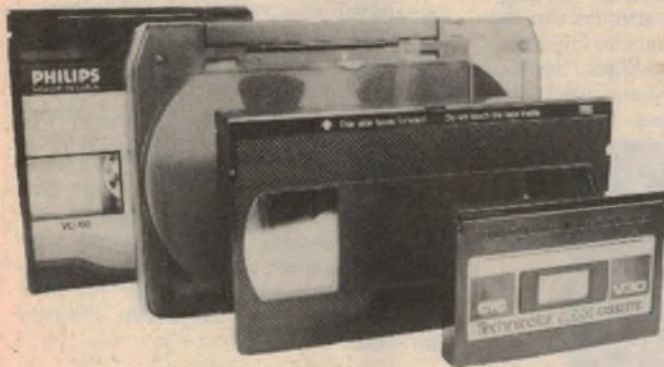

Left: Technicolor's compact video cassette, compared with other formats including the VHS immediately behind. Below, it is pictured alongside a normal audio cassette. The two are not interchangeable, however, the video cassette being of different mechanical design and carrying 6.25mm tape.

Mentioned in our December issue and pictured in February, Technicolour's ultra-compact VCR may well emerge as the "dark horse" in the video cassette race. By far the smallest and lightest VCR to go into production, the Technicolour VCR is not something projected for the future. Prototypes for the Australian PAL market are already here and the first stocks are due about the time you get to read this article!

As mentioned in December, the idea of a video cassette similar in size to a compact audio cassette was first conceived by Akai but was later taken over by the Funai Electric Trading Co of Osaka, Japan. Funai made good progress, but they also realised that a massive injection of capital would be necessary if the system was to get anywhere in a highly competitive market.

The backing and the capital they needed was provided by Technicolour of USA who, in turn, had realised their need to diversify from a film centred operation that was threatened by burgeoning video technology.

And the Funai system offered the right "angle" — a system that would appeal especially to a whole new breed of non-professional movie makers. They had in mind not just amateurs in the home, but business users (eg estate agents) police, utilities and local government officers, who might be attracted to video photography if it was inexpensive, versatile, portable and easy to use.

Now, with the technology of the Funai system sorted out, Technicolour are moving to launch it on a world scale.

An NTSC version was exposed through the media in the USA during September/October and the enormous influx of orders not only showed that the

The Technicolor portable VCR is at the rear left and, alongside it the power unit/charger. A removeable battery pack is in front of the VCR, with a V30 cassette in foreground. Other items are for antenna connection and switching.

A miniature helical scan system is used.

system was commercially viable — it also established it as a "standard".

The PAL version has arrived hard on the heels of NTSC and VHF/UHF RF modulators to suit receivers in different countries, including Australia.

And, in this country, the Technicolour compact video recorders are being distributed through Dynasound Pty Ltd, 333 Princess Highway, St Peters, 2044. (Phone 02 519 5284). The price is quoted as \$1349 plus \$1299 for a high quality colour camera with instant in-built video playback (mono) viewing.

As a portable recorder the Technicolour VCR measures 25 x 26 x

7cm, and weighs about 3kg complete with nicad battery. For domestic use, it is simply coupled to its own mains supply/RF modulator, which powers the VCR, re-charges the nicad battery in situ, and provides a signal for the domestic TV colour receiver.

The VCR can be used to record programs, with the addition of a tuner, and provides a picture with 240-line resolution, with definition and sound quality directly comparable with standard full-size domestic VCRs.

The fantastic thing is that it all happens on an audio-size cassette, which plays for up to 60 minutes and costs around \$12.50!



NEW

# 32 MEMORY AUTOMATIC TELEPHONE DIALLER

### FEATURES:

12 digit display showing number dialled, stopwatch, or actual time of day.



Telecom  
Approval No.  
C/78/4/25

The Easydial  
AD7902

- One touch connection to any of 32 numbers stored in memory;
- ISD and STD capacity;
- Automatic redial of engaged numbers;
- Convenient touch pad dial for ringing numbers not in memory;
- Time/stopwatch and number dialled on green display;
- Inbuilt speaker — no need to pick up handpiece until other party answers;
- Fully guaranteed for six months;
- Telecom approved.

AVAILABLE NOW FROM:

## RADIO PARTS GROUP

562 Spencer Street,  
West Melbourne, 3003.  
Ph. 329 7888

1103 Dandenong Road,  
East Malvern, 3145.  
Ph. 211 8122

### ORDER FORM:

RADIO PARTS GROUP  
PO Box 124,  
North Melbourne, 3051.

PLEASE SEND ME  AD7902 DIALLER @ \$299 ea

This price includes packing and freight within Australia.  
I enclose Cheque. Money Order or debit my Bankcard

--	--	--	--	--	--	--	--	--	--	--	--

No. . . . \$ . . . .

Signed: . . . . .

Name: . . . . .

Address: . . . . .

PI/Code . . . . .



## AUDIO-VIDEO ELECTRONICS — continued

HANIMEX PTY LTD have enlisted a "humanoid robot floating through musical space" to draw attention to the release of a new line of quality Fuji audio cassettes. The silver-on-black symbol features on the publicity and packaging for the new series tapes: Fuji FL, low



noise; FX-1, normal dynamic premium cassette; FX-II, high-bias Beridox coated; Fuji metal coated. New coatings and new binders render the new series tapes particularly resistant to temperature and humidity effects, making them well suited for use in vehicles or portable recorders. For details: Ken Dobson, General Manager, Fuji Film, Hanimex Pty Ltd, Old Pittwater Rd, Brookvale, NSW 2100. Tel. (02) 938 0400.

EXTRA LONG PLAY AUDIO, or rather extra long play hifi stereo, was demonstrated recently by Pioneer in

Japan. Using principles closely related to their laser video disc, Pioneer demonstrated a 15cm diameter double-sided optical disc which offered a playing time of three hours per side. The player, measuring 17(H) x 42(W) x 30(D)cm is designed for front loading, with the disc inserted vertically, as for a front-loading cassette player. An in-built microcomputer system allows any particular item to be located within two seconds. Pioneer have no immediate plans to market the unit but they obviously see it as a candidate for consideration as a future audio industry standard.

PIONEER ELECTRONICS AUST PTY LTD say that they are delighted with the reception accorded by audiophiles to their linear tracking turntable, model PL-L1000. At \$699, it is not an inexpensive item, but it does happen to be the lowest priced linear tracking turntable available on the Australian market — without sacrificing desirable features. More than that, a return-for-service figure of less than 1% indicates a high order of reliability. Managing Director, Les Black, estimates that the PL-L1000 is accounting for about 25% of Pioneer's top-end turntable sales. For details: Pioneer Electronics Aust Pty Ltd, 178-184 Boundary Rd, Braeside, Vic 3195. Tel. (03) 90 9011.

## "Cockpit" style hifi from National

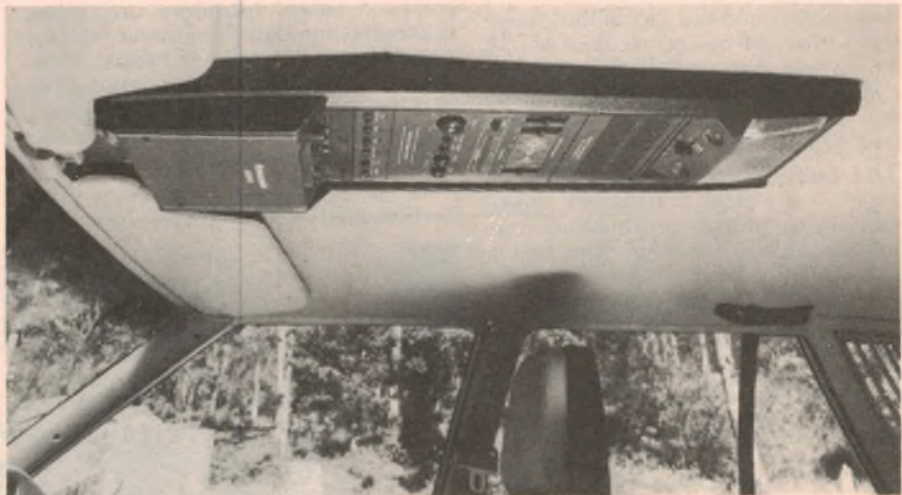

National have a ready answer for motorists who simply cannot fit the hifi facilities they want in or around the fascia panel. Their new RM-310 "Cockpit" system concentrates an AM/FM-stereo tuner, cassette deck, three-band graphic equaliser and preamplifier into an overhead unit, as pictured. Considering the facilities which it provides, the "Cockpit" console has quite modest dimensions: 708 x 219 x 68mm.

National say that a total audio power of 46 watts is available, which can be fed to either two or four loudspeakers. "Touch button" control allows the major functions to be selected with a minimum of distraction to the driver. Other facilities include balance and loudness controls, noise impulse damping, and DX, muting and mono switches. The cassette player has locking fast forward and re-wind, and automatic eject. (National Panasonic Aust Pty Ltd, 95 Epping Rd, North Ryde NSW 2113. Phone (02) 887 0144).

# Video products for the '80s from Toshiba

At a series of well supported symposia in the capital cities, Toshiba (Aust) Pty Ltd gave dealers and the press a preview of some of the video products they have on hand or under development for the '80s.

For the normal TV market, they showed no less than 23 models, ranging from a take-anywhere domestic portable to full-size 63cm consoles. Tuners range from Rotary VHF only to push-button VHF/UHF and to infra-red remote control.

Also on show was a remote control TV receiver capable of displaying the time on-screen. If desired, the picture could be blacked out and the remote control used as a simple 4-function calculator, with figures displayed on the TV screen. Or, again, a by-month calendar could be displayed, with a time-scale of 10,000 years.

Yet another TV set was voice operated, turning on and off as ordered, and changing channels by numbers. If the command was not clear, a female voice would request: "Repeat?"

On a larger scale, Toshiba also had on show a projection TV receiver intended for the home market, while a few of the visitors got to handle and use the smallest exhibit, pictured at right. It is a tiny all solid-state TV receiver, with clock, measuring about 18 X 8 X 1.8cm. The monochrome picture is built up on a liquid crystal screen measuring about 31 X 41mm and comprising 52,800 elements. A zoom feature allows the centre of the picture to be blown up to fill the entire screen.

Considerable interest centred on a

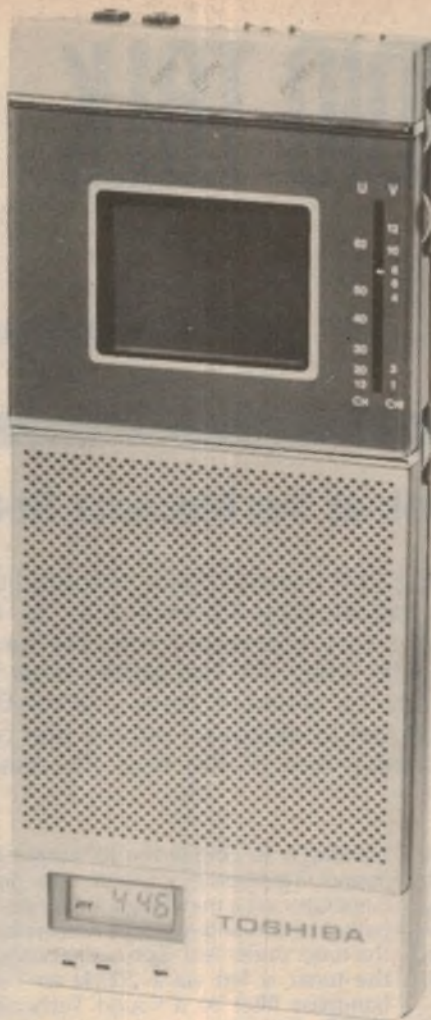

Toshiba CED video disc player, using the RCA Discovision system. Picture quality was excellent. Toshiba also plan to market the Matsushita/JVC VHD player and, if necessary, an optical disc player as well.

And, of course, Toshiba Beta-format video cassette machines were well to the fore.

**ROSE MUSIC PTY LTD** have been appointed Australian distributors for the Audio Technica range of professional microphones. The "Artist" series includes omnidirectional and unidirectional instrument microphones and unidirectional voice microphones. All feature a wide, uniform frequency response. Audio Technica have been best known in the past as a manufacturer of phono cartridges, although they have also diversified into the manufacture of tonearms and headphones, as well as domestic and professional microphones.

**THE PHILIPS/SONY** compact audio disc made a significant move towards the top of the class when it received a majority endorsement from companies attending the Digital Audio Disc Standardisation Conference held recently in Tokyo. Not the least significant factor was the backing forthcoming from Matsushita (National/Technics) who endorsed the com-

act disc over the AHD capacitive disc developed by their own subsidiary, JVC. The endorsement is a set-back for those who had wanted to see a standard player capable of handling either video or hifi audio discs but the set-back is not final. AHD (Audio High Density) discs may still appear anyway.

**SANYO AUST PTY LTD** has added six new models to its range of car loudspeakers, with special emphasis on multi-way systems. The SP778 is a 16 x 23cm three-way system with a cone type mid-range and a horn tweeter, retailing at \$117.50. Type SP738 is another three-way system rated to handle 30W and retailing for \$104. In fact, Sanyo claim to have a car speaker for every application, with prices starting from a low \$27. Details from Mr G. Boucher, Sanyo Aust, Pty Ltd, 225 Miller St, North Sydney. Tel. (02) 436 1122.

## Piv·telli<sup>®</sup> MULTI-DIRECTIONAL AUDIO/VISUAL BRACKETS

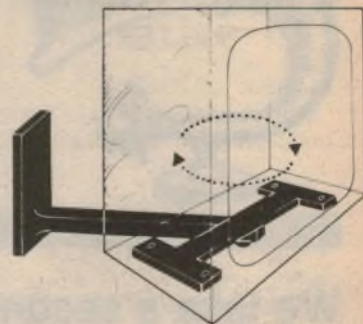

- 5 different models available.
- Holds anything from 195 mm to 1204 mm in width (7" to 4').
- Holds up to 110 kilograms in weight.

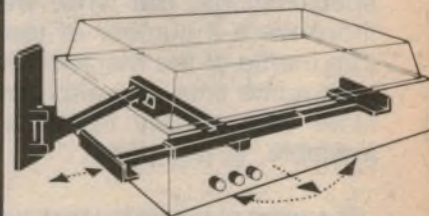

- Available with horizontal pivot and vertical tilt.
- Saves valuable floor space.
- Complete with all necessary fixings.
- Solid high grade steel, finished in matt black or gloss white.



NOW AVAILABLE IN AUSTRALIA

Please send me free brochure/price list

Name \_\_\_\_\_

Address \_\_\_\_\_

Postcode \_\_\_\_\_

**ASSOCIATED STEEL EQUIPMENT P/L**  
Sole agent in Australia  
11 Horscroft Place,  
Moorabbin, Victoria. 3189  
Phone (03) 555 9921

Perth: Gibson Benness Ind. 323 8686  
Adelaide: Orion Distributors 332 3777



# AUDIO TALK

by Paul de Noskowski

## We take a second look at the Marantz St-8

Last month's review of the Marantz St-8 FM/AM Tuner indicated that here was a tuner which was significantly advanced in its FM specifications. But while we were very impressed with the tuner, there were a number of test results which did not quite reveal the true mettle of the Marantz. Just how far ahead of the rest of the field took some time and effort on our part to discover, but we can now state categorically that it is probably one of the best FM tuners available, at any price!

As a result of our endeavours, we can now publish new quieting curves for the Marantz St-8 which are far ahead of any tuner we have ever measured and better than any tuner we have ever seen reviewed in any other magazine, either local or overseas!

Referring to the accompanying curves it will be seen that the ultimate signal-to-noise ratio in the MONO mode now measures 85dB, instead of 72dB – an improvement of 13dB! A blow-by-blow

quieting is to couple the RF output of a Sound Technology 1000A FM Signal Generator via a matching transformer (or balun) to the antenna input terminals of the tuner under test. The audio output of the tuner is fed via a 200Hz to 15kHz bandpass filter to a Sound Technology 1700B Distortion and Noise Meter, which is used for making measurements of limiting, quieting, distortion, frequen-

tally, this Standard specifies that a 200Hz to 15kHz bandpass filter shall be used for all tests other than frequency response, stereo separation, hum and ultrasonic output.

In addition we bridge the auxiliary inputs of an audio amplifier directly across the tuner's output terminals. The amplifier feeds our reference loudspeakers, so that we can audibly monitor the signals coming from the tuner. Optional equipment includes an oscilloscope to provide visual monitoring of noise, distortion components and so on.

When carrying out the original quieting measurements on the Marantz St-8 we noticed that as we approached ultimate quieting (high RF input level) the audible "white" noise almost disappeared whilst we became aware of a low-level tone of approximately 400Hz. This was confirmed by oscilloscope inspection.

As the St-8 includes a 400Hz test oscillator we presumed that we were hearing (and measuring) crosstalk from within the tuner itself. As the copy deadline for the March issue of EA was fast approaching we finished writing our Review, and included criticism of this 400Hz leakage in the St-8, since we considered it a blemish on its performance.

Notwithstanding this apparent defect in performance, we felt that the St-8 was capable of above average quieting if only its 400Hz oscillator could be muted. So we contacted Marantz (Australia) Pty Ltd who kindly loaned us a Service Manual, which we closely studied for details and location of the 400Hz oscillator. Having decided upon a method we then proceeded to disable the internal oscillator. Surprise! No

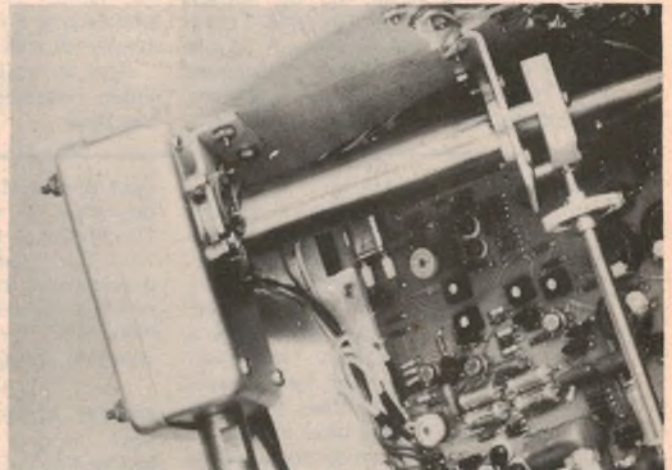

At left is our Sound Technology ST 1000A/1100A FM Test Set while at right is a view of the oscillator can and piston attenuator.

description of the manner in which we arrived at the revised figure may well be of interest to readers, particularly those who test analog devices and are sometimes puzzled as to why expected performance may not be obtained in practice.

Our normal procedure for measuring

cy response etc. We carry out the tests in accordance with the conditions outlined in American National Standard no. 185-1975, also known as the IHF standard except that we use 50 $\mu$ s pre-emphasis, not 75 $\mu$ s as used in the USA. 50 $\mu$ s pre-emphasis is the characteristic used by Australian FM stations. Inciden-

measurable or audible difference. Why? Could it be our own FM Signal Generator?

We hurriedly substituted an ancient valve-operated AM Signal Generator set to CW (continuous wave, no modulation). Result: while there was hum, there was no 400Hz tone! The "leakage" was

# “Instant” purebreds just don't exist.

A good-looking component stereo system can be launched overnight. But an excellent-sounding system that will delight audiophiles is another matter. Excellent results require that each individual unit be outstanding. That takes experience and special skills beyond mere technology. It takes the hi-fi expertise of Sansui, the audio specialist with decades of dedication to 1st class reproduction.

SUPER COMPO systems weren't created overnight. From the very beginning, each unit was conceived with the other units in mind. The result is matching that goes beyond handsome styling. Or mere "power" matching. SUPER COMPO systems are distinguished by "in-depth matching." This means that certain priorities such as extremely low dynamic distortion were followed throughout.

An added feature of SUPER COMPO is the incorporation of the latest advances in electronics. The dual benefits are greater accuracy and increased operating ease. Typical refinements include computerized track sequence selection turntables, quartz-PLL digital synthesizer tuner with 12 pre-set station selection and LED station centering, full logic cassette deck with versatile auto functions, DC-servo amplifiers with auto volume adjust and LED peak power level meters. And more.

An enormous amount of care went into SUPER COMPO "in-depth" matched systems. They are the purebreds on today's market. They are for discriminating listeners who appreciate the finest.

**SUPER COMPO**



**SUPER COMPO 9000**



**Sansui**

SANSUI ELECTRIC CO., LTD. 14-1 Izumi 2-chome, Suginami-ku, Tokyo 168 Japan  
VANFI (AUST.) PTY. LTD. 297 City Road, South Melbourne, Victoria 3205, Australia Tel: 690-6200  
283 Alfred Street, North Sydney, N.S.W. 2060, Australia Tel: 929-0293

# NOT ALL OF THE BEST SPEAKERS ARE IN POLITICS.

But many of them depend on our speakers to make themselves heard. Because we're specialists in the manufacture of loudspeakers for just about any application — P.A. systems, car stereo, hi-fidelity, radio, TV and communications.

Whatever your loudspeaker requirements are the specialists at Magnavox can help.

Just send in the attached coupon for details of our complete range or contact your nearest Magnavox distributor.

Qld. R.A. Venn Pty. Ltd. 67 Doggett Street, Fortitude Valley Qld. 4006  
Ph: 525421 N.S.W. Standard Components Pty. Ltd. 10 Hill Street, Leichhardt  
N.S.W. 2040 Ph: 6606066. VIC TV Tuner Service Pty. Ltd. 21 McLauchlan  
Street, Mt. Waverly Vic. 3149 Ph: 2779143. S.A. Gladiola Company 11 Laurel  
Avenue, Linden Park S.A. 5065 Ph: 792665. Protronics Pty. Ltd. 180 Wright  
Street, Adelaide S.A. 5000 Ph: 2123111. W.A. Everett International Pty. Ltd.  
17 Northwood Street, West Leederville  
W.A. 6007 Ph: 3815500.

**MAGNAVOX**

Australia Pty. Ltd.



To: Magnavox Australia Pty. Ltd. PO Box M345. Sydney Mail Exchange. N.S.W. 2012.  
Please send me information on Magnavox  High fidelity range  General purpose range.

Name \_\_\_\_\_

Address \_\_\_\_\_

Postcode \_\_\_\_\_



obviously occurring in our own FM Signal Generator.

We then removed the paragraphs in which we had alluded to the 400Hz problem. All this just in time for the final deadline!

With time pressures somewhat reduced we decided to investigate further – to seek the source of the 400Hz tone and (hopefully) eliminate it. So we reconnected the FM Signal Generator to the Marantz St-8. From previous experience in similar test situations we knew that if we “tapped” the cabinet of the Generator we would hear a “microphonic” sound in the monitor loudspeakers; at a frequency somewhere around 400Hz. Apart from

50mm square, was supported on two standoffs approximately 20mm long. Soldered to the underside of the card was the tank coil, an air-cored inductor of some six or seven spaced turns approximately 10mm in diameter. This coil is located over the entrance to the piston attenuator such that the RF field propagates down the attenuator cylinder. Incidentally this tube is actually a waveguide operating below cut-off, and attenuation down the cylinder follows a precise logarithmic law. The output pickup loop (actually a 51Ω resistor) is mounted on a piston which is moved up and down the cylinder by the calibrated RF Level Control.

Our hypothesis was that mechanical

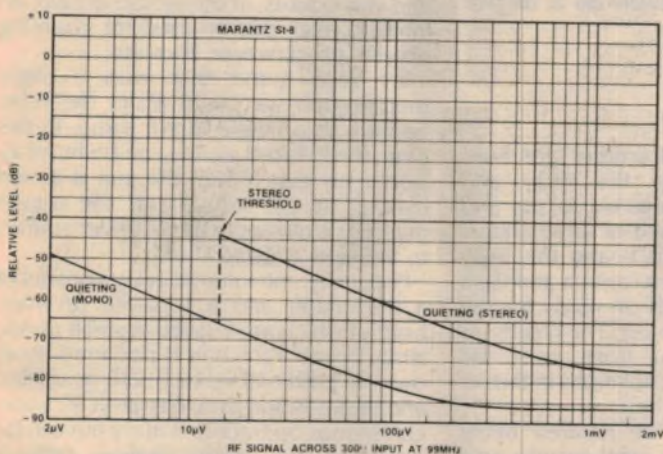

This is the revised graph of the Marantz St-8 quieting characteristics.

avoiding bumping the instrument whilst taking measurements we had never previously looked into the reasons for this occurrence. Incidentally the microphonic effect existed for all settings of the Function Switch including CW, which effectively disables all modulator and pilot tone sections from the RF oscillator. Thus it appeared as if the problem lay within the RF section alone.

Removing the top cover from the instrument, we gently tapped various areas and quickly arrived at the conclusion that the most sensitive section was the metal box containing the RF unit. In fact a light tap on this can was sufficient to create a loud gong-like sound with quite an extended decay. As a matter of interest the RF section consists of a single transistor oscillator located in the above-mentioned box to which is attached the piston attenuator. Removing the cover from this box we saw that the variable tuning capacitor was mounted to one side, whilst the remaining space was taken up by a printed circuit card containing all the other components making up the RF oscillator section. Further gentle tapping (inside the can) localised the problem to the printed circuit card.

This card, measuring approximately

vibration of this coil was creating the microphonic effects. And that the “mechanical” resonant frequency of the coil assembly was approximately 400Hz. Displacement of the coil will change both its distance from the attenuator tube (and hence the RF output level, especially for small amounts of attenuation), and also its stray capacitance to ground which will alter the oscillation frequency. Two schools of thought arose amongst our staff members – one school claiming that it was variations in RF level which were responsible for the microphonics, the other that it was the variation in frequency which was responsible. However both schools agreed that coil vibration was the culprit.

Further, it was felt that mechanical vibration from the power transformer was being transmitted along the chassis to the offending RF assembly, and exciting it into its natural mechanical resonance – thus producing the steady tone. We managed to tighten the transformer clamping screws by about a quarter-turn each. This appeared to improve the signal-to-noise ratio by some 2 or 3dB, although we felt it was inconclusive, as the microphonic response remained unchanged.

So we tried another approach. We cut and shaped pieces of damping material which were then carefully inserted down the centre of the coil, and also between the coil and the circuit board. The Unit was switched ON. Success! No audible trace of the 400Hz tone, and whilst tapping of the can could still be heard in the loudspeakers, it was as a “thud” not a resonant gong. Ultimate mono signal-to-noise ratio of the Marantz St-8 now measured 85dB, ie a 13dB improvement!

A complete replacement set of figures for mono quieting was taken. Naturally there was no change at low RF input levels. But at inputs of 20μV and above, the new curve diverged such that – as already mentioned – the ultimate S/N ratio was improved by 13dB, and 2dB better than the Marantz specification.

The revised measurements for stereo quieting were then carried out – and although a substantial improvement was obtained, with the S/N ratio for 1000μV input reading 76dB (the same as the Marantz specification), we have a suspicion that we might be measuring (and hearing) noise slightly above the stereo noise floor of the St-8. It is possible that some noise may be introduced by the modulator section of the Signal Generator.

Thus ultimate stereo S/N ratio may possibly exceed 76dB. Unfortunately pressures of other work commitments forced us to call a halt to further investigation at this point in time. Even at this stage it must be remembered that we have achieved better quieting figures than we have every previously recorded. In addition our test figures now meet or exceed the Marantz quieting specifications.

We should point out that the original specification for the Sound Technology 1000A FM Signal Generator quotes a figure of less than 25Hz for residual FM in the CW mode. It also states that this permits measurements of quieting down to -70dB. As will be recalled from last month's Review of the St-8, the unmodified Generator provided us with figures better than 70dB for both mono and stereo quieting. So no criticism of the Generator – it more than met its own specification.

However, we have made representations to the local distributors for Sound Technology equipment, Dindima Group Pty Ltd, in the hope that they or their principals can comment in detail on our modifications and perhaps suggest further improvements.

Just one final niggling issue remains. If our test results last month did not show the Marantz in true light, were there other tuners reviewed by us in the past which were similarly disadvantaged? To this we can say No. Other tuners tested by us in the past gave quieting performance which closely conformed with the manufacturer's specifications. The Marantz St-8 was the first tuner we had tested where the manufacturer's specs were way ahead of our test results. 2

# Infrared light-beam relay

Interested in capturing spectacular wildlife shots like the one on our front cover? You can, by building this new infrared relay unit. It uses only two CMOS ICs plus a few transistors, and can also be used as a shop entry monitor, an "invisible" burglar alarm, or even as a target game.

by RON DE JONG

Light beam relay systems are popular for many applications but most suffer the disadvantage of using a visible light beam. These circuits are invariably quite limited in range, are critical to set up and adjust, and can be falsely triggered by changing ambient light conditions. Indeed, most simple light beam relay systems are virtually useless in bright sunlight and are suitable only for fixed installations indoors.

All these problems are overcome in the circuit presented here. It uses a modulated beam of infrared light for greatly improved range and sensitivity, and will operate reliably in conditions ranging from total darkness to bright sunlight without adjustment. Other advantages include insensitivity to changing ambient light levels and the invisible nature of the beam itself (important in burglar alarm applications).

One of our photographers was quick to realise that the unit could be used as a camera trip for photographing wildlife.

The receiver and transmitter are both battery powered so the relay and camera unit can be quickly set up and left unattended. If a bird or other animal interrupts the infrared beam, the relay triggers a motor-driven camera and flash and the camera winds on ready for the next unsuspecting subject. The results, as you can judge by our front cover and some of the other photographs in this article can be spectacular.

The invisibility of the infrared beam also makes the relay ideal for use as a burglar alarm. The relay could be positioned across an appropriate doorway or even across a whole room so that when the invisible beam is broken by an intruder, an alarm is activated. Since the unit is battery-powered, it is completely portable and easy to set up in any location. Alternatively, the unit can be powered from a 9V DC plugpack and

the batteries used as a back up.

Conventional applications such as a shop entry indicator are also possible, or it could be used to automatically open and close doors. In the industrial field, an infrared relay can be used for counting objects on conveyor lines etc.

We also found that with a slight modification we could make the relay operate as a simple target game. In this case, the infrared source can be fitted inside a toy gun. When the gun is aimed directly at the sensor and the trigger pressed, a buzzer in the receiver sounds to indicate a "good shot".

Physically, the infrared relay consists of a transmitter and a separate receiver, both of which are housed in small plastic zippy boxes. Each unit is powered by its own 9V battery (Eveready 216 or similar) and these should provide about 50 hours continuous operation. Battery life can be increased by using alkaline cells if desired.

An open-collector transistor is used at the output of the receiver and can be used to activate an internal buzzer, a relay, or other low power devices. For



Taken from colour slides, these b&w reproductions do not do justice to the actual results. Note that the series is NOT in sequence.

photographic work, the open-collector output can be used to directly trigger most motor-driven cameras.

The range of the relay — ie the maximum distance between transmitter and receiver — is about five metres in sunlight. No lenses are used and no adjustment of sensitivity is required — just point the transmitter in the general direction of the receiver and you're in business. If greater range is desired, the transmitter current can be increased (more on this later).

## HOW IT WORKS

Looking now at the circuit diagrams for the transmitter and receiver we can see that two CMOS ICs and six transistors are used. The circuit is more complex than the usual light beam relay — which typically includes a light bulb, a lens and a phototransistor — but then it has quite a few more features.

The source of light in the transmitter is an infrared LED and rather than merely providing a continuous source of light, it is flashed on and off at 10kHz. This is done so that the receiver can selectively amplify the signal from the transmitter and completely reject ambient light. The result is a high degree of sensitivity without any need of adjustment and it also allows us to use quite low current drive through the transmitting LED.

A standard three-inverter CMOS oscillator is used in the transmitter and consists of gates IC1a,b,c from a 4011 quad NAND package. The frequency of the oscillator is determined by the 4.7k $\Omega$  resistor and .0068 $\mu$ F capacitor and is nominally 10kHz. Gate IC1d permanent-

ly enables the oscillator, since its output is always high.

Some readers may be wondering why IC1d has been included in the circuit. Why not simply connect pin 2 directly to the positive supply rail? The reason is simply that the transmitter printed circuit board pattern is exactly the same as that used in a previous project (Infrared

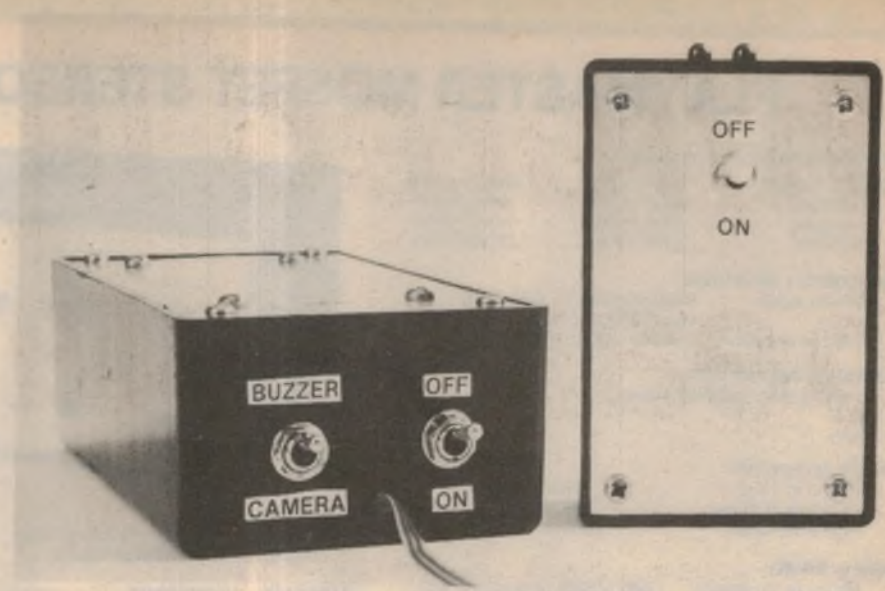

The completed infrared relay receiver together with its companion transmitter (right). Both units are compact, battery powered and portable.

Remote Volume Control, October 1979). The circuit configuration, however, is slightly different and leaving IC1d in circuit happens to be the easiest way of adapting the board for its present application.

Either way, it makes no difference to circuit operation.

The CMOS oscillator drives an output stage consisting of a BC547 transistor (Q1) and two infrared light emitting diodes. The infrared diodes used are

quire the greater range, otherwise the relay may not trip reliably close in due to reflections caused by the high light output.

Infrared light generated by the LEDs is picked up at the receiver by a special infrared photodiode. This is also a Philips device type number BPW50, and is

specifically designed to match the CQY89A LED. The BPW50 also has an integral infrared filter that almost completely rejects visible light.

Referring to the circuit diagram of the receiver, the photodiode is connected with its cathode to the +9V rail via an RC decoupling network, while the anode is connected via a 470k $\Omega$  resistor to ground. In operation the photodiode acts as a current source, ie it generates a current proportional to the incident light. This current signal is converted to a voltage signal by the 470k $\Omega$  resistor.

Clearly the larger the resistor value is series with the photodiode the greater

Philips type CQY89A. They are plastic-pack devices and are similar in appearance to the familiar red LED except that the plastic encapsulation is a deep violet colour.

Current drive through the two LEDs is limited by the 680 $\Omega$  resistor. If greater range is required, this resistor may be reduced to a minimum value of 150 $\Omega$  with a consequent adverse effect on current consumption. Do not reduce the value of the resistor unless you do re-



# PLAYMASTER MOSFET STEREO AMPLIFIER

Performance of prototype:

POWER OUTPUT	One channel	Both channels
4 ohms	64W (72W)	45W (60W)
8 ohms	50W (56W)	42W (50W)
16 ohms	37W (38W)	31W (31W)

### FREQUENCY RESPONSE

Phono inputs	RIAA equalisation within 1dB from 30Hz to 20kHz
High level inputs	25Hz to 20kHz ±1dB

### CHANNEL SEPARATION

(with respect to 50W) 10kHz	-40dB
1kHz	-47dB
100kHz	-50dB

### INPUT SENSITIVITY

Phono at 1kHz	2mV	56k
Overload at 1kHz	120mV	
High level inputs	190mV	36k (minimum)

### HUM & NOISE

Phono (with respect to 10mV)	73dB (75dB) unweighted with typical cartridge
Other inputs	80dB (82dB) unweighted with inputs open circuit

### TOTAL HARMONIC DISTORTION

At full power with both channels operating from 25 to 20kHz: less than 0.2%  
Typically less than 0.05% at normal listening levels



### tone controls

Bass	+12, -13dB at 50Hz
Treble	±10dB at 10kHz

### DAMPING FACTOR

at 1kHz	> 50
at 30Hz	> 50

### STABILITY

Unconditional  
(Figures in brackets refer to the performance with the Ferguson PF 4361/1 transformer.)

PCB \$9.90

Output transistors

Front panel \$11.00

- Complete kit of parts ..... \$159.00 ea
- Front panel ..... \$11.00 ea
- PCB 80Sa 10 to suit ..... \$9.90 ea
- Mosfets to suit 2Sk133 ..... \$7.50 ea
- Mosfets to suit 2SJ48 ..... \$7.50 ea

## KITS

## KITS

## KITS

## KITS

## KITS

## KITS

## KITS

Kit for Exidy Sorcerer EPROM Programmer to be released in August EA Kit price including Scotchcal Front Panel \$75.00

### TV PATTERN GENERATOR

Kit of parts as featured in EA JUNE 1980. Dot. Greyscale, Crosshatch, Raster, Check  
COMPLETE KIT (including Scotchcal front panel) \$54.90  
KIT WITHOUT BOX \$39.90

### EPROM PROGRAMMER KIT

Kit of parts as featured in EA JULY 1980 Programs 2708, 2716 & 2532 Usw with TRS 80, Sorcerer & Compucolour. Kit does not include connector from the programmer to computer

COMPLETE KIT (inc Scotchcal Front Panel) \$72.49  
KIT WITHOUT CASE \$59.99

### DIGITAL PANEL CAPACITANCE METER

Kit of parts as featured in EA MARCH 1980  
Four Digits. Extremely popular.

COMPLETE KIT (inc Scotchcal Front Panel) \$52.49  
KIT WITHOUT CASE \$47.50

### TV CRO ADAPTOR KIT (EA MAY 1980)

COMPLETE KIT (inc Scotchcal Front Panel) \$29.00  
(without power adaptor)

### POWER ADAPTORS TO SUIT

- 1 240V to 6/7.5/9V \$9.50
- 2 240V to 9V \$5.95

### KITS

#### ETI SERIES 4000 60W STEREO AMP KIT

Complete Kit Rack Mounting Case \$199.00  
Woodgrain Sided Case \$189.00

#### PARTS AVAILABLE SEPARATELY

Front Panel	\$10.90
Rack Mounting Case	\$55.00
Wooden Sided Case	\$49.00
ETI 471 PREAMP KIT of parts	\$45.00
ETI 472 PS KIT of parts (without transformer)	\$47.00
ETI 470 60W Kit of parts (without heatsink)	\$24.00
ETI 480 50W KIT of parts	\$26.50
ETI 480 100W KIT of parts	\$23.00
ETI 084 Car Alarm KIT	\$17.50
EA TV CRO ADAPTER KIT	\$29.00
EA 300W POWER AMP MODULE	\$63.50
EA 466 300W PA MODULE	\$63.50
EA DIGITAL CAPACITANCE METER KIT (EA March 1980)	\$52.99
AUTOCHIME KIT	\$29.75

### MK3 Drill Speed Control

\$13.50

CAPACITOR DISCHARGE IGNITION \$32.50

MUSICOLOR MK3 KIT \$69.50

DISCO STROBE KIT \$34.50

LEDS & LADDERS (EA August) \$15.75

ETI 149 Two Tone Generator \$34.00

ETI 563 Nicad Fast Charger \$54.00

DREAM 6802 KIT \$109.00

Power Supply TO Suit \$29.50

Hex Keypad \$24.90

ETI 568 Sound or Light Operated Flash Trigger \$25.90

ETI 147 ELECTRONIC DUMMY LOAD KIT \$99.00

SERIES 3000 "MINI" STEREO AMP KIT \$79.90

ETI 561 Metal DETECTOR KIT \$32.50

PLAYMASTER 40+40 AMP KIT \$129.00

PLAYMASTER AM/FM TUNER KIT \$129.00

PLAYMASTER GRAPHIC EQUAL \$99.50

PLAYMASTER GRAPH ANALY KIT \$99.50

EA 79SF9 Sound Flash Trigger \$15.00

ETI 585H Ultra Sonic RX \$15.95

ETI 585T Ultra Sonic TX \$8.95

ETI 576 ELECTROMYOGRAM KIT \$89.00

## LE GONG

Fantastic doorbell using the new Siemens SAB 0600 chip.  
Kit of parts \$15



## INCREDIBLE!!!

E/A has really done it this time. Display your Hi/Fi response on your colour TV. It will really impress your friends. Kit of parts \$99



### EA Power Saver

August EA, an interesting approach to power savings. Kit of parts \$32.50

### ETI147 OCT 80 ELECTRONIC LOAD

Kit parts \$75.00

### ETI327 TURN HAZARD UNIT

Kit parts \$22.00

### EA DIGITAL ENGINE ANALYSER

Oct 80 80TM8a/10 kit parts inc front panel \$44.95

### EA CAR BATT VOLTAGE MON

Oct EA kit parts \$6.50

### EA BIPOLAR TRAIN CONTROLLER

Nov 80 kit parts \$26.00

### EA DIGITAL STORAGE CRO

Adapter Nov 80 kit parts \$78.00

### EA LIGHT BEAM RELAY NOV 80

Kit of parts \$13.00

### EA RS232 PRINTER INTERFACE

Nov 80 kit parts \$15.00

Please debit my Bankcard.

Bankcard No. ....

Expiry Date .....

Name .....

Signature .....

Post & Pack \$2.50 small kits, heavier kits add extra postage

Prices subject to change without notice. Send 60c and SAE for free catalogues.

MAIL ORDERS: PO Box 135, Northcote, Vic 3070. Minimum pack and post \$1.00.

Phone (03) 489 8131.

# ROD IRVING ELECTRONICS

425 HIGH STREET, NORTHCOTE 3070, MELBOURNE, VICTORIA. Ph (03) 489 8131



the voltage output. There is a limit to all good things though, and the maximum resistance we can use is set by the highest frequency we want to receive, the junction capacitance of the photodiode, and the input capacitance of the following stage.

We have reduced the junction capacitance to a minimum in this circuit by reverse biasing the photodiode. This theoretically results in a capacitance of about 10pF which, combined with the 470kΩ resistor and the 5pF (approx) capacitance of the following stage, gives a rolloff above 22kHz.

The signal from the photodiode is fed to the input of Q1, a 2N5485 JFET. The FET is connected as a "source follower" and offers a high input impedance, a low output impedance, and a voltage gain of 0.3 to 0.5. This sort of impedance matching would be almost impossible to obtain using transistors and the circuit would be more complex than the simple "self biasing" JFET circuit we have used.

Output impedance of the FET stage is about 100Ω and this drives a bandpass filter consisting of transistors Q2 and Q3. The centre frequency of the filter is about 10kHz and it has a Q of 10; ie the bandwidth is 1kHz. This bandwidth is wide enough to pass the 10kHz signal from the transmitter, even allowing for some mistuning, yet effectively eliminates interference from other sources (eg fluorescent lights).

Disregarding the two .0068μF capacitors for the moment, Q2 and Q3 form a two-stage inverting amplifier. Both transistors operate as common emitter amplifiers, with the second stage providing two separate outputs: one from the junction of the two 330Ω resistors and the second from Q3's collector. The first output has a low impedance and is used to drive the filter and to provide DC feedback via the 47kΩ resistor to bias Q2.

As already mentioned, the amplifier is used as a "multiple feedback" bandpass filter. The filter components are the two .0068μF capacitors and the 47kΩ bias resistor which, together with the low output impedance of the previous FET stage, determine the centre frequency and Q of the filter.

The collector output of Q3 provides an amplified version of the filter output. This output is DC-coupled to the next stage which consists of transistor Q4 in another common emitter amplifier circuit. Gain of this stage is at least 150. A 0.1μF emitter bypass capacitor is included to provide further attenuation of unwanted low frequency signals.

Following Q4 the signal is coupled to IC1a which is a CMOS Schmitt trigger. When the signal peaks from Q4 exceed

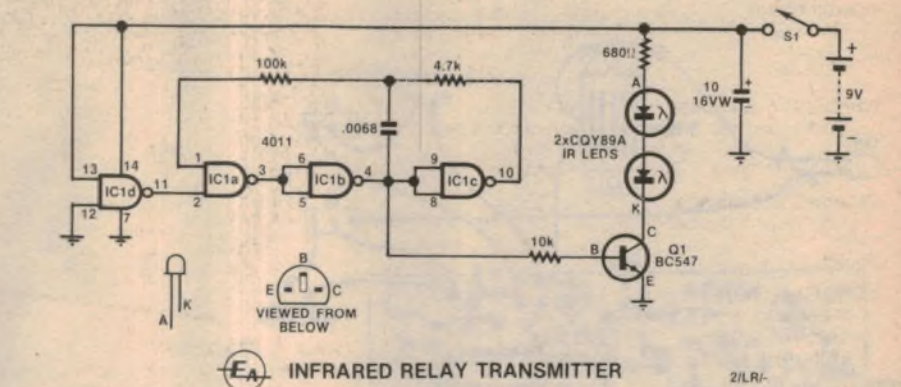

Output from the transmitter is a 10kHz pulse train of infrared light which is picked up and selectively amplified by the receiver.

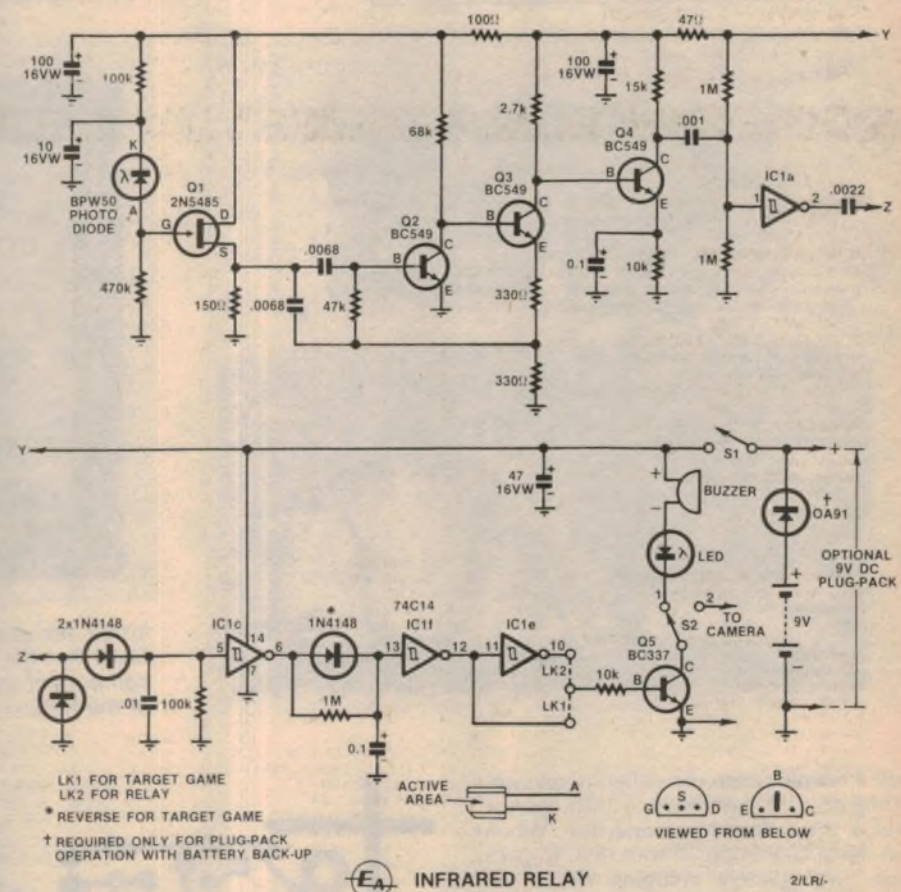

the upper and lower trigger thresholds of the Schmitt trigger, the device will square up the signal and generate a constant 10kHz square wave output. If the infrared beam is interrupted, or the input signal drops below the trigger thresholds, the 10kHz output signal will cease and the Schmitt will remain in its last state: ie either high or low.

To convert the presence or absence of the 10kHz signal into a simple high or low signal, the output of IC1a is rectified and filtered by two 1N4148 diodes, the

.0022μF and .01μF capacitors, and a 100kΩ resistor.

The signal is now squared up by IC1c to give either a logic high when the beam is broken or a logic low when the beam is intact. While this signal could be used to directly trigger a camera or an alarm, it must be realised that the output of IC1c will be high only while the beam is broken. If the beam is only broken momentarily, the alarm time will be very short or the camera may not trip.

To overcome this problem we have ad-

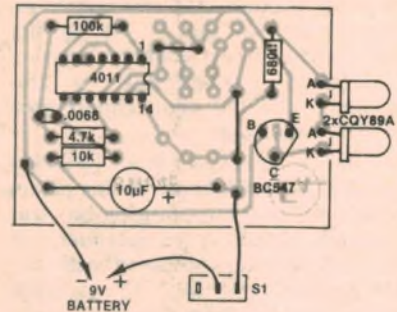
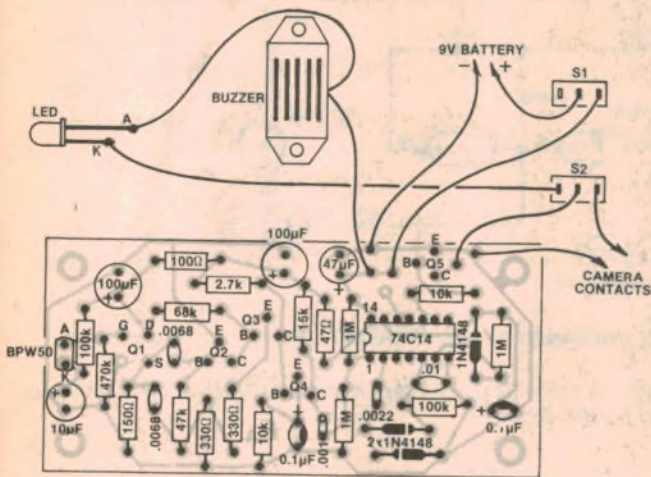

Here are the wiring diagrams for the receiver (left) and the relay transmitter (right). The buzzer can be replaced by a 2.2kΩ resistor if not required.

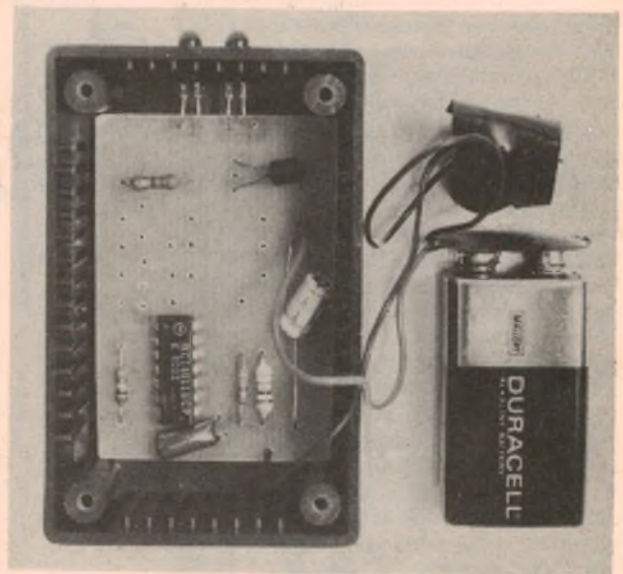
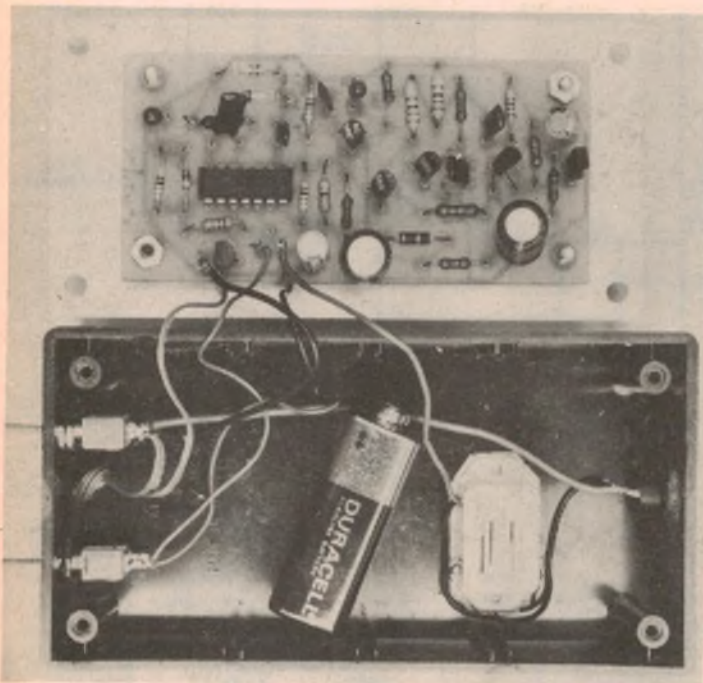

Inside the completed transmitter and receiver units. Note that the two wire links shown on the transmitter component overlay have been wired to the underside of the PCB.

ded a simple pulse extender circuit consisting of a 1N4148 diode, a 1MΩ resistor and a 0.1µF tantalum capacitor. When the signal ceases the output of IC1c goes high, immediately charging the 0.1µF capacitor. If the signal is restored, the output of IC1c goes low. The diode is now reverse biased and the capacitor will slowly discharge via the 1MΩ resistor.

The length of the pulse to the input of IC1f will thus be at least as long as the time constant of the 1MΩ resistor and 0.1µF capacitor, ie about 0.2 seconds. This is long enough to trigger a camera but the delay can be increased to two seconds for an alarm by changing the 0.1µF capacitor to 1µF.

IC1f and IC1e square up the signal from the pulse extender and drive transistor

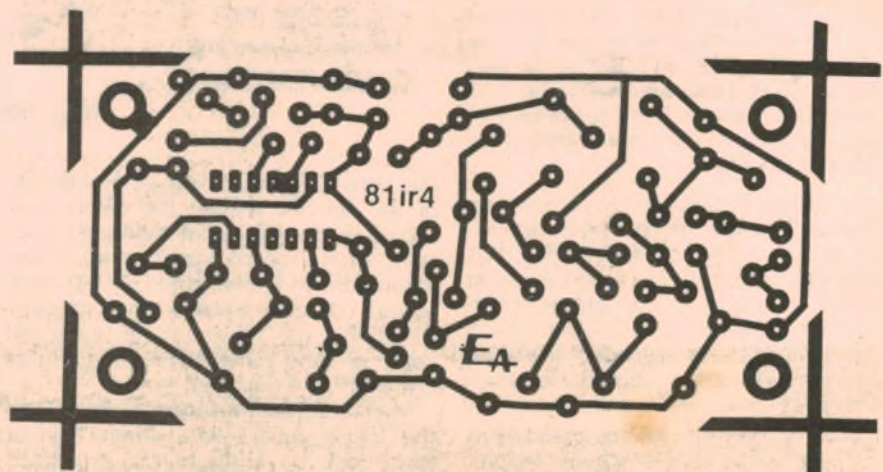

Actual size reproduction of the receiver PCB pattern.

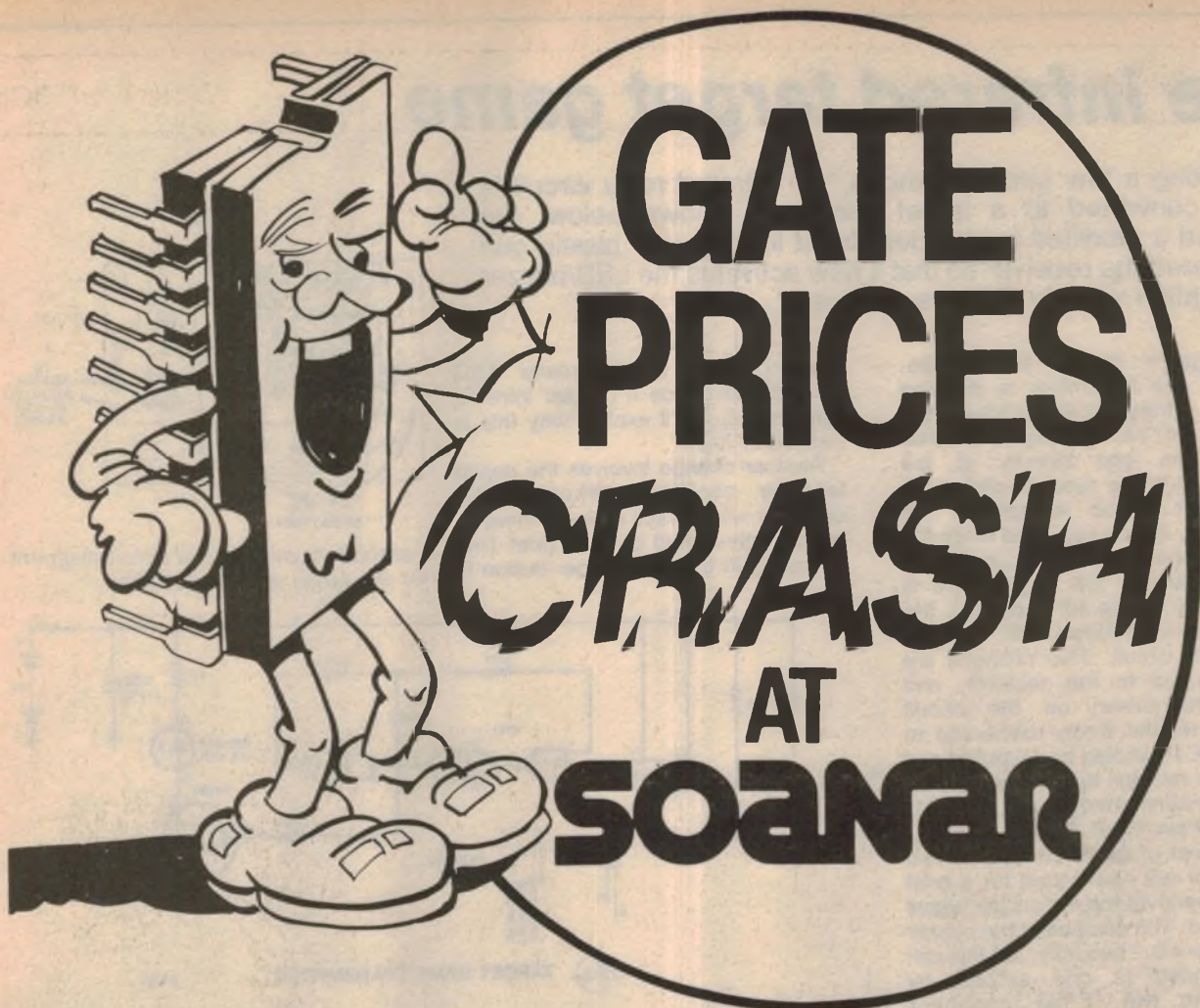

LOW PRICES ON PRIME SPECIFICATION

# CMOS/74LS

WHILE STOCKS LAST



**PHILIPS**

**signetics**



**MOTOROLA**

Phone our Sales Office in your State for a  
Fantastic Deal

Vic. (03) 89 0661

S.A. (08) 51 6981

Qld. (07) 52 1131

N.S.W. (02) 789 6733

W.A. (09) 381 9522

Tas. (003) 31 6533

Call us:— we can save you a mint.

**soanar**

**SOANAR ELECTRONICS PTY.LTD.**

A MEMBER OF THE A+R-SOANAR ELECTRONICS GROUP  
30 Lexton Road, Box Hill, Vic., 3128, Australia. Telex: 32286.

# The infrared target game

By making a few circuit changes, the infrared relay circuit is easily converted to a target game. As shown below, we mounted a modified transmitter circuit inside a toy plastic gun and altered the receiver so that it now activates the LED/buzzer combination when a signal is received.

The game works as follows: normally, the transmitter is disabled and no infrared light reaches the receiver. To "hit" the target, one has to aim the gun directly at the photodiode in the receiver and press the trigger button to activate the transmitter. A hit is recorded when the buzzer sounds and the LED comes on.

The circuit for the target game is quite similar to the infrared relay, the main difference being the modified transmitter circuit. Two changes are also required to the receiver, and these are shown on the circuit diagram: ie, the diode connected to pin 6 of IC1c should be reversed and the 10kΩ resistor to the base of Q5 should be connected to pin 12 of IC1f instead of pin 10 of IC1e.

The effect of these changes is that the buzzer will now sound for a brief period whenever the transmitter signal is received. The duration of the buzzer will be about 0.2 seconds, but this can be extended to one second by increasing the 0.1μF capacitor connected to pin 13 of IC1f to 0.47μF.

The changes in the transmitter circuit are more complex, necessitating separate circuit and wiring diagrams. Referring to the circuit we can see that it still uses a 3-gate CMOS oscillator driving a transistor and an infrared LED. However, the LED current limiting resistor has been reduced to 22Ω,

resulting in a much greater LED current and hence a greater infrared light output. We'll explain why this is necessary later.

Another change involves the gating for the oscillator. Whereas the oscillator was always on in the relay, it is now only turned on for a brief 7ms period each time the trigger button is

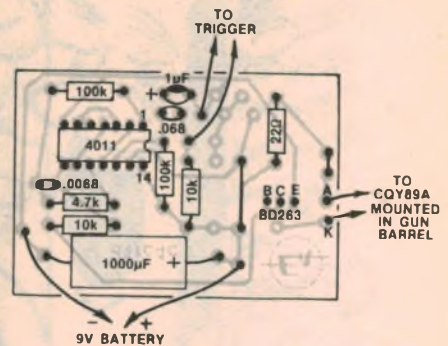

Component overlay and circuit diagrams for the target game transmitter.

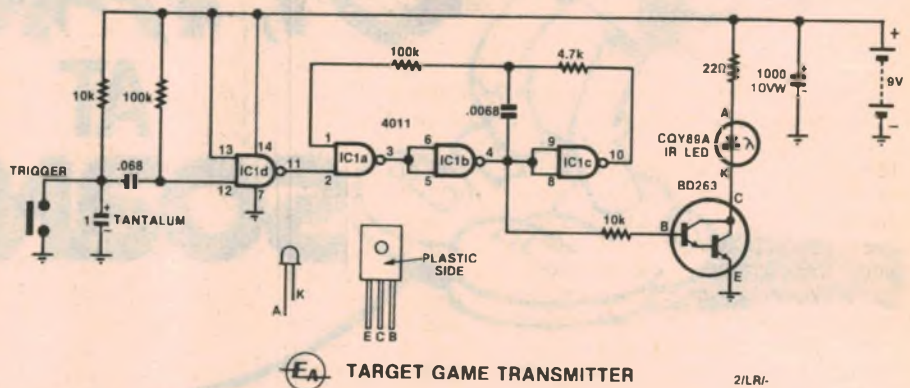

pressed. This is accomplished by its output connected to pin 1 of IC1a and so can enable or disable the oscillator. The input of IC1d, pin 12, is connected to an RC trigger network consisting of 10kΩ and 100kΩ resistors and a .068μF capacitor.

The trigger circuit works as follows: when the trigger switch is open circuit, both sides of the .068μF capacitor are

pulled high due to the 10kΩ and 100kΩ pullup resistors. The output of IC1d will thus be low and the oscillator will be disabled. When the trigger is pressed the switched side of the .068μF capacitor is pulled down to ground and, because the voltage across the capacitor cannot change immediately, pin 12 of IC1d will also be pulled low, enabling the oscillator.

Eventually, the pin-12 side of the

Q5 so that when the beam is broken Q5 turns on. The collector output can be switched to an internal buzzer and LED which can be used directly as the alarm in a shop minder situation, or as a quick indication that the unit is working when used as a camera trip. The output can also be switched to an external alarm (eg a Sonalert), or directly to a camera.

Some readers may wish to eliminate the internal buzzer, yet retain the LED indicator. In this case, the buzzer should be replaced by a 2.2kΩ resistor to limit the current through the LED (ie connect a 2.2kΩ resistor in series between the LED and the positive supply rail).

If the unit is used as a camera trigger, a motor driven camera is necessary for unattended operation. The actual con-

tacts from the camera should be connected between ground and the collector output so that the transistor just looks like a switch. We found that this works quite well and has advantages over a relay output in terms of power consumption and speed – the only delay is the time taken for the reflex lens of the camera to swing down.

That virtually completes our discussion of the circuit. The only additional points to note are the optional 9V DC pluggack supply and the use of several decoupling capacitors in the supply to prevent feedback in the amplifier section. Note that the diode in series with the battery is required only for pluggack operation with battery backup, and can be omitted for battery or pluggack operation alone.

## CONSTRUCTION

Most of the components in the receiver mount on a single printed circuit board (PCB) board coded 81ir4 and measuring 97 × 46mm. Mount the components on the PCB according to the component overlay diagram provided, paying particular attention to the orientation of transistors, diodes and electrolytic capacitors. The BPW50 photodiode has its sensitive area on the flat front of the package and its anode lead is longer than the cathode.

The receiver is housed in a small plastic zippy box measuring 130 × 68 × 41mm. When the board is completed it can be mounted to the aluminium lid of the box using machine screws and nuts. Note





The completed target game transmitter inside a plastic gun. Although the PCB layout differs from the overlay, the two are electrically identical.

.068 $\mu$ F capacitor will charge up via the 100k $\Omega$  pull up resistor to the transition voltage of the CMOS gate. IC1d's output will then suddenly switch low, disabling the oscillator. The total period for which the oscillator is enabled is set by the time constant of the .068 $\mu$ F capacitor and 100k $\Omega$  resistor, ie about 7ms.

The 1 $\mu$ F tantalum capacitor is included to provide switch debouncing.

Whenever the trigger button is pressed therefore, a brief 7ms 10kHz pulse of infrared light is emitted. This will normally trigger the receiver, regardless of the direction in which the transmitter is pointed. Clearly this is unsuitable for a target game so when the transmitter is installed in a suitable plastic housing, say a toy gun or rifle, the light output from the infrared LED

has to be collimated or restricted to a narrow beam.

While the beam could be collimated with a lens, a far simpler solution is to use two or more opaque discs with holes drilled in their centres. If the LED and discs are lined up and spaced at say 4cm intervals, and if the holes are sufficiently small, quite a narrow beam results. A single disc made of aluminium foil with a small pin hole also gave good results.

Note that very little of the LED's output is actually used and this is why it is pulsed on so hard.

The case used for the transmitter is up to the constructor but as a guide we have included a photograph of one unit we built. We used a discarded gun from a TV game and found it quite easy to adapt to its new role.

## PARTS LIST

### RECEIVER

- 1 PC board, code 81ir4, 97 x 46mm
  - 1 zippy box, 130 x 68 x 41mm
  - 2 miniature SPDT toggle switches
  - 1 Solid state buzzer
  - 1 large LED & mounting bezel
  - 1 9V battery, Eveready 216 or equivalent
  - 1 battery clip to suit
  - 1 74C14 CMOS Schmitt trigger IC
  - 1 2N5485N channel JFET
  - 3 BC549 NPN transistors
  - 1 BC337 or BC547 NPN transistor
  - 1 BPW50 infrared photodiode
  - 3 1N4148 diodes
  - 1 OA91 diode (optional for battery back up)
- RESISTORS: (1/4W, 5%)
- 3 x 1M $\Omega$ , 1 x 470k $\Omega$ , 2 x 100k $\Omega$ , 1 x 68k $\Omega$ , 1 x 47k $\Omega$ , 1 x 15k $\Omega$ , 2 x 10k $\Omega$ , 1 x 2.7k $\Omega$ , 2 x 330 $\Omega$ , 1 x 150 $\Omega$ , 1 x 100 $\Omega$ , 1 x 47 $\Omega$

### CAPACITORS

- 2 100 $\mu$ F 16VW PC electrolytics
- 1 47 $\mu$ F 16VW PC electrolytic
- 1 10 $\mu$ F 16VW PC electrolytic
- 2 0.1 $\mu$ F 25VW tantalum
- 1 .01 $\mu$ F greencap
- 2 .0068 $\mu$ F greencap
- 1 .0022 $\mu$ F greencap
- 1 .001 $\mu$ F greencap

### RELAY TRANSMITTER

- 1 PC board, code 81rc4c, 61 x 42mm
- 1 zippy box, 83 x 54 x 28mm
- 1 SPDT miniature toggle switch
- 1 9V battery, Eveready 216, or alkaline equivalent
- 1 battery clip to suit
- 1 4011 CMOS quad NAND gate
- 1 BC337 or BC547 NPN transistor
- 2 CQY89A infrared LEDs
- 1 10 $\mu$ F 16VW electrolytic capacitor
- 1 .0068 $\mu$ F greencap capacitor

### RESISTORS (1/2W, 5%)

- 1 x 100k $\Omega$ , 1 x 10k $\Omega$ , 1 x 4.7k $\Omega$ , 1 x 680 $\Omega$

### TARGET GAME TRANSMITTER

- 1 PC board, code 81rc4c, 61 x 42mm
  - 1 suitable plastic gun (see text)
  - 1 momentary contact pushbutton
  - 1 9V battery, Eveready 216 or alkaline equivalent
  - 1 battery clip to suit
  - 1 4011 CMOS quad NAND gate
  - 1 BD263 NPN Darlington transistor
  - 1 CQY89A infrared LED
  - 1 1000 $\mu$ F 10VW axial lead electrolytic capacitor
  - 1 1 $\mu$ F 16VW tantalum capacitor
  - 1 .068 $\mu$ F greencap capacitor
  - 1 .0068 $\mu$ F greencap
- RESISTORS (1/4W, 5%)
- 2 x 100k $\Omega$ , 2 x 10k $\Omega$ , 1 x 4.7k $\Omega$ , 1 x 22 $\Omega$ .

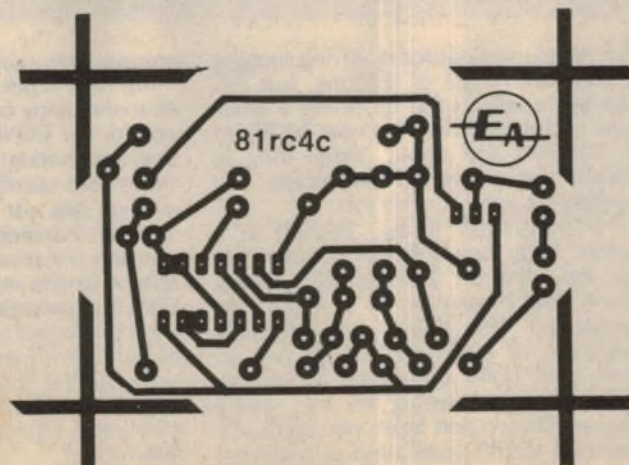

Actual size artwork for the transmitter PCB. The same board is used for both the relay transmitter and the target game transmitter.



THE SETUP! (left): this retouched photograph shows the setup used by Sungravure photographer Bob Donaldson to capture the superb shot on our front cover. The transmitter and receiver units are mounted on wooden beams, and arranged so that the Infrared Relay is triggered as a bird comes in to land at a food table (centre foreground)!

Photographic details are as follows: Camera — 35mm Leica R3 SLR fitted with motor drive (essential) and a

250mm lens; Flash rate — 1/2,500s (high speed necessary to freeze wing motion); Film — Kodak EPR ASA64; Aperture — F8.

In practice, the relay units are moved closer together than shown here — just outside the picture area — so that the subject will be correctly centred. The camera is mounted about 1 metre from the subject while two flash units with variable power ratio controls are used, one on either side of the camera.

that the earth track on the PCB goes to one of the mounting holes so that when the board is mounted the lid is earthed. This is to provide some measure of shielding.

Now drill holes in the box for the on/off and buzzer/camera switches S1 and S2, as well as an exit hole for the camera lead. Alternatively use a DIN socket to mate with a suitable camera lead. Drill a 10mm hole for the light beam to enter the receiver, positioning it so that the centre of the hole lines up with the centre of the BPW50 photodiode.

When the unit is fully assembled the photodiode should be recessed about 20mm from the light beam entry hole. This does not reduce the range of the unit but is intended to prevent direct light from falling on the BPW50 and thus reducing its sensitivity. We still found

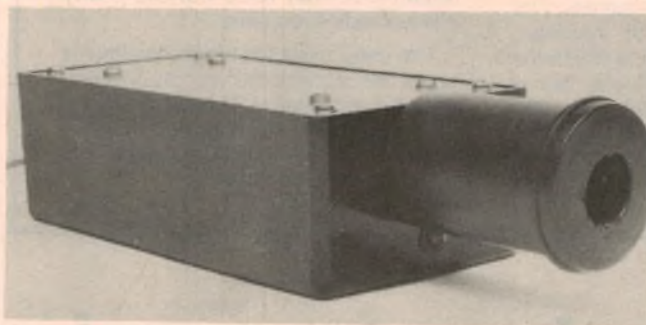

A plastic film canister makes an ideal light-tube for the receiver.

that when used outdoors, strong sunlight reduces the range of the unit, but this can be readily cured by fitting a small tube of non-reflective material 20-30mm in diameter and about 50mm long in front of the receiver. A black plastic film canister is ideal for this job.

The transmitter is also housed in a plastic zippy box and the components are mounted on a single PCB coded 81rc4c and measuring 61 x 42mm. As mentioned, this board was originally designed for a remote control unit so quite a few holes are unused. Mount the components according to the wiring diagram shown and again pay particular attention to the orientation of polarised

components, including the infrared LEDs.

The only holes which need to be drilled in the zippy box are two holes at one end for the CQY89A infrared LEDs and a single mounting hole on the aluminium lid for the on/off switch. This done, the wiring can be completed and the transmitter/receiver combination tested.

Switch the receiver on and switch the output to the internal buzzer and LED. With the transmitter off, both the buzzer and LED should turn on. Now switch the transmitter on and aim it at the receiver — the buzzer should stop. Finally, check that the buzzer/LED combination is activated whenever the beam is interrupted.

We estimate that the current cost of parts for this project is approximately

**\$40**

including sales tax.

**Vicom International Pty. Ltd.**

68 Eastern Road,  
South Melbourne,  
Vic. 3205  
Phone (03)6996700

339 Pacific Hwy,  
Crows Nest, NSW  
2065  
Phone (02)4362766

**Authorised Dealers N.S.W.**

Sydney: Sideband Electronic Sales  
4384191

Newcastle:  
Elektron 2000  
262644

Wagga Rivercom  
212125  
W Gong: Macalec  
291455

**Queensland**

Brisbane: CW Electronics 486601  
Cairns: GCG Communications 541035  
Gold Coast: Amateur's Paradise 322644  
Townsville: Robco Equipment 722633

**Victoria**

Melbourne: Eastern Communications 8368635  
Moe: Codlin Communications 274516  
Hamilton: Hamilton Electronics 723333  
Ballarat: Wecam 392808

**South Australia**

Adelaide: Compucom 437981  
I.C.S. 473688  
Mt Gambier Set Services 252228

**Western Australia**

Perth: Willis Electronics 217609  
Netronics 463232  
Kalgoorlie: Hocks TV 211906

**Tasmania**

Launceston: Gelston 443882  
Advanced Electronics 317075  
Hobart: Harvey Skegg 436337

**Dealer enquiries invited**

**VICOM**

# How to be the biggest "know all" in town.



**Regency M400 Scanner**

Listen to police, ambulance, fire brigades, hams etc. 90 day warranty. AC/DC operation (includes approved AC adaptor). 30 channels (no crystals required). Full scan 60-90 MHz, 144-174 MHz, 420-512 MHz. Nicad memory battery included. The capabilities of the M400 are awesome. At home or on the go, the M400 will connect you with all the action, with more frequency receiving capability, than any other scanner of its size. Perfectly adaptable to most car installations, the M400 is a great addition to your home or radio shack. 10 channel model available (M100) **\$425**. Price model M400 (inc AC adaptor) **\$490**



**Famous Leader Dip Meter.**

For the experimenter. Almost essential if you're into Ham, CB, or other communications operation. Determines IC network frequency resonance and can be used to adjust wave traps, find parasitic oscillations and align receivers. Frequency Range: 1.5 to 250 MHz in 6 bands. Power supply: 9V battery (P & P \$3 extra)

**\$99**

**Wideband Receiver Antennas.**

Ideal for use with scanners. Discone 65-520 MHz Model scan-X **\$41** (receive only) Model GDx-1 **\$93** (Tx/Rx)

**\$41**

**VHF Pocket Receivers.**

Vicom has a range of pocket sized VHF & UHF channelised receivers, ideal for foremen, taxi drivers and people on the go. HF12 10 channels VHF **\$159** (crystals extra) MR2G 10 channels VHF **\$354** (crystals extra)

**\$159**



**NEW**

**The ultimate in cordless operation for mobile systems.**

The Infrared RM 940 provides complete flexibility which makes it ideal for mobile use. Its "No

Cord" operation assists driving safety. It unobtrusively clips in clothing to allow hands free operation while you drive. Its infrared optic/electronic principle ensures that the mic to infrared sensor channel is completely unaffected by spurious radiation. For in-car use, it is possible to use a second mic. from the rear seat position.

**\$139**

**Kenwood Tells It All.**

The fantastic digital-readout R1000 is a high class general coverage communications receiver, covering 30 bands, from 200 kHz to 30 MHz. AM/SSB/CW modes. Excellent frequency stability. AC operated. Quartz clock. Great sensitivity. Simple operation. Built in noise blanker.

**\$541**

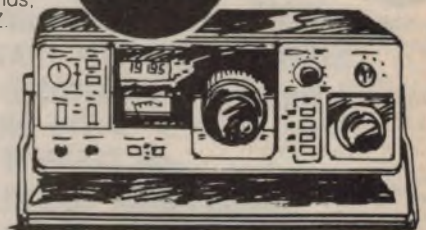

**Leader RF Signal Generator.**

Leader's LSG16 is a very versatile solid-state, wide band signal generator. Designed especially for the radio experimenter, hobbyist and education teachers. Frequency range 100 KHz to 100 MHz in 5 ranges. Accuracy ± 1.5%. Internal modulation 1 KHz. External modulation facility. (P & P \$5 extra)

**\$153**



# HERE'S THE PROOF!...

POSSIBLY...NO, PROBABLY YOU ARE ONE OF THE MANY 100'S WHO WAIT 10/12 — EVEN 15 DAYS OR MORE FOR YOUR ORDER, ONLY TO FIND THAT MANY OF THE ITEMS AREN'T EVEN IN STOCK WHEN ADVERTISED!!!

WELL FELLAS..

THAT'S FINISHED!

THIS & ALL ORIGINAL ORDERS SHOWN HERE ARE ON FILE.

This order arrived at 9.50 a.m. 12.1.81. Out at 11.00 a.m. (1 HOUR 10 MIN.)

WE EVEN HAD ONE FROM NINTH RYDE IN N.S.W.!

The orders are coming in from everywhere... WE MUST BE RIGHT AFTER ALL!

THE ONLY REASON WE WON'T HAVE STOCK THAT IS ADVERTISED IS

IF THE ORDERS CLEAN IT OUT QUICKLY... Promise...

**guarantee**

- No Stock Advertised unless in store.
- Every Mail — Phone — Telex Order will be despatched by 4.30 p.m. day of receipt.
- Acknowledgement of time IN/OUT plus relevant information on any item will be included with 2 spare M/O Forms in every despatched order.
- Absolute PRIORITY SERVICE. HELP and ADVICE at all times! Just as if you were at our Counter.

ORDER RECEIVED 9.35 a.m. 8/1/81  
DESPATCHED 11.00 a.m. 8/1/81

Order From: W.V. ANDERSON  
P.O. BOX 26,  
STOCKTON  
N.S.W.

- 1 x 2155 Transformer \$3.95
- 1 x 6672 Transformer \$5.95
- 2 x Mini Relays \$5.00
- 1 x S/Iron Stand \$5.00
- 40 x Packs of 100 Resistors at \$1 each \$40.00

This and all original orders are on file. \$59.90

AND WHAT'S MORE HE SAVED OVER \$100 COMPARED TO D.S.E. NORMAL PRICES. It's a FACT Man!

Order From: M.L. FREEMAN,  
32 BOWLEY ST.,  
MOSS VALE,  
N.S.W.

5 x 19" BLK ANODISED RACK MOUNTING CABINETS at \$35 ea. \$175.00  
100 x 1N914 DIODES at 3c ea. \$3.00  
\$178.00

A SAVING OF \$74.75 HERE

GREGORY FREEMAN,  
HARROGATE RD.,  
NAIRNE, S.A.

- 3 x S.P.S.T. std Switches at 95c ea. \$2.85
- 140 x Rectangular Red Leds at 20c ea. \$28.00

TOTAL \$30.85

ORDER RECEIVED 9.40 A.M. 14/1/81  
DESPATCHED 2.15 P.M. SAME DAY

Yes... we dare to compare with ANY Australian company

...Believe us, some of the comparisons would be too silly for words! We're not talking just prices. If we thought we could win on price alone we'd be bonkers!

Service, continued service with quality and value is the lasting benefit. We've just got to be the Best Alternative to your present supplier...Doesn't matter who he is!

These sample orders go to prove that even with major organisations close to them... WE MUST BE OFFERING SOMETHING THE OTHERS DON'T.

DICK SMITH'S NORMAL PRICE IS IN EXCESS OF \$45

Cylon Voice Simulator P.C.B.'s only \$2.50

PETER GARGANO,  
37 JALANGA CRES.,  
ARANDA, A.C.T.

- 100 x 1N914 DIODES \$3.00
- 200 x RESISTORS \$2.00
- 200 x 3mm RED LEDS \$7.00
- 100 x 5mm RED LEDS \$8.00
- 1 x 2155 TRANSFORMER \$3.95 (S.E.C. Approved)

\$24.95

D.S.E. Prices Total \$50.00! That's twice the price.

ORDER IN 9.40 A.M. 12.1.81  
OUT BY 12 NOON 12.1.81

JUST ARRIVED... No Room on the other page!... CERAMIC MAGNET for These

85 Hz — 10KHz RESPONSE

7W EXTENSION SPEAKERS CAR SPEAKERS P.A.'S ETC. \$3.50 ea. + P. & P.

6 1/2" x 8" SPEAKERS 2 for \$5.99

And Vic's got more Electronics Stores than Sunny Days.

ALEC J. PHILLIPS,  
89 O'DONNELL AVE.,  
MYRTLEFORD VIC.

- 10 x Orange LEDS \$3.00
- 20 x 1N4007 DIODES \$2.60
- 10 x 1N5404 DIODES \$3.00
- 10 x 1N5408 DIODES \$2.50
- 1 x UB1 JIFFY BOX \$1.75
- 1 x UB3 JIFFY BOX \$1.95
- 2 x P/T/M SWITCHES \$0.80
- 2 x P/T/B SWITCHES \$0.90
- 1 x MU65 PANEL MTR. \$10.00

TOTAL \$25.90 + \$1.00 P. & P.

SAME STORY HERE IN & OUT IN 3 HOURS

from: J. WILLIAMS  
FLAT 2,  
6 BAYLEY ST.,  
GLEBE HOBART,  
TASMANIA, 7000.

Dated 13/1/81

D.S.E. PRICES \$73.95

- 2 x JIFFY BOX UBI \$3.50
- 2 x JIFFY BOX UB1 \$5.50
- 2 x JIFFY BOX UB2 \$2.70
- 2 x JIFFY BOX UB3 \$7.90
- 2 x T/FORMER 2155 \$5.90
- 2 x T/FORMER 2851 \$5.95
- 1 x T/FORMER 6672 \$59.35

STAGED SAVER

IN JAN. 15/1/81  
9.40 A.M. OUT 11.00 A.M.  
PROBABLY RECEIVED BY 18/1/81. 5 DAYS IN ALL.

ARE YOU AN ELECTRONICS RESELLER? IN QLD, NSW, VIC, S.A., OR TAS — CITY OR COUNTRY ARE YOU VIBRANT, DYNAMIC, ALIVE DO YOU WANT TOP PRODUCTS WITH TOP DEMAND AT REALISTIC PROFIT MARGINS? WHAT ARE YOU WAITING FOR? PHONE JACK O'DONNELL (09) 381 7233.

**ALTRONICS** ONE STOP ELECTRONICS SHOP  
105 Stirling St. PERTH  
All MAIL ORDERS: BOX 8280 PERTH Stirling St. WA 6000 (09) 328 1599 for instant service

Rush in your order NOW, we will rush it back

YOU CAN SELL OUR PRODUCTS AT OUR PRICES AND GIVE THE MANUFACTURER, THE SERVICEMAN, A FIGHTING CHANCE TO BUY FROM YOU!

THE DYNAMIC ALTERNATIVE THE DYNAMIC ALTERNATIVE THE DYNAMIC ALTERNATIVE THE DYNAMIC ALTERNATIVE

**CARBON FILM RESISTORS**  
ALL PRIME SPEC  
WE'RE SELLING MILLIONS!

1/4 watt - packs 200.  
**ONE VALUE**

1/2 watt - pack of 100  
**ONE VALUE**

All Popular Values Stocked  
From 1 ohm to 10 Mega ohm

**75Ω TV COAX**  
100m rolls \$19.50  
Your APRIL ONLY Price!  
YES. \$22.50 roll

RG 58 U/52 ohm  
100m Rolls at Only

FANTASTIC FREQ RANGE  
**8" TWIN CONE SPEAKER** from \$7  
50% better than our competitors

**TOUGH LUCK** if you've just paid \$500 for a pair of Hi-Fi speakers for a fraction of the cost you could have bought this incredible dual cone Hi-Fi speaker. It delivers the same gutsy sound - lots even the experts. Hear them for yourself and you'll be sold. Buy several while they last. Great frequency range 30HZ - 15KHZ.  
1 only \$7.95 2 for \$15 10 up \$7 ea

**DIGITAL ACCURACY**  
'Univolt'  
PRO-STANDARD  
**MULTI METER**  
MODEL DT-810

- 3 1/2 Digit Display
- D.C.V. A.C.V. D.C.A. - Ω
- Diodecheck
- Conductance Check - hte
- Bi Polar Auto Switch
- Sampling Time 0.4sec

LOOK AT THIS!  
K.O. PRICE  
**\$115**

Carry Case \$5.25  
H.F.E. Probes \$3.50  
I.C. Leads \$3.10  
Univ Test Leads \$7.25

Shipment just arrived of  
**PRO-QUALITY 13/12 TINNED HOOK UP WIRE**  
8 COLOURS in 100m rolls

Introductory PRICE  
**\$4.95 ROLL**  
Or 8 Rolls for **\$35**

BLACK  
BROWN  
RED  
ORANGE  
YELLOW  
GREEN  
BLUE  
WHITE

**NEW! \$35**  
**FIG 8 CABLE**  
19/193 200M  
**10¢** METRE

JUST WHY PAY 25c FROM YOU KNOW WHERE

All Electronics Cables Supplied on Spools - **\$20 ROLL**  
We do NOT supply loose hanks!

PRICE IS BEATEN TO A  
**SPEAKERS PULP HERE!**

**Magnificent MAGNAVOX**  
EXTENSION SPEAKERS

Huge 15w capacity  
**HI-FI** \$139. NOW **\$69** PAIR

Superb Quality Danish Teak Finish  
Ideal - Patios, Poolside Games Rooms, etc.

**LIMITED STOCKS**

**You're a LOSER if you get your project TRANSFORMERS anywhere else but from us.**

2851 240V/12.6C.T. 150MA **\$2.96**  
2155 240V/6.3-15V 1A multitap **\$3.95**

S.E.C. APPROVED AS WELL  
DON'T TAKE RISKS!

NOW ANOTHER only **\$6.50**  
K.O! 2156

2 AMP version of the 2155

**AMAZING! 6672 TRANSFORMER**

240V/15-30V  
1A multitap  
These won't last!!

**\$5** BLOCKBUSTER PRICE

**MO216 MINI AUDIO TRANSFORMERS**  
1KC C.T. - 8ohm - 350mw  
Ideal replacement Audio project kits

**50¢** 1/2 Normal Price

**REED SWITCH AND COIL**  
NOW THRASHED TO RIBBONS

**60¢** **30¢**

WANT A REAL PROFESSIONAL FINISH LIKE 'NAKAMICHI' 'TECHNICS' - ETC?

Then you'll really get it with our FABULOUS BLACK ANODISED MOUNTING RACK BOX

Just great for the NEW MOSFET AMPLIFIER PROJECT

**from \$35** 5 up **\$39.95**

**SEMI'S MASSIVE SAVINGS**

- MEL 12 Darlington Photo Transistor 60c 50c
- 2N6027 P.U.T. 50c 40c
- W001 Bridge Rectifier 1A/100V 35c 30c
- W02 Bridge Rectifier 1.2A/200V 50c 40c
- W04 Bridge Rectifier 1.2A/400V 50c 40c
- IN 914 Diode 4c 3c
- LT 302 Display 0.3" \$1.25 \$1.10
- LT 303 Display 0.3" \$1.25 \$1.10
- LT 547 Display 0.5" \$1.25 \$1.10
- Pin for pin equiv. FND 500 \$1.00

- AL 12 L.D.R. Dark 200K, light 330n. 50c 45c
- BF 115 V.H.F. AMP 50c 45c
- 2N 5458 (MPF 105) 50c 45c
- 2N 5459 (MPF 106) 50c 45c
- 106D S.C.R. 80c 75c
- L.E.D. 5mm Red 1-9 10-24 25up
- 5mm Green 16c 10c 8c
- Orange 28c 20c 15c
- Yellow 34c 30c 22c
- 55c 30c 25c
- Prime spec. NE 555 Timer 45c 35c
- 741 I.C. 40c
- R.B.L.L. Caps O.I. ufd to 100 ufd Preferred Values (tantalum substitutes) ALL 30c EACH

**8 x SPST D.I.L. P.C.B. SWITCH**  
**\$2.30**

**TA7205 I.C.** 1/3 off **\$2.95**

**RELAY** from \$1.00

- 8-12 V.D.C. operation
- 225 OHM coil resistance
- Silver change over (S.P.D.T.) contacts handle up to massive 2 AMPS @ 24 V DC or 100 V AC
- Mounts directly on to PCB
- Ideal for many applications

1's 10's 25 up  
\$1.50 \$1.20 \$1.00

**GLOBES** Plenty in Stock NOW!

M.E.S. 6V 12V 25c 20c  
Lilliputs 6V 12V 30c 25c

M.E.S. LILLIPUTS

**REPEAT PERFORMANCE CHAMPION PRICE**  
Instrument 12-16V **10¢** 5 up **\$8** EACH Per 100

**NEW ALUMINIUM PROJECT BOXES**  
2 HANDY SIZES

lower prices

Quality Aluminium Bright Finish. \* Complete with all Screws.

**HO355...\$1.95**  
100 x 58 x 45 mm

**HO358...\$2.95**  
125 x 100 x 70 mm

A must for projects requiring shielding!

**HEY... COP THIS!**  
**2ND SHIPMENT NOW HERE**

Soldering iron stand

**\$5** HEAVY BASE

**WOW! LOOK AT THIS!**  
For a WALKIE TALKIE! (POCKETCOM)  
FIRST IN, FIRST SERVED!

Out of 1000's sold... we have a few that with little effort can be made to work O.K. Or will provide many dollars in spare parts & components. We don't have the time or inclination to tie up our service section.

**WE HAVE STOCK!**

8 PIN D.I.L. CA3130's and CA3140's (F.E.T Input) (OP. Amps)

RUSH FOR THESE! Both Only **\$2 ea.**

**PRINTED STRIP BOARDS**  
BE QUICK

Plated Strips - Alpha Numeric Grid the most versatile board of the lot. Etched copper strips are pre drilled and plated for soldering ease. These boards have an Alpha Numeric Grid to facilitate positive Pin identification.

254MM SPACING x 76MM x 153MM

**\$150 ea**

**SWITCHES**

SAVE ON OUR BULK PRICES!

A. S.P.S.T. Mini P/On momentary action	7-9 10 up	24c 20
B. S.P.S.T. STD P/On	1.40	1.20
C. S.P.S.T. STD P/On-P/Off	1.60	1.45
D. D.P.D.T. Toggle C/Off	1.95	1.75
E. D.P.D.T. Toggle	1.65	1.50
F. S.P.D.T. Toggle Mini	1.30	1.20
G. 3Pos D.P. Slider Al. Knob	50	40
H. D.P.D.T. Slider C/Off	25	20
I. D.P.D.T. Slider Sub/Min	25	20
J. S.P.S.T. Toggle Glow Handle	1.95	1.80
K. D.P.D.T. Slider Mini Alum Knob	25	20

These are QUALITY!

**TUNING GANGS** **85¢ ea**

ideal MW & SWV receivers

WHILE STOCKS LAST!

Guaranteed up to 1000 Charges!

**NICADS** 1-9 10up **\$190.160**  
**NICADS** 1 ea **1ea**

**XENON FLASH TUBE**  
**\$2.50** Trigger Transformer To Suit 90c

**BEZELS L.E.D.**

RED OR GREEN OR ASSTD

1-9 IOUP **60c 50c**

SAVE HERE!  
great quality! great price!

**P&P Only \$1**  
**All Orders**  
Add to Your Total Order

Electronics + Fitness = Health

# Heart Rate Monitor to

A quick and convenient way of measuring your heart rate can be useful in many circumstances. Our Heart Rate Monitor provides performances comparable to commercially available models at a much lower cost, and features a digital display in Beats Per Minute, a selection of two measurement periods and easy calibration. The sensor used to detect the heart beat slips quickly onto a finger or wrist for comfortable use, and the instrument incorporates some ingenious principles which could be put to use in many other applications.

by JOHN CLARKE

An accurate and reliable Heart Rate Monitor has many uses. Those undertaking exercise programs, practising relaxation or yoga, and anyone interested in their own state of health will find that a measurement of their heart rate is a valuable piece of information.

Interesting and useful information can be gained by checking the heart rate before and after exercising, or by continuously monitoring the pulse while using an exercise bike or similar device. It is also interesting to note the change in heart rate after a cup of coffee or a glass of beer and in particular the slower "resting heart rate" which results from increased fitness after a sustained exercise program.

Generally the heart rate is related to a person's level of tension, anxiety or excitement, and can be used as a measure of the degree of stress or relaxation. Some readers may be interested in taking advantage of this fact to use the Monitor to measure and control their own degree of tension, or less seriously, as the basis for lie detection (stress monitoring equipment).

Many professional heart rate monitors use electrodes placed on the body to detect the electrical activity of the heart. This approach makes the equipment inconvenient to use, quite apart from the fact that special (expensive) electrodes are necessary. Our monitor, however, is simple and convenient. It measures the tiny expansion and contraction of the arteries of the hand caused by pumping

action of the heart. The monitor detects this variation using an optical pickup. An instrument of this type is commonly known as an "optical plethysmograph", from the Greek "plethysmos", an enlargement.

Before going on it might be best to mention that the equipment is completely safe. There is no electrical connection of any kind between the instrument and the person being monitored. A finger stall containing an infrared LED and a photodiode is slipped over the finger of the "patient" and the heart rate is read in beats per minute from the digital display.

The digital readout of the HRM will display heart rates from 30 to 240 Beats Per Minute (BPM), more than adequate for the heart beat variation of healthy

people. The normal "rest heart rate" is generally taken to be 70 BPM for an adult. However, this can be much higher in the case of children and possibly down in the 30's for a really fit athlete. Any heart rate outside this range will result in an "E" on the display. This can also occur when first setting up the HRM.

Basically the monitor operates as a period meter which counts the number of clock pulses of a known frequency between heart beats. The faster the heart rate, the fewer clock pulses counted; the slower the heart rate the greater the number of clock pulses counted. This gives an inverse value to what we want to display. (A fast heart rate will give a low reading and a slow heart rate will give a high reading.)



Pictured above is the Heart Rate Monitor together with the wrist-strap sensor. It can be used during any stationary exercise such as pedalling an exercise bike, as pictured at top left (Photo courtesy of "Vital" magazine).

& Happiness!

# Build

To overcome this problem a look-up table, stored in non-volatile memory is used. The look-up table inverts the numerical value of the clock pulses counted between heart beats to give a true Beats Per Minute reading.

The circuit of the Heart Rate Monitor can be divided into four sections. These are the detector and amplifier, the counter, the look-up table and display, and the power supply section. We will look at each section in turn.

The optical detector consists of an infrared light emitting diode (IRLED) and a photodiode. The IRLED is run continuously at about 6mA. In operation the sensor assembly is arranged so that light from the IRLED penetrates the finger of the person being monitored and is reflected by the finger bone and received by the photodiode. The intensity of the reflected light will be modulated by the expansions and contraction of the arteries of the finger in response to heart beat pulsations, and this modulation will be detected by the photodiode and amplified by IC8c.

IC8c forms a DC amplifier with its bandwidth restricted above 4.8Hz by the .033 $\mu$ F Capacitor across the 1M $\Omega$  biasing resistor. The output of IC8c is fed to two stages of amplification, IC8d and IC8a. Both these stages have 0.48Hz high pass filters at their inputs and 4.8Hz low pass filters across the feedback path, and are AC coupled with gains of about 100. The stage formed by IC8a however, has a gain control which can reduce the gain of that stage to 10.9. The high and low pass filters around these amplifiers allow only heart beat frequencies to be processed through the circuit, and heavily attenuate any other frequencies, preventing interference from other modulated light sources, the mains etc.

Following the amplification stages is a Schmitt trigger formed by IC8b. This transforms the amplified signal from the sensor into a square waveform. The output of the Schmitt trigger swings between zero and 12 volts, but is clamped to 5.1 volts by a zener diode to allow the signal to be fed to the following digital circuitry. The output of the Schmitt trigger also drives the righthand decimal

point of the display directly, to indicate that a heart beat signal is being correctly received by the amplifier circuitry.

At this point we should mention that the power supply for the op amps of IC8 is derived in a somewhat unusual way. Since we have +5 volts already at the power supply it might be expected that we would use these for the op amp supply. However in doing this current loops can be formed which will upset the op amp circuitry. Remember that we have amplifier gains near one million! To prevent such problems, the positive 12 volt supply rail is regulated to 5.6 volts and filtered with a 22 $\mu$ F capacitor to supply the reference to the op amps. The positive supply is then 12 volts and a steady reference voltage is assured for the op amps.

From the output of the Schmitt trigger the heart beat signal is passed via switch S2 to counter IC4 and flipflop IC5b. Switch S2 selects either the heart beat signal or the calibration signal as the driving source for the counter. IC4 is a decade counter, so that the two outputs, pins 2 and 3, will go high every 10 heart beats. As shown by the timing diagram, Fig. 2, this will allow the clock

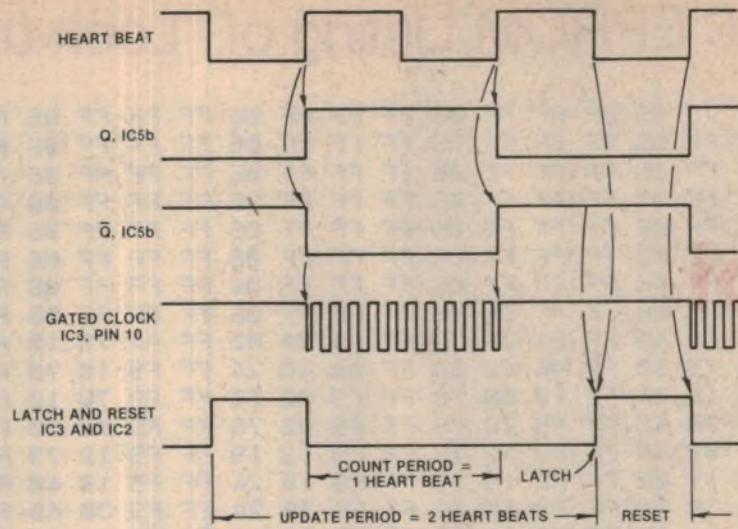

FIG. 1 : TIMING DIAGRAM FOR "TWO HEART BEAT" UPDATE PERIOD

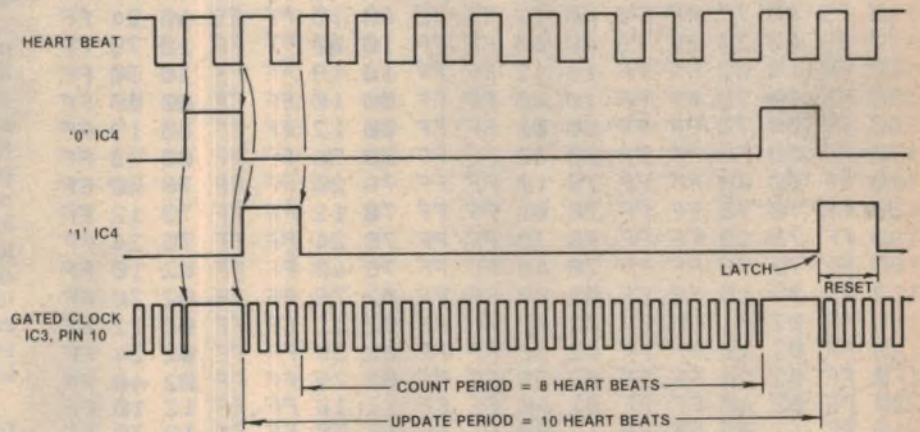

FIG. 2 : TIMING DIAGRAM FOR "TEN HEART BEAT" UPDATE PERIOD

output to be gated to counter IC3 for a time corresponding to eight heart beats. Flipflop IC5b produces a pulse with a length of one heart-beat period and, as will be seen from Fig. 1, the output of the clock is gated to count IC3 for a counter period of a single heart beat. The count is latched and the counter reset every two heart beats.

This arrangement allows us a choice of two counting and update periods for the monitor, selected by the switch S1. With S1 in position one, the clock signal derived from the 555 timer, IC6, (set to 1024Hz by the 22k $\Omega$  trimpot and 68k $\Omega$  resistor) and counter IC3 will be driven by the output of IC5b.

1024Hz was chosen as the frequency for this count as it takes eight clock cycles to bring output Q4 of IC3 (the least significant bit of the count) high. Eight clock cycles multiplied by 256 are required to cycle through the whole of the look-up table of IC1 to reach the uppermost memory location, or 30 BPM. This corresponds to 2048 clock cycles in two seconds, or 1024Hz.

The clock signal to pin 10 of IC3 is gated by IC9a when the Q-bar output of IC5b or pin 3 of IC4 goes high. The ad-

# 2708 EPROM Listing of "Look-up" table for circuit

```

0000 FF FF 0E FF FF FF 0E FF FF FF 0E FF FF FF 0E FF
0010 FF FF 0E FF FF FF 0E FF FF FF 0E FF FF FF 0E FF
0020 FF FF 0E FF FF FF 0E FF FF FF 0E FF FF FF 0E FF
0030 FF FF 0E FF FF FF 0E FF FF FF 0E FF FF FF 0E FF
0040 FF FF 0E FF FF FF 0E FF FF FF 0E FF FF FF 0E FF
0050 FF FF 0E FF FF FF 0E FF FF FF 0E FF FF FF 0E FF
0060 FF FF 0E FF FF FF 0E FF FF FF 0E FF FF FF 0E FF
0070 FF FF 0E FF FF FF 0E FF FF FF 0E FF FF FF 0E FF
0080 A4 19 40 FF A4 30 30 FF A4 24 02 FF A4 79 10 FF
0090 A4 79 30 FF A4 40 00 FF A4 40 24 FF F9 10 78 FF
00A0 F9 10 24 FF F9 00 78 FF F9 00 30 FF F9 78 10 FF
00B0 F9 78 12 FF F9 78 79 FF F9 02 78 FF F9 02 30 FF
00C0 F9 02 40 FF F9 12 78 FF F9 12 19 FF F9 12 79 FF
00D0 F9 19 00 FF F9 19 12 FF F9 19 24 FF F9 19 40 FF
00E0 F9 30 78 FF F9 30 12 FF F9 30 24 FF F9 30 40 FF
00F0 F9 24 00 FF F9 24 02 FF F9 24 19 FF F9 24 24 FF
0100 F9 24 40 FF F9 79 00 FF F9 79 02 FF F9 79 12 FF
0110 F9 79 30 FF F9 79 79 FF F9 79 40 FF F9 40 00 FF
0120 F9 40 78 FF F9 40 12 FF F9 40 19 FF F9 40 24 FF
0130 F9 40 79 FF F9 40 40 FF F9 10 00 FF F9 10 78 FF
0140 FF 10 02 FF FF 10 12 FF FF 10 19 FF FF 10 30 FF
0150 FF 10 79 FF FF 10 40 FF FF 00 10 FF FF 00 00 FF
0160 FF 00 78 FF FF 00 02 FF FF 00 12 FF FF 00 19 FF
0170 FF 00 30 FF FF 00 30 FF FF 00 24 FF FF 00 79 FF
0180 FF 00 40 FF FF 78 10 FF FF 78 00 FF FF 78 00 FF
0190 FF 78 78 FF FF 78 02 FF FF 78 12 FF FF 78 12 FF
01A0 FF 78 19 FF FF 78 30 FF FF 78 24 FF FF 78 24 FF
01B0 FF 78 79 FF FF 78 40 FF FF 78 40 FF FF 02 10 FF
01C0 FF 02 10 FF FF 02 00 FF FF 02 78 FF FF 02 78 FF
01D0 FF 02 02 FF FF 02 02 FF FF 02 12 FF FF 02 12 FF
01E0 FF 02 19 FF FF 02 30 FF FF 02 30 FF FF 02 24 FF
01F0 FF 02 24 FF FF 02 79 FF FF 02 79 FF FF 02 40 FF
0200 FF 02 40 FF FF 02 40 FF FF 12 10 FF FF 12 10 FF
0210 FF 12 00 FF FF 12 00 FF FF 12 78 FF FF 12 78 FF
0220 FF 12 02 FF FF 12 02 FF FF 12 02 FF FF 12 12 FF
0230 FF 12 12 FF FF 12 19 FF FF 12 19 FF FF 12 19 FF
0240 FF 12 30 FF FF 12 30 FF FF 12 30 FF FF 12 24 FF
0250 FF 12 24 FF FF 12 24 FF FF 12 79 FF FF 12 79 FF
0260 FF 12 79 FF FF 12 40 FF FF 12 40 FF FF 12 40 FF
0270 FF 19 10 FF FF 19 10 FF FF 19 10 FF FF 19 00 FF
0280 FF 19 00 FF FF 19 00 FF FF 19 78 FF FF 19 78 FF
0290 FF 19 78 FF FF 19 78 FF FF 19 02 FF FF 19 02 FF
02A0 FF 19 02 FF FF 19 12 FF FF 19 12 FF FF 19 12 FF
02B0 FF 19 12 FF FF 19 19 FF FF 19 19 FF FF 19 19 FF
02C0 FF 19 19 FF FF 19 30 FF FF 19 30 FF FF 19 30 FF
02D0 FF 19 30 FF FF 19 24 FF FF 19 24 FF FF 19 24 FF
02E0 FF 19 24 FF FF 19 24 FF FF 19 79 FF FF 19 79 FF
02F0 FF 19 79 FF FF 19 79 FF FF 19 40 FF FF 19 40 FF
0300 FF 19 40 FF FF 19 40 FF FF 19 40 FF FF 30 10 FF
0310 FF 30 10 FF FF 30 10 FF FF 30 10 FF FF 30 10 FF
0320 FF 30 00 FF FF 30 00 FF FF 30 00 FF FF 30 00 FF
0330 FF 30 00 FF FF 30 78 FF FF 30 78 FF FF 30 78 FF
0340 FF 30 78 FF FF 30 78 FF FF 30 78 FF FF 30 02 FF
0350 FF 30 02 FF FF 30 02 FF FF 30 02 FF FF 30 02 FF
0360 FF 30 02 FF FF 30 12 FF FF 30 12 FF FF 30 12 FF
0370 FF 30 12 FF FF 30 12 FF FF 30 12 FF FF 30 19 FF
0380 FF 30 19 FF FF 30 19 FF FF 30 19 FF FF 30 19 FF
0390 FF 30 19 FF FF 30 19 FF FF 30 30 FF FF 30 30 FF
03A0 FF 30 30 FF FF 30 30 FF FF 30 30 FF FF 30 30 FF
03B0 FF 30 30 FF FF 30 24 FF FF 30 24 FF FF 30 24 FF
03C0 FF 30 24 FF FF 30 24 FF FF 30 24 FF FF 30 24 FF
03D0 FF 30 79 FF FF 30 79 FF FF 30 79 FF FF 30 79 FF
03E0 FF 30 79 FF FF 30 79 FF FF 30 79 FF FF 30 79 FF
03F0 FF 30 40 FF FF 30 40 FF FF 30 40 FF FF 30 40 FF

```

dress outputs of the ripple carry counter IC3 are given time to settle, then the count is latched into IC2 (an octal latch) by IC9b. The counter is reset at this time also, but the reset response time of IC3 is considerably longer than the time required to latch the previous count, so there is no conflict.

When switch S1 is in position two the clock frequency is 128Hz, determined by the 100kΩ trimpot and 560kΩ resistor. From Fig. 2, it can be seen that the clock signal to IC3 is gated off when the "0" output of IC4 goes high. Latching of the count and resetting of the counter occurs when the "1" output goes high, and the count begins again after the "1" output goes low again, removing the reset. Thus the clock is gated to IC3 for a period of eight heart beats, and the count is updated every 10 heart beats.

To ensure that the reading from the monitor is correct it is necessary to wait for the count to be updated, and it is wise to wait for a second update period and take a second reading to check the first. For this reason the short update period (S1 in position 1) will be found more convenient for quick readings and initial checking. However the heart rate is never constant and some variation will occur between beats. Consequently the longer update per period will give more consistent readings since the variations in heart rate will be averaged over a longer period.

The binary counter IC3, counts the number of clock pulses between heart beats, and the most recent count is periodically latched into IC2. With the latch holding the counted value on the address lines of the EPROM 1C1, a particular location is accessed in the EPROM and the data at this location appears on the data lines Q0 to Q7 of IC1.

Note that only the eight most significant of the 10 address lines of the EPROM, A2 to A9, are connected to the latch. This means that the binary counter, IC3, accesses the memory in 4-byte blocks, with a total of 256 blocks provided by the 1K EPROM. Of the remaining address lines, A0 is connected to the clock frequency (IC6) and A1 is connected to IC5a, a D-type flipflop wired as a divider, with an output at half the clock frequency. This means that these two address lines cycle between zero and three (in binary) at the clock frequency, allowing each byte of the 4 byte block addressed by the counter to be accessed sequentially at the clock rate.

This method allows us to multiplex the displays with the required data by driving each of the seven segments of the displays from the data lines of the EPROM, via switching transistors Q1 to

*At left is the Hex listing of the "look-up" table for the 2708 EPROM. At right is the full circuit of the Heart Rate Monitor.*





Bill Edge's

# ELECTRONIC AGENCIES

bankcard welcome here

115-117 Parramatta Road Concord 2137  
(Corner Parramatta Rd & Lloyd George Ave)  
Tel. 745 3077 (two lines)

what else do we carry?  
HARDWARE \* TOOLS \* WIRE \* SEMIS  
VALVES \* HI-FI \* KITS \* PA EQUIPMENT  
MIKES \* SPEAKERS \* BOOKS

MAIL CHARGES  
\$5-\$9.99 .....  
\$10-\$24.99 .....  
\$25-\$49.99 .....  
\$50-\$99.99 .....  
\$100 or more .....

\$1.00 All heavy or bulky items  
\$2.00 (over 20kg) sent 'Freight-on'  
\$3.00 through carrier. Bankcard  
\$4.00 welcome—by mail, phone or  
\$5.50 over the counter.

look at this

TRADING HOURS  
9am—5:30pm  
Mon-Fri  
9am—noon  
Saturday  
10am—2pm  
Sunday

**NEW**

## HI-CHARGE gets you going!



6A output!

THERMAL CUTOUT

If you've got a battery that doesn't get much use, or you just don't want to get caught with a flat battery, this new kit from EA (Feb '81) is the go. With an output of up to 6A, it can get you going in minutes instead of the hours that a 'pluggack' type can take to charge.

Includes front panel meter so you can monitor the charge rate

**\$59.90**

## 300W of power! Playmaster quality

Yes, the famous EA designed 300W power amp module. All you need to add is a power supply & case to build a complete 300W power amplifier. Perfect for stage or home use. Check our prices on all the options for this amp—power supply kits, cases, speaker protectors. We've got the lot!

Only **\$85.00** (complete kit for the module only)

## NEW oscilloscope switch kit

Convert your single trace CRO to dual trace with this simple to build kit.

- Kit includes  
\* 12V pluggack  
\* IC sockets  
\* Fibreglass PCB  
\* Metal front panel  
\* All hardware  
Complete kit

**ONLY \$65.00**

See EA Feb '81

**Special offer!**

**FANTASTIC!**

## DICK SMITH 6.5MHz CRO

The Dick Smith CRO is ideal for the hobbyist's workbench—now you can own the CRO and the superb dual trace adaptor kit and SAVE MONEY! BUY BOTH TOGETHER FOR ONLY

**\$249 save \$16**



if purchase separately **\$199**

## SOLDERING IRONS BY MICO

Lightweight, safe low voltage irons from Mico. A top quality Australian made product.

- MINIATURE 10 watt models  
4 volt, 6 volt and 12 volt \$12.50  
GENERAL PURPOSE 20 watt models  
4 volt, 6 volt and 12 volt \$14.50  
MICO SOLDERING TIPS  
10 watt 'A' (taper 2.4mm) 85c  
10 watt 'B' (parallel 3.6mm) 85c  
20 watt 'A' (parallel 3.2mm) \$1.10  
20 watt taper 4.6mm \$1.10

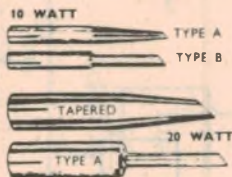

## Hard-to-find semis at hard-to-beat prices!

As well as all the standard semiconductors that you can get anywhere, we've got a huge range of hard-to-find parts that might be just what you're after. Here are just some of them—if what you want isn't here, give us a call.

BC327	36c	LM339	\$1.10
BC328	36c	LM380 8DIL	\$2.90
BC337	45c	LM393	\$2.40
BC338	36c	LM394	\$4.30
BC550	40c	LM3911	\$1.95
BC556	40c	74C30	70c
BDV64B	\$3.56	74C48	\$2.86
BDV65B	\$3.56	74C90	\$1.65
BF469	\$1.40	74C175	\$1.78
BF470	\$1.40	74C925	\$8.18
BF494	49c	4014	\$1.20
BFR84	\$2.40	4038	\$2.00
MJE340	\$2.20	4040B	\$1.75
MJE350	\$2.50	4046	\$2.40
2S149	\$7.50	4052B	\$1.70
2S134	\$7.50	4069	76c
2.5W 62V zener	\$1.00	4082	50c
2.5W 75V zener	\$1.00	4093	78c
		4MHz crystals	\$9.95

## Toroidal powered Playmaster amplifier

The acclaimed Playmaster series of amplifiers now has a 50 watt per channel model with MOSFET outputs giving incredibly low distortion—and our kit has an exclusive TOROIDAL transformer for lower hum and improved performance.

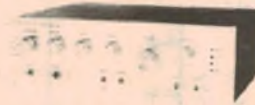

MOSFET **\$159**

call in and see it working

SEE THE REVIEW OF OUR KIT IN THIS MAGAZINE

## Cylon Voice 'Le Gong' doorbell kit

Tired of that ho-hum voice? Build this kit and change to the latest in fashion voices—Cylon Voice! Great effect.

**\$18.95**

Why spend a fortune on a doorbell when this great new kit can do the job simply, cheaply and pleasantly (or use it to replace that passe 'ding-dong' job you've got now!)

**\$15.00** (pushbutton not included)

**NEW**

\*\*\*\*\* Look out for the new computer kit designed by ETI! \*\*\*\*\*  
**OPEN 7 DAYS**

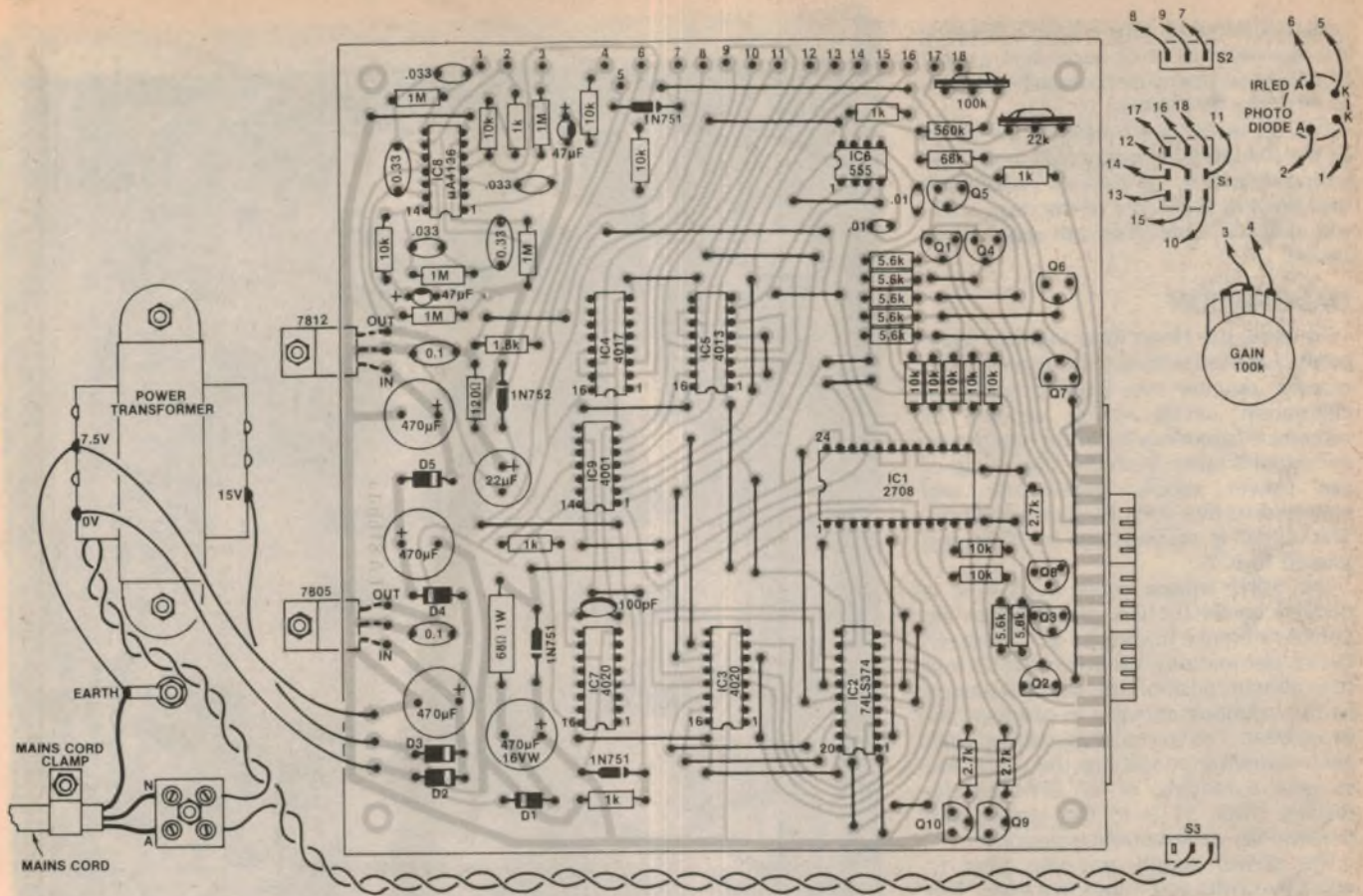

These two PC boards are soldered together at right angles to form one assembly.

Q7, and enabling each digit of the display in turn. The most significant digit of the display is enabled by data line Q7 from IC1, the next significant digit by A0 and the least significant digit by A1.

Each display digit is assigned to one of the bytes of a 4-byte block, and as each digit of the display is enabled, the corresponding byte of the data block is accessed and used to drive the seven segments of the display. For example when A1 and A0 are both low the most significant digit can be accessed and the most significant display digit enabled when data output Q7 of the EPROM is taken high. A1 low and A0 high will access the next most significant digit and enable the appropriate display, while A0 high and A1 low will access the least significant digit and enable that display. When A0 and A1 are both high no information is sent to the segments.

So each display digit will be enabled in turn and driven with the required seven segment display code for that digit. Of course, with only three displays the fourth location of the 4-byte block of memory holding each reading will not be required to supply information to the display, and can be left unprogrammed.

Once we can access each memory location for each reading we need to devise the code for each digit we want to display, remembering that a "0" will activate a segment via the associated switching transistor. To display an "8" for

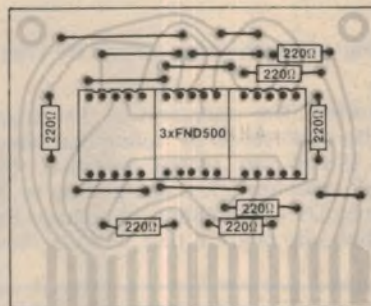

example, we need to light all the segments, so the code is 00000000, or 00 in hexadecimal. A "1" is 01111001, or 79 in hex. The leading zero in both these cases indicates that the number will be displayed in the least or middle digit position. To enable the most significant digit requires a 1 in the leading position, so that the code for a "1" in the most significant digit position would be 11111001.

We estimate that the current cost of parts for this project is approximately

**\$82**

including sales tax.

Now that we know how to program the EPROM, the next question is what numbers are required to be placed in the EPROM? We have 256 blocks of information to fill and we know that the highest count or address (256) is the slowest heart rate to be measured. We have chosen 30 BPM to be the slowest heart rate, so location 256 should contain 30. At the 128th location, then, the value should be 60; the 64th location, 120; the 32nd location, 240. Below this we have placed the letter E to signify overrange.

## TWO-FIGURE ACCURACY

Note that the numbers from 30 to 60 are placed in 128 locations, meaning that the same number is repeated in several locations, whereas the numbers from 120 to 240 have to fit in 32 locations. This gives two figure accuracy for all values of heart beat. The resolution below 90 BPM is one BPM and falls to seven BPM resolution at close to 240 BPM.

The switching transistors driving the segments of the displays are chosen for their low saturation voltage to ensure that all the segments will be of equal brightness when activated. The output of the clock circuit, IC6, which drives the least significant and middle digits, is made as close to a square wave as possible by making the resistor from pin 7 to the 5V rail small in comparison with the

resistors between pins 6 and 7, keeping the activated time of each digit almost equal, again to ensure that each segment is of similar brightness.

Pull up resistors are used at the bases of the switching transistors Q1 to Q7, ensuring that they will turn off completely and prevent segments of the display being dimly lit when they are required to be off.

## CALIBRATION

To allow the Heart Rate Monitor to be easily adjusted without the use of a frequency counter we have provided a calibration circuit which derives its reference frequency from the mains. An AC signal is taken from the 15-volt tap of the power supply transformer and clamped to five volts by a zener diode. This signal is squared up by IC9c and passed to IC7.

The 50Hz square wave from IC9c is divided by 64 by IC7, providing an accurate reference frequency of 0.78Hz (47 cycles per minute). When switch S2 is in the calibrate position this signal is passed to the counting circuitry in place of the heart beat. The trimpots associated with each sampling period are then adjusted to give a reading of 47 BPM on the display when S1 is in the appropriate position for each counting period.

The power supply provides plus 12 volts, five volts and minus five volts. This is achieved with a centre-tapped 15-volt transformer. Full-wave rectification and filtering with a 470 $\mu$ F capacitor provides 10 volts which is regulated with a five volt regulator. The minus five volts is provided by a half-wave rectification circuit clamped at five volts with a zener diode. A 470 $\mu$ F capacitor filters this supply.

About 30V DC is generated by a tripler circuit consisting of bodies D4, D5 and 470 $\mu$ F capacitors, C1 and C2 together with the full-wave rectifier already

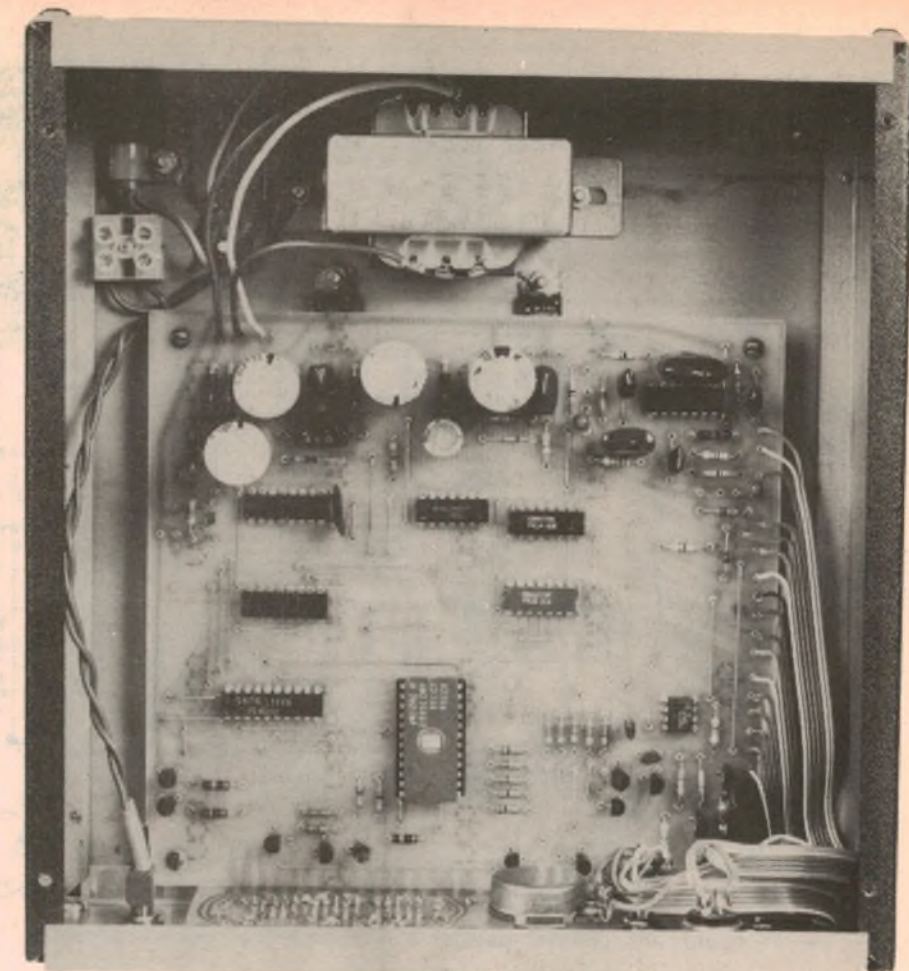

Wiring within the Monitor can be kept neat by using rainbow cable.

described. The operation of the circuit can be understood by noting that when the 15-volt tap swings negative, the 470 $\mu$ F capacitor C1, is charged up to 20 volts by D4 which effectively clamps the positive side of C1 at plus 10 volts. Now

when the 15-volt tap swings positive D4 is reverse biased and the charge on C1 is dumped onto C2 by D5. This voltage is then regulated with a 12-volt regulator.

We constructed the Heart Rate Monitor on two printed circuit boards.

## PARTS LIST

- 1 PC board coded 81hb4a and measuring 159 x 150mm
- 1 PC board coded 81hb4b and measuring 72 x 59mm
- 1 Scotchcal front panel
- 1 2155 power transformer
- 1 100k $\Omega$  linear potentiometer
- 1 3-pole 2-way toggle switch
- 2 single pole, 2-way toggle switches
- 1 Horwood case measuring 203mm x 76mm x 228mm (W x H x D)
- 1 knob
- 1 24-pin socket DIL socket
- 1 4-pin DIN plug and socket
- 1 mains cord and plug
- 4 10mm PC tapped standoffs
- 4 rubber feet
- 1 grommet
- 1 cord clamp
- 1 2-way terminal strip
- 1 earth lug

## INTEGRATED CIRCUITS

- 1 2708 1K EPROM (programmed with Heart Rate Monitor Listing)
- 1 745374 Tri-state octal D flipflop
- 2 4020 ripple-carry binary counters
- 1 4017 decade counter/divider
- 1 4013 dual flipflop
- 1 4001 quad 2-input NOR gate
- 1 4136 quad operational amplifier
- 1 555 timer
- 1 7812 12V regulator
- 1 7805 5V regulator

## SEMICONDUCTORS

- 1 LD271/COQY89A infrared LED
- 1 BPW34/BP104/BPW50 photodiode
- 3 1N751 5.1volt 400mW zener diodes
- 1 1N752 5.6volt 400mW zener diode
- 5 1N4002 100PIV rectifier diodes
- 7 BC327 PNP transistors
- 3 BC337 NPN transistors

## 3 FND500 common-cathode displays

## CAPACITORS

- 3 470uF/35VW PC electrolytics
- 1 470uF/16VW PC electrolytic
- 2 47uF/6.3VW tantalum electrolytics
- 1 22uF/6VW PC electrolytic
- 2 0.33uF metallised polyester
- 2 0.1uF metallised polyester
- 3 .033uF metallised polyester
- 2 .01uF metallised polyester
- 1 100pF disc ceramic

## RESISTORS (1/4W 10%)

- 5 x 1M $\Omega$ , 1 x 560k $\Omega$ , 1 x 68k $\Omega$ , 11 x 10k $\Omega$ , 7 x 5.6k $\Omega$ , 3 x 2.7k $\Omega$ , 1 x 1.8k $\Omega$ , 5 x 1k $\Omega$ , 7 x 220 $\Omega$ , 1 x 120 $\Omega$ , 1 x 68 $\Omega$  1W, 1 x 100k $\Omega$  vertical trimpot, 1 x 22k $\Omega$  vertical trimpot

## MISCELLANEOUS

Hook-up wire, four-way wire for sensor, nuts, bolts, washers, solder, copper wire etc.

# SERVICE TECHNICIANS!

Specialised Soldering  
and other Tools from...

# SCOPE

**SCOPE PANAVISE** hold it anywhere you want it —  
tilts turns and rotates to any position.

**SCOPE PANAVISE SELF SELECTION CHART :**  
**INTERCHANGEABLE HEADS  
AND BASES.**

**STEP 1**

SELECTION OF HEADS



**STEP 2**

SELECTION OF BASES

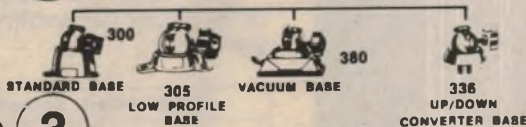

**STEP 3**

SELECTION OF BASE MOUNTS

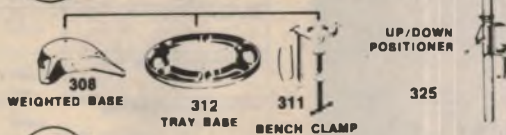

**STEP 4**

SELECTION OF ACCESSORIES

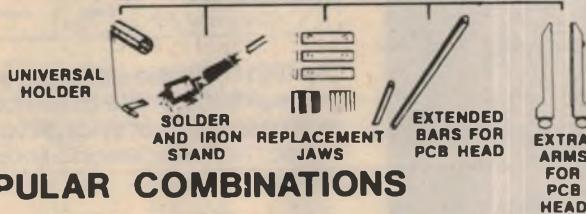

**POPULAR COMBINATIONS**

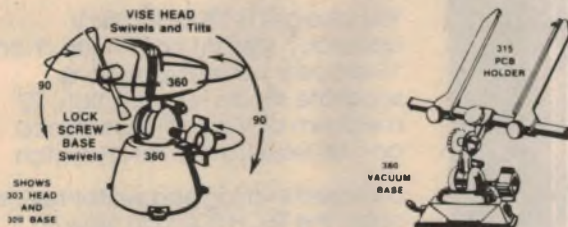

**MINI SUPERSPEED 20-75 WATTS**  
5 Second Heating

MANUAL TEMPERATURE CONTROL OPERATES FROM SCOPE TRANSFORMER CODE : M.S.

**SUPERSPEED 150 WATTS**  
5 Second Heating CODE : S.S.

MANUAL TEMPERATURE CONTROL OPERATES FROM SCOPE TRANSFORMER

**RECHARGEABLE CORDLESS 60W**

USES TWO NICD CELLS 6 SECOND HEATING CODE : C60

3-RECHARGE OPTIONS

**STEP DOWN TRANSFORMER**

240V/3.3V

CODE : TF

**AUTOMATIC TEMP. CONTROL**  
TC60 — 240 VOLT IRON

SELECT ANY TEMPERATURE BETWEEN 200°C — 400°C 13 TIPS AVAILABLE CODE : TC60 0.8mm — 6.4mm

**12 VOLT HOBBY IRON**

WORKS FROM CAR BATTERY SAFE EVEN IN WET CONDITIONS CODE : HI (6.4 Mmre Lead)

**METAL ETCHING PEN**

WRITES ON ANY METAL OPERATES FROM SCOPE TRANSFORMER CODE : MEP

**"SELF" CLEANING SOLDER REMOVER**

(REPLACEABLE) TEFLON NOZZLE CODE : SR 3A

**30X POCKET MICROSCOPE FOR :-**

• PRINTERS  
• COIN COLLECTORS  
• ELECTRONICS  
• BUILT IN LIGHT  
• EASY FOCUS SYSTEM

CODE : MK III

Want more  
information



... then  
contact

VIC. — SCOPE LABORATORIES PTY LTD (03) 338-1566  
N.S.W. — JONES & PARK PTY LTD (02) 546-6144  
S.A. — SCOTT THOMPSON PTY LTD (08) 223-2261  
Q'LD. — K. H. DORE & SONS (07) 221-1933  
TAS. — W. P. MARTIN PTY LTD (002) 34-2811, (003) 31-5545  
W.A. — SIMON HOLMAN & CO. PTY. LTD (09) 381-4155  
NEW GUINEA — PORT MORESBY, 25-7796 LAE, 42-2172  
NEW ZEALAND — WELLINGTON 85-95/8  
NEW ZEALAND — AUCKLAND 57-4043

And ask for a FREE brochure and the name of your nearest Dealer

SCOPE LABORATORIES — 3 Walton Street, Airport West, Victoria, 3042 — Telephone : (03) 338-1566

# S

SCOPE

Beckman  
brings a  
new dimension  
to hand held  
digital  
multimeters...



**BECKMAN**

For further technical information contact your nearest Warburton Franki Office.

## true RMS capability.

Now you can measure the exact power content of **any signal** . . . regardless of waveform. Beckman delivers the new TECH<sup>®</sup> 330 multimeter with true Root Mean Square capability and many more fine performance features.

Unlike the common average responding multimeters calibrated to measure only sine waves, the TECH 330 with true RMS capability gives you accurate readings of both sine and non-sine waveforms.

True RMS makes a significant difference in accuracy when measuring switching power supplies, flyback power circuits, SCR or TRIAC controlled power supplies or any other circuit generating a non-sine signal.

**Measurement Comparison Chart**

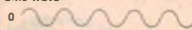
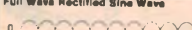
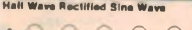
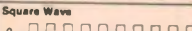
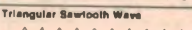
Waveforms (Peak = 1 Volt)	Average Responding Meter	Beckman TECH 330	Correct Reading
Sine Wave 	0.707V	0.707V	0.707V
Full Wave Rectified Sine Wave 	0.288V	0.707V	0.707V
Half Wave Rectified Sine Wave 	0.382V	0.500V	0.500V
Square Wave 	1.110V	1.000V	1.000V
Triangular Sawtooth Wave 	0.545V	0.577V	0.577V

The TECH 330 also accurately measures the entire audio band up to 20 kHz. But that's not all you can expect from Beckman's finest multimeter.

You also get 0.1% basic dcV accuracy, instant continuity checks, 10 ampere current ranges, a separate diode test function, 22 megohm dcV input impedance, and an easy-to-use rotary switch.

Enclosed in a rugged water-resistant case, the TECH 300 can take a 2-metre fall onto concrete and still perform up to specification. And to further ensure reliable, trouble-free operation, the TECH 330 gives you 1500 Vdc overload protection, RF shielding, 2000-hour battery life, gold switch contacts, and fewer electronic components to worry about.



**WARBURTON FRANKI**

• ADELAIDE (08) 356-7333 • BRISBANE (07) 52-7255 • HOBART (002) 28-0321  
• MELBOURNE (03) 699-4999 • PERTH (09) 277-7000 • SYDNEY (02) 648-1711  
• AUCKLAND N.Z. (09) 77-0924 • WELLINGTON N.Z. (04) 69-8272

WF 761/80

one coded 81hb4a, measuring 159 x 150mm, and the other coded 81hb4b and measuring 72 x 59mm. The smaller board is used for the display and associated resistors. The complete PCB assembly was contained in a Horwood case measuring 203 x 76 x 228mm (W x H x D).

On the large 81kb4a PC board there is a bus which brings out the connections for the display board. This edge should be filed until the copper track is flush with the edge of the PC board. This allows the small display PC board 81hb4b to be soldered to the larger board.

Start construction by placing the wire links, the resistors and the socket for the EPROM on the PCB. Position the capacitors, trimpots, diodes and transistors and solder them, using the PC board overlay diagram as a guide and taking care with the orientation of the diodes and transistors. When soldering the CMOS ICs make sure that the power supply pins are soldered first, and have the barrel of your soldering iron connected to the negative supply rail.

The voltage regulators should be soldered to the underside of the PCB, with their leads just protruding through to the top of the board. The regulators can then later be bolted to the base of the case for heatsinking.

Solder the links and resistors to the small display PCB and when soldering the displays make sure that they are not upside down. Do not solder this PC board to the main PC board yet.

Using the Scotchcal front panel as a

guide, drill the holes for the potentiometer, switches, DIN socket and a row of holes around the required rectangular hole for the display. File this rectangular hole until the display fits squarely and snugly.

Use tapped 10mm spacers for mounting the large PC board. Screw these spacers to the PC board with short screws so that the PC board can stand securely on the spacers. The Horwood case at this stage will have to be drilled for the self tapper screws and the base plate secured to the sides. With the front panel bolted as well to make a complete case except for the lid, place the large PC board in the case.

The small display PC board should be secured in the rectangular cut out on the front panel. Slide the large PC board up to and in line with the display PC board. Mark with a pencil on the back of the display PC board the point where the top of the large PC board meets the display PC board. Remove both PC boards from the case and solder tack the two end copper bus tracks of the display board to the large PC board.

Make sure that the PC boards are at right angles to one another and that when the display PC board is in position the standoffs on the large PC board are seated on the base of the case. When the two boards are correctly positioned the remainder of tracks can be soldered.

At this stage the holes for the PC board standoffs can be drilled in the base of the case, as well as the holes for the regulators, transformer, terminal block, earth lug, cable clamp and grommet. We used ribbon cable for the wiring of the PC board to the front controls making a neater appearance than with separate hookup wire. Follow the wiring diagram and make all of the connections to the switches, potentiometer and socket which can now be positioned on the front panel.

Use 250VAC rated insulated wire to run from the on/off switch to the terminal block and use sleeving on the mains switch lugs, including the unused lug. Clean away the paint around the earth lug and bolt the earth lug to the case. Keep the earth lead from the mains cable long enough to ensure that if the active and/or neutral wire is pulled from the terminal block the earth wire will remain intact.

Make sure that the mains cable is grommetted at the rear cable entry and that the cable clamp secures the lead tightly.

Constructing the sensor involves some handyman work but is not difficult. We have provided diagrams to demonstrate how we made our sensors. We constructed three different sensors, all of which consist of the IRLED and photo diode mounted in a small block of

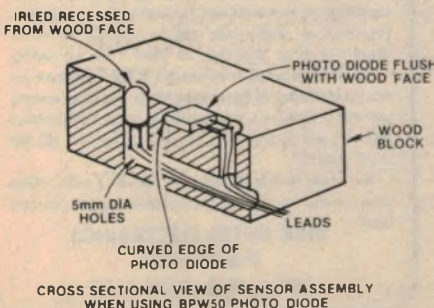
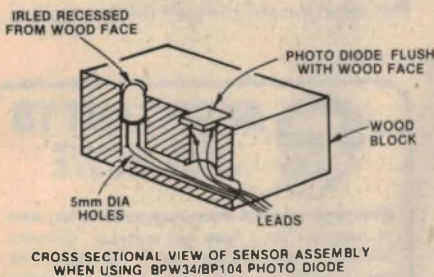

These diagrams show details of construction of the sensors.

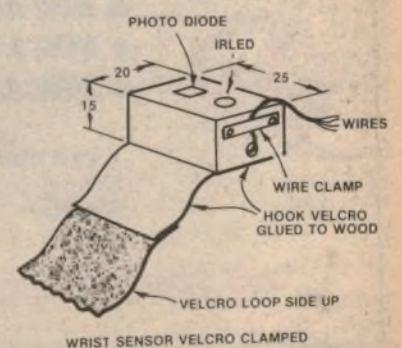
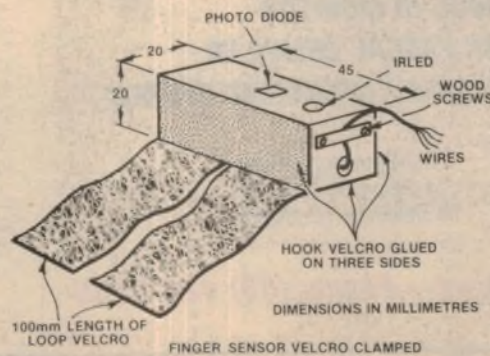
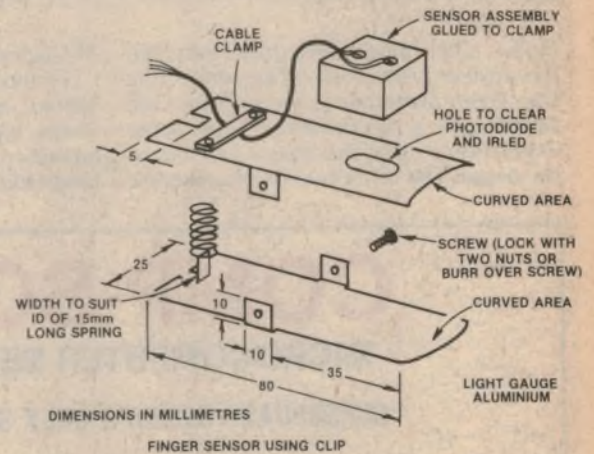

## HEART RATE MONITOR

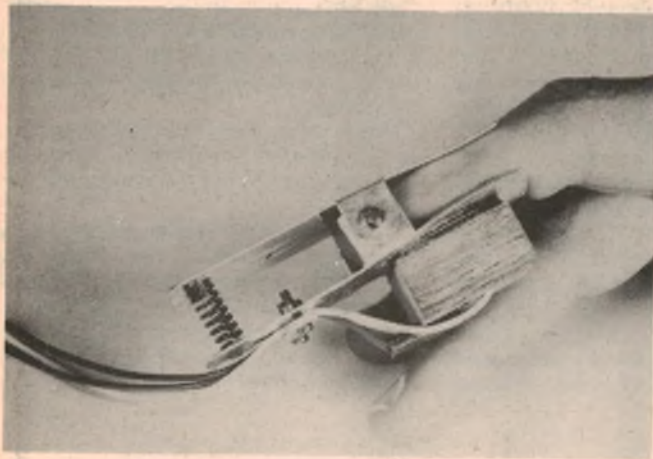
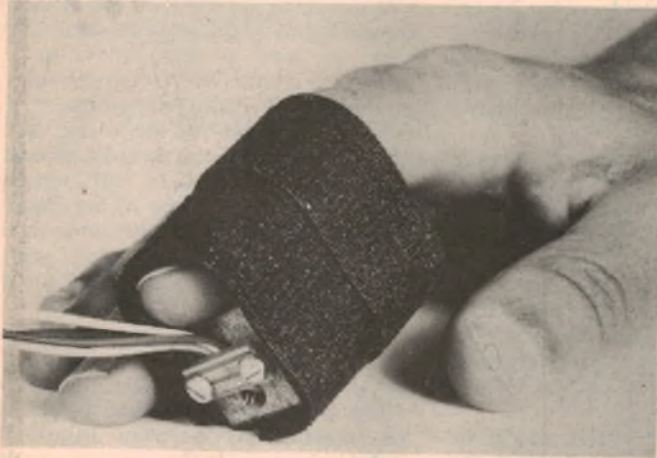

*These three photos show how the sensors are worn. They should not be strapped on too tightly otherwise blood circulation will be impeded.*

wood. The major difference between the devices is the method of connecting the sensor assembly to the person. One sensor uses a clip fashioned from scrap aluminium so that the sensor can clip to the finger. The other two involve the use

of Velcro material to secure the sensor. For those who have not come across Velcro material, it consists of two different types of fabric that when contacted to one another form a gripping longitudinal bond but which can be easi-

ly torn apart.

The Velcro material is glued to the wooden surface with contact adhesive. Make sure that the soft material of the Velcro is the one which contacts the skin rather than the nylon hook material which is rather uncomfortable.

It is not necessary to construct more than one sensor, however each sensor presented serves a particular application. For a quick reading the clip type sensor would be best. It involves the most work of the three types. The sensor with Velcro to clamp to the finger is very comfortable and can be worn for long periods of time. The sensor with the long Velcro material is intended to clamp to the wrist for use with children and when hand movement is necessary while the heart rate is being measured.

Before use the monitor should be calibrated. Switch the heart rate/calibrate switch to the calibrate position and select one of the update periods. Adjust the appropriate trimpot until a reading of

## COMP-SOFT MICROCOMPUTER SERVICES

**SUPERBOARD SERIES II ONLY \$365 + tax**

- NEW DABUG III MONITOR
- NEW 3.5K PASCAL COMPILER
- NEW OS65D 4.1 OPERATING SYSTEM

**IN STOCK**

Tues & Wed 9.30am to 5.30pm  
Friday 4.30pm to 7.30pm  
Saturday 9.00am to 12.30pm

**235 Swan St, Richmond — Phone: (03) 428 5269**



### ASSISTANT TO JIM ROWE

Most people in the Australian electronics industry have heard of Jameson ("Jim") Rowe, who worked at "Electronics Australia" for almost 20 years - the last 9 as Editor. For the last 18 months he's been working for me, as Technical Director. But we've got so much work for him to do that he's threatened to leave unless I get him an assistant! Jim says he'd really like someone fairly young, but with a good knowledge of electronics and (preferably) microcomputers. Experience in programming and for software evaluation would also be an advantage, as would a flair for writing.

Sounds a pretty tall order, doesn't it? But if you think you meet at least some of these requirements, and fancy working with one of Australia's best known and respected electronics engineers and authors, why not write to him and tell him about yourself?

Don't take too long, though - the way Jim's been looking lately, he might up and leave me if he doesn't get an assistant soon!

**DICK SMITH ELECTRONICS,  
P.O. Box 321,  
North Ryde NSW 2113**



**NEW!**

**"THE BIG BOARD"  
OEM - INDUSTRIAL - BUSINESS - SCIENTIFIC  
SINGLE BOARD COMPUTER KIT!  
Z-80 CPU! 64K RAM!**

**NEW!**

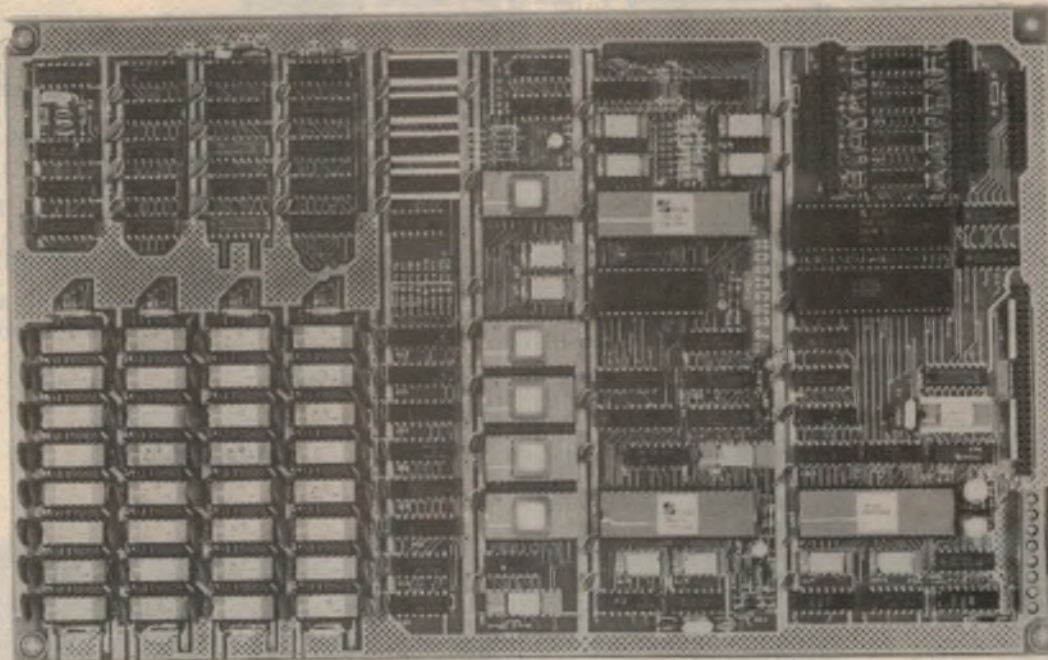

**THE FERGUSON PROJECT:** Three years in the works, and maybe too good to be true. A tribute to hard headed, no compromise, high performance, American engineering! The Big Board gives you all the most needed computing features on one board at a very reasonable cost. The Big Board was designed from scratch to run the latest version of CP/M\*. Just imagine all the off-the-shelf software that can be run on the Big Board without any modifications needed! Take a Big Board, add a couple of 8 inch disc drives, power supply, and an enclosure, and you have a total Business System for about 1/3 the cost you might expect to pay.

**\$695.00** (64K KIT BASIC I/O)

SIZE: 8 1/2 x 13 1/4 IN.  
SAME AS AN 8 IN. DRIVE.  
REQUIRES: 5V @ 3 AMPS  
12V @ 5 AMPS

**FEATURES: (Remember, all this on one board!)**

**64K RAM**

Uses industry standard 4116 RAM'S. All 64K is available to the user, our VIDEO and EPROM sections do not make holes in system RAM. Also, very special care was taken in the RAM array PC layout to eliminate potential noise and glitches.

**Z-80 CPU**

Running at 2.5 MHZ. Handles all 4116 RAM refresh and supports Mode 2 INTERRUPTS. Fully buffered and runs 8080 software.

**SERIAL I/O (OPTIONAL)**

Full 2 channels using the Z80 SIO and the SMC 8116 Baud Rate Generator. FULL RS232! For synchronous or asynchronous communication. In synchronous mode, the clocks can be transmitted or received by a modem. Both channels can be set up for either data-communication or data-terminals. Supports mode 2 Int. Price for all parts and connectors: **\$95**

**BASIC I/O**

Consists of a separate parallel port (Z80 PIO) for use with an ASCII encoded keyboard for input. Output would be on the 80 x 24 Video Display.

**24 x 80 CHARACTER VIDEO**

With a crisp, flicker-free display that looks extremely sharp even on small monitors. Hardware scroll and full cursor control. Composite video or split video and sync. Character set is supplied on a 2716 style ROM making customized fonts easy. Sync pulses can be any desired length or polarity. Video may be inverted or true.

**FLOPPY DISC CONTROLLER**

Uses WD1771 controller chip with a TTL Data Separator for enhanced reliability. IBM 3740 compatible. Supports up to four 8 inch disc drives. Directly compatible with standard Shugart drives such as the SA800 or SA801. Drives can be configured for remote AC off-on. Runs CP/M\* 2.2

**FOUR PORT PARALLEL I/O (OPTIONAL)**

Uses Z-80 PIO. Full 16 bits, fully buffered, bi-directional. User selectable hand shake polarity. Set of all parts and connectors for parallel I/O: **\$45**

**REAL TIME CLOCK (OPTIONAL)**

Uses Z-80 CTC. Can be configured as a Counter on Real Time Clock. Set of all parts: **\$25**

**PFM 3.0 2K SYSTEM MONITOR**

The real power of the Big Board lies in its PFM 3.0 on board monitor. PFM commands include: Dump Memory, Boot CP/M\*, Copy, Examine, Fill Memory, Test Memory, Go To, Read and Write I/O Ports, Disc Read (Drive, Track, Sector), and Search. PFM occupies one of the four 2716 EPROM locations provided. It does not occupy any of the 64K of system RAM!

**CP/M\* 2.2 FOR BIG BOARD**

The popular CP/M\* D.O.S. modified by MICRONIX SYSTEMS to run on Big Board is available for \$150.00.

**TERMS CASH CHEQUE OR BANKCARD (MIN \$100 DEP)**

**ALL PRICES PLUS TAX IF APP**

**REGISTERED PACK & POST \$5.00**



**RITRONICS WHOLESALE**  
425 HIGH ST., NORTHCOTE VIC  
481 1923 489 7099 PO BOX 235

Copy of manual and assembly instructions \$15. Refundable on purchase of board. Photocopy exchanged for original. Delivery ex stock.

**Bankcard Mail Orders Welcome**

Please debit my Bankcard

Bankcard No. ....

Expiry Date .....

Name .....

Signature .....

Facts from Fluke on low-cost DMM's

## For a measurement like this, every millivolt matters.

In digital multimeters, accuracy and resolution go hand in hand. After all, an extra millivolt of resolution means nothing unless you can trust its accuracy. For critical measurements like checking avionics, calibrating medical systems, or simply verifying the performance of your circuit, it takes a precision DMM to fill the bill.

The new 4½-digit Fluke 8050A delivers 0.03% basic dc accuracy and 0.005% of full scale resolution. Measure ac and dc voltages with 10 µV of sensitivity. Or resolve 10 nA of current and 10 milliohms of resistance. All guaranteed for one full year.

That's the kind of performance you demand in a

bench/portable DMM. And it's from Fluke, the leader in DMM's with a thirty year reputation for reliable, high-quality precision instrumentation.

Of course, there's more to the 8050A story. With our hybrid True RMS converter you get honest, accurate ac answers to 50 kHz without missing any significant distortion components. A dB function features 16 selectable reference impedances. And the relative mode lets you make offset measurements in all instrument functions.

You'll also find all the other dependable Fluke features on the new 8050A. Conductance for those high resistance and leakage measurements to 100,000 Megohms. Extensive overload protection and safety features. A full line of accessories. And a low price.

For all the facts on the new 8050A's accuracy and reliability, use the coupon below; or contact your Fluke stocking distributor, sales office or representative.

**FLUKE**



- Please send data on Fluke DMMs.  
 Please have a representative call me.

Name .....  
Position .....  
Company .....  
Address .....  
Postcode .....  
Phone .....

**ELMEASCO**  
**Instruments Pty. Ltd.**

PO BOX 30, CONCORD, NSW 2137  
13-15 McDonald Street, Mortlake, 2137  
Tel: (02) 736 2888 Telex: AA25887  
PO BOX 107, MT WAVERLEY, VIC 3149  
21-23 Anthony Drive, Mt Waverley 3149  
Tel: (03) 233 4044 Telex: AA36206  
Adelaide: 219 4241 Brisbane: 229 3161  
Perth: 398 3362

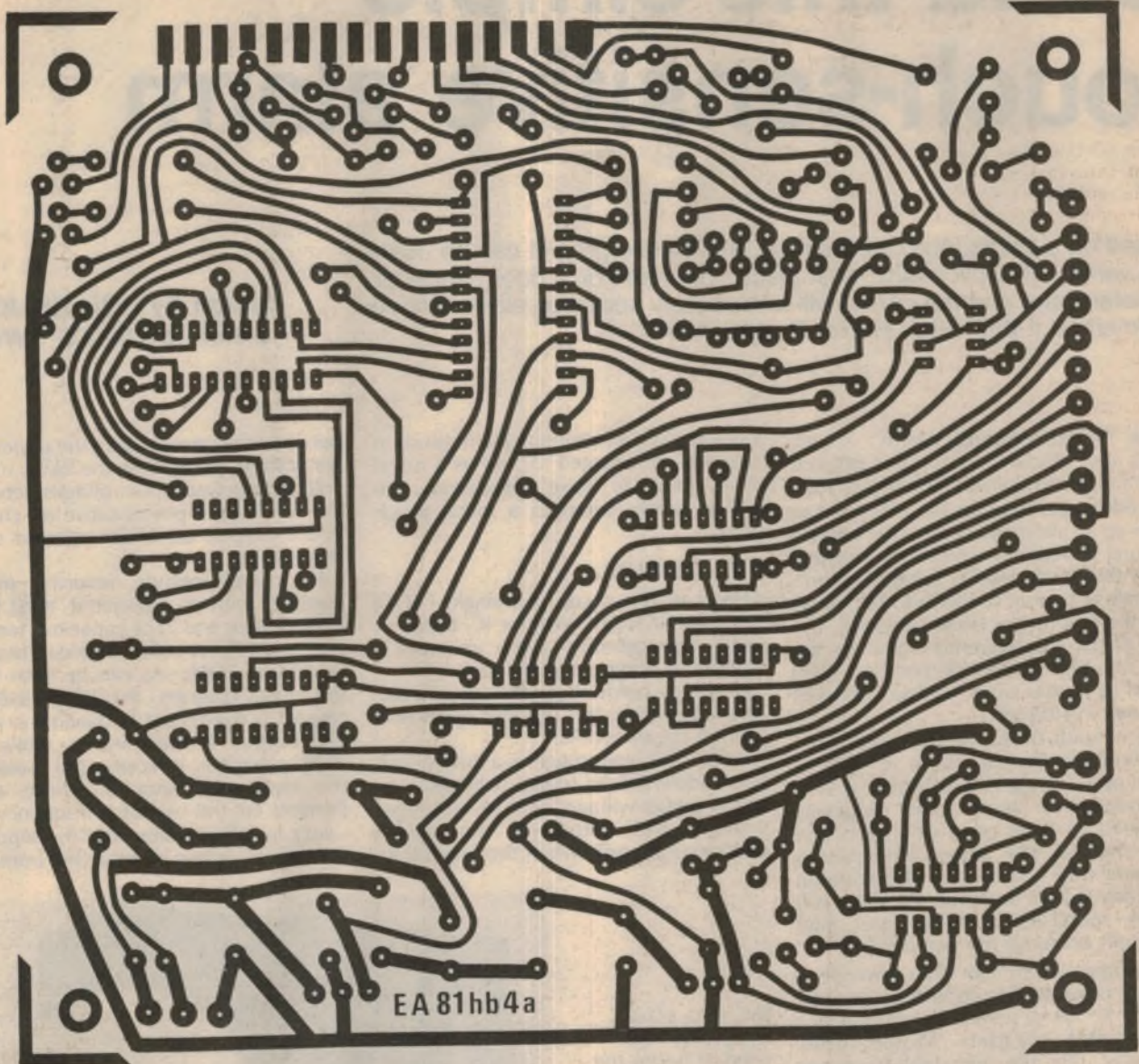

47 is obtained on the display, then switch to the other update period and adjust the other trimpot for the same reading. Make sure that the EPROM is in place at this point! After calibration the Heart Rate Monitor is ready to be used.

To operate the HRM, the sensor is clipped to the finger or wrist making sure the sensor is not too tight. The sensor should be located over the pad of the finger. Overtightening the sensor on the finger will reduce the blood flow and prevent the sensor from receiving the blood pulses. Starting with the gain control at minimum, the gain should be turned up until there is a steady pulse reading as indicated by the flashing decimal point on the display. Too high a setting of the gain control can result in a "double beating" effect which should be avoided.

Once a constant heart beat is detected wait for an update period before taking the heart beat reading.

*Here is the full-size artwork of the PC boards.*

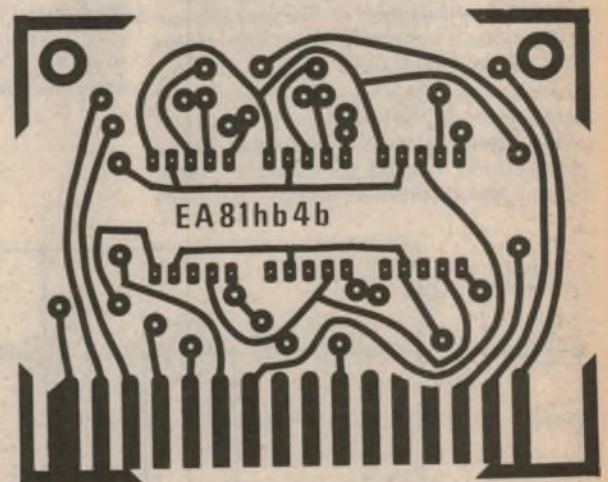

Velcro material can be obtained from the haberdashery sections of department stores. We expect that at the time of printing preprogrammed EPROMs will

be available from the usual component suppliers. Alternatively we have provided a complete 1K listing for those who have access to an EPROM programmer.

# Build this simple touch-sensitive alarm

Based on a single integrated circuit, this simple project can be used in a variety of applications. Just place your hand on a door handle or a metal plate, and the circuit will immediately sound an alarm. We've nicknamed it the "Little Horror Burglar Alarm".

design by **RON DE JONG**  
article by **GREG SWAIN**

The "Portable Burglar Alarm" — well, that's our official title for this project. And a dull and uninspired title it is too.

It didn't take long for the office wit to think up an alternative title. After hearing the unit in action, he promptly christened it the "Little Horror Burglar Alarm", this title in honour of the "horrible" noise that the unit makes when activated. The new name subsequently stuck to the unit, although some staff members were heard to mutter other names whenever the unit was tested.

But in spite of the flippant nickname, the Portable Burglar Alarm is really a most useful gadget. Essentially, it is a touch-sensitive alarm unit, originally designed to hang on a doorknob and thus monitor the door. Whenever a potential thief touches the doorknob on the other side of the door, the alarm will briefly sound to warn the user (and hopefully scare off the intruder).

The new alarm can thus provide a degree of protection against an intruder in your home, or whenever you stay at a motel/hotel. Readers should note, however, that the unit does have one drawback — because of the way the circuit works, it cannot be used with doors that have a metal door jamb.

While this drawback does limit the usefulness of the device as a burglar alarm, the circuit has many other useful applications. It could, for example, be used as a touch sensitive bedside alarm for

a sick person, an attention alarm on shop counters, or adapted for use as a novel door chime. In these applications, the unit is simply wired to a metal touch plate.

## THE CIRCUIT

Heart of the circuit is a single 74C14 hex Schmitt trigger inverter IC, together with a piezoelectric alarm unit and a handful of other components.

However, before becoming too involved in the circuit, let's first find out how a Schmitt trigger works.

Briefly, a Schmitt trigger is a device with two widely spaced trigger voltages — an upper trigger voltage and a lower trigger voltage. The output of the device changes state only when the applied in-

put voltage is greater than the upper trigger voltage, or less than the lower trigger voltage. Applied input voltages between the two trigger points cause no change in the output, an effect referred to as hysteresis.

The first Schmitt inverter (IC1a), together with its associated 10kΩ feedback resistor and 22pF capacitor, forms a simple oscillator with a nominal frequency around 1MHz. As can be seen from the circuit diagram, the 10kΩ feedback resistor is connected between the input and output of the inverter, while the 22pF capacitor is connected between the input and ground. These components set the oscillator frequency.

Let's initially assume that the input to the inverter is low and that the output is

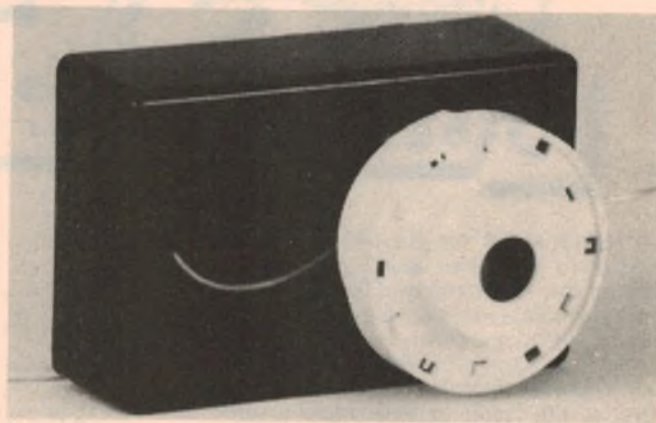

*RIGHT: a plastic zippy box was used to house the prototype. The alarm unit is held in position with epoxy adhesive.*

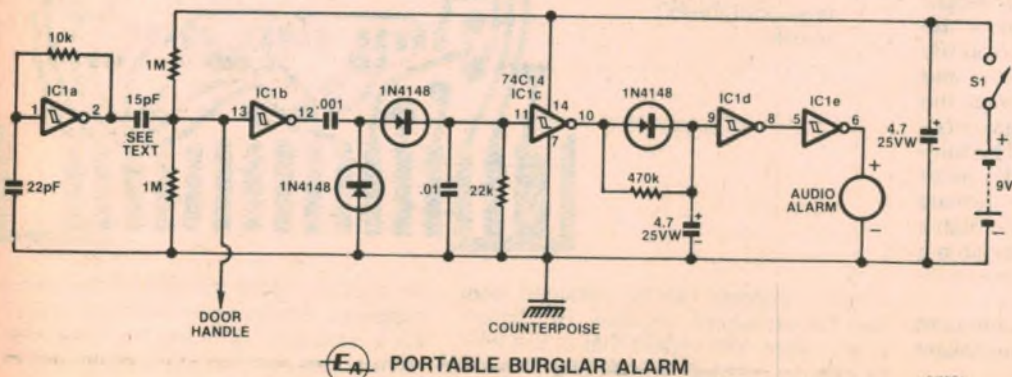

*The device consists of an oscillator driving a rectifier circuit via Schmitt trigger IC1b, together with Schmitt triggers IC1c, IC1d and IC1e. When the metal door handle is touched, the input to IC1c goes low and the alarm turns on.*

high. The capacitor on the input will now charge up via the feedback resistor until it reaches the upper trigger voltage and switches the output of the inverter low. At this point, the capacitor discharges via the resistor into the output until its voltage reaches the lower trigger point. The inverter then switches over again, and so the process continues indefinitely.

The oscillator output passes via a 15pF capacitor to a second Schmitt inverter, IC1b, which in turn is AC-coupled to a full-wave rectifier circuit. As long as the door handle (or metal plate) is left untouched, the oscillator output will alternately switch the input to IC1b above and below its two trigger voltages. IC1b's output will thus switch alternately low and high at the clock rate to drive the rectifier circuit.

The output of the rectifier charges a .01µF capacitor to almost full supply voltage, thus holding the input of IC1c

## PARTS LIST

- 1 audio alarm, Dick Smith L-7024 or similar
- 1 PC board, 81ma4, 53 x 43mm
- 1 zippy box, 83 x 54 x 28mm
- 1 SPDT miniature toggle switch
- 1 9V battery, Eveready 216 or similar
- 1 battery clip to suit above
- 1 74C14 CMOS hex Schmitt trigger
- 3 1N4148 signal diodes
- 2 4.7µF 25VW electrolytic capacitor
- 1 .01µF greencap (metallised polyester) capacitor
- 1 .001µF greencap
- 1 22pF polystyrene or ceramic capacitor
- 1 15pF polystyrene or ceramic capacitor
- 2 1MΩ resistors
- 1 470kΩ resistor
- 1 22kΩ resistor
- 1 10kΩ resistor
- MISCELLANEOUS
- Solder lugs, 22 SWG tinned copper wire
- 2 metres hook-up wire.

above its upper trigger voltage. As a result, the outputs of IC1c, IC1d and IC1e will be low, high and low respectively, and the alarm will be off.

If, however, the door handle or metal plate is touched, most of the signal from the oscillator will be capacitively shunted to the counterpoise which forms a pseudo earth. Pin 13 of IC1b will now be held at half supply voltage by the two 1MΩ bias resistors (ie between the two trigger voltages) and the output (pin 12) will thus remain either high or low.

Whether or not IC1b's output is held high or low depends on its state at the moment the signal from the oscillator is interrupted. Either way, it makes no dif-

# IF YOU WANT TO UNDERSTAND MORE ABOUT MICROPROCESSORS

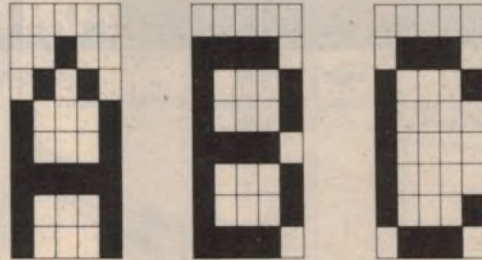

## APPLY HERE...

One of the fastest growing sections of the electronics industry is microprocessing and its associated technology. A sound basic knowledge and a constant up-dating of that knowledge is necessary to stay informed of the developments within this exciting new technology.

Stott's Technical Correspondence College has produced an up-to-the-minute home study course specifically designed for people interested in this subject.

This Stott's home study course has been meticulously prepared by experts in this field and takes you through the stages necessary to reach a basic understanding of micro-computers and the processing techniques needed for their application, whether for consumer or industrial use. To this basic training you can add further knowledge and gain more experience.

The course is prepared in three stages. It begins with initial training in basic electronics, goes on to digital electronics and then proceeds to an in-depth study of microprocessors.

For further information on Stott's Microprocessors Course or other courses which interest you, mail the coupon below.

# Stotts



TECHNICAL CORRESPONDENCE COLLEGE

The name to trust in correspondence education

Melbourne, 159 Flinders Lane, 3000. Tel. 63 6212  
 Sydney, 383 George Street, 2000. Tel. 29 2445  
 Brisbane, 290 Adelaide Street, 4000. Tel. 31 1627  
 Adelaide, 85 Pirie Street, 5000. Tel. 223 3700  
 Perth, 25 Richardson Street, 6005. Tel. 322 5481  
 Hobart, 1st Fl. 29 Argyle Street, 7000. Tel. 34 2399  
 Singapore, P.O. Box 3396, Singapore 1

Please send me free and without obligation full details of the following courses:

(PLEASE PRINT) \_\_\_\_\_

MR MRS MISS \_\_\_\_\_ AGE \_\_\_\_\_

ADDRESS \_\_\_\_\_

POSTCODE \_\_\_\_\_

Stott's undertake that no sales counsellor will visit you

The Stott's range of courses in Electronics is:

Radio for Amateurs  
 Introduction to Electronics  
 Digital Electronics  
 AM Radio Receivers  
 Radio/TV Servicing  
 Colour Television  
 Amateur Radio Operators' Certificate  
 A full range of Hobby and Business courses also available.

ALA/ST1926/EA481

# NEW HOBBY-BLOX™

## A MODULAR CIRCUIT BUILDING SYSTEM FOR ELECTRONIC HOBBYISTS

**\*921500**

**TRAY**

All 14 modules fit into the tray which is the basis of the Hobby-Blox system

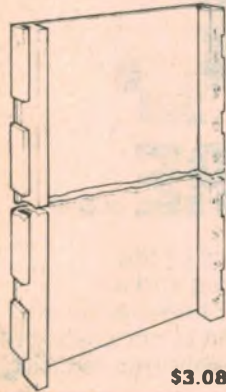

**\$3.08**

**\*921505**

**TERMINAL STRIP PACK**

2 terminal strips and 1 spacer/support strip. 26 3-tie-points.

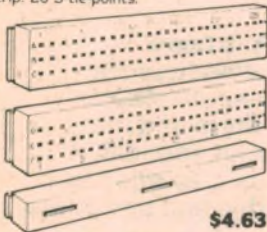

**\$4.63**

**\*921510**

**DISTRIBUTION STRIPS**

2 distribution strips with 2 x 26 tie-point terminals

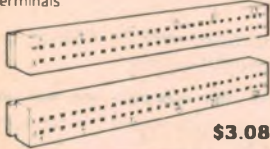

**\$3.08**

**\*921515**

**DISCRETE COMPONENT STRIP**

14 terminals each with 5 tie-points on 2" grid.

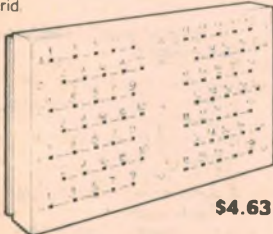

**\$4.63**

**\*921520**

**BUS STRIP**

2 continuous rows of 60 tie-points terminals

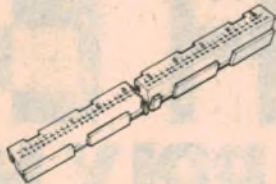

**\$4.63**

**\*921525**

**3 x 16 TERMINAL STRIP**

3 patterns of terminals each containing 2 rows of 8 contacts

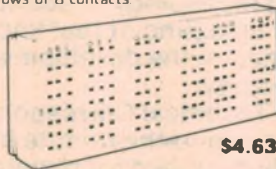

**\$4.63**

**\*921530**

**L.E.D. STRIP**

Accepts 6 LED's

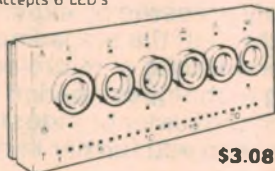

**\$3.08**

**\*921535**

**VERTICAL TRAY PACK**

Includes a smaller tray and an adaptor strip that allows perpendicular tray mounting

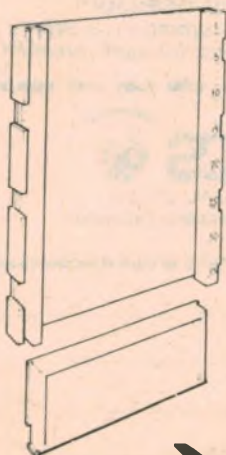

**\$2.62**

**\*921540**

**SPEAKER PANEL PACK**

2 speaker panels and 2 spacer/support strips.



**\$2.62**

**\*921545**

**CONTROL PANEL PACK**

2 control panels and 2 spacer/support strips

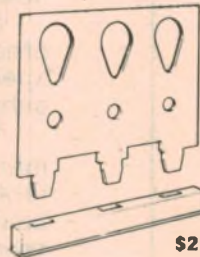

**\$2.62**

**\*921550**

**BLANK PANEL PACK**

A custom piece - drill holes in any configuration required



**\$2.62**

**\*921555**

**BATTERY HOLDER PACK**

Includes battery holder and connector (Battery not included)

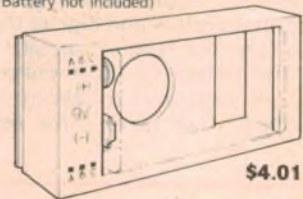

**\$4.01**

**\*921560**

**BINDING POST STRIP**

3 5-way binding posts electrically connected to solderless plug-in tie-point.

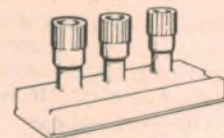

**\$5.57**

**\*921570**

**TRAY EXTENDER CLIPS**

4 clips to extend Hobby-Blox system horizontally or vertically



**\$2.00**

**\*921480**

**DISCRETE COMPONENT STARTER PACK**

INCLUDES:

- 1 x 921500
- 1 x 921515
- 1 x 921555

**SAVE \$1.50**

PLUS:

Complete instructions to build 10 discrete component projects  
\$11.72 value for **\$10.20**

921591:

The complete discrete component kit to build these 10 projects **\$4.72**

**\*921490**

**INTEGRATED CIRCUIT STARTER PACK**

INCLUDES:

- 1 x 921500
- 1 x 921505
- 1 x 921510

**SAVE \$1.50**

PLUS:

Complete instructions to build 10 integrated circuit projects  
\$10.79 value for **\$9.27**

921592:

The complete integrated circuit component kit to build these 10 projects. **\$10.76**



# XENITEK

**FREE CATALOGUE**

AVAILABLE FROM:

N.S.W. - Radio Dispatch Service 211 0191

MAIL ORDER: Add \$1.50 to order value for postage and packaging. Send cheque mail order to Xenitek Pty. Limited, P.O. Box 128 Brookvale 2100 or write for your FREE CATALOGUE.



This view shows how the counterpoise is taped to a door. Unit is hung from the door handle using tinned copper wire.

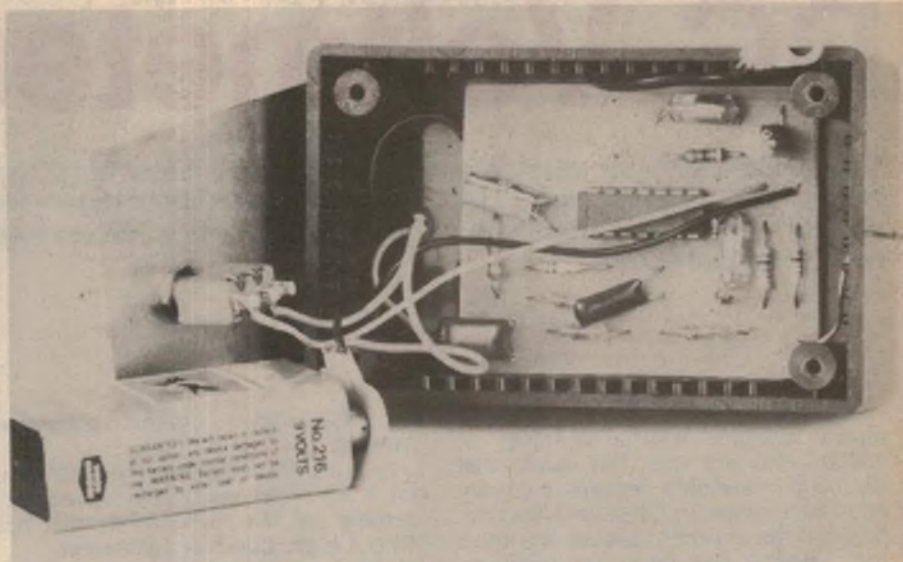

Inside the prototype. Note how several of the capacitors have been pressed against the circuit board to make room for the battery.

We estimate that the current cost of parts for this project is about

**\$15**

including sales tax.

ference to the operation of the circuit. As long as IC1b's output is held in one state, no signal can reach the rectifier circuit to charge the .01 $\mu$ F capacitor.

The .01 $\mu$ F capacitor now discharges via the 22k $\Omega$  resistor, pulling pin 11 of IC1c low. This forces pin 10 high, pin 8 (IC1d) low, and pin 6 (IC1e) high to sound the alarm. The alarm will continue to sound for as long as contact is made with the door handle.

Included in the circuit is a simple time delay network consisting of a 4.7 $\mu$ F capacitor, a 470k $\Omega$  resistor and a 1N4148 diode. Its purpose is to provide a minimum alarm time should momentary contact only be made with the touch plate. The delay circuit works as follows:

When pin 10 of IC1c goes high, the 4.7 $\mu$ F capacitor is charged to almost the full supply voltage via the diode. If pin 10 subsequently goes low (ie contact with the touch plate ceases), the diode will be reverse biased and pin 9 will initially be held high by the charge on the capacitor. The 4.7 $\mu$ F capacitor then discharges into the output of IC1c via the 470k $\Omega$  resistor, reaching the lower trigger voltage of

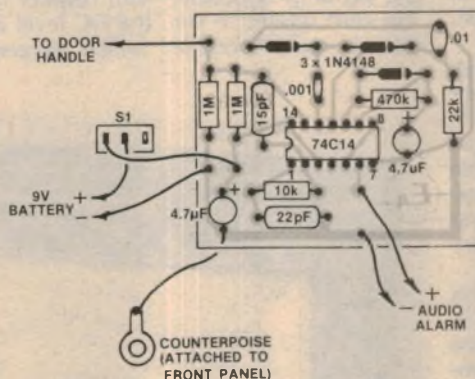

Above is the wiring diagram while at right is an actual size artwork for the PCB.

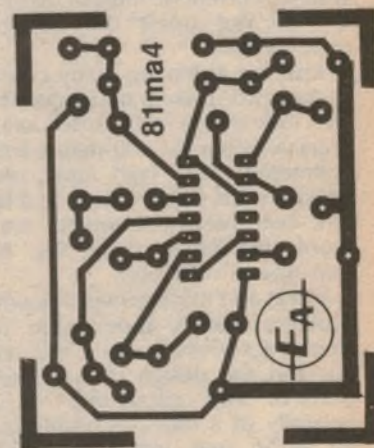

IC1d and shutting of the alarm after about two seconds.

Power for the unit is derived from a single 9V battery, with decoupling provided by a second 4.7 $\mu$ F electrolytic capacitor. An alternative is to use a plugpack supply if you intend using the unit in a fixed installation.

### CONSTRUCTION

Commence construction by fitting and soldering the components to the printed circuit board (PCB), as shown in the overlay diagram. This board is coded 80ma4 and measures 53 x 43mm. Pay particular attention to the orientation of the diodes, electrolytic capacitors and IC.

Note the 74C14 is a CMOS device. When soldering it into circuit, earth the soldering iron barrel to the earth track on the board using a small clip lead, and solder the power supply pins (pins 7 and

14) first. These precautions are to prevent possible damage to the IC by static charges.

The assembled PCB, together with the battery, is mounted inside a small plastic zippy box measuring 83 x 54 x 28mm. Use a thin piece of foam rubber to prevent shorts between the battery and circuit board components.

The audio alarm used in the prototype was supplied by Dick Smith Electronics, and carries a catalogue number L-7024. Similar alarms from other retail outlets should also be suitable. Do not use a solid state buzzer though – these require rather more current to drive them than the circuit can deliver.

We simply glued the alarm unit to the rear of the case using epoxy adhesive and drilled a small hole to pass the leads to the PCB. Additional holes were drilled in the lid for the on-off switch and in one

(Continued on p133)

# A low cost meter with high input impedance

## DC Voltmeter

This simple voltmeter uses an economy 1mA FSD meter but it has an input resistance of over 11M $\Omega$ . It may be used without regard for polarity of the test probes and a LED indicator tells when reverse polarity is connected.

By IAN POGSON

Regular moving-coil DC voltmeters are readily available with a sensitivity of 20000 ohms per volt. This means that the basic movement requires a current of 50 microamps for full scale deflection. Some of the cheaper varieties are much less sensitive but there are very few which are more sensitive than the figure just quoted. Voltmeters of this type are useful for many types of measurements where a current of 50uA or up to 1mA or so will not upset the circuit under measurement.

However, there are many circuits such as transistor biasing networks which are not tolerant to this order of current drain. Modern FET voltmeters and digital voltmeters have high input resistance which avoids this problem to a large extent but these instruments are rather more expensive than the ordinary moving-coil voltmeter.

A neat and inexpensive way out of this problem recently appeared in "Radio & Electronics Constructor" and we have adapted the design to suit local components and conditions. It consists basically of a moving-coil meter driven by an op amp with a very high input resistance. This enables us to have an instrument with a very high resistance, so offering very light loading to the circuit under measurement.

Also, we are able to use a less sensitive and cheaper meter movement. As a bonus, we are also able to modify the circuit so that it is not polarity sensitive, thereby giving a forward meter reading regardless of the polarity of the probes.

Few components are used in the circuit and these are readily available at low cost. One integrated circuit, one transistor and five diodes complete the list of semiconductor devices. The integrated circuit is a CA3140 FET-input operational amplifier. The op amp functions as a current driver with the meter movement placed in the negative feedback network. This has the effect of cancelling the non-linearity and voltage drop of the diode bridge network.

A 1k $\Omega$  resistor in the output of the op amp restricts the total current from the device and a silicon diode is used to pro-

tect the meter against excessive overload.

There are two trimpots. The 10k $\Omega$  trimpot is an offset control which enables "zeroing" of the meter while the 1k $\Omega$  trimpot is provided for calibration.

A feature of this instrument is that it gives an indication on a LED when the normal input polarity to the instrument is reversed. When the input to pin three of the op amp is positive with respect to the zero reference line, the DC level at pin six goes positive, which reverse

in the series with the LED is to limit the current.

The unit is powered with two Eveready 216 9V batteries. With a current drain of only 3mA from each battery, they should last quite a while under normal service. It is worth noting however, that when the reverse polarity LED is brought into play, that the current from the battery on the negative side rises to about 7mA. To cope with the rising impedance of the batteries as they age, each one has been shunted with a 100uF electrolytic capacitor.

At the time of writing, all components for the High Impedance DC Voltmeter are readily available. However, a few comments on the more important items may be helpful. The meter used on the prototype was supplied by Radio Despatch Service, 869 George Street, Sydney, 2000. It is type ST-100 DC 1mA. Radio Despatch Service are also making

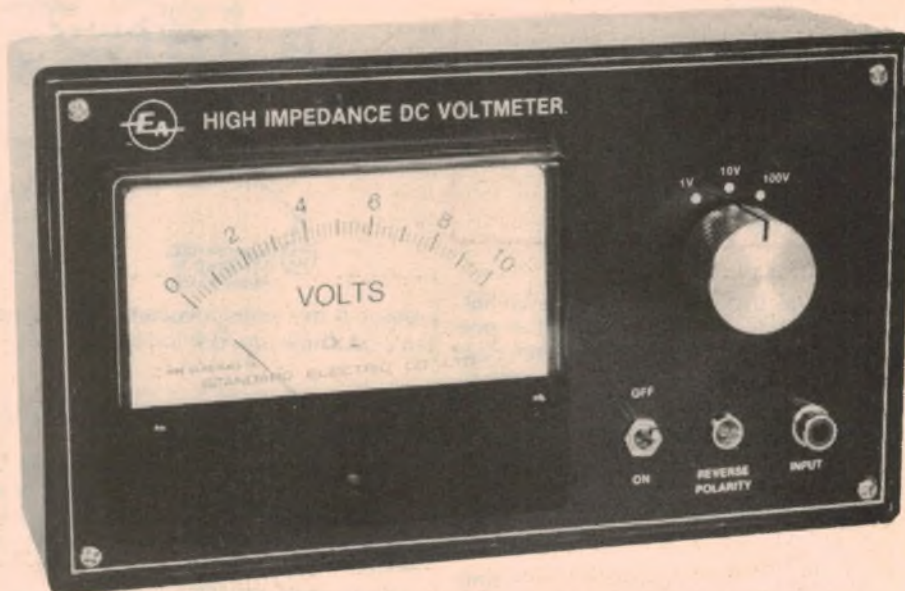

Very easy to build, this meter uses just one IC in the circuit.

biases the input of the BC558 transistor. This prevents the transistor from conducting and the LED does not light up. When the input to pin three is negative with respect to the zero reference line, the BC558 transistor is forward biased and it conducts. The LED in the collector circuit lights, giving a reverse polarity indication.

With only a very small input voltage, the LED lights dimly at first, rapidly rising to full brilliance with only a few per cent of full scale deflection. The 2.2k $\Omega$  resistor

a special scale available for the meter. Suitable meters and a scale may be also available from other components suppliers.

The box which houses the unit is readily available from such places as Radio Despatch Service, Rod Irving Electronics, Dick Smith Electronics and others. The printed circuit board and the Scotchcal front panel overlay should be available from the usual outlets by the time this appears in print. If any difficulties are experienced in obtaining these items, we



# The Australian CB SCENE

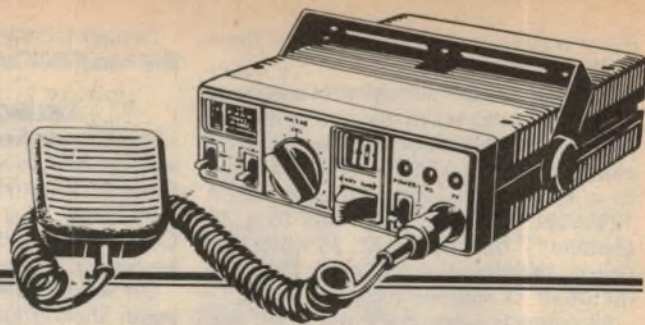

## Handsome prizes for 250 well chosen words!

As envisaged a couple of months back, and to add extra interest to the CB column, I am happy to announce a competition open to all readers except those connected with the sponsor, the magazine itself, or yours truly. You can win, as first prize: a Contact PSC-301 18-channel mobile rig, complete with a 5' helical with base and lead (value \$289.00). Or, as runner up, a Ferguson SSB regulated power supply (value \$39.00).

When I raised the matter with the Editor-in-Chief, he pointed out that the magazine itself was already involved in, and committed to other competitions with major advertisers and that there would be difficulties in slotting in another one immediately. However, he suggested that we could organise our own competition within the framework of this column, provided it was conducted along proper lines.

I can assure you that it will be. It is being sponsored by Olbis Industries of 2164 Ipswich Road, Oxley, Brisbane. Olbis Industries carry a large range of CB radios and accessories and have been selling and repairing them since their introduction into Australia. Bernie Bischa, the owner of the business (who, by the way is a qualified senior technician) together with his brothers Peter and George and their staff, have been long-time backers of CB in Australia, and have been notable for their assistance to Scout displays, marathons and other activities aimed at raising money for worthy causes.

I am delighted to have their support, with the handsome list of prizes as mentioned above. The Contact is shown in the accompanying photograph. Here's what it's all about:

**WHAT YOU HAVE TO DO:** Explain, in your own words: "Why I took up CB and what it means to me now". Entries should be of 250 words or less and must be clearly written or typed. Credit will be given for content, clarity of expression, correctness of spelling, etc.

**YOUR NAME AND ADDRESS** must be printed clearly on the first sheet of your entry.

**SEND YOUR ENTRY** to Jan Christensen, Australian CB Scene, PO Box 406, Fortitude Valley, 4006.

**CLOSING DATE:** Entries must be posted so as to reach the post box on or before June 30.

**A CONDITION OF ENTRY** is that submissions to the competition may be published in full, in the "Australian CB Scene" or paraphrased or summarised at the discretion of Jan Christensen and the Editor-in-Chief of "Electronics Australia".

**JUDGING** will be the responsibility of Jan Christensen and Bernie Bischa. Their decision will be final and no correspondence will be entered into.

**THE WINNER'S NAME** will be published as soon as possible after the closing



From Olbis Industries of Oxley, Qld: a Contact PSC-301 18-channel AM/SSB mobile rig.

date. He/she will be advised by telegram and the prize delivered, if appropriate, by Ward's Air Cargo.

Coincidentally there was a human interest story on one of the current affairs programs here in Brisbane the other night. The story was about a man in his 50s who has lost both legs, is a chronic asthmatic and also has emphysema. The only joy he gets out of life now is his CB. I wonder how many other people have the same sort of problems which CB helps to overcome. By the way, this gentleman DXs and QSLs so, if any readers would like to exchange QSL cards with him, please contact me

with your name and address and I will pass the letters on to him.

**SKIP CONTACTS** have really been booming into Brisbane lately and, even if one doesn't actively chase them, it is almost impossible to have a local QSO without at least one long distance breaker coming in. Of course, this will not last forever, and I believe that we are on, or soon will be on the downhill section of the sunspot cycle. At times I think how fantastic that will be, with no more DX interference, but then I do an about turn and think of the number of friendships which have begun through skip contacts.

**INTERNATIONALLY SPEAKING:** As you may be aware, the NCRA is affiliated with the National CB Council of Ireland, and is one of the foundation members of the World Personal Radio Congress. In this role, the Association is keeping a close watch on events overseas, where they relate to CB.

Almost by accident, the National Director of the NCRA, Terry Watkin,

came into contact with his "opposite number" in the UK, Walter Stevenson, Chairman of the Mobile Radio Users Association of the UK. Lengthy discussions followed, the upshot of which is that the NCRA is working with its UK counterparts to try to have a dual 27 and 476/7MHz service introduced there. The British CBers were not aware that the cost of UHF sets could be as low as they are here and, from information available at this time, they are very interested in having some of the sets landed into the UK, for testing purposes only, of course. More on that in further issues.

lesser quality contact with ZL1BVA from 1233UTC to 1251UTC.

Briefly, the station equipment used was - VK2ZRU: 40 watts to a 18 element yagi antenna. VK2BDN: 250 watts to a 88 element yagi on 432MHz and 100 watts to a 46 element loop yagi antenna on 1296MHz. VK2AHE: 100 watts to a 48 element "J" beam. ZL2TAL: 35 watts to a pair of skeleton slot antennas. Detail of the other ZL stations were not given.

All contacts were made using SSB and the distance between VK2AHE and ZL2TAL was approximately 2000 kilometres.

The outstanding two metre effort reported was by John Telfer, VK2BTQ at Mollymook on the NSW south coast.

John had 61 contacts with north island New Zealand stations over a three day period January 26-27-28, between the hours 2045UTC to 1330UTC. All contacts were in FM, most through New Zealand repeaters, but direct contacts were made after a repeater contact with some stations.

The equipment used was a TR2400 handheld driving an amplifier with 60 watts output to a 20 element phased array. John said the barometric reading was 1000 millibars, the same as in 1979 when he worked 218 ZLs on two metres FM.

#### WICEN REPEATERS

The Department of Communications has informed the Wireless Institute of Australia that the Department is prepared to authorise the use of "portable repeater" stations to be operated by the Wireless Institute Civil Emergency Network (WICEN) within the bands 144 - 148MHz and 420 - 450MHz.

Prior approval is not required when an approved portable repeater is put into operation as part of a declared civil emergency. In the case of WICEN exercises, in accordance with the general provisions in the Amateur Operators Handbook (December '78), prior approval is required.

Each WIA state division must accept full responsibility for the proper operation of the portable repeater used by their WICEN group.

Certain technical provisions set out in the handbook are to be complied with.

#### URUNGA FIELD DAY

The Urunga Convention and Field Day will be held over the Easter weekend (April 17-19). Activities will commence at 8pm Friday 17 at the Ocean View Hotel. On Saturday, a range of field events will be held at the Urunga School of Arts.

On Sunday, the venue will be the Bellingen Showground where there will be trade displays and another day of field events followed by prize presentation. The event is being organised by the Coffs Harbour and District Amateur Radio Club.

For further details write to CHDARC, PO Box 655, Coffs Harbour 2450, or telephone (066) 55 1115, or (065) 68 1470.

#### BITS & PIECES

QSL'ing, the practice by amateurs of exchanging their verification cards, is as old as amateur radio itself. But the practice has lost some of its initial significance since it is now easy to work into practically any part of the world. The number of active amateur stations in a given location seems to denote the value of a QSL card, if an award is not being strived for.

The practice of some DX'peditions requiring donations to finance the trip with a guarantee of a QSL card, or the required "green stamp" accompanying your own QSL card, has also been with us a long while. The rights and wrongs of such practice is the subject of acid letters appearing in some local and overseas magazines.

POLY-TOWER PHASED ARRAY. If you have a space problem for multi-band antennas, then the article in QST January, 1981, may be the answer. Using PVC pipe and centre fed vertical dipole antennas the results are claimed to be efficient as well as economical.

WHO INVENTED RADIO? Credit is given to Marconi, but other claims have

been made. The latest appears in an article in December, 1980, issue of "73 Magazine". The story is that the people of Murray, Kentucky USA claim that Nathan B. Stubblefield discovered the means of transmitting voice by wireless. The inscription on his gravestone makes that claim, as does a resolution by the Kentucky Legislature, 1944, which "... publicly recognises Nathan B. Stubblefield ... as the true inventor of the radio ...".

However, the article, which includes a reproduction of the patent taken out, indicates that it was magnetic induction; not the use of Hertzian waves.

It seems that Stubblefield was the first man to successfully transmit and receive the human voice without a connection by wire.

AUTOMATIC CW IDENTIFIERS are in wide use in repeater installations. What about talking identifiers without the use of tape recording? Well, an article by Peter A. Stark, K2AOW in the December 1980 issue of "73 Magazine" describes how it is done digitally.

The secret is in knowing how to program an EPROM (Erasable Programmable Read Only Memory) by the use of a computer.

The article is interesting reading, particularly for computer buffs.

NEW REPEATER INSTALLATION: The Shepparton and District Amateur Radio Club are installing a two-metre repeater on Mount Wombat, Victoria. Tests indicate that coverage along the Hume Highway will be greatly improved. In fact, coverage could extend from Melbourne to north of Albury.

As the repeater will be of benefit to all two-metre operators within the area of coverage, there may be many who could assist the project financially. Donations or inquiries should be directed to - SADARC, PO Box 692, Shepparton, Vic, 3630.

Radio clubs and other organisations, as well as individual amateur operators, are invited to submit news and notes of their activities for inclusion in these columns. Photographs will be published when of sufficient general interest, and where space permits. All material should be sent to Pierce Healy at 69 Taylor Street, Bankstown.

### ATTENTION: AMUSEMENT MACHINE OPERATORS & TECHS WE'RE THE COIN MACHINE INDUSTRY'S SERVICE CENTRE

MOST COMPUTER BOARD REPAIRS DONE WITHIN 24 HOURS

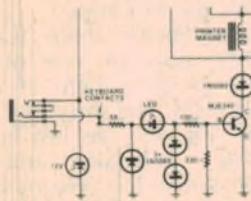
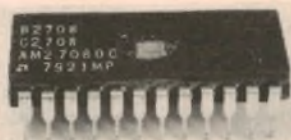

EPROMS COPIED WHILE YOU WAIT. SEND CIRCUIT BOARDS, EPROMS, OR WHOLE MACHINE TO:

### AUTOMATIC RECREATION

REMEMBER!!! SERVICE IS OUR BUSINESS

ALSO FOR SALE: ELECTRONIC PINBALLS FROM \$399  
COIN OPERATED VIDEO GAMES FROM \$300

31 Watland St,  
Spring Wood, Qld, 4127  
(07) 2088333  
Telex AA44658

### SO YOU WANT TO BE A RADIO AMATEUR?

To achieve this aim, why not undertake one of the Courses conducted by the Wireless Institute of Australia? Established in 1910 to further the interests of Amateur Radio, the Institute is well qualified to assist you to your goal. Correspondence Courses are available at any time. Personal classes commence in February each year.

For further information write to  
**THE COURSE SUPERVISOR,  
W.I.A.**  
P.O. BOX 123,  
ST. LEONARDS, NSW 2086

# AMATEUR RADIO

1957/58 was the International Geophysical Year (IGY) and also the year when the first satellites were placed in orbit. Gil, with his keen interest in radio astronomy, organised the Sydney "Moonwatch" Group and set up an observing station where the orbiting satellites were tracked visually.

To assist the observers to readily detect the small moving spec of light among the myriads of visible stars, Gil enlisted the help of amateur radio. Members of the WIA VHF group in Sydney formed a VHF relay station link to Forbes (central west NSW) which, compared to the Sydney area, had a very low noise level and the weak radio signal from the satellite beacon could be detected as the satellite rose above the horizon. When the beacon signal was heard the information was relayed to

"Moonwatch" (quicker than through country manual telephone exchanges) which made visual identification easier.

A lot of the equipment used by the "Moonwatch" group was designed and built by Gil, including the telescope lenses, which he ground.

Publicity on the group's activities was given on the front page of the Sun-Herald, October 6, 1957.

Throughout the years Gil's interest in amateur radio never flagged. In more recent times he experimented with amateur slow scan television, with fellow amateurs around the world. He made several trips overseas, including two to England to meet and confer with fellow experimenters.

In 1979 during a visit to Nottingham, England, he was elected president of the "Narrow Bandwidth Television Society".

The NBTV system enables moving pictures to be transmitted on High Frequency bands using 6kHz bandwidth. Successful transmissions had been made between Sydney and Melbourne using equipment designed and built by Gil in collaboration with United Kingdom and Australian amateurs.

Gil's last project was to reproduce some 1929 television equipment for presentation to the Museum of Applied Arts and Sciences, Sydney. In fact, it was still on the bench in his workshop at Campsie, where he was making final adjustments to it.

Among his large collection of photographs and papers there are many records of historical interest. Unfortunately space does not allow us to cover, more fully, the work of this Australian radio pioneer and amateur radio experimenter.

## MOUNT GAMBIER CONVENTION

The 17th Annual South East Radio Group convention will be held at Mount Gambier, South Australia on the Queen's Birthday holiday weekend on June 6-7-8, 1981.

The South East Radio Group celebrates its 21st birthday this year, and a special dinner is being arranged on the Saturday evening of the convention.

In anticipation of a larger crowd than in 1980 (250 persons), a much larger venue, the main pavilion at the Mount Gambier Showground, has been booked for the event.

The usual type (plus new) field events will be held and there will be an extensive range of equipment in the trade displays.

Prizes will be awarded to the winners of all events, plus the South East Radio Group perpetual trophy for the best overall performance.

Further information and registration forms may be obtained from the Convention Registrar, C/- SERG, PO Box 1103, Mount Gambier South Australia, 5290, or telephone Peter Becker, VK5ZBF, convention co-ordinator on (087) 25 6336 (Bus), or (087) 25 1226 (A/H).

## TELEVISION DX

In direct contrast to the lead story and the first television broadcast in Australia, an interesting note was received from Todd Emslie of West Ryde, NSW. Todd is an avid TV DXer and his note details reception of overseas TV signals since mid-March, 1980.

As well as details of day-to-day TV reception over that period, there are also reports of signals from two-way communication channels, in the 41 to 48MHz range, from Russia, Hawaii, Mexico, South America, and Africa.



Here are some extracts relating to TV DX - March 20, 21, 1980: Russian Channel R1 49.745MHz from 0045UTC to 0455UTC. April 13, 1980: China Channel R1 49.75MHz very strong signal from 0103UTC to 0524UTC. New Zealand Channel 1 was received almost daily for varying periods until Channel 0 Sydney, began transmissions.

These were not just spasmodic results, but were repeatedly recorded during the 10 month period.

The log also includes Australian stations such as Channel 0 Melbourne, ABTQ-3 Townsville (86.25MHz), ABNS-1 South Australia (57.25MHz), and several low power relay stations.

With the notes were off-screen photographs of test pattern and identification cards of New Zealand BCNZ-TV1 and Channel 0/28 Melbourne.

## TRANS TASMAN VHF/UHF

Openings on 144MHz and 432MHz occurred on January 26-27, 1981. Several stations in Sydney, NSW, worked the north island of New Zealand on 144MHz using SSB and through the Sydney FM repeaters. At the same time contacts were made on 432MHz SSB.

On the 432MHz band, on January 26, Ross Usher, VK2ZRU, and Dick Norman, VK2BDN, in Sydney, worked ZL1TCX, ZL1AXX, ZL1TAB and ZL1AVZ between 0950UTC and 1300UTC.

On January 27, VK2ZRU and VK2BDN worked ZL2THG with signal reports ranging from Readability 5, Strength 1, to R5-S8 from 0920UTC to 1040UTC. VK2BDN and ZL2THG tried to make contact on 1296MHz without success.

Also on January 27, Barry Parsons, VK2AHE, at Newcastle worked ZL2TAI on 432MHz from 1150UTC to 1233UTC at excellent readability and signal strength. This was followed by a much

**NOW — AVAILABLE DIRECT**

**SOLAR-POWER ALARM WATCHES**

**"5 YEAR" SOLAR BATTERY POWER**

**BEEP! BEEP!!**

**WITH 12/24 HOUR SYSTEM**

**\$135**

**\$85**

**WATERPROOF TO 100FT.**

**YES — This is the latest "Superior Quality" Super Slim "Solar-power" Alarm Chronograph -- Displays 12 Functions WITH 1/10 sec. Lap-Time, Stop-Watch, 12/24 Hour Selectable System, AND Loud Daily Alarm. Waterproof to 100ft, Shockproof, 100% Stainless Steel, Mineral Glass, Instructions, 2 Year Guarantee.**

Send name & address for your ...

**FREE** FULL DETAIL COLOUR PHOTOS OF RANGE TO:-

**QUARTEX INTERNATIONAL**  
G.P.O. BOX J666, FORREST PLACE,  
PERTH, W.A. 6001.

**TRADE ENQUIRIES WELCOME**

# A blueprint for your success.

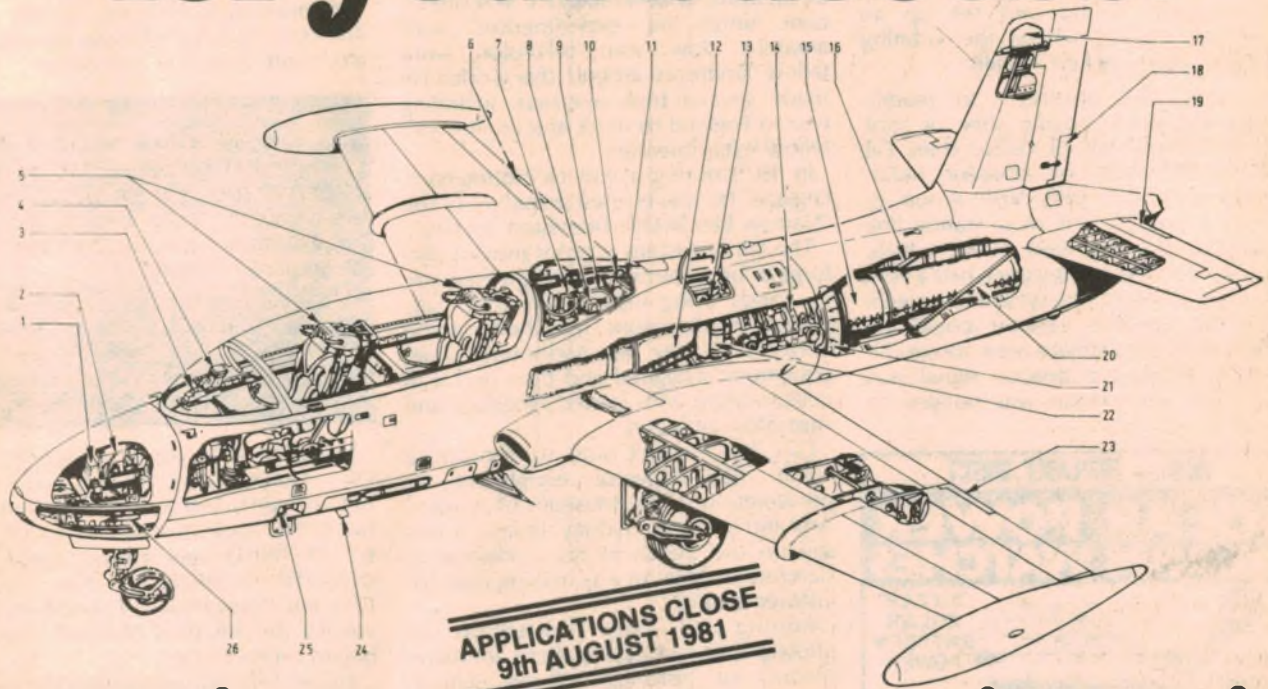

## An Air Force Apprenticeship.

### Opportunities no shop floor Apprenticeship can offer.

Right now, you can take an RAAF Apprenticeship and become a specialist in Airframes, Armaments, Radar, Communications, Propulsion Systems, Flight Systems or Motor Transport.

### Full time training recognised and respected by Australian employers.

For the first 2½ years, you will be taught on some of the most up-to-the-minute equipment under the expert guidance of professional instructors. In modern laboratories, classrooms and workshops.

Understandably, when you have completed your initial training we expect you to spend another 6½ years working for us. On full adult pay of course.

### It's not easy!

Success demands application. And a disciplined approach to work. As an RAAF Apprentice you'll be required to study in your own time. And regularly sit for exams. The rewards are there. Many Apprentices go on to become Officers.

### It's not all work.

You will have stacks of time to relax provided you're on top of your studies. At both training bases (Wagga Wagga and Laverton) excellent sports facilities abound. Gyms, football grounds, golf courses, swimming pools, tennis courts and many clubs.

### What about entry qualifications?

You need to be 15 and under 17½ years on 1 January, 1982 and an Australian citizen. We also expect you to have passed (or be in the process of passing) your 10th year of formal schooling with above-average marks in maths and science with a physics content. And be reasonably fit.

### The scope for the future is enormous.

On completion of your Apprenticeship, you'll be part of a team servicing, repairing and testing some of the most advanced and sophisticated aircraft and equipment in the country. The technology of the future will be in your everyday working life.

### Apply now!

Air Force Apprenticeships are very popular. So the sooner you have a chat

with a Careers Officer the better. The address is in the phone book and there's no obligation.

Alternatively send or phone for the facts:

Brisbane: 226 2626	Townsville: 71 3191	Sydney: 212 1011	Newcastle: 2 5476
Wollongong: 28 6294	Parramatta: 635 1511	Canberra: 82 2333	Melbourne: 61 3731
Hobart: 34 7077	Adelaide: 212 1455	Perth: 325 6222	

To:  
**RAAF CAREERS  
ADVISER. G.P.O. Box XYZ**  
in the capital city nearest you.  
**Yes! I am interested in an RAAF  
Apprenticeship. Please send me  
full details.**

Name \_\_\_\_\_

Address: \_\_\_\_\_

State: \_\_\_\_\_ Postcode: \_\_\_\_\_

Date of Birth: \_\_\_\_/\_\_\_\_/\_\_\_\_

AFAP431.FP.EA

**You're somebody  
in Today's Air Force**

Authorised by Director-General Recruiting Dept. Defence

AFAP431.FP.EA

# AMATEUR RADIO



by Pierce Healy, VK2APQ

## Tribute to Gil Miles — a true pioneer

Broadcasting, television, astronomy, meteorological research, rain making, aeronautics and amateur radio were among the lifetime interests of one of Australia's radio pioneers — Gilbert Miles.

One of the radio and television pioneers in Australia, Gilbert Miles, VK2KI, died suddenly on January 26, 1981, at the age of 77 years. Well known locally and overseas, his death leaves another gap in the link with the early days of radio and television experiments.

Gil Miles, as he was known among his many friends and acquaintances, became interested in radio as an amateur when he joined the Wireless Institute of Australia in Victoria in 1919. In 1921 he had the call sign "311".

He joined the RAAF in 1922 and became involved in the radio section of the air force after successfully demonstrating shortwave equipment on 32 metres. He made the first radio contact between the RAAF station at Point Cook and Admiralty House, London. Gil also took part in many aerial survey flights and transmitted the first positional

report made from an aircraft in flight in Australia.

After leaving the air force Gil entered the commercial radio field.

In 1928 he joined "Radio and Television Laboratories" in Melbourne, engaged in the design and construction of television and facsimile equipment.

On January 10, 1929, the first public "Radiovision" transmission in Australia was made from Melbourne radio station 3UZ. Gil was responsible for the technical side of that historic broadcast, using equipment which he had assisted in designing. Later another Melbourne radio station, 3DB, participated in the experiments.

Although crude by today's standards, due to the limitations of the mechanical system used, it was nevertheless a beginning for television in Australia.

The experiments, under Gil's watchful

eye, were made over a period of about 12 months and are believed to be comparable with those carried out during the same period by Logie Baird in England. The great depression saw the demise of the company's activity.

A full scale working replica of the television equipment used in that historic event was built by Gil and presented to the Science Museum of Victoria in May 1972. (See Electronics Australia, December, 1969, and July, 1972; also Sydney Morning Herald, January 4, 1979).

During 1931 and 1932 Gil was chief engineer with radio station 3UZ, and from 1932 to 1936 construction engineer building radio station 3AW.

In 1936 he was engaged in building station 7HT in Hobart, Tasmania, and remained for four years as chief engineer.

In 1941 Gil and his family moved to Croyden, in Sydney, and from then until 1947 he was with AWA Sydney as engineer in charge of number one transmitter test room.

In 1947 Gil joined the Council for Scientific and Industrial Research, Division of Radiophysics and worked there until he retired about 15 years ago.

An interest in gliding, and electronics in the radio control of models, led him to join the CSIRO. He became involved in radio astronomy, meteorological research, rain making, and other aspects associated with the CSIRO. Among the papers prepared by Gil on his work are — Test flight of a radio-controlled 8ft span glider (1947); Radio control of model aircraft — description of four channel transmitting and receiving equipment (1948); A homing glider for meteorological research (1953); The results of large-scale measurements of natural ice nuclei (mid 1960s).

One of Gil's experiments was of particular interest to amateurs with memories of post World War II VHF disposals equipment. In 1947/48 Gil used a modified SCR 522A communication set, working on 140MHz, as a radio control unit for gliders used in his meteorological research work.

In recognition of his work in meteorological research he was made a Fellow of the Royal Meteorological Society, London in 1963.

Gil Miles, pictured in 1973 with his slow-scan TV equipment.



## Hewlett-Packard

STILL POST FREE!

### NEW MODELS AND PRICES

In the HP41C System  
HP41C Calculator \$318 (\$285)  
Memory module for HP41C \$39 (\$35)  
4K application ROM \$39 (\$35)

**NEW HP41CV** with 2000 steps \$412 (\$370)

**SYSTEM 1** HP41CV and card reader \$630 (\$565)

**SYSTEM 2** HP41CV, card reader and printer \$1066 (\$958)

Quad memory module (1600 steps) for HP41C/CV \$122 (\$109)

Card reader for HP41C/CV \$273 (\$245)

Printer for HP41C/CV \$489 (\$439)

Optical Wand for HP41C/CV \$159 (\$142.50)

(Prices in brackets excl. Sales Tax)

WRITE OR PHONE  
FOR FULL  
DETAILS

## INTERTEC

Computer Systems

AND  
FREE  
BROCHURES

### SUPERBRAIN SYSTEM:

● **MODEL 1** 32K RAM, 340K disks, 24 lines x 80 character display, dual 280 CPU's.

● **MODEL 2** 64K RAM, 700K disks version.

● 5Mb and 10Mb Winchester disk drives

● 4 Printer options.



### NEW COMPUTER MULTIUSER SYSTEM

EACH WITH 64K RAM, dual Z-80 CPU's.

UP TO 255  
TERMINALS

- Model 10 no disk drives
- Model 20 340K drives
- Model 30 700K drives
- Model 40 1.6Mb drives.
- 10, 32 and 96Mb hard disk drives.

### SOFTWARE:

Basic interpreter and compiler, pascal, fortran, cobol, APL, IBM, etc.

### BUSINESS SOFTWARE:

Debtors, creditor and general ledger, invoicing stock order entry, word processing, direct mail, etc.

**FULL SUPPORT SERVICES**  
Installation, maintenance, etc.

## THE PERFECT HOME COMPUTER THE APF IM1

Including colour monitor, built-in sound synthesizer, cassette, games controllers.



ONLY  
\$990

**BEGINNERS PACK** — incl 22 programs and huge book only \$65

Extra 8K RAM \$125

72K disk drive \$495

Disk drive interface (for up to two drives) \$255 IM1 with PAL converter for your TV \$730.

Also printers, user club, etc.

# Calculator & Computer

DISTRIBUTORS

### OUR NEW SHOWROOMS

3 ROWLEY ST.,  
SEVEN HILLS,  
NSW 2147

PHONE (02) 624 8849

8.30am to 3.30pm

## NEW PRODUCTS FOR YOUR COMMODORE MICRO-COMPUTER

### HI-RESOLUTION GRAPHICS

Now you can give your 40 column PET or CBM a High Resolution Graphics capability with the MTU Graphics hardware and software package. The hardware is easily installed and the new graphics board provides 5 extra ROM sockets and 8K RAM memory expansion which can be used for program or data storage when graphics are not required. A powerful graphics software package is included, and contains many extra BASIC commands for drawing lines, defining shapes etc. The graphics hardware does not affect normal operation of the Commodore.

Prices vary depending on the configuration required.

Maximum price is \$700 incl tax.

### COMMUNICATIONS KIT

With the Micropro RS232C Interface, and the KC NETKIT, you can give any Commodore Micro-Computer a communications capability. The interface features switch selectable baud rate up to 19,200 baud, word length of 5 to 8 bits, odd, even or no parity and one or two stop bits. The interface connects directly to Commodore's IEEE-488 bus. The NETKIT facilitates communications programming via ten new SERIAL BASIC commands for the Commodore. The extra commands are included on a ROM chip and greatly simplifies the programming required for serial communication.

Interface is \$350. NETKIT is \$270 (incl Tax).



MICROCOMPUTER SYSTEMS DESIGNERS

### B. S. MICROCOMP,

4th Floor,  
561 Bourke Street,  
MELBOURNE, 3000.

Tel: 614 1433. 614 1551.



## Letters to the editor

### For 'em but agin 'em!

I agree with most of Neville Williams' analogy in "Forum" for February but the part about Dick Smith sacrificing \$300,000 to back an administration, and his staff being abused for not stocking illegal items . . .

Really!

I'll bet you could fit the abusive customers into a telephone booth - all at the one time!

Can any intelligent person imagine DS passing up \$300,000, etc. He's obviously confusing it with his CB advertising budget.

Dick is a master at grinding his own axe.

True, Dick put a heap of effort into the introduction of the CB service, but let's not kid ourselves. He had already made a small fortune and stood to make a killing if a service came to pass.

DSE is selling 40-channel sets and illegal (use only) telephones because there are good \$\$\$ to be made and, legally, the vendor can't be touched.

I can't say I blame him and I don't see any answer to it all but let's not have Dick sounding so sanctimonious. Amen!

Jack O'Donnell,  
Altronics, Perth, WA.

### Aids for the blind

I was very impressed with your article "Electronic Aids for the Blind" in the January issue and the products which Wormalds now have on sale in Australia. You may be interested to know that the Mowat sensor was invented by a New Zealand radio manufacturer who owned a firm called Mowat Industries, while the Sonic Torch was invented by Professor Kay of Canterbury University. Both ideas thus have their basis here in New Zealand.

Arthur Cushen,  
Invercargill, NZ.

### Licensees for inventions

The Patents and Licensing Section, Marketing Branch, Australian Department of Industry and Commerce (DIAC) is responsible for the evaluation, protection and exploitation of inventions originating in Defence Research Organisations and DIAC Factories.

The Section is looking for licensees in Australia and overseas to manufacture these inventions under Australian and overseas patents. Many of these inventions have potential for application and development in other areas of manufacturing industry, and this Section regularly produces a brochure describing them.

For further details contact: Assistant Secretary, Marketing Branch, Department of Industry and Commerce, Anzac Park West, Canberra, ACT 2600, Australia.

Julienne R. Boston,  
Patents and Licensing Officer.

### Radioactivity & coal-fired power stations

Your News Highlights item about the radiological hazards of coal-fired power plants (Feb 1981) underscores the need for stack-gas scrubbers, etc. The other hazards of such firing can be even worse, but those of nuclear plants must still be treated as unique.

One of the few parallels between fossil and nuclear-fuelled plants is that economics, not public health, has always been the paramount issue. Therefore, let's ask some money-based questions in the nuclear debate.

The Enrico Fermi fast breeder reactor was located a mere 55 kilometres from Detroit, Michigan, a heavy industrial centre. In 1969, the Fermi had a fuel-melt accident that bordered on a complete

melt-down or, as one Fermi engineer put it: "We almost lost Detroit".

Recall the 1929 bankruptcy of the New York Stock Exchange - the world's largest gaming casino, bar none. How would the gamblers have reacted had the Fermi "gone China" and Detroit was merely evacuated - not lost - for a year or two?

What kind of a fossil-fuelled plant accident could likewise drive us back into the economic Dark Age of the 1930's?

George Lindley,  
Redfern, NSW.

**COMMENT: whatever the problems of nuclear plants may be, the disadvantages of coal-fired power stations still exist!**

### YE OLDE PETITION

*WHEREAS in the Sovereign State of Queensland (wherein such Frivolities as Lotto, Poker Machines and Daft Time are eschewed, and Certain Editions of such Magazines as Playboy and Penthouse are persona non grata) the Royal and Antient Sport of Pools is practised most assiduously throughout the Length and Breadth of the Realm; therefore your Petitioner humbly prayeth that you will modify change and otherwise alter a Certain Project to whitt Selectalott published in a Recent Issue of your Illustrious Journal so that it may enable the Production of Sufficient Random Numbers to allow the Effective Practice of the aforementioned Essential Sport; in Consideration whereof your Humble Petitioner undertaketh to give unto you Ten per Centum of any Winnings resulting from the Application of such Modified Device to the Practice of the Aforesaid Sport.*

*GIVEN under my Hand this Third Day of February 1981 at the Ninth Hour in the Forenoon (God's Time) [10am Daft Time]*

*H Swan  
BULIMBA 471.*

## BIDIRECTIONAL INTERFACE

The components saved in the case of the second version are IC2 and 3 together with the associated pullup resistors and DIP switches.

Before mounting any components you should check the board carefully, looking for broken or jointed tracks and un-drilled holes. When satisfied that there are no faults on the board, proceed to the assembly stage.

The first components to go on the board are the wire jumpers of which there are 44. These consist of tinned copper wire with the exception of one adjacent to LK6, 7, 8 and 9 which is insulated. The next components to go on the board are the resistors, followed by capacitors and IC sockets (if used).

Once the IC sockets have been soldered to the board mount the DIP switches if you have elected to use them, otherwise solder appropriate wire links in place of each switch. These can then be selectively cut to set the baud rate and address. Another alternative is to use IC sockets and solder headers. Refer to Table 1 for the link options.

Having done this, mount the diodes and the transistors onto the board, carefully checking their orientation against the overlay diagram as you go. Follow these up with the three voltage regulators and the crystal.

With assembly complete hook the board up to the transformer and test the three power supplies. We suggest that these be checked at each of the IC locations.

### WIRING THE FULL SYSTEM

The wiring between the computer expansion bus and between the interface unit and the peripheral can be implemented with plug and socket combinations such as those used in our prototype unit. The computer bus was connected to the interface unit via a flat cable and 37-pin "D" type plug and socket in the prototype, but this adds quite significantly to the cost.

The photograph of the prototype unit shows a number of slide switches mounted on the rear panel of the case. These were fitted to allow us to reconfigure the link options without having to open the case every time we changed from System 80 to TRS-80. These would not generally be required by the person building the interface to suit just one particular system.

We fitted the board and the transformer into one of the cabinets from the Horwood range, measuring 255mm x 75mm x 250mm, including the handles.

We suggest that you solder the +5V regulator to the bottom of the board and bolt it to the baseplate. If this method is not used, then a heatsink will have to be fitted to the regulator as shown in the photograph.

The transformer for the unit needs to have a 24V centre-tapped winding so that the  $\pm 12$  volt supplies can be generated. The one we used in the prototype is the A&R 6672A which is not compatible to the Dick Smith 6672. Also suitable is the Ferguson PL24/20VA.

### SOFTWARE

So much for the construction of the unit, but how do we drive it with the computer? Well, the answer to that is quite simple: we require suitable I/O routines to be written to replace the existing ones resident in the computer's firmware.

We have written programs for both the TRS-80 and the System 80 computers that will allow the machines to operate interactively with a remote terminal and

tion of the output instruction. In the System-80 version it is a true Z80-output instruction since all of its I/O is I/O-mapped, whereas with the TRS-80 the output is performed by loading a data byte into a memory address.

The printer device control block for both of these systems is located at the same address, namely 16421 decimal or 4025 hex. The first byte in the block is used to indicate the block type, while the following two contain the address of the resident driver, which is changed to the address of the new driver that we have written.

The resident driver in the computer is called up by the new driver and when it returns a check is made to see if the last character sent was a carriage return. If not, then the next character is loaded into the accumulator and transmitted, this test being conducted on each character sent. If a "carriage return" is found, it too is transmitted, after which a "line feed" is

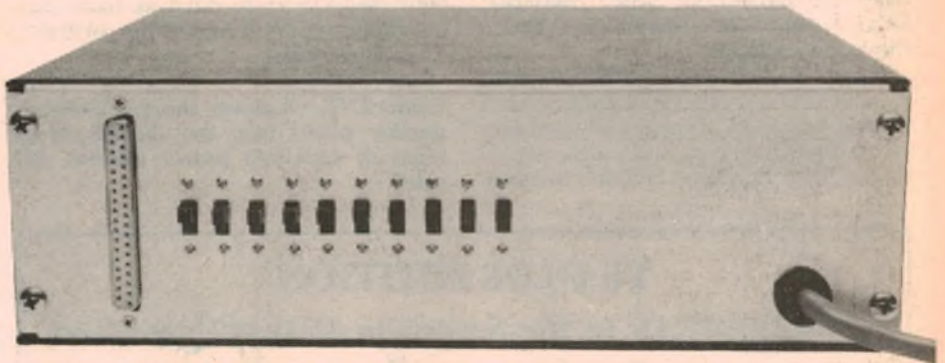

Our version was wired with 10 slide switches for the changeover functions of links one to 19.

also use a serial printer at the parallel printer address.

All of the programs are written in assembly language but are "POKED" into memory using a short BASIC program. The routines are addressed to the various device control blocks which are areas of memory used by the computer as a look-up table for the various input and output functions.

Three of these device control blocks are affected with the use of these routines, and we will examine these one by one.

All computers have a special set of programs called a system monitor. Of these routines there are a number that are dedicated to looking after all the input and output of information between the computer and the outside world.

In both the System 80 and TRS-80 computers there are three routines of this type that perform the functions of keyboard scanning, video display control and printer control. It is these three routines that must be changed in order to implement remote terminal and printer operation using the new interface unit.

The first program is the driver for the printer on the System-80 computer. It should be noted that the driver for the TRS-80 is identical to this with the excep-

tion.

Unfortunately the resident printer driver will not issue a "line feed" after a carriage return, this not being necessary with most parallel printers, as most of them generate a line feed upon receipt of a carriage return. This is not so in the case of most serial printers. A branch in the new driver issues a line feed after a carriage return has been transmitted, and then goes back to print out the next line of information.

When this short BASIC program is run it will load the machine-language driver into the top of memory and initialise the two bytes in the printer device control block with the address of the new driver. The last function it performs is to erase itself leaving the computer set up with the new printer driver located in memory.

The other programs, for both the System 80 and the TRS-80, set the machines up to work in the interactive mode with a remote terminal or modem. Both of the programs are again identical with the exception of the input and output instructions. All of these are true I/O instructions in the case of the System 80, and memory-reference instructions for the TRS-80 version.

(Continued on p134)



# MOST WANTED

## S100 MICROMODULES: AFFORDABLE, COMPATIBLE, EXPANDABLE...



### INSTRUCTOR 80:

Ideal starting package. Uses DGZ80 CPU, DG640 VDU, RCA Keyboard and comes complete with manuals and programming course. S100 based system needs no special interface to expand to any configuration. Don't be fooled with single board imitations, the Instructor 80 is fully software supported with basic, assembler, games and even Pascal and CP/M!

IN-Z80-K INSTRUCTOR 80 KIT **\$399.00**

### DGZ80 Z80/S100 SINGLE BOARD COMPUTER:

Most popular Z80/S100 SBC in Australia. Features Z80 CPU, PIO, CTC for powerful I/O and timing, 2K ROM/2K RAM on board, 2 or 4 MHz operation. With DGOS Monitor in ROM the DGZ80 needs only a keyboard and DG640 VDU for minimum system.

DG-Z80-2K 2MHZ DGZ80 KIT **\$199.00**  
DG-OS-1.4 DGOS MONITOR IN ROM **\$40.00**



### DG640 VISUAL DISPLAY UNIT:

This super functional S100 PCB is an industry standard. Generates 64 characters per line, 16 lines per page, full upper/lower case and graphics. Built in crystal time base locks onto TV sync. Watch out for outdated "El Cheapo" 32 character/upper case only displays, they just don't suit most software requirements.

DG-640-K DG640 KIT **\$149.50**

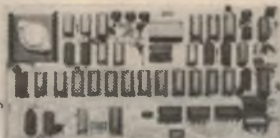

### TCT PCG HIGH RESOLUTION GRAPHICS:

Need high resolution graphics and programmable characters? The TCT PCG option connects to the DG640 to produce 512x256 bit resolution. Supplied with StarWars and table tennis programs on cassette and has built in joy stick interfaces.

PCG KIT **\$140.00**



### AT16K ECONOMY 16K STATIC MEMORY:

Just released, the AT16K uses proven 2114 static memory chips to produce a 16K block locatable ram module with write protect and bank select (port or switch controlled). AT16K is supplied burned-in and tested ready for years of trouble free service!

AT-16K-4A ASSEMBLED/TESTED AT16K (450NS) **\$199.00**

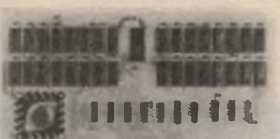

### TCT 16K BLOCK LOCATABLE RAM:

This versatile 16K ram module is configured in four independent 4K blocks each with write protect and independently locatable at any location in 64K address space. The board is fully socketed and includes dip switches for easy location.

TCT-16K-K TCT16K IN KIT FORM **\$209.00**

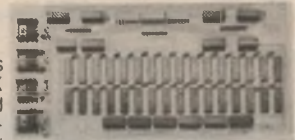

### 2650/S100 SINGLE BOARD COMPUTER

Released at last this top class design now brings the 2650 to the S100 bus. Feature laden board contains 2650 CPU, 8255 PPI, serial and parallel ports, on-board ram (to 4K), on-board rom and bank select facility to address up to 512K. The 2650/SBC is available in kit form or as a PCB with manual and control ROM.

SBC-2650-K 2650-SBC KIT WITH MANUAL **\$209.00**  
SBC-2650-SK 2650-SBC PCB/MANUAL/ROM **\$80.00**

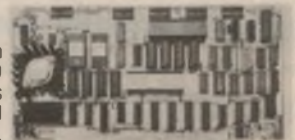

### SCVT S100 SERIAL VIDEO TERMINAL

Described in EA Oct 1980, the SCVT uses the Thomson-CSF VDU Controller to produce this versatile serial terminal. Features on board UART with BAUD rate generator (50 to 1200), cassette interface, RS232 ASCII encoded keyboard to output 64 characters/16 lines and attributes include reverse or flashing characters, cursor addressing and hardware scrolling. With a keyboard such as the Clare C/O, and a suitable TV set, the SCVT becomes a cost effective "Dumb" terminal suitable for many microprocessor applications.

SCVT-T100-K SCVT TERMINAL KIT **\$189.50**



Full product descriptions and specifications are detailed in our 1981 catalog (see ETI March 1981). Note that prices quoted include sales tax. Please add \$4.00 to cover packaging and registered postage.

# APPLIED TECHNOLOGY PTY. LTD.

MAIL ORDERS TO:  
PO Box 355, Hornsby 2077  
Please add \$2.00 per order towards cost of post and packing

OFFICE/SHOWROOM  
1a Pattison Avenue, Waitara 2077  
Hours: 9-5 Monday to Saturday  
Telephone: 487 2711

AND NOW AT GOSFORD -  
1 Debenham Road, West Gosford (behind the Pizza Hut) 043 24 2711

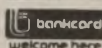

# KITS ☆ KITS ☆ KITS



Analogue/digital storage CRO kits

Digital kit  
\$78.00



Analogue & digital kit  
\$169.00

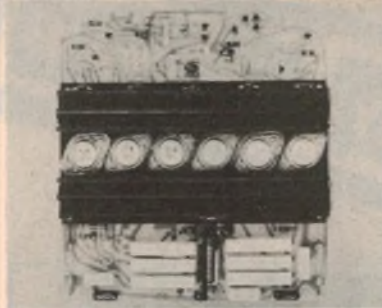

Brute power amplifier  
\$63.50

Heart rate monitor ..... \$82.00



Versatile tv pattern generator ..... \$54.90

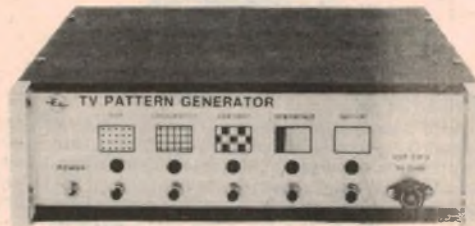

Infrared light beam relay ..... \$39.00

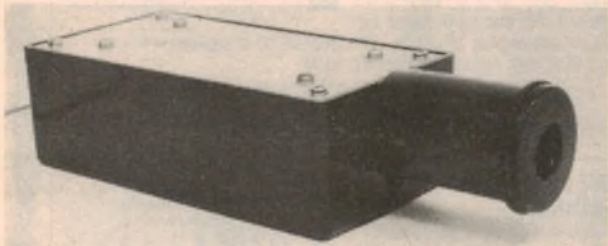

Engine analyser kit  
\$44.95

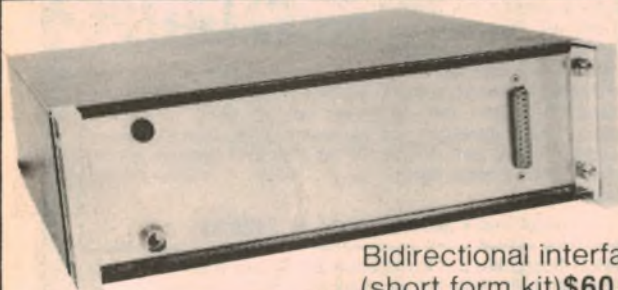

Bidirectional interface (short form kit) \$60.00



"Selectalot"  
\$22.50



Oscilloscope switch  
\$58.50



Simple fuzz box  
\$19.00

## ROD IRVING ELECTRONICS

HEAVIER ITEMS ADD ADDITIONAL POSTAGE EXTRA HEAVY ITEMS SENT COMET FREIGHT ON PRICES SUBJECT TO CHANGE WITHOUT NOTICE. SEND 60c & SAE FOR FREE CATALOGUE  
MAIL ORDERS: PO BOX 135, NORTHCOTE, VIC 3070. MIN PACK & POST \$1.00  
PRICES CURRENT UNTIL MAY 15 1981

## BIDIRECTIONAL INTERFACE

output of 153.6kHz (9600 baud). This 153.6kHz signal is then fed to a binary ripple counter which provides all the other baud rates with the exception of 110 baud. The latter is derived by dividing the frequency for 1200 baud (19.2kHz) by 11 to give 1745Hz.

One point about the oscillator which should be kept in mind when setting the unit up for the first time has to do with the capacitors. These may have to be adjusted to provide reliable operation. A value of 18pF has been given for one of them while the other has not been allocated a value. We found that leaving this capacitor out altogether to start with is a good idea, and then if the oscillator does not run to gradually increase the value from zero until stable operation is achieved.

### INTERFACES

Three types of output circuit have been incorporated into the design of the project, TTL, RS-232C and 20mA current loop.

The TTL interface consists of no more than direct connections to the serial input and output lines of the UART. The 20mA loop is driven on the output side by transistor Q1 operating in open-collector mode with a suitable current-limiting resistor. The input side (receiver) of the 20mA loop is an opto-coupler followed by a transistor inverter Q4.

The transmitter section of the RS-232C interface consists of transistor Q2 connected to the output of the current loop interface, to provide the  $\pm 12V$  swings required for the RS-232C standard.

The receiver for the RS-232C interface is transistor (Q3) with diode protection at the base, to clip the negative half cycles of the data stream.

In normal use the user would just set the unit for the type of interface required; TTL, 20mA or RS-232C, and set the UART to operate at the required baud rate. This then only leaves the address for the unit to be programmed with either DIL switches or with links.

### CONSTRUCTION

We designed a printed circuit board on which almost all of the components are mounted. It is coded 81si3 and measures 210 x 121mm. We have assumed a reasonable degree of soldering skill on the part of the constructor, and therefore have used a rather dense layout. The main requirement here is a small tip on the soldering iron. Some of the tracks on the board are rather narrow and require care when being soldered.

Before we go into the construction there are a few points worth noting. Firstly, you will notice that the price estimate does not include such things as the case, the 37-way connector and the DIP switches. These are all optional ex-

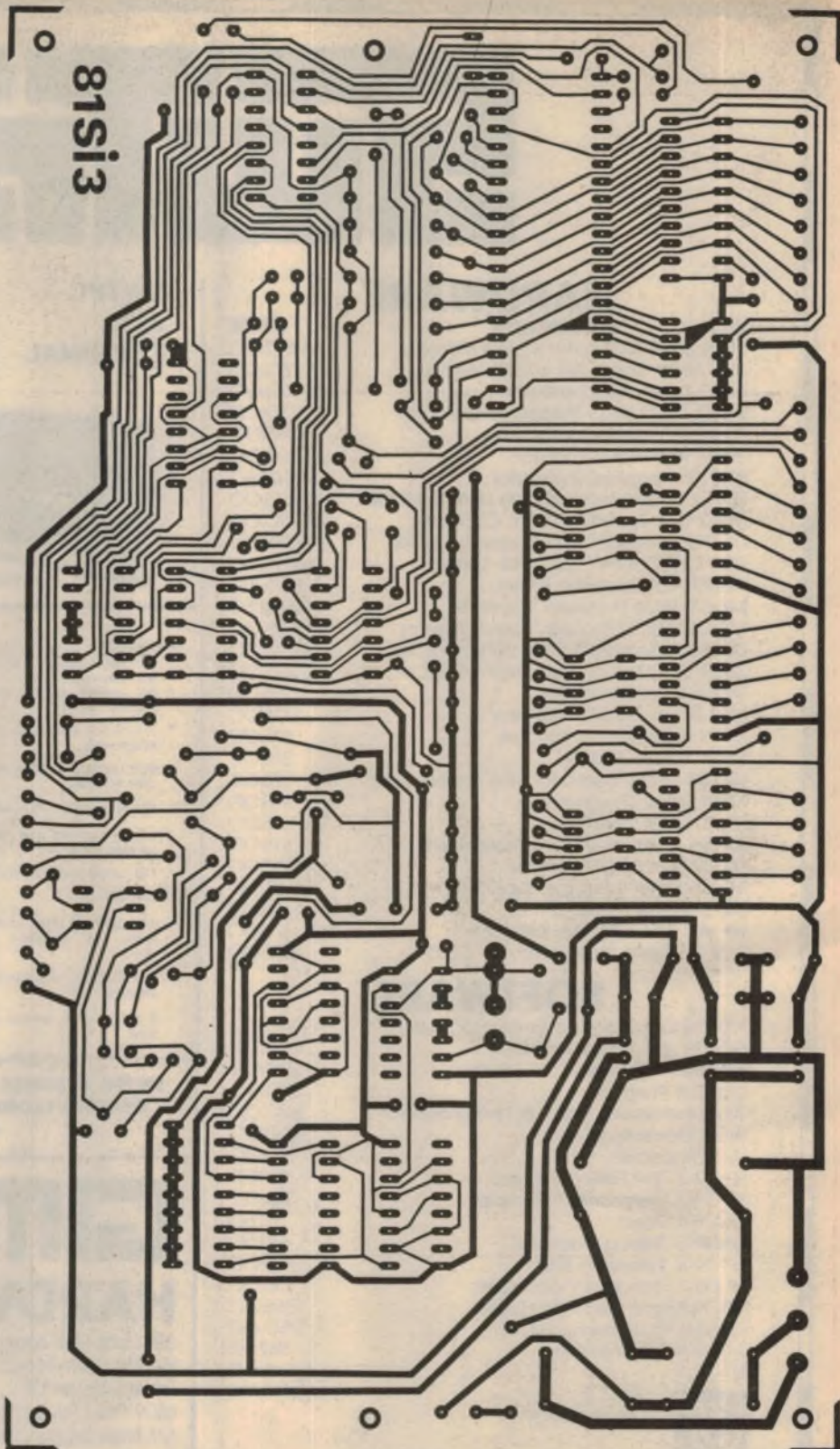

The PC pattern is reproduced above, shown actual size.

tras which can be fitted, depending on the amount of money you wish to spend and flexibility you require. The 25-way connector can also be left out if compliance to the RS-232 standard connection is not important in your particular application.

There are basically two versions of the

unit which can be built. The first is the TRS-80 version which also serves all other 8080 and Z80 based systems since it allows the interface to be either memory or I/O-mapped, while the second version, using a few less ICs, is dedicated to operating in the computer's I/O space.

# SWTPC

## HARDWARE

KIT	DESCRIPTION	PRICE
S/O9	6809 Computer w/128K Memory	\$3450.00
/O9	6809 Computer w/56K Memory	\$1760.00
6540	Printer 132 characters	\$2350.00
S/OO	S/O9 W/O Process/Mem card	\$730.00
DT-80	12" Terminal w/monitor	\$985.00
8209	Terminal w/monitor	\$1050.00
8212	12" Terminal w/monitor	\$1175.80
DT-5	2 double track double density 1-9 MB	\$1950.00
DMF2	Disk System w/2.5m Capacity	\$2750.00
D5-2	double side/double density 720KB	\$1395.00
CDS-1	Winchester Hard Disk System	\$4835.00
PR-40	Alphanumeric Printer	\$275.00
MP-O9	6809 Processor Board Kit	\$192.50
MP-O9A	6809 Process/Board (Assem)	\$225.00
D5-2	double side/double density 720KB	\$1395.00
3809	128K Memory Expansion for S/O9	\$2305.00
MP-LA	Parallel Interface	\$65.00
MP-L2	Dual Parallel Interface	\$135.00
MP-N	Calculator Interface	\$75.00
MP-P	Power Supply	\$76.00
MP-QP	Circuit Board for SP-3 (assembled)	\$78.00
MP-R	Eprom Programmer	\$75.00
MP-S	Serial Interface	\$55.00
MP-SA	Serial Interface (Assembled)	\$78.00
MP-S2	Dual Serial Interface	\$135.00
MP-SX	Serial Interface Expansion	\$27.50
MP-T	Interrupt Timer	\$62.25
MP-WP	IBM Selectric Interface	\$76.00
S-32	Universal Static Memory Card	\$125.00

## SOFTWARE

ASMO9	Optimizing Assembler (5" or 8")	\$110.00
Flex O9	ver. 2.6/5 w/manual	\$38.50
Inventory	Program	\$110.00
Mail List	Program	\$110.00
Word processing	Editor & Text processor	\$165.00
Word Processing	Editor	\$110.00
Text processor		\$66.00
SP-O9-2	Text Editing System	\$38.50
SP-O9-3	Mnemonic Assembler	\$44.00
SP-O9-4	Basic	\$71.50
SP-O9-5	Debug Package	\$82.50
SP-O9-6	Extended Basic	\$110.00
SP-O9-7	Standard Precompiler	\$55.00
SP-O9-8	Extended Precompiler	\$55.00
UniFLEX	Multi-tasking BASIC	\$150.00
SP-O9-10	Sort/merge	\$82.50
SP-O9-11		\$66.00
	* UniFLEX - Prices ex Sydney	\$495.00



PRICES SUBJECT TO ALTERATION  
EXPORT PRICES UPON APPLICATION

ALL HARDWARE PRICES PLUS 15% ST WHERE APPLICABLE

## SWTPC 8212 TERMINAL



(ASSEMBLED IN AUST)

### FEATURES

- Over 140 software driven functions
- 82 X 24 or 82 X 20 screen format — software selectable
- High resolution 7 X 12 matrix characters — P-31 green phosphor
- Upper/lower case character set — plus graphics character set
- 56-key alphanumeric keyboard — plus 12-key cursor numeric pad
- Internal editing functions — insert, delete, scroll, roll, slide, etc.
- Parallel printer I/O port
- 50 to 38,400 baud operation — programmable
- Cursor type, cursor position, print control characters, protected fields, shift inversion, dual intensity and many other features

**\$1,175.80**

### FEATURES

- 96 displayable characters, upper/lower case
- 32 control codes displayable in Monitor mode
- 7 X 9 dot matrix plus 2 lower case descenders
- High resolution display monitor, non-glare screen
- Typewriter-style keyboard
- 14-key numeric pad plus 8 special function keys
- Full cursor sensing and addressing
- Line editing
- Programmable video attribute: high intensity (or underline or reverse video)
- EIA RS-232C and 20mA current loop interface
- 8 transmission speeds up to 9600 baud

## DT-80



**\$985.50**

Bidirectional auxiliary RS-232C interface  
Block mode feature for form fill application

**SWTPC BUSINESS SOFTWARE: ACCOUNTS RECEIVABLE, GENERAL LEDGER, INVENTORY, PAYROLL, MAIL LIST AND MANY OTHERS.**

# GIMIX inc.

## HARDWARE

32K Static Ram Board	\$580.00
16K Static Ram Board	
Expandable to 32K	\$368.00
6809 Plus CPU Card	\$532.00
5/8 Single Density Controller Board	\$249.00
5" Double Density Controller Board	\$383.00



## SOUTH WEST TECHNICAL PRODUCT CORPORATION

(COVERING AUSTRALASIA)

7a BURTON STREET, DARLINGHURST, N.S.W. 2010.  
P.O. BOX 380 DARLINGHURST N.S.W. 2010. PHONE (02) 357 5111

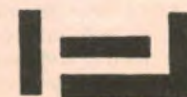

## PARTS LIST

### SYSTEM-80 VERSION

- 1 printed circuit board 210 x 121mm (81si3)
- 1 1000uF/25VW PC electrolytic capacitor
- 1 2200uF/25VW PC electrolytic capacitor
- 6 10uF/25VW tantalum capacitors
- 3 0.1uF metallised polyester capacitors
- 1 18pF ceramic capacitor
- 1 6.8pF ceramic capacitor (\*see text)
- 1 x 25-pin "D"-type socket
- 1 x single-pole, single-throw miniature toggle switch
- 1 transformer 240V/24CT, A&R 6672A or Ferguson PL24/20VA

### RESISTORS

- 1 x 10M $\Omega$ , 1 x 68k $\Omega$ , 1 x 33k $\Omega$ , 3 x 10k $\Omega$ , 13 x 4.7k $\Omega$ , 2 x 1.5k $\Omega$ , 1 x 1k $\Omega$ , 1 x 180 $\Omega$ , 1 x 470 $\Omega$ /2W

### SEMICONDUCTORS

- 2 x 1N914, 1N4148 diodes
- 4 x 1N4002 or similar diodes
- 2 x BC547 NPN transistors
- 1 x BC337 NPN transistor
- 1 x BC557 PNP transistor
- 1 x red LED and mounting bezel
- 1 x LM340T-5 voltage regulator
- 1 x LM340T-12 voltage regulator
- 1 x LM320T-12 voltage regulator
- 1 x MM5303, AY31014A, AY31015, S1883, TMS6011, AY-S-1012 UART
- 1 x 74LS85 4-bit magnitude comparator
- 1 x 74LS04 hex inverter
- 1 x 74LS27 triple three-input NOR gate
- 1 x 74LS132 quad 2-input Schmitt NAND gates
- 1 x 74LS245 octal bus transceiver
- 1 x 74LS139 dual 2-line to 4-line decoder
- 2 x 4526 programmable 4-bit binary down counters
- 1 x 4049 CMOS hex inverter/level translator

- 1 x 4040 12 stage binary counter
- 1 x 4069 CMOS hex inverter
- 1 x 2.304MHz crystal
- 1 x 4N28 opto-isolator

### ADDITIONAL PARTS FOR TRS-80 VERSION

- 2 x 74LS85 4-bit comparators
- 8 x 4.7k $\Omega$  resistors

### OPTIONAL COMPONENTS

- 3 x 4-way DIL switches
- 1 x 9-way DIL switch
- 1 x 6-way DIL switch (for links 20-25)
- 1 x Horwood case 76 x 250 x 255mm (including handles)

### MISCELLANEOUS

- 1 x 2-way plastic insulated terminal block
- 1 x "P"-type cable clamp
- 1 x rubber grommet
- 1 length three core cable, mains rated
- 1 x 3-pin mains plug
- Screws, nuts, washers, hookup wire etc.

bits in the data byte together and add one (1) to the result if the sum is odd. If the sum is even, nothing is added. This parity bit is then stripped off at the other end after the data has been checked. The opposite is true in the case of odd parity.

NDB1 and NDB2 are used to select the length of the data byte that is to be received or transmitted. These two lines are programmed in binary to select any one of four possible word lengths, these being 5, 6, 7 and 8 bits.

The NSB line sets the number of stop bits, used at the end of each word to indicate the end of a character. This line will select either one or two stop bits, with 1½ being selected when the word length has been set to five bits.

The last line, CS is used to latch all of the above signals into an on-board register, but we have just tied the line permanently high in our unit, via link LK25.

The other signals have also been provided with links, which when soldered to the board will pull the respective lines low. A table setting out the programming of these options appears elsewhere in the article.

The final signal to be discussed is the reset line. The UART should be reset before it is first used, and it should also be reset by the reset signal from the computer. We have provided two links (LK16 and 17) which are used to select the sense of the reset signal, ie either active high or active low. One or other of the links will be soldered to the board, depending on the system that the interface is operated with.

For both the System 80 and TRS-80 the reset signal is active low, which means it has to be inverted before being applied to the UART's reset input. This is done by closing link LK17, leaving LK16 open. Other computers may have active high reset lines, in which case they will be of the right polarity to reset the UART. In this case LK16 would be closed and LK17 left open.

We estimate that the current cost of parts for this project is:

Minimal System **\$60**  
excluding case and optional components.

Full System **\$120**  
including case, optional components, and connectors.  
These prices include sales tax.

### BAUD-RATE GENERATOR

The third section of the interface is the baud-rate generator. Our baud-rate generator uses relatively few components when compared with other designs, the only exception being the single chip versions. The drawback with the single chip baud rate generators is the special crystal required, not to mention cost and availability.

We took a look at several designs for discrete generators, but most of these were rather complex and required a

minimum of six ICs. After taking a closer look at some commonly available crystals, we came across the magic figure of 2.304MHz. This is the frequency of the crystal that was used in the Playmaster AM/FM tuner described in November, December 1979 and January 1980.

The reason that this is such a magic number is simple to explain. We decided that the highest baud rate that would be required would be 9600. Keeping in mind that the clock frequency to the UART must be 16 times the baud rate, it turned out that for a 9600 baud transmission we would need a clock of 153.6kHz. It just so happens that when 2.304MHz is divided by 153.6kHz, we end up with a convenient number of fifteen (15). Therefore, dividing the crystal frequency by 15 results in the exact frequency required for 9600 baud.

All the other baud rates, with the exception of 110 are then further derived from this frequency of 153.6kHz by successive division by two. The frequency required for 110 baud is 1.76kHz and it turns out that dividing the frequency for 1200 baud by 11 gives us 1745Hz which is so close to the exact frequency that it doesn't matter.

In all, four ICs were used to implement the baud-rate generator IC7 (4069), a hex-inverter package for the oscillator, IC6 and IC9 4-bit programmable down-counters, and IC8 (4040) a binary ripple counter.

The oscillator is a standard three-inverter design consisting of IC7a, b and c with the output buffered by IC7d. This is fed to the clock input of IC6 which is programmed to divide by 15, giving an

character, this being the RDA line which is connected to RD0 on the output bus. This flag is interrogated by the computer to see if the UART has a character ready for collection. The flag is in fact part of the Status Word, which is enabled onto the data bus by a low going signal at the SWE input. If the flag is set, the computer will pass a signal to the RDAR and RDE lines via the address decoder and reset the flag, as well as reading the data onto the bus.

Once the data has been read onto the bus, the UART is ready to receive the next character. This procedure is repeated for each character received.

The third control line, TDS, is used to load the transmitter data register with the data to be transmitted, which appears on the bus at the time this line is pulsed low. Here again we have to first check that the register is empty before we load new data into it. This is done by again reading the status word and testing bit 7, which is the TBMT (transmit buffer empty) flag. When this flag is high, the UART is ready for the next character to be transmitted.

Taking a closer look at the actual hardware in this section we can see that the control signals come from the address decoder section. Two of these control lines, SWE and RDE are connected to the inputs of a two-input Schmitt NAND gate and then to another NAND gate connected to function as an inverter. The purpose of this is to enable the outputs of IC4 whenever a read operation is taking place. The first NAND gate, IC13d is in fact being used as a negative-logic OR gate, so that if either RDE or SWE go low, the output bus will be enabled.

The two clock inputs to the UART are connected together since we wish to have the transmitter and receiver both working at the same baud rate. These inputs are fed from the output of the baud rate generator, the next section to be discussed.

It is worth noting at this stage that the clock to the UART is passed through inverter IC15d. This inverter is used as a level translator to convert the 12-volt clock signal from the baud rate generator to a 5-volt signal that the UART can use.

Six other lines to the UART are important to its operation. These are used to program a set of operating parameters into the UART so that it "knows" what to do. These signals are NPB (no parity bit), NSB (number of stop bits), NDB1 and NDB2 (number of data bits per character), POE (odd or even parity select) and CS (control strobe input).

The NPB line is used to select parity for both the transmitted and received data byte. Parity, by way of clarification, is an extra bit added to the data received or transmitted and used as an error check. This signal, together with the POE line are used to select the type of parity to be applied to the data. If even parity is selected, then the UART will add all the

LK#	System-80		TRS-80		Function
	Printer Operation	RS-232 Operation	Printer Operation	RS-232 Operation	
1			V	V	Selects memory mapped operation
2	V	V			Selects I/O mapped operation
3					Used if memory mapped (except TRS-80)
4	V	V			Used if I/O mapped (except TRS-80)
5	V	V			Used with all systems except TRS-80
5A			V	V	Used only with TRS-80 systems
6					Address decode (Selects A2 = high)
7					Address decode (Selects A2 = low)
8					Address decode (Selects A1 = high)
9					Address decode (Selects A1 = low)
10			V	V	Used to select port position (see text)
11	V	V			Used to select port position (see text)
12	V	V			Used to select port position (see text)
13			V	V	Used to select port position (see text)
14	V		V	V	Closed when printer address selected
15		V		V	Used for normal RS-232 & 20mA loop
16					Selects positive going reset from computer
17	V	V	V	V	Selects negative going reset from computer
18		V		V	Selects RS-232 Interface
19					Selects 20mA loop interface
20					Selects parity checking
21	V	V	V	V	Closed = 1 stop bit; open = 2 stop bits
22					Selects word length (see table below)
23					Selects word length (see table below)
24					Selects parity sense: open = even; closed = odd
25	V	V	V	V	Enables control word

LK22	LK23	Word Length
Closed	Closed	5 bits
Closed	Open	6 bits
Open	Closed	7 bits
Open	Open	8 bits

*These two tables should be used when programming the link options which determine the operating environment for the interface unit. (see text).*

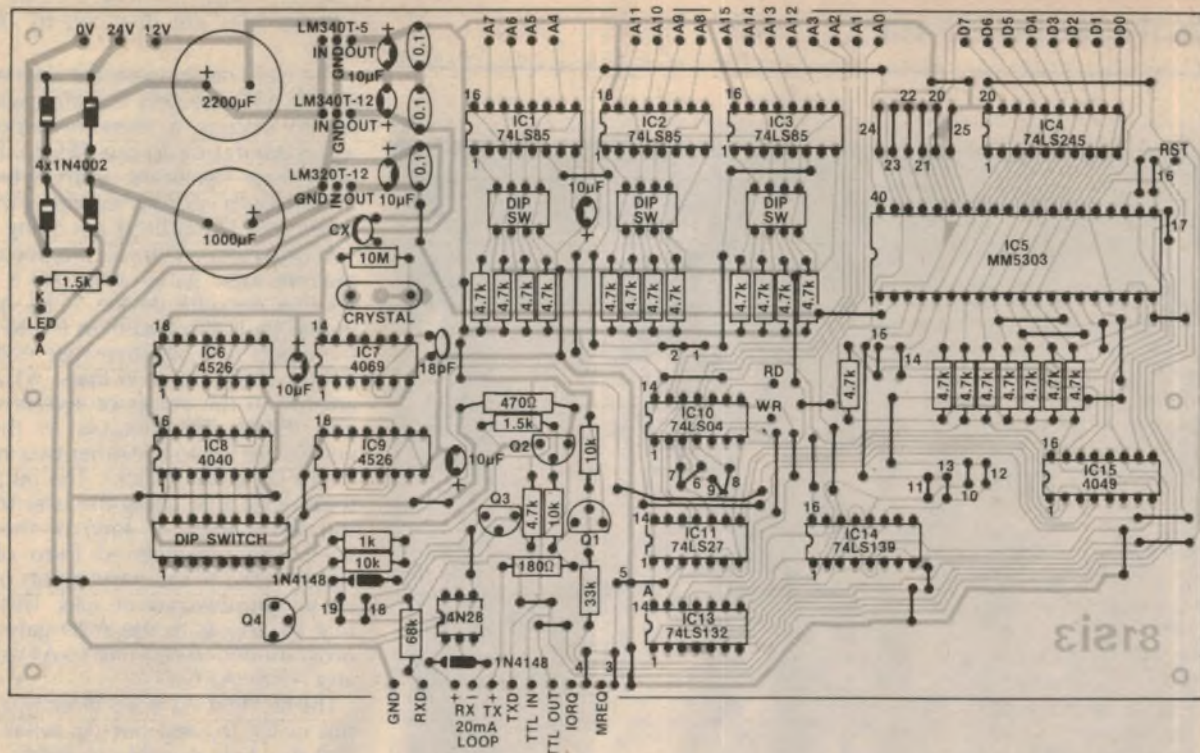

The overlay diagram, shown above should be used to locate the components on the printed circuit board. Note that there is one insulated link on the board, shown curved, just above IC11.

a common clock.

The UART we have used is the MM5303 from National Semiconductor, but equivalents are made by other manufacturers under a variety of different part numbers. This device has two sets of data lines; one for transmitted data (TD) and another for received data (RD). There are also a number of other lines that are used for UART control, for parameters such as word length, number of stop bits and odd or even parity. Pins 13, 14, 15, 19 and 22 are used to indicate the status of the UART, which allows us to check whether the UART is ready to receive or transmit data.

There are two clock inputs to the UART: one for the receiver and one for the transmitter. The clock frequencies at these inputs have to be 16 times the desired baud rate. If for example a baud rate of 1200 bits per second were to be used, then the clock frequency would have to be  $16 \times 1200$ , which gives a frequency of 19.2kHz.

The data bus from the computer is connected directly to the TD inputs of the UART while the RD outputs of the UART are fed to the data bus via an octal three-state buffer IC4.

The status outputs of the UART are also three-state, and we make use of this feature by connecting the outputs. The status lines and the data outputs are independently enabled when interrogated by the computer, but more about this later. IC4 is used to avoid bus conflicts between outputs and inputs to the UART.

The third input to IC11a is controlled by another set of link options that are also used to determine the addressing format for the interface unit. One of the two lines, MREQ (memory request) and IORQ (input/output request) is used to set the interface in either memory or I/O space. These lines are enabled by links LK3 and LK4 respectively. Two other links, LK5 and LK5a serve a special purpose when the interface is connected to a TRS-80 system, but let us for the moment assume that the interface is to be connected to the System 80.

Since the RS-232C interface for the System 80 is located in the I/O map, the links should be programmed to set up this condition. In this case we close links LK2, LK5, and LK4. LK2 sets the address decoder into the 8-bit "mode", while LK4 and LK5 set the device into I/O space.

The output of IC11a, which is a low-going pulse, is fed to one of two inputs on each of IC13a and IC13b, these being two-input Schmitt NAND gates, type 74LS132. Two other signals, WR and RD, are inverted by IC10e and IC10f respectively, and fed to the remaining inputs on IC13a and IC13b. The output of IC13a is connected to the enable input of one of the two line to four line decoders in the 74LS139 package, IC14. When this input goes low, a valid address has been decoded, and a write-operation is in progress. The same applies to the output of IC13b, which is used to enable the second decoder in IC14, but in this case a read-operation is being performed when this line goes low.

The B-inputs to the two-line-to-four-line

decoders (IC14) are connected to ground since we only need to decode two out of the four possible output states. The A0 line is then used to decode these two states when the respective decoders are enabled by a low-going pulse on the G-inputs.

When the interface unit is used with the TRS-80, link 5A must be installed to ground input pin 3 of IC10a. In other versions of the unit this pin is driven either by the MREQ (memory mapped version) or the IORQ signal (for the I/O mapped version). On the TRS-80 these two signals are gated together with the RD and WR signals, and appear on the expansion connector simply as RD and WR (Read and Write), which are fed to IC13 via inverters IC10e and 10f. MREQ and IORQ signals do not appear on the expansion connector of the TRS-80.

The outputs from the address decoder section discussed earlier are used to enable certain functions of the UART. Three inputs are used to control the operation of the UART: the SWE (Status Word Enable), TDS (Transmitter Data Strobe) and RDE (Receiver Data Enable) and RDAR (Receiver Data Available Reset) which are tied together. To understand how the UART handles the data present on the bus we must first look at the function of each of these signals.

The RDAR and RDE lines are connected together and treated as a single line which is used to (a) reset the data available flag and (b) enable the output data lines. The receiver sets a flag as soon as it has received a whole

## BIDIRECTIONAL INTERFACE

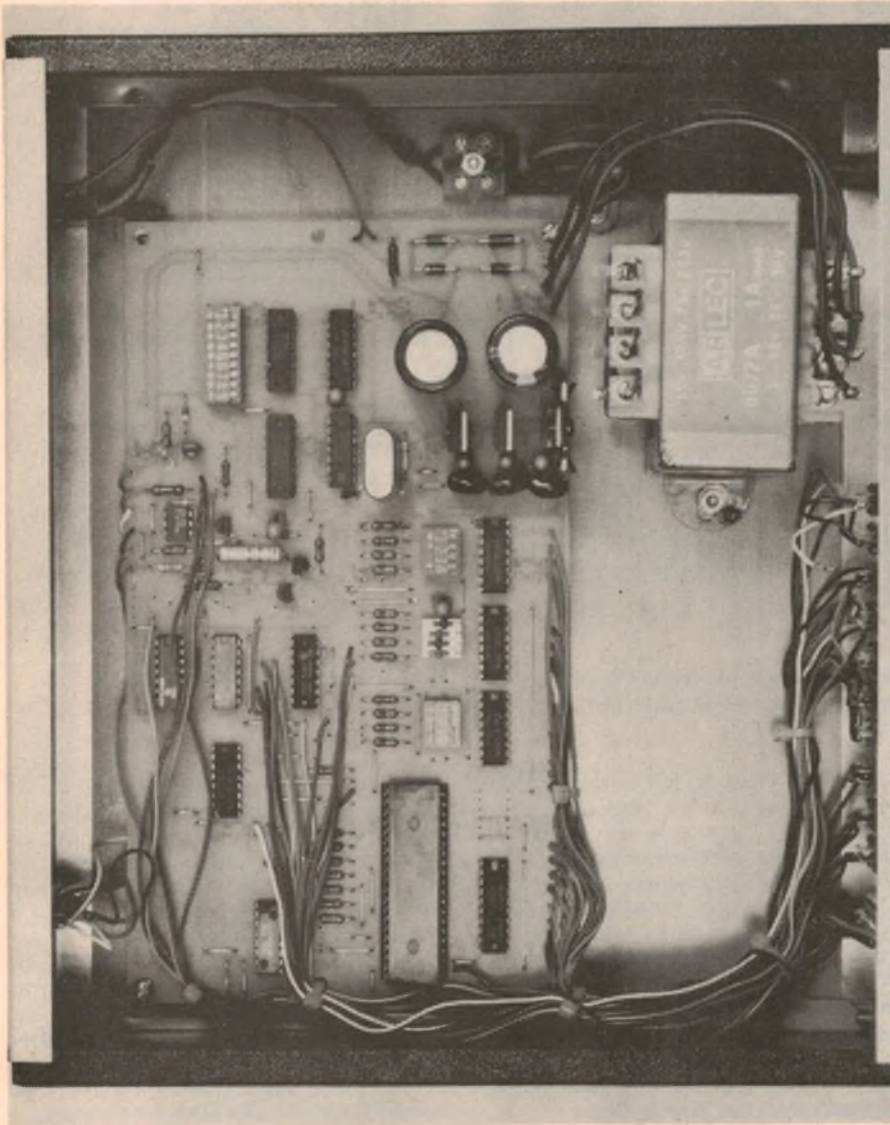

This photograph shows the method of construction used in our prototype unit. The switches on the rear panel are optional, as mentioned in the text.

In the TRS-80, address 37DF is used for both input and output of data, while address 37DE is used for UART control and status information. In general, the only programs that will be affected by these differences are those that turn the computers into data terminals for use with time-share networks.

Keeping these differences in mind we can now turn our attention to the circuit diagram for the new interface unit.

It can be seen from the circuit that all sixteen of the address lines have been brought to the board, together with the eight data lines. Other signals used by the interface unit are the memory and I/O read and write control lines, MREQ (memory request) and IORQ (input/output request) lines and the master reset line.

The interface circuit can be divided into four distinct sections: address decoding, parallel-to-serial and serial-to-parallel conversion (the UART), baud-rate generator, and finally, interfaces. We will take a look at each of these sections in turn and then tie them all together.

### ADDRESS DECODING

The address decoder is used to decode both memory addresses as well as I/O addresses so that the unit can be used with both the System 80 and the TRS-80 machines. Sixteen address lines are decoded by a series of comparators to produce the unique addresses required by the computer for its communications. The 12 most significant address lines are decoded using three 4-bit comparators

(74LS85), while the four least-significant address lines are decoded by discrete logic.

The eight most significant address lines (A8 to A15) are only required when we are to decode a memory address, as when interfacing to the TRS-80, but the eight least significant address lines are used in both versions for either memory address or I/O address decoding.

Address lines A1 to A3 are decoded by discrete logic gates while A0 is fed to another decoder device, IC14. A3 is inverted by IC10b and then fed to one of the inputs of a negative-logic AND gate, IC11b. The other two lines, A1 and A2 are fed to the inputs of inverters IC10c and IC10d. The outputs of these inverters are fed to the other two inputs of IC11b via a pair of links. The purpose of these links is to allow the user to select the sense (high or low) of these two lines. The non-inverted form of these signals is fed to the same inputs of IC11b via yet another pair of links. This means that the inputs to the AND gate can be programmed to respond to A1 or A1-bar and A2 or A2-bar.

The fact that A3 is fed directly to the input of IC11b, and not via a link means that it is only possible to locate the address of the interface in increments of eight.

The output of IC11b is inverted by IC15a and then fed to one of the inputs of another negative logic AND gate, IC11a.

Address lines A4 to A7 are decoded by a 4-bit comparator, IC1. The A=B output is fed to the cascade input of IC2, another 4-bit comparator, but it is also made available to a second input to IC11a via a link, LK2.

The last eight address lines, A8 to A15 are decoded by the other two 4-bit comparators, IC2 and IC3. These devices are cascaded by tying their A=B inputs and outputs together in daisy-chain fashion. The final A=B output, pin 6 of IC3, is fed to IC11a via link LK1. Links LK1 and LK2 are used to select either memory mapped or I/O mapped operation but there are other links to be programmed as well, as we shall see.

Well, that just about covers the address decoding section. It may appear a little strange at first because it is designed to operate in a memory mapped as well as an I/O mapped environment.

### PARALLEL-TO-SERIAL CONVERSION

The next section we will look at is the serial-to-parallel interface unit, or UART (Universal Asynchronous Receiver Transmitter). This is a device designed to allow asynchronous communications to take place between a serial data terminal and the parallel data bus of a computer.

The term asynchronous refers to the device's ability to transmit and receive information without being synchronised to the other end of the system. In other words, the two parts of the system, the computer and the terminal, do not share



# Both sides now

North Star Announces —

**Double Density x 2 Sides = Quad Capacity!**

The North Star Horizon now delivers quad capacity by using two-sided recording on new mini drives! That's 360,000 bytes per diskette! A four drive North Star system accesses over 1.4 megabytes of information on-line! Think of the application flexibility that so much information storage can give you!

North Star has quadrupled the disk capacity of the Horizon computer but prices have increased a modest 15 percent. On a dollar per byte basis, that's a bargain that is hard to beat!

The proven North Star disk controller was originally designed to accommodate the two-sided drives. North Star DOS and BASIC are upgraded to handle the new capacity, yet still run existing programs with little or no change. Of course, single sided diskettes are compatible with the new disk system.

**CATALOGUES \$1.00 & FREE SYSTEM ANALYSIS**



North Star Horizon Computer

Prices (with 32K RAM):

Horizon-1-32K-Q \$2995

Horizon-2-32K-Q \$3595

Horizon-1-32K-D \$2695

Horizon-2-32K-D \$3095

PLUS TAX

Get both sides now! Quad capacity is available from your North Star dealer.

**NorthStar<sup>★</sup> Computers**

Postal Address: 54 Power St, Hawthorn 3122  
Telex: AA38466. Phone 819 2411.

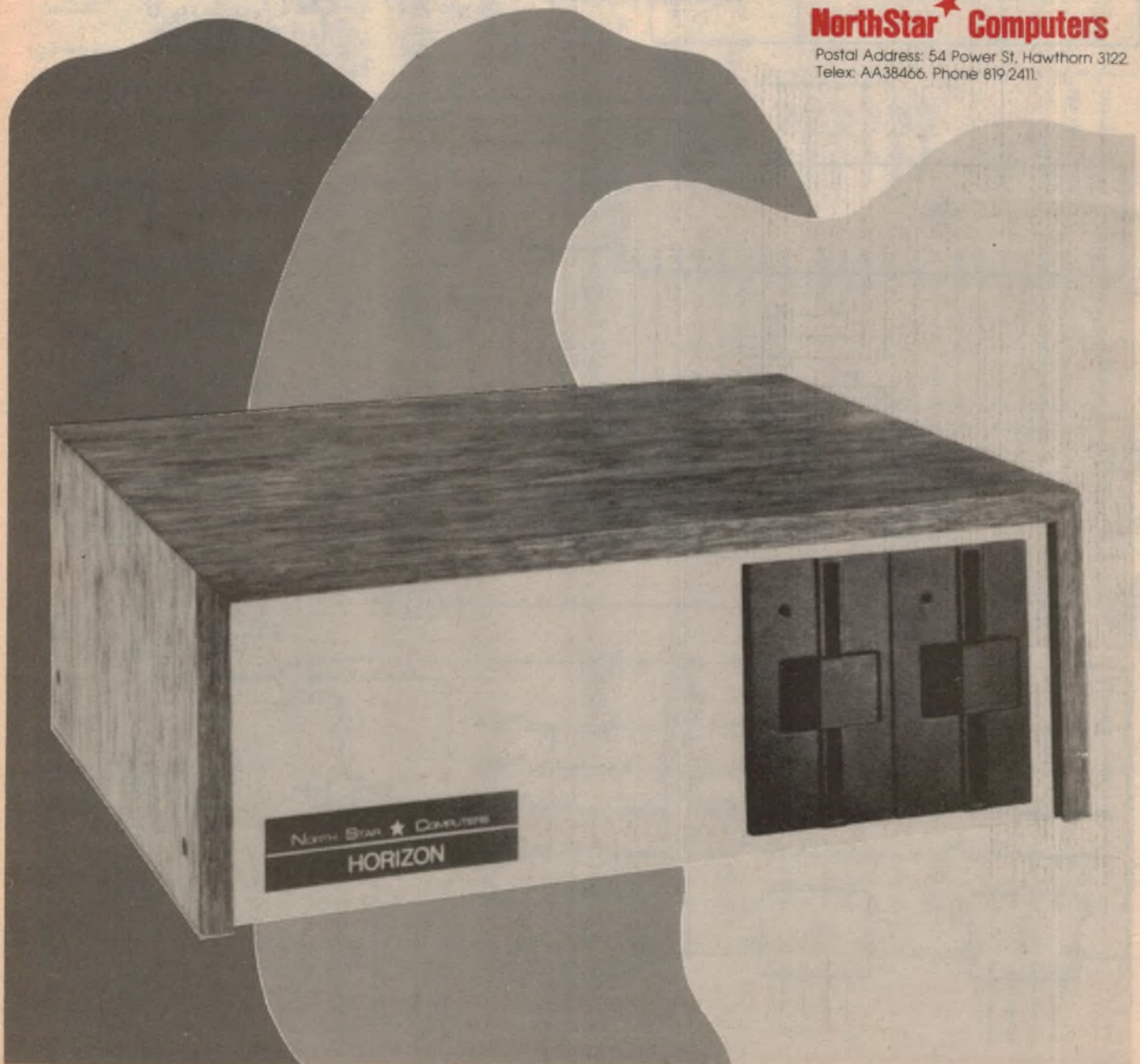

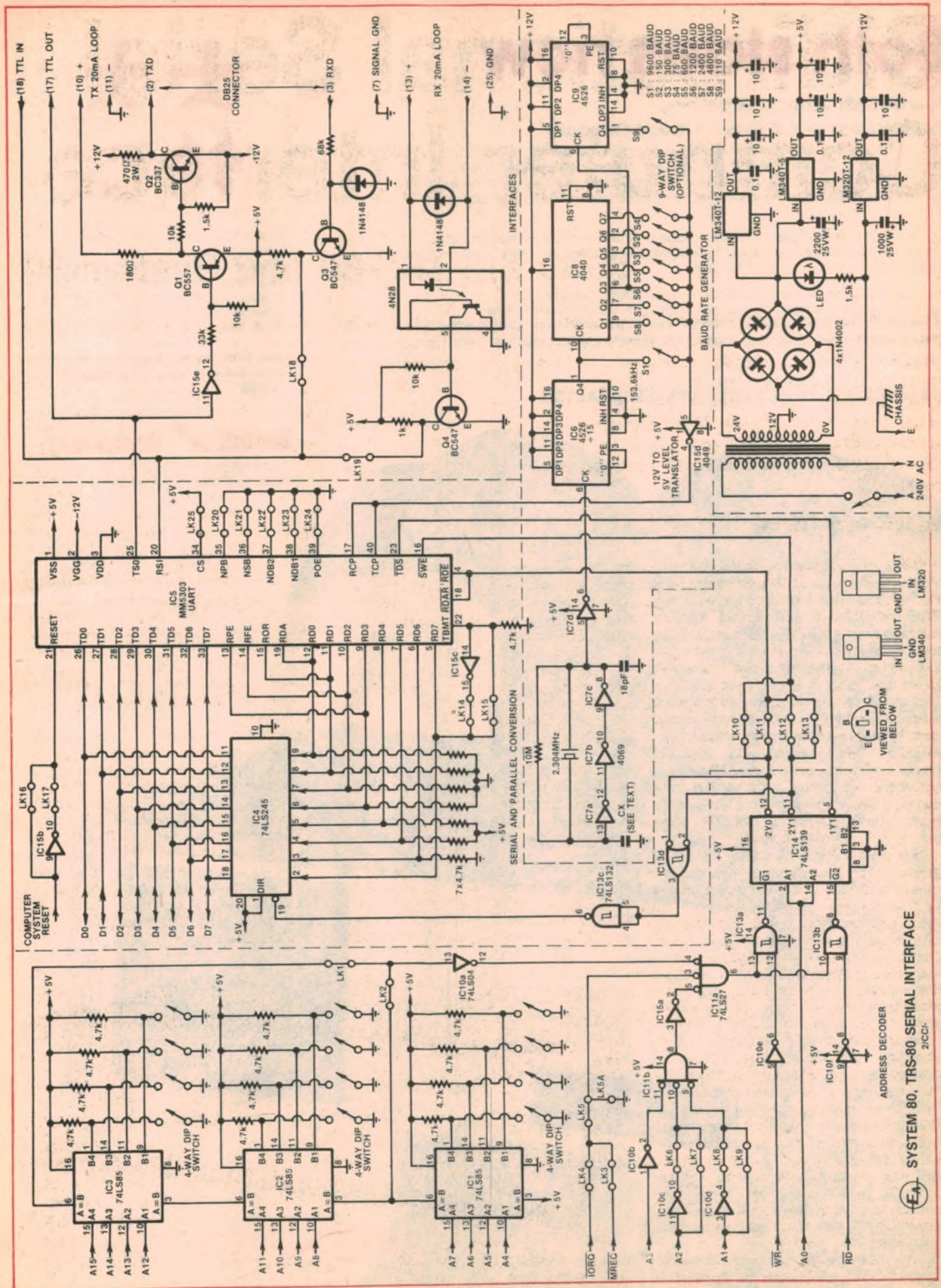

# Bidirectional Serial Computer Interface

## suits the TRS-80 and System-80

The System-80 and TRS-80 computers are extremely popular machines, particularly in light of their sales figures. One result of this popularity is the availability of a host of add on peripherals made by manufacturers other than Radio Shack or Dick Smith Electronics. Unfortunately most of these are designed for use with only one or other of the two systems. This problem has been overcome to some extent with our new bidirectional serial interface. It will allow both of these systems to be used with serial printers, modems and remote terminals.

by GERALD COHN

Although designed primarily for use with System 80 and TRS-80 computers, the interface unit will interface with any 8008, 8080 and Z80 based system. Another major feature is the range of options available to the user. For example, it is possible to place the unit in memory space and treat it like a memory location, or alternately it can be placed in I/O space operating as a true input/output port. It supports three types of interface: RS-232C, 20mA current loop, and TTL levels. It also has an on-board baud-rate generator supporting eight of the most popular baud rates, plus 75 baud for those people wishing to use their computers in RTTY applications.

One great advantage of this unit is its ability to be interfaced to the parallel printer interface port, whether memory or I/O mapped, allowing the use of a serial printer. This means that the existing printer driver routines can be used. The only exception is with those printers that have to be issued with a separate linefeed after a carriage return, but this is easily overcome with the aid of a simple software patch, as we shall see later.

Other uses for the interface include program and data exchange via a modem, remote terminal operation and machine control via a serial data link.

We have not included all the handshaking signals for modem control since their usefulness did not warrant the extra circuitry. (It is a simple matter to switch between transmit and receive modes manually in the case of an acoustic modem such as the one presented in the September 1980 issue of "Electronics Australia".)

If remote terminal operation is desired, then any TTY or VDU can be hooked to

the interface unit via a serial data cable, a short software routine installed in the top of memory space and you're in business. A perfect application for this would be a factory environment where the use of a computer is desired, but the dirt problem makes this impractical. Here a rugged TTY or similar terminal could be used while the computer itself is located in another, cleaner part of the building.

Perhaps you have numerically controlled machinery that requires data to be updated from time to time. This could all be done from one central point via a serial data link.

The number of applications for a device such as this are only limited by imagination. The great news however is that there is now a unit that can be used with all of the most popular computers

available, since it is not dedicated for use with only one machine.

When it came to designing the interface we encountered a number of problems, not the least of which are the differences in hardware between the two machines. Although the TRS-80 and the System 80 are software compatible, they are not hardware compatible.

The first difference shows up when a printer is to be hooked into the system using one of the low cost interfaces that plugs directly onto the expansion bus. The printer port on the TRS-80 is "memory mapped", and located at memory address "37E8" while the printer port in the System 80 is located in the I/O map at I/O address "FD". This difference would not normally show up since each of the systems "knows" where to find the printer when the LLIST or LPRINT commands are used, but if no expansion interface unit is used, it makes a lot of difference.

The other major difference between the two machines is in the addressing used for the RS-232C communications ports. The TRS-80 uses the two memory addresses "37DE and 37DF" whereas the System 80 uses I/O addresses "F8" and "F9". In the System 80, OUTPUT data to the UART is written to port F9, while INPUT data from the UART is read from port F8. Conversely, output information for UART control is written to port F8 while input information on UART status is read from port F9.

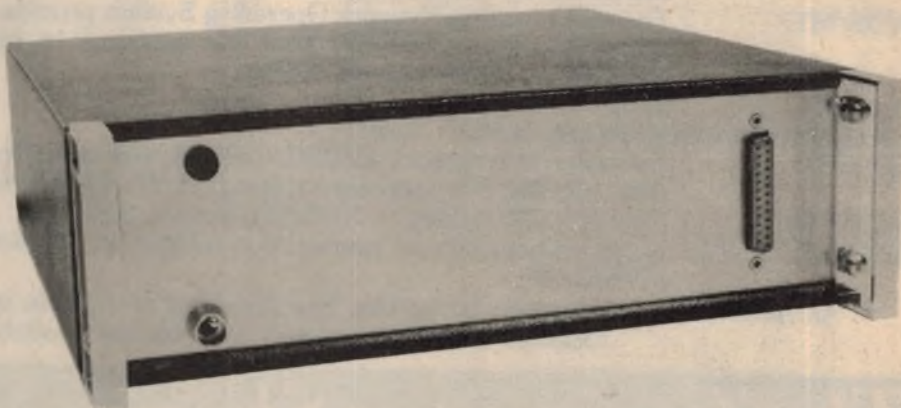

Above is a photograph showing the completed interface unit in a Horwood case, while on the right is the circuit for the unit.

# The M9900 16 Bit Computer

on the S-100 (IEEE) Bus  
with multi user capability

## M9900 CPU



The processor board of the M9900 family: Includes TMS9900 16 bit processor with hardware multiply and divide, complete S-100 bus interface supporting both 8 and 16 bit memories, vectored interrupts, DMA, and both S-100 I/O and bit-addressable M9900 I/O. Assembled & tested: \$750, Kit: \$600. This price includes the Disc Executive Operating System, BASIC, Edit, Assembler, Linker, Utilities and Word Processing.

## PROM/RAM



The board includes 2K bytes of PROM, 1K bytes of RAM, a serial I/O port with programmable baud rate, and programmable real time clock. The board provides room for up to 8K bytes of user PROM. This board is supplied with debug monitor and disc boot in PROM. Assembled: \$400, Kit: \$300.

## FDC-2

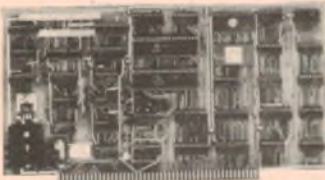

The Teletek Disc Controller is a high performance (CP/M compatible) S-100 board which will handle up to four single or double density, single or double sided standard floppy disc units, regardless of CPU clock speed, with simultaneous seek. The FDC-2 will control all popular standard floppy disc units. Assembled and tested: \$450.

## 64K RAM

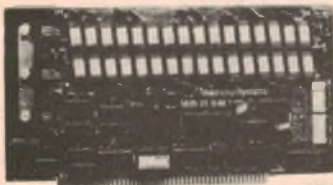

Our 64K RAM board provides 64K bytes of storage which operates in 16 bit mode, doubling system performance compared with 8 bit S-100 memories. The board includes programmable memory management hardware permitting bank selection in blocks of 4K bytes. Total system memory when using multiple 64K boards can be as large as 16 megabytes. Assembled and tested: \$1100.

## QUAD SIO



This board provides four independently programmable synchronous or asynchronous serial I/O ports, with speeds up to 19200 baud. Terminal or modem interfaces and four independent timers are provided (cables included). Assembled and tested \$400.

The minimum single user system, which includes comprehensive software, consists of the M9900 CPU, PROM/RAM, an S-100 compatible 64K RAM and the FDC-2 mounted in an S-100 card frame.

## SOFTWARE

Many users need no other Software than that supplied with the M9900 CPU. We provide the following advanced software.

### NOS/MT:

The multi tasking Network Operating System provides for multiple users, multiple printers, device spooling, UNIX-like files, file space of 16 billion bytes, multi level security and hierarchical directories etc. \$300.

### PASCAL:

\$150

### EXTENDED COMMERCIAL BASIC: \$150

### QBASIC:

Compiles almost all C-BASIC Code without modification and runs up to 11 times faster than popular 8 bit processors using CP/M. \$300 (manual \$20).

### GETCPM:

Converts CP/M files to NOS/MT format. \$20.

### USER MANUAL:

A comprehensive user manual is available for \$50 deductible from the purchase price of a M9900 CPU.

All hardware prices exclude Sales Tax. Specifications and prices subject to change without notice. Detailed specifications and price list are available on request.

# The Computer Shop

PO Box 429, Norwood, SA 5067  
Phone (08) 332 4780

# CIRCUIT & DESIGN IDEAS

We invite readers to submit circuit ideas and solutions to design problems. Explain briefly but thoroughly the circuit's operating principle and purpose. Sources of material must be acknowledged and will be paid for if used. As these items have not necessarily been tested in our laboratory, responsibility cannot be accepted.

## Up/Down Glide Tone Generator

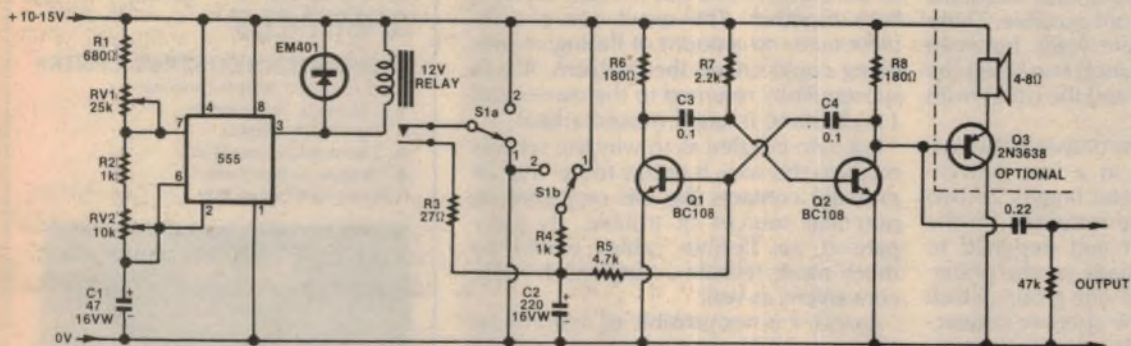

An up/down glide tone generator can be simply realised by combining the versatile 555 timer with a multivibrator. The circuit can produce a large variety of audible effects, which are obtained by varying the component values around both the 555 timer and the multivibrator.

By adding a simple output stage the device can directly drive a loudspeaker, and could be used as the "hooter" of a burglar alarm. However the current drain is greatly increased, so it is not recommended that it be powered from dry batteries when so modified.

Referring to the circuit it will be seen that Q1 and Q2 are connected in a normal free-running multivibrator configuration, except that R5, the base return resistor or Q1, is connected to the junction of C2 and R4.

Varying the DC potential across C2 will change the operating frequency of the multivibrator. Raising the voltage increases the frequency, lowering it vice versa. If the relay contacts are closed it will be seen that S1a determines whether the initial potential across C2 is zero or Vcc; at the same time S1b returns R4 to either Vcc or zero, ie the converse of S1a.

When the relay contacts open the potential across C2 gradually changes to the other state, the rate of change being determined by the time constant of C2 and R4; thus varying the frequency of oscillation, and providing the "glide", up or down as selected by S1.

The 555 timer is used as a free-running astable with its mark/space ratio adjustable by means of RV1 and RV2. Its output pulses are used to energise the relay which controls the multivibrator. With RV1 and RV2 set to give a

mark/space ratio of about 1:10, and with S1 in position 1, the resultant sound is similar to a warship's action siren.

As R4 serves to control the rate of frequency change, if this is made variable even more interesting sounds can result. In fact the permutations and combinations that may be obtained by varying C1, C2, C3, C4, R4, R5, R7, RV1 and RV2

are limited only by the user's imagination.

The modification for the simple output stage is to add a PNP transistor, Q3, connected as an emitter follower to drive the loudspeaker. Signal from Q2's collector is fed directly to the base of Q3, whilst its own collector is connected to the zero voltage rail.

(J. W. Monegal, Frankston, Victoria.)

## Simulation of ignition primary circuit pulses

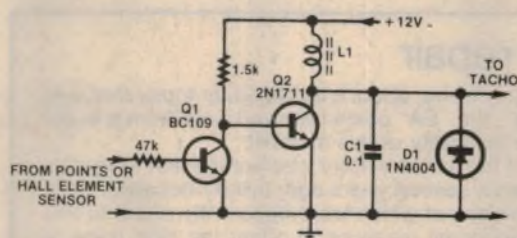

L1 = APPROX 300T THIN WIRE ON FERRITE CORE

It is fairly well known that the majority of electronic tachometers do not function satisfactorily with CDI ignition systems, being primarily intended for use with the conventional Kettering coil and condenser system. This circuit couples a CDI installation to a tachometer. Used with a Hall element sensor, it can provide tachometric readings on any rotating machinery such as diesel engines.

Q1 and Q2 form a simple switching circuit with Q1 normally off and Q2 normally on. L1, in conjunction with C1, functions as a dummy ignition coil, with

Q2 taking the place of the points in a conventional ignition system. When Q1 is turned on by positive pulses from the points arriving at its base, Q2 is turned off, which allows a large oscillatory voltage to be developed across L1, in the manner of a normal ignition coil primary circuit. D1 protects Q2 against reverse voltages.

(Editor's Note: When the circuit is triggered, Q2's collector potential may rise to well over 100V. Thus it may be desirable to utilise a transistor with a higher  $V_{ce}$  rating than the 2N1711 suggested.)

(J. Ekstrom, Moonee Ponds, Victoria.)

## THE SERVICEMAN — continued

So now it was time to look at the other side of the board, where I suspected I would find a dry joint. The board was held in with a self tapping screw in one corner, and a plastic clip in the opposite corner. When released, the board came away complete with ferrite rod and dial mechanism, leaving behind only the batteries, speaker, and a tone control switch.

At this point I had intended to switch the set on again and begin probing the other side of the board, but suddenly realised that this was not possible. There were only two flexible leads between the board and the cabinet, one being the negative battery lead and the other from the telescopic aerial.

Six other connections between the two sections were made in a less conventional manner. Six metal fingers, in two groups of three, were mounted on the inside of the cabinet and designed to mate with six metal pads on the underside of the board. And one group, which happened to carry the speaker connections, was in the exact position where I had observed the most sensitivity to pressure.

There seemed to be little doubt that this was where the trouble lay, and that a little cleaning and tensioning would be all that was needed. But there was a more subtle reason for the failure. All three fingers were at substantially the same height, but the three pads with which they mated were not identical.

Two of the pads had substantial thicknesses of solder on them, while the third (a speaker connection) had no solder. This part of the board was in a corner remote from either of the anchor

points, with the result that the two thicker pads tended to lift the corner of the board slightly, moving the third, thinner, pad away from its contact.

I suppose it would have been easy enough to simply increase the tension on this contact, but I decided on the opposite approach. With a hot iron I carefully ran a small quantity of solder onto the pad, aimed at matching its thickness to the other two.

Then I wiped some cleaning fluid over all the surfaces and put the two sections back together. The result was a complete cure; no amount of flexing or prodding could create the problem. It was subsequently returned to the owner and I understand it hasn't missed a beat.

But I am puzzled as to why the set was made in this way. It seems to me that six pressure contacts like this represent six potential sources of trouble. By comparison, six flexible cables would be much more reliable — and much more convenient as well.

As it is, it is not possible to operate the set once the board is removed from the cabinet. Had I needed to work on the underside of the board while the set was functional, I would have needed to bridge the contacts with clip leads — with the ever present risk of shorts between adjacent clips, no matter how careful one may be.

But that sort of thing is par for the course in the service game: "Ours not to concern why — ours but to do or die". Well, perhaps the "die" part is an exaggeration, but you know what I mean. The designers create the problems and we have to fix 'em — for which we get paid!

## About that tripler repair

Following the story in the January issue, about a flashed-over tripler that was repaired with "Five Minute Araldite", the "EA" office received a call from a larger service organisation, querying the suitability of this material.

It seems that our contributor of the January story was not the first to try this trick. The service organisation used it several years ago, initially because there was a shortage of triplers early-versions of which were apparently prone to this fault — and subsequently as an economy measure to offset the high price of triplers.

Unfortunately, repairs appeared not be permanent. Apparently the Araldite eventually breaks down as an insulator and the flashover recurs, with the added complication that the Araldite appears to be flammable in these circumstances, and the tripler can be further damaged.

This service department subsequently discovered an alternative product, after consultation with the manufacturers, and this has been in the field for over two years with completely satisfactory results.

It is a Dow Corning product, distributed by Selleys Chemical Co, called "Clear Silicone Sealant". It is sold in 75g tubes and was originally called "Silicone Rubber Sealer". It is also sold in 330g packs, for use in caulking guns, as "Clear Silicone Sealant 781". All three products have the same electrical properties.

It is a single mixture product which cures on contact with the air. It forms a skin in about five minutes, cures to the touch in an hour, and is fully cured in 24 hours.

Information on Silicone rubber adhesive/sealants can be obtained from Dow Corning Aust. Pty Ltd, at 21 Tattersall's Rd, Blacktown, NSW; or from 103 High St, Prahan, Vic.

*Have you heard?*

## CASH-MORE

have a surplus stock of:

Disco units — confetti canons — cob webb machines — microphones — mirror-balls — discos — speakers — amplifiers — chasers — rope lights — infinity panels — lito 250 effects projector — detonator box — firing box — flash cartridges — the "pea souper" — fuzziLite.

## LOOK AT THESE GREAT DISCO SPECIALS

### HY5000 SOUND CONTROL CENTER

*Ideal for disco or mike mixing*

- 2 phono or line-in inputs
- 2 microphone inputs.
- 5 band graphic equalizer.
- Headphone monitoring.
- Mixers start from \$200



### LITO 250 EFFECTS PROJECTOR

- 250 watt Projector with spectacular effects.
- 14 attachments available.
- Wide selection of cassettes and 6" wheels.
- \$310 Rotators: \$39; Cassettes/Wheels: \$24.

### THE PYROFLASH

The most sophisticated theatrical pyrotechnic system available.

This unique system uses a completely new concept in detonation, ensuring maximum effectiveness and safety. The system comes complete with Detonator Box, Firing Box and all connections. A variety of effects cartridges are available extra.

- Detonator Box: \$195; Firing Box: \$65; Flash Cartridges: from \$50 per dozen.



### BUBBLE MACHINE

A real fun machine using a harmless liquid to produce showers of gently descending bubbles. Unit can produce up to 1,000 bubbles per minute, and adds a tremendous climax to any show when used with effects lighting. It is particularly good with the Blockbuster StrobeLite.

*• Second hand ex-hiring stock gear in good condition also sold. AND if this isn't enough we have band rehearsal facilities and a TV and film studio.*

For information contact:

**CASH-MORE ENTERPRISES,**  
356 Liverpool Rd, Ashfield, NSW  
2131. Phone (02) 798 6782;  
797 7022; 798 5647.

*Brochures and price list on request, mail orders accepted.*

# ROD IRVING ELECTRONICS

425 HIGH STREET, NORTHCOTE 3070, MELBOURNE VICTORIA. Ph. (03) 489 8131.

## NEW PRODUCTS



**JUST WRAP™**

- 30 AWG wire
- 0.025" square points
- Daisy chain or point-to-point
- Built-in cut off
- No stripping or soldering required—just wrap
- Includes 50 ft. wire

Part No.	Wire Color	Price
JW-1-B	Blue	\$24.99
JW-1-W	White	24.99
JW-1-Y	Yellow	24.99
JW-1-R	Red	24.99

**JUST WRAP™ Replacement Wire**

Part No.	Color	Price
R-JW-B	Blue	50 ft. roll \$4.99
R-JW-W	White	50 ft. roll 4.99
R-JW-Y	Yellow	50 ft. roll 4.99
R-JW-R	Red	50 ft. roll 4.99

## COMPONENTS

4116 RAM	\$3.00
2114 RAM	2.90
2708 EPROM	6.90
741's 10 up	2.50
555's 10 up	2.90
BD139 1U up	5.50
BD140 10 up	5.50
SC141D 10 up	11.00
SC151D 10 up	21.10
RED LEDS 10 up	1.40
RED LEDS 100 up	11.00
YELLOW LEDS 10 up	2.30
8 PIN I/C SKTS 10 up	2.00
BC548	0.15 ea.
BC549	0.19 ea.
MJ802	3.60
6.800/50V CAPS (LUG)	4.50
5.600/40V CAPS (PCB)	1.90

## COMPUTER COMPONENTS

Attention Sorcerer & TRS 80 owners. Memory expansion kits available. We also offer full service on the popular computer projects and systems.

**SPECIAL 4116 RAM OFFER**  
**8 OFF PRIME SPEC 4116 I/Cs \$23.00**  
**16 4116s for \$40.00**

**STATIC RAM KIT 16K S-100**  
**2114 \$2.90; 2716 \$11.00; 2708 \$6.90**

## SCOTCHCAL FRONT PANELS FOR ETI & EA PROJECTS:

ETI 452 Guitar Practice Amp	\$4.80
Series 4000 Any colour	\$12.50
MOVING Coil Pre Amp	\$2.00
577 Power Supply	\$2.00
455 Loud speaker protector	\$2.70
Variable power supply	\$2.70
Linear ohmmeter	\$2.50
Muscle activity meter scale	\$1.40
ETI 576 Electromyogram	\$2.80
561 Metal Detector	\$2.50
EA Capacitance meter	\$3.50
EA Flash exposure meter	\$4.25
EA Sound triggered flash	\$3.50
EA Slave flash	\$1.20
EA Playmaster graphic analyser	\$8.50
EA Metal Detector 79md9	\$3.90
EA Pulse generator	\$4.80
EA Square wave oscillator	\$2.50
EA RF Z Bridge	\$3.25
EA Thyristor tester	\$2.40
EA Quartz frequency ref.	\$2.70
EA Multi monitor	\$1.90
EA Experimenters Supply	\$2.80
EA Quiz master	\$3.70
EA Variable wiper delay	\$1.10
EA Playmate stereo Amp	\$4.50

ALL FRONT PANELS AVAILABLE FROM DAY OF RELEASE OF MAGAZINES. WHEN ORDERING FRONT PANELS, SPECIFY COLOUR OF LETTERING FIRST, THEN COLOUR OF BACKGROUND.

## 10 TURN POTENTIOMETERS

Stock resistance values  
 50R, 100R, 200R,  
 500R, 1K, 2K, 5K,  
 10K, 20K, 50K,  
 100k.

Spectral model 534 1/2" shaft  
 Price 1-9 \$8.50  
 10 + values may be mixed \$7.90

## EPROM PROGRAMMER KIT

Kit of parts as featured in Electronics Australia July, 1980 Programs 2708, 2716 and 2532 Use with TRS80, Sorcerer, and Compucolor. Kit does not include connector from the programmer to computer

Complete Kit	\$72.49
Kit without case	\$59.99
Pack and post	\$2.50

## DIG CAPACITANCE METER

Kit of parts featured in Electronics Australia March, 1980. Four digits

Complete Kit	\$52.49
Kit without case	\$39.99
Pack and post	\$2.50

## KITS & CIRCUIT BOARDS

### ETI SERIES 4000 AMP

- Complete Kit \$199.00
- Quality front panel to suit above 10.90
- ETI 470 kit of parts 22.50
- ETI 480 kit of parts 100w (incl. bracket) 19.75
- ETI 470 PS kit of parts 19.50 (includes relay, not transformer)
- Transformer to suit 22.90
- ETI 471 pre-amp 45.50
- ETI 585R ultra sonic RX 15.95
- ETI 585T ultra sonic TX 8.95
- EA 79 SF9 sound flash trigger 15.00
- All parts available for DREAM computer project.
- P.C.B.'s (all quality fibreglass boards)
- ETI 574 disco strobe 2.80
- ETI 549A metal detector 2.75
- DREAM circuit board 10.90



SCHUGART SA 400  
 5in Minifloppy Drive

\$399.00 Tax Inc  
 \$347.00 ex

### RITRON COMPUTER GRADE P/S

+5V reg 10a 16V unreg @ 1A  
 KIT \$79.95 inc  
 Built and tested \$99.50

### ETI636 MOTHERBOARD

7 Slot Motherboard \$90.00  
 Built and Tested \$120.00  
 ACTIVELY TERMINATED

### INTERSIL LCD \$34.50 3 1/2 DIGIT PANEL METER KITS

Build a working DPM in 1/2-hour with these complete evaluation kits. Test these new parts for yourself with Intersil's low cost prototyping kits complete with A/D converter and LCD display (for the 7106) or LED display (for the 7107). Kits provide all materials including PC board for a functioning panel meter ICL7106EV (LCD)

## DIP PLUGS

Ideal for use with flat ribbon cable or to mount components on

14 pin	\$1.20
16 pin	\$1.40
24 pin	\$1.20



## COMPUTER COOLING FANS

Muffin fan 4 1/2" square

110V	\$39.50
240V	\$26.50

Range of larger fans available. Send for details

## POWER TRANSFORMERS SPECIALLY DESIGNED FOR MICROCOMPUTERS

- Good regulation electrostatic shield
- RI 810 8V @ 10A 2 x 15V @ 1A \$24.50
- RI 820 8V @ 20A 15V @ 1A 15V @ 3A \$35.50

## 20 TURN CERMET TRIM POT

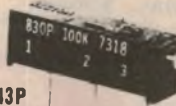

## SPECTROL 43P ACTUAL SIZE

STOCK RESISTANCE VALUES  
 10R, 20R, 50R, 100R, 200R, 500R, 1K, 2K, 5K, 10K, 20K, 50K, 100K, 200K, 500K, 1M, 2M

1-9	\$1.40
10-99	\$1.30
100	\$1.20

Values may be mixed

## Hexadecimal Keypad

\$24.50/each



19-key pad includes 1-10 keys ABCDEF and 2 optional keys and a shift key

Ideal for dream project

## MULTIDIALS



Dials to suit 10 T Pots

Model 21 1 8" dia	\$16.50
Model 16 9" dia	\$12.50
Model 18 1 1/2" x 1.75" dia	\$20.60

## cermel single TURN TRIM POT

Spectral model 63P  
 ACTUAL SIZE

STOCK VALUES  
 10R, 20R, 50R, 100R, 200R, 500R, 1K, 2K, 5K, 10K, 20K, 50K, 100K, 200K, 500K, 1M, 2M

1-9	\$1.00
10-99	0.90
100	0.80

Values may be mixed

## P.C. EDGE CONNECTORS



S100 gold plated wire wrap	\$8.50
S100 solder tail	\$6.90
D2 Motorola bus	
43/86 solder tail	\$8.50
43/86 gold plated wire wrap	\$10.50

## HAVE YOU BUILT A DREAM YET!

### ELECTRONIC AUSTRALIA MICROCOMPUTER PROJECT

Kit for main board (including programme 2708) \$109.00

Also available re-designed

6802 PCB \$11.90

PCB (Fibre glass) only \$10.90

2708 programmed \$15.50

Key Pad 19 Keys \$24.50

Kit (less key pad) \$94.00

PCB for power supply \$3.50

HEAVIER ITEMS ADD ADDITIONAL POSTAGE EXTRA HEAVY ITEMS SENT COMET FREIGHT ON PRICES SUBJECT TO CHANGE WITHOUT NOTICE. SEND 60c & SAE FOR FREE CATALOGUE  
**MAIL ORDERS: PO BOX 135, NORTHCOTE, VIC 3070. MIN PACK & POST \$1.00**  
**PRICES CURRENT UNTIL MAY 15 1981**

the latter when of the "spoilt rotten" variety.

I had a favourite trick in the old days, when confronted with these little monsters. Having charged a 0.1µF capacitor across the first filter capacitor – about 350V in those days – I would "accidentally" leave it lying around with the pigtailed suitably folded. Sooner or later mummy's little darling would grab it – and bellow like a stuck pig when it bit him/her.

Of course, I was always on the other side of the room when it happened, and was always just as puzzled as to what had happened as was the child's fond mama. But the little monster would invariably leave my things alone after that.

The next story is from my own work bench. It did not involve any great technical mystery, but the fault was interesting for a couple of reasons. For one thing, it involved a unique (to me) form of construction which, in itself, was potentially unreliable.

It was one of those after thought jobs which often result from a major service call. I had finished a fairly routine job on the customer's TV set and was gathering up my tools, when the lady of the house suddenly remembered another item that was faulty.

It turned out to be a fairly typical portable radio; a National model R-238W dual-wave set measuring about 20cm x 13cm. It featured a large straightline dial running almost the full length of the cabinet, with a tuning indicator and press-button operated dial lights. There was also a telescopic aerial to supplement the in-built ferrite rod, external aerial terminal, external power supply socket, earphone socket etc. All in all, a quite useful set.

According to the owner it was a few years old and had performed perfectly until recently. Then it had suddenly become sensitive to position or handling; it would cut out if the case was flexed slightly, or even when it was rested in certain positions. She demonstrated this to me, then handed it to me to try. It certainly was touchy.

I reasoned that it should not be too hard to find and, as the lady was not in a hurry for it, it was agreed that I take it away and do it at any convenient time.

It was some days before I had a chance to look at it, but it still behaved in exactly the same manner. I removed the back board fitted around a large battery compartment containing three "D" size cells.

Not wishing to disturb things more than necessary I switched it on again and flexed the case, whereupon it responded as before. Next I tried gently tapping the board, and it responded to this also. The trouble was it was so touchy as to make it difficult to reach any conclusion. But I eventually did narrow it down to an area near the bottom left hand corner, where the slightest pressure brought a response.

TADIRAN

# The Fail-Safe 10-Yr Lithium Batteries

BY TADIRAN ISRAEL ELECTRONICS

Power CMOS with single cell.  
Nominal Voltage 3.4V per cell.

TECNICO ELECTRONICS

P.O. Box 50, Lane Cove, N.S.W. 2066. Tel. (02) 427 3444

P.O. Box 520, Clayton, Vic. 3168. Tel. (03) 544 7833

## One-Second Desoldering with SODER-WICK

1. Hold Soder-Wick on termination with hot soldering tip. Wicking action soaks up solder.

2. Remove tip and braid. Termination is left clean and free of solder.

Soder-Wick is a specially treated copper braid which soaks up molten solder like a sponge. Desolders a P.C. pad in a second or so; acts as a heat sink to protect circuits and components.

From your Components supplier or ring:

### Royston Electronics

(02) 709 5293	(07) 391 8011
(03) 543 5122	(08) 42 6655
(002) 34 2233	(09) 381 5500

SW-3

## BRIGHT STAR CRYSTALS PTY LTD

35 EILEEN ROAD, CLAYTON, VICTORIA, 546 5076  
(ALL MAIL TO: — PO Box 42, SPRINGVALE, VIC, 3171)

ALL IN STOCK

### CRYSTAL UNITS FOR QUARTZ CRYSTAL CLOCK WATCH CRYSTALS

HC-18IU

HC-6/W

HC-18IU

HC-18U

#### SPECIFICATIONS

	MODEL HC-6/W 4130 30kHz	MODEL HC-18IU 4130 30kHz
Nominal frequency	Frequency to be variable upon request	
Frequency tolerance	Max. ±20 ppm	
Storage temperature range	-20°C to +80°C	
Operating temperature range and temp. vs. temp. character	Frequency shift at each temperature when 25°C is set to be reference within 10°C to 150°C. Temperature range to be as follows.	
Loading capacity	12pF	10pF
Series impedance	Power: to be variable upon request	
Drive level	max 400 µW	max 500 µW
Parasitic capacitance	4 pF	3 pF
Capacitance ratio	1.5% max. (30ppm/Hz)	
Aging rate	Freq. change: Max. ±2 ppm/Year	
Vibration	Reson. change: Max. ±10%	
Shock	Freq. change: Max. ±2 ppm	
	Reson. change: Max. ±10%	

\* Natural's freq. refer to the board from height of 50 cm

#### DIMENSIONS

HC-6/W  
Unit: mm

HC-18IU  
Unit: mm

**INTERSTATE AGENTS**

- \* HOSE & EQUIPMENT  
SYDNEY 666 8144
- \* DILMOND INSTRUMENTS  
HOBART 479077

R S C TELEX AA36004

CRYSTALS

**\* WESTEST ELECTRONICS**  
PERTH 337 6393

**\* FRED HOE & SONS PTY LTD**  
BRISBANE 277 4311



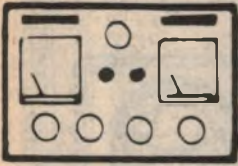

# The Serviceman

## In-home servicing is not all beer and skittles!

While most servicemen undoubtedly prefer the privacy and convenience of their own workshops, most customers prefer service jobs to be done in their own lounge rooms. And, at least where larger appliances are concerned, the lounge room usually wins. But it is less than ideal at the best, and little short of impossible at the worst.

My main story this month emphasises the lounge room trauma quite effectively. It is a contributed story, from another professional serviceman, and also emphasises the kind of "on-the-spot" repairs one often needs to make in such situations. The contributor is Mr P. H. of Burwood, NSW, and this is how he tells it:

Reading your story in the December issue about "microsurgery" on those three pieces of malfunctioning gear reminded me of a somewhat similar job I did recently.

The call came from a good friend, who had a mate, who had a wife, who had a TV set that didn't work. Which is a round about way of explaining that it was what you have called a "love" job. Perhaps "inside" job would be a better term.

I called around one evening, only to find a party in full swing — not exactly the kind of atmosphere conducive to fault finding. Nevertheless, I was pointed towards the set and told that smoke came from the back of it and that nothing had happened since.

The set was an early model Pye monochrome which had been kept, as much as anything, because of the really nice cabinet which seemed to fit in with the rest of the furniture.

I removed the back and turned the set on. The result was two orange glows in the EHT cage. One came from the anode of the 6CM5 line output valve which, fairly obviously, was not getting any signal at its grid to drive the latter negative, and so was drawing heaps of current. The other glow was from the damper diode, for reasons not immediately obvious.

I measured zero volts on the line oscillator valve plate and, after tracing out the HT for this stage, I realised that the HT was also missing from the IF section.

About this time I noticed that a small child had surrounded himself with my screwdrivers and had somehow managed to pull the knobs off my transistor tester! After cleaning up the mess and replacing the knobs, I resumed my search for the missing HT.

Eventually I found the charred remains of a 2.2k $\Omega$  decoupling resistor; obviously the source of the "smoke from the back of the set". Both the line oscillator valve and the IF stages were supplied via this decoupling network.

That there was an HT short somewhere was fairly obvious, but where? I connected the ohmmeter to the HT line and it showed virtually zero resistance to chassis. Then I removed each IF valve in turn, suspecting that it was an interelectrode short in one of the valves and would go away when I removed the faulty valve. But it didn't go away.

Next, all the appropriate capacitors were pulled out by one pigtail — the set was constructed on a printed board, in spite of its age — but still the short remained. Someone handed me a beer

and I took a breather, convinced that each of the IF transformers would have to be painfully removed until the short vanished.

But was it really in the IF section? To prove the point I cut the HT line foil leading to the IF section. And, yes, the short vanished. I traced the first foil branching off the HT line to an IF transformer and removed the shield can.

I found a two-turn winding around the main tuned winding with one end to chassis and the other end unconnected. It was fairly obviously a "gimmick capacitor" and, while there were no signs of heating or other indications of a breakdown, I was suspicious enough to unwind it. And as I did the ohmmeter swung to the other end of the scale.

Well, at least I'd found the fault, and I must admit to feeling some pride at having done so in such a distracting environment. But now I had to repair it. Standing up from behind the set I asked if anyone had any fingernail polish. After the inevitable bout of giggles and limp wristed gestures the lady owner produced some green polish which she had never used.

I painted the main winding with a generous coating, waited for it to dry, then wound on a new two-turn capacitive winding. And, as a further precaution, I inserted a .01 $\mu$ F capacitor in series with this winding and earth.

I replaced the burnt out 2k decoupling resistor, repaired the foil track where I had cut it, and prepared for the big test. There was only one more thing that worried me; a closer look at the EHT transformer revealed that it was cracked like you wouldn't believe. Was this the result of the excessive 6CM5 plate current? And had it damaged the transformer in any way?

I crossed my fingers and switched on. Imagine my relief when everything warmed up normally and a first class picture appeared on the screen.

Another triumph for microsurgery under difficult conditions.

Well, that's Mr P. H.'s story, and I can only agree that it was a job well done in the most difficult circumstances. I can also sympathise regarding the problem of babies and small children; particularly



"You can go in now!"



Yes, a fully-functioning ready-wired computer for around the same cost as a television set. Simply plug into your TV or a line printer and you're in business!

This TRS-80 4K Level I computer has 1,001 uses for the businessman, professional, educator and the family. Some applications include: accounts receivable, inventory control, mailing lists, stock market forecasting, scheduling, teaching programmes, even as an appointment diary. The list is endless and new programmes are being developed all the time. Your TRS-80 computer will take these new programmes as they become available thus ensuring you keep up with the very latest technology.

The TRS-80 certainly is the star of the show with close to 300,000 units sold all over the world. It's a comfort to know that others have placed their trust in the same system, so much so that the TRS-80 Level I is the world's best-selling 'small computer'.

So take a trip to tomorrow, today with the advanced TRS-80 computer, available only from Tandy Electronics. Call into one of our conveniently located Computer Centres in your capital city for a free "hands-on" demonstration.

TRS-80 Level I 4K RAM. 269-9001 .....	499.00
TRS-80 Level II 4K RAM. 269-9004 .....	679.00
Modulator (For use with TV Monitor). 269-9401 .....	15.95

## TRS-80 easily an award winner!

On Show Now at Your Nearest Tandy Store

# TANDY ELECTRONICS

Available at all Tandy Stores and Participating Dealers Around Australia or  
Mail Order Department, P.O. Box 229, Rydalmere, N.S.W. 2116.

\*Television not included



# HIGH IMPEDANCE DC VOLTMETER

+

+

1V

10V

100V

+

+

OFF

+

+

+

+

+

ON

REVERSE  
POLARITY

INPUT

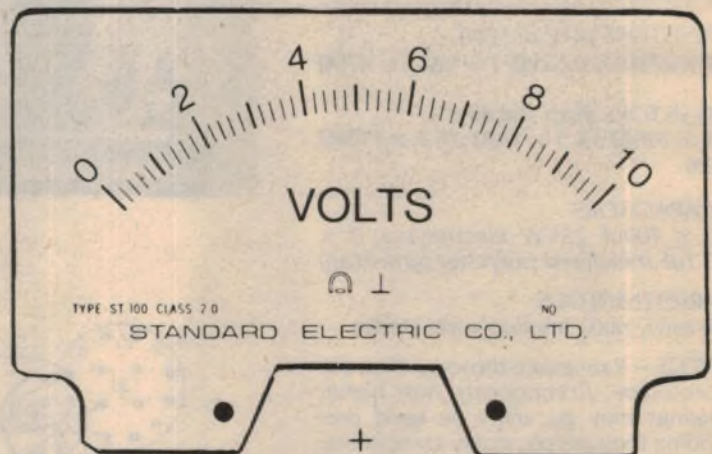

*Presented on this page is the full-size artwork for the front panel, meter scale and printed circuit board.*

potentiometer is then set to give a reading matching that of the meter against which the new meter is being calibrated. The remaining two ranges will be calibrated automatically.

In use, the new High Impedance DC Voltmeter is similar to any other voltmeter. It is always wise to set the range switch to the highest range and when a reading has been taken, the range switch may be changed as required. It is good practice to set the range switch so that the meter needle reads as high as possible on the scale, consistent with the ranges available. In the case of this instrument, it is not necessary to consider the polarity of the test prods. As mentioned earlier, reverse polarity is indicated by the LED lighting up. It should be kept in mind, that the LED takes extra current from one of the batteries and continuous use this way would shorten the life of that battery. 2

the tolerance of the resistors.

If a reference instrument of known accuracy is not available, a basic calibration will have to be performed using any available voltage source with a value known as accurately as possible. It would be preferable to have a value which gives as close as possible to a full scale reading, consistent with an appropriate setting of the range switch.

Calibration of the instrument should ideally be carried out by comparison with a reference instrument of known accuracy. A stable source of DC voltage should be used and of such a value that a near full scale reading will be obtained on the meter to be calibrated. In other words, a source of 1V, 10V or 100V, with the range switch appropriately set, would be ideal. The 1kΩ calibrating

## DC VOLTMETER

### PARTS LIST

- 1 Utility box 197mm x 113mm x 60mm
- 1 Meter 1mA FSD 101mm x 80mm with special scale. Standard Electric ST-100 or similar
- 1 Miniature DPDT toggle switch
- 1 Single-hole mounting RCA socket
- 1 Scotchcal front panel
- 1 Knob for range switch
- 1 Rotary switch single-pole three position shorting contacts (see text)
- 2 9V batteries type 216
- 2 Clip leads to suit batteries
- 1 Clamp for batteries 60mm x 25mm
- 1 16mm tapped spacer for battery clamp
- 4 rubber feet
- 1 Printed circuit board 97mm x 72mm, code 81vm2
- 1 10kΩ miniature horizontal trimpot
- 1 1kΩ miniature horizontal trimpot
- 5 1N914 silicon small-signal diodes
- 1 CA3140 8-pin DIL op amp
- 1 BC558 PNP transistor
- 1 8-pin DIL socket
- 1 red LED

#### RESISTORS (¼W or ½W)

1 x 27kΩ 1 x 2.2kΩ 1 x 1kΩ 1 x 470Ω

#### RESISTORS (high stability)

1 x 10MΩ 5% 1 x 1MΩ 2% 1 x 110kΩ 2%

#### CAPACITORS

2 x 100µF 25VW electrolytics, 1 x 0.1µF metallised polyester (greencap)

#### MISCELLANEOUS

Screws, nuts, hookup wire, solder

**NOTE** – Ratings are those used on the prototype. Components with higher ratings may generally be used providing they are physically compatible. Components with lower ratings may also be used in some cases, provided the ratings are not exceeded.

the front panel. When mounting the range switch, it is important that it be orientated so that when the knob is fitted, its pointer corresponds with the ranges on the panel.

The PC board is mounted directly on the back of the meter, using the meter screw terminals. But before doing this, all leads running from the PC board to points outside, should be fitted. These will include leads from the battery clips. If the battery clips are fitted with leads already, it may be necessary to lengthen the two which run to the centre zero rail on the PC board.

The remaining leads are terminated to the switches, input socket and the LED. The earthy lead from the board which terminates on the range switch is carried

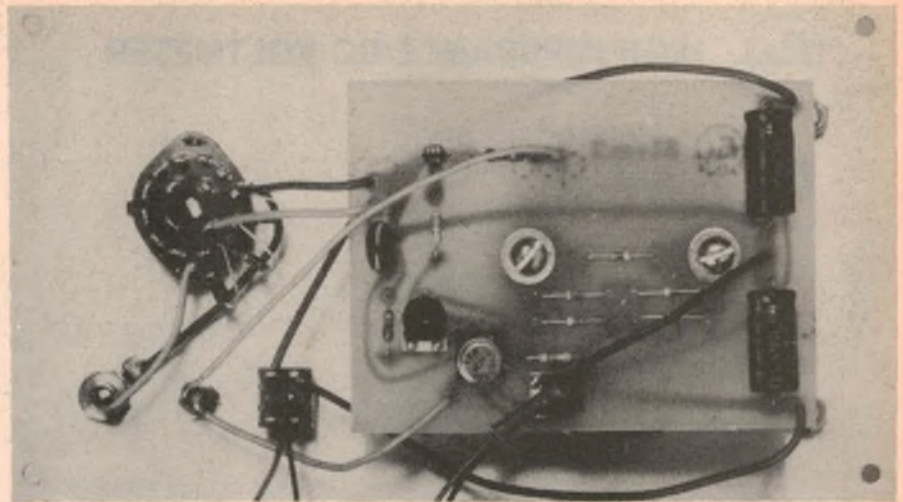

Use these photos and the diagram below when wiring the meter.

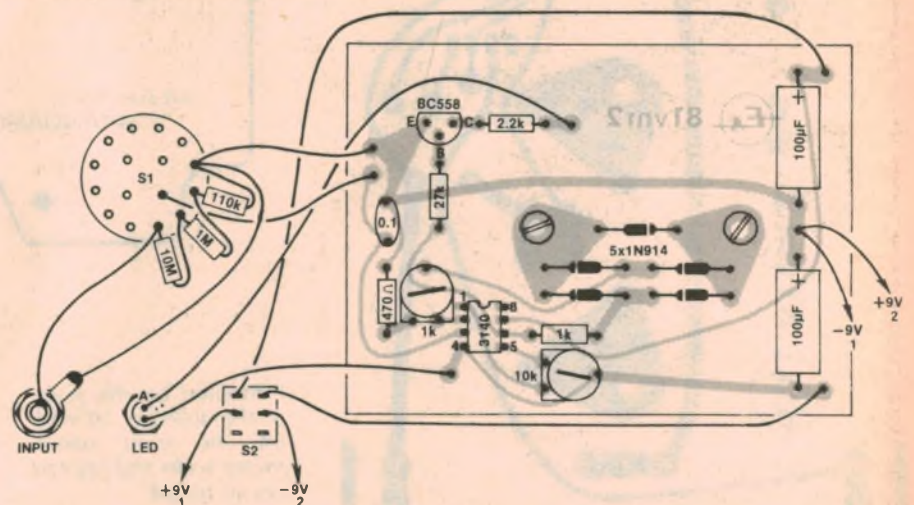
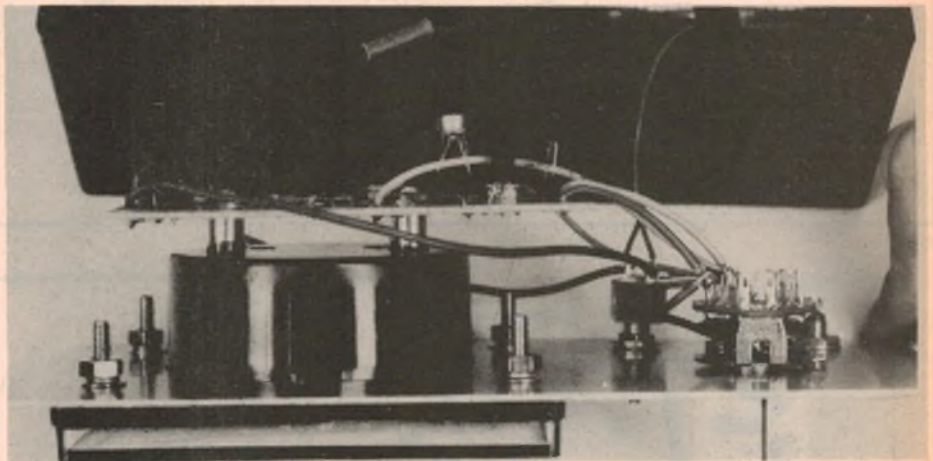

on to the corresponding lug on the input socket.

Incidentally, you will need a set of probes. We used a standard set from which we removed the banana plugs and terminated the two leads on an RCA plug, which matches the input socket.

We are now ready to put the voltmeter into operation, after having made a final check to be sure that there are no errors or omissions. Set the two miniature trim-pots to mid-travel and then set the range switch to "1V" without any probes plugg-

ed into the input. Switch on and the meter needle will probably settle a little above zero on the scale. Carefully rotate the 10kΩ trimpot to obtain a zero scale reading on the meter. It is important to make sure that the mechanical zero adjustment on the meter is correct before carrying out the above operation.

With the sensitivity set on one range, all other ranges will be determined by the voltage divider. As high stability resistors have been specified, the accuracy of each range should be within



# Cromemco computers

## ON THE MOVE!

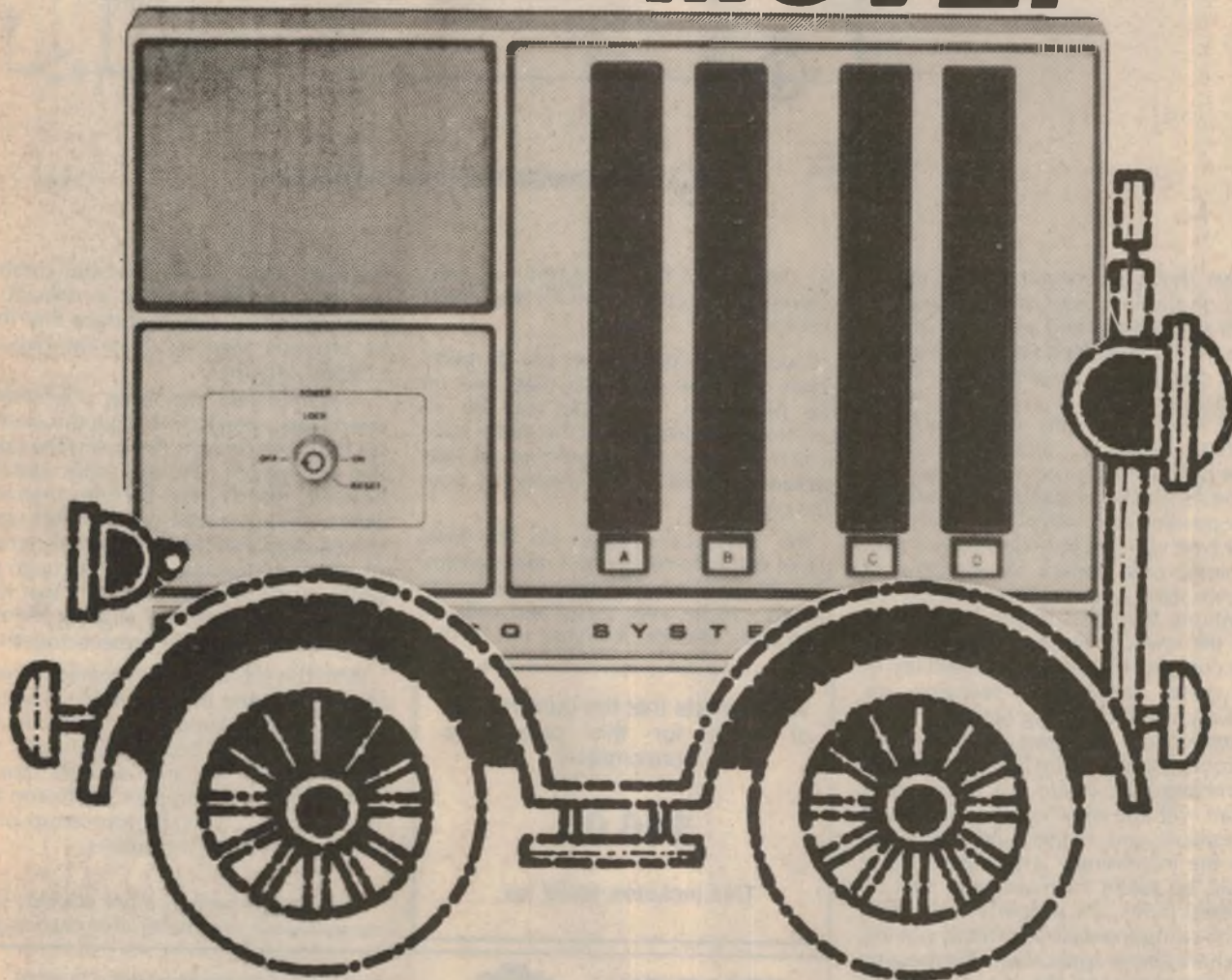

The versatile and reliable range of computers and peripherals supported by Australia's most technically advanced CROMEMCO dealer and supplier of supportive software.

# **AE ADAPTIVE ELECTRONICS P/L**

ON THE MOVE to our new centrally located display and service centre at  
418 ST. KILDA ROAD, MELBOURNE 3004.

Ph: (03) 267 6800 (4 lines). Telex: AA32565



Oh, by the way, I am back in the traces again with the NCRA. In a moment of weakness I agreed to take back my old job as National Liaison Officer.

**FROM KEN, AGAIN:** I have received another letter from Ken Upton, the Omega One. Waratah State REACT were guests at a recent Omega club meeting, the actual guest speaker being Mr Peter Herman, who was assisted by Shane. Ken and other members of his club asked some very pointed questions, some of which the guests were not able to answer.

There was one in particular which I would also like to know the answer to, and that was in relation to the ownership of the name and the trademark of REACT: Is it true that General Motors (USA) own the name REACT and the symbol, and if that means that General Motors may, if they wish, withdraw the name, and symbol from not only REACT in the US but also from REACT in Australia? The organisation's representatives told the meeting that they did not know, but that REACT in the US would be contacted and the answer ascertained.

I understand that Mr Bob Saint, the Secretary of the Lima Alpha club is to address a meeting of the Omega club as this goes to press so I hope to have news of that for you in the next issue. Bob was the recipient of the NCRA-South Pacific Radio CB Merit Award for 1980, and is well known for his good work on CB. He and Ian Camiller are the NCRA representatives in NSW.

**OOPS SORRY!** It appears that I neglected to mention the fact that the Viking CB Club was also instrumental in arranging the Combined CB meeting which I told you about in the February issue, so my apologies to that club for the oversight.

**FIRST THINGS FIRST:** I would like anyone who sends in material for this column to bear in mind that there are several points which material must satisfy before it finally appears in print. Firstly, the material must pertain to points of interest in the immediate past, to informative items or to events which will occur after the magazine appears on the stands. Secondly, I have only so much space available each month, so there is a matter of priorities to be considered. Thirdly, when there is a lot of information for one issue, I have to edit what I have and try to include as much as possible of everything; therefore I cannot always go into a lot of detail.

Last but not least, if I over estimate the amount of material to prepare, further "cutting to fit" may take place in the editorial office.

Please bear that in mind if some of the items are shortened but, keep writing all the same. You provide the breadth of interest; I merely get it together. Until next month...

**Jan Christensen.**

# SPELLBINDER

is the wordprocessor  
for YOU

## FORMS PROCESSOR

draw your form on the screen fill it in and print only the information on your pre-printed tax form, order form, etc.

## SECURITY FEATURE

add non-printed comments to your letters.

## FULL MAIL MERGE and BOILERPLATE

insert customers' names into form letters. Include special paragraphs for particular customers.

**PLUS — FULL MAILING LIST FEATURE — MULTIPLE COPY PRINTING — PROPORTIONAL FORMATTING — COMPLETE FORMAT MEMORY — GLOBAL EDITING**

**AND . . . It's cheaper than you think!**  
Full range of software and peripherals for the **SORCERER**. Call or write for our FREE catalogue.

PO Box 364  
Edgecliff 2027  
Ph. 33 4536

*Software  
Source*

# LOOPY VIDEO

SHOP: 418 Bridge Road (03) 429 5674  
MAIL: PO Box 347 Richmond 3121 Vic

Second hand video recorders and tapes.  
cheap. Also new

## OSI HARDWARE FOR OHIO COMPUTERS

Superboard II	\$367.00
SII Covers/VDU Stands Plastic	\$ 18.95
RF Modulators 5/9V	\$ 19.95
8K Ram Kits	\$ 79.00
EPROM with Single Key Basic & Cursor Control	\$ 49.95

## OSI SOFTWARE FOR OHIO COMPUTERS

Over 100 varieties for C1P/SII.  
Many available for C2/4P; enquire  
Categories are: Games, Education, Business, Text, Instructions (Modifications), and Utilities

**K.2. Catalogue. Brief description of all programs, free hints. New enlarged version: \$3.50 PLUS \$1.00 P & P.**

### Example of titles:

U.24 Sound Effects	\$ 9.95
G.40 Pyramid (Adventure)	\$18.95
G.41 Othello	\$ 9.95
I.25 RTTY for C1P	\$16.95
U.20 Mini Assembler	\$ 9.95
U.21 Single Key Basic	\$ 9.95

Now available blank digital tapes C10 \$1.85 each less for lots of 10 or 100.

Mail orders allow postage. eg: OSI Software

1 or 2 \$1.00;	3.5 \$1.50;	6.9 \$2.00;
10 or more items \$2.50		

All prices INCLUDE sales tax.  
Prices subject to change without notice.

# CQ electronics

and get your components

SHOP 9 TOWN CENTRE 195 REGENT STREET  
30 CAMPBELL STREET CENTRAL RAILWAY

blacktown. 621 5809  
sydney. 698 8079

## SCHOOLS, MANUFACTURERS, RETAILERS

Note we have a large stocks of the following items.

### SLIDE POTS

#### SINGLE GANG 45mm

50k LOG	}	ONLY \$15.00/100
2k LIN		
10k LIN		
100k LIN		

#### DUAL GANG

5k LIN A	}	ONLY \$20.00/100
100k LIN B		
250k LIN B		
500k LIN B		
2M LOG (200K TAP)		

### CERAMIC CAPACITORS

12pF — V	}	ONLY \$2.00/100
15pF — V		
100pF — 500V		
220pF — 1KV		
270pF — 500V		
330pF — 1KV		
470pF — 2KV		
680pF — 3KV		
1000pF — 50V		
.02mF — 500V		

### TRANSISTORS

SE 7055 (BF 336) CRT DRIVERS  
ONLY \$20.00/100

### WIRE

1000M rolls of 1/061"  
ONLY \$20.00 PER ROLL  
Limited colours and stocks left  
P&P extra \$2.00 per roll.

### PLASTIC PRINTED CIRCUIT BOARD PILLARS

3mm 0 x 10mm separation  
ONLY \$3.00/100

### ALLIGATOR CLIPS

Black & Red. App. 40mm long  
ONLY \$7.00/100

### PLASTIC TRANSISTOR COVERS

For TO 3 type transistors  
ONLY \$12.00/100

### LAMPS

6.3V 200mA fly leads  
ONLY \$3.00/100

### CASTORS FOR SPEAKERS ETC

40mm dia. ball type sets of 4  
25 sets for \$100.00

### CERAMIC INSULATOR BEADS

3mm dia x 6mm long  
ONLY \$1.00/100

### ELECTROLYTIC CAPACITORS

100MF 250V PC type Siemens Brand  
only \$20.00/100

**FREE CHUCK WITH EVERY  
EMCO — UNIMAT 3 LATHE**

**ONLY \$450.00** P&P EXTRA \$10.00

Capacitors and resistors, integrated circuits, Wires and cables, semiconductor, fuses, knobs, Radio and TV valves, plugs and sockets, pots, Manufacturers of PC boards and disco lighting

Prices subject to change without notice  
Pack and postage within Australia \$1.00

02-621 5809

CQ ELECTRONICS  
30 CAMPBELL ST  
BLACKTOWN 2148

WRITE

# SHORTWAVE SCENE



by Arthur Cushen, MBE

## “WORD” — new gospel radio station in Lebanon

For some months the “Voice of Hope” has operated on medium-wave from southern Lebanon. Now a new powerful shortwave relay with the call sign WORD has been heard on 6215kHz.

The station also uses the slogan “King of Hope” and relays the medium-wave station with signals observed from 0400UTC onwards. At 0530UTC, Country & Western music has been noted with an English news broadcast at 0550. At 0600UTC the station announces that the following hour is in Arabic, with news and music for listeners in Lebanon. Time announcements are in both UTC and Lebanon time, which is two hours ahead of UTC.

The station is based in Marj 'Urun in southern Lebanon, and opening announcements indicate that it covers the Middle East, Europe, Africa and North America. The station has also announced plans to extend its schedule to eventually broadcast 24 hours a day.

Tests were first reported in late January on 6215kHz in parallel with the medium-wave frequency 945kHz. Signals during our morning listening period are blocked by Radio Cairo to 1745UTC. According to announcements, WORD has requested reports from listeners to be sent to their offices in The Arizin Motel, Metulla, Israel.

It is understood that the power of the shortwave transmitter is 20kW and future plans are for an expansion of the services into other languages of the Middle East and Eastern Europe.

### AFRICA NUMBER ONE

Last year, many readers heard the test broadcasts of Africa Number One in which they offered a French automobile as a prize in a world-wide contest. The tests have now concluded and Africa Number One has commenced regular broadcasting on 4808kHz and operates 0500-2300UTC. The transmission is in French when observed around 0600UTC and it has been announced that Radio France International will be using some of the transmitters for a relay into Africa.

Notes from readers should be sent to Arthur Cushen, 212 Earn Street, Invercargill NZ. All times are UTC (GMT). Add eight hours for WAST, 10 hours for EAST and 12 hours for NZT.

The transmitters are located at Moyabi and consist of four 500kW transmitters. These are operated by a private company which plans to lease time to international broadcasters. The station has studios in Franceville and, according to the 1981 Word Radio & Television Handbook, verifications will be issued if accompanied by two IRCs.

### BBC LESOTHO OPENS

The new 100kW shortwave transmitter is now operating on a tentative schedule, reports Chris Martin of Sydney. It appears that reports of reception of BBC programs to Africa on 11720kHz were actually originating from the Ascension relay base and not Lesotho as first thought. The new BBC Relay Station will carry the World Service and is to operate on the following schedule: 9525kHz 0400-0545; 11710kHz 0545-1430; 7185kHz 1430-1615 and 7250kHz 1615-2030UTC. The broadcasts will be taken off the air for rebroadcast on this transmitter.

Reception reports should be sent to the BBC World Service, Bush House, London.

### NEW TILR SCHEDULE

Radio Noticias del Continente, broadcasting from San Jose, Costa Rica, has been heard for several months on 9615kHz with Spanish programming to Latin America. The station has been the cause of considerable friction between governments in South America because of the nature of its broadcasts. Operating on 9615kHz TILR has been heard closing at 0500UTC and opening again at 0900UTC, but at this time suffers interference from KGEI San Francisco.

The new program schedule includes revised broadcasting times. According to the BBC Monitoring Service, the station now opens at 1700UTC and continues through to 0500UTC. The program from 0900UTC is a repeat of the previous broadcasts. From 0400UTC there is news and interviews and at 0445UTC the station previews the following day.

Verifications have been received in the

form of a postcard. Reports should be sent to Ap. 876, Centro Colon, San Jose, Costa Rica.

### NEW BOTSWANA STATION

The Voice of America is installing a 50kW transmitter 350km north of Gaborone which will carry VOA programs to South Africa from the commencement of broadcasting in June. Chris Martin of Sydney reports that the service will be on medium-wave only and will carry VOA programs during the morning and evening transmissions. The balance of the programming (nine hours) will be relays of the Botswana domestic programs.

Radio Botswana is installing three 50kW transmitters to supplement the two 10kW at present on shortwave, but these new facilities are not expected to be operating until the end of the year. Radio Botswana has not verified reception reports for the past four years. The station claims that there has been duplication of reports from some countries and obvious attempts to obtain false verifications. It is a pity that the station has taken this attitude, as it denies the keen shortwave listener verification of this country. It would appear that one country only has been the area from which faked reception reports have been received.

### RECENT VERIFICATIONS

**NICARAGUA:** A letter verification has been received from Radio Nacional Managua, Nicaragua on 5950kHz. The verification now gives the slogan as “La Voz De Nicaragua” and the letter is signed by the Director. The power on the frequency is 50kW and the transmission is heard closing at 0600UTC.

**UNITED STATES:** One of the interesting low-powered stations operated on shortwave has verified our reception with the information that it was the first report outside North America. KVHF operates on 6420kHz with 250W and has been broadcasting for the last five years from a site in southern California. The station is off the air at the moment awaiting the granting of a shortwave license from the Federal Communications Commission.



**2 YEAR WARRANTY**  
See E.A. - Review Feb '81 for V352

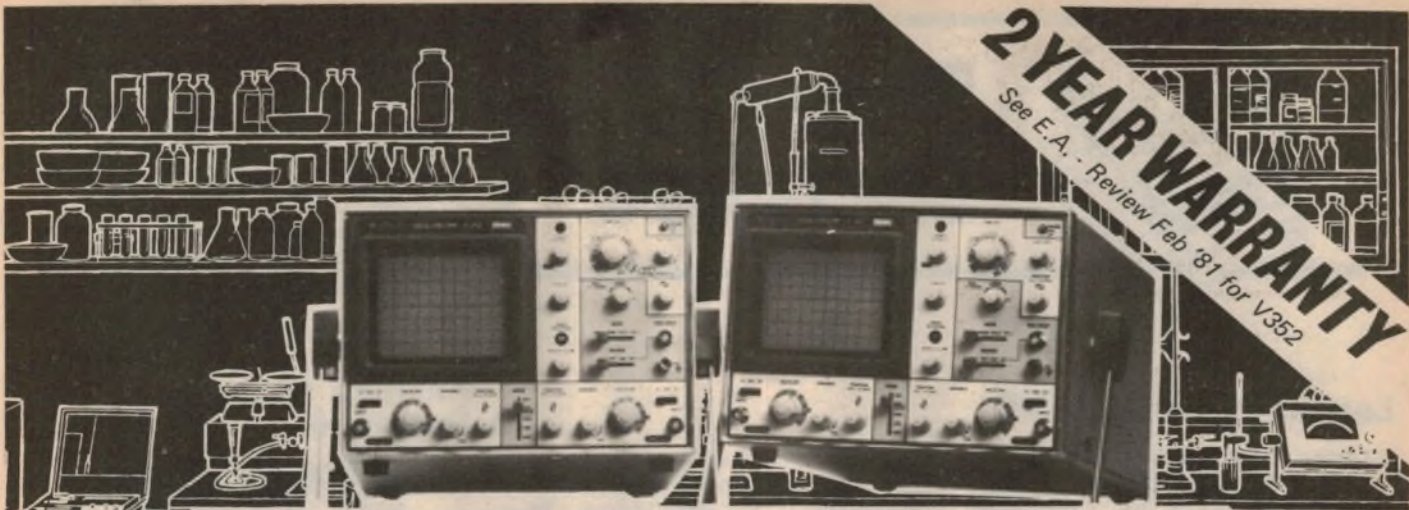

**HITACHI** proudly announce  
**2 entirely new professional oscilloscopes**

Oscilloscopes designed for the Professional by Japan's largest Electronics group.

These new oscilloscopes are undoubtedly the most advanced available from Japan, featuring new case design — carry handle — tilt stand, 3% basic accuracy (horizontal and vertical axis), square CRT with internal graticule, 1mV sensitivity, fast sweep range, superior trigger circuitry and very realistic prices.

V202 20 MHZ DUAL TRACE **\$714** V352 35 MHZ DUAL TRACE **\$1,149** Plus Tax

HITACHI AVAILABLE FROM:

N.S.W. Radio Despatch Service, David Reid Electronics,  
Standard Components, Emtronics, D.G.E. Systems (N'stle)  
Vic. Ellistronics, G.B. Telespares, David Reid Electronics,

J. H. Magrath Co. Pty. Ltd.  
Old. Audiotronics, ECQ Electronics, St. Lucia Electronics.  
S.A. Bee Jay Electronics  
Tas. George Harvey Electric Launceston and Hobart.  
W.A. Reserve Electronics.

**RADIO DESPATCH SERVICE**

869 George St, Sydney 2000 Near Harris St.  
Phone 211 0816, 211 0191

**G W TEST INSTRUMENT**

MODEL GOS-955  
130mm  
OSCILLOSCOPE



\$217.50 EX ST  
\$250.00 INC ST

**GENERAL**

GOS-955 is a compact general purpose 130mm (5") oscilloscope with wideband (DC to 5MHz) and high sensitivity (10mVp-p/cm) characteristics. It is designed for maximum usefulness in service shops, technical schools and laboratories. It features FET's in input circuits, DC-coupled amplifiers, phases (up to 140°) line frequency sweep and vertical calibration voltage. Return trace blanking is provided for clear waveform display.

**SPECIFICATIONS**

**Vertical Axis.** Deflection Sensitivity — 10mV p-p/cm or better; Bandwidth, —3dB — DC, to 6.5MHz, AC 2Hz to 6.5MHz; Input Impedance — 1MΩ ± 5% within 35PF; Input Control — X1, X10, X100, and fine adjuster; Calibration

Voltage — 0.05Vp-p 1kHz square wave. Maximum Input Voltage — 600Vp-p or 300V (DC × AC peak).

**Horizontal Axis.** Deflection Sensitivity — 250mV p-p/cm or better; Bandwidth, —3dB — DC to 500kHz; Input Impedance — 1MΩ ± 10% within 35PF. Maximum Input Voltage — 100Vp-p or 50V (DC × AC peak).

**Sweep Circuit.** Frequency — 10Hz to 100kHz in 4 steps with fine adjuster. Synchronization — Internal — & +, external, line. Sensitivity: Internal, 1D1V vertical amplitude. External, over 1Vp-p

**BUY TEXAS CALCULATORS**

	Excl ST	Incl ST
TI 30 SP	20.00	22.10
TI 1750	16.40	18.15
TI BAII	40.97	45.35
TI 50	36.40	40.30
TI 55	55.35	59.00
TI Programmable 58C	132.00	149.00
TI Programmable 59	265.00	299.90
PC 100C Printer	210.00	237.00
Specialty Packettes	8.00	9.00
Library Modules	30.50	34.50

**COMPUTER COOLING FANS**

Muffin 240V	\$28.75
Sprite 240V	\$30.76

All PC Boards for EA & ETI Projects Front panels for some 1979 and 1980 EA & ETI projects. Black or silver background by the Scotchcal System.



Hirose and Ansley Ribbon Cable Connectors fitted same day.

**CANNON AUDIO CONNECTORS**



We are distributors for Canon plugs and sockets.

**MAIL ORDER CUSTOMERS**

Packing charge	\$1.00
Postage Local min	\$1.00
Postage Interstate min	\$1.50

**OPEN: Mon-Fri 8am to 5.30pm. Thursday night late shopping till 8.30pm. Saturday 8am to 11.45 am.**

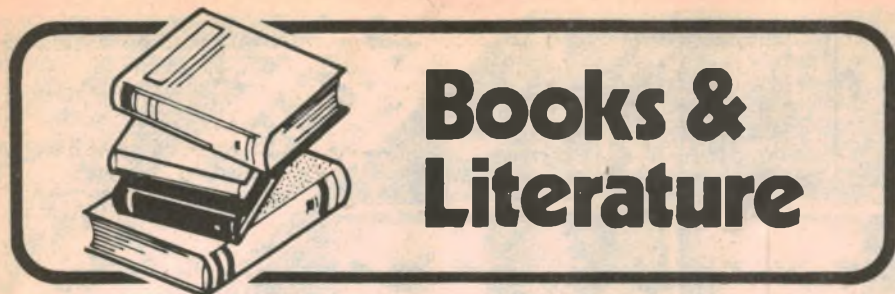

# Books & Literature

## Learning Level II BASIC

**LEARNING LEVEL II**, by David A. Lien. Soft covers, 352 pages, 230mm x 178mm. Published 1979 by Compusoft Publishing, San Diego, California. Price in Australia \$17.95.

TRS-80 Level I is well supported by the Level I User's Manual, a book which has become well known for its breezy style and clear and comprehensive treatment of Level I Basic. Until recently however TRS-80 Level II was documented only by the Level II Reference Manual, a booklet which assumed that the reader had a complete knowledge of Level I and was familiar with the Basic language.

Now that so many users are starting off with Level II systems the combination of the Level I User's Manual and the Level II Reference Manual is not a satisfactory solution to the problem of documentation. As the author says "Level II was only a gleam in the eye when the Level I book was written."

To fill the gap, David A. Lien, the author of the Level I Manual, has written this book which starts where the Level I User's Manual left off, and fully explains Level II Basic in the same relaxed, highly readable style. Like the Level I manual the book is illustrated with cartoons and places the emphasis on immediate "hands on" experience of each new concept as it is introduced.

"Learning Level II" is written with two types of readers in mind. — those who are upgrading from a Level I system and so are already competent in Level I Basic, and those who are starting off with a Level II machine and have not had any previous experience with Basic.

Part I of the book goes through the Level I Manual chapter by chapter, describing the changes which must be made so that the Level I Manual can be used as a guide to the Level II machine. This part provides an alternative text which can be cut out and pasted over the appropriate pages of the Level I Manual. Thoughtfully the publishers have also provided the alternative text in Appendix Z of the book, printed on one side of the page only, so that it can be cut out while leaving the body of the book intact.

Those already familiar with Level I can skim through Part I and update their Level I Manual, then move on to Parts II and III of the book. Part II, "New Power at the Command Level" gives an overview of Level II

Basic, and then discusses the powerful editing facilities of Level II, the extended error messages (23 in standard format, rather than the WHAT? HOW? and SORRY of Level I), and the automatic line numbering feature.

Part III of the book is the lengthiest Part, as is to be expected since it covers the program statements of Level II. There are five chapters on the extended string functions of Level II and two chapters on the intrinsic mathematical and trigonometrical functions, as well as chapters on the PRINT USING statement and linking machine language routines to Basic programs, to mention but a few.

Conversion of programs from Level I to Level II is also fully covered, including instructions for using the taped conversion program supplied by Radio Shack. There is also a guide to the TRS-80 expansion interface and dual cassette operation.

In addition to Appendix Z, four other Appendices cover error messages, the ASCII code, Level II reserved words, and provide a summary of Level I Basic and Level I shorthand.

"Learning Level II" is a very complete guide for the TRS-80 Level II user who is already familiar with some form of Basic. When used in conjunction with the Level I User's Manual, it is also well suited to those users of Level II who have no previous programming experience. Once again, David A. Lien has demonstrated that learning to use a computer can be fun as well as a great source of personal satisfaction.

Our copy came from Dick Smith Electronics, 125 York St Sydney 2000 (P.V.)

## The Australian Electronics Industry

**THE AUSTRALIAN ELECTRONICS INDUSTRY. A report by the Electronics Industry Advisory Council.**

Although actually issued to the Commonwealth Minister for Productivity about 12 months ago, this report may still be of interest to those who have not had a chance to study it in detail.

Meeting in an advisory capacity, the Council involves about 25 members drawn from all levels of the industry: engineering, educational, trades, administrative, manufacture, import, retail,

consumer, government and government departments.

The report covers an overview of the industry, employment, education and training, R&D, Government purchasing and policies, the National Communications Satellite System and future prospects.

Stiff paper covers, 106pp 250mm x 175mm. The Australian Government Publishing Service, Canberra. ISBN 0 642 05029 5.

## Amateur Radio Handbook

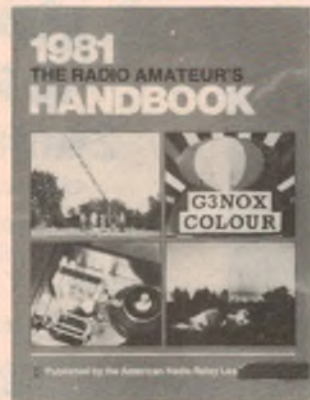

**1981 RADIO AMATEUR'S HANDBOOK**, published by the American Radio Relay League, Newington, CT.06111, USA. Stiff paper covers, pages not numbered, 272mm x 207mm, freely illustrated. Price in Australia \$14.95.

Having already grown taller and wider than its pre-'79 forebears, this 58th edition of the ARRL Handbook is also fatter by about 64 pages than the 1980 version. According to the foreword, the extra space has been occasioned by an update in both the tutorial and constructional areas, prompted by the most recent FCC examinations.

The actual chapter headings are identical with the previous edition and may be summarised as follows:

1 Amateur radio; 2-5 Basic theory and practice; 6-10 Transmitting and receiving systems, VHF and UHF, fixed and mobile; 11-14 Modes, code, SSB, FM, specialised systems; 15 Interference; 16 Test equipment and measurements; 17 Construction and data tables; 18-21 Antennas and transmission lines for HF, VHF and UHF; 22 Operating a station; 23 Vacuum tubes and semiconductors. Index.

At the stated price of \$14.95, and by today's standards, the book represents exceptional value for anyone with an interest in amateur radio or even in communications technology generally. Not everyone will want every copy of the ARRL Handbook but, if you've missed a couple of years, the up-date should be well worth having.

Our copy came from Technical Book and Magazine Co Pty Ltd, 289-299 Swanston St, Melbourne 3000. Phone 03 663 3951. (W.N.W.)

## Broadcasting Standards

STANDARDS FOR TELEVISION AND LOCAL RADIO STATIONS. IBA Technical Review, 13.

Published by the Independent Broadcasting Authority, the book brings together current IBA technical codes of practice relating to television studios, local radio studios and outside broadcast facilities. The book is intended for engineers, firms and engineering students, particularly those involved in the supply of equipment. It is also available to technical libraries and educational centres in the UK and overseas. Stiff paper cover, 72pp, 226mm x 194mm, illustrated.

Individual copies are available free to appropriate users on application to: Engineering Information Service, IBA, Crawley Court, Winchester, Hampshire, UK SO21 2QA.

## IERE Proceedings

INTERNATIONAL CONFERENCE ON THE ELECTRONIC OFFICE. IERE Conference Proceedings No. 45.

Organised by the IERE, the above conference was held in the London Penta Hotel, April 22-25, in association with the Institution of Electrical Engineers, the Institute of Electrical and Electronics Engineers, the Chartered Institution of Building Services and the British Computer Society.

The proceedings are available as a 274-page book with stiff paper covers 297mm x 209mm, illustrated. It contains 23 papers in all, presenting a wide overview of the human, business and organisational aspects, plus a look at technology and equipment. In all, a most helpful publication for those interested in the subject. UK and overseas price £25.00 including surface postage. Contact: Publication Sales Controller, Institution of Electronics & Radio Engineers, 99 Gower St, London, UK WC 1E 6AZ.

☆ ☆ ☆

RETRAINING IN THE ELECTRONICS INDUSTRY FOR THE MICROPROCESSOR AGE. IERE Conference Proceedings No. 46.

Organised by the IERE and held at the London Penta Hotel on July 3, 1980. The proceedings are similar in presentation to those mentioned above but are limited to eight papers occupying 78 pages.

The papers look at training and retraining within the electronics industry, as well as the demands made on a typical technical college. Staff awareness is discussed and the problems of transition to a microprocessor based industry. The material relates primarily to Britain but those involved in this general subject would inevitably find parallels in the Australian scene. The UK and overseas price is £12.00 including surface postage and the address is as above.

# NEW BOOKS

NEW — NEW — NEW

Latest editions of some of the most popular books on the subject.

The Radio Amateur's Handbook — ARRL 1981 Edition Just out!! A must for the Radio Amateur and Professional	\$14.95
R S G B Handbook Volume 1	\$21.85
R S G B Handbook Volume 2	\$18.90
Reference Data for Radio Engineers (New Edition) I.T.T.	\$39.95
Radio Handbook (William Orr) 21st Edition	\$27.75
Australian Amateur Operator's Handbook — Postal & Telecommunications Department	\$3.60
Radio Amateur Callbook 1981 editions — Just out! US Listings	\$25.40
DX Listings — all other countries	\$24.00
World Radio TV Handbook 1981 — Just out — Complete directory of the world's radio and TV stations — short medium and long wave. The listener's bible	\$17.95

### Adam Osborne Books

The 8086 Book — Rector	\$18.00
Z8000 Assembly Language Programming — Leventhal	\$15.00
Introduction to Microcomputers, Osborne	
Vol 0 — Beginners Book	\$9.55
Vol 1 — Basic Concepts 2nd ed	\$15.00
Vol 2 Some Real Microprocessors — New Edition. Loose-leaf w/out Binder	\$19.00
With Binder	\$30.00
Vol 3 Some Real Support Devices — New Edition. Looseleaf w/out Binder	\$19.00
With Binder	\$28.00
6800 Programming for Logic Design	\$13.50
8080 Programming for Logic Design	\$12.55
Z80 Programming for Logic Design	\$13.50
Z80 Assembly Language Programming	\$13.80
6800 Assembly Language Programming	\$15.00
8080A/8085 Assembly Language Programming	\$15.00
6502 Assembly Language Programming — Leventhal	\$15.00
8089 1/0 Process handbook — includes 8289 Bus Arbiter	\$7.15
Pet and the IEEE 488 Bus (GP1B) — Fisher & Jensen	\$18.00
Pet/CBM personal computer guide—Donahue & Enger	\$18.00
CRT Controller Handbook — Gerry Kane	\$7.15

### New Books from T.A.B.

Complete Handbook of Robotics — Safford, Jr	9.95
Master IC Cookbook — Hallmark	\$12.50
Antenna Construction for Ham, CB & SWL	\$7.50
Beginners Guide to Computers & Microprocessors with Projects	\$8.50
Master Handbook of 1001 Practical Electronic Circuits	\$17.50
Master Handbook of 1001 More Practical Electronic Circuits	\$15.95
Towers International Transistor Selector	\$12.50
How to Build Your Own Working Robot	
Pet — DaCosta	\$8.50
The Active Filter Handbook — Tedeschi	\$8.50
Complete Handbook of Radio Receivers — Carr	\$10.95
Complete Handbook of Radio Transmitters — Carr	\$10.95
The Complete Handbook of Magnetic Recording — Jorgensen	\$13.50
How To Design & Build Your Own Custom TV Games — Heiserman	\$13.50

### American Radio Relay League

ARRL Antenna Handbook	\$8.30
The Radio Amateur's License Manual	\$6.80
FM & Repeater for the Radio Amateur	\$8.80
Single Sideband for the Radio Amateur	\$8.00
Ham Radio Operating Guide	\$7.20
Electronic Data Book	\$7.20
Solid State Design for the Radio Amateur	\$9.80
ARRL Antenna Anthology	\$6.80

### Microprocessor Books

The Basic Handbook — Lien	\$17.95
Learning Basic Fast — DeRossi	10.95

Just a few of the thousands in stock. Call in or write. Prices subject to fluctuation. Correct at time of going to press.

If the book you require is not listed below, it can be ordered from us.

6502 — Applications Book — Zaks (Sybex)	18.20
6502 — Software Design — Scanlon	14.20
TRS-80 BASIC — A self-teaching Guide — Albrecht, Inman & Zamora	12.55
TRS-80 Interfacing Book I — Titus	\$11.95
Microprocessor Interfacing Techniques — Zaks & Lesea-Sybex	\$16.95
Practical Microcomputer Programming The M6800 — Weller	\$36.55
Some common basic programs for the pet — Cassette	\$18.00
Some common basic programs for the TRS-80 — Cassette	\$18.00
Basic programming primer — Waite & Pardee	\$12.70
Computers & computing — Australian Yearbook 1980 ETI	\$4.95
Introduction to low resolution graphics — (Scebi)	\$12.95
Microcomputer interfacing with the 8255 PPI chip — Goldbrough	\$12.70
6502 software gourmet guide & cookbook — (Scebi)	\$14.25
8080/8085 software design book 1 — Titus, etc	\$13.60
8080/8085 software design book 2 — Titus, etc	\$13.50
TEA: an 8080/8085 co-resident/assembler — Titus	\$12.70
Z-80 microcomputer handbook — Barden	\$11.95
Z-80 microprocessor programming & interfacing book 1 — Nichols etc	\$15.60
Book 2 — Nichols etc	\$17.80

### Howard W. Sams Books

TTL Cookbook (Lancaster)	\$12.95
TV Typewriter Cookbook (Lancaster)	\$13.50
The Cheap Video Cookbook (Lancaster)	\$7.95
Active Filter Cookbook (Lancaster)	\$17.95
Transistor Substitution Handbook	\$7.95
TTL Cookbook — Lancaster	\$12.95
IC Op Amp Cookbook — Jung — New 2nd Edition	\$19.95

### Pianos, Organs etc.

The Art of Organ Building — Audsley Volume II	\$17.50
The Organ — Its Evolution, Principles of Construction and Use — Sumner	\$29.95
The Cinema Organ — Reginald Foot	\$9.30
The Reed Organ: Its Design and Construction — Milne	\$6.00
Piano Servicing Tuning & Rebuilding — Arthur Reblitz	\$19.15
Player Piano Treasury — Harvey Roehl	\$20.00
Harpichord design and construction — Kern	\$25.00
Restoring & Collecting Antique Reed Organs — Presley	\$10.95

### Other Titles

Practical Guide for Concert Sound — Hell	\$13.35
Tilt — The Pinball Book — Tolbert Home	
Maintenance, History, Hot Tips	6.95
Questions & Answers for the Novice Licence — Westlake Radio	\$5.95
Electric Guitar Amplifier Handbook — Darr	\$15.00
73 Dipole and Long-wave Antennas (Edward M. Noll)	\$7.50
73 Vertical, Beam and Triangle Antennas	\$7.80
Basic Television — Principles and Servicing — 4th Edn (Bernard Grob)	\$18.75
The World in My Ears — Cushen	\$15.95
Beam Antenna Handbook — New 5th Edition (William I. Orr & Stuart D. Cowan)	\$5.95
Better Shortwave Reception — New 4th Edition (William I. Orr & Stuart D. Cowan)	\$6.60
All about Cubical Quad Antennas — Amateur Radio Theory Course — Ameco	\$8.70
Electronic Projects for Musicians — Anderson (Guitar Player Pubs)	\$9.95
Ham & CB Antenna Dimension Charts, Noll	\$3.20

MAIL ORDERS BY RETURN

PLEASE ADD 90c per parcel postage (Vic)  
\$1.70 per parcel interstate

TECHNICAL BOOK & MAGAZINE CO.

295-299 Swanston St., MELBOURNE 3000. Ph. 663 3951.



# NEW PRODUCTS

## Kaise SK-6110 digital multimeter

Standard Components Pty Ltd have just released the Kaise range of low cost digital multimeters. Equally suited to the professional or hobbyist, the range of four meters all have large liquid crystal displays, plus comprehensive input and overrange protection. We reviewed the top-of-the-line model Kaise SK-6110.

Designated the SK-6110 Digital Multitester, the meter comes in a light impact-resistant case measuring 83 x 153 x 35mm (W x H x D) including knobs and feet. Mass is just 250 grams. A large rotary knob and three keyswitches allow function selection while a separate on/off switch is provided which can also switch the alarm facility off.

The meter operates from two size AA cells and has a claimed battery lifetime of 300 hours, continuous operation. The unit is supplied with a pair of test leads, a spare fuse and an instruction manual.

The liquid crystal display is a high contrast type and is visible over a wide range of viewing angles. Over-range indication is by a "flashing 1" which is displayed at the most significant digit. Polarity indication is with a minus symbol.

The function selector gives a positive feel at each position and selects 200mA, 20mA/10A, Ohms and Volts. Ranging and AC/DC selection is done with the separate keyswitches which are labelled AC/DC, LO Ohm/Ohm; Range; and Zero Adjust.

The AC/DC, LO Ohms/Ohms keyswitch allows selection of either AC or DC measurement when the volts function is selected. At first switch-on, the display defaults to DC and Automatic Ranging. One push of the above mentioned switch will provide an AC Auto-Ranging measurement and "AC" is then shown on the display. A second push of the switch will provide DC measurement again.

When the function switch is in the "Ohms" mode, the display defaults to Auto and Ohms. A push of the LO Ohms/Ohms keyswitch will provide the Low-Power Ohms selection. A further push of the switch will bring the measurement back to normal Ohms once more. This Low-Power Ohms is very useful for measuring in-circuit resistors, as the low current will not turn on any diode junctions likely to affect the reading.

The Range keyswitch disables the Auto

Ranging and allows the selection of the available ranges. Each push of the switch moves the decimal point along in a cyclic fashion. A change in decimal point by a factor of 1000 will alter the display to show the correct units. (For example, k ohms and mA can be displayed.) To retrieve Auto Ranging, the Range switch is pressed for a few seconds.

The Zero-Adjust keyswitch allows measurement to start from a particular value to provide an offset and can be used to zero the "ohms" measurements as well as the 200mV DC range.

The meter has an alarm for continuity checks. This is a useful feature allowing the user to check a circuit without watching the display. The response time for the alarm to sound is over one second. The alarm also operates as an overload warning and range switch warning.

DC voltage ranges are 200mV, 2V, 20V, 200V and 1000V on both the Auto Ranging and manual ranges. The AC voltage ranges are 2V, 20V, 200V and 600V. DC and AC current ranges are 20mA, 200mA and 10A. A separate socket is provided for measuring on the 10A range.

The ohms ranges are 200, 2K, 20k, 200k and 2000k for the normal ohms range and all are available on the LO Ohms range except for the 200 ohms.

Accuracy of the SK-6110 is reasonably good. Accuracy of the DC voltage range is claimed to be  $\pm 0.5\%$  of reading  $\pm 0.2\%$  of full scale. The accuracy of the AC voltage ranges is  $\pm 1\%$  of the reading  $\pm 0.4\%$  of full scale for the 2V range and  $\pm 1\%$  reading  $\pm 0.25\%$  full scale for the other ranges. DC current has a claimed accuracy of  $\pm 1\%$  of reading  $\pm 0.2\%$  of full scale. The AC current ranges are a little higher at  $\pm 1.3\%$  of reading  $\pm 0.25\%$  full scale.

Accuracy of resistance measurement is  $\pm 0.5\%$  of reading  $\pm 0.2\%$  of full scale for all ranges except the 2000k ohms range of  $\pm 1.8\%$  of reading  $\pm 0.25\%$  of full scale. The LO Ohms range has slightly higher

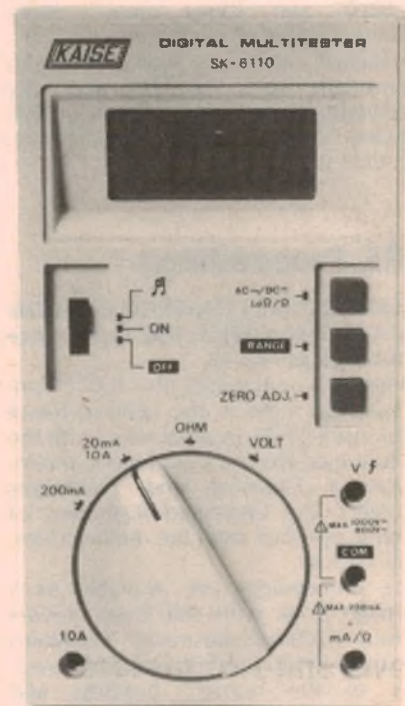

figures of  $\pm 1\%$  of reading  $\pm 0.5\%$  of full scale for all ranges except the 2000k range of  $\pm 2\%$  of reading  $\pm 0.5\%$  of full scale.

We checked the accuracy of the meter and found it to meet the specifications claimed. The frequency response of the meter is claimed to be from 40Hz to 500Hz and we were able to verify this.

We also checked the "normal mode" rejection ratio of the DC voltage ranges. This term is a measure of the rejection ratio of AC voltages superimposed on DC. This was easily tested by using a transformer in series with a DC voltage reference. We noted no change in the DC reading with the AC voltage superimposed on the DC voltage even though the peak AC voltage was as high as the DC voltage.

Overall, the meter is a useful tool for the experimenter and hobbyist as well as for professional use. Its accuracy is not exceptional but the Auto Ranging, continuity checker and 10A range make the meter an attractive unit.

The price of the Kaise SK-6110 is \$131.37 including tax. The Australian distributors are Standard Components Pty Ltd, 10 Hill Street, Leichhardt, NSW 2040. (J.C.)

## 90GHz GaAs FETs

Mitsubishi Electric Corporation has released its MGF series of low noise Gallium Arsenide FETs and low noise FET amplifiers in Australia. The MGF series uses an N channel Schottky barrier gate, and the hermetically sealed metal and ceramic packages assure minimum parasitic losses and are suitable for mounting directly in microstrip circuits. The maximum frequency of oscillation of the FETs is given as 90GHz.

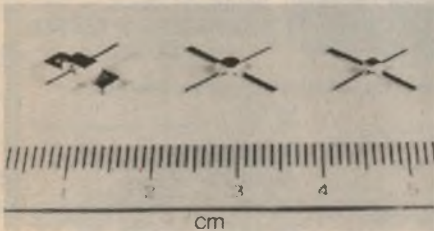

The main application for these devices is in satellite to ground broadcast reception, and they are particularly suited as first stage amplifiers in satellite ground station receivers. The high efficiency, low noise FETs can also be used in microwave burglar alarms, door sensors and other products.

Complete low noise amplifier assemblies are also available from Mitsubishi, designed for use in satellite communications earth stations. For details contact Melco Australia Pty Ltd, PO Box H129, Australia Square, Sydney, NSW 2000.

## New range of meters



C & K Electronics (Australia) Pty Ltd now has available a wide range of taut-band, moving coil analog meters from Sifam of England.

Sifam meters are available as DC or AC voltmeters, millivoltmeters, ammeters, milliammeters and microammeters, and for special requirements such as decibel meters and temperature indicators. Apart from the standard pointers and scales fitted to the meters many other types of pointers are available and scale markings, including colour printing, can be provided to suit individual applications. Customer's names and logos will be printed on dials as required.

C & K Electronics has also announced

that it has appointed GHE Electronics, of Argyle St, Hobart, and York St, Launceston, as its agent for Tasmania, carrying the full range of switching and connector products handled by C & K.

A new catalog outlining the total range of switching devices manufactured by C & K of America has been released. The 71 page catalog is offered free of charge on application to C & K Electronics (Aust) Pty Ltd, PO Box 101, Merrilands, NSW, 2160.

## Sunnex low voltage work lamp

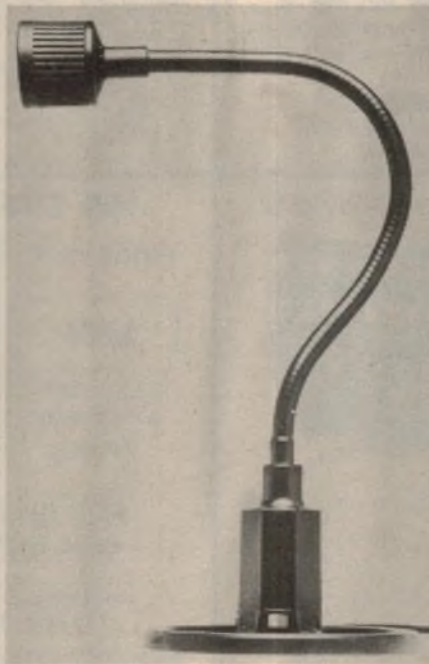

The Sunnex low voltage work lamp, from Consolidated Ultrasonics (A'asia) Pty Ltd, is said to be ideal for close work which requires intense light. The lamp operates from 12 volts, and the halogen bulb draws only 20 watts, yet it has an output of 4400 lux at 40cm, compared to 850 lux from a standard 80 watt bulb at that distance.

The lamp is mounted on a rubber sleeved flexible arm which can be adjusted through 360° vertically or horizontally. The lamp housing itself is small and will not obstruct the work area, and the lamp can be supplied with various forms of mounting — screw on, C-clamp, magnetic, or table base.

More information, and a catalog of their complete product range, is available from Consolidated Ultrasonics (A'asia) Pty Ltd, 77 Allen Street, Leichhardt, NSW 2040.



**More  
New Products ▶**

# Coming Next Month\*

## At last! The Nova 80 Computer



Yes folks, it has finally arrived! After seeing it in the DSE catalog a year ago, after all the rumours about the "Never 80", it has materialised and we shall present the first article on this highly competitive single-board Z80 computer with BASIC interpreter in the May 1981 issue. It will have been worth waiting for!

Some of the Nova 80's features are: full-sized ASCII keyboard, RF modulator output to TV monitor, S-100 buss, up to 48K of RAM.

## WIN A MARANTZ CASSETTE DECK or FM/AM TUNER!

We're having a competition and you can win either a Marantz ST-510 quartz-synthesized FM/AM tuner with microprocessor-controlled tuning or a Marantz SC-5010 stereo cassette deck. Two of these prizes are up for grabs so make sure you get your entry in.

\*Our planning for this issue is well advanced but circumstances may change the final content. However, we will make every attempt to include the articles mentioned here.

# ROD IRVING ELECTRONICS

425 HIGH STREET, NORTHCOTE 3070, MELBOURNE, VICTORIA.

## S100 COMPUTER PRODUCTS

### 16K EPROM CARD-S 100 BUSS



**\$89.50**  
**KIT**

FIRST TIME OFFERED!  
BLANK PC BOARD - \$39

USES 2708's!

Thousands of personal and business systems around the world use this board with complete satisfaction. Puts 16K of software on line at **ALL TIMES!** Kit features a top quality soldermasked and silk-screened PC board and first run parts and sockets. Any number of EPROM locations may be disabled to avoid any memory conflicts. Fully buffered and has WAIT STATE capabilities.

OUR 450 NS 2708'S  
ARE \$6.95 EA. WITH  
PURCHASE OF KIT

ASSEMBLED  
AND FULLY TESTED  
ADD \$36

### 32K S-100 EPROM CARD

**NEW!**



**\$99.95**

KIT  
USES 2716's  
Blank PC Board — \$45  
ASSEMBLED & TESTED  
ADD \$30

SPECIAL: 2716 EPROM's (450 NS) Are \$11 EA. With Above Kit.

#### KIT FEATURES:

- |   |   |
|---|---|
| 1. Uses +5V only 2716 (2Kx8) EPROM's          | 7. Any or all EPROM locations can be disabled                   |
| 2. Allows up to 32K of software on line!      | 8. Double sided PC board, solder-masked, silk-screened          |
| 3. IEEE S-100 Compatible                      | 9. Gold plated contact fingers                                  |
| 4. Addressable as two independent 16K blocks  | 10. Unselected EPROM's automatically powered down for low power |
| 5. Cromemco extended or Northstar bank select | 11. Fully buffered and bypassed                                 |
| 6. On board wait state circuitry if needed    | 12. Easy and quick to assemble                                  |

### 16K STATIC RAM KIT-S 100 BUSS

KIT \$229  
A&T \$259

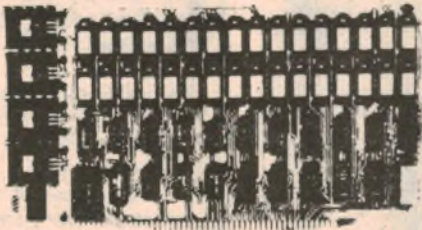

#### KIT FEATURES

- Addressable as four separate 4K Blocks
- ON BOARD BANK SELECT circuitry (Cromemco Standard) Allows up to 512K on line
- Uses 2114 (450NS) 4K Static Rams
- ON BOARD SELECTABLE WAIT STATES
- Double sided PC Board with solder mask and silk screened layout Gold plated contact fingers
- All address and data lines fully buffered
- Kit includes ALL parts and sockets
- PHANTOM is jumpered to PIN 67
- LOW POWER under 1.5 amps TYPICAL from the +8 Volt Buss
- Blank PC Board can be populated as any multiple of 4K

BLANK PC BOARD W DATA \$49

LOW PROFILE SOCKET SET \$19

SUPPORT IC'S & CAPS \$27

ASSEMBLED & TESTED ADD \$30

OUR #1 SELLING  
RAM BOARD!

### 16K STATIC RAM SS-50 BUSS

PRICE CUT!

**\$229**

FULLY STATIC  
AT DYNAMIC  
PRICES

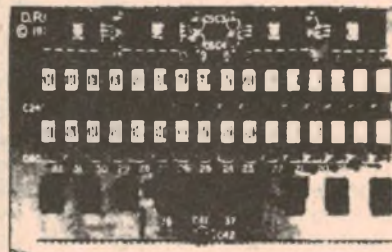

FOR SWTPC  
6800 BUSS!

ASSEMBLED AND  
TESTED - \$30

#### KIT FEATURES

- Addressable on 16K Boundaries
- Uses 2114 Static Ram
- Runs at Full Speed
- Double sided PC Board Solder mask and silk screened layout Gold fingers
- All Parts and Sockets included
- Low Power Under 1.5 Amps Typical

BLANK PC BOARD — \$45 COMPLETE SOCKET SET —  
\$19 SUPPORT IC'S AND CAPS — \$45

### ITHO Model 8300 PRINTER. \$810 plus 15% sales tax.

This 80-column printer provides quiet operation, making it suitable for use in offices, classrooms and homes. Specifications include 125 cps, 60 lines per minute, paper loading from bottom or rear and Centronics-compatible, parallel interface.

A bidirectional, dot matrix impact printer with a print head designed for 100 percent duty operation, assuring a print life that exceeds 100 million characters. The precision sprocket-feed mechanism permits printing forms from 4 1/2 to 9 1/2 inches wide. A 96 ASCII character set prints in upper and lowercase with the added capability of producing double-width fonts in boldface. The vertical format unit provides preprogrammed/programmable tab positions, top of form and bottom of form for complete formatting capabilities.

### ETI636 7 SLOT MOTHERBOARD WITH ACTIVE TERMINATION

Kit of Parts \$79.00 Assembled and tested \$105.00 inc. tax.  
RITRON COMPUTER GRADE POWER SUPPLY: +5V Reg. 10A,  
± 16V Unreg. Kit of parts \$79.95 inc. tax. A&T \$99.95 inc. tax.

Write for list of other power supplies. Tax free prices also available.

### JUST WRAP KIT - JWK-6 \$39.50

• 50ft ea blue, white, red, yellow wire • Just Wrap Tool • Unwrap Tool

### \*\*\* AVAILABLE AGAIN \*\*\*



- 16K Dynamic Ram Board
- Fully Expandable to 64K
- Assembled, tested and guaranteed
- \$100 Compatible

16K Dynamic RAM Board assembled and tested:  
Special \$269 plus tax (2MHz), \$299 plus tax (4MHz)  
This must be the best offer available on quality tested  
dynamic RAM boards

32K Assembled and tested	\$309 plus tax (2MHz)
	\$339 plus tax (4MHz)
48K Assembled and tested	\$349 plus tax (2MHz)
	\$379 plus tax (4MHz)
64K Assembled and tested	\$389 plus tax (2MHz)
	\$419 plus tax (4MHz)

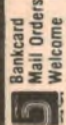

Please debit my Bankcard.  
Bankcard No.  
Expiry Date  
Name  
Signature

General enquiries (03) 488-8131. Mail order enquiries (03) 481-1438. Ritronics Wholesale (03) 488-7099.

Prices current till May 15, 1981. Heavier items add additional postage. Extra heavy items sent Comet freight on. Prices subject to change without notice. Send 60c and SAE for free catalogues. MAIL ORDERS PO BOX 135, Northcote, Vic 3070. Minimum pack and post \$1.

## New Products

### An Easter sample bag from Jaycar

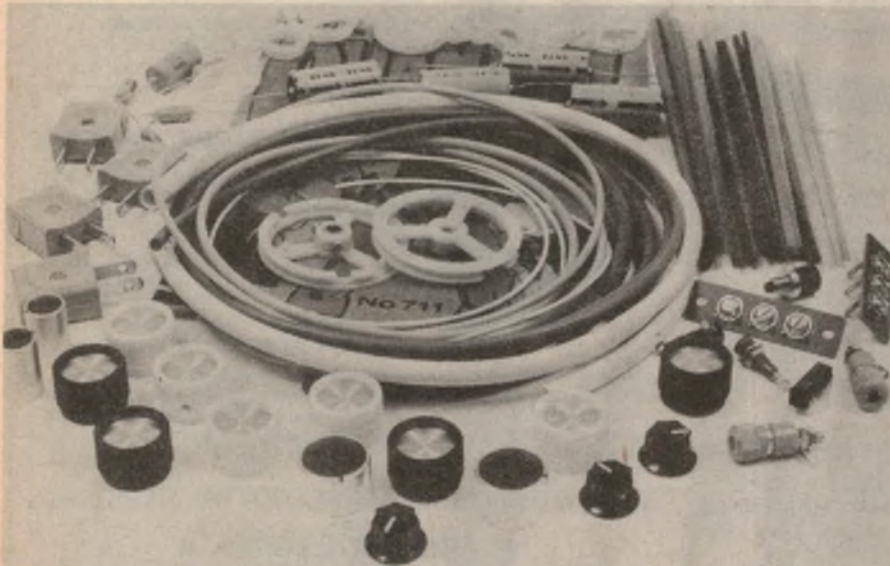

Jaycar Pty Ltd is celebrating Easter, and Jaycar's customers will reap the benefit. Illustrated above is the contents of the Jaycar sample bag which will be available to every customer over Easter. The bag includes seven packs of assorted knobs, connection hardware, polyester sleeving, grommets and a mystery kit — a small electronic project which can be assembled by anyone with a minimum of experience. Also included is a TMS 4030 dynamic RAM, a Phantom comic, and for those with a sweet tooth, an all-day sucker.

Retail value of the sample bag contents is claimed to be over \$50. Price is just \$4.50 (P&P \$1.00).

Jaycar is currently building a new, greatly expanded store at the same Sydney site, designed to cater for the hobbyist who requires the widest possible range of kits and components. Metalwork, PCBs, transformers and parts will be stocked for most EA projects, in addition to a complete range of semiconductors and ICs.

A catalog is currently in preparation, and should be available in July. Readers can have their name entered on the Jaycar mailing list by writing or calling in to Jaycar Pty Ltd, 380 Sussex St, Sydney 2000. If you call in don't forget your sample bag!

### New Philips PM2528 5½-digit DMM

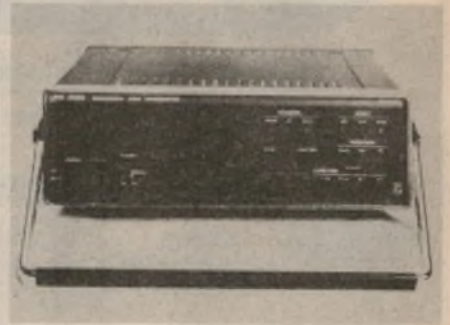

Philips Test & Measuring Instruments has introduced a new 5½-digit "systems oriented" multimeter. The new PM2528 measures DC and true rms AC voltage, DC and AC currents, resistances, temperatures, and optionally, high frequency and peak voltages.

Maximum reading of the instrument is 240,000 with 1μV resolution and 0.02% ±1 digit accuracy. Low level current measurements may be made with 100 picoamp resolution, and true rms measurements can be made on signals with frequencies up to 100kHz with the standard model, and 700MHz with special options.

"Systems oriented" means that the instrument is designed to be used with other equipment, possibly with computer control. Full remote control of all functions is available via an IEC instrument bus interface connector, and both normal and high speed operating modes are provided for automatic measurement taking.

For more information on the PM2528 contact Philips Test & Measuring Instruments, 25 Paul St, North Ryde, NSW 2113.

### Belt drive switch reduces fire risk

Swann Electronics International Pty Ltd recently announced a belt drive cutout switch designed to cut off the power to electrical machinery in the event of the drive belt breaking. The switch is installed under the belt tensioner or idler pulley spring, and responds to a belt breakage by immediately switching off the power to the driving motor, preventing any fire risk or damage to the machinery and motor.

The cutout switches are rated at 250V at up to 15 amps, and can withstand temperatures of 105°C. They measure 36mm × 12.5mm × 13.5mm, making them suitable for mounting in virtually any type of machinery.

For more information contact Swann Electronics International Pty Ltd, PO Box 350, Mt Waverley, Vic 3149.

## CHECK 'EM IN CHECK 'EM OUT

### WITH NEAL-FERROGRAPH'S LOW COST AUDIO TEST EQUIPMENT

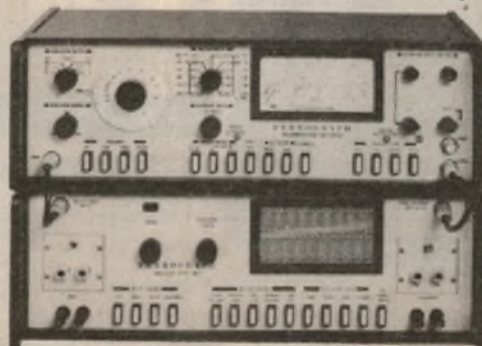

PUSH BUTTON ANSWERS FOR:—

- Distortion
- Wow & Flutter
- Gain
- Frequency Response
- Drift
- Sensitivity on all Amplifiers, Tape Recorders, Dolby™ Filters, and other equipment.

FULL SPECIFICATIONS & INFORMATION FROM:—

**BRITISH MERCHANDISING PTY LTD**

**49 YORK STREET, SYDNEY.**

**Tel: 29 1571 Tlx: 24922**

## ELECTRONICS CENTRE

BARGAIN PRICES • PERSONAL ATTENTION • SLICK MAIL ORDER SERVICE • SATISFACTION

• WARNING •  
After April 1982.  
Price Rise



**ETONE  
12" SPEAKER  
SPECIAL**

**GUARANTEED TOP QUALITY  
BRAND NEW BARGAIN**

Rugged diecast frame  
8 and 15 ohms available  
**12" Woofer, 30 Watts RMS**  
Resonance 65Hz  
Freq response 50-8000Hz  
**\$21.00 each or 2 for \$37.95**  
**12" Twin Cone, 30 Watts RMS.**  
Resonance 65Hz  
Freq respon 50-15kHz

**\$22.00 each or 2 for \$39.95**

	Speaker	NSW	Interstate
Pack	1	\$2.00	\$2.75
Post	2	\$2.75	\$3.75

### MOTOROLA TOP GRADE 2N3055 TRANSISTORS

10 for \$7.75 P.P. NSW \$1.50  
INTERSTATE \$2.50  
MOUNTING KITS — CHROME  
NUTS, BOLTS, WASHERS, MICA.  
10 for \$2.50 P.P. 75c

### FM WIRELESS MICROPHONES



NO CABLE TO TRIP OVER  
OPERATE WITH FM RECEIVER,  
88-106MHz

MINI MODEL WMI  
100H x 35W x 25D mm  
**\$11.95 P&P \$1.00**

UNIDIRECTIONAL MODEL  
(ILLUSTRATED) **\$34.75 P&P \$2.50**  
OMNIDIRECTIONAL MODEL  
**\$26.75 P&P \$2.50**

TIE TACK MODEL WITH SEPARATE  
POCKET SIZE TRANSMITTER  
**\$39.95 P&P \$2.50**

SEND SAE FOR TECH DATA

### • SUPER SCOOP • 15" PLESSEY FOSTER HIGH POWER SPEAKERS

BASS-LEAD GUITAR • Hi Fi • PA •  
Organ • Electric Piano etc •  
180 Watts Cont. 240 Watts Peak  
Model C380K60 16 OHMS ONLY  
40-4500Hz  
Model C380K61 8 OHMS ONLY  
40-4000Hz

**\$95** P.P. NSW \$4.50 SA. Q.  
EACH V. T. \$6.75. WA. NT \$9.75

## BSR

WORLD'S LARGEST MANUFACTURER  
RECORD CHANGERS/PLAYERS

MODEL P-200

### BELT DRIVE STEREO PLAYER



MECHANISM AND CARTRIDGE ONLY.  
P-P NSW \$4.50  
V. Q. SA. T. \$5.50  
WA. NT. \$6.50

**\$105**  
**\$137.50** OR MOUNTED IN  
STYLISH CABINET  
WITH PERSPEX COVER

**\$137.50** P-P NSW \$6.50  
INTERSTATE \$8.50

Specs. 240VAC 50Hz, auto or manual operation • Plays 17, 25, 30cm (7, 10, 12in) records • 33 and 45 rpm, adjustable counter weight and stylus pressure • cueing lever • Bias compensator and anti skate control • Big platter with mat • RCA audio plugs and cable, 3-core power cable and plug • High quality ADC magnetic cartridge • Diamond Stylus • Cut-out Template, instruction book •

AN EXTRAORDINARY OPPORTUNITY TO OWN A TRULY PROFESSIONAL SET

### • MURPHY EX-RAN •

• **B40 COMMUNICATION RECEIVERS** •  
Good clean condition, but not air-tested. 240VAC 50Hz operation. 6 Bands. 640kHz to 30.5MHz Variable selectivity. 2 RF and IF stages Crystal gate Band spread. Circuit LIMITED STOCKS.

**\$89** PACKING AND CARTAGE TO RAIL OR ROAD HEAD \$20.  
FREIGHT EXTRA OR FON  
• A FEW 5 BAND 15KC-700KC B41 RECEIVERS AVAILABLE —  
SAME PRICE.

# Danish design. Peerless precision.



Loudspeakers from Peerless make your present system sound like new.

Not only will the new precision-built Peerless PAS series improve the sound from your present system, but the beautiful Danish designed natural wood-veneer cabinets complement any interior.

Now you can enjoy tight clean bass responses, with accurate mid-range and crisply defined treble notes.

The new mini Peerless models PAS 20 and 30 are designed for shelf use (upright or horizontally) while models PAS 40, 50 and 80 are floor standing speaker systems. All models handle up to 100 watts RMS inputs.

Contact us now and discover where you can hear Peerless loudspeakers — then let your ears make up your mind.



G.R.D. GROUP Pty. Ltd.

698 Burke Rd. Camberwell, Victoria 3124  
Telephone: (03) 821256 Telex 31712

P1380

Please send me literature and dealer list on the PAS Loudspeakers.

NAME \_\_\_\_\_

ADDRESS \_\_\_\_\_

POSTCODE \_\_\_\_\_



## New Products

### VHF-UHF Communications Receiver

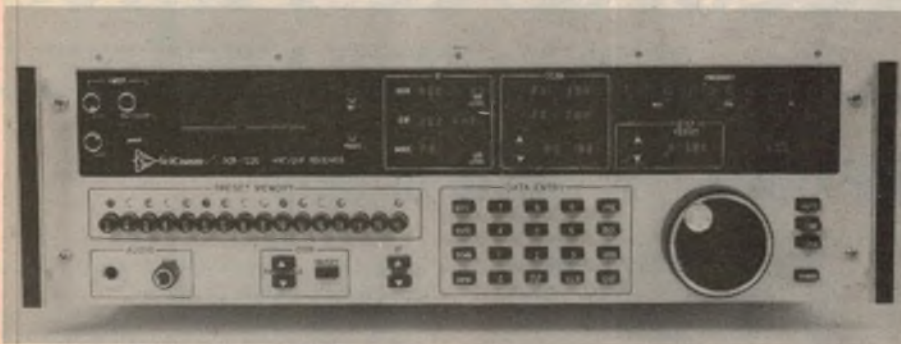

Vicom International Pty Ltd, Australian agents for SciComm Inc of the United States, currently have available the new SCR-7220 VHF-UHF receiver from that company.

The SCR-7220 is a general purpose digitally controlled communications receiver designed to provide search and monitoring capabilities for signals in the frequency range of 20 to 1200MHz. The control section of the receiver uses a 6809 microprocessor to provide versatile operation, including an RF scanning capability, memory storage of preset receiver conditions, memory scanning capabilities, and the ability to act in a

master/slave configuration with other receivers using a similar bus structure.

The receiver is designed to be used as a stand alone unit or as an integrated part of a larger system. The standard model provides for manual, semi-automatic and full automatic control. In the manual (or local) mode, the operator controls the receiver directly. In the semi-automatic operating mode the receiver will scan between two preset frequencies, or scan over a fixed dispersion centred on the selected tuned frequency.

In the automatic mode of operation all the functions of the receiver are remote-

ly controlled via the IEEE-488 bus connector provided.

For further information contact Vicom International Pty Ltd, 68 Eastern Rd, South Melbourne, Vic 3205, or 339 Pacific Highway, Crows Nest, NSW 2065.

### PCB mounting rotary switch from ICS

ITT Jeanrenaud has released a new rotary switch designed for printed circuit board mounting and available through Instant Component Service, the marketing division of ITT-Cannon Components. The new switch, the RT.A, is a flat package with pins set on a pitch of 2.54mm, and can be supplied with a screwdriver slot or standard knob, with an adjustable stop, and with solder tags instead of the PCB mounting pins.

Also available from ICS is a range of "Circuitboy" subminiature toggle switches from Nikkai of Japan. The range is available with standard, short, flat or straight flat toggles, with straight, right angle and vertical mounting brackets. One of the features of the range is that they are "washable", being hermetically sealed to prevent the entry of flux, dust or cleaning fluid. Contact rating is .4VA max at a maximum voltage of 28V. A complete catalog is available on request.

For further information contact Instant Component Service, 248 Wickham Road, Moorabbin, Vic 3189.

## ENTER THE '80s WITH

# UNI-BOARD



## THE "UNIVERSAL" CIRCUIT BOARD

SIZES	Fiberglass
SINGLE MODULE PACK 5 x 6.3cm (2" x 2 1/4")	\$2.60
TWIN MODULE PACK 5 x 11.5cm (2" x 4 1/2")	\$3.80
SIX MODULE PACK 16.5 x 11.5cm (6 1/2" x 4 1/2")	\$9.90

ALL BOARDS FULLY DRILLED ON 0.1" MATRIX WITH PRE-SOLDERED TRACKS

### AVAILABLE FROM

#### NSW

Radio Despatch Service,  
869 George Street,  
Sydney 2000.

Hawkesbury Electronics Centre,  
111 George Street,  
Windsor. 2756.

Tomorrows Electronics & Hi-Fi,  
68 William Street,  
Gosford. 2250.

Trilogy Wholesale Electronics,  
40 Princes Highway,  
Fairy Meadow. 2519.

Pre-Pak Electronics  
1A West Street  
Lewisham. 2049.

#### VIC

Tasman Electronics,  
12 Victoria Street,  
Coburg. 3058.

David Reid Electronics,  
Lonsdale Street,  
Melbourne. 3000.

Stewart Electronic Components,  
118 Lonsdale Street,  
Melbourne. 3000.

All Electronic Components  
118 Lonsdale Street,  
Melbourne. 3000.

Ray Cross Electronics,  
151 Boronia Road,  
Boronia. 3155.

Kalex Electronics,  
101 Burgundy Street,  
Heidelberg. 3084.

QLD  
Amateurs Paradise,  
Cnr Scarborough & Nind Streets,  
Southport. 4215.

Tableland Radio Service,  
47 Toiga Road,  
Atherton. 4833.

Keller Electronics,  
218 Adelaide Street,  
Maryborough. 4650.

ACT  
George Brown & Co Pty Ltd.

23 25 Whyalla Road,  
Fyshwick. 2600.

#### WA

Atkins Carlyle Ltd,  
1-9 Milligan Street,  
Perth. 6000.

#### TAS

Kingston Electronics & Records,  
Channel Court,  
Kingston. 7150.

Advanced Electronics,  
5A The Quadrant,  
Launceston. 7250.

Aero Electronics,  
131 Bathurst Street  
Hobart. 7000.

## INTRODUCING THE NEW

# BASIC-BOARD

A "VERO" TYPE BOARD  
IN

## FIBREGLASS

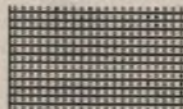

SIZES:	
17" x 3"	\$7.99
8 1/2" x 6"	\$7.99
3" x 5 1/2"	\$2.99

INTRODUCTORY PACK (AVAILABLE ONLY ON MAILORDER) \$3.90.

Consisting of: 1 BASIC BOARD 17" x 3"  
1 UNI-BOARD TWIN PACK

### OR MAIL ORDER DIRECT

TO: ADVANCED ELECTRONIC SYSTEMS PTY LTD,  
MONMIA BUILDING,  
7/378 GLENHUNTLY ROAD,  
ELSTERNWICK. 3185  
Phone: (03) 523 9098

Please supply:  
UNI-BOARDS @ \$ ea.  
BASIC-BOARDS @ \$ ea.  
INTRODUCTORY PACK @ \$ ea.

I also enclose 70c P & P

Name

Address

PICode



REVIEWS OF RECENT

# Records & Tapes

CLASSICAL • POPULAR • SPECIAL INTEREST

## DEBUSSY TRANSCRIPTIONS: "A waste of time"

**TRANSCRIPTIONS — Debussy. L'Après-midi d'un Faune; Berg. Adagio; Schonberg. Kammer-symphonie. Played by the Boston Symphony Chamber Players. DG Stereo Disc 2531213.**

Transcriptions from one instrument or combination of instruments, as written by the composer, to different mediums — or media — have been permissible — even fashionable — at least since the baroque days when they received the attention of no less a figure than the great Johann Sebastian Bach.

Some, most often by Bach or Liszt have been memorable works of art. In less skillful hands, others have been deplorable. I place this lot in the latter category.

For instance the transcription of Debussy's L'Après-midi d'un Faune by, apparently, Hanns Eisler — no-one else's name is connected with it — reminds one of the sort of music provided by the best of the silent-cinema bands. This, if you respect the original.

In a work that was so sensitively scored, that it stands out as one of the world's masterpieces of its kind, the difference between French and German appreciation of music in this transcription is not difficult to discern. Just think of Bruckner played in Paris and the reception he would receive, or Poulenc in Berlin.

I must confess that, wherever possible, the transcriber of L'Après-midi has left solo passages on their original instruments; elsewhere it is a mess. Just listen to the piano pretending to be a harp and the tone of the woodwind more suitable to the sound in a Beethoven symphony. My only reaction was one of disgust although I have heard worse!

Some years ago a conductor/arranger who busies himself nowadays on TV and occasionally styles himself "maestro" tried to accompany a couple of indifferent dancers in the old Elizabethan Theatre with a tiny combination attacking the love-potion scene from Tristan.



That indeed was something to remember!

Also on this disc is Schonberg's Kammer-symphonie transcribed for violin, clarinet, cello, flute and piano by Anton Webern. I don't really care much what happens to this ugly little "symphony", although here and there you will hear an

occasional sentimental bar that gives it the illusion of lyrical music.

One must also remember that Webern was a master of the miniscule and reduction to a minimum was no trouble to him. More than one note at a time was often too much for him, while Schonberg's scoring was as dense as uncooked dough. All told, not too much damage is done!

The Alban Berg Adagio from his Piano Concerto, transcribed by himself for piano, violin and clarinet is in no way as outrageous as the others mentioned. In its mediocre way it is not a patch on his later compositions, but it does at least betray that sense of lyricism that he could never quite shake off.

In my opinion this whole exercise is a waste of time, trouble and material. Sorry to seem so negative but that's the way I feel. (J.R.)

## DVORAK Piano Quartets — "delightful companions"

**DVORAK — Piano Quartets Op 23 in D major and Op 87 in E flat. Beaux Arts Trio with Walter Trampler (viola). Philips Stereo Disc 6500452.**

The piano starts this work so loudly that you may be tempted to reduce the gain on your set. Don't do so or you'll throw the rest of the quartet out of balance.

Neither of the works on this disc show any great depth of thought, although they're both delightful companions to have about the house.

The difference in techniques between the two widely separated opus numbers should be noticed even by a tyro, although this is not meant to denigrate the earlier, Op 23. The scoring is rich and varied in both; that in Op 87 shows slightly more resource, but not quite as much as you might expect. As to the playing, well, it comes right up to what one has come to expect from this redoubtable combination. As a small ex-

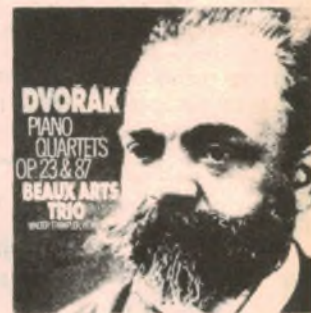

ample, the curious broken rhythms of the Scherzo of 87 are beautifully stressed but never angular.

The writing in the prominent piano part will often remind you of the cembalom, that wide-ranged kind of zither that often figures in Czech and Hungarian music. The guest of the Trio, Walter Trampler, joins the party with complete success, suiting his style and weight admirably to his companions'.

Curiously, Philips have put the later work on Side 1 of this disc instead of the other way round, as one might have expected. If you are interested in what I wrote above about the varying maturity of the works, beware of which one you are listening to, in order that my remarks should make sense.

No. 23 starts modestly and goes along

Reviews in this section are by Julian Russell (J.R.), Paul Frolich (P.F.), Neville Williams (W.N.W.), Leo Simpson (L.D.S.), Norman Marks (N.J.M.), Greg Swain (G.S.), and Danny Hooper (D.H.).

in the same mood until it speeds up into a spirited allegro. It is constantly changing tempo in a beguiling way that never lets the attention wander, in case something extra nice might be missed. These complex changes offer no difficulties to the distinguished players.

The second movement is a set of variations notable for the fact that the melancholy mood of the theme in no way prepares the listener for the enchanting differences in the ensuing variations. And this happens right away, in the very first variation.

The Finale is in a strange form combining the functions of both Scherzo and Finale so successfully that it all sounds very natural and not a bit unusual. And, to be different again, Dvorak casts his Coda in the form of a jig. The sound is splendid. (J.R.)

☆ ☆ ☆

**DVORAK — Piano Concerto in G Minor. Sviatoslav Richter (piano) with the Bavarian State Orchestra conducted by Carlos Kleiber. World Record Club compatible Quadrophonic/Stereo. QRO5474.**

Let's face it: right away, the Bavarian State Orchestra is not up to the very high standard of the same country's radio combination, despite the presence of that fine conductor Carlos Kleiber at the desk.

And there is little said in the sleeve notes about the peculiarities of the piano part, even though it is played by the great Sviatoslav Richter. It is common knowledge among pianists that the composer was never really satisfied with this feature of the work. Indeed, it has been described by one musician as a part written for two right hands. Dvorak fiddled with the piano part so often that it is difficult, unless stated — which it is not — which version is being played!

This is all the more curious because Dvorak wrote very comfortably for the piano elsewhere, especially in his chamber music. He was, himself, a pianist, although not one of any great merit. So, which version Richter is playing remains a mystery — at any rate, to me. Perhaps he is offering a challenge by playing the original clumsy version! But, whichever it is, he is his usual brilliant self, exploiting countless different sonorities, some of them of the most extreme delicacy, almost Chopin-like in the slow movement; elsewhere full of energy but always avoiding harshness.

Whenever he sounds momentarily ill-at-ease, the fault must be attributed to the composer and not his outstanding exponent.

The piano tone is particularly faithful and, if the orchestra cannot be placed among the world's best, it makes a workman like job of the accompaniment. And the cheerfulness of the Finale which both soloist and orchestra seem to enjoy playing brightens up the end. (J.R.)

## DIGITAL BAND MUSIC — traditional folk themes

**FREDERICK FENNEL. THE CLEVELAND SYMPHONIC WINDS. Digitally mastered stereo, Telarc DG-10050. (From P. C. Stereo, PO Box 272, Mt Gravatt, Qld 4122. Phone (07) 343 1612.)**

Frederick Fennell and the Cleveland Symphonic Winds — largely the reed-brass-percussion section of the Cleveland Symphony Orchestra — have already made their mark through Telarc with a Holst/Handel/Bach recording and a group of marches. This recording is completely different again.

It opens with three fanfares by Leo Arnaud — occupying about three minutes in all.

Then follows Toccata Marziale by R. Vaughn Williams and a suite of folk songs: "Seventeen Come Sunday", "My Bonny Boy" and "Folk Songs From Somerset". The thrust of these selections, emphasised in the notes, is the interest in band music displayed by Vaughn Williams and his determination to make a substantive contribution to band repertoire.

Side 2 continues this theme but centres, this time, on Percy Grainger. His



"Lincolnshire Posy" occupies most of the side, being a suite of six compositions based on folk tunes, which Grainger personally captured, first in brief musical notation and later with the aid of a "portable" Edison cylinder recorder. His "Shepherd's Hey", concludes the recital, which is distinguished by the fact that the phrasing seeks to preserve the broken tempos and the verbal nuances of the original songs.

I would imagine that this whole presentation could pose a real challenge to any band keen to explore a more enterprising and "orchestral" sound.

The whole performance of the Cleveland Symphonic Winds is what you would expect, and so also is the technical standard of the recording: clean, well balanced and unstressed in terms of the considerable dynamics. (W.N.W.)

**CIMAROSA — Requiem. Elly Amelin (soprano); Birgit Finnila (contralto); Richard van Vrooman (tenor); Kurt Widmer (bass) with the Chamber Orchestra of Lausanne and the Montreux Festival Chorus conducted by Vittorio Negri. Philips Living Baroque Stereo Series Disc 9502 005.**

Cimarosa is best remembered nowadays as a composer of baroque operas so that it comes as no surprise to find operatic tendencies in his Requiem's solos and duets all nicely varied with the introduction of choruses within and between. I do not write this pejoratively; after all, the same charge of theatricality can be successfully sustained against Verdi in the great Requiem.

But Cimarosa is not without surprises. Who else, for instance, would think of giving the Tuba Mirum to a soprano soloist instead of the usual trombones or other brass instruments. That two horns also enter does nothing to mitigate the surprise. The tameness of the Dies Irae also runs contrary to expectations. Yet somehow, despite these — and other — eccentricities mixed in with the common characteristics of the religious ceremony Cimarosa successfully avoids any hint of triviality.

The production's strength is in the fine quality of the orchestral playing and the beauty of the women's voices; its weakness in the rather woolly chorus singing and a recording that betrays its age.

The work was originally issued 10 years ago and reissued in the same form last year, this last time earning a Grand Prix du Disc de Paris. Not that I pay much attention to the value of this award, ever since it was awarded by General de Gaulle. Whatever interest the good general had in music has never been disclosed — except in the Marseillaise, of course. (J.R.)

☆ ☆ ☆

**MUSSORGSKY — Pictures at an Exhibition. (Ravel orchestration).**

**RAVEL — La Valse. New York Philharmonic conducted by Zubin Mehta. CBS Masterworks Stereo Disc SBR 236010.**

Mehta faces up well to multitudinous competitors in other recordings of this popular suite. Despite this, his reading is more or less a run of mill effort supported of course, by his distinguished orchestra — themselves no strangers to this work on the concert platform and in the recording studio.

Very early in the performance, clarity is achieved at some slight loss of picturesqueness but, by the time the Old Castle is reached, all have settled down into the real mood — or rather moods of the work. Mehta is at his best in expressing, in the Tuileries, the difference between the playing children and the nagging ones. Nor are their nannies neglected in the middle section. You are also immediately aware that you are listening to a great orchestra.

## RECORDS & TAPES — continued

A word of warning though. The recording is very forward so watch how you set your gain.

Unvaried immaculacy is an outstanding feature in the Ballet of the Chicks. And Mehta — together with the composer, of course shows a keen sense of characterisation in Samuel Golden and Schmuyle, the first a rich fur clad Jew of pompous manner, the other a pathetic little nonentity begging a loan — obviously, as expressed in the last bar, unsuccessfully.

The Market Place at Limoges always refreshes me with its restless activities but Mehta takes it a bit too fast for my complete enjoyment. he makes it sound much too showy. His reading of The Catacombs turns it into a fine chorale and I found that the concluding item, the Great Gate of Kieff, needed a bass boost on my equipment.

On the whole the production might be described as useful but others add just a trifle more to that feature.

The fill is Ravel's La Valse in which the clarity of the very low, very quiet opening bars provides something of a novelty. Indeed here, as later, Mehta is never less than completely successful. La Valse is graceful rhythmically and atmospherically and the whole performance so expressive of its subject that you can almost smell the women's scent. (J.R.)

☆ ☆ ☆

**RHAPSODY AND BLUES.** The Crusaders. Stereo, MCA Records, MCA-5124. Astor release, also available on Musicassette.

This double-fold album is strong on artistic design but not as helpful as it might be in terms of actual information.

In fact, the Crusaders, talented negro



musicians Wilton Felder, Stix Hooper and Joe Sample have a long track record as a successful touring group, and as session musicians who have featured in something like 200 gold albums. Singly,

and as a group, they have had about a dozen top-selling albums of their own.

The Crusaders composed the music for the six tracks on this new disc and head up the performance, backed by about 10 other musicians from the Hollywood recording scene.

The opening track "Soul Shadows" features CBS vocalist Bill Withers, reminiscing about jazz greats of the past. The remaining tracks are instrumental, varied in style, predominantly in jazz idiom but punctuated by synthesiser and orchestral like passages. Stix Hooper describes their music as "Gulf Coast".

Track titles are: Soul Shadows — Honky Tonk — Elegant Evening — Rhapsody and Blues — Last Call — Sweet Gentle Love.

The performance is of a very high standard throughout and the recording quality is excellent. Well worth a hearing if the contents appeal. (W.N.W.)

## JAZZ — direct cut

**A NIGHT IN TUNISIA.** Art Blakey and the Jazz Messengers. Stereo, direct-cut, Philips RJD-4. (From MR Acoustics, PO Box 165, Annerley, Qld 4103. Phone (07) 48 7598. \$13.00.)

While it carries the familiar Philips logo, this recording owes its technology solely to Japanese sources. It was recorded in February '79 at the Victor studios in Tokyo and produced under the auspices of Nippon Phonogram.

However, the group itself features Art Blakey (drums), Davis Schmitter (tenor sax), Robert Watson (alto sax), Valery Ponomarev (trumpet), James Williams (piano) and Denis Irwin (bass). As is customary with experienced jazz groups, they betray no sign of tension as they face the demands of two 16-minute non-editable direct cuts.

Side one has one long track only "A Night in Tunisia" (Dizzy Gillespie — Frank Paparelli). There are two tracks on side



two: "Moanin'" (Tomy Timmons — I. C. Hendriks) and the "Blues March" (Benny Colson).

I may as well confess that I am not a devotee of jazz, but the album should please those who are.

The sound is very clean, unspoiled by any hint of distortion, noise of overload. And, if you're inclined to buy, MR Acoustics make it somewhat easier by listing this direct cut at \$13.00, which is about \$6 below what a lot of these audiophile discs commonly sell for. Fine, if it's your kind of music. (W.N.W.)

## CALCULATORS

### APF-8602 Scientific (Advanced)

- 12 Digit Display — 8 Digit Mantissa with sign, 2 Digit exponent with sign.
- Scientific Functions: Sin, Cos, Tan, Sin<sup>-1</sup>, Cos<sup>-1</sup>, Tan<sup>-1</sup>, e<sup>x</sup>, 10<sup>x</sup>, Log, L, Y<sup>x</sup>, X<sup>2</sup>, √x, 1/X, DMS to degree, π
- 2 Levels of parenthesis
- Degree/radians/grads key
- Statistical Functions: mean value, variance, standard deviation
- Normal Distribution
- Permutations & Combinations
- Polar-Rect
- Deg/Rad/Grad Conversions
- Hyperbolics
- Factorial



**\$29.95**

#### DISTRIBUTED BY:

**VICTORIA:** CALCULATOR SUPERMARKET, 435 Bourke St. Melbourne Ph: (03) 67 6412  
 RADIO PARTS GROUP, 562 Spencer St. West Melbourne Ph: (03) 329 7888  
 1103 Dandenong Road, E. Malvern Ph: (03) 211 8122  
**KALEXTRONICS**, 101 Burgundy St. Heidelberg Ph: (03) 458 2976  
 Shop 11, Melton Shopping Centre, Western Highway, Melton Ph: (03) 743 1011  
 Ph: (03) 547 9011  
 SELECTED CHEMWAY CHEMISTS

## COMPUTER WITH COLOUR MONITOR

3 MONTHS GUARANTEE

### LOTS MORE MODELS

12 months guarantee  
 Sales tax exemption for students

Trade enquiries welcome.



### APF 2303 Metric Converter

- Wallet & Batteries included
- Metric — Imperial — US
- Length
- Area
- Volumes
- Temperature

**\$19.95**

**NSW:** AUSTRALIAN ELECTRONIC INDUSTRIES 1-3 Sydenham Road, Brookvale Ph: (02) 938 4243  
**QLD:** CUSTOM COMPUTER SERVICES, 41 Diamond Ave. Kallangur Ph: (07) 204 4995  
**SA:** GRANVILLE DISTRIBUTORS, 2B Gordon St. Glenelg Ph: (08) 295 4779  
**WA:** ELECTRONIC SYSTEMS, PO BOX 828 Fremantle 6160 Ph: (09) 335 7313  
**TAS & NT:** APF ELECTRONICS AUST PTY LTD Ph: (03) 602 4092

# STUDY THIS PAGE



Courtesy A.D.E.. Mt Waverley.

Which ever way you look at it, good support means everything for computers. This desk will give it to you.



Courtesy Dick Smith Electronics, Richmond



Courtesy Terang High School

Features vinyl leather inlay, feed slot for printer paper two deep, spacious drawers, solid construction, excellent value.

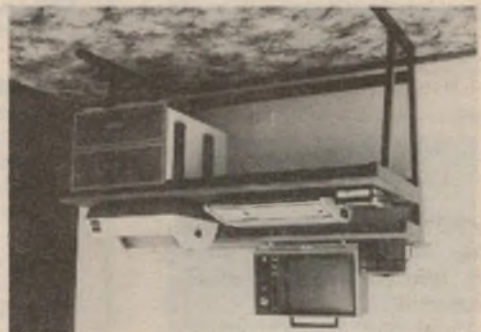

Registered Design No. 82711



Courtesy Rai & Sek Enterprises. Warrnambool.

Just \$170.00, plus freight, will give your system the solid support it deserves.

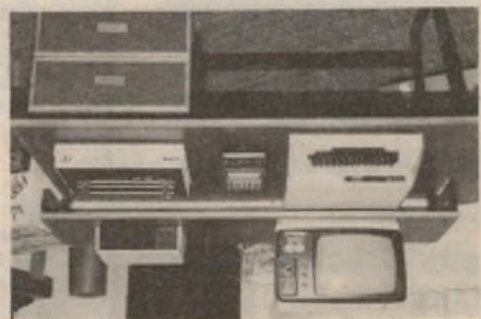

Courtesy Looky Video. Richmond

*Cheque or money order to:*

**D. J. GILLIN**

**TEL: (055) 624376**

**LOT 85, CHERLIN DRIVE,  
WARRNAMBOOL, 3280, VIC.**

## Sensitized Copper Board Riston 3000 Coated

(Fibreglass Base)

	Single	Double
36 x 24	\$45.00	\$57.00
24 x 18	\$22.50	\$30.00
18 x 12	\$12.50	\$16.00
12 x 12	\$ 8.00	\$10.75

OTHER SIZES ON APPLICATION

Developer	\$4.25 litre
Concentrate (1 = 4)	\$9.50 litre

All plus 15% ST & Freight if applicable

*"The **BPF**  
Imagination Machine  
Colour Computer"*

Full business and games capability.  
Console Monitor Power Supply.  
\$865 + ST if applicable.

# KALEX

101 Burgundy St,  
Heidelberg 3084  
(03) 458 2976  
Telex AA37678  
MELTON  
(03) 743 1011

ELECTRONIC COMPONENTS & ACCESSORIES

● SPECIALIST SCHOOL SUPPLIERS

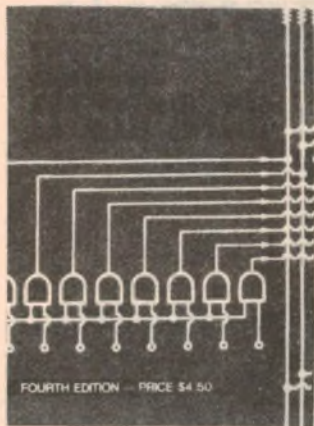

FOURTH EDITION — PRICE \$4.50

*Just off the presses!*

An Introduction to

## Digital Electronics, 4th Edition

You don't need any previous knowledge of digital electronics — this book starts from scratch and covers all the basic concepts you need. Latest edition now includes chapters on anaog-to-digital and digital-to-analog conversion!

Available from "Electronics Australia", 57 Regent St, Sydney. Price \$4.50. Also by mail order from "Electronics Australia", PO Box 163, Beaconsfield 2014. Price \$5.20.

## RECORDS & TAPES — continued

**THE MORRISTON ORPHEUS MALE CHOIR.** Conducted by Ivor E. Sims. World Record Club stereo R 02167.

Ultimately, there is probably no sound more stirring than a large male choir in full voice. But it is also true that such a sound is very difficult to record satisfactorily. That is why I found this disc of the Morriston Orpheus Male Choir particularly satisfying. It is well recorded and is backed by a truly magnificent organ.

In fact, I must go further than that and state that this is the best Welsh choir recording I have ever heard! That is really saying something because the last record of the Morriston Orpheus Male Choir I reviewed some years ago is just not in the same class (although this choir is acknowledged to be one of the world's finest).

If you turn up the sound level as I did, you will notice some tape hiss and some surface prickle, but it is quite easy to get carried away and "turn up the wick" regardless of everything. I enjoyed the record so thoroughly I could not decide

which track I liked the best, but I thought the most utterly heart-wrenching track is "We'll Keep A Welcome". On the other hand, perhaps the Welsh National Anthem "Hen Wlad Fy Nadhau" is the best. I really cannot decide but I can thoroughly recommend the disc.

Apart from the two already mentioned, there are 12 tracks: Land Of My Fathers — Song Of The Jolly Roger — Tydi A Roddaist — Roll, Jordan, Roll — Rock Of Cader Idris — All Thro' The Night — God Bless The Prince Of Wales Aberystwyth — Lullaby (Brahms) — Chorus of Hebrew Slaves (Verdi) — Deus Valutis — The Long Day Closes. (LDS).

☆ ☆ ☆

**BREAKER MORANT.** Music from the film featuring Edward Woodward. Stereo, Cherry Pie CPF-1046. (Cherry Pie Records, PO Box 225, Pennant Hills, NSW 2120. (02) 819 6151.)

This album of film music holds more than the usual interest because of its Australian origin, the publicity which

## Recent devotional releases

**TELL ME THE OLD, OLD STORY.** Tennessee Ernie Ford. Stereo, Word WSB-8841. (From Word Records, Aust, 18-26 Canterbury Rd, Heathmont, Vic 3135.)

Years ago, and at a time when Tennessee Ernie had his own network radio show, there were many who regarded him as the world's leading gospel singer. With his strongly masculine voice and excellent diction, he built this reputation with no gimmickry and no more than merely competent backing.

Inevitably, there will be many who will be glad to have this album of old-time hymns, the more so because, according to the jacket, they do not appear on previous albums:

Tell Me The Old, Old Story — Send The Light — When We All Get To Heaven —



Let Others See Jesus In You — Stand Up For Jesus — Only Believe — Yield Not To Temptation — Are You Washed In The Blood? — Standing On The Promises — Revive Us Again.

The diction is good and, technically, the pressing is well up to normal standards. With these old hymns, arrangements by Jack Fascinato and a frontespiece portrait of Tennessee Ernie, it will have its own appeal as a momento of another era of Gospel music. (W.N.W.)

**GREAT GOSPEL SONGS, Volume 2.** Various artists. Stereo, Word WSB-8843. (From Word Records Aust, 18-26 Canterbury Rd, Heathmont, Vic 3135.)

Although entitled "Great Gospel Songs" this is more like a sampler, to introduce the listener to artists to be heard on other Word albums.

The titles: The Cornerstone (Tom Netherton); Blessed Assurance (orchestral, Anita Kerr); Without A Doubt (B. J. Thomas); Amazing Grace (organ, Billy Preston); Live For Jesus (Honeytree); Special Delivery (Evie); Am I A Soldier Of The Cross (Tennessee Ernie Ford); I'd Rather Have Jesus (Bev Shea); Because

He Lives (The Bill Gaither Trio); My Tribute (Dave Boyer).

Sampler or no, it has the same advantages and disadvantages. Advantage — a variety of music on one album. Disadvantage — the problem of having traditional gospel soloists like Ernie Ford and Bev Shea cheek by jowl with contemporary artists. Or an easy listening orchestra under Anita Kerr one track away from Bill Preston's organ solo, which could be used as the basis of a "guess the tune" competition!

If your tastes are wide, that's fine; if they're not, select another album you're more certain to enjoy in toto. (W.N.W.)

has surrounded the story and film, and the familiarity of the music itself. However, although it looks like a soundtrack album, it strictly isn't. It has been re-arranged and re-recorded for and by Cherry Pie with the requirements of an audio recording in view. And it is a highly successful production.



Featured are: Soldiers of the Queen (vocal, Edward Woodward); The British Grenadiers; Minstrel Boy; The Floral Dance; Sarie Marais (vocal, Stephen Bennett); The Girl I Left Behind Me; At Last (vocal, Edward Woodward); March In "Scipio"; Land of Hope And Glory; Lochaber No More; Cock Of The North; Soldiers Of The Queen.

Contributing to the music is the NSW Police Pipe Band, Pipers Bill Brown and Kevin Metcalfe, the Leonine Consort and Cliff Bingham playing the Sydney Opera House grand organ.

It's more than just a reminder of a successful film. You'll probably end up playing it quite a lot because of the nature and variety of the music and its excellent sound quality. (W.N.W.)

★ ★ ★

**OTHER PLACES OTHER TIMES.** Don Burrows and George Golla. *Cherry Pie* stereo CPF 1043. [PO Box 225, Pennant Hills, NSW 2120. Tel (02) 819 6151].

There is no doubt that the key to modern jazz is improvisation, but for improvisation to "work" the listener must be able to appreciate it. The listener must be carried along with the feeling the musician (or musicians) is trying to extract from the basic theme.

On this record, Don Burrows and George Golla do quite a lot of improvisation but for me it did not quite work. Don and George were too obviously "feeling their way" on several tracks.

That is a little disappointing, because they have certainly provided me with a lot of enjoyment in the past, both on record and in live performance. Recording quality was okay but I suggest you sample a few tracks before you buy to see if it appeals.

Only nine tracks are featured but playing time is about right at 49 minutes in total. The tracks are: Modinha - Brown Shoes Blues - Have You Met Miss Jones? - Colours - Nelly - Other Places Other Times - The Song Is You - Do You Know What It Means To Miss New Orleans - El Dorado. (LDS).

★ ★ ★

**IMPROVISATIONS EAST-WEST.** Rene Clemencic (Flutes) and Chemirani (Zarb). Stereo, World Record Club WRC R-06221.

From the French Harmonia Mundi label, this Club release takes the listener back in time but, more particularly, half-way round the World to the now political hot spot - Iran. But politics has nothing to do with this recording.

Flautist Rene Clemencic here seeks out the source of Persian music, which filtered through the Arab world, to Spain, to the troubadours and to western ears.

He is joined by Chemirani playing zarb, hand drums which can provide intricate rhythmic patterns. Side one is devoted to flute and zarb playing separately and together. Side two has four distinct tracks: solo flute, solo zarb, double solo flute, and flute and zarb.

How the individual will react to the album is a strongly personal matter. The sound is gentle and, to some, will summon the immediate mental picture of a cobra swaying gently to its charms; some will find it merely monotonous; to others it will fulfill the original intention of providing an introduction to the music of Persia - or Iran. You will have to judge for yourself.

The sound quality? Quite clean. (W.N.W.)

## SPECIAL PURCHASES

### NEW PLESSEY-FOSTER & AWA HI-FI SPEAKER SYSTEMS POWER RATING 50 WATTS RMS FREQUENCY RANGE 30 to 18000 CYCLES

This HI-FI speaker system uses the top of the range Foster C00F05 8" woofer which is a free edge cone speaker with a resonant frequency of 27 cycles and a 2" voice coil, weight 3577G (magnet weight 607G) Two AWA 4" tweeters with ceramic magnet & curve-linear cones are supplied also crossover components, grille cloth, innabond lining & cabinet plans. (Cabinet not supplied.)



**\$69.00**

(List price was over \$100)  
Post & packing NSW \$5.50 per kit  
Qld, Vic \$5.50; SA, WA \$8.00 per kit  
Foster C00F05 8" woofer max power  
80W available as separate unit at \$55.50 +  
post & pack as kit.

### RANK-ARENA 2 WAY SPEAKER

- 10 Watts RMS
- 8 ohm impedance
- 8" woofer with tweeter
- Supplied with leads and plugs
- Teak finish

**\$42.00  
PER PAIR**



A similar system available in walnut finish. Dimensions 18"H. 11"W. 9 1/2"D. Freight extra per rail air or road transport

### 56 TRANSISTORS FOR \$4.80 PLUS 12 DIODES P&P \$1.00

**TRANSISTORS.** 24 BC108 general purpose audio, 6 BC 109C low noise audio, 6 TT770 low level amp NPN, 12EM404 silicon rectifiers 400 volt 1 amp. PLUS 20 mixed silicon transistors.

### 100 CAPACITORS FOR \$3.50 Post \$1.00

**CAPACITORS.** 100 comprising approx. equal quantities of Philips tubular polyester (315 series) Polyester film "greencaps" & Styroseal in standard values to 47 mfd with a list price of over \$18.00

### ELECTROLYTIC CONDENSERS P&P \$1.00

3300 UF 75V - \$1.50 2200 UF 50V - 75c upright mounting

### NEW EMI RECORDING TAPE

HI-FI LOW NOISE  
At less than 1/2 list price  
HDP12 5" reel 1,200ft  
double play 2.95 4 for \$10.00.  
PP \$2.00



### EMI SUPER C90 CASSETTES

8 for \$10, P&P \$2.00



### NEW STANDARD BSR RECORD CHANGERS MODEL C129R

**\$36.00**

Fully automatic turntable plays up to six records automatically and single records automatically or manually as required. 11" turntable. Cue & pause control. Record speeds 33 1/3, 45 and 78 rev/min. Finished in black with silver trim. Player and changer spindles supplied. Fitted with ceramic cartridge. Post & packing extra. NSW \$2.70; Vic, Qld, SA \$3.70; WA \$4.70 (registered post \$2 extra if required).

### NEW AWA HI-FI SPEAKER KITS 8" 2 WAY 3 SPEAKER SYSTEMS

AT LESS THAN 1/2 LIST PRICE

POWER RATING, 20 WATTS RMS. IMPEDANCE 8 OHMS Frequency range 46 TO 18,000 CYCLES

Supplied in kit form (less cabinet) each kit comprises: One AWA 8WAC 8in bass unit, two AWA 4MBC 4in tweeters with ceramic magnets & curve-linear cones, crossover components, grille cloth, innabond lining and cabinet plans.

CABINETS AVAILABLE **\$20**  
Post & packing extra: NSW \$2.50; Interstate \$3.50 **PER KIT**

## CLASSIC RADIO

245 PARRAMATTA RD., HABERFIELD 2045

PHONES 798-7145, 798-6507

# Column 80

by JAMIESON ROWE

Technical Director,  
Dick Smith Electronics

## Assembly language and assemblers

Nowadays the nearest even professional computer people get to programming in their computer's own machine code is writing programs in so-called assembly language. Do you know what this is, what an assembler does, and why you would want to use one anyway? Here's a quick rundown.

As we noted last month, the only real "language" a computer understands is machine code, which consists of nothing more than a string of binary numbers. All programs ultimately must be translated into this form before they can be run.

But while a computer may love munching through these long strings of binary numbers, we humans don't find them too palatable. Hence the development of so-called "high level" languages, like BASIC, which allow us to conceive and write our programs in more understandable form. The computer itself is then used to translate them from this form into its own "real" or object code, using utility programs known as compilers and interpreters.

The only problem with this approach is that high level languages just don't provide the flexibility of a computer's own repertoire of instruction codes. By their very nature, these languages must provide a set of more abstract commands and functions, each of which corresponds to a specific sequence of machine code instructions. So if you need to get the computer to perform jobs that are at all intricate or out of the ordinary, the chances are that you'll have to think in terms of its own instruction set.

Luckily, unless you have a very tiny computer, this needn't mean that you have to write your programs in machine language (or hex code, which as we saw last month is basically machine code in another guise). Providing your machine has a memory of around 16k, there are utility programs called **assemblers** to make the job easier.

What is an assembler? Well, like a compiler and an interpreter, it's a utility program designed to translate other programs into machine code. But in this case it is designed to perform a relatively simple translation, from a language which is basically a set of easily-remembered words or "mnemonics". Each mnemonic is directly equivalent to one of the computer's instruction codes, and is designed to be a "shorthand"

name for the operation performed by that instruction.

A few examples from the assembly language for the very popular Z-80 processor should make this a bit clearer.

As we saw last month, the Z-80 has an 8-bit instruction code which tells it to return from a subroutine. This has the binary code 1100 1001, which has the hexadecimal equivalent C9 - a bit better, but still not all that easy to remember. The assembly language mnemonic for this instruction is RET, which as you can see is much more helpful.

Similarly the Z-80 has a 16-bit instruction code which tells it to negate the number in the Accumulator (ie, replace it with its negative equivalent, in 2's-complement binary arithmetic). The binary code for this is 1110, 1101, 0100, 0100, or in hex the still cryptic ED 44. But the assembly language mnemonic is the rather clearer NEG.

The third example we used last month was the 24-bit code to tell the Z-80 to take the number stored in a particular memory address, and load it into its accumulator register. This looks like 0011, 1010, 1100, 0101, 0111, 1110 in binary or 3A, C5, 7E in hex, but note that the last 16 bits/4 hex digits are actually the address, and vary depending upon the address you want. The assembly language equivalent of this instruction is:

```
LD A, (7EC5H)
```

or, more generally,

```
LD A, (nnnnH)
```

where "nnnn" is the memory address, in hex, which contains the number you want the Z-80 to load into its accumulator.

A further example. Another instruction code tells the Z-80 to test its "zero flag" (which is set to a 1 if the last arithmetic or logic operation performed resulted in a 0), and to jump forward or back in the program by so many address locations if the flag is NOT set (ie, if the operation performed did NOT give zero). The binary code for this instruction is 0010, 0000, nnnn, nnnn, where the last eight

digits form a positive or negative number indicating the number of memory locations forward or backward. The hex equivalent of this code is 20 nn, but the assembly language mnemonic is:

```
JR NZ, (nnH)
```

where "nn" is the size of the jump, in hex. Note how the mnemonic reminds you that it is a **Jump Relative** instruction, but only when the result was **Not Zero**.

So an assembler lets you write what is basically a machine language program, but in a form which is much easier to remember than either the real binary code or its hexadecimal equivalent. The assembler then translates your assembly language mnemonics into binary "object code" so that the program can be run.

Actually most assemblers do even more than this. They also take care of a lot of the worry about addressing, by letting you give "symbolic labels" to particular instructions and data storage locations. So that if you need to jump back to an early instruction from later in the program, for example, you can give the early instruction a label like "LOOP", and then use this symbol instead of an address in the jump instruction used to jump back there:

```
LOOP LD A, (7EC5H)
      NEG
      INC HL
      DEC BC
      ADD A, (HL)
      JR NZ, LOOP
```

Don't worry about all of the mnemonics in this example; it's only meant to show how an assembler lets you jump back to an earlier instruction (here the one labelled LOOP), without having to worry about how many addresses are involved. (The example doesn't make much sense, in fact; I simply made it up to illustrate the point!)

Some of the more recent assemblers also let you define what are called **macros**, where a macro is a sequence of instructions that your program uses over and over again (perhaps with different addresses involved). After a macro is defined and given a pseudo-instruction mnemonic, the assembler will generate the appropriate sequence of instructions whenever you specify that pseudo-mnemonic.

Hopefully you can see from this brief description of assemblers that they make it much easier to write programs in what is really "machine language in disguise".

(Continued on p134)



# CAN YOU AFFORD NOT TO SUBSCRIBE TO MICRO-80?

MICRO-80 is a monthly magazine dedicated to users of SYSTEM 80 and TRS-80 microcomputers. Owned and produced entirely in Australia, each issue of MICRO-80 contains at least six programs, articles, useful hints and answers to readers' problems; all designed to help YOU get the most out of your SYSTEM 80 or TRS-80. Since MICRO-80's first issue in December 1979, we have published over 80 major pieces of software and 10 hardware projects. Most of the programs and articles are written by our readers to whom we pay publication fees thus enabling them to make their hobby pay. MICRO-80 readers can save money by buying Tandy products at 10% discount from an authorised dealer — for details see any issue of MICRO-80. Our sister business, MICRO-80 PRODUCTS, sells Australian designed and produced software and high quality, imported goods at low, sensible prices. We repeat, if you own a SYSTEM 80 or TRS-80,

**CAN YOU AFFORD NOT TO SUBSCRIBE TO MICRO-80? . . . . . 12 month subscription delivered to your door, only \$25.00**

**CASSETTE EDITION only \$60.00 for 12 months**

If you do not have enough time at the keyboard to type in the program listings which are published in MICRO-80 each month, then you need a cassette subscription. As well as MICRO-80 magazine, you receive a cassette each month containing all the programs listed in the magazine.

## SPECIAL OFFER TO ALL NEW SUBSCRIBERS TO MICRO-80

A FREE cassette containing 6 programs (3 Level I + 3 Level II), together with complete documentation, will be sent to every new subscriber to MICRO-80.

Suspicious of mail order? Then send \$2.50 for a single copy of MICRO-80 and see for yourself that this is the magazine for you!

## Daisy Wheel Typewriter/Printer

MICRO-80 has converted the new OLIVETTI ET-121 DAISY WHEEL typewriter to work with the TRS-80 and SYSTEM 80 or any other microcomputer with a Centronics parallel port (RS 232 serial interface available shortly). The ET-121 typewriter is renowned for its high quality, fast speed (17 c.p.s.), quietness and reliability. MICRO-80 is renowned for its knowledge of the TRS-80/SYSTEM 80 and its sensible pricing policy. Together, we have produced a dual-purpose machine: an attractive, modern, correcting typewriter which doubles as a correspondence quality Daisy-wheel printer when used with your micro-computer.

How good is it? - This part of our advertisement was typeset using an ET-121 driven by a TRS-80. Write and ask for full details.

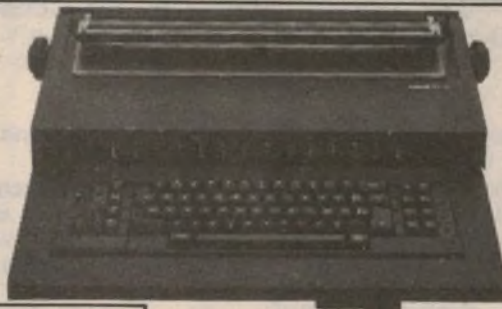

### MPI DISK DRIVES

MPI is the second biggest manufacturer of mini floppy disk drives in the world. They produce a family of high quality 5 1/4" drives with super-fast track-to-track access times (5ms!)

**40 TRACK SINGLE HEAD . . . . . \$339**  
**40 TRACK DUAL HEAD . . . . . \$449**  
**80 TRACK SINGLE HEAD . . . . . \$499**  
**80 TRACK DUAL HEAD . . . . . \$599**

Dual head drives use both sides of the disk and occupy two drive positions — it is like having two drives for little more than the price of one!

Prices quoted are for bare drives. Add \$10 per drive for a cabinet and \$30 per drive for a power supply.

### SYSPAND 80 FOR THE SYSTEM 80 \$119.00

SYSPAND 80 is a self-contained module which connects to the expansion port on your SYSTEM 80 and gives you a CENTRONICS parallel port to drive a printer PLUS the TRS-80 40 line bus SYSPAND 80 allows you to connect all Tandy peripheral, including the expansion interface, disk drives, MICROTEK MT-32 memory expansion unit and the fabulous EXATRON STRINGY FLOPPY.

### TRS-80 MEMORY EXPANSION UNIT MT-32 ... \$149.00

The MT-32 is manufactured by MICROTEK Inc., USA. It provides a CENTRONICS printer port and sockets for up to 32K of dynamic RAM. It comes complete, ready to plug into the expansion port of your Level II 16K machine. (Will also work with your SYSTEM 80 via SYSPAND 80).

MT-32A without RAM . . . . . \$149.00  
 MT-32B with 16K RAM . . . . . \$204.00  
 MT-32C with 32K RAM . . . . . \$249.00

### 16K MEMORY EXPANSION KIT

**ONLY \$55 incl. p&p**

These are prime, branded, 200 ns (yes, 200 ns!) chips. You will pay much more elsewhere for slow, 350 ns chips. Ours are guaranteed for 12 months. A pair of DIP shunts is also required to upgrade the CPU memory — these cost an additional \$4.00. All kits come complete with full, step-by-step instructions, no soldering is required. You don't have to be an electronic type to install them.

### DISK DRIVE HEAD CLEANING DISKETTES

**\$29.00 plus \$1.20 p & p**

Disk drives are expensive and so are diskettes. As with any magnetic recording device, a disk drive works better and lasts longer if the head is cleaned regularly. In the past, the problem has been, how do you clean the head without pulling the mechanism apart and running the risk of damaging delicate parts. 3M's have come to our rescue with SCOTCH BRAND, non-abrasive, head cleaning diskettes which thoroughly clean the head in seconds. The cleaning action is less abrasive than an ordinary diskette and no residue is left behind.

**ONLY \$1995 INC. S.T.**

To: MICRO-80

P.O. Box 213, Goodwood, S.A. 5034

Please rush me the items checked below:

- 12 month subscription to MICRO-80 and my free software cassette . . . . . \$24.00
- 12 month subscription to MICRO-80 and the cassette edition, plus my free software cassette . . . . . \$60.00
- The latest issue of MICRO 80 . . . . . \$2.50

PLUS THE ITEMS LISTED BELOW

DESCRIPTION	PRICE
TOTAL ENCLOSED	

Name .....

Address .....

Post Code .....

**bankcard** No .....  
 welcome here

Please debit my Bankcard \$ .....

Expiry date .....

Signature .....

EA

### DISKETTES FOR TRS-80

NASHUA 40 track single side . . . \$4.50 ea  
 VERBATIM 40 track double side. . \$5.90 ea  
 VERBATIM 77 track single side . . \$5.90 ea

### THE FABULOUS NEWDOS 80 IN STOCK NOW!

ND 80 . . . . . \$149

The disk operating system that gives:

- New basic commands that support variable record lengths up to 4095 bytes long.
- Mix or match disk drives — supports any number of tracks from 18 to 80. Use 35, 40 or 77 track 5 1/4" mini disk drives or 8" disk drives, or any combination.
- A security boot-up for basic or machine code programs. User never sees "Dos-ready" or "Ready" and cannot "break" clear screen or issue any direct basic statement including "List" . . . . . and much, much more

### 77 TRACK DISK DRIVES DOUBLE YOUR CAPACITY

DD-7S . . . . . \$775

Micropolis Floppy Disk, 77 Track, 100% larger capacity than most mini-floppy drives, complete with cable, power supply, chassis, and includes NEWDOS '80.

### AUSTRALIAN SOFTWARE

We have a wide range of Australian software available. Send for a free catalogue

## MICRO 80 PRODUCTS

(08) 272 0966

433 MORPHETT STREET.

ADELAIDE S.A. 5000

TRS 80 and SYSTEM 80 OWNERS TRS 80 and SYSTEM 80 OWNERS

# A low-cost, graphics-oriented computer

# COSMAC VIP

RCA have now released an updated version of their COSMAC VIP single board microcomputer. Featuring a video output and cassette interface plus many optional peripherals, the COSMAC's low cost should interest beginners.

Most of our readers will be familiar with the DREAM 6800 microcomputer, but few may realise that it was largely a 6800 version of RCA's COSMAC. In fact, the CHIPOS language operating on the DREAM is derived from the CHIP-8 language interpreter on the COSMAC and the video display is virtually identical.

The similarities do not end there either: both use a hex keypad for data entry, a cassette interface for program or data storage and a speaker output. It's natural then to compare the DREAM and the COSMAC's other features. The most obvious advantage of the COSMAC is that it is fully assembled on a double sided PC board, all you have to do is solder up the power supply, video and cassette leads. Also the COSMAC only requires a single +5V power supply which is readily obtained from the on-board regulator and a 9V DC plug pack.

With the various connections to the cassette, and VHF modulator or video monitor made it is a simple matter to get the COSMAC up and running. Just flip the RUN/RESET switch to RUN, hold the "C" key on the hex keypad down and you are into the monitor. Four hexadecimal digits have to be entered first and these form an address which is displayed on the lower left of the screen in the DREAM's familiar "chunky" graphics. The COSMAC then displays the two digit hexadecimal data at that

memory location on the lower right of the screen.

Monitor commands are particularly straightforward, in fact there are only four commands, viz memory read, memory write, tape read and tape write.

The commands are selected by pressing one of four keys on the bottom row of the hex keypad immediately after entering the address. If memory write is selected, then the next two hexadecimal digits entered on the keypad will be stored at the memory location selected. The address is then automatically incremented ready for the next location to be written into, making it easy to enter long programs.

Programs can be checked using the memory read command and then saved using the tape write command. The only

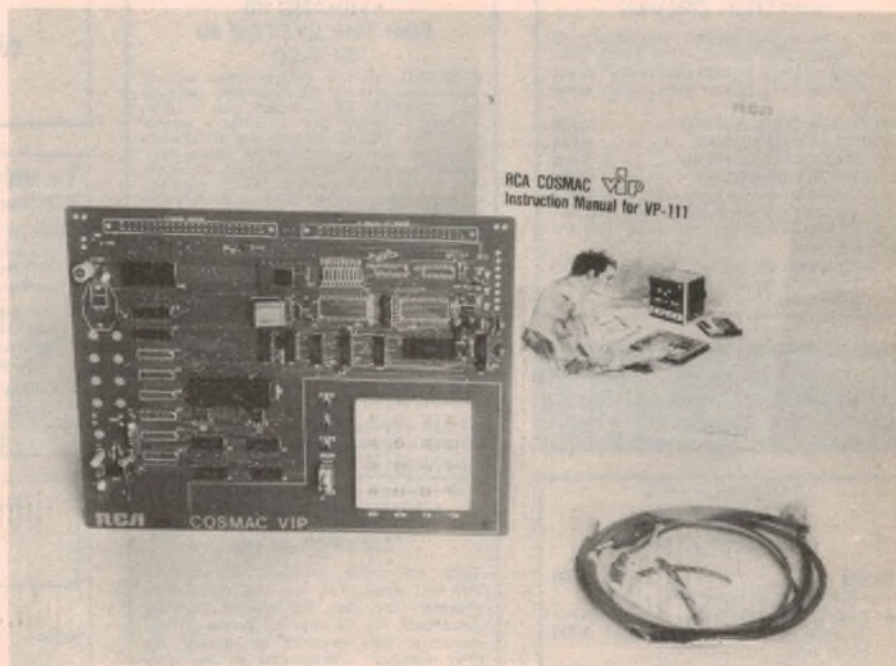

## System-80 and TRS-80 Users

**SALE! VERBATIM DISKETTES x 10 + Plastic Filing Box (while stocks last) \$39 + ST**

### BOOKS FROM USA

TRS 80 Disk & other mysteries	\$27.00
Microsoft Basic Decoded (new)	\$37.00
Modem (Ex PMG)	\$150 + freight
10 x C10 Cassettes	\$7.00
Suppressor Plugs, ea	\$7.00
Gold Edge Connectors x 3	\$34.00

Prices include S/T where applicable

Australianised abridged version Osborne/McGraw Hill (two or three disc system)

**COMPLETE BUSINESS SYSTEM** (Tandy Basic)  
Creditors/Debtors/Gen Ledg/Cash Book/Invoicing  
All for \$400 or \$120 each

<b>AUSTRALIAN MAILABEL</b>	\$50.00
Mailabel + GSF Fastsort	\$75.00
3 Label Wide Printout	Fast Data Entry
Line by Line Listing	Chop & Combine lists at will
<b>BASIC COMPILER</b> (Tiny Comp)	\$35.00
<b>PRACTICAL SOLAR ENERGY</b>	\$100.00

Send for free list of over 100 Programmes



**PITT ST MICROCOMPUTERS**

BOX A344 SYDNEY SOUTH, PITT ST SYDNEY 2000

Free postage in Australia



information required by the tape write command is the starting address, which is merely the address just entered, and the number of "pages" of memory to be written out. Programs are not named as in larger microcomputers so it's up to the user to position the tape when loading. In most cases, this means it's only convenient to store one program per side of a cassette. One feature we did like about the cassette interface though, is that it has a relatively fast 100 characters/sec transfer rate.

The actual code which is entered into memory can be either CHIP-8 or machine code for the COSMAC's CDP1802 CMOS microprocessor. This micro was apparently intended as an in-

dustrial controller where the noise immunity of CMOS is an advantage but it has not enjoyed the same degree of popularity as the 6800, 8080 etc. It does have quite a good instruction set though, and there should be little difficulty in programming in machine-code alone.

Some beginners may prefer to use the CHIP-8 interpreter language which offers a more powerful instruction set for generating displays and interfacing with the keypad etc, plus 16 general purpose "variables". One slight disadvantage with CHIP-8 on the COSMAC system is that the CHIP-8 interpreter is not ROM resident as on the DREAM, but has to be entered into memory from a hex listing. This of course only has to be done once, since it can then be saved on cassette tape and reloaded whenever required.

The actual video display on the COSMAC consists of a matrix of chunky squares, 64 squares horizontally and 32 squares vertically. Each point can be individually turned on or off to generate either video games or numbers and digits. The monitor for example generates the hexadecimal address and data display by forming each digit from a 4x5 cell. While each point can of course be accessed directly from machine code, CHIP-8 also provides a high level instruction for XY graphics.

Looking at the hardware now, the hex keypad is a 4x4 matrix of membrane switches. These provide virtually no tactile feedback but the monitor does generate a "bleep" from the speaker during each keypress, in effect indicating a valid keystroke. Incidentally the actual keyboard scanning circuitry consists of a CMOS 4515 4-to-16 multiplexer which is used to software-scan the keyboard and the common line from the keypad goes to one of the four sense inputs on the 1802.

One advance made on the original COSMAC is the CDP1816 video controller chip which generates all the video-refresh addresses plus the horizontal and vertical sync and replaces a large number of discrete counters and monostables. Despite this the COSMAC, like the DREAM, uses a crude video-refresh scheme. For half the field period of the TV, the video accesses memory via the bus generating the TV display, for the other half the microprocessor gets access to the bus. This results in a display which occupies only slightly more than half the screen and it also means that the micro is only working half the time. In this non-critical application though this is quite acceptable.

1K of on-board memory is supplied consisting of two 1Kx4 bit static RAMS. Additional sockets are provided for six more chips so that a total of 4K can be obtained without further expansion. Using the expansion interface it would be possible to extend this to 32K or add various peripherals.

A large number of peripherals are available for the COSMAC including an Expansion Kit with 3K additional RAM, 8-bit I/O ports (sockets already provided on-board), 4K RAM expansion kit, a locally developed PAL colour board, two channel "Super Sound Board" music synthesiser, EPROM Programmer, Auxiliary keypad, Tiny BASIC, ASCII keyboard with touch keys and a Floating-Point BASIC.

The COSMAC VIP Instruction manual which comes with the computer gives a quite reasonable introduction and covers the initial connection procedure to cassette, TV, loading memory, saving on cassette, complete descriptions of the CHIP-8 and machine languages, complete circuit diagrams, hexadecimal listing of the operating system and seven video games programs. While this manual is adequate for the experienced programmer we recommend the Users Guide which gives a more detailed discussion of CHIP-8 programming.

Clearly the COSMAC VIP is not in the same league as the TRS-80, System-80 and Sorcerer, but then it is a fraction of the cost of these micros and should provide enough computing power for the beginner. It is also important to note that it is less expensive than the DREAM and it comes fully assembled so there should be no problems in getting it up and going. Add to this the large number of peripherals available and you have an attractive low-cost system.

The computer we reviewed came from J.R. Components, PO Box 128, Eastwood, NSW 2122. (02) 85-3976. Quoted price of the COSMAC is \$139 including sales tax. A 9VDC plug pack and 5V regulator are \$10 extra.

# RCA

## RCA COSMAC VIP COMPUTERS

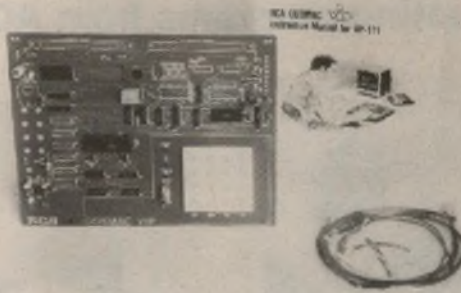

**\$149 ASSEMBLED\***  
**TESTED AND GUARANTEED**

Build a computer system one board at a time! Start at this very low price and expand as you learn up to COLOUR and FULL BASIC . . .

### FEATURES . . .

- RCA 1802 Microprocessor
  - ROM Operating System
  - 1k Bytes of Static RAM. Expandable to 4k on card, off-card to 32k, and with more select logic to 64k
  - Video Output to monitor, or via an RF Modulator to a TV
  - CHIP-8 Interpreter Language or Machine Language programmable. CHIP-8 has you programming the very first night!
  - Cassette Interface — 100 bytes/sec!
  - Audio Tone Generator
  - Hexadecimal Keypad
  - Single 5 Volt operation
  - Instruction Manual, with games, schematics, CHIP-8 and much more.
  - 7-day Money-Back Guarantee
  - 3-month Parts and Labour Guarantee
  - Thousands sold in USA
  - Ideal for low cost control applications
- \* User need only connect cables (supplied), a power pack, regulator and modulator (optional) and an 8 ohm speaker (supplied).

### OPTIONAL ACCESSORIES . . .

User Guide — Additional information for the beginner and the newcomer to CHIP-8 Recommended.

Expansion Kit — Extra RAM, and full expansion facilities allowing the use of the following —

Memory (RAM) Boards	EPROM Board
Sound Generator — 256 note	EPROM Programmer
Stereo Music Synthesiser	Auxiliary keypads
Quadraphonic Expander Board	Tiny BASIC (Integer)
ASCII/Numeric keyboard	Floating Decimal Point BASIC (16k!)

Colour Board (PAL) and Interactive Data Terminal — Coming Soon!

Software — the US User Group has already gathered hundreds of programmes, applications and hardware ideas.

Several books have been published, in addition to RCA's own manuals.

Phone Cash-On-Delivery (ie, collect at PO) orders accepted.

Units are ex-stock. Cut out or copy coupon.

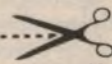

<input type="checkbox"/> VPIII Microcomputer	\$149.00	\$ . . . . .
<input type="checkbox"/> Power Pack and Regulator	\$10.00	\$ . . . . .
<input type="checkbox"/> User Guide Manual	\$5.00	\$ . . . . .
<input type="checkbox"/> RF Modulator Kit	\$5.00	\$ . . . . .
<input type="checkbox"/> Post Pack Insurance - Cash Orders	\$3.00	\$ . . . . .
<input type="checkbox"/> Post Pack Insurance - COD Orders	\$5.00	\$ . . . . .
<input type="checkbox"/> Priority Paid Mail (Optional Extra)	\$2.00	\$ . . . . .
	<b>TOTAL:</b>	<b>\$ . . . . .</b>

Name \_\_\_\_\_ Signature \_\_\_\_\_  
 Address \_\_\_\_\_  
 \_\_\_\_\_ Postcode \_\_\_\_\_  
 Phone Nos: Home \_\_\_\_\_ Work \_\_\_\_\_  
 I understand that this order is subject to a 7-day Money-Back Guarantee

EA4/81

## J. R. COMPONENTS PTY LTD

PO Box 128, Eastwood, NSW 2122  
Ph (02) 85 3385

# Microcomputer News & Products



## Accounting programs from ADE

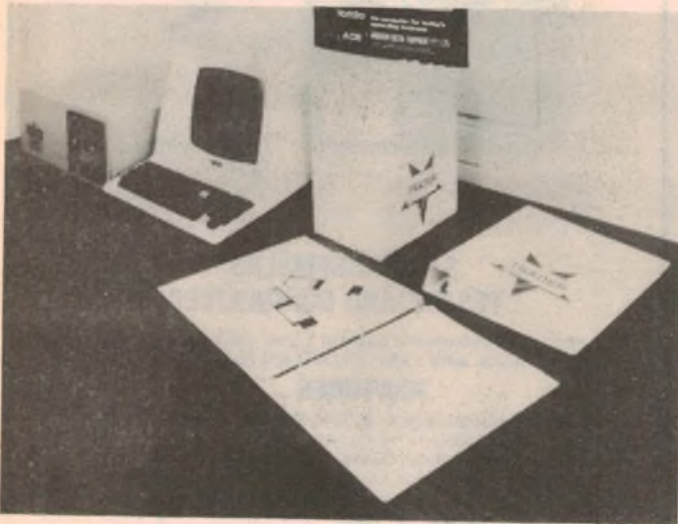

*Trader includes detailed instruction manuals for each group of programs, explaining step by step how to operate the system.*

With the motto "Let Trader look after your accounts while you look after your business", Anderson Digital Equipment have released a new software package designed to run on the North Star microcomputer systems distributed by the company.

"TRADER" stands for Total Real-time Accounting from ADE, and is a fully integrated set of computer programs designed and written in Australia to provide a total accounting and stock control package for the small business. The package handles invoicing, stock control, debit debtors ledger, creditors ledger and general ledger, using a data base which is common to all of the programs. This approach is said to contribute greatly to the system's ease of use and speed of operation.

The accounting system was designed from the start to be easy to learn and easy to operate. In addition to comprehensive, easy-to-follow manuals, each user of the system will receive a diskette containing sample data which allows the user to teach himself or train a new operator without the risk of damaging his own business data. ADE will also run monthly training courses on the system for those who desire more formal instruction.

ADE will be offering the system with the North Star S-100 microcomputer with the Z80 processor and 64K of RAM. Each system will be supplied with a Televideo terminal and a choice of either daisywheel or dot-matrix printers. ADE dealers and representatives will be fully trained in the use of the system and will

be able to advise prospective users on the benefits of Trader.

For further information contact Anderson Digital Equipment Pty Ltd, PO Box 341, Pennant Hills, NSW 2120 or PO Box 322, Mt Waverley, Vic 3149.

## Word processor for the System-80

A new low-cost word processor software package for the System-80 and TRS-80 Model 1 Level II computers has been introduced by Dick Smith Electronics. Called "WORP-1", the new package offers most of the features available on full-scale word processors at a fraction of the cost.

WORP-1 is a character-oriented word processor, unlike other low cost word processors which often require the re-typing of complete lines when text is edited. It is available in two versions; a cassette version which will run on machines with 16K of memory, and a disk-based version which requires an expanded machine with at least one 40-track disk drive and 32K of RAM. Both versions offer the same text handling, editing and printing capabilities.

WORP-1's features include automatic text wrap-around on text entry, a flashing cursor, a user-formatted text input mode for headings and tables, automatic conversion of the computer's keyboard to the typewriter shift mode, and adjustable printing width (from 1 to 60 characters per line).

More Micronews p127



### FOR THE GOURMET



#### COMMODORE COMPUTERS

The range starts with the PET (illustrated) at under \$1,000 for personal use, through to complete business systems. We have a wide range of software covering Business, Education, Application and Entertainment

### OUR BREAD & BUTTER LINES

#### TRIO TEST INSTRUMENTS

CS-1560All \$650 including probes and tax.

Other lines include:

B & K Test Gear  
TRENDCOM Printers  
PLESSEY & ETONE Speakers  
MOTOROLA Tweeters  
MOTOROLA KSN 1001A  
KSN 1025A



\$13.00 ea  
\$25.00 ea

Prices include delivery

### THIS MONTH'S SPECIAL

#### PET FOOD (PROGRAMS)

ACROBAT, SPACE INVADERS, NIGHT DRIVE TREASURE TROVE OF GAMES, MASTERMIND MATH PUZZLES, LANGUAGES, PHYSICS STATS, USER PORT COOKBOOK, SORT DATA BASE UTILITY, STRATHCLYDE BASIC COURSE.

These are but a few of our tempting titles for your PET. write for complete list and prices.

# EDIBLE ELECTRONICS

50 PARK STREET, ABBOTSFORD, 3067.  
PHONE: (03) 41 5708.

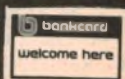



# MENSA COMPUTERS

Suite 3, 454 St. Kilda Road, Melbourne, 3004. Telephone: (03) 26-5683, 26-6150.

## FINDEX, The Real Computer



### THE WORLD'S FIRST PORTABLE MICROCOMPUTER Battery or mains operated

RAM 48K to 2 megabytes, bubble memory to 2MB, gas plasma display, optional audio, printer, mass storage mini floppys to 800K bytes, hard disk to 195 megabytes, acoustic coupler, S-100 bus, battery optional, CPU with real time clock. For dynamic businessmen on the move. Ideal for real estate agents, insurance brokers and accountants.



Powerful, multi-purpose microcomputer systems.

## BUSINESS SYSTEMS

Priced competitively from as low as \$45.00 p.w. lease cost including sales tax and software.

### TYPICAL APPLICATIONS

Debtors ledger and statements, creditors ledger and remittances, general ledger and trial balance, order entry/invoicing, sales analysis, payroll/wages, enquiry, word processing, mailing, record keeping, ledger card, doctors office, real estate, agency accounting, hotel/motel accounting, branch office accounting.

#### Also:

Facilities management consulting.  
Software and computer sales.  
Computer data preparation.

**INTRODUCING**

## MENSA G.F. 1000

### BASIC SPECIFICATIONS

CPU 8080 and Z80 operating at 4MHZ. 64K bytes Dynamic RAM expandable to 2MB storage bytes of unformatted data on two double density drives. Optional external hard disk storage can be connected using the optional S-100 Bus. Floppy Disk. All modules mounted to base. CRT in a rigid aluminium frame. Disk Drive assemblies are mounted into special brackets for ease of servicing.

### WINCHESTER DISK

26MB of Winchester Disk complete with controller and easy backup. Disk has special capacity to only back up files accessed during the last period. Disk operating system CP/M.

### OPTIONAL SOFTWARE

FORTRAN, COBOL, BASIC.

Application packages. Extensive software development tools are available from leading software vendors, including software for the following applications: payroll, accounts receivable, accounts payable, inventory control, general ledger and word processing.

Mensa computers provide a service network throughout Australia at major service centre locations to minimise response time to service calls. To ensure that equipment will operate at peak performance, engineers and technicians are trained to ensure the highest possible standard of service.

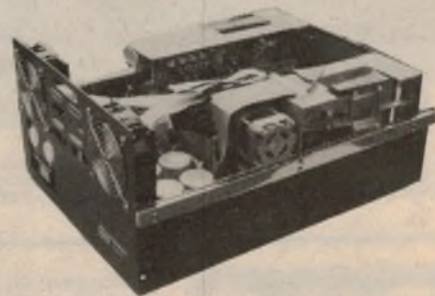

# S. M. ELECTRONICS — S100 SYSTEMS

**SBC200**



Z80 single board computer. 4MHz. 16K EPROM. 1K RAM. 16K EPROM. 1 serial port. power on jump. 2K monitor. 2716 4 channel counter/timer. software controlled baud rate generator. modem look alike. vectored interrupt. centronics printer port

**KIT \$395.00 ASS & TESTED \$465.00**

**MPB100**



Z80 CPU board switchable 2 or 4 MHz operation. power on jump to any 4K boundary on board. 2716 PROM socket. optional front panel provision. wait state generator. 2K monitor available. will suit dynamic RAMs

**KIT \$310.00 ASS & TESTED \$365.00**

**16K STATIC RAM**



2114 low power RAM chips. 4K address boundary. standard bank select (40H) 4 MHz operation with no wait state required when using our chips. wait state generator for above 4MHz plated thru holes. solder resist. optional 300nS RAMs available.

**KIT \$315.00 ASS & TESTED \$380.00**

**32-64K DYNAMIC RAM**



Bank select. 200 nS chips standard up to 4MHz speed. will accept 64K RAMs to give 256K per board. switch selectable boundaries. invisible refresh phantom output. standard S100 plated thru holes. solder resist. components overlay.

**KIT 32K-\$525 48K-\$625 64K-\$725  
A&T 32K-\$605 48K-\$715 64K-\$815**

**2708 EPROM**



Switch selectable as 8 or 16K card 8K address boundary. wait state gen. suites industry standard. 2708's standard S100 plated thru holes. solder resist.

**KIT \$98.00  
ASS & TESTED \$125.00**

**SERIAL-PARALLEL I/O PORT**



Dual serial ports with RS232 & TTY outputs. nine programmable parallel ports. wire wrap cross link area for parallel I/O. switch selected baud rates. 9600 75 baud. 4 byte address decoding for I/O. switch selected. plated thru holes. solder resist.

**KIT \$189.00 ASS & TESTED \$225.00**

**SINGLE DENSITY DISK CONTROLLER**



iBM 3740 soft sectored. operates standard 8" or 5" drives. single or double sided drives. utilizes FD1771 controller chip. runs CP/M disk opp software. operates with Z80 8085 & 8080 CPU. CP/M. BIOS & diagnostic prompts to suit are available.

**KIT \$295.00 ASS & TESTED \$345.00**

**SINGLE/DOUBLE DEN DISK CONTROLLER**



Operates with single & double den. single & double sided drives & 8" or 5" drives in any combination of 4 drives simultaneously. phase lock loop data recovery. with SDOS operating system you can run all CP/M and CDOS programmes.

**KIT \$440.00 ASS & TESTED \$495.00**

**80 x 24 VIDEO**



On board Z80 80 char. x 24 lines. 7 x 10 matrix. keyboard interface. 96 up & lower character. 32 special characters. optional 128 extra char composite video. for true scrolling. XY address cur. blinking underline reverse video & field protect.

**KIT \$470.00 ASS & TESTED \$535.00**

**EPROM PROGRAMMER**



2708 2758 2716 2516 2732 EPROMS. switch selected. 26V generator. 2IF socket. CP/M driver program. max. time 100 sec for 16K bit EPROMS. mod. available for TMS 2716 EPROMS. optional PROM based driver routines. STD S100. plated thru holes.

**KIT \$255.00 ASS & TESTED \$295.00**

**EXTENDER/TERMINATOR**



True active termination. fuse protect supply rails to extension socket. numbered test points. reset line (75) not terminated. solder resist. plated thru holes. standard S100 D.I.L. resistor packs. this board is a must for reliable operation.

**KIT \$85.00 ASS & TESTED \$105.00**

**WIRE WRAP PROTOTYPING BOARD**



Now with plated thru holes. GND & supply rails on both sides. +5V +12V & -12V regulator provision. Hole array is 1 x 3 to suit all IC package sizes. provision for filter bypass caps. 5V reg is TO3.

**BOARD ONLY \$38.50**

**TVI-912B TERMINAL**



80 x 24 intelligent terminal. 2 page screen. printer port. dual intensity upper/lower. case 110.9600 baud. numeric pad. cursor control. XY cur. block mode. self test. micro based. lear sieger. ADM31 look alike. full editing capabilities.

**\$1295.00**

**DGURA PRINTER RD-136E**



120 CPS. 7 x 9 Dot Matrix. 128 ASC11 Char. tractor feed and friction feed. 6/8 lines per inch. centronics interface std. RS232 serial opt. RD136E.  
RD136G - Graphics Version  
RD137K - 24 Pm Graphic Version  
RD136E \$2150, RD136G \$2250

**Z80 STARTER KIT**



Onboard keyboard & HEX display. Kansas City cassette. PROM programmer. S100 interface. 2K RAM. 4K EPROM. 2K monitor. CTC timer. interrupts. 2 x 8 bit ports. wire wrap area. 120 page manual. single 5V supply. single step. breakpoints.

**KIT \$430.00 ASS & TESTED \$495.00**

## S-100 & 6800 CHASSIS

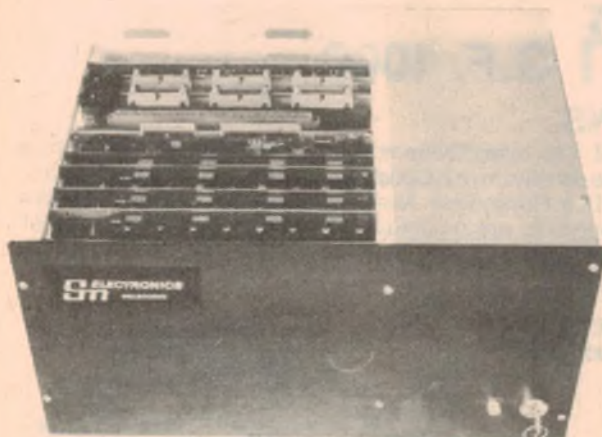

11 slot backplane, fully card guided. 15 amp power supply. fan. key switch. bench mount. rack mount. anodised aluminium. 5 edge connectors standard. S-100 Bench Kit \$365. S-100 Rack Kit \$325. 6800 Bench Kit \$390. 6800 Rack Kit \$350. Assembled prices add \$100.

## PMS100

Introducing the PMS100 by SME Systems, an all new package microcomputer based on a Z80 CPU. This system will suit all users ranging from computer technicians, programmers and small to medium company accounting requirements.

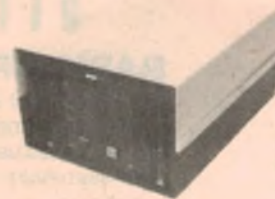

Technical specifications are as follows:

4 Mhz Z80 CPU. 64K Dynamic memory with bank select to allow up to 8 pages of 64K each. and up to 256K of RAM on a single board. RS232 serial port and 8 bit parallel ports. Up to 16K EPROM which can be switched out after power up to allow a full 64K of user RAM per bank. Dual 8" SHUGART SABOIR drives running at single or double density. Density selection is automatically chosen by the use of double or single density formatted disks. External Mini drives can also be interfaced to the controller. The DOS supplied is compatible with standard CP/M and CDOS to allow a wide selection of software to be used, such as MBASIC, CBASIC, COBOL, ALGOL, PASCAL, FORTRAN, ASSEMBLY LANGUAGE, WORD PROCESSING, MULTIUSER, MULTITASKING, AND ACCOUNTING PACKAGES. All of which can be supplied from SME Systems.

The PMS100 is AUSTRALIAN designed and built and can be supplied as a basic system or as a complete turnkey system including terminal, printer and software. \$5500 Standard format.



Melbourne: Ph (03) 874 3666.  
22 Queens Street, Mitcham, Vic 3132.  
PO Box 19, Doncaster East, 3109.  
Telex AA37213.

DEALER: Adelaide — 223 6539.  
Sydney — 661 9237.

## S. M. ELECTRONICS

Send 66c in stamps for COMPUTER PRINTOUT CATALOGUE for more details.  
ALL PRODUCTS AUSTRALIAN MADE AND EX STOCK (ALMOST)  
DEALER ENQUIRIES WELCOME  
Prices and specs subject to change without notice.  
All prices tax free, for retail prices add 15 per cent.



# IT'S NOT HARD!!



## NOT ANYMORE!

No this isn't a "Hard Disk". We used to call it that, sometimes. But somebody muddled the water.

"Hard Disk", unfortunately, now calls something else to mind. That little bitty guy with no backup capability and no way of switching media? It's a "Hard Disk" to work with, all right, in business applications. Some even say "Impossible Disk".

We'd like to avoid confusion between our Cameo database solution and the one that doesn't work so well. The Cameo DC-500 subsystem employs a decade-proven **cartridge** disk. Our backup capability is built in, and takes four minutes. The ability to switch applications (by exchanging the removable cartridge) means you can use your computer for more kinds of work. A ten megabyte (5 fixed + 5 removable) subsystem costs \$5995, for your **TRS-80 (Mod. I or II), Apple, 6800 or S-100** computer.

So call us "The **Cartridge Disk** Guys", please, and call us soon. We'll show you the **really** cost-effective solution to microcomputer database storage.

*DEALERS REQUIRED AUSTRALIA-WIDE*

**SME**  
SYSTEMS

**S. M. ELECTRONICS**

**22 QUEEN ST, MITCHAM 3132  
MELBOURNE, AUSTRALIA**

**PHONE (03) 874 3666.**

**TELEX: AA37213**

# OVER 20 ORIGINAL LETTERS TYPED AND READY TO SIGN IN 10 MINUTES!

The Compucolour "Word King" and the North Star "North Word" make it simple to produce original repeats of any letter as many times as you need, each one perfect and ready for your signature.

See a free demonstration at

## THE **LOGIC** SHOP PTY. LTD.

212 High Street, Windsor, Vic. 3181, (03) 51 1950.  
91 Regent Street, Chippendale, NSW 2008, (02) 699 4910, 699 4919.  
Shop 16 Adelaide Street, Civic Arcade, Brisbane, Qld 4000, (07) 31 2330.  
454 William Street, Perth, WA 6000, (09) 328 7345.

LS1-02



### Computer Products Manager

**Wanted:**

Dynamic sales-oriented person 25-35 years to manage our Computer Products Division. This is a newly created position reporting directly to the Supply Manager.

**Duties:**

Sourcing and evaluating computer products, development of software programs through liaison with software consultants, marketing and providing a customer back-up service for our growing range of micros.

**Pre-requisites:**

Good understanding of micros and BASIC, ability to communicate, thorough, organised and work with minimum supervision. Sales experience in micros a definite advantage.

**Salary:**

An attractive package will be negotiated according to experience.

**Written applications please to:**

**Mark Sim — Supply Manager**  
**Dick Smith Electronics**  
**P.O. Box 321**  
**North Ryde 2113**



# MICROCOMPUTER PRODUCTS

130 Military Road, Gullford,  
NSW 2161. Phone (02) 632 6301,  
(02) 632 4966. Telex AA70664.

## THE ULTIMATE VIDEO CARD: **ESM** VB3

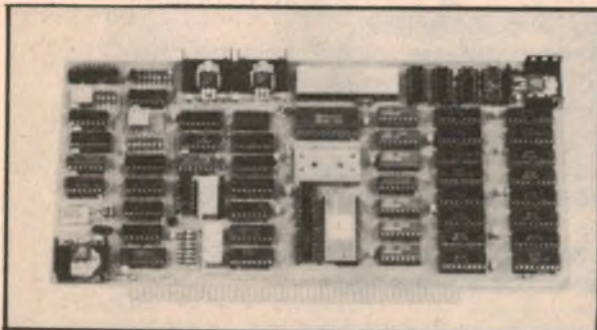

80 x 24 standard. Options: 80 x 48; 132 x 28.

VB3 is the perfect video interface for word processing and other applications requiring 80 characters per line. It produces a standard 80 x 24 display or as much as 80 x 48 for a full page of text. VB3 can display upper and lower case characters, up to 256 user defined symbols, and a 160 x 192 matrix for graphics.

VB3 is memory mapped, but occupies memory only when activated. So one or more VB3s can be located at the same address with a full 65K of memory still available to the user.

It generates both US and European TV rates and includes a keyboard input. Software includes a CP/M compatible driver routine.

*Stop press: VB3 prices are down due to massive US sales success!*

### WE ARE S100 SPECIALISTS — COMPLETE COMPUTERS DOWN TO INDIVIDUAL PARTS.

If you are computing, interested in hardware or software, if you are a businessman, an engineer, educator, student or hobbyist — see us before you make any rash decisions you will regret!

**• COMING SOON — PROGRAMMING COURSES — CALL FOR DETAILS •**

**Trading hours Mon-Sat 9AM to 6PM.**

**See previous ads in EA and ETI.**



## Microcomputer News & Products

Both versions of WORP-1 come complete with a 33-page user's manual, giving full details of the system's facilities and use. The cassette version of the package is catalog number X-3758 and is priced at \$59.50. The disk based version is catalog number X-3759 and is priced at \$79.50. Both versions are available from Dick Smith Electronics stores and resellers in all states.

### 16-channel A/D for microprocessors

Edible Electronics of Melbourne now has available the AIM16 Data Acquisition module, a 16-channel analog-to-digital converter module which is designed to connect to any microcomputer system with 8-bit input and output ports. The AIM16 is addressed by the user's program to convert one of sixteen analog inputs between 0 and 5.12V into its equivalent decimal value (0-255).

The analog inputs may be derived from light and temperature sensors, pressure transducers, humidity gauges — from any transducer providing an output in the required voltage range in fact — allowing

the computer to be used to monitor a variety of devices in the external world.

For the Commodore PET computer, Edible Electronics can supply the Petset1, which allows the AIM16 to be interfaced to the PET. The system consists of five modules. The Petmod plugs into the PET at the IEEE and User ports and provides the user with two IEEE ports, one user port, and a port for the Data Acquisition Module. A cable supplied with the set connects the Petmod to the AIM16. A "manifold module" plugs into the AIM16 and provides screw terminals for the ground, reference, and analog inputs. A power supply module is also included in the package.

For more information contact Edible Electronics, PO Box 1053, Richmond North, Vic 3121.

### Micom 6502 interest group

Micom, the Microcomputer Club of Melbourne, has announced the formation of a new special interest group. The emphasis within the new group will be on machines based on the 6502 processor, including the Kim, Aim, Sym and Ohio Scientific machines. The club already has established interest groups for the Apple, TRS-80 and System-80 computers and a CP/M User Group.

The groups maintain large libraries of

software which are available free of charge to members.

In addition to separate user group meetings, Micom meets at the AMRA hall in Wills St, Glen Iris, Victoria at 2.00pm on the third Saturday of each month. The mailing address is PO Box 60, Canterbury, Vic 3126.

### ZX80 User's Club

The National Sinclair ZX80 User's Club has sent us a copy of their newsletter, "Zebra X-ray 80", which seems to be a well-produced publication. The club has only recently been formed, with the object of providing ZX80 users with programming tips, sample programs, answers to problems specific to the ZX80 and discussions of overseas developments.

The sample newsletter we received contained three programs with explanations, some hints on using the ZX80 cassette interface, programming hints and information on a new 8K ROM for the machine.

A six-month membership of the club will cost you \$10 joining fee, plus six large, self-addressed envelopes. The address to write to is 24 Peel Street, Collingwood, Vic 3066.

Micronews continued p13



### MAIL ORDER TO AUSTRALIA

32 Lloyd Avenue, Cremorne, NSW. 2090. (02) 908 2235. Telex AA20149.

**BUSINESS HOURS** — Between 9 and 5 weekdays, and also 7 to 10pm, Monday through Thursday, so that our Australia wide clients can use STD when it's cheap (after 9pm save 60% on your call.)

**SERVICE** — We provide full service, equal to any in the business, on all our lines. We support fully the manufacturer's warranty, and provide complete after warranty service (we give this undertaking in writing on our invoice).

**DELIVERY** — (door to door)

Customer pick up. Or if arranged by us the charges being:

a) For one Apple, a printer, or a VDU.

NSW \$24.00 Perth \$33.00

Melb. Bris. Adel \$22.00 WA \$42.00

Vic, Qld, SA \$31.00 Tas \$34.00

b) Items under 5kg — \$10 anywhere in Australia.

c) Smaller items by certified post, charges being under \$5.

**ALL CHARGES INCLUDE INSURANCE TO THEIR FULL VALUE**

**PAYMENTS** — 1) Personal cheque, but allow time to clear.

— 2) Bank Cheque, Postal or Money Order or Cash.

A Receipt/Invoice will be immediately issued for all monies received. If you require the protection of a written contract between us, we can issue you with a Proforma Invoice.

**PLEDGE** — Any orders that we cannot supply from stock we will specify a despatch date on your receipt. Failure to dispatch by this date will require us to immediately issue a full refund unless instructed otherwise by the customer.

## APPLE

### EX STOCK AT DISCOUNT PRICES

The beginning of this year has been difficult for Apple people. With a severe US shortage of Apple computers caused probably by the design changes required by the US authorities to limit interference to TV reception and an accompanying price rise effective in February, we at DCS have not been able to supply ex stock.

However, now we can (with most items). Apple computers, disc drives, Pascal, the graphics tablet, interfaces together with videos, printers and most CCS, Mountain Computer, Microsoft products — are in stock.

**WHAT ABOUT PRICE?** — Still at a good discount. For example:

16k Apple II Plus	\$1220	Trendcom 200	\$630
48k Apple II Plus	\$1340	Printer Interface	\$193
Disk + Controller	\$630	Graphic Tablet	\$744
Disk only	\$476	Green Screen	
		Monitor	\$297

(Tax free prices only — add 15% for tax paid)

### THIS MONTH'S SPECIAL

**PASCAL LANGUAGE SYSTEM**  
\$396 Tax Free \$455 Tax Paid

Prices subject to change and exclude delivery charges.

**ANY NEW PRODUCTS?** — Yes!

DOS 3.3 and 16k memory upgrade kits, the Microline 80 printer, RF modulator, and probably a card reader.

**FOR THE WHOLE STORY** — send for our new hardware and software catalogue available this month — it's free.

# The NDK S-4000 Wordprocessing Printer —

(SOLE AUSTRALIAN DISTRIBUTORS John F. Rose Computer Services P/L)

For all bulk wordprocessing applications where reliability, speed and sustained print quality are of prime importance.

The **NDK S-4000** is supplied with a heavy duty 16 wire head producing single pass high quality 17 x 16 matrix characters at 75 characters/second for wordprocessing quality and 150-200 characters/second for drafts.

Four fonts (dot matrix, wordprocessing, super/subscript and Greek) are supplied as standard. Typical scientific, mathematical and currency symbols are included as standard. The fonts can be intermixed as bold faced (by overprinting or by offsetting characters), enlarged (5 CPI, 17 x 23 matrix), reduced (12 CPI) or normal (10 CPI). Other fonts can be specified by the user. Each dot on the 16 x 16 matrix can be programmed by the host computer to produce special graphic effects (such as Letterheads and trade marks). Full page graphics is possible by controlling 10 wires of the printer and executing half-line feeds. The special graphic patterns can be printed at the rate of 900 dot columns/second at a resolution of 4.7 dots/mm (120 dots per inch) both horizontally and vertically. A horizontal dot resolution of 240 dots per inch can be produced using half dot timing.

<sup>Super</sup>scripts and <sub>sub</sub>scripts are produced by the superposition method enabling complicated mathematical formulae to be produced quickly and easily. The subscripts and superscripts are half normal size and the printing pitch is half that of the PICA (see Specification).

## Control Codes and their functions

					<b>Regular or Draft</b>	<b>Sub or Superscript</b>
BEL	(07) hex	2 Khz alarm noise produced for 1 second.	ESC P		10 (5) CPI	20 (10) CPI
LFH	(08) hex	Half line feed (1/12").	ESC E		12 (6) CPI	24 (12) CPI
LF	(0A) hex	Line feed (1/6").			( ) = Elongated.	
VT	(0B) hex	Vertical Tab.	ESC I		Start <b>Underline</b> .	
FF	(0C) hex	Form Feed.	ESC O		Cancel Underline.	
CR	(0D) hex	Carriage Return.	ESC <		<b>Expand dot mode data.</b>	
SO	(0E) hex	Initiate elongated characters.	ESC >		Cancel expansion of dot mode data.	
SI	(0F) hex	Cancel elongated characters.			Print following data as <sub>sub</sub> scripts.	
SLT	(11) hex	Enable operation from an external device.	ESC L		Print following data as <sup>super</sup> scripts.	
DSL	(13) hex	Disengage operation from an external device.	ESC U		Change back to previous mode.	
CAN	(18) hex	Cancel data stored in line buffer.	ESC N		Spacing is 1/60 x n where 0 < n < 256.	
ESC R		Select Regular mode.	ESC S	n		
ESC D		Select Draft mode.	ESC M	LhL1	Activate Dot Mode.	

The printer has a built-in test mode and the following STATUS signals are displayed on the control console:

0	Out of paper.	6	Failure of 30 volt DC supply.
1	Over-run.	7	RAM error.
2	VFU Over-run (no punched hole found).	8	ROM error.
3	Sensor Alarm - failure or timing sensor or carriage locked.	9	Input error (more than 20 software mode changes/line).
4	Head drive Protect - failure of drive circuit of printhead.	A	Firmware failure.
5	Motor drive protect.	B	5v supply failure.

## PRICE

The following come as standard and are included in the price shown.

- |   |   |
|---|---|
| a. Parallel or RS232c Serial (which includes ETX/ACK and X-ON/X-OFF protocols). | g. Ease of maintenance (only 3 major sub-assemblies). |
| b. Front or rear paper feed.  | h. 6 month's warranty.                                |
| c. Adjustable tractors.   |   |
| d. 2 x Form Control Loops & 2 Ribbons.  |   |
| e. Variable pitch (10 CPI, 11.7 CPI AND 5 CPI).                                 |   |
| f. Sound proofed contoured casing.  |   |

**Printer \$3,190.00**  
**Stand \$160.00**

All prices exclude sales tax

MICROPRO INTERNATIONAL'S Wordstar/Mailmerge (\$575.00) has been fully implemented for the NDK S-4000 printer. One of our user's has even implemented Wordstar to produce the full Greek scientific character set included with the S-4000 printer!

## FABS

**FABS** (Fast Access Btree Structure) by Computer Control Systems is an assembly language implementation of a classic Btree structure designed to provide rapid access to very large data files (up to 65k records depending upon key size).

In order to achieve fast access times, data record keys are maintained in a key sequential, multipath, balanced tree using an efficient page buffer allocation scheme. Data integrity is assured by automatic buffer flushing after each FABS call which caused a buffer change. This feature is defeated during the build function to improve execution speed when initially creating large key files. The Btree function itself occupies 11k of memory including all necessary buffers.

Interfacing instructions are included for use with either CBASIC.2, SBASIC, BASIC-80, PL/I-80, PASCAL MT+, Fortran-80, or the Microsoft Basic Compiler.

PRICE \$195.00

## LIFELINES

**Lifelines** is a monthly software newsletter published by Lifeboat Associates.

Although Lifelines contains features and columns dealing with new software products on the market, product comparisons, the CP/M Users Group and other items of general interest, the principal role of the periodical is to provide timely notice to owners about their software. Each month, new revisions are reported, together with information on the purpose for each such release, be it for the correction of "bugs" or the addition of features and facilities.

The software products distributed by Lifeboat Associates are frequently both complex and costly. We recommend that all serious users of software should take out subscriptions to Lifelines, ensuring that they are automatically informed about the current state of their software tools and thus get full value for their purchase.

### Subscription Costs

\$36.00 for 12 issues. Price includes postage for anywhere in Australia.

\$5.00 each for back issues. Price includes postage for anywhere in Australia.

All orders must be prepaid.

Write to:

**John F. Rose Computer Services Pty Ltd,**

PO Box 745,

Crows Nest

2065

## HARDWARE NEWS

John F. Rose Computer Services Pty Ltd has released several new systems in the OPAL range including a 128K RAM, 27 Megabyte multi-user MP/M system and a complete network system based on a Shugart SA1004 10 megabyte hard disk using a version of CP/NET. These new systems are available for demonstration at our St Leonards showroom, please ring for an appointment.

## Hardware Catalogue

Price \$1.00 (which includes postage in Australia only. Overseas add \$1.80). This catalogue covers our full hardware range and includes a description of some software products. Version 3.00 of the Catalogue is 84 pages.

## Software Omnibus

Price \$5.00 (which includes postage in Australia only. Overseas add \$3.80). The Omnibus covers the full range of Australian and Lifeboat Associates software sold by John F. Rose Computer Services Pty Ltd. Descriptions include comments from users and bug fixes where appropriate. Version 3.00 of the Omnibus is 173 pages.

All prices  
exclude sales  
tax and are  
discounted for  
cash.

**JOHN F. ROSE  
COMPUTER SERVICES PTY. LTD.**

33-35 ATCHISON STREET, ST. LEONARDS, N.S.W., 2065, AUSTRALIA.  
TELEPHONE: (02) 439 1220 TELEX: AA 27901



## COMMODORE AND MICROPRO DESIGN JOIN FORCES!

MicroPro Design is now able to offer the Commodore microcomputer systems at prices you can afford! We specialise in the design and manufacture of custom microcomputer equipment and have turned our efforts to the CBM and PET.

Besides having the full range of standard Commodore products available, we can offer interfaces to allow virtually any piece of equipment to be connected to the CBM through the IEEE 488 bus.

You can now also use our MicroCon general purpose microcomputer as a slave to the CBM. This allows you to connect A/D, D/A converters, digital inputs and digital outputs for industrial control, monitoring and data acquisition. Programs for the MicroCon can be created in the CBM and loaded down the IEEE 488 bus into the MicroCon for execution.

A few of the current devices now available for use with CBM and PET:

One PROM programmer for CBM user port	\$400
Barcode reader large quantity discounts	\$870
IEEE488 RS232 interface	\$320
IEEE488 Centronics interface	\$250
IEEE488 Microcon interface	\$150
Diablo daisy wheel printer	\$3000
Diablo WP printer (with interface)	\$3500

**Above prices include all cables and connectors where applicable but do not include sales tax. (Dealer enquiries invited.)**

**Write or call for prices on all the Commodore equipment.**



**MicroPro Design  
Pty. Ltd.**

PO BOX 153, NORTH SYDNEY, NEW SOUTH WALES, 2060, AUSTRALIA.  
SUITE 205, WENTWORTH HOUSE,  
6-8 CLARKE ST., CROWS NEST,  
NSW, 2065. PHONE: (02) 438 1220.

## Microcomputer News & Products

### Versatec printer/plotter

Datamatic has released a new hard copy device claimed to incorporate significant advances in electronic and mechanical design.

The Versatec V-80 uses an electrostatic method to imprint and develop the hard copy output.

The V-80 prints 1000 132-column lines per minute, and is more than three times faster than comparably-priced impact printers. It is also a high-speed, high-resolution plotter, plotting a 22.5cm x 20cm plot with 80 dot-per-centimetre resolution in seven seconds.



Integral software for the printer/plotter consists of subroutines which are compatible with pen plotter routines. Most programs originally written for pen plotters can be used with the Versatec plotter.

Further information can be obtained from Datamatic Pty Ltd, 60-64 Dickson Ave, Artarmon, NSW 2064, or 9/118 Church St, Hawthorn, Vic 3022.

### Disk controller boards from Pennywise Peripherals

Pennywise Peripherals now has available two different floppy disk controller cards for use on the Motorola EX-ORciser (TM) bus.

The first controller is Pennywise Peripheral's own design, and will control any mixture of up to four 14cm or 20cm single or double-sided floppy disk drives. The recording mode is IBM-compatible, soft-sectored single-density. Also on the controller card is an RS-232 asynchronous interface with software-controllable baud-rate selection. This interface can be used for driving a printer or an addition VDU.

Pennywise Peripherals are also the Australian distributors for Percom Data products and can now supply the LFD-800EX floppy disk controller, which handles up to four 14cm single-sided drives. The controller card is normally supplied with a pair of Micropolis 77-track disk drives, and is set up to occupy 4K of memory space, with the Disk Operating System supplied in two 1K PROMs.

The Percom system is completely self-contained and is said to be ideal for interfacing to the D2 or D3 kit or other 6800/6802 processor cards. Software available includes an editor, assembler, text processor, disk Basic, data base management system and a General Ledger package.

For further information contact Pennywise Peripherals, PO Box 398, Camberwell, Vic 3124.

MICRONEWS  
CONTINUED →

# Synertek

A Honeywell Company

#### TICK ITEMS OF INTEREST

- Static RAMS
- EPROMS
- Custom ROMS
- SYM-1 Single Board Computer
- Keyboard terminals, KTM-2 & KTM-2/80
- 8K BAS-1 & 8K RAE-1 Resident Assembler Editor for SYM-1 ROM Resident
- $\mu$ P Computer Module, Super-Jolt
- 6500 Micro's & peripheral IC's
- Low cost/low quantity custom LSI's
- Industrial systems engineering

Please send information on items ticked. My application is:

- HOBBY
- INDUSTRIAL
- PROFESSIONAL

Name: .....

Company: .....

Address: .....

Post Code ..... Phone: .....



### ROYEL MICRO SYSTEMS PTY. LTD.

VIC: 27 Normanby Rd., Notting Hill, 3149. Phone 543 5122  
NSW: 15/59 Moxon Rd., Punchbowl, 2196. Phone 709 5293

SRC100A

## Microcomputer News & Products

### English court upholds software copyright

The US magazine "InfoWorld" recently reported an English case, *Molimerx vs Kansas City*, in which the court held that microcomputer software is covered by the same copyright legislation that applies to written documents. The question of the "copyrightability" of computer programs has been an open one for some time now.

A. J. Harding of Molimerx Pty Ltd was reported in "InfoWorld" as saying that the case was the first he had heard of in which an English court held that microcomputer software could be the subject of copyright. Molimerx is the authorised distributor for Microsoft products in the British Isles, and the company brought a suit against Kansas City Systems, of Chesterfield, Derby, claiming that they had sole rights to the Microsoft Level IV Basic which Kansas City was distributing.

Under a provision of English law which permits confiscation of materials which violate copyright, copies of Microsoft's Level IV Basic for the TRS-80 were removed from the premises of Kansas City Systems. The case was later settled out of court, with Kansas City agreeing to a court order which prohibits it from duplicating or marketing Level IV Basic.

Australian copyright law is based on the English law, and the decision in *Molimerx vs Kansas City* is likely to carry great weight with Australian courts if a similar case arises here.

### Pro-Thello III a winner

Instant Software's new microcomputer program, Pro-Thello III, was a clear winner at the Santa Cruz Open Othello Tournament held during January in Santa Cruz, California. In a tournament to determine the best Othello computer program Pro-Thello III defeated all competitors running on both microcomputers and minicomputers.

The program was scheduled for release in March 1981 by Instant Software Inc, and will be available from Instant Software resellers in both cassette and disk versions for the TRS-80 computer.

### Single board computer

Royal Micro Systems Pty Ltd recently announced details of a new single board computer, the Synertek CP110 "Super Jolt", designed for use as a stand alone microcomputer or in dedicated applications.

The single board computer measures 108mm x 178mm, and is based on the 6502 microprocessor. Standard features include 1K of static RAM, 28 bi-directional I/O lines, an interval timer, and three serial interfaces (RS-232, TTL levels and 20mA current loop). Also on the board is a 1K ROM containing the "Demon" monitor/debug program.

A 4K RAM card is also available, allowing memory expansion up to 32K bytes in 4K blocks. Fully buffered address, data and control signals are available from an edge connector on the CPU board.

Full details of the "Super Jolt" computer and the new testing and repair service are available from Royal Micro Systems Pty Ltd, 27 Normanby Rd, Notting Hill, Vic 3168 or Royal Micro Systems, 15/59 Moxon Rd, Punchbowl, NSW 2196. ☐

## ATTENTION YOUNG COMPUTER BOFFINS!



Dick Smith Electronics is looking for someone to take over the operation of the company's "Computer Hot Line" service.

This involves advising customers about technical aspects of its computer products: the highly successful Dick Smith System-80 and Exidy Sorcerer computers, their associated peripherals and software.

The person we are looking for is probably a bright young computer enthusiast, around 19 or 20, and bursting with knowledge about, and enthusiasm for, personal computers.

If you think you answer this description, write to our Technical Director, Jim Rowe, at the address below, giving brief details of yourself and an idea of the salary you would expect.

**DICK SMITH ELECTRONICS**  
P.O. Box 321, North Ryde NSW 2113.

# TANDY

## COMPATIBLE

Printers, Expansion Units,  
Disc Drive, Software.

### DIRECT FROM THE U.S.

Write for our Catalogue

### COMPUTER IMPORTS PTY. LTD.

P.O. BOX 7, PORT ADELAIDE,  
S.A., 5015  
PHONE (08) 26 88065

## COME TO COMPUTER COUNTRY

For one of the largest selections of software and books in Australia for the Apple, Northstar, TRS-80 and Pet range of microcomputers.

Let the professionals at Computer Country solve your microcomputer problems.

*Computer Country Pty. Ltd.*

338 Queen Street, Melbourne, Vic, 3000.  
(03) 329 7533

Enquire about participating in our "National Adventure Tournament".

In Queensland contact:

**COMPUTER CITY**

600 Old Cleveland Road,  
Camphill, Brisbane, Qld.  
(07) 398 6759.



## INFORMATION CENTRE

**GRAPHIC EQUALISER:** I have just completed assembly of the Playmaster Graphic Equaliser from a kit produced by the Dick Smith organisation. I find on completion, even though I followed the trouble-shooting section of the instruction manual closely, I cannot correct the faults I have encountered. (S. R., Northmead, NSW.)

● A simple trouble-shooting procedure would be as follows. First check the +15 and -15V supplies, then with no input signal check that the output voltage of each op amp is about 0V. This may provide some clue as to which section of the circuit is faulty. We would also suggest that you check the orientation of the ICs and tantalum capacitors against the component overlay.

**CASSETTE DECKS:** In this day and age of cassette recorders and decks I have not seen much in the way of articles about the working principles of the modern cassette recorder. I have some ideas, but also a lot of doubts.

The reason I ask is that I have three beat-up cassette recorders which I have collected over a period of time from friends and upon checking them out I found the motor drive, heads, etc all okay.

Could Electronics Australia come up with something? I think a lot of us would enjoy rebuilding a cassette recorder; in most cases only the printed circuit board and casing need replacing. Do you have any circuits or ideas I could use please? (L. E., Yarra Glen, Vic.)

● A cassette recorder project is fairly impractical considering the low prices of good quality decks nowadays. We did, however, do such a project in August and October 1974 and another in February 1978 which should provide some useful information on the operation of cassette decks.

**DUPLEX LOUDSPEAKER:** As a reader of Electronics Australia for many years, may I communicate a suggestion from myself and a circle of serious HiFi followers.

We remember the amazing quality of bass heard at the Sydney Consumer Electronics Show in '76 from the DD88M duplex woofer, cone-to-cone speaker, that you later described in EA, December '76.

Would it be possible to publish a design for such an arrangement for the serious constructor, this would undoubtedly be a breakthrough in what is offering in any market today.

We understand that this commercial

speaker arrangement was discontinued for cost reasons in early '78, and the provisional patent application was not proceeded with. (D. L., Artarmon, NSW.)

● While the Duplex loudspeaker was a novel and interesting application of the loudspeakers available to AWA at the time of design, it would have to be re-designed to suit readily available loudspeakers. If this was done, there is no guarantee that the complicated enclosure would yield better results than a more conventional design to Thiele/Small principles.

● The LM372 is still made by National Semiconductor and as far as we know, has not been superseded by a device of the same type. However, National Semiconductor have produced a set of IC's specifically for remote control applications and these are used widely in remote control toys selling in the price range \$30 to \$60. We can also refer you to a ready built transmitter/receiver system marketed by Dick Smith Electronics.

We do not think the circuit would work well at voltages below 15V.

**SELECTALOTT:** I have recently constructed your Selectalott project described in December 1980. When attempting to use the device nothing happened and I found that IC1 began to get hot; this was replaced with another, with the same result.

Comparing your component layout with the circuit diagram it appears to me that the diagrams differ in the connection of IC1. Anyway I reversed IC1 and found that the unit worked basically, but with the following faults. When the "go" button is pressed all the diodes light up weakly with the exception of column 4 representing numbers four, 10, 16, 22, 28 and 34 which glow about half brightness. When selections are made usually two diodes come on (a single comes about one in six). The pattern is usually a diode from column four lights and a corresponding diode in the row which bisects the column also lights, eg 28+25 or 16+18 and so on.

One other thing, when the unit is switched off with say the last number 30 selected being 30; and the unit then turned on again 30 will be on fully bright as though it retains a memory of the last number. (S. Novak, South Kingsville, Vic.)

● IC1 was shown reversed on the component overlay, and this error was noted in January 1981 Notes and Errata. We

apologise for the inconvenience caused. Concerning the problem with column four of the Selectalott display it would seem that it has been permanently enabled. This explains why a LED in column four is always on as well as a LED on the same row but in another column. We suggest that you carefully check the wiring related to column four for shorts etc, also examine the outputs of IC2 and IC3 to see if they are functioning properly.

Your comment about the apparent memory of the unit is quite correct. The cause for this apparent memory is the two 22 $\mu$ F supply decoupling capacitors which, when the unit turned off will quickly discharge down to about 2V, a figure set by the voltage drop across the LED and diode. This voltage is just enough to keep the CMOS circuitry "on" and hence retain memory.

This memory effect can be removed by connecting a resistor from the supply rail to ground. Alternatively the switch S2 can be wired so as to switch the supply rail between the battery and ground.

**1980 MULTIBAND SUPERHET:** Since I still attend High School my finances are very limited and for months I have been searching for a simple and easy circuit for a superhet shortwave receiver and in the November issue of EA my searching ended. The 1980 Multiband Superhet will allow me to listen to the world without sending me broke.

I know the receiver has the basic circuitry but is there any way of applying an AGC circuit to the existing circuitry and if so, is there a possibility of adding an S-Meter as well?

Is there a BFO circuit that can be used with a receiver with a 1.8MHz IF such as the 1980 Multiband Superhet? The BFO circuit printed in the September issue of EA can only be used with a receiver with a 455kHz IF. Is there any way of changing this circuit so that it may be used with your receiver? (R. F., Green Valley, NSW.)

● To add AGC to the 1980 Multiband Superhet would require a major redesign, which would move it into a higher price bracket — away from the constructors to whom it is directed. Further, when a simple receiver is used for either CW or SSB transmissions, it is usually necessary to disable the AGC so that its BFO cannot assume control of the RF gain. Thus, if AGC is installed, it becomes necessary to both provide IN/OUT AGC switching facilities, and at

the same time retain manual RF gain control when AGC is disabled.

Whilst S-type meters can be added to receivers without AGC, unless there are calibrated gain positions for the RF gain controls, the readings they provide are meaningless. However, if you are interested in tuning to the centre of a carrier, you could try inserting, say, a 0.1 milliammeter between the 9-volt rail and the 8.2K resistor feeding the collector of Q4, the class-B detector. This should provide some sort of indication of signal strength, but in the absence of calibrated gain controls its readings will be purely arbitrary.

Referring to your third query regarding the adaptation of the simple BFO project published in September EA, this is not necessary. Whilst it should be possible to substitute a 1.8MHz ceramic filter for the 455kHz one used in the BFO unit, these are not readily available. However, it is quite unnecessary to add a BFO to the 1980 Multiband Superhet, since the regeneration control can be used for the same purpose, as explained on the first page (p44) of the article. Additional information on the operation of this control is contained in the para "Hints on Using the Multiband Superhet" on page 49.

**MULTIBAND SUPERHET:** I read with much interest your article on the Multiband Superhet in the November edition of EA and intend to build this set. I would like to mount all the coils and to use a rotary switch to change bands.

Before I start building the receiver I thought I would ask if this would cause any interference or reduce the performance by mounting them together. (P. S., Lenah Valley, TAS.)

● We avoided the approach you suggest on account of the complexities that would arise. It must be born in mind that the 1980 Multiband Superhet was designed to provide fairly high performance at a moderate cost. Eight-pole, four position switches are not readily available off the shelf, and in addition would incur a substantial increase in the cost of parts. Further, the correct interconnection of some 40 leads could easily lead to errors by the beginner, to whom this project was directed.

In addition, the published design does not readily lend itself to easy mechanical mounting of the coils, bearing in mind that leads should be kept short — especially those of the higher frequency coils. A further point to watch is that an unused lower frequency coil self-resonates at a frequency which occurs within the passband of a higher band coil, and can cause degradation — greater or lesser dependent upon proximity to the in-circuit coil and leads — of performance around this frequency. It is for this reason that communication receivers often incorporate switching which shorts out the unused coils. Apart from special switches designed for commercial units, the other way to overcome this problem is to add further

poles, which further increases cost and complexity.

Summing up we suggest you construct the Multiband Superhet in its designed form, rather than enter the area of the great unknown.

**PIPE & WIRING TRACER:** I have been a regular receiver of your fine magazine for approximately 16 years and have seen projects updated time and again with the exception of a "Pipe and Wiring Tracer" published in September 1965. It is mainly a plumber's and electrician's tool. As an electrician, what about an updated version? Thanking you for past projects and features. (O. G., Rhodes, NSW.)

● We will consider a new version of this project. Thanks for the suggestion.

**REVERBERATION UNIT:** I am building myself a Guitar Amplifier and would like to include a "reverb" function into the pre-amp. If you can, I would appreciate information on how to do this. (A. S., Stonyfell, SA.)

● You should be able to adapt the reverberation unit intended for the Playmaster 760 Electronic Organ to your Guitar Amplifier. This design is based on a spiral-spring delay line, currently available from A.C.E. Radio, 136 Victoria Rd, Marrickville, NSW or CQ Electronics, PO Box 557, Blacktown, NSW. Photocopies of this project (File No. 1/EM/39) published in the May, 1976 issue of Electronics Australia are available from our Reader Service priced at \$3 each.

An alternative approach could be to use a "Bucket Brigade" Audio Delay Line, such as was described in our November, 1978 issue. We still hold limited stocks of this issue, priced at \$2 each. The Bucket Brigade essentially provides "echo" which simulates reverberation. Some feel that the ideal artificial reverberation is provided by initially delaying the signal via a delay line by some 25 to 100 milliseconds, and then adding the desired amount of reverberation, then "mixing" this processed signal with the "dry" (or direct) original sound.

**CAR BATTERY VOLTAGE MONITOR:** Over the last few months I have built up a number of circuits pertaining to automotive electronics. All of the items have given me a great deal of pleasure as well as having practical use in my vehicle.

The latest article, the Car Battery Voltage Monitor published in October 1980, has been built up and I would like to relate my experience to you.

I found that I could not get the red LED to flash until I altered the value of the 0.1 $\mu$ F capacitor to 0.22 $\mu$ F.

I also found that a 7½ volt zener gave a reading closer to the 8.2 volts specified. The 8.2V zener actually gave a reading of 8.8 volts. Both of these problems could be due to component tolerances. The thing that concerns me the most is the current drain of the whole circuit.

The drain for my particular board is much higher than that quoted in the article, and boy, does that zener run hot.

Could you please advise me as to where I may have gone wrong. I have checked all the resistors and replaced the IC — the result remaining the same. I don't think I've done anything wrong but no doubt you may be able to give me some guidance. By the way, it's a great indicator circuit. (G. F., Homebush, NSW.)

● We suspect one component in the circuit, the 220-ohm resistor. We suggest that you measure the value of this resistor. You do mention that you have checked the resistors, but it is possible that the one in place of the 220-ohm resistor is in fact 22 ohms. This would dramatically increase the current drain of the circuit and cause the zener to run hot.

---

## Notes & Errata

**PLAYMASTER MOSFET STEREO AMPLIFIER** (December, 1980, January, 1981, 1/SA/65, 66, 67): Three errors have appeared on the PCB layout on page 48 of the January issue. First Q103 is labelled Q17. Second, the 4.7 $\mu$ F output capacitor from the pre-amplifier (involving Q101 and Q102) is wrongly polarised. Finally, pins 29 and 31 should be swapped.

The following errors have appeared in the parts list: The four 100 $\mu$ F capacitors in the power amplifiers may be 100VW or 63VW; There are only 12 0.1 $\mu$ F green-caps required; The 33 $\Omega$  resistor was mistakenly listed as 33k $\Omega$ ; Only nine 56k $\Omega$  resistors are required; two 15k $\Omega$  resistors are required instead of one and the 2.2k $\Omega$  resistor associated with the BZX79 zener diode should be rated at one watt.

---

## Touch Sensitive Switch . . .

ctd from p69

end of the case for the lead to the touch plate (or door handle).

Note that the circuit earth must be connected to the lid of the case. The best way of doing this is to connect the earth lead to a solder lug. The lug is then held in position under the lid by one of the lid securing screws (see photograph).

Three insulated wires about 60cm long are used to make the counterpoise. These are soldered together at one end to a solder lug which is attached to the lid of the case. In use, the three leads are taped to the inside of the door as shown in the photograph. A length of tinned copper wire is used to make the connection to the door handle.

Finally, if you intend to power the unit from a plugpack supply in a fixed installation, the counterpoise will not be necessary. In this instance, the power supply itself should provide sufficient capacitive coupling to earth. A small piece of scrap aluminium can be used as a touch plate. ☺

# MARKETPLACE

## FOR SALE

**R. F. IMPEDANCE BRIDGE** Wayne Kerr — This laboratory grade instrument is a once in a lifetime offer. 1% accuracy 1-100MHZ complete with source (5-100MHZ) and detector. Measures parallel equivalent impedance as  $G \pm jX$  excellent for measuring components transmission lines and antennas. \$975. Phone V. Turner (09) 386 2010 or write to 130 Princess Rd, Nedlands, WA.

**AMIDON CORES** — Large range of ferromagnetic cores for all receiver and transmitter applications. Send large SASE for data/price list to: R. J. & U. S. Imports, Box 157, Mortdale, NSW 2223.

**SINCLAIR ZX80 ACTIVE DISPLAY** — now you can write those games or use the ZX80 for "hands off" continuous data monitoring. This routine lets you decide how long a display will hold before a program continues (1/50 sec to approx 10 mins). This essential routine includes a useful HEX loader utility. Send only \$12.00 inclusive for this program or write for free catalogue to K. Macdonald, PO Box 533, South Melbourne, Victoria 3205.

**FREE** . . . List of bargain electronic components, ideal for hobbyists, servicemen, Radio Clubs, etc. Send 9" x 4" SAE. Now!! Micronics, PO Box 175, Randwick, NSW 2031.

**ELECTRONIC BOOKS FOR BEGINNERS.** Wide range of books covering basic concepts to use and design of standard circuitry. Expressly written in simple English for those with little previous knowledge of electronics or electronic construction. Send stamped self-addressed envelope for catalogue and price list to: Hobby Electronic Books, PO Box 525, Gosford, NSW 2250.

**REPAIR'S AND SPARES FOR ALL GRUNDIG RADIO'S, DETECTING MACHINES HI FI, ALL TYPES AND MAKES OF TRANSFORMERS, IC REGULATORS VALVES.**

**GRUNDIG**  
490 Queen St,  
Brisbane 229 5445

**"\$100 CHASSIS-BENCH MOUNT**, 11 slots 15A power supply, fan, key switch — mfg by SM Electronics \$275. Call David Liell (02) 29 5093 days.

**BARGAIN — ELECTROS**, 2200 $\mu$ F 25v AXIAL LOTS OF 25 — \$6, 100 — \$20, 1000 — \$100 \$1 Package & Post, J. Schofield, 15 Francis St, St Agnes, South Australia 5097.

**QUALITY CASSETTE SOFTWARE** for OSI Challengers. Write for full details to Computer Cottage, Box 455, Charters Towers 4820.

**"ALL YOU NEED TO KNOW ABOUT TV.** Aerials (from local to deep fringe) is contained in this 78 page practical book titled, TV & FM Aerial Installations) \$5 covers cost & postage plus a free 44 page catalogue with a special hobbyist price list enclosed." Hi-Q Aerials, 69 Maitland Road, Irlington, NSW 2296.

## READER SERVICE

**KIT TROUBLES?** Don't pitch it. We fix by mail. Fair rates, incl explanation of fault. Howe Electronics, Box 186, Wynnum 4178.

### MAIL-ORDER FROM HONG KONG

If you are looking for following electronic products with high quality expectancy, write to us now for our free catalogue:

Microprocessor-based handheld games and toys  
AM/FM car stereo cassettes  
Radio cassette recorders  
Digital clock radios  
Multi-band radios  
TTL & CMOS ICs  
Electronic components

Our long established direct connections with major manufacturers bring you products at almost ex-factory prices with well proved quality standards. Just put your name and address in an envelope and mail to:

**L & L INTERNATIONAL**  
PO Box 10156 Cheung Sha Wan,  
Hong Kong

## Serial Computer Interface . . . ctd from p93

These programs, poke two separate machine-language drivers into the top of the memory area and initialise the other two device-control blocks to the new driver addresses. One very important point that should be made at this stage concerns the initialisation of the computer at power up. Some memory must be reserved at the top for the machine language drivers. If this is not done the monitor stack will be overwritten and the computer will "crash". A safe initialisation for all the listings provided is 32600.

These programs, when run, disable the internal keyboard and video drivers, placing the computer under the control of the new drivers. The computer's video screen will blank out and the keyboard will be disabled.

If you wish to have only the video returned to the internal driver control,

then a simple line in BASIC such as that shown below can be used, either in a program or at the command level. POKE 16414,88: POKE 16415,4: REM RETURNS OUTPUT TO COMPUTER VIDEO.

The above line, when executed, will change the driver address in the video device control block back to the internal driver. It is also possible to have both the internal video and external output operating at the same time by writing a new output driver that first calls the internal routine and then outputs the same data to the interface unit.

Unfortunately, lack of space prevents us publishing all the programs and listings described here as they are quite extensive. Instead, they will be available from our Information Service (see page 136), in photostat form, for a fee of \$2.00, which includes postage and packing.

**DISPLAY ADVERTS IN MARKETPLACE** are available in sizes from a minimum of 2cm x 1 col rated at \$12 per col cm.

**Please state classification:** For Sale, Wanted, Reader Service, Position Vacant, Position Wanted, Business For Sale, etc.

**CLASSIFIED RATES** \$3 per line per insertion payable in advance. Minimum two lines.

**CLOSING DATE** is six weeks prior to the on-sale date. Issues are on sale the first Monday of each month.

**ADDRESS** all classified orders, copy, enquiries, etc. to: The Advertising Manager, **ELECTRONICS AUSTRALIA**, Box 162, Beaconsfield 2014.

## FOR HIRE

**MICROCOMPUTERS FOR RENTAL.** Commodore PETs (8k) at \$25 per week (minimum period 1 week) Software tapes & manuals included, plus BASIC instruction course and book. David B Bates Microcomputer Consultant, Ph (02) 630 8652.

## CLUBS

**SA DXERS, LISTEN TO THE WORLD!** DXing, the scientific hobby for active shortwave mediumwave, utility, and amateur listeners. Monitoring, reception reporting and receiving verifications from stations worldwide make DXing a hobby for all ages and vocations. Australian Radio DX Club members receive the monthly "Australian DX News" full of loggings, QSL notes, equipment reviews, schedules, branch activities. ARDXC welcomes newcomers; low under-18 rates. Many club services and publications available. Send a 22c stamp for full details to: ARDXC, 8 Olive Avenue, Broadview, SA 5083.

### BASIC ELECTRONICS

Basic Electronics begins with the electron, introduces and explains components and circuit concepts, and progresses through radio, audio techniques, servicing, test instruments, etc.

Available from:  
"Electronics Australia", 57 Regent St, Sydney  
**PRICE \$3.50 OR** by mail order from "Electronics Australia", PO Box 163, Beaconsfield 2014 **PRICE \$4.20**

## Column 80 . . . ctd from p118

So if you need to write a machine language program, a good assembler program is really an essential tool.

If you're the proud owner of a System-80 or TRS-80 computer, I can really recommend the Microsoft Editor/Assembler-Plus. This has many powerful features, including a macro facility, and comes complete with a text editor to make it easier to prepare your "source" program in assembly language. It also has a "debug" program to let you troubleshoot the final code if it doesn't do what you expected.

In short, it provides just about all the basic facilities you need to develop assembly language programs. We sell it in our stores as catalogue number X-3680 (\$39.95), but it's available from other sources as well.



## RESISTORS

150 ohm, 5W	20c
10 ohm, 5W	20c
47 ohm, 5W	20c
12 ohm, 3W	20c
2.5 ohm, 3W	20c
33 ohm, 3W	20c
8 ohm, 10W	25c
4000 ohm, 10W	25c
100 ohm, 5W	20c
330 ohm, 10W	25c
220 ohm, 5W	20c
5 ohm, 5W	20c
220 ohm, 10W	25c
950 ohm, 3W	20c
115 ohm, 5W	20c
10 ohm, 5W	20c
1k ohm, 5W	20c
5000 ohm, 5W	20c
6.8k ohm, 3W	20c
3300 ohm, 10W	25c
6800 ohm, 10W	25c
1500 ohm DUAL 21W	50c
50 ohm, 5W	20c
330 ohm, 5W	20c
1k ohm, 5W	20c
820 ohm, 5W	20c
12 ohm, 10W	25c
470 ohm, 7W	20c
4700 ohm, 4.5W	20c
5000 ohm, 10W	25c
8.2 ohm	5W
3.3K	7W
27 ohm	5W
10K	7W
2.5 ohm	3W

## CAPACITORS

0.0039uF, 1500V	20c ea
6N8 1500V	20c ea
0.0068uF, 1500V	20c ea
1200PF, 400V	10 for \$1
0.068uF, 400V	5 for \$1
2200PF, 630V	10 for \$1
0.47uF, 250V	10 for \$1
0.10uF, 400V	5 for \$1
0.082uF, 160V	10 for \$1
26k 250V	10 for \$1
0.041uF, 400V	10 for \$1
0.033uF, 250V	5 for \$1
0.027uF, 100V	20 for \$1
220uF, 10V	10 for \$1
1uF, 350V	10 for \$1
470uF, 40V	5 for \$1
1000uF, 16V	25c
2.2uF, 200V	10 for \$1
0.047uF, 1500V	50c
47uF, 25V	4 for \$1
680uF, 40V	50c
22K, 100V	20c
330uF, 25V	25c
2.2uF, 200V	30c
470uF, 40V	50c
680uF, 35V	50c
0.015uF, 250V	25c
1uF, 100V	25c
1000uF, 16V	50c
220uF, 16V	50c
2000uF, 63V	\$1
0.47uF, 400V	50c
680K, 250V	25c
012, 250V	10c
15Nf, 250	10c
120K, 250V	20
10uF, 315V	25c
0.056 250V	10c

<b>Slide Pots</b>	
250K-50K	3 for \$1
Dual 500K	3 for \$1
1 Meg	3 for \$1
2 Meg	3 for \$1
Including Fancy Gold Knobs	
25K dual	2 for \$1

<b>SPECIAL</b>	
100 mixed resistors, all useful	\$2
100 mixed capacitors, fresh stock	\$2

<b>AUDIO LEADS</b>	
3.5m to 3.5m, 7ft	75c
3.5m to 6.5m, 7ft	75c
6.5, 7ft	50c

<b>MICRO SWITCH</b>	
5A, 250V AC	75c ea

<b>TUNING CAPS</b>	
2 and 3 gang	\$1 ea
Min 2 gang	50c

<b>FUSES</b>	
0.5A, 2A, 3.25	10 for \$1
In line fuse holders	30c
RCA jack plugs and sockets	40c pair
1A, 10 for	\$1

# L. E. CHAPMAN

122 PITT ROAD, NTH CURL CURL.  
MAIL ORDERS: BOX 156, DEE WHY, NSW. 2099.  
TELEPHONE 93-1848.

## SPECIAL TRANSISTORS

AD 161 162	\$2.50 pr
BSC 901A	\$1.50 ea
BC 548	10 for \$1
AD 149	\$3 pr
OC9554	50c
BD202N	50c
BD135	50c
2NC055	\$1

## ELECTROS

470uF, 25V	5 for \$1
400uF, 10V	5 for \$1
47uF, 63V	5 for \$1
350uF, 16V	2 for \$1
27uF, 160V	5 for \$1
25uF, 63V	10 for \$1
22uF, 160V	10 for \$1
47uF, 16V	5 for \$1
47uF, 200V	5 for \$1
220uF, 10V	10 for \$1
68uF, 16V	10 for \$1
100MFD, 350V chassis mount	\$1

- Telescopic aerials, \$1.50
- 6 inch ferrite rods, 75c
- Rainbow lead, 5 strand, 20c per metre
- Line output transformers, 600 ohm, to 15 ohm, 20 watts, \$5
- Line output transformers, 1200 to 3/ohm, 5 watt, \$1
- Power supply units, filtered, 240 to 20 volt, \$12

Power leads 240 volt, suit most tape recorders, radios, etc. \$1 each

TV Stick Rectifiers 20SC \$1.00

Philips Colour TV Convergence Boards, \$3 each

455KC IF Transformers for valve radios, \$1 each Also aerial and OSC coils, 75 cents each

## POTS ROTARY

1/2 Meg	30c
1 Meg	30c
100K	30c
100K Switch	50c
50K Double Pole Switch	50c
7.500	30c
10K Switch	50c
250K	30c
50K	30c
20K	30c
10K Min Pots	25c
50 Ohm	50c
1/2 or 1 Meg Switch	50c
1/2 1 meg dual Concentric tapped at 100K	\$1
2 meg ganged double pole switch	\$1
1.5 meg dual ganged	50c
2 meg ganged log	\$1
1 meg dual ganged	\$1
1/2 meg dual ganged LIN	75c
25K 50K dual ganged Concentric double switch	\$1
200K single line	30c
20K wire wound	75c
dual log 10K	75c
100K dual ganged linear pots	75c
10K sub min log pots	50c
250K ganged pots	75c
25K lin ganged pots	75c

HOR Drive 3021 transformers for colour TV \$2  
TV Colour Convergence Units 11270 44 x 6 \$3

**PILOT LIGHTS**  
Screw in 6.3V 10 for \$1.50  
24V 10 for \$1.00  
Pilot light holders \$1.50

- Car radio suppressors, 3 for \$1
- 3 position slide switch, 50c
- Toggle switches, 25c
- 2 position push button switch, 50c
- 6 position push button switch, \$1
- 4 position push button switch, 75c
- Transistor ear plugs & leads, 3 for \$1
- In-line fuse holders, 4 for \$1
- 4 pole 2 position rotary switches, 50c

Pick up Cartridges BSR universal type Ceramic Stereo \$5  
Audio Technica AT6 diamond stylus stereo \$12

## DIODES

OA 626	4 for \$1.00
OA 662	4 for \$1.00
EM 410C	4 for \$1.00
DS 150A	50c
DSY 130YO	50c
OA 636	50c
HR 15	50c
Dodes BYX 55, 300	30c
BY 188	30c

## SUPER SPECIAL

GRAMOPHONE motor and pickup 3 speed stereo balanced arm

240 volt \$9.75  
PP NSW \$1.50  
Interstate \$2.75  
WA \$4

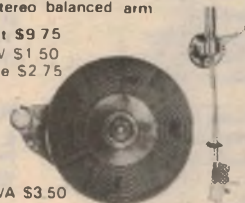

\$250 WA \$3.50

## VALVES

6V6	\$2.50	12AQ5	\$2.00
6AN7	\$2.00	12AV6	\$2.00
6AV6	\$2.00	12BE6	\$2.00
6DX8	\$2.30	6BL8	\$2.00
6V4	\$1.50	6BM8	\$2.50
1S5	\$1.00	PCL82	\$2.00
1S2	\$2.00	6E2	\$2.00
5A54	\$2.00	DL96	\$2.00
6AR7	\$3.00	UY41	\$2.00
EM34	\$2.50	6DA6	\$2.00
6DQ6	\$3.50	6S2	\$2.00
6HG8	\$2.00	6BD7	\$2.50
6B26	\$2.00	6SK7	\$2.50
12AN7	\$2.00	6SA7	\$2.50
6AL3	\$3.00	6AX4	\$3.00
6BA6	\$2.00	6BV7	\$3.50
6BQ5	\$2.00	6V9	\$2.50
6CG7	\$2.00	6W6	\$2.00
6AN8	\$2.00	EF37A	\$2.00
12BE6	\$2.00	6AD8	\$2.50
6EM5	\$2.00	6CW7	\$1.00
6AF42	\$2.00	3S4	\$1.50
6BH5	\$2.00	6EA8	\$2.00
6BHB	\$2.00	6AH6	\$2.00
6BH5	\$2.00	EB8CC	\$2.00
6B8	\$2.50	12AV6	\$2.00

**PICK UP ARMS**  
Mono \$3.50  
Inc Ceramic Cartridge & Stylus

<b>TRIMPOTS</b>	
200 ohm	10c
5K	10c
100K	10c
47K	10c
10K	10c
470 ohm	10c

Miniature speaker and drive output transformers \$1 pr  
Special mixed tag strips 10 for \$1

## SPEAKER SYSTEMS



Inc one 6 x 4 speaker, 5W RMS, \$4.75 ea  
P&P: NSW \$1.80, Interstate \$2.80 WA \$4  
(For singles or pairs)

## SPEAKER SPECIALS

15 ohm 4" — 2 for \$2  
6x9 15 ohm \$5 each  
5x7 15 ohm \$4 each  
8x4 15 ohm \$4 each  
6x4 15 ohm \$3 each

5" x 3.5" or 15 ohm \$3.50 each

## SUPER SPECIALS FM STEREO TUNER KITS

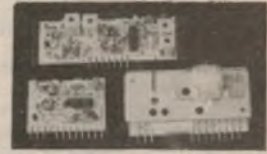

Sets of 3 modules include FM tuner, decoder and IF detector. Circuit diagram supplied. Can be used with amp modules

ONLY \$22  
P&P \$1.00

## TRANSISTORS

2N3055	\$1.20
SE1002	4 for \$1
BF459	50c
B544 DE6	50c
C106 F1	50c
TIP 110	50c
608EK	4 for \$1
BCE548	10 for \$1
2SB186	50c
2SA101	50c
BD263	50c
BSB405	50c
2SB77	50c
2SB303	50c
AC187	50c

## VU & BALANCE METERS



STEREO VU \$3.00



12Kn 100uA \$2.00

## PHILIPS TV TUNERS

Transistor NT3024, P&P \$1.



\$10 ea.

# Electronics Australia Reader Service

"Electronics Australia" provides the following services:

**PHOTOSTAT COPIES:** \$3 per project, or \$3 per part where a project spreads over multiple issues (price includes postage). Requests can be handled more speedily if projects are positively identified, and if not accompanied by technical queries.

**CHASSIS DIAGRAMS:** For the few projects which require a custom metal chassis (as distinct from standard cases) dyeline plans showing dimensions are normally available. \$3 including postage.

**PC BOARD PATTERNS:** High contrast, actual size transparencies: \$3, including postage. Please specify positive or negative.

**PROJECT QUERIES:** Members of our technical staff are not normally available to discuss individual projects, either in person at our office, or by telephone.

**REPLIES BY POST:** Limited to advice concerning projects published within the last three years. Charge \$3. We cannot provide lengthy answers.

undertake special research, or discuss design changes. Nor can we provide any information on commercial equipment.

**OTHER QUERIES:** Technical queries outside the scope of "Replies by Post" or submitted without fee may be answered in these pages, at the discretion of the Editor.

**COMPONENTS:** We do not sell electronic components. Prices and specifications should be sought from advertisers or agents.

**BACK ISSUES:** Available only until our stocks are exhausted. Within six months of publication, face value. Seven months and older, if available, \$2 (includes storage fee). Post and packing 70c per issue extra.

**REMITTANCES:** Must be negotiable in Australia and made payable to "Electronics Australia". Where the exact charge may be in doubt, we recommend submitting an open cheque endorsed with a suitable limitation.

**ADDRESS:** All requests to the Assistant Editor, "Electronics Australia", Box 163, Beaconsfield, 2014.

## ELECTRONICS AUSTRALIA PRINTED CIRCUIT BOARDS AND FRONT PANELS

Some readers have indicated problems obtaining PC boards and front panels for projects. Many of our advertisers sell these items and advertisements in the magazine should be carefully checked in the first instance. Failing satisfaction from this source, the following is a list of firms to which we supply PC and front panel artwork. Some may sell direct, others may only be prepared to nominate sources from which their products can be obtained.

### N.S.W.

Applied Technology Pty Ltd,  
1a Pattison Avenue,  
Waitara, NSW 2077

Dick Smith Electronics,  
PO Box 321,  
North Ryde, NSW 2113

Electronic Agencies,  
115-117 Parramatta Road,  
Concord, NSW 2137

RCS Radio Pty Ltd,  
651 Forest Road,  
Bexley, NSW 2207

Radio Despatch Service,  
869 George Street,  
Sydney, NSW 2000

### VIC.

Kalextronics,  
4 Burgundy Plaza,  
101 Burgundy Street,  
Heidelberg, Vic. 3084

Rod Irving Electronics,  
425 High Street,  
Northcote, Vic. 3070

### S.A.

James Phototronics,  
522 Grange Road,  
Fulham Gardens, 5024

### W.A.

Jemal products,  
8/120 Briggs Street,  
Welshpool, WA 6106

### TAS.

D & H Electronics,  
108 Campbell Street,  
Hobart, Tas. 7000

### N.Z.

E H Earl Ltd,  
PO Box 834,  
Wellington, NZ

Marday Services,  
PO Box 19 189,  
Avondale,  
Auckland, NZ

Mini Tech Manufacturing Co Ltd,  
PO Box 9194,  
Newmarket, NZ

Printed Circuits Limited,  
PO Box 4248,  
Christchurch, NZ

## ADVERTISING INDEX

ADVERTISER	PAGE
A. & R. Soanar	45
Ace Radio	110
Acoustic Electronic Developments Pty Ltd	126
Adaptive Electronics	72
Advance Electronics	111
Altronic Distributors Pty Ltd	50, 51
Ampec Electronics Pty Ltd	8
Applied Technology	92
Associated Steel Equipment	35
Audio Telex Communications Pty Ltd	27
Automatics Australia	99
BS Microcomp	95
BWD Instruments Pty Ltd	7
Bright Star Crystals	77
British Merchandising Pty Ltd	109
CQ Electronics	101
Caporale, J. F.	98
Cash-More Enterprises	79
Cema (Distributors) Pty Ltd	14
Chapman, L. E.	135
Classic Radio	117
Computerland Australia	2
Computer Country Pty Ltd	131
Computer Imports Pty Ltd	131
Computer Shop, The	81
Comp-Soft Microcomputer Service	62
Cunningham, R. H.	30
Danish Hi-Fi	110
David Reid Electronics	26
Defence Force, Recruiting	97
Dick Smith Electronic Group	22, 126, 131, 62
Direct Computer Retail Pty Ltd	127
Edible Electronics	122
Electrocount Pty Ltd	114
Electrocraft Pty Ltd	71
Electronic Agencies	56
Electronic Calculator Discounts	95
Elmeasco Instruments Pty Ltd	64
Gillen, D. J.	115
Grundig Sales & Service	134
Hagemeyer (Aust)	IBC
Instant Software	84
JR Components	121
Jaycar Pty Ltd	13
John F. Rose Computer Service Pty Ltd	128, 129
Kalextronics	116
L & L. International	134
Logic Shop, The	126
Looky Video	101
Magnavox Australia Pty Ltd	38
Marantz (Aust) Pty Ltd	OBC
Mensa Computers Pty Ltd	123
Micro 80	119
Micro Pro Designs	130
Mitsui Computer Systems (A'asia) Pty Ltd	32
Paris Radio Electronics	89
Pitt Street Microcomputer Centre	120
RCS Radio	25
Radio Despatch Service	103
Radio Parts Group	34
Rod Irving Electronics	42, 63, 78, 91, 108
Royal Microsystems Pty Ltd	130
Roysten Electronics	77
SM Electronics	124, 125
Sansui Electric Co Ltd	37
Sinclair Equipment	16, 17
Scope Laboratories	59
Software Source	101
Sony (Aust) Pty Ltd	IFC
Standard Components Pty Ltd	103
Stolts Technical College	67
Tandy Electronics	75
Technical Book & Magazine Co	105
Technico Electronics	77
Vicom International	49
Warburton Franki	60
Wireless Institute of Australia	99
Xenitek	68

## SUBSCRIPTION SERVICE



# ELECTRONICS Australia

**Subscription Rates**  
\$23.50 per year  
within Australia  
\$27.50 per year  
elsewhere

Make sure you receive every copy of the magazine by ordering it from your newsagent or the publisher. For publisher subscriptions post this coupon, with your remittance to Electronics Australia Subscription Dept., John Fairfax & Sons Ltd, GPO Box 506 Sydney 2001. Subscription will start with first available issue.

Name . . . . .  
Address . . . . .  
Postcode . . . . . Enclosed is . . . . . for . . . . . years

# UNTIL WE DEVELOPED THE STEREO GROOVE, HI-FI WAS PRETTY HO-HUM!



The world of hi-fi owes a lot to the original and continuing innovation of JVC. Few companies, if any, have done as much to help turn records and record-players into the virtual musical instruments they are today ... or to lead the way in developing so many *firsts* in the more recent concepts of sound amplifiers, cassette decks and computer-designed speaker

systems. Hi-fi, as we know it today, had its beginnings in 1956, with JVC's development of the 45°/45° groove for stereo records. The fact that this system still remains as the world standard is, in itself, outstanding testimony to the technology of JVC. The development revolutionised not only the record-making industry, in which we've been involved since 1930; it also paved the way for enormous advancement in the design and engineering of record-playing equipment. Now, hi-fi has expanded to



R-S77. Super-A FM/AM Stereo receiver

embrace a wealth of highly-sophisticated electronic equipment; and it's not surprising that JVC has continued to play a leading role in so much of its development.



HR-3660 EA. VHS Colour Video Cassette recorder

## THAT WASN'T OUR ONLY FIRST, EITHER.

We also pioneered Japan's television industry, introducing their first TV receiver just over 40 years ago. A more recent innovation is VHS, the home video recording system now gaining world-wide acceptance as *the* system for such equipment. In the course of staying ahead, we've introduced a number of world *firsts* of radical importance: the Quartz Lock turntable is one of them.

## THE QUARTZ LOCK TURNTABLE. MANY TIMES MORE ACCURATE.

It stands to reason that if your equipment is at the top end of the range, then your turntable must be capable of comparable performance. Only Quartz Lock ensures this, tying the speed of the turntable to the unvarying pulse of the atom, and providing a level of accuracy far in excess of conventional turntables.



## MORE MILESTONES IN HI-FI.

To match the superb quality of Quartz Lock, we produced the S.E.A. graphic equalizer system. Then we refined it to such a degree it even compensates for the effect your furniture has on sound when it leaves the speakers! To expand the capabilities of tape, we designed ANRS and



SEA-80. Stereo Graphic Equalizer

Super ANRS — automatic noise reduction systems which not only reduce distortion and 'hiss' but actually extend the dynamic range of the tape. Similarly, with speakers: at JVC we employ computers in their design to help provide the ultimate in sound reproduction.

## AND NOW, SUPER-A.

In its own way, as significant a hi-fi development as the stereo groove. Imagine an amplifier which combines the *best* features of the two recognised amplifier classes (A and B) ... an amp which combines the *efficiency* of one with the *low distortion* of the other. Some engineers said it couldn't be done; but not those at JVC. Enter the Super-A amplifier ... the *latest JVC first!*

Distributed and Serviced by ...  
**HAGEMEYER**



the right choice

## THE FUTURE.

It's already with us. For instance, we were so far ahead in the new metal tape technology that our cassette decks were metal-compatible before the tapes were generally available. And now there's the JVC Electro-Dynamic Servo Tonearm, damping tonearm resonance by means of a purely electronic system and two 'thinking' linear motors. Who was it who dubbed JVC, 'the innovators'?

# RARE ADDITIONS FROM MARANTZ. SLIMLINE COMPONENTS.



**Rare:** very valuable.

**Additions:** the things added.

**Marantz:** a range of ultra-high performance Slimline Components which blend state-of-the-art engineering with operational versatility.

## **MARANTZ ST450 AM/FM STEREO TUNER**

Electronic Gyro-Touch tuning and digital display enable precise and speedy station selection which can be servo-locked for drift-free operation.

## **MARANTZ EQ20 STEREO GRAPHIC EQUALIZER**

Beautifully styled, the EQ20 provides highly personalised tone control flexibility with its ten detented slide controls per channel – the perfect finishing touch to any high quality audio system.

## **MARANTZ SC500 STEREO PREAMPLIFIER**

Traditional Marantz performance in the all important first stage of amplification. Moving coil cartridge head-amp and different cartridge load inputs are just two of the comprehensive number of facilities.

## **MARANTZ SM500 DC POWER AMPLIFIER**

Perfectly complements the SC500 and delivers 50 watts RMS per channel. Output is displayed on two large, peak responding power level meters.

## **MARANTZ PM350 INTEGRATED AMPLIFIER**

Bass, mid and treble controls and LED power level meters, combined with an output of 30 watts RMS per channel, make this the ideal amplifier for normal listening levels.

## **MARANTZ SR1100 AM/FM STEREO RECEIVER**

Slim, stylish and component width, the 30 watt RMS per channel SR1100 provides a new concept in compact audio sophistication.

## **MARANTZ SD5010 STEREO CASSETTE DECK**

Forerunner to a new generation of superior cassette decks, the SD5010 has soft-touch controls, LED meters, metal tape facility, fine bias control and an electronically controlled linear skating mechanism operating the cassette drawer.

Shown are but a few of the new Marantz Slimline Components. If you see your hi-fi as an investment and, if you demand critical performance standards as well as the best value for money, listen to the future.

Listen to Marantz.

**marantz**  
Now you're listening.

Distributed by MARANTZ (AUST.) PTY. LTD.  
P.O. Box 604, Brookvale, N.S.W. 2100  
Telephone: (02) 939 1900 Telex AA24121  
Melbourne (03) 329 7655 Brisbane (07) 446 478  
Adelaide (08) 223 2699 Perth (09) 276 2944