

# ELECTRONICS

**AUSTRALIA**

**VIDEO, HIFI & COMPUTERS**

AUST \$1.80\* NZ \$1.90

OCTOBER 1981

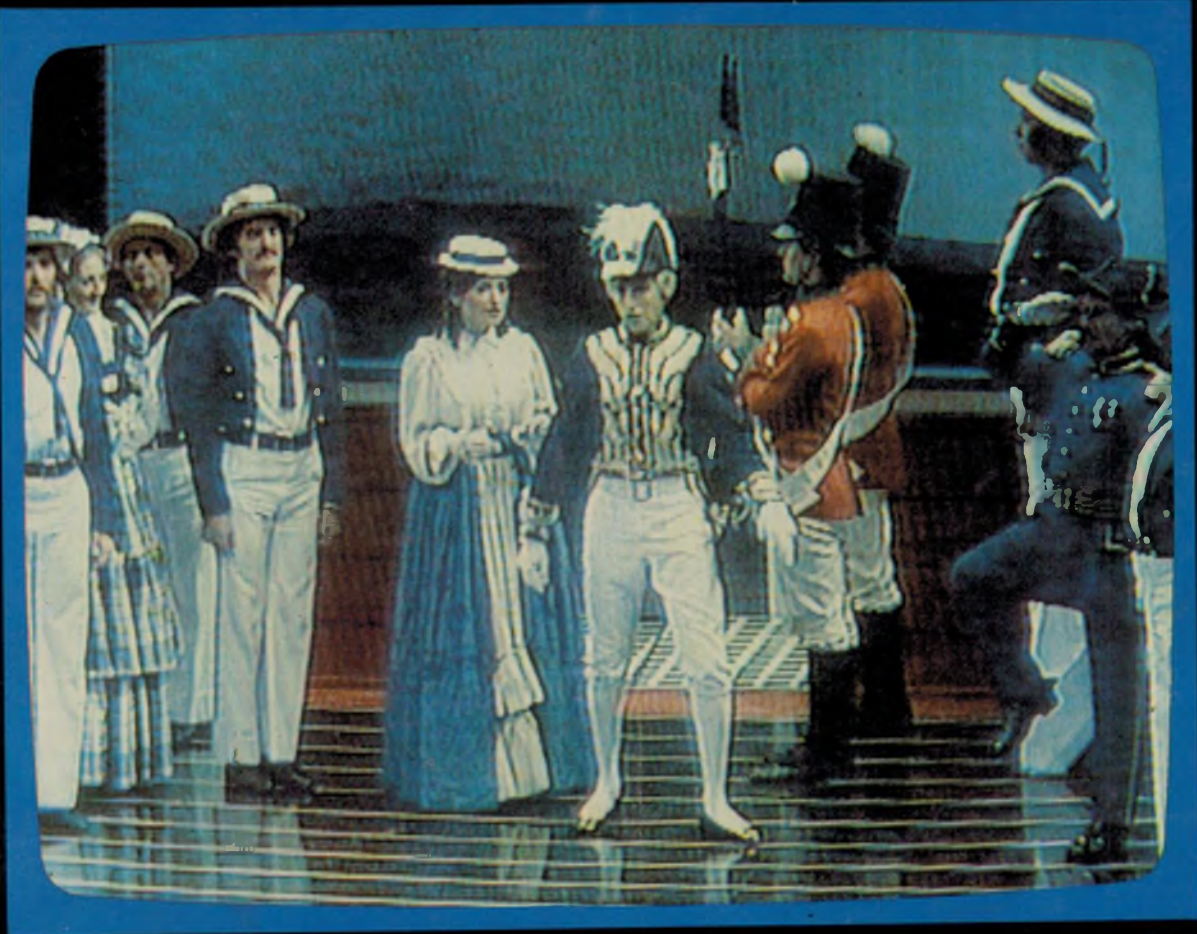

## **AUSTRALIA'S FIRST OPERA SIMULCAST!**

- Wind Speed Indicator
- Optimise tape bias with our Audio Test Unit
- Power blackouts: were computers to blame?



**BUILD  
THIS 73-NOTE  
ELECTRONIC  
PIANO**

# The Highest Fi on Wheels.

Close the car door, turn on your Sony car stereo and let us give you the finest sound on wheels.

Imagine your car filled with the sound of the Sony XR-77 car Hi-Fi with built-in 20W + 20W power amplifier and loudness control. Imagine the cassette player with Dolby noise reduction, metal tape capability, an automatic music sensor, locking fast-forward and rewind.

Imagine the sound of the powerful AM/FM receiver with quartz-locked PPL synthesizer tuning, a digital frequency readout, 5FM + 5AM station memory presets, and auto-scan tuning. Top it all off with a built-in quartz clock, and you have a hi-fi set-up that will fill your car with some of the finest sounds money can buy.

Listen to it, and imagine how good it would sound in your car.



# SONY®

# ELECTRONICS

## AUSTRALIA

Volume 43, No. 10  
October, 1981

**AUSTRALIA'S HIGHEST SELLING ELECTRONICS MAGAZINE**

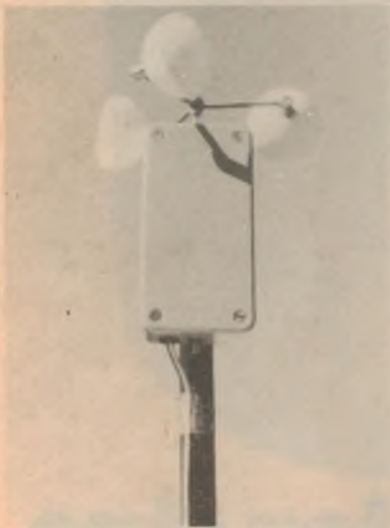

Our windspeed indicator will interest anyone who spends time outdoors. It is highly accurate and provides a direct meter readout of windspeeds up to 100km/h. Details page 50.

Just how dangerous are microwaves? Today we live in a field of radio frequency energy of ever-increasing strength, but very little is known about the effects on human beings. Find out more on page 12.

COMING NEXT MONTH! — Find out what's coming by turning to page 56.

### On the cover

A scene from HMS Pinafore — the subject of Australia's first opera simulcast, to go to air on October 11. Our article on page 18 has the behind-the-scenes technical story. Also shown is our new touch-sensitive 73-note electronic piano. Construction starts on page 42.

### FEATURES

- MICROWAVES: A HEALTH HAZARD?** *Is there a risk to human beings?* 12  
**AUSTRALIA'S FIRST OPERA SIMULCAST** *Behind the scenes* 18  
**QUESTIONS AND ANSWERS ON RADIOTELETYPE** 24  
**50 & 25 YEARS AGO** *Interesting snippets from the past* 105

### HIFI, VIDEO AND REVIEWS

- VIDEO DOMINATES THE AMERICAN SHOW SCENE** *Report from Chicago* 32  
**HIFI REVIEW SONY TA-AX5** *Integrated stereo amplifier* 39

### PROJECTS AND CIRCUITS

- LYREBIRD ELECTRONIC PIANO** *73-notes, touch sensitive, special effects* 42  
**WIND SPEED INDICATOR** *Read wind speed direct from a meter* 50  
**SUPER-80 DO-IT-YOURSELF COMPUTER** *Expansion details & full circuit* 60  
**AUDIO TEST UNIT FOR CASSETTE DECKS** *Adjust your deck for optimum response* 76

### MICROCOMPUTERS

- COLUMN 80** *Modems and telephone communication* 118  
**MICROCOMPUTER NEWS & PRODUCTS** *A personal computer from IBM* 120

### AMATEUR RADIO, CB SCENE, DX

- AMATEUR RADIO** *Jamboree-on-the-Air* 99  
**CB SCENE** *Police/CB confrontation in Queensland* 102  
**SHORTWAVE SCENE** *Radio Apintie, Surinam, widely heard in Australia* 104

### COLUMNS

- THE OFFICIAL LINE** *Comments wanted on final CB report* 9  
**FORUM** *Power failures — were computers to blame?* 28  
**THE SERVICEMAN** *Would we be better off without fuses?* 88  
**RECORD REVIEWS** *Classical, popular & special interest* 112

### DEPARTMENTS

- EDITORIAL 3 — NEWS HIGHLIGHTS 4 — CIRCUIT AND DESIGN IDEAS 92 — LETTERS TO THE EDITOR 94 — BOOKS AND LITERATURE 106 — NEW PRODUCTS 108 — INFORMATION CENTRE 130 — MARKETPLACE 134 — NOTES AND ERRATA 133**

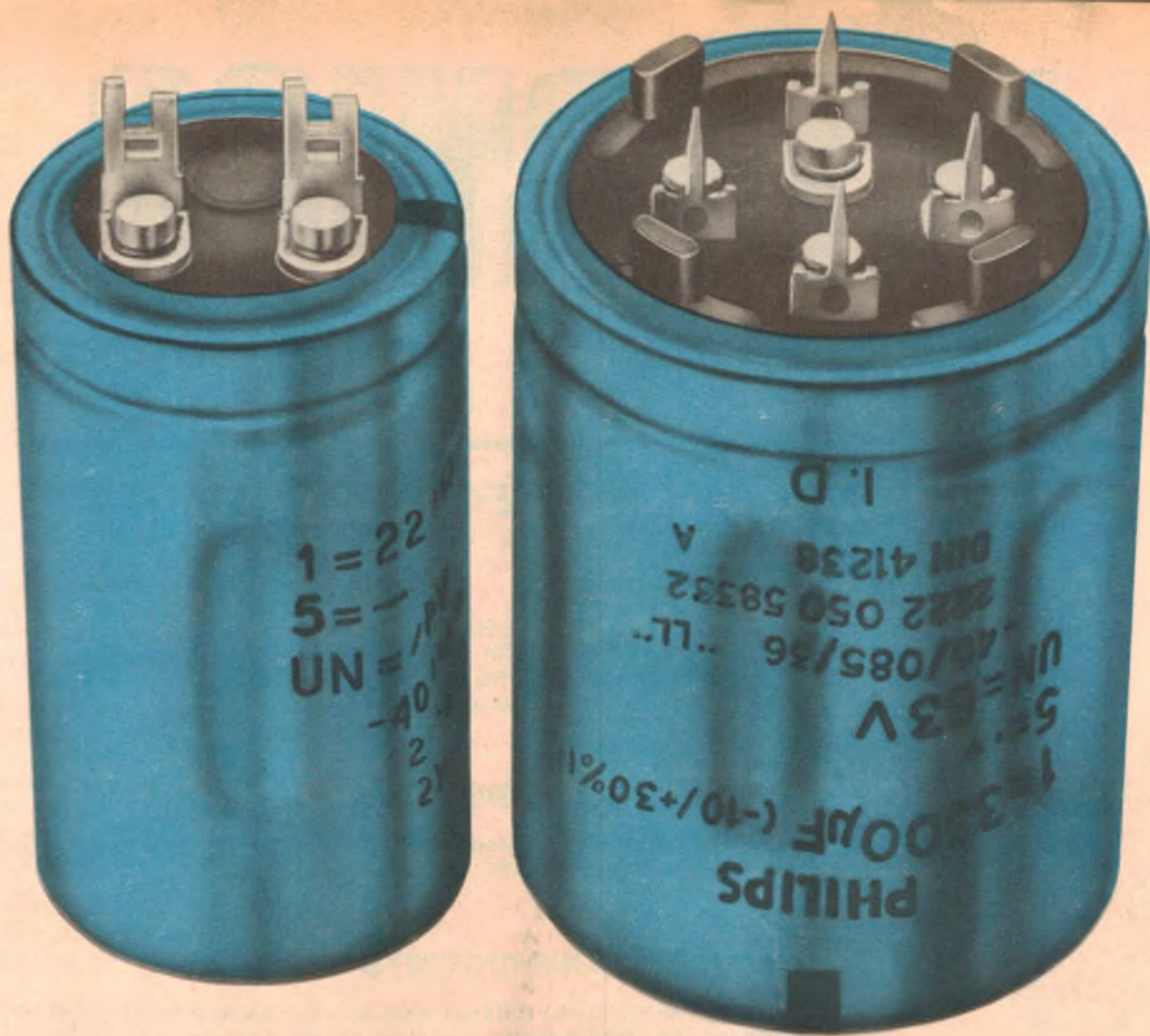

# More power. Smaller size. Philips chunky capacitors.

Philips' new, smaller 'chunky' 050 capacitors give designers improved volume efficiency.

Providing 470  $\mu\text{F}$  (100v) to 68,000  $\mu\text{F}$  (10v) coverage in can sizes substantially smaller than the earlier 071, the 050 meets all the requirements of IEC 384-4 specifications.

Excellent performance is achieved by special construction giving high resistance to shock and vibration, and capacitors are completely cold welded and proof against

high charge and discharge currents.

Typical life expectancy 200,000 hours at 40°C.

And a Philips first is the choice of two versions, either with solder tag terminations or pinned terminations designed to drop into printed wiring boards.

For further information tick reader service enquiry or contact your Philips distributor.



Electronic  
Components  
and Materials

## PHILIPS



# Editorial Viewpoint

## CABLE TV: a word of warning . . .

**EDITOR-IN-CHIEF**  
Neville Williams  
M.I.R.E.E. (Aust.) (VK2XV)

**TECHNICAL EDITOR**  
Leo Simpson

**ASSISTANT EDITOR**  
Greg Swain, B.Sc. (Hons. Sydney)

**TECHNICAL PROJECTS**  
Ron de Jong, B.E. (Hons. NSW), B.Sc.  
John Clarke, B.E. (Elect. NSWIT)  
Peter Vernon, B.A. L.L.B. (NSW)  
Paul de Noskowski

**GRAPHICS**  
Robert Flynn

**PRODUCTION**  
Danny Hooper

**SECRETARIAL**  
Pam Hilliar

**ADVERTISING MANAGER**  
Selwyn Sayers

**CIRCULATION MANAGER**  
Alan Parker

Mr Israel Switzer, an international cable television consultant from Canada, made the headlines with his keynote address to the recent IREECON International in Melbourne. He told the audience, mainly members of the Institution of Radio and Electronics Engineers Australia, that we should be very wary about committing ourselves to the US-style cable television system.

He pointed out that there are 60 million television homes in the USA and that a mere 1% of the potential audience is still 600,000 homes – sufficient to constitute a viable audience sector.

“Can anyone in Australia tell me that a similarly fertile situation exists in Australia?” he asked. “Even my limited knowledge of the country leads me to say no. Australia has only 14 million people, a population only 7% of the US population and, while Australia has a healthy economy, it is not so large and diverse as the American economy.”

He went on to point out that something like 50,000km of cable would be required to service three million Australian homes, at a cost of \$300 million. Add in the distribution equipment, the corporate infrastructure and all the rest, and the all-up figure would look more like a billion dollars.

By about 1990, when the money had been spent and Australia's cities and towns had been linked by US-style coaxial cable systems, we would wake up to the fact that it was obsolete, anyhow, and that we had passed up the opportunity to put in a more effective and universal system using fibre optics.

Such remarks stand in vivid contrast against other press reports of local and overseas companies jockeying for a place in the Australian TV cable scene. It would be unthinkable that they are not aware of the kind of reservation expressed by Mr Switzer, or that they are consciously keen to fund obsolescence.

Their attitude, more likely, is based on self-perpetuation. If there is to be a new development in communications, they want a part of the action. They don't want to be dependant on their competition.

This is understandable, but it could also hustle us on to the technological merry-go-round: If the technology exists, and they have it overseas, we must follow suit in Australia! Perhaps we should pause and ask whether we should be responsive to technology or social need.

**Neville Williams**

Registered by Australia Post — publication No. NBPO240.

Printed by Magazine Printers Pty Ltd. of Regent Street, Sydney and Masterprint Pty Ltd of Dubbo, NSW, for Magazine Promotions, of Regent St, Sydney

**Editorial Office**

57 Regent St, Sydney 2008

Phone (02) 699 3622 Telex 25027

Postal Address PO Box 163, Beaconsfield 2014

**Advertising Offices**

Sydney — 57 Regent St, Sydney 2008

Phone (02) 699 3622 Telex 25027

Representative: Narciso (Chit) Pimentel

Melbourne — 392 Little Collins St, Melbourne 3000. Phone (03) 602 3033.

Representative: Mark Christian

Adelaide — Charles F. Brown & Associates Ltd.

254 Melbourne St, North Adelaide 5006

Representative: Sandy Shaw (08) 267 4433.

Perth — 454 Murray Street, Perth 6000

Representative: Ashley Croft (09) 21 8217.

**Subscriptions**

Subscription Dept. John Fairfax & Sons Ltd. GPO

Box 506, Sydney 2001

Enquiries: Phone (02) 20944, ext 2589.

**Circulation Office**

21 Morley Ave, Rosebery, Sydney 2018

Phone (02) 663 3911.

**Distribution**

Distributed in NSW by Magazine Promotions, 57

Regent St, Sydney; in Victoria by Magazine Promotions, 392 Little Collins Street, Melbourne; in South

Australia by Magazine Promotions, 101-105

Weymouth St, Adelaide; in Western Australia by

Magazine Promotions, 454 Murray Street, Perth; in

Queensland by Gordon and Gotch (A'asia) Ltd; in

Tasmania by Ingle Distributors, 93 Macquarie St,

Hobart; in New Zealand by Gordon and Gotch (NZ)

Ltd, Adelaide Rd, Wellington.

**Copyright. All rights reserved.**

Devices or arrangements shown in this magazine

may embody patents. Information is furnished

without responsibility for its ultimate use, or for

failure of equipment to operate as expected, or for

any damage, loss or injury which may be sustained.

Material intended for publication is submitted

at the sender's risk and, while care will be taken,

responsibility for any possible loss will not be accepted by "Electronics Australia".

\*Recommended and maximum price only.



# News Highlights

## Electricity Board goes on Charade!

The South East Queensland Electricity Board (SEQEB) recently tested its first official electric vehicle, a Daihatsu Charade. Industrial Engineer George Gishkariany said the Board followed the Australian Electric Vehicle Association's test recommendations plus some RACQ guidelines, and that the results were very encouraging.

Tests were held at the Surfers Paradise International Raceway. The Charade was fitted with a fifth wheel which measured speed and distance and carried an additional 68kg of instruments, including an auxiliary battery and a multi-pen chart recorder. This weight plus the driver made up the equivalent of two people, the Charade's normal seating capacity.

Acceleration, maximum speed, hill climbing, handling and energy consumption were tested. Performance under the driving conditions found in urban areas was particularly emphasised. "Compared with other electric vehicles that have completed the AEVA tests, the Charade's performance was significantly better," said Mr Gishkariany.

To determine range at a constant speed, the Charade was driven twice from Brisbane to Surfers Paradise – first at 60 then at 70km/h on a single charge. At 60km/h the vehicle travelled the 76 kilometre route with plenty of battery capacity remaining at the end of the journey. At 70km/h there was "some charge left" by the time the car reached Surfers Paradise.

Undergoing a test known as the "urban driving cycle", which calls for repeated



stop/start driving and sudden acceleration, results showed that under the very worst conditions a range of around 27-29 kilometres could be expected. Stability during cornering and road holding capabilities proved to be excellent – better than the petrol-driven service vehicles used by the SEQEB.

The next step is to compare the

servicing and maintenance costs of the Charade electric vehicle. This information will be of particular interest to owners of car fleets, such as the electricity authorities. In general, electric vehicles have a higher initial cost but much lower running costs and a significantly longer service life than petrol vehicles.

## Women find noise is on the nose

Psychologists from the Universities of Warwick and Cardiff claim to have shown conclusively that noise is much more irritating to women than it is to men. In a report presented to the British Psychological Society they describe experiments that were conducted under controlled conditions on a variety of people. These included men and women who had shown high and low scores on a questionnaire enquiring about their sensitivity to noise. BBC

World Service reported:

None of the subjects was in any way deaf or otherwise abnormal in terms of hearing ability. Nevertheless there was a considerable difference in the degree of noise that irritated them. Overall there was a discrepancy of more than 10 decibels between noise-sensitive and noise-insensitive individuals. In other words, some people could tolerate a noise intensity three times greater than others.

The surprising finding, however, was that women as a group appear to be MUCH less tolerant of noise than men. In this experiment men seemed to be able to accept noise levels which, on average, were 13 decibels greater – that's an energy difference of more than four times.

Why this should be the case is a complete mystery, but it explains to a certain extent why some people find it easier to work in a noisy office whilst others can only work efficiently in solitude.

## Dr David Lewis to have another crack at the Antarctic

Dr David Lewis and a group of adventurers will take a tiny 21-metre schooner down to the Antarctic in this coming December to commemorate the 100th anniversary of Mawson's expedition to the South Magnetic Pole. Officially known as the Oceanic Research Foundation, the group will attempt to find a way through the pack ice to raise the Australian flag again at Mawson's old hut at Commonwealth Bay.

A vast sector of Australian Antarctic Territory, as large as Victoria, has been almost completely neglected by Australia since Mawson left nearly 70 years ago. The Oceanic Research Foundation's expedition biologists and glaciologists aim to update Mawson's baseline findings in a three month research effort. Is the continental ice sheet, that constitutes Australia's "weather factory", advancing or retreating? Have penguin and seal colonies grown or declined?

Never before has such a small boat attempted passage into Commonwealth Bay, hard-by the South Magnetic Pole, through grinding pack-ice and between towering icebergs. Some experts say it is impossible, but these intrepid expeditioners believe it can be done.

There is always, of course, the risk of being crushed between two and three metre-thick ice floes, but the hull is so shaped that the little ship should be pressed up out of danger (they hope). Food and fuel for a year is being carried.

Research around Commonwealth Bay will be no armchair undertaking. After travel by sledge and ski over the crevassed ice where Mawson nearly lost his life and his companion, Ninnis, perished, the expedition will culminate in a hazardous three week iceberg study in tiny inflatable rafts.

The schooner will sail from Sydney on December 15 this year. First port of call is Hobart, to load a sledge and other equipment. From there the expedition will sail to the French Antarctic base at Dumont D'Urville, then a hundred kilometres beneath 75-metre ice cliffs to Commonwealth Bay. Research along the coast and ashore will continue until the last week in February.

After the shore research the plan is to move out through the pack ice and find a large iceberg for study and tracking over a three week period. Return to Sydney is scheduled for March.

Apart from Dr David Lewis, the expedition will include Dorothy Smith who was with Lewis on the voyage of Solo in 1977-78, and other veterans of the Antarctic.

Some members are still required for the expedition. They are looking for a radio operator with a full amateur licence, a diesel mechanic, cook, botanist, and an oceanographer. All ex-



*Pictured is Dr David Lewis, leader of the expedition.*

pedition members are volunteers and are contributing towards the cost of the voyage. If you are interested, contact the Oceanic Research Foundation Ltd, Dangar Island, NSW, 2253.

A feature-length film will be made of

the expedition for the Seven Network with likely scenes scripted beforehand. The expedition is being sponsored by several companies, including Dick Smith Electronics and our parent company, John Fairfax & Sons Ltd.

## Electrifying Cure for Chronic Pain

Chronic pain has a devastating effect on the lives of those who suffer. Its cause is sometimes obscure — perhaps even genetic, as in the case of a missing enzyme in the body — so the patient is forced to live in unremitting pain.

In the last decade, however, medical science has developed a wide range of techniques for treating intractable pain. All of the methods, chemical and physical, involve blocking the pathways of pain. One technique which is arousing a great deal of interest involves the use of weak electrical currents which interfere with the transmission of nerve impulses to the brain.

One institute at the forefront of pain treatment research is the Pain Relief Foundation at Liverpool, England. One method under research by the Foundation involves applied electrical signals directly to the skin. Transcutaneous Electrical Neural Stimulation (TENS) involves passing a low voltage high-frequency current through pads applied to the skin.

The result is para-esthesia, a tingling sensation which has the same effect as rubbing the painful area.

Phantom-limb pain, the inexplicable ache in a limb which has been amputated, has been successfully treated by another technique called dorsal column simulation. DCS uses a transmitter to induce a signal in a receiving circuit implanted in the spinal cord.

The patient uses the transmitter to induce the signal when needed. Four patients treated by the Liverpool Foundation reported that the need for electrical simulation became less and less as they continued the treatment. One even returned his transmitter, saying that he had beaten the pain.

Also under investigation is a technique for transmitting signals directly to the brain through precisely planted electrodes. Unlike other forms of "psycho-surgery" the method is not destructive. At any time the electrodes can be withdrawn.

Another method is definitely destructive. This is the Italian discovery that up to 2ml of pure alcohol injected into the pituitary gland at the base of the skull can relieve intractable pain (and quite a few other worries as well, one supposes).

# NEWS HIGHLIGHTS

## Sanyo to release Video Disc Player

In a surprise move, Sanyo is planning to release its optical system video disc player in Australia by April next year. At this stage it will probably retail for around \$799.00, with prices for discs anticipated to range from \$15-\$25 each, depending on the program.

The disc has a plastic base with a metal film coating and is read by a laser. Controls are "soft-push" type. Functions include stop, play, forward and reverse search, forward play, reverse play, fast play and reverse and frame index. An infinitely variable speed control enables you to slow down the action to just above freeze frame.

Individual frames can be seen, one at a time by either manually pressing the pause control or selecting the minimum setting on the variable speed control.

The optional cordless, infrared remote control has duplicate functions to the player with the addition of index programming. If, for example, you want to see section 4000 to 5000 and you are at frame 2000, you can program the player to search forward to 4000, play



up to 5000 and revert to where you left off at frame 2000.

Another model using the Japanese developed VHD (Very High Density) system is also expected to be available in Australia around August 1982.

Discs for this system will be a similar

price to optical system discs. The VHD player will probably sell for \$699.00 retail.

Sanyo has also developed a CED disc player for the American NTSC market, but no plans have been made to release it in Australia.

# DON'T MISS OUT

## 27 DO-IT-YOURSELF PROJECTS FROM ELECTRONICS AUSTRALIA



If you like building electronic projects in your spare time, this exciting new book of popular projects is a must. There's a tachometer, a dwell meter and a CDI unit for your car; a Doppler burglar alarm; a digital clock; a loudspeaker protector; a variable power supply; plus much more. Order your copy now!

Use this handy order form



ONLY  
\$3.00\*  
+ 70c pack & post

To: Electronics Australia, PO Box 163, Beaconsfield 2014.

Please send me ..... copies of "PROJECTS & CIRCUITS NO. 2" at \$3.70 each. (Price includes packing and postage.)

NAME .....

ADDRESS .....

..... STATE ..... POSTCODE .....

I enclose a cheque/postal order to the value of \$ .....



# QUALITY KITS AT A LOW PRICE=JAYCAR!

## AUDIO OSCILLATOR \*



**ONLY \$64.50**

(Ref. EA June 1981)  
Extremely low distortion Audio Oscillator. Our kit includes a quality "Horwood" instrument case, specially printed and punched front panel suit... as well as all other components of course!!

## ON-SCREEN ANALYSER



**FROM \$69**

(Ref. EA March 1981). Short form kit normally \$88 - now \$69 save \$20!!! Colour option only \$25 and specified Horwood box to suit only \$16.50. We need the space so we are specifying this size.

## MUSICOLOR IV



**ONLY \$94.50**

\*\*\* \*\* \*\* \*\* \*\*  
(Ref. EA August 1981)  
This is our third production run! Remember our kit uses the originally specified box (which means that the front panel fits!) Don't forget also that this is a chaser (4 channel) AS WE'LL AS a 4 channel Musicolor!!  
Great lightbank to suit above unit ONLY \$29.50 (Check last months ad for details)

## SOUND LEVEL METER

**ONLY \$32**



(Ref. EA May 1981)  
A must for audio or environment conscious people. This unit has specifications which are only matched by meters costing up to hundreds of dollars more!!!  
**GREAT VALUE AT ONLY \$32** (They were \$39.50)

## ETI489 AUDIO ANALYSER



(Reprinted in ETI "30 Audio Projects")  
This compact instrument displays relative energy content of audio spectrum via a 10 band LED Bar Graph display. Fast "real time" response. Ideal for analysing deficiencies in studios, halls, rooms, etc.  
**WAS NEW RECTANGULAR LEDS TOO!!!**

## ETI current trip car alarm

(Ref. ETI July 1981)  
A great kit that is easy to install and has built in false trigger preventative mechanism. This kit has been held up due to non availability of the LM394 I.C. This device is now becoming available.  
Kit in Diecast box (complete).

**ONLY \$24.50**

## stereo equaliser

(Based on the popular ETI 485 unit) Model 2010  
Like its sister the 2010 comes in a black & beautiful 19" Rack Cabinet and normally sells for \$162 - but you can have one for only

**SAVE NEARLY \$119.50 \$40!!!**  
(If you are quick!! Offer ends 30/10/1981)

## HIGH POWER IONISER \$24.50

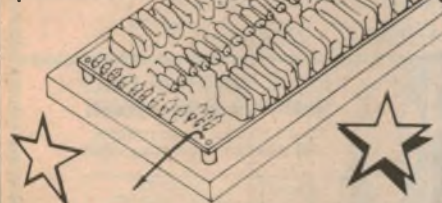

The Jaycar ioniser runs directly from the 240V mains and is capable of producing a high intensity electric field. Output voltage of the unit is around 7.5KV. This remarkably low cost ioniser has been produced for the enthusiast who wishes to experiment with the effects of ionized atmospheres. We must emphasize that whilst this ioniser can be made to produce small quantities of ozone it will not do so unless you specifically configure it to do this.

## 1/3 OCTAVE EQUALISER



**\$198**

Basically a single channel graphic equaliser which slices the audio spectrum up into 28 sliders. If you have a home recording studio, or you are in a band, have a disc or are associated with P.A. you will know how essential this unit is. For more information see previous issues (this year) of EA or ETI. Commercial units start at around twice the \$198 that we ask for this unit.

## 300 watt amp



**\$489**

(Based on the ETI 466 300W r.m.s. Modules)  
Complete with work of art 18" rack cabinet weighing over 20 kilos, this amp is a glass shattering machine. Over 300 watts r.m.s. into 4 ohms (each channel) with dual power supplies. Great for ambitious disco operators or low flying rock groups. For more information see our ads in earlier issues of EA and ETI.  
**ONLY \$489** for the complete kit including 28 page instruction manual. Freight subsidised at only \$5.50 extra.

## ETI729 UHF Masthead Amp.

(Ref. ETI April 1981)  
If you are on the "fringe" of UHF reception this could be the answer. Watch out for kits that don't include the die cast box!!  
**OURS DOES AND ONLY COSTS**

**\$35**

## 2 Channel Infra-Red Relay

(Ref. EA May 1981)  
This great kit has a range of over 60 feet and can independently control 2 appliances. Be lazy - why walk?  
Our kit is complete and ONLY

**\$65**

## "Le Gong"

(Ref. EA March 1981)  
The electronic "Ding Dong Dell" chords and all. This has a musical sound as opposed to some of the earlier "electronic" doorbells that we have heard!  
Complete, including the expensive (we think) Siemens SA80600 gong chip. (We now supply the case).

**\$14.95**

## P.C. Birdies

(Ref. EA May 1981)  
The "giggle kit" of the year! The two canaries packed into this circuit would fool Sylvester the Cat!  
Complete kit ONLY

**\$14.95**

## FM X'TAL TRANSMITTER

Ideal for a high quality wireless microphone system. We have taken the idea of the simple 1 transistor "toy" wireless microphone a step further. The problems with the simple unit is that they "drift" to an appreciable amount giving the AFC in the front end of the average FM tuner too hard a job to keep track of the signal. By keeping the design simple and using quartz crystal control, we have produced what is still a simple transmitter but has the ability to send a quality drift free signal.

This means that you can use this unit with a quality microphone and modest Hi-Fi tuner to produce a good quality stage wireless microphone system!  
Housed in a small all plastic box measuring 85 x 56 x 29mm it is a compact unit. A cannon type connector can be fitted to one end of the box for example enabling it to plug on to the end of a stage mic. Naturally the transmitter has many other applications as well. You can try one of these great little transmitters out for ONLY \$29.95 including the box.

**\$29.95**

## OTHER KITS

ETI (in no particular order)	
466 Audio limiter (short form)	\$8.00
480/50 watt Module	\$23.00
480/100 watt Module	\$27.00
480 2 input preamp/mixer (short form)	\$30.00
466 300 watt amp module	\$70.00
473 100 watt MOSFET module (inc. bracket)	\$50.00
473 Moving Coil preamp absolutely complete	\$95.00
135 UHF converter complete	\$32.50
458 Peak level meters NOT \$33.50 BUT	\$29.50
480/100 complete slave P.A. inc. P/S and box	\$130.00
581 +/- 15V Power Supply	\$15.50
445 General purpose preamp	\$7.99

## JAYCAR'S OWN KITS

88 note 1/3 octave electric piano kit	\$588.00
4-voice polyphonic string synthesiser	\$445.00
3002 SP Speaker protector 2 channel	\$13.00
3002 PM Power meter (LED) 2 channel	\$18.00

ELECTRONICS AUSTRALIA KIT	
Fuzz box complete EA Feb	\$19.50
(See above for other EA kits)	

## parts for new kits

(Once again in no particular order)	
ETI (ALL pcb's are fibreglass)	
330 Car alarm PCB	\$2.50
729 UHF masthead amp PCB	\$2.50
735 UHF converter PCB set	\$2.50
458 Peak reading meters PCB	\$3.55
446 Audio limiter PCB	\$3.50
5000 Preamp metalwork set	\$99.00
478mc Moving Coil cartridge PCB	\$3.50
478mc Moving Magnet cartridge PCB	\$3.50
5000 Power amp heatsink front panel	\$49.50
5000 Power amp complete metalwork	\$99.00

EA	
75CD-7 Cap Discharge Ignition PCB	\$2.50
81GA-3 Graphic analyser PCB	(Phenyl) \$5.00
81CDS PC Birdies PCB	(DITTO) \$1.00
81AD-8 Audio oscillator PCB	\$3.70
81SP-5 Sound pressure meter PCB	\$3.00
81RC4A	
81RC4B 2 channel IR control	\$1.50 each
81RC4C	

P.S. We have lots of vintage ETI PCB's. See our "Specials" ad last month or call us!

# Jaycar

NOTE! NEW SHOP HOURS  
Mon - Sat 9am - 5:30pm  
Sun 10am - 2pm  
Open Thursday night until 8pm

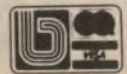

**380 Sussex St Sydney 2000**

Ph. 2646688 Telex 72293  
Mail Orders To: Box K-39 Haymarket 2000

POST AND PACKING: \$5-\$9.99 (\$1.00): \$10 - \$24.99 (\$2.00):  
\$25 - \$49.99 (\$3.00): \$50 - \$99.99 (\$4.00) \$100 up \$5.50



### JUST WRAP™ WIRE WRAPPING TOOL

WHY CUT? WHY STRIP? WHY SLIT?  
WHY NOT JUST WRAP?

JW-1-B	BLUE WIRE
JW-1-W	WHITE WIRE
JW-1-Y	YELLOW WIRE
JW-1-R	RED WIRE



### PRB-1 DIGITAL LOGIC PROBE

- DC to > 50 MHz
- 10 Msec. pulse response
- 120 KΩ impedance
- Automatic pulse stretching to 50 Msec.
- Automatic resetting memory
- Open circuit detection
- Automatic threshold resetting
- Compatible with all logic families 4-15 VDC
- Range extended to 15-25 VDC with optional PA-1 adapter
- Supply 0 V P.P. to < 70 VDC
- No switches, no calibration

PRB-1 DIGITAL LOGIC PROBE



### JUST WRAP REPLACEMENT ROLLS

R-JW-B	BLUE WIRE	50 ft. Roll
R-JW-W	WHITE WIRE	50 ft. Roll
R-JW-Y	YELLOW WIRE	50 ft. Roll
R-JW-R	RED WIRE	50 ft. Roll



### UNWRAP TOOL FOR JUST WRAP

JUW-1 UNWRAPPING TOOL



### JUST WRAP KIT

JWK-6 JUST WRAP KIT



### "HOBBY" WIRE WRAPPING TOOL BATTERY POWERED

BW-2630 FOR AWG 26-30

Use "C" size NICAD Batteries, not included. Bits not included.

BT-30 BIT FOR AWG 30  
BT-2628 BIT FOR AWG 26-28

### HOBBY WRAP TOOLS

WSU-30	REGULAR WRAP
WSU-30M	MODIFIED WRAP



### PRE-STRIPPED WIRE WRAPPING WIRE

Wire for wire wrapping, AWG 30 (0.25mm) KYNAR® wire, 50 wires per package stripped 1" both ends.

• KYNAR PENNVALT

30 B 50 010	30 AWG Blue Wire	1' Long
30 Y 50 010	30 AWG Yellow Wire	1' Long
30 W 50 010	30 AWG White Wire	1' Long
30 R 50 010	30 AWG Red Wire	1' Long
30 B 50 020	30 AWG Blue Wire	2' Long
30 Y 50 020	30 AWG Yellow Wire	2' Long
30 W 50 020	30 AWG White Wire	2' Long
30 R 50 020	30 AWG Red Wire	2' Long
30 B 50 030	30 AWG Blue Wire	3' Long
30 Y 50 030	30 AWG Yellow Wire	3' Long
30 W 50 030	30 AWG White Wire	3' Long
30 R 50 030	30 AWG Red Wire	3' Long
30 B 50 040	30 AWG Blue Wire	4' Long
30 Y 50 040	30 AWG Yellow Wire	4' Long
30 W 50 040	30 AWG White Wire	4' Long
30 R 50 040	30 AWG Red Wire	4' Long
30 B 50 050	30 AWG Blue Wire	5' Long
30 Y 50 050	30 AWG Yellow Wire	5' Long
30 W 50 050	30 AWG White Wire	5' Long
30 R 50 050	30 AWG Red Wire	5' Long
30 B 50 060	30 AWG Blue Wire	6' Long
30 Y 50 060	30 AWG Yellow Wire	6' Long
30 W 50 060	30 AWG White Wire	6' Long
30 R 50 060	30 AWG Red Wire	6' Long

### TRI-COLOR DISPENSER

WD-30-TRI TRI-COLOR DISPENSER

R-30-TRI REPLACEMENT ROLLS

### WIRE DISPENSER

WD-30-B	BLUE WIRE
WD-30-Y	YELLOW WIRE
WD-30-W	WHITE WIRE
WD-30-R	RED WIRE

### DISPENSER REPLACEMENT ROLLS

R-30B-0050	30-AWG BLUE 50 FT. ROLL
R-30Y-0050	30-AWG YELLOW 50 FT. ROLL
R-30W-0050	30-AWG WHITE 50 FT. ROLL
R-30R-0050	30-AWG RED 50 FT. ROLL

• KYNAR PENNVALT



### HOOK-UP WIRE

HK-18	18 AWG	25 FT.	SOLID CONDUCTOR
HK-20	20 AWG	25 FT.	SOLID CONDUCTOR
HK-22	22 AWG	50 FT.	SOLID CONDUCTOR
HK-24	24 AWG	50 FT.	SOLID CONDUCTOR
HK-26	26 AWG	50 FT.	SOLID CONDUCTOR
SHK-18	18 AWG	25 FT.	STRANDED CONDUCTOR
SHK-20	20 AWG	25 FT.	STRANDED CONDUCTOR
SHK-22	22 AWG	50 FT.	STRANDED CONDUCTOR
SHK-24	24 AWG	50 FT.	STRANDED CONDUCTOR
SHK-26	26 AWG	50 FT.	STRANDED CONDUCTOR



### PROTOTYPE BOARD (CM-100)

TERMINALS: 1 020 TEST POINTS 188 separate 5 point terminals, plus 2 horizontal bus lines of 40 common test points each

SIZE: 6 1/2" Wide, 5" Long

CM-100 MODULAR PROTOTYPE BOARD



### PROTOTYPE BOARD (CM-200)

TERMINALS: 630 TEST POINTS 94 separate 5 point terminals, plus 4 bus lines of 40 common test points each

SIZE: 6" Wide, 3 1/2" Long

CM-200 MODULAR PROTOTYPE BOARD



### PROTOTYPE BOARD (CM-300, CM-400)

CM-300 and CM-400 have two separated rows of five interconnected contacts each. Each pin of a DIP inserted in the strip will have four additional tie-points per pin to insert connecting wires. They accept leads and components up to .032 in. diameter. Interconnections are readily made with RW-50 Jumper Wire. All contact sockets are on a .100 in. square grid (1%, in. wide).

CM-300 MODULAR PROTOTYPE BOARD

CM-400 MODULAR PROTOTYPE BOARD

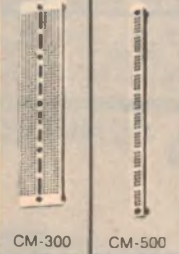

### MODULAR BUS STRIP

CM-500 is a bus strip to be used in conjunction with CM-300 and CM-400 for distribution of power and common signed lines. Two separate rows of common terminals, grouped into clusters of five. All contact sockets are on a .100 in. square grid.

CM-500 MODULAR BUS STRIP



### DIP IC INSERTION TOOLS WITH PIN STRAIGHTNER

Narrow profile. Pin straightener built into tool. Automatic ejector.

INS-1416 14-16 PIN DIP/IC INSERTER

### MOS, CMOS-SAFE

GROUND STRAP NOT INCLUDED

MOS-1416 14-16 PIN MOS CMOS SAFE INSERTER

MOS-2428 24-28 PIN MOS CMOS SAFE INSERTER



### 36-40 PIN (CMOS-SAFE) IC INSERTION TOOL

Aligns bent out pins. Includes terminal lug for attachment of ground strap.

GROUND STRAP NOT INCLUDED

MOS-40 36-40 PIN CMOS SAFE INSERTION TOOL



### DIP IC EXTRACTOR TOOL

Extracts all LSI, MSI and SSI devices of from 8 to 24 pins.

EX-1 EXTRACTOR TOOL



### 24-40 (CMOS-SAFE) EXTRACTOR TOOL

Removes 24-40 pin IC's, .600" centers. C-MOS safe. Includes terminal lug for attachment of ground strap.

GROUND STRAP NOT INCLUDED

EX-2 CMOS SAFE EXTRACTOR TOOL

AMPEC ELECTRONICS PTY. LTD. 1 Wellington Street, Rozelle 2093 Ph: (02) 818 1166 Available from: NSW: Applied Technology -487 2711 George Brown & Co 519 5855 Jaycar 264 6688 Radio Despatch. 211 0191. Sheridan Electronics 699 5922 NSW Country Area: Newcastle Elektron 2000 26 2918 Gosford Tomorrows Electronics & Hi Fi 24 7246 VIC: Ellistronics 602 3282 Ritronics 489 8131 QLD: L E Boughen 36 1277 N S Electronics 36 5061 SA: Computer Imports 268 8065 Electronic Components & Equipment 212 5999 WA: Altronics 328 1599 Reserve Electronics 275-2377 Taimac 328 1988



# The Official Line

— from the Department of Communications

## Committee of Inquiry calls for comments on final CB radio report

The final report of the Committee of Inquiry into CB radio has been released, and the Department of Communications wants to hear the comments of users of the service. This article summarises some of the main recommendations of the report which is intended to iron out any lingering problems associated with the CBRS.

Those wishing to comment on the final report of the Committee of Inquiry into the Citizens Band Radio Service (CBRS) should ensure that their comments are with the Department of Communications no later than November 15, 1981. Interested organisations and individuals can obtain copies of the report from the Australian Government Publishing Service bookshop in each of the capital cities. The Minister for Communications, Mr Ian Sinclair, has said that Government approval of the recommendations should be possible before the end of 1981.

It is not practicable in this article to try to deal with all the report's recommendations in detail. Rather the intention is to give some background to the CBRS inquiry, and then talk about the principal recommendations.

When the CBRS was introduced into Australia in 1977 it was given 18 channels at 27MHz in the High Frequency (HF) band and 40 channels at 477MHz in the Ultra High Frequency (UHF) band. At that time it was intended that use of the 27MHz frequencies would be phased out by July 1982.

There was increasing concern about the appropriateness of this phasing-out decision and in March 1980 the Department was requested by the Minister to hold an inquiry to review this decision and to determine the most appropriate radio frequency arrangements, conditions and regulations for the CBRS. Submissions were sought and more than 2200 were received from CB users, industry groups and interested persons.

The Committee was instructed to report as soon as possible on the 27MHz question and in its interim report, issued in October 1980, it recommended that the CBRS should continue to operate on both frequencies. This recommendation was accepted by the Government.

Earlier this year, in July, the Minister for Communications, Mr Sinclair, announced the key recommendations of the final report pending its release. This was done in order to give interested groups and individuals more time to comment on the

report before the closing date on November 15.

These key recommendations are:

- to expand the 18-channel 27MHz CBRS to 40 channels from January 1, 1982;
- to continue AM (Amplitude Modulation) and SSB (Single Side Band) services on the 27MHz CBRS;
- to retain the "short distance" concept of the CBRS, for communications within the geographical limits of Australia;
- to designate emergency and calling channels by law;
- to allow existing services, affected by the expansion and possibly operating on frequencies offset to the proposed CBRS, to remain or shift to new frequencies, as desired by the users; and
- to introduce UHF repeaters that use offset frequencies outside the current band to extend the operating range of the CBRS. It was recommended that a committee consisting of representatives from the Department, industry bodies and CB users should work out conditions regarding the licensing of these repeaters.

Some of the other recommendations contained in the final report are:

- to review operation of the 27MHz CBRS in 1990;
- that all sets licensed before January 1, 1982 should remain eligible for licensing;
- that sets incorporating any or all of the new 40-channel systems should be licensable from January 1, 1982, subject to suitable technical standards;
- that there should be no objection to long-distance communication which was possible on the 27MHz CBRS under certain ionospheric conditions, providing it

fell within the geographical limits of Australia;

- that the Department of Communications should continue to consult with CBRS users.

The Department considers that these recommendations should have a favourable effect on the CBRS and improve the service for its many users all over Australia.

The increase in the number of 27MHz channels from 18 to 40 will enable more of the radio frequency spectrum to be made available for CB users. This should make CB communications easier and allow for two frequencies to be set aside for emergency and call channels.

The recommendation to allow existing services to remain or shift to new frequencies, if affected by the expansion of the 27MHz service, would give users greater freedom of choice.

The introduction of UHF repeaters, as recommended in the report, would improve and extend the operating range of CB users, while still retaining the idea of the CBRS being used for short-distance communications within Australia.

In recommending that CB radio signals should not deliberately extend overseas, the Committee had to consider Australia's commitment to the International Telecommunications Union agreement on this subject, to which this country is a signatory.

This Department hopes that the recommendations of the inquiry will help to iron out lingering problems associated with CBRS, such as interference to television and other electronic equipment. From its introduction the CBRS has met the need in this country for a personal radiocommunication service. The inquiry's recommendations should ensure that the Service continues to be an important element in the range of communications available in Australia, and enable the CBRS to meet the requirements of its users.

It should be pointed out, however, that the Committee's recommendation of a further review of the 27MHz CBRS in 1990 was made because it considered that with changing technology and community needs any radiocommunication service, including the CBRS, did not have an absolute right to remain permanently in any portion of the radio frequency spectrum. All radiocommunication services are periodically reviewed in accordance with this principle.

R. B. Lansdown, Secretary,  
Department of Communications.

## Warburton-Franki to distribute Topaz

Warburton-Franki has announced an agreement with Topaz Electronics of San Diego, California to distribute the Topaz range of power conditioning peripherals in Australia. Topaz manufactures a complete line of equipment for protecting computer installations and other electronic equipment from erratic operation or failure due to power line noise, voltage fluctuations and black-outs.

# We offer a career - not just a job!

Enjoy electronics as a hobby? Why not make it a career? At Dick Smith Electronics, hundreds of electronic enthusiasts just like you have found satisfying and rewarding positions. We're expanding - and we need more people in all facets of our operation. The following positions are vacant NOW if you'd like to work for us, why not give us a call!

## Opportunities:

### Store Staff:

Junior, self motivated staff for our stores. Basic knowledge of electronics required.

### Trainee Managers:

Dynamic sales people interested to be managers of new stores.

Please contact store managers in your area.

NEW DIGITAL

## DICK SMITH WORLD CLOCK

Ever missed a 'sked'? With this superb world clock that can give you accurate time anywhere in the world, you won't be missing those important appointments ever again.

Y-1054

ONLY \$19<sup>95</sup>

## A POCKET SIZE

### PRINTER/CALCULATOR

Yes! Here it is - the fantastic hand-held miniature calculator printer. Check these features: ● Percentage, Square Root, Tab (floating decimal point) keys, ● 10 digit LCD display, ● Print/No print function etc etc Outstanding!

Paper to suit 60¢ (Q-3021)

ONLY \$67



Q-3020

## 1981 CALLBOOK



If you're an amateur you need one of these! Gives a complete listing of amateurs in Australia and Papua New Guinea. An essential part of your radio shack!

ONLY \$3<sup>95</sup>

B-2321

## UNDERSTANDING DC POWER SUPPLIES



If you're a radio/electronic apprentice or technician, or even a hobbyist, this book is a MUST. It gives a comprehensive guide to power supplies. An invaluable tool to the student who is preparing to take on an examination which includes power supply principles.

ONLY \$9<sup>95</sup>

B-3623

## AMATEUR OPERATORS HANDBOOK

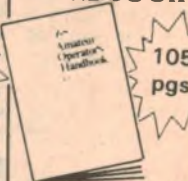

A must for all amateurs or persons sitting for the AOCF & LAOCF. Gives valuable information of all aspects of amateur operation. Essential!

ONLY \$3<sup>60</sup>

B-2310

Over 500 sockets that will accept component leads of 0.25 to 0.85mm, spaced 2.54. Designed to carry up to 1 amp. Even supplied with a component mounting panel for pots etc. Fantastic value!

ONLY \$23<sup>50</sup>

P-4612

## GIANT H'BOOK OF ELECTRONIC CIRCUITS

880 pages of circuits relating to virtually all aspects of electronics. There are circuits for hams, auto buffs, radar & sonar, games, inverters, power supplies plus many, many more. Ideal for the study or workshop!

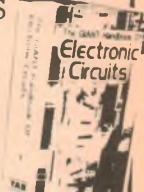

B-1780

ONLY \$18<sup>95</sup>

TOP-VALUE!

# SAVE UP TO 50%

## DICK SLASHES THE PRICE OF GENUINE 'CANNON' PLUGS!



	TYPE	CAT. No.	WAS	NOW
CANNON	3 pin line socket	P-1620	\$3.60	\$2.95
AUDIO	3 pin panel plug	P-1622	\$3.50	\$1.95
PLUGS	3 pin line plug	P-1624	\$3.80	\$2.00
	3 pin panel socket	P-1626	\$4.00	\$3.20
CANNON				
COMPUTER	25 pin 'D' type plug	P-2690	\$5.60	\$4.75
CONNECTORS	25 pin 'D' type socket	P-2691	\$7.95	\$6.20

YOU REAP THE BENEFIT!

## TOP VALUE PRECISION DIECAST ALUMINIUM BOXES

Cat. H-2201	
190(d) x 60(h) x 110(w)mm	1-9 \$12.00ea
10 or more	\$12.00ea
Cat. H-2206	
150(d) x 50(h) x 80(w)mm	1-9 \$8.95ea
10 or more	\$8.00ea
Cat. H-2211	
120(d) x 40(h) x 65(w)mm	1-9 \$5.20ea
10 or more	\$4.75ea
Cat. H-2221	
100(d) x 25(h) x 50(w)mm	1-9 \$3.50ea
10 or more	\$3.20ea

Cat. D-1802

THE FANTASTIC

# APOLLO UHF CB 40 ch.

NOW IN STOCK!  
Now is the time to switch to UHF CB with the Apollo. Has all of the features including light dimmer, tone, squelch, RF gain etc. plus advanced electronics. Why wait until 1982 - get UHF CB NOW!

ALL THIS FANTASTIC COMMUNICATION \$389



ANTENNA TO SUIT APOLLO \$9.50

# AM/SSB 18 Ch. SUPER PANTHER

This fully approved classy 18 Ch. radio is packed with heaps of features. Has LED readout, PA, NR, Local/DX switching. Also contains light dimmer for LED readout, maximum legal power on AM & SSB. The bands won't be the same once you get on with this little beauty! Mic, mounting bracket, spare fuse included.

NEW ONLY \$235



D-1711

# MAJOR DICK SMITH RE-SELLERS

These re-sellers stock a large range of our products. However we cannot guarantee they will have all items in stock, or at the prices we advertise.

ATHERTON QLD: Joe Sue's Radio Service 55 Main St. Phone 811 208

BENDIGO Vic: Sumner Electronics 95 Mitchell Street. Phone 431 977

BALLINA NSW: A Cummings & Co. 91-93 River St. Phone 862 285

BLACKHEATH NSW: Goodwin Electronics 173 Station Street. Phone 878 375

BROKEN HILL NSW: Crystal TV Rentals 68 Crystal Street. Phone 6897

CAIRNS QLD: Thompson Instrument Services 79 81 McLeod Street. Phone 512 404

COFFS HARBOUR NSW: Coffs Harbour Electronics 3 Coffs Harbour Plaza Park Ave. Phone 525 684

DARWIN NT: Kent Electronics 42 Stuart Highway. Phone 814 749

DUBBO NSW: Dubbo Electronic Services 157 Brisbane St. Phone 829 355

EAST MAITLAND NSW: East Maitland Electronics Cnr Lewis & High Streets 337 327

FAIRY MEADOWS NSW: Trilogy Wholesale Elect 40 Pinxax Hwy. Phone 831 218

GERALDTON WA: KB Electronics & Marine 161 Main Terrace. Phone 212 176

GOSFORD NSW: Tomorrow's Electronics & Hi Fi 68 William Street. Phone 247 246

HOBART TAS: Aero Electronics 123/3 Balguy Street. Phone 348 232

KINGSTON TAS: Kingston Electronics & Records Channel Court. Phone 296 807

LAUNCESTON TAS: Advanced Electronics 5a The Quadrant. Phone 317 075

LISMORE NSW: Decra Electric Magellan St & Brunner Hwy. Phone 214 137

MACKAY QLD: Stevens Electronics 42 Victoria St. Phone 511 723

MARYBOROUGH QLD: Kellar Electronics 218 Adelaide Street. Phone 214 559

MORUYA NSW: Coastal Electronics 43 Vulcan Street. Phone 742 545

MT GAMBIER SA: Hutchesson's Communications 5 Elizabeth Street. Phone 258 404

MUSWELLBROOK NSW: Silicon Chip Electronics Suite 3 58 Bridge Street. Phone 431 1058

NAMBOUR QLD: Nambour Electronic Shop Shop 4 Lower Kause Ave St. Phone 411 604

NEWCASTLE NSW: Elektron 2000 181 Wharf Road. Phone 267 664

ORANGE NSW: M&W Electronics 48 McNamara Street. Phone 826 491

ROCKHAMPTON QLD: Purely Electronics 15 East Street. Phone 21 058

SOUTHPORT QLD: Amateur's Paradise 121 Newing Street. Phone 322 644

TAMWORTH NSW: Sound Components 78 Brisbane Street. Phone 861 383

TOOWOOMBA QLD: Hunts Electronics 18 Neil Street. Phone 328 977

TOWNSVILLE Qld: Tropical TV 49 Fullum Rd. Vincent Village. Phone 791 421

TRARALGON VIC: Power N Sound 147 Argyle Street. Phone 743 838

WAGGA NSW: Wagga Wholesale Electronics 87 Fyfe Street

WODONGA VIC: A & M Electronics 78a High Street. Phone 244 588

WHYALLA NORRIE SA: Mellar Enterprises Shop 2 Forzyth Street. Phone 454 164

### Dear Customer:

Quite often, the products we advertise are so popular they run out within a few days. Of unforeseen circumstances might hold up goods so that advertised lines are not in the store by the time the advert appears. Please don't blame the store manager or staff, they cannot solve a stock strike on the other side of the world, or even locate a shipment that has gone astray. What we are trying to say is that, if you are about to drive across town to pick up a particular line at a Dick Smith Store, why not give the store a ring first (addresses/phone numbers below) just in case! Thanks Dick Smith & Staff.

# TOP VALUE! METAL/DOLBY DECK



Due to our direct import buying we're proud to offer you this remarkable metal/dolby deck. This superb deck has normal, chrome dioxide, metal tape facilities. L & R recording level controls, LED meter, tape counter, & oil damped doors. With impressive looks & top quality electronics, makes this unit an attractive buy to anyone.

LOOK AT THIS PRICE \$115

A-3503

# SAVE A FORTUNE ON TRANSFORMERS

## MODEL 2851

Specs: Primary-240V AC, Secondary voltage-12.6V CT, Secondary current-150mA, Termination flying leads



\$390

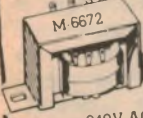

## MODEL 6672

Primary-240V AC, Tapped secondary-15, 17.5, 20, 24, Voltages-27.5, 30 volts, Secondary current-1A, Termination-solder lugs



\$390

## MODEL 2840

Primary-240V AC, Secondary voltage-9V CT, Secondary current-150mA, Termination-flying leads

MANUFACTURERS, ASK FOR QUANTITY PRICE

# NEW 60° SOLAR CELLS

These incredible cells have a very high output level for their size - 450mV @ 95mA (43mW per cell). Join 6 together & form 60mm dia circle with over 2.5V output (or over 10 amp in parallel!!) Get your FREE power now!

ONLY \$298 VALUE AT

SAVE 33% TACHOMETER I.C. ONLY \$28

Hey experimenters! Check this amazing tachometer IC. Ideal for many applications. Have a go! build your own tachometer with this SAK 140 IC.

NEW! YAESU PA-2 Mobile charger/Power Supply ONLY \$29.90

SOLDER A LOT ON PCB'S? MINISCOPE IRON'S FOR YOU! ONLY \$26.50

DON'T THROW AWAY MONEY! NICADS \$2.25 EA. LOOK AT THESE: 'D' SIZE \$4.95 EA. 'C' SIZE \$4.60 EA.

WATCH THIS SPACE Did you miss out on our BELOW COST SPECIAL LAST MONTH: BONDZA SUPER GLUE ONLY 93¢ NORM \$2.25 SAVING YOU \$1.32 NEXT MONTH: ?????

# DICK SMITH Electronics

MAIL ORDER CENTRE: P.O. Box 321 North Ryde, NSW 2113. Ph. (02) 888 3200

NSW: 145 Parramatta Rd Auburn 648 0558. 613 Princes Hwy Blakehurst 546 7744. 818 George St Broadway 211 3777. 531 Pittwater Rd Brookvale 93 0441. 147 Hume Hwy Chullora 642 8922. 162 Pacific Hwy Gore Hill 439 5311. 30 Grose St Parramatta 683 1133. 125 York St Sydney 290 3377. 173 Maitland Rd Tighes Hill 61 1896. 263 Keira St Wollongong 28 3800.

ACT: 96 Gladstone St Fyshwick 80 4944. QLD: 166 Logan Rd Buranda 391 6233. 842 Gympie Rd Chermide 59 6255. SA: 60 Wright St Adelaide 212 1962. VIC: 399 Lonsdale St Melbourne 67 9834. 656 Bridge Rd Richmond 428 1614. Cnr Dandenong & Springvale Rds Springvale 547 0522. 260 Sydney Rd Coburg 383 4455. WA: Cnr Wharf St & Albany Hwy Cannington 451 8666. 414 William St Perth 328 69 44

Order Value Charges  
\$5-\$9.99 \$1.20  
\$10-\$24.99 \$2.20  
\$25-\$49.99 \$3.30  
\$50-\$99.99 \$4.40  
\$100 or more \$6.00  
These charges for goods sent by Post in Australia only - Not airmail, overseas or road freight

DSE A038RB

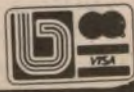

# Microwaves: a health hazard?



In spite of the widespread use of microwave RF energy, very little is known about the effects of radio frequencies on human beings. At high power levels the risks are obvious; people have been killed by pulses from powerful radar transmitters, and obviously you don't stand in front of the business end of an RF welding machine when it is operating. But are there more subtle effects, measurable only over years, and perhaps masked by other factors in our environment?

by PETER VERNON

## What are microwaves?

Microwaves are electromagnetic waves which occupy the frequency spectrum between the upper limit of the UHF band and the infrared region. Medium-band radio wavelengths are measured in hundreds of metres (256 metres for 2CH); short waves are measured in tens of metres (approximately 30 metres in the case of Radio Australia); television wavelengths are in the metre range (ABC Channel 2 transmits on 4.5 metres).

Microwave wavelengths range from 1mm to 30cm, corresponding to frequencies from 3000GHz to 1GHz respectively. Because the quantum energy carried by radiation is inversely proportional to its wavelength, microwaves are the most energetic of all radio waves, although far less energetic than light, X-rays or gamma rays, which have even shorter wavelengths.

Microwave radiation does not carry sufficient energy to separate bound electrons from atoms and molecules. It is said to be "non-ionising", in contrast to gamma rays, for example, which do have an ionising effect. In organic matter, microwaves at sufficient power levels produce a heating effect, and for many years this was considered the main danger of microwave radiation.

The energy of a microwave transmitter can be easily concentrated into a narrow beam — the shorter the wavelength and the bigger the antenna, the narrower the beam. Such beams travel in straight lines, and will not propagate significantly beyond the curvature of the Earth. Their high frequency and potentially wide bandwidth, however, mean that a single beam can carry a great deal of informa-

tion — thousands of telephone channels, for example.

Magnetrons and klystron tubes can produce megawatts of power at microwave frequencies, while Gunn diodes allow low power microwave oscillators to be constructed. These oscillators are now used by the millions in signal processing.

In addition to man-made sources of microwaves, the whole Earth is exposed to weak microwave radiation from the depths of space. This "decay radiation" is seen by many astronomers as evidence for the "Big Bang" theory of the origin of the universe.

There are other natural sources of microwaves in the Milky Way and distant galaxies, as well as occasional microwave lasers formed in nebulae. Radio astronomy began with the discovery of the 21cm "hydrogen line", and radio astronomers at Parkes and overseas are hunting for microwave signals on other frequencies which would indicate the presence of organic molecules in space.

## Applications of microwaves

Microwaves are used extensively for cooking in homes and restaurants. They are beamed between telephone exchanges throughout our capital cities and the country. There are microwave satellite relays and microwave links between studios and radio and television transmitters. Mobile communications links, airport radars, weather radars and marine navigation radars are other major areas of application.

Microwaves are also used for the welding of plastics, in many burglar alarms and for medical, research and educational purposes. Every high school

has at least one microwave teaching set, universities and colleges have many more, and the NSW police force operates over 100 microwave speed measuring radars.

Not all of these microwave sources are leak-proof, and some are not meant to be.

In big cities such as Sydney or Melbourne, the leakage from a multitude of microwave sources creates a low intensity "microwave background". Concentration, reflection, diffraction and interference effects can produce "hot spots" where the power density is much above the average background level.

Elmar Laisk, at the University of NSW, has used a portable microwave radiation monitor to explore the incidence of microwave radiation within the Sydney metropolitan area. The map (Fig. 1) is provisional only, based on a random survey, and is by no means complete. It identifies what appear to be microwave "hot spots" around Mascot Airport, in Redfern, Marrickville, Bondi, Silverwater, Epping, Chatswood and St Leonards. Other "hot spots" may exist in other places which would be pin-pointed by a more systematic survey.

Readers not familiar with Sydney should note that the "hot spots" shown on the map correspond well with the position of airport radar and aircraft navigation beacons, major microwave communications relays and television stations. No doubt similar surveys in other cities would show approximately the same situation.

But is there a health hazard?

## Microwave safety standards

The effects of microwaves on the human body have been investigated since the first 3cm X-band radars were introduced in World War II. The research was initiated primarily by Defence Departments for the safety of their own

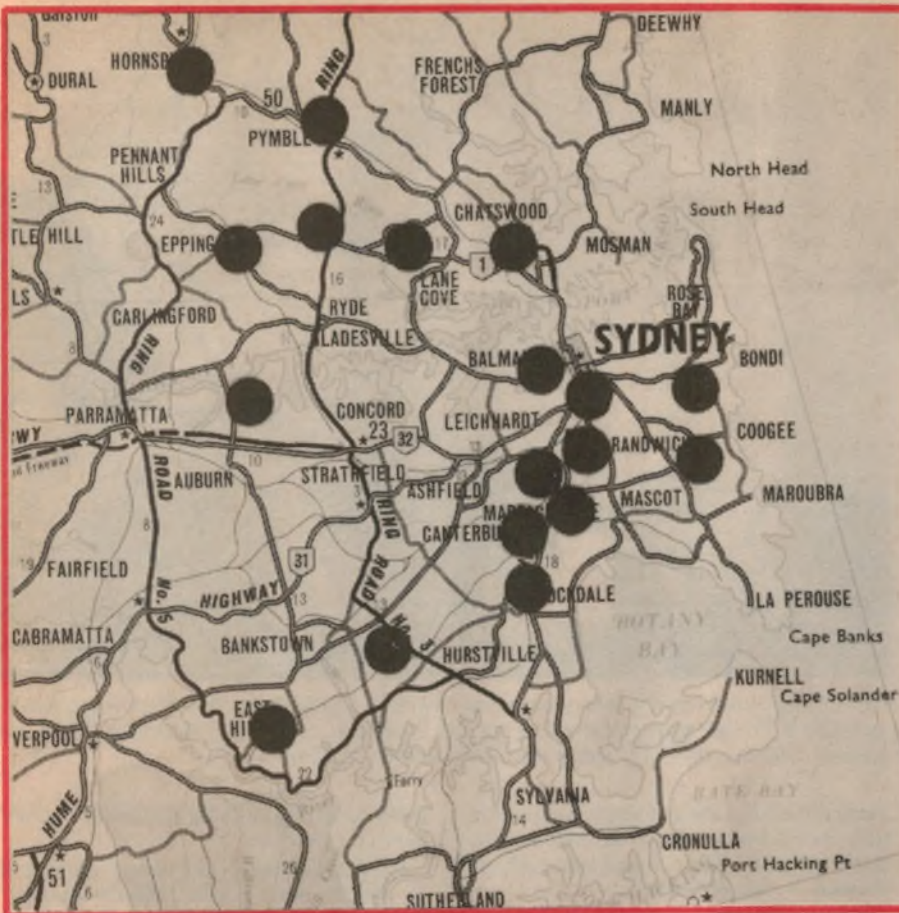

## Sydney's microwave "hot spots"

*Fig. 1 Based on a random survey of the Sydney metropolitan area, this map shows some areas where microwave radiation is particularly concentrated. No power readings were taken, but it is likely that power levels correspond to those found in similar overseas studies — around 0.5 to 1mW/cm<sup>2</sup>.*

*Readings taken at street level are due to leakage and reflection effects. Power levels directly in the path of a concentrated beam, as from an airport radar or microwave relay tower would be much higher. Because of the extensive use of microwaves for communications, a survey of other Australian cities is likely to show similar results.*

personnel, and has concentrated mainly on the effects of high power microwaves.

The health hazards of microwaves would appear to be due mainly to their heating of body organs and tissues. They can penetrate the body and heat from the inside out, as in a microwave oven. Since "inside" lacks the effective nerve alarms that operate on the skin, damage can be done without much warning, especially with prolonged and repeated exposures.

At power levels below those which produce gross heating effects, microwaves are suspected of causing cataracts — coagulations of the fluid of the eye, leading to blindness unless treated surgically.

With the tremendous spread of microwave ovens and industrial and commercial microwave equipment, most Western countries have established microwave safety standards based on gross heating effects of the radiation.

Although no international standard exists, the safe level of microwave radiation is generally considered to be 10 milliwatts per square centimetre (10mW/cm<sup>2</sup>). For microwave ovens, Australian Standard 3301 sets the permissible leakage level at 5mW/cm<sup>2</sup> at a 5cm distance. Several inexpensive leak detectors are available, including one designed by the CSIRO. These detectors give only a "go/no go" indication

however, and, of course, only operate on one frequency (2.45GHz).

Safety standards based on a simple power density criterion have been criticised. For a given power density, the amount of energy absorbed can vary by orders of magnitude depending on the frequency of the radiation, the ratio of body size to wavelength, orientation of the subject to the wave, the physical environment etc. For these reasons observed effects of a particular frequency on small animals may differ from the effect of the same frequency on human beings, and findings based on animal experiments must be considered in this light.

In the Soviet Union and other Eastern European countries the safety standard for microwave radiation has been set 1000 times lower than the Western standard: 10 microwatts per square centimetre.

In 1978 the US Environmental Protection Agency surveyed 40 locations in New York and found an average microwave power density of 0.07µW/cm<sup>2</sup> at street level. They also found a few hot spots of 32.5µW/cm<sup>2</sup> at the Empire State Building, 10.3µW/cm<sup>2</sup> at the Pan Am Building, and 6.8µW/cm<sup>2</sup> at the World Trade Centre. Sears Tower in Chicago had a reading of 66µW/cm<sup>2</sup> and one location in Miami, Florida showed a peak reading of 97µW/cm<sup>2</sup>.

In the absence of quantitative

measurements, we could reasonably expect similar microwave radiation levels in the "hot spots" shown in Fig. 1. Note, however, that the street level reading, even at its peak, is still 100 times below the current Western safety limit.

In the light of these figures it might appear that there are no grounds for concern, except for three pertinent facts. The Soviet Union has done much more extensive research on the effects of low level microwave radiation, and their safety standards are 1000 times lower than Western limits. An increasing number of Western scientists, after first rejecting the Russian reports, are now producing experimental evidence to support them — and the United States is now in the process of lowering its safety standard by a factor of 10, to 1mW/cm<sup>2</sup>. Many observers expect that an even more restrictive standard will eventually be imposed.

Thirdly, the use of microwaves and other radio frequencies is growing at such a rapid rate that it may not be long before "background" leakage radiation reaches levels considerably higher than those reported by the Environmental Protection Agency three years ago in New York. In Australia, very little research has been done on the effects of low level radiation on living organisms, and almost none at all on the effects of long term exposure to microwatt power levels.

## Soviet safety standards a thousand times lower

Although the Russian microwave safety limit has been set at  $10\mu\text{W}/\text{cm}^2$  since 1958, much of the data justifying this low value has not been accepted in the West, despite the fact that until recently almost no attempt was made to experimentally test the findings (Spectrum magazine, Dec 1980).

It has been suggested by some that the Soviet  $10\mu\text{W}/\text{cm}^2$  limit is not meant for safety but for state security — as an anti-espionage measure preventing passive microwave listening by foreign agents but aiding such listening by the Soviets.

Although one microwave beam cannot interact directly with another, the air vibrations in the space where two beams intersect can be recovered by a holographic technique involving "common path interferometry" — provided that background radiation levels are very low.

It's an elegant way or remote spying without spies, electronic "bugs" or risk. All that is required is a source of microwaves and a receiver capable of recovering the modulation of the reflected or scattered microwave beam. Use of such techniques, it is said, is the main reason the Soviet Union restricts microwave radiation to such low levels.

Against this view is the fact that the Soviet standard was instituted before such remote listening applications became technically feasible, and only after findings of mental disturbance and biochemical changes among groups of Soviet workers exposed to low level microwave fields.

Others say that, in the United States at least, safety standards have been set at an arbitrarily high level — the highest level consistent with avoiding the verified dangers of microwaves. Various motivations are given, including the need for continued military use of high power microwave transmitters, the protection of manufacturers of microwave equipment, and the fact that the standards carry great weight in a court of law. Until recently, legal action by people exposed to microwaves was prevented by the existence of the  $10\text{mW}/\text{cm}^2$  safety limit (see box: "A test case for microwaves").

Regardless of such speculations, scientists in the United States have lately begun to take a fresh look at the Soviet reports. Hundreds of researchers in the Soviet Union and Eastern European countries have reported effects ranging from psychological complaints, headaches, fatigue, sleeplessness and anxiety to changes in blood chemistry and circulation.

### Why the difference?

There has been an on-going controversy in the West concerning the validity of work showing biological effects of exposure to low level radio frequency energy. Up to 10 years ago, very few Western scientists would have

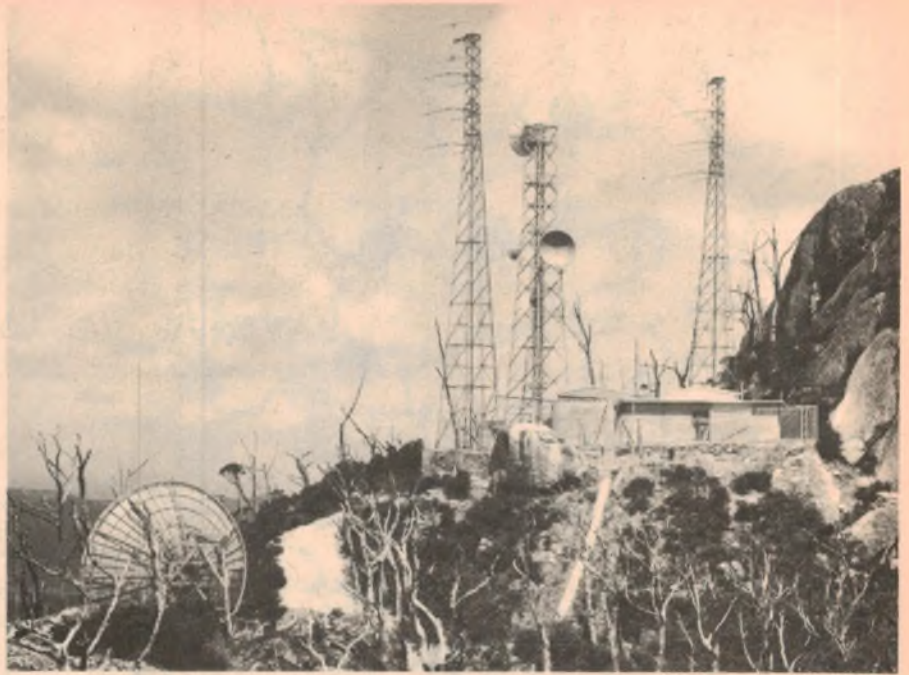

*Mt. Oberon microwave relay station on Wilson's Promontory is one of many which provide a TV link and telephone service to Tasmania. Since the photo was taken the towers carrying the Yagi antennas have been dismantled.*

agreed with the idea of microwave radiation levels below those known to produce heating effects could have any influence on living tissue.

Few today would deny the existence of some biological effects of low level radiation at some frequencies. There is a growing body of evidence and theory to support the proposition that microwave electromagnetic radiation does have pronounced effects on living organisms at levels far below those which produce heating — and at levels far below currently accepted safety standards.

---

**"Living tissues may actually use internally generated electromagnetic fields in their normal operation"**

---

The slow acceptance of this proposition has stemmed from a divergence of theoretical outlook. Those arguing against the effects of low-level radiation start from the premise that living tissue is generally a passive receptor of electromagnetic energy. On this basis they argue that radiation levels which are too low to heat tissue would produce internal fields which are much weaker than the electromagnetic "noise" produced by the normal functioning of the tissue, and would therefore have no effect.

With increasing knowledge of the complexities of the nervous system this view has been strongly challenged. An alternative hypothesis has emerged — living tissues may actually use internally

generated electromagnetic fields in their normal operation.

The human brain contains an estimated 10 billion nerve cells called "neurons" and another 100 billion of a second type called "glial" cells. The fluid bath in which these cells are suspended is a vital element in their electrochemical interactions. A large neuron might have as many as 10,000 points of contact ("synaptic knobs") with other neurons. Interactions between these arrays of cells is more and more coming to be seen in terms of electric field phenomena.

Increasingly, researchers are rejecting the idea that nervous system functioning can be explained in terms of electrical pulses travelling between individual cells — a view that compares the brain to a switching network or "living computer". Instead, new theories emphasise the importance of the slow electromagnetic waves which can be observed on an electroencephalograph. The functioning of the brain may be more like that of an exceedingly complex non-linear oscillator or amplifier than a digital computer.

One implication of this theory is that the nervous system is far more sensitive to electromagnetic radiation than previously thought possible. If only neuronal impulses are important to nervous system functioning, then internal fields of the order of  $15\text{kV}/\text{cm}$  would be needed to cause an effect — (neuronal impulses being of this order of magnitude themselves).

On the other hand, the slow brainwaves, with frequencies up to about 30Hz, are of much lower amplitude — around  $10\text{mV}/\text{cm}$  — and are, it seems, far



# What's new from **SCOPE**

## PROFESSIONAL P.C.B. IRON . . . The Improved Model TC60

OFFERS THE ECONOMY OF DIRECT 240V MAINS OPERATION AND THE SOLDERING MUSCLE OF 80 WATTS.

### COMPARE THESE FEATURES:

- AVOIDS THE COST AND WEIGHT of a 24V Transformer and offers greater portability.
- REDUCES SWITCHING PROBLEMS of contact wear and R.F. discharge. Mains voltage ensures 8 to 10 times less current to be interrupted.
- STEPLESS TEMP. ADJUSTMENT 20°-400°C. — no need to change tips to vary temperature.

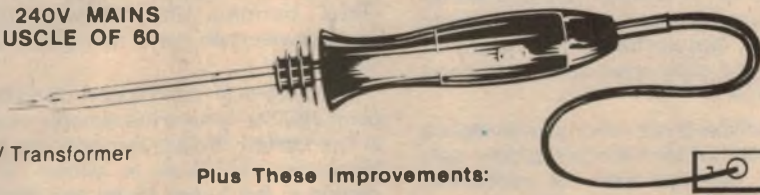

### Plus These Improvements:

(Compared with previous Model)

- 15% THINNER POWER LEAD — lighter & more flexible.
- LONGER TIP LIFE — new aluminium coating of iron plated copper, cuts heat and flux damage.

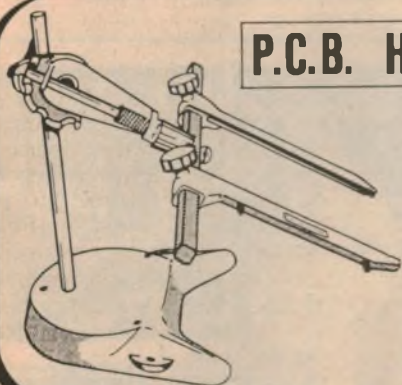

## P.C.B. HOLDER — Rotates, Tilts & Locks

### Scope Panavise — Model 333

#### COMPARE THESE FEATURES:

FIRM — NO SLIP WORK ANGLES.

- Choose from 4 pre set angles of tilt and 8 axial positions at 45° increments.
- FLEXIBLE CAPACITY
- Holds single or multiple boards to 750mm. (using extra arms and longer bars) yet allows full rotation.

## SOLDER REMOVER — Without Burnt Fingers

### Scope SOLDER BLOTTER in a metal tipped dispenser

#### COMPARE THESE FEATURES:

- Keeps your finger tip away from heat, yet places braid precisely.
- Pull braid to dispense — rotate pack to re roll surplus braid.



## SIDECUTTERS

### High Speed

NEW 'SHEAR' CONCEPT CUTS FATIGUE



### Scope Flushcutters

#### COMPARE THESE FEATURES:

- LOW EFFORT CUTTING ACTION aids speed. Radical 'shear' action needs about 50% less force than traditional 'crush' method.
- CUSHION GRIP extends further to protect finger and thumb tip.
- OPERATIVES CAN SUSTAIN SPEED due to Spring Loading & low mass (43 gm.).



**SCOPE**

BOX 63 NIDDRIE,  
VIC. 3042  
TEL: (03) 338-1566  
TLX: AA38318

### FOR FURTHER INFORMATION — CONTACT OUR AGENTS LISTED BELOW:

SYDNEY, N.S.W. (02) 548-6144	BRISBANE, QLD (07) 52-5231	ROCKHAMPTON, QLD (079) 27-3370	LAUNCESTON, TAS. (003) 31-5545	WELLINGTON, N.Z. 85-9578	PORT MORESBY, P.N.G. 25-7796
ADELAIDE, S.A. (08) 223-2261	TOWNSVILLE, QLD (077) 71-3448	HOBART, TAS. (002) 34-2811	PERTH, W.A. (09) 381-4155	AUCKLAND, N.Z. 57-4037	LAE, P.N.G. 42-2172

## A test case for microwaves

When New York telephone technician Samuel Yannon died seven years ago, pneumonia was listed as the principle cause of death. Recently, however, a New York State Workers' Compensation Board held that his pneumonia and a host of other illnesses which plagued Mr Yannon in his last years were caused by prolonged exposure to microwaves used by the telecommunications equipment he serviced from 1957 to 1968.

The ruling is now being contested by the New York Telephone Company, Mr Yannon's former employer. If it stands some experts believe it will be the first of thousands of law suits against manufacturers and users of radar and microwave communications equipment.

Dr Milton Zaret, who gave evidence on behalf of Mr Yannon's widow, said "It is the first case of microwave sickness in this country that has been acknowledged as such. It is also the first I know of where death has been attributed to microwaves."

Unshielded, even relatively low power microwaves can penetrate and cook meat at short range, as in a microwave oven. In the Yannon case,

however, it was argued that microwaves can have a cumulative effect that can cause sickness at power levels well below those that would "cook" an exposed person.

The argument that microwaves can have serious negative effects on living tissue without causing obvious heating has been a controversial one, with the majority view dismissing such claims. Dr Sol Michaelson, a radiation expert at the University of Rochester testified for the defence in the Yannon case. He says: "There is just no scientific basis for this kind of decision." He denies any hazard other than superficial burning and denies that microwaves can have a cumulative effect.

Supporters of the Yannon decision point out that despite the majority view in the United States, the concept of microwave sickness is widely accepted in the Soviet Union and other Eastern European countries, where hundreds of cases have been recognised. They believe that the United States will gradually come to accept the concept and have been encouraged by recent US moves to lower the present safety standard by factor of ten, from  $10\text{mW}/\text{cm}^2$  to

$1\text{mW}/\text{cm}^2$ . Such a limit would still be 100 times higher than the Soviet safety standard of  $10\text{uW}/\text{cm}^2$ .

Moves to lower the safety standard have been supported by a growing body of US researchers who argue that microwaves can have harmful effects on living tissue at power levels well below currently accepted "safe" levels. An impressive amount of experimental evidence supports their contentions.

Paul Brodeur, author of "The Zapping of America" (NY 1977) a controversial attack on growing "electromagnetic pollution", likens the Yannon decision to the Borel case of 1973 which gave legal recognition to the health dangers of asbestos. Others say such statements are premature. The crucial test, they point out, will be an action filed by Mrs Yannon in 1976 against RCA Corporation, the manufacturer of the equipment on which her husband worked. The case has yet to come to trial, and is unlikely to be heard this year.

If the case is decided against RCA it may trigger an avalanche of public concern and legal action which will rock the entire foundation of our "electromagnetic society."

more sensitive to externally imposed fields.

Experimental evidence is now accumulating to demonstrate that the functioning of the human brain can be affected by low-level electromagnetic radiation. In 1956, Dr C. A. Terzuolo and Dr T. H. Bullock showed that patterns of neuronal firing could be altered by electromagnetic fields as low as  $8\text{mV}/\text{cm}$ . In 1967, researchers at the University of California in Los Angeles showed that individual neurons could both receive and transmit electromagnetic waves in the Extremely Low Frequency (ELF) range.

By far the most extensive evidence for the existence of biological effects of low-level radio frequency energy comes from experiments dealing with the interaction of the nervous system with extremely low frequency fields and microwave radiation modulated at extremely low frequencies.

In 1967, Dr Rutger Wever of the Max Planck Institute of West Germany showed that human beings isolated from the extremely weak ELF fields of the Earth experienced disruptions of their circadian (24-hour) rhythms. He placed groups of volunteers in Faraday cages which shielded them from the ambient electromagnetic fields and found that their internal cycles became desynchronised when compared to a control group. The symptoms are closely akin to an advanced case of "jet lag".

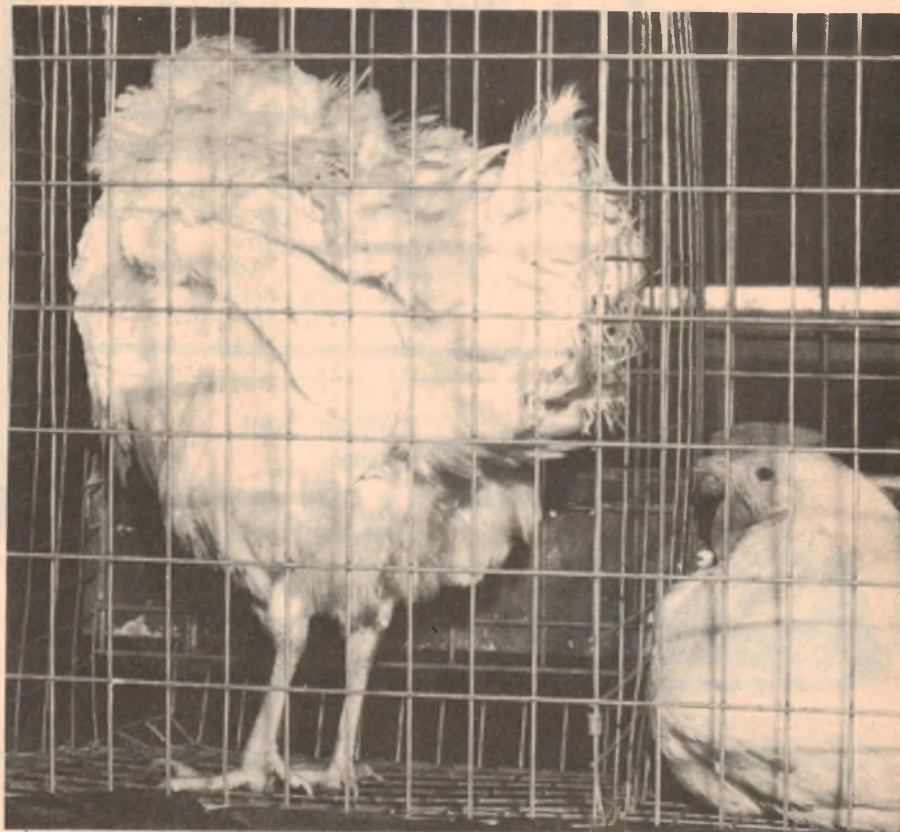

*In an experiment testing the effects of microwaves on birds, an irradiated bird shows its discomfort while the bird out of the field is unaffected. Power levels involved are equivalent to a radar pulse several kilometres from the transmitter.*

## Microwaves — more research needed

Dr Wever hypothesised that the extremely weak resonant fields of the Earth — with field intensities of 1mV/metre and frequencies of 7.8, 14.1, 20.3, 26.4 and 32.5Hz — might when coupled with human EEG frequencies act as natural timers, organising our perception of time and the functioning of many natural body rhythms.

Experiments have since shown that human time perception and animal reaction times can be modified by weak ELF fields. In these experiments the internal field strengths generated by the imposing radiation was estimated at no more than  $10^{-7}$ V/cm.

A number of researchers have demonstrated that radio frequency radiation modulated at extremely low frequencies could affect brain function. In 1972, Dr Suzanne Bawin at UCLA showed that 147MHz radiation at power levels of  $1\text{mW/cm}^2$ , amplitude-modulated at brain wave frequencies, could reinforce the conditioned production of specific brain wave responses in cats.

At higher power levels (around  $4\text{mW/cm}^2$ ), Dr K. V. Sudakov of the P.K. Anokhin Institute in Moscow has demonstrated profound changes in brain wave activity and behaviour in mice exposed for two hours to 40MHz radiation modulated at 60Hz.

An independent line of research has shown evidence of biological effects of unmodulated low-level radio waves. Dr Frank Barnes of the Department of Electrical Engineering at the University of Colorado has suggested that cell membranes in general can act as diode-like rectifiers, converting electromagnetic waves into DC potentials, and in some cases amplifying them in a sort of biological transistor action.

Although a familiar concept in electronics, many engineers and physical scientists have been reluctant to accept that nature may have evolved the equivalent of amplifiers, despite the fact that such amplification has been shown to take place in the eye. Natural amplification mechanisms may exist within the nervous system which magnify the interaction between living organisms and external fields at frequencies close to those used by the nervous system.

By far the most controversial question, however, concerns the long term effects of low-level microwave radiation. Soviet studies for the past 30 years have consistently shown significant changes in brain waves, blood circulation and immune system response resulting from exposure over a period of weeks and months to power levels as low as  $500\mu\text{W/cm}^2$  and in some cases at levels of  $50\mu\text{W/cm}^2$ .

Chinese studies have shown changes in the heart rhythms of rats exposed to  $200\mu\text{W/cm}^2$  fields for four to five mon-

ths. Another study has shown that a group of workers exposed to fields of less than  $200\mu\text{W/cm}^2$  had, on average, double the rate of neurological complaints compared to a matched control group, double the rate of abnormal cardiac responses, and nearly 10 times the rate of brachycardia (abnormally slow heartbeat).

Other reported or demonstrated effects of microwave radiation above  $10\mu\text{W/cm}^2$  include hormonal alterations and changes in the blood/brain barrier which protects the brain from the effects of contaminants in the blood stream. Impairment of central nervous system functioning, chromosomal and genetic changes and adverse effects of prenatal body and brain weight have also been reported and demonstrated in experiments with animals.

### More research needed

The question of what level of radiation is actually safe is very much an open one, although it must be emphasised that there is as yet no evidence of a general public health danger. The extensive long term research needed to clarify the effects of all types of radio frequency energy on living organisms has not been done.

Research on the biological effects of both modulated and unmodulated microwaves is urgently required. Studies of the effects of extremely low frequency radio fields is also required, particularly in light of the proposals to use high-power ELF transmitters in satellite-based navigation systems and submarine communications networks. Simulations to determine which particular frequencies have the most marked effects on the human brain (as predicted by the "brain-as-oscillator" theory) should also be carried out.

Benefits of such a research project extend beyond the protection of those exposed to hazardous levels of radiation. The insights to be gained by considering the electromagnetic aspects of living organisms may have wide applications to medical problems. By illustrating the fundamental links between all life forms, such research might also have a profound impact on our thinking about social issues.

Information for this article has been compiled from a number of sources, including IEEE Spectrum magazine for December 1980 and May 1979, the US National Telecommunications and Information Administration (Department of Commerce, fifth report on electromagnetic pollution, March, 1979) papers from the 1980 IEEE International Microwave Symposium Digest, Proceedings of the IEEE, and lecture notes on Microwave Safety provided by Elmar Laik, Visiting Research Fellow in Physics at the University of NSW.

## HAVE YOU TRIED SOLAR CELLS?

Keep up with the latest technology! These highly efficient Silicon semiconductors convert light directly to electricity. Ideal for designers and experimenters. Use them to recharge NiCad batteries, power transistor radios, clocks, run toys, remote sensors, trickle charge batteries, alarms, etc. All cells are rated at  $100\text{mW/cm}^2$  light intensity at  $25^\circ\text{C}$ .

### THESE ARE PRIME-SPEC, FIRST GRADE SOLAR CELLS

Type 1: Solar cell assembly for LCD Calculators 3V 43uA 47 x 27mm. each	\$6.50
Type 2: 20 x 10mm 0.45V 45mA, pack of 5	\$10.00
Type 3: 30° segment of 75mm dia 0.45V 78mA, pack of 12	\$14.40
Type 4: 60° segment of 60mm dia 0.45V 95mA, pack of 6	\$10.80
Type 5: 60° segment of 75mm dia 0.45V 155mA, pack of 6	\$12.00
Type 6: Quarter of 75mm dia 0.45V 280mA, pack of 4	\$12.60
Type 7: Quarter of 100mm dia 0.45V 475mA, pack of 4	\$18.00
Type 8: Half of 75mm dia 0.45V 560mA, pack of 4	\$21.00
Type 9: 75mm Round cells 0.45V 1.1A, pack of 2	\$19.90
Type 10: 100mm Round cells 0.45V 2A, pack of 2	\$30.00

Please add \$2.00 for Certified post & packing.

**AMTEX**  
ELECTRONICS



Suite 104/11 Spring Street,  
Chatswood 2067.  
Phone (02) 411 1323

Please send me ..... = \$  
Certified post & packing ..... = \$ 2.00  
Cheque/Money order enclosed \$ .....  
Please charge my Bankcard No .....  
Exp date ..... Signature .....  
Name .....  
Address .....

The behind the scenes action of

# Australia's first opera simulcast

On Sunday October 11th (at 8pm), Australia's first opera "simulcast" will be put to air by the ABC. The production, a combined television/FM stereo broadcast of Gilbert and Sullivan's *HMS Pinafore*, posed special problems for ABC engineers. Here's a behind-the-scenes account of what happened.

by **ROGER PARKER** ABC Music Producer

Let me say first that this is an actual account of some of the events which took place in the recording of Australia's first opera simulcast. It is not shop window material, but rather what happened behind the scenes. The washing is on the line so to speak and it is for you to judge how clean it is. Any project of this magnitude is bound to have setbacks, and we were not without ours, including one which nearly torpedoed us just before production.

The venture was conceived last year

when the ABC and State Opera of South Australia (SOSA) negotiated to both televise and sound record in stereo a performance of *HMS Pinafore* by Gilbert and Sullivan. The whole project had the right ingredients for success: the large Adelaide Festival Theatre has good facilities for lighting and placing cameras, a large orchestral pit which by most opera house standards produces a good sound, and we knew we would be taking delivery of the necessary stereo sound video recorders a couple of weeks

before production. Perhaps most importantly, it was the right sort of repertoire to present as a first opera simulcast, because G&S has a large following (as confirmed by a survey carried out by the Australia Council last year). For the musical pedants, I know it's really an operetta, but it's more an opera than a musical.

Hifi fanatics might have preferred something with a larger orchestra, but I'm sure they won't be disappointed because the overall sound, including sound effects, would give anybody's stereo equipment a run for its money.

Having decided to do *Pinafore* as a simulcast, the next question was how should we tackle it. The ABC has recorded TV opera before, and recorded many for stereo FM, but a simulcast is not simply putting the two techniques together. For a start, the most obvious conflict between TV and stereo is one of dimension — the picture is about 53cm wide, whereas the stereo can be spread up to three metres. This apparent conflict between the eye and the ear can be minimised with a little care.

First, because the orchestra is never seen, it can be laid out using the full width of the stereo. Second, the stage which is seen can be narrowed to say one third to one half the width of the stereo, which brings the voices within the general limits of just either side of the TV screen. In fact this was built in for us in the production, as most of the main action took place in the centre half of the stage. Any entrances and exits were followed by the camera and the stereo naturally moved with it, and I believe the eye is fooled into believing it's following the ear. In the chorus sections the ear hears nearly full width stereo and the camera picks out some of the performers, rather like you would if you were sitting in the theatre. As the ear cannot locate the particular sound on camera, there's no confusion.

On that reasoning, wide shots would seem to be the only problem, but in practice, providing good television shooting grammar is used, the TV and stereo sound work in harmony.



Taking a final bow; Dennis Olsen as Sir Joseph Porter, Judith Henley as Josephine and Roger Howell as Captain Corcoran in *HMS Pinafore*, soon to be televised.

Those of you who watched the Royal Wedding and heard it in stereo will remember how the wide shots seemed to be as wide as the stereo sound, because I suspect we get caught up in the drama of seeing and hearing an exciting event. A simulcast of a live show can make you feel you are there — sitting in the front row of the stalls.

Because we had to put cameras in the audience area SOSA gave us a special TV performance, and this was sold as such to the audience. However, we still needed camera rehearsal and this we were able to do during the dress rehearsal. We also got some cover shots and preparation in the interim performances leading up to the TV performance. Preparations to record the simulcast were proceeding, but unknown to us at the time a disaster was looming from the sidelines, but we'll come to that in a moment.

The key figures in the ABC crew were TV Producer Hugh Davison, Technical Producer John Newman and sound man Mike Fitzhenry. Allan Dent became a key figure for reasons which will become clear later in the story.

My chief concern was the sound production, and as we had recorded opera from the Adelaide Festival Theatre before, we were not sailing into too many uncharted waters. The major problems for sound were that all microphones had to be hidden — even hanging was out of the question because of shadows over lighting. You can probably guess the other problems such as stage rumble, the conductor's sweeping arms, and upstage action away from microphone vantage points.

With all this in mind we decided to use four C414's (AKG) microphones on the orchestra, low enough not to be seen over the pit wall, but far enough away to give equal coverage over the front of the orchestra. A few spotters were scattered around the orchestra, but we ended up only using woodwind spotters. The front of the stage was covered with five C451 E's (AKG) on knuckles at floor height and insulated from the stage to reduce rumble from the dancing.

The left stage mike presented a problem because the ship was actually built down into the pit through a manhole. In a number of places in the production, sailors entered and exited through the manhole right where our left mike was placed. This mike had to be closed at certain times to avoid interference. The offstage choir was handled with a Schoeps stereo mike.

Our final hurdle was the upstage action. I rejected shotgun mikes because even the best has an unmusical sound and because I did not want a "spotted" type of sound. So we ended up hiding mikes in the stage scenery — behind railings and behind the mast. These mikes actually caused us a lot of problems — SCR buzz from the dimmer lights (this fault doesn't usually appear when setting up, only when the lighting plots are in ac-



Dennis Olsen in the State Opera of South Australia's production of *HMS Pinafore*.

tion) wrecked our dress rehearsal, and during one of the performances a railing mike was blasted into ear shattering distortion when a performer knocked it with his hand.

By the second rehearsal we were down to 18 mikes, or up to would be a better description, because we worked basically on the 4 orchestral mikes and five stage and added the others as necessary, such as the two woodwind mikes, the three KM84's (Neumann) hidden on the stage, a stereo pair for the off stage choir, and a stereo pair for the audience.

A submix of the six orchestral mikes on to two channels helped mixing, because essentially the internal balance of the orchestra does not change. This allowed us to concentrate on the 10 stage mikes, six of which (left front stage, 3 on stage and stereo off stage) had to be opened and closed on cue as well as to the unpredictable audience applause. Just to make it harder we added a little electronic reverberation to all the music, but diced in on the dialogue.

On two rehearsals we had plotted all our fader settings which were marked in

the score and used as a guide when we came to do the recording. I say as a guide because although the performances were very consistent one has to be prepared for the unexpected. A classic instance was a cannon shot (right next to a stage mike) which failed to go off on cue. When it did fire it finished up wrapping the meter needles around the stops, and that's the way it will be broadcast.

Another menace to contend with was wind noise from rustling skirts and cloaks and, in spite of careful cueing from our preparation, a little still escaped on to tape, but we were able to fix this in the editing. Incidentally, the whole show was mixed on to 2-track stereo, not because of lack of facilities, but to maintain the highest technical quality of sound. The sound was also Dolby'd using the A system.

Well most of these problems are par for the course in a live opera recording, but I mentioned earlier a disaster that was to befall us just before the production.

It concerned the special stereo sound



Judith Henley as Josephine and Thomas Edmonds as Ralph Rackstraw in "Pinafore".

video recorders which were due for delivery a couple of weeks before the recording. The delivery was delayed until a date some time after the Pinafore production! Immediately all sorts of discussion started taking place to save our sinking Pinafore, but it appeared we simply could not do the simulcast without the special video recorders. Or could we?

We already knew that the electronic equipment to slave a sound recorder to a video was at a price which could not be justified for a one-off, and anyway it wouldn't arrive in time. Sure, most VTRs carry more than one sound track, but the quality is just not good enough for FM stereo broadcast.

Meanwhile a couple of back-room boys in the ABC, Paul Lawson from radio and Allan Dent from TV were putting their heads together and looking at ways of driving a sound recorder with a video recorder, using existing equipment and maintaining the necessary high quality of sound. One thing seemed clear to them: if the VTR frame pulse was recorded with the sound track on a sound

recorder, there were at least two ways we could later synch the sound with the vision. Allan's account of how he designed the synching equipment, which has now affectionately been labelled "The Dent Box", is in the accompanying panel.

We were saved from disaster, and it was full speed ahead with the HMS Pinafore simulcast. We were also beginning to realise that we had turned our setback into a bonus. If we could lay sound on a separate tape to the vision, film editing technique became available to us.

Incidentally, the SMPTE standard for sound and vision synching in film is 1/50th of a second. During experiments with the Dent Box, we compared the stereo sound from the audio tape recorder with the mono sound track of the VTR (a combined split from the original stereo) and found the phase shift to be negligible. We were well within standard!

Now to the editing. The basic material used for the broadcast was from the special TV performance, but there were a number of places where material

recorded the previous night needed to be edited in. In this case the vision (with the VTR mono sound track kept for synching reference purposes) was edited together as usual, and the ATR 4-track sound tape was cut-edited afterwards in the same places, in much the same way as separate magnetic film. This left us with an edited videotape and a separate sound track edited to stay in sync.

The next process was to tidy up some of the pictures and the sound. This could be done by dropping in shots without changing the control track. I could also tidy up the sound tape providing the control track on track four was kept the same length.

For example, the chorus at the end of Act II was good visually but a little untidy in sound and it had been better the previous night. So I simply exchanged the two nights, except that the earlier night was 24 seconds and 10 frames duration to be fitted into the master tape from the TV night which was 24 seconds and three frames duration. All I did was snip off seven frames, which was only reverberation anyway (7 frames is just over a half a second).

I mentioned earlier some wind noise which came up on tape. This was edited on the four track sound tape in the same way. The total editing took me just two days using only the 4-track recorder (avoiding valuable TV studio time), and this included audition and editing. Testing to make sure the vision and sound stayed in sync amounted to one morning. I miscalculated on a couple of edits, but we easily found the error by advancing or retarding using the switch Allan had incorporated. The number of frames jumped to come back into sync indicated how the sound tape had to be rectified.

Having completed the editing in sound and vision, we elected to transfer both onto the stereo VTR's which had now arrived. We were hesitant to do this, because it left us with a third generation picture (not really a problem these days) and a second generation Dolby'd sound with some very high levels. But this had to be weighed up against going to air live with the Dent Box synching the vision and sound. In spite of its proven reliability, it was just using too much equipment in an ad hoc situation — Murphy's Law and all that.

The dilemma we will have to face for the next simulcast from Adelaide is whether to again use the technique outlined above, or use the stereo VTR's now in the system. I suspect it might be a repeat performance because it offers much more flexibility and is much less time consuming, because sound and vision can be worked on separately.

From what I've said it appears that only seven people pulled off a simulcast. In fact, of course, the whole TV crew put everything they had into the recording, knowing that failure in any facet of the production would have jeopardised the whole project. ☺

# HMS Pinafore — overcoming a difficult technical problem

When it became apparent that the special stereo VTRs would not arrive in time for the production, ABC engineers were forced to look at various alternatives. The solution — use an existing video recorder to control a separate 4-track audio tape recorder.

by Allan Dent

ABC TV Technical Officer

The way to lock any signals on two tape recorders is to have some recoverable reference signal which can then be compared with a master reference in a phase locked servo system. We had already planned that Kym Klopp, the VTR operator on duty at the time of the recording, would attend to this fundamental requirement. Knowing that the video tape recorder being used, an AMPEX UP-2000, uses a reference called a "Control Track" (C/T), a split of this reference signal was recorded simultaneously on the 4th track of separate 4-track AMPEX AG-440 audio tape recorder (ATR) which was used for the stereo sound track. Track four was selected to achieve maximum separation from the stereo sound track on tracks one and two.

My job was to design and build a control box to synchronise and lock these two C/T signals during subsequent replays. I had a three week deadline to meet to design, construct and debug my control box. All this had to take place in between my normal maintenance duties although some of my normal load carried for me by workmates. The deadline was met with the final adjustments being made just before the preview started.

The Control Track signal on the VTR consists of a 250Hz sinewave with — a 12.5Hz PAL frame pulse superimposed. Basically, the 250Hz is used to reference the video head servo and the 12.5Hz is used by the capstan servo during the VTR lock up. These signals are compared with station sync pulse references in the respective servo systems to achieve a servo lock.

The AG-440 ATR has a servo controlled capstan which uses a 9600Hz crystal reference. The obvious way to control the ATR was then to replace

the crystal reference with a phase locked loop (PLL) system with a 9600Hz VCO output. This would use the VTR C/T as the PLL reference and the ATR C/T as the feedback input.

To lock these two C/T signals the 12.5Hz frame pulse has to be recovered and then processed into a usable signal for the PLL. First of all it passes through an active full wave rectifier, then splits to feed an averaging DC filter and a voltage divider. The out-puts of these are fed into a voltage comparator. The voltage divider is set so that the 250Hz component sits below the average DC and the frame pulse will cross the comparator threshold thus recovering the frame pulse.

constant of the AG-440 servo controlled capstan. At the first preview we noticed slight flutter on the stereo sound track. Although this would probably not be noticed by the majority of viewers — in fact it was only noticed by a small percentage of people at the preview — it was definitely not to broadcast standard. Too fast a time constant had caused the flutter, where-as too slow a time constant would cause the system to be sluggish and overshoot during lockup. After a few measurements, critical damping was achieved with the externally controlled capstan having the same wow and flutter figures as when the internal crystal was used.

To get the machines in sync at the

Fig 1: The circuit used to detect the frame pulse from the VTR.

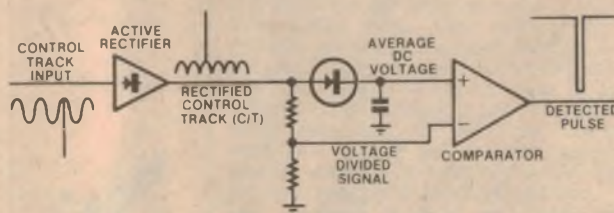

FIG. 1 FRAME PULSE DETECTOR

The recovered pulse triggers a 40ms oneshot to generate a 12.5Hz square wave. This process is applied to both C/T signals with the VTR providing the reference for the PLL and the ATR the feedback signal. The resultant error voltage is filtered and fed to a VCO with a 9600Hz centre frequency. In a PLL there is an inherent 90° phase shift which also has to be corrected. This is done by inserting an extra 20ms delay between the Frame Pulse detector and the 40ms oneshot of the VTR C/T processor circuitry.

The characteristics of the filter are fairly critical as it has to match the time

start of the sound track, a 4000Hz cue pip was recorded on the VTR cue track 10 seconds before the start of program. On replay this was detected with a tone decoder chip and used to start the ATR, which had also been cued up 10 seconds before the start of program. As the ATR has an almost instantaneous start the machines consistently come up with their sound tracks in sync. If for some reason they don't, the PLL circuitry has a speed override built in which allows us to speed up or slow down the ATR capstan until sync is achieved. The PLL is then allowed to take over to keep the machines locked.

Fig 2: Block diagram of the PLL control box used to sync the audio recorder to a VTR.

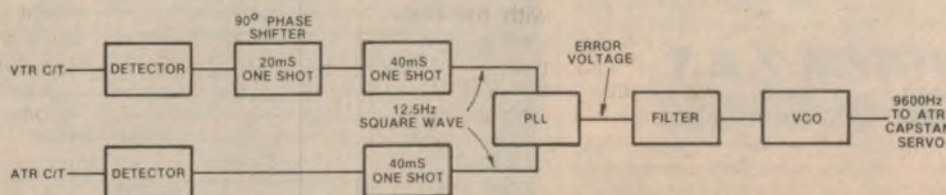
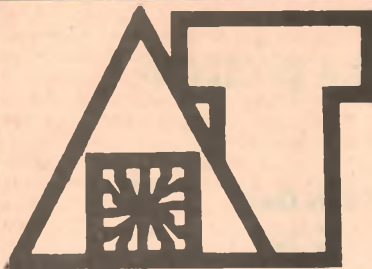

FIG. 2 CONTROL BOX PLL



# APPLIED TECHNOLOGY PTY. LTD.

Office/Showroom: 1a Pattison Avenue, Waitara 2077  
 Hours: 9-5 Monday to Saturday. Telephone: (02) 487 2711  
 Mail orders to: PO Box 355, Hornsby 2077  
 Please add \$2.00 per order to cover packing and postage.  
 Prices correct and goods in stock at time of going to press.



## PROFESSIONAL Z80 / S100 COMPUTER \$1095 ANNOUNCING SYSTEM Z.A.T.

Here it is at last! A fully built and tested business quality computer system at less than the cost of its single board non S100 competitors. The Applied Technology SYSTEM Z.A.T. offers the business and home computer user an unbeatable combination of computing power both in the basic machine and in flexible and inexpensive hardware and software expansion. Our extensive range of S100 support cards, peripherals and world standard software means the SYSTEM Z.A.T. will suit the most demanding user now and in the future.

The basic SYSTEM Z.A.T. is supplied with our fast Z80A single board computer, 16K of RAM, MW640 memory-mapped VDU with 16 lines of 64 characters (upper/lower case plus graphics), a 10 slot mother board and a heavy duty power supply. The whole machine is mounted in a professional rack width EURO-STYLE desk cabinet (illustrated). The keyboard is a stand alone unit featuring full 70 key set and its own attractive case. The Z.A.T. comes with the powerful DGOS monitor resident in ROM so you can enter programmes, set the in-built real time clock, save and load on cassette as well as make block moves, compare memory and search for bytes in memory. The system Z.A.T. requires only a video monitor or modified TV for immediate use. Peripherals such as serial printers and various I/O devices can be interfaced directly with the Z80A card—no extra interfaces are needed. Programmes can be run and developed in powerful MICROWORLD LEVEL II BASIC, either from cassette with our fantastic USCII interface or you can fit the MW2516 EPROM CARD and have your programmes in EPROM. The MW1632 S100 EPROM programmer allows programmes you have developed to be put into ROM for immediate access!

Our machine differs fundamentally from single board computers such as SORCERER and APPLE. It uses all S100 plug in boards right from the start. For \$1095 you are not buying a machine which is basically one big PC board. You are buying a powerful S100 machine with a very heavy power supply and seven slots waiting for expansion. Your S100 expansion unit is built in at no extra cost.

When you buy our machine, you are investing in the best value, most flexible personal computer on the market today.

### SYSTEM Z.A.T. FOR BUSINESS

With the addition of extra memory, disc drives, a printer and support software, a system Z.A.T. can form the ideal basis of an office system. A configuration for virtually any small or medium size business is pictured. It comprises a SYSTEM Z.A.T. with

48K RAM, word processor daisy wheel printer, Micropolis 1053 Mod II 630K Disk Drive system, high resolution green screen monitor and support software including CP/M 2.2 disk operating system, MDOS, 24K MBASIC, and various utility programmes. With the addition of any of the widely available programme packages for accounting, inventory control, word processing etc., the SYSTEM Z.A.T. (48K/WP/DD) configuration is equal to and in some cases superior to commercial systems being marketed for over \$10,000. Because the SYSTEM Z.A.T. is on the S100 bus and will run CP/M without modification, you are assured of a machine which will not become obsolete and which will run the finest business and scientific packages.



The comparison chart below shows clearly why the SYSTEM Z.A.T. is the best value Z80 / CPM computer available today.

BASIC UNIT	Apple II 16K	Sorcerer 32K	SYSTEM Z.A.T.
Memory	16K	32K	16K
Cost (with tax)	\$1524	\$1395	\$1095
Processor	6502	Z80	Z80A
Memory type	dynamic	dynamic	static
VDU	40 x 16	64 x 30	64 x 16
S100 expansion	n/a	\$575	built-in
48K CP / M	\$3664(1)	\$4116(2)	\$3170

NOTES: For comparison we have selected the 48K / CP / M configuration as this is the most common basis for business systems. Popular ROM / BASIC machines such as the TR580 and SYSTEM 80 need substantial conversion and a special version of CP / M and the reader is asked to make his own comparison. Prices used have been taken from current advertising for all models.

(1) To convert the Apple you need 32K of RAM (\$110), Z80 softcard (\$330), disks (\$786 + \$594), CP / M (\$160).

(2) To convert the Sorcerer we used S100 expansion interface (\$575), 16K RAM card (\$199), MICROPOLIS 1043 (\$1149) and 1023 (\$649) disk drives and CP / M (\$149).

(3) To equip the SYSTEM Z.A.T. you need 32K RAM (\$400) and MICROPOLIS 1053 MOD II 615K package with CP / M 2.2 (\$1,675).



# WHY CP/M?

CP/M is a powerful disk operating system from DIGITAL RESEARCH that has become the industry standard system for virtually all 8 bit microcomputers. Although only suited to Z80/8080 processors you can now buy a Z80 plug-in for the APPLE (about \$300), the SOFTBOX for the PET (\$900), mods for the TRS80

and no doubt the Atari in the near future. Hewlett Packard's new HP-125 uses the Z80A and CP/M and also the Xerox Model 820 features CP/M with the Z80! This formidable line-up suggests that to produce a worthwhile computer system you really need a system capable of running CP/M on a Z80. The enormous library of powerful and proven software is fully transportable between CP/M systems and means that any CP/M user has this at his fingertips.

The SYSTEM Z.A.T. is available with customised BIOS program to suit any configuration required. The soon-to-be released MICROWORLD MEGAMEMORY hard disk system will come with multi-user MP/M and will pave the way for networking under CP/M as well.

In the fast-moving world of micro-computing, three significant milestones have been the Z80 chip, the S100 bus and CP/M operating system and SYSTEM Z.A.T. employs them ALL.

APPLIED TECHNOLOGY have a wide range of cost-effective S100 cards which make expansion exciting and painless.

**MEMORY**  
We offer two choices of proven reliable static memory. Both cards have very low power consumption, one voltage (between +7 and +14 Volts) and suit all S100 systems as well as SORCERER, TRS80 and SYSTEM 80 AT16K

Uses reliable 2114 static RAMS and may be configured to any 16K boundary using on-board select logic. Board also has bank select, provision for write select and phantom line memory priority control. Fully built and tested. Assembled and tested \$199.00

**TCT 16K**  
Memory arranged in four independent 4K blocks. Three DIP switches locate memory at any location in 64K address space. Can be configured to higher or lower priority memory through use of phantom line. Kit form \$209.00

**ROM CARD**  
MW2516 S100 ROM card stores programmes permanently in up to 16K of low cost 2516 EPROMS. Built and tested \$99.00  
Also available with MICROWORLD 12K BASIC plugged in \$160.00

## HIGH RESOLUTION GRAPHICS

Our TCTPCG (programmable character generator) will expand your graphics to a fantastic 512 x 256 bit resolution! You can produce graphs, bar charts, even develop your own TV game! Board comes complete with extensive documentation, joystick interfaces and controls and even two game programmes on cassette. Kit price \$140.00

**INPUT/OUTPUT**  
With the powerful DG750 I/O card you can connect 3 further programmable 8-bit ports, 2 serial interfaces and have on board baud rate generation. Kit price \$195.00

**SERIAL TERMINAL**  
The SCVT100 (as described in EA Oct. 1980) gives a serial input and output, keyboard port, cassette interface and RS232 on one board. Kit price \$190.00

**DIGITAL TALKER**  
Give your computer a voice for under \$150.00. The MICROWORLD DIGITAL TALKER uses the latest speech processing unit and speech ROMs from NATIONAL SEMICONDUCTOR. Although it is on S100, the DIGITAL TALKER can be readily adapted to interface with virtually any micro, including SORCERER, TRS80 and SYSTEM 80. DIGITAL TALKER comes complete with applications notes and typical software. DIGITAL TALKER Kit with notes and full instructions \$149.50

# SOFTWARE NEW RELEASES



- DGOS format on Cassette Tape.  
Cassette with documentation  
**WUMPUS**. The popular cave hunting game \$5.50  
**LIFE**. A fascinating use of graphics on the VDU \$5.50  
**CALENDAR-MAKER**. Prints calendars for any year you want to. \$5.50  
**MAZE-MAKER**. Prints mazes to any specified width and length. \$5.50  
**BANNER-PRINT**. Prints your name in big characters. \$5.50  
**BIG VDU**. Converts the MW640 to produce large characters on the screen. \$5.50  
**BYORITHM**. Impress your friends and print out their points at a party game. \$5.50  
**TYPE DRILL** - Teach yourself to touch type. \$5.50  
**ELIZA**. The first artificial intelligence program. \$5.50  
**HEXAPAWN**. A chess type game, but the computer learns by its mistakes. \$5.50  
**PILOT**. The simplest to use language. Ideal for education and string oriented application. \$14.75  
**MICROWORLD LEVEL II**. Basic 12K of powerful program on cassette. \$19.75  
Or in ROMS. \$75.00

# PERIPHERALS

## PRINTERS

NEW RELEASE. ITOH 8500  
GRAPHICS/DOT MATRIX.

A little beauty! This latest printer from ITOH is a clever microprocessor controlled unit that uses a dot matrix head to produce top quality characters and graphics.

Printing at a rate of 100 characters/second (44 lines/minute full 80 character print) this is an ideal printer which has built in friction feed and sprocket feed for all paper types. Features true descenders and logic seeking circuitry for extra speed. \$895.00

## FOR WORD PROCESSING

TEC TE 1500 Daisy wheel printer accepts sheet paper. Company letterheads etc or continuous stationery up to 400mm wide. Uses standard DIABLO print wheels and ribbon cartridges.

A wide range of fonts is available. Prints about twice as fast as a golfball printer and is now available with RS232 or Centronics interface.  
TEC TE 1500 RS232 \$1,895.00  
TE 1500 Centronics \$1,865.00

## DISK DRIVES

Proven Micropolis Quad Density Drives are one of the best known 5 1/4" drive packages on the market. They store 315K on a single disk and are fully S100 compatible.

### 1043 MOD 11.

S100 controller, drive package in cabinet with power supply, and full software includes 24K BASIC, MDOS and MICROWORLD RES.

Add on Drive \$995.00  
\$645.00

### 1053 MOD 11.

Dual drive package has 630K of storage in top quality case with power supply and S100 controller.

Now available with full software plus CP/M 2.2 and MICROWORLD RES \$1,675.00

# REAL COMPUTERS START FROM \$399

Do you want to build a computer which won't end up limiting your needs and interests? Then the SUPER INSTRUCTOR 80 offers you the finest take-off point in personal computing today. While offering you unparalleled facilities for learning computer basics now, the SUPER INSTRUCTOR has the built-in S100 facilities of the Z.A.T. system, but without the power supply, case and memory board of the latter. It gives you an ultra powerful CPU board with built-in printer and other interfaces, and a professional VDU board with upper and lower case (and a screen which doesn't flicker each time you key something in).

- The SUPER INSTRUCTOR 80 includes
- RCA touch keyboard \$89.50
  - 4 slot motherboard with two S100 sockets \$45.00
  - DGZ80 CPU card kit \$199.00
  - DGOS monitor ROM with manual \$40.00
  - MW640 VDU (built and tested) \$159.00
- Normal full price \$532.50  
Package Price \$399.00  
SAVE \$133.50

## ADVANCED 16K BASIC SYSTEM

As a special deal to SUPER 80 buyers, we are offering our AT16K RAM card plus the MW2516 ROM card with MICROWORLD BASIC in ROM for an all-up price of only \$269, a saving of \$90 on the normal price for the two boards. Your INSTRUCTOR 80 with BASIC 80 pack outclasses TRS80, SYSTEM 80 and SORCERER and you don't have to spend \$500 if you want to expand memory or go to disk.

INSTRUCTOR 80 \$399 plus  
BASIC 80 PACK \$269 equals

POWERFUL 16K/BASIC S100/Z80 processing

## 12K BASIC + 16K RAM \$269



# Questions & answers on radioteletype

Interest in amateur radioteletype (RTTY) communication is steadily increasing. The RTTY amateur now has available a wide variety of specialised equipment, and a growing number of contests and awards exist to promote radioteletype activities. For those thinking of getting into this fascinating hobby, this article answers the most frequently asked questions about RTTY.

## Why work Radioteletype?

Radioteletype is one of those quickly growing "specialised" forms of amateur communications. The attraction to its devotees is probably a mixture of the magic of modern digital communications coupled with the convenience of written rather than coded or voice communications. If you participate in the popular autostart nets, it's not even necessary to be home when receiving an RTTY message — the printer or display will record the text for you to read at your convenience. RTTY is very popular among "rag-chewers" and "engineers" alike; in fact, you get to do a bit of both.

The rapid growth of digital electronics has carried over to both RTTY and the new home computer hobby. ASCII communications between computers lacks only final FCC approval. If your "bag" is chasing DX, what could be more satisfying than a DXCC certificate for all RTTY? There are several DX RTTY contests sponsored every year with heavy participation. So, rather than ask "Why?" ask "How?"

## What do I need to work RTTY?

An amateur RTTY station needs a transmitter, receiver and antenna just like any RF communications system, in addition to some "special boxes" to make the RTTY part work. Some considerations for the equipment are outlined below.

(1) Receiver Transmitter: The RTTY receiver and transmitter (or transceiver) should be stable, well calibrated, and capable of extended transmitter operation. When you are transmitting RTTY, the full carrier is on for longer periods of time than for CW or SSB voice. So, check your manual and manufacturer for RTTY specifications and, if in doubt, reduce transmitter power somewhat. For HF work, a good SSB rig in LSB mode works well with RTTY tones (more on tones, later). Most VHF-FM transmitters work with RTTY, but avoid overloading the

transmitter as mentioned above.

(2) Antenna: A good antenna will buy you the same benefits in RTTY as it does in other modes. One caution though, the traps on some antennas may not handle as much power in continuous RTTY operation as they do for CW or SSB voice. This can especially be true of trap yagi antennas for the HF bands.

(3) RTTY Demodulator: The demodulator connects to the receiver audio output and converts the RTTY tones to keying pulses. The quality of your printed signal is determined more by demodulator performance than by any other portion of the system. Demodulators come in all shapes, sizes and prices.

(4) Tone Keyer: The tone keyer circuitry converts the keying pulses from your keyboard into audio tones to drive the transmitter. This circuitry is closely related to that of the demodulator.

(5) Terminal: The terminal is the device that prints or displays the received signals while allowing you to type your transmitted message. The terminal is sometimes divided into a keyboard and a printer or display section. The terminal can be as simple as an old surplus TTY machine.

## How do I hook it up?

Probably the most frightening thing to the RTTY beginner is the thought of all those wires that must be connected to make it work. A particularly complicated RTTY station can have a real "rats-nest" of wires, but it didn't start that way. Make connections in a logical and step-by-step manner and all will work well. All transceivers are slightly different, but, in general, you will have to make these connections.

(1) Grounding: Before making any other connections, decide approximately where your equipment will be located and run short, low-inductance ground wires (shield braid recommended) between the cabinet grounds of all equip-

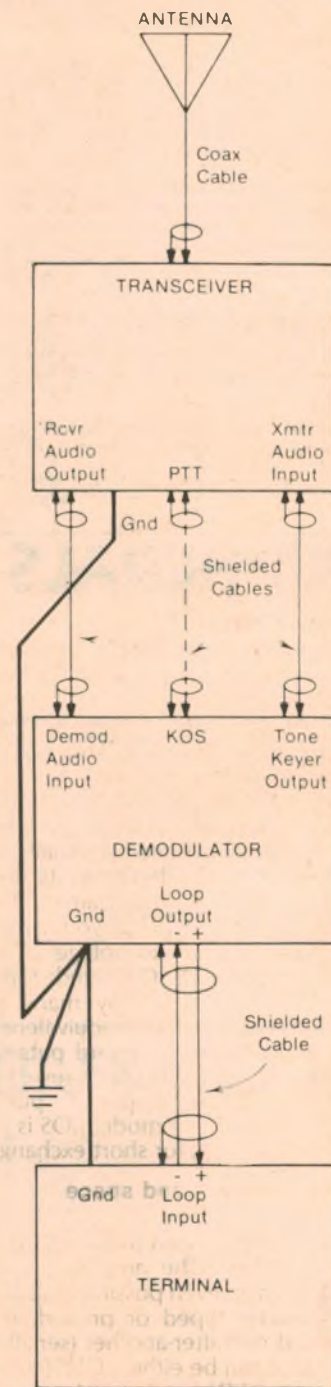

Fig. 1 Basic equipment and connections for radioteletype operation.

This article printed here courtesy HAL Communications Corp, Box 365, Urbana, Illinois, 61801, USA.

ment and machines. Run separate RF grounds in addition to the AC safety ground. Lack of adequate RF and safety grounds causes more problems in RTTY installation than any other source.

(2) Receiver to demodulator: Use shielded cable to connect a 500 ohm audio output of the receiver to the demodulator audio input jack. If you do not have a 500 ohm output, the 4-8 ohm speaker output will work, but not as well; a speaker to 500 ohm line transformer would be a good part to add when possible.

(3) Tone keyer to transmitter: Use shielded cable to connect the tone keyer output of the demodulator to the transmitter audio input. Often, a rear-panel "phone-patch" or "auxiliary" input is provided. If not, connect directly to the microphone connector.

(4) Demodulator to terminal: Use shielded cable to connect the terminal to the demodulator. Use the current loop connection for each. When connecting to a solid-state terminal, be sure to observe the proper polarity as indicated in the operator's manuals. Be extremely careful when wiring the loop circuit - potentially lethal voltages are present when the equipment is turned on (200 VDC at 60mA). Also, be sure that no part of the loop circuit is connected to chassis ground in machines or other equipment. All RTTY equipment is connected in series when the current loop output is used.

(5) Control circuits: Since the control requirements differ with manufacturer, study your transceiver manual carefully to determine how to control the transmit-receive function. Usually, you can control the push-to-talk (PTT) line through a pin on the microphone connector, a front panel switch, or a rear panel accessory connector. Initially, try to manually switch between transmit and receive until you are familiar with RTTY operation. Eventually, you will probably want to take advantage of the automatic Keyboard Operated Switch (KOS) feature provided by many terminals. KOS is the RTTY equivalent to VOX; typing on the keyboard puts you into transmit mode. If you pause long enough, the KOS "drops-out" putting you back into receive mode. KOS is particularly convenient for short exchanges.

### What is this mark and space business?

The RTTY signal from the terminal is a series of pulses. The amateur Baudot RTTY signal has seven possible pulses for each character typed or printed, each transmitted one-after-another (serial).

Each pulse can be either "ON" (current flow in the RTTY loop) which is called "MARK" or "OFF" (no current flow), the "SPACE" condition. To keep decoders synchronised, the first pulse of a character, the START pulse, is always a SPACE (current off); the last pulse, the STOP pulse, is always a MARK (current on). The 2nd through the 6th pulses can

be either MARK or SPACE, depending upon the coding required for a character. The START and all five data pulses are the same length; the STOP pulse may be either equal to or longer than the others. The computer ASCII code uses START and STOP pulses but has eight instead of five intermediate data pulses, thus allowing a greater number of characters to be encoded. Although all machines and electronic terminals use pulses, the MARK and SPACE pulse conditions are converted into MARK and SPACE audio tones for easy radio transmission.

### What is the difference between FSK and AFSK?

Transmitting RTTY signals via radio could be done like Morse code with on-off keying of the transmitter carrier. However, the interference received during off-times would give badly distorted printout. Rather, HF RTTY is transmitted with Frequency Shift Keying (FSK) so that the mark pulse condition corresponds to one radio frequency and the space to another. Amateur radio convention has it that the mark radio frequency is higher than space and that the separation or "shift" of the signal is standardised at 170Hz or 850Hz. (425Hz shift is also used by commercial RTTY stations.)

Most present-day amateur RTTY stations use 170Hz shift exclusively. The FSK signal is received with the BFO turned on, giving two audio frequency tones for the mark and space conditions. The audio tones are, in turn, detected in the demodulator and the resulting pulses drive the display or printer. Note that changing the transmitter or receiver frequency (on purpose or through frequency drift) will change the audio output frequency to the demodulator. The HF system is therefore quite drift sensitive. Present HF equipment frequency stabilities are quite adequate for FSK RTTY, but it is only very recently that VHF equipment was available with similar stability. Therefore, VHF RTTY has traditionally been transmitted by first keying audio tones with the RTTY pulses and then using these tones as the audio modulation of an AM or FM VHF transmitter. This is called AFSK for Audio Frequency Shift Keying.

Current amateur convention is to make the mark audio frequency lower than the space frequency by the amount of the shift. Since the RTTY data is audio modulation of the carrier, frequency drift of either transmitter or receiver is a lot less critical. The audio frequency of the tones transmitted is set to be the same as those in the receive demodulator.

The required radio frequency keying can be done in two different ways: shift the frequency of a transmitter oscillator directly with the RTTY pulses or use an SSB transmitter with audio tones. Direct FSK keying circuits are described in most amateur journals and are generally simple, but require modification of the equipment; genera-

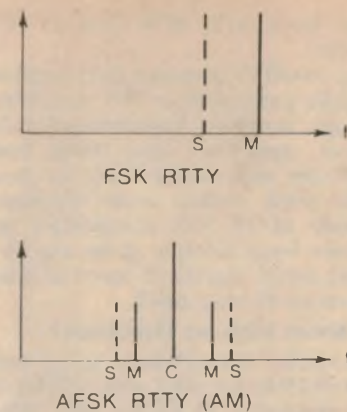

Fig. 2: In FSK, the mark condition is one frequency and the space another. In AFSK, audio tones are used to modulate the carrier frequency.

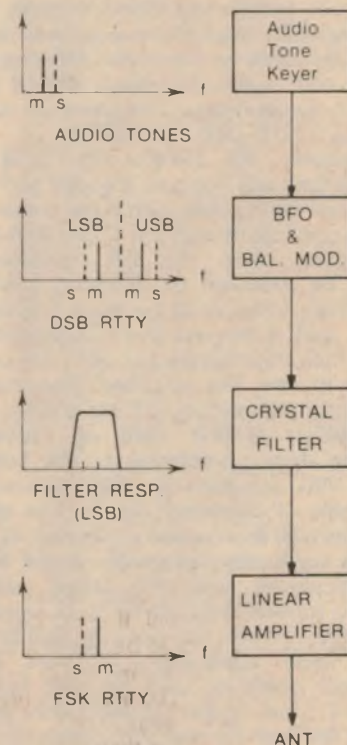

Fig. 3: A block diagram of a typical RTTY transmitting rig. Audio tones drive a lower sideband (LSB) transmitter via the BFO and balance modulator.

tion of FSK with an SSB transmitter is as follows: If a Lower Sideband Transmitter (LSB) is driven with a 2125Hz audio tone, the RF output of the transmitter will be at a frequency 2125Hz below the suppressed carrier frequency. A properly adjusted LSB transmitter will have no other output frequencies.

If the input tone is changed to 2295Hz (170Hz shift), the RF frequency is now 2295Hz below the carrier frequency. Thus, audio tones into the LSB transmitter have produced FSK carriers out of the transmitter. Note that, because the LSB mode was used, the 2125Hz standard mark tone for VHF AFSK has become the higher radio frequency. Thus, the same demodulator and tone keyer can be us-

ed for both VHF AFSK and HF FSK operation.

Most HF RTTY amateur radio stations use audio tones with an SSB transmitter. Although "standard" audio tones for VHF amateur operation have long been 2125Hz for mark and 2975Hz for space (850Hz shift), limited audio frequency response of HF SSB transmitters and receivers have recently given rise to a second set of "standard" tones at lower frequencies ("Low-tones").

#### How about high- vs low-tones?

Historically, demodulator tones were set to 2125Hz for mark and 2975Hz for space reception of 850Hz shift. When transmitter stability improved, 170Hz shift was used and the space frequency changed to 2295Hz (mark remained at 2125Hz). These three tones were, and still are, a standard for US amateur RTTY. However, in the early 1960's, virtually all commercially available transmitters and receivers became filter-type SSB equipment with audio pass-band limited to speech frequencies, sometimes as narrow as 2.1kHz (300 to 2400Hz).

Obviously, the 2974Hz (850Hz shift space) tone will not pass through such a filter and 850Hz shift with these tones is not possible (although the 170Hz shift is). Therefore, either the SSB equipment must be modified or different, lower-frequency tones must be used if 850Hz RTTY shift is desired. Both approaches have their advantages and both are currently in use. The so-called "low-tone" standard sets mark at 1275Hz and space at 1445Hz (170Hz shift) or 2125Hz (850Hz shift), conforming to the European IARU standard. So, there are now two sets of "standard" tones, low and high (as well as a myriad of others), all of which work interchangeably on HF RTTY. However, since the actual audio tone is transmitted for VHF AFSK operation, the two sets are not compatible in VHF AFSK applications. Current US amateur operation uses the high tones for VHF. Thus, to use a demodulator and keyer for both HF and VHF operation, it should be set up for high-tone operation.

#### What frequencies do I use for RTTY?

HF RTTY operation has evolved to heavy operation on the 80 and 20 metre bands (CW segments) with sporadic operation on other HF bands. Eighty metre RTTY stations tend to operate between 3600 and 3650kHz and 20 metre stations between 14.075 and 14.100MHz. 170Hz shift is used almost exclusively with mark being the higher radio frequency. 60wpm (45 baud) is the most popular RTTY speed, but 100wpm (74 baud) is gaining in popularity.

VHF RTTY operation in most areas is concentrated on two metre FM with 146.700MHz being the popular operating frequency. Virtually all stations are now using the "high-tones", usually with 170Hz shift. As with HF RTTY, 60wpm (45 baud) is most popular on VHF.

## Radioteletype in Australia

In Australia, radioteletype is transmitted on HF and VHF bands. The most commonly used shift frequency is 170Hz, with the mark frequency being 2125Hz. Both low and high tones are used on HF, while high tones are used on VHF as in the US.

RTTY transmissions can be copied on 3.5MHz, 7.045, 14.090, 21.090 and 28.090MHz. The standard international frequency is 3.54MHz. On VHF the frequency most used is 146.6MHz. Two repeaters in NSW operate with output frequencies of 146.625 and 146.675MHz, and a Brisbane repeater works at 146.625MHz.

ANARTS, the Australian National Amateur Radio Teleprinter Society, has been active now for almost four years, and has a membership of over 600. The Society provides information and technical assistance to members, transmits RTTY news and views, and also makes available kits of parts for RTTY equipment.

ANARTS news broadcasts from Sydney are at 0030UTC each Sunday on 7045kHz, 14.090, 14.095 and 146.6MHz. The news broadcast is repeated at 0930UTC on 3545kHz, 146.6 and 146.675MHz, and VHF relays of the broadcast are made to other states. At 0130UTC on Sunday an RTTY DX bulletin is transmitted, and according to publicity office Sid Molen, ANARTS is the only station in the world providing detailed DX information for radioteletype.

The Society meets on the first Tuesday of every second month, at the Wireless Institute Centre, 14 Atchison St, Crows Nest, NSW. The next meeting will be held on August 4. The postal address is PO Box 860, Crows Nest, NSW 2065. An RTTY

group also meets in Perth.

In Australia there are no restrictions on the codes that may be transmitted. Amateur radioteletype enthusiasts may use "any recognised code" at a shift frequency of not more than 850Hz. Baudot code at 45.5 baud is most commonly used although some experimenters are transmitting in ASCII. On the HF bands, ASCII transmissions are very prone to noise, and experiments are being carried out with error-correcting codes.

Radioteletype transmissions from the USA and Europe can be received throughout Australia. Two notable stations are W10W, the American Radio Relay League station, and GB2ATG, the British Amateur Teletype Group. GB2ATG broadcasts daily at 0730UTC on 14.090MHz, while W10W transmits four times a day, at 0100, 0400, 1500 and 2200UTC on 14.095, 21.095 and 28.095MHz. Stations in Europe can also be contacted, and some of these stations operate as message switching centres, storing and forwarding messages from one amateur to another.

Using a surplus Baudot teleprinter, and modulator and demodulator kits from ANARTS, the RTTY amateur can be on the air for as little as \$150 above the cost of a transceiver. Radioteletype is particularly suited to novices, who are restricted to a maximum transmitter power of 30W PEP. Since radioteletype is a "key down" mode, with the transmitter in continuous operation, most transceivers need to be de-rated to about 30% of their maximum power output for RTTY use. Novices thus face much less competition from high power broadcasts in the radioteletype mode.

#### Who do I talk to on RTTY?

RTTY enthusiasts run the full range of ages and interests, but tend to be technically inclined. The typical RTTY'er is always modifying his station, likes to talk, and usually has more ideas than you have printer paper (or display screen)! Some operators are good typists; most aren't. Recently, the home computer hobby has become quite popular with RTTY people and you may find a lot of help in debugging your programs if that's your interest. There are also an increasing number of DX stations on RTTY.

#### How much does it cost?

RTTY is like any other hobby — it can cost as much or as little as you want it to. If you buy used machines and build kits or your own designs, the total RTTY cost can be quite low. Because most RTTY products are current loop compatible, you can add devices as your interests (and wallet) indicate. For the

beginner, we have the following recommendations:

(1). Demodulator: Assuming you already have a good transceiver and antenna, your first major RTTY purchase should be a good demodulator. If you select a high-tone transceiver it will be usable for either VHF or HF (170Hz shift) RTTY operation; if you are only interested in HF RTTY (for shortwave listening to press stations, for example), a low-tone unit may be a better choice. Either way, put high priority on a good demodulator.

(2). Terminal: You can spend very little or a lot on the terminal. A surplus machine can often be acquired for little cash investment. However, by the time you figure out how it works, fix it, and buy parts and manuals the total cost may not be so low. If you do, you'd better be prepared with tools, oil, and patience. Newer machines require less work, but also cost more. 

# CW PORTABLE W / RTTY / ASCII TELEREADER

COMMUNICATIONS  
COMPUTER

CWR-685



- ★ Fully self-contained with built-in green screen monitor and keyboard
- ★ Automatic (or manual) transmit/receive switching of your transceiver
- ★ 12-14 V dc (1.5 amp)
- ★ 323 W x 276 D x 127 H mm in size
- ★ Visual display in both transmit and receive modes
- ★ Optional printer (240 V ac) available



Shortwave Listeners enquire  
about CWR-670 receive only  
unit

#### Other features:

- Automatic CW speed adjustment on receive.
- Variable CW transmit speeds from 20 to 200 characters per minute
- 6 transmit and receive speed on RTTY & ASCII
- Output for external monitor if required
- Built in interface for hardcopy from inexpensive dot matrix printers
- Similar keyboard layout as a standard typewriter with automatic function insertions
- 32 character x 16 line per page
- Two page memory called up via keyboard
- Noise filter helps prevent garbled display during signal intermission
- Buffer memory of 53 characters
- Keyboard correction or erase of buffer memory
- Correction facilities for transmitted messages
- Buffer can be loaded while unit in transmit mode
- CW identification (800 Hz available on RTTY)
- Built-in demodulator for High and Low shifts on 170 Hz, 425Hz, 725Hz all with fine tuning
- Echo functions
- Automatic CR and/or LF
- Five memory channels
- Word mode operation if required

NOVICE - FULL CALL - COMMERCIAL  
SHACK - MOBILE - CAMPING - FIELD DAYS

# CW

**ELECTRONICS** 416 LOGAN RD. (Pacific Hwy) STONES  
CORNER, BRISBANE. TEL: (07) 397 0808, 397 0888. PO BOX  
274 SUNNYBANK QLD. 4109. TELEX AA40811.



# FORUM

Conducted by Neville Williams

## I have lunch with "A girl like Alice".

In case you should think that I have taken to philandering in my twilight years, I must hasten to add that the young lady referred to in the heading above is an imaginary 1981 version of the one who features in Lewis Carroll's novel "Alice in Wonderland" — a girl with a penchant for fantasy.

You may recall this incident from the Mad Tea Party:

*"Have some wine" the March Hare said in an encouraging tone. Alice looked around the table but there was nothing on it but tea. "I don't see any wine", she remarked.*

*"There isn't any," said the March Hare. "Then it wasn't very civil of you to offer it," said Alice angrily.*

*"It wasn't very civil of you to sit down without being invited," said the March Hare.*

But I must get to the point:

On Thursday, August 6, I did as I often choose to do around lunch time: I pushed the typewriter aside, put my feet on the desk and prepared to relax for a while with a cup of coffee (not tea), a couple of sandwiches and some fruit, and a copy of "Financial Review" — one of our corporate newspapers.

FR doesn't feature much in the way of violence and sex, but it does have a fair bit to say about national and world affairs, some of which, I must admit, have about them an air of fantasy.

### SOME LIGHT READING

On that particular day the Review was running the last of three articles by Christopher Jay, commenting on the electricity supply position in Australia, with particular reference to New South Wales. The instalment was entitled "Things that go wrong in the dark".

I began to read it with mild, but not acute, interest.

As you have probably gathered from press reports, the electricity supply authorities in NSW (and elsewhere) are facing a situation where the generating capacity is barely able to keep pace with demand. Over and above the normal increase in power usage, industrial demands have been very heavy and,

during the past winter, there has been a massive rejection of oil heating for homes, with many consumers using electrical appliances instead.

Anticipating a need for added capacity, the State Electricity Commission long ago decided against a multiplicity of more modest generators and opted for the 660 megawatt monsters which are currently being brought into service. And monsters they are with (according to "Financial Review") "a replacement cost 10 times that of a Boeing 747" — an observation that will be seen later to have an interesting significance.

But, for all their massive proportions, such huge turbine-generators have to be treated with extraordinary care, so great is the amount of mechanical and electrical energy involved in their operation.

You just don't start 'em up and throw a switch when they're runnin'.

For example, according to Christopher Jay, oil has to be forced into the bearings by "jacking" pumps to lift the spindle free of the white metal surface, as rotation begins. Then, as the turbine is run up carefully to its ultimate 3000rpm rotational speed, lubrication is handled in sequence by other sets of mains or mechanically driven pumps, with a further set on emergency standby, powered by DC from a bank of giant batteries.

Similarly, to bring the unit to a standstill, you don't just throw a switch and hope for the best. It has to be done carefully, over a matter of hours, lest unequal contraction of rotating and stationary components should bridge the tiny clearances between them, causing metal-to-metal contact and self-destruction.

Indeed, self-destruction is no idle possibility because, if the rotor locks up in its casing, the huge moment of inertia can rip the casing from its bed and send the whole thing careering through the power station.



Cartoons by John Tenniel from "Alice's Adventures In Wonderland" (Puffin/Penguin)

Reportedly, something like this actually happened, some years ago, in NSW's Wangi power station, when a smaller unit tore free and went right out through a wall into the canal. What could happen with a 660MW unit is fearsome, with the possibility that it could obliterate the control room and rip through mains loaded with superheated steam at a pressure of about 14,000kPa (2000psi).

### WHAT'S THAT IN km?

To quote one technician: (if that sort of thing happened) . . . "I wouldn't want to be within two miles of it!"

And this is merely the mechanical aspect, with another whole huge area of concern with the procedures involved in merging the unit with the State grid, taking up the load or shedding the load as the case may be, controlling the steam supply and so on.

Not surprisingly, the job of monitoring, sensing and controlling individual units and the system as a whole is being entrusted more and more to electronics and computers. Under the watchful eye of system control operators, a great many things should ideally happen automatically and smoothly, with the computers coping with the variety of situations and duties for which they have been programmed.

But things can go wrong and, according

to Christopher Jay, "Commission outage (blackout) reports are peppered with references to software failures". But he goes on to detail one particular series of interactive and traumatic events which were apparently triggered by an operator switching error in the Munmorah power station.

*"Mine is a long sad tale" said the Mouse, turning to Alice and sighing.*

*"It is a long tail, certainly," said Alice, looking down with wonder at the Mouse's tail . . .*

*"But why do you call it sad?"*

Well, the switching error produced a reaction throughout the entire State grid, with a sudden drop in voltage being followed by a sharp surge as standby emergency equipment in the Snowy Mountains cut in automatically – this, hundreds of kilometres away from the original incident.

### WATTS GOING ON?

Presumably, it was attempting to take up a consumer load that didn't exist!

At still another power station, Vales Point, a computercontrolling the first and then relatively new 660MW generator found itself unable to cope with the unfamiliar situation and (modestly) switched itself off. By so doing it initiated disconnection of the 660MW generator from the grid.

But, because of an alleged oversight in the computer programming, or some secondary routine, the shut-down also switched off the pumps supplying oil to the turbine bearings – still running at 3000rpm.

Quick thinking by an operator got oil back into the bearings in time to prevent the ultimate catastrophe but not before the unit had suffered so much damage that it was out of service for a whole six months – putting a huge hiccup into the Commission's planning and maintenance schedules.

*Then the Mock Turtle drew a long breath and said "That's very curious".*

*"It's all about as curious as it can be," said the Gryphon.*

In living memory, we have "progressed" from the situation where many of us lived by the light of individual kerosene lamps, cooked and warmed ourselves with wood we hauled as a family from the bush, and drank water from tanks replenished by rain on the roof. We've "progressed" to the stage where we are almost totally dependant on centralised services, including electricity.

Yet that service, in huge lumps, can be vulnerable to something as obscure as an inadvertant operator error or an oversight in a computer program or other such routine.

The nub of the matter is that a computer-dependant system always will be especially vulnerable to the unforeseen until such times that the data ac-

quisition and the response programming can match the powers of deduction of skilled operators.

Until we reach that somewhat idyllic stage, it is vital that operators should have a level of training and a day-to-day familiarity with the system – computers and all – such that they can react quickly and appropriately to any conceivable situation.

As an example, I quote from the account of what happened at Vales Point: "The operators had trouble believing their eyes. The end of the huge turbine unit began turning black!"



It was this visual clue, not any instrumentation, that alerted them to the fact that the lubrication system had shut down and they knew the equipment well enough to take the appropriate action. And just as well.

Now back to that earlier reference to the Boeing 747.

These giant aircraft are heavily dependant on electronic systems and are well able to fly themselves efficiently for most of the time. But airline operators go to great lengths to ensure that their pilots' skill and their reactions are not diminished by undue reliance on the electronic systems.

Qantas, for example, have elaborate flight simulators in their Sydney training centre, in which the environment, instrumentation, sounds and movements are as close as they can get them to a real aircraft. Pilots undergoing training or periodic checks not only have to prove their ability to do the right thing in normal situations but they have to react appropriately to simulated – but realistic – emergencies dreamed up and set up by the examiner.

### IN POWER STATIONS?

According to the supporting editorial in "Financial Review", no such training facilities and no such simulation exists, as yet, for the operators who are expected to control the huge new power stations. They have to gain their experience right on the job and face up to crises when they actually happen – perhaps involving generating units with a "replacement cost 10 times that of a 747".

For sure, the loss of life from a failed

# NEW ZEALAND CUSTOMERS!

## got your DICK SMITH catalogue?



If you haven't, you're missing the chance to make **BIG SAVINGS** on a wide range of electronic products.

Call or write for a copy. Only 75¢ plus 25¢

postage.

**DICK SMITH Electronics**  
MAIL TO: Dick Smith  
Mail Order Centre  
98 Carlton Gore Rd.  
Newmarket Auckland, 1. NZ



USE ADDRESS

# Find out how easy it is to shop by mail order

Over the past years there have been many 'fly-by-night' mail order companies that have given mail orders a bad name. During the past 14 years there has been a mail order service with a difference. With over 62 000 satisfied customers & 200 000 mail orders despatched, Dick Smith Mail order dept. takes pride in giving the 'red carpet' treatment to all our valued customers. So here's the chance to take that first big step, why not phone in with your Bankcard no. or fill in the form below.

With a 24 hr turn-around service & 14 day satisfaction guarantee (if not completely satisfied) - you can't go wrong. You'll quickly gain the confidence you may lack with many other mail order companies.

14 YEARS OF RELIABLE MAIL ORDER SERVICE

14 DAY SATISFACTION GUARANTEE

SHOP BY PHONE

OVER 200,000 SUCCESSFUL MAIL ORDERS

24 HOUR TURNAROUND



## DICK SMITH MAIL ORDER CENTRE

PO Box 321 North Ryde  
NSW, 2113.  
Australia. Ph. 888 3200

**FREE**  
Fantastic full colour wall chart of the resistor & other colour codes. Invaluable to the amateur or pro.  
Limited quantity only with this mail order

Why not make this your first mail order & get your FREE wall chart

**Delivery instructions**  
Heavy and bulky items cannot be sent by post.

- MAIL ORDER (see table bottom right)
- AIRMAIL (Add \$3 to P&P value)
- REGISTERED MAIL (\$2 extra)
- ROAD FREIGHT COMET (\$7 anywhere in Australia.)
- ROAD FREIGHT INSURANCE (\$1 per \$100 value, \$300 max.)
- AIRFREIGHT \$5.50 air envelope to 3kg, \$9.50 air Superpack to 10kg - to NZ & Papua New Guinea \$19.50 to 10kg

Name \_\_\_\_\_

Address \_\_\_\_\_

Postcode \_\_\_\_\_

Have you bought by mail order from us before YES  NO

Cat. No	Qty	Description	\$	¢
Crossed Cheque <input type="checkbox"/> Money Order <input type="checkbox"/> Shipping/Packing _____			<b>TOTAL</b>	
Bankcard No. 496 .....				
Signature .....				

**Postage & packing charges**

ORDER VALUE	CHARGES
\$ 5 - \$9.99	\$1.20
\$ 10 - \$24.99	\$2.20
\$ 25 - \$49.99	\$3.30
\$ 50 - \$99.99	\$4.40
\$100 - or more	\$6.00

These rates are for goods sent by post in Australia only

**Check your mail order**  
Is the name & address clear?

**Send to:**  
**Dick Smith Electronics**  
PO Box 321 North Ryde  
NSW. 2113 Australia.



## FORUM: "A girl like Alice!"

turbine may not be as instantaneous or as dramatic as a crashed airliner but how do you identify and sum the human misery and suffering that resulted from the chain of events that paralysed the electricity supply, some years ago, to New York and its environs.

Or the total failure of a state grid in Australia that could conceivably last for up to two days.

That would be a far cry from the Mad Tea Party. It would be more a case of Alice in Blunderland!

*Alice was very nearly getting up and saying "Thank you sir for your interesting story" but she could not help thinking there must be more to come, so she sat still and said nothing.*

## HIFI INTERLUDE

In fact, there was more to the story but, just then, the phone rang, the call being from a reader who wished to thank me for the article in the August "Forum" entitled "Sampled Sound: You've been listening to it all your life!"

As it transpired, it may well have been long distance from Wonderland ... the Mock Turtle or somebody.



The caller said that he had found the article very interesting and he agreed with many of the points I had made. But he was still worried because, try as he might, he could not settle back and enjoy a digitally mastered disc. After the initial impact and "spectacle" of the reproduction he invariably started to worry that it didn't sound quite "right".

Nor was he talking about the performers, the performance or even the acoustics. These could be good, bad or indifferent, as with any other system. He was simply talking about digital sound.

I tried to discover the basis for his discomfort but this led nowhere, particularly as he had to accept that the distortion or intermodulation measurable in a digital system was usually an order of magnitude lower than with an analog master.

Ultimately, I put to him, for consideration, the suggestion that the system may be so much more "transparent" than it was revealing qualities in the sound that were not obvious, either though an analog recording system, or through the acoustic "murk" that thickens the sound as heard in the auditorium.

In short, that the "difference" that was worrying him might not be an aberration

at all but, rather, something that was unacceptable because he was aware of it for the first time.

Historically, each new step in the process of recording and reproduction has thrown new emphasis on problems elsewhere, and there is no special reason why the principle should not still hold. With this he agreed and, at that point, I had to close off the conversation and get back on the job — because even editors have to work now and again!

It was only after I had hung up the phone that I realised how weird the conversation had been.

Forum had made the point that virtually all the reproduced sound we hear involves sampling; AM radio, FM/stereo radio, so-called "analog" tape recorders; all sample the sound at the carrier, the diplexing or the bias rate.

I had written the article; he had read it and had specifically thanked me for it.

Yet here we were discussing digital mastering as if it was something utterly distinct and isolated. Neither he nor I had thought to examine the question as to why, if he was perturbed by digital sampling, he was not equally upset by FM-stereo sampling which occurs at an even lower frequency.

How readily we revert to established lines of thinking; just as if contrary views had never been expressed! Perhaps there's a little bit of Alice in all of us. Or the dodo?

*"At any rate, I'll never go there again," said Alice, as she picked her way through the wood. "It's the stupidest tea-party I ever was at in all my life!"*

## POWER STATIONS AGAIN

But I did contact Alice later to round out the business about power stations.

Subsequently, I told her, the Electricity Commission of NSW had taken a full page advertisement in "Financial Review", to answer their allegations with "facts".

"Financial Review" followed this up with an editorial accusing the Commission of dealing selectively with three allegations only, but avoiding any kind of detailed or documented response to the basic thrust of Christopher Jay's articles.

What if the Commission had now acquired a simulator, as revealed in response to the articles? It had been of no help to the operators who had had to cope with the system to date.

Doubtless the arguments will continue, paralleling those in the State Parliament, to the puzzlement of the community generally, who remember the blackouts that couldn't possibly happen, and that shouldn't happen again!

*"I think I should understand that better," Alice said very politely "if I had written it down, but I can't quite follow it as you say it."*

## Every printed circuit

ever published by EA & ETI

- Accurate machine printed etched circuits
- Send \$5.00 for Computer Printout listing every project in stock
- Specials to your artwork
- Postage on PCB's add \$1.00

81P19	7.20	81UC8	4.60	Front panels also	
81GA9	4.30	81CL9	4.10	478MM	3.50
478MC	3.50	81MC8	6.60	81SM7	3.20
ETI607	4.80	ETI1503	4.00	ETI332	3.90
810R7	10.40	81MC7	3.60	81SW7	4.70
EA81P6	3.50	ETI258	3.20	ETI330	3.40
HE113	3.70	HE112	2.80	HE111	2.80
ETI458	5.30	ETI156	4.70	HE107	3.30
HE102	3.00	ETI735	6.10	ETI257	3.10
ETI256	3.20	HE104	2.80	HE105	2.80
HE106	2.80	81UA6	6.20	81PI6	5.00
81A06	5.60	81DT5	3.60	81MP6	5.00
81SS4	6.20	81RC4B	2.80	81RC4A	4.80
81CC5	3.50	81SP5	3.80	567	4.60
1501C	2.80	1501B	3.10	1501A	3.20
729B	6.20	599D	3.20	599C	3.30
599B	2.80	ETI599A	3.00	81S13	6.80
81VM2	3.00	81MA4	2.80	81HB4B	3.00
81HB4A	6.20	81RC4C	2.80	81R4	3.20
80GA12	5.90	81DC3A	7.00	81GA3	9.20
81DC3B	5.40	ETI329	2.80	598B	2.80
598A	2.80	80F12	2.80	81SP1	3.00
81DC2	2.80	81SW1	3.50	80FB12	3.00
477	4.00	32B	2.80	80RM12	3.00
80SA10	7.00	80AD12	3.00	ETI1500	9.00
ETI1500	9.00	ETI572	3.50	80RAM12	5.50
80MV11	2.80	80LS12	3.20	ETI476	4.00
ETI476	4.00	247	2.80	80TRS11	2.80
255	2.80	80DC10	4.80	80AW10	3.00
80LBR12	2.80	80BM10	2.80	80ST10B	2.80
80TC12	2.80	80TM8B	2.80	EA80TMB8A	5.00
80ST10A	4.50	327	2.80	ETI147	3.00
568	2.80	ETI457	3.00	ETI326	2.80
ETI475	4.00	80B7	2.50	80DM9	4.50
80LPG9	3.50	250	2.50	564	10.50
80TR9	3.50	80LL7	2.80	80M07	3.00
ET1324	3.50	80LL7	2.80	80M07	3.00
80PC7	3.00	80CH7	4.80	565	3.50
563	2.80	467	4.00	149	2.80
80PP/B	2.50	80PP7A	5.00	80RF5	2.80
80G6	4.80	578	2.50	636	16.00
80D6	3.00	78AF2	3.00	ET58820	10.00
80PA6	12.00	77CB12	2.60	78EK3	3.30
80BB3	2.80	ET135	3.00	781A2	2.60
454	3.00	80HH56	2.80	ET716	4.00
80AW4	4.00	325	2.50	ET245	2.50
80C14	2.80	80PC4	3.00	78S3	2.60
466	6.00	562	3.30	77PH12	2.60
80AU3	3.00	453	2.80	80PG6	5.00
264	2.50	566A	2.50	80HLA5	2.50
322	2.80	80GSP3	2.80	80TV8	3.30
80S1	2.50	496	5.00	566B	3.00
ET560	2.80	496G	6.50	80F3	2.80
ET151	2.50	80CM3A	3.20	ET152	2.80
79D10	2.80	561	2.80	726	8.00
79T11	2.80	80GA3B	3.20	80CM3B	2.80
ET262	2.50	79SB10	2.80	455	3.00
ET150	2.80	ET452	4.50	80GA3A	5.00
79PG9	3.00	80SA3	4.50	ET474	2.80
ET573	2.80	79EB12	2.80	ET321	3.50
790M9	3.00	ET270	2.80	79FE11	2.80
79RR8	4.20	ET261	2.50	79PC12	2.50
79BT9	2.60	ET146	2.50	ET263	2.50
79AC9	3.50	79MD9	2.80	ET260	2.50
ET576	4.20	ET577	2.80	79PS11	2.50
ET730	3.50	79PS10	2.80	ET606	3.00
ET252	3.00	79SF10	2.50	ET473	3.50
79WF6	3.20	79TT7	2.60	79R18	2.80
79PS6	2.80	79SF9	2.60	79A19abc	4.20
ET451	2.50	ET574	2.80	79W9	2.80
6800	8.50	ET814	2.80	ET731	3.00
79UPS6	2.50	79SR8	2.80	ET575	2.50
ET144	3.50	79UT8	3.00	ET725	3.50

## HOURS OF TRADING

Mon to Fri: 9am to 5pm; Sat: 10am to 3pm.

Special 48 hr prototype service now available.

Ask for our FREE quotation.

MAIL cheque or money order  
(add postage) direct to—

**RCS** radio pty ltd

651 FOREST RD, BEXLEY,  
NSW 2207. 587 3491.

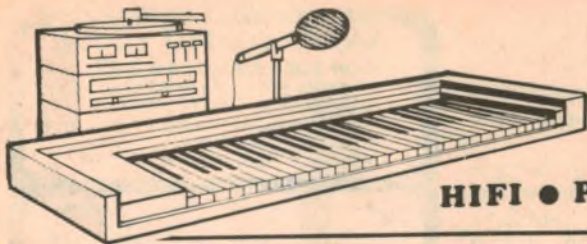

# AUDIO - VIDEO ELECTRONICS

HIFI • PROFESSIONAL AUDIO • ENTERTAINMENT

## Video dominates the American show scene

according to  
GEORGE TILLET



Although delayed in transit by mailing problems, this report from our US correspondent, George Tillett, makes interesting reading. While there is plenty of activity in the audio/hifi area, interest at the Chicago Consumer Electronics Show was centred firmly in video, with VCRs, video disc players, large screen TV and satellite TV all competing for attention.

This year, the Summer Consumer Electronics Show was larger than ever with nearly 900 exhibitors spread over 51,000 square metres of space. The extra 4,600 sq m recently added to McCormick Place was fully occupied and there were some 3200 demonstration rooms at the adjacent McCormick Inn and the Pick Congress hotels — plus a number of others at hotels all over Chicago.

As with other recent Shows, the main interest centred on video, emphasised by an impressive array of satellite dishes lined up near the main entrance.

V-disc players were also attracting a lot of attention and, in most cases, they were stacked up to produce a dramatic "video wall".

Although the new RCA SelectaVision model has only one audio channel and lacks many of the features of its competitors, it has been well received, partly because of its lower price. Several major companies like Sanyo, Toshiba and Sears have opted for this system, which uses a

stylus and groove playback method.

The VHD system, developed by JVC, also uses a "stylus" pickup but it glides over the record surface. New VHD models were shown by Yamaha, GE, Quasar and Sharp — the last-named deciding to go with VHD "because of its superb stereo sound". Sansui were demonstrating a VHD model as well as an RCA type (now known as CED), apparently uncertain which kind to make.

At present, only two concerns make Laser players: Pioneer and Magnavox; they are backed by an organisation called "The Laser Association" which was giving a separate and unusual demonstration.

Four vertically stacked cameras had been used to film a popular Hollywood Star, Susan Anton, and the segments transferred to four video discs. Playback was made on four TV sets, stacked vertically to give a life-size image!

Pioneer announced that they will be the exclusive licensee of all programs produced by Covent Garden Video Pro-

ductions and they have also signed an agreement with Columbia Pictures. But cross-licensing agreements are currently being made between the different Hollywood program sources so the same movies will eventually be available in all three formats: VHD, CED and Laser. It's a step in the right direction but life would have been much simpler if we had only had one standard!

### TAPE FORMATS

We have had to live with Beta and VHS standards for VCR's for some time but it now looks as if we will have to contend with yet another system using 6.3mm tape instead of 12.7mm.

Technicolor were the first on the scene with their miniature camera-recorder last year and they introduced a matching tuner unit at the Show. The cassettes are only slightly larger than the compact audio type and weigh a scant 57 grams.

Now, a number of Japanese manufacturers, especially those specialising in photographic equipment, who see their market vanishing, are following Technicolor's example. Canon have already released their Camcorder and several other models are known to be in prototype stages. Sony have retailed with the SL-2000 portable which turns the scales at less than 4kg and is called the "Betapak".

VCR's sell at between \$650 and \$1200 (US) compared with \$500 for V-disc players and pre-recorded tapes are quite expensive. However, the situation may change very soon, as Matsushita were showing a high speed video tape duplicator which can copy a four hour tape in four minutes. The process is called "Video Anhyseric Transfer Printing". The machine itself is expensive but the number of tapes being duplicated in this way is steadily increasing and their lower cost will help sustain VCR sales. At present, tapes are duplicated in "real time" which is costly.

There are persistent rumours of a disc process that will permit home recording but details are so vague and conflicting. But I do know that a playback-only VCR, made by a firm in New England, is

# Sabtronics.

## An entire range of low-cost, top-quality instruments.



### 3½ DIGIT MULTIMETER

Basic accuracy 0.1% (0.8% on 2040).  
 AC/DC Volts – 100microV to 1000V.  
 10 Mohms input impedance AC/DC  
 Amps – 0.1microA to 2A. (10A on bench & autorange models). OHMS – 0.1 ohm-20Mohm (2Mohm autorange).  
 OVERLOAD-1200V(DC or AC peak) 1000V on Auto and hand held fused on other ranges excl 10 Amp range.  
 NO BATTERIES SUPPLIED, Bench type will take AC adapter input. HV and Touch and Hold probes available extra.

### FREQUENCY COUNTERS 600MHz or 1GHz

GATE TIME— 0.1, 1, and 10sec.  
 RANGES— 10MHz, 100MHz & 600MHz or 1GHz  
 SENSITIVITY— 10 to 20 mV on 10MHz range to 150mV RMS on top range  
 RESOLUTION— 1Hz on 10s 10MHz range on 8 digit meter – 0.1Hz on 10s 10MHz range on 9 digit meter.  
 TIME BASE— ± 1ppm for 40C°, – ± 5ppm per year.  
 NO BATTERIES SUPPLIED. Can take AC Adapter input.

### FUNCTION GENERATOR 1Hz to 200kHz

– 5020 SINE – 1% Dist, SQUARE – 250nSec, TRIANGLE SHORT PROOF, OUTPUTS-HIGH (10Vpp). TTL and LOW(40dB down). SWEEP INPUT, ± 10V for 100:1 FREQ. DC variable offset. Power 12VAC 300mA via jack. KIT \$183.00. ASS \$208.00.  
 (NB Distortion analyser required for kit)

**LOGIC PROBE: PULSE, LEVEL, TTL & CMOS. 10MHz, 50nSec \$38.00 Assembled.**

*Making Performance Affordable*

**sabtronics**   
 INTERNATIONAL INC.

**CHRISTIE RAND PTY LTD**  
 PO BOX 48 EPPING, 2121 NSW. TEL 868 1209.

Multimeters	kit	assembled
Bench LCD 2015	\$140.00	\$165.00
Bench LED 2010	\$120.00	\$140.00
2035 Handheld LCD	\$105.00	\$130.00
2037 Handheld LCD with temp probe (–50C° to +150C°)	\$120.00	\$145.00

Frequency Counters	kit
8 dig 600MHz 8610A	\$176.00
9 dig 600MHz 8610B	\$199.00
9 dig 1GHz 8000B	
ALL ABOVE + POST & PACK \$3.00 AND SALES TAX 17½%	
Distributor Enquiries welcome	

# RARE ADDITIONS FROM MARANTZ. SLIMLINE AMPLIFIERS.



**Rare:** very valuable.

**Additions:** the things added.

**Marantz:** a range of ultra-high performance Slimline and three-quarter size Amplifiers which blend state-of-the-art engineering with operational versatility.

Although all units in a hi-fi system must be compatible in order to achieve optimum sound quality, there is no question that their final standard of performance relates directly to the main amplifier. It is the heart of the system and the point at which distortion is most likely to be introduced.

Marantz engineers have developed special techniques for reducing the various forms of distortion to minuscule levels. This is achieved by the use of a highly efficient negative feedback system and operation in class AB, with the careful selection of "shortest path" wiring to avoid interaction between different stages in circuitry and with the other channel.

The more powerful models are equipped with a heat-loop cooling system for the output stage transistors. This NASA invention enables the heat dissipated at high power levels to be rapidly removed so that a considerably improved power-to-size ratio is obtained.

If you see your hi-fi as an investment and, if you demand critical performance standards as well as the best value for money, listen to the future.

Listen to Marantz.

**marantz**  
Now you're listening.

Distributed by MARANTZ (AUST) PTY. LTD.  
19 Chard Road, Brookvale, N.S.W. 2100  
Telephone (02) 939 1900 Telex AA24121  
Melbourne (03) 544 2011 Brisbane (07) 44 6478  
Adelaide (08) 223 2699 Perth (09) 278 3706

scheduled for release later this year. Presumably they hope to compete price-wise with video disc players.

No less than 14 satellite receivers and antennas were on display this year and it is estimated that 10,000 are already in use, in spite of their uncertain legality. A typical antenna dish has a diameter of 4.66m and weighs 283kg. The signals are focussed into a feed horn and passed to a low-noise preamplifier and a down-converter. This shifts the 3.7 to 4.2GHz signals to a TV frequency (channel 3 or 4) and provides an RF output for direct connection to a VCR.

The satellite commonly used is Satcom 1, but Satcom 11, Westar II, and Comstar II are also popular. Price of an earth station installation varies between \$3000 and \$15,000.

## PROJECTION SYSTEMS

Projection TV is steadily growing in popularity and estimates put the 1981 sales at 75,000 units. Sylvania unveiled a 125cm rear-projection model and Kloss introduced a two-unit system with a 2m diagonal screen. Also released was a three-tube projector suitable for ceiling mounting.

Before leaving the wonderful world of video I ought to mention the boom in video accessories which include adaptors for cable TV, all manner of switch boxes for multi-unit installations, editing monitors, RF converters, colour processors, image enhancers and so on. The last-named units are for use when tape copying and the object is to restore some of the definition lost in the process. Some models merely consist of variable peaking circuits but one unit, made by Showtime, uses a delay line to



Exhibited by Sony (prototype left) and by North American Philips (right) the 12cm diameter compact disc system is scheduled for a market launch in the latter half of next year.

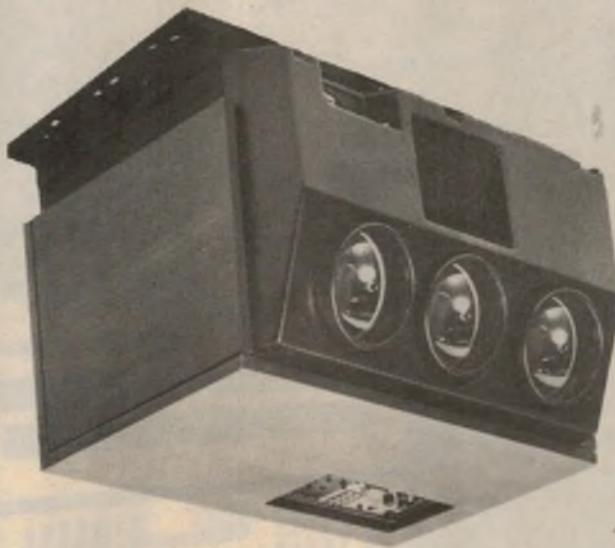

No, we haven't accidentally printed this picture upside down. It is a Kloss Novabeam television projection unit, intended to mount against the ceiling.



Despite their uncertain legality, satellite antennas and receivers were much in evidence, with an estimated 10,000 installations already made. The price of a domestic installation ranges from \$US3000 to \$15,000, depending on circumstances.

feedback some of the information in a kind of comb filter circuit.

One of the most interesting audio components seen was a FM tuner which was demonstrated by the Carver company. Multipath distortion is virtually eliminated by a circuit called "Asymmetrical Charge Coupled Detector" and Bob Carver is not telling how it works. He just sits there with a triumphant grin on his face!

And it certainly does work: after tuning in a weak station with lots of background noise and distortion — a touch of a switch and the signal is clean with hardly any background noise. Stereo separation is not affected and — here's something: the FM sensitivity in stereo is 3.5 uV for 50 dB of quieting! To make certain there's no confusion, the words "yes, that's three point five" appear next to the specification on the leaflet.

Among the other features of this tuner (designated TX-11) is Auto-scan with digital readout and full synthesis.

Yamaha's two top AM-FM receivers boast an Auto-Phono function which turns out to be an automatic switch to put the receiver back to a selected program source after the end of a record has been reached.

# Q. Will wireless remote control and micro-computer memories reduce distortion by even 0.000001%?

## A. A flat no!

Q. Then why should I be interested in Sansui's memorable Super Compo?

A. Because distortion-free reproduction isn't an end in itself. Enjoying that reproduction is what Sansui's system is all about.

Keep in mind that all Super Compo units were specifically designed for "in-depth matching." That means specs which easily challenge or surpass those of comparable unmatched separates. Features include Quartz PLL digital synthesizer tuning, direct-drive turntable with computerized random 7-program track selection, metal tape compatible deck with AMPS (Automatic Music Program Search), stereo graphic equalizer, and a host of other features for the finest in fidelity.

Let's leave the superb specs aside for a moment. Let's be realistic. Isn't it nicer to just relax and select your music source without leaving your comfortable seat? Isn't it easier to pre-program the record selections you'd like our patent-

pending D-O-B arm to play? Just think of the time and nerves you save with 12 preset tuner stations activated by instant one-touch buttons — from your favorite listening chair.

We'll bet you'll be a happier audiophile with all these micro-computer conveniences. After all, fiddling with controls is surely second fiddle to delighting in the subtle nuances of a violin from Sansui's Super Compo 9900.



FR-D55: Computerized Track Sequence Selection Full Auto DD Turntable RS-7: Infrared Remote Control System RG-7: Stereo Graphic Equalizer Console with reverb/mixer T-9: Digital Quartz-PLL Synthesizer Tuner with 12 FM/AM Station Pre-sets and Auto Search Tuning A-9: Integrated DC Servo Amplifier, 65W RMS x 2 D-300M: Full logic Metal-Compatible Cassette Deck GX-95: Audio Cabinet with Headphone Jack S-65: 4 Way Speaker System 12 1/2" Woofer, 105W

**SUPERCOMPO 9900**

SANSUI ELECTRIC CO., LTD. 14-1 Izumi 2-chome, Suginami-ku, Tokyo 168, Japan  
VANFI (AUST.) PTY. LTD. 297 City Road, South Melbourne, Victoria 3205, Australia Tel: 690-6200  
283 Alfred Street, North Sydney, N.S.W. 2060, Australia Tel: 929-0293

**Sansui**

## AUDIO-VIDEO ELECTRONICS — cont.

Another innovation — probably more useful — is a "Spatial Expander Control" which is claimed to widen the stereo image. It appears to work by delaying a portion of the signals from one channel and feeding them to the other.

Both of these receivers use the Yamaha "X" output stage which makes use of two separate power supplies, high voltage and low voltage. The latter is used continuously but the high voltage is switched on automatically to handle higher power. Fast rise detectors turn on the high voltage ahead of time so switching distortion cannot occur, say Yamaha. Thus, the circuit appears to be similar to Soundcraftsmen's "Class H" which, if my memory serves me correctly, appeared on the scene about five years ago.

### AMPLIFIERS, RECEIVERS

The majority of medium power receivers and amplifiers use a modified Class-B output circuit discussed in these pages some months ago. Nevertheless, Class-A is still alive and well in spite of its inefficiency.

"SAE" "X" series of amplifiers use Shockley diodes in a circuit to reduce the idling current. No details were available but it was stated "Previous attempts to increase Class-A efficiency have strayed from the classic approach and have obtained Class-A benefits only at the expense of other forms of sonic degradation". Here, they were referring to the variable bias approach which can introduce IM distortion.

Top-of-the-line in the "X" series is the X-25A which is rated at 375 watts per channel into 4 ohms at less than 0.02% IM.

Denon were showing a 200-watt amplifier using no negative feedback — at least in the output stage — but few details were available.

The new Sony TA.N900 in the Esprit series uses complementary power MOSFETS in the output stage, again with no negative feedback. It uses a modified Class-A output circuit and it is said that distortion is reduced by "controlling the drive voltage to produce linearity compensation". TIM is eliminated and THD is less than 0.005 per cent over the whole frequency range. Among the features of this unusual amplifier is a pulse-locked power supply obtained from a 20kHz square wave generator using four power switching transistors. Rated output is 200 watts and matching preamps are available, as well as a versatile equaliser.

The Esprit division is headed by Masaru Nagami who was responsible for many of Sony's more innovative products. I asked him: why Esprit? He replied, "Ah, in Japanese it means yon!" So now you know . . .



Despite the interest in unconventional loudspeaker systems, B&W were able to impress show visitors with their new model 801S, seen here as control room monitors. Bass, mid-range and tweeter units are stacked in a visually obvious manner, the mid-range enclosure being made from a cement/plastic aggregate mix.

The RTR ESR-24 loudspeaker system is essentially a plain black panel just over 2m tall, 76cm wide and 5cm thick. But it accommodates 24 electrostatic drivers in two vertical stacks, handling the ranges 130Hz to 2.2kHz and 2kHz to 35kHz respectively. It is meant to be used with a separate sub-woofer.

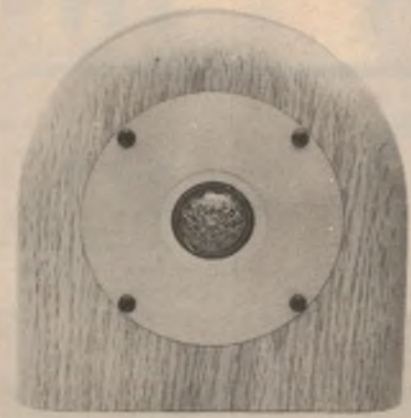

Also from RTR Industries Inc. comes this "acoustic filament" tweeter. The Dupont Kevlar fibre is applied in a specific pattern to a soft dome, which serves purely as a seal. A soft surround and ferro fluid damping combine, further, to provide a piston action to a claimed 40kHz.

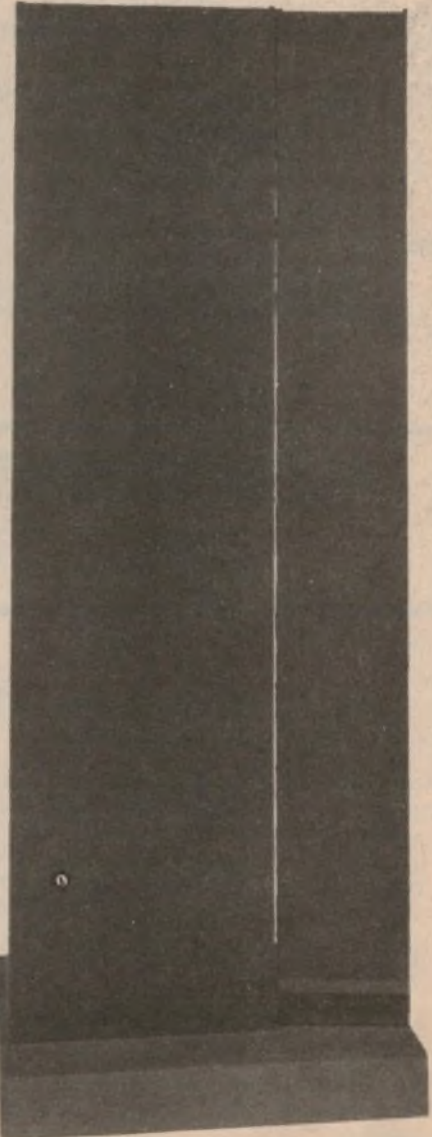

## AUDIO-VIDEO ELECTRONICS — continued

Also being demonstrated was the APM-8 Esprit speaker system which is a floor-standing model using four drivers — all with flat diaphragms. The bass unit has a square diaphragm measuring 907 square cm and it is driven by four voice coils. Crossover frequency is 320Hz and it is claimed that the use of four voice coils increases the piston motion by two octaves. A fine-sounding system quite comparable with Mr Nagami's elaborate horn-loaded monster I heard when I visited his home some 4 years ago.

The new Quad electrostatic loudspeaker, the ESL-63, is quite small, measuring 92.5cm high, 66cm wide and only 27cm deep, including the base. Compared to the present model, the radiation angle is much wider and the low end extended. Delay lines are used to feed the signal to the diaphragm so the "sound pressure pattern is an exact replica of that from an ideal source plac-

ed some 30cm behind the plane of the diaphragm". It goes without saying that the demonstration revealed a clean, tight bass with the overall sonic transparency typical of electrostatics. Price is \$3300 a pair.

Another fine demonstration was put on by B&W who were devoting much of the time to the new model 8015. It uses an acoustically dead material for the midrange enclosure, which sits on top of the main cabinet. This inert material is made from a plastic cement mixture and the improvement in sound clarity over the original wooden enclosure was quite startling.

RTR were showing a new electrostatic panel consisting of two vertical arrays of 12 units. One section handles frequencies from 130Hz to 2.2kHz while the other radiates from 2kHz to above 20kHz. It is designed to match a sub-woofer. Another RTR model uses a novel tweeter which has a plastic

diaphragm reinforced by a geometrical arrangement of Kevlar fibre threads so it looks like a Geodetic dome. (Kevlar is a Dupont material which is five times stronger than steel). Ferrofluid is used in the gap. The low frequency limit is 750Hz, while the first top-end resonance occurs at 40kHz.

Back in 1974, the Ohm company introduced the Walsh loudspeaker system which used a single large driver firing downwards into an enclosure and radiating in all directions from the rear of the composite cone. Because of the high price and relatively low efficiency, this model enjoyed only limited success but a smaller version, the Ohm Walsh 2 should be more popular. It stands 80cm high by 29cm square, using a reflex design, and the wave propagation is said to be coherent over 180 degrees. The makers state, "while the original Walsh theory utilised 360 degrees dispersion, psycho-acoustical research and practical experience has taught us that 360 degrees omnidirectionality decreases the apparent effect of high frequency sound pressure levels ... Because of rear reflections, precise room placement is mandatory".

## Compact hifi from Rank Australia

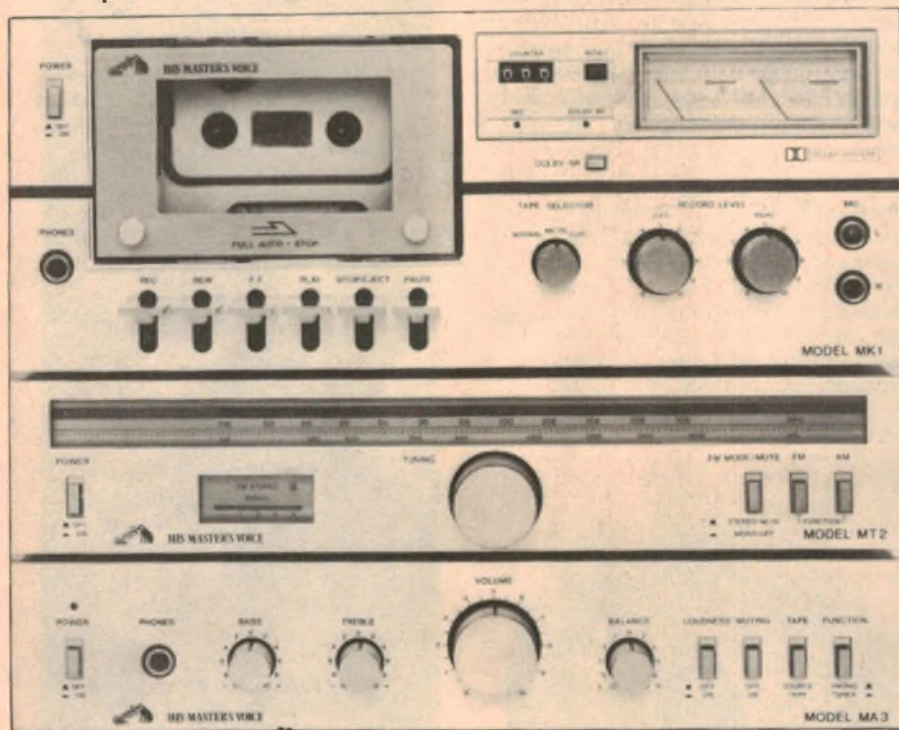

Under the brand "His Master's Voice", the Rank group have just released a mini component hifi system which should catch the eye of enthusiasts who are pushed for space. Manufactured by NEC in Japan, the system combines a cassette deck type MK1 (Dolby and metal compatible), an AM/FM-stereo tuner MT2, and an integrated amplifier with a power rating of 20W RMS per channel at 0.05% distortion. Provision is made to attach a phono deck with magnetic cartridge, if desired. Stacked as shown, the units have frontal dimensions of 300mm wide and 245mm high. If placed side by side, the dimensions are 600mm and 122mm. The system can be used with most reasonably sensitive stereo loudspeakers but Rank recommend their SP-20 compact 3-way system. Assembled in a die-cast aluminium enclosure, the units measure 182mm(H) x 112mm(W) x 105mm(D). For further details, enquire at your local hifi department or supplier, or direct from Graham Oakes or Ken Thompson, Rank Industries Aust Pty Ltd, 12 Barcoo St, East Roseville, NSW, 2069. Tel. (02) 406 0444.

## NOISE REDUCTION

A number of cassette decks now offer Dolby-C noise reduction and at least one model, the Onkyo TA.2090 offers Dolby-B, Dolby-C and dbx. Several other manufacturers, including Yamaha, Teac, Technics and Marantz have opted for dbx on some models.

Competition between Dolby and dbx is now quite fierce with the later emphasising the greater dynamic range plus noise reduction over the whole band. Dolby's answer was the HX circuit followed by Dolby-C and clinching the matter by pointing out that there are 100 million Dolby decks out there so compatibility is most important. Nakamichi now make an add-on Dolby-C unit and no doubt others will be on the market soon.

Separate dbx units have been available for a long time and a new one for car use, Model 22, was demonstrated at the Show.

National Semiconductor were demonstrating their "DNR" noise reduction system which is in the form of a two-channel IC. It works on the same principle as the Burwen-KLH system introduced some years back. In other words, a dynamic filter reduces the high frequencies with low amplitude signals and opens up when the signals are loud enough to mask any background noise. Attack time is less than one-thousandth of a second, with a release time of fifty thousandths. Effective noise reduction is claimed to be 10dB (CCIR weighted) but the big advantage of the system is that it is single-ended; it does not require encoded material.

CBS are planning to use the CX (Compatible Expansion) system on all their



## From DSE- Listen while you walk



Pictured on the right is the Soundic SC-300 "Walkie Stereo" cassette player, with tone control, talk button and provision for two pairs of headphones. Price is \$99.00. Cat. A-4055. The "Sound Tripper 1", pictured on the right, can also accommodate two pairs of headphones but takes its program off air, from any of the FM stereo or AM radio stations. Price as pictured is \$49.50. Dick Smith Catalog number A-4330.



## Chicago CES — continued

records soon and their goal is to make it the industry standard. Warners are believed to go along with the idea but nothing has been heard from RCA or any other record company. In some respects, the CX system is like the dbx: it uses linear expansion in playback but it does not function over the whole dynamic range. Furthermore, no pre-emphasis is used in the encoder. What happens when CX records are played without a decoder? Well, CBS claim that they will be "audibly acceptable" with no change in frequency response and noise will be no worse. Played with a decoder, dynamic range and signal-to-noise will be increased by 20dB — adding up to a range of 80 to 85dB for the best records.

CX decoders were demonstrated by Phase-Linear, MXR, Audionics and Sound Concepts although only one record has been released so far.

### IN BRIEF

Onkyo's new TA-W80 cassette deck has two separate cassette compartments and dubbing is facilitated by the provision of a double speed (9.5cms) . . . Sharp were demonstrating a turntable that can play both sides of a record

without turning it over. It is vertically mounted and there is provision for random play on either side, repeat on one or both sides. Interesting — but hardly "an electronic breakthrough that could revolutionise the home audio industry." It uses the straight-line tracking (SLT) principle, as does Pioneer's new model which has a polymer graphite arm . . . But the turntable that really impressed me was one made by Denon. The platter weights 14kg and it boasts a "triple fluid damping" while the AC motor is mounted on a 68kg diecast chassis. Speed is continuously variable from 33 to 78rpm and is fully servo controlled . . . I was also intrigued by Sony's turntable isolators which consist of two magnets of opposite polarity mounted so they repel each other, thus giving a nice springy action . . . Several talking calculators were to be heard: in fact, that section of the Show sounded like an electronic aviary with all kinds of chirps and screeches. The Precision Electronics watch wakes its owner up with Boccherini's "Minuet" and follows it by announcing the time. Sharp's calculator plays "On the Bridge of Avignon" while a Casio model tinkles sedately through Chopin's "Nocturne Number 2, Opus 9".

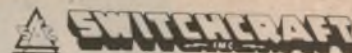

## CONNECTORS & ELECTRONIC COMPONENTS

Superb quality and reliability from one of the oldest and most experienced manufacturers in the USA.



QG Audio Connectors  
Die Cast Shell, PA & General Applications  
Available Nickel or Mat Black



QGP Professional Audio, Non-Reflective Vel-Tone Finish, Positive Ground, Die Cast Zinc Shell

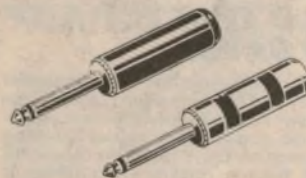

Phono Plugs, Available Plastic or Brass Handle, Wide Range of Configurations



JP Series — Modular Jack Panels, Black Anodised Up to 40 Configurations

### AUSTRALIAN DISTRIBUTORS

## AUDIO TELEX COMMUNICATIONS PTY LTD

SYDNEY  
1 Little Street  
Parramatta, 2150  
Tel: 633 4344

MELBOURNE  
7 Essex Road  
Mt Waverley, 3149  
Tel: 277 5311

BRISBANE  
394 Montague Road  
West End, 4101  
Tel: 44 6328

# DICK SMITH'S SOUND VALUE!



## 3 WAY STEREO CAR SPEAKER SYSTEM

for the car  
**HI FI!**

These incredible speakers handle 30 watts per channel (max.) with quality tweeter, mid-range and woofer speakers for great sound! They'll make your stereo cassette or FM radio sound better than ever! Finished in strong grey plastic with mesh grille and angled bracket for mounting.

Cat. A-7082

**SOUND  
VALUE!**

**\$92 PER  
PAIR**

## STORE YOUR CASSETTES

This vinyl cassette case has carry handle and fastener and stores up to 16 cassettes in their cases. Ideal for the car or home.

**SOUND  
VALUE!**

Cat. C-3810  
**\$3.95**



## TOP VALUE! SHURE MAGNETIC CARTRIDGES

### Model M-91ED

The Shure M-91ED is a first class magnetic cartridge. It has high trackability with a recommended tracking weight of between 3/4 and 1 1/2 grams. Complete with elliptical diamond stylus. Cat. C-5515

**\$47.50**

### Model M-70EJ

This cartridge has a tracking weight of 1 1/2 to 3 grams and a frequency response of 20 - 20,000Hz. Complete with elliptical stylus. Cat. C-5512

**\$18.50**

### Model M-70B

The same superb specifications as the M-70EJ but has a spherical diamond stylus. The same stylus is supplied with the Dick Smith turntable. Cat. C-5511

**\$13.50**

### Replacement Styli

for the M-91ED cartridge. Cat. C-5036

**\$19.95**

for the M-70EJ cartridge. Cat. C-5034

**\$14.50**

for the M-70B cartridge. Cat. C-5032

**\$9.95**

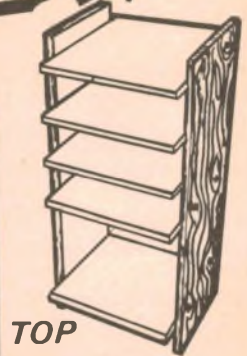

## TOP VALUE HI FI STAND

A beautifully prepared kit cabinet, comes to you in knock-down form and complete with full instructions for easy assembly. Finished size: 370mm (d) x 470 (w) x 940mm (h). Wood grain finish. Cat. A-0105

**SOUND  
VALUE!**

**\$72.00**

## BUILD THIS TOP AMP AND SAVE!

This Playmaster Amplifier now includes the latest 'BI-FET' operational amplifiers in the input stages for the ultimate in low noise, high performance signal handling characteristics. Yet it costs less than it did in 1979! Save a fortune by building it yourself!



Cat. K-3412

**GREAT VALUE!!! \$77**

**OVER 10,000 SOLD!**

## Head Demagnetizer

Ideal for use with all audio tape machines using magnetic tape. Simply plug into 240V AC and use like a wand to 'sweep' away excess magnetism! If excess noise is plaguing your recordings, this could be the answer!

**\$7.75** Cat. C-7222



## DICK'S OWN QUALITY TAPE



Good quality cassette tape, at a lower price. Even greater savings if you buy 10 or more!

**C60 Low Noise**  
Cat. C-3350 **\$1.50**

**C90 Low Noise**  
Cat. C-3352 **\$2.00**

**C90 Extended  
Dynamic Range**  
Cat. C-3354 **\$2.75**

**SOUND VALUE!**

## TRANSFORMERS FOR THE ABOVE AMP

Team this incredible 'C core' power transformer with the above and you've got a 40 w p.c. amp for under \$100! M-0148

**\$22.50**

**SAVE \$30 ON LAST YEARS AMP & POWER SUPPLY PRICE!**

Standard low noise transformer for 25 w p.c. output. Cat. M-0146

**\$12.50**



Cat. C-4103

## ECONOMY STEREO 'PHONES WITH VOLUME CONTROL

Great headphones at a great price! Volume control for left and right channels. Rated at 8 ohms

**\$9.95**

Cat. A-2460



## PHONE PICKUP

Record from phone to tape via suction pad fitting. Cat. C-7300

**\$1.50**

Use subject to Telecom approval

All our stores carry a full range of audio leads and plugs.

## CASSETTE LIBRARY

Two cartons containing two cassette holders which lock together, can be screwed into the wall or made free standing (as illustration). Holds up to 32 cassettes horizontally or 20 cassettes vertically.



Cat. C-3800

**SOUND  
VALUE!**

**\$6.50**

## MYLAR 'PHONES

Slim, lightweight 'phones. Supplied with lead and stereo jack. Adjustable headband. Great sound!

**VALUE \$19.50**

Cat. C-4105



## TOP VALUE

Impressive speakers at a bargain price! Rated at 8 ohms impedance. 15 w p.c. Why not buy a pair for the patio or rumpus room and have music all over the house!

## Extension speakers

**SOUND VALUE!** **\$47.50 EACH!**

# DICK SMITH Electronics

NSW 145 Parramatta Rd AUBURN 648 0558 • 613 Princes Hwy BLAKEHURST 546 7744 • 818 George St BROADWAY 211 3777 • 531 Pittwater Rd BROOKVALE 93 0441 • 147 Hume Hwy CHULLORA 642 8922 • 162 Pacific Hwy GORE HILL 439 5311 • 396 Lane Cove Rd NORTH RYDE 888 3200 • 30 Grose St PARRAMATTA 683 1133 • 125 York St SYDNEY 290 3377 • 173 Maitland Rd TIGHES HILL 61 1896 • 263 Keira St WOLLONGONG 28 3800 ACT 96 Gladstone St Fyshwick 80 4944 QLD 166 Logan St BURANDA 391 6233 • 842 Gympie Rd CHERMSIDE 59 8255 SA 60 Wright St ADELAIDE 212 1962 VIC 399 Lonsdale St MELBOURNE 67 9834 • 260 Sydney Rd COBURG 383 4465 • 656 Bridge Rd RICHMOND 428 1614 • Cnr Dandenong & Springvale Rds SPRINGVALE 547 0522 WA Cnr Wharf St & Albany Hwy CANNINGTON 451 8666 • 414 William St PERTH 328 6944  
Mall Order Centre: PO Box 321, North Ryde 2113. Phone (02) 888 3200



DSE/A053/LM

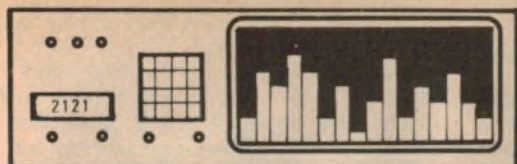

# HIFI REVIEW

## New Sony amplifier has many innovative features

Bristling with new and different features, the Sony TA-AX5 Integrated Stereo Amplifier marks a departure from current practice in terms of front panel presentation and methods of control and may well be pointing the way to a whole new generation of amplifiers, engineered for the 1980s.

Referring to the accompanying photo, it will be seen that there is not a single slide or rotary type control! Instead, all control is carried out on either pushbutton or rocker type switches. Six relatively large pushbuttons, located on the lower right hand section of the front panel, are provided for input selection. Illuminated windows above each pushbutton indicate which source has

operated to lower the output level by 20dB. Under this MUTE button is a small rocker switch, the BALANCE control, which functions similarly to the volume control to vary the left to right level balance. When pressed, the bar-graph volume display changes to show left to right "balance", with the centre display position indicating equal gains in left and right channels. A couple of seconds after

square pushbuttons marked + and -, are used (in similar fashion to the rocker switch for the left/right BALANCE control) for accentuating or attenuating the tone response. A vertical bar-graph display indicates five steps of boost, or five steps of cut.

And now we come to what is probably the most interesting and useful of the state-of-the-art facilities designed into this amplifier - the inclusion of two memories for retaining selected settings for both tone controls and filters. Located on the top right hand side of the front panel are three narrow pressbars, two of which are used for recalling memories 1 and 2, the third for reverting to the "flat" unequalised response. Sony label the memories "Acoustic Flavour 1" and "Acoustic Flavour 2", names which we find inappropriate as they tend to make us turn to thoughts of food and drink.

Recall of an "Acoustic Flavour" is confirmed by the display of either "1" or "2" in the upper left hand area of the display panel, together with a complete

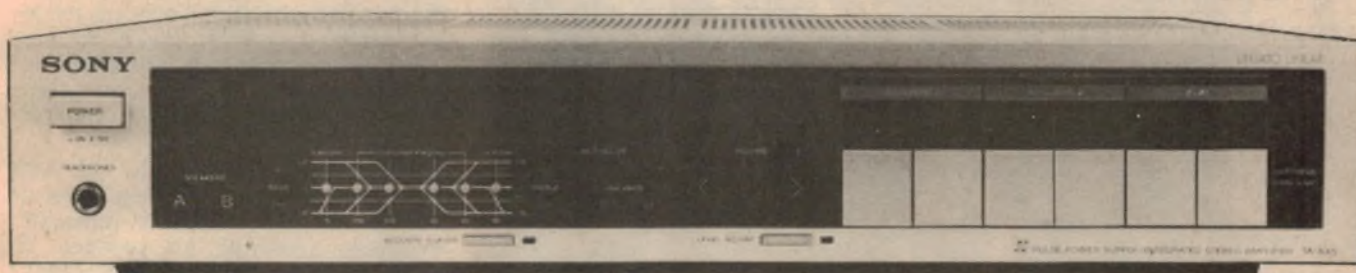

been selected.

So far nothing really is unusual. But to the left of the input selector buttons is a large rocker switch, which functions as the volume control. Above this switch are two seven-segment displays showing the selected attenuation in dB, with a range from -∞, -79 to 0dB in 1dB steps. Pressing and holding the right hand side of the rocker switch raises the level, with the readout changing accordingly.

The majority of the left hand side of the front panel is made up of an illuminated "function" display, together with small operating pushbuttons and a rocker switch. Just to the left of the previously mentioned seven-segment displays is a small bar-graph display, arranged with nine segments reading from left to right. This normally operates in conjunction with the "volume control" and seven-segment displays such that each segment covers a 10dB range.

Directly under the bar-graph is a rectangular pushbutton, which may be

the BALANCE rocker switch is released, the bar-graph automatically reverts to the volume display.

The left hand end of the display panel contains the controls and readouts for the tone controls and high pass/low pass filters. Simple push-push switches serve to bring the filters into or out of circuit. Turnover frequencies are 15Hz for the high pass (subsonic) filter, and 9kHz for the low pass (hi-filter). Being single-section circuits, maximum attenuation in the stop bands is only 6dB per octave, which, in this reviewer's opinion, is not steep enough to be fully effective at either end of the passband. When selected, illuminated symbols representing graphical outlines of the modified frequency response appear in the display window.

Similar miniature push switches are used for selecting the turnover frequencies available for the tone controls. Alternatives are 250Hz or 500Hz for the BASS control, and 3kHz or 6kHz for the TREBLE control. Two small

readout of filter and tone control settings. Acoustic Flavour functions has resulted in the omission of the usual "loudness" facility. (Good! - Ed.)

At the left hand end of the front panel are located the mains POWER switch, stereo headphone outlet jack, and two small rectangular buttons for selection of the A and B loudspeaker systems. When both buttons are pressed the switching circuitry is arranged to connect the two systems in series which we regard as undesirable as it reduces the effective damping applied to each system.

Another weakness in series switched speaker circuitry is that the sound level in one system will drop by 6dB when the second system is switched on. This corresponds to reducing the power to one-quarter of the original, and a significant change in audible level.

Produced in Japan, the Sony TA-AX5 is well designed and constructed, with good quality finish both externally and internally. Only three screws need removing to release the top cover and

# & we've got the software!

Learning's easy with these great educational programs

Cat. X-3682

## Typing Tutor



**\$19<sup>95</sup>**

This program teaches you to touch type. Claimed to teach typing skills faster than any other method. Widely acclaimed by business colleges. It monitors your typing skill continuously and adjusts your progress to suit. Requires 16K.



## LEARN MUSIC

Written by an experienced music teacher, this program helps the beginner learn to read music and finds notes on the piano keyboard — quickly and easily. Requires 16K.

ONLY

**\$34<sup>95</sup>**

Cat. X-3640

## SPEED READING COURSE

Two cassettes, with 4 programs to help readers of all ages improve their reading skills. Can be set for reading skills as high as 0.1 seconds per line. Requires 16K.

**\$19<sup>95</sup>**

Cat. X-3692

Children, have fun and learn too, with Learning Fun

## Scurve Invaders



**\$9<sup>95</sup>**

A unique program that combines maths drill with the ever popular 'Space Invaders' game. Tremendous fun yet very effective in developing proficiency in maths. Three levels of difficulty, sound effects. Requires 16K. Cat. X-3694

## HANGMAN/CONCENTRATION

Help to increase your familiarity with words. Hangman and Concentration, both are computerised versions of the well known games. What a fun way to learn! Requires 16K.

**\$9<sup>95</sup>**

Cat. X-3696

## ALPHABET COUNTDOWN/RHYME TIME

Alphabet Countdown — place a large group of words in alphabetical order in the shortest time. Rhyme Time — a series of unfinished rhymes, you fill in the missing word from the clues supplied. Both require 16K. Cat. X-3698



**\$9<sup>95</sup>**

## Poker Pete

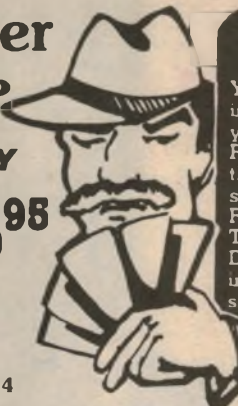

ONLY

**\$15<sup>95</sup>**

Cat. X-3664

Like to play a game of poker with Pete? He's a pretty shrewd player — hard to beat. Maybe you can be the one to beat him! This program has some quite intriguing graphics. Requires 16K.

## SIMUTEX PACKAGE ONE

**\$17<sup>95</sup>**

Cat. X-3685

Not one, but five space fantasy games! Avoid the Klingon torpedoes, stop the Worg invasion of Earth, plant your bomb on the Death Star and much more! Complete with instruction booklet. Requires 16K.

## SUPER MAZE

The maze game to end all maze games! Generates mazes up to 100 x 100 elements — it could take you hours to find your way out. Requires 16K.

Cat. X-3672

**\$17<sup>95</sup>**

## RESCUE AT RIGEL

You're Sudden Smith, the intrepid space adventurer, and your beautiful friend Delilah Rookh has been captured by the evil High Tollah inside a secret base on the moonlet Rigel. Can you overcome the Tollah and escape with Delilah? One of the most impressive programs we've seen! Requires 16K.

**\$22<sup>50</sup>**

Cat. X-3649



## FLIGHT SIMULATOR

A surprisingly good simulation of flying a small plane — has excellent real time graphics. Learn basic flight control, including take-offs and landings, then play the exciting British Ace 3D battle game. Requires 16K.

Cat. X-3684

GREAT VALUE!

**\$34<sup>90</sup>**



## SPACE INVADERS

The ever-popular arcade game that has become a cult. Can you shoot down the aliens before they destroy you and the Earth? Fast moving, good graphics (written in machine language). Requires 16K.

Cat. X-3699

ONLY

**\$9<sup>95</sup>**



## INTERLUDE

A game for adults only. How's your love life — getting a little dull? When the kids have gone to bed, run this program on your broadminded System 80 and it will come up with some imaginative ideas for the rest of the evening.

ONLY

**\$22<sup>50</sup>**

Cat. X-3675



For sale to those 18 years of age and over.

## DICK SMITH Electronics

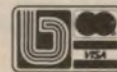

Prices correct and stock available at press time.

NSW 145 Parramatta Rd AUBURN 648 0558 • 613 Princes Hwy BLAKEHURST 646 7744 • 818 George St BROADWAY 211 3777 • 531 Pittwater Rd BROOKVALE 93 0441 • 147 Hume Hwy CHULLORA 642 8922 • 162 Pacific Hwy GORE HILL 439 5311 • 396 Lane Cove Rd NORTH RYDE 888 3200 • 30 Grose St PARRAMATTA 683 1133 • 125 York St SYDNEY 290 3377 • 173 Maitland Rd TIGHES HILL 61 1896 • 263 Keira St WOLLONGONG 28 3800 ACT 96 Gladstone St Fyshwick 80 4944 QLD 166 Logan Rd BURANDA 391 6233 • 842 Gympie Rd CHERMSIDE 59 6256 SA 60 Wright St ADELAIDE 212 1962 VIC 399 Lonedale St MELBOURNE 67 9834 • 260 Sydney Rd COBURG 383 4455 • 656 Bridge Rd RICHMOND 428 1614 • Cnr Dandenong & Springvale Rds SPRINGVALE 647 0522 WA Cnr Wharf St & Albany Hwy CANNINGTON 451 8666 • 414 William St PERTH 328 6944

Mail Order Centre: PO Box 321, North Ryde 2113. Phone: (02) 888 3200

DSE/A040/LM

# Super-80 Computer

- \* S100 expansion
- \* Basic in EPROM
- \* Trouble-shooting

**PLUS:  
Full circuit diagram**

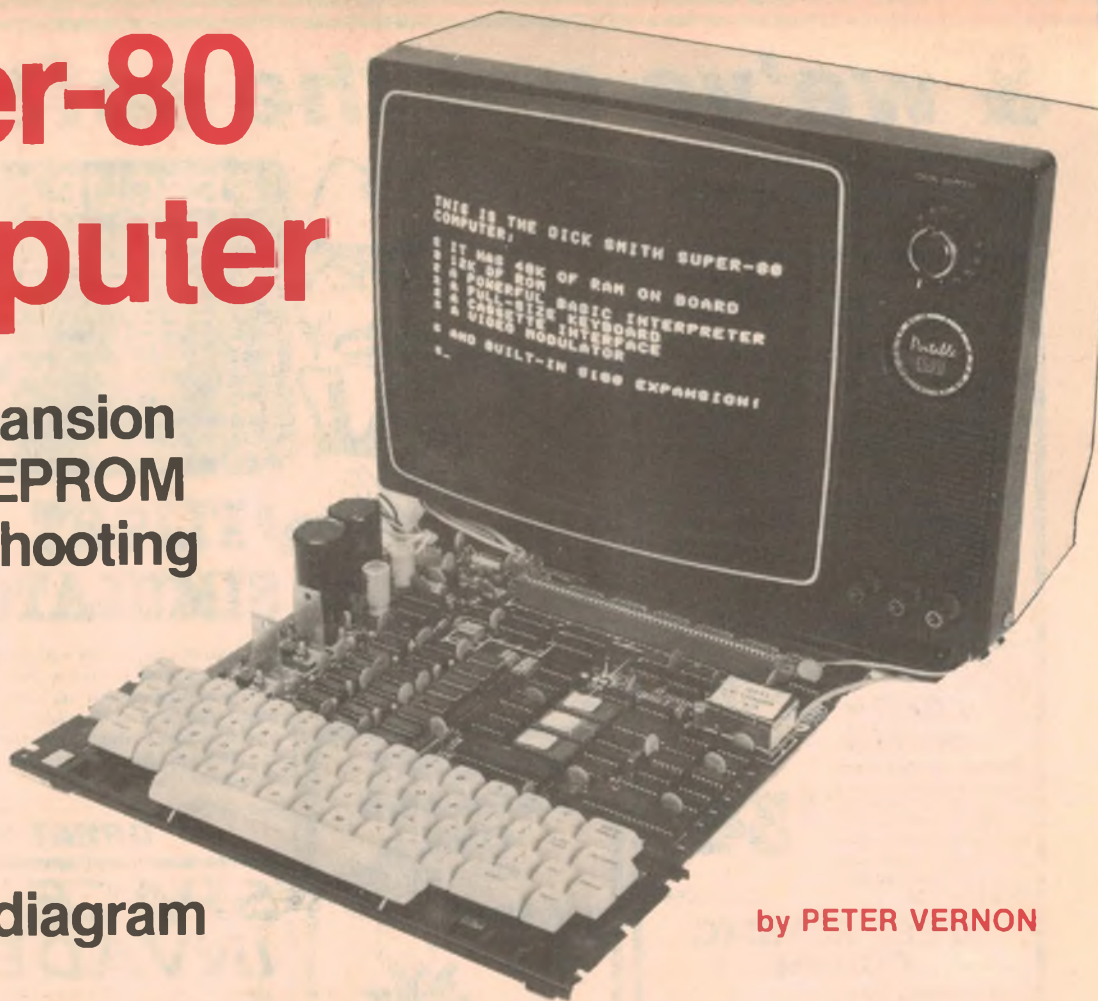

by PETER VERNON

The Super-80 single board computer has already proved very popular with readers, with over 890 being sold by early September and with good reason. In this article we describe more features of the machine — the assembly of the S100 expansion interface, addition of Basic in Read Only Memory and more RAM. We also cover testing and trouble-shooting procedures and provide full circuit diagrams.

Such was the interest created by our first article on the Super-80 that many hundreds of readers either purchased or ordered kits for this project. One reader was so enthusiastic and intrepid that he even built his from the photographs in the original article. He had to ring Dick Smith Electronics about a few resistor values but with these clarified the system worked. As Dick Smith would say, "Incredible!"

For those readers who are somewhat more cautious, we continue our description of the Super-80 by detailing the optional S100 interface, and conclude by mentioning the ROM Basic and additional RAM.

## The S100 bus interface

The S100 bus was first introduced in computer kits based on the 8080 microprocessor, and has become one of the most popular microcomputer interconnection schemes in use today, if not the industry standard. "Standard" is a word which must be used with caution

in this area, however. More than 300 S100 boards are advertised by various manufacturers and not all of them use exactly equivalent connections.

An S100 board is 250mm wide by 133mm deep and fits into a 100-pin edge connector (50 pins per side on 3.2mm spacing). The circuit board contacts, or "fingers", are offset to one side so that the board cannot be inadvertently inserted backwards. On the Super-80 PCB the contacts of the connector are numbered from right to left, with pins 1 to 50 closest to the rear of the board and pins 51-100 towards the front. S100 boards are numbered with pins 1-50 on the component side of the board and pins 51-100 on the opposite side.

The S100 expansion interface of the Super-80 conforms to IEEE 696 specifications, with the exception that it does not support Direct Memory Access operations. This specification should be consulted for further information. To effectively use the expansion interface, the

specification of the board you contemplate installing should be studied carefully. All boards must have the required connections on the correct pin, or provision for wire links to be installed to tailor the board.

Only one S100 board can be supported by the expansion interface of the Super-80 as only one edge connector is provided and the power supply on the main PCB will only suffice for one board. For more information the reader should consult the Technical Manual available from Dick Smith Electronics or a book such as "The S-100 & other Micro Buses" (Howard Sams & Co Inc NY 1979).

In the S100 interface area there are spaces for four wire links (E, F, G and H). These links may be used to alter the memory map configuration of the computer by disabling the selection of parts of the memory on the main PCB, allowing memory on an S100 board to occupy the same address spaces without conflict.

Without the main relevant link in place elements of memory on the main board will not be selected. For example, if you have an 8K ROM board which you want to use on the S100 bus, the main board ROMs in address spaces D000 and E000 (hex) can be disabled by leaving links F and G off the board. Normally these address spaces would be occupied by 2532

EPROMs. Note that if you disable the Monitor ROM in address space C000 by removing link H, the Super-80 Monitor program will be inoperable and the "Start of Day" circuit will not work correctly. Removal of link E will disable the entire RAM on the board, although it is hard to say why this would be required.

To reconfigure the memory map first remove the unwanted device from the PCB. Remember that EPROMs are static sensitive devices, and should be stored in conductive foam or similar protective packaging. Remove the link associated with the device. Now other memory can be fitted into the S100 bus connector, occupying the same address space as the memory removed from the main board.

### S100 Interface Construction

First step in the construction of the S100 expansion interface is to insert and solder the 100-pin edge connector flush with the top of the PCB. Next insert and solder capacitor C3, which supplies extra filtering for the 8V power supply to allow one Super S100 board to be used with the Super-80.

If you haven't already done so, insert and solder the five IC sockets in the S100 area of the board (indicated by the heavy white line and cross-hatching). Remember to orientate the sockets with the notch indicating pin 1 to the right hand side of the board.

If you are confident that you will not need to disable the selection of any of the memory devices on the main board now is the time to insert and solder the four wire links E, F, G and H. Use of a four-way DIP switch in place of the links gives added flexibility to the computer, but is not really necessary.

With the links and sockets in place we can proceed to the installation of the integrated circuits of the interface. First insert U6, then turn on the power and check for the presence of negative-going pulses at pin 6 of the IC. Check pins 25 and 76 of the S100 edge connector for positive pulses. You will need a logic probe or oscilloscope for this task.

If you cannot detect positive pulses on pin 76 of the 100-pin connector, either U6 is at fault or the contacts of the connector itself are faulty. Test them with a multimeter set to a resistance range (with power to the computer off). If there is no signal on pin 25 of the edge connector test pin 1 of U3 and the edge connector contact itself.

U7 is a quad NAND gate which generates the S100 status signals from the control signals of the Z80, as shown in the circuit diagram of the S100 interface. It should be installed next. After it is inserted in its socket check for positive-going pulses on pin 46 of the S100 con-

At right is the circuit for the S100 interface. Note that while U4, U6, U7, U11 and U12 are exclusive to the S100 interface, the rest of the IC's shown are part of the basic Super-80 circuit.

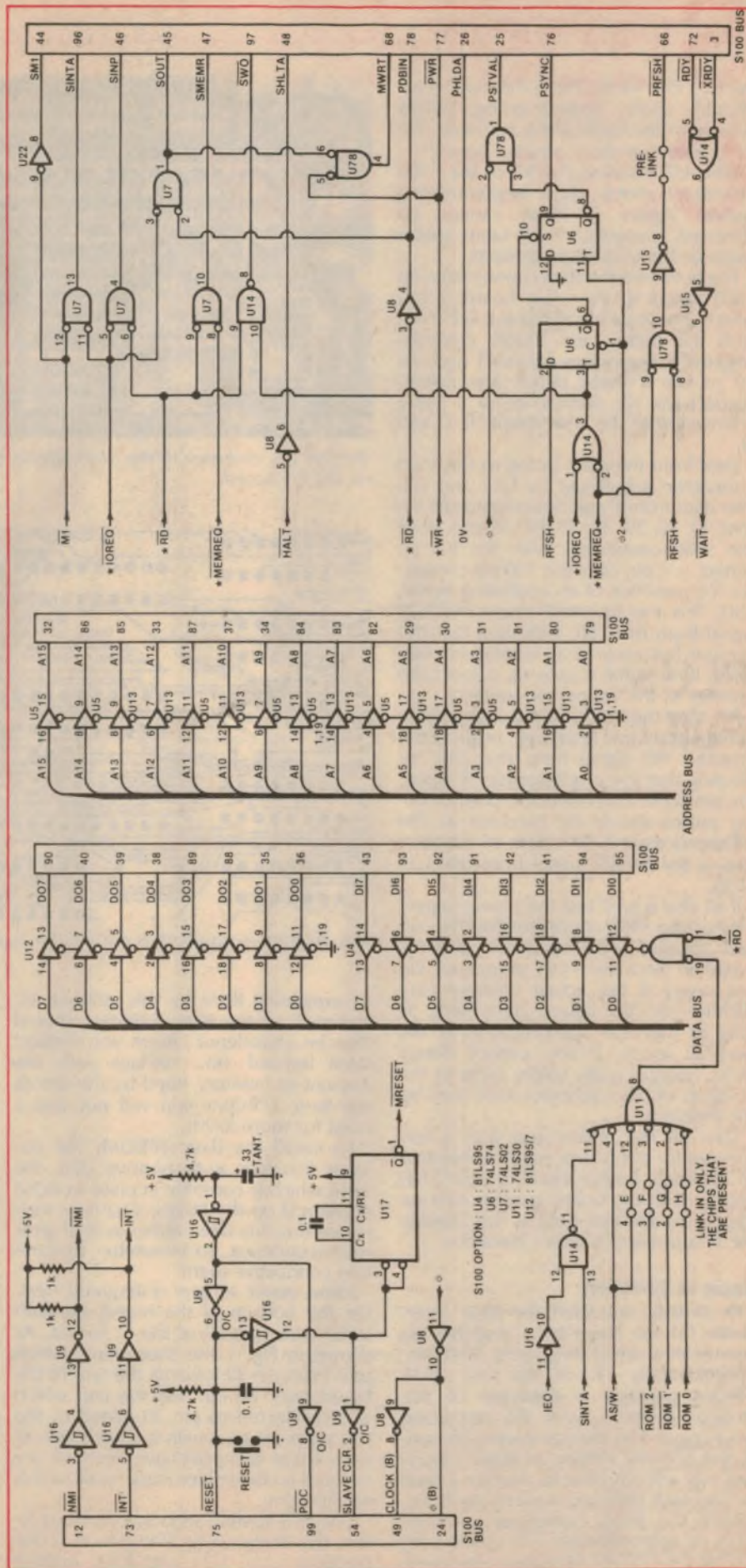

necter. Pin 45 of the S100 connector should show positive-going pulses whenever the keyboard is operated. Pin 47 should also show positive pulses.

With U7 installed pin 97 of the S100 connector should show negative-going pulses. Again, if these cannot be detected, suspect U7 itself, faulty solder joints or the connector contacts.

The buffer for the data coming from an S100 board to the main board is U4, which should be installed next. U11 controls this buffer, and should generate negative-going pulses on pin 1 and pin 19 of U4. If these pulses are absent, suspect the ICs themselves or a faulty connection of the wire links E, F, G and H.

Data from the main board to the S100 connector is buffered by U12 and U4. The data from these buffers appears on pins 90, 40, 39, 38, 89, 88, 35 and 36 of the S100 connector. With the ICs inserted, test pin 44 of the 100 pin connector for presence of an oscillating signal, SM1. This is an inverted version of the  $\overline{M}$  signal from the Z80, indicating that the present bus cycle is an operation code fetch. If no signal is present, suspect the inverter or the connector contacts.

Pin 48 of the S100 connector should be continuously low (inactive), as this is the inverted  $\overline{H}$  signal from the Z80, indicating that the processor has stopped. On pin 68 of the connector, positive going pulses should be detected as the microprocessor writes data to memory (this is the MWRT signal from pin 4 of U78).

If all else is well test the power supply pins of the S100 connector for the correct voltages (+8V on pins 1 and 51, +16V on pin 2 and -16V on pin 52). Do not worry if the actual voltages vary slightly from the figures given here, as long as they are approximately at the nominal levels. If you cannot detect these voltages faulty solder joints or the contacts of the connector itself may be the problem.

Turn off the power and wait a few minutes for the power supply capacitors to discharge before inserting your S100 board. With the board in place turn on the power and test it out as described in the board manufacturer's literature.

### Basic in EPROM

As already described the Basic interpreter for the Super-80 is available on tape or in a set of three 2532 EPROMs. Approximately 2K of the first 2532 EPROM contains a duplicate of the Monitor program, with the remaining 10K occupied by the interpreter. The use of the EPROM version of Basic means that you will not have to wait for a tape to load each time you want to use Basic.

Since the Basic interpreter on tape takes up approximately 10K of RAM, installing the EPROM version is equivalent

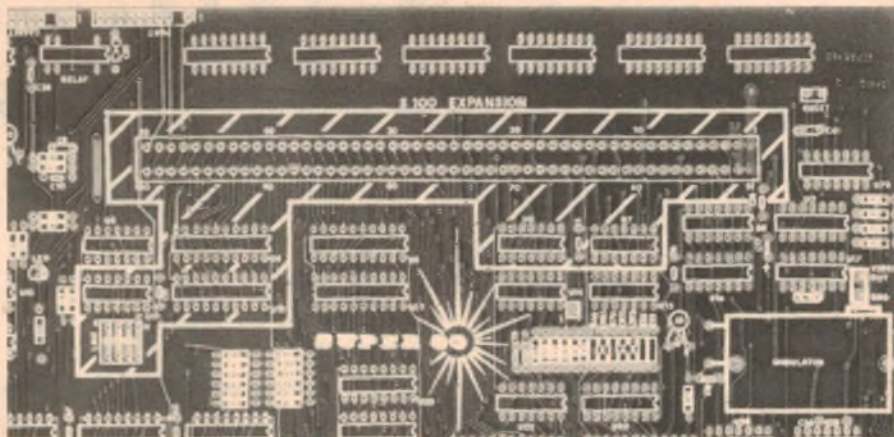

The five ICs exclusive to the S100 interface are highlighted in this crosshatched area on the PC board.

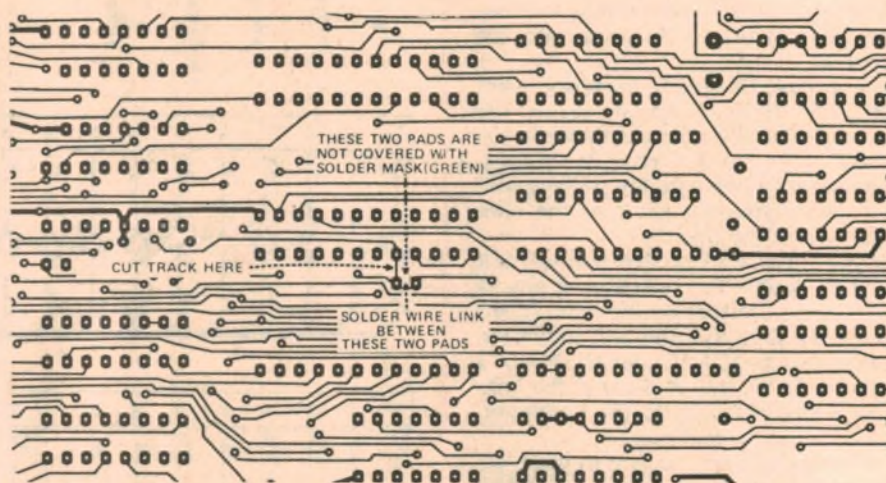

This diagram is supplied as part of the installation instructions for the EPROM Basic.

to expanding RAM by this amount. Installation of the Basic EPROMs should thus be considered before you expand RAM beyond 16K. Perhaps with the amount of memory freed by the use of the Basic EPROMs you will not feel a need for more RAM.

To install the Basic EPROMs the obvious first step is to remove U26, the 2516 which is currently in place in ROM position 0 on the board. You may wish to use the chip later, either as is or after re-programming, so remember to store it in conductive foam.

Some minor surgery is required next. On the bottom of the board, beneath U26, locate pin 20 of the IC socket. As shown in Fig. 1 the short track which runs from pin 20 towards the rear of the board must be cut and the pad which was connected to pin 20 joined to the pad adjacent to it with a short piece of wire. These two pads have been left uncovered by the solder mask to allow this modification.

Once the modification is completed insert the three 2532 EPROMs in ROM positions U26, U33 and U42, making

sure that the correct EPROM is inserted in each position.

If you want to use only Basic and not the Monitor program or other machine language programs, you can permanently close link B by soldering a wire in place in the link position. With the link in position, Basic will automatically be run when the computer is first turned on, and a Reset will return you to Basic.

If you leave link B open the computer will begin running with the Monitor program active. To enter Basic type G D000 then press return to instruct the Monitor to Go from the starting address of the Basic interpreter. Basic will initialise its memory areas and create an empty program space ready for use. If at any time you wish to re-start Basic without destroying the previously created program space, type G D003 followed by a Return for a "warm start".

### Memory expansion

As described in the previous article, memory expansion is a very simple process. If you installed sockets in all RAM positions during initial construction you

# THE ANALOGUE SLASHER ADVANCES

**NEW  
10 AMP**

**NEW  
10 AMP**

**NEW  
10 AMP**

**AC & D.C. RANGE**

**AUTO RANGING  
DIGITAL  
MULTIMETERS**

**FROM: \$49-95  
INCLUDING TAX**



**OTHER FEATURES:**

- Low cost
- Overload Protection
- Low battery indication
- Long battery life
- High contrast 3½ digit LCD display

THIS NEW AUTORANGING DVM BY SOAR IS NO ACCIDENT OR FLUKE. IT HAS BEEN DESIGNED WITH YOU, THE SERVICEMAN IN MIND.

**AVAILABLE FROM ALL LEADING ELECTRONIC DISTRIBUTORS**

**AMPEC ELECTRONICS PTY. LTD.**

1 Wellington St, Rozelle, 2039. PO Box 132, Rozelle 2039. Ph (02) 818-1166.

Available from: **NSW:** Applied Technology, 487 2711. George Brown & Co, 519 5855. Jaycar, 264 6688. Radio Despatch, 211 0191. Sheridan Electronics, 699 5922. **NSW Country Area:** Newcastle: Elektron 2000, 26 2918. Gosford: Tomorrows Electronics & Hi Fi, 24 7246. **VIC:** Ellistrionics, 602 3282. Ritronics, 489 8131. **QLD:** L.E. Boughen, 36 1277. N.S. Electronics, 36 5061. **SA:** Computer Imports, 268 8065. Electronic Components & Equipment, 212 5999. **WA:** Altronics, 328 1599. Reserve Electronics, 275 2377. Taimac, 328 1988.



# Bill Edge's ELECTRONIC AGENCIES

115-117 Parramatta Road Concord 2137  
(Corner Parramatta Road & Lloyd George Ave)  
Telephone: (02) 745 3077 (two lines)

All prices correct & goods in stock at time of going to press. Please phone to check current availability

Mail orders:  
PO Box 185  
Concord  
2137



TRADING HOURS  
Mon-Fri ..... 9am-5.30pm  
Saturday ..... 9am-noon  
Sunday ..... 10am-2pm

MAIL CHARGES  
\$5-\$9.99 ..... \$1.00  
\$10-\$24.99 ..... \$2.00  
\$25-\$49.99 ..... \$3.00  
\$50-\$99.99 ..... \$4.00  
\$100 or more ..... \$5.50  
All heavy or bulky items (over 20kg) sent  
Comet Road Freight \$8.00  
Anywhere in Australia

what else do we carry? HI-FI \* KITS \* PA EQUIPMENT \* MIKES \* HARDWARE \* TOOLS \* WIRE \* SEMIS \*

## Electros at dirt cheap prices UP TO 90% OFF!

Top quality electrolytic capacitors at prices you won't believe. All are brand new, prime spec devices from distributor's liquidated stock—their loss is your gain! But you'll have to be quick as the stock is strictly limited.

Axial lead Value & Voltage	Cat. No.	Approx. Normal Price	Special Price	Quant. Avail.
1/50	RES300	28c	3c	290
3 3/100	RES301	35c	8c	88
8/350	RES302	55c	20c	163
10/160	RES303	45c	12c	35
16/350	RES304	90c	24c	71
22/160	RES305	80c	22c	600
33/16	RES306	28c	4c	642
33/50	RES307	35c	8c	156
47/6 3	RES308	28c	8c	56
47/100	RES309	45c	12c	53
330/25	RES310	84c	20c	72
330/63	RES311	95c	30c	95
2200/35	RES312	\$1.70	50c	150
2200/16	RES313	\$1.20	40c	600

RB (PC Mount)	Cat. No.	Normal Price	Special Price	Quant. Avail.
1/50	RES320	20c	2c	19,000
2 2/16	RES321	20c	4c	89
10/315	RES322	90c	20c	50
22/160	RES323	75c	16c	150
100/10	RES324	28c	5c	36
330/63	RES325	\$1.00	18c	48
470/63	RES326	\$1.20	20c	280
2500/16	RES327	\$1.20	20c	38
2500/25	RES328	\$1.30	25c	600
4700/25	RES329	\$2.00	45c	12

limited stock—stock up now!

## NOW A computer for \$99! Available October ETI 660

No one would have believed it a few years ago. Features include—colour capability, operates from optional 9V plugpack. 1K memory expandable to 3K on board, single board construction, cassette interface, audio output (play tunes), simple to program (uses Chip 8). Expansion projects coming up include: ASCII keyboard, light pen, games software etc.

Starter Kit (1K RAM, B&W video) \$99.00  
9V 200mA plugpack to suit \$6.50  
Colour video option \$8.00  
RAM expansion (add to PCB) \$17.00  
Pre Programmed 2716 ROM \$18.50  
We expect this kit to be in stock in October. Please phone for precise details. Cat. KE6600

## This month only LED SPECIALS

All brand new, top quality LEDs—at rock bottom prices. Save up to 50% on our normal low prices. All colours, all shapes and sizes.

	Cat. No.	Normal Price	This month
3mm Red	ZE1811	20c	12c
3mm Green	ZE1819	28c	15c
3mm Yellow	ZE1821	28c	15c
5mm Red	ZE1832	16c	10c
5mm Green	ZE1836	28c	18c
5mm Yellow	ZE1840	34c	20c
Rect. Orange	ZE1844	34c	20c
Rect. Red	ZE1850	40c	20c
Rect. Green	ZE1854	40c	20c
Rect. Yellow	ZE1856	40c	20c

## Wind speed indicator



This is a great new project from EA. Measures wind speeds from 0-100km/h, indicating on an easy to read analog meter. Sender unit uses a light chopper for high accuracy and minimum maintenance. Now all you yachtsmen can check the wind from the comfort of your own home! Kit includes all parts as per the EA article (October 1981)

KE1630 \$44.50

## SCOOP PURCHASE Aluminium project cases



Special purchase of top quality aluminium boxes. Woodgrain finish top and sides. Save about 50% on equivalent cases. We have approximately 40 of each so get in quick for these never to be repeated prices.	Cat. No.	Dimensions W x D x H	Price
	HE1350	150 x 220 x 100mm	\$4.50
	HE1355	200 x 220 x 100mm	\$6.50
	HE1360	250 x 220 x 100mm	\$7.50
	HE1365	300 x 220 x 100mm	\$9.50
	HE1370	400 x 220 x 100mm	\$12.50

Now you can afford to house all your projects

## ETI4000 series speakers

top sound value

Widely regarded as the best kit speakers ever. Performance costing hundreds of dollars more. See our catalogue or the original articles in ETI for full details. ETI4000/1 4 way Kit includes all drivers and crossover CE2430. Fully built cabinets to suit CE2470 ..... \$499.00 pair  
ETI4000/2 3 way Drivers and crossovers kit CE2440 ..... \$250.00 pair  
Fully built cabinets to suit CE2480 ..... \$380.00 pair  
Fully built cabinets to suit CE2480 ..... \$200.00 pair

## Musicolour IV

The incredible combined light chaser and Musicolour from EA. One of the best value lighting effects units on the market. Our kit includes all parts as specified by EA, including the original case. See EA August 1981.

KE3025 \$89.90

## Foster 250mm woofer

Here's a speaker that didn't get into our catalogue. The Foster C250L09 is a top quality 250mm woofer with power handling of 50W, resonant frequency of 30Hz and sensitivity of 92dB (1W, 1m)

\$25.50



Cat. CE2119

## Clarion Tweeters

One of our most popular economy tweeters—over 400 sold! Ideal for upgrading that twin cone to a two-way system. Power handling of 3W continuous (about 40W system power), 50mm cone, 2kHz to 13kHz, 8 ohm impedance. And look at our price! Cat. CE2000 ONLY \$1.99. \$1.50 each for 10 or more

## Fluke multimeter

Fluke—the name that means top quality hand held DMMs. This is the 8022A. A 3 1/2 digit instrument with 0.25% accuracy, LCD display and 24 ranges. Incredibly rugged and reliable. Phone for full specs or see our catalogue. QES225 \$169.00



## Playmaster Mosfet Amplifier

Our kit includes all parts as per the original EA article—including the specified Ferguson transformer for full output and lower hum. \$169 KE4180

## ETI1500 Metal Detector \$199

We've now sold hundreds of these great metal detector kits. Equals the performance of \$500 commercial units. Absolutely complete kit including head & handle, special case and meter (all available separately).

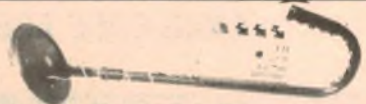

MISSED OUT ON OUR CATALOGUE LAST MONTH? If you haven't got your copy of the Electronic Agencies 32 page catalogue, just send us 75c (to cover postage and packing). See postal address at the top of this page.

need only plug eight 4116 dynamic RAM chips (or the equivalent National MM5290) into the next memory bank and change a wire link to add 16K of RAM to your system. If you have a DIP switch in place of the wire links, the process is even easier.

The wire links referred to are "C" and "D". Without these links installed the Monitor program will determine that 16K of RAM is installed. With link "C" in place the memory size will be taken as 32K. Both links "C" and "D" in place indicate that 48K of RAM (three banks) is installed. In the previous article it was stated that only one of these two links should be in place at the same time, but this is in fact not correct. Both must be in place for the computer to operate with its full complement of RAM.

Note that since each RAM chip stores one bit for each of 16000 memory locations (as explained in the previous article) it is not possible to expand the memory in less than 16K increments. Installing four RAM chips in memory bank number one, for example, will not give you an additional 8K of memory. Rather, four chips would provide 16000 4-bit memory locations, which cannot be used by the computer at all.

If you did not install sockets for the three banks of memory at the time of construction it might be advisable to remove the presently installed RAM while you solder in the new sockets. All of the address and data lines of the memory chips are connected in parallel, and a tiny transient from an improperly earthed soldering iron could overload the inputs of the chips, making them unusable. Remember, though, if you do remove the chips from the board they must be stored in protective packaging to protect them against static electricity discharges.

### Trouble-shooting tests

Let's backtrack a bit now and assume for the sake of something to do that your computer doesn't work. Suppose that at the stage of the first test with a video display no white rectangle appeared on the video screen (sad!). At this point the only integrated circuits in place on the board will be U15, U16, U22, U23, U28, U29, U30, U31, U35, U36, U39, U40, U45, U50, and U76.

If all seems well with the power supplies to the board check the chips themselves. An integrated circuit which is installed backwards in its socket will usually get hot very quickly, and won't be much use for anything at all unless you're very quick in turning off the power. (Understatement, here . . . Ed.)

If you are using a normal television set connected to the computer via a video modulator, the next step is to check the tuning of the modulator. The metal cover of the modulator can be held in

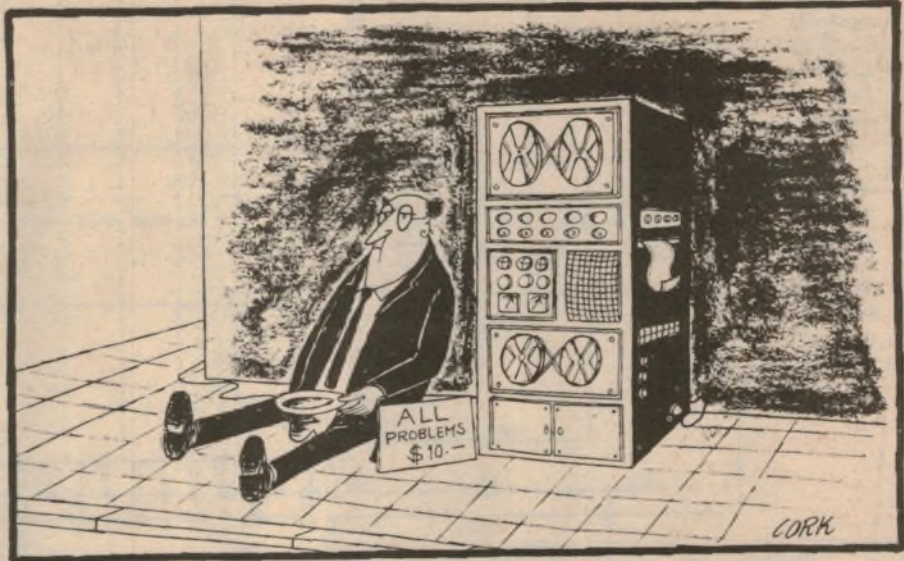

place by turned edges, and can be eased off with a screwdriver. Carefully adjust the ferrite slug which tunes the modulator, making only a small adjustment at a time and returning it to its original position after each unsuccessful adjustment. As a last resort, beg or borrow a video monitor with a direct video connection and bypass the on-board modulator altogether. If you obtain a picture this way, the fault is obviously in the modulator.

If there is still no picture, even with a direct entry video monitor, the real work begins, unless you prefer to use the "Return for Service" coupon supplied with the kit.

If you decide to go ahead with troubleshooting yourself first use some methylated spirits and a small brush to clean excess solder resin from the board. Go over the board with a magnifying glass looking for solder bridges and damaged printed circuit tracks. Look for incorrectly oriented components and resistors and capacitors of wrong value. If in doubt check the parts list again, working systematically through the entire circuit and comparing the values of components on the board with the values given in the parts list.

From this point on an oscilloscope or frequency counter will be required. If these are unavailable a logic probe which can detect fast pulse trains as well as high and low logic levels can be used.

For test purposes a link is required between pins 23 and 25 of the socket of U46, the microprocessor itself. Use a piece of short wire no thicker than an IC pin for this link or the wire may strain the spring action of the socket, making it prone to intermittent faults.

### Video display circuit

Refer to Fig. 2, the circuit diagram of the main part of of the computer. All

timing signals for the system are ultimately derived from the 12MHz oscillator consisting of U39, a hex inverter. Operation of this circuit can be checked by looking for a 12MHz signal on pin 12 of U39. If there is no signal look at pin 13. A signal on pin 13 but not in pin 12 indicates that this inverter stage is faulty. Replace the IC and try again. If you are still unsuccessful, chances are you have a bad crystal.

The 12MHz master oscillator signal is fed to a divider chain made up of U45, U40, U36, U31 and U29. Pin 11 of U45 should show a 750kHz signal. The next stage of the divider chain divides this frequency by eight and produces an output of 93.75kHz on pin 11 of U40. U36 divides this frequency further to provide a 7.81kHz output on pin 12. Pin 8 of U36 provides the line sync frequency for the video display, and should show an output of 15,625Hz.

The output of pin 12 of U36 is further divided by ten by U31 so a 781Hz signal should be present on pin 12 of this chip. U29 divides this frequency by 16 to produce a 48.8Hz output on pin 11. This is the frame sync for the video circuitry, and is close enough to the 50Hz mains frequency to avoid any problems with vertical stability.

If these signals are present then the signals which generate  $\text{BUSREQ}$  and clock data out of memory for use by the character generator should also be present. The video display memory addressing circuitry should be examined next.

The most important signal to in-

*Over the page is the major part of the Super-80 which we have re-drawn from diagrams supplied by Dick Smith Electronics. The remainder of the circuitry is shown on pages 61 and 71 of this article. The circuit was designed by Peter Snape of Brisbane.*

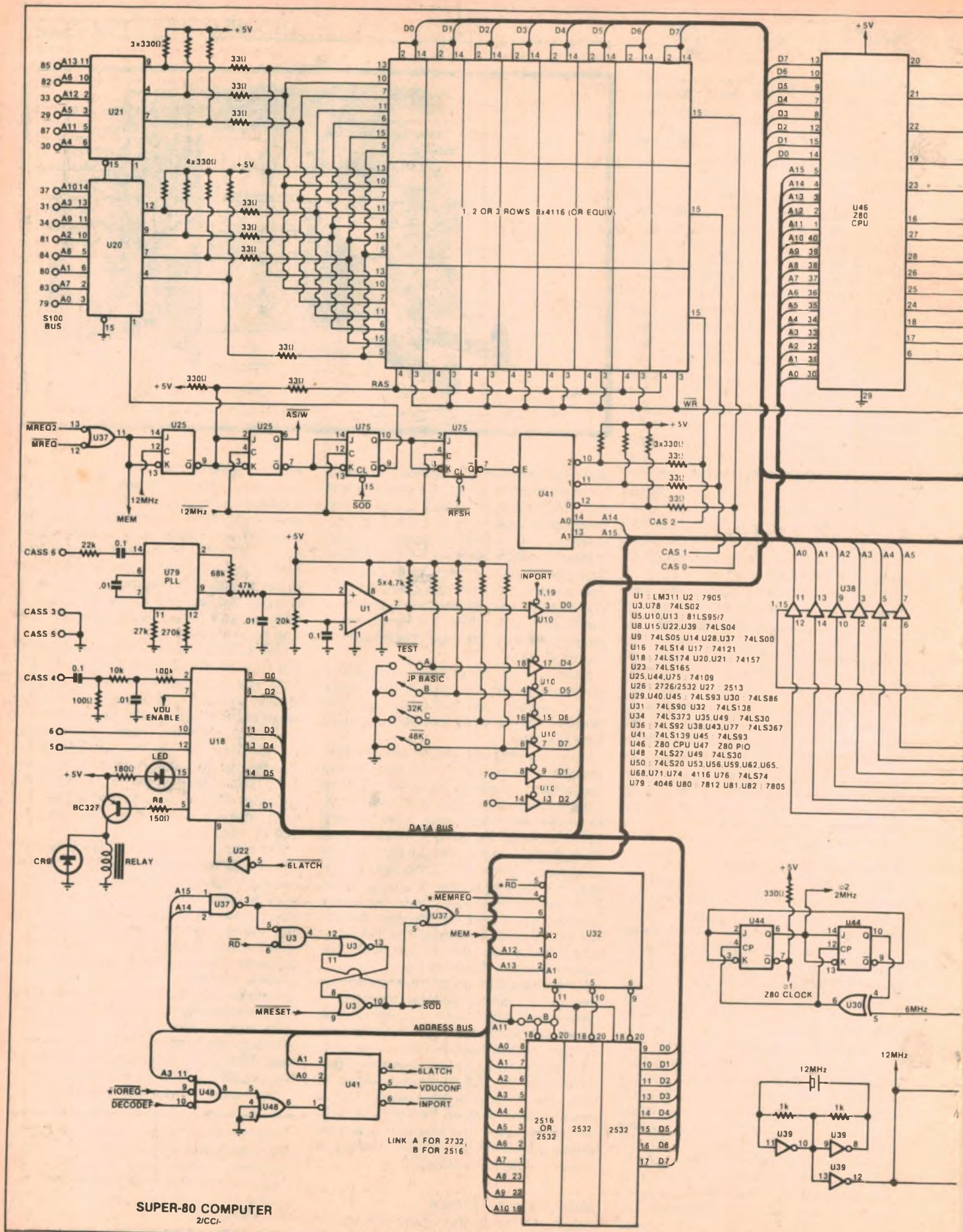

**SUPER-80 COMPUTER**  
2/CC-

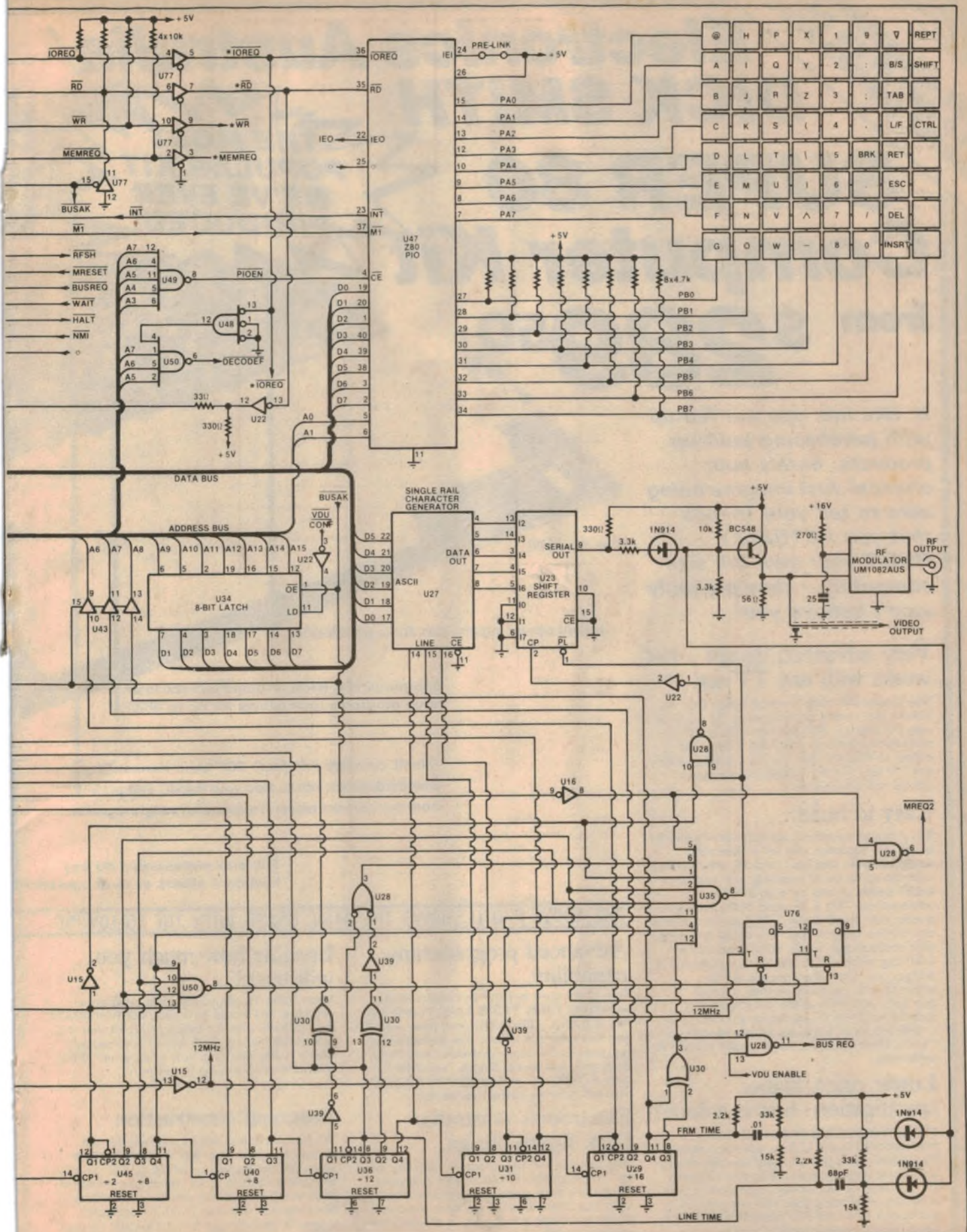

**FIRST CONSIGNMENT  
SOLD OUT IN 2 1/2 DAYS!  
STRICTLY LIMITED STOCKS**

# **Electronics Australia/ DICK SMITH**

## **SUPER 80 Computer Kit**

**from \$289<sup>50</sup>**

*If, like me, you are fed up with purchasing built-up products, here's your chance! Just imagine being able to tell your friends that you **ACTUALLY BUILT** your own full size computer — they probably won't believe you!*

**Very advanced design - but works with any TV set!**

The 'Super 80' offers a specification that we believe just cannot be bettered at the price. It uses the popular Z80 Microprocessor IC, a professional keyboard and has a direct RF output so that you can use the computer with any TV set (you don't need to purchase a special video monitor).

**Easy to build.**

Even though we would not recommend this kit to the raw beginner, this kit is extremely straightforward and easy to build. Any person who can use a small soldering iron and can solder neatly should have no difficulty in construction. This is because of the unique double side board design which means there is virtually no other wiring. The board is covered with professional 'solder mask'; this makes soldering much easier without the problems of bridges, etc. Once the components are soldered onto the board in their marked positions over 98% of the construction is completed. Even if you cannot get the completed kit to work, we have a special "Sorry Dick it doesn't work" repair service to assist you.

**Lower price, higher specification - how is it done?**

Most computers sold in Australia are manufactured in the U.S.A. where extremely high labour rates prevail - and you pay dearly for this on built up units. With this computer kit, you provide the labour and therefore save a fortune. And remember, this computer does not have a small toy-like calculator keyboard but a full size professional typewriter keyboard.

**THE MOST  
POPULAR KIT  
WE'VE EVER  
PRODUCED!**

Cat. K-3600

**Inbuilt power supply: just add a transformer**

**Enormous 16K RAM on board lets you load large programs (pcb allows for up to 48K)**

**Inbuilt cassette interface: 300 baud Kansas City Standard allows you to load your BASIC interpreter from any cassette player. You can also swap programs**

**Full size professional 60 key keyboard allows ease of operation**

**THE ABOVE PHOTO SHOWS THE BASIC BOARD WITH THE FOLLOWING**

**Advanced programming capability.**

One of the most popular computers in the world (the Tandy TRS80 Level 1) only has 4K of BASIC. The BASIC we have with this unit is a large 9K. When you consider that our popular Sorcerer computer (over 2,000 sold) only has an 8K BASIC and sells for over \$1,000, it is obvious that by building yourself, you are saving real money.

**Electronics Australia/  
Dick Smith design.**

This is not a half baked design with no back up. The resources of Electronics Australia, Australia's most popular electronics magazine, and Dick Smith Electronics have combined to design and bring you this kit in the interests of computer enthusiasts actually building and not just buying. The design is fully Australian.

**Imagine how much you will learn!**

Most computer enthusiasts can program a computer but would have absolutely no idea of how to build one. By building this kit you will learn both the technical side of construction, how it works and then how to program. What a fantastic background for a future...

**Sectional construction.**

We have designed this kit not only for the serious computer user but also for first time users like the student or hobbyist. This is why we have a short form kit which may be added to as you build (and as you have the money!). For example, you may build the computer originally and operate it with 'BASIC on tape' and then add 'BASIC in ROM', add the S-100 and provide other parts at a later stage.

Relay to operate cassette unit automatically

2K Monitor program supplied

Character generator giving a full 64 characters  
32 character x 14 line screen

Spare IC positions for prototyping  
and user customising

IC sockets available as  
an optional extra

RF modulator inbuilt: connects  
to any TV set.

Optional S-100 provision: simply  
add socket and IC's

Professional double sided PC board with  
plated thru holes for ease of construction,  
fully masked and with component overlay

Special design allows keyboard to be  
mounted remotely: simply cut board here

12MHz quartz crystal

Optional 9K SUPER BASIC in ROM simply  
plugs in here

Famous Z-80 microprocessor as used in  
Tandy & System 80 computers

## Comprehensive manuals available:

The construction details will be given in  
Electronics Australia magazine and full  
copy\* of the EA article will be supplied with  
each kit. We also have available two very  
comprehensive manuals to assist in  
construction and programming:

Combined construction, assembly  
and technical manual.

Cat B-3600



**\$12<sup>50</sup>**

Cat R-3602

**\$14<sup>50</sup>**

## Super 80 Basic does this:

Over 50 separate versatile commands.  
Features: arithmetic and integer functions  
user-defined functions, machine language  
routines, text editing, string operations.  
Also contains 25 error codes to assist you  
in programming.

\*'Super 80 Basic' reference manual

## Short Form Kit

Designed for computer applications  
where 'Basic' programming is not  
required. Kit supplied with Eprom  
Monitor and 16K RAM. Cat. K-3600 **\$289.50**

Add these items to make a fully operating  
computer system to your own requirements:

Transformer to suit .....	M-2325	<b>\$22.50</b>
BASIC program (interpreter) on cassette.....	K-3602	<b>\$24.50</b>
IC Socket set (recom.) .....	K-3603	<b>\$12.50</b>
BASIC program in EPROM (set of 3 IC's).....	K-3604	<b>\$99.50</b>
S-100 Expansion .....	K-3606	<b>\$19.50</b>

## OPTIONAL EXTRAS ADDED: S-100 EXPANSION, IC SOCKETS, FULL 48K RAM

## 'Sorry Dick, It Doesn't Work'

All parts with this kit are guaranteed tested and new, but we cannot guarantee the labour content provided by you. If, after completion, your Super 80 fails to operate, you may take advantage of our 'Sorry Dick, It Doesn't Work' service.  
Our Service Centre will check and repair your Super 80 for a lower than normal service fee. This fee includes any necessary replacement of components, etc.  
If you send your Super 80 to us under the 'Sorry Dick, It Doesn't Work' service, it must have been constructed using IC sockets. If we receive a kit which does not use IC sockets, or if the kit is so badly constructed as to make effective repair impossible, we reserve the right to return your kit in the condition received, together with the service fee.  
Under our 7 day satisfaction guarantee, you may return any kit in its original condition for a full refund of the purchase price. We cannot give a refund once construction has commenced, if any internal packs of components are opened or if the carton or kit is damaged.

## 7 DAY SATISFACTION GUARANTEE

Purchase this kit and inspect it for up to 7 days. If you do not wish to go ahead and construct this kit, simply return to us in condition as supplied and your money will be refunded in full.

**Yes, this makes the full 16K  
computer with 9K basic on  
tape, transformer and IC  
Sockets — only — \$349!**

# DICK SMITH Electronics

DSE/A019/LM



NSW AUBURN 648 0558 • BLAKEHURST 546 7744 • BROADWAY 211 3777 • BROOKVALE 93 0441 • CHULLORA 642 8922 • GORE HILL 439 5311 • NORTH RYDE 888 3200  
PARRAMATTA 683 1133 • SYDNEY 290 3377 • TIGHE HILL 61 1896 • WOLLONGONG 28 3800 ACT Fyshwick 80 4944 QLD BURANDA 391 6233 • CHERMSIDE 59 6255  
SA ADELAIDE 212 1962 VIC COBURG 383 4455 • MELBOURNE 67 9834  
RICHMOND 428 1614 • SPRINGVALE 547 0522 WA CANNINGTON 451 8666  
• PERTH 328 6944

Mail Order Centre: PO Box 321, North Ryde 2113. Phone (02) 888 3200

**SUPER 80  
EXCLUSIVE TO  
DICK SMITH'S**

# LOW PRICES FOR TOP TOOLS

SAVE!!

## 12V ECONOMY IRON

This superb iron works on 12 volts AC and 12 volts DC, so it can be used in the home, car, boat etc. Comes complete with car cigarette-lighter plug attached to a lead.

Cat. T-1910  
**\$3.95**

**DICK SMITH**

## 12V MINIATURE SOLDERING IRON

Not much larger than a pencil in length and not much thicker either. What an ideal iron for those really small PC board jobs, it is so light & easy to handle. Comes complete with lead & is rated 6W.

ONLY **\$6.95**

## DICK WICK

Specially treated copper braid used to remove solder from PC board. Clean and efficient.

NOW ONLY **\$2.00**

## SOLDER HOBBY PACK

1.25mm (18g) hobby pack N-1638

0.71mm (22g) hobby pack N-1636

**\$1.20 ea. VALUE!**

Yes! We have large rolls of solder for the serious hobbyist or professional! Just ask at your nearest Dick Smith Centre.

## CABINET OF DRAWERS

This cabinet is ideal for small components, screws, nuts and bolts plus many other items. 18 drawer cabinet measures 300 x 180 x 140mm.

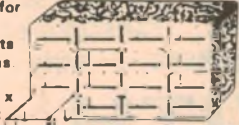

~~\$17.50~~

**\$13.25**

## TOOLBOX

This rugged polypropylene toolbox has a multitude of uses for the fisherman, technician, tradesman or automotive bits and pieces. A generous 427 x 230 x 200mm size with 2 trays, 15 compartments. Rustproof and lightweight.

GREAT VALUE  
**\$27.25**

## BUILDING THE SUPER 80? YOU NEED THIS SUPERB

### WELLER SOLDERING STATION

Transformer powered soldering station, complete with a low voltage, temperature controlled soldering pencil. The special Weller closed loop method of controlling maximum tip temperature is employed, there by protecting temperature sensitive components while the rounded tip protects voltage and current sensitive components e.g. CMOS. Definitely the best we've seen.

**\$62.50**

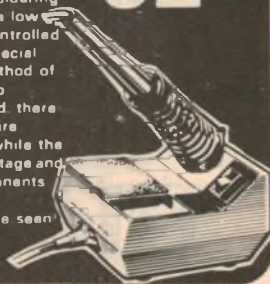

Cat. T-1000



**SOLDER SUCKER**  
ONLY **\$13.50**

Rugged, all metal construction solder sucker, complete with Teflon tip and nozzle sweeper. Light thumb release mechanism for easy removal of solder from your board. Don't pay twice the price elsewhere!

Cat. T-2560



**GENUINE TULLEN SNIPS**  
**\$3.10**

Dick Smith now stocks the famous Tullen Snips. This tool will cut almost anything! Working on the principle of shearing rather than cutting, this ensures a neat cut every time. Never needs sharpening!

**EVEN CUT TINPLATE!**  
Cat. T-4930

## HOBBYIST SOLDERING CENTRE

If you're going to build a super 80 one of these is a MUST! Holds your PCB securely & firmly, while being able to turn over. Also holds a roll of solder and your iron. No more burnt fingers!

**\$19.50**



## NEON TEST DRIVER

Ideal tool to carry in your pocket (it has a pen clip!) for testing the presence of AC. At this price, why take chances? Completely insulated.

**\$1.00**



## LUG CRIMPING TOOL

Complete with a pack of lugs ready to use. Also will strip & cut wire. Great value!

**\$1.99**

Cat. T-3520

## NIPPERS

Transistor Nipper. Ideal for PC work.

Mini Diagonal Cutting Nipper. Drop forged steel construction.

**\$3.95**

Cat. T-3561



# DICK SMITH Electronics

- AUBURN 648 0558
- BLAKEHURST 548 7744
- BROADWAY 211 3777
- BROOKVALE 93 0441
- CHULLORA 642 9822
- GORE HILL 439 5311
- PARRAMATTA 683 1133
- SYDNEY 290 3377
- NEWCASTLE 61 1896
- WOLLONGONG 28 3800
- CANBERRA 80 4944
- BURANDA 391 6233
- CHERMSIDE 59 6255
- ADELAIDE 212 1962
- MELBOURNE 67 9834
- RICHMOND 428 1614
- SPRINGVALE 547 0522
- COBURG 383 4455
- PERTH 328 6944
- CANNINGTON 451 8666

MAIL ORDER CENTRE: P.O. Box 321 North Ryde, NSW 2113 Ph (02) 888 3200



**NOW IS THE TIME TO BUY!**

DSE/A007/LM

investigate is  $\overline{\text{BUSREQ}}$ . One stage of the exclusive OR gate U30 combines the outputs from pins 8 and 11 of U29 to produce a signal on pin 3 of U30 which coincides with the frame sync signal and is active for 10ms out of every 20ms. When VDU ENABLE is high this signal is passed through NAND gate U28, appearing on pin 11. This in effect disconnects the Z80 from the system bus and allows the video circuitry to read the memory and output its contents to the character generator for display.

During the time  $\overline{\text{BUSREQ}}$  is active a block of 512 bytes of memory is addressed by signals derived from the divider chain rather than by the Z80. Every 10ms the address lines applied to the inputs of buffers U38 and part of U43 cycle through 512 sequential states. The buffers are Tri-state types, and are controlled by  $\overline{\text{BUSAK}}$  — a signal produced by the Z80 which indicates that it has responded to the bus request signal by giving up control of the system bus. In response to  $\overline{\text{BUSAK}}$  the addresses produced by the divider chain are placed on the address bus to read data for display from RAM.

In order for the memory to respond to the addresses from the video circuitry it must receive a read signal, and since the control lines of the Z80 are Tri-stated, this signal must be produced by the video circuitry. This is done by inverting the  $\overline{\text{BUSAK}}$  signal (which thus appears on pin 8 of U16) and gating it with the output of pin 9 of U76.

The Reset input of U76 (pin 13) is driven from the output pin 8 of U50. U50 is a quad input NAND gate which combines the outputs from the four elements of divider U45 to produce short, negative going pulses at a frequency of 750kHz. These pulses are applied to flipflop U76 to produce  $\overline{\text{MREQ2}}$  signals at the correct frequency to read data from each memory location as it is addressed by the frequency divider chain signals. Note that the effect of U28 is to ensure that  $\overline{\text{MREQ2}}$  signals are only produced when  $\overline{\text{BUSAK}}$  is active. The  $\overline{\text{MREQ2}}$  signal appears on pin 6 of U28, as shown in the circuit diagram.

Correct operation of this part of the circuit is indicated by a 48.8Hz signal ( $\overline{\text{BUSREQ}}$ ) on pin 11 of U28, a 750kHz signal on pin 9 of U76, and bursts of 750kHz signals every 10ms on pin 6 of U28. Note however that since the microprocessor is not in place in its socket, there will be no  $\overline{\text{BUSAK}}$  output. The effect of this signal is simulated by linking the  $\overline{\text{BUSREQ}}$  input (pin 25) to the  $\overline{\text{BUSAK}}$  output (pin 23) of the Z80 by the wire link inserted in the socket of the U46.

Ground pin 13 of U28, simulating the effect of the VDUENABLE signal going low. This should inhibit the generation of the  $\overline{\text{BUSREQ}}$  signal and cause the video screen to go blank.

### Character generation

As each byte of data is read from memory it is applied to the character generator U27. At this stage U27 should not be in place on the board, so the inputs of shift register U23 will float high. In normal operation data from the character generator is loaded into the shift register by negative going pulses from pin 8 of U35.

The inputs of U35 are derived from the frequency divider chain and are arranged so that an output pulse is produced every 1.33 microseconds, loading new data from the character generator for each row of the character which is built up on the screen.

The individual dots making up each row of a character are clocked out of the shift register by a 6MHz signal derived from pin 12 of U45. This signal is inverted by one stage of U15 and applied to pin 10 of U28. Pin 9 of U28 is driven by the output of U35, which has the effect of in-

hibit the dot clock output of U28 (pin 8) whenever a parallel load pulse occurs.

With the inputs of the shift register floating high a continuous stream of dots should appear on the output, pin 9, in the form of short, positive going pulses. It is these dots which should produce a white rectangle on the video screen, as long as the line and frame sync pulses are present.

With dot, line and frame sync signals being produced by the video circuitry, failure of the video display can only be caused by a fault in the video generator portion of the circuitry, which combines the sync and frame information into a composite video signal. Incorrect resistor and capacitor values can prevent this circuit from operating correctly. The orientation of the three diodes and the transistor in the circuit should also be checked. Test whether the video signal is appearing on the base and the emitter of the BC548 transistor adjacent to the

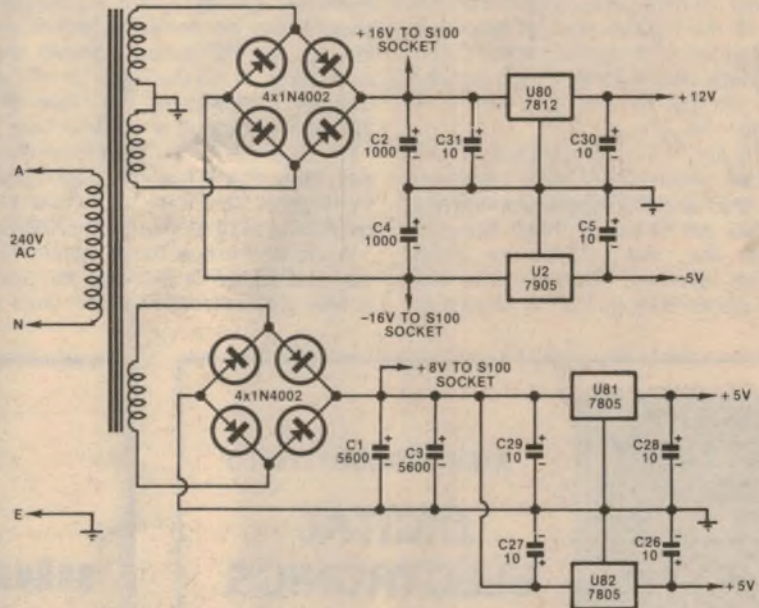

Above is the complete circuit of the Super-80 power supply, including C3 which is necessary to supply the current drain of the S100 interface when an S100 board is actually in use.

hibiting the dot clock output of U28 (pin 8) whenever a parallel load pulse occurs. The output of U28 is inverted by one stage of U22 and applied to the clock input of the shift register U23 (pin 2). In effect, the shift register is either loading new parallel data from the character generator or clocking out dots in serial form to represent a character, but not both.

Having verified that the master oscillator and the divider chain are working correctly, look for a signal on pin 8 of U35. If not present, or present with the wrong timing, trace each of the inputs of U35 back to its source. A defective inverter gate in ICs U28, U30 or U39 should be suspected. Check that the signal appears on pin 1 of U23, and

modulator.

Once you get a display of characters on the VDU continue with construction as described in the previous article, installing U8, U9, U14, U17, U34, U38, U43 and U44.

The next step is to test the operation of the 2MHz clock oscillator. Using a frequency counter or oscilloscope check for a clock signal on pin 7 of U44. If the signal is not present either U44 or the relevant stage of U30 is defective and should be replaced.

To test the master reset circuitry press the reset button and check that pin 12 of U16 goes from low to high for each press of the button. If this is not the case check the values of the resistor and capacitor shown adjacent to the pushbutton. As a



last resort try replacing U16, remembering that it is a Schmitt trigger type.

If the pushbutton reset operates, verify that the power on reset also operates correctly by turning the power off for one minute then turning it on again. Pin 12 of U16 should stay high for about 0.25 second and then go low. From U16 the reset pulse is applied to the monostable U17, which produces an exactly timed reset pulse for each push of the button. Pin 1 of U17 should go low in response to a reset pulse from U16. The timing for this pulse is dependent on the capacitor connected between pins 10 and 11 of the monostable, so verify that it is of the correct value (0.1μF) before continuing.

## Microprocessor tests

Without the microprocessor in place on the board, check the signals to the socket of U46. Remember to store the processor safely if you remove it from the board for these tests. Verify that pins 1 to 5 of the socket are not held continuously low. U34 would be the culprit here. Check that a 2MHz clock signal is present on pin 6, and that pin 11 is receiving +5V.

Pins 16 and 17 of the socket of U46 should be continuously high. These are the  $\overline{RD}$  AND and  $\overline{WR}$  inputs respectively, and a low on either of these lines will prevent the microprocessor from operating correctly. Source of the fault will be either U16 or U9, as shown on

the circuit diagram of the S100 interface. Pin 24, the  $\overline{WAIT}$  input, should also be continuously high to allow the processor to operate. This signal is generated by U14 (pin 6) and U15 pin 6.

With the Z80 in place in its socket, pins 19 and 27 should show a continuous oscillation as it attempts to fetch data from memory. These are respectively the  $\overline{MREQ}$  and  $\overline{MEM}$  outputs of the processor.  $\overline{MREQ}$  indicates that the processor is accessing memory and  $\overline{MEM}$  indicates that the present instruction cycle is the fetching of an operation code. It may be necessary to press the reset button after switching on, in order to activate the system.

Pin 20 of the Z80 should be continuously high, as this is the  $\overline{IOREQ}$  output, and will only go low if the processor is attempting to input or output data from an Input/Output port. Pin 21, the  $\overline{RD}$  output should show a continuous oscillation as the Z80 attempts to read from memory. Pin 22 is the  $\overline{WR}$  output and should also be oscillating continuously. Pin 28, the  $\overline{RFSH}$  output, should also be oscillating, as it is the signal to refresh the dynamic memory of the Super-80. Pin 18, the  $\overline{HALT}$  output, should be high.

Pin 23 is the  $\overline{BUSAK}$  output from the Z80, indicating that it has given up control of the system bus. It should show a 49Hz oscillation in response to the  $\overline{BUSREQ}$  input.

If one or more of these signals is incorrect and all else is working, the problem is the Z80 microprocessor chip itself.

This is extremely unlikely however, unless the chip has been subjected to excessive heat (300°C for more than 10 seconds) or the processor has been damaged by being removed or inserted with the power on, or installed backwards in its socket.

If the Z80 seems okay, check the outputs of U77. This chip is the buffer of four of the control lines of the Z80, as shown on the main circuit diagram. Check that the outputs of the buffer follow the state of the control signals already described. Note that when  $\overline{BUSAK}$  is low (active), pin 11 of U77 will have a low output and will drive the  $\overline{RD}$  line low, allowing the video circuitry to read from memory.

The signal required to control the multiplexing of the addresses for the RAM is generated by U37, on pin 11, and is created by gating together the  $\overline{MEMRQ}$  signal from the processor and the  $\overline{MREQ2}$  signal generated by the video addressing circuitry.

If U18 is installed on the board, remove it, then ground pin 7 of the socket with a flying lead. This should result in an oscillating signal appearing at pin 11 of U37 when the  $\overline{MREQ2}$  signal is enabled. Note that pin 7 of U18 is an output, and grounding the output of any chip could cause an excessive current to flow which could destroy the gate on the chip. For this reason this test should only be tried if U18 is not in place on the board.

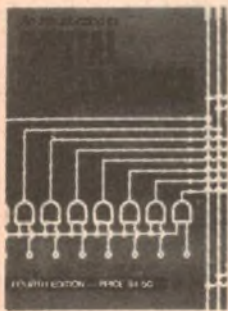

## AN INTRODUCTION TO DIGITAL ELECTRONICS

FOURTH EDITION

**Electronics is going digital.  
This book can help YOU go  
right along with it.**

Electronic equipment now plays an important role in almost every field of human endeavour. And every day, more and more electronic equipment is "going digital". Even professional engineers and technicians find it hard to keep pace. In order to understand new developments, you need a good grounding in basic digital concepts, and An Introduction to Digital Electronics can give you that grounding. Tens of thousands of people — engineers, technicians, students and hobbyists — have used the previous editions of this book to find out what the digital revolution is all about. The fourth edition has been updated and expanded, to make it of even greater value.

Available from "Electronics Australia", 57 Regent St, Sydney.  
**PRICE \$4.50** OR by mail order from "Electronics Australia",  
PO Box 163, Beaconsfield 2014. **PRICE \$5.20.**



## SERVICE MANAGER'S ASSISTANT

**Know the service game backwards? Capable of looking after a busy Service Department and twenty staff? We need you!**

**Our Service Manager badly needs an assistant. Someone who is prepared to get stuck into the service work with absolute minimum supervision — but who will also take over management duties when required.**

**The opportunities for advancement are very, very good for the right person. Salary depends on just how good you really are.**

**Interested? Call our Service Manager for an appointment —**

ring **GARY CRAPP**  
**DICK SMITH ELECTRONICS PTY LTD**  
**NORTH RYDE (02) 888 3200**

Verify that an oscillating signal appears at pin 11 of U37 when pin 7 of U18 is grounded. Pin 13 of U37 should be continuously high, and pin 12 of U22 should show an oscillating signal. U18 is a latch which accepts and provides for cassette recorder motor control and outputs the cassette write signal. Pin 7 outputs the VDU ENABLE signal, and grounding this pin should disable the generation of  $\overline{MREQ}$  as described previously. Pin 12 of U22 provides an inverted  $\overline{RD}$  signal which is applied to the  $\overline{WR}$  inputs of the RAM to control reading and writing data to the memory.

Remove the link which you used to ground pin 7 of U18. Verify that pin 3 of U37 shows an oscillating signal. Insert U3 in its socket and check that pin 4 of this chip shows an oscillating signal. This is the "Start of Day" circuit which governs and activates the Read Only Memory selector following a reset. Pin 10 of U3 should show a negative pulse after a reset if this circuit is working correctly. Pin 6 of U37 should show an oscillating signal — although it might be necessary to push the reset button to trigger the oscillation.

#### Memory address decoding

Install U48, a triple three input NAND gate which decodes the  $\overline{MREQ}$  signal from the Z80 (pin 9) and gates it with address line 3 (pin 11) to provide signals which control the input and output circuitry. Install U26, the Monitor ROM, and U41, the decoder for the I/O signals. When you turn on the power to the board and the video monitor you should see a jumble of characters on the screen, with the words "SUPER-80" on the second line.

If this does not occur, check that an oscillating signal appears on pin 8 of U48. Check pin 6 of U50 for the presence of the  $\overline{DECODE}$  signal.

The next stage is address buffers U5 and U13 (shown on the S100 section of the circuit diagram). Check each output of these buffers for oscillating signals. Again, the frequency of the signals is not important, as long as no outputs are at fixed high or low levels. Fixed levels indicate that one of the buffer elements is faulty, or that U38, U34 or U43 is defective. Trace the address lines back through the circuit to determine where the problem arises.

The address multiplexers for the RAM are U20 and U21. The seven outputs of these chips should show a varying signal as the microprocessor attempts to access the memory. Again, fixed levels indicate a fault, which should be isolated by first checking the inputs to U20 and U21, then the address buffers etc.

Without installing U75, temporarily ground pin 9 of the socket of U75 and again check the seven outputs of the address multiplexers, verifying that the outputs show oscillating signals. Remove the link used for this test as soon as completed.



## "HOW TO TURN ELECTRONIC THEORY INTO PRACTICE AND MAKE IT PAY..."

"If you understand and enjoy radio and electronics and want to extend your knowledge and experience, then we at Stott's can help you.

Stott's have home-study courses for complete beginners in Radio theory and basic Electronics through to the standards needed to maintain and service Colour Television.

Anyone who has these skills at their fingertips can make it pay by turning a fascinating hobby into a lucrative part or full time profession."

Athol H. Kelly B Com (Hons) AASA FCIS  
Principal, Stott's Technical Correspondence College



**Stotts**  
TECHNICAL CORRESPONDENCE COLLEGE

The name to trust in  
correspondence education

Melbourne 159 Flinders Lane, 3000 Tel: 63 6212  
 Sydney 383 George Street, 2000 Tel: 29 2445  
 Brisbane 290 Adelaide Street, 4000 Tel: 31 1627  
 Adelaide 85 Pirie Street, 5000 Tel: 223 3700  
 W Perth 25 Richardson Street, 6005 Tel: 322 5481  
 Hobart 1st Fl, 29 Argyle Street, 7000 Tel: 34 2399  
 Singapore P.O. Box 3396, Singapore 1

Please send me free, and without obligation,  
full details of the following courses

#### The Stott's range of courses in Electronics is:

- Intro to Electronics
- Digital Electronics for Technicians/ Servicemen
- Microprocessors
- AM Radio Receivers
- Radio/TV Servicing
- Colour Television
- Radio for Amateurs
- Amateur and Novice Radio Operators Certs
- Electrical Mechanics

A full range of Hobby and Business courses also available

ALA/ST 1929/EA/1081

\_\_\_\_\_  
(PLEASE PRINT)

MR MRS MISS \_\_\_\_\_ AGE \_\_\_\_\_

ADDRESS \_\_\_\_\_

\_\_\_\_\_  
POSTCODE \_\_\_\_\_

Stott's undertake that no sales counsellor will visit you

KITS

KITS

KITS

KITS

KITS

KITS

KITS

KITS

**\$48.50**

Engine Analyser Kit

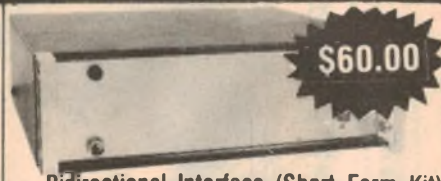
**\$60.00**

Bidirectional Interface (Short Form Kit)

**\$169.00**

Analogue and Digital Storage CRO Kit

**\$58.50**

Oscilloscope Switch

**\$39.00**

Infrared Light Beam Relay

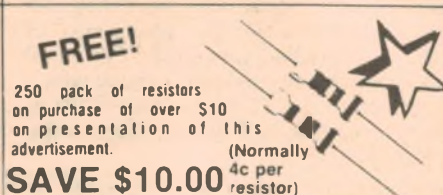
**FREE!**

250 pack of resistors on purchase of over \$10 on presentation of this advertisement.

**SAVE \$10.00**

(Normally 4c per resistor)

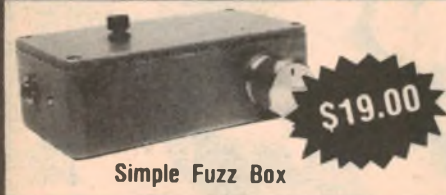
**\$19.00**

Simple Fuzz Box

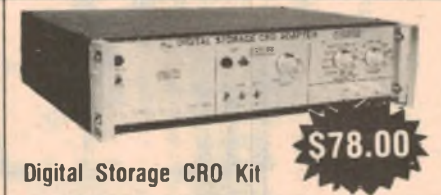
**\$78.00**

Digital Storage CRO Kit

**POOLS/LOTTO SELECTOR****RRP \$25****MUSICOLOUR IV****\$79.00**

Digital Clock and Thermometer

**\$80.00****THIS MONTH'S KIT****\$49.00**

Audio Test Unit for cassette decks

## TV PATTERN GENERATOR

Kit of parts as featured in EA June 1980, Dot, Greyscale, Crosshatch, Raster, Check COMPLETE KIT (inc Scotchcal front panel) KIT WITHOUT BOX

\$48.49  
\$36.90

## EPROM PROGRAMMER KIT

Kit of parts as featured in EA July 1980 Programs 2708, 2716 &amp; 2532 Use with TRS 80, Sorcerer &amp; Compucolour Kit does not include connector from the programmer to computer

\$72.49  
\$59.99

## COMPLETE KIT (inc Scotchcal Front panel)

## KIT WITHOUT CASE

## DIGITAL PANEL CAPACITANCE METER

Kit of parts as featured in EA MARCH 1980

Four Digits Extremely popular

## COMPLETE KIT (inc Scotchcal Front Panel)

## KIT WITHOUT CASE

## TV CRO ADAPTOR KIT (EA MAY 1980)

COMPLETE KIT (inc Scotchcal Front Panel)

(without power adaptor)

## POWER ADAPTORS TO SUIT

1 240V to 6/7 5/9V

2 240V to 9V

\$9.50  
\$5.95

## KITS

## ETI SERIES 4000 60W STEREO AMP KIT

Complete Kit Rack Mounting Case

Woodgrain Sided Case

\$199.00  
\$189.00

## PARTS AVAILABLE SEPARATELY

Front Panel \$10.90

Rack Mounting Case \$55.00

Wooden Sided Case \$49.00

ETI 471 PREAMP KIT of parts \$45.00

ETI 472 PS KIT of parts \$47.00

(without transformer) \$24.00

ETI 470 60W Kit of parts \$26.50

(without heatsink) \$23.00

ETI 480 50W Kit of parts \$17.50

ETI 480 100W Kit of parts \$22.50

ETI 084 Car Alarm KIT \$11.50

EA TV CRO ADAPTER KIT \$29.00

EA 300W POWER AMP MODULE \$63.50

ETI 466 300W PA MODULE \$63.50

EA DIGITAL CAPACITANCE METER KIT (EA

March 1980) \$52.99

AUTOCHIME KIT \$29.75



2 channel infrared remote control

**\$65.00**

## LE GONG

Fantastic doorbell using the new Siemens SAB 0600 chip. Kit of parts \$15



LE GONG

## INCREDIBLE!!!

E/A has really done it this time. Display your Hi/Fi response on your colour TV. It will really impress your friends. Kit of parts \$99



## EA Power Saver

August EA, an interesting approach to power savings. Kit of parts \$32.50

## ETI147 OCT 80 ELECTRONIC LOAD

Kit parts \$75.00

## ETI327 TURN HAZARD UNIT

Kit parts \$22.00

## EA DIGITAL ENGINE ANALYSER

Oct 80 80TM8a/10 kit parts inc front panel \$44.95

## EA CAR BATT VOLTAGE MON

Oct EA kit parts \$6.50

## EA BIPOLAR TRAIN CONTROLLER

Nov 80 kit parts \$26.00

## EA DIGITAL STORAGE CRO

Adapter Nov 80 kit parts \$78.00

## EA LIGHT BEAM RELAY NOV 80

Kit of parts \$13.00

## EA RS232 PRINTER INTERFACE

Nov 80 kit parts \$15.00

Please debit my Bankcard.  
Bankcard No. ....  
Expiry Date .....  
Name .....  
Signature ..... EA 10/81

Post &amp; Pack \$2.50 small kits, heavier kits add extra postage

Prices subject to change without notice. Send 60c and SAE for free catalogues.  
MAIL ORDERS: PO Box 135, Northcote, Vic 3070. Minimum pack and post \$1.00.  
Phone (03) 489 8131.

# ROD IRVING ELECTRONICS

425 HIGH STREET, NORTHCOTE 3070, MELBOURNE, VICTORIA. Ph (03) 489 8131. Telex No. 38897

Place a temporary link in the "B" position on the board, or close the switch if you are using one. Install U10, and check that pin 12 of U41 shows an oscillating output. U10 is a latch which places the settings of links A, B, C and D on the data bus, as shown in the circuit diagram. Pin 12 of U41 is an output which selects the first bank of RAM (the topmost bank on the circuit diagram).

Install U25 and U75, the flipflops which control the timing for the RAM. The critical outputs here are pins 7 and 9 of each chip. They should show oscillating signals as the processor selects the memory for reading and writing. Insert U18 and watch the LED and the VDU. They should both flash on and off with a cycle time of approximately eight seconds. At the same time the cassette motor control relay should open and close.

If this does not happen first check the outputs of the latch itself for the correct signals (a low level occurring every eight seconds on pins 5, 7 and 15 of U18). If these are correct check that the LED and the BC327 transistor are correctly orientated. Also check that the resistors and capacitors of this portion of the circuit are of the correct values. At the completion of the test remove link B, or open the switch in the B position.

At this point, install the first row of RAM chips (Bank 0). Switch on the computer and look for a pattern of characters on the screen of the VDU. Close link A and push the reset switch if necessary. The screen should clear and the words "SUPER-80" Vn.n" will appear at the top centre. On the left of the next line a full stop should be displayed.

With U78 installed, check that pin 8 of U15 shows an oscillating signal. This is the  $\overline{RD}$  signal for the S100 connector, and may be used by S100 boards which require refreshing. When U49 is installed, pin 8 of the chip should show an oscillating signal, shown as  $\overline{RD}$  on the circuit diagram. This signal is produced by NANDing address lines A3 to A7 together, and is applied to the Chip Enable input of the PIO. Unless the signal is present the PIO will not be able to read the keyboard.

To determine whether the PIO is operating correctly look for signals on the pins of Ports A and B. The pins to examine are shown in the keyboard section of the circuit diagram. Also check the values of the eight pull-up resistors shown on the Port B lines of the PIO.

If the cassette interface is not working correctly, first repeat the calibration procedure given in the previous article. Try reading the Basic interpreter tape while monitoring pin 3 of U10 with an oscilloscope. The input to this buffer is on pin 2. Trace the signal from the cassette through the decoder circuitry (U79, U1 and associated components).



### Memory Test Program

21 00 01	LD HL, 0100	Load 0100 into HL
01 00 10	LD BC, 1000	Load 1000 into BC
16 AA	LD D, AA	Load AA into D
72 LOOP	LD (HL), D	Load contents of D into address in HL
0B	DEC BC	Decrement BC (Subtract 1 from Count)
78	LD A,B	Load contents of B into Accumulator
B1	OR C	OR contents of C with Accumulator
CA 04 C0	JP Z C004	Result will be 0 if B and C are both zero so jump back to Monitor
23	INC HL	otherwise increment HL (add 1)
18 F6	JR LOOP	And return to LOOP to repeat program

Check that all component values are correct. If no errors can be discovered try replacing U79, the Phase Locked Loop decoder, and/or the LM311 used as a comparator. Also check the cables you are using for faults or bad connections to the printed circuit board.

We have gone to some length in describing these tests, trying to cover any eventuality and also give some details of the circuit operation at the same time. Readers contemplating building the Super-80 should not see this section as a catalog of faults which have occurred. In fact, provided normal care is taken with assembly we fully expect that most Super-80s will work the first time they are switched on.

### Memory test program

Although in general memory chips are highly reliable, and pass stringent tests before being distributed, occasional errors can happen. Two types of failure can occur. "Hard" errors cause the loss of ability to change the state of one or more bits in RAM. "Soft" errors allow a bit to change but cause it to revert to its original state after a period of time.

This short program fills a block of memory with any selected character. Both the length of the block and the star-

ting address can be selected by the user. Once the program is run, use the "H" command of the Super-80 Monitor to verify that the memory has been correctly loaded. Do not attempt to load data into the top 1K of RAM, as this area is used by the Monitor program itself.

Register pair HL holds the 16-bit address of the start of the block of memory we want to test. For illustrative purposes we will begin the test at 0100 (hex), so the first 256 (in decimal) memory locations will not be filled (a good thing too, otherwise our program would wipe itself out). Register pair BC will hold the number of bytes (memory locations) to be tested. We will test a 4K block (1000 in hex). A single register, D, will hold the character to be loaded into each memory location (FF in this case, but it could be any value up to 255).

Enter the numbers on the left hand side of the column, using the Monitor "E" command and starting at address 0000. Use the "G" 0000 command to run the program. Inspection of the results will quickly uncover any faulty areas of memory.

That's all there is to it. Watch out for the big Super 80 Competition to be announced next month.

# Audio test unit for cassette decks

## Adjust your deck for optimum frequency response

Just about everyone these days who has a stereo system also has a good cassette deck but not many people are able to get the best performance from it. Our new Audio Test Unit allows you to set your cassette recorder's bias for optimum frequency response for a given tape or alternatively, it allows you to find out which tape is best for your recorder.

By **PAUL DE NOSKOWSKI**

Who has not longingly regarded one of those fancy new microprocessor-controlled cassette decks? Those decks where the microprocessor runs a short length of tape, flashes lights and then reverses the tape to the start and "Presto!" the equalisation, bias and recording level are optimised for that particular tape? Those of us who cannot afford this esoteric gear would still like to have an optimum match between our cassette deck and the tape. Our new Audio Test Unit is designed to do exactly this task and save you many hundreds of dollars in the process. Let us now briefly discuss how a cassette deck can be adjusted for optimum results from a particular cassette and then show how our new

Audio Test Unit can fulfil this purpose.

Some microprocessor-controlled decks, like the Nakamichi 700ZXL reviewed in our July 1981 issue, adjust quite a few of their operating characteristics to obtain very good results from just about any tape. But by far the most important parameter is the level of supersonic bias signal impressed upon the tape. If this is too high, the high frequency response of the tape will be seriously curtailed. Alternatively, if the bias is too low, the frequency response may be extended but the recorded harmonic distortion may be excessive.

When the microprocessor-controlled decks referred to above adjust their operating characteristics, they do so by

measuring the response of the tape at a number of selected spot frequencies. Similarly, the Teac A-430 cassette deck, (reviewed in the January 1980 issue of "Electronics Australia") which has an auto-bias feature, measures the response at just one frequency, 10kHz, and its motor driven bias potentiometer rotates until the maximum response at 10kHz is achieved.

No bias optimisation system on a commercial deck that we know of actually performs a corresponding check on the recorded harmonic distortion on the tape. It is too complicated, especially where a number of spot frequencies are concerned. The assumption seems to be that if the bias is adjusted for a reasonably good but not unduly extended high frequency response, then harmonic distortion should be within reasonable bounds. And that should be the case if the designer of the machine has arranged for a reasonable trade-off between frequency response and harmonic distortion within the range of the machine's bias adjustment control.

So if the user is to be able to perform a similar bias optimisation, his machine must have a bias control, either on the front panel or within the unit. With the bias control and our Audio Test Unit, he can easily arrive at the optimum bias setting for a particular tape. Alternatively, even those people who do not have a front-panel bias control on their decks (or are loathe to fiddle around inside the machine) can still use our Audio Test Unit to determine which tape is best for their deck.

Our Audio Test Unit combines an audio oscillator and an AC millivoltmeter within the one case. The oscillator has four spot frequencies, at 40Hz, 1kHz, 10kHz and 15kHz. It has a variable output control which can be set to provide the 1V RMS (or thereabouts) signal required to give 0VU on the average cassette deck and a toggle switch to reduce the signal level by exactly 20dB. This is necessary because it is standard practice to measure the frequency response of all cassette decks at -20dB below 0VU.

The millivoltmeter uses a VU meter movement and has a sensitivity and fre-

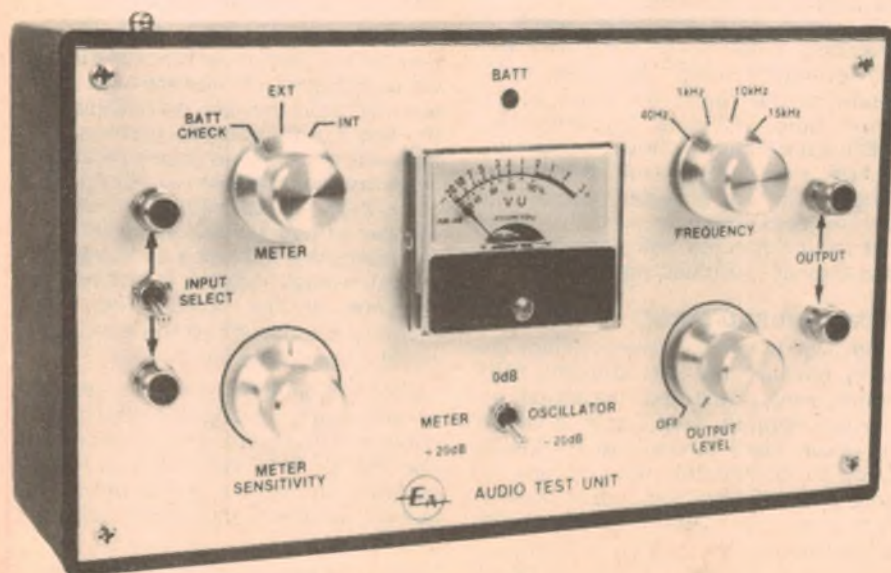

The completed prototype, housed in a low-cost plastic zippy box. Scotchcal front panels for this project are available from the usual retailers.

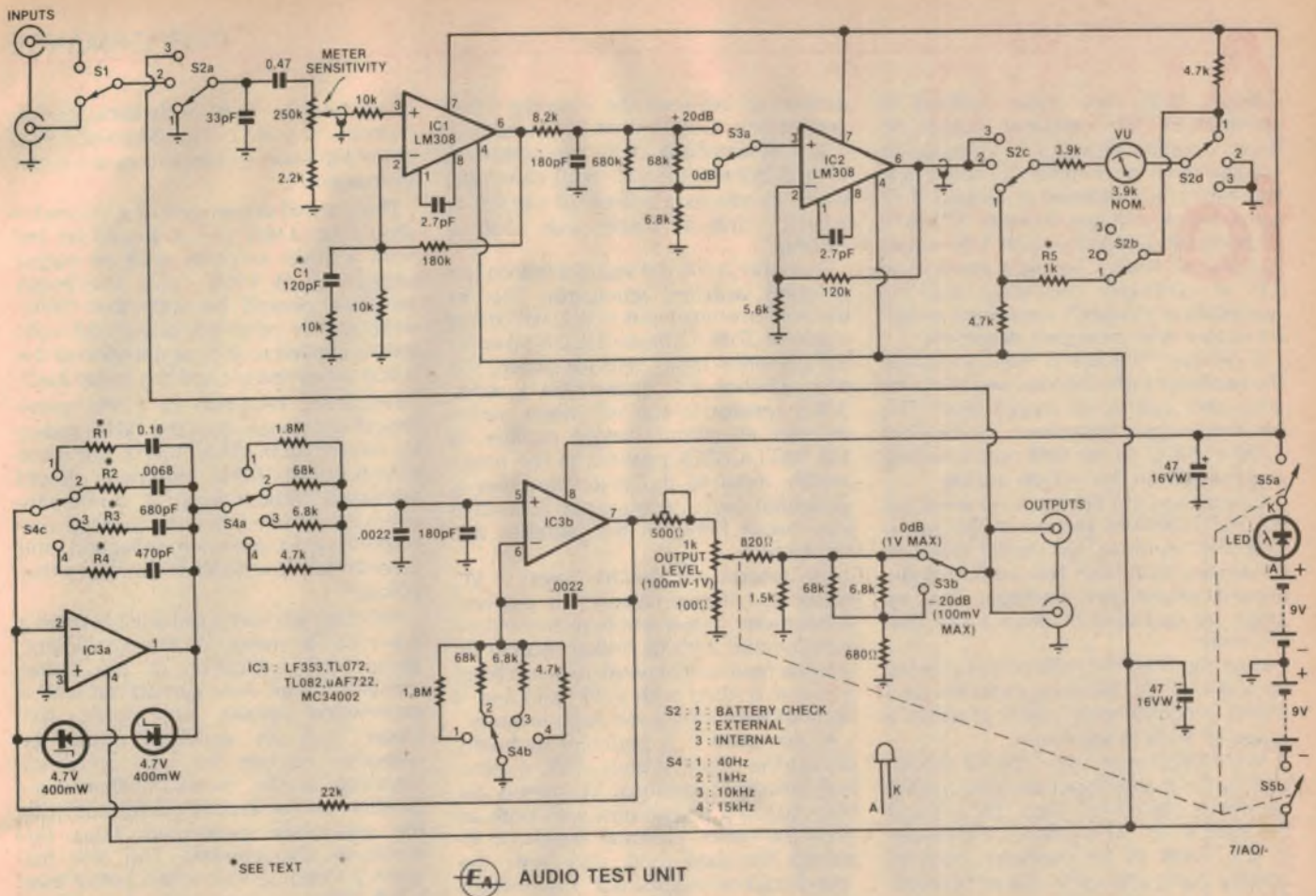

\*SEE TEXT

**EA AUDIO TEST UNIT**

The circuit combines an audio oscillator (IC3a, IC3b) with an AC millivoltmeter (IC1, IC2).

quency response which complements the audio oscillator section. It is also designed so that when the audio oscillator output is reduced by 20dB, the sensitivity of the millivoltmeter is increased by exactly the same amount, so that meter deflection remains the same.

Parallel output sockets are provided for the oscillator, so that both left and right inputs of the cassette deck may be fed with signal. Similarly, there are two input sockets for the millivoltmeter, together with a toggle switch, so that either left or right output of the cassette deck can be monitored.

With appropriate cabling the Audio Test Set could be left permanently connected to your stereo system. This could be achieved by connecting the oscillator outputs to the AUXILIARY INPUTS (usually rarely used) of the amplifier; then installing Y-adaptors on the outputs of the cassette recorder so that signal feed is simultaneously applied to the metering inputs, and the TAPE MONITOR inputs of the amplifier. All that would be required to bring the unit into operation would be to switch "on", and select AUX on the amplifier's function switch.

Referring to the circuit diagram it will be seen the oscillator is designed around a dual Fet-input op amp, with three phase shift networks incorporated in the amplifier/feedback loop. Since IC3a is connected in the inverting configuration,

and IC3b in the non-inverting, the phase change between the input of IC3a and the output of IC3b is nominally 180°. At a frequency where the phase is retarded by a further 180° due to the effect of the three phase shifting networks, the total phase rotation will be 360°, so that the circuit will oscillate at this frequency.

We have taken advantage of the high input impedance of the dual Fet-input op amp by making the capacitor in two of the phase-shift networks fixed and switching the resistors. This allows a cost saving by reducing the number of capacitors required and reduces switching transients when changing frequency. We will explain why the third phase-shift network requires a fixed resistor and switched capacitors, in a moment.

A particular advantage of this phase-shift oscillator design when compared with a more conventional Wein-bridge oscillator is that the envelope stability is very good and remains the same regardless of falling battery voltage (there is a limit of course, and then the oscillator will "clip"). Envelope stability, or to put it another way, a constant amplitude is important when measuring frequency response. One must be sure that any deviations in amplitude are due to the equipment being measured rather than in the oscillator output waveform.

Two zener diodes connected back-to-

back across op amp IC3a keep the oscillator output constant. If the oscillator output tends to increase, the zener diodes begin to conduct, thus clipping the waveform and reducing the loop gain. Any distortion caused by this clipping of IC3a's output is then largely filtered out by the following phase-shift networks. In fact, the 22kΩ resistor in the third phase-shift network (connected to pin 2 of IC3a) just biases the zener diodes into conduction. It was because we needed to maintain the zener current constant that we had to "fix" the value of the 22kΩ resistor and switch the capacitors instead. The resistors R1 to R4, in series with these switched capacitors, allow the oscillator to be adjusted so that its output is exactly the same on each spot frequency.

Note that it is necessary to use 400mW zener diodes, because insufficient current is available to operate 1W (or higher) zeners above their "knee"

We estimate that the current cost of parts for this project is approximately

**\$47**

including sales tax and batteries.

voltage. With this zener method of stabilisation, the oscillator output remains constant down to 11 volts supply voltage (60% of nominal 18 volts); and the harmonic distortion is around 0.3% for all supply voltages down to 12V (67% of nominal). Distortion with 11V supply is 0.5%. At supply voltages lower than 11V it continues oscillating, but the waveform is "clipped", resulting in reduced output with increased distortion.

A resistive network is used to isolate the oscillator from the load and allow for adjustable control of output level. The resulting output impedance varies from 520Ω to 680Ω on the 0dB output setting and is 620Ω on the -20dB setting.

Rather than use Fet-input op amps for the millivoltmeter section of the Audio Test Unit, we used two LM308 precision op amps which have low current drain, around 0.4mA per package. The op amps are cascaded to drive a low cost VU meter.

Input signal to the millivoltmeter is fed via a 0.47μF DC blocking capacitor to a 250kΩ potentiometer which provides a range of 40dB in sensitivity.

As LM308's incorporate internal protective diodes in their input circuitry, a 10kΩ resistor is placed between the pot and the input to IC1. This protects the diodes in the event of an excessive external voltage being applied to the instrument. IC1 is connected as a non-inverting amplifier with a gain of just over 25dB. An optional high frequency boosting network - referred to later in the text - is

connected between the inverting input and ground. Output from IC1 is fed to a 1.3μs de-emphasis network, consisting of an 8.2kΩ resistor and 180pF capacitor, which produces a roll-off of -0.3dB at 30kHz, -1dB at 60kHz and -3dB at 120kHz.

From this point, the signal is fed via the 0/-20dB switched attenuator, S3a, to the non-inverting input of IC2, which has a gain of 27dB. Output of IC2 is taken to the 3-position rotary selector switch, S2c from whence it is applied via a series 3.9kΩ resistor to the VU meter, which includes an internal bridge rectifier. In the BATT CHECK position of the rotary switch, input to the meter amplifier is grounded, and a resistive pad is brought into circuit between the batteries and the meter.

The reason we decided upon a VU meter movement instead of conventional meter movement (which could be incorporated with its bridge rectifier inside the feedback network of an op amp) is that it is fitted with a dB scale and is likely to have very good scale linearity.

At this point it is pertinent to briefly discuss the characteristics of VU meters. High priced professional VU meters are manufactured to conform with both an ANSI (American National Standards Institute) Standard, and also with the "good engineering practice" notes which are appended to the Standard. Characteristics which concern us are sensitivity, impedance, frequency response and ability to withstand overload. Other

characteristics such as dynamic performance and scale colour (Munsell 2.93Y) are of little consequence to its use in this instrument.

The internal impedance of a VU meter should be 3.9kΩ and it should be fed from a driver amplifier with an output impedance of 3.9kΩ also. The meter sensitivity should be such that "0VU" deflection is obtained when 1.28 volts RMS is applied to the combination of the 3.9kΩ series resistor and the meter itself.

Frequency response of a VU meter should not depart from the 1kHz reading by more than 0.2dB at 10kHz, nor more than 0.5dB at 16kHz. The meter should withstand without injury a momentary overload of ten times the voltage corresponding to reference deflection, and a continuous overload of five times that voltage.

Although we have used and specified a low-cost VU meter for this instrument, design and evaluation of the meter amplifier circuit were carried out with a professional quality VU meter. This meter had an excellent frequency response, so that the high frequency response of the meter/amplifier combination almost exactly conformed with the previously mentioned 1.3μs de-emphasis characteristic. The low frequency response was within better than 0.5dB down to frequencies lower than 10Hz. Maximum amplifier output with fresh batteries was approximately 5.5V, RMS which is only 4.3 times the voltage (1.28V) required for reference deflection - thus satisfying the "continuous overload" requirement.

Scale linearity was within better than 0.3dB between -20 and +3dB - this being largely due to maintaining the correct 3.9kΩ source impedance to the meter.

We then substituted several different representative low-cost VU meters, with varying results. Some produced the same frequency response, others were down at high frequencies; the internal impedance of some was within ±20% of the nominal 3.9kΩ, others were quite different; most exhibited the required sensitivity ±1½dB, but one was about 7dB insensitive. Not one of the meters was perfect, but neither did any meter exhibit all faults.

We feel that by either making due allowance for non-conformity with the aforementioned parameters, or by making minor modifications to the circuit, any of these meters could be pressed into service. For instance, if the insensitive meter were used, batteries would have to be changed more frequently, as the voltmeter would not function satisfactorily at a low supply voltage, which would still suffice for a normal meter. In addition, it would probably be necessary to increase the value of R5 (the shunt

## PERFORMANCE OF PROTOTYPE

### OSCILLATOR

Frequencies: 40Hz, 1kHz, 10kHz, and 15kHz

Output Level (open-circuit):

0dB max 1V RMS	-20dB max 100mV RMS
min 100mV RMS	min 10mV RMS

Output Level Stability: within ±0.5dB

Internal Output Impedance: 600Ω ±15%

Distortion: 0.3%

### AC MILLIVOLTMETER

Input Impedance: 250kΩ in parallel with 50pF

Sensitivity (uncalibrated) - for reference deflection

0dB min 5V RMS	+20dB min 500mV RMS
max 40mV RMS	max 4mV RMS

Frequency Response: within ±0.5dB from 10Hz to 25kHz

### BATTERIES

Type: 2 X 9 volt Eveready 216, or equivalent

Current Drain: 4.5mA

Service Life: approx 150 hours for 2 hours use per day

resistor in the pad which samples battery voltage).

For example, if the Dick Smith VU meter was used (catalogue Q-2050), it would be necessary to reduce the value of the 3.9kΩ resistor to 150Ω and reduce R5 to between 8.2kΩ and 10kΩ.

We chose to use a "Kyoritsu KM48" meter, (purchased from Radio Despatch Service) which had an internal impedance of about 4.5kΩ, and approximately normal sensitivity. Thus we had no problems with either sensitivity or battery life. However, the frequency response of this particular meter was down about 0.5dB at 15kHz with an increasing error as the frequency was raised. To compensate for this problem, we applied complementary high frequency boosting by means of C1, at the inverting input of IC1. The value of C1, for this meter, was found to be 120pF. Note that there is a 10kΩ resistor in series with C1 to limit boost to the lower ultrasonic frequencies.

Power from the batteries is applied via a "switchpot", which then functions as the oscillator output level control. The positive rail is fed through a series LED to give indication of the "batteries on" condition. By this method no additional current drain is incurred, and the slight drop (1.5V) is of little consequence as far as operation is concerned.

Note that all quoted test figures were taken with this LED in circuit.

### CONSTRUCTION

We built our unit into a plastic "zippy" box measuring 196(W) × 113(H) × 60(D)mm, and constructed the circuit on a printed circuit card measuring 119 × 78mm and coded 81a010.

Construction may start by assembling the components onto the printed circuit card. However since some of the components (C1 and R1 to R4) will require adjusting on test, it is advisable to omit them at this stage. Leave the space for C1 open-circuit, and install individual shorting links across R1 to R4. As these four links will be removed later, it is suggested that they be placed on the underside of the card to facilitate their later removal.

Start assembly by installing and soldering into place all the terminal pins to which the external leads will be attached. Then install the four "links", diodes and resistors. Follow the overlay provided to assist in the orientation and positioning of the components. Then mount the "taller" components (trimpot, ICs, and capacitors). Make sure that all polarised items are correctly oriented, and that the resistor and capacitor values are as per the circuit. Also ensure that, in addition to the four permanent links, the four temporary links (across R1 through R4) are in place.

Readers will note that the PC card can

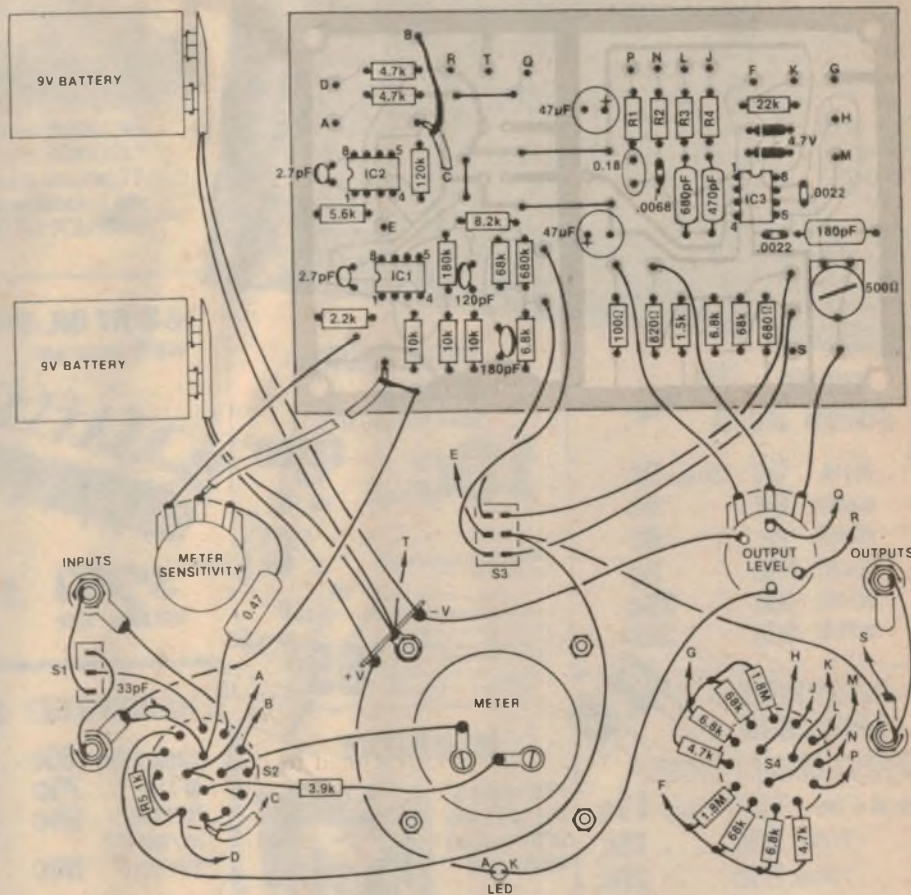

Follow this diagram when wiring up the Audio Test Unit. The PC board can be cut in half and the two sections used separately if desired.

be cut down the middle and the circuit built in two sections if desired. With this in mind, we made provision for two extra supply bypass capacitors, which explains the two vacant component spaces on our prototype card.

Once the printed circuit card is complete, the case can be drilled to accept the two battery mounting clips (we used 16mm "tool clips"). This done, drill mounting holes for the printed circuit card, and mount it in the case with plated machine screws and nuts, using 6mm clearance spacers between the floor of the case and the card. It is inadvisable to use longer spacers, as there could be interference between the components on the panel and those on the card.

The next step is to fix the self-adhesive Scotchcal label to the front panel, and drill the holes for the controls and meter. Now mount the meter and controls, and wire up the rear of the panel according to the diagram. Note that the tagstrip for the battery leads is mounted under one of the nuts securing the meter to the panel. Be sure to fit insulating sleeves over the lead junctions to the LED.

We now come to the final and most difficult part of the construction, which is

the interwiring between panel and card. Select the various pieces of "ribbon" cable, as per the wiring diagram, and terminate them onto the card terminals exactly according to the diagram. With the card positioned in the case, lay the front panel face down in front of the case. Now, one by one, cut each cable to length and connect to the appropriate point on the front panel. It must be emphasised that care should be exercised to ensure that the connections are made exactly as per the wiring diagram, as one error could prove quite difficult to locate.

Note that there are two lengths of shielded cable used in the interconnections. One is from the moving arm of the meter sensitivity potentiometer to the card; the other is from the meter amplifier output (card terminal pin) to the 3-position meter selector switch.

Construction should now be complete. If the interconnecting cables are correctly dressed, you should be able to "fold" the panel onto the top of the zippy box, similar to closing the cover on a book.

### TEST AND ALIGNMENT

Turn the meter selector switch to the BATT CHECK position, the meter sen-





## Sony TA-AX5 stereo amplifier

gain access to the neatly laid out interior. Layout follows conventional practice with a major printed circuit card supplemented by several smaller cards as required. Overall dimensions are 430mm wide  $\times$  325mm deep  $\times$  80mm high, and the mass is 4.9kg — only about half the mass of other amplifiers of similar size and power.

Notwithstanding the inclusion of the switch mode power supply, there is a small transformer of about 10VA located behind the display area of the front panel, and which we presume is used for powering the displays.

Instead of the usual heatsinks for the power output stages, Sony have opted for a copper heatpipe with 32 square radiating fins (approx 60  $\times$  60mm).

The particular model we had in for review was a Japanese prototype. As such, it was neither earthed, nor double-

We found that the maximum continuous power output at the onset of clipping, with both channels driven, was 55 watts into 16 $\Omega$ , 85 watts into 8 $\Omega$ , and 34 watts into 4 $\Omega$ . With only one channel driven, the figures were 63 watts, 100 watts and 35 watts respectively. At 70 watts output per channel (simultaneously) into 8 $\Omega$  loads, the 1kHz distortion measured 0.014%, rising to 0.07% at 10kHz and 0.1% at 20 kHz. For 45 watts output into 16 $\Omega$  loads, the distortion figures were essentially the same. These are very good figures indeed.

An altogether different picture was revealed when feeding the output into 4 $\Omega$  loads. At 30 watts output per channel, the distortion was about 0.3% between 40Hz and 10kHz, rising to 1% at 20kHz. Reducing the output to 20 watts per channel, distortion improved to

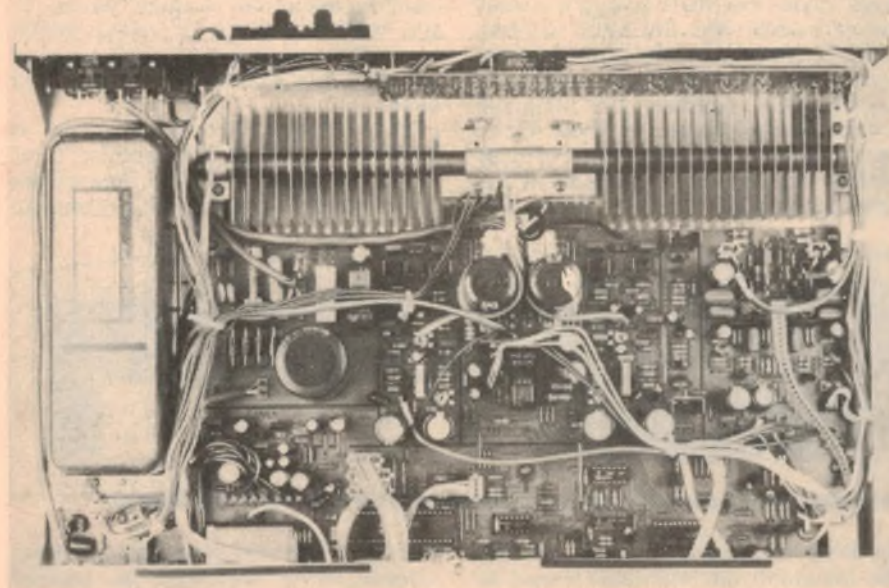

Note the heatpipe for the power transistors and the box for the switch-mode supply.

insulated and was intended for operation from a 100 VAC supply. Sony (Australia) Pty Ltd have assured us that all versions to be offered for sale in Australia will be modified for 240 VAC operation and be double-insulated.

For the TA-AX5 Sony claim a power output of 70 watts per channel (both channels driven) into 8 $\Omega$  loads with distortion of 0.005%. Performance testing, using a regulated 240 VAC source feeding a large Variac, was carried out after our standard one hour preconditioning at 40% of rated output. While there was no deterioration in performance, the perforated area of the top cover — above the heatpipe and its fins — became almost too hot to touch during the power output tests. Thus adequate space should be made available around and above the TA-AX5.

0.07% between 40Hz and 10kHz, rising to 0.1% at 20kHz. So the TA-AX5 can really only be classed as a "20 watt" per channel amplifier when driving 4 $\Omega$  loads! And now the reason behind the series speaker switching is apparent. The TA-AX5 is one of those rare amplifiers which have insufficient current drive capabilities to comfortably work into 4 $\Omega$  loads.

Under normal load conditions the TA-AX5's ability to handle square waves was excellent. It was only if the 8 $\Omega$  load were shunted with a capacitor of 0.5 $\mu$ F or larger, that a small damped oscillation became visible at the half-cycle transitions. As almost all other amplifiers exhibit similar characteristics, the TA-AX5 must rate highly in this test. Tests for stability with sinusoidal input signals and varying capacitance shunting the load,

indicate that the TA-AX5 is unconditionally stable.

Frequency response for the "high level" inputs is within  $\pm 0.5$ dB from 10Hz to 15kHz, 1dB down at 25kHz, and 3dB down at 50kHz. RIAA equalisation on the phono inputs is within  $\pm 0.5$ dB between 20Hz and 10kHz, falling to -1dB at 20kHz.

Unweighted signal-to-noise ratio on the high level inputs is 93dB with respect to 70 watts into 8 $\Omega$ , corresponding to 75dB below one watt output — an excellent figure. On the MM phono inputs, the signal-to-noise ratio is 74dB with respect to an input level of 5mV at 1kHz, using a typical MM cartridge as the input termination — another excellent figure.

[We have referred the signal-to-noise figures for the MM phono inputs to a reference 5mV signal @ 1kHz, not 10mV as used in our previous amplifier reviews. We have done this to conform with the Institute of High Fidelity (IHF) Standard, IHF-A-202 (1978), which is the accepted yardstick for such testing.]

The TA-AX5 is furnished with a changeover switch to enable selection between MM and MC phono cartridges. In the MC mode, the input impedance is reduced to 100 $\Omega$  and the voltage gain is increased by 23dB. Unweighted signal-to-noise ratio is 68dB with respect to an input level of 500 $\mu$ V at 1kHz — the IHF standard input reference level for MC phono inputs — using a 100 $\Omega$  resistor (the IHF standard input termination) as the input termination. While this is the first time we have measured and published MC phono input S/N figures for a commercial amplifier, we believe that this figure of 68dB is very good.

Phono input overload, in the MM mode, occurred with an input level of 120mV at 1kHz which is adequate. Maximum sensitivity (to produce 70 watts into 8 $\Omega$ ) measured 0.17mV (170 $\mu$ V) on the MC phono inputs, and 2.4mV on the MM phono inputs. Ultimate sensitivity on the high level inputs was 140mV.

Interchannel separation was 90dB at 1kHz, 86dB at 10kHz and 80dB at 20kHz — an excellent performance, and probably the best we have ever recorded for separation. The figures were essentially the same for both high level and phono inputs.

Playing selections of music through the TA-AX5 confirmed our test results. Apart from its marginal performance into 4 $\Omega$  loads, and the circuitry for A plus B loudspeaker switching, the TA-AX5 is above average in performance in its class and also offers many unique features which could well make it just what you have been looking for.

Recommended retail price of the TA-AX5 is \$499 including tax. Further information can be obtained from high fidelity retailers, or the Australian distributor — Sony (Australia) Pty Ltd, 453-463 Kent St, Sydney, NSW, 2000. (P.de N.)

# Cleans your heads twice a play.



At Maxell, we give you 25 centimetres of head cleaner at the start and finish of every tape we make.

It's right there on our leader.

Our leader also tells you which side of the tape you're playing, A or B.

And it also gives you a five second

cueing mark, so you can set your recording levels without wasting tape.

Then there is the tape itself. Maxell is recognised by most critics as the finest recording tape money can buy.

What else would you expect to follow our leader?

**maxell®**

A 73-note piano for home or stage

# LYREBIRD

- \* TOUCH-SENSITIVE!
- \* WITH SOFT & SUSTAIN PEDALS



In these days of home-centred entertainment a piano is a joy to behold and a pleasure to play or listen to. Unfortunately, not many people can afford the cost of a new piano, at around \$2000 or more, but most people could afford and accommodate our new Lyrebird electronic piano. It is light and compact, offers the full facilities of a piano and more, at a fraction of the cost. And you will never need the services of a piano tuner.

by LEO SIMPSON & GREG SWAIN

There is no gain saying the fact that to most people, a piano is a highly desirable instrument. Fortunate indeed are those people who have a piano in their homes and still more fortunate if they can play it. But desirable as they are, pianos are not without their drawbacks. They are large and bulky and their weight makes them very difficult to move. And whether it is played or not, a piano should be regularly tuned. It should also be proofed against mice and moths as well as being generally looked after.

Our Lyrebird piano does not have any of these problems. Being all electronic, it is light and compact and very easy to carry. If necessary it can be stored away in a closet and you can tune it yourself with just one single adjustment.

The Lyrebird has 73 keys which is adequate for just about all types of music and it has the normal Soft and Sustain pedals of a piano.

Where the Lyrebird differs substantially from a conventional acoustic piano is in the extra facilities it offers. For a start, you can connect an ordinary pair of stereo headphones so that you can play in absolute silence and not disturb anyone. That can be a decided advantage to students and professional performers who need to put in long hours of practice.

Other facilities offered by the Lyrebird are additional piano voices such as Honky-Tonk and Harpsichord and effects such as Tremolo and Phasor. These voices and effects can be used singly or in combination to achieve a wide range of satisfying sounds — it can even be made to sound like a Jamaican Steel Band!

One point which must be emphasised is that the Lyrebird represents a considerable refinement over electronic organs which happen to offer a piano voice. Electronic organs have keys which

have a simple on-off action so that the only way you can add "expression" is with the swell pedal. By contrast, the Lyrebird is touch-sensitive to imitate the keyboard action of a real piano.

An experienced player can elicit a tremendous range of expression from a conventional piano. He exploits the fact that the piano hammer mechanism varies the loudness and tonal quality of the note, depending on how hard the key is struck. The Lyrebird imitates this action by employing circuitry which measures the speed of key depression so that the harder the key is pressed the louder the note.

We must admit that the Lyrebird does not go all the way in imitating a real piano. For example, it cannot distinguish between very quick and light playing and fortissimo (very loud) playing. Nor can it vary its harmonic structure depending on whether it is played softly or loudly. Even so, an experienced player will quickly adapt to it and exploit its full dynamic range which is over 30dB.

What other features does the Lyrebird have? As presented, it is intended mainly for stage use and it requires an external power amplifier and loudspeaker system. If you wish to use it in the home it could be built as we present it or it could incorporate its own power amplifier and loudspeaker system within a piano-style cabinet.

For easy portability, the Lyrebird can be fitted with removable legs which also have provision for changing the keyboard angle when used in conjunction with other keyboard instruments.

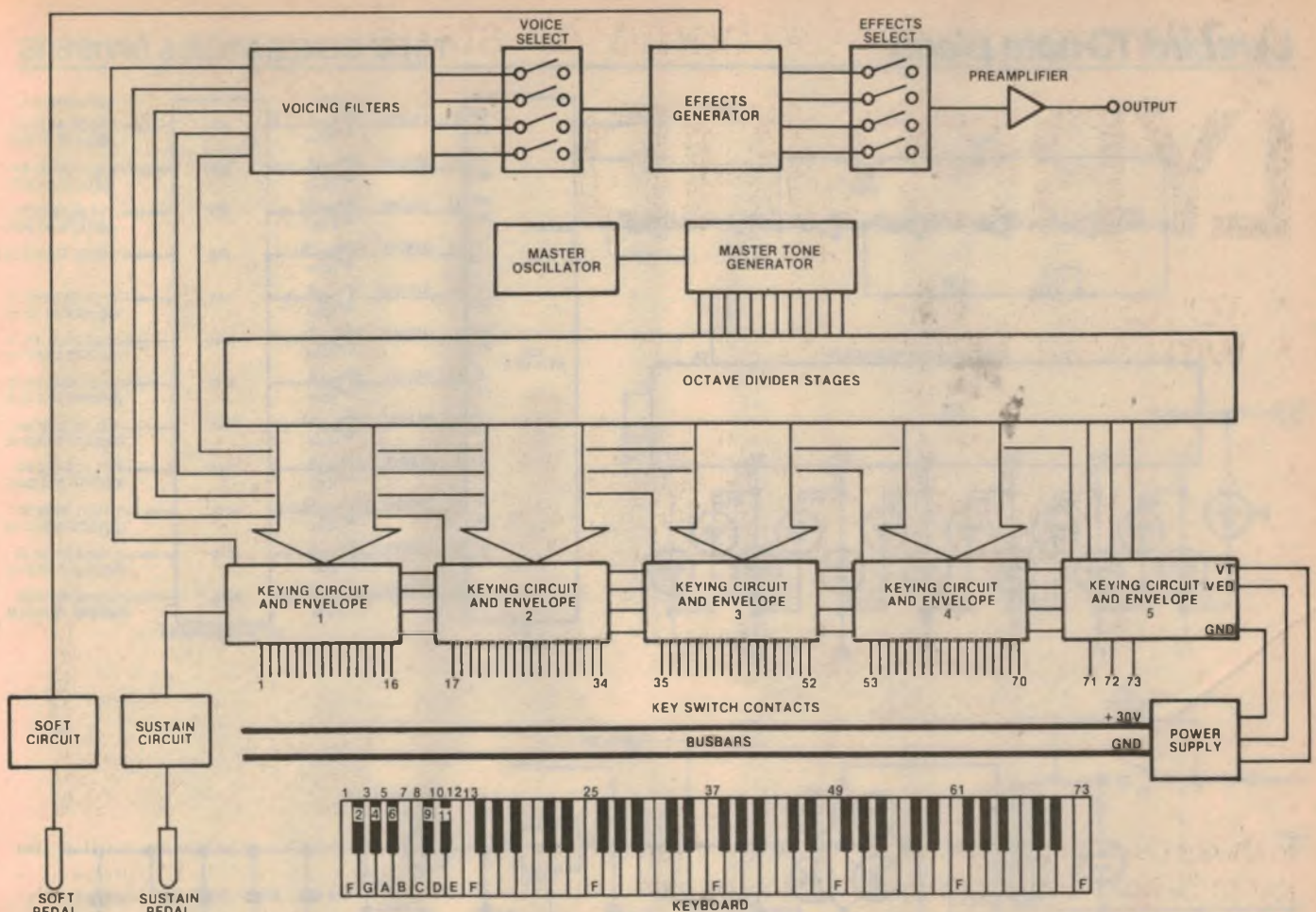

This block diagram shows all the features of the Lyrebird piano. Each note on the keyboard has a number from one to 73 and there is a corresponding octave divider output and keying circuit. Middle-C is key 32 while A-440 is key 41.

Whichever way you decide to house it, we are sure that that will find the Lyrebird project very satisfying to build. While there is quite a lot of work in the assembly, construction is straightforward and can be done in easy stages.

And how much is all this likely to cost? Around \$525 or so, plus the cost of a power amplifier and loudspeaker system. If you already have these, then you will be so much further ahead. Either way, the cost is but a fraction of the cost of a brand new full size piano.

As far as the power amplifier is concerned, a minimum requirement is a rating of 30 watts RMS, with 50 to 100 watts RMS being preferable. And unless your loudspeakers are particularly rugged, do not think of using your hifi system for this job. While a typical hifi amplifier of 50 or 100 watts is quite suitable the loudspeakers must be designed for the rugged requirements of musical instruments. Since the piano relies on very high peak power signals of short duration to produce an acceptable average power level, it is quite easy to overload conventional loudspeakers.

Now let us have a look at the block diagram of the Lyrebird and discuss the function of the different sections.

As with most electronic organs these days, the Lyrebird derives the frequencies for all its notes from a single master oscillator. This is divided down by factors from 239 to 451 in a top octave generator IC to give 12 separate frequencies, each related to the next by the 12th root of two. These are then divided by octave divider stages to give a separate waveform for each key, in this case, 73 outputs.

Each piano key controls a pair of changeover contacts which control an individual envelope keying circuit. In other words, there are 73 keys and 73 individual envelope circuits. There are five separate envelope circuit PC boards and these feed a large PC board containing the voicing filters and effects circuitry (Tremolo, etc). Also accommodated on this board is circuitry for the Sustain and Soft pedals. Finally, the power supply produces regulated rails for the dividers and the voicing filter PC board as well as supply rails for the envelope keying circuits.

The circuit of the Lyrebird is adapted from an 88-note piano design currently being supplied by Jaycar Pty Ltd, 380 Sussex Street, Sydney, who will also be supplying kits for the Lyrebird. We thank

Jaycar for their assistance and co-operation in this project which would not otherwise have been possible.

For the remainder of this article we shall concern ourselves with the large PC board which accommodates the power supply, master oscillator and tone generator plus the octave divider stages. Now refer to the circuit of this board. This has been abbreviated because a large amount of the circuit is repetitive.

In its abbreviated form, the circuit of the tone generator board looks quite simple but remember that it uses a total of 18 ICs and some 154 diodes!

IC1, a 4069 hex inverter, is used for the master oscillator. All six inverters in the package are hooked together in a slightly offbeat arrangement which oscillates at around 1.588MHz. A 1kΩ trimpot provides a small range of adjustment for the oscillator so that the Lyrebird can be tuned to match other instruments.

The master oscillator is used to clock IC2, a General Instruments Top Octave Generator (or Synthesizer) type AY-1-1012, which produces an octave of frequencies from 3520Hz (A) to 6642Hz (G-sharp). These 12 outputs are buffered by two hex inverters, IC3 and IC4, before being fed to 12 4024 7-stage ripple counters which develop the frequencies for the six octave range of the Lyrebird which is from G, 43.6Hz to G, 2795Hz.

In order to roughly simulate the harmonic structure of a real piano the

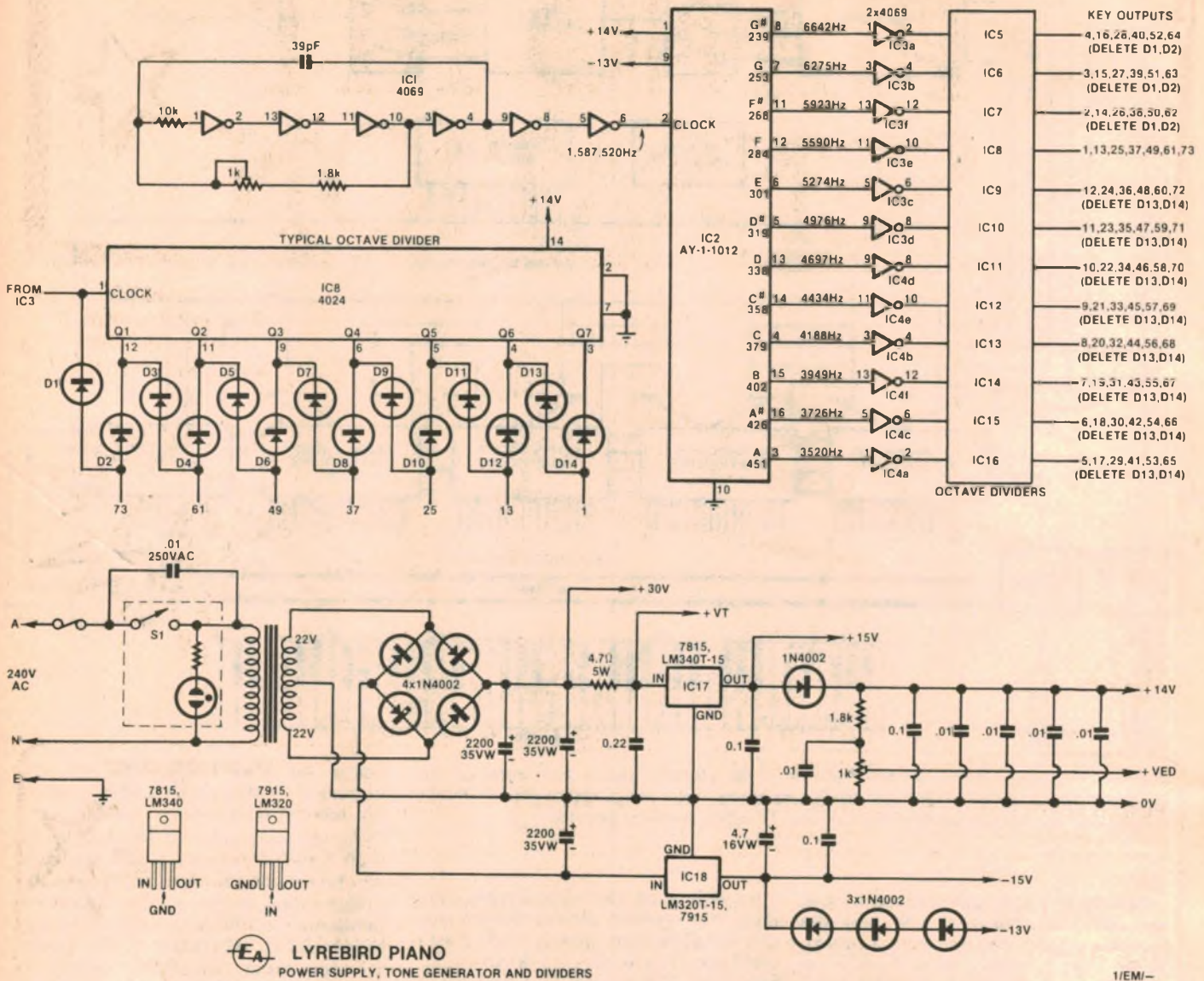

In order to keep the size of this circuit within reasonable bounds only one of the divider stages, IC8, is shown complete. The other 11 dividers are shown in block form with a table of diodes to be deleted.

envelope keying circuits are fed with a waveform which has a mark:space ratio of 25%. This is obtained by diode mixing as is depicted on the circuit by showing just one of the 4024 octave dividers, IC8. This has a network of 14 diodes, two for each output. IC8 actually produces all the F notes on the keyboard. Similarly, IC5 produces the six G-sharp (shown as G#) notes, IC13 produces the six C notes and so on.

IC8 produces the waveform for the top F-note on the keyboard (note 73, 2795Hz) by mixing the clock input (5590Hz), pin 1, with the first divided output Q1, at pin 12 (2795Hz), to produce a 25% mark/space waveform with a repetition rate of 2795Hz. When fed through the appropriate voicing filter circuits, this gives a note with a harmonic structure which approximates that on a real piano.

Similarly, the waveform for F above middle-C is produced by mixing the Q3 and Q4 outputs. The reason why we have shown IC8 is that it uses all seven outputs to produce the seven output waveforms which go to keys 1, 13, 25, 37, 49, 61 and 73 on the keyboard. For all the other dividers, IC5 to IC7 and IC9 to IC16, only six outputs are required, so two diodes are omitted from each. This is shown in tabular form on the circuit.

So, reading from the circuit, IC16 produces the six A notes for keys 5, 17, 29, 41, 53, and 65 with the Q7 output being unused and diodes D13 and D14 deleted.

Besides providing the mixing action referred to above, the diodes associated with each 7-stage ripple counter also block signals from the counter outputs to the connecting harness and thereby prevent "beehive" sounds being picked

up by the voicing circuitry. The diodes and the envelope keying circuit actually form an AND gate for each key. We will describe this gating in the discussion on the envelope boards next month.

While the circuitry just described requires only two supply rails, the complete piano requires no less than seven rails. Hence the power supply is fairly complicated. We used a Jones JT-180 centre-tapped 44 volt transformer to power the Lyrebird. Besides being economical, the transformer has plenty in reserve to run a power amplifier of about 35 watts RMS if required. If you do not intend to add an internal power amplifier at a later stage, you could use a lower rated transformer such as the Ferguson PL40/20VA.

The Jones JT-180 transformer, by the way, was used in the Playmaster Twin Twenty Five stereo amplifier and should be readily available.

The transformer drives a bridge rectifier to produce unregulated  $\pm 30V$  rails. Since the positive 30V rail has a much



# PIANO KIT SENSATION



Amazing new E.A. "Lyrebird"  
electronic piano  
Has realistic piano sound!

INCLUDES  
ALL components  
down to the last  
screw and washer!

**TOUCH SENSITIVE**  
The harder you play it  
the louder it gets  
over 30dB range



ONLY  
**\$525**  
COMPLETE



(Stand available as optional extra \$75)

— AS FEATURED IN E.A. OCTOBER — NOVEMBER 1981 —

## BUY THE INDIVIDUAL MODULES

**POWER SUPPLY AND TONE GENERATOR KIT PSTG-2 \$87.50**

Includes transformer, fuse holder, fuse, mains cord and socket, P.C.B. and all components necessary to construct the tone generator and power supply

**ENVELOPE ASSEMBLY KIT KIT EA-2 \$94.00**

Includes P.C. boards and all resistors, capacitors and diodes. P.C.B. pins are provided for easy connection to the tone generator.

**VOICING AND EFFECTS GENERATOR KIT EVG-2 \$58.50**

Includes P.C.B. and all components including switches, knobs and output sockets.

**HARDWARE & CONTACTS PACK KIT HCP-2 \$47.00**

Includes all nuts and bolts, wire and switch mounting brackets. The contact pack includes silver contact springs, gold plated rod, rod supports, spacers and screws.

**CABINET KIT CB-2 \$82.50**

Partially assembled cabinet with solid timber ends and front ready for oiling or staining and including pre-folded and punched black marviplate cover, plus front and rear panels, pre-punched and silk screen printed.

**73 Note Keyboard including hinge for mounting KIT KB-73 \$169.50**

**PEDAL ASSEMBLY KIT PA-2 \$47.00**

A free standing unit containing two pedals in a neat black box with rubber feet. Each pedal operates its own SPDT contact. Contacts have solder tags and a grommated hole and cable clamp are included.

Complete construction manual — FREE with any of the above or  
**\$5.00 including postage**

## FULL SPECIFICATIONS

### MUSICAL COMPASS

6 Octaves F — F

### FREQUENCY COMPASS

Fundamental Frequency Range

43.67Hz—2795Hz

Master Oscillator 1.588 MHz

### TOUCH CHARACTERISTICS

Dynamic Range greater than 30dB

Key Action approximately 50 grams

### SOUND ENVELOPE

Touch Range 2 to 40mS

Attack Period less than 1mS

Early Decay 500mS nominal

Sustain 2 to 6 seconds

### CONTROLS

On/Off Switch

Normal Voice Select

Mellow Voice Select

Bright Voice Select

Harpsichord Voice Select

Honky Tonk Voice Select

Tremolo Effect Select

Phase Effect Select

Sustain Foot Pedal

Soft Foot Pedal

Pitch Control

Pedal Output

High Level Output

Headphone Output



# Jaycar

NOTE! NEW  
SHOP HOURS  
Mon - Sat 9am - 5.30pm  
Sun 10am - 2pm  
Open Thursday night  
until 8pm



**380 Sussex St Sydney 2000**

Ph. 2646688 Telex 72293

Mail Orders To: Box K-39 Haymarket 2000

**CALL IN AND PLAY THE PIANO YOURSELF!**  
A demonstration cassette is available for only \$5

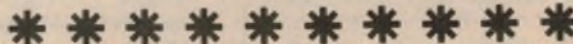

If you are an organ enthusiast why not check out our  
String Ensemble kit while you are at the showroom?

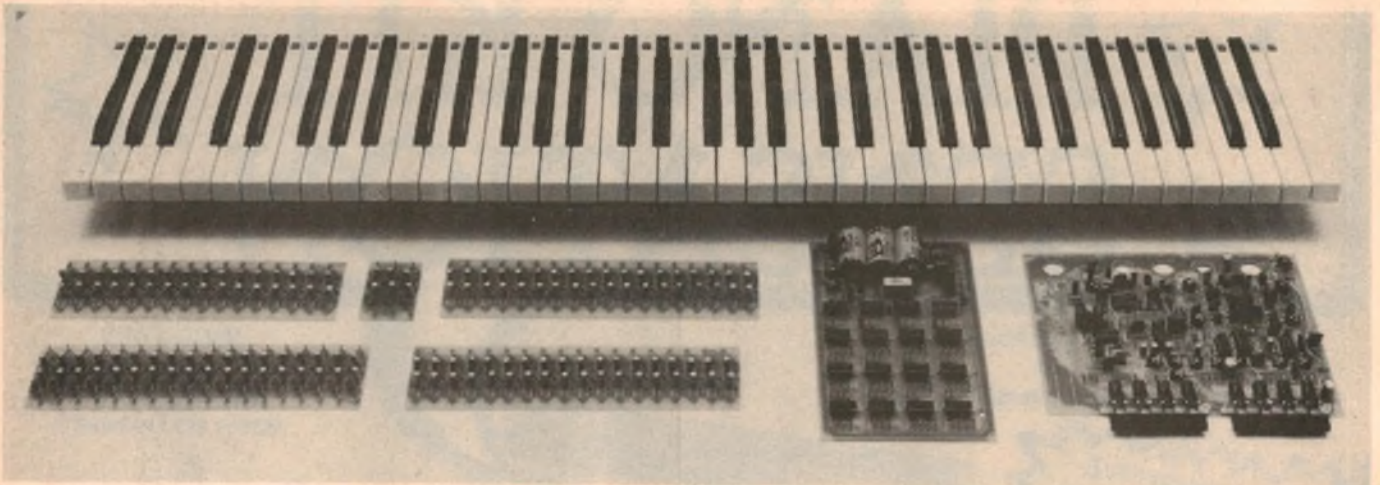

*Pictured above are the main component assemblies for the Lyrebird piano; the five envelope boards are on the left while the voicing board is on the right. At left is the completed piano mounted on its optional legs but with the pedals not shown. Below is the assembled prototype board which differs slightly from the diagram across the page.*

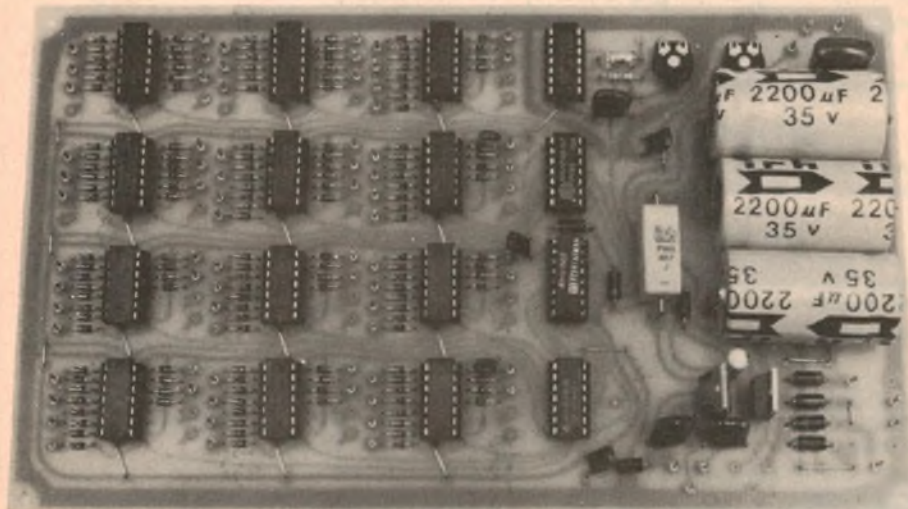

higher current drain it has two 2200µF/35VW capacitors while the negative rail has only one capacitor of this value.

A large portion of the current drain from the positive 30V rail is fed to the envelope boards via a 4.7Ω/5W resistor. This rail is labelled +VT. Positive and negative three-terminal regulators derive

±15V rails while additional series diodes are used to derive +14V and -13V rails. Finally, a voltage divider with a trimpot is connected across the +14V rail to derive V.E.D. which is connected to the envelope boards. Supply bypass capacitors are sprinkled over the tone generator board to keep hash to a minimum

Construction of the tone generator board is straightforward but should be done in stages with testing at the end of each stage before proceeding to the next. Before starting assembly carefully examine the board for any bridges between tracks or breaks in the tracks themselves. These should be marked and repaired before proceeding further. Also check that all the holes are drilled because it is annoying to have to drill a partially assembled board and there is a risk of damage to the components.

Install the links first and then the PC pins. PC pins are mandatory for this project since once the boards are installed you will not have ready access to the undersides. You will need 82 pins for this board. Make sure you obtain those which are tight fit before they are soldered: you don't want them coming loose when you solder wires to them.

Now install the components for the power supply. Make sure that you check the polarity of each component before you install it and note that the pin outs for the two regulators are not the same. The regulators do require flag heatsinks but these need not be fitted until you install the board in the piano cabinet.

With all the power supply components in place and soldered, you are ready for your first test. First double check all your wiring and then temporarily wire up the mains transformer to a three-core flex fitted with a moulded three-pin plug.

Just because this is a temporary expedient that does not mean it can be done carelessly. First connect the earth wire to the transformer mounting foot via a solder lug attached securely with screw and nut. Then connect the active and neutral wires to the transformer primary via an insulated terminal block.

Wrap the insulated terminal block thoroughly in insulating tape to make sure that there is no way that you can accidentally come in contact with the mains supply. Now apply power and check each supply voltage, while using a 1kΩ 1W resistor as a load.



Since the current drain from the +30V is negligible at this stage there will be no corresponding voltage drop across the 4.7Ω 5W resistor and so +VT should equal the actual value of the +30V rail. Note that the remaining voltages will be subject to the normal tolerances applying to 15V regulators, ie, ±0.3V.

With all voltages checked and correct, install the remaining passive components and ICs 1, 2, 3 and 4. Sockets are optional and probably not worth the trouble except in the case of IC2, the top octave generator.

When soldering the CMOS IC's use a

## PARTS LIST (Power supply and tone generator board)

1 power transformer, 44V CT 1.25 amps, Jones JT-180 or similar  
1 3-core mains flex with moulded three-pin plug  
1 fuseholder and 0.5A fuse  
1 SPST mains switch with integral neon pilot  
1 tone generator PC board (available from Jaycar and selected distributors)

### SEMICONDUCTORS

3 4069 hex inverters  
1 AY-1-1012 top octave generator  
12 4024 7-stage ripple counters  
1 7815, LM340T-15 three-terminal regulator  
1 7915, LM320T-15 three-terminal regulator  
8 1N4002 silicon rectifier diodes  
146 1N4148, 1N914 small signal diodes

### CAPACITORS

3 2200μF/35VW pigtail electrolytic  
1 4.7μF/16VW tantalum electrolytic  
1 0.22μF metallised polyester (greencap)  
3 0.1μF greencap  
5 .01μF greencap  
1 .01μF/2kV ceramic or 250VAC metallised dielectric  
1 39pF NPO ceramic or polystyrene

### RESISTORS

1 x 10kΩ/¼W, 2 x 1.8kΩ/¼W, 1 x 4.7Ω/5W,  
2 x 1kΩ horizontal mounting trim pots.

small soldering iron with the barrel connected to the 0V rail on the board and solder the supply pins of each IC first, before soldering the remaining pins.

If you have a frequency meter you can now check the operation of the four ICs just installed. The master oscillator frequency can be measured at pin 6 (strictly speaking, at all the other active pins of this IC) and should be around 1.5 to 1.6MHz. Check that it can be varied with the appropriate trim pot.

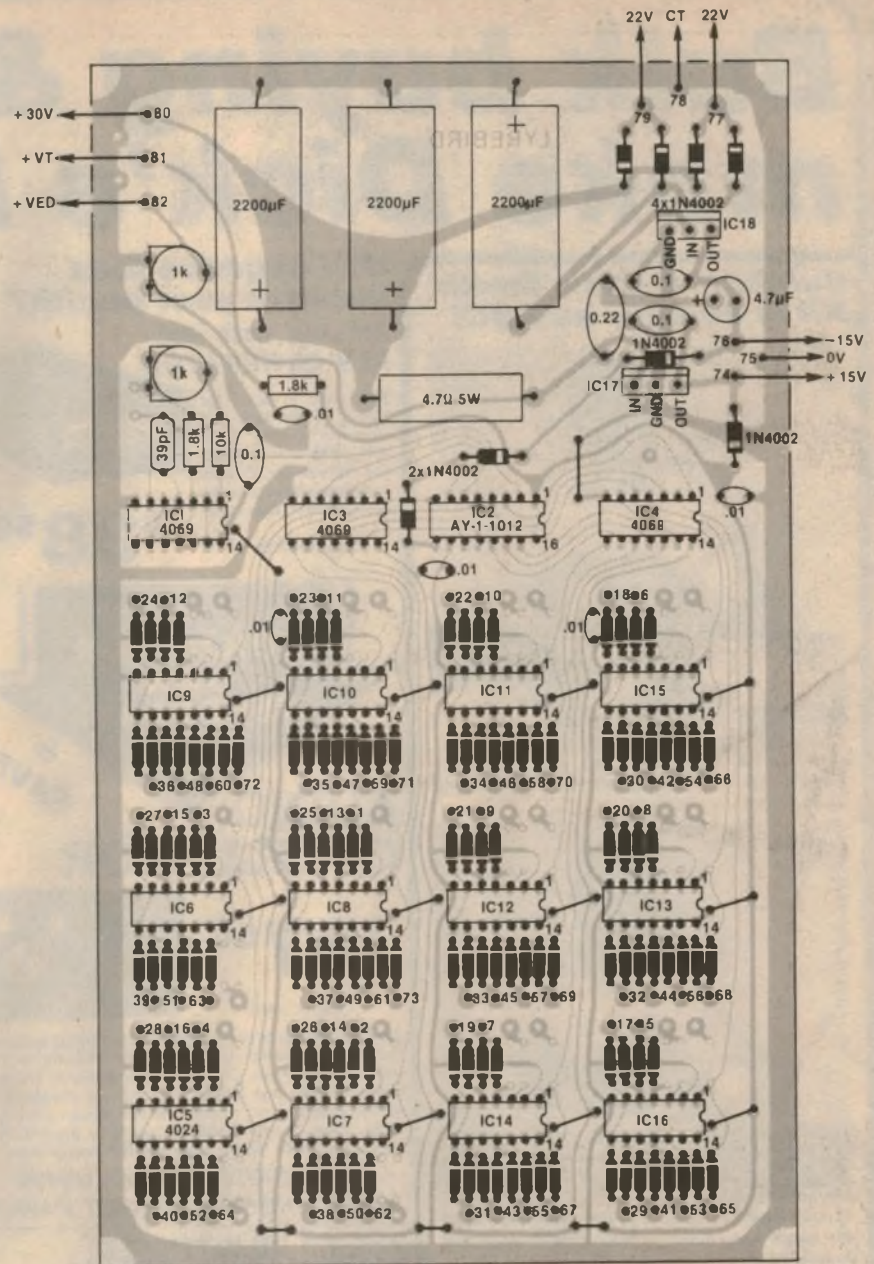

This board provides 73 outputs, one for each note on the keyboard.

Now measure the frequency at pin 3 of IC2 and confirm that it is close to 3.5kHz. If so, adjust the master oscillator trim pot to that the frequency at pin 3 of IC2 is exactly 3520Hz. That done, measure the frequencies at the 11 remaining output pins of IC2. The relevant figures are shown on the circuit diagram. You can also measure these frequencies at the outputs of each of the inverters in IC3 and IC4, and thereby confirm that these are working too.

The next step is to install the 146 diodes associated with ICs 5 to 16, the 12 ripple counters. Note that the diodes all face with their cathode stripes pointing to their associated IC.

Some few (or many) hours later you will be at the stage where you can install the remaining 12 IC's. You may decide to go to bed instead. If it's later than

11.00pm we suggest that you do so . . . Feeling refreshed? That is good. Now go through and reinstall those diodes that are facing the wrong way. Check all solder connections for dry joints and other invisible faults. They are certain to be there so you may as well look carefully for them.

Finally, not too many hours later (we hope), you may install those remaining IC's. Go carefully now and use the same procedure for soldering as described above.

With all the IC's in place you can then use your frequency meter to check each divider stage. An oscilloscope can also be used for this task. Next month we shall describe the envelope keying circuits and the keyboard assembly.

(To be continued.)

# Bulk buying & quality make Dick's Kits the

**Building a Dick Smith Kit is as easy as ABC!**



Everything you need is supplied — parts, solder, even nuts and bolts. And most kits include detailed instruction manuals, making construction a breeze!



It goes together so easily; you don't have to be an expert to build a kit. Just follow the instructions!



And it's finished! Sit back and enjoy your project; because you did it yourself!

**and they look so good your friends won't believe you built it!**

**Will negative ions improve your health?** find out with this **ION GENERATOR**

This easy to build kit breaks down dust and cigarette smoke particles, aids to a healthier and happier life. Comes complete with exclusive Dick Smith emitter head



**\$38<sup>50</sup>**

Cat. K-3335

**BUILD YOUR OWN TEST GEAR!**

**& SAVE!**

**AUDIO OSCILLATOR**

**\$37<sup>50</sup>**



Cat. K-3469

An essential piece of test gear for the serious hobbyist. Covers frequencies from 15Hz to 150kHz in four overlapping ranges. Distortion is less than 0.1% max. between 20Hz and 20kHz. Useful piece of equipment for the experimenter's bench. Simple design and easy to build. Parts supplied include specially printed front panel, attractive 'Zippy' case and full instructions

**DICK SMITH'S EXCLUSIVE SILK SCREENED FRONT PANEL!**

**RLC BRIDGE**

Check the values of new and used components and determine the actual value of wide tolerance capacitors such as electrolytics and ceramics. 10 measurement ranges from 10 ohms to 10 megohms; from 10 picofarads to 10 microfarads. Kit includes specially printed front panel.

**\$37<sup>50</sup>**

Cat. K-3468



**LOW DISTORTION OSCILLATOR**

**\$67**

Cat. K-3467

This audio oscillator provides a low distortion sine wave output and covers a frequency range of 15Hz to 150kHz in four overlapping ranges.

**SOUND DB METER**

Cat. K-3476

**\$35<sup>50</sup>**

Keep potentially harmful noise levels in check, in your home or factory! This meter will measure sound levels of less than 20dB. to over 120dB.

**AND YOU REAP THE BENEFIT!**

**build your own synthesizer!**



Cat. K-3506

**the brilliant**

**Electrochune**

A versatile keyless monophonic organ that uses the circuitry of a synthesizer! It has variable attack/decay, tremolo and mixing control. Plus its own inbuilt amp and speaker with separate volume control. Touch sensitive keyboard. Ideal for people who like to experiment!

**ONLY \$69<sup>90</sup>**

**AND FOR YOUR BENCH**

**BENCHMATE**

An indispensable tool for the bench. Combination 1W audio amplifier and 1.25 — 16V power supply @ up to 1A. Great value!



**\$46**

Cat. K-3478

**EARTH LEAKAGE ELECTRONIC CIRCUIT PROTECTOR**

Cat. K-3315

**\$49<sup>50</sup>**



Avoid electrocution! Build yourself a core-balance leakage detector and you could save a life — maybe your own! Less than half the price of built-up units!

**POOLS/LOTTO SELECTOR**

Picks your winning numbers at random!

**\$19<sup>50</sup>**

Cat. K-3392

**HOT CANARY**

An electronic bird whistle that sounds authentic. Keeps the kids amused for hours!

**\$15<sup>50</sup>**

Cat. K-3395

# control tops!

## AUDIO KITS

### General Purpose Pre-amp

This versatile unit can be built up as a magnetic cartridge pre-amp for upgrading your stereo, a tape or auxiliary pre-amp with 40, 55 or 80dB gain. Extremely simple: uses only one special IC and is very small — all parts fit on a PCB less than 65mm square. Needs no special power supply, from 10 to 40V will do, full instructions supplied.



**\$8<sup>90</sup>**

Cat. K-3427

### Mixer Pre-amp



Completely adaptable mixer for all uses. Has 4 inputs, each with 100k impedance (suitable for guitars, microphones), also provides bass, treble, presence controls plus a master level control. Does not include power transformer, case or any mains wiring, so it's great for 'building in' to other equipment.

Cat. K-3035

**\$29<sup>50</sup>**

### LIGHT CHASER



One of the 'most asked for' projects. This chaser design not only makes the lights chase each other, it can also invert the action and make the 'shadows' chase each other. Even reverse direction or varies the flash rate.

Cat. K-3145

**\$71<sup>50</sup>**

### INFRA RED BEAM RELAY

Pre-activated relay is set off once beam is cleared. Ideal for burglar alarms, door minder, etc.

Cat. K-3375

**\$38<sup>50</sup>**

### INFRA RED REMOTE CONTROL

Uses remote control to switch on and off any appliance within 10 metre range. Controls appliances up to 1200 watts.

Cat. K-3380

**\$65<sup>95</sup>**

### CHEAP PROTECTION! CAR ALARM!

New improved design. Without false triggering problems. Simple installation. Protect your valuable property from would-be thieves!



**\$28<sup>50</sup>**

Cat. K-3253

### LEDS & LADDERS

Electronic version of the popular game. Can you climb out of the well without being plummeted down again! Was \$16.75 in 1978!

**\$16<sup>50</sup>**

Cat. K-3390



## LOOK AT THESE GREAT NEW KITS

### Build the fantastic new SUPER 80 computer

Cat. K-3600

It was worth the wait! The Super 80 is by far the best value you'll find in a computer — and you'll be able to tell your friends you built it yourself!

"No matter how you look at it, the Super 80 must be a winner."

(Electronics Australia, August, 1981)

For more details of this exciting new kit, see our double page advert elsewhere in this issue.



**\$289<sup>50</sup>**

### UNIVERSAL TIMER

An incredibly versatile, 7 function timer. Can be used as a kitchen timer, stop watch, rally timer and industrial timer — with bright 4 digit, 7 segment LED display.

ONLY

**\$39<sup>50</sup>**

Cat. K-3435



### DIGITAL CLOCK/THERMOMETER

Short Form Kit

Huge bright red digital display, 6 display modes. Time and temperature display, alarm and control for clock, radio, etc. 12/24 hour — C/F Battery back up facility.

Cat. K-3436

**\$49**

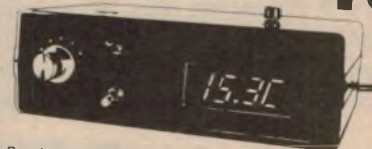

Panel not supplied. Case shown optional (Cat. H-2505)

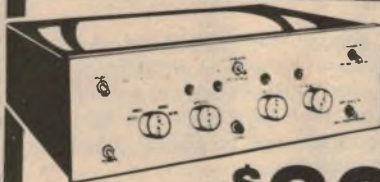

### MUSICOLOR Mk. IV

Musicolor IV is a flexible light controller. It has all the features of the Mk III, plus lots more! Including 4 controlled channels, plus a light chaser with four chase patterns and a reverse switch for startling effects. Connects to speaker terminals of your amp. Completely safe — adds another amazing effect to your stereo — LIGHT!

Cat. K-3143

Includes our famous 'Sorry Dick It Doesn't Work' Guarantee

**\$89**

## PARTS FOR NEW KITS Printed Circuit Boards

### Semiconductors

Cat. Y-1053	MA1026 ALR Clock/Therm Module	\$29.50
Cat. Z-6816	MM5865N Uni Timer IC	\$9.75
Cat. Z-6300	ICL7106 3.5 Digit Driver	\$9.50
Cat. Z-5747	ICM7216B Frequency per counter	\$29.95
Cat. Z-6823	SN76488N Uni synthesiser IC chip	\$4.95
Cat. Z-6083	LM394B Dual diff. super mix pre-amp	\$4.50
Cat. Z-6810	LM334Z Tempur/Sensor	\$1.95
Cat. Z-4175	LCD Display — 4 digit	\$8.95
Cat. Z-6030	TL 071 Bifet Op. Amp.	95c
Cat. Z-6034	TL 074 Quad. Bifet Op. Amp.	\$2.75

E.A. OCTOBER	Cat. H-8414 Wind Speed Indicator	\$2.50
	Cat. H-8415 Audio Test Unit	\$2.95
E.A. SEPTEMBER	Cat. H-8640 Uni Sound Synthesiser	\$2.50
E.A. AUGUST	Cat. H-8411 815M7 Pevlavs Bagatelle	\$2.95
	Cat. H-8410 Musicolor Mk IV	\$9.95
	Cat. H-8402 Super 80 Computer	\$97.50
	Cat. H-8410 Musicolor/Chaser	\$9.95
E.A. JULY	Cat. H-8404 Electrochune	\$11.50
	Cat. H-8403 Pools/Lotto Selector	\$2.50

## DICK SMITH Electronics



DSE/A039/LM

NSW AUBURN 648 0558 • BLAKEHURST 546 7744 • BROADWAY 211 3777 • BROOKVALE • CHULLORA 842 8922 • GORE HILL 439 5311 • NORTH RYDE 888 3200 • PARRAMATTA 683 1133 • SYDNEY 290 3377 • TIGHES HILL #1 1896 • WOLLONGONG 28 3800 ACT Fyshwick 80 4944 QLD BURANDA 391 6233 • CHERMSIDE 69 6265 SA ADELAIDE 212 1962 VIC MELBOURNE 67 9834 • COBURG 383 4455 • RICHMOND 428 1614 • SPRINGVALE 547 0522 WA CANNINGTON 451 8668 • PERTH 328 8944

Mail Order Centre: PO Box 321, North Ryde 2113. Phone (02) 888 3200



*Build this simple, low-cost*

# Wind Speed Indicator

Measures wind speeds to 100km/hr

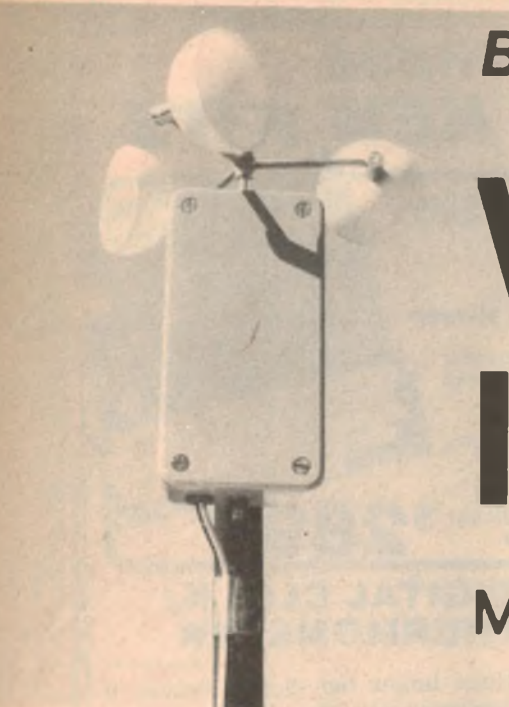

Here is a project which will appeal to a diverse range of people. Capable of high accuracy in measuring wind speed, our wind speed indicator provides this information for considerably less cost than current commercial devices. The indicator is useful for people following various outdoor activities and for those interested in using it as the basis for their own weather station.

by JOHN CLARKE

Virtually all people involved in outdoor activities are interested to some degree in knowing the wind speed. Although not all find it necessary to actually measure the speed, a quantitative measurement would rule out some of the guesswork which undoubtedly occurs.

Some of the people who would benefit from measuring the wind speed are: kite flyers, boating enthusiasts, surfers, parachute jumpers, hang glider pilots, sail boat enthusiasts, boat and aircraft modellers, those organising athletic events, people on the land and amateur radio operators.

A decision can be made by outdoor activists as to whether their activity is practicable on that day simply by a glance at the wind speed indicator. For instance, kite flyers and sail boat enthusiasts need not consider pursuing their activities if the indicator shows an extremely light wind or alternatively, modellers contemplating a test flight may balk at the fact that the wind indication is showing gale force winds.

High winds can cause serious damage to crops and various structures. In particular, radio operators with expensive roof-mounted antennas could use the wind speed indicator to give a warning when they should lower the antenna to prevent damage. Farmers can use the indicator as a guide, as to where wind

breaks should be placed to prevent damage to crops and as an indication of the likely strength of winds in a particular area, such that structures can be built solidly enough and windmills placed in the best position.

By far the most common and practical method of measuring wind speed is with an impeller. An array of cups allowed to spin in a horizontal plane are driven by the wind to provide a direct wind speed to rotational speed conversion. The resulting shaft speed is measured and calibrated as wind speed. An advantage of this system is that the impeller does not need to be oriented into the wind, the impeller being operable from all wind directions.

Various methods are used to obtain a shaft speed reading. A generator or alternator can be used, providing a direct voltage output proportional to wind speed. The problem with this, especially with small DC electric motors used as a generator, is that the permanent magnets create a drag on the shaft and combined with the friction of the commutating bushes, reduces the sensitivity of the anemometer, or wind speed indicator.

A better alternative is to detect a change in light intensity as the shaft turns by chopping a light source with a light chopper mounted on the shaft and detecting this with a phototransistor.

Using this method, there is no drag, caused by breaking the light beam, on the shaft. This is the approach upon which our project is based.

## MECHANICAL DETAILS

Having decided upon the approach, the problem was to design a mechanically compact and modern unit which uses readily available components. Fortunately, with the use of brass rod, ball bearing races, tapped brass spacers (normally used to support PC boards) and table tennis balls, we managed to arrive at what we consider is a reliable unit. In addition, the construction is quite straightforward.

By looking at the photos of the unit and the diagrams of Fig. 2 and 3, the simplicity of construction can be seen, particularly when compared to some of the recent anemometer constructional articles we have seen. Fig. 3 shows the basic construction of the anemometer cups which are driven by the wind. Three half table tennis balls are used as the cups which are secured to brass stand-offs with brass screws. These stand-offs are held at a distance from the central stand-off with brass rod. The whole assembly is soldered together.

Fig. 2 shows the shaft speed detector using the light chopping disc. To make construction as trouble-free as possible, the light chopping disc has been designed as part of the printed circuit board. The basic layout of the disc and light source/detector pair can be readily seen. Two PCBs are held by the slots in the side of the case; one PCB holds the phototransistor and the other, the LED light source. The disc is supported between the PCBs by the shaft allowed to run free by the bearings at the ends of the case.

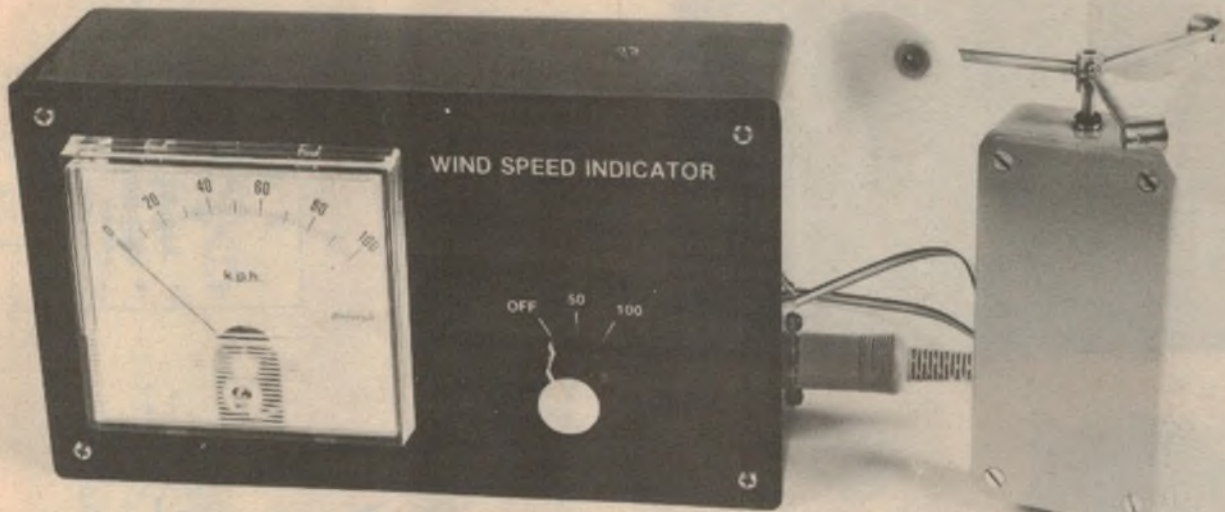

A rubber "O" ring at each end of the shaft is close to but not quite touching the bearing to prevent water from entering the case at the bearing points. This method of sealing is based on the fact that water surface tension prevents water entering small recesses unless under pressure.

### CIRCUIT DESCRIPTION

Refer now to the circuit diagram. An infrared LED provides the light source for the phototransistor. The light supplied to the phototransistor is chopped by a slotted vane mounted on the shaft. The faster the shaft rotation, the faster the light is chopped and the more flashes of light are sent to the phototransistor. There are 16 light pulses produced per shaft revolution. About 35mA are supplied to the LED to ensure enough light to the phototransistor. A small current is passed through the phototransistor, about 370 $\mu$ A, determined by the 22k $\Omega$  resistor, which was selected for the best compromise between response time of the phototransistor and sensitivity.

An operational amplifier, IC1, is used as a Schmitt trigger to square up the signal provided by the phototransistor. The resulting rectangular waveform is fed to a charge pump circuit consisting of C1, D1 and D2, and C2. The output of

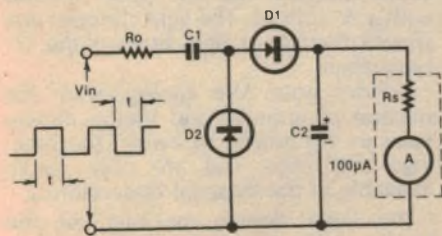
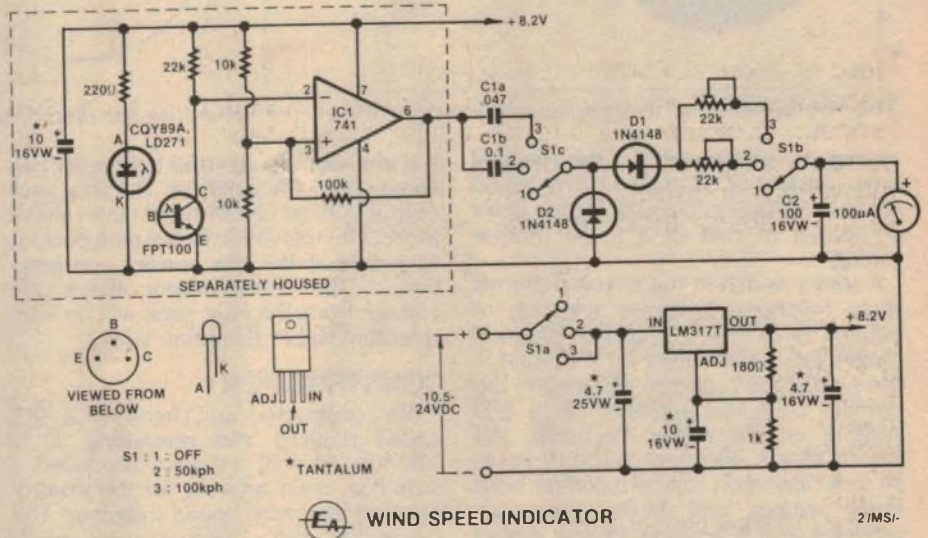

FIG. 1

$$C2 \gg C1$$

$$R_s C2 \gg R_o C1$$

$$t > R_o C1$$



WIND SPEED INDICATOR

2/MSI

Schmitt trigger IC1 squares up the signal from the phototransistor and drives a diode charge pump and 100 $\mu$ A meter. Unit operates from a 10.5–24V DC supply.

the charge pump is a DC voltage level that is proportional to the rate of pulses at its input.

Operation of the charge pump is as follows: Referring to Fig. 1: Initially C1 and C2 are discharged. When Vin goes high, C1 begins to charge through D1, C2 and Ro, the output resistance of the Schmitt trigger. Because C1 is much smaller than C2, C1 fully charges earlier than C2 and when this occurs, the current ceases, leaving C2 with a small charge increase. When Vin goes low, C1 discharges via D2, but C2 does not discharge since D1 blocks the discharge path.

Note that it is important for the period of Vin to be longer than the charge and discharge times of C1, since correct operation of the charge pump relies upon C1 fully charging and discharging. Eventually under this process of charg-

ing and discharging C1, the capacitor C2 would become fully charged, if it were not for the meter across C2. Since it has a resistance, Rs, C2 will be continually discharged to a point where an equilibrium is reached between the discharging and charging rate. Consequently a voltage remains across C2 which is proportional to the frequency of charging pulses.

Note that we are using a 100 $\mu$ A full scale deflection meter which has a resistance of 2k $\Omega$ . We can consider the meter to consist of an ideal meter with zero resistance in series with, Rs, a 2k $\Omega$  resistor. So for a FSD reading on the meter we need 100 $\mu$ A to flow through Rs or 0.2 volts across the meter.

Returning now to the circuit diagram, the two 22k $\Omega$  trim pots in series with the meter and C2 are for calibration of the meter reading. The larger the resistance

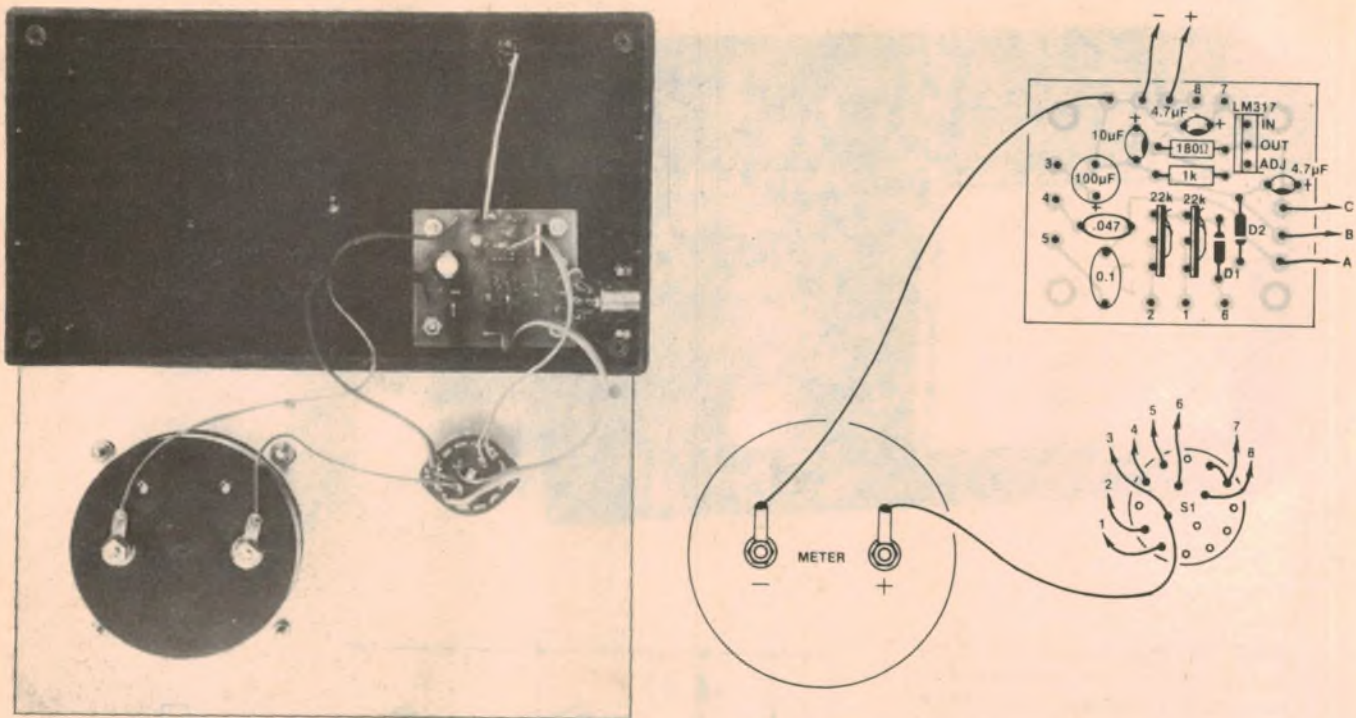

This photograph and wiring diagram show the construction details for the diode charge pump and voltage regulator.

setting, the greater will be the charging time constant of C2 and so there will be a lower voltage produced at this point compared to that of a lower trimpot setting.

A rotary switch in the circuit performs three functions. It allows selection of either C1a or C1b so that two different ranges can be obtained on the scale — the smaller the capacitor, the greater the number of pulses required for a FSD reading on the meter. Secondly, the switch allows selection of the trimpots so that calibration can be made for both range settings, and thirdly the switch provides an off position for the power supply.

Power for the circuit is supplied from a three terminal adjustable regulator. It is important for the circuit to be supplied with a constant voltage since the calibration of the meter reading is dependent upon the supply voltage. The regulator is set to about 8.2 volts, although the exact figure is not important. We selected the regulated voltage to be low enough so that the regulator will not drop out when supplied by the variable supply voltage of a car battery.

Various capacitors are used in the supply circuit. The 10µF capacitor across the supply in the Schmitt trigger circuit is for decoupling as are those at the input and output of the regulator. The capacitor at the adjust terminal of the regulator improves ripple rejection.

As far as the prime power source is concerned, we envisage that the unit will operate from a DC plug pack adapter in its final form. However, as we will mention later in the calibration procedure,

the unit can be operated from a car battery or from dry batteries. The plug pack output voltage can be rated nine volts or more. The regulation of the plug packs is such that at the low current consumption of the circuit, about 40mA, the voltage from the plug pack will be considerably higher than nine volts.

### CONSTRUCTION

We constructed our circuit on a PCB coded 81ws10 and measuring 47 x 116mm. As well we have produced a Scotchcal label artwork for the control panel of the wind speed indicator. The circuitry is housed in two cases, one a small ABS plastic or diecast aluminium unit, measuring 100 x 25 x 50mm, which contains the mechanical light chopper, light source and detector. The larger plastic utility box, measuring 60 x 113 x 196mm, contains the charge pump circuitry and meter.

As supplied, the PCB for the circuit is in one piece and it is necessary to cut it into

four sections. One section is for the LED circuit, another for the phototransistor circuit, the third for the charge pump and voltage regulator and the final section is the light chopper disc.

Cut each section of the PCB along the dotted lines and file them to size. Both of the small PCBs slide into the slots of the smaller case as shown in Fig. 2. The top corners of the phototransistor PCB may need to be filed so that the lid will fit properly. The light copper disc should be filed round to a diameter of 20mm. Slots can then be cut along the etched pattern with a hacksaw blade. Cut through the area where there is no copper and only cut as far as the pattern shows.

To complete the chopper disc, drill a 1/8" hole in the centre and solder a 9mm x 6mm diameter tapped brass spacer to the copper side of it. The easiest method to solder them together is to first secure them with a screw from the PCB side through into the brass spacer. The spacer can then be heated with a soldering iron and the solder flowed around the base of the spacer and copper pattern on the disc. When cool, remove the screw and drill out the spacer threads with a 1/8" drill bit. The light chopper unit should then be a tight fit over the 1/8" brass shaft.

(Editor's note: We apologise for the mixture of Imperial and metric dimensions in this article. However, the bearings and brass rod are only readily available in the Imperial dimensions.)

The large donuts on each of the smaller PCBs should be drilled out to 6mm diameter so that clearance is allowed for the shaft.

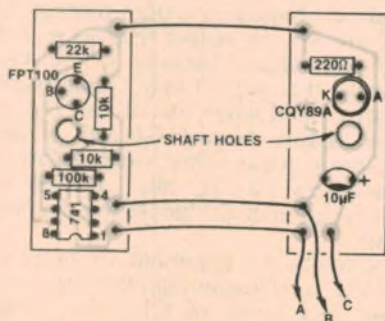

Component overlay for the sender unit PCBs. The chopper disc rotates between them.

At this stage, the holes can be drilled for the bearings where they are supported in the ends of the case. Note that the hole should be in the centre of the inside dimension of the box when the lid is closed, in other words 12.5mm from the external base of the case, or the light chopping disc will jam within the case.

The bearings should be lubricated with a light grade of oil.

The outside diameter of the bearing is  $\frac{1}{4}$ " and consequently it is advisable to drill a smaller hole first and gently open up the hole with a reamer or by twisting a round file in the hole until a tight fit is obtained for the bearing. The bearing can be permanently secured in place with a suitable glue. Be careful not to get any glue in the bearing and wipe off any excess glue.

Now that the light chopper has been made and the bearings fitted, the shaft can be sawn off to 120mm long and, after cleaning the ends with a file, it can be tested for fit between the bearings. If the shaft appears to be too tight, lightly narrow the gauge with a very fine grade of "wet and dry" paper. Be careful here as removing too much will render the shaft loose in the bearing. The idea is for the shaft to be a tight fit into the bearing. Assemble the shaft, disc and unassembled PCBs as shown in Fig. 2. Check the operation.

The light chopping disc should not foul with the base of the case or the lid when in position. Check that the disc runs reasonably true. If not resolder the disc to the spacer after determining what adjustments are needed. The shaft should pass through the holes in the PCB and there should be no possibility of the PCB touching the shaft.

At this stage we will discuss the construction of the impeller as shown in Fig. 3. You will need the spacers and three 45mm lengths of the brass rod. Each of the spacers require  $\frac{1}{8}$ " holes to support the rod. The centre spacer has three holes drilled  $120^\circ$  apart around its circumference. You can mark off the angles by placing the spacer on the plan drawing of Fig. 3 and scribing the three positions. Drill the holes at the centre of the length of the spacer and make sure each hole is at right angles to the spacer edge. Only drill to the centre of the spacer.

The remaining three spacers are drilled 2.5mm in from the end and are drilled right through. Fit the impeller pieces together, line them up and solder the joints. The rods passing to the centre spacer should be just visible when looking through the tapped hole. This hole can then be drilled to  $\frac{1}{8}$ " diameter. Make sure that all the supporting arms rotate in the same plane and that the anemometer cup spacers are at right angles to the central shaft. If not melt the solder joints and readjust.

The brass screws to support the table tennis ball cups will probably need to be cut to length. The length should be such that with the washer the screw will

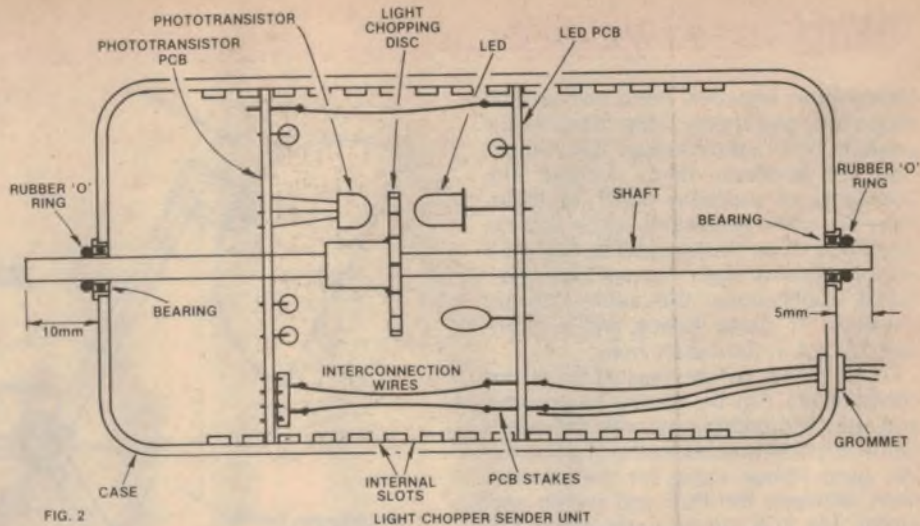
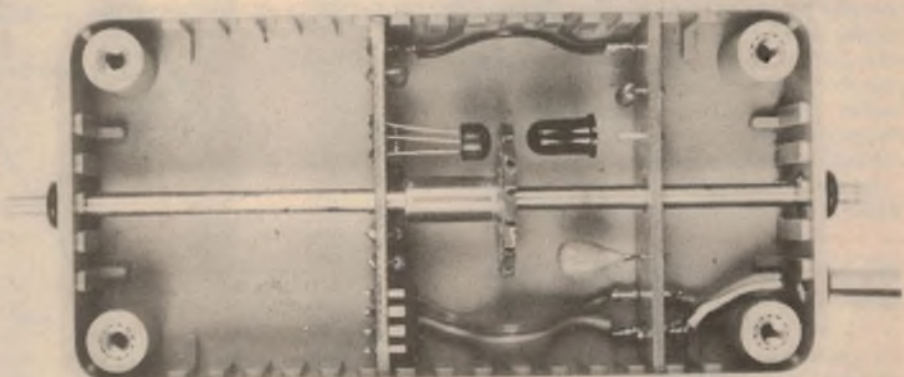

FIG. 2



This photograph and diagram show the mechanical details of the light chopper sender unit. The LED and the phototransistor should be about 5mm apart.

tighten up on the washer and just touch the rod at the other end of the screw. After cutting the screw, file the end so that the thread will start properly. The whole impeller assembly can be cleaned up with some fine emery paper and the end of the rods filed where they protrude from the cup support spacers.

The table tennis balls are best cut in half with a sharp knife or single edge razor blade. Note that the balls are constructed in two halves. The outside diameter of one half fits inside the diameter of the other. Use this join as the line around which to cut. The half which is not reinforced with the double thickness is the one to discard. Clean the edge with a file.

To mark the position for the mounting hole of the half ball, place the ball curve side down on a hard flat horizontal surface. With a sharp pencil find the point where pushing into the curvature of the ball does not tend to rotate the ball. This is the centre of the ball diameter. Drill the  $\frac{1}{8}$ " hole at this point. Secure each half ball on the impeller and the impeller is complete. The impeller is then a force fit on the shaft.

Note that we have used brass fittings throughout. It is preferable also to use

brass washers behind the cups. The use of the one material throughout helps to prevent corrosion due to dissimilar metal contact. As a further safeguard against corrosion, the brass fittings can be painted with an exterior paint. If it is envisaged that the unit will be a permanent outside installation, then painting the table tennis balls will prolong their life.

Turning now to the electronics, start with the two small PCBs and use the overlay diagram to mount all the components with the exception of the LED and phototransistor. Make sure that the polarity conscious components are oriented correctly. It is necessary to use PC stakes for the external connections on the PCBs. The PC stakes on the LED PCB where they connect to the external wiring should be inserted in the PCB from the copper side so that equal lengths of PC stake protrude on both sides of the PCB. These are used as a through connection.

Place the phototransistor and LED in position and before soldering place both PCBs in the case seven slots (35mm) apart as shown in Fig. 2. Adjust the LED and phototransistor so that there is

about 5mm between them and so that they are in alignment. Solder them in this position. The light chopper disc should now fit between them without the possibility of touching either of them. Now the interconnecting wires and external wires can be soldered in. We used ribbon cable for both. For permanent external applications, the cable can be sheathed in plastic tubing and a grommet placed in the outlet hole.

Turning now to the final PCB, all the components can be placed in position and soldered taking care with the orientation of polarity conscious components. We used ribbon cable for the connections between the PCB and switch and meter. The PCB can be supported in the case with screws, nuts and short standoffs. We used a DIN plug and socket to connect the wires from the light chopper sender unit to this circuit. As well we used a 2.5mm panel socket for the external power supply connection. The type of socket used here depends upon the plugpack used. In any case be sure that the right polarity is applied to the circuit.

Use the Scotchcal artwork as a guide to marking out the holes for the switch. We

We estimate that the current cost cost of parts for this project is approximately

**\$40**

This includes sales tax but not the plugpack.

left no markings for the cutout for the meter as this depends upon the meter used. In any case, when the Scotchcal label is applied to the front panel, which incidentally, should be sprayed with a hard setting clear lacquer, drill holes for the switch and meter and mount these on the panel.

The plastic window of the meter can be removed and the "microamp" lettering rubbed out with an ink eraser and replaced with a "kilometres per hour" marking with Letraset rub on lettering. Do not erase the calibrated markings.

To test the unit apply the power and check that the supply voltage is around 8.2 volts. By spinning the shaft by hand, a reading should be seen on the meter on both switch ranges.

Calibration of the wind speed indicator can be achieved with the aid of a vehicle driven on a windless day. The anemometer impeller together with the light chopping sender unit should be mounted at least 500mm above the roof of the vehicle by securing it to the roof rack or to a long pole protruding upwards through the window. The meter can be temporarily installed on the dashboard and the power supply derived from the car battery via the cigarette

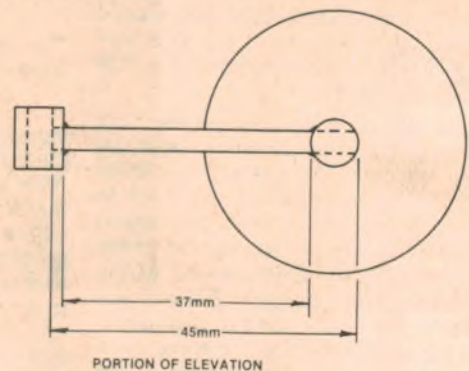
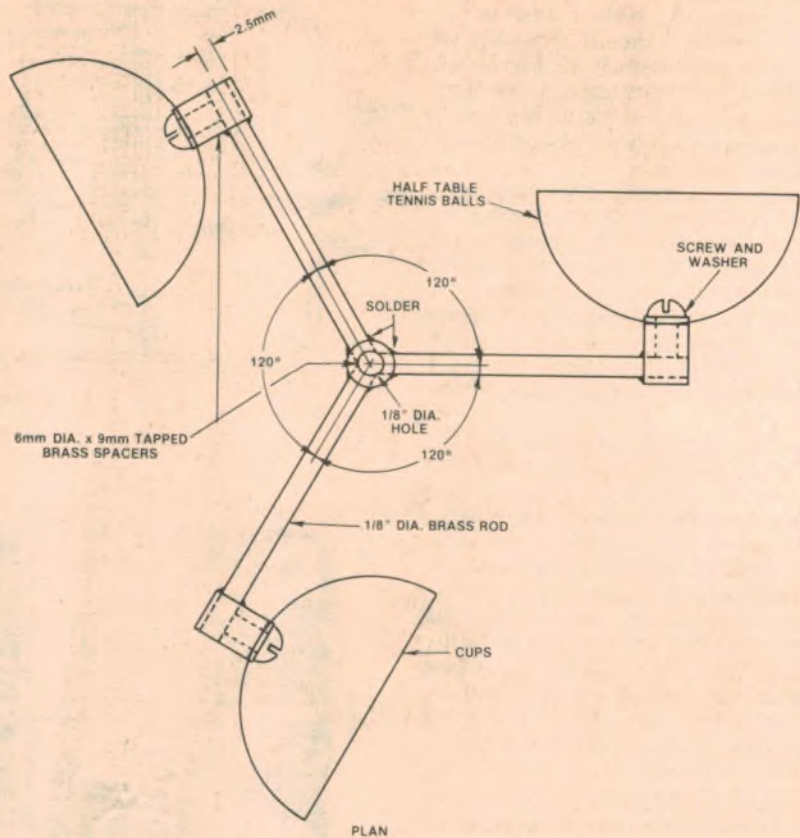

FIG. 3

The impeller is made from table tennis balls, brass rod and four brass spacers.

lighter socket or some other convenient outlet.

By driving at a constant speed, the trim-pots can be adjusted until the correct reading is obtained. The calibration should be checked for various speeds including some at the top end of the scale range. It would be preferable if you have a passenger perform the adjustments. If you had an accident with a long pole extending upwards out of your window, some funny questions might be asked!

Installation of the unit depends upon the application. Suitable mounting brackets can be fashioned and screwed to the case. The unit should be mounted where the wind can flow without any major obstructions. Finally, if the unit is

to be permanently mounted outside, the lid of the case and cable entry can be sealed with rubber sealant such as Silastic.

That just about completes the construction of the wind speed meter. Perhaps it should be mentioned that the light chopper unit on its own could be used for shaft rotational speed measurement. By connecting the light chopper to the shaft to be measured with a rubber connector, and applying a 9-volt power source to the unit the rotational speed can be read from a frequency meter connected to the Schmitt trigger output. The speed in revolutions per second can be obtained by dividing the frequency meter readout by 16.



# RITRONIC ROD RIVING ELECTRONICS

425 HIGH STREET, NORTHCOTE, VIC.  
Phone (03) 489 8131. Telex: 38897

## PLAYMASTER MOSFET AMP. KIT. HURRY... LIMITED STOCKS

Incredible 50 watts per channel is featured with E.A.'s superb new kit. This Playmaster features a full range of controls inc. bass, treble, loudness and muting. (Also available — Playmaster Graphic equalizer and Playmaster Graphic Analyser. Phone for a quote.

NOW ONLY \$159

## BLANK CASSETTES T. D. K.

TDK ADC60	1 for \$3.60	10 for \$26.00
TDK DC60	1 for \$2.10	10 for \$18.00
TDK DDC60	1 for \$3.50	10 for \$31.00
TDK SAC60	1 for \$3.30	10 for \$29.00
TDK SAXC60	1 for \$5.70	10 for \$46.00
TDK DC90	1 for \$3.05	10 for \$21.00
TDK ADC 90	1 for \$3.50	10 for \$28.00
TDK SAC 90	1 for \$4.20	10 for \$37.00
TDK DDC90	1 for \$4.70	10 for \$45.00
TDK SAXC90	1 for \$5.50	10 for 49.00
TDK DC120	1 for \$4.50	10 for 37.00
TDK ADC120	1 for \$5.40	10 for \$46.50

## THE \$99 COMPUTER IS ★ SOON AVAILABLE ★

Wow! What we've all been waiting for, the ETI 660. Features include colour capability, 1K memory expandable to 3K on-board, single board construction, cassette interface, audio output and it is simple to program. Expansion projects will be available soon.

Starter Kit (1K RAM, B & W Video)	\$99.00
9V, 200ma plugpack to suit	\$ 6.50
Colour Video option	\$ 8.00
RAM expansion (add to PCB)	\$17.00

Please phone first to check stocks!

## COOL IT! COMPUTER COOLING FANS



Hurry! must go. 4" \$19.50

## FREE!!

250 pack of resistors on purchase of over \$10 on presentation of this advertisement Save \$10 (Normally 4c per resistor)

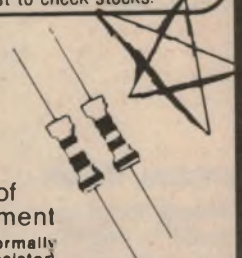

## AUSTRALIA'S FIRST UNDER \$200 COMPUTER... SINCLAIR Z x 80

FEATURES: Includes leads etc. Basic on board in PROM unique basic interpreter affords single key functions up to 26 string handling powerful editor high resolution graphics. All documentation included single ROM contains basic interpreter cha gen, operating system and monitor less RAM required due to large PROM expandable to 16K small compact size connect your TV direct and cassette recorder and you're away. Ready Built.

Now available for the Z x 80:

BK ROM: Tax exempt \$69.00; Tax Paid \$75.00

16K RAM: Tax exempt \$135.00; Tax Paid \$150.00

HURRY

\$195

## SOAR Model ME-501



4 digit LARGE LCO DISPLAY Send for specs. \$79

Send for specs \$69 plus 15% sales tax Add \$3 P&P and Certified Mail

## BUILD YOUR OWN SPEAKERS WITH PHILLIPS

PART No	PRICE	PART No	PRICE
ADO140T8	\$11.86	AD5060-SQ4	\$22.05
ADO1610T8	\$16.95	AD5060-SQ8	\$22.05
ADO1605-T8	\$16.54	AD5060-W8	\$17.59
ADO162-T15	\$18.78	AD5061-M8	\$17.08
ADO162-T15	\$13.03	AD70601-W8	\$20.40
ADO162-T8	\$13.77	AD70620-M8	\$21.54
ADO210-SQ8	\$32.70	AD7063-M8	\$20.78
ADO2160-SQ8	\$36.91	AD70630-M8	\$20.78
ADO2161-SQ8	\$33.46	AD70650-W8	\$26.96
AD10100-W8	\$52.72	AD7066-W8	\$26.96
AD12100-HP8	\$85.10	AD80601-W8	\$20.24
AD12100-M15	\$79.11	AD8061-W8	\$20.24
AD12100-M8	\$79.11	AD80652-W8	\$26.20
AD12100-W8	\$53.99	AD8066-W4	\$27.66
AD12200-W8	\$73.12	AD8081-M8	\$9.81
AD12250-W8	\$90.52	AD9710-M8	\$41.11
AD12650-W8	\$73.12	ADF1600-B	\$19.44
AD2273-T8	\$5.03	ADF500-4500-B	\$19.44
AD4060-W8	\$19.06		

## PANEL METERS

MU 65 - DC 30V	\$10.00
MU 65 - DC 20V	\$10.00
MU 65 - DC 10A	\$10.00
MU 65 - DC 1A	\$10.00
MU 65 - DC 1MA	\$10.00
MU 65 - DC 100 UAS	\$10.50
MU 45 - DC 300 V	\$ 7.50
MU 45 - DC 50 V	\$ 7.50
MU 45 - DC 20 V	\$ 7.00
MU 45 - DC 15 V	\$ 7.00
MU 45 - DC 10 A	\$ 7.00
MU 45 - DC 5 A	\$ 7.00
MU 45 - DC 1 A	\$ 7.00
MU 45 - DC ± 50 UAS	\$ 7.00
MU 45 - DC 1 MA	\$ 7.00
MU 45 - DC ± 100 UAS	\$ 7.50
MU 45 - DC 50 UAS	\$ 7.00
MU 45 - VU	\$ 7.00
MU 65 - E VU	\$12.00

See us for all your electronics

YOU NAME IT WE HAVE IT

SAVE!!!

## LOOK AT THIS! HEAVY BASE SOLDERING IRON STANDS



\$5.90

NEW

## VIDEO MONITOR

Can also be used normal T.V.

WAS \$139 NOW ONLY

\$105

## SWITCHES

- C&K 7101. 1 to 9 90c; 10 to 85c; SPDT.
- C&K 7201. 1 to 9 \$1.30; 10 up \$1.20; DPDT
- E1-Cheapo SPDT. 1 to 9 75c; 10 up 70c.
- E1-Cheapo DPDT. 1 to 9 \$1.20; 10 up \$1.10
- Single pole momentary push-button E1-Cheapo. 1 to 9 25c; 10 to 25 23c; 25 up 22c

## DIODES

	10-99	100+
IN4001	6c	5c
IN4002	6c	5c
IN4004	7c	6c
IN4148	5c	4c
IN5404	30c	25c
IN5408	35c	30c
IN4007	12c	11c

JOIN THOUSANDS OF SATISFIED MAIL ORDER CUSTOMERS AND RECEIVE FREE CATALOGUE!

## RECTANGULAR LED'S

Priced to sell. Available in Red, Green and Yellow 36¢ ca.

## TOP QUALITY NI-CAD BATTERIES

D-Cell size \$6.90. C-Cell size \$6.25. P&P add 30¢ per cell. Also available in protected pack form for specific voltage and current applications. Prices and information on request.



## TWIN CONE SPEAKERS

10 watt speakers with great response \$7.50 each

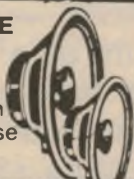

## HORN SPEAKERS

Ideal for alarm 5 watt \$6.90 10 watt \$17.50



## DIP PLUGS

Ideal for use with flat ribbon cable or to mount components on 14 pin \$1.20 16 pin \$1.40 24 pin \$1.20



## HEATSINKS

	High Thermal Capacity		Black Anodised	
	1-4	5-9	10-49	50-99
HS1 - 38mm	1.85	1.75	1.50	1.35
HS2 - 75mm	3.00	2.90	2.50	2.00
HS3 - 150mm	5.80	5.40	4.90	3.80
HS4 - 225mm	8.10	7.60	7.10	5.90
HS5 - 300mm	8.90	8.40	7.90	6.50

Unanodised		100		500	
HS11 - 38mm	1.40	1.20	1.00	0.90	0.80
HS12 - 75mm	2.50	2.20	1.90	1.60	1.25
HS13 - 150mm	4.90	4.50	4.00	3.20	2.45

## SPECIAL ULTRA-SONIC TRANSDUCERS

\$11.00 a pair 40 Hz TX & Rx.



## LED'S

Red	1-9 10c	10 up 9c
Green	25c	22c
Yellow	25c	22c

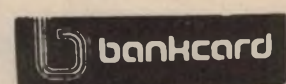

Enclose your personal cheque. Money Order or Bankcard Numbers as specified below. Check and fill in:  Cheque or Money Order Enclosed  Charge to my Bankcard No.

CARD HOLDER'S NUMBER

496 \_\_\_\_\_

SIGNATURE

Card Expiry Date

TO ORDER: Heavy items sent Come freight-on. Mail Order phone 481-1436. Wholesale customers phone RITRONIC WHOLESALE 489-7099 or 489-1923. Mail orders to PO Box 235, Northcote 3070. Minimum mail order \$2. Add extra for heavy items, registration and certified mail. Prices & spec. subject to change without notice.

Here is the actual-size artwork for the PCB. As supplied, the PCB is in one piece and must be cut into four sections along the dotted lines.

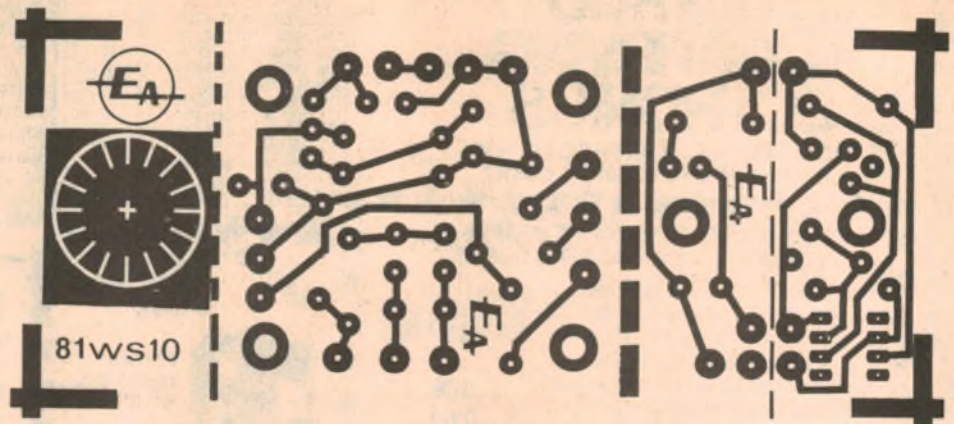

### SPECIAL ITEMS

Several items used in this project are unusual in that they are not available at electronics stores. The table tennis balls are relatively easy to obtain from sports stores or department stores at a very economical price. The brass rod and ball bearing races are available at Hobbyco Pty Ltd, 561 George Street, Sydney, NSW 2000. They accept mail order and the rod at present costs 95 cents and the bearings 45 cents each. Extra money should be sent for postage.

Alternatively, the brass rod is available from large hardware stores for a similar price. The bearings available from Hobbyco are of the uncaged ball variety and consequently offer a higher friction than caged ball bearing races, but they should be adequate for the work expected from them. For those people, however, who require a higher quality caged bearing, they can try various bearing suppliers for an F144 bearing which is unflanged or an FLR144 flanged type. These numbers are Consolidated Bearing Company type numbers, but they are difficult to obtain and are quite expensive.

The rubber "O" rings are available from bearing suppliers, large hardware stores and service stations. They are the smallest available and are 3mm inside diameter.

### PARTS LIST

- 1 Printed circuit board coded 81ws10 measuring 47 × 116mm
  - 1 Scotchcal label
  - 1 plastic utility box measuring 60 × 113 × 196mm
  - 1 ABS plastic or diecast aluminium box measuring 100 × 25 × 50mm
  - 1 100µA meter measuring 85 × 75mm
  - 1 3-pole 3-way rotary switch
  - 1 knob
  - 7 PC stakes
  - 1 small grommet
  - 4 standoffs and screws to suit
  - 1 300mm length of 1/8" brass rod
  - 2 single row, deep groove ball bearing races, 1/4" OD × 1/8" ID × .0937" width
  - 2 BS006 "O" rings
  - 5 9mm long × 6mm tapped brass spacers
  - 3 table tennis balls
  - 3 3mm ID × 8mm OD brass washers
  - 3 brass screws to suit tapped spacers
- SEMICONDUCTORS
- 1 LM317T 3-terminal adjustable regulator

- 1 CQY89A, LD271 infrared LED
- 1 FPT100 phototransistor
- 1 741 op amp
- 2 1N4148 small signal silicon diodes

### CAPACITORS

- 1 100µF/16VW PC electrolytic
- 2 10µF/16VW tantalum electrolytic
- 1 4.7µF/25VW tantalum electrolytic
- 1 4.7µF/16VW tantalum electrolytic
- 1 0.1µF metallised polyester
- 1 .047µF metallised polyester

### RESISTORS (1/4W, 10%)

- 1 × 100kΩ, 1 × 22kΩ, 2 × 10kΩ, 1 × 1kΩ, 1 × 220Ω, 1 × 180Ω, 2 × 22kΩ large vertical trim pots

### MISCELLANEOUS

Ribbon cable, solder, 1 three way panel socket and line plug, 1 socket to suit plugpack, screws, nuts, etc.

NOTE: Components specified are those used in the prototype. Higher capacitor voltage ratings and higher resistor wattage ratings may generally be used providing they are physically compatible.

## Coming in November\*

On sale Wednesday  
November 4

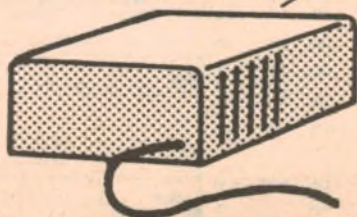

**"Electronics Australia"**  
**SLIDE SHOW — to control and give automatic fade of two slide projectors for really polished slide shows.**

\* Our planning for this issue is well advanced but circumstances may change the final content. However, we will make every attempt to include the articles mentioned here.

# MORE GREAT SPECIALS FROM JAYCAR!

## ELECTRET INSERT



**ONLY \$1.49**  
SAVE NEARLY 40%

Electret inserts back special!!  
For those who missed out in July. These are normally \$2.45 each. GRAB THEM NOW ONLY \$1.49!!  
SAVE NEARLY 40%!!!!

## OM350 Philips Hybrid Wide Band RF Amp



**WAS \$9.50 NOW \$6.50**  
SAVE \$3

Were scarce - now we're buried in them!!  
We need the cash so you get a bargain!!

## 8 CHANNEL MIXER KIT

A few specs:

- 19" rack or console mount
- Balanced inputs and 2 outputs
- Equalisation on each input
- Uses latest NE5534 Op amps
- Very low noise
- Effects (e.g. "Echo" etc)
- Foldback send
- Switchable line and mic. level inputs with separate attenuation control

Don't buy a mixer until you have seen this one!  
Send SAE for more information.



## DIP EXTRACTION TOOL

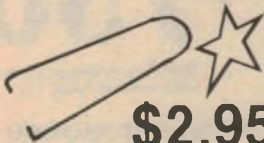

**\$2.95**

Ideal for the hobbyist or laboratory engineer. One piece spring steel construction. Will extract from 8.24 pin devices safely.

## DIP INSERTION TOOL

Industrial quality. Narrow profile enables work in densely packed areas. Tool includes a remarkable pin straightener built into the handle.

**\$5.95**

## XURO GRIP



**\$4.95**

"Mini Shear" pliers \$5.50  
Fine nose pliers \$4.95  
Both feature:  
- Made in the USA quality  
- Fantastic soft grip cushion handles  
- Spring loaded  
Why buy South Asian junk when you can have the best for less?

## 19" RACK CABINET

\*\*\*\*\*  
**\$45**  
\*\*\*\*\*

19" black anodised rack boxes are back! We have had trouble keeping up with the demand for these 5 1/2" x 19" rack cabinets. They feature a magnificent 3mm black anodised and finished front panel.  
**BEWARE OF RACK BOXES THAT DO NOT CONFORM TO STANDARD RACK DIMENSIONS!!! OURS ARE ONLY \$45.00 EACH**



## \* great new ABS & DIECAST boxes \*

IMPORTED FROM CANADA  
We are pleased to announce that you can obtain a QUALITY small project box from Jaycar. At long last we have found a source of supply of ABS (not cheap styrene) plastic project cases. These cases feature a matching moulded lid (not a flimsy aluminium panel) and brass inserts for the metal thread counterbore retaining screws. Sizes range from 85 x 56 x 29 to a massive 190 x 110 x 54 in (would you believe!) the COLOURS of black, grey and orange! They look great and start from \$2.75 each.  
Die Cast boxes with a quality finish. We also have a range of these from 91 x 38 x 25 to 185 x 185 x 64.  
Prices start from a low \$2.95  
AT JAYCAR YOU PAY NO MORE FOR QUALITY

**top value**

POST AND PACKING		
\$5 - \$9.99	\$1.00	\$1.00
\$10 - \$24.99	\$100 up	\$2.00
\$25 - \$49.99	\$5.50	\$3.00
\$50 - \$99.99		\$4.00

## EA & ETI

### BELOW COST

We make no secret of the fact that we are in a out of the way location. To encourage you to call in to our store you can pick up the latest copy of EA or ETI at ONLY

**\$1.00**  
THAT'S BELOW OUR INVOICE COST

We will subsidise the sale of these magazines until further notice. Remember that's nearly a 50% saving! (We also have back issues of EA and ETI for only \$1)

## AUDIO AMPLIFIER IC's SLASHED!!

TYPE	POWER	NORMALLY	THIS MONTH
TA A611B	2W	\$2.50	0.50c
TBA810	6.5W	\$4.50	0.95c
TBA651	AM Tuner IF	\$6.50	0.50c

FREE DATA SHEET WITH EACH UNIT!

## \* HOBBY BLOX \*

The most versatile breadboarding system in the world is now at Jaycar.  
Breadboard strips start from ONLY \$3.95  
The Hobby Blox system is so expandable it could be called "Electronic Lego"!!!!

**ONLY \$3.95**

## WELLER & XCELITE

Jaycar is now an official Weller and Xcelite tool distributor for these quality tools. Call in and see the fabulous Weller Electronic Soldering Station (it will cost you \$245) or the Xcelite tool kit in attractive case at only \$199. Naturally we carry the range of Weller products that you see everywhere else - but at great savings on other prices!

## NEW exciting range

## ARLEC SUPER SWITCH

**SUPER XXXX SPECIAL!!**  
NORMALLY \$23.50  
OCTOBER ONLY \$17.50  
BE QUICK

**ONLY \$17.50**

HAVE YOU SEEN OUR \$49.95 AUTO RANGING DMM?? IT'S A PRICE BREAK THROUGH

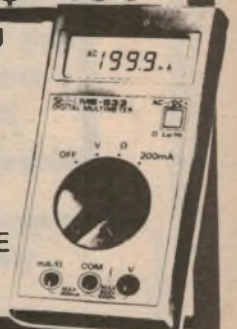

**\*\* AT LAST \*\***  
programmable master rhythm generator fully imported!!



This project was originally described in the UK publication "Practical Electronics". We have the fully imported "Ciel" kit version. This attractive kit is presented in an attractive metal cabinet with silkscreened front panel.  
The Master Rhythm can be programmed (in RAM) to play back:  
- Twenty four Rhythm patterns  
- Eight parallel tracks  
- Twelve instruments!  
It is also capable of Sequence operation  
**THIS IS THE ULTIMATE RHYTHM GENERATOR!!!**

complete **\$199** LOW POWER BATTERY DRIVEN

# Jaycar

**380 Sussex St Sydney 2000**

Ph. 2646688 Telex 72293

Mail Orders To: Box K-39 Haymarket 2000

NOTE: NEW SHOP HOURS  
Mon - Sat 9am - 5:30pm  
Sun 10am - 2pm  
Open Thursday night until 8pm



*The affordable computer!*

*the brilliant*  
**DICK SMITH  
 SYSTEM 80**



**OVER 3000  
 SOLD**

**ONLY  
 \$750\***

Note: price includes increased Government Sales Tax

**Outstanding value for money . . .  
 plus programs especially written  
 for Australia!**

**Australia's fastest selling  
 computer — and small wonder!**

**Compare the System 80 with its  
 competitors: you'll see why!**

**And now it's even better: with new  
 features to make your computing  
 even better.**

**Join the thousands of system 80  
 users now: turn yourself into a  
 computer expert!**

Cat. X-4005

\*Monitor and Expansion Unit not included.

**REMEMBER: OUR COMPUTER COMES WITH AN INBUILT CASSETTE, DON'T PAY EXTRA!**

**Compare the  
 features —  
 the System 80  
 comes out  
 in front!**

PARAMETER	SYSTEM-80	TRS-80 (Level II)
1 CPU type	Z-80	Z-80
2 Speed	1.7MHz	1.7MHz
3 S-100 compatible (with expansion unit)	Yes	No
4 Amount of RAM (basic computer)	16K	16K
5 Built-in cassette recorder	Yes	No
6 Built-in video RF modulator (use with any TV)	Yes	No
7 Capacity of BASIC ROM	12K	12K
8 Cassette recorder ports (basic machine)	2	1
9 Motor control for cassette recorders	Yes (2)	Yes (1)



**S-100  
 EXPANSION**

**ONLY \$509**

**UNLEASH THE FULL  
 POTENTIAL  
 OF YOUR  
 COMPUTER . . .**

To get the most from your computer, you need to add peripherals. This expansion unit gives you this capability. Made to world standard S-100 system, so you aren't tied to any one supplier for your add-ons.  
 Cat. X-4010

**LOOK AT DICK'S  
 PRICE FOR A GREEN  
 PHOSPHOR MONITOR!**

For the professional user — or even the hobbyist who uses his system for long periods, a Green Screen Monitor is a must. Superb definition, with bright, sharp print that can be looked at for hours longer with less fatigue.  
 Cat. X-1198



**STILL AT  
 PRE-BUDGET  
 PRICE!**

**\$199**

**NOW WITH IN-BUILT AMPLIFIER FOR  
 PROGRAMS WITH SOUND EFFECTS!**



# etone Loudspeakers



## LOUDSPEAKER SENSATIONS!!!

Since introducing ETONE speakers to our city showroom we have been staggered by the interest. Why? Because they are about the most underrated product made in Australia today. Call in today and find out why so many people are switching over to ETONE for both P.A. and Hi Fi applications.

### P.A. SPEAKERS

SIZE	MODEL	DESCRIPTION	POWER HANDLING (RMS)	FREE AIR RESONANCE Hz	PRICE
25 CM (10")	131	GUITAR BASS GUITAR GENERAL AMPLIFIED INSTRUMENTS AND GENERAL PURPOSE P.A.	60	50	\$51.50
30 CM (12")	246	EXTENDED RANGE SPEAKER FOR GENERAL P.A. SPEECH REPRODUCTION, STAGE MONITORS AMPLIFIED MUSICAL INSTRUMENTS DISCO SOUND	80	65	\$78.00
	267	WHEN COMBINED WITH SUITABLE HIGH-FREQUENCY DRIVER THIS SPEAKER HANDLES THE BASS AND MIDS RANGE OF SYSTEMS FOR LIVE BAND P.A. SPEECH REPRODUCTION THEATRE SOUND, STAGE MONITORS DISCO SOUND BY ITSELF THIS SPEAKER CAN BE USED FOR AMPLIFIED INSTRUMENTS SUITABLE FOR USE IN HORN TYPE ENCLOSURES AS MIDRANGE SECTION OF BAND P.A.	150	50	\$131.00
38 CM (15")	801	WHEN USED IN HORN TYPE ENCLOSURE THIS SPEAKER HANDLES THE LOWER MID FREQUENCY RANGE (250-1,200 Hz) OF LARGE LIVE BAND P.A. SYSTEMS WHEN USED IN COMPACT BASS-REFLEX ENCLOSURES TOGETHER WITH SUITABLE HIGH FREQUENCY DRIVER THIS SPEAKER HANDLES THE BASS AND MIDS RANGE OF SYSTEMS FOR LIVE BAND P.A. STAGE MONITORS THEATRE AND DISCO SOUND	200	30	\$214.00

**FREE SPEAKER CABINET DESIGNS**

\*We believe that this is the best speaker that ETONE makes. Its a worldbeater.

### ETONE HI FI SPEAKERS

Call in for free advice regarding your custom Hi Fi speaker system.

15 CM (6")	600	PASSIVE RADIATOR DESIGNED SPECIFICALLY FOR USE WITH 608 WOOFER IN THE PLAYMASTER 3-13L SPEAKER SYSTEM. SYSTEM DETAILS AVAILABLE ON REQUEST			\$18.50
	605	HI-FI MIDRANGE FOR USE IN HIGH QUALITY SYSTEMS. CAN BE CROSSED OVER AS LOW AS 200Hz, BUT GENERALLY USED TO COVER THE RANGE 500-5,000Hz	120 when crossed over at 500 and 5,000Hz	80	\$32.00
	608	HI-FI WOOFER DESIGNED SPECIFICALLY FOR USE WITH 600 PASSIVE RADIATOR IN THE PLAYMASTER 3-13L SPEAKER SYSTEM. THIS SYSTEM OFFERS EXTENDED LOW BASS RESPONSE IN A SUPER COMPACT ENCLOSURE (13 LITRES)	80 when used in Playmaster 3-13L System	50	\$34.55
25 CM (10")	108	HI-FI WOOFER MAINLY INTENDED FOR USE IN SEALED ENCLOSURES OF 25 TO 35 LITRES	50	30	\$33.00
30 CM (12")	518	HI-FI WOOFER DESIGNED MAINLY FOR USE IN SEALED ENCLOSURES OF 50 TO 80 LITRES	100	30	\$49.00



## ETI 5000 PREAMP & POWER AMP &

*Super Finish*

The Jaycar Front Panel



\$245



\$299

If even works better than it looks!!  
If you have read the articles on this project you could not help but be impressed with the amazing low hum and noise figures for this amp. It is our business to keep abreast of audio developments around the world and we can say that nothing anywhere compares to this Do-it-Yourself preamp.  
The Jaycar kit is supplied complete down to the last screw and washer. Included is a high quality 1 1/2" x 19" rack cabinet with quality finishes, anodised and silkscreened front panel with specially imported matching knobs.  
Metal film resistors are used THROUGHOUT (even where not specified!) English "Lorlin" rotary switches are also used.  
The Jaycar 5000 preamp is a cut above the rest but costs no more at only \$245.  
(Parts are available separately)

The kit amplifier of the decade. Virtually distortionless (0.0005%). This amplifier is converting jaded audio enthusiasts over to MOS-FET technology. You can own a 5000 amp with ETI front panel for ONLY \$289 (complete kit) or for \$10 extra you can have the Jaycar SUPERFINISH front panel - total \$299 (complete kit).  
SUPERFINISH front panel. Special fine grain aluminium machined, drilled and tapped and finished in special low-gloss black enamel ONLY \$49.50.  
This panel stands up to a close inspection!  
OTHER 5000 parts available separately - check our earlier ads or call.



### PIEZO HORN TWEETERS

Sensational Frequency Response.

Model	Description	Freq. Resp.	Price
KSN1005A	3.5" super horn	3kHz-40kHz	\$15
KSN1025A	2" x 6" super horn	2kHz-22kHz	\$24

## Jaycar

NOTE! NEW SHOP HOURS  
Mon - Sat 9am - 5:30pm  
Sun 10am - 2pm  
Open Thursday night until 8pm



380 Sussex St Sydney 2000

Ph. 2646688 Telex 72293

Mail Orders To: Box K-39 Haymarket 2000

Jaycar Dealer:

D.E.S. ELECTRONICS 157 Brisbane St. Dubbo Ph. 829355

SEE OUR OTHER ADS FOR P&P CHARGES

sitivity control to minimum, the 20dB meter/oscillator switch to 0dB, and the oscillator frequency selector to 1kHz. Now switch ON. The red LED should be illuminated, and the meter pointer should indicate approximately 0VU.

Assuming there have been no errors in construction, you should be able to rotate the meter selector switch to the INTERNAL (oscillator) position; and by advancing both the oscillator output and meter sensitivity controls a little over half-way, obtain a steady reading on the meter.

Slightly vary the position of each of these controls, and observe that the meter reading rises or falls, according to which direction each control is moved. This should indicate that both oscillator and meter circuits are operative.

Now remove the card from the case, and connect a standard multimeter – set to the 3 (or 2.5) volts AC range – between the input to the 500Ω trimpot and ground. The reading should lie between 2.0 and 2.5 volts. Whilst exact value is of no consequence at this stage, note the reading.

Rotate the frequency selector to each of the other frequencies in turn, noting the readings obtained. Determine which frequency produces the lowest level. This will be the key frequency and level to which we will match the output of the other frequencies. By substituting resistors for each of the temporary links (R1 to R4) it is possible to reduce the output level at each frequency. Assume that 10kHz produced the lowest level (your own instrument may well be any one of the other frequencies, as this effect is largely due to variations in component tolerances), and that the level at, say, 40Hz was about 0.5dB higher.

Take a resistor of, say, 220Ω and temporarily install it in the 40Hz (R1) position, in lieu of the temporary link. Now compare the altered 40Hz level with the original (10kHz) level. Hopefully the levels will be essentially the same. However, if the 40Hz level is still too high, try a larger, say 270Ω resistor. And if, instead, the altered 40Hz level is now too low, try a smaller, say, 180Ω resistor. When you have decided upon the required resistor value, install it tidily on top of the card.

Next move to, say, 1kHz and repeat the aforementioned procedure, except that this time the resistor position is R2. Finally, set the level for the remaining frequency as previously, remembering to install the chosen resistor on top of the card. When this has been completed, remove the remaining temporary link and install a neat link across the top of the card. Note that a maximum of only three resistors is required, since the initial lowest level frequency will always be served by a permanent link. We have included four resistors – ranging in value from 180Ω to 330Ω – for this purpose on

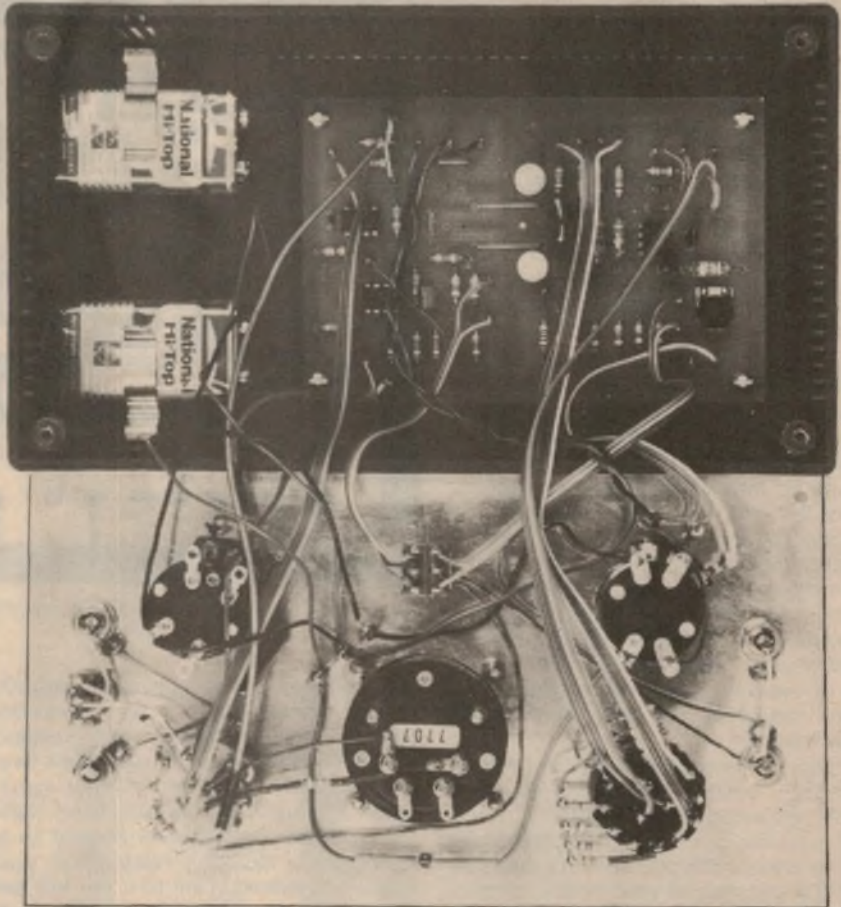

*View inside the prototype. Note that shielded cable is used to the wiper of the meter sensitivity potentiometer and between S2 and the meter amplifier output.*

the parts list; and as only three will be required, this should suffice for most situations.

Having completed this procedure, move the multimeter from the input to the trimpot, to the oscillator's output terminals. Turn the output level control to maximum, and measure the output voltage at 1kHz. It should be one volt. If not, adjust the card-mounted trimpot to obtain exactly one volt. As a final check, measure the output level at each of the four frequencies. Deviation should not exceed  $\pm 0.3$ dB.

Your oscillator should now be properly aligned, so we can proceed to check and adjust the millivoltmeter section. This is less time-consuming, as we only have to measure and trim, if necessary, the frequency response at high frequencies.

Most accurate method of checking frequency response is to use an external signal generator, which has a "flat" response to about 40kHz. If access to such an instrument is unavailable, then we can use the Audio Test Set's internal oscillator, but accuracy will be less since its highest frequency is 15kHz. However the method is the same in both cases.

Check that C1 has not been in-

advertently installed, then apply 1kHz to the input to the instrument and adjust the meter sensitivity to obtain reference deflection. Increase the frequency to 15kHz and note the reading. If using an external generator, increase the frequency to, say, 30kHz and note the reading.

If the response is approximately  $-0.15$ dB at 15kHz and  $-0.5$ dB at 30kHz, then your meter has a "flat" response, and no compensation is required. In fact, if attempted, you would probably only make it worse. However, if the response is down, say 0.5dB at 15kHz (and still more at 30kHz), then your instrument requires compensation. Try installing the supplied 120pF capacitor in the C1 position. With luck, you will achieve the desired response – as we did with the Kyoritsu KM48. But if the response is still down, try a slightly larger capacitor in the C1 position; conversely, if the response is now above the zero level, try a smaller capacitor.

A word of warning. On no account over-compensate such that the response is rising at 15kHz, as the rise will be far larger at 30kHz and above (hence the suggestion to use an external oscillator and check at 30kHz and above), which

could lead to overload and stability problems.

Well, now all that remains to be done is to check the BATT CHECK function, adjusting R5 if required. With fresh batteries in place, observe the meter deflection in the BATT CHECK position. The reading should lie between 0 and +1VU. If incorrect, change the value of R5(1kΩ). Slightly increase its value if the pointer deflection is insufficient; or decrease its value if the deflection is excessive. Note that R5 is located across the contacts of switch S2.

## OPERATION

Referring to the earlier part of this article, you will recall that we gave some suggestions as to how the instrument could be interfaced with your cassette recorder. Assuming that you have it connected to your recorder, you are in a position to commence the evaluation of your blank cassettes and to fine trim the vernier HF bias control. Even if your recorder is not furnished with such a facility, your Audio Test Set will prove to be of assistance in determining which blank cassettes are most suitable for your machine.

Before commencing evaluation of your cassettes, ensure that your recorder's noise reduction system (Dolby B, ANRS etc) is disabled, as otherwise mistracking of the encode/decode circuitry could affect the accuracy of your measurements.

Switch on your Audio Test Set with the meter/oscillator switch set to 0dB, and the oscillator frequency set to 1kHz. Rotate the oscillator output control to minimum. Then set the left and right record level controls on your recorder to

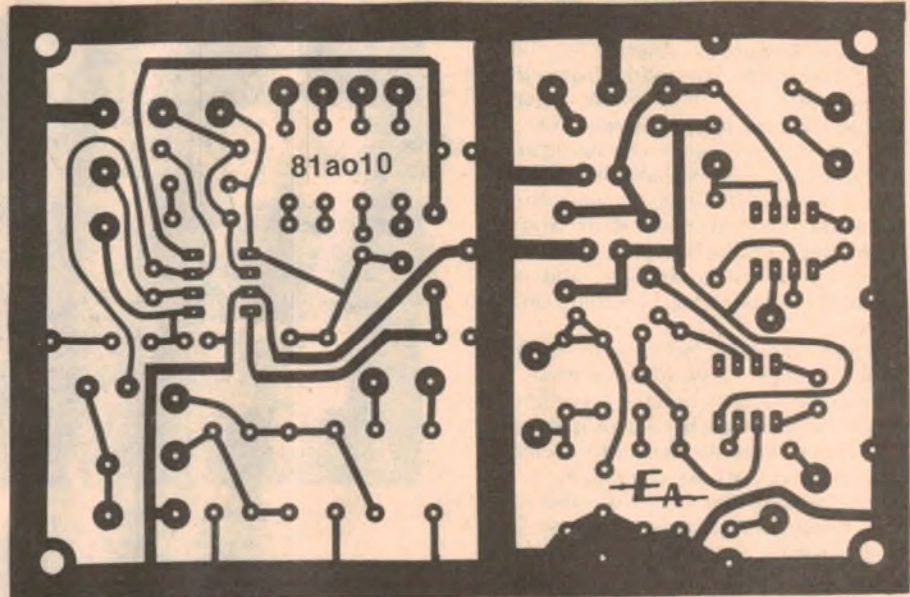

Here is an actual size artwork of the PC board.

their normal operating position (usually about three-quarters max rotation). Engage the PAUSE function and preselect the RECORD mode. The recorder's level meters should indicate an input signal, albeit at a lower than normal level. Raise the oscillator output level control so as to obtain a 0dB(VU) reading on your machine's meters. Fine trim the left and right record level controls such that both recorder meters are reading exactly 0dB.

Now turn the millivoltmeter selector to INTERNAL. Adjust the meter sensitivity control to read about 0VU (dB). Then rotate the selector to EXTERNAL, and re-

adjust the meter sensitivity to once again read "0" (this is the monitoring output of your cassette recorder). Change the toggle switch selector to the other input so as to check the operation of the recorder's other channel.

Reduce the oscillator output by selecting the -20dB switch position. Note that the reading may now disappear off the recorder's own internal meters but due to the complementary action of the meter/oscillator switch, the meter reading on the Audio Test Set should remain unchanged.

Now record about 15 seconds of 1kHz

## PARTS LIST

- 1 "zippy" box, 196 × 113 × 60mm
- 1 Scotchcal front panel
- 4 small self-adhesive rubber feet
- 1 printed circuit card 81ao10, measuring 119 × 89mm
- 1 small VU meter, Kyoritsu KM48 or similar
- 4 RCA-type phono sockets, single-hole mounting
- 1 4 pole, 3 position rotary switch
- 1 3 pole, 4 position rotary switch
- 1 SPDT miniature toggle switch
- 1 DPDT miniature toggle switch
- 4 knobs
- 1 3-lug tag strip
- 2 battery retaining clips
- 2 clip leads for batteries
- 2 9 volt batteries, Eveready 216 or equivalent
- 1 metre light-duty shielded audio cable

- 1 metre 12-conductor rainbow ribbon cable
- 1 metre 10 × 0.12mm hookup wire

### SEMICONDUCTORS

- 2 LM308 8-pin DIL op amps
- 1 LF353 or TL072 IC dual op amp
- 2 BZY88/C4V7 400mW zener diodes
- 1 small red LED

### CAPACITORS

- 2 47μF PC electrolytics
- 1 0.47μF greencap (metallised polyester)
- 1 0.18μF greencap
- 1 6800pF greencap
- 2 2200pF greencaps
- 1 680pF polystyrene
- 1 470pF polystyrene
- 2 180pF polystyrene or ceramic NPO
- 1 120pF polystyrene or ceramic NPO

- 1 33pF ceramic NPO
- 2 2.7pF ceramic NPO

### RESISTORS

- (¼ watt, 1% metal film)
- 1 × 680Ω, 4 × 4.7kΩ, 4 × 6.8kΩ, 1 × 22kΩ, 4 × 68kΩ, 1 × 680kΩ, 2 × 1.8MΩ

### (¼ watt, 5% carbon film)

- 1 × 100Ω, 1 × 180Ω, 1 × 220Ω, 1 × 270Ω, 1 × 330Ω, 1 × 820Ω, 1 × 1kΩ, 1 × 1.5kΩ, 1 × 2.2kΩ, 1 × 3.9kΩ, 1 × 5.6kΩ, 1 × 8.2kΩ, 3 × 10kΩ, 1 × 120kΩ and 1 × 180kΩ.

- 1 × 500Ω horizontal mount trimpot
- 1 × 1kΩ logarithmic potentiometer with DPST switch (switchpot)
- 1 × 250kΩ logarithmic potentiometer

MISCELLANEOUS – Screws, nuts, 6mm clearance spacers, terminal pins, solder, etc.



# fact: five new Shure Cartridges feature the technological breakthroughs of the V15 Type IV

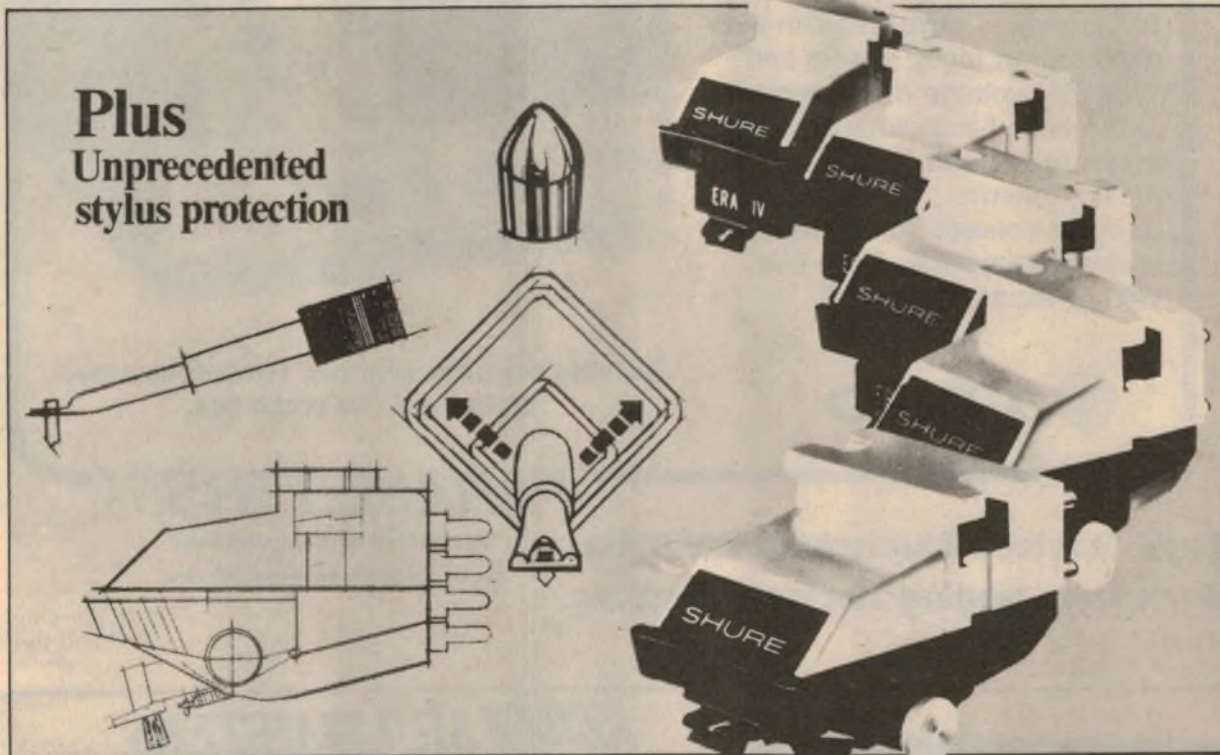

## the M97 Era IV Series phono cartridges

Shure has written a new chapter in the history of affordable hi-fi by making the space-age technological breakthroughs of the incomparable V15 Type IV available in a complete line of high-performance, moderately-priced cartridges: the M97 Era IV Series Phono Cartridges, available with five different interchangeable stylus configurations to fit every system and every budget.

The critically acclaimed V15 Type IV is the cartridge that astonished audiophiles with such vanguard features as the Dynamic Stabilizer — which simultaneously overcomes record-warp caused problems, provides electrostatic neutralization of the record surface, and effectively removes dust and lint from the record — and, the unique telescoped stylus assembly which results in lower effective stylus mass and dramatically improves trackability.

Each of these features . . . and more . . . has been incorporated in the five cartridges in the M97 Series — there is even an M97 cartridge that offers the low distortion Hyperelliptical stylus!

What's more, every M97 cartridge features a unique lateral deflection assembly, called the SIDE-GUARD, which responds to side thrusts on the stylus by withdrawing the entire stylus shank and tip safely into the stylus housing before it can bend.

For Technical service and advice, contact the Audio Engineers representative at the office in your State.

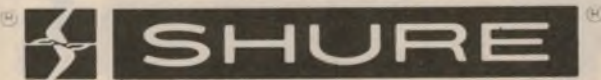

or send this coupon to:

AUDIO ENGINEERS 342 Kent Street  
SYDNEY, N.S.W. 2000 Tel: 29-6731

Please send me your 'free' brochure on Shure Cartridges.  
(PLEASE PRINT NAME AND ADDRESS)

NAME: \_\_\_\_\_

ADDRESS: \_\_\_\_\_

Postcode: \_\_\_\_\_

EA781

AUDIO ENGINEERS PTY. LTD.  
342 Kent Street  
SYDNEY, N.S.W. 2000

NOMIS ELECTRONICS P/L  
689 South Road  
BLACK FOREST S.A. 5035

AUDIO ENGINEERS (Qld)  
51 A Castlemaine Street  
MILTON Qld 4064

AUDIO ENGINEERS (Vic.)  
2A Hill Street  
THORNBURY, Vic. 3071

ATHOL M. HILL P/L  
33 Wittenoom Street  
EAST PERTH, W.A. 6000  
AE161

**AUSTRALIA'S BIGGEST SELLING SCOPE**, the 15MHz dual trace TRIO CS1560AII is ideal for industry, service, school and university use ... offers 10mV/div sensitivity and sweep times 0.5 $\mu$ S to 0.5S/div ... auto free run aids detection of input signals and simplifies voltage measurements ... the wide bandwidth ensures accurate X-Y and Lissajous phase measurements ... stabilised dc-to-dc converters maintain stable displays free from line voltage fluctuations.



 **TRIO**

Supplied complete with two 100MHz switched probes and five probe tips.

**PARAMETERS<sup>PTY</sup>LTD**

"Perfection in Measurement"

Sydney 439 3288 Melbourne 580 7444

**Sold and Serviced Throughout Australia.**  
**Ex Stock from leading electronics stores.**

**KAISE MULTIMETERS**

*Professional performance at a realistic price.*

This range of precision engineered analogue multimeters covers virtually all applications—from household checks to laboratory bench.

**ILLUSTRATED:**

**SK550 \$92.00**  
Top quality 100kohm/V (DC) meter ideal for demanding use where circuit loading must be avoided. Features include:  
 Fast acting relay protection — with LED and buzzer indication.  
 27 ranges including 12A AC & DC current.

**SK510 \$77.00**  
The same accuracy and ranges as the SK550, but without the relay protection and with the addition of a transistor test function.

**SK520 \$82.00**  
Identical to the SK510, but with 4 capacitance ranges instead of the transistor test function.

**SK50 \$50.00**  
Ideal general purpose meter. 50kohm/V — 22 ranges including 3 capacitance scales (using external AC source). Diode and fuse protection.

**SK110 \$38.00**  
30kohm/V meter with transistor tester 19 standard ranges

**SK240 \$29.50**  
Popular 20kohm/V meter. Compact size. 22 ranges. Ideal for field, school or home use.

**SK242 \$28.50**  
Identical to the SK240 but housed in a bright yellow case and with a Lux scale for ambient light measurements (using optional low cost probe).

**Lux Probe for SK242 \$19.50**

**SK2 \$14.95**  
Compact 5kohm/V. Ideal meter for the kitchen drawer or the toolbox. 16 ranges cover most needs.

*All prices are plus tax if applicable.*

**Available from:**  
NSW Standard Components (02) 660 6066  
Radio Despatch Service (02) 2110191  
David Reid Electronics (02) 296601  
Emtronics (02) 2110531  
D G E Systems Newcastle (049) 691625  
QLD. Audiotronics (07) 447566  
E C Q Electronics (07) 3765677  
St Lucia Electronics (07) 523547  
S.A. Bee Jay Electronics (08) 3525959

Vic. G. B. Telespares (03) 328 4301  
Ellitronics (03) 602 3282  
Stewart Electronic Components (03) 543 3733  
Teleparts Geelong (052) 217085  
Ballarat Electronic Supplies (053) 311947  
Tas. George Harvey Electric  
Hobart (002) 342233  
George Harvey Electric Launceston (003) 316533  
W.A. Reserve Electronics (09) 2752377  
Atkins Carlyle (09) 3210101



tone. Leave a silent space of two to three seconds – this will assist identification on replay – then record a similar length of tone at 10kHz. Leave another space of two or three seconds, then record about 15 secs of 15kHz tone. Stop recording, rewind the cassette, and replay it. Watch the meter, whilst alternately switching from one channel to the other.

Ideally all tones on both left and right channels should replay at the same level. Unless yours is a near perfect machine (optimised to the cassette), you are unlikely to obtain such a result. More likely you will find that the response is down at 10kHz with respect to the 1kHz level, and down still further at 15kHz (sometimes it may be almost unreadable at this frequency!).

Assuming that this was the result you obtained, reduce the amount of HF bias, and make a repeat recording of the three tones as per previous. Rewind and replay this new recording.

If the response is now, say, +2dB at 10kHz and -2dB at 15kHz, then this is probably the optimum bias setting for that type of cassette on your recorder. But, if the high frequency response is still drooping, further reduce the bias level setting, and repeat the response tests. In this way, by trial and error, you will arrive at the optimum bias setting for that cassette on your recorder. Make a note of this setting of the HF bias control for future use with this specific type of cassette.

Should your first test run have resulted in excessive high frequency response, then proceed in a similar manner to the above, except that you will need to increase the HF bias level, not reduce it.

Put simply, reduce bias to increase high frequency response; increase bias to reduce the high frequency response.

It is worthwhile to carry out similar tests for each brand of cassette tape you are likely to use; and also for the different formulations within one brand (eg TDK, AD, D, and OD). Keep records of the required bias settings for future use. You may also investigate the performance of your recorder at low frequencies by comparing the 40Hz level with the reference 1kHz. You will probably discover small differences in 40Hz response between different tapes, and more particularly with different cassette lengths. Many C90 cassettes are slightly down in 40Hz response, and almost all C120 cassettes exhibit this low frequency droop due to their thinner magnetic coating. However, there is nothing that you can simply do to compensate for low frequency errors, as changes in the amount of HF bias are primarily effective at the high frequency end of the band.

For those readers whose recorders do not incorporate a variable HF bias control, it is still possible to test the performance of your recorder with various cassettes, although you will not be able to readily compensate for response errors. However, by testing various dif-

ferent cassettes in your machine, you should be able to find which ones are most suitable to your particular machine. For instance, if your problem is a rising high frequency response; changing to one of the lower coercivity formulations (such as TDK "D") should result in a flatter response. Conversely, if you have a falling high frequency response, a change to a higher coercivity formulation (such as TDK "AD") will usually flatten the frequency response.

In this way you can determine which cassettes are most compatible with your own machine. By using such cassettes you will find that you will be able to make far better music recordings with your equipment in the future.

But do not be misled to think that the most suitable cassettes for your machine are necessarily the absolute "best"; nor that cassettes which do not perform well on your recorder are "bad". All that you are doing is finding the best compromise for your own particular machine; and a cassette which you might be tempted to classify as "bad" could well be a far better quality cassette, when used on a recorder which has been optimised for its use.

Thus the foregoing should assist you in gaining a clearer understanding of the optimising of recorders to cassettes. We hope that this Audio Test Set will prove beneficial to your future recording activities. Good luck!

Below: actual size reproduction of the front panel artwork.

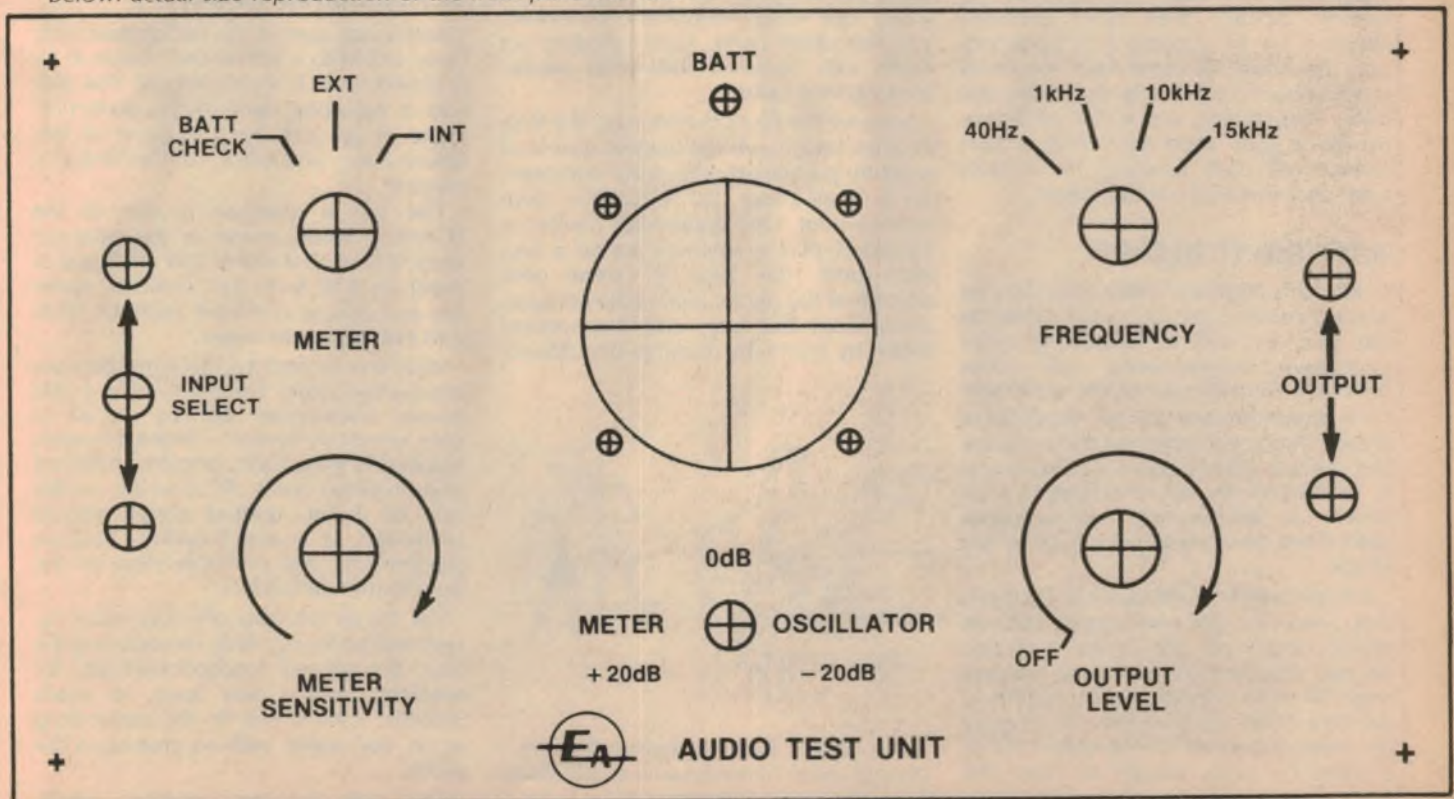

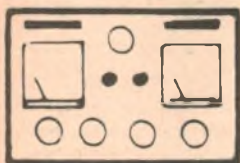

# The Serviceman

*We'd be better off without fuses  
... if we didn't need them so much!*

Ever since the first monochrome TV set appeared on the Australian market, TV servicemen have been fighting a running battle with fuses and the engineers who specify them. It has developed into a kind of love/hate relationship in which each concedes that the other has a point, but feels that his point is the stronger one.

At first sight the idea of fuses in a TV set seems a perfectly logical one; suitably placed throughout the circuit, and with appropriate ratings, they should be able to protect expensive components which might otherwise be at risk when a minor component fails. After all, the fuse is a well established protective device that has been with us for years.

Why, then, do servicemen sniff when fuses are mentioned? The truth is that fuses have never been the complete success in TV sets. Granted, in the overall picture, they have probably saved a lot of expensive components, but the most die-hard fuse supporter would have to admit that they have also been responsible for a lot of breakdowns in their own right. And a basic service call costs as much for a faulty fuse, as it does for anything else.

## WHY DID IT BLOW?

Nobody complains when a fuse fails for a good reason; then it is only doing its job and, as well as protecting more expensive components, can often provide a valuable clue to the main fault.

It is when the fuse fails for no apparent reason that servicemen get the twitches. Did the fuse fail of its own accord, or was it destroyed by an intermittent fault which, as like as not, will re-appear before the serviceman gets back to the shop?

A basic problem with fuses in TV sets is that many of the component failures, which occur, do not create a drastic enough situation to blow a fuse; but they may still draw enough excess current to damage other components. As a result, the rating for a fuse can be quite critical; it must be high enough to carry the normal current safely, but low enough to

provide protection for relatively small overloads.

The theory now is that fuses can fail due to metal fatigue. Because they are so finely rated they tend to heat up slightly when the set is on, so that the metal expands and then contracts when the set is switched off. Do this often enough and the metal becomes brittle and fractures.

Fortunately, such failures tend to be distinctive. There are no globules of molten metal, no blackening of the glass tube; just a fuse which may appear to be intact, but which measures open circuit. On the other hand, some genuine set faults can cause a somewhat similar looking fuse failure.

Next to the fuses themselves, the fuse holders have been the biggest source of trouble, particularly the more elaborate kind designed to simplify fuse replacement. One drawer-like device, in moulded plastic, seemed to be a fine idea until the heat in some sets deformed the plastic, pulled the contacts away from the fuse, and then added insult to injury by locking the drawer



*"They didn't have a 3-amp fuse so I bought three 1-amp fuses instead!" (From Popular Electronics magazine).*

firmly in position!

All of which adds up to a situation where many servicemen contend that fuses cause as many problems as they solve – or even more in some cases. While I wouldn't go as far as this, I would have to agree that they do create their share.

All of which is by way of background and, as far as the fuses themselves are concerned, has led us to adopt a rough but fairly accurate rule of thumb; if the failure has been catastrophic – globules of metal inside a blackened glass tube – then there is most likely a real fault and the fuse has done its job well. If, on the other hand, the fuse appears intact, but is open circuit, then metal fatigue is the most likely culprit.

## A PUZZLING CASE

And it was against this background that I was called to a set recently because of a blown fuse. It reminded me that this was a recurring fault in this particular make of set and that the cause of the failure was – and still is – something of a mystery.

The set in question is one of the "General" brand made by the Japanese company of that name and marketed in Australia with both the "General" name tag and also, at one time, with the HMV and Healing trade marks.

With few exceptions the symptoms are always the same: The mains fuse, in the power transformer primary circuit, is very obviously blown – blobs of metal, blackened glass tube, or even shattered glass in some cases. All of which, by the rule of thumb quoted above, should indicate a catastrophic failure somewhere, and probably close to the transformer secondary.

Yet, by all the tests one can make, no fault will be found. And, on replacing the fuse, the set will function normally for anything from a few hours to many months. Then it will do the same thing again, and again, with no clue as to the cause.

The cure for the problem came,

eventually, from the Australian "General" agent's service department. Unfortunately, while the cure appears to have been completely successful, the explanation offered as to the cause is less satisfactory.

The relevant portion of the circuit is relatively simple. The power transformer has a 120V secondary winding which feeds a full-wave bridge rectifier, followed by a 300 $\mu$ F electrolytic capacitor, another fuse, and then a voltage regulator system. The fact that the second fuse invariably remains intact should be noted.

The only other component is a 0.1 $\mu$ F, 1000V DC capacitor across the transformer secondary, and this appears to be the culprit. At any rate, replacing it with a similar, but not necessarily identical, unit supplied by the manufacturer has, so far, proved completely effective.

### WHAT'S THE REASON

But why does the original capacitor blow the fuse, then apparently return to normal for possibly several months before repeating the sequence? The service department's explanation is that the capacitor is, either by design or accident, a self-healing device; that it breaks down, blows the fuse and, simultaneously, heals its own breakdown.

Self-healing capacitors are not new. At least one Australian manufacturer — AEE if I remember rightly — used to market a paper capacitor of this type. It used metal deposition to form the plates on the paper dielectric. The plates were therefore very thin which not only reduced the size of the capacitor but enabled the plates to act as their own fuse in the event of a breakdown, thus clearing the fault.

This suggested explanation is all very nice, but I have my reservations for a couple of reasons. One was an incident which occurred shortly after the agents announced their cure for the problem. A customer called me to his set for just such a failure and I discovered that I had run out of the replacement capacitors. So, with the customer's full knowledge, and because he was anxious to get the set going immediately, I simply removed the capacitor.

And, as you have probably guessed, before I could obtain the correct replacement and go back and fit it, the set blew the fuse again. So how could the capacitor be blamed when the capacitor wasn't there? It couldn't, of course; at least not on the breakdown theory. But had the fuse blown due to the lack of capacitance? Perhaps due to a spike on the mains?

Quite frankly, I can't envisage any likely mains spike, regardless of its amplitude, having enough energy to blow a fuse. I imagined the capacitor was there to suppress any such spikes, which might

otherwise damage the bridge rectifier.

But if the spike theory was tenable it would suggest that the original capacitors were going open circuit rather than short-circuit; a condition which is less likely to be revealed by the simple tests which a serviceman would apply. Unfortunately, it has not been practical for me to check the capacitance of one of these capacitors up till now. However, if I encounter another case I intend to check the capacitor out thoroughly.

In broader terms, this problem raises another important point. Both the original capacitors, and the replacement ones, appear to be polycarbonate types and, as I understand it, plastic dielectric capacitors in general, and polycarbonate types in particular, do not take kindly to AC operation.

In fact, for mains suppression applications, the paper capacitor is still preferred by many engineers. Not the cheap wax-dipped things which caused so many faults in the old radio days, and the early days of TV, but high quality units encapsulated in moisture impervious epoxy. And once again, if I remember rightly, it was the Australian AEE company who marketed these a few years ago.

But that is by the way. The real point of this story is that the exact cause of the blown fuses is still a mystery. Perhaps that point is only academic but I, for one, would be happier if I knew the answer. At least I would be in a better position to select a replacement capacitor in the event that the agents could no longer supply the recommended type.

Finally, I must add that on a few occasions I have found this fuse blown for a very good reason. In these cases the fault is in the de-gaussing circuit and, more specifically, in the thermistor in series with the de-gaussing coil. These go virtually short-circuit, putting the coil directly across the mains. In such cases I am only too thankful that there was a fuse in circuit to cop the wallop.

### ANOTHER STRANGE ONE

My second story this month concerns a much more specific fault, but one which led me on a false trail for a few minutes. It concerns a Kriesler 59-1 colour TV chassis which, according to the owner, was "... on the blink, and it smells as if something's burning."

I was able to ascertain that "on the blink" meant that there was no picture, no raster, and no sound. That was serious enough, but the burning smell was the real worry; it could easily mean a burnt printed board, something which can be quite expensive.

When I finally came to grips with the monster in the customer's home I simply switched it on to confirm the symptoms. Sure enough, there was no picture, raster, or sound but, by the time the tube would have been working, a couple

*Have you heard?*

## CASH-MORE

have a surplus stock of:

Disco units — confetti canons — cob webb machines — microphones — mirror-balls — discos — speakers — amplifiers — chasers — rope lights — infinity panels — lito 250 effects projector — detonator box — firing box — flash cartridges — the "pea souper" — fuzzlite.

## LOOK AT THESE GREAT DISCO SPECIALS

### HY5000 SOUND CONTROL CENTER

*Ideal for disco or mike mixing*

- 2 phono or line-in inputs
- 2 microphone inputs.
- 5 band graphic equalizer.
- Headphone monitoring.
- \* Mixers start from \$200



### LITO 250 EFFECTS PROJECTOR

- 250 watt Projector with spectacular effects.
- 14 attachments available.
- Wide selection of cassettes and 6" wheels.
- \* \$310 Rotators: \$39; Cassettes/Wheels: \$24.

### THE PYROFLASH

The most sophisticated theatrical pyrotechnic system available.

This unique system uses a completely new concept in detonation, ensuring maximum effectiveness and safety. The system comes complete with Detonator Box, Firing Box and all connections. A variety of effects cartridges are available extra.

- \* Detonator Box: \$195; Firing Box: \$65; Flash Cartridges: from \$50 per dozen.



### BUBBLE MACHINE

A real fun machine using a harmless liquid to produce showers of gently descending bubbles. Unit can produce up to 1,000 bubbles per minute, and adds a tremendous climax to any show when used with effects lighting. It is particularly good with the Blockbuster Strobelite.

\* Second hand ex-hiring stock gear in good condition also sold. AND if this isn't enough we have band rehearsal facilities and a TV and film studio.

For information contact:

### CASH-MORE ENTERPRISES,

Brochure available or telephone

(02) 799 6129

Office, Showroom at 356 Liverpool Rd. Ashfield. 2131.

Brochures and price list on request, mail orders accepted.

## THE SERVICEMAN — continued

of sniffs confirmed the burning symptom. I also sensed that the EHT was working.

I switched off, removed the back of the cabinet, and examined those boards which were immediately visible. I could find no signs of burning here so I swung the linescan/frame scan board around to expose the component side but, again, there was no obvious sign of burning.

Well, there was only one thing to do; I crossed my fingers and switched on again. And in a few seconds a thin wisp of smoke pinpointed the culprit; a 1 ohm "safety" resistor (R779) in the supply line to a transistor (TR690) in the line scan circuit.

Failure of this resistor is not uncommon and in all previous cases it has been due to a breakdown in the transistor TR690. In fact, the resistor's main function is more akin to that of a fuse, being of about one quarter watt rating and only just adequate in normal circumstances. Hence the designation, "safety resistor".

My first reaction was to assume that this fault was at least similar to all the others I had encountered involving overload of this resistor, though I had noted that the symptoms were not identical. Normally, when TR690 fails, the set continues to function, but with reduced picture width — anything up to 50mm from each edge.

I removed R779 then checked TR690, expecting to find it broken down. In fact, there appeared to be nothing wrong with it and I suddenly realised that I had a quite different fault, and a rather puzzling one, to boot. The truth is, that with TR690 cleared there wasn't much else in that part of the circuit which could draw excess current.

So it was back to basics. This part of the circuit involves a 25V rail derived from a winding on the line output transformer (pin 8) via a couple of diodes (D776, D777) and smoothed with a couple of 680 $\mu$ F electrolytics (C780, C781). There is also a fuse (F180) and this provides a convenient voltage check point.

### THE MISSING VOLTS?

In fact, there was very little voltage here, only about three volts, instead of the expected 25. Well, at least that explained a lot. This 25V rail is a major voltage source for the set, providing, among other things, an 18V regulated supply for the convergence board, and a 12V regulated supply for the tuner and IF amplifier. Little wonder there was no picture or sound.

But what had happened to the 25 volts? There seemed to be two possibilities; either one of the diodes, D776 or D777, had failed — a not uncommon fault, incidentally — or there was a fault on the other side of the fuse which was loading

the circuit severely.

I tended to discount this latter idea. It seemed unlikely that a fault severe enough to pull the voltage down from 25 to 3 would fail to blow the fuse. It seemed much more likely that it was one of the diodes.

The only snag was that both diodes checked out OK, thus supporting the excessive load theory. This idea seemed to be even further supported when I pulled out the fuse, thus isolating the rest of the set, and the voltage shot up to over 40.

But I was still convinced that the intact fuse was a vital clue. (Take back all the nasty things I said about fuses in my other story.) Which seemed to throw suspicion back on the diodes, in spite of my checks. If only because it was easier to double check the diodes than to start chasing a possibly imaginary fault around the entire set, I decided to replace the diodes anyway.

It so happened that I replaced D777 first and, Hey Presto! that was it. (Murphy must have taken a day off.) With the fuse replaced the voltage came down to 25, sound came forth from the speaker and, as the tube warmed up, there was the picture.

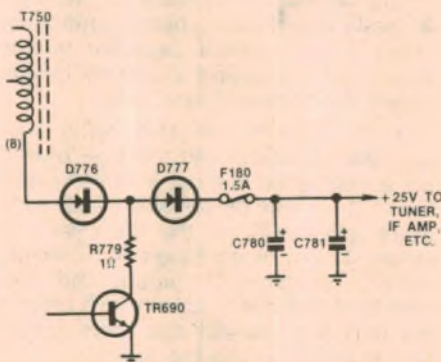

The case of the missing volts!

It wasn't a full scan, because I had previously removed the charred 1 ohm resistor, but that was easily fixed. A new 1 ohm resistor and everything was back to normal, even if there were still a couple of unanswered questions in my own mind.

First, why had the 1 ohm resistor overheated — and led me on a wild goose chase — when there was no fault in TR690 or its associated circuit? The answer is almost certainly that it was due

If you have a factual and interesting story to tell about electronic servicing, write it in your own words and send it to "The Serviceman", c/o "Electronics Australia", Box 163, Beaconsfield 2014. If the Serviceman uses it in his column, we will pay an appropriate fee.

to the increased voltage — 40 or more instead of 25 — causing increased current through TR690. And, with the benefit of hindsight, it is significant that the resistor only overheated, and did not burn out, as it usually does.

Second, why did the diode appear to be OK when checked with a meter, yet was plainly faulty? Frankly, I don't know. I can only suggest that it was some kind of non-linear resistive fault whereby the resistance appeared low for the low current used to test it, but appeared high under a heavy load.

But that is pure speculation and I can only add that this is not the first time that I have been caught by solid state devices which did not behave in the circuit as tests indicated that they should. Which brings us to an adage that is nearly as old as radio itself; the ultimate test of any component is in the circuit in which it is to operate. Or, when in doubt, replace.

### TV/POWER OUTLETS

Finally, here is a brief, but important, comment on my story in the May issue concerning combination power points and TV antenna outlets. It is from Mr J. Lawler, Hon Secretary of the Television and Electronic Technicians Institute of Australia (TETIA), Tasmanian Division, and is in the form of correspondence between TETIA and the Tasmanian Hydro-Electric Commission regarding these devices.

Mr Lawler's letters to the Commission queried the legality of TV technicians making connections or adjustments to the TV antenna portion of these combination outlets, and also drew their attention to the story in the May issue.

The Commission's reply, over the signature of Mr L. M. Maynard, Chief Distribution Engineer, reads as follows:

"We thank you for your letter of 6th May, 1981, and advise that the licensing regulations are administered so as not to preclude a TV serviceman from making connections to the TV portion of a combination TV, power outlet H.P.M. Cat. 789 TV, Clipsal Cat. 15XTV, or Ring Grip Cat. SC1TV, provided the shroud covering the terminals of the power outlet has been correctly fitted.

"This may be checked by easing the flushplate clear of its mounting by a few millimetres and where no shroud is present the flushplate should be resecured and the matter referred to a licensed electrical contractor.

"We trust that this information proves to be of value to you."

Well, thank you, Mr Lawler and I am sure that readers will find this information useful. However, readers should realise that this is the view of only one supply authority. Other authorities, in other states, may take a different view, and it would be wise for the individual serviceman to know what these are. ☺

# ROD IRVING ELECTRONICS

425 HIGH STREET, NORTHCOTE 3070, MELBOURNE, VICTORIA. TELEX NO. 38897.

## S100 COMPUTER PRODUCTS

### 16K EPROM CARD-S 100 BUSS



**\$89.50  
KIT**

**BLANK PC BOARD  
\$45  
USES 2708's!**

Thousands of personal and business systems around the world use this board with complete satisfaction. Puts 16K of software on line at **ALL TIMES!** Kit features a top quality soldermasked and silk-screened PC board and first run parts and sockets. Any number of EPROM locations may be disabled to avoid any memory conflicts. Fully buffered and has WAIT STATE capabilities.

**OUR 450 NS 2708'S  
ARE \$6.95 EA. WITH  
PURCHASE OF KIT**

**ASSEMBLED  
AND FULLY TESTED  
ADD \$36**

### 32K S-100 EPROM CARD

**NEW!**



**\$99.95**

**KIT  
USES 2716's  
Blank PC Board — \$55  
ASSEMBLED & TESTED  
ADD \$30**

**SPECIAL: 2716 EPROM's (450 NS) Are \$8 EA. With Above Kit.**

- KIT FEATURES**
- |  |  |
|--|--|
| 1 Uses +5V only 2716 (2Kx8) EPROM's          | 7 Any of all EPROM locations can be disabled                   |
| 2 Allows up to 32K of software on line!      | 8 Double sided PC board, solder-masked, silk-screened          |
| 3 IEEE S-100 Compatible                      | 9 Gold plated contact fingers                                  |
| 4 Addressable as two independent 16K blocks  | 10 Unselected EPROM's automatically powered down for low power |
| 5 Cromemco extended or Northstar bank select | 11 Fully buffered and bypassed                                 |
| 6 On board wait state circuitry if needed    | 12 Easy and quick to assemble                                  |

### 16K STATIC RAM KIT-S 100 BUSS

**KIT \$189  
A&T \$219**

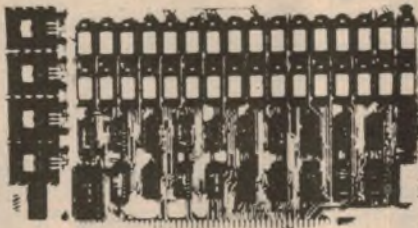

**KIT FEATURES**

- 1 Addressable as four separate 4K Blocks
- 2 ON BOARD BANK SELECT circuitry (Cromemco Standard) Allows up to 512K on line
- 3 Uses 2114 (450NS) 4K Static Rams
- 4 ON BOARD SELECTABLE WAIT STATES
- 5 Double sided PC Board with solder mask and silk screened layout Gold plated contact fingers
- 6 All address and data lines fully buffered
- 7 Kit includes ALL parts and sockets
- 8 PHANTOM is jumpered to PIN 67
- 9 LOW POWER under 1.5 amps TYPICAL from the +8 Volt Buss
- 10 Blank PC Board can be populated as any multiple of 4K

**BLANK PC BOARD W DATA \$49  
LOW PROFILE SOCKET SET \$22  
SUPPORT IC'S & CAPS \$29  
ASSEMBLED & TESTED-ADD \$30**

**OUR #1 SELLING  
RAM BOARD!**

### 16K STATIC RAM SS-50 BUSS

**PRICE CUT!**

**\$199 KIT  
A&T \$219**

**FULLY STATIC  
AT DYNAMIC  
PRICES**

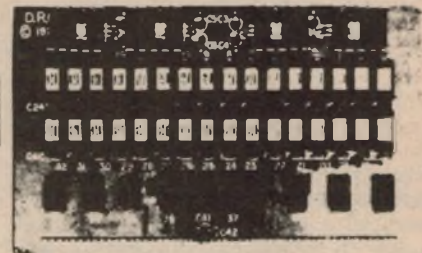

**KIT FEATURES**

- 1 Addressable on 16K Boundaries
- 2 Uses 2114 Static Ram
- 3 Runs at Full Speed
- 4 Double sided PC Board Solder mask and silk screened layout Gold fingers
- 5 All Parts and Sockets included
- 6 Low Power Under 1.5 Amps Typical

**BLANK PC BOARD —\$45 COMPLETE SOCKET SET —  
\$22 SUPPORT IC'S AND CAPS — \$45**

### ITOH Model 8300 PRINTER

**\$770.00 plus 15% sales tax**

This 80-column printer provided quiet operation, making it suitable for use in offices, classrooms and homes. Specifications include 125cps, 60 lines per minute, paper loading from bottom or rear and Centronics compatible, parallel interface

A bidirectional, dot matrix impact printer with a print head designed for 100% duty operation assuring a print life that exceeds 100 million characters. The precision sprocket-feed mechanism permits printing forms from 4 1/4 to 9 1/2 inches wide. A 96 ASCII character set prints in upper and lowercase with the added capability of producing double-width fonts in boldface. The vertical format unit provides preprogrammed/programmable tab positions, top of form and bottom of form for complete formatting capabilities



**REDUCED TO  
\$690 + TAX**

### ETI636 7 SLOT MOTHERBOARD WITH ACTIVE TERMINATION

Kit of Parts \$89.00. Assembled and tested \$115.00, inc tax.  
RITRON COMPUTER GRADE POWER SUPPLY: +5V Reg, 10A,  
± 16V Unreg. Kit of parts \$79.95 inc tax A&T \$99.95 inc tax

Write for list of other power supplies. Tax free prices also available.

### \* \* \* AVAILABLE AGAIN \* \* \*



- 16K Dynamic Ram Board
- Fully Expandable to 64K
- Assembled, tested and guaranteed
- S100 Compatible

16K Dynamic RAM Board assembled and tested:  
Special \$269 plus tax (2mHz), \$299 plus tax (4mHz)  
This must be the best offer available on quality tested  
dynamic RAM boards.

32K Assembled and tested	\$308 plus tax (2mHz)
	\$330 plus tax (4mHz)
48K Assembled and tested	\$348 plus tax (2mHz)
	\$378 plus tax (4mHz)
64K Assembled and tested	\$388 plus tax (2mHz)
	\$418 plus tax (4mHz)

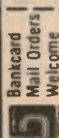

Please debit my Bankcard EA 10/81  
Bankcard No  
Expiry Date  
Name  
Signature

General enquiries (03) 489-8131, Mail order enquiries (03) 481-1436. Ritronics Wholesale (03) 489-7099.

Prices current till November, 1981. Heavier items add additional postage. Extra heavy items sent Comet freight on. Prices subject to change without notice. Send 60c and SAE for free catalogues. MAIL ORDERS PO BOX 135, Northcote, Vic 3070. Minimum pack and post \$1.

# Circuit & Design Ideas

Interesting circuit ideas from readers and technical literature. While this material has been checked as far as possible for feasibility, the circuits have not been built and tested by us. As a consequence, we cannot accept responsibility, enter into correspondence or provide constructional details.

## Marine Auto Pilot For Small Boats

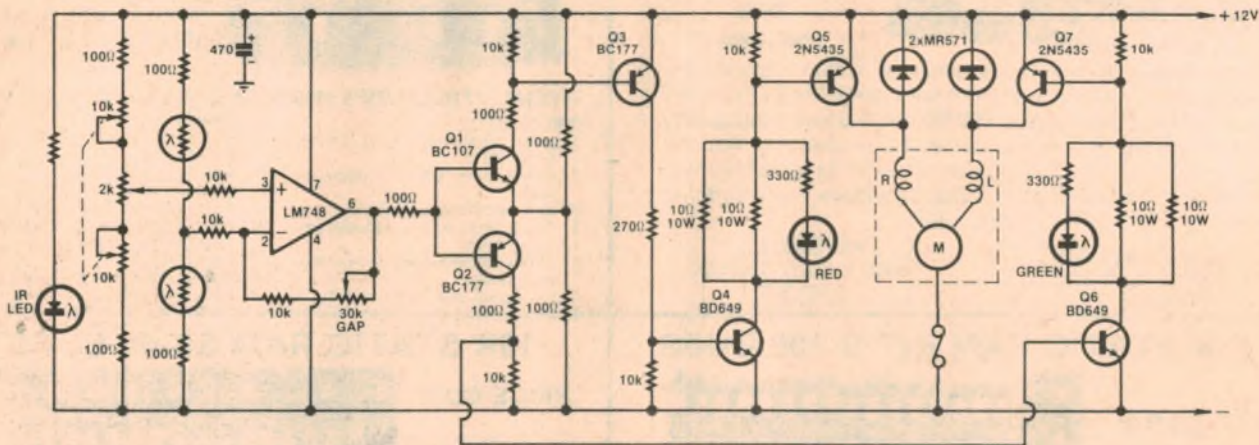

This idea is based on the use of a modified compass which controls drive power to a reversible motor which is coupled to the steering (rudder) linkage.

All markings must firstly be removed from the face of the compass, after which a single white line, approx .5mm wide, is painted radially from the centre to the edge.

An infrared LED is arranged between two light dependent resistors (LDRs) such that some light will be reflected on to both LDRs from the white line. A 748 IC is used as a comparator, with approximately half the supply voltage being applied to the non-inverting input. The LDRs are wired in series across the supply, with the junction of the two being taken to the inverting input of the 748. Assuming equal light falling on each LDR, the output of the 748 will be at half the supply voltage.

As the emitters of both Q1 and Q2 are tied to a half supply voltage point, they will both be switched off. When the boat changes direction (and the white line moves) more light will be reflected onto one LDR than the other, hence changing the potential at the inverting input of the 748, resulting in the output being driven towards either the positive or negative supply rails.

This switches on either Q1 or Q2, with the appropriate output current being amplified by either Q3, Q4 and Q5 or Q6 and Q7; such that either Q5 or Q7 is able to provide high current for energising the reversible motor. Red and green LED indicators are included to show port or starboard as appropriate.

Note that a suitable dual winding (reversible) motor is used in the tailgates of Holden station wagons. The four 10Ω, 10 watt power resistors should be mounted on a suitable heatsink. The same applies to Q4, Q5, Q6 and Q7. Note also that the modified compass does not have to be adjusted for accuracy (it works separately from the main compass).

To use the device, put the boat on course, and line up the infrared LDR with the compass line. Now switch the unit on, and the Auto Pilot will drive the steering linkage left or right to maintain

the craft on the reference course.

The dual 10kΩ potentiometer allows for trimming the rudder into the centre position, whilst the "gap" can be adjusted with the aid of the 50kΩ potentiometer.

S. H. Grunbauer,  
Southport,  
Queensland.

Editor's Note: The 2N5435s are germanium PNP power transistors which may be difficult to locate. Perhaps a pair of MJ4502s or 2N3771s could be substituted for each 2N5435.

## Pseudo Random Number Generator Routines

Here are three subroutines for a pseudo random number generator (for the 6809, Z80 and Cosmac PRC), which were developed to be both fast in operation and as utterly "random" as possible. All the routines are written for RAM only as they contain their scratchpad areas. Some alterations would be required if it were necessary to write ROM versions.

1: Z80 subroutine:—

0000: E5D5 211D 007E C602 E60F 775F 1600 1923

0010: 8677 2B7E 3C23 AEOF 2B77 D1E1 C901 FFFF

0020: FFFF FFFF FFFF FFFF FFFF FFFF

This is relocatable except that it contains one absolute address which refers to itself. This is at locations 0003 and 0004 in the example, and is the address of the byte immediately preceding the seed. This address must be altered when

the subroutine is moved. As shown, the seed is from 001E to 002D. The seed values may be anything at all. Execution time is 91.5μs.

2: 6809 subroutine:—

0000: 3410 308C 1CC6 02EB 84C4 0FE7 8030 85EB

0010: 84E7 84E6 825C E801 5424 02CA 80E7 8435

0020: 9001 FFFF FFFF FFFF FFFF FFFF FFFF

0030: FFFF

As shown the addresses are entirely arbitrary, and this routine is completely relocatable. It is called at its beginning, and will return with a random byte in ACC. B. The seed is the 10H area from 0022 to 0031 shown as FFH. Seed values may be anything at all. Execution time is 71μs.

(continued on p93)



## CIRCUIT & DESIGN IDEAS

3: Cosmac subroutine:—

```
00D0: 93B0 F8EF A0E0 F0FC 02F9 F150
A0FA 0FF4
00E0: 73F8 01F4 60F3 20F6 C7F9 8073
A0D5 C401
00F0: FFFF FFFF FFFF FFFF FFFF FFFF
FFFF
```

This version can be moved from one page to another, but must always be located at XXD0-XXFF (as shown for page 00 above). Since there is no simple way of saving registers in the Cosmac, routines are normally accompanied by a statement of resources used. In this case,

R0.1 is clobbered, R0.0 returns the random byte, X is "clobbered" and D will be clobbered by the SCRT linkage if used.

Whilst this subroutine is compatible with the RCA SCRT subroutine linkage, if this is not used, it must be called by a program using R5 as PC by a SEP R3 call after pointing R3 to the subroutine. Execution time is  $120\mu\text{s}$ , plus time to implement the sub call. The seed is from XXF0 to XXFF, and may contain anything.

It should be pointed out that each time

the same seed is loaded into a computer, the computer will produce the same sequence of values as every other time. This explains why a PRNG may be thought to be "not sufficiently random".

Thus, some method of re-seeding must be done before using a PRNG. However there are several ways of overcoming this problem; such as keeping it intact by re-recording to get continuity, or by re-seeding deliberately with a random value, or by accessing the PRNG a large, random number of times — for example, in a loop while waiting for the first key press in a particular program.

It will have to be left to the individual user to select the approach best suited to his needs.

I. B. Crisp,  
Bayswater, Victoria.

## Variable-Phase All-Pass Filter

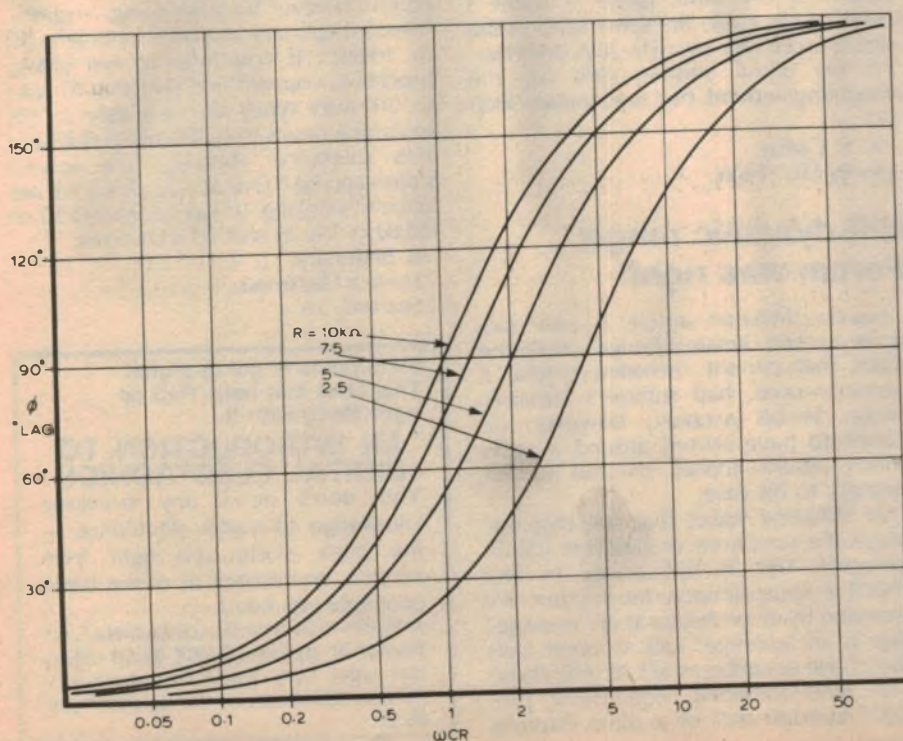
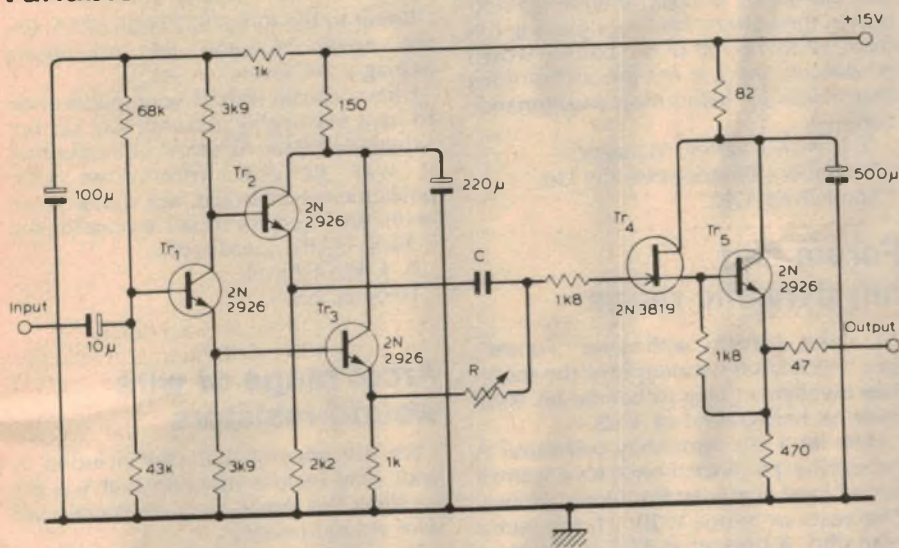

This filter provides a constant output amplitude, together with a frequency range to 100kHz. At 1V rms output, the harmonic distortion is less than 0.1%.

Transistor Tr1 is a "phase-splitter", and drives emitter followers Tr2 and Tr3. A CR phase shifting network is connected across the low impedance outputs of Tr2 and Tr3. The output of this network is applied to Tr4 and Tr5. A 1.8kΩ resistor is connected in series with the gate of Tr4 to guard against parasitic oscillations, which might otherwise occur. Output is taken from the emitter of Tr5.

If a 10kΩ rheostat is substituted for R, and a suitable value assigned to C (appropriate to the frequency band it is desired to shift), the phase of a waveform can be varied from zero to nearly 180° or, by interchanging C and R, from 180° to nearly zero. A DPDT switch could be added to the circuit to enable the interchange of C and R.

The accompanying graph shows the normalised all-pass phase response for four values of R.

"Wireless World",  
May, 1980.

## CORRECTION — Electronic Thermometer

We have been advised by Mr D Mills that he made two errors in his circuit for an "Electronic Thermometer with Digital Display" published in the May, 1981 issue. Firstly, the junction of the 0.33µF capacitor, 1kΩ and 6.8kΩ resistors should be taken to the +5V rail. Second, the update frequency is always 4Hz irrespective of whether pin 6 of IC1 is taken to ground or left disconnected. If a change to 96Hz is desired, connect pin 6 to the +5V supply rail.

**PSSST!** Got any neat circuit ideas? Why not send 'em in to us? We pay between \$5 and \$20 per item, depending on how much work we have to do to publish it.



# Letters to the editor

## More on exploding batteries

I thought you may be interested to hear that in the course of my employment as an Ophthalmology Registrar at the teaching hospitals in South Australia I have collected a series of eye injuries caused by exploding lead acid batteries. I have fully examined and in many cases treated these patients myself. To date no one has had to have an eye removed as a result of injury, but five of my own cases have ended up legally blind in one eye, and several are still having difficulties up to 12 months after injury.

I have written a paper on these injuries which I understand will be published in the new year. I have also submitted a paper to the Annual Scientific meeting of the Royal Australian College of Ophthalmologists in September this year.

My purpose in telling you all this is the hope that you and your staff will continue to pursue the matter of battery explosions and put whatever pressure you can on manufacturers to design a safe battery. I am aware that this can be done but I am at a total loss to explain why it has not been done. Perhaps what is required is for one or two of my patients to sue the manufacturer concerned!

Dr S. Siebert,  
St Peters, SA.

## ... and in Bundaberg

We read with interest your Serviceman article in "Electronics Australia", June, 1981, regarding an exploding low maintenance battery; and feel you would be interested in a similar happening.

In this instance the battery in question was one of a pair of 12 volt low maintenance units providing starting power for a diesel alternator standby power plant for the local broadcasting station studio.

The battery system floated across the mains on a trickle charge which would be measured in milliamps. The standby plant is housed in a room 5m x 35m x 3m and apart from a work bench and a couple of cupboards is the sole occupant; and although the 15kA unit is a modern unit which does not occupy much space, one of the double doors to the room is open for a large percentage of the working day, so one feels it is unlikely a large concentration of gas would be likely.

The explosion occurred when the

starter switch was made on a test run and only the bottom plate of the battery was left intact. Fortunately the operator escaped injury, however he is now careful to put the plant between himself and the battery when starting either the studio or transmitter power plants.

We feel in this instance the explosion was caused by a faulty internal connection in the battery; however proving this from what was left of the battery would be difficult and it is not the sort of thing that makes for faith in low maintenance batteries.

G. L. McKennarley, Manager,  
Bundaberg Broadcasters Pty Ltd,  
Bundaberg, Qld.

## Forum and hifi dynamic range

I agree entirely with your "Forum", July, 1981. I, too, wonder how the suburban dweller is going to handle his 90dB over his background of 35dB.

How loud is a symphony orchestra? A personal experience: I once took a small sound level meter to the Opera House. Our seats were box V 20, 21, the meter read dBA. It peaked at 87dBA. Playing a record of the same piece at home I could easily attain the same level in the sitting room with my twin 20W amplifier.

If we allow another 8dB for the weighting network that only makes 95dB SPL.

R. S. Caddy,  
Ewey Bay, NSW.

## Hifi dynamic range: Forum was right!

Neville Williams' article in your July issue on "Hifi Dynamic Range" made the point that current recorded media, if properly used, had sufficient dynamic range. In his account, however, he seems to have skirted around a point which would appear to add further strength to his case.

Mr Williams states that the dynamic range of a symphony orchestra is 100dB. However, this is misleading. In fact 100dB is approximately the loudest SPL provided by an orchestra at an "average" seat in an "average" hall. Concert halls don't have an ambient SPL of 0dB; those with air-conditioning equipment probably average that of a quiet listening

room (30dB SPL, not allowing for bursts of coughing). Therefore, any sound below 33dB would hardly be noticed. In short the useful dynamic range of a symphonic orchestra is probably below 67dB.

A. Reisner,  
North Ryde, NSW.

**COMMENT:** Sorry but, if you re-read the article, you will find that Neville Williams criticised the figure of 100dB and proceeded to the conclusion on page 29 that "this would suggest that the dynamic range of a fully rehearsed orchestral performance is comfortably below 90dB". Further observations on the subject appeared in the September issue.

## A policeman in shoes?

I refer to the June 1981 issue of EA. On the cover "Caught! EA Advertising Manager Sel Sayers ... etc."

I have usually found your publication to be a reasonably accurate journal, but surely, a mistake like this!! I thought that it was general knowledge that policemen wore boots, not shoes, while in uniform! Very informative nonetheless — keep up the good work.

A. J. McClymont,  
Telopea, NSW.

## Arcol range of wire wound resistors

We are grateful that you included in your June issue a mention that we are handling the Arcol range of metal clad wire wound resistors.

The information included in the release could however be misleading — quote: "the resistors are available in ranges 1Ω to 100kΩ". If you refer to our glossy brochure, you will find that the 10 watt to 50 watt types are available in 5% tolerance down to 0.1Ω and to 0.05Ω at 10% tolerance. Actually, the lowest values can be 0.01Ω at 10%. Also, we are actually stocking 16 values from 0.1Ω to 0.82Ω in 15, 25 and 50 watt sizes.

R. Sedunary,  
Everest Electronics,  
Seaford, SA.

**Electronics is going digital. This book can help YOU go right along with it.**

### AN INTRODUCTION TO DIGITAL ELECTRONICS

You don't need any previous knowledge of digital electronics — the book starts you right from scratch, and covers all of the basic concepts you need.

Available from "Electronics Australia", 57 Regent St, Sydney. **PRICE \$4.50** OR by mail order from "Electronics Australia", PO Box 163, Beaconsfield, 2014. **PRICE \$5.20.**

# Join the people who have made the Air Force their life



"I've seen a lot of Australia. Now I'm looking forward to being posted overseas."



"I enjoy being a member of the team that keeps our F111's fully operational."



"You're trained to work on some of the most advanced equipment in the world."



"The opportunities for promotion with more pay and responsibility are there."



"You don't mind working hard if it's for a specific purpose like the country's security."



"At 23 I found myself promoted to Section Head. That kept me on my toes."



"It isn't all work. I have time to relax and play my favourite sport."



"The training has set me up with a career for life — it's really professional."

## The satisfaction and rewards are immense.

A new lifestyle. New friends. New interests. New qualifications. New places visited.

And you start on full adult pay too! After training we'll pay you even more! Then there's four weeks annual leave and the opportunity to continue studying for higher qualifications. So if you want to reach a higher rank, it's up to you.

### It's not an easy life.

Success demands application. A disciplined approach to your work. What's more, you'll be part of a special team that's proud to wear the Air Force uniform.

Normally you'll work a five day week. But at times we expect you to do extra duties.

You must be prepared to join us for a minimum of six years and be prepared to live and work on any one of our bases.

### Your future.

Is it in Flight Systems, Propulsion Systems, Air Frames, Telecommunications, Engineering, Administration, Weaponry, Supply or Motor Transport?

The choice is vast. The scope unrivalled.

So if you're aged between 17 and 34 years (17 and 43 years if no trade training is required), an Australian citizen or meet our nationality requirements, we would like to meet you. (People with civilian qualifications and experience are most welcome to apply.) Enquiries are also invited for Apprenticeships.

Today, walk into the Air Force Recruiting Office nearest you and have a chat with a Careers Adviser. The address is in the phone book. It could be your first important step to an exciting new career. Alternatively send the coupon or phone for the facts:

Brisbane 226 2626	Townsville 71 3191	Sydney 212 1011
Wollongong 28 6294	Parramatta 635 1511	Canberra 82 2333
Hobart 34 7077	Adelaide 212 1455	Perth 325 6222
Melbourne 61 3731	Newcastle 2 5476	



To:  
RAAF CAREERS  
ADVISER, G.P.O. Box XYZ  
in the capital city nearest you  
Yes! I am interested in an RAAF  
career. Please send me full details.

Name

Mr/Miss

Address

State

Postcode

Date of Birth: / /

RG.416.FP.11EA

# You're somebody in Today's Air Force

Authorised by Director-General Recruiting Dept. Defence

# UNBEATABLE

**"DICK SMITH guarantees to advertised Australian YAESU**



Cat D-2862

## FT 101Z SERIES

Look at this superb FT-101Z. And what a transceiver! It includes variable IF bandwidth, built-in RF speech processor, all current HF bands (inc WARC), 180W input (SSB/CW) & AM/CW/SSB operation.

**FANTASTIC OFFER:** With every purchase of a 101Z a **FREE** digital display worth \$139 will be included (2 MONTHS ONLY)

**LOOK AT THIS PRICE!**

**FT 101Z \$795 ONLY**

**ONLY \$769**  
SOLID STATE  
WAS \$785.00

**FT 101ZD** Reduced to \$849, this unit is packed with features such as HF speech processor, IF bandwidth, & much, much, more. Was selling for \$889, now selling for \$849, saving you \$40. So be quick, these certainly won't last long at this price.

Cat. D-2859

**OUR MOST POPULAR TRANSCEIVER**

Cat D-2869



**THIS COULD BE YOUR LAST CHANCE TO BUY**

*The incredible*  
**FT-7B**

There aren't many transceivers in Australia which are particularly suited to novices - but which won't disgrace them either. The Yaesu FT-7B suits the novice as well as the full call amateur. It gives you the current HF bands, with a variable power output of 50 watts. You have the option of AM, CW or SSB, with the choice of VFO or a crystal locked channel. The FT-7B is ready when you are: just hook up your power & antenna, & away you go. Makes a great base or mobile.

**STILL ONLY \$599.00**

**SAVE \$30.00 \$569**

Cat D-2868

# NEW! NEW! NEW! NEW! NEW!

## VHF Handy FM Transceiver **FT-208R**

The FT-208R transceiver brings a new flexibility to today's active 2M operator. An easy to read LCD display is coupled with a 4-bit microprocessor, bringing 10 memories & a scanning function. Only with Yaesu can you get these important features at such an economical price. Check it out NOW!

**INC. CHARGER** Cat D-2889

**ONLY \$369**



## 2 METRE PORTABLE **FT 290R**

The FT-290R is a highly sophisticated compact multi-mode transceiver for the 2M amateur band. Featuring PLL synthesis in 100Hz, 1kHz, 5kHz, or 10kHz steps. The FT-290R utilizes a Liquid Crystal Display for digital readout for the operating frequency, 10 memories, scanning of the band or memory channels, two VFOs, & receiver offset tuning makes the FT-290R a significant breakthrough in technology. So be quick, these are going to go fast! Don't miss out!

**ALL MODE**  
☆ FM ☆ SSB ☆ CW

**ONLY \$395**

Cat D-2885

# YAESU PRICE!

beat or match any genuine price\*\*



\* OUR POLICY ON YAESU PRICES: If you produce a copy of a current advertisement appearing in the national media, with a Yaesu price below our advertised price AND the advertiser has the goods in stock, Dick Smith Electronics guarantee to match or better that price. Verbal or written quotations are not acceptable



## FT 720RVH

Yaesu brings you the flexibility and performance you need in today's amateur world. The FT-720RVH not only gives you top performance, it's also the most flexible Yaesu transceiver. It comes apart - so you can locate the microprocessor-controlled 'works' close by you, with the 'RF' end out of the way. Or just as easily snap the two sections back again for a complete transceiver. That's versatility! This great little performer gives you scanning, 5 memory channels, LED Pwr/S meter, 25W output & full 144 - 148MHz operation & much, much more. A must for the person who lacks space in the mobile!

WAS \$450.00

**NOW \$370**

**SAVE \$80.00**

Cat D-2890

## YAESU'S FT 227RB

One of the most popular Yaesu transceivers we have ever had the pleasure to operate. The incredible FT-227R. This classy PLL scanner will take you anywhere within the 2 metre band instantly - just press the scan button on the microphone - not bad hey! No need to worry about reaching for the selector switch in heavy traffic. And you have 4 memory channels to choose from, with a 600kHz repeater split for working standard repeaters, or 4MHz split for unusual repeaters or requirements. For value-for-money, you can't go past the FT-227RB. It's a winner!

WAS \$379.00

**NOW \$329**

**SAVE \$50.00**

Cat D-2891

## 2 Metre Handheld FT 207R

Imagine a hand-held 2 metre transceiver with all the punch of the big guns - with digital display, 800 channels, 4-bit CPU chip for frequency control, 4 memory channels, repeater splits, auto scan (up or down), weighing just 680g. How does it perform? How about 0.32uV sensitivity or 7.5kHz selectivity (-60dB) or a power output of 2.5W (min). So what are you waiting for, go on, indulge yourself with this little beauty!

WAS \$358.00

**NOW \$308**

Cat D-2888

**SAVE \$50.00**

THIS COULD BE YOUR

# LAST CHANCE TO BUY!

## DICK SMITH ELECTRONICS

SEE OUR OTHER ADS FOR ADDRESS DETAILS



CREDIT TERMS AVAILABLE TO APPROVED APPLICANTS

Prices correct and stock

available at press time.

DSE A041RB

## ELECTRONICS CENTRE

BARGAIN PRICES • PERSONAL ATTENTION • SLICK MAIL ORDER SERVICE • SATISFACTION

### BSR

#### SUPA-DUPA SPECIAL



BELT DRIVE STEREO RECORD PLAYER MODULE

**\$92.95**

P-P NSW \$7.50 INTERSTATE \$8.50

25% OFF FACTORY PRICE

VERY LATEST MODEL

TRENDY LOW PROFILE CABINET. SATIN SILVER VINYL FINISH. TINTED PERSPEX COVER. ALL THE LATEST FACILITIES. AUTO OR MANUAL OPERATION. 33-45 RPM CUE LEVER. ADJUSTABLE COUNTER WEIGHT ANTI SKATE. BIAS CONTROL. BIG PLATTER. ADC MAGNETIC CARTRIDGE. DIAMOND STYLUS. ALL CABLES INCLUDED. ETC. ETC.



#### GENUINE FACTORY PRICES ETONE 12" SPEAKER SPECIALS

GUARANTEED TOP QUALITY BRAND NEW BARGAINS Rugged diecast frame 8 and 15 ohms available 12" Woofer, 30 watts RMS Reson 65Hz freq 50-8000Hz \$26.50 each OR 2 for \$46.50. P-P for 1 speaker NSW \$2.00 12" Twin Cone 30WRMS Reas 65Hz Freq 50-15,000Hz Interstate \$3.00 \$27.50 each OR 2 for \$48.00. P-P for 2 speakers NSW \$3.00. Interstate \$4.00

#### EX-COMPUTER SOLID STATE POWER SUPPLIES • LAST OFFER •

• 240VAC 50Hz INPUT • FULLY FILTERED • REGULATED • THERMAL CUT-OUT • 3 MODELS • ADJUSTABLE • SIZE APPROX 500 X 160 X 150MM WT APPROX 15KGS

11 to 14.5VDC 12.5 AMPS CONT	\$69.00
11 to 14.5VDC 15 AMPS CONT	\$79.00
4.5 to 7.5VDC 24 AMPS CONT	\$89.00

P-P NSW \$4.00 V SA QT \$7.00 WA NT \$10.00



PRIMARY 240V 50Hz

#### C-CORE TRANSFORMERS

LOW NOISE • HIGH EFFICIENCY • ALL THE ONE PRICE •

MODEL	SEC.V.	AMPS
JT 266	0-18V	8A
JT 235	26-0-26V	2A
JT 248	0-10V	10A
JT 249	8.5-0-8.5V & 15VCT	4A
JT 274	0-9.5V & 2x0-12V	1A

**\$27.95**

Pack and Post NSW \$2.95 V Q SA T \$3.75 WA NT \$5.50 JT320 36-0-36V 2A

#### ELECTRONIC JUNK

Throw out — mostly ex-Army, Navy, RAAF surplus. No reasonable offer refused. Personal Shoppers Only

#### ENGLISH POLAR

Silver Plated 100pf air spaced variable capacitor 1" x 1/4" dia shaft, ceramic insulation, super quality \$4.50 P-P 75c

#### JEAN RENAUD ROTARY SWITCHES

Instrument quality, plated contacts, non-shorting, 1/4" shaft, miniature wafers, dia approx 25mm.

5 position 2 pole 2 bank **\$2.95**  
6 position 2 pole 1 bank **\$1.95**  
4 position 2 pole 1 bank **\$1.95**  
Add P-P 75c

#### "FRESH AS A DAISY"

#### ELECTROLYTICS

8000 UF 75VW chassis mt, 2 for \$12.00.  
3300UF 75VW ch mt, 2 for \$8.95.  
4700UF 35VW axial, 4 for \$7.00.  
1000UF 40VW axial, 10 for \$5.95.  
2200UF 63VW ch mt, 10 for \$8.50.  
1000UF 63VW ch mt, 10 for \$7.50.  
100UF 200VW ch mt, 10 for \$6.50.  
Add P-P NSW \$2.00. Interstate \$2.75.

#### VARIABLE SPEED CONTROLLER

Solid state. 240 VAC 50 HZ 2 BA. Ideal for electric drills, motors, etc. **\$6.50 P-P 90c.**

#### 300 WV. AC. CAPACITOR

3 in 1 2UF + 1UF + 8 UF Can size 70 x 35mm with Mt Bracket.

**\$3.95 EA. OR 2 FOR \$7.00**

P-P NSW 90c Interstate \$1.50

#### CANNON

Ex-computer 25 pin gold plated D-type connectors. Plug, socket and cover. **\$5.75 P-P 75c**

#### 16 OHMS ONLY

#### • SUPER SCOOP • LIMITED STOCK • FACTORY SELLOUT •

Plessey Foster 15" — high power speakers. Bass/lead guitar • Hifi • PA • Organ 15" Max power 180 watts (cont) 240W peak. (Don't miss out)



Model C380K60/61,

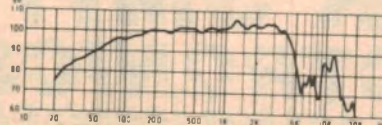

Sound pressure level 101 ± 2dB  
Freq response 4500Hz  
Freq reson 40 ± 8Hz Voice coil dia 80mm  
Flux density 10800 gauss  
Weight 8.5kg was \$125  
PP NSW \$3. SA Q V T \$6.75 WA NT \$9.75

• THIS IS THE LAST OFFER • **\$99**

#### MAGNAVOX 15 WATT 8 OHM SPEAKER SYSTEM

MODERN • ATTRACTIVE • VERY RUGGED • EASY-CARE WALNUT VINYL CABINET • 500 H X 340 W x 270 D mm. Frequency response 60-14000HZ

**\$55 PER PAIR** P-P NSW \$4.50 V SA Q T \$5.50 NT WA \$6.50

#### • NEW BSR STEREO RECORD PLAYER • MANUAL OPERATION •



MODEL C198

Model P 207104 • 240V AC 50Hz • Auto Stop • S Shape tone arm • Ceramic cartridge diamond stylus • 33 45rpm • Play 17 25 30cm (7, 10, 12in) records • Cue lever • Template for cut out • Operating instructions

#### • ALSO BSR STEREO COMBINATION CHANGE/PLAYER •

With the above features, plus changer facilities. has 4 pole shielded motor. Fitted with ceramic cartridge. **\$58** OR fitted with magnetic cartridge **\$68** P-P NSW \$4.50. V O SA T \$5.50. NT WA \$6.50.

#### READY TO OPERATE



#### 4-CHANNEL COLOUR ORGAN AND LIGHT CHASER

FULLY CONSTRUCTED • THOROUGHLY TESTED • **\$129.95** P-P NSW \$3.50. V SA QT \$4.50. WA NT \$5.50.

#### HEAVY DUTY NI-CAD RECHARGEABLE BATTERIES

SIZE	VOLTS	AH	CHARGE	PRICE EA	PRICE FOR 4 P-POST
D	1.2	4	400ma 14hrs	\$7.50	\$27.00 \$2.00
C	1.2	2	200ma 14hrs	\$6.00	\$21.80 \$2.00
C	1.2	1.2	120ma 14hrs	\$3.75	\$13.00 \$2.00
Sub C	1.2	1.2	120ma 14hrs	\$4.75	\$17.20 \$2.00
AA	1.2	5	50ma 15hrs	10 for \$16.50	\$2.00

FAMOUS BRANDS USED BY MANY GOVT DEPTS. STD TORCH SIZES.

#### GEARED MOTOR 240VAC 50HZ 3W

**\$3.50** P-P 75c



5 RPM Plenty of torque With Cam and N/O N/C microswitch 15 switch contacts per min OA size 65 x 60 x 35mm Refer Dec 79 EA New Products Review.

# AMATEUR RADIO



by Pierce Healy, VK2APQ

## Scouts & Guides enjoy Jamboree-on-the-Air

Three items in this month's notes — the Jamboree-on-the-Air, the Remembrance Day Contest, and recent WICEN activities — emphasise most effectively how the amateur can, and does, render valuable service to the community. There is also more about power problems on Pitcairn Island.

The weekend October 17-18, 1981 will see Scout and Guide groups throughout the world exchange greetings and messages of goodwill via amateur radio.

This will be the 24th occasion the Jamboree-on-the-Air has been held. During the weekend thousands of young people will converse with each other, demonstrating the friendship that exists between those having a common interest.

For the Scouts and Guides the interest will be in comparing activities in remote areas and other countries with their own. Through this, the life-styles, ambitions, and achievements of their counterparts will be better understood, be it within the remote areas of Australia or in places where the culture and aspirations may differ vastly from their own.

For the amateur it will be an exercise in community service and an opportunity to demonstrate amateur radio as a worthwhile activity in its own right: one which can become a fascinating and educational hobby, and also provide an insight into a wide field of possible careers.

JOTA is not a contest. The basic rules are:

1. Observe national licensing regulations.
2. Use only authorised frequencies and transmission modes.
3. Advise branch organisers of intention to participate.
4. Report your station activities promptly to the branch organiser, for inclusion in the official report.

Activities will commence at 0001 local time Saturday 17th and conclude at 2359 local time Sunday. Each station may select its own operating period. Official World Scout calling frequencies are: (phone) 3.740MHz, 3.940MHz, 7.090MHz, 14.290MHz, 21.360MHz, 28.990MHz; (CW) 3.950MHz, 7.030MHz, 14.070MHz, 21.140MHz, 28.190MHz.

Note that the first two phone frequencies are outside the Australian frequency allocation and 28.990MHz is outside the Australian Novice allocation.

The official opening ceremony will take place through the Scout Headquarters station VK1BP, operating from the grounds of Government House, Canberra. It is anticipated that an opening message will be broadcast by the Governor General, Sir Zelman Cowan as Chief Scout, and by Lady Cowan as president of the Girl Guides Association of Australia. It is expected that the ceremony will commence at 2.00pm Saturday, followed by call backs from representative stations in each state.

The official report on the 1980 JOTA, compiled by national organiser, Noel Lynch, shows that, in Australia, just on 20,000 Scouts and Guides participated. This figure was based on reports received, and would have been much higher had all groups sent details of their activities.

Amateur Radio societies and individual amateurs will be providing facilities for large groups of Scouts and Guides. Among these will be the Illawarra Amateur Radio Society at the 100 hectare campsite at Bass Point, just south of Shell Harbour on the NSW south coast. Also, the NSW Division WIA transmitting site at Dural will be the venue for the groups in that area.

Special certificates will be available to stations taking part. It is expected that the World Bureau Scout station HB9S will be operating from its permanent location in Geneva, Switzerland.

All amateurs are invited to participate, either by inviting groups of Scouts or Guides to visit their station, or by operating portable from a Scout hall or camp. Contact your local Scout or Guide group or branch organiser.

Further information from: National organiser — Commissioner Noel Lynch, 15 Noeline Street, Dorrington, Qld 4060.

Branch organisers (Scouts): Qld — Les Weller, 110 Cardiff Road, Darra 4076;

NSW — Eric Van deWyer, 12A/22 Bellevue Road, Bellevue Hill 2023; ACT — E. D. Napier, 27 Robertson Street, Curtin 2065; Vic — Max Dawkins, 74 Springvale Road, Nunawading 3131; Tas — to be advised; Sth Aust — Geoff Taylor, 16 Fairmont St, Black Forest 5035; W Aust — Peter Hughes, 58 Preston St, Como 6152.

Branch organisers (Guides) — Qld — Miss Julie Hummel, 223 Wrecker Road, Mansfield 4122; NSW & ACT — Mrs Valada Lambert, 76 Ula Crescent, Baulkham Hills 2153; Tas — Miss Sue Wyatt, c/- State Guide HQ, 91-93 Davey Street, Hobart 7000; W Aust — Mrs June Retallack, 224 The Strand, Bedford 6052; Vic and Tas — to be advised.

### REMEMBRANCE DAY CONTEST

The annual WIA Remembrance Day Contest, which perpetuates the memory of those amateurs who paid the supreme sacrifice in World War II, was held over the weekend August 15-16, 1981. The opening address on this occasion was recorded by the Hon Ian Sinclair, Minister for Communications.

"First of all I would like to say to all those involved in amateur radio operations around Australia, thanks for the job you do, not only in times of emergency but throughout the year in maintaining contact in a way that most of us really only can do over the telephone.

"Of course it is true that before the telephone became part of our daily lives the general contact between amateurs was perhaps more important than it is today.

"It is incredible how the number of amateur radio operators has increased. I am told, the present total in Australia is just short of 15,000.

"Of course today is the day when you remember the contribution made by your fellows during World War II, when some 35 amateur radio operators gave their lives in the service of their country.

"The government does recognise the very valuable contribution radio communication services provide, in particular during emergencies. Of course you also provide valuable technical train-

Radio clubs and other organisations, as well as individual amateur operators, are invited to submit news and notes of their activities for inclusion in these columns. Photographs will be published when of sufficient general interest, and where space permits. All material should be sent to Pierce Healy at 69 Taylor Street, Bankstown.

ternational understanding and co-operation.

"In this respect, I know the third party traffic agreement that has recently been concluded with Canada by the Australian government, is yet another step towards facilitating that concept."

Mr Sinclair went on to refer to approaches being made to other countries and the use of various new modes of emission, continuing with:

"There has also been a combined novice/limited licence introduced and there have been moves to introduce the new bands, agreed to at the 1979 World Administrative Radio Conference, and this I am told is proceeding as quickly as possible. The idea being that some use will be permitted from January 1, 1982.

"This Remembrance Day serves both to commemorate the service of your forebears and to ensure that there is a recognition of the tremendous contribution that you and your fellows make in the world of communication.

"I know that fixed and mobile stations participate in the contest of which this is part and that the Remembrance Day Contest is really not just a way of maintaining contact but of improving your standards and ensuring your greater efficiency.

"Congratulations to whoever the ultimate winners maybe.

"Thank you for the privilege and pleasure of participating with you and I now officially declare open the 1981 Remembrance Day Contest of the Wireless Institute of Australia."

## PITCAIRN ISLAND ENERGY PROBLEM

The July 1981 issue carried a story from QST about Tom Christian, VR6TC, an amateur on Pitcairn Island. Further to the story, I have had a letter from John Anderson, VK9JA, on Norfolk Island. John, who has regular contacts with Tom Christian, gives details of life on Pitcairn Island and problems faced in providing electrical energy. John says:

Pitcairn Island is about 1200 hectares in area, located 1600km south east of Tahiti. The population is around 60 persons, 11 of whom are able-bodied men who do all the heavy work. This includes going out in longboats in sometimes dangerous seas to trade and take delivery of supplies from ships that call only every four or five months. When they do a drum of diesel oil for the 20kW generator costs over \$200 to land.

Therefore, other methods of power generation are being evaluated. Whether it is to be a wind or solar device is not only a question of economics but how, because of the topography of Pitcairn, large heavy equipment can be landed safely.

The island's administration radio sta-

## WICEN links for "City-to-Surf" & air crash

On Sunday August 9, 1981, three Sydney WICEN groups – Sydney North, Sydney South, and Sydney West – combined in what has become a regular annual exercise: providing communications for the annual "Sun" City-to-Surf foot race.

This race is the largest of its kind in Australia, and probably in the world. There were just on 25,000 entrants this year, who competed over a hilly, 14km, course from the centre of the city to the pavilion at Bondi Beach. The winner completed the course in 40m 8s – a record.

The organisation behind such a race is massive, and fast and accurate communication is essential. Details of the medical facilities alone, with which WICEN was closely associated, gives some idea of the organisation involved.

Along the route there were 15 first-aid posts at approximately 1km intervals. These were manned by St John's Ambulance first-aid attendants, plus a WICEN operator in contact with the WICEN control centre at Bondi. At Bondi there were two first-aid rooms, one in the Pavilion and one at a nearby Scout hall, again manned by St John's Ambulance personnel. In all, some 90 St John's Ambulance personnel took part.

There were also two medical wards, of 20 beds and eight beds respectively, under the direction of Dr Roley Richards, a specialist in sports medicine. He was assisted by a team of eight doctors, 10 nursing sisters, 16 physiotherapists, and a number of trainee nurses. There was also a fleet of ambulances standing by to rush to any part of the course in the event of a serious medical problem.

But none of these facilities would have been of much value without the means to contact them in an emergency and to co-ordinate their response. This was one of WICEN's main jobs; operators were stationed at the first-aid rooms, the ambulance station, to "shadow" Dr Richards, and to "shadow" Brigade Commander Sparkes in charge of St John's Ambulance personnel.

"Shadow" operators were also provided for a number of executive and organisational personnel, and a total of 50 WICEN operators took part, using six

tion is operated by Tom Christian, a direct descendent of Fletcher Christian of "Bounty" fame. Since 1953 a wind generator has been used to charge the 24V battery to power the Marconi emergency transmitter.

Consideration is now being given to purchasing two solar panels from New Zealand to replace the wind generator.

The station is used to communicate with Fiji and send weather reports twice daily. Tom is assisted in this task by his wife Betty, whom he has trained to be a proficient operator, capable of operating

frequencies in the HF, VHF and UHF bands.

A large amount of traffic was handled, particularly in the hectic period when the main body of runners reached the finish line. For a while some circuits were working almost continuously with medical and administrative traffic.

At the conclusion of the event the organisers expressed themselves as most appreciative of a job well done.

On Wednesday August 12, 1981, WICEN was activated in a more serious role. For several days a full scale search had been under way for a light aircraft, with five men aboard, missing in the Dunggog/Barrington Tops area some 200km north of Sydney.

Direct communication between the search area and the Department of Transport's Search Co-ordinating Centre at Mascot (Sydney) presented a problem and the Police rescue team requested that WICEN provide a link. WICEN was activated at 0930 and, within a couple of hours, Harry, VK2DHH, and "Blue", VK2ABL, had moved into a Department of Transport building at Mascot set up HF and VHF aeriels and transceivers and, as VK2WIY, established a 7MHz link with the search area.

Others assisting at the Sydney and were: Mike, VK2BMM, Dave, VK2ZMZ, Keith, VK2DKC, and Christo, VK2ZAX. Several other WICEN members were standing by in case the exercise was prolonged.

In the search area the Hunter division of WICEN, VK2WIH, operated under the regional co-ordinator, Kim, VK2DKP, assisted by Paul, VK2BQZ; Alan, VK2BUL; Doug, VK2AVO; Roma, VK2NZW; John, VK2ZMK; John, VK2ZJA/VLR; and VK2KBN (name not available). With the 7MHz link established a VHF link was set up, using the channel 6800 repeater at Heathcote, south of Sydney, and this performed faultlessly.

The links operated until 1130 (VHF) and 1543 (HF) the following day and a large number of messages were passed for the Department. By that time the Department had been able to set up its own link, and WICEN was stood down. The Department expressed its appreciation for a job well done.

the station and receiving Morse messages while he is engaged in other duties. These include assisting with the longboats when a ship arrives, repair and maintenance of electric generators, Island Council meetings, and attending gardens – so important to a community isolated for long periods without supplies.

Tom also evaluates new developments that would be of benefit to the island community.

One of these is the Sunfire Project, a 5kw solar generator being built by



volunteers in Los Angeles, USA. When completed it was hoped to transport it to Pitcairn to supply electricity.

Construction began in the early 1970s as an attempt to prove that solar energy could provide electricity for home use at a relatively low cost. It was a student project involving a physics class. In 1975 it was moved to the jet propulsion laboratories in Pasadena, California.

The unit comprises 240 parabolic mirrors arranged so that radiation from the Sun is focused onto two 510mm long high pressure boilers. Each boiler is thermally insulated and contains about 60 metres of stainless steel tubing, preheaters around the focus point.

Water is injected into these boilers, turned into steam by the solar radiation, then routed to the steam engine, a 350cc Honda motor coupled to the generator. Tracking the Sun is by an automatic motor assembly which slowly rotates the concentrator. It is a very large assembly and weighs 20 tonnes. A problem that confronts Tom Christian, is how it could be landed on the island.

Motorola, who provided the solar panels for Tom's amateur station would be willing to construct a 25kW solar panel system that would meet the island's requirements but the cost — \$500,000 — is more than the island can afford, as the population is small and isolated. Their revenue, derived from stamps, and selling produce and carvings to passing ships, is limited and passing ships are fewer and fewer.

An attempt was made, in 1975, to use wind driven generators but problems with the rotor and the limited capacity of 2kW rendered it unsuccessful.

Some day this remote island may have the latest energy technology supplying its electric power. Whatever method is used, it will be of interest to similar communities in other parts of the world.

#### WIA NEWS

CALL BOOK 1981/82, of Australian amateur stations, published by the WIA, is now on sale. Cover price is \$3.95. Add postage for "250 to 500 gram other articles" rate. Order from your state division offices or Magpubs, WIA, Box 150, Toorak, 3142 Victoria.

### SO YOU WANT TO BE A RADIO AMATEUR?

To achieve this aim, why not undertake one of the Courses conducted by the Wireless Institute of Australia? Established in 1910 to further the interests of Amateur Radio, the Institute is well qualified to assist you to your goal. Correspondence Courses are available at any time. Personal classes commence in February each year.

For further information write to  
**THE COURSE SUPERVISOR,**  
W.I.A.

P.O. BOX 123,  
ST. LEONARDS, NSW 2085

## BRIGHT STAR CRYSTALS

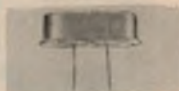

WATCH CRYSTALS

CRYSTAL UNITS FOR QUARTZ CRYSTAL CLOCK

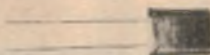

CRYSTAL OVENS AND OVEN OSCILLATOR UNITS



Specifications, Dimensions and data sheets available on request

#### BULK ORDERS:

In addition to our normal range we can supply quantity orders (100 up) at very competitive prices. All we ask is 50% of cost with order balance 30 days.

DELIVERY: 5-6 weeks from receipt of Order.  
Ring for quote:  
(03) 546 507 Telex:  
AA 36004.

## BRIGHT STAR CRYSTALS

35 EILEEN RD, CLAYTON, VIC.  
ALL MAIL TO: PO BOX 42 SPRINGVALE 3171

## Do-it-yourself BARGAINS

RMS 25 WATT  
8 OHM 3 WAY  
SPEAKER KIT SALE!  
WALNUT finish, ready-made boxes, black speaker cloth  
8 WOOFER + 5 MID-RANGE + 3 TWEETER + X-OVERS + wire and Innerband + screws!  
Can be finished in 2 hours!  
Great sound!  
55Hz-OR-18KHz  
PER PAIR \$69  
ASSEMBLED & TESTED \$109  
Speakers Separately: 8" Woofer \$7.50 ea  
5" Mid-range 500Hz-12KHz \$5.95 ea  
3" Tweeter 5KHz-18KHz \$4.50 ea

ELECTRONIC LOCK KIT WITH PUSH-BUTTON KEYBOARD  
\$19  
ELECTRONICS AUSTRALIA PROJECT JULY 1979  
Thousands of combinations, operate a relay or electric latch with your secret code! Digital design c/w ins.  
LIGHT DIMMER KIT ex MOTOR SPEED CONTROL \$4.99  
UP TO 2kW WITH HEATSHIELD, HAS REI SUPPRESSOR, BUY 2 FOR \$9  
2 TRANSISTOR RADIO KITS \$3.50  
COMPLETE WITH PCB, TUBING GANG, CRYSTAL EARPHONE  
Ideal beginners project, instructions and diagrams supplied for easy assembly. SPECIAL PRICES FOR SCHOOLS, 10¢ \$3.00, 25¢ \$7.75, 50¢ \$7.50, 100¢ \$7.25

Power Transformers 240V AC INPUT  
Bulk purchase of new, best quality mains transformers used in M and K chassis AWA-Thorn colour TV sets.  
M Primary: 0,120V,125V, plus 0,120V, 125V for 240V or 250V operation.  
M Sec: 0,120V 1Amp plus 6V 1Amp  
K Primary: 0,240V,250V  
K Secondary: 0,105V 1.3 Amp plus 6V 0.9 Amp plus 12V 0.75 Amp.  
\$9 EXTRA POST.  
YOKES FOR AWA COLOUR TV's  
MANUFACTURERS EXCESS STOCK!  
Brand new picture tube deflection yokes for AWA 63cm M chassis and 53cm K chassis colour TV sets. at \$8 ea  
SQUIRREL-CAGE Heavy Duty BLOWERS 220V  
POWERFUL AIR FLOW, QUIET  
FULLY TESTED, G'FEED, EX-COMPUTER  
300mm long x 180mm diameter  
Safety Cutout Switch  
\$24

PRE-PAK electronics  
SHOP, 1A WEST ST., LEWISHAM NSW  
569-9797  
MAIL P.O. BOX 43, GARDON NSW 2322  
PAC/POST: ADD 1.7  
AMAZING Free! electronics CATALOG Send today

# The Australian CB SCENE



## Police/CB confrontation in Queensland

Mobile police patrols in Queensland appear to be continuing, even escalating, their activities against CB operators. Indeed, one CBER was pulled over twice in the same evening by different patrols, each threatening to confiscate the CB set — and the car battery — if he was caught again without his CB licence in the car.

The threat by the police to confiscate the battery arises from their claim that the battery is the power supply for the CB equipment and therefore a part of the CB station.

All this comes in the face of a spirited confrontation mentioned briefly last month, between the police and Terry Watkins, National Director of the NCRA. He sought to acquaint the officers concerned with the full Department of Communications' regulations in the matter. We (for the NCRA) also sent a letter to the Queensland Police Commissioner, Mr Terry Lewis, which remained unanswered.

The most recent action has been an exchange of telexes between myself, on behalf of the NCRA and Mr Ross Ramsay, The First Assistant Secretary, Radio Frequency Management Division, Department of Communications, Canberra. The telexes speak for themselves:

SEC COM

QLD POLICE CURRENTLY BLITZING CB OPERATORS IN BRISBANE AREA RE ABILITY TO PRODUCE CB LICENCE ON SPOT. THREAT OF SEIZURE IN ALL CASES INCLUDES SEIZURE OF CAR BATTERY AS POWER SOURCE.

I AM SEEKING AN INTERVIEW IMMEDIATELY WITH COMMISSIONER LEWIS. PLEASE REPLY MOST IMMEDIATE WITH DATA ON NEED TO CARRY LICENCE.

I WILL PRODUCE YOUR REPLY AT INTERVIEW. NCRA CONSIDERS THIS MOST URGENT.

MY AGENT AWAITING THIS ADDRESS FOR YOUR REPLY. PLEASE ADDRESS YOUR REPLY AS BELOW. COPY DOC BRISBANE.

SINCERELY

JAN CHRISTENSEN  
NATIONAL LIAISON OFFICER NCRA,  
OLBIS AA42088

FROM: M.R. RAMSAY  
TO: JAN CHRISTENSEN 31.7.81

SUB REGULATION 10 (3) OF THE WIRELESS TELEGRAPHY REGULATIONS REQUIRES THE LICENSEE TO EXHIBIT THE STATION

LICENCE IN THE PLACE WHERE THE EQUIPMENT IS INSTALLED.

YOUR QUERY HAS CAUSED THE DEPARTMENT TO REALISE THAT OUR PROCEDURES ARE DEFECTIVE IN THAT WE ISSUE ONLY ONE LICENCE COVERING UP TO FIVE CB SETS WHICH MAY BE INSTALLED IN DIFFERENT PLACES. A LICENCE CANNOT BE SIMULTANEOUSLY HELD WITH THE SET AT HOME AND WITH THE ONE IN THE CAR.

I SUGGEST THAT YOU POINT OUT TO THE POLICE THAT OUR LICENCING BROCHURE RB14A PARA 4.16 ADVISES THAT THE LICENCE SHOULD BE HELD AT THE RESIDENTIAL ADDRESS OR WHERE THE STATION IS MOST USED.

THE DEPARTMENT CONSIDERS THAT A REASONABLE APPROACH IN THE CIRCUMSTANCES WOULD BE FOR THE POLICE TO PERMIT A REASONABLE PERIOD FOR A PERSON QUESTIONED TO OBTAIN HIS LICENCE PAPERS FROM HIS RESIDENTIAL ADDRESS AND THEN PRODUCE THEM TO THE POLICE. HOWEVER THE DEPARTMENT HAS NO AUTHORITY REGARDING LAW ENFORCEMENT PROCEDURES BY THE POLICE AND ONLY THE COURTS CAN DETERMINE WHAT IS A REASONABLE APPROACH IF COURT ACTION RESULTS.

THE DEPARTMENT BELIEVES THAT THE CAR'S ELECTRICAL SYSTEM INCLUDING ITS BATTERY IS PART OF THE CAR NOT PART OF THE CB SET. AGAIN THE COURTS ARE THE ARBITERS.

THE DEPARTMENT WILL RECTIFY THE ANOMALY BY ALTERING THE LICENCING PROCEDURES OR THE REGULATIONS BUT THIS WILL TAKE TIME. IN THE MEANTIME I HOPE THAT YOUR MEETING WITH MR LEWIS WILL SOLVE THE PROBLEM AND THAT THIS TELEX WILL BE USEFUL TO BOTH OF YOU.

I WOULD BE HAPPY TO JOIN YOUR DISCUSSION BY TELEPHONE SHOULD MR LEWIS AND YOU DESIRE IT.

BEST REGARDS  
ROSS RAMSAY

I would suggest to Queensland readers, in particular, that you make a photocopy of this column including the telexes and keep them in your car, along with a copy of the RB14 and RB14A. I

don't drive anywhere without them these days, just in case I come across an overly eager police officer. I would also emphasise the following:

- (a) That you DO have a CB licence and
- (b) That you keep a photocopy of your licence and your renewal slip in the car at all times but leave offering these to the police as a last resort only.

I have contacted Commissioner Lewis's office and a meeting has been arranged shortly after this month's deadline. Hopefully, there will be a full report on the meeting in the next issue.

Once again, my sincere thanks, both personally and on behalf of the NCRA must go to Ross Ramsay for his fast action. As you can see, the Department is only too willing to help where possible but neither they, the NCRA nor I can do anything if we don't know the problems. Write to me at the address at the bottom of this column and we will see what we can do.

### THE OMEGA CLUB

Ken Upton (Omega One) has sent me further info on the raft trip I mentioned in an earlier issue. It does seem the guys had a great time. The CREST Divisions which took part in the exercise were: Blue Mountains; Hawkesbury, Prospect and Nepean.

Ken also sent me a copy of a letter received by the Omega Club from the Red Cross Calling Appeal, also mentioned in an earlier issue:

*A belated note to say a warm "thank you" to the members of your club for the wonderful assistance you gave to our Red Cross Calling Appeal. It is gratifying to know that we have the support of groups such as yours for, without your help, Red Cross could not continue its humanitarian work.*

*You will be pleased to note that, to date, our Appeal has raised in excess of \$419,000, and our Parramatta figure is a record in excess of \$16,000.*

*May I make a special note of the way Ken Upton helped our Committee. It would be very comforting to us to know that we could call upon your club to help again next year!*

*Please find enclosed a certificate of appreciation which you may care to post in*

your Minute Book.  
Jim Little (Red Cross Calling)

## FROM THE NCRA

The NCRA has appointed two new State representatives. The first is Mr Trevor Davis-Goff in Townsville, Queensland. Trevor owns an engineering business (marine) and travels all over the "top end" in the pursuit of it. He really has his finger on the pulse of the CB scene in that area, and I am looking forward to receiving reports from him. I had the pleasure of meeting Trevor when he was last down here in Brisbane.

The second State representative appointed is Mr Ralph (Max) Newman who resides in Denmark, Western Australia. We so very rarely hear anything from our largest State that I am sure that you, like myself, are anxiously waiting for Ralph's information to come through.

I am still looking for correspondents in South Australia, Victoria, Tasmania, the ACT and the Northern Territory (although Trevor will undoubtedly provide some information from the latter).

## CB IN BRITAIN

A recent issue of "Practical Electronics" contained a 20-page booklet explaining the CB system adopted in Britain.

Forty channels are provided between 27.60125 and 27.99125Mhz, for FM transceivers having a maximum RF power output of 4W (for an ERP or 2W max). The channels deliberately do not coincide with those most commonly found in illegal American AM/SSB transceivers.

Twenty more channels are available in the 934MHz band where the ERP can be 25W.

## RI's ON THE JOB

I don't know about the other States, but the Radio Inspectors in Brisbane are making their presence felt. Coming out of a doctor's surgery the other day I ran into an old acquaintance from DOC Brisbane. Daryl had spotted an antenna and was going into the premises to check it out. I understand that there are a number of would be CBers around the place who are finding it hard to operate without their equipment!

If you don't have a current licence, please get one as soon as possible, and try to encourage your friends to do the same. If you are aware of anyone operating illegally or improperly, please try to encourage them to change their ways. It is for the benefit of us all that they do.

Well, I hope that you all have an enjoyable month, and don't forget to write to me with any information which you feel would be of interest to other readers. Write to me at Australian CB Scene, PO Box 406, FORTITUDE VALLEY, 4006.

Jan Christensen

## Fundamentals of Solid State



Fundamentals of Solid State has been reprinted, revised and updated showing how popular it has been. It provides a wealth of information on semiconductor theory and operation, delving much deeper than very elementary works but without the maths and abstract theory which make many of the more specialised texts very heavy going. It begins with atomic theory, diode types, unijunction, field effect and bipolar transistors, thyristor devices, device fabrication and microcircuits. A glossary of terms and an index complete the book.

Available from "Electronics Australia", 57 Regent St, Sydney. **PRICE \$3.50.** OR by mail order from "Electronics Australia", PO Box 163, Beaconsfield 2014. **PRICE \$4.20.**

## IRON POWDER CORES

Buy direct from the sole Australian distributors for Micrometals Inc, USA. Low level RF toroidal cores, ex stock:

CORE	Material				
	-0	-2	-6	-10	-12
T25 (6.5mm O.D.)	26c	35c	36c	39c	35c
T30 (7.8mm O.D.)	29c	37c	39c	45c	41c
T37 (9.5mm O.D.)	—	43c	46c	53c	45c
T50 (12.7mm O.D.)	—	52c	63c	81c	—
T68 (17.5mm O.D.)	—	66c	86c	—	—

Matl - 0 is phenolic, perm = 1 and a typical freq. range of 50-250MHz.  
Matl - 2 is carbonyl E, perm = 10 and a typical freq. range of 25-10MHz.  
Matl - 6 is carbonyl SF, perm = 8.5 and a typical freq. range of 2.0-30MHz.  
Matl - 10 is carbonyl W, perm = 6.0 and a typical freq. range of 10-100MHz.  
Matl - 12 is synthetic oxide, perm = 4.0 and a typical freq. range of 20-200MHz.  
Hi-level and wide band balun toroidal cores, ex stock.  
T80-2 (20mm O.D.) at 82c. T106-2 (27mm O.D.) at \$1.68. T200-2 (51mm O.D.) at \$3.74 and T225-2B (57mm O.D., 36mm I.D., 25mm Ht) at \$7.48. The T225-2B is ideal for high power baluns, having over twice the core volume of the T200.

Note: These cores are manufactured in the USA by Micrometals, Inc, and are distributed by Amidon, Palomar, Whitehouse, etc The Australian Acoustic Co is the sole Australian distributor for Micrometals.

Prices include Sales Tax. Add Post and Packing as follows: Orders up to \$10 add \$1.10; orders over \$10 add \$1.60; for orders of more than two units T200-2, increase the p+p allowance by 50c each, for more than one T225-2B, increase by 75c each.

We also have a wide range of cores for inductors in switching power supplies and for EMI suppression.

Payment in full with order please. Callers by appointment only.

## THE AUSTRALIAN ACOUSTIC COMPANY

20-24 Ward Street, Eudunda, S.A. 5374. Telex: AA88599 AAACEUD.

## Sensitized Copper Board Riston 3000 Coated

(Fibreglass Base)

	Single	Double
36 x 24	\$45 00	\$57 00
24 x 18	\$22 00	\$30 00
18 x 12	\$12 50	\$16 00
12 x 12	\$ 8 00	\$10 75

OTHER SIZES ON APPLICATION

## DEVELOPER PROMOTION SPECIAL

Concentrate (1=4) \$4 25 litre

**\*\* 5 litre \$19.50 \*\***

FULLY FORMULATED TO INDUSTRIAL SPECIFICATION

## SAME SIZE COPPER

QUANTITY	DISCOUNTS
\$100 +	10%
\$250 +	12½%
\$1000+	15%

All plus S Tax if applicable

"The **BPF** Imagination Machine Colour Computer"

Full business and games capability. Console, Monitor, Power Supply. \$865 + ST if applicable.

- CUSTOM
- CIRCUIT
- BOARD

- LAYOUT
- MANUFACTURE
- ASSEMBLY

PROMPT DELIVERY

**KALEX**

101 Burgundy St, Heidelberg 3084 (03) 458 2976 Telex AA 37678 MELTON (03) 743 1011

ELECTRONIC COMPONENTS & ACCESSORIES ● SPECIALIST SCHOOL SUPPLIERS ●

# SHORTWAVE SCENE



by Arthur Cushen, MBE

## APINTIE'S 350W SIGNAL WIDELY HEARD IN AUSTRALIA

Radio Apintie, broadcasting from Surinam, is one of the lowest powered stations to be received throughout Australia and the Pacific. Apintie transmits on 5005kHz, and is generally heard opening at 0830UTC.

Radio Apintie, the low powered broadcaster at Paramaribo, Surinam, has confirmed reception with a letter, silk pennant and program schedule. Radio Apintie commenced broadcasting on shortwave in September 1979 using 50 watts, with programs for listeners in the interior. Recently the transmitter has been coupled to a Linear Amplifier of 350 watts and a Doublet Log periodic antenna. Radio Apintie also operates an FM Stereo transmitter of 1000 watts with 6 repeaters and a 1000 watt mediumwave transmitter.

The schedule for Radio Apintie shows that they sign-on each day at 0830UTC in Hindi and sign-off on Monday at 0330, Tuesday and Wednesday 0430, Thursday, Friday and Saturday 0630 and on Sunday 0430UTC.

The address of the station is: PO Box 595, Paramaribo, Surinam and as well as a verification letter and pennant, a travel brochure about Surinam will be sent in reply to reception reports.

### NEW MAURITIUS FREQUENCY

The Mauritius Broadcasting Corporation has made a frequency change and is now being heard on 4855kHz, closing at 1830UTC. For many years the transmissions were carried on 4850kHz but the powerful signal of Cameroon on this channel has led to a frequency change. The broadcasts from Mauritius have been tuned in at 1800UTC when the BBC World News is relayed in English followed by an announcement in French and generally light music until closing at 1830. The sign-off is in French and this is followed by a short version of the National Anthem. The Mauritius Broadcasting Corporation uses 10kW on this channel and the address for reception reports is Broadcasting House, Louis Pasteur St, Forest Side, Mauritius.

### BOLIVIAN SIGNALS

As well as Radio Panamericana now using 6105kHz and opening at 1030UTC, many other signals from Bolivia have been noted. On 6025kHz the Voice of Bolivia Radio Illimani at La Paz opens at 1000UTC with a spoken program and is heard from 1030 with normal morning programming, with the same service on 4945kHz. This latter frequency has been giving better reception around 0400UTC in New Zealand.

In the 60 metre band several other signals from Bolivia have been noted including Radio Movima on 4467kHz, Radio Riberalta on 4695kHz, and Radio Abarua now using 4730kHz. All these signals have been received around 04150UTC and are generally heard again around 1100UTC.

### DX PARTY LINE ANNIVERSARY

Twenty years ago the first broadcast of the DX Party Line went out over the air waves from Quito. During 1981 HCJB are celebrating their 50th anniversary so it is appropriate that the station also recognises the 20th anniversary of the DX program. It was on May 6, 1941 that Clayton Howard the former DX Party Line host during most of its 20 years, arrived in Quito for the first time. The month of May marked 40 years of service by Clayton with HCJB in Ecuador.

The originator of the program was Hardy Hayes who is now serving as station Manager for KVMV-FM in McAllen, Texas. KVMV-FM is a sister station to HCJB and is also affiliated with the World Radio Missionary Fellowship Inc, the parent organisation operating HCJB.

Starting as an occasional program, the DX Party Line was popular from the beginning. It was not long before it was made a regular monthly feature. A few years later it was expanded to a once-a-week program and continued to grow in popularity. In 1974 the ANDEX Club was inaugurated to enhance the effectiveness of the DX Party Line radio broadcasts. At that time the program was enlarged to its present format with

three programs each week. The present schedule includes 13 half hour releases per week. There are three to the South Pacific, six to Europe and four to North America.

The transmission to the South Pacific of DX Party Line is broadcast on Monday, Thursday and Saturday on 6130kHz at 0900UTC, while the other two frequencies, 9745 and 11900kHz, carry a different program.

In July Roger Stubbe, who has been with HCJB for the past 16 years took over as compere of DX Party Line. Roger Stubbe is well known to many readers in Australia and New Zealand as he toured these two countries in March and April last year. He is the present Frequency Management Officer at HCJB in charge of their frequency assignments and as he does considerable monitoring of their broadcasts when visiting Latin American countries, he plans to include information about radio stations he visits in forthcoming programs. Roger Stubbe is an active radio amateur and keen shortwave listener and his knowledge is certain to be used in future programs which may include items from Latin America that have been lacking in past broadcasts.

### INTERESTING PNG RECEPTION

Signals from stations in Papua New Guinea in the 49 metre band are seldom reported in New Zealand, or in southern Australia, so that a report on their reception from Ray Crawford, Gladstone, Queensland, gives some interesting news. Ray Crawford was formerly of Invercargill NZ and since moving to Australia has noted the difference in reception of many stations.

The signals observed include 5965kHz Radio Western Highlands closing at 0630UTC; 5985kHz Radio East New Britain closing at 0700UTC; 6020kHz Radio North Solomons heard at 0615; 6040kHz Radio Milne Bay sign off 0630 and on 6140kHz Radio East Sepik observed at 0615UTC. Radio Milne Bay is the strongest signal and when closing they advise listeners to tune to the 90 metre band for a continuation of the program. The only station not heard is Radio Western on 6080kHz, due to the frequency being blocked by the Voice of America.

Notes from readers should be sent to Arthur Cushen, 212 Earn Street, Invercargill NZ. All times are UTC (GMT). Add eight hours for WAST, 10 hours for EAST and 12 hours for NZT.

# The Personal Computer Your information window

## An extension of your brain

An Apple Personal Computer puts you at the forefront of the technological revolution. Use it well and it will mediate the availabilities of a wealth of conceptual tools, data bases, communication channels and information processes. An Apple will help you simplify a myriad of tasks from ordinary data processing through information retrieval to economic forecasting.

## Apple is versatile

Your Apple is an extremely powerful and robust problem solver backed by a comprehensive set of software programmes. Already, over 300,000 Apples are used for business, domestic, educational research and recreational purposes.

## Apple as information processor

An Apple personal computer performs a full range of standard functions like statistics, word-processing, graphics, number crunching, filing, storage/retrieval and cross-referencing.

## Apple as super-brain

Aside from the more pedestrian functions of retrieving and processing information, Apple performs other sophisticated functions such as econometric modelling, financial forecasting, graphics, topological modelling and trend analysis.

## Apple is convenient

Apple is portable. It can be used at home or in the office. You can address it in ordinary English or gain full computer literacy in BASIC PASCAL, COBOL, FORTRAN or PILOT. Full step-by-step training comes with your Apple. If you can use a calculator and speak English, Apple shows you the rest.

## Apple as communicator

Apple combines many of the functions of telephones, telexes, citizens' band radios and library access terminals. It allows you the very latest access to data bases and information services and mail electronically locally or world wide.

## Apple as challenger

Apple is fun. From a perfect game of Chess to Star Wars—not only for the children—preparing them for the future in this high-technology age.

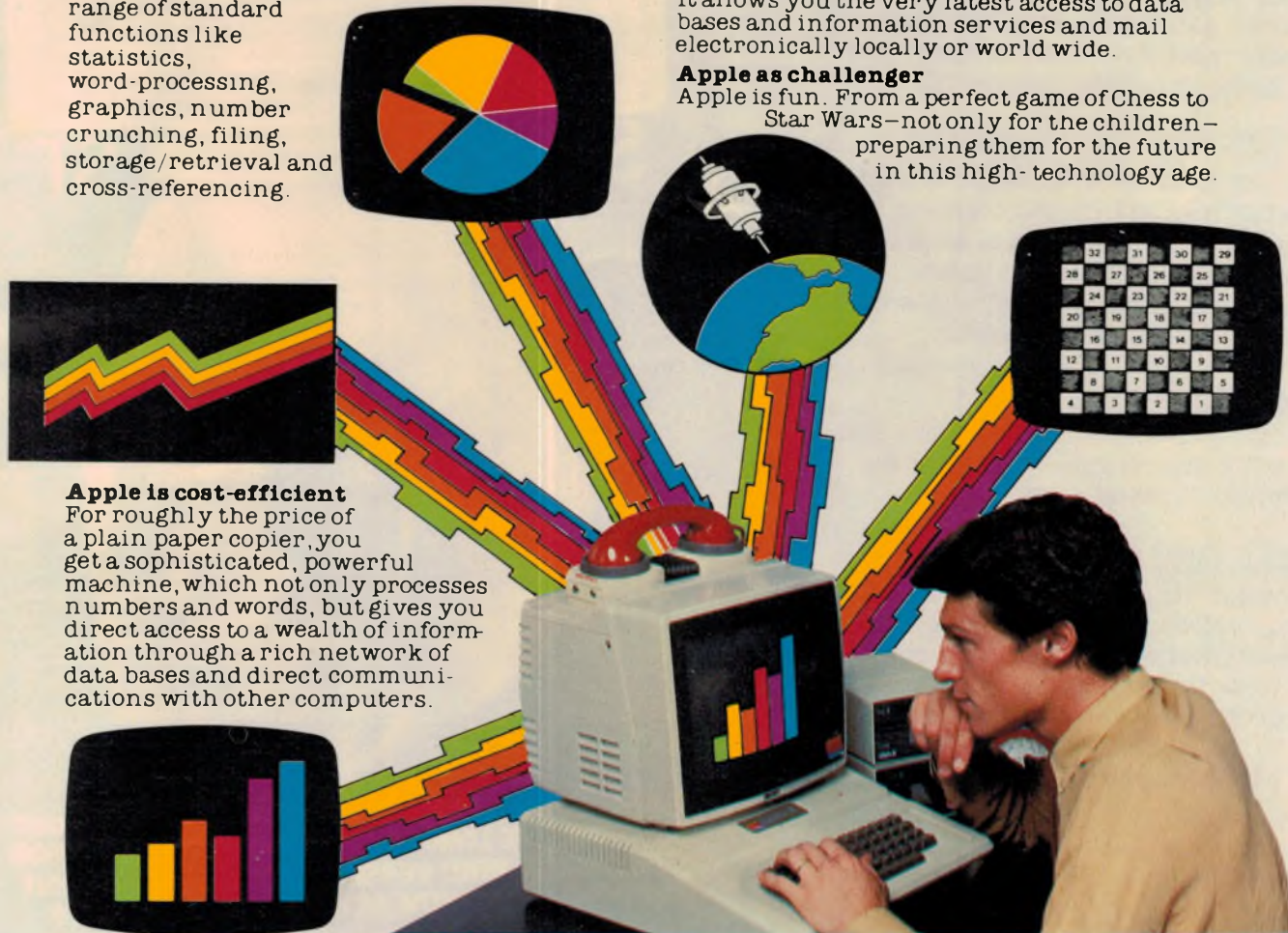

## Apple is cost-efficient

For roughly the price of a plain paper copier, you get a sophisticated, powerful machine, which not only processes numbers and words, but gives you direct access to a wealth of information through a rich network of data bases and direct communications with other computers.

Mail this coupon for an "Apple Pack" brochure or talk to your local Apple authorised dealer about the specific applications for you.

If the coupon has been removed, send your name and address to:

ELECTRONIC CONCEPTS PTY LTD,  
55 CLARENCE STREET,  
SYDNEY, NSW 2000



apple computer

Mail to: PPCB374B  
ELECTRONIC CONCEPTS PTY LTD,  
55 CLARENCE STREET, SYDNEY, NSW 2000  
Please send me a free "Apple Pack" brochure.

NAME \_\_\_\_\_

ADDRESS \_\_\_\_\_

POSTCODE \_\_\_\_\_

PROFESSION \_\_\_\_\_

APPLE APPLE = PERSONAL COMPUTER PERSONAL COMPUTER = APPLE APPLE

# WHEN YOU READ THE LATEST OMEGA YOU SAY A LOT ABOUT YOURSELF

## YOU'RE QUESTIONING...

fascinated, for instance, by findings that suggest mental attitudes may affect cancer ... that life began in outer space ... that mother love is crucial to human happiness.

## FUTURE-LOOKING ...

eager to know how science and detectives are revolutionising the fight against crime ... the vital plan to ensure next century's food ... the far-reaching ideas of Australia's most influential man of science.

## AWARE ...

valuing a fantastic full-colour liftout on the space age. And after the space shuttle — what next?

## IMAGINATIVE ...

enough to speculate with believable experts on what may explain the UFO phenomenon ... or why women live longer than men ... or what happened "overnight" to the dinosaurs.

## THOUGHTFUL ...

examining the theory of Creation itself. How DID the cosmos come into being?

## CREATIVE ...

enjoying the best in speculative fiction. Revelling in Omega's magnificent visual quality.

## ORIGINAL ...

you'd have to be — you're reading the most original new Australian magazine of our time.

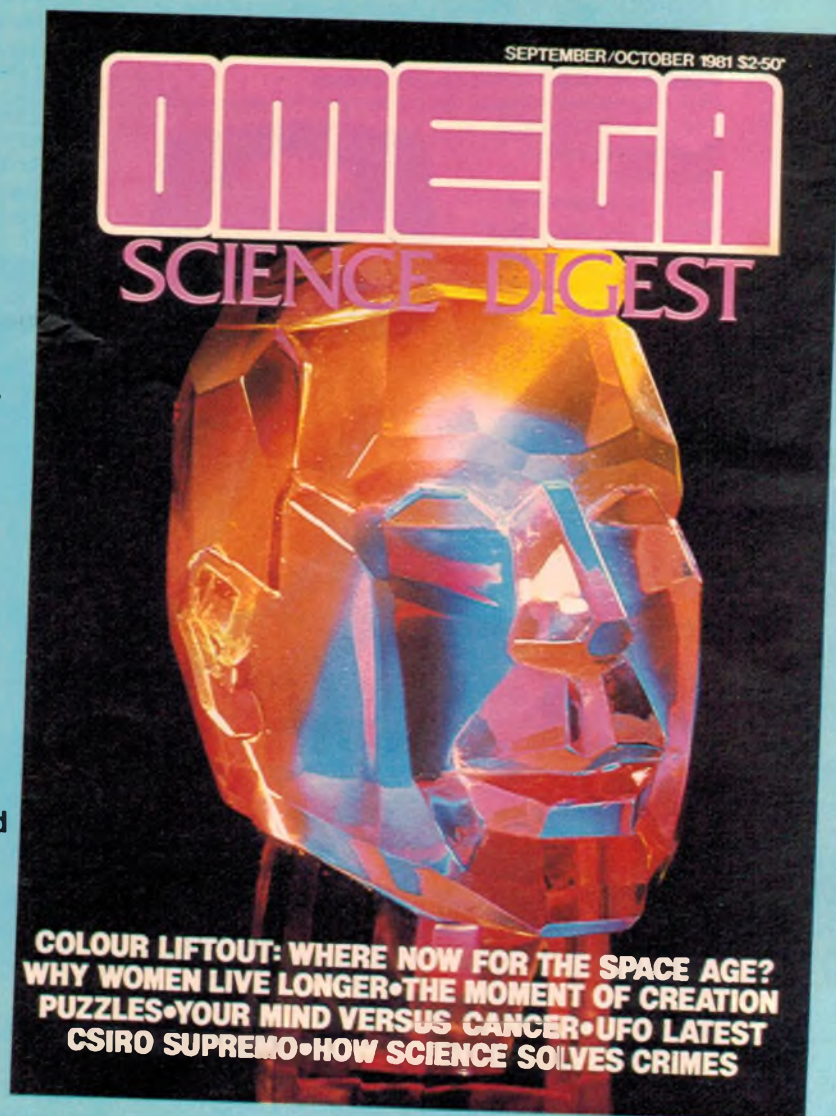

THE OMEGA EXPERIENCE  
WILL CHANGE THE WAY  
YOU FEEL ABOUT  
MAGAZINES.

BUY IT AT YOUR  
NEWSAGENT

# 50 & 25 YEARS AGO



October, 1931

British listeners were very near to being entertained by the abhorred sponsored advertising programs this year, when treasury officials were looking in all directions for new sources of income. It has just been revealed that the officials seriously discussed a proposal to appropriate the entire listeners' licence revenue, leaving the BBC to subsidise its programs by selling advertising time.

☆ ☆ ☆

It is reported that the Hearst newspaper interests have acquired WGBS, making it the first newspaper-owned station in New York. The American press, in many instances, now tends to "buy-in" on broadcasting.

☆ ☆ ☆

With the running of the Melbourne Cup on Tuesday, November 3, the ABC will enlarge upon the comprehensive broadcasting arrangements that were made in connection with the race last year. Since the running of the last Cup telephonic communication has been made with West Australia, and this will enable the broadcast description of the Melbourne Cup to be relayed to 6WF Perth, thus completing the full circuit of stations. More than 4500 miles of telephone lines will be used.

Listeners might ask themselves why it is that a horserace should receive such consideration, and the obvious answer would be, because it is the Melbourne Cup. No happening in Australia receives such widespread consideration. For weeks before the race is run it is an outstanding topic of conversation from Cape York to Cape Leeuwin. Perhaps the great interest in the race is handed down from the "nineties", when the Victorian Racing Club provided a stake of £10,000, thus making it the richest race in the world.

☆ ☆ ☆

**Listen for London:** Our experience tends to prove that with the listener who is breaking into short waves for the first time the main ambition at first is to log London, and ascertain for himself what it really feels like to hear voice and music right from the heart of the Empire. We know from our correspondence file also that keen disappointment has been experienced by many beginners at not being able to satisfactorily log 5SW London, during the last couple of months.

That Australian music is well on the way should be amply proved to listeners to 2FC's broadcast on Saturday night, when an "All Australian" program of choral and orchestral work will be relayed from 3LO, Melbourne. The Postal Institute Choir will sing works by Mr Fritz Hart, Miss Esther Roye, and a composition entitled "To Melba in Paradise", by its popular conductor, Mr George English.

☆ ☆ ☆

**The South African Tour:** Extensive preparations have been made by the Australian Broadcasting Company, in connection with the forthcoming cricket season, when the visiting South African team will test the strength of the Australian champions, in a series of five Tests. After the first match - South Africa v West Australia, on October 22 - the station in which State the South Africans are playing, will broadcast a description of the play from start to finish.

☆ ☆ ☆

**Listeners to the German station** at Langenberg, who were enjoying a program of dance music, were surprised to hear violent Communist propaganda superimposed upon the music. The police, after a long search, discovered that Communist agents had tapped the relay line between the studio and the transmitter.



August, 1956

It is not generally realised that the Totalisator was invented by an Australian, the late Sir George Julius, who designed, made and installed the world's first Totalisator at Ellerslie (New Zealand) in 1913. Since then, the Australian firm of Automatic Totalisators Limited, founded by Sir George, has made installations throughout the world, including England, France, South Africa, India, Malaya, North and South America.

☆ ☆ ☆

**Transistorised—valve portable:** The use of transistors in American radio circuits excites no greater interest these days. Particularly in the portable field, new models are being produced which employ them in all circuits, although suitable transistors for use in the RF sections of the set are not yet available here.

The receiver detailed here and recently placed on the market, is known as the Transistor Seven, the makers being RCA Victor.

Its companion set is a very much smaller five-transistor model, and together they represent a complete breakaway from the more conventional valve types.

It is not a cheap set by USA standards, as it sells for about \$70, but its extremely modest battery requirements make it an attractive buy for all that.

☆ ☆ ☆

**During the past few months,** the citizens of Sydney have watched two tall TV masts grow from the high ground on the North side of Sydney Harbour. These belong to ATN and TCN, the two commercial stations, one of which has already transmitted test programs. They carry the aerial arrays which, for efficiency, must be as high as possible above the surrounding terrain.

TCN's antenna is particularly interesting. It was designed and pre-fabricated in Holland by Philips, while the 500ft tower on which the antenna is now mounted, was pre-fabricated in Italy. The mast itself is not the radiator of energy. It merely serves to elevate the radiator to a height to obtain the largest possible radius of television coverage.

The antenna consists of a series of six cylindrical spirals (helices). These are wound around a steel cylinder which supports the insulators, which in turn support the helices.

The helix, in its simplest form, is usually designed for VHF communication systems, the diameter chosen so that the length per turn is equal to the wavelength radiated. Such an "end fire" helix, with its axis horizontally placed, radiates circularly polarised waves.

☆ ☆ ☆

**Flying saucer airborne.** The new radar "early warning" version of the Super Constellation which Lockheed Aircraft Corporation has developed for the US Navy is now undergoing intensive flight testing at Edwards Air Force Base, USA. Its "flying saucer" ellipsoid, measuring 30 feet across, houses secret electronic equipment that will enable the plane to scan an even larger area. The WV-2 radar Super Constellation now duty with the Navy flying at 10,000 feet can direct its radar beams over a surface of approximately 45,000 nautical miles. Lockheed test pilots Herman (Fish) Salmon and Roy Wimmer report that the disc does not jeopardise stability or control.

☆ ☆ ☆

**Latest innovation for bank clerks** in the United States is the use of television. Installed at the Mechanics and Farmers' Savings Bank at Bridgeport, Connecticut, by the Mosler Safe Co, it allows a customer to bank his money from a roadside kiosk large enough for a motorist to remain seated in his car. The kiosk contains a TV camera, monitor tube and two-way speaker system. Transactions are carried out by means of pneumatic tubes to the teller, located some hundred feet away.



## Books & Literature

### Robot Intelligence

**ROBOT INTELLIGENCE** with experiments, by David L. Heiserman. Soft covers, 322 pages, 131 x 210mm, illustrated with flowcharts and programs. Published 1981 by TAB Books, USA. Price \$13.95.

The primary purpose of this book is to give you a chance to see artificial intelligence at work on the screen of your personal computer. All of the programs are in BASIC and designed to operate on Tandy TRS-80 though the programs could well be adapted to other machines such as the APPLE or PET. Flowcharts are also provided to clarify the programs and simplify conversion to other languages.

Robot intelligence can vary from the purely reflexive to the almost unpredictable according to the author, and as such he has classified robots into three categories, viz Alpha, Beta and Gamma classes. The first chapter discusses the various features of these robots: the Alpha class is the simplest and is purely reflexive to conditions in its environment while Beta robots are Alphas equipped with a memory of past experiences — in other words they can learn. Gammas are one further step in the evolutionary chain and as well as having memory they can generalise what they know to other situations.

These classes can be further subdivided into Alpha I and Alpha II, Beta I and Beta II. The Alpha I and Beta I only have a single sensory mode and response mode while the Alpha II and Beta II have more than one response mode or sensor mode. The book deals with each class in an evolutionary order with chapters 3, 4, 5 and 6 discussing the Alpha I machine, chapters 7 and 8 on Alpha II, chapters 9, 10 11 on Beta I, Beta II machines are covered in chapters 12 and 13 and finally Gamma I machines in chapter 14 and 15.

Well so far it may sound quite esoteric but you do get some quite concrete results and a great deal of satisfaction after developing these programs. For example in the case of a Beta II machine the TRS-80 screen shows a "creature", represented as a small square, moving about the screen and reacting to various obstacles presented on the screen as four sets of two rows of characters. After successfully tackling one obstacle, albeit after several attempts, the "creature" learns and so quickly tackles the other obstacles on the screen.

Robots are certainly a new field for most people and it would seem that the author has done quite a lot of basic groundwork in the subject. He presents it in a clear and well defined fashion with plenty of flowcharts and programs making it also a very good practical book.

Our review copy came from McGill's Authorised Newsagency, 187-193 Elizabeth St, Melbourne, 3000. (R.del).

### Buyers Guide

**THE PERSONAL ELECTRONICS BUYERS GUIDE.** By Charles J. Sippl & Roger J. Sippl. Stiff paper cover, 133mm x 75mm, 338 pages, freely illustrated. Published 1979 by Prentice-Hall Inc, USA. Price in Australia not quoted.

Charles and Roger Sippl correctly identified an area of major interest in this book about electronics and its impact at family level. The chapter headings are;

Introduction — The Personal Computer — Electronic Games — The Television Revolution — Solar Energy — Home Security & Appliance Control — Computers That Talk And Sing — Education And Art — Communications — Of Things To Come.

On each of the subjects, they provide general background information, at a readable level, look at the products that are available and express opinions about future trends.

While they have tackled the task of preparing the book with insight and enthusiasm, the inescapable fact is that the book was published in 1979 and obviously prepared some time before that. It is sprinkled with quotes from magazine articles circa 1977/8, which is a long time back in terms of the domestic electronic revolution. Tandy's Level 1 computer was new and the only model in their range; home TV cameras were black and white; digital sound digitally mastered records were also new and the video scene was in an early stage of flux.

Add to this the fact that the book was written primarily for American readers and a large discount has to be applied to its relevance in Australia for 1981.

If you are prepared to apply that discount on detail, the overall message could still be of interest. Our copy came from Prentice-Hall of Australia Pty Ltd, 209 Glenhuntly Rd, Elsternwick, Vic 3185. Phone (03) 528 2866 (WNW).

### 6809 Language

**6809 ASSEMBLY LANGUAGE PROGRAMMING** by Lance Leventhal. Soft covers, 528 pages, 235mm x 167mm, illustrated with diagrams and tables. Published by Osborne/McGraw-Hill Inc 1981. Price \$20.20.

The 6809, a development of Motorola's 6800 microprocessor, is considered by many to be the most powerful 8-bit microprocessor available. In many applications the 6809 is directly compatible with the earlier 6800, but it has added features which correct some of the short-comings of the 6800, such as extended addressing modes and enhanced 16-bit arithmetic instructions. Perhaps the most interesting of these features is the 8-bit multiply instruction, which is not available on any other 8-bit processor. Various instructions have also been added which allow the 6809 to be used equally well as a dedicated controller of other equipment or as the basis for a complete computer system.

This new book from Osborne/McGraw Hill will be of interest to anyone wanting to find out about the 6809. The book is comprehensive and very detailed, well laid out and written in a clear and easy to follow style. Basic information is highlighted by bold-face printing, with explanations and expansions of the basics in a lighter type, so that the book can be used as a detailed guide to the 6809 or as a handy reference text by those already using the processor.

The book is organised in five sections, with a total of 22 chapters. Each section covers a particular topic, with the chapters treating particular areas of the topic. The first section is an introduction to assemblers and assembly language and the standard 6809 assembler in particular. Section II contains introductory problems with example programs and problems for the reader to solve. This section covers simple programming techniques, character coding and code conversion, arithmetic problems and techniques for creating tables and lists.

Section III moves on to advanced topics, including subroutines, I/O techniques, interrupts, and use of the 6820 Peripheral Interface Adapter (PIA) and the ACIA serial adapter. Software development is covered in Section IV, with detailed guides to problem definition and program design, documentation and testing and debugging. The instruction set of the 6809 is dealt with in the last section, which fully explains the operation of each instruction and gives examples of its use.

Throughout the book the text is supported by clear diagrams, tables and flow charts, and each chapter concludes with a list of references for further reading on each topic. Five appendices are provided, including a summary of



the 6809 instruction set, a summary of the 6809 indexed and indirect addressing modes, and 6809 instruction codes, memory requirements and execution times. Another useful feature is the inclusion of a separate index to the program examples used in the book. Seventy sample programs are provided with full listings, ranging from simple transfers of 8-bit data to character code handling and conversion, multiple precision arithmetic and routines for using seven segment displays, keyboards, D/A and A/D conversion and teletypewriter driver routines. For the 6809 assembly language programmer these sample programs alone are worth the price of the book.

This is one of the best texts we have seen on the 6809. It is well organised and written, and contains a good balance of hardware and software information and principles and program examples. The book attempts to take the reader from fundamentals to a broad working knowledge of the 6809 processor, and on the whole it succeeds very well.

Our review copy came from McGill's Authorised Newsagency Co Pty Ltd, 289-299 Swanston St, Melbourne, 3000.

## Practical Electronics

**ELECTRONICS. A Practical Introduction.**

By B. Brown and P. Carr. Published by Heinemann Educational Australia. Stiff paper covers, 92 pages, 245mm x 185mm, freely illustrated. Price in Australia, \$5.95.

The authors are both teachers at the Yarra Valley Church of England school and, not surprisingly, the book is written with one eye to its use in a class situation. However, it could still be used readily enough by an individual reader, hopefully with some assistance on the side.

The book opens with an introduction to basic DC circuits, followed by a chapter on measurement, involving access to a multimeter and a CRO.

Chapters follow on components, power supplies and linear circuits — all relatively simple but intended to convey concepts and to reinforce them by simple exercises.

Pages 48-65 cover the basics of digital circuits, including such things as logic concepts, truth tables, flip-flops, clocks and counters.

The final major section is devoted to design exercises, which would give the student an insight into what determines component values in typical circuits. For some it could provide a refresher course.

While perhaps not ideal for a passive reader, the book should be well worth its modest purchase price — by present-day standards — for the reader or student who is prepared to contribute something by way of time, effort and initiative. Our review copy came from Hebook Distributors, 85 Abinger St, Richmond, Vic 3121. Phone (03) 429 3622. (W.N.W.)

# NEW BOOKS

NEW — NEW — NEW

Latest editions of some of the most popular books on the subject:

The Radio Amateur's Handbook — ARRL 1981 Edition Just out! A must for the Radio Amateur and Professional	\$14 95
RSGB Handbook Volume 1	\$21 85
RSGB Handbook Volume 2	\$18 90
Reference Data for Radio Engineers (New Edition) ITT	\$39 95
Radio Handbook (William Orr) 21st Edition Australian Amateur Operator's Handbook — Postal & Telecommunications Department	\$ 3 60
Radio Amateur Callbook 1981 editions — Just out! US Listings	\$25 40
DX Listings — all other countries	\$24 00
World Radio TV Handbook 1981 — Just out — Complete directory of the world's radio and TV stations — short medium and long wave The listener's bible	\$16 95

## Adam Osborne Books

Introduction to Microcomputers, Osborne	
Vol 0 — Beginners Book	\$ 9 55
Vol 1 — Basic Concepts 2nd ed	\$15 60
Vol 2 Some Real Microprocessors — New Edition, Loose-leaf	\$30 00
With Binder	\$30 00
Vol 3 Some Real Support Devices — New Edition, Looseleaf w/out Binder	\$16 50
6800 Programming for Logic Design	\$13 50
8080 Programming for Logic Design	\$12 55
Z80 Programming for Logic Design	\$13 50
Z80 Assembly Language Programming	\$13 80
6800 Assembly Language Programming	\$15 00
8080A/8085 Assembly Language Programming	\$15 00
68000 Microprocessor Handbook — Kane	\$ 7 15
The 8086 Book includes the 8088 — Rector	\$18 00

## COMPUTER BOOKS

Computer Games for Businesses, Schools & Homes — Nahigian	\$14 75
Computer Programming For The Complete Idiot! — McCunn	\$ 7 15
Creative Computing Vol. 3 — Ahl	\$10 75
Experiments In Artificial Intelligence For Small Computers — Krutch	\$ 9 50
Inside Basic Games — Mateosian (Sybex)	\$17 95
Learning Level II — david Lien	\$19 15
Practical Hardware Details for 8080, 8085, Z80, and 6800 MICROPROCESSOR Systems — Coffron	\$29 75
TRS-80 Disk & Other Mysteries — Pennington	\$25 15

## New Books from TAB

Complete Handbook of Robotics — Safford, Jr	\$ 9 95
Master IC Cookbook — Hallmark	\$12 50
Towers: International Transistor Selector	\$12 50
How to Build Your Own Working Robot Pet — DaCosta	\$ 8 50
The Active Filter Handbook — Tedeschi	\$ 8 50
The Complete Handbook of Magnetic Recording — Jorgensen	\$13 50
How To Design & Build Your Own Custom TV Games — Heiserman	\$13 50

## American Radio Relay League

ARRL Antenna Handbook	\$ 8 30
The Radio Amateur's License Manual	\$ 6 80
FM & Repeater for the Radio Amateur	\$ 8 80
Single Sideband for the Radio Amateur	\$ 8 00
Ham Radio Operating Guide	\$ 7 20
Electronic Data Book	\$ 7 20
Solid State Design for the Radio Amateur	\$ 9 80
ARRL Antenna Anthology	\$ 6 80

## Microprocessor Books

The Basic Handbook — Lien	\$17 95
Learning Basic Fast! — DeRossi	\$10 95
6502 — Applications Book — Zaks (Sybex)	\$18 20
6502 — Software Design — Scanlon	\$14 20
TRS-80 BASIC — A self-teaching Guide — Albrecht, Inman & Zamora	\$12 55
TRS-80 Interfacing Book I — Titus	\$11 95
Microprocessor Interfacing Techniques — Zaks & Lessea-Sybox	\$16 95
Practical Microcomputer Programming: The M6800 — Weller	\$36 55
Basic programming primer — Waite & Pardee	\$12 70
Microcomputer interfacing with the 8255	

Just a few of the thousands in stock. Call in or write. Prices subject to fluctuation. Correct at time of going to press.

If the book you require is not listed below, it can be ordered from us.

PP1 chip — Goldsbrough	\$12 70
6502 software gourmet guide & cookbook — (Scelb)	\$14 25
8080/8085 software design book 1 — Titus, etc	\$13 60
8080/8085 software design book 2 — Titus, etc	\$13 50
TEA an 8080/8085 co-resident/assembler — Titus	\$12 70
Z-80 microcompressor programming & interfacing book 1 — Nichols etc	\$15 60
Book 2 — Nichols etc	\$17 80
Engineer's Notebook — Integrated Circuit Applications — Tandy	\$ 3 10
Introduction to TRS-80 Level II Basic and Computer Programming — Zabinski	\$14 75
Microcomputer Experimentation with the Motorola MEK 6800D2 — Leventhal	\$22 95
CP/M Primer — Howard Sams	\$15 95
Mostly Basic: Applications for your pet — Howard Sams	\$14 75
Mostly Basic: Applications for your Apple II — Howard Sams	\$14 75
Mostly Basic: Applications for your TRS-80 — Howard Sams	\$14 75
Bipolar Transistor, Fet & Linear IC Circuits — Ed Noll's SS Circuit Files Vol 1	\$10 75
TTL & CMOS Circuits — Ed Noll's SS Circuit Files — Vol 2	\$10 75
Circuit Design Programs for the TRS-80 — Berlin (Blacksburg series)	\$17 50
More Basic Computer Games — Ahl	\$ 9 00

## Byte Books New Series On Computers:

Mondeb — An advanced M6800 Monitor Debugger — Peters	\$ 7 00
Tiny Assembler 6800 Version 3.1 — Emmerichs	\$12 60
K2FDOS — A Floppy Disk operating system for the 8080 — Welles	\$28 00
Ciarcia's Circuit Cellar — Ciarcia	\$11 20
Tracer — 6800 Debugging Program — Grappel	\$ 8 40
Link 68 — An M6800 Linking Loader — Grappel	\$11 20
Byte Book of Computer Music — Morgan	\$14 00
RA6800ML — Relocatable Macro Assembler — Hemenway	\$35 00
Numbers in Theory and Practice — Programming Techniques — Liflick	\$12 55
Byte Book of Pascal — Liflick	\$35 00

## Howard W. Sams Books

TTL Cookbook (Lancaster)	\$12 95
TV Typewriter Cookbook (Lancaster)	\$13 50
The Cheap Video Cookbook (Lancaster)	\$ 7 95
Active Filter Cookbook (Lancaster)	\$17 95
Transistor Substitution Handbook	\$ 7 95
TTL Cookbook — Lancaster	\$12 95
IC Op Amp Cookbook — Jung — New 2nd Edition	\$19 95

## Pianos, Organs etc

Pianos-care and Restoration — Smith	\$23 85
The Organ — Its Evolution, Principles of Construction and Use — Sumner	\$29 95
The Cinema Organ — Reginald Foot	\$ 9 30
Piano Servicing Tuning & Rebuilding — Arthur Reblitz	\$19 15
Restoring & Collecting Antique Reed Organs — Presley	\$10 95

## Other Titles

Electric Guitar Amplifier Handbook — Darr	\$15 00
73 Dipole and Long-wire Antennas (Edward M. Noll)	\$ 7 50
73 Vertical, Beam and Triangle Antennas	\$ 7 80
Basic Television — Principles and Servicing — 4th Edn (Barnard Grob)	\$18 75
All about Cubical Quad Antennas —	\$ 5 70
Amateur Radio Theory Course — Ameco	\$ 8 70
Electronic Projects for Musicians — Anderson (Guitar Player Pubs)	\$ 9 95
Ham & CB Antenna Dimension Charts, Noll	
Practical Transformer Design Handbook — Lowdon	\$29 75
Two-metre Antenna Handbook — Judd	\$12 00

MAIL ORDERS BY RETURN

PLEASE ADD 1.50 per parcel postage (Vic)  
\$2.50 per parcel interstate

TECHNICAL BOOK & MAGAZINE CO.

295-299 Swanston St., MELBOURNE 3000. Ph. 663 3951.



# New Products

## Quality regulated power supplies from Goodwill

Goodwill have another potential winner in their line of low cost test equipment. This time it's the GPS-3060 DC Power Supply which features a single output adjustable from 0 to 30 volts and an adjustable current limit from 0 to 6 amps.

The appearance of the GPS-3060 is certainly on a par with other lab quality equipment and features two large panel meters on either side of the front panel, one for output voltage the other for current. Coarse and fine current and voltage controls are located below the associated meter on the front panel and the outputs are via binding post terminals. Dimensions of the unit are 250 x 185 x 310mm (W x H x D) and weight is 7.6kg.

In operation, the required output voltage is set using the coarse voltage control, and if necessary the fine control can be used to get the exact required voltage. The maximum output current can be similarly set using the coarse and fine current controls. Two LEDs on the front panel indicate whether the power supply is operating in the normal "constant voltage" mode or whether the output is current limited to the value set by the current controls — this is referred to as the constant current mode.

For the current and voltage meter readings to have any significance the meter calibration should be reasonably accurate — in the case of the GPS-3060 they were virtually "spot on". Using a DMM we measured a meter calibration of better than 2% for both the current and voltage meters.

Performance of the unit is also very good. We measured only 10mV of ripple at five amps and the load and line regulation were unmeasurable using a 3½-digit DMM. In fact as far as the line regulation was concerned we had to drop the mains input down to 130VAC before the GPS-3036's output voltage changed with a 1-amp load. The actual quoted figures are: line regulation 0.02%±2mV and load regulation of .01%±3mV.

One feature of the GPS-3060 which it shares with other lab power supplies is a pair of internal relays which automatically select the appropriate voltage tap on the secondary of the transformer depending on the output voltage required. The only noticeable effect this has is that you can hear the two relays click over as you



The Goodwill GPS-3060 — 0-30V output and adjustable current limit from 0-6A.

wind the voltage level up or down and pass the "trigger points" at 6V, 16V and 25V.

The major benefit of this scheme, and the reason it is often used commercially, is that at low output voltages and high currents the series pass transistors do not have to dissipate as much power. This reduces overall power consumption and heatsink size as well as giving cooler operation.

Looking inside the unit, the chassis is well laid out and fairly spacious with just a transformer, filter capacitor and a single PC board on which most of the components are mounted. The series pass transistors consist of four 2N3055's mounted on a large heatsink at the back of the unit.

An instruction manual supplied with the unit details the specifications, theory

of operation, circuit diagram and parts list. Since the outputs are fully floating, two of these power supplies could be connected in series to obtain a split supply. If the power supply outputs have to be earth-referenced, a shorting bar supplied with the unit connects the negative terminal to the earth terminal on the front panel.

Overall the unit is well made, easy to use and with its excellent electrical specifications we can highly recommend it. Quoted retail price of the GPS-3060 is \$281.00 including tax. A smaller unit, the GPS-3020 sells for \$129.99 including tax and features a 0 to 30V output range with currents up to 2 amps.

Our review sample came from Radio Despatch Service, 869 George St, Sydney 2000, phone (02) 211 0816 or 211 0191. (R.de J.)

## New Products

### "Meteosat" weather satellite receiving system



Vicom International Pty Ltd has announced the release of the "Meteosat" weather satellite receiving system manufactured by UKW Technik of West Germany. Another system, Orbit 137, is available for reception of signals from the US NOAA and TIROS satellites and the Soviet METEOR.

Systems available for geostationary satellites comprise a 1.5m parabolic antenna, super high frequency (SHF) preamplifier and down converter, VHF receiver and video processor. When using this equipment the received image is

photographed from the video processor with a Polaroid camera, although another system is available which uses a laser printer to provide hard copy.

The system is designed for reception of the GOES-W satellite which is located over the Pacific Ocean and can be received throughout the Pacific region and the east coast of Australia.

Further information, prices and engineering advice is available from Vicom International, 57 City Rd, South Melbourne, 3205; or 339 Pacific Hwy, Crows Nest, 2065.

### Static protection bags from 3M Australia

Transparent static shielding bags to protect printed circuit boards are part of 3M Australia's new range of static control products. The static shielding bags have the same protective properties as standard black conductive bags, but because they are transparent the contents of the bag can be inspected without removal from the bag and the risk of damage due to static electricity.

3M bags are made from a laminate consisting of an inner surface of antistatic polythene bonded to a coating of tough dielectric polyester. A vapour coating of nickel on the outside of the bag forms a conductive layer to produce a Faraday cage effect around the bag. Unlike aluminium coatings, the nickel will not be affected by corrosion.

For more information on the anti-static bags and other 3M static protection products contact 3M Australia Pty Ltd, PO Box 99, Pymble, NSW, 2073.

### New heatsink washers need no grease

A new thermally conductive, greaseless heatsink insulator is now available through Scientific Electronics. Called the SIL-PAD 400, the washer is a composite of silicone rubber and fibreglass specially formulated for use as a thermally conductive insulator. It is non-toxic, flame retardant and unaffected by cleaning agents.

SIL-PAD 400 is fast and easy to use in production, as it eliminates the need for applications of silicone grease. Components mounted with the pads can be put through solder baths or cleaning tanks as there is no grease to wash away or contaminate the baths. Styles are available to suit most device packages and can be supplied in a variety of thicknesses.

For more information contact Scientific Electronics, 6 Holloway Drive, Bayswater, Vic, 3153.

*New Products continued p111*



## ELECTRONIC TECHNICIANS

We require the services of several electronic technicians to work in our Service Department at North Ryde. The work involves repair of an enormous variety of electronic equipment in our air conditioned workshops. Applicants should ideally possess the E&C certificate, have had several years experience in the industry and be able to work without supervision. Salary negotiable and generous staff benefits apply. If you think that you're the person that we need, please apply in writing to:

**Gary Crapp**  
**Service Manager**  
**DICK SMITH ELECTRONICS**  
**P.O. Box 321, North Ryde**  
**N.S.W. 2113.**

### AN INTRODUCTION TO DIGITAL ELECTRONICS

Electronic equipment now plays an important role in almost every field of human endeavour. And every day, more and more electronic equipment is "going digital". Even professional engineers and technicians find it hard to keep pace. In order to understand new developments, you need a good grounding in basic digital concepts, and *An Introduction to Digital Electronics* can give you that grounding. Tens of thousands of people — engineers, technicians, students and hobbyists — have used the previous editions of this book to find out what the digital revolutions is all about. The fourth edition has been updated and expanded, to make it of even greater value.

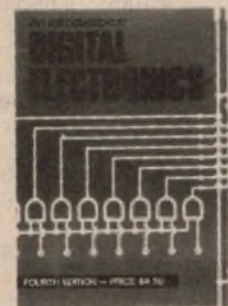

**ONLY**  
**\$4.50**  
**+ 70c**  
**p&p**

Available from "Electronics Australia", 57 Regent St, Sydney **PRICE \$4.50** OR by mail order from "Electronics Australia", PO Box 163, Beaconsfield, 2014 **PRICE \$5.20.**

# ARLEC 75000 SERIES

## P.C.B. TRANSFORMERS

*Ideal for electronic instruments, power supplies, emergency lighting systems, industrial control circuits etc.*

**Features**

- Designed to suit standard 0.1" P.C.B. grid
- Lightweight and convenient. Simply solders into position.
- Insulated to Australian standard C 126.
- Low price.
- Available in 7 ratings — 1, 2, 3, 5, 7, 10 and 12 VA
- Can be supplied in multi-tapped or dual winding form.
- Telecom approved
- Readily available in large or small quantities (min 50)

**Specially designed for printed circuit board mounting.**

SEND FOR DATA SHEET

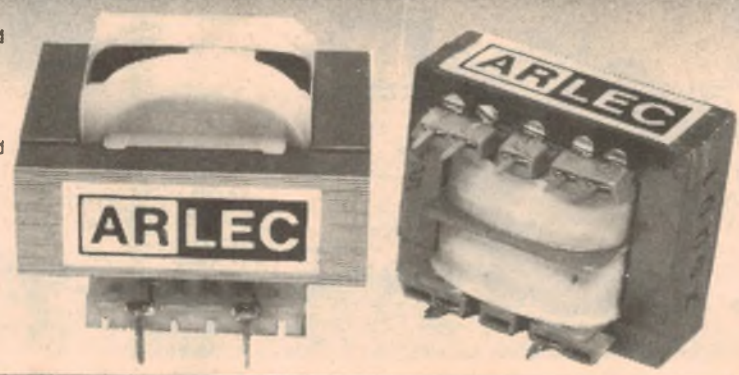

### A & R ELECTRONICS PTY. LTD.

A MEMBER OF THE A & R SOANAR ELECTRONICS GROUP

30 Lexton Road, Box Hill, Vic., 3128, Australia. Telex: 32286

VICTORIA: 89 0661  
 N.S.W.: 789 6733  
 Sth. AUST.: 51 6981  
 QUEENSLAND: 52 1131  
 WEST. AUST.: 381 9522  
 TASMANIA: 31 6533

## RADIO DESPATCH SERVICE

869 George St, Sydney 2000 Near Harris St.  
 Phone 211 0816, 211 0191

### OCTOBER SPECIALS

Universal Current/Polarity Checker Model CC250	\$4.00
"Ferguson" T/Former Type PL12/20VA/2	\$5.50
"M/Sound" 8-track cartridge capstan and head cleaner kit model: M39	\$2.99
"Jabel" Rotary Switch 3 pole, 2 position	75c
2-Speaker Fader Control Model SC-40	\$2.00
4-Section Top Cowl Car Aerial Model: CA30	\$4.75
"Kambrook" trouble finder lamp holder	\$3.75
"Stadium" 12V/6W fluorescent lead light	\$11.50
"M/Sound" super groovemaster record cleaner	\$5.95
"Victory" television game unit model: MPT02	\$78.95
Extra cartridges to suit	\$18.95
Tape head cleaner fluid-small bottle	\$2.00
"Philips" computer program tapes C-10	90c
Oval type car radio speaker 6" x 4" 15OHM	\$1.95
"Ferguson" t/former P.C.B. model PF3965 Prim: 240V Sec: 12v-420MA	\$4.00
<b>Car Head Lamps:</b>	
Model 4003 6" 12V-37.5/50W	\$3.78
Ditto 5001 6" 12V-50W	\$3.10
Ditto 7010 7" 12V-35/50W	\$3.78
Ditto 7019 7" 12V-M-6	\$3.78

The Power Semiconductor Data Book for Design Engineers — by Texas Instruments \$8.95

"Austenna" FM antenna model: FM3	\$17.50
"Amphenol" 4261B M/turn Potentiometer Res: 20kΩ ± 5% Lin ± 0.25%	\$3.00
2-metre extension cord with 3 pin plug only	\$1.80

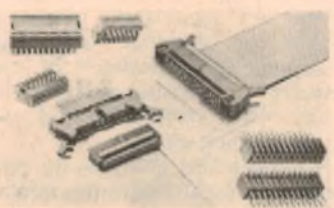

**Hirose and Ansley Ribbon Cable Connectors fitted same day.**

**COMPUTER COOLING FAN MUFFIN 240v** \$22.94

All PC Boards for EA & ETI Projects Front panels for some 1979 and 1980 EA & ETI projects. Black or silver background by the Scotchcal System.

### "NEUTRIK" PROFESSIONAL AUDIO CONNECTORS



Available in 3, 4 & 5 pin plug & socket, cord & panel types.

### BUY TEXAS CALCULATORS

Calculators	Excl. S/Tax	Incl. S/Tax
TI Programmable = 58C	\$141.11	\$158.48
TI Programmable = 59	\$233.09	\$264.48
TI Printer = PC-100C	\$216.28	\$242.78
TI Business Analysis — II	\$41.48	\$46.67
TI 55 Scientific	\$54.27	\$60.96
TI Programmer	\$62.44	\$69.79
Library Modules	\$33.40	\$37.60

### MAIL ORDER CUSTOMERS

POSTAGE LOCAL	\$2.50
POSTAGE INTERSTATE	\$3.00

**OPEN: Mon-Fri 8am to 5.30pm. Thursday night late shopping till 8.30pm. Saturday 8am to 11.45 am.**

## New Products

### Jaycar Pty Ltd expands its product range

Jaycar, well-known kit and component supplier, has further expanded its range of components with the purchase of the entire stock of the Sydney-based mail-order company "Micronics". Jaycar purchased a wide range of components at low cost and are passing the savings on to their customers.

Tens of thousands of small signal transistors, 5W audio ICs and a large variety of "AE" prefix 4000 series CMOS devices are on sale at bargain prices.

Jaycar also stock a wide range of Weller soldering products and Xcelite servicing tools. Included in the Weller range is the well-known Weller temperature-controlled soldering station, while the Xcelite products stocked include the TC-200 S/T attache-style tool case. Over 40 useful service tools are contained in the rugged black Durahyde case, which also holds a removable pallet with tool pockets.

A full list of components and prices is available by calling in at the Jaycar's Sydney showroom or by sending a stamped, addressed envelope to Jaycar Pty Ltd, 380 Sussex St, Sydney, NSW, 2000. A swift response to mail orders is assured.

### Prestel in Australia

Consolidated Electronic Industries Pty Ltd of Melbourne has been appointed the Australian agents for three British manufacturers of Prestel equipment:

- Technalogs Computing Ltd of Liverpool, a major supplier in Europe of Prestel Intelligent Videotext editing terminals. They also manufacture a unique adaptor that allows home computers to be connected to a Prestel system.
- Oracle Electronics Ltd, manufacturers of videotex adaptors and desk top business and editing terminals; and
- Metrotech Management Services Ltd of London, who have developed a software system that enables any organisation with a microcomputer running CP/M to operate their own in-house videotex system.

Principals of each of the British companies visited Australia recently for Information Technology Week and IREE CON'81 in Melbourne.

Consolidated Electronic Industries is the largest Australian manufacturer of recorded information equipment, and has gained a strong position in the emerging videotex industry.

Peter Robinson, Marketing Manager for CEI Pty Ltd can assist with further information. The address is 15A Anderson Rd, Thornbury, Vic, 3071.

### New bar code reader from Nortronic Instruments



Nortronic Instruments has announced the release of a new fixed scanning bar code reader designed to read code printed on identification badges, time cards and similar documents. According to Sales Manager Harold Norrie, bar code symbols are easily added to ID badges and the readers can then be used for time recording, control of building access and other "medium security" applications.

The reader is operated by sliding an encoded card along a slot where the code is optically sensed, decoded and transmitted to a computer. Most commonly used bar codes can be read.

There are no moving parts in the reader so it can be used without problems of wear and tear. The card itself is re-usable, providing a substantial cost saving over other techniques.

Further information is available from Nortronic Instruments Pty Ltd, GPO Box 995, Sydney, NSW, 2001.

### Hand-held video game

Dick Smith Electronics has released a new hand-held computer game called "Super Space-Jack". The game is a version of Invaders, and requires the player to defend his base against a swarm of attacking UFOs.

Eight different levels of skill are available, and the game can be played alone or tournament-style. It comes complete with sound effects and the compact hand-held unit uses either 4 AA batteries or a plugpack.

Cost of the game is \$39.95, and it is available from all Dick Smith Electronics stores and resellers.



### WANTED: A Professional Amateur

Are you a keen amateur radio hobbyist? Perhaps you're retired — but a bit bored with having nothing challenging to do.

You've probably built a lot of your own gear. You're active in the club circuit and maybe the WIA. You read CQ, QST, 73, etc. — and have a pretty good knowledge of electronics.

You may have had a business career — and miss the opportunity to use your entrepreneurial and marketing talents.

If we're talking about you, we could have the answer: you could become an advisor to the management team at Dick Smith Electronics. Your job would include sourcing new amateur radio products — visiting the East to find the latest and best products for Australian amateurs.

You'd also assist in the marketing and merchandising of these products.

To learn more about this exciting position, please apply in writing to:

THE MANAGING DIRECTOR  
DICK SMITH ELECTRONICS  
PO BOX 321,  
NORTH RYDE, NSW 2113

# Software Source

## WE ARE MOVING

Come and visit us in our  
new Showroom at  
**89 OXFORD ST,  
BONDI JUNCTION**  
and see the most complete  
range of

### SORCERER products

anywhere in Australia!  
Anything that will fit INTO or  
ONTO a Sorcerer . . . we  
have it!

Write for new  
**FREE catalogue**

PO Box 364 Edgecliff 2027  
Phone (02) 389 6388



REVIEWS OF RECENT

# Records & Tapes

CLASSICAL • POPULAR • SPECIAL INTEREST

## LEONARD BERNSTEIN: In the footsteps of Stokowski

**PROKOFIEFF — Symphony No. 5 in B Flat Major. Israel Philharmonic conducted by Leonard Bernstein. Recorded digitally and reproduced on chromium dioxide tape. CBS Masterworks Cassette HMT35877.**

I have often alluded to Bernstein as the Stokowski of the latter part of this century. They frequently share the same pursuit of lush tone, the same swooningly romantic phrasing, and the electrifying effect of a perfectly prepared climax that carries you along, willy nilly, and leaves emotional exhaustion in its train. Admittedly, disc recording owes much to Stokowski's generous enthusiasm in its early days and many of his suggestions — and performances — led to a great improvement in sound reproduction. In consequence, he can be forgiven much for what many regard as his lapses of taste.

These thoughts are prompted by Bernstein's treatment of this symphony. In it, Prokofieff is beginning to work towards a more lyrical style than previously. The work was written in a very short time, when Prokofieff's mood had lightened as the war began to turn in Russia's favour.

It is this lyricism that Bernstein has seized upon to romanticise rather more than the composer would have approved of. This is evident in the very first bars, which might have been directed by Stokowski himself in the late 1920s, had the work been in existence then. (It was not composed till 1944.)

But, despite lapses of taste, Bernstein has a quite uncanny gift of riveting the attention of his audience. Try as you might, you cannot escape his mesmerism or, at a live performance, his caperings on the rostrum until the symphony finishes and tension is relaxed.

If you want details in this performance, lack of space reduces me to make only a minimum of comment. For instance, the heavy-handed fondling of the first big lyrical theme defeats Prokofieff's characteristic carefully weighed scoring.

As to the sound, the use of the most



modern techniques of digital mastering and transfer to chromium dioxide tape still produces, in this example, a sound a bit too thick in the middle in fully scored passages. Yet, in the more delicate ones, it defies criticism of any kind.

The graceful light-hearted fresh second

movement is a superb example of the progress of modern recording. The cleanness of the sound, the audibility of every note and Bernstein and his orchestra's splendid playing are quite extraordinary. The whole scherzo-like movement is a delight.

In the third movement (adagio) you again have Bernstein thickening that texture in a way that puts him out of the running when compared to the 12-year-old Karajan recording. But Bernstein gives us a jolly finale.

Those who remember his Verdi's Fallstaff might recall his tendency to jog you in the ribs, so to speak, to share with him a more than usually telling shaft of wit; you will recognise the same impulse here. But it's all gay if a little more hearty than ironic. (J.R.)

## SHOSTAKOVICH 5th: the composer approved . . .

**SHOSTAKOVICH — Symphony No. 5. The New York Symphony Orchestra conducted by Leonard Bernstein. CBS Mastersound digitally recorded disc IM 6535864.**

Here is another digitally recorded Fifth Symphony, this time by Shostakovich and on a disc. This is the composer's most popular symphony, as is Prokofieff's Fifth. Have you ever noticed how many Fifth Symphonies are their composer's most popular with the public? Beethoven's Tchaikovsky's, Dvorak's (New World under old numbering), Sibelius' and if you think you'll find others. But try and think of a symphony in E Major and see how you get on if you except Bruckner's and Melbourne composer's Richard le Gallienne's?

But, to return to Bernstein, emphasis is again on the side of romanticism, the violence of the drama, the orchestra's discipline in the daintier passages and so on.

His interpretation again bears the



marks of his very vivid personality — extroverted to the Nth degree. Yet he always exercises some inexplicable form of restraint, sufficient to enchant his supporters and largely defeat his detractors. By the way, Shostakovich is said to have heard Bernstein conduct this symphony in Moscow and approved Bernstein's treatment. (Indeed it does serve Bernstein's temperament better than the Prokofieff.)

The recording under review, however, was played and recorded somewhat unusually in Tokyo by the Americans and processed by the Japanese. The result is excellent. Leaving out the fact that it does work better for Bernstein than the Prokofieff, the sound is cleaner on this disc than on the above mentioned cassette, especially in middle register of the loud passages.

This last statement is in no way

Reviews in this section are by Julian Russell (J.R.), Paul Frolich (P.F.), Neville Williams (W.N.W.), Leo Simpson (L.D.S.), Norman Marks (N.J.M.), Greg Swain (G.S.), and Danny Hooper (D.H.).

intended to disparage CBS' achievement in top quality recording. The same conditions of occasional unevenness often apply to analogue discs issued by the finest record companies; some are inevitably better than others. But after having read all that I said critically above, forget it, for this is the most moving performance of the work I have yet heard.

As in his First Symphony Shostakovich uses a piano in the orchestra, not as a solo instrument, concerto-wise, but as a modest member of the ensemble. Its surprising entrance lends still more emphasis to the CBS' superb engineering of this work.

The recording I can only describe as stupendous. The second movement is so rhythmically beguiling that it encourages foot-tapping. It has a strongly Mahlerian air about it, although that has never made me feel like dancing to any of his music – even in his Fourth Symphony.

The third movement grips you in an embrace, the concentration of which never relaxes for a moment. An extraordinary achievement. Strongly recommended. (J.R.)

## A matter of opinion

**BEETHOVEN – Symphony No. 3 (Eroica). New York Philharmonic Orchestra conducted by Zubin Mehta. CBS Masterworks cassette digitally recorded on to chromium tape. HMT35883.**

This is rather controversial Eroica, certainly not flawless. It is reputed to be the first digitally recorded example put out by CBS and shows most of the improvements issuing from that technique.

My performance, by way, is in disc form, to which the Cr02 cassette can safely be compared. The sound is clear, refined and perfectly balanced. Indeed it is so good that it tends to emphasise Mehta's failure to realise all the grandeur of the Symphony. And good though the sound is it has something of the rather dry effect that haunted London's Festival Hall before it was finally corrected.

There are forceful statements in plenty but to me they don't add up to a satisfactory whole. Perhaps one of the weakest spots in the first movement is the tameness of the fugal passage that leads up to the repeated fortissimo chords which in turn lose some of their designed emphasis, their incontrovertible assertions. The orchestra has plenty of presence and I liked specially the way the woodwind soloists performed perfectly their duties, without the aid of monitored spotlighting. Notable, too, is the sensitive difference between piano, mezzo-forte and forte.

Mehta keeps the great Funeral March moving in the second movement, so preserving its marchlike character instead of gloom. Here we mourn the

## HOLST: The Planets "excellent recording..."

**HOLST. The Planets. Scottish National Orchestra conducted by Sir Alexander Gibson. Digital master stereo, Chandos ABRD 1010. (From P. C. Stereo, P.O. Box 272, Mt Gravatt, Qld 4122, Phone 07 343 1612).**

The jacket notes indicate that this work was first performed in London in September 1918. The composer himself conducted the London Symphony Orchestra for the first mechanical recording in 1922/3, and for the first electrical recording in 1926. Since then, at least twenty further performances for the English catalogues have been recorded by leading composers.

This particular one, recorded in 1979 in the Henry Wood Hall, Glasgow, may well be the first on a digital master and, without a first-hand knowledge of all the others, I doubt that any of them could better it technically. Whether in the remoteness of Neptune (The Mystic), the blaring brass of Uranus (The Magician) or the sonic conflict of Mars (The Bringer of



War), the recording is completely equal to the task.

And so, too, I would say is the Scottish National Orchestra and their Musical Director, Sir Alexander Gibson.

All seven segments of the suite are included and, by way of assistance to those who may know the work more by name than by content, the double fold jacket contains very detailed notes on the composer, the conductor and the orchestra, plus the structure of each segment: Mars, Venus, Mercury, Jupiter, Saturn, Uranus and Neptune. (Exceptionally, not a word about the digital equipment itself!)

An excellent example of modern recording. (W.N.W.)

death of a philosopher and not the blaze of glory in which bully-boy Siegfried goes out in *Götterdämmerung*.

As to the third movement, I prefer this scherzo to sound a little more rumbustious. Mehta's treatment is so gentlemanly that the piece is a bit reminiscent of a county hunt. The playing however is always strictly disciplined.

There are no joyous shouts after the fugal portion – the bars in which Beethoven introduces dotted passages that produce a sort of bullocky effect. And the last movement doesn't help the missing grandeur of so much of the rest of the performance. I have perhaps been somewhat severe in summing up this performance but it faces such formidable competition that I think the assessment a fair one.

The performance – and engineering – has many good points as well as its weaknesses – I refer in particular to the refinement of many of its quieter moments. But this, I suppose, serves to underline the – I hate to say it – miniaturisation of the symphony. Don't forget its title, whether it was Beethoven's or not. (J.R.)

☆ ☆ ☆  
**TCHAIKOVSKY – Symphony No. 3 in G (The Polish). The Concertgebouw Orchestra conducted by Bernard Haitink. Philips Stereo Cassette 7300 850.**

There are several unusual features about this seldom played symphony that may be of interest, even to those who think their knowledge of the composer is wider than average.

It is nicknamed "Polish" for the slimmest of reasons – because the last movement often uses polacca rhythms. It is in five instead of the usual four movements. It was composed and scored in less than two months. There are five movements because Tchaikovsky wrote two "scherzos", the first of which is marked *Alla Tedesca*, in the German manner.

The symphony suggests it may belong to an early period of the composer's career, yet it is a contemporary of Swan Lake and the B Flat Minor Piano Concerto. It starts with a quite funereal intro, then goes on to a typically Russian theme, while still remaining sombre. Then follows an allegro that is pure Tchaikovsky in his most nationalistic mood.

As you might imagine, Haitink handles these multiple changes of speed and mood with all his usual elan, while always remaining faithful to the composer's score. There is no coming between the composer and his music in the Bernstein manner. He leads his players to an exciting end to the movement, yet the compelling bustle never becomes a scramble.

Then follows the first scherzo mentioned above, a graceful Tchaikovsky waltz owing nothing to Vienna and without the characteristic anticipated and prolonged second beat in the bar. It has a wonderfully neat middle section and proceeds to an ingenious combination of the two themes in an admirable stroke of technique. I found the whole movement quite enchanting.

The third movement has an unusual

shape and is always alluring. It has more than its full share of ingenuities, each perfectly brought off by the conductor. Then comes the second scherzo, this time a real one taken at a brisk clean tempo.

All through the work this fine orchestra is at the top of its form. The Finale's resemblance to a true polacca stresses that form's more formal, processional style. This does not persist but goes into a disappointingly mediocre theme which becomes even less attractive when it starts to go fugal — all very pedantic and long. It leads, however, into a chorale-like pre-ending that re-establishes the listener's good humour.

This is an interesting work but mainly to Tchaikovsky scholars. The general run of Tchaikovsky fans will prefer any of the three last symphonies, the tone poems, and the big ballets.

The sound is first class. (J.R.)

★ ★ ★

**HAYDN: La fedelta premiata (faithfulness rewarded).** Lucia Valentini Terrani, contralto; Tony Landy, tenor; Frederica von Stade, mezzo-soprano; Alan Titus, baritone; Ileana Cotrubas, soprano; Luigi Alva, tenor; Maurizio Mazzieri, bass; Kari Lovaas, soprano; Susse Romande Radio Chorus; Lausanne Chamber Orchestra; conducted by Antal Dorati. Philips Grandioso Series stereo disc 6570 096.

Haydn's last comic opera was performed at Esterhaza in 1781 and had its next airing at the Camden Festival of 1971! It suffers from a hopelessly confusing and confused plot and I doubt that even the full performance (these are only excerpts from it) could make it dramatically acceptable. Luckily, that is its only shortcoming.

The music of this opera is really quite splendid; there are some very fine arias, instrumentation which is uncommonly rich for its period and a constant flow of beauty and liveliness. Yet, with all this, it does not really come through as theatre music and this, I suspect, is to be blamed on the libretto. The singing is excellent throughout, but it should be noted that neither of the sopranos is heard in solo among these excerpts — each appears only in a septet. Maestro Dorati, now a seasoned Haydn specialist, keeps

## OPUS 3 JAZZ — “well done”

**NEW SIDES.** Peoria Jazz Band. Stereo, mono compatible disc, Opus 3 7911 (From M.R. Acoustics, PO Box 165, Annerley Qld 4103. Phone 07 48 7598).

After a fairly lengthy session, listening to and writing about “The Planets”, reviewed elsewhere, this recording by the Peoria jazz band came, unexpectedly, like a long, cool drink.

I had to rely on the jacket notes to discover that the Peoria jazz band has been something of an institution in Sweden since 1960 even though, not surprisingly, only two of its original members still feature in this 1980 performance.

What they play is time honoured trad jazz, not too far removed from the dance floor, and requiring neither technical knowledge nor an intellectual effort to enjoy.

Acoustic instruments only are used: trumpet, flugelhorn, valve trombone, clarinet, trombone, banjo, bass and drums. And the recording itself has apparently involved a maximum of care and a minimum of electronic gimmickry — the purist approach.

everything moving in a lively fashion and the orchestral performance is, on the whole, pretty good. Recorded sound is all one could ask for and the disc can be warmly recommended for its music, if not for drama. (P.F.)

★ ★ ★

**MOZART Clarinet Concerto in A Major K622. Concerto For Flute and Harp K299. WRC R 03291 Erato release from World Record Club.**

This record from the World Record Club combines the considerable talents of Jacques Lancelot on Clarinet, Jean-Pierre Rampal on Flute, Lily Laskine on



Sufficient to say that the two factors combine to produce a sound which is very clean, very forward, right there in your listening room. Helpful, too, is the fact that a group like this and music like this makes no extreme demands in terms of dynamic range.

I almost overlooked to list the tracks: Milenberg Joys — Flat Foot Foogie — Dancing On The Ceiling — Rent Party Blues — Taps Miller — Since You First Came My Way — Dark Eyes — Big Butter And Egg Man — At Sundown — Get Out Of Here And Go On Home.

To Opus “a small, independant Swedish record company, dedicated to timeless acoustic music” ... well done. (W.N.W.)

NEW 3.5 DIGIT LCD DIGITAL MULTIMETER KIT  
MODEL DMM-803

Cheque, Postal Note, Bank or Diners Card Accepted. Post and Packing Free Within Australia.

includes tax  
**COMPLETE KIT \$79.86**

The DMM-803 Digital Multimeter is a compact, hand-held instrument designed for both field and laboratory use. Measurement functions include DC voltage, AC voltage, DC current and Resistance. All functions are protected by diodes and transistors against overload. The large LCD read-out features easy-to-read numerals, polarity indication and low-battery warning. The DMM-803 is available in kit form containing all the parts necessary for making a finished Digital Multimeter and a detailed assembly manual to ensure easy assembly by yourself.

**Measurement Ranges:**

Function	Accuracy	Range	Resolution	Overload
DC V	± (0.8% of rdg + 1 dgt)	2 V	1 mV	DC 1000 V
		20 V	10 mV	
		200 V	100 mV	AC 1000 Vrms
		2000 V	1 V	
AC V	± (1% of rdg + 0.3% F.S. + 1 dgt)	500 V	1 V	AC 1000 Vrms
		2 KΩ	1Ω	
		20 KΩ	10Ω	DC 250 V
		200 KΩ	100Ω	
OHM	± (0.5% of rdg + 1 dgt)	2 MΩ	1 KΩ	AC 250 Vrms
		200 μA	100 nA	
		2 mA	1 μA	1 A
		20 mA	10 μA	
DC mA	± (1% of rdg + 1 dgt)	200 mA	100 μA	

ONLY AVAILABLE FROM:

**RADIO PARTS GROUP**

562 Spencer Street, West Melbourne, 3003 (03) 329 7888  
1103 Dandenong Road, East Malvern, 3144 (03) 211 8122



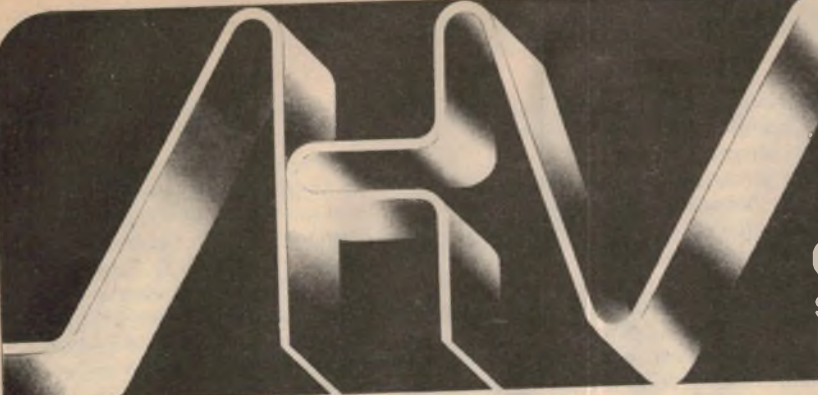

# 1982 Australian Home Video Convention

Sydney Hilton  
February 13/17, 1982

**A**ustralia is the world's fastest growing market for home video software and hardware. Both the general public and the trade are invited to participate in the 1982 Convention which will include extensive display areas featuring the latest in video software and hardware available from Australian and International exhibitors. The 1982 Convention will feature top Australian and International speakers who will lead workshop sessions on a variety of areas including:

- Copyright law
- Pirating
- Censorship
- Retailing
- Merchandising
- Promotion
- Closed circuit applications
- Software Developments
- Hardware Developments
- Video for education and training
- Video for recreation and pleasure
- Video production
- Video resources

For further information about attending and/or promotional facilities contact the Convention organisers:—  
L.D. Graham & Associates Pty. Ltd.  
Management Consultants,  
155 Drummond Street, CARLTON,  
Vic. 3053  
Tel. (03) 347 3437 or (03) 347 5076

Name: \_\_\_\_\_

Address: \_\_\_\_\_

PI/Code: \_\_\_\_\_

## COMMODORE GOODIES

**HIGH RESOLUTION GRAPHICS** — Now you can give your PET/CBM a High-Resolution Graphics capability with the MTU Graphics Hardware and Software Packages. The Hardware is easily installed and the new graphics board provides five extra ROM sockets and 8K RAM Memory Expansion which can be used for program or data storage when graphics are not required. A powerful graphics software package is included and contains many extra BASIC commands for drawing lines, defining shapes, etc. The Graphics Hardware does not affect normal operation of the Commodore.

- for 2000 Series 8K PETs (Old ROMs): . . . . . \$600.00
- for 3000/4000 Series 16/32K CBMs: . . . . . \$635.00
- for 8000 Series 32K CBM: . . . . . \$665.00

**All prices quoted are exclusive of Sales Tax.**

**SPECIAL OFFER!!!** THE FIRST 10 PEOPLE TO SHOW THIS AD AND BUY A HIGH-RESOLUTION GRAPHICS PACKAGE FROM US WILL RECEIVE A \$100 DISCOUNT OFF THE NORMAL RETAIL PRICE.

Add extra commands to your Commodore's BASIC:—  
 Programmers Toolkit — AUTO, RENUMBER, FIND, TRACE, APPEND, DELETE, STEP, HELP  
 for BASIC 1.0 Old ROM PETS: . . . . . \$75.00 — for all others: \$50.00  
 Command-O Toolkit — Adds 19 additional commands. . . . for 4000 Series: \$100.00 — for 8000 Series: \$100.00

**Plus many other goodies. Don't forget your PRINTOUT Magazine Subscription!!!**



MICROCOMPUTER SYSTEMS DESIGNERS

B. S. MICROCOMP Pty Ltd,  
4th Floor,  
561 Bourke Street,  
Melbourne 3000.  
Tel 614 1433/614 1551

## DO YOU NEED

**Greater Profitability,  
Improved Personal Performance,  
Fewer Operating or Driving Errors.**

## USE

The **elevit** Impulse Field.

Today we live and work behind walls of glass, steel and concrete or travel inside cabins of steel, glass and aluminium. Even when air conditioned, these artificial environments upset our biological equilibriums.

The technique of **Elevit** impulse field generation has been widely tested and scientifically proven.

Eight years of research, development and large scale field testing by leading universities, motoring authorities and industrial organisations showed **Elevit** provides:

**10%** Efficiency improvement.

**20%** Better objective wellbeing.

**22%** Reduction in errors.

**Elevit** is not a negative ion generator — it does not produce ozone.

**Elevit** impulse field generation is the only technique in the world which reproduces nature's ideal air electrical conditions with the above scientific results.

**elevit** Mobile

Scientific results from the use in cars, office, schools & hospitals.

Latest West German technology. Patented and protected world wide.



\$149.00 inc batteries, postage. 2-year guarantee.

Small, handy, pleasing appearance. 125 X 62 X 17mm.

Large room installations available.

TO:

**elevit**

AUSTRALIA PTY LTD

47 Huntingdale Road,  
Burwood, 3125.



Please forward Elevit mobiles at \$149.00 ea. (Price inc packing & postage.) I enclose \* Cheque/Money Order/Bankcard Authority for \$149.00. (\*Indicate which applies.) Please debit my Bankcard Account.

My number is:

□□ □□ □□ □□□□□□

Signature .....

Name .....

Address .....

Postcode .....

For Free Information:  
Phone (03) 288 9512; 763 6109; 288 9129.

## RECORDS & TAPES — continued

Harp, together with The Jean-Francois Paillard Chamber Orchestra, in two concerti from Mozart.

Both are in three parts, the concerto for clarinet being Allegro, Adagio and Ronda and the concerto for flute and Harp being Allegro, Andantino and Ronda Allegro.

The performance of all concerned is impeccable, making it a delightful record that comes afresh with each playing. It was rather incongruous to see Jean-Pierre Rampal recently as the guest artist on the "Muppet Show" but, even there, his mastery of his instrument shows clearly, despite the contrived idiocy of Kermit and his friends. The World Record Club does a great service to its members in bringing music and performances such as this to light that may not see local release otherwise.

The overall quality is good, perhaps not up to some of the discs one hears lately, but nevertheless, excellent value. (N.J.M.)

★ ★ ★

**O SOLE MIO. Luciano Pavarotti Sings Favourite Neopolitan Songs. World Record Club WRC R 08285.**

This is music straight out of "World Famous Tenors" or "Singers Of Renown" with 13 tracks of Neopolitan love songs, sung with enthusiasm and vocal skill by Luciano Pavarotti.

There are two orchestras involved, The

Teatro Comunale, Bologna, and the National Philharmonic Orchestra, the tracks having been recorded in Bologna and The Kingsway Hall, London.

Some of the titles are: 'O Sole Mio — O Surdato 'nnammurato — Fenesta Vascia — Marechiaro — Torna A Surriento — Piscatore 'E Pusilleco — Maria, Mari — Funiculi Funicula. The sleeve notes inside carry the lyrics in Italian and English for those peasants like me who have only one language! (NJM)

★ ★ ★

**BEAT OF LOVE. Randy Vanwarmer. Bearsville Records L 37588. Festival release.**

Another refreshing album by the young American Randy Vanwarmer, including ten new tracks.

The tracks are: Suzi Found A Weapon — Always Night — Don't Hide — Amen — I Guess It Never Hurts — Frightened By The Light Of The Day — Hanging On To Heaven — The Beat Of Love — When I'm Dead And Gone — Don't Wake Me Up.

The tracks on the album range from up-beat rock 'n roll to ballads.

Recording quality is very good. (D.H.)

★ ★ ★

**MADE IN AMERICA. The Carpenters. A & M Records L 37597. Festival release.**

Karen and Richard Carpenter — brother and sister recording stars, whose albums always deliver brilliant vocals and harmonies — are back with their latest

## A storm in your lounge room

**THE POWER AND THE MAJESTY. Stereo cassette pre-recorded at normal speed, CR02 tape, Dolby-B NR. Mobile Fidelity/Sound Lab. MFSL C-004. (Obtained via BASF Aust Pty Ltd, Chelsea House, 55 Flemington Rd, North Melbourne 3051. Phone 03 32 9955).**

Along with some other members of the technical press, I received my copy of this cassette from BASF, along with an invitation to meet a couple of BASF executives out here on a visit from Germany. By coincidence, about the same time, I noted a review of another audiophile cassette from Mobile Fidelity in an overseas hifi mag. Their direct mailing address is given as Mobile Fidelity Sound Lab, PO Box 919, Chatsworth, CA 91311, USA.

For cassettes duplicated at normal replay speed on to BASF Cromdioxid Super II tape, it is not surprising to note that they are described as "limited edition", with (I imagine) a price to match. From the artists listed, it would appear that the catalogue is predominantly drawn from the pop scene.

The sample cassette, to hand from BASF, has "The Storm" on side 1 — and



this is the real thing. It plays for a quarter hour or so and starts with the patter of rain on the roof. Then the thunder is heard and it builds in intensity as the storm passes directly overhead. It's the most convincing thunder I have ever heard from a recording, with the scary transients and house-shaking qualities which, on a good system, aren't too far removed from the real thing outside.

On side 2 is a mix of steam and diesel locos hurtling by with much blasting of hooters and horns. They're sonically startling too, but the storm is too hard an act to follow!

To judge by this sample cassette, MFSL have made an impressive debut in the business of putting audiophile cassettes up against audiophile digital discs. Most impressive! (W.N.W.)

## DEVOTIONAL: But if you can't follow the words . . .

**REBA, CONFESSIONS.** Light LS 5777 Lexicon Music Release. (From Word Records Aust, 18-26 Canterbury Rd, Heathmont, Vic 3135).

It is a pity there is no listing of the lyrics with this record, as Reba Rambo's vocal style makes it difficult to follow the words. In a Gospel music situation, the message is surely a vital aspect of the performance.

The titles are — He Never Turned His Back On Me — I Won't Last A Day — I Cry Out To You — Struggle For Survival — Don't Give Up — At Last I Found Love — With A Friend Like You — Because Of Whose I Am — I've Got It All — A Perfect Heart.

The sound quality is good but the backing group, unnamed, tends to override the singer on some tracks. (N.J.M.)

★ ☆ ☆  
**MICKI, LOOK AGAIN** Dayspring DST 4021 (From Word Records Aust, 18-26 Canterbury Rd, Heathmont, Vic 3135).

Micki Furhman is a young lady of many



talents, made very obvious by this album. Not only is she very attractive but she has written half the lyrics and music for it. The liner notes carry all the words but she exhibits excellent diction and the backing musicians do not override the singer.

Most of the music is gentle rock with a few ballad style for good measure. Some of the titles: Look Again — People Call Him Jesus — God Is Missing A Child — Hold On — Bibbling — You're The Reason — Now That I've Found Your Love.

The message in each song is unmistakable and direct and the technical quality is the usual high standard one expects from Word Records. In other words a record to enjoy time and time again. (N.J.M.)

release.

The ten tracks on the album are: Those Good Old Dreams — Strength Of A Woman — Back In My Life Again — When You've Got What It Takes — Somebody's Been Lyin' — I Believe You — Touch Me When We're Dancing — When It's Gone — Beechwood — Because We Are In Love.

The tracks range from ballads to dance numbers, including an excellent presentation of a 1960's sounding record.

An excellent album, with the usual haunting vocals and memorable musical arrangements. (D.H.)

★ ☆ ☆  
**FIRST MEN ON THE GOON.** Parlophone PMCO 7132 Mono World Record Club Release.

In typical Goon fashion, the title of this record has nothing to do with the two episodes, these being "Foiled By President Fred" and "Robin Hood And His Merry Men".

The first story covers the exploits of a gas meter inspector from the South Balham Gas Board in his attempt to get payment of an overdue bill from President Fred who has fled to South America and is found in the midst of a revolution as usual.

The Robin Hood story bears little resemblance to the traditional story with his henchman, Friar Balsam getting them into all sort of strife. One dreadful pun breaks loose when the baddies threaten to tie Bluebottle to a steak; he protests by saying that he is a vegetarian! If you are a Goon fan you'll enjoy it as I did. (N.J.M.)

**PAM AYRES: Some of me poems & songs.** Stereo, World Record Club, WRC R-05976.

I'd almost forgotten Pam Ayres until reminded of her by a certain fruit juice advert on television. Then the World Record Club sent me this recording of one of her shows and I was able to share with the audience her simple but effervescent humour.

All told, there are 18 tracks on this album, or nearer 14 if you don't count the songs, which are scarcely her strong point.



I guess that the titles have been around for a while but most of them were either new — or forgotten. To quote a few: The Battery Hen — I Wish I'd Looked After Me Teeth — In Fear Of The Butcher — Like You Would — The Stuffed Horse — Fling Another Chair Leg On The Fire Mother — Oh No . . . I Got A Cold!

Diction on the record is good and, if you don't already own a Pam Ayres' album in your collection, this one is good for the light-hearted interlude. (W.N.W.)

**ELECTROCRAFT**  
will put you in the picture  
with the largest range  
of Antenna  
accessories in  
Australia



68 Whiting Street, Artarmon NSW  
Telephone 438 4308 (ext 6)  
or 438 3266 (ext 6)

WE ARE SPECIALISTS  
30 years in the antenna  
business. Hours: 8am to 5pm.

**LOOPY VIDEO**

Shop: 418 Bridge Road, Richmond, Vic.  
Mail: PO Box 347, Richmond, 3121, Vic.  
Phone: (03) 429 5674

**SAMPLE OF NEW SOFTWARE  
TITLES FOR OHIO**

G 44 Collide M/C	\$ 9 95
G 45 Vampire Castle (Adventure)	\$18 95
G 46 Alien IV M/C	\$18 95
G 47 Minos (Maze, 3D View)	\$11 95
G 48 Interceptor M/C	\$14 95
G 49 Labyrinth	\$14 95
G 50 Monster Maze M/C	\$11 95
G 51 Rocket Jockey	\$ 9 95
B 6 Bookkeeping the Easy Way	\$129 00
B 7 Payroll	\$49 95
B 8 Inventory	\$59 95
B 9 Accounts Receivable	\$99 95
T 6 'Forth' Language-3 Books	\$19 95
T 7 CIP Series2 User Manual	\$10 00
K 1 Hardware Catalogue INC P&P	\$1 00
K 2 The First 100 Items of Software	\$1 95
I 27 TTL Level Port	\$4 95
I 28 EPROM Burner Instr	\$6 95
U 15 Dissassembler Plus	\$14 95
U 23 32 x 64 Swap Tape SERIES 2	\$8 95
U 24 Sound Effects	\$9 95
U 25 FUL Editor/Assembler	\$19 95
U 26 High Speed SAVE/LOAD	\$14 95
U 27 Renuberer M/C	\$11 95
U 28 'Forth' on Tape	\$34 95
U 30 'Pascal' tape&book	\$34 95
U 31 Sound Driver	\$8 95
U 33 Tiny Compiler	\$19 95
U 34 Trace-Single Step	\$12 95

**AND WE NOW STOCK DISKS**

# Column 80

by JAMIESON ROWE

Technical Director,  
Dick Smith Electronics

## Modems and Telephone Communication

You're probably heard of modems, and know that they're something to do with computers "talking with one another" over the telephone. But do you know what a modem actually is and what it does? Here's a quick introduction to the basics of data communication.

As the number of small computers in use grows, more and more users are interested in getting them to communicate with one another – and with large computers and "data bases" – via the telephone network. Because of this, I thought it might be a good idea this month to talk about the basics of data communication.

Let's start by looking at the term "data communication" itself. This is rather a weird one, actually, because the normal definition of "communication" includes the idea of transmitting and receiving information. And the word "data" is basically just a synonym for "information". So to say "data communication" is really a little redundant.

You may think that this redundancy is meant to indicate that we are transmitting only a computer's "data", and not its "program". But that's not true either. In fact from the communication point of view, it's just as easy to transmit programs as it is to transmit data – they're both just a string of numbers, after all.

The basic idea behind the term is simpler than you'd think. Traditionally, information has been sent over telecommunication lines in one of two main forms: as either normal speech signals, or encoded digitally in Morse or some other code. For many years, telecommunications people distinguished between the two forms of transmission by using the terms "telephony" and "telegraphy", but in the last few years there has been a tendency to drop both of these rather quaint terms in favour of "speech" and "data". So to a certain extent, "data" means information sent in some form other than as speech signals – although there is a little more to it than that.

Although Morse, telex and other telegraphy is basically the transmission of information in direct digital form over "telephone" lines, it is done at a relatively low rate. As soon as people tried to send information in this form at a higher rate, they found that the electrical characteristics of telephone lines just weren't good enough. The signals became too distorted. It was obvious

that if information in digital form was to be transmitted at the really high rates possible with computers, some other approach was going to be needed.

The system they adopted was to use the digital information to modulate an audio tone, which could then be transmitted over the telephone lines without distortion. Then at the other end, the tone was demodulated again to recover the information in its original digital form. Rather like radio transmission, if you like, but using an audio frequency "carrier" rather than one at radio frequencies. And this is still the system used to transmit "data" nowadays, at rates of up to millions of bits per second (although at these rates it isn't really possible to use an "audio" carrier tone).

*This modem can be used in the Answer or Originate modes and has a flexible linkage so that it can be made to fit any telephone handset.*

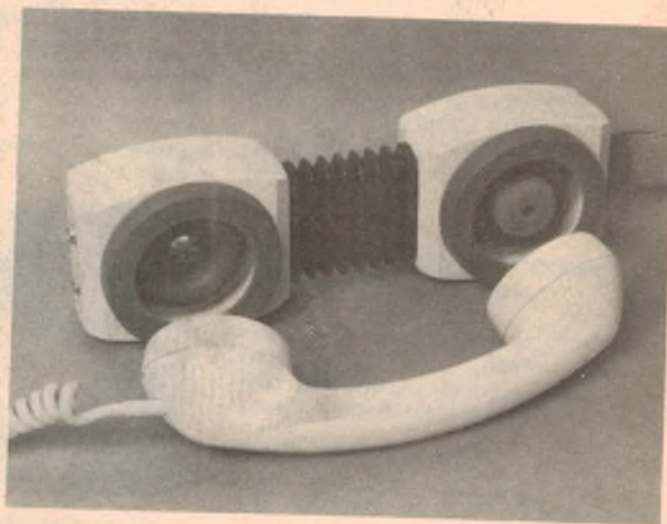

So when a computer is to transmit and receive information over the telephone lines, it needs a tone modulator/demodulator unit to change the information from digital to tone form and back again. And if you haven't already guessed, another name for a tone modulator/demodulator unit is MODEM.

The type of modulation used in modems is frequency-shift keying, or "FSK". Without going into this too deeply, the audio tone sent by the modulator

part of the modem is switched between two frequencies, one corresponding to digital "1" and the other to "0". The demodulator of the modem at the other end then detects these two frequencies, and produces a digital signal whose value is "1" when the received tone has one frequency, or a "0" when it has the other.

Like human speech communication, data communication usually needs to take place in both directions simultaneously. As a result, most modems are designed to be able to transmit and receive at the same time, over the same line. How is this done? By using two frequencies for transmission one way and another two frequencies for transmission the other way. This is called "duplex" data communication.

Modems designed for duplex communication are therefore made to transmit on one pair of frequencies and receive on another. But the frequencies used for transmit and receive can't be fixed rigidly, or a modem would only be

able to communicate with another modem whose tone frequencies were set to the opposite of its own! So each modem is provided with the ability to swap its transmit and receive frequencies, either by a manual switch or via a control signal from the computer.

Actually a standard has been adopted, whereby the modem which "originates" a call has its transmit and receive frequencies set a certain way and the

*(Continued on page 129)*

# PRINTER SURPRISE:

Fan form paper • 80/40/132 columns • 9 x 7 dot matrix bi-directional impact printer.

## Unbelievable Performance

125 characters/second or 64 lines per minute • continuous printing • many functions such as vertical format unit and more.

## Unbelievable Quality

Full 96 characters, upper and lower case • adjustable sprocket feed, 115 to 240mm wide • 7-bit parallel interface - Centronics type.

## Unbelievable Price

Available NOW at a substantial saving on our normal price • use cash, Bankcard, or Credit Terms (available to approved personal shoppers only).

**\$920**

Price includes recent Sales Tax increase

**C. ITOH**  
Model 8300P  
Cat. X-3255

DICK SMITH

**DICK SMITH  
ELECTRONICS**

See our other advertisements for store addresses.



DENSO

# Microcomputer News & Products



## Single-board computer with Tiny Basic

Radio Despatch Service now has available an INS-8073 based single-board computer from the Digi-Key Corporation. The 8073 is a National microcomputer chip which directly executes a version of Tiny Basic adapted for industrial control and program development. Digi-Key's 125mm x 175mm demonstrator board offers an unusually comprehensive set of features for these applications. Because the INS-8073 is a complete microcomputer on a single chip, the minimum demonstrator system consists of only nine integrated circuits. Together

also provides 128 bytes of RAM for use by assembly language programs.

A fully operational system requires only the board itself, a source of power (+5V, -12V and +25V) and a serial video terminal or teletype. Once a program is developed it can be written into a 2716 EPROM using the on-board programmer and any specialised devices required by a particular application easily interfaced via the 40 parallel I/O lines.

Read Only Memory on the microcomputer chip itself contains the NSC Tiny Basic interpreter. Programs written in

Input and output operations are well supported, as are the interrupt facilities provided by the system. Assembly language programs can be LINKed to Basic programs for use where speed of execution is critical. Programs are relocatable, and a number of programs may reside in memory at the same time, each allocated memory by the command NEW (address), where (address) is the location in memory where the first line of the new program will be stored.

The use of Tiny Basic rather than assembly language provides obvious advantages when it comes to writing and checking programs. The power and simplicity of the language combined with the built-in editing and debugging capabilities making it suitable for every stage of program development and use, and the single-board computer itself is designed so that it may be used alone to develop programs then incorporated into other equipment as a controller board.

The standard computer board costs \$260 plus tax, with the operating manual a further \$15. Sole importers are Semtech Pty Ltd, 1 Johnston Lane, Lane Cove, NSW, 2066. Radio Despatch Service is at 869 George St, Sydney, 2000.

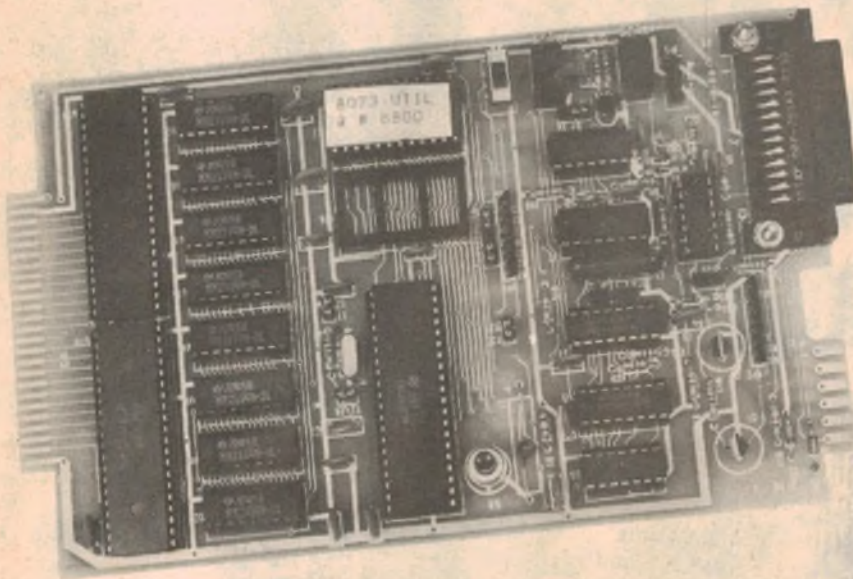

they provide 1K of RAM in addition to the 64 bytes of memory on the computer chip itself, a programmer for 2716 EPROMs, a 20mA current loop Teletype interface, an RS232C interface, and complete decoding for a fully expanded system.

Space is provided on the board for additional RAM in the form of 2114 1K x 4 bit chips, for a total of 4K of programmable memory. Also on the board are sockets for two 2716 EPROMs for the user's own applications programs (4K total). Addition of an 8225 programmable peripheral interface and an 8154 RAM/IO chip provide a total of five 8-bit parallel ports which can be programmed for input, output or bi-directional communication. As a bonus, the 8154 device

NSC Tiny Basic eliminate the need for an Editor, assembler and Monitor programs, all of which consume large amounts of memory.

Tiny Basic is a simplified version of Basic, but it provides all the functions required for industrial control uses and the development and testing of controller programs. Twenty-six variable names are supported each representing a 16-bit signed integer. There are no fractions or floating point operations. Numeric constants may be expressed in either decimal or hexadecimal, and the standard relational and arithmetic operators are provided. Also provided are logical operators (AND, OR and NOT) which perform the designated operation bit by bit on 16 bit arguments.

## A personal computer from IBM

IBM has made its long-awaited entry into the personal computer market. Announcing its first "personal" computer in New York in August, the company illustrated how far it has moved from its traditional market - the new machine is priced at around \$1500 for a basic system.

So far, the small computer field has been dominated by companies such as Apple, Tandy and Commodore. Last year over 10 million personal computers were shipped in the United States alone, and the size of the market has tempted many large-scale computer manufacturers to consider entering the field.

IBM's personal computer marks a new level of performance with its use of a

Micronews  
Continued ►

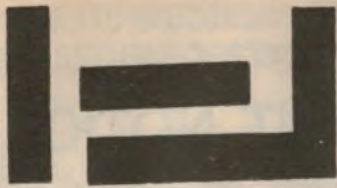

# PARIS RADIO ELECTRONICS

## HARDWARE DESCRIPTION

S/09 6809 Computer w/128K Memory  
 /09 6809 Computer w/56K Memory  
 6540 Printer 132 characters  
 8212 12" Terminal w/monitor  
 DMF 2 Disk System w/2.5m Capacity  
 CDS-1 Winchester Hard Disk System  
 MP-09A 6809 Process/Board (assem)  
 D5-2 double side/double density 720KB  
 3809 128K Memory Expansion for S/09  
 MP-LA Parallel Interface  
 MP-L2 Dual Parallel Interface  
 MP-N Calculator Interface  
 MP-R Eprom Programmer  
 MP-S Serial Interface  
 MP-64 Memory board 64K  
 MP-S2 Dual Serial Interface  
 MP-SX Serial Interface Expansion  
 MP-T Interrupt Timer  
 S-32 Universal Static Memory Card  
 MB 68XX 6809 Mother Board

## SOFTWARE TSC

ASM09 Optimizing Assembler (5" or 8")  
 Flex 09 ver 2.8 1w/manual  
 Inventory Program  
 Mail List Program.  
 Word Processing Editor & Text Processor  
 Word Processing Editor  
 Text Processor  
 SP-09-2 Text Editing System  
 SP-09-3 Mnemonic Assembler  
 SP-09-4 Basic  
 SP-09-5 Debug Package  
 SP-09-6 Extended Basic  
 SP-09-7 Standard Precompiler  
 SP-09-8 Extended Precompiler  
 UniFLEX Multi-tasking BASIC  
 SP-09-10 Sort/merge  
 SP-09-11 Utilities  
 Uniflex Operating System  
 Uniflex Basic  
 Uniflex Pascal  
 Pascal for Flex 09  
**Microware Systems Corporation**  
 OS9 Level I Operating System  
 OS9 Level II Operating System  
 Basic 09  
 Stylograph Word Processor  
 OS9 Macro Text Editor  
 OS9 Interactive Assembler  
 OS9 Interactive Debugger

**D-5** Two double sided, double density, 5" disk drives with a total on line capacity of 720,000 bytes of data. Includes cabinet, power supply, connecting cable and controller. Controller will operate up to four drives. This is an ideal disk system for small stand alone word processing systems, or for businesses that do not work with large inventories.



**DMF-2** Double sided, double density, dual eight-inch disk system with an on line capacity of 2,400,000 bytes. Our "top of the line" disk system features a DMA type controller for fastest possible data transfers. This drive was designed for larger businesses and multi user installations. The DMF-2 will provide the fast operation necessary for systems running multiterminals under the UniFLEX operating system. Complete with a heavy duty 1/8 inch metal cabinet, power supply, connecting cable and controller. The controller will operate up to four drives.



## MB-68XX MOTHER BOARD

The MB-68XX Mother Board is an extremely versatile and universal mother board for SWTPC and similar SS-50 based systems. It provides 8 slots for full sized (SS-50) boards and 8 slots for I/O sized (SS-30) boards. Its main features are:

1. Switch selectable 6800/6809 I/O addressing.
2. Switch selectable 4/16 addresses per I/O slot.
3. Baud rate generator for SS-50C and S/09 compatability.
4. Schmitt trigger buffers on all data, address & control lines to I/O bus.
5. Physical size & mounting replaces existing SWTCP 6800/09 mother boards.
6. Extra thick 3/32" Epoxy board.
7. High quality double sided plated through holes.

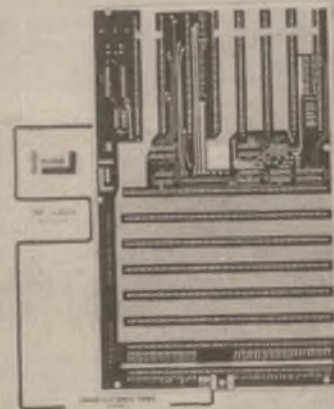

## Talbot Microsystems

t Forth, t Forth +, Firmforth  
**Computer Systems Centre**  
**Dynamite Disassembler**  
**6800/6809**

## Universal Data Research Inc

Data Base Manager for Flex  
 for Uniflex  
 Payroll, General Ledger  
 Manufacturers Inventory  
 Accounts Receivable, Accounts Payable.

## Washington Computer Services

Record Management System  
 Data Base Management

# GIMIX inc. HARDWARE

32K Static Ram Board  
 16K Static Ram Board  
 Expandable to 32K  
 6809 Plus CPU Card  
 5/8 Single Density Controller Board  
 5" Double Density Controller Board  
 5", 8" DMA DD Controller



## PARIS RADIO ELECTRONICS

7a BURTON STREET, DARLINGHURST, NSW 2010  
 PO BOX 380, DARLINGHURST, NSW 2010. PHONE (02) 357 5111

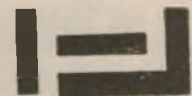



## COMMODORE AND MICROPRO DESIGN JOIN FORCES!

MicroPro Design is now able to offer the Commodore microcomputer systems at prices you can afford! We specialise in the design and manufacture of custom microcomputer equipment and have turned our efforts to the CBM and PET.

Besides having the full range of standard Commodore products available, we can offer interfaces to allow virtually any piece of equipment to be connected to the CBM through the IEEE 488 bus.

You can now also use our MicroCon general purpose microcomputer as a slave to the CBM. This allows you to connect A/D, D/A converters, digital inputs and digital outputs for industrial control, monitoring and data acquisition. Programs for the MicroCon can be created in the CBM and loaded down the IEEE 488 bus into the MicroCon for execution.

A few of the current devices now available for use with CBM and PET:

One PROM programmer for CBM user port	\$650
Barcode reader large quantity discounts	\$750
IEEE488 RS232 interface	\$320
IEEE488 Centronics interface	\$250
IEEE488 Microcon interface	\$150
Diablo daisy wheel printer	\$3200
Diablo WP printer (with interface)	\$3700
SPECIAL: CBM 4016 NOW	\$1025

**Above prices include all cables and connectors where applicable but do not include sales tax. (Dealer enquiries invited.)**

**Write or call for prices on all the Commodore equipment.**



**MicroPro Design  
Pty. Ltd.**

PO BOX 153, NORTH SYDNEY, NEW SOUTH WALES, 2060, AUSTRALIA.  
SUITE 205, WENTWORTH HOUSE,  
6-8 CLARKE ST., CROWS NEST,  
NSW, 2065. PHONE: (02) 438 1220.

## APPLE AND NORTHSTAR MICROCOMPUTER BUYERS APPLE AND NORTHSTAR MICROCOMPUTER OWNERS

### IMPORTANT NOTICE

It is now not necessary to trade off getting the expert pre-sales advice and after-sales service and back-up that Computer Country has long been famous for in order to get low prices. Computer Country because of its large volume and keen sourcing ability is now probably able to match or beat any quote you may get elsewhere on a large range of Apple and Northstar products, printers, books and software.

It should be noted that Computer Country is Victoria's oldest existing Apple dealer and is an Apple factory authorised service centre.

**MAKE A SMART MOVE**

## COME TO COMPUTER COUNTRY

338 Queen Street,  
MELBOURNE, VIC 3000  
(03) 329-7533

*\*Call or write now to get on our free mailing list to be notified of future special sales and to get free invitations to our upcoming microcomputer seminars.*

## AMUSEMENT MACHINES

WE'RE THE COIN MACHINE INDUSTRY'S SERVICE CENTRE!



FAST ELECTRONIC CIRCUIT BOARD REPAIRS AND REPROGRAMMING.

**SAME DAY SERVICE** SEND YOUR BOARDS FROM ANYWHERE IN AUST/NZ/PNG.

**FOR SALE** ELECTRONIC PINBALLS FROM \$299; VIDEO TABLES FROM \$800; NEW VIDEO TABLES FROM \$2200; HOME PINBALLS FROM \$159.

## AUTOMATIC RECREATION MACHINE CO PTY LTD

PHONE, WRITE OR CALL FOR COMPREHENSIVE PRICE LIST



31 WATLAND ST,  
SPRINGWOOD, QLD

PHONE (07) 208 8333. TELEX 44658



Tel: 375 2144.



### BASF DISKETTES

5 1/4" Soft Sect. \$4.00 + S.T.  
8" Single Density \$4.00 + S.T.

### SILICON VALLEY

#### COMPONENTS

4116 RAMS \$2.00\* 2114 RAMS \$2.30\* 2708 EPROM \$6.00\*  
TMS 2716 16K BIT EPROM \$6.00\*

**LNW TRS-80 System 80 Expansion Interface Boards, 32K Memory Boards, 32K Memory — \$515**

\*plus sales tax **BASF** 40 Track Single Sided Drives \$370\*  
Double Sided Drives \$390\*

284 Union Road, Moonee Ponds, Vic, 3039.



## Microcomputer News & Products

16-bit microprocessor, the Intel 8088, rather than the 8-bit processors used by other small machines. The 8088 is actually a compromise, using 16-bit words internally but communicating with the outside world with 8-bit words. This means that it has higher performance than any 8-bit processor, but is not quite as fast as a true 16-bit device. With clock speeds of up to 10MHz however, it is not likely that any user will notice the difference.

The computer system consists of a separate keyboard unit and a processor module connected by a flexible cord. Two slots for optional disk drives are incorporated in the main module, which also contains 40K of Read Only Memory and from 16K to 256K of RAM for user programs. A 30cm monochrome video monitor is also offered, able to display 25 lines of 80 characters.

An 80 character per second dot matrix printer is available. The basic computer uses a cassette system for storage, with a more elaborate system with its own video monitor and a single disk drive costing around \$3000. For business applications a system with two disk drives and its own printer is available for about \$4500 (all prices are in US dollars, and are preliminary estimates only).

By offering an expandable system, IBM plans to have the right computer for every user. "This is the computer for just about everyone who has ever wanted a personal computer at the office, on the university campus or at home", says Mr C. B. Rogers Jr, of IBM's General Business Group.

Software for the new system looks like being no problem. Already available are programs for word processing ("Easywriter" - specially designed for authors), accounting and games including the "Adventure" series by Microsoft.

Digital Research has been contracted to develop a version of its CP/M86 operating system for the computer, and SofTeck Micro will provide its UCSD-p (Pascal) system. When these become available thousands of programs written under the two systems will be available for use on the IBM machine.

In the US, IBM has adopted a new marketing strategy for their personal computer. The company has set up its own sales unit for the machine, which will also be available through retail chains such as Computerland and possibly IBM's own computer retail computer stores.

Deliveries in the United States are expected to begin this month. No plans have been announced for sales elsewhere as yet.

## Business computer system from Ritronics



Ritronics Wholesale has just released a new computer system designed for professional and business use. The computer is supplied with a CP/M disk operating system and is capable of running Mbasic, Fortran, Cobol, Pascal, Cbasic2 and software including Wordstar, Spellguard and Z80 Assembler.

Supplied with the system are two 20cm double-sided disk drives which provide a total storage of 1.02 megabytes of formatted data. Single-sided disks can also

be read by the drives, eliminating a possible source of incompatibility.

Several configurations of the system are possible. It can be supplied with a separate keyboard and video monitor, a fully enclosed keyboard/monitor or with a serial terminal. Both serial and Centronics standard parallel printer interfaces are available.

For more information contact Ritronics Wholesale, 425 High St, Northcote, Vic 3070.

## IMS expands, exports software

Integrity Management Services Pty Ltd has announced further expansion and reorganisation of its operation. Part of the expansion is within Australia, and offices have also been opened in the United States.

On the local scene, the company has established IMS Computer Systems Pty Ltd to continue the development, marketing and support of its microcomputer software products. The support facility has been expanded to cope with the expanding sales of both CP/M software and packages specially developed for the Commodore and Tandy computer systems. Products supported include a totally integrated business system, designated Version 3.0 which

provides for word processing, accounting and data processing.

A division of the company has also been formed locally to co-ordinate the overseas activities of the group. An office has already been established in Los Angeles to market a range of microcomputer software.

Managing Director Mr Brian Gardiner says "the West Coast Computer Faire confirmed to us that our Version 3.0 software is superior and offers more flexibility than any product on offer. Results of demonstrations to prospective purchasers re-inforced that view."

IMS Computer Services Pty Ltd is at 582 St Kilda Rd, Melbourne, 3004.

## Travel maps by computer

Drivers of the future may be able to pull into a service station and ask a computerised mapping system for print-outs of maps of the area they are travelling through. According to a report in the "New York Times" maps available could include a conventional road map updated to show the location of repair work in progress, a map of historical sites on the route, a map showing the types of plants and animals in the area and a map of property values if they are considering a holiday house.

Rather than being a science fiction scenario, such a system is quite feasible at present. Map-makers are already making wide use of computers, and the equipment and software is available now

to translate any kind of geographical, environmental, economic, social or historical data into information that a computer can store and retrieve in the form of a map.

Programs are available which allow computers to rearrange and combine the stored information in any way on request, to supply views of the countryside, geological cross-sections or population distribution. Increasingly, map-makers are becoming manipulators of information, not just recorders. The flexibility added by the use of computer techniques could bring advances in cartography as significant in their own way as the efforts of the early navigators.

*More micronews p129*

**sinclair** : you're the  
*greatest, now  
 better than  
 ever.*

**ZX81**



*Personal  
 computer,*

**\$250**

Incl. sales tax,  
 pack/post.

**COMPLETE WITH  
 MAINS ADAPTOR,  
 LEADS & BASIC MANUAL**

**ORDER FORM — SINCLAIR EQUIPMENT (AUSTRALASIA) P/L**  
 86-88 Nicholson Street, Abbotsford, Victoria, 3067. Telephone: 419 3033.

QUANTITY	ITEM	ITEM PRICE	TOTAL
	Ready assembled ZX81 Sinclair Personal Computer including mains adaptor, leads, BASIC manual	\$250	
	16K-BYTE RAM pack	\$150	
	8K-ROM (Only required for ZX80)	\$ 75	
	ZX Printer (to be announced)		

Total \_\_\_\_\_

Enclose cheque/Bankcard/Diners/Amex

Name \_\_\_\_\_

Address \_\_\_\_\_ Postcode \_\_\_\_\_

Signature \_\_\_\_\_

EA



**NEW  
 BASIC  
 MANUAL SINCLAIR ZX81**

Every ZX81 comes with a comprehensive, specially written manual — a complete course in BASIC programming, from first principles to complex programs.

**For your free catalogue on software, send stamped, self-addressed envelope to Sinclair Equipment (Australasia) P/L.**

**Reach advanced computer comprehension in  
a few short hours with the new, mighty**

# **Sinclair ZX81**

1980 saw a genuine breakthrough — the Sinclair ZX80, world's first complete personal computer for \$300, the ZX80 offered a specification unchallenged at the price.

Over 50,000 were sold, and the ZX80 won virtually universal praise from computer professionals.

Now the Sinclair lead is increased: for just \$250, the new Sinclair ZX81 means an even bigger saving. At \$250 it costs less than the ZX80.

## **Lower price; High capability**

With the ZX81, it's just as simple to teach yourself computing, but the ZX81 packs even greater working capability than the ZX80.

It uses the same microprocessor, but incorporates a new, more powerful 8K BASIC ROM — the 'trained intelligence' of the computer. This chip works in decimals, handles logs and trig, allows you to plot graphs, and builds up animated displays.

And the ZX81 incorporates other operation refinements — the facility to load and save named programs on cassette, for example, or to select a program off a cassette through the keyboard.

## **Higher specification, lower price — how's it done?**

Quite simply, by design. The ZX80 reduced the chips in a working computer from 40 or so, to 21. The ZX81 reduces the 21 to 4!

The secret lies in a totally new master chip. Designed by Sinclair and custom-built in Britain, this unique chip replaces 18 chips from the ZX80!

The ZX81 comes complete with all leads to connect to your TV (colour or black and white) and cassette recorder.

## **New, improved specification**

- Z80 a microprocessor — new faster version of the famous Z80 chip, widely recognised as the best ever made.
- Unique 'one-touch' key word entry: the ZX81 eliminates a great deal of tiresome typing. Key words (RUN, LIST, PRINT, etc.) have their own single-key entry.
- Unique syntax-check and report codes identify programming errors immediately.
- Full range of mathematical and scientific functions accurate to eight decimal places.
- Graph-drawing and animated-display facilities.
- Multi-dimensional string and numerical arrays.
- Up to 26 FOR/NEXT loops.
- Randomise function — useful for games as well as serious applications.
- Cassette LOAD and SAVE with named programs.
- 1K-byte RAM expandable to 16K bytes with Sinclair RAM pack.
- Able to drive the new Sinclair printer (not available yet — but coming soon)!
- Advanced 4-chip design, microprocessor, ROM, RAM, plus master chip — unique, custom-built chip replacing 18 ZX80 chips.

## **If you own a Sinclair ZX80 . . .**

The new 8K BASIC ROM used in the Sinclair ZX81 is available to ZX80 owners as a drop-in replacement chip. (Complete with new keyboard template and operating manual.)

With the exception of animated graphics, all the advanced features of the ZX81 are now available on your ZX80 — including the ability to drive the Sinclair ZX Printer.

## **16K-byte RAM pack for massive add-on memory**

Designed as a complete module to fit your Sinclair ZX80 or ZX81, the RAM pack simply plugs into the existing expansion port at the rear of the computer to multiply your data/program storage by 16!

Use it for long and complex programs or as a personal database. Yet it costs as little as half the price of competitive additional memory.

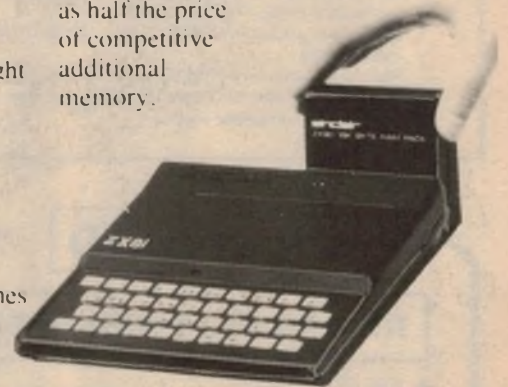

## **Coming soon — the ZX Printer**

Designed exclusively for use with the ZX81 (and ZX80 with 8K BASIC ROM), the printer offers full alpha-numerics across 32 columns, and highly sophisticated graphics. Special features include COPY, which prints out exactly what is on the whole TV screen without the need for further instructions. The ZX Printer will be available in Summer 1981.



**For your free catalogue on software, send stamped, self-addressed envelope to Sinclair Equipment (Australasia) P/L.**

**Direct  
Computer  
Sales**



MAIL ORDER  
TO  
AUSTRALIA

32 Lloyd Avenue, Cremorne,  
Sydney 2090.  
(02) 908-2235. Tlx AA20149

**BUSINESS HOURS:** Our office is open between 9 and 5 weekdays and also 7 to 10pm Monday through Thursday so that our Australia wide clients can use STD when it's cheap (after 9pm save 60 percent on your call).

**SERVICE:** We provide full service equal to any in the business, on all our lines. We support fully the manufacturer's warranty and provide complete after warranty service.

**PAYMENTS:**

- 1 Bank cheque
- 2 Local Letter of Credit — ask your bank
- 3 Personal cheque — allow time to clear
- 4 For organizations who must receive delivery before payment we are strictly 7 days with a surcharge of 3 percent of the total invoice value applying for 30 days.

A receipt will be issued immediately for all monies received. If you desire the protection of a written contract between us we can issue you with a Proforma invoice (or quote).

**DELIVERY:** (door to door)

- 1 Customer pick-up (arrangement) from our premises
  - 2 To capital cities — everything except big printers, colour monitors and peripheral cards — \$15.00 each article.  
To all other places — NSW \$15; Vic, Qld, SA, Tas \$20; WA, NT \$25; each article.
  - 3 Peripheral cards — \$4.00 each by certified mail
- These prices include full insurance and also apply each way for goods returned for post warranty service.

# APPLE DISCOUNTED

and now

## MOUNTAIN COMPUTER'S MULTIFUNCTION CARD

The famous M.H. Clock is now combined with a serial and parallel interface

**FOR \$287** (introductory price)

We have stocks and can send you its full specs. The same goes for Epson's new 15" printer, the MX-100 which sets new standards in price and performance.

For all our other lines which include the full Apple product line of CCS, Mountain Computer, Microsoft and of course Apple; the Seikosa, Anadex, the two Paper Tigers and the Sanders printers and many of the little things you need

- we are rarely out of stock of hardware items.
- we offer free freight on warranty repairs.
- can mail you full specifications on all our lines.
- and offer most of the best prices — here's some:

16k Apple II Plus	\$1220	Disk + Controller	\$630
16k Apple II Plus + 32k	\$1340	Disk add-on	\$476
Pascal Language System	\$433	Graphics Tablet	\$744
CCS Serial Interface	\$180	Pal Colour Card	\$198
CCS Printer Interface	\$176	M.H. A/D-D/A	\$399
Dick Smith's Daisy Wheel	\$1695	(\$1874 tax paid)	

Prices quoted are tax free. For tax paid prices add 17 1/2%  
Prices subject to change and exclude delivery charges

Our software and hardware catalogues have our complete range and prices and contain helpful information on the products listed — it's free and available on request

**PLEDGE.** Any order that cannot be supplied ex-stock we will specify a despatch date on our receipt. Failure to despatch by this date will require us to immediately issue a full refund, unless otherwise instructed by the customer.

**AED**

+

**VB3**

=

**INCOMPARABLE  
COMPUTING**

### THE SSM VB3 SUPERVIDEO CARD

- IEEE S100 design.
- Memory mapped, yet doesn't consume any real memory.
- Superfast operation.
- 80 character x 24 line display, expandable to 132 characters wide or 48 lines long.
- Halftone, reverse video, underline, strike-thru, flashing characters.
- Chunky graphics (160 x 96 resolution), fine line graphics.
- 256 character ROM Programmable Character Generator in addition to the standard character set.
- Special support software available from AED.

See review "Your Computer" #3!

### The AED Un-Serial Terminal

- VB3 video driven.
- Green phosphor 12" 18MHz bandwidth display.
- 103 key hall effect keyboard with numeric pad, user legible and edit function legended keys.
- Single unit design, or separate video monitor and keyboard in three different styles.
- Intelligent keyboard and driver options for CP/M based microcomputers.

**Most of these features are not available from any other Turnkey manufacturer in Australia. Some are not available anywhere else on earth!** Open 9am to 6pm Mon-Sat \* Prices and specifications subject to change without notice

### SUPERAED

Featuring:

- **MONAED MONITOR**  
Wow! A primary level monitor that can be switched in and out directly with a single keystroke. You can use the monitor even whilst deep inside a business program under CP/M. I repeat. Wow! Other people could have done it, but they didn't. We did, and are very proud of it.
- **PRINTER SELECTION**  
Up to 8 CP/M list devices can be selected from keyboard or software.
- **SPEED SELECTION**  
Because this terminal is so bl\*\*y fast, display speed control is provided at your finger tips and from within software.

Plus ...

- AUTOMATIC BACKGROUND MEMORY TESTING.
- KEYBOARD LOCKOUT WITH PASSWORD RE-ENTRY.
- AUTOMATIC MEMORY CORRUPTION CHECKSUM MONITORING.

Plus...

Many other features too numerous to list and too fantastic to imagine!

Send for the Real Thing, or at least a Manual!



**MICROCOMPUTER  
PRODUCTS**

130 Military Road, Guildford, NSW 2161.  
Phone (02) 681 4966 (3 lines). Telex AA70664.



# In the world of personal computers there is just one that is known as the best: the PET

**NOW  
16K RAM  
AT 8K PRICE  
\$999**

The Commodore PET has become the standard for the Personal Computer Industry.

The Pet is completely integrated, with the processor, memory, keyboard and visual display unit contained within a robust housing, allowing easy transportation with no interconnecting cables necessary. In order to retrieve and save your data and programs, a storage device is used which operates like a cassette recorder, with your information recorded reliably on standard cassettes. The PET has 16k bytes of RAM. Optional equipment permits expansion to 32k. Also, it has 14k bytes of ROM.

The Pet communicates in BASIC—the easiest computer language. Easy to learn and easy to use, BASIC has now become the standard for personal computers, with literally thousands of programmes available. The PET is also programmable in machine language, allowing more efficient use of the system.

The full-size keyboard is capable of producing letters, numbers and graphic symbols. Upper and lower case is standard. Characters appear

on the screen in a pleasant green colour designed to reduce eye fatigue and may be displayed in normal or reverse print.

PET's IEEE-488 Bus—just like H.P.'s mini and full size computers—permits direct connection to over 200 pieces of compatible equipment such as counters, timers, spectrum analysers, digital voltmeters and printer plotters from H.P., Philips, Fluke, Tectronix and others.

The full range of Commodore Disk Drives and Printers are plug-compatible with the PET and a comprehensive range of cassette and disk based programmes are available through the extensive network of Commodore Dealers.

#### APPLICATIONS

The Commodore PET is a creature of many faces. Its applications are limited only by the user's imagination.

The future of the PET is virtually unlimited; its present capabilities are already many and impressive. As a personal computer, the PET can teach languages and mathematics; play games; create graphic designs; store meal recipes and change

number of portions; maintain budgets, personal records and checkbooks; operate appliances and temperature controls.

As a management tool, it delivers the information the executive needs, in the form he can use, and available to him alone. Trend analyses charts and graphs can be almost instantly available.

The professional may use the PET for maintaining appointment schedules, recording income and expenditures and filing all the specialized information and forms he may need to make his work more efficient—from medical records for a doctor to income tax computations for an accountant.

The engineer, mathematician, physicist, has a tool far superior to the very best programmable calculators yet developed... at a cost that is comparable... and with almost infinitely greater versatility.

And the businessman has a computer that can maintain inventories, keep payroll records, operate accounts payable and receivables, issue cheques and handle correspondence.

#### Commodore PET 1016 Computer Technical Specifications.

##### Computer/Memory

Read/Write Memory (RAM) 16K bytes available to the user.

Read Only Memory (ROM) 14K bytes in total, divided into:

8K BASIC interpreter available immediately you turn on your PET.  
5K Operating System  
1K Test Routine

The 6502 micro-processor chip makes the PET one of the fastest and most flexible BASIC systems. Significant features of Commodore BASIC are:

- 960 simple variables
- 960 integers
- 960 string variables
- 960 multi-dimensional array fields for the above 3 types of variables
- Up to 80 characters per program line with several statements per line
- Upper/Lower case characters and graphics capability
- Built in clock
- 9-digit floating point binary arithmetic
- True random number generator
- Supports multiple languages, machine language accessibility

##### Keyboard

74-Key professional keyboard.  
Separate calculator/numeric pad.

Upper-case alphabetical characters with shift key to give 64 graphics characters.  
Can be set for lower case and shifted upper case characters.

##### Screen

40 characters wide by 25 lines (1000 characters in 8 × 8 dot matrix).

23 cm screen phosphor screen.

Brightness control.

64 ASCII plus 64 graphics characters.

Blinking cursor with full cursor control, including programmable control.

##### Screen editing capabilities

Full cursor control (up, down, left, right).

Character insert and delete.

Reverse character field.

Overstriking.

Return key sends the entire line to the CPU, regardless of cursor position.

##### Input/Output

8 bit parallel input/output port.

IEEE-488 Bus (HP-IB and IEC Bus) allows up to 12 other peripherals to be connected.

Two cassette ports.

Video signals for additional displays.

Serial output port.

##### Technical Data

Dimensions Height 355 mm (14"), Width 419 mm (16.5"), Depth 185 mm (18.5").

Shipping Weight 20.9 kg (46 lbs).

Power requirements 240V ± 10% Frequency 50 Hz. Power 100 Watts.

#### Commodore BASIC

APPEND	GOSUB	RETURN	STOP	SPC
BACKUP	IF	THEN	SYS	LEFT\$
CLOSE	INPUT		VERIFY	RIGHT\$
CLR	INPUT *		WAIT	MID\$
CMD	LET			CHR\$
COLLECT	LIST		SGN	ASC
CONCAT	LOAD		INT	LEN
CONT	NEW		ABS	VAL
COPY	ON	GOSUB	SQR	STR\$
DATA	OPEN		SIN	TI
	POKE		COS	TI\$
DEF/FN	PRWT		TAN	ST
DIM	READ		ATN	DS
DIRECTORY	RECORD		LOG	DS\$
DLOAD	REM		EXP	+
DO/PEN	RENAME		AND	-
DSAVE	RESTORE		OR	*
END	RUN		NOT	/
FOR/NEXT	SAVE		TAB	↑
GET	SCRATCH		POS	π

# Commodore

## microcomputers

For details of your local dealer send to: Commodore Information Centre, Box 336, Artarmon, NSW 2064, Australia. Phone (02) 437 6296

# THE MOST POWERFUL MICROCOMPUTER



**SORCERER NOW HAS 32K RAM AT NO EXTRA COST!**

Yes! With every 16K Sorcerer computer, we now include at no extra charge, an additional 16K of RAM! Here's your chance to buy the superb Sorcerer, and save money at the same time.

## Plus these other winning features:

- Built-in serial and parallel ports — standard!
- 2 cassette control ports — both with motor control!
- Unbelievable graphics capabilities.
- Expandable to 48K on board.
- Uniquely versatile ROMPACS™ — instant change to dedicated processor, and back again!
- Built-in 4K ROM resident monitor.
- Economic disk storage now available (optional) with Exidy's new FDS — floppy disk subsystem (does not need expansion interface).

**All this for only \$1395**

including 32K memory and standard BASIC ROMPAC

Cat. X-3002

## ROMPACS™ Give the Sorcerer its incredible versatility

One moment it's a word processor. Then it's a production controller. Or a standard computer running a program. All you do is plug in the Rompac™. The Sorcerer does the rest!



### Word Processor Pac™

Not only more powerful than most other systems it's far cheaper! It features auto text wrap-around, auto checking of drastic commands, a search function, auto commands & macro programming etc. etc. (X-3085)

**\$279<sup>50</sup>**

### EPROM PAC™

Designed for users who want to use the Sorcerer for a dedicated job & can program their own EPROMs to do it. Up to 16K of ROM available. (X-3095)

**\$75<sup>00</sup>**

### Development Pac™

A powerful dedicated development tool. Contains a debug, text editor, linking loader, assembler & I/O routines. Complete with 90p manual. (X-3090)

**\$139<sup>50</sup>**

### Standard BASIC

(Supplied with Sorcerer computer in basic price - not available as a separate item)

## UTILITY SOFTWARE ON CASSETTE

### Z-80 DISASSEMBLER \$17<sup>98</sup>

This program disassembles Z-80 machine language programs & it translates them back into easier to follow assembly language. It is a BASIC program, but may be used to examine any machine language program in the Sorcerer's memory. X-3622

### DEBUG \$17<sup>98</sup>

Designed to make it much easier to troubleshoot Sorcerer machine language programs. Lets you run programs one instruction at a time, examine contents of processor registers & insert breakpoints into the program wherever needed. X-3624

### DUMB TERMINAL \$9<sup>98</sup>

Allows your Sorcerer to act as a 'dumb' communications terminal for communication with a larger computer or with other terminals via the RS-232C serial port. Allows both duplex & half duplex operation.

## SORCERER GAMES SOFTWARE ON CASSETTE

### Tank Trap



An enemy tank is on the rampage. Your job is to build a wall around it without getting run over. Fascinating! X-3625

**\$14<sup>98</sup>**

### Martian Invaders

Very similar to 'Space Invaders'. A very challenging game, requiring skill & a fast mind. X-3626

**\$17<sup>98</sup>**

### \* Voodoo Castle

An action packed adventure in the Voodoo castle. Hours of fun! But beware of the Voodoo Man. X-3636

**NEW LOW PRICE**

**\$6<sup>88</sup>**

### \* Wildemess

Here you trudge through the uncharted wilderness fighting foul monsters of many types. Great fun! X-3639

**\$12<sup>50</sup>**

### \* The Count

One of the most challenging games ever written! You awaken in a bed in Transylvania. You don't know why you're there but you'd better solve the puzzle before it's too late! X-3638

**\$12<sup>50</sup>**

### Magic Maze

Ten levels of play. You wander through a maze trying to stay on the right path and avoid pitfalls. Fantastic! X-3620

**\$14<sup>98</sup>**

## DISK UTILITIES FOR FDS & MICROPOLIS

### EXIDY CP/M with EXBASIC \$445

Identical with Exidy CP/M. EX-BASIC is an extended disk version of Microsoft™ BASIC 80. Complete with comprehensive documentation. X-3710

### DSKCITOH/PPRINT \$99

Disk driver & proportional printing driver for the Sorcerer Word Processor. Check these features: ability to save & load word processor files on disk, perform proportional spaced & bold faced printing. X-3725

### MICROSOFT EXT. DISK BASIC FOR FDS \$350

The most extensive version of BASIC available for Z-80 based computers. Features full line editing, all normal disk facilities & commands, & much more! X-3712

# DICK SMITH Electronics



Mail Order Centre: PO Box 321, North Ryde 2113. Phone (02) 888 3200

NSW	145 Parramatta Rd	AUBURN	648 0558	QLD	186 Logan Rd	BURANDA	391 6233
	613 Princes Hwy	BLAKEHURST	546 7744		842 Gympie Rd	CHEERSIDE	59 6255
	018 George St	BROADWAY	211 3777	SA	60 Wright St	ADELAIDE	212 1962
	531 Pittwater Rd	BROOKVALE	93 0441	VIC	399 Lansdale St	MELBOURNE	67 9834
	147 Hume Hwy	CHULLORA	642 8922		260 Sydney Rd	COBURG	383 4455
	162 Pacific Hwy	GORE HILL	439 5311		658 Bridge Rd	RICHMOND	428 1614
	396 Lane Cove Rd	NORTH RYDE	888 3200		Cnr Dandenong & Springvale Rds	SPRINGVALE	547 0522
	30 Grose St	PARRAMATTA	683 1133	WA	Cnr Wharf St & Albany Hwy	CANNINGTON	451 8666
	125 York St	SYDNEY	290 3377		414 William St	PERTH	328 6944
	173 Maitland Rd	TIGHE HILL	81 1898				
	283 Kaira St	WOLLONGONG	28 3800				
ACT	96 Gladstone St	FYSHWICK	80 4944				

## Microcomputer News & Products

### Video from AED — the "Un-serial" terminal

AED Microcomputer Products has announced a comprehensive software support package for the powerful SSM VB3 video card which they market. The package has been developed over a period of 18 months at a cost of \$50,000. Software provided includes a powerful video driver, a Monitor program and extensions to the CP/M disk operating system, and is designated "SUPERAED".

Also available from AED is a software-hardware combination based on the VB3 video board which AED are calling the "Un-Serial" terminal. The terminal uses a VB3 video board, a high bandwidth green screen video monitor and a Hall effect keyboard, and is available in a choice of three case styles. It provides more local processing power than normal "intelligent" serial terminals, and also allows simulation of standard terminals.

More information is available from AED Microcomputer Products, 130 Military Rd, Guildford, NSW, 2161.

### Column 80 . . . from p118

modem which "answers" the call is set to the matching "opposite" configuration. The actual frequencies used depend upon the data rate at which the information is to be transmitted, but for typical communication at 300 baud, the modem set in "originate" mode transmits at 980Hz and 1180Hz for "1" and "0" respectively and receives at 1650Hz and 1850Hz. The modem at the other end must be set to "answer" mode, which is for reception at 980/1180Hz and transmission at 1650/1850Hz.

Finally, a word about modems themselves. There are two different types: the direct type and the acoustic-coupled type. As the names suggest, the first type connects directly to the telephone line, in place of a standard telephone, whereas the other type couples in acoustically via the microphone and earphone of the telephone handset itself. The direct type of modem tends to be capable of rather higher performance and reliability, but because it has to meet a number of quite stringent requirements concerning safety isolation, etc, it tends to be more expensive.

Because of this most communication between small computers is currently done via acoustic modems, like the one pictured. This is a high quality unit of Australian design and manufacture, which is sold by DSE (Cat No. X-3270) for \$399. Similar units are available from other firms.

## News from the Clubs

- The Macarthur Computer Users Association of Campbelltown, NSW is open to everyone interested in computing on any scale. The club meets on the first Monday of each month, and interested readers should contact the President, Mr C. Wylie, 85 O'Sullivan Rd, Leumeah, NSW, 2560, telephone (046) 26 1625.

- Users of the Texas Instruments TI-99/4 computer are reminded of the Users' Group formed recently in Sydney. Branches have also started in Perth and Ipswich, Queensland, and a group will soon be commencing in Melbourne. In Canberra, Shane Andersen, the group co-ordinator demonstrates the TI computer at Nock & Kirbys Canberra TV Store every Saturday. A free club software cassette is available for the asking.

For more information contact the Group at PO Box 101, Kings Cross, NSW, 2011.

- Wollongong Computer Club is offering members a unique opportunity to learn about computers by building their own. The planned computer offers a colour video display and built-in cassette interface, and is estimated to cost \$110. A course of instruction will be provided by the club, beginning with the use of a soldering iron and moving on to the construction of a full computer and programming.

For more information write to Paul Jason, PO Box 397, Dapto, NSW 2530, or phone 61 5451.

- The NSW 6800 Users Group can be contacted by writing to 27 Georgina Avenue, Keiraville, NSW, 2500.

- Also at Keiraville is the Australasia ZX80/MicroAce Users Group. The address is 87 Murphys Avenue, Keiraville, NSW, 2500.

- Tamworth Basic Users Group would like to hear from users of TRS-80, Sorcerer, Ohio Scientific and System-80 computers. The group is mainly concerned with programming and systems design from hobbyist to business levels. Contact the Secretary, P. Purcell, C/o 18 Inala Crescent, Tamworth, NSW, 2340.

- The South Australian Microprocessor Group has sent us a copy of their Newsletter for August/September which, among other things, contains circuit diagrams and a complete description of an 8085-based video display controller. The Group meets monthly, and the address to contact is PO Box 113, Plympton, SA, 5038.

- The Microcomputer Journal of the Microprocessor Special Interest Group (MICSIG) of the Australian Computer Society (Canberra Branch) is always well produced and contains a wealth of interesting information. Topics covered recently include use of a computer as a communications terminal, music synthesis on the Z80 and CSIRONET, the Australian-wide computing network operated by the CSIRO.

The Group can be contacted by writing to PO Box 446, Canberra City, ACT, 2601.

## Gold Coast computers

Gold Coast City Council has announced plans for the installation of microcomputers in public libraries. The Council has budgeted between \$16000 and \$20000 for the supply of four computers and appropriate software to council libraries in Burleigh Heads, Southport, Coolangatta and Palm Beach. Release of the tenders was described as "Phase 1" of a long term plan to increase awareness of the uses of microcomputers in everyday life.

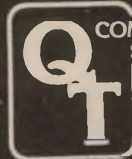

COMPUTER SYSTEMS (AUST.)

# DISK DRIVES SPECIALIST!!

283 Clarence Street  
Sydney NSW 2000  
Telephone 29 2402 - 922 1709  
Associated with QT Inc - USA

### TRS-80 OR SYSTEM 80 EXPANSION

The LNW SYSTEM expansion board features 32K bytes memory - Floppy disk interface - Parallel printer - Serial I/O - Dual cassette interface - Screen printer bus - Power supply on board - Full user documentation - A FRACTION OF THE TRS-80 OR SYSTEM 80 EXPANSION INTERFACE

LNW EXPANSION INTERFACE B/B \$95.00  
Double density disk storage conversion for TRS-80 or SYSTEM 80 includes PERCOM DOS 3.2D software LNDoubler + DOS 3.2D \$205.00

### DISKETTES BOX (10)

5 1/4" sgl sided, sgl density \$40.00  
5 1/4" dbl sided, dbl density \$55.00  
8" sgl sided, sgl density \$45.00  
8" dbl sided, dbl density \$65.00

PRICES DO NOT INCLUDE SALES TAX OR DELIVERY AND ARE SUBJECT TO CHANGE WITHOUT NOTICE

### DISK DRIVES

Y-E DATA — dbl sided, dbl density (851R) compatible \$625.00  
SHUGART sgl sided, dbl density SA 800 (refurbished) \$395.00  
TEAC 5 1/4" sgl sided, dbl density FD-50E 80 tracks \$405.00  
FD-50A 40 tracks \$275.00 FD50C 77 tracks \$405.00

### DISK DRIVES CABINETS

Dual Mini Drive Cabinet with P/S \$156.00  
Single Mini Drive Cabinet with P/S \$99.00  
Dual 8" Drive Cabinet with P/S \$260.00  
Single 8" Drive Cabinet with P/S \$180.00

bankcard welcome here



## INFORMATION CENTRE

**MOSFET AMPLIFIER:** I received a kit of the Mosfet Amplifier recently and have nearly completed the chassis assembly with the PF4361/1 transformer.

A few comments:

1. The 2.0 metres of figure-8 shielded cable is not enough. Even by running the cable straight across close to the chassis I did not have quite enough for the final phono run. I stuck the runs by contact adhesive to the surface of the chassis.

2. I can only place 4 1k $\Omega$  trimpots — six shown on the parts list.

3. The over the PCB shielded connections from pins 1, 2, 3 to 34, 35, 36 and 37 provide multiple earth paths. I suggest that the screens be attached to pins 34 and 36 only and the sides of the balance potentiometer to pin 2.

4. The 200mm-long heatsink was undrilled so while thinking about the best way to match drill it occurred to me that vertical ribbing of the heat sink would be more appropriate — but instead of cutting the heatsink and drilling for vertical fins I would have put it in as planned.

Referring to Mr Whitehouse's letter in your June issue, is there any simple way to select quiet transistors with millivoltmeter and scope? (E.A.B., Mosman Park, WA.)

● Thank you for bringing these errors in the parts list to our attention. While we agree that the shielded cable is earthed more than necessary, there is little to be gained by deleting some connections.

Unfortunately there is no simple way to select low noise transistors. A test amplifier circuit could be built up and the output monitored while different transistors are tried in it, but this would probably not be considered a simple approach.

**REGULATED POWER SUPPLY:** I have recently developed a keen interest in Electronics and received a copy of the handbook "Projects & Circuits No 2" from a friend in order to construct the Regulated Power Supply described on pages 58 to 61.

The parts list includes a 1mA meter which can be switched to show either voltage or current readings. After building the unit exactly as described in the article I am unable to obtain full scale deflection on the meter at 30V and cannot get any movement at all on the meter when set in the current mode.

Obviously, I am using a 1mA meter with an internal resistance which is not suitable for the circuit but, after repeated attempts with different multiplier and

shunt resistors, we have failed to obtain a satisfactory reading in either the voltage or the current mode.

I feel sure that the only way to overcome this problem is to replace the meter with identical specifications to the one used in your prototype and ask if you would be kind enough to forward full details of the meter used.

Would it not help your readers, especially beginners like myself, to include information regarding internal meter resistance in your articles and projects — and why is it that the manufacturers do not stamp their meters with this critically important detail? (S.D.G., Wellington, NZ.)

● It is possible that the transformer is developing insufficient voltage to allow the circuit to deliver 30 volts. It may only deliver 28 or 29 volts when set to maximum output. This is not a fault as such. You can confirm whether this is the case by measuring the input and output voltages with a multimeter of known accuracy. The minimum voltage drop across the LM317K regulator for it to continue operating as a regulator, rather than just as a series pass transistor, is about two volts.

As for your zero reading when the meter is switched to current, this is normal. No current flows until you connect a load. Have you done so? Remember that to achieve a halfscale reading on the current range (ie, one amp) you will have to connect a low value resistor. For example, at a voltage setting of 15 volts you will require a 15 $\Omega$  load.

As far as the meter movement is concerned, it is not critical. Just about all meter movements are designed to give a voltage drop across them, when at full scale, of 100 millivolts. For a 1mA movement, this corresponds to an internal resistance of 100 $\Omega$ . The only time when this is important is where the voltage drop across the meter interferes with the measurement of current, ie, introduces inaccuracies. This is often referred to as the "burden voltage".

**AMPLIFIER DAMAGE:** Is it possible to damage an amplifier by running it without the speakers connected or can it hurt to run 4 $\Omega$  speakers off one channel and 8 $\Omega$  off the other. (B. M., Ashfield, NSW).

● It was possible to damage some valve amplifiers by operating them without a load but a solid-state amplifier is unlikely to be harmed. Nor does it make any great difference (to the amplifier) if one

channel has a 4 $\Omega$  load and the other channel a load of 8 $\Omega$ , although the power delivered will differ by a factor of two.

Some small complementary-symmetry amplifiers designed in the past had the loudspeaker included in the bias network for the bias stage. In this case, disconnecting the loudspeaker would render the amplifier inoperative but no damage results.

**TRAIN CONTROLLERS:** My interest has been renewed in model railroads and having read all the back issues of EA about controllers for trains I find that you have not published any articles on AC powered systems. I know of at least two HO train systems available in Australia that use 6-17 volt AC.

I think there is a growing interest in AC after the beginners discover the shortcomings of DC track layouts etc. With the advent of solid state devices I feel that an AC controller for slow running, inertia, overload protection would be of great interest to me and other AC train enthusiasts.

Looking forward to your comments and continued good reading in EA. (A. B., Castle Hill, NSW).

● While two German manufacturers are using AC systems, with Marklin a conventional two-rail system and Fleischmann a three-rail system, we would have thought that there would be more interest in a carrier control system similar to the Hornby Zero One. Would other readers care to comment and express their interest?

**SLIDE PROJECTOR UNIT:** Many thanks for the article back in February 1977 on the construction of the linear scale ohmmeter. I only discovered this article recently and after building the instrument I wonder how I got by before in resistor identification. As I am red-green colour blind it has always been an automatic procedure to check these components before construction of a project with a normal multimeter. The annoyance of reading a non linear scale together with zeroing when changing between scales has been avoided. Thank you.

With regards to future projects there are two that may be of interest to a number of readers including myself:

(1.) A radio control system that makes use of the maximum allowable transmitting power would be of interest to many modellers and almost anyone wanting a remote control system that can operate



over a considerable distance.

(2.) A thyristor-controlled slide projector unit that allows the use of two automatic slide projectors for an audio-visual show. Currently available "fade in-fade out" units appear to be rather highly priced and beyond the means of many small groups such as schools that may already have two automatic slide projectors.

Finally, thank you for the series of articles on infrared remote control and beam relay systems. Most useful. (I. McD., East Malvern, Vic).

● We can satisfy one of your wishes next month, when we publish our Slide Projector Dissolve Unit. In the meantime, we shall keep your other suggestion in mind.

**AUSTRALIAN RADIO:** Years ago, before tariff reductions killed local manufacture of transistor radios and such, you could buy radios with all the main call signs on the dial. Instead of having to remember the station frequency, you just tuned the pointer in the middle of 2UE or 3LO (or whatever) label and the station was there. No searching back and forth between vague "10" and "12" markings as on today's oriental masterpieces. What about doing a good AM broadcast receiver with a proper dial on it? I am sure it would be a "goer". (L.D., Dee Why).

● Your letter certainly struck a responsive chord amongst some of the older staff at "Electronics Australia". We shall certainly give consideration to this project idea.

**Z-80 MICROPROCESSOR:** I was wondering whether you could send information and pin connections of the Z-80 microprocessor. I have read many data books but I can't find anything on the Z-80.

If you can't send the information could you tell me where I could get the information. (B.R., Campbelltown, NSW).

● Have a look at the circuit and accompanying description of the Super-80 in this month's issue. That should fill you in on the Z80.

**RLC BRIDGE:** I have just recently completed building an RLC Bridge which was a project listed in one of your editions of Electronics Australia. I have thoroughly gone over the circuit and wiring of the bridge and all seems to be in order, but the accuracy of the instrument is somewhat limited due to the fact that I only obtain a 40% meter movement even with the gain at maximum.

There were no details given as to what meter deflection one could expect and I'm wondering if the 40% meter deflection I am getting, even with the gain at maximum, is correct or perhaps I have a fault. The meter I am using is 400 $\mu$ A FSD. (G.M. Wonga Park, Vic.)

● The RLC Bridge was described in the March, 1978, issue. The fact that you only can obtain a 40% full scale reading on

the meter suggests that the gain of amplifier is on the low side. This could be caused by faulty transistors or incorrect resistor values, particularly in the feedback circuit.

Perhaps you should check the 10k $\Omega$  gain potentiometer to ensure that it is the correct value and also that its resistance reduces to zero at the maximum gain setting. If everything seems in order then the 470 $\Omega$  resistor in the emitter of the BC549 can be reduced to increase the gain of the circuit.

**DIGITAL CAPACITANCE METER:** I recently completed the Digital Capacitance Meter. After redoing all the shielded cable with good quality coax, the scales work reasonably well up to about .047, .47, .0047 but if testing .068, etc, the readout tends to hunt around and not remain steady. I used low tolerance capacitors to line up the meter OK. On the  $\mu$ F range the right hand display shows 1 or 0 but all other ranges are zeros. Could you suggest any likely area to check? Also how can you check electrolytic capacitors if they are over 100 $\mu$ F.

I built your SCR-PUT tester and have used it OK to detect faulty components but how can you check Triacs? Could you use the Anode lead to the A2 terminal, gate to gate and cathode lead to A1 and push KG button — appears OK that way? Keep up the good projects in the magazine as it is still the best around. (B.H., Clermont, Q.)

● Since the display of your capacitance meter tends to hunt only at the higher end of each scale, ie, where the frequency of the capacitance oscillator is quite low, we would guess that there may be some hum injection into the circuit. Note that in Notes & Errata for April, 1980, we mentioned that the circuit board should be earthed to the case to prevent interference from hum fields. It is also

possible that the multiplexed outputs of the 74C926 could be causing interference — for this reason we suggest that you route your wiring away from the display and possibly use a shield around the input terminals.

Regarding the SCR&PUT Tester (September, 1979, File 7 VT/16), you could connect up a Triac just as you have described but you would have to increase the gate trigger current to at least 50mA (typical for most Triacs at 25°C). This can be readily accomplished by reducing the 39 $\Omega$  resistor connected to the emitter of the BC559 transistor to 10 $\Omega$ . The Triac should also latch on when the KG trigger button is released. Unfortunately the minimum latching current is typically around 100mA so will also have to include an 82 $\Omega$  resistor in parallel with the 390 $\Omega$  resistor and LED.

Due to the increased current drain when testing Triacs we would suggest that you use a larger 9V battery or 9V regulated supply capable of delivering at least 150mA.

**SOUND LEVEL METER:** I wish to clarify two points with regard to the Sound Level Meter project as described in the May issue of "Electronics Australia". I purchased a kit from Dick Smith which was most satisfactory and readily assembled. I have access to a B and K type 2203 Precision Sound Level Meter which I used to calibrate the completed project and there the problems began.

In the Fast Mode, the meter would not go above 0dB. This I traced to the diodes connected to the input of IC5 going into conduction when the meter reading was just less than 0dB. Disconnection of these diodes overcame this.

In the Slow Response mode, the meter would not read greater than -7dB, irrespective of the attenuator setting or sound level. Voltage checks showed 2.3



**DEPARTMENT OF INDUSTRY & COMMERCE  
GOVERNMENT AIRCRAFT FACTORIES  
FISHERMEN'S BEND, VICTORIA**

*have several vacancies for:*

## **TECHNICAL OFFICER (ENGINEERING) Grade 1 SALARY \$13,539 - \$16,495**

Duties: Conduct electronic tests and measurements on a wide range of aircraft, guided weapons and associated support equipment. Calibrate and maintain laboratory test equipment.

Qualifications: An approved certificate from a technical college or institute of technology or its equivalent, or such other qualifications as the Public Service Board considers appropriate, together with requisite experience. Applications will be considered from persons who do not possess the above qualifications, provided they have relevant experience over a minimum period of six years. Such an applicant, if selected, will be required to pass a test to establish eligibility for the position.

Experience in the construction and testing of electronic circuitry is highly desirable.

Australian Public Service conditions include four weeks recreation leave, cumulative sick leave, long service leave, superannuation and flexible working hours totalling 36 $\frac{3}{4}$  hours per week.

To be appointed to these permanent positions, Australian citizenship or British citizenship, with permanent residence status, is required.

Applications, quoting Ref. No. VF.81/228 should be forwarded to:

**The Personnel Manager, Government Aircraft Factories,  
Private Bag No. 4 PO, PORT MELBOURNE, VIC. 3207.  
By: 30th October, 1981.**

## RESISTORS

150 ohm, 5W	20c
10 ohm, 5W	20c
12 ohm, 3W	20c
2.5 ohm, 3W	20c
33 ohm, 3W	20c
8 ohm, 10W	25c
4000 ohm, 10W	25c
220 ohm, 5W	20c
5 ohm, 5W	20c
220 ohm, 10W	25c
950 ohm, 3W	20c
115 ohm, 5W	20c
10 ohm, 5W	20c
1k ohm, 5W	20c
5000 ohm, 5W	20c
6.8k ohm, 3W	20c
3300 ohm, 10W	25c
6800 ohm, 10W	25c
1500 ohm DUAL, 21W	50c
50 ohm, 5W	20c
1k ohm, 5W	20c
820 ohm, 5W	20c
12 ohm, 10W	25c
470 ohm, 7W	20c
4700 ohm, 4.5W	20c
5000 ohm, 10W	25c
8.2 ohm	5W
3.3K	7W
27 ohm	5W
10K	7W
2.5 ohm	3W

## CAPACITORS

0.56 250V	40c ea
2000 MFD VDCw25	75c ea
0.0039uF, 1500V	20c ea
6N8, 1500V	20c ea
0.0068uF, 1500V	20c ea
1200PF, 400V	10 for \$1
0.068uF, 400V	5 for \$1
2200PF, 630V	10 for \$1
0.47uF, 250V	10 for \$1
0.10uF, 400V	5 for \$1
0.082uF, 160V	10 for \$1
26k 250V	10 for \$1
0.041uF, 400V	10 for \$1
0.033uF, 250V	5 for \$1
0.027uF, 100V	20 for \$1
220uF, 10V	10 for \$1
1uF, 350V	10 for \$1
470uF, 40V	5 for \$1
1000uF, 16V	25c
2.2uF, 200V	10 for \$1
0.047uF, 1500V	50c
47uF, 25V	4 for \$1
680uF, 40V	50c
22K, 100V	20c
330uF, 25V	25c
2.2uF, 200V	30c
470uF, 40V	50c
680uF, 35V	50c
0.015uF, 250V	25c
1uF, 100V	25c
1000uF, 16V	50c
220uF, 16V	50c
2000uF, 63V	\$1
0.47uF, 400V	50c
680K, 250V	25c
012, 250V	25c
15NF, 250V	10c
120K, 250V	20c
10uF, 315V	25c
0.056, 250V	10c
500 MFP 10 VOLT	5 for \$1

## SPEAKER TRANSFORMERS FOR VALVE RADIOS

5,000-15 ohm	\$2 50
7,000-15 ohm	\$2 50
10,000-15 ohm	\$2 50

## TV Stick Rectifiers 20SC \$1 00

<b>Slide Pots</b>	
250K-50K	3 for \$1
Dual 500K	3 for \$1
1 Meg	3 for \$1
2 Meg	3 for \$1
Including Fancy Gold Knobs	
25K dual	2 for \$1

## SPECIAL

100 mixed resistors, all useful	\$2
100 mixed capacitors, fresh stock	\$2

## AUDIO LEADS

3.5m to 3.5m, 7ft	75c
3.5m to 6.5m, 7ft	75c
6.5m, 7ft	50c

## MICRO SWITCH

5A, 250V AC	75c ea
-------------	--------

## TUNING CAPS

2 and 3 gang	\$1 ea
Min 2 gang	50c

# L. E. CHAPMAN

122 PITT ROAD, NTH CURL CURL.  
MAIL ORDERS: BOX 156, DEE WHY, NSW. 2099.  
TELEPHONE 93-1848.

## SUPER SPECIAL

GRAMOPHONE motor and pickup 3 speed stereo balanced arm.  
240 volt \$9.75

PP NSW \$1 50  
Interstate \$2 75  
WA \$4

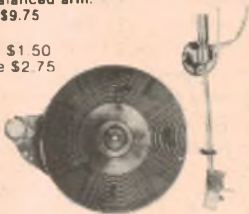

## COLOR FRONT END COMPLETE PUSH BUTTON TUNER SECTION

TO SUIT PHILIPS, PYE, KRIESLER, ETC. \$25

\$27.50  
PORTABLE 4 speed RECORD PLAYER



P&P NSW \$1.60  
INTERSTATE \$4.00

## SUPER SPECIALS

### FM STEREO TUNER KITS



Sets of 3 modules include FM tuner, decoder and IF detector. Circuit diagram supplied. Can be used with amp modules.

ONLY \$22  
P&P \$1.00

## SPEAKER SYSTEMS



Inc one 6 x 4 speaker 5W RMS \$4 75 ea  
P&P: NSW \$1 80; Interstate \$2 80; WA \$4 (For singles or pairs.)

## Power leads and sockets 240 volt, suit most tape recorders, radios, etc. \$1 each

455KC IF Transformers for valve radios. \$1 each. Also OSC coils, 75 cents each.

## SPECIAL TRANSISTORS

AD 161-162	\$2.50 pr
BSC 901A	\$1 50 ea
BC 548	10 for \$1
AD 149	\$3 pr
OC9554	50c
BD202N	50c
BD135	50c
2NC055	\$1

## ELECTROS

470uF, 25V	5 for \$1
400uF, 10V	5 for \$1
47uF, 63V	5 for \$1
350uF, 16V	2 for \$1
27uF, 160V	5 for \$1
25uF, 63V	10 for \$1
22uF, 160V	10 for \$1
47uF, 16V	5 for \$1
47uF, 200V	5 for \$1
220uF, 10V	10 for \$1
68uF, 16V	10 for \$1
100MFD, 350V chassis mount	\$1

## TV TUNERS

\$2.50 + P + P

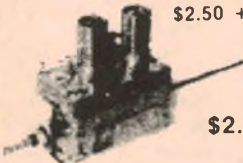

\$2.50

## VU & BALANCE METERS



STEREO VU \$3.00



12Kn 100uA \$2 00

## Recording Level Meter \$2.50

- Telescopic aerials \$1 50
- 6 inch ferrite rods, 75c
- Rainbow lead, 5 strand, 20c per metre
- Line output transformers
- Line output transformers, 1200 to 3/ohm 5 watt \$1
- Power supply units, filtered, 240 to 20 volt, \$12

## FUSES

0.5A, 2A, 3 25	10 for \$1
In line fuse holders	30c
RCA jack plugs and sockets	40c pair
1A, 10 for	\$1

HOR Drive 3021 transformers for colour TV \$2  
TV Colour Convergence Units 11270 44 x 6 \$3

## PILOT LIGHTS

Screw in 6 3V	10 for \$1 50
24V	10 for \$1 00
Pilot light holders	10 for \$1 00

- Car radio suppressors, 3 for \$1
- 3 position slide switch, 50c
- Toggle switches, 25c
- 2 position push button switch, 50c
- 6 position push button switch, \$1
- 4 position push button switch, 75c
- Transistor ear plugs & leads, 3 for \$1
- In-line fuse holders, 4 for \$1
- 4 pole 2 position rotary switches, 50c

## POTS ROTARY

1/2 Meg	30c
1 Meg	30c
100K	30c
100K Switch	50c
50K Double Pole Switch	50c
7,500	30c
10K Switch	50c
250K	30c
50K	30c
20K	30c
10K Min Pots	25c
50/ohm	50c
1/2 or 1 Meg Switch	50c
1/2 1 meg dual Concentric tapped at 100K	\$1
2 meg ganged double pole switch	\$1
1.5 meg dual ganged	50c
2 meg ganged log	\$1
1 meg dual ganged	\$1
1/2 meg dual ganged LIN	75c
25K 50K dual ganged Concentric double switch	\$1
200K single line	30c
20K wire wound	75c
dual log 10K	75c
100K dual ganged linear pots	75c
10K sub min log pots	50c
250K ganged pots	75c
25K lin ganged pots	75c

2 Min Transistor 450 IF KC Coils Plus 1 Min Oscillator Coil 3 for \$1

TV EHT Leads 4'6" in length 50c each

Pick up Cartridges BSR universal type Ceramic Stereo \$5  
Diamond stylus stereo magnetic \$12

## DIODES

OA 626	4 for \$1 00
OA 662	4 for \$1 00
EM 410C	4 for \$1 00
DS 150A	50c
DSY 130YO	50c
OA 636	50c
HR 15	50c
Diodes BYX 55, 300	30c
BY 188	30c

DIODES PAN20 10 for \$1

Valve sockets 7 pin	10c
Valve sockets 9 pin	10c
OCTAL	10c
09478	5 for \$1 00
BX279	5 for \$1 00

Power transformers 240V, 117V, 2/25V Tapps 6.3 — \$7.00

SPARK GAPS 500 volt 20 cents  
THERMISTERS 20 cents

## PICK UP ARMS

Mono \$3 50

Inc Ceramic Cartridge & Stylus

<b>TRIMPOTS</b>	
200 ohm	10c
5K	10c
100K	10c
47K	10c
10K	10c
470 ohm	10c

Miniature speaker and drive output transformers \$1 pr

Special mixed tag strips 10 for \$1

## SPEAKER SPECIALS

5 inch in 3.5, 8 or 15 ohms	\$3 50
15 ohm 4"	2 for \$2
6 x 9 15 ohm	\$5 ea
5 x 7 15 ohm	\$4 ea
8 x 4 15 ohm	\$4 ea
6 x 4 15 ohm	\$3 ea
6 x 4 27 ohm	\$4 50 ea
6 x 3 27 ohm	\$3 50 ea
5 x 3 27 ohm	\$3 50 ea
5 x 3 47 ohm	\$3 50 ea

## TRANSISTORS

2N3055	\$1 20	AC187	50c
SE1002	4 for \$1	2NC3055	50c
BF 459	50c	2SB407	\$1 00
B544 DE6	50c	BC549	5 for \$1 00
C106 F1	50c	25C154B	50c
TIP 11K	50c	OC96B	5 for \$1 00
608EK	4 for \$1	608EK	5 for \$1 00
BC554B	10 for \$1	DS113AG	75c
2SB186	50c	BD236	50c
2SA101	50c	BD139	50c
BD263	50c	BD135	50c
BSB405	50c	25A240	75c
2SB77	50c	BF469	50c
2SB303	50c	BD235	50c

volts positive and 6.4 volts negative with respect to the earth rail. The reason for this is that the VU meter current flowing from the positive rail to earth was such that the earth rail was pulled up toward the positive rail. This would cause the entire amplifier to malfunction.

This was not apparent in the Fast Mode due to the decoupling effect of the 100 $\mu$ F capacitors in parallel with the 4.7k $\Omega$  resistors. By connecting the Sound Level Meter to two six volt batteries in series with the mid point of these batteries connected to the earth rail, calibration was possible and results within 3dB were obtained when checked against the B and K 2203. I regard these problems as a result of inadequate design and would appreciate your comments. (D.W., Darwin, NT).

- During development work of the Audio Test Unit published in this month's issue we tested the Dick Smith VU meter and found that it was considerably less sensitive than the ANSI VU meter standard specified. This is confirmed by your experience. In our prototype Sound Level Meter we used a Kyoritsu KM48 which complied reasonably closely to the standards. We have since been advised by a Dick Smith staff member that the lack of sensitivity appears to be caused by the fact that the Dick Smith meter uses two diodes and two resistors instead of a bridge rectifier. We hope that this situation is corrected in the future.

In the meantime, modifications along the lines you suggest are necessary if the Dick Smith VU meter is used. Alternatively, you could dismantle the meter itself and install a bridge rectifier which would probably bring the sensitivity up to par.

**METRONOME:** In recent years the digital computer has been gradually looming larger and larger in many walks of life, and now consideration of the electronics of these machines seems to occupy at least half of the magazine.

I venture to suggest that there are many like me who find this branch a bit beyond them, and are not very interested in learning too much about it. I wonder whether your magazine (and others like it) ever consider undergoing

"binary fission", and becoming TWO magazines (with two lots of advertising revenue from the same advertisers!), the one concerned with simple devices, audio, video and the other with digital electronics and computers.

While I have pen to paper, and further to display my ignorance, I wonder if you have ever printed a design for a simple metronome using currently available parts? I am aware of your rather involved (to me unnecessarily so) accented-beat instrument. All I require is a device capable of ticking at adjustable intervals, with perhaps an accompanying LED flash. I feel sure that if I were a little more knowledgeable this could be achieved with a 555 integrated circuit and very few others parts in a compact container. (J.M.H., Wollongong, NSW).

- We appreciate your negative feelings about computers but many readers would reply that "this is where it's all happening". Unfortunately for you, computer technology will continue to make inroads into every area where electronics is presently used. Why not stick with us for a little longer — perhaps you may even become interested in these infernal machines.

Concerning the Metronome with Ac-

cented Beat (published July 1976, File No 3/MS/64), it can be simplified by merely leaving out all the accent beat circuitry and using the 555 to drive the loudspeaker directly via a 100 $\Delta$  resistor connected to the positive supply. We will publish a simple circuit together with a small PC board in the near future.

**EPROM PROGRAMMER:** Could you please advise me whether your Eprom Programmer of July and August 1980 would be suitable for the System 80 computer without any further modification to it or the software. (P.W., The Basin, Vic).

- The Eprom Programmer requires no modification for operation from the System 80 computer. To wire the programmer to your computer expansion bus, follow the Sorcerer article, since these bus signals are very similar to those of the System 80. The System 80 user's manual explains the pin outputs of the expansion bus and you should have little trouble in comparing these to the circuit diagram of the Eprom Programmer. As the System 80 is virtually software compatible with the Tandy TRS80 computer, we would expect no changes necessary to drive the programmer with the program listed in the July 1980 issue.

## Notes & Errata

**INFRARED LIGHT BEAM RELAY (April, 1981, 2/LR/7):** The 2.7k $\Omega$  resistor connected to the collector of Q3 in the receiver circuit should be 3.3k $\Omega$ . When using a 9VDC pluggack connect a 39 $\Omega$  resistor in series with the supply and a 9.1V zener from the circuit side of the resistor to ground. If a buzzer or other load is used on the collector of Q5 connect the supply side of the load before the zener regulator.

**SOUND LEVEL METER (May, 1981, 7/M/59):** The VU meter supplied by Dick Smith catalogue No. Q-2050, does not comply with the ANSI VU meter standard and as such is not compatible with the circuit described. We recommend

the Kyoritsu KM-48 VU meter, which is available from Radio Despatch Service. If the Dick Smith Meter is used, separate positive and negative supplies will be necessary instead of the resistive divider network used in the circuit. The input diodes to IC5 will also have to be removed as these will conduct due to the higher voltage required to drive the Dick Smith meter.

**MUSICOLOUR IV (August, 1981, File 2/PC/31):** Three-core mains cable should be used for the speaker wires inside the unit, to avoid any possibility of the speaker wires shorting to the live Triac heatsink. At the same time, the cable should be dressed so that it is not touching or close to the heatsink.



# COMMODORE COMPUTERS

*From the Vic to the 4000 and the 8000 series, we have the computer and peripherals to meet your needs*

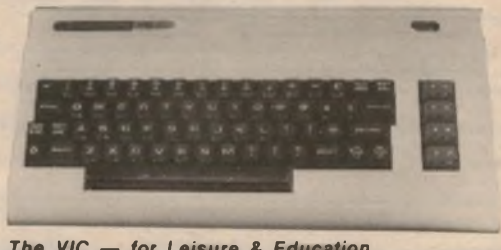

8032 — For Business

The VIC — for Leisure & Education

EDIBLE ELECTRONICS

50 PARK STREET, ABBOTSFORD, 3067.  
PHONE: (03) 41 5708.

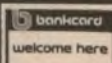

welcome here

# MARKETPLACE

## FOR SALE

**AMERICAN STANDARD VCR** (Sony) and latest model 22" colour set, incl remote control, clock on screen, automatic search etc. \$420 the lot. Ring Perth 364 3134 weekday afternoons or write 842, Cang H'wy, Applec, 6153.

**AMIDON FERROMAGNETIC CORES** — Large range for all RF receiver and transmitter applications. Closed during November. Send large SASE for data and price list to R.J. & U.S. Imports, Box 157, Mortdale, NSW, 2223.

**IVC COLOUR VIDEORECORDER** Model 826 PC. Good working order, offers over \$500 to J. Kolega CSHE, University of Melbourne, Vic, 3052. Phone (03) 341 7065 (B/H) for further details.

**INTERNATIONAL 482 AMP** \$70 ETI series 4000 wooden sided case \$15 2 Albert St, Kilburn, SA.

**ROLLER INDUCTOR** — Solidly and superbly crafted by us in Western Australia High Q Coil, compressed mica supports and heavy duty brass conductors. Continuously variable 1.45uH. Ideal for ATU's. To view this ultimate piece of RF hardware send us an SASE and we will forward you its photograph. And a circuit. Alternatively send us \$95.50 and we will deliver the real thing. High Frequency Engineering, PO Box 238, Nedlands, WA 6009.

### MAIL-ORDER FROM HONG KONG

If you are looking for following electronic products with high quality expectancy, write to us now for our free catalogue:

- Microprocessor-based handheld games and toys
- AM/FM car stereo cassettes
- Radio cassette recorders
- Digital clock radios
- Multi-band radios
- TTL & CMOS ICs
- Electronic components

Our long established direct connections with major manufacturers bring you products at almost ex-factory prices with well proved quality standards. Just put your name and address in an envelope and mail to:

**L & L INTERNATIONAL**  
PO Box 10156 Cheung Sha Wan,  
Hong Kong

**TANDY MODEL 3** complete with 48K RAM, Line Printer (7) and system desk. \$1850.00. Phone Mike, home (02) 768 112 or bus (02) 82 1943.

**USED RADIO VALVES** good condition, also new valves SAE many radio spares (003) 94 4126. G. Bracey, PO Exeter, West Tamar, Tas.

**TEST GEAR** Tek CROs. 545db, 30mhz. \$275 Tek 517A, 50mhz with up to 100mhz TB direct early model, but good cond. \$175. Sanders m/wave Gen 4-8 GHZ. \$150. RFL AC/DC calibrator NATA orig cost over \$3000. \$500. Box 437, Gawler, SA, 5118.

**CB RADIOS** 23AM \$49, 18AM \$69, 40 with scanner 99, 18SSB \$179, 40SSB \$195, FRG7 \$275 VHF Aeradio \$45, RTTY \$120, MLA 2500 2KW Linear \$750 Post anywhere \$5. Park Disposals, 32 Park St, Sydney, 2000 Ph (02) 264 7515.

**CHEAP COMPUTER** Sinclair ZX80 6 mths old. Perfect condition only \$120, 1/42 Tasma St, Nth Hobart, 7000.

**2114.2 RAMS** memory 1C static TTL 1k x 4 Bits fast R/W time \$3.50 over 50 \$3 each. Low power suit ETI Feb 79 16k Ram Project. Contact 699 9297 (H) or 1 Wilson Lane, Redfern, 2016.

**EPROM PROGRAMMER** — Outstanding features. Professional performance. Connects to ANY uP System. See our Ad October ETI. More info send large SAE Nutek Sales, PO Box 95, Eastwood, NSW, 2122. Ph (02) 871 7042.

## Microrepair

pty. ltd.

- MICROPROCESSOR AND DIGITAL REPAIR SPECIALIST
- FLOPPY AND HARD DISC REPAIR AND ALIGNMENT
- EPROM PROGRAMMING
- CUSTOM DESIGN AND MANUFACTURE
- SALES

Dicks System 80 — Microace — Ritronics Computer Products Inc — Big Board — Cosmac VIP — Software — Heatshrink — Edge Connectors — Components — ICs Inc 74LS00 to 670 — Books — Chartpak Draughting Aids — Riston Pre-Coated Laminate — Extender & Prototype PCBs — LNW8D PCBs — Compucovers — Secondhand Bargains

**MICROREPAIR (ELECTRONICS) PTY LTD**  
SHOP 30, CRANE ST.  
CONCORD, SYDNEY 2137  
TEL (02) 747 1061



welcome here

**DISPLAY ADVERTS IN MARKETPLACE** are available in sizes from a minimum of 2cm x 1 col rated at \$15 for a col cm.

**CLASSIFIED RATES** \$3.60 for 40 letters or part thereof an insertion payable in advance. Minimum 80 letters.

Please use coupon below.

**CLOSING DATE** is six weeks prior to the on-sale date. Issues are on sale the first Wednesday of each month.

## CLUBS

**HEAR THE WORLD:** Australian Radio DX Club offers a monthly bulletin covering reception of shortwave, mediumwave, utility and amateur radio. Monitoring reception reporting, and receiving verifications (QSLs) from radio stations worldwide make DXing the hobby for all ages. A wide range of publications and services are available to members. Send a 24c stamp for details to ARDXC, 12 High St, Cheltenham, SA, 5014, or 16 Marma Rd, Murrumbena, Vic, 3163. metion EA

## FOR HIRE

**MICROCOMPUTERS** for rental. Commodore Pets 68k at \$25 per week (minimum period 1 week). Software tapes and manuals included, plus Basic instruction course and book. David B Bates Microcomputer Consultant. Ph (02) 630 8652.

## POSITION VACANT

**MICROCOMPUTER ENTHUSIAST** who wants to make a living out of his/her hobby selling micros and accessories is required by computer shop in Neutral Bay/Mosman area. Ring (02) 498 1622.

## THE MIGHTY MICRO

*electromagnet*

\* LIFTS MORE THAN 25 kg!  
(125 TIMES ITS OWN WEIGHT)

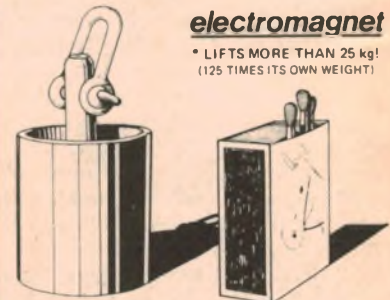

- HOBBIES Ideal for model cranes, boats, trucks, etc
- GIFT Educational gift (Handbook gives experiments)
- TOOL For use as a recovery tool
- EXPERIMENT Use for relays, solenoids, etc.
- WORKSHOP Use for clamping (e.g.: jig welding)

**SPECIFICATIONS:**  
DIMENSIONS: 35 mm diameter, overall height 65 mm (including shackle)  
WEIGHT: approximately 200 grams  
LEADS: 2 x 7/0.2 mm pvc covered approx. 450 mm long  
VOLTAGE: 6 to 12 volts  
CURRENT: approximately 1 amp at 12 volts  
DUTY CYCLE: 10 mins on, 10 mins off at 12V. Continuous at 6V  
\*LIFT CAPACITY: more than 25 kg at 12V. More than 15 kg at 6V  
(FULL FACE CONTACT ON 6 mm THICK MACHINED STEEL PLATE)

**SPECIAL**  
pre-Christmas  
**PRICE**  
**\$19.50**  
incl.

### ORDER FORM

Name ..... Address ..... Postcode .....

PLEASE SEND ME ..... (QTY) MY CHEQUE FOR \$ ..... IS ENCLOSED  
MIGHTY MICROS .....  
SEND TO: SERPENT & DOVE, P.O. BOX 149 (ALLOW UP TO 4 WEEKS)  
COLLARY BEACH, NSW 2097

## CLASSIFIED ADVERTISERS

To the Advertising Manager, ELECTRONICS Australia, Box 162, Beaconsfield, 2014.

- Please insert the following advertisement in the first available issue.  
● Tick the classification required
- FOR SALE     WANTED     FOR HIRE  
 CLUBS     POSITION VACANT     POSITION WANTED     READER SERVICE
- Please print in ball-point pen using capital letters only where necessary.

\_\_\_\_\_

\_\_\_\_\_

\_\_\_\_\_

\_\_\_\_\_

\_\_\_\_\_

Signed \_\_\_\_\_ I enclose Cheque Money Order for \$ \_\_\_\_\_  
Address \_\_\_\_\_ being full payment for \_\_\_\_\_ letters at \$3 60  
for 40 letters or part thereof (minimum 80 letters).

# A VERSATILE COMPETITOR IN THE FIELD... or the lab.

The BWD 830 Dual Trace oscilloscope provides these outstanding facilities -

- 35MHz band width ● 1mV/div sensitivity
- 20mS/div to 5 sec/div time range
- <50MHz triggering ● Delay line
- Delayed trigger or sweep
- Simultaneous alternate line or frame video displays
- Variable trigger hold off
- Floating ground operation
- AC, DC or battery with fast or trickle charge.

**CHECK THESE ADDITIONAL BENEFITS:**

- \* The BWD "All buttons out for normal operation" facility.
- \* Internal graticule CRT
- \* <3% calibration 0-40%/C 95% RH.
- \* Designed to IEC 348.
- \* Factory backed service.

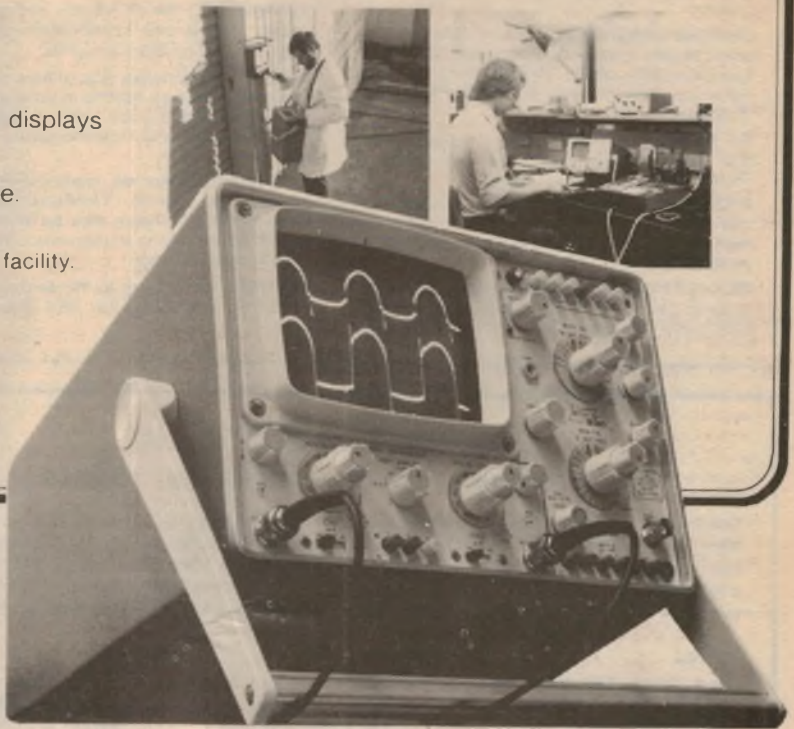

## BWD INSTRUMENTS

Victoria	BWD Instrument Pty Ltd Melbourne Ph 561 2888	Queensland	L E Boughen & Co Brisbane Ph 36 1227
New South Wales	Amalgamated Wireless Ltd Sydney Ph 884 1111	Western Australia	Widubson Frank Perth Ph 287 7000
New South Wales	George Brown & Co Pty Ltd Sydney Ph 519 5850	Tasmania	D S Agnew Hobart Ph 23 2842
South Australia	Arthur Fisher Limited Ph 253 Adelaide Ph 253 2768	New Zealand	W Arthur Fisher Limited Auckland Ph 59 2629

# COMPUTER CONSULTANTS

*Specialising in comprehensive proven packages with top quality hardware  
— Installed with stationery, training, full back-up and maintenance.*



**SORD M223 III**  
THE "ROLLS-ROYCE" OF  
5 1/4" COMPUTERS  
EXPANDABLE TO  
HARD DISK OR  
4 FLOPPIES.

COMPUTERS YOU WILL BE  
PLEASED AND  
PROUD TO  
OWN

**BE TOP OF THE CLASS**  
DO YOUR SUMS RIGHT WHEN YOU BUY YOUR BUSINESS COMPUTER

**OUR SUPERB SORD OR DIABLO HARDWARE** + **OUR PERSONALLY CUSTOMISED SOFTWARE AND FULL SUPPORT** = **ANOTHER SATISFIED CUSTOMER**

**NEW**  
**DIABLO 3100**  
WITH BUILT-IN  
10 MB HARD DISK & 1.25MB FLOPPY



LET US  
INTRODUCE  
YOU TO OUR  
SATISFIED  
CUSTOMERS

# Calculator & Computer

DISTRIBUTORS

3 Rowley Street, PHONE 8.30am to 3.30pm  
Seven Hills, N.S.W. 2147 (02) 624 8849  
OPEN THURSDAY NIGHTS TILL 8PM (02) 624 8400

# Electronics Australia Reader Service

"Electronics Australia" provides the following services:

**PHOTOSTAT COPIES:** \$3 per project, or \$3 per part where a project spreads over multiple issues (price includes postage). Requests can be handled more speedily if projects are positively identified, and if not accompanied by technical queries.

**CHASSIS DIAGRAMS:** For the few projects which require a custom metal chassis (as distinct from standard cases) dyeline plans showing dimensions are normally available. \$3 including postage.

**PC BOARD PATTERNS:** High contrast, actual size transparencies: \$3, including postage. Please specify positive or negative.

**PROJECT QUERIES:** Members of our technical staff are not normally available to discuss individual projects, either in person at our office, or by telephone.

**REPLIES BY POST:** Limited to advice concerning projects published within the last three years. Charge \$3. We cannot provide lengthy answers.

undertake special research, or discuss design changes. Nor can we provide any information on commercial equipment.

**OTHER QUERIES:** Technical queries outside the scope of "Replies by Post" or submitted without fee may be answered in these pages, at the discretion of the Editor.

**COMPONENTS:** We do not sell electronic components. Prices and specifications should be sought from advertisers or agents.

**BACK ISSUES:** Available only until our stocks are exhausted. Within six months of publication, face value. Seven months and older, if available, \$2 (includes storage fee). Post and packing 70c per issue extra.

**REMITTANCES:** Must be negotiable in Australia and made payable to "Electronics Australia". Where the exact charge may be in doubt, we recommend submitting an open cheque endorsed with a suitable limitation.

**ADDRESS:** All requests to the Assistant Editor, "Electronics Australia", Box 163, Beaconfield, 2014.

## ADVERTISING INDEX

ADVERTISER	PAGE
A&R Soanar	110
Ace Radio	98
Acoustic Electronic Developments Pty Ltd	126
Altronic Distributors Pty Ltd	80, 81
Ampec Electronics Pty Ltd	8, 63
Amtex Electronics	17
Applied Technology	22, 23
Audio Engineers Pty Ltd	85
Audio Telex Communications Pty Ltd	37
Australian Acoustic Co, The	103
Automatic Recreation Machine Co	122
BS Microcomp	115
BWD Instruments Pty Ltd	135
Bright Star Crystals	101
CPM Data Systems	122
C.W. Electronics	27
Calculator & Computer Distributors	135
Cash-More Asian Imports	89
Chapman, L. E.	132
Christie Rand Pty Ltd	facing 32
Commodore Information Centre	127
Computer Country Pty Ltd	122
Consolidated Marketing	124, 125
Dept of Industry & Commerce (Melb)	131
Defence Force, Recruiting	95
Dick Smith Electronic Group	10, 11, 29, 30, 38, 48, 49, 58, 59, 68, 69, 70, 72, 96, 97, 109, 111, 119, 128.
Direct Computer Sales	126
Edible Electronics	133
Electric Blue	115
Electrocraft Pty Ltd	117
Electronic Agencies	64
Electronic Concepts	facing 104
Elevit	116
Hagemeyer (Aust) Pty Ltd	41, IBC
Jaycar Pty Ltd	7, 45, 57, 82
Kalextronics	103
L&L International	134
Looky Video	117
Marantz (Aust) Pty Ltd	facing 33
Micropro Design	122
Microrepairs	134
Parameters Pty Ltd	86
Paris Radio Electronics	121
Philips	2
Pre-Pack Electronics	101
QT Computer Systems	129
RCS Radio	31
Radio Despatch Service	110
Radio Parts Group	114
Rod Irving Electronics	55, 74, 91
Rothmans of Pall Mall (Aust) Ltd	OBC
Sansui Electric Co Ltd	34
Scope Laboratories	15
Serpent & Dove	134
Software Source	111
Sony (Aust) Pty Ltd	IFC
Standard Components Pty Ltd	86
Stotts Technical College	73
Technical Book & Magazine Co	107
Wireless Institute of Australia	101

## ELECTRONICS AUSTRALIA

### PRINTED CIRCUIT BOARDS AND FRONT PANELS

Some readers have indicated problems obtaining PC boards and front panels for projects. Many of our advertisers sell these items and advertisements in the magazine should be carefully checked in the first instance. Failing satisfaction from this source, the following is a list of firms to which we supply PC and front panel artwork. Some may sell direct, others may only be prepared to nominate sources from which their products can be obtained.

#### N.S.W.

**Dick Smith Electronics,**  
PO Box 321,  
North Ryde, NSW 2113.  
Telephone: 888 3200

**Electronic Agencies,**  
115-117 Parramatta Road,  
Concord, NSW 2137.  
Telephone: 745 3077

**RCS Radio Pty Ltd,**  
651 Forest Road,  
Bexley, NSW 2207.  
Telephone: 587 3491

**Radio Despatch Service,**  
869 George Street,  
Sydney, NSW 2000.  
Telephone: 211 0816

#### VIC.

**Kalextronics,**  
4 Burgundy Plaza,  
101 Burgundy Street,  
Heidelberg, Vic. 3084.  
Telephone: 743 1011

**Rod Irving Electronics,**  
425 High Street,  
Northcote, Vic. 3070.  
Telephone: 489 8131

**Sunbury Printed Circuits,**  
10 Counihan Street,  
Sunbury, Vic. 3429.  
Telephone: 744 2852.

#### S.A.

**James Phototronics,**  
522 Grange Road,  
Fulham Gardens, 5024.

#### W.A.

**Jemal Products,**  
8/120 Briggs Street,  
Welshpool, WA 6106.

#### N.Z.

**Marday Services,**  
PO Box 19 189,  
Avondale,  
Auckland, NZ.

**Mini Tech Manufacturing Co Ltd,**  
PO Box 9194,  
Newmarket, NZ.

**Printed Circuits Limited,**  
PO Box 4248,  
Christchurch, NZ.

## SUBSCRIPTION SERVICE



### Subscription Rates

\$23.50 per year  
within Australia  
\$27.50 per year  
elsewhere

Make sure you receive every copy of the magazine by ordering it from your newsagent or the publisher. For publisher subscriptions post this coupon, with your remittance to Electronics Australia Subscription Dept, John Fairfax & Sons Ltd, GPO Box 506, Sydney 2001. Subscription will start with first available issue.

Name .....

Address .....

Postcode ..... Enclosed is ..... for ..... years



## WE CAN PUT ALL THIS IN THE PALM OF YOUR HAND.

What you are looking at is perhaps the most advanced VHS home video system you can buy.

The tape glides in and out of the machine, automatically.

The two-way shuttle search lets you view the picture at ten times the normal speed, so you can quickly find any segment you want to play again.

The variable speed playback lets you view the picture at double speed, in slow motion, frame by frame or freeze frame. The sound quality is always good because it is filtered through a Dolby noise reduction system.

If you go away, this home video system will record programmes for up to 14 days on up to eight channels.

In fact, this system has so many features, we don't have space enough to list them all.

It was made by JVC, the people who invented the VHS system. And being the inventors of VHS means that we are always one step ahead in refining the system.

For instance, look at our cordless remote control unit. With every function of the machine itself, there is no other remote control that gives you so much control.

If you'd like to know more about the many innovations JVC has brought to the VHS home video system and you live in Sydney, you can visit our Video Information Centre, at Garema Circuit, Kingsgrove.

There you can make use of our transfer and editing facilities.

If you live elsewhere, write to us for a brochure or call into any JVC dealer.

Then you'll see why JVC equipment is recognised as The State of the Art.



For further information, write to JVC Advisory Service, 5-7 Garema Circuit, Kingsgrove N.S.W. 2208, or phone (02) 750 3777.

The mild one  
with the miracle filter...

PETER STUYVESANT  
EXTRA MILD



THE  
INTERNATIONAL  
PASSPORT  
TO SMOKING  
PLEASURE

THE WORLD'S FASTEST GROWING EXTRA MILD

PSEM1.F6  
CC624/81

AMERICAN CIGARETTE COMPANY