

# ELECTRONICS

**AUSTRALIA**

**VIDEO, HI-FI & COMPUTERS**

JUNE, 1982

AUST \$2.00 NZ \$2.50

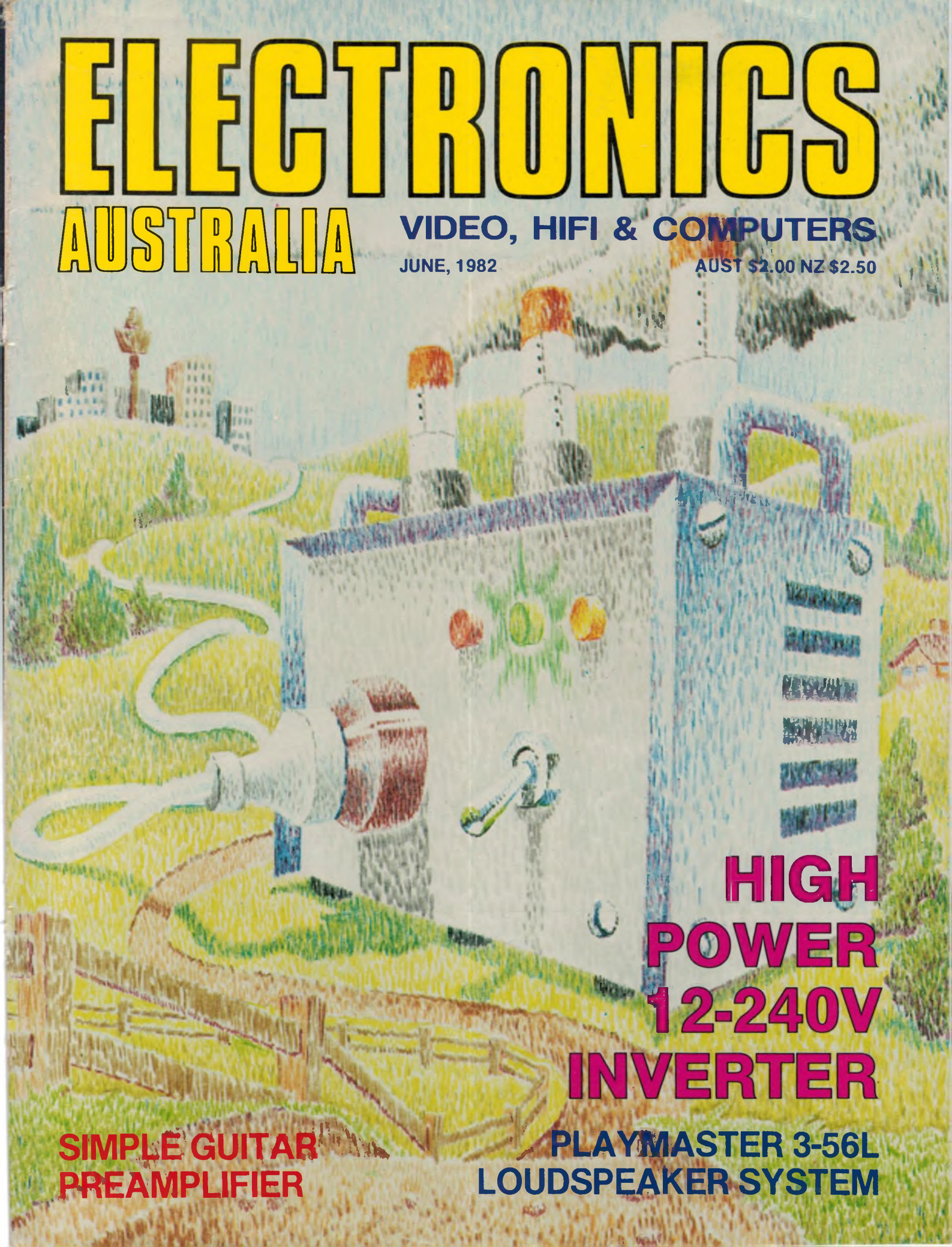

**HIGH  
POWER  
12-240V  
INVERTER**

**SIMPLE GUITAR  
PREAMPLIFIER**

**PLAYMASTER 3-56L  
LOUDSPEAKER SYSTEM**



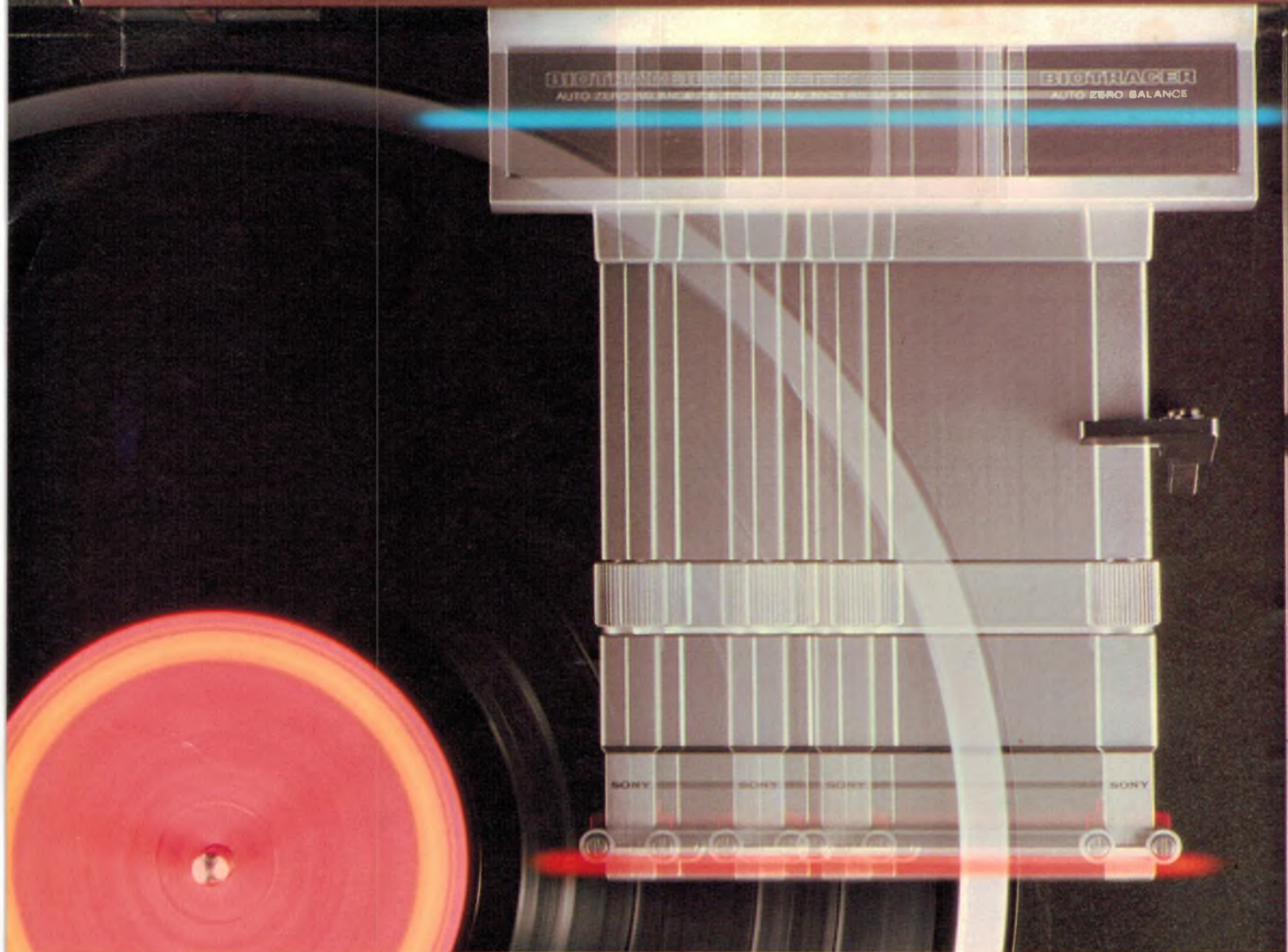

## Off on a tangent with Sony.

We didn't jump into tangential tracking turntables right off the bat. And Sony hopes you didn't either. Because while most lateral tonearms don't exactly shift gears as they travel down their path, they do run into some rough spots. A hang-up called "cogging" that inhibits totally free flowing movement, and hampers left and right stereo separation.

Sony has alleviated cogging and out of phase problems with an invention called Tangential Tracking Biotracer.

Controlled by two microcomputers and four sensors, the motion of the Biotracer tonearm is continuously fluid for precise phase alignment of the stylus.

To the average person these differences may sound slight. But if your standards are as high as Sony's, you'll understand the angle we're driving at.

PS-X800



**SONY**  
THE ONE AND ONLY

SON 0116



# ELECTRONICS

## AUSTRALIA

Volume 44, No. 6  
June, 1982

### AUSTRALIA'S LARGEST SELLING ELECTRONICS MAGAZINE



Our new 12/230V DC-AC Inverter is capable of driving mains appliances rated up to 300VA and features voltage regulation and full overload protection. Turn to p38 for the details.



This inexpensive preamplifier will let you use your guitar with a normal stereo amplifier. Find out how to build it on page 76.

COMING NEXT MONTH! - Find out what's coming by turning to page 122.

#### On the cover

We hope that readers will appreciate our send up of the power crisis situation on this month's front cover. The inverter depicted is capable of driving mains appliances rated up to 300VA, and features full overload protection (see p38). Cover artwork by Andrew Powell.

#### FEATURES

- RADIO MOSCOW AND THE dB WAR *Why the Russians are winning* ..... 12  
JAPAN: RESEARCH MAKES THE DIFFERENCE *A special report* ..... 18  
50 AND 25 YEARS AGO *Interesting items from past issues* ..... 21

#### HIFI, VIDEO AND REVIEWS

- A LOOK AT THE QUAD ESL-63 LOUDSPEAKER *The technical details* ..... 28  
DISCO SOUND BRITISH STYLE *Equipment and manufacturers* ..... 32  
HIFI REVIEW *Technics RS-M07 stereo cassette recorder* ..... 34

#### PROJECTS AND CIRCUITS

- HIGH POWER 300VA 12/230V INVERTER *Features full overload protection* ..... 38  
PLAYMASTER 3-56L LOUDSPEAKER SYSTEM *Build it yourself!* ..... 56  
THE XR-2243 TIMER IC *For extra-long time delays* ..... 74  
GUITAR BOOSTER FOR STEREO AMPLIFIERS *Has treble and gain controls* ..... 76  
BETTER BASS FOR ELECTRONIC ORGANS *An inexpensive solution* ..... 80  
THEREMIN: A WEIRD MUSIC MACHINE *Science fiction sound effects* ..... 86

#### PERSONAL COMPUTERS

- BUILD AN RS-232C CASSETTE INTERFACE *Simple computer project* ..... 94  
PERSONAL COMPUTER REVIEW *Concord II bare-board microcomputer* ..... 120  
PERSONAL COMPUTER REVIEW *System 80 blue label computer* ..... 124  
MICROCOMPUTER NEWS & PRODUCTS ..... 127

#### AMATEUR RADIO, DX

- IARU S-METER STANDARDS *Precise measurements vs signal strength* ..... 73  
SHORTWAVE SCENE *50th anniversary of BBC Shortwave Services* ..... 102  
AMATEUR RADIO *Novice licensing a resounding success* ..... 104

#### COLUMNS

- FORUM *Why don't journalists get things right?* ..... 24  
THE SERVICEMAN *A lot of good worry wasted for nothing!* ..... 62  
RECORD REVIEWS *Classical, popular, special interest* ..... 112

#### DEPARTMENTS

- EDITORIAL 3 - NEWS HIGHLIGHTS 4 - CIRCUIT AND DESIGN IDEAS 83 -  
LETTERS TO THE EDITOR 99 - BOOKS AND LITERATURE 100 - NEW PRO-  
DUCTS 106 - INFORMATION CENTRE 130 - MARKETPLACE 134 - NOTES  
AND ERRATA 128, 132.





### Fantastic new Panel Meter 0-1mA DC.

Easy to fit,  
No cut-out needed.

Remember the last time you fitted an 0-1mA panel meter — hard cutting out the hole wasn't it?

Try our new flush mounting meter. Mounts easily with 2 screws or double sided adhesive pads — all supplied.

**88.46**



### MINITOOL ELECTRONICS TOOLS

These tools have to be seen to be believed. Perfect for electronic work, modelling, carving — any job that requires a fine, detailed, professional finish.

Jig Saw } All  
Orbital Sander } **\$37.00 each**  
Pistol Drill } Tax exempt  
Drill Stand }  
Power Supply }  
Angle Grinder } **\$47.00 each**  
Flexible Shaft & } Tax exempt  
Grindstick }  
All accessories available

**MM2708  
EPROM  
Only \$2.50 ea.**

## MAGRATH'S 6-PACK SPECIALS

6 for the price of 5

### DIGITAL & LINEAR

6x4016B	\$1.50
6x4066B	\$2.40
6x4511B	\$3.45
6x74LS00	\$1.00
6x74LS14	\$2.00
6x74LS90	\$2.10
6xLM324	\$2.10
6xLM340KC-12	\$6.00
6xLM340T-5	\$2.55
6x74C04	\$1.00
6x74C02	\$1.00

### TANTALUM CAPACITORS

QUALITY KEMET RESIN  
DIPPED ALL 20% TOLERANCE

	NORMAL PRICE EACH	SPECIAL PRICE PER PACK OF 6
0.33 uFD 35V	6c	30c
0.47 uFD 35V	11c	55c
1.5 uFD 35V	12c	60c
3.3 uFD 35V	12c	60c
6.8 uFD 35V	25c	\$1.25
10 uFD 35V	29c	\$1.45
22 uFD 25V	81c	\$4.05
4.7 uFD 20V	15c	75c
10 uFD 16V	16c	80c

### BOURNS MODEL 3006P CERMET TRIMPOTS

15 TURN 1.25 WATT  
ALL POPULAR VALUES

Pack No. 1	Pack No. 2
One of each value	One of each value
200 ohms	500 ohms
1K	2K
5K	10K
20K	50K
100K	200K
500K	1 MEG
Price per pack <b>\$5.16</b>	Price per pack <b>\$5.16</b>

**Hurry — while stocks last**

### TRIO TEST INSTRUMENTS

#### OSCILLOSCOPES

15MHz, 130mm Dual-Trace  
Triggered Sweep  
CS-1560A11  
**\$610.00** inc. probes.

10MHz, 130mm Dual-Trace  
Triggered Sweep  
CS-1562A  
**\$580.00** inc. probes.

15MHz, 75mm Dual-Trace  
Triggered Sweep, Portable  
CS-1352  
**\$699.00** inc. probes.  
Battery extra.



#### DIGITAL MULTIMETER

DL703  
**\$250.00**

#### E SERIES

RF Signal Generator,  
100kHz — 30MHz  
SG-402  
**\$112.00**

CR Oscillator, 20Hz —  
200kHz  
AG202A  
**\$149.00**

Other TRIO Test  
Instruments plus all  
accessories available.

### Logic Designer in a pencil box.

All you'll ever need to design and experiment with logic circuitry is found in this small battery powered instrument.

- Solderless breadboarding
- 8 LED's
- 8 Logic Level Switches.
- 2 Debounced Pushbuttons.
- Variable Clock.
- Attractive Carrying Case.

Kit **\$102.00**  
Assembled **\$134.00**

### HILLS TV ANTENNAE

Designed to provide the best possible reception in your area. Built to highest electrical standards, simple, lightweight, strong and easy to install.

#### VHF

Gold Anodised elements and booms. Impedance matched to better than 2:1 (dSWR). Frequency response over wanted channel  $\pm 0.5$ dB  
E.F.C 2 **\$35.41**  
E.F.C 3 **\$57.63**

#### UHF TRICOLOR SERIES

Designed to cover all proposed or feasible UHF Channels.  
TC10 **\$20.70**  
TC18 **\$26.07**

### MAGRATH'S MONEY SAVERS

#### DIGITAL & LINEAR

See 6-Pack Specials for super prices on asterisked products

4011B	.19c
* 4016B	.30c
4023B	.19c
4028B	.55c
* 4066B	.44c
* 4511B	.69c
4520B	.74c
7406	.20c
7414	.33c
74164	.48c
74365	.37c
* 74LS00	.20c
* 74LS14	.40c
74LS47	.72c
* 74LS90	.42c
74LS161	.53c
81LS95	.87c
81LS98	.88c
LM301A DIP	.35c
LM308 DIP	.49c
* LM324	.42c
LM339 DIP	.42c
* LM340KC-12	<b>\$1.20</b>
* LM340T-5	.51c
LM340T-15	.60c
LM386M	.60c
LM555	.25c
LM741N DIP	.23c
LM741 DIP	.36c
* 74C04	.20c
* 74C02	.20c
74C89	<b>\$1.50</b>
IN4002	.05c
IN4148	.04c

### LORLIN ROTARY SWITCHES

CK 1024	1 Pole 12 Way Non Shorting	<b>\$1.70</b>
CK 1025	2 Pole 6 Way Non Shorting	<b>\$1.70</b>
CK 1026	3 Pole 4 Way Non Shorting	<b>\$1.70</b>
CK 1027	4 Pole 3 Way Non Shorting	<b>\$1.85</b>

### C&K SWITCHES

The best in the business.

Model Number	PUSH BUTTON	
8121	SPDT	Snap acting <b>\$2.10</b>
8221	DPDT	Snap-acting <b>\$3.05</b>
8161	SPDT	Alternate action 6A <b>\$1.80</b>
8531	Mom N O	Subminiature <b>\$1.12</b>
8533	Mom N O	Subminiature <b>\$1.12</b>
8631	Mom N O	Microminiature <b>\$1.20</b>

#### TOGGLE SWITCHES

7101 SPDT	<b>\$0.90</b>
7103 SPDT	<b>\$1.35</b>
7105 SPDT	<b>\$1.52</b>
7107 SPDT	<b>\$1.62</b>
7108 SPDT	<b>\$1.35</b>
7201 DPDT	<b>\$1.40</b>
7203 DPDT	<b>\$1.90</b>
7205 DPDT	<b>\$2.35</b>
7207 DPDT	<b>\$1.87</b>
7208 DPDT	<b>\$1.85</b>
7211 DPDT	<b>\$2.80</b>
7301 3PDT	<b>\$3.10</b>

### "Eddystone" Diecast Boxes

10% Off List All popular sizes

	Dimensions MM	Now
6357P Diecast	187 7x119.5x77.8	<b>8.61</b>
6827P Diecast	187 7x119.5x52.4	<b>7.16</b>
6908P Diecast	119.1x93.6x52.4	<b>4.50</b>
7970P Diecast	187.3x187.3x63.5	<b>18.18</b>
7134P Diecast	111.1x60.3x27.0	<b>2.88</b>
7969P Diecast	92.1x38.1x27.0	<b>1.52</b>
9732P Diecast W/Prf	125.0x80.0x45.0	<b>12.83</b>
9920P Diecast W/Prf	220.0x120.0x66.0	<b>32.53</b>
9902M Plastic	119.0x93.7x52.3	<b>2.92</b>
9901M Plastic	111.1x60.3x27.0	<b>2.52</b>



**J.H. MAGRATH & Co.** EA 2  
208 Little Lonadale Street,  
Melbourne, Vic., 3000.  
Telephone: (03) 663 3731

Add Sales Tax if applicable  
Prices valid until stock sold.  
Prices subject to alteration





# Editorial Viewpoint

## EDITOR-IN-CHIEF

Neville Williams  
M.I.R.E.E. (Aust.) (VK2XV)

## EDITOR

Leo Simpson  
B. Bus. (NSWIT)

## ASSISTANT EDITOR

Greg Swain, B.Sc. (Hons. Sydney)

## TECHNICAL PROJECTS

John Clarke, B.E. (Elect. NSWIT)  
Peter Vernon, B.A. L.L.B. (NSW)  
Jeff Skeen  
Colin Dawson

## GRAPHICS

Robert Flynn

## PRODUCTION

Danny Hooper

## SECRETARIAL

Pam Hilliar

## NATIONAL ADVERTISING MANAGER

Selwyn Sayers

## CIRCULATION MANAGER

Alan Parker

## The Gordon River Scheme ...

By the time you read this, Tasmania will have elected a new government in what must have been the quietest and most subdued campaign on record. The major and perhaps only issue in the campaign was the desirability of one or other of the Hydro-Electric Commission's dam schemes for the Gordon River system. That the HEC had planned to spend \$80,000 during the campaign to promote the most favoured scheme against a lot of local opposition shows how topsy-turvy things have become in Australia's smallest state. One must visit there to see how all powerful and ubiquitous the HEC is in Tasmania.

Tasmania generates more electric power per head of population than anywhere else in the world, and that by a long margin. Most of this power is sold to large metal refining operations such as Comalco at Bell Bay and Electrolytic Zinc Industries at Risdon, Hobart.

Considering the large number of dams already in Tasmania and the very large dam project presently under construction on the Pieman River system, one wonders why they need yet another large dam on the sole remaining undammed stretch of river in the whole State. That the dam scheme will only produce an average power output of 180MW at an enormous capital cost must raise more queries.

Consider also that the power from the proposed Gordon River scheme is also roughly equivalent to the three generators yet to be installed in the Strathgordon dam which used to be Lake Pedder.

Just recently I went to see the Gordon River. It is indeed a very beautiful river which flows through a large Myrtle rainforest and past the last remaining stands of Huon Pine, one of the world's slowest growing and long-lived trees. Finally, the Gordon flows into one of the world's largest and most heavily polluted harbours, Macquarie Harbour. This is polluted by mining residues from another river.

That this vast area should be even further ravaged by the rush of "progress" is a question that every Australian should be concerned about.

The main justification for the Gordon River scheme seems to be that it will add to future employment. In fact, after they have been constructed, such dams add very little to employment. They are remotely-controlled by the HEC from Hobart! And any future large commercial developments requiring a lot of power are likely to be capital intensive, again employing few workers.

Let us hope that the new Tasmanian government makes the right decision. Otherwise just as you cannot visit Lake Pedder as it was, you may also not be able to visit the Gordon River as it was. Is less than 200 megawatts of power worth that?

**Leo Simpson**

Registered by Australia Post — publication No. NBP0240.

Printed by Magazine Printers Pty Ltd, of Regent Street, Sydney and Masterprint Pty Ltd of Dubbo, NSW, for Magazine Promotions, of Regent St, Sydney.

### Editorial Office

57 Regent St, Sydney 2008.

Phone (02) 699 3622 Telex 25027.

Postal Address: PO Box 163, Chippendale, 2008.

### Advertising Offices

Sydney — 57 Regent St, Sydney 2008.

Phone (02) 699 3622 Telex 25027.

NSW Advertising Sales Manager: Narciso (Chit) Pimentel.

Melbourne — 392 Little Collins St, Melbourne  
3000 Phone (03) 602 3033.

Representative: Mark Christian.

Adelaide — Charles F. Brown & Associates Ltd,  
278 Halifax St, Adelaide, 5000.

Representative: Sandy Shaw (08) 267 4433

Perth — 454 Murray Street, Perth 6000.

Representative: Ashley Croft (09) 321 8217.

### Subscriptions

Subscription Dept, John Fairfax & Sons Ltd, GPO  
Box 506, Sydney 2001

Enquiries: Phone (02) 20944, ext 2589.

### Circulation Office

21 Morley Ave, Rosebery, Sydney 2018.

Phone (02) 663 3911.

### Distribution

Distributed in NSW by Magazine Promotions, 57  
Regent St, Sydney; in Victoria by Magazine Promo-  
tions, 392 Little Collins Street, Melbourne; in South  
Australia by Magazine Promotions, 101-105

Waymouth St, Adelaide; in Western Australia by  
Magazine Promotions, 454 Murray Street, Perth; in  
Queensland by Gordon and Gotch (A'asia) Ltd; in  
Tasmania by Ingle Distributors, 93 Macquarie St,  
Hobart; in New Zealand by Gordon and Gotch (NZ)  
Ltd, Adelaide Rd, Wellington.

### Copyright. All rights reserved.

Devices or arrangements shown in this magazine may embody patents. Information is furnished without responsibility for its ultimate use, or for failure of equipment to operate as expected, or for any damage, loss or injury which may be sustained. Material intended for publication is submitted at the sender's risk and, while care will be taken, responsibility for any possible loss will not be accepted by "Electronics Australia".

\* Recommended and maximum price only.





# News Highlights

## Robots are not so marvellous, says Ford

Engineers at Ford Motor Company in the United States are beginning to question the company's commitment to robot workers on its assembly lines, according to a report in "Electronics" for January 27. Dan Kuckens, an electrical design engineer at Ford's California assembly plant says that robots are still not ready for prolonged work in a factory environment.

Speaking at a panel discussion on industrial robots held recently in San Francisco, Kuckens summarised his 10 year's experience with assembly line robots by saying that some of the problems with the \$100,000 robots are "horrendous".

Contrary to the idea of robots as untiring workers,

they are in fact very prone to break-downs. When a robot becomes "ill", repairs may take anywhere from an hour to a one and half days, depending on the extent of the break-down. Often it is necessary to replace the robot with two human welders.

Answering objections that only older robots were prone to break-downs, Kuckens stated that eight of the 13 robots used in the Ford plant were only a year old. The break-downs, he said, may have occurred because the robots were not designed to cope with the

prolonged welding periods demanded in US assembly plants.

Part of the problem is that US factories are not designed to make best use of robots. In Japan, automobile factories are designed from the ground up for a robot labour force.

## While British agonise over microprocessors

Unlike the Japanese, who are developing microprocessors, and applications for them, at an ever increasing rate, less than half of Britain's manufacturers use, or are planning to use microelectronic technology in their products or production processes. The majority who do use them are large

companies or British subsidiaries of foreign owned groups.

These are some of the findings of a study published recently by the British Policy Studies Institute. The Institute says that British industry may have already fallen behind many of its overseas competitors in the

use of microelectronics.

Many users said that the main obstacle to applying the technology on a wider basis was the lack of skilled staff.

Generally poor economic conditions were also given as a reason for the lack of application of the new technology.

## New Guidance System for Ikara missile



The guidance system for Australia's Ikara anti-submarine weapon has been redesigned to extend its life into late this century, according to a recent announcement by the Minister of Defence, Mr D. J. Killen. By taking advantage of modern technology, reductions in size, weight and maintenance have been achieved, and performance and reliability enhanced.

The Ikara weapon, which consists of a rocket-propelled pilotless aircraft carrying a homing torpedo, is launched from a parent ship towards a target located either by the warship's own sonar or from data provided by other ships or by helicopters. Developed by Australian defence scientists 20 years ago, Ikara has seen many years valuable service in the Royal Australian Navy, the Royal Navy and the Brazilian Navy.

Existing Ikara systems use the technology of the early 1960's: discrete transistors and simple integrated circuits. The system is bulky and heavy, being housed in 13 cabinets of electronics each weighing more than 200kg and interconnected by several hundred wires weighing many tonnes.

In its new form the Ikara guidance system will comprise three cabinets below deck, with a slightly larger tracker mounted on the super-structure to replace the existing unit. System inter-connection will be via a data "highway" carrying multiple signals on a single wire, thus eliminating the bulky and heavy multi-wire cables. The system will be fully automatic, dispensing with the operator now required.



## Fancy a \$2.75 Rolls Royce?

And now for some intriguing statistics! According to Charles E. Sporck, president of National Semiconductor Corporation, a Rolls Royce would cost \$2.75, get three million miles per gallon, and deliver enough power to drive the Queen Elizabeth II if the efficiency and cost of the automobile had improved at the same rate as micro-electronics in the past two decades!

Speaking on his 15th anniversary at the helm of National Semiconductor, Sporck noted that a 12.5cm wafer (left) contains several thousand integrated circuits, or 10.8 times as many as the adjacent 3.75cm wafer. This huge productivity increase translated into sharply reduced prices — from \$34 for that particular IC in 1967 to just 60c in today's marketplace.

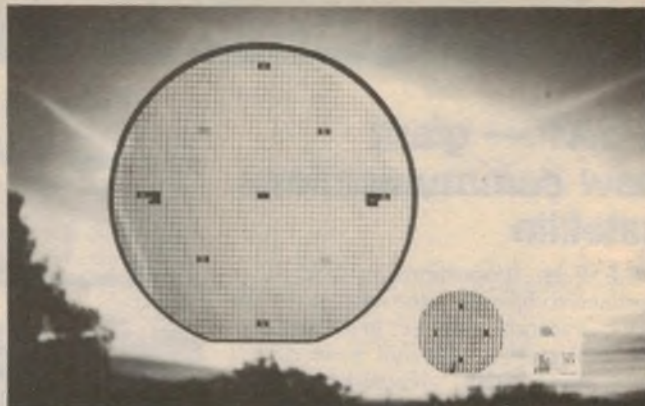

## VCR sales slump with world recession

Until very recently, Japan could not make enough video recorders to satisfy the booming world market. From the moment sales began seven years ago, production of VCRs has been doubling each year, but has been still only just meeting demand.

Late in 1981 things began to change.

The video cassette recorder industry felt the first effects of world-wide

recession and sales began to slow, leaving many manufacturers in the middle of big expansion programs which no longer seemed necessary. Now the industry is burdened with excess manufacturing capacity and big stockpiles of VCRs in both the US and Europe.

Observers are predicting that during the next five years the number of VCRs sold will increase by 15 to 25% per year. Such a growth

rate, by the standards of most other industries, would be exceptional but for the VCR manufacturers, accustomed to a growth rate of 100% a year, it represents a very sharp and very abrupt downturn.

Japanese producers (who account for more than 90% of the world supply of video recorders) last year made 9.5 million units, according to the Electronic Industries Association of Japan. Sales

estimates for 1981 were somewhat less than eight million.

The result is that unsold stocks of VCRs in the United States amount to four months of sales, and in Japan and Europe inventories are estimated at almost three months of sales. Executives in the industry are concerned that excess capacity and stocks may spark a price-cutting war between competing manufacturers.

## Parkes telescope discovers new quasar

A team of Australian and British astronomers have discovered a quasar at the edge of the Universe — the most distant object ever observed. The discovery culminates an intensive six-year search using radio and optical telescopes in Australia.

Quasars are the most distant and the most energetic of astronomical objects. More than 200 have now been discovered, but the source of their intense radiation remains unknown.

The new quasar, known as PKS 2000-330, is pouring out 100 million million times the energy of the Sun, making it the most luminous known object in the Universe. It is 20,000 million light years from Earth, and moving away at almost 300,000 kilometres per second.

PKS 2000-330 was discovered using the CSIRO's 64-metre radio telescope at Parkes. An ac-

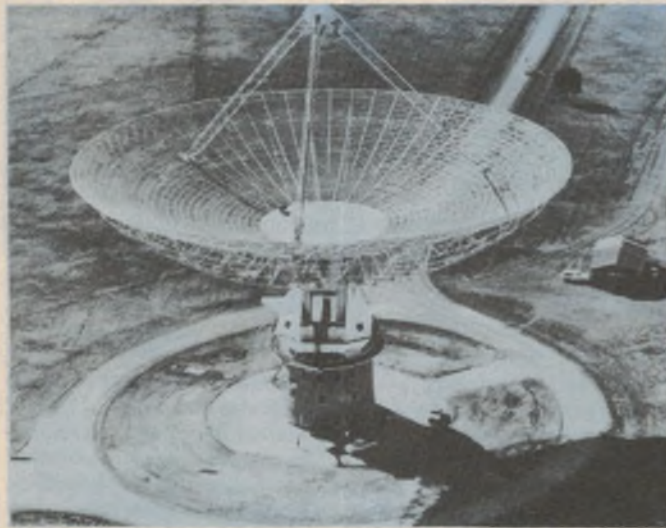

The 64-metre radio telescope at Parkes, NSW.

curate radio position was measured using the Tidbinbilla radio interferometer at the Deep Space Network near Canberra, while the UK Schmidt telescope at Siding Spring Mountain near Coonabarabran was used to

identify the object optically. An optical spectrum obtained on the Anglo-Australian telescope, also at Siding Spring, proved conclusively that the quasar was further away than any other known object in the Universe.

## Readers Digest to market Apple software

The international publishing group Reader's Digest, has signed a two year contract with Apple Computers in the United States to develop and market a range of educational programs to be used on Apple computers.

The agreement marks the first entry of a major publishing organisation into microcomputer software, although Reader's Digest already has a 51% interest in the US database service "The Source". Reader's Digest will not only produce the software, but will use its huge marketing network to distribute the programs.

Apple will support the Digest's efforts by providing technical information, computer training for Digest workers and some marketing support. The programs will be aimed at educational institutions, where the Apple computer is widely used.



## L-SAT — giant new communications satellite

The huge proportions of L-Sat 1 — destined to be one of the most powerful communications satellites in the world — are conveyed by this full scale model built by British Aerospace (BAe) Dynamics Group. Spanning 55 metres and rising 7.6 metres from the shop floor, the model was made to aid design work on equipment the satellite will carry when it is launched by Ariane rocket in 1986.

The L-Sat system will extend and improve the reception of television signals beamed direct to the home where domestic dish antennas will allow the user to pick up a wide range of programs. Business communications will also be possible between small earth stations installed on commercial premises.

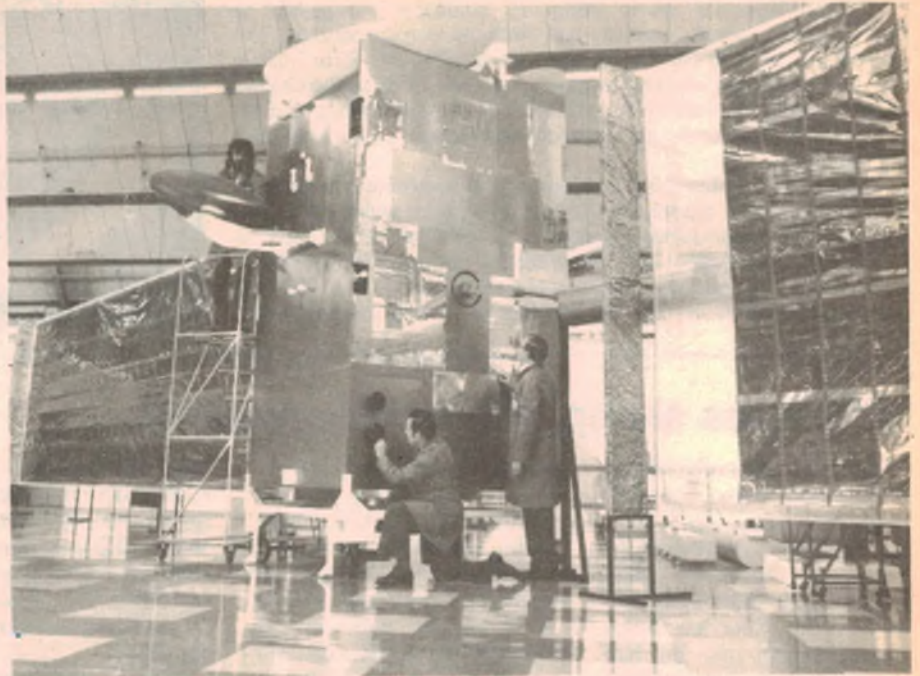

## Silicon chip slump puts \$100m Canberra plant in doubt

Flat demand world-wide for its silicon chips has forced National Semiconductor Corp to delay any decision on construction of a proposed \$100 million fabrication facility in Canberra.

Last year the Federal Government promised \$19 million towards the cost of setting up the semiconductor component factory.

Despite this commitment and favourable results from

a 1981 feasibility study, National Semiconductor said it still had sizable capacity in its other manufacturing centres world-wide.

Fierce price-cutting in the electronic component industry has aggravated National Semiconductor's problems and seen the company turn in lacklustre financial results for 1981.

The company stopped

work on a 27,000 square metre facility in Arlington, Texas, in August last year. This project will be restarted before Canberra's proposed 22,000 square metre factory gets approval.

A spokesman for the company said the primary goal was to fully use its 20 existing manufacturing sites, spread across eight countries, before expanding production capacity.

## IBM MOVES INTO ROBOTS

IBM, the world's largest computer company, is to introduce a robotic system. The new system, called the IBM 7535, will be the first robot to be sold on the open market by the company. It will be manufactured by the Sankyo Seiki company of Tokyo to IBM specifications, and is designed to work with the recently introduced IBM Personal Computer. At \$US28,500, the robot will be a relatively inexpensive system for a broad range of industrial tasks, from assembly to

loading, unloading, and packaging in factories.

IBM is known to use robots on its own production lines, and late last year began a test marketing program for a larger robotics system called the IBM RS 1. Fifteen of these systems have been installed at various manufacturing sites as part of the test.

An IBM Personal Computer to program the new robot will cost \$US5,575. Only one computer will be required to control any number of the robots in most applications.

## Software the major problem

Portable computers could become a \$US5 billion market by 1991, according to a new report published by International Resource Development Incorporated, a US market research firm. The study predicts that within 10 years more than one million portable computers will have been shipped. The current figure for the US is 55,000.

Software development continues to be a costly problem according to the report.

## TALKING AIRCRAFT!

DC-9 airliners and US Air Force F-4 Phantom fighters are talking to their crews these days.

The planes carry an electronic speech system, which is used to warn of dangerous situations. The device, called "CAW" (for Central Aural Warning system), is made by McDonnell Douglas Electronics Company.

Twenty-two critical aircraft functions are monitored by CAW, which issues a spoken message to the aircrew if something goes wrong. Spoken messages are preceded by a distinctive tone for further emphasis.

For example, if the aircraft's landing gear fails to extend and lock before landing the crew would hear a horn followed by a spoken "Landing Gear — Landing Gear". An engine fire would be signalled by a bell followed by "Fire, Engine, Left" or "Fire, Engine, Right".

Along with the choice of messages, CAW users can pre-program the degree of urgency of each message — from a "calm comment to an urgent command", as the press release puts it.



# How to get in on the action.



M400EO \$499

There's nothing like being in on the action as it happens. Fire, weather, rescue – all kinds of civil authorities are on the air constantly, reporting crises and emergencies the instant they happen. And they happen on frequencies most people can never hear.

The best way to tune in on the action is with a Regency Scanner, from the deluxe programmable 30 channel M400EO and the 10 channel M100EO models to the hand-held 6 channel H604E Pocket Scanner.

The M400EO Scanner allows you to select and programme 30 channels from around 15,000 frequencies, and then to scan them automatically, or manually select a channel. The priority function allows you recall to your favourite frequency. And you can use scan delay which allows you to hold a frequency before scanning resumes.

The entire range of around 15,000 frequencies is always available, however.

The search and search-hold features allow you to search between selected band edges. And you can adjust the band spacing. These features themselves are programmable.

And as well, it comes with a Nickel Cadmium memory battery, and an Australian Approved supply unit for your safety. Plus a DC cord for mobile use.

The M100EO gives you almost all the features of the M400EO but is for those who only wish to programme 10 channels.

The pocket scanner gives you three bands Lo VHF, Hi VHF or UHF, advanced circuitry, step control and two antennas all in this tough compact package.

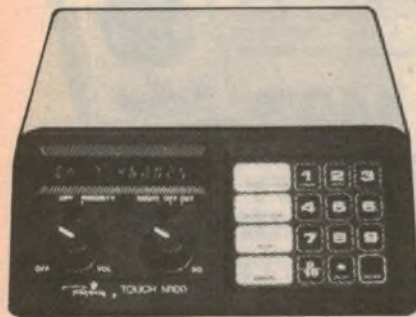

M100EO \$419

Regency Scanners – whichever model suits your needs – are the best value for money in Scanners. Compare us with the opposition, and hear for yourself.

And they're available from Vicom, the authorised distributors, and our authorised dealers. That ensures you get the usual Vicom 12 month warranty and expertise.



H604E \$199

(excludes crystals)



Vicom's own retail outlets are open 9 am to 5 pm Monday to Friday, and 9 am to 12 noon on Saturdays.

Prices are subject to change without notice.

## VICOM INTERNATIONAL PTY. LTD.

**Authorised Dealers: N.S.W.:** Newcastle: Elekron 2000, 26 2644. Wagga: Rivercom 21 2125. Wollongong: Macelec 29 1455.

Gunnedah: Landlink Communications 42 2838. Springwood: Springwood Hi-Fi 51 3091.

**Victoria:** Melbourne: Eastern Communications 288 3107. Bendigo: Sumner Wholesale 43 1977. Port Fairy: Ansonic Electronics 6 8113.

Ballarat: John Lewis Electrical 31 3322. Wecam 39 2808. Cheltenham: Power Band Communications 584 7631. Frankston: Worldwide Radio 789 3412.

Moe: Codlin Communications 27 4516. Hamilton: Hamilton Electronics 72 3333.

**Western Australia:** Perth: Willis Electronics 21 7609. Netronics 46 3232. Kalgoorlie: Hocks TV 21 1906. Derby: Hydra Electronics Services 91 1307.

**Tasmania:** Launceston: Gelston 44 3882. Advanced Electronics 31 7075. Hobart: Harvey Skegg 47 6674. Burnie: VK Electronics 31 1708.

South Launceston: Graeme Thomson Electronics 44 4733.

**Northern Territory:** Darwin: Darwin Communications 85 3184.

**Queensland:** Brisbane: CW Electronics 397 0808. Gold Coast: Amateur's Paradise 32 2644. Townsville: Robco Equipment 72 2633.

Gladstone: Jones Communication 72 1116. Cairns: R. E. Hunter & Associates Pty. Ltd. 51 5092. Enoggera: Elite Electronics 352 5222.

**South Australia:** Adelaide: Compucom 43 7981. Mt. Gambier: Set Services 25 2228. Port Adelaide: International Communications 47 3688.

Whyalla: Gulf Communications 45 0208.

BURROWS DOBLE LAWRENCE /VIC088/EA



**MEET A  
MAN WHO KEEPS  
74,961 CUSTOMERS  
HAPPY!**



He's got to get that adrenalin flowing — so it's off for a quick jog around the park before work. This is David Broome, our Mail Order Manager. He'll probably never meet our 75,000 mail order customers: but to David, this makes looking after them even more important!



A quick shower, shave and bowl of Kellogs — and David's ready to start another day. First job is to check the computer for overnight orders received via the Electronic Shopping System.



Then it's onto the mail — enough to gladden the heart of even Santa Claus. Up to 10 staff are on hand to open and process each batch of mail.

## The good news

// These top quality products are all available by Mail Order at direct import prices. //

**1%  
TOLERANCE  
RESISTORS**

**WHY SETTLE  
FOR LESS?**

**WHY METAL FILM?**  
High stability — Very low temperature coefficient — High reliability — Ruggedly made — Professional quality

**SAVE OVER \$5.00  
BARGAIN PACK**

Cat. R-7015 **\$12<sup>90</sup>**

300 precision 1% 1/4W metal film resistors. \$18.00 value!

Cat. A-1000



**AVAILABLE LATE JUNE**

**NOW MINIATURE HI FI  
THAT DOESN'T  
COST A  
FORTUNE!**

This 3-in-one system offers big performance. It's the ideal system for flats, bedrooms, etc. It features: AM/FM stereo tuner — Integral cassette deck with noise reduction and chrome facilities — 10 watt amplifier with LED VU meters, full switching and 2 phono preamps — Separate 2-way Hi Fi speakers. Small in size, big in sound!

**DON'T  
PAY \$500  
OR MORE!**

**ONLY  
\$249**

**FOUR WAY RADIO  
CONTROL**

4 CHANNEL DIGITAL  
HERE AT LAST! A 4 channel radio control for bringing life to your model boats, tanks, cars, etc. This fantastic unit will make every boy the envy of fellow modellers.



Cat. Y-1240

**\$149<sup>50</sup>**

**DON'T PAY  
FANCY MODEL  
SHOP PRICES!**

**FREE POWER!  
SOLAR CELL SECTOR**  
22nd Century technology! Connect these in series or parallel to power your projects. 450mV @ 125mA  
Cat. Z-4835

**\$2<sup>95</sup>**

**CHEAP RESISTANCE!  
Resistance Substitution Wheel**  
Convenient size with large, easy to read value selections from 5 ohms to 1 M ohm in 36 steps. Complete with leads and crocodile clips.  
Cat. Q-1410

**\$7<sup>95</sup>**

**DIGITAL  
MULTIMETERS UNDER \$50**

Cat. Q-1446

**AUTORANGING DIGITAL**

At last — a fantastic full autoranging budget priced multimeter! This LCD Digital is a portable 3 1/2 digit, compact-sized tester ideally suited for field, lab, shop and home applications. Just look at these features: Overload protection — Battery operated — Low cost — 0.8%, 1.35% DC V reading error. All these features for only \$49.50!

Cat. Q-1446

**ONLY**

**\$49<sup>50</sup>**



**TOP QUALITY TEXAS  
CALCULATOR UNDER \$20!**

**That's the Slimline T130**

This calculator is great for any student and well within their reach at this low Dick Smith price! Just look at these features:

- Easy-to-read Liquid Crystal Display
- AOS Algebraic operating system allows you to enter mathematical sequences in the same order that they are algebraically stated.
- Constant memory feature holds numbers in a user memory even while the calculator is turned off.

**ONLY**

**\$19<sup>95</sup>**

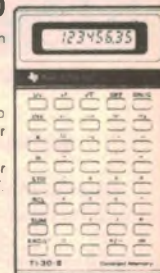

Cat. Q-3737



**18¢  
m**

**VALUE!**

**LIGHT DUTY  
SPEAKER CABLE**

Ideal cable for use with Hi Fi systems for speaker connections or with intercoms. Twin plastic insulated conductors, insulation marked with a trace to keep speakers correctly polarised.  
Cat. W-2010  
Bulk price 100m or more — 15¢/m





As soon as the mail orders are entered in the customer record system (just in case good old Aust. Post send an order to Upper Cumbuckta West instead of lower Woop Woop) they're rushed through to the assembly section, where a staff of eager enthusiasts is ready to pounce on every order in record time.



It's like a mini Dick Smith store — but the customers are missing. Instead, our mail order assemblers rush your order around, choosing the items you've ordered. David has made sure the most popular items are closest to the front — minimising delays in getting your order on its way.



Once assembled, your order is double checked to make sure everything is there, then the pricing is checked. You'd be surprised how often we find that customers are overcharging themselves — mainly because they don't know the items on 'special', etc.

# and . . . the good news

// You don't have to buy by Mail Order, we have 30 stores around Australia, all offering the same value and service. //



## Here's why you should insist on quality DICK SMITH SEMI'S

- ★ All top quality recognised brand names
- ★ Up to 1/2 the price of other suppliers. Save up to 66%.
- ★ Guaranteed Quality
- ★ No need to buy 10 when you only want one
- ★ Quantity discounts
- ★ No job lots, end of run or below spec. devices
- ★ When you buy semiconductors from DS you buy with confidence

### TOP SELLERS

Cat. No.	Description	1-9	10 up
Z-1300	DS547	.14	.12
Z-1308	DS548	.14	.12
Z-1319	DS549	.34	.30
Z-1329	DS549c	.17	.15
Z-1340	DS657	.17	.15
Z-1348	DS658	.17	.15
Z-1359	BC159	.55	.50
Z-1443	BD139	.55	.50
Z-1444	BD140	1.00	.95
Z-2145	2N3055	.20	.17
Z-2242	BC328	.35	.30
Z-2252	BC338	.20	.15
Z-3042	DSOA91	.08	.06
Z-3120	IN9141	.10	.08
Z-3202	IN4002	.15	.13
Z-3204	IN4004	.20	.15
Z-3207	IN4004	.45	.35
Z-3222	IN5404	.40	.30
Z-3531	6V8 Zener diode	.40	.30
Z-3547	15V Zener diode		
Z-3228	IN5408	.50	.45
Z-4000	Flashing LED	.45	.40
Z-4010	Sml Red LED	.20	.18
Z-4020	" green LED	.28	.25
Z-4030	Lge red LED	.30	.25
Z-4032	" green LED	.55	.45
Z-4034	Yellow LED	.45	.35
Z-4040	Rect. red LED	.45	.35
Z-4042	" green LED	1.35	1.20
Z-4150	FND500	1.50	1.25
Z-4510	Triac SC141D	.80	.70
Z-4802	Double LDR	.40	.35
Z-5601	4001 Norgate	1.20	1.10
Z-5617	4017 Dec. counter	2.00	1.80
Z-6105	UA4136 quad amps	.40	.35
Z-6145	DS555 timer	.40	.35
Z-6382	LM741 op. amp	1.20	1.00
Z-6545	7805	1.20	1.00
Z-6552	7812	3.95	3.50
Z-9310	4116 RAM		

### AMAZING VALUE ON AMAZING FLASHING LED

Cat. Z-4000  
All you need to make these amazing LEDs work, is your own voltage. Dozens of uses!

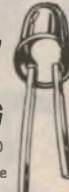

SAVE 70%  
NOW 45¢

### IC TIMER HANDBOOK

This new book is packed with projects and experiments as well as exploring the world of IC timers. Cat. B-1610

NEW COMPUTING TITLES \$8.95

COMPUTER GRAPHICS 29 ready-to-run programs to develop your graphic skills. Entertaining and enlightening book. Cat. B-2350

Available Mid June  
TRS-80 DISK, and OTHER MYSTERIES 130 pages of actual memory maps and samples. Cat. B-2347 \$29.95

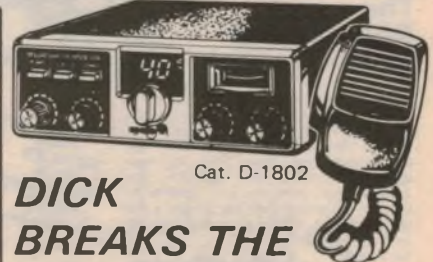

Cat. D-1802

## DICK BREAKS THE PRICE BARRIER FOR 40ch UHF CB!

Full 40 channel operation with delayed action squelch for flutter free reception. The RF gain control lets you increase faint signals and decrease strong local signals. A truly amazing radio for the cost conscious person!

## APOLLO 40ch UHF

ONLY \$280



# DICK SMITH Electronics

SEE PAGE 27 FOR ADDRESS DETAILS





Down the conveyor belt to the packing section (sometimes with a pricer hanging on — they're so keen, they sometimes forget to let go: David's working on that one . . .) And your order is carefully packed to make sure you don't receive double the number of pieces you ordered!



Your order is weighed, stamped and entered into a despatch ledger (once again, just in case . . .) And within an hour, it's on its way to the Post Office — one of 5 batches of orders to leave every day! By the end of the day the label lickens have almost run out of lick!



'What do I do about this, David?' Carefully avoiding getting Vegemite on the paperwork (he's not really that tidy — just doesn't want to lose his Vegemite) David answers another query. Queries don't stop just because it's lunch-time!

**\$10 CHEAPER THAN WELLER!**

**The DICK SMITH Solder Station**

If you are serious about soldering, there's only one way to do it - with a temperature controlled soldering iron. Dick Smith brings you this brand new temperature controlled station, offering you the best quality at an unbelievably low price. AND it's fully approved by the Energy Authority. The station comes complete with lightweight iron, iron holder and cleaning sponge, with a comprehensive instruction manual with full servicing information. Cat T-2000



**PRO QUALITY AT A HOBBYISTS PRICE**

now **\$59<sup>50</sup>**

**Latest micro technology makes you a musician with The amazing VL TONE**



Small enough to fit into the palm of your hand but gives you performance and flexibility that would have been thought impossible a couple of years ago. It gives you ten different background rhythms, records the melody you've just played, 5 different instrument sounds PLUS the ability to create millions of sounds of it's own. You'll be playing tunes in a couple of minutes. And...

**IT DOUBLES AS A CALCULATOR!**  
Cat Y-1156  
only **\$89<sup>95</sup>**

**AVAILABLE MID JUNE**

**Look at Dick's price for quality! Belt Drive Turntable**

Here's top value: a semi automatic belt-drive turntable, with all the 'mod cons' such as variable speed, strobes, anti-skate, auto return etc. etc. — mounted in a deluxe shock-damped plinth with perspex hinged lid. Cat A-3080



only **\$169<sup>00</sup>** (Inc. Cartridge)

**HITACHI QUALITY - DICK SMITH PRICE!**

**HITACHI 15MHz Dual Trace Cro**

**Model V-152B**

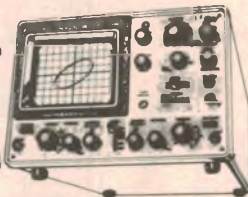

For the service bench, technical college, university or school - or even the serious hobbyist or amateur who simply wants a top-of-the-line CRO without breaking the bank, we have the outstanding Hitachi V-152B 15MHz Dual Trace Oscilloscope.

It costs no more than our previous CRO's which didn't have anywhere near the number of features of the Hitachi V-152B. Features like ★Extra high sensitivity ★TV Sync-separator circuit for rapid video measurement ★5 display modes ★Trace rotation via front panel control ★One touch wave-form shifting ★One touch 10x sweep magnifier AND LOTS MORE! Cat Q-1242

**SPECIFICATIONS**

Vertical sensitivity: 5mV/div-5V/div  
Bandwidth: DC-15MHz, -3dB  
Rise time: 24ns  
Non-dist max amplitude: More than 4 div @ 15MHz  
Input R and C: Direct 1M ohm, approx 30pF  
Maximum input voltage: 600V P-P 1300V AC + DC peak  
Display modes: CH1, CH2 DUAL ADD DIFF  
Sweep time: 0.2us-0.2s/div, 19 calibrated steps  
Power requirements: 120-240V, 40W

**great value**

**\$655**

**100MHz x 1 x 10 CRO PROBE**

This versatile probe gives you features you would pay \$88 more for and will suit virtually any CRO. You get a Basic probe with built-in 1x10 switch, 1.5 metres of cable with core-type CRO connector and wandering earth lead with alligator clip, IC adaptor tip, spring clip, insulating shroud, BNC adaptor, trimming tool, and a 100ohm resistor for safe sweeping. Cat Q-1246



only **\$32<sup>50</sup>**  
Compares with \$70 Probe Sets!

**HUGE SCOOP PURCHASE! Looking for a good BASE STATION?**



A fantastic base station CB that lets you communicate to others from the comfort of your own home! Has 18 channels available and comes ready to connect to your antenna. Features include a quality loudspeaker with headphone socket, large easy to read power/signal meter, delta tune for receiving stations slightly off frequency, built in power supply - just plugs into mains\*. Finished in attractive wood grain. Cat D-1432

\*Requires 240V to 110V external stepdown transformer. value \$ **169** at

**DICK SMITH LOW COST SOLDERING IRON**

A general purpose iron that can be plugged into the 240V AC mains and will give 25 watts of heat very quickly. That is more than enough for most jobs around the home or workshop. It has a stainless steel barrel and comes with a copper tip. Complete and ready to use with mains plug and cord attached. Cat T-1300



10,000 SOLD! only **\$9<sup>75</sup>**

**SAVE \$8**

**MINI CASSETTE RECORDER**



This palm sized recorder is ideal for recording anything that would be ordinarily very difficult with standard sized recorders, such as lectures, interviews and conferences etc.

Uses standard cassette tape, has thumb operated controls, and inbuilt microphone. Can be connected to external power source and has earphone jack. AND it features a review button allowing automatic playing after rewinding a cassette. Cat A-4050

only **\$39<sup>50</sup>**

**YOU REAP THE BENEFIT!**







Calls may come in from Perth to Papua — checking about products, querying orders — or even ordering by 'phone. Our 'phone-in Bankcard ordering system has proven really popular. It is one way to get your order on the way very quickly.



And any goods not in stock (shame!) are 'back-ordered' and sent later at our expense. As soon as we receive it, you'll get it — David and Dorothy make sure of that!



It's somewhere between 5pm and Midnight when David finally decides he had better head home (he's only been married a few months and Penny starts getting anxious after about 8 o'clock). One last check — and he's off. Don't forget the light on the way out, David!

## SAVE ON TEAC HI-FI!

Dick Smith offers you this superb TEAC Hi-Fi system at an unbelievable low price.

**System Comprises**  
**35 watt RMS amplifier BX-330B**  
 Features LED power meters, low distortion, dual speaker outputs and a frequency response of 10Hz - 100kHz

Cat A-1301 **\$249**

**AM/FM tuner TX-550B**  
 Unbelievable performance - not just on FM but on AM too!

Cat A-1501 **\$199**

**Metal tape deck V-30**  
 For those with a discerning eye for style and quality. Has Dolby NR switch, peak level display, tape (Bias/EO) switch, pause key and much much more.

Cat A-3505 **\$169**

**Turntable P-50**  
 Semi-automatic belt driven turntable in modern silver and black finish and with tinted vinyl dust cover. Superb performance.

Cat A-3079 **\$169**

**Two litre speakers**  
 Designed as bookshelf speakers but can be used on the floor also. Each contains a 200mm woofer and a tweeter for top end sound.

Cat A-2460 **\$95 pr.**

**Superb Hi-Fi stand**  
 Store all your Hi-Fi equipment on this quality stand. Separate compartments for amp, cassette deck, tuner and turntable. Great little space saver!

Cat A-0105 **\$72**



## The Affordable CRO!



### DICK SMITH 6.5MHz 75mm Laboratory CRO

This oscilloscope is ideal for the laboratory, the classroom, in field service, in bench service in assembly centres and, of course, in hobby applications. Solid state electronics (apart from the tube!) ensures extremely low drift and fast warm up. Features include retrace blanking for a clearer display, fibreglass PCB, lower threshold triggering; sharper focus; and colour coded input terminals. Cat Q-1280

OVER 2000 SOLD!  
 only **\$199**

### CRO BNC ADAPTOR

This smart little adaptor plugs into the input terminals on the Dick Smith laboratory oscilloscope, converting the banana socket terminals to a BNC type, as used on more expensive oscilloscopes. Cat Q-1281

**\$990**



## WANT A DISK BASED COMPUTER SYSTEM?



### The SYSTEM 80 Mk II saves you \$750 straight away!!

When cassette operation is too slow for business usage, this System 80 is the answer. The normal inbuilt cassette mechanism has been removed (even though we've still allowed for external cassette connection) to allow for connection to a disk drive. Features of this superb computer are: flashing cursor; numeric keypad; 12K microsoft BASIC; screen print facility; FULL upper and lower case display plus provision for full expansion to 48K of memory. Cat X-4100

WAS \$1495  
**SAVE \$745!**

NEW LOW PRICE ONLY  
**\$750**

YOU REAP THE BENEFIT!



## NO BOAT IS TOO SMALL

### DICK SMITH 5 watt 6 ch Hand Held



only **\$125**

Now a transceiver offering the maximum legal power on the 27MHz marine band (5 watts) and a choice of up to 6 channels. Operates from 12 volts. A real workhorse. Cat D-1123

DOC Approval No 242M161

# DICK SMITH Electronics



SEE PAGE 27 FOR ADDRESS DETAILS



## Why Radio Moscow is WINNING the dB WAR

Shortwave listeners in the United States have found that signals from Radio Moscow appear to be much stronger than signals from other stations. We can't be certain why, but this may be the reason.

**STANLEY LEINWOLL \***

Fig. 1: Signals from the Russian transmitter at Simferopol travel more than 1600km farther than those from the BBC or Deutsche Welle. They also follow a more northerly path, putting them closer to the auroral zone.

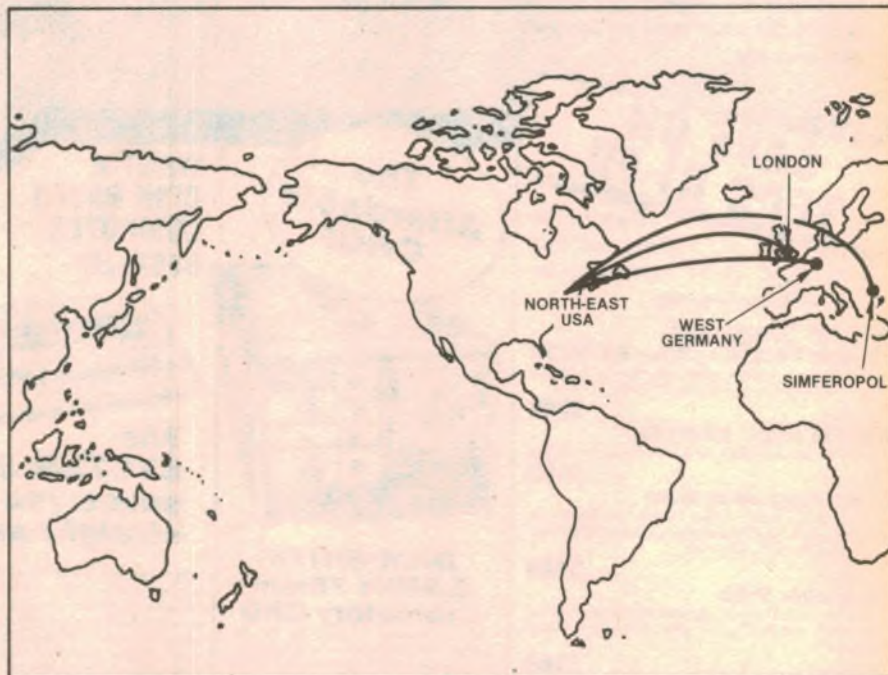

**R**ADIO MOSCOW'S addition of a World Service in English several years ago provided yet another example of the strong emphasis the Russians have placed on shortwave broadcasting as a highly effective and economical medium for the mass dissemination of information. (A "World Service" is a 24-hour-a-day operation that serves all parts of the world; that differs from Moscow's earlier English-language service where broadcasts occurred only at certain times of day and were aimed only at English-speaking regions.) The Russians are by far the world's largest broadcaster. Using approximately 200 shortwave transmitters operating around the clock, they transmit in 65 different

languages and dialects to virtually every corner of the globe.

The Soviet effort in broadcasting has not been concentrated solely on quantity. Listeners in North America have observed that many Soviet shortwave signals are stronger than most competing broadcasts. In some cases, signals coming direct from the USSR are stronger than the relays coming from Cuba, leading US listeners to believe that radiated power levels from the Russian-based transmitters are enormous.

Technically, however, one would not expect that to be the case, and there is, in fact, growing evidence to indicate that the Russians are instead considerably ahead of the West in the application of antenna and propagation theory for long-distance shortwave communication.

As an example, consider one of the principal transmitting sites used by the Soviets for their broadcasts to North America. Located in Simferopol, in the Crimea, it is approximately 8000km from the north-eastern United States. Yet, signals from that transmitter site are considerably stronger in North America than signals from the BBC and Deutsche Welle, in spite of the fact that the transmitters for the latter two are at least 1600km closer to their target areas.

The world map shown in Fig. 1 illustrates the normal paths that those signals travel. Note that not only does the Russian signal need to travel more than 1600km farther than the signals from BBC and Deutsche Welle, but that the path of the Soviet signals is farther north and closer to the auroral zone. Both factors are quite significant.

\* Stanley Leinwoll is Director of Engineering, US, for Radio Free Europe — Radio Liberty.



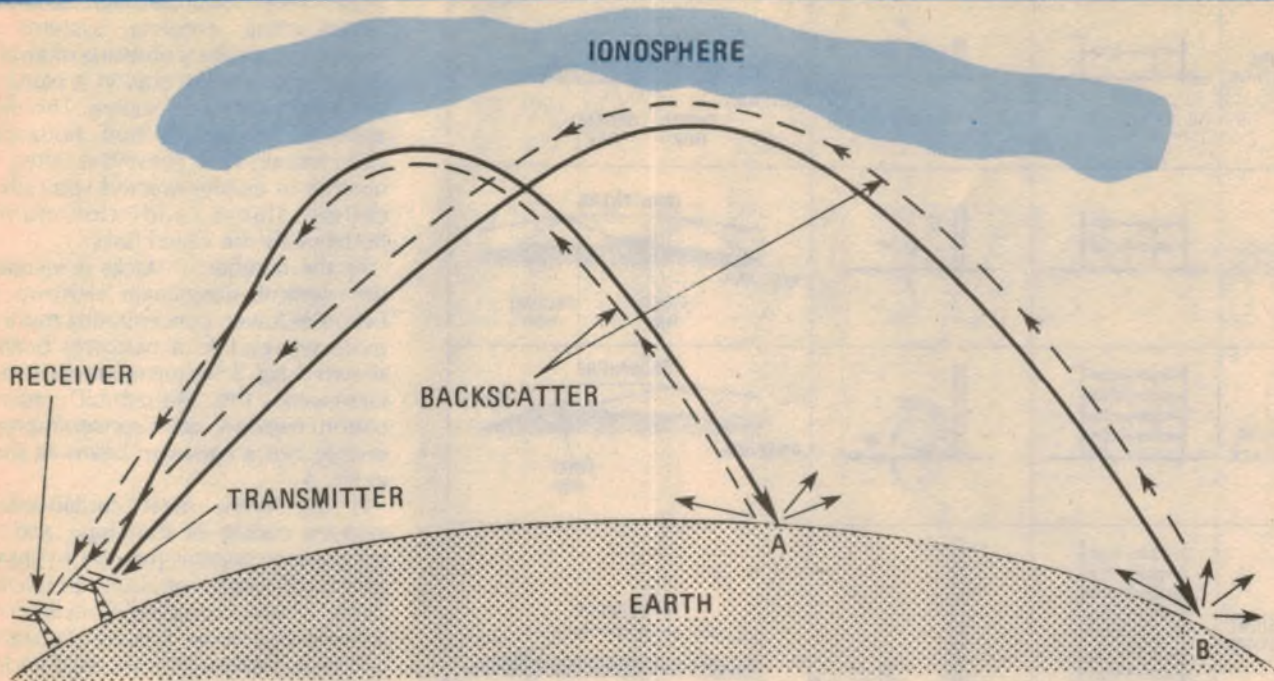

Fig. 2: When signals strike the earth they are reflected; some of the energy is reflected back towards the transmitter where a receiver can pick it up. In an operational backscatter system, that reflected signal is used to determine which frequency and angle of radiation are the most effective at the time.

In general, the farther radio signals must travel from a transmitting station, the weaker they are. Based on the location of the BBC, Deutsche Welle, and Radio Moscow transmitters, we would expect the signals from the Soviet station to be 10 to 12 dB weaker than signals from the BBC and Deutsche Welle — all other things being equal. Yet, Radio Moscow's signal strength is generally about 10 decibels higher than the BBC's.

The more northern path of the Russian signal is important because the ionosphere in the auroral zone is frequently unstable. Northern lights, or auroras, are very common in that zone and adversely affect radio transmissions passing through the zone or close to it. During periods when the ionosphere is disturbed, the auroral zone moves south and signals that are normally stable are weakened. That is why transmissions from the BBC to North America, for example, "break up" before signals from Rome and Madrid. The paths of the latter signals lie farther to the south and those signals are therefore less prone to auroral effects even during ionospheric disturbances. But despite their more northerly path, Radio Moscow's signals remain strong even under adverse ionospheric conditions.

If shortwave listeners receive Radio Moscow signals about 10dB more strongly than signals from the BBC, and if we consider that the BBC uses 250-kilowatt transmitter and high-gain

curtain antennas that are located more than 1600km closer to America than those of Radio Moscow, then a few simple calculations would seem to lead us to the conclusion that the power output of the Radio Moscow transmitters is on the order of 32,000 kilowatts (32 megawatts) or more! But that is not the case, for — as far as is known — the most powerful transmitters the Russians use for international broadcasting have power outputs on the order of 500 kilowatts. What, then, are the Russians doing that is, in effect, giving them a power gain of over one hundred?

The mystery deepens if you listen carefully to Radio Moscow when it first comes on the air. Frequently the Russian signal will rise and fall in strength over a period of several minutes; that rise and fall is not related to normal fading of DX signals. After that, the signal level increases to a peak value and then remains very high for the remainder of the broadcast.

### Backscatter

Scientists are becoming convinced that they have unravelled the mystery. Since the Soviets are apparently not using super-power transmitters, they must be doing something to their signals. The signal variation may be related to a technique called "backscattering". In addition, the Russians appear to be using antenna systems that are more sophisticated than anything currently

available in the West.

The principle of backscatter has been known for a long time. Essentially, on returning to earth after being reflected by the ionosphere, a radio signal is scattered in all directions because of the irregularities in the earth's surface (see Fig. 2). A small fraction of the energy is returned to the transmitter site — having been "scattered" back in the direction from which it came. The strength of the "backscatter" echo depends on the strength of the signal that struck the ground after reflection by the ionosphere.

It follows that if a wide range of frequencies is transmitted, some frequencies will penetrate the ionosphere and go into space, some will be absorbed, and some will be reflected. Backscattered signals will be received only for the frequencies that are reflected. Furthermore, the round-trip time delay of a very short pulse of radio energy is related to how far away from the transmitter the scattering took place; the longer the time delay, the farther away the signal was returned to earth.

A number of very useful facts can be obtained from an operational backscatter-system: We can determine the range of frequencies that the ionosphere is reflecting at any given time. From the strength of the backscatter signal we can learn which frequencies are strongest on reaching the earth from the ionosphere, and that tells us which frequencies the ionosphere is propagating best. From the time delay of the returned pulse and the characteristics of the transmitting-antenna pattern, we can also learn the height of the ionosphere from which the



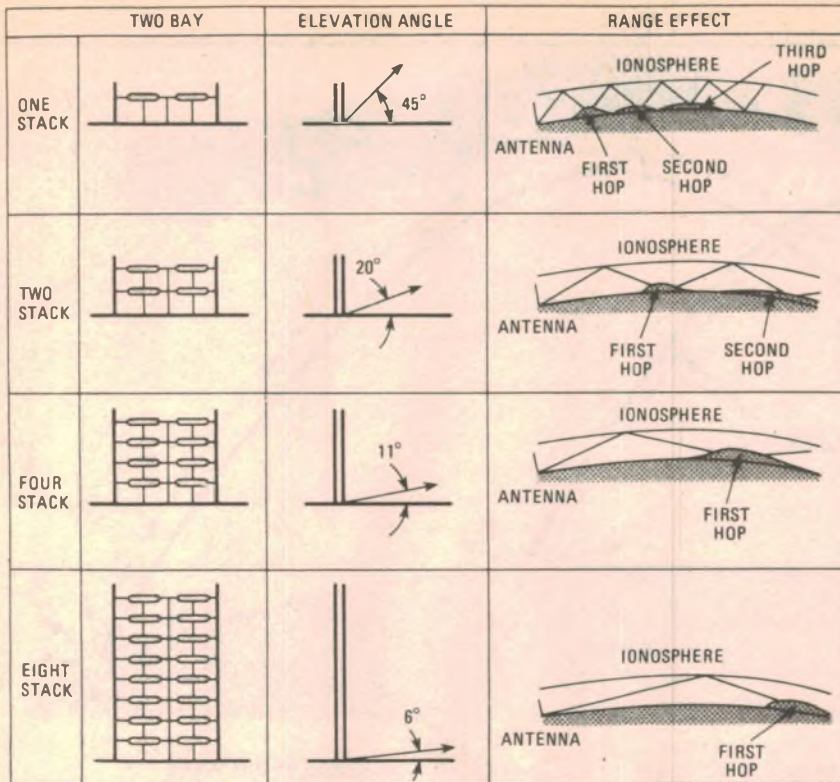

Fig. 3: The more stacks a curtain antenna has, the lower its angle of radiation.

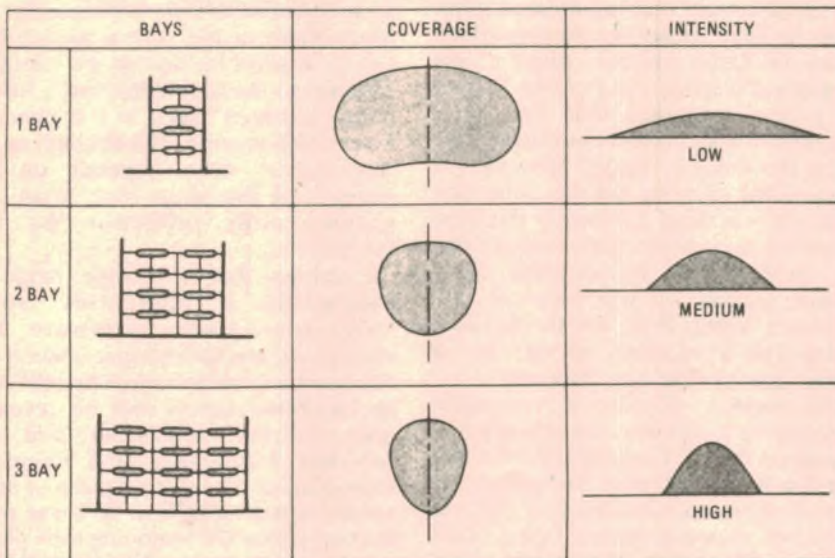

Fig. 4: The width of the beam narrows, and the strength of the signal delivered to the target area increases, as the number of bays of a curtain antenna increases.

signals are being reflected. Using that information, it is possible to schedule frequencies that will deliver the best signals to a given target area. But, better still, that information makes it possible to determine the optimum radiation angles.

Suppose, for example, that in using conventional radio-forecasting techniques, the Russians have determined that at a particular hour the 7MHz band should be optimum for transmission to the United States. The

best radiation angle for that transmission will depend upon the height and state of the ionosphere at that time. A backscatter system that transmits very short pulses at various vertical angles could tell the broadcaster which radiation angle was returning the strongest signal, and consequently which angle would deliver the strongest signal. Appropriate adjustments in the vertical radiation angle of the antenna could then be made.

## Antennas

The most sophisticated shortwave broadcasting antenna systems are known as curtains, consisting of arrays of dipole antennas erected in a plane and fed from a common source. The dipole antennas are arrayed both horizontally and vertically (one above the other). The number of dipoles erected vertically are called stacks and the number horizontally are called bays.

As the number of stacks is increased, the vertical firing-angle narrows and becomes lower, concentrating more and more energy into a narrower beam as shown in Fig. 3. As the number of bays is increased, the horizontal radiation pattern narrows, again concentrating the energy into a narrower beam as shown in Fig. 4.

In the West, most curtain-antenna systems consist of four bays and four stacks. Such systems provide an antenna gain on the order of about 20 decibels. There is now considerable evidence to indicate that some Russian transmitting antennas, especially those used for long-distance broadcasting, consist of eight bays and eight stacks, giving an antenna gain of the order of about 20 decibels. Furthermore, curtain antennas can be slewed — that is, the vertical and horizontal angles at which the antenna radiates can be varied — by adjusting the phasing of the signals being fed to each bay and stack of the antenna.

Experiments have shown that a gain of from six to 10 dB is possible if the ionosphere's height is properly used. Slewing is one way that the gain can be achieved. It would appear, therefore, that slewing, combined with a backscatter system, is the method used by the Russians to deliver such strong signals to the United States.

The use of optimum vertical radiation angles would also account for the Russian signals' remaining so strong during ionospheric disturbances. We have learned that during certain types of disturbances the ionosphere "tilts" and is no longer parallel to the earth's surface. Such tilts could affect optimum radiation angles, and backscattering for optimum angles would be invaluable.

The Russians tell us very little about their technical facilities, and we can only make some guesses from what we observe. But based on the strength of the signals from the BBC and Deutsche Welle using known antenna gains and transmitter powers, we must conclude that the Russians are using facilities and techniques that the United States will not be able to duplicate for at least three to five years.

Reprinted with permission from Radio Electronics. Copyright © 1981 Gernsback Publications Inc, New York.



# The ROYEL touch . . .

## . . . for high reliability soldering

. . . for the  
beginner or  
home hobbyist



**DUOTEMP**  
Manual temperature control  
3 mm . . . D 30  
5 mm . . . D 50  
Fitted with non-seize tip.

. . . for the  
professional  
engineer, or  
technician on  
the move.



**THERMATIC**  
Line voltage. Sensitive  
in-handle electronic  
circuitry for feedback  
temperature control.

. . . for the workshop that  
demands state-of-the art  
soldering equipment.

**ECT...  
DIAL DIRECT**  
for controlled  
temperature  
soldering and  
desoldering.

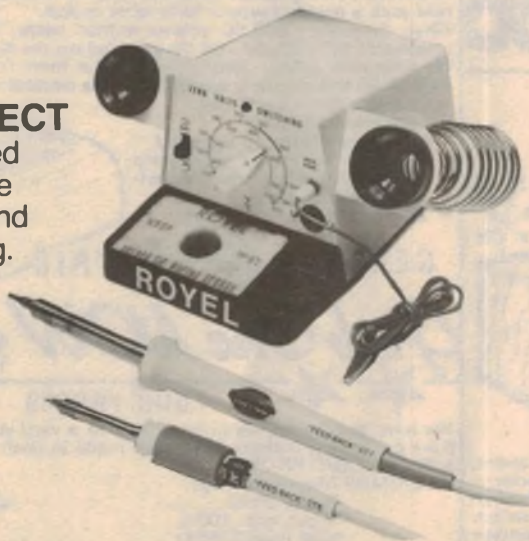

Power unit contains double wound transformer with electrostatic shield for low voltage tools. Infinitely variable direct reading temperature control. Inbuilt temperature lock.  
Features: Zero voltage switching, zero tip potential and auxiliary ground connection for maximum component protection. Large tip-wiping sponge.  
\*Accepts soldering tools CT6 (1/8" tip) or CT7 (3/16" tip).



**FASTER, NON-DESTRUCTIVE  
PACKAGE  
REMOVAL**

Controlled temperature, all-lead reflow solder/desolder accessory enables multi-pin packages to be removed and/or replaced in PC boards at safe temperatures in 2-6 seconds.  
• Operates from ECT power unit.  
CAT. No. AL 130.

Available through trade resellers . . .

# ROYEL

**Royston Electronics**

N.S.W.	(02) 709 5293	QLD.	(07) 277 4311
VIC.	(03) 543 5122	S.A.	(08) 42 6655
TAS.	(002) 34 2233	W.A.	(09) 381 5500

RT001/B



# MORE SPECIALS

## HANIMEX

PRINTING CALCULATOR  
- MASSIVE PRICE BREAKTHROUGH

- Quality Hanimex Brand Model MC 1500P
- 12 Digits, (12 Digit Print Plus D.P. Comma & Two Symbols)
- Seiko Printer
- Uses Standard Plain Paper Rolls (not expensive and hard to get Aluminium coated paper)
- Floating or Fixed Decimal Point
- Selectable % Mode, & most of the usual features found in machines costing well over \$100!!
- A Real Accountant's Special
- Weighs over 3Kg!!
- Roll of Paper Supplied - available virtually everywhere.

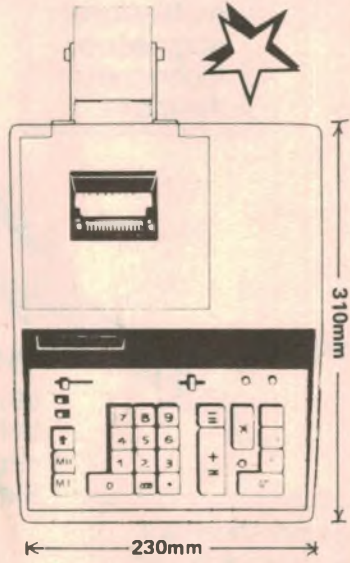

WE ONLY HAVE A SMALL QUANTITY OF THESE UNITS. STRICTLY ONE PER CUSTOMER

Staggering Value **\$5950**

### \* FAMOUS \* GENERAL ELECTRIC

BURGLAR ALARM SLASHED!!!  
HUGE SCOOP PURCHASE - ONCE SOLD FOR OVER \$100

Slashed to  
**\$29.50**



Amazingly low price for a full-feature ultrasonic proximity/burglar alarm. + Completely self contained + 12 month manufacturer guarantee + Instant or delayed alarm + Handsome imitation woodgrain + Cabinet measures 180Wx85Hx100D + Programmable multi-code disable switch + Single 9V Alkaline battery\* lasts one year + Unit beeps when battery gets low + Contains two receiver elements for greater sensitivity without false triggering + Uses State-of-the-art LSI circuitry + Worth the money for parts alone + Comprehensive 24 page manual included + Comes complete with 4 window deterrant stickers + Absolutely no installation needed. \* Battery extra

SAVE A FORTUNE - COMPARES WITH UNITS OVER \$100

Best low cost distress stock - Factory orders to sell.

PCB EDGE CONNECTORS - Lowest in Australia  
- Tell us if we're wrong!!!!

- 0.1" DOUBLE SIDED SPECIALS
- 2x18 WAY GOLD SOLDER 1.9 \$2.50 10+ \$1.95
  - 2x36 WAY GOLD WIRE WRAP 1.9 \$3.25 10+ \$2.50
  - 1x39 WAY GOLD WIRE WRAP 1.9 \$2.00 10+ \$1.50
  - \* 2x85 WAY GOLD WIRE WRAP PCB MOUNT
  - \* CAN BE CUT TO ANY LENGTH METAL END CLIPS 30c ea.
- THIS IS PART OF OUR HUGE BULK PURCHASE. WE ALSO HAVE 0.125" AND OTHER SIZES - CALL IN!!

S-100 0.156" solder tail gold plated pins QUALITY

1.9 \$4.95 10+ \$4.50

S-44 0.156" solder tail Z2 way gold plated QUALITY

1.9 \$2.95 10+ \$2.50

### PLESSEY-FOSTER MORE SLASHINGS!!

We have purchased most of the remaining stock of these high quality units. Grab them now at not-to-be repeated prices.

12" 50WRMS C300K05 Normally \$69.50  
This month \$39.50  
Unbelievable!! Ten pcs or more \$29.50  
SAVE UP TO 57%!!

15" 240WRMS C380K50 Normally \$245  
April Price \$175  
May \$145  
THIS MONTH JUNE \$140

IS THIS WHAT THEY CALL A DUTCH AUCTION??  
HI FI  
12" 20WRMS C300L05 Normally \$29.95  
This month \$19.95  
SAVE \$10.00

Where else would you get a 12" Hi Fi speaker for this price???

8" 20W C200L19 Normally \$15.00  
This month \$7.95  
SAVE \$7.05

5 1/2" 30W Midrange C130M06 Normally \$11.50  
This month \$9.50  
SAVE \$2.00

4" 50W Midrange C120K04 Normally \$5.00  
This month \$2.95  
SAVE \$2.05

6" 10W Widerange C160K03 Normally \$12.95  
This month \$6.95  
SAVE \$6.00



### CONSUMER FLOP

One of the greatest consumer flops of the last decade was the Ionization Chamber Smoke Detector. Even though it is a brilliant product (reliable compact, easy installation, fail-safe etc) it just did not sell. Human nature being what it is finds safety-oriented products just not worth the investment. We all know that accidents and fires never happen to US!! As smoke is the greatest killer in a fire, the market research gurus thought that such a product would have wide appeal.

When they were \$49.50 no-one wanted them. The price fell to a very reasonable \$29.50 and still they stayed on the suppliers shelves. We have now been instructed to clear them for less than 1/2 of \$29.50

- At \$14.50 this device is worth it for the parts alone.
- Contains Americium 241
- Ionization Chamber
- 9V Mallory Duracell included
- Contains very loud solid state buzzer and other useful electronic components.
- 12 month factory warranty



### GENERAL ELECTRIC

Grab One NOW **\$14.50**

### LOGIC PROBES

We have purchased the entire stock of a very well-known supplier. We have probes and pulsers (injectors) made in both the USA & Far East.

MF504 LOGIC PROBE  
TTL/CMOS Minimum Pulse Width 20nS  
Input imp. 100K  
Max Freq 30MHZ  
Multi-LED readout  
Stainless Steel Probe Tip  
Normally \$49.50  
This month \$24.50  
SAVE \$25.00

MF520 SIGNAL GATE  
Used to extend the operation range of probes. Will open "time window" to let logic probe signal state in that window . . . . .  
Normally \$29.50  
This month \$12.50  
SAVE \$17.00

LOGIC PULSER MF512  
TTL/CMOS Will Generate Pulses (10% High 90% High) at 0.5pps or 400 pps  
Output protected  
Normally \$59.50  
This month \$29.50  
SAVE \$30.00



SAVE OVER 50%!!!



# — READ & REAP

## AUTORANGING DIGITAL MULTIMETER SENSATIONAL NEW PRICE!!

This fantastic meter is apparently exclusive to Dick Smith! Well we have been selling a meter that is identical to his Q-1446 except that ours weighs only 250 grams whereas (if you believe his new catalogue) the Q-1446 weighs 250kg. Perhaps that's why his is exclusive!! It certainly is not as portable as ours!!

We have made a bulk buy of these units as well as the model with the buzzer that gives GO/NO GO short circuit checks.

GRAB ONE NOW WHILE STOCKS LAST

— 2 MODELS —

ME533 (Similar to D.S. Q-1446 except that it does not weigh in at 250kg)

**ONLY \$45 SAVE \$4.95**

CLUBS CAN BUY IN LOTS OF 10 (FOR CASH) FOR ONLY \$42.50

ME532 with low ohms buzzer **ONLY \$54 SAVE \$5.95**

CLUBS CAN BUY IN LOTS OF 10 (MIXED WITH ME533 IF YOU LIKE)  
FOR \$52.50 (CASH)

(SAVINGS ARE SHOWN OFF OUR NORMAL PRICES)

\* PLUG-IN \*  
1% CURRENT  
SHUNT (TO 30 AMPS)  
TO SUIT BOTH  
METERS ONLY  
\$8.50

From Only **\$42.50**



**SOAR  
BRAND**

FEATURES: — 3 1/2 DIGITS LCD  
— AUTO RANGING  
— AUTO POLARITY  
— SAMPLING RATE: 2/sec  
— 0-1KV DC +/-1.35% worst case  
— 0-600VAC +/-2.3% worst case  
— 0-2Mohm  
— 0-200mA  
— POWER CONSUMPTION 5mW  
ME532 ONLY — RANGE CHANGE  
INDICATION BY ELECTRONIC BEEPER  
— SHORT CIRCUIT GO/NO GO BEEPER

### AT LAST! REALLY HIGH POWER CAR SPEAKERS AT A LOW PRICE

SCOOP PURCHASE 3-WAY 6x9" 35WRMS 100W/HF MUSIC POWER  
We have snapped up a smallish quantity of a South-American made "NOVIK" speakers.  
They feature a MASSIVE magnet assembly, (we mean it) weighing 570g, 1 1/4" diameter voice coil.  
These speakers are ideal for high power car installations or Hi Fi.  
Available individually. (Note: Due to their size they may not fit into car door panels — 100mm deep).  
THESE UNITS ARE 4 OHMS IMPEDANCE

6x9" Professional grilles to suit \$4.50 each.

**ONLY \$29.50** ea  
(\$59)/pair



### "INTERSIL" LCD PANEL METER EVALUATION KIT

BARGAIN OF THE CENTURY!!! ICL7106EV

This kit has featured in numerous construction projects. Until the Jaycar DPM-200 it was the lowest cost LCD DPM around.  
It normally sells for around \$45.00

GRAB ONE NOW FOR ONLY \$29.50

SAVE 35%!!

KIT INCLUDES:

- High Contrast 3 1/2 digit LCD module
  - Intersil 7106 LSI
  - PCB and all passives
- FEATURES
- +/-1 count over +/-2000 counts
  - Guaranteed zero reading for 0 volts
  - Differential input

**\$29.50** \* Power Supply Not Included



### EXPERIMENTER BREADBOARDS

We stock a great range of experimenter breadboards.

WB-TH — total 200 holes	\$8.95
WB-2N — total 840 holes	\$12.95
WB-4N — total 1680 holes	\$24.50
WB-6N — total 2420 holes	\$39.50



### 470 OHM THERMISTORS (NTC) DISC TYPE

A MUST IN EVERY JUNK BOX

**5 for \$1.00**

### NEED A NEW MUFF??

We keep spare earmuffs for the "Industry Standard" Sennheiser HD-414 Headphones

Maybe you have never seen a blue muff before but ours are and they come in pairs.

**\$3.95 set**

**Jaycar**

125 YORK ST SYDNEY 2000

Ph. 2646688 Telex 72293

Mail Orders To:

Box K-39 Haymarket 2000

Post and Packing charges

\$5-\$9.99 (\$1.20) \$10-\$24.99 (\$2.40)

\$25-\$49.99 (\$3.50) \$50-\$99.99 (\$4.60)

\$100 up (\$6.20)

SHOP HOURS

Mon-Fri 9 to 5.30

Sat 9 to 2

Thurs night to 8pm





A special report by Gene Gregory\*

# Japan: research makes the difference

Japanese electronics manufacturers have astounded the world with their speed of innovation and the range of new products introduced. Japanese success in high technology is not a matter of chance, but the result of a massive pre-planned research effort.

A microelectronics revolution that is already transforming virtually every facet of Japanese industry seems bound to advance even more as major Japanese electronic manufacturers give new emphasis to high technology. Following the successful development of VLSI (very large scale integration) technology, every Japanese electronics firm that expects to be in business by the end of the 1980s has stepped up expenditures on research and development. Most have reorganised their rapidly growing R&D establishments, and an increasing number are appointing technical experts to top management posts.

Investments in R&D by electronics companies which, on average, have been doubling every five years for the

past decade, continue to increase at approximately 15% per annum.

At Hitachi, R&D outlays rose from \$A140 million in fiscal 1972 to \$A492 million in fiscal 1981. The two next largest – Toshiba Corporation and Mitsubishi Electric Company – have been following the same investment pattern. In fiscal 1980, Toshiba boosted its R&D outlay to \$A285 million, an increase in one year from 3.4 to 4.0% of sales, while Mitsubishi raised R&D expenditures 20.9% to \$A200 million, or 4.3% of sales turnover.

Major appliance makers are also preparing to harness VLSI technology. Although Matsushita Electric's strength traditionally has been in its sales power, it has added substantial technological prowess during the 1970s, expanding its R&D annually at about 15%. From 1976 to 1980, outlay by Matsushita's 23 research laboratories rose from \$A228

million to \$A390 million, and produced a whole new generation of integrated circuit applications, which will affect virtually every product of the company's 40-odd independent manufacturing divisions. Among electrical/electronics equipment manufacturers, Matsushita now ranks second only to Hitachi in terms of absolute R&D expenditures.

At NEC, leader in telecommunications and semiconductors and one of the "big three" computer makers, R&D spending also increased 15% in fiscal 1981, more than 2.5 times the outlay for 1977. And although Fujitsu does not regularly publish R&D outlay, they reportedly spend a whopping 9.5% of sales on development.

Global expenditures of Japan's integrated electrical/electronic equipment manufacturers tend to understate the level of investments in high-technology electronics. The particular strength of

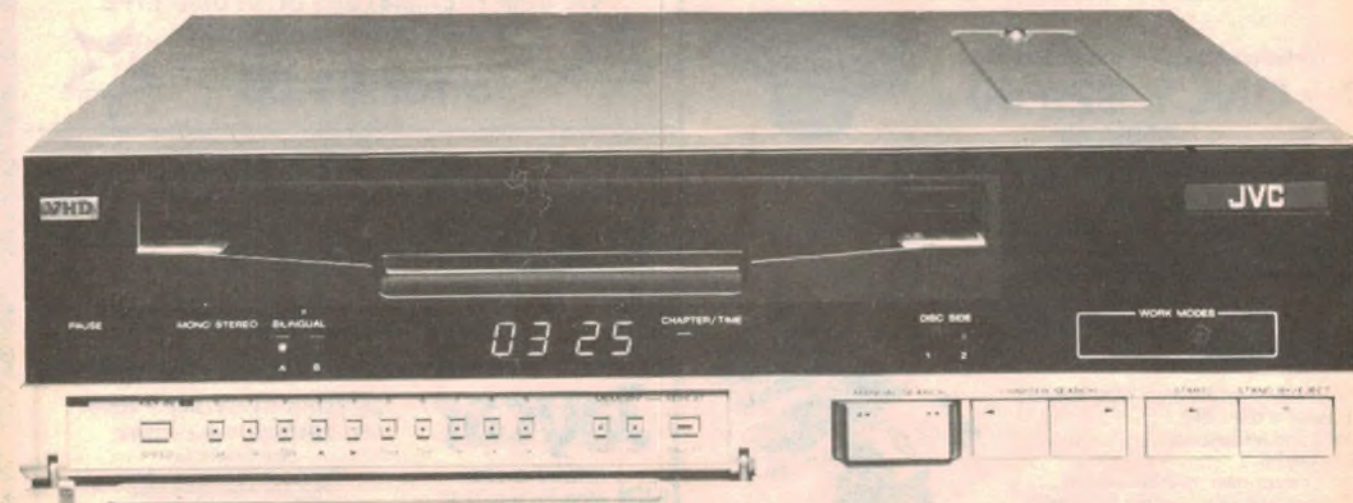

VHD video disc player from JVC uses a front loading disc caddy, provides a wide range of playing modes. (Note: products featured on page 18 and 19 not yet commercially available.)



## Flat screen TV sets from National (below) and Sony (right)



these highly diversified firms is that their large total revenues make possible the concentration of substantial R&D resources in cash-hungry advanced electronics technology.

As a result, R&D spending on integrated circuit research by the 11 top Japanese makers averaged approximately 18% annually during the 1970s; and it continues to run high as makers prepare for production of 256K bit dynamic RAMs by 1983, and 1 megabit RAMs in the second half of the 1980s.

Even those manufacturers of limited highly specialised ranges of integrated circuits are now devoting substantial sums to VLSI research. Sanyo Electric, which commands over 70% of the market for audio amplifier chips, and supplies about 40% of its own IC needs, is a case in point: during the four years 1981-1985, they will spend more than \$A31 million on VLSI research alone.

A critical task now is the development of applications technology. Timing the introduction of new VLSI devices already developed depends largely on market demand, so it has become vitally important to develop applications for the new devices. Competitive power for VLSI in global markets will ultimately depend on how rapidly makers can obtain the combined advantages of high yield large scale production and learning, and these

in turn will be functions largely of the rate of diffusion of the new devices through product application.

In this process of diffusion, Japanese IC manufacturers have a special and often decisive advantage in the diverse equipment they manufacture – including computers, communications equipment, robots, medical equipment, office equipment, home appliances, and audio-visual equipment – which make possible rapid and extensive IC application. Through central laboratory networks, specialised development laboratories, and factory applications engineering, Japanese manufacturers are able to speed the diffusion of new semiconductor technology, obtaining both economies of production of new semiconductors and competitive advantages in product innovation.

The main propulsion for this momentum is provided by intense competition. Despite the large scale of Japanese electrical/electronic equipment manufacturers, which would normally lead to an oligopolistic market, (ie, a few sellers), competition within the Japanese market is fierce. And since the Japanese market for integrated circuits is larger than that of all Europe combined, this competition tends to gear the Japanese industry to a rapid innovation pace.

Added to this primary competitive

thrust are two substantial secondary forces: the race with US semiconductor, computer, and office equipment manufacturers for world markets on the one hand, and, on the other, the increasing competitive threat of South Korea, Taiwan, Hong Kong and Singapore to global consumer goods markets. And, since VLSI circuits make possible drastic reductions in size and cost of many industrial and consumer products, competitive power in the marketplace will depend largely on the timely diffusion of VLSI devices. This entails not only the redesign of the products themselves, but very often major modifications in production processes.

At the outset, when VLSI costs are relatively high, the main opportunities lie in industrial applications. Dimensions and costs of computers will be reduced while performance and functions will be expanded several times by the introduction of logic circuits of several 10,000 gates and dynamic random access memories with capacities of 256K or 1-megabit. At the same time, large-capacity memories using megabit VLSI are speeding the development of voice input-output and image input-output systems, as well as Japanese alphabet printers.

Research laboratories are therefore reviewing virtually every industrial elec-



## "Virtually every Hitachi product is being re-designed"

tronic product for possible advantages in the new VLSI technology.

Likewise, consumer electronic products and their manufacturing processes are being subjected to the same kind of technological reassessment. Home entertainment equipment, household appliances, cameras, automobiles, toys and games will all undergo major transformations, while a whole generation of new devices such as home facsimile, personal computers, and word processors, will appear as soon as VLSI circuits are available at low prices. More accurately, as soon as these products have been re-designed or developed for the market and a demand created, the volume production of VLSI devices, which is necessary to bring their costs down, will become possible.

The implications for equipment and integrated circuit manufacturers are far-reaching. Depending upon the rate of innovation, markets built up over long years could vanish in a year or two. For other makers, of course, this means that the timely introduction of new products can bring rapid improvements in market share in an equally short time.

The recent "flash from nowhere" by Japanese semiconductor makers to take 40% of the world market for 16K dynamic RAM devices and an even larger share for 64K dynamic RAM devices is but a foretaste of things to come. Similarly, personal computer manufacturers in Japan recently increased their combined market share from 20 to 80% in a year or so, and this will no doubt be repeated for a vast range of products in many markets.

Japanese manufacturers were able to move rapidly to obtain large shares of world markets, despite early leads by American manufacturers, because of superior mass production capabilities and higher quality; achieved through more capital and a more appropriate management system. And these advantages are likely to serve Japanese firms equally well in future direct confrontations for market shares.

But such competitive advantages, in the absence of a strong lead in technology, tend to breed trade friction and the inevitable protectionist measures which follow. Moreover, competitive power based upon mass production capabilities peculiar to the Japanese business environment is not readily transferred to offshore production sites, and this is becoming increasingly necessary to abate protectionist pressures.

A strong position in original technology — as earlier US leadership in computers and semiconductors clearly showed, and Japanese leadership in VCRs confirms —

gives manufacturers more options, greater flexibility, and greater bargaining power.

In addition, the more advanced electronic technologies are clearly energy-saving, materials-saving, space-saving, and manpower-saving. And, no less important, they assure stability in foreign exchange earnings as well as bargaining power with "resource-rich" countries, which will improve conditions of raw materials and energy supply.

Innovation, in both VLSI design and application, has therefore taken on a much greater importance than in earlier generations of integrated circuit development. To speed innovation, not only are Japanese electronic manufacturers spending more on R&D and on equipment required for new production processes, but R&D activities are also being restructured to assure greater flexibility to changing market demand and increasing competition.

sales of these products.

Reflecting this corporate change, capital expenditures during the past five years have shifted from heavy electrical apparatus and consumer products to industrial electronics. According to Nomura Research Institute, Hitachi's capital spending in electronics has increased by about 20% annually over the past five years, with particular emphasis on micro-electronics and its applications. And the appointment of Katsushige Mita, an engineer who has played a major role in the development of Hitachi's industrial electronics activities, suggests that this trend will continue. Mita has made it clear that he wants industrial electronics to account for at least 30% of total sales within five years, up from 19% in fiscal 1980.

The main thrust of Hitachi's R&D is on basic and electronics research. Although 30% of current R&D expenditures concern basic research, this percentage is



Multi-colour LCD dashboard developed by Optex Corporation, Tokyo.

Since its founding 70 years ago, Hitachi Ltd has placed heavy emphasis on R&D to decrease its reliance on imported technology. Research and development operations, which employ more than 10,000 research personnel in 13 laboratories, are diverse and wide-ranging, reflecting the comprehensive range of Hitachi's electrical and electronic products. But in the past five years, as total R&D outlay mounted steadily, the company shifted its emphasis in allocation of funds and personnel sharply toward electronics.

While Hitachi's increase in R&D expenditures, to \$A492 million in fiscal 1981 from \$A139 million in 1972, has been nothing less than spectacular, the company's emphasis has been more that of a specialised electronics manufacturer than an electrical/electronics company. During the past decade, R&D spending at Hitachi has been largely due to heavy outlays for computers and semiconductors; between 13 and 15% of annual

slated to rise, reflecting the importance which the company now attaches to developing its own technology. Several high priority basic research programs are currently underway:

- At the Consumer Products Research Centre, virtually every Hitachi consumer product is being re-designed, and new ones developed, to replace mechanical with electronic systems wherever possible;
- The Hitachi Research Laboratory is developing new materials and electrical machinery employing new basic technologies;
- Solar power, nuclear fusion, and the improvement of coal-fired generating facilities are under development at the company's Energy Research Laboratory; and
- Special emphasis is being given at the Systems Development Laboratory to new technologies that integrate the considerable range of Hitachi's technological expertise.



## US manufacturers gear up for battle

Japanese manufacturers have 70% of the world market for 64K memory chips, and that fact is causing considerable concern for the United States Government. Although plans are in the early stages, some reports indicate that the US Government may resort to seldom-used provisions of US trade laws which allow the President to restrict imports which "pose a threat to national security".

The Government's fear is that the imports will prevent the development of an effective manufacturing capacity for the chips in the United States. US military leaders maintain that lack of domestic computer memory chips

could leave the country vulnerable in war-time.

In response to these concerns, the Japanese Ministry of International Trade and Industry (MITI) has asked leading manufacturers of RAM chips to voluntarily restrict the quantities of chips exported to the United States, and to use "discretion" in future export campaigns.

Seeking another answer to Japan's increasing dominance in high technology areas, William C. M. Norris of Control Data Corporation in the United States has proposed that US microelectronics and computer manufacturers begin joint efforts in research and development.

Norris is the chairman of CDC, and

his words carry considerable weight in industry circles in the United States. In February this year he presented a draft prospectus for the formation of a joint venture company called Microelectronics and Computer Technology Enterprises Inc, intended to allow United States companies to co-operate rather than compete with each other when faced with rising foreign competition.

Most US commentators believe that government sponsorship of cooperative basic research in Japan gives the Japanese an unfair advantage in the world market, ignoring the fact that much of the funding of their own industry comes from military projects.

The result is some of the world's most advanced systems, including the first integrated production process computer control system using optical fibres, water purification and waste water treatment control systems, a highway monitoring control system, and building administration systems.

To develop new production systems which at once use these new technologies and manufacture new products employing them, Hitachi has established a Production Engineering Research Laboratory which, among other achievements, has kept Hitachi in the forefront of robot manufacture and application. In addition, there are independent research groups in each factory, coordinated by special research centres, which administer and promote major R&D plans.

At Toshiba Corporation, to boost the company's innovative capabilities, a General Technology Committee was established in 1978 to formulate overall technology policies. The same committee was further charged with supervising technology strategies coordinating all Toshiba new product and production technology development.

An increase of R&D expenditures by 2.5 times in the past five years has spurred a similar expensive reorganisation of NEC's R&D activities. To obtain greater overall research flexibility, NEC's management, in July 1980, restructured the company's Central Research Laboratories in Kawasaki, spinning off six separate laboratories: basic technology research, opto-electronics research, C&C (computers and communications) systems research, software product engineering, resources and environment protection research, and a scientific computer centre.

These six laboratories have clearly defined goals for developing new basic information technologies; the main innovative force of the future. Research in opto-electronics and advanced computer software is given special emphasis in this new arrangement; two critical fields where Japanese technology still lags behind American leaders. At the same time, the new structure is intended to integrate developments in these respective fields into a powerful, comprehensive whole with particular stress on combinations of new technologies.

This pattern of intensified investment in R&D and shift to industrial electronics by heavy electrical and communications equipment makers has its parallel in developments at the leading consumer appliance makers such as Matsushita, Sanyo and Sharp. Again, R&D organisations have been restructured to assure rapid development of VLSI technologies and their application to consumer products.

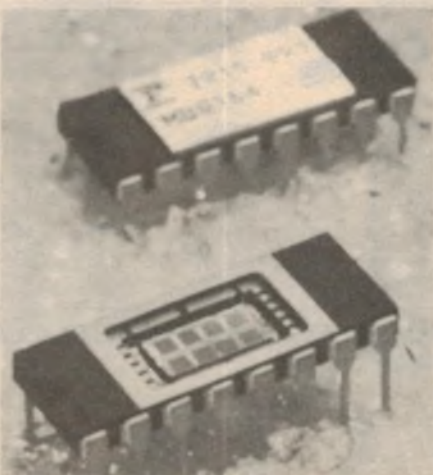

64K RAM chips from Fujitsu.

At the same time, each of these major home appliance makers is diversifying into office automation equipment, a process which began at Sharp in the late 1960s with the development of the first electronic calculator. Each is also investing heavily in solar energy technology, having added research and development of amorphous solar cells to their solar energy projects.

If the mounting wave of R&D activity by electronic equipment manufacturers, and their continuing shift of resources to the development of new electronics technology, are paramount forces in the incipient VLSI revolution, they are but symptomatic of a prevalent burst of innovative activity throughout the industry. Specialised research laboratories at Fujitsu Fanuc, Sony, Japan Victor, Pioneer, Omron, Canon, TDK, Kyoto Ceramics, and a legion of smaller manufacturers of new materials, components, instruments and machinery, add further prodigious innovative force to the development of new high-technology electronic products and production processes.

The upshot of this explosion of R&D activity, as Matsushita Electric made quite apparent at its special technology exhibition in Chicago last June, will be a widespread transformation of home, office and factory, making the 1980s the age of the semiconductor.

Japanese industry is clearly determined to demonstrate the full measure of its creative power, and all indications are that creativity will find its foremost manifestation in the ingenuity with which manufacturers combine silicon chips with almost everything, transforming more and more products through the magic of memories and micro-processors.



**WILL**  
**YOUR BUDGET PROBABLY WON'T STRETCH TO AFFORD OUR PROFESSIONAL SERIES ALL ALUMINIUM RACK CABINETS**

NOW YOUR PREAMPS, AMPS, CONTROL MODULES MONITOR PANELS ETC. CAN LOOK EVERY BIT AS GOOD AS TECHNICS, NAKAMICHI AND OTHER TOP MANUFACTURERS

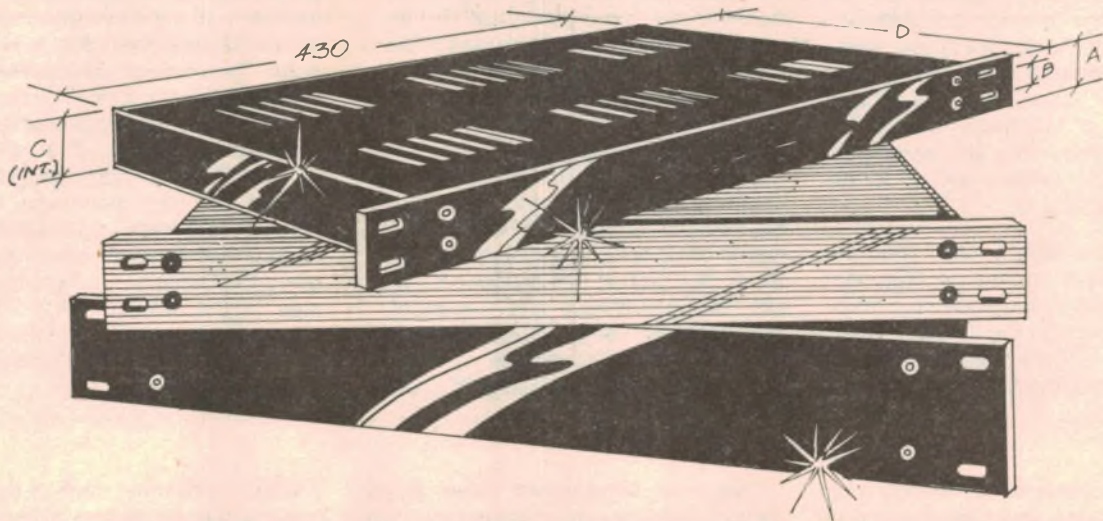

**THREE YEARS AGO** or so we were selling nicely finished racking cabinets for around \$60-\$70 but, alas the maker kept increasing the prices until we would have had to sell them for a price way beyond the reach of the average constructor - so, sadly we discontinued the range.

**MASS PRODUCTION TOOL UP SLASHES COSTS** Well, of course, the demand for our rack cabinets continued, so to meet the challenge of high labour and handling costs we have tooled up with all the necessary dies etc. to mass produce high quality precision finish rack cabinets to International Dimension Standards with remarkable cost savings.

**SIX NATURAL AND BLACK FINISH MODELS** The Black or Natural finish cabinets are each available in 44mm, 88mm or 132mm high models. Mounting hole centres conform exactly to International racking specifications both vertically and horizontally.

\* These beautifully crafted rack cabinet boxes will give your equipment a real 1st class appearance. \* All aluminium construction. \* REMOVABLE TOP AND BOTTOM PANELS. \* All dimensioning conforms to the International standard. \* Natural or Black finish. \* Ventilated lid. \* Deluxe brushed

finish anodised front panel. \* Individually cartoned. \* Supplied in Flat Pack Form - Easily assembled in minutes.

**Side Elevation:**  
 D = 254mm C (Internal Chassis Height)  
 B (Mounting Bolt Centres)

**INTRODUCTORY PRICES**

Cat. No.	Finish	A	B	C	PRICE	5 or More
H 0401	Natural	44	34	38	\$39.50	\$38.00
H 0402	Natural	88	57	82	45.00	42.50
H 0403	Natural	132	89	126	49.50	45.00
H 0411	Black	44	34	38	39.50	38.00
H 0412	Black	88	57	82	45.00	42.50
H 0413	Black	132	89	126	49.50	45.00

Beware of other rack boxes that do not conform to international rack sizing.

**INCREDIBLE SAVINGS ON SCREWS AND SPACERS**

Yes we are now producing huge quantities of hardware overseas - all to exacting quality standards - all quality plated and all at a fraction of the price your used to paying

**1/8th inch WHITWORTH STEEL NUTS AND BOLTS ROUND HEAD ZINC PLATED**

Length	Pack Qty.	Price
H 1000 9mm	25	.65
H 1002 9mm	500	4.25
H 1005 12mm	25	.65
H 1007 12mm	500	4.75
H 1009 25mm	25	.75
H 1011 25mm	500	6.50
H 1020 Hex Nut	30	.65
H 1022 Hex Nut	500	5.00
H 1030 S/Proof Washer	50	.80
H 1032 S/Proof Washer	500	6.20
H 1040 Flat Washer	50	.65
H 1042 Flat Washer	500	5.00

Huge Savings with Trade Packs (Contents: 500)

**BA NUTS AND BOLTS Bolts Plated Round Head Steel, Nuts Brass**

	Pack	Price
H 1050 4BA x 12mm	25	.75
H 1052 4BA x 12mm	500	5.70
H 1060 6BA x 12mm	25	.75
H 1062 6BA x 12mm	500	6.25
H 1070 Nut Hex 4BA	25	.75
H 1072 Nut Hex 6BA	500	12.50
H 1082 Nut Hex 6BA	500	7.50
H 1090 4BA S/Proof Washer	50	.75
H 1092 4BA S/Proof Washer	500	5.95
H 1095 4BA Flat Washer	50	.75
H 1097 4BA Flat Washer	500	5.95

**SELF TAPPING SCREWS Cadmium Plated Steel**

	Pack	Price
H 1100 No. 4 x 6mm	25	.65
H 1102 No. 4 x 6mm	500	3.95
H 1110 No. 4 x 12mm	25	.70
H 1112 No. 4 x 12mm	500	4.95
H 1120 No. 8 x 12mm	25	.75
H 1122 No. 8 x 12mm	500	6.50

From less than 1c each.

**SPACERS (STANDOFFS) SUPERB NICKEL PLATED BRASS**

UNTAPPED 4 BA or 1/8" CLEARANCE

TAPPED 4 BA

Cat.	Length.	Pack Qty.	Price	Cat.	Length.	Pack Qty.	Price
H 1305	6mm	8	.95	H 1379	9mm	8	1.00
H 1359	6mm	100	8.50	H 1380	9mm	100	9.50
H 1372	12mm	6	.95	H 1383	12mm	8	1.20
H 1373	12mm	100	11.00	H 1384	12mm	100	12.50
H 1375	25mm	4	.95	H 1387	25mm	4	1.00
H 1376	25mm	100	15.00	H 1388	25mm	100	16.00



## AT DOUBLE THE PRICE OUR DAINICHI HIGH FIDELITY SPEAKERS WOULD STILL REPRESENT OUTSTANDING VALUE

Altronics have teamed up with one of Japans most respected speaker designer/manufacturers (Dainichi manufacture OEM speakers for Pioneer) The result, an outstanding range of pure fidelity speakers available to you at IMPORT PRICES for which we will no doubt incur the wrath of our competitors.

**CONE TWEETER 50 WATT**  
50 watt max. power 8 OHM Z.

Amazing performance budget price.  
Frequency response 2 KHZ-18 KHZ 110mm Diam. Hole centres 79 mm. Australia's best value at this price.



C 3020 . . . . . \$7.50  
4 or more . . . . . \$7.00

**DOMTWEETER 60 WATT**  
60 watt max. power.

Silky smooth frequency response 1.5 KHZ to 20 KHZ Wide Angle dispersion. Massive power handling capacity. Diam. 94 mm. High spectrum Purity. Incredible low price!



C 3010 . . . . . \$14.50  
4 or more . . . . . \$13.50

**MIDRANGE 50 WATT**  
Midrange clarity that has to be heard to be appreciated!

Absolutely 1st class reproduction of mid-range - piano, vocal, guitar, violin etc. Huge 50 watts max. input. 8 OHM. Frequency response 700 - 5 KHZ. Value Plus!



C 3030 . . . . . \$17.50  
4 or more . . . . . \$16.90

**WOOFER 307 mm (12 in.)**  
40 watts max. power 8 OHM.

Roll edge cone suspension. Resonant to 30 HZ. Frequency range 30-2 KHZ. Smooth, faithful bass speaker. Ideal Hi-Fi replacement. 48 mm voice coil.



C 3040 . . . . . \$29.50  
4 or more . . . . . \$27.50

**OUR MAX POWER RATINGS** are conservative RMS ratings NOT music power or peak power ratings that some manufacturers quote.

**MAKE UP A LOW COST STEREO SYSTEM** The combination of C3010/C3030/C3040 will enable you to make up a simply superb speaker system for less than \$150 (less cabinets) - send stamped addressed envelope for enclosure and crossover designs.

### GREAT NEW MOSFET PA AMPLIFIER KIT FROM ETI.

See June '82 150 watts power output.



**UNCONDITIONALLY STABLE SOUND STUDIO SPECIFICATIONS**

**OUTPUT IMPEDANCE** Selectable to low Z voice coil or 100V or 70V line out.

**INPUTS** 2 mic inputs HI or low Z with speech filter.  
1 Aux input.

- Low noise 5534 op amps used
- Noble W/wound power resistors used in output stage for guaranteed stability.

K5030 complete kit as illustrated \$239.00

OR

want a Deluxe studio format finish?

The above kit is also available housed in the superb H0413 racking cabinet.

K5035 . . . . . \$269.00

### ETI 469B PERCUSSION SEQUENCER KIT

Use with the ETI 469 percussion synthesiser. Programmes 8 beats per sequence. Fully synchronised and variable tempo.

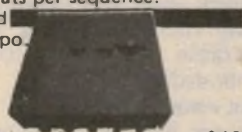

K1042 . . . . . \$19.50

### GUITAR PREAMP KIT

SEE EA JUNE '82

NOW YOU CAN OPERATE YOUR GUITAR DIRECT INTO ANY HIFI AMP.

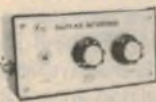

K 1080 . . . . . \$14.50

### GO ANYWHERE 240V PWR. KITS

See EA May and June 82. These great new inverter kits enable you to power 240V appliances for your car, caravan or boat.

#### 40 WATT

Suits small appliances i.e turntable, tape deck, shaver etc.



K6700 . . . . . \$55.00

#### 300 WATT

Use to power HIFI, TV set, mains lighting etc. Fully regulated and overload protected



Low age rate xstal used. All sockets provided for IC's.

K6750 . . . . . \$185.00

### THEREMIN KIT

SEE EA JUNE '82

SUPERFUN WEIRD AND WONDERFUL MUSIC AND SCIENCE FICTION SOUND GENERATOR - WORKS ON HAND CAPACITY.



K1200 . . . . . \$29.50

### SUPERB PEN WATCH

\$12.50 VALUE, ABSOLUTELY FREE WITH EVERY ORDER OF \$100 or MORE!

Offer expires 31/7/82  
Uses standard Parker refills  
Includes gift box and instructions

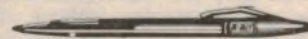

CAT X1000 . . . . \$12.50 if purchased sep.

### NEW 24 HOUR 7 DAYS P/WEEK PHONE ORDER SERVICE FOR BANKCARD HOLDERS

Take advantage of "off peak" low STD phone rates and phone your order to our new recorded 24 hour order service. Give your name, address with postcode, phone number, bankcard number and expiry date then your order - and presto your order will be processed and back to you in a flash - Please nominate Jetservice if you want overnight delivery.

**\$2 Delivery Australia Wide:** We process your order the day received and despatch via Australia Post. Allow approx. 7 days from day you post order to when you receive goods. Weight limited 10kgs.

**\$4 Delivery Australia Wide:** We process your order day received and despatch via Jetservice for delivery next day.

Bankcard Holders can phone order up to 8pm: (EST) for next day delivery - Sounds incredible doesn't it? Alright you cynics just try us! Weight limit 3.3kgs. Jetservice cannot deliver to P.O. box numbers (Australia Post would have a fit!!)

**ALTRONICS**  
105 Stirling St. PERTH  
(09) 328 1599  
for instant service

All MAIL ORDERS:  
BOX 8280 PERTH  
Stirling St. WA 6000

ALTRONICS ... ALTRONICS ... ALTRONICS ... ALTRONICS ...

ALTRONICS ... ALTRONICS ... ALTRONICS ... ALTRONICS ...





# FORUM

Conducted by Neville Williams

## Why don't (we) journalists get things right?

During recent weeks, I seem to have been collecting letters of complaint about the way technical subjects are dealt with in the popular press. "If that's how they handle electronics", readers say, "what credence can we attach to the coverage of other subjects?"

We, too, have noticed technical howlers at various times and it would be easy, at this point, to indulge in ridicule and belly-laughs at the expense of the writers concerned. But we are restrained by a certain fellow feeling and by the thought that "There, but for the grace of God, go I!"

In thinking about journalists, whether writers or broadcasters, we tend to forget that they are not necessarily experts in any particular subject. Their basic specialty is that of communicating information and ideas by the efficient use of words, written or spoken, supported by pictures, where appropriate.

The information is assembled from available sources, duly processed and then communicated to readers, listeners or viewers.

For sure, some journalists do tend to concentrate on a certain subject area and they may become so familiar with it that they are accepted as almost an authority in their own right. But, even so, they still have to rely on others for information which is beyond their own resources. (And so do we, at "Electronics Australia"!)

### "OTHERS" FALLIBLE

Unfortunately, the "others", whom they (we) choose to consult, may or may not have accurate knowledge (despite their pretensions) and their judgment may or may not be inhibited by commercial or political loyalties. Beyond that, they may or may not be able to express technical ideas succinctly enough for a journalist to grasp them and re-express them in language which can be comprehended by non-specialist readers.

In some instances at least, the blame for garbled newspaper and magazine

reporting must rest with those who know but who are too aloof, or too preoccupied, or too inhibited to pass on the unvarnished facts to someone who is seeking them on behalf of readers/listeners/viewers.

A perfect example of this occurred last year when the media, on behalf of the public, was seeking an explanation for the sudden power crisis in New South Wales.

Christopher Jay, for the "Australian Financial Review", was one of many writers who tried to uncover the facts but the lack of hard information made it an up-hill assignment. He was accused of getting things wrong by some of the parties involved, whose own statements, at times, seemed to be as open to debate as the article they challenged.

### WONDERLAND

We took the matter up in our October '81 issue and, with tongue planted firmly in cheek, likened the whole affair to a chapter out of "Alice in Wonderland".

This prompted a letter from a seemingly well informed employee of the State Electricity Commission who, apparently unaware of official reticence, deplored the unwillingness of reporters to put straight questions to the people who knew the answers. This done, he proceeded to give us his version of what had triggered partial collapse of the system. This was summarised in our January '82 issue.

However, as it turned out, all of this proved to be a skirmish before the main battle and now, months later, the State is still facing a continuing crisis, with a significant part of its generating capacity immobilised.

How come?

The answer to that question depends on whom you prefer to listen to – and I'm not talking here about journalistic opinion.

Some people near the top of the technological tree are maintaining quite firmly that the crisis is directly traceable to poor equipment design and, by inference, to an unwise choice at the time of purchase.

### ON THE OTHER HAND . . .

Others are claiming, with no less credibility, that good equipment has simply been run into the ground – the victim of inadequate attention and maintenance.

In fact, the issues are many and varied and the State Government has responded, in part, by referring the whole matter to the State Ombudsman, whose report has yet to surface.

Which brings me back to the point I was trying to make earlier: a journalist/writer can hardly be expected to get things totally right when his legitimate sources of information are so inhibited, so devious and in such utter conflict that they bewilder the State Government itself and test the considerable resources of the State Ombudsman!

But enough of that.

To get back to the letters referred to earlier, the first comes from a Sydney reader who, for some strange reason, must have been thumbing through a two-year-old copy of the Sydney "Daily Telegraph". In it was a feature prompted by the opening of two new commercial FM stations: 2DAY-FM and 2MMM-FM.

After explaining that Sydneysiders must expect good and bad areas for FM reception, the writer continued:



**"FM radio is superior to AM because of its cleaner signal and truer sound. The quality of FM is equal to that of a good stereo home system."**

Fair enough, but it was the next paragraph that set our correspondent back on his haunches and I, too, must confess to a double-take, when I read it.

**"Technically, FM gives a better reception because the S-shaped AM sound waves are flattened out and lengthened."**

Ouch!

This is an example, if ever I saw one, of a writer venturing beyond his technical depth.

It invokes a picture of someone poring, with considerable puzzlement, over the traditional line drawings of an amplitude modulated and a frequency modulated carrier wave and then trying to explain what they saw. Seemingly a clear case of the blind leading the blind!

I guess that most of us, at times, are guilty of discussing things we don't know much about.

The real problem arises when we know so little of the things we are talking about that we don't even realise how little we know!

## **"HELPFUL" HINT**

Letter number two was from another Sydney reader correspondent who was listening contentedly to one of the local FM stations when they broadcast this "helpful" hifi tip:

**To get the best out of your LP records, moisten them with water just before you begin to play them.**

That didn't seem to accord with what he remembered having read, some time previously, in a copy of "Electronics Australia", which he proceeded to turn up. What we have is a carbon copy of his letter addressed to the station management and quoting "Electronics Australia", June 1979, pages 29 through 32.

In this case, it is probably fairly safe to assume that the helpful man at the mic did not invent the idea himself of moistening LP records before playing them. The idea has been around for many years and may well have been passed on, in good faith, from an apparently reputable source.

What's more, it is supported by a certain primitive logic: If most of the wear and some of the noise in a disc system is occasioned by stylus/groove friction, reduction of that friction by a film of moisture should be helpful.

But it appears that such is not the case and the strongest evidence that I know of, to that effect, emerged from research work performed by Stanton Magnetics Inc, in the USA, with the aid of an electron microscope. We reported this work

in the June '79 issue and the final part of the article read as follows:

*Last but not least, Alexandrovitch uncovered some fascinating evidence to do with the playing of discs when the surface had been deliberately wetted. An instinctive reaction would be to expect a reduction in groove wear because of lubrication of the surfaces.*

*In fact, the opposite appeared to be the case, with a thin film of water producing a quite unexpected deterioration of the vinyl in the area of stylus contact.*

*The explanation appears to be that, under the pressure of a fast-moving stylus, the vinyl actually liquefies momentarily at the point of contact. The stylus therefore floats on this liquid film, which, of course, solidifies immediately afterwards.*

## **TOO COLD TO SKATE**

*The Author likens this to ice skating, where the metal blade does not really skate on ice at all, but on a very thin film of water, due to momentary melting of the ice. He points out that, if the temperature is too low for this to happen, one simply cannot skate!*

Tests at Stanton Magnetics Inc have shown a definite connection between ambient temperature and the tendency of the vinyl surface to tear under pressure at the point of stylus contact. It seems likely that the cooling effect of water on the groove surface prevents the vinyl from behaving in a liquid/elastic fashion, thus increasing rather than decreasing surface abrasion.

So much for wetting the surface of LP discs.

From HS in Bulimba, Qld comes a letter carrying "greetings from the Sovereign State of Queensland, to all of the unfortunate denizens of the Land of Daft Time."

I imagine that the above was phrased with pen in cheek!

He goes on to say that he came across a copy of "Choice" magazine in his local library and found in it a review of certain AM/FM receivers. Contained in the review was a statement which I paraphrase as follows:

**Broadcasts on the AM band cannot be of true high fidelity, if only for the reason that the highest frequency which can be transmitted is 4.5kHz. Any modulation frequency higher than this would interfere with neighbouring stations. Indeed, none of the receivers examined took full advantage even of this range, the best of them having a response to only 3.6kHz.**

Here it would seem, the writer has drawn some highly dubious conclusions from circumstantial evidence.

The first is the hoary old assumption

## **UV LIGHT BOX**

- 4 X 20" UV Tubes
- Electronic Timer
- Sliding Tray
- Safety Micro-switch  
\$295.00 (+S.T.)

## **DEVELOP/ETCH TANK**

- Rigid PVC
- Heater
- Standard Hose Fittings
- 24" Wide 12" High  
\$195.00 (+S.T.)  
2 Compartment  
\$285.00 (+S.T.)  
3 Compartment

## **IDEAL 'IN HOUSE' EQUIPMENT FOR USERS OF:**

- RISTON 3000 or other Printed Circuit Board
- 3M Scotchcal
- 3M Image 'N Transfer
- Electroplating

**DISTRIBUTOR ENQUIRIES WELCOMED**

**KALEX**

101 Burgundy St.  
Heidelberg 3084  
(03) 458 2976  
Telex AA 37678  
MELTON  
(03) 743 1011

**ELECTRONIC COMPONENTS & ACCESSORIES**

- SPECIALIST SCHOOL SUPPLIERS ●



## We're happy to oblige, H.S.

Dear Mr Williams,

Your somewhat angry reply to my last letter, back in July 1980, made me resolve never, ever, to write again to any editor for any reason whatever and I have resisted, nobly, any temptation to do so since that date.

However, your January 1982 Forum tempted me and I unable to prevent myself from bending it a little in the form of a request.

Please, Mr Williams, I ask — nay, I beg — you to kindly ask your resident cartoonist to illustrate your, in my opinion, deathless prose which follows:

“... the media started asking questions, only to be fac-

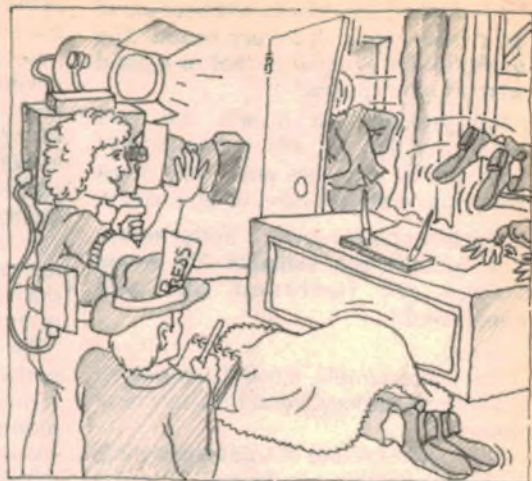

By staff cartoonist, Andrew Powell.

ed by politicians and supply authorities ducking for cover in all directions.”

Yours Faithfully,  
H.S. (Bulolo, PNG.)

that the highest modulation frequency must not exceed half the separation between adjacent channels. With a channel separation in Australia of 9kHz, that would mean a maximum modulation frequency of 4.5kHz.

In fact, normal practice is to allow the sidebands to run almost to the adjacent channel, so that the effective audio bandwidth, as transmitted, approaches 9kHz. This is not as good as for FM but it is a whole lot better than implied in the “Choice” report.

To minimise the risk of interference between AM radio stations, it is normal practice to allocate adjacent channel frequencies only to stations which are geographically isolated from each other. In some cases, the authorities also stipulate the use of directional transmitting antennas.

It is unfortunately true that AM receiver manufacturers rarely provide the front-end bandwidth to take full advantage of the AM transmission actually available. They settle for a compromise based on simplicity and economy and tolerated by their customers, thereby passing up the chance to enjoy some excellent quality AM transmissions.

Even so, I do wonder at the figure of 3.6kHz quoted by “Choice” as the upper frequency limit of the best receiver on test. Most receivers have a quite rounded selectivity curve, with no abrupt high frequency cut-off. A lone figure of 3.6kHz, unqualified by a decibel reference, really doesn't mean a great deal.

The remaining item was a clipping from “The Australian Financial Review”, dropped in to our office by an interested EA reader.

Under the heading “Hifi Speaker Breakthrough”, the article sought to make the point that it was no longer necessary to rely on high power amplifiers (eg 80W per channel) to provide adequate hifi listening; that a new generation of higher efficiency loudspeakers could provide the same sound levels with less power input.

### HALF RIGHT OR ... ?

As a statement, I regarded it as about half right — which is about the same as branding it half wrong!

But then I read that the breakthrough which made this possible was the work of two Australian “acousticians”, Messrs A. N. Thiele and R. H. Small. That, too, is half right; Dr Dick Small is an American on the staff of Sydney University. But I quote:

“By measuring the various factors of moving parts within a speaker and the air

vibrating in the cavity, they managed to calculate the various factors needed in speaker design to bring about high fidelity with low power input.”

The reader could be excused for concluding that Neville Thiele and Dick Small had aimed at and achieved this design objective — a conclusion that would be supported by the final paragraph:

“It should now be possible, given the efforts of Messrs Thiele and Small, to buy a system of no more than 25 watts per channel, which will give you true fidelity sound performance.”

That hardly accords with the position, as I understand it.

Thiele and Small's work has been published in a whole series of papers and, most recently, was examined and extrapolated in two papers by Brian Davies in our August and September issues for 1981. (Brian Davies is Reader in Theoretical Physics at the Australian National University, Canberra, ACT).

The prime aim of the work was to investigate and rationalise the behaviour of bass drivers in sealed and vented loudspeaker enclosures. This they succeeded in doing extremely well, rendering obsolete a large amount of earlier literature based on inadequate data and observations.

If there was any “breakthrough”, this was it although, in conversation, Dick Small disowns the word.

Thanks to Thiele and Small, and others, it is now possible to predict with accuracy the behaviour and relative merits of sealed and vented enclosure designs and to make an optimum choice to suit individual circumstances.

The design of vented enclosures and of bass drivers to suit them has even been

translated into computer programs. Data can now be digested and processed in seconds that would once have taken hours of figuring with paper, graphs and slide rule.

But here's the bottom line: it has also become evident that a trade-off situation exists between bass response and efficiency. If you want extended bass response, you have to sacrifice efficiency — or use a bigger enclosure. Or you can insist on efficiency and sacrifice response. Yet again, you can sacrifice both response and efficiency in order to achieve small size.

### NO MAGIC

What Thiele/Small-based data does NOT do is to provide any magic key to notably high efficiency PLUS notably extended bass response PLUS a notable degree of compactness or economy.

More than that, the Thiele/Small work is directed mainly at bass-end performance below about 200Hz. True hifi reproduction requires no less concentrated attention on the middle and upper register.

So, should we blame the writer in “Financial Review” for what would seem to be debatable emphasis?

Perhaps not.

Without being able to pin down a specific case, we have noted enough casual remarks about higher efficiency, higher fidelity and the invocation of Thiele/Small research to add up to a false impression.

Perhaps, before throwing stones at a journalist, members of the hifi industry should make sure that they are not, themselves, living in a house fabricated from a brittle, translucent non-crystalline form of silica!



**MORE OPPORTUNITIES TO SAVE!**

# DICK SMITH OPENS 2 NEW STORES

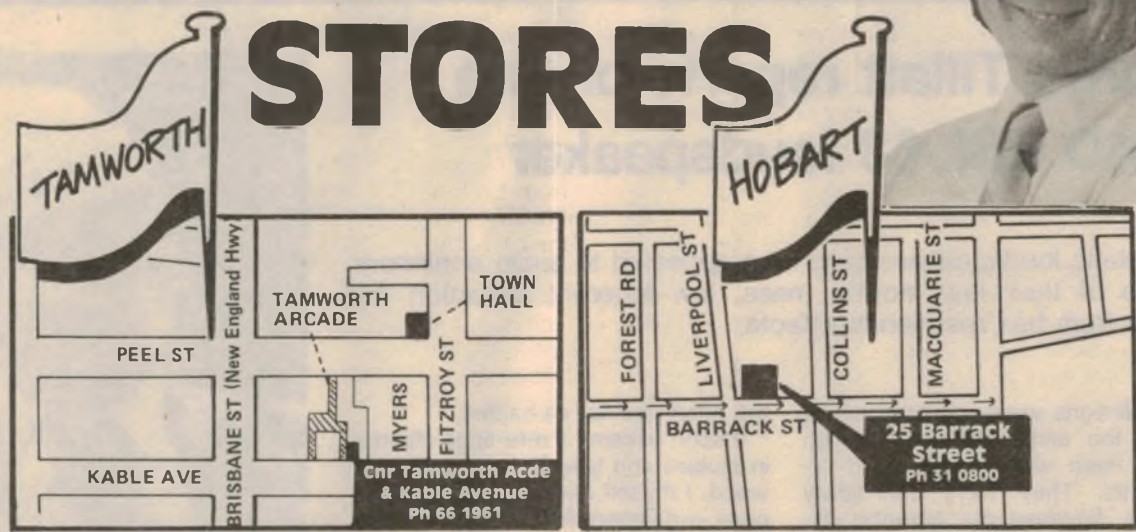

## DICK SMITH ELECTRONICS



### MAJOR DICK SMITH RESELLERS

- ATHERTON, QLD:** Joe Sue's Radio Service  
55 Main Street Phone 91 1208
- BENDIGO, VIC:** Sumner Electronics  
7 Edward St. Bendigo Ph 43 1977
- BALLINA, NSW:** A. Cummings & Co  
91-93 River Street Phone 88 2285
- BROKEN HILL, NSW:** Crystal TV Rentals  
188 Argent Street. Phone 8897
- CAIRNS, QLD:** Thompson Instrument Services  
79-81 McLeod Street. Phone 51 2404
- COFFS HARBOUR, NSW:** Coffs Hbr Electronics  
3 Coffs Plaza Park Ave Phone 52 5884
- DARWIN, NT:** Kent Electronics  
42 Stuart Hwy. Phone 81 4749
- DARWIN, NT:** Ventriconics  
24-28 Cavanagh Street
- EAST MAITLAND, NSW:** East Maitland Elect.  
Cnr Lewis & High Streets Phone 33 7327
- GERALDTON, WA:** KD Electronics & Marine  
381 Main Terrace Phone 21 2176
- GOSFORD, NSW:** Tomorrow's Electronics  
88 William Street Phone 24 7246
- KINGSTON, TAS:** Kingston Electronics  
Channel Court Phone 29 8802
- LAUNCESTON, TAS:** Advanced Electronics  
5a The Quadrant Phone 31 7075
- LISMORE, NSW:** Decro Electric  
Magellan St & Brunner Hwy. Phone 21 4137
- MACKAY, QLD:** Stevens Electronics  
42 Victoria Street. Phone 51 1723
- MARYBOROUGH, QLD:** Keller Electronics  
218 Adelaide Street Phone 21 4559
- MT GAMBIER, SA:** Hutchesson's Comm.  
5 Elizabeth Street Phone 25 6404
- MILDURA, NSW:** McWilliams Electronics  
40 Lemon Avenue. Phone 23 6410
- NAMBOUR, QLD:** Nambour Electronic Shop  
Shop 4 Lower House Ann Street. Phone 41 1804
- NEWCASTLE, NSW:** Elektron 2000  
Shop 18 Hunter Shopping Village Phone 28 2644
- GRANDE, NSW:** M & W Electronics  
173 Summer Street. Phone 82 6491
- PENRITH, NSW:** Acorn Electronics  
Shop 12 541 High St. Phone 38 1468
- PORT MACQUARIE, NSW:** Hall of Electronics  
113 Horton Street. Phone 83 5488
- ROCKHAMPTON, QLD:** Purity Electronics  
15 East Street. Phone 21 058
- SOUTHPORT, QLD:** Amateur's Paradise  
121 Nerang Street. Phone 32 2844
- TAMWORTH, NSW:** Sound Components  
111 Bridge Street. Phone 32 9877
- TOOWOOMBA, QLD:** Nunta Electronics  
18 Neil Street. Phone 32 9877
- TOWNSVILLE, QLD:** Tropical TV  
45 Fulham Road. Vincent Village Phone 79 1421
- TRARALGON, VIC:** Power'n'Sound  
147 Argyle Street. Phone 74 3838
- WAGGA, NSW:** Wagga Wholesale Electronics  
82 Forsyth Street
- WOODONGA, VIC:** A & M Electronics  
78a High Street. Phone 24 4588
- WHYALLA, SA:** Mellar Enterprises  
Shop 2 Forsythe Street. Phone 45 4764

These are our major dealers, however we cannot guarantee they will have all these items in stock and at the prices advertised.

### DICK SMITH STORE LOCATIONS

- NSW 145 Parramatta Rd AUBURN 648 0558 ● T55 Terrace Level BANKSTOWN SQUARE 707 4888 ● 613 Princes Hwy BLAKEHURST 546 7744 ● 552 Oxford St BOND JUNCTION 387 1444 ● 818 George St BROADWAY 211 3777 ● 531 Pittwater Rd BROOKVALE 93 0441 ● 147 Pacific Hwy GORE HILL 439 5311 ● 396 Lane Cove Rd NORTH RYDE 888 3200 ● 30 Grose St PARRAMATTA 683 1133 ● 125 York St SYDNEY 290 3377 ● Cnr Kable Ave & Tamworth Acde TAMWORTH 66 1961 ● 173 Maitland Rd TIGHES HILL (Newcastle) 61 1896 ● 263 Keira St WOLLONGONG 28 3800 VIC 399 Lonsdale St MELBOURNE 67 9834 ● 260 Sydney Rd COBURG 383 4455 ● 656 Bridge Rd GEELONG 78 6363 ● Cnr Ross Smith Ave & Nepean Hwy FRANKSTON 783 9144 ACT 196 Gladstone Rd FYSHWICK 80 4944 QLD 166 Logan Rd BURANDA 391 6233 ● 842 Gympie Rd CHERMSIDE 59 6255 TAS 25 Barrack St HOBART 31 0800 SA 60 Wright St ADELAIDE 212 1962 ● 435 main North Rd ENFIELD 260 6088 ● Cnr Main South & Flagstaff Rds DARLINGTON 298 8977 WA Cnr Wharf St & Albany Hwy CANNINGTON 451 8666 ● 414 William St PERTH 328 6944 Mail Order Centre PO Box 321 North Ryde 2113. Phone (02) 888 3200

**Dear Customer,**

Quite often the products we advertise are so popular they run out within a few days. Or unforeseen circumstances might hold up goods so that advertised lines are not in the store by the time the advert appears. Please don't blame the store manager or staff, they cannot solve a dock strike on the other side of the world, or even locate a shipment that has gone astray. What we are trying to say is that, if you are about to drive across town to pick up a particular line at a Dick Smith store, why not give the store a ring first... just in case! Thanks

**Dick Smith and Staff.**

**SHOPS OPEN 9am to 5.30pm (Saturday: 9am till 12 noon) BRISBANE: Half hour earlier. ANY TERMS OFFERED ARE TO APPROVED APPLICANTS ONLY**

**POST & PACKING CHARGES**

ORDER VALUE	CHARGES
\$5.00 - \$9.99	\$1.40
\$10.00 - \$24.99	\$2.40
\$25.00 - \$49.99	\$3.50
\$50.00 - \$99.99	\$4.60
\$100.00 or more	\$6.20

Charges for goods sent by post in Australia only not airmail, overseas or road freight

MAIL ORDERS SEND TO:  
DICK SMITH ELECTRONICS PTY. LTD. P.O. BOX 321,  
NORTH RYDE N.S.W. 2113 AUSTRALIA

Please send  copies of the 1982 Dick Smith Electronics Wholesale Catalogue. I enclose  cheque,  money order for \$ (\$1.25 each catalogue).

NAME .....

ADDRESS .....

POSTCODE .....

Please add my name to your mailing list to receive regular monthly specials  
**SEND TO: PO BOX 321 NORTH RYDE NSW 2113**





# Audio-video Electronics

HIFI • HOME VIDEO • PROFESSIONAL AUDIO

## George Tillett reports on the QUAD ESL-63 loudspeaker

Electrostatic loudspeakers have long appealed to audio engineers, because of their low moving mass, low inherent distortion and freedom from box resonance effects.

Many designs were patented as far back as the early 1920's, although most of them were single-sided arrangements. They were intrinsically non-linear, because the potential difference between two plates — in this case between one plate and a flexible diaphragm — varies inversely as the square of their separation.

The first patent for a push-pull version was made by H. Riegger, who filed it in March, 1920 but it was not until 30 years later that the first commercial full-range model appeared on the scene. This was the Quad ESL, developed by Peter Walker of the British Acoustical Company. It uses three diaphragms, with the bass section in the middle, so

the other two act as baffles.

It soon became a reference standard in studios and laboratories all over the world. I myself use a pair for this purpose — numbers 50 and 51! However, high frequency dispersion does leave something to be desired, because of the relatively large size of the diaphragm; so the optimum listening area is almost restricted to the "stereo seat".

A few months ago, the Quad company introduced the ESL-63, which has a nearly ideal radiation pattern, although it is roughly the same size as the original model. Known to the cognoscenti who are addicted to acronyms as FRED, or Full Range Elec-



*Born in 1916, and with literally a lifetime interest in audio, Peter Walker of the British Acoustical Company is a true pioneer of British hifi and the "father" of electrostatic loudspeakers.*

trostatic Doublet, the new system stands 92.5cm high, 66cm wide and 27cm deep at the base.

On my recent visit to the factory in England, Peter Walker explained the concept behind Fred as follows: "An ideal loudspeaker can be imagined perhaps as some form of pulsating or vibrating sphere, neither which is practical if a reasonable power output is required.

"Suppose, however, we were to plot the air particle velocity components normal to a plane interposed between an imaginary ideal source and the observer; if we now substitute a plane surface with the same distributed velocity pattern, it follows (if the surface is sufficiently large) that a replica of the curved wavefronts would be created and we would have an accurate acoustic picture of our ideal source".

Now, holding up a large sheet of thin, transparent plastic, Peter went on to say, "you will hear no difference to the sound of my voice when I speak through it.

"Now, if we could move this plastic by electrical means to produce the same air particle velocity, we would have a loudspeaker with no colouration, producing an accurate acoustic picture".

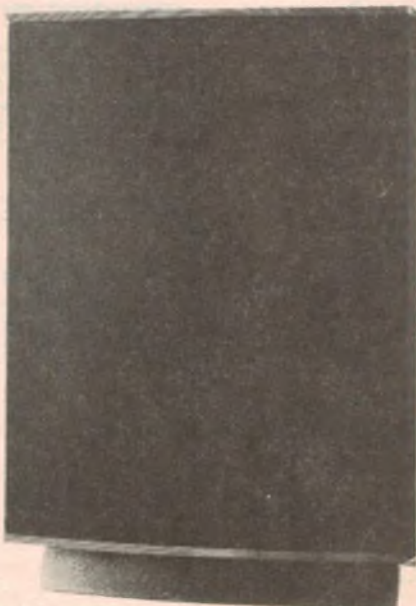
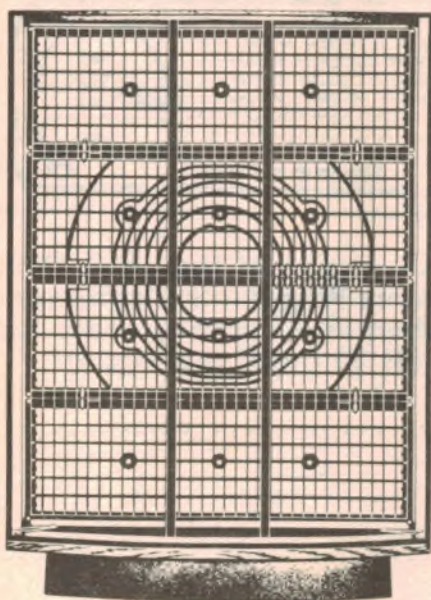

*Fig. 2 (left): The diaphragm in the new QUAD ESL-63 electrostatic loudspeaker is actually a series of concentric rings, fed through a sequence of delay lines. In its normal garb (centre) it is a fairly plain looking system but one with a very special kind of sound and a high degree of unit/unit consistency.*



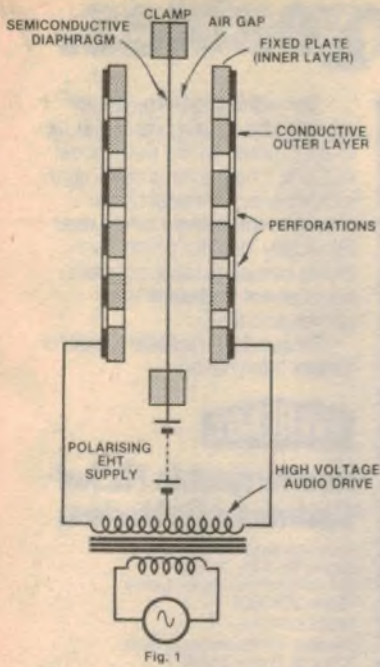

Fig. 1

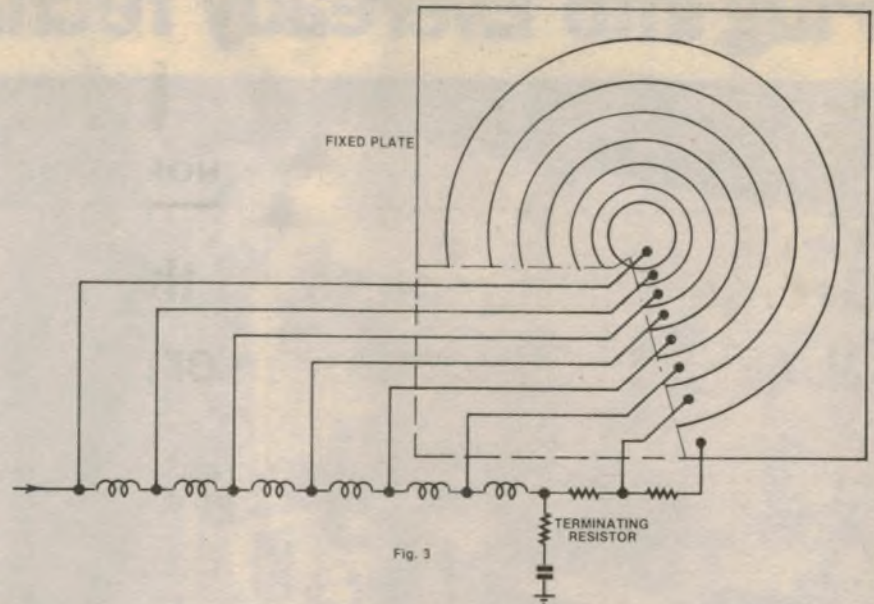

Fig. 3

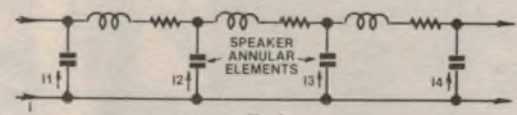

Fig. 4

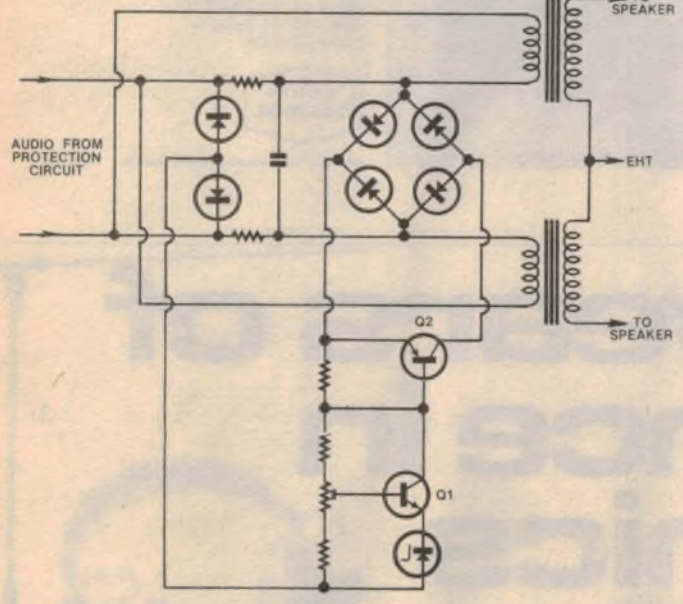

Fig. 5

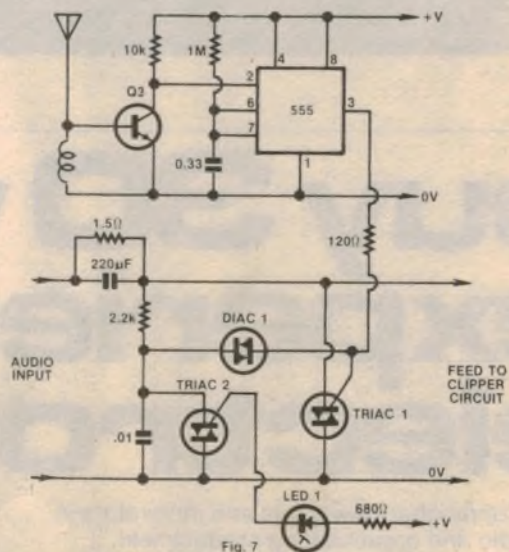

Fig. 7

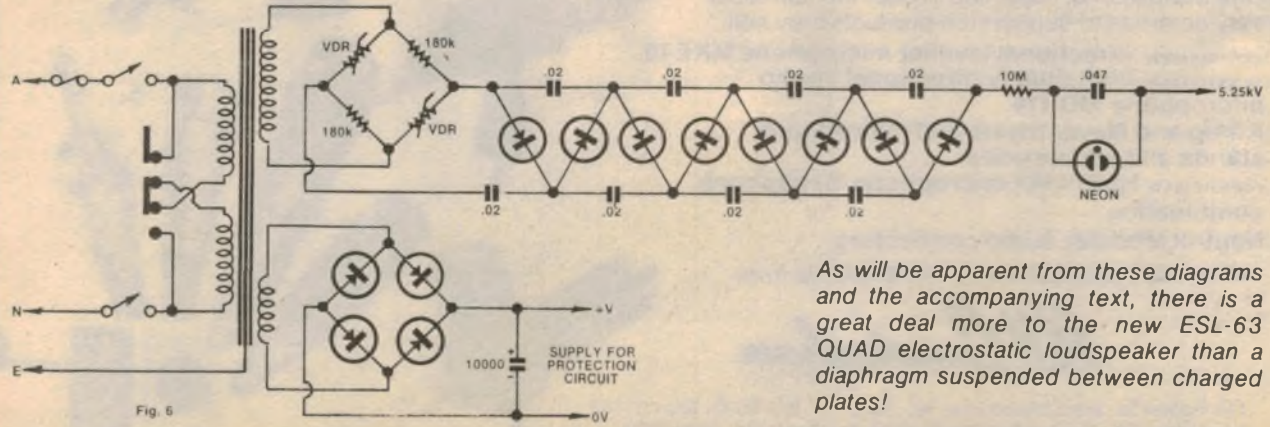
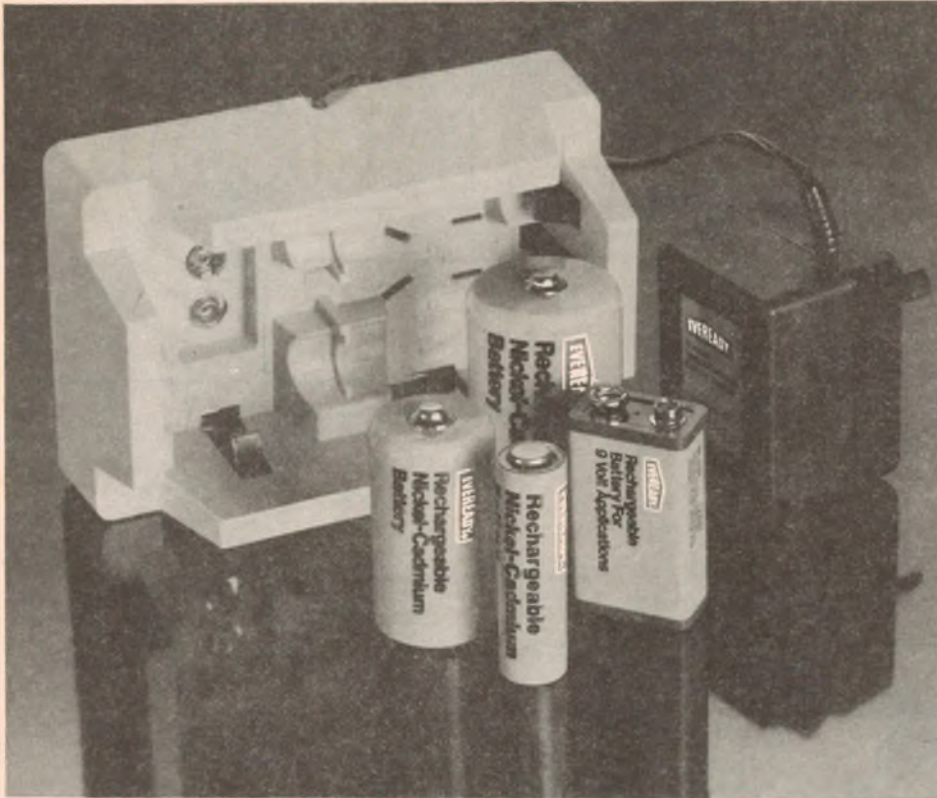

Fig. 6

As will be apparent from these diagrams and the accompanying text, there is a great deal more to the new ESL-63 QUAD electrostatic loudspeaker than a diaphragm suspended between charged plates!



# Plug into 'Eveready' rechargeables.



Our rechargeable range, in popular sizes, can be charged up to 1000 times on the new model ACC50E Charger, thus offering an extremely economical power source to the heavy-battery user. Especially ideal for photo-flash, movie cameras, tape recorders, transceivers and electronic games and toys.

Please don't hesitate to call for further information.

**EVEREADY**

## Rechargeable Nickel-Cadmium Batteries.

Union Carbide Australia Limited,  
Battery Products Division,  
157-167 Liverpool Street, Sydney.  
Phone: 269 0656

SALES OFFICES:  
Brisbane: 47-49 Sherwood Road,  
Toowong. Phone: 371 6877  
Adelaide: 121 Greenhill Road,  
Unley. Phone: 272 0611  
Melbourne: 14 Queens Road.  
Phone: 26 1241, 26 2332.  
Perth: 901 Hay Street.  
Phone: 321 2926.

**UNION  
CARBIDE**

Eveready and 'Union Carbide' are registered trade marks. 085 P B34A

# buy 30 years of experience in electronics

R. H. Cunningham suppliers and innovators in the audio and broadcasting product field, have the professional expertise in both the technical and service areas to support the products they sell.

1. SENNHEISER directional lavalier microphone MKE40
2. SENNHEISER high quality directional studio microphone MD 419
3. König and Meyer music and microphone stands and accessories
4. SENNHEISER HMD 414X microphone/headphone combination
5. Neutrik Modular audio connectors

*All of the above products are available from*

**R.H. Cunningham**  
PTY.LTD

146 Roden St., West Melbourne, Vic. 3003 Tel. 329 9633 Telex 31447.  
4-8 Waters Rd., Neutral Bay, NSW 2089 Tel. 909 2388 Telex 21707.



RHC 014



Of course, this is a simplistic explanation but it does convey the general idea.

The diaphragm in the ESL-63 measures about 75 by 60cm and is suspended between two sets of electrodes made from copper-coated plastic, which is perforated (Fig. 1).

This diaphragm is only 2 microns thick and it is coated with a conductive material having a resistance in the thousands of megohms range — necessary to stop the electrical charge from "migrating".

A polarising voltage of 5kV is applied between the moving diaphragm and the fixed plates giving a potential gradient in the gap of about 2kV/mm. Thus the gap and the maximum possible diaphragm excursion is 2.5mm.

Here is where the ESL-63 differs from its predecessor: each of the aforementioned copper plates is cut to form annular rings (Fig. 2) and the audio signal is fed sequentially to each set of rings by a series of inductors and capacitors which form delay lines, as shown in Fig. 3.

Part of the capacitance is supplied by the speaker elements (see Fig. 4) but there is some cross-coupling too, while further correction is made by short-circuited loading coils coupled to the inductances. Delay per section is  $24\mu\text{s}$ , which corresponds to a path length difference of just over 8mm in air.

### PRESSURE WAVEFRONT

The resultant pressure wavefront produced by the sequentially delayed audio signal is the same as what would be produced by a theoretical "pulsating sphere" placed some distance behind the diaphragm of the ESL-63. At the same time, the directivity curves have a smooth horizontal and vertical energy pattern which would also be expected from a pulsating sphere.

Two hefty input transformers are employed, wired with their secondaries in series (a neat way to reduce size as well as leakage inductance) as shown in Fig. 5. Q1 functions in a preset voltage control circuit and, when the input voltage exceeds 40 volts, Q2 will turn on, thus reducing the primary voltage.

Fig. 6 shows the basic high voltage supply: the neon at the end is bridged by a capacitor and, together with the series 10-megohm resistor, the circuit forms a familiar flashing neon relaxation oscillator. The number of flashes per second is proportional to the rate at which the charge is applied to the diaphragm so the circuit acts as a monitor.

Because of the high voltages, ionisation could occur, leading to a flashover

if suitable precautions were not taken; the protection circuit is quite ingenious. The onset of ionisation produces some high frequency radiation and this is picked up by a miniature receiver (Fig. 7).

It is detected by Q3 which triggers the 555 timer, firing the Triac 1 to short circuit the audio input.

Also included in Fig. 7 is a circuit to prevent large audio signals being applied to the ESL-63 when the mains power is off. When power is present, Triac 2 is normally conducting and no voltage is present across Diac 1. In the absence of power, audio voltage is applied to the Diac which fires Triac 1 when the input exceeds about 30 volts.

Compared to the original model, the ESL-63 has an extended bass response but the most dramatic improvement is in the radiation pattern. The sound quality is completely transparent, with a remarkable sense of

presence, while the stereo image is spacious with a good sense of depth.

The systems are incredibly consistent and a favourite trick of Peter Walker's is to place a microphone in between a pair which are fed with a 1kHz square wave signal. Microphone output is displayed on a scope and when the signal to one speaker is phase-reversed, a slight touch on the amplifier's balance control and the square wave is cancelled out. Yes, it completely disappears!

This "balancing act" is actually part of the test procedure, which also includes checks of the frequency and impedance against a standard scope curve. Each sub-assembly is thoroughly tested and the panels are checked for capacitance, Q factor and other parameters.

One other point: the load presented to the amplifier is less complex than the older model, being largely resistive and varying between 4 and 30 ohms.

## THE AUDIO — VIDEO SCENE — In brief



**RANK ELECTRONICS** have announced the release of a new miniature electret microphone — the Beyer model MCE5. It is a high quality unit and is available in several versions to suit specific applications such as: direct attachment to the Beyer TS83 or other radio microphone system; use with the Nagra SN miniature tape recorder; use with amplifiers, tape and cassette recorders generally. One particular version of the MCE5 has in-built volume control and bass roll-off facilities.

An interesting application, illustrated above, is for close miking acoustic stringed instruments such as violins, violas and cellos. The MZGH5 expansion

mount permits convenient and inconspicuous fitting.

The microphone body is 23mm long by 7mm wide and is supplied complete with a removeable windshield.

For further information, contact Rank Electronics in the capital cities. In Sydney: 16 Suakin St, Pymble, 2073. Phone (02) 449 5666.

### ORTOFON CARTRIDGE

**ORTOFON**, who made their first moving coil phono cartridge in 1948, say that their MC30 is the finest cartridge in their range but it has two disadvantages: it is expensive (\$650) and its use is confined mainly to the highest quality turntables owned by well-heeled audiophiles!



Sensing this, Ortofon engineers have now come up with a new moving coil cartridge, the MC200. They describe it as: "a high quality moving coil cartridge, compatible with a wide range of turntables and arms . . . not finicky to instal . . . giving the sonic advantages that any moving coil can bring. It simply plugs into the end of any S-shaped tonearm with standard socket."

*Continued on page 33*



# Disco Sound — British Style

Discotheques are a significant part of the leisure industry, and more and more specialised equipment is becoming available in Britain to meet the needs of disc jockeys and their public. And, of course, there is more to it than simply the ability to play loud music.

by DONALD ALBOUS \*

In addition to sound systems, lighting is of major importance, because it adds to the stimulus of high volume sound. In both these fields, technology has advanced a long way since the days of a single record playing deck with mono connection to an external amplifier and loudspeaker.

An example of the latest in British made disc consoles is the FAL Stereo Graphic unit. It incorporates a preamplifier equipped with every facility that the disc jockey needs, as well as a graphic equaliser circuit. The latter permits every disc played to be "tailored" to obtain the desired sound quality from the loudspeaker system employed.

The specification includes two channels with mini-toggle switches, and a tape stereo inlet with jack and DIN sockets. There is autofade with variable depth, a recovery time of two seconds to 200 milliseconds and an LED indicator.

The system has an integral power amplifier delivering 50W per channel into 4 ohms. By fitting toroidal transformers, the power unit is compact enough for the operator who wants a portable system. The disc inputs are by 180-degree, five-pin DIN sockets, while the mains outlets to turntables are compatible with Belling and Lee L2295, Bulgin P670, Rendar R48632200 and a variety of other equipment.

It is often said that what makes or breaks a sound system for disco ap-

plications is the power handling capacity and sound diffusion of the loudspeaker array. Another maxim is that the higher the sound quality, the less power is needed. Mounting the loudspeakers as high as possible is another simple method of increasing the level of sound reaching the audience.

Obviously the gyrating human body absorbs a lot of sound energy, but it appears that about 100W per channel of clean stereo power will cater for some 200 people. Thus, unless there is a very efficient loudspeaker array, a high output amplifier is essential.

Citronic's<sup>2</sup> Thames console stereo

deck develops 110W per channel, and has split cue pre-mixing, stereo tape cassette, and jingle auto-stop.

Transit problems are always present, but the new Court Acoustics<sup>3</sup> Proflex system has a 1kW rating and features a new design of bass unit in two sizes of horizontally and vertically based cabinets. These use two 381mm, 200W drivers producing an SPL of more than 100dB. An advantage of this system is that it is modular, permitting the addition of the bass system to existing mid/high components when desired.

The general reduction of the size and weight of equipment has been a boom to the mobile operator. Roger Squire's<sup>4</sup> new DXL 100 cabinet, for example, handles 100W of power in cabinet speakers measuring only 483 x 305 x 254mm.

CDC<sup>5</sup> markets several impressive loudspeaker systems of a heavier type. Its System B, for example, which has a



Citronic's "Thames" stereo console has its own in-built power amplifier capable of delivering 110 watts per channel to 4 ohm speakers.

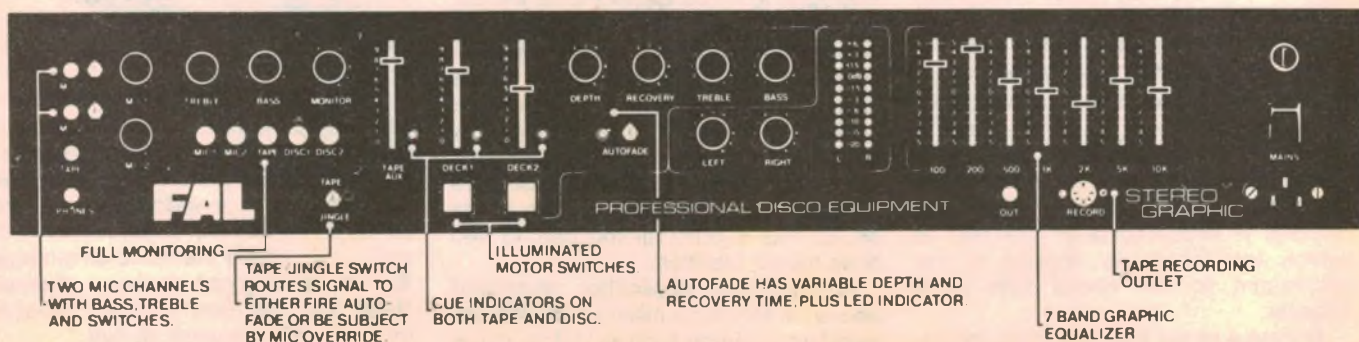

The control panel of FAL's Stereo Graphic unit is equipped with every facility for the disc jockey.





# Marantz Gold. Life couldn't sound more beautiful. —

A day is made perfect by its ending.  
Sunset, anticipation for the evening  
to come.

Soothing, sounds of your favourite  
music. The day's problems disappear.

The moment is Marantz. Unmatched in  
its eloquence, unmatched for its purity of  
sound reproduction.

Elegant, indulgent.

The Marantz Gold Renaissance 1000.  
Top-of-the-line in a range of superbly crafted  
hi-fi systems from Marantz.

Six separate components of unsurpassed  
technical excellence. Highly sophisticated  
Pre-amplifier and Power Amplifier, 14-station

preset AM/FM Stereo Tuner, Cassette Deck,  
Equalizer and fully automatic Turntable —  
subtly burnished gold tone.

And finally, the magnificent system  
speakers — matched in quality and luxury of  
design to rosewood finish furniture pieces.

Marantz Gold Renaissance Series.

Life couldn't  
sound better.

**Marantz Gold.**  
**The New Audio Standard.**

**marantz**  
Now you're listening.

Distributed by: MARANTZ (Australia) Pty. Limited, 19 Chard Road, Brookvale, NSW, 2100.  
Telephone (02) 939 1900 Telex AA24121, Melbourne (03) 544 2011, Brisbane (07) 44 6477,  
Adelaide (08) 223 2699, Perth (09) 276 3706, Townsville (077) 72 2011

Design and specifications subject to change without notice.



# There's more to bein a burn up at the



For those officers who really want to fly high, there is also a science degree.

At the RAAF Academy you get your Degree through the University of Melbourne and we pay you quite handsomely for the privilege.

But when you graduate as an officer you will have more than a Bachelor of Science. You will also have your pilot's wings and a job waiting for you.

By the time you're 23 the RAAF will have given you an incomparable foundation upon which to build a fulfilling career.

## GIVE YOUR CAREER A FLYING START.

With a degree from the RAAF Academy, your career will certainly have a flying start.

However, it takes more than simply a good education to fly a plane. When the F18 breathes fire it could be travelling at up to Mach 1.8 — nearly twice the speed of sound. At speeds like that you can't afford to have your head, as it were, in the clouds. You have to be alert. You have to be able to make split second decisions. And you have to know the aircraft backwards.

That not only takes training. It takes the right mind, and the right temperament. So, if you want to dream, cut out the plane. But if you want to fly, cut out the coupon. Or ring any RAAF Careers Adviser.

So long as you are an Australian Citizen, under 20 on January 1st of your year of entry,



# g a pilot than having speed of sound.



and so long as you're matriculating this year or have already matriculated and meet our selection requirements you're eligible for entry.

*However, if you matriculate next year you could be eligible for a scholarship to help you through. Just tick the appropriate box.*

- |           |               |
|-----------|---------------|
| MELBOURNE | (03) 61 3731  |
| SYDNEY    | (02) 212 1011 |
| CANBERRA  | (062) 82 2333 |
| PERTH     | (09) 325 6222 |
| ADELAIDE  | (08) 212 1455 |
| HOBART    | (002) 34 7077 |
| BRISBANE  | (07) 226 2626 |

The RAAF Academy, Pt. Cook. It's the one place where you will literally give your career a flying start.



Application forms are available now.  
Send to: Air Force Careers Office,  
GPO Box XYZ, in your State  
Capital

I would like more information on:  
 The RAAF Academy, Point Cook  
 The RAAF Academy Scholarship

Name .....

Address .....

..... Postcode .....

Birthdate .....

## Air Force Officer.

Authorised by the Director General of Recruiting, Department of Defence

AFA7/DPS-111



# THE CREATIVE POWER OF YOUR DREAMS

The images that come from our unconscious minds can be disturbingly powerful. New research suggests ways in which we can learn to use that power for our own good.

## PLUS

- \* The truth about ESP
- \* People who never need to eat
- \* The life-and-death balance within your body



# OMEGA

Buy it  
at your  
newsagent

**TOMORROW'S MAGAZINE TODAY**



high output and controlled dispersion, is made of 18mm birch ply, is fitted with bass, upper bass, mid-range, and two super tweeters, and weighs 130kg. Two of these FR.500 stacks can be driven from one 250W per channel amplifier, or can be bi-amped or tri-amped according to individual requirements. Rated power handling is 300W RMS with a sensitivity of 108dB at 1W, 1M.

The range and variety of loudspeakers for disco and public address work seen at the recent Discotek 81 show in London reflected British expertise in this area. The vital requirements for all disco systems are simplicity and reliability, in view of the fact that the equipment has to be lugged up and down stairs and in and out of vans, and yet work immediately it is switched on.

Many British loudspeaker manufacturers have created driver designs specifically for use in disc jockey systems.

Fane<sup>®</sup> has concentrated on solving the special problems of building disco loudspeakers to withstand the punishment of modern amplifier electronics. To meet the demands of very high power handling capacity, Fane had to undertake research into speech coils, which are now known as "glass fibre" coils. The introduction of this type of construction has enabled the company to more than double the power rating of its speakers.

Its units have pressed steel assemblies with girder construction,

but cast aluminium chassis types are still available to order. The company's catalogues list more than 50 models.

The impact of disco sound is magnified by lighting the audience. Some of Light Engineering's<sup>7</sup> Parabeam light sources can be attached to a standard ceiling rose, while the Parabeam 300 has a Par 56 lamp giving defined spot beam. It is supplied complete with Europlug and socket power connection. Advanced displays using multi-coloured fluids, picture wheels, picture liquid wheels, kaleidoscope, zoomers and so on are supplied by Pluto Electronics<sup>8</sup>.

#### KEY TO MANUFACTURERS.

1. Futuristic Aids Ltd, Audio House, 104 Henconner Lane, Leeds, West Yorkshire LS13 4LQ, England.
2. Citronic Ltd, Halifax Road, Bowerhill, Melksham, Wiltshire SN12 6UB, England.
3. Court Acoustics Ltd, 35-39 Britannia Row, London N1.
4. Roger Squire's Ltd, Barnet Trading Estate, Park Road, Barnet, Hertfordshire, England.
5. CDC Audio and Visual, 143 Croydon Road, Caterham, Surrey, England.
6. Fane Acoustics Ltd, 286 Bradford Road, Batley, West Yorkshire WF71 5PW, England
7. Light Engineering, 50 Beulah Road, Walthamstow, London E17 9LE.
8. Pluto Electronics Ltd, Pluto House, North Way, Andover, Hampshire SP10 5BN, England.

## IN BRIEF — continued

The MC200 has a boron cantilever, making it light and rigid, with minimal inherent resonance, while the remainder of the cartridge exploits Ortofon's advanced technology. The total weight is 16.5 grams but the makers warn that, being a moving coil type, the very low output of 0.09mV makes it essential to use it with a step-up transformer or moving coil preamplifier. The MC200 is priced at £320.

For further details: Harman Australia, LMB 12, North Ryde, NSW 2113. Phone (02) 887 3233.

**CBS (in the USA)** would not know quite which way to aim, if they happened to see a recent issue of the British magazine "Practical HiFi". On one page, American contributor Bob Angus notes that "CBS is making quiet progress, with their CBS compatible audio noise reduction system". However, on an earlier page in the same issue, writer Adrian Hope questions the basic validity of a system that is supposed to do all the things that CBS claim without involving serious compromises, at least in the context of

good quality audio reproduction. According to Adrian Hope, purists in the USA are getting uptight about the whole thing and are suggesting that the CBS (CX) system will gain acceptance "over our dead bodies!"

**SANYO AUST PTY LTD** have come up with a novel concept in portable cassette-radios. Their new model M-X66 is described as a "super compact" stereo portable, featuring a "fully self-contained lift-out tape recorder and radio." When removed, the lift-out unit becomes a small but efficient AM/FM radio, with microcassette record and playback facilities, operating from its own two "AA" size batteries. With the lightweight headphones supplied, it offers the user all the advantages of a personal portable system. When returned to the master unit, much higher output becomes available, through two 7.7cm loudspeakers. Recommended retail price of the new M-X66 is \$339. Details from Mr W. Fabiszewski, Sanyo Aust Pty Ltd, 225 Miller St, North Sydney.

## Sweep away the Snow



Clean up your snowy or ghosting TV pictures. First check your aerial, is it suitable for your area? If not, replace with one more suitable; the second step is to fit a Masthead Amplifier. By adding a Masthead say of 20dB with a ratio of 10 times, you can increase a weak signal say of 100uf to 1000uf or 1mV. A good Masthead such as a MH20, at the cost of \$85, has the following features:

- \* **SUPERIOR PERFORMANCE**  
— Low noise planar transistors.
- \* **LIGHTNING PROTECTION**  
— Diode protection from electrostatic discharge.
- \* **CORROSION FREE**  
— AC voltage to amplifier prevents electrolysis action.
- \* **EASY TO INSTALL**  
— Screw terminals. Power supply includes 2 way splitter so that amplifier can provide a signal for one or two TV receivers.
- \* **ECONOMICAL**  
— No balun required, 300 ohm or 75 ohm input from aerial. 300 ohm or 75 ohm output.
- \* **SAFE**  
— Power supply short circuit protected.
- \* **LONG LIFE**  
— The components are carefully selected, and are built into a strong, weatherproof ABS plastic housing.

### MH20WN \$91

Designed specifically for use in the Newcastle & Wollongong areas. The strong local channels 3 & 5A are attenuated, allowing amplification of distant Sydney channels 2, 7, 9 & 10 without cross modulation problems. Three versions are available with — 10dB, — 20dB, — 30dB attenuation.

Contact **ELECTRORAFT** we will be able to give you good verbal advice on ...

Updating your antenna.

Providing an extra outlet & splitter for that second set. Providing an FM, stereo antenna outlet. Installing an antenna for that new channel or UHF translator which started recently.

We have the largest selection of TV antenna's in N.S.W.

**ELECTRORAFT** PTY LTD  
68 Whiting Street, Artarmon N.S.W.  
Telephone 438-4308 or 438-3266





# HIFI REVIEW

## Technics RS-M07 cassette recorder

Smallest in the new range of Technics Cassette Recorders, the RS-M07 is an attractively styled compact machine capable of excellent performance, notwithstanding its moderate price tag. Whilst its small size makes it ideal as a second machine for dubbing and other purposes, it could equally well serve as the sole recorder in a hifi system.



Obviously a lot of thought has gone into the design of the RS-M07 so as to keep production costs down; yet it still provides the essential facilities and performance of upmarket machines. Top and all four sides of the cabinet are a one-piece plastic moulding, in a smart silver-grey colour. Front panel layout is neat, with the cassette compartment and transport controls being located on the left hand side while twin analog level meters, tape counter, separate record level controls, Dolby B selector and microphone and headphone jacks are on the right hand side.

In addition there are three small rectangular LEDs (located between the tape counter and Dolby selector) to indicate the tape type in use. Similarly to the other machines in Technics' new range, the M07 senses the identification recesses at the rear of the cassette shell to automatically switch HF bias and equalisation, according to the cassette in use. Manual override is not provided, but selection is shown by one of the abovementioned three LEDs. In common with most contemporary machines, there is no provision for ferrichrome cassettes — which have never really caught on anyway.

Dolby B noise reduction is controlled by a pushbutton which is depressed when Dolby is selected. As no illuminated indicator for this function is provided, it is difficult to tell from a quick glance which position the selector is in. If an indicator cannot be provided, we would prefer to see a lever key or toggle switch perform selection, rather than a pushbutton switch.

To minimise costs Technics provide anchored 0.9 metre cables with RCA phono plugs for line input and output connections. Apart from a slight loss of flexibility (should longer cables be required) we found this satisfactory.

Access for servicing is from the base and is not easy. Firstly, five screws have to be removed to take off the metal base plate. Whilst this exposes the component side of the printed circuit board for simple checks, another nine screws (irregularly located) and two knobs must be removed should attention to the transport mechanism or component replacement be required. Although the transport and PCB may now be lifted from the upturned cabinet, they retain umbilical connection to it (with leads to the power transformer, line in/out cables etc) which further complicates servicing.

Reassembly can also be frustrating because three screws are recessed approx 30mm below the PCB, and are difficult to relocate.

In common with contemporary practice, control of the various transport modes is by soft-touch pushbuttons. However, unlike its more expensive brothers (which use electronic control), those on the RS-M07 operate a mechanical logic system which implements pushbutton commands by a cam and gear arrangement. While lacking the ultimate refinement of microswitch-controlled electronic designs, this system is far smoother in operation than the piano-key mechanisms. One minor drawback to a simple mechanical system is that it cannot be easily remote controlled. But then, how often do we wish to control a cassette recorder from a remote location?

One excellent feature of the M07 is the audible cueing facility available on fast forward and rewind. By simultaneously pressing fast forward (or rewind) and play, one can listen to the recorded items — albeit speeded-up — and thus audibly locate the spaces between items. In the above mode both buttons remain locked until the stop button is activated; but if one is playing an item and rewind (or fast forward) is pressed the fast mode (with audible cueing) only operates whilst the rewind button is activated. On release the transport reverts to the play mode. This is very handy for repeating a section of an item. All in all, this cue facility is far more useful than the exotic memory rewind functions fitted to up-market cassette decks.

Automatic replaying or recording can be carried out when using the machine in conjunction with an external timer. Whilst a separate front panel selector switch is not provided for this function, the mechanical logic system has been designed to accept a replay (or record) command with the power "off". Then, when power is applied (by the timer) the previously selected command is implemented, putting the M07 into the replay (or record) mode. With this method the pressure roller remains disengaged until power is applied, so there is no danger of pressure roller rubber deformation as would occur with conventional piano-key mechanisms.



The M07 is double-insulated (being identified as such by the international "double square" symbol), and is supplied with a two-core figure-8 mains cable and plug.

Physical dimensions of this recorder are 297mm wide x 123mm high x 230mm deep, and mass is 4kg. Thus it can be appreciated that the M07, as previously indicated, is truly a compact, lightweight machine.

Level metering is performed by twin analog meters, which have somewhat similar scale calibrations to standard VU meters. Scale accuracy is better than 1dB over the majority of the range. Dynamic characteristics appear fairly close to those of VU meters, with negligible overshoot nor floppy pointer movements as occur on many low cost meter movements. If anything, their damping may be a little greater than that of standard VU meters. These characteristics should ensure that recordings made on the M07 will be at a sensible – but not excessive – level; and certainly not at the low levels which can occur on so many of the machines equipped with quasi-peak bar graph meters.

The Dolby symbol is at the +3dB point, and a 200nWb/m Dolby test cassette replays to this mark. Thus lineup level (0dB) corresponds to 141nWb/m. At this metering point the line output level is 380mV open-circuit. Internal output impedance of the line output circuit is under 2k $\Omega$ .

Tape speed was 0.5% slow, whilst fast forward and rewind times were each 90 seconds – a good performance for this class of machine. Peak wow and flutter lay between 0.07 and 0.1% DIN weighted, an excellent result for a low-price recorder.

A conventional mechanical (rotating drum) tape counter is fitted, and one count corresponds to two revolutions (turns) of the takeup spindle. This is the same as both the Technics RS-M230 and RS-M280. It would appear as if Technics may be standardising on this ratio for their new machines; and we agree with the move as it ensures easy place location from one (Technics) machine to another. We hope that the manufacturing industry sees fit to adopt such a standard for cassette counters in the future.

As received, the azimuth alignment of the single record/replay head closely agreed with the Philips' standard; as did the replay frequency response which was within 2dB to 10kHz, the upper limit on our test tape.

We checked the overall (record, rewind, then replay) performance of the M07 with samples of IEC types I, II and IV tapes. As previously indicated there is no provision for IEC type III (ferrichrome) cassettes.

With a TDK OD (type I) cassette the frequency response was within  $\pm 2$ dB bet-

ween 40Hz and 15kHz, and only 3.5dB down at 30Hz. Above 15kHz the response falls sharply being 8dB down at 16kHz and 20dB at 17kHz. This sharp cut-off is mainly due to the MPX notch filter (in the record channel) which cannot be disabled as is standard practice in higher priced machines. However, this is of no real consequence in use as there is negligible audible content in the band above 15kHz; and it is doubtful if even 0.1% of users would be aware of the cut-off beyond 15kHz. Further, many competitive recorders have a frequency response which is already falling – albeit slowly – by 10kHz, and this can only be discerned by critical listeners.

Essentially the same overall frequency response (as given by the type I cassette) was obtained when using TDK SA (type II) and TDK MA (metal, type IV) cassettes. Similarly, the 1kHz sensitivity for all three cassette types was approximately the same, lying between 0 and -1dB.

Turning our attention to total harmonic noise and distortion, we found that at 1kHz all three cassette types produced 1% distortion for a recorded level of 141nWb/m. It is possible that the distortion measurements at this level may have been affected by the noise floor of the machine, thus disguising what could well be even lower distortion figures.

Raising the input level by 6dB and then 10dB, we measured 1.5% and 5% distortion respectively when using TDK OD, 2.4% and 6½% using TDK SA, and 2.7% and 7% using TDK MA. These distortion figures (for all three cassette types) approach the best we have obtained. And, indeed, surpass those of most other machines we have tested, irrespective of price.

Unweighted signal-to-noise ratio below a reference level of 200nWb/m (Dolby reference level) measured 50dB for type I cassettes, 52dB for type II, and 51dB for type IV cassettes. Engaging Dolby B noise reduction improved these figures to 56dB, 56dB and 55dB respectively.

The limiting factor to noise performance appeared to be 50Hz hum, so that when we repeated the measurements – in the Dolby mode –

with a 400Hz high pass filter, the figures showed further improvement to 60dB, 62dB and 61dB respectively. Whilst these figures are slightly inferior to some other machines, most exhibit a residual 50Hz hum component. This is due to the problem of completely shielding the replay head from the stray field of the power transformer. Notwithstanding the above, the practical noise performance of the M07 is on a par, or slightly better than, the majority of contemporary machines.

Interchannel separation was 40dB or greater (50dB at 1kHz) for frequencies between 100Hz and 3kHz, decreasing to 32dB at 10kHz and 28dB at 15kHz. At the low frequency end it measured 35dB at 50Hz and 30dB at 30Hz. With Dolby selected the separation figures improved by 5-6dB at frequencies of 1kHz and above.

Crosstalk between forward and reverse tracks (tks 2 and 3) was below the noise floor of the recorder over the entire audio pass-band. Thus separation and crosstalk performance is excellent, being quite comparable to top-of-the-line decks. In fact, of the recorders we have tested, this is only the second on which we have been unable to observe crosstalk between forward and reverse tracks.

Using the RS-M07 for its normal purpose of recording and replaying musical numbers and the human voice confirmed our test results. It performed impeccably, providing recordings and playbacks with quality on a par with machines costing considerably more. Providing you do not require facilities such as three heads with independent record and replay channels, remote control, inbuilt test oscillator, digital readouts etc, it should satisfy all your requirements. We can thoroughly recommend the RS-M07.

Recommended retail price of the RS-M07 is \$239 including sales tax. Further information can be obtained from high fidelity retailers or the distributors – National Panasonic (Australia) Pty Ltd, 95-99 Epping Rd, North Ryde, NSW, 2113. (P de N).

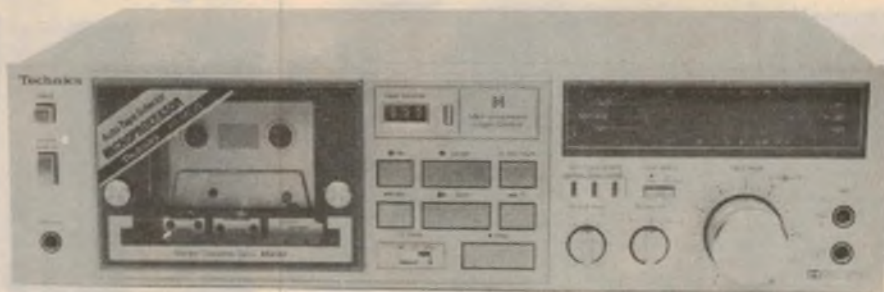

This mid-priced cassette deck has also been recently released by Technics. Called the RS-M230, it has a microprocessor logic system and tape equalisation and bias are automatically selected.



# \$100 CPU, VDU I/O CARDS

Whether you're a hobbyist or professional user of S100 cards and systems, you should know about Applied Technology's range of S100 products. We design and manufacture some of the world's most innovative (yet inexpensive) S100 products right here in Australia. Our 'MEGAMEMORY' static memory card and the powerful MW6545 programmable VDU card are recognized industry leaders.

## DGZ80 Z80/S100 CPU

Now a legend in its class. And it's easy to see why. The DGZ80 is about the most powerful single board computer on the S100 bus. A powerful on-board monitor (DGOS), on-board RAM, and Z80 CPU, PIO and CTC means the DGZ80's interfacing power is fantastic. You get two 8 bit programmable I/O ports, four timer channels, a further input port, and power-on-jump. Real time clock facility is on-board under DGOS. Well over 1,000 DGZ80's are now in the field, in a range of applications from industrial control to business to instructional use. DGZ80 built and tested with DGOS in ROM

**\$249.00**

## MW640 Professional VDU

This superb memory mapped VDU works under the DGOS monitor of the DGZ80 for fast easy programming. The crisp 64 characters by 16 lines display has upper/lower case, flashing characters black on white and 128x64 'chunky' graphics

MW640 VDU built and tested

**\$159.00**

## TCT PCG HiRes Graphics

If you need programmable high resolution graphics, this board gives 512x256 bit resolution. It works in with the MW640 and comes complete with two joystick ports.

TCT PCG (kit form)

**\$140.00**

## DG750 I/O

This versatile I/O board has 2 programmable serial I/O lines (RS232) and 3 programmable 8 bit I/O lines, all controlled by a programmable interrupt controller. The number of serial and parallel lines can be easily doubled.

DG750 I/O card Built and tested

**\$195.00**

# \$100 STATIC MEMORIES

## AT16K 16K Static Memory

The AT16K gives you reliable static memory, inexpensively. It can be located at any 16K boundary using on-board select logic. Write protect and phantom line memory priority control are included.

AT16K Built and tested

**\$165.00**

## MW884 MEGAMEMORY

Our Megamemory card is a breakthrough in static memory performance. It's combination of high speed (6MHz), and low power (it uses only 4W fully populated) with low cost, have made it the industry leader. And we designed it here in Australia!! Available in 32K, 48K and 64K formats, Megamemory uses the popular 6116 CMOS RAMs. These RAMs are pin compatible with standard 2516 EPROMs. The board is fully IEEE compatible and features extended bank addressing, and phantom. The top 8K of memory can be deselected as 2K 'windows' to enable monitors and disc drives to be used.

32K built and tested

**\$325.00**

48K built and tested

**\$425.00**

64K built and tested

**\$495.00**

## MW6545 Programmable VDU

One of our newest and most powerful products, the MW6545 is built around the 6545 programmable VDU chip. So the screen format can be programmed to 64x16, 80x24, 132x40 etc. Light pen facility is built in and there's extended addressing and port controls. The display is full professional format, with upper/lower case, built in programmable graphics and transparent screen refresh. A colour option is in the pipeline and a special ROM is now available to replace DGOS if you are running a DGZ80. The ROM gives you normal MW640 format on startup but you can change to 80x24 format under MicroWorld 56K CP/M. So you get the best of both worlds!!

MW6545 built and tested

**\$325.00**

## MW ROMBLASTER

This memory mapped EPROM programmer suits 2516, 2716, 2532 and 2732 single voltage EPROMs. Programming supply is on-board. The RomBlaster can be located anywhere in memory and ROMs can be verified under DGOS. Programming is very easy, just make a single block move under DGOS.

MW ROMBLASTER

**\$195.00**

# \$100 CARD FRAMES

## MW300 Wirewrap Card

This general purpose wirewrap card conforms to standard IEE696 S100 bus standard. The board has built in address and data buffers and accepts T0-3 and T0-220 regulators, 50, 34, 26, 10 pin headers and has provision for in-line resistor packs for pull up or pull down terminations.

MW300 card

**\$39.50**

## SCVT, 2850 Cards

We still have stocks of these cards, (see article in EA and ETI for details). Please write for details.

## MW1550 Mother board

This 10 slot mother board now comes with S100 sockets soldered in ready for use. The board can be connected to the MW800 power supply. It fits the MW600 card frame.

MW1550 ready for use

**\$100.00**

## MW600 Card Frame

This card frame accepts the MW1550 mother board and has provision for internal power supply, cooling fan and I/O connectors. The frame takes standard 19" rack mount hardware

**\$100.00**



## Euro Case

This professional desk top case is the best we've seen. Moulded from high impact plastic, it features adjustable mounting feet, ventilation, carrying handles and comes with an anodized front panel and reset button. The card frame slides into the Eurocase, providing superb protection and appearance.

Eurocase

**\$200.00**



## Complete Cardframe/Eurocase

The cardframe, 10 slot mother board, full 10A S100 power supply and Eurocase are available complete and ready to use. This combination offers outstanding value.

Eurocase/cardframe

**\$450.00**

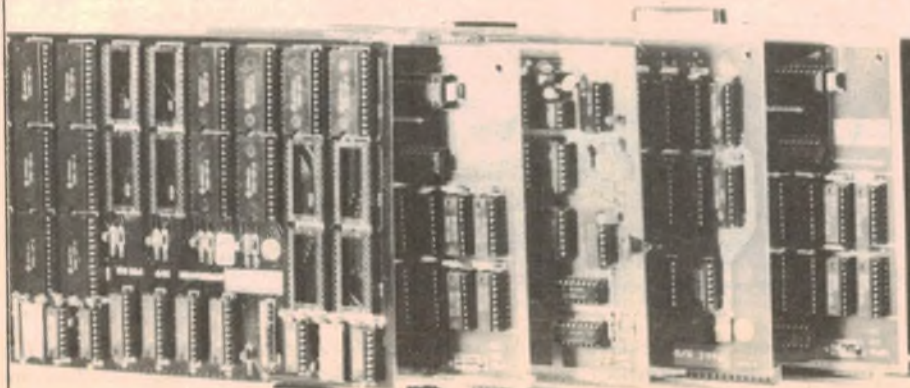



# PRINTERS EPSON MX100

We are delighted to be selling Epson's new range of dot matrix printers. Examine the constructional quality and print output of these machines and you'll quickly appreciate why they are by far the best value dot matrix printer you can buy.

The print output of both the MX80 and MX100 is a full 9x9 matrix with true descenders. Condensed, enlarged and emphasized printing is selectable. The resulting performance is more in keeping with a machine in the \$3,000 bracket. Now you can have a correspondence quality machine without paying out a

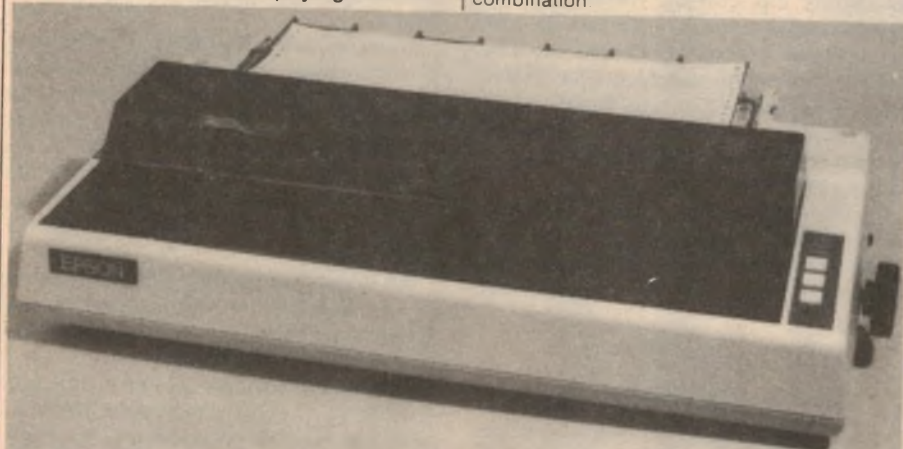

fortune. Not surprisingly, Epson have been selling over 50,000 of these printers per month to the American market. There's simply nothing else like them.

## Epson MX100

Epson's newest model, the MX100, is the most powerful printer in its class. First class mechanicals have been combined with an incredible range of features. The full 96 character ASCII set has true descenders. And there's 8 international character sets with switch selection for font variation. The printer also offers ultra high resolution bit image printing up to 1632x8 dots per line. Normal, condensed and enlarged printing is available and is further programmable. Form feeding is programmable up to 127 lines and 12 horizontal and 8 vertical tabs are available.

The MX100 has a full 15 inch carriage and will handle single sheets or continuous stationary. Paper feed is by adjustable sprocket feed or by friction feed, with a normal typewriter style platen. The MX100 has a standard Centronics 8 bit parallel port. Both the MX100 and the MX80 share a versatile range of interfacing options. Printing rate of the MX100 and the MX80 is a fast 80cps in text mode. Printing is bidirectional with logic seeking.

# PRINTERS EPSON MX80

The MX80 is currently the world's top selling printer. It differs from the MX100 only in its paper handling size and the range of paper handling formats. The base MX80 Model I is straight tractor feed. The slightly more expensive MX80 II FT is both friction and tractor feed and incorporates the incredible graphics capability of the MX100. Both MX80 machines take up to 9.5 inch paper (tractor feed). Both come standard with Centronics parallel interface. They accept all the interface options with the MX100. The MX80 provides up to 80 column (132 column condensed) printing. We currently have an MX80 on demonstration with the MicroBee and we recommend them as a really superb combination.

<b>Model</b>	
MX80 Model I (tractor feed)	<b>\$795.00</b>
MX80 Model II FT (plus graphics)	<b>\$915.00</b>
MX100 FT (with graphics)	<b>\$1195.00</b>
<b>Options</b>	
8141 Serial Interface	<b>\$95.00</b>
MicroBee Cable	<b>\$55.00</b>
TRS80/System 80	<b>\$110.00</b>
IEE488 PET	<b>\$135.00</b>
Apple II (Model I)	<b>\$135.00</b>
Apple II (Model II)	<b>\$170.00</b>
All prices include user manuals and 90 day warranty.	

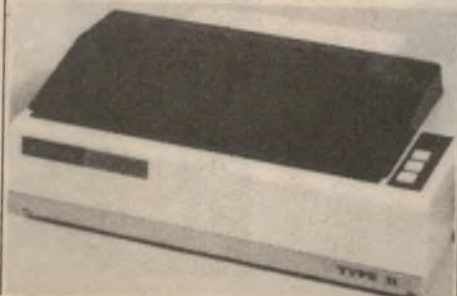

# MONITORS NEW HIGH RES.

## New High Resolution Monitor

Yes! A high resolution monitor which doesn't cost a fortune. We have been able to obtain supplies of these superb Green Screen monitors at way below normal price. The P31 phosphor, wide (18MHz) bandwidth and removable anti glare screen means higher resolution and less eye strain. If you're using professional screen formats or high resolution graphics (such as those on the MicroBee) then we recommend the HiRes monitor. HiRes Monitor

**\$299.00**

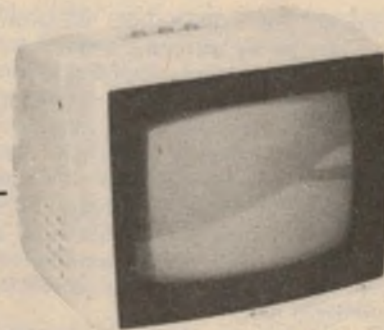

## Low Cost Video Monitor

This low cost 12" white phosphor monitor provides an excellent video display for hobbyist use. It is suitable for use with the MicroBee or any other Personal Micro.

Low cost monitor

**\$129.00**

# AT APPLIED TECHNOLOGY

Showroom/Office: 1A Pattison Ave. Waitara  
Hours: 9-5 Monday to Saturday.  
Phone: (02) 487 2711  
Telex: APPTTEC AA72767

If you need goods in a hurry, join our 10,000 active mail order customers. Order direct on the Hotline number below. We'll give you Blue Ribbon mail order service. If you need goods in a real hurry, ask for our high speed freightbag service.

Hotline Number  
**(02)487 3798**

Mail Orders to:-  
PO Box 311 Hornsby 2077



Sick of driving all over town, only to find that what you want is out of stock? Do you own a Bankcard? Then order direct. Phone on the Hotline, give your name and Bankcard number and we check stocks and get the goods on their way. We'll make it easy for you.



High power design is voltage regulated

# 12/230V inverter with overload protection

Our latest inverter provides 230V at 50Hz and is capable of driving mains-operated appliances rated up to 300VA from a 12V battery. The output is voltage regulated, and has current limiting with ultimate thermal shutdown.

by JOHN CLARKE

In the past few months there has rarely been a day go by without a request for an inverter capable of supplying up to 300VA at mains potential and operating from a standard automotive battery. Until now the only inverter suitable for this application was the 12-230V inverter project described in the February 1979 issue. The new inverter described here is based on the 1979 circuit, contributed by I. M. Woodhead, which has proved to be a reliable unit.

The sudden upsurge in reader demand for inverter circuits is no doubt due to

the power generation problems of the eastern states and the threat of blackouts this coming winter. In addition, a high-power inverter can be used to operate mains equipment in areas where the mains supply is unavailable. Such areas include remote building sites and farms, as well as situations where it is dangerous to operate equipment from a long extension cord.

Typical applications include the operation of audio and video equipment (TV, VCR, turntable, amplifier and tape deck); and powering electric hand drills, solder-

ing irons, sanders and saws. Campers will also appreciate being able to use electrical appliances brought from home.

There are two alternatives to obtaining a mains supply voltage in these applications: either an engine driven alternator or an inverter operating from a storage battery. If a large power output is required, or if it is necessary to operate the supply for an extended period of time, an engine-driven alternator is the obvious choice.

But if energy requirements are relatively low, an inverter has the advantages of quietness, efficiency, and the possibility of exact frequency control.

A transistor inverter can be either self-oscillating or driven. However, the low-cost and relative compactness of a self-excited inverter are outweighed by two disadvantages: frequency and output voltage are notoriously variable with changes in supply voltage and load. In addition, the transformer used in a self-excited inverter has to meet tight specifications on leakage inductance, mutual inductance, and winding resistance if the operating frequency is to stay within the design limits.

In a driven inverter, on the other hand, these problems are eliminated. The output voltage can be controlled by pulse width modulation and if it is necessary to control the frequency precisely (to drive chart recorders, turntables, or tape recorders for example), then this can be done using a crystal oscillator. It is the drive circuitry which determines the characteristics of the driven inverter; the transformer is merely used for voltage conversion so its specifications are not critical.

For all these reasons, a driven inverter is considered the most versatile and so



The completed unit can operate mains appliances rated up to 300VA.



forms the basis of the design described here.

## Circuit description

Refer now to the circuit diagram. IC1a, a CMOS NAND gate wired as an inverter, is used to form a crystal oscillator operating at 4MHz. This signal is applied to the clock input, pin 14, of IC2, which divides this signal by 10 at the carry out, pin 12. IC3, IC4 and IC5 each further divide by 10 to provide 400Hz at pin 12 of IC5. IC6, an up/down binary counter, is used to divide by four, giving 100Hz at the Q2 output, pin 11, and by eight, giving 50Hz at the Q3 output, pin 14.

At this stage readers may be wondering why we have not used the MM5369EYR/N IC, which was used in the inverter described last month to divide down from 3.58MHz. There are two reasons: first, a 100Hz signal is required and this is unavailable from the 5369; second, the 50Hz signal from the 5369 does not have an even duty cycle.

An uneven duty cycle causes a DC component in the transformer primary which wastes power and reduces inverter efficiency. This loss is not important with low power inverters, but as the current drawn increases, the loss does become significant. Consequently we opted to divide down from a 4MHz crystal to provide the necessary 50% duty cycle.

A 4MHz crystal is used rather than a 1MHz type since the higher frequency crystals cost about two thirds less, a saving of close to \$6.

The 50Hz signal from IC6 (pin 14) is inverted by IC1b to provide two 50Hz signals 180° out of phase with each other. These outputs are fed via NAND gates IC1c and IC1d to drivers consisting of BC559 and BD140 PNP Darlington pairs. These, in turn, drive two TIP3055 NPN transistors and two parallel connected 2N3771 Darlington pairs, which drive the primary windings of the transformer. The NAND gates are capacitively coupled to the drivers to prevent one driver conducting should the oscillator fail.

Two output transistors are used for each phase. These ensure adequate gain, the typical gain of a 2N3771 being 20 at 15A, and 10 at 30A. The use of a transistor pair also reduces the saturation voltage since the current in each transistor is halved.

The ideal way of ensuring that two parallel transistors take on equal current is to use emitter resistors chosen so that the voltage across each resistor is of the order of 0.5V. This applies negative current feedback which reduces gain and saturation voltage variations between the two transistors. However, this is rather wasteful of energy when large currents are involved. To avoid this, 0.1Ω resistors are used in the base of each

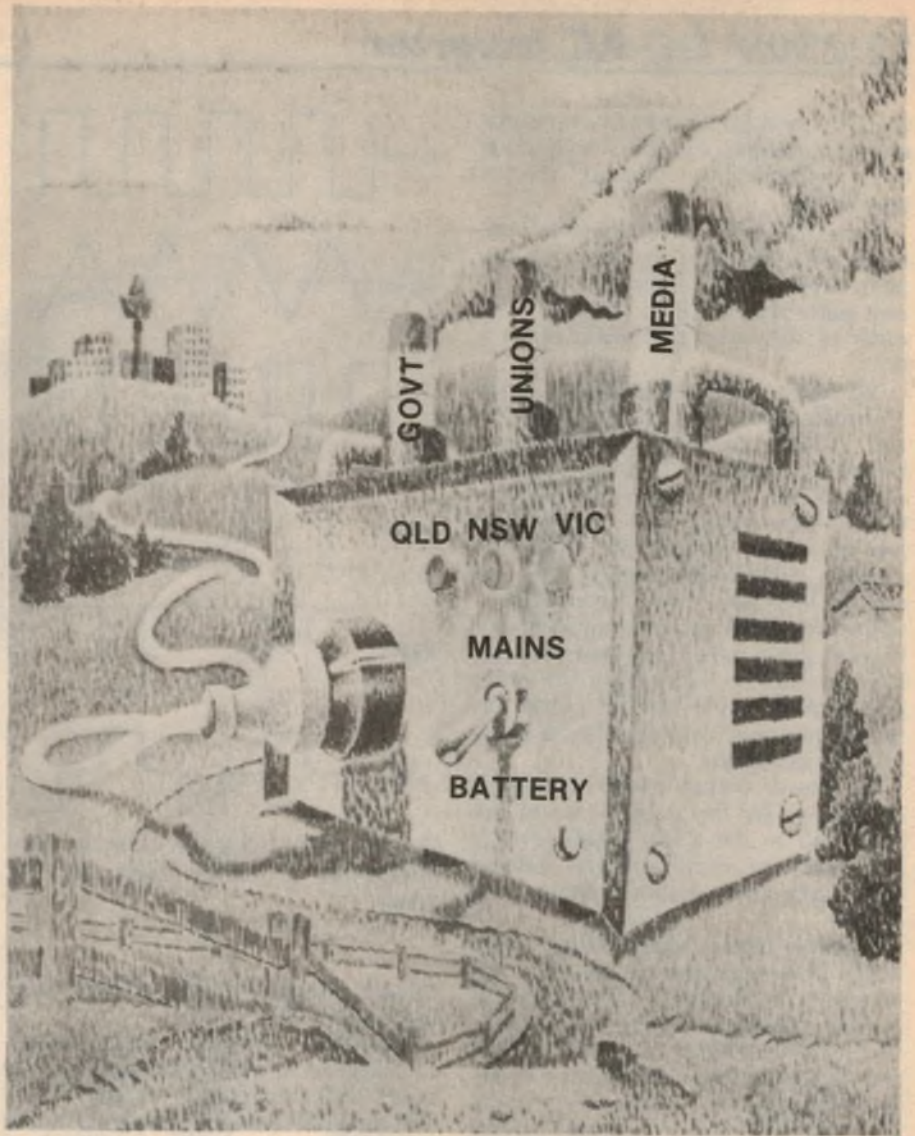

## SPECIFICATIONS

<b>NOMINAL SUPPLY VOLTAGE</b>	12V DC
<b>OUTPUT VOLTAGE</b>	see table
<b>FREQUENCY</b>	50Hz ± .005%
<b>REGULATION</b>	see table
<b>MAXIMUM LOAD</b>	300VA
<b>CURRENT LIMITING</b>	30A (primary)
<b>EFFICIENCY</b>	see table

RESISTIVE LOAD W	OUTPUT VOLTAGE (RMS)	INPUT CURRENT (A)	EFFICIENCY (%)	BATTERY LIFE 40Ah/20h RATE (MINUTES)
no load	210	1.2	0	—
40	235	4.5	60	240
100	240	11.3	62	80
140	240	15.0	69	60
200	240	20.1	78	50
240	240	24.0	79	32
300	235	29.6	82	28



# 12/230V DC-AC Inverter

2N3771 transistor to equalise transistor collector currents. Current sharing using this method has proved to be satisfactory.

Diodes D1 and D2 conduct the reactive current after their opposite transistor pairs have ceased conduction. The current pulse they have to pass is of the order of 30A when the power factor is 0.2.

The 100Hz square wave from IC6 (pin 11) is differentiated by the 100k $\Omega$  resistor and 150pF capacitor combinations before being fed to the inputs of each phase driver. This slows the switching times of the drivers from 10 $\mu$ s to 60 $\mu$ s and therefore reduces the maximum possible pulse width of each phase to slightly less than 180 $^\circ$ , ensuring that under the conditions of maximum power transfer, the current in one transistor pair has decayed to zero before the other pair begin to conduct. At full power this results in a switching loss of only 0.6W which is negligible.

The power output of the inverter is determined by the pulse width of the signal fed to the driver stages. This is controlled by error voltages derived from both the output voltage and current.

A sample of the output voltage is obtained from secondary winding S1. This voltage is rectified by a full-wave bridge rectifier consisting of diodes D9, D10, D11 and D12, filtered by a 390 $\Omega$  resistor and 100 $\mu$ F capacitor, and applied to the inverting input of operational amplifier IC7a via the output voltage control potentiometer VR1. The resulting DC voltage is compared with a 5.6V reference set by zener diode D5 to yield a voltage error signal at the output of IC7a.

To obtain a current error signal, the supply current to the output transistors is passed through R1 to develop a small voltage proportional to current. This voltage is averaged by two 220 $\Omega$  resistors and a 100 $\mu$ F capacitor, and compared by IC7b against a reference

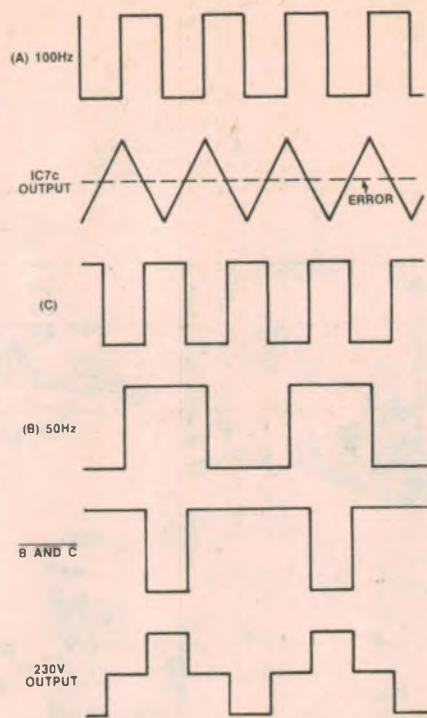

Fig. 1: This diagram shows the waveforms at various points on the circuit.

voltage derived from D4, which is pre-regulated by D5.

Operational amplifier IC7b, which amplifies the current error signal, has a large feedback capacitor (6.8 $\mu$ F) to ensure stability when the inverter is in the current limited mode. The amplifier has, in this configuration, a large DC gain equal to the open loop gain of the amplifier — about 100dB — and an AC gain of almost unity.

The outputs of IC7a and IC7b are fed via a diode OR gate, D6 and D7, to the non-inverting input of IC7d. A delay circuit, consisting of 39k $\Omega$  and 4.7k $\Omega$  resistors and a 47 $\mu$ F capacitor, controls the rate of change of voltage on this input. This is necessary because the long

time constant of the voltage sensing circuit would otherwise cause the output voltage to overshoot when the unit was switched on. The 4.7k $\Omega$  resistor is included to allow a small rapid change to be made to the output voltage. IC7d is used as a comparator.

The DC error signal is compared with a 100Hz triangle wave fed to the inverting input of IC7d. The triangular wave is generated by IC7c which integrates the 100Hz square wave obtained from IC6. The result of the comparison in IC7d is a pulse width modulated 100Hz square wave. This signal is fed via an inverter to the NAND gates of each phase of the 50Hz drive, the phasing being such that the off-time of each phase is proportional to the error signal.

Reference to Fig. 1 will clarify the formation of the various waveforms. Waveform A shows the 100Hz square waveform and, below it, the triangle wave derived by IC7c. When the error voltage and the triangle wave intersect, comparator IC7d changes state. The lower the error voltage, the shorter the "high" output from IC7d, waveform C. When C and B, the 50Hz square wave, are NANDed by IC1c the result is the B and C waveform.

A similar waveform occurs at the output of IC1d and is 180 $^\circ$  out of the phase to the waveform at IC1c. It is these signals that actually turn on the driver transistors to switch the transformer. If the error voltage is high then the full duty cycle of the 50Hz waveform is applied to the transformer. Conversely, if the error voltage is low, representing either an output regulated signal (low load) or a current overload, then the output waveform applied to the transformer has a narrower pulse width applied to it. This can be seen as the 230V output waveform.

A National LM324 (or RCA CA324) quad op-amp is specified for IC7. This was chosen because, for the current error amplifier, the inputs are almost at zero volts. The 324 can be kept in the linear mode, even when the inputs are at ground potential.

The outputs of the error amplifiers, IC7a and IC7b, are fed to LED indicators via limiting resistors to indicate the running mode. A green LED is used to indicate output voltage regulation, while an orange LED indicates current overload.

Thermal overload sensing and protection is provided by Q15, a germanium transistor, and SCR1. The higher the temperature, the higher the leakage current through the transistor, and the higher the voltage at the cathode of diode D8. The actual rate of rise of voltage with respect to temperature is

## WARNING!

Equipment to be operated from this inverter must be in a safe condition, since the voltages produced are at mains potential. This means that frayed cords, exposed unearthed metal parts (unless double insulated), and broken or wet insulators must be repaired before the item is used. Note that contact with both output lines could prove fatal!

It is also important to keep the electrolyte level of the battery above the plates. This prolongs battery life and reduces the risk of battery explosion. When charging the battery, do so in a well ventilated area. The hydrogen given off from a charging battery is highly explosive. When connecting the inverter to the battery, make sure that the inverter is switched off at the on/off switch so that sparks do not occur near the battery.



## CIRCUIT DIAGRAM

adjusted by trimpot VR3 and filtered by a  $16\mu\text{F}$  capacitor.

When the voltage at the cathode of D8 reaches 2.7V with respect to the anode, the diode conducts and turns on the SCR. With the SCR on, the 1.5A fuse blows, cutting off the supply to the circuit and hence drive to Q5 and Q6. The inverter is then disabled. To indicate the open circuit LED fuse, the red thermal overload LED lights. This derives its supply from V1, the current flowing via a  $1.5\text{k}\Omega$  limiting resistor and the conducting SCR.

Supply filtering is provided by a  $100\mu\text{F}$  electrolytic capacitor and two  $0.1\mu\text{F}$  capacitors. These decouple the supply from high frequency signals which could upset the operation of the circuit.

Reverse polarity protection is provided by D1, D2 and D3. These diodes conduct when the supply is reversed, protecting the circuitry from the reverse current until the fuses blow. Reversing the supply and replacing the fuses will restore normal operation. Although D1 and D2 are only rated at 10A, they are capable of withstanding the heavy current surge until the fuse blows.

R1, the current sensing resistor, is simply a strip of copper on the printed circuit board (PCB). This strip of PCB is cut off from the main PCB and mounted on the chassis of the inverter case.

### Construction

Most of the low-power components are mounted on a PCB measuring  $143 \times 156\text{mm}$  and coded 82iv6. A K&W instrument case measuring  $255 \times 165 \times 155\text{mm}$  houses the electronics and, on the prototype, was fitted with handles so that the inverter could be easily carried.

All the components used in this project are normal stock items, with the exception of the power transformer. This is manufactured by Transcap Pty Ltd (Brookvale, Sydney) and distributed through Watkin Wynne Pty Ltd, 32 Falcon St, Crows Nest 2065. It will be available from a number of component retailers by the time this article appears in print.

As can be seen from the artwork, the PCB has been designed to plug into an edge connector socket with 3.81mm (0.15-inch) spacing between the pins. Although 24 pins are specified for the socket, only 21 are used to make the electrical connections to the PCB. The

Right: A crystal oscillator (IC1) driving a power amplifier (Q1-Q10) and a step-up transformer forms the basis of the circuit. Main features include voltage regulation of the output and full overload protection.

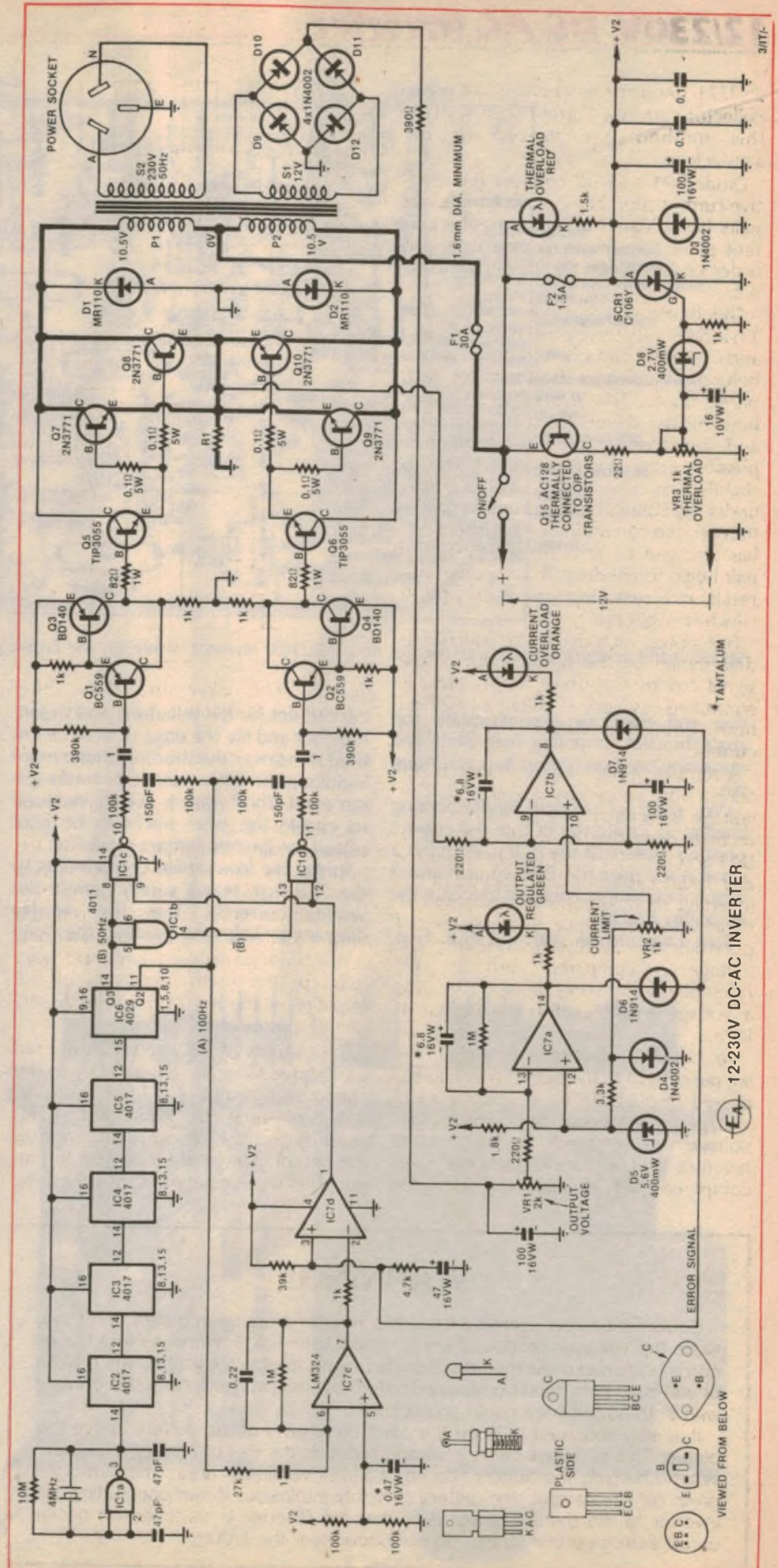







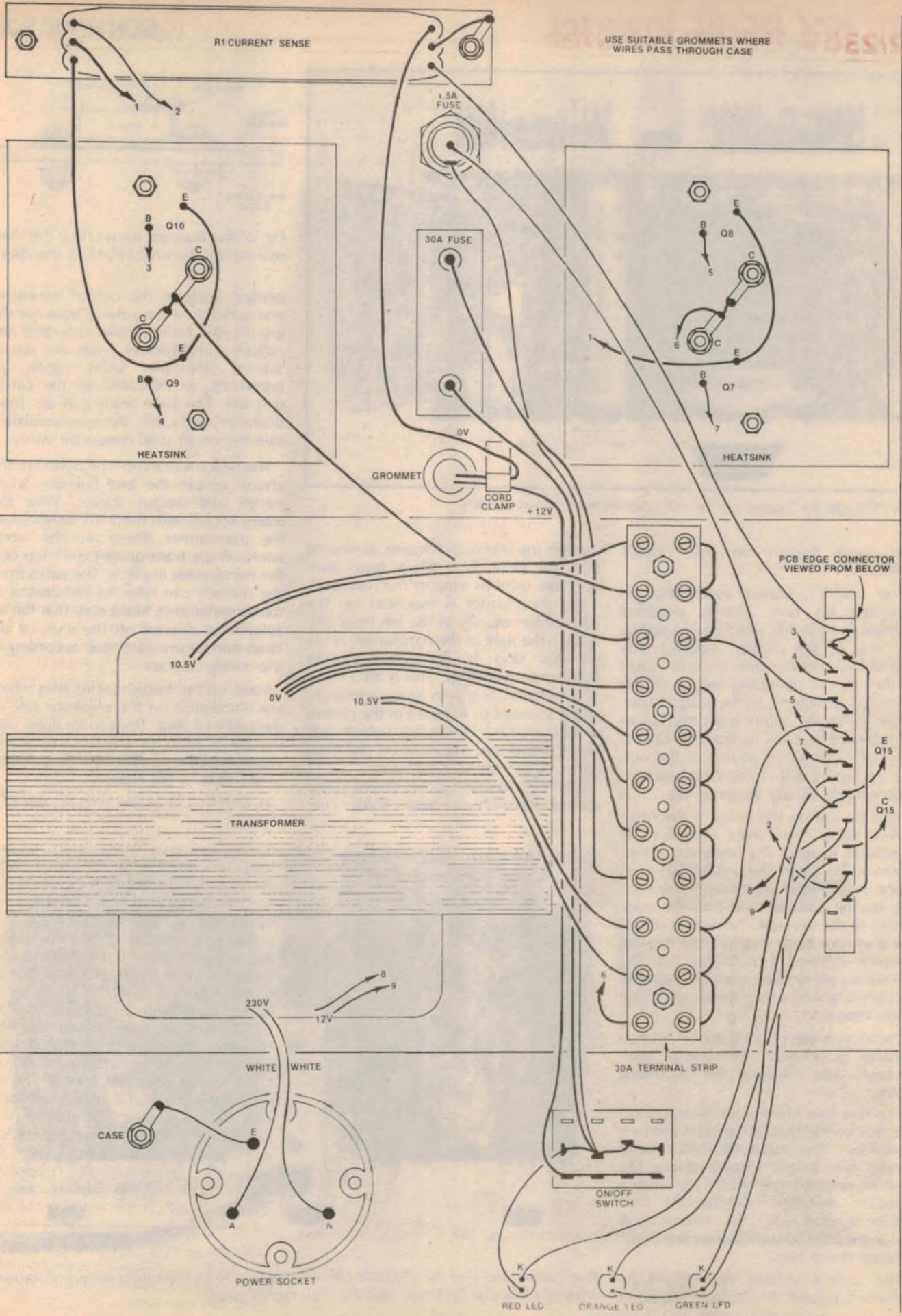

R1 CURRENT SENSE

USE SUITABLE GROMMETS WHERE WIRES PASS THROUGH CASE

HEATSINK

HEATSINK

TRANSFORMER

PCB EDGE CONNECTOR VIEWED FROM BELOW

30A TERMINAL STRIP

WHITE WHITE

POWER SOCKET

RED LED

ORANGE LED

GREEN LED



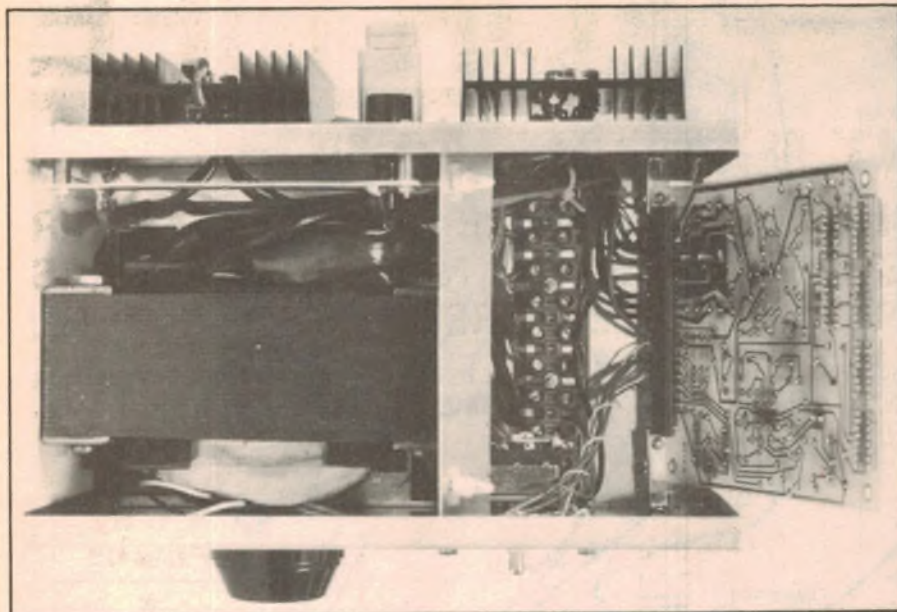

The PCB can be hinged out of the case for easy service access.

and work begun on the chassis assembly.

The 2N3771 output transistors are mounted on two 200mm extruded aluminium heatsinks which are bolted to the rear of the chassis. Although the heatsinking requirements are quite small in the normal operating mode, all the power is dissipated in the output transistors when the output is shorted, so an appropriate heatsink is required. Q15 is thermally connected to one of the output transistors with a flag type heatsink. Mounting details are shown in Fig. 2.

Start by drilling the holes in the heatsinks, using the mica washers as templates to mark the necessary holes. Clean up any swarf and deburr the holes. Place heatsinking compound between the mating surfaces and bolt the transistors to the heatsink. Note that one of the transistor bolts should have the flag heatsink screwed to it. Ensure that the transistors are isolated from the heatsink by checking with a multimeter set to the ohms range.

The chassis can now be drilled by temporarily positioning the various components and marking the mounting holes.

The two fuse holders are mounted on the rear of the chassis between the two heatsinks. The standard 3AG panel mount fuse holder mounts above the ceramic encased fuse holder, the latter a standard domestic switchboard fuse holder rated at 32A, 250V. Grommeted holes are used to pass connecting leads through the chassis.

The current sensing resistor, R1, is mounted parallel to the top left hand

edge of the rear of the chassis, as viewed from the front. Two 10mm brass standoffs are used to support the resistor.

The transformer is mounted on the base of the chassis, in the left front corner. To the right of the transformer is the terminal strip which terminates the transformer windings. This is an 11-way 30A terminal strip with screw terminals, and is screwed to the base of the chassis at four points. The mains socket and on/off switch are mounted on the front panel, as are the LED indicators.

With the necessary holes drilled in the chassis, assembly can begin. Solder con-

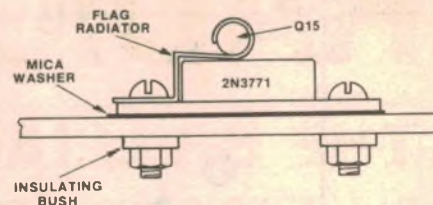

Fig. 2: this diagram shows how the thermal sensing transistor (Q15) is mounted.

necting leads to the output transistors and bring these into the chassis via the grommeted holes. Make sure that the collector and emitter leads are run in 1.6mm diameter solid cable, or equivalent, as indicated on the circuit diagram. The base leads can be 1mm diameter solid cable. We used insulating sleeving on all solid conductor wires.

The heatsinks can now be bolted to the chassis as can the fuse holders, on/off switch and output socket. Wire the mains socket with the 240V windings of the transformer (these are the white wires on the transformer) and then bolt the transformer in place. The wires from the primary can now be terminated in the terminal strip. Make sure that the insulation is cleaned off the ends of the leads and secure each lead according to the wiring diagram.

Make up the bridging wire links which are terminated on the opposite side of the terminal strip. This can be done with the aid of pliers to achieve a neat job. The terminal strip can now be screwed to the base of the chassis.

In order to fit in the chassis, the PCB

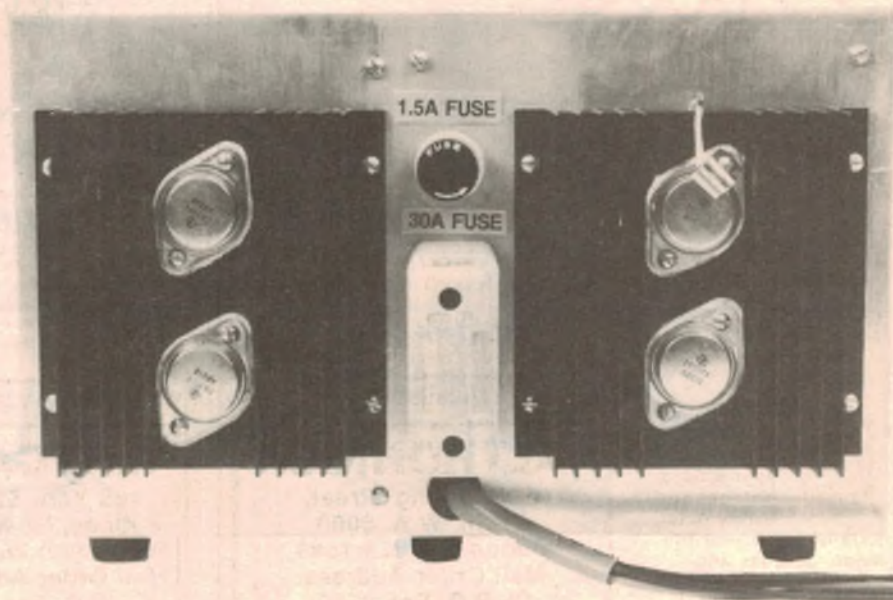

Rear panel layout of the 12/230V DC-AC Inverter. Note mounting details of thermal sensing transistor Q15 (see also Fig. 2 at top of page).



# RADIO — FOR LIFE

## THE BRILLIANT MARC NR 82 FI

BUY THIS SPECTACULAR PERFORMANCE 12 BAND RECEIVER AND YOU WILL NEVER NEED ANOTHER. NEVER BEFORE HAS SUCH AN AMAZING RADIO BEEN OFFERED FOR THE PRICE.

FEATURING: Digital frequency Display, SSB/CW, FM/AM reception, B.F.O., Double Conversion, Double Super-het, crystal controlled (VHF) Local Oscillator, 4 inbuilt antennas and good looks, you will spend hours just learning how to drive it!

★  
\$10  
Pack and  
Postage  
anywhere in  
Australia

only  
**\$349**



**3 Way  
Power**  
★  
**Digital  
Tuning**  
★  
**HI FI  
SOUND**  
★  
**4 Inbuilt  
Antennae**

**STRICTLY  
LIMITED  
STOCKS**

**SPECIFICATIONS:**

Semi-conductors: 1 - LSI, 4 - IC's, 7 - FET, 34 - Transistors, 1 - Voltage regulator and 42 - Diodes

**Frequency range:**

LW	145-360	KHz	VHF1	30-50	MHz
MW	525-1600	KHz	VHF2	68-86	MHz
SW1	1.6-3.8	MHz	VHF3	88-108	MHz
SW2	3.8-9	MHz	VHF4	108-136	MHz
SW3	9-22	MHz	VHF5	144-176	MHz
SW4	22-30	MHz	UHF	430-470	MHz

**Output power:** 5.0W (Max.)  
**Power supply:** AC 240V 50Hz DC 12V (8 x "D" cells). Ext. DC 12V Car/Boat

**Speaker:** 12.5cm Permanent Dynamic Speaker (3.2 ohm)  
**Antenna:** Ferrite Bar Antenna for LW, MW and SW1  
3 x Telescopic Antenna for SW, VHF and UHF

**Controls:** Power ON-OFF switch — Digital display ON-OFF switch — Tape-Radio switch, Wide-Narrow band selector switch, AM band selector (LW/MW SW1/SW2/SW3/SW4), VHF band selector (VHF1/VHF2/VHF3/VHF4/VHF5/UHF), Ant. Selector (Telescopic ANT./EXT. ANT.), Tuning control (direct gear drive), volume control, Bass control, Treble control, Squelch control, BFO pitch control, RF gain control, Antenna adjustor control, Mode switch (USB-NOR-LSB/CW)

**Terminals:** Ext. Speaker/Headphone Jack, Tape IN-OUT jack, VHF/UHF ANT. connector (coaxial), SW EXT. ANT. terminal (Screw), Ext. battery jack

**Meter:** Tuning Meter

**Digital Frequency Counter Section:**

**Display:** LW/MW/SW-1 KHz  
SW2-4/VHF1-5 MHz

**Control:** SW Calibrator

**Dimensions:** 452mm (W) x 288mm (H) x 130mm (D)

**Quantities strictly limited:** Grab one now for only \$349. 7 Day money-back guarantee

Available from either of the following stores



Order with your Bankcard — simply include your B/Card Number and expiry date

together with your full name, address and telephone number. Allow approx. 7 days for delivery

### ALTRONICS

105 Stirling Street,  
Perth, W.A. 6000  
Phone (09) 328 1599  
Mail Order Address:  
C/- P.O. Box 8280,  
Perth, Stirling St., WA 6000

### JAYCAR

125 York Street,  
Sydney, NSW 2000  
Phone (02) 264 6688  
Mail Order Address:  
C/- P.O. Box K39,  
Haymarket, NSW 2000

**SEVEN DAY  
SATISFACTION  
GUARANTEE  
AND OF COURSE  
90 DAY 100%  
PARTS AND LABOUR  
WARRANTY**



# THINKING APPLE MICROCOMPUTERS

## THINK COMPUTER COUNTRY

We are one of Australia's oldest Apple Dealers  
and the oldest in Victoria!

We carry probably one of the largest ranges of  
Apple Products in Australia!

**GREAT PRICES!  
GREAT SERVICE!**

**WHY GO ELSEWHERE!**

Come to the  
Computer Country Group  
for all Your Apple needs

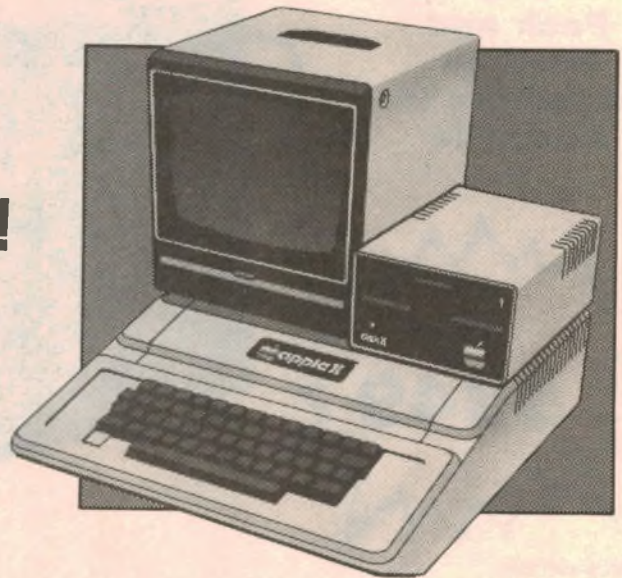

**COME TO  
COMPUTER COUNTRY (VIC) PTY LTD**

338 Queen Street Melbourne Vic 3000 (03) 329 7533

**IN QUEENSLAND CONTACT**

Computer City 600 Old Cleveland Road Camp Hill Qld 4152 (07) 398 6759

**IN SOUTH AUSTRALIA CONTACT**

Key Computer 1055 South Road, Edwards Town SA 5039 (08)  
277 8936

**SOON TO BE OPENING IN PERTH**

For further information call Computer Choice (09) 322 5651.





## PARTS LIST

- 1 K&W case, 255 × 165 × 155mm
- 1 printed circuit board, code 82iv6, 143 × 156mm
- 1 300VA transformer: primary 10.5-0-10.5V; secondaries 230V 1.5A, 12V 0.1A
- 1 Scotchcal front panel, 153 × 254mm
- 2 finned channel heatsinks, 28 × 100 × 100mm
- 1 35A SPST switch
- 1 30A fuse holder, Federal 250V, 32A.
- 1 3AG bayonet fuse holder and 1.5A 3AG fuse
- 1 panel mount mains socket
- 1 11-way 30A rated terminal strip
- 1 24-way edge connector (Swann Redline 3.81mm (0.15-inch) spacing with one open and one closed mounting bracket. No. 1333-13-19)
- 3 9mm ID grommets
- 5 5.5mm ID grommets
- 1 cord clamp
- 3 cable ties
- 6 rubber feet
- 2 plastic "snap-in" PCB supports, 5mm high
- 2 19mm brass standoffs
- 3 LED bezels
- 2 earth lugs

- 4 TO-3 insulating kits (mica washers, bushes, lugs and screws)
- 2 large automotive battery clips
- 1 piece of aluminium, 1mm × 160 × 30mm
- 1 4MHz parallel resonant crystal

### SEMICONDUCTORS

- 1 4011B quad two input NAND gate
- 4 4017 decade divider
- 1 4029 presettable up/down 4-stage counter
- 1 LM324 quad op amp
- 1 C106Y SCR
- 2 MR110 10A, 100PIV stud mounting diodes
- 6 1N4002 1A silicon diodes
- 2 1N4148, 1N914 small signal diodes
- 1 2.7V 400mW zener diode
- 1 5.6V 500mW zener diode
- 2 BC559 PNP transistors
- 2 BD140 PNP transistors
- 2 TIP3055 NPN transistors
- 4 2N3771 NPN power transistors
- 1 AC128 PNP transistor
- 1 Red LED
- 1 Green LED
- 1 Orange LED

### CAPACITORS

- 3 100μF/16VW PC electrolytic

- 1 47μF/16VW PC electrolytic
- 1 10μF/16VW PC electrolytic
- 2 6.8μF 16VW tantalum
- 3 1μF metallised polyester
- 1 0.47μF tantalum
- 1 0.22μF metallised polyester
- 2 0.1μF metallised polyester
- 2 150pF polystyrene
- 2 47pF ceramic

### RESISTORS (¼W, 5% unless noted)

- 1 × 10MΩ, 2 × 1MΩ, 2 × 390kΩ, 6 × 100kΩ, 1 × 39kΩ, 1 × 27kΩ, 1 × 4.7kΩ, 1 × 3.3kΩ, 1 × 1.8kΩ, 1 × 1.5kΩ, 8 × 1kΩ, 1 × 390Ω, 3 × 220Ω, 2 × 82Ω 1W, 1 × 22Ω, 4 × 0.1Ω 5W, 1 × 2kΩ ten-turn trimpot, 2 × 1kΩ ten-turn trimpots.

### MISCELLANEOUS

- 2 metres of 1.6mm diameter solid conductor wire, 2 metres of 1mm solid conductor wire, 2 battery leads (see text), nuts, bolts, washers, insulating tubing, heatsink compound, solder etc.

NOTE: Components specified are those used in the prototype. Components with higher ratings may generally be used provided that they are physically compatible.

must be mounted at an angle. Support for the PCB is provided by the edge connector socket, which is fastened to the front and rear panels by two angle brackets. Two plastic standoffs mounted on a cross-member secure the top of the PCB. Details are shown in the mechanical drawing of Fig. 3.

The advantage of this method is that the PCB can be hinged out of the case, allowing easy access for the necessary setting-up adjustments.

With the edge connector socket mounted, the remainder of the wiring can be completed. Note that more than one terminal on the socket is used in some cases to make contact to individual tracks on the PCB. It is important to use all of these terminals when securing the leads, so that current limits of the PCB are not exceeded.

Note that the negative supply rail from the battery is earthed to the chassis at R1, as shown in the wiring diagram. Connecting leads to the battery should be run in heavy-duty cable, red for positive and black for negative. We used two short parallel lengths of 3mm 512-strand test lead wire for each lead. Light duty jumper leads are also ideal for this application, especially if long leads (greater than 0.5m) are required.

Six rubber feet are used to support the chassis. We mounted four at each corner

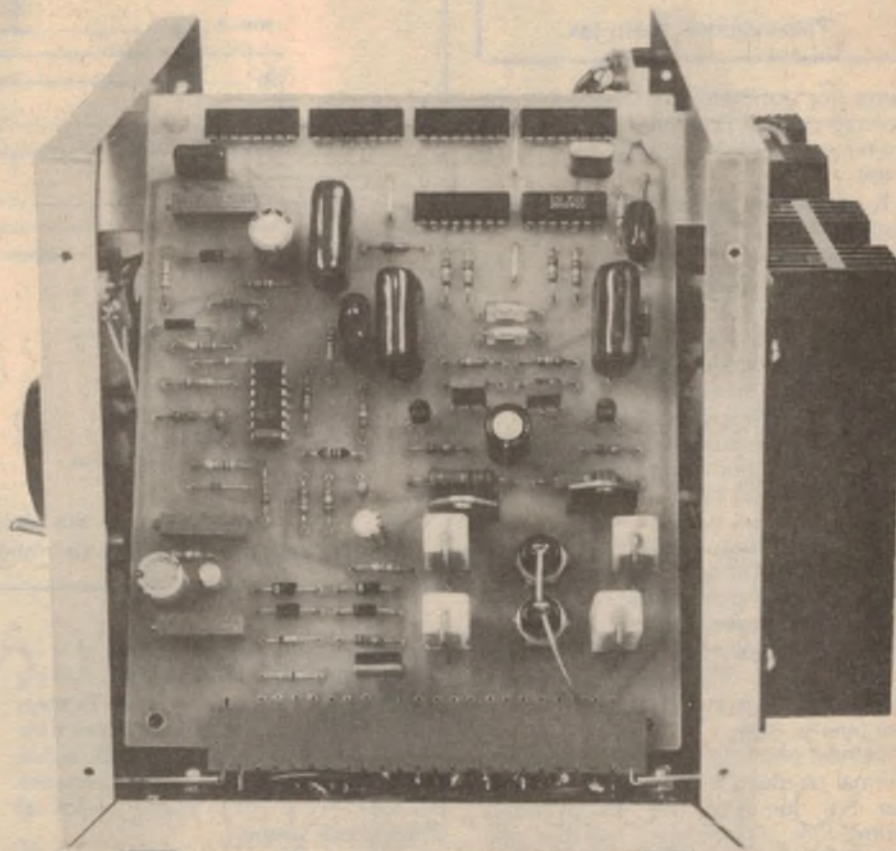

Close-up view of the assembled PCB mounted inside the metal case



and two near the centre of the chassis next to the transformer mounting bolts. The carrying handles are optional extras. We obtained ours from a hardware store, but some parts retailers may offer them as part of a complete kit.

### Setting up and testing

Now that construction is complete, the inverter is ready to be tested. Before switching on, rotate thermal overload trippot VR3 fully clockwise and VR1 and VR2 fully anticlockwise. To do this, rotate the screw of each trippot by at least 15 turns, so that the trippot is sure to be at the end of its travel. Apply power and, if the unit has been correctly wired, it will operate with either the regulated LED or current overload LED lit.

To set the output voltage, either a true RMS voltmeter will be required, or the adjustment will have to be carried out using an approximate comparison method. If an RMS meter is available, lightly load the inverter (using a 100W

We estimate that the current cost of parts for this project is approximately

**\$186**

This includes sales tax.

lamp for example) and advance the voltage control potentiometer until the meter, connected to the output, reads 240V.

To adjust the output using the comparison method, put a 100W lamp on the inverter output beside another 100W lamp connected to the mains. Advance the voltage control until the light output of each lamp appears the same. If during this procedure the overload LED is illuminated, advance the current control trippot (VR2) one turn.

Note that because the waveshape of the output is non-sinusoidal, a normal voltmeter will give an erroneous reading.

After the output voltage has been set, put a 300W load on the inverter (three 100W lamps) and adjust the current control potentiometer until the inverter is just at the point of going into the overload state. Alternatively, if a true RMS ammeter is available, set the current limit to 30A.

The next step is to check and adjust the thermal overload protection. To ensure that it is operative, turn the overload control fully anticlockwise and then put a large load, for example a 1kW heater, on the output and switch on. The protec-

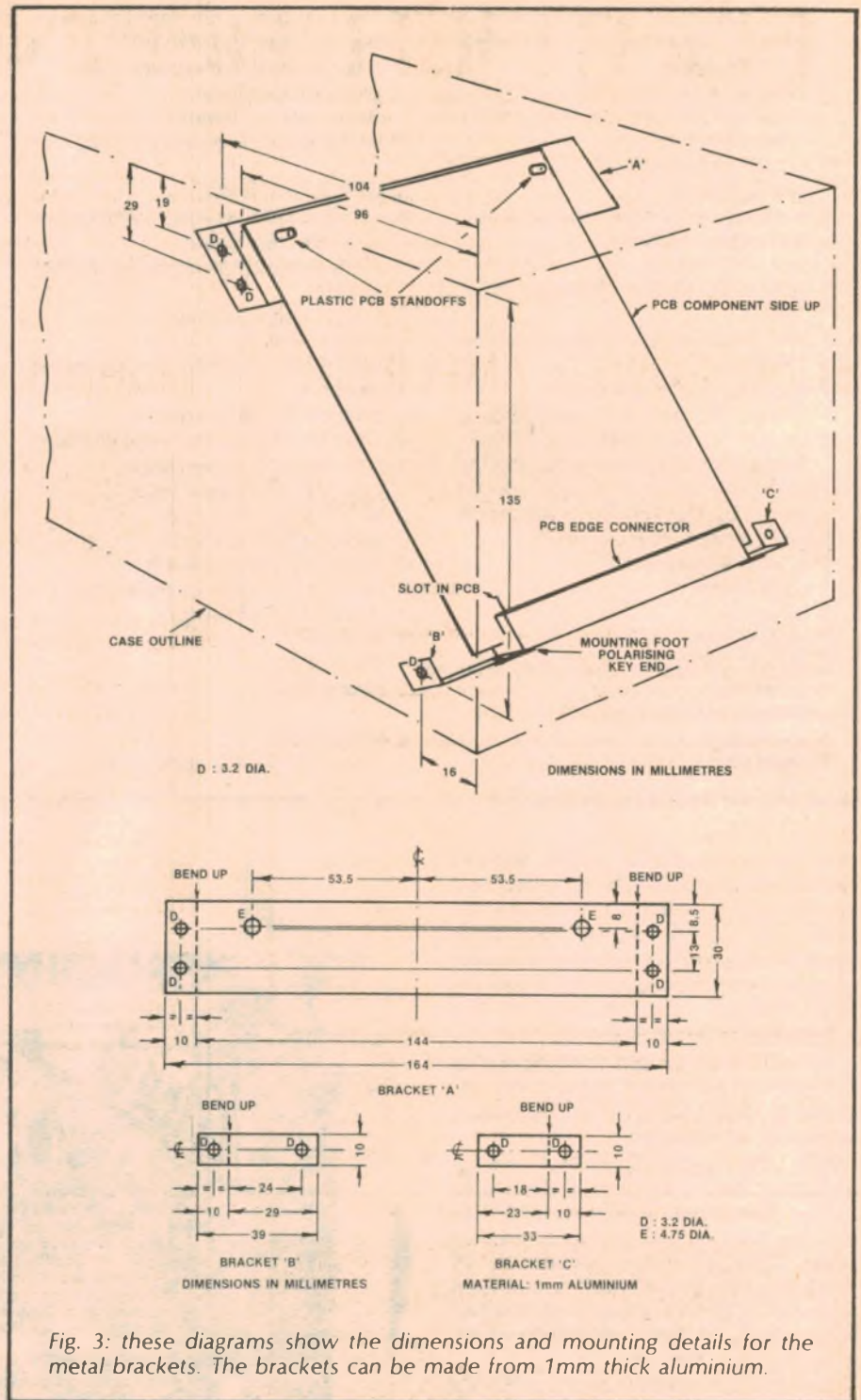

Fig. 3: these diagrams show the dimensions and mounting details for the metal brackets. The brackets can be made from 1mm thick aluminium.

tion circuit should shut down the inverter within about 30 seconds, lighting all the LEDs. However as a precaution, keep a finger on one of the output transistors. If the thermal overload circuit hasn't shut the unit down by the time the transistor is too hot to touch, switch off and recheck wiring.

Assuming that everything functions correctly, all that remains is to set the

shutdown temperature. Allow the unit to cool and set the control (VR3) fully clockwise. Switch on again and, when the transistors are almost too hot to touch, remove the load and turn the control back until the unit goes into the overload mode. Alternatively if a contact thermometer is available, set the temperature limit when the transistor case reaches 65-70°C.



# 5000 AMPS FURTHER REFINEMENT

**5000 POWERAMP** – Much has been said about the brilliant 5000 Mosfet PA by David Tillbrook. Justifiably so in our opinion. If you wish to know more send us a SAE for a descriptive leaflet. If you are well versed with the 5000 PA you may like to know that we now supply Beryllium Oxide (high thermal conductivity) TO-3 ceramic washers in place of the poor conductivity – and flimsy – mica washers, STANDARD in our kit. You may have also noticed a number of suppliers offering 'versions' of the 5000 PA and Preamp which to some could be interpreted as the same as the quality Jaycar kit. Whilst we could be smug and say that imitation is the sincerest form of flattery, we would be kidding ourselves. We still firmly believe that the Jaycar 5000 kits are the best for many reasons: Among which are: – Only the finest components go in e.g. 1% Metal film resistors. – Continuing refinement. e.g. Beryllium washers, superior export packing. – superior cosmetic appeal.

**PREAMP REFINEMENTS** – For quite some time now we have been using the LM194CH ultra-matched transistor array in the M.C. section of the preamp. We felt that this expensive military grade component was justified. We also used the Mil-spec MAT-01GH by Precision Monolithics Inc. of the USA. National Semiconductor now has a device called the LM394H which we now intend to use exclusively in our "Blueprint" series preamps. The H version is EVEN QUIETER than the CH versions in the past. While this component is considerably more expensive than the standard LM394 we feel that the extra investment on our part is justified. Yet another example of "Further Refinement".

## 5000 POWER AMPLIFIER



FROM

\$289

**EXCLUSIVE!! Beryllium Oxide TO-3 heatsink washers now used. (Safety pink type).**

- STANDARD (ETI) FRONT PANEL \$289.00
- SUPERFINISH (RECOMMENDED) FRONT PANEL \$299.00 (SUPERFINISH PANEL ILLUSTRATED)

### LABORATORY MEASURED PERFORMANCE FIGURES:

POWER OUTPUT  
FREQUENCY RESPONSE

100W RMS into 8 ohms (both channels driven)  
8Hz to 20kHz, +0 -0.4dB  
2.8Hz to 65kHz, +0 -3dB  
Note: These figures are determined solely by passive filters

INPUT SENSITIVITY  
HUM  
NOISE

1V RMS for 100W output  
-116dB below full output (flat)  
-116dB below full output (flat, 20kHz bandwidth)

2nd HARMONIC DISTORTION

<0.001% at 1kHz (0.0007% on prototypes) at 100W output using a +56V supply rated at 4A continuous

3rd HARMONIC DISTORTION

<0.0003% for all frequencies less than 10kHz and all powers below clipping

TOTAL HARMONIC DISTORTION  
INTERMODULATION DISTORTION  
STABILITY

Determined by 2nd harmonic distortion (see above)  
<0.003% at 100V (50Hz and 7kHz mixed 4:1)  
Unconditional

### BERYLLIUM OXIDE WASHERS

If you wish to upgrade the quality of your existing 5000 PA with Beryllium washers you can have a set of 8 for \$15 plus P&P – High thermal shock capacity – Perfectly safe if not EATEN!! – Ceramic material that conducts better than Aluminium – High dielectric strength – As used in Military Aerospace equipment – Precision cut for TO-3 profile.

Freight outside NSW only \$15. Within NSW \$10



## "Blueprint" 5000 preamp



FROM

\$245

**EXCLUSIVE!! NEW LM394H EXTRA LOW NOISE ULTRA-MATCHED TRANSISTOR PAIR USED IN M.C. PREAMP.**

STANDARD (STILL GOOD) VERSION ONLY \$245.00  
"BLUEPRINT VERSION"

FEATURES:

- EXTREMELY CLOSE TRACKING TO RIAA PHONO EQUALISATION
- GOLD PLATED CONNECTORS ON PHONO INPUTS
- ENGLISH "LORLIN" LOW NOISE SELECTOR SWITCHES USED
- LOW NOISE 1% 50ppm METAL FILM RESISTORS USED
- TINNED FIBREGLASS PCB's
- LOW CAPACITANCE SCREENED CABLE USED THROUGHOUT
- QUALITY I.C. SOCKETS PROVIDED
- SPECIAL REAR PANEL
- MULTICOLOURED LED DISPLAY

### SPECIAL OFFER

If you have the good taste to purchase both the 5000 PA and Preamp during June, we will give you our exclusive

JAYCAR

– SOUND ENGINEERING –

T-shirt absolutely FREE. Tell us how big you are or it may not fit!! Available separately for only \$6.50 each.

## at last!! \* the new 8 channel MIXER KIT

† Balanced (600 ohm) mic inputs/line inputs † Balanced output † Input attenuators † Cannon connectors included in the price † Bass, mid & treble equalization on each input † "Effects" (i.e. echo etc) capability † Foldback on all 8 inputs † Stereo pan on all 8 inputs † 60mm slide faders used throughout † 19" rack mount capability (or console mount) † Professional black front panel with format borders and multicoloured knobs to assist function identification † Designed for quick easy service † VU metering † Only high quality components used † 5534A OP amp used for low noise and very low distortion.

**BASIC MIXER KIT with all features. Includes 19" rack panel all knobs and electronic components AND 10 CANNON connectors \$495**

**Console mount chassis in steel, plated and pre-punched. Includes power supply for mixer and wooden end pieces. \$98**

## Jaycar

125 YORK ST SYDNEY 2000  
Ph. 2646688 Telex 72293

Mail Orders To:

Box K-39 Haymarket 2000  
Post and Packing charges

SHOP HOURS  
Mon-Fri 9 to 5.30  
Sat 9 to 2  
Thurs night to 8pm

\$5-\$9.99 (\$1.20) \$10-\$24.99 (\$2.40)  
\$25-\$49.99 (\$3.50) \$50-\$99.99 (\$4.60)  
\$100 up (\$6.20)

SEND SAE FOR FULL DATA ON 5000 SERIES AND THE NEW STEREO MIXER KIT



## KAISE MULTIMETERS

*Professional performance at a realistic price.*

This range of precision engineered analogue multimeters covers virtually all applications—from household checks to laboratory bench.



**ILLUSTRATED:**

**SK550 \$89.50**

Top quality 100kohm/V (DC) meter ideal for demanding use where circuit loading must be avoided. Features include:

- Fast acting relay protection — with LED and buzzer indication.
- 27 ranges including 12A AC & DC current.

**SK510 \$76.00**

The same accuracy and ranges as the SK550, but without the relay protection and with the addition of a transistor test function.

**SK520 \$81.00**

Identical to the SK510, but with 4 capacitance ranges instead of the transistor test function.

**SK50 \$41.00**

Ideal general purpose meter. 50kohm/V — 22 ranges including 3 capacitance scales (using external AC source). Diode and fuse protection.

**SK110 \$32.50**

30kohm/V meter with transistor tester. 19 standard ranges.

**SK240 \$29.50**

Popular 20kohm/V meter. Compact size, 22 ranges. Ideal for field, school or home use.

**SK242 \$28.50**

Identical to the SK240 but housed in a bright yellow case and with a Lux scale for ambient light measurements (using optional low cost probe).

**Lux Probe for SK242 \$16.00**

**SK2 \$13.50**

Compact 5kohm/V. Ideal meter for the kitchen drawer or the toolbox. 16 ranges cover most needs.

*All prices are plus tax if applicable.*

*Imported and distributed by*

**STANDARD COMPONENTS PTY LTD**  
10 Hill St, Leichhardt. NSW.

*For information and your nearest dealer, please contact:*

SYDNEY — (02) 660 6066; MELBOURNE —  
(03) 781 4898; BRISBANE — (07) 286 4816.

# sabtronics PRECISION INSTRUMENTS

## NEW LOW PRICES FROM CHRISTIE RAND

### DIGITAL MULTIMETER



- BASIC ACCURACY 0.1%DC, 0.5% AC
- DC & AC VOLTS 100uV to 1000V
- AC VOLTS TO 40KHz
- DC & A C AMPS 0.1uA to 10A
- RESISTANCE 100n to 20M
- OVERLOAD PROTECTION TO 1.2 KV DC OR PEAK AC
- DIODE TEST

**BENCH DMM**

**PRICE TAX**

- 2010 LED kit \$110 \$13.28
- 2010 LED asbl \$120 \$13.28
- 2015 LCD asbl \$140 \$15.32

**HAND HELD DMM 2A MAX**

- 2035 LCD kit \$110 \$13.28
- 2035 LCD asbl \$120 \$13.28
- 2037 WITH TEMP PROBE -50+150
- 2037 LCD kit \$135 \$15.32
- 2037 LCD asbl \$145 \$15.32

### FREQUENCY COUNTER



- GUARANTEED 10Hz to 600MHZ
- TYPICAL 5Hz to 750Hz
- SENSITIVITY 10mV RMS to 100MHZ & 70mV to 600MHZ
- GATE TIME 0.1, 1.10 SEC
- AGEING RATE ± 5PPM/YEAR
- TEMP STABILITY 1PPM/C°
- INPUT PROT 90V RMS TO 10KHz

**8610A 8 DIGIT**

**PRICE TAX**

- 8610A LED kit \$159 \$18.38
- 8610A LED asbl \$174 \$18.38
- 8610B 9 DIGIT \$179 \$19.95
- 8610B LED asbl \$259 \$21.00
- 8000B 9 DIGIT 1 GHz
- 8000B LED asbl

**Batteries Not Supplied**

*Postage & packing \$3.00*

### FUNCTION GENERATOR



- 1Hz TO 200kHz
- SINE SQUARE & TRIANGLE
- DC OFFSET
- SINE WAVE ACCURACY 1%
- OUTPUTS  
HIGH 10 VPP 600  
LOW -40 dB  
TTL
- SWEET INPUT 100:1 RANGE
- 5020 kit \$151 \$13.92TX
- 5020 asbl \$161 \$13.92TX

Distributor Enquiries Welcome

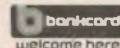

## CHRISTIE RAND PTY LTD

PO BOX 48 EPPING,  
NSW, 2121  
PHONE (02) 868 1209



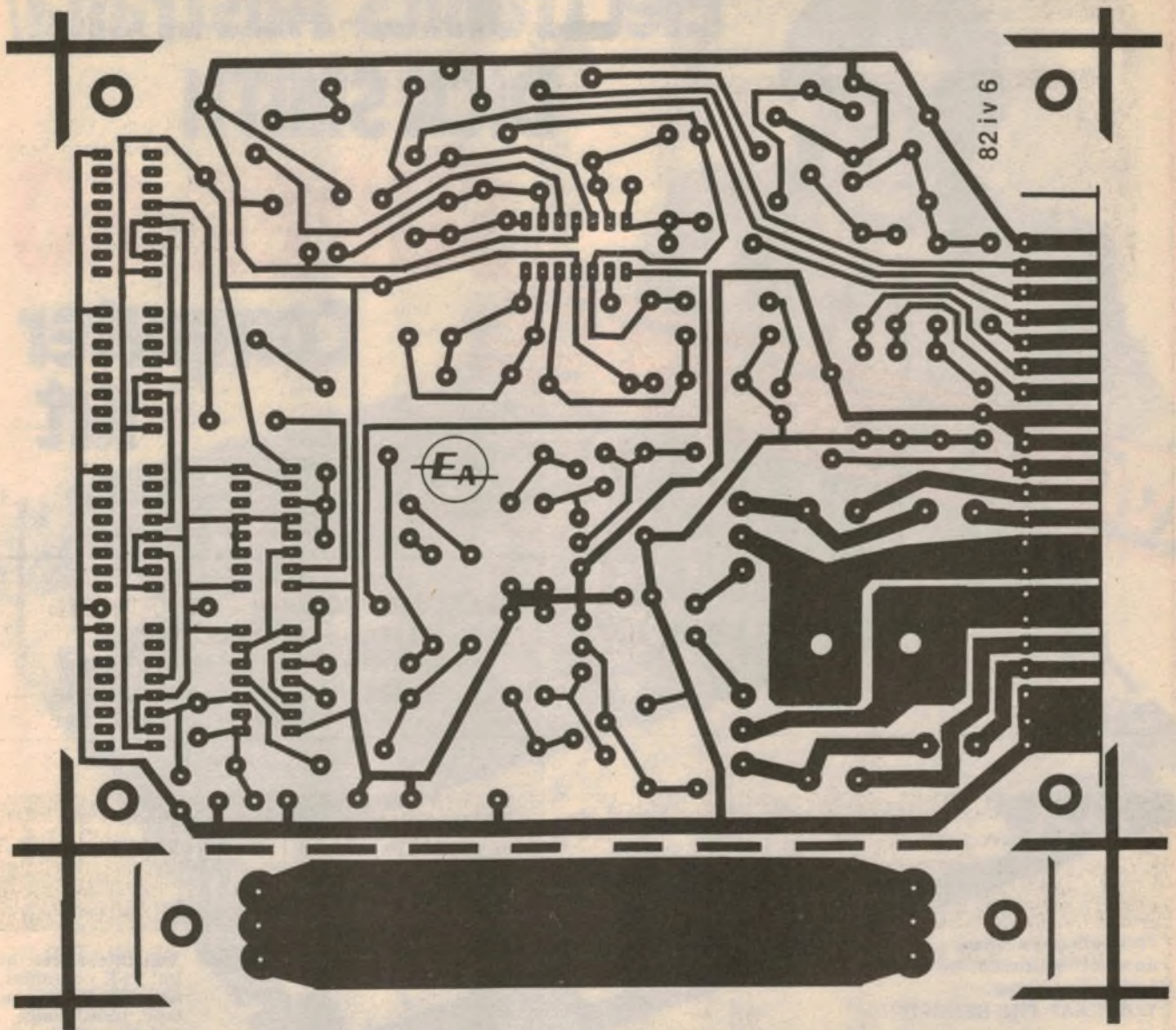

Actual size reproduction of the PCB. The shorting strip at right is to allow the edge connectors to be gold plated.

## Performance

The inverter can handle power factors from zero to unity, lagging or leading. The output voltage is within  $\pm 5\%$  of 240V except for zero load and power factors deviating too far from unity. This is due to the voltage sensing circuit, which reads the average output voltage rather than the RMS value.

The accompanying table summarises the performance of the prototype inverter. The efficiency is 82% at full load, however this drops to 60% at light loads. The output voltage at low loads is controlled by the voltage regulation circuit. At high currents, the output voltage is dependent upon the battery voltage, saturation voltages of the 2N3771 transistors, and the voltage drops across the battery supply leads. Our tests were done with a fully charged battery.

The final column of the table shows the expected discharge time of a battery powering the inverter. The figures were calculated assuming a fully charged battery rated 40Ah. The discharge time for a 40Ah specification is 20 hours; ie the battery can supply 2A for 20 hours. However, if the battery is discharged over a shorter time, then the capacity decreases inversely to the rate of discharge. Consequently we would expect four hours life with a 40W load and only 1.5 hours from a 100W load. This diminishes to just 28 minutes with a 300W load.

The use of a traction battery or a higher-rated battery would enable longer life. If heavy loads are connected, the output voltage of the inverter falls as the battery loses its charge and could be as low as 220VAC when the battery is

discharged to 10.8V. Because of this, we have nominally called the unit a 12-230V inverter.



"Run and see if daddy's got the TV set fixed yet". (PF Reporter).



# Electronics Australia/ DICK SMITH SUPER 80 Computer Kit



**NEW LOW PRICE**



Production costs have now been absorbed due to fantastic response — YOU REAP THE BENEFIT!!

**NEW SUPER LOW PRICES**

Yes, this makes the full 16K computer, with 9K BASIC on tape, transformer and IC sockets — only

**\$289.50**

was \$289.50  
**NOW**  
**\$239.50**  
save \$50

Photo shows the basic board with the following options: S-100 expansion, IC sockets and a full 48K of memory.

- SHORT FORM KIT:** Designed for computer applications where 'BASIC' programming is not required. Kit supplied with EPROM monitor and 16K RAM. (Cat. K-3600)  
 WAS \$289.50 — SAVE \$50.00 ..... **\$239.50**  
 Transformer to suit (Cat. M-2325) ..... **\$23.00**  
 IC Socket Set (Cat. K-3603) ..... **\$12.50**  
 BASIC program (interpreter) on cassette (Cat. K-3602)  
 WAS \$24.50 — SAVE \$12.00 ..... **\$12.50**  
**OTHER OPTIONS:**  
 Case to suit (Cat. H-3200) ..... **\$39.50**  
 BASIC program in EPROM (Set of 3 IC's) (Cat. K-3604)  
 WAS \$89.50 — SAVE \$40.00 ..... **\$49.50**  
 S-100 Expansion (Cat. K-3606) ..... **\$19.50**  
 Character Generator (upper/lower case) (Cat. K-3607)  
 WAS \$69.00 — SAVE \$20.00 ..... **\$49.00**  
 Detailed construction manual (Cat. B-3600)  
 WAS \$12.50 — SAVE \$3.00 ..... **\$9.50**  
 BASIC manual (Cat. B-3602)  
 WAS \$14.50 — SAVE \$5.00 ..... **\$9.50**  
 RAM expansion to 48K (2 sets 16K RAM IC's)  
 (Cat. X-1186 x 2) ..... **\$59.90**



# EX-STOCK Available NOW! OVER 2000 SOLD!

The SUPER 80 is the proven computer kit with over 2000 sold and it is available ex-stock! Why wait for others – check out our prices with the competition and whilst you are doing that, check out the features too! Dick Smith Electronics have reduced the price of the SUPER 80 as the enormous design costs have now been absorbed by the superb sales of this superlative kit computer – read on . . .

Check the Super 80 against all others

- IS IT S-100 EXPANDABLE
- DOES IT EXPAND TO 48K ON BOARD
- DOES IT HAVE RF OUTPUT FOR TV CONNECTION
- WAS IT FEATURED IN ELECTRONICS AUSTRALIA – AUSTRALIA'S LEADING ELECTRONICS MAGAZINE
- IS IT AVAILABLE EX-STOCK
- HAS IT SOLD OVER 2000 AND BEEN PROVEN AGAINST TEETHING TROUBLES

SUPER 80	OTHER
<input checked="" type="checkbox"/>	<input type="checkbox"/>
<input checked="" type="checkbox"/>	<input type="checkbox"/>
<input checked="" type="checkbox"/>	<input type="checkbox"/>
<input checked="" type="checkbox"/>	<input type="checkbox"/>
<input checked="" type="checkbox"/>	<input type="checkbox"/>
<input checked="" type="checkbox"/>	<input type="checkbox"/>

CHECK OUT THESE FEATURES: \* Relay operates cassette unit automatically \* 2K Monitor program supplied \* Character generator giving full 64 characters, 32 characters x 14 line screen \* Spare IC positions for prototyping and user customising \* RF modulator inbuilt, connects to your TV set \* Optional S-100 provision \* Keyboard can be remotely mounted if required \* 12MHz quartz crystal \* Optional 9K SUPER BASIC in ROM plug in facility \* Full size professional 60 key keyboard \* Inbuilt power supply \* 16K RAM on board plus provision for on board expansion to 48K \* Inbuilt cassette interface

## 'Sorry Dick, It Doesn't Work'

This service is specifically intended for constructors who have completed their Super 80 kit, but have difficulty in getting it to work correctly. We will not complete half-built kits, then get them to work: your kit must be complete before taking advantage of this service.

Your kit must have been constructed using IC sockets.

Our Service Centre will check and repair your Super 80 for the cost of \$100. This fee includes necessary replacement of components, etc.

## 7 Day Satisfaction Guarantee

Another exclusive Dick Smith offer: purchase this kit and inspect it for up to 7 days. If, for some reason, you do not wish to go ahead and construct the kit, simply return it to us in original condition and packing (ie. before construction has commenced) and with all instructions, cards, etc. and we will refund your money in full. What have you got to lose?



*This is what Reg Hesper, Technical Officer of Gladesville had to say about 'Super 80' "I enjoyed building the Super 80 project and felt it worthwhile, of immense educational value and quite easy to construct. It worked as soon as I turned it on and has provided many hours of enjoyment"*



SEE PAGE 27 FOR ADDRESS DETAILS

Very Advanced design – but works with any TV set!

The 'Super 80' offers a specification that we believe just cannot be bettered at the price. It uses the popular Z80 Microprocessor IC, a professional keyboard and has direct RF output so that you can use the computer with any TV set (you don't need to purchase a special video monitor).

### Easy to build

Even though we would not recommend this kit to the raw beginner, it is very easy to build. Any person who can use a small soldering iron and can solder neatly should have no difficulty in construction. This is because of the unique double-sided board design which means there is virtually no other wiring. The board is covered with professional 'solder mask'; this makes soldering much easier without the problems of bridges, etc. Once the components are soldered onto the board in their marked positions over 98% of the construction is completed. Even if you cannot get the completed kit to work, we have a special "Sorry Dick it doesn't work" repair service to assist you.

### NEW lower price, higher specification - how is it done?

Most computers sold in Australia are manufactured in the U.S.A. where extremely high labour rates prevail - and you pay dearly for this on built up units. With this computer kit, you provide the labour and therefore save a fortune. And remember, this computer does not have a small toy-like calculator keyboard but a full size professional typewriter keyboard.

### Advanced programming capability

The Super 80 Computer gives you a huge 9K of BASIC – comparable in fact, with the BASIC on our very popular Sorcerer computer (over 2000 sold) – and this machine sells for over \$1,000. Many other computers currently available do not offer as much BASIC programming capability as the SUPER 80 – it is obvious that by building it yourself you are saving real money!

### Electronics Australia/Dick Smith design

This is not a half baked design with no back up. The resources of Electronics Australia, Australia's most popular electronics magazine, and Dick Smith Electronics have combined to design and bring you this kit in the interests of computer enthusiasts actually building and not just buying. The design is fully Australian.

### Imagine how much you will learn!

Most computer enthusiasts can program a computer but would have absolutely no idea of how to build one. By building this kit you will learn both the technical side of construction, how it works and then how to program. What a fantastic background for the future. . . . .

### Sectional construction

We have designed this kit not only for the serious computer user but also for first time users like the student or hobbyist. This is why we have a short form kit which may be added to as you build (and as you have the money!). For example, you may build the computer originally and operate it with 'BASIC on tape' and then add 'BASIC in ROM', add the S-100 and provide other parts at a later stage.





See the new 250mm system in this month's E.A.

Now two new magnificent

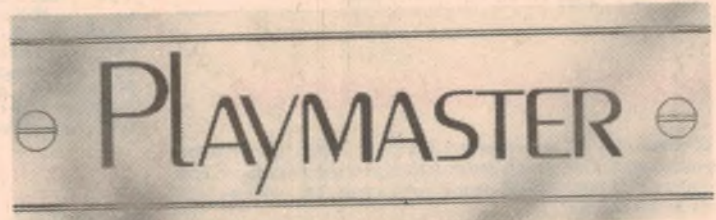

## build-it-yourself hi fi speaker systems

Dick Smith brings you these superbly styled speaker systems to suit your room, your decor ... and your pocket!

Acoustically designed by Neville Williams, MIREE (Aust.), Editor-In-Chief of Electronics Australia magazine, they feature a **completely new format and style**, starting with the strikingly **handsome new grilles** with the new **'Playmaster' logo** - and ending with a **performance you'll be amazed at!**

You'll **save a fortune** over comparable commercial speakers - because you build them yourself. And all it takes is a couple of hours construction time, a tube of glue and a screwdriver.

They look so good, and sound so great, your friends will never believe you built them!

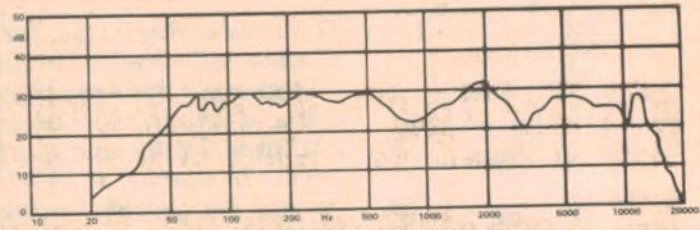

Measured response of Playmaster 300mm speaker system. Compare this performance with speaker systems you'd pay 3 or 4 times as much for.

(Measurements performed by Dick Smith Electronics Technical staff)





The boxes simply fold together - no wood-working knowledge needed. All panels are pre-cut, pre-rebated and pre-drilled. We've even heard of schoolchildren building their own Playmasters: they're that simple!



**What the experts say:**

"... the end result represents outstanding value for money. Whether you buy it in kit form or fully assembled, we are sure you will be pleased with sound quality."

"... the new Playmaster 3-70L has generous power handling capacity so that it can give a good account of itself on virtually any type of music."

Neville Williams & Leo Simpson  
(EA, March 1982)

All you need is a tube of glue and a screwdriver - everything else is supplied for you. The wiring loom for the speakers is pre-assembled - the connectors just push on. And the speakers drop into position in the holes provided. If you can read simple instructions, you can build your own commercial quality speakers.



**Look at these new features:**

- ★ All new design in simulated woodgrain finish to complement decor
  - ★ Separate level control for high and mid ranges\* - tailor the sound to suit your listening environment
  - ★ Special speaker sealant material supplied to ensure absolute air tightness
  - ★ New design ribbed woofer with massive 30cm cone for accurate bass reproduction
  - ★ Built-in plinth to raise speaker off floor level for minimum audio colouration
  - ★ Manufactured to the exacting standards of the original design published in Electronics Australia magazine
  - ★ Acoustically transparent silk-like grille cloth heat welded to support frame.
- \*300mm system only

And now you're finished. Settle back with a drink, play your favourite record or tape. The sound quality will make you more than happy and your friends will never believe you built them!

300mm SYSTEM	250mm SYSTEM*
<b>Speaker kit, crossovers &amp; faders</b> This kit includes 300mm woofers, high and mid range faders, and 3 way crossover with high power handling capacity. Cat C-2042 ..... <b>\$175.00</b>	<b>Speaker kit, and crossovers</b> This kit includes 250mm woofers and 3 way crossover with medium power handling capacity. Cat C-2044 ..... <b>\$149.00</b>
<b>Enclosure kits</b> A pair of large 70 litre cabinets for the ultimate in sound reproduction. Cat C-2632 ..... <b>\$159.10</b>	<b>Enclosure kits</b> A pair of large 53 litre cabinets to give great sound reproduction. Cat C-2634 ..... <b>\$143.10</b>
<b>Deluxe speaker grilles</b> Handsome new design featuring the new 'Playmaster' logo. Cat C-2612 ..... <b>\$39.90</b>	<b>Deluxe speaker grilles</b> Handsome new design to fit 53 litre cabinets, featuring the new 'Playmaster' logo. Cat C-2610 ..... <b>\$35.90</b>
<small>Note: All prices are per pair.</small>	
<b>TOTAL SYSTEM ONLY</b> <b>\$374 per pair!</b>	<b>TOTAL SYSTEM ONLY</b> <b>\$328 per pair!</b>



\*250mm System available early July. Phone your nearest store for full details of availability.

# DICK SMITH Electronics



SEE PAGE 27 FOR ADDRESS DETAILS

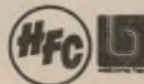

DSE/A285/PA1LM



Just right for the average living room

# Playmaster 3-56L loudspeaker system

Here's a do-it-yourself loudspeaker system that won't break the bank. It features three drivers, attractive styling, and a 56-litre cabinet that should fit easily into most living rooms.

by GREG SWAIN

When we described our new Playmaster 3-70L loudspeaker system in the March issue, we knew that readers would like the sound, the styling and the price. At \$374 for the pair, the Playmaster 3-70Ls represent excellent value for money.

Certainly, the response from readers has been enthusiastic.

If we were aware of just one limitation, it has to do with the size of the 3-70Ls. Let's not beat about the bush. A 70-litre enclosure requires a fair amount of floor space and two of these can be difficult to accommodate in some living rooms, attractive styling notwithstanding. There must be many readers who gazed

longingly at the 3-70Ls but will not buy for this very reason.

Hence the new Playmaster 3-56L loudspeaker system described here. It uses exactly the same tweeter and mid-range driver as the larger 3-70L system, but substitutes a 250mm woofer in place of the 300mm unit for the bass end. The three drivers are mounted in a sealed 56-litre enclosure, together with a modified crossover network.

While a reduction in size from 70 litres to 56 litres might not seem significant, the difference in visual impact is considerable. The new Playmaster 3-56Ls require far less floor space than the 3-70Ls and, in the author's opinion,

are just right for the average-sized living room.

Styling of the 3-56L system is identical to that of the larger system. Compared to the earlier 3-53L design featured in June, 1977 (and now superseded), the 3-56L features a taller, narrower enclosure and a clip-on grille cloth frame instead of an acoustic foam panel. The baffle is now finished in simulated woodgrain veneer, while a 60mm plinth is included to raise the enclosure off the floor.

The drivers are mounted vertically in-line, and mount on the front of the baffle after the enclosure has been assembled. Unlike the 3-70L system, however, the constant impedance level controls are not specified as standard. This was done in order to keep costs down, although you can fit the level controls as an extra-cost option if you wish.

We'll have more to say about the level controls later.

As with the 70-litre enclosure, a packaged cabinet kit will be marketed by Dick Smith Electronics, making it possible for almost anyone to assemble a pair of enclosures to commercial standards — without a workshop,



Two views of the Playmaster 3-56L loudspeaker system, with and without grille cloth frame. Note that the optional level controls have been fitted.



without an elaborate tool kit, and without any special skills. All connections to the loudspeakers and the crossover network are made using a clip-on wiring harness, so you don't even need a soldering iron!

In addition, we have prepared a drawing which shows all the dimensions of the enclosure and the way it goes together. If you have the necessary tools and skills, you can build your own cabinets from scratch. While this involves a lot more work, you will also save a worthwhile amount of money.

## Performance

Whichever options you choose, we are sure that you will be pleased with the performance of the Playmaster 3-56L system. It has reasonable efficiency and generous power handling capacity, and can give a good account of itself on virtually any type of music. Overall performance is very similar to the larger 3-70L system although, as is to be expected, there is a little less weight in the low bass region.

More to the point, the new 3-56Ls outperform the earlier 3-53L design. In particular, bass definition is much improved, this difference due partly to the slightly larger enclosure and partly to a better bass driver.

Power handling capacity remains the same – 60 watts music power. What this means is that it will comfortably handle the full output of an amplifier rated up to 60W RMS per channel on normal music program material. Amplifiers with higher output ratings may also be used, provided the volume control is adjusted sensibly.

Correctly assembled, the Playmaster 3-56Ls are capable of delivering more than sufficient sound output for the average domestic situation. At an all-up cost of \$328 for the pair – \$46 cheaper

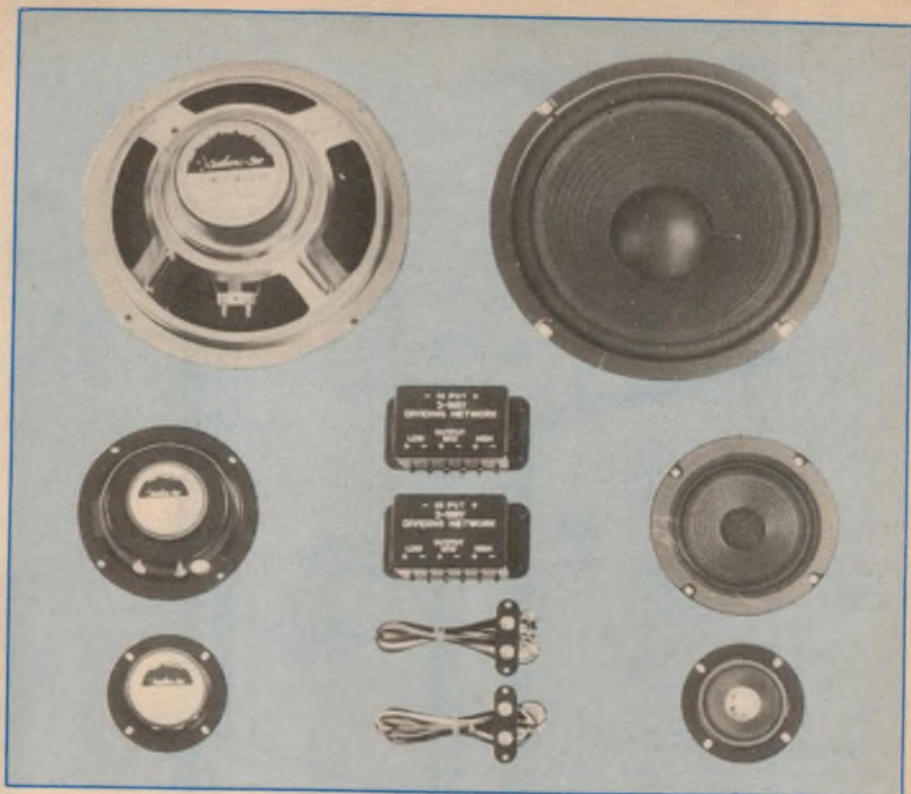

This photograph shows the loudspeaker drivers used in the Playmaster 3-56L system, together with the crossover networks and wiring harnesses. As mentioned in the text, the mid-range and tweeter are exactly the same as used in the larger 3-70L system. Both are cone-type units with closed-back construction so that they are unaffected by back pressure from the bass driver. The mid-range has a nominal diameter of 140mm and an effective cone diameter of about 90mm, after allowing for the cloth roll surround.

The tweeter has a curvilinear paper cone with an effective diameter of 55mm. An aluminium dust cap not only improves the appearance but aids in maintaining the high frequency response.

A 250mm woofer is used in the Playmaster 3-56L, and has marginally better performance than that used in the original 3-53L design. It has a heavy ribbed curvilinear cone and a large treated cloth roll surround, giving a free-air resonance of about 35Hz which rises to around 65Hz when installed in the enclosure. The chassis is of pressed steel and is fitted with a reasonably large ceramic magnet.

The two crossover networks are supplied as part of the loudspeaker kit, and will be clearly marked to indicate that they are for use with the 3-56L system.

## Playmaster 3-56L crossover network

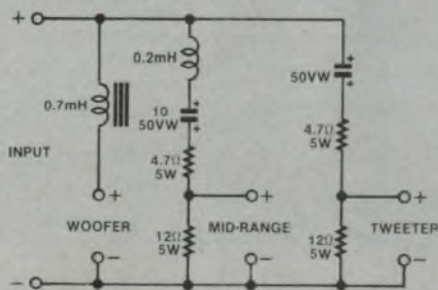
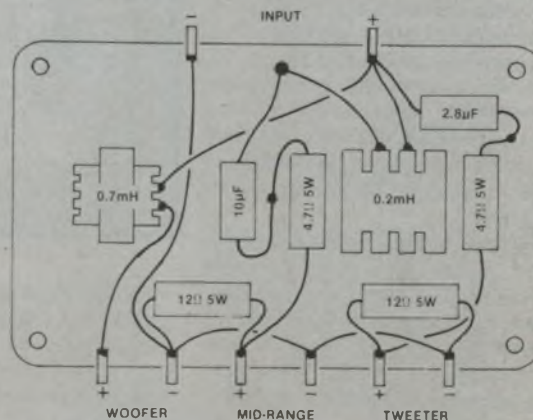
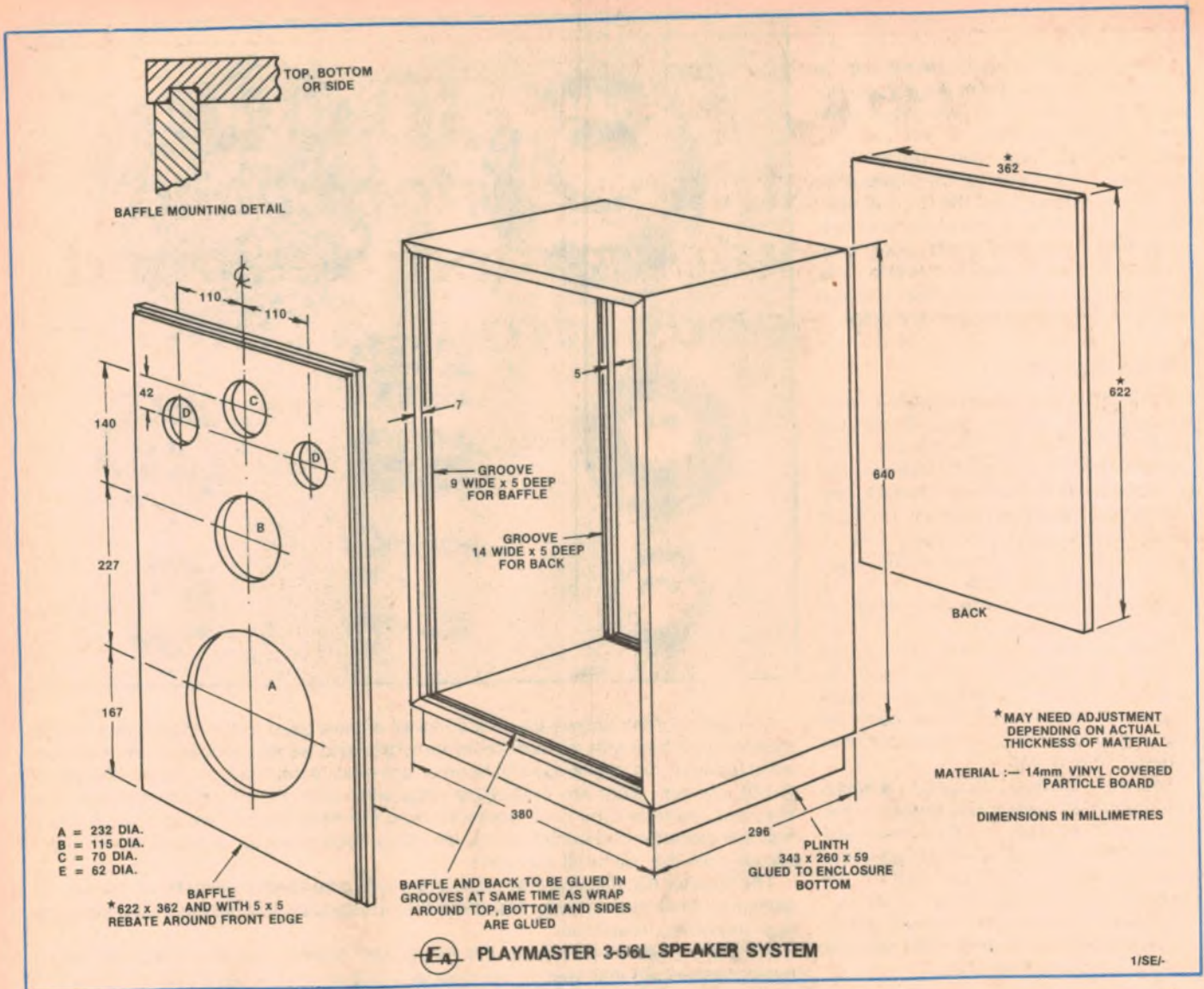

Fig. 1 (above) is the circuit diagram of the crossover network while Fig. 2 (right) shows the wiring details. This network is supplied ready wired for use without level controls.







Dimensional details of the Playmaster 3-56L enclosure, as supplied in kit form. Note that if you intend fitting the optional

level controls, you will have to cut the necessary mounting holes yourself.

than the 3-70Ls – we think that they represent excellent value for money when compared to commercial units with similar performance.

### Design

Unfortunately, eliminating the constant impedance level controls means that the crossover network, as used in the 3-70L system, must be modified. Initially, we tried connecting the three drivers directly to an unmodified network, but to say that the resultant system was “over-bright” would be something of an understatement.

This result was entirely expected. In the larger 3-70L system, the level controls attenuate both the tweeter and the mid-range driver by about 6dB when set to the “normal” or flat position. If we eliminate the level controls, therefore, the crossover network must be modified so that the overall acoustic balance of the system is maintained.

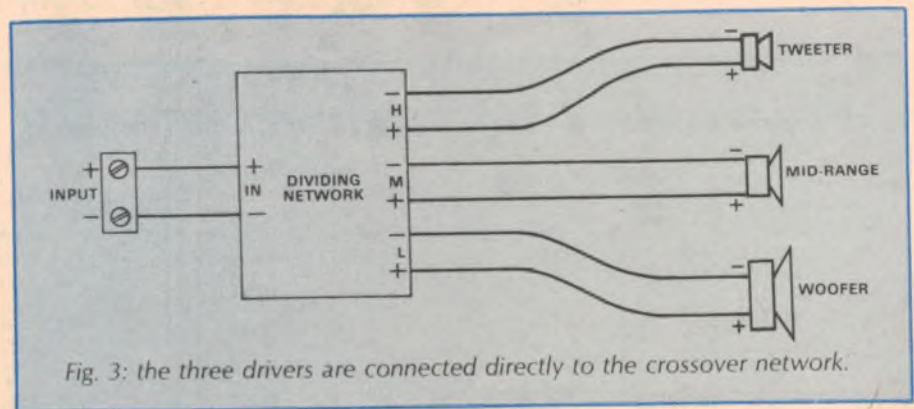

In practice, this is achieved by padding down the tweeter and the mid-range using fixed-value 5W resistors. As can be seen from the circuit diagram, a 4.7Ω 5W resistor is connected in series, and a 12Ω 5W resistor is connected in parallel, with each driver. This has the effect of

attenuating each driver by the requisite 6dB, while still maintaining correct system impedance.

Crossover frequencies are as for the 3-70L system – nominally 1500Hz from woofer to mid-range and 5kHz from mid-range to tweeter. These figures are



# NEC PC-8000

## A low cost, high performance microcomputer system designed for your needs..from \$1,500

PC8000 combines the most wanted features of several leading microcomputers together with a few wonders of its own

includes sales tax



Check these features..

- 5 user-programmable function keys. Up to 10 different user-defined routines can be activated using these keys and the shift key.
- 82-key keyboard features function keys and numeric keypad.
- 248-symbol character set.
- Z-80A equivalent microprocessor, running at 4MHz.
- CP/M™ disk operating system compatibility.
- N-key rollover.
- Standard memory features 24K bytes of ROM and 32K bytes or RAM
- 64K RAM is available with the PC-8012AI/O unit.

- 160 x 100 matrix of high resolution graphics, powerful control directly from the keyboard.
- Interfaces include color monitor, monochromatic monitor, audio cassette, Centronics™ printer.
- Screen formats of 20 or 25 lines and 36, 40, 72 or 80 characters per line, with adjustable scrolling window.

- A powerful editor simplifies programming and includes 4-way cursor control, character insert and delete.
- Terminal mode available with a single command.
- I/O unit for plug-in circuit boards.

INTRODUCTORY OFFER  
FREE MEMBERSHIP IN THE  
'AUSTRALIAN BEGINNING'  
NORMALLY \$100

# HANIMEX

## means business

For Authorised Dealers phone:

SYDNEY 938-0400 ● MELBOURNE 64-1111 ● BRISBANE 262-7555 ● ADELAIDE 46-9031 ● PERTH 381-4622



# How to add level controls to the 3-56L

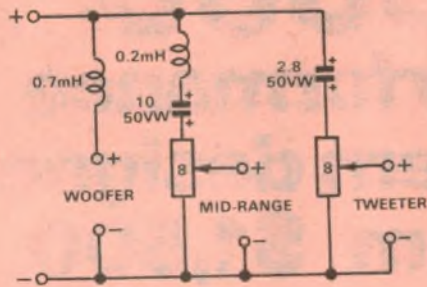
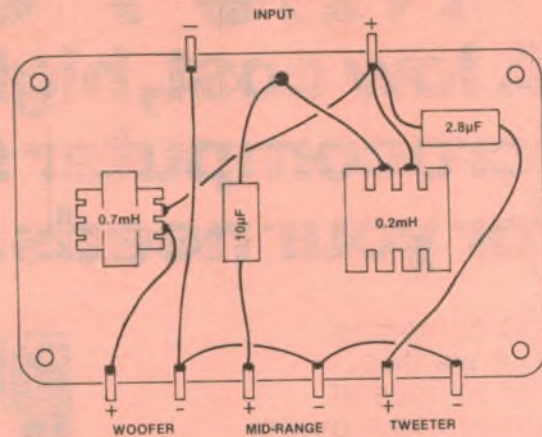

Fig. 4 (above): circuit diagram of the crossover network with optional level controls. Fig. 5 (right) shows how the pre-wired network is modified for use with the level controls.



dictated largely by the characteristics of the drivers and, in the case of the lower figure, by the value of the iron-cored inductor in series with the woofer. Attenuation is 6dB/octave after the crossover point, without allowing for the rise in driver impedance due to the voice coil inductance in each case.

Admittedly, the crossover network is a fairly modest design, but we regard it as a reasonable compromise between cost and performance.

Readers should note that the necessary modifications to the crossover network will be carried out in the Dick Smith Electronics kit department, so you don't have to worry about adding the resistors yourself. The modified unit will be clearly marked to indicate that it is for use with the 3-56L system. On no account should it be used with the larger 3-70Ls.

The impedance curve of the completed system is quite normal for a sealed system, with a peak corresponding to the woofer resonance at 65Hz. From there, the impedance rises and falls in predictable fashion over the whole audio range. Nowhere does the impedance fall below 7.5 ohms, which means that there should be no problems with the driving amplifier.

Because the system is sealed and because the enclosure is loosely filled with Innerbond acoustic damping material, the bass response falls smoothly away below the resonance at 65Hz and is 3dB down at 60Hz. Close microphone tests with sinewave signals indicate that the on-axis frequency response can be expected to be within about  $\pm 6$ dB from 55Hz to 18kHz, with usable bass response to below 50Hz.

## Level controls

As mentioned earlier, it is possible to fit level controls to the tweeter and mid-range units as an extra-cost option. However, you will have to cut the

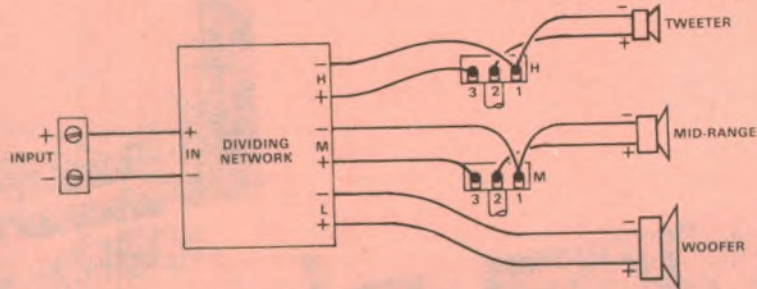

Fig. 6: how the level controls are wired into circuit.

necessary mounting holes yourself since the baffle for the 3-56L is supplied with only the speaker holes pre-cut. In addition, you will have to perform some minor surgery on the crossover network to convert the circuit back to that used for the 3-70L system — ie, the 4.7 $\Omega$  and 12 $\Omega$  5W resistors are removed if the level controls are used.

The crossover network is modified by prising the plastic cover free from the cardboard base and de-soldering the four resistors from circuit. The free ends of the two bipolar capacitors are then connected to their respective wiring terminals as shown in Fig 5. Fig 4 shows the circuit diagram of the crossover network when the constant impedance level controls are employed.

Our preference would be to fit the level controls, added expense notwithstanding. For an extra \$16 outlay, they allow you to balance the sound exactly to your liking or to make adjustments to suit living room acoustics. Turned right down, they effectively remove both the tweeter and mid-range from circuit. Turn them up, and you can summon all the "presence" you are ever likely to want for solo voice or solo instrument.

## Construction

As with the 3-70L system, Dick Smith Electronics will be selling the Playmaster 3-56L kit in two parts. The first includes the six drivers, two crossover networks, two rear terminal panels and two sets of wiring harnesses. In other words, this part of the kit includes all the electrical components for two systems.

The second part comprises all the components to make the two enclosures, and includes the pre-cut cabinets themselves plus Innerbond acoustic filling material, two covered grille cloth frames, loudspeaker securing screws and the grille cloth frame mounting sockets. In addition, a roll of foam-backed adhesive tape to make the loudspeaker gaskets is included.

Each cabinet kit consists of a separate baffle and rear panel, while the sides, top and base are cut from a single length of vinyl veneered particle board. Ninety degree grooves are milled where the corner joints will be, leaving the four sections held together only by the vinyl veneer. Additional grooves are milled near each edge of the sections to take the baffle and rear panel.

When adhesive is run into the grooves and the sections folded around the



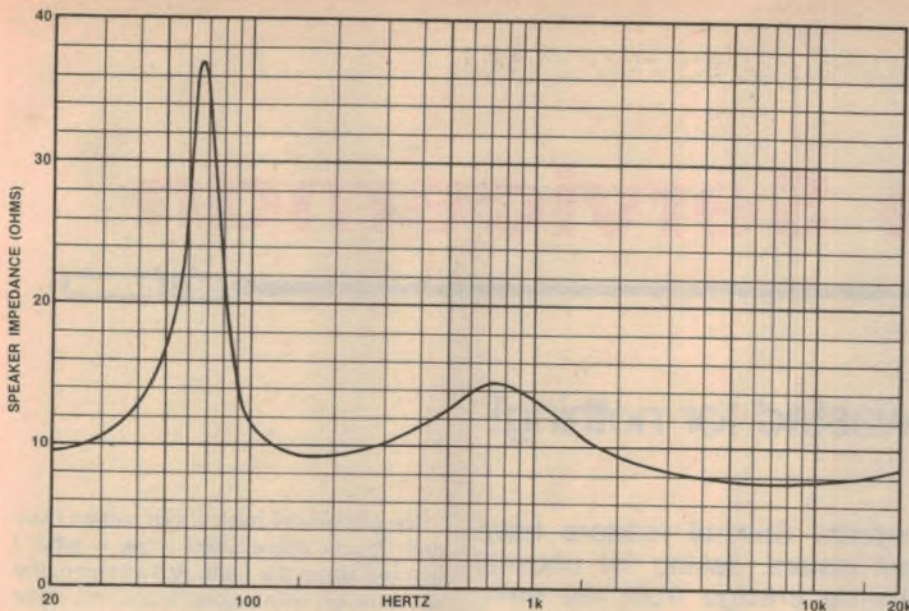

The impedance curve is typical of a sealed enclosure, with a 37Ω peak corresponding to the woofer resonance at 65Hz. Minimum impedance is about 7.5Ω.

baffle and the rear panel, a rigid and potentially airtight enclosure is formed.

Construction of the 3-56L system is exactly the same as for the 3-70Ls described in the March issue. In addition, a leaflet with full constructional details is included with each kit. We won't repeat all the details here, but simply reiterate the main points:

● Make sure that the completed enclosures are completely airtight. Each

join and each hole in the enclosure which is intended for mounting a loudspeaker driver, level control or terminal panel is a potential air leak which must be sealed. Use the foam-backed adhesive tape supplied to make suitable gaskets.

● Correct phasing of the loudspeaker drivers is important. Ensure that you connect the positive terminals on the crossover network to the positive terminals on the drivers, and the negative terminals to negative.

● Be careful when handling and mounting the loudspeakers. A careless attitude could result in a finger or a screwdriver through one of the loudspeaker cones!

● Mark the loudspeaker mounting holes with a pencil and remove the loudspeakers before drilling. Angle the holes very slightly away from the cutout edge to minimise the risk of splitting the particle board.

● Don't overtighten the loudspeaker mounting screws. Apply more pressure than necessary and you could strip the hole.

Whether or not you fit the plinths to the cabinets is up to you. If you elect to install the cabinets on a wall, the plinths could be omitted. Alternatively, you could purchase a pair of proprietary speaker stands to raise the cabinets off the floor by about 200mm. This will improve the clarity of the lower registers by avoiding undue augmentation of the bass by floor reflection.

With the job completed, stand the enclosures the right way up, wipe over with a damp cloth, and press the grille frames into place. You've just got yourself a pair of speakers that will give you hours of listening pleasure.

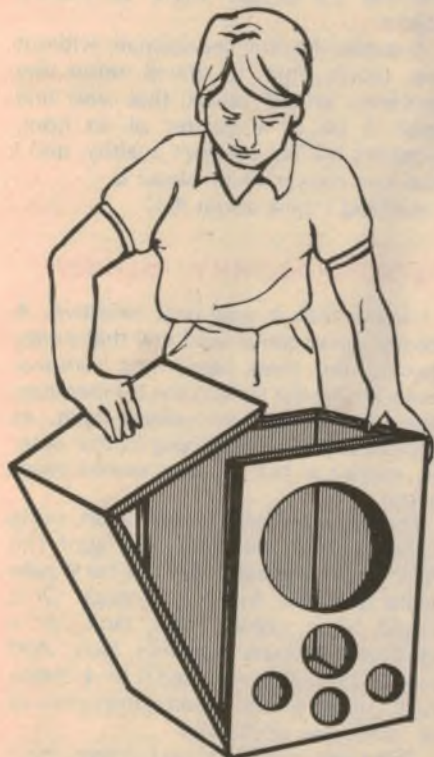

This drawing depicts the cabinet assembly (courtesy Dick Smith Electronics).

## "SERVICEMEN"

HAVING TROUBLE BUYING

# BELTS

FOR REPLACEMENT IN TAPE RECORDERS, CASSETTE DECKS, CAMERAS, VCR'S, etc?

### TRY THESE FOR SIZE!

#### SQUARE BELTS

Diam.	Thick.	Length	Price
19.0	x 1.2mm	60mm	0.45
22.0	x 0.8mm	69mm	0.45
25.0	x 1.2mm	78mm	0.45
27.0	x 1.2mm	84mm	0.45
31.0	x 1.2mm	97mm	0.45
33.0	x 1.2mm	103mm	0.45
35.0	x 1.2mm	110mm	0.45
37.0	x 1.2mm	116mm	0.45
40.0	x 1.2mm	125mm	0.55
43.0	x 1.2mm	135mm	0.55
46.0	x 1.2mm	144mm	0.55
49.0	x 1.2mm	154mm	0.55
51.0	x 1.2mm	160mm	0.55
54.0	x 1.2mm	169mm	0.65
57.0	x 1.2mm	179mm	0.65
60.0	x 1.0mm	188mm	0.65
63.0	x 1.2mm	198mm	0.65
66.0	x 1.2mm	207mm	0.65
67.0	x 1.2mm	210mm	0.65
69.0	x 1.2mm	216mm	0.75
72.0	x 1.1mm	226mm	0.75
75.0	x 1.2mm	235mm	0.75
80.0	x 1.2mm	251mm	0.75
85.0	x 1.2mm	267mm	0.75
90.0	x 1.2mm	282mm	0.90
97.0	x 1.3mm	304mm	0.90
105.0	x 1.4mm	330mm	0.90
112.0	x 1.4mm	352mm	0.90
120.0	x 1.4mm	377mm	\$1.00
136.0	x 1.2mm	427mm	\$1.00

#### ROUND BELTS (CONT.)

Diam.	Thick.	Length	Price
80.5	x 1.2mm	253mm	0.80
85.0	x 1.2mm	267mm	0.90
89.0	x 2.1mm	280mm	\$1.00

#### FLAT BELTS Turntables

Diam.	Thick.	Length	Price
189x0.5x5mm		594mm	\$3.70
195x0.6x6mm		612mm	\$3.75
201x0.6x6mm		631mm	\$3.85
205x0.6x6mm		644mm	\$3.95
222x0.6x6mm		687mm	\$4.00
262x0.6x6mm		823mm	\$4.30
292x0.6x6mm		917mm	\$4.30
305x0.6x6mm		958mm	\$4.30
317x0.6x6mm		995mm	\$4.30
330x0.6x6mm		1036mm	\$4.30

#### VCR BELTS - BETA

Diam.	Thick.	Length	Price
32x1.0mm		100mm	Sq. 0.65
49x1.9mm		154mm	Sq \$1.20
87x1.9mm		273mm	Sq \$1.55
95x1.0mm		298mm	Sq. 0.70
104x0.9mm		327mm	Sq. 0.75
108x0.9mm		339mm	Sq. 0.75
109x1.9mm		343mm	Sq \$1.50
119x2.2mm		374mm	Sq \$1.55
127x2.2mm		400mm	Sq \$1.60
81mm		254mm	Flat \$1.60
93mm		292mm	Flat \$1.60
96mm		301mm	Flat \$1.60
146mm		465mm	Flat \$3.30

#### ROUND BELTS

Diam.	Thick.	Length	Price
30.0	x 0.8mm	94mm	0.60
36.0	x 0.8mm	113mm	0.60
42.0	x 1.2mm	132mm	0.60
50.0	x 1.2mm	157mm	0.60
62.0	x 1.2mm	195mm	0.70
70.0	x 1.2mm	200mm	0.70
75.0	x 1.7mm	235mm	0.70

#### VCR BELTS - VHS

Diam.	Thick.	Length	Price
48x1.9mm		151mm	Sq. 0.80
104x1.9mm		327mm	Sq \$1.55
24mm		75mm	Flat \$1.15
34mm		107mm	Flat \$1.15
60mm		188mm	Flat \$1.40
79mm		248mm	Flat \$1.40
96mm		301mm	Flat \$1.60

### DISCOUNTS APPLIES TO ABOVE ONLY

OVER \$25, LESS 10%, OVER \$50 LESS 15%  
OVER \$100 LESS 20%, OVER \$250 LESS 25%

### BELT KITS FOR VALUE-

- FOR REEL-TO-REEL, CASSETTE AND CARTRIDGE
- 59 ROUND, SQUARE AND FLAT BELTS
- UP TO 3 EACH OF MOST POPULAR SIZES
- INDIVIDUAL PRICES TOTAL OVER \$29.90 **\$19**



### HOW TO MEASURE-

Stretch the faulty belt between the points of 2 pens or pencils on top of a piece of paper and mark the paper with the pens when the belt is firmly extended (not stretched). Measure the distance between the 2 marks in mm and double it to determine the total length. See the list above for the nearest size available. The next smallest size is the best choice as most belts will have stretched. If the belt has broken, just measure the length to find the correct replacement.

### AVAILABILITY

This list represents our current ex-stock availability, however, we can obtain over 200 different sizes, so....

BELT US AROUND AND STRETCH US TO THE LIMIT WITH YOUR ENQUIRIES!

### JAPANESE SEMICONDUCTORS

PACK & POST \$2.50

We also specialize in selling exact original replacement semiconductors, so send for our free list of available stocks.

### SEMICONDUCTOR IMPORTS

SALES AGENT  
PRE-PAK electronics p/l  
1a West St, LEWISHAM NSW  
PHONE: 569-9797





# The Serviceman

## A lot of good worry wasted for nothing!

It is contributors' month this month. Several readers have responded to the panel in recent issues, asking for unusual stories, and these make a welcome change from my own, sometimes routine, experiences. They also help to emphasise that I am not the only one who encounters strange technical faults and/or customers!

My first letter is from J. L. of Tasmania, who has contributed a number of stories in recent months. In fact, his opening remarks comment on this fact.

"I can't believe that I'm the only literate serviceman in Australia, yet I have been featured in three of the past five issues. I don't mind really, but my colleagues are beginning to say rude things about me.

"Nevertheless, strange things continue to happen to me and the attached story is one of them."

No, J.L., you are not the only literate serviceman, as you may have gathered from the introduction, but you have been the most prolific in recent months. As for your uncouth colleagues and their rude remarks: ignore them, they're only jealous.

J.L.'s story is a mixture of technical and psychological problems. On the technical side the symptoms must surely be the strangest and most puzzling that I have ever heard of, and it would be interesting to know if anyone else has ever experienced them. As for the psychological problem — well, I'll let J.L. tell it as it happened.

### TOO MUCH DETAIL

How often have you been given a radio or TV set to repair without any information about the nature of the fault? The Serviceman has mentioned this problem on many occasions. One that comes to mind was about a long and complicated repair to the sound circuit of a TV set belonging to a deaf couple, who couldn't hear it anyway!

Lack of detail about a job certainly makes it harder. We have to imagine what would worry the customer and, as

our standards are usually more critical, we twiddle and tune until the set is perfect.

Yet the opposite situation, too much information, can sometimes be a problem, as this story will show. In this case the service job was not so troublesome, but the circumstances leading up to it caused me as much worry as any job I have ever done.

A minor but very painful illness had taken me to hospital for a few days and when Mrs J.L. called to take me home she mentioned that a good friend and customer had rung to say that his TV set was giving trouble. All we knew at this time was that the colour was taking a long time to come up.

I was faced with a few days convalescence, so I thought to ring my friend, find out something more about the fault, then refresh my memory about the particular set before I faced up to the job. This was where I came unstuck.



"The hardest part of this job is trying to keep up with advances in the field."  
(Radio Electronics).

The phone call took about half an hour and this, in abbreviated form, is what I learned about the fault. At switch-on, the set came on with a good black and white picture. After 15 minutes a purple line appeared at the bottom of the screen and began to move slowly upwards. Underneath the line was normal, but weak, colour.

When the line reached centre screen another line appeared at the top and began moving down, again with colour following it. About 25 minutes after switch-on the lines met and disappeared. The set then performed normally as long as it remained switched on. If switched off for five minutes, the bottom line appeared almost immediately and colour was restored in about five minutes. A 10 minute switch-off required the full 25 minute cycle to restore colour.

A normal healthy serviceman, without too much time to dwell upon the problem, would attack that one and finish it off in a quarter of an hour, wouldn't he? But I wasn't healthy, and I had four days to think about it.

And did I think about it!!!

### WORRY, WORRY, WORRY!

I knew that it was heat sensitive. A freezer spray can should find that pretty quickly. But then, most heat sensitive faults create the fault as the temperature rises, not correct an existing fault, as appeared to be happening in this case. So maybe a hot air gun would work better.

Then again, where would I start, using either a spray can or a heat gun? The fault could originate with the burst gate pulse from the line output stage. Or it could be a colour killer fault, or a chroma bandpass amplifier fault. And why a "purple" line? Could it be a matrix fault cutting off the green component of an otherwise white line?

There was also the slow recovery from the bottom and top of the screen. This seemed to point to some connection with the vertical deflection circuits. ☹



So, in planning how I would attack the job when I eventually reached it, I had the choice of starting anywhere from the video detector to the picture tube. I convinced myself that there was no way to come to grips with this one without a pattern generator and an oscilloscope, and I made a note to see that they were in the van when I left for the job.

My convalescence took about four days and, in that time, I came to dread the thought of facing my friend and his TV set. I could not explain what was happening, nor could I make up my mind which part of the set to attack first. In short, I hadn't a clue.

The day of truth arrived and the set performed exactly (and I mean *exactly*) as my friend had described. His timings were within 30 seconds. Such precision! While waiting for the colour to appear I had tried all the user controls and, of course, everything had seemed to work perfectly.

With colour on the screen, I removed the cabinet back and looked at the usual array of circuitry. The only thing I could safely ignore was the speaker.

Still with no plan of action I grabbed the freezer spray can and prepared to do battle. It was not until I had my finger on the button that I decided to hit the chroma chip first. There's nothing like starting a problem job in the middle.

And guess what? The instant the spray hit the chip, the colour disappeared. A warm finger soon restored the colour, another spray turned it off again. A new chip produced instant over-saturated colour and no amount of spraying could turn it off. Just to be sure I replaced the old chip and was treated to an instant replay, purple lines, weak colour, and all.

So the job was done in record time and four days of intense worry were all wasted. Ah well, such is life.

Well, thank you J.L. I'm sure readers will enjoy your story as much as I did. And I'm sure there is a moral there about worrying, and how futile it often is. There is an old saying, "Today is the tomorrow you worried about yesterday — and all's well." Or, as someone else put it more succinctly, "Cheer up mate, it might never happen."

I also liked J.L.'s reference to "wasted worry". It reminds me of one of the EA staff members, whose philosophy is that we are issued with only a limited amount of worry each week. If we waste it on trivial things, then we have no worry available when something really serious happens.

In short, we would be overdrawn on our worry bank. And, as he puts it, "That way lies madness".

But enough of the philosophy; who's next on the list? Ah yes, Mr L.S. of Queensland. And stick around J.L., because it appears that Mr L.S. was

inspired, at least in part, but one of your stories. He also has some nice things to say about these notes.

He starts off, "I am another fan of your column. This article is the first I look up and read when my magazine is delivered. I have obtained many useful hints from these stories. Keep up the good work."

Thank you L.S. It is gratifying to know that the notes have proved useful as well as merely entertaining. That is what we aim for. Now here is L.S.'s story, more or less in his own words.

The following incident happened on the same day as I read J.L.'s story in the February issue and, in particular, the section about how much punishment electronic devices can take.

It concerns a Philips model TR 530, C1 chassis, a transistor type 60cm monochrome TV set. Having been in the service trade for some 25 years, I have come across many and varied faults, but this was one of the most outstanding.

I have serviced a number of receivers, mainly TV sets, brought to me from both the Sunshine Coast and the Gold Coast near Brisbane. As we all know, all sets gather a fair amount of household dust from inner suburbia, which cause a myriad of faults. If these sets are then taken to the coast, the salt air mingling with the dust can be disastrous to EHT circuits.

## NO PICTURE, NO SOUND

When this set was brought to me the complaint was "no sound or picture". Removing the back I was not surprised to see a great crevice across the top of the EHT rectifier support, which also acts as the line output transformer cover. This cover, for those not familiar with the arrangement, is a piece of plastic, 9 x 9cm, with a pillar in the centre where the DC EHT lead passes with a clip to connect to the EHT stick rectifier.

There is about 17kV at this centre point of the cover, which is horizontal and on which dust, coming through the top vents of the cabinet back, can settle. The result is corona and eventual breakdown if these conditions are not checked. This breakdown, or tracking through of the EHT voltage, is often disastrous to one or more components in the EHT and drive circuitry.

Removing the cap and examining the parts underneath I could see no obvious damage. Connecting up without the cover, I switched on. Nothing, except for the heater glow in the picture tube. Checking with the meter showed no voltage on the boost diode. Examining this part of the circuit I found a 3.9Ω 6W resistor missing from the circuit board. This is a limiting resistor in the main supply rail.

A search of the bottom of the cabinet revealed no trace of the resistor, but on

# BRIGHT STAR CRYSTALS



WATCH  
CRYSTALS

CRYSTAL UNITS  
FOR QUARTZ  
CRYSTAL CLOCK

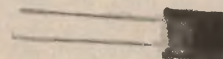

CRYSTAL  
OVENS  
AND OVEN  
OSCILLATOR  
UNITS



*Specifications, Dimensions and data sheets available on request*

## BULK ORDERS:

In addition to our normal range we can supply quantity orders (100 up) at very competitive prices. All we ask is 50% of cost with order balance 30 days.

**DELIVERY:** 5-6 weeks from receipt of Order.

Ring for quote:

(03) 546 5076

Telex: AA 36004

**NEW N.S.W. AGENT:**  
APP Master Communications,  
Sydney, (02) 682 5044

# BRIGHT STAR CRYSTALS

35 EILEEN RD, CLAYTON, VIC.

ALL MAIL TO: PO BOX 42 SPRINGVALE  
3171



## THE SERVICEMAN — continued

picking up the plastic rear cover, there it was, imbedded in the plastic. It had become so hot that the solder holding it in the printed board had melted and it had dropped out into this spot.

Freeing it, I replaced it in the circuit, and switched on again. Result, some life appeared; arcing from one end of the boost diode, which had apparently also been hot enough to melt the solder. Switch off — solder — switch on. The familiar salt covered component sizzle, then — presto — a picture!

Point to note: We have an EHT stick rectifier, a line output transformer, a BU205 transistor as line output, an OA636 diode, and a 6W resistor, all very much overloaded and most of them easily destroyed by overload, yet they still functioned perfectly.

I replaced the diode (they seem to have only a limited life anyway), the resistor, and the cover. A clean up with metho and CRC, a smear of grease on the ulitor cap, and the job was finished. Another working set and happy customer.

Well, that's the contribution from the Sunshine State — notice how we're getting around: Tasmania, Queensland, and something from NSW yet to come. Thank you L.S., and good luck with future tricky ones.

### BACK AT THE RANCH

And now back to home territory; NSW. This story is from Mr W. P. of Croydon, and this is how he tells it:

My little National monochrome mains/battery TV set (TR505DU) had been acting up for some time but, as customers come before family, it had received minimal attention.

Living with a failing set in one's own house is quite different to having a customer give a non-technical account of a set's history and symptoms but, in this case, although I knew the facts at first hand, they led me astray.

A year or so ago it had been noticed that the sound would give forth with a healthy crackle at random times, and the picture would break up for a moment. Several months later the set began cutting right out, but the family discovered that the problem was somewhere near the removable power lead plug at the back of the set, and learned how to jiggle it back into life. Noting this, I squeezed the plug contacts to improve their connection and the trouble seemed to go away.

However, a different fault developed during the following months and I finally made the momentous decision to service my own set. The new problem was

that two bars of snow were drifting slowly up or down the screen — most noticeably on my favourite Sydney channel — channel 2.

It was obviously mains-related interference, varying in and out of step with the steady vertical scan but, since it happened all the time, it seemed unlikely to be originating outside the set. When operating on batteries there was no trace of the trouble.

I vaguely wondered whether we had a failing electrolytic at some critical point in the power supply, or a faulty rectifier diode, or maybe some nasty leakages in the power transformer itself — any of which might radiate hash. But why only on channel 2? An obscure ripple getting through to the tuner perhaps? All these would be easy to check once I removed the case.

Anyway, as I mentioned the imminence of the repair in the hearing of No. 2 Son, he commented that the power lead was hot. Not very worried, I put a finger on the plastic plug — and jumped! It was hot all right. So we borrowed a power lead from a cassette recorder and — voila! — all problems vanished. No bars, no snow, no heat — just like that. Surely doubtful pin/plug connections could not have been so consistently and reliably faulty?

The surprise came when I applied the ohmmeter. On the low range there was no continuity between the ends of the power lead! How did the set work at all? Dissecting the plug revealed the cause, and I enclose a photo for your inspection.



*The faulty power plug. The pocket of carbon adjacent to the inner end of one of the pins is clearly visible.*

Apparently the initial problems were due to the continual flexing of the power lead and resultant weakening of the connection between the plug and socket pins, until the slightest bump would cause the set to fail. Enough heat had been generated by this process to reduce the plastic to a carbon path (mixed with copper oxide from the wire

strands) just in time to bridge the gap and carry the current when the wire failed completely. None of this was evident from outside the plug.

A point of interest about this story is that this fault could not occur in the average TV set. The plug would either melt because of the current level involved, or it would simply go open circuit. But, of course, the bigger sets do not have such a plug, as they do not require the mains lead to be removed for other types of operation.

This set is rated at only 14W on AC (6W on batteries) so that only about 60mA was being drawn ... and somewhat less with a high resistance in the power lead. Since the set was working quite well, there can have been only two or three watts dissipated in the plug — just enough to burn a carbon path without fuss or fire.

A new one on me — but it's nice to be able to repair a set without removing one screw!

Some time later, with a brand new lead in place, I checked on how the set operated on reduced voltage — using a Variac — and was unable to duplicate the bars of snow. So the problem was not just one of a set being robbed of the full 240V and failing to cope. My guess is that the charred plug was not passing a clean or linear current and the resulting noise was being radiated to the rod aerial immediately above. And, since channel 2 is the weakest channel in our area, it was the one affected.

Thank you, W.P., for a most interesting and unusual story. I'm sure readers will appreciate it just as much as I did. Incidentally, I'm not surprised that reducing the voltage artificially did not create the bars of snow. As you suggest, they were almost certainly being generated by the current arcing through the carbon path in the plug.

The susceptibility of channel 2 to this interference, over the higher frequency channels, doesn't surprise me either. The fact that channel 2 is weak in this area was doubtless a contributing factor, but interference of this kind, as commonly generated in faulty or poorly maintained power lines, is always worst on the lower frequency channels.

In fact, I've seen it render channel 2 virtually unwatchable, yet be barely visible on channels 7, 9, and 10. It works the other way too; it can be barely visible on channel 2, yet cutting channel 0 to pieces. As I understand it, it is simply that these harmonics — which is what they are — naturally become weaker with increasing frequency.

And that's all for this month. Next month I will have more stories from my own bench, but I'll try to squeeze in a reader's story if there is room. So think about your most unusual experience and whether it might be worth submitting. ☺



# IARU conference proposes S-meter standards

At the last Regional IARU\* Conference, held at Brighton, England, from April 27 to May 1, 1981, the Netherlands Amateur Radio Society, VERON, presented a paper suggesting precise measurements to replace the subjective "S"-system currently used to report received signal strength.

In order to make a uniform reporting system on the amateur bands possible, taking into account the widespread use of the subjective S-system, and the large deviations between the characteristics of S-meters on current amateur equipment, the IARU Region 1 recommends the use of the S-system for signal strength reporting on the amateur bands, based on the following standards:

- (a) One S-point corresponds to a level difference of 6dB.
- (b) On the bands below 30MHz a meter deviation of S-9 corresponds to an available power of a CW signal generator connected to the receiver input terminals of -73dBm.
- (c) On the bands above 30MHz this power shall be -93dBm.
- (d) The metering system shall be based

on quasi-peak detection with an attack time constant of 10ms  $\pm$  2ms and a decay time constant of at least 500ms. (0dBm is 1mW, in this case in 50 $\Omega$ ).

### Comments:

1. Signal reporting on the amateur bands at the moment is based on the well-known subjective RST system. Although the system is very useful, the availability of modern, sometimes professionally made, receiving equipment, makes the use of a less subjective system for the measurement of the strength of the received signal possible. The system to be chosen, however, must not deviate too much from the subjective system.

2. The first, and most important, standard to be recommended, will be the definition of an S-point. A value of 6dB seems very practical. It corresponds to an already widespread "unofficial" stan-

dard and gives the least problems for non-mathematically oriented amateurs.

3. Once having agreed upon the value of one S-point, a second, less important, but very useful recommendation would be the definition of a reference level.

Taking into account the practical situation it will not be possible to define one reference level for all amateur bands. On the HF bands a level of -73dBm (50 $\mu$ V in 50 ohms) does not deviate too much from current practice. On the higher bands, however, where thermal noise is in many cases the limiting factor, a lower level must be chosen, and -93dBm (5 $\mu$ V in 50 ohms) seems appropriate.

4. Although the standards given above are based on continuous signals, in real traffic non-continuous signals (ie A3j) will be encountered. It is therefore necessary to define in more detail the measurement system.

In many cases the S-meter is coupled to the AGC system of the receiver. Therefore a quasi-peak detector will be taken as the standard, with an attack time constant of 10ms and, although of less importance, the decay time constant shall be more than 500ms.

5. We hope that the current recommendation will be followed by all equipment manufacturers and that they try to avoid publication of receiver designs which do not in principle use the recommended standards. Simple means for calibration of at least the 6dB level ratio should be published.

S	HF bands		Bands above 30MHz	
	dBm	(V in 50 $\Omega$ )	dBm	(V in 50 $\Omega$ )
9 + 40 dB	-33	(5mV)	-53	(500 $\mu$ V)
+ 30 dB	-43	(1.6mV)	-63	(160 $\mu$ V)
+ 20 dB	-53	(500 $\mu$ V)	-73	(50 $\mu$ V)
+ 10 dB	-63	(160 $\mu$ V)	-83	(16 $\mu$ V)
9	-73	(50 $\mu$ V)	-93	(5 $\mu$ V)
8	-79	(25 $\mu$ V)	-99	(2.5 $\mu$ V)
7	-85	(12.6 $\mu$ V)	-105	(1.26 $\mu$ V)
6	-91	(6.3 $\mu$ V)	-111	(0.63 $\mu$ V)
5	-97	(3.2 $\mu$ V)	-117	(0.32 $\mu$ V)
4	-103	(1.6 $\mu$ V)	-123	(0.16 $\mu$ V)
3	-109	(0.8 $\mu$ V)	-129	(0.08 $\mu$ V)
2	-115	(0.4 $\mu$ V)	-135	(0.04 $\mu$ V)
1	-121	(0.21 $\mu$ V)	-141	(0.02 $\mu$ V)

This table shows the proposed "S" meter readings versus signal strength. The values shown do not tally exactly with those produced by the "EA" editorial calculator, although the differences are largely academic. They are probably due to fairly severe rounding off of some values early in the original calculations.

\*IARU: International Amateur Radio Union.

Reprinted from the NZART journal, "Break-in", for September, 1981.



# New timer IC from Exar

## XR-2243 timer: for extra-long time delays

This new timer IC from Exar Integrated Systems, Incorporated, takes over where the 555 leaves off. Called the XR-2243, it is capable of producing delays up to several days in duration. Features include compatibility with TTL and DTL circuitry, a typical accuracy of 0.5%, monostable or astable operation, a wide range of supply voltage and low power consumption.

by JEFF SKEEN

Most people constructing projects have used a 555. Over the past eight years or so, it has become one of the standard building blocks for circuit design. They have one failing however and that is in the region of long time delays.

Time delays greater than several minutes are not possible using a 555 timer unless external divider circuitry is used. This is because the 555 derives its basic timing period from the charging of an external resistor-capacitor network. A long timing period means a large value of resistor, or capacitor, or both.

Large values of capacitance mean that either an electrolytic or a tantalum capacitor must be used.

Trouble then arises with the leakage current of these capacitors which is of

the order of several microamps and provides a practical limit to the size of the resistor through which the capacitor charges. A high value of resistance means that the charging current will be small and may be close to the value of the leakage current. If the leakage current equals or exceeds the charging current then the capacitor will never be able to charge up and therefore the 555 won't work.

### Frequency divider

The answer, then, is to provide some form of frequency divider circuit on the output of the 555. This will allow the 555 to operate at faster rate while still preserving a low overall output frequency. A better method would be to include the

divider circuit and the timer circuit together in the one integrated circuit. Until recently no such integrated circuit existed but now Exar Integrated Systems, Inc has released the XR-2243.

The XR-2243 contains an 11 stage divider, allowing it to produce delays ranging from microseconds to days. It comes in two package types, plastic or ceramic, both with an operating temperature range of 0°C to +75°C. The ceramic package has a maximum rated power dissipation of 385mW and the plastic package 300mW. Typical values of supply current are 45 to 250µA in the operating mode, depending upon supply voltage.

The recommended range of supply voltage (Vcc) is from 2.7 to 15 volts with an absolute maximum of 18 volts. Typical timing accuracy of the device is quoted as being 0.5%. Timing resistors in the range 5kΩ to 10MΩ and timing capacitors in the range .005µF to 1000µF can be used but the maximum frequency of operation should typically not exceed 35kHz. Both the trigger and reset inputs have a typical voltage threshold of 1.4 volts and an input impedance of 25kΩ. The counter section also has a voltage threshold of 1.4 volts but with an input impedance of 15kΩ. Each output on the XR-2243 can sink up to 10mA.

### How it works

Upon application of a trigger pulse, the control flipflop sends a signal to the bias circuit telling it to begin supplying current to other parts of the circuit. The circuit is powered up in a fixed order to prevent any spurious output pulses. First to be supplied with current are the resistors R1, R2 and R3 which form a voltage divider to provide reference voltages for the comparators. Once these reference voltages have been

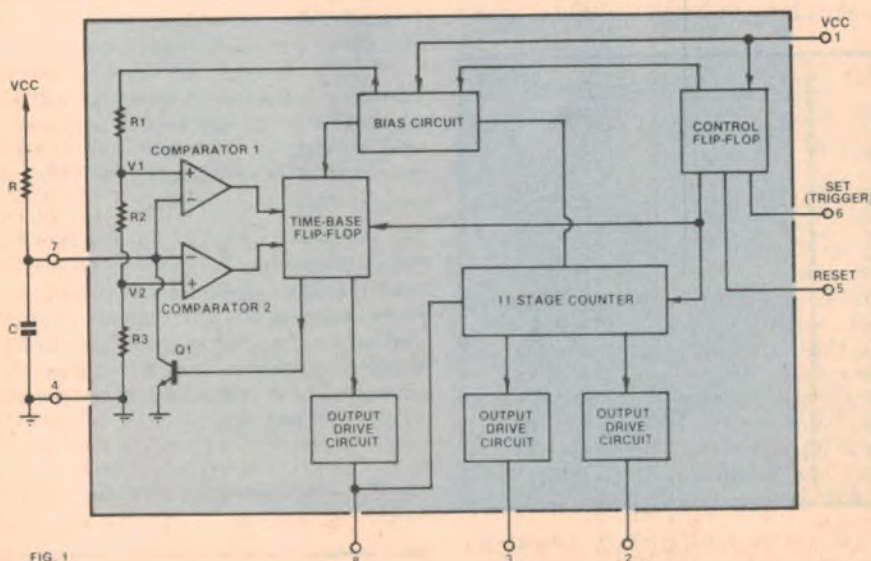

Fig. 1: block diagram of the XR-2243 timer IC. An 11-stage counter makes possible delays of up to several days in duration.



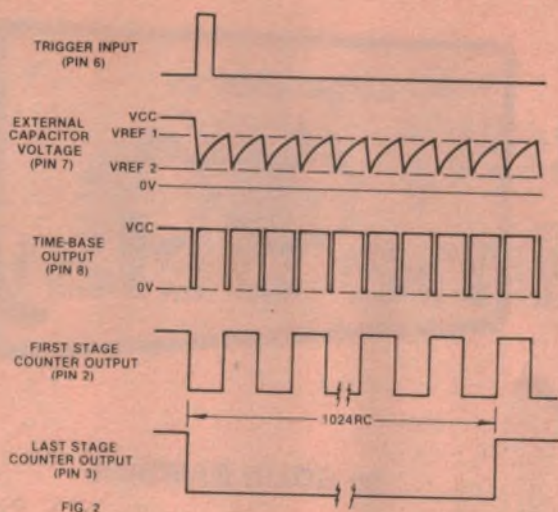

FIG. 2

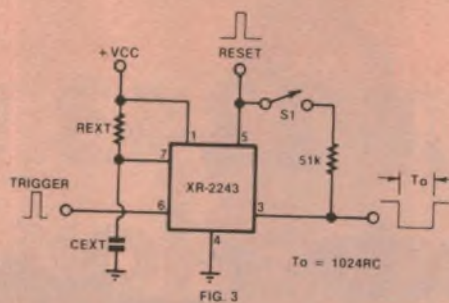

FIG. 3

Fig. 2 (left) shows the waveform timing diagram, while Fig. 3 (above) shows how the device is wired for either astable (S1 open) or monostable operation.

established, the bias circuit supplies current to all the internal current sources, thus providing power for the comparators, the timebase and the counter sections.

The lefthand portion of Fig. 1, consisting of the two comparators, the transistor Q1 and the timebase flipflop, forms an oscillator. The frequency of this oscillator is dependent on the values of resistor and capacitor connected to pin 7. The oscillator works as follows, with an initial assumption that the external capacitor is fully charged (to Vcc), Q1 is off and the trigger pulse referred to above has just turned the bias circuit on and "set" the timebase flipflop.

The timebase flipflop then turns on transistor Q1 which discharges the external capacitor C. The effect of C discharging is to reduce the voltage fed to the inverting inputs of the two comparators. When the voltage across C is reduced to just below V1, the reference voltage for comparator 1, the output of this comparator goes from low to high and the same thing will happen when the capacitor voltage drops just below V2, the reference voltage of comparator two. In the latter case, the timebase flipflop is forced to change state which causes Q1 to turn off so that the external capacitor C can begin recharging towards Vcc.

When the capacitor is charging, it is not until it exceeds the reference voltage for comparator 1 that the timebase flipflop is again forced to change state which again turns on Q1 to discharge C to just below V2. Thus, the cycle is repeated with capacitor C charging and discharging between V1 and V2. This can be regarded as a relaxation oscillator which has a sawtooth waveform.

The next stage of the circuit to consider is the counter section. This consists of 11 D-type flipflops in series, each one inter-

nally connected so that it divides by 2, giving a total division of 2048.

Output drive circuits are connected to the outputs of the first and the eleventh flipflops.

The input signal to the counter section comes from the timebase flipflop which is also connected to the output drive circuit at pin 8. The waveform at pin 8 is shown on Fig. 2. The negative-going spikes occur when C is discharging.

The first dividing flipflop provides a signal to the output drive circuit on pin 2. This output waveform is also shown in Fig. 2 and it is a square wave of period 2RC. The output of the 11th D flipflop is connected via an output drive circuit to pin 3. This output will be a square wave with a period of 2048RC.

### Astable & monostable modes

Fig. 3 shows the device connected for either astable or monostable operation. Astable operation is achieved by opening switch S1 and applying a positive pulse to the trigger input. The circuit will begin to oscillate and the voltage waveforms shown in Fig. 2 will appear on the respective outputs. The circuit will continue to work, generating square waves, until a reset pulse is applied to the reset input.

Monostable or "one shot" operation can be achieved by closing S1. With the application of a trigger pulse the circuit will begin oscillating as before and will continue to do this until the output of the last counter section goes high. When this happens the voltage will be fed back, via S1 and the 51k resistor, to the reset input where it will force the control flipflop to reset the circuit and stop the oscillator.

The circuit now needs another trigger pulse to begin operation again, hence the name "one shot". In this mode the delay time is the duration between the

trigger pulse and the last flipflop output going high. This time duration will be given by 1024RC.

The output drive circuits on pins 2, 3 and 8 will sink up to 10mA each. They will not source current so any device that is to be controlled directly by an output drive circuit will need to be placed between Vcc and the appropriate pin on the integrated circuit.

### Cascading

For applications where a really long time delay is required, a number of XR-2243 integrated circuits may be cascaded together. If the cascaded circuits have their counter sections connected in series then the total time delay of the combination increases geometrically according to the equation: T.D. =  $(1024)^n RC$  where "n" is the number of XR-2243 devices cascaded together and T.D. is the time delay measured in seconds.

To cascade devices like this, the second and subsequent integrated circuits have their timebases (timing oscillators) disabled by connecting pin 7 on each device to ground via a 1k resistor. The last stage output of the first integrated circuit is then connected directly to the input of the counter section (pin 8) of the second integrated circuit. This connection is repeated between the second and third integrated circuits, third and fourth, and so on. The last stage output of the final integrated circuit is then connected via a 51k resistor back to the reset input on each integrated circuit in the series. The output of the circuit is then taken from pin 3 on the last device in the series, before the 51k resistor.

The XR-2243 is distributed by Total Electronics, 1 Johnston Lane, Lane Cove 2066. The device is available retail from Radio Despatch Service, 869 George St, Sydney 2000.





by COLIN DAWSON

# Guitar Booster for stereo amplifiers

This inexpensive preamplifier will let you use your guitar with a normal stereo amplifier. It has treble and gain controls and is powered by a nine-volt battery.

Most stereo amplifiers require a signal of about 150 millivolts or more at their Line inputs so the average electric guitar, which delivers a signal of about 20 millivolts RMS, requires a preamplifier to make up the difference. Our Guitar Booster serves this purpose and also has a Treble boost control which will be useful for lead guitarists using conventional music amplifiers which are already suitable for electric guitars.

Quite often, during the performance of "pop" music, the lead guitarist will briefly take over from the vocalist as the predominant performer. This is known as a "lead-break" and usually requires a significant increase in the guitarist's volume. It is played predominantly on the treble strings of the guitar, and for this reason our Guitar Booster has up to 15dB of treble boost. In addition to the normal gain of the device, this should contribute to a most effective "lead-break"!

Our Guitar Booster is housed in a small plastic zippy box with two knobs and a switch on the control panel. The knobs are for Gain and Treble boost. At one end there is a 6.5mm socket for the

guitar jack while at the other end is an RCA phono socket for the output to the Auxiliary input on your stereo amplifier.

With a current consumption of typically less than two milliamps, the circuit should give a long life from the 9V battery. We used an Eveready type 216.

## How the circuit works

A single transistor and a Fet-input op amp comprise the circuit. The transistor provides the treble function while the op amp provides overall gain and output buffering.

Transistor Q1 is connected as a common-emitter amplifier stage with the emitter resistor essentially unbypassed for high emitter degeneration (current feedback). This results in an overall gain from this stage of little more than unity, as mainly determined by the ratio of the 6.8k $\Omega$  collector resistor to the 4.7k $\Omega$  emitter resistor. For frequencies above 300Hz, the emitter resistor is increasingly bypassed by the 0.1 $\mu$ F capacitor and the 1k $\Omega$  and 25k $\Omega$  potentiometer in series. If the pot is set to its minimum resistance, the emitter resistor is bypassed with 1k $\Omega$

and 0.1 $\mu$ F, giving a maximum gain for frequencies above 3kHz of about 8. In other words the gain is much higher at these frequencies, which is the same as saying the treble is boosted. The amount of boost, expressed in decibels, is the ratio of gain at the higher frequencies to the gain at frequencies below 300Hz. The ratio is about 6 or about 15dB.

The output from Q1 is coupled via a 0.1 $\mu$ F capacitor to the non-inverting input of the op amp to which DC bias is also applied by a 100k $\Omega$  resistor from a voltage divider across the 9V supply. The bias sets the output of the op amp to half the supply and so allows it to clip symmetrically for maximum output voltage capability.

A feedback network from the op amp output to the inverting input (pin 2) sets the voltage gain. Minimum gain of the op amp is set to 1.7 by the 2.2k $\Omega$  and 1.5k $\Omega$  resistors while maximum gain is obtained with the 25k $\Omega$  gain pot set to maximum resistance. In this case the gain is 13 or 22dB. The output signal from the op amp is coupled via the 4.7 $\mu$ F capacitor.



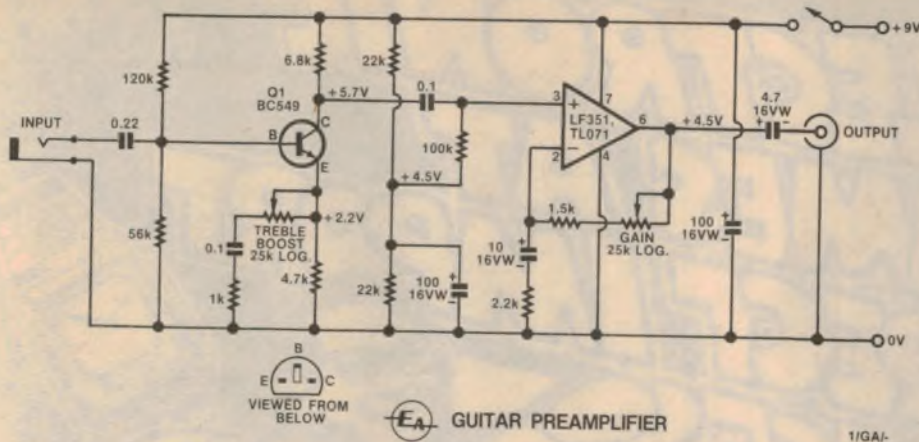

**GUITAR PREAMPLIFIER**

A transistor amplifier stage and a Fet-input op amp make up the circuit.

## PARTS LIST

- 1 PCB, code 82ga5, 63 x 36mm
- 1 plastic utility box, 130 x 67 x 41mm
- 1 6.5mm jack socket
- 1 RCA phono socket
- 1 SPST switch
- 2 knobs for front panel
- 10 PC pins
- Shielded and unshielded hook-up wire.
- 1 9V battery, type 216 with snap connector
- 1 TL071, LF351 Fet-input op amp
- 1 BC549 NPN transistor

### CAPACITORS

- 2 100µF 16VW electrolytic
- 1 10µF 16VW electrolytic
- 1 4.7µF 16VW electrolytic
- 1 0.22µF metallised polyester (greencap)
- 2 0.1µF greencap

### RESISTORS (5%, 1/2W)

- 1 x 120kΩ, 1 x 100kΩ, 1 x 56kΩ, 2 x 22kΩ, 1 x 6.8kΩ, 1 x 4.7kΩ, 1 x 2.2kΩ, 1 x 1.5kΩ, 1 x 1kΩ, 2 x 25kΩ (log) potentiometers

## Putting it together

The printed circuit board (PCB), coded 82ga5 and measuring 63 x 36mm, has been designed to fit into the slots of a plastic utility box, measuring 130 x 67 x 41mm. Before assembling the PCB, check that it will fit into the slots. If not, it may be necessary to file it down to size.

Mount the PC pins first then the resistors and capacitors. Note the polarity of the electrolytics when installing them. Now insert the transistor and IC, again noting the correct orientation. Check all your solder connections for

missed or cold joints.

Having completed the PCB construction, you will need to drill the box to accept the input and output sockets, the two pots and the power switch. The input socket, a 6.5mm mono type, should be mounted at one end of the box, and the RCA output socket at the other end. Use shielded wire for the connections to the input and output sockets. All the other connections can be made with unshielded hook-up wire.

You will need some means of securing the battery in position. We simply used

## Specifications

Frequency response:	Flat to beyond 100kHz, -3dB at 40Hz.
Input impedance:	30kΩ
Output impedance:	Less than 1kΩ
Maximum output:	More than 2 volts RMS with 9V supply
Voltage gain:	Adjustable from 2.3 to 17.6 (7 to 25dB)
Treble boost:	15dB maximum at 10kHz, +3dB corner at 300Hz
Harmonic distortion:	Typically 0.1% over whole audio band.
Signal/noise ratio:	60dB with respect to 150mV RMS output and at maximum gain
Current consumption:	Typically less than 2 milliamps at 9V

# LOOKY VIDEO

MAIL ORDER DEPARTMENT: PO Box 254, Heidelberg, 3084.  
Phone: (03) 435 3004, Monday - Saturday 1.00pm to 6.00pm

## COMPUTER EARS



- ★ TALK TO YOUR COMPUTER
- ★ TEACH IT A SPOKEN VOCABULARY
- ★ PROGRAM IT BY VOICE
- ★ SPEAK YOUR COMMANDS
- ★ CAN REPLACE THE KEYBOARD
- ★ A BOON TO THE HANDICAPPED
- ★ A NEW LEVEL OF TECHNOLOGY TO EVERYONE

NEEDS A SIMPLE MOD TO MOST COMPUTERS.  
ALL INSTRUCTIONS ARE INCLUDED.

When ordering specify brand of computer.  
PRICE: Excluding Sales Tax \$43.75  
Sales Tax \$5.25 Pack & Post \$2.00  
ALSO: Looky Video is Australasia's largest software house for Ohio  
WRITE FOR: K1. Ohio Hardware Catalogue - Super Board II \$1.00  
K2. Ohio Software Catalogue - SII and Cap. \$1.95  
PRICES FOR K1 and K2 INCLUDE P. & P.  
Air Mail to NZ or New Guinea add \$1 or W.A. 50c

**S** BUSINESS  
**O** OR  
**R** PLEASURE  
**C** IT'S THE  
**E** BEST  
**R** COMPUTER  
**E** MONEY  
**R** CAN  
**E** BUY  
**R** ACCOUNTING  
WORD PROCESSING  
MAILING LIST  
DATA BASE  
MANAGEMENT  
EDUCATION  
GAMES  
HOBBIES  
GRAPHICS  
FULL  
SOFTWARE  
&  
HARDWARE  
SUPPORT

*Software Source* Pty. Ltd.

WRITE FOR FREE CATALOGUE  
89 OXFORD ST (02) 389 6388 PO BOX 364,  
BONDI JUNCTION EDGECLIFF, 2027



# ELECTRONIC GAMES AT DIRECT IMPORT PRICES



**ALL NEW POCKET COM II MINI TWO WAY**

A full 2-way transmission and a size that fits secretly into your pocket. A great gift for any child. Buy a few and start a 'spy ring'! No licence required.

**ONLY \$995**

Cat D-1101



**NOW A DIGITAL WATCH AT A DICK SMITH PRICE**

This watch features:

- digital readout stop watch
- watch countdown timer
- hour alarm plus visual and audio alarm plus visual with attractive liquid crystal display.

**ONLY \$4450**

Cat Y-1045

**SAVE \$200 ON THIS PEN/WATCH**

A superbly styled silver ball-point pen complete with an LCD digital clock inside the pen. Shows day date and seconds.

**NORMALLY \$995 THIS NOW \$795**

Cat Y-1030

**SHOP BY PHONE**

**(02) 888 3200**

QUOTE YOUR BANKCARD NUMBER



**TEXAS QUALITY DICK SMITH PRICE**

**SPEAK & SPELL** ONLY \$8300

Helps develop skills in spelling, pronunciation and reading. It pronounces the word and can tell you whether your answer is correct. Cat Y-1300

**SPEAK & READ** ONLY \$9900

The Speak and Read™ helps beginning reading skills. It introduces more than 250 of the most basic English words. Cat Y-1313

**SPEAK & MATH** ONLY \$8900

This amazing unit can generate over 100,000 math problems. It will also talk to you telling you what the problem is and whether you are right or wrong. Cat Y-1310



**SEE & HEAR SONIC INVADERS**

Looks like something out of Star Wars! It has a multicoloured display with realistic sound effects.

**AMAZING \$4900 VALUE**

Cat Y-1153



**NEW NEW! WORLD WATCH**

Now you can tell the time anywhere in the world! In 20 different time zones.

**VALUE \$6495**

Cat Y-1051



**ENHANCE YOUR DECOR CUTIE PHONE**

The very latest in modern phones. When not in use the mouth piece sits conveniently folded. It has attractive push button keys, with a memory re-dial for engaged calls.

**WAS \$7200 NOW \$5500**

**SAVE \$1700**

NOTE: Not Telecom permitted

Cat Y-1179



**ECONOMY TV GAME**

Turn your old black and white TV into a games centre with this unit. Four great games ideal for the whole family.

**WHY PAY MORE \$1995**

Cat Y-1170



**WHY PAY MORE LCD CALCULATOR**

This ultra-slim handy calculator is great for school, home, office in fact anywhere. Supplied complete with batteries and instructions.

**ONLY \$995**

Cat Q-3022



**COMPUTER CHESS**

Become a chess grandmaster with six graduated levels of learning to increase your skills. It even plays against itself.

**\$275**

Cat Y-1260

**DICK SMITH Electronics**



SEE PAGE 27 FOR ADDRESS DETAILS

DSE/A235/5B







Recycle a TV cabinet to obtain

# Better Bass for electronic organs

Achieving adequate bass response from electronic organs can be difficult, particularly in the domestic environment where space is limited and loudspeaker appearance important. This article gives basic details for a bass speaker system which offers impressive performance, yet is compact, inexpensive and easy to build.

by PETER HALL \*

Many owners of electronic organs concede that their instruments lack the realism of pipes, especially when sounding the bass end of the musical spectrum. There are two main reasons for this. The first is the surroundings in which most organs are played. In homes or small churches the listening area is likely to be too small to allow balanced bass to be produced. Room resonances are often a problem even before more subtle propagation and reflection effects are considered. Short of moving the instrument to a cathedral sized listening room there is little that can be done and most of us live with, or rather in, the problem.

A second, and more easily tackled reason for poor bass is the type of loudspeaker baffling employed by most organ manufacturers. For economy reasons few manufacturers take much care in choosing the loudspeaker acoustic environment. The drivers (or driver) are usually mounted in what is effectively an open baffle in the organ console. The effect is two-fold: The acoustic output falls at the bass end, and significant frequency doubling occurs in the bass driver because of inadequate acoustic loading.

In practice these effects mean that the listener may not hear much fundamental in pedal notes. The higher harmonics of the pedal voice selected, together with the doubled components, often dominate the fundamental, producing a very "electronic" sounding bass.

It is not usually practical to provide an adequate enclosure for the bass driver within an existing console because of space limitations. Most attempts to provide better bass, including my own, place the bass section in an external enclosure.

The lowest note on an organ pedalboard has a fundamental component of about 32Hz and ideally the bass audio

enclosure tuning is usually different from that predicted from simple theory. If the box is tuned to the frequency predicted by such theory the acoustic reactance of the air in the port at higher bass frequencies can lead to reduced output (or dips) at these frequencies. Many designers tune the enclosure to higher frequencies and obtain good results, but considerable experiment is necessary.

A sealed enclosure (acoustic suspension) was then considered and found to be an acceptable solution. Such an enclosure requires no tuning and is well modelled as a second order high-pass system. As such it ought to provide a better phase and transient response than the fourth order vented system although I do not claim that these areas of performance are of great importance at the very low cut-off frequencies encountered.

For an excellent summary of the design

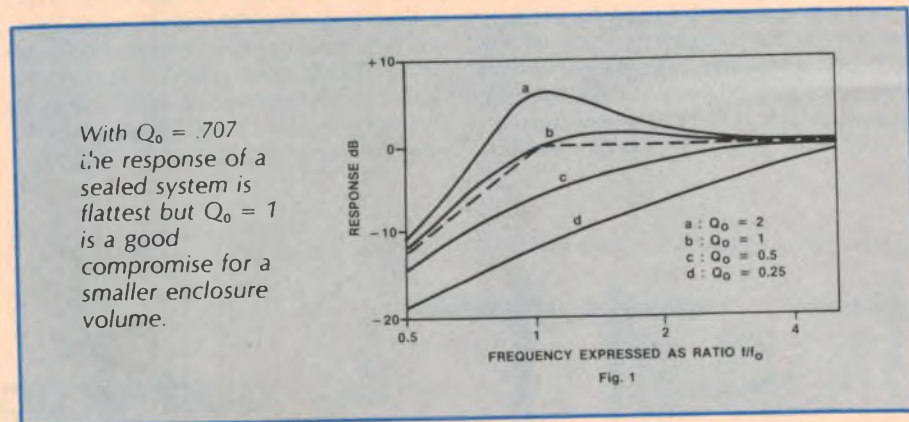

system should reproduce this faithfully. As a design goal I aimed for a response not more than 3dB down at 30Hz. By using one of the low resonance, high compliance woofers now available such a performance can be obtained from a large, but practical, enclosure.

## Enclosure design

Initially, a vented enclosure was considered but calculations showed that with typical drivers a very large enclosure would be necessary. Also, when a very low resonance woofer is used in a vented system, the optimum

techniques for vented enclosures and some interesting comparisons between sealed and vented systems see Brian Davies' articles (EA, August and September 1981). I have retained Davies' notation in the following discussion.

Three important parameters are usually specified by driver manufacturers. They are:

- the free-air resonant frequency,  $f_s$
- the free-air total Q,  $Q_T$
- the equivalent volume,  $V_{AS}$ , that an enclosure must have for the enclosed air to have the same compliance as the driver.

\* B. Eng, BSc (Hons), MIREE (Aust); Physics Department, University of Tasmania.



# Bass speaker for organs

When the driver is mounted in a sealed enclosure the resonant frequency rises to  $f_o$  and the Q of the resonance increases to  $Q_o$ . These parameters are easily related by two basic design equations:

$$f_o = (f_s/Q_T) Q_o \dots \dots \dots (1)$$

$$Q_o = (1 + V_{AS}/V_B)^{1/2} Q_T \dots \dots \dots (2)$$

where  $V_B$  is the enclosure volume.

For a given value of  $f_s/Q_T$ ,  $f_o$  is chosen to be as low as possible consistent with an acceptable response. The response is chosen by the designer by the selection of  $V_B$  (which determines  $Q_o$ ). If  $Q_o$  is too large ( $V_B$  too small) the response peaks around  $f_o$ . If  $Q_o$  is very small (large box) the response begins to fall away at frequencies much higher than  $f_o$ . Fig. 1 illustrates this behaviour. The flattest response occurs when  $Q_o = 0.707$  with a box volume given by

$$V_B = 2V_{AS}Q_T^2/1 - Q_T^2 \dots \dots \dots (3)$$

In practice it is found that  $V_B$  can be reduced significantly without major change to the response. A realistic design figure is  $Q_o = 1$  and for this value

$$V_B = V_{AS} Q_T^2/1 - Q_T^2 \dots \dots \dots (4)$$

There are several large woofers available which are suitable for use in a low frequency enclosure. A Tandy Electronics 40-1007 305mm unit was chosen as a compromise between performance, power handling, and price. The driver is rated to handle 50W (average power) and this figure should probably be taken as the upper limit for the large enclosure to be described.

Specifications give  $V_{AS} = 520$  litres,  $Q_T = 0.57$  and  $f_s = 20$ Hz. Measurements are in close agreement to these values.  $f_s/Q_T$  is 35Hz and with  $Q_o = 1$  this is also the cut-off frequency ( $f_o$ ) of the driver in the enclosure. For  $Q_o = 1$  equation 4 gives a box volume of 250 litres (0.25m<sup>3</sup>). The prototype volume is 190 litres giving  $Q_o = 1.1$  (equation 2), still an acceptable value.

## Enclosure construction

The original enclosure was built around the remains of a monochrome TV set cabinet. The cabinet was solidly built and the finish matched my Conn organ well. I added a 19mm particle board rear panel and baffle, as well as internal cleats and braces and a grille panel. The enclosure was lined with 25mm acoustic insulation, the damping effect of which probably brings the total system Q back to about unity.

Regardless of how the enclosure is made it must be air-tight and rigid. Internal joints and seams should be caulked and the connector used on the rear panel should be air-tight. I used a Tandy Electronics recessed type which has a

flange under which caulking compound can be spread.

It is wise to make the baffle removable and adhesive-backed foam strip can be used as a gasket between the baffle and internal front cleats. The 40-1007 woofer is equipped with a rear-mounted gasket but if a front mounting technique is used caulking compound should be spread

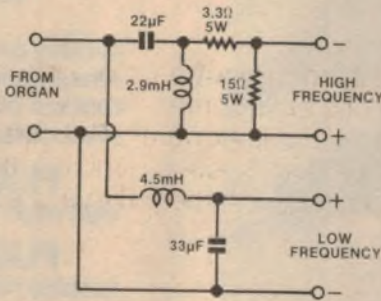
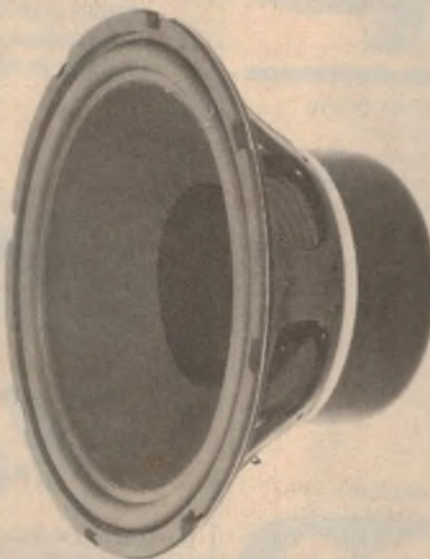

Fig. 2

under the driver rim to ensure a seal.

The form of the enclosure is not too important but avoid cubical and tubular shapes. Depending on the form chosen it is likely that at least one surface will require internal bracing. Ideally, braces should divide surfaces into unequal areas. Do not neglect bracing since significant flexing will otherwise occur and cause box re-radiation.



The woofer used by the author is a Tandy type 40-1007 which has a nominal diameter of 30cm. (Photo courtesy of Tandy Corporation).

## Performance

The driver mounted in the 190 litre enclosure exhibits a resonance at 35Hz. The impedance at resonance is about 50

ohms. With the enclosure in a quiet, unobstructed out-door setting a frequency response test was conducted using a Bruel and Kjaer 2204 precision sound level meter fitted with a type 4145 25mm condenser microphone with a response flat ( $\pm 1$ dB) from 4Hz to 12kHz. The measured enclosure response was within  $\pm 2$ dB from 35Hz to 300Hz and was down 3dB at 30Hz (slightly higher than predicted theoretically) and 5dB at 500Hz. A sensitivity of 86dB (1W, 1m) was measured at 80Hz.

When connected to the organ the result was very impressive. There was no evidence of frequency doubling on loud passages and the only problem encountered was loose room fittings vibrating at the lowest frequencies.

## Mid-range and treble

My measurements confirm the Tandy recommendation that the cross-over frequency for the woofer should be about 500Hz and certainly no higher than 1kHz. Electronic cross-over networks are easily synthesised and are ideal if separated high and low frequency amplifiers are available. In cases where the organ already uses multiple amplifiers the internal woofer is disconnected and the external enclosure connected.

I have used a single amplifier and an LC cross-over network. Fig. 2 is a schematic of the 8 ohm 500Hz network which is of the "Offset B2" type described by P. Gonda (Proc IREE, Sept 1981). Both inductors should be air-cored and the 4dB pad is included to match typical high frequency driver sensitivities to the relatively insensitive woofer. A variable L-pad can be used if desired. The high frequency output can be fed back to the console loudspeaker or routed to an external high frequency system. A few comments on the latter approach may be helpful.

It is not always desirable to have a very good high frequency response in an organ sound system. Depending on the organ a response above 7 or 8kHz may accentuate keying clicks as well as producing a rather "reedy" sound on some voices. This may be due to organ designers emphasising higher harmonics in anticipation of a fairly poor console audio response. In my case, I found that feeding the output above 500Hz to a mid-range driver (mounted in a small sealed enclosure) produced a good balanced treble response.

For the small cost (under \$100) and effort involved the audible improvement gained by adding the external loudspeaker system (mainly the woofer) is remarkable. The sound is very clean and undoubtedly more pipe-like.



# CIRCULAR PLASTIC CONNECTORS

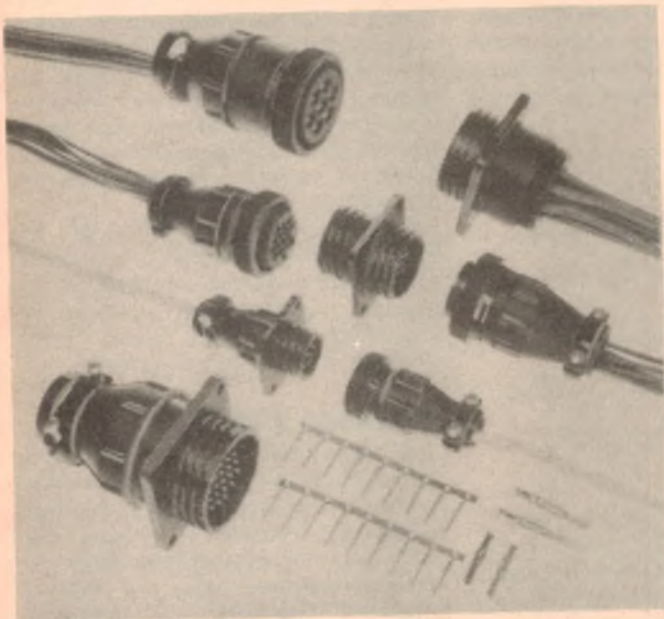

## AUSTRALIAN AMP

AMP circular plastic connectors are designed for use in commercial applications such as automotive, aircraft, instrumentation, computer, and peripheral equipment. These connectors offer many advanced design features which assure their high performance characteristics.

### Features

- Quick connect-disconnect capability with thread assist
- Available in panel or chassis mounting versions
- Wide choice of contacts
- 5-key polarization for proper mating of connector halves
- Various shell sizes available

Technical information available on request.

# SOANAR

## Soanar Electronics Pty Ltd

30-32 Lexton Road, Box Hill, Vic., 3128, Australia.

VICTORIA: 840 1222    QUEENSLAND: 52 1131  
 N.S.W. 789 6733    WEST. AUST. 381 9522  
 STH. AUST. 42 8918    TASMANIA: 31 6533

# Neutrik 3,4,5,6 Pin Plugs

Not only do we offer you a bigger range, we also offer a choice of finishes. There's black with gold contacts, black with silver contacts, and silver with silver contacts.

**PLUS** We have right-angle male and right-angle female cable connectors.

**PLUS** Neutrik offers a professional lockable phone jack. Mates with all 1/4" 2 and 3 circuit phone plugs.

**PLUS** Neutrik also has male and female PC-Board, mounting connectors with both vertical and horizontal contacts.

**PLUS** Neutrik has NLE connectors with 240 volt power offering 5 amps maximum. Approved by the S.E.C.

**PLUS** The Neutrik series of modular components representing a unique and economical approach to assembly in-line accessories for various applications. Unified thread permits all combinations; standard O-ring available to fit modules to enable alignment of latching sections.

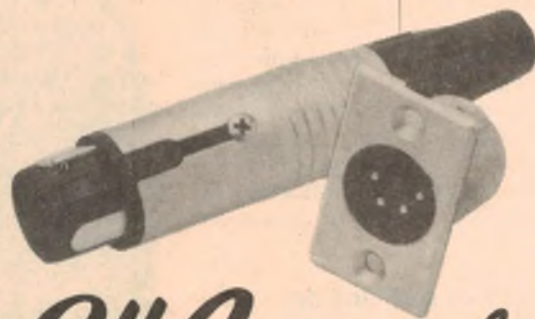

## R.H. Cunningham

PTY. LTD.

146 Roden St. West Melbourne, Vic. 3003. Ph. 329 9633. Telex: AA31447  
 4/8 Waters Rd. Neutral Bay, N.S.W. 2089. Ph. 909 2388. Telex: AA21707

Send for our new free Neutrik connector brochure showing the full range of quality products.

NAME \_\_\_\_\_

ADDRESS \_\_\_\_\_

P/C \_\_\_\_\_

(Please print)

Return this coupon to:

R. H. Cunningham Pty Ltd. P.O. Box 4533, MELBOURNE.

RH4016

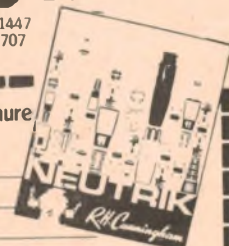



# Circuit & Design Ideas

Interesting circuit ideas from readers and technical literature. While this material has been checked as far as possible for feasibility, the circuits have not been built and tested by us. As a consequence, we cannot accept responsibility, enter into correspondence or provide constructional details.

## Electronic Thermostat

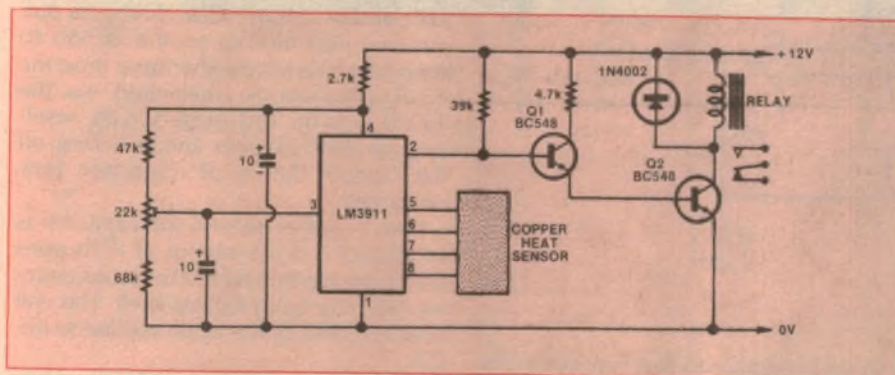

This circuit for an accurate electronic thermostat is useful for controlling temperatures over the range from  $-25$  to  $+85^{\circ}\text{C}$ . The output of an LM3911 temperature controlling IC is applied to a relay via two transistors connected as a Darlington pair. Current drain from a 12 volt supply is approximately 2.5mA when the relay is not energised, but will be increased by the current drain of the relay coil whenever the relay is activated.

Central to the design is an LM3911 which incorporates a stable voltage reference, a temperature sensor and an op amp. As the internal shunt regulator is connected across the power input of the LM3911, an external resistor ( $2.7\text{k}\Omega$ )

be connected in series with the supply to limit the current. Thus the reference voltage across the input pins may be used for calibration of the temperature setting. The output voltage of the temperature sensor is directly proportional to temperature in degrees Kelvin at  $10\text{mV}/^{\circ}\text{K}$  and is internally applied to the non-inverting input of the op amp.

If the inverting input pin of the op amp is connected to the output pin, the op amp functions as a unity gain inverter to act as a buffer for thermometer applications. But in this design the inverting input is connected to the slider of a potentiometer which is shunted across the voltage reference. So the op amp operates as a comparator, switching out-

put states as the voltage from the temperature sensor rises above or falls below the preset reference. The output of the op amp is applied to the relay via the transistor buffers, such that the relay contacts changeover whenever a change in op amp output state occurs.

It should be pointed out that the LM3911 die is on the base of the package and that pins five to eight have no internal connections, therefore coupling via a copper heat sensor to these pins will ensure the best transfer of heat energy to the internal temperature sensing elements. Further, the LM3911 should be operated at the lowest possible power level to avoid raising the sensor's temperature much above ambient. Limiting the operating current to 1mA raises the package temperature only  $1.2^{\circ}\text{K}$ . Similarly, whilst the op amp output can drive loads up to 5mA, this is also undesirable because any internal heating affects accuracy. Hence the two-stage buffer.

Should a more "vernier" response be required for the control potentiometer, the resistors ( $47\text{k}\Omega$  and  $68\text{k}\Omega$ ) on each end of the potentiometer may be increased in value — thus reducing the range of control.

D.A. Lemke,  
Port Fairy, Vic.

## Audible Logic Tester

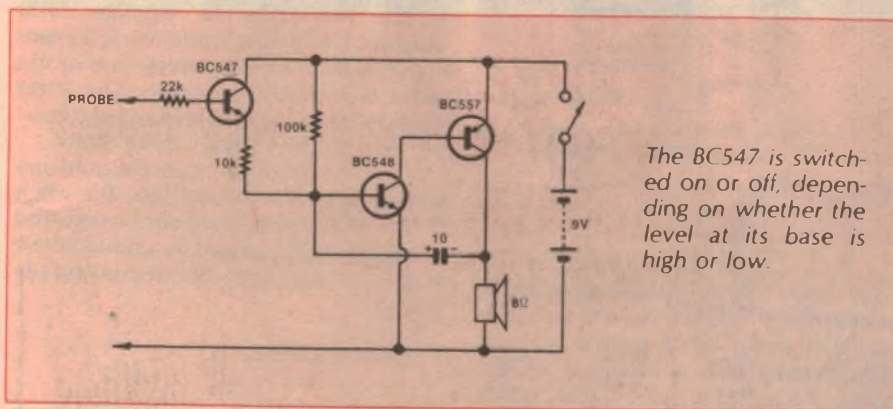

*The BC547 is switched on or off, depending on whether the level at its base is high or low.*

The majority of circuits for logic probes use LEDs to provide visual indication of the status ("high" or "low") of the point

being analysed. An alternate approach is to provide audible monitoring. This design produces clicks in a miniature

loudspeaker, with the repetition rate (fast or slow) giving indication of the highs and lows.

Two transistors, a BC548 and BC557, are connected in a simple astable multivibrator configuration with the  $100\text{k}\Omega$  resistor and  $10\mu\text{F}$  capacitor determining the repetition rate. The loudspeaker serves as the load for the BC557, being connected between its collector and the negative supply rail. A BC547 and  $10\text{k}\Omega$  resistor are connected in parallel with the  $100\text{k}\Omega$  resistor such that when the probe is taken "high" the BC547 is switched on, raising the repetition rate.

G. McLean,  
Gore, Southland, NZ.



## Cudlipp's Brother

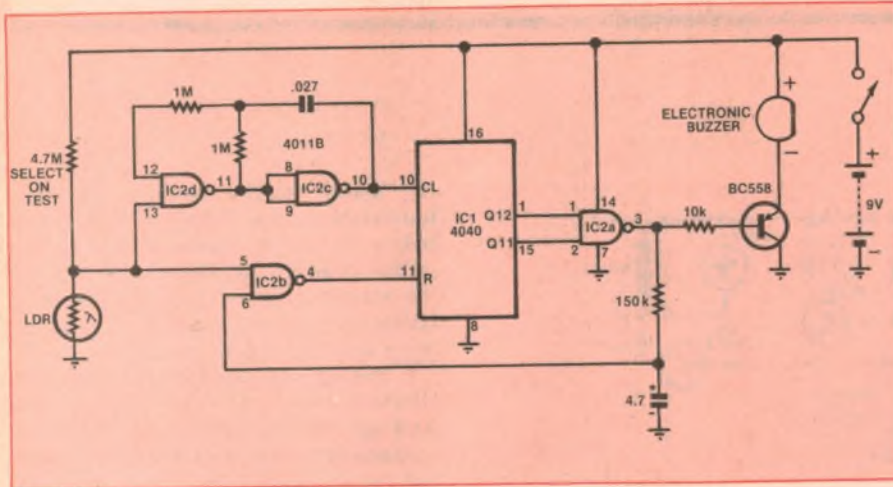

In what way is Cudlipp's brother related to Cudlipp? It will be recalled (EA, February, 1982) that Cudlipp responds to sounds with a chirp. If you shut up, he shuts up. If you make a noise, he makes a noise.

Cudlipp II, on the other hand, responds to darkness with a delayed series of short chirps. His main application is to place him in a bedroom so that his victims are made aware of his presence, since he complains endlessly about the lack of light. Not until a victim turns the light back on will he be satisfied and shut up. And of course, this makes it really dif-

ficult for his victims to find him! When his victims go back to bed and extinguish the lights, he waits a couple of minutes and then resumes his complaints. And so on.

Cudlipp's brother responds to the outside world by means of a light dependent resistor (LDR), and needs only a handful of components to activate an electronic buzzer.

Referring to the circuit it will be seen that with power applied and light falling on the LDR, there will be negligible voltage at the junction of the 4.7MΩ resistor and the LDR (since LDRs have

low resistance in the presence of light). Thus, the output of the NAND gate IC2b will be high and, as this is applied to the reset input of IC1 (a 4040 12-stage binary counter), all IC1's outputs will be low. Consequently the output of gate IC2a will be high, and the BC558 PNP transistor will be biased off.

The LDR resistance goes high in the absence of light, allowing the oscillator IC2c and IC2d to oscillate; and switching IC2b's output low, thus permitting IC1 to count. After about 2½ minutes IC1 reaches a count such that the Q11 and Q12 outputs trigger IC2a, driving its output low and turning on the BC558 to sound the buzzer. At the same time the 4.7µF capacitor is discharged via the 150kΩ resistor. This triggers IC2b, resetting the 4040 counter and switching off the buzzer the 4.7µF capacitor now recharges.

After a further second the capacitor is recharged and the output of IC2b goes low again, permitting IC1 to restart counting and the cycle repeats itself. This will continue until light is again applied to the LDR.

Summarising, when placed in the dark a period of 2½ minutes elapses before the buzzer "chirps". The chirp is of one second's duration, and a further 2½ minutes elapses before the next one-second chirp. Note that when re-exposed to light the oscillator is inhibited (by the low applied to gate IC2d).

Note also that the exact value of the 4.7MΩ resistor may have to be selected on test, as different LDRs exhibit different dark resistances.

J. Pittar,  
Cook, ACT.

## Pseudo PC Board

This handy hint is applicable to those occasions when it may be desired to construct a project for which no printed circuit board is readily available (eg from articles published in overseas magazines).

Firstly obtain a photostat copy of the PC "artwork" from the article and cut to size. Next, paste this print onto a piece of Laminex sheet approximately 1.5mm thick and cut to size.

Working from the "print" side drill holes according to their locations on the print. Now mount the components on the opposite side to the print, and bend their "pigtailed" to make "tracks" over the printed plan. In those places where the pigtailed are of insufficient length, they may be extended with the aid of, say, 20 gauge tinned copper wire. If there appears any likelihood of adjacent wires touching, insulate them with the aid of sleeving.

W. Ford,  
Canterbury, NSW.

## Lights for Model Railways

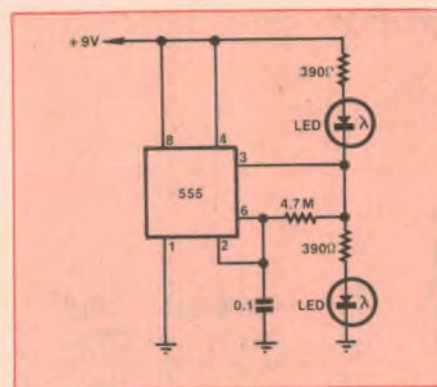

This simple circuit enables two LEDs to be alternately flashed on and off, producing a similar effect to the warning lights for road traffic at railway crossings.

Heart of the circuit is a 555 timer which is connected for a stable operation. Frequency of oscillation is determined by the 4.7MΩ resistor and 0.1µF capacitor. With these values the frequency is ap-

prox 1½Hz. To increase the frequency, decrease the value of either the capacitor or the resistor. Conversely, to decrease frequency, increase the value of either the capacitor or the resistor.

Output (pin 3) of the 555 timer is taken to the two LEDs via separate 390Ω resistors. Depending upon the 555's output state (high or low), either one or the other LED will be activated. The 390Ω resistors serve to limit the current flowing through the LEDs to about 20mA.

Whilst the circuit will operate from any voltage between 5V and 16V, the value of the 390Ω resistors should be adjusted to keep the LED current to approx 20mA when operated from the desired supply voltage.

A. Norris,  
Yarralumla, ACT.

**PSST!** Got any neat circuit ideas? Why not send 'em to us? We pay between \$5 and \$20 per item, depending on how much work we have to do to publish it.



# YOU BENEFIT

from JAYCAR'S great prices! 

**DIGITAL CAPACITANCE METER** \* \* \*

Ref: EA March 1982  
This kit uses a CD display/driver module  
Data below. Capable of measuring  
capacitance from 10p to 19.99µF  
It is a must in every workshop or lab.  
Kit includes case.



**BOTH \$59 each**  
**Digital EA2&2 Thermometer**

Ref: EA Feb 1982  
Place the thermometer in your room for  
optional room C in fact to within 0.1 degree C.  
Fantastic resolution on a bright, easy  
to read display. INC CASE



**LOW-COST COLLET-TYPE KNOBS**

Made in England. Quality Economical slide  
go fit to any 3/4" shaft pot with flat fit. Sober  
or Jaycar (col). Dual black finish on body with  
choice of SILVER bright coloured wash-in top.  
Knob body ONLY \$0.50 ea 10+  
\$0.45 ea 10+



**Cap Colors Red, Green, White, Yellow, Gray, Blue and Black**

**PEB EDGE CONNECTORS** - Lowest in Australia  
- Tell us if we're wrong!!!!

S-100 0.156" solder tail gold plated pins QUALITY  
S-44 0.156" solder tail 22 way gold plated pins QUALITY

1.9 \$4.95 10+ \$4.50  
1.9 \$2.95 10+ \$2.50  
1.9 \$2.50 10+ \$1.95  
1.9 \$1.25 10+ \$2.50  
1.9 \$2.00 10+ \$1.50



**Digital Storage CRO Adaptor**

Ref: Feb 1982 EA  
Not only can you record by using an oscilloscope  
CRO but you can also use the features  
of the REALLY expensive oscilloscope!  
Can print digital data  
Includes 1000' digital storage  
CRO 1000' digital storage  
CRO 1000' digital storage  
CRO 1000' digital storage  
CRO 1000' digital storage



**500MHz Digital Frequency Period Meter**

REF: EA Dec '81 - Feb '82  
The best version of this kit in  
Australia is now back in stock. Why settle for an inferior  
kit at the same price as ours?  
500MHz option only \$26 extra  
50MHz Version \$119

**ONLY \$119**

**THE BEST QUALITY OF THIS PROJECT IN AUSTRALIA**

Tilting Ball to suit ONLY \$4.95  
Close choice may appear to be selling this kit for less.  
By your kit level! Features Jaycar features:  
+ Heavy gauge front panel. Pre-wired and  
+ High quality IC sockets produced in AUSTRALIA  
+ Kit manual. High quality printed manual (A5)  
+ High quality components used (500MHz) + Therm  
+ High quality components used (500MHz) + Therm  
+ High quality components used (500MHz) + Therm

**Lyrebird Piano Kit**  
**NEW LOW PRICE \$475**

SAVE \$50!!!!  
we are shipping keyboards and other  
components in bulk due to high demand, we can save average  
\$50!!!!



**NEW LOW PRICE \$475**

**SAVE \$50!!!!**

**EA dual tracking P/S**

EXCLUSIVE!!  
US MADE  
10 TURN 25K  
LINEARITY POT  
Used for greater  
accuracy  
Ref: EA March '82  
\$84.50  
Kit at a reason.



**Function Generator** Ref: EA April 1982

Compare this to the new 500MHz DFM. Low distortion  
generator of sine, square and triangular waveforms. From below 20Hz  
to over 100kHz. Inbuilt 4 digit frequency counter in de base Pico-Tec  
case. Only \$85  
JAYCAR EXCLUSIVE. This 500mhz metal film resistors used for  
stability and it's still only \$85!!!!



**\$770**

**Sub-Woofer Sensation** \*

Free Air Resonance 32Hz  
SPEC'S Diameter 10" (254mm) cast frame • OT= 0.28 • V=300 631  
+ Magnet Assembly 100W (RMS)  
+ Magnet Assembly 100W (RMS)  
+ Magnet Assembly 100W (RMS)  
+ Magnet Assembly 100W (RMS)  
+ Magnet Assembly 100W (RMS)

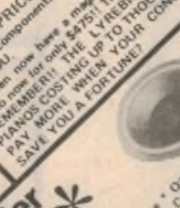

**150W MOSFET AMPLIFIER KIT**

EXCLUSIVE!!! Special  
heavy duty EXTRUDED  
hastelook bracket.  
Ref: ET1 March 1982  
A1 can high power, with the stability and  
constant output of 150W at 75%  
duty cycle. You only need to connect the  
50W transformer and three 600 ohm resistors!  
600 ohm resistors, 100W 5% 200W 5%  
ET1 MODULE ONLY \$79.50  
\$39.50

**Only \$85**

**CUDLIFF CRICKET**

One of the most popular kits ever produced by Jaycar. Cuddlipp chirps  
back to you when you talk. It's all about frustration! Great fun to have in  
the Jaycar kit comes exclusively with 8 great big colourful 2 watt  
carbon resistors that you use as legs.  
Great fun for only  
**\$12.50** \*

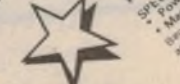

**PRICE FOR THIS UNIT ONLY \$79.50**  
CABINET DESIGN IS PROVIDED WITH  
THIS UNIT. INSTRUCTIONS AND A FULL LIST OF COMPONENTS ARE INCLUDED WITH  
A FULL KIT.

**JAYCAR Pty Ltd**  
showroom  
125 YORK ST.,  
SYDNEY 2000

Phone 264 6688  
Telex AA72293  
mail orders  
**BOX K-39**  
**HAYMARKET**  
**SYDNEY 2000**  
POST & PACKING  
\$5-\$9.99 (\$1.40) \$10-\$24.99 (\$2.40)  
\$25-\$49.99 (\$3.50)  
\$50-\$99.99 (\$4.60)  
\$100 plus (\$6.20)



You'll have a wailing good time with the

# Theremin: a weird music machine

This project is a unique musical instrument called a Theremin. Named after its Russian inventor, Leon Theremin, this device has been popular in science fiction films. It is played without actually touching it, and the sound varies from that of a musical saw to a berserk space invaders machine.

By COLIN DAWSON

To produce weird sound effects and music, the player merely moves his hands about near two capacitor plates. One of these plates controls pitch and the other controls volume. By careful positioning of the hands, the player's body capacitance enables him to play tunes on the Theremin. Most people, however, seem to prefer making science fiction sound effects, for which purpose the Theremin is quite effective.

The range of frequencies which can be produced by the Theremin is virtually the entire audio spectrum. Moving the hand towards the pitch plate will cause the frequency to increase with a sliding

or glissando effect, whilst wavering the hand will produce a vibrato effect. On our prototype Theremin, the hand was usually moved between 0 and 20cm from the pitch plate – but this is largely a matter of adjustment.

The volume control is not as subtle as the pitch control – the hand is effective up to only a few centimetres from the plate. Additionally, the volume control is not as progressive as the pitch control, with the volume changing quite suddenly from low to high. This assists in changing from one note to another without the glissando effect. The maximum volume available from the Theremin is

(mercifully!) limited by the small audio amplifier used. If you thought an inexperienced violin player sounds awkward, wait until you hear an inexperienced Theremin player!

If you should, however, require additional volume, an audio output is available for use with an external amplifier.

The audio frequencies are the result of heterodyning two radio frequency signals to produce a "beat" or difference frequency. Most readers will have heard a similar kind of whistle, produced when an oscillating radio receiver, or one fitted with a BFO (beat frequency oscillator), is tuned across a station.

The two oscillators used to produce the radio frequency signals are set up to oscillate at nominally the same frequency. One oscillator frequency is fixed, but the other is variable by means of the pitch plate which forms part of its circuitry. As a hand is brought near to the pitch plate, the adjustable oscillator changes its frequency. This produces a difference frequency between the two

*EA staff member Colin Dawson demonstrates how the Theremin is played. Below is a close-up view of the completed unit.*













which fits into the zippy box. The other PCB — 82em6b — replaces the aluminium front panel of the zippy box. It has two large pads of copper which serve as the capacitor plates.

The loudspeaker — a miniature 8Ω type — is mounted on PCB 82em6b (191 x 107mm). To avoid the use of mounting hardware, we suggest that you simply glue it in place using a suitable adhesive. If this PCB has not been drilled to allow the sound from the loudspeaker to escape, drill some holes of about 5mm diameter where the speaker will mount. Additionally, drill one small hole in each pad to accommodate the connecting wires.

The copper pads on the front panel would normally become tarnished after repeated contact with the hands. To prevent this, it is advisable to lacquer it. A PCB lacquer or clear varnish would be suitable.

As the project is intended to operate

We estimate that the current cost of components for this project is

**\$30**

This includes sales tax, but does not include the plugpack transformer.

from a plugpack, it will be necessary to install a suitable socket in the zippy box. This is normally a 2.5mm socket for 9V DC plugs. This should mount on the right hand side of the zippy box.

Now mount the components on PCB 82em6a (145 x 103mm). Start with the small unpolarised components — resistors, capacitors and RF chokes. The orientation of the trimmer capacitors and transformer is fixed by their lead configuration. Next mount the zener diode, transistors and the IC. Be careful of the polarity of these semiconductors. Again, with the electrolytic capacitors, watch the polarity.

Connections will have to be made to PCB 82em6a for the power supply, the two capacitor plates, and the loudspeaker. For this purpose, connect six lengths of insulated hook-up wire to the board, then mount the board in the zippy box. On the box we used, the board was simply clipped into position. Other boxes, with vertical slots, will require the use of brass spacers to mount the board. Note also that the PCB may have to be trimmed slightly to fit inside the vertical slot cases.

The connecting wires can now be cut to a suitable length and soldered to their



## “HOW TO TURN ELECTRONIC THEORY INTO PRACTICE AND MAKE IT PAY”..

“If you understand and enjoy radio and electronics and want to extend your knowledge and experience, then we at Stott's can help you.

Stott's have home-study courses for complete beginners in Radio theory and basic Electronics through to the standards needed to maintain and service Colour Television.

Anyone who has these skills at their fingertips can make it pay by turning a fascinating hobby into a lucrative part or full time profession.”

*Athol H. Kelly*

Athol H. Kelly B Com (Hons) AASA FCIS  
Principal, Stott's Technical Correspondence College



**Stotts**  
TECHNICAL CORRESPONDENCE COLLEGE

The name to trust in correspondence education.

Melbourne. 159 Flinders Lane. 3000. Tel. 63 6212  
Sydney. 383 George Street. 2000. Tel. 29 2445  
Brisbane. 290 Adelaide Street. 4000. Tel. 31 1627  
Adelaide. 85 Pine Street. 5000. Tel. 223 3700  
W Perth. 25 Richardson Street. 6005. Tel. 322 5481  
Hobart. 1st F. 29 Argyle Street. 7000. Tel. 34 2399  
Singapore. P.O. Box 3396. Singapore 1

Please send me free, and without obligation, full details of the following courses:

The Stott's range of courses in Electronics is:

- Intro. to Electronics
- Digital Electronics for Technicians/ Servicemen
- Microprocessors
- AM Radio Receivers
- Radio/TV Servicing
- Colour Television
- Radio for Amateurs
- Amateur and Novice Radio Operators Certs
- Electrical Mechanics

A full range of Hobby and Business courses also available.

ALA/ST 1929EA682

\_\_\_\_\_  
(PLEASE PRINT)

MR MRS MISS \_\_\_\_\_ AGE \_\_\_\_\_

ADDRESS \_\_\_\_\_

\_\_\_\_\_  
POSTCODE \_\_\_\_\_

Stott's undertake that no sales counsellor will visit you





# TAX TIME SELLOUT — \$ 'OUCH!' \$

YES! It's that dreaded tax time again and as we're compelled to grace the Treasury Coffers with just about all our ready cash (and some of the banks!) we are liquidating all of these quality products at cost or even below cost — YOU REAP THE BENEFIT!

## VELOSTAT

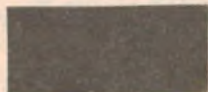

Non-static sheeting for storing CMOS IC's, LSI's etc. 1000 times better than aluminium foil. Will store up to 150 IC's on one 225 x 150mm sheet.

H 0500 ... ~~\$3.50~~ per sheet  
**NOW \$2.00 a sheet — GAD!**

## WEATHERPROOF SIREN HORN

12V DC operated — Deafening Siren Wail. Super handy for audio signalling, security systems etc. Current drain 500MA approx. Completely weatherproof. Attractive off-white PVC finish.



S 5058 ... ~~\$19.50~~ **NOW \$15.00 ea. STRENGTH!**

## MINI BUZZER 5-15V DC



Handy little solid-state audio "Buzzer" or signalling device. Just the shot for communicator panels, or for timer alarms or in the car. Polarity conscious.

S 5062 ... ~~\$1.95~~  
**NOW \$1.00 each**

## PIEZO ALARM

Similar to "Sonalert" type. Absolutely ear piercing sound. Recommended voltage 5-15V DC. Ideal for almost all audio signalling applications, i.e. fire, water and gas signalling, computer alarms, etc.

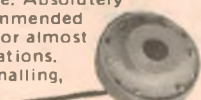

S 5066 ... ~~\$4.95~~ **NOW \$3.00 each HEY!**



## SOLDERING IRON STAND UNIVERSAL TYPE

T 1302 ... ~~\$5.95~~ **NOW \$4.00 GOSH!**

## DIL SWITCH 8 WAY

8 Pole PCB Mount Dil Switch. Quality self wiping contacts.

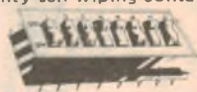

S 3060 ... ~~\$2.00~~ **NOW \$1.50 each FANDAMTASTIC!**

## MIC INSERT ELECTRET

Great little replacement for tape recorders, etc. Handy for hobby projects. Includes data sheet and application circuit. 50 HZ - 15 KHZ



C 0170 ... ~~\$1.95~~ **NOW \$1.00—OUCH!**

*Incredible!*

## UNIVERSAL MULTIMETER PORTABLE WITH BENCH STAND

23 ranges at less than \$1 per range.

\* 20,000 OHMS/Volt DC \* 10,000 OHMS/Volt AC \* Mirror backed scale \* Overload protected \* Unique carry handle doubles as a bench stand \* High-impact resistant case \* Uses 1 AA Penlight batter (incl.) \* Comes complete with battery, test leads and Instructions. RANGES: DC Voltage 0-.25, 1, 2.5, 10, 25, 100, 250, 1000. AC Voltage 0-10, 25, 100, 250, 1000 Decibels 20 to +22db DC Current 0-50, 500 UA, 0-5, 50, 500MA OHM Meter 0-6 megohms in 4 ranges, 30 ohms centre scale. Size 135 x 91 x 39

Q 1002 ... ~~\$22.50~~ 4 or more ... ~~\$21.00~~



A FREE Carry Case Cat. Q 1012 \$3.50 value with every meter purchased from this advert — YES! that's right — yours for the asking.

## MC MURDO ROCKER SWITCH DPDT ILLUMINATED RED

250V Neon lamp inbuilt. Contact rating 250V AC 15A. Panel cutout 27 x 22mm. Positive "snap in" mounting.



S 3240 ... ~~\$2.50~~  
**NOW \$1.25 each**

## LAVALIER (LAPEL)

Superb little microphone. Clips to tie, shirt etc. Ideal for lecturers, religious speakers, stage work etc. Uses 1.5V alkaline manganese LR44 batter (supplied). Includes tie clip.



C 0353 ... ~~\$29.95~~  
**NOW \$20.00 each**

## MINI SPEAKER 57mm

200MW 8 OHM

Large Ferrite Magnet. Ideal replacement speaker. Great for hobby projects.



C 0610 ... ~~\$1.90~~  
**NOW \$1.00**

## FUSE HOLDER 3AG

32 x 6.3mm Fuse



S 6000 ... ~~.95~~  
**NOW .60c**

## FND 500 .5 IN DISPLAY

Z 0190

**NOW .80c**

**\$2 Delivery Australia Wide:** We process your order the day received and despatch via Australia Post. Allow approx. 7 days from day you post order to when you receive goods. Weight limited 10kgs.

**\$4 Delivery Australia Wide:** We process your order day received and despatch via JetService for delivery next day.

Bankcard Holders can phone order up to 8pm (EST) for next day delivery — Sounds incredible doesn't it? Alright you cynics just try us! Weight limit 3.3kgs. JetService cannot deliver to P.O. box numbers (Australia Post would have a fit!)

**ALTRONICS**  
 105 Stirling St. PERTH  
 (09) 328 1599  
 for instant service

**ALL MAIL ORDERS:**  
 BOX 8280 PERTH  
 Stirling St. WA 6000

Dear Customer — Yes all these products are all first quality — and what's more, we're up to the rafters with stock.

## PERSONAL SHOPPERS ONLY

With every store purchase of \$30.00 or more ask for a FREE \$5.00 purchase voucher. This voucher can then be used with any subsequent purchase from ALTRONICS — NOT VALID UNTIL DAY AFTER ISSUE DATE. Sorry not available to mail order customers.

**INCREDIBLE OFFER ON EA's and ETI's  
 JUST \$1.00 EACH TO PERSONAL STORE CUSTOMERS!**

That's right — EA and ETI Magazines are just \$1.00 each to our valued Electronic Enthusiast store customers. We want more Electronic Enthusiasts to buy these great magazines and build the fascinating projects described each month — So as an ALTRONICS customer service to you **WE ARE SELLING THEM FOR AROUND HALF PRICE — JUST \$1.00 EACH**

Limit: 1 of each mag. per customer. Sorry, this offer is not available to Mail Order Customers.



## PARTS LIST

### GENERAL HARDWARE

- 1 plastic utility box, 196 x 113 x 60mm
- 1 printed circuit board, code 82em6a, 145 x 103mm
- 1 printed circuit board, code 82em6b, 191 x 107mm
- 1 1k $\Omega$ : 8 $\Omega$  miniature speaker transformer
- 1 50mm-diameter miniature 8 $\Omega$  loudspeaker
- 4 330 $\mu$ H RF chokes
- 1 2.5mm socket to suit plugpack supply

### SEMICONDUCTORS

- 1 LM3080 operational transconductance amplifier IC
- 7 BC547 NPN transistors
- 1 8.2V zener diode

### CAPACITORS

- 2 1000 $\mu$ F 16VW electrolytics
- 1 100 $\mu$ F 16VW electrolytic
- 5 0.1 $\mu$ F metallised polyester (greencap)
- 1 .082 $\mu$ F greencap
- 10 .01 $\mu$ F greencap
- 1 .0022 $\mu$ F greencap
- 1 470pf ceramic

- 1 270pF ceramic
- 1 27pF ceramic
- 2 4.7pF ceramics
- 2 5-90pF trimmer capacitors

### RESISTORS (1/4W, 5%)

- 1 x 2.2M $\Omega$ , 4 x 560k $\Omega$ , 2 x 220k $\Omega$ , 3 x 150k $\Omega$ , 1 x 100k $\Omega$ , 1 x 47k $\Omega$ , 3 x 33k $\Omega$ , 1 x 22k $\Omega$ , 1 x 10k $\Omega$ , 1 x 6.8k $\Omega$ , 1 x 2.2k $\Omega$ , 2 x 1.2k $\Omega$ , 9 x 1k $\Omega$ , 1 x 470 $\Omega$ , 2 x 100 $\Omega$ , 1 x 27 $\Omega$ .

### MISCELLANEOUS

Hook-up wire, machine screws and nuts, solder, brass spacers, etc.

respective wiring terminals.

The Theremin is now ready for testing. Don't be disappointed if it doesn't work immediately — it will almost certainly need to be tuned. To do this, put your hand on the volume plate, and adjust the pitch trimmer capacitor until a sound is heard. Continue adjusting until the frequency is at minimum. If you can't get any sound at all from the Theremin, try rotating the volume trimmer capacitor through about a quarter turn and then repeating the pitch trimming procedure.

If you are still unable to get any sound out of the instrument, it may be that the tolerance of the 270pF and 470pF capacitors in the pitch oscillators has resulted in the difference signal being too high in frequency. If you suspect that this is the case, try soldering a 50pF capacitor in parallel with the 470pF capacitor connected to Q1. If this does not work, disconnect the 50pF capacitor and connect it in parallel with the 270pF capacitor across Q2. Repeat the tune-up procedure for each case.

When the pitch control is satisfactory, you can adjust the volume control. As the volume control trimmer is rotated (with your hand on the volume plate), you will notice a quite sudden transition from low to maximum volume. Set the trimmer just below the threshold of this transition. Putting your hand on the plate should once again achieve this transition and lifting it off should cause a controllable reduction in volume.

This completes the tuning procedure, but you may find that it takes several readjustments to each of the controls before the Theremin is operating to your satisfaction. As far as we know, there has never been any music written for the Theremin — it is very much a case of "playing by ear". Lest you should decide that it is impossible to play, it is on record that the Theremin performance was given in Lima, Peru, in 1964. 

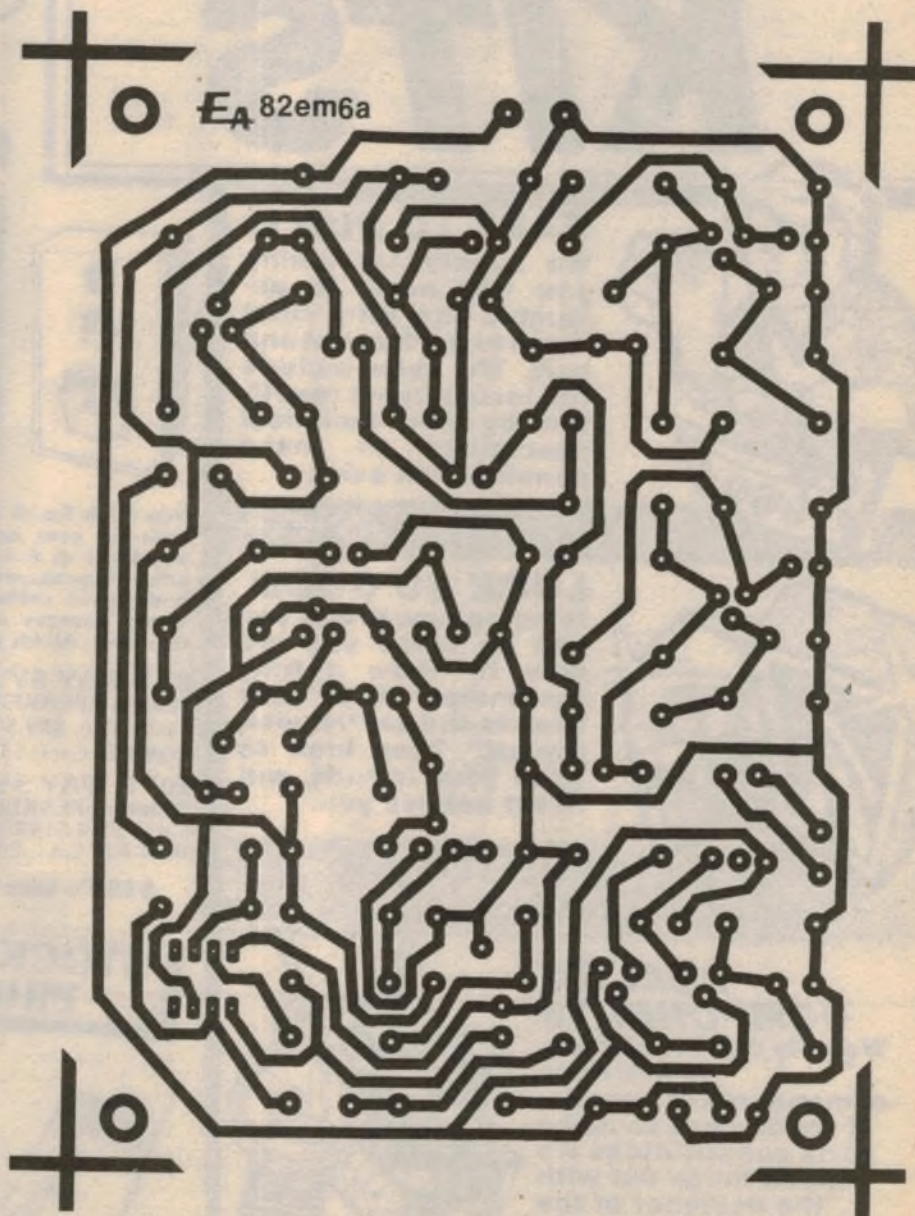

Actual size artwork for the main PCB. Artwork for the capacitance plate PCB has been omitted due to the simple layout and the need to conserve space.



# DICK SMITH KITS

## EASY TO BUILD

We supply everything you will need to assemble the kits, right down to the last nut and bolt. We even include full instructions rewritten by our technical specialists to make construction easy.



## LOOK SO GOOD

Imagine how proud you will be when you are able to show a fully assembled kit to your friends and say 'I built it myself!' They look so good your friends will never believe you.



## QUALITY COMPONENTS

We only use brand new, prime spec components in our kits. If we do have to make parts substitutions we check these out with the designer of the project first before we make the change.



**NEW**

## FUNCTION GENERATOR

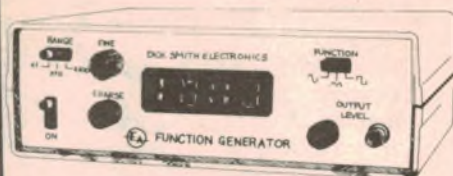

This kit produces sine/triangle and square waves over a frequency range from below 20Hz to over 160KHz! it has four digit LED readout enabling accurate frequency setting. This kit makes an ideal companion for our frequency counter kit (Cat K-3439). The case shown above is optional at extra cost (Cat H-2505 \$19.95).  
Cat K-3520

SEE EA APRIL 82

**\$59<sup>50</sup>**

**SAVE A FORTUNE ON THESE QUALITY SPEAKER KITS!**



*Famous Playmaster*

Now Dick Smith offers you these superb speaker kits just right for your needs. All are manufactured to exacting standards of E.A. specifications. All kits include 3 magnificent speakers (woofer, mid-range and tweeter), superbly re-designed cabinets to suit any decor, full instructions, wiring harness with clip on connections (no soldering required). All kit prices are per pair.

### 8" 3 WAY SYSTEM

200mm SPEAKER KIT

Cat C-2046 \$89.50

BOX KIT Cat C-2626 \$82.00

### 10" 3 WAY SYSTEM

250mm SPEAKER KIT

Cat C-2044 \$149.00

BOX KIT Cat C-2624 \$99.00

ONLY \$ **171<sup>50</sup>**

ONLY \$ **248**

\$100's less than equivalent pre-built units!

**STOCKS LIMITED AT THIS PRICE - SO HURRY!!**

## SOUND LEVEL METER

This unit will measure noise in its many forms. Measures levels of less than 20dB to levels greater than 120dB with fast or slow response times. A large VU meter gives easy readings and the meter range is selectable in 9 steps. The kit is mounted in a zippy box and is battery powered.  
Cat K-3476



ONLY \$ **35<sup>50</sup>**





**NEW**

**PERCUSSION SYNTHESIZER**

Now we've got rhythm with this percussion synthesizer. Produces the sounds of drums, cymbals, snares and bongos. You can play manually or by total electronic control. By the simple connection of a sequencer you can have automatic rhythm, just right for learning the basics of timing in music.  
Cat K-3517

**ONLY \$47<sup>50</sup>**



**NEW**

FOR FAMILY FUN  
REDISCOVER THE CRYSTAL  
SET WITH THE

**DICK SMITH  
CRYSTAL SET**

- ★ No batteries
- ★ Surprisingly good sound
- ★ Foolproof circuits

A most satisfying project that will give you lots of satisfaction. It can pull in a surprising number of broadcast stations and produce good sound when connected to a stereo system. AND it even works during a blackout!  
Cat K-2650

**ONLY \$6<sup>90</sup>**

SEE EA APRIL 82



Cat. K-3518

**PERCUSSION SEQUENCER**

Look at this great new kit!  
Single PCB kit enables percussion synthesizer (Cat. K-3517 above) to be controlled externally by this rhythm generator, and it does it automatically! You could start your own band! Also useful for taping and dubbing.

**ONLY \$12<sup>50</sup>**

**BUILD IT YOURSELF  
FOR UNDER \$100!**

**The Dick Smith  
Professional Frequency  
Counter**

\*500MHz, 7 digit resolution \*with optional pre scaler  
A completely new frequency & period counter using the latest IC technology. The low component count makes it a very reliable and easy to build unit. It will measure frequency to 500MHz (with optional pre scaler) and period both with a 7 digit resolution.  
Features include: ★ Professional design and finish - use high quality instrument case ★ Easy to build with virtually all wiring on PCB's ★ High accuracy ★ All switches are integral to the display board and front panel. Based on E.A. design Dec 81 issue  
Cat K-3439

**\$99<sup>50</sup>**

**PRE SCALER**

Convert your Cat K-3439 Frequency Counter to 10-500 MHz with this optional pre-scaler. It's a must for just

**\$29.95**

with exclusive  
**DICK SMITH**  
simplified circuit  
board wiring, step  
-by-step  
instructions &  
quality pre-  
punched & printed  
front panel

**150 WATT MOSFET PUBLIC ADDRESS/GUITAR AMPLIFIER** Cat. K-3525

Guitar and public address amplifier utilising ETI's 499 Mosfet 150 watt power amplifier module as published in ETI March, 1982.

Comes complete with pre-amp PCB and special Hitachi mosfets 2SJ49 and 2SK134. Also includes on board power supply, just add transformer (PF4361/1 Cat. M-0153).

**Short Form Kit —  
case and transformer  
not supplied**

**ONLY**

**\$119**

**Transformer to suit \$52<sup>50</sup>  
Cat. M-0153**



**HOT CANARY**

This great gimmick kit will keep any child, or adult, amused for hours. An electronic bird noise maker that sounds just like a real bird! Cat K-3395

**ONLY**

**\$15<sup>50</sup>**

**PROTECT YOUR  
LIFE &  
EQUIPMENT  
CORE BALANCE RELAY**



This could save your life and protect your equipment. The Core Balance Relay electronically detects fault currents and trips a relay which cuts the power. The relay cannot be reset until the fault has been corrected. Portable unit moulded into a tough plastic case and runs off 240V.  
Cat K-3315

**\$52**

**Multi-function Timer Stopwatch**

Use as a stopwatch, countdown timer or 'event timer'. Selectable timing rates between 0.01 and 1.0 seconds make this ideal for sporting events, darkrooms etc. Wiring for the unit for any of seven different functions is possible.  
Cat K-3435



**ONLY \$39<sup>50</sup>**

**YOU COULD WIN  
A MILLION!**

**LOTTO/POOLS  
SELECTOR**

Push button, with large LED display makes it easy. Supplied with an attractive front label. Good luck!  
Cat K-3392



**\$19<sup>95</sup>**

**LEDS AND LADDERS**

Based on the old 'Snakes and Ladders' game, we've replaced snakes with LEDs! This kit has been updated with new circuitry and simplified controls so the whole family can enjoy playing. Complete kit includes front panel sticker and zippy box  
Cat K-3390



**ONLY \$16<sup>50</sup>**



**DICK SMITH  
Electronics**



SEE PAGE 27 FOR ADDRESS DETAILS



DSE/A283/LM



## Build an RS-232C cassette interface

Audio cassette recorders are used extensively for recording data from hobby computers, but the various data formats and interfaces are not usually compatible with each other. This article describes a simple cassette recorder interface using the RS232C standard and which can be used with a wide variety of equipment.

by G. KOKINAKIS\*

Although audio cassette recorders for storing digital information are commonplace in the personal computer field, they rarely conform to the RS232C standard and usually handle serial data at a rate of 300 baud. Handling data at 1200 baud means that the tasks of recording and reproducing programs, data files or other serial data can be accomplished in one quarter of the time.

A recorder provided with an RS232C interface is also highly versatile. Data stored on such a recorder by one type of equipment can be read by different types of equipment so you are no longer restricted to exchanging tapes with owners of the same type of computer. The only hardware they must have in common are a serial data port with an RS232C interface and the ability to operate at the same baud rate.

For instance you may have a computer capable of driving a particular high quality but expensive printer through its RS232C interface. You also happen to know someone with that particular printer. If you require a printout all you

have to do is connect your cassette recorder in place of the printer and execute the program as you would with a printer. You can then transport the cassette recorder to the printer to obtain your printout.

As another example, suppose you want to transmit data generated by your program but the data communications equipment is not available. Run your program and save the data to be transmitted on cassette. When the data communications equipment becomes available you can accomplish the task by transmitting the data from the cassette recorder.

Invariably, equipment with an RS232C interface uses a UART or a USART to convert parallel data to serial and vice versa. In the receive mode, these devices sample serial data in the middle of the bit so that small non-accumulative time errors are ignored. This is what makes this low cost 1200 baud digital recorder possible.

The basic objectives of this project were minimum component cost, simplicity and component availability. Originally FSK modulation was considered in conjunction with a phase locked loop demodulator but the idea was abandoned in favour of the present

100% amplitude modulation scheme, despite its inferior noise immunity, because of its simplicity.

### The modulator

The modulator is extremely simple, and uses a Schmitt trigger 2-input NAND gate (1Cb) as a gated oscillator. There are two points to be noted in this section of the circuit. First – and most important in this application – it provides some form of synchronisation, in that the positive transitions of the digital waveform input and the first transition of the carrier it generates are coincident. The second point is that D1 and the 120Ω resistor have been added to improve the symmetry of the carrier waveform.

The waveforms and timing of the modulator are shown in Fig. 1. The lack of synchronisation on the negative transitions of the input may cause a timing error during reproduction which is proportional to the carrier period. Therefore the higher the carrier frequency the less the error.

The carrier frequency is 6.1kHz, the highest that the recorder used in this project could handle efficiently. A prototype operating at 7.5kHz in conjunction with a high quality recorder was



Fig. 1 MODULATOR WAVE-FORMS

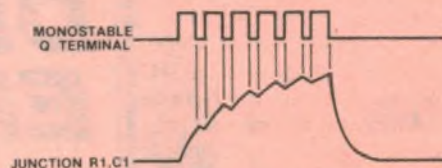

Fig. 2 DEMODULATOR WAVE-FORMS

\* Mr Kokinakis is a freelance digital electronics engineer. His address is PO Box 833, Chatswood, NSW 2067.



capable of handling 2400 baud. The output of the modulator is conditioned for the particular recorder used in this project, but it can be conditioned to feed the recorder of your choice.

The read-write switch at the modulator input disables the carrier while reading to avoid possible interference with the incoming low level carrier from the tape recorder.

### The demodulator

The signal from the tape recorder is amplified by IC1a and IC1b, part of an LM3900 quad op amp. The value of the input coupling capacitor (.0022 $\mu$ F) was determined experimentally so as to filter out the low frequency noise inherent in DC biased tape recorders. Amplifiers IC1a and IC1b are DC offset so that only the negative portion of the input signal is amplified, thus excluding the noise present when the carrier is zero. The output of IC1b is fed to the trigger input of the monostable IC2, which has a pulse width of more than half the period of the carrier. An integrating network is connected to the Q output (pin 6) of the monostable. Waveforms relating to this part of the circuit are shown in Fig. 2.

The operation of this circuit relies on the fact that the capacitor charging time is longer than the discharging time, therefore the net result is a positive charge. This is amplified by IC1c and IC1d and converted to TTL levels by a Schmitt trigger NAND gate (IC3a). An additional gate (IC3c) restores the correct logical sense.

Amplifier IC1c has an offset adjustment which is used to set the correct timing relationship of the reproduced digital waveform. This demodulator has the advantage that the loss of a single carrier cycle per data bit does not generate an error. The use of an AGC circuit was considered unnecessary, as with the present amplifier gain the input signal amplitude may vary by as much as 80% without an error being generated.

### The tape recorder

A Philips cassette recorder, model N2238, was used with the prototype interface, but the circuit can be adapted to serve with any other audio tape recorder with good high frequency response. The Philips machine was selected because it is low priced and readily available. It is a very simple DC bias, DC erase machine and therefore provides a good test of the recording technique.

There are also a couple of other advantages: the recorder has an inbuilt AC power supply and is fitted for remote control. In addition, the connectors provided include a DIN socket, and there is a tape counter, a very useful feature for locating the beginning of individual recordings.

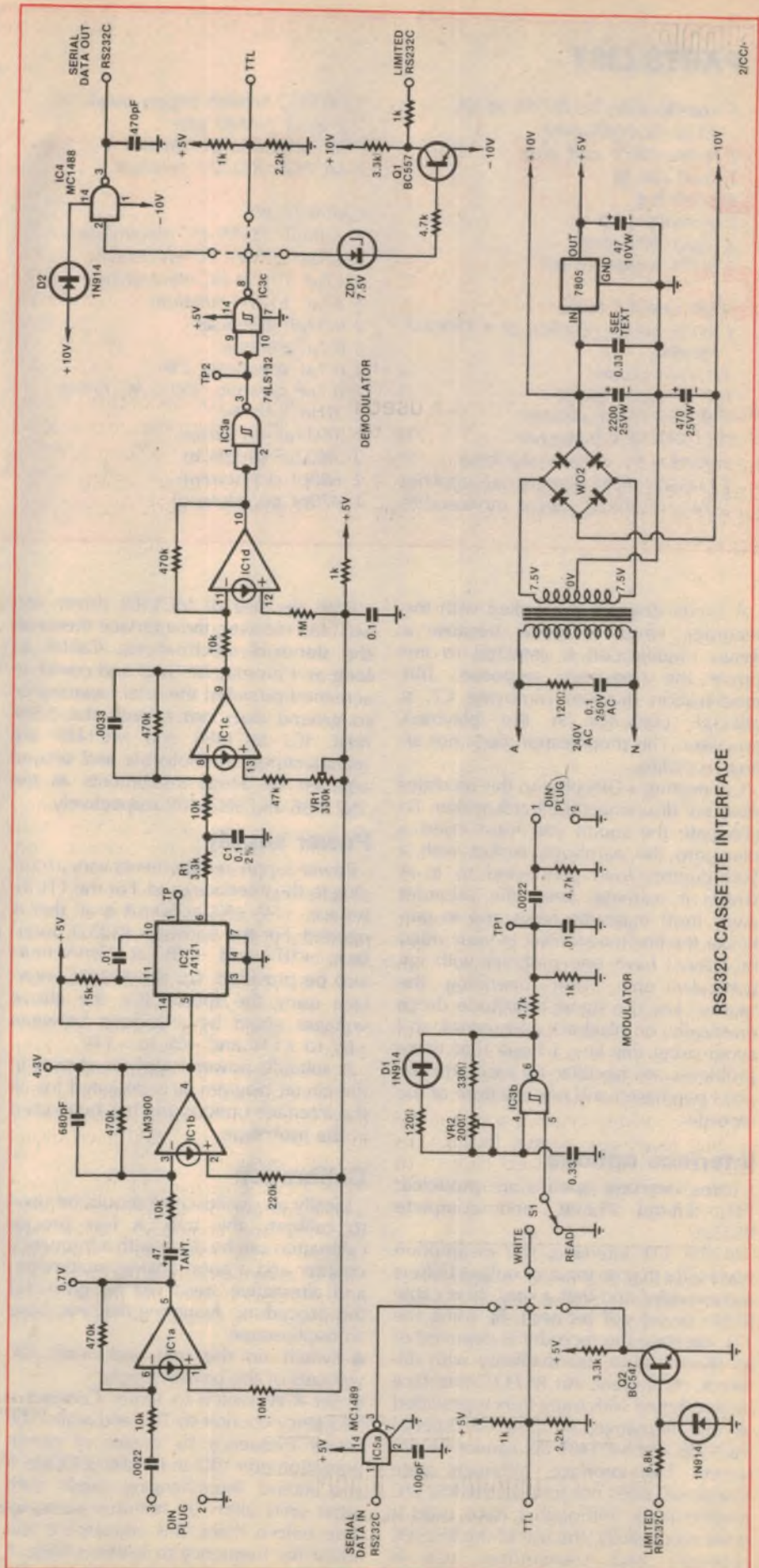



## PARTS LIST

1 transformer, 7.5-0-7.5V at 1A,  
2155 or equivalent  
1 mains cable and plug  
1 cord clamp  
1 earth lug  
1 terminal strip  
2 3-pin DIN plugs  
1 SPDT toggle switch

### SEMICONDUCTORS

1 WO2 bridge rectifier, or 4 1N4002 diodes  
3 1N914 diodes  
1 7.5V zener diode  
1 BC557 PNP transistor  
1 BC547 NPN transistor  
1 7805 +5V voltage regulator  
1 LM3900 quad operational amplifier  
1 74121 Schmitt trigger monostable

1 74LS132 Schmitt trigger quad  
2-input NAND gate  
1 MC1488 RS232C driver  
1 MC1489 RS232C receiver

### CAPACITORS

1 2200 $\mu$ F 25VW PC electrolytic  
1 470 $\mu$ F 25VW PC electrolytic  
1 47 $\mu$ F 10VW PC electrolytic  
1 47 $\mu$ F 10VW tantalum  
2 0.33 $\mu$ F greencap  
5 0.1 $\mu$ F ceramic  
1 0.1 $\mu$ F greencap, 2%  
1 0.1 $\mu$ F ceramic, 250V AC rating  
2 .01 $\mu$ F ceramic  
1 .0033 $\mu$ F greencap  
2 .0022 $\mu$ F greencap  
1 680pF polystyrene  
1 470pF polystyrene

1 100pF polystyrene

### RESISTORS

( $\frac{1}{4}$ W 5% unless otherwise specified)  
1 x 10M $\Omega$ , 1 x 1M $\Omega$ , 4 x 470k $\Omega$ , 1 x 220k $\Omega$ , 1 x 47k $\Omega$ , 1 x 15k $\Omega$ , 4 x 10k $\Omega$ , 1 x 6.8k $\Omega$ , 3 x 4.7k $\Omega$ , 3 x 3.3k $\Omega$ , 2 x 2.2k $\Omega$ , 5 x 1k $\Omega$ , 1 x 330 $\Omega$ , 1 x 120 $\Omega$ , 1 x 120 $\Omega$ 1W, 1 x 330k $\Omega$  trimpot, 1 x 200 $\Omega$  trimpot

### MISCELLANEOUS

Stripboard, hook-up wire, 2-wire cable, machine screws and nuts, case, etc.

Note: the parts list includes components for all interface sections of the circuit. Some parts may be omitted depending on which interface(s) are required.

A circuit diagram is supplied with the recorder, which is handy because a minor modification is required to improve the frequency response. This modification involves removing C7, a .0033 $\mu$ F capacitor in the playback equaliser. This modification does not affect recording.

Connecting a DIN plug to this recorder does not disconnect the loudspeaker. To eliminate the sound you must insert a plug into the earphone socket with a 10 $\Omega$  dummy load connected to it. A word of warning: keep the recorder away from magnetic fields and in particular the line transformer of your video monitor. I have one problem with my particular unit. After operating the "pause" key the signal amplitude drops drastically, on playback and record, so I avoid using this key. I hope that these problems are peculiar to the particular unit I purchased and not a feature of the recorder.

### Interface options

Three interface options are provided: TTL, limited RS232C and complete RS232C.

In the TTL interface, the assumption was made that no input or output buffers are provided and that a very short cable (0.5m or so) will be used. By using the TTL interface the recorder is deprived of its main feature, compatibility with different computers. An RS232C interface implemented with transistors is provided as an alternative, in case the special MC1488 and MC1489 ICs cannot be obtained. This interface, although quite functional, does not fulfil all the RS232C requirements. Although I have used it quite successfully, the use of the RS232C receiver and transmitter ICs is recommended.

With the use of MC1488 driver and MC1489 receiver, the interface meets all the standard specifications. Cables as long as 15m may be used and could be screened provided the total capacitance to ground does not exceed the 2.5nF limit. ICs MC1488 and MC1489 are manufactured by Motorola and second sourced by Texas Instruments as the SN75188 and SN75189 respectively.

### Power supply

Power supply requirements vary according to the interface used. For the TTL interface, +5V  $\pm$ 5% at 50mA is all that is needed. For the transistor RS232C interface, +10V and -10V at 20mA must also be provided. For the RS232C interface using the special ICs, the above voltages could be anywhere between +8V to +14V and -8V to -14V.

A suitable power supply is shown in the circuit diagram. It is designed for all the interface options and has been used in the prototype.

### Calibration

Ideally an oscilloscope should be used to calibrate this unit. A less precise calibration can be done with a frequency counter and a good analog multimeter, and alternative steps will be given for this procedure. Assuming that you have an oscilloscope:

- Switch on the unit and verify DC voltages of the power supply;
- Set R/W switch to write. Connect a frequency counter to TP1 and adjust the carrier frequency by means of preset potentiometer VR2 to 6.1kHz  $\pm$ 100Hz. If you intend interchanging tapes with other units allow 30 minutes warm up time before doing this adjustment and adjust the frequency to within  $\pm$ 50Hz. If a frequency counter is not available, the

oscilloscope timebase may be used to adjust for the correct carrier period, 164 $\mu$ s.

- Insert the DIN plug in the tape recorder. Set the R/W switch to read and record for a few minutes. Play back the tape while monitoring the serial data-out terminal on the oscilloscope. Turn the cassette volume control clockwise until random pulses appear, then turn it counter clockwise until all pulses disappear. Turn the control a few more degrees to secure a good noise margin.
- Supply a 600Hz symmetrical square wave to the serial data-in-terminal, and set the amplitude to levels according to the interface chosen. Most audio generators will provide this signal but if you use the TTL interface, a TTL signal must be applied. (The RS232C signal levels are between -5V and -15V and +5V to +15V).
- Set the R/W switch to write and record for a few minutes.
- Set the R/W switch to read. Replay the tape while monitoring the serial data-out terminal on the oscilloscope. Adjust the preset potentiometer VR1 to obtain a symmetrical waveform. The signal should be stable but if not, turn the volume control slightly counter clockwise to stabilise it. Ignore minor jitter. When in practical use, the volume control setting is not critical, as amplitude changes of more than 80% can be tolerated.

### Calibration without a CRO

- Insert the DIN plug in the tape recorder. Set the R/W switch to read and record for a few minutes. Replay the tape while monitoring the serial out point with an analog voltmeter. Turn the volume control clockwise until random

*Continued on p131*



# SBC THE NEW 800

Z80 \$100 SINGLE BOARD COMPUTER

The SBC-800 is a \$100 Z80 Single Board Computer with dual serial ports, Real time clock, on board Ram & Eprom, for use as the main CPU card in a Microcomputer.

The SBC-800, a very powerful Single Board Computer, provides all of the necessary facilities needed for a standalone processor.

The heart of the board is a Z-80 Microprocessor. Running at 4 Mhz, the processor communicates with all of the SME Systems range of boards. The board includes a CTC counter timer, for generating the baud rates for the 2 serial ports on board, as well as 2 vector interrupt driven channels for off board interrupt processing, or on board timing functions.

Serial I/O consists of a DART which provides 2 serial

ports which may be modems, terminals or printers. Each one of these serial ports operates independently of the other.

Parallel I/O consists of a pair of 8255, Programmable Peripheral Interfaces. The first of these devices provides all the I/O lines necessary to talk with the Centronics Port, as well as the on board Real Time Clock. The second device, provides up to 22 general purpose I/O lines which can be programmed in a number of different modes of operation.

The board also provides four 24 pin sockets for installing up to 16 Kbytes of Eprom, using 2732 devices, or 8 Kbytes of Eprom, using 2716 devices. The sockets have provision for installing 2 Kbytes of ram in up to 3 sockets, to provide 6 Kbytes of Static Ram in lieu of Eprom.

An on board, rechargeable battery, provides power for the Real Time Clock, as well as the CMOS static memory which has been fitted to the board

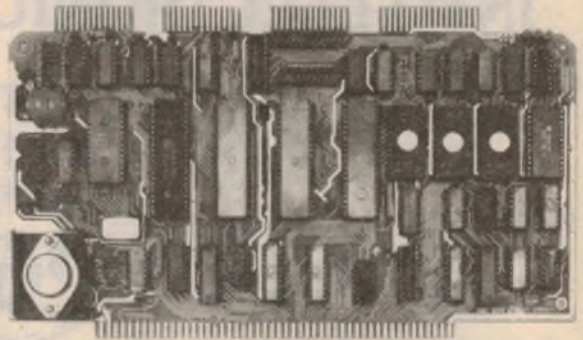

## FEATURES

- \$100 Bus Compatible (IEEE 696)
- Z-80 Microprocessor running at 4 Mhz.
- Two Serial RS232 Communication Ports.
- Software programmable Baud rate generator.
- Parallel Centronics Printer Port.
- 22 Programmable, General Purpose I/O Lines
- Real Time Clock, Battery backed.
- 2K CMOS ram standard, 6K option.
- Provision for up to 12K EPROM on board.
- Standby Rechargeable Battery on card.
- Power on Reset/Power Fail detect.
- Power on Jump to Monitor/Bios.
- On board memory disable.

# SBC 400

The SBC-400 is a low cost CPU card for use in a system where the power of the SME Systems SBC-800 Single Board Computer is not required.

SBC-400 price reduced from \$465 to \$395.

**SME**  
SYSTEMS  
S. M. ELECTRONICS

22 Queen Street,  
Mitcham, Australia. 3132 Phone (03) 874 3666 Telex AA 37213



# TWICE THE FUN!

WITH  
DICK SMITH

## FUN WAY INTO ELECTRONICS

**Vol 1** For the absolute beginner, this book is a must 20 exciting projects - all built without the need to solder. The unique "breadboard" method of construction enables you to follow the circuit via the wires, and because every project is battery powered, they are perfectly safe! Learn electronics the FUN WAY! Cat. B-2600

**Vol 2** We now have this superb book in stock again. Packed with 20 exciting projects to build (see Kit list below) this book provides fun AND education! From printed circuit boards to using a multimeter, it's all there - and it's fun. Cat. B-2605

\$4<sup>95</sup>

\$6<sup>95</sup>

POST AND PACKAGE  
\$1 PER BOOK

# TWICE THE VALUE!

BOOKS  
& KIT PACKS

### FUN WAY VOL. 1 VALUE PACK

An easy to follow system of learning basic electronics. 20 exciting projects for you to build ranging from a beer powered radio to an electronic siren. Completely safe, no need to solder, suitable for all ages. Hours of fun building educational projects. Find out what electronics is all about - the easy way! Cat. K-2615

ONLY  
**\$17<sup>95</sup>**

### FUN WAY VOL. 2 GIFT PACK WITH SOLDERING IRON

Fantastic savings! Over \$25 value! Everything you need to build an actual working project, including a hobbyist soldering iron and pack of solder, a 9 volt battery, a copy of 'Fun Way Vol. 2' and a Wireless Microphone Kit. The 'Fun Way Vol. 2 Gift Pack' makes electronics fun, easy, and now, economical. Cat. K-2620

ALL FOR  
**\$19<sup>95</sup>**

## FUN WAY TWO KITS: EASY, SAFE & ECONOMICAL!

#### MULTI-PURPOSE LED FLASHER . . . . \$2.95

A really simple kit that can be used as a warning device, electronic jewellery, etc. Cat. K-2621

#### DING DONG DOORBELL \$4.50

Welcome visitors to your home with this integrated circuit doorbell! Cat. K-2622

#### MORSE CODE TRAINER \$4.50

This simple oscillator circuit lets you learn Morse code the easy way! Cat. K-2623

#### UNIVERSAL TIMER . . . . \$5.50

Use it as an egg timer, a dark-room timer, etc. in fact, it's got a lot of applications! Cat. K-2624

#### ELECTRONIC DICE . . . . \$4.95

Throwing a dice is old hat: do it electronically! Simple circuit has other uses too. Cat. K-2625

#### MONOPHONIC ORGAN \$7.95

Easy to build, and easy to play! And it even has 'vibrato' - just like the big ones! Cat. K-2626

#### POCKET TRANSISTOR RADIO . . . . \$7.95

Simple to build, and it's nice and small! Listening is so much more fun! Cat. K-2627

#### TOUCH SWITCH . . . . \$5.50

One touch on, next touch off - or 'on while touched'. Dozens of uses in the home. Cat. K-2628

#### MOSQUITO REPELLER \$4.95

Don't get eaten by mozzies scare them away electronically. Take it anywhere. Cat. K-2629

#### SIMPLE AMPLIFIER \$6.50

A useful little amplifier for all those projects needing audio amplification. Cat. K-2630

#### WIRELESS MIC. . . . \$6.50

A tiny transmitter that can be received on any FM receiver. A great little kit! Cat. K-2631

#### LIGHT ACTIVATED SWITCH \$5.50

Highly useful for alarms, night light switches, etc. etc. Sensitive and reliable. Cat. K-2632

#### METAL/PIPE LOCATOR \$8.50

A simple BFO circuit you can use to find metals, pipes, wiring, etc - maybe gold! Cat. K-2633

#### SOUND ACTIVATED SWITCH \$8.95

Picks up sound waves and trips a relay. Use as a telephone bell extender, too. Cat. K-2634

#### HOME/CAR BURGLAR ALARM \$8.50

Learn how burglar alarms work when you install your own! For home or car. Cat. K-2635

#### ELECTRONIC SIREN \$4.95

Great for alarm use - or where any warning is required. Good for kids toys, too! Cat. K-2636

#### LED LEVEL DISPLAY \$8.95

This fascinating project shows you the audio level of any amplifier. Cat. K-2637

#### INTERCOM UNIT \$8.95

Communicate! Build this intercom and talk between rooms, etc. Cat. K-2638

#### LED COUNTER MODULE \$7.95

Learn how digital circuits work by building a counter. Count slot car laps, etc. Cat. K-2639

#### SHORTWAVE RECEIVER \$8.95

Listen in to the exciting world of shortwave radio, amateurs, foreign countries! Cat. K-2640

**SCHOOLS, RE-SELLERS, ETC.:**  
We'll negotiate a special price for bulk quantities on either books or kits, or both!

# DICK SMITH ELECTRONICS



DSE  
A170M  
LM

SEE PAGE 27 FOR ADDRESS DETAILS





# Letters to the editor

## WORP-9 word processing package

Many thanks to EA and reviewer Peter Vernon for the favourable review of our "WORP-9" word processing package, published in your March issue. However there are a couple of points I would like to clarify.

On page 118, Peter says that Dick Smith Electronics recommends that for serious use with WORP-9, the user should add "a second 16K memory board" to the expansion interface, to give a total of 48K of RAM. Well, we do recommend that people expand their system to the full 48K of RAM, but they don't need to buy a second memory board to do this.

Assuming they are using the X-4010 Expansion Unit with X-4016 RAM card, all they need to do is buy one of our X-1186 RAM Upgrade Kits (\$29.95), and drop the eight memory chips into the vacant row of sockets on the X-4016 board. The newer X-4020 Expansion Unit is expanded in virtually the same way.

The other point is that WORP-9 has an important "hidden" feature. Whenever it is "booted up" (ie loaded in from the disk and set running), it automatically checks to see if there is any text in its memory buffer. If there is, it gives you the option of either using the text, or "erasing" it.

This is important if the computer is reset by a random mains transient before you have either printed the text out or saved it on disk. The word processor normally re-boots, re-initialises all its pointers, and consequently "forgets" all

about your text. This is so frustrating, because you know the text is still there, but there's no easy way of recovering it! WORP-9 protects against this mains-spike amnesia!

Jim Rowe, Technical Director,  
Dick Smith Electronics.

## Airplane mix-up

As an aviation buff, I must compliment you on Bill Sweetman's article: "Are Automatic Airliners Ready To Take Off?" (EA Feb, 1982). This article was most informative and was obviously well researched.

I feel, though, that I must bring to your attention the fact that the "Boeing 767" pictured on page 17 is, in fact, an Airbus A-300B!

Thank you for a great article.  
Mike Comiskey,  
Mansfield, Qld.

**COMMENT: You're right of course. We didn't discover the error until after we had received the first printed copies of the issue.**

## 500MHz DFM — beware of live chassis TVs!

In the February 1982 edition of "Electronics Australia" there is described the calibration, troubleshooting etc of the 500MHz Frequency Meter.

The calibration technique described is fair enough, but I must comment on the

very real dangers that could be present:

- Some colour TV chassis are either live or at least at "half mains potential" — connection of the counter earth lead to the chassis of the TV will result in the instant destruction of power supply diodes, fuses, choppers etc;

- Perhaps more important is the danger that the person attempting calibration will get between "earth and chassis" — disaster!

Since your magazine is read by many inexperienced people, a word of warning should have been sounded at the start of the calibration section.

Thank you for an excellent magazine.

B. E. Baynes, Senior Teacher,  
Radio, Television & Industrial  
Electronics,  
Hobart Technical College.

**COMMENT: Thank you for your letter. Readers who have built the 500MHz Frequency Meter should take note.**

## February front cover

My congratulations to the staff involved in the concept and artwork in your January 1982 front cover.

The resemblance to your Editor-in-Chief was not lost on astute readers. The likeness was clearly the work of one who had long worked and trembled under the awesome gaze of one whose thunder and lightning might be invoked by the least slip of a transistor or reversal of a non-critical diode.

At first I felt the cover was a cry for help from some poor mortal Electronics Engineer — no doubt chained to an oscilloscope by a master who could blow terror through an office of straw, sticks or even bricks and mortar (if you grasp the classical allusion).

But, because the artist had removed those heavy reading glasses, I perceived beneath those Menzies eyebrows the kindly eyes of one on whose stability rests Australia's only real time-proven electronics magazine.

B. B. Wolfe.

Croydon, NSW.

## GET THE MOST OUT OF YOUR VIC WITH . . .

ONLY  
VIC20 \$399

Stack 27K Memory Board (for 32K VIC) . . . . .	\$330.00
Memory Battery Support . . . \$45.00	Light Pen . . . . . 55.00
Game Port Multiplexer . . . . . 69.00	Joysticks . . . . . 35.00

### Over 100 programs for your VIC from \$12.00

Some of the \$12.00 programs are: Avengers, City Bombers, Alien Blitz, Vicalc, Tank Wars, Victrek, 3D Invaders, Satellites Meteorites, Astro Transporter, Typing Trainer

Write or call in for a complete list of software & accessories

OPEN SATURDAY

**EDIBLE ELECTRONICS** 50 PARK STREET, ABBOTSFORD, 3067.  
PHONE: (03) 41 5708.







# Books & Literature

## Home Security

**ELECTRONIC PROJECTS FOR HOME SECURITY**, By Owen Bishop, Published by (Newnes) Butterworths Pty Ltd, 271-273 Lane Cove Road, North Ryde 2113. Soft covers 136mm x 217mm 92 pages. Numerous line illustrations and photographs. \$8.95

In these times more and more people are finding it necessary to install some form of intruder deterrent either passive, or active in the form of alarms, such as described in the 12 chapters of this book. The Author assumes a reasonable electronic knowledge on the part of any would be constructor as he takes us through a discussion on various types of detectors, alarms, fire detectors, infrared, gas and light operated devices plus exit timers and timers to operate lights, radio etc to give a dwelling a lived in look.

All the circuits are given layouts on "Vero" board to simplify construction, together with the circuit diagram, some of the more complex have either a photograph or line drawing to clarify the mechanical construction. Most of the components should be readily available on the local market, so construction should not provide any major problems.

I would query the power supply circuit given in chapter 12, where the main filter capacitor is placed after the series regulator transistor and the Zener diode in the base circuit of the transistor is fed straight from the output of the rectifier without any filtering.

This would tend to make the 2N3055 ineffective in coping with the ripple in the base circuit as well as the ripple current in the filter capacitor.

Apart from this comment this appears to be a useful publication for anyone seeking to protect his home at a reasonable cost. (N.J.M.)

## Z80 Computer Construction

**BUILD YOUR OWN Z80 COMPUTER: By Steve Ciarcia**, Soft covers, 322 pages, 215 x 275mm, illustrated with diagrams and charts. Published by Byte Books, McGraw Hill Inc 1981. Price \$22.05.

Steve Ciarcia will be familiar to readers of the US "Byte" magazine as the author

of those entertaining and informative constructional articles which open each month's issue. This book is based on those articles, a series dealing with the Z80 microprocessor, construction of peripheral ports and D/A conversion. The articles have been tidied up and linked together to create what must be one of the best books around for the home constructor of computers.

In the nine chapters and five appendices the author covers the design and construction of a Z80-based computer system offering 2K of RAM and 2K of EPROM, extensive input/output circuits and ultimate expansion to a keyboard and video terminal. On the way he covers some of the theory of power supply design, microprocessor fundamentals, construction techniques and operating system software.

The book opens with a chapter on power supply design. Unlike other books which provide only circuits, this book explores the considerations involved in designing a power supply, choosing transformers, regulators and filter capacitors by formula to suit the desired parameters of the supply. Although the chapter describes the construction of a supply for the US 120VAC mains, this theoretical treatment allows the reader to easily adapt the design for 240V supplies.

The section on microprocessor basics is clear and easy to understand, without being heavy going, before the book moves into the actual design and construction details. Many of the circuits given in the book will be valuable to anyone interested in computers, even if they have no plans to follow this particular design. Circuits for I/O ports, memory decoding etc are presented and explained, with alternative approaches given in many cases that can be applied to almost any digital construction project.

Also unlike many constructional books that have appeared recently, this one goes beyond the basics, although the bare-bones project is well chosen as a starting point. From a hexadecimal keyboard and seven-segment LED displays, full instructions are given for expanding the project to an alphanumeric

keyboard and CRT terminal. In addition details of construction and connection of digital to analog and analog to digital converters are given, so that the basic computer can be used in real applications.

This section of the book includes a novel approach to using digital to analog converters to digitise speech waveforms which can then be stored in memory and read back through an analog to digital converter to reproduce speech quite intelligibly. Full details of hardware and software are provided.

Equally valuable is the chapter on Monitor software, which covers programming an EPROM (Erasable Programmable Read Only Memory) as well as the software and the rationale behind each function offered. This software is intended to be used in conjunction with the "single-stepping" circuits of the book so that the user can fully grasp the principles of microprocessor operations.

Appendices cover construction techniques, including wire-wrapping, provide specification sheets for every major component used, list ASCII codes and the full contents of the EPROM Monitor program and give detailed specifications of the Z80 CPU.

Although we thought the book to be somewhat pricey for a soft cover publication, examination has shown its value. "Build your own Z80 Computer" is well worth looking at, either if you are thinking of building a computer or adding to an existing system or are simply curious about how microprocessor systems work. A very good book.

Our review copy came from Technical Book and Magazine Co Pty Ltd, 289-299 Swanston Street, Melbourne, Vic 3000. (PV).

## Digital Communications

**DIGITAL PROCESSING OF SIGNALS IN COMMUNICATIONS. IERE Conference Proceedings No. 49.** Soft covers, 531 pages, 207 x 299mm, illustrated. Price £39.00.

This book contains the complete proceedings of the International Conference on the above subject held in London between April 1-7, 1981. Forty-five papers were presented in all, in five sessions which covered the following subject categories: Digital Filters, Pre-Processing Techniques, Modem Techniques, Adaptive and General Techniques, and Digital Speech.

Altogether this is a most useful reference on digital techniques. The UK and Overseas price is £39.00 including surface postage. Contact: Publication Sales Controller, Institution of Electronics and Radio Engineers, 99 Gower St, London UK WC1E 6AZ.



## Facts on the TRS-80 Color Computer

"The Facts" is a detailed guide to the inner workings of the TRS-80 Color Computer. It provides a general description of the machine and separate sections on each of the main components of the system. The Basic interpreter is given in a commented listing, together with details of disk Basic. Full circuit diagrams of the computer are also included — all in all, excellent value.

"The Facts" was written by Tom Rosenbloom and published by Spectral Associates of Tacoma, Washington. Under licence from the original publishers, Greg Wilson (PO Box 504, Potts Point, NSW, 2011) has printed an Australian edition, complete except for (unfortunately) four Motorola data sheets on the main components of the system. It is available for \$10 plus \$1 postage by writing to Greg.

Also available from Greg is "The Rainbow", a monthly magazine published by a group of United States users of the Color Computer. Issues we saw were very well presented and packed with facts and ideas for Color Computer users. Single copies of the magazine cost \$2, and are available from Greg at the address given above.

## Electronic Projects for your car

**ELECTRONIC PROJECTS IN THE CAR.** Martin George. Paper covers, 87 pages, 220mm x 135mm, Photos & line drawings. Published by Butterworths Pty Ltd 271-273 Lane Cove Road, North Ryde 2113

This is one of a number of books from this publisher under the banner of "Newnes Constructors Projects" covering a range of hobby interests involving electronic projects for the home constructor.

There are 15 projects covering alarms, light reminders, wiper delay unit, cassette power supply, tachometer, timing light, electronic ignition and a rather unusual approach to a battery charger, using high frequency pulses to control two silicon controlled rectifiers that make up part of the bridge rectifier. Each article is well illustrated with layout drawings for Vero board, schematic of the circuit and photos of the completed project.

The usual caution would apply: to ascertain supply of all the parts before launching into the construction of a project, a number of which are frequently described in local magazines. For anyone interested in the theory, each project is clearly described as to its operation, together with a setting up procedure. (NJM)

# NEW BOOKS

## NEW — NEW — NEW

Latest editions of some of the most popular books on the subject

World Radio TV Handbook 1982 Edition — order now from our advance shipment Air-freight copies here now	\$21 95
The Radio Amateur's Handbook — APRIL 1982 Edition Just Out! A must for the Radio Amateur and Professional	\$14 95
RSGB Handbook Volume 1	\$21 85
RSGB Handbook Volume 2	\$18 90
Reference Data for Radio Engineers (New Edition) ITT	\$39 95
Australian Amateur Operator's Handbook — Postal & Telecommunications Department	\$3 60

## Computer Books

Creative Computing Vol 3 — Ah1	\$10 75
Digital Counter Handbook — Frenzel	\$14 75
Discovering computers — Giedhill	\$10 95
40 Computer Games from Kilobaud Microcomputing	\$9 55
TRS-80 disk & other Mysteries — Pennington	\$25 15
The Basic Handbook — Lien	\$17 95
Learning Basic Fast — DeRossi	\$13 95
6502 — Software Design — scanlon	\$14 20
TRS-80 BASIC — Self-Teaching Guide — Albrecht, Inman & Samora	\$12 55
TRS-80 Interfacing Book 1 — Titus	\$11 95
Basic Programming Primer — Waite & Pardee	\$12 70
Microcomputer interfacing with the 8255 PPI Chip — Goldsbrough	\$11 95
Musical Applications of Microprocessors — Hal Chamberlin	\$36 00
Digital Troubleshooting — Gasperini	\$16 00

## Adam Osborne Books:

Apple II User's Guide — Poole	\$19 00
Business System Buyer's Guide — Osborne with Cook	\$11 30
Basic User Guide — Osborne	\$19 00
CRT Controller Handbook — Kane	\$9 90
CP/M User Guide — Hogan	\$17 80
Osborne 4 & 8-bit Microprocessor Handbook — Osborne	\$25 00
Osborne 16-bit Microprocessor Handbook — Includes 2900 Chip Slice Family — Osborne	\$25 00
PET/CBM Personal Computer Guide — Osborne	\$19 00
A User Guide to the UNIX System — Thomas	\$20 00
6502 Assembly Language Programming — Leventhal	\$21 30
6800 Assembly Language Programming — Leventhal	\$20 00
8080A-8085 Assembly Language Programming — Leventhal	\$20 00
Introduction to Microcomputers, Osborne Vol 0 — Beginners Book	\$9 55
Vol 1 — Basic Concepts 2nd ed	\$17 80
Vol 2 — Some Real Microprocessors — New Edition, Looseleaf	\$30 00
Vol 3 — Some Real Support Devices — New Edition, Looseleaf	\$16 50
6800 Programming for Logic Design	\$11 40
8080 Programming for Logic Design	\$12 55
Z80 Assembly Language Programming	\$13 80
Z80 Programming for Logic Design	\$11 40

## Byte Books new series on Computers:

Mondeb — An advanced M6800 Monitor Debugger — Peters	\$7 00
Tiny Assembly 6800 Version 3.1 — Emmerichs	\$12 60
K2FDOS — A Floppy Disk operating System for the 8080 — Welles	\$27 60
Ciarcia's Circuit cellar — Ciarcia	\$11 20
Tracer — 6800 Debugging Program — Grappel	\$8 40
Link 68 — an M6800 Linking Loader — Grappel	\$11 20
Byte Book of Computer Music — Morgan	\$13 80
RA6800ML — Relocatable Macro Assembler — Hemenway	\$35 00
Numbers in Theory and Practice — Programming Techniques — Liffick	\$12 55
Byte Book of Pascal — Liffick	\$35 00
Build your own Z80 Computer — Steve Ciarcia	\$22 05

## Sybase Computer Books:

Apple Pascal Games — Hergert & Kalash	\$17 95
Programming the 6502 (Vol 1)	\$17 95
Programming Exercise for the 6502 (Vol 2)	\$17 50
6502 Applications Books (Vol 3)	\$17 50
6502 Games Book (Vol 4)	\$17 50
Basic Programs for Scientists & Engineers	\$19 95
CP/M Handbook (With MP/M)	\$18 95
Don't (or How To Care For Your Computer)	\$15 95

Just a few of the thousands in stock Call in or write Prices subject to fluctuation Correct at time of going to press

If the book you require is not listed below, it can be ordered from us.

Easing into Pascal with UCSD Systems	\$19 95
Fifty Basic Exercises	\$17 50
Fifty Pascal Programs	\$17 95
Inside Basic Games	\$19 95
Introduction to Pascal (Including UCSD Pascal)	\$19 95
Introduction to Personal & Business Computing	\$9 50
Microprocessor Interfacing Techniques	\$23 50
Microprocessors: From Chips to Systems	\$17 50
Microprogrammed APL Implementation	\$45 95
Pascal Handbook	\$24 95
Pascal Programs for Scientists & Engineers	\$22 50
Programming the Z800	\$19 95
Programming the Z80	\$19 95
Sybase Book of Pascal Games	\$19 95
Your First Computer — A Guide to Business & Personal Computing	\$11 95

## Amateur Radio

ARRL Antenna Handbook	\$8 30
The Radio Amateur's License Manual	\$6 80
FM & Repeater for the Radio Amateur	\$8 80
Single Sideband for the Radio Amateur	\$8 00
Ham Radio Operating Guide	\$7 20
Electronics Data Book	\$7 20
Solid State Design for the Radio Amateur	\$9 80
ARRL Antenna Anthology	\$6 80
The Contest Cookbook — Zachary	\$7 95
The Magic of Ham Radio (History) — Swank	\$6 60
New Zealand ART Call Book 1981	\$5 85
VHF Antenna Handbook — Barvicks	\$8 50

## Howard W. Sams Books

TTL Cookbook (Lancaster)	\$12 95
TV Typewriter Cookbook (Lancaster)	\$13 50
The Cheap Video Cookbook (Lancaster)	\$10 75
Active Filter Cookbook (Lancaster)	\$19 95
Transistor Substitution Handbook	\$7 95
TTL Cookbook (Lancaster)	\$12 95
IC Op Amp Cookbook — Jung — New 2nd Edition	\$19 95
Applesoft Language — Blackwood	\$12 95
The S-100 and other MicroBuses — Goodwin & Poe	\$11 95
Pascal Primer — Fox & Waite	\$22 95
Intimate Instructions in Integer Basic — Blackwood	\$9 95
Experiments in Artificial Intelligence for Small Computers — Krutch	\$11 95
Basic Business Software — Brooner	\$15 95
Microcomputer Dictionary — Sippl	\$18 95

## Other Titles

Practical Transformer Design Handbook — Lowdon	\$32 95
Complete Handbook of Robotics — Safford Jnr	\$11 50
How to Build your own Working Robot Pet — DaCosta	\$9 95
The Active Filter Handbook — Tedeschi	\$11 50
How to Design & Build your own Custom TV Games — Heiserman	\$13 50
Piano Servicing & Tuning & Rebuilding — Arthur Reblitz	\$21 00
Hi-Fi Loudspeakers & Enclosures — Cohen	\$25 50
How to build your own self-programming Robot — David Heiserman	\$9 95
Fairchild — CMOS Data Book	\$9 95
Motorola M6800 Microprocessor Applications Manual	\$16 70
Motorola MC6800 16-BIT Microprocessor User's Manual	\$25 00
Motorola Programming the 6800 Microprocessor	\$11 05
National CMOS Databook	\$7 50
National Linear Databook	\$11 25
National Logic Databook	\$10 00
National Audio Radio Handbook	\$6 25
Video Games — Len Buckwalter	\$5 95
Videocassette Recorders Theory & Servicing — McGinty	\$20 00

**MAIL ORDERS BY RETURN**  
PLEASE ADD \$1.50 per parcel postage (Vic)  
\$2.50 per parcel interstate

## TECHNICAL BOOK & MAGAZINE CO.

295-299 Swanston St, MELBOURNE 3000. Ph. 663 3951.



# Shortwave Scene

by Arthur Cushen, MBE



## 50th Anniversary of BBC Shortwave Services

On December 19, 1932 the BBC commenced overseas broadcasting from Daventry. The "Empire Service", as it was called, initially broadcast for only a few hours each day but today, 50 years later, transmissions are continuous in English. In addition, some 36 other languages are also broadcast.

The first highlight was on December 25, 1932 when King George V inaugurated the annual Christmas message to the Commonwealth over the transmitters at Daventry. Since those days, the BBC has pursued a policy in keeping with its motto: to form a friendly link of information, culture and entertainment; to give news of world-wide importance as it is known in Britain; to show what the British nation as a whole is thinking about the news; and to reflect the British way of life.

The external Service has gone under three names in the English language section: the "Empire Service", the "General Overseas Service" and, in 1969, the "World Service". Broadcasting around the clock in English and 36 other languages, there are 44 transmitters employed in the United Kingdom at four sites, and from bases overseas on Ascension Island (4), Antigua (2), Masira (2), Cyprus (8), Singapore (8) Lesotho (2). In addition, transmitters operated by the Voice of America and Radio Canada International also carry BBC programs.

To mark the 50th Anniversary of the BBC Shortwave Services several competitions are being run by the World Service. And in London, tours of Bush House, the site of the External Services in the Strand, are being conducted and many moments of BBC activity are on sale.

In the past 50 years, listeners in Australia and New Zealand have taken for granted the good reception of BBC transmissions in this area. No one can overcome the disturbance from ionospheric problems or sunspots but, generally speaking, London is well

received throughout the area. The writer, for the past 40 years, has been the Technical Representative of the BBC in New Zealand and hundreds of international telegrams, weekly reports and recordings have gone to Bush House in an endeavour to give the shortwave listener the best possible service.

The BBC World Service is scheduled to Australia in three time slots: 0600-0915UTC on 7150, 9640, 11955 and 15070kHz; 0900-1330UTC on 11750, 21550 and 25650kHz; and 2000-2230UTC on 9410, 11750, 15070 and 21710kHz.

### ENGLISH FROM NOUMEA

For the first time in many years, English broadcasts are now a regular feature of Radio Noumea, identifying as FR 3 (French Regional 3) and broadcasting from Noumea, New Caledonia on medium and shortwave. The frequencies of 666kHz medium-wave, and 3355 and 7170kHz shortwave, are heard between 0900-1100UTC. The transmissions include a two-hour popular music program with announcer Johnny Knight introducing the recordings, with identification in French given every 30 minutes.

It is over 40 years since English was broadcast from Noumea and in those days the American Forces station, the Mosquito Network operated from Noumea on medium-wave. Before then there was a radio service from Noumea operated by amateur FK 8AA, who used the 49-metre band for transmissions, while another station, Radio Electric, also broadcast from Noumea over a period in the late 1930s.

English from Noumea is unusual, as the station has predominantly broadcasts in French throughout its long history. Listeners in Australia, New Zealand and the South Pacific are already reporting good reception of this Saturday evening transmission.

The broadcast in English is between 0900-1100UTC. There is the closing announcement in French and the French National Anthem ends the transmission for the day. The station is requesting reports to "Knight Flight", Radio Noumea, FR 3, Post Office Box G3, Noumea, New Caledonia, and promises confirmation of reception.

### WORLD OF RADIO

A special program for the shortwave listener, Glen Hauser's "World of Radio", is now carried on WRNO, New Orleans. This is a weekly session of 30 minutes and is broadcast on Sundays at 2330UTC on 11955kHz, and repeated on Tuesdays at 1900UTC on 15420kHz.

Glen Hauser's "Shortwave Digest", broadcast by Radio Canada International, Montreal is heard on Saturdays 2135UTC on 15150, 15325, 17820, 17875kHz, and repeated on Monday at 0405UTC on 5960, 9535, 11845kHz.

### NEW SAIPAN STATION

A new station broadcasting shortwave programs to Japan and operating with 100kW is soon to commence operation from Saipan. The station, assigned the call KYOI, will be commercial and carry programs exclusively in Japanese. KYOI will broadcast contemporary music, mainly on the Top 40 variety and aimed at the 20-34 age group.

Marcom, the operators of the station, claim that this type of music is not played by Japanese radio stations and this new shortwave service is intended to fill the gap. The program will be entirely in Japanese with no news broadcasts.

According to an interview on Radio Nederland's "Media Network", the station plans to open on September 1.

The cost of the entire project is around \$1M and it is estimated that the 100kW output will provide a strong signal throughout Japan. The US Federal Communications Commission will have to check the transmitter and facilities before granting the station permission to operate, as Saipan is a US Trust Territory. Transmission frequencies will be allocated by the FCC just as they are for KTWR at Agana, Guam.

Notes from readers should be sent to Arthur Cushen, 212 Earn Street, Invercargill NZ. All times are UTC (GMT). Add eight hours for WAST, 10 hours for EAST and 12 hours for NZT. In areas observing daylight time, add a further hour.



# AMATEURS read this, avoid an expensive mistake

**NOW IN STOCK**

THE  
FANTASTIC  
**FT-ONE**  
GENERAL  
COVERAGE  
TRANSCIVER



Cat D-285Z

SELLING IN  
USA FOR  
**\$2995!**

Now Dick Smith and Yaesu bring you this superb general coverage transceiver with outstanding features for such a low, low price. Just look at some of the features: ★ All mode - even FM\*. ★ All band - receives from 150kHz to 30MHz continuous, with resolution down to 10Hz. ★ Transmitter includes all the WARC bands; ★ All microprocessor controlled. ★ Runs from 100-120 or 200-240V AC or 13.5 DC, and much more! And the price?

An  
unbelievably  
low  
**\$1795**

\*FM board optional  
extra



HAND HELD FM  
**The FT 208R**

2.5W/.25W

The FT 208R transceiver brings a new flexibility to today's active 2M operator. An easy to read LCD display is coupled with a 4-bit microprocessor, bringing 10 memories and a scanning function. Only with Yaesu can you get these features at such an economical price. Cat D-2889

Complete with  
battery & charger

ONLY  
**\$368**



NEW!  
FM 2 metre  
**FT 230R**  
and it's only

**\$375**

It's here! The brand new Yaesu FT 230R with features you'd pay \$\$\$\$ more for. 3W/25W output full 144-148MHz band coverage, fully synthesised, 12V operation. Plus two VFO's, LCD readout, 10 memories, scanning, hi/lo power switch, and much, much more. Check it out now!

Cat D-2893

**SUPER COMPACT!**



100 WATT

SUPERB  
MOBILE/BASE  
**FT 707**

ONLY  
**\$795**

What a performer packed into such a tiny package! It's a full power all HF band (including WARC) multi-mode transceiver not much bigger than the average 2 metre mobile! And you get digital display as well LED S/power meter, push button operation etc, etc. Team it up with an FT-707 supply and you have a superb base station too! What more could you ask for?  
Cat D-2869

Dear Amateur,  
Consider these two recent reports of amateurs who purchased Yaesu equipment from 'backyard' importers: both these cases were told by the purchasers to our store staff in trying to get some help.

Case History No. 1:  
Mr X from Adelaide bought a transceiver by mail order. After waiting some time for delivery, the unit arrived but shortly after the digital display failed. Mr X rang the supplier to be told the repair would take 6 to 8 weeks, and he would have to pay freight charges both ways. Mr X ended up having the unit repaired in Adelaide at his own cost.

Case History No. 2  
Mr Y from Sydney bought a 'new' transceiver from the same source. On opening the carton, Mr Y strongly suspected the unit was not new, but had been 'refurbished'. It failed to operate at all - the PA stage was inoperative. Mr Y rang the supplier to be told that parts were unavailable and the repair would take at least three months. As it was supposed to be a brand new unit, Mr Y asked for a replacement. This was refused.

Other problems:  
We have often heard of transceivers supplied without instruction manuals, or with Japanese language instruction manuals... Obviously these units were intended for the Japanese domestic market, and never intended to be exported. The warranty is not valid in Australia on these units.  
Many 'backyard' importers do not have any service facilities whatsoever - let alone spare parts. They are not authorised by Yaesu, (or usually anyone else) and often have little expertise.  
Is it worth the risk?

\*Dick Smith is the only authorised Yaesu dealer offering full 12 month warranty!

**Dick Smith**  
VK2ZiP



ALL-MODE

2 metre SSB-FM-  
CW with scanning  
**FT 290R**

only  
**\$395**

The brilliant Yaesu FT290R. For the person who can't quite decide whether they want a portable or a mobile set. This one is both! And what's more, it's fully microprocessor controlled offering up to 10 memory channels, scanning, LCD display, high or low power operation, all modes plus full 144-148MHz band coverage. All this in a transceiver which can be operated both portable (from internal batteries and whip antenna) or mobile (ext antenna and power sockets fitted). Complete with carry strap, scanning microphone and whip antenna. Cat D-2885

## DEMO CLOSEOUT SALE

Ex-demo and store stock, some slightly marked.

Full 12 month warranty

FT 207R	2 mtr hand held with charger. <b>SAVE \$60!</b>	(D-2888)	\$235.00
PA 2	Mobile charger supply for FT 207H. <b>SAVE \$10!</b>	(D-2894)	\$19.95
<b>SPECIAL PACKAGE - BOTH UNITS FOR \$246.50!!</b>			
FT 107M	Solid state HF transceiver (power supply built-in)	(D-2853)	\$850.00
FT 7B	Solid state portable HF transceiver <b>SAVE \$50!</b>	(D-2868)	\$549.00
FT 901D	Transceiver 160 - 10 mtrs (built-in power supply) <b>SAVE OVER \$70!</b>	(D-2854)	\$999.00
FT 901/902	Memory unit for 901/902 series <b>SAVE \$40!</b>	(D-2858)	\$99.00
FT 901/902 DC-DC	DC power supply for 901/902 series <b>SAVE \$20!</b>	(D-2856)	\$49.00
FT 720RVH	2 mtr mobile transceiver <b>SAVE \$60!</b>	(D-2890)	\$369.95
FT 1012D	101 digital HF transceiver with WARC bands (built-in power supply) <b>SAVE \$60!</b>	(D-2859)	\$850.00
FT 227RB	2 mtr FM mobile with scanning <b>SAVE \$60!</b>	(D-2891)	\$319.00
FV 707DM	Digital VFO for FT 707 <b>SAVE OVER \$30!</b>	(D-2896)	\$265.00
MMB2	Mounting bracket for FT 707 <b>SAVE \$9!</b>	(D-2897)	\$25.95
YM-34	Galbraith paddle morse key <b>SAVE \$2.55!</b>	(D-7103)	\$14.95
	Desk Mic for FT 707 <b>SAVE \$14.55!</b>	(C-1114)	\$29.95

Some stores have limited or no stock available. Ring Jim Powell at Head Office (02) 888 3200 for details on where to find these bargains.

# DICK SMITH

## Electronics



See Page 27 for address details

DSE/A240/PAI



# Amateur Radio

by Pierce Healy, VK2APQ



## Novice licensing a resounding success

Introduced in March 1976 amidst controversy and doubts as to the effectiveness of the scheme, Australia's novice radio licence is now six years old. Results have exceeded expectations in many cases.

"QSP" in "Q code" terminology means "I will relay . . . free of charge" or in amateur parlance "I have information . . ."

Some interesting facts relating to novice licensing in Australia — at the present time and over the past 10 years — were brought to mind when reading "QSP" in the April issue of the WIA publication *Amateur Radio*, written by federal president Peter Wolfenden, VK3KAU.

Referring to papers prepared for the IARU (International Amateur Radio Union) Region III Association conference in Manila during April 1982, mention was made of a WIA contribution dealing with "the first five years of the Australian novice licence".

In brief, points made were: ". . . it is worth noting that, in general, Australian novices are upgrading . . ." ". . . a recent survey revealed 56% have upgraded . . ." "The significance of this is that the Australian novice licence scheme is working — as many, including the Institute, hoped it would".

Readers of these notes a decade or so ago, especially those who were among the first to obtain their novice licence, will recall the era 1968-1972 when the WIA refuted the policy concept of novice licensing, and procrastinated for several more years. During that period publicity supporting the introduction of novice licensing was strenuously given in these notes and other sections of "Electronics Australia". [See June 1971 and many succeeding issues. A full resume was given in August 1975 prior to the first novice licence examination (NAOCP) in March 1976 and reviewed in June 1976 of "EA".]

Having been the amateur most publicised, and often castigated, in the efforts to see novice licensing introduced in Australia, I (VK2APQ) am delighted

that after six years (or should it be 14 years?) the results are now presented to an international forum so — ". . . that countries which may wish to swell their amateur ranks could take advantage of our type of novice licensing . . ."

Understandably, since the introduction of the NAOCP, a lot of thought, work and co-operation between officers of the Department of Communication (Radio Branch) and the WIA has been necessary to eliminate problems as they arose.

However, one aspect that causes concern is the attitude and thoughts expressed on air by a few of probably the more recently licensed NAOCP operators. This is the apparent belief that they have exclusive right to operate within the novice segments of the amateur bands or on a particular frequency whenever they wish, irrespective of the frequency currently in use.

To these few it is suggested that a closer study be made of their copy of the *Amateur Operators Handbook* and thought given to the *Amateur's Code*, or that they upgrade their licence and operating technique.

After all, it was the full call AOCOP holders who helped to get the NAOCP privileges now enjoyed, and raise the state of the art to its present level.

How many can remember the hetrodyne bedlam in the Remembrance Day or similar contests in the days of amplitude modulation and less stable equipment?

### PORT MACQUARIE FIELD DAYS

The Oxley Region Amateur Radio Club, with headquarters at Port Macquarie, NSW, will hold its annual field day over the Queen's Birthday weekend June 12-14, 1982. All amateurs, their families and friends are invited to Port Macquarie to join in the activities.

In addition to the usual type of contests

ie, quizzes, scrambles, hidden transmitter hunts etc, two unusual contests will be held. Entries are invited from all amateurs:

**HOME BREW RECEIVER CONTEST:** The receiver must be designed for use on any amateur band or bands, constructed from reasonably common parts.

A panel of three judges will allocate points to decide the winner, taking into consideration performance, simplicity and cost. Judges decision will be final.

Entries will close at 2.00pm June 12, 1982 and the winner announced on June 13, 1982.

### HOME BREW ANTENNA CONSTRUCTION AND ERECTION CONTEST:

The following criteria will apply — (a) Antenna must be multi-band, capable of working on 80-40-20-15-10 metre bands. (b) No adjustment of any tuning device is permitted. (c) SWR must be 2 : 1 or better on all bands mentioned. (d) Entrant must be one individual person. (e) All masting and necessary hardware to be supplied by the entrant. (f) Existing trees and local structures in or outside the contest area must not be used. (g) Contest erection times will be 10am to 2pm Sunday, June 13, 1982. (h) Judges decision will be final.

Further information on the field day can be obtained from the club publicity officer, Lewis Smith, VK2LS, on air or by writing to 30 Cunning Street, Port Macquarie, NSW 2444.

### THE NORTH WEST RADIO SOCIETY

The North West Radio Society originated in Port Hedland, Western Australia and now has affiliated clubs in other areas.

Club net is at 1130UTC Sundays on 3605kHz, with local mobile net as required on 28.445MHz. A bi-monthly newsletter is mailed to members. The society sponsors the "Northwest Award".

Port Hedland: Club call VK6ANW. Repeater VK6RNW channel 7000. Meetings at club rooms on first Friday of month. Postal address PO Box 283, Port Hedland, WA 6721. Enquires: John



# VIC 20

## COLOUR COMPUTER

from **DICK SMITH ELECTRONICS**

for only

# \$399

*DON'T PAY \$599!*

Digital cassette recorder connects here: for loading or saving programs.

Exciting range of games cartridges simply plug in!

Obtain access to data banks and other computers with a Modem: it just plugs in!

Your colour (or B&W) TV set connects here: no need to buy an expensive colour monitor.

Add 'joystick' controls here for even more games fun.



Cat X-2600

look at these features

look what it can do!

- ★ Colour graphics in up to **eight** colours – directly addressable from the keyboard!
- ★ Memory expandable up to 32K with plug-in modules.
- ★ Typewriter-style keyboard, with programmable function keys: you're really in control!
- ★ An inbuilt tone generator for music and sound effects!
- ★ It's ready to use immediately you turn it on – and it's expandable as your experience and budget require.

Yes, the VIC 20 is a truly remarkable breakthrough in computer technology – and it represents outstanding value for money. And it is fully backed with Dick Smith's own satisfaction guarantee. Try it for yourself: if you're not completely happy you can return it within 7 days for a full refund! You can't lose!

- ★ Play a wide variety of full colour games – like space invaders, chess, etc. All you do is plug in a games cartridge!
- ★ Or write your own computer programs: with full colour display and an incredible range of graphics to choose from. Your imagination is the only limit!
- ★ Create computer music and sound effects to go with your programs! It's so easy with the VIC 20.
- ★ Give your family an introduction to the exciting world of computers: using the most exciting computer available in the world today!

come in to one of our stores and see for yourself!

# DICK SMITH Electronics



See our other ads in this issue for store addresses

WIN A DATSUN STANZA  
Details in all stores



# POWERFUL QUALITY

FROM "HITACHI" & "KOBE"



You can join countless manufacturers throughout the world who already fit HITACHI and KOBE batteries as original equipment.

- Ni-Cd Cylindrical Cells
- HIGPACK Sealed Lead-acid Gel Cells  
for emergency lighting, burglar alarms, portable TVs, children cars, etc.

 *Manufacturers & Exporters*  
**Shin-Kobe Electric Machinery Co., Ltd.**

ADDRESS: P. O. BOX 218, MITSUI BLDG. SHINJUKU-KU, TOKYO 160, JAPAN  
TELEPHONE: (03) 344-2811 TELEX: 2324107 SKEMCT J  
CABLE: HIGHLONGBATTERY TOKYO



*We got off to a  
flying start with 2 pilots,  
2 mechanics and 5 planes.*



The Air Force of the 80's is a far cry from the Australian Flying Corps where it all began in 1916.

Today, without doubt, our aircraft, equipment and electronic systems reflect the technology of the future.

But one thing hasn't changed - the comradeship and dedication of our people. We're proud of that.

Security of employment, training and job satisfaction are something our members have enjoyed over the years. They're all part of the lifestyle in Today's Air Force.

The Air Force of the 80's is a young, modern, dynamic organization - young in its thinking, progressive and innovative in its action.

*You're somebody  
in Today's  
Air Force.*





# WATCH OUT FOR THE NEXT ISSUE OF

# video MAG

**FIRST AUSTRALIAN ISSUE**  
FEB/MAR. 1982 AUST \$1.90 NZ \$2.30

**1981-82 ANNUAL**  
AUST \$7.75 NZ \$9.00

**SECOND GREAT AUSTRALIAN ISSUE**  
APR/MAY 1982 AUST \$1.90 NZ \$2.30

**PREVIEW: PIONEER VIDEO DIS HITCHCOCK - MASTER OF THE LIGHTING FOR HOME VIDEO C**  
**WE LOOK AT TOSHIBA'S NEW SONY "35mm" CAMERA USES**

**Exclusive: A NEW PORTABLE SANYO SYSTEM**

**60 YEARS OF HO-HO FILMS**  
**THE NEW 7200 VCR FROM NATIONAL**

**ON SALE JUNE 9TH**

**CINESOUND FILMS FOR HOME VIDEO**



VK6AFA, (091) 72 1022. Mark VK6WV, (091) 72 2513.

Newman Chapter: Club call VK6MN. Repeater channel 6900 licence applied for. Postal: PO Box 378 Newman, WA 6753. Enquiries: Mal VK6NV, (091) 75 1317, Lindsay VK6NO (091) 75 1579.

Karratha Chapter: Repeater VK6RWP channel 6800 under construction. Enquiries: Nigel VK6KHD, (091) 85 1779, John VK6ZOH, (091) 85 1330.

Wickham Amateur Radio Club: Repeater channel 6700 licence applied for. Enquiries: Gordon VK6NCN, (091) 87 1074, Pat VK6NHP.

Information as supplied by John Faran, VK6AFA, Hon Secretary NWRs.

### AMATEUR RADIO IN CHINA

Here are some points relating to the approval for re-opening amateur radio activities in China. These were taken from information issued by Cheng Ping, secretary-general of the China Radio Sport Association, in January 1982.

"Thanks to the support given by all leading bodies concerned and through the active preparation made by departments involved, the Supreme Executive Council of China has officially approved the re-opening and development of the long awaited activities of amateur radio in China.

"Amateur radio stations to be established shall be organised on a club system basis with a leader in charge.

"The first station to be on air will be BY1PK in Beijing, followed by others in provinces, regions and cities.

"From experience gained gradual steps will be made to facilitate extension of the scope and activities of such stations.

"It is envisaged that amateur radio station will be established in various military physical education schools, universities, colleges, youth culture centres, science and technical institutions.

"For the time being, no permit will be issued to stations on an individual basis.

Those wishing to take up amateur radio must first receive training, pass examination, and acquire certification for operation before participating in the activities of the designated club stations.

"Use of frequencies, extent of communication and activities will be in general along the lines established in the international amateur radio regulations."

The information released also refers to ideology and other attributes which must be cherished by those participating in amateur radio.

Emphasis is also given to the advantages that amateur radio will bring to the community through the training of individuals in radio telecommunications and electronic fields. Particularly stressed are the benefit for youth in gaining knowledge, the exchange of technical knowledge, and the enhancement of friendship between enthusiasts in China and foreign countries.

### EXPEDITION EPILOGUE

The return of the "Dick Smith Explorer" to Sydney on March 15, 1982 brought to a successful conclusion the Oceanic Research Foundation scientific expedition to the Antarctic Continent.

Since then it has been a pleasure to discuss many aspects of the work done by crew members; in particular the radio communication and equipment used by Don Richards, VK2BXM/VKODL.

One aspect was the sustained interest maintained by the operators participating regularly in the daily sked with the expedition. It is thought that the involvement of families and friends of the crew, often by direct personal communication, plus the messages of congratulations and good wishes that were passed, reduced the anxiety of those at home and created a daily interest for those experiencing the cold harsh Antarctic conditions. In fact — "What was the sked like last night" — was a regular inquiry by crew members not on watch at the time of the sked.

Several technical aspects were highlighted. It was found that a 14MHz dipole antenna gave better results than the broadband helicals on the mast-head and stern of the schooner. It was agreed that there is room for experimentation to find which antennas give the best signal from that type of vessel.

Concentric controls for bandpass and IF filters were very difficult to adjust under such cold conditions, very often accompanied by unpredictable movement of the boat.

It was also found necessary to provide some warmth to the all-solid-state type equipment. This was achieved by wrapping units and low wattage lamps in padded covers. The Kenwood TS820S transceiver using the 6146B's in the final stage was not affected.

Radioteletype (RTTY) with video display was a most satisfactory mode, particularly under very weak signal conditions. Even with character errors causing misspelt words or what appeared at first glance undecipherable text, RTTY could be understood much more easily and with greater accuracy than voice at low signal strength, through band noise and QRM.

Experience was probably the major benefit gained by those who participated in the net and no doubt the contribution to public awareness of what the amateur service can provide was a notable highlight.

### DO YOU WANT TO BE A RADIO AMATEUR?

The Wireless Institute of Australia, established in 1910 to further the interests of Amateur Radio, conducts a Correspondence Course for the A.O.C.P. and L.A.O.C.P. Examinations conducted by Telecom. Throughout the Course, your papers are checked and commented upon to lead you to a successful conclusion.

For further information, write to

#### THE COURSE SUPERVISOR W.I.A. (N.S.W. DIVISION)

P.O. Box 123,  
ST. LEONARDS, N.S.W. 2065.

Radio clubs and other organisations, as well as individual amateur operators, are invited to submit news and notes of their activities for inclusion in these columns. Photographs will be published when of sufficient general interest, and where space permits. All material should be sent to Pierce Healy at 69 Taylor Street, Bankstown, NSW 2200.



A CONTROL UNIT FOR INTERMITTENT WIPER ACTION  
AN UNGRADED CAPACITOR DISCHARGE IGNITION SYSTEM  
A DWELL METER FOR ENGINE TUNE-UPS  
TACHO FOR TUNE-UPS  
A TRAFFICATOR REPEATER FOR CARAVANS AND TRAILERS  
LOUDSPEAKER PROTECTOR FOR HIFI SYSTEMS  
DIGITAL METRONOME WITH ACCENTED BEAT  
REMOTE TV HEADPHONES  
TOROID FILTER CUTS RADIO, TV BREAKTHROUGH  
SIMPLE MIXER FOR PICK-UP AND MICROPHONE  
UNIVERSAL HEADPHONE UNIT  
ACTIVE FILTER UNIT FOR CROSSOVER NETWORKS  
VOICE-OPERATED RELAY  
SPEED CONTROL FOR ELECTRIC DRILLS  
FULLY PROTECTED, REGULATED POWER SUPPLY  
MOODLIGHTING WITH THE VARILIGHT MK 2  
POWERMATE: 13.6V SUPPLY FOR TRANSCEIVERS

Available from "Electronics Australia", 57 Regent St, Sydney. PRICE \$3.00 OR by mail order from "Electronics Australia", PO Box 163, Chippendale, 2008. PRICE \$3.90.

PREAMPLIFIER FOR 27MHz  
SHORT-WAVE CONVERTER FOR THE 27MHz BAND  
10GHz RADAR BURGLAR ALARM  
MODEL TRAIN CONTROL WITH SIMULATED INERTIA  
MULTI-BAND VERTICAL AERIAL  
AN ELECTRONIC ROULETTE WHEEL  
AN IN-CIRCUIT TRANSISTOR TESTER  
MODULAR DIGITAL CLOCK  
NOVEL "LEDS AND LADDERS" GAME  
SIMPLE PROXIMITY SWITCH FOR A NOVEL DOOR CHIME  
HEE-HAW SIREN FOR TOYS  
MODEL TRAIN SIGNALLING SYSTEM  
MICROPHONE PREAMPLIFIER  
TEMPERATURE ACTUATED SWITCH  
WATER LEVEL ALARM  
2-PHASE CMOS CLOCK OSCILLATOR  
ECONOMICAL CRYSTAL OVEN



# New Products...

Product reviews, releases & services

## 120W Modules from Pre-Pak Electronics

Pre-Pak Electronics Pty Ltd is now importing a range of pre-assembled audio modules from Wangine Pty Ltd. The modules can be built up into a complete 120W RMS amplifier that can be tailored to meet the needs of the constructor.

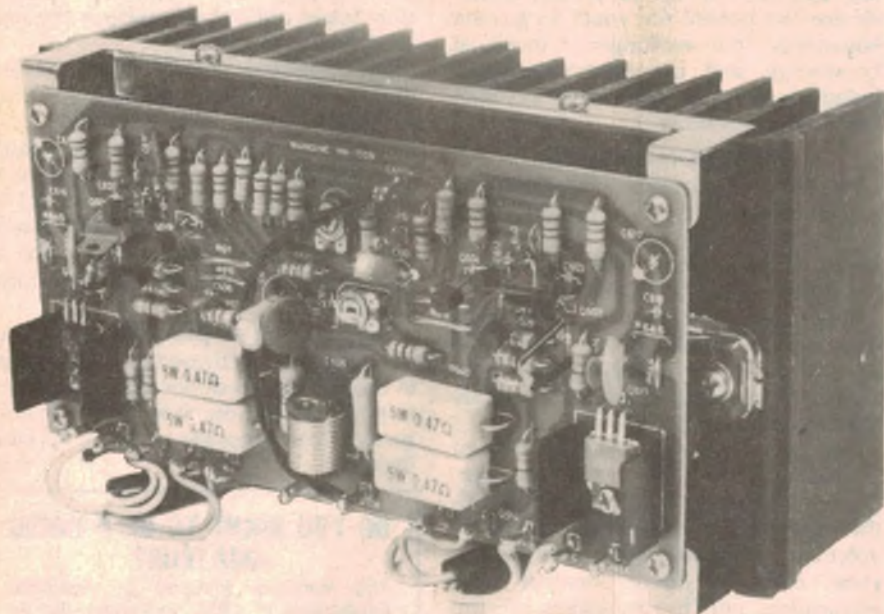

Basis of the system is the power amplifier module, which is completely self-contained and constructed on a printed circuit board bolted to the heavy duty heatsink. Of course, you need two modules for stereo, at \$54.90 each, including tax.

When used with the other Wangine modules, the built-up amplifier is specified at less than 0.1% total harmonic distortion, with 87dB signal to

noise ratio. Power output of the amplifier module is specified as 120W RMS into 8 $\Omega$ .

The other modules available include a microphone preamp for PA use, a phono preamp requiring 2.8mV input levels and a tone control module, providing bass, mid-range and treble controls with up to 10dB boost or cut. A power supply module is also available, providing regulated plus and minus 22V to power

all modules except the power amplifiers.

The power amplifier modules require a  $\pm 60V$  supply at around 1.5A per channel. Pre-Pak recommends using an unregulated supply derived from a 5A bridge rectifier and two 10,000 $\mu F$  65VW or higher filter capacitors.

The Wangine range also includes a speaker protection module which provides delayed switch-on of the speakers until the power amplifier has stabilised, and an emergency cut-out to guard against the effects of short circuits of the speaker outputs. All of the modules can be purchased separately, or as a complete kit which builds a single channel amplifier for around \$125.

Data sheets accompanying the set of modules provide full specifications of the amplifier, module connection and wiring diagrams, suggested layouts for a stereo amplifier, full circuit diagrams, including instructions for connecting accessories such as power output meters, and written assembly and operating instructions.

The Wangine modules are supplied fully assembled and tested and are covered by a 90 day guarantee against faulty components or workmanship. Pre-Pak is also offering a service program for a further 12 months covering the cost of repair or replacement of any defective module for 25% of the recommended retail price.

For further information on the amplifier modules contact Pre-Pak Electronics, PO Box 43, Croydon, NSW, 2132, or call at their shop at 1A West St, Lewisham, NSW.

## Solar thermostat, switch-mode supplies from Amtex

From Amtex Electronics comes news of a differential temperature thermostat for the control of solar hot water or solar heating systems. Called the "Delta-T", the unit will automatically turn a circulation pump or blower on or off when the temperature of the collector in a solar heating system exceeds the storage temperature by a preset differential value.

The Delta-T incorporates a circuitry to prevent the pump or blower from being continuously switched on or off in response to small changes in

temperature. This chattering, or hysteresis, shortens the life of the switching relay and pump/blower. The patented hysteresis circuitry provides an "OFF" differential of 1.4 $^{\circ}C$ , and an "ON" temperature differential which may be varied between 2.8 $^{\circ}C$  and 11 $^{\circ}C$ .

The standard Delta-T model can control pumps or blowers of up to 250W and controls for equipment of up to 2kW are available. All models have a LED indicator to show when the pump is on, and top of the range models provide digital read-out of either the ON or OFF

temperature differential setting.

Also from Amtex Electronics is a new switch-mode 50W power supply, intended primarily for microprocessor applications. The AMT series power supplies use a combination of switch mode supply on the main (+5V) output and linear regulators for auxiliary  $\pm 12V$  and -5V outputs.

Top of the range is the AMT-20 power supply, which provides +5V at 5A and  $\pm 12V$  and -5V at 1A. Other models also provide 5A at 5V with a choice of auxiliary output voltages. Input voltage is



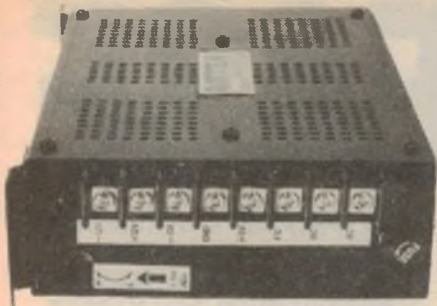

given as 180-260VAC at 47-440Hz, and efficiency as 70%. The 5V main output is adjustable over a range of +20% to -5%.

Maximum output is given as 50W, with foldback over-current protection. Over-voltage protection is available as an option.

The units are compact with dimensions of 129 x 47 x 205mm (H x W x D), and weigh 0.7kg. Inputs and outputs is by means of a barrier strip at one end of the power supply module.

For more information on the Delta-T solar heating controller, or the AMT power supply modules, contact Ampdex Electronics, PO Box 285, Chatswood, NSW, 2067.

### Automatic multimeter from Philips



Philips Scientific and Industrial Equipment has released a new four-and-a-half digit multimeter, the PM 2521. The microprocessor-controlled digital multimeter includes features such as full current autoranging, relative reference levels, dB readings and frequency counting as standard.

Accuracy of the new meter is given as 0.03%, with resolution down to 10µV, 1nA and 10mohm (that's microvolt, nanoamp, and milliohm). Apart from the microprocessor, which provides a full readout of all measuring information, the PM2521 includes a newly designed current measuring system to compensate for circuit loading and a 100kHz bandwidth for true RMS measurements. Temperature measurement and a data storage facility are available as extras.

Additional facilities are available from the meter's internal microprocessor, such as relative reference measurements, which allow chosen levels to be

(Continued on page 109)

# MPI Hi-D Mini Drives

freedom  
of choice



Our  
way . . .

or theirs

Professional, push-button disk eject, or industry standard flip-front . . . Either way, MPI builds the quality in. Head load for media protection, 6mSec track-to-track and a choice between 48, 96, 100TPI, single or double sided 5 1/4" Floppy Drives.

TRUE FREEDOM OF CHOICE.

### Authorised Dealers:

Sydney: (02) E&M Electronics 51 5880, Applied Technology 487 2711, QT Computers 29 5599, Micro Repair 747 1061, Computer Components 868 3614. Wollongong: (042) Macelec 29 1455. Brisbane: (07) Baltec 36 5183, A.C.T.: (062) Ortex 80 5283, Boulevard 48 5411. Perth: (09) Micro Controls 325 2444, Electronic Systems 335 7313. Adelaide: (08) DC Electronics 223 6946, Micro'80 211 7244. Melbourne: (03) Stewart Electronics 543 3733, Ellistronics 602 3282, Ritronics 489 8131, Pennywise Peripherals 82 2389, De Forest Software 877 6946, Comp-Soft 428 5269. Tasmania: Coastal Computers (004) 31 3259.

## daneva australia pty ltd.

66 Bay Road, Sandringham, Vic., 3191.  
Ph: 598 5622. Telex: AA34439





# USE NO GREASE

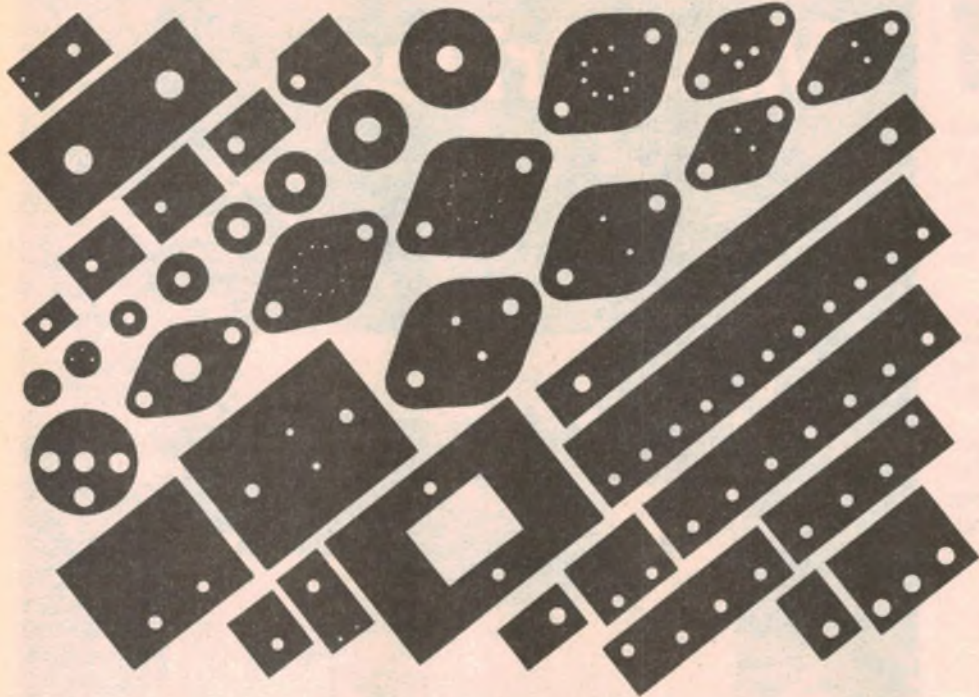

**SIL-PAD 400 is a greaseless heat sink insulator that provides electrical isolation and maximum heat transfer.**

- Available for a wide range of packages.
- No grease — no mess
- Low thermal resistance
- High electrical isolation
- Non toxic
- Fast, easy to use, neat
- Flame retardant
- Will not support fungal growth
- Can be sent through soldering and cleaning agents
- No deterioration with age
- Will not chip or break
- Maximum cut through resistance

Available only from

**Scientific Electronics**



6 Holloway Drive,  
Bayswater, Vic. 3155  
Tel. (03) 762 5777  
Telex AA36308

**The Power Supply Specialists**

## RADIO DESPATCH SERVICE

869 George St.,  
Sydney, NSW 2000.  
(Near Harris Street)  
phone 211 0816, 211 0191  
Open Mon-Fri 8am to 5.30pm  
Thursday night late shopping  
till 8.30pm. Sat 8am to 11.45am

New unused 4 inch equipment cooling fans.  
Choice of  
EBM or  
Rotron (Muffin)  
240v A/C



1+ \$18.93 Ex.  
\$21.20 Tp.

10+ \$17.04 Ex.  
\$19.31 Tp.

**MAIL ORDERS:—**  
**INTERSTATE \$3.00, LOCAL \$2.50.**

## LOOK AT OUR JUNE SPECIALS

Weller WTC-PN  
solder iron station  
240v A/C



1+ \$63.00  
10+ \$58.50

24 pin Zero Insertion  
Force DIL I/C socket  
TEXTTOOL lever type  
operation

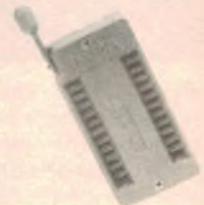

1+ \$10.85 Ex.  
\$11.96 Tp.

10+ \$9.77 Ex.  
\$10.88 Tp.

Trio  
CS1560A-II  
Oscilloscope  
15MHz Dual  
trace. Triggered  
sweep. 10mV/Div.



1+ \$480.00 Ex.  
\$547.37 Tp.  
7 Only

25 AMP Toggle switch 4  
Pole 3 position centre off  
(9A 250v A/C)



1+ \$3.80 Ex.  
\$4.00 Tp.

10+ \$2.80 Ex.  
\$3.00 Tp.

Oscilloscope Probe Kit  
SP-100 complete with  
accessories and carry  
case.



1+ \$25.00 Ex.  
\$28.54 Tp.

10+ \$22.50 Ex.  
\$26.04 Tp.

TEXAS programmable  
calculator TI-58c now  
extra special low price  
offer.



\$107.00 Ex.  
\$120.26 Tp.

15 Only



## New Products

zeroed and subsequent measurements to be displayed as deviations from this reference level. Frequency can be counted up to 10MHz with a resolution of 0.1Hz and stated accuracy of 0.005%  $\pm 1$  count. Time interval measurements are also possible.

For further information contact Philips Scientific and Industrial Equipment, 25-27 Paul St, North Ryde, NSW 2113.

### New Pac-Tec case



The latest Pac Tec case is a convenient hand-held size, measuring 91 x 140 x 33mm (W x D x H) and moulded in impact resistant ABS plastic. A separate compartment inside the case and accessible from the bottom holds a 9V transistor battery, and a battery clip is included in the purchase price.

Pac Tec cases are distributed by Associated Controls Pty Ltd, 55 Fairford Rd, Padstow, NSW, 2211.

### FM test set



The new CE-31A FM Radio Test Set from Cushman Electronics combines four basic radio servicing instruments in one lightweight package. Designed for portability, the test set weighs around 12kg, and is optionally available with internal batteries or equipped to run from a 12V car battery via a cigarette lighter plug.

Standard features of the CE-31A includes a deviation meter, a frequency error meter, an FM signal generator and a 1kHz tone generator. An oscilloscope driver output makes it easy to observe modulation output waveforms.

In the repair shop it is obviously faster to make one connection and run through four tests by setting switches rather than connecting four separate instruments one at a time. In the field service the savings in time and transport costs are even greater.

The CE-31A radio test set is distributed by Warburton Franki, who can supply further details through their local offices.

### Hefty switch mode power supply

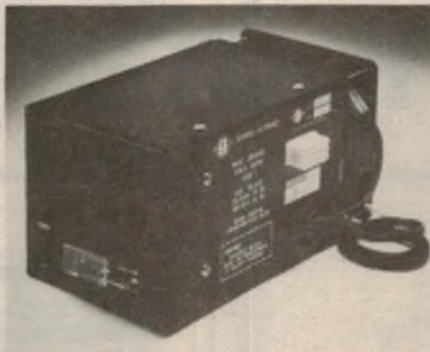

For those who need a hefty power supply, but still want the benefits of switching type supplies, Scientific Electronics has announced the development of a switching power supply with an operating frequency of 200kHz.

Generally speaking, the higher the operating frequency of a switching power supply the lighter and more compact the power supply transformer can be, with consequent savings in the weight and bulk of the overall supply. Until recently the construction of a 200kHz switching power supply has been difficult because of the lack of fast switching power FETS and diodes.

The SM150ACI is the latest in a long line of switch mode supplies manufactured by Scientific Electronics. It provides three rails with nominal voltage and current ratings which can be varied to suit customer requirements. The unit is fan cooled, and specified for outputs of 5V at 20A and  $\pm 12V$  at 2A. Input voltage range is from 200V to 280V or 100V to 140V, at 400Hz.

The unit is supplied with an IEC voltage power connector which incorporates an integral fuse holder and a convenient voltage selector to allow operation from

120VAC or 240VAC supplies.

Load regulation is given as better than 0.1% and line regulation as better than 0.1% at efficiencies of around 75%. Overall dimensions of the supply are 119 x 121 x 220mm (H x W x D).

Further information is available from Scientific Electronics, 6 Holloway Drive, Bayswater, Vic 3153.

### Accessories for BWD oscilloscopes

BWD Instruments Pty Ltd has a wide variety of accessories for its range of popular oscilloscopes, including the BWD 830 and the Powerscope.

A pair of P32 Duo Range 100MHz probes are supplied with the 35MHz BWD 830, but alternative probes are available separately in seven varieties. Also available are two cameras, the lower cost 7000 Series or the Super 7 Series with fixed hinge mounting and alternative film pack or 35mm roll film holders.

Other accessories include a carrying case, accessory case, viewing hood, dust cover, instrument trolley, application and service manuals, clear CRT filter and BNC or 4mm connectors and cables. Probes, cameras, trolleys and accessory cases can also be supplied to suit most other manufacturers' products.



The BWD C82 accessory case is primarily designed to carry a full set of probes and a camera for the BWD Powerscope, but it can be used with any instrument. The case is moulded in a tough red plastic, with a foam lining divided into compartments that provide a snug fit for a 7000 Series camera and hood, a folding viewing hood, a P82 current probe and cable, additional probes, manuals, film packs and power cord.

Full details of the BWD range can be obtained from BWD Instruments Pty Ltd PO Box 325, Springvale, Vic 3171.

(Continued on page 111)



# ★ HEWLETT-PACKARD 41C/CV SYSTEM

HP41C	\$360	(\$320)	HP-IL Interface Module	\$180	(\$160)
HP41CV	\$468	(\$416)	Digital Cassette Drive	\$792	(\$703)
Card Reader	\$309	(\$275)	New 82162A Printer	\$713	(\$633)
Printer	\$555	(\$493)	Series 80 HP-IL Card	\$425	(\$377)
Wand	\$180	(\$160)	Data Mini Cassettes	\$137	(\$121)
Quad Mem					
Mod	\$137	(\$121)			
4K Rom	\$43	(\$38)			
Extended Function/Mem					
Module	\$108	(\$96)			
Extended Memory					
Module	\$108	(\$96)			
Time Mod	\$108	(\$96)			

(PRICES IN BRACKETS EXCL TAX)

PLUS ALL

ACCESSORIES



## OTHER POPULAR MODELS

HP32E	\$79	(\$70)
HP33C	\$129	(\$115)
HP34C	\$216	(\$192)
HP11C	\$195	(\$172)
HP12C	\$216	(\$192)

## CASIO —

602p	\$171	(\$150)
702p	\$233	(\$205)
FA-2	\$46	(\$40)

## FP-10 PRINTER

	\$114	(\$100)
PACKAGE 702p, FA2,		
FP-10	\$383	(\$335)

## TEXAS INSTRUMENTS —

Ti59	\$290	(\$255)
Ti58c	\$128	(\$111)
PC100C	\$237	(\$210)

ALL POST FREE

**PHONE**  
**(02) 629 2333**

**SUITE 4,**  
**THE VILLAGE CENTRE,**  
**29-31 WINDSOR RD,**  
**KELLYVILLE,**  
**NSW 2153.**

# Calculator & Computer

DISTRIBUTORS



**SANYO**  
**DM8112CX**

**12" GREEN PHOSPHOR**  
**VIDEO MONITOR**

The new DM5109CX solid state data display is a precision engineered product designed for use with the computer system which outputs a composite video signal.

This picture tube employs on implosion proof, green phosphor. This data display is equipped with DC restoration (In the absence of a data signal, the data display screen will be fully black: no raster). Solid state electronics used in the DM5109CX provides improved reliability and superior performance even in continuous duty applications.

**\$100 SPECIALISTS**

## AED MICROCOMPUTER PRODUCTS

130 MILITARY RD GUILDFORD, NSW PHONE (02) 681 4966

The new DM8112CX solid state data display is a precision engineered product designed for use with the computer system which outputs a composite video signal.

This picture tube employs on implosion proof, green phosphor. This data display is equipped with DC restoration (In the absence of a data signal, the data display screen will be fully black: no raster).

Solid state electronics used in the DM8112CX provides improved reliability and superior performance even in continuous duty applications.

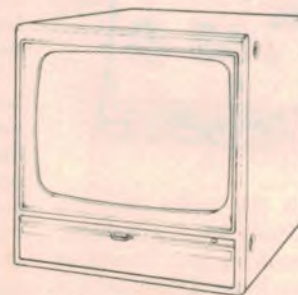

**9" GREEN PHOSPHOR**  
**VIDEO MONITOR**

**SANYO**  
**DM5109CX**



## New Products

### Light box & developer tanks from Kalextronics

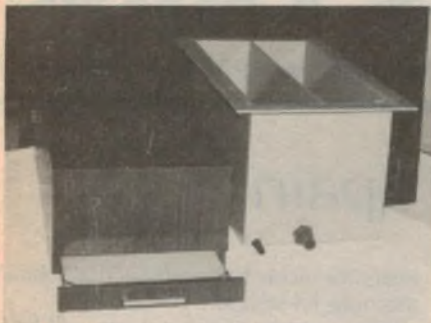

The recent introduction by Kalex of their new UV Light Box and range of Developer/Etch Tanks is seen as filling an urgent need in the "in house" manufacture of printed circuit boards and self adhesive panels and labels based on photo-sensitive products.

They provide a low cost alternative to users of "Riston 3000" pcb material and 3M Scotchcal and Image and Transfer material. Up till now such users have had the choice of high capital cost, full scale industrial production plant, or "do it yourself" equipment.

The Light Box incorporates many new features including fully flexible electronic timer and safety auto-shutoff. Kalex are interested in distributor enquiries in all states (see advert p25).

### Economy multimeters from Altronic

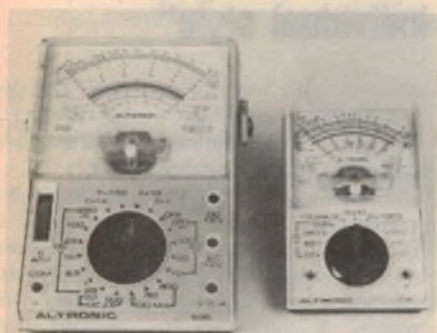

Altronic have introduced two economy multimeters. The first is very small, has eleven ranges and a DC sensitivity of  $2k\Omega/V$  making it suitable for automotive and non-critical electronic service. Price is just \$12.50.

The larger model priced at \$22.50, has  $20k\Omega/V$  sensitivity and 23 ranges making it more suitable for general electronic service.

Both meters are available with a vinyl carry case which will be included free to any reader ordering during June who mentions this news item.

# 50 & 25 YEARS AGO

"Electronics Australia" is one of the longest running technical publications in the world. We started as "Wireless Weekly" in August 1922 and became "Radio and Hobbies in Australia" in April 1939. The title was changed to "Radio, Television and Hobbies" in February 1955 and finally, to "Electronics Australia" in April 1965. Below we feature some items from past issues.



June 1932

**Blattnerphone:** A feature of British educators work in connection with broadcasts to schools has been the extensive use of the new German recording apparatus known as the "Blattnerphone". With this device, an entire 20-minute talk can be preserved on a magnetised steel tape and reproduced when desired.

☆ ☆ ☆

**AVC:** An ingenious method for avoiding overloading on local stations with powerful receivers. A few weeks ago we mentioned the subject of automatic volume controls and ever since we have noticed a lot of interest displayed in this subject.

In America the most popular scheme seems to revolve around the use of an extra valve, operating solely as an automatic volume control. Such an idea may be quite all right in America, where valves are quite cheap, but we cannot imagine that it would appeal to the Australian public.

☆ ☆ ☆

**Button Mike for Interviews:** Measuring less than  $1\frac{1}{4}$ in diameter by  $\frac{1}{4}$ in thick and provided with a handy clip, the new lapel mike is worn by speakers for complete freedom of action and a more natural performance on the stage or in the open. Radio interviews are said to be made free by its inconspicuousness.

☆ ☆ ☆

**Television prospects:** It seems that radio would not be as popular today as it is if it were not for the fact that the radio does not require one's whole attention. In the average suburban home the radio belts away all day and evening, and everybody in the home carries on his or her work or play, only hearing the radio in a sub-conscious way. So we do not think, even if television is introduced, that the whole family will care to sit around in a circle and concentrate their attention on a flickery image on a small screen.



June 1957

**Tetra transistors:** A dual-triode transistor, with emitter of one unit and collector of the other section of same germanium region, provides performance of two triode unit with considerable reduction of circuit components when compared to two individual units. A superheterodyne receiver in which first four stages are replaced with two tetra-junction units is described. This information appeared in Electronics for April 1957 as a Hazeltine report.

☆ ☆ ☆

**Paris fights noise:** The city that amazed the world by successfully silencing its auto horns and cutouts, and even muffling its all but irrepressible motor-cycles, will now try to pull off another miracle. The Paris Municipal Council is going to throw all its battle-trained anti-noise forces into a spring offensive against blaring radios.

Meanwhile, the hubbub-hating officials of Paris have been digging deeper to get at the source of another urban noise problem. They are putting rubber tyres on Paris subway trains. In the past half-year, they have "rubberised" two of the 12 main lines in the Paris "Metro" network, and the experiment has proved so soothing to "rush-hour nerves" that the subway management plans to spend another £100,000 to put rubber tyres on every subway train in the city.

☆ ☆ ☆

**Electric toothbrush:** A Brisbane dentist, Dr H. Goldfinch, recently returned from Japan with an electric toothbrush. Dr Goldfinch said the Japanese used the brush with sodium fluoride toothpaste to clean teeth and also combat decay.

The process was similar in principle to the electrolytic process of metal plating, he said. The electric current in the brush transformed the solid fluoride chemical into liquid fluoride, which then washed over the teeth with the movement of the brush. Brushing teeth with an electric toothbrush causes a faintly tingling sensation.





REVIEWS OF RECENT

# Records & Tapes

CLASSICAL • POPULAR • SPECIAL INTEREST

## ALBENIZ/WILLIAMS: "Echoes of Spain"

**ALBENIZ — Echoes of Spain.** A recital of mostly well known piano pieces transcribed for guitar. John Williams (guitar). CBS Audiophile Mastersound Stereo digitally recorded CB-331.

These pieces, all by Albeniz, are transcribed from piano solos, yet the real talent of Williams goes far to suggest that they were originally composed for classical guitar. At any rate, worthwhile literature for guitar has still to be created and its players are always handicapped by its paucity. Think of how often the Concerto of Aranjuez crops up on discs and in concerts.

It is strange but very true that much good "Spanish" sounding music has been written by non-Spaniards, many of whom never set foot in Spain: Rimsky-Korsakoff, Ravel, Tchaikovsky, Chabrier, to mention only the best known. What gives Spanish music its characteristic sound is the tuning of the guitar in fourths: the string sections of other European music tune in fifths.

Another reason is that, until fairly recently, Spanish music was dominated by Spanish players, mostly flamenco, the classical players having to rely on transcriptions. Bach always figured largely — to make up a recital program. The greatly gifted John Williams can play any kind of music on his classical guitar — and classical Spanish, Flamenco, and even Jazz. And all equally well!

### DIGITAL AT ITS BEST

Let me interpose here that I think that the engineering of this disc also demonstrates digital at its best. It captures the exact timbre of a guitar played in a chamber music hall — one like the small chamber off the main big hall in the Beethoven Halle in Bonn which I visited some years ago. The suspended notes last just the right time until they fade or are cut off by the performer. The engineer is perforce restrained from assaulting the ear and exercises so faithful a reproduction that you'd be prepared to swear that Williams was in



the room. Moreover he keeps his dynamic range exactly suited to his surroundings.

Indeed, there is a bloom on his instrument that I have never heard recorded before, even by his great master Segovia. Occasionally you hear one of Williams' fingers press a stret but you'd hear that anywhere except perhaps in London's Albert Hall in the old days where, as Artur Schnabel once said to me: "It is the only hall in the world where a pianist

hears the echo before he actually hears the note he struck!"

Many readers of this column will have heard many of the pieces before, usually on a piano. They pay tribute to the variations of style in different Spanish cities — Granada, Asturias, Seville and so on with a couple of short extra pieces, a Tango and Zambra Granadina thrown in. Williams plays them peerlessly.

You have romance in Granada, wonderfully smooth accenting in Asturias, not quite such steady rhythm in Seville but with an enchanting slow interlude in the middle. Majorca was new to me but is equally appealing. In Cordoba, Williams starts with a quiet almost bell-like Russian effect that I found engagingly novel, just before he goes on to its well-known melody. The Tango will bring back memories to the older listeners and I wager a tear to many a female eye. Altogether a masterpiece of a disc in every way. (J.R.)

## MICHELANGELI: "Strongly individual style"

**BRAHMS — Four Ballades**

**SCHUBERT — Piano Sonata in A Minor.**  
Arturo Benedetti Michelangeli (piano).  
DGG Digital Stereo Disc 2532 017.

The first of the Brahms Ballades is of unusual interest because it has a program — The Scottish ballad "Edward" — and Brahms very seldom wrote program music, ie, music which sets out to tell a story. This, together with the fact that the soloist is Michelangeli, adds to the interest — and enjoyment.

The ballad is in form of question and answer, when a mother wants to know why her son has come home with blood on his sword. Question and answer in this piano work are unmistakable and Michelangeli, who always has his own way of doing things, gradually builds the piece into a gruesome climax.

The splendour of this climax is overwhelming, especially as it slowly

declines into macabre silence. The second ballade is almost in the form of a berceuse and continues in this style coaxingly played by the pianist.

Brahms called the 4th Ballade an *Intermezzo*. Under Michelangeli, it becomes a restless work, going from mood to mood without warning and exploiting a great variety of sonorities. This makes it necessary to explain that Michelangeli plays all these pieces on a 60-year-old piano, not a veteran as pianos go, but one with a lovely patina on its tone and one that is obviously loved by the player.

Indeed, the manner in which this piano tone is caught is one of the best examples of digital recording that I have so far heard. Seeing that the record was made last year, that makes his piano a product of the early 1920s, some 20 years older than the Bechstein I learned on. This had a beautifully clear treble — which of course I didn't appreciate in those days — but not the lovely resonant



bass of a Bluthner of the same period.

Pianos are not like violins and other instruments of the string family. While good strings improve with age and playing, the piano tends to deteriorate. The movement tends to rattle; likewise, the keys. But Michelangeli's instrument has been tended with loving care and maintained in the state in which it emerged from the Bechstein factory.

Michelangeli stresses his strongly individual style in the last ballade, a kind of rhapsodic love song in a nocturnal mood. In this he seems to listen to the tone he produces with even more attention than usual — which is always very keen. Not everyone will welcome this deviation from the orthodox. I loved it!

Michelangeli attacks the first movement of the Schubert Symphony so that the first subject contrasts superbly with the second. He spreads his interest all over the keyboard in almost a Schumanesque manner but never for a moment relaxes his firm rhythmic control over the dotted rhythm (6/8) passages and knits together with unchallengeable logic the various opposing elements.

The strict time he maintains in the Allegretto is reminiscent of "the saunter through the Prater" in the big C-major Symphony. The only slight changes occur when something unusual seems to attract his eye. But his tempo makes it clear that, despite his enjoyment of the walk, he has no intention of being late for luncheon!

He is not afraid to develop his virtuosity in the Finale which he takes with unashamed brio. And although I must repeat my admiration for the digital recording, I have to add that no piano was ever made to sound like this instrument in Schubert's day. (J. R.)

## DEBUSSY/ARRAU — Pictures in sound

**DEBUSSY — Images and Estampes for piano solo. Claudio Arrau (piano). Philips Analog Stereo Disc 9500 965.**

In this recital, Arrau seems to have chosen pieces which express more strongly than others among Debussy's piano music the musical picture suggested by the title. He gives "Evening in Granada" the mood of a romantic Spanish night with a habenera hovering in the background. His "Gardens in the Rain" calls up impressionistic glimpses of alternate rain and sunshine in April.

"Pagodas", inspired by an Indochinese exhibition in Paris, is more static; "Reflections in the Water" is nothing like Ravel's sparkling fountain but rather the deep and often treacherous sea. "Bells through the Trees" sounds just like that; no clanging but a nostalgic atmosphere

## "THE PINES" — LIMITED EDITION

**RESPIGHI: Feste Romane; The Pines Of Rome. The Cleveland Orchestra conducted by Lorin Maazel. Stereo, "Original Master Recording", Mobile Fidelity Sound Lab MFSL 1507.**

**From Emerson Radio (Aust) Pty Ltd, 106 Belmore Rd North, Riverwood, NSW 2210. Phone (02) 534 5266.**

What is an "original master recording"? As used by Mobile Fidelity Sound Lab, and carrying their trademark symbol, the term refers to a disc that has been processed with the greatest possible care from an original master tape, itself of outstanding merit. "Greatest possible care" refers in this case to an Ortofon cutter, with a top quality tape deck and recording lathe, both operating at half speed, and a limited number of pressings made from the stampers, in special quality vinyl. You've heard it all before, of course, from the makers of other audiophile discs!

The performance itself is not a recent one, with the copyright being acknowledged to Decca and London Record Company in 1977. And, although I don't have what I presume would have been an earlier standard issue, the cover design looks rather familiar.

However, one doesn't have to listen for long to "Feste Romane" on side 1 to gain the impression that this is a very modern cut that could as easily have come off an equally modern digital master. But, no; with a 1977 dateline, it just has to be a traditional analogue tape, albeit a top-line tape, which has been revealed in a new light by specialised — if costly — disc making techniques.

The bass is quite massive and the sound content enormously complex as

of autumn always present. In "Goldfish", the title is self explanatory. And so on till simple titles like "Movement", a perpetuum mobile, "Homage to Rameau", and so on.

There are nine pieces altogether, all played poetically. In some he follows Debussy's desire to make the piano sound as if it had no hammers. At other times he plays with both pedals held down all the time; this he does much more successfully than the procedure used by Roger Woodward in the first movement of Beethoven's "Moonlight" Sonata, when he probably didn't take into consideration that Beethoven's old Broadwood didn't have the same sustaining power as a modern grand.

But Arrau doesn't always seek delicate impressionistic washes, for in "Reflection in the Water" he achieves a truly grand climax while in "Homage to Rameau" Debussy pays generous tribute to the many sides of that composer's genius.



Respighi portrays the tumult of the crowd in the Roman circus and the frantic clamour elsewhere. To accommodate the signal, without risk of groove breakdown, MBSL engineers have run the grooves almost to the label on this side.

"The Pines" is more restrained, as a whole but there are climactic passages nevertheless, particularly in "The Pines of the Appian Way", as Respighi re-lives some of the scenes of the past — a very easy thing to do, even in the 1980s, despite the cars, buses and bitumen.

The Cleveland Orchestra under Maazel gives an impressive account of all this, as might be expected from MFSL's choice of the performance for special re-issue. However, in drawing attention to it, one should also remind readers of Julian Russell's review in the February '81 issue of a new record club performance by Seiji Ozawa and the Boston Symphony Orchestra, which contained also "The Fountains of Rome". Said Julian: "A new recording of considerable merit . . . The Fountains is my favourite among the three suites".

Choices, choices! (W.N.W.)

The analog sound is excellent, especially when the after-sound of struck notes hangs magically in the air. He plays "Movement" with fluency but quite without flashness, not making it an example of empty virtuosity. His "Bells" is a lovely bit of musical landscaping. Debussy, together with Arrau, put their "Goldfish" into a misty pool and not a glass bowl and it's under this veil that they move, sometimes darting, sometimes hovering. Yet Debussy was not inspired by the fish or pool but by a beautiful piece of Japanese lacquer.

There is an antiquity about the sound of the "Moon Sinking Over a Ruined Temple" that reminds one of a similar atmosphere that permeates his score of his opera "Pelleas and Melisande". "Pagodas" has naturally a Chinoiserie style but in remembered snatches of things seen. By the way, the piano "Images" are not to be confused with the three long orchestral suites of the



## A BRITISH OCCASION — IN AMERICA!



**MUSIC FROM A ROYAL WEDDING.** Diane Bish playing the Ruffatti Organ. Stereo, Word Medallion Series WSB-8869. (From Word Records Aust, 18-26 Canterbury Rd, Heathmont, Vic 3135).

Branching out from their normal "Gospel" format, Word Records have announced the new Medallion series, presumably intended for those interested in religious music of the more formal or classical variety. This is one of the first in the series.

To Australian ears, it may have something of an anomalous character — organ music identified with British Royal weddings and other occasions, played by a lady organist in tailored velvet, on the organ of the Carol Ridge Presbyterian Church in Fort Lauderdale, Florida.

In saying this, I am not trying to detract from Diane Bish's reputation as an experienced and capable organist; it's just that an Australian (or other non-American) organ buff would tend to expect and prefer a British recording of such distinctly British occasional music.

In terms of pipe ranks and decibels, the Ruffatti organ at the Carol Ridge Church would seem to be quite an instrument but, as heard on the recording, the sound tends sometimes to be more massive than musical. Registration, acoustics and the balance of the recording might all have had something to do

with it but, on my system, which I normally play "flat", it proved helpful to boost the treble slightly and reduce the bass.

The actual track titles are: "The Trumpet Voluntary" (Jeremiah Clark); "Westminster Abbey" (Henry Purcell); "The Water Music Suites" (George Frederick Handel); "Fanfare in C", "Bell Symphony in C" (Henry Purcell); "4th Pomp and Circumstance March" (Sir Edward Elgar); "Trumpet Tune and Air" (Jeremiah Clark); "Air in F" (Handel); "Crown Imperial Coronation March" (Sir William Walton); "Choral Prelude on Rhosmedre" (Vaughn Williams); "God Save The Queen" (Purcell); "Toccatto from the 5th Organ Symphony" (Charles Widor).

The cover notes describe Diane Bish's playing as "Stunning, virtuoso, fiery and astonishing" but it would be unfair to pass comment on the basis of a recording as ponderous as this one. Indeed, the most convincing track on the disc is the very last — the well known Widor Toccatto. (W.N.W.)

## DEBUSSY — continued

same name. In "Gardens under Rain" listen carefully for a couple of French nursery songs hidden behind the raindrops, but don't bother if you don't know them. (J.R.)

☆ ☆ ☆

**JUST FOR YOU. Pepe Jaramillo. World Record Club R 08604**

If your taste in relaxing music runs to piano playing of a high standard in a popular vein, then this offering from The World Record club is certainly worth a hearing.

Included are: Just For You — Love Is In The Air — My Love — The Touch Of Your Lips — How Deep Is Your Love — Distant Horizon — That's When The Music Takes Me — Walk In Love — I Only Have Eyes

For You — A-Ba-Ni-Bi — It Must Be Him — Rivers Of Babylon.

Most of the tracks are played with a distinct Latin flavour, with the backing of the Tony Osborne Orchestra, making in all an easy-to-listen-to program. The sound quality is good except for a slight break-up on some of the louder piano passages. In fact, the overall recording level seemed to be fairly high. (N.J.M.)

☆ ☆ ☆

**ESCAPE TO THE LIGHT. Rusty Goodman. Canaan CAS 9864. (Distributed by Word Records Aust, 80-26 Canterbury Rd, Heathmont, Vic 3135).**



There is plenty of musical talent around in the Gospel music field these days and Rusty Goodman is another voice with a worthwhile message.

Ten tracks, ranging from up-tempo to gentle ballad style, make up the album: Jesus Knows All About It — Heartmender — Paradise — Only For His Eyes — I Escaped To The Light — All I Ever Have To Be — Hold On — The Woodsman — I Am — Wrapped Up.

With 22 backing musicians and six background singers, the sound is fairly rich and, with excellent diction, there is no problem in following the lyrics. These, by the way, are printed on the inner sleeve. The sound quality is up to the usual "Word" high standard. (N.J.M.)

For information on World Record Club albums, contact the club at 605 Camberwell Road, Hartwell, Victoria, 3124. Tel. 29 3636.

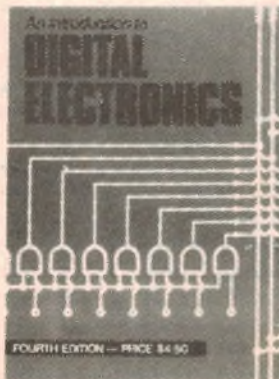

An Introduction to

## Digital Electronics, 4th Edition

Electronic equipment now plays an important role in almost every field of human endeavour. And every day, more and more electronic equipment is "going digital". Even professional engineers and technicians find it hard to keep pace. In order to understand new developments, you need a good grounding in basic digital concepts, and An Introduction to Digital Electronics can give you that grounding. Tens of thousands of people — engineers, technicians, students and hobbyists — have used the previous editions of this book to find out what the digital revolution is all about. The fourth edition has been updated and expanded, to make it of even greater value.

Available from "Electronics Australia", 57 Regent St, Sydney. Price \$4.50. Also by mail order from "Electronics Australia", PO Box 163, Chippendale 2008. Price \$5.40.



# DAVID REID ELECTRONICS



IF YOU'RE INTO  
ELECTRONICS  
COME IN AND SEE US!

WE'RE A POSITIVE FORCE IN SYDNEY AND THE  
LARGEST ELECTRONICS DISTRIBUTOR IN NEW  
ZEALAND — WITH THOUSANDS OF ELECTRONIC  
PRODUCTS, COMPONENTS AND ACCESSORIES

YOU'LL SEE THE SIGN

**DAVID REID ELECTRONICS LIMITED**

Takapuna • Auckland City • Te Papapa • Hamilton  
Palmerston North • Petone • Wellington  
Christchurch • Dunedin • Sydney

# THE DICK SMITH SYSTEM 80 — TRS 80 SOFTWARE CATALOGUE



Dick Smith brings you this superb catalogue choc-a-bloc full of software for your System 80 (and TRS 80 with Level II BASIC).

Inside are details of:

- 1) Educational Software, a great way to introduce your children to the growing world of computers
- 2) Business Software, specially designed to help make your business more efficient and profitable.
- 3) Games, with plenty of excitement to give endless hours of fun in the comfort of your own home

**AVAILABLE IN ALL STORES!**

Why not call in to your nearest Dick Smith retailer and pick one up or send the coupon below

**SEND TO:  
INTERNATIONAL MAIL ORDERS  
DICK SMITH ELECTRONICS  
PO BOX 321, NORTH RYDE  
NSW 2113**

Please send me a copy of the Dick Smith Software Catalogue.

NAME .....

ADDRESS .....

DSE A227M PAI

## BASIC ELECTRONICS



## Basic Electronics

For the beginner, or for the hobbyist as a reference book and almost certainly the most widely used manual on basic electronics in Australia.

It is used by radio clubs, in secondary schools and colleges, and in WIA youth radio clubs.

Begins with the electron, introduces and explains components and circuit concepts, details the construction of simple receivers. Separate chapters on test instruments, servicing, amateur radio, audio techniques, stereo sound reproduction.

Available from "Electronics Australia", 57 Regent St, Sydney. PRICE \$3.50 OR by mail order from "Electronics Australia", PO Box 163, Chippendale 2008. PRICE \$4.40.

# PROFESSIONAL SCOPE PROBES

(As used by AWA, BHP, CSIRO, Universities, Techs etc.)

**AT LESS THAN  
HOBBYIST PRICES!!**

**\$29.50**

Inc. Sales Tax, \$25 Tax Free



P&P FREE.

Generous quantity discounts.



Supplied complete in deluxe heavy duty plastic pouch

COLINE SP100

passive probe incorporates

a 3-position slide switch in the head and has a cable length of 1.5 metres

**SPECIFICATION:** Position x1 Bandwidth: DC to 10MHz • Input R: 1M (scope input) • Input C: 40pF • scope cap. • Working Voltage: 600Vdc (inc peak ac)

Position Rel Scope input grounded. Probe tip grounded through 9M  
Position x10 Bandwidth: DC to 100MHz • Risetime: 3.5nS • Input R: 10M when used with scopes having 1M input (probe 9M + 1%) • Input C: 11.5pF when used with scopes having 30pF input capacitance • Compensation Range: 10-60pF • Working Voltage 600V dc (inc peak ac)

See Coline SP100 probes at leading electronics stores or call

**ELMEASCO**  
Instruments Pty. Ltd.

Sydney	736 2888	Brisbane	229 3161
Melbourne	233 4044	Perth	398 3362
Adelaide	271 1839		



## RECORDS & TAPES continued

**SILVERWIND.** Sparrow records SPR 1041.  
[From Spotlight Music, 262 Pitt St, Sydney. Phone (02) 264 7922]

Silverwind is a three member vocal group, two female and one male, with an eight piece backing group, who produce a bright, up-tempo Gospel sound on this 10 title album.

These tracks: Taking The Narrow Street – When I Looked In Your Eyes – Your Love – Give Him Your Heart, Child – I Don't Worry – I Am In Love – Ode To A Lost Innocence – Never Had A Reason – Walking This Road – I Will Bless The Lord.

Most of the titles have a very commercial sound about them but the lyrics are in the right vein. "Ode To A Lost Innocence" is a plea to the American people to return to the Christian faith of the founding fathers but the theme could apply to any country, including our own. The lyrics are on a sheet slipped in with the record. (N.J.M.)

☆ ☆ ☆

**HYMNS THAT HAVE LIVED 100 YEARS.**  
George Beverly Shea. World Record Club R10045.

This record, originally released on RCA, has been around for a long time but don't let that fact detract from the

enjoyment it can bring. Beverly Shea has for many years been involved in the Billy Graham Evangelistic Crusades and must be one of the best known voices ever in the sacred music field.

On this record, with backing from orchestra, voices and organ, he sings 12 hymns that have stood the test of time: Stand Up, Stand Up For Jesus – Holy, Holy, Holy – God Moves In A Mysterious Way – Rock Of Ages – Free As A Bird – Fairest Lord Jesus – The Spacious Firmament – Nearer, My God To Thee – O Sacred Head Now Wounded – My Faith Looks Up To Thee – Abide With Me – Sun Of My Soul.

The setting and pace of this music suits its age, but I feel that these hymns will still be around for a long time yet! The dynamics of the recording might lack some of the sparkle of more recent recordings but it can still bring inspiration to many. (N.J.M.)

☆ ☆ ☆

**THE LIGHT MUSIC SOCIETY ORCHESTRA.** Percy Grainger, etc. World Record Club R09871.

If one was to write the full title of this record it would take up quite a few lines but it is a collection of some of the delightful light music written by such

composers as Percy Grainger, Roger Quilter, Geoffrey Toye, Cecil Armstrong Gibbs and Henry Balfour Gardiner.

The Grainger compositions included are: Country Gardens – Molly On The Shore – Londonderry Air – Handel In The Strand – Mock Morris – Shepherds Hey. Other tracks are: Children's Overture (Quilter) – The Haunted Ballroom (Toye) – Dusk (Armstrong Gibbs) – Shepherd Fennel's Dance (Balfour Gardiner).

Even if you don't recognise the titles, you will recognise the music. These are the tunes that often show up as continuity themes in movies and TV features and as set pieces for orchestra. It's all very enjoyable. (N.J.M.)

☆ ☆ ☆

**WHITE HORSE INN.** His Master's Voice OCSO 1255. World Record Club release R09904.

Most people of mature years must surely be familiar with the melodies from "White Horse Inn", the work of composers, Robert Stoltz and Ralph Benatzky. Like most operettas, the plot is full of romantic intrigue and misunderstandings, but it provides an ideal excuse for the principals to burst into song at the slightest provocation.

Starring in this recording are Andy Cole, Mary Thomas, Rita Williams, and Charles Young, with backing from The Rita Williams Singers and the Tony Osborne Orchestra. The 12 tracks cover all the main music from the overture to the finale, with songs like White Horse Inn – Happy Cows – Goodbye – In Salzkammergut.

If memory serves me correctly, it's a recording that has been around for quite a while and one that is, for some reason, cut at quite a high level. But I found it quite enjoyable, nevertheless. (N.J.M.)

☆ ☆ ☆

**ALL ROADS,** Kevin Somerville. Fiasco Records, PO Box 255, Kingsgrove NSW 2208.

This record arrived at the office with a note from the artist, providing background information on the recording. It was made in New York at the Mediasound Studios, with backing from his band "The Streetfighters".

Kevin Somerville uses a mixture of styles from solid rock to a gentle ballad in nine tracks: The Best Of Me – Now I Lay Me Down To Love You – There's Nothin' A Little Bit Of Love Can't Change – Midnight Girl – That's The Way I Rock And Roll – All Roads Lead Me To You – Break It To Me Gently – Running Around – Looking For You. The balance is good throughout the album between the vocal and the backing, which provides a pleasant change from a lot of records one hears these days. (N.J.M.)

# Master Electronics the new Practical way.

• Copyright 1981



## Conquer the 'Chip' – Easy-Fast-Exciting !

**(1) BUILD YOUR OWN SOLID STATE OSCILLOSCOPE**

This professional instrument employs the latest state of the art components including I.C.s – all solid state precision construction.

**(2) READ AND UNDERSTAND MODERN CIRCUITS DIAGRAMS.**

You also obtain enough theoretical knowledge to design your own circuits.

**(3) CARRY OUT MORE THAN 40 EXPERIMENTS.**

Use your oscilloscope to SEE what happens in all circuits. Learn digital Electronics through your construction of a digital voltmeter

F  
R  
E  
E

To: The Australian School of Electronics,  
P.O. Box 108, Glen Iris, Vic., 3146.

A REGISTERED CORRESPONDENCE COLLEGE

Please send me without obligation your free colour brochure.

NAME: \_\_\_\_\_

ADDRESS: \_\_\_\_\_

EA5



# TCHAIKOVSKY 5th — Ormandy, the Philadelphia

**TCHAIKOVSKY: Symphony No. 5.** Eugene Ormandy conducting the Philadelphia Orchestra. Digital stereo, Delos DMS 3015. (From P. C. Stereo Pty Ltd, PO Box 272, Mt Gravatt, Qld 3122.)

Released earlier this year, this new Delos digital of the Tchaikovsky 5th is indeed a recent production. It was recorded in the historic "Old Met" in Philadelphia. A one-time spacious 4500-seat opera house, built in 1908 by Oscar Hammerstein I, the Met became a second home for the Metropolitan Opera and recording venue for the late Leopold Stokowski.

But, with the surrounding area falling into depression, the building lost favour until "rediscovered" in 1977 as a desirable recording venue for major works — environment notwithstanding.

For conductor Eugene Ormandy, this particular performance must have held many memories. It was way back in October 1931 that he first conducted the Philadelphia orchestra, stepping into a breach created by the sudden illness of Toscanini who was in turn, filling in for Stokowski. Ormandy made such an impression that he became Musical Director in 1936 and held the post until 1980.

And what better work for such an occasion than the Tchaikovsky 5th, with its familiar theme in the second movement



and its waltz-like third movement that might as easily have come out of "Swan Lake" or "Sleeping Beauty". Tchaikovsky himself felt self-conscious about the work for a time ("a certain gaudiness and artificiality") but later reacted much more warmly to it.

Those who do not know the work well will find it very listenable and the jacket notes inside give a detailed and progressive insight into the music.

In the notes, Harold Lawrence points out that the 5th Symphony exploits the full dynamic spectrum in the first four minutes but, while the digital system handles it well, it does so with typical "Delos" restraint, as distinct from the sometimes ostentation of Telarc.

The performance is as one would expect from Ormandy and the Philadelphia orchestra. The sound is clean and the pressing is quiet. In short, well worth consideration, if you have a place for it in your collection. (W.N.W.)

## **BILL WYMAN. Bill Wyman, A & M Records L37768 (Festival release).**

This solo album from Bill Wyman (a member of the Rolling Stones) shows his multi talents when he sings lead vocals, backing vocals, plays bass guitar, synthesiser, harmonica and also produces this self-titled album.

There are 10 tracks on the album, featuring two hit singles "(Si Si) Je Suis Un Rock Star" and "Come Back Suzanne". The other eight tracks are: Ride On Baby — A New Fashion — Nuclear Reactions — Visions — Jump Up — Rio De Janeiro — Girls — Seventeen.

The style of music is popular, with many memorable tunes. A very refreshing album. (D.H.)

☆ ☆ ☆

## **STARSTRUCK, (Movie Soundtrack), Mushroom Records L37783, Festival release.**

This Australian album contains songs and music from the movie "Starstruck".

The 13 tracks on the album are: Starstruck Overture — Starstruck — Gimme Love — Temper Temper — It's Not — Enough — Tough — Humming A Tune — I Want To Live In A House —

Body & Soul — My Belief In You — Turnaround — Monkey In Me — Starstruck Finale.

Six tracks are performed by the female star of the movie, Jo Kennedy. Other notable appearances are four tracks by "The Swingers" and one by "Mental As Anything".

You won't have to see the movie to enjoy the soundtrack. While the offbeat musical has been attracting the young in droves, it really does have a wider appeal. So too, does this fresh album. (D.H.)

**Watch out for the  
June/July issue of**

## **VideoMag**

**A companion magazine to  
"Electronics Australia"**

**but written for readers in-  
volved in video. Available  
at your newsagent June  
9th.**

# AMS

MAIL  
ORDER  
CENTRE

## TAPES CHEAP!

**BULK TAPES DISCOUNTED**

**TDK**

SA-X C90	SUPER AVILYN	
	DUAL COATING	10 for \$49
SA C90	SUPER AVILYN	10 for \$39
AD C90	ACOUSTIC DYNAMIC	10 for \$30
D C90	DYNAMIC	10 for \$24

**maxell.**

UDXL IIS C90	EPITAXIAL	12 for \$58
UDXL II C90	EPITAXIAL	12 for \$49
UDC 90	ULTRA DYNAMIC	12 for \$38
LN C90	LOW NOISE	12 for \$28

**BASF**

CRO <sub>2</sub> C90	CHROMDIOXIDE	10 for \$48
FE C90	FERROCHROME	10 for \$38
LH C90	LOW NOISE	10 for \$25

**VIDEO — OPEN REEL — METAL**

MAXELL, TDK, BASF, AKAI

SEND FOR COMPLETE TAPE PRICE  
LISTS — FREE

## HI-FI SYSTEMS

AMPLIFIERS, TUNERS, TAPE DECKS,  
TURNTABLES, SPEAKERS,  
HEADPHONES, RECEIVERS

OUR RANGE INCLUDES:

**Sansui PIONEER**  
**marantz AKAI**  
**SOUND DYNAMICS KSW**

## CAR SOUND

RECEIVERS, TAPE PLAYERS,  
BOOSTERS, EQUALISERS, SPEAKERS  
— INCLUDING

**PIONEER VOXSON**  
**ACCESSORIES**

CARTRIDGES, STYLII, CLEANERS,  
DEMAGNETISERS, DISCWASHER



PARABOLIC STYLUS —  
COMPLETE RANGE

**ortofon**

MOVING COIL  
AND MAGNETIC  
CARTRIDGES

**RING OR WRITE FOR  
FREE PRICE LISTS!**

**TAPE ORDERS:**

**ADD: PACK AND POST \$3.00  
PER ORDER AND SEND  
CHEQUE/MONEY ORDER TO:**

# AMS

MAIL ORDER CENTRE,  
135 HAWTHORN ROAD,  
CAULFIELD, VIC 3162  
(03) 528 1149

STOCK AT PRICES SHOWN AVAILABLE  
AT TIME OF GOING TO PRESS



# BIG SAVINGS for NZ hobbyists

## HEY KIDS (& elders!) LEARN ELECTRONICS THE FUN WAY

**FUN WAY VOL 1**  
4th PRINTING! 72 pages packed with 20 exciting projects to build ranging from an electronic siren to a beer powered radio! No soldering required. Safe and ideal for all ages.  
Cat. B-2600 P&P \$1.00



**FUNWAY VOL. 2**  
3rd PRINTING! 130 pages. Once you've mastered Vol.1 projects, this book will take you step by step through 20 projects while teaching you basic electronic laws, component codes etc. Make a home intercom, mosquito repeller, LED counter & other exciting projects.  
Cat. B-2605 P&P \$1.00



**\$5.95 NZ**

**\$7.95 NZ**

**GREAT RANGE OF KITS AVAILABLE!**

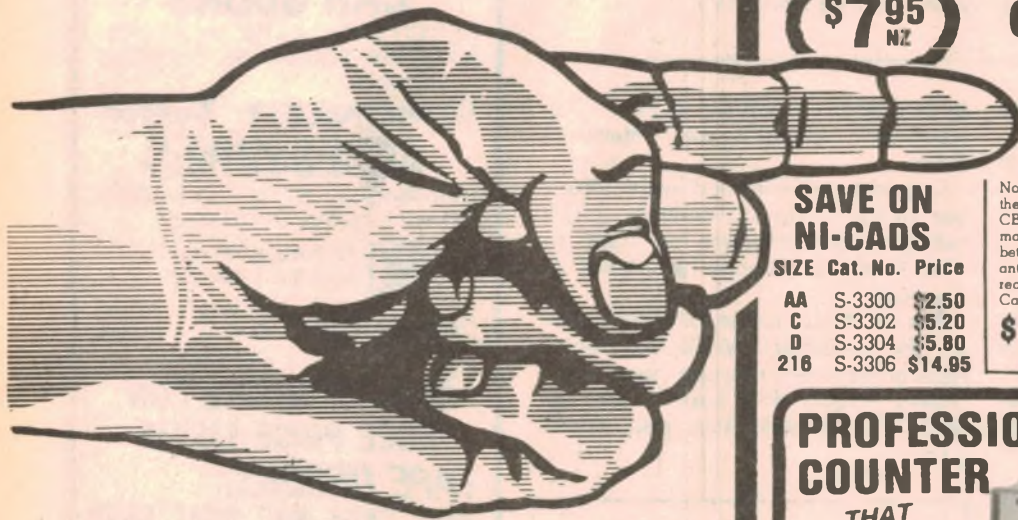

For the convenience of our thousands of New Zealand customers, Dick Smith Electronics now has a retail centre open in Auckland. With a large range of quality Dick Smith products (as much as we're allowed to bring into New Zealand), this store is open to both retail and wholesale customers. It offers prices up to 50% less — and more — than the prices you've been forced to pay in the past — and since we've opened, we've found many of our competitors' prices have dropped — which is good for all hobbyists, whether they're Dick Smith customers or not. We also have a large number of authorised re-sellers throughout New Zealand, so you're never far away from quality, value & service.

### SAVE ON NI-CADS

SIZE Cat. No. Price

AA	S-3300	\$2.50
C	S-3302	\$5.20
D	S-3304	\$5.80
216	S-3306	\$14.95

### POWER/SWR METER

Now you can measure the output power of a CB transmitter and the matching conditions between transmitter and antenna. Large easy to read measurements.  
Cat. O-1350



**\$19.95 NZ**

### PROFESSIONAL FREQUENCY COUNTER

Cat. K-3439

THAT YOU BUILD YOURSELF!!!



- Accuracy better than .005%
- Huge bright efficient 7 segment display
- 3 ranges - 0-10MHz, 0-50MHz, 10-500MHz (with optional prescaler)
- 4 gating times - 0.1, .1, 1, 10 seconds
- 4 period measuring ranges - 1, 10, 100 & 1000 input cycles
- PLUS MUCH MORE!

Based on EA design DEC '81 issue.

**\$139.50 NZ**  
P&P \$5.50  
Optional Instrument Case: ONLY \$31.50 (H-2505)  
Optional Prescaler 500MHz: ONLY \$45.00 (K-3432)

**ULTRASONIC TRANSDUCERS \$7.95 NZ EA**  
Hundreds of applications: alarms, TV remote control etc etc. Transmitter (L-7050), receiver (L-7052)





**"Why pay more when you can build your own computer & save \$\$\$!"**

# THE DICK SMITH SUPER 80

**No. 1 for quality & value!**

Imagine telling your friends that you actually built your own computer! Now you can with this superb kit. Not only do you end up with a powerful computer, you learn so much about computer technology while you are building it.

**LOOK AT THESE GREAT FEATURES:**

- Full size professional keyboard
- Cassette interface on board
- Budget tape 'BASIC' or optional 'EPROM BASIC'
- Supplied on board memory of 16K, expansion to 48K RAM
- On board video modulator - works on any TV
- All components on board except transformer
- S-100 expansion system for add-ons
- PLUS MUCH MUCH MORE!!!



**ONLY \$545 NZ**

Cat. K-3600 P&P \$5.50

**ACCESSORIES TO SUIT:**

Cassette BASIC to suit Super 80	Cat. K-3602	\$29.90
IC Socket Kit (recommended)	Cat. K-3603	\$18.50
ROM BASIC for Super 80	Cat. K-3604	\$120.00
\$100 Expansion System for Super 80	Cat. K-3606	\$39.75
Super 80 Character Generator	Cat. K-3607	\$109.50

**DATA SHEETS that save you time AND Money!**

How to Install your own Burglar Alarm	B-6000	\$1.95 NZ
How to Install your own TV or FM antenna	B-6010	75c NZ
A Guide to Printed Circuit Board Making	B-6005	75c NZ



**AM/FM TUNER MODULE**

Into low cost cost quality hi-fi? Then here's the one for your money!

- Loop stick antenna fitted for AM stage
- Accepts 12V-16V DC & has overload protection
- Built in FM muting, tuning & signal meter circuits
- Built in 19kHz & 38kHz notch filters for MPX stage
- Geared 5 gang variable capacitor
- High image rejection over 50 decibels.

**NZ \$139**

**COMPARE OUR PRICES SOLD ELSEWHERE FOR \$7.00!!!**

**57mm MINI SPEAKER**

This 57mm mini speaker has performance - in fact we found that it offered more performance than speakers up to 75mm in diameter! Nominal impedance of 8 ohms make it ideal for many purposes.

**WHY PAY MORE THOUSANDS OF USES**

**\$2.95 NZ**



**DEMAGNETIZE IT!**

Demagnetizes tape recorder heads, removing excessive noise levels & saving your tapes from possible loss of quality

**\$14.95 NZ**

Cat. C-7222 P&P \$2.00



**COMPUTER VERIFIED CASSETTE TAPE**

Famous 'Microsette' C10 cassette gives 5 minutes per side - over 40K capacity per side!

**\$3.95 NZ** Cat. X-3502

**One unnamed company sells a similar tape for \$18.00!!!**

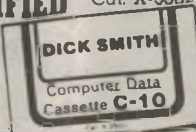

**FREE 2nd Edition NZ CATALOGUE!**

Packed with lots of goodies for Kiwi enthusiasts, hi-fi buffs, amateur & CB freaks, computer nuts etc etc etc.

If someone pinched yours from this magazine, don't worry. Just send \$1.05 to our address below. We'll take care of the rest!!!

DSE A269NZ

**LOW COST SIGNAL INJECTOR**

Check out both audio and RF circuits (harmonics extend to many MHz) simply and easily. Self contained, battery operated with probe and earth clips.

**AND ONLY \$11.80 NZ**

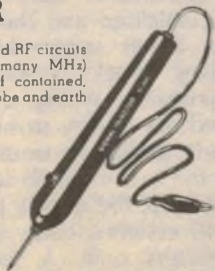

**INTERCOM PICK-UP**

Place suction cap to your phone or intercom etc. With lead & plug to connect to your amp or tape recorder.

**\$4.50**



**DICK SMITH Electronics**

98 Carlton Gore Rd. Newmarket Auckland. Tel: (649) 50 4409

Mail Orders: PO Box 9452, Newmarket NZ

**WHY PAY MORE?**

Store Hours: Mon - Fri 8.30am to 5pm.





# The Concord II bare-board microcomputer

*The Concord II from Bill Edge's Electronic Agencies is a "bare board" computer with some advanced features. High resolution graphics and sound effects are standard, and expansion to a colour system is easily achieved.*

by PETER VERNON

The Concord II is constructed on a double sided printed circuit motherboard, with a separate 410mm x 170mm PCB carrying the keyboard and a numeric keypad, both mounted in a sturdy aluminium panel. Eight 50-pin connectors on the motherboard provide plenty of room for expansion of the basic system.

The standard computer consists of a 6502A microprocessor, running at a clock speed of 1.02MHz, with 48K of RAM provided in the form of 4116 16K dynamic RAM chips. A powerful Basic interpreter and machine language Monitor is included on the board in six 2716 EPROMs. Also on the main board is circuitry for a 1500 baud cassette interface,

sound effects, input/output and a direct connection for the NTSC composite video signal.

Input/output consists of a single-bit output for a speaker (included with the system), and a "games interface", an empty 16-pin socket which allows connection of up to four potentiometers (joysticks) and three pushbuttons. Four latched TTL outputs are also provided together with one strobed output for single bit control of other peripherals. At the left side of the board are the eight 50-pin expansion slots which provide access to the data, address and control lines of the microprocessor. A large variety of expansion boards are available.

We tried out the Concord recently and found that, on the whole, it is an excellent system, with features normally only found on computers selling for twice the price. Our only criticism would be the keyboard. Although provided with sculptured keytops in a comfortable "stepped" arrangement, the keys themselves have a heavy feel but characters tend to be inadvertently entered with the slightest pressure.

Program editing is also difficult. Movement of the cursor, for instance, requires two keystrokes, "ESC" to enter the edit mode and then a letter key, such as "J" for left, "I" for up, "K" for right. Looking at the arrangement of the keyboard explains the choice of these keys, but we found them difficult to use because of what seems to be the slow keyboard scanning. While the first "ESC-I" combination moves the cursor up, the second keystroke often prints an "I". Lack of attention to detail at this stage leaves odd letters scattered through the program you are editing, if you are not careful.

With that gripe aside, let's move on to look at the Concord II in detail.

We tested the basic unit. Getting it running was a matter of connecting a power supply, plugging in the keyboard connector (a 16-pin dual-in-line header) and attaching a video monitor. On switching on, the speaker "beeped" as the system was initialised and then the Basic prompt, a left square bracket, and the flashing block cursor appeared. Experimentally typing a few lines, we found the display to be clear and rock steady, a pleasure to use.

In the text mode in which the system comes up, the display provides 24 lines of 40 columns each, with upper case characters only. A "chunky" graphics mode, in which each character cell is

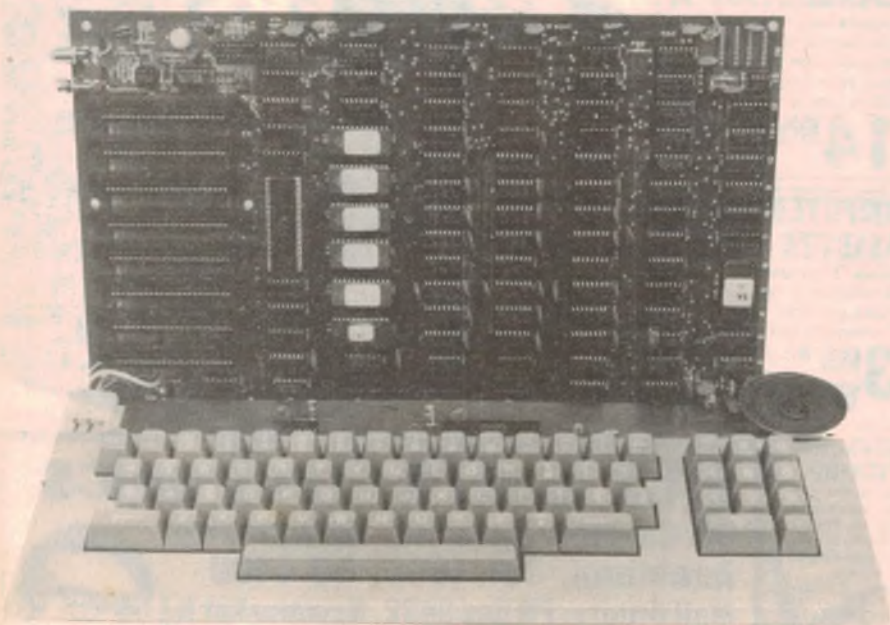

*Concord II computer provides 6502A processor, 48K of RAM and 12K of Read Only Memory with robust full-size keyboard and room for eight plug-in expansion boards.*



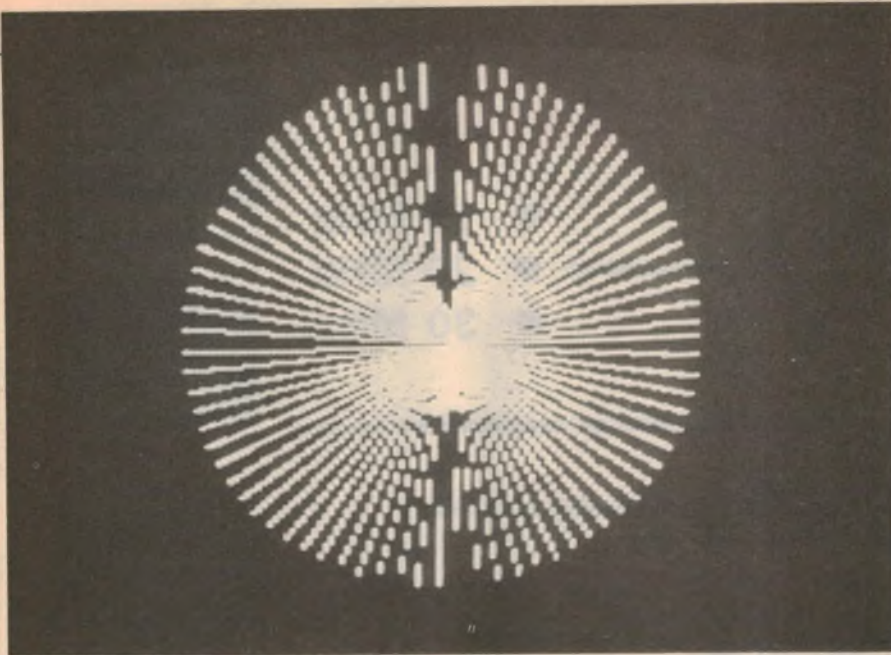

High resolution mode plots 280 x 192 points. Design is made up of line segments.

divided into four graphics points, provides 40 x 48 screen resolution for plotting graphs and charts, etc. A further high resolution graphics mode provides a resolution of 280 points horizontally by 192 points vertically for high definition graphics.

Addition of a PAL video board in one of the expansion connectors on the main board provides colour output. In the chunky graphics mode you can assign any one of 15 colours to any co-ordinate point on the screen, using the statement "COLOR=". In the high resolution graphics mode you have a choice of two groups of four colours each (including black, which of course resets a point, and white). These colours are specified with the statement "HCOLOR=".

We did not test the PAL option nor did we test the Concord using an NTSC monitor. However we did check all the colour graphics commands.

### Concord Basic for graphics

Concord Basic shows its Microsoft heritage, with all of the familiar statements and functions. (See below). Most of the unfamiliar statements have to do with the graphics of the system, which are extensively supported.

Perhaps the best way to convey the feeling of these graphics statements is to

follow the development of a simple program:

Firstly, for plotting in low resolution, we call up the graphics screen, with the statement GR. When this statement is executed, the text screen disappears. The display goes black except for four lines at the bottom of the screen called the "text window". Above the window is a 40 x 40 graphics area. If desired, we can eliminate the text window, allowing the full 40 x 48 line area to be used for graphics, by the statement POKE-16302,0.

The next step is to choose the colour we will plot in. For simplicity, we will use one colour, say dark blue. This is specified by the statement COLOR=2. To turn on co-ordinate point we use the statement PLOT X, Y, where X is between 0 and 39 and Y and 0 and 47. We can put a border around the screen, plotting horizontal lines with HLIN and vertical lines with VLIN. For example, a vertical line at the left hand side of the screen can be specified with VLIN 0,39 AT 0 — a line from row 0 at the top of the screen to row 39 at the bottom, at column 0, the left side of the screen.

Note that in programming graphics it is necessary to specify a colour code even when using a monochrome display, as we did. The default code is black, ie no

colour, in fact, no picture. On a black and white display the various colours show up as different shades of grey, so interesting half-tone graphics effects are possible.

If required, we can verify and determine what colour is displayed at any point on the screen with the statement C=SCRN (X,Y). When this statement is executed variable C will contain the colour code of the point X,Y. This allows us to manipulate points on the basis of their colour — very useful for graphics programs.

High resolution graphics are where the Concord really shines. Resolution in this mode is, as mentioned, 280 x 192. Although fewer colours are available, much finer lines can be plotted on the screen.

Two pages are available for high resolution graphics, initialised by HGR and HGR2 respectively. First step in using this mode is to set aside an area of memory to contain the graphics page. This can be done by setting LOMEM: 24576, setting aside 16K of RAM (two graphics pages) below the Basic program area. Alternatively, it is possible to set HIMEM: 8191, giving 8K for program memory and placing the graphics area above the program in memory.

Using one page of the high resolution graphics allows the use of the high resolution graphics statements. Use of the second page for graphics allows only the use of PEEK, POKE and CALL statements for setting up the display.

The high resolution graphics mode uses eight colour codes, but four of these produce either black or white, actually giving only four different colours, green, violet, orange or blue on the screen. HCOLOR= sets the colour code to a value between 0 and 7. Note the spelling of this command — "COLOUR" will produce a syntax error.

In high resolution mode, H PLOT X, Y will set a single point to the colour previously selected. Using H PLOT X1, Y1 TO X2, Y2 will draw a line between two points on the screen. Further refinements are possible with H PLOT X1, Y1 TO X2, Y2 TO X3, Y3 TO . . . which, as you might have guessed, draws lines between the points specified.

In addition to co-ordinate plotting, the Concord allows the use of "shape tables" to display and manipulate complex figures. After setting up a list of vectors (move up, down, left, right, etc) the shape can be displayed with the statement DRAW 1 AT X,Y, which will draw shape number 1 at the point X,Y. XDRAW erases the shape, without affecting the background. ROT= rotates the shape, in increments of about 3 degrees.

SCALE = provides the ability to

### Concord II Basic statements

END, FOR, TO, NEXT, DATA, INPUT, DEL, DIM, READ, GR, TEXT, PR, IN, CALL PLOT, HLIN, VLIN, HGR2, HGR, HCOLOR=, H PLOT, DRAW, XDRAW, HTAB, HOME, ROT=, SCALE=, SHLOAD, TRACE, NO TRACE, NORMAL, INVERSE, COLOUR=, POP, VTAB, HIMEM:, LOMEM:, ONERR, RESUME, RECALL, STORE, SPEED=, LET, GOTO, RUN, IF, RESTORE, GOSUB, RETURN, REM, STOP, ON, WAIT, LOAD, SAVE, DEF, POKE, PRINT, CONT, LIST, CLEAR, GET, NEW, TAB, FN, SPC, THEN, AT, NOT, STEP, AND, OR, SGN, INT, ABS, USR, FRE, SCRIN, PDL, POS, SQR, RND, LOG, EXP, COS, SIN, TAN, ATN, PEEK, LEN, STR\$, VAL, ASC, CHR\$, LEFT\$, RIGHT\$, MID\$.



# A NEW WAVE IS ON THE HORIZON



- 15 MHz
- 20 MHz
- 30 MHz



## National

Probes supplied as standard accessory

... **FROM \$389.00** (not including sales tax)

Available in four models VP-5215A, VP-5216A, VP-5220A and VP-5231A

— these low cost oscilloscopes feature:

- 1 mV/Div sensitivity
- Stable automatic trigger 'AUTO FIX'
- Full range of triggering mode
- Bright and sharp CRT with Auto Fix
- TV(V) and TV(H) sync separator circuit
- Rectangular tube, illuminated internal graticule (VP-5220A and VP-5231A)
- Built-in delay line for observation of pulse transient (VP-5231A only)
- High reliability — MTBF 15,000 hours

National have a wide range of scopes — to 300 MHz. Please call or write for further information.



### SCIENTIFIC DEVICES AUSTRALIA PTY LTD

2 JACKS ROAD, SOUTH OAKLEIGH, VICTORIA, 3167. PHONE: 579 3622.

31 HALSEY ROAD, ELIZABETH EAST, S.A., 5112. PHONE: 255-6575  
35-37 HUME STREET, CROWS NEST, N.S.W., 2065. PHONE: 43-5015



# Coming Next Month \* \* \*

## HEART RATE MONITOR



Ideal for joggers and fitness fiends, the portable Heart Rate Monitor helps you keep tabs on your ticker. It has an LCD readout for daylight viewing and adjustable gain to cater for heavy heart throbs or weak pulses. Just hold the case and get instant assurance that you are still alive.

### Commodore VIC20 reviewed

Over 1000 VIC 20's were sold in March of this year, so this computer has really taken off. We give a complete review of this colour machine.

### COMING SOON:

### CAR COMPUTER

### ON SALE:

**Wednesday, July 7th**

\* Our planning for this issue is well advanced but circumstances may change the final content. However, we will make every attempt to include the articles mentioned here.



## Review — the Concord II computer

draw the shape to any size by specifying a multiplication factor which is applied to the shape table.

Once designed, the shape table can be saved on tape using Monitor commands, and recalled with SHLOAD. The Monitor can also be used to set up high resolution graphics screens, with routines for writing to one screen as the other is displayed, allowing animated graphics for example.

We won't go into the intricacies of shape tables. Suffice it to say that considerable planning and thought must precede any attempt to design fancy graphics using this approach, but the results are worthwhile. Numerous programs are available on cassette which demonstrate these capabilities in games and other applications.

In the text mode a number of statements are available to add interest to text output. INVERSE, for example, will display text printed out in inverse (black on white) video. NORMAL will revert to standard white on black display, while FLASH will alternate between the two modes at about 15 times a second, adding interest to any text output.

Sound effects also add interest to programs, and the Concord is equipped to provide them. A single output bit connected to an amplifier and speaker on the board allows simple sounds to be produced. The speaker is used by the Concord interpreter to signal program errors, etc, and can be accessed by printing a Control-G character. More complex effects require machine language programs to toggle the output bit on and off at a selected frequency.

There are drawbacks to this approach of course. With the microprocessor occupied in switching of the speaker bit on and off, it can do nothing else, so sound effects cannot be co-ordinated with screen movement, for example. Further, there is no control over the volume of the sound — the speaker is either on or off. Despite this, the sound circuitry is a useful adjunct to various programs.

Also useful is the games interface. Any one of four potentiometers can be read with the PDL statement, which returns a value between 0 and 255 corresponding to the setting of the pot. Three push-buttons connected to this interface socket can be read by PEEKing the appropriate location. Four latched output bits and one strobed output can be used to drive relays, speakers or lights, etc, for peripheral control and communication with the outside world. All in all, the games interface, while simple, adds considerably to the usefulness of the Concord.

We have mentioned the machine language Monitor several times. The

Monitor program of the Concord is quite extensive, with commands for examining and changing the contents of single memory locations or blocks of memory, examining and changing the registers of the 6502 processor and saving and loading machine language data with a cassette recorder. Blocks of memory can also be moved around or compared with another block, or filled with a single character (useful for setting the background colour of the screen).

The Monitor can also be used for re-directing the input and output of the computer. If a printer interface board is in place in one of the expansion slots, a Monitor command allows output to be re-directed to the printer. Input can also be accepted from peripheral boards rather than from the keyboard, as when a modem board is used to turn the Concord into a remote terminal.

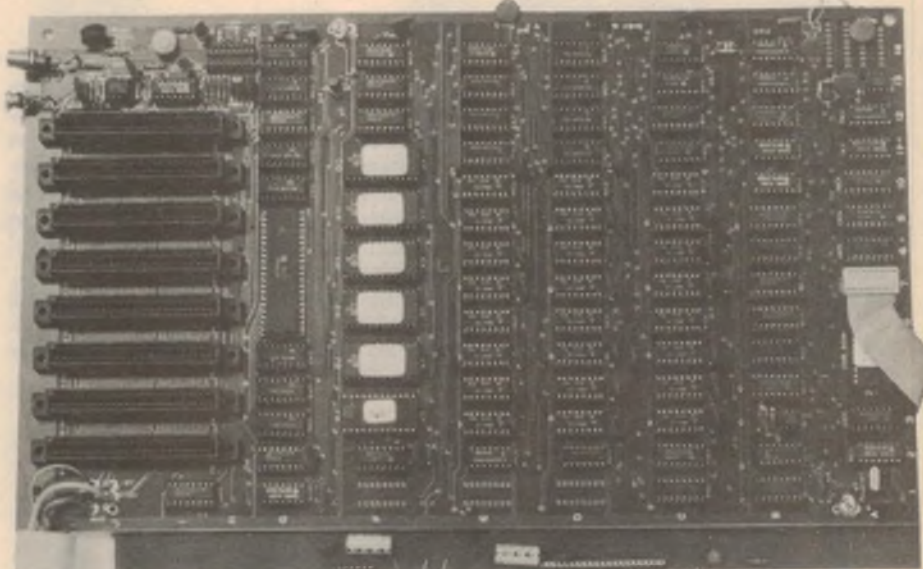

Close-up view of the processor board shows connector for keyboard at right.

Another useful feature is the ability to do hexadecimal addition and subtraction using the Monitor, simplifying the hand assembly of machine language routines. The Monitor is called from Basic with the command CALL -151 and the return to Basic by a Control -C.

### What's it all cost?

The Concord II computer described here costs \$899 fully assembled. No kit versions are available. A power supply is required, supplying +5V at 2.5A, +12V at 1.5A, -5V at 250mA and -12V at 250mA. Electronic Agencies can provide a suitable power supply for \$60.

For video output a number of choices are available. For monochrome video, you can use either a black and white video monitor (around \$140) or the video signal can be fed to a VHF modulator for display on an ordinary

television set. Electronic Agencies has a suitable modulator available for \$5.50.

For colour displays you can purchase a PAL video encoder board, for around \$220, which slots into one of the expansion connectors on the main computer board. A video modulator used in conjunction with this board enables colour displays on a standard colour television set. Alternatively, an NTSC monitor can be purchased (perhaps costing as much as or more than the computer itself) — a dubious choice.

One other refinement, a suitable case, may also be required. Certainly some protection for two boards costing \$899 will be necessary. Electronic Agencies have plans to produce a case, depending on demand. Initial price estimates range from \$80 to \$100, but these are estimates only.

The Concord II is advertised as being fully compatible with Applesoft (TM) programs and hardware add-ons for the Apple II computer. Certainly if you buy a

Concord there will be no shortage of software, and a large range of expansion boards are available, ranging from disk controllers to printer interfaces and appliance controllers.

Finally, if the Concord II sounds intriguing, but you're not sure, Electronic Agencies are offering a seven day free trial period. You can try the computer out in your own home, and if not satisfied bring it back (in original condition and packaging, of course) for a full refund of the purchase price.

Interested? Further information is available from Electronic Agencies, either at 115-117 Parramatta Rd, Concord (so that's where they got that name!), NSW, or at their new store at 123 York St, Sydney. The postal address is PO Box 185, Concord, NSW, 2137, and if buying by post there is a \$5 packaging and mailing charge.



# The System 80 'blue label' computers

Just released by Dick Smith Electronics Pty Ltd is a new "Blue Label" version of the System 80 computer. It includes both upper and lower case characters, sound effects and new programming features, yet costs less than the previous Mk I model!

by PETER VERNON

Most readers will be familiar with the features of the System 80. Just to summarise, the Mark I model includes a built-in cassette recorder with level control and tape counter for saving programs and data, a full size keyboard and 12K of ROM containing a powerful Microsoft Basic interpreter. Also included is VHF modulator so the computer can be connected to any black and white TV set. 16K of RAM is standard, although expansion is possible to 48K.

to 17 digits precision, although only 16 will be printed or displayed. For ordinary use this may not seem important, but in a long sequence of calculations individual round-off errors can accumulate to the point where answers become almost meaningless unless a high precision interpreter is used.

Other powerful functions such as ON ERR GOTO and the diagnostic commands "TRON" and "TROFF" are also provided as standard.

through an additional 1.5K of Read Only Memory which extends the 12K Basic interpreter. These functions include the new keyboard and display routines, the statement renumber command and a machine language monitor.

### Lower case

When it is first switched on, the Blue Label System 80 will not produce lower case letters. It is first necessary to enable the extra routines. This is done by entering SYSTEM, followed by a carriage return. The System prompt "\*" will appear, and "/12288" should be entered. After pressing the Newline key, a flashing block cursor will appear, indicating that the new features are enabled.

From this point on lower case letters are available by use of the Shift key. The computer normally operates in the upper case mode. Pressing the shift key in conjunction with a character key will give lower case (this is, of course, the opposite of a typewriter, but the same as a Teletype keyboard). In many ways this is a more logical arrangement for a computer keyboard, as commands and programs are normally entered in upper case. In the absence of a shift-lock key, it is the only sensible arrangement.

Another feature of the keyboard of the new machine is the "auto-repeat" function. This means that if any key is held down for more than about a second the character will be displayed on the screen again, and then again, repeating at intervals of about a quarter of a second. It's very handy, especially for the cursor control keys. Simply holding down the "left arrow" key, for example, moves the cursor left for as long as the key is held down.

While a flashing cursor is a great



The 12K Basic of the System 80 is a very powerful version of the language, with many features not available in smaller interpreters. Statements such as PRINT USING and PRINT@ are available to provide easy formatting of text output, and the full IF-THEN-ELSE sequence is available, rather than IF-THEN. When writing programs with a lot of conditional branches this full structure provides for a much more logical and efficient program structure.

System 80 Basic also provides a "double precision" arithmetic mode, with up

The Blue Label System 80 retains these features and adds more. The new System 80 has both upper and lower case characters, automatic repeat function on all keys, a built in amplifier and speaker for sound effects, a "screen print" facility, a flashing block cursor, a Basic renumbering routine and a machine language monitor program in ROM for developing programs in the actual machine code of the Z80 microprocessor.

Most of the extra functions available in the Blue Label System 80 are produced



attention-getter, some users may find that it is distracting. Fortunately for them the flashing cursor can be turned off. After enabling the new functions as previously described, pressing Shift/Break will turn off the flashing cursor. Pressing Shift/Break a second time will turn it on again. If you definitely don't want the flashing cursor, however, the new ROM functions can be enabled without the flashing cursor by entering /12299 instead of /12288 during the initial selection of the ROM functions.

The screen print routine is entered by pressing shift, down arrow, P. When entered the routine will transfer the information displayed on the video screen to the printer. If no printer is connected, or the printer, is off, the routine will skip printing, rather than locking up the computer while waiting for the printer to be turned on (a bad habit of TRS-80s and early System-80s).

Both alphanumeric and graphics characters on the screen will be transferred to the printer, but of course, only those printers which recognise the graphics characters will be able to print them.

Another new feature is the renumber command which is added to Basic. After the new ROM functions have been enabled typing "RE X, Y" will renumber any Basic program in memory, with the first line becoming number X and the following lines renumbered in increments of Y. For entering new lines into tightly packed programs or simply for making your programs look good this feature is invaluable. If you don't enter X and Y, by the way, the renumber routine will default to 10, 10 — just the way it should be.

The renumber routine is also very fast, and of course automatically takes care of matching GOTO and GOSUB with their correct destinations in the renumbered program.

## Sound Effects

Many programs written for the TRS-80 include a routine which toggles the cassette motor control relay on and off to produce tones of varying frequencies. With suitable programming quite extensive sound effects can be produced in this way. The lack of such sound effects when the same program is used on the System 80 has been on major incompatibility between the two computers.

This problem has been overcome with the Blue Label System 80. A simple 2-transistor amplifier and speaker is connected to two data bits of the cassette output port. Setting bit two of this port (FF) to "1" turns on the motor of either the internal cassette recorder or a se-

cond, external, recorder depending on the state or bit 4 of port FE. Setting bit two of port FF to "0" enables the sound effects, with bits 0 and 1 switched on and off to actually produce the sounds.

Each transition of either of these 2-bits produces a single "click" from the internal loudspeaker, while programs which toggle the 2-bits can produce a wide range of tones. Since 2-bits are used to drive the amplifier, toggling either one or both of these bits together allows the volume of the sound to be varied.

Using a Basic program to drive the speaker does not give any indication of the full range of sound effects available. For example, the program line:

```
10 OUT 255,0:OUT 255,1:GOTO 10
```

will produce a maximum frequency slightly above 100Hz because of the time taken by the Basic interpreter to execute the statements.

For best results, a machine language program must be used. With a suitable program, frequencies well above the audible range can be produced (this is of limited value, we admit). In fact most programs would incorporate a delay loop between toggling the speaker bits. The longer the delay, the lower the frequency of the sound produced. Once you get the hang of it, any sound can be produced.

## Machine language monitor

One drawback of the TRS-80 Model I is the lack of any convenient way to enter machine language programs into memory and run them. Using Basic requires a tedious conversion of hexadecimal object code into decimal which is then POKEd into free memory locations. Using a program such as T-BUG requires that the program cassette first be loaded before the T-BUG commands can be used.

The first version of the System 80 suffered from the same disadvantage — not particularly important for business users, perhaps, but an obstacle to the hobbyist interested in exploring machine language programs.

The machine language monitor of the Blue Label System 80 allows the user to enter, modify, display and execute Z80 machine language programs, set breakpoints and display and alter the registers of the microprocessor. As such it is quite a powerful monitor, and has the overwhelming advantage that it is resident in memory at all times.

To enable the monitor program you simply type SYSTEM, (NEW LINE) then "/12710". After the final NEW LINE the machine language monitor will display the contents of the processor's registers. Single letter commands then activate

particular functions of the monitor. For example, D6000 will display the 16 bytes of memory starting at location 6000 (all in hexadecimal). "R" will allow you to modify registers, while "B" returns to Basic. All in all there are five monitor commands.

Not available through the monitor is the ability to save and reload machine language programs from cassette. This can be overcome by first entering the program into memory via the monitor, then returning to Basic and reading the program with "PEEK" statements, which automatically converts each value to decimal. The machine language program can be read into an array which can be saved along with a Basic program.

## Manuals

A disappointing feature of the new System 80 is that it comes with the same old manuals, with a loose 4-page update sheet covering some of the new features and a stick-in paragraph or two on the renumbering command. The best of the three manuals are the User's Manual and "Programming for Beginners", which are profusely illustrated and well written. The "Basic Manual", though, is rather poorly organised, and here the Dick Smith publication "Easy Ways to Programming in Basic" for the System 80 is a worthwhile investment for beginners.

A cassette of demonstration programs is also provided with the computer. The first program displays a picture of "you know who" in the 128 x 47 resolution graphics mode of the system. The other programs are more useful, consisting of a cost analysis program, statistical plotting in bar graph format, a biorhythm calculator and a "Star War" game.

## The bottom line

Overall, we are very impressed with the Blue Label System 80. On a dollar per function basis it probably represents the best value around for a ready-built computer. Other systems can be bought for less, but ultimately they are not as powerful or as readily expandable as the System 80. There is also the matter of software, and here the System 80 really scores, with hundreds of compatible programs available for the TRS-80 as well as those specially written for the System 80.

Note also that the price of the System 80 (currently \$690) includes the built-in cassette recorder, while the internal RF modulator means that no special video monitor is required.

If you want a general purpose, "work horse" computer, at a price that won't break the bank then the Blue Label System 80 could well be the one to go for. ☺



## ELECTRONICS CENTRE

BARGAIN PRICES • PERSONAL ATTENTION • SLICK MAIL ORDER SERVICE • SATISFACTION

**\$28**  
EACH  
OR  
**\$49**  
PAIR



**\* SUPER SCOOP \***

### PIONEER Hi - Fi SPEAKER SYSTEM.

35 WATTS MAX. 25 WATTS NOM. 8 OHMS.  
MODEL A20-EP 70-01F. EXTENDED FREQUENCY  
RANGE. LATEST DESIGN SATIN SILVER VINYL  
COVERED CABINET. 48H 28W. 19D. CM.  
P-P NSW. \$4. V. Q. SA. T. \$5. WA. NT. \$7.50.

### TRIAxIAL 3-WAY HI-POWER CAR SPEAKERS

15 X 23CM. (6" X 9" WOOFER. 2 1/4" MIDRANGE 2" TWEETER.)  
100W. MAX. 35 W.R.M.S. 4-8 OHMS.  
FREQ. 60-20,000 HZ. ROLLED FOAM SURROUND IN BUILT CROSS-  
OVER. CHUNKY 570G. FERRITE MAGNET. SUPERSOUNDSOUNDSUPER.



**\$30 EA.** OR 2 FOR **\$57**  
P-P NSW \$2.50 P-P NSW \$3.50  
INTERSTATE \$3 INTERSTATE \$4.50

6" X 9" TOP QUALITY GRILLE FOR ABOVE  
SPEAKERS. MATT FINISH BLACK METAL. **\$5 PAIR.**



### GENUINE FACTORY PRICES ETONE 12" SPEAKER SPECIALS

GUARANTEED TOP QUALITY BRAND NEW BARGAINS  
Rugged diecast frame. 8 and 15 ohms available  
12" Woofer, 30 watts RMS Reson 65Hz Freq 50-8000Hz

**\$26.50** each OR 2 for **\$46.50**. P-P for 1 NSW \$3. Interstate \$4 50  
12" Twin Cone 30WRMS Reson 65Hz Freq 50-15,000Hz

**\$27.50** each OR 2 for **\$48**. P-P for 2. NSW \$4.50. Interstate \$6.50

### EXTRA SPECIAL — • LAST OFFER AT THESE PRICES.

12" 60 WATT RMS. 8 OHM HI-FI WOOFER.  
HEAVYDUTY DIECAST FRAME. FOAM SURROUND. FREQ. 30-4000Hz.  
RESON. 30Hz.

**\$32.95** EACH. OR 2 FOR **\$59.75** P-POST AS ABOVE.

### • AWA CARPHONE • TRANSCEIVER



76MHz. 3 CHANNEL • LOW BAND • FM •  
6 - 12 VDC SOLID STATE POWER SUPPLY • (INBUILT).  
22 MINI TUBES, 7 AND 9 PIN. PLUS TYPE 6146 IN FINAL •  
N.B. CRYSTALS ARE NOT SUPPLIED, NOR ARE THE SETS AIR  
TESTED • INTERCONNECTING CABLE AND CABINET IS  
SUPPLIED • CONVERSION TO 6 METRE BAND IS EASY • DATA  
AVAILABLE • WE GUARANTEE THE SETS TO BE COMPLETE AND  
IN EXCELLENT CONDITION •

**EX AMBULANCE \$35** P-P NSW \$4.50.  
V. Q. SA. T. \$7.50.  
WA. NT. \$11.50.

### LEDs.

TIL-220. 5mm RED. 10 FOR \$1.45  
TIL-220. 5mm GREEN. 10 FOR \$2.25  
P-P 60c.



### 240/250V 150W FLOODLIGHT

PAR 38 SEALED BEAM  
REFLECTOR LAMP

NORMAL PRICE \$6-\$7.  
**\$3.75** P-P 75c

### GEARED MOTOR

240VAC 50HZ 3W  
**\$3.50**  
P-P 75c



5 RPM Plenty of torque With Cam and  
N/O N/C microswitch 15 switch con-  
tacts per min OA size 65 x 60 x 35mm.  
Refer Dec 79 EA New Products  
Review.

### KRIESLER

240 VAC  
50Hz

BRAND NEW  
GUARANTEED

**\$66**



Features — big aluminium turntable • 2 speeds 33-45rpm • Cue lever •  
Calibrated adjustable counterweight • Calibrated anti-skate • Auto return-  
stop • Switch click suppressor • Power cable, RCA connectors •  
OUR BEST PRICE EVER. BE QUICK.

### BELT DRIVE STEREO PLAYER

• MAGNETIC  
CARTRIDGE AND  
DIAMOND STYLUS •

P-P NSW \$4.50  
Q. V. T. SA \$5.50  
WA. NT \$6.50



### EX — AWA CHASSIS. COVER

AND DETACHABLE  
CRADLE.

HEAVY DUTY  
ALUMINIUM

PROFESSIONAL FINISH

SIZE OA. 145 W. 110 D. 90 H. MM.  
CHASSIS SIZE. 145 W. 110 D. 33 H.  
MM.

**\$4.50** P-P \$1.50

### A1 QUALITY FIBREGLASS PRINTED CIRCUIT BOARD

350 x 81MM. 4 FOR **\$2.95**

P-P NSW \$1. INTERSTATE \$1.50.

### 6V and 12VDC VARIABLE OUTPUT EX-COMPUTER — SOLID STATE POWER SUPPLIES

TWO MODELS.

11 to 14.5VDC. at 12.5 AMPS. CONT. **\$69.**

P-P. NSW. \$4.

Q.V.T. SA. \$7.

4.5 to 7VDC. at 25 AMPS. CONT. **\$89.**

WA. NT. \$10.

PROFESSIONAL QUALITY • TESTED UNDER LOAD • GUARANTEED •  
FULLY FILTERED • REGULATED • THERMAL CUT-OUT • INPUT  
240VAC 50 Hz • SIZE 500 X 160 X 150MM • WEIGHT 15KG.



### ANOTHER BSR FACTORY SCOOP • STEREO RECORD CHANGER/PLAYER

MODEL C129R • 240VAC 50Hz • AUTO/MANUAL OPERATOR • 3  
SPEEDS, 33, 45, 78rpm • BIG 28cm PLATTER • CUE-PAUSE CON-  
TROL • 2 SPINDLES • CERAMIC CARTRIDGE • TEMPLATE, INSTRU-  
CTIONS •

**\$38.95** • LIMITED STOCK •

P-Post NSW \$4.50. Q, V, T, SA \$5.50. WA, NT \$6.50

### HEAVY DUTY POWER TRANSFORMERS

BRAND NEW STOCK.  
ALL 240VAC 50Hz. PRIMARY

PF2050. 0-285V. 250MA. 2 x 35V.  
1A. 6.3V. 4.5A. 6.3V. 1A.

**\$22.50**

Type 216. 325V-0-325V. 300MA.  
6.3V. 12A. 5V. 3A.

**\$22.50**

Type PVD 109. SEC HT 126, 136,  
146VAC. For voltage doubling to —  
330, 355, 380V DC 180MA SEC LT.  
6.3VCT 3A. 6.3V 4A.

**\$25.00**

Type H1. 285VCT. 180MA. 6.3VCT.  
6A. 5V. 3A.

**\$28.50**

Type H2. 300VCT. 250 MA. 6.3VCT.  
4A. 6.3V 8A.

**\$35.00**

P-P NSW. \$4.50. V. Q. SA. T. \$5.50.  
WA. NT. \$7.50.

### PUSHBUTTON KEYBOARD

**\$2.95** P-P 75c



8 TOUCH BUTTON SWITCHES AND 8  
RED LEDS MOUNTED ON PRINTED  
CIRCUIT BOARD. REF. PAGE 78. AUG  
1980 EA REVIEW.

### BRAND NEW TRANSISTORS.

SE 4010 BC 108. BC 327. 546. 547.  
548. 549. 556. 558. 559. 2N 4248.

**10 MIXED FOR \$1.**

BD 135. 136. 10 FOR \$4. P-P 75c  
MINIMUM ORDER \$5.

### Plessey Foster 180 watts (cont) 240W peak. Bass/lead guitar • Hifi • PA • Organ 15" speakers

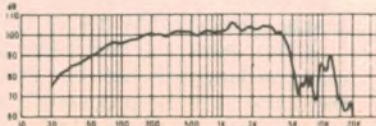

Sound pressure level 101 ± 2dB  
Freq response 4500Hz  
Freq reson 40 ± 8Hz Voice coil  
dia 80mm  
Flux density 10800 gauss  
Weight 8.5kg was \$125  
P-P NSW \$3. SA. O. V. T. \$6.75  
WA. NT \$9.75

16 OHMS ONLY.  
VERY LAST  
SPECIAL OFFER

**\$99.**

### PROTECT YOUR HOME AND FAMILY WITH THE GENERAL ELECTRIC ULTRASONIC BURGLAR ALARM

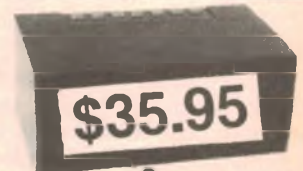

• UNWANTED INTRUDERS.  
BURGLARS. MOLESTERS — BEWARE •  
NO WIRES • EASY TO SET UP • COMPACT 175 x 100 x 80mm • 9  
VOLT (BATT) • LASTS 12 MTHS) • WHEN ACTIVATED SOUNDS FOR 5  
MINUTES. THEN AUTO-RESET • SELECT YOUR OWN PUSH BUTTON  
SWITCH OFF CODE • INSTANT/DELAY ON • COMPREHENSIVE IN-  
STRUCTION BOOK

• P-P NSW \$1.50.  
INTERSTATE \$2.50.



# Microcomputer News & Products



## Spectrum computer in shaky business

"Spectrum sales on shaky ground" according to a press release from D. D. Webster Electronics Pty Ltd announcing that the Spectrum-II minicomputer has been selected to take over seismology monitoring of all earthquake activity in Victoria.

The Seismology Research Centre of the Phillip Institute of Technology (formerly the Preston Institute) has installed the Spectrum-II in its seismology observance

Electronics Pty Ltd. Additional hardware for the system consists of four terminals, a line printer, daisy wheel printer, plotter, oscilloscope and colour graphics system.

Data collected by a network of seismographs in the field is brought to the Centre on cassette tape and copied onto the Spectrum's floppy disks. Measurements made by the computer allow the seismologists to determine the

pak's own range of S-100 systems designed around the Japanese manufactured V-10 CPU board. They also have the Sorcerer for program development and peripheral demonstrations.

Compak also manufactures power supplies for computers, a disk controller for the TRS-80 Model I and has plans for a double-sided disk drive for the Apple II. Another speciality is the application of typewriters as computer printers, and the company can supply interfaces for the IBM Golfball, Olivetti, Adler and Olympia machines. The accent at Compak is on business and word processing systems, and they sell a wide range of peripherals.

For more information contact Compak at 44 The Esplanade, Brighton Beach, Vic 3186. Phone (03) 592 6285, or the new shop, 81A Foster st, Dandenong, Vic 3175. Phone (03) 793 5701.



*Seismologist Gary Gibson with a Spectrum-II computer and digital seismograph earthquake monitor at the Seismology Research Centre in Victoria.*

section. According to the Centre's director, Mr Gary Gibson. Victoria experiences over 250 earthquakes each year, although only about 10 of these are large enough to be detected without instruments. Once every 10 years, on average there is an earthquake of sufficient force to cause damage to buildings.

Even very small earthquakes are important to Gary Gibson's team however. Small tremors provide information on the relative levels of earthquake activity and help to determine active geological fault areas. These details are of vital importance to engineers undertaking large building projects in the state, such as dams, roads, bridges and power stations.

Staff at the Centre have spent six years in developing and perfecting the software that will be used with the Australian designed and built Spectrum SS23DP4, a \$30,000 minicomputer with a quarter of a megabyte of main memory and 20 megabytes of disk storage, manufactured by D. D. Webster

earthquake location, origin time and size, and predict the rate — in some cases for up to 1000 years — that tremors are likely to occur in a given area. This data is then used to calculate the earthquake parameters in a fraction of the time taken prior to computerisation.

For further information on the Spectrum range of Spectrum minicomputers contact D. D. Webster Electronics Pty Ltd, 17 Malvern St, Bayswater, Vic 3153.

## Compak opens in Dandenong

Compak Computer Shop has opened a new store in Dandenong, Victoria.

The new shop, at 81A Foster St, Dandenong carries the same product range and offers the same support services as Compak Brighton, covering a wide range of systems. Archives, Tandy, Apple, Orange and Peach (from Hitachi) computers are available, as well as Com-

## IBM hasn't touched Apple yet

Introduction of the IBM Personal Computer in the US doesn't seem to have hurt Apple sales. Apple Computer Inc recently reported an 83% increase in net income and a 98% increase in net sales for the first quarter of fiscal year 1982 compared to the same period last year.

Both figures set company records, with worldwide sales increasing from \$US67.6 million a year ago to \$US133.6 million. It is the first time that quarterly sales have exceeded \$US100 million, and Apple employees in the US were awarded an extra week's holiday to mark the occasion.

Introduction of the Apple II "family system" was partly responsible for the record result, and sales of the Apple III are also up, according to company president Mr A. C. Markkula Jr. Six major software packages for the Apple III went on sale during the quarter, and large scale assembly operations for the Apple III began at the company's Dallas, Texas, plant. The company also commenced production of its new "ProFile" hard disk storage system for the Apple III during the quarter.

In Australia, Electronic Concepts Pty Ltd, the sale distributors of Apple computer, is hoping to better their principal's result, aiming at a 100% increase in sales this year.







## HP85 & Apple II in measurement & control

Two new software packages from Analog Devices Inc provide the necessary software to transform the HP-85 and Apple II computers into programmable measurement and control systems using Analog Devices uMAC-4000 control system.

The uMAC-4000 hardware provides analog inputs and outputs under control of its own on-board microprocessor. Screw terminals allow direct interfacing of analog measuring devices such as thermocouples, strain gauges and light sensors, while the on-board processor handles signal amplification, channel selection, sensor calibration and conver-

communications between the uMAC-4000 and the host Apple II or HP-85 computer. The user can select any one of 21 Basic subroutines to access a full range of analog and digital measurement and control functions, including reading analog inputs, setting digital outputs and outputting a specific analog value. Each driver program includes a sample application program to help the user come to grips with the system.

The Apple II driver program, designated AC1820, is available on an Apple format diskette, while the HP-85 driver program, AC1818, is available on a data cartridge. This program is also



Analog Devices software and measurement system allows the HP85 to perform measurement and control tasks.

sion of inputs to engineering units.

Analog and digital outputs allow for control of motors, valves and actuators in all process control and energy management applications.

The new software drivers handle all

compatible with the HP-83 and 9915 computers.

Both products are distributed in Australia by Parameters Pty Ltd, 41 Herbert St, Artarmon, NSW 2064, and 53 Governor Rd, Mordialloc, Vic 3195.

## Big retail network for 3M Computers

3M Australia Pty Ltd have entered the microcomputer marketplace in a big way. Up to 230 retailers nationally will stock the 3M "Ibex" microcomputers released recently by the company.

Until the announcement of their plans to market computers, 3M were better known as one of Australia's biggest suppliers of computer media.

Japanese maker Logic Systems International will supply computers to 3M.

The proposed distribution network, the which will be the biggest in the country once fully implemented "will take the microcomputer to the suburbs" according to Mr David Clancy, Product Manager of 3M Australia's Recording Products division. The company's national network of authorised distributors of Scotch brand computer media will also be distributors of the microcomputers.

Initially six models of the Ibex computers will be sold by 3M, ranging from the 2100 at \$3360 to the Model 7202 at \$9500. Prices do not include sales tax.

All of the models are based on the Z80 CPU, running at 2.5MHz, and are offered as a keyboard console and a video display unit which also includes one or two disk drives, depending on the model. All of the systems offer CP/M 2.2 and a Basic interpreter as standard.

The Model 2100 offers 58K of RAM and a 23cm video monitor in a cabinet with a single 14cm floppy disk drive providing 80K bytes of storage. The Model 2200 adds a second single-sided, single density disk drive, and \$840 to the price. Top of the line is the Model 7202, with 64K of RAM, a 30cm video display and two 20cm double-sided, double density disk drives providing 2.2 megabytes of storage. Cost is \$9500 plus tax. A parallel printer port and serial RS232C serial port are included on all models, and a hard disk storage system will be available for the Model 7202.

The Applied Technology Semiconductor Hotline. Just a phone call away are just about all the semis you'll ever need. No minimum order, no minimum quantity - no wasted time. Just phone in your order & give your Bankcard number. We'll check stocks, confirm prices and your goods are on their way. Another unique feature of Applied Technology - for data on any of our semiconductors all you have to do is add 20¢ to your order for each device you need data on, and it's yours.

As well as our enormous range of semis, we've got a comprehensive range of resistors, capacitors IC sockets and computer connectors.

What about our prices? Just as a sample - 7400s for 25¢, 4001s for 30¢. BC547s for 15¢ and Z80 CPUs for \$8.75 - and these are one-off, tax inclusive prices! Why not give us a try? All it takes is a phone call to our Semiconductor Hotline.

What about our range? How about 193 different 74LS, or 180 7400, 140 4000 series CMOS - over 1500 different semiconductors in stock. Because we manufacture computers, we're constantly aware of the latest developments in semiconductors -and we stock all the latest ICs for our customers. Our full range is listed on our exclusive Semiconductor Wall Chart - yours for the asking.



Glover & Assoc. AT/22





## INFORMATION CENTRE

**PLAYMATE AMPLIFIER:** I refer to the Playmate Amplifier Project, which appeared in the January 1980 edition of Electronics Australia. I recently completed the above project, with the addition of a magnetic pre-amplifier, but I have encountered a major problem. I am getting a large amount of hum. This increases as the volume control is increased, until it reaches a point where the hum "breaks-up". The volume potential has been checked and seems okay. It appears to be a filtering problem in the mains circuitry. I would appreciate any advice you could give. (S.P., Avondale Heights, Vic.)

● The problem is most likely caused by an earth ground loop between the amplifier and the magnetic preamplifier. Make sure that the system is earthed only at one point and not at every input and output socket. It may be necessary to isolate the input earth from the case of the Playmate amplifier, and rely upon the earthing from your magnetic preamplifier.

**TV ADAPTER:** I am a regular reader of Electronics Australia and enjoy it very much. I would like to make the following suggestions, hopefully for inclusion in future issues.

Firstly, with the popularity of video recorders, home computers and other hardware that supplies program material to a colour TV, a project to adapt colour television sets for direct video and audio in and out would have wide appeal.

Whilst I acknowledge that all sets are different and some may not be adaptable at all, a general article pointing out what to look for and pitfalls involved would be appreciated. The overall result would be better pictures and colour renditions without the need to use RF modulators.

Whilst on the topic of video another article of interest would be to publish and describe the circuit diagrams for a commercial video cassette recorder and video camera. A few articles in yours and other magazines have treated this matter in general terms without getting down to the "nitty gritty".

Lastly, as the price of digital multimeters is coming down, projects to extend their use would be of interest to the younger or less financial readers. By this I mean units that a DMM can be

plugged into to provide capacitance readings, frequency readings, transistor gains, temperature, pH readings etc. (P. A. W., Marion SA.)

● The easiest way to make a direct video connection to a TV set is to feed the input signal direct to the video amplifier; ie, immediately after the video detector. If you have access to a circuit diagram of the set you should be able to find the appropriate spot without too much trouble.

Ideally, the circuit will also show the shape and amplitude of the composite sync/video waveform which is normally present at the input of the video amplifier stage.

Some television sets may even have a clearly identified "test point" which is used to check the performance of the video circuitry during manufacture!

In some sets, the video waveform at the input to the video amplifier may be inverted when compared to the external

signal. This will result in incorrect picture sync and a negative (ie reversed) picture. The solution in this case is to build a single-stage common-emitter amplifier that will provide the necessary waveform polarity reversal. Further details on direct video connections were published in our May, 1980 issue.

On the subject of video gear, most of the circuitry these days is contained in inscrutable little ICs, which make a detailed article on how they work virtually impossible. Thank you for your ideas on projects — we will keep them in mind.

**METRONOME:** I have just built the Metronome described in your January, 1982 issue. It is quite a nice little thing and the audible click is very good even if the range 30 to 40 clicks is not very useful for musicians and cramps the upper end of the range.

The problem is that, according to musicians, who usually practice during the day, the light of the small 3mm diameter

### Test records & cassette tapes

**TEST RECORDS:** I realise that this request is outside the bounds of your normal service, but any help you can give will be greatly appreciated.

I am looking for a test record, a test cassette and a test reel-to-reel tape (7½ips and 3¾ips). I have the necessary test equipment (millivoltmeter, CRO, distortion analyser, etc) and in the process of designing my own hifi equipment I need these test media as a reference.

Your magazine conducts regular product reviews and you must use the test media that I am referring to. Could you please advise me how and where I can obtain them? (D. M., Balwyn, Vic.)

● As you are probably aware, test records and tapes are not often stocked by retail stores, although some will obtain them for you on order.

Whilst several record companies market test records of one kind and another, the audio industry generally considers the CBS and Bruel & Kjaer series of test records as being the most suitable for development and evaluation purposes. Perhaps CBS STR-130 would be the one best suited to your requirements. Enquiries should be directed

to CBS Records Australia Ltd, 15 Blue St, North Sydney, NSW.

Test cassettes are marketed by both Teac and BASF. BASF test cassettes are handled by BASF Australia Pty Ltd, 9 Sydney Gate, Waterloo, NSW, whilst Syntec International Pty Ltd, 53 Victoria Ave, Chatswood, NSW can supply information on the Teac MTT series of test cassettes. Note that test cassettes are available for both the 120µs (ferric oxide) and 70µs (chrome and metal) characteristics.

Of the several alternatives, Ampex and MRL are probably the most popular of the reel-to-reel test tapes. The MRL Test Tapes are imported by Syntec International of Chatswood, whilst Ampex Australia Ltd, 65 Waterloo Rd, North Ryde, NSW handle the Ampex range of test tapes. Test tapes are normally supplied for only one tape speed (ie two separate tapes are required to cover 7½ and 3¾ips), and one recording characteristic (ie two tapes required to cover the IEC and NAB characteristics). Depending on requirements, it could be necessary to have four tapes to cover both speed and recording characteristic permutations.



LED is not visible enough in the daylight because it is very small.

Replacing the small LED with the bigger one (5mm diameter – orange) was not very successful. Even when I used a lower value series resistor than the 22Ω, the light from the 5mm LED was much weaker.

I would be grateful to you if you could advise me how the big LED could be used in this circuit so that its light would be at full brightness. (J. V. S., Kingston, Tas.)

● The cramped scale at the upper end of the range of the Rate Control is due to the taper of the potentiometer. Commencing calibrations at 40 rather than 30 beats per minute would make little practical difference to the cramped upper scale and would have restricted the “two-second” clicks which can be useful for (photographic) timing applications.

Ideally the potentiometer should have an “antilog” characteristic to overcome the cramping problem. However, as these are not normally stocked by retailers and the project was in the “basic electronics” category, we felt that it was better to use the linear potentiometer.

Light output from the LED indicator is largely a function of the pulse length of each click. As this pulse length is less than one millisecond, the light output is somewhat limited.

It is therefore necessary to increase the pulse duration to significantly increase the light output. One method which could be used is to interpose a

monostable multivibrator between the output of the BC635 and the LED. It should be possible to use a 555 timer for this purpose, with its pulse duration set to, say, 5ms. Note, however, that current drain would increase from approximately 0.8mA to 6 or 7mA, thus reducing battery life.

**PLAYMASTER MOSFET STEREO AMPLIFIER:** I am presently a student at Murtoa High School and shortly after the Playmaster Mosfet Stereo Amplifier was released I purchased a kit and (almost) successfully built it. From the moment I first switched on, up to now I have had an audible hum from each channel. Advancing the volume makes no difference to the level of the hum, but when the muting switch is turned on the level drops dramatically and is almost inaudible.

It is not a very loud hum but loud enough to be recognised as abnormal and annoying at low volume settings. Apart from the hum every part of the amp works very successfully; the tone controls, volume, and amplification (with very little distortion at full output).

I had access to a CRO recently and eagerly took the opportunity to inspect the circuitry. I connected a 1kHz sine wave to one of the high level inputs and proceeded to inspect the preamps. This is where I presumed the hum originated (as the volume control has no effect, yet the muting circuits do). But the entire preamps checked out perfectly. I then

## RS-232C

from p96

fluctuations are observed on the meter. Turn the volume control counter-clockwise until the fluctuations cease. Turn the control a little further for the best noise margin.

● Set the R/W switch to read. Replay the tape while monitoring TP2 with the voltmeter. Adjust the preset potentiometer VR1 for a reading of +2.2V.

This adjustment leaves a lot to be desired and it might not be possible to exchange tapes with other units. 2.2V is the average voltage of the symmetrical square waveform, assuming a nominal peak value of 4.4V. The analog voltmeter, due to its inertia, will indicate the average value rather than peak.

Unfortunately, the peak value varies from IC to IC and the low value is not zero but approximately 0.2V. This also varies for different ICs. To this, the error inherent in the voltmeter must be added.

## Construction hints

The prototype was wired up on a printed circuit prototyping board. When designing a PC board, care should be taken with the layout. The amplifier and

monostable (LM3900, 74121) circuitry should be treated as a separate entity, with its own supply rails. Several 0.1μF decoupling capacitors were used in the prototype. They are not shown on the circuit diagram as their number depends on the layout. The rule is that each IC should have one connected close to its supply pins. This does not mean one capacitor per IC as two ICs in close proximity may share the same capacitor.

Tracks to the monostable timing components should be kept short and the supply track to the 15kΩ resistor connected directly to the nearest decoupling capacitor. The 0.33μF capacitor in the power supply circuit may be required to prevent instability. Tracks carrying the RS232C voltages (+10V, -10V), should be arranged so that accidental contact with other parts of the circuit is not likely to take place.

With the calibration complete your cassette interface is ready to use. Connect to a 1200 baud RS232C interface and try sending a stream of data out of the serial port. Then rewind the tape, switch to “play” and read the data back in. Compare it with what you originally wrote to the tape as a final test of correct operation. Ⓜ

# For kitsets & projects and all general SOLDERING

ADCOLA PRECISION  
ADCOLA PRECISION SOLDERING  
ADCOLA PRECISION SOLDERING TOOL  
REFLECTIVE NO. 85 50  
FOR THE HULL OPERATOR

RADIO  
TELEVISION  
AUDIO HI-FI  
INSTRUMENTS  
PRINTED CIRCUITS

SELECTED BY  
**Good Design**  
FOR AUSTRALIAN DESIGN INDEX  
INDUSTRIAL DESIGN CENTRE OF AUSTRALIA

SAFETY STANDARD APPROVED  
FOR THE HULL OPERATOR

Complete soldering instructions are printed on the back of each card.

**Available from your  
electronic parts supplier**

## DISTRIBUTORS

N.S.W: (02) 709 5293    QLD: (07) 277 4311  
VIC: (03) 543 5122    S.A: (08) 426 655  
TAS: (002) 34 2233    W.A: (09) 381 5500

RS 50



# Direct Computer Sales

We sell. . .



and

**Commodore**  
Business Systems

## BUSINESS USES —

We support you with;

- thorough hardware & software knowledge,
- staff training,
- on-site service,
- hardware & software design using our staff programmer and engineer.

**PRIVATE BUYERS —**  
use our expertise, it's yours for the asking.

**PRICES —** we are very competitive, try us. We now have two shops. . .

## BANKSTOWN

Cnr North Terrace & The Appin Way  
Bankstown Shopping Centre.

## HURSTVILLE

198 Forest Road  
Hurstville Shopping Centre  
(02) 570 8344  
Telex: AA 20149

continued to check the main amplifiers, where I revealed an abnormal waveform.

Points A and B at the bases of Q6 and Q7 checked out perfect once again. But Point C on the collector of Q8 was producing a waveform as illustrated (many traces jumbled together).

This waveform was then repeated throughout the following circuitry to the output. This "dual tracing" at the peaks could only be seen after close examination on the CRO and I presume it is the cause of the hum. These results were taken with a pair of headphones plugged into the headphone socket, acting as a load, as I did not have any dummy loads which would have handled 50W.

Apart from this "dual tracing" at the peaks, I was very impressed with the quality of the waveform produced at the output. No clipping or distortion took place over the entire frequency range of 20-20kHz at full power.

I am also building a speaker system using the Playmaster drivers, 250mm 60W woofer, 125mm midrange, and 64mm tweeter. Would this woofer be suitable in a 30-litre sealed enclosure? If not, do you know of similar woofers which would be suitable, both for the box size and the Playmaster crossover network?

Also, have you any constructive comments, opinions or ideas which may be of interest with respect to someone becoming an electronics engineer, ie, what type of work are you involved in? Was the course difficult, but rewarding? etc. I can get a lot of information from careers advisors but it is good to get ideas first hand. (J. S., Minyip, Vic.)

● Unfortunately, your exercise with the CRO has merely confirmed what you already know. The amplifier works perfectly but has hum. In fact, if you had switched the timebase down to a lower speed you would have found that the 1kHz signal had a 50Hz or 100Hz signal superimposed upon and that was what caused the effect that you referred to as "dual tracing".

It is fairly clear from your description that the hum does originate in the tone control stages, as you have deduced. However, what is not clear is the mechanism by which it occurs. If you once again had access to the CRO, you could find some clues.

For example, with no signal applied to the amplifier, you could examine the residual hum signal and check to see whether it was predominantly 50Hz or 100Hz. You could do this by checking the timebase speed (say, 10ms/division) and seeing how many cycles occurred for so many division on the screen. If, for example, you get one complete cycle for two divisions (for 10ms/div), the period is then 20ms and the frequency is 50Hz.

Now if the residual hum is predominantly 100Hz, it is possible that

you may have a faulty filter electrolytic capacitor which is injecting hum into the tone control stages. However, since these stages are fed from zener-stabilised supplies we think that this possibility is unlikely.

A more likely possibility is that 50Hz or 100Hz harmonics from the transformer leakage field are inducing the signal into the amplifier circuitry. This is more likely if you have the C-core transformer and if it is incorrectly oriented. This transformer will also radiate more hum if the amplifier quiescent currents are higher than the specified figure of 70 milliamps in each channel. The recommended Ferguson transformer does give a noticeably lower residual hum.

It is unlikely that you would obtain satisfactory results by installing a 250mm loudspeaker in such a small enclosure. We suggest that the volume of the Playmaster 3-53L enclosure, which was designed to take your speakers, is about as small as you can go without seriously prejudicing results.

As far as your ambition of becoming an electronics engineer is concerned, we can vouch for the fact that most engineering degree courses are a real slog. And you must resign yourself to doing a course which is generally fairly uninteresting but essential theory in the first two or three years of a six-year part-time degree.

As to the work you will be required to do, that question is as wide as it is long. About the only comment we can make is that if you work for the public service or a public utility you will probably do very little substantive work and learn very little. If you really want to become a useful electronics engineer you have a better chance of doing so by taking your training in private industry. You will be required to work harder and may not earn as much as first but eventually you will gain a lot of job satisfaction as well as reasonable remuneration.

## NOTES & ERRATA:

**FUNCTION GENERATOR:** (April 1982, File 7/AO/35): In some cases, due to low level hash on the audio waveform, the frequency meter may indicate double the correct value. This can be cured by soldering a .0015 $\mu$ F capacitor across the 2.2k $\Omega$  resistor connected to pin 11 of IC1. Also, to prevent mains spikes reaching the Schmitt trigger IC7d, it is desirable to place a 0.1 $\mu$ F capacitor from pin 13 of IC7d to the -5V rail.

**LARGE-SCREEN STORAGE CRO ADAPTER:** The shield of the output socket should be connected to chassis via a solder lug. Pin 15 of IC8 is connected to the  $\pm$ 5V rail rather than 0V, as shown on the circuit diagram.



LET THE

# AUSTRALIAN BEGINNING

BRING MAINFRAME POWER INTO YOUR HOME OR OFFICE



## THE AUSTRALIAN BEGINNING PTY LTD

The Australian Beginning Pty Ltd is an Australian company, with Australian based computer facilities, using the Australian Telecommunications network to offer Australian clients Australian information services and software.

WE ARE PROUD TO ANNOUNCE THE LAUNCHING OF AUSTRALIA'S FIRST MICROCOMPUTER INFORMATION UTILITY

The AUSTRALIAN BEGINNING is Australia's first microcomputer information utility, aimed at giving the average microcomputer user access to the computer data banks and also massive storage space previously only available to large Mainframe installations. The era of home computers has now officially begun in Australia, now that the AUSTRALIAN BEGINNING is here: as now, any small businessman or student can have on his desk for an extremely small cost, a system that has the level of storage power and access to data banks for which only a few years ago, government departments and large private users were paying millions of dollars.

The AUSTRALIAN BEGINNING can be accessed through a number of 'approved' personal computers, and terminals, by use of an acoustic coupler or modem.

Users will receive a number of benefits which will include:

### INFORMATION SERVICES

Members will have access to a number of information sources which will include the latest news, sports results, financial reports, and farm information.

### NATIONWIDE COMMUNICATION

Members will be able, also, to communicate nationwide with other AUSTRALIAN BEGINNING members through our system.

THE AUSTRALIAN BEGINNING RECOMMENDS 3M DISKETTES

### SOFTWARE BANK

Users will have access to a myriad of computer programs that will include entertainment, educational aids, programming and diagnostic tools, and financial applications.

### MAINFRAME POWER

Users will have the capability to make use of the Mainframe's huge storage capacity by using any of our large programs, or storing your large programs on our system.

### SHOP AT HOME

You can take advantage of our shopping by computer system to get the best prices on a number of popular consumer items.

### EXTREMELY EASY TO USE

You do not have to be a computer programmer to make use of the AUSTRALIAN BEGINNING. All of the instructions are in everyday English, so that even the younger members of your family will be able to operate the system.

### LOW COST

While services like these used to cost tens of thousands of dollars to the government departments and large corporations who used them, they are now available to you for less than the cost of a packet of cigarettes a day for the 'average' user.

You can join the AUSTRALIAN BEGINNING by paying a one-time joining fee of \$100, and a small hourly user charge of \$10 an hour 8 a.m. - 6 p.m. and \$4.50 an hour 6 p.m. - 8 a.m.

TO JOIN THE AUSTRALIAN BEGINNING FAMILY, AND TAKE ADVANTAGE OF THE EXCITING SERVICES WE WILL BE OFFERING, PLEASE COMPLETE THE COUPON BELOW:

#### MEMBERSHIP REQUEST

Yes, I think the idea of the AUSTRALIAN BEGINNING is great! I enclose \$100 so please send me my user manual and password

I have a computer, Brand.....

Model.....

Please send me information on low cost equipment packages I can use to take advantage of the AUSTRALIAN BEGINNING'S services.

NAME: .....

ADDRESS: .....

CITY: .....

STATE: ..... POSTCODE: .....

PHONE: .....

THE AUSTRALIAN BEGINNING (SALES) PTY LTD.

364 La Trobe Street,  
Melbourne, Victoria, 3000.  
Tel: (03)329.7998

I am interested, but I need more information.

DEALER INQUIRIES INVITED



# MARKETPLACE

## FOR SALE

**CB RADIOS.** \$69, walkie-talkies, shortwave radios, military, outback, business, amateur marine, repairs, aerials, 40CH conversions, new rigs weekly, Bridge Disposals, 12 Old Town Plaza, Bankstown Rail Station. Ring Sam, 7pm-9pm only. (02) 407 1066.

**TECHTRONIX** 465 Lab quality oscilloscope, \$2800.00 ono; National colour video cassette recorder, \$450.00 ono; Playmaster 136 amplifier, \$80.00. V. Mifsud, 10 Richards Ave, Croydon 3136.

**DREAM** 2k Eprom, as reviewed in Dream No 17, \$17.50; as above for hires, runs old progs, without mod, \$24.50; will convert your working Dream with any Ram ext to hires, \$25. K. Semrad 4/8 Underwood St, Paddington 2021. (02) 356 8997.

**ELECTRONICS MADE SIMPLE.** Series of low cost books of circuits, projects and guides written for students and experimenters with little previous knowledge or experience. Send stamped addressed envelope for catalogue and price list to Hobby Electronic Books, PO Box 92, East Gosford, NSW 2250.

**AMIDON FERROMAGNETIC CORES.** Large range for all receiver and transmitter applications. For data and price list send 105x220 SASE to: R. J. & U.S. IMPORTS, PO Box 157, Mortdale, NSW 2223.

**ZX81 OTHELLO.** Challenge the computer, \$15 + \$1 P&P (16K Ram req'd). For full list, SAE to K. J. Software, 8 Cawrse St, Elizabeth Field, SA 5113.

**IC'S** 4017 Decade Counter 10 for \$8.00; 4510 BCD Counter, 10 for \$8.00; 16 pin DIL IC sockets, 20 for \$3.40; speaker lead, twin flex, heavy duty, 14/0076 no trace 100 yards, \$6.50; Hi qual 1 pole 30 position rotary switch adjustable stops, 1/4 inch shaft, \$7.50 each; feedthru bypass caps, 0.001  $\mu$ F, 40 for \$4.00; panel mtg, 3AG fuse holders, 8 for \$4.00. Prices include post and pack. Cheque or money order to Helen Gerard Trading, PO Box 60, Kallista 3791.

**SUPER 80** game cassette now available. "Noughts and Crosses" to order. Send cheque/money order for \$19.50 to: Spartek Electronics, 6 Worthing Court, Mulgrave, Vic 3170.

**COMPUCOLOR II** Owners. Two new products available: Programmable Character Generator, Music Synthesizer. For full particulars, write: I. Felrus, 6/92 Charles St, Abbotsford 3067.

**PRINTED CIRCUIT BOARD** etching tank. Manufacturer — Circuitape system Autopos, processing unit, incl exposure unit and gold plating gear and some chemicals, \$300 ono. (02) 666 7969.

**CRO** Telequipment S43, single trace, two plug-in amps A, JD, 100uV — 50V/cm and 25MHz BW with delay line. As New. \$295 ono. Epping (02) 869 7247.

**DISPLAY ADVERTS IN MARKETPLACE** are available in sizes from a minimum of 2cm x 1 col rated at \$15 for a col cm. **CLASSIFIED RATES** \$3.60 for 40 letters or part thereof an insertion payable in advance. Minimum 80 letters. **Please use coupon below.** **CLOSING DATE** is six weeks prior to the on-sale date. Issues are on sale the first Wednesday of each month.

## FOR HIRE

**MAN WITH HP4193A** RF Vector impedance meter, measures  $Z \pm jX$  from 400 KHz to 120 MHz, please ring Mr Pride on (09) 450 4379 for further details.

## CLUBS

**CALL FOR PAPERS.** The Microprocessor Special Interest Group of the ACS (Canberra) are sponsoring a National Conference on Microcomputer Software and Hardware Exhibition, Aug 18-21, 1982. Any person intending to participate is asked to contact Peter Bramwell (062) 31 8586, MICSIG, Box E237, Canberra, ACT 2600.

## READER SERVICE

**COMPUTER CLINIC.** Repairs and services, Apple, Sorcerer, Pet, TRS80, System 80, Super 80, etc. (07) 269 8573. PO Box 68, Aspley, Brisbane 4034.

## POSITION VACANT

**APPLICATIONS ARE INVITED** for Electronics Technician to manage and operate a maintenance facility in the central territory. Must be capable of repairs and maintenance of all classes of aircraft electronics as well as standard equipment. Licences not required. Commensurate salary \$18,000 plus share of profits. Applications to: T. J. McDonnell, PO Box 154, Tennant Creek, NT 5760. Phone (089) 62 2707.

## DREAM 6800 SOFTWARE/HARDWARE

Dreamtext, Supertype dream, Chip-8 Disassembler, Branch off set Calculator, Machine code Disassembler. Block move, tape verify, Block compare. Double sided PCB for 8K RAM expansion — includes space for 2 x PIA's, 3 x 2K EPROMS. Hardware encoded ASCII Keyboard instructions. For more information: Send stamped SAE to **DREAMSOFT P.O. Box 139 Mitcham 3132 Vic. Aust.**

## RETAILERS WANTED IN ALL STATES

We make superb quality durable mobile antennas for CB, Ham and Commercial users. These are luxury items at reasonable prices and outperform and outlast all others tested. We also make bases and roller inductors. Excellent profits assured. If your shop has a possible place for us then please write for further details to:

**ANTENNA SCIENCE & ENGINEERING,  
P.O. BOX 238, NEDLANDS, WA**

## BROADCASTING ASSISTANT

(REF 147)

### THE UNIVERSITY OF NEW SOUTH WALES DIVISION OF POSTGRADUATE EXTENSION STUDIES

Technical assistant required to work in the University's Radio and Television Stations. Duties will include dubbing and editing of audio tapes and servicing equipment.

Matriculation-level Higher School Certificate or equivalent and drivers licence required. Interest in the fields of radio and television and undertaking of an approved technical course (preferably BOCP) also necessary.

Position available initially for one year.

Further information from Mr L. Porter (02) 662 2694.

**Salary: \$10,690 range \$11,091.**

Commencing salary according to qualifications and experience. Juniors according to age.

Applications close 18 June 1982.

Application form from the General Staff Office (02) 663 0351.

## CLASSIFIED ADVERTISERS

To the Advertising Manager, ELECTRONICS Australia, Box 163, Chippendale, 2008.

- Please insert the following advertisement in the first available issue.
  - Tick the classification required
  - FOR SALE
  - WANTED
  - FOR HIRE
  - CLUBS
  - POSITION VACANT
  - POSITION WANTED
  - READER SERVICE
- Please type or print in ball-point pen on a separate piece of paper.

Signed

I enclose Cheque/Money Order for \$

Address

being full payment for letters at \$3 60

for 40 letters or part thereof (minimum 80 letters)



## CAPACITORS

0.56 250V	40c ea
2000 MFD. VDcw25	75c ea
0.0039uF. 1500V	20c ea
6N8, 1500V	20c ea
0.0068uF. 1500V	20c ea
1200PF. 400V	10 for \$1
0.068uF. 400V	5 for \$1
2200PF. 630V	10 for \$1
0.47uF. 250V	10 for \$1
0.10uF. 400V	5 for \$1
0.082uF. 160V	10 for \$1
26k. 250V	10 for \$1
0.041uF. 400V	10 for \$1
0.033uF. 250V	5 for \$1
0.027uF. 100V	20 for \$1
220uF. 10V	10 for \$1
1uF. 350V	10 for \$1
470uF. 40V	5 for \$1
1000uF. 16V	25c
2.2uF. 200V	10 for \$1
0.047uF. 1500V	50c
47uF. 25V	4 for \$1
680uF. 40V	50c
22K. 100V	20c
330uF. 25V	25c
2.2uF. 200V	30c
470uF. 40V	50c
680uF. 35V	50c
0.015uF. 250V	25c
1uF. 100V	25c
1000uF. 16V	50c
220uF. 16V	50c
2000uF. 63V	\$1
0.47uF. 400V	50c
680K 250V	25c
0.12. 250V	25c
15NF. 250V	10c
120K 250V	20c
10uF. 315V	25c
0.056. 250V	10c
500 MFP 10 VOLT	5 for \$1
68uF 63V	5 for \$1

## SPECIAL TRANSISTORS

AD 161-162	\$2.50 pr
BSC 901A	\$1.50 ea
BC 548	10 for \$1
AD 149	\$3 pr
OC9554	50c
BD202N	50c
BD135	50c
2NC055	\$1

## ELECTROS

470uF. 25V	5 for \$1
400uF. 10V	5 for \$1
47uF. 63V	5 for \$1
350uF. 16V	2 for \$1
27uF. 160V	5 for \$1
25uF. 63V	10 for \$1
22uF. 160V	10 for \$1
47uF. 16V	5 for \$1
47uF. 200V	5 for \$1
220uF. 10V	10 for \$1
68uF. 16V	10 for \$1
100MFD. 350V chassis mount	\$1

Circuit Diagrams supplied

CRYSTALS FOR COLOUR TV 03061 NDK \$2.50

COLOUR INFRA RED AUDIO TRANSMITTER \$5

FM RADIO AERIALS \$1

<b>SPEAKER TRANSFORMERS FOR VALVE RADIOS</b>	
5,000-15 ohm	\$2.50
7,000-15 ohm	\$2.50
10,000-15 ohm	\$2.50
7,000-3.5 ohm	\$2.50

TV Stick Rectifiers 20SC \$1.00

<b>Slide Pots</b>	
250K-50K	3 for \$1
Dual 500K	3 for \$1
1 Meg	3 for \$1
2 Meg	3 for \$1
Including Fancy Gold Knobs	
25K dual	2 for \$1

<b>SPECIAL</b>	
100 mixed resistors, all useful	\$2
100 mixed capacitors, fresh stock	\$2

<b>AUDIO LEADS</b>	
3.5m to 3.5m. 7ft	75c
3.5m to 6.5m. 7ft	75c
6.5m. 7ft	50c

<b>MICRO SWITCH</b>	
5A. 250V AC	75c ea

<b>TUNING CAPS</b>	
2 and 3 gang	\$1 ea
Min 2 gang	50c

# L.E. CHAPMAN

122 PITT ROAD, NTH CURL CURL.  
MAIL ORDERS: BOX 156, DEE WHY, NSW. 2099.  
TELEPHONE 93-1848.

## SUPER SPECIAL

GRAMOPHONE motor and pickup 3 speed stereo balanced arm. 240 volt \$9.75

PP NSW \$1.50  
Interstate \$2.75  
WA \$4

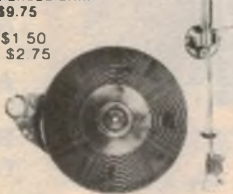

## SUPER SPECIALS FM STEREO TUNER KITS



Sets of 3 modules include FM tuner, decoder and IF detector. Circuit diagram supplied. Can be used with amp modules.

ONLY \$22  
P&P \$1.40

Colour deflection boards to suit Kriesler, Philips, Pye etc \$35.



PP NSW \$1.80  
Interstate \$3.00  
WA \$4.00

## BSR DELUX RECORD PLAYER

11 INCH TURNTABLE. CUNING DEVICE. SHIELDED MOTOR. MAGNETIC CARTRIDGE \$50. BASE & PERSPEX TOP \$22 EXTRA

P&P NSW - \$4.50; INT - \$5.50  
WA - \$6.50  
NT - \$8.50



SPEAKERS 2 1/2 INCH 2 FOR \$1

Power Transformers 240V 2/6.3 Windings 0.15 AMP (suit clock modules) \$3.00  
Power Transformers 240V 1/130V x 12V 60 Mill \$6.00

## MAGNAVOX SPEAKERS

8 INCH DUAL CONE. 16 OHM. 10 WATT

\$6



PP NSW \$1.80  
INTERSTATE \$2.75  
WA, TAS, NT, \$4.

## CLOCK MODULES \$3



P&P NSW \$1.80 INTERSTATE \$2.80

## COLOUR FRONT END COMPLETE PUSH BUTTON TUNER SECTION

TO SUIT PHILIPS, PYE, KRIESLER ETC. \$25



## SPECIAL

## Record player PYE

11 inch turntable, belt drive, balanced arm ceramic cartridge \$29.00  
P&P NSW \$4.50  
INT \$5.50  
WA & NT \$6.50

## VU & BALANCE METERS



STEREO VU \$3.00



12Kn 100uA \$2.00

## SPEAKER SYSTEMS

\$29.50 PAIR

2 x 6" Dual Cone Magnavox Speakers in each cabinet 10 watts RMS  
P&P NSW \$4.50 INT \$5.50 WA \$6.50  
- NT \$6.50

## Colour Power Supply Boards \$25



PP NSW \$2.00  
Interstate \$3.50  
WA \$4.50

## SPECIAL MAGNAVOX SPEAKERS \$20 PAIR

10 INCH WOOFER  
10 INCH MID-RANGE  
8 OHM SYSTEM. 20 WATTS RMS



P&P NSW \$3.50 - INT \$4.50 - WA \$5.50  
NT \$6.50

## SPECIAL

SPEAKER CROSSOVER NETWORKS 2WAY FREQ 4KHZ 30W 80HM

\$2



## POTS ROTARY

1/4 Meg	30c
1 Meg	30c
100K	30c
100K Switch	50c
50K Double Pole Switch	50c
7 500	30c
10K Switch	50c
250K	30c
50K	30c
20K	30c
10K Min Pots	25c
50/ohm	50c
1/2 or 1 Meg Switch	50c
1/2 1 meg dual Concentric lapped at 100K	\$1
2 meg ganged double pole switch	\$1
1 5 meg dual ganged	50c
2 meg ganged log	\$1
1 meg dual ganged	\$1
1/2 meg dual ganged LIN	75c
25K, 50K dual ganged Concentric double switch	\$1
200K single line	30c
20K wire wound	75c
dual log 10K	75c
100K dual ganged linear pots	75c
10K sub min log pots	50c
250K ganged pots	75c
25K lin ganged pots	75c
2 Min Transistor 450 IF KC Coils Plus 1 Min Oscillator Coil	3 for \$1
TV EHT Leads	
4 1/2" in length	50c each
Transistor sockets	20c each

MIXED SCREWS, SELF TAPPERS, BOLTS, NUTS ETC. 200 \$1 PP - \$1.

Pick up Cartridges BSR universal type Ceramic Stereo \$5  
Diamond stylus stereo magnetic \$12

Cable 4 Strand 5 Metres 50c

## DIODES

OA 626	4 for \$1.00
OA 662	4 for \$1.00
EM 410C	4 for \$1.00
DS 150A	50c
DSY 130YO	50c
OA 636	50c
HR 15	50c
Diodes BYX 55, 300	30c
BY 188	30c

## DIODES BAV20 10 for \$1

Valve sockets 7 pin	10c
Valve sockets 9 pin	10c
OCTAL	10c
09478	5 for \$1.00
BZX79	5 for \$1.00

Power transformers 240V, 117V, 2/25V Tapps 6.3 - \$7.00

SPARK GAPS 500 volt 20 cents  
THERMISTERS 20 cents

Transistors AD161-162 \$2.50 pair  
Transistors AD149 \$3 pair

## PICK UP ARMS

Mono \$3.50  
Inc Ceramic Cartridge & Stylus

## TRIMPOTS

200 ohm	10c
5K	10c
100K	10c
47K	10c
10K	10c
470 ohm	10c

Miniature speaker and drive output transformers \$1 pr

Special mixed tag strips 10 for \$1

## SPEAKER SPECIALS

5 inch in 3.5, 8 or 15 ohms	\$3.50
15 ohm 4"	2 for \$2
6 x 9 15 ohm	\$5 ea
5 x 7 15 ohm	\$4 ea
8 x 4 15 ohm	\$4 ea
6 x 4 15 ohm	\$3 ea
6 x 4 27 ohm	\$4.50 ea
6 x 3 27 ohm	\$3.50 ea
5 x 3 27 ohm	\$3.50 ea
5 x 3 47 ohm	\$3.50 ea
2 1/2"	2 for \$1
6 x 4 3.3 ohm	\$3.50
Magnavox 4 ohm 8" 10 watt	\$5

Power leads and sockets 240 volt, suit most tape recorders, radios, etc. \$1 each.

455KC IF Transformers for valve radios, \$1 each. Also OSC coils, 75 cents each  
Aerial coils 75c

I.C. Sockets 18 pin 10c  
28 pin 25c  
Shielded Cable single strand 500 metres \$25.00

## PILOT LIGHTS

Screw in 6.3V	10 for \$1.50
Pilot light holders	10 for \$1.00
12V	10 for \$1.00



# EA Magazine Holders



The binders and magazine holders are available over the counter from Electronics Australia, 57 Regent Street, Sydney, NSW — Price: \$5.10 binders, \$4.50 holders

Mail orders should be sent to Electronics Australia, PO Box 163, Chippendale, NSW 2008

Prices including postage are:

Holders: \$5.50 NSW; \$5.60 other states; or six for \$29.00 NSW; \$31.50 other states, \$A33.00 NZ

Binders: \$7.00 NSW; \$8.50 other states; or six for \$33.00 NSW; \$36.00 other states, \$A37.00 NZ

## ADVERTISING INDEX

ADVERTISER	PAGE
A & R Soanar	82
AMS Systems	117
Ace Radio	126
AED Microcomputer Products	110
Altronic Distributors Pty Ltd	22, 23, 45, 90
Antenna Science Engineering	134
Applied Technology	36, 37, 128, 129
Australian School of Electronics, The	116
Bright Star Crystals	63
Calculator & Computer Distributors	110
Chapman, L. E.	135
Christie Rand Pty Ltd	50
Computer Country Pty Ltd	46, 133
Cunningham, R. H.	30, 82
Daneva Controls	107
David Reid Electronics Ltd	115
Defence Force, Recruiting	in colour section
Dick Smith Electronic Group	8, 9, 10, 11, 27, 52, 53, 54, 55, 78, 92, 93, 98, 103, 115, 118, 119, in colour section
Direct Computer Sales	132
Dreamsoft	134
Edible Electronics	99
Electrocraft Pty Ltd	33
Elmeasco Instruments Pty Ltd	115
Hanimex Ltd	59
Jaycar Pty Ltd	16, 17, 49, 85
Kalextronics	25
Looky Video	77
Marantz (Aust) Pty Ltd	in colour section
Parameters Pty Ltd	IBC
Pre-Pak Electronics	61
Radio Despatch Service	108
MaGrath's	2
Rod Irving Electronics	65, 66, 67, 68, 69, 70, 71, 72
Royel Components	15
Royel International	131
S. M. Electronics	97
Scientific Devices	122
Scientific Electronics	108
Shin-Kobe Electric Machinery Co Ltd	in colour section
Software Source	77
Sony (Aust) Pty Ltd	IFC
Standard Components Pty Ltd	50
Stotts Technical Correspondence College	89
Tandy Electronics	IBC
Technical Book & Magazine Co	101
Union Carbide of Australia	30
University of NSW	134
Vicom International	7
Wireless Institute of Australia	105

## EA PC BOARDS AND FRONT PANELS

Some readers have problems obtaining PC boards and front panels for projects. Many of our advertisers sell these items and their advertisements should be checked in the first instance. Failing that, below is a list of firms which produce or sell PC boards and front panels.

### NSW

**Dick Smith Electronics,**  
125 York Street,  
Sydney, 2000.  
Telephone 290 3377.  
DSE also has branches and resellers throughout Australia.

**Electronic Agencies,**  
115-117 Parramatta Road,  
Concord, 2137.  
Telephone 745 3077.

**Jaycar Pty Ltd,**  
380 Sussex Street,  
Sydney 2000.  
Telephone 264 6688.

**Radio Despatch Service,**  
869 George Street,  
Sydney 2000.  
Telephone 211 0816.

### RCS Radio Pty Ltd,

651 Forest Road,  
Bexley, NSW 2207  
Telephone: 587 3491

### VIC.

**Rod Irving Electronics,**  
425 High Street,  
Northcote, 3070.  
Telephone 489 8131.

**Kalextronics,**  
101 Burgundy Street,  
Heidelberg 3084.  
Telephone 743 1011.

**Sunbury Printed Circuits,**  
10 Counihan Street,  
Sunbury 3429.

### SA

**James Phototronics,**  
522 Grange Road,  
Fulham Gardens, 5024.

### WA

**Altronic Distributors,**  
105 Stirling Street,  
Perth 6000.  
Telephone 328 1599.

**Jemal Products,**  
8/120 Briggs Street,  
Welshpool, 6106.

### N.Z.

**Marday Services,**  
PO Box 19 189,  
Avondale, Auckland.

**Mini Tech Manufacturing Co Ltd,**  
PO Box 9194,  
Newmarket.

**Printed Circuits Limited,**  
PO Box 4248,  
Christchurch.

## SUBSCRIPTION SERVICE



**ELECTRONICS  
Australia**

### Subscription Rates

\$28.00 per year  
within Australia  
\$A29.50 per year  
elsewhere

Make sure you receive every copy of the magazine by ordering it from your newsagent or the publisher. For publisher subscriptions post this coupon, with your remittance to Electronics Australia Subscription Dept, John Fairfax & Sons Ltd, GPO Box 506, Sydney 2001. Subscription will start with first available issue.

Name .....  
Address .....  
Postcode ..... Enclosed is ..... for ..... years



# Choose the System the Experts Are Raving About — Tandy's TRS-80 Color Computer!

*"The Color Computer is THE best buy in the market today. It's jam-packed with hardware capabilities and the graphics commands of Extended Color BASIC are excellent. Look at it!"*

— William Barden, Jr., Author

*"Tandy's Extended Color BASIC is a breakthrough in colour graphics for personal computers. It's fast, easy-to-use, and capable of producing striking graphics."*

— Stan Miastkowski  
BYTE Magazine

*"Anyone seeking a machine that will serve well as a teacher and a base for a home communication and entertainment centre will find the TRS-80 Color Computer a strong contender."*

— Carl Warren  
Popular Electronics

*"The TRS-80 Color Computer has the most potential of any computer on the market today; more versatile, more expandable, easily interfaced, and easier to use — bar none!"*

— H.C. Pennington, Author

The experts agree ... the Tandy TRS-80® Color Computer lets you create spectacular high-resolution colour graphics at an amazingly low price!

A Programmer's Dream at Only \$849. Our 16K Color Computer with Extended Color BASIC uses one-line commands to make the creation of sophisticated graphics easy. Now you can produce colour diagrams, business and engineering charts, even simple animation with a screen resolution of up to 49,152 programmable pixel points (256x192). You get eight vivid colours, sound, a 32x16 screen format, editing, user-definable keys, error messages, PEEK, POKE, a built-in RS-232 serial interface, and much more.

We Don't Skimp on Documentation. Our easy-to-understand tutorial manuals on our Standard and Extended Color BASIC will quickly have you using the full potential of your TRS-80 Color Computer.



The biggest name in little computers™

A DIVISION OF TANDY CORPORATION  
Retail prices may vary at individual dealer stores.

Instant Fun and Games! Just plug-in a Program Pak™ for exciting game action! Our TRS-80 Color Computer connects to any standard TV set.

Expand At Any Time. Add a disk drive for only \$699, and get 156K-bytes of on-line storage. Add more memory, a printer, and other accessories, too.

See It Today! Come in for a demonstration at a Tandy Computer Centre, store or dealer near you.



Tell me more! Please send me your free TRS-80 Computer Catalogue. 320060

Tandy Electronics, Advertising Dept,  
PO Box 229, Rydalmere 2116.

Name: \_\_\_\_\_

Company: \_\_\_\_\_

Address: \_\_\_\_\_

City: \_\_\_\_\_ State: \_\_\_\_\_

Postcode: \_\_\_\_\_ Tel: \_\_\_\_\_



# Unrivalled Performance at a Price You Can Afford TRIO CS-1830

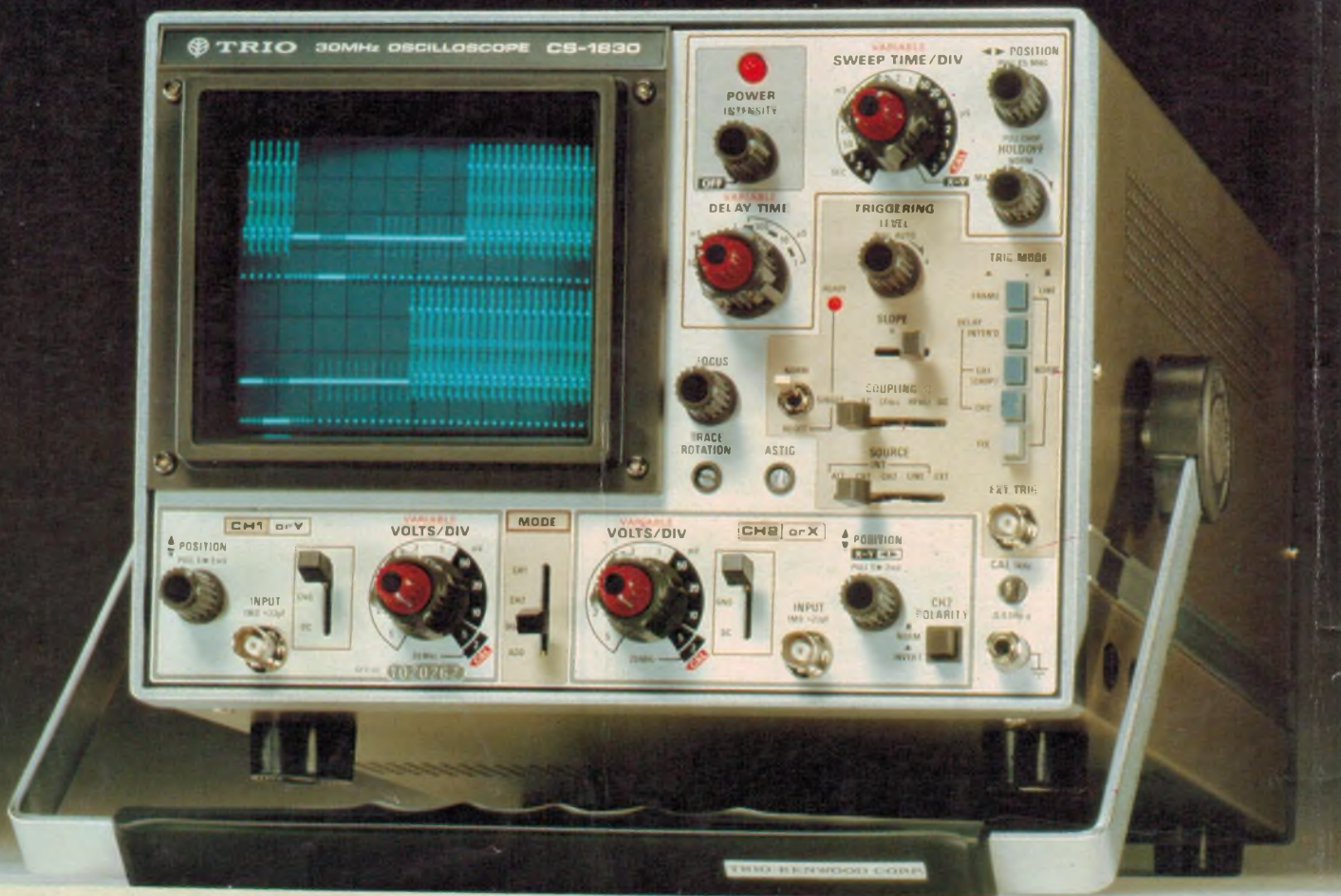

## 30MHz Trigger Delay

The CS-1830 is a delayed sweep, dual-trace oscilloscope with a guaranteed sensitivity of 2mV/div. to 30MHz (it will typically trigger on as little as half a division).

Many of its features are found only on scopes twice its price. Features such as a rectangular post accelerator CRT with a graduated inner face (to eliminate parallax errors and to increase reading accuracy); a full eight divisions displayed without distortion; ALT delay sweep; alternate trigger and auto synchronisation (FIX) mode.

In addition, Video Synch, Auto Free Run and XY mode combine to make the CS-1830 the most sophisticated oscilloscope available in its price range.

Many applications are found in laboratories, service centres, teaching institutions and on hobbyists' benches.

**Don't Accept Second Best,  
Insist on TRIO!**



PERFECTION IN MEASUREMENT

Sydney: (02) 439 3288 Melbourne: (03) 580-7444