

ELECTRONICS

AUSTRALIA

VIDEO, HI-FI & COMPUTERS

JULY, 1982

AUST \$2.00 NZ \$2.50

**100 WATT
SUB-WOOFER
AMPLIFIER**



**CAR COMPUTER TO BUILD
PORTABLE HEART RATE MONITOR
VIC-20 COLOUR COMPUTER REVIEW**



TC-FX6C

Deep C.

Sony presents a dramatic new standard in noise reduction: Dolby C.*

Silence has an indispensable part to play in the reproduction of recorded sound. So naturally, the newest advances in the science of noise reduction are featured on the latest Sony tape decks: TC-FX6C and FX5C.

Dolby C dramatically quiets hiss across the entire audible range, and it is particularly effective in the high frequencies where background noise is most disturbing. At 5kHz and above, hiss is suppressed by 20dB. What's more, an anti-saturation circuit reduces the possibility of over-extending the capacity of

tape when confronted with especially high amplitude signals. For

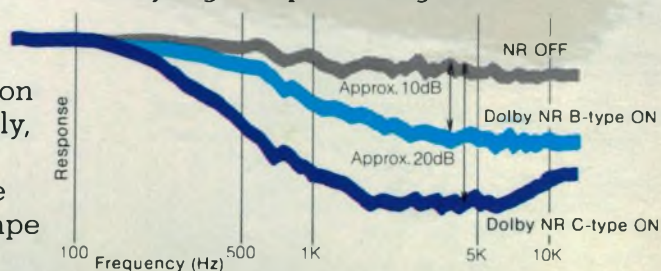

example, at 10kHz the saturation threshold is expanded by 4dB.

In conjunction with conventional Dolby (B type), Sony's new "C" decks do not simply cover up unwanted sound debris. They take it all the way down to clean silence.

*Recording of certain materials may infringe copyright unless permission is given by the copyright holder.
*Dolby is the registered trade mark of Dolby Laboratories

ELECTRONICS

AUSTRALIA

Volume 44, No. 7
July, 1982

AUSTRALIA'S LARGEST SELLING ELECTRONICS MAGAZINE



Build this Car Computer for your car and get immediate feedback on fuel consumption, plus a host of other readouts. Part 1 begins on page 56.



Keep tabs on your "ticker" with this new portable heart rate monitor. It features an optical sensor, in-built calibration, and a 3½-digit liquid crystal display. Details page 62.

COMING NEXT MONTH! — Find out what's coming by turning to page 135.

On the cover

Star billing on this month's front cover goes to our new 100W power amplifier module. This module is specifically designed to drive a sub-woofer loudspeaker in a tri-amped hifi system, and uses four power Mosfets for rugged, reliable operation.

FEATURES

- THE SECRETS OF 3D TELEVISION *How it works* 12
- ELECTROMAGNETIC MASS LAUNCHERS *Faster than a speeding bullet* 18
- TECHNOLOGY — MEETING SOCIETY'S NEEDS? *We report on ANZAAS* 24
- 50 AND 25 YEARS AGO *Interesting items from past issues* 113

HIFI, VIDEO AND REVIEWS

- ON BEING ASKED FOR ADVICE ON HIFI *How do you react?* 30
- HIFI REVIEW *Teac X-1000R open-reel tape recorder* 38

PROJECTS AND CIRCUITS

- 100W SUB-WOOFER POWER AMPLIFIER *Uses Mosfet transistors* 44
- CAR COMPUTER TO BUILD *State-of-the-art feature project* 56
- PORTABLE HEART RATE MONITOR *Keep tabs on your "ticker"* 62
- A DECIMAL POINT FOR THE 500MHz DFM *Simple add-on circuit* 78
- SIMPLE POWER MONITOR *Checks household appliances* 84

PERSONAL COMPUTERS

- PERSONAL COMPUTER REVIEW *The VIC-20 colour computer* 114
- EXTRA MEMORY FOR THE SINCLAIR ZX80 *IC bricklaying* 121
- A CASE FOR THE SUPER-80 *For a professional finish* 122
- MICROCOMPUTER NEWS *Sinclair colour computer released in UK* 126

AMATEUR RADIO, DX

- AMATEUR RADIO *Amateur radio societies plan for WCY 1983* 89
- SHORTWAVE SCENE *Winter listening provides variety of signals* 92

COLUMNS

- FORUM *Electronic spare parts: there are two sides to the issue* 26
- THE SERVICEMAN *Power supplies, valves — and splattered aliens* 70
- RECORD REVIEWS *Classical, popular, special interest* 106

DEPARTMENTS

- EDITORIAL 3 — NEWS HIGHLIGHTS 4 — CIRCUIT AND DESIGN IDEAS 74 —
- LETTERS TO THE EDITOR 86 — BOOKS AND LITERATURE 94 — NEW
- PRODUCTS 98 — INFORMATION CENTRE 130 — MARKETPLACE 134 —
- NOTES AND ERRATA 133.

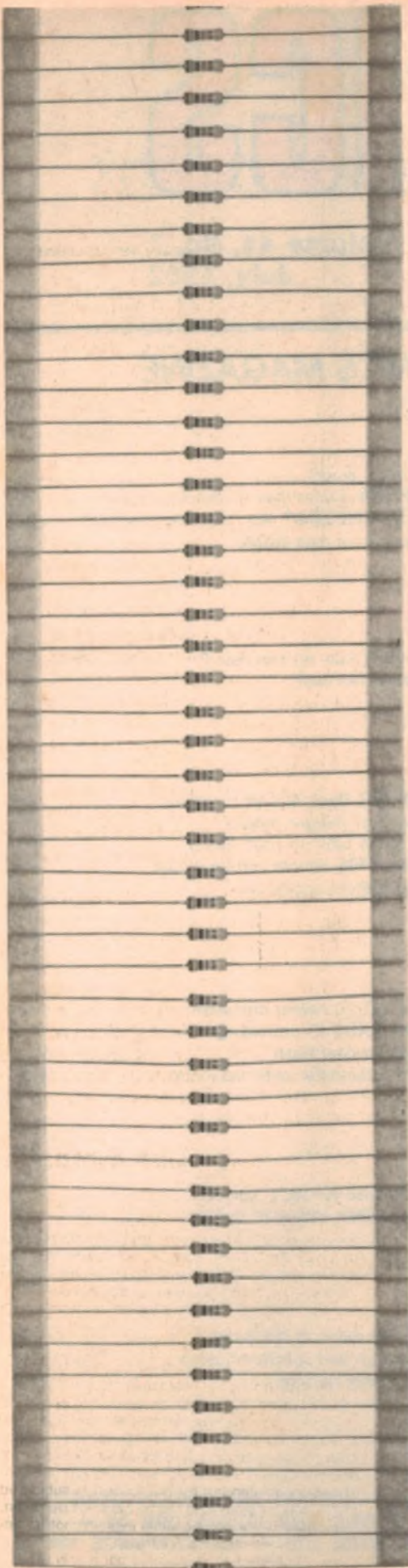

Metal Film technology at carbon prices

SFR

Standard Film Resistors PHILIPS

At last. A range of metal film resistors with improved performance over carbon film types, at the low prices you'd expect to pay for carbon film resistors!

We're talking about Philips' new SFR25 range of 5% tolerance — ¼W metal film resistors. With a quality and price made possible only by advancements in metal film technology and the massive scale of our automated manufacture.

SFR25's feature a 'clean lead' finish and are constructed to the same high standard as the Company's 'MR' series. Resistance coverage from 1Ω to 1MΩ (E24 values) with a tolerance of ±5% is assured. Maximum power dissipation is 0.33W at 70°C ambient.

They have a noise figure of less than 0.1 μV/V (a tenth of the carbon film noise figure) and a temperature coefficient of less than 250ppm/°C. Even more important, neither parameter shows degradation with increasing ohmic value. These improvements stem primarily from the homogeneity and stability of the resistive deposition.

So there you have it. Another quality product, ahead of its time, from Philips.

For further information phone:

Philips Electronic Components and Materials,
P.O. Box 50, Lane Cove, 2066. Phone: **Sydney** 427 0888,
Melbourne 542 3333, **Adelaide** 243 0155, **Brisbane** 44 0191
Perth 277 4199.



**Electronic
Components
and Materials**



Editorial Viewpoint

EDITOR-IN-CHIEF

Neville Williams
S.M.I.R.E.E. (Aust.) (VK2XV)

EDITOR

Leo Simpson
B. Bus. (NSWIT)

ASSISTANT EDITOR

Greg Swain, B.Sc. (Hons. Sydney)

TECHNICAL PROJECTS

John Clarke, B.E. (Elect. NSWIT)
Peter Vernon, B.A. L.L.B. (NSW)
Jeff Skeen
Colin Dawson

GRAPHICS

Robert Flynn

PRODUCTION

Danny Hooper

SECRETARIAL

Pam Hilliar

NATIONAL ADVERTISING MANAGER

Selwyn Sayers

CIRCULATION MANAGER

Alan Parker

Is your computer software "good enough"?

Recently we had the chance to try out another new word processor program on a personal computer system. The price of this total package was considerably cheaper than an equivalent "dedicated" word processor system and besides that, the new package was claimed to be "user friendly" which is a big selling point.

Well, we thought, this should be a good system to try out. So one of our staff members dutifully read the user's manual and made ready to try the system out. Or so he thought. The first shock to his confidence came when he realised that the multi-way plugs to connect the system were not polarised. That was bad enough but then he could not find any instructions on this matter. Hmm. What to do? He could not immediately seek help from the technical people who distributed the machine and to do so would have been quite embarrassing. Who could be so foolish as to be unable to make such simple connections?

So our intrepid staff member took his courage in both hands and decided to hook up the system in a "logical" way, reasoning that if damage was likely to occur, the manufacturer would have polarised the plugs or warned against wrong connections. As might be expected, the system did not work and when he finally did strike the correct combination of connections, it turned out that he had somehow damaged the program on the floppy disc. Luckily, he had a spare copy. So he looked up the user manual for the procedure on making another copy. "Press this button and that, and then the computer will tell you what to do". And so it did.

But the procedure for making the copy was so long and repetitive that our staff member again began to wonder whether he should seek assistance after all. Eventually he did succeed in making a copy but by that time his patience had been sorely tried. And if that had been the end of his problems, one might just put it all down to experience. But it was not. Far from it.

When he later discussed these problems with the distributors of the equipment they admitted that they were aware of them. But they were not proposing to correct the situation because, as they pointed out, their competitors had similar if not worse drawbacks in their systems. This was really more than we could bear. Computers and personal computers in particular, have always been notorious for having insufficient documentation but this should no longer be acceptable. After all, they have been produced and sold for quite a few years now. Why should the user be "chucked in at the deep end" and left to figure it all out for himself? That is just not good enough!

How about it, all you computer distributors? How do your products stand up by comparison to the one described above? Are they better, worse or just good enough? And good enough for whom? The seller or the buyer?

Leo Simpson

Registered by Australia Post — publication No. NBP0240.

ISSN 0313-0150

Printed by Magazine Printers Pty Ltd, of Regent Street, Sydney and Masterprint Pty Ltd of Dubbo NSW, for Magazine Promotions, of Regent St, Sydney.

Editorial and Advertising Office

57 Regent St, Sydney 2008.
Phone (02) 699 3622 Telex 25027.
Postal Address: PO Box 163, Chippendale, 2008.

NSW Advertising Sales Manager: Narciso (Chit) Pimentel.
Melbourne — 392 Little Collins St, Melbourne 3000. Phone (03) 602 3033.

Representative: Mark Christian.

Adelaide — Charles F. Brown & Associates Ltd, 278 Halifax St, Adelaide, 5000.
Representative: Sandy Shaw (08) 267 4433.
Perth — 454 Murray Street, Perth 6000.
Representative: Ashley Croft (09) 321 8217.

Subscriptions

Subscription Dept, John Fairfax & Sons Ltd, GPO Box 506, Sydney 2001
Enquiries: Phone (02) 20944, ext 2589.

Circulation Office

21 Morley Ave, Rosebery, Sydney 2018.
Phone (02) 663 3911.

Distribution

Distributed in NSW by Magazine Promotions, 57 Regent St, Sydney; in Victoria by Magazine Promotions, 392 Little Collins Street, Melbourne; in South Australia by Magazine Promotions, 101-105

Waymouth St, Adelaide; in Western Australia by Magazine Promotions, 454 Murray Street, Perth; in Queensland by Gordon and Gotch (A'asia) Ltd; in Tasmania by Ingle Distributors, 93 Macquarie St, Hobart; in New Zealand by Gordon and Gotch (NZ) Ltd, Adelaide Rd, Wellington.

Copyright. All rights reserved.

Devices or arrangements shown in this magazine may embody patents. Information is furnished without responsibility for its ultimate use, or for failure of equipment to operate as expected, or for any damage, loss or injury which may be sustained. Material intended for publication is submitted at the sender's risk and, while care will be taken, responsibility for any possible loss will not be accepted by "Electronics Australia".

* Recommended and maximum price only.



News Highlights

Software piracy — multi-million dollar headache

Computer software piracy has become a major headache for software manufacturers in the US. A few people in jail might help solve the problem says one lawyer.

Software piracy is a multi-million dollar problem in the US and it's getting worse. In fact, "the value of illegal software copied and sold by pirates may equal the value of the legitimate software market," according to Mr Gervaise Davis, General Counsel for Digital Research Inc, and a specialist in copyright law.

The pirates have become a major headache and expense for US software houses. Digital Research, like several other major software producers, now has a staff of legal experts to handle the task of tracking down and taking action against the illegal copiers of its products.

Another company, Micropro International, which publishes Wordstar, one of the most popular word processing systems for personal computers, offers a reward to anyone supplying information

leading to pirates. Their efforts paid off last March in what is believed to be the first court room test of the 1980 amendment to US copyright law which made software subject to copyright.

In that action, the Federal District Court in San Francisco granted an injunction against a company called Dataforce, prohibiting it from copying microcomputer software.

Many software suppliers, such as Visicorp and Apple, put so-called "locks" on software disks to make it "impossible" to copy them using standard software supplied with personal computers. Apple and IBM also have built a degree of software protection into their machines. But programs that confound these locks are sold openly — and legally.

"Until we put a few people in jail, and



people begin to realise that copying is illegal, we will continue to have a problem," says Mr Davis.

PAY TV FOR REMOTE OUTBACK AREAS?

Australia's first pay television service could be operating within a few months — this is, if a new company called Television Australia — Satellite Systems has its way. The company has already lodged licence applications with the Department of Communications, and plans to offer television programming to 250,000 residents in remote areas of Australia who are as yet without TV.

Programs offered will be a selection of those broadcast on Sydney's three commercial channels. The company says it intends to provide support and program material to local operators who will actually run the service for their own communities.

HBO challenges private ground stations

The growing number of private earth stations capable of receiving satellite TV transmissions is beginning to concern a great number of movies suppliers in the US. Recently, Home Box Office, a major software supplier, announced plans to scramble its pay-TV signal — possibly by the end of this year. The company will spend up to \$5 million to provide decoders for all cable systems using the service.

The digital encryption system will include an individually addressable feature permitting HBO to control the decoding device from a central point and to

change the encryption/decoding patterns as often as necessary. According to HBO, the coding system is tamperproof as it depends on the code being used. Duplicating the electronics in the decoder is useless without knowing the code in use.

Efforts by some organisations to encourage HBO to permit private dish-owners to pay for a reception licence are falling on deaf ears. HBO has repeatedly stated that it has no interest in becoming involved in the retailing of programs directly to individual owners of private earth-stations.

Getting to the core of Three Mile Island

What do you do with a damaged nuclear reactor core? Ignore it and hope that it will go away? Give it a decent burial with an appropriate grave-side service? Or trade it in on a new one?

None of these things, according to a recent US report. The reactor core in question, that from the Three Mile Island Nuclear power plant, is to be taken to Idaho after removal from the plant in 1985.

The US Energy Department is arranging for the core, centre of the 1979 accident, to be taken to the Idaho National Engineering Laboratory where it is to be examined in an effort to learn more about what happened during the accident, and how well the core stood up to the stresses created.

The reason for the delay until 1985 is the massive cleanup which is still underway. Prior to its removal, and probably later this year, a TV camera will be used to take a look at the damaged interior.

And what will it all cost? About \$US120 million, of which \$US30 has already been spent. Hopefully, the effort may help prevent another Three Mile Island "incident".

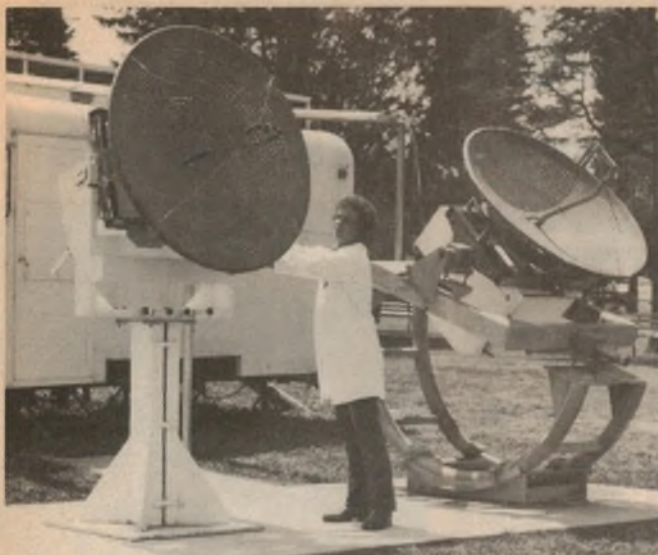

Telecom dishes don't hold water!

The strength of microwave signals between a communication satellite and a ground station can be seriously reduced by heavy rain. To help overcome these effects Telecom Australia's Research Laboratories have begun taking measurements in Melbourne of satellite signals.

Research carried out so far has concentrated on the effects of rain in tropical areas. To obtain comparison data for temperate areas, two sensitive radiometers (shown at left) have been set up in Melbourne. With the help of the Bureau of Meteorology, Telecom researchers have built up an attenuation prediction model which can be used to forecast signal interference in any part of Australia.

The model mainly covers the frequency band from 10GHz to 15GHz which will be used by the Australian domestic satellite system, AUSSAT. The Australian results have been included in International Telecommunications Union (ITU) reports on the subject.

Invention monitors power line temperatures

In high voltage power distribution systems using overhead lines, the temperature of the conductors can provide valuable information for the supervising engineers. High temperatures may indicate that the line is approaching its full load capacity, while very low temperatures may indicate ice formation in very cold weather, with the risk of line damage.

Monitoring these temperatures has always been a problem, but a team from the James Cook University of North Queensland, Professor P. L. Arlett and Mr K. P. O'Neill, have successfully developed a novel solution.

The heart of their sensing device is an

AT cut 4.8MHz quartz crystal, the temperature response curve of which is accurately calibrated. This operates in an oscillator circuit, power being derived from the line via a current transformer.

Output from the oscillator is divided down to around 150kHz which may then be transmitted along the line within the power line carrier spectrum to the monitoring point.

The complete sensor is built as two half cylinders, with a channel for the cable, around which it is clamped. At the control room the signal is decoded and fed into the logging system. Tests indicate an accuracy of $\pm 0.5^{\circ}\text{C}$.



WIND POWERED GENERATOR

Engineers of the Defence Science and Technology Organisation are developing a new type of wind-powered generator with potential for use by the Australian Army.

The new equipment is based on the Darrieus turbine, a design which uses upright vanes moving in a circular path about a vertical axis. The vertical blade system does not require turning into the wind like multi-blade or propeller-driven generators, and operates generating equipment which can be located at ground level for easy access.

Designed by two mechanical engineers, Mr M. L. Robinson and Mr W. R. Crook, at the Defence Research Centre at Salisbury, South Australia, the equipment can provide enough electricity for a small army field communications centre. The turbine, measures 3.7 by 3.7 metres, and can be easily dismantled and carried in a truck.

When completed, the new generator will have an average power output of 1kW at wind speeds above 25km/h. Peak power output will be 4.6kW at 300rpm.

Videodiscs retreat from marketplace

They may not be spinning the way they're supposed to, but videodiscs are in a mad whirl following two major events. The first was the dropout of IBM and MCA from the optical-disc race, leaving Pioneer and North American Philips as the LV format's virtually exclusive managers. The second event was RCA's \$150 reduction in the suggested list price of its new CED player model to \$349.95, with the former model now selling at \$299.95 and very often below.

Combined with the recent and not notably successful Japan-market debut of the laser optical system, what effect will those developments have on the as-yet-unintroduced Japanese grooveless capacitance VHD system, scheduled for introduction here at midyear, and earlier on the Japanese market? The initial signs are that they're close to devastating. VHD was designed as a sort of middle-ground system, with many of the special effects of the optical technique and a price closer to CED. But that design was based on two assumptions: (1) A highly successful market for special-effects discs, and (2) CED players selling at around the \$500 level. Those assumptions have not been borne out.

JVC, the originator of the VHD system, announced the "indefinite postponement" of its Japan-market debut, blaming "stagnant consumer demand" and "the sluggish market situation." Earlier, JVC's parent Matsushita Electric (Panasonic and Quasar in the US) presumably had decided to delay manufacture of VHD players. US introduction of the system had been planned shortly after midyear by General Electric, Matsushita, Quasar, and Sharp. Now it seems likely that at the very least there'll be a relatively long postponement of marketing. (*Radio Electronics*)

Renewed pressure for Telecom videotex service

The Federal Government is coming under renewed pressure from sections of the business community to soften or reverse its decision last year barring Telecom from providing videotex services.

According to a recent report in the "Australian Financial Review", the issue is high on the list of loose ends in the Communications portfolio now awaiting the attention of the new minister, Mr Neil Brown.

Telecom had already prepared a new case on the issue for former minister Mr Ian Sinclair before the last ministerial reshuffle intervened, without Mr Sinclair sighting the fresh submission.

Leading the push is General Electric Corporation, which is the Australian agent for the Prestel videotex system developed in Britain by British Telecom in the early 1970s.

GEC says that it is calling for a review of the policy "because the private sector has not run with the ball". The company

went on to state that interest in videotex is in danger of disappearing because no one can fill the role of Telecom.

Telecom Australia had advanced plans last year to introduce videotex (access to computer data using telephones and TV screens) before Federal Cabinet blocked the scheme in mid-October. The decision was particularly welcomed by Myer Emporium, which said that it wanted to introduce videotex itself and that the field should be left to the private sector.

The Myer plans were recently reiterated at a public demonstration of the Myer videotex system in Sydney last April. According to the manager of Myer's videotex branch, Mr Glen Davis, the company still planned to have a public system up and running later this year.



US chip manufacturers may move back "on-shore"

US silicon chip manufacturers are currently taking a long hard look at their present manufacturing policies. These provide for the basic wafer to be manufactured in the US, then shipped to factories in South America or South East Asia for cutting, lead fitting, and packaging.

This process — rather coyly referred to as "off-shore production" — is, of course, designed to take advantage of the very low labour costs available in these countries. In fact, most manufacturers claim that they cannot compete on the world market in any other way.

But some companies are now beginning to question whether these cost advantages may not soon be outweighed by changing conditions and some disadvantages. One such change is rising labour costs in these countries, and another is improved automation which should reduce mainland labour costs.

One major disadvantage is the increased turn-around time it creates, particularly where customers require relatively small runs of specially designed, or specially programmed (burnt-in) chips. It can take up to three weeks to get a new set of program instructions on-line in an off-shore plant, a delay unacceptable to some customers.

At least one company, Indy Electronics Inc, has sub-contracted its assembly pro-

cess to a plant in California. They claim that this enables them to offer their customers faster service and better quality, while the sub-contractor plans to increase his staff from 400 to 1500 by next year.

Other manufacturers are taking the opposite approach; improving their off-shore facilities to reduce delays and improve quality. This includes adding pro-

gramming facilities, or improving those already installed, and adding final test facilities so that the goods can be shipped direct to the customer from the off-shore site.

Another company, RCA, is planning to use a satellite link to its off-shore plants in an attempt to reduce the traditional three-week delay time for program updates to a mere 24 hours.

COMPACT LSI SPEECH RECOGNITION CIRCUIT

Matsushita Electric Co has announced that it will begin marketing a compact voice recognition unit based on a single LSI chip.

The MN-1263 is an LSI chip which integrates spectrum analysis and pattern matching circuitry to recognise up to 64 words spoken by the voice the chip is programmed to accept.

Potential applications of the single board system include voice control of electronic appliances in home or factory, equipment for the physically handicapped and any job where the operator's hands must be kept free.

Advantages of the single chip over other systems include smaller size, lower cost and simpler manufacture of speech recognition systems. Conventional

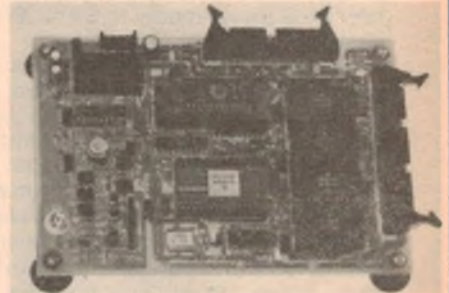

speech recognition systems use input filters and expensive high-speed analog to digital converters.

Matsushita's chip uses a mathematical procedure called the "Walsh-Hadamard" transform, an approach which eliminates the initial analog filtering of the speech signal.

VALUE & PERFORMANCE INSTRUMENTS FOR THE SERIOUS USER



Time proven under Australian conditions TRIO oscilloscopes represent the best value available. Performance and reliability to please you—and prices to keep you happy!

CS-1560 All 15 MHz Dual-trace, Triggered Sweep \$525



The most popular in the range!

- * Sensitivity 10mV/Div. (Triggers at 0.5 Div. Typ.)
- * CH1 CH2 DUAL ADD and SUB
- * Risetime 23nS
- * XY Mode
- * Triggered Sweep and Auto
- * Sweep Time 0.5μS/Div. -0.5S/Div. and XY
- * Price does not include probes

NEW!

CS-2070 4 Channels, 8 Traces 70 MHz Only \$1,995



TREMENDOUS VALUE NEW RELEASE

A 70 MHz Scope for less than the price of many 50 MHz Scopes

Features include:

- * 4 Channel, 8 Trace display making use of alternating delayed sweep
- * Dual sweep with completely independent A and B sweeps
- * 1mV/Div. sensitivity all the way to 70 MHz.
- * Sweep time to 5nS/Div. for easy-viewing of fast signals
- * Delayed sweep intensity control
- * Bright, Clear CRT
- * Price includes 2 probes.

TRIO CS 1820 \$965 20MHz Dual Trace, Delayed Sweep



Expand your capability!

- * Sensitivity 2mV/div
- * Selectable trigger coupling
- * Frame synch
- * Trigger hold off
- * Trigger delay
- * XY mode
- * Sweep time 0.2μS/Div. — 0.5S/Div.
- * Price does not include probes

B & K SA1010 Signature Analyser \$952



\$1,000 barrier broken! Fast, easy trouble shooting of digital equipment.

- * 20MHz operating speed
- * 10nS set-up time
- * Compatible with TTL, MOS, CMOS
- * Unstable signature indicator
- * Active logic probe
- * Synchronising signal output
- * Bright LED display

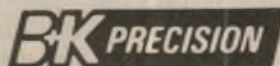

Thurlby \$395 1503 D.M.M.



Better Performance at a Better Price.

- * 4^{1/2} digits (±32,768 counts)
- * 10μV, 10mΩ, 1nA resolution
- * 0.05% basic DCV accuracy
- * LCD display
- * Fully field portable
- * 7 functions including frequency
- * 10MΩ/1000MΩ input impedance
- * Unique diode test facility

B & K LA1025 Logic Analyser \$2,680

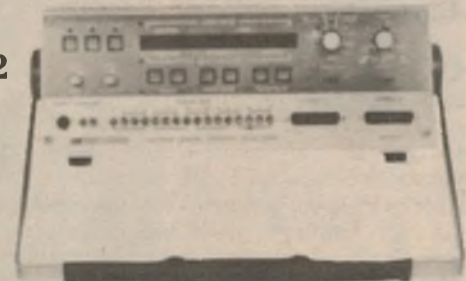

Best of both worlds, both a logic and signature analyser

- * DC to 20MHz
- * 16 Channels (logic analysis) displayable on almost any scope
- * 16 bit x 250 word memory
- * 18 qualifiers
- * 12 digit LED display
- * TTL, MOS or CMOS operation
- * Programmable trigger, clock and event delays
- * Word recognition triggering of external equipment
- * Integral display of four data formats

All prices plus Sales Tax if applicable

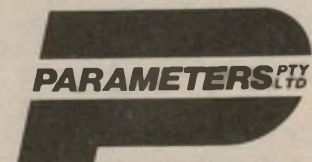

PERFECTION IN MEASUREMENT

Sydney: 439 3288
Melbourne: 580 7444.

Available at a Leading Stockist near you

Sanwa's new versatile auto-ranging family!

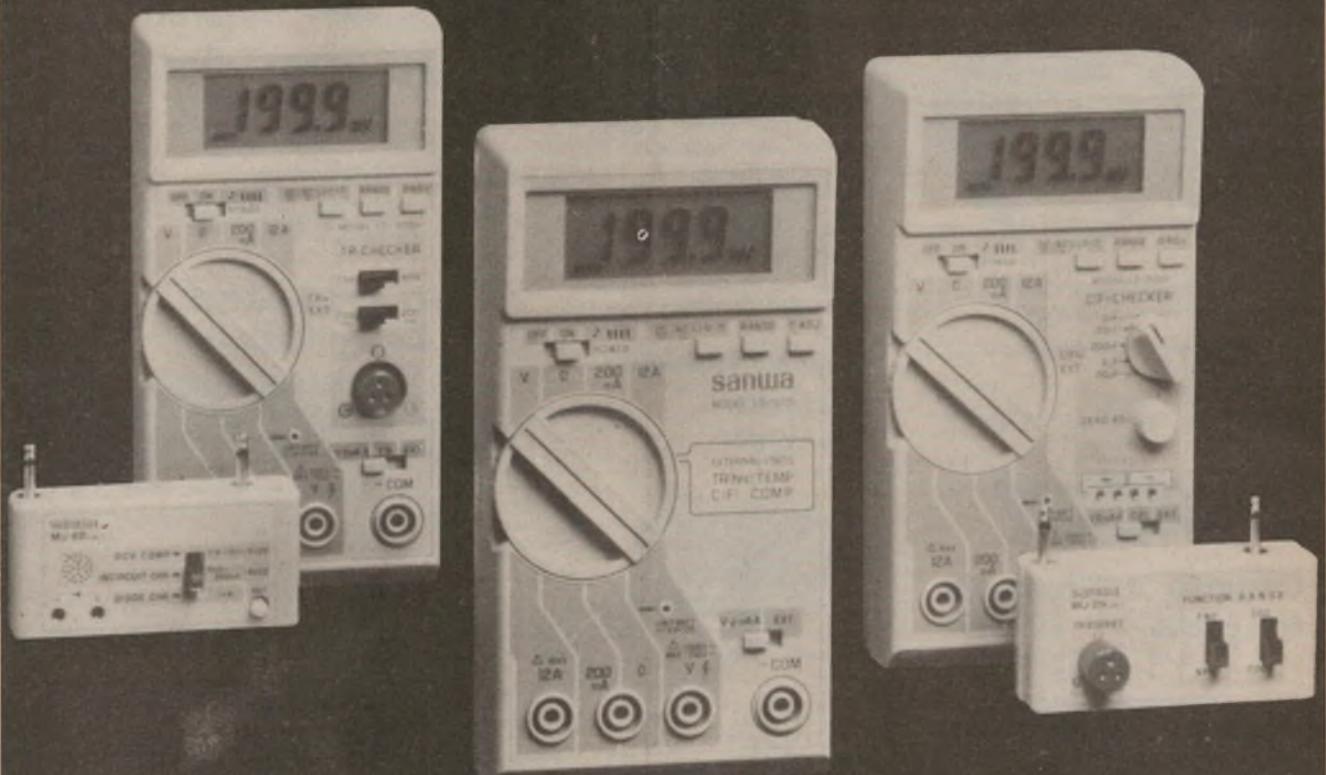

LD-520H

In addition to the functions of the LD-510, the LD-520H also has built-in hFE ranges of 200 and 2000. Measuring ranges are the same as the LD-510. Accuracies: DCV: $\pm(0.5\%rdg + 0.2\%fs)$ ACV: $\pm(0.8\%rdg + 0.25\%fs)$ Ω : $\pm(0.5\%rdg + 0.2\%fs)$ LO- Ω : $\pm(0.8\%rdg + 0.5\%fs)$ DCmA: $\pm(0.9\%rdg + 0.2\%fs)$ ACmA: $\pm(1.2\%rdg + 0.25\%fs)$.

LD-510

Automatic range selection for DCV, ACV and OHM. Manual selection and range holding devices provided. In addition to the basic measuring ranges, optional adaptor units add the functions of hFE, capacity, temperature and circuit check. Supplied with safety test leads which have vanishing pins and protected test tip.
DCV: 200m, 2, 20, 200, 1000. ACV: 2, 20, 200, 750. Ω : 200, 2k, 20k, 200k, 2000k. LO- Ω : 2k, 20k, 200k, 2000k. DCA: 200m, 12. ACA: 200m, 12. Indication: 3.5 digits, max 1999, LCD, first figure "1" flashes when an overload occurs with the piezo electric buzzer sounding simultaneously. Automatic polarity selector provided. Cells: 1.5V (UM-3 or R6) x 2. Dimensions & weight: 168 x 90 x 46.5mm & 400g.

LD-530F

The LD-530F also has built-in capacitance ranges of 2n, 20n, 200n 2 μ , 20 μ F. Measuring ranges and accuracies are the same as the LD-520H except the hFE ranges. Other specifications are the same as the LD-510/LD-520H.

Optional adaptor units: MU-1F (capacity), MU-2H (hFE value), MU-3T (temperature), MU-6B (circuit check).

sanwa

WARBURTON FRANKI

• ADELAIDE (08) 356-7333 • BRISBANE (07) 52-7255 • HOBART (002) 28-0321 • MELBOURNE (03) 699-4999
• PERTH (09) 277-7000 • SYDNEY (02) 648-1711 • AUCKLAND N.Z. (09) 50-4458 • WELLINGTON N.Z. (04) 69-3016



Emergency aid for the disabled

If an elderly or disabled person needs to summon aid, but cannot reach or use the telephone, how do they call for help? Answer — by either squeezing a pendant or pushing a single button on a unit which is connected to the telephone.

With "Vitalcall" that action is all that's required to automatically telephone three people (personally chosen by the user) and deliver a prerecorded message requesting urgent help. The chosen contacts may be family, neighbours or friends and, if any two of these fail to answer, the Vitalcall unit will automatically alert a 24-hour emergency team.

Vitalcall consists of two parts: a tiny

radio transmitter contained in an unobtrusive lightweight pendant worn around the neck, and an electronic device which is connected to the telephone. The pendant has been designed so that even arthritic and disabled people can use it with ease. It can be used up to 100 metres from the telephone, so it can work effectively both inside and outside the house.

As a safety measure, the Vitalcall unit reports each day to a central computer to enable staff to check that the unit is functioning correctly. In addition, the unit can operate from an internal battery in the event of a mains failure, and will even continue to function if the phone is



left off the hook.

For further information, contact Dr Richard Thomson or Tony Ashworth on (02) 438 3311.

New oscilloscope has flat panel display

The total replacement of the cathode ray tube by solid state display devices is still a long way off, and the conventional CRT type oscilloscope is likely to be around for a long time.

However, a British company, Scopex, is now marketing a solid state display oscilloscope which at least goes part of the way to achieving this ideal. So far, performance is limited, but this is offset by several advantages in certain applications.

The display consists of a 10cm x 6cm liquid crystal panel, 3mm thick, forming a 128 x 256 dot matrix of 32,768 elements.

A dual trace facility is provided by interleaving alternate columns. The top frequency response is 150kHz which, while modest by conventional standards, is still adequate for many applications, including audio work.

The advantages of the system include compactness, ruggedness, low power consumption (2W from six "C" size Nicad cells), and high legibility in bright sunlight. It is ideally suited for use in potentially explosive atmospheres — mining, petrol refineries, etc — or in military applications where its small size and self-contained power pack have obvious advantages.

Satellites could stop illegal fishing

Satellites could make illegal fishing in the North Atlantic a highly unprofitable undertaking within 10 years. Canada and Norway are joining forces in a satellite program for the surveillance of their coastal fishing grounds that could detect ships in all weathers and at night.

At present it takes 24 hours for pictures from radar satellites to be interpreted, by which time the "poachers" have moved on. The proposed new satellite system would use computers to interpret the satellite data, passing images of ships in the area to coastal authorities within one hour.

Do children benefit from classroom computers?

Do young children really benefit from the use of computers in the classroom? It is a question that is being raised in the US where an estimated 13% of public elementary schools already have computers and more are planning to buy them despite shrinking education budgets.

With US schools expected to spend a total of \$1.5bn on computers by the end of 1985, a group of educators in California led by Dr A. Daniel Peck, Professor of Education at San Francisco State University and a specialist in education technology, are mounting a campaign against what they see as the misuse of public school funds to purchase computers.

According to Dr Peck, and his "ad hoc committee on basic education" the money would be better spent on basics.



"Money spent on computers is money wasted that could better be used in improving curriculum, teacher strengthening, greater basics emphasis, and utilisation of established simplified, dedicated techniques and technologies."

Dr Peck and his supporters are taking a

stand against the popular view that it is important to expose children to computer technology and ultimately to make them computer literate.

"The microcomputers will become dinosaurs relegated to the back of the classroom and unused, once the fashion for computers in schools wears off," the committee predicts.

The "back to basics" educators suggest that, historically, education has repeatedly been guilty of climbing on "fear motivated" bandwagons as panaceas to its problems. "Instead of solving problems they create more with untold wasteful expenditure of huge sums of taxpayers' dollars.

"We are not anti-technology in the classroom," says Dr Peck, "but we believe that the general purpose microcomputer is overkill." 3

Here's why you should insist on quality DICK SMITH SEMI'S

- ★ All top quality recognised brand names
- ★ Up to 1/3 the price of other suppliers. Save up to 66%.
- ★ Guaranteed Quality
- ★ No need to buy 10 when you only want one.
- ★ Quantity discounts
- ★ No job lots, end of run or below spec devices.
- ★ When you buy semiconductors from DS you buy with confidence.

TOP SELLERS

Cat. No.	Description	1-9	10 up
Z-1300	DS547	.14	.12
Z-1308	DS548	.14	.12
Z-1319	DS549	.14	.12
Z-1329	DS549c	.34	.30
Z-1340	DS557	.17	.15
Z-1348	DS558	.17	.15
Z-1369	BC159	.55	.50
Z-1443	BD139	.55	.50
Z-1444	BD140	1.00	.95
Z-2145	2N3055	.20	.17
Z-2242	BC328	.35	.30
Z-2252	BC338	.20	.15
Z-3042	DSOA91	.08	.06
Z-3120	IN9141	.10	.08
Z-3202	IN4002	.15	.13
Z-3204	IN4004	.20	.15
Z-3207	IN4004	.45	.35
Z-3222	IN5404	.40	.30
Z-3531	6V8 Zener diode	.40	.30
Z-3547	15V Zener diode	.40	.30
Z-3228	IN5408	.50	.45
Z-4000	Flashing LED	.45	.40
Z-4010	Sml Red LED	.20	.18
Z-4020	" green LED	.28	.25
Z-4030	Lge red LED	.20	.10
Z-4032	" green LED	.30	.25
Z-4034	Yellow LED	.55	.45
Z-4040	Rect. red LED	.45	.35
Z-4042	" green LED	1.35	1.20
Z-4150	FND500	1.35	1.25
Z-4510	Triac SC141D	1.50	.70
Z-4802	Double LDR	.80	.70
Z-5801	4001 Norgate	.40	.35
Z-5617	4017 Dec. counter	1.20	1.10
Z-6106	UA4136 quad amps	2.00	1.80
Z-6145	DS555 timer	.40	.35
Z-6382	LM741 op. amp.	.40	.35
Z-6545	7805	1.20	1.00
Z-6552	7812	1.20	1.00
Z-9310	4116 RAM	3.95	3.50

AMAZING FLASHING LED!

Amazing! Inside this standard size (5mm) red LED is a tiny microcircuit which causes it to flash! All you do is apply voltage. Think of the dozens of uses where a flashing warning is needed. Cat Z-4000

FANTASTIC VALUE!
SAVE 70%!

45¢



NOW A HIGH RESOLUTION MONITOR AT AN AFFORDABLE PRICE

With this monitor added to your computer system, you'll be able to use it for almost limitless applications such as accounts/statistics, medical, education, amusement etc. Features an anti-glare screen allowing for easier and sharper viewing. A must for the serious hobbyist or professional. Cat X-1200



\$349

The best Chess Game we've seen! 6 LEVEL CHESS COMPUTER

Become a chess grandmaster with this amazing unit. Easy to master with six graduated levels of learning to increase your skills, and it even plays against itself. Because it doesn't play two games the same way, you can never predict what moves it will make. Forward and backward keys allow you to retrace moves and grasp general patterns. Cat Y-1260

INCLUDES CHESS MEN & POWER SUPPLY

ONLY \$275

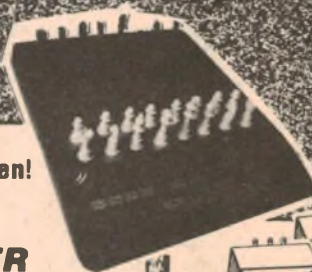

27MHz 5 FOOT WHIP ANTENNA

We now have in stock this superb quality antenna just right for your CB or marine radio. Comes complete with PL 259 plug. Cat. D-4074

\$14⁹⁵



VALUE TRANSFORMERS

If your project is costing too much, try one of our quality transformers, specially made for us so we can bring you quality at a down to earth price.

Model M-2840 with a primary voltage of 240V AC, secondary voltage 9V CT current of 150mA, flying leads termination. Cat M-2840

\$3⁹⁰

Model M-2155 with a primary voltage of 240V AC, secondary voltage 6.3, 7.5, 8.5, 9.5, 12.6 and 15, multi-tapped, current 1 amp, solder lug termination. Cat M-2155

\$4⁹⁹

WHY

SINCLAIR ZX81 OWNERS

NEW MATRIX PRINTER

LOWEST COST!

NOW AN 8K COMPUTER

LESS THAN \$200!
The Incredible ZX81 by Sinclair



Designed exclusively for use with ZX81 the printer offers full alpha-numeric across 32 columns. AND highly sophisticated graphics. Cat X-5004

ONLY \$190

Paper to suit printer
5 rolls **\$24⁵⁰**
Cat X-5005



EXPANSION PACK

ONLY \$150



Expand the ZX 81 to a massive 16K bytes — the maximum it can handle. Simply plug it onto the expansion edge connector at the back of your computer and away you go! Cat X-5002

POWER SUPPLY

This Sinclair ZX 81 Power Supply simply plugs into any 240V socket and gives an output of 9.5V DC @ 700mA. Cat X-5001

ONLY \$1750



RAINBOW CABLE

12 colour coded strands of insulated conductor bonded together in a flat cable ideal for wiring looms or intercoms etc. Cat W-2045
Minimum order 5 metres
90¢/m
100m or more 70¢/m



NEW

DICK SMITH SOLDER STATION

ONLY \$59⁵⁰

UNBELIEVABLE QUANTITY SOLD!

Before you buy a soldering station, check 1) is the temperature continuously variable without changing the tip? 2) Do you have a meter readout of the temperatures? Why buy an iron without these useful features?

DON'T PAY OVER \$70.00

If you're serious about good soldering, there's only one way to do it — with a temperature controlled soldering iron. Until now, temperature controlled soldering irons have been expensive but Dick Smith has solved that problem! This superb soldering iron offers you the best quality at an unbelievably low price. Cat T-2000

PAY MORE?

BUY AT DICK SMITH'S CONSISTENTLY LOW PRICES!



PANEL MOUNT METERS

High quality range of moving coil meters with full scale accuracy of better than 2%. All meters have a fine needle for optimum accuracy in reading and all have a mechanical zero adjustment. Mounting is by four bolts, with nuts and washers supplied. Dimensions: Scale area — 58 x 31mm Overall — 58 x 52mm

0-1mA (100 ohms) Cat. Q-2010

0-50uA (2400 ohms)
Cat. Q-2020

0-50A (3 ohms shunt)
Cat. Q-2030

0-20V DC (100 ohms)
Cat. Q-2040

VALUE! **\$8⁹⁵** each 10 or more **\$7.95** each



METRIC KNOBS

An aluminum knob with fine vertical lines. Superb on amplifiers, etc. 40mm dia., 20mm deep. Cat. H-3846
\$1.60 each 10 or more **\$1.40** each
Satin aluminum finish with knurled body for positive grip. 25mm dia., 17mm deep. Cat. H-3843
90c each 10 or more **80c** each

VALUE HEATSINKS

ROUND TO-5

Manufactured to exacting tolerances for a snug fit to give the best heat transfer. Cat. H-3412

55c each
10 or more **45c** each

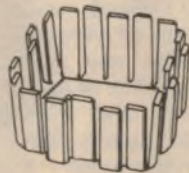

POWERFIN FOR TO-3

This TO-3 heatsink gives the greatest possible heat dissipation in the smallest possible space. Unique fin design. Cat. H-3400

\$1.35 each
10 or more **\$1.20** ea

100MHZ x 1/x 10 CRO PROBE

This versatile probe set will suit virtually any CRO and give you all the features of a probe set you would pay \$\$\$ more for!

Cat. Q-1245
Working Voltage: 600V Pk (or 600V DC)
Includes: IC Adaptor tip — Spring clip — Insulating shroud — BNC Adaptor — Trimming tool — Plastic Wallet for safe keeping!



\$32⁵⁰
GREAT VALUE!

MIYAMA HOOK PROBE

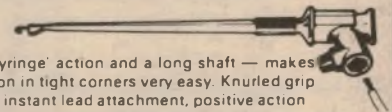

With a 'syringe' action and a long shaft — makes connection in tight corners very easy. Knurled grip screw for instant lead attachment, positive action and sure grip for all your test work.

RED Cat. W-4589

BLACK Cat. W-4590

WHY PAY MORE? **\$2⁵⁰** each

PRECISION CUTTERS

Highest quality cutters. Ideal for PC board, transistor and IC work. These cutters are spring loaded for ease of operation. Length 110mm, jaws 24mm. Cat. T-3310



\$8⁵⁰

MINI LONG NOSE PLIERS

Drop forged steel, chrome plated finish with soft plastic handle grips. Long nose complete with in-built cutter. Length 100mm. Cat. T-3562



\$4²⁵



NOW a hand held computer at a DICK SMITH PRICE!

The all new Casio FX-702P was designed with the 'professional' in mind. It incorporates BASIC computer language and some great features, especially for its size! Features include: 7 program modes, multi-function keyboard, two function keys and the ability to program in multi-mode, 10 digit accuracy, 62 character input buffer, 9 error codes, 226 maximum memory. With all this going for it, the Casio FX-702P could well be our most popular portable computer ever! Why not drop into one of our stores, and see for yourself! Cat. X-5100

UNBEATABLE VALUE \$259

ALSO AVAILABLE: Cat. Q-3125 Cassette Interface

\$51.90
Cat. Q-3127 Printer **\$126.50**

DICK SMITH Electronics

SEE PAGE 52 FOR ADDRESS DETAILS



The secrets of 3D television

Three dimensional television has been a dream cherished by a few engineers for years. The technical problems have been solved, however — we could have 3D TV on our screens now.

by CHARLES SMITH*

The television of today is old hat. The last real advance we enjoyed was colour, and that goes back 25 years in the US, 17 years in Europe and seven years in Australia. What could we have instead? The answer is television in three dimensions. Why don't we have it? Because the economic conventions that rule the lives of people who manufacture the television sets (and those who make the programs) militate against anything more daring than replacing the bulky cathode ray tube with a flat screen.

But the 3D effect that technology could produce would not be ideal — we might have to wear special glasses or be prepared to keep our heads still while viewing. These limitations show that "TV in 3D" is still in the doldrums as far as the television industry is concerned.

So, how long before 3D TV is here? It could be within five years, if broadcasters and manufacturers decided to go ahead. Or it could be 25 years away if nobody is prepared to pay for the preparatory work. Britain's well-known conservatism makes it difficult to believe that 3D TV will happen here soon, even though some of the best research and

development has been done in the UK. The market, as usual, seems open to the Japanese.

The ability to transmit 3D television lies well within the scope of today's technology, once enough money is devoted to designing and developing a working system. The visual and psychological requirements of viewing three-dimensional programs are well understood, from the experience of people who make 3D films, and from published analyses of the factors that control how an image is reproduced — a field in which Britain once held a world lead.

3D TV is already in use for closed-circuit television. For some purposes, such as observation and remote manipulation in radioactive environments or underwater drilling, (where closed-circuit TV is now a standard tool), 3D viewing has proved not merely an advantage, but an essential. Tasks that require men to align one component against another using remotely controlled manipulators take a tenth of the time with 3D TV than with conventional 2D TV. For an operation such as

the remote control of an underwater buggy, 3D vision can make the difference between being able to drive up and stop within reach of an object, or driving full-tilt into it.

I was invited recently to a private demonstration of three-dimensional television that one can watch without special glasses. The screen was "direction-selective" which is jargon for being fitted with lenses that reflect parts of the image to each eye. The demonstration was set up merely to prove that you can achieve a satisfactory 3D effect from this technique. But although it seems simple, this technique (which I shall describe in greater detail later) could have a revolutionary effect on television programs. Three-dimensional television will give not merely a more accurate picture but one that is fundamentally different in character from present-day "flat" images.

Three-dimensional movies shown on large screens in the cinema give life-sized

** Charles Smith runs a consultancy for the video industry in London, and is one of the acknowledged pioneers of 3D films and images and films in Britain.*

Below, 3D as everybody knows it, with audiences at an early feature wearing red and green spectacles.

Polarising glasses



Fig. 1: Screens that polarise the image for each eye and polaroid glasses make 3D easy, but are too bulky for the home.

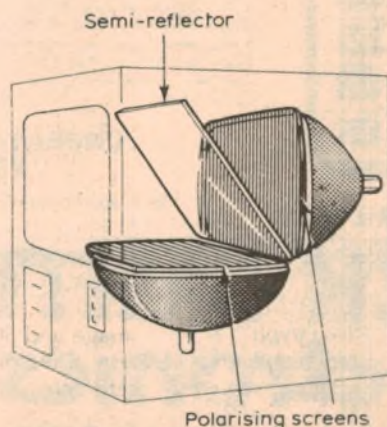

images free from distortion with vistas stretching into the far distance. But can this large scale effect be reproduced on the tiny (by comparison) screen of a television set? Will puppet-sized living figures in box-sized sets be acceptable to television watchers? Trials indicate that they will be. The human brain can as readily adapt to miniaturised 3D images as it has to tiny two-dimensional pictures. And it is the human brain that does the work. If you show a person two flat images, each containing different details of the same scene corresponding to each eye's viewpoint and hold in appropriate positions, his brain will combine them in such a way that he thinks he is seeing a 3D view.

There are three obstacles to starting up a 3D television service: nobody has decided what "viewing system" should be adapted as a world standard; no broadcast authorities have decided to allocate any frequencies; and nobody has developed suitable techniques for camera operators.

Viewing systems are the most fundamental, so I shall start with them. Engineers have proposed about four or five methods of projecting the 3D images on television.

The simplest technique — demonstrated many years ago — is to use two screens each fed with the right or left eye's view of an image (Fig. 1). This is a so-called two-channel system. The two screens are placed side by side, at right angles to each other, and a semi-

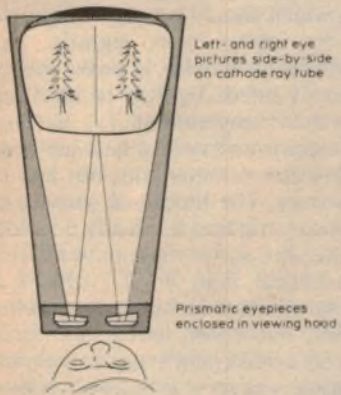
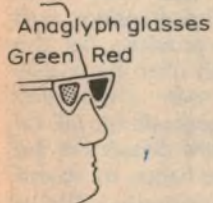

Fig. 2: Splitting the image on a single screen and beaming each to the appropriate eye.



Germans preview 3D television

On 28th February this year many German television watchers sat down for a surprising evening of viewing.

If they missed the massive publicity preceding the event they probably wondered why they were seeing double: one red and one green image of the same TV scene.

They were in fact watching the world's first "made for television" 3D spectacular, but without the necessary anaglyph spectacles to make sense of the scene.

If Germany's TV watchers put the red/green spectacles on however (and six million pairs were distributed, subsidised by a video equipment manufacturer), the blurred images sprang into spectacular depth, filling the space between the viewers and the screen.

Although familiar to movie goers of the 50s, the three dimensional technique was being tried for the first time on television. At the NDR studios in Hamburg, director Hans-Joachim Herbst produced two features specially designed to use and explain 3D effects for the show.

There have been many attempts to transfer the technique of three dimensional cinema to television. Two factors make the difference between success and failure — the viewing angle of each shot and the amount of interference between the images intended for each eye.

Herbst had taken special care to get the geometry of each shot of his films exactly right, ensuring optimum

viewing angles for 3D. A team of researchers from Philips solved the cross-talk problem.

For three dimensional movies the red and green colours used to isolate each eye's view of every frame of the film are quite separate, so interference between the two images is not a problem. This technique however cannot be used with television.

In television the red, green and blue colours are mixed in the transmitted signal, but only imperfectly decoded by the domestic colour receiver. This means that even if the spectacle filters are precisely matched to the phosphors on the TV screen, some of the information intended for one eye leaks across to the other and confuses the illusion of depth.

Philips engineers overcame the problem by relying on the power of the brain to make sense of an incomplete stimulus. Most TV sets fail to interpret only a few of the frequencies that give part of the red, green and blue images from a camera. By leaving out those frequencies, cross-talk between the two images is avoided, without any significant loss of picture definition.

Obviously, a lot of time and trouble went into Germany's three dimensional TV spectacular. Perhaps one of Australia's more innovative and adventurous TV stations might give it a try. If reports of Herbst's programs are anything to go by, it could be a lot of fun.

reflecting mirror is placed between them. This is adjusted so that it optically superimposes one image on the other. There are also polarising screens in front of each picture screen, that prevent the left eye from seeing what should be the right eye's exclusive preserve. The viewer then wears spectacles in which each lens has the same polarisation as the corresponding screen. The technique gives good quality, and the pictures can be in full colour. But it is cumbersome and the polarising screens

and glasses reduce the brightness of the image. These disadvantages will prevent it being used for domestic television, but it is satisfactory for industrial tasks, such as assembly and inspection.

Another method that is widely used in industry is to pass the picture information for the 3D image through a single communication channel and to feed it into a television set whose screen is split in the vertical plane, with the left eye picture on the left, and the right eye's view on the right (see Fig. 2). A viewing-hood over the screen has prismatic lenses that bend the sight-lines outward, so the two eyes can comfortably see the widely-spaced pictures. The system is simple and inexpensive but gives an unattractive "upright" picture shape which is nothing like the ones that viewers are familiar with. Also it needs a separate set for each viewer. The single-lens camera that the film maker must use distorts the image and 50% of the horizontal resolution of the picture is lost. This method is satisfactory for some medical and industrial tasks but it is not acceptable for

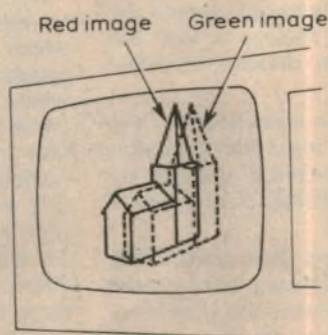

Fig. 3: The earliest method for 3D movies and TV is the "anaglyph" technique using images projected in red and green.

The secrets of 3D television

entertainment.

A third option is to go back to the old "anaglyph" system (that pre-dates the 1936 invention of polarising filters) in which viewers wear spectacles with a red filter in the left eye and a green filter in the right eye (Fig. 3). Using a colour receiver, one displays a pair of monochromatic images, one in red and one in blue or green. The viewer's spectacles blank out the unwanted image from each eye, so the viewer can see the 3D image. This technique also uses a single channel, and is the only system available now for entertainment television. It is already in use in the Cablevision service in the United States, and a 90 minute 3D spectacular has been shown on West German television (see Box). Given careful selection of the spectacle colours in relation to the phosphors that coat the screen tube, the anaglyph method produces a satisfactory 3D image. However, the red/green spectacles are unnatural and cause eye strain. And it is, of course, impossible to see a full colour picture. This system is suitable as a temporary novelty, but it does not offer a long-term solution.

The fourth, and most promising technique, is the direction-selective screen, because no viewing aids are needed. In this case, 3D information is shown on a screen, but an array of cylindrical lenses (arranged in columns) directs left and right eye images to the appropriate points. This is called a lenticular screen. But in return for the freedom from spectacles, this method restricts how far the viewer can move his head. If the head is moved 65 mm (the distance between most people's eyes) to the left, the right eye will see the image previously seen by the left eye. So no more than, say, 30 mm sideways movement of the head is permissible. There is no restriction in the vertical plane.

This method can be used with a lenticular screen directly on the picture tube (see Fig. 4) in which case the set needs to be able to scan with high precision and it loses 50% of the definition in any event.

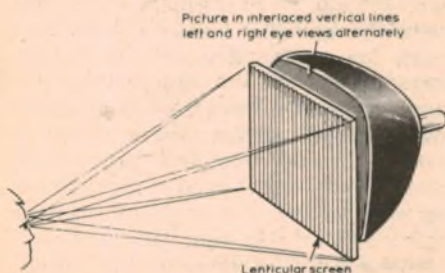

Fig. 4 Most promising of the new methods is the direction selective lenticular screen.

Solid-state screens, when they come, will give the necessary precision to allow two perfectly-matching pictures to be produced. An alternative is to use two channels, rear-projecting the two images into a dual lenticular screen (Fig. 5). This retains full horizontal and vertical definition.

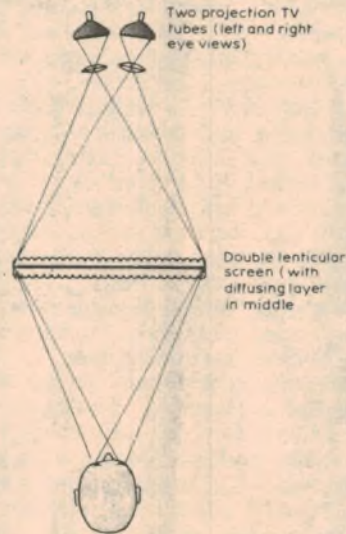

Fig. 5 Even more effective is the lenticular screen with separate TV tubes for each view.

Another development of the lenticular-screen system is to allow screens to store more than two pictures at any time, easing the restrictions on head movements. Looking well into the future, I think that it will be possible to transmit multiple viewpoints, possibly four at first, and later eight to 10. This will permit the viewer to move more freely while watching television; when the head is moved 65 mm to the left, the right eye will then see the former left eye picture, but it can be arranged that the left eye sees a new image from a viewpoint even further left, so a stereoscopic view is retained. In this technique the viewer will also see a fresh perspective, as he changes his viewpoint, permitting him to look around the subject, rather as he can do when examining a hologram.

Which of these methods should be adopted? My own feeling is that the future lies with the direction-selective screen.

The lenticular screens needed for TV in the home can be moulded in plastic, making them economical enough for mass-production. Suitable screens have already been made.

When broadcasters start transmitting 3D programs, the images can be seen either on sets with lenticular screens or televisions designed to be viewed

through polaroid spectacles. Where there is a large number of spectators, the same images may be projected on to a large screen for polaroid viewing. But polaroid methods are light-absorbing, whereas the direction-selective screens are light-concentrating, and hence save energy.

Because of the lack of space in the frequency bands, the use of twin channels for a single program is ruled out. The limitations do not apply to cable distribution, so cables may bring us the first large-scale 3D TV broadcasts. Indeed, the ability to present 3D images may be the greatest attraction of cable television in Britain, which is fortunate to have good broadcast television programs.

Technical developments can be expected anyway to reduce the spread of frequencies needed to transmit 3D television programs. Although 3D requires the transmission of a pair of pictures, the information required is certainly less than twice that of a 2D transmission. The two images consist of pairs of points, each with the same vertical location, each with the same tonal values, and differing only in the very small horizontal displacements that carry the depth information. A method will certainly be found for carrying this extra displacement information within the single channel. This will probably be made possible by digital signal techniques, which should permit a single channel to carry two signals. Such developments would cut down the extra frequency needs by 70% to about 30% more than conventional TV. Makers of 3D programs will need a new generation of television cameras, but not any new technology. The theory of stereoscopic image construction is already developed for films, but some requirements will be more critical than in 2D. Lenses and screens will have to be positioned more precisely and zoom lenses will need to focus on a dead-centre point, without introducing weave — unwanted sideways movement of the image — but lighting levels and studio space will not need to be changed, so the extra production costs will be relatively low.

In all visual media, not just television, we are entering a change-over period, in which we are beginning to be able to produce three-dimensional images where before we had only two-dimensional ones. This transition will take many years to complete. But the cathode-ray tubes with their 2D images that are everywhere today are already obsolete. Future generations will be astonished that for a few decades in the 20th century we were happy to accept these flat images as a representation of the real three-dimensional world.

FEAST YOUR EARS ON TDK



We would be delighted to send you our free 26-page Guide to Better Recording.
Just write to: TDK (Australia) Pty. Ltd., Unit 5, Level B South, 100 Harris Street, Pyrmont, NSW 2009.

When buying TDK cassettes select from the D, AD and OD series for all decks,
the SA and SA-X series for high bias position and the MA and MA-R series for metal position.

"TDK does amazing things to my system."

Note: Any person practising tape-recording should observe the provisions of the Copyright Act 1968.

John Bevins TDK 05

CRAZY SPECIALS- logic probe IC *slaughterer*

We have purchased the entire stock of a very well-known supplier. We have probes and pulsers (injectors) made in both the USA & Far East.

MF504 LOGIC PROBE
TTL/CMOS Minimum Pulse Normally \$49.50
Width 20nS This month \$24.50
Input imp. 100K SAVE \$25.00
Max Freq 30MHz
Multi-LED readout
Stainless Steel Probe Tip

OK TOOL CORP (USA) MADE PROBES PRB-1 LOGIC PROBE DC-50MHz

Will deflect 10nS pulse. Pulse stretcher, $\pm 70V$ overvolt protection. RTL, DTL, TTL, MOS, CMOS, uP compatible. This is the ultimate probe worth over \$100.00.

YOURS FOR ONLY \$39.50

PLS-1 LOGIC PULSER

Single or train of pulses. 2uS nominal pulse. Auto polarity sense, auto current limit. High input impedance. Compatible with all logic families. A MUST FOR THE TROUBLE SHOOTER!!

WORTH WELL OVER \$100.00

NOW ONLY \$39.50

Both "OK" units come in attractive case with coiled leads.

MF420 PROBE RACK

Designed to mount Logic Probes, Pulsers and Gates in parallel with only one power supply required.

**WERE OVER \$100.00
NOW SACRIFICED TO \$19.95**

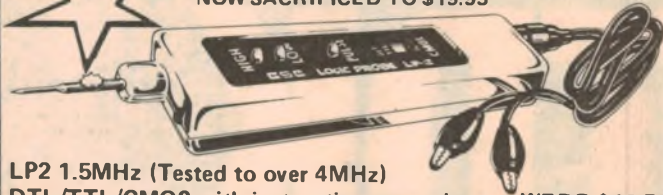

LP2 1.5MHz (Tested to over 4MHz)

DTL/TTL/CMOS with instruction manual **WERE \$49.50
NOW \$19.50 SAVE \$30.00!!**

US Made by Continental Specialities.



LOGIC PULSER MF512
TTL/CMOS Will Generate
Pulses (10% High
90% High) at
0.5pps or 400 pps
Output protected

**Normally \$59.50
This month \$29.50
SAVE \$30.00**

SAVE OVER 50%!!!

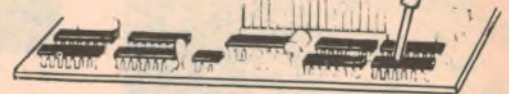

EDGE CONNECTOR SELLOUT

Jaycar has been instructed to liquidate what is probably the broadest range of Edge Connectors available ex-stock in Australia at present. Part of the range is down below, however, we have small quantities of other sizes and styles.

Type	1-9	10+
.156 Double side wire wrap 44 pin	\$2.95	\$2.50
.156 Double side wire wrap 50 pin	\$3.50	\$3.00
.156 Double side PCB 86 pin	\$4.50	\$3.95
.156 Double side Solder Tail 86 pin	\$4.95	\$4.50
.1 Double side wire wrap 50 pin	\$2.95	\$2.50
.1 Double side PCB 72 pin	\$3.50	\$2.95
.1 Double side wire wrap 72 pin	\$3.25	\$2.50
.1 Double side PCB 98 pin	\$3.95	\$3.50
.1 Double side Solder Tail 170 pin	\$4.50	\$3.95
.1 Single side PCB 78 pin	\$2.00	\$1.50

ALL OTHERS \$2.00

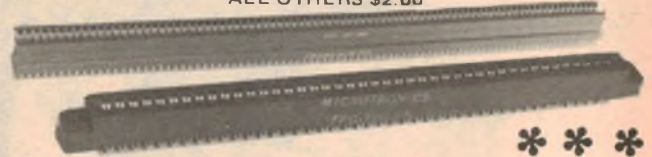

PLESSEY-FOSTER

We still have a small quantity left of the stock shown below:
P.A. SPEAKERS

12" 50W RMS C300K05	NORMALLY \$69.50 NOW \$39.50 SAVE \$30.00	
10 pcs OR MORE	\$29.50 - UNBELIEVABLE!!	
15" 180W RMS C380K50 (240W PEAK)	NORMALLY \$245.00 NOW \$140.00 SAVE \$105.00	
A FEW ONLY LEFT - HURRY!!		
HI FI/GENERAL		
12" 20W RMS C300L05	NORMALLY \$29.95 NOW \$19.95 SAVE \$10.00	
6" 10W MIDRANGE C160K03	NORMALLY \$12.95 NOW \$6.95 SAVE \$6.00	

E-Z-HOOK

OVER 60% OFF!!!
These are the GENUINE made in the USA product - not cheap Taiwanese types.

STYLE	DESCRIPTION	PRICE	NORMALLY
XM-5	Pack of 10 mixed colours micro EZ Hook	\$3.95	\$9.95
*X-100WS	Pack of 10 mixed colours mini EZ Hook	\$4.95	\$12.95
XL 1-S	Pack of 10 mixed colours macro EZ Hook	\$8.95	\$19.95

We have bulk quantities of all colours of above (i.e. You can order 10 x green). The same prices apply - minimum 10.
Colours: Red, Black, Green, Blue, Orange, Mauve, Gray, White, Yellow and Brown.
* Limited stock of X-100WS



"INTERSIL" LCD PANEL METER EVALUATION KIT

BARGAIN OF THE CENTURY!!! ICL7106EV
This kit has featured in numerous construction projects. Until the Jaycar DPM-200 it was the lowest cost LCD DPM around. It normally sells for around \$45.00

GRAB ONE NOW FOR ONLY \$29.50

KIT INCLUDES: SAVE 35%!!

- High Contrast 3 1/2 digit LCD module
- Intersil 7106 LSI
- PCB and all passives

***** \$29.50**



CHECK THEM OUT!

AUTORANGING DIGITAL MULTIMETER SENSATIONAL NEW PRICE!!

GRAB ONE NOW WHILE STOCKS LAST

Sorry, but the ME533's have sold out. But the news is not all bad. You can now have the fantastic ME532 for **ONLY \$49.50** That's right, at the same price as Dick's 250Kg model!! Once again we expect demand to be brisk, so hurry with your orders.

The illustration shows the ME533 which is no longer available but the ME532 is almost identical.



**SOAR
BRAND**

Clubs can buy in lots of 10 for **ONLY \$45 ea (cash)**
(Savings are shown off our normal price)

ME532 with low ohms buzzer **ONLY \$49.50**
SAVE OVER \$10.00

From **\$45**

- FEATURES:**
- 3 1/2 DIGITS LCD
 - AUTO RANGING
 - AUTO POLARITY
 - SAMPLING RATE: 2/sec
 - 0-1KV DC +/-1.35% worst case
 - 0-600VAC +/-2.3% worst case
 - 0-2Mohm
 - 0-200mA
 - POWER CONSUMPTION 5mW
- ME532 ONLY - RANGE CHANGE INDICATION BY ELECTRONIC BEEPER**
- SHORT CIRCUIT GO/NO GO BEEPER

**BETTER MODEL
THAN DICK'S
Q-1446
AT NO EXTRA
COST!!**

* PLUG-IN *
1% CURRENT
SHUNT (TO 30 AMPS)
TO SUIT BOTH
METERS ONLY
\$8.50 *

**REED SWITCH/
MAGNET ASSEMBLY**
Good quality moulded design.
ONLY \$1.25 SET
10+ \$1.00 SET
NORMALLY \$1.95
SAVE ALMOST 50%

spring reverb

We have purchased a small quantity of high quality US-made spring reverb units. This 3-spring model is the one used in such amps as 'PEAVEY' etc. Grab a spare now or build a complete reverb system with free circuit supplied.

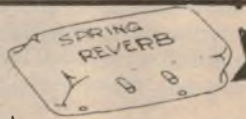

34.50

NEW MUFFS FOR OLD

We keep spare earmuffs for the "Industry Standard" Sennheiser HD-414 headphones. Maybe you have never seen a blue muff before but ours are and they come in pairs.

\$3.95 set



Ioniser Kits

Save a fortune on our very popular Ioniser kits.
SHORT FORM Normally \$24.50
SAVE \$5.00 NOW ONLY \$19.50
FULL KIT Normally \$45.00
SAVE \$5.50 NOW ONLY \$39.50



AN ECONOMICAL MAINS FILTER!! 250VAC @ 3A

250V AC @ 3A. Insertion loss:
line-to-line 20dB 0.8 - 30MHz.
Line-to-ground 30dB 0.7-30MHz
Ideal for computers, amps etc.

* **only \$14.50** *

CUDLIPP CRICKET Ref. EA Feb 1982

One of the most popular kits ever produced by Jaycar. Cudlipp chirps back to you when you talk. Talk about frustrating! Great fun to hide in someone's desk!!
The Jaycar kit comes exclusively with 8 great big colourful 2 watt carbon resistors that you use as legs.
Great fun for only

* * * * * **\$12.50**

Z-80A SPECIALS

We have been able to buy the FAST (4MHz) Z-80 Family at such a great price that we don't bother to stock the 1.7MHz version!
Now you can pay no more for a full spec. Z-80A product. Note: most product stocked is genuine ZILOG manufacture. We reserve the right to ship OTHER product if ZILOG becomes in short supply.

Z80A CPU	\$8.50	MEMORY	1-9	10+	
Z80A CTC	\$8.50	2102A	\$1.95	\$1.65	
*Z80A DMA	\$20.95	2114 400nS	\$1.45	99	XXXXXXX
Z80A P10	\$8.50	4116 150nS	\$2.50	\$2.00	EXTRA
*Z80A S10/0	\$20.95	6116	\$12.50	\$9.90	SPECIAL
*Z80A S10/1	\$20.95	2708	\$7.95	\$6.95	PRICES
*Z80A S10/2	\$20.95	2716(S/Supply)	\$8.95	\$7.95	XXXXXXX
*Z80A DART	\$32.95	2532	\$14.95		
		2564	\$35.00		

OEMS: Ring Phil Gleason (02)264 6688 FOR QUANTITY BUYS

4067B CMOS 16 CHAN MULTIPLEXER WE HAVE IT! ONLY \$2.95

HITACHI 2SC2545 THE AUDIOPHILE'S DREAM COME TRUE.

Here's what Leo Simpson had to say about the 2SC2545. "We tried these transistors in our prototypes and found them to be excellent. In fact in the MC mode they are actually better than the LM394....."
Unfortunately they WERE very scarce. Now we have 'em!! Grab these ULTRA-MATCHED transistors now for only \$1.95 each.
(A free data sheet is supplied with each unit).

Jaycar

125 YORK ST SYDNEY 2000

Ph. 2646688 Telex 72293

Mail Orders To:

Box K-39 Haymarket 2000

Post and Packing charges

NEW SHOP HOURS

Mon-Fri 8.30 to 5.30pm

Sat 8.30 to 1.00pm

Thurs night to 8.30pm

\$5-\$9.99 (\$1.20) \$10-\$24.99 (\$2.40)

\$25-\$49.99 (\$3.50) \$50-\$99.99 (\$4.60)

\$100 up (\$6.20)

Faster than a speeding bullet . . .

Electromagnetic mass launchers

From science fiction to fact; rail guns and mass drivers herald a new age of propulsion.

By **DANIEL RUBY** and **DAVID LAMPE**
ILLUSTRATION BY WALTER HORTENS

IT LOOKS LESS like a gun than a cobbled-up collection of electrical leftovers. The device clamped to a bench top in Richard Marshall's lab at the University of Texas consists of bolted-together plastic slabs with a square, copper-walled bore. Large capacitors on the floor are wired to terminals on the device and a section of cotton-stuffed drainpipe dangles on wires a short distance ahead of the muzzle. Marshall loads a 1.5cm plastic cube in the breech and a technician reads the countdown. At zero, there's a bang, a flare of light, and the drainpipe swings lazily back and forth. The embryonic rail gun has just fired a projectile faster than a conventional gun ever will.

One state to the west, Max Fowler of Los Alamos Scientific Laboratory and Ronald Hawke of Lawrence Livermore Laboratory and their colleagues are set to test a similar electric

gun. Their 1.8 metre-long device is set up among sandbags at the Ancho Canyon firing range because firing it involves an explosion that would be dangerous in a lab. As the explosive discharges, it squeezes a magnetic field behind a cubic three-gram plastic bullet and sends it speeding into a rag-filled garbage can at such acceleration that the cube breaks up into dozens of tiny pieces. Reconstructing the test, the scientists calculate that the projectile left the muzzle with almost the velocity needed to escape Earth's gravity!

In an exhibition hall at Princeton University, Henry Kolm and some graduate-student assistants are demonstrating a device they call Mass Driver I. A "bucket" consisting of superconducting coils is at rest at the left end of a 10cm-dia tube. When power is switched on, observers are amazed to see the bucket materialise at the right end before their eyes have seen it leave the left.

"A Star Trek experience," Kolm calls it — an apt description, because until recently such devices have been more at home in science-fiction scenarios than in scientific laboratories. But now electromagnetic guns and launchers are getting serious academic, industrial, and military attention that could soon lead to important applications.

Two types of accelerating devices are under study: rail guns, in which a magnetic field generated between parallel conducting rails drives a projectile forward, and synchronous

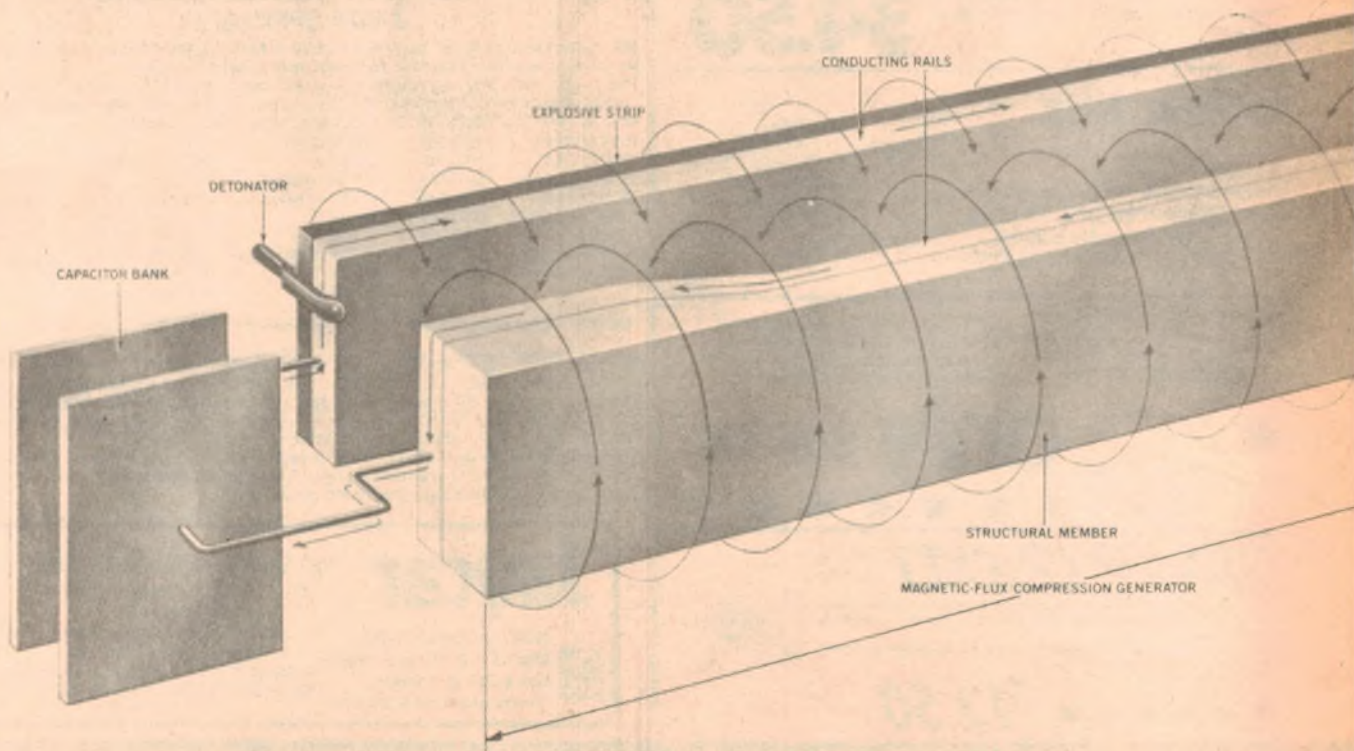

How it all began

A rail gun built in 1968 at the Australian National University initiated a worldwide upsurge of interest in electromagnetic mass drivers. Using a homopolar generator for power, the gun fired 1 gram projectiles at speeds of up to 6 kilometres a second.

A team led by Richard Marshall developed the gun while exploring possible methods of triggering nuclear fusion by high velocity impact. When the project was shelved Richard Marshall moved to the United States, where he is continuing his work.

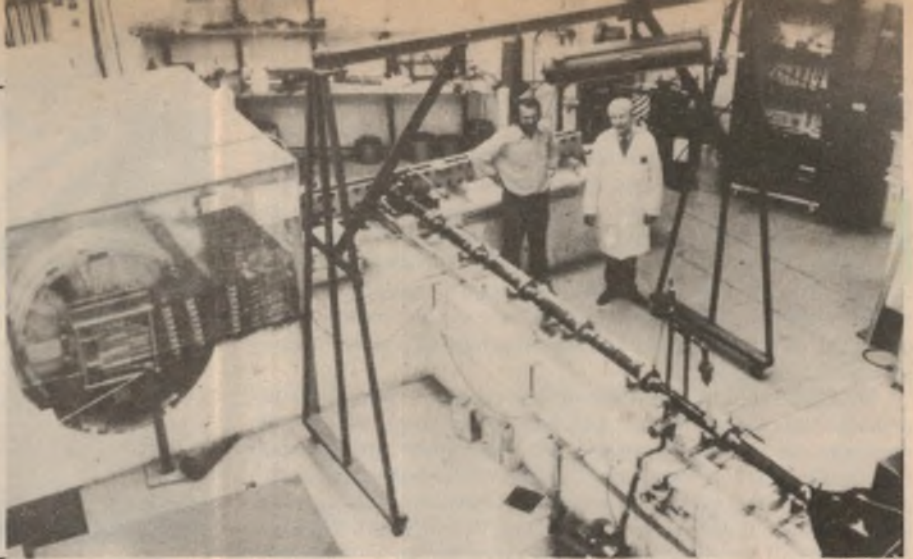

coaxial accelerators, which produce travelling magnetic waves that carry projectiles to great speeds. Among the fascinating possible applications for either type:

- Artillery or anti-aircraft weapons that could pierce armour that withstands ordinary projectiles.
- Space launchers that would operate at much lower cost than chemical-fuel rockers.
- Pellet accelerators that might pack enough punch to release nuclear-fusion energy.

"Electromagnetic guns can propel things to much higher velocities than is possible with conventional guns, which are limited by the expansion rate of chemical gases," says Harry Fair, chief of propulsion technology for the Army's Large Caliber Laboratory in Dover, New Jersey, and principal ad-

vocate of electric launchers within the military. Researchers in this field refer to velocity in units of kilometres per second. For reference, Earth-escape velocity is about 11 kilometres per second; high-power rifles fire at about two kilometres per second. Rockets reach higher speeds, but only because they carry their fuel and engines on board; thus, the weight of useful payload on a rocket is a tiny fraction of the total. "With electric launchers," says Fair, "the only physical limit is the velocity of light. Of course, there are still engineering limitations".

The engineering problems have stymied potential developers for more than half a century. As far back as 1920 researchers realised that electric launchers could be built based on the Lorentz force – the force exerted on an object mov-

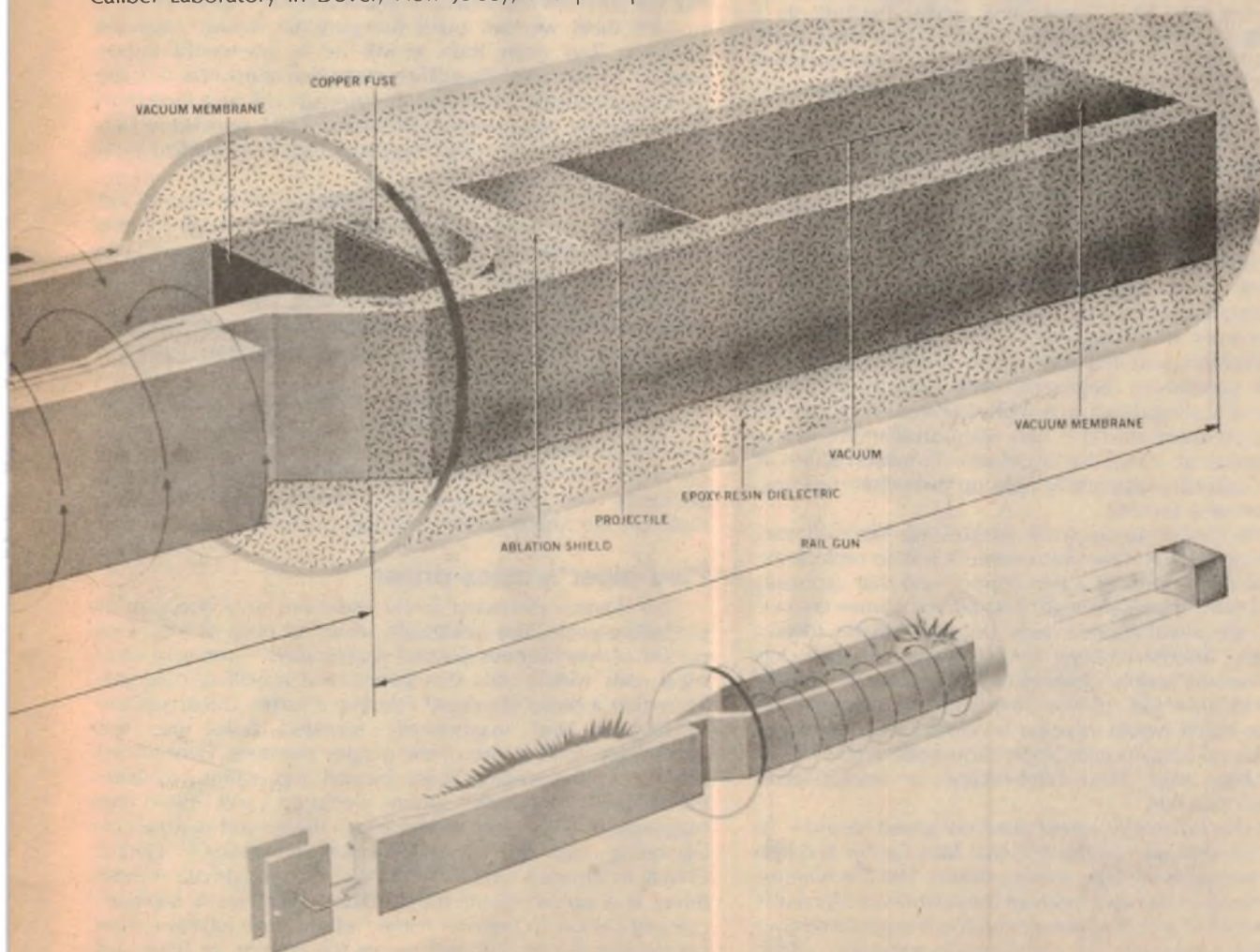

ing in an electromagnetic field that is the basis of any electric motor. The simplest such device would be a single turn linear motor consisting of two parallel conductors joined by a sliding armature. When connected to a power source, the current would generate a magnetic field perpendicular to it. The interaction between the field and the current in the armature would drive the armature ahead. If a projectile were placed in front of the armature, it would accelerate at speeds proportional to the square of the current. Thus, in such a device the potential velocities would increase dramatically with modest increases in current.

That's the theory. In practice it has proved very difficult to provide the superpowerful but controlled surge of current necessary to power a practical gun. The earliest attempt may have been by Edwin Northrop, founder of the aerospace company, who built a primitive gun that lobbed projectiles across the Princeton University campus. During World War II the Germans worked on an electric missile launcher for a while and Westinghouse developed an aircraft launcher called Electropult that worked, but not as efficiently as conventional devices. All these attempts were premature, says Kolm, because the necessary energy storage and switching technology was not yet developed.

Shot heard 'round the world

The birth of modern rail gunnery took place in 1968 when Richard Marshall and colleagues at the Australian National University in Canberra first coupled a device called a homopolar generator to an elementary rail gun in an early effort to develop an accelerator that might initiate a nuclear-fusion reaction. The homopolar generator is not new. First invented in 1821 by an obscure English mathematician, Peter Barlow, it consists of a conducting wheel rotating in a magnetic field with retractable brushes to pick off the current at the wheel's edge. They don't generate electricity but store energy fed from external sources over several minutes and release it in a powerful burst.

Using a large homopolar borrowed from a synchrotron, Marshall's group was able to accelerate gram-sized plastic cubes to velocities of six kilometres per second. Then, because the Australians decided on magnetic confinement as a more likely route to fusion, the program was killed.

So Marshall took his rail-gun experience to the United States — first to Westinghouse, where he helped establish a rail-gun program, then to the University of Texas Centre for Electromechanics, where he joined forces with its director, Bill Weldon. Weldon and Marshall went to work perfecting homopolar generators, beginning with monstrously huge machines and scaling down to a workable size. Their current version is a compact model — only 58cm in diameter and a veritable feather at 550kg. Yet it delivers 30 million joules of energy, enough to momentarily light up a medium-size city, for a fraction of a second!

While the power-supply work progressed, Marshall continued refining his gun. One improvement was to replace the sliding metal armature with a thin copper fuse that vaporises when the current rushes through. This plasma carries the current just as the metal contact does, but it eliminates friction with the rails. Another change involved what Marshall calls "distributed power supply". Instead of accelerating the projectile with one super-jolt, power units spaced out along the length of the barrel would increase its velocity stage by stage. "Make the barrel long enough, apply thousands of jabs of current," Marshall said, "and Earth-escape or impact-fusion velocities are possible".

The gun that holds the current unofficial speed record — 10 kilometres per second — is the one that Max Fowler and Ron Hawke are testing in the New Mexico desert. The Los Alamos-Livermore design duplicates many of the features of Marshall's gun, but instead of a homopolar generator, it is powered by a device called a magnetic-flux compression generator, which

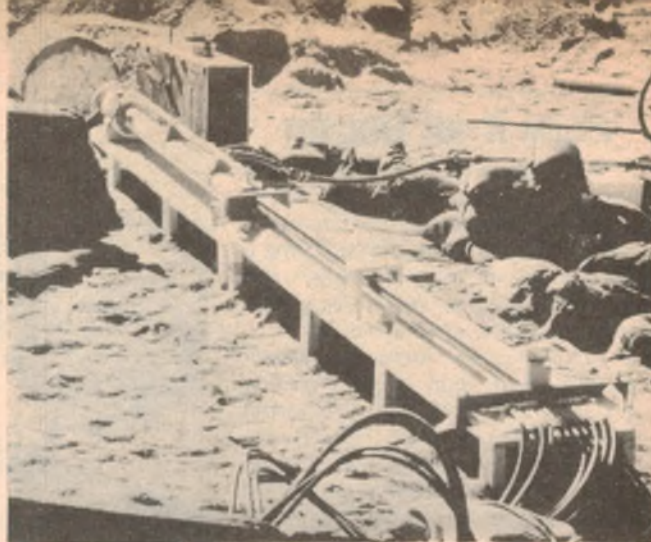

Los Alamos-Livermore gun achieves speeds of up to 10km a second.

uses an explosive to rapidly compress and amplify a magnetic field introduced by a capacity bank (see drawing). Fowler has built flux compressors for a variety of experimental devices for many years. For this application, he designed a very long generator that uses a relatively slow explosive to stretch out the time pulse and therefore ease the stresses on the projectile.

Even so, the pulse from Fowler's device is considerably shorter than one from a homopolar generator, so long-barrel launch applications are probably not possible. On the other hand, the currents are much higher, which accounts for the record velocities. There are problems, though — most notably that the gun rails and structure are destroyed with every shot.

"We think we can build the guns to include reusable elements, but even then it will be a low-repetition-rate device," Fowler says. That's the reason that some others in the field are sceptical that the flux compressor will be a long-term answer to the power-supply problem. "Still," says Harry Fair, "the work is valuable in that it gives us high-velocity data early in the program."

Meanwhile, Fowler and Dennis Peterson of Los Alamos are working on new gun and generator designs that will achieve even higher velocities. One is an integral gun that would use the same rails for gun and flux compressor. Another is an "inside-out" generator that would have two compression spaces and the explosive in the middle, theoretically doubling the current. They are also developing circular-bore guns and metal-warhead projectiles.

"I would be disappointed if we didn't attain 20 kilometres per second within a year," Fowler says. That's still far short of fusion velocities (calculated at 100 to 200 kilometres per second) but more than fast enough to make advances in what physicists call equation-of-state experiments, in which materials are tested under very high pressure.

Pied piper's mass driver

The devices discussed so far represent only one way of propelling projectiles electrically. Another class of machines consist of synchronous co-axial accelerators — series of electrical coils within coils that generate a travelling magnetic wave that a projectile could ride like a surfer. Linear particle accelerators and magnetically levitated trains use this technology. In fact, one of the maglev pioneers, Henry Kolm of MIT, is the driving force behind this variety of electromagnetic launching. Kolm designed and built the Magneplane flying train in the early 1970s, and is now collaborating with the space-colonisation visionary Gerard O'Neill to develop what O'Neill calls the mass driver. A mass driver is a pulsed linear motor that accelerates a payload-carrying bucket to high velocities, releases the payload, then decelerates the bucket and reuses the energy. Its drive coil

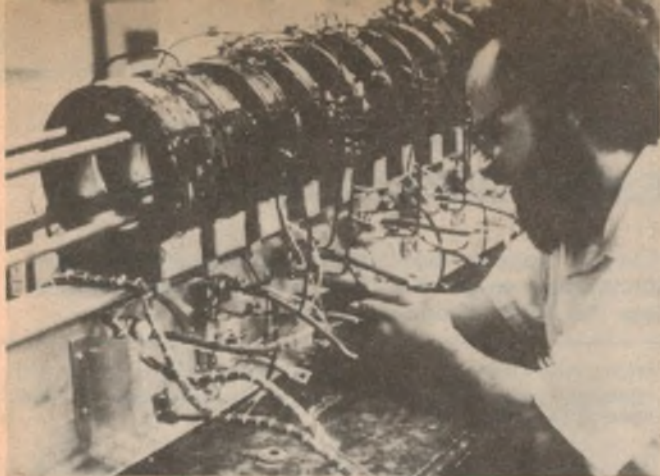

Mass Driver 1 discharges capacitors into outer coils to accelerate aluminium coil "buckets" along copper rails.

would be energised by tuned capacitors that would be continuously recharged by a primary power supply, probably via a large inductor. But since the accelerating mechanism is much more efficient than a rail gun, gigantic power supplies are not needed.

"In a rail gun practically all of the energy is wasted in resistive heating of the rail," Kolm says. "With the mass driver, since the energy passes back and forth from coils to storage, you don't need a barrel filled with magnetic energy." He claims up to 90% efficiency for the mass driver, two of which have already been built.

O'Neill and Kolm are full of ideas for mass-drivers applications. They have performed calculations and designs for moon-based launchers that would propel lunar minerals to points in space where colonies and manufacturing plants would be located. Revised to work as a reaction engine by firing aluminum washers out the back, a mass driver could latch onto a metal-rich asteroid and tug it into Earth orbit. Most promising — and not at all pie in the sky, says Kolm: an Earth launcher to loft fuel and supplies into orbit.

"This is economically viable right now," Kolm says. "Our present idea is an electromagnetic launcher that would replace only the first stage of a standard rocket. It would accelerate the vehicle to two kilometres per second, putting it out of the atmosphere in about a second, after which the remaining rocket stages would take over. This would reduce the energy requirement to an amount that can be gotten almost on-line from a big power plant."

Kolm even has a site picked out. The launcher would be built on the west slope of one of the big mountains of the Sierra Nevadas, which are just a short distance away from a huge DC power line that runs the length of California. It would cost only about \$200 million, he says, and consume only \$1.40 worth of electricity per kilogram of payload.

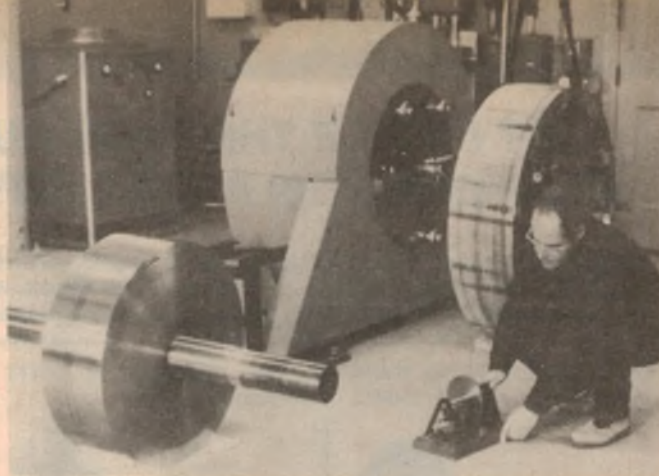

University of Texas' homopolar generator (disassembled). Alongside David Lampe views a model of an 1821 design.

Kolm is a man of many ideas — "a pied piper", Fair calls him, his enthusiasm is so infectious. In addition to space and military launchers, he is also working on a device that could send gliders carrying cargo or people into inaccessible terrain. "I've already built a glider that would be radio-controlled to deliver supplies to the front lines of a battlefield. It might also be used to fight forest fires, move material to off-road sites, or unload ships onto beaches."

Harry Fair agrees that none of this is impossible. Which applications get pursued is really a matter of funding and political interest. The Department of Defence is more than slightly interested, but it is too early for Fair to single out the military application to which electromagnetic launching is best suited. "Air-defence guns, anti-tank weapons, artillery pieces, aircraft launchers . . . it could be any of these. The one thing that is out of the question is an electric rifle, because the power supply could not be portable."

Now that the technology is nearing the application stage, private companies are getting involved. Fair ticks off the names: "General Dynamics, Litton, Vaught, Jaycor, and of course, Westinghouse."

Westinghouse is now finishing work on a large rail gun that will be powered by a homopolar generator and fire heavy projectiles (½ kilogram) to velocities of three kilometres per second. The device will be turned over to Fair's laboratory by the end of this year, where it will serve as a national user facility available to researchers from other companies, universities, and the armed forces. "It represents a major milestone," Fair says, "because unlike the university devices built, this may be the first gun that is not put together with baling wire and sealing wax".

Reprinted with permission from "Popular Science", November 1981. Copyright © Times Mirror Magazines Inc.

APPETIZERS FOR YOUR VIC* AT . . .

VIC PRINTER ONLY \$479.00

**VIC 20 COLOUR COMPUTER
ONLY \$399.00**

**VIC SOFTWARE AND PERIPHERALS
NOW AVAILABLE**

**EDIBLE ELECTRONICS, 50 PARK STREET,
ABBOTSFORD 3067. PHONE: (03) 41 5708**

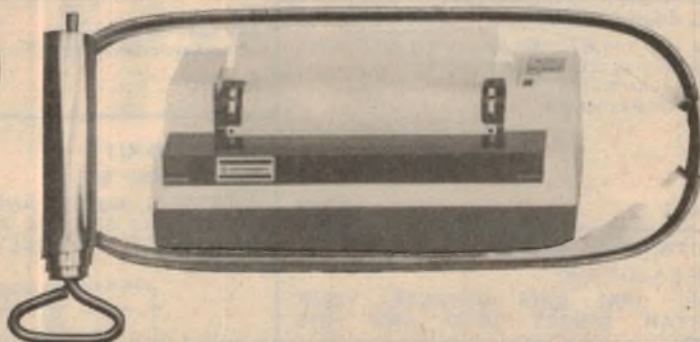

EDIBLE ELECTRONICS

**50 PARK STREET, ABBOTSFORD, 3067.
PHONE: (03) 41 5708.**



WILL
YOUR BUDGET PROBABLY WON'T STRETCH TO AFFORD OUR PROFESSIONAL SERIES ALL ALUMINIUM RACK CABINETS

NOW YOUR PREAMPS, AMPS, CONTROL MODULES MONITOR PANELS ETC. CAN LOOK EVERY BIT AS GOOD AS TECHNICS, NAKAMICHI AND OTHER TOP MANUFACTURERS

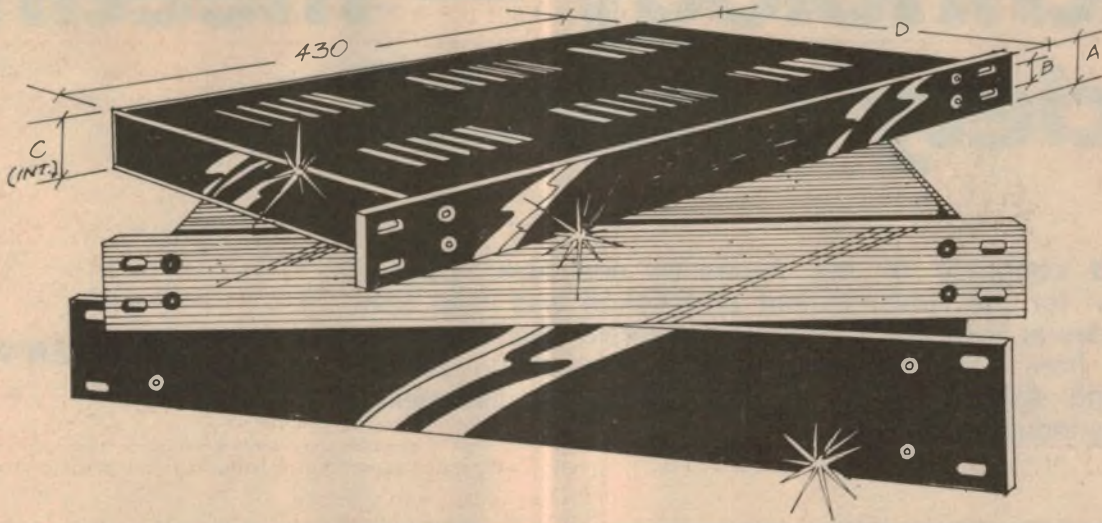

THREE YEARS AGO or so we were selling nicely finished racking cabinets for around \$60-\$70 but, alas the maker kept increasing the prices until we would have had to sell them for a price way beyond the reach of the average constructor — so, sadly we discontinued the range.

* These beautifully crafted rack cabinet boxes will give your equipment a real 1st class appearance. * All aluminium construction. * REMOVABLE TOP AND BOTTOM PANELS. * All dimensioning conforms to the International standard. * Natural or Black finish. * Ventilated lid. * Deluxe brushed

finish anodised front panel. * Individually cartoned. * Supplied in Flat Pack Form — Easily assembled in minutes.

Side Elevation:
 D = 254mm C (Internal Chassis Height)
 B (Mounting Bolt Centres)

MASS PRODUCTION TOOL UP SLASHES COSTS Well, of course, the demand for our rack cabinets continued, so to meet the challenge of high labour and handling costs we have tooled up with all the necessary dies etc. to mass produce high quality precision finish rack cabinets to International Dimension Standards with remarkable cost savings.

SIX NATURAL AND BLACK FINISH MODELS The Black or Natural finish cabinets are each available in 44mm, 88mm or 132mm high models. Mounting hole centres conform exactly to International racking specifications both vertically and horizontally.

INTRODUCTORY PRICES						
Cat. No.	Finish	A	B	C	PRICE	5 or More
H 0401	Natural	44	34	38	\$39.50	\$38.00
H 0402	Natural	88	57	82	45.00	42.50
H 0403	Natural	132	89	126	49.50	45.00
H 0411	Black	44	34	38	39.50	38.00
H 0412	Black	88	57	82	45.00	42.50
H 0413	Black	132	89	126	49.50	45.00

Beware of other rack boxes that do not conform to international rack sizing.

INCREDIBLE SAVINGS ON SCREWS AND SPACERS

Yes we are now producing huge quantities of hardware overseas — all to exacting quality standards — all quality plated and all at a fraction of the price you used to paying

1/8th inch WHITWORTH STEEL NUTS AND BOLTS ROUND HEAD ZINC PLATED

Length	Pack Qty.	Price
H 1000 9mm	25	.65
H 1002 9mm	500	4.25
H 1005 12mm	25	.65
H 1007 12mm	500	4.75
H 1009 25mm	25	.75
H 1011 25mm	500	6.50
H 1020 Hex Nut	30	.65
H 1022 Hex Nut	500	5.00
H 1030 S/Proof Washer	50	.80
H 1032 S/Proof Washer	500	6.20
H 1040 Flat Washer	50	.65
H 1042 Flat Washer	500	5.00

Huge Savings with Trade Packs (Contents: 500)

BA NUTS AND BOLTS Bolts Plated Round Head Steel, Nuts Brass

	Pack	Price
H 1050 4BA x 12mm	25	.75
H 1052 4BA x 12mm	500	5.70
H 1060 6BA x 12mm	25	.75
H 1062 6BA x 12mm	500	6.25
H 1070 Nut Hex 4BA	25	.75
H 1072 Nut Hex 4BA	500	12.50
H 1080 Nut Hex 6BA	25	.75
H 1082 Nut Hex 6BA	500	7.50
H 1090 4BA S/Proof Washer	50	.75
H 1092 4BA S/Proof Washer	500	5.95
H 1095 4BA Flat Washer	50	.75
H 1097 4BA Flat Washer	500	5.95

SELF TAPPING SCREWS Cadmium Plated Steel

From less than 1c each

	Pack	Price
H 1100 No. 4 x 6mm	25	.65
H 1102 No. 4 x 6mm	500	3.95
H 1110 No. 4 x 12mm	25	.70
H 1112 No. 4 x 12mm	500	4.95
H 1120 No. 8 x 12mm	25	.75
H 1122 No. 8 x 12mm	500	6.50

From less than 1c each.

SPACERS (STANDOFFS) SUPERB NICKEL PLATED BRASS

UNTAPPED 4 BA or 1/8" CLEARANCE				TAPPED 4 BA			
Cat.	Length.	Pack Qty.	Price	Cat.	Length.	Pack Qty.	Price
H 1305	6mm	8	.95	H 1379	9mm	8	1.00
H 1359	6mm	100	8.50	H 1380	9mm	100	9.50
H 1372	12mm	6	.95	H 1383	12mm	8	1.20
H 1373	12mm	100	11.00	H 1384	12mm	100	12.50
H 1375	25mm	4	.95	H 1387	25mm	4	1.00
H 1376	25mm	100	15.00	H 1388	25mm	100	16.00

Technology — meeting society's needs?

The 52nd congress of the Australian and New Zealand Association for the Advancement of Science was held from 10-14th May at Sydney's Macquarie University. Scientists and engineers from Australia, New Zealand, the United States, Europe and Asia gathered for discussions on the theme "Australia's Industrial Future".

by PETER VERNON

With more than 2000 scientists and researchers from all over the world and around 900 papers presented in 44 sections, it is hard to assess ANZAAS '82. Topics under discussion ranged from anthropology to musicology and included robotics, law, computers, resource development and manufacturing strategies, with many of the sessions held simultaneously over four days.

Indeed, many of those attending wished for a more relaxed pace, with individual sections running on separate days, rather than in parallel. At least then one wouldn't have to choose between hearing Mr Peter Holmes a Court on Australia's domestic satellite system or Professor Thring on the role of robots in society. The need for such choices means that any one person can only see a small part of the Congress.

However to me at least, one of the most valuable aspects of the Congress was that it brought together so many people with diverse interests, yet all with a contribution to make to the expansion of knowledge and the directions in which our society is moving. The general sessions, open to all who attended the Congress, clearly put the questions at issue; What sort of society do we want? What are the constraints on our choices?

In the first general session, conferences from all disciplines heard Professor Boulding of the University of Colorado on the problems facing advanced industrial countries, and heard Justice Elizabeth Evatt, Chief Judge of the Family Court of Australia, argue for a re-orientation of the values of our society, a move away from materialism and accumulation of capital to more human values.

She reminded the Congress that in a time of ever-accelerating technological change, basic human needs and feelings remain the same. The satisfaction of those needs, equitably and for all, the Judge argued, should not be subordinated to material progress.

Those attending the Robotics section of the Congress had the good fortune to hear Professor M. W. Thring on "The Role of Robots in the Creative Society". An engineer turned social critic, Professor Thring presented a path out of our present dilemmas to a just, sustainable social organisation which he called the "Creative Society".

Arguing that the world is heading for disaster, brought about by nuclear war, the tensions created by poverty and the growing gap between the rich and the poor countries, population explosion, unemployment and social breakdown and depletion of our natural resource, Professor Thring presented a program which he conceded would be controversial and exceedingly unpopular.

The chief danger, he suggested, was that decisions taken on a short-term basis are leading us precisely in the wrong direction, away from our own long-term good.

"The essential condition for a stable, peaceful civilisation in the next century is that the great majority of human beings have a decent life in which they have a worthwhile and not dangerous, uncomfortable or excessively exhausting job which enables them to earn a fully adequate standard of living for themselves and their children. It is in the long term self-interest of the people in the rich countries to devote their skills to this objective because the alternative

is World War III and no wealth now can possibly justify that fate for one's children or grandchildren."

In addition to outlining his work in robots for the handicapped and remote manipulators for dangerous and unpleasant jobs, Professor Thring presented a four-point plan to ensure that there is a world future.

- The only humane way to level off the population in the poor countries is to give nearly everyone an adequate standard of living and an adequate education within one generation.

- To avoid World War III it is essential to reduce the gap between the standards of living in rich and poor countries.

It is not possible to bring the whole



Professor Meredith Thring at ANZAAS. (See also his article in April 1982 EA).

world's population (which will rise to 8000 million in the next 30 years unless war or total disaster comes first) to the same per capita consumption of energy and raw materials as in the rich countries. "Hence it follows that an essential condition is that the consumption per capita in rich countries falls to about one third of the present figure".

● The rich countries must devote sufficient resources of research manpower, materials and installation to solve the world's problems. The only way this can be done is by accepting the transfer of a great part of the effort they devote at present to military projects to what the Professor calls "humane technology", that can be used to the benefit of people in all countries.

The contribution of the Government, presented by the Minister for Science and Technology, Mr David Thompson was along the lines that if world-wide economic activity picks up then so will Australian industry. He reminded the Congress that the Government's approach to the promotion of science and technology in industry was based on the "maximum restraint in expenditure" and his announcement that the Government had accepted the recommendations of the Kirby Commission on the role of government institutions coincided almost to the day with the slashing of the productivity and innovation programs of the Department of Science and Technology.

Robots and biotechnology

Under the heading of the general theme many and varied subjects were covered. Australian research and development in microelectronics received much attention in the engineering sections of the Congress. The international nature of the microelectronics industry and Australia's almost exclusive reliance on imported integrated circuits sometimes obscures the fact that there is a high level of local effort in the field.

Industrial robots and automation also concerned many of the engineering delegates, as did the role of education and government programs in fostering innovation and in industry. The subject of alternative fuels from plant wastes and coal was also high on the agenda.

"Bio-technology", covering subjects such as genetic engineering, in vitro fertilisation and the ethical considerations of organ transplants from the newly dead, understandably attracted much media attention at the Congress.

It was the first time that lawyers were invited to participate in the Congress, and their contributions to the subjects of medicine, computer abuse and industrial relations stimulated lively debate. Once again the value of an inter-disciplinary Congress was emphasised.

Processes based on biotechnology have the potential to create new techniques in many areas of the chemical, food, pharmaceutical and mining industries, as well as in agriculture. Cloning of bacteria to produce vital drugs or to mine iron ore are definite possibilities, perhaps leading to a move away from our present energy intensive methods of production.

Indeed, perhaps even the sheep shearing robot under development by the Australian Wool Corporation may be outmoded by a drug or artificially developed virus that makes sheep moult naturally at shearing time!

In his Presidential address to the Mining and Geology Section of the Congress, Mr R. Woodall, the Director of Exploration for Western Mining Corporation Limited, claimed that "the minerals industry is an endangered species".

He argued that high wages and high levels of taxation were crippling the industry by choking off exploration and development. "The minerals industry is being asked to satisfy an unreasonable lust for social benefits and ease of living while at the same time it is being deprived on the profits it needs and the risk capital it needs for the exploration and development on which the industry's survival depends".

Conservation and the environment were important issues for other sections of the Congress. Studies in ecology, climate and Australia's unique fauna and flora held the attention of many participants. Elsewhere, advances in education, criminology, economics and the study of multi-national corporations were reported.

The overall impact of the 52nd ANZAAS Congress was to emphasise the range and depth of Australian research in many vital scientific fields. Although some researchers are handicapped by lack of adequate funds and an economic climate geared more to the needs of large corporations and investors, the competence and enthusiasm of Australian scientific workers was plainly evident.

The wealth of this country is most frequently assessed in terms of mineral deposits and agricultural production. In the furore of scientific and economic debate it is easy to lose sight of the fact that, as Elizabeth Evatt said, "People are our greatest resource".

To me, at least, it was both significant and highly encouraging to note that papers on the social impact of technology were equally as numerous as descriptions of new technical advances. Whether we like it or not we are facing a revolution in the means of production and lifestyle with consequences which will affect everyone. The issue is in our own hands — what sort of society do we want for ourselves and our children? ♻

DID YOU MISS THESE PROJECTS?

EXPOSURE METER

Here is where the electronic flash exposure meter comes in very handy. Just set it up at the position of the subject to be photographed, set the moveable scale to the film ASA rating and pop the flash gun(s). Presto, the meter reads the light value and holds it for you until reset. Then you can read your exact exposure off the moveable scale.

Commercial flash exposure meters range in price from \$100 up to \$150 or more. Our unit can be built for less than \$40. What a bargain!

Estimated cost of parts \$38.

AUTODIM

The Autodim functions as a normal light dimmer and can provide soft lighting for parties, watching TV and listening to music. With the "Autodimming" feature as well, the Autodim can automatically dim lights at an adjustable rate and to an adjustable level ideal for creating a "sunset" effect while a child is falling asleep.

Estimated cost of parts \$25.

LIGHT BEAM RELAY

The most obvious application of a light beam relay system is monitoring shop doorways, particularly where a lone operator has to divide his time between the shop and a workroom at the rear. Used with a suitable light beam across the doorway it will trigger a buzzer (and a relay) whenever the beam is broken by a customer — or a shoplifter! That's just one application — there are literally dozens of others.

Estimated cost of parts \$13.

CAR BATTERY VOLTAGE MONITOR

The battery in your car is a crucial component which can sometimes let you down at the most inopportune times. One way of lessening this possibility is to have a battery voltage monitor which can tell you the state of charge of your battery at a glance. This circuit does just that, with one IC and three LEDs.

Estimated cost of parts \$6.50.

MODEM

One of the most satisfying aspects of personal computing is writing your own programs and exchanging these programs with other computing enthusiasts. Now we have made it easier to communicate: you can send your programs over telephone lines with our acoustically-coupled modem. It is simple to build and uses just a handful of readily available economical ICs.

Estimated cost of parts \$48.

Complete construction details (we do not sell parts) available from: Electronics Australia, 57 Regent St, Chippendale 2008. PRICE \$3.00 each project or by mail order, PO Box 163, Chippendale 2008. PRICE \$3.00 each project (includes postage). Please state project required.



FORUM

Conducted by Neville Williams

Electronic spare parts: There are two sides (or more) to the issue:

Mention of electronic servicemen and their problems in the February and May issues has prompted quite a bit of informal discussion about the scarcity of both circuit information and spare parts. But the honours must go to a serviceman who volunteered "a few remarks" on the subject, occupying one whole side of a C-90 cassette!

In saying this, I don't want to put him down in any way, because I know him personally and I know his background. He does not want to be identified, however, so I've agreed to use make-belief initials: XYZ or something. Let's just refer to him as X.Y.

X.Y. has done radio, hifi and TV service work in both city and country areas, both here and overseas. He has worked in the field and in an administrative situation overseeing a large servicing operation. Currently, he is running his own servicing business, handling both consumer equipment and professional gear.

If anyone knows the servicing game from inside, he does, and it was therefore with interest that I listened to what he had to say.

He started off by commenting on the correspondents, whose letters were quoted in the respective instalments of "Forum". I risk further argument by summarising his remarks on the views expressed.

Concerning M.B. of Derby, WA ("Forum", Feb '82, p22) he fastened on M.B.'s own statement:

"I may be biased and I may look at things only from a service point of view but it seems . . ."

"I think he is biased," X.Y. said, "and is taking the rather narrow view.

"And I don't buy the implication that modern electronic equipment is truly characterised by 'lousy wiring and aluminium shavings'.

"But I can understand his feelings. And I can understand how a man can get thoroughly browned off trying to cope with technical problems in the cir-

cumstances he has to put up with."

In regard to D.B. of Lane Cove, NSW ("Forum", May '82, p25) our tape respondent remarked:

"I do not question that there may well be a large element of truth behind what he says but he does seem to be very bitter about it.

"Like it or not, there is another side to the argument about companies being jealous about the servicing of high technology equipment. I'll say more about that later."

But K.P. of Kimba, SA ("Forum", May '82, p25) wins X.Y.'s warm support for a matter-of-fact statement about the trials and tribulations of a country serviceman.

"I, too, have had the run-around," he says, "and know what it is to waste an excessive amount of time chasing spare parts."

He went on to point out that the situation can develop into a real bind for a serviceman. If he relies on order forms

and phone calls, slow delivery can get him a bad reputation. If he spends too much time tripping around and thumping counters, he loses out financially. And he also has to be careful about inviting the customer to do the counter thumping. If the customer is too successful, he is likely to conclude that the serviceman didn't really try hard enough — forgetting the small matter of the man-hours involved!

Right now, he added, he had on the bench a TV set — just out of production — waiting for a replacement CRT socket; a hifi system held up because a pair of loudspeakers could not be serviced or replaced; a VCR waiting for replacement belts; another hifi system held up for output stage ICs.

But, having said that, X.Y. went on to voice some sympathy for service supply managers, having at one time been in a somewhat similar position himself.

As he put it, the supply and demand situation in the electronics industry is a vicious circle, in which everyone is trapped. The manufacturers offer, and the public expect, a constant stream of new models with new gimmicks, often marketed on the slimmest of margins. "Deals" are currently par for the course in the electronic industry.

Service supply managers have to order

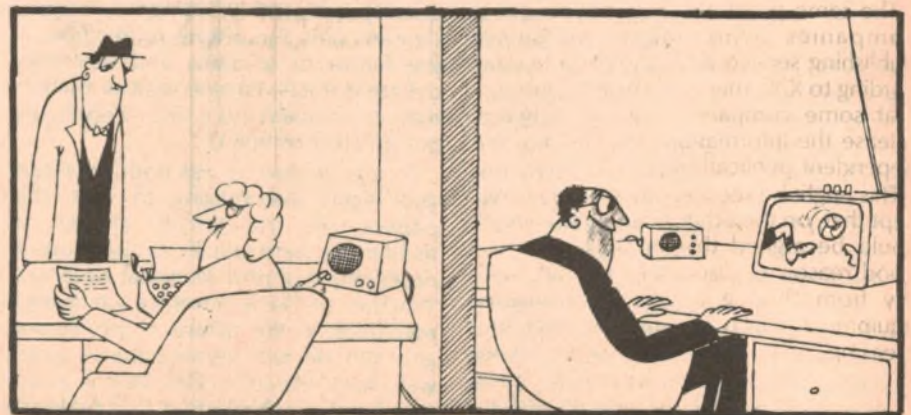

"I'm terribly sorry, sir, but our spare parts manager has been rushed off his feet!"

and stock an ever-growing inventory of spare parts – to the dismay of the company accountants, who see it in terms of dead capital.

It wouldn't be so bad if the supply lines from the original component supplier flowed freely – but they don't. It is all too easy for desperately needed spares to sit around in ships or on wharves while people unconnected with the electronics industry fight about pay and conditions.

In the case of the hifi system mentioned earlier, the replacement ICs were sitting around in a container, somewhere, along with other spares. The company had ordered another batch of ICs by airfreight – which will probably mean a surplus when they all finally end up in the store!

In the opinion of our tape respondent X.Y., there is not much point in blaming or exonerating individual companies, because they all face much the same problems. They have good patches and bad patches; just when you think one company is better than another, the positions reverse!

"Having been there, I sometimes feel sorry for service supply managers but, most of the time, nowadays, I feel sorry for myself!"

SERVICE DATA

X.Y. agrees that the difficulty in obtaining service data is a very real problem, which he faces personally, despite his long experience in the industry. He feels that servicemen doing warranty work are looked after somewhat better than others but even they still have reason for complaint.

The reasons, he feels, are complex.

The mere task of keeping mailing lists up to date presents a major problem in an unstructured industry; unlike so many other tradesmen, these days, electronic servicemen are not licenced or registered.

Again, as equipment becomes more complex, the manuals also become more complex, more costly to produce and more costly to reprint if stocks become exhausted.

The same problems face independent companies who might consider publishing service data. In any case, according to X.Y., there is reason to believe that some companies are unwilling to release the information, anyway, for independent publication.

This might be seen as an indictment except that, on the other side of the coin, it could be argued that companies have good reason to discourage all and sundry from "having a go" at consumer equipment which involves an ever increasing level of technology. Not everyone who calls himself a "serviceman" has the skills to back up such a claim.

IF YOU WANT TO UNDERSTAND MORE ABOUT MICROPROCESSORS

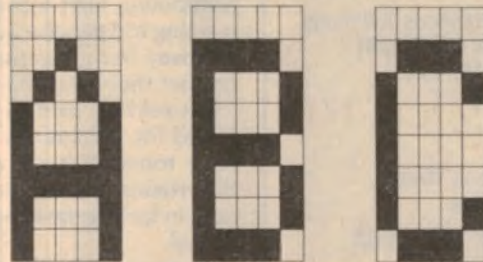

APPLY HERE...

One of the fastest growing sections of the electronics industry is microprocessing and its associated technology. A sound basic knowledge and a constant up-dating of that knowledge is necessary to stay informed of the developments within this exciting new technology.

Stott's Technical Correspondence College has produced an up-to-the-minute home study course specifically designed for people interested in this subject.

This Stott's home study course has been meticulously prepared by experts in this field and takes you through the stages necessary to reach a basic understanding of micro-computers and the processing techniques needed for their application, whether for consumer or industrial use. To this basic training you can add further knowledge and gain more experience.

The course is prepared in three stages. It begins with initial training in basic electronics, goes on to digital electronics and then proceeds to an in-depth study of microprocessors.

For further information on Stott's Microprocessors Course or other courses which interest you, mail the coupon below.

 <p>Stott's TECHNICAL CORRESPONDENCE COLLEGE The name to trust in correspondence education.</p>	<p>Melbourne, 159 Flinders Lane, 3000. Tel: 63 6212 Sydney, 383 George Street, 2000. Tel: 29 2445 Brisbane, 290 Adelaide Street, 4000. Tel: 31 1627 Adelaide, 85 Pine Street, 5000. Tel: 223 3700 W Perth, 25 Richardson Street, 6005. Tel: 322 5481 Hobart, 1st Fl, 29 Argyle Street, 7000. Tel: 34 2399</p>
<p>Please send me free and without obligation full details of the following courses:</p> <p>(PLEASE PRINT) _____</p> <p>MR MRS MISS _____ AGE _____</p> <p>ADDRESS _____</p> <p>_____ POSTCODE _____</p> <p>Stott's undertake that no sales counsellor will visit you</p>	<p>The Stott's range of courses in Electronics is:</p> <p>Radio for Amateurs Introduction to Electronics Digital Electronics AM Radio Receivers Radio/TV Servicing Colour Television Amateur Radio Operators' Certificate A full range of Hobby and Business courses also available</p>
<p>ALAI/ST3714/EJA782</p>	

SILVERTONE NEWS

Newsletter of Silvertone Electronics
Specialists in Radio Control

ROBOTS

DISPLAY AND ENTERTAINMENT TYPE

A completely new approach to small (up to 1.5 metres) ROBOTIC PUPPETS

- Up to 24 simultaneous functions
- Full Proportional Movement
- Programmable Memory
- Radio Controlled
- Mobile
- Realistic
- Voice Synchronous Mouth
- Transmitted Voice

MAY BE BUILT TO YOUR REQUIREMENTS
HOLLYWOOD TECHNOLOGY

SILVERTONE ELECTRONICS

6/2 SCHOFIELD ST,
RIVERWOOD, NSW, 2210
Phone (02) 533 3517

6/2 Schofield Street, Riverwood, NSW, 2210
Telephone: 533 3517

LO-DOY VIDEO

MAIL ORDER DEPARTMENT: PO Box 254,
Heidelberg, 3084.
Phone: (03) 435 3004, Monday — Saturday
1.00pm to 6.00pm

NEW SOFTWARE

SUPERBOARD & C1P — OHIO TAPE PROGRAMS — OHIO:

Games:

G55	Thief M/C	\$14.95
G56	Surface Attack	\$14.95
G57	CAGE	\$ 8.95
G58	Berzerker	\$ 9.95
G59	Night Driver	\$14.95
G60	Caterpillar	\$14.95
G61	Asteroids M/C	\$12.95
G62	Graphics Adventure	\$14.95
G63	Trek Adventure	\$14.95

Utilities:

U42	New Tiny Compiler	\$19.95
U43	Word Processor II	\$19.95

Disks — Ohio:

FD 5	Superdisk	\$24.95
FD 6	Superdisk II	\$29.95
FD 8	Supercopy	\$15.95
FD 9	Disk Catalogue	\$14.95
FD11	Fantastic Copy	\$24.95
FD13	Tiny Pascal	\$23.00

C1P Series 2 Colour Board Kit \$69.00
C1P/C4P Video Board Kit \$139.00

All prices include Sales Tax.

Write for **SALE** Price List — FREE.

FORUM — continued

While he admits that he cannot provide statistical support for his figures, X.Y. feels that not more than about 25% of radio-TV-hifi servicemen could be regarded as capable, top-line technicians. A further 25% get by well enough but the remainder diminish all the way down to hopeless!

He can well understand companies distributing high technology equipment wanting to keep the last named group as far away from it as possible — simply to protect their own brand reputation.

It would be nice to think that, having talked for 40 minutes or so, X.Y. would have rounded it off with a five-minute dissertation on how to repair the situation. In fact, his final five minutes is rather dismal.

He doesn't know how you can produce a dramatic increase in the proportion of "capable, top-line" technicians. Licensing might be a step in the right direction, he says, but the initial effect would be small and the end result not an automatic guarantee of proficiency.

Companies could help by providing regular, systematic familiarisation sessions for technician groups, each time a new and different product is launched. Some companies do this already but the opportunities are often too few and too restricted. And some of them turn out to be a waste of time because company technicians can't communicate, and company communicators don't understand

the technicalities!

X.Y.'s final observation really capped it all.

He observed that he seldom faced the same kind of difficulties when called upon to service professional equipment. Service data and spare parts could normally be accessed through a logical procedure, in some cases on an emergency basis.

Why?

Perhaps, he suggested, because manufacturers and agents don't have to cope with such a competitive and a frantic turnaround in models. The prices, moreover, are not chiselled down to the last dollar, making it possible to provide for adequate back-up support.

If only the consumer electronics industry could learn that lesson . . .

If and when that happens, X.Y., I'll promise not to show surprise should a flight of pigs glide gracefully through the office window!

Having passed on the cogitations of X.Y., I suggest you consider the letter below from another reader in Western Australia. Over the years, I have heard mention of voltage levels in that State but it could be that they present an additional risk to VCRs in particular.

In the meantime, I have a number of other letters and observations about the contentious matter of service data. Hopefully, I will be able to deal with them in the next issue.

Is mains voltage a problem?

Dear Sir,

Having read your "Forum" pages for February '82, and learned of the problems with VCRs in the north of this State, it occurs to me that one possible source of trouble may have to do with the mains power supply to the equipment concerned. I would imagine that, in the north-west, there would be a large number of users with private supplies.

It would indeed be interesting to know what order of voltage regulation is encountered in such situations. And, beyond more voltage regulation, it could be that the waveform may contain quite a few spikes, which can cause their own problems.

On the score of voltage from the normal power supply mains, it is part of my occupation (not SEC) to be aware of variations in the supply. At one time, the nominal 250V was recorded as going over 270V at night, where I was stationed, on a regular basis.

Maybe these comments could spark off some consideration of local mains voltage, private power supplies, regulators, protection devices — who knows what — but affecting readers in more distant parts of our country.

Let me add one more thing: being an old timer, I do wonder whether the complicated equipment of today will exhibit the same kind of longevity which I have enjoyed from my National HRO (1935 vintage) which still gives very good performance and is reasonably easy to repair when it goes wrong. And would you believe that I'm still using the 1946 "Little General" as well!

Congratulations to "Electronics Australia" as a worthy successor to "Radio & Hobbies". However, comparing the present editions to those from the mid '40s, it becomes obvious how easy it was then, by comparison, to understand the subject.

K.C. (East Fremantle, WA)

KIT BARGAINS - FROM JAYCAR

MAGNIFICENT TEST EQUIPMENT KITS FROM EA.

EXCLUSIVE! ALL TEST EQUIPMENT KITS NOW INCLUDE I.C. SOCKETS AT NO EXTRA COST.

500MHz Digital Frequency Period Meter

REF: EA Dec '81 - Feb '82

NOW BACK IN STOCK! The best version of this kit in Australia is now back in stock. Why settle for an inferior kit at the same price as ours?

500MHz option only \$26 extra
50MHz Version \$119



Tilting Bail to suit ONLY \$4.95

Other people may appear to be selling this kit for less. But you GET less!! Exclusive Jaycar features:
* Heavy gauge front panel. Pre-punched, and silkscreened. (NOT Scotchcal). * Low aging rate 10,000 MHz crystal * Quality IC sockets provided (A MUST) * All metal film resistors used (1% 50ppm) * Therm-alloy heatsink for +5V regulator
Beware of advertised units that do not conform to the original design. They may have inferior performance.



THE BEST QUALITY KIT VERSION OF THIS PROJECT IN AUSTRALIA

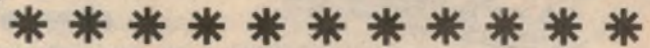

Function Generator

Ref: EA April 1982

"Pigeon Pair" companion to the new 500MHz DFM. Low distortion generator of sine, square and triangular waveforms. From below 20Hz to over 160kHz. Inbuilt 4 digit frequency counter in de-luxe Pac-Tec case. Only \$85

JAYCAR EXCLUSIVE - 1% 50ppm metal film resistors used for stability and it's still only \$85!!!



Only \$85

Unit pictured with EA Panel

Digital EA2/82 Thermometer

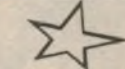

Ref: EA Feb 1982

Read the temperature in your room (or outside) from 0 degrees C to 100 degrees C in fact to within 0.1 degree C. Fantastic resolution on a bright easy-to-read display.

INC CASE



\$69

DIGITAL CAPACITANCE METER

Ref: EA March 1982

This kit once again uses the amazing DPM 200 LCD display/driver module

Capable of measuring capacitance from 1pF to 19.99uF.

It is a must in every workshop or lab.

Kit includes case.



\$69

HEART RATE MONITOR

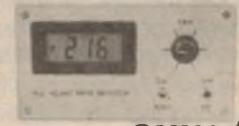

ONLY \$79

This unit enables you to measure your own pulse instantly and accurately. It is light enough even for joggers to carry. A must for people who may have heart problems. Complete kit including LCD Display.

EA dual tracking P/S

EXCLUSIVE!! US-MADE 10 TURN 25% LINEARITY POT used for greater accuracy

\$84.50

Ref: EA March '82



1% resistors used NOT 2%.

At last!! A dual-tracking power supply with fixed +5V reg at a reasonable price!!

YOU PAY NO MORE FOR A QUALITY JAYCAR KIT!!

Large Screen Storage CRO

Ref: Feb 1982 EA

Not only can you avoid buying an expensive CRO but you can have the features of the REALLY expensive ones!!

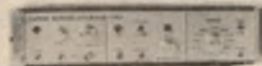

\$110

Can display very slow waveforms - DC-100kHz bandwidth
One shot triggering - capable of storage operation
Inbuilt graticule shows on TV screen - Staggering value at \$110.
Crystal locked timebase

NEW!!! LCD TACHO KIT!

ref:

EA

May

1982



\$49.50

- USES NEW DPM-05 DISPLAY
- FITS INTO YOUR DASHBOARD
- RPM, DWELL DISPLAY

STOP PRESS!! * * *

STOP PRESS!! STOP PRESS!! EXOCET REPELLENT - A MUST FOR SOUTH ATLANTIC TRAVELLERS
We have contracted with a leading aerosol manufacturer to produce a special aerosol mixture. When it is sprayed at an EXOCET missile, the rocket is repelled. We expect demand from the world's navies to be great so get your order in early.

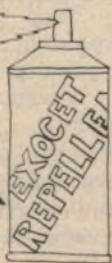

Handy pocket size 600g can with 45mm nozzle.

ONLY \$178 000

GOOD-BYE 3002

This 2x300WRMS P.A. Head is a classic toad amp. Ruggedly constructed, 19" rack mount makes an ideal main P.A. or foldback unit. Great for Disco use as well.



We are discontinuing this amp because it is becoming too expensive to make. The metalwork costs alone now account for well over 50% of the unit. Because of this we have reluctantly decided to discontinue the unit. You can grab one now while they last for only \$399

SAVE \$89!!!

\$489 \$399

VOICE OPERATED RELAY KIT



Ref: EA April '82
Extremely useful circuit, has dozens of applications.

ONLY \$14.50

EPROM PROGRAMMER

\$59

Ref: EA Jan 1982
This versatile kit enables you to program the popular EPROMS, WITHOUT a computer!!!

Includes 24 pin socket. Zero insertion force socket to suit only \$12.50.

Jaycar

125 YORK ST SYDNEY 2000

Ph. 2646688 Telex 72293

Mail Orders To:

Box K-39 Haymarket 2000

Post and Packing charges

\$5-\$9.99 (\$1.20) \$10-\$24.99 (\$2.40)
\$25-\$49.99 (\$3.50) \$50-\$99.99 (\$4.60)
\$100 up (\$6.20)

NEW SHOP HOURS

Mon-Fri 8.30 to 5.30pm

Sat 8.30 to 1.00pm

Thurs night to 8.30pm

EXCLUSIVE! ALL TEST EQUIPMENT KITS NOW INCLUDE I.C. SOCKETS AT NO EXTRA COST.

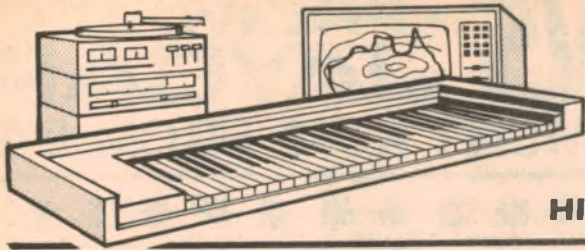

Audio-video Electronics

HIFI • HOME VIDEO • PROFESSIONAL AUDIO

How do you react when they ask for advice about hifi?

"I want to buy some hifi gear. I wonder if you could give me a bit of advice?" From time to time, most people who are active in electronics, face that question from friends or relatives. I wonder how it is answered? Thoughtfully, helpfully, or otherwise?

by NEVILLE WILLIAMS

Let me follow up that question with the account of just such a conversation, which I had recently. It may provide food for thought, or argument, or some guidance for readers who happen to be thinking their way into the hifi scene.

For the purpose of discussion, I am assuming that the question is being put by an "average" friend or relative, whose knowledge of hifi sound and equipment is strictly limited. In short, not someone who is half-way to being a hifi buff!

I am also assuming that you — the person to whom the question is directed — are not a hifi salesman, because hifi salesmen can be expected to have set answers, conditioned by the products which you/they are accustomed to selling.

Toshiba's answer to the space problem is a high quality, compact unit which can attach to the wall. It can be used with separate speakers, in general, the larger the better for good quality.

What started me on this track was a telephone call from a female employee of our parent company who presumably — but wrongly — assumed that the Editor-in-Chief of "Electronics Australia" should be able to provide instant, unbiased, unambiguous, definitive advice for a would-be hifi enthusiast.

I had to disillusion her by explaining that while I — like other electronic buffs — might have a basic knowledge of hifi equipment and theory, few of us make a practice of haunting hifi shops and mentally cataloguing brands, models and prices. Faced with the need to buy something, we tend to do like everyone else: check through advertisements, catalogues, displays, and etc, to discover who is selling what, for how much at the relevant time.

She should accept the need to do likewise, time and effort notwithstanding.

Nothing daunted, she proceeded to tell me what she had already picked up from other informants:

"I was talking to a man the other day," she said, "and he told me that loudspeakers were the things that really governed sound quality. Whatever else I bought, I should make sure to get Bose speakers!"

"Another man said he preferred English speakers to American but both were better than Japanese!"

"Tell me; what do you think of Bose speakers?"

"They're well known," I said, "and a



Sanyo's MX-960K 4-band radio/cassette recorder is versatile, powerful, portable and in every way a fun machine but it isn't really intended for the traditional hifi market. With 3-channel audio, and 5 speakers, including a super woofer, it is the husky "big brother" to the ubiquitous AM/FM-stereo cassette portable. It's also quite expensive at an rrp of \$665.



popular brand but they're not everybody's favourite, because of their rather special design philosophy.

"But it isn't wise to consider loudspeakers in isolation, important as they are. They have to suit the amplifier, and they have to fit in with the needs of the individual and the nature and decor of the listening room."

"I guess so."

"To be really helpful," I said, "one has to discover something about the inquirer — their resources, their ideas, their requirements. Only then can one start to identify the kind of equipment they should be looking for."

"So let's start with you," I said, "rather than Bose, or any other speakers!"

So to the first and quite basic question: How much did she have in mind to spend on the system?

"Oh . . . up to a thousand dollars. No more! I should be able to get something fairly decent for that, shouldn't I?"

"Most definitely."

A thousand dollars is a fairly common benchmark for aspiring hifi enthusiasts, but it is not a bad idea to help the inquirer relate the figure to hifi equipment prices generally.

NO UPPER LIMIT

So, while agreeing that it should be possible, for that money, to obtain a system that would look and sound well, I pointed out that, given a big enough cheque book, it was entirely possible to spend that much and more on a single hifi component. Some do so because they are seeking the ultimate in sound quality for its own sake; some do so because they just like owning the best; some do so to keep up with their social rivals — the "Jones", I believe!

This particular lass didn't have the kind of money or that kind of aspiration. That is helpful to know, because the choice of equipment can become very complicated if it is going to be subjected, forthwith, to scrutiny and snobbery!

So to the next fundamental question: what sort of music was she in the habit of listening to?

If the answer had been popular, middle-of-the-road music (in Sydney, "good" music from 2CH) the amplifier system would probably have it fairly easy. The sound quality would need to be clean and well balanced, but that's about all.

But, if the inquirer turns out to be a rock fan — particularly one given to entertaining — the requirement is going to be for a pair of husky loudspeakers and amplifier watts to spare. This, plus plenty of boomy bass!

At the other extreme is the classical music enthusiast, particularly one with a

TWO TYPICAL ONE-BRAND SYSTEMS

From
Technics



Apart from their individual hifi components, Technics offer more than a dozen systems ranging from the budget priced "Sigma 424" to the top-of-the-line "Sigma Grand Prix". The one illustrated above is the "Sigma Z-11", with a "going price" of around \$999. At the top is the SL-D202 semi automatic direct drive turntable. Then comes an SU-Z11 25W/channel amplifier, an ST-Z11 AM/FM stereo tuner, an SH-8015 stereo equaliser (optional extra), and an RS-M205 "metal" tape cassette. The audio rack is included and two SB-2055 loudspeakers.

From
Marantz

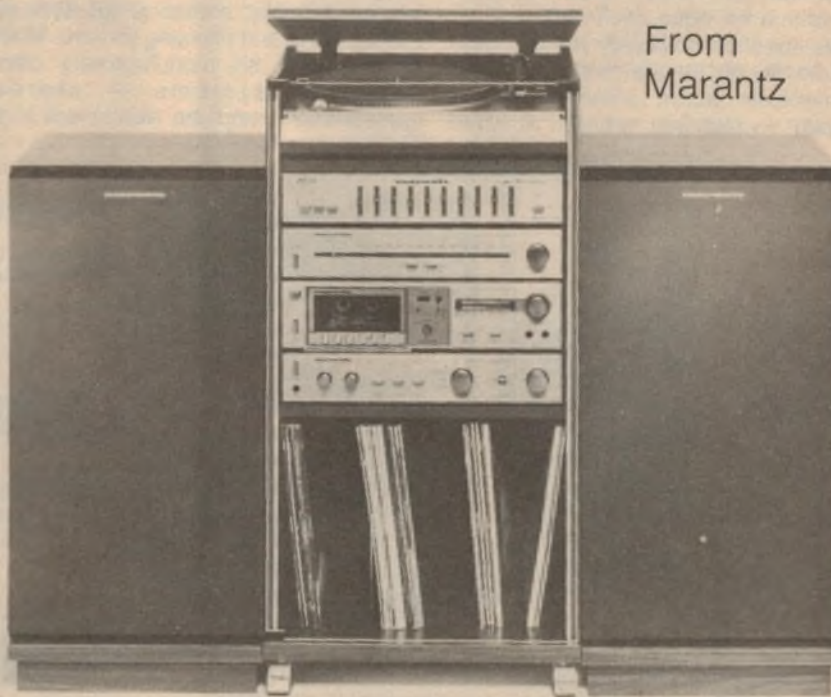

Marantz is another company which is big in hifi systems. The one illustrated above is the "Trend 500T", with a recommended retail price of \$869, plus \$199 for the optional EQ10 stereo equaliser. Involving what Marantz describe as "three-quarter size components" it comprises (from top) a TT2200 direct-drive turntable, an EQ10 stereo equaliser, an ST25 AM/FM stereo tuner, an SD25 "metal" cassette deck and a PM25 25W/channel amplifier. The loudspeakers are 3-way and the equipment rack has a full-length glass door.

penchant for classical organ. Such a person, above all others, is likely to encounter or develop an awareness of orchestral detail, high frequency overtones and and low frequency fundamentals.

They are also likely to face the greatest problem in stretching limited funds to buy equipment that will give them reasonable satisfaction.

As it happened, this particular lass seemed to have a fairly modest taste in music — “a bit of everything”, according to her mood, “but never very loud”. Nor did she have friends who were likely to be unduly demanding or critical. For that, she could be thankful!

PHYSICAL ASPECT

Next, I raised the matter of the size and appearance of the equipment she might buy; and where in the room it could stand. Fairly obviously, she hadn't given this much thought.

I pointed out that hifi equipment does have to be accommodated. The loudspeakers should be positioned to the front left and front right of the listening position for proper stereo effect. The turntable, amplifier, cassette deck, etc, can go in any convenient position but they do have to be put somewhere — in a wall unit, on shelves, on a cupboard top, or in a hifi equipment rack.

This question obviously posed some difficulty for my inquirer and she began to speculate about something more compact — like the oversize portable

cassette-radios that are currently becoming so popular. I had to point out that, while these units were a lot more pretentious than ordinary cassette radios, they could hardly qualify, as a class, for the description “high fidelity”.

If space was a problem, she would be better advised to invest a “mini” hifi player/tuner/amplifier system but to use it in conjunction with a couple of good quality, reasonably large loudspeaker systems. Modern mini hifi components can be excellent, I explained, but mini loudspeakers are seldom as good as larger ones.

She pondered for a while but apparently worked out that, by shifting this here and that there, she could organise space along one wall for a couple of on-the-floor loudspeakers. But where to put the rest of the equipment . . .

That, of course, led to a discussion of what the “rest of the equipment” should comprise. She would obviously need a stereo amplifier, with a power output — I suggested — of not less than 25 watts per channel, and the usual range of control facilities. A record player? Yes! A cassette deck? Probably. An AM/FM stereo tuner? Hadn't thought too much about it, but she guessed so!

“You know,” I said, “I think you ought to give some thought to a complete system, in which someone has done all the worrying and planning for you. Most of the major hifi manufacturers offer complete systems — stereo loudspeakers, and the equipment in a

furniture style rack — for about \$700 upwards.

“I've noticed them in advertisements but are they as good as units you buy separately?”

“There's no reason why not, on a dollar for dollar basis. In fact, the markup on a complete system might well be less than it would be on the same or equivalent components, purchased separately.”

“Even if I picked them up cheaply, somewhere? Like that discount place near . . . ?”

“DISCOUNT PLACE”

“Inexperienced hifi buyers should be wary of discount places,” I warned, “because they are less likely to be able to offer any real assistance if something doesn't work properly. Nor can you expect much help from the manufacturers if you run into compatibility problems with a random mixture of brand-name components.”

With this in mind, I suggested that she do the rounds of hifi and department stores, looking specifically at complete systems in the intended price bracket. Pick up brochures where they are available but, in any case, she should keep careful note of the model, price and specifications of those systems which appealed to her and which would suit the decor and space in the room.

The object of the exercise would be to determine which systems, if any, offered the kind of sound, the facilities

From
Sharp



The Sharp VZ-3000Z provides another interesting option for situations where space is at a premium. A complete phono/radio/cassette system, it can rest on a shelf or attach to a wall. It was reviewed at length in our January '82 issue. The small loudspeakers illustrated fall short of full hifi standards but, in the review we remarked: “It certainly produces a better than average performance in each of its functions and provides a satisfying sound . . . at some

later date, it would be simple to substitute better loudspeakers with the knowledge that the electronic performance is of a high standard.”



A P PRODUCTS

9450 Pineneedle Drive • P.O. Box 603 • Mentor, Ohio 44060
(216) 354-2101 • TWX: 810-425-2250

In Europe, contact: A P PRODUCTS GmbH
Baumlesweg 21 • D-7031 Weil 1 • W. Germany

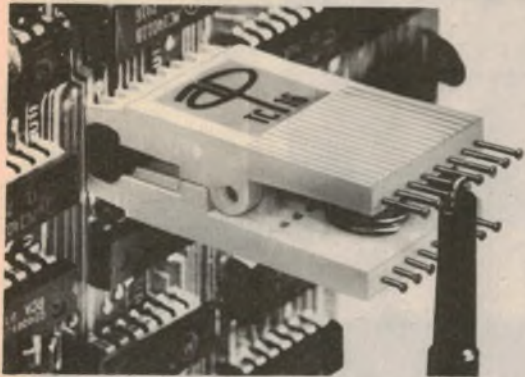

IC TEST CLIPS — We've improved on the original

The Super-Grip II IC Test Clip has a narrow nose for fitting on DIP's on high-density boards. "Open-nose" design also permits probe tip access at DIP leads. New "duck-bill" contacts are flat, won't roll off narrow DIP leads. Contact comb fits between DIP leads, eliminates shorts. New "nail-head" contact pins keep probe hooks from sliding off. Offset pin rows allows probes to hang free on longer top row pins and not interfere with shorter lower row. Sizes to fit all DIP's (TC-14 fits 14-pin DIP etc.). Gold-plated or unplated alloy-770 pin contacts. Simplifies testing, trouble-shooting and QC inspection. Also available with long, headless lead pins for attaching cable connectors.

IC Test Clips — AP No.				IC Test Clips
Alloy 770		Gold-Plated		
Std.	Headless	Standard	Headless	
923695	923690-08	923743-08	923739-08	TC-08
923698	923690-14	923739-14	923739-14	TC-14
923700	923690-16	923743-16	923739-16	TC-16
923702	923690-16LSI	923743-16LSI	923739-16LSI	TC-16LSI
923703	923690-18	923743-18	923739-18	TC-18
923704	923690-20	923743-20	923739-20	TC-20
923705	923690-22	923743-22	923739-22	TC-22
923714	923690-24	923743-24	923739-24	TC-24
923718	923690-28	923743-28	923739-28	TC-28
923720	923690-36	923743-36	923739-36	TC-36
923722	923690-40	923743-40	923739-40	TC-40
923724	923690-48	923743-48	923739-48	TC-48
923726	923690-64	923743-64	923739-64	TC-64

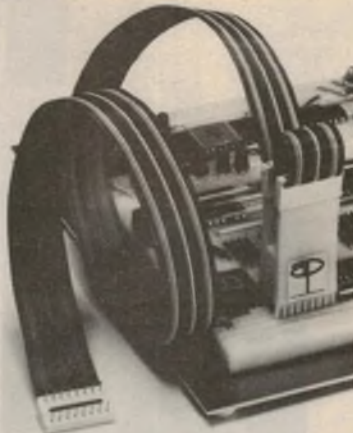

LOGICAL CONNECTIONS

A P Logical Connections are a Test Clip/Jumper Assembly combined. They are ideal for microprocessor-to-logic analyzer connections. The Test Clip end is a pair of single-row socket connectors attached to the pins of a Super-Grip II Test Clip. The remote end is a DIP connector. Connectors are molded onto the 18" color-coded flat ribbon cable. Probe access holes in backs of all connectors. Factory tested.

LOGICAL CONNECTION (Test Clip and Jumper)		JUMPER ONLY (No Test Clip)	
End	AP No.	AP No.	
With	923884-16	922594-16	
DIP	923884-24	922594-24	
Plug	923884-40	922594-40	
No	923880-16	922590-16	
DIP	923880-24	922590-24	
Plug	923880-40	922590-40	

Suffix denotes No. of pins.



CONNECTOR PINS AND SOCKETS

Two sizes cover from .019" to .035" pin dia. Solder cup accepts up to 22 AWG wire. Has exceptionally secure grip. Units cannot be over-stressed, are practically indestructible. Pins are hard brass. Sockets are beryllium copper with brass sleeve, permit no contact damage. Gold-over-nickel plated. (100/pkg.)

MINIATURE 8-PIN CONNECTORS

Shown above; incorporates above pins and sockets. No. 923625 fits A P test clips with long, headless contact pins and fits on .025" sq. posts. No. 923626 fits all A P plug-in circuit boards. Cover provides excellent strain relief. Glass-filled nylon body.

AP No.	Pins and Sockets
923610	Connector sockets .019"/.028"
923612	Connector sockets .028"/.035"
923614	Connector pins .019"
923616	Connector pins .030"

AP No.	8-pin Connectors
923625	8-pin connector .028"/.035" (F)*
923626	8-pin connector .030" (M)
923627	8-pin connector .019"/.028" (F)
923628	8-pin connector .019" (M)

*Attaches to test clip.

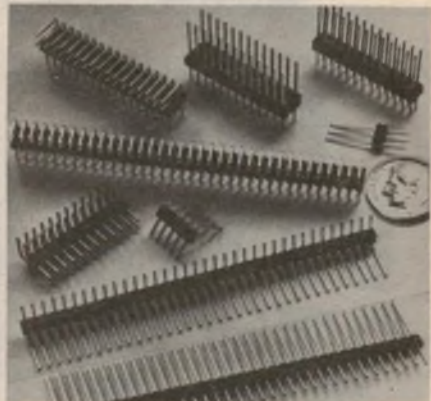

MALE AND FEMALE HEADERS

Molded-in, straight and right angle male headers have 36 posts per row. They are stackable to make up matrices of .025" sq. posts on PC boards or to use as patchboards for discrete connections. All mate with female connectors on .100" spacing. Posts extend .235" and .100" beyond .100" sq. header for wire wrapping and soldering. "Break to row length" feature. Posts are alloy 770, unplated. Female headers also are stackable and mate with matrices of .025" sq. or round posts on .100" centers. 36 "tuning fork" contacts per row are molded into header strip with .100" solder tails for PC board mounting or cable attachment. "Cut to row length" feature. Contacts are alloy 770, unplated. Dual-row headers are ultra-sonically welded at factory.

AP No.	Headers	No. Rows
929974	Female header	1
929975	Female header	2
929834-01	Male header, straight	1
929836-01	Male header, straight	2
929835-01	Male header, rt. angle	1
929838-01	Male header, rt. angle	2

INTRA-CONNECTOR and INTRA-SWITCH

Connector mates in-line with standard .1" x .1" dual-row socket connectors & headers. Right-angle pins permit probing or daisy-chaining. Intra-Switch permits in-line, on-off switching to test individual circuits. Switches actuated with pencil or probe tip.

AP No.	Description
922576-20	20-pin connector
922576-26	26-pin connector
922576-34	34-pin connector
922576-40	40-pin connector
922576-50	50-pin connector
922578-20	20-pin switch
922578-26	26-pin switch
922578-34	34-pin switch
922578-40	40-pin switch
922578-50	50-pin switch

DIP JUMPERS

DIP jumpers fit standard DIP sockets. Ideal for jumpering within PC boards; between boards, back planes, and motherboards; I/O signals, etc. Connectors molded onto cable for optimum strain relief; factory tested; probe access holes on back. Conductors: 28 AWG. Color-coded cable uses 10-color sequence.



BREADBOARD JUMPER WIRE KIT



Each kit contains 350 wires cut to 14 different lengths from 0.1" to 5.0". Each wire is stripped and the leads are bent 90° for easy insertion. Wire length is classified by color coding. All wire is solid tinned 22-gauge with PVC insulation. Packaged in a convenient plastic box.

JK1 Wire Kit... 923351

Dip Jumper		
Connector on both ends		
AP No.	No. Pins	
924106-06	14	
924106-12	14	
924106-18	14	
924106-24	14	
924106-36	14	
924116-06	16	
924116-12	16	
924116-18	16	
924116-24	16	
924116-36	16	
924126-06	24	
924126-12	24	
924126-18	24	
924126-24	24	
924126-36	24	
924136-06	40	
924136-12	40	
924136-18	40	
924136-24	40	
924136-36	40	

Suffix in AP No. is length (-06 = 6 in.)

RIFA PTY. LTD.
(02) 570-8122
(03) 480-1211

IN
— STOCK —
AT

XENITEK PTY. LTD.
(02) 938-4311
(03) 419-6606

SILVERTONE NEWS

Newsletter of Silvertone Electronics
Specialists in Radio Control

Radio Remote Control

**CUSTOM MADE, HI SECURITY, LOW
POWER RADIO CONTROL UNITS**

IDEAL FOR THE RADIO REMOTE SWITCHING OF
A MYRAID OF MECHANICAL DEVICES
INCLUDING

- Doors and Gates
- Lights
- Cameras
- Slipways
- Vehicles

A FULL DIGITAL SYSTEM, BINARY CODED FOR
MAXIMUM SECURITY WITH SWITCH SELEC-
TABLE CODING

For details contact

**SILVERTONE
ELECTRONICS**

6/2 SCHOFIELD STREET,
RIVERWOOD, NSW 2210
Phone 533 3517

6/2 Schofield Street, Riverwood, NSW 2210
Telephone: 533 3517

AUDIO-VIDEO ELECTRONICS — continued



Styled somewhat like one of the more expensive systems mentioned earlier, the Rank Arena RA-50 "Music Centre" is the modern counterpart of the one-time domestic stereogram. The phono deck, cassette deck, AM/FM-stereo tuner and amplifier are in one integrated unit which can rest on a shelf or on the furniture rack illustrated — an optional extra. The specifications are modest, as also is the power output at 5W per channel, but the price is about half that for a full-scale hifi system. Rank Arena recommended the RA-50 "for those who want a second sound system for the rumpus room . . ."

ITOH 8510A!

**THE MOST REMARKABLE
DOT-MATRIX PRINTER
FOR UNDER \$1000!**

FULL CHARACTER SET WITH MATHS SYM-
BOLS, GRAPHICS AND LOWER CASE
DESCENDERS.

120 CHARS PER SECOND BI-DIRECTIONAL
LOGIC-SEEK PRINT.

FULL PRECISION PROPORTIONAL PRINTING FOR
LETTER-QUALITY WORD PROCESSING.

UP TO 136 COLUMNS ON 9½ INCH PAPER.
(15-INCH MODEL AVAILABLE).

NEGATIVE LINEFEED CAPABILITY.

TRACTOR & FRICTION FEED BUILT IN.

AVAILABLE FROM:

**Software
Source Pty Ltd.**

89 Oxford Street,
Bondi Junction. 389 6388
P.O. Box 364, Edgecliff 2027.
DEALER ENQUIRIES INVITED

and the appearance that she was seeking. With a bit of luck, she would find something suitable and her search would be over. Indeed, as I pointed out, sales figures clearly show that a large proportion of hifi buyers do end up buying a complete one-brand system.

"What brand would you recommend?"

"Frankly, I'd be guessing, without an up-date on what's offering. But any of the major brands should be satisfactory. There'll be differences, of course, depending on stocks, clearances, offers etc, but the hifi game is pretty competitive at the moment. By and large, you'll get the overall quality that you pay for, brand notwithstanding!"

But what if I don't like any of the systems?"

"You'll still be ahead. You'll know why you don't like them and you'll be in a much better position to discuss with a hifi specialist the kind of thing you really want."

"A hifi specialist?"

"Yes, don't rely on bargains picked up from a discount house. Find a hifi dealer that you feel you can trust and make sure that they have technical back-up, if the equipment needs service. Buy the whole system from them and it will be their responsibility alone to

make sure you're looked after.

And there we left the matter. I have heard nothing since, which may mean that the lass in question is now listening to hifi sound — systematically!

Or maybe she's still searching for the ideal equipment, or has forgotten the whole thing!

You never know, when you give advice!

NEW MICROPHONE FROM SENNHEISER



New in the Sennheiser range and bridging the gap between the MD417 — the highest quality dynamic "amateur" microphone — and the lowest-priced studio directional

microphone MD421 is the new MD419 studio microphone illustrated.

The transducer system used, which has been newly developed, is spring mounted in a way that renders the anti-vibration qualities of the MD419 exemplary within its price range.

The frequency response of the new microphone extends from 30 to 15,000Hz and it incorporates a bass tuner similar in design to that employed in the MD421 and MD441. Physically, it has the same contour as its bigger brothers. A quick-change terminal, which can also be mounted on a stand, is provided.

POWDERWORKS RECORDS & TAPES say that negotiations have been concluded for the purchase of the Astor disc pressing plant in Melbourne. Relocation of the factory equipment and installation of a cutting lathe at the Brookvale plant will effectively double Powderworks' present capacity. Any further enquiries for information should be directed to Ken Harding at Powderworks Records & Tapes Pty Ltd, 28 Cross St, Brookvale, NSW 2100. Phone (02) 938 2200.

AUDIO TELEX COMMUNICATIONS PTY LTD are distributing in Australia industrial loudspeakers manufactured by Atlas Sound. Model SPB-3C, as illustrated, is an efficient, heavy duty compression driver, with a power rating of 24 watts and the ability to work through high ambient noise levels such as mines, manufacturing areas, engine rooms, etc. It is dust and vermin proof

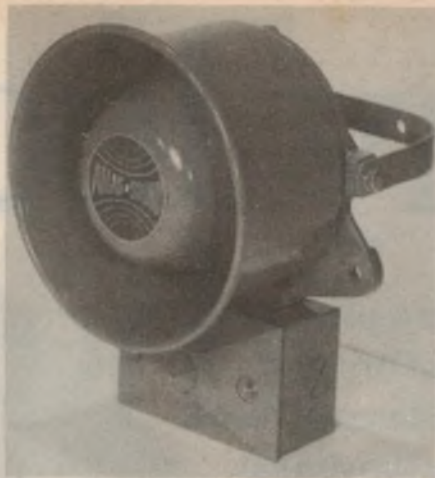

and rated for marine operation.

The dimensions are quoted as 17 x 23.2 x 12.1cm and the weight 2.8kg. Response is quoted as 300-9000Hz, dispersion 130 degrees, and impedance 16 ohms. Audio Telex are at 1 Little St, Parramatta, NSW 2150. Phone (02) 633 4344. Also in Melbourne and Brisbane.

THE VHD VIDEO DISC is still being held back from launching by its chief supporters JVC and Matsushita. It was originally due to launch in October '81 but the date was set back to April '82, reportedly to enable the companies to perfect their disc manufacturing technology. But April came and went, with JVC saying that they would prefer to wait until the world economy improves and provides a better climate for a completely new video product.



This Technicolor video camera is part of a miniature video system, using a scaled down cassette recorder. The cassettes use 6.35mm wide tape and weigh only 57g. The recorder weighs 3kg and measures 25.5 x 11 x 7cm. Horizontal resolution is given as 240 lines. It is powered from NiCad batteries, a mains supply, or a car lighter socket. The camera has an electronic viewfinder, a power zoom lens and macro facility. Further details from Dynavision Sales Pty Ltd, 327 Princes Highway, St Peters, NSW 2044.

Tandon

HARD DISK DRIVE ADD-ONS

For
APPLE
TRS80
S100
MULTIBUS
S.T.D.

Your Computer

FOR AROUND
\$2,950.00

inc. tax

*For further details
contact*

MARTIN COLLETT

AE

**ADAPTIVE
ELECTRONICS P/L**

**418 St. Kilda Road,
Melbourne, 3004
(03) 267 6800**

*O.E.M. Enquiries
Welcome*

Why Technics their dbx

You can't fit a quart in a pint pot. Dynamic range is what brings music truly 'alive'. It's the difference in sound level between the proverbial 'drop of a pin' and the cannons' roar in a digital recording of the 1812. This difference represents more than 100 decibels of dynamic range – a figure regularly exceeded by a full orchestra or live rock band in full flight.

However, even with modern tape formulations, this full dynamic range cannot be captured on a cassette recording due to the inherent limitations of the tape itself. The quietest passages become submerged in tape hiss, whilst the louder parts suffer distortion through tape saturation. Clearly, the capabilities of the cassette tape have been stretched to their limits. How, then, can further performance increases be achieved?

Technics proves 2 into 1 does go! The new generation of Technics cassette decks are equipped with dbx encoding/decoding equipment – a system already well established in professional recording studios.

When a recording is made through the Technics dbx system, the input signal is compressed (encoded) to half its 'sound level', electronically,



so a performance with a wide dynamic range can be stored within the narrower dynamic capabilities of a cassette.

On playback, a 'mirror image' expansion (decoding) takes place and the original full dynamic range is released. The results are dramatic. Simply compare the performance of a Technics dbx deck with an ordinary machine and the difference will stagger you.

And, as an interesting by-product of the process, your recordings will benefit from around 30 decibels of noise reduction, too.

With Technics, you're ready for dbx recordings, too. In hi-fi terms,

have developed cassette decks.

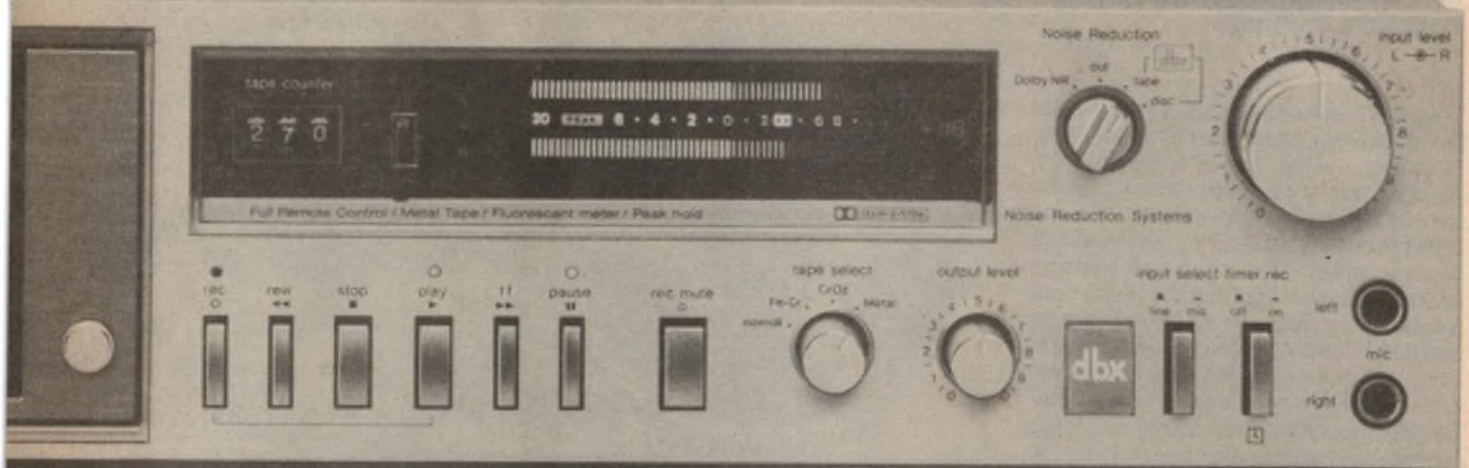

the quality of pre-recorded cassettes has left much to be desired. But when dbx recorded material is released in Australia, you'll notice a big difference. Play a pre-recorded dbx tape through your Technics dbx cassette deck and you may well think you're listening to a good quality disc.

And whilst on the subject of discs, there are dbx albums being made, too. Naturally, Technics have taken this into consideration. And you'll find a DISC position on the dbx selector, so you can play dbx-encoded albums through your existing system.

Technics RS-M270X dbx cassette deck. A typically advanced Technics component that combines

stable, reliable tape transport with highly sophisticated electronics. Direct drive motors for both capstan and reel drive; IC logic solenoid controls; 2-colour, peak-hold FL meters; 20-20,000 hz frequency response with metal tape; 110 db dynamic range.

Let Technics expand your music experience to new horizons.

Listen to a Technics dbx cassette deck and hear the amazing difference for yourself.

Of course, all Technics components carry a two-year warranty.

Technics
Expanding the music experience.



HIFI REVIEW

Teac X-1000R open-reel tape recorder

Packed with features to attract a hifi enthusiast, the Teac X-1000R open-reel tape recorder provides performance equal to or better than the best cassette recorders and, in addition, offers facilities for cueing and editing which cannot be performed on the cassette medium.

As it is quite a long while since we last reviewed an open-reel tape machine (October, 1978 to be precise), we thought that a few introductory words on the relative merits/demerits of the open-reel and cassette mediums would not go amiss. The open-reel medium allows for higher tape speeds with consequent improvement in high frequency saturation characteristics, lower distortion, and ease of editing (a very important feature when making live recordings). Generally, the higher the tape speed, the bigger the improvement in each of the above characteristics. It is for this reason that most professional recording is carried out at 15 ips.

Penalties are the increased size and price of open-reel tape machines and, more importantly, the considerably increased cost and size of open-reel tapes to store the same recorded material as could be conveniently stored in the cassette medium. A visit to the vaults of a recording studio would quickly indicate the large space required to store hundreds of open-reel tapes. Further, many people find threading an open-reel machine a chore, compared with the easy loading of a cassette.

Perhaps the ideal domestic situation would be to have both an open-reel machine and a cassette recorder. Original recordings could be made on the open-reel machine and then edited with the aid of razor blades and splicing tape. Thereafter they could be transferred to cassettes for subsequent entertainment. The original open-reel tape could then be erased and used for fresh recording. With this system only a relatively small library of open-reel tapes would be required.

The Teac X-1000R would fit admirably into such a scheme. It is a three-head, quarter-track stereo machine with inbuilt dbx encoders and decoders and is available at a very competitive price. It also provides solenoid-



Teac's X-1000R open-reel recorder. Note that the black version we tested does not have buff VU meters, as mentioned in the text.

controlled forward or reverse two-speed operation (7½ or 3¾ ips), mic/line mixing and facilities for remote control and external timer. Unlike most cheaper machines it can handle 10½ inch NAB tape spools, and without effort, since the spooling motors are adequately-powered.

Tape handling is much more sophisticated than was common with machines of the previous generation. Supply and takeup tensions are dynamically controlled with feedback being obtained from the angular positions of the supply and takeup tension "arms". This results in essentially constant tape tension irrespective of the quantity of tape on the supply and

takeup reels. Two switched tension options are available — normal for 5 inch and 7 inch EIA reels; or additional for the heavy 10½ inch NAB reels.

Dual capstans (one on the supply side, the other on the takeup side of the heads) are used to control tape motion across the heads. This is known as the "dual capstan tight (or closed) loop" tape drive system, and provides constant tape-to-head contact. Note that to keep the tape taut across the heads the takeup capstan has to rotate fractionally faster than the supply one. When the machine is in reverse mode the speed differential between the capstans also has to reverse. Teac engineers overcame this problem by machining two

steps of slightly different diameter on each capstan pulley flywheel. When the capstan motor reverses, the drive belt moves across by itself onto the correct areas of the flywheels to maintain the speed differential.

A further aid to smooth tape motion is the provision of two inertia rollers each located between a tension arm and a capstan. The right-hand roller is rubber-tired (with peripheral grooves to prevent air trapping, and consequent tape slippage at high spooling speeds) to detect tape movement, which is displayed in terms of real time on an electronic digital tape counter. This is another advantage of the open-reel tape medium since the counter is calibrated in hours, minutes and seconds, and is accurate to within better than three seconds in a 30 minute period. Note that at the present state-

be restricted as it produces a fair amount of heat.

Power consumption is 100 watts. A two-core mains lead with moulded plug is fitted to the machine, which is double-insulated and identified with the international double-square symbol.

The lower area of the front panel is taken up with audio level meters and all controls and switching for the audio functions. Between this area and the tape deck itself is a narrow strip containing power switch, digital tape counter and switches and controls for the tape transport mechanism.

Apart from the normal quota of pushbuttons for transport control (including two "play" buttons — one for forward, the other for reverse tape motion), controls are provided for reel size, tape speed, manual or automatic reversing (with the aid of metal-sensing

previously encountered. It operates in conjunction with an "Auto Spacer" slide control (located just above the head block), to produce preset muting periods (to a maximum of eight seconds) whenever the Mute button is pressed during recording. This is an excellent way of obtaining equal-length spaces between individual items of a full length recording.

An interesting sidelight to this function is that during the muting operation the tape counter displays the length of the muting period, but reverts to its normal function when recording is again initiated.

Three rotary controls are located to the right of the level meters, two serving for independent control of microphone and line input levels; the third controlling the line output level — of which more later. Positioned under these three knobs are pushbutton switches for A-B monitoring, dbx selection and tape type (ferric oxide or EE).

The black-faced level meters display the letters "VU" prominently in the centre of their scales, and are driven from half-wave peak rectifier circuits. (Strictly speaking to conform with VU standards, scale background colour should be buff, and meter movements should be driven from full-wave average responding rectifier circuits. Non-standard meters should be labelled "dB", not "VU".)

Scale accuracy was very good, with the error being less than 0.5dB over the range from -10 to +3dB. But as expected (due to the departure from the rectifier standard), dynamic readings on program material are only roughly the same as those obtained from genuine VU meters.

This reviewer was a little confused by the operation of the Output control. With the A-B selector in the Source position, level metering was unaffected by setting of the Output control. It only served to vary the output level to ancillary equipment (for level matching). Good, no argument. But in the Tape position both output level to ancillary equipment and meter readings are simultaneously varied!

Using a tape of different sensitivity to that for which the X-1000R had been set-up, and adjusting the Output control to obtain identical meter readings, we found that the levels fed to ancillary equipment differed by 5dB between the Source and Tape positions.

Other tape and cassette recorders overcome this problem in one of several ways. The simplest method is to connect the metering circuit (in the replay mode) to a point prior to the common Output control. With this method internal and external meter readings will be in agreement with one another. If a tape of different sensitivity is used there

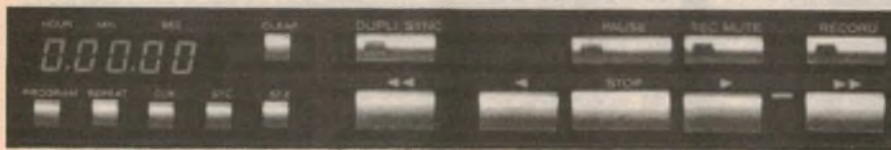

Close up view of the tape transport controls and digital readout.

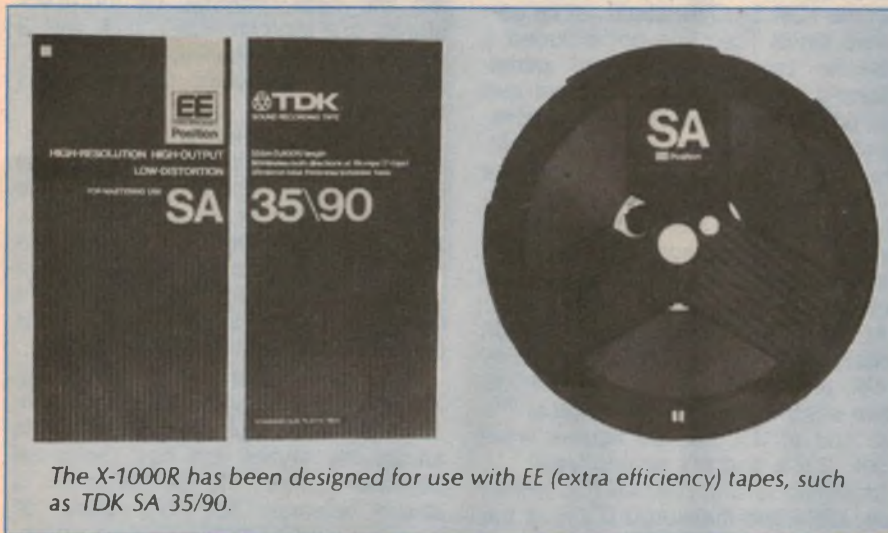

The X-1000R has been designed for use with EE (extra efficiency) tapes, such as TDK SA 35/90.

of-the-art, a cassette deck's counter only counts turns of the supply or takeup spindles.

Perforce a machine incorporating the above features (especially the ability to handle NAB spools) must be larger than a basic domestic tape recorder. And so it is with the Teac X-1000R. Its dimensions are 472mm wide X 486mm high X 262mm deep, and mass is 26kg. It is contained in a wooden case with an attractive grained timber finish. Unfortunately there are no carrying handles nor finger slots, so that it is a bit of a brute to lift from the floor, or to carry for anything more than short distances.

It can be used horizontally or vertically but, either way, ventilation must not

foil at the ends of the tape), tape lifter — which permits audible cueing in the fast winding modes — and pitch control, which allows up to $\pm 7\%$ variation (measured) of the nominal tape speed. Unless withdrawn this knob is inoperative, so that there is little likelihood of an incorrect tape speed being inadvertently used.

Other transport controls include counter reset and pushbuttons for automatic fast winding to either the counter "zero" or to a preset "cue" position (on the tape), which had been previously entered by means of another pushbutton.

The record "mute" function is rather more sophisticated than any we have

TEAC X-1000R TAPE RECORDER

will be level differences between Source and Tape levels — but at least the internal and external readings will be in agreement.

Another method is to convert the "output" level control to strictly a "replay" only level control, with 0dB meter deflection providing the same line output level in either the Source or Tape modes. This suffers the disadvantage of not being able to "level match" the recorder's output to other audio sources in the equipment system. By adding a separate "output" level control (after the metering point) — common to both Source and Tape — level matching can be achieved, and the problem is solved.

So much for a description of the salient points of the X-1000R. How does it perform? In a nutshell, superbly. Peak wow and flutter measured 0.07% at 7½ ips and 0.1% at 3¾ ips. These figures were essentially the same for either forward or reverse tape motion. Tape speed was 0.2% fast at both speeds, in either direction.

Eighty-five seconds were required to fast wind a seven-inch spool of long-play tape (1800ft) in either direction. Note that an 1800ft reel of tape provides 48 minutes of recording time in each direction (total 96 minutes) at 7½ ips; and 96 minutes (total 192 minutes) at 3¾ ips.

Using a 7½ ips Ampex NAB test tape the replay frequency response was within ± 1.5 dB to 15kHz (the upper limit of the test tape) on either track in either direction in the ferric oxide modes. However this reviewer disagrees with the choice of NAB characteristic (50 μ s and 3180 μ s) since both the draft Australian Standard (on tape recorders) and the professional audio industry specify the IEC characteristic (70 μ s).

As yet no national or international standard has been set for extra-efficiency (EE) tapes, but the Japanese manufacturing industry (who are pioneers in this field) are using 35 μ s and 3180 μ s at 7½ ips, and 50 μ s and 3180 μ s at 3¾ ips. It can only be hoped that these characteristics will be adopted internationally.

Playing the test tapes in this position (EE), the 10kHz response dipped by 3dB at 7½ ips, and 5dB at 3¾ ips, exactly as theory dictates. Incidentally, the ferric oxide characteristic at 3¾ ips is 90 μ s and 3180 μ s, which fortunately is the same for both NAB and IEC.

In the record and replay tests we used Ampex 407 tape for the ferric oxide mode (Teac LH-I), and TDK SA tape for the EE mode. As a matter of interest

TDK SA appears to be the same Super Avilyn formulation which we know well from their chrome-compatible SA cassettes.

Overall frequency response at 3¾ ips was within ± 2 dB between 25Hz and 20kHz using the Ampex 407 tape, and 3dB down at 20Hz and 21kHz. In the EE position (with TDK SA tape) this slightly improved to $\pm 1/2$ dB between 25Hz and 20kHz, with the -3dB points being at 20Hz and 22kHz.

At 7½ ips the overall response improved to be within ± 1 dB between 200Hz and 27kHz for both tape types, although at 30kHz the figures were -3dB (EE tape) and -4½dB (ferric oxide). Low frequency response was down 3dB at 20Hz (both tape types), and was within ± 1 dB between 25 and 35Hz. Strangely, both tape types exhibited a +2dB "plateau" between approximately 50 and 120Hz. This is not a real problem, being of academic interest only.

As received the X-1000R had a +2dB "sensitivity" increase at 1kHz with the Ampex 407 tape, and -1dB with the TDK SA. This could not be corrected since Teac has not included a two-tone test oscillator and panel-mounted presets for record level and bias adjustment. This is a little surprising as there can be quite significant differences between the characteristics of the different tape brands and formulations which are available. Further it has become the practice for top-of-the-line cassette recorders to include such facilities. So why not the X-1000R?

At 1kHz the total harmonic distortion measured 0.6% at 0dB input level, 1.4% at +6dB and 3% at +10dB when using the Ampex 407 tape at 7½ ips. And at 3¾ ips the figures were 0.9%, 2.3% and 5% respectively.

Changing to the TDK SA (EE mode) tape, distortion measured 0.7% at the 0dB level, 2% at +6dB and 4.7% at +10dB at 7½ ips. The figures improved to 0.7%, 1.8% and 4.3% respectively at 3¾ ips. This is to be expected since the chrome-compatible tapes come into their own at the shorter wavelengths. In fact it is probably better to use ferric oxide tapes at high tape speeds, and chrome-compatibles at the lower tape speeds.

It should be noted that we adjusted the input gain controls to produce a recorded level of 185nWb/m at the 0dB reference for both tape types in all these distortion tests. In other words 0dB corresponds to the same 185nWb/m recorded level for both the Ampex 407 and TDK SA tapes.

Similarly we referred all noise measurements below the replay output

level corresponding to a recorded level of 185nWb/m.

The unweighted signal-to-noise ratio measured 52dB at 7½ ips and 50dB at 3¾ ips using the Ampex 407 tape. In the EE mode (with TDK SA tape) it marginally improved to 53dB and 52dB respectively.

With dbx selected all figures improved to approximately 67dB, which was virtually inaudible under domestic listening conditions. But, if we recorded a 'blank' section of tape in the "normal" mode, and replayed it in the dbx mode, the signal-to-noise ratio dramatically improved to 84/85dB. Further investigation revealed that the main noise component was 10Hz hum, which was apparently being generated by the encoder section of the dbx processor.

We would imagine that this was due to a fault in our review machine, but unfortunately time did not allow us to investigate further and bring the matter to a conclusion. But we would suggest that you check out this aspect of performance before purchase.

Interchannel separation was greater than 50dB for all frequencies above 30Hz. This was only to be expected in some designs since the track format for left and right channels on four-track stereo quarter-inch tapes is 1 and 3 (and 2 and 4), resulting in a "whole" track space between left and right channels.

However, significant crosstalk between forward and reverse programs can occur in some designs since the tracks are adjacent. But, in case of the X-1000R it was of negligible magnitude, being below the noise floor at frequencies of 100Hz and above. It measured 43dB at 70Hz, 34dB at 50Hz and 30dB at 30Hz.

Our conclusions are that the X-1000R is a ruggedly designed, well-made domestic tape recorder, which is attractively styled and has fool-proof solenoid control. Its performance is above average for this class of machine, and it has the obvious attractions of forward and reverse operation, inbuilt dbx processing and full three-head function in either direction (of tape motion). As mentioned at the beginning of this review it would make an ideal "master" recorder for an elaborate hi-fi system.

Recommended retail price of this Teac X-1000R reel-to-reel tape recorder is \$1,228 including sales tax. It is also available in a moulded plastic case (with finger slots for carrying, tool) in lieu of the timber cabinet. This version had an RRP of \$1,176. Further information can be obtained from high fidelity dealers, or from the distributors: Teac Australia Pty Ltd, 115 Whiteman St, South Melbourne, Victoria, 3205 (P.de N).



A P PRODUCTS

9450 Pineneedle Drive • P.O. Box 603 • Mentor, Ohio 44060
(216) 354-2101 • TWX: 810-425-2250

In Europe, contact A P PRODUCTS GmbH
Baumlesweg 21 • D-7031 Weil 1 • W. Germany

ACE ALL-CIRCUIT EVALUATORS

Two kits and five assembled breadboards for quick build-up and check-out of experimental circuits. All models have integral voltage distribution system with solderless, plug-in tie points on universal .100" x .100" matrix for excellent circuit design flexibility. These ACE's accept all DIP's, TO-5's, discrete components and solid wire patch cords to .032". Use buses for voltage, ground, reset and clock lines, shift command, etc. Five-way binding posts. Aluminum base serves as ground and has gold-anodized protective surface. Multi-tie-point terminals are non-corrosive nickel silver. Four rubber feet included.



ACE 236

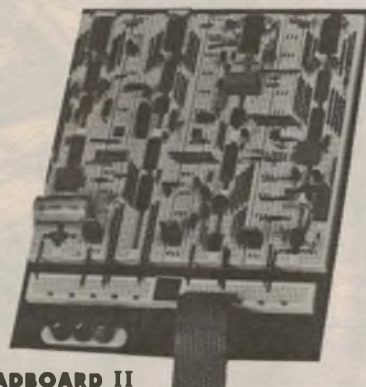

BREADBOARD II

Fully assembled. Unique system of 3 distribution strips, two levels of printed circuits and 3 binding posts. 18 buses are color coded and internally connected to 3 corresponding color binding posts. High distributed capacitance and low inductance design minimizes unwanted voltage spikes, provides superior low impedance system. Same solderless, plug-in matrix features as ACE's. Laminated NEMA G-10 glass epoxy; circuits and gnd. plane are 2-oz. copper; terminals are copper alloy 770.

AP No.	ACE's and Breadboard II	Tie-Pts.	DIP Cap.	No. Buses	No. Posts	Size (inches)
923333	ACE 200-K (kit)	728	8(18's)	2	2	4 3/4 x 5 3/4
923332	ACE 208 (assem.)	872	8(18's)	8	2	4 3/4 x 5 3/4
923334	ACE 201-K (kit)	1032	12(14's)	2	2	4 3/4 x 7
923331	ACE 212 (assem.)	1224	12(14's)	8	2	4 3/4 x 7
923326	ACE 218 (assem.)	1760	18(14's)	10	2	6 1/2 x 7 1/8
923325	ACE 227 (assem.)	2712	27(14's)	28	4	8 x 9 1/4
923324	ACE 236 (assem.)	3648	36(14's)	36	4	10 1/4 x 9 1/4
923605	BB II (assem.)	2896	36(14's)	18	3	7 x 9

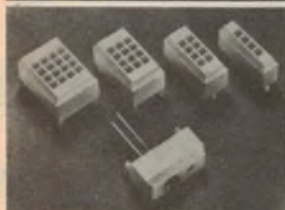

TIE-POINT BLOCKS

Four models available with .1" matrix of solderless, plug-in, 4-tie-point terminals for custom layouts, attaching relays, displays, in/out patching. LED block accepts 1/8" dia. bulb (not included). All models have solder tails and mount by press-fitting into holes. All styles packaged 20 per pack

AP No.	Tie-Point Blocks	Tie-Points
923297	TB1 (single)	4
923299	TB2 (double)	8
923301	TB3 (triple)	12
923303	TB4 (quad)	16
923305	LB1 (LED)	1

Assortment: 4 each of above 5 styles

TERMINAL AND DISTRIBUTION STRIPS

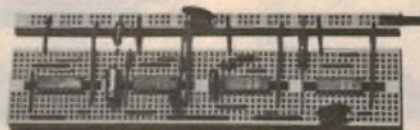

For building custom breadboards. Solderless, plug-in matrices on .1" x .1" centers that accept all DIP's, TO-5's, discretes and solid wire jumpers to .032". Terminal strips available in 4- and 5-tie-pt. single and dual rows. Distribution strips available with 2 or 6 buses. Includes integral, non-shorting mounting backing.

AP No.	Terminal Strips, Distribution Strips and Super-Strips	Buses, Terminals and Tie Points	DIP Capacity	Size (in.) L. x W.
923273	217L Terminal strip	34 five-tie-point term.	2 (16's)	1.8 x 1.36
923269	234L Terminal strip	68 five-tie-point term.	4 (16's)	3.5 x 1.36
923265	248L Terminal strip	96 five-tie-point term.	6 (14's)	4.9 x 1.36
923261	264L Terminal strip	128 five-tie-point term.	9 (14's)	6.5 x 1.36
923291	154R Terminal strip	54 four-tie-point term.	*	6.5 x .63
923289	264R Terminal strip	128 four-tie-point term.	9 (14's)	6.5 x 1.1
923285	206R Distrib. strip	2 buses of 24 tie points	3.5 x .35
923281	209R Distrib. strip	2 buses of 36 tie points	4.9 x .35
923277	212R Distrib. strip	2 buses of 48 tie points	6.5 x .35
923293	606R Distrib. strip	6 buses of 24 tie points	6.5 x .43
923252	SS-2 Super-Strip	128 five-tie-point term. & 8 buses of 25 tie points	9 (14's)	6.5 x 2.25
923748	SS-1 Super-Strip†		9 (14's)	6.5 x 2.25

*Model 154R is a single strip of terminals: all others are dual row for DIP's.

†Gold-plated copper alloy terminals. #Height of all strips is .32 inches.



Powerace 101
923101 ... 120 VAC
923221 ... 220 VAC

Powerace 102
923102 ... 120 VAC
923222 ... 220 VAC

Powerace 103
923103 ... 120 VAC
923223 ... 220 VAC

POWERACE POWERED BREADBOARDS

Fully assembled. All three Powerace models offer a new dimension in convenience for fast, solderless, circuit building and testing. Each incorporates two A P Super-Strips with 1680 plug-in tie points to hold up to 18 14-pin DIP's. Breadboards accept all DIP sizes including RTL, DTL, TTL and CMOS devices, TO-5's and discretes with leads up to .032" dia. Built-in groundplane — ideal for high-frequency and high-speed/low-noise circuits. Interconnect with any solid 20 or 30 AWG wire via plug-in tie-point blocks on panels. Operate on 200 to 240 VAC at 50 Hz or on 110 to 130 VAC at 60 Hz (with fused power supplies). Ripple/noise is ≤ 10 mV at full load. Dimensions of all three Poweraces are: 7.5" wide, 11.5" deep, 4.0" high at the rear, but only 0.75" high at the front for working-level convenience. Weights are approx. 2.5 lb. Complete operating instructions included.

POWERACE 101 — General purpose for all types of circuits. Power supply is regulated, adjustable from +5 to +15 VDC at 600 mA. Line and load regulation is ≤ 3%. O-15 VDC meter for monitoring power supply or circuits.

POWERACE 102 — For prototyping digital circuits. Power supply is regulated +5 VDC at 1 amp. Line load regulation is ≤ 1%. Built-in pulse detection with memory — combined with three buffered logic indicators, provide free built-in logic probe. Also contains two logic switches, four data switches, a clock generator and a one-shot pulse generator.

POWERACE 103 — Triple-output power supply for linear and digital circuits has outputs of +5 VDC at 750 mA; +15 VDC at 250 mA; and -15 VDC at 250 mA (±15-volt outputs track). Line and load regulation is ≤ 1%. Meter is built-in 15-O-15 VDC. Also contains two buffered logic indicators, two logic switches and two data switches.

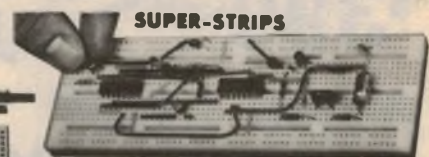

Universal, breadboarding elements have 840 solderless, plug-in tie points, integral, low-impedance distribution system, accepts all DIP's, TO-5's, discretes and solid jumpers to .032". Hold up to nine 14-pin DIP's. Choice of contact finishes. Includes integral, non-shorting, instant-mounting backing.

Australia's most popular computer now even better!



Full upper and lower case video display capability

Screen print facility (obtain a print-out of any 'page' appearing on the screen)

Built-in speaker

OVER 6,000 SOLD!

WAS \$750

All new Expansion Unit — you save!

A brand new model — now with extra value! The first row of 16K RAM is fitted as standard in this unit, with provision for an extra 16K (which gives the System 80/Expansion Unit 48K total memory). And it's \$100 cheaper than the previous model! It provides as standard, a floppy disk controller capable of controlling up to 4 single density disk drives. Although the exterior of the unit is similar to the previous model, there are significant changes internally; the Centronics printer port is still standard, but the RS 232C interface and connector are now only available as an option. The S-100 motherboard has been removed, and is available as a second option for those who require S-100 expansion capability.

\$100 less than previous model!

Cat. X-4020

Cat. X-4005

\$399



Colour Graphics

Cat. X-3275

Now you can have colour with your System 80 computer! This kit gives you 8 different colours AND it has a PAL encoded modulated RF output which allows it to be used with any standard colour TV receiver.

Only experienced hobbyists or technicians should attempt this kit

\$129.00

NEW LOW PRICES ON PRINTERS!

UNDER \$500 PRINTER!

Superb dot-matrix printer that uses ordinary fan-fold sprocketed paper up to 204mm wide. Its most unusual feature is the single hammer print-head — this means very few moving parts for increased reliability. Fitted with a standard Centronics type parallel data interface making it compatible with most modern computers. Cat. X-3252

WAS \$495!

\$399



ITOH 8300P DOT MATRIX PRINTER

The ITOH 8300P features high speed, bi-directional printing (125 characters per second), with full upper and lower case character set. It accepts standard fan-fold sprocketed paper up to 240mm wide. This means you can do 80, 40 or 132 column printing. Fitted with standard Centronics type parallel port. A great seller with great features. Cat. X3255

WAS \$920!

\$799



NEW DAISY WHEEL WORD PROCESSOR PRINTER

This new Dick Smith daisy wheel printer delivers ultra sharp copy which is a definite prerequisite for word processing. It will accept standard office stationery or continuous stationery up to 400mm wide. The cartridge ribbon and economical Diablo print wheels are freely available making this a very versatile printer with an unbelievable speed of 40 ch/second. Cat. X-3265

\$1995



DICK SMITH SYSTEM 80

Monitor program
(suitable for the
hobbyist to program
in machine language)

Flashing cursor

**NOW
ONLY**

\$690

and look at this great new software!

KILLER BEETLES

Pit your skills against the killer beetles. You dig traps and when the beetle falls in you bury him. Problem, they don't stay buried! Cassette based, req. 16K. Cat. X-3598 **\$19.95**

GHOST HUNTER

The aim is to eat the energy dots in the maze before the ghost can get you. Random power pills will assist you in chasing them. Cassette based, req. 16K. Cat. X-3597 **\$19.95**



GALAXY INVASION

Real time graphics and sound, the idea is to destroy the invaders and save Earth, but beware of the Flagships! Cat. X-3693 **\$19.50**



SUPERMAZE

The maze game to end all maze games. It can generate mazes up to 100 x 100 elements — it can take you many hours to find the way out! Cassette based, req. 16K. Cat. X-3672 **\$17.95**

DEPTH CHARGE

The latest version of the arcade favourite. Your mission is to destroy the enemy submarine pack. Good graphics and includes sound. Cassette based, req. 16K. Cat. X-3686 **\$14.95**

RAIN ANALYZER

A most useful program for the man on the land, the geography student, etc. By keying rain patterns for your area in the past (these figures normally available at your local post office, etc.) you can predict rain fall patterns, volumes, etc. Cat. X-3767 **\$19.95**

TREK 78

The classic computer game based on the ever popular TV series 'Star Trek'. This game utilises good graphics and provides continuous 'status' reports. Your aim is to destroy the enemy and save the Galaxy. Cassette based. Cat. X-3644 **\$12.95**

New Exciting Games ...

PENETRATOR

You are the sole survivor of a fighter squadron, whose mission is to invade enemy defence forces and destroy their illegal neutron bomb caches. But the bomb stores have individual defence circles, each with its own special dangers. Once you get through and destroy the bomb deposits, you have to return through the defence rings. Cat. X-3673 **\$34.50**

STOCKMARKET

For one to four players, accumulate wealth by buying and selling shares. Stay ahead of the market index by as big a margin as possible, and watch out for the other players too! The market index starts at 100 and is updated each time a share value changes. Financial fun for the whole family. Cat. X-3768 **\$19.50**

**WIN A
DATSUN
STANZA**



When you purchase a VIC-20, System 80 or Sorcerer computer from Dick Smith Electronics, you become eligible to win this superb

**DATSUN STANZA
GL four door sedan**

So hurry in for your fabulous System 80
NOW!

Not valid in states where this contravenes State Laws.

Permit No. TC82/278

issued under the Lotteries and Art Unions Act

Still cheapest per byte!

These superb disk drives cost so much less than the Tandy disk drives. Each drive has a high storage capacity 40 tracks and is suitable for both single and double density recording. With double density recording (using X-3540 Double Density Adaptor),

you can store more than 180K bytes per diskette!

The disk drives are suitable for use with most computers and disk controllers using the standard 34 way connection bus — such as the System 80, TRS 80 etc. (Don't pay their prices for disk storage.)

Cat X-4060 Drive 0

Cat X-4061 Drive 1

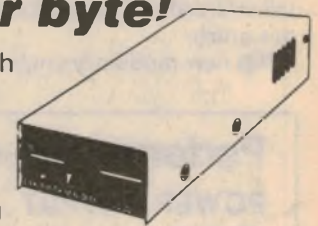

ONLY \$419

DICK SMITH ELECTRONICS

See page 52 for address details

DSE/A230M/PAI



100W sub-woofer power amplifier

Capable of up to 120 watts RMS into 4-ohm loads and up to 80 watts RMS into 8-ohm loads, this power amplifier module has been specifically designed for use as a sub-woofer driver amplifier in a tri-amped hifi system. It uses four power Mosfets for rugged, reliable operation.

by LEO SIMPSON

Since publishing the Playmaster Mosfet Stereo Amplifier in the December 1980 and January, February 1981 issues, Mosfets have gained an enviable reputation as rugged and reliable devices. The above amplifier has proved to be remarkably trouble-free but we have had a steady stream of requests for something more powerful but equally reliable.

So when we began development of this sub-woofer system, a Mosfet power module capable of around 100 watts into 8-ohm loads was our target. This has been substantially met although we shall talk more about the performance later in this article.

This new module is single channel only

and incorporates the power supply circuitry including two 8000 μ F/75VW electrolytic reservoir capacitors which are surprisingly compact and efficient. Also provided on the module printed circuit board is a low-pass filter circuit which is identical in configuration to that published in our February 1980 issue, under the title, "Super-Bass Filter".

Since this module is intended as a sub-woofer driver in conjunction with an existing stereo amplifier, the power level in the sub-woofer should be directly in proportion to the signal level fed to the stereo speakers. In other words, the sub-woofer level should be directly under the control of the main volume control on the stereo amplifier. There are two

ways of achieving this.

The first and most suitable way is possible if your stereo amplifier has preamplifier outputs. This would allow the left and right signals to be fed to the low pass filter via isolating resistors. (This method is also possible if you have a separate preamplifier/control unit and stereo power amplifier.)

The second and more practical method, for most owners of stereo systems, will be to take the signal directly from the drive to the left and right loudspeakers. Again, isolating resistors are used and the signal level adjusted by a common preset control. Thus, in our circuit, the left and right input signals are fed via 10k Ω resistors to a common 1k Ω preset shunt control.

Let us now discuss the power amplifier itself. This is almost identical in configuration to that of the Playmaster Mosfet Stereo Amplifier mentioned above and to that described in the original Hitachi literature on the power Mosfets. The power transformer is also the preferred type used in the above amplifier.

Since the Playmaster Mosfet Stereo Amplifier was stated to be only capable of delivering 55 watts RMS into an 8-ohm load with one channel driven, readers may wonder how the new amplifier manages to deliver up to 80 watts into an 8-ohm load and 120 watts into a 4-ohm load. And why do we entitle the unit a "100W Sub-Woofer Power Amplifier"?

Let's make it clear from the outset, that this amplifier configuration will not deliver 100 watts into an 8-ohm load with the specified transformer. Even under pulse power conditions with the supply rails rock-steady at $\pm 50V$ the

Performance of prototype

POWER OUTPUT

4 ohms	120W (see text).
8 ohms	80W (see text).

FREQUENCY RESPONSE

Power amplifier	20Hz to 20kHz ± 0.25 dB.
Low pass filter	-3dB at 96Hz, slope 18dB/octave.

HARMONIC DISTORTION

See graphs.

HUM & NOISE

Power amplifier alone	-92dB ref 10W/8 Ω input shorted.
	-103dB ref 10W/8 Ω input open.
Amplifier and filter	-99dB ref 10W/8 Ω input open all figures measured with bandpass filter 20Hz to 20kHz -3dB.

DAMPING FACTOR

At 1kHz ≥ 50 .
At 30Hz ≥ 50 .

STABILITY

Unconditional.

HOW IT WORKS:

The circuit of this sub-woofer amplifier is basically a low pass filter followed by a conventional power amplifier which uses four power Mosfets in the output stage.

Input signal is fed from the left and right channels of the main stereo amplifier in the system (from either the loudspeaker outputs or preamplifier outputs) via 10k Ω mixing resistors and then attenuated to the appropriate level by a 1k Ω shunt trimpot. The common mono signal thus obtained is then fed to the low pass filter which uses a single Fet-input op amp and three RC networks.

This combination active/passive filter gives a Butterworth response (maximally flat in the passband) and a -3dB point at 96Hz. This can be moved up or down in frequency by scaling the capacitor values (see the article). The filter has a gain of unity in the passband and an ultimate slope of 18dB/octave above the corner frequency (-3dB point).

Since the op amp has supply rails of $\pm 15V$ its maximum output signal

is far in excess of what can be handled by the following power amplifier. The op amp also causes negligible deterioration of the distortion and residual noise performance of the whole module.

The resulting sub-woofer signal has a maximum possible bandwidth (at the -3dB points) of 7Hz to 96Hz although, in practice, the low frequencies would rarely extend below 30Hz.

The output signal from the filter is fed via a 22 μF bipolar capacitor (to ensure low distortion) to the amplifier input. A 1k Ω resistor and 27pF capacitor form a simple RF filter which is more important if the amplifier is to be used without the foregoing low-pass filter.

Two high voltage BC556 PNP transistors, Q1 and Q2, comprise the input differential pair. The "tail" of this differential pair is a 47k Ω resistor instead of the commonly found "constant current" transistor which is often used with amplifiers having lower supply rails.

A trimpot (VR2) between the emit-

ters of Q1 and Q2 allows minor balance adjustments to be made to the differential pair and thus obtain zero offset voltage at the output.

The input differential pair drives another differential pair, using NPN transistors Q3 and Q4 together with current mirror Q5. These transistors have a collector voltage rating of 250V and were designed specifically for class-B video stages in television receivers. As such, they are ideally suited to use as low distortion driver stages as they have a good gain-bandwidth product of 100MHz or better and quite good beta linearity over their likely range of operating current.

The current mirror scheme for the second differential pair is a variation on the constant-current load which is often used for class-A driver stages in audio amplifiers. It has the effect of providing a higher gain from the stage, better gain linearity over the full voltage swing and gives a greater voltage swing than could be obtained from a simpler class-A stage with

Continued on page 46

Below: all circuitry, including the power supply and low pass filter, is mounted on a single PCB. Note that the Mosfet power transistors must be isolated from the heatsink (see p53).

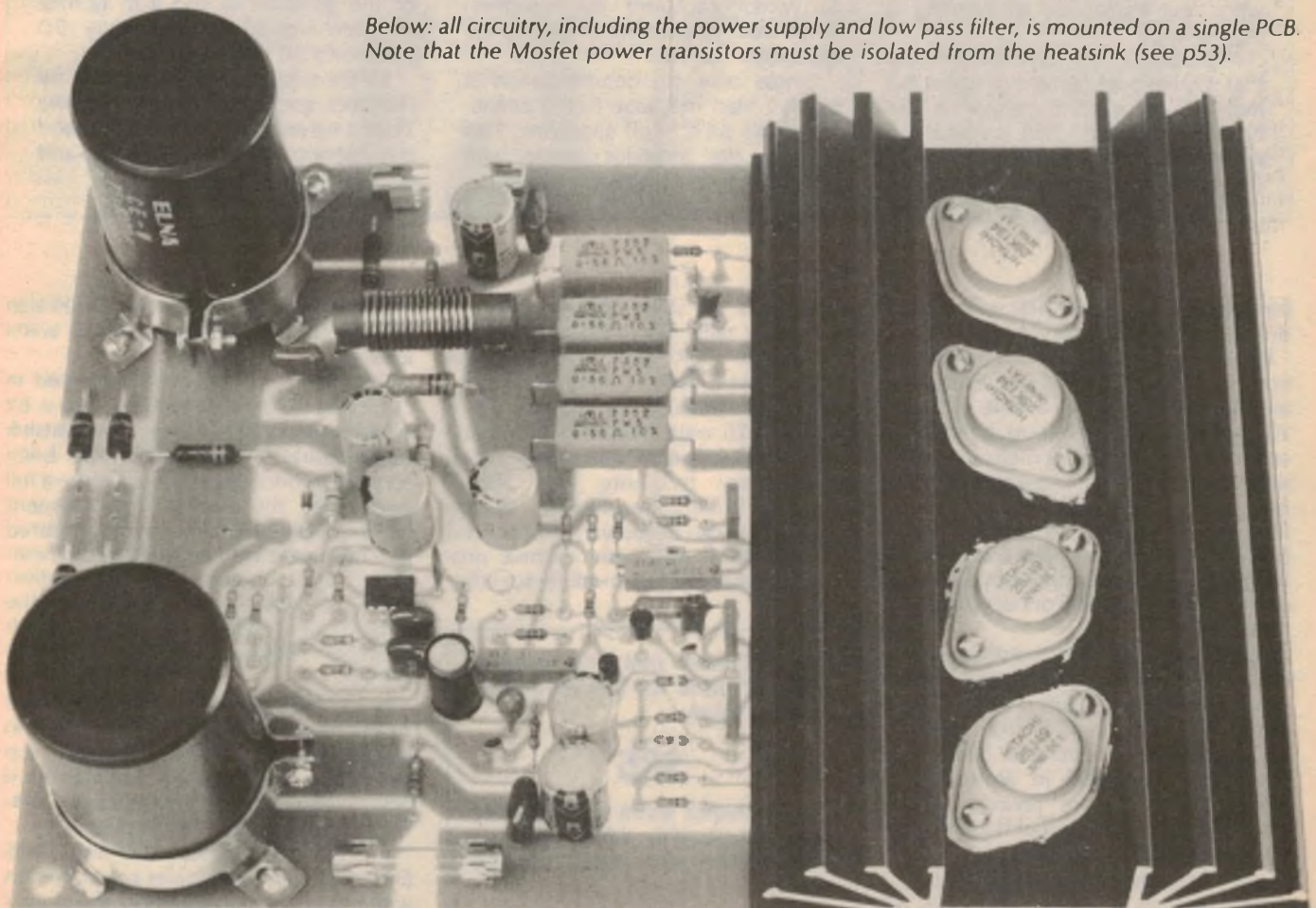

HOW IT WORKS . . . continued

a boot-strapped resistive collector load.

The two differential stages provide all the voltage gain of the amplifier as the Mosfet output stage is run in source-follower mode (similar to emitter-follower mode for bipolar transistors). With the AC feedback disabled, the open-loop gain of the prototype amplifier was around 35,000 or 90dB.

Each of the four power Mosfets has a $0.56\Omega/5W$ source resistor which helps ensure that each pair (of Mosfets) shares the load current equally. It also gives increased stability to the quiescent current setting. This is defined by the voltage between the gates of the complementary Mosfets and is adjusted by the $1k\Omega$ trimpot which is wired as a variable resistor (VR3).

There is a trade-off between the value of quiescent current and the amount of distortion produced at low power levels. While higher current settings will certainly give lower distortion values, the improvement that can be obtained is not commensurate with the great increase in heat dissipation which necessarily results when four transistors are running at high voltage.

Accordingly, we have determined that a quiescent current of about 30 milliamps in each transistor is the best compromise. This enables the heatsink to run at quite modest temperatures (warm but not hot)

when program is being handled at low levels.

One hundred ohm resistors are connected in series with the gate of each Mosfet as "stoppers" to prevent parasitic oscillation.

We also experimented with the addition of small capacitors between gate and source of the 2SK134s (which have smaller gate capacitance) but found this tended to cause parasitic oscillation which was manifested as a rise in harmonic distortion at medium power levels.

No protection circuitry is incorporated in the output stage apart from fuses in the supply lines. While these do require that extra supply bypassing be added to compensate for the impedance of the fuse, it does mean that no fuse is necessary in series with the loudspeaker where its non-linearity can cause distortion.

Supply fuses also have the benefit of protecting against malfunction in the amplifier itself as could happen for example when a transistor fails or the wiper of the quiescent current setting trimpot goes open-circuit. The supply fuses also provide a convenient current monitoring facility (when replaced by resistors) when trouble-shooting or setting the quiescent current.

Single pole lag compensation is applied from the base to the collector of Q3 via a $27pF$ capacitor. This renders the amplifier stable with overall negative feedback applied.

Voltage gain of the power amplifier is set by the ratio of the $47k\Omega$ and $2.2k\Omega$ resistors at the base of Q2. The lower cutoff frequency is set by the $10\mu F$ capacitor in series with the $2.2k\Omega$ resistor. This capacitor also sets the DC feedback at 100% so that the DC gain is unity.

A final refinement, which has been incorporated in recent Playmaster amplifiers, is the RLC network in the output. This is a rationalisation of the Zobel (RC) and LC networks often used in amplifiers and is based on a paper by A. N. Thiele and published in the September 1975 issue of "Proceedings of the IREE". This helps render the amplifier unconditionally stable, with the proviso that short circuits or large capacitive loads will blow the fuses.

Power supply circuitry is fairly simple. A centre-tapped transformer drives a bridge rectifier and two $8000\mu F/75VW$ capacitors to obtain unregulated supply rails of about $\pm 50V$ at no signal. This drops to about $\pm 46V$ when the amplifier is driven to full power (continuous) of about 70 watts into 8-ohm loads. If the supply rails are better regulated or the amplifier is fed with normal program signals, it will deliver 80 watts into 8Ω before clipping.

$\pm 15V$ supply rails are derived by resistors and zener diodes for the TL071 op amp. These are bypassed and decoupled by 68Ω resistors and $470\mu F/16VW$ capacitors.

module will not deliver 100 watts unless driven beyond the onset of clipping.

If you examine the power versus distortion curves you will see that the amplifier module is really only capable of about 70 watts RMS (continuous) before the onset of clipping. This is measured using the Ferguson PF4361/1 transformer and a regulated 240VAC mains supply. The difference in continuous power rating between this module and the previous Playmaster design comes about because of the use of parallel-connected output Mosfets.

These allow greater currents to be delivered to the load for a given voltage drop across each half of the output stage. Or to look at it from another angle, the transconductance of the output stage, expressed in amps/volt, is higher and so more power can be delivered for a given signal voltage from the driver stage.

Either way, the ultimate limiting factor in the amount of power that can be

delivered is the value and regulation of the supply rails. The no-signal value of the supply rails with the Ferguson PF-4361 and a 240VAC input is close to $\pm 50V$. This drops to about $\pm 46V$ when delivering 70 watts into an 8-ohm load.

If the regulation of the supply is improved, say by using the 300VA Ferguson PF4362 transformer, slightly more power can be delivered, at around 80 watts RMS. And under normal program conditions, the module together

We estimate that the current costs of parts for this module is approximately

\$85

This includes sales tax but does not include the power transformer and other chassis parts.

with the PF4361/1 transformer could also be expected to deliver about 80 watts RMS.

One other proviso must be noted in talking about these power measurements and that is the heatsink temperature. If the heatsink has been allowed to become very hot before a full power test, the resultant measurement will be significantly reduced compared to a test made with an initially cold heatsink. This is because the transconductance of Mosfets is reduced as the temperature rises — a factor which prevents thermal runaway in these devices.

By contrast, the gain of bipolar transistors normally increases with a rise in temperature and there is usually no significant difference in the maximum power output of a bipolar circuit between hot and cold measurements.

In order to guarantee 100 watts RMS (into an 8-ohm load) under any condition with this circuit configuration, the supply

PARTS LIST

- 1 PC board 228 × 170mm, code 82pa7
- 1 heatsink, single sided 170mm long, Thermalloy 6169, Ritronics, or equivalent
- 1 14μH choke, 19 turns of 16 gauge enamelled copper wire close wound on Neosid F14 ferrite 40mm × 10mm diameter
- 4 fuse clips, Swann Electronics FC1
- 2 5A 3AG fuses
- 4 TO-3 mica washers
- 8 insulating bushes

SEMICONDUCTORS

- 1 1N4148, 1N914 silicon signal diode diode
- 2 15V, 1W zener diodes
- 4 1N5404 silicon rectifier diodes
- 1 TL071, LF351 Fet-input op amp
- 2 BC556 PNP transistors
- 2 BF469 NPN transistors
- 1 BF470 PNP transistor
- 2 2SK134 power Mosfets
- 2 2SJ49 power Mosfets

CAPACITORS

- 2 8000μF/75VW electrolytics (with mounting brackets)
- 2 470μF/16VW electrolytics
- 4 100μF/63VW electrolytics
- 1 22μF/50VW bipolar electrolytic
- 1 10μF/35VW tantalum or low leakage electrolytic
- 3 0.1μF greencap (metallised polyester)
- 1 .082μF greencap
- 1 .068μF greencap
- 2 .0068μF greencap
- 1 .0047μF greencap
- 2 27pF ceramic

RESISTORS (¼W, 5% tolerance)

- 1 × 100kΩ, 6 × 47kΩ, 2 × 10kΩ, 2 × 3.9kΩ, 1 × 2.2kΩ, 3 × 1kΩ, 9 × 100Ω, 2 × 68Ω

OTHER RESISTORS

- 1 × 12kΩ/1W, 2 × 1.8kΩ/1W, 2 × 220Ω/5W (for set-up adjustment), 1 × 10Ω/1W, 4 × 0.56Ω/5W, 2 × 1kΩ multi-run trimpots, 1 × 1kΩ vertical trimpot

MISCELLANEOUS

Heatsink compound, PC stakes, screws, nuts, washers, solder.

CHASSIS PARTS

- 1 chassis to suit (eg, Playmaster Twin 25)
- 1 transformer, Ferguson PF4361/1, 70V CT
- 1 SPST mains toggle switch
- 1 .01μF/2kV ceramic or 250VAC metallised dielectric capacitor
- 1 3-way insulated terminal block
- 1 solder lug
- 1 1A fuse and fuseholder
- 1 mains cord, plug and cord clamp

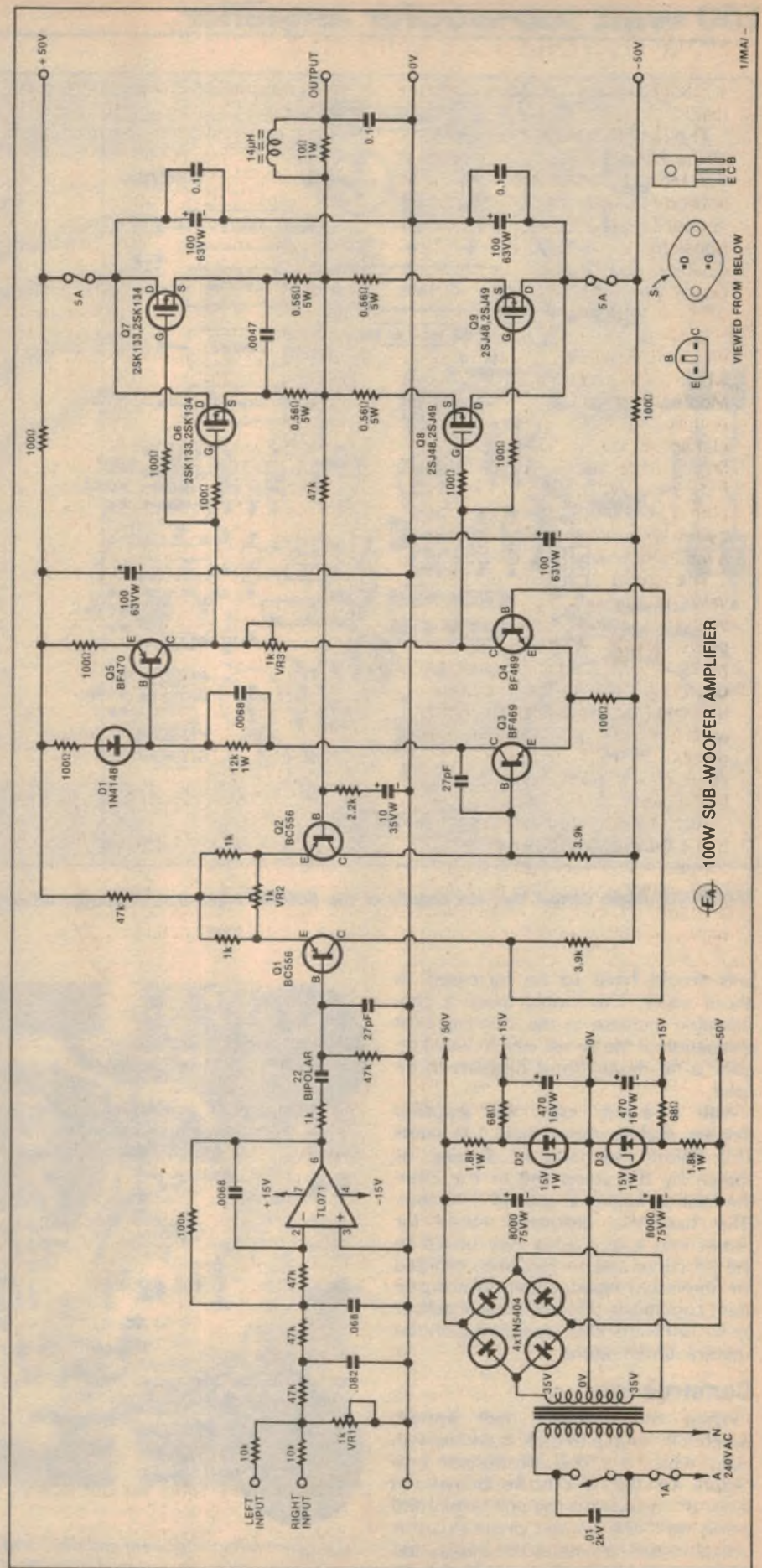

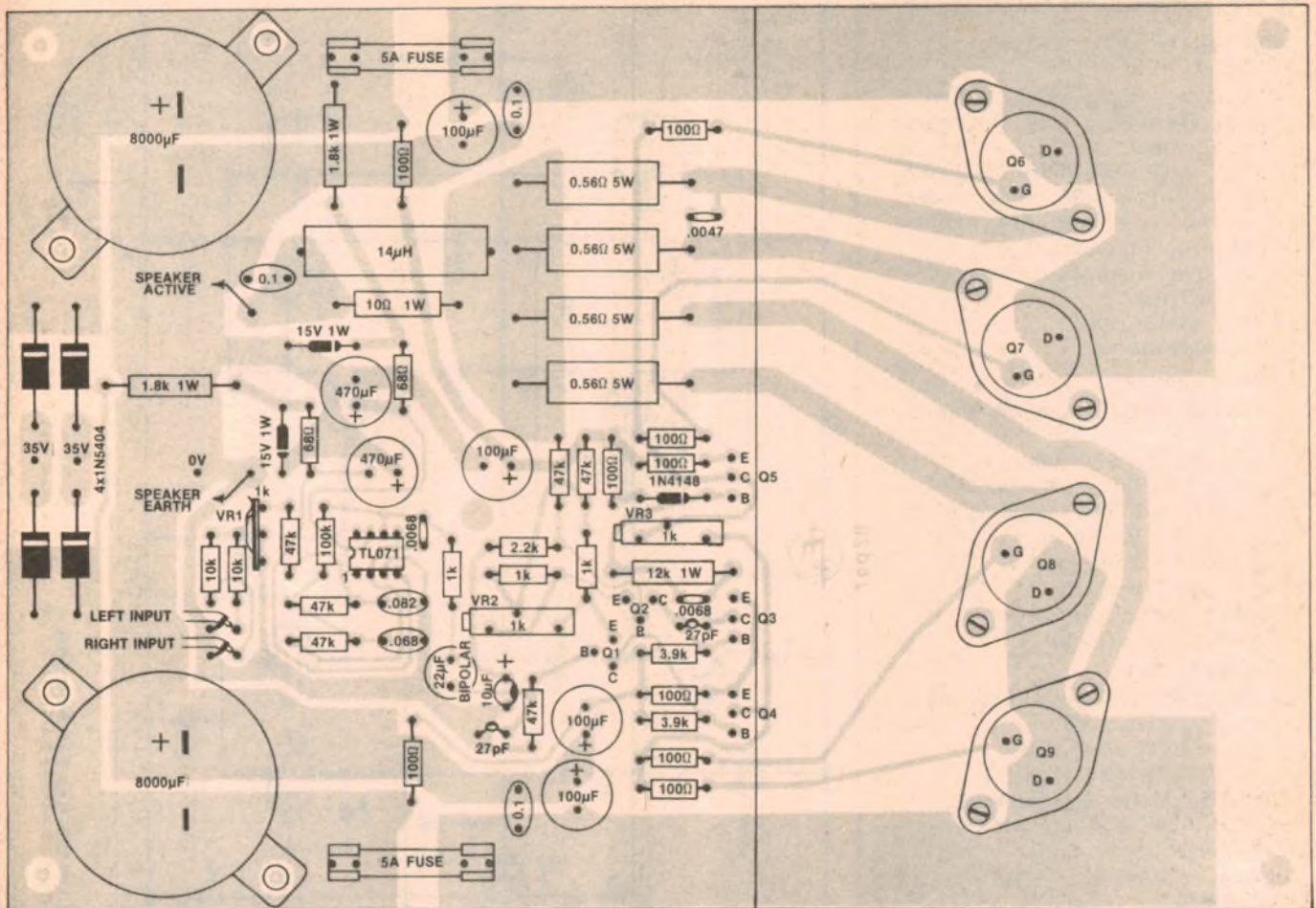

WARNING: Make certain that the polarity of the 8000uF capacitors is correct when they are installed.

rails would have to be increased to about $\pm 65V$. This would mean a considerable increase in the standing heat dissipation of the circuit which would require a far more robust heatsink to be used.

With a 4-ohm load, the amplifier delivers slightly more than 100 watts RMS before the onset of clipping, as shown by the steep rise in the intermodulation figures at around this value. (The harmonic distortion curve for power into a 4Ω load is very similar to the IM curve and so has been omitted for simplicity.) Again, under normal program conditions, the module will deliver up to 120 watts RMS, depending on the heatsink temperature.

Construction

While this module may appear delightfully simple to look at and easy to build, which it is, the construction procedure we suggest must be followed in order to ensure that the unit works and works well. The printed circuit board is critical to the success of the design and its layout is arranged to avoid any in-

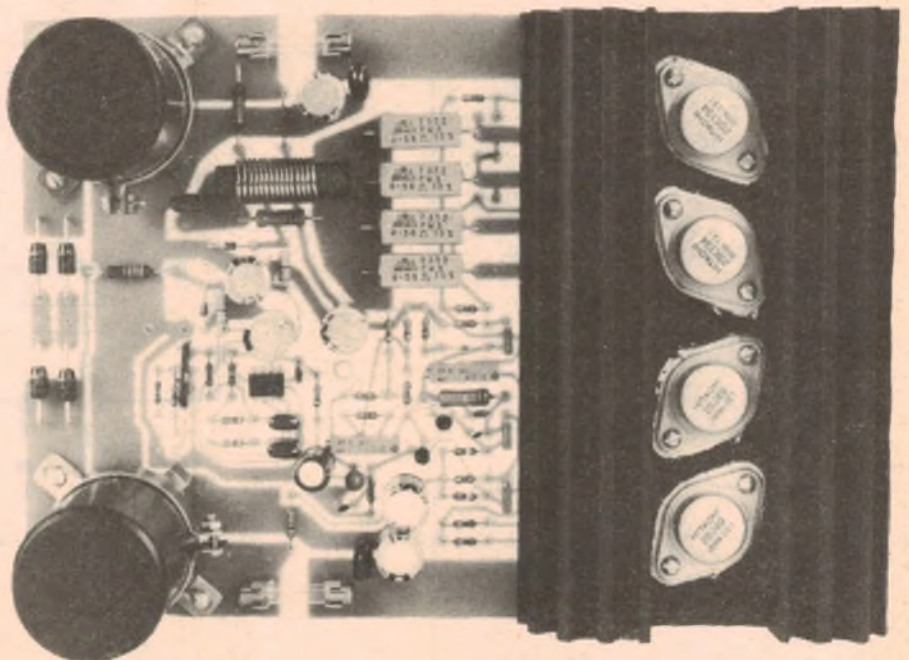

Take care with component polarity, and use a multimeter to check that the Mosfet power transistors are isolated from the heatsink.

ROD IRVING ELECTRONICS

425 HIGH STREET, NORTHCOE 3070, MELBOURNE. (03) 489-8131.

ELECTRONIC COMPONENT SUPPLIERS, DESIGNERS & MANUFACTURERS.
RITRONICS WHOLESALE (03) 489-7099. MAIL ORDERS (03) 481-1436.

TELEX: AA38897

For heavier items add additional postage. Extra heavy items sent Comet freight on. Prices subject to change without notice. Send 60c and SAE for free catalogues. Minimum pack and post \$1.00. Bankcard Mail Orders welcome.

SUPER SPECIALS

2708	\$ 4.50	BU326	\$ 1.80
2718	\$ 4.80	Z80S10	\$21.00
2732	\$ 8.00	1771	\$18.00
8800	\$ 7.90	1791	\$59.00
8802	\$11.00	4118	\$ 1.95
8809	\$22.00	2114	\$ 1.95
8085	\$12.50	TA7205	\$ 3.30
8080	\$ 7.00	100 Red Leds	\$ 9.00
8821	\$ 3.50	BUX80	\$ 3.90
Z80P10	\$ 5.00	BU128	\$ 1.80

CMOS	74C04	40	LF356-AN	1.10	UA4558TC	1.40	7494	90
4000	74C08	40	LF357	1.10	MM5837	2.50	7495	45
4001A	74C10	40	LM358	70	LM7555	1.80	7496	80
4001B	74C14	90	LM373	4.10	MC10116L	95	7497	2.50
4002	74C20	40	LM374	5.40	LF13741	60	74107	80
4006	74C30	40	LM376	70	LF1374-1H	70	74109	70
4007	74C32	40	LM377	2.90	DS75452	60	74116	2.20
4008	74C42	1.10	LM379	5.70	76477	4.90	74121	65
4009	74C48	1.55	LM308 8Pin	1.30	75451	60	74122	45
4010	74C73	75	LM380	75.91	75491	1.40	74123	30
4011	74C74	70	14PIN	1.50	75492	1.40	74125	55
4012	74C76	75	LM318A-N	2.40	TTL (s)	74126	60	
4013	74C83	1.40	LM518N	1.80	74500	80	74132	80
4014	74C85	1.20	LM382N	2.00	74502	80	74141	40
4015	74C86	80	LM383	2.70	74504	80	74145	85
4016	74C90	80	LM384	2.40	74510	75	74147	2.00
4017	74C93	1.40	LM386	1.00	74511	75	74148	1.40
4018	74C95	95	LM387	1.30	74532	75	74150	1.20
4019	74C107	70	LM391	1.80	75551	75	74151	60
4020	74C150	3.40	LM393	80	74574	1.20	74152	4.90
4021	74C151	1.00	LF398	5.00	74586	1.40	74153	70
4022	74C160	90	8038	6.00	745112	1.20	74154	1.20
4023	74C192	90	NE530	1.10	745135	2.20	74155	90
4024	74C164	1.10	OM350	9.90	745138	3.20	8T28	3.00
4025	74C173	1.00	555	40	745157	2.95	9310	65
4026	74C174	80	556	1.10	745158	2.95	9311	1.00
4027	74C175	1.00	LM565	1.30	745187	3.30	9312	1.35
4028	74C192	1.20	LM565CH	2.00	7400 SERIES	74156	1.50	
4029	74C195	1.00	NE566	2.50	7400	40	74157	60
4030	74C221	1.90	LM567	1.50	7401	40	74161	1.00
4031	74C373	1.80	NE571	6.50	7402	40	74162	1.00
4034	74C374	2.00	LM709 14Pin	70	7403	40	74163	85
4035	74C901	90	UA710CA	60	7404	40	74164	60
4039	74C902	90	LM710-CH	90	7405	50	74165	60
4040	74C905	11.20	711	80	7406	50	74174	50
4041	74C906	90	UA711-H	85	7407	50	74175	50
4042	74C907	80	UA716MC	6.25	7408	40	74176	1.10
4043	74C915	1.50	723	50	7409	40	74177	1.10
4044	74C922	6.00	LM723CH	1.10	7410	40	74180	90
4046	74C923	5.00	LM725	3.90	7411	40	74181	2.30
4047	74C925	7.80	LM733	1.20	7412	40	74182	90
4048	74C926	7.80	UA739	2.00	7413	50	74184	1.20
4049	74C927	5.90	741	25	7414	70	74185	1.20
4050	74C932	5.50	LM741 H	1.20	7416	50	74189	1.50
4051	80C SERIES	7417	UA747	1.00	7417	60	74191	1.00
4052	MM80C95	90	UA747MC	2.20	7420	40	74192	1.70
4053	80C96	90	UA748	50	7421	40	74193	80
4060	MM80297	90	UA748MC	1.25	7423	50	74194	1.10
4066	80C98	90	UA753	1.80	7425	45	74195	65
4068	LINEAR	7426	UA760MC	4.10	7426	40	74196	85
4069	LM0002	9.50	UA777	2.40	7427	40	74197	0.5
4070	LM0022CD	16.60	UA777MC	2.65	7430	40	74198	1.10
4071	LM0042CH	8.60	9334	1.70	7432	40	74199	1.30
4072	LM0070	12.70	UA743	1.00	7437	50	74221	90
4073	LM0071	12.70	UA760MC	4.10	7438	50	74290	90
4075	LM071	1.00	UA796MC	1.70	7440	50	73293	90
4076	LM072	1.50	LM802	1.10	7441	1.00	74365	80
4078	LM082	1.50	LM1310N	2.40	7442	50	74366	60
4081	60 SAK140	2.20	1408	4.90	7443	1.40	74367	1.00
4082	60 UAA170	3.50	LM1458	60	7444	1.20	74368	1.00
4083	60 UAA180	3.50	UA1488	1.50	7445	1.10	8T96	1.80
4089	1.00 TCA220	2.20	UA1489	1.50	7446	1.00	9314	1.30
4093	80 LM301	50	MC1495	7.30	7447	1.00	9368	1.75
4503	60 LM301 H	50	MC1496L	11.40	7448	1.00	9370	2.00
4510	1.50 LM304 H	1.70	LM1558	1.50	7450	50	74LS260	90
4511	1.50 LM305 H	80	LM1596	1.40	7451	50	74LS266	90
4512	1.00 LM307 CN	40	LM1380	3.10	7453	40	74LS273	1.60
4514	2.50 LM307 H	90	LM2902	1.40	8126	2.20	74LS279	65
4516	1.40 LM308	70	LM2917	9300	9300	60	74LS283	1.15
4518	1.50 LM308 H	1.20	8PIN	2.80	9307	1.80	74LS290	1.10
4519	55 LM310 N	2.20	LM2917	3.10	9308	1.20	74LS293	1.15
4520	1.60 LM310 H	2.60	CA3028	1.80	7454	60	74LS295	1.60
4522	1.25 311	60	LM3039	90	7472	60	74LS298	1.00
4527	1.20 LM311	1.20	CA3046	1.70	7473	60	74LS299	1.10
4528	1.25 LM311 H	1.20	3065	45	7474	60	74LS311	1.30
4529	1.60 LM318	2.80	LM3080	1.20	7475	60	74LS313	50
4539	1.60 LM322	3.80	LM3089	3.90	7476	60	74LS314	90
4541	1.60 LM324	1.20	CA1301	1.40	7480	65	74LS315	90
4543	2.00 LM325	3.10	CA1301E	1.80	7482	1.80	74LS320	40
4553	5.50 LM329-DZ	1.40	CA1340	1.40	7483	80	74LS321	40
4555	1.00 LM334 Z	1.30	3401	1.10	7485	80	74LS322	40
40097	95 LM335	12.40	3611	1.10	7486	80	74LS313	50
40098	95 LM336 Z	3.20	LM3900	90	7489	2.60	74LS328	40
40175	1.00 LM339	1.00	LM3909	1.00	7490	70	74LS330	40
74C SERIES	LM348	1.10	LM3914N	3.90	7491	55	74LS332	40
74C100	40 LM349	1.80	4136	1.40	7492	60	74LS337	50
74C02	40 LF351-N	70	LM4250	1.75	7493	60	74LS348	50

DIP SWITCHES SPST			18 Pin		1.50		1.40		22.000uf		25V		12.90	
P/N	No. Switches	Price	20 Pin	1.80	1.60	22.000uf	40V	23.00	22.000uf	40V	23.00	27.000uf	35V	23.50
SD3	3	1.60	22 Pin	1.90	1.70	33.000uf	16V	23.50	33.000uf	16V	21.50	68.000uf	10V	20.50
SD4	4	1.70	24 Pin	2.00	1.80	100.000uf	10V	20.50						
SD5	5	1.90	28 Pin	2.20	2.10									
SD6	6	2.30	36 Pin	2.60	2.40									
SD7	7	2.40	40 Pin	2.90	2.70									
SD8	8	2.50												
SD9	9	2.70												
SD10	10	3.00												

WIRE WRAP 3 LEVEL			COMPUTER GRADE ELECTRO.		MICRO CHIPS		MULTISTRAND RIBBON CABLE	
8 Pin	1.00	10-25	2900uf	40V	6.50	10 Way	1.9	10+
14 Pin	1.10	1.00	6800uf	16V	6.40	12 Way	1.00	.80
16 Pin	1.20	1.00	10.000uf	16V	9.00	16 Way	1.20	1.10
			10.000uf	25V	9.50	20 Way	1.70	1.60
			10.000uf	40V	11.90	40 Way	3.20	3.00
			15.000uf	40V	12.00			

74LS40	50	61LS97	2.10	2N5874	1.40	TIP32C	1.00	8295	25.00
74LS42	75	TRANSISTORS		2N5961	30	TIP33A	1.10	DM8578	3.50
74LS47	85	2N301	2.20	2N5963	1.10	TIP34A	1.20	Av-5-2376	19.56
74LS48	1.00	2N657	60	2N6027	60	TIP24B	1.50	8748A	99.00
74LS49	1.00	2N930	60	2N201	90	TIP428	1.10	8755A	99.00
74LS51	40	2N1613	1.10	AC127	70	TIP110	1.30	MC12	90.00
74LS54	50	2N1711	50	AC128	70	TIP120	1.30	MC16	3.30
74LS55	55	2N1893	1.30	AC187	70	TIP2955	1.20	MC1275	1.50
74LS58	65	2N2219A	60	AC188	70	TIP3055	1.20	MC6671	3.00
74LS73	55	PN2222	20	AD149	2.50	VN88AF	2.50	4N28	.85
74									

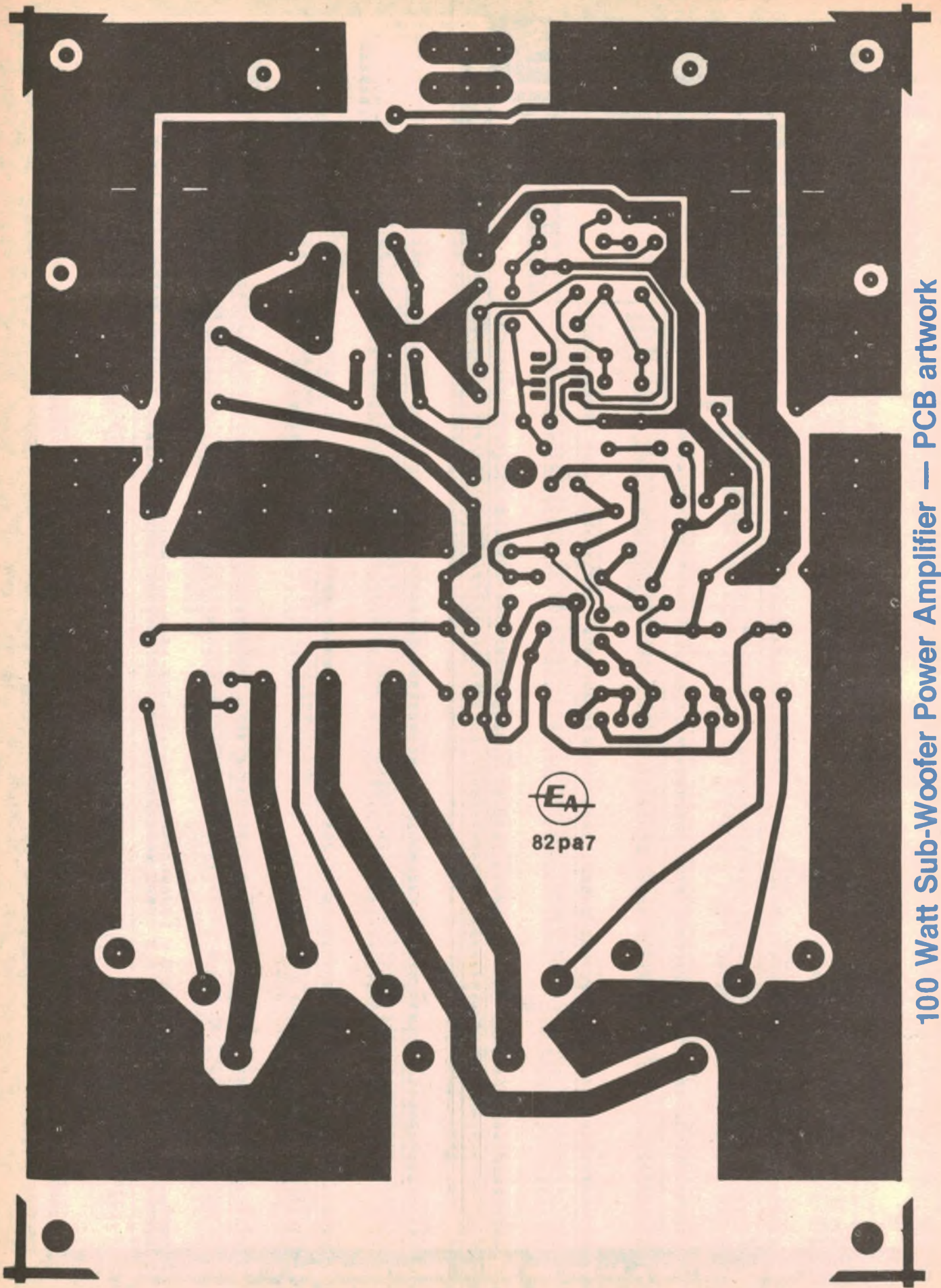

100 Watt Sub-Woofers Power Amplifier — PCB artwork

How to get 50% more sound without turning up the volume.

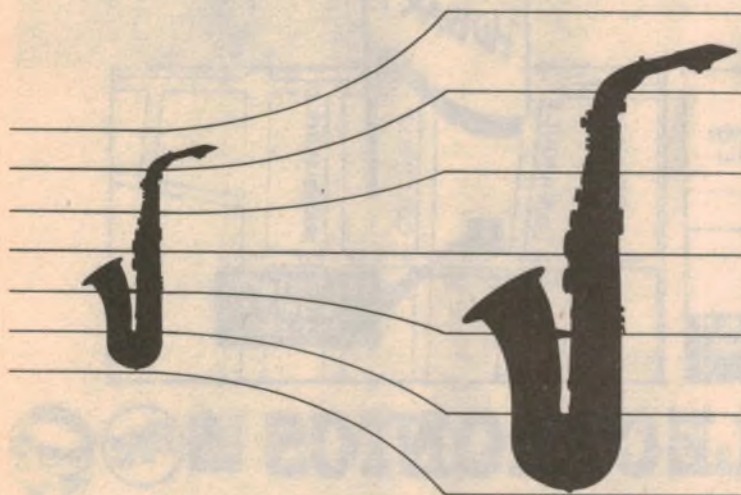

A dbx Dynamic Range Expander restores the music dynamics that were lost in the recording process - giving you up to 50% more sound. The technology is based on a technique originally developed by dbx for professional recording studios.

There's a whole range of sound in a live performance that you never hear from your stereo system. And it's not a question of turning up the volume.

The problem is in the records you play.

When recording engineers master a record, they electronically eliminate up to half the music. They literally compress the sound to make it "fit" on the vinyl record.

Fortunately, there's one solution to the problem: dbx Dynamic Range Expanders.

A dbx Dynamic Range Expander in your system restores most of the lost music. And it reduces annoying record surface noise by as much as 20 dB. So instead of a compressed 50 or 60 dB of dynamic range, you get a full 75 to 90 dB. The loud passages begin to thunder. The softs are truly subtle. All your music comes to life.

And you can use a dbx Dynamic Range Expander not only with your records, but also with tapes and FM broadcasts.

Visit your authorized dbx retailer for a demonstration of the 1BX, 2BX and 3BX Dynamic Range Expanders. Then select the model that's best for your system.

Because there's a lot more to music than has been reaching your ears.

dbx

Making good sound better

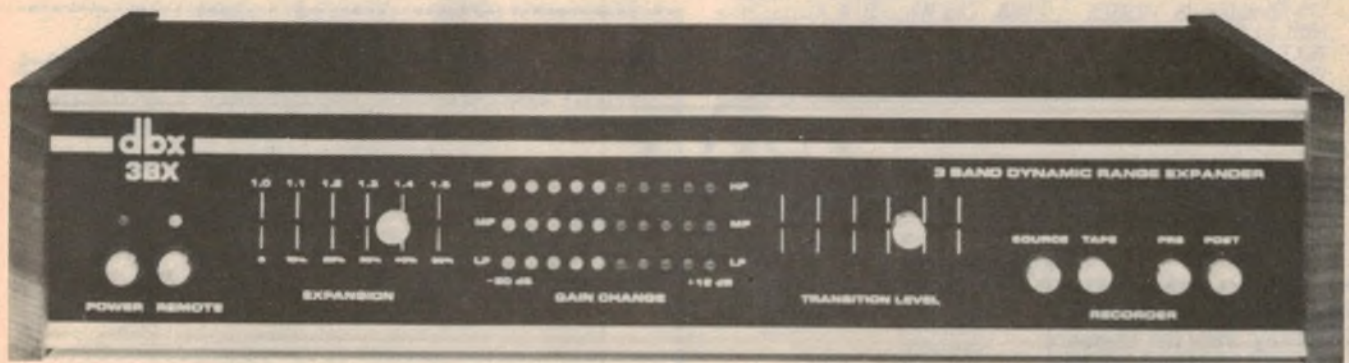

AUDIO ENGINEERS PTY LTD
342 Kent Street
SYDNEY NSW 2000

NOMIS ELECTRONICS P/L
689 South Road
BLACK FOREST SA 5035

AUDIO ENGINEER QLD
47 Castlemaine St
MILTON. QLD 4064

AUDIO ENGINEERS (Vic)
2A Hill Street
THORNBURY. Vic 3071

ATHOL M. HILL P/L
Unit 5, 66 Wellington Street
PERTH WA 6000
HAWKINS AE165

MORE OPPORTUNITIES TO SAVE!

DICK SMITH OPENS 2 NEW STORES

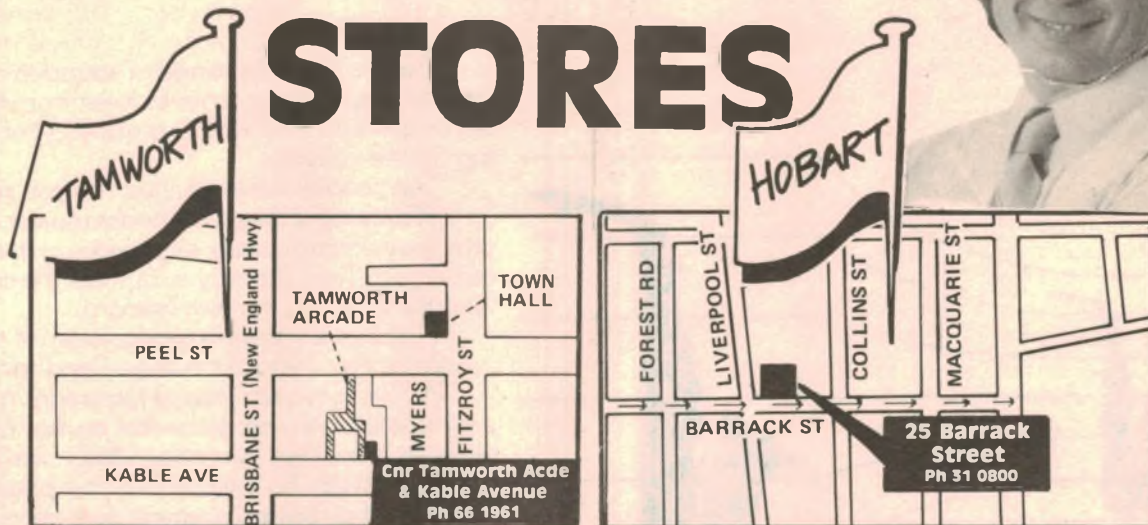

DICK SMITH ELECTRONICS



- NSW 145 Parramatta Rd. AUBURN 648 0558
 T55 Terrace Level, BANKSTOWN SQ. 707 4888
 613 Princes Hwy, BLAKEHURST 546 7744
 552 Oxford St. BONDI JUNCTION 387 1444
 818 George St. BROADWAY 211 3777
 531 Pittwater Rd. BROOKVALE 93 0441
 147 Pacific Hwy. GORE HILL 439 5311
 396 Lane Cove Rd. NORTH RYDE 888 3200
 30 Grose St. PARRAMATTA 683 1133
 125 York St. SYDNEY 290 3377
 Cnr Kable Ave & Tamworth Acde. TAMWORTH 66 1961
 173 Maitland Rd. TIGHES HILL 61 1896
 263 Keira St. WOLLONGONG 28 3800
- VIC 399 Lonsdale St. MELBOURNE 67 9834
 260 Sydney Rd. COBURG 383 4455
 656 Bridge Rd. GEELONG 78 6363
 Cnr Ross Smith Ave & Nepean Hwy. FRANKSTON 783 9144
- ACT 196 Gladstone Rd. FYSHWICK 80 4944
- QLD 166 Logan Rd. BURANDA 391 6233
 842 Gympie Rd. CHERMSIDE 59 6255
- TAS 25 Barrack St. HOBART 31 0800
- SA 60 Wright St. ADELAIDE 212 1962
 435 Main North Rd. ENFIELD 260 6088
 Cnr Main South & Flagstaff Rds. DARLINGTON 298 8977
- WA Cnr Wharf St & Albany Hwy. CANNINGTON 451 8666
 414 William St. PERTH 328 6944

MAJOR RESELLERS

Atherton QLD: Jue Sue's Radio Service, 55 Main St 91 1208 ● Bendigo VIC: Sunnet Electronics 7 Edward St 43 1977 ● Ballina NSW: A Cummings & Co. 91-93 River St 86 2285 ● Broken Hill NSW: Crystal TV Rentals, 166 Argent St Ph 6897 ● Cairns QLD: Thompson Instrument Services, 79-81 McLeod St 51 2404 ● Coffs Harbour NSW: Coffs Hbr Electronics, 3 Coffs Plaza, Park Ave 52 5684 ● Darwin NT: Kent Electronics, 42 Stuart Hwy 81 4749 ● Darwin NT: Ventronics, 24-26 Kovanagh St ● East Maitland NSW: East Maitland Electronics, Cnr Laws & High Sts 33 7327 ● Geraldton WA: KB Electronics & Manne, 361 Main Terrace 21 2176 ● Gosford NSW: Tomorrow Electronics, 68 William St 24 7246 ● Kingston TAS: Kingston Electronics, Channel Court, 29 6802 ● Launceston TAS: Advanced Electronics, 50 The Quadrant, 31 7075 ● Lismore NSW: Decro Electric, Magellan St & Brunner Hwy, 21 4137 ● Mackay QLD: Stevens Electronics 42 Victoria St 51 1723 ● Maryborough QLD: Keller Electronics, 218 Adelaide St 21 4559 ● Mt Gambier SA: Hutcheson's Comm 5 Elizabeth St 25 6404 ● Mildura NSW: McWilliams Electronics, 40 Lemon Ave 23 6410 ● Nambour QLD: Nambour Electronics, Shop 4 Lowan House, Ann St 41 1604 ● Newcastle NSW: Elektron 2000, Shop 18, Hunter Shopping Village 26 2644 ● Orange NSW: M & W Electronics, 173 Sumner St 62 6491 ● Penrith NSW: Acom Electronics, Shop 12, 541 High St 36 1466 ● Port Macquarie NSW: Hall Of Electronics, 113 Horton St 83 5486 ● Rockhampton QLD: Purely Electronics, 15 East St 21 058 ● Southport QLD: Amateur's Paradise, 121 Nerang St 32 2644 ● Tamworth NSW: Sound Components, 111 Bridge St 32 9677 ● Toowoomba QLD: Hunts Electronics, 18 Neil St 32 9677 ● Townsville QLD: Tropical TV, 49 Fulham Rd Vincent Village, 79 1421 ● Traralgon VIC: Power 'n Sound, 147 Argyle St 74 3638 ● Wagga NSW: Wagga Wholesale Electronics, 82 Forsyth St ● Wodonga VIC: A & M Electronics, 78a High St 24 4588 ● Whyalla SA: Mellor Enterprises, Shop 2, Forsyth St 45 4764

THESE ARE OUR MAJOR DEALERS. HOWEVER WE CANNOT GUARANTEE THEY WILL HAVE ALL ITEMS IN STOCK AND AT THE PRICES ADVERTISED

Dear Customer,

Quite often, the products we advertise are so popular they run out within a few days. Or, unforeseen circumstances might hold up goods so that advertised lines are not in the store by the time the advert appears. Please don't blame the store manager or staff: they cannot solve a dock strike on the other side of the world, or even locate a shipment that has gone astray. What we are trying to say is that if you are about to drive across town to pick up a particular line at a Dick Smith store, why not give the store a ring first - just in case! Thanks



Dick Smith and Staff.

SHOPS OPEN 9am to 5.30pm (Saturday: 9am till 12 noon) BRISBANE: Half hour earlier. ANY TERMS OFFERED ARE TO APPROVED APPLICANTS ONLY

POST & PACKING CHARGES

ORDER VALUE	CHARGES
\$5.00 - \$9.99	\$1.40
\$10.00 - \$24.99	\$2.40
\$25.00 - \$49.99	\$3.50
\$50.00 - \$99.99	\$4.60
\$100.00 or more	\$6.20

Charges for goods sent by post in Australia only not airmail, overseas or road freight

MAIL ORDERS SEND TO: DICK SMITH ELECTRONICS PTY. LTD. P.O. BOX 321, NORTH RYDE N.S.W. 2113 AUSTRALIA
 Prices and availability of stock of all items advertised in Dick Smith ads in this magazine are correct at time of going to press.

Please send copies of the 1982 Dick Smith Electronics Wholesale Catalogue. I enclose cheque, money order for \$ (\$1.25 each catalogue).

NAME

ADDRESS

POSTCODE

Please add my name to your mailing list to receive regular monthly specials
SEND TO: PO BOX 321 NORTH RYDE NSW 2113

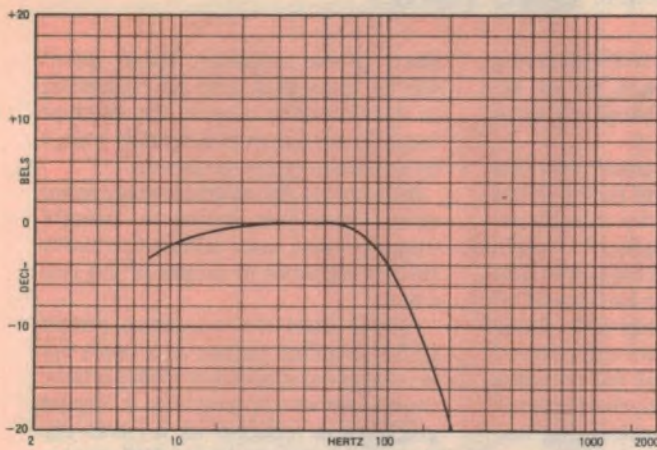

Above is the frequency response curve of the low pass filter stage, while at right are the distortion versus frequency curves for the power amplifier stage.

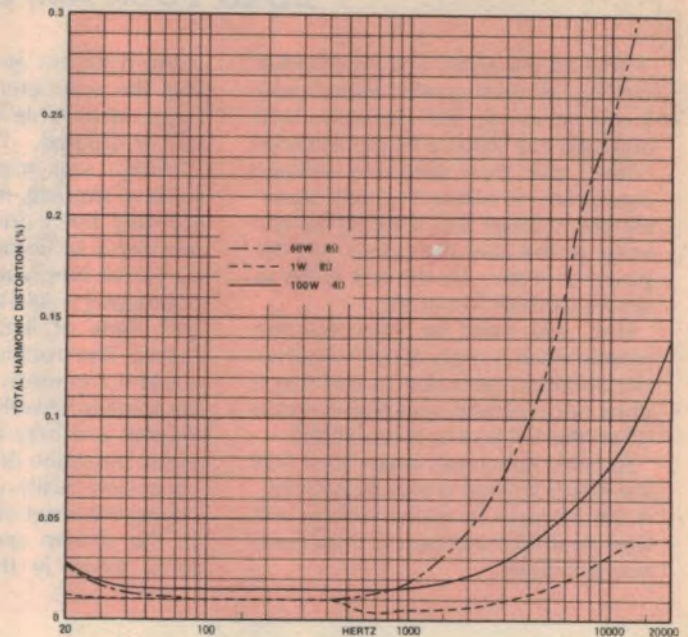

Below: power output versus distortion for the power amplifier stage. Maximum output is 70W RMS continuous into 8 ohms.

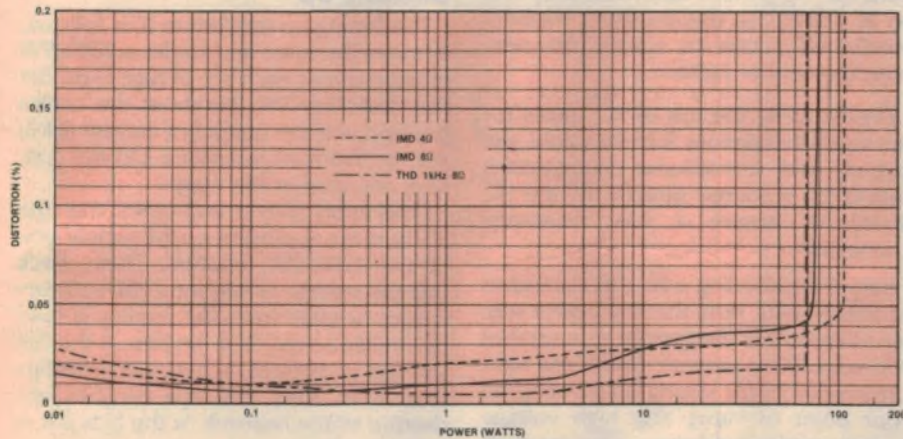

teraction between output and input currents.

All the amplifier circuitry, including the power supply components, is accommodated on a large PC board measuring 228 × 170mm and coded 82pa7. This also accommodates the heatsink for the four Mosfet transistors. The single-sided heatsink is 170mm long and 105mm long and is adequate for typical program material peaking at full power.

If you intended using the amplifier

module in a more rigorous application such as for stage use, a much bigger heatsink or fan cooling will have to be employed.

Multi-turn trim pots are provided for adjustment of quiescent current and output offset voltage. We have not made provision for single turn trim pots in these positions as they are considerably more difficult to adjust.

We assume that kitset suppliers will provide drilled heatsinks but if they do

not, you should use the copper pattern of the PCB as a template for marking the heatsink hole positions.

Make sure that the heatsink is completely deburred before mounting it and the output transistors on the PC board. Follow the drawing of the heatsink assembly cross-section to assemble the insulating washers and bushes. The bushes surrounding the mounting bolts are standard mounting bushes with the integral washer removed (with a razor blade). These washers are used later so do not throw them away.

With a smear of heatsink compound on each side of the mica washer, assemble each transistor onto the heatsink and PC board, tighten up the screws and solder the nuts to the copper. It is a good idea not to solder the source and drain leads yet, just in case the insulation is faulty and the Mosfet has to be removed.

Check the insulation of each Mosfet from the source (case) to heatsink with an ohmmeter as you finish mounting each one. If there is a short circuit, repair the fault immediately as it is difficult to find the fault when they are all assembled. Retighten the Mosfets after the heatsink compound has time to spread under pressure and recheck the insulation.

With those checks complete, solder the drain and gate leads of the Mosfets and then proceed with assembling the other smaller components onto the PC board.

When mounting the 5W resistors, solder them with at least 1mm spacing above the PCB to allow cooling and to avoid their charring the board. Take care in orienting the polarity-conscious com-

Power Mosfet mounting method

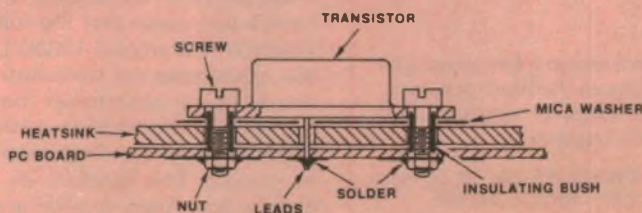

DOES YOUR AMPLIFIER GIVE 100W?

How do you verify that an amplifier delivers its rated power? Superficially it is quite simple. Just connect a load and feed in a signal until the amplifier "clips" and then take the voltage measurement across the load. Squaring the voltage and dividing by the value of the load then gives you the power in watts. Ah, but is it really as simple as that? Not at all!

First, you must be sure that the resistive load is really 8Ω (or whatever the nominal load value is) and that it does not overheat and rise in value when the full power is dissipated.

Second, you must make sure that the mains voltage is exactly 240VAC. A 5% increase in mains voltage will lead to a 10% increase in maximum power output.

And it almost goes without saying that the voltmeter must be as accurate as possible because any error will be squared.

Thirdly, you must determine the onset of clipping. In the past this has normally been done by visually inspecting a CRO for signs of "flattening" of the sinewave at the peaks. The input signal would then be backed off until signs of flattening just disappeared. The trouble with this method is that it can mean that the amplifier can actually be well into the region of clipping and may be producing harmonic distortion of 1% or 2%.

The only really consistent way of judging the onset of clipping is to look for the sudden appearance of additional spikes in the distortion pro-

ducts of the amplifier. These spikes will be consistent with any flattening of the sinewave output. The method requires access to a distortion bridge or audio spectrum analyser.

By ignoring the methodology listed above and just taking a "rough" measurement, your results can easily be 20% or more in excess of the real value.

Finally, does the maximum power of the amplifier reduce as it heats up? As explained elsewhere in this article, the "onset of clipping" for a Mosfet amplifier is reduced as it heats up, due to reducing transconductance. This effect is quite significant and can easily reduce the power output by more than 10% (after taking all the above effects into account).

ponents such as the diodes, transistors and electrolytic capacitors.

Wind the $14\mu\text{H}$ choke to the specification in the parts list and clean the ends of the winding before tinning and soldering the unit to the PC board.

Make sure the holes for the $8000\mu\text{F}$ capacitors are correctly positioned and of the right size. The bracket for the negative supply capacitor must be rotated to fit the board mounting holes. Make sure that polarity is correct as you install these capacitors as it is not possible to check once the capacitors are in place. If you apply reverse voltage to large capacitors such as these they will be wrecked and will spray nasty vapour all over the place!

The securing screws for the capacitor mounting brackets must be isolated

from the PC pattern otherwise they will be at $\pm 50\text{V}$. Use the insulating washers mentioned above to isolate the nuts from the copper pattern.

Finally, while the use of PC stakes for the input connections is permissible, the output and transformer connections should be soldered directly to the PC board to ensure a low resistance connection.

Before proceeding with the discussion of adjustments, note that the power supply voltages are dangerous, as a total of 100 volts DC is present. Under the right circumstances (or wrong, depending on your point of view), this high voltage power supply could give a nasty or even lethal shock. So be very careful and treat this module with the respect it deserves.

Setting up

The setting up procedure is as follows: Remove the fuses and solder a $220\Omega/5\text{W}$ resistor across each set of fuse clips. Set the offset pot VR2 to about the centre position and the quiescent current (VR3) pot to minimum resistance. Do not connect any load at this stage.

Now apply power and check that the $\pm 50\text{V}$ rails are present on the supply side of the $220\Omega/5\text{W}$ resistors. Then check that the voltage across the 220Ω resistors is zero or quite low. The reading should be similar across each resistor. If the full voltage is present across the fuseclips then it is likely that the Mosfets are shorted to the heatsink or the bias pot is open-circuit.

Now adjust the bias trimpot (VR3) to obtain 13 volts across each 220Ω resistor. This coincides to a total of 60mA quiescent current in the output stage or 30mA for each Mosfet. If you have a digital multimeter you can check that each Mosfet is sharing the quiescent current equally by checking the voltage across each $0.56\Omega/5\text{W}$ resistor. It should be about 17mV.

Adjust the offset trimpot for zero voltage at the amplifier output. This can more easily be done with a digital multimeter but if you do not have one you can first do a coarse check with your multimeter on its lowest voltage range. Then switch to the lowest current range (which will mean that the full scale sensitivity is now around 100mV) and repeat the adjustment for minimum voltage. It should be possible to set the voltage to be less than or equal to $\pm 20\text{mV}$.

Next month we will give details of how to mount the module in a suitable chassis and team it with a sub-woofer enclosure.

3



MICROPROCESSORS & PERSONAL COMPUTERS

Order your copy now!

Microprocessors and personal computers, little more than a dream a few years ago, are now changing the face of electronics. This book introduces the basic concepts, describes a selection of microprocessor and personal computer systems, and details a build-it-yourself computer designed especially for beginners.

Available from "Electronics Australia", 57 Regent St. Sydney. **PRICE \$5.00** OR by mail order from "Electronics Australia", PO Box 163, Chippendale, 2008. **PRICE \$5.90.**

LOW COST-BUT JAYCAR QUALITY

THE ONLY THING THAT JAYCAR DOES'NT DISCOUNT IS QUALITY!!!

ETI 498 150(RMS) P.A. AMP

Ref: ETI JUNE 1982



Featuring 150W Mosfet power, Automatic microphone level, 100/70V line-out. Jaycar has all the parts for this much-sought-after project.

ETI 499 Mosfet module	\$79.50
PF4361/1 Power transformer (or sim)	\$39.50
ETI 498 Module	\$39.50
K2W C-1284 Case	\$16.50
300mm Heatsink	\$11.95
OP 590 Line out transformer	\$45.00

Lyrebird Piano Kit REF: EA 11/81-1/82 NEW LOW PRICE



\$475
SAVE \$50!!!

NEW LOW PRICE!! Because we are shipping keyboards and other expensive components in bulk due to high demand, we can pass savings on to YOU. You can now have a magnificent "Lyrebird" six octave touch sensitive piano for only \$475! That's a staggering \$50 off the old price. **REMEMBER!! THE LYREBIRD OUTPERFORMS READY BUILT PIANOS COSTING UP TO THOUSANDS OF DOLLARS MORE. WHY PAY MORE WHEN YOUR CONSTRUCTION KNOWLEDGE CAN SAVE YOU A FORTUNE?**

7% OCTAVE (88 NOTE) VERSIONS \$589

* Stand \$75 extra

EXPERIMENTER BREADBOARDS

As many disappointed customers are aware, we have been unable to keep up with demand. We now have ample stocks with an extended range.

WB. DN- TOTAL 100 HOLES	\$2.50
WB. TN- TOTAL 640 HOLES	\$8.95
WB. 2N- TOTAL 840 HOLES	\$12.95
WB. 4N- TOTAL 1680 HOLES	\$24.50
WB. 6N- TOTAL 2420 HOLES	\$39.50

We also have a small quantity of US Made "Continental Specialties" Experimenter Boards at up to 50% off! Hurry! Personal shoppers only.

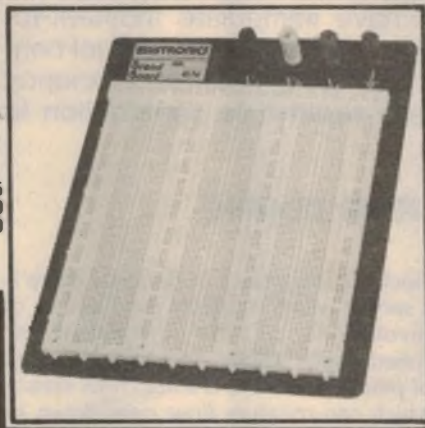

'TEX TOOL'



\$12.50

24 PIN Zero-Insertion Force I.C. Sockets. Great for E-PROM Burners etc.

SUBWOOFER



This unit has been extremely popular with audio enthusiasts right across Australia! EA have designed a special crossover/boosted amp just for this unit. Now you have no excuse to build a subwoofer system to enjoy those thrilling low notes from pipe organs, synthesizers, 1812 cannons etc!!

SPECS:

Diameter 10" (250mm) Cast frame
QT = 0.39 VAS = 63l
Power handling - 100WRMS
Free Air Resonance - 32Hz ± 1Hz
Voice Coil - 2" (51mm) DIA
Magnet Assy - 3kg (6.6 lbs)

ONLY \$79-50

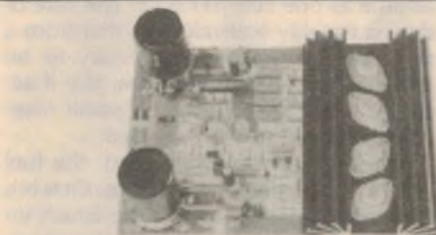

Speaker cabinet design provided FREE with each unit!!!

Amplifier/crossover to suit subwoofer

Ref: EA JULY 1982

State-of-the-art power Mosfet technology combined with an active low pass filter results in a subwoofer amp without equal anywhere!!

FEATURES: Around 100WRMS Drive capability
Low pass (subwoofer) filters on board.
Can hook up to preamp out or poweramp out.
Power supply on board.
(Transformer needed. ONLY \$39.50)

ONLY \$79

vocal canceller

* Ref: EA April 1982

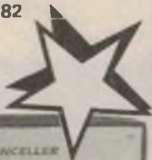

This project enables you to cancel out a singers voice on a record so that you can insert your own.

BE A STAR FOR ONLY

\$19.50

GUITAR BOOSTER FOR STEREO AMPS

REF: EA JUNE 1982

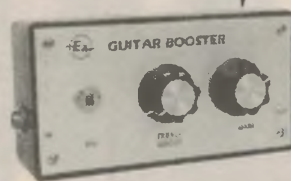
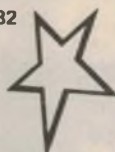

Use your Electric Guitar on your home Hi-Fi. Saves you the expense of a practice amp.

Complete kit - ONLY \$ 14.50

syntom

Original design from the UK magazine "Electronics and Music Maker" April 1981. Self-contained unit produces a variety of fixed and falling pitch effects. Trigger by tapping the unit itself or by striking a drum to which the unit is attached. The Jaycar SYNTOM comes complete with high quality pre-moulded all ABS box 152 x 80 x 47mm with professional silk-screened front panel.

FEATURES: Decay from less than 0.1 second to several seconds; pitch control, sweep control and volume on off!



Only **\$32.50**

THIS MONTH ONLY!! SAVE \$4.00

Jaycar

125 YORK ST SYDNEY 2000

Ph. 2646688 Telex 72293

Mail Orders To:

Box K-39 Haymarket 2000

Post and Packing charges



NEW SHOP HOURS

Mon-Fri 8.30 to 5.30pm

Sat 8.30 to 1.00pm

Thurs night to 8.30pm

\$5-\$9.99 (\$1.20) \$10-\$24.99 (\$2.40)

\$25-\$49.99 (\$3.50) \$50-\$99.99 (\$4.60)

\$100 up (\$6.20)

CAR COMPUTER PART ONE

With this Car Computer you will have immediate moment-to-moment feedback on the effect of your driving habits on fuel consumption. You will be able to drive your car at optimum efficiency for all driving conditions and make a worthwhile contribution to energy conservation.

by LEO SIMPSON and JOHN CLARKE

At present, there are only a few cars which can be purchased with a dashboard computer and there is only one car computer, that we know of, which can be fitted as an accessory. That is about to change, particularly now that "Electronics Australia" has designed this computer to suit locally available cars and components. That means this computer is equally suited to measuring the fuel consumption of gas guzzlers and sippers — the economical four-cylinder cars which are becoming ever more popular.

The EA Car Computer uses a microprocessor and other supporting integrated circuits to keep track of three parameters: *time*, *distance* and *petrol flow*. To keep track of time, the car computer has its own crystal controlled

clock. To keep track of distance, there is a sensor which monitors the number of revolutions of the drive-shaft or speedometer cable. And to keep track of petrol flow there is a fluid flow sensor which can measure flow rates down to as little as one litre per hour! This rate of flow is roughly equivalent to that from a fast dripping tap! It is necessary to be able to measure this very low rate if accurate fuel consumption of small four-cylinder cars is to be recorded.

Depending on the type used, the fuel sensor can be one of two forms. One is a miniature turbine with a vane which interrupts a beam of light to a phototransistor. The other type uses a ball running in a circular race to also interrupt a beam of light to a phototransistor.

There are also two types of sensor for distance. One uses a coil placed close to magnets on the spinning driveshaft. The other uses a vane attached to the speedo cable to interrupt a beam of light to a phototransistor.

By keeping track of the above three parameters, the Car Computer is able to give readings of 11 separate functions from its four-digit seven-segment display. These are called up by pressing one or two of the 12 colour-keyed buttons and the function being displayed is indicated by LEDs above the buttons which have just been pushed.

All the functions are continually updated by the computer, regardless of the function actually being displayed. In order to display these functions, the computer is initialised at the start of each journey. This sets the clock to zero. The length of the journey to be taken is entered and if petrol has just been purchased, this is entered in too. If the journey to be taken is identical to the previous journey the computer will be automatically initiated with this information, since its memory circuits are permanently energised.

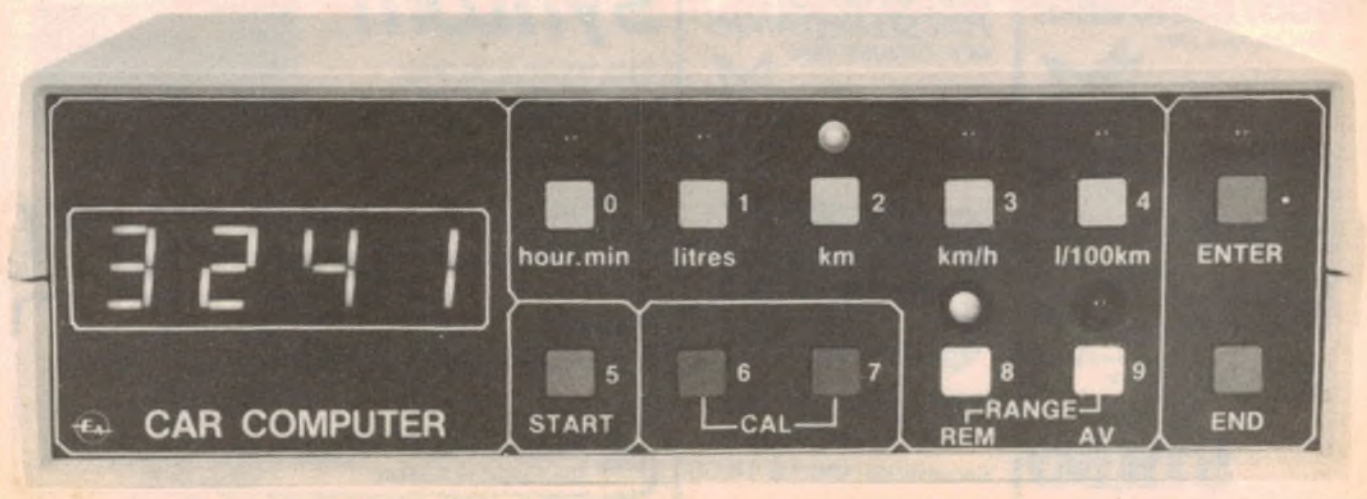

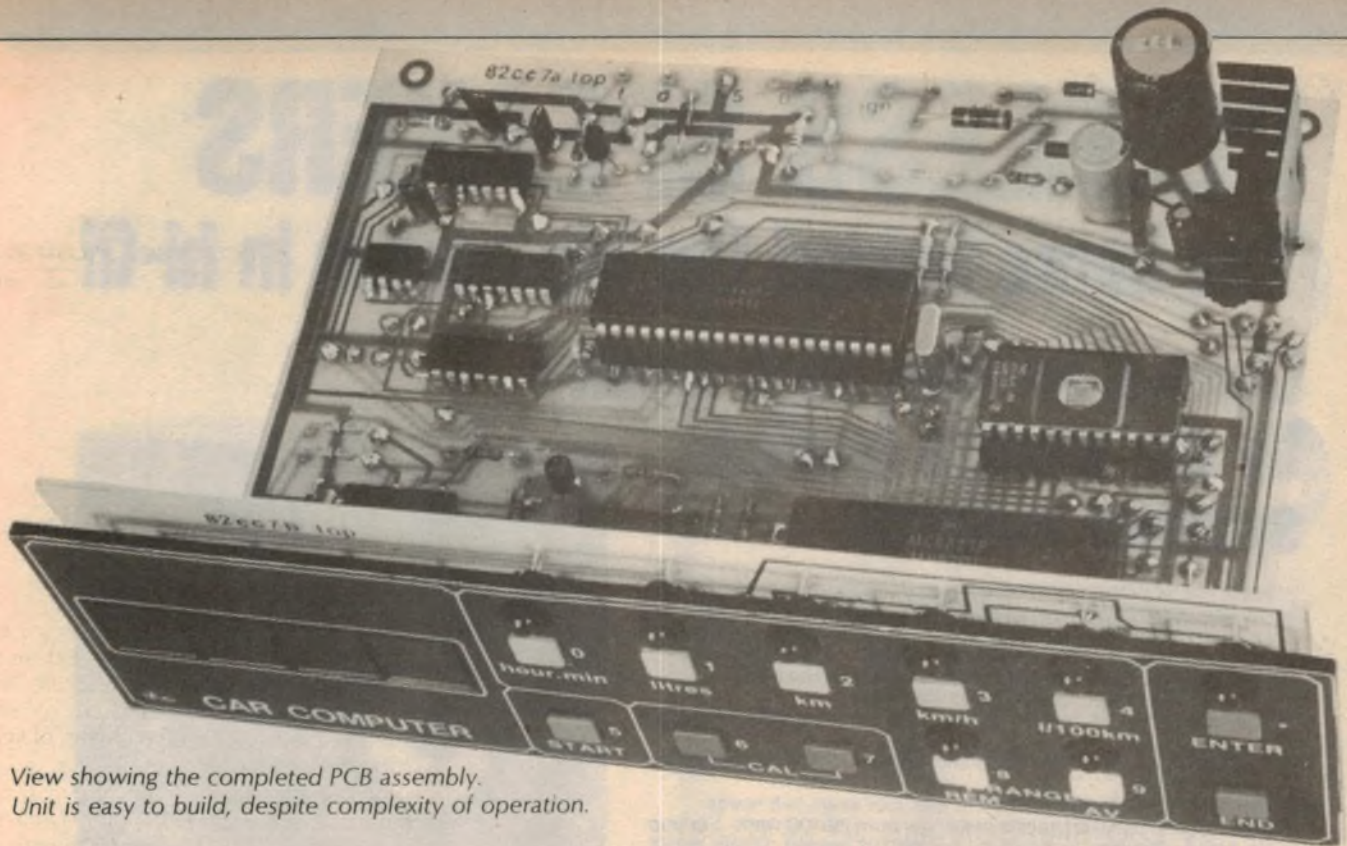

View showing the completed PCB assembly.
Unit is easy to build, despite complexity of operation.

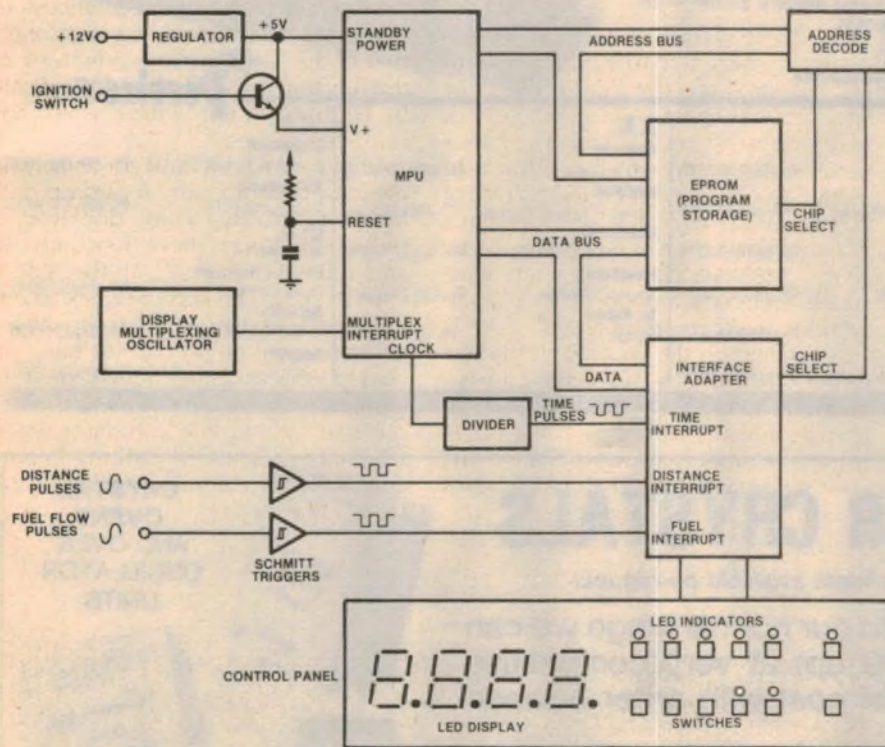

This block diagram shows the general concept of the Car Computer.

Functions

Twelve separate values can be displayed, as follows:

- hour. min – elapsed time. This is the time in hours and minutes since the start of the journey. The reading is updated every minute and the decimal point after

the hours digit flashes at a one second rate.

- This is called up by pressing button "0".
- hour. min REM – time remaining. This is the time in hours and minutes which will be required to complete the journey at the present average speed recorded since the start of the journey. Again, the

decimal point flashes at a one second rate and the reading is updated with every kilometre covered or every minute. This is called up by pressing buttons "0" and "8".

- litres – fuel used. This is the amount of fuel consumed since the start of the journey. This is displayed in litres with 0.1 litre resolution. The reading is updated for every 0.1 litres of fuel consumed. This is called up by pressing button "1".

- litres REM – fuel remaining. This, as you might expect, is the amount of fuel remaining in the tank, not allowing for losses by leakage or evaporation. Again it is displayed in litres with 0.1 litre resolution and updated for every 0.1 litres of fuel consumed. This is called up by pressing buttons "1" and "8".

- litres REM RANGE – capacity of fuel tank in litres. This is called up by pressing buttons "1" and "9".

- km – distance travelled. This is the distance travelled since the "START" button was pressed. This can record a maximum trip length up to 9999 kilometres over a period of several days, weeks or months, as this information is stored whether the ignition is on or not. The reading is updated with every kilometre travelled and is called up by pressing button "2".

- km. REM – distance remaining of journey. Updated every kilometre travelled and called up by pressing buttons "2" and "8".

- km REM RANGE – distance that can

PEERLESS SPEAKERS

The name behind the big names in hi-fi!

Chosen for their high quality by the world's leading speaker makers!

Peerless is a world authority on loudspeaker design. In fact, many of the world's top hi-fi manufacturers select Peerless speaker components for inclusion in their own Brand Speaker Systems. Made in Denmark, Peerless speakers are incomparable for their high-power handling, smooth frequency response, low distortion and colouration.

Peerless speakers can be purchased three ways:—

1. Fully-assembled in timber cabinets — from bookshelf to floor-standing models.
2. Speaker Kits — build-it-yourself and save up to 40% on assembled speaker prices.
3. Individual speaker components to suit your exact hi-fi needs.

Peerless makes speakers to suit amplifiers from 20-100 watts. For true-to-life sound, Peerless is the name behind the biggest names in hi-fi. Hear Peerless speakers at one of the authorised dealers below — or contact the sole importer for full technical details.



Sole Australian Importer: G R D GROUP PTY LTD
698 Burke Road, Camberwell, Vic. 3124. Trade Enquiries welcome



N. S. W.	VIC.	S. A.	W. A.
Bondi Junction Danish Hi-Fi Aust Pty Ltd Ph (02) 387 5878	Ballarat Turner Audio Ph (053) 32 2042	Adelaide Hi-Fi Acoustic Ph (08) 223 6774	Claremont Danish Hi-Fi Aust Pty Ltd Ph (09) 384 2852
Concord Electronic Agencies Ph (02) 745 3077	Camberwell Danish Hi-Fi (Aust) Pty Ltd Ph (03) 82 7348	Adelaide Danish Hi-Fi Aust Pty Ltd Ph (08) 51 2124	Kalamunda Kalamunda Hi-Fi Ph (09) 293 4333
Crows Nest Deeva Hi-Fi Ph (02) 439 3999	Cheltenham Beland Electronics Ph (03) 550 2279	Goodwood The Acoustic Foundry Ph (08) 271 0276	QLD. Brisbane Brisbane Agencies Audio Centre Ph (07) 221 9944
Dee Why David Ryall Electronics Ph (02) 982 7500	Geelong Steve Bennett Audio Ph (052) 21 6011	Hawthorn Sound Craftsmen Ph (08) 272 0341	Barunda G Mills Stereo Ph (07) 391 5606
Wagga Wagga Car Radio & Hi-Fi Centre Ph (069) 21 4618	Hawthorn Twoli Hi-Fi Ph (03) 818 8637	St. Peters Miltronix Ph (08) 42 3781	Redcliff Hi-Fi Sales Ph (07) 284 2495
	Warrnambool Bruce Henderson Audio World Ph (055) 62 5147		

★ BRIGHT STAR CRYSTALS

Specifications, Dimensions and data sheets available on request

BULK ORDERS: In addition to our normal range we can supply quantity orders (100 up) at very competitive prices. All we ask is 50% of cost with order balance 30 days.

DELIVERY: 5-6 weeks from receipt of Order. Ring for quote: (03) 546 5076. Telex: AA 36004.

NEW NSW AGENT: APP Master Communications, Sydney (02) 682 5044

BRIGHT STAR CRYSTALS

35 EILEEN RD, CLAYTON, VIC
ALL MAIL TO: PO BOX 42, SPRINGVALE 3171



WATCH CRYSTALS

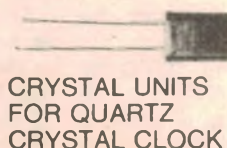

CRYSTAL UNITS FOR QUARTZ CRYSTAL CLOCK

CRYSTAL OVENS AND OVEN OSCILLATOR UNITS



CAR COMPUTER

be travelled in kilometres. This is based on the number of litres left in the fuel tank and on the average fuel consumption since the beginning of the journey. This is updated for every kilometre travelled or for every 0.1 litre of fuel used. Called up by pressing buttons "2" and "9".

- km/h — speed in kilometres per hour. This is updated every one second and is called up by pressing button "3".

- km/h AV — average speed. This is based on the elapsed time of the journey and distance travelled, since pushing the Start button. This is updated every minute or every kilometre travelled.

- l/100km — instantaneous fuel consumption. Gives the fuel consumption for every one or eight-second period, depending on the fuel sensor used. Press button "4".

- l/100km AV — average fuel consumption for journey, based on fuel used so far and distance travelled. Updated every kilometre travelled or 0.1 litres used. Press buttons "4" and "9".

Data entry

Data is entered into the Car Computer by pushing three buttons, START, ENTER and END. When the START button is pressed the computer displays "rEdY" and zeros the following functions: elapsed time, fuel used and distance travelled. It also enters in the previous journey, ie, km REM.

To change data in the computer, such as the amount of fuel in the tank, the ENTER button is pressed and this changes the function of all buttons (except END) to numerical data entry. The ENTER button itself is the decimal point.

When you have the correct data shown on the display, pushing the END button loads it and reverts all the buttons to their normal functions. If you have made an error in your data values, such as not entering the decimal point for the fuel quantity, the data will not be entered when you press END and the display will show "F. Err" which signifies an error in the fuel quantity. Brilliant, isn't it?

Calibration

Two buttons are provided for calibrating the sensors. Button "6" calibrates the fuel sensor (using the ENTER procedure briefly described above). Here the user enters the manufacturer's stated number of pulses per litre.

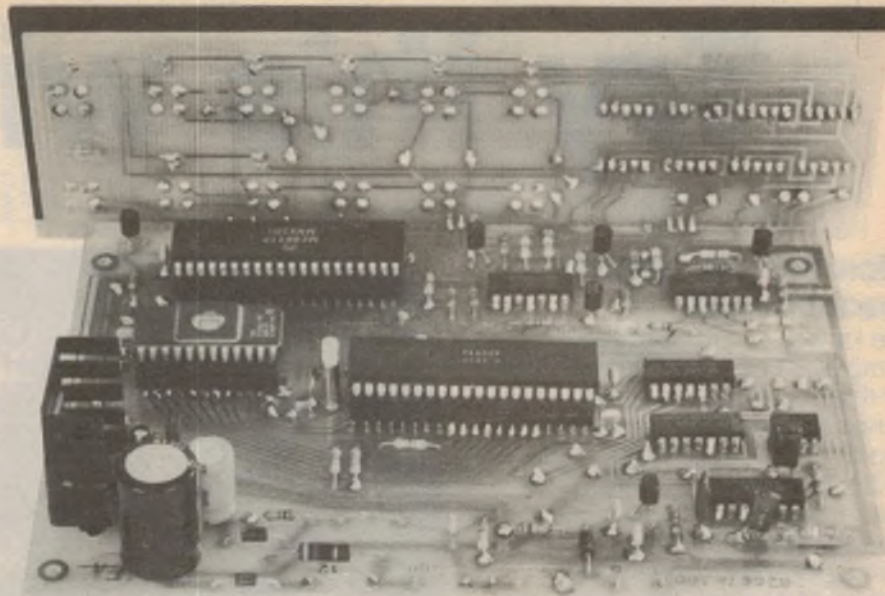

All the circuitry is accommodated on two double-sided printed circuit boards which are soldered together at right angles. Apart from connections to the sensors and battery, there is no discrete wiring.

Button "7" calibrates the distance sensor and this is done by trial and error between kilometre posts during an on-road test. Thus the Car Computer is not subject to the vagaries of normal car speedometers. Note though that the Car Computer does not take into account the varying effects of tyre slip — this can only be accounted for by using a fifth wheel.

Presentation

The Car Computer is housed in a compact and smart cabinet which will look well on or in the dash or console of any car. The front panel is black with labelling in white for easy legibility. The LED readouts have integral red filters for ease of visibility in high ambient light.

Inside there is almost no wiring at all with all the circuitry accommodated on two double-sided PC boards. A vertical board accommodates the LED readouts, eight LEDs and 12 pushbuttons while the larger horizontal board accommodates the integrated circuits.

All the connections from the Car Computer to the car battery and external sensors are made via a quickly detachable multi-way plug and socket. In fact, if you were so inclined, it would be possible to transfer the Computer from one vehicle to another, provided each vehicle was fitted with sensors.

Hardware

The total semiconductor complement is really quite small, as can be seen from

the accompanying photographs. Apart from the previously noted four LED readouts and eight LEDs, there are three major integrated circuits and six minor, one 5V regulator, seven transistors and four diodes.

The block diagram shows the general concept of the Car Computer. The eight-bit microprocessor is the Motorola 6802 which is a variant of the well-known 6800 which has 72 instructions and six different addressing modes (see the series on "How to Program in Machine Language" beginning March 1982). The 6802 has all the facilities of the 6800 and has a built-in clock and a divide-by-four circuit to allow an external 4MHz clock to be used. In our particular case, the clock runs at 3.579MHz. Also incorporated into the 6802 is 128 bytes of RAM and the first 32 bytes of this memory may be operated in a low power mode to prevent loss of data when normal power is off (power down).

Teamed with the 6802 processor is the 6821 peripheral interface adapter which has two 8-bit bidirectional data buses and four control lines. This device scans the front panel push-buttons and the fuel and distance sensors for input signals and drives the LED readout in multiplex mode.

The machine language program for the Car Computer is stored in a 2716 2048-byte EPROM (Electrically Programmable Read Only Memory).

Next month we shall give the circuit and software description plus details of construction. Don't miss out on your copy of the August issue.

Try this with any

MicroBee, the visual breakthrough.

The power of the personal computer lies in what it can do on the screen. MicroBee brings you superb graphics capabilities under easy to use BASIC control. Both high and low resolution graphics can be combined with text. And text is full upper/lower case. This makes MicroBee the finest low cost educational machine you can buy. MicroBee has been chosen for use in NSW government schools.

MicroBee, your guide into programming.

Your MicroBee isn't just a computer it's a complete learning package. You get a step by step construction guide (and a service coupon if you get into trouble). The BASIC tutorial and BASIC manual give you the knowledge you need to master programming. You'll quickly learn how to use MicroBee's powerful BASIC language. And you'll be able to enter a whole range of demonstration programs which show you how to use MicroBee. As a MicroBee owner, you become a member of the MicroWorld Users' Group. You'll receive our Newsletter. So you'll be in contact with other MicroBee users.



Programming has never been simpler.

MicroBee is very powerful, yet easier to use than other Micros. Because they're under

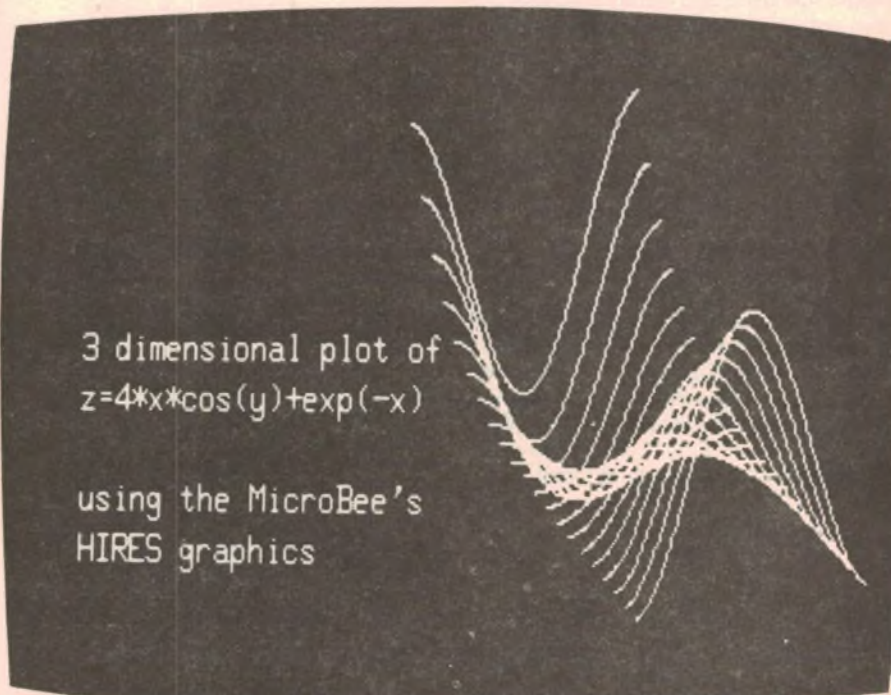
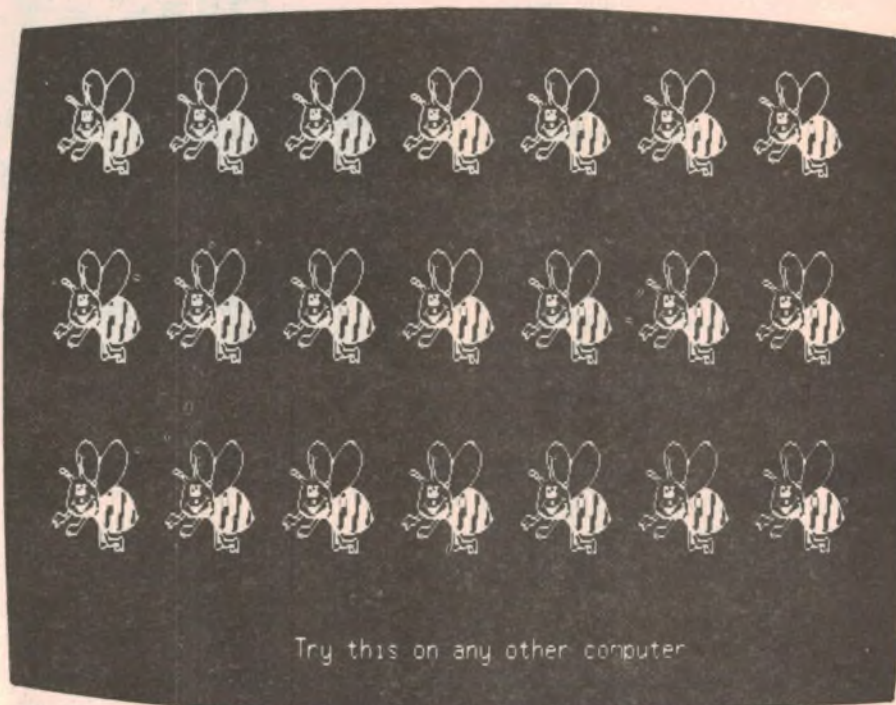

other computer

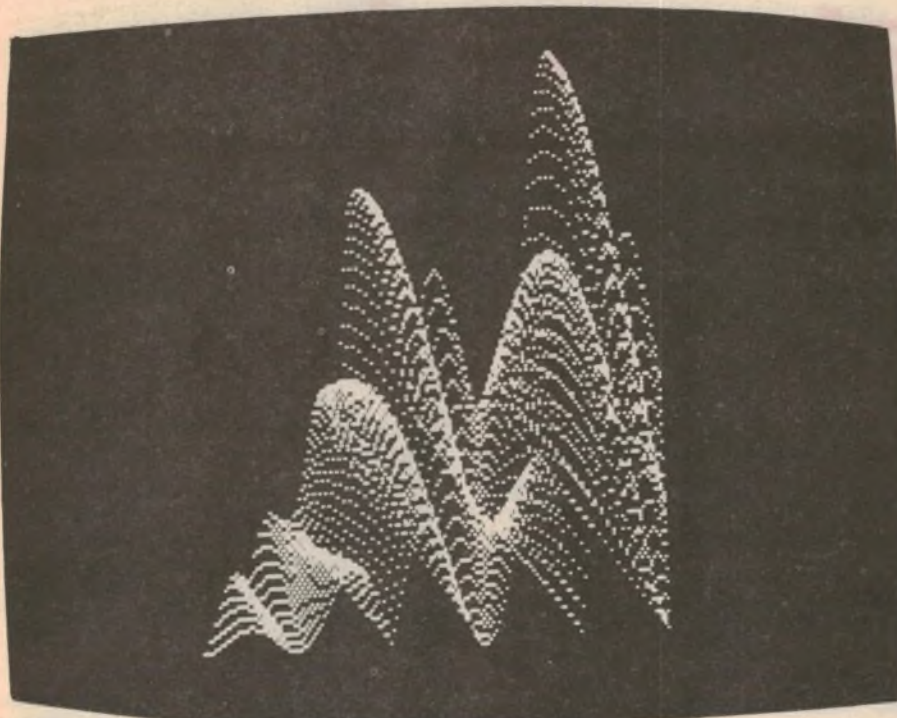

BASIC, the sound and graphics are easy to master. The BASIC also controls printers and modems. So interfacing your MicroBee is easy. When you want to go further, MicroWorld Editor/Assembler helps you write in Z80 code.

Ready for expansion.

Your MicroBee is equipped with a programmable RS232 port, so you can connect a printer or modem straight on. A dual speed cassette interface is fitted. Continuous memory means you can move to a new location and your program and data are still there!!

MicroBee is complete.

MicroBee kit including all manuals, 16K BASIC in ROM, Power Supply, IC sockets, 16K RAM. **\$399.00**

Editor/Assembler in ROM **\$49.50**

Video monitor **\$129.50**

Cassette Recorder **\$35.00**

Order direct on our Hotline number.

Just phone (02)487 2711.

Or use our Blue Ribbon mail order service:- PO Box 311, Hornsby NSW 2077

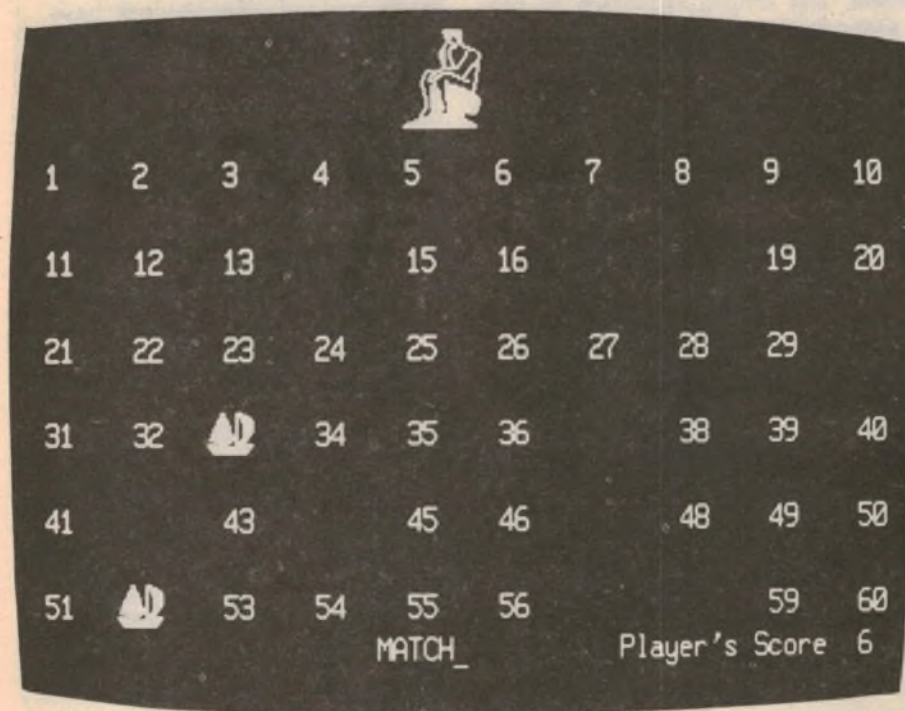

AT APPLIED TECHNOLOGY

Showroom/Office: 1 A Pattison Ave. Waitara.

Hours:- 9-5 Monday to Saturday.

Phone (02)487 2711

Telex APPTEC AA72767

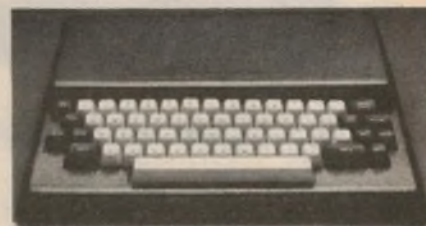

Keep tabs on your ticker with this

Portable 3½-digit heart rate monitor

Here is a new heart rate monitor designed specifically for use by the dedicated fitness seeker. Small enough to carry when jogging or exercising, it features an optical sensor, no electrical connections to the body, an in-built calibration circuit, and direct readout on a large liquid crystal display (LCD).

by JEFF SKEEN

Our first Heart Rate Monitor was described back in April, 1981, and, within the constraints of components available at that time, was a very successful design. In fact, a version of it is still being used by a reader with a heart condition, who is under a strict medically prescribed training program. He uses it to monitor his heart rate while exercising, and hold it to a prescribed figure within close limits.

But the design had its limitations. It was mains operated and therefore had to be used within reach of a power point. It also had to use a relatively complicated circuit, with a large number of components, all housed in a large and rather expensive case, and was dependent on a specially programmed EPROM which was only available from a few sources.

More recently we realised that it might now be possible to design a very much smaller and simpler device. The thought

was inspired by the DPM-200 module – already used in several projects – and which is, basically, a millivoltmeter with a large 3½-digit liquid crystal display.

The DPM-200 requires only a tiny fraction of the power needed by the LED display used in the previous design, and is well within the scope of battery operation. The implication was obvious; a monitor which would be light enough and small enough to carry, and use, anywhere.

Another advantage of the DPM-200 module is that it made possible a different, and simpler, approach to processing the heart pulse signals. The result is a monitor which is cheaper, simpler to build, and compact enough for the athlete and fitness enthusiast to use "on-the-job".

There are many potential uses for a heart rate monitor and a portable ver-

sion makes many of these a lot more practical.

It is generally acknowledged that exercise is a valuable aid to physical fitness. Unfortunately, people often exercise for a while, then give it away because they can see no benefit for their effort. This is because the benefits are gradual and the individual cannot detect the small improvements resulting from each session.

Our Heart Rate Monitor can help solve this problem. By providing an instant display of the heart rate, measured before, during, and after exercise, it allows comparisons to be made on a day-to-day and week-to-week basis. A written record of such measurements will prove infinitely more valuable than mere subjective judgement.

And what kind of readings should one expect? This is a very complex subject, and quite outside the scope of this article. A heart beat can vary from as low as 30 in a young highly trained athlete, at rest, to as high as 160 for an elderly person indulging in unaccustomed (and perhaps dangerous) exercise. Almost any figure in between may be good or bad, depending on the immediate circumstances and the person's medical history.

For more precise details consult some reliable literature on the subject first. One such reference is "Aussierobics", by Mr P. Russo of the Cumberland College of Health Sciences. This contains a lot of information on heart rates for various age groups and exercise conditions.

Above all, don't rush blindly into a bout of strenuous exercise, particularly after a long period of idleness; it could do more harm than good. We seriously recommend that anyone contemplating such a program should consult his doctor first, and be guided by his advice.

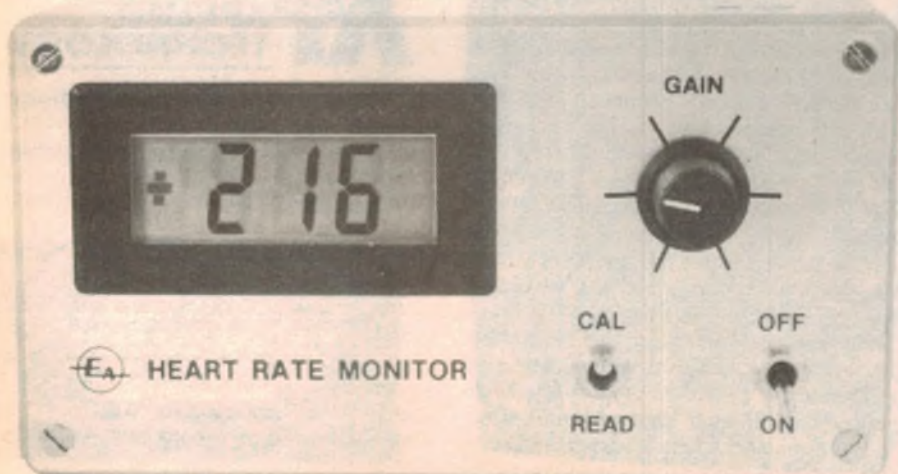

This photograph shows the new Heart Rate Monitor operating in the calibration mode. Note sensor cutouts on the top of the case.

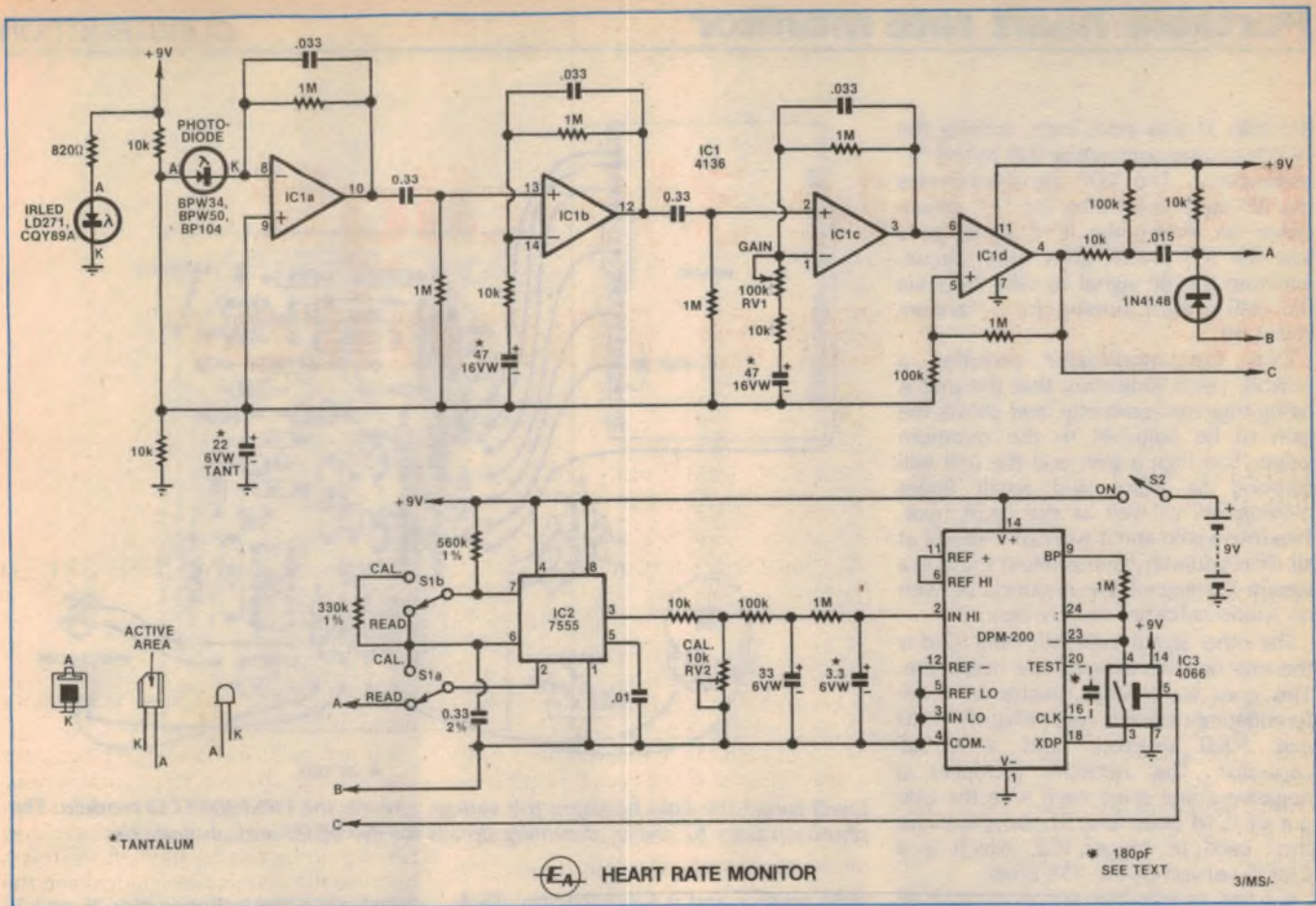

How it works

Having said all that, let us look at our new Heart Rate Monitor in greater detail. Briefly, the circuit is a frequency to voltage converter that converts the heart beat frequency into a proportional voltage, in millivolts. This voltage is displayed by the DPM-200 panel meter in digital form, each millivolt corresponding to 10 beats per minute.

The circuit can be split into four basic sections. Three of these correspond to integrated circuits IC1, IC2 and IC3 and the fourth is the DPM-200 module. Section 1 (IC1) is an amplifier used to amplify the sensor output; section 2 (IC2) converts this output into constant length pulses, then averages these to form a DC voltage proportional to the heart beat rate; and (IC3) is an electronic switch that activates the "+" annunciator on the DPM-200 module.

Section 4, the DPM-200 module, was featured in the February, 1982 issue of "Electronics Australia", so we will not go into its internal operation here. Suffice to say that the DPM-200 is simply a high input impedance voltmeter with a full-scale reading of 199.9mV.

To begin the circuit description we start with the sensor, then follow the signal path through the circuit until we reach the meter.

The sensor consists of two parts: an in-

frared light source, and an infrared detector. The infrared light source is an infrared light emitting diode (IRLED) and the detector is an infrared photodiode. The diode appears as an open circuit when no infrared light reaches it and behaves as a normal diode under infrared light. The two devices are mounted side by side on the top of the case, and the IRLED run continuously at about 10mA.

When a finger is placed over the two devices, infrared light passes through the finger, is reflected off the bone, and passes back through the finger to the photodiode. On the way, the light is intensity modulated by the expansion and contraction of small arteries in response to the heart beat. This intensity modulated light is turned into an amplitude modulated electrical signal by the photodiode, and then amplified by IC1a.

IC1a is an inverting DC amplifier with a bandwidth limited to 4.8Hz by the .033 μ F capacitor across the 1M Ω feedback resistor. The output of IC1a then undergoes two stages of amplification, in IC1b and IC1c respectively. Both these stages have 0.48Hz high pass filters on their inputs and 4.8Hz low pass filters in the feedback paths, and are AC coupled with gains of about 100. IC1c, however, has a gain control which can reduce the

gain of this stage from 100 to 10.

This allows the sensitivity of the detector to be varied, providing a means to control the effects of small finger movements, which could otherwise modulate the signal in the same way as a heart beat. The high and low pass filters around the amplifier stages allow only heart beat frequencies to be amplified, thus providing a large degree of immunity from external modulated infrared light sources, eg light bulbs, radiators etc.

Following the amplification stages is a Schmitt trigger formed by IC1d. This transforms the amplified sensor signal into a square wave with an amplitude approximately equal to the supply voltage.

From here the signal path is split, one path being used to trigger IC2 and the other to control the "+" annunciator on the module. The "+" annunciator is wired to flash each time the sensor detects a pulse. The user can thus determine when the unit is triggering correctly off his/her heart beat because the annunciator maintains a steady rhythmic flashing.

To enable the "+" annunciator, it is necessary to connect pins 23 and 24 of the DPM-200 module to XDP (pin 18). This is achieved by means of IC3, a 4066 CMOS switch.

Here's how it works. When the output of IC1d goes high the control input of

I.B.M., Digital and other industry giants have gone the CP/M way!

YOU CAN TOO WITH THE BRILLIANT SORCERER!

Some of the world's leading computer manufacturers are now producing CP/M based systems to utilise the vast range of existing software. The only problems for you are 1): Some of the CP/M-based systems are not yet available in Australia, and 2): Some of them may cost up to, and over, \$5,000! So why not check out ...



The Incredible Sorcerer

For the serious personal computer user, it offers a truly outstanding performance - plus the ability to run the industry-standard CP/M operating system at lower cost than any other computer. The Exidy Sorcerer MkII — the most powerful, flexible and businesslike machine in its class.

Look at the features

- Built in serial and parallel ports
 - 2 cassette control ports
 - Powerful graphics capabilities
 - Expandable to 48K on board
 - Uniquely versatile ROMPACS™ — instant change to dedicated processor, and back again!
 - Built-in 4K ROM resident monitor
 - Economic disk storage now available (optional) with Exidy's FDS — floppy disk subsystem (does not need expansion interface)
 - 8K Microsoft BASIC
- Cat X-3002

VIDEO MONITOR, FDS & SOFTWARE MANUAL NOT INCLUDED IN PRICE OF COMPUTER

OUR BETTER BUYING POSITION MEANS WE CAN PASS ON THE SAVINGS TO YOU!!

SAVE NEARLY \$200

~~was \$1398~~

NOW ONLY

\$1195!

SAVE \$100's FDS Disk Drive doesn't need an expansion unit!

The FDS Disk Drive comes with CP/M as standard. It has a storage capacity of 308K Bytes and has its own controller system and logic to run itself and up to two other drives! Add it to your Sorcerer and you have the lowest cost CP/M system available in Australia.
Cat X-3220

**and it's only
\$1290**

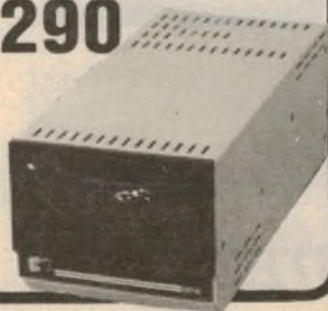

GREAT NEW SOFTWARE ON TAPE

- ZAP 80**
"Secret Code Disassembler" - it will display all those unknown instructions Zilog never talk about!
Cat X-3625 **\$24.95**
- FORTH**
Forth is a new language for your Sorcerer using postfix notation (RPN).
Cat X-3629 **\$49.95**
- DUMB TERMINAL vs. 3**
Enables your Sorcerer to be used as a low cost, user configured communications terminal.
Cat X-3637 **\$9.95**
- COPYFILE**
A disk to file transfer program essential for the single drive CP/M user. Automatically loads itself onto your disk.
Cat X-3714 **\$14.95**

& MANY MORE

UTILITIES ON DISK

- EDOS**
Adds disk operating commands and many enhancements to ROMPAC™ BASIC. Requires X-3205 Disk System.
Cat X-3602 **\$49.00**
- EXTENDED BASIC FOR FDS**
Features include double precision variables, constants, maths, full line editing and all normal disk facilities and commands.
Cat X-3712 **\$399.00**
- DSKCITOH/PRINT (FDS)**
Soft sectored disk driver and proportional print driver to be used with the FDS and the word processor ROM PAC.
Cat X-3726 **\$129.00**

ASK FOR OUR FREE SORCERER BROCHURE

DICK SMITH ELECTRONICS

SEE PAGE 52 FOR ADDRESS DETAILS



DSE/A236/PAI

High quality PCB artwork materials

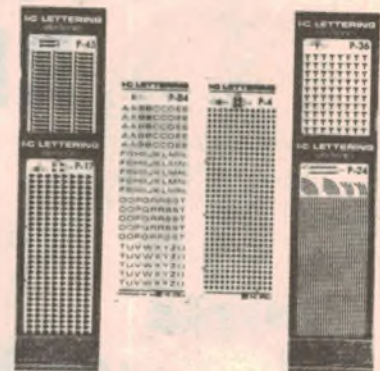
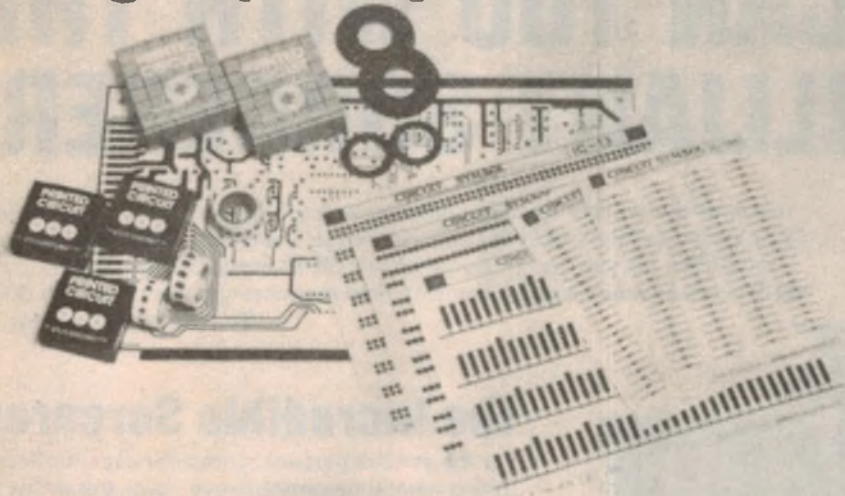

**Direct Etch
Transfer Lettering
for PCB artwork**

20% CHEAPER THAN MOST BRANDS BUT NO SACRIFICE IN QUALITY

Izumiya I-C pressure sensitive artwork tapes and films satisfy all of your PCB design and schematic requirements. Our **I-C Tapes** come in 47 different widths, from 0.25mm to 20.00mm \pm 0.05mm. The tapes are available in two colors; black crepe and transparent red. The **I-C Packs** come in eight different shapes, including circles, squares, teardrops, triangles, etc., 91 sizes, and two colors. Sizes are guaranteed to \pm 0.05mm. Our **I-C Circuit Symbols** offer a complete line of connector films and schematic symbol films in 143 sizes for maximum flexibility. Of course we can custom make any lettering, symbol, logo, etc. at your request. Available 1 to 1 or 2 to 1. *Send 50 cent Stamp for Illustrated Catalogue

IC IZUMIYA I-C INC.
Sole Australian Distributor

ELLISTRONICS PTY LTD

289 LATROBE ST. MELBOURNE. 3000
PHONE (03) 602-3282, 602-3836. TELEX AA37758 LSTRON.

ELLISTRONICS SOLDERLESS BREADBOARD

Designed around two interlocking modular units, the WBDN is a distribution strip for power etc. and contains 100 contacts grouped in clusters of five. The WBTN is the terminal strip containing 640 contacts in two separate rows of five intercon-

nected contacts each separated by a .300" median. Contacts are made from non-corrosive nickel silver alloy and are reliable for more than 10,000 insertions. The boards accept all DIP size including RTL, TTL, DTL, CMOS and most passive

devices and interconnect with 20 to 29 awg solid wire. All boards are interlocking and elements are mounted on ground plane. Ideal for H.F., High Speed, Low Noise application.

		RETAIL PRICE
WBDN	Distribution Strip	\$1.80
WBTN	Terminal Strip	6.80
WB2N1	1 Distribution + 1 Terminal Strip	8.35
WB2N 2	Distribution + 1 Terminal Strip	10.30
WB2NB*	2 Distribution + 1 Terminal Strip	14.50
WB4N3*	1 Distribution + 2 Terminal Strips	17.00
WB4N1*	3 Distribution + 2 Terminal Strips	20.50
WB4N*	4 Distribution + 2 Terminal Strips	23.00
WB6N*	5 Distribution + 3 Terminal Strips	31.50
WB8N*	7 Distribution + 4 Terminal Strips	44.50
WB16N*	10 Distribution + 8 Terminal Strips	83.50
WB24N*	20 Distribution + 12 Terminal Strips	126.50
Experimentor Kit	Contains 1 x WB2N and 2 Experimentor Circuit Boards + Design Pad	14.50
Experimentor Board	A drilled and etched circuit board to match WB2N	1.60

*WB2NB thru to WB24N are mounted on an aluminium base plate complete with non scratch rubber feet and appropriate binding posts.

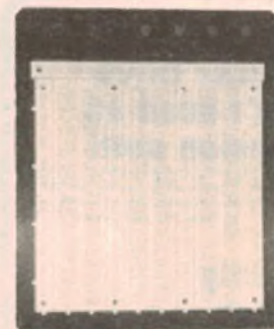

DEALER ENQUIRIES INVITED

Heart rate monitor

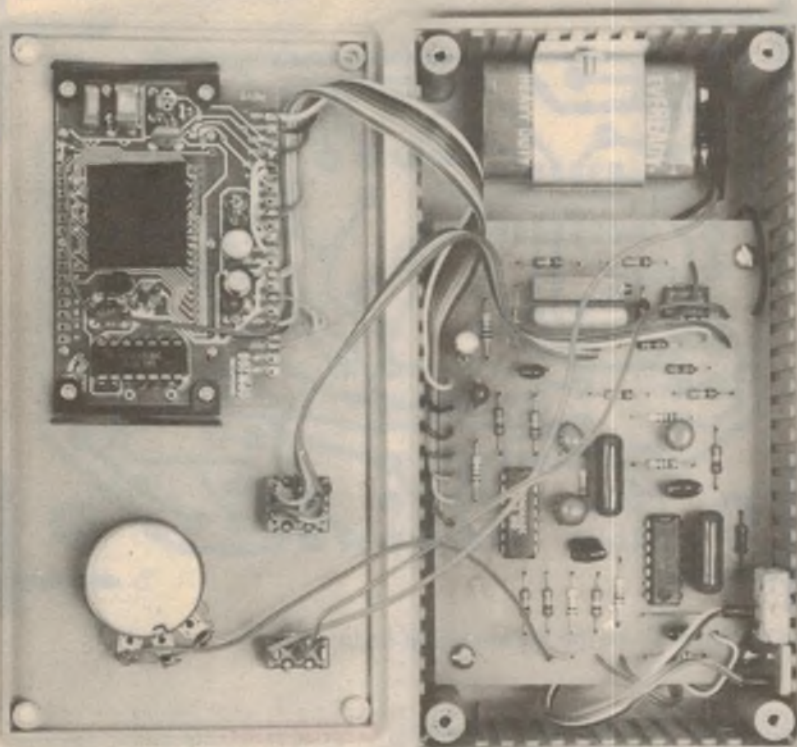

This internal view shows the prototype with wiring complete.

components on the PCB according to the overlay diagram. Note that there is a wire link to be fitted near IC1. When soldering the CMOS devices make sure that the power supply pins are soldered first, and connect the soldering iron barrel to the negative supply rail using a small clip lead.

When all components have been mounted on the PCB, you can begin assembling the electronics into the case. It is a good idea to start by trimming the

Scotchcal front panel, since this can serve as a drilling and cutting template. Using a sharp pair of scissors, trim the panel along the inside of the black border which surrounds it. This done, cut out the opening for the DPM-200 display module, cutting along the black rectangular border marking out this area.

Temporarily locate the Scotchcal panel on the lid of the box (do not remove the backing paper) and push a sharp pin through the centre of the targets mark-

PARTS LIST

- 1 printed circuit board, code 82hb6, 102 x 71mm
- 1 plastic case, measuring 152 x 80 x 47mm
- 1 SPDT toggle switch
- 1 DPDT toggle switch
- 1 DPM-200 panel meter module
- 1 Scotchcal front panel, 149 x 79mm
- 1 9V battery, Eveready 216
- 1 9V battery clip
- 4 12mm PC board spacers
- 1 ½-metre length 10-way ribbon cable

SEMICONDUCTORS

- 1 4066 quad analog switch
- 1 7555 timer IC
- 1 4136 quad op amp
- 1 1N4148 diode
- 1 CQY89A infrared light emitting diode
- 1 BPW50 infrared photodiode

CAPACITORS

- 2 47µF 16VW tantalum
- 1 33µF 6VW PC electrolytic
- 1 22µF 6VW tantalum
- 1 3.3µF 6VW tantalum
- 2 0.33µF greencaps
- 1 0.33µF 2% greencap
- 3 .033µF greencaps
- 1 .015µF greencap
- 1 .01µF greencap

RESISTORS (¼W, 5% unless stated)

- 8 x 1MΩ, 1 x 560kΩ 1%, 1 x 330kΩ 1%, 3 x 100kΩ, 7 x 10kΩ, 1 x 820Ω, 1 x 100kΩ linear potentiometer, 1 x 10kΩ multiturn potentiometer.

MISCELLANEOUS

- Machine screws and nuts, small piece of scrap aluminium sheet, small piece of wood, solder, etc.

Actual size artwork for the front panel. Finished Scotchcal panels will be available from the usual retail outlets.

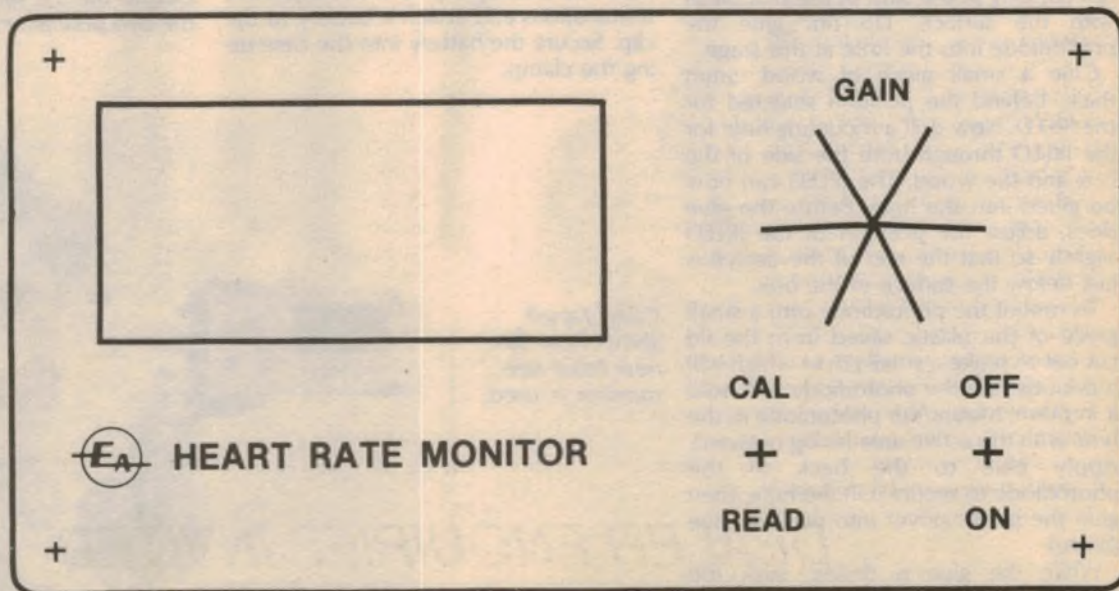

ing the gain control and switch positions. The resulting "dents" in the plastic will provide an accurate drilling guide. Before removing the Scotchcal, use a pencil to trace around the outline of the cutout for the DPM-200 display.

Remove the Scotchcal, drill the gain control and switch holes, then cut out the section for the DPM-200 display. Note that the latter should neatly accommodate the bezel supplied with the DPM-200. Save the scrap plastic from this cut-out. Next, place the PCB in the bottom of the box, towards one end, and use it as a template to drill its mounting holes.

The battery clamp is made from a small piece of scrap aluminium bent into an S shape so that it fits snugly over the battery (see photo). Drill a hole in one end of the clamp, then place the battery and clamp in position in the box. Mark the correct position for the battery clamp mounting hole, remove the battery and clamp, then drill the hole through the side of the box.

Mount standoffs on the PCB, and sit the PCB in position in the box. Select a suitable location in which to mount the sensor components that is both comfortable to reach and does not foul the PCB. The best location is at the top right hand corner of the box so that the fleshy end of a finger can lie comfortably across the sensor while the hand is holding the box.

Once the sensor location is selected, remove the PCB from the box and mark out positions for the IRLED and photodiode. The distance between the centres of the two devices should be about 8 to 9mm. Drill a small hole for the photodiode, then enlarge this with a small file to fit the shape of the photodiode. The photodiode mounts horizontally in the side of the box, flush with the surface. Do not glue the photodiode into the hole at this stage.

Glue a small piece of wood, 5mm thick, behind the position selected for the IRLED. Now drill a mounting hole for the IRLED through both the side of the box and the wood. The IRLED can now be glued into the hole. Before the glue dries, adjust the position of the IRLED slightly so that the end of the device is just below the surface of the box.

To mount the photodiode trim a small piece of the plastic saved from the lid cut-out to make a small cover which will mount behind the photodiode and hold it in place. Mount the photodiode in the hole with the active area facing outward. Apply glue to the back of the photodiode to secure it in the hole, then glue the plastic cover into position (see photo).

While the glue is drying, stick the Scotchcal panel into position on the lid

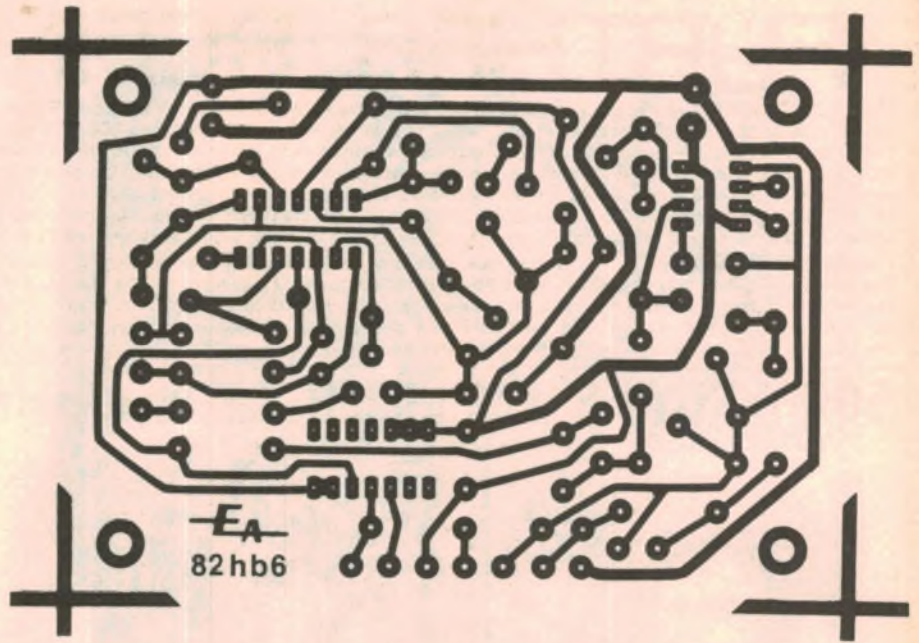

Actual size artwork for the printed circuit board.

of the box and use a sharp knife to trim away the material covering the gain control and switch holes. Mount the DPM-200 module, the switches, and the gain control on the lid of the box, and complete the wiring that runs between these components and the PCB. Do not forget to wire in the shorting links between the various module pins.

When the glue holding the sensor assembly is dry, trim the IRLED and photodiode leads to about 6mm and solder on wires to run between both devices and the PCB. Place some short lengths of spaghetti tubing over the bare leads to prevent shorts. Solder the leads from the battery clip to their respective terminations and attach a battery to the clip. Secure the battery into the case using the clamp.

Calibration

To calibrate the monitor, first turn RV2 fully clockwise. As already mentioned, this is a multi-turn pot and the extremes of travel are indicated by a series of clicks as the shaft is turned beyond this point. Adjustments to the pot are most conveniently made before the PCB is mounted in the box.

Prop up the lid of the heart rate monitor so that you can see the display, then turn the monitor on. The display should read 000 with the "+" annunciator flashing on and off sporadically. Switch S1 to the CAL position and slowly adjust RV2 until the display reads 215. Due to the 6.6 second time constant of the two pole filter section there is a con-

Continued on page 105

Cathy Farrell shows how the new heart rate monitor is used.



5000 AMPS FURTHER REFINEMENT

5000 POWERAMP — Much has been said about the brilliant 5000 Mosfet PA by David Tillbrook. Justifiably so in our opinion. If you wish to know more send us a SAE for a descriptive leaflet. If you are well versed with the 5000 PA you may like to know that we now supply Beryllium Oxide (high thermal conductivity) TO-3 ceramic washers in place of the poor conductivity — and flimsy — mica washers, STANDARD in our kit. You may have also noticed a number of suppliers offering 'versions' of the 5000 PA and Preamp which to some could be interpreted as the same as the quality Jaycar kit. Whilst we could be smug and say that imitation is the sincerest form of flattery, we would be kidding ourselves. We still firmly believe that the Jaycar 5000 kits are the best for many reasons: Among which are: — Only the finest components go in e.g. 1% Metal film resistors. — Continuing refinement. e.g. Beryllium washers, superior export packing. — superior cosmetic appeal.

PREAMP REFINEMENTS — For quite some time now we have been using the LM194CH ultra-matched transistor array in the M.C. section of the preamp. We felt that this expensive military grade component was justified. We also used the Mil-spec MAT-01GH by Precision Monolithics Inc. of the USA. National Semiconductor now has a device called the LM394H which we now intend to use exclusively in our "Blueprint" series preamps. The H version is EVEN QUIETER than the CH versions in the past. While this component is considerably more expensive than the standard LM394 we feel that the extra investment on our part is justified. Yet another example of "Further Refinement".

5000 POWER AMPLIFIER



FROM

\$289

EXCLUSIVE!! Beryllium Oxide TO-3 heatsink washers now used. (Safety pin k type).
— STANDARD (ETI) FRONT PANEL \$289.00
— SUPERFINISH (RECOMMENDED) FRONT PANEL \$299.00 (SUPERFINISH PANEL ILLUSTRATED)

LABORATORY MEASURED PERFORMANCE FIGURES:

POWER OUTPUT
FREQUENCY RESPONSE

Around 100W RMS into 8 ohms
8Hz to 20kHz, +0 -0.4dB
20kHz to 65kHz, +0 -3dB
Note: These figures are determined solely by passive filters

INPUT SENSITIVITY
HUM
NOISE
2nd HARMONIC DISTORTION

1V RMS for 100W output
-100dB below full output (flat)
-116dB below full output (flat, 20kHz bandwidth)
≤0.001% at 1kHz (0.0007% on prototypes) at 100W output using a +56V supply rated at 4A continuous
≤0.003% at 10kHz and 100W
≤0.0003% for all frequencies less than 10kHz and all powers below clipping

3rd HARMONIC DISTORTION
TOTAL HARMONIC DISTORTION
INTERMODULATION DISTORTION
STABILITY

Determined by 2nd harmonic distortion (see above)
≤0.003% at 100W (50kHz and 7kHz mixed 4:1)
Unconditional

"Blueprint" 5000 preamp



FROM

\$245

EXCLUSIVE!! NEW LM394H EXTRA LOW NOISE ULTRA-MATCHED TRANSISTOR PAIR USED IN M.C. PREAMP.

STANDARD (STILL GOOD) VERSION ONLY \$245.00
"BLUEPRINT VERSION"

FEATURES:

- EXTREMELY CLOSE TRACKING TO RIAA PHONO EQUALISATION
- GOLD PLATED CONNECTORS ON PHONO INPUTS
- ENGLISH "LORLIN" LOW NOISE SELECTOR SWITCHES USED
- LOW NOISE 1% 50ppm METAL FILM RESISTORS USED
- TINNED FIBREGLASS PCB'S
- LOW CAPACITANCE SCREENED CABLE USED THROUGHOUT
- QUALITY I.C. SOCKETS PROVIDED
- SPECIAL REAR PANEL MULTICOLOURED LED DISPLAY

only \$275

SPECIAL OFFER

If you have the good taste to purchase both the 5000 PA and Preamp during June, we will give you our exclusive

JAYCAR

— SOUND ENGINEERING —

T-shirt absolutely FREE. Tell us how big you are or it may not fit!! Available separately for only \$6.50 each.

BERYLLIUM OXIDE WASHERS

If you wish to upgrade the quality of your existing 5000 PA with Beryllium washers you can have a set of 8 for \$15 plus P&P — High thermal shock capacity — Perfectly safe if not EATEN!! — Ceramic material that conducts better than Aluminium — High dielectric strength — As used in Military Aerospace equipment — Precision cut for TO-3 profile.

Freight outside NSW only \$15. Within NSW \$10

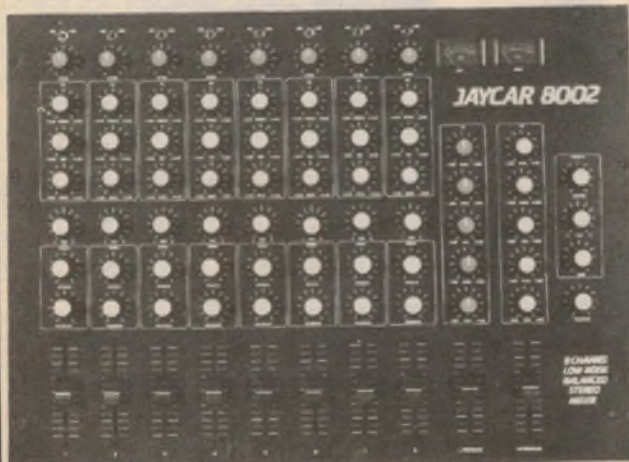

at last!! * the new 8 channel MIXER KIT

† Balanced (600 ohm) mic inputs/line inputs † Balanced output † Input attenuators † Cannon connectors included in the price † Bass, mid & treble equalization on each input † "Effects" (i.e. echo etc) capability † Foldback on all 8 inputs † Stereo pan on all 8 inputs † 60mm slide faders used throughout † 19" rack mount capability (or console mount) † Professional black front panel with format borders and multicoloured knobs to assist function identification † Designed for quick easy service † VU metering † Only high quality components used † 5534A OP amp used for low noise and very low distortion.

BASIC MIXER KIT with all features. Includes 19" rack panel all knobs and electronic components AND 10 CANNON connectors \$495

Console mount chassis in steel, plated and pre-punched. Includes power supply for mixer and wooden end pieces. \$98

Jaycar

125 YORK ST SYDNEY 2000

Ph. 2646688 Telex 72293

Mail Orders To:

Box K-39 Haymarket 2000

Post and Packing charges

NEW SHOP HOURS

Mon-Fri 8.30 to 5.30pm

Sat 8.30 to 1.00pm

Thurs night to 8.30pm

\$5-\$9.99 (\$1.20) \$10-\$24.99 (\$2.40)

\$25-\$49.99 (\$3.50) \$50-\$99.99 (\$4.60)

\$100 up (\$6.20)

SEND SAE FOR FULL DATA ON 5000 SERIES AND THE NEW STEREO MIXER KIT

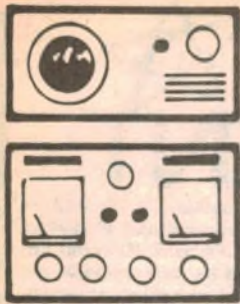

The Serviceman

Power supplies, valves — and splattered aliens!

I have several short stories to tell this month. While none is particularly earth-shattering, each has its own element of mystery which, at the time, caused some head scratching.

The first story concerns a Kriesler model 59-1 colour set which, according to the customer, was completely dead — ie no sound and no picture. He went on to explain that the set had failed while running, but while the family were out of the room for a few minutes. As a result, he couldn't give me any details as to what symptoms might have been displayed at the moment of failure. As it transpired, this really didn't matter.

On switching it on in the customer's lounge room it was obvious that he was right; it was very dead. I immediately suspected a total power failure and, when this was confirmed, my next guess was that the regulator transistor in the power supply, TR120, had failed. This assumption was based on previous experience, this transistor being the most usual cause of power supply failure.

When this transistor fails it invariably takes out a 2A fuse, F120, so this was the first thing I checked. In fact, the fuse was intact and this was the first hint that it might not be a simple routine fault. There are lots of other faults which can put this power supply out of action, including dry joints on the main board, the auxiliary power supply control unit board, the power transformer, the main filter capacitor (C112), and even the connectors to the auxiliary board.

NOTHING OBVIOUS

I looked for obvious indications of any of these faults but, superficially at least, they appeared to be ruled out. My next step was to backtrack towards the mains input, using a meter with the set switched on. The first clue was the absence of any voltage across the bridge rectifier.

The next logical check point from here was the two mains fuses, F101, F102. These are on a front panel which swings out for easy access. As well as the fuses, this carries the mains switch and a net-

work of RF chokes and bypass capacitors.

I didn't need to test these — one look was enough; they were very much blown, if you know what I mean. But why? There was a number of possibilities, such as a failure of one or more diodes in the bridge rectifier, or a fault in the de-gauss circuit.

The only snag was that meter measurements across these components, and also across the mains input circuit as a whole, failed to reveal anything like a short circuit, and certainly nothing that would destroy fuses as violently as these had been destroyed. Could it have been a momentary mains surge? Or an intermittent internal short which had now vanished?

The mains surge seemed to be a long shot, but I couldn't rule out either possibility. And there was only one way to find out. I fitted a new set of fuses, left the panel open so I could watch it, and switched on. SPLAT! Both fuses disintegrated in a flash. So that was that — whatever the fault was it was still

there, and it was also one that wouldn't show up on the meter.

I have known de-gauss circuits to be a bit tricky in this regard, so I disconnected this one, fitted another pair of fuses, and tried again. The splat was just as violent as before. So it had to be on the power supply board.

I pulled the board out, took it into a good light, and studied it carefully. I wasn't quite sure what I was looking for, but I became suspicious when I noticed a slight darkening of the board beside the main filter capacitor, C112. This is a vertically mounted can type capacitor and, in this case at least, it did not sit snugly on the board, leaving a couple of millimetres under it.

Pearing into this gap I thought I detected a continuation of the brown mark, or even a blackening. I reached for the ohm meter leads and checked between the capacitor terminals for any sign of a short, but there was none.

That left no option but to remove the capacitor, which is a bit tricky because it is a multi-lug device. But when it was off I had the answer. There was a burn mark on top of the board (away from the copper side) between the positive and the negative terminal slots.

A LEAKY ELECTRO

It was obvious now what had happened. The electrolytic capacitor had leaked onto the board, providing a path which had encouraged tracking between the two high voltage points, destruction of the board material, formation of carbon, further tracking, and so on. What, in fact, had been eventually created was a non-linear resistor; a resistor whose value was very high at the low voltage applied by the ohmmeter, but which was catastrophically low at the peak mains voltage across the capacitor.

On a more practical side, I had to decide whether I could repair the board, or whether the customer would have to stand the expense of a new one. Closer examination revealed that the track was mainly superficial and a little scraping revealed clean board material.



"That's nothing! You should try turning it on when its plugged in." (Radio-Electronics).

On this basis I decided that it was perfectly practical to repair the board. I cleaned away all signs of the carbon and burnt surface, smeared some insulating compound over the scar, and fitted a new capacitor. I fitted the board back in place, switched on, and up came the sound, followed by the picture.

Another happy customer.

BACK TO VALVES!

My next story concerns one of the old Decca 33 series; a hybrid valve/transistor model from the early days of colour. And, although they are now a bit ancient, there are still a lot of them around giving good service.

According to the customer, the set had been left idle for a couple of weeks while the family was on holidays. On returning they switched the set on but the picture had barely appeared before it started to shrink from all four sides, eventually vanishing altogether.

These symptoms seemed a little unusual, since it is rare for this model set to shrink from all four sides. If the customer's observations were accurate, it seemed most likely that there were two separate faults; a line fault and a frame fault.

When I first switched the set on there was some sound, but no sign of a picture. Switching off, I delved into the innards and made for the line output section. More specifically, I picked on the thermal spring-off resistor, R464, on the screen of line output valve, a PL509, and wasn't really surprised when I found that it had tripped.

The most likely causes of overload in this part of the circuit would be failure of the PL509, failure of the boost diode, PY500A, or failure of the line drive due, in turn to failure of the line oscillator valve, PCF802.

I reset the thermal spring-off and switched on again. There was still no sign of line output, but I made quick check and confirmed that there was line drive. That left PL590 and PY500A as the prime suspects so, to save time, I replaced both. I reasoned that if the set worked I could sort out the real culprit later.

In fact, the set did work, although there was some loss of both height and width. The loss of height was easily taken care of, being only slight and easily within the range of the height control, with plenty to spare. It seemed most likely that some resistors in the vertical circuit had drifted a little high — not an unusual occurrence in these sets — but not enough to warrant the cost of replacement while there was adequate height control remaining.

The loss of width was more serious, and not so easily dealt with. And, as well as the width problem, there was evidence of flashover from the ultor to the aquadag. A common cause of reduced width in these sets involves a pre-set

width control in the form of a 2M Ω trim-pot, VR451. These can become pitted at the point where the slider rests on the element, producing a high resistance contact.

As it turned out, this was not the problem this time, so I considered another possibility in this part of the circuit. There are two 820k Ω , 1/2W resistors, R452A, R452B, in series with the aforementioned pot slider, and these have a habit of going high. An ohmmeter check confirmed my suspicion, both having gone substantially high. Two new resistors restored the scan to normal width.

That left the arcing problem at the ultor cap. While problems like this can often be solved with a blob of Silastic Sealant in the ultor cap, it was obvious that this one wasn't going to be that easy. In this case the rubber ultor cap had perished with age and the EHT had punched a hole through it.

This meant it needed a new ultor cap, but these are not normally available as separate items, meaning that the customer is often put to the expense of a new tripler, just to replace the ultor cap or lead. To cope with this I make it a habit to save all the ultor lead assemblies I can from genuinely defunct triplers.

With a little dexterity one can get the old components — a series resistor in some cases — out of the cap and fit the latter to the EHT lead. This may take 10 or 15 minutes but the extra labour charge is still much less than the price of a new tripler. The caps off the old Rank triplers are ideal for this trick but I don't get many of these, since the triplers appear to be very reliable.

Anyway, I fitted a new cap in this case, added a dab of Silastic under it, and away went the set without a sizzle or splat of any kind. Based on past experience that will last for years; probably longer than the rest of the set.

That left only one point to be clarified; which of the two valves that I had replaced was really faulty? Changing each valve individually soon answered the question; it was the PY500A diode which was faulty, having developed an internal short.

After that it was simply a matter of the normal routine check; purity, grey scale, convergence etc to bring the set back to a like-new performance.

My next story concerns an AWA-Thorn colour TV set, one of the older imported British 3504 series. As with the Kriesler 59-1 set in my first story this set was also completely dead and, again, I punted on a power supply failure with the regulator transistor as the most likely cause.

And this time I was right. There was no output from the power supply, and it was due to a faulty regulator transistor; a short circuit to be more precise. Well, that seemed straightforward enough. I duly extracted the faulty one and fitted a replacement.

But then came the moment of truth. Was that all that was wrong with the set? Had the transistor simply failed within itself, or had it succumbed to a more subtle fault somewhere else in the set? In the event, it seemed my fears were groundless. There were no signs of distress, the sound came up immediately, and a picture appeared in due course.

THERMAL OVERLOAD?

I gave a (mental) sigh of relief — and the next moment wished I hadn't. The thermal mains overload device tripped, and the set went dead once more. I reset the thermal, switched on, and made a few quick checks, including the main rail voltage, which seemed to be spot on at about 65V.

I switched off and checked everything I could think of with the ohmmeter, hoping that I might find a clue, but also remembering the nasty trick the Kriesler set had played on me. In fact I found nothing.

I switched on again and let the set run. This time it ran for several minutes, then out went the thermal device again. I made some more checks, including some re-checks of what I had already done, but found nothing. Finally, I suggested to the owner that we would try re-setting the thermal once more and, if it didn't hold this time, it would be a job for the workshop.

AN INTRODUCTION TO DIGITAL ELECTRONICS

Here are the chapter headings:

- | | |
|--------------------------------|------------------------------|
| 1. Signals, circuits and logic | 12. Basic readout devices |
| 2. Basic logic elements | 13. Multiplexing |
| 3. Logic circuit "families" | 14. Binary arithmetic |
| 4. Logic convention and laws | 15. Arithmetic circuits |
| 5. Logic design: theory | 16. Timing & Control |
| 6. Logic design: practice | 17. Memory: RAMs |
| 7. Numbers, data & codes | 18. ROMs & PROMs |
| 8. The flipflop family | 19. CCD's & magnetic bubbles |
| 9. Flipflops in registers | 20. D-to-A converters |
| 10. Flipflops in counters | 21. A-to-D converters |
| 11. Encoding and decoding | |

Available from "Electronics Australia", 57 Regent St, Sydney. PRICE \$4.50 OR by mail order from "Electronics Australia", PO Box 163, Chippendale 2008. PRICE \$5.40.

DICK SMITH
WHOLESALE

NEW ZEALAND ENTHUSIAST'S CATALOGUE

1982 '83

INSIDE THIS ISSUE
- WORTH 75¢!!!

FREE



DICK SMITH'S 1982 '83 NEW ZEALAND CATALOGUE OUT NOW!

YES! It's our Second Edition Catalogue - even bigger than last year's. Packed with goodies for the hi-fi buffs, computer boffins, CB & amateur freaks, fanatical kit builders - you name it! And there's even a special data section - some specially written for New Zealand. So grab yours now - it's FREE in this magazine!!!

DROP IN TODAY & CHECK OUT OUR GREAT RANGE OF GOODIES

DICK SMITH ELECTRONICS
98 Carlton Gore Rd, Newmarket,
Auckland 1. Ph: 504 409

AUCKLAND

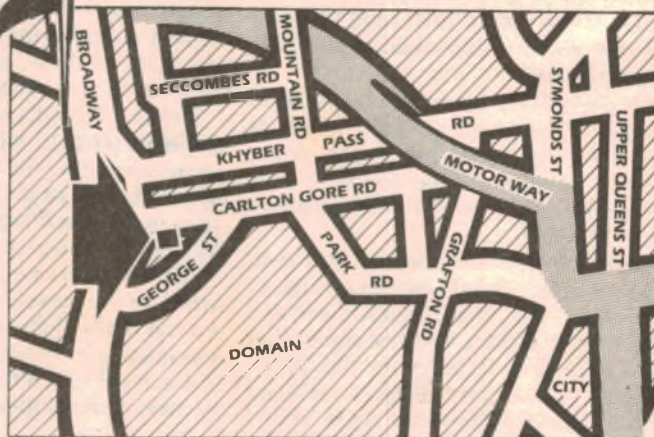

THERE'S A DICK SMITH DEALER NEAR YOU!

- A1 Computers HAMILTON Ph: 436 181 • Amos Electronics HAMILTON Ph: 434 628 • Audio Developments MORRINSVILLE Ph: 6675 • Barcham Projects HASTINGS Ph: 88 788 • Barnetts Radio & TV CENTRAL OTAGO Ph: 406 • Bennett Electrical Supplies TWIZEL Ph: 231 • David Brice Electronics FEILDING Ph: 37 141 • The Byte Shop AUCKLAND Ph: 32 860 • The CB Electronic Centre Ltd NAPIER Ph: 55 527 • Collerons Colourvision MASTERTON Ph: 83 348 • Computers & Electronics CHRISTCHURCH Ph: 62 894 • Datalink Ltd WELLINGTON Ph: 724 634 • Deerness Teletronics WANGANUI Ph: 56 175 • Eclipse Radio & Hobbies DUNEDIN Ph: 778 102 • Egley Electrical WELLINGTON Ph: 850 603 • Electromania Elect. Ltd ROTARUA Ph: 479 507 • Electronic Component Distributors PALMERSTON NORTH Ph: 72 249 • Electronic Mail Order Co. LOWER HUTT Ph: 698 007 • KM Electronics TIMARU Ph: 81 580 • Ken France Electronics ALEXANDRIA Ph: 6719 • Griffith Radio Services NELSON Ph: 84 898 • Home Appliance Centre BLENHEIM Ph: 89 501 • House & Home Hardware MANGAKINO Ph: 280 • Kane Agencies NELSON Ph: 84 066 • Leading Edge Computers DUNEDIN Ph: 44 439 • M B & H Customer Services EDGECUMBE Ph: 49 512 • Mayos Electrical & Gift Centre CHRISTCHURCH Ph: 385 954 • Oliver Electronics KERIKERI Ph: 78 836 • Penwardens Radio & TV TOKOROA Ph: 67 675 • Porterfield Computers Meadowbank, AUCKLAND Ph: 582 285 • Searle Electronics WHANGAREI Ph: 82 445 • Shoreline Electronics HAVELock NORTH Ph: 776 395 • SICOM CHRISTCHURCH Ph: 796 259 • The Sound Centre LEVIN Ph: 85 879 • Taranaki Micro Electronics NEW PLYMOUTH Ph: 84 067 • Town & Around TV MASTERTON 276 Queen St. • Trend Electronics TAURANGA Ph: 85 154 • Triad Electrical Service GISBORNE Ph: 5258 • Tricity House CHRISTCHURCH Ph: 67 443 • Viscount Electronics PALMERSTON NORTH Ph: 86 696.

WHAT!

NO CATALOGUE?

If someone got to this magazine before you, don't worry. Just cut out the coupon opposite & send in for your FREE copy NOW!

(Offer lasts this month only)

Send coupon to 'Free Catalogue', P.O. Box 9452, Newmarket.

Please send me a FREE copy of the 2nd Edition Dick Smith Catalogue. (Mine was swiped from this magazine when I wasn't looking!)

NAME

ADDRESS

NORMALLY \$1.05 POSTED!!!

ONLY VALID FOR NEW ZEALAND

DSEA292 CJM

Maybe that frightened the set; anyway, whatever the reason, the thermal held this time. After about 15 minutes, during which time I gave the various adjustments a routine once-over, I decided that it wasn't going to trip. I packed up, advised the owner to contact me immediately if it gave further trouble, and went on my way.

I need hardly add that I wasn't very happy with the situation. Faults like this seldom really cure themselves; they simply lie dormant and re-appear at the most inconvenient time. I fully expected to be called back within the next couple of days. In fact, a fortnight went by and I was on the verge of ringing the owner, in case he felt diffident about calling me again. Then the phone rang and it was him at the other end.

"You'd better drop in when you're out this way and have another look at the set."

"OK", I replied, "I've been expecting you to ring. I thought that trouble would have shown up again before this."

Then came the surprise. "Oh no, it isn't that. The set's giving a perfect picture. It's just that we have no sound." Well, I thought, that's a turn-up. I fished out the circuit, had a good look at the sound chain, made sure I had any spares likely to be needed for it, and set off.

At the customer's home I confirmed that there was not a vestige of sound from the speaker, and then made a quick voltage check of the audio amplifier. Nothing seemed to be wrong there; all voltages were correct, and there were even some minor voltage fluctuations which could have been due to sound signals in the amplifier.

Becoming suspicious, I put my ear to the speaker and listened carefully. It was absolutely dead; not a vestige of hum, frame buzz, or anything else. I switched the set off and turned my attention to the speaker. A quick check confirmed my suspicion; an open circuit voice coil.

This set uses a special speaker with an 80Ω voice coil, so that was one spare that I didn't have with me. And not because I had forgotten to bring one; I just don't carry specials like that in stock.

So I had to order one, wait a couple of days for it to be delivered, then make another trip to fit it. And what of the original fault? That remains a mystery. Many more weeks have gone by without so much as a flicker from the set.

I only hope it stays that way.

To change the scene, here is a story from a technician in a quite different field. He is Mr J. P. of Cook, ACT and he is a sea-going technician whose basic job is looking after navigation equipment. But, as he puts it, he encounters

Antenna Fatality

In my May 1982 notes I reported a live antenna fatality which occurred in the Bega district, on the south coast of NSW. The victim was a 17-month-old baby who touched a downpipe on which the TV antenna was mounted.

It was subsequently reported, in the Sydney "Sun" that Bega police had charged a 34-year-old electrical contractor with manslaughter, as a result of the baby's death. Latest information is that the accused is due to face committal proceedings in the Bega Court on July 28.

technical problems ranging all the way from satellite navigation gear to tape recorders and watches, these latter items mainly from passengers and crew.

And, apparently, even when on duty in the home port, he is the one that everyone turns to when their favourite piece of electronic gear fails to do what is expected of it. What's more, these calls for help can come at the most inconvenient times. As he puts it, "A simple job may not be so simple at the wrong time".

The following is a typical example, told more or less in J. P.'s own words.

SPLATTERED ALIENS

It was ship's crew change-over time, and I was waiting for my relieving technician to come on board before heading for home on a spell of leave. Clad only in a towel, I was heading for the shower when a six-year-old youngster, close to tears, stopped me outside my cabin door. "Mummy's friend said you could fix this."

He was holding up a brand new toy ray-gun. "Batteries", I thought, stepping back into my cabin. There were two cells, and they both tested at 1.66V unloaded, which was OK in my book. So I went through the motions of cleaning those contacts I could reach, while youngster explained what he thought the device was supposed to do.

Between us we decided that the toy projected images of splattered aliens on the wall, from film in a changeable cartridge. Pulling the trigger changed the picture and completed the lighting circuit. Electrically, it appeared to be just a torch built in a cheap and nasty manner. The bulb was obscured by the film and a frosted screen. Operating the switch produced no light, no sound — nothing.

Just as I started extricating the bulb for testing the relieving technician arrived, bags and all, plus several mates and the necessary ingredients for a farewell party. Still clad only in a towel, I found the atmosphere less than favourable for solving puzzling technical problems.

I managed to extract the bulb and it looked OK, while a measurement showed some nominal low resistance. More people had arrived and the party was now in full swing, with standing room only.

With a couple of helpers I held the toy together in various configurations in order to test the contact mechanism. Eventually it was exonerated, although it was hard to test due to the physical construction of the toy. The switch mechanism itself was completely inaccessible, but it showed a low resistance when switched. Was there some audio device between it and the globe?

A current measurement showed 120mA. That seemed a bit low, but was it? The circuit was obviously being completed and the trigger pressure made little difference. Why couldn't any light be seen? Maybe we misunderstood the operation of the toy. Were the batteries faulty, in spite of my test. I tried the batteries from my torch. Nothing.

By now the relieving technician was interested and suggested that we remove the batteries and bulb and determine the current without the intervention of any toy-related mechanism. Plenty of hands were available for this test, so I left for my long overdue shower.

On my return I was nearly laughed out of my own cabin. Brand new toy though it was, it had a 6V bulb (not 3V) in it! In my hurry I had neglected to check it, even though I had had it in my hands three times!

By the time my taxi arrived we had seen all three cartridges of well known cartoon characters, to the accompaniment of appropriate animal noises from the more jovial gentlemen present. And the youngster had discovered that, by quick-firing, the pictures made up short animated sequences, reminiscent of "the flicks".

So everything ended happily.

Thank you J. P. That story will take a lot of trumping but the aspect of it which appeals most to me is that it was quite obviously a "love" job; the only reward was to dry the youngster's tears. So we're not all money grabbing rip-off merchants.

If you have a factual and interesting story to tell about electronic servicing, write it in your own words and send it to "The Serviceman", c/o "Electronics Australia", Box 163, Chippendale 2008. If the Serviceman uses it in his column, we will pay an appropriate fee.

Circuit & Design Ideas

Interesting circuit ideas from readers and technical literature. While this material has been checked as far as possible for feasibility, the circuits have not been built and tested by us. As a consequence, we cannot accept responsibility, enter into correspondence or provide constructional details.

Programmed switch-on for IR remote control

In the original article on the Stereo Infrared Remote Volume Control (October, 1979), it was suggested that in view of its very low power consumption it be left permanently switched-on. For this reason the power switch was deliberately omitted. However some constructors prefer to switch the unit off when not in use, and have found that at switch-on the unit can set itself to any random audio level (even to full volume). A very simple modification can solve this problem.

All that is needed is to momentarily apply a high signal to pin 1, the preset

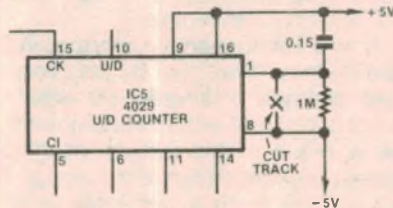

enable input of the 4029 Presettable Up/Down Counter (IC5), at switch-on. This is easily accomplished by cutting the track to pin 1 and bridging the cut with a 1MΩ resistor. A 0.15μF capacitor is then connected between pins 1 and 16 (adjacent) of IC5.

As pin 16 is connected to the +5V rail, pin 1 will be "high" at switch-on, but will revert to "low" as the 0.15μF capacitor is charged via the 1MΩ resistor (the other end of which is connected to the -5V rail).

Thus, at switch-on the 4029 counter is preset to audio level 2 (due to the switching-on sequence of IC3), and after a delay of about a quarter-second the 4029 counter functions normally, with up/down control of audio level being available from the infrared transmitter.

J. Forest,
Corrimal, NSW.

Resuscitation training aid

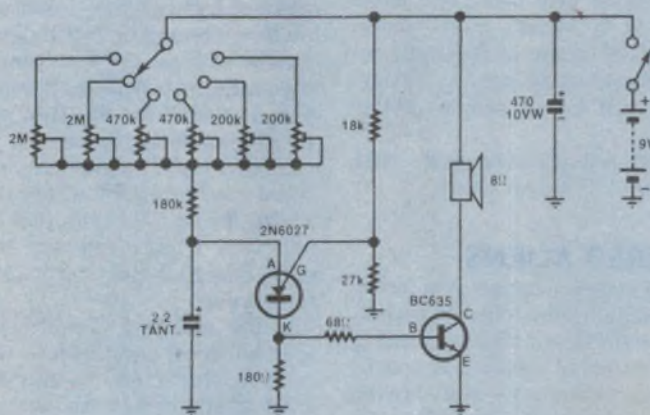

The simple Metronome described in EA for January 1982 can be adapted as a training aid for students of expired air resuscitation and external cardiac compressor. It is important that students become accustomed to using exactly the right rate.

To this end, six trimpots are

substituted for the single rate pot used in the original metronome circuit. This allows the recommended rates for resuscitation and cardiac compression to be preset and selected with a rotay switch.

A. Harvey,
Holland Park, Qld.

Low cost transistor checker

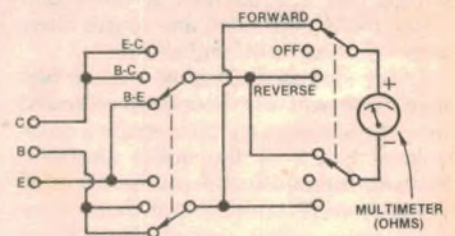

This transistor checker is about as simple as you can get. The circuit uses just two two-pole three-position switches, together with a standard analog multimeter.

The switch selector enables "continuity"/open-circuitry checks between each of the three pairs of transistor electrodes in both the forward and reverse polarity modes. If doubt exists as to the condition of a "used" transistor, performing the same checks on a known "good" transistor of the same type permits comparison of the measured parameters with those of the unknown transistor.

In use, the multimeter is switched to a resistance range, and the transistor parameters measured as desired. Note that in the resistance measuring mode normal analog multimeters produce a negative potential on the positive probe, and a positive potential on the negative probe.

D. Shawcross,
Perth, WA.

Measuring tape speed on cassettes

A precise method of measuring tape speed involves the time taken for a known length of tape to pass the head. For example, a 10 metre length of tape takes almost exactly 210 seconds (209.97s, actually) to pass the head at the designated cassette tape speed of 47.625mm/sec.

Extract 10 metres of tape from a standard cassette and mark this distance from the end of the leader with an additional piece of leader inserted to make a break in any recording. Now record 1kHz tone which can be checked on playback with a stopwatch to find its exact duration and ultimately, by calculation, the tape speed.

R. Caddy,
Kensington, NSW.

**NEW
MODEL**

**the low cost
answer to
model
control**

**The
DICK
SMITH
four
channel
digital
proportional
radio control**

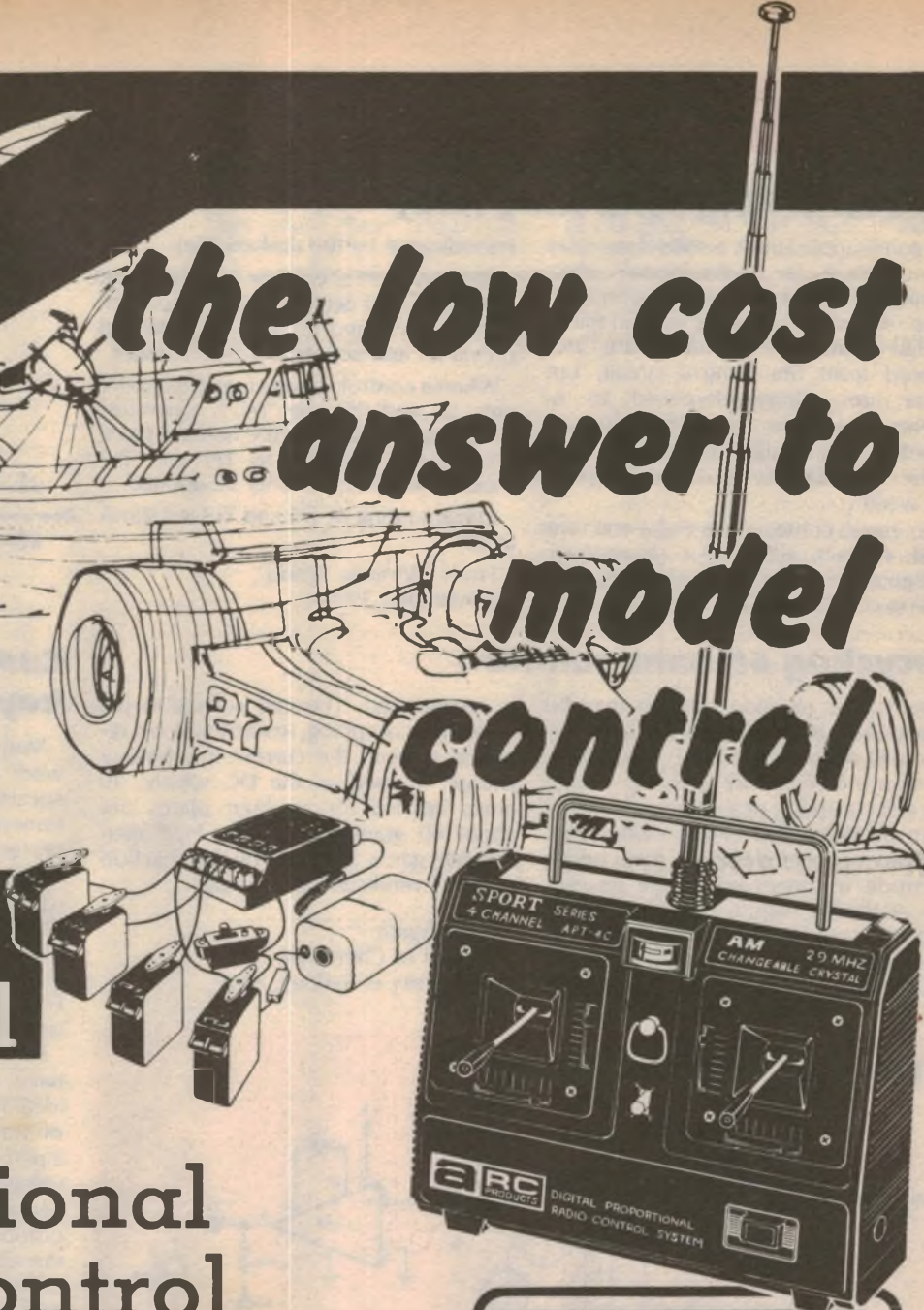

HERE AT LAST!! A 4 channel radio control for bringing life to your model boats, tanks, cars, planes — in fact anything that will take radio control including yachts!

You can now control such things as retractable undercarriage, bomb bay doors on your WW II Bombers and many features of your models that up until now have been wasted.

AND the best part is the price! For under \$150 you get features you would pay \$\$\$\$ more for. Features like:

- Top range transmitter and ultra-sensitive receiver
- Comes complete with receiver, battery holder and four servos
- Suits all models
- Changeable crystals for different operating frequencies.

● Requires 12 pen light cells (Cat S-3003 22¢ ea.)

**A MASTERPIECE IN
STATE-OF-THE-ART RADIO
TECHNOLOGY**

Still available: Limited stocks of the 3 channel digital controller
Cat Y-1230. LOW LOW PRICE ONLY \$79.00

WAS \$99
SAVE \$20!
↓

Complete with transmitter;
receiver; battery holder

**DICK BREAKS THE
PRICE BARRIER!**

**ONLY
\$149.50**

Cat Y-1240

DSE/A182M/PAI

**DICK SMITH
Electronics**



SEE PAGE 52 FOR ADDRESS DETAILS

Fast switching solid state relay

In some applications a solid-state relay can replace a conventional electromagnetic one to provide a faster switching response. It must be kept in mind, though, that the contacts are not isolated from the control circuit, but rather are voltage-referenced to it. However, where miniaturisation is desired – as in radio controlled models – the solid-state relay can save space and weight.

This circuit contains one make and one break contact; although a changeover configuration could be obtained by connecting contact points 1 and 3 together

(as indicated by the dashed line).

With no control voltage applied, Tr1 is turned off and acts as an open contact. Tr2 is also turned off, but Tr3 is turned on via R3 and acts as a closed contact.

When a control voltage is applied to inputs "a" and "b", the "relay" operates, reversing the status of the contact pairs. D1 prevents damage to Tr1 and Tr2 should the wrong polarity be applied.

Current rating of Tr1 and Tr3 is 750mA at 20V.

From "Wireless World", November, 1980.

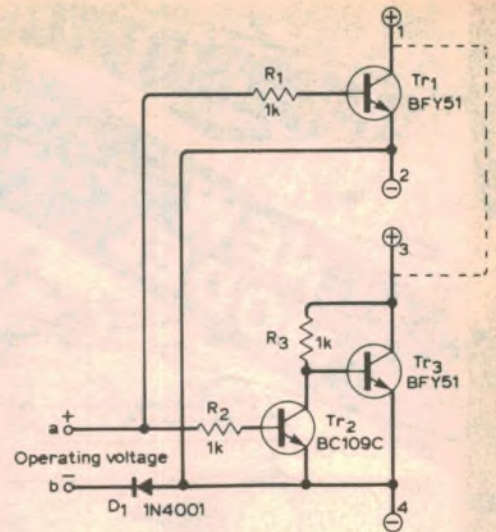

Recycling etchant solution

Spent ferric chloride solution may be regenerated electrochemically and the dissolved copper recovered. The etching reaction is reversed by applying voltage to a cell consisting of a carbon electrode (from an exhausted D-size carbon-zinc cell) and a copper electrode. The carbon electrode is connected to the positive side of the DC supply and the copper electrode connected to the negative side. Copper plates out onto the copper electrode and the ferric chloride solution

is regenerated. The cell voltage is 2.6 volts so a dropping resistor will be required to limit the current if a battery charger is used as the DC supply. 10 amps applied for an hour plates out about 60 grams of copper. Hydrogen chloride gas is liberated by the reaction so good ventilation is essential.

S. Bathgate,
School of Chemistry,
University of Sydney, NSW.

Customised keytops

Many keyboards for computer or RTTY work are supplied with blank keys for special functions, or have keys with functions that can be altered. A quick and professional means of altering the character on the keycap would be useful. One easy way to do this is to use Letraset rub-on lettering. The characters are available in a large range of colours and sizes, and stick easily to the plastic. Errors can be fixed simply by lifting the lettering off with a small scraper.

However, once applied the letters have to be protected. Mat varnish is ideal for the job, and the dished surface of most keycaps makes it easy to obtain a perfectly smooth finish. Simply thin the varnish down and place a drop onto the keycap. Move the keycap around to distribute a thin film of varnish all over the surface then leave to dry. The varnish will be slightly thicker towards the centre of the keycap, but as long as only a small drop is used the effect will be unnoticeable.

A similar "painting" technique can be used to change the colour of the keycap, or to blank out an existing character before applying a new one. In this case plastic model paint is the best, as it comes in a wide range of colours in tiny tins.

J. Richards,
Jamboree Heights, Qld.

TRS-80 Cassette Control

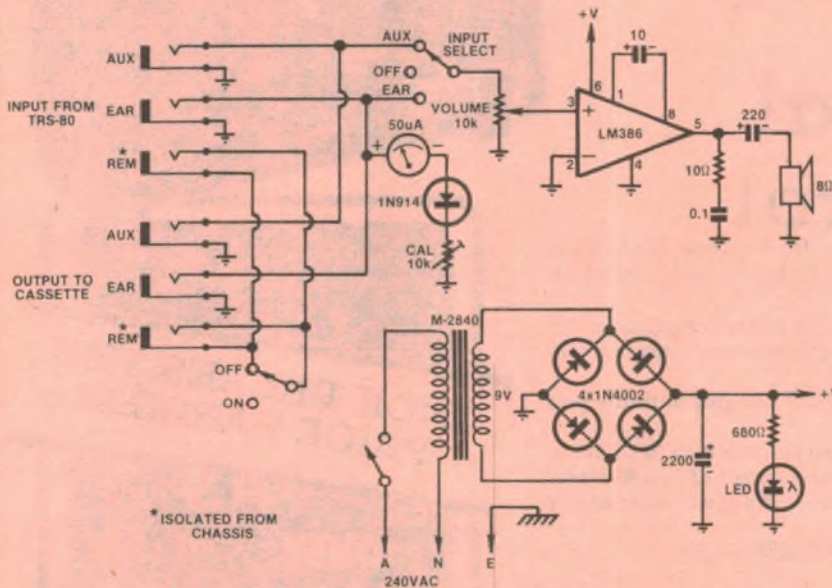

This circuit allows the operator to have full control of the cassette storage system. It assists in loading programs and has an amplifier (LM386) for sound effects or program monitoring.

The input select switch is a DPDT "centre-off" type which monitors

signals from the earphone or Aux socket. The "centre-off" position allows peace and quiet.

The level meter is calibrated by the 10kΩ trimpot when loading tapes which are known to be reliable.

P. Wakim,
North Brighton, SA.

Circuit ideas wanted

PSST! Got any neat circuit ideas? We pay between \$5 and \$20 per item, depending on how much work we have to do to publish it. Send your idea to "Electronics Australia," PO Box 163, Chipendale 2008.

Bill Edge's

ELECTRONIC AGENCIES

115-117 Parramatta Rd. Concord 2137
(Corner Parramatta Rd & Lloyd George Ave)
Telephone (02) 745 3077 (two lines)
117 York St. Sydney Phone 29 2098

bankcard
welcome here

TRADING HOURS
BOTH STORES
Mon-Fri 9am-5:30pm
Thursday 9am-8pm
Saturday 9am-12pm

Mail Orders:
PO Box 188
Concord
2137

MAIL CHARGES
\$5-\$9.99 \$10-\$24.99
\$25-\$49.99 \$50-\$99.99
\$100 or more

what else do we carry? HI-FI ★ KITS ★ TEST EQUIPMENT ★ SEMICONDUCTORS ★ COMPONENTS ★
All prices correct and goods in stock at time of going to press. Please phone to check current availability

★ **NEW ADDRESS** ★
FOR YORK ST. STORE.
Moved one door to 117 York St
*Two doors from Dick Smith's Phone 29 2098

NEW *PIONEER*

Separate Speakers now available. Compare these prices for power handling and quality!

12 INCH WOOFER
14 oz. Ferrite Magnet
Power Rating 65 WATT (RMS)
Nominal Resonant Freq (fo) 23.28 Hz
Nominal Sensitivity 97(dB/W)
Response Range 16 - 2500 Hz
\$32.50
CE2121

12 INCH WOOFER
30 oz. Ferrite Magnet
Power Rating 90 WATT (RMS)
Nominal Resonant Freq (fo) 20.25 Hz
Nominal Sensitivity 96(dB/W)
Response Range 16 - 2000 Hz
\$45.00
CE2128

4 1/4 INCH MID RANGE
30 oz. Ferrite Magnet
Power Rating 15 WATT (RMS)
Nominal Resonant Freq (fo) 1000 Hz
Nominal Sensitivity 96(dB/W)
Response Range 700 - 6000 Hz
\$6.50
CE2070

10 INCH WOOFER
11 oz. Ferrite Magnet
Power Rating 50 WATT (RMS)
Nominal Resonant Freq (fo) 25.30 Hz
Nominal Sensitivity 96(dB/W)
Response Range 16 - 2500 Hz
\$27.50
CE2117

8 INCH WOOFER
9.3 oz. Ferrite Magnet
Power Rating 30 WATT (RMS)
Nominal Resonant Freq (fo) 45.50 Hz
Nominal Sensitivity 96(dB/W)
Response Range 16 - 3000 Hz
\$15.50
CE2111

5 INCH MID RANGE
302 Power Rating
30W (RMS)
\$13.50
CE2078

2 1/2 INCH HOEN TWEEETER
2.2 oz. Ferrite Magnet
Power Rating 12 WATT (RMS)
Cross Over Freq (fo) 3000 Hz
Nominal Sensitivity 101(dB/W)
Response Range 2000-20000 Hz
\$9.50
CE2014

1 INCH DOME TWEEETER
0.3 oz. Ferrite Magnet
Power Rating 25 WATT (RMS)
Cross Over Freq (fo) 2000 Hz
Nominal Sensitivity 95(dB/W)
Response Range 2000-30000 Hz
\$12.50
CE2015

ETI 5000 POWER AMP

NOW WITH SUPERB FINISH PANEL LOOK

- Superb Finish Front Panel Headskin topped so no screws are visible
- Ferguson transformers supplied, not cheaper equivalents
- Pre Built chassis designed in conjunction with David Tibbock, with a screw lid for easier access
- Specially written instructions by Phil Waite
- Bill own Kit Constructors guide
- WHY RISK BUYING A POWER AMP WITHOUT ALL THESE FEATURES

STILL ONLY \$295
KE25050

ETI 5000 SERIES "PROFESSIONAL" PREAMP

UPGRADED VERSION

- Includes
- Gold Plated sockets on ALL inputs not just phono 24 in all
 - 2 Gold RCA Plugs for phono
 - IC sockets provided where physically possible
 - All metal film resistors
 - Silver Anodised rear panel with silkscreened lettering and format borders
 - Bill's kit constructor guide

ALL THIS FOR THE PRICE OF THE NORMAL KIT
\$245
KE5000

SAVE **\$30**

OTHER NEW SPEAKERS

MAGNAVOX 8MV Mk 2
(updated 830)
CE2113 \$29.50
40 watt RMS handling

NEW MAGNAVOX 4W 4" WOOFER
15 watts RMS
CE2100 \$17.50

NEW DOME MIDRANGE
50 watt handling
Freq Response 700 Hz-5kHz
Beautiful clarity
CE2079 \$14.50

NEW CROSSOVER NETWORK
3 way 100 watts 12 db
Crossover at 700 4500 Hz
Impedance 8 ohms
CE2106 \$17.50

All Published Printed Circuit Board from EA and ETI from 1975 to current ones are available ex stock in both our Concord and York St stores.

4000/1 SPEAKERS

All Good Things must come to an end. Duty on some important speakers went up in May as well as a 10% increase from Philips in Holland. This means that the 4000/1 is due for price increase. We found out just in time and made a bulk buy so this is your last chance to buy at the old price. July only or until stocks run out.

Speakers
\$499.00
PE CE2430

Cabinets available
\$280.00
CE2470

NEW RACK CASES

Black HE 1500 Silver HE1510 \$39.00
Black HE 1501 Silver HE1511 \$45.00
Black HE 1502 Silver HE1512 \$49.00
Quality 10 gauge construction. Front Panel 3mm Removable Top and Bottom Panels.
Height 44 mm 88 mm 132 mm

JULY KIT SPECIALS

Playmaster Model Amp with Ferguson transformer \$159 Save \$10 KE4180
ETI 1500 Metal Detector \$179 Save \$20 KE1460
ETI 480 50w Amp Module \$16 Save \$3.50 KE3060
ETI 480 100w Amp Module \$20 Save \$5.00 KE3070
ETI 480 Power Supply \$15 Save \$4.50 KE3050

MONSTER CABLE

You will be amazed (like we were) when you hear the difference this cable makes. Who would have imagined that replacing your ordinary speaker cable with Monster cable will make as much difference to the sound as changing to a moving coil cartridge. This is a must for serious audiophiles. How much you need for each speaker and when you normal wire. Measure and when you need for each speaker and when you purchase it we fit on the connectors at the ends. You can use either gold banana plugs or gold spade connectors. We used gold pins. The spade terminals on your amp if you have screw terminals and the banana and speaker terminals and sample order list push type terminals and sample order list.

Mail Order customers —
1 length 4 metres 2 gold pins to 2 gold spades — left speaker
1 length 6 metres 2 gold pins to 2 gold spades — right speaker
Cable — \$3.75 per metre
Gold Pins — \$2.50 pair
Gold Spades — \$4.00 pair
Gold Bananas — \$15.00 pair

HEARING IS BELIEVING!

CONCORD COMPUTER

See Review in EA last month
FIRST SHIPMENT LOST OUT

STILL ONLY \$899 KE2000
BUILT UP POWER SUPPLY
\$100.00 ME7000

DONT BE FOOLED by advertising kit prices! Does the kit include everything you need to complete the job? Buying a kit is like buying a used car. Until you see what condition its in (how many parts not supplied) you don't know if its good value. With an Electronics Agencies kit you are assured every part needed is included and you won't be up for more money for those hidden extra parts. Don't be fooled by clever advertising. We excel at making the best kit.

SPEAKER CLOTHS

New Range available
Brown with black stripe CE2754
Brown — all brown CE2755
White — with black and gold fleck CE2756
Gray — silk CE2753
Black — silk CE2752
All available in rolls 5' long
Price per 1 metre 2.5
CE 2754/5/2 \$10.50 mt
CE2756/3 \$6.50 mt

SPEAKED FLEX

14" Dia Fig 8
100 mt roll \$6.95
WE2027
If ordered separately
P&P \$4.00

BEST SELLING KITS

Voice Operator Relay KE1130 \$15.00
Voice Canceller KE1155 \$20.00
Negative Ion Generator KE1100 \$39.00
Car Alarm (with Discant Box) KE1725 \$99.50
Transistor Assisted Ignition KE1835 \$35.00
Epron programmer Kit KE1880 \$52.50
PH Meter: KE4050 \$109.50
Wideband Receiver KE4110 \$75.00
Function Generator KE4095 \$85.00
Frequency Meter KE1815 \$119.00
Colour Graphic Analyser KE4150 \$119.00
Wind Speed Kit KE1630 \$44.50
Wind Direction (add on) KE1631 \$25.00
ETI 660 Colour Computer KE4600 \$99.00
Microwave Oven Leak Detector KE1100 \$14.95
Cylon Voice KE1110 \$14.95

ALL KITS NOW INCLUDE OUR KIT CONSTRUCTIONS GUIDE
WE APLOGISE FOR THE DELAYS IN MAKING THIS AVAILABLE

NEW MOVING COIL CARTRIDGE SUIT ET15000 SERIES

Cartridge CE6520 \$49.95
Stylus CE6040 \$27.99
MC-100 HIGH OUTPUT MOVING COIL CARTRIDGE

This high performance cartridge is easy to install, standard 1/2" mount. Does not require a transformer due to its unique structure and the use of powerful samarium cobalt magnets. The economical cost and the ease of stylus replacement allows everyone to enjoy the superb quality of a moving coil cartridge.

SPECIFICATIONS
Type: Moving coil type stereo cartridge
Frequency characteristics: 15-35,000 Hz
Output Voltage: 2.5mV (1kHz/50mm/s)
Output Balance (1kHz): within 1 dB
Channel separation (1kHz): 25 dB
DC Resistance: 120
Impedance: 120
Vertical Tracking Angle: 20°
Compliance: 8 x 10⁻⁹ cm/dyne
Tracking Force: 20 ± 0.3gr
Stylus Tip: 0.6mil Diamond
Weight: 4gr
Mounting Standard: 1/2" (12.7mm)

NOW AVAILABLE NEW ETI 5000 SERIES

Moving coil and magnet preamps now available separately
Components and PCB supplied
Moving Coil KE4600 \$19.50
Moving Magnet KE4610 \$14.50

NEW CONTACT US FOR THE CAR COMPUTER KIT FROM EA

Contact us for the car computer kit from EA. Don't buy a kit until you see the exclusive Electronic Agencies kit!

NEW 12V FLASHER KIT
This kit runs off 12 volt and is supplied with a 12 volt Red base! Just right for mounting on the dash to make it look like you have one of those expensive car alarms. See ETI Dec 79 KE1086 \$5.95

NEW ELECTRONIC TUNING FORK KIT
To match our metronome kit for all you budding Paul McCartneys. Kit is complete with everything except plug pack. See ETI NOV 79 KE1068 \$23.00

NEW MULTIPURPOSE VOLTAGE REGULATOR KIT
Adjustable from 125 volts to 37 volts at currents up to 15 AMP using LM317T PCB and components only. See EA APRIL 80 KE1960 \$9.95

NEW TOUCH SWITCH KIT
Turn your reading lamp or appliances on and off with a touch. See EA MAY 80 KE1912 \$12.00

NEW DRUM SEQUENCED KIT
For Drum Machine. Includes quality C&K mini D&L switch KE1076 \$19.50
Drum Machine KE1075 \$89.00

Decimal point switching for the 500MHz DFM

simple circuit lets you read directly in MHz or μ s

Using just two low-cost CMOS ICs and a handful of other components, this circuit will add the convenience of decimal point indication to the 500MHz Digital Frequency Meter described in the December, 1981 issue. Now you can read frequency and period directly in "MHz" and " μ s".

by COLIN DAWSON

As we expected, the 500MHz Digital Frequency Meter is proving to be a popular project. Many hundreds of kits have now been sold and demand continues. That's hardly surprising considering you can build a full 500MHz DFM with switchable gating and period measurement capability for around \$145.

But the project does have one drawback: it does not have decimal point indication, making it necessary to refer to a table (on page 49 of the February, 1982 issue) in order to decipher readings. While this may be satisfactory for occasional readings, it can become tedious when taking multiple readings on different ranges.

The design featured here was contributed by Mr A. Maurer (VK3YWV) of Mitcham North, Victoria, who developed it for use in his own 500MHz

DFM. Rather than simply present his idea in Circuit and Design Ideas, we decided to design a suitable PCB and described the circuit as a full project. The resulting circuit is inexpensive, simple to install, and will automatically drive the appropriate decimal point for various settings of the DFM.

In addition to the PCB, we have also prepared a new front panel artwork for use with new kits equipped with the decimal point option, which can be retrofitted to older kits if you so wish. The new artwork is compatible with the existing front panel of the DFM, and simply indicates that the display can now be read directly in MHz and μ s.

For example, a reading of 4.99498 in the frequency mode will be 4.99498MHz, while a reading of .14573 in the period mode is .14573 μ s.

How it works

The circuit makes use of unused poles on the range switch (S1), while double pole switches are now required for the

gating switch (S3) and the function switch S4. In many kits, however, double pole switches have been supplied instead of the single pole units specified, so replacements may not be necessary. No other component substitutions are required.

Refer now to the circuit diagram. Each position of the gating switch is assigned a 2-bit binary code equivalent to a decimal value of 0, 1, 2 or 3 (10s, 1s, 0.1s and .01s gating respectively), irrespective of whether the DFM is in the frequency mode or the period mode. This binary number is fed to the A1 and A2 inputs of IC1, a 4008 4-bit binary adder.

The values assigned to the range switch (S1) positions depend upon the mode selected by the function switch (S4b) – for frequency they are 0, 1 and 2; and for period they are 3, 2 and 1 (0-10, 10-50 and 10-500MHz range respectively). These values, in binary form, are fed to the B1 and B2 inputs of IC1.

IC1 adds the two binary numbers produced by the gating switch and the range

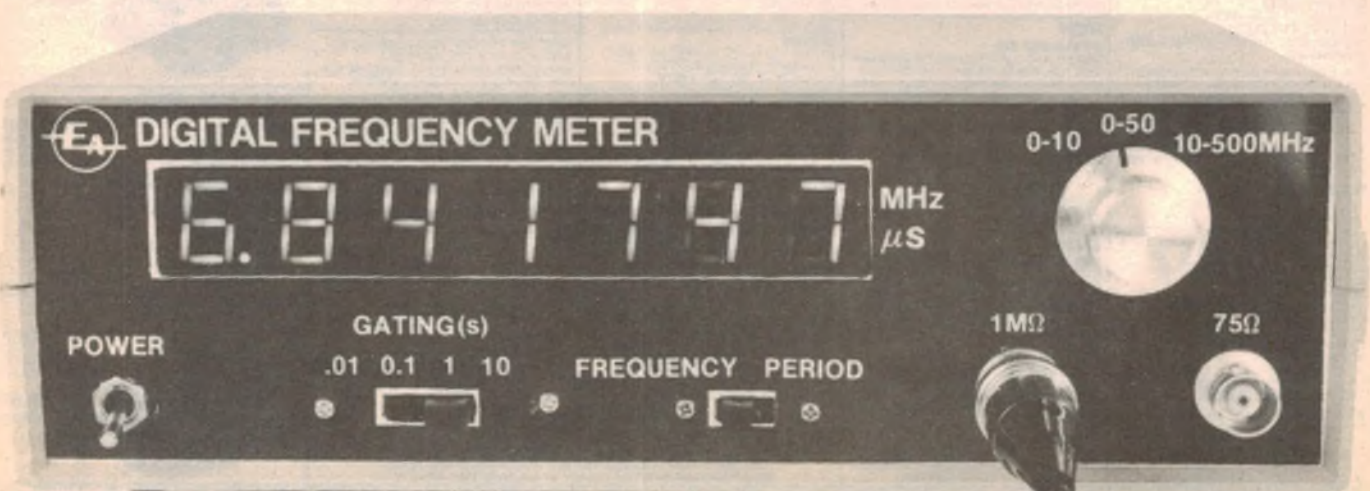

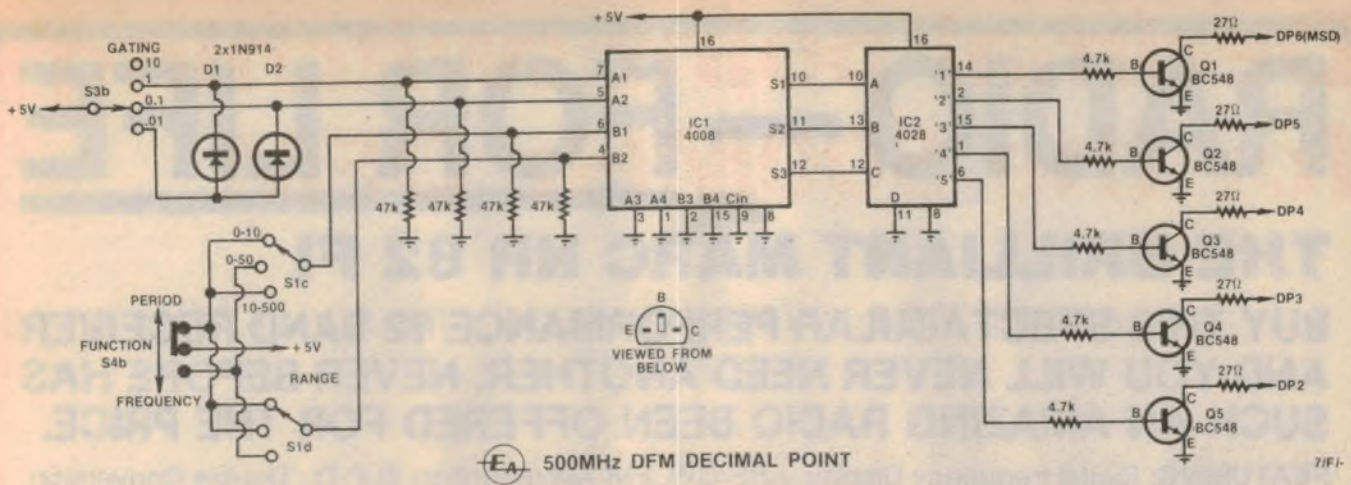

EA 500MHz DFM DECIMAL POINT

71F1

The circuit consists of a binary adder (IC1), a BCD to decimal decoder (IC2), and five driver transistors.

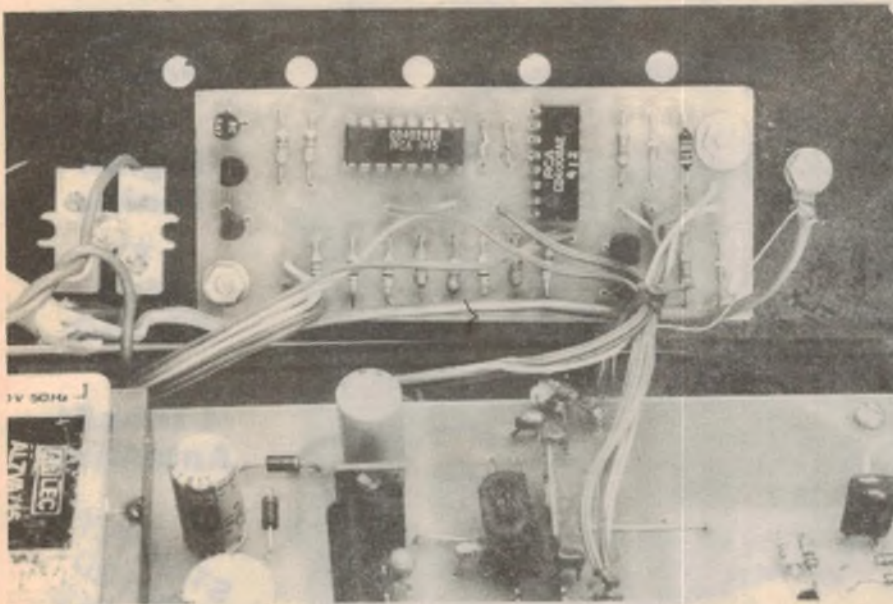

The PCB is mounted on the rear panel of the DFM case using machine screws and nuts. External wiring connections can be run in rainbow cable.

PARTS LIST

- 1 printed circuit board, code 82dp6, 90 x 41mm
- 1 Scotchcal front panel, 197 x 59mm (see text)
- 1 panel mounting 2-pole 4-position slide switch. (see text)
- 1 panel mounting 2-pole 2-position slide switch (see text)

SEMICONDUCTORS

- 1 4008 4-bit full adder IC
- 1 4028 BCD to decimal decoder IC
- 5 BC548 NPN transistors
- 2 1N914 silicon diodes

RESISTORS

- 4 x 47k Ω , 5 x 4.7k Ω , 5 x 27 Ω

MISCELLANEOUS

- Rainbow cable, machine screws and nuts, solder etc.

switch together. The resultant number is the decimal point position in binary coded decimal (BCD). This is decoded by IC2, a 4028 BCD to decimal decoder, which turns on one of five decimal point driving stages (transistors Q1 to Q5).

Let's take a closer look at IC1 and see how it works.

Being a 4-bit adder, IC1 has eight inputs labelled A1-A4 and B1-B4. The device operates by first adding A1 to B1 and presenting their sum at output 1 - or S1 (pin 10). If there is a carry (ie. their total is more than 1), then the carry is presented to S2 and added to the number produced by adding A2 to B2. If this total is greater than 1), a carry is presented to S3.

The third and fourth adders (A3 plus B3, A4 plus B4) work in exactly the same fashion. In this circuit, however, the third and fourth adders are not needed, and

are tied to ground. The reason for this is that only two inputs are required to provide codes for the four possible positions of the gating switch, and similarly for the three possible positions of the range switch.

In summary, IC1 simply adds together two binary numbers representing the positions of the gating and function switches, and presents the result at outputs S1, S2 and S3 (S4 not used here). This is illustrated by Table 1, which is the truth table for IC1 when the DFM is in the frequency mode. Outputs S1, S2 and S3 are decoded by IC2, which turns on the appropriate driver transistor.

The range switch connections to B1 and B2 are similar to the gating switch connections but, since the range switch has only three positions, no additional diode logic is required. There is, however, one complication with respect

to the range switch. For any given switch position, the binary number generated will depend on whether the frequency or period mode is selected. For example, on the 0-10MHz range, the number required is binary 00 (B1 and B2 low) for frequency measurements, and 11 binary for period measurements. Function switch S4b provides the appropriate compensation for the mode selected.

IC2, the BCD to decimal decoder, drives transistors Q1 to Q5 via 4.7k Ω base current limiting resistors. In addition, 27 Ω resistors are included in the collector circuits of the driver transistors to limit the peak current through the decimal point indicators. The reason for the low resistor value here is that, although the driver stage provides continuous power to the appropriate indicator, the whole display is still scanned by the digit multiplexing. Hence, the

RADIO — FOR LIFE

THE BRILLIANT MARC NR 82 FI

BUY THIS SPECTACULAR PERFORMANCE 12 BAND RECEIVER AND YOU WILL NEVER NEED ANOTHER. NEVER BEFORE HAS SUCH AN AMAZING RADIO BEEN OFFERED FOR THE PRICE.

FEATURING: Digital frequency Display, SSB/CW, FM/AM reception, B.F.O., Double Conversion, Double Super-het, crystal controlled (VHF) Local Oscillator, 4 inbuilt antennas and good looks, you will spend hours just learning how to drive it!

★
\$10
Pack and
Postage
anywhere in
Australia
★

only
\$349



3 Way
Power
★
Digital
Tuning
★
HI FI
SOUND
★
4 Inbuilt
Antennae

STRICTLY
LIMITED
STOCKS

SPECIFICATIONS:

Semi-conductors: 1 - LSI, 4 - IC's, 7 - FET, 34 - Transistors, 1 - Voltage regulator and 42 - Diodes

Frequency range:

LW	145-360	KHz	VHF1	30-50	MHz
MW	525-1600	KHz	VHF2	68-86	MHz
SW1	1.6-3.8	MHz	VHF3	88-108	MHz
SW2	3.8-9	MHz	VHF4	108-136	MHz
SW3	9-22	MHz	VHF5	144-176	MHz
SW4	22-30	MHz	UHF	430-470	MHz

Output power: 5.0W (Max.)

Power supply: AC 240V 50Hz DC 12V (8 x "D" cells) Ext DC 12V Car/Boat

Speaker: 12.5cm Permanent Dynamic Speaker (3.2 ohm)

Antenna: Ferrite Bar Antenna for LW, MW and SW1
3 x Telescopic Antenna for SW, VHF and UHF

Controls: Power ON-OFF switch — Digital display ON-OFF switch — Tape-Radio switch, Wide-Narrow band selector switch, AM band selector (LW-MW/SW1/SW2/SW3/SW4), VHF band selector (VHF1/VHF2/VHF3/VHF4/VHF5/UHF), Ant. Selector (Telescopic ANT./EXT. ANT.), Tuning control (direct gear drive), volume control, Bass control, Treble control, Squelch control, BFO pitch control, RF gain control, Antenna adjustor control, Mode switch (USB NOR LSB/CW)

Terminals: Ext. Speaker/Headphone Jack, Tape IN-OUT jack, VHF/UHF ANT. connector (coaxial), SW EXT. ANT. terminal (Screw), Ext. battery jack

Meter: Tuning Meter

Digital Frequency Counter Section:

Display: LW/MW/SW-1 KHz
SW2-4/VHF1-5 MHz

Control: SW Calibrator

Dimensions: 452mm (W) x 288mm (H) x 130mm (D)

Quantities strictly limited: Grab one now for only \$349 7 Day money-back guarantee



Order with your
Bankcard —
simply include
your B/Card
Number and
expiry date

together with your full
name, address and
telephone number.
Allow approx. 7 days
for delivery

Available from either of the following stores

ALTRONICS

105 Stirling Street,
Perth, W.A. 6000
Phone (09) 328 1599
Mail Order Address:
C/- P.O. Box 8280,
Perth, Stirling St., WA 6000

JAYCAR

125 York Street,
Sydney, NSW 2000
Phone (02) 264 6688
Mail Order Address:
C/- P.O. Box K39,
Haymarket, NSW 2000

SEVEN DAY
SATISFACTION
GUARANTEE
AND OF COURSE
90 DAY 100%
PARTS AND LABOUR
WARRANTY

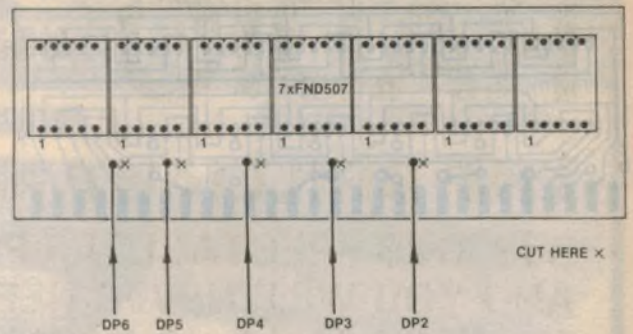
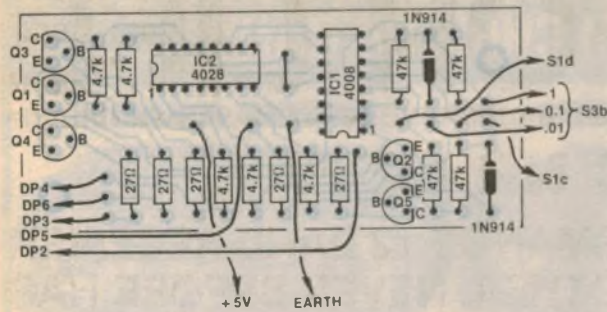

The diagram at right shows the extra wiring to the display PCB. Note the cuts to be made to the copper track linking the decimal points.

decimal point indicators have a low duty cycle and require high current pulses.

Before moving on to the construction, we should point out that this simple circuit does have some minor limitations. In all, some seven different multiplier values are required to correctly decipher all possible readings on the 500MHz DFM — ie. seven different decimal point locations are required. The problem is that this circuit is only capable of driving five different decimal points.

One of the missing decimal points occurs in the frequency mode with the 0-10MHz range and 10s gating selected. This combination results in a divide by 10^6 "multiplier", which corresponds to a decimal point at the eighth digit. Since the display only has seven digits (D0-D6), it is clearly impossible to display this point.

The other missing decimal point is at the second digit (D1), and is required when the DFM is in the period mode with 0-10MHz and .01s gating selected. In both cases, however, the position of the decimal point can be quickly established by altering the setting of the range switch or the gating switch.

The remaining problem has to do with the fact that the DFM has leading zero suppression. This means that for readings less than 0.1MHz or $0.1\mu\text{s}$, leading zeros between the decimal point and the most significant digit are suppressed. In practice, there is no difficulty in counting the number of blank digits between the decimal point and the most significant digit.

Undoubtedly, all the above problems could be solved by a more elaborate circuit, but this would be difficult to retrofit to existing units. For this reason, the simple circuit described here is a good solution, as the drawbacks are relatively minor.

Construction

Construction is straightforward, with all components mounted on a printed circuit board (PCB) coded 82dp6 and measuring $90 \times 41\text{mm}$. Assemble the

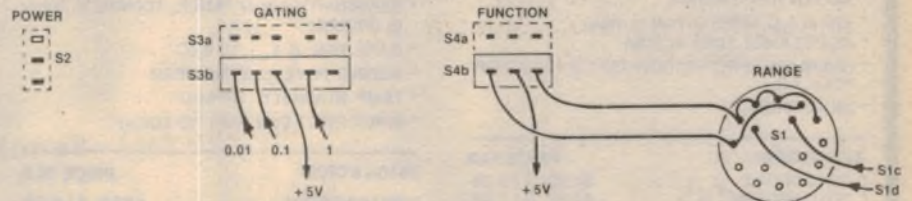

This diagram shows the additional wiring to the front panel switches. The +5V connections can be derived from S1a and S1b (see text).

FREQUENCY MODE		INPUTS				OUTPUTS		
RANGE	GATING	A1	A2	B1	B2	S3	S2	S1
0-10MHz	10	0	0	0	0	0	0	0
	1	1	0	0	0	0	0	1
	0.1	0	1	0	0	0	1	0
	0.01	1	1	0	0	0	1	1
0-50MHz	10	0	0	1	0	0	0	1
	1	1	0	1	0	0	1	0
	0.1	0	1	1	0	0	1	1
	0.01	1	1	1	0	1	0	0
10-500MHz	10	0	0	0	1	0	1	0
	1	1	0	0	1	0	1	1
	0.1	0	1	0	1	1	0	0
	0.01	1	1	0	1	1	0	1

TABLE 1: truth table for IC1 when the 500MHz DFM is in the frequency mode. Outputs S1, S2 and S3 are decoded by IC2, which turns on the appropriate driver transistor (Q1-Q5).

PCB according to the overlay diagram, leaving the two ICs till last. The ICs are CMOS devices, so observe the usual precautions: connect the barrel of your soldering iron to the earth track on the

PCB (use a small clip lead), and solder the supply pins (pins 8 and 16) first.

With assembly complete, sit the PCB adjacent to the rear panel of the DFM and commence the wiring to the front panel switches and the display board. Full details are shown in the accompanying diagrams. Note that switches S3 and S4 will have to be replaced with double pole types if these are not already fitted.

Access to switches S3 and S4 can be gained by temporarily lifting the main PCB assembly out of the case. The +5V supply for the circuit and to S3b and S4b can be derived from any convenient

We estimate that the cost of parts for this project is approximately

\$7.50

This includes sales tax but does not include the optional Scotchal front panel or replacement switches for S3 and S4.

sabtronics PRECISION INSTRUMENTS

NEW LOW PRICES FROM CHRISTIE RAND

DIGITAL MULTIMETER



- BASIC ACCURACY 0.1%DC, 0.5% AC
- DC & AC VOLTS 100uV to 1000V
- AC VOLTS TO 40KHz
- DC & A C AMPS 0.1uA to 10A
- RESISTANCE 100n to 20M
- OVERLOAD PROTECTION TO 1.2 KV DC OR PEAK AC
- DIODE TEST

BENCH DMM	PRICE TAX
• 2010 LED kit	\$110 \$13.28
• 2010 LED asbl	\$120 \$13.28
• 2015 LCD asbl	\$140 \$15.32

HAND HELD DMM 2A MAX

• 2035 LCD kit	\$110 \$13.28
• 2035 LCD asbl	\$120 \$13.28
• 2037 WITH TEMP PROBE	-50+150
• 2037 LCD kit	\$135 \$15.32
• 2037 LCD asbl	\$145 \$15.32

FREQUENCY COUNTER



- GUARANTEED 10Hz to 600MHZ
- TYPICAL 5Hz to 750Hz
- SENSITIVITY 10mV RMS to 100MHz & 70mV to 600MHz
- GATE TIME 0.1, 1, 10 SEC
- AGEING RATE \pm 5PPM/YEAR
- TEMP STABILITY .1PPM/C^o
- INPUT PROT 90V RMS TO 10KHz

8610A 8 DIGIT	PRICE TAX
• 8610A LED kit	\$159 \$18.38
• 8610A LED asbl	\$174 \$18.38
• 8610B 9 DIGIT	
• 8610B LED asbl	\$179 \$19.95
• 8000B 9 DIGIT 1 GHz	
• 8000B LED asbl	\$259 \$21.00

Batteries Not Supplied
Postage & packing \$3.00

FUNCTION GENERATOR



- 1Hz TO 200KHz
- SINE SQUARE & TRIANGLE
- DC OFFSET
- SINE WAVE ACCURACY 1%
- OUTPUTS
HIGH 10 VPP 600
LOW -40 dB
TTL
- SWEET INPUT 100:1 RANGE
- 5020 kit \$151 \$13.92TX
- 5020 asbl \$161 \$13.92TX

Distributor Enquiries Welcome

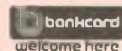

CHRISTIE RAND PTY LTD
PO BOX 48 EPPING,
NSW, 2121
PHONE (02) 868 1209

buy 30 years of experience in electronics

R.H. Cunningham suppliers and innovators in the audio and broadcasting product field, have the professional expertise in both the technical and service areas to support the products they sell.

Products:

1. VSC - Variable Speech Control Tape Recorder
2. Sound effect Vocoder - VSM 201
3. Universal level meter
4. Dowkey Series 60 SPDT Remote Coaxial Relay
5. Impedance meter ZP3

All of the above products are available from

R.H. Cunningham
PTY.LTD

146 Roden St., West Melbourne, Vic. 3003. Tel. 329 9633. Telex 31447.
4-8 Waters Rd., Neutral Bay, NSW. 2089. Tel. 909 2388. Telex 21707.



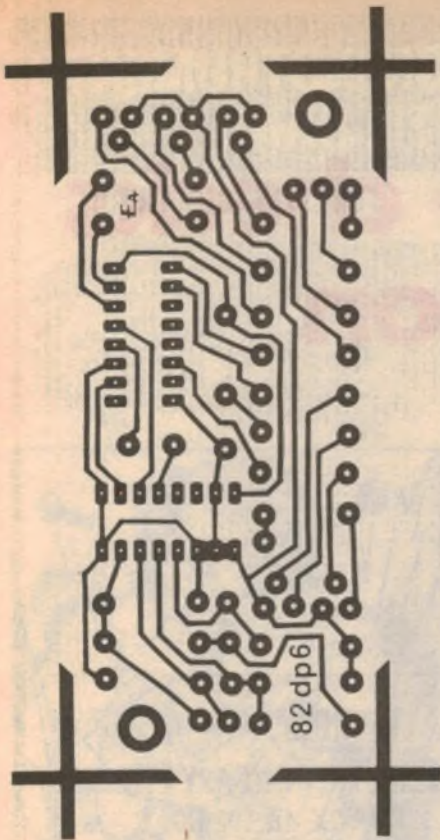

Above and right are actual size artworks for the PCB and front panel.

point on the main PCB, or from S1a and S1b (see circuit p45, December 1981). The use of rainbow cable is recommended for all wiring connections.

Connections to the display PCB involve running leads to the decimal point indicators (pin 5) of digits D2 to D6. No connections are made to D0 or D1. Note that it will be necessary to cut the track linking the decimal point indicators, as shown on the overlay diagram for the display PCB.

The decimal point PCB can now be mounted on the rear panel using machine screws and nuts, and the unit re-assembled and tested. If the decimal point appears in the wrong position, check your wiring to S3b, S4b and to the display PCB. If you are unable to get any decimal point indication at all, check the +5V and earth connections to the PCB.

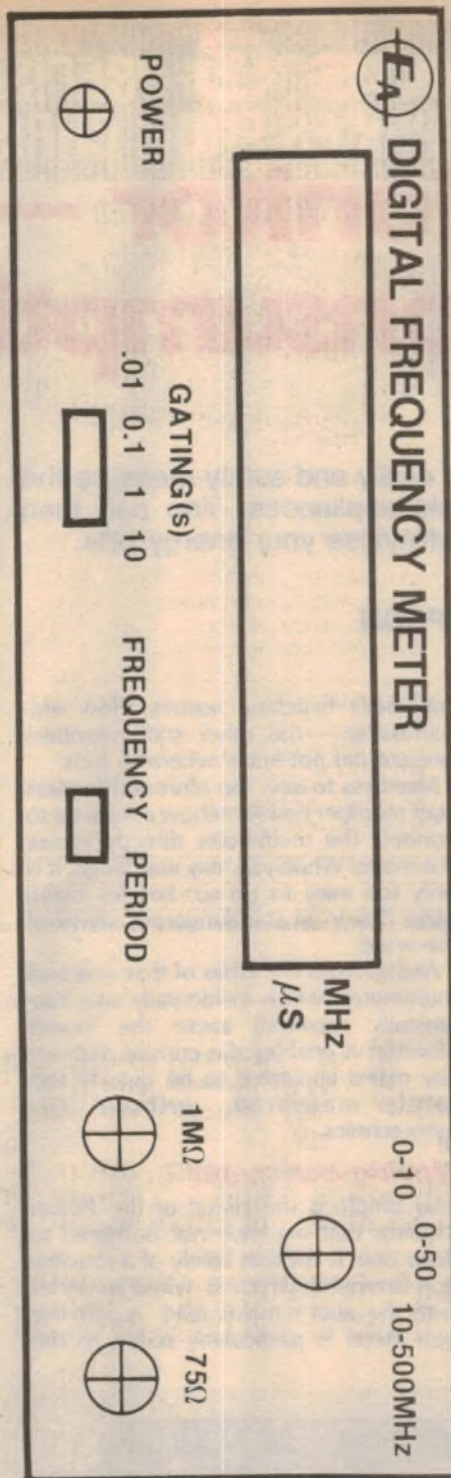

ELECTRONIC TECHNICIANS

We require the services of several electronic technicians to work in our Service Department at North Ryde. The work involves repair of an enormous variety of electronic equipment in our air conditioned workshops. Applicants should ideally possess the E&C certificate, have had several years experience in the industry and be able to work without supervision. Salary negotiable and generous staff benefits apply. If you think that you're the person that we need, please apply in writing to:

Gary Crapp
Service Manager
DICK SMITH ELECTRONICS
P.O. Box 321, North Ryde
N.S.W. 2113.

DSE928

Did you miss these projects?

INFRASONIC RUMBLE FILTER

Rumble can still be a problem when listening to records, particularly with amplifiers having response down to DC. This low cost infrasonic rumble filter effectively removes all rumble noises below 20Hz and can give a substantial improvement to record reproduction in some circumstances. Estimated cost of parts \$10.

HEADLIGHT REMINDER ALARM

Ever had a flat battery in the car because you left the headlights on? If so, then you know how inconvenient it is and how expensive it can turn out to be. There is a way to avoid this inconvenience and possible expense, with our simple, yet effective Headlight Reminder Alarm. Estimated cost of parts \$5.

Complete construction details (we do not sell parts) available from: Electronics Australia, 57 Regent St, Chippendale 2008. PRICE \$3.00 each project or by mail order, PO Box 163, Chippendale, 2008. PRICE \$3.00 each project (includes postage). Please state project required.

JUNE/JULY

video

ON SALE AT YOUR NEWSAGENT

Reduce your electricity bills

Power Monitor — checks energy consumption

Use this simple Power Monitor to easily and safely measure the energy consumption of household appliances. You can then calculate running costs and thus minimise your energy bills.

by LEO SIMPSON

There are two reasons why this project came into being. The first is the increasingly important energy consciousness of the community and the consumer's need to know the energy consumption of typical domestic electric appliances.

The second reason is far more cogent and arises out of a recent embarrassing event in the EA laboratory. A certain senior member of the technical staff was attempting to measure the mains current of a piece of equipment, with an eye to calculating the power requirement. He was doing this with the aid of a multimeter which had a ten-amp AC range and a couple of jumper leads. All very informal and quite dangerous!

Unfortunately for the said staff member he was twice interrupted by phone calls before he could complete this hazardous measurement and, when he finally applied power, splat! — there was a small explosion from within the multimeter and then a sad-looking puff of smoke wafted into the stunned staff

member's twitching nostrils. How embarrassing — the other staff members present did not know where to look.

Needless to say, the aforesaid hapless staff member had somehow contrived to connect the multimeter directly across the mains! While you may well laugh, it is only too easy to do so, besides being quite "hairy" in the dangerous sense of the word.

And so from the ashes of that wrecked multimeter (which incidentally was successfully repaired) arose the Power Monitor. It enables the current drain of any mains appliance to be quickly and safely measured, without any pyrotechnics.

Moving-iron meter

So simple is the circuit of this Power Monitor that we have not bothered to draw one. It consists solely of a moving-iron ammeter which is wired in series with the active mains lead. A moving-iron meter is particularly suited to this



Don't let this happen to you!

application since it responds closely to the RMS value of the current.

This response to the RMS value of current is important for two reasons. First, it means that a moving-iron meter will respond equally well to direct or alternating currents (of low frequency) and no rectifier is required. Second, some AC loads tend to distort the usual sinusoidal current waveform and this could lead to inaccuracies if the more common moving-coil meter with rectifier was used.

This is because a moving coil meter

PARTS LIST

- 1 0-10A moving iron meter
- 1 diecast case, 120 × 65 × 40mm
- 1 ten-amp plug
- 1 ten-amp in-line socket
- 1 length of ten-amp power flex, 60cm
- 2 cord clamps, 2 solder lugs, 2 grommets,
- 1 two-way insulated terminal block,
- 4 screws and nuts to suit.

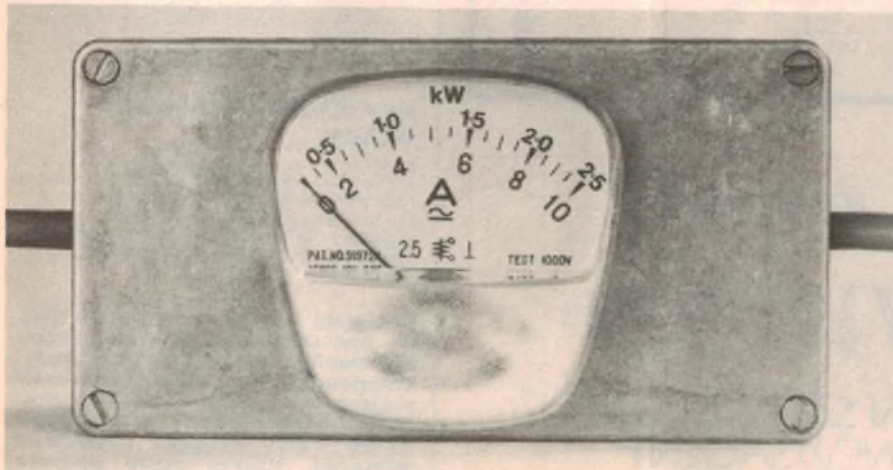

Power Monitor lets you measure energy consumption directly in kilowatts.

responds to the average value of the current waveform and when calibrated to read RMS values, the assumption is that the waveform will be sinusoidal (ie, a pure sine wave).

As supplied, the moving iron meter we used is calibrated up to ten amps (AC or DC). We have added a "kW" designation and the necessary numerical values so that the meter also reads power up to 2.5kW.

In adding the extra power range we have avoided the need to draw in an extra scale by assuming that the mains voltage is 250VAC rather than the nominal 240VAC. This has enabled us to use the existing amp scale markings. Naturally, this will lead to a small error if the mains voltage is not exactly 250VAC when you make a measurement but in most cases this will not be important.

Power factor

We should add another important qualification to the power measurements made by this mains monitor. Power in an AC load is calculated by multiplying the applied voltage by the current but this calculation is only valid when the current is exactly in phase with the voltage, as is the case for a resistive load such as a radiator or toaster.

Another way of expressing this important criterion is the parameter known as power factor. This is the cosine of the phase angle between the voltage and current. For a resistive load, as mentioned above, the power factor is one ($\cos 0^\circ = 1$). For all other loads, such as motors and transformers, the power factor is less than one which means that the voltage and current are not exactly in phase.

What this means as far as our Power Monitor is concerned is that the power reading for loads with less than unity power factor will be higher than reality. If you know the exact power factor of the load concerned you can calculate the power with the following formula:

Power = VI. $\cos \alpha$
where α is the phase angle and $\cos \alpha$ is the power factor.

Most people will not want to bother with that and will be reassured to know that for the important energy consuming loads in the household, such as refrigerators and washing machines (where induction motors are used under more or less constant and heavy loads), the power factor will be close to unity and the Power Monitor readings will be reasonably close to reality.

Another point we should make is that a typical domestic appliance will often draw more power than its nameplate rating. Often this discrepancy can be as much as +10% or more. This can be explained by the fact that the nameplate rating refers to a particular voltage

(which is usually 240VAC) and the fact that manufacturing tolerances must be taken into account.

Construction

The moving iron ammeter we used is available from Dick Smith Electronics (cat Q-2090). Some readers may wonder why we did not incorporate the matching 20V moving meter which is also available from DSE to provide voltage monitoring as well. However, in common with all moving-iron meters, these movements consume about one watt at full scale deflection. If we were to add the necessary series multiplier resistor to run the 20V movement from 240VAC it would dissipate about 11W and consequently become very hot!

We housed the meter movement in a

A hole must be drilled in each end of the box for the power cord. The size of this hole will depend on the particular grommet you use – ours required a 12mm hole. A total of six 3mm holes will also need to be drilled. Two of these are in the front panel (lid), to retain the meter.

For the location of the other screw holes, check the inside photograph of the Power Monitor. The screws and terminal block must not foul the rear of the meter housing.

Mount the meter on the case lid to make it easier to handle when altering the scale. The clear escutcheon unclips easily to provide access to the scale itself. We used Letraset rub-on lettering to add the "kW" and numerical markings. We would suggest a 12pt medium

The moving iron ammeter is simply wired in series with the mains active lead, while the neutral wires are terminated in an insulated terminal block.

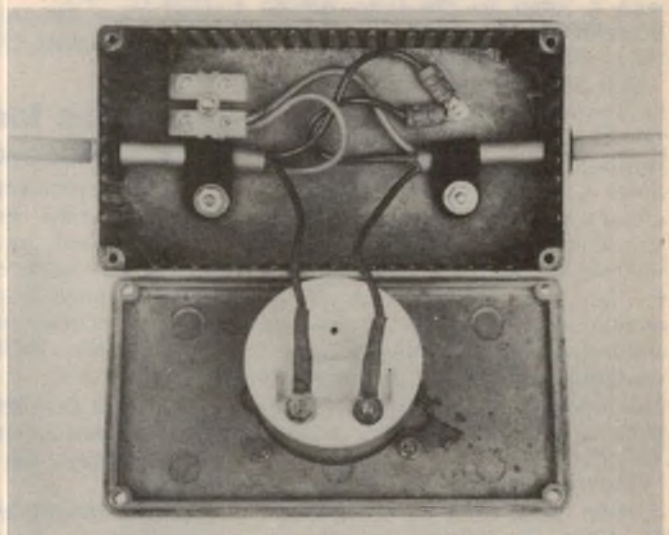

small diecast aluminium box which is more robust and safer than plastic or sheet metal boxes. After all, if you accidentally step on it you don't want your knee-cap impacted into your molars!

Start by cutting a 45mm diameter hole in the front panel of the box for the meter. A hole saw would be ideal for this purpose, provided that you have access to a drill press. If not, a hand drill can be used to drill numerous small holes around the inside of the circumference of the mounting hole. Use a coping saw to join the small holes and file the mounting hole out to size. Note that this hole is not centrally located on the front panel due to the eccentric shape of the meter.

We estimate that the current cost of components for this project is approximately

\$18.00

This includes sales tax.

or bold Helvetica type font as being suitable. If you make a mistake with the lettering it is easily lifted off with adhesive tape to enable you to start again. We also suggest you anchor the meter point with a small piece of adhesive tape to avoid it being damaged.

Wiring

You will need a 60cm length of ten-amp three-core power flex, plus a three-pin plug and an in-line socket which must also have ten-amp ratings. An alternative, which may be cheaper and more convenient, is to purchase a ready-made ten-amp extension lead with moulded-on plug and socket. Whichever way you do it, you must make sure that active and neutral conductors are not transposed between plug and socket.

The earth (green or green with yellow stripe) wire of each cord section should be connected via solder lugs to the case so that the earth connection between plug and socket is continuous. The neutral (black or light blue) wires should

Continued on page 102



Letters to the editor

Windmill power and car alternators

Since the article "Windmill Power for Australia; Pt 2", by John Andrews appeared (July 1978) I have rewound an alternator (a Chrysler automotive type) and recently made measurements of its performance. However, in agreement with a Letter to the Editor by G. J. Bowden in EA, July 1981, I have found the performance disappointing.

One particular fact, not mentioned in Dr Bowden's letter, is the extreme reduction in efficiency due to increased wire resistance in the stator. By using three times as many turns the resistance is increased by about $3^2=9$ times because of size limitations in the stator. The effective stator resistance increases from a few tenths of an ohm to a few ohms. For an output current of 10A say, the original stator dissipates a few tens of watts, the rewound stator, a few hundred watts. This is a severe power loss since the output power is, for a 12V alternator, only 120W at 10A.

From my measurements it appears that a better approach is a step-up in speed by some gearing mechanism which would be much more energy efficient.

R. Baldick
Roseville, NSW.

COMMENT: We agree that rewound car alternators are not necessarily the best for use with wind generators. Automotive alternators are designed for low cost and weight, rather than for efficiency, and rewinding is a compromise solution at best. We plan to publish further articles on this subject in the near future.

Power restrictions

I read with interest your editorial in the April issue of "Electronics Australia". Your statements regarding energy consumption are of course perfectly correct. However, in respect to avoidance of power restrictions, energy consumption is in many cases not the main factor involved.

One of the most common causes whereby an electricity authority has to implement power restrictions is its inability to meet maximum demands which create "peaks" exceeding the generation capacity. In such cases, if the

use of devices with high power ratings could be restricted, supply interruptions could be minimised.

I would consider it worthwhile to point out to the thousands of readers of your excellent magazine that energy conservation is good for their pockets and will assist in maintaining a continuous supply of electricity by reducing demand at peak periods.

A.E. Dyer, MIE (Aust),
Mount Gravatt, Qld.

Cartoons for the serviceman

Purely by accident, I was looking at the February 1962 issue of "Electronics Australia" and, lo and behold, I came across the same cartoon on the Serviceman page as printed on the April 1982 Serviceman page.

Barrie Lakey, VK3BL,
Bendigo, Vic.

EDITORIAL COMMENT: In 1962, the Serviceman was a mature gentleman. Now in his dotage, his memory is steadily failing.

SERVICEMAN'S COMMENT: This cartoon was chosen by a member of the editorial staff who, on his own admission, was only 11 years old in 1962!

A thank you note

Dear Mr Williams,

It has long been in the back of my mind to write to you and let you know my opinion of "Electronics Australia". I haven't written before because (a) I had nothing constructive to say; and (b) you most probably get plenty of letters telling you what a great magazine it is, (in the first paragraph that is, then proceeding to tell you of all its faults in the next dozen pages). However I've finally decided to put my right forefinger to keyboard and write.

Whilst I realise that your magazine is aimed at the hobbyist, and the electronic enthusiast, I do not fit into either category. The only construction kit I've ever had a go at was a device to slow down an electric drill, and it cost me more to get Dick Smith to fix it than it did to buy it. The fascination that your magazine (& ETI) hold for me is that it informs me of what is being done in the world of science, what can be done, and

what will be done. Where else is this information available? Nowhere, except "New Scientist" and "Scientific American", at twice the price, and written for the Mensa Mob.

The two Australian electronics publications have widened my horizons, and opened up new worlds to me. I do not know how a MOSFET works, but now at least I know that such a thing exists, and some of its uses. I know now why I can pick up AM stations at night from places as far away as Adelaide, yet sometimes have difficulty in getting Gosford during the day. You may well say big deal! You'd be right, it is a big deal; such things were unfathomable to me at one time. Now I know that the answer is quite simple, yet needs no knowledge of radio to comprehend.

As "the boss" of EA you are obviously closely involved with all the sub-sections of the magazine, perhaps too closely to appreciate the enormous range of topics that each issue may cover. February really does go from A to Z (Aviation to Zilog), and I know that each article is factual and authoritative, not sensationalised half-truth. Each issue really is a mine of news and information.

As you may well have gathered by now, I am a fan of EA. Long may you flourish!

Thank you for introducing me to real hifi, thank you for introducing me to computers, and thanks for all the things that were never dreamt of in my philosophy . . . and all for just over six cents a day.

L. McDonald,
Rosebery, NSW.

Correction to crystal set article

On page 71 of the April issue of your magazine under the heading of "Dick Smith and the Crystal Set", it is stated that Dick Smith took his first job working with Maurice Findlay at Findlay Communications Pty Ltd.

This statement is quite erroneous because Dick Smith's first employment was with Weston Electronics Pty Ltd. Maurice Findlay also worked with Weston Electronics as Chief Engineer during the 1960s. Upon leaving the company, Maurice Findlay founded Findlay Communications and I believe Dick Smith subsequently worked for Findlay Communications.

Both Dick Smith and Maurice Findlay have certainly built up very successful enterprises and deserve much credit. However, as founder of Weston Electronics Pty Ltd, I must point out that they both worked for Weston Electronics Pty Ltd before forming their own respective organisations.

Sel Weston,
Pymble, NSW.



“ICS gave me the break I needed.”

— 23-year-old Greg Marr. ICS Student.

“I applied for over 30 jobs in the computer industry but kept getting knocked back.

There were plenty of jobs about; it was just that there were always people with more qualifications than me.

That’s when I decided to apply for an ICS course.”

“It was as if I was the only ICS student.”

“The ICS program quickly gave me an understanding of the job I wanted. I studied at my own pace and the tutor really helped a lot.

Unlike a classroom where the tutor deals with up to 40 people at a time, your ICS tutor gets to know you personally. If you work at a slower or faster rate, you won’t be penalised because the class is ahead or behind you.

ICS doesn’t just send you text books, you receive a complete learning system.

Each program is accompanied by notes and questions that allow you to understand and remember every point . . . before moving onto the next one.”

What you put in. What you get out.

You’ll have to put aside a couple of hours a day. But with ICS you can pick and choose just when and where you study.

You have to take assignments and tests. But your ICS tutor will guide you and give you advice every step of the way.

It may take time. But in the end you’ll emerge with extra skills that may help you pick and choose jobs, ask for more money or set your own conditions.

“I got the job I wanted.”

After a few months of study and a

couple of exams, Greg Marr used his ICS experience to apply for another job. Today he is a computer technician.

He is just one of 9 million people around the world who have proven the success of ICS.

If you’d like to join them, apply now for enrolment to one of the ICS Career Programs listed below.

By return mail you will receive complete details of courses, fees and the unique ICS study method.

Choose the ICS course which interests you most

Send now for details and an enrolment application.

- | | | |
|--------------------------|--------------------------------------|-----------------------|
| • Automotive | • Refrigeration and Air Conditioning | • Secretarial/English |
| • Building Sciences | • TV Servicing | • Art |
| • Drafting | • Accountancy | • Writing |
| • Electronics | • Business Management | • Dressmaking |
| • Mechanical Engineering | • Sales and Marketing | • Interior Decorating |
| • Electrical Engineering | • Computer Programming | • Guitar |
| • Civil Engineering | • Hotel/Motel Management | • Photography |

The course I am most interested in is _____
 (If the subject you want is not listed above, please write it in)
 Please send me without cost or obligation the ICS Careers Information Guide which tells me everything I need to know about the course I wish to receive information on.

Mr/Mrs/Miss _____ Please Print _____
 Address _____ postcode _____
 Occupation _____ Age _____ Phone _____

International Correspondence Schools Tick here if currently full time student
Sydney: 400 Pacific Highway, Crows Nest, NSW 2065. Tel: (02) 43 2121
Melbourne: 18-20 Collins Street, Melbourne, VIC, 3000. Tel: (03) 656 1950
Brisbane: 131 Elizabeth Street, Brisbane, QLD, 4000. Tel: (07) 221 0178
Adelaide: 28 Grenfell Street, Adelaide, S.A. 5000. Tel: (08) 219 4154
Perth: P.O. Box D157, Perth, W.A. 6001. Tel: (09) 321 8530
New Zealand: 182 Wakefield Street, Wellington C.I. N.Z. 0344

I'VE RE-ORGANISED MY STORES - YOU REAP THE BENEFITS!!

NOW THERE'S A DICK SMITH STORE NEAR YOU WITH A



- A full, comprehensive range of amateur equipment and accessories at the most competitive prices!
- Run by a licensed amateur - with full information on all gear and technical specifications. With demo equipment in operation - and a 'HOT LINE' to the head office YAESU technical support facility
- It's the best thing to happen to amateur radio in Australia: ever!



CHECK OUT THESE SUPER DEALS AT YOUR



FT208R
2 metre hand held 800 channel fully synthesised hand held with LCD readout
Cat. D-2889
~~\$368~~
\$325



~~\$795~~
\$765
FT707 HF mobile
Talk to the world from your car/boat or plane. Full HF band coverage. 100W. Ideal mobile (or base with optional supply.)
Cat. D-2869

FT408R 2 metre
THE BIG GUN!!!
All mode 2 metre with everything that opens and shuts! Cat. D-2887

\$514 was \$525
with bonus 5/8 antenna & base.
THIS MONTH ONLY.

FT230R
2 metre mobile. Amazingly small - but a full 25w output. Ideal for today's compact cars.
Cat. D-2893

FP707 13.8V was \$106 **\$168**
Mains power supply to suit FT707. Cat. D-2895

FRG7700
The go anywhere all mode receiver. Covers everything from 150kHz to 30MHz.
Cat. D-2840

\$525 was \$589



~~\$375~~

\$359 **\$568**

FL2100Z
For real amateur power! Run your station at maximum legal power - and the FL2100Z is just coasting Cat. D-2548 **\$580**



~~\$395~~

\$349

FT290R
2 metre all mode portable/mobile. Our most popular 2 metre rig! Loaded with features. Incredible performer.
Cat. D-2885

FT-ONE THE ULTIMATE
Every ham's dream - now can be yours. And this month ONLY get a bonus FM board absolutely FREE with your FT-ONE
Sells for \$2995 in the USA. Cat. D-2852

\$1975

Come in & checkout these bargains, talk to the specialist - Play with the gear - Then buy the best at the BEST PRICE with the famous Dick Smith 12 month full warranty & terrific after sales service - You can't go wrong with Dick!!!!!!

DEMO AND STORE STOCK with full 12 months warranty - making room for new models - you reap the benefit!!!!

DESCRIPTION	CAT	WAS	NOW
FT207R 2m h/held - ONLY A FEW LEFT!	D-2888	\$358	\$235.00
PA2 Mobile charger for FT207	D-2994	\$29.95	\$19.95
SPECIAL OFFER: BOTH OF THE ABOVE FOR A RIDICULOUS \$246.50!!!!!!			
FT107M HF band, all solid state	D-2863		\$850.00
FT720RVH 2 metre 25W "save \$80"	D-2890	\$449.95	\$369.95
FT1012D The Famous '101' "save \$60!!"	D-2859	\$910	\$850.00
FT227RB 2 metre with scanning "save \$60"	D-2891	\$379	\$319.00
FV707DM Digital VFO for 707	D-2896	\$299.50	\$265.00
MMB2 Mobile bracket for 707	D-2897	\$36.00	\$26.95
FT107DMS HF WARC band, with DMS "SAVE \$103"	D-2871		\$1225
FT7B HF solid state mobile	D-2868	\$599	\$649
FT901D HF base station	D-2854	\$1075	\$950.00
901DC CONV DC/DC Converter for FT901/902	D-2856	\$69.00	\$49.00
SPECIAL OFFER: BOTH OF THE ABOVE (D-2854/2856) FOR ONLY \$990			
901 MEM Memory unit for FT901/FT902	D-2858	\$139.50	\$99.00

Gailbraith Paddle - make your own Morse Keyer D-7103 ONLY \$14.95
Some stores have little - or no - stock available. Jim Powell (02) 888 3200 knows where all these bargains are!!!

NOW BACK IN STOCK!

Dick Smith's Australian Amateur Radio Handbook. All new, completely revised edition. Everything you wanted to know about amateur radio in Australia. Great for the old ham, the young novice or the aspiring hopeful. Cat. B-2320



HOBBYISTS EXPERIMENTERS SCOOP PURCHASE
YC221 DIGITAL DISPLAY
D2898 \$29
worth over \$100
7 digit freq display unit
converts to beaut freq. counter



PLEASE NOTE:

The stores at left, stock the complete range of Dick Smith Amateur Radio equipment. All other Dick Smith stores stock some amateur equipment, but may not be able to give you the service of the 'HAM SHACK' stores listed.

DICK SMITH Electronics



- SYDNEY - 125 York St.
- GORE HILL - 162 Pacific Hwy.
- NORTH RYDE - 396 Lane Cove Rd.
- PARRAMATTA - 30 Grose St.
- ADELAIDE - 60 Wright St.
- MELBOURNE - 399 Lonsdale St.

- SPRINGVALE - Dandenong Rd.
- RICHMOND - 656 Bridge Rd.
- PERTH - 414 William St.
- BURANDA - 166 Logan Rd.
- CHERMSIDE - 842 Gympie Rd.

Amateur Radio

by Pierce Healy, VK2APQ



Amateur radio societies plan for WCY 1983

World Communication Year, 1983, IARU Region III Association convention, WIA 46th annual federal convention and illegal maritime mobile operation are subjects this month.

Long distance communication, be it by the spoken word, visual signs, or in written format, is a worldwide necessity of mankind. The many forms of communication in the world today are in some way connected with the International Telecommunication Union. This century-old United Nations organisation has its headquarters in Geneva Switzerland.

Amateur Radio is a minor but nevertheless important international means of communication, and has been a driving force in bringing to today's standard the many modes of radio communication now in use.

Next year, 1983, has been decreed as World Communication Year, sponsored by the ITU and the World Health Organisation (WHO). The 155 member nations of the ITU are urged to conduct some form of local or international activity to bring to peoples' attention, worldwide, the current state of the art. There is a pressing need to improve and extend all modes and take full advantage of modern technological improvements.

Several countries have already indicated their plans for promoting the ITU aims. One international contest sponsored by the ITU is "Youth in the Electronic Age". This is a world wide photo and drawing competition for three age groups 8-12 years, 13-15 years and 16-18 years. The theme is to be "Telecommunications for everyone". The medium should be photographs, drawings or other art forms, written text is not included.

Full details for Australian participants should be obtained from Department of Communications, Marland House, 570 Bourke Street, Melbourne Vic. 3000.

Judging in the first place will be on a national level, with those selections judged by an international panel in Geneva to decide the ultimate winners.

On the amateur radio scene, national radio societies are considering in what

ways amateurs can commemorate WCY 1983.

One of the first reports comes from Africa. The Nigeria Amateur Radio Society (NARS), one of the largest amateur radio organisations on the African continent, has set up a special committee to collaborate with the Federal Ministry of Communications in planning and publicising activities that may be undertaken for WCY. This committee, NARS-WCY 83, plans to launch a nationwide campaign to disseminate information on the aims of the Year, to stimulate public awareness of the role played by communications in daily life, and the need to develop them to promote national development.

In Australia consideration is being given to ways that the Museum of Applied Arts and Sciences amateur radio station, VK2BQK, in Sydney, NSW, could participate in activities that would interest the general public during WCY 1983.

WIA FEDERAL CONVENTION

Here are a few extracts from the 46th Annual Federal Convention WIA, held in Melbourne, 1st-3rd May 1982.

● Federal council recognises that the subject of increases in novice licence privileges has been regularly raised but that the status quo has been and is maintained. It recommended that local contacts should be conducted, where possible, on the 10-metre wave band so as to relieve any congestion on the 80-metre band.

● The use of the 10MHz band for WIA broadcasts is not to be encouraged.

● Efforts are to be made to promote co-ordination between third party traffic networks (which are to be supported) and authorised amateur emergency networks.

● Third party agreements with other countries must continue to be pursued.

● The executive is to investigate formulation of standards relating to the transmission of ASCII.

● Rules for affiliating Australia-wide special interest organisations to the federal body were adopted.

● Forward planning proposals were adopted, including public relations for "WCY - 83".

● Continuing WIA pressures to exempt amateurs from the sticker or label proposal to identify the legality of possession of transmitting equipment (vide trial run in Tasmania).

NEW BOOK FOR AMATEURS

A new publication by the Wireless Institute of Australia on Amateur radio in Australia is now available. Both historical and contemporary interests are catered for with a selection of articles and projects. See "Books and Literature" in this issue for a full review.

IARU REGION III CONFERENCE

The fifth Region III Association conference held recently in Manila, Philippines, adopted several proposals designed to promote uniformity within the International Amateur Radio union member societies. Among these were:

● That there should be worldwide uniformity in the sub-division of amateur bands into certain transmission modes. The IARU Region I band plan was adopted for the 18MHz bands in Region III.

● The policy regarding changes in the IARU constitution was adopted, in that the policy making body will consist of representatives from the three regional organisation, and the headquarters society.

● To overcome the effect of more than one society representing amateurs in a particular country, the conference passed a resolution by which society membership of IARU could be terminated.

● That financial provisions be made for the possible attendance of Region III observers at four ITU conferences in 1986, as these four conferences potentially affect amateur radio in Region III.

● The Japan Amateur Radio League has undertaken to produce at least three issues of the "Region III News" per year.

NOW the most complete range available in Australia of
**SEALED, RECHARGEABLE
MAINTENANCE-FREE
RECOMBINATION ELECTROLYTE
BATTERIES**

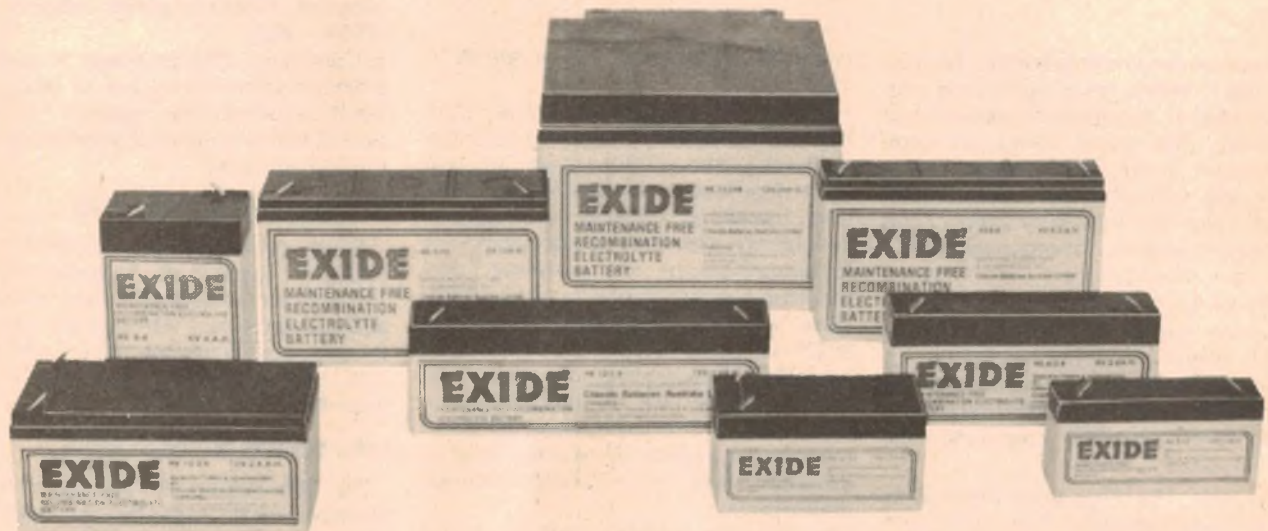

APPLICATIONS

The Exide RE sealed Maintenance-free batteries are being used successfully in cyclical and float charge applications. Small physical sizes and high energy density make these batteries a logical choice.

Typical Uses and Applications

- Point of Sale Terminals of Centrally-controlled Cash-Register system
- Electronic Cash Registers
- Portable Test Equipment
- Portable Digital equipment
- Fire and Security Systems
- Communications Equipment
- Photography Equipment

- Portable Power Tools
- Computer Memory Systems
- Portable Televisions
- Medical Instrumentation
- Emergency Lighting Systems

FEATURES

- True Maintenance-free operation
- Usable in any position
- 4 to 5 year float service life
- Up to 1000 charge/discharge cycles
- Low self discharge for long storage life
- No electrolyte leakage from case or terminals
- Broad operating temperature range of -20°C to 60°C

AVAILABLE FROM:

CHLORIDE
Chloride Batteries Australia Limited

Sales & Service

New South Wales State Office
23A Nyrang Street, Lidcombe. 2141
Telephone: (02) 646 2244

Victoria State Office
2-4 Beaufort Street, Preston. 3072
Telephone: (03) 480 2711

Queensland State Office
Cnr. Cornwall St. & Fairfield Rd.,
Dutton Park. 4102
Telephone: (07) 44 1751 (9 lines)

South Australia State Office
161 West Beach Road, Richmond. 5033
Telephone: (08) 43 8091

Western Australia State Office
10 Cleveland Street, Dianella. 6062
Telephone: (09) 271 7377

Tasmania State Office
220 Argyle Street, Hobart. 7000
Telephone: (002) 34 4022

GIRL GUIDE MUSTER

The Girl Guide Association NSW is conducting muster at Dubbo, NSW, from 29th August to 5th September, 1982.

For the first time in NSW, and probably in Australia, at the request of many guides who have taken part in the Jamboree-on-Air, an amateur radio station will operate as part of the activities.

The station will use the official NSW Girl Guide Association call sign, VK2GGA. Operation will be on the 3.5MHz, 7MHz, 14MHz, 21MHz, 28MHz and 144MHz bands with particular attention to the Scout net frequencies 7.090MHz, 14.190MHz and 21.190MHz.

The station will operate from 0900 to 2100 EAST each day, the girls taking part during the day and guide leaders during the evening.

Further details from Valda Lambert, Public Relations, Dubbo State Muster, 76 Ula Crescent, Baulkham Hills, NSW 2155.

A COMMUNITY SERVICE

Here is an example of a service provided by amateur radio where amateurs in several countries were involved.

The story was received from Duane Foster, VK2VE/VE6IV, a Canadian currently living in Sydney and is an excellent example of international cooperation among amateurs. Duane wrote:

"On 6th January, 1982, I had an urgent third party message to relay to Austria at 0300 hours EDST. As I do not have HF equipment I attempted to raise someone on two metres with that capacity, but with no success. I drove to Hyde Park (Sydney) and asked Sam VK2BVS if I could use the station he had set up there for the Festival of Sydney. he kindly assented.

"The message pertained to the sudden and untimely death of Mrs Pamela Fryer, aged 43. Her son Martin, was on a skiing trip during his university vacation in Europe. We had experienced considerable difficulty attempting to use commercial means of communication to contact Martin. Fortunately the fraternity of amateur radio knows no boundaries.

"I contacted Chas W5QOU in the United States on 14MHz but signal conditions were marginal. He put me in contact with Jim W6KRP, who was strength 5, readable 9 copy, and I relayed the message to him. He passed it to Fernando EA3SF in Spain who relayed the message to Austria.

"Approximately 20 minutes after I contacted W6KRP Martin rang his father to make arrangements to return home."

1982 ANTARCTIC EXPEDITION

Following the success of the 1982 Oceanic Research Foundation summer expedition to Antarctica, plans are being made for another expedition, by a smaller group for a longer period. The leader will be Dr David Lewis, who led the previous expedition.

It is intended for the vessel to be "frozen in" and the group carry out a summer and winter research program being arranged in conjunction with the Australian national Antarctic Research Expeditions.

The research area will probably be in the vicinity of the Rauer Islands, about 100km from the Australian base of Davis.

The team will consist of five or six people and vacancies now exist. Each member will require several skills. These skills range from bird identification to diesel engine maintenance, photography, scientific observations, cooking, sailing and radio communication.

The Foundation wants to hear from people who have the required skills and wish to join the expedition. The address is: The Oceanic Research Foundation, PO Box 788, North Sydney, NSW 2060, Australia.

Here is an opportunity for an amateur radio operator with other skills and an adventurous longing to join the select band of VK0 operators.

Training for the expedition will commence in Sydney, NSW, on 18th October, 1982, and departure will be on 14th November, 1982. The planned return to Sydney is for March, 1984.

CLUB NEWS

Tamworth Amateur Radio Club will hold their annual Noel Taylor Memorial Field Day on the weekend 4th and 5th September, 1982 at Duri Hall.

Editorial Note: this will be the final instalment of the "Amateur Radio" column. In future, items of particular interest to amateur radio operators will be highlighted in the news pages. All material should now be sent to "Electronics Australia", PO Box 163, Chippendale 2008. A special vote of thanks to Pierce Healy for his effort in producing these pages over the past 20 years.

BASIC ELECTRONICS

Basic Electronics begins with the electron, introduces and explains components and circuit concepts, and progresses through radio, audio techniques, servicing, test instruments, etc.

Available from: "Electronics Australia", 57 Regent St, Sydney.
PRICE \$3.50 OR by mail order from "Electronics Australia", PO Box 163, Chippendale, 2008. PRICE \$4.20.

All the usual field events, competitions, and displays will be conducted on both days.

A highlight will be a social evening on the Saturday evening.

Full details form E. Mogor, VK2DVQ, Victor Street, Wallabadah, NSW 2343.

ILLEGAL MARITIME OPERATION

Although full details have not been received it has become apparent there is growing concern among many amateurs regarding a seemingly increasing tendency to overlook the misuse of amateur bands by mobile marine stations.

It has been stated that a widespread net is operating in the Pacific Islands on the high end of the 14MHz band. While this net is believed to be controlled by a licensed operator, several of the station call signs used by those joining the net are obviously false and the users are therefore under suspicion as "pirate" operators.

Because such stations are operating from yachts moving around the islands, sometimes in hazardous weather conditions, the illegal use of amateur frequencies is condoned by some legitimate amateur operators, to the extent of handling their third party traffic or passing official ship weather forecasts.

It seems that while commercial intruders are the cause of dismay among amateurs, there are some amateurs who like to make their own rules concerning activities they have an interest in.

If this practice is allowed to continue unchallenged it is conceivable that the officialdom may decree that the amateur bands can be used by certain groups who desire to do so; such as seagoing pleasure craft operating maritime mobile.

Sure, in cases of emergency every assistance must be given, but through the correct channels and authorities. ☺

DO YOU WANT TO BE A RADIO AMATEUR?

The Wireless Institute of Australia, established in 1910 to further the interests of Amateur Radio, conducts a Correspondence Course for the A.O.C.P. and L.A.O.C.P. Examinations conducted by Telecom. Throughout the Course, your papers are checked and commented upon to lead you to a successful conclusion.

For further information, write to

THE COURSE SUPERVISOR W.I.A. (N.S.W. DIVISION)

P.O. Box 123,
ST. LEONARDS, N.S.W. 2065.

Shortwave Scene

by Arthur Cushen, MBE



Winter listening provides variety of signals

Listening during the winter is best during the daylight hours, with a wide variety of stations available on all bands.

AUSTRALIA: Radio Australia's program for the short-wave listener, "Spectrum" is now broadcast on the first and third Sunday of each month at 0612, 0810, 1612, 2112 and on Monday at 0330. The broadcast at 0810UTC is best received on 9570kHz.

AUSTRIA: Vienna broadcasting to Australia is now scheduled 0400-0700 UTC on 21500kHz; 0700-0900 on 15235; 0900-1100 on 17825 and 1200-1300 on 15415 kHz. English language programs are transmitted daily at 0430-0500 and 0830-0900UTC.

BULGARIA: Radio Sofia uses 11900kHz at 0400UTC with a broadcast in English to North America. This is the best received frequency of several used for this transmission.

CANADA: Radio Canada International has cancelled its 0400-0429UTC transmission to North America which was heard in the South Pacific. The last broadcast from Montreal is now at 0300-0329UTC, on 5960, 9735, 9755, 11845 and 11940kHz. "Short-wave Digest" is now heard in the 0300UTC transmission on Monday.

GREECE: Athens broadcasting to Australia in Greek and English at 0900-0950UTC is now using two frequencies, 15525 and 17570kHz. Most of the transmission is in Greek but English news is heard at 0940UTC.

GUAM: KTW, Agana, Guam, was established in September, 1977 with two 100kW transmitters and now uses four transmitters and four curtain array antennas. The transmission best received in Australia is in English at 0745-0930UTC with "DX Listeners Log" now broadcast on Saturday at 0900UTC on 11840kHz. Other English broadcasts are at 1430-1600 on 11945kHz, and 1445-1500UTC on 11920kHz, Sundays to Wednesdays only.

WEST GERMANY: Deutsche Welle has dropped the use of 11850kHz for its transmission in English 0930-1020UTC to Australia. The transmission is still

available on 15275, 17780, 17800, 21540 and 21680kHz. The broadcast for our morning reception is at 2100-2150UTC on 7130 and 9765kHz. Transmissions in German to this area have also been altered and at 2000-2200 frequencies 6155 and 9620kHz have been dropped and replaced with 9735 and 11950kHz. Broadcasts at 0200-0400 and 0600-1000UTC remain on the same frequencies.

EAST GERMANY: Radio Berlin International has been noted on 11960kHz at 0330-0415UTC and gives fair reception on this new frequency. Other frequencies used are 11840 and 11890kHz. English is broadcast to the Pacific at 0545-0630UTC on 15450, 17700, 21465 and 21540kHz.

ITALY: Rome Radio is continuing to adjust its frequencies in order to improve reception in Australia of their two Italian broadcasts which are carried daily with the first transmission at 0830-0930UTC on 9585, 11810, 15330, 17780 and 21615kHz. The second broadcast at 2050-2130UTC is on 9710, 11800 and 15330kHz.

PHILIPPINES: Radio Veritas Asia can be heard with English at 0300-0330UTC on 15215, 15275 and 17705kHz. A later transmission at 1130-1200UTC is on 9605, 11770 and 15210kHz. The last transmission is 1430-1500 on 9670, 11955 and 15210kHz.

The Armed Forces Radio & Television Service uses a transmitter in the Philippines on 15305kHz at 2000-0030UTC. This frequency suffers some interference from Radio Swiss International. Other transmissions are 0000-0400UTC on 21670kHz and 0400-1900UTC on 26000kHz.

SOUTH AMERICAN SIGNALS

BRAZIL: Radio Clube Paranaense on 11935kHz has been heard opening at 0900UTC by Sam Dellit of Melbourne and the station gives details of two short-wave frequencies, 6045 and 11935kHz.

After opening a religious program is broadcast. Radio Marumby has also been heard on 9765kHz opening at 0900kHz.

COLOMBIA: Radio Transamazonica has been heard on the new frequency of 6035kHz opening at 1015UTC. A new transmitter and antenna system is now being used, and the station is keen to receive reports (written in Spanish), addressed to the Manager, Transamazonica, Apt Aereo 16555, Bogata, Colombia.

PERU: A relatively new station, Radio Rioja, has been heard on 5045kHz around 1015UTC, opening transmission, with closing at 0500UTC.

Radio America is often heard on 9510kHz on Sundays around 0700 causing interference to the BBC Antigua. Another frequency, 6010kHz, has been noted at 1017UTC according to Wayne Watt and Andrew Elwell in DX Post, Adelaide.

NEW ANTENNA SYSTEM

The Marconi Company is installing a new antenna system at the BBC relay base in Cyprus at a cost of \$A4.5 million. The antennas will improve the audibility of the BBC's World Service and vernacular programs on the increasingly congested broadcasting bands. The contract was placed by the Foreign and Commonwealth Office for improvements at the Zygi relay base, from which BBC External Service programs are beamed to many parts of the world. The work includes the dismantling of a number of existing towers, the erection of new ones, and the provision of 25 high-gain, wide-band, wide-slew, short-wave curtain arrays.

KENYA'S NEW VOICE

The Voice of Kenya will be heard worldwide when their new 250kW transmitter is put into operation. The transmitter will be located at Koma Rock, 65km southeast of Nairobi. The BBC Monitoring Service also report that extensive medium-wave coverage will be obtained by the introduction of several new transmitters throughout Kenya.

Notes from readers should be sent to Arthur Cushen, 212 Earn Street, Invercargill NZ. All times are UTC (GMT). Add eight hours for WAST, 10 hours for EAST and 12 hours for NZT. In areas observing daylight time, add a further hour.

**DICK'S DIRECT
IMPORT PRICES**

SAVE ON 40CH

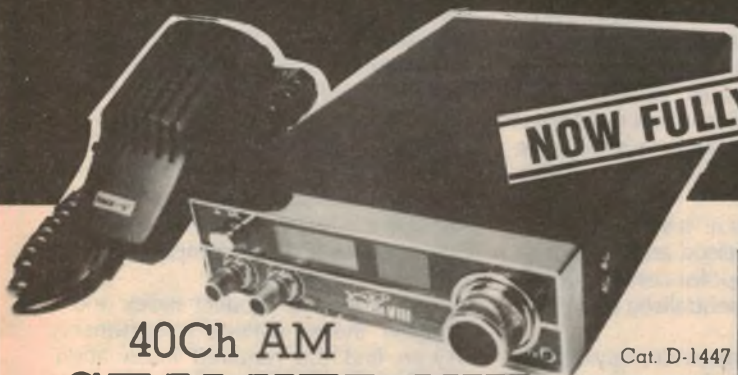

40Ch AM STALKER VIII

Cat. D-1447

Don't take chances in buying CB radio... buy your CB from Dick Smith, Australia's CB expert! The superb Stalker VIII CB features the new legal 40 channels, complete with microphone and mounting bracket. Large LED channel readout, easy to use and has maximum legal output.

FANTASTIC VALUE!

DOC Approval No. 249A001

~~\$149.00~~
NOW ONLY
\$97.50

NOW FULLY APPROVED



Cat. D-1710

40Ch AM/SSB DICK SMITH HORNET II

This unit is the latest in 40 channel CB technology. With the massive 12 watts p.e.p. output on SSB, this set meets the high DOC standard RB249A. Frequency range is 26.965MHz to 27.405MHz and accessories include DC power cable with built-in fuse and microphone clip.

WAS \$239.50

DOC Approval No. 249A006

SAVE \$40!

THIS MONTH ONLY \$199

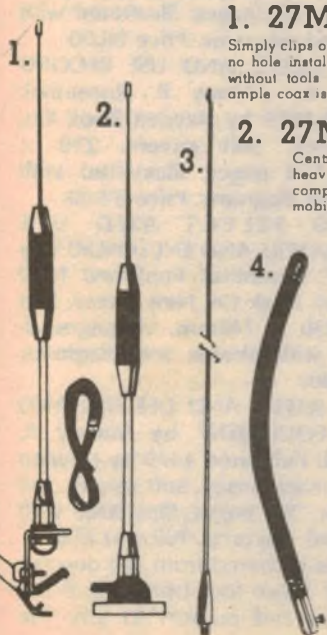

1. 27MHz Gutter Grip

Simply clips onto the rain gutter of any vehicle. Features no hole installation and can be installed or removed without tools. Antenna has centre loading coil and ample coax is supplied. **\$25.00** Cat. D-4411

2. 27MHz Magnet Base

Centre loaded stainless steel construction with heavy magnetic base. 16 feet of coax supplied, complete with PL259 plug. Ideal for 'instant' mobile use. **\$25.00** Cat. D-4412

3. 1/4 Wave Whips

Your choice of stainless steel or fibre-glass. Each is approx. 275mm long, ideal for marine or CB use. **\$15.80** Cat. D-4416 **\$19.95**

4. 'Rubber Duck'

Indestructible and very flexible, perfect for handheld sets. Only 300mm long, great replacement antenna! **\$8.50** Cat. D-4629

TOP VALUE HAND HELD

Cat. D-1102

For the weekend boatmen who don't want the more expensive full power transceivers, but who still need that reassurance of having a safety transceiver on board. Three channels available, one fitted with 27.620MHz, the others left blank for your own choices. Crystals are reasonably priced, and easy to fit. This set takes 8 'AA' pencil batteries. **WAS \$51.00**

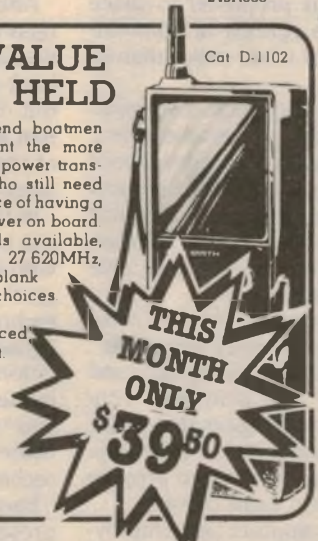

THIS MONTH ONLY \$39.50

FULL RANGE OF ACCESSORIES AT LOW DICK SMITH PRICES!

DICK SMITH Electronics

SEE PAGE 52 FOR ADDRESS DETAILS



Terms available to approved applicants through... **HFC**





Books & Literature

Technology and Work

SLEEPERS, AWAKE! Technology & the future of work, by Barry Jones. Soft covers, 283 pages, 130mm x 199mm. Published by Oxford University Press, 1982. Price \$9.95.

In 11 chapters Barry Jones charts and analyses the historical movement from pre-industrial to "post-service" society, arguing that the power of present technology has radically altered the nature of the production process. No longer is output proportional to the input of energy, material and labour. Computers and automated machinery can actually provide a larger output at a lower cost.

Jones calls for a new analysis of the labour force to clearly delineate the changes brought about by technology. In addition to the traditional three sector division into primary, secondary and tertiary occupations, he proposes a fourth sector to include all workers who work with information, as this group is the one most affected by the new technology.

A fifth sector, covering unpaid work, housework and participation in voluntary organisations is proposed to place employment in the context of commitment and the use of time, rather than of income.

Later chapters of the book distinguish between two types of employment; labour and time saving, as against labour and time absorbing. At present the most valued form of production is that which saves time and labour costs, because profit is considered to be the sole criterion of efficiency.

Labour absorbing work is most characteristic of the "service industries", says Jones. Productivity is not high, and "cost effectiveness" is a peripheral consideration. Barry Jones argues that a certain degree of inefficiency is tolerable, and even necessary, if we are to provide jobs to all those who want them.

Chapters on "Computers and Employment" and the relationship between unemployment, inflation, demand and productivity provide a valuable overview of the responses of conventional economics to technological unemployment, and analyse the failure of traditional policies to provide solutions.

Education, and the reasons for the declining percentage of Australians undertaking tertiary studies are also examined.

The problem of control of information is another issue for the "information society". Who decides what is worthy of inclusion in information data-bases? At least today interested parties can produce printed hand-outs, brochures etc relatively cheaply. Getting an unpopular viewpoint into an "electronic newspaper" could be much more difficult.

As Barry Jones puts it "Is access to information to be centralised and subject to monopolist or oligopolist control, or is it to be dispersed, decentralised and widely available?"

Barry Jones also argues strongly against the "technological determinism", the view that technology itself has its own momentum – that if human beings are capable of doing something, they will do it. "We have no choice" is the catch-cry of the determinists, ignoring the fact that every use of technology is the result of a decision made by human beings.

Attempts to argue for a rational use of technology are often met by an accusation along the lines of "you want to go back to cave-man days!" As Jones points out, this response is based on the view that technology is indivisible – "breeder reactors or starvation" would be one expression of this view.

In fact as Barry Jones makes out, there are many different types of technology, with varying effects on resources, society and the environment. Every technological change has an equal capacity to enhance or degrade the conditions of human life, depending on how it is used. The distinction between "hard" and "soft" technology is often ignored by those who either glorify or condemn technology for its own sake.

Barry Jones is no "doomster". He presents an extensive political program which aims to ensure that we get the best, and not the worst, from the technological revolution. His recommendations will be controversial, and should not go unchallenged. Even worse, however, would be a failure to respond at all. (P. V.).

Government Assistance

GOVERNMENT ASSISTANCE TO THE SCIENTIFIC INDUSTRY: By Lionel A. Wisbey. Published by the Australian Scientific Industry Association. Soft covers, 170 pages, 175 x 250mm. Price \$10, plus \$2 p&p.

DAMSEL: By Lionel A. Wisbey. Published by the Australian Scientific Industry Association. Soft covers, 156 pages, 175 x 250mm. Price \$10, plus \$2 p&p.

The first of these two books is based on papers presented at the Association's Canberra seminar in June 1981. It covers various aspects of government assistance to the scientific industry, including IR & D grants, export incentives, research, patents, tax, and education. One section also deals with the services available from the CSIRO.

The second book, DAMSEL, (Directory of Australian Manufactured Scientific Equipment and Laboratoryware) is, as its name implies, a directory of Australian scientific equipment manufacturers.

The information is set out under company names, in alphabetical order, with a list and a brief description of each product it produces. Each company entry is numbered for indexing.

There is both a product index and a company index, making it reasonably easy to find the required information, regardless of the approach.

Both books are available from the Australian Scientific Industry Association, PO Box, Dickson, ACT, 2602. (PGW).

Selecting hifi equipment

HOW TO SELECT AND USE HIFI AND STEREO AMPLIFIERS by Murray P. Rosenthal. Published 1979 by Hayden Book Co, New Jersey. Soft covers, 230 x 148mm, 122 pages, illustrated with photos and diagrams. Price \$8.00

HOW TO SELECT AND USE RECORD PLAYERS by Murray P. Rosenthal. Published 1979 by Hayden Book Co, New Jersey. Soft covers, 230 x 148mm, 122 pages, illustrated with photos and diagrams. Price \$8.00.

HOW TO SELECT AND USE LOUDSPEAKERS AND ENCLOSURES by Murray P. Rosenthal. Published 1979 by Hayden Book Co, New Jersey. Soft covers, 230 x 148mm, 90 pages, illustrated with photos and diagrams. Price \$7.00.

HOW TO SELECT AND USE HIFI AND STEREO EQUIPMENT by Murray P. Rosenthal. Published 1979 by Hayden Book Co, New Jersey. Soft covers, 230 x 148mm, 265 pages, illustrated with photos and diagrams. Price \$12.00

As may be gathered from the descriptions above these four books have the same format and purport to give the

would-be hifi purchaser the necessary background to make knowledgeable decisions about new acquisitions. The largest of the four volumes, on hifi and stereo equipment, is a condensation of the other three. And each of the four volumes has more or less common introductory chapters.

As I began leafing through these small volumes I gained the initial impression that they would indeed be helpful to the budding hifi enthusiast. They are well laid out and illustrated and quite readable. Unfortunately though, I did not have to read too far before modifying my impressions because there are a number of technical "bloopers".

The book on loudspeakers really talks in the most general terms and very little theory is given. Various types of enclosures are mentioned but there is none of the depth of information which would enable an enthusiast to "select and use" an enclosure. Electrostatic speakers are briefly described but the author more or less dismisses them by saying that they are really not useful for frequencies below 1kHz. Most people with only a small knowledge of hifi would know of at least one full range electrostatic, the English brand, Quad, which has a worldwide reputation.

As an example of what happens when the author starts to talk in technical terms, consider the following: "Even though a speaker is most efficient at its resonant point, you'd only get a fraction of the power delivered from the amplifier to the speaker. Don't worry about this fact; both amplifier and speaker manufacturers have done something about it. The former have designed amplifiers with increased regulation and 'damping' whereas the latter have constructed their speakers so that the impedance is 'damped', that is, it doesn't rise to a high peak of resonance. Between the two, the efficiency curve has been made a lot smoother for our benefit." Well there is an element of truth in everything the author says there, but he has made a thorough job of confusing it. It would take a whole chapter to straighten that mess out.

There is a brief chapter on headphones but unfortunately the book was written before the newer supra-aural type of phones developed for "personal portables" were envisaged.

Much of the material in the volume on amplifiers must have been written about 15 years ago. It dwells on valve amplifiers and early transistor circuitry. There is a "newer" section on four-channel technology such as QS, SQ and CD-4 but this would be largely useless to the beginner since this equipment has completely disappeared from the market.

An excerpt I found particularly hard to

(Continued on page 97)

BOOKS

Just some of the books from the largest range of computer radio and electronics books in Australia.

If the book you require is not listed below, it can be ordered from us.

NEW EDITIONS:

NOW AVAILABLE:

World Radio TV Handbook 1982	\$17.95
Radio Amateur's Handbook 1982	15.95
Radio Handbook (Orr)	39.95

MICROCOMPUTERS MICROPROCESSORS BOOKS:

PASCAL:

Speaking Pascal (Bowen)	16.00
Pascal: The Language and its Implementation (Barron)	37.50
Problem Solving Using Pascal (Bowles)	15.00
Foundations of Programming with Pascal (Moore)	12.95
Apple Pascal Games (Hergert)	19.95
Beginner's Guide for the UCSD Pascal Systems (Bowles)	16.50
Introduction to Pascal Including UCSD Pascal (Sybex)	18.95
Pascal (Heiserman)	15.95
The Pascal Handbook (Sybex)	24.95
Data Structures Using Pascal (Tenenbaum)	25.95

BASIC:

Illustrating Basic (Alcock)	9.50
Computer Programming in Basic (Monecs Basic)	9.95
50 Basic Exercises (Sybex)	17.50
Basic Programming (Kemeny & Kurtz)	23.75
Computer Programs in Basic (Friedman)	14.75
Basic Made Easy (Swanson)	18.95
The Basic Cookbook (Tracton)	7.95
Inside Basic Games (Mateosian)	19.95

FORTRAN:

An Introduction to Computer Programming in Fortran (Monecs Fortran)	10.95
Fortran Programming Using Structured Flowcharts (Haskell)	18.00
Elementary Computer Programming in Fortran IV (Boguslavsky)	19.95
Fortran Getting Started (Davis)	5.95
A Guide to Fortran IV Programming (McCracken)	23.75

COBOL:

An Introduction to Computer Programming in Cobol (Monecs Cobol)	9.95
Information Systems Through Cobol (Philippakis)	14.80
Learning to Program in Structured Cobol Parts 1 & 2 (Yourdon and others)	29.75
Cobol: A Vehicle for Information Systems (Grauer)	28.25
A Simplified Guide to Structured Cobol Programming (McCracken)	26.55
Cobol Environment (Grauer)	26.95

OTHER COMPUTER TITLES

Programming the Z8000 (Mateosian)	19.40
80 Practical Time Saving Programs for the TRS-80 (Carroll)	15.95
Telematic Society: A Challenge for Tomorrow (Martin)	17.50
The S-100 Bus Handbook (Bursky)	21.50
How to Design, Build & Program Your Own Advanced Working Computer System (Haviland)	15.95
6502 Assembly Language Programming (Leventhal)	19.60
32 Basic Programs for the Apple Computer (Rugg)	29.50
Illustrating Computers (Without Much Jargon) (Day)	14.95
6801, 68701 & 6803 Microcomputer Programming & Interfacing (Staugaard)	21.95
How to Build Your Own Working Microcomputer (Adams)	13.95

Teaching Your Computer to Talk (Teja)	13.95
Invitation to Forth (Katzan)	21.00
Threaded Interpretive Languages (Loeliger)	26.15
Starting Forth (Brodie)	21.50
Introduction to Word Processing (Quible)	19.95
The Computer Solution (Behan & Holmes)	12.95
101 Microprocessor Software & Hardware Projects (Tedeschi)	13.95
Discovering Computers (Giedhill)	15.00
Z80 Assembly Language Programming (Leventhal)	19.60
Master Handbook of Microprocessor Chips (Adams)	15.95
LISP (Winston)	16.95
Basic Microprocessors and the 6800 (Bishop)	25.05
Intermediate Programming for the TRS-80 (Heiserman)	14.95
Design of Phase-Locked Loop Circuits, with Experiments (Berlin)	14.75
Playing the Stock & Bond Markets with the Personal Computer (Schmeltz)	15.95
The ADA Programming Language (Pyle)	19.95

ROBOTICS

Robot Intelligence with Experiments (Heiserman)	13.95
The Year of the Robot (Chen)	12.95
Build Your Own Working Robot (Heiserman)	11.50
The Complete Handbook of Robotics (Safford)	12.50
How to Build Your Own Working Robot PET (DaCosta)	9.95
How to Design & Build Your Own Custom Robot (Heiserman)	17.95
Karel the Robot: A Gentle Introduction to the Art of Programming (Pattis)	8.35

ELECTRICITY/ELECTRONICS

Electrical Principles for the Electrical Trades (Jennison)	11.75
Laser Age in Optics (Tarasov)	3.95
TV Typewriter Cookbook (Lancaster)	17.50
PLL Synthesizer Cookbook (Kinley)	12.50
Packet Radio (Rouleau)	16.95
Modern Recording Techniques (Ronstein)	19.25
How to Build Hidden Limited Space Antennas That Work (Traister)	15.95
I.C. Timer Handbook (Carr)	13.95
Master Handbook of Acoustics (Everest)	19.95
Master Handbook of Telephones (Traister)	17.50
Designing, Building & Testing Your Own Speaker Systems (Weems)	12.50
Regulated Power Supplies (Gottlieb)	26.95
Complete Handbook of Radio Transmitters (Carr)	14.95
Complete Handbook of Videocassette Recorders (Kybett)	15.95
Newnes Electrical Pocket Book	17.95
Complete Guide to Car Audio (Clifford)	13.50
The 2-Meter FM Repeater Circuits Handbook Using FM For Amateur Radio (Sessions)	10.50
Sound System Engineering (Davis)	29.75
Understanding DC Power Supplies (Davis)	9.95
Beginners' Guide to Amateur Radio (ARRL)	10.95
Modern Radar: Theory, Operation & Maintenance (Safford)	22.50
Secrets of Ham Radio DXing (Ingram)	11.50
New Penguin Dictionary of Electronics (Young)	9.95
Australian Electrical Wiring, Theory & Practice Vol. 1 (Pethebridge)	13.95
Vol. 2 (Pethebridge)	13.95

We also carry a large range of overseas and local computer magazines

For Mail Orders please add: \$1.50 Local; \$2.50 Interstate.

McGill's Authorised Newsagency Pty Ltd,

187 Elizabeth Street, MELBOURNE.

Phone: (03) 60 1475-6-7 60 1505 (4 lines)

Prices Subject to Alteration

The ultimate in frequency counting

Philips' compact, microcomputer-based frequency counters offer outstanding accuracy over a 10 Hz to 1500 MHz measuring range, plus many powerful new performance features.

Choose from the 120 MHz PM 6673, 550 MHz PM 6674, directly-gated 600 MHz PM 6675 or 1500 MHz 6676.

Microcomputer-controlled reciprocal counting eliminates the traditional ± 1 cycle error, ensuring maximum accuracy at low frequencies. So now you get at least 7-digit resolution per second of measuring time. And automatic switchover to conventional counting at 10 MHz guarantees peak performance at higher frequencies.

Advanced front-end circuitry provides error-free triggering, with excellent noise immunity over a wide dynamic range. In addition, there's a choice of five timebase crystal oscillators — with even the most stable version ($5 \times 10^{-10}/24$ h) battery-operable for field use.

Interface options including the IEC 625/IEEE 488 bus also put programming capability at your disposal for production and quality assurance testing.

Maximum input sensitivity is a high 10 mV, and facilities are included for burst and multiple burst frequency average measurements.

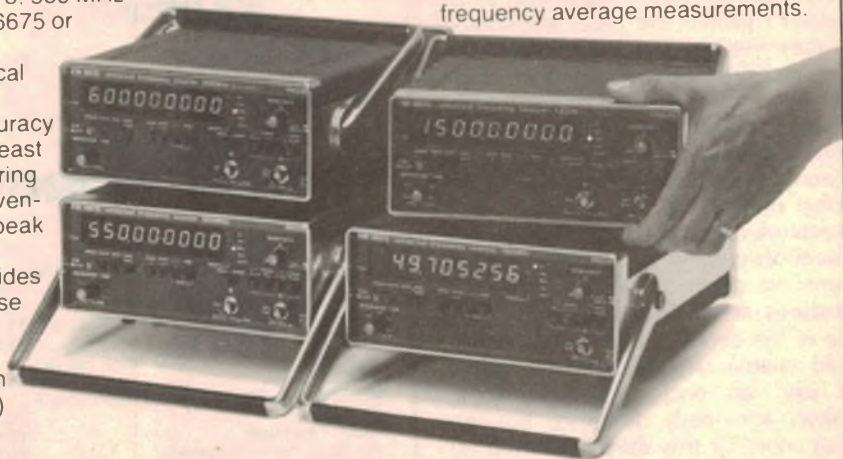

From Philips, of course

For more detailed information phone
Philips Scientific and Industrial
Equipment:
Sydney — Graham Adams or
Mike Meehan 888 8222
Melbourne — Ralph Brown 690 6366

Brisbane — Eleanor Futter 44 0191
Adelaide — Duncan Glenn 223 4022
Perth — Lois Woodcock 277 4199
NEW ZEALAND
Wellington — Steve Morris 859 859



Test & Measuring
Instruments

PHILIPS

AHEARN SI 51

Tap the SOUL of your instrument with the fantastic C-ducer

By sticking a flexible tape microphone onto your acoustic instrument, you can 'shape' the sound according to your taste **before** using tone controls. You can actually create a **personal** sound.

You have a choice of preamplifiers too. A C-ducer Gigster which clips onto your belt and plugs into a stage amp/mixer, or a C-ducer Professional unit for studio and high quality stage performance.



For professionals, semi-professionals or the serious amateur or simply anyone who wants to bring out the real soul of their acoustic instrument — the C-ducer flexible tape microphone is for you.

R.H. Cunningham
PTY LTD

146 Roden St, West Melb Vic 3003 Ph: 329 9633 Telex 31447
4-8 Waters Rd, Neutral Bay, N S W 2089 Ph: 909 2388 Telex 21707



RHC005

swallow was as follows: "For minimum acceptable hifi . . . the amplifier should reproduce frequencies as low as 30 and as high as 15kHz. The better amplifiers now available range from 20 to 20kHz and higher". Really. Accompanying that text is a "typical response" curve of a "satisfactory" amplifier which is riddled with peaks and troughs. I would like to know how anybody would produce such an amplifier!

If you are particularly interested, the main volume at \$12 is the best one to go for although little, if any, of the equipment featured is available now. And be aware of the "bloopers". As indicated above, some are serious, others are just laughable. The books are distributed in Australia by Butterworths Pty Ltd, 271-273 Lane Cove Road, North Ryde NSW 2113. (L.D.S.).

WIA History

WIA BOOK Vol. 1 edited by B. R. Bathols, VK3UV. Published by the Wireless Institute of Australia 1982. Soft covers, 160 pages 210mm x 135mm. Illustrated with photographs and diagrams. Price \$3.50 to members of the WIA.

The publication of the WIA Book, Volume I, marks the first of a proposed series dealing with amateur radio in Australia, with further volumes until the 75th anniversary of the WIA in 1985. Volume I contains a wealth of information both historical and current relating to amateur activity and the Wireless Institution of Australia.

In the historical section there is a chronological table of events 1729 to 1925, with emphasis on events within Australia. There are details of WIA federal conventions since the first in 1924, names of federal presidents and honorary life members, and Remembrance Day memorabilia.

There are also short items on such subjects as; amateurs in emergencies, WIA constitution, policies and organisation; Contests, Awards, illustrations of notable events and documents, plus notes on available amateur publications, ionospheric predictions, call signs, and QSL's.

A VHF section contains projects for 52MHz, 144MHz, 432MHz and 576MHz bands, various designs for 144MHz antennas, plus very useful reference data on band plans, repeater channels, and metric conversion.

While this book is published mainly for sale to WIA members and as a library reference book, the contents will no doubt be of interest to all amateurs.

It is particularly recommended to those

who have more recently joined the amateur radio fraternity and who may be taking an active part as an affiliated club or WIA officer.

Nearly three-quarters of a century of history and progress of the oldest national amateur radio society makes very interesting reading.

Details of availability etc, may be obtained from — MAGPUBS, PO Box 150, Toorak, VIC. 3142. (P.H.)

Basic Programs

BASIC PROGRAMS FOR SCIENTISTS AND ENGINEERS: by Alan R. Miller. Published 1981 by Sybex Inc. Soft covers, 318 pages, 175mm x 227mm, extensive program listings. Price \$19.95.

This book serves a double purpose. As an educational textbook it can take the beginning programmer to a high standard of competence in Basic while engineers, scientists and students will find it a helpful reference and a library of useful sub-routines.

The book has 11 chapters. The first concerns the evaluation of a Basic interpreter or compiler for precision and range in floating point arithmetic operations. Others provide discussion and programs for dealing with statistical calculations, vectors and matrix operations, solutions of linear equations, curve fitting, sorting and integration and other advanced applications.

All programs are written in a "lowest common denominator" Basic, so that they can run on microcomputers such as the Apple, the TRS-80 or Commodore machines. However users are encouraged to upgrade the programs as much as possible, and details are given of additional features which can be used to advantage on more powerful computers.

In fact the line numbers of the 48 program listings in the book have been integrated so that there is a minimum of conflict. The author has thoughtfully arranged the programs so that particular subroutines have the same line numbers throughout the book, so that, for example, the main program has line numbers from 1 to 500, sorting routines begin at line 3000, Newton's method of solving equations at line 8000 and so on.

Sections of the book containing program listings are clearly labelled and indexed for ready reference, but the greatest benefit from this book is obtained by reading straight through. Each chapter discusses and develops programming examples that are used again in later chapters. The mathematical concepts behind each program are described before the program is presented, and in most cases samples of typical program

outputs are shown. Each chapter also contains exercises to develop the reader's understanding of the text. Some experience with vector operations and calculus would be helpful in making best use of the book.

Our review copy came direct from the publishers, but Sybex books are distributed in Australia by ANZ Book Company Pty Ltd, 10 Aquatic Drive, Frenchs Forest, NSW, 2086. (P.V.).

Apple Software

THE BOOK OF APPLE COMPUTER SOFTWARE 1982, by Jeffrey Stanton and John Dickey. Published 1981 by The Book Company, California, USA. Soft covers 213mm x 276mm, 399 pages, illustrated with charts and diagrams. Price \$24.00.

This new edition of "The Book of Apple Computer Software" updates previous editions with new articles, reviews and evaluations of new software. Allowing for the fact that it is impossible for any one publisher to list and review all the hundreds of programs available for the Apple II "The Book" is an excellent reference for any Apple user.

Seven chapters including a lengthy introduction, discuss programs for business, education, utilities and games and entertainment, while an additional chapter examines hardware. The final chapter, "Software Houses" is a list of suppliers of programs. As they are all in the United States, this is not of much use in this country. Programs are indexed in the last section by name and category.

Each program dealt with is reviewed, sometimes at length, and given a percentage evaluation on factors such as ease of use, documentation, reliability, error handling and visual appeal. The reviews are not all favourable, which, to this reviewer, is a good sign.

Other articles throughout the book make interesting reading, such as "How to Write Games that Last". In passing, it might be well to mention that the chapter on games and entertainment programs is further subdivided in 13 sections, bearing out the editors' contention that most users like to have fun with their Apple. Games categories include fantasy and role playing, adventure type games, war games, sports, gambling and card games, puzzles etc.

"The Book" answers questions such as whether programs require a disk or tape, Integer Basic or Applesoft, or 16, 32 or 48K of RAM. Similarities between various programs are noted, and a guide is given to what the editors call "price/usefulness" ratio. All in all, a thoroughly useful book.

Our review copy came from Computer Gallery, 66 Walker St, North Sydney, 2060. (P.V.).

New Products ...

Product reviews, releases & services

Bearcat scanner from Dick Smith Electronics

Dick Smith Electronics now has available a scanning receiver which is said to be the most inexpensive desk-top scanner available in Australia. The Bearcat 150FB Scanner monitors fire brigade calls, police channels, and public service broadcasts, and is being advertised with the slogan "hear tomorrow's news today".

The Bearcat 150FB is a 10-channel programmable scanner covering UHF frequencies from 406 to 490MHz and VHF from 66-98MHz and 144-174MHz, including the two metre amateur band. The receiver does not use crystals. Frequencies are programmed via a touch sensitive keyboard and read out from an eight-digit display.

Sensitivity is quoted as 0.5uV on VHF and 0.8uV on UHF. Scanning speed is 16 channels a second, with a selective two second delay. The unit is mains powered and supplied with a telescopic antenna, although an external antenna can be added if required.

The Bearcat 150FB Scanner costs \$275, and is available from all Dick Smith Electronics stores.



The Bearcat 150B programmable scanning receiver offers 10 channels and features a touch sensitive keyboard, lighted display and five band coverage. A telescope antenna is supplied, and the unit is mains powered.

A/D converters, digital panel meters

A new 8-bit digital to analog converter from Dattel-Intersil provides a maximum conversion time of around 900ns and ± 2 least significant bit accuracy over an operating temperature range of -55°C to $+125^{\circ}\text{C}$ for the military spec version.

The Dattel-Intersil ADC-5010 converter uses the successive approximation method and provides TTL compatible outputs in either serial or parallel form. Nine input voltage ranges can be programmed by simple single-pin connections. The converter is available in a 24-pin hermetically sealed ceramic package.

Dattel-Intersil also has available a 12-page technical brochure on their DM-31 single board differential digital panel meter. This module is very similar to that used in a range of projects published in Electronics Australia, such as the heartrate monitor in this issue.

The brochure gives all electrical and mechanical specifications of the DM-31

and includes block diagrams, mounting and connection methods, technical notes, applications circuits and ordering details.

Dattel-Intersil products are available from Elmease Instruments Pty Ltd, PO Box 30, Concord, NSW, 2137, or PO Box 107, Mt Waverley, Vic 3149.

Soanar Electronics to distribute Stanley LEDs

Soanar Electronics Pty Ltd has announced that it has been appointed the Australian distributor for the Stanley Electric Co Ltd of Japan.

Stanley Electric began as a small firm 60 years ago, manufacturing automobile light bulbs. Since its foundation the company has grown to be one of the leaders in Japan's automotive lighting and related electronics industries.

The company began production of semiconductors in 1960, following a policy of intensive research and development. In 1976 Stanley Electric developed

"high intensity" LEDs, claimed to be the brightest LEDs available. The company now manufactures the high intensity LEDs in red, yellow, green and amber.

"High intensity" LEDs have a luminous intensity of up to 10 times normal devices at the same current. For example, the Stanley super bright red LED has a light output of 160mcd (millicandelas), compared to around 16mcd for normal "high efficiency" red LEDs.

Stanley has been instrumental in developing new applications for LEDs, in cameras, audio equipment, computers, automobile dashboard displays, measuring instruments and communications equipment. The company has also just completed preparations for the mass production of coloured liquid crystal displays (LCDs).

Soanar Electronics will be marketing the full range of Stanley high intensity LEDs together with a comprehensive variety of 7-segment displays in both LED and LCD types. For further information contact Soanar Electronics Pty Ltd, 30 Lexton Road, Box Hill, Vic. 3128.

Hard disk controller from Daneva Australia

Daneva Australia Pty Ltd has recently released a controller board for Winchester type hard disks. The WD1000, from Western Digital, is a stand-alone general purpose Winchester controller, able to interface up to four hard disk drives to a host computer.

All necessary buffers and receiver/drivers are included to allow the drive to be connected directly to the board. Either 34-pin (14cm) or 50-pin (for 20cm disk drives) connectors are provided. Data to be written to or read from the disk, status indication and macro commands are transferred via a separate bi-directional 8-bit bus. An on-board buffer allows data transfers to the host computer independently of the actual data transfer rate of the drive.

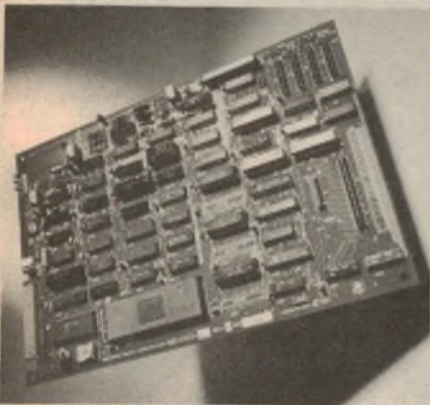

For further information contact Daneva Australia Pty Ltd, PO Box 114, Sandringham, Vic 3191.

C&K Electronics has solid-state switches

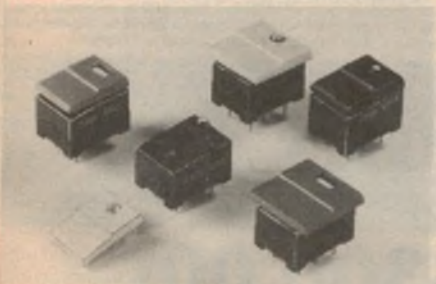

C&K Electronics has introduced a new range of pushbutton switches in their solid-state Pushbutton Series SS01. The switches include internal electronics for contact debounce and for driving an in-built LED indicator. A single jumper change in the external circuit determines whether the switches are momentary contact or alternate action types.

A wide supply voltage range (3-16V)

and complementary outputs are additional features of the DIP compatible switches. Eight cap colours and a choice of round or rectangular LEDs in three colours are also available.

For additional information contact C&K Electronics (Australia) Pty Ltd, PO Box 229, Parramatta, NSW 2150.

“Striplite” indicators

SL Strip indicators are solid state neon plasma bar type displays, available as either a dual channel indicator or as a single channel display with high and low alarm set points. Called “Striplite”, the indicators are designed for applications in process control equipment.

When used as a dual indicator the device will accept and display input voltages signals from 0V to 5V on a variety of standard scales, or on specially produced non-standard scales. Single channel indicators display the input on the right hand strip and the settable high and low alarm values on the left hand side.

Both versions of the indicator provide integral signal conditioning to give an analog output of 0V to 2V for monitoring purposes.

The Striplite indicators are manufactured by Penny & Giles Ltd of the UK, and distributed by British Merchandising Pty Ltd, GPO Box 3456, Sydney, NSW, 2001.

S-100 processor board and disk controller

New from Q. T. Computer Systems are a Z80A based processor board for S-100 systems and a floppy disk controller board.

The processor board, QT SBC 2/4, provides on-board RAM and ROM, a bi-directional RS232 interface, two programmable timers and parallel input and output ports. It can be used as a stand-alone system or as the heart of a larger computer system.

California Computer System's 2422 Floppy Disk Controller can control up to four disk drives, in any combination of 14cm or 20cm, double and single density. An on-board 2K EPROM provides an operating system which is compatible with the SBC 2/4 CPU. The board uses Western Digital's FD1793 disk controller chip, and is designed for Shugart 800/850 and 400/450 drives and other compatible disk drives.

The board costs \$396 including the monitor software and a copy of CP/M for use with the SBC 2/4.

For further information contact Q.T. Computer Systems (Australia) 283 Clarence St, Sydney, NSW 2001.



Rechargeable batteries from Sanyo

Sanyo has released a new range of rechargeable batteries and simple-to-use chargers. The batteries are said to offer a service life far in excess of the best conventional alkaline dry cells available.

In addition, the “Cadnica” batteries are capable of being recharged more than 500 times with a convenient charger which plugs into a power point. Recharging time is given as 14 to 16 hours.

The batteries can be used in place of dry cells of the same size, and are especially suited for use with equipment which performs better with a constant battery voltage. The discharge voltage of the Cadnica cells remains constant for about 90% of the discharge period.

The Model NC 452 recharger is designed to charge four AA size batteries. Sanyo also has a model NC 1230 recharger which is designed so that all three battery sizes (D, C and AA) can be accommodated.

The Sanyo batteries and rechargers are available from electrical retailers and Sanyo service centres throughout Australia.

Plastic sealant for co-axial cable work

Hy-Tech Distributors of Queensland can now supply “Coax-Seal”, a new, mouldable plastic said to be suitable for sealing a wide variety of coax connectors.

Coax-Seal for industrial users comes in rolls of 10cm wide plastic tape on backing paper which can be peeled away. The material can be wrapped on to coax connectors, baluns, beam antenna parts and connectors and pressed into place to form smooth, moisture-proof connections for efficient coupling of VHF and UHF equipment. It is said to be the only material which will adhere to vinyl and polyvinyl coax outer covers.

Coax-Seal will also allow fittings to be disconnected and later resealed using the same material.

For further information contact Hy-Tech at Building 51, Archerfield Aerodrome, Qld, 4108.

LISTEN IN TO SECRET RADIO



There are literally thousands of radio transmissions every day that you've never had the chance to listen to - simply because there's never been an economic way to listen to them. NOW there's a way. The new Bearcat 150FB scanning receiver from Dick Smith Electronics!

COVERS THE FOLLOWING 'SECRET' FREQUENCY BANDS:

66-88MHz
Business radio

144-148MHz
Amateur radio band

148-174MHz
Business radio, tow trucks, harbour marine etc

406-470MHz
Amateurs, business radio, police etc

470-490MHz
UHF CB, Taxi, other emergency services

Inbuilt 240V power supply - it works anywhere there's a power point - with a special battery memory back-up in case of power failure. You don't lose any of those special frequencies you've found with this amazing scanner...

Super sensitive front end for the ultimate in reception: uses latest frequency synthesis circuitry to eliminate expensive quartz crystals as found in inferior models.

Telescopic whip antenna for reliable local area communication, plus provision for external monopole or beam antenna for extra long range reception.

Huge fluorescent digital readout for optimum readability in all light conditions (beware of LED or LCD readouts which can cause problems).

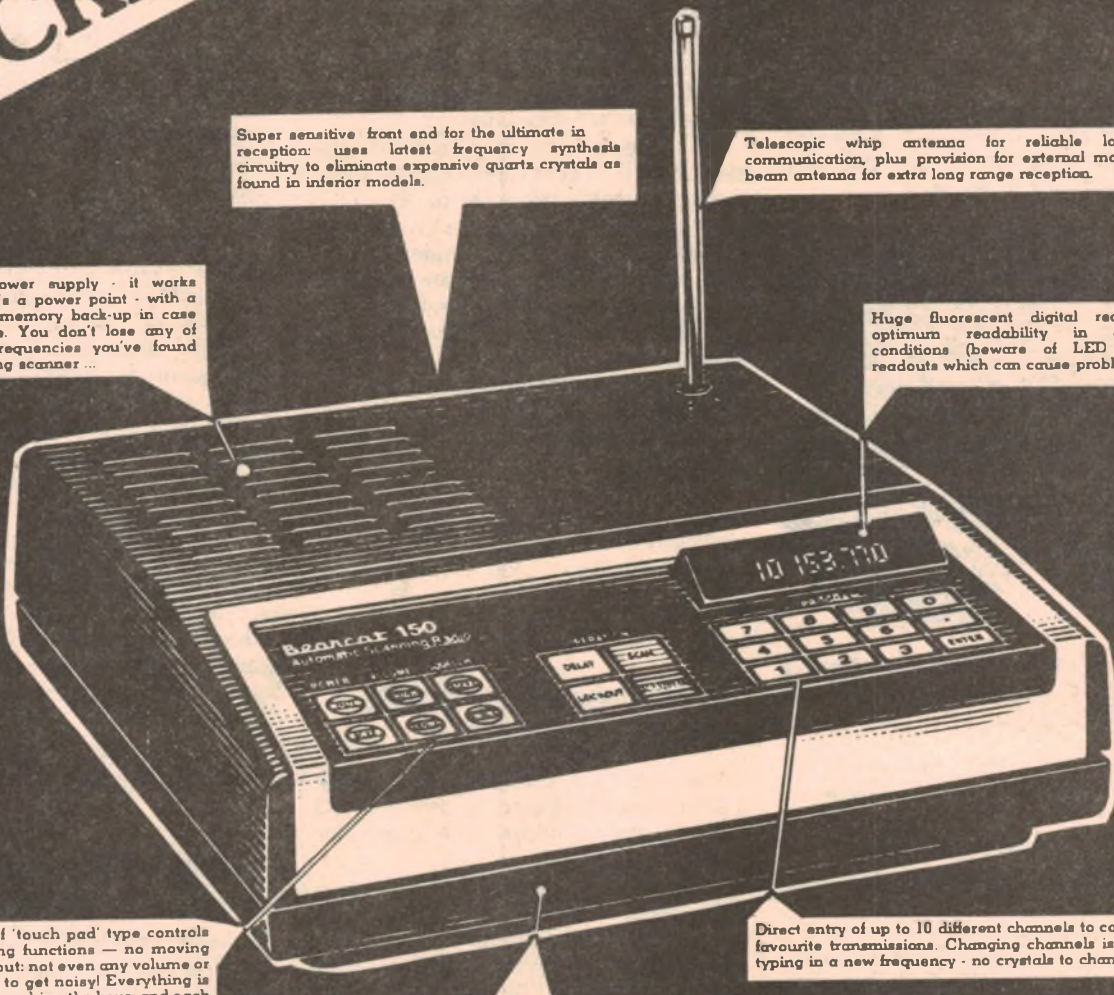

Moisture proof 'touch pad' type controls for all scanning functions - no moving parts to wear out: not even any volume or other controls to get noisy! Everything is controlled by touching the keys: and each key gives you an answering 'bleep' to let you know it's understood.

Internal microprocessor integrated circuit - virtually a mini computer in one chip - to make child's play of the normally extremely complex controls and functions of the scanner. You'll only take a couple of minutes to learn to use this incredible device!

Direct entry of up to 10 different channels to cover all your favourite transmissions. Changing channels is as easy as typing in a new frequency - no crystals to change!

AND IT'S UNDER \$300.00!

The amazing Bearcat 150FB Australia's lowest priced synthesised scanner radio receiver. Incredible value for all those interested in listening to stations using the VHF & UHF spectrum - includes amateurs, business, police, fire, ambulance & other emergency services. Imagine you could be listening to tomorrow's news - today!
Bearcat 150FB Scanner: exclusive to Dick Smith Electronics.
Cat D-2800

DICK SMITH Electronics

ONLY \$275⁰⁰

SEE PAGE 52 FOR ADDRESS DETAILS

New Products

New navigation system uses both Satnav and Omega fixes



Rediffusion Radio Systems Ltd, represented in Australia by Vicom International, has recently developed a hybrid navigation system which combines both Omega and Satnav satellite data.

The NV10 Navigation Management System uses a weighting algorithm which considers the accuracy of the satellite data to produce a position reading based on the most reliable data. A single combined antenna receives both Satnav and Omega signals.

The NV10 has undergone extensive sea trials over many months in vessels including an ocean-going merchant ship in the Atlantic, Caribbean and Pacific, a survey vessel of the British Royal Navy and a luxury yacht.

Also available from Vicom is the NC 6000 VHF direction finder, developed by Regency Electronics of the United States. The add-on direction finder converts any VHF transceiver into a direction finder by measuring the direction of an incoming signal. The display indicates relative bearing of the signal source on a circle of LED indicators.

For further information contact Vicom International Pty Ltd, PO Box 366, South Melbourne, Vic 3205.

Do-it-yourself battery checks with Arlec charge indicator



Arlec Pty Ltd has available a handy charge indicator for 12V car batteries. Using six LEDs on a graduated scale

the charge indicator shows the amount of charge remaining in a battery, indicates the condition of a battery on charge, and can be used to check performance of the alternator and voltage regulator.

LEDs light progressively as the battery is being charged and flash if overcharging occurs. Dimensions of the unit are 115mm x 50mm x 20mm and it comes complete with integral leads and battery clips. A 12 month guarantee covers the charge indicator against faults.

For more information contact Arlec Pty Ltd, 30-32 Lexton Rd, Box Hill, Vic, 3128.

AUSTRALIAN AMP

LOW-PROFILE DIP SOCKETS

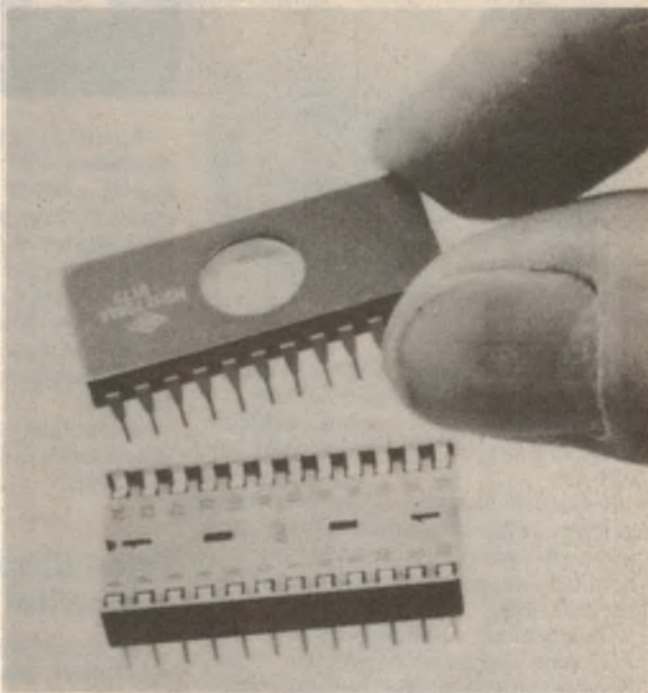

DIPLOMATE

Features

- Low Profile
- Dual wiping contacts
- Large target area, with tapered lead-in ramps
- Designed for automatic machine insertion—
- Tin or gold plated phosphor bronze or beryllium copper contacts
- Closed bottom
- Visual polarization
- Designed to meet EIA RS-415
- Stackable end-to-end and side-to-side for high board density.

Technical information available on request.

SOANAR

Soanar Electronics Pty Ltd

30-32 Lexton Road, Box Hill, Vic., 3128, Australia.

VICTORIA: 840 1222 QUEENSLAND: 52 1131
N.S.W. 789 6733 WEST. AUST. 381 9522
S.T.H. AUST: 42 8918 TASMANIA: 31 6533

New Products

"Micropower" switching regulators

Raytheon's micro-power switching regulators, RC 4191/92/93, now offer designers a universal solution to low power requirements. Raytheon's family of switching regulators are all available in 8-pin mini-dips and are specifically designed for battery operated instruments.

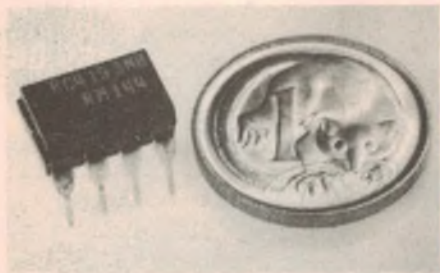

In its most popular configuration, step-up, the RC 4193 (for example) can use fewer battery cells, making available more board space and lengthened battery life.

A practical example of the advantages of these regulators would be an instrument designed to operate from a nominal voltage 9 volt power supply using a RC 4193.

The instrument could be powered with only nine components; steering diode, three resistors, inductor, two capacitors, an RC 4193 and a 9V battery. The RC 4193 could be programmed to operate when the battery voltage has decayed to 7V, and until this point is reached the chip will act as a voltage follower operating at approximately 100% efficiency.

When the battery voltage has decayed to 7V the RC 4193 will turn on, maintaining a constant 7V out until the battery voltage has decayed to 2.5V.

Soanar Electronics Pty Ltd has also been appointed the sole Australian distributor for the range of RFI power line filters manufactured by Curtis Industries of the USA.

Manufacturers and users of digital devices are increasingly recognising the need for RFI power line filters in their equipment. When digital equipment is interconnected, interference created by one device can adversely affect others using the same mains supply unless power line filters are fitted in the system.

The Curtis Industries filter design is said to meet and surpass Government regulations on power line noise emission.

For further information contact Soanar Electronics Pty Ltd, PO Box 170, Box Hill, Vic. 3128.

New metal etching pen from Scope Laboratories

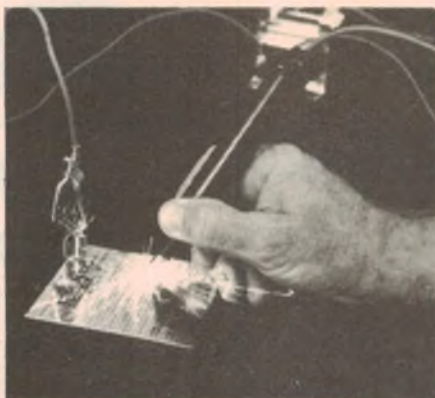

Aluminium identification plates for machinery and other equipment can be quickly printed by hand using a new metal etching pen marketed by Scope Laboratories of Melbourne.

The pen operates from a 4V source which is also marketed by Scope. It leaves a permanent message on a metal of any hardness, provided the surface is not painted or coated with an electrical insulator.

For further details contact Scope Laboratories, 3 Walton St, Airport West, Vic. 3042.

Price drop for SME typewriter conversion

The cost of converting Olympia ES 100 typewriters into printer/terminals has been greatly reduced by SME Systems.

SME has been manufacturing conversion boards for the ES 100 for the past two years. Previously the boards were only available through a tied wholesaler arrangement.

Now SME is offering the boards, with manual and fitting instructions, directly to the public, and through its distributors for \$245 (plus tax).

Mike Pratt, Managing Director of SME, says his company's conversion hardware and software has made the Olympia the most versatile typewriter on the market. With the board, the Olympia ES 100 is also a word processing quality printer and a stand-alone hard copy computer terminal.

In both functions it is compatible with any machine with RS 232C communication protocols. When not directly communicating with a computer system, the ES 100 can still be used as a typewriter.

Mr Pratt said that the board could be fitted by the customer in less than 20 minutes, though his firm was happy to do the installation for an extra \$20. For further information contact SME Systems, 22 Queen St, Mitcham, 3132.

Bill Edge on the move

Bill Edges' Electronic Agencies have moved from 123 York Street, Sydney, to more spacious premises at 117 York Street. Their Concord store remains at 115-117 Parramatta Rd, Concord, NSW. The company has advised that they now stock Trio oscilloscopes and can supply the full range of Trio products as well as B&K instruments.

Continued on p105

Mains Monitor

connect to the insulated terminal block. Finally the active (red or brown) wires from each cord section should connect to either side of the meter movement.

Use cord clamps to secure each cord section. Make a final check of your wiring and then screw the lid to the case. Now check with a multimeter that the earth connection is continuous between plug and socket and has no short circuits to active or neutral. Similarly, check that the active pin on the plug is connected to its respective slot on the socket. Do the same with the neutral connections.

Now you are ready to use the Power Monitor on the mains. Plug it into a power point with no load connected to the socket. There should be no pointer deflection on the meter. Then connect an appliance of known power rating and check that the meter reading is roughly the same.

One final point should be kept in mind in using the Power Monitor and that is

ctd from p85

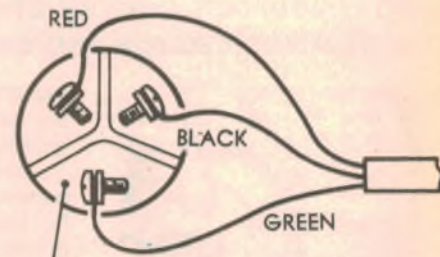

POWER PLUG
(LOOKING AT SCREWS)

Wiring of the mains plug. See the text for the new mains wiring colour code.

the difference between power demand and energy consumption. Since many domestic appliances are thermostatically controlled (some radiators, stoves, ovens and grillers) while others are used intermittently (refrigerators), their maximum power demand is not necessarily a guide to their energy consumption over an extended period of time. 

THINKING APPLE MICROCOMPUTERS

THINK COMPUTER COUNTRY

We are one of Australia's oldest Apple Dealers
and the oldest in Victoria!

We carry probably one of the largest ranges of
Apple Products in Australia!

GREAT PRICES!
GREAT SERVICE!
WHY GO ELSEWHERE!

Come to the
Computer Country Group
for all Your Apple needs



**COME TO
COMPUTER COUNTRY (VIC) PTY LTD**

338 Queen Street Melbourne Vic 3000 (03) 329 7533

IN QUEENSLAND CONTACT

Computer City 600 Old Cleveland Road Camp Hill Qld 4152 (07) 398 6759

IN SOUTH AUSTRALIA CONTACT

Key Computer 1055 South Road, Edwards Town SA 5039 (08)
277 8936

IN WESTERN AUSTRALIA CALL

Computer Choice, 1297 Hay Street, West Perth, W/A 6005.
(09) 322 5651

New Products

The Trio range includes a portable 15MHz CRO, a 100MHz model and test equipment – frequency counters, function generators, a colour pattern generator, multimeters and an acoustic measuring system.

For more information contact Electronic Agencies at 115 Parramatta Rd, Concord or 117 York St, Sydney.

“Talkman” transceiver leaves hands free

GFS Electronic Imports of Mitcham, Victoria recently announced the release of a new personal Mobile VHF FM transceiver, the C-900 Talkman.

Designed to provide users with two-way communications over a distance of up to 1km, the Talkman is extremely simple to operate. It makes use of a lightweight headset to leave the user's hands free, and its compact size, light weight (250g) and voice operated transmitter make the Talkman suitable for hundreds of different applications.

The Talkman is approved by the Department of Communications and operates on a frequency of 55.02MHz. A minimum of controls are provided to make operation of the transceiver as simple as possible.

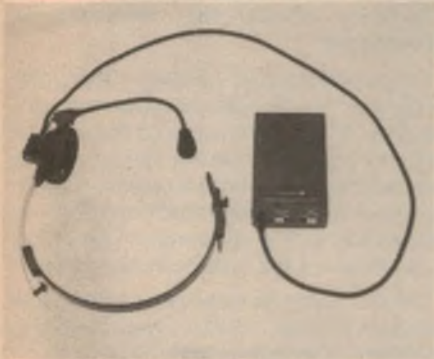

GFS has also been appointed the Australian distributor of “Satellite TRVO Digest”, a technically orientated magazine covering the design of 3.7 to 4.2GHz satellite television receive-only terminals.

The magazine, published monthly by Satellite TVRO Technology, a United States company, will be available on a subscription basis from GFS. A 12-month subscription will cost \$60 in Australia and \$84 in New Zealand, New Guinea and the Pacific Islands, including air freight.

For additional information contact GFS Electronic Imports, 15 McKeon Road, Mitcham, Vic 3132.

For moving messages — the Textlite

“Textile” displays preprogrammed messages in movement with a variety of special effects.



Dynavision Sales Pty Ltd now has available the “Textlite MM-300”, an illuminated sign which displays messages in motion. The display is also capable of special effects, such as pauses, flashes, jumps and rolls.

Measuring 520mm long by 80mm high, the message display can be used in shops, hotels, service centres, banks and exhibitions — anywhere, in fact, where a moving display message is required.

At the heart of the Textlite MM-300 is a built-in microprocessor that remembers and repeats the message. To use the unit the operator needs only to key-in the desired message on the typewriter style

keyboard on the back of the unit. Messages can extend to 1023 characters, or around 200 words, which are run as sentences and repeated as long as the user desires.

Small backup batteries within the unit provide enough auxiliary power to allow the Textlite to be unplugged and moved to a new location without fear of erasing the message from the memory of the microprocessor.

The Textlite MM-300 is available from Dynavision Sales Pty Ltd, 327 Princes Highway, St. Peters, Sydney, and costs under \$500.

Digital thermometer for industrial use

A digital thermometer designed for industrial use is now available from Duff & Macintosh Pty Ltd of Crows Nest. The “Contherm 208” thermometer has a measuring range of -50°C to 1200°C , and features auto-ranging, so there is no selector switch or range buttons on the impact resistant case, just an on-off switch.

For further information contact Duff & Macintosh Pty Ltd, 67 Chandos St, Crows Nest, NSW 2065.



Heart rate monitor

siderable delay between adjustment of RV2 and its effect upon the display, so adjust RV2 slowly.

With the meter display now reading 215, the heart rate monitor is fully calibrated and ready to use. Switch S1 to the READ position and place a finger across the sensor so that the fleshy pad on the end of the finger just covers the two sensor components. Do not press too hard or the blood flow will be reduced to the point where the sensor will not pick up any pulses. A light finger pressure is sufficient.

Now adjust the gain control until a regular on-off flashing of the “+” annunciator is obtained. If a double flash of the “+” annunciator occurs for each heart beat it means that there is too much gain and the gain control should be reduced.

In some cases, it may not be possible to completely remove the double flash effect, particularly from strong signals. However, this usually does not affect the

... ctd from p86

display reading since the second pulse occurs while the monostable output is still high from the first pulse and, during this time, the monostable cannot be retriggered. Once a steady flashing of the “+” annunciator is achieved, it is necessary to wait several seconds until the display reaches a stable value. Some small variations in the reading will occur due to slight variations in the heart rate, however these should only be about 1 or 2% of the reading.

Two points to watch when taking a reading are that you don't hold your breath, and that you don't concentrate too hard on making the “+” annunciator appear. Both these actions will increase your heart beat above the normal resting value.

Finally, some readers may wish to use a remote sensor to monitor their heart rate while exercising. Full constructional details for three different remote sensors were published in the April 1981 issue of “Electronics Australia”.



REVIEWS OF RECENT

Records & Tapes

CLASSICAL ● POPULAR ● SPECIAL INTEREST

WEINBERGER "Schwanda" — the first recording

WEINBERGER — Schwanda the Bagpiper. First recording of the complete opera. Lucia Popp, Hermann Prey, Siegfried Jerusalem, Gwendolyn Killbrew and others, with the Munich Radio Orchestra and Bavarian Chorus conducted by Heinz Wallberg. Three boxed discs (analogue) CBS Stereo 79344.

Early in the 1930s, when the ABC was establishing its Subscription Symphony Concerts conducted by overseas stars, many a concert finished with the Polka and Fugue from Schwanda the Bagpiper. Few people knew much about the opera itself or its composer Weinberger and, as I remember, there wasn't much information in the program, either.

As it happened, Weinberger was a prolific Czech composer whose Schwanda had considerable vogue all over Europe and America until World War 2, when it quietly died. Nowadays, it is a rare event to come across Weinberger's name in a concert program or a classical record catalogue.

The set under review is the first to be recorded, although the opera was first produced in Prague in 1937. It soon won popularity and remained among the favorites until the war. Weinberger died as recently as 1967 — by an overdose of narcotics.

Despite his large output, his music seemed doomed to oblivion, despite such an encouraging start. Yet "Schwanda" is an engaging work, a merry fairy tale folk opera, quite as worthy of repeated revivals as its co-national "The Bartered Bride". Nowadays, despite his industry, Weinberger remains only precariously remembered as the composer of Schwanda.

Entrepreneurs everywhere refuse to put the work on because they argue there has only been one successful Czech opera, despite the many composed by Dvorak. The successful one is Smetana's Bartered Bride.

Many musicians have wanted for years to hear a complete recording of



"nothing like a Scottish pibroch . . ."

Weinberger's opera and we should be grateful to find an excellent one put out at last by CBS. (By the way, talking of the popularity of Czech operas, the west had not yet caught up with Janacek and Sir Charles Mackerras is owed much gratitude for a good deal of what we know of him nowadays).

Just think of it, an opera (Schwanda) which ran for over 150 performances all over the world — except Australia — and died without trace after the War. The popular Polka and Fugue excerpt exhibited unusual talent, style and uplifting exuberance. Indeed we now know that the whole opera is full of these merits. In fact, its key note is exuberance. It has a singable — and often melodious — vocal line especially when compared to what we have to suffer nowadays from

composers like Boulez and the rest of the avant garde.

In Schwanda there are two vocal solos that can easily be put into the Aria class. It is gorgeously orchestrated in the manner of Richard Strauss at his most sumptuous — but is quite original, all the way from the most complex to the most delicate sounds imaginable. It is a good-humoured opera from beginning to end and, importantly, just the right length for an evening's entertainment.

Outstanding among the women singers is Lucia Popp, always sweet, light toned and deadly accurate in pitch, no matter how difficult the interval she is encompassing. The men are all extremely competent and all remain well in character throughout. There is much to commend about this set, not only the music, but the mass of information it conveys about the mysterious Weinberger.

One small word of warning — the word "bagpiper" might mislead some. Schwanda doesn't play until well into the second act and you hear nothing like a Scottish pibroch but a cute little fugue like a dainty woodwind quartet which builds up in magnitude as it goes along. If you enjoy it as much as I did, you're in for a treat.

Oh yes, I almost forgot to mention the Bavarian Chorus, which is grand and the excellent analogue sound. (J.R.)

ARRAU: Grieg, Schumann — "Recommended"

GRIEG — Piano Concerto in A Minor.
SCHUMANN — Piano Concerto in A Minor. Claudio Arrau (piano) with the Boston Symphony Orchestra conducted by Sir Colin Davis. Philips Stereo Analogue 9500 891.

Recordings of this coupling must be legion, many of them current, others discarded into the deleted bin. True, there must have been a difference between the various issues — of balance between soloist and orchestra, of inter-

pretation, of quality, of sound and many other, sometimes small, sometimes important divergences.

I think it was Debussy who made a remark to the effect that "Grieg's music is like snow wrapped in pink paper". Well many of the recorded performances have made the concerto sound just like this. Others have given it more weight. I remember a performance in the Sydney Town Hall when the late Julius Katchen and the now Sir Charles Mackerras magnified the work into true near-heroic proportions — with, to me, outstanding success.

Reviews in this section are by Julian Russell (J.R.), Paul Frolich (P.F.), Neville Williams (W.N.W.), Leo Simpson (L.D.S.), Norman Marks (N.J.M.), Greg Swain (G.S.), and Danny Hooper (D.H.).

Well here is still another version – and it has given me much enjoyment. Soloist and conductor play both concertos almost as if they were chamber works. By that I don't mean they demean either. Correct proportions are always observed but the range of dynamics is discreet, the styling classical and their love for the works obvious. And, importantly, both are of the same mind.

Arrau begins the Grieg by caressing the first subject gently – not with great crushing love, and he uses the same treatment for the second subject. Many may miss the usual sweeping contrast. There is never a brittle note from either pianist or orchestra and, if Arrau approaches sentimentality on a rare occasion, he skillfully avoids this yawning pitfall. To me it's as graceful a recording as I ever expected to hear.

Don't look for any fireworks. There aren't any. Arrau's performance of the whole concerto is like one long song and the same might be said for the Boston Symphony under Colin Davis. To some it may sound spiritless, to others – and I am one – the essence of refinement. It's certainly different from any other recording of it I've ever heard, and I love it.

The Schumann shows the same refinement and you might find it interesting to compare it – through my ears of course – with another version reviewed in this issue. It has the same lovely recorded tone as the Grieg and, in sympathy with its nature, has a little more fire here and there than that work. But this is never overdone, always kept within strict Apollonian boundaries. Even the very sprightly finale never relaxes its elegance. I recommend it even if you already have a different version. (J.R.)

ASHKENAZY: "Over-expresses the music"

SCHUMANN – Piano Concerto in A Minor. Introduction and Allegro in D Minor. Introduction and Allegro in G. Op. 134. Valdimir Ashkenazy (piano) with the London Symphony Orchestra conducted by Uri Segal. Decca Stereo. Analogue SXL 6861.

Few musicians would not agree that Vladimir Ashkenazy is a fine pianist and musician, as is Claudio Arrau, yet I like the former's performance of this concerto much less than Arrau's. He is not content to let the work speak for itself but adds an occasional rubato, little pauses and a tendency to accelerate here and there. In other words, he over expresses the music.

I am aware that Schumann was an impetuous composer and that many might argue that, for that reason Ashkenazy is right but to me he tends to destroy much

UHQR (Ultra High Quality Record) disc from Emerson Radio (Aust)

FINGER PAINTING. Earl Klugh. Stereo, "Original Master" recording, limited edition. Mobile Fidelity Sound Lab MF-QR 1-025. From Emerson Radio (Aust) Pty Ltd, 106 Belmore Rd North, Riverwood, NSW 2210. Phone (02) 534 5266.

This recording comes to hand as just about the most elaborate single album package that I have yet received. The disc is in what is claimed to be an anti-static envelope, protected by a cardboard folder, which then slips inside a normal album envelope. But this is then packed between foam plastic sheets in a stout box.

Inside the box is a signed certificate indicating that the particular disc is number 1611 of a 5000-run limited edition custom pressing, made from the master stamper at the JVC factory in Yokohama, Japan, during May 1981.

Reportedly, the presses and the processes are those which have been set up by JVC to press their VHD video discs. The vinyl formulation was that developed for their CD-4 quadrasonic discs and the heating-cooling cycle takes two and a half minutes per pressing – five times that required for a normal LP disc!

And what does all that mean? A 6-page folder spells it out: Transcribed at half-speed directly from the master tape, with an Ortofon cutter, to heavy, super-flat, super vinyl discs, which offer an extreme S/N noise ratio, distortion approaching the theoretical minimum, a response within 0.5dB of the ideal, channel separation improved by up to 12dB, and so on.

of the work's classical character. He starts the introductory bars very assertively, goes on tenderly enough to the first subject but always sounds just a little coarse in the solo bits. Nor do I like Ashkenazy's little hesitations in the first movement and his many variations of tempo.

He plays the second movement beautifully but then so do others, many of whom lack Ashkenazy's great talent. The music here is indescribably lovely, so lovely that one feels it would have to be deliberately destroyed to spoil it. Of the whole concerto, I liked the Finale best. Ashkenazy gives it great authority and makes it sound splendidly majestic, without overdoing things or, indeed, boasting great virtuosity. And, for a change, he plays it straight, without any nuancing.

Schumann wrote only three pieces for



Despite all this, purists might be disturbed to read that the lead group and backing strings were recorded separately on opposite sides of the USA and subsequently mixed. The master tape was presumably analogue, which will please some and displease others; and one would judge from the sound that amplified bass was freely used.

I make these remarks, not to criticise the record, but to point up aspects which some audiophiles may find anomalous.

As for the music itself, it is basically a rhythm guitar and bass sound, with some backing from strings, horns and voices. It is melodic and easy on the ear, even for non-lovers of the guitars and drums. It will also give your woofers plenty to do.

Track titles are: Dr Macumba – Long Ago And Far Away – Cabo Frio – Keep Your Eye On The Sparrow (Baretta's Theme) – Catherine – Dance With Me – Jolanta – Summer Song – This Time.

The quality? Tops! The surface is dead silent, the sound completely clean and smooth. A member of my household summed it up thus: "What marvellous dinner music for a group of younger people". There's just one problem: to judge by the US retail price, the disc would cost more than the dinner! (W.N.W.)

piano and orchestra, all of which are on this disc. There have always been complaints about his unsatisfactory orchestration and this piece, the D minor, goes a long way toward supporting them. For some reason, we are spared this fault in the transparent scoring of the concerto but it is heard at its worst in this piece which, incidentally, Ashkenazy conducts from the piano.

I think part of the reason for this failure is the fact that, much of the time, the piano part consists largely of figurations and it is the gruesome orchestral part that dominates the sound. Nor does the composition hang together very well.

It is a later work than the Piano Concerto and, around about this time, Schumann and his wife had become very friendly with the young Brahms, who might easily have talked Schumann into copying his own grumous style of scor-

ing. Whatever the reason, the work doesn't shape very well, although at least offering small compensation in a spirited march section. There are many cadences that might have been taken from the Piano Concerto but, generally speaking, the whole piece is pretty small cheese.

The last Introduction and Allegro in G is tragically worse for it was composed later still, at a time when the composer was losing his mind and ready to spend the rest of his life in an institution. The opening promises much. Here, one thinks, is the old Schumann, but it soon degenerates. Indeed, as the work progresses, the piano part carries most of the interest, which is only slight and also full of memories of the Concerto in an almost rambling way. The orchestral part is not only commonplace but a bore.

The piece is too long for the type of material it contains and evidence of the composer's loss of talent shows only too clearly. The last few minutes are really woeful and fill one with pity when Schumann's best works are remembered. (J.R.)

☆ ☆ ☆

BRIDESHEAD REVISITED. Original TV soundtrack. Chrysalis L37745. (Festival release).

As schedules would have it, it fell to my lot to listen to this new album before having a chance to watch any of the episodes. And, despite all the publicity about Brideshead, I found myself hoping that there would be more action on the screen than there seemed to be in the soundtrack.

There are 16 titles on the record but it is all so restrained that each track seems to merge into the next like so much "wallpaper" music.

I couldn't help but contrast it with the theme music from "Chariots of Fire", which is well up on the American Top-40 list and likely to turn up in situations not even remotely connected with the movie. It has an appeal all its own.

But enough of that. Without trying to speculate on the appeal of this present disc to "Brideshead" viewers, it is certainly pleasant enough to serve as an appropriate background to a quiet meal.

ALLEN DOES IT AGAIN!

ORGAN FAVOURITES — Carlo Curley playing the Allen System 705 Computer Electronic Organ. Stereo, DLW-1023. (From Allen Organs Australia, 32 Woodhouse Rd, Doncaster East, Vic 3109 or from Allen interstate distributors.)

These days, one does not need any special insight to anticipate the nature of the sound which will emanate from a recording featuring Carlo Curley and an Allen computer organ.

Carlo Curley can be relied upon to turn on a colourful virtuoso performance, exhibiting complete mastery of the chosen instrument and of any technical difficulties which the items may present.

And the Allen organs can likewise be relied upon to create the complex sonic impact of a large pipe instrument — albeit without their sometime acoustic

The orchestra is not named but the conductor is Geoffrey Burgon, who composed the music for the series. (N.J.M.)

☆ ☆ ☆

THE BEST OF FRIENDS. Movie Soundtrack. Infinity L37755 (Festival release).

This soundtrack from the Friendly Film Company's production can stand on its own, as the songs and instrumentals are quite enjoyable, without reference to the movie.

There are 10 tracks in all: I Guess It's Time — Here We Go Again — The Best Of Friends — Amber — I Guess It's Time (instrumental) — Here We Go Again (vocal) — The Best Of Friends (instrumental) — You've Got What It Takes — Peach



muddiness. This one is no exception, but the surprising thing is that the model 705 is not itself an oversize instrument — rather, a median 2-manual classically styled organ, but with 41 stops, the equivalent of 50 ranks, and provision for additional "alterable" voices.

The real role of the recording, apart from providing a great deal of listening pleasure, is to demonstrate the potential of a medium-size Allen organ, that would be within the means of many larger churches.

If you happen to be on the organ committee of such a church, the recording would be a relevant reference. But, committee or not, it contains nine varied and highly listenable selections: "Fugue in G Minor" (Little), J. S. Bach; "Sleepers 'Wake", J. S. Bach; "Sonata No. 1. in F Minor", Mendelssohn; "Rejoice Beloved Christians", J. S. Bach; "Pomp and Circumstance March No. 1", Elgar; "Saviour, Again To Thy Dear Name We Raise", Hopkins; "Sinfonia from Cantata No. 29", J. S. Bach; "Moment Musicale in F-Minor", Schubert; "As The Dew From Heaven Distilling", Daynes.

The sound is sometimes delicate, sometimes brilliant, sometimes massive but always very clean. In the final item, with the aid of an "alterable" voice card, Curley simulates the wooden clarinet and oboe stops of the famous Mormon Tabernacle instrument. For organ buffs, especially electronic organ buffs, another fascinating album! (W.N.W.)

THE TWENTY-SECOND EDITION OF RADIO HANDBOOK

\$39.95
OUT NOW

AVAILABLE AT:

**McGILL'S AUTHORISED
NEWSAGENCY PTY LTD**

OR BY POST — Add postage and packaging: Victoria \$1.50
Rest of Australia \$2.50

187-193 ELIZABETH STREET,
MELBOURNE 3000, VICTORIA.

Phone: 60 1475 (3 lines), 60 1505 (4 lines)



SAVE 50% ON ELECTROS

We've made a huge purchase of top quality computer grade electros and we're passing on our savings to you. Stocks are limited. So get your order in today to avoid disappointment!!



Value MFD	DC Volts	Price	Value MFD	DC Volts	Price	Value MFD	DC Volts	Price
500	250	\$5.00	9100	60	\$10.00	39000	25	\$10.00
880	350	\$6.50	10000	25	\$6.00	39000	30	\$13.00
1800	50	\$3.50	10000	40	\$6.50	47000	25	\$17.00
2400	50	\$4.00	13000	60	\$10.00	55000	3	\$6.00
3000	75	\$5.00	14000	25	\$5.50	65000	35	\$20.00
3300	75	\$5.50	14000	40	\$9.00	67000	10	\$12.50
3600	25	\$3.25	15000	3	\$3.50	76000	25	\$22.00
3700	30	\$3.50	20000	25	\$8.75	88000	10	\$14.50
4300	25	\$3.75	22000	10	\$6.00	100000	3	\$7.00
5400	35	\$4.25	22000	75	\$19.00	110000	10	\$15.00
7000	35	\$5.00	26000	10	\$6.50	110000	20	\$20.50
8000	35	\$6.00	33000	16	\$12.00	120000	15	\$18.00
8700	40	\$7.50	36000	20	\$7.75	200000	3	\$12.00

OTHER VALUES ARE AVAILABLE. PLEASE WRITE OR PHONE FOR LIST.

SHERIDAN ELECTRONICS

164-166 Redfern St., Redfern NSW 2016. Phone (02)699 6912, (02)699 5922
Mail Orders to Dept EA, PO Box 229 Redfern NSW 2016

Mounting brackets are available. Phone for details.

Trading Hours:
Mon-Fri 9am-5:30pm
Thursday 9am-7pm
Saturday 9am-12noon

Mail Charges
\$5.00-\$9.99 \$2.50
\$10.00-\$24.00 \$3.00
\$25.00-\$49.99 \$5.00
\$50.00-\$99.99 \$6.00
\$100.00 or more \$7.00

Heavy or Bulky items sent freight forward by 'Overnights'

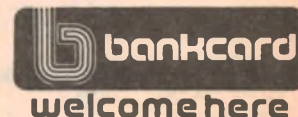

RADIO DESPATCH SERVICE

869 George St., Sydney, NSW 2000 (Near Harris Street)
Phone 211 0816 • 211 0191
Open: Mon-Fri 8am to 5.30pm
Thursday night late shopping till 8.30pm
Sat 8am to 11.45am

SOAR DIGITAL MULTIMETERS

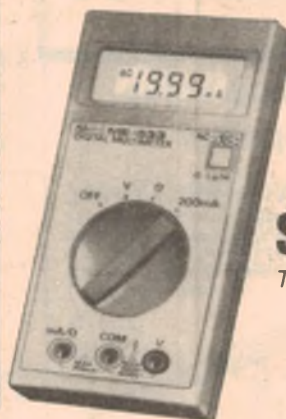

ME-533

\$49.95

Including Tax

\$44.74

Tax Exempt



ME-532

\$59.95

Including Tax

\$53.69

Tax Exempt

(WITH CONTINUITY BUZZER)

All Models: 3 1/2 Digits, 2AA Cells and Test Leads included

AUTO RANGE

DC V 0.2 2.0 20 200 1K
AC V 2 20 200 600
OHM 200 2K 20K 200K 2M
DC A 0 - 200 MA
AC A 0 - 200 MA

ALSO WITH CONTINUITY BUZZER AND 10 AMP AC/DC RANGE ME-531

STAR VALUE

\$79.00

Including Tax

\$69.64

Tax Exempt

COME AND SEE US NOW!



MAIL ORDERS TO: RADIO DESPATCH SERVICE

869 George St., Sydney 2000

Phones: (02) 211 0191 • 211 0816

Pie — The Best Of Friends Medley. The vocals are sung by Kerrie Biddell, Madeline Bell and Mick Leyton, with Joe Tattersall on Drums, Rick Price On Bass, Ken Francis on Guitar and Brian King on keyboards; the strings and horns are arranged by George Brodbeck. The stars of the movie are Angela Punch McGregor and Graeme Blundell. (N.J.M.)

☆ ☆ ☆

THE BEST OF RALPH CARMICHAEL — Light LS5798 stereo. Two record set. (From Word Record Aust, 18-26 Canterbury Rd, Heathmont, Vic 3135).

Ralph Carmichael has been a part of the popular music scene for more than 25 years, with wide experience on both the secular and Gospel scene. He has a number of film and TV scores to his credit, as well as being an arranger for such people as Bing Crosby, Peggy Lee and Rosemary Clooney.

If you read through the 23 titles on the sleeve, you could be excused for thinking that this is a straight Gospel album; but it isn't. For sure, the themes are borrowed from popular Gospel songs but they have been arranged, in the main, as music to sit back and enjoy in the Mantovani-Mancini manner. Only a few vocal tracks from the Ralph Michael Chorus serve to remind us of their origin.

But don't get me wrong. The music is of a high standard, both from the technical and musical point of view, making for a very enjoyable listening experience for anyone with an ear for devotional music.

Ten of the tracks were composed by Ralph Carmichael; others have been around for longer than I care to remember. Some of the titles are: Beyond The Sunset — Goin' Home — Jericho — Nobody Knows The Trouble I've Seen — Just A Closer Walk With Thee — Over In Bethlehem — Reach Out To Jesus — Beyond All Time — How Great Thou Art — Sun Of My Soul — Every Time I Feel The Spirit — Shadrack — In The Cross Of Christ I Glory — The Lord Is My Shepherd — The Savior Is Waiting.

One thing is for certain: the album demonstrates the considerable musical skills that are going into the Gospel oriented records these days. (N.J.M.)

☆ ☆ ☆

HYMNS TRIUMPHANT — The London Philharmonic Choir and The National Philharmonic Orchestra, conducted by John Alldis. Birdwing BWR 2023. [From Spotlight Music, 262 Pitt St, Sydney, Phone (02) 264 7922].

This two record set, released locally by Spotlight Music, contains some top-line performances of 42 well known hymns. As a novel touch, the hymns have been

arranged under headings, using the verses of the Lord's Prayer.

The one sour note is about a minute of "snap, crackle and pop" surface noise on the first side of the review record. Apart from this, the performance and technical quality is of a high standard. Indeed, one would seldom hear music of this standard other than in a large cathedral or as part of a festival of choral music.

As to the contents, under the heading, "Thy Kingdom Come" we find the following hymns: What Child Is This — O Come O Come Emmanuel — The First Noel — Silent Night — Angels We Have Heard On High — Hark The Herald Angels Sing — O Come All Ye Faithful.

Some of the other hymns are: Immortal, Invisible — This Is My Father's World — Holy Holy Holy — Eternal Father Strong To Save — O For A Thousand Tongues To Sing — Praise To The Lord The Almighty — O Sacred Head — When I Survey The Wondrous Cross — Now

Thank We All Our God — Amazing Grace — Jesus Lover Of My Soul — Rock Of Ages — I Need Thee Every Hour — Abide With Me — Jesus Christ Is Risen Today — Crown Him With Many Crowns — Onward Christian Soldiers — Sevenfold Amen.

The choir consists of a hundred voices, singing as one, bringing a rare and pleasurable experience to anyone listening to these records. (N.J.M.)

☆ ☆ ☆

ONE MORE DAY. Cleo Laine. Sepia L37751 (Festival release)

Whatever Cleo Laine sets out to sing, she sings with a superb style all her own. These 12 tracks are no exception: Driving Home — All The Skinny Schoolgirls — Tomboy — First Love, Half Light — Good-bye Friend — Over The Moon — Shall We Get Married — Settling Down — One More Day — Move — Lovers & Friends — The Year Is Gone.

As the sleeves notes explain, the theme for the album could be taken from some of the episodes in any woman's life, some sad, some happy and some like, "Shall We Get Married", very tongue in cheek. The lyrics are given in full on the inner sleeve.

More than 20 musicians and singers provide the backing and the recording engineers have done the whole performance justice. (N.J.M.)

For information on World Record Club albums, contact the club at 605 Camberwell Road, Hartwell, Victoria, 3124. Tel. 29 3636.

Master Electronics the new Practical way.

• Copyright 1981



Conquer the 'Chip' — Easy-Fast-Exciting !

(1) BUILD YOUR OWN SOLID STATE OSCILLOSCOPE.

This professional instrument employs the latest state of the art components, including I.C.s — all solid state precision construction.

(2) READ AND UNDERSTAND MODERN CIRCUITS DIAGRAMS.

You also obtain enough theoretical knowledge to design your own circuits.

(3) CARRY OUT MORE THAN 40 EXPERIMENTS.

Use your oscilloscope to SEE what happens in all circuits. Learn digital Electronics through your construction of a digital voltmeter.

F
R
E
E

To: The Australian School of Electronics, P.O. Box 108, Glen Iris, Vic., 3146.

A REGISTERED CORRESPONDENCE COLLEGE

Please send me without obligation your free colour brochure.

NAME: _____

ADDRESS: _____

EA6

DIGITAL MODEL DM 200

BASIC ACCURACY 0.8% (dc Volts)
FUSE OVERLOAD PROTECTION

DISPLAY: 3½ digit, LCD, 12mm high, reading up to 1999
RANGING: Manual, POLARITY & ZEROING: Automatic
OVER RANGE INDICATION: left end digit "1" displayed
POWER SUPPLY: 9V battery, CONSUMPTION: 20mW.
BATTERY CHECK: "Lo Bat" displays when 20% use remains
BATTERY LIFE: approx 200 hrs. TERMINALS: 4mm Sockets

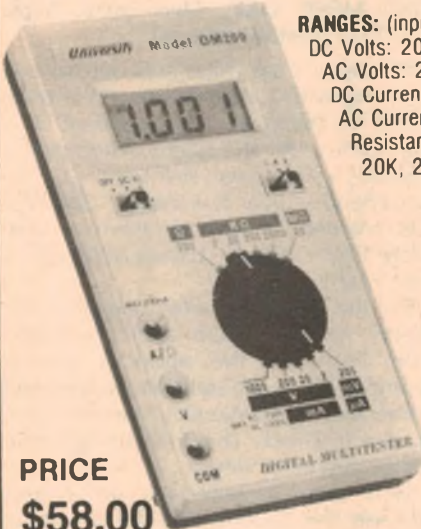

PRICE
\$58.00
+ S. Tax

RANGES: (input impedance 10MΩ)
DC Volts: 200mV, 2V, 20V, 200V, 1000V.
AC Volts: 200mV, 2V, 20V, 200V, 750V.
DC Current: 200μA, 2mA, 20mA, 200mA.
AC Current: 200μA, 2mA, 20mA, 200mA.
Resistance: Protection 200V AC/DC. 200Ω 2K, 20K, 200K, 2M, 20MΩ.

MVA 20 SPECIFICATIONS:

- **CORE MAGNET** Shielded Movement with spring loaded jewel suspension
- **POLARITY REVERSING SWITCH**
- **SIMPLICITY of OPERATION** multicolour mirror scale
- **SUPER THIN** Slimline design polycarbonate unbreakable case
- **OVERLOAD PROTECTION** double diode for movement and fuse for circuit protection

University New Attractive MULTIMETERS

Digital Model HD-31
Auto-Ranging, 10 amp
AC and DC. Special
only \$88 + Tax.

SPECIALISTS MVA 20



PRICE
\$25.00
+ S. Tax
Supplied with case, leads battery and instructions

- **WIDE MEASUREMENT RANGES**
DC current from 1μA to 10A
DC Volts from 2mV to 1000V
DCV: 0.1, 0.5, 2.5, 10, 50, 250, 1000V (20 k ohm per Volt)
ACV: 10, 50, 250, 1000V (8 kΩ/V)
DCA: 50μA, 2.5, 25, 250mA, 10A.
Resistance: R x 1, R x 10, R x 100, R x 1 k, R x 10 k.

UNIVERSITY GRAHAM INSTRUMENTS P/L
106 BELMORE RD NORTH, RIVERWOOD 2210
PO Box 204, ENFIELD, NSW 2136
PHONE: (02) 53 0644. TELEX: AA21398
Melbourne Office: (03) 583 1125

MICROPROCESSOR Typical crystal oscillators

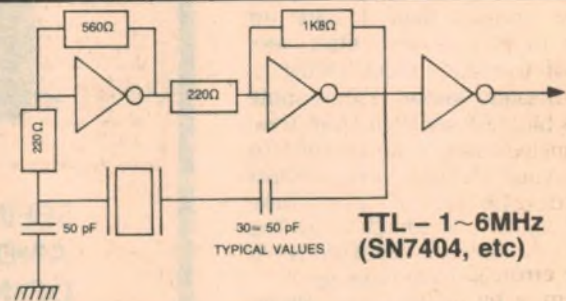
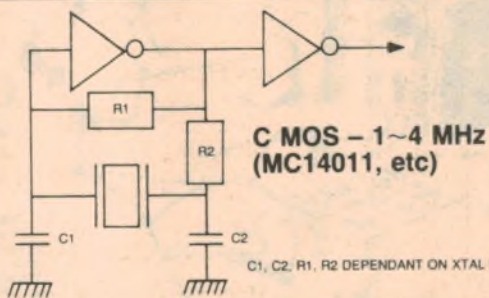

STANDARD MICROPROCESSOR FREQUENCIES

XTAL f	Holder	XTAL f	Holder	XTAL f	Holder
1.0000 MHz	HC6μ/W	2.09715 MHz	HC6μ/W	4.1943 MHz	HC6μ/W, HC18μ
1.2288 MHz	HC6μ/W	2.4575 MHz	HC6μ/W	4.43361 MHz	HC6μ/W, HC18μ
1.6384 MHz	HC6μ/W	3.2768 MHz	HC6μ/W	5.0688 MHz	HC6μ/W, HC18μ
1.8432 MHz	HC6μ/W	3.57954 MHz	HC6μ/W, HC 18μ	5.1850 MHz	HC6μ/W, HC18μ
2.0000 MHz	HC6μ/W	4.0000 MHz	HC6μ/W, HC 18μ	5.7143 MHz	HC6μ/W, HC18μ

The crystals listed are a small selection of our low cost range, suitable for microprocessor and timing devices.

Rakon also manufacture crystals to MIL-SPEC. and individual requirements. Inquiries concerning price and delivery are invited and should be forwarded to:

New Zealand manufactured crystals are competitively priced and duty-free in Australia.



9 George Street, Mt. Eden. P.O. Box 9308, Newmarket, Auckland.
Cables: "RAKON". Telex: 21682. Phone (64-9) 605-010, 605-270.
Civil Aviation Department Approval No. AWB556.

BCA 7096

50 & 25 YEARS AGO

"Electronics Australia" is one of the longest running technical publications in the world. We started as "Wireless Weekly" in August 1922 and became "Radio and Hobbies in Australia" in April 1939. The title was changed to "Radio, Television and Hobbies" in February 1955 and finally, to "Electronics Australia" in April 1965. Below we feature some items from past issues.



July 1932

Cock-a-doodle-do! The Prague broadcasting authorities enticed a loud-voiced cock into a gramophone studio, and recorded his voice, which listeners to the Prague station may hear at six o'clock every morning. Arrangements with the cock, we understand, are on a royalty basis, but he has been advised not to count his chickens before they are hatched.

☆ ☆ ☆

Letter to the editor: Dear Sir, I would like to draw your attention to the very bad way in which 2KY is transmitting. The matter they broadcast is quite acceptable to certain parts of the community, but why, in the name of goodness, don't they improve their transmission.

Listening in at Narrabeen over the week-end to the wrestling bout, I was forced to turn off in disgust.

Apart from having their mike right at the ringside, where they receive all extraneous noises, their Pommy announcer is an ear-sore, and is just typical of the station itself. With a wealth of talent available they must pick this bird. Possibly his brother-in-law or uncle is one of the Trades Hall heads. Yours etc, "Variable-Mu", Leichhardt (21/6/32).

☆ ☆ ☆

Graft or error: On July 19 I went to the IRE meeting to hear our worthy visitor, Captain Eckersley, detail his scheme for Australian broadcasting. I went there with a head full of superhet circuits but soon forgot them under the influence of the captain's witty speech. After such meetings there are always a few highlights which stand out clearly in after-thoughts. I was greatly amused when the speaker paused after saying "Now the scheme is going to cost £80,000, and we have £90,000, which leaves £10,000 for error," and some wag piped up the single word "Graft."

Male chauvinist pigs: All radio dealers will readily recognise the Kriesler Meccanoized Radio Set, details of which appear in this issue, a product which will receive immediate popularity with the public ... especially as it is so simple that a woman, or even a child, can fit it up in two hours without any trouble. Soldering iron, pliers and screwdriver are also included - all at £9/17/6. Order today from Fox & MacGillycuddy, Merino House, 57 York St, Sydney, NSW.

☆ ☆ ☆

Crocodiles or alligators?: Bringa will give a talk on "Northern Territory Alligators". He will discuss the great fear in connection with German airmen, who were lost in the Northern Territory, the fear that they may have been attacked by alligators and eaten. Scientists class these saurian monsters as crocodiles, but the average Australian classes and prefers to speak of them as alligators. The life history of the Northern Territory alligators will be told in full, along with the many interesting as well as sad stories connected with them. - 2BL, Sunday, 4.45.



July 1957

Compact computer: A high-speed digital computer, not much larger than a home television set and requiring less power to operate has been developed at Bell Telephone Laboratories. This newest addition to the family of electronic "brains" was developed under Air Force contract. It has been named "Leprechaun," after the tricky sprite of Irish folklore.

Compared with previous computers, Leprechaun operates with a drastically reduced number of components. Excluding its magnetic cores, it uses only about 9000 electrical components. More than half of these are transistors.

Do amplifiers sound different?: Recently the opinion that the loudspeaker is the weakest link in the reproducing system and that amplifiers have progressed about as far toward perfection as it is possible to go has been widely expressed. As a basis for this conclusion, it is stated that the residual degree of various kinds of distortion present in modern amplifiers is so small as to be impossible to hear. However, many are not yet satisfied that this philosophy is true.

☆ ☆ ☆

Rubber aircraft: In Kansas recently, Richard Ulm unfolded a rubber aircraft from a bundle little bigger than a TV set, inflated it, fixed a wooden propeller and took off into a thunderstorm.

Ulm is a pilot for the Goodyear Co, and his demonstration of the aircraft - called "Inflatoplane" - was staged at a naval air station.

The aircraft is made of rubberised fabric.

It has a 23ft wingspread when inflated and weighs about 200lb.

Its 44-horsepower engine can pull it through the air at better than 60 mph, and uses so little fuel it can stay aloft for eight hours.

☆ ☆ ☆

Harp under control: What will happen if a Harp rocket should get out of control when tests are carried out at Woomera late this year? An armed Meteor jet fighter will shoot it down.

The Harp experiments will be part of Australia's contribution to the International Geophysical Year program.

The word Harp stands for high-altitude research project.

The authorities will take elaborate safety precautions in case a rocket should head the wrong way.

Radar will track the rocket in flight.

☆ ☆ ☆

Atom powered navies: Britain's Navy of the future is likely to consist of task forces each with a carrier armed with atomic planes and weapons, a cruiser, destroyers and frigates.

Parliamentary Secretary to the Admiralty Christopher Soames says that while such forces would be employed in the most advantageous manner around the world, they would also be capable of concentrating at any given point.

A force of destroyers and frigates mothered by a cruiser could effectively control the sea.

3

The VIC-20 colour computer

You've probably heard a lot about the VIC-20, but what's it really like? We tried Commodore's new low-cost computer recently and found a very versatile "fun machine", providing, we think, very good value for money.

by PETER VERNON

The VIC-20 is a white plastic console measuring 400mm x 200mm x 65mm (W x D x H at rear). A 62 key keyboard and four programmable function keys occupy the top of the console, with the power cord socket, on/off switch and a games port connector (for joysticks etc) on the right side, and a serial port, cassette connector, user port, video connector and expansion port at the rear. The expansion port is intended to take Commodore "program cartridges".

The computer comes well packed, fitted into a polystyrene foam box with a separate power supply and video modulator, a video cable and a copy of a 164 page spiral bound book "Personal Computing on the VIC-20." Another

brochure has the setting up instructions.

The separate power supply is a transformer which provides 11V AC from 240VAC. It does not have its own power switch, so Commodore advise that the power supply should be unplugged when not in use. The power switch for the VIC is a very small rocker switch. A red LED on top of the keyboard console indicates that the power is on.

The computer has a 5-pin DIN socket at the rear which provides a standard composite video signal. The metal-cased video modulator is connected here, with a second cable (supplied) connecting the modulator to the TV set. A switch on the modulator lets the user choose between VHF Channel 0 or Channel 1.

VIC-20 program cartridges (of which more later) plug into the expansion port. The cassette port is for connection of a cassette recorder, and does not provide for control of the recorder motor. Commodore accessories such as a printer or disk drive can be plugged into the serial port. Very little information is given on the user port, other than that it is "for special accessories".

A pin-out diagram at the back of the manual indicates that this port provides connections for three joysticks, a light pen, cassette motor control, a serial device and Reset. Also on this connector is one half of a VIA, or Versatile Interface Adapter, which provides a bidirectional parallel port with handshaking signals.

Only pin-out information is provided for the rear panel connectors, with no indication of how they might be used. This shortcoming may be rectified by the "VIC Programmers Reference Guide", which is available separately, and which we haven't seen. Manuals accompanying the VIC printer (a custom manufactured version of the GP80 dot matrix printer) and the VIC cassette recorder give details of the use of these accessories.

VIC-20 Graphics

The most noticeable defect of the VIC-20 is poor quality of the display. We used the VIC with a late model colour television, as would most users. With the modulator set for VHF Channel 1 the picture quality was reasonable, but with no colour! On Channel 0 we had colour, but the amount of colour "shimmy" in the picture made it hard on the eyes. Careful fine tuning of the television was necessary to get even that far.

Dick Smith Electronics Pty Ltd who provided us with the review VIC-20 do have available a technical bulletin which

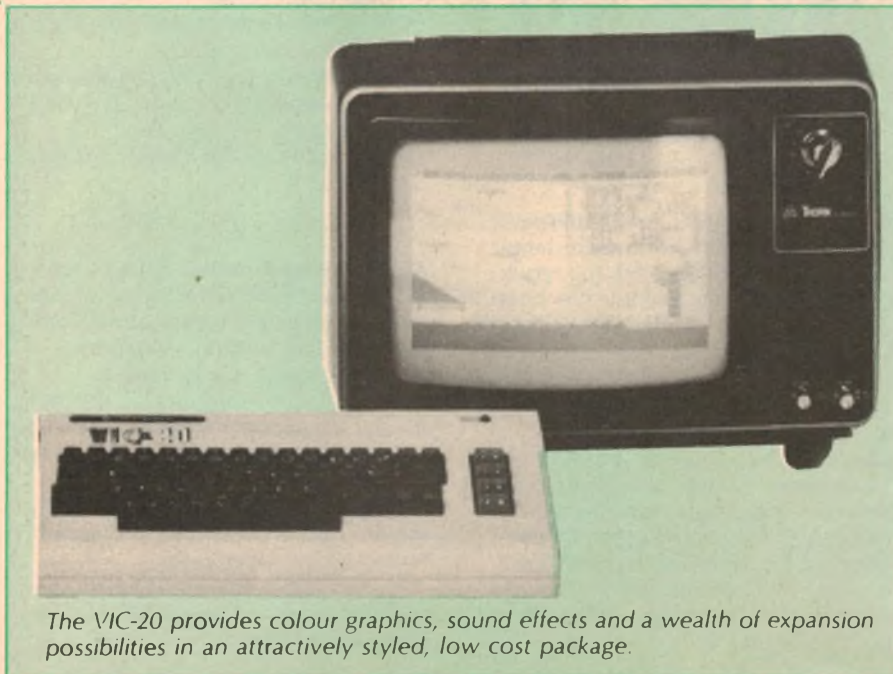

The VIC-20 provides colour graphics, sound effects and a wealth of expansion possibilities in an attractively styled, low cost package.

describes adjustment of the video sync and level controls inside the VIC. "Tweaking" these controls can give quite a useful improvement in the video display, even when an RF modulator is used.

But even with these tweaks you can expect to find yellow fringing around black characters and similar extraneous defects when some other colour combinations are used. Some of these defects are almost certainly due to bandwidth limitations in conventional television receivers but the remainder are due to limitations in the RF modulator supplied with the VIC-20.

We have seen much better colour displays from the VIC-20 when used with a video monitor which has direct connections for video and audio. Dick Smith Electronics has a specially modified 35cm colour television receiver (priced at \$379) which serves this purpose admirably.

Making allowance for the quality of the video display, the colour and graphics of the VIC-20 are very good, although there are some weak points.

Characters are displayed on the screen in 23 lines of 22 characters each. The characters are big, and are displayed in an area which is about two-thirds of the TV screen. A coloured border occupies the remainder of the screen.

Computing magazines from the UK (where Commodore is the biggest seller) indicate that a "VIC-40" with 40 characters per line, will be available some time in the future. This will avoid the awkward effect of those 22 character lines and large characters. In the VIC-20, program statements can be continued on more than one line, but legibility suffers with this approach.

In addition to normal upper case characters and numbers, the VIC provides 66 special graphics characters from the keyboard and lower case letters. Pressing "Shift" gives access to the graphics characters marked on the right hand front of each key. Pressing another key marked only with the Commodore logo provides a second set of graphics characters, shown on the left-hand front of the keys. Pressing both together gives upper/lower case mode, until the two keys are pressed a second time.

In the lower case mode only the graphic characters marked on the left side front of each key are available. Also, in this mode the whole of the screen display changes to lower case but it is possible to use the shift lock key to type a word or line in upper case.

The keyboard itself is a pleasure to use, with big, positively acting keys arranged in a standard typewriter format. It seems that Commodore have learnt a lot since



Another view of the system, showing the separate power supply (right) and video modulator (left of the console) and a program cartridge.

the days of the calculator-style keyboard of the first PET machines.

Cursor control keys are provided with automatic repeat, so moving the cursor on the screen for editing programs is easy. The cursor movement characters can also be used from within a program to produce movement on the screen. When used in this way, in a PRINT statement for instance, the cursor control

codes are displayed as various inverse graphics characters. The space bar also had an auto-repeat function.

When the VIC is first switched on or reset, the screen will be white with a border of cyan, with characters displayed in dark blue. The top row of keys, from 1 to 8, control the colour of characters. Pressing the Control key in combination with one of these colour

Table 1: Commodore VIC-20 features

Processor:	6502
RAM:	5K, expandable with plug-in cartridges
ROM:	8K
Interfaces:	Serial port, user port, cassette interface, printer port, games connector port, expansion interface
Keyboard:	62 keys typewriter style, 4 function keys
Display:	22 x 23, upper and lower case
Graphics:	176 x 184 (optionally available), 8 colours, graphics characters
Sound:	Three tone generators, white noise generator
Peripherals:	Plug in program cartridges, disk drive, expansion motherboard, RS-232 interface, printer, modem
Documentation:	Setting up guide, users manual — good for beginners

VIC-20 BASIC STATEMENTS

AND, NOT, CLOSE, CLR, CMD, CONT, DATA, DEF, DIM, END, FOR, GET, GOSUB, GOTO, INPUT#, LET, LIST, LOAD, NEXT, OPEN, POKE, PRINT, PRINT#, READ, RESTORE, RETURN, SAVE, STEP, STOP, SYS, THEN, VERIFY, WAIT, ABS, ASC, ATN, CHR\$, EXP, FRE, LEFT\$, MID\$, PEEK, RIGHTS, RND, SGN, SIN, SPC(, SQR, STR\$, TAB(, USR, VAL

Review — the VIC-20 computer

keys will change the colour of the displayed characters. Colours available are black, white, red, cyan, purple, green, blue and yellow.

As with the cursor control keys, the colour codes can be used with a program, using "PRINT" to change the colour of characters displayed on the screen. Using the Control key in conjunction with "RVS ON" displays all characters in the inverse mode (character and background colours interchanged) until "RVS OFF" is selected. Again this can be done from within a program.

There are three inter-related colour areas: the screen, where characters are displayed, the border around the screen, which cannot be written into, and the characters themselves. Eight colours are available for the screen border and sixteen for the screen.

There are 255 different combinations of screen and border colour. Each combination is invoked by poking a value to memory location 36879. As an example of these screen/border combinations, POKE 36879,122 will give a yellow screen with a red border. POKE 36879,255 will give a light yellow screen with a yellow border. These values, and the colour combinations they invoke are given as a chart on p37 of the instruction manual.

Using the graphics characters and cursor control characters within programs can produce creditable animation, with no perceptible flicker at a speed suitable for games etc.

The other approach to graphics is to use POKE statements to place character codes directly into screen memory. The VIC-20 has an unusual memory structure because of the use of the Video Interface Chip (VIC, of course), which is a Commodore proprietary chip used to control the video display and sound effects.

Each of the 506 locations on the screen has two memory representations. Screen memory begins from location 7680 (decimal). The contents of each location in the screen memory determines which character will appear in the corresponding location on the screen. A separate 506 byte area of memory, starting at 38,400 (decimal) determines the colour of the character in the corresponding screen location.

Sound effects

Sound effects on the VIC-20 are exceptional. Four "voices" are provided, three tone and one white noise, which can independently produce tones or a mix of tones and white noise, over a range of three octaves.

Volume of the four sound sources is

under the control of a single variable POKEd into memory location 36878. Volume can range from 0 (sound off) to 15 (the loudest sound). Actual volume levels depend on the setting of the volume control of the TV set, as the sound signals are modulated along with the video signal fed to the television set.

The sound effects are exceedingly versatile, and fairly easy to use. The VIC manual provides a list of the values required to produce musical notes over the three octave range and some sample tunes. Another sample program lets you play tunes from the keyboard of the VIC. An appendix to the manual provides 20 sample programs for producing sound effects such as musical scales, birds chirping, UFO landing and an assortment of bombs dropping, phaser fire and explosions for those more violent games.

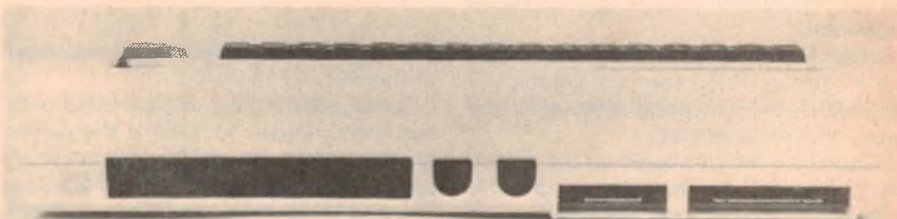

A view from the rear. From left to right are the expansion connector, video output, serial port, cassette connector and user port.

VIC-20 Basic

The Basic used by the VIC-20 is similar to that of other Commodore machines. One useful feature is the statement "CMD" which re-directs screen output to any other device specified. It is used as follows:

OPEN 1,4 Opens device number 4, which is a printer;
CMD 1 Re-directs all output to the printer;
LIST Will list the program on the printer, not the screen;
CLOSE 1 Will return output to the screen.

Other devices can be OPENed and used in the same way, including disk drives, cassette recorder or a modem connected to the serial port. Once a device is OPEN, the statement GET# will input one character at a time, while INPUT# will allow variables to be entered into a program from the specified device. PRINT# will allow variables to be sent to an OPEN file or device.

Definable functions are also allowed, and the usual string functions are provided. Cassette operations allow programs to be saved and loaded by name, and include a useful "VERIFY" command, which checks the program on tape against the copy held in memory. PRINT# is used for storing arrays of data on tape.

Another interesting feature is the timer built into the computer. The VIC reserves the string variable TI\$ for use as a real-time clock, with a value automatically updated every second. It is cleared when the machine is turned on, but can be set to any value by the programmer, and once set indicates the elapsed time in hours, minutes and seconds. The variable TI is also updated automatically, every 1/60th second, and can be used for time delays, timed movement in games etc.

Both integer and real variables (up to 9 digit precision) can be used with the VIC, and multi multi-dimensional arrays are permitted. See Table 1 for a complete list of VIC Basic.

Editing functions of VIC Basic are very good. When a program is listed, the cursor control keys (two keys with shift, for movement in four directions) can be used to move the cursor to the line to be changed. Changes are typed in over the

old line, and are recorded on pressing RETURN.

Machine language programming is supported by two statements, USR and SYS. USR(X) will transfer control to a machine language program whose starting point is contained in memory locations 0001 and 0002, with the value of X passed as a parameter to the routine. SYS followed by a decimal number or variable in the range 0 to 65,535 will transfer control to a machine language program at the address specified, but does not allow parameters to be passed to the routine. Users are referred to the Programmers Reference manual for details of these commands.

Program cartridges

A range of programs is available for the VIC-20 in cartridges which plug into the rear of the machine. We tried "Jupiter Lander", an animated game where the player controls the engines of a lander module, attempting to make safe landing before the fuel runs out. The game is well presented, but quickly becomes monotonous, as the terrain is unvarying. Other cartridges are available with games such as "Super Alien", "Draw Poker" and "Midnight Drive" (a night driving simulation).

Each cartridge costs around \$40.

Other programs are available on

THE COMPUTER COUNTRY GROUP

One of the most powerful new microcomputers on the market which uses the 6809 microprocessor. Comes with excellent super high resolution graphics — 640 x 200 dots and has a 40/80 character x 25 lines user programmable screen configuration.

HITACHI PEACH PROFESSIONALS

STANDARD FEATURES:

ADVANCED 8/16 BIT MICROCOMPUTER TECHNOLOGY (WILL ADDRESS 1 MEGABYTE) NUMERIC KEY PAD, 10 (5 WITH SHIFT) PROGRAMMABLE FUNCTION KEYS, PROTECTED BREAK KEY, TYPEWRITER STYLE KEYBOARD, CLOCK, SPEAKER WITH VOLUME CONTROL, RF SHIELDING THROUGHOUT, 24K ROM (READ ONLY MEMORY), 32K RAM (RANDOM ACCESS MEMORY), TERMINAL CAPABILITIES, SIX EXPANSION SLOTS FOR PERIPHERALS, AND TWO FOR MEMORY (ALL WITH CLIP-IN PLASTIC DUST PROTECTORS), "MAIN FRAME" QUALITY CONSTRUCTION, SPECIAL CHARACTER GENERATION, 40 and 80 COLUMN SCREEN x 25 HORIZONTAL LINES OF TEXT, 8 BRILLIANT COLOURS, UPPER AND LOWER CASE, 640 x 200 DOT HIGH RESOLUTION GRAPHICS (ALL PIXELS BYTE-ADDRESSABLE FOR TOTAL CONTROL), TEXT AND GRAPHICS ON SAME SCREEN, **MICROSOFT COLOUR BASIC**, MACHINE LANGUAGE, FULL DOCUMENTATION, AVAILABILITY TO **THE AUSTRALIAN** BEGINNING DEMONSTRATION SOFTWARE PACKAGE (ON CASSETTE OR DISKETTE) WITH GAMES, GRAPHICS, PHONE/MAIL SYSTEM, ETC, CONNECTIONS FOR RS232, "CENTRONICS", LIGHT PEN, AUDIO, MONOCHROME VIDEO, COLOUR VIDEO, CABLES FOR CASSETTE DECK AND VIDEO, CP/M, FLEX, AND OS-9 SOFTWARE AVAILABILITY, AND MORE . . .

**COMPUTER COUNTRY (VICTORIA) PTY LTD
338 QUEEN STREET, MELBOURNE, VIC 3000
(03) 329 7533**

**IN QUEENSLAND CALL COMPUTER CITY
600 OLD CLEVELAND ROAD, CAMP HILL, QLD 4152
(07) 398 6759**

**IN SOUTH AUSTRALIA CALL KEY COMPUTERS
1055 SOUTH ROAD, EDWARDSTOWN, SA 5039
(08) 277 8936**

**IN WESTERN AUSTRALIA CALL COMPUTER CHOICE
1297 HAY STREET, WEST PERTH, WA 6005
(09) 322 5651**

**BUYING A COMPUTER?
BUY IT FROM DICK SMITH
& YOU COULD**

WIN A DATSUN STANZA



**DATSUN STANZA GL
FOUR DOOR SEDAN
VALUE \$6720!**

**YOU'D BE CRAZY TO
BUY A COMPUTER
ANYWHERE ELSE!**

Everyone seems to be selling computers these days: every time you look, another has popped up like a mushroom.

Think carefully about where you buy your computer: ask yourself the following questions:

Who else offers a 7 day money-back satisfaction guarantee?

Who else offers you the range of computers that Dick Smith offers?

Who else offers their own in-house service facilities, with over \$100,000 worth of specialised computer test equipment?

Who else has 30 company stores around Australia for helpful and reliable assistance?

Who else gives you the chance to win a Datsun Stanza when you buy a computer?

Only Dick Smith Electronics offers you ALL this — and more — you'd be crazy to buy a computer anywhere else!

Yes, you become eligible to win this Stanza when you purchase the winning

VIC 20 COLOUR COMPUTER FROM DICK SMITH

LOOK AT THESE WINNING FEATURES

- ★ Colour graphics in up to 8 colours directly addressable from the keyboard.
- ★ Memory expandable up to 32K with plug-in modules.
- ★ Typewriter style keyboard, with programmable function keys.
- ★ An inbuilt tone generator for music and sound effects.

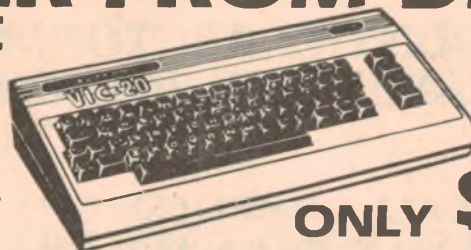

LOOK AT THIS WINNING PRICE

**ONLY \$399
AND ONLY FROM**

Why waste hard earned money on a more expensive colour computer and do no better? With the Dick Smith VIC-20 Colour Computer you get the latest technology, at a price YOU CAN AFFORD!
Cat X-2000

DICK SMITH ELECTRONICS
SEE PAGE 52 FOR ADDRESS DETAILS



DSE/A233M/PAI
Patents No. 1282-2 (6) issued under the Letters and Patents Act 1953-54. Not valid in states where the Copyright Act 1968-69 applies.

cassette, including educational programs offering practice in mathematics and a set of six home finance/management programs. Cassette programs are around \$15.

Paddles and joysticks are available, as is a "Super Expander" cartridge which is said to provide 3K of expansion memory, high resolution graphics plotting and sound commands for Basic and 1024 x 1024 dot screen plotting. This cartridge costs \$69 and would considerably enhance the capabilities of the VIC-20.

As standard, the VIC-20 is supplied with only 5K of memory. Various RAM expansion cartridges are available, for 3K, 8K or 16K of additional memory. Also available is a memory motherboard, which allows you to connect combinations of memory expansion modules to the system. In any case, the maximum memory which can be used is 32K.

Prices

One of the drawbacks of the VIC system is that all devices used with the computer must be custom made by Commodore. The VIC-20 uses an unusual serial version of the IEEE interface format for communication with cassette recorders, disk drives and printers. Standard equipment will not work with VIC so the user is locked into using Commodore peripherals.

The Commodore cassette recorder, at \$99, is much more expensive than "cheapo" types that give good results with other types of computers. A single floppy disk drive, custom made for the VIC, is priced at \$699 with controller. Each drive provides 170K bytes of storage on a 14cm disk.

The basic VIC-20 is priced at \$399 from Dick Smith Electronics Pty Ltd, although it is also distributed by other dealers. It is a convenient starter machine, although in no way suitable for business applications, as some advertisements suggest.

Choosing between the VIC-20 and the TRS-80 Color Computer, its nearest rival in terms of price and performance, would be difficult. The VIC is less expensive, unless the cost of a colour monitor is taken into account. The VIC provides more colours, but the standard version lacks any high resolution graphics mode. On the other hand, the sound effects of the VIC are superior, although those of the Color Computer are easier to use.

We could go on, getting into the issue of the 6809 processor versus the VIC's 6502, for example, or "calculator style" keys against a proper keyboard. Ultimately, though, we'll have to leave it up to readers. The VIC-20 is certainly worthy of consideration. (All prices are correct at the time of going to press, but are subject to change without notice).

MPI Mini Drives

taking care of business

Just when you were convinced that only massive 8-inch drives could handle the big jobs, along comes MPI Hi-D, with up to 1 Megabyte capacity, 5 milli-second track-to-track, pushbutton media eject and head load for longer media and head life, all neatly squared away with the elegance and power efficiency of a 5¼-inch drive.

Need less storage? . . . MPI builds 40-, 77- and 80-track, single or double head 5¼-inch drives with the same classic 8-inch features.

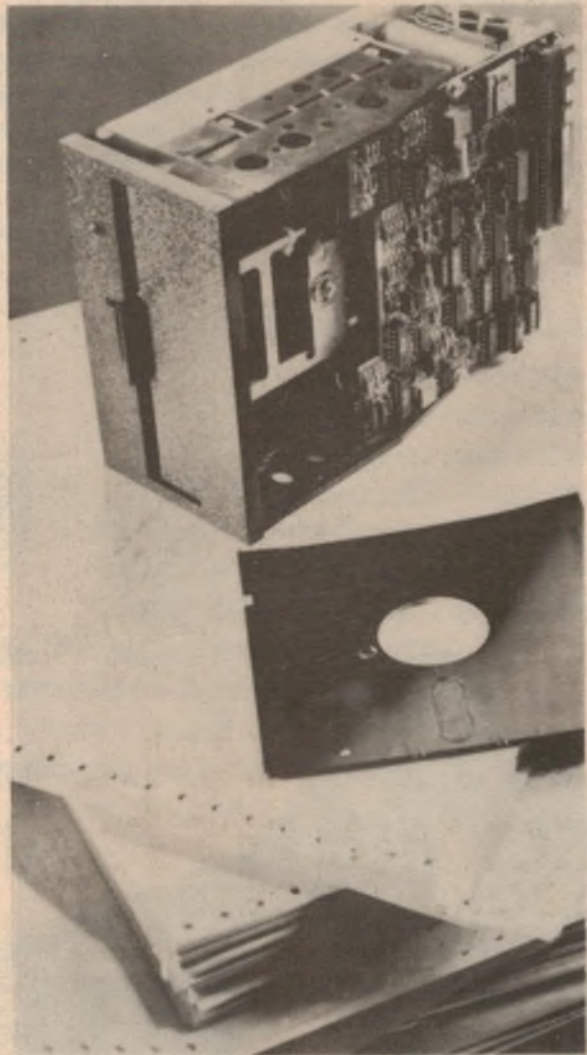

COMP-SOFT

MICRO COMPUTER SERVICES

235 SWAN STREET, RICHMOND, VICTORIA,
AUSTRALIA, 3121
Telephone: (03) 428 5269

“Why buy just a video game when you can get a full colour computer for this price.”

A computer like this would have been science fiction a few years ago. Now it's a reality. It's the Commodore VIC-20, a full-fledged, expandable colour computer that costs little more than video games.

Everybody loves video games and the VIC-20 has some of the best. But the Commodore VIC-20 can also help the kids with their homework and mum with her budgeting. Dad can even take the light, portable VIC-20 to the office for financial and business applications.

And Commodore has many more applications on the way.

With Full Capability For:

- Education programs
- Recreational programs
- Personal computing
- Includes Microsoft, PET BASIC
- Full-size typewriter-style keyboard
- Easy to follow instruction manual
- Memory expansion to 32K RAM
- Connects to any TV set
- 66 graphic characters
- 25K total memory
- 4 sound generators
- 16 colours



The computer for everyone.

The VIC-20 is the friendliest way we know to learn computing. It has a full computer keyboard even a small child can operate.

It plays music, has exciting graphics and lets you create pictures. It even tells you when you've made a mistake and how to correct it. The VIC-20 can take your children from pre-school through post-graduate studies.

Why get just another game that could end up in the closet? Get an honest-to-goodness computer for just \$399. Get the Commodore VIC-20.

Learn more about Commodore, the micro-computer you can depend on. Call or write for the name and location of your Commodore dealer nearest you.

The Commodore Information Centre,
3 Campbell St., Artarmon NSW 2064. Phone: 437 6296.

 **commodore**
COMPUTER

Extra memory for the Sinclair ZX80

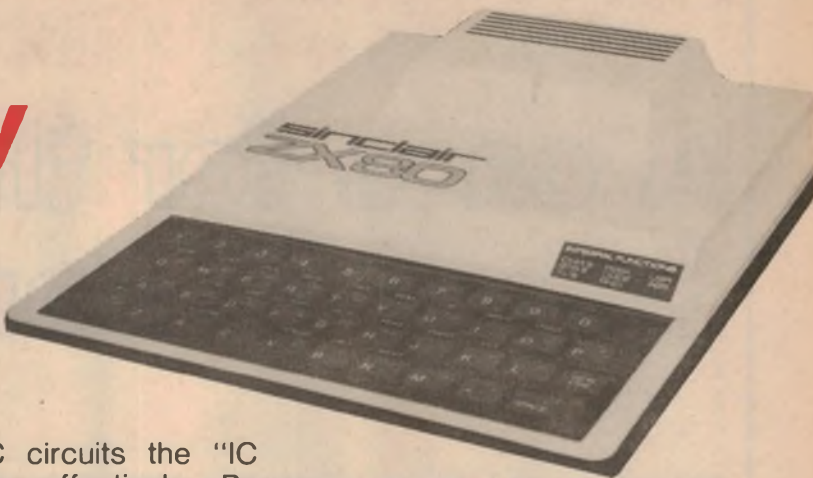

by K. WALTERS

For simple additions and alterations to IC circuits the "IC bricklaying" technique can be used quite effectively. By mounting new integrated circuits directly on top of existing packages new facilities can be easily added, such as an extra 1K of RAM for the ZX80.

One major drawback of the Sinclair ZX80 is its 1K of on-board RAM. Although add-on adapters can be obtained which add up to 3K in one version and 16K in the other, these represent poor value for money when you consider what they consist of.

Any "Micro-Ace" owner who has added the optional 1K of extra on-board memory will tell you what a tremendous difference this makes. With 1K you always seem so tantalizingly close when you run out of RAM space — 2K does just nicely.

The memory chips used in the ZX80 are 2114 1K x 4 bit RAMs. Wherever 2114s are used, all the corresponding data and address pins of each four bits are connected in parallel; only the Chip Enable (\overline{CE}) pins are different. As a result, it is perfectly feasible to simply mount another pair of RAMs on top of the originals, with only the Chip Enable (\overline{CE}) pins connected differently.

The ZX80 does not decode address lines 10 to 13 in the basic 1K version. It simply assumes that the address on lines 0 to 9 is the total address, so if you POKE at any location beyond the limits of the RAM the data will appear in the corresponding position in the available RAM. The \overline{CE} for the on-board 1K goes via a 22k Ω resistor to the memory ICs. The \overline{CE} input to the chips themselves also goes to one of the pins on the output port. When extra memory is added, driving this line high will disable the internal chips when required.

To expand the memory it is necessary to build a suitable decoder into the computer. This can be constructed from a 74LS00 using the circuit shown. The IC is again mounted on top of an existing chip

(IC12 for convenience). All the pins are cut short except 7, 14 and 9. Pins 7 and 14 (power) are soldered to the same pins on IC12 while pin 9 is soldered to pin 8 of IC12. It will just reach if twisted properly.

The other connections are made as shown on the circuit (Fig. 1), using short lengths of hook-up wire soldered direct to the pins of the new 74LS00. A10 of the Z80 is conveniently available at the cathode of D5. Resistor R19 could be removed but it has no effect on the

be as reliable as an IC socket. The case will just fit back on with the new ICs fitted.

The decoder works by enabling the new RAM when it detects a high on A10 of the Z80 and a low on pin 8 of IC12 (the \overline{CE} for the original RAM). At the same time it applies a high to the \overline{CE} of the original RAM. Since this is on the other side of R19 the previous \overline{CE} signal has no effect.

While I have not tried it, it should be possible to add more RAMs if the

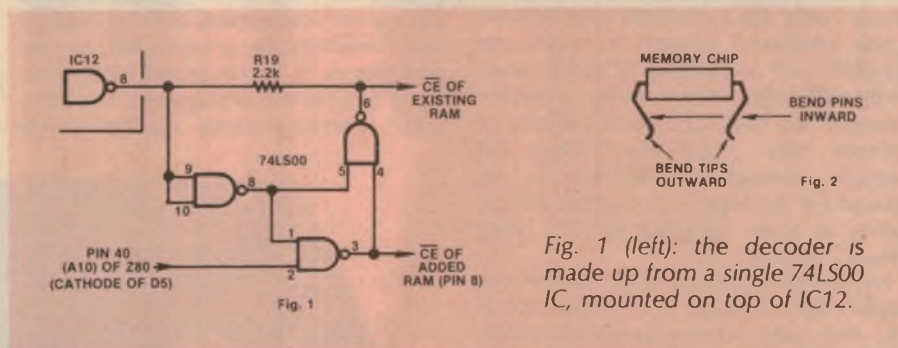

operation and provides a handy solder point. The \overline{CE} pins of the new RAMs are bent out and connected to pin 3 of the new 74LS00.

To mount the new RAMs, I bent the pins inward slightly then belled the bottoms out so that they would slip easily over the pins of the original RAMs whilst ensuring a good grip (see Fig. 2). Although you could solder all the pins, just doing the corner ones (1, 9, 10 and 18) should be sufficient and will facilitate later removal if necessary. If the pins are tensioned correctly the contact should

decoder is expanded further. They could be mounted underneath the PCB although this will mean that the pins will all have to bend up the other way. It might be possible to use a wire-wrap socket with long pins crossed over as required if you don't want to risk damaging the RAMs.

In any event, the extra 1K of RAM is a useful expansion of the ZX80's capabilities — achieved for just the cost of the chips and an hour's work.

16 Kings Way, Three Kings, Auckland, NZ.

A case for the Super 80 computer

Not many ready-built computers come with a steel case, but you can have one for your Super-80. Quite apart from the enhanced appearance of your system, the case is a useful protection against spilt coffee, the family cat etc . . . and it suppresses RF interference.

by PETER VERNON

Our article on the Super-80 printer interface showed our computer in a case (or rather, the bottom half of a case). We thought readers might be interested in how it was done, so this article covers the installation of the Super-80 computer in a steel case, which Dick Smith Electronics has had specially designed and produced for the Super-80.

First step, of course, is to get a case. The Super-80 Marviplate case costs \$39.95 and is available from Dick Smith Electronics. (Marviplate, by the way, is a trade name for a specially treated steel plate protected against corrosion and finished with a cladding of black vinyl). You will also need some insulated spacers and nuts, bolts and washers of various sizes. Apart from these, the various connectors, switches etc required for the Super-80 in a case are the same as those required for the "bare board" version.

Measurements of the case are 395mm wide x 400mm deep. It is 100mm high at the rear, with a front keyboard section 25mm high. There is not much clearance inside the case and positioning the Super-80 circuit board requires some careful thought.

The most difficult part of the operation is the positioning of the keyboard. If the board is mounted too far forward or back in the case there will not be sufficient clearance for the keys in the cut-out provided for the keyboard. If keys at the top or sides of the keyboard make contact with the edge of the keyboard cut-out the keys could be forced down. In this case your Super-80 will not work. The computer will interpret the stuck key as a key which is being pressed by

the operator, and will suspend processing until the key is released.

The case is supplied pre-drilled but a few extra holes were necessary in our prototype. Try a "dry run" first to establish the position of the PCB inside the case. Note the location of the two holes which must be drilled in the circuit board to match with the holes already drilled in the bottom of the case.

We found that the PCB must be drilled about 4mm in from the two rear corners of the board, but it is important to check this out for yourself and drill the holes to suit. Preferably use a hand drill, to prevent pieces of circuit board being scattered around the workings of the computer. Carefully clean up the circuit

board after each hole is drilled, and make sure that no printed circuit board tracks are cut by the holes you drill.

We used four spacers, two 20mm long at the rear of the board and two 25mm types to support the metal keyboard frame at the front of the case. The metal frame is already drilled to take the screws of the spacers. It may be necessary to use extra washers to raise the keyboard to a comfortable height in the opening provided.

Once you know where the circuit board will sit in the case remove the board and prepare to mount the transformer, rear panel connections and switches.

The case is pre-drilled to take the stan-

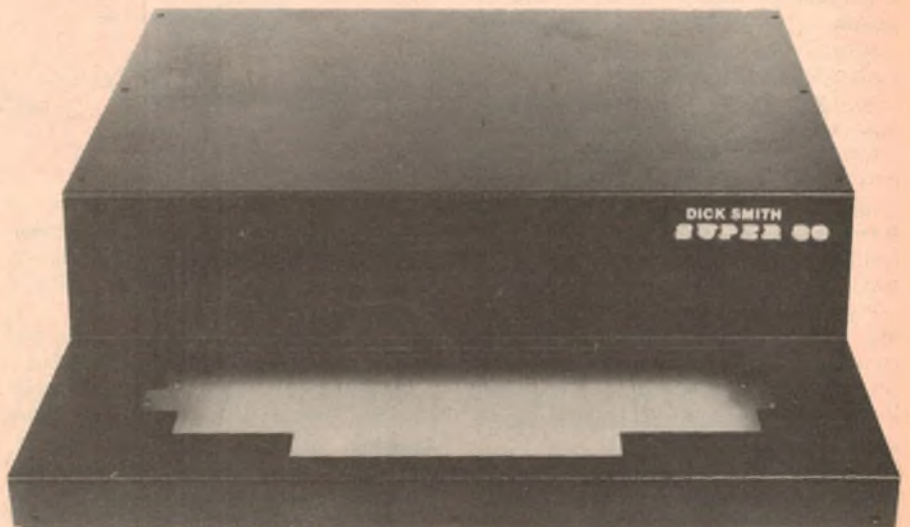

Specially designed for the Super 80, the black vinyl finished steel case is an attractive enhancement to the do-it-yourself computer.



A complete Super 80 computer system with case, printer, and a green phosphor video monitor. (Monitor courtesy Paris Radio Electronics)

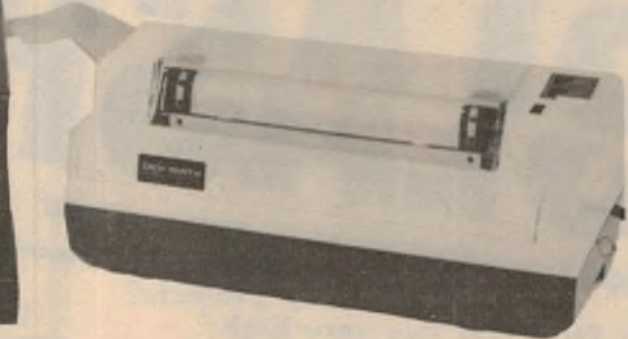

standard Dick Smith Electronics transformer used by the Super-80, but we found that an extra hole must be drilled to mount the mains terminal strip so that the power cord is not kinked. If required, an extra hole should also be drilled and reamed in the left hand side rear of the bottom section of the case to take a standard 3AG fuse-holder.

Drill this hole mid-way between the top hole (where we put the power switch), and the hole provided for entry of the mains cable, then ream it out until the fuse holder can be mounted.

Use a rubber grommet to protect the power cord against chafing at the point where it enters the case. Clamp the cord securely inside the case (there is a hole provided for the cable clamp). Use an earth lug to secure the earth lead of the power cable to the case. One of the transformer mounting bolts provides a convenient earth point. Make the earth lead longer than either the active or neutral power connections, so that if any strain is placed on the power cord the earth lead will be the last to give way.

Terminate the active and neutral power lines to a mains terminal strip bolted to the bottom of the case. From the terminal strip take the neutral lead to one side of the transformer primary. The active lead goes first to the fuse-holder, if used, and then to the power switch. The other side of the power switch goes to the transformer primary.

To connect the transformer secondary to the PCB we used a Utilux connector, matching the female connector on the PCB. If this connector is unavailable though, it is quite permissible to solder the secondary leads directly to the PCB.

Having carefully checked the location of the PCB and the transformer in the case, put this assembly aside and mount the reset switch, video connector and cassette connector on the right hand side of the rear of the bottom section of the case. We put the reset switch at the top, the video connector in the centre and the cassette connector at the bottom, although this depends to some extent on personal preference. It may be necessary to enlarge some of the holes in this part of the case. Use a reamer, and make sure that no metal filings are left in the case at the completion of the operation.

We used a 4mm diameter pushbutton for the reset switch. It was necessary to

extend the leads between the switch and the circuit board before the switch could be mounted. We used a screw-in female RCA socket for the video connector. Use a length of shielded cable between the PCB and this connector.

For the cassette connections we used a 5-pin DIN socket, with the cables to the cassette recorder terminated to a 5-pin DIN plug. Earth connections for the three cassette cables (Ear, microphone and remote control) can be made to a common pin on the DIN socket, with signal connections to separate pins. Use shielded audio cable between the cassette connector and the connection points on the PCB, although this is not really necessary for the remote control signal.

A close-up of the power supply wiring. Note the use of a terminal strip and cable clamp for mains connections, and the position of the fuse-holder and power switch.

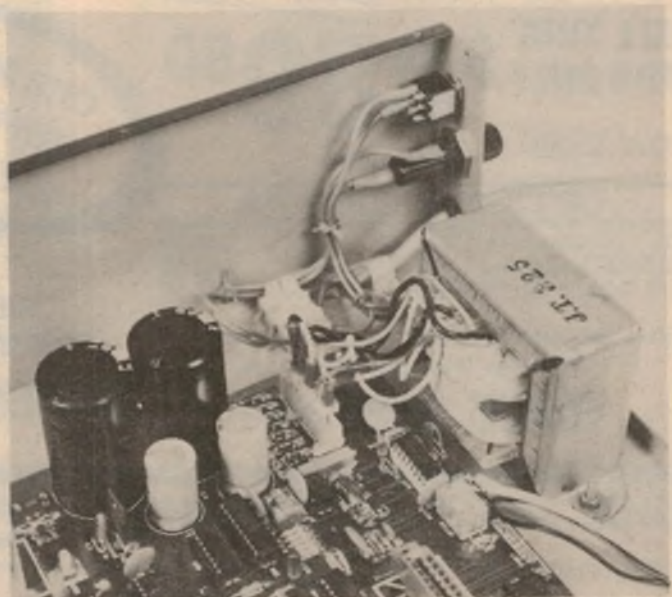

SUPER 80 PRICE SLASHED

Because such a huge number of SUPER 80 Computer Kits have been sold, many of the development costs have been amortised. Therefore where possible, we have slashed our prices accordingly.

it had to happen!

OVER 1600 SOLD

Are you fed up with 'built up' projects?

Why not build this very high quality kit computer and save over 50% on equivalent built up units!

A FULL SIZE COMPUTER KIT

You are supplied with a full board including power-on EPROM monitor, 16K of RAM, cassette interface (relay activated) for universal control of any tape recorder, TV modulator and direct video output PLUS full size professional keyboard — not a 'feel less' toy.



SAVE \$55.50!

ALL THIS FOR ONLY \$ **239⁵⁰**

Cat. K-3600

WAS \$295

OUR MOST POPULAR KIT EVER!

Any extra parts shown in illustration are sold as separate chargeable items

OPTIONAL EXTRAS

- Transformer (M-2325) \$23.00
- BASIC Interpreter (tape) (K-3602) ... \$12.50
- IC Socket Set (K-3603) \$12.50

Yes, this would make the fully assembled computer with above options

ONLY \$287.50!

THE FANTASTIC SUPER 80

Construction details and a full copy of the EA article is supplied with each kit. We also have available two very comprehensive manuals to assist in construction and programming:
 SUPER 80 Technical Manual (B-3600) \$9.50
 SUPER 80 BASIC Handbook (B-3602) \$9.50
 This book has over 50 separate versatile commands. Features arithmetic and integer functions, user-defined functions, machine language routines, text editing, string operations. Also contains 25 error codes to assist you in programming.

- ★ ★ ★ ★ ★ ★ ★ ★ ★ ★ ★ ★ ★ ★ ★ ★
- ADVANCED OPTIONS AVAILABLE:
- Lower Case Generator Option (K-3607) \$49.00
 - BASIC in EPROM (K-3604) \$19.50
 - S-100 Expansion Unit (K-3606) \$39.50
 - Metal Case (H-3200)
- ★ ★ ★ ★ ★ ★ ★ ★ ★ ★ ★ ★ ★ ★ ★ ★

DICK SMITH ELECTRONICS

SEE PAGE 52 FOR ADDRESS DETAILS



A case for the Super 80

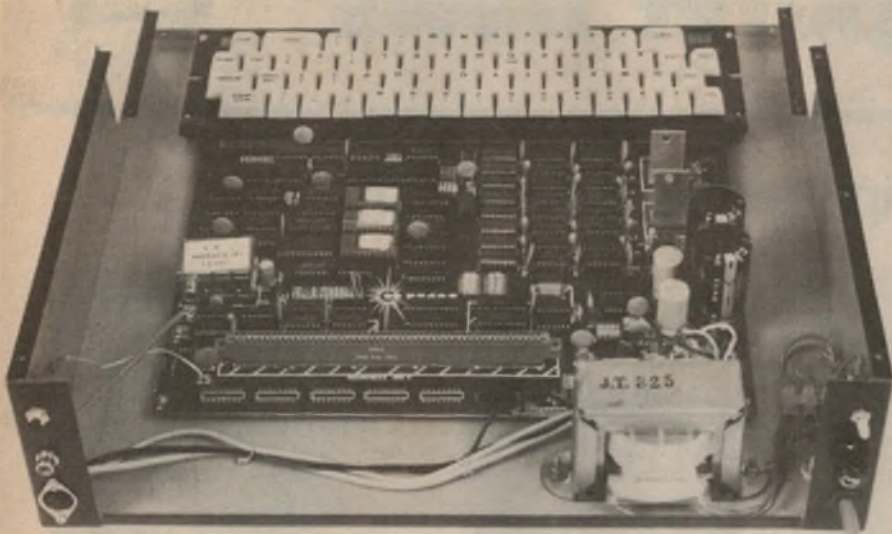

Note the cassette and video cables and the position of connectors.

Run the cassette cables from the PCB along the rear of the case to the connector and tie them into a neat bundle. Actual connections to the DIN socket will depend on the configuration of your existing cassette cables.

There is one final step, and that is the LED on the circuit board which indicates correct loading from the cassette recorder. With the top on the case it is obviously not possible to observe this LED, so it should be moved to the front of the case.

Drill a 5mm hole in the vertical front section of the top of the case, above the keyboard cut-out. Carefully remove the LED from the PCB and connect two insulated wires in its place. These leads go to the LED mounted on the front panel, making sure that the correct polarity of the LED is preserved. Use a 5mm plastic LED mounting bezel to secure the LED in the front panel.

With all holes drilled, brush out the bottom section of the case, making sure that no metal filings are left to complicate matters when the Super-80 board is installed. Mount the transformer, fuseholder, power switch and mains cord. Mount the circuit board in the bottom of the case, again making sure that there is sufficient clearance around the keyboard when the top cover is in place.

Make the connections to the reset switch, video connector and cassette connector. Keep all wiring as short as possible without straining any connections.

Before connecting the power transformer secondaries to the Super-80 PCB check the voltages from these leads. Remember to observe the correct phasing of the 20V (nominal) secondary lines, as described in the September 1981

issue of Electronics Australia, p78.

When all is complete place the top cover of the case in position and secure it with the self-tapping screws provided. We suggest that you place screws at the front of the keyboard and at the rear top of the case. Screw these down tightly and then connect the computer to your video display and switch on. If the Super-80 does not perform as normal the most likely cause is obstruction of the keyboard by the case. Loosen the screws at the front of the case and try moving the keyboard slightly.

Make sure that all the keys are free to move up and down to their full extent. If everything is satisfactory, leave the computer on while you insert and tighten the remaining screws. If at any time the cursor stops flashing on the screen check the keyboard clearance again.

Note that there is another cut-out in the rear of the top section of the case. This rectangular opening is designed for the possible installation of an edge connector or as a convenient exit point for the cable from the Super-80 printer interface board described in a previous issue.

On the subject of the interface board, note that the case is not high enough to take a standard sized S-100 board. If you use such a board you could still use the bottom section of the case but would have to make your own arrangements for a top cover. The Super-80 serial and parallel interface board is a non-standard size S-100 board, and fits quite comfortably inside the case even with the edge connector for the printer cable in place.

That completes the installation of the Super-80 in its case. The result is an attractive unit, solidly protected from the vagaries of the environment — well worth the price of the case and a few hours of careful work.

Direct
Computer
Sales

We sell. . .

apple
personal computers



and

commodore
Business Systems

BUSINESS USES —

We support you with:

- thorough hardware & software knowledge,
- staff training,
- on-site service,
- hardware & software design using our staff programmer and engineer.

PRIVATE BUYERS — use our expertise, it's yours for the asking.

PRICES — we are very competitive, try us. We now have two shops . . .

BANKSTOWN

Cnr North Terrace & The Appin Way
Bankstown Shopping Centre.

HURSTVILLE

198 Forest Road
Hurstville Shopping Centre
(02) 570 8344
Telex: AA 20149

Microcomputer News



Sinclair colour computer released in UK

It looks like Sinclair Research has done it again! From the company that brought you the ZX80 and ZX81 computers comes a new machine, with high resolution graphics, 16 colours, sound effects, and last, but by no means least, an improved keyboard!

The Sinclair ZX Spectrum, as it is called, was introduced at a press conference in London in April. Selling for around £125 (about \$200), the new machine will be a serious challenger in the low end computer market. Based on a Z80A microprocessor running at 3.5MHz, the ZX Spectrum comes with 16K of RAM, with provision for memory expansion to 48K inside the case.

Packaged in a black plastic case with grey keys and coloured key markings, the machine measures just 233mm x 144mm x 30mm. The 40 keys are larger than those of the ZX81 and have moving rubber keytops which give a light click when a key is pressed. It is possible to provide more audible feedback with the command POKE 23609,255, which will produce a soft beep with each key press.

Like the previous Sinclair computers each key has several different functions, including graphics characters. Upper and lower case characters are standard, and like the ZX81 all the Basic keywords are obtainable by pressing single keys.

The ZX Spectrum screen display consists of 22 lines of 32 characters each, but in addition each pixel on the screen is memory mapped in a high resolution 256 x 192 display. This uses a special 6144 byte display file located at the beginning of RAM, each bit of which maps directly into a pixel on the screen.

There are four new Basic statements to take advantage of the high resolution graphics; PLOT x,y, which displays a point at co-ordinates x and y, PLOT OVER, which erases a point (like UNPLOT of the ZX81), DRAW, which draws a line from the last point plotted to the new co-ordinates specified and CIRCLE x,y,a, which draws a circle with centre at x,y and radius a.

Brightness of the display in a particular



character space can be changed by either FLASH or BRIGHT. The first statement causes the specified character(s) to alternate between normal intensity and a high intensity mode, while the second is a continuous high intensity display mode.

Eight colours are available for foreground and background of the display. Colours are black, blue, red, purple, green, cyan, yellow and white. Any character location has both a foreground colour (called INK in Spectrum Basic) and a background colour (called PAPER). A number from one to eight specifies the colour for both these statements. The statement BORDER will set the colour around the screen area, and INVERSE can be used to reverse the foreground and background colours.

The ZX Spectrum incorporates a built-in loudspeaker which can produce sound over a range of 10 octaves (actually, 130 semitones). This is controlled by the statement BEEP, which requires parameters to specify the frequency and duration of the sound.

There are a few differences between Spectrum Basic and the ZX81 version. The ZX Spectrum operates at the speed of the ZX81 in the FAST Mode with the steady display of the SLOW mode, so it

does not include these two commands. The ZX Spectrum asks the user whether a screen scroll is required each time the screen is full.

The ZX Spectrum also uses the standard ASCII character code rather than the non-standard code used by the ZX81.

Programs can be saved on cassette at 1500 baud. The cassette format used however is not compatible with that of the ZX81, so program cassettes cannot be interchanged between the two machines.

The ZX81 16K RAM pack cannot be used with the ZX Spectrum, but the printer is compatible, and can be used to print out a full upper and lower case character set, using LLIST, LPRINT and COPY.

With the introduction of the ZX Spectrum, Clive Sinclair also announced another breakthrough. Later this year the ZX Microdrive, will be available, a miniature disk drive that stores 100K bytes of data on a disk just 58mm in diameter. Up to eight of the new "2 1/4 inch" disk drives can be connected to the ZX Spectrum! The drives are expected to sell for around £50 each.

We do not know when the ZX Spectrum or the disk drives will be available in Australia.

SWTPC OF AUSTRALIA

DISCOVER THE WORLD OF THE 6809 MICROPROCESSOR



6809 COMPUTER

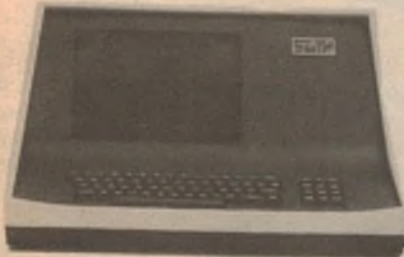

8212 TERMINAL
(ASS IN AUSTRALIA)

HARDWARE DESCRIPTION

S/09 6809 Computer w/128K Memory
 /09 6809 Computer w/64K Memory
 8212 12" Terminal w/monitor
 DMF 2 Disk System w/2.5m Capacity
 CDS-1 Winchester Hard Disk System
 MP-09A 6809 Process/Board (assem)
 D5-2 double side/double density 720KB
 3809 128K Memory Expansion for S/09
 MP-LA Parallel Interface
 MP-L2 Dual Parallel Interface
 MP-N Calculator Interface
 MP-R Eprom Programmer
 MP-S Serial Interface
 MP-64 Memory board 64K
 MP-S2 Dual Serial Interface
 MP-SX Serial Interface Expansion
 MP-T Interrupt Timer
 S-32 Universal Static Memory Card
NEW PRODUCTS SOON



DMF DISK SYSTEM 2.5M



**D-5 720k
DT-5 1.3M**

SOFTWARE SPECIALIST FOR THE 68XX SERIES

MICROWARE SYSTEM CORP

OS-9 Level 1 Operating System	\$195.00
OS-9 Level 2 Operating System	\$495.00
Basic 09 Programming Language	\$195.00
Pascal OS-9	\$440.00
Macro Text Editor	\$ 95.00
Assembler	\$ 95.00
Debugger	\$ 35.00
Stylograph Word Processor	\$175.00
Cobol Programming Language	\$995.00
C Programming Language	\$440.00

TECHNICAL SYSTEMS CONSULTANTS

UNIFlex Operating System	\$550.00
UNIFlex Basic	\$200.00
UNIFlex Pascal	\$250.00
UNIFlex Fortran 77	\$350.00
UNIFlex Relocating Assembler & Language Editor	\$175.00
General Purpose Flex 6809	\$165.00
General Purpose Flex 6800	\$165.00
Exorcisor Flex 6809	\$165.00
SWTPC Flex 6809	\$ 45.00
GIMIX Flex 6809	\$ 99.00
TRS80C Colour Flex	\$ POA
Extended Basic	\$110.00
Utilities	\$ 82.50
Pascal for Flex	\$220.00
68000 Cross Assembler for Flex	\$275.00

Sort Merge Package	\$ 82.50
Text Editor	\$ 55.00
Assembler	\$ 55.00
Debug Package	\$ 82.00
Diagnostics	\$ 82.50
Text Processor	\$ 82.50

FRANK HOGG LABORATORY, INC

XForth	\$165.00
Basic Programmer Tool Kit	\$ 77.00
Extended Use Utilities Pack	\$ 77.00
Password Protection Pack	\$ 99.00
Dynasoft Pascal Flex	\$ 99.00
Bill Payer System	\$185.00
Spell Test	\$220.00
Super Sleuth	\$110.00
Stylograph 2:0	\$325.00
Dynastar Full Screen Editor OS-9, Flex	\$ 99.00
CRASMB Cross Assembler, Flex, 6809, 6800, Z80, 8080, 6502	\$149.00
Dataman + DBM	\$220.00
Plot	\$ 49.00
Tabula Rasa	\$110.00
Job Control Program	\$ 99.00

WASHINGTON COMPUTER SERVICES

6809RMS DBM for Flex	\$220.00
6809 RMS DBM for UNIFlex	\$330.00
6809 RMS DBM for OS-9	\$275.00

UNIVERSAL DATA RESEARCH INC

DBM 2 Flex	\$450.00
DBM 2 UNIFlex	\$550.00
Payroll	\$495.00
Accts Receivable	\$495.00
Accts Payable	\$495.00
General Ledger	\$495.00
Inventory	\$495.00

TALBOT MICROSYSTEMS

tForth	\$ 99.00
tForth+	\$275.00

COMPUTER SYSTEM CENTRE

DYNAMITE Dissassembler	\$ 66.00
DYNACALC	POA

DUGGERS GROWING SYSTEMS

6809 C Compiler ver 2:0	\$130.00
-------------------------	----------

OMEGASOFT PRODUCTS

PCS2 Pascal Compiler Flex, OS-9, MDOS	\$490.00
Rall1 Relocatable Assembler & Linking Loader	\$150.00

SWTPC

EDIT Word Processing Editor Flex	\$110.00
C Compiler for UNIFlex	\$ POA

* Prices subject to alteration without notice, \$5 handling and packaging plus postage.

AVAILABLE FROM

PARIS RADIO ELECTRONICS
 7A Burton Street, DARLINGHURST,
 NSW 2010
 TEL: (02) 357 5111

J. H. MAGRATH & CO
 208 Little Lonsdale Street,
 MELBOURNE, VIC 3000
 TEL: (03) 663 3731

Microcomputer News

Australian Beginning offers a "package deal"

The Australian Beginning computer information service is offering a special package deal starting this month.

Under the "Early Bird" package the Australian Beginning in conjunction with Sigma Data Corporation will provide permanent membership of the service, a Sigma Data video terminal, a modem, and an initial 60 hours of computer time.

The Early Bird package costs \$2495, including full instructions and a 90-day equipment warranty. Alternatively the same package is available for a payment of \$20 a week over five years.

At present, access to the information service is via a Melbourne phone number, but it is expected that in the future users in other capital cities will have access for the cost of a local call.

For further information contact The Australian Beginning Pty Ltd, 364 Latrobe St, Melbourne, Vic 3000.

(For a full description of the facilities offered by The Australian Beginning, see our May, '82 issue).

Two new Tandy computer centres

Tandy Electronics has opened new Computer Centres in Brisbane and Adelaide. Headed by Greg Trigger (Brisbane) and John Shipp (Adelaide) the Centres will provide complete sales, service and training for Tandy's TRS-80 microcomputers.

The new Computer Centres will feature demonstrations of Tandy's Network system, which enables a classroom of students to use separate computers which can be linked together for special lessons. Only the teaching station requires disk drives, printers or other peripherals, which can be shared by up to 16 student stations — a significant cost saving.

Tandy Electronics is the largest electronic retail organisation in the world, with almost 9,000 outlets. In Australia there are 10 Computer Centres in major capital cities and a further 17 Computer Departments in selected retail stores. All Tandy Computer Centres offer TRS-80 service agreements as well as training classes for everyone from first-time users to experienced programmers.

The two new Computer Centres are at 301 Wickham St, Fortitude Valley, Brisbane, and 240 Morphett St, Adelaide.

Osborne Computer opens in Australia



Osborne Computer Corporation has established an Australian subsidiary to market its unique portable business computer, the Osborne 1.

Heading the new company is Richard Graham, former general manager of Computerland Australia. Osborne Computer Corporation Australia Pty Ltd will be fully operational from this month.

The Osborne 1 packages a complete business computer including display screen, disk drives and communications capabilities into a briefcase-sized unit weighing 11kg. Included in the \$2595

price is advanced software such as the Wordstar word processing program with Mail Merge mailing list option, the Super-Calc "electronic spreadsheet" calculator, CBasic and MBasic and the CP/M operating system.

Since its release in the United States last year, the Osborne 1 has been selling at the rate of 10,000 a month. It has been available in Australia through Computerland and President Office Machines, who will continue to carry the machine, but the establishment of a local Osborne subsidiary should expand the distribution.

Fifth generation computers may be intelligent

If you can't lick 'em, join 'em!

Britain is taking a leading role in focusing the attention of western nations on Japan's far-reaching plans to develop fifth generation computers.

The Japanese have recently revealed what is called its "fifth generation computer system" program. The challenge is so great and the stakes so high that they have invited other nations to share the burden of the research. Japan has also declared its intention to share the results of its own research and development program with its partners.

In response, SPL International, a leading British systems and software company, in association with computer organisations in the United Kingdom, western Europe and North America, is organising an international conference in London, called "The Fifth Generation Dawn of the Second Computer Age," to be held in July.

Giving details of the conference, Mr Alex d'Agapayeff, chairman of the British

Computer Society's special group on expert systems, said that fifth generation computers would mark a real revolution in computer technology. It would mean a radically new family of computers for the 1990s. Where current computers could perform 1000 to 10,000 instructions per second, the goal for the 1990s was to perform 100 million to 1000 million per second.

Another goal was to build a dataflow machine comprised of from 1000 to 10,000 processors.

Computer programming of the future will also be different and instead of telling a computer how to do something by using a program such as Cobol, the operator will tell it what to do by using a rule based system. Mr d'Agapayeff foresaw the computer of the future as a small machine with an artificial intelligence able to carry on a normal conversation. It might even have a screen with a face with which the operator could converse!

SPHERE COMPUTERS



Box 380 Darlinghurst NSW 2010

AN ADVANCED SYSTEM BASED ON THE 6809 MICROPROCESSOR

- * EFFICIENT
- * VERSATILE
- * EXCELLENT SUPPORT
- * SUPERB SOFTWARE
- * MK2 MULTI USER AND MULTI TASKING



PERIPHERALS
Additional VDUS, Dot Matrix Printers, Daisy Wheel Printers, 8" and 5" Floppy Disk Systems, and a hard disk drive of up to 40MB may be connected to the system. Interface boards and software are available to support all these devices in a singular or multi-user environment.

INPUT/OUTPUT
8 I/O Boards slots are provided, each of which may be fitted with a dual serial or dual parallel interface board using DB-25 "D-TYPE" Connectors. Many other types of interface Boards are also available.

CABINET
The Cabinet is made of heavy gauge (approx 1/8") Aluminium Anodised in Delightful blue.

SIZE
Approx: 16" wide by 20" deep by 7.5" high.

WEIGHT
Approx 10KG (including supply, CPU, 64K RAM, and I/O board)
A/C POWER INPUT 115-240 VOLTS A/C +/- 10%, 50-60Hz.

MK 1 and MK 2 SPECIFICATIONS

PROCESSOR
The heart of the system is the Motorola 6809 CPU and considered to be the most powerful 8 bit Microprocessor available today. The CPU board is fitted with Memory Management hardware which allows it to directly address up to 1 Megabyte of memory using a 20 Bit address bus.

The system is provided with a 2716 compatible 2k Monitor ROM or EPROM
MEMORY
A 64K Ram board is provided as standard. However the system may be provided with as little as 8k if desired and more added later.

POWER SUPPLY
Provides 8.5V, +12V, -12V unregulated supply to the buss. All components are P.C. board mounted and fuses readily accessible.

Distributed by: **PARIS RADIO ELECTRONICS** SYDNEY (02) 357 5111 Tlx-AA 22579
J. H. MAGRATH & CO. PTY. LTD. MELBOURNE (03) 663 3731



AND InfoSoft JOIN FORCES

SYSTEMS INCORPORATED

WE WAGED WAR ON INCOMPATIBILITY AND WON! WITH 3 NEW OPERATING SYSTEMS:

I/OS SINGLE USER

**MULT/OS MULTI TASKING
MULTI USER**

**MULT/NET NETWORKING
SYSTEM**

ALL THREE OPERATING SYSTEMS ARE CP/M & CDOS COMPATIBLE, AND ARE MANY TIMES MORE POWERFUL. AVAILABLE ON THE FABULOUS "AED SUPERCOMPUTER" OR EASILY IMPLEMENTED ON YOUR OWN HARDWARE!

SPECIAL OFFER IF YOU OWN CPM OR DCOS YOU CAN BUY I/OS FOR HALF PRICE \$120.00 WRITE FOR DETAILS. AED ARE EXCLUSIVE AGENTS FOR INFOFOT • OEMS • WELCOME •



MICROCOMPUTER PRODUCTS

130 MILITARY RD GUILDFORD 2161
TEL 02 - 681 4966 - TLX AA70664

**OPEN
9am-6pm
MONDAY-SAT.**



INFORMATION CENTRE

ELECTRICITY SUPPLY: I have just been listening to the news about the electricity supply situation in NSW. A recent lecturer, from America I think, decried the high temperature at which Australians kept their hot water systems, as this was a common cause of death and injury to children and the aged. It also used more energy and costs more to heat and to maintain a temperature which is higher than necessary for the particular circumstances.

You undoubtedly have Elektor's 300 Circuits. Circuit No. 227 on page 181: "Immersion heaters which are used to heat water consume considerable amounts of power if left on continuously even when the hot water tank is well lagged . . . The circuit described here provides one-shot operation of the immersion heater so that water can be heated as required . . . The heater will not operate again, even when the thermostat closes, until the one-shot button is again pressed . . ."

I thought that many of your readers may be interested in saving energy and/or money by a device like this adapted to components available here. Note: Suitable LDRs that will withstand 240V AC are made by Heimann and are available in UK from Guest Distribution. (A.H., Holland Park, Qld).

● Thank you for your suggestion for modification to a water heater. We are of the opinion that it would be better to reduce the thermostat setting rather than to make non-standard additions to the circuit which would undoubtedly not be approved by the various state energy authorities. There is also the problem whereby the user must remember to reset the circuit.

For those readers who are interested, it is quite an easy matter to adjust the thermostat on most hot water storage systems. Switch off the power at the switchboard and remove the coverplate. There, along with the connections to the element, you will find the screwdriver adjustment for the thermostat which usually has a coarse temperature scale. We suggest that the thermostat should not be set above 80 degrees Celsius.

CDI CIRCUIT: In March 1982, you published my submission for "Circuit and Design Ideas" under the title "Switch Mode Control for Low Voltage DC Motors".

However you elected to delete some comments from my text while adding some descriptions of your own. By doing so you may cause your readers some difficulty and confusion. This letter comes as an attempt to put things clearly again.

Firstly, you failed to mention the major advantage of the circuit: namely that its efficiency, which I have measured to be approximately 90% at low settings, is much higher than rheostat controllers, which only manage around 10% at similar settings. This makes my circuit vastly superior when used with battery operated equipment such as models.

Secondly, you were not aware of the full purpose of the 1N5401 diode. This diode is not fitted, as you said, for "spike protection". In fact it functions in this circuit as a "freewheeling diode": it provides a circuit for the current still flowing in the motor after the power transistor switches off at the end of each cycle, preventing a large back-emf voltage, but more importantly, greatly improving the efficiency of the circuit at medium to low settings.

I will again point out that a small heat-sink is required for the output transistor where the average current is above 4A. This was pointed out on my original circuit. I have also recently discovered that at least one brand of 555 IC (National Semiconductor) allows operation of the circuit down to 3V supply, in which case about 2.5A at 2V is still available. Gets the last drop out!! (P. A., Summer Hill, NSW.)

● Thank you for your additional comments on this circuit. We referred back to your original contribution to see if we did indeed "elect to delete some comments". However, apart from stating that your circuit "operates in the highly efficient switching mode" no particular mention was made in your letter of the advantage of efficiency. You did make a point about very smooth low speed running, which we did include.

You made no mention at all of the freewheeling diode but your above comments state that it prevents a "large back emf voltage". Is this not the same thing as "spike protection"? We agree that the diode will certainly improve circuit efficiency.

We admit that you did make mention of the heatsink on the circuit but not in your circuit description.

In the case of all CDI items published, our circuit description at least partly reflects the quality of the original submission. In many cases we have to spend a considerable amount of time trying to fathom out how a circuit works before we can accept or reject it for publication. We do not always see the finer points as this can often only be gleaned from first-hand knowledge of the circuit.

SHORTED TURNS TESTER: Regarding the shorted turns tester circuit I submitted in EA June '78 in "Circuit & Design Ideas", I have had numerous readers writing to me to say they cannot get it to work and suggesting the circuit may be incorrect but a few pointers may help those who did not have success.

Firstly, the tester will not work with iron cored coils such as ignition coils and power transformers. It will work with ferrite cores however, such as yokes and line output transformers and air-cored coils. The tester will work satisfactorily with BC548 transistors or equivalent. Readers are reminded of the different base connections between BF115 and BC548. If the circuit is built into a multimeter the meter movement must be disconnected from all other circuitry including shunts and diodes of the multimeter circuit.

The meter movements used by some readers may not be sensitive enough to show a deflection but this can be overcome easily by increasing the 120pF coupling to the base of the meter drive transistor up to as much as .01uF and deleting the 10kΩ shunt resistor.

Another point to watch is that if a coil such as a yoke is placed on a metal surface, such as a metal topped work bench or TV set, the tester will see the coil as shorted.

Lastly the meter will not show any deflection when switched on unless it is connected to a good coil as the coil under test forms part of the oscillator circuit. Hoping this clears up the matter for all the readers who wrote and haven't received an answer. (R.D.S., Nanango, Qld.)

SONY 2001: In the February 1982 issue of EA, I read of the plight of R.A. of Auckland, NZ in the information pages (his story on page 125). As I do not know the limits of the Sony 2001 radio I cannot guarantee that this is a cure, but would like to suggest that he use a SAFT

rechargeable cell of 1.2 volts with a capacity of four amp hours. I purchased these for about \$15 each sometime last year at Dickson-Clarke in Hobart who supply batteries of every imaginable type.

It would only give him 3.6V instead of 4.5V, but maybe if the set was not run flat out the amount of distortion would not be too much to bear, although if he pays this much for a small radio then he would expect only the best as I do. I do not know if there is a cell with 1.5V, but if this is found at this capacity his problem will be solved giving him about eight hours continuous reception at full volume. (R.T., Hobart, Tas.)

● Thank you for your suggestion, R.T.

PLAYMASTER 3-75L: I recently started building the Playmaster 3-75L speaker system which was supplied with the new drivers used in the 3-70L, EA March '82. In that article you state that the volume should not be changed by more than 5%. What effect will this volume difference have?

Also the kit came with two metres of Innerbond per speaker whereas the original article EA May '77 specified 3m/speaker. I bought 4m and find that it completely fills the enclosures. What is the correct amount? (M.U., Ridgehaven, SA.)

● With any sealed enclosure, the effect of reducing the internal volume will be to raise the resonant frequency of the woofer and to increase the Q of that resonance, ie, the value of the impedance at resonance will be increased. An increase in enclosure volume will produce the opposite effect. In your case, the new drivers are entirely suitable for the older and slightly larger enclosure.

It is not necessary to jam the enclosure tight with Innerbond. A loose fill is all that is required. A piece of Innerbond one metre by two metres will be adequate for each enclosure.

AM AERIALS: Could you please help me with information regarding ordinary AM aerials. I live in a hollow beside a river and surrounded by mountains. General reception with high quality equipment (Kenwood KR5 150, Akai, Silver National) is poor.

I want to record off air certain educational programs for them but the quality must be free of all interference/static etc. I would like to bypass the normal ferrite rod system and use some form of band spreading. Can you help me in any way? (DHL, Upper Coomera, Qld.)

● In your situation the only answer is to install a random "long wire" aerial. It is, as the name indicates, a horizontal length of wire as long as possible. We would suggest you try a horizontal 100-metre length of wire placed broad-

ZX81 keyboard modification

MODIFIED ZX81: I too have had difficulties with the ZX81 keyboard (I guess Aussie hands are bigger than English hands). So spurred on by Peter Vernon's article in EA April 82, I decided to expand the keyboard to operate more like a full size computer by providing separate keys for the most used commands and functions.

The shifted commands, functions and the shift key were lettered in red and the graphics in black. This provides an instant reference to which keys require the shift for operation. This is a fairly time consuming task, but I feel that the results justify the effort. When all keys were labelled they were sprayed with satin lacquer. Both paint and lacquer come in

This photo shows just what can be done in adapting a conventional keyboard to the Sinclair ZX81.



The keyboard wiring was completed as described and then I bridged from the chosen keys to the vacant keys and moved some positions to suit. This means that some keys are effective in three places. These include the print, break, delete, edit, run, new stop and function. I also included separate positions for semi colon, brackets, quotes and cursor movements.

By spray painting over with the colour of the original keys (those with commands which are not needed) I provided the base for including the new commands in Letraset.

This included the functions and graphics on the front face of the keys.

side to the transmitter and as high above the ground as is practical.

FUNCTION GENERATOR: I am writing to you to ask for help with your EA function generator. The trouble is in the display area and I am hoping you may have had the trouble I am having with mine.

The display functions OK on the x1 and x10 range but when it comes to x100, the digits flicker and you are not able to discern any numbers at all. What I mean is the A, B, C, D, E and F on the FND500 are lit (and flickering) and the G bar is flickering. I have checked the count cycle (10ms) pin 10 (IC6c).

The only time I am able to get a pretty

inexpensive spray cans.

I also decided that a plug in the ZX81 would be a good idea so I included an Amphenol 14 pin plug and socket in the right hand side of the case where there is plenty of room. The finished keyboard has a lacquered wooden enclosure and a black perspex surround for the keys.

In practice the operation is very simple since only the commands used are shown on the keys. This has provided a keyboard very similar to most keyboards in use and an ease of operation superior to any I have used.

This project has meant the difference between selling or shelving the ZX81 or making full use of its unique qualities.

constant readout (except the last digit is flashing in the 8 form) is when I shorted pins 5 and 4 of IC6b together with my probe. I have changed all ICs and checked for incorrect links and switch connections and solder connections on the track side.

I would appreciate it if you would be able to assist me with some more ideas or know the remedy. (T. T. Birkdale, Qld.)

● Although we have not experienced the problem with our own prototype, we would suggest that you try applying a short delay to the 50Hz clock input to IC6b. This involves breaking the PCB track between IC7d pin 12 and IC6b pin

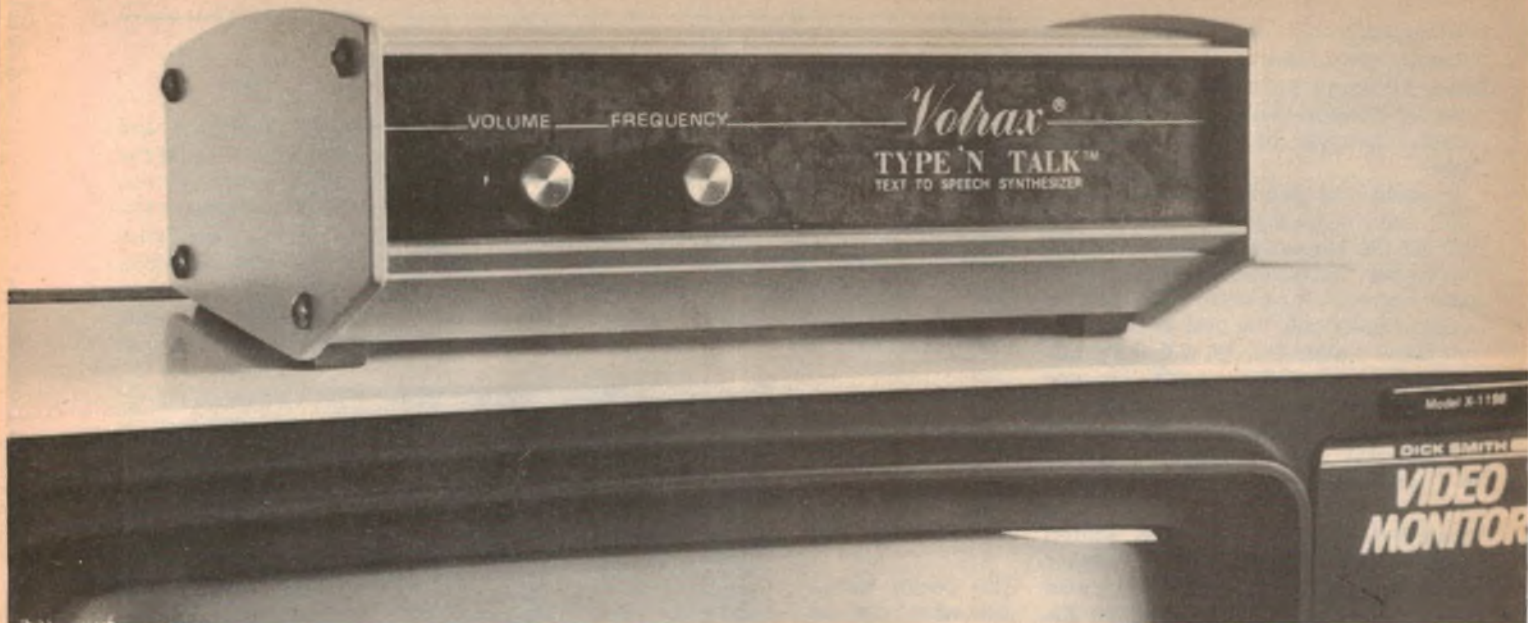

Cat X-3290

TYPE-'N-TALK™ IS T.N.T.

The exciting text-to-speech synthesizer that has every computer talking.

- Unlimited vocabulary
- Built-in text-to-speech algorithm
- 70 to 100 bits-per-second speech synthesizer

Type-'N-Talk™, an important technological advance from Votrax, enables your computer to talk to you simply and clearly — with an unlimited vocabulary. You can enjoy the many features of Type-'N-Talk™, the new text-to-speech synthesizer, for just \$525.00.

You operate Type-'N-Talk™ by simply typing English text and a talk command. Your typewritten words are automatically translated into electronic speech by the system's microprocessor-based text-to-speech algorithm.

The endless uses of speech synthesis.

Type-'N-Talk™ adds a whole new world of speaking roles to your computer. You can program verbal reminders to prompt you through a complex routine and make your computer announce events. In teaching, the computer with Type-'N-Talk™, can actually tell students when they're right or wrong — even praise a correct answer. And of course, Type-'N-Talk™ is great fun for computer games. Your games come to life with spoken threats of danger, reminders, and praise. Now all computers can speak. Make yours one of the first.

Text-to-speech is easy.

English text is automatically translated into electronically synthesized speech with Type-'N-Talk™. ASCII code from your computer's keyboard is fed to Type-'N-Talk™ through an RS-232C interface to generate synthesized speech. Just enter English text and hear the verbal response (electronic speech) through

your audio loud speaker. For example, simply type the ASCII characters representing "h-e-l-l-o" to generate the spoken word "hello".

TYPE-'N-TALK™ has its own memory.

Type-'N-Talk™ has its own built-in microprocessor and a 750 character buffer to hold the words you've typed. Even the smallest computer can execute programs and speak simultaneously. Type-'N-Talk™ doesn't have to use your host computer's memory, or tie it up with time-consuming text translation.

Data switching capability allows for ONLINE usage.

Place Type-'N-Talk™ between a computer or modem and a terminal. Type-'N-Talk™ can speak all data sent to the terminal while online with a computer. Information randomly accessed from a data base can be verbalized. Using the Type-'N-Talk™ data switching capability, the unit can be "de-selected" while data is sent to the terminal and vice-versa — permitting speech and visual data to be independently sent on a single data channel.

Selectable features make interfacing versatile.

Type-'N-Talk™ can be interfaced in several ways using special control characters. Connect it directly to a computer's serial interface. Then a terminal, line printer, or additional Type-'N-Talk™ units can be connected to the first Type-'N-Talk™, eliminating the need for additional RS-232C ports on your computer. Using unit assignment codes, multiple Type-'N-Talk™ units can be daisy-chained. Unit addressing codes allow independent control of Type-'N-Talk™ units and your printer.

Look what you get for \$525.00. TYPE-'N-TALK™ comes with:

- Text-to-speech algorithm
- A one-watt audio amplifier
- SC-01 speech synthesizer chip (data rate 70 to 100 bits per second)
- 750 character buffer
- Data switching capability
- Selectable data modes for versatile interfacing
- Baud rate (75-9600)
- Data echo of ASCII characters
- Phoneme access modes
- RS-232C interface
- Complete programming and installation instructions

The Votrax Type-'N-Talk™ is one of the easiest-to-program speech synthesizers on the market. It uses the least amount of memory and it gives you the most flexible vocabulary available anywhere.

DICK SMITH Electronics

SYDNEY 290 3377
 NEWCASTLE 61 1896
 WOLLONGONG 28 3800
 CANBERRA 80 4944
 MELBOURNE 67 9834
 ADELAIDE 212 1962
 PERTH 328 6944
 BRISBANE 391 6233



Mail Order Centre: PO Box 321, North Ryde 2113. Phone: (02) 888 3200

ANY TERMS OFFERED ARE TO APPROVED APPLICANTS ONLY.



DSE/A122/LM

6 and placing a 100Ω resistor in series between these two points. A 1000pF capacitor is connected from pin 6 of IC6b to the negative rail of IC6b, pin 7.

METER RESISTANCE: I don't want to make too much of what may be a minor matter, but the latest Dick Smith catalogue (page 130) gives instructions on how to find the internal resistance of a meter. Making the test in the way shown will lead to large errors.

A formula may be derived for meter resistance giving the circuit published by Dick Smith. This formula will certainly not be $R_m = R_b$ as claimed by Dick Smith.

I have lost count of the occasions I have seen this test published elsewhere in this form without making clear that, as it is a current test, a high ratio of circuit resistance to meter resistance must be used, or else the test made from a constant current source (which a simple battery and series resistance can only crudely represent). (A. F., Pennant Hills, NSW.)

● We have spoken to the people concerned at Dick Smith Electronics and they agree that the stipulation regarding high circuit resistance has been omitted. They have undertaken to have the item corrected in their next catalogue.

760 ELECTRONIC ORGAN: This letter comes as a matter of information, complaint and suggestion. It refers to the series of articles run in 1976 describing the design and construction of the "760 Electronic Organ". I used "the alternative MOS keyers" described in June 1977. To my dismay, a number of faults became apparent. These were: gross distortion on some notes, a high-pitched, continuous "singing" and severe "keyclick".

Talking to others who have built these circuits, I soon discovered that these faults were common. So for information, here is what I did about some of them.

Firstly, the TOS (Top Octave Synthesiser) chip is unable to drive the divider chips hard enough. This results in the dividers either distorting badly or skipping one step of division. To overcome this, I inserted 4050 CMOS current drivers between the output of the TOS and the inputs of the dividers.

Secondly, to overcome the first problem, the original design puts a small negative bias on the TOS so its output swings between -0.7V and +12V. These outputs go to the dividers (and then to the keyers) which have a 0-12V supply. This is OK, but the top octave 2' notes are the tones from the TOS and run directly to the keyers. Since the 4016 keyer chips have a 0-12V supply the tones cannot be completely turned off, leaving the residual 0.7V tone which is heard as the "singing noise". Of course, this is worst on the 2' output, but as the output buses run almost parallel on the keyer boards, capacitance coupling

Electronics Australia Reader Service

"Electronics Australia" provides the following services:

PHOTOSTAT COPIES: \$3 per project, or \$6 where a project spreads over multiple issues (price includes postage). Requests can be handled more speedily if projects are positively identified, and if not accompanied by technical queries. We reserve the right to supply complete back issues instead of photostats, where these are available.

CHASSIS DIAGRAMS: For the few projects which require a custom metal chassis (as distinct from standard cases) dyeline plans showing dimensions are normally available \$3 including postage.

PC BOARD PATTERNS: High contrast, actual size transparencies: \$3, including postage. Please specify positive or negative.

PROJECT QUERIES: Members of our technical staff are not normally available to discuss individual projects, either in person at our office, or by telephone.

REPLIES BY POST: Limited to advice concerning projects published within the last three years.

Charge \$3. We cannot provide lengthy answers, undertake special research, or discuss design changes. Nor can we provide any information on commercial equipment.

OTHER QUERIES: Technical queries outside the scope of "Replies by Post" or submitted without fee may be answered in the "Information Centre" pages, at the discretion of the Editor.

COMPONENTS: We do not sell electronic components. Prices and specifications should be sought from advertisers or agents.

BACK ISSUES: Available only until our stocks are exhausted. Within six months of publication, face value plus 90c for post and packing for each issue. Seven months and older, \$3 (includes post and packing and storage fee).

REMITTANCES: Must be negotiable in Australia and made payable to "Electronics Australia". Where the exact charge may be in doubt, we recommend submitting an open cheque endorsed with a suitable limitation.

ADDRESS: All requests to the Assistant Editor, "Electronics Australia", Box 163, Chippendale, 2008.

allows it to be also heard on the upper 4' output.

This may be overcome by running the drivers (4050s) from the 0-12V supply. However, if "singing" persists or if distortion continues, it will be necessary to run the 4050s from the -0.7V to +12V supply. Disconnect the normal top octave 2' outputs on the keyer boards and put these through separate 4016 keyers also running from the -0.7V +12V supply.

The third problem, however, is not so easily cured. In fact, a communication with the original designer has proved that there may be no solution. Keyclick (basically) occurs when the tone is turned on part of the way through the wave cycle, such that the waveshape is altered and different harmonics are produced. To overcome this, the keyer circuit puts the tone through one stage of a 4017 CMOS bilateral switch. The output of the switched is controlled by a control voltage which, when a key is pressed, rises from 0V to 12V over about 50ms by way of an RC circuit.

As the 4016 is an "analog" switch it must have been assumed that the output of the switch would be proportional to the control voltage. This is not the case. As the control voltage rises, the output is proportional until it reaches about 2.5V (which is the switch threshold) at which time the switch turns hard on and a click is heard.

Now I realise that the "760" design was only ever intended as a small instrument but the "alternative CMOS keyer" was designed to make it possible to build bigger organs. So perhaps you could suggest a suitable modification to the original design so that many people don't have to waste so many boards.

On the other hand, in light of your recent success with the electronic piano, one of your whiz-kid designers could come up with a new design for an organ

so that I will have something to wire into my nice, mute console. (J. P., Merrylands NSW).

● In the light of experience we agree that bilateral switches are not suitable as keyers and the only really satisfactory approach using a discrete circuit is to use a separate transistor for each keyer. The transistor and its biasing components can then be designed to give a "soft" switch-on with no clicks. Alternatively, a neater approach may be to use the Philips TDA1008 gating frequency divider IC. This has frequency dividers directly coupled to a gating system with controlled sustain.

In a typical circuits, a top octave synthesiser would be coupled to 12 TDA1008's and only one busbar per manual would be needed to obtain five octave-related tones per key. However, we have not used this device and we unaware whether Philips have stocks in Australia. ☺

Notes & Errata

FUNCTION GENERATOR (April 1982, File 7/AO/35): Constructors experiencing problems with a flickering display on the x100 range may cure the problem by creating a short delay in the 50Hz clock input to IC6b. This involves breaking the PCB track between IC7d pin 12 and IC6b pin 6 and placing a 100Ω resistor in series between these two points. A 1000pF capacitor is connected from pin 6 of IC6b to the negative rail of IC6b, pin 7.

12/230V 300VA INVERTER (June 1982, File No 3/IT/12): While strictly speaking, the 4MHz crystal should be a parallel-resonant type as specified, a series-resonant type may be substituted because the resulting small shift in frequency is not important in this application. ☺

MARKETPLACE

FOR SALE

ELECTRONIC PROJECTS: low cost books containing circuits of projects for experimenters, constructors and students. Written in simple language expressly for beginners. Send stamped addressed envelope for catalogue and price list to Hobby Electronic Books, P.O. Box 92, East Gosford, NSW 2250.

ISOLATION TRANSFORMERS 240 volts primary 115 volts secondary 500VA rating. Made in Australia by Transcap to SA 126 specifications of the standards association. 3 types available open . . . \$40. Metal end caps . . . \$45. Full enclosed metal box . . . \$50. For purchase and enquiries contact Louise Hatton, Marantz (Aust) Limited, Tel (02) 939 1900.

HEWLETT-PACKARD 85 A Personal Computer, with I/O ROM, Matrix ROM, serial interface option 16K memory module. Very new, \$5000. Ph (02) 438 4322 or (07) 391 1969.

NICAD BATTS. Cheap. A.A., C. & D. sizes up to 4 amps capacity fast charge types, also constant current chargers, variable to 1 amp. Ph (02) 636 1592 anytime.

CB RADIOS \$67, walkie-talkies, shortwave radios, military, outback, business, amateur, marine, repairs, aerials, 40 ch conversions, new rigs weekly. Bridge Disposals, 12 Old Town Plaza, Bankstown Rail Station. Ring Sam 7pm — 9pm only (02) 407 1066.

OVER 2000 AMATEUR Circuit designs available. \$2.50 ea. State requirements plus SAE. Box 316, Manly 2095. Ph (02) 938 3417.

TERMINET 300 Printing Terminal with cassette. Use as RS 232 Printer. \$450. Sydney (02) 635 4103.

SONY VO-3800P U-matic colour video recorder, Porta-Pak with power supply/battery charger and battery. \$800. (065) 647 152. 35 High St, Bowraville 2449.

AMIDON FERROMAGNETIC CORES — Large range for all receiver and transmitter applications. For data and price list send 105x220 SASE to: R.J. & U.S. IMPORTS, P.O. Box 157, Mortdale, NSW 2223.

FOR HIRE

MICRO RENTAL Microcomputer systems of various models and configurations with peripherals, are available for hire from DORF MICROCOMPUTER. Start-up and reference manuals included. Sydney (02) 922 1644 or (02) 960 1808 (AH).

MAN WITH HP4193A RF vector impedance meter, measures $Z \pm jX$ from 400 KHz to 120 MHz. Please ring Mr Pride on: (09) 450 4379 for further details.

CLUBS

A.M.E.C.C. — Australia's only microcomputer correspondence club — seeks members. Send \$2 for sample newsletter to:— A.M.E.C.C., PO Box 172, Ryde 2122.

DISPLAY ADVERTS IN MARKETPLACE are available in sizes from a minimum of 2cm x 1 col rated at \$15 for a col cm.

CLASSIFIED RATES \$3.60 for 40 letters or part thereof an insertion payable in advance. Minimum 80 letters.

Please use coupon below.

CLOSING DATE is six weeks prior to the on-sale date. Issues are on sale the first Wednesday of each month.

READER SERVICE

COMPUTER CLINIC repairs & services Sorcerer, Pet, Apple, System 80, Tandy & others. Ask about our SUPER 80 DEBUGGING service. (07) 269 8573, PO Box 68, Aspley, Qld.

RCS Radio Pty Ltd
Tel. (02) 587 3491

IS THE ONLY COMPANY
WHICH MANUFACTURES AND
SELLS EVERY PCB & FRONT PANEL
published in EA and ETI
651 Forest Road Bexley 2207
AUSTRALIA

RING FOR INSTANT PRICES
24 HOUR TURNAROUND SERVICE

CLASSIFIED ADVERTISERS

To the Advertising Manager, ELECTRONICS Australia, Box 163, Chippendale, 2008.

- Please insert the following advertisement in the first available issue.
 - Tick the classification required FOR SALE WANTED FOR HIRE
 - CLUBS POSITION VACANT POSITION WANTED READER SERVICE
- Please type or print in ball-point pen on a separate piece of paper.

Signed _____ I enclose Cheque/Money Order for \$ _____
Address _____ being full payment for _____ letters at \$3.60
for 40 letters or part thereof (minimum 80 letters).

RETAILERS WANTED IN ALL STATES

We make superb quality durable mobile antennas for CB, Ham and Commercial users. These are luxury items at reasonable prices and outperform and outlast all others tested. We also make bases and roller inductors. Excellent profits assured. If your shop has a possible place for us then please write for further details to:

ANTENNA SCIENCE & ENGINEERING,
P.O. BOX 238, NEDLANDS, WA

ELECTRONICS AUSTRALIA

MICROPROCESSORS & PERSONAL COMPUTERS

GENERAL

THE PERSONAL COMPUTER REVOLUTION	2
MICROPROCESSORS: THE BASIC CONCEPTS	14
PLOT BIORHYTHMS WITH YOUR TRS-80	67
UNDERSTANDING BASIC PT 1	80
UNDERSTANDING BASIC PT 2	83
GIVE YOUR COMPUTER AN RS-232C INTERFACE	110

MICROPROCESSORS

INTEL 8080A & SDK-80 EVALUATION KIT	20
INTEL 8035 & SDK-85 SYSTEM DESIGN KIT	24
MOTOROLA 6800 & MEK6800D2 EVALUATION KIT	26
MOTOROLA 6802D3 EVALUATION KIT	30
NATIONAL SEMICONDUCTOR SCIMP CHIP & EVALUATION KIT	32
SIGNETICS 2650 CHIP & EVALUATION SYSTEMS	36
FAIRCHILD F8 & F8 DESIGN EVALUATION KIT	40
MOSTEK F8 & MOSTEK EVALUATION KIT	43
SIGNETICS 8X300 & EVALUATION KIT	46
NATIONAL SEMICONDUCTOR PACE & DEVELOPMENT SYSTEM	48
TEXAS INSTRUMENTS TM990/189 TRAINING SYSTEM	50

PERSONAL COMPUTERS

TANDY ELECTRONICS TRS-80 PERSONAL COMPUTER	10
EXIDY SORCERER PERSONAL COMPUTER SYSTEM	58
HEATH H8 HOME COMPUTER SYSTEM	60
HEATH H11 16-BIT MINICOMPUTER KIT	62
COMPUCOLOR II PERSONAL COMPUTER SYSTEM	64

MISCELLANEOUS EQUIPMENT

E & M ELECTRONICS CASSETTE INTERFACE KIT	45
PARATRONICS MODEL 100A LOGIC ANALYSER	70
PARATRONICS MODEL 10 TRIGGER EXPANDER	72
LEAR SIEGLER ADM-3 VIDEO TERMINAL KIT	74
TAPE READER KIT FOR HOBBY COMPUTERS	76
SIGNETICS INSTRUCTOR 50 TRAINING SYSTEM	78

DREAM 6800 COMPUTER

INTRODUCTION TO THE DREAM 6800	86
BUILDING THE DREAM 6800 COMPUTER	93
INTERESTING PROGRAMS FOR THE DREAM 6800	98
CHIP-8 PROGRAMMING FOR THE DREAM 6800	103
DREAM 6800 POWER SUPPLY	107

Available from "Electronics Australia", 57 Regent St, Sydney. **PRICE \$5.00 OR** by mail order from "Electronics Australia", PO Box 163, Beaconsfield 2014. **PRICE \$5.90.**

L. E. CHAPMAN

122 PITT ROAD, NTH CURL CURL.
MAIL ORDERS: BOX 156, DEE WHY, NSW. 2099.
TELEPHONE 93-1848.

SUPER SPECIAL

GRAMOPHONE motor and pickup 3 speed stereo balanced arm. 240 volt \$9.75

PP NSW \$1.50
Interstate \$2.75
WA \$4



P&P NSW \$1.60 INTERSTATE \$2.80
COLOUR FRONT END COMPLETE
TOUCH PUSH BUTTON TUNER
SECTION
TO SUIT PHILIPS, PYE, KRIEGLER ETC. \$25

SPECIAL
Record player
PYE 12 VOLT
11 inch turntable belt drive
balanced arm ceramic cartridge
\$29.00 P&P NSW \$4.50
INT \$5.50
WA & NT \$6.50

VU & BALANCE METERS

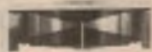

12Kn 100uA \$2.00
STEREO VU \$3.00

SPEAKER SYSTEMS
\$29.50 PAIR
2 x 6" Dual Cone Magnavox
Speakers in each cabinet
10 watts RMS
P&P NSW \$4.50 INT \$5.50 WA \$6.50
— NT \$6.50

POTS ROTARY

1/2 Meg	30c
1 Meg	30c
100K	30c
100K Switch	50c
50K Double Pole Switch	50c
7.500	30c
10K Switch	50c
250K	30c
50K	30c
20K	30c
10K Min Pots	25c
50/ohm	50c
1/2 or 1 Meg Switch	50c
1/2 1 meg dual Concentric tapped at 100K	\$1
2 meg ganged double pole switch	\$1
1.5 meg dual ganged	50c
2 meg ganged log	\$1
1 meg dual ganged	75c
1/2 meg dual ganged LIN	75c
25K, 50K dual ganged Concentric double switch	\$1
200K single line	30c
20K wire wound	75c
Dual log 10K	75c
100K dual ganged linear pots	75c
10K sub min log pots	50c
250K ganged pots	75c
25K lin ganged pots	75c

SUPER SPECIALS FM STEREO TUNER KITS

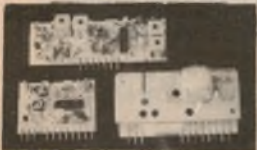

Sets of 3 modules include FM tuner, decoder and IF detector. Circuit diagram supplied. Can be used with amp modules

ONLY \$22
P&P \$1.40

ELECTROS

470uF, 25V	5 for \$1
400uF, 10V	5 for \$1
47uF, 63V	5 for \$1
350uF, 16V	2 for \$1
27uF, 160V	5 for \$1
25uF, 63V	10 for \$1
22uF, 160V	10 for \$1
47uF, 16V	5 for \$1
47uF, 200V	5 for \$1
220uF, 10V	10 for \$1
68uF, 16V	10 for \$1
1000uF, 50V	\$1
1000uF, 63V	\$1
2000uF, 25V	75c

BSR DELUX RECORD PLAYER

11 INCH TURNABLE CUIING DEVICE
SHIELDED MOTOR MAGNETIC CARTRIDGE
\$50. BASE & PERSPEX TOP \$22 EXTRA

P&P NSW — \$4.50; INT — \$5.50
WA — \$6.50
NT — \$6.50



SPEAKERS 2 1/2 INCH 2 FOR \$1

Power Transformers 240V 2/6 3 Windings
0.15 AMP (suit clock modules) \$3.00
Power Transformers 240V 1/130V x 12V 60
Mii \$6.00

MAGNAVOX SPEAKERS

8 INCH DUAL-CONE. 16 OHM, 10 WATT

\$6 PP NSW \$1.80
INTERSTATE \$2.75
WA, TAS, NT, \$4.



SPECIAL MAGNAVOX SPEAKERS

10 INCH WOOFER \$20 PAIR
10 INCH MID RANGE
8 OHM SYSTEM, 20 WATTS RMS



P&P NSW \$3.50 — INT \$4.50 — WA \$5.50
NT \$6.50

SPECIAL

SPEAKER CROSSOVER NETWORKS 2WAY
FREQ 4KHZ 30W 80HM

\$2



CLOCK MODULES \$3



TRANSFORMER TO SUIT \$3

Next Month in Electronics Australia . . .

Stereo Simulator

Designed especially for VCR users, the intriguing circuit uses a bucket-brigade device to produce an evenly spread stereo effect from a mono signal. It can also be used to enhance normal stereo signals.

Car Computer

The second article on this exciting project will provide a full technical description and details of construction. Make sure that you do not miss out on this key project for 1982!

100W Subwoofer

Teamed with this month's 100W module, this system gives extended bass response to 30Hz and below.

Wide Coverage Receiver reviewed:



This unusual receiver gives coverage of low, medium and shortwave bands as well VHF and UHF reception. It has digital readout and three power options.

On Sale:
Wednesday, August 4

* Our planning for this issue is well advanced but circumstances may change the final content. However, we will make every attempt to include the articles mentioned here.

EA Magazine Holders



The binders and magazine holders are available over the counter from Electronics Australia, 57 Regent Street, Sydney, NSW — Price: \$5 10 binders, \$4.50 holders.

Mail orders should be sent to Electronics Australia, PO Box 163, Chippendale, NSW 2008

Prices including postage are:

Holders: \$5.50 NSW; \$5.60 other states or six for \$29.00 NSW; \$31.50 other states, \$A33.00 NZ.

Binders: \$7.00 NSW; \$8.50 other states or six for \$33.00 NSW; \$36.00 other states, \$A37.00 NZ.

EA PC BOARDS AND FRONT PANELS

Some readers have problems obtaining PC boards and front panels for projects. Many of our advertisers sell these items and their advertisements should be checked in the first instance. Failing that, below is a list of firms which produce or sell PC boards and front panels.

NSW

Dick Smith Electronics,
125 York Street,
Sydney, 2000.

Telephone 290 3377.
DSE also has branches
and resellers throughout
Australia.

Electronic Agencies,
115-117 Parramatta Road,
Concord, 2137.

Telephone 745 3077.
117 York Street,
Sydney 2000.

Telephone 29 2098.

Jaycar Pty Ltd,
380 Sussex Street,
Sydney 2000.

Telephone 264 6688.

125 York Street,
Sydney 2000.

Telephone 264 6688.

Radio Despatch Service,
869 George Street,
Sydney 2000.

Telephone 211 0816.

RCS Radio Pty Ltd,

651 Forest Road,
Bexley, NSW 2207.
Telephone: 587 3491

VIC.

Rod Irving Electronics,
425 High Street,
Northcote, 3070.
Telephone 489 8131.

Kalextronics,

101 Burgundy Street,
Heidelberg 3084.
Telephone 743.1011.

Shop 11,
Regional Shopping Centre,
Melton 3338.
Telephone 743 1011.

Sunbury Printed Circuits,

Lot 14, Factory 3,
MacDougal Road,
Sunbury 3429.
Telephone 744 2714

SA

James Phototronics,
522 Grange Road,
Fulham Gardens, 5024.

WA

Altronic Distributors,
105 Stirling Street,
Perth 6000.
Telephone 328 1599.

Jemal Products,
8/120 Briggs Street,
Welshpool, 6106.

N.Z.

Marday Services,
PO Box 19 189,
Avondale, Auckland.

**Mini Tech Manufacturing
Co Ltd,**
PO Box 9194,
Newmarket.

Printed Circuits Limited,
PO Box 4248,
Christchurch.

ADVERTISING INDEX

ADVERTISER	PAGE
A & R Soanar	101
AED Microcomputer Products	129
AP Products	33, 41
Adaptive Electronics	35
Altronic Distributors Pty Ltd	22, 23, 80, 109
Antenna Science Engineering	134
Applied Technology	60, 61
Audio Engineers Pty Ltd	51
Australian School of Electronics, The	111
B.H.A.S.	IBC
Bright Star Crystals	58
Chapman, L. E.	135
Chloride Batteries (Aust) Ltd	90
Christie Rand Pty Ltd	82
Commodore Information Centre	120
Comp-Soft Microcomputer Service	119
Computer Country Pty Ltd	104, 117
Cunningham, R. H.	82, 96
Danish Hi-Fi	58
Dick Smith Electronic Group	10, 11, 42, 43, 52, 65, 72, 75, 83, 88, 93, 100, 115, 124, 132
Direct Computer Sales	125
Edible Electronics	21
Electronic Agencies	77
Ellistronics	66
International Correspondence Schools	87
Jaycar Pty Ltd	16, 17, 29, 55, 69
Looky Video	28
McGills Newsagency Pty Ltd	95, 108
Marantz (Aust) Pty Ltd	OBC
National Panasonic (Aust) Pty Ltd	36, 37
Parameters Pty Ltd	7
Paris Radio Electronics	127, 129
Philips	2, 96
Marantz (Aust) Pty Ltd	OBC
RCS Radio	134
Radio Despatch Service	110
Rakon Industries	112
Rod Irving Electronics	49, 103
Sheridan Electronics	110
Silvertone News	28, 34
Software Source	34
Sony (Aust) Pty Ltd	IFC
Stotts Technical Correspondence College	27
TDK (Aust) Pty Ltd	15
University Graham Instruments Pty Ltd	112
Warburton Franki	8
Wireless Institute of Australia	91

SUBSCRIPTION SERVICE



**ELECTRONICS
Australia**

Subscription Rates

\$28.00 per year
within Australia
\$A29.50 per year
elsewhere

Make sure you receive every copy of the magazine by ordering it from your newsagent or the publisher. For publisher subscriptions post this coupon, with your remittance to Electronics Australia Subscription Dept, John Fairfax & Sons Ltd, GPO Box 506, Sydney 2001. Subscription will start with first available issue

Name

Address

Postcode Enclosed is for years

Don't retaliate



Insulate with BHAS Lead

When noise is a problem, one way to solve it is to insulate yourself from the source. That's where BHAS lead insulation pays off. Lead is an efficient insulating material and it's available in sheets to suit most building applications.

Mail coupon today for a free booklet on lead insulation techniques—or contact Mr. L. I. Goff, Phone (03)658 3945.

Don't fight it.

LEAD



ZINC

CONCORD/BHAS/43

Please send me your free booklet "Noise Isolation with Lead Sheet".

Name _____

Address _____

Postcode _____

To: The Broken Hill Associated
Smelters Pty. Ltd.,
55 Collins Street,
Melbourne,
Australia
3001.

Exclusive to Marantz.
 Very sophisticated. Very superior. Very expensive.



Very high fi indeed.

These Marantz Gold components represent the world's most advanced, most inspired, most stringently tested and sophisticatedly engineered audio equipment.

For the wealthy—exclusive toys.

For the connoisseur—the finest hi-fi money can buy.

The Marantz TT1000 (around \$2500), with its precision-made high density glass and golden aluminium sandwich structure, is justifiably described as one of the most beautiful turntables ever.

'Playing a series of direct-recorded discs, warped discs, discs with nasty low frequency content and discs requiring unusual track-ability performance, showed clearly that this system borders on the superlative in areas where even most good turntables only provide good to above average performance.'

'...the resonance characteristics of the TT1000 are the lowest we have yet seen from any turntable irrespective of its selling price.'

'This is top-of-the-line equipment for people who rate hi-fi as their greatest pleasure in life'.
 — Louis Challis, *Electronics Today International*, April 1981.

Similarly, the Marantz SM1000 Stereo Amplifier (around \$5000) is designed to be the ultimate in luxury and performance.

When it was benchmarked by ETI Magazine in an exhaustive lab study, Louis Challis stated 'The Marantz SM1000 Amplifier has the capability to provide superlative performance at home, in a laboratory, in a studio, or in a rock band with the ease and panache of a professional.'

'The power output claims are modest for the unit is readily capable of producing 625 watts into an 8 ohm load with both channels driven...'

And when the Marantz ST8 FM/AM Tuner (around \$700) was

put through its paces so technically surprising was its performance that a second series of tests was devised to check the first results.

'As a result... the Marantz ST8... far ahead of any tuner we have ever measured and better than any tuner we have ever seen



The TT1000's adjustable, high-absorption air suspension audio insulator feet.

reviewed in any other magazine, either local or overseas.' — Paul de Noskowski, *Electronics Australia*, April 1981.

**Marantz Gold.
 The New Audio Standard.**



Detailed specifications of these exclusive Marantz Gold components are available on request by writing to:

Marantz (Australia) Pty. Limited,
 19 Chard Road, Brookvale, NSW 2100
 Phone (02) 939 1900 Telex AA24121
 Melbourne (03) 544 2011
 Brisbane (07) 44 6477
 Adelaide (08) 223 2699
 Perth (09) 276 3706
 Townsville (077) 72 2011

