

AUSTRALIA'S NUMBER ONE ELECTRONICS MAGAZINE

# ELECTRONICS

## AUSTRALIA

Registered by Australia Post — publication No. NBP0240.

VIDEO, HI-FI & COMPUTERS

DECEMBER, 1982

AUST \$2.00 \* NZ \$2.50

*Build this high-performance*

# AM TUNER



**For low distortion & wide frequency response**

**Laser weapons in space! Fact or fiction?**

**Texas Instruments TI-99/4A computer**

**How the ABC covered the Games**

**Digital pH meter**

# Power you can taste.



Sony's new TA-AX5 amplifier with memory is a high fidelity feast.

Its multiple memory lets you create your own acoustic "flavours." Bass and treble tone settings, turnover frequencies, high and low filter are all programmable.

At a touch you can instantly recall the recipe for bittersweet country, hot 'n' spicy rock, or a well-seasoned Stravinsky. And electronic displays graphically show you everything the amp is cooking up.

Sony's Audio Signal Processor means that every function is touch controlled. This knives through the usual maze of audio circuitry for a streamlined design of the future. Pure and simple, it sounds delicious.

The ideal companion for this tasty new amplifier is Sony's ST-JX4 synthesizer tuner. Why not make a reservation for two?

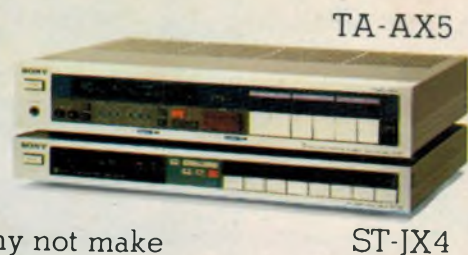

**SONY**  
THE ONE AND ONLY

SON 0118

# ELECTRONICS

## AUSTRALIA

Volume 44, No. 12  
December, 1982

**AUSTRALIA'S LARGEST SELLING ELECTRONICS MAGAZINE**



The Texas Instruments TI-99/4A home computer has a lot to offer. Our in-depth review starts on p100.



This new digital pH meter has many uses around the home, from fish tanks to gardening and swimming pools. Resolution is 0.1 pH units, making it suitable for laboratory use as well. See p54.

### On the cover

Pride of place on this month's cover goes to our new Playmaster AM tuner. Features include first class sound quality, a digital frequency readout and a bar-graph signal strength meter. Our first article begins on page 44.

### FEATURES

<b>LASERS GET READY FOR WAR</b> <i>Could they knock out ICBMs?</i> .....	12
<b>HOW THE ABC REPORTED THE GAMES</b> <i>Australia-wide, live from Brisbane</i> .....	16
<b>EXPEDITION BY SAIL TO THE ANTARCTIC</b> <i>Modern day adventure</i> .....	22
<b>50 &amp; 25 YEARS AGO</b> <i>Interesting items from past issues</i> .....	111
<b>INDEX TO VOLUME 44</b> <i>Features, projects, computers</i> .....	148
<b>COMING NEXT MONTH</b> <i>See into the future</i> .....	8

### HIFI, VIDEO AND REVIEWS

<b>HIFI REVIEW</b> <i>Audiosound Linz 8066 studio monitors</i> .....	30
<b>RECORDING TAPE IS GETTING BETTER ALL THE TIME</b> .....	34
<b>COMPACT AUDIO DISC</b> <i>Sony previews 1983 launch</i> .....	40

### PROJECTS AND CIRCUITS

<b>A HIGH PERFORMANCE AM TUNER: PART 1</b> <i>For first class sound</i> .....	44
<b>EASY TO BUILD DIGITAL PH METER</b> <i>For home or laboratory</i> .....	54
<b>DRIVEWAY SENTRY TURNS ON THE LIGHTS</b> <i>Safety at home</i> .....	62
<b>THE MIND-BLOWING BOGGLE GOGGLES</b> <i>Great gimmick for parties</i> .....	68
<b>CIRCUIT &amp; DESIGN IDEAS</b> .....	83

### PERSONAL COMPUTERS

<b>DATUM MICROPROCESSOR TRAINER</b> <i>Monitor software and programs</i> .....	92
<b>TEXAS INSTRUMENTS TI-99/4A COMPUTER</b> <i>Personal computer review</i> .....	100
<b>MICROCOMPUTER NEWS</b> <i>Single board development system</i> .....	135

### COLUMNS

<b>FORUM</b> <i>Warranties are fine — provided they're effective</i> .....	26
<b>THE SERVICEMAN</b> <i>Modern TV faults can be difficult to analyse</i> .....	86
<b>SHORTWAVE SCENE</b> <i>50 years of BBC shortwave broadcasting</i> .....	125
<b>RECORD REVIEWS</b> <i>Classical, popular, special interest</i> .....	128

### DEPARTMENTS

<b>EDITORIAL</b> 3 — <b>NEWS HIGHLIGHTS</b> 6 — <b>LETTERS TO THE EDITOR</b> 106 —
<b>BOOKS AND LITERATURE</b> 113 — <b>NEW PRODUCTS</b> 116 — <b>INFORMATION</b>
<b>CENTRE</b> 144 — <b>MARKETPLACE</b> 150 — <b>NOTES AND ERRATA</b> 147.

**THINKING ABOUT  
BUYING A SCOPE?**

# FOR PERFORMANCE & VALUE AARON HAS TO BE YOUR FIRST SCOPE CHOICE

All these scopes are dual trace and incorporate the latest features such as high brightness rectangular CRTs.

**SIGNAL AND  
TIMEBASE DELAY**



- 7.7nS risetime
- Single sweep
- Trigger delay
- TV sync
- X-Y, dual, chop, add, subtract etc.

**45MHz/1mV**  
BS625 **\$990.00**

**ALTERNATE AND  
DELAYED TIMEBASE**



- 21 range timebase
- 100mS-1 uS trigger delay
- Front panel trace rotate
- X-Y, dual, chop, add, subtract etc.

**35MHz/1mV**  
BS635 **\$790.00**

**BUILT-IN  
COMPONENT TESTER**



**New low price  
for popular  
AARON scope**

- Check components on screen
- 19 range timebase
- Triggerable to over 30MHz
- 17nS risetime

**\$485.00**  
**20MHz/5mV**  
BS601 ~~\$550.00~~

**BATTERY  
PORTABLE**



- 2 hour operation from built-in NiCad battery
- Automatic recharging
- Auto trigger free run
- TV sync

**15MHz/2mV**  
BS310 **\$720.00**

## QUICK SPEC CHECK

MODEL	B WIDTH	SENS	SIG DEL	TRIG DEL	SCREEN	T BASE
625	45MHz	1mV	Y	Y	150mm	0.2uS - 0.5S/div
635	35MHz	1mV	N	Y	150mm	0.1uS - 0.5S/div
601	20MHz	5mV	N	N	150mm	0.5uS - 0.5S/div
310	15MHz	2mV	N	N	95mm	0.5uS - 0.5S/div

All prices are plus sales tax if applicable and subject to change without notice

# ELMEASCO

## Instruments Pty. Ltd.

P.O. Box 30, Concord  
N.S.W. 2137  
13-15 McDonald Street,  
Mortlake, N.S.W.  
Telephone (02) 736 2888  
Telex 25887

P.O. Box 107, Mt. Waverley  
Victoria 3149  
21-23 Anthony Drive,  
Mt. Waverley, Victoria  
Telephone (03) 233 4044  
Telex 36206

Adelaide: (08) 271 1839  
Brisbane: (07) 369 8688  
Perth: (09) 398 3362



N.S.W. George Brown 519 5855 • DGE Systems (049) 69 1625 • Radio Despatch 211 0191 • Vimcom (042) 28 4400  
VICTORIA Radio Parts 329 7888 • Browntronic 419 3986 • G.B. Telespares 328 4301 • Elanco 428 4345 • Ellistronics  
602 3282 QUEENSLAND L.E. Boughen 36 1277 • Colourview Wholesale 275 3188 • Audiotronics 44 7566 • Electronic  
Shop (075) 32 3632 • Nortek (077) 79 8600 • W.G. Watson (079) 27 1099 S.A. Protronics 212 3111 • Trio Electrix 51 6718  
W.A. Atkins Carlyle 321 0101 • Hincro Eng 381 4477 • Brookeades 276 8888 • Protronics 362 1044 A.C.T. Actiec  
(062) 80 6576 N.T. Thew & McCann (089) 84 4999 T.A.S. G.H.E. Electronics 31 6533 & 34 2233

## COLINE SP100 PROBE

Professional 100MHz probe offering x1, ref, x10 positions. 1.5m lead with BNC connector and selection of tips.

Complete in heavy duty plastic pouch. **\$25.00**



## MAIL COUPON FOR FREE GUIDE

Please send me a copy of your shortform oscilloscope guide.

NAME \_\_\_\_\_

ADDRESS \_\_\_\_\_

POST CODE \_\_\_\_\_

TELEPHONE \_\_\_\_\_



# Editorial Viewpoint

## The Davidson report ... a disaster!

### EDITOR-IN-CHIEF

Neville Williams  
F.I.R.E.E. (Aust.) (VK2XV)

### EDITOR

Leo Simpson  
B. Bus. (NSWIT)

### ASSISTANT EDITOR

Greg Swain, B.Sc. (Hons. Sydney)

### TECHNICAL PROJECTS

John Clarke, B.E. (Elect. NSWIT)  
Peter Vernon, B.A. L.L.B. (NSW)  
Jeff Skeen  
Colin Dawson

### PRODUCTION

Danny Hooper

### GRAPHICS

Robert Flynn

### SECRETARIAL

Pam Hilliar

### ADVERTISING MANAGER

Selwyn Sayers

### CIRCULATION MANAGER

Alan Parker

Anyone who has read the initial accounts of the Davidson report and is concerned about the state of communications in Australia must react in dismay. The report advocates an end to Telecom's monopoly of network services and its restructuring as a taxable public company with a minimum of government control. This has wide ranging consequences both for consumers and for employment in the Australian electronics industry.

Taking the employment angle first, it is vital that Australia's remaining electronic industry be maintained. Telecom already gives a substantial amount of business to overseas concerns. Further reductions in the Australian content of our telephone system will have drastic effects on employment and the "reservoir" of skill. In the present climate of doom and gloom, this is ludicrous to contemplate.

For consumers, three of the Davidson recommendations must inevitably cause a big increase in charges: first, that Telecom pay government rates and taxes; second, that billing for all local calls be time-based and third, that cross subsidisation of loss-making "rural" services should cease. I presume that the National Party will have a great deal to say about that.

Consider the social implications of making local calls time-based. The telephone is one of the few aids of modern technology which allows people to communicate with each other in an unfettered way. Making calls time-based must inevitably impinge heavily upon the poor and socially disadvantaged, supposing that they are lucky enough to afford a telephone in the first place. Can you imagine anyone ringing Lifeline if they know there is a three-minute time limit for their twenty cents?

I concede that the increase of data transfer via the telephone system means that modem calls should be time-based, otherwise the whole network may rapidly become overloaded. However it would be relatively easy to confine this to those calls where a modem is used.

There is also the aspect of research and development. Telecom is one of the few Australian bodies that perform substantial R&D in electronics. By forcing Telecom to become more "efficient" much of this R&D activity would cease.

Reading between the lines, all the accounts of the Davidson report seem to indicate that it advocates giving private enterprise a free rein in all of Telecom's presently profitable activities. Pity Poor Telecom. Whatever its faults, Telecom has developed an excellent service. I am sure most people would be happy to see Telecom become more efficient but no-one wants to see it disembowelled!

**Leo Simpson**

### Editorial and Advertising Office

57 Regent St, Chippendale 2008.  
Phone (02) 699 3622 Telex 25027.  
Postal Address: PO Box 163, Chippendale, 2008.

Advertising Sales Manager: Sel Sayers.

Melbourne — 392 Little Collins St, Melbourne 3000. Phone (03) 602 3033.

Representative: Mark Christian.

Adelaide — Charles F. Brown & Associates Ltd, 278 Halifax St, Adelaide, 5000.

Representative: Sandy Shaw (08) 267 4433.

Perth — 454 Murray Street, Perth 6000.

Representative: Ashley Croft (09) 321 8217.

### Circulation Office

Unit 3B, Sydneygate, Waterloo, 2018.  
Phone (02) 699 2388.

### Subscriptions

Subscription Dept, John Fairfax & Sons Ltd,  
GPO Box 506, Sydney 2001.  
Enquiries: Phone (02) 20944, ext 2589.

### Distribution

Distributed in NSW by Magazine Promotions, 57 Regent St, Chippendale; in Victoria by Magazine Promotions, 392 Little Collins Street, Melbourne; in South Australia by Magazine Promotions, 101-105 Waymouth St, Adelaide; in Western Australia by Magazine Promotions, 454 Murray Street, Perth; in Queensland by Gordon and Gotch (A'asia) Ltd; in Tasmania by Ingle Distributors, 93 Macquarie St, Hobart; in New Zealand by Gordon and Gotch (NZ) Ltd, Adelaide Rd, Wellington.

Registered by Australia Post — publication No. NBPO240.

### Copyright. All rights reserved.

Devices or arrangements shown in this magazine may embody patents. Information is furnished without responsibility for its ultimate use, or for failure of equipment to operate as expected, or for any damage, loss or injury which may be sustained. Material intended for publication is submitted at the sender's risk and, while care will be taken, responsibility for any possible loss will not be accepted by "Electronics Australia".

Printed by Magazine Printers Pty Ltd, of Regent Street, Chippendale and Masterprint Pty Ltd of Dubbo NSW for Magazine Promotions, of Regent St, Chippendale.

ISSN 0313-0150

\* Recommended and maximum price only.

# Measure it - time it - tabulate it!

WITH THIS  
BRILLIANT

## Calculator/Clock/ Rule

It really is the Exception to the Rule! Amazing technology breakthrough has put both an LCD clock AND a calculator INSIDE the rule! Ultra-Long battery life (batteries replaceable) and rule has both metric & imperial graduations

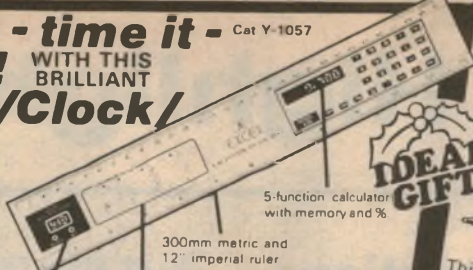

Handy imperial/  
Metric conversion  
table.  
Robust clock shows  
hours, minutes, sec-  
onds, month & date

FOR  
ONLY

**\$19<sup>95</sup>**

Why pay \$1000  
or more?

## 6 level Chess Computer



Cat Y-1260

You could become a chess Grandmaster! Computerised chess set has the very latest sensor board so it can recognise individual pieces, and offers six levels of skill. It will even play against itself! Built-in draw storage for pieces, too. Complete with power supply.

Complete  
with chessmen  
& power supply!

ONLY  
**\$289**

Cat R-7015

## 1% RESISTOR VALUEPACK

Yes - a specially selected pack of 1/4 watt resistors (normally 6¢ each) almost Half price. No rubbish - this pack includes the price. No rubbish - in service and project values most used in more stable, construction. Metal films are better have an amazing 1% tolerance and better temperature coefficient. Now there's no excuse not to use them!

**\$9<sup>95</sup>**

BUILD  
YOUR  
OWN

## THERMOMETER/CLOCK

All the advantages of a Digital alarm clock and a thermometer. The thermometer will display in either Fahrenheit or Celsius and the clock will even turn your radio on for you! Supplied with an alarm and snooze button, the clock runs on mains & battery

MODULE ONLY  
Optional case available:  
H-2505 **\$13.50**

Cat Y-1053  
ONLY  
**\$34<sup>95</sup>**

**LAST CHANCE  
TO SAVE!**

ON  
FAMOUS  
AMPEX TAPES!

C-3088 C-90EDR **\$2.99**  
C-3078 C-90ELN **\$1.50**  
C-3080 C-45EDR **\$1.99**  
C-3082 C-60EDR **\$2.49**

You won't buy better! Famous Ampex brand - we bought a huge shipment at below manufacturer's cost. You reap the benefit!!!

## NEW IMPROVED MODEL!

## DICK SMITH GREEN PHOSPHOR MONITOR

Now with audio amplifier for programs with sound effects! Yes - THE monitor for those serious about computing! Green screen means sharper, clearer images, less eye fatigue and strain.

OUR MOST POPULAR MONITOR!  
**\$239 ONLY** Cat X-1198

## GIVE YOUR COMPUTER A VOICE!

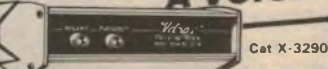

Cat X-3290

## VOTRAX Synthesizer

Yes! Your computer can actually talk (we're still working on the breathing and walking part). Not only talk, but talk in clear, intelligible English. It connects to any computer's RS-232 port. The unique Votrax Type n Talk opens up a whole new world of computing - it comes complete with a detailed user manual and power supply. All you add is a speaker!

FOR ONLY **\$549<sup>00</sup>**

## RELAY BARGAIN

Heavy Duty PC mounting relay, with DPDT contacts rated At a huge 10A (@ 120VAC). Relay coil 160ohms - quite happy to operate on 12V so it's great for a huge range of transistor operated projects



AT ONLY **\$3<sup>50</sup>** VALUE!

## DICK'S ZIPPYS ORIGINAL & BEST! -ORIGINAL & BEST!

The only genuine Zippy Boxes - the ones with the all rounded deep ribbing. Don't be fooled by inferior copies - this is the one used by the major electronics mags, because of its versatility. Insist on the one and only - genuine - Zippy Box from Dick Smith!

Small UB5 (28x54x83mm) Cat R-2755 **\$1.80**  
Medium UB3 (41x68x130mm) Cat H-2753 **\$2.75**  
Large UB1 (50x90x150mm) Cat R-2751 **\$2.80**  
Giant UB2 (80x113x150mm) Cat H-2752 **\$3.99**

BATTERY OPERATED  
- TAKE ANYWHERE!



## DICK SMITH WELLER CORDLESS IRON



This soldering tip is supplied with iron.

Built-in light for hard to get at corners.

On-off switch heats tip to 370 degrees in seconds. Body contains built-in Ni-cad battery.

The most versatile soldering iron you'll ever own! The Weller Cordless - it goes anywhere you go, without the hassle of trailing cords or troublesome tip voltages to cook expensive IC's. And even more, it has a light built in so you can see into those dark corners! It's equivalent to a 15W mains iron - so it's ideal for working with fine PCB tracks and heat sensitive components. Heats in seconds; finger tip control. Comes complete with a mains re-charger and fine pointed tip; other tips are available.

EVEN HAS  
A BUILT-IN  
LIGHT!

AMAZING  
VALUE COMPLETE  
WITH CHARGER!

## SPARE TIPS TO SUIT

3mm Screwdriver Tip	Cat T-1240	\$3.75
1.5mm Screwdriver Tip	Cat T-1242	\$3.75
1.5mm Long Reach Tip	Cat T-1244	\$3.75
0.8mm Conical Tip	Cat T-1246	\$3.75

ONLY  
**\$34<sup>95</sup>**  
Cat T-1050

## QUALITY SPEAKERS THAT DON'T COST A FORTUNE!

An economical answer to getting decent speakers without spending a fortune!

Just the shot for around the pool... or out on the patio on summer nights. 2-way speakers, because of their small size they're ideal for bookshelf use too (size only 394 x 268 x 170 mm). 8 ohms impedance. So they'll suit almost all Hi-Fi amplifiers! At our low price, you can afford two for stereo use!

AND  
ONLY  
**\$49<sup>50</sup>**  
each  
Cat A-2460

GREAT  
XMAS  
GIFT  
VALUE!



ALSO IDEAL  
EXTENSION  
SPEAKERS

## NEW! VIC20 SOFTWARE

Get totally wired with these specials!  
Maths Hurdler Cat X-2075  
Teaches basic Arithmetic skills.

## PAK Bomber

Destroy the city in order to land  
Cat X-2076

## Skiier

Put yourself in the boots of a downhill  
racer Cat X-2077

AT  
ONLY  
**\$13<sup>95</sup>**  
EACH

## HALF PRICE!

Cat W-2010  
SPEAKER CABLE  
Ideal cable to use with Hi-Fi Systems for speaker connections or for Intercoms. Marked with a trace  
NOW @9c/m  
was 18c/m

RG58U COAX CABLE  
75 ohm coax for all TV installations. Minimum ghosting

NOW  
@20c/m  
was  
40c/m

Cat W-2080

MERRY  
CHRISTMAS  
DICK SMITH AND STAFF



A337/LA/AB

**DICK SMITH ELECTRONICS**  
See page 98 for full address details



# News Highlights

## IBM launches new prosecutions — moves to protect trade secrets

IBM has once again demonstrated its determination to preserve its trade secrets. After action against executives of Hitachi and Mitsubishi (see EA, Sept 1982) the company has filed a suit against three of its own employees, alleging that they disclosed confidential information about peripherals for the IBM Personal Computer.

It is alleged that the employees formed their own company, Bridge Technology Incorporated, to design, produce and sell products compatible with the IBM Personal Computer while they were still employees of IBM and had access to secret information.

One of the defendants, William Erdman, a former product manager for IBM, says that he resigned from the company with effect from September 2, two weeks before IBM says it fired him. He denied having any association with Bridge Technology and said he was "dumbfounded by the whole thing."

John Opel, IBM's president, says "We regret having to file this action against IBM employees, but they violated their company's trust in them".

In another development in the IBM versus Hitachi and Mitsubishi saga, charges

against the first three defendants in the case have been dropped because of the US Government's refusal to hand over documents on links between IBM and the FBI.

Twenty-one Japanese executives from Hitachi and Mitsubishi were originally charged with the attempted theft of computer secrets from IBM. The defendants were arrested after an FBI undercover operation designated "Sting".

Defence lawyers for three defendants claim that documents in the possession of the US Government would show that the FBI and IBM were in collusion, to "set up" the defendants in order to embarrass foreign competition. If true, this allegation would lead to a defence of "entrapment" — essentially, a claim that the defendants were led into the crime by government agents.

The government claims that the documents sought by the defence are irrelevant and that their release would "jeopardise on-going investigations". A successful prosecution in the case is important to the government in order to justify its argument that US technology is at risk from espionage.

### Just the thing to beat the traffic!

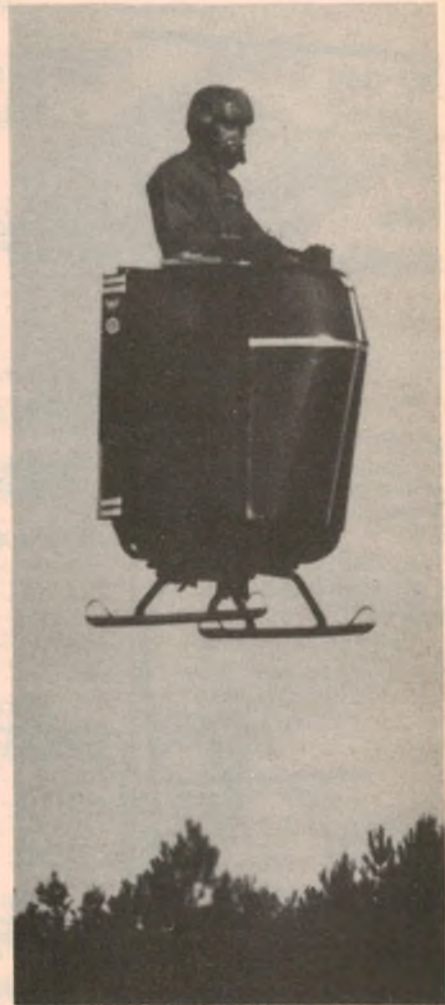

Could this be the ultimate in personal flying machines? This compact one-man flying "platform", currently being tested by the US Army, can take off vertically and fly a man for 30 minutes at speeds up to 100km/h.

Called WASP II, the machine is powered by the same 60cm-long turbofan engine used for cruise missiles. To operate it, the pilot simply stands on the platform, starts the engine, and manipulates two controls: a throttle on the right to adjust height and speed, and a lever on the left to turn left or right.

Pitch in any direction is controlled by weight shift, while an emergency parachute in the top front compartment provides back-up in the case of engine failure.

## NEW METER CUTS ELECTRICITY BILLS

*Trials of a new metering and energy management system that could help householders save money on their electricity bills are to be held in three areas of Britain by electricity boards in conjunction with British Telecom.*

*The trials will last a year, and involve a system based on an electronic terminal device known as a credit and load management unit (CALMU) which could eventually replace the familiar household meter and timeswitch. Each unit contains a microcomputer and can receive and send signals via telephone lines without affecting normal use of the telephone.*

*Part of the CALMU is a wall mounted display panel similar in appearance to a large pocket calculator, which may be installed at any conven-*

*ient position in the home. By pressing a button on the display panel, the customer is able to find out the state of his electricity account or how many kilowatts is being used at any time. The display panel could also provide similar facilities for gas, telephone and water.*

*CALMU provides customers with three separately metered supplies. The first is for lighting, cooking and power sockets; the second for appliances such as freezers and immersion heaters; and the third for loads such as storage radiators.*

*Because the cost of electricity in Britain varies throughout the day, customers using CALMU in the trials may be able to save on electricity bills by adjusting their pattern of usage to take advantage of cheaper periods.*

# 3 WEEKS TO GO!

## HOME QUALITY SOUND IN YOUR CAR!

### with this amazing DICK SMITH THREE-IN-ONE STEREO SYSTEM!

Professional quality Hi-fi stereo sound for your car! Take your favourite sound with you!

- Separate AM/FM stereo push button tuner
- Separate Auto Reverse stereo cassette
- Separate 30W/Ch stereo amplifier with 7 band graphic equalizer, LED level meters & front/rear fader.
- Five mounting brackets with quick release system for security. Great for trucks & vans etc

ALL FOR ONLY

**\$299**

Cat A-6500

**Xmas day & no batteries - Wouldn't you be popular?**

### SAVE WITH HI WATT

		1.9	10 up
Cat S-3001	D size metal jacket	40c	35c
Cat S-3002	C size metal jacket	35c	30c
Cat S-3003	AA penlight	30c	25c
Cat S-3004	AAA size	35c	30c
Cat S-3005	UM 5 (R 11)	25c	20c
Cat S-3006	216 9V Transistor	80c	50c

### NI-CADS IN POPULAR SIZES

Don't throw these away - they recharge time and time again

Cat S-3300	1.2V Ni-cad Pencil	\$2.45	\$2.20
Cat S-3306	7.2V (size 216)	\$11.00	\$10.25
Cat S-3302	'C' size cells	\$8.20	\$5.80
Cat S-3304	'D' size cells	\$8.80	\$5.95

### NI-CAD CHARGING CARTRIDGE

Charges virtually any size rechargeable battery. Includes test meter & 5 separate LED indicators to show the strength of batteries being charged.

Cat M-9519



ONLY **\$19.95** AMAZING VALUE

### SAVE A FORTUNE

Why keep replacing costly batteries? Use one of my fully approved plug-packs - it will pay for itself in no time.

### 3V - 6V - 9V DC SUPPLY

With 3 output voltages - 3, 6, & 9 volts DC at 200 milliamps. Ideal for small cassettes, radios, toys etc.

Cat M-9525

AND ONLY **\$9.95**

### 9V DC @200mA

For all equipment requiring 9V DC at a max. of 200mA. Plugs directly into 240V AC power socket.

Cat M-9514

ONLY **\$6.30**



Cat Y-1156

even doubles as a calculator!

### CASIO VL-TONE

A programmable music synthesizer with 10 different rhythm backgrounds, plus the ability to create a large range of instruments. Even doubles as a calculator!

**\$89.95**

GIFT IDEA

### AMAZING GIFT IDEA!



### MINI-POCKET FM STEREO

Unbelievable quality - you've really got to hear this amazing FM radio to believe it. Tiny design - fits into a shirt pocket - and comes complete with superb padded stereo headphones. Covers standard FM bands. Includes batteries. Make someone happy this Christmas!

Cat A-4000

HURRY - THEY'LL SELL FAST

**\$49.95**

### NEW SYSTEM 80 SOFTWARE



An enraged Gorilla holds your Lady Love captive, to save her you must master several frames containing rolling barrels, elevators, conveyor belts and dancing flames.

Cat X-3592

MUCH REQUESTED ONLY **\$24.50**

### YOUR OWN LOW COST SURVEILLANCE CCTV CAMERA

Monitor your swimming pool - Keep an eye on the kids from the comfort of your living room. Security monitoring in shops, banks, libraries, the home etc - the possibilities are unlimited. Operates with any TV set.

Cat Y-1195

**\$299**

USE WITH YOUR OLD 86W TV OR DICK SMITH MONITOR AT \$149.50 Cat X-1196

Anyone can be a musician right away with the amazing

### YOUR OWN XMAS GIFT?

### THE DICK SMITH 6.5MHz 75mm Laboratory CRO

This oscilloscope is ideal for the laboratory classroom, in field service, in bench service, in assembly centres & hobby applications.

- Solid state electronics
- Retrace blanking - cleaner display
- Low threshold triggering
- Sharper focus

Why pay \$\$\$ more and do no better? Cat Q-1280

The affordable CRO!

**\$199.00** OVER 2000 SOLD



BELOW MANUFACTURER'S COST!

### The Amazing CRAIG LANGUAGE COMPUTER

Cat Y-1340



ORIGINALLY SOLD FOR \$250 **\$89.50**

### SAVE 60% - MODULES

FRENCH (Y-1341)	\$19.50	SPANISH (Y-1348)	\$19.50
JAPANESE (Y-1342)	\$19.50	BAR & WINE GUIDE (Y-1354)	\$10.00
GERMAN (Y-1343)	\$19.50	CALORIE COUNTER (Y-1346)	\$9.50
ITALIAN (Y-1344)	\$19.50	PHONETIC (Y-1347)	\$9.50

### CASSETTE HEAD CLEANER

Not only cleans the head (special cleaning fluid supplied) but demagnetises it as well. Your ears will say thanks!

**99c**

Cat C-7080



### RECORD CLEANER KIT

Plush velvet pad with special groove cleaning fluid to keep your records sparkling clean, plus soft stylus brush to remove dust.

**\$4.50**

Cat C-7092





## SIMULATED LIGHTNING STRIKE!

The photograph at right shows the leading edge of a helicopter rotor blade at the instant it is struck by a simulated lightning bolt. Experiments such as this at Culham Laboratory in England are becoming increasingly important as composite materials are now being used more and more in aircraft to save weight. The reason: an all-metal skin gives an aircraft far more protection in the event of a lightning strike than glass-fibre or carbon-fibre composites, which are not good conductors of electricity.

An aircraft in regular use is struck, on average, once a year, normally with few after-effects other than scorching and slight pitting of the skin.

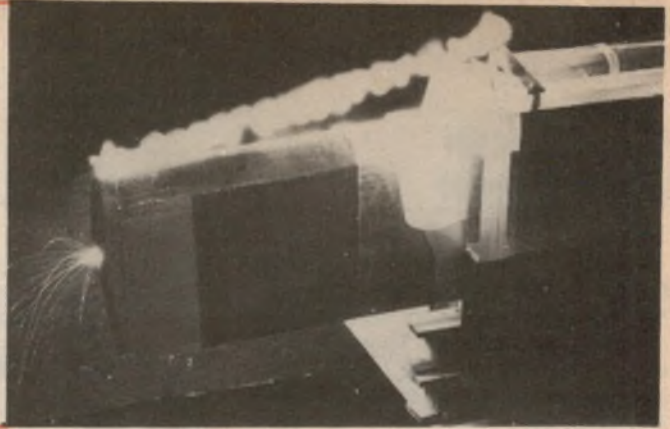

## Shuttle wins Aussat launch deal

Australia's first two domestic communications satellites will be launched aboard the US space shuttle in the second half of 1985, according to a recent Federal Government announcement.

The contract price would not exceed \$US37 million.

In winning the contract, the shuttle fought off a major challenge from its commercial competitor, the European Ariane rocket. The shuttle has already made a series of successful manned flights, and was due to carry its first commercial satellite aloft as this issue went to press.

The Ariane, a conventional disposable rocket, has failed on two of its five launches. Its first operational flight, launched last September, ended with its two satellites crashing back to earth.

In spite of this setback, Ariane will remain in the competition to launch Australia's third satellite.

## Are airships making a come-back?

Forty-five years ago, the age of the airship came to an abrupt end with the fiery crash of the Hindenburg in New York. Airships may be making a come-back though.

At the recent Farnborough Air Show, a European company, Airship Industries, demonstrated the latest model airship, the "Skyship 500". Filled with helium rather than inflammable hydrogen, the Skyship is 50 metres long and weighs 2.5 tonnes. Maximum speed is 120km/h.

The Skyship 500 is designed for coastal patrol and observation, but the company has plans for other versions that will carry both passengers and cargo. Airships offer several advantages over aircraft. As well as being able to stay aloft for longer they are cheaper to run than conventional aircraft.

## Compact disc ready for 1983 launch

European release of the Compact Disc, the domestic digital audio disc, has been postponed until March, 1983. Previous plans called for the introduction of the system late this year. Manufacturers of the disc players are blaming the disc makers for the delay, while disc manufacturers say that not enough disc players are being produced.

Compact Disc is a miniature version of the laser videodisc system. Each 12cm diameter record holds 60 minutes of digitally encoded stereo sound, and is read by a solid-state laser diode.

The companies that developed the system, Philips and Sony, are making the disc players along with other Japanese companies, including Hitachi, Mitsubishi

and Sansui. All discs for the European market, however, will be manufactured by a Polygram factory in Hanover, Germany. Polygram is a subsidiary of Philips and Siemens.

Japanese companies had planned to launch the audio disc system late this year, but are now claiming that Polygram cannot produce enough discs. Polygram deny this, claiming that their factory can produce 20,000 discs a day. It says that the Japanese companies have failed to make sufficient players to justify a release this year.

Meanwhile, Sony recently demonstrated its version of the compact disc in Sydney, and says it plans to launch the system in Australia next year (see p40).

## Computer-controlled heart pacemaker

Implantable heart pacemakers have been in use for some time, but they are steadily increasing in sophistication.

The first pacemakers were quite inflexible, typically giving the heart muscle a steady series of electric shocks to trigger it into activity at a fixed rate of around 70 beats per minute. Most patients, however, did not need such regular assistance, so with the help of microelectronics pacemakers were designed to operate "on demand".

Another refinement was to vary the pace in accordance with the patient's needs, speeding up for exercise and slowing down when the patient is relaxing. Thanks to microprocessors even

more advanced devices are now possible.

A new computerised pacemaker recently implanted in a patient at the National Heart Hospital in London actually stores information on the heart's performance and reports it to the patient's doctor.

To communicate with the implanted pacemaker the doctor holds a coil of wire against the patient's body. Linked inductively with another coil attached to the pacemaker, the external coil is connected to a computer which allows the doctor to interrogate and re-program the pacemaker without any physical connection.

## New ICs have 1mm lead spacing

Toshiba Corporation of Japan has begun production of integrated circuits in flat packages with leads on a 1mm pitch. Standard IC packages have a lead spacing of 2.54mm (0.1 inch). Flat package, 1mm pitch integrated circuits are currently used in some cameras and other limited areas, but Toshiba is the first company to market general purpose devices to these specifications.

The increasing drive to miniaturisation of components is the motive behind the move.

## Airborne laser depth sounder

Some of the charts of Australia's coastal waters date back to the days of Mathew Flinders, who explored the coastline 180 years ago. These charts are the most up-to-date information available on some coastal stretches, and are still in use.

Times are changing, though, and the latest plans call for a survey of the entire Australian coastline using a Laser Airborne Depth Sounder (LADS) aboard a Fokker F27 aircraft.

The Commonwealth Aircraft Corporation is preparing the airborne system, under contract to Thorn-EMI Electronics, Australia Pty Ltd. The aircraft is expected to be commissioned late in 1984 after a series of trials following the installation of the LADS system.

Accurate surveying requires that the LADS aircraft maintains a constant 136



The laser depth sounder will be installed aboard a Fokker F27 aircraft.

knot speed at a height of 503 metres. The airborne laser will scan a path approximately 270 metres wide, providing depth soundings at every 10 metres across and along the path.

The laser transmitter used by the system produces two simultaneous pulses at different wavelengths, one a low energy wide angle infrared beam and the other a green wavelength at twice the frequency.

The infrared beam is reflected from the surface of the water while the green beam propagates through the water and is reflected from the seabed. A mirror is used to deflect the green beam from side to side, producing a rectangular scanning pattern. Separate receivers in the aircraft detect both reflections and the depth of the water is calculated by measuring the time between the detection of the two reflections.

## Weighing up the British pound!



With this new British device, up to 150 currency notes can be counted accurately by weight, and their value shown on a liquid crystal display. When used for coin, the Tellermate (as the device is called) can deal with up to 2kg per single weighing.

Torn or incomplete notes, or those repaired with tape, are detected and a help sign illuminates instead of a faulty value being displayed. The result of each weighing operation can be added or a shift's total can be indicated. An optional printer is available. Enquiries to Perkhams Ltd, 7 Rosehart Mews, London, UK.

## US networks to broadcast teletext

Two of the major US broadcast companies – NBC and CBS – have announced that they will inaugurate full scale teletext services next year. Their decisions have given a major boost to the fledgling consumer information service industry in the US and represent the first real tests of the economic viability of such services in the US.

The announcements were, however, a major setback for British hopes to establish UK technology as an international standard for teletext – the one-way broadcast information systems – and videotext – the interactive systems which rely upon telephone lines.

Both of the American broadcasters have chosen the North American teletext technical standard for their services – a standard which is compatible with both the French and Canadian technologies but not with the older British standard used for Ceefax and Oracle.

The British standard has clearly lost out to its competitors, but what is worse, there is a growing body of opinion which suggests that TV information services have little potential in the US consumer market in their current form, and that the fight between the three existing national standards has been futile.

## Coming Next Month\*

\*CIRCUMSTANCES COULD ALTER THE FINAL CONTENT



## REVISED TRANSISTOR IGNITION SYSTEM

Next month, we represent our Transistor-Assisted Ignition System which has dwell extension for a high-energy spark. The revised circuit contains a number of modifications to improve reliability and to reduce power dissipation.

PLUS an infrared remote volume control for your TV set.

**ON SALE:  
Monday, January 3rd**

# The change to excellence in sound...

TU - 750

TU - 710

PMA - 750  
80W + 80W

PMA - 710  
40W + 40W

DR - F7

- 170

## needn't cost you a fortune.

Denon, the name associated worldwide with professional audio equipment has available in Australia their range of high quality integrated stereo amplifiers, tuners and cassette tape decks, incorporating the most advanced features at competitive prices.

High performance amplifiers, analog and digital tuners, and cassette tape decks featuring both Dolby "B" & "C", are the result of 30 years of research and technology, offering you the

ultimate combinations of performance, reliability and cosmetic styling.

See the exciting range of amplifiers, tuners and cassette decks at your Denon dealer now, you'll find their prices rather exciting as well.

# DENON

Professional Audio Brand.



**AMALGAMATED WIRELESS (AUSTRALASIA) LIMITED**  
554 Parramatta Road, Ashfield, NSW 2131 Phone 797 5757

Canberra	Melbourne	Launceston	Adelaide	Brisbane	Townsville	Perth
80 5200	560 4533	44 5155	272 2366	44 1631	79 6155	271 0888

# GLUB! GLUB!

## JUMBO SPEAKER CABLE

Now you can have super-quality cable without breaking the bank! Each conductor contains a MASSIVE 259 strands of 0.12mm wire!! It could carry 30 amps! Great for Hi Fi or high power amps.

Only \$2.50/m  
100m \$2.00/m



## THIS ONE MISSED THE BOOK PAGE - CMOS DATA '82 FROM NATIONAL SEMICONDUCTORS

Complete data on National 4000 and 74C series CMOS as well as the CMOS LSI devices produced by N.S. Size: 170w x 230h x 6d.

ONLY \$8.95

## final runout of GE Consumer Products

WE HAVE SOLD OVER 1000 OF EACH OF THESE ITEMS. ONLY A FEW ARE LEFT NOW.

WHY NOT BUY ONE FOR YOUR MUM?

## Smoke Detector Burglar Alarm



FROM \$12.50

- Contains Americium 241 Ionization Chamber
- 9V Mallory Duracell included
- Contains very loud solid state buzzer
- 12 month factory warranty.

One of the greatest consumer flops of the last decade was the Ionization Chamber Smoke Detector. Even though it is a brilliant product (reliable compact, easy installation, fail-safe etc) it just did not sell. Human nature being what it is finds safety-oriented products just not worth the investment. We all know that accidents and fires never happen to US!! As smoke is the greatest killer in a fire, the market research gurus thought that such a product would have a wide appeal. When they were \$49.50 no-one wanted them. The price fell to a very reasonable \$29.50 and still they stayed on the shelf. We have now been instructed to clear them for less than 1/2 of \$29.50.

GENERAL ELECTRIC

BURGLAR ALARM SLASHED!!!  
HUGE SCOOP PURCHASE -  
ONCE SOLD FOR OVER \$100

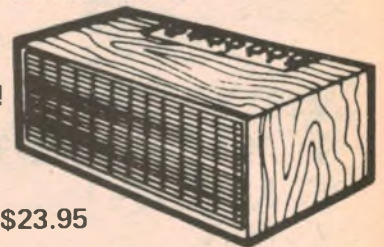

FROM \$23.95

Amazingly low price for a full feature ultrasonic proximity/burglar alarm. + Completely self contained + 12 month manufacturer guarantee + Instant or delayed alarm + Handsome imitation woodgrain + Cabinet measures 180(w)x85(h)x100(d)mm + Programmable multi-code disable switch + Single 9V Alkaline battery\* lasts one year + unit beeps when battery gets low + Contains receiver element designed for greater sensitivity without false triggering + Uses state-of-the-art LSI circuitry + Worth the money in parts alone + Comprehensive 24 page manual included + Comes complete with 4 window deterrent stickers + Absolutely no installation needed \* Battery extra.

### QUANTITY PRICES

1-\$14.50: 2-5 \$13.50ea: 6-10 \$13.00ea: 10 up \$12.50ea

1-\$29.50: 2-5 \$25ea: 6-10 \$24.50ea: 10up \$23.95ea

Buy one for Mum for Christmas. . .

### 4116 RAMs 150nS - GOING CHEAP

We have secured a quantity of 4116 (150nS) RAMs at a price which means great savings to you. Why are they cheap? Well they don't actually have 4116 branded on them. They have 9016 FPC on their little backs. They are used in a well known TV game computer and this is the 'House Number' for these 4116. If you have ever had to buy a non-standard replacement part you will know that the 'House Number' part can be VERY expensive. We don't want to sell them as 9016 FPC's, we want to sell them as 4116's - and at a great price. The normal (ie lower than most) price for our 250nS 4116 is \$2.50. You can grab a 9016 FPC (150nS) 1 off for only \$1.95!!! For larger quantities see below.

1-9 pcs \$1.95  
10-24 pcs \$1.85  
25-99 pcs \$1.75  
100+ \$1.65

This price includes sales tax!!

### THE ULTIMATE 6.5mm SOCKET??

You don't think sometimes. We saw these in an obscure part of our warehouse some time ago but did not think much about them. After idly playing with one on his bench one day our technician realised how fantastic they actually were. He'd dreamed of such a component in the past but never really thought that they were made. Basically this all metal device is a steep 6.5mm (1/4") jack. When a plug is inserted, however TWO SEPARATE single pole single throw switch contacts are opened. The switched contacts are isolated from the signal. Just imagine you can actually turn the appliance on and off simply by plugging in! No need for a separate switch! (Note that the contacts are normally closed and go open when a plug is inserted). Such a component would normally sell for about \$2.95. But, December only \$1.00!! (Limit 5 per customer)

DECEMBER ONLY  
JUST \$1.00 EACH

### JUMBO SPAGHETTI PACK

Genuine P.V.C. Spaghetti tubing. Always handy. From 1mm I.D. through to 13mm. Over 20 metres in all! Many colours.

ONLY \$3.50



### JUMBO HEATSHRINK TUBING PACK

Amazing value. A huge bag of lengths of Heatshrink sleeving. At least 5 different colours in sleeving ranging from 3mm Ø to 32mm Ø. You will probably never need to buy heatshrink again.

ONLY \$3.50

### HEAVY DUTY UMBILICAL CONNECTOR

This magnificent connector has to be seen to be believed. It consists of two halves which screw together in similar fashion to the US style Military connectors. The body of each half is machined out of SOLID BRASS and is then heavily Nickel plated. Both halves have heavy duty strain relief mechanisms. The male half has three heavy duty silver plated pins set into a quality thermosetting plastic dielectric. The pins are recessed inside the body of the connector for protection. A polarising key is brazed into the solid body. The female half contains 3 equally heavy silver plated socket pins with a polarising keyway in the dielectric. We estimate that each contact could carry at least 10 amps. The applications for such a high quality device are endless, but a few: 12V linear amps, Power supplies, Marine connectors or anywhere where you want to disconnect high current, high voltage or both. Even if you have no need for one right at this moment someday you will. Never before has such a high quality connector been offered at this price. We estimate that this connector could easily fetch \$20 if specified by the military. So you will gasp when you hear the price - \$2.95 that's right!! We dare any manufacturer to make this connector in 1000 lots for TWICE THE PRICE!! Each connector measures 92mm (l) x 28mm (d) assembled and weighs 150 grams. Limit of 2 per customer.

\$2.95



### X'TAL FILTERS

Narrow band-pass type - ideal for communications equipment. High quality multi-stage unit suitable for precision I.F. work. Incredible value. Manufacturers distress stock - YOU SAVE.

SAVE \$1.05 -  
Now ONLY \$3.95  
Worth 4 times this amount.

Oscillator crystals to suit:

10.240MHz or

10.695MHz

SAVE \$1.50

now ONLY \$1.00 Less 25% on each price for 10 or more



JAYCAR'S BUYER  
LOOKING FOR MORE  
BARGAINS.....



# we're drowning in more BOTTOM-OF-THE-HARBOR BARGAINS!!

COULD IT BE THE  
CHRISTMAS TIDE???

## S 100 Socket Sensation

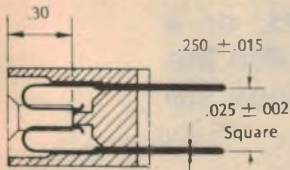

ONLY \$4.95 each  
10+ \$4.45 each

A socket of this quality is normally around \$12. Not this bottom of the harbor special!  
We dredged these from the mighty Yarrall!

We have secured a bulk-buy of HIGH QUALITY S-100 card edge connectors. Remember! the S-100 Standard is a "queer" 0.125" pitch. Each connector features gold plated bifurcated contacts with wire wrap pins in a Diallyl Phthalate moulded body. If you want to solder into a PCB this is O.K., simply cut the pins down to suit.



Quantities strictly limited.

### rotary mains switch 99¢



— A 20 year throwback. These days all we do is flick our toggles. In the past a quick twist of the knob turned things on.  
You can relive this experience with our DPST mains switch. Convenient bushing mount with 1/4" shaft. Ideal replacements. Genuine 240VAC 3 amp rated.

### micro headphones

AS REVIEWED  
SEPT EA Page 45  
FEATURES:  
MODEL MT310  
Samarium Cobalt magnets  
102dB/mW  
Weight 15 grams  
Response: 50Hz-20kHz  
Impedance: 32 ohms



Unit fits into the cusp of your ear. Can be worn under motorcycle helmets. Unbelievably clean sound.

ONLY \$19.50

### fibreglass matrix board

Not flimsy Bakelite junk. You will be able to use this board over and over again without deterioration. Measuring a massive 115x164mm and contains 2816x1.0mm dia. holes. Worth over \$8 but our special for December only \$2.95 ea. Source: Brisbane river.

\$ 2.95



### Motorola Piezo Horns



Model KSN 1005A 50 WATT P.A. ONLY \$17.00 EACH  
Model KSN 1025A 100 WATT P.A. ONLY \$26.00 EACH  
Model KSN 1038A 50 WATT HI-FI/P.A. ONLY \$17.00 EACH  
Model KSN 1039A 50 WATT HI-FI ONLY \$13.00 EACH

### Factory Seconds

YOU COME  
FIRST...

We have secured a smallish quantity of 5 pin DIN to 4 RCA audio leads that are the wrong side of the Q.C. inspection. Shame though. Because the DIN plug is ALL METAL and GOLD plated. So are the RCA plugs. Problem is that the gold plating is bubbling on the gold DIN plug. (As far as we can see the 4 gold RCA's are PERFECT.) An ordinary NICKEL PLATED lead set like this costs around \$4.75. The gold versions normally are around \$9.95 You can have one of these for \$2.95 and that's better than Nickel any day! Worth it for the 4 RCA's alone!

ONLY \$2.95 SAVE \$1.00!!!

### Electric Eels?? ★ ★

No. One metre long 7.5A appliance cords. Each (black) cord has a moulded 3 pin approved mains plug on the end. Why so cheap? Well they ARE only a metre long. But consider this:  
— Any benchtop piece of equipment only needs a short mains cord. A long mains cord gets in the way and is positively dangerous!!  
— Ideal for power supplies or any bench or rack mounted audio or test equipment.  
We have HEAPS. But we have said that before.  
Buy in bulk and save. We doubt whether you will ever see mains cords this cheap again.

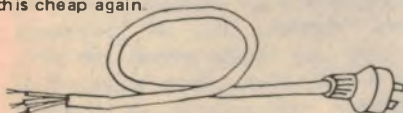

1-9pcs 69 cents each  
10-24pcs 50 cents each  
25-99pcs 45 cents each  
100 up 39 cents each

GENUINE APPROVED cords from the Parramatta River

### Jaycar NUMBER 1 FOR KITS

125 York Street, Sydney 2000  
Phone: 264 6688 Telex: 72293

"Nevilles Corner"  
Cnr. Carlingford & Pennant Hills Road,  
Carlingford  
Phone: 872 4422

Mail Orders To: Box K-39 Haymarket  
Sydney 2000

POST AND PACKING CHARGES  
\$5-\$9.99 (\$1.20) \$10-\$24.99 (\$2.40)  
\$25-\$49.99 (\$3.50) \$50-\$99.99 (\$4.60)  
\$100 up (\$6.20)

NEW SHOP HOURS  
Mon-Fri 8.30 to 5.30pm  
Sat 8.30 to 12.00pm  
Thurs night to 8.30pm

MAIL ORDER BY  
BANKCARD VIA  
YOUR  
PHONE



# Lasers get ready for war

*Are they the cure to the threat of nuclear holocaust, or a technological extravaganza that will dangerously destabilise the balance of power? After spending \$2 billion, the Pentagon still doesn't have all the answers! By Jeff Hecht.*

THE IDEA OF USING a beam of light as a weapon goes back at least to the Greek legend that Archimedes set fire to Roman ships besieging Syracuse in 212 BC by focussing sunlight onto them with mirrors. Just before the turn of the century, H. G. Wells equipped the Martians invading Earth in *The War Of The Worlds* with deadly heat rays that ignited whatever they touched.

Generations of science-fiction writers followed with even more exotic weapons. Now military researchers in the United States and the Soviet Union are spending billions of dollars trying to develop a high-energy laser that could blunt a nuclear missile attack, blind spy satellites, or destroy battlefield targets.

Scientists still debate whether Archimedes could have performed his legendary task. Similarly, the idea of laser weaponry still sounds unreal to many observers, and its feasibility is the subject of hot debate. Advocates claim that laser weapons could not merely add new capabilities on the battlefield, but also could represent a dramatic breakthrough in defence against nuclear attack. Opponents say that laser weapons will not do the desired tasks, and warn that attempts to build them could destabilise the strategic balance and possibly trigger a nuclear war.

In the United States, the unlikely occupant of the middle ground is the Department of Defence, which spent \$300 million between October 1981 and September 1982 on research aimed at finding out who is right. Cumulative expenditures of some \$2 billion on laser weapon research make it the Pentagon's single largest technology program.

The allure of laser weapons is their conceptual simplicity and potency. A high-energy laser would send destruction on its way at the speed of light. On the battlefield, that would essentially eliminate the need for tracking the target while the missile is on its way (leading) which is essential in aiming conventional weapons. It takes light a little over three millionths of a second to travel one kilometre: in this time an aircraft moving at twice the speed of sound will move only about two millimetres.

Some leading — firing slightly ahead of a moving target — would be needed in aiming a space-based laser weapon at a ballistic missile a few thousand kilometres away, but even then the beam would reach its target in only about 1/50th of a second, in which time a missile travelling at six times the speed of sound would move only 40 metres.

Laser weapons have other potential advantages, such as the ability to hit enemy targets near friendly craft. They could rapidly fire a series of shots, dwelling for a second or so on each

target to "kill" it. The beam could be redirected simply by turning a mirror. The laser is likely to be very expensive, but military planners believe that fuel for a single shot from a laser weapon would cost somewhere between several hundred and a couple of thousand dollars. That figure sounds eminently reasonable when compared to the \$20,000 to \$500,000 price tag on new tactical missiles which a battlefield laser might replace.

The most controversial role envisaged for laser weapons is in orbiting battle stations that would defend against nuclear attack. The first big public push for the idea came in late 1979, when Senator Malcolm Wallop, a conservative Republican from Wyoming, proposed spending some \$10 billion to build and launch 18 satellites equipped with high-energy laser weapons. The idea was proposed to Wallop by engineers from four major military contractors: Lockheed, TRW, Perkin Elmer, and Charles Stark Draper Laboratory. It called for each satellite to contain a 5 million-watt laser, a 4-metre mirror to direct the beam onto the target, a system to spot and track the target, and electronics to control the battle station.

At the time, Wallop said that the "first-generation (system) could protect against all Soviet heavy missiles, about 300 other intercontinental ballistic missiles, nearly all submarine-launched ballistic missiles, and all long-range bombers and cruise-missile carriers", even if the Soviet Union triggered its worldwide complement of strategic weapons within 15 minutes.

The proposal has since been modified

**Opponents say that laser weapons will not do the desired tasks, and warn that attempts to build them could trigger a nuclear war!**

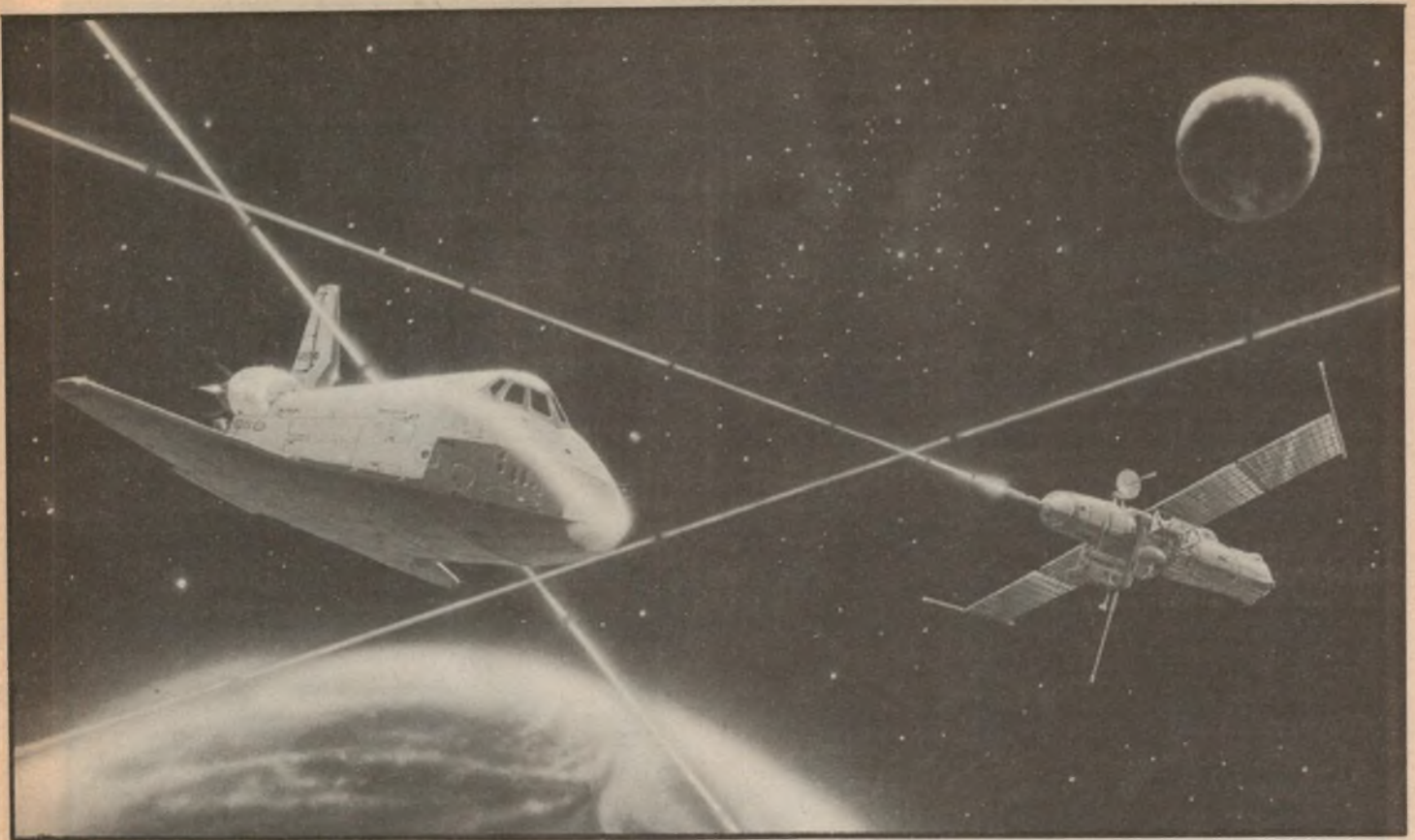

ILLUSTRATION BY PHIL COLVILLE.

somewhat. Angelo Codevilla, an aide to Senator Wallop and one of the most outspoken advocates of laser weapons in space, says that technological advances make it feasible to consider battle stations using 10-million-watt lasers and 10-metre mirrors, which would have greater range than the 5000km originally envisaged. However, the basic thrust remains the same — using space-based lasers to destroy nuclear weapons before they can reach their targets.

There is an undeniable appeal to a concept that would provide an effective defence against nuclear attack. According to Senator Wallop, "We have spent money, dollar after dollar and billions and billions, for weapons whose only consequence is to kill people. Now we have within our capability the possibility of developing weapons whose only real role in the world is to kill the things that kill people."

It is not quite that simple, however. For one thing, some nuclear-armed weapons might leak through any space-laser network that could be built in the near future. Another concern is that the development of laser weapons might disturb the uneasy nuclear balance of terror known as "mutually assured destruction" or MAD, in which both sides hold off starting a nuclear war because they both know that it would destroy both sides. Kosta Tsipis of the

Massachusetts Institute of Technology warns that any attempt to build a satellite battle station could trigger a pre-emptive strike by the other side, even if — as Tsipis believes — the laser would be an ineffectual weapon.

Other observers are more optimistic. Barry J. Smernoff, an arms-control consultant based in Briarcliff Manor in New York state, believes space laser weapons "can facilitate a gradual transition from the contemporary world of nuclear offence toward a more hopeful future in which the most vital of American interests — national physical survival as a democratic society — is protected by testable hardware instead of by reliance on the tenuous psychological "software" of nuclear deterrence".

Although ballistic missile defence is the most dramatic application of laser weapons, so far more money has been spent trying to develop more mundane tactical weapons for use on the battlefield. Ground-based lasers would rely on the same mechanisms for inflicting damage as those used for ballistic missile defence in space. The laser might try to blind optical or infrared sensors used to guide the weapon to its target. Alternatively, it could punch a hole through the metal skin of a missile or aircraft and damage sensitive guidance equipment, disable the warhead, or trigger an explosion of fuel

or the warhead. Although it takes more energy, blowing up the target is one way to be sure it's put out of commission; otherwise it is hard to be sure the target has been disabled. The idea of vaporising (distinguishing) targets is purely fictional — it is not a cost-effective use of energy.

At least in theory, lasers could be used as antipersonnel weapons, not to kill soldiers, but to blind them. The infrared output of high-energy lasers can burn the front surface of the eye. There have been unconfirmed reports that Soviet lasers were used to blind Chinese soldiers during the war between that country and Vietnam. However, it is unclear how severe the damage was and how seriously anyone is working on antipersonnel lasers.

In the US, all three armed services are working on battlefield laser weapons. The Army would like a weapon that could attack enemy helicopters, tactical missiles or aircraft; something the size of a tank would be needed to haul the laser around. In the mid-1970s, the Army shot down unmanned helicopters with its Mobile Test Unit, a carbon-dioxide laser emitting about 30 to 40kW, which had been squeezed into a tank. Planners are now working on another demonstration, called the Forward Area Laser Demonstration or FAL-D.

The Navy's main interest is in defending ships against air attack, particularly by

adaptive mirrors that direct laser beams at their targets must be accurate to within a small fraction of the laser wavelength, 3 to 4 $\mu$ m for the infrared chemical lasers that are the leading contenders for first-generation laser weapons.

Space-based laser weapons require large mirrors to hit their distant targets; the 4-metre mirrors proposed by Senator Wallop are two-thirds the diameter of the largest mirror in a ground-based optical telescope. Building such a large mirror that can maintain its accuracy and survive launch stresses yet be light enough to put into orbit is no minor challenge. Ground-based mirrors can be smaller, but they must be able to respond in about one-thousandth of a second because atmospheric turbulence occurs on that time scale.

That is not all that is needed. The system for tracking and pointing the beam must identify a target, pinpoint a vulnerable spot, and keep the beam on the weak point long enough to disable the target. That is particularly tough for space laser-weapons, which must aim at targets thousands of kilometres away. The system also needs to verify that the target has been "killed", which is not an easy task unless the laser triggers an explosion.

Another problem area is the possibility of counter-measures to foil laser attack. Conceptually, one simple counter-measure would be to polish the surfaces of potential targets so they reflect most of the laser light. But that is far from adequate, so military researchers are working on more sophisticated ideas. One possibility is a coating which, when vaporised by a laser beam, would produce a light-absorbing plasma that would shield the target from an attacking laser beam. On the battlefield, thick layers of smoke or even foul weather could impair the pointing and tracking optics as well as transmission of the laser beam. There is also a real fear that the pointing and tracking optics might be vulnerable to enemy laser attack.

By the end of September 1982, the United States will have spent some \$2 billion trying to overcome these problems. The rate of spending is increasing, jumping from \$206.2 million between October 1980 and September 1981 to \$340.8 million this year. This year's figure is higher than the Pentagon had requested because Congress added \$50 million for space-laser research, much less than the \$250 million boost that Senator Wallop had originally proposed. The Reagan government's proposed budget for October 1982 to September 1983 includes \$433.3 million for laser weapon research.

The American program now has two main experimental thrusts. One is demonstrating the "lethality" of laser

## Lasers as anti-satellite weapons

One oft-mentioned potential use of laser weapons is anti-satellite warfare. The most likely mission is blinding the sensitive electronic eyes of the spy satellites that continually watch for any sign of the launch of intercontinental ballistic missiles that would signal a nuclear attack. These satellites play a critical role in strategic defence. They are also particularly vulnerable to laser attack from the ground or space because they are designed to be sensitive to light.

In the mid-1970s, the American magazine *Aviation Week and Space Technology* reported that analysts in the US believed the Soviet Union had temporarily blinded an American spy satellite with a ground-based laser. Something clearly did happen; the satellite's infrared detectors were temporarily overloaded by a light source within the Soviet Union. At the time, much of the American defence community seemed to accept the notion that the satellite was blinded by a high-energy infrared laser. However, officials in the Pentagon now attribute the incident to a large natural gas-fire, and *Aviation Week* appears to have quietly forgotten about it.

Antisatellite laser weapons would undoubtedly be useful because of the key roles that spy and communication satellites play in modern military strategy. Satellites are also vulnerable targets, particularly the low-orbit spy satellites that record high-resolution images. However, although a country might want to blind spy satellites before launching a nuclear attack, the very act of blinding the satellites would serve as a warning. The likelihood that even temporary blinding of a single satellite might stimulate a panic reaction raises doubts that one side would choose to test an antisatellite laser on the other side's satellite.

weapons on the battlefield, using the Airborne Laser Laboratory and the new test range under construction at White Sands. Only after success in these demonstrations will the Pentagon give the go-ahead for work on specific weapon systems.

Meanwhile, the Defence Advanced Research Projects Agency is building hardware for ground-based tests of the concepts of space lasers. Key equipment to be tested includes Alpha, a 5MW chemical laser; LODE, the Large Optics Demonstration Experiment; and Talon Gold, a pointing-tracking subsystem.

It is difficult to be sure what the Soviet Union is doing. Papers on high-energy lasers and their effects are more common in Soviet scientific journals than in their American counterparts, but that may reflect differences in classification or publication policy. Recent leaks indicate that at least some Pentagon analysts believe the USSR may try to put an antisatellite laser system into orbit within the next five years.

Late last year, a Pentagon publication, *Soviet Military Power*, warned that "The Soviet high-energy laser program is three to five times the US level of effort and is tailored to the development of specific laser weapon systems . . . (Soviet) development of moderate power weapons capable of short-range ground-based applications, such as tactical air defence and antipersonnel weapons, may well be far enough along for such systems to be fielded by the mid-1980s. In the latter half of this decade it is possible that the Soviets could demonstrate

laser weapons in a wide variety of ground, ship and aerospace applications."

The reality of these threats remains open to doubt. The Pentagon's love for scary stories rivals that of any addict of late-night horror movies. What is more, most reports focus exclusively on the laser, which is probably the easiest part of a weapon system to build. Without sophisticated pointing, tracking and focussing optics, an "operational" high-energy laser would have a lot of trouble hitting a target. The ability to kill targets reliably is critical for most of the strategic defence applications envisaged.

So far all the laser battles have been waged with words. In the December 1981 issue of *Scientific American*, Tsipis asserted that "lasers have little or no chance of succeeding as practical cost-effective defensive weapons". Views of the opposite end of the spectrum most often appear in *Aviation Week and Space Technology*, whose senior military editor Clarence A. Robinson Jr has written a series of articles in which often-unnamed sources have been cited as calling space-based lasers a dramatic breakthrough in military technology. Most of the people active in the development of laser weapons have been avoiding the strident debate, and many of them express little respect for some of the most vocal people on either extreme.

Reprinted by permission from "New Scientist", Vol 94, No. 1309, Copyright © IPC Magazines, 1982.



A technological tour-de-force

# How the ABC covered the Games

**Undoubtedly the most notable TV programming during 1982 was the ABC coverage of the Commonwealth Games in Brisbane. Some 350 ABC staff were gathered together for the games broadcasts, in addition to about 750 broadcasting staff from competing countries. Editor Leo Simpson had a look at the installations during the games.**

by LEO SIMPSON

Australia was the host country for the 1982 Commonwealth Games and so the ABC was the host broadcaster. Accordingly, the ABC via its Brisbane-based Commonwealth Games Unit, provided all the radio and television facilities to all the competing countries. To do this the ABC assembled a vast array of equipment which was spread around the venues. Some of the equipment was purchased especially for the Games while a great deal was loaned from ABC stations around Australia.

For example, there were eight outside broadcast (OB) vans including two which had been built or acquired with the

Games in mind. The biggest of these was the MPC (major production control) van, a 28-tonne unit built on a 12.4m semi-trailer chassis and hauled by a Mercedes prime mover. Costing over \$1.5 million, this air-conditioned van accommodates 18 production staff. One of the four rooms inside this van is pictured on the opposite page.

In conjunction with another van, the MPC van can control up to 12 cameras. The van was mainly built for future cricket coverage but with the Games in mind. It was set up with another outside the major venue, the QEII athletics stadium. As with the OB vans at other

venues, it was linked to the Games Broadcast Centre via Telecom lines and a 2.5GHz microwave link.

All the OB vans were re-equipped with new vision mixers, effects units and QuantaFont caption consoles to give a uniform presentation. Each van typically has four one-inch video tape recorders. Two of these are used for instant slow-motion replays. One machine also provides an archive service. In addition to providing a permanent record, this allows subsequent transmission of a sports event if there happens to be a breakdown in the transmission equipment at the venue.

Each venue also had its own results computer so that results could be formatted for the TV screen and presented to air using a standard character font and style. The results computer was fed with the statistics of every individual competitor so these could be flashed on the screen at will. Also interfaced to television was the electronic timing and scoring at swimming, cycling, athletics, diving, boxing, wrestling and weightlifting events.

As well as the direct television coverage from each of the eight major venues, archery and shooting events were videotaped and edited by the ABC for subsequent broadcasting of highlights. Extensive radio coverage was provided for all events. Rather than provide all the gear, the ABC hired the equipment required for commentators and line-monitoring from the Canadian Broadcasting Corporation. The CBC originally built the gear to cover the 1978 Games in Edmonton.

Some people watching the ABC coverage of the Games were worried by

*If you wondered how the camera tracked the swimmers back and forth over the full length of the pool, this photo shows how it was done. The camera was towed along a miniature railway. Who said humans were no longer used as beasts of burden? Incidentally, the man towing the camera is known as a grip.*

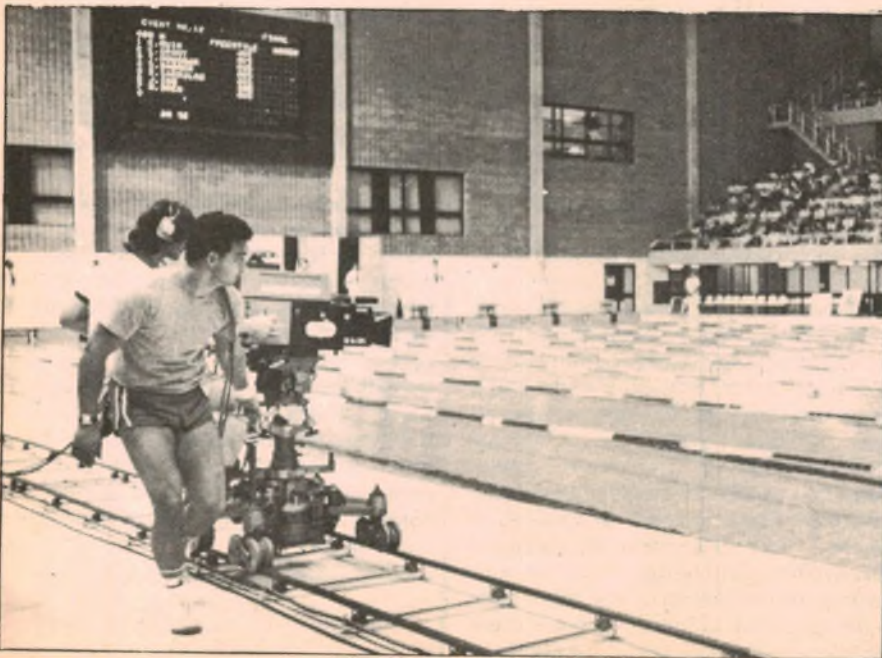

## The elements of high-energy lasers

The Pentagon defines a high-energy laser as one that emits a continuous beam or a series of pulses with average power about 20kW. The most powerful laser known to have operated is the 2.2MW MIRACL (for Mid-InfraRed Advanced Chemical Laser) system which will be used at the High Energy Laser National Test Range in New Mexico. A larger chemical laser called Alpha, under construction for the Defence Advanced Research Projects Agency, is designed to produce 5MW.

High-energy lasers have been compared to rocket engines, and it is not surprising that most of the contractors building them are aerospace companies. The first high-energy laser, the gas-dynamic carbon-dioxide laser, was developed in 1967. In it, combustion of carbon monoxide produces hot carbon dioxide, which is then expanded through nozzles to produce the right conditions for laser action. The excited carbon dioxide molecules in the rapidly flowing gas emit energy in the form of photons, which are reflected back and forth between two mirrors to produce a laser beam with a wavelength of  $10\mu\text{m}$  in the infrared region of the spectrum.

Gasdynamic lasers can produce high powers — up to 400kW in the Airborne Laser Laboratory — but they are too bulky and complex for weapon systems; one developer compared the gas-dynamic laser to a "10-tonne watch". Current work on

carbon-dioxide lasers concentrates on versions in which an intense electron beam or electrical discharge deposits energy in the gas, which is then extracted in the form of a  $10\mu\text{m}$  laser beam in much the same way as in gasdynamic lasers.

The leading contender for the first generation of laser weapons is the chemical laser. Its name, like its energy, comes from the chemical reaction of hydrogen with fluorine to produce excited hydrogen fluoride.

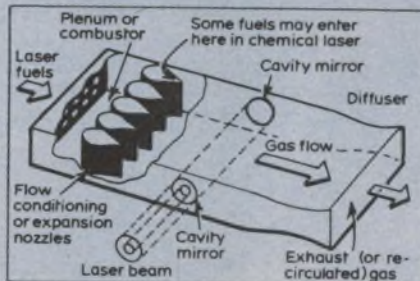

*Schematic diagram of a high-power laser. The laser gas flows rapidly from left to right, expanding through the nozzles into a low-density region. In chemical lasers, one of the reactants may be injected at the nozzles so the reaction producing excited hydrogen fluoride occurs downwind of the nozzles. The laser cavity is defined by two mirrors on opposite sides of the gas flow; the laser beam escapes from the cavity around the edge of the smaller-diameter mirror (in the foreground).*

A laser beam is produced in a way similar to the gasdynamic laser, but the chemical laser is simpler to build. Fuels for a chemical laser (generally not pure hydrogen and fluorine but compounds containing the gases that are themselves hard to handle) are light and compact, while electrical lasers require bulky power supplies.

Hydrogen fluoride emits a laser beam at wavelengths of 2.5 to  $3\mu\text{m}$ , where atmospheric absorption is strong. However, use of deuterium, the heavy isotope of hydrogen, shifts the output wavelengths to about 3.5 to  $4\mu\text{m}$ , where there is little absorption. Thus developers of laser weapons plan to use deuterium fluoride on the ground and the less costly hydrogen fluoride in space, where there is no air to absorb its light.

Future generations of laser weapons may use different types of laser. There is widespread interest in moving to shorter wavelengths, where photons carry more energy and where tight focussing would be possible with more compact optics. Several types of laser are under development, including so-called excimer lasers emitting in the ultraviolet, and free-electron lasers which promise efficient operation over a wide range of wavelengths. Another potential candidate is the newly developed X-ray laser, although doubts about some of the proposed scenarios for turning it into a weapon are widespread.

cruise missiles. Navy researchers in 1978 shot down anti-tank missiles with a 400kW chemical laser, and are now working on a demonstration that will use a 2.2MW chemical laser. Those tests will be performed on the High Energy Laser National Test Range under construction at White Sands Missile Range in New Mexico.

The Air Force would like to mount high-energy lasers in aircraft for use against hostile aircraft, air-to-air or ground-to-air missiles, and possibly against satellites. Last year the US Air Force tried but failed to shoot down air-to-air missiles with its Airborne Laser Laboratory, a 400kW carbon-dioxide laser mounted in a military version of a Boeing 707. Further tests are planned, but their status is classified.

The failure of the Airborne Laser Lab tests points out the biggest problem with laser weapons. The laser itself worked, and Air Force officials were confident enough about that to announce plans for

the tests. But when the plane was in the air, the laser missed its target, and embarrassed military officials were then faced with headlines reading "Laser Weapon Flunks A Test". In seeming contradiction to common sense, it turns out to be much easier to build big lasers than to get the beam from the laser to the target. At White Sands, the 2.2MW chemical laser for the High Energy Laser National Test Range is ready to go, but the equipment needed to get the beam to the target is far from completion.

For battlefield applications, the most serious problem is the atmosphere. Although air looks transparent, it does absorb a small fraction of the light going through it. When an intense laser beam is going through the atmosphere, the air absorbs enough energy to heat it, causing thermal expansion. As the air expands, its refractive index drops, making the air function as a "negative lens", which spreads the laser beam. This is known as "thermal blooming" and

reduces the beam's intensity at the target.

The air is also full of random turbulence that we do not normally notice, but which can become significant for a powerful laser beam. One way to get an idea of the effect is to look down a swimming pool with a pattern on its bottom, and watch how the turbulence of the water bends the light, so the pattern appears to be continually changing. Additional problems come from non-uniformities common in the output beams of high-energy lasers.

To attempt to solve these problems of beam transmission and quality, military researchers are working on "adaptive optics". Their goal is to build optical elements that can adjust the phase of the wavefront leaving the laser to compensate for atmospheric fluctuations and other problems of beam propagation. Real progress has been made in adaptive optics, but there is clearly a long way to go. Surfaces of

the intensely patriotic nature of the commentary, especially that given to the swimming events. However, while the ABC certainly provided all the TV pictures for international broadcasts, each nation provided its own commentary and interviews with the competitors.

At the swimming events for example, there were 17 commentators' desks and each of these were fitted with a colour TV monitor which showed the same pictures as those going to air. Thus, even radio commentators had the benefit of slow-motion replays to assist in their portrayal of the events.

### Broadcast centre

The major partner in broadcasting the Games was Telecom. Apart from existing control of ABC landlines and transmitters (soon to change?) Telecom provided the accommodation for the ABC Broadcast Centre in the Woolloongabba Telephone Exchange (that's right, just near the famous 'Gabba cricket ground).

Since Telecom builds its exchanges with many years' expansion in mind, the new 'Gabba exchange building had six floors vacant which was fortuitous for the ABC. It occupied four of these floors



*This is one of the four rooms inside the ABC's largest OB van. On the far wall are the various monitors. At the lower desk are the audio mixer (black) and the video mixer and effects unit. In the foreground, left, is the Quantafont caption console.*



*Above: The ABC Games Unit television packaging suite. In the immediate foreground is the audio mixer and at the far end of the bench is the vision mixing console. Also visible are eight one-inch video tape machines made by Ampex. Below: The central apparatus room where incoming and outgoing signals were switched and synchronised.*



while the top floor of the building was an ideal site for the 2.5GHz microwave dish antennas.

Now dismantled, the broadcast centre had seven television packaging suites, 10 radio suites and a central apparatus area. Of the radio suites, one was used by the ABC, one by Radio Australia, two by the BBC, two by the CBC (for broadcasts in English and French), one by the Broadcasting Commission of New Zealand (BCNZ) and one by a consortium of Australian radio broadcasters. The two remaining radio facilities were available to be booked by any other competing nation.

Each radio suite was, in effect, a complete radio station except for the transmitter and tower. Each suite had a small studio (6.5 sq metres) with a CBC commentary unit and a video program monitor. Allied to each studio was an office and a control room with a 16-channel audio mixer, four CEI Mk-V tape recorders and equalisation.

The video monitor (of which there must have been hundreds spread through the broadcast centre) was fed with a 24-channel RF link and selector which gave access to all Games events coverage, all the Brisbane TV stations and even some of the local AM and FM stations. (Just why all the personnel in the installation had to have this comprehensive access was not made clear to this writer.)

Of the seven television packaging suites, one was used by the ABC, one by the Nine network, one by the BBC, two by the CBC (again for English and French transmissions), one by the BCNZ and

# How the ABC covered the 1982 Commonwealth Games

one by the ABC Games unit itself for making video program packages for all the competing nations who have television services.

The television packaging suites were impressive installations. Each had a combined control and videotape room (with as many as six full-size videotape machines) and most had a two-camera studio. In the studios, one camera was used for the commentator while the other was used for the background in conjunction with an inbuilt chroma-key system.

All of the competing nations listed above used the satellite stations at Moree in NSW and Ceduna in South Australia, although some programs were relayed via Sydney Channel 2 for standards conversion. In addition, a large number of program tapes were despatched by airmail.

## Central apparatus room

All of the incoming signals from the OB vans were routed to the central apparatus room and then fed to a 100-input by 110-output switcher. Why all the channels? Don't forget that as well as providing all the video signals, each venue had its own effects sounds (ie, audience sounds) as well as commentary from as many as 24 commentator desks.

Since the video signals from the various OB vans were not synchronised, they were fed through "frame stores" of which there were 10. As the name suggests a frame store stores a TV frame and then "spits" it out in synchronism with a master timebase signal. This system is superior to the "genlock" master sync system which requires a two-way microwave link in the case of remote sources.

## Road coverage

A special problem for coverage was presented by the four road events of which the marathon was probably the most memorable. For close-up coverage of the runners there was a camera car which was a standard Ford Falcon utility with a camera and operator's chair mounted on the tray. The camera mount was actually a modified helicopter camera mount. This was found to be very successful and quite free of any vibration problems.

Two helicopters were also used to cover these events. One provided the necessary RF link from the camera car to the broadcast centre while the other functioned as an aerial camera, again with a direct RF link to the broadcast centre. Unfortunately on the day of the marathon, early morning fog prevented much in the way of aerial coverage.



*In the weightlifting pavilion, there were cameras monitoring the "lifts" and the backstage area. At right is a view of the gimbal-mounted camera in the back of a Ford utility. This was used to cover the marathon and road cycling events. Two ABC helicopters were used in these events, with one pictured below. Note the cameraman standing on the landing skids.*



## Equipment purchases

Amongst the large amount of equipment purchased by the ABC especially for the Games were over 60 Ampex video recorders using one-inch tape. To make sure that these gave reliable performance, 15 Ampex technicians were on hand around the clock.

Also purchased were 24 of the latest Sony ENG colour cameras and 60 broadcast quality audio tape recorders. One of the cameras is shown mounted in the back of a Ford utility, in the photo above.

As might be imagined, all that new equipment will not go to waste now that the Games are over. Every piece of equipment has been allocated to ABC TV and radio installations around Australia. Let us hope that this will help maintain the high standard of broadcast attained during the Games.

*Footnote: All photographs in this article were taken before the Games were held and were provided by courtesy of the ABC Commonwealth Games Unit and "Broadcast Engineering News".*

# “Why buy just a video game when you can get a full colour computer for the same price.”

A computer like this would have been science fiction a few years ago. Now it's a reality. It's the Commodore VIC-20, a full-fledged, expandable colour computer that costs the same as a video game.

Everybody loves video games and the VIC-20 has some of the best. But the Commodore VIC-20 can also help the kids with their homework and mum with her budgeting. Dad can even take the light, portable VIC-20 to the office for financial and business applications.

And Commodore has many more applications on the way.

## With Full Capability For:

- Education programs
- Recreational programs
- Personal computing
- Includes Microsoft, PET BASIC
- Full-size typewriter-style keyboard
- Easy to follow instruction manual
- Memory expansion to 32K RAM
- Connects to any TV set
- 66 graphic characters
- 25K total memory
- 4 sound generators
- 16 colours



## The computer for everyone.

The VIC-20 is the friendliest way we know to learn computing. It has a full computer keyboard even a small child can operate.

It plays music, has exciting graphics and lets you create pictures. It even tells you when you've made a mistake and how to correct it. The VIC-20 can take your children from pre-school through post-graduate studies.

Why get just another game that could end up in the closet? Get an honest-to-goodness home computer for just \$299. Get the Commodore VIC-20.

Learn more about Commodore, the home-computer you can depend on. Call or write for the name and location of your Commodore dealer nearest you.

**The Commodore Information Centre,  
3 Campbell St., Artarmon NSW 2061. Phone: 437 6296.**

 **commodore**  
COMPUTER

MI 11655

# ★ AVOID SALES TAX ★

**[ON THESE TOOLS]**

On Jan. 1st, 1983 all hand tools become subject to Sales Tax — beat this savage cost increase by buying these superb quality direct import electronics tools now!

## BATTERY POWERED PCB MINI DRILL BARGAIN \$10

Handy for printed circuit work. Battery powered (2 x C cells, not supplied). 6000 RPH. Drill size capacity 8 - 1.2 mm. Supplied complete with 1 mm drill and tommy bar.



T 2300 ... \$17.50

### GENERAL PURPOSE WORKSHOP SERIES

\* 115mm Long \* Drop Forged Steel \* Box Jointed Construction \* Insulated Handles

#### DIAGONAL CUTTERS

Suit medium to small work. Spring Return.



T 2010 ... \$5.95

#### LONG NOSE WITH DIAGONAL CUTTER

Fine tips 2 mm x 3 mm 125 mm length. Chrome finish.



T 2030 ... \$5.95

#### HEAVY DIAGONAL CUTTERS AND WIRE STRIPPER

Rugged cutters with 1.2mm and 1.6 mm stripping holes. Ideal for wiring construction work.



T 2035 ... \$5.75

#### SIDE CUTTING PLIERS

25 mm Jaws 150 mm Length Ideal for Technician, Electrician. Super Tough!



T 2045 ... \$5.95

### LABORATORY SERIES

Finest carbon steel. Superb precision tools. Will withstand years of use. Box-jointed construction with finely aligned edges. Insulated handles. 110 mm length. Spring return action.

#### DIAGONAL CUTTERS



T 2050 ... \$8.50

#### FLAT NOSE PLIER

Smooth jaws for delicate work.



T 2060 ... \$8.95

### MICRO TOOLS

Highly recommended for fine precision work. Finest carbon steel. Insulated handles.

#### MICRO CUTTERS 100mm (L)



T 2070 ... \$7.50

#### MICRO LONG NOSE PLIER 125mm (L)

Will handle work as fine as a human hair. Diagonal cutting edge.

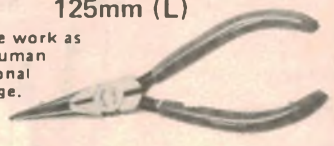

T 2075 ... \$7.25

### ★ Gold Embossed "Leather Look" Carry Case Included at No Extra Cost ★

## HOLE PUNCH SET Fantastic Value

A must for every enthusiast or serviceman. Cuts holes in metal up to 1.6 mm (16 gauge). Set of 5 punches and tapered reamer.

Punch sizes:  
16mm  
18mm  
20mm  
25mm  
30mm



T 2360 ... \$15.00

### SHEETMETAL NIBBING TOOL

Cuts any shape cut out in steel, aluminium or plastic. Very easy to use. Capacity steel .6 mm. Aluminium 1.6 mm.



T 2355 \$14.50

## NEW SHIPMENT JUST ARRIVED

1st SHIPMENT SOLD OUT IN DAYS

## \* PANBRAKE SHEET METAL BENDER

Our Panbrake Sheet Metal Bender proved to be so incredibly popular that the 1st shipment went in no time. Now at last they're back in stock. Make your own chassis and save a fortune!

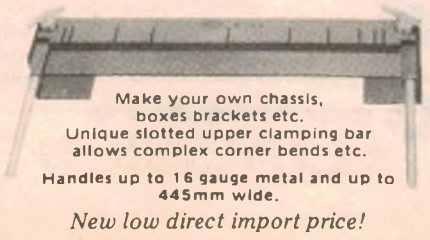

Make your own chassis, boxes brackets etc. Unique slotted upper clamping bar allows complex corner bends etc.

Handles up to 16 gauge metal and up to 445mm wide.

New low direct import price!

T 2400 ... \$69.50

### NEEDLE FILE SET

Use for contacts, points, general electronic work. Very handy! Set of 5 files, round, square, half round, triangular and flat.



T 2350 ... \$7.95

## ★ WIRE WRAP TOOL

Ideal hobbyist tool or for use with prototypes etc. Strips, wraps and unwraps.

T 2384 ... \$4.50



STRIP WRAP UNWRAP

ALTRONICS ... ALTRONICS ... ALTRONICS ... ALTRONICS ... ALTRONICS ... ALTRONICS ... ALTRONICS ... ALTRONICS ... ALTRONICS ... ALTRONICS ...

ALTRONICS ... ALTRONICS ... ALTRONICS ... ALTRONICS ... ALTRONICS ... ALTRONICS ... ALTRONICS ... ALTRONICS ... ALTRONICS ... ALTRONICS ...



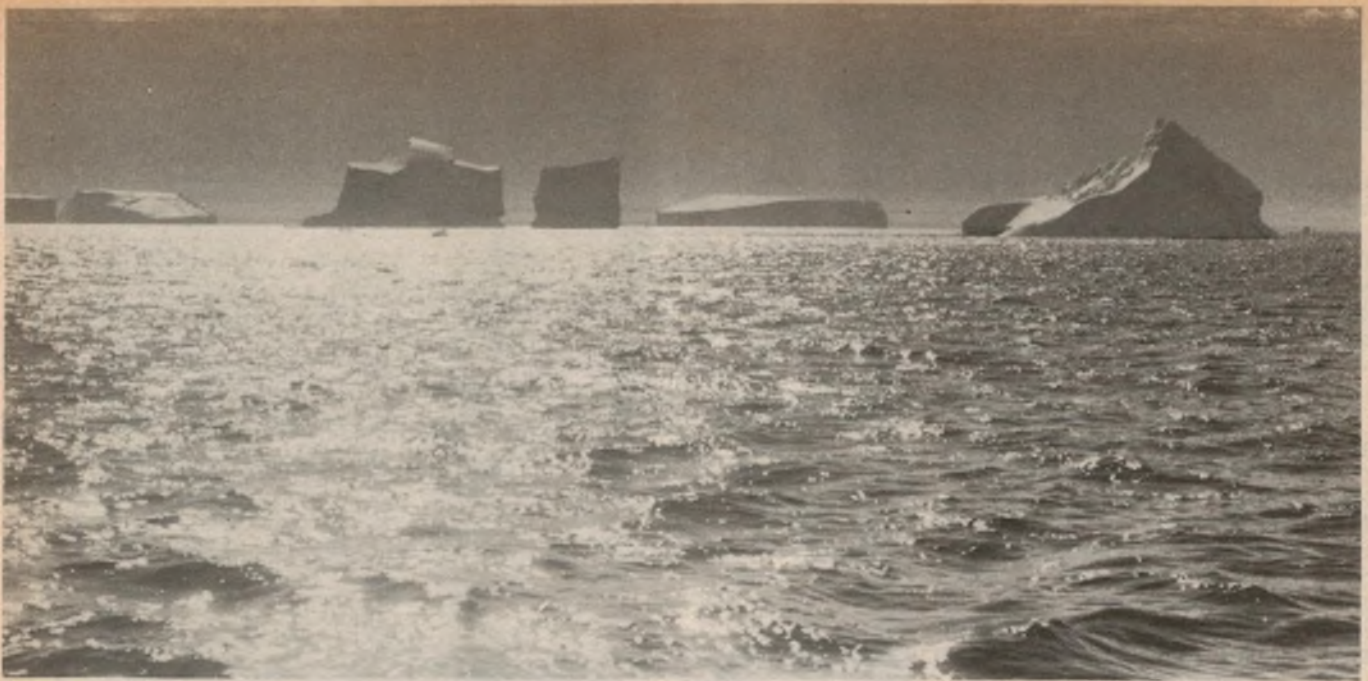

*Close to Antarctica icebergs became a common sight. Temperature in the wheel-house hovered around 0°C.*

amateur link, with Barry White, VK2AAB, and Mike Barry VK2IH, as back-up. Early contact with this group revealed an audio problem with the FT-ONE on transmit so we arranged some help from amateurs in the Hobart area.

On arrival in Hobart, Brian Proudlock, VK7BP, and Sojo Jonges (later VK0SJ) were particularly helpful in carrying out tests and tidying up our hasty installation. An RF choke was wound up on a toroid former and installed in the DC feed-line from the engine room, connecting cables were re-routed and shortened, and the line checked for voltage drop. The connector to the bumpkin vertical was re-sealed. Sojo tested the FT-ONE on air in his shack and received good reports, one in particular from Frank Pain, VK2DYP. While we were not able to duplicate these results when the unit was re-installed in the wheelhouse of "The Dick Smith Explorer", the audio quality was much improved.

### **South from Hobart**

The next leg of the trip was to Boat Harbour in Commonwealth Bay, almost directly south of Tasmania, on the Antarctic continent, and about 1700 nautical miles away. Our departure from Hobart was full of interest. On the day we had excellent contacts with New Zealand and Sydney stations, from both the boat and from Ted Beard, VK7EB, mobile at the wharf.

Karen spoke to friends in New Zealand and Ted gave an on-the-air commentary as we moved out. Within 24 hours we had made contact with Pierce on 14.105MHz, also Mike and Barry, Tony Ward, ZL1AZV, Dave Robinson, ZL2BJI, Brian Cooper, ZL2AZM, Herman, VK0HW, at Casey Base, and Alan Nutley, VK0AN at Macquarie Island.

We also established contact on the ship-to-shore bands with Casey and Mac-

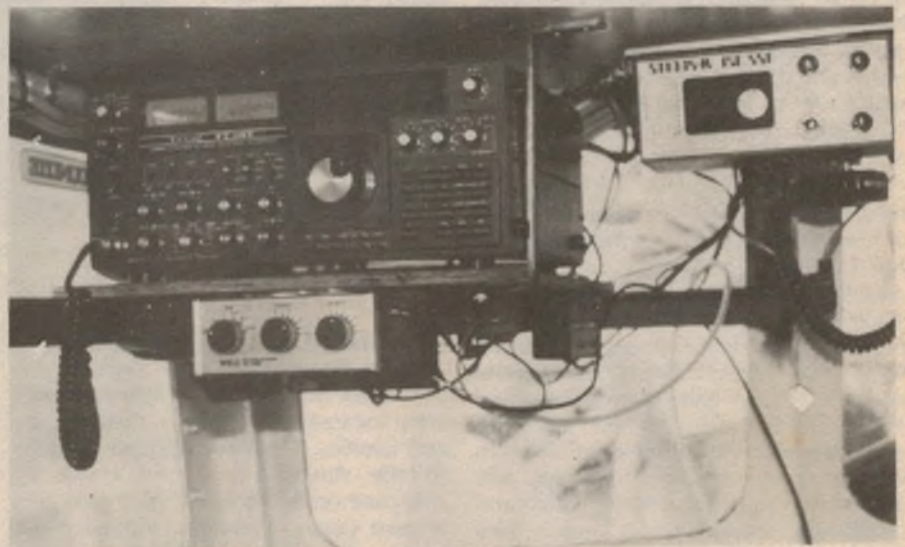

*The Yaesu FT-ONE gave sterling service under difficult conditions.*



*Don Richards on the net. Amateur bands were used for most communication.*



# Expedition to the Antarctic

quarie Island, made phone calls to Sydney via Sydney Radio, passed meteorological observations to Hobart Radio and commenced our practice of reporting latitude and longitude, course and speed, sea and wind conditions to the Antarctic bases and the amateur net – a busy time for one operator!

As we progressed south through the “roaring forties” and the “furious fifties” we came into heavy weather more and more frequently and quite often made good speed sailing under storm jib alone. At other times we hove-to until the gale passed. Radio conditions during that time were good and only two schedules were missed – one on December 29, due to ionospheric conditions and another on January 8, when we ran out of battery power.

Christmas Day was fine and clear and the cooks prepared an excellent meal of ham, chicken and the trimmings. Attendance, however, was poor; the sea was rough and the few days in Hobart meant that some of the crew had to develop “sea-legs”, or “sea-stomach”, all over again.

However, a few days later the seas died down and people started turning up at meal times again. Also, the birds arrived! Or, more accurately, we arrived amongst the birds! Albatrosses, tiny shearwaters, mollymawks, prions in hundreds – circling the boat in ones and twos or swooping in flocks between the ocean swells. Penguins were also sighted and our bird-people, Jeni and Paul, were on constant call from those on watch to identify species. As it turned out, Jeni and Paul, with help from the watch and bird-books, were able to keep a bird observation log for almost 24 hours each day while we were at sea.

At about 55°S our magnetic compass became useless due to proximity to the south magnetic pole. The Satnav set worked well but was dependent upon a satellite being “visible”. Apparently, over the years, the navigation satellites, originally evenly spaced, have tended to bunch together (for company?) thus gaps can occur in their coverage. So our navigator, David Lewis, was left with the sun (which was seldom visible), the swell and the wind to guide us for long periods.

During this long and, at times, trying passage we were busy each evening from 8.00pm on 14.105MHz with an interchange of messages between families, news of the day's doings, reporting the surrounding conditions, and seeking assistance with the various problems that arose with the bits and pieces of equipment on board.

Pierce had been able to set up a net of “regulars”, including New Zealand sta-



*The Dick Smith Explorer at moorings in Boat Harbour, Commonwealth Bay. The expedition spent almost three weeks in the bay, exploring the surrounding area.*

tions, that were on frequency each night. At least three of the New Zealand stations were friends of crew members and were located fairly close to their homes and families. The same applied to most of the Australians in the crew, so everyone on board was able to pass and receive family messages. Indeed most spoke directly with parents, wives, brothers and sisters and so on, at some time or other. When conditions were variable we were often able to contact New Zealand at good strength and a New Zealand station would relay messages to the net controller in Sydney and vice-versa.

“The Dick Smith Explorer” was now sailing through ice floes and icebergs. The wheel-house temperature had dropped to 0°C and I had installed heaters, in the form of small low-voltage globes, around the FT-ONE. The commercial equipment had been fitted with temperature probes and heaters before installation.

The decks were slippery with ice, and ice hung from the rigging and spars. We had all now changed to Antarctic clothing, wearing thermal underwear and socks, heavy insulated boots, several gloves or mittens and balaclavas. Often we had to thaw out the water pipes (using Barbara's hair-dryer!) before we could make a morning cup of tea.

A satellite navigation fix on January 9 told us we were close to the Antarctic mainland and we made landfall at Cape Hunter, one of the headlands of Commonwealth Bay, during the afternoon of the following day. I had a quick schedule with the net that evening as we made preparations to enter Boat Harbour. By 10.00pm, in full daylight, the boat was in Boat Harbour and moored to the shore, fore and aft, after a hectic hour or so in 30-40 knot winds, blowing (fortunately) directly off the continent.

Boat Harbour is about 100 metres wide and 400 metres long with about six metres of water under the keel at high tide. It shelves to a rocky edge on either side and at the head; we bounced on the rocks on the eastern side when mooring in the strong winds.

On January 11 I reported to Pierce that we were safely moored in Boat Harbour in Commonwealth Bay. Our navigator had brought us to this tiny indentation in a tiny bay on the coastline of a continent twice the size of Australia, and a new phase of the expedition had begun.

Next month, the story continues with scientific expeditions and a visit to Mawson's hut, still standing after 70 years. (Photographs in these articles were taken by the author.)

# Expedition by sail to the Antarctic

in commemoration of Sir Douglas Mawson

A group of 12 people aboard the steel schooner "The Dick Smith Explorer" left Circular Quay on December 12, 1981, to carry out scientific studies in the Commonwealth Bay area of Antarctica. Communication to the outside world was by amateur radio. This is the expedition story, as told by the mate and radio operator.

by **DON RICHARDS**  
**VK2BXM/VK0DL**

On a Sunday morning during November, 1981, a message came over the WIA (Wireless Institute of Australia) broadcast to the effect that an expedition to the Antarctic continent required an amateur radio operator with sailing experience. I had been planning to crew on a "maxi" yacht in the Sydney to Rio race, but this sounded more interesting, so I arranged to meet the expedition leader, Dr David Lewis.

The expedition was to commemorate the birth of the Australian explorer, Sir Douglas Mawson, and to carry out studies of marine and bird life, ice and weather phenomena, in the Commonwealth Bay area of the Antarctic Continent. Dr Lewis planned to moor the schooner "The Dick Smith Explorer" in

Boat Harbour in Commonwealth Bay, within metres of Mawson's hut, and put ashore parties of scientists and observers.

Communication was to be by commercial ship-to-shore radio and amateur radio, which had proved so successful during a previous voyage to the ice in the yacht "Solo". David Lewis also wanted someone to help him sail the boat as very few of the group had previous experience. The Expedition was organised by the Oceanic Research Foundation and funded by sponsors and public donations.

It all seemed very fine to me so I offered my services and was accepted. The party, with Dr Lewis and myself, consisted of: Dot Smith and Margaret Huner-

bein, crew members; Barbara Muhvich, journalist; Malcolm Hamilton, cameraman; Harry Keys, geologist; Karen Williams, observer; Dick Hefferman, Paul Ensor and Jeni Bassett, animal biologists; and Garry Satherley, diesel mechanic. Twelve in all — seven Australians and five New Zealanders.

The equipment I had to look after consisted of: Two Stingray ship-to-shore transceivers from Findlay Communications, a Tracor satellite navigator from AWA, a Furuno radar from Greenwich Marine, a Yaesu FT-ONE transceiver from Dick Smith, a Kenwood TS820S also from Dick Smith, antenna tuners from Emona and Kenwood, a Tono Theta 7000 E RTTY keyboard, demodulator, and display from Vicom and four Midland 27MHz walkie-talkies. I also took my Atlas 210X, Sony 2001 general coverage receiver and tools, test equipment and spares.

For antennas, we erected a 12MHz helical on top of the main mast, a 4-10MHz helical at the rail near the wheelhouse and a tuned 14MHz helical on the bumpkin (the bit that sticks out the back). The main medium frequency commercial antenna was a wire running from the top of the main mast to the spreaders on the mizzen mast and just clear of the main sail. All vertical antennas were tunable by changing plugs and the wire antenna was automatically tuned with each frequency change.

The vessel left Circular Quay for Hobart on December 12, the idea being to use this part of the trip to settle into sailing watch routine and to test equipment. We soon found that "The Dick Smith Explorer" was an excellent sea-boat — stable, easy to control, and with an easy motion. Under-canvassed for coastal sailing, she performed well in the winds below 40° latitude.

Pierce Healy, VK2APQ, had agreed to act as coordinator for the Sydney



*The Dick Smith Explorer sets out on the first leg of the four month voyage.*

# The change to excellence in sound...



## needn't cost you a fortune.

Denon, the name associated worldwide with professional audio equipment has available in Australia their range of advanced magnetic tapes. The result of 30 years of research and technology offers the listener true excellence in sound.

Six dynamic tapes – the LX, DX1, DX3, DX5, DX7 and DXM provide a range to suit any requirement in high grade recording and reproduction.

See the exciting range of tapes at your Denon dealer now, you'll find their prices rather exciting as well.

# DENON

*Professional Audio Brand.*



**AMALGAMATED WIRELESS (AUSTRALASIA) LIMITED**

554 Parramatta Road, Ashfield, NSW 2131 Phone 797 5757

Canberra 80 5200	Melbourne 560 4533	Launceston 44 5155	Adelaide 272 2366	Brisbane 44 1631	Townsville 79 6155	Perth 271 0888
---------------------	-----------------------	-----------------------	----------------------	---------------------	-----------------------	-------------------



# FORUM

Conducted by Neville Williams

## Warranties are fine — provided they're effective!

One of the pleasures of buying a new piece of equipment is that of receiving, along with the receipt, a guarantee or warranty from the manufacturer or their agent covering normal use of the item over the next 12 months or more. But that pleasure can turn to pain if the warranty is not honoured for any reason.

How important a warranty can be was illustrated recently when a relative mentioned to me that he was considering the purchase of a new colour TV receiver. His old set was getting "a bit long in the tooth" and, being a hybrid valve/transistor console design, was costing him \$75 per year for full insurance cover.

He had worked out that he could buy a new receiver for around \$700, and it would come with a three-year warranty. That would save him at least \$225 in service fees — plus the chance of picking up a few dollars for the old set or letting it run, without insurance, for as long as it might last.

Because the TV receiver industry is fairly stable, these days, there was no special reason to question the basis for such calculation but it does depend very heavily on the manufacturer or their representative honouring the warranty effectively over a full three-year period.

### "NEW" TAPE RECORDER

Unfortunately, there do appear to be exceptions and what appears to be one of them was brought to my notice by a NSW reader. At this late stage, we can't expect to help him in any way but the mere recounting of the circumstances may cause others to be a little more careful about what they buy, from whom, and in what circumstances.

In discussing the matter, I do not propose to identify the reader, the supplier or the manufacturer:

(a) So as not to prejudice any current negotiation or proceedings, and  
(b) to avoid impugning the supplier or manufacturer on the basis of a single complaint. There may be another side to the story; in fact, it would be quite unusual if there weren't!

Somewhat abbreviated, the letter reads as follows:

*Rather more than nine months ago, I purchased a . . . tape deck from a hifi dealer.*

*Within two weeks, it had to be returned to the manufacturer because one channel had failed completely. It was only as I was re-packing the deck that I realised that the earth pin had been sawn off. Why I did not notice this before I don't know; maybe the excitement of the purchase!*

*All told, the deck has been returned for service eight times in the nine months and it has still not been repaired satisfactorily.*

*Apart from the sawn-off earth pin, there was trouble with the patch cords, supplied but not under warranty.*

*One channel failed completely; then an intermittent condition affected the right channel, and an intermittent on the same channel turned up on the Type II tape setting.*

*The level meters did not read the same on a mono signal input and they were a long way out on the metal setting.*

*Fine bias adjustment appeared to have the opposite effect on the left and right channels.*

*All told, out of the nine months I have owned the recorder, it has been in my possession for a total of only about six weeks!*

*The questions I would like you to raise are these:*

*1. Does the consumer have any way of finding out if what he has just bought is actually new? The sawn-off earth pin would indicate that it was not so in my case. The deck was not bought at a sale, or as a demonstrator.*

*2. Should the consumer be obliged to pay freight charges if the manufacturer fails to effect proper repairs?*

*3. Is my deck still "new", even assuming it was so in the first place? It has now*

*been freighted eight times, fiddled with, and test run for long periods by both the supplier's and manufacturer's technicians over a period of nine months!*

*4. Consumer Affairs tells me that while the manufacturer is trying to repair the deck, there is nothing the Department can do.*

*5. Does a company have an obligation, in such a case, to replace the faulty unit with a new one or, in the event of the model no longer being current, to offer a reasonable substitute?*

*Yours sincerely . . .*

### A RAW DEAL?

On the face of it, the correspondent does seem to have had a pretty raw deal and I don't blame him for speculating as to whether or not the deck was genuinely new, as delivered. How one can be sure about this poses a real problem.

Probably the most reassuring evidence is if the goods are accepted over the counter, or delivered to the home in the original carton, sealed and with the original staples in place. It adds up to a strong indication that the contents are indeed "factory fresh".

If the goods are delivered by someone who is also going to install them — as commonly happens with VCRs — it is a good idea to look at the carton immediately it is brought into the home and verify that it is being opened for the first time. If it isn't, you are within your rights to be as difficult as you choose!

But these guidelines are not completely infallible. The Australian distributors do sometimes open the cartons to insert local literature, additional cables or accessories, or even perform their own quality check. In such a case, the cartons may show evidence of having been opened and re-sealed — although normally in a quite professional way. One thing is certain: distributors would never consign equipment with the carton hanging open!

So beware if the carton is open and especially if the cables and the manual have a "handled" look. You could be buying a demonstration model or, worse, one that has been repossessed.

It's a matter of reading the signs and making a judgment about the supplier. If in doubt, demand a new and unopened unit, or check with the brand distributor, or go somewhere else!

In preparing this article, I discussed the whole problem with the marketing manager of a large local distributor. He was adamant that his company — and other reputable distributors, for that matter — do not re-issue, as new, items of equipment that have been used for evaluation, demonstrations, etc. They are normally sold to members of staff, he said, or to friends or trade contacts as "seconds".

He would regard it as an automatic obligation for any of his company's dealers to indicate to customers that a particular unit had been used for showroom demonstration. He professed to be "horrified" by the apparent implications of the case currently under discussion.

As to the correspondent's second question, most guarantees that I can recall do place upon the purchaser the responsibility of returning a unit for service to a nominated service centre. I can't say that I'm happy about the requirement but it seems to be common practice.

But eight sets of freight charges in nine months! Who can blame the correspondent for querying the justice of it?

Is the deck still "new" after all that tripping around, being dismantled several times and run for long periods trying to pinpoint an intermittent condition?

One would hardly think so but that appears to be one of the unfortunate penalties of inadvertently buying a "lemon", whether it be a tape deck or a motor car!

It would appear that the Department of Consumer Affairs had no option but to accept the situation. As long as the manufacturer was making an attempt to correct the faults, there was (reportedly) nothing they could do about it!

As to the last question, our experience has been that most large companies will

exchange a faulty product or refund the purchase price (on return of the goods) rather than get involved in a damaging and time-consuming hassle with a customer.

I am surprised that it did not happen in this case but there could be a very "human" explanation.

In lodging a complaint, it is fairly normal for a customer to contact the sales person from whom they bought the goods, or lodge a service call, or ring the manufacturer and talk to "someone" there. For minor problems, this low-key approach may be adequate and automatic but not for an obscure or intermittent fault.

### THAT BLOKE AGAIN!

By the time the unhappy customer has lodged several futile complaints, the recipients have grown tired of the sound of his voice and only too ready to fob him off.

No less to the point, people at this routine level seldom have the authority (or the confidence) to initiate special measures to solve a special problem — even if they recognise it as such!

A lot of executives around Australia are going to hate me for saying this but it is the advice I gave to our correspondent:

If you have been landed with a clearly faulty product, or are the victim of bad service on that product, compose a letter setting out the problem courteously, clearly and concisely and address it to the Marketing Manager, the General Manager, or the Managing Director of the brand distributor in Australia. These are the people who are concerned about their brand image and who can get things done.

But one thing I should add; only do that if your complaint is genuine and reasonable. Top executives may go to considerable lengths to preserve the good name of their company. They can also become very impatient if they think they're being got at by a humbug!"

## A lament from across the Tasman:

To change the subject completely, we might spare a thought for our New Zealand readers who have inherited a problem we once thought was indigenous to Australia.

I refer to FM (frequency modulation) broadcasting — or the lack of it.

About every 12 months, we seem to get a letter from somebody across the Tasman, lamenting their rather limited radio and television services, and in particular, the continued absence of FM/stereo.

In a way, the letters remind us of the "In Memorium" notices which appear in

the daily papers.

The most recent lament came to us via Ben Furby who, in 1967, was a co-founder of the Newlands Broadcasting Society, formed with the express purpose of working for FM and community broadcasting in New Zealand. Ben Furby is now living in Sydney, within the sound of seven or more FM stations, but he has forwarded a recent article written by V. M. Stackpoole, still in Wellington, New Zealand, and still fighting for the cause. Here it is:

From the first stirrings of interest in FM stereo broadcasting in NZ to the first public broadcast on an experimental

# AMS

MAIL  
ORDER  
CENTRE

## TAPES CHEAP!

**BULK TAPES DISCOUNTED**

**TDK**

SA-X C90	SUPER AVILYN	
	DUAL COATING	10 for \$49
SA C90	SUPER AVILYN	10 for \$39
AD C90	ACOUSTIC DYNAMIC	10 for \$30
D C90	DYNAMIC	10 for \$24

**maxell**

UDXL IIS C90	EPITAXIAL	12 for \$58
UDXL II C90	EPITAXIAL	12 for \$49
UDC 90	ULTRA DYNAMIC	12 for \$38
LN C90	LOW NOISE	12 for \$28

**BASF**

CRO <sub>2</sub> C90	CHROMDIOXIDE	10 for \$48
FE C90	FERROCHROME	10 for \$38
LH C90	LOW NOISE	10 for \$25

**VIDEO — OPEN REEL — METAL**

MAXELL, TDK, BASF, AKAI

SEND FOR COMPLETE TAPE PRICE  
LISTS — FREE

## HI-FI SYSTEMS

AMPLIFIERS, TUNERS, TAPE DECKS,  
TURNABLES, SPEAKERS,  
HEADPHONES, RECEIVERS

OUR RANGE INCLUDES:

**Sansui** **PIONEER**  
**marantz** **AKAI**  
**SOUND DYNAMICS KSW**

## CAR SOUND

RECEIVERS, TAPE PLAYERS,  
BOOSTERS, EQUALISERS, SPEAKERS  
— INCLUDING

**PIONEER** **Voxson**  
**ACCESSORIES**

CARTRIDGES, STYLII, CLEANERS,  
DEMAGNETISERS, DISCWASHER

**gei**

PARABOLIC STYLUS —  
COMPLETE RANGE

**ortofon**

MOVING COIL  
AND MAGNETIC  
CARTRIDGES

**RING OR WRITE FOR  
FREE PRICE LISTS!**

**TAPE ORDERS:**

**ADD: PACK AND POST \$3.00  
PER ORDER AND SEND  
CHEQUE/MONEY ORDER TO:**

# AMS

MAIL ORDER CENTRE,  
135 HAWTHORN ROAD,  
CAULFIELD, VIC 3162  
(03) 528 1149

STOCK AT PRICES SHOWN AVAILABLE  
AT TIME OF GOING TO PRESS



basis by a Wellington community group in 1969 took only a couple of years but, from then until the present, the increasing public pressure has been met by growing government resistance, in the form of inquiries, excuses, delays, commissions and tribunals.

In the last two elections, FM has appeared in the manifestos of both major political parties (albeit in small print). Indeed New Zealand's conservative government, made to look foolish by the antics of a number of unlicensed FM stations (one named "Radio Templeton" after the then rather controversial Minister) was forced to allow the Broadcasting Tribunal to hold hearings and eventually to permit the establishment, in theory at least, of approved FM stations.

The timing of the inquiry and the report, just before the 1981 election may have been coincidental!

Limited approval has been given for the establishment of two high powered stations in Auckland, and to the issue of a peculiarly Kiwi compromise, the "short term warranty". This permits a station to transmit on a strictly limited schedule for up to a month, using low power, at this stage 20 watts EIRP (effective isotropically radiated power).

The first major shock to the potential FM listener must have been the specification for the transmissions. They are to be "commercial". That is likely to mean they will carry the conventional "Top Forty" format, which means that the hifi enthusiast (more likely to be into classics, jazz or rock) is going to miss out since as a group they don't represent a very big market for advertisers.

Shock number two was the tribunal decision that the ZM stations (government owned but carrying the pop format) would have to close, since their continued existence would render the commercial viability of the FM stations doubtful in what the Tribunal obviously sees as a strictly limited market.

This decision has merely confirmed the views of some astute observers that service to the listener must take second place to the profits of broadcasters. Indeed, the decision seems at first sight to be about the worst possible choice, even if only in the fact that we are to lose one AM channel, and merely transfer its activities to VHF.

Clearly the tribunal never thought of increasing the listener's options by following the suggestion of the Broadcasting Corporation that FM should start initially with a national network carrying a multi-purpose format.

In retrospect, however, the decision is not surprising. Firstly, the tribunal is made up largely of lawyers and businessmen, the sole professional

member being the ex-head of the NZ commercial network.

Secondly, the submissions to the tribunal came very largely from powerful commercial interests in Auckland; said submissions, by and large, seem to have carried the day.

Thirdly, the presentation by the New Zealand Broadcasting Corporation, which one might have expected to have been enthusiastic and forward looking, turned out to be a rather arid description of the enormous technical problems that could arise due to interference generated by intermodulation between high power FM and TV stations.

Fourthly, Radio New Zealand, the BCNZ's sound broadcasting arm, presented a singularly unenthusiastic submission, seeming to argue that FM coverage of the cities would have to wait for rural coverage to be complete.

Lastly, conspicuous by their absence were recorded music societies, audio groups, universities and technical institutes, and community organisations who might have been expected to benefit from non-commercial services.

## PRESENT POSITION

At this date (June, 1982) FM broadcasting so far has been limited to a number of short term broadcasts by university student groups, and exhibition broadcasts by private commercial stations and Radio New Zealand.

Most interesting of these were those transmitted from the capital's Industrial Fair during the May school holidays. Two stations were on. Radio New Zealand despite its enormous technical resources and library of stereo productions stretching back more than a decade, but never heard by the under-privileged Kiwi listener, presented a strictly teenage rock format.

Radio Windy, a Wellington private commercial station with only limited facilities, produced a wide ranging program including live broadcasts of both popular and classical music. Surprisingly sponsors were found for these programs amongst large professional companies who had never bothered to advertise on the AM station.

Governments are traditionally numbered amongst the slow learners. In the last 30 years New Zealand has dropped from third to about 20th in the standard of living stakes and governments still cannot believe that it has to be their policies; but they must be kicking themselves over the FM struggle. The immediate result of the Tribunal decision has been the almost total cessation of any public concern or interest in FM, and the pirates have vanished like the dew after sunrise!

## Beeforth On Oscilloscopes



If you have anything to do with electronics then I bet you can't think of many jobs where an oscilloscope isn't useful. I guess it all comes about from the old adage 'a picture is worth a thousand words'. Now, in less than a thousand words, I'll put you in the picture regarding TRIO's CS-1560All oscilloscope.

The 1560All is a dual trace, 15MHz, honest-to-goodness value for dollar instrument. It is well suited to industrial applications, TV servicing, production line testing, educational or hobby work. It is rugged, reliable, easy to use and very portable. Vertical sensitivity is good without sacrificing large signal input capability. Sweep rates are from a high 0.5µS to 0.5S per division and a high persistence P7 Phosphor is now available as an option to make full use of the slowest ranges.

Triggering can be normal or via a video sync separator and has to be the best in any low-cost oscilloscope ever made. How often have you used a big name, high performance oscilloscope for routine work and been driven mad by the constant fiddling needed to maintain a stable triggered display particularly when the input is variable. With one wave of a CS-1560All the problem vanishes. Up to its rated 3db point of 15MHz it will produce a locked display with only 0.2 of a division deflection amplitude. At 20MHz it requires only 0.3 of a division to lock and at 25MHz, 0.7 of a division. That is real triggering!

Along with the rest of TRIO's range, this instrument is slanted toward useability, the kind of convenience and practicability that makes you reach past the "Gee wizz" technoscope to grab the little TRIO with the sharp, stable, bright blue trace that shows the whole picture quicker than I can tell it.

The best way to see why I'm so keen on the CS-1560All is to check it out for yourself at any Parameters location or stockist right throughout Australia.

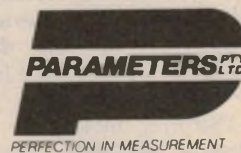

Trade Enquiries Sydney (02) 439 3288  
Melbourne (03) 580 7444

Adelaide	PROTRONICS TRIO ELECTRIX K. D. FISHER & CO	(08) 212 3111 (08) 51 6718 (08) 277 3288
Brisbane	ST LUCIA ELECTRONICS	(07) 52 3547
Canberra	GEORGE BROWN & CO ORTEX	(062) 80 4355 (062) 82 4995
Hobart	IMBROS GEORGE HARVEY ELECTRIC	(002) 34 9899 (002) 34 2233
Launceston	GEORGE HARVEY ELECTRIC	(003) 31 6533
Melbourne	RADIO PARTS GROUP GEORGE BROWN & CO ELLISTRONICS	(03) 329 7888 (03) 419 3355 (03) 602 3282
Newcastle	D G E SYSTEMS GEORGE BROWN (NEWCASTLE)	(049) 69 1625 (049) 69 6399
Perth	W J MONCREIFF CO PROTRONICS	(09) 325 5277 (09) 362 1044
Rockhampton	PURELY ELECTRONICS	(079) 2 1058
Sydney	GEORGE BROWN & CO DAVID REID ELECTRONICS	(02) 519 5855 (02) 29 6601
Townsville	RADIO DESPATCH SERVICE	(021) 211 0191
Wollongong	NORTEK MACLEEC	(077) 79 8600 (042) 29 1455



# Hifi Review

## Audiosound Linz 8066 studio monitors

Audiosound Laboratories has long been a recognised supplier of monitoring equipment to the Australian Broadcasting Commission. The Linz 8066 represents the latest studio monitor to be developed by Audiosound for the ABC and a contingent of these were supplied for the 1982 Commonwealth Games coverage.

To the average high fidelity enthusiast studio monitor loudspeakers often represent something of an enigma. On the one hand they are usually large, powerful and expensive while on the other, they are often quite different in sound quality from typical highly regarded "domestic" high fidelity loudspeakers; seemingly overbright in the middle registers and often harsh in the upper registers.

We suspect that this is partly due to the preferences of recording and broadcast engineers but when you consider these obvious differences it is a wonder that records and broadcasts sound as good they usually do. As for the size of these monitors, one often wonders how they could be used to best advantage in the cramped confines of many studios, particularly radio studios.

Having cast aspersions on the philosophy of using monitor speakers in studios and by association, the practice of selling "monitor" loudspeakers for domestic use, let us now consider the Audiosound Linz 8066 loudspeaker system. According to Audiosound, this is described as a high performance medium size floor-standing, three-way system designed for "accurate balancing in small to medium size studios", whatever that may mean.

Regardless of the above description, most people will regard the Linz 8066 as a large and bulky speaker. Dimensions are 333mm wide x 420mm deep x 855mm high, including the small plinth and the projecting grille cloth cover. Mass is about 30kg so they are also relatively heavy. The cabinets are very well finished in walnut veneer on top and sides while the baffle and rear panel are finished in matt black enamel.

The grille cloth frame is removable to reveal the three drivers and the adjustable attenuators. The Linz 8066 is a tuned reflex system and so it has a large port measuring 86mm in inside diameter and about 180mm in length.

Audiosound claim that not only was

this speaker system designed to the principles espoused by Neville Theile and Richard Small but it was actually produced in collaboration with these two eminent engineers!

The woofer is of Australian origin, with a cast aluminium chassis, large ceramic magnet and a foam rubber roll surround.



The ribbed paper cone has a very large dust cap hiding a not-so-large magnet pole-piece which is about 40mm in diameter. The effective cone diameter is about 200mm.

Both the tweeter and midrange units appear to be imported, with the midrange probably made by Foster of Japan. The midrange is a nominal 10cm cone driver with a roll surround and mounted in a sub-enclosure to isolate it from the woofer. The tweeter is a 25mm dome type. The mounting position of the dome is a little unusual in that it is

placed below the midrange, following the practice of some loudspeaker systems made in England.

Both the tweeter and midrange driver have associated attenuators but, in keeping with the concept that this is a high fidelity system, they have a range which is limited to  $\pm 3\text{dB}$ . We agree with this concept. After all, if a loudspeaker is claimed to be capable of high fidelity reproduction, there should be no need to vary its response over a large range.

In keeping with Audiosound practice over quite a few years, the Linz 8066 loudspeakers have a very complex crossover network using air-cored inductors and metallised polyester capacitors for minimum distortion and high power handling. Crossover frequencies are stated to be 400Hz and 3kHz.

The impedance curve of the system is as expected of a system of this type. There are two peaks at the bass resonances of 16Hz and 56Hz and the minimum is 6.3 ohms which will not present any problems to driving amplifiers. Power handling is 100 watts RMS maximum on program signals and system efficiency is about average.

Listening tests confirmed that this is a very fine loudspeaker. In fact, in a direct comparison with the original and the latest Quad electrostatics, the Linz 8066 was preferred by this reviewer. In comparison with other fine three-way systems the Linz also performed well although the tweeter does not appear to have as wide dispersion as those made by Philips or Peerless. However, the tweeter certainly does sound very smooth.

Midrange and bass also appear to be very smooth, being well maintained down to around 35Hz. There is some tendency for the bass to be on the boomy side compared to typical sealed enclosures though, and this may be improved by raising the enclosures off the floor. Overall though, the Linz 8066 speakers are impressive.

High quality does not come cheaply though as the price for a pair of these speakers is \$1220. This includes a set of throwover covers which protect the fine finish when the systems are not in use. For further information contact Audiosound Laboratories, 148 Pitt Road, North Curl Curl, NSW 2099. Phone (02) 938 2068. (L.D.S.)



**IN 1953 I BUILT MY FIRST KIT...  
I WOULD STILL RATHER BUILD A KIT  
THAN BUY READY-MADE - BECAUSE  
I KNOW I'M SAVING  
MONEY!**

### **Why build from a kit?**

For the best reason: you'll save a fortune! You supply the labour, instead of paying for a production line (and the Managing Director's Ferrari). You can save 50% and more by building it yourself.

### **Exclusive 'Sorry Dick It Doesn't Work' Guarantee.**

On our major kits, we even include a repair service: if for some reason your kit fails to work, we will diagnose the faults and repair them for a lower than normal fixed service fee. This includes any parts you may have damaged during assembly. So you cannot fail with a Dick Smith Kit!



### **Dick Smith's money-back offer.**

We're confident you'll be delighted with our kits. But if you're not (for any reason at all — even the fact that you might think construction is beyond you) you can return any kit to us in original condition and packaging (that is, before construction has commenced) and we'll refund your purchase price in full. What could be fairer than that?

### **Can I do it?**

Let's answer that one by asking you a question: can you read and follow simple instructions? If the answer is yes, then you can build our kits: most come with our exclusive step-by-step instructions. You can't go wrong!

# **BUILD A DICK SMITH KIT**

**AS  
EASY  
AS  
ABC!**



Everything you need is supplied — parts, solder, even nuts and bolts. AND most kits include detailed instruction manuals, making construction a breeze!



It goes together so easily; you don't have to be an expert to build a kit, just follow the instructions.



And it's finished! Sit back and enjoy your project, because you did it yourself!

LOOKS SO GOOD-YOUR FRIENDS WON'T BELIEVE YOU BUILT 'EM!

# The EA CAR COMPUTER — YOU CAN SAVE A FORTUNE!!!

Cat. K-3400

**\$93<sup>50</sup>**



YES! The kit you've been waiting for is now a reality. Electronics Australia's new Car Computer is the ideal way to find out how your car is performing — and how much it is costing you to run it!

Now you'll be able to check fuel consumption — instantly — and find out exactly how much damage a lead foot does to your pocket.

All those questions you ask yourself as you're driving along can be answered — electronically — in a fraction of a second... How much fuel is left? — Can I make it to the next town? — What's my exact speed (much more accurate than the speedo!)?

DOES NOT OPERATE ON DIESEL ENGINES

**EXCLUSIVE!** Our unique construction manual. We had a technical writer prepare a special step-by-step construction manual for most of our kits — so you won't have any problems. Everything is clearly and logically presented, with all construction information from the magazine — plus any other traps for young players we discover along the way. We discover any problems before they affect you!



**EXCLUSIVE!** Our unique 'Sorry Dick It Doesn't Work' repair service. In the unlikely event that you can't get your kit working successfully, our Service Department will, for a fixed fee, repair and adjust your kit\* as necessary to get it working properly. This fee includes all parts necessary. \*Sorry Dick. It Doesn't Work service available on specifically nominated kits and we reserve the right to return your kit, with your service fee, should it be so badly wired or damaged as to make repair uneconomic.

## MORAY FUEL FLOW SENSOR

Don't be fooled — the ONLY fuel flow sensor to give optimum results with the car computer is the fully imported Moray unit. Dick Smith Electronics are the sole authorised Australian agents for this magnificent device.  
Cat. K-6100

**EXCLUSIVE! \$69<sup>50</sup>**

## DRIVELINE SPEED SENSOR

Knowing how incredibly difficult it can be to cut successfully a speedometer cable without risk of damage, we've decided to use the alternative (and, we think, much better) driveline sensor. A lot easier to install, it is not subject to the problems of speed cables.  
Cat. K-6102

**\$8<sup>25</sup>**

## SPECIAL OFFER

Buy both sensors and get the speed sensor for \$3.00! YES! the exclusive Moray Fuel Flow Sensor plus the Driveline Sensor at the bargain price of just \$72.50! This makes the complete Dick Smith Car Computer only \$166.

**\$166**

## 7 DAY TRIAL OFFER

If you're not completely happy, you can return the CAR COMPUTER within 7 days in original condition and packing for a full refund! You owe nothing — not even an explanation! So why not try the CAR COMPUTER today!

## REMOTE DISPLAY OPTION

SEE EA OCT '82

**\$21<sup>50</sup>**

Introducing the exclusive Dick Smith Electronics car computer remote display option. It simply connects in parallel to the existing displays in the main computer and also with five of the push buttons. And all it measures is a tiny 110 x 70 x 50mm — complete with its own mounting bracket! Cat. K-3405



## Electronics Australia/ Dick Smith SUPER 80 COMPUTER KIT

**NEW LOW PRICE!**

**OVER  
2300 SOLD!**



## Build one for Christmas!

You are supplied with a full board including power-on EPROM monitor, 16K of RAM, cassette interface (relay activated) for universal control of any tape recorder, TV modulator and direct video output PLUS full size professional keyboard — not a 'feel less' toy! Cat. K-3600

### CHECK THE SUPER 80 AGAINST ALL OTHERS

Super 80 Other

- ★ Is it S-100 expandable?
- ★ Does it expand to 48K on board?
- ★ Does it have RF output for TV connection?
- ★ Was it featured in Electronics Australia — Australia's leading electronics magazine
- ★ Is it available ex-stock?
- ★ Has it sold over 2300 and been proven against teething troubles?

**SAVE \$50!!!**

was **\$295!** **\$245**

Yes this makes the full 16K computer with 9K BASIC on tape, transformer, construction manual and IC socket set only **\$304.75!**

**SHORT FORM KIT:** Designed for computer applications where 'BASIC' programming is not required. Kit supplied with EPROM monitor and 16K RAM.  
Cat. K-3600 ..... **WAS \$295.00** ..... **\$245.00**

Transformer to suit Cat. M-2325 ..... **\$24.50**

IC Socket Set Cat. K-3603 ..... **\$13.25**

BASIC program (interpreter) (cassette) Cat. K-3602 ... **WAS \$24.50** ... **\$12.50**

### OTHER OPTIONS:

Case to suit Cat. H-3200 ..... **\$41.25**

BASIC program in EPROM (3 IC's) Cat. K-3604 ..... **WAS \$89.50** ..... **\$50.75**

S-100 Expansion Cat. K-3606 ..... **\$21.00**

Character Generator (upp./lower case) Cat. K-3607 ... **WAS \$69.00** ... **\$50.50**

Detailed construction manual Cat. B-3600 ..... **WAS \$12.50** ..... **\$9.50**

BASIC manual Cat. B-3602 ..... **WAS \$14.50** ..... **\$9.50**

RAM expansion to 48K (2 sets 16K RAM IC's) Cat. X-1186 x 2 ..... **\$59.90**

Serial Interface Cat. K-3610 ..... **\$69.50**

**OUR MOST POPULAR  
KIT EVER!!!  
PLAYMASTER  
MOSFET AMP**



Cat K-3515.  
See EA Jan/81

This 'Top of the line' Amplifier with a huge 50W per channel has just about everything you'll need in an amplifier! It's equivalent to units costing two and three times as much with features like:

- Full speaker switching between two sets of speakers (either, both or neither).
- LED indication of input selection
- Full tape monitoring facilities
- Loudness and mute controls
- State-of-the-art circuitry featuring power mosfets in the power amplifiers
- Low distortion - typically less than 0.05% at normal listening levels

Comes complete with our exclusive step-by-step instruction manual. High performance — up to the minute design — looks fantastic — and easy to build! What more could you ask for? The price?

COMPLETE WITH PROFESSIONALLY DESIGNED FRONT PANEL

★  
UPGRADE YOUR HI-FI NOW FOR ONLY

**GREAT VALUE AT ONLY \$175**

**DON'T LET THEM STEAL YOUR CAR!**



This alarm is very easy to install, as it simply connects to a point which is normally 'live' at all times e.g. clock or starter solenoid. Facility is also provided for the alarm to be triggered if an external triggering point is earthed, such as bonnet opening. This alarm includes an LED which flashes once per second when the alarm is set. Cat. K-3253

**\$22<sup>50</sup>**

SEE EA JUNE '81

**Transistor Assisted Ignition** Cat. K-3300

This kit incorporates circuitry with dwell extension which results in a hotter spark at high engine speeds and is compatible with modern electronic tachometers. Comes complete with a custom made aluminium box and all components are supplied. SEE EA NOV '79

**NEW METALWORK! \$29**

**BUILD YOUR OWN NEGATIVE ION GENERATOR \$38<sup>50</sup>**

You've heard all about Negative Ion Generators and their benefits, now buy the kit and find out what it's all about. Our kit runs on 12V DC, you can put one in your car! Includes exclusive Dick Smith emitter head, power pack and tough moulded plastic case. Cat. K-3335 SEE ETI APRIL '81

**THE BRILLIANT ELECTROCHUNE**



The Electrochune is a keyless monophonic organ and uses the circuitry of a synthesizer to give variable attack/decay times, tremolo and square/sine wave output mixing. It even has a built-in amplifier and speaker with separate volume control. Complete with plugpack and full instructions. SEE EA JUNE '81 Cat. K-3506

**Was \$75.00 \$45<sup>00</sup>**

**YOUR OWN DISCO LIGHTING! DISCO STROBE**

Now's your chance to put one of these great Disco Strobes together yourself! This kit is quite simple to build, but it does use high voltages, so experience is most definitely required. The flash rate of the unit is variable from 1 flash/sec to 20 flashes/sec. Comes complete with metalwork, reflector and perspex cover. SEE ETI SEPT. '75

**\$35<sup>50</sup>**



Cat. K-3152

**PLAYMASTER AM/FM TUNER WITH CLOCK \$139<sup>00</sup>**

**Why buy one without FM?**

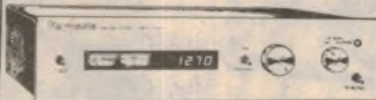

Professional quality pre-built tuner module means all the hard part of this kit is done for you. Dick solved the problem of FM alignment by importing a pre-built and pre-aligned tuner module ready to be built into a project. EA came up with a design incorporating digital frequency readout that doubles as a clock. Easy to build, comes with instruction manual. Superb tuner sound at this low price will be hard to find anywhere else! Cat. K-3494 SEE EA NOV '78

**MUSICOLOR & LIGHT CHASER**

Cat. K-3143

Built-in microphone allows any sound to trigger Musicolor. Comes with sturdy chassis and exclusive Dick Smith front panel with LED display. Detailed step-by-step instructions are supplied.

**\$91<sup>50</sup>**

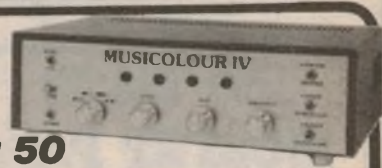

SEE EA AUGUST '81

**NEW \* NEW COMPUVOICE** Cat. K-3530 SEE EA OCT '82

Now you can have the advantages of a full phoneme — type speech synthesizer for a fraction of the normal cost! With features like: unlimited vocabulary, variable pitch control (vary the speech from baritone to a soprano), easy to program AND it works with any computer fitted with a Cantronics type parallel printer port such as the System 80, Super 80 and TRS 80.

Case to suit Cat. H-2505 \$13.50  
Transformer to suit Cat. M-2851 \$2.90

**\$97<sup>50</sup>**

**SUPER SIREN**

Cat. K-3505  
SEE EA NOV '82

**\$19<sup>95</sup>**



This siren has got an ear-splitting sound, yet it is compact and draws very little current. It uses a piezo-electric tweeter, which can be soldered directly to the PC board. Has many uses: as an equipment malfunction alarm, intruder alarm, car alarm (separately powered and not dependant on the car battery).

**STEREO SYNTHESIZER**

Cat. K-3420

SEE EA SEPT '82

If you've compared mono and stereo sound, you'll be aware of the advantages of stereo reproduction. Now you can enjoy the benefits of stereo sound from your video cassette recorder, TV or AM tuner with this Stereo Synthesizer. Easy to build, you can choose between normal and synthesized stereo sound and between two different monophonic sound sources.

**only \$52<sup>50</sup>**

**LCD PANEL METER**



An incredibly versatile and highly accurate panel meter with a highly visible LCD display with HUGE 15mm digits. Uses the famous 'Intersil' chip (as used in a huge number of professional test circuits), and its low cost makes it an extremely attractive and viable replacement for conventional analog equipment. The display is removable from the rest of the PCB for remote or angled placement. Full Scale: 200mV; Resolution: 100uV; Power Supply 5-15V DC. Cat. K-3450

**\$29<sup>50</sup>**

**MORE SUPERB, EASY TO BUILD DICK SMITH KITS**

**EASY TO BUILD - EXCEPTIONAL VALUE!**

**SYSTEM 80 OWNERS!**

**JOYSTICK INTERFACE**

Ever wish you could hook up a joystick to your System 80, so you could play games faster and with greater realism? Well, your wish has been answered. This little adapter won't strain your piggy bank and can be assembled very easily. It plugs in, and away you go! Cat. K-3455  
NOTE: Compatible with most US games software designed to work with the Alpha joystick.

only **\$37<sup>50</sup>**



**JOYSTICK**

This is the joystick to go with the above adapter. Standard Atari-type joystick, with sensors for four primary directions of motion and separate "fire" button. Complete with cable and DB-09 connector. Also suit VIC-20 computer! Cat. X-2020

only **\$19<sup>90</sup>**

**150 WATT MOSFET PA/GUITAR AMP**

Guitar and public address amplifier utilizing ETI's 499 Mosfet 150 watt power amplifier module, as published in ETI March 1982. Comes complete with pre-amp PCB and special Hitachi mosfets 2SJ49 and 2SK134. Also includes on board power supply, just add transformer (PF4361/1 Cat. M-0153). Case not supplied, short form kit only. Cat. K-3525

SEE ETI JUNE 82

**\$119<sup>00</sup>**

**STOP PRESS FROM EA**

**NEW KIT FOR DECEMBER DRIVEWAY SENTRY**

Turns home lights on for predetermined time — activated by headlights! Cat. K-3305

SEE EA DECEMBER 82

**\$29<sup>50</sup>**

**BUY NOW FOR CHRISTMAS!**

**WOW!**

**LEDS & LADDERS**

This has to be one of our most popular novelty kits. Can you climb out of the well without getting dumped back in? Easy to construct, comes complete with full instructions. A kit for all the family! Cat. K-3390

SEE EA JULY '80

**\$16<sup>80</sup>**



**ELECTRONIC CRICKET**



His name is Cudlipp and he imitates insects perfectly! He's bound to be a conversation piece — once he's been unearthed! Easily constructed, he speaks when others do and flashes his eyes impressively. But just try to find him! When all is quiet, he doesn't make a sound. SEE EA FEB 82 Cat. K-3397

**\$12<sup>50</sup>**

**24 TUNES! LATEST MICRO TECHNOLOGY AUTOCHIME**

Fantastic electronic doorbell that uses micro-processor technology! This unit plays one of 24 DIFFERENT tunes each time you press the front door button. It then automatically moves to the next tune in sequence. More, if you install a back-door button, it will play a particular tune only — to tell you which door to attend! Cat. K-3502

**\$31**

SEE EA SEPT 79



**SOUNDBENDER \$24<sup>50</sup>**



With this great kit you can sound like a Dalek, Darth Vader, a Cylon or any one of a dozen robotic spin-offs! A versatile unit, it may also be used for special effects on electric guitars and other musical equipment. SEE ETI FEB 82 Cat. K-3509

**PERCUSSION SYNTHESIZER**

Now we've got rhythm with this percussion synthesizer. Produces the sounds of drums, cymbals, snares and bongos. You can play manually or by total electronic control. By the simple connection of a sequencer, you can have automatic rhythm, just right for learning the basics of timing in music.

Cat. K-3517



SEE ETI MARCH 82

**\$47<sup>50</sup>**

**PERCUSSION SEQUENCER**

How's this for a great kit! Single PCB kit enables percussion synthesizer (Cat. K-3517 above) to be controlled externally by this rhythm generator, and it does it automatically! You could start your own band! Also useful for taping and dubbing. Cat. K-3518

SEE ETI JUNE 82

**\$12<sup>80</sup>**

**DICK'S ORIGINAL 1952 CRYSTAL SET**

Want a radio that works during blackouts and doesn't need batteries? Then this is just for you! Dick's own crystal set kit. A satisfying project that will give you lots of fun. It can pull in a surprising number of broadcast stations and produce good sound even when connected to a stereo system.

SEE EA APRIL 82

Cat. K-2650

only **\$7<sup>95</sup>**



**EARPHONES**

Crystal — high impedance ear-piece with 3.5mm plug. Budget priced! Cat. C-2765

**\$1.75 each**

**CHOOSE OPTIONAL HEARING DEVICE**

Magnetic — high impedance. Ideal for your crystal set. As used by spies everywhere! Cat. C-4000

**\$7.95 each**

**MASSIVE MUSIC POWER**

This fantastic amplifier kit gives you tremendous scope for boosting the output of your existing sound system — use one module to produce 300 WATTS RMS into 4 ohms or 2 units to give a truly massive 600 WATTS RMS continuous power. This is the ideal unit for public address, rock groups, etc. — or wherever high power is required. Kit comes complete with all components and instructions. (Not including transformer and heatsink)

SEE ETI FEB 80

Cat. K-3444

**\$72<sup>00</sup>**

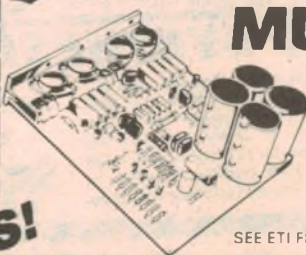

**CAPACITOR DISCHARGE IGNITION**



This has got to be the best value CDI available. Your car will be easier to start — when cold or hot, your plugs will last longer, keeping your car in tune and using less petrol. This CDI will pay for itself in no time at all! SEE EA JULY 75. Cat. K-3280

**\$29<sup>50</sup>**

**DICK SMITH Electronics**



See page 98 for address details



# Audio-video Electronics

HIFI • HOME VIDEO • PROFESSIONAL AUDIO

## Recording tape is getting better all the time

Superficially, the recording tape you buy today doesn't look much different from the product you might have bought 20 years ago. But looks are deceiving. Performance figures are being edged up all the time by small but cumulative advances in tape technology.

by RALPH HODGES\*

If they ever stop to think about it all, tape buffs probably do not sufficiently appreciate the fact that the rapid progress in tape-machine performance over the past couple of decades has been matched, innovation for innovation, by advances in tape manufacturing and formulation.

New developments in audio tape have particularly benefited of late from useful discoveries made in the fields of video and computer tape, with the result that we are once again looking at a "new generation" of high-performance audio tapes that will begin to reach the market within the next few months.

The first of this new wave of tapes to appear will lay emphasis on recording objectives that have not previously been paramount in tape designs. The second wave should bring some new magnetic materials, some older ones in new forms, and the advent of multi-application tapes.

At least one manufacturer plans to introduce a cassette that will handle analog and digital (PCM) audio with equal aplomb. Another expects to produce a tape that will accommodate analog, digital — and video to boot! The common sense of this is quite plain when you realize that all video tapes will likely have two tracks of audio, and sooner or later these will be very high-quality tracks indeed.

Wrenching secrets from tape manufacturers is only a little less difficult than, say, discovering the full nuclear potential of the Soviet Union. The industry is notoriously competitive, and if some advance information should accidentally happen to leak out the door on Friday, it could mean mass executions by Monday.

Still, by reading between the lines of

press releases and paying as much attention to what manufacturers won't talk about as to what they will, it's possible to get some idea of what the future holds.

A tape can be divided into three parts: backing (or base), binder, and magnetic material. (There is also an optional fourth part, a back-coating, that some manufacturers favour, some



*After having proved unsatisfactory in the early days of tape research, pure metal coated tapes have set new standards in audio response and output level. But they pose a challenge to win equivalent results from oxide and "doped" formulations.*



*A VHS-C format video cassette, loaded with HG tape. Who could have believed, 20 years ago, that a small cassette like this would accommodate a half-hour or more of colour, sound video?*

don't, and some change their minds about from time to time.) All three parts are critical, and all three are candidates for improvement.

The backing, a clear base film of ten-silised polyester, would probably be the least problematic of the three if so many manufactureres didn't have to get it from outside suppliers. Surface irregularities in the backing material cause coating-thickness variations in the finished tape, and such thickness variations are a principal mechanism in the production of modulation noise, no matter how well controlled the total thickness of the backing-plus-coating may be.

One manufacturer reports that he was unable to convince his supplier of this problem until he embarked on the production of a very tricky video formulation and the final tape didn't work.

### Higher standards

Clearly, backings will have to advance to a higher standard of uniformity for the proposed new tapes, but it's unlikely that you will hear much about the heroic efforts that will be required to accomplish this.

On the other hand, there are excellent reasons why a backing should not be perfectly smooth and uniform. A texturized backing give the capstan and pinch-roller a better grip on the tape and combats what is generally referred to as "slippage." According to one company's view, a good backing is not so smooth as to be slippery and not so rough as to prevent a good recording.

Back-coatings, which are sometimes applied to the nonmagnetic side of the tape in the final production stages, can provide texturising without interfering with the properties of the backing itself, and at the same time they create a scratch-resistant surface to prevent polyester debris from fouling the recording system.

Binders are simply glues, mixed with solvents and other additives. Ideally

\*Reprinted from "Stereo Review" magazine, New York, by arrangement.



The RPG  
1982/1983  
Comprehensive  
Catalogue



**IS NOW AVAILABLE**

THE WIDEST RANGE OF ELECTRONIC PRODUCTS STOCKED  
IN AUSTRALIA NOW DESCRIBED IN DETAIL IN ONE DELUXE  
328 PAGE PUBLICATION.

**OVER  
11,000  
PRODUCTS**

THIS CATALOGUE IS  
**THE BEST**  
WE HAVE EVER PRODUCED  
PACKED WITH  
ILLUSTRATIONS &  
TECHNICAL DETAILS  
IT IS SET OUT IN AN EASY  
TO FOLLOW SEQUENCE  
A COMPREHENSIVE INDEX  
MAKES FINDING PRODUCTS  
QUICK & EASY

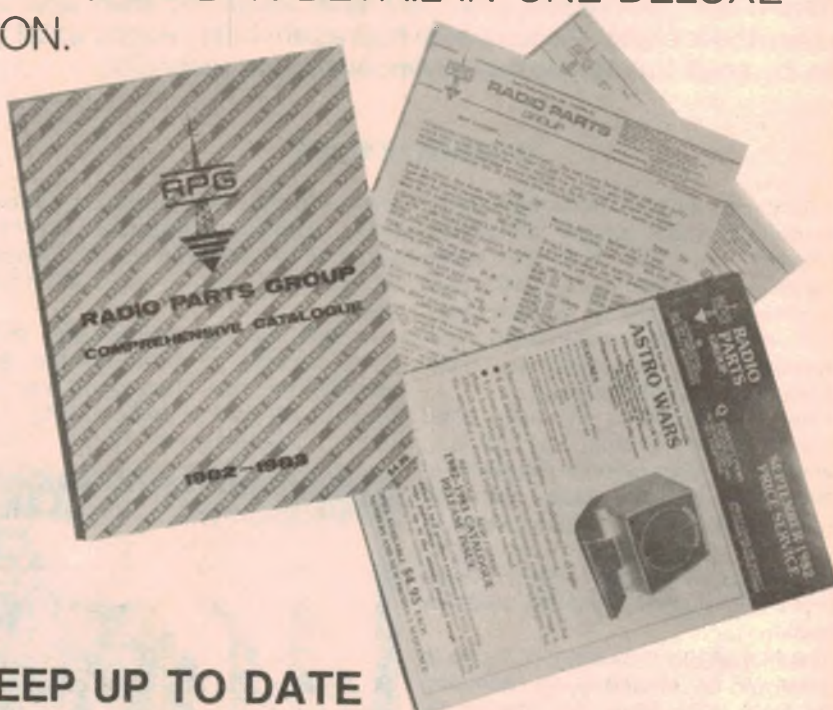

**KEEP UP TO DATE  
WITH PRICES & NEW PRODUCTS**

**SUBSCRIBE TO OUR MONTHLY MAILING SERVICE  
MORE THAN 5,000 DO!**

- NEW LINES ● MONTHLY SPECIALS
- COMPUTERISED PRICE LIST ● SEASONAL CATALOGUES



**RADIO PARTS GROUP**

562 Spencer St, West Melbourne 3003, Vic  
PO Box 124, North Melbourne 3051

EA  
DEC  
82

PLEASE SEND ME YOUR COMPREHENSIVE CATALOGUE OR  
COMPREHENSIVE CATALOGUE & PRICE SERVICE FOR 1 YEAR  
ANNUAL SUBSCRIPTION \$25.00 (INCLUDING \$3.00 P&P)  
CATALOGUE ONLY \$6.45 (INCLUDING \$1.50 P&P)

Enclosed is my Cheque/Money Order/Order No. (If Account Customer)

or please debit my Bankcard No.

NAME

COMPANY NAME

ADDRESS

PLEASE PRINT CLEARLY TO ENSURE CORRECT MAILING



they should start out by holding the magnetic particles in a perfectly dispersed suspension during the coating process and end up by bonding the particles to the backing in a very permanent way.

On the way from liquid to semi-solid to fully cured solid, a binder system should be fluid enough to permit free rotation of the magnetic particles as they are oriented in the intended recording direction, then malleable enough to respond well to the calendaring and polishing processes, then soft enough to permit slitting of the tape into its final widths without crumbling at the edges, and, finally, hard enough to resist scratching and flaking when the tape is used.

## Research

Binder systems are constantly being tested and changed. Some manufacturers stick faithfully to binder systems whose changes of state are timed to the production cycle. Others are willing to interrupt the production process in midstream to let the tape sit and "cure" its way into the next desired state.

Quizzing a tape manufacturer on what's new in binder systems is something like asking a medieval alchemist to describe his technique for transmuting lead into gold: the best you can expect is to receive no misinformation. Chemical analysis of the final tape doesn't help very much because so much of the binder brew goes up in volatile fumes during tape production (it will also go up in flames if the maker is not exceedingly careful).

Still, together with the crystallization techniques for making the magnetic particles, the chemistry and technology of binder systems have been keys to the fine tapes of today and will be the starting point for the superior tapes of tomorrow.

## Magnetic Materials

The crystalline forms that magnetic tape particles assume are not found in nature but are synthesised through the control of temperature, pressure, pH values, catalysts, and the timing of the crystal-growth cycle. From the first, the goals for magnetic particles in recording tape have been the same: a "clean," needle-like shape free of pits or branches ("dendrites"), appropriate size, and uniformity from particle to particle.

In recent years, particle size has been getting smaller and smaller, and the premium tapes appearing now are typically endowed with "needles" one-quarter the size of their predecessors. Coercivity, which affects high-frequency performance at slow recording speeds, is enhanced by small particle size, but the general feeling in the industry is that, with metal tape, we

## BASF: "Kiss the hiss goodbye!"



*BASF's Chromdioxid II was introduced to the Australian market, just over 12 months ago, by visiting company executives Dr Manfred Ritter and Mr Wilhelmus (Bill) Andriesson, (our issue, November '81). In the meantime, according to BASF, it has become firmly established as the best-selling top quality tape in Europe. Now in a re-styled pack, Chromdioxid II cassettes are being publicised in Australia under the slogan "Kiss the hiss goodbye". Here to talk to retailers and the technical press, BASF executive Henry Spuhler and Ray Gugler claim that Chromdioxid II is the quietest tape in the world, the least abrasive of all tapes in terms of head wear, and housed a state-of-the-art cassette housing. It was these qualities, they said, that persuaded Mobile Fidelity Sound Lab to choose Chromdioxid II cassettes for their "Original Master" cassette releases.*

have achieved as much coercivity as we need.

The new emphasis is on what smallness, uniformity, and cleanliness can do to improve the packing density of magnetic material in the tape coating, which will lead to increased remanence and better performance at the longer wave-lengths (lower frequencies).

The chemical composition of the various tape particles we'll be offered should lead to some interesting competitive skirmishes. Maxell and TDK want to pursue, respectively, their Epitaxial and Super Avilyn materials, both of which are ferric oxides sufficiently refined (by cobalt-absorption processes) to accomplish "almost anything," in the words of a TDK spokesman. Fuji seems bent on pursuing the technology of pure metal.

BASF remains committed to chromium dioxide for its premium products and believes that it has superior characteristics for digital (PCM) recording as well as video. And Sony recently introduced an IEC Type II ("high bias") cassette employing a very small iron-oxide particle with a coating scheme said to afford exceptional remanence and squareness ratio. The

company is carefully keeping up its involvement with many other materials, however, even to the point of using them in dual-coated products such as ferri-chrome.

Most major manufacturers promise flexibility and further research in new materials, and mixtures of materials, seems a likely possibility in the near future. As for vapour-deposited pure-metal coatings (pioneered in Matsushita's Angrom microcassette), there are some doubts as to the technique's capabilities for longer-wavelength recording as well as some hopes for its potentially superior remanence, especially if appropriate metallic alloys are used.

A not-unexpected finding that the metal-tape market is somewhat limited by high product cost has persuaded a number of manufacturers to move in the direction of improving more conventional tape coating: TDK, for example, now feels it can for all practical purposes, match the performance of metal using variants of Super Avilyn. In its available forms, metal has shown greatest strength in the area of coercivity, and TDK has countered with SAX, a dual-layer cassette tape that has a thin,



*In the realm of modern high performance video tapes the Sony Betamax cassette (partly obscured) and the TKD VHS format cassettes shown here are typical. As tape quality continues to improve it will benefit both the video and audio fields.*



high-coercivity layer on top and a thicker, high-remnance layer below — both composed of Super Avilyn material.

In the future, the company will be working closely with hardware manufacturers to produce a cassette that is adaptable to PCM recording (digital tapes are expected to be more critical in terms of tape guidance than in magnetic properties). Dupont is working on a two-layer chrome tape.

Maxell has introduced its XL-S line of cassettes to represent refinements in particle-growth and coating techniques. Their processes for both are said to be unique and highly effective in improving packing density and tape-to-head contact.

The most interesting development at Maxell, however, is a new type of tape with particles oriented along the tape path but with some pitched into and out of the tape at about a 45-degree angle as well as some parallel to the surface. This enables the tape to take advantage of the fact that flux lines from the recording heads pass through the tape surface in an arc; since more particles will be aligned with the flux, the tape will be capable of greater energy storage. (The particles are reported to be very short, by the way — about 0.1 micrometer.)

In general, the industry is moving toward what it terms a "balanced" cassette tape, adequate in high-frequency performance to match the

capabilities of current cassette recorders and augmented at lower frequencies to deal with the noise and dynamic-range limitations of previous machines. Most manufacturers plan to increase the performance of their cassette tapes so that this year's medium-quality tapes will be just about equal to last year's premium tapes, and the premium tapes will be one step better than before.

These improvements will be achieved through developments that are described as incremental rather than revolutionary. More and more, the key ingredients of non-premium cassettes come from outside suppliers who have pulled their standards up to acceptable levels.

### The Future of Open Reel

It is the intention of four companies — Maxell and TDK on the tape end, Akai and Teac on the hardware end — to establish a new standard for consumer open-reel recording. BASF is also expected to cooperate in this venture. According to joint statements by these companies, the new EE ("Extra Efficiency") standard is destined to "take-over" the home open-reel tape market.

The impetus behind the EE innovation is a desire to apply technology gained in cassette development to the open-reel format. The motivation comes from market studies, one of which found that production of open-reel tape decks in Japan exceeds 200,000 a year and is holding steady. This is a market large

enough to be attractive, yet small enough to be manipulated.

The EE innovation is expected to encourage market growth to some degree, but, more important, it might compel open-reel devotees to abandon their current equipment for new and improved models.

New open-reel models are needed to handle the EE tapes, which resemble the high-coercivity, high-remnance cassette formulations more closely than anything that has been seen in open-reel heretofore. They require higher bias and, concurrently, some changes in equalisation if they are to perform at their best. That best should yield improvements comparable to what cassettes have demonstrated in recent years: lower noise, higher output levels and sensitivities at all frequencies, and greater consistency of performance. Again, these gains are evolutionary.

The benefit most emphasised by the four companies is the potential improvement at lower tape speeds, one that promises the equivalent of the performance offered now by the next speed up. The first EE-optimized decks are now arriving in the US, so we'll soon know exactly how good it is.

### Other Developments

Dual-layer products are going to continue to be available in the tape repertoire, even though one manufacturer preceded his comments on them with a few unprintable adjectives. The real problem, as he has experienced it, has to do with the transition point between the coating layers.

Making the two layers similar in magnetic properties smoothes the transition, but it throws away the advantages of going to two layers in the first place. Making the layers dissimilar (the outer layer strongly favouring highs, the inner one favouring lows) exploits the technology to its fullest but it runs risks in the mid-range that can upset noise-reduction tracking and inter-machine compatibility even if the average listener does not notice obvious impairment of frequency response.

Vapour-deposition metal tape, although attractive as an idea, is not universally attractive in practice. Some companies are pursuing it avidly; others are going to wait and see. The majority view is that vapour deposition is going to be of great benefit for the very short wavelengths employed in data processing and video, even though the resultant coating appears, at the moment, to be too fragile.

The word from Japan is that micro-cassettes are going to sweep the market for automotive and portable uses. Certainly they will have an impact, reinforced by new recording techniques and new noise-reduction



# How to get 50% more sound without turning up the volume.



A dbx Dynamic Range Expander restores the music dynamics that were lost in the recording process—giving you up to 50% more sound. The technology is based on a technique originally developed by dbx for professional recording studios.

There's a whole range of sound in a live performance that you never hear from your stereo system. And it's not a question of turning up the volume.

The problem is in the records you play.

When recording engineers master a record, they electronically eliminate up to half the music. They literally compress the sound to make it "fit" on the vinyl record.

Fortunately, there's one solution to the problem: dbx Dynamic Range Expanders.

A dbx Dynamic Range Expander in your system restores most of the lost music. And it reduces annoying record surface noise by as much as 20 dB. So instead of a compressed 50 or 60 dB of dynamic range, you get a full 75 to 90 dB. The loud passages begin to thunder. The softs are truly subtle. All your music comes to life.

And you can use a dbx Dynamic Range Expander not only with your records, but also with tapes and FM broadcasts.

Visit your authorized dbx retailer for a demonstration of the 1BX, 2BX and 3BX Dynamic Range Expanders. Then select the model that's best for your system.

Because there's a lot more to music than has been reaching your ears.

## dbx

Making good sound better

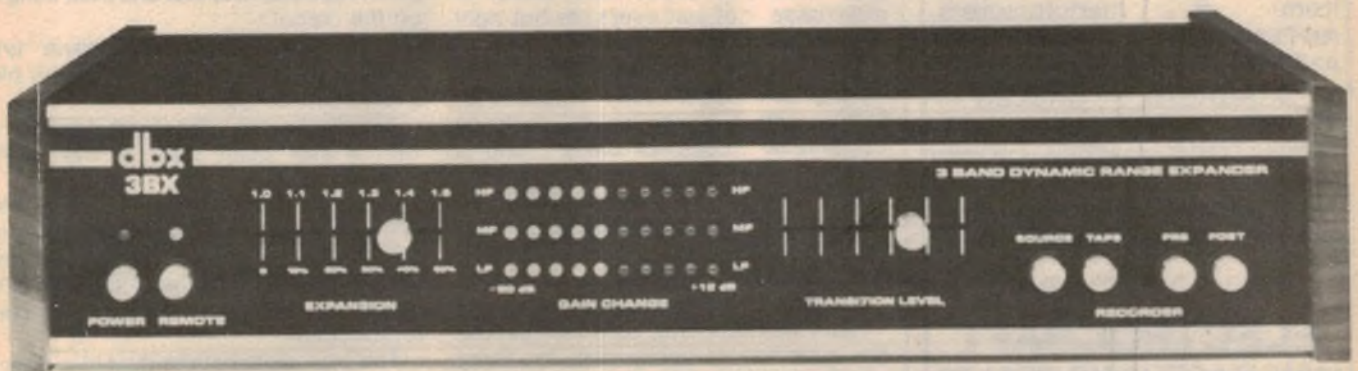

AUDIO ENGINEERS PTY LTD  
342 Kent Street  
SYDNEY, NSW 2000

NOMIS ELECTRONICS P/L  
689 South Road  
BLACK FOREST, SA. 5035

AUDIO ENGINEER QLD  
47 Castlemaine St  
MILTON, QLD. 4064

AUDIO ENGINEERS (Vic)  
2A Hill Street  
THORNBURY Vic 3071

ATHOL M. HILL P/L  
Unit 5, 66 Wellington Street  
PERTH WA 6000  
HAWKINS AE165

# REWARDS



## \$3000

Are you a member of the public who has spent approximately \$3000 minimum on your

**HI-FI — TELEVISION — VIDEO RECORDER**

and are you trying to operate all this valuable equipment on an inside aerial or an old system 10-20 years old. If so you should have spent \$150 less on your equipment and \$150 or more on a new antenna or antenna system. The end result would be:—

**GOOD VIEWING —**

**GOOD SOUND —**

**GOOD RECORDING.**

Regardless of what you have spent on your equipment, it can only perform as well as your aerial system will allow it.

The E.F.C.3/03S by "Hills" is their top of the range antenna for Sydney, Melbourne and Brisbane fringe areas, very good gain and good for ghosting situations.

We have the largest stocks of antenna equipment available from 5 manufacturers, ANTENNA'S — BOOSTERS AND MAST HEAD AMPLIFIERS — BRACKETS — CABLES — PLUGS — FILTERS — ATTENUATORS, anything you may require.

Treat yourself to an Xmas present and have a happy Xmas from

**ELECTROCRAFT  
MANUFACTURING PTY LTD  
TRADE SUPPLIED**

Free verbal advice given

Phone or call 438 4308 or 438 3266

68 Whiting St ARTARMON 2066

Hours 8am to 5pm Mon: to Friday

Off Street Parking at rear

## AUDIO-VIDEO ELECTRONICS — continued

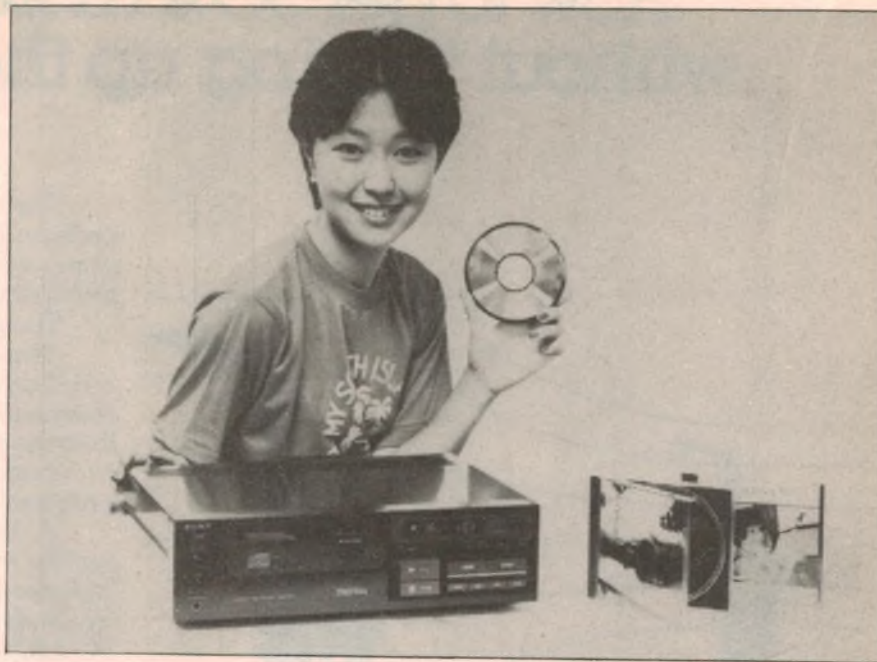

*Just in case you're confused, DAD does feature in this picture!*

## SONY INTRODUCES US TO DAD!

During mid October, Sony representatives from both Japan and Australia invited dealers, technocrats and members of the press to meet DAD — not a blood relative, in this case, but a glistening, 12cm rainbow-hued Digital Audio Disc which seems all set to take over from the familiar LP microgroove album.

For many of those who accepted the invitation, it wasn't a surprise, nor even the first time they had met up with DAD. The significance lay in the formality of the occasion. Sony was saying to consumer representatives in Australia: "We'd like you all to meet DAD officially, and as a group."

At long last, it looked as though the predictions and the promises of the past couple of years were about to materialise, not just overseas but right here in Australia.

As firm evidence, here was a team of visiting and local Sony executives, armed with a dozen or so distinctly commercial "compact discs", and a distinctly commercial compact disc player, set up and ready to demonstrate to a local audience. This, in EMI's modern 301 Studio complex in Castlereagh St, Sydney.

It had to be a significant occasion.

Right at the outset, as if to reassure the audience, a spokesman for Sony emphasised that the new, small discs were not easily damaged:

"This one is covered in fingerprints; it's been deliberately scuffed against the carpet and even scored with a ballpoint pen.

"Yet, as you will hear, it still plays

normally, without consequent noise or loss of signal."

There was a touch of *deja vu* about the statement.

I recalled a function, best part of 30 years ago, in Sydney's Australian Hotel, where a spokesman for Decca had held aloft the first long-playing microgroove disc that many of us had seen.

"It's quite durable" he said, as he bent it this way and that and then flung it on the carpet.

"The new long-playing discs are flexible; they don't shatter like the old shellac pressings!"

Admittedly, no one tried scoring it with a ball point pen. A ball point what...?

Now we were facing the probable demise of the mechanical microgroove era — not as an abrupt traumatic event but a gradual phasing out, as had happened to 78rpm records and mono reproduction.

The new digital audio disc is a direct spin-off from the laser/optical video disc, developed some years ago by Philips and Sony. In that system, the luminance, chroma and stereo sound signals for up to 60 minutes of video programming are digitally encoded and processed on to a reflective metallic



*The Japanese commercial compact disc player CDP-101 is strongly reminiscent of video cassette and disc equipment, with automatic loading and eject, logic touch controls and infrared remote control. Functions include play, pause, fast forward and search in both directions, track selection, repeat, digital readout, timer, headphone output and an output analog signal for connection to a normal amplifier system.*

surface of a 30cm dia. disc, as a long spiral of microscopic pits.

For playback, the pits are tracked and "read" by a laser/optical head, which glides above the surface without touching it. The recovered digital signal is decoded by special circuitry and reconstituted as normal video and audio information.

While Philips and Sony could have adapted the same 30cm format for a super-quality multi-channel audio disc, they opted for a much smaller laser/optical disc — 12cm diameter — which would nevertheless accommodate up to one hour of top quality stereo music. This has now been virtually accepted as a hifi industry standard, with something like 40 companies licensed to produce discs and/or playback equipment.

And while we have referred to it thus far as DAD, for Digital Audio Disc, Philips at least would prefer to see it described as the "compact disc" — a companion product for their compact cassette.

Certainly the new discs have the potential to revolutionise the standard of recorded music available in the home. Using a 16-bit linear digital sampling system (44.1kHz) they offer a frequency range of 5Hz to 20kHz  $\pm 0.5$ dB. The dynamic range and signal/noise ratio is better than 90dB, as also is the channel separation. Harmonic distortion is less than 0.004% at 1kHz and wow and flutter is unmeasurable.

While it would be unwise to draw too many conclusions from a structured demonstration, the impression that came through did align with the specifications: the compact disc system is an extremely "transparent" one, which allows the listener in the home really to hear what is on the master tape.

If the master is a modern digital recording, the clarity and detail can be startling.

If, for historic or commercial reasons, the desired performance exists only on an analog master, the inherent limitations of the analog system may well be audible to the consumer.

And, as a Sony spokesman pointed out, if the recording is a "pop" performance, subject to "processing" in the mixing desk, any imperfections in either equipment or technique could be very obvious, via compact disc.

## RECORDING TAPE

(Continued from page 38)

systems such as B&O's HX Professional. And the next generation of microcassettes (as well as the players they will be employed in) promises to be superb.

All of which leaves me in something of a quandary about the final justification for multi-application tape formats. They will provide convenience to the consumer (any tape on hand can do the job he needs done) and a certain amount of the same to the manufacturer (any tape he produces can be sold for any application), but will they be the best possible for each individual application?

Analog audio, requiring excellent performance at both short and long wavelengths, calls for some fairly sophisticated tape design. Whether it will still show up at its best in multi-application tapes remains a question. Perhaps the answer lies in a house joke popular at 3M: one day packing density will have become so great that the tape will be able to record and play without having to move at all! That will surely spell the end of magnetic recording as we know it, inspiring tape manufacturers to move on to the next thing. ☺

## UV LIGHT BOX

- 4 × 20" UV Tubes
  - Electronic Timer
  - Sliding Tray
  - Safety Micro-switch
- \$295.00 (+S.T.)

## DEVELOP/ETCH TANK

- Rigid PVC
- Heater
- Standard Hose Fittings
- 24" Wide 12" High \$195.00 (+S.T.)
- 2 Compartment \$285.00 (+S.T.)
- 3 Compartment

## IDEAL 'IN HOUSE' EQUIPMENT FOR USERS OF:

- RISTON 3000 or other Printed Circuit Board
- 3M Scotchcal
- 3M Image 'N Transfer
- Electroplating

## DISTRIBUTOR ENQUIRIES WELCOMED

**KALEX**

101 Burgundy St.  
Heidelberg 3084  
(03) 458 2976  
Telex AA 37678  
MELTON  
(03) 743 1011

## ELECTRONIC COMPONENTS & ACCESSORIES

- SPECIALIST SCHOOL SUPPLIERS ●

# IT PAYS TO BUY YO

WHY? BECAUSE JAYCAR KITS COST NO MORE & ARE BETTER QUALITY

**Digital Thermometer**  
**\$69**  
 EA282

Read the temperature in your room (or outside) from 0 degrees C to 100 degrees C in fact to within 0.1 degree C. Fantastic resolution on a bright easy-to-read display. Includes case.

**DIGITAL CAPACITANCE METER** Ref: EA 3/82  
 This kit once again uses the amazing DPM 200 LCD /driver module. Capable of measuring capacitance from 1pF to 19.99uF. It is a must in every workshop or lab.

**\$69**



**HEART RATE MONITOR**  
 Ref: EA 7/82  
 WAS \$79 SAVE \$10



This unit enables you to measure your own pulse instantly and accurately. It is light enough even for joggers to carry. A must for people who may have heart problems. Complete kit including LCD Display.

**LCD tacho**  
 ref: EA May 1982  
**\$49.50**

- USES NEW DPM-05 DISPLAY
- FITS INTO YOUR DASHBOARD
- RPM, DWELL DISPLAY

**500MHz Digital Frequency Period Meter**  
 REF: EA Dec '81 - Feb '82



ONLY **\$119**

Other people may appear to be selling this kit for less. But you GET less!!! Exclusive Jaycar features:

- \* Heavy gauge front panel. Pre-punched and silkscreened. (NOT Scotchcal).
- \* Low aging rate 10.000MHz crystal
- \* Quality IC sockets provided (A MUST)
- \* All metal film resistors used (1% 50ppm)
- \* Thermalloy heatsink for +5V reg.

Beware of advertised units that do not conform to the original design. They may have inferior performance.

**EXCLUSIVE**

- Gold plated BNC Input Connectors
- 500MHz option only \$26 extra
- 50MHz version \$119
- Tilting bail to suit ONLY \$4.95

**Function Generator** FREE! TILTING BAIL WORTH \$4.95 included



**\$99**

Ref: EA April 1982

"Pigeon Pair" companion to the new 500MHz DFM. Low distortion generator of sine, square and triangular waveforms. From below 20Hz to over 160kHz. Inbuilt 4 digit frequency counter in de-luxe Pac-Tec case. Only \$85. JAYCAR EXCLUSIVE - 1% 50ppm metal film resistors used for stability

STEREO STEREO STEREO STEREO

## Synthesiser

Creates a very realistic stereo sound from mono sources i.e. AM tuners, TV or video units. Very easy to build and comes complete.

ONLY **\$49.50**



COMPLETE

Ref: EA September 1982

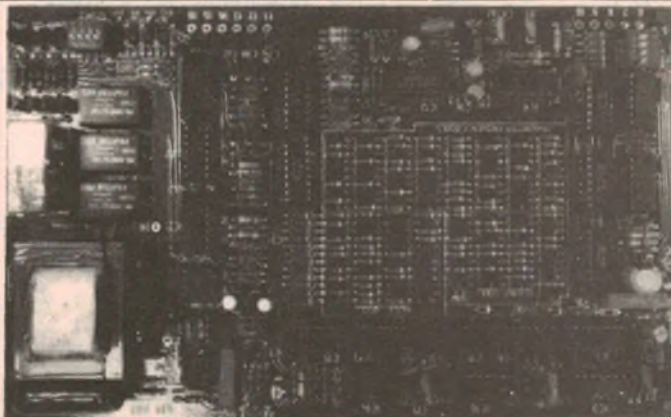

**ETI 644 direct connect modem**

Ref: ETI October 1982  
 SHORTFORM KIT

**\$169**

FULL KIT

**\$189 NEW**

Two models (i) Short form which contains ALL PCB components as specified by ETI (BEWARE!!). The genuine ETI PCB with plated-thru holes, solder mask and component overlay is supplied. We also supply at NO EXTRA CHARGE a full set of quality I.C. sockets. A must with plated-thru PCB's. Remember this when making comparisons.

(ii) Full kit. Includes: all of above plus 12V plugpack, case, front panel, switch and LED bezel and Cannon DB-25 RS-232 connector. Makes a complete stand alone modem.

\* Capable of a range of Answer/Originate operating modes \* Selectable Baud rate \* Software controlled \* Uses new patented technique \* More reliable and faster than most acoustic modems.

\*\*\*\*\*

## Lyrebird Piano Kit NEW LOW PRICE...

GREAT NEW FEATURES!!

- FREE! A stand (like the one illustrated but not exactly the same). Worth around \$50 but yours at no extra charge with each 73 or 88 note kit.
- FREE! A soldering iron (worth around \$19). Yours to keep to give years of faithful service after you have completed your Lyrebird. (88 note only)
- FREE! A 200g roll of solder. You will need some to build the Lyrebird but there will be plenty left over for other projects. (73 & 88 note versions).
- FREE! Quality IC sockets provided in both kits.

REF: EA 11/81-1/82  
 7 1/2 OCTAVE (88 NOTE) VERSION  
**\$589**

# OUR KITS FROM US

WHY? BECAUSE JAYCAR KITS COST NO MORE & ARE BETTER QUALITY

**NEW**

## EA FUZZ BOX KIT

Ref: EA January 1981  
Economic way to get great guitar sounds! The Jaycar kit contains a heavy duty foot-switch and diecast box. All components only



**\$19.50**

Staggering value



## 'Power UP'

**ONLY \$39.50**

Ref: EA 11/82

What will they think of next???! Sensational project that detects the current drawn by one appliance to switch on up to 4 others - **AUTOMATICALLY!** Great for computers, component Hi Fi etc. when you have to normally switch on several items in a system. Will switch total load of 240V 10A. Complete kit including outlets, box, mains relay etc. **ONLY \$39.50**

# EA CAR COMPUTER KIT new low price!

**BUY THE WHOLE KIT** Ref: August EA 1982  
**(INC. FUEL & SPEED SENSORS!) FOR ONLY \$165!! NOW \$159.00!**

**WE TOO** have the genuine Moray fuel sensor. We buy it from the same factory as Dick Smith!! We also have an EA APPROVED Speedo Cable sensor. The speedo cable sensor gives better results at very low speed.

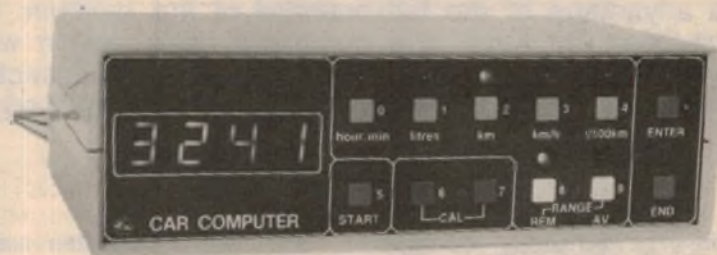

### TAILSHAFT SPEED SENSOR

This unit also has the EA stamp of approval! The sensor kit includes two powerful magnets, two long Nylon locking straps to secure the magnets to the tailshaft (we recommend that you Araldite the magnets as well) and a plated mounting stud with nut and shakeproof washer.

**ONLY \$14.50**

### JAYCAR EXCLUSIVE

Only necessary if your car has a fuel by-pass system (Many European and Japanese cars). Enables by-pass system to operate without affecting the accuracy of the flow sensor. Has special restriction in T section.

**ONLY \$3.95**



### SPEEDO CABLE SENSOR

This device has been tested and endorsed by EA. It works on cars that don't have tailshafts! We won't treat you like an imbecile and say not to buy it in case your speedo cable breaks - how often does THAT happen? At \$29.50 you may as well leave it in the car when you sell it, as it is cheaper than most speedo cables anyway.

**ONLY \$29.50**

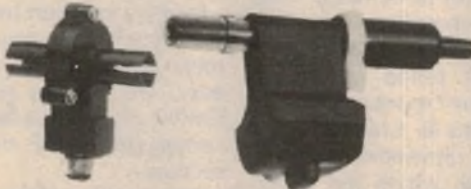

### FUEL FLOW SENSOR - NEW MODEL

This is the LATEST VERSION of the Moray fuel sensor. The early models had a turbine/impeller moulded in ordinary Nylon. Apparently this component absorbed moisture & expanded. The expanded impeller then gave slightly inaccurate results. The Jaycar/Moray LATEST MODEL impeller is now moulded in DELRYN. This does not absorb moisture & the flow sensor remains accurate over the life of the car. If you do not buy a Jaycar Car Computer Kit make sure that you are getting the LATEST MODEL fuel flow sensor.

**ONLY \$59.50**

### PRICING INFORMATION

**ALL ELECTRONICS** including both PCB's plated through, programmed EP-ROM, 1% metal film resistors, and other high spec. components. You also get a **CHOICE** of either tailshaft or speedo cable type speed sensor (PLEASE SPECIFY) **ONLY \$99.50**  
Pre-punched genuine AMERICAN PAC-TEC case (as used by EA) and NOT a Hong Kong copy, with special silk-screened front panel and multi-way connector **ONLY \$39.50**  
Genuine MORAY high resolution fuel sensor - LATEST VERSION **ONLY \$59.50**

**NEW**

## DIGITAL pH METER KIT

At last a true scientific instrument for a fraction of the cost of commercial units. Great for checking swimming pools, fish tanks and countless other uses. The Jaycar kit comes complete with DPM-05 display, ABS case and all components as specified by EA. 'Ionode' probe to suit only \$69 Ref: EA December 1982



**ONLY \$69.00**  
(probe extra)

## syntom

As used by Warren Cann of 'Ultravox'

Original design from the UK magazine 'Electronics and Music Maker' April 1981. Self-contained unit produces a variety of fixed and falling pitch effects. Trigger by tapping the unit itself or by striking a drum to which the unit is attached. The Jaycar 'SYNTOM' comes complete with high quality pre-drilled moulded all ABS box 152 x 80 x 47mm with professional silk screened front panel. FEATURES: Decay from less than 0.1 second to several seconds, pitch control, sweep control and volume on/off.

**ONLY \$36.50**



**\$6 OCTAVE \$475**



**NEW LOW PRICE!!** Because we are shipping keyboards and other expensive components in bulk due to high demand, we can pass savings on to YOU. You can now have a magnificent "Lyrebird" 6 octave touch sensitive piano now for only \$475!! That's a staggering \$50 off the old price. **REMEMBER!! THE LYREBIRD OUTPERFORMS READY BUILT PIANOS COSTING UP TO THOUSANDS OF DOLLARS MORE. WHY PAY MORE WHEN YOUR CONSTRUCTION KNOWLEDGE CAN SAVE YOU A FORTUNE?**

## Jaycar NUMBER 1 FOR KITS

125 York Street, Sydney 2000  
Phone: 264 6688 Telex: 72293

"Nevilles Corner"  
Cnr. Carlingford & Pennant Hills Road,  
Carlingford  
Phone: 872 4422

Mail Orders To: Box K-39 Haymarket  
Sydney 2000

POST AND PACKING CHARGES  
\$5-\$9.99 (\$1.20) \$10-\$24.99 (\$2.40)  
\$25-\$49.99 (\$3.50) \$50-\$99.99 (\$4.60)  
\$100 up (\$6.30)

NEW SHOP HOURS  
Mon-Fri 8.30 to 5.30pm  
Sat 8.30 to 12.00pm  
Thurs night to 8.30pm

MAIL ORDER BY  
BANKCARD VIA  
YOUR PHONE



Add a new source to your hifi listening

# A high performance AM tuner: Pt. 1

Although many people are aware of the high quality reception available from FM tuners, few are aware that AM radio is also capable of really excellent sound quality. Very few AM tuners take advantage of the full potential of this medium. Our new Playmaster AM tuner is a completely new design which can provide first class sound quality that no AM section in a commercial AM/FM tuner can match, regardless of price.

by JOHN CLARKE

While most high fidelity enthusiasts do not seriously consider AM radio as a hifi medium, a large proportion of the Australian radio audience listens almost exclusively to AM. The audience ratings figures continually bear this out although the FM stations are gaining listeners as time goes on. In many areas too, FM reception is poor or there may be no FM service at all. For people living in these areas a high quality AM tuner would be a boon.

So if you are one of the many who consistently listens to AM in preference to FM, there is now an opportunity to enjoy much improved sound quality. In every respect, whether it be with regard to frequency response, harmonic distortion, signal-to-noise ratio or freedom from mains radiated interference, this new Playmaster design is superior to any currently available AM tuner that we know of.

Modern AM transmitters have an audio bandwidth which is flat to at least 15kHz

and many of the better stations broadcast without restricting this bandwidth. However, it is not possible for a practical tuner to have an unrestricted bandwidth. For a start, the 9kHz spacing between AM stations means that 9kHz whistles will become troublesome at night when radio propagation improves. For this reason, the Playmaster tuner has a 9kHz filter with a very deep null.

Apart from the whistle filter the tuner audio bandwidth is rolled off above 10kHz to avoid undue "monkey chatter" which is characterised as a high pitched interference from unwanted stations whose sidebands fall within the band-pass of the tuner. For daytime listening then, the wide/narrow switch is placed in the wide position to obtain excellent listening.

At night time though, some listeners may find that monkey chatter is troublesome even with the bandwidth restricted to around 10kHz. At these times, the wide/narrow switch is set to

narrow. This restricts the bandwidth further, to 3kHz. While this may seem rather narrow it is still better than many AM tuner sections in typical AM/FM tuners or receivers and, in any case, the Playmaster in narrow mode is still superior in terms of distortion and noise.

Possibly the most obvious feature of the Playmaster tuner is the 4-digit readout. This reads the tuned frequency to within 1kHz and has been designed to be completely free of the jitter which troubles some digital readouts. Another bonus of the digital readout, as far as the constructor is concerned, is that it makes precise alignment possible without the need for an expensive RF generator. Precise alignment is necessary if best performance is to be obtained and we are very pleased to be able to solve this problem in this fashion.

By the way, apart from a multimeter no special tools are required for the alignment procedure. To make the job really easy, we will be presenting a simple CMOS oscillator which will be used in conjunction with the digital readout section.

Also on the front panel is a 12-LED signal strength indicator which is a useful tuning aid, particularly when orienting the loop antenna for best results.

## Noise-cancelling antenna

While the circuitry in the Playmaster AM Tuner certainly contains much that is new and innovative, the incorporation of a large loop antenna is probably the most important factor in the low noise reception obtained. Since the loop antenna is a balanced circuit it acts to cut out "common mode" mains radiated interference. This means in practice that there is an almost complete lack of interstation noise and almost no interference at all when tuned to a station. In fact, in many locations where AM reception is normally almost unlistenable due to mains interference, the clean reception provided by the new Playmaster tuner will be a revelation.

The antenna consists of a large single

## Performance of Prototype

TUNING RANGE	520-1630kHz
FREQUENCY RESPONSE	see graph
HARMONIC DISTORTION	less than 0.6% at 30% modulation
SENSITIVITY	40 $\mu$ V for a 50mV audio output
AUDIO OUTPUT	500mV RMS into 4.7k $\Omega$ load at 100% modulation
AGC RANGE	54dB for a 6dB change in audio output
SIGNAL TO NOISE RATIO	65dB with respect to full output

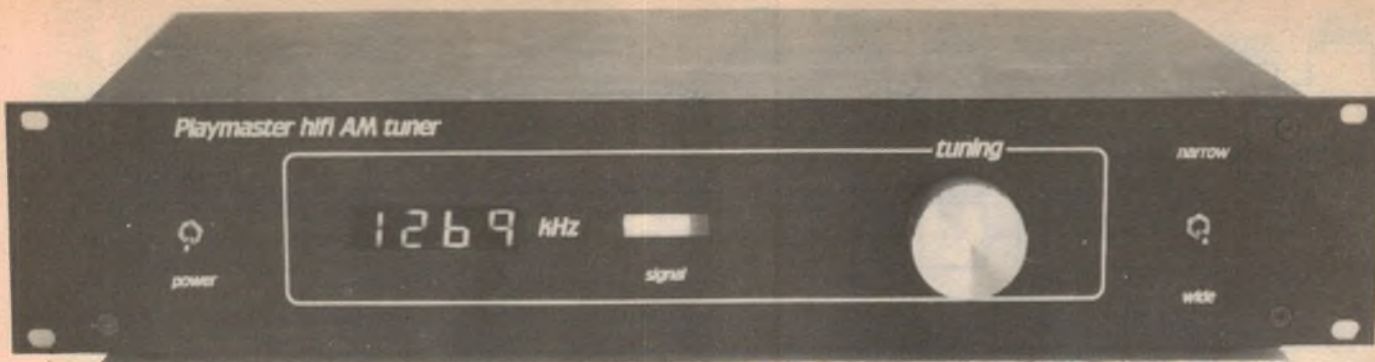

The new Playmaster AM tuner is built into a rack mounting case and fitted with a silk-screened front panel.

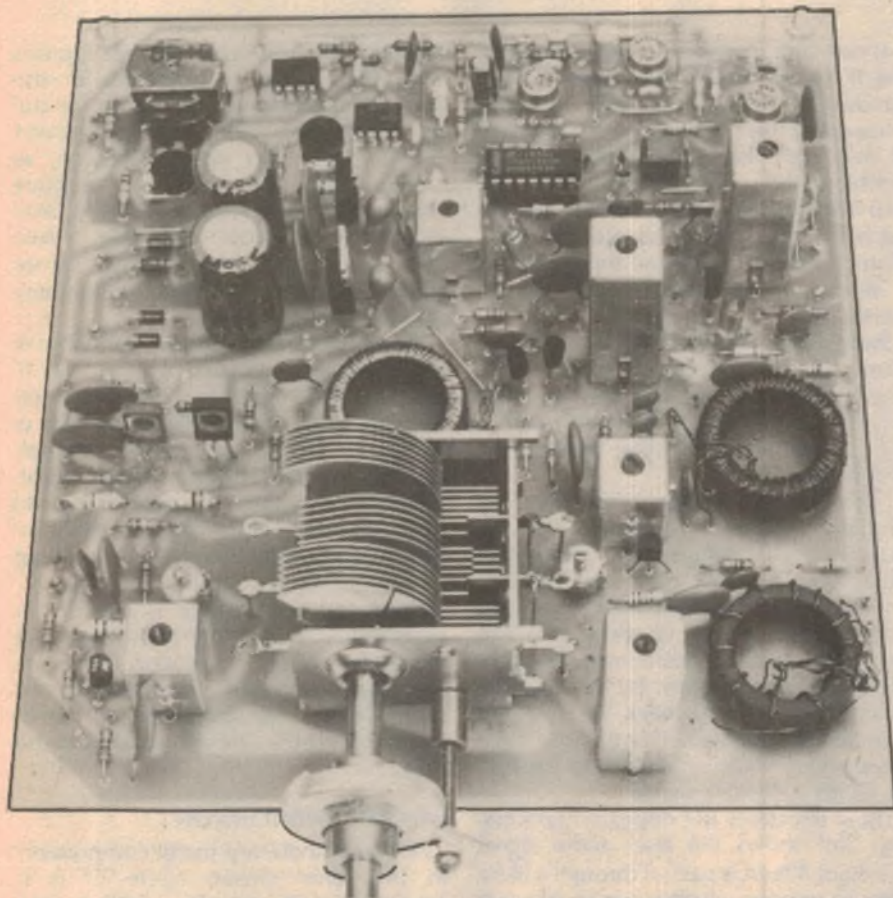

This view shows the main tuner PCB, fully assembled. Note that the version shown is an early prototype – the final version differs in a few details.

loop of hookup wire about 2.5 metres square – the larger the better. It is terminated to a pair of binding post terminals on the rear of the tuner. Associated with these terminals is a screwdriver preset level control which enables the antenna input to be attenuated in very strong signal areas.

Finally, the audio output from the tuner is connected to a pair of RCA phono sockets. This makes it convenient for connection to a stereo amplifier and also provides for a synthesised stereo option which we will publish at a later date.

The performance details of the tuner are summarised in the accompanying panel and graphs. Note that the signal-to-noise ratio and harmonic distortion

levels are better than those achieved by many AM transmitters presently in use.

### Block diagram

Let us now discuss the general circuit features of the new Playmaster tuner by referring to the block diagram (Fig. 1). Broadly speaking, it is a superheterodyne tuner. As the name suggests, this uses a method of heterodyning or beating two signals together.

The method is as follows: The incoming signal frequency from the broadcast station is "mixed" with the signal from a tunable oscillator. This is called the local oscillator. In some tuner designs the oscillator and mixer functions are provided by one transistor which is known, not

surprisingly, as a self-oscillating mixer. The difference between the oscillator and incoming RF signal is known as the intermediate frequency (IF) and this is amplified by one or more IF amplifier stages.

Finally, the intermediate frequency is fed to a detector which recovers the audio frequency modulation which is then fed to an amplifier and loudspeaker.

Incidentally, the term superheterodyne is a contraction of "supersonic heterodyne", although some textbooks state that the word "super" refers to the fact that the local oscillator frequency is greater than the incoming signal.

In the present design, the loop antenna described above feeds the broadcast signal frequencies to a pair of cascaded tunable RF bandpass filter stages which are controlled by two sections of the tuning gang.

The 1st and 2nd bandpass filters allow signals within a defined frequency passband to be amplified while attenuating all other frequencies. In our tuner, the filters pass signals about  $\pm 10\text{kHz}$  of the centre frequency, ie, 20kHz wide. By varying the capacitance of the tuning gang, the centre frequency over which the 1st and 2nd RF filter passes the signal can be altered while the bandwidth remains essentially constant.

Obtaining this broad passband is accomplished by stagger tuning. This involves peaking the 1st RF filter to a higher frequency than the 2nd RF stage, at the low frequency end of the broadcast band (520kHz). Toward the high frequency end (1630kHz) of the broadcast band the stagger tuning is unnecessary and the coils peak at the same frequency. To understand why it is only necessary to stagger tune at the low frequency and not the high frequency end it is necessary to understand the Q of a tuned circuit.

The Q of a tuned circuit is defined as the centre frequency (resonance) divided by the 3dB roll off points. The higher the Q the narrower the frequency bandwidth of the tuned circuit. As the tuned frequency increases, the 3dB points

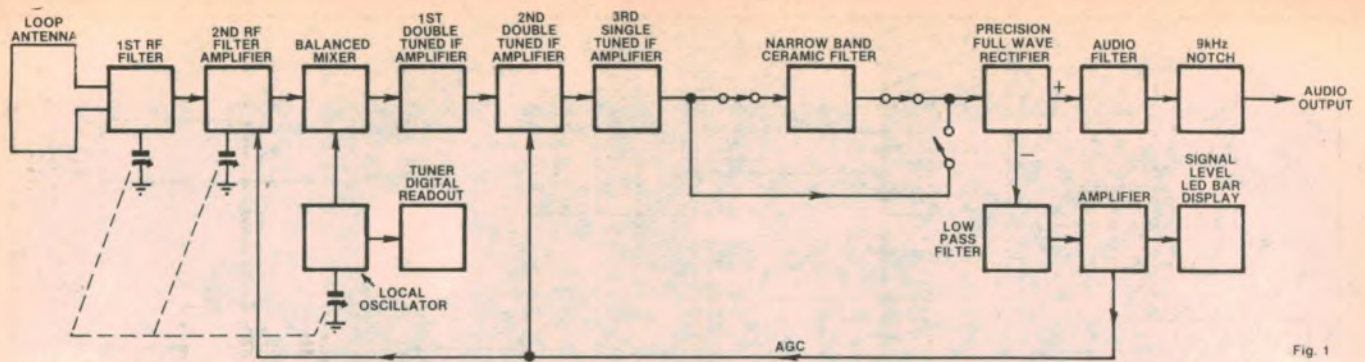

Fig. 1

The circuit is a full superhet design with two RF bandpass filters, three IF stages and a precision rectifier.

become wider for a given Q value and a wider bandwidth is obtained without the need for stagger tuning.

At the high frequency end of tuning, 1630kHz, the capacitor gang is at its lowest capacitance setting. Consequently, with the addition of small trimmer capacitors, the 1st and 2nd RF filters can be peaked to the same frequency by altering the trimmer capacitance by a small amount. At the low frequency end, the capacitor gang is at its largest value and the effect of these trimmers is very small. The ferrite slugs in the RF coils are then adjusted to peak at differing frequencies. As can be deduced, the stagger tuning effect progressively decreases until at the high frequency end the effect disappears.

The balanced mixer performs the mixing function described above except that, because it is balanced, the local oscillator and input RF signals do not appear at the output. The local oscillator is varied by the third section of the tuning gang so that the two RF filters already mentioned and the local oscillator "track" each other, ie they vary in tandem with each other. The mixer output is the intermediate frequency at 455kHz.

The local oscillator is designed to operate over the frequency range of 520kHz + 455kHz to 1630kHz + 455kHz. This frequency is counted by the Tuner Digital Readout described in the October 1982 issue. The Tuner Readout subtracts the 455kHz offset from the oscillator signal and displays the tuned frequency.

Three filter stages are used to amplify the IF signal. These each have a wide bandwidth to maintain the response allowed by the RF filters. The 1st and 2nd IF stages provide amplification and are double-tuned, meaning that there are two separate resonant circuits within each IF stage. The total number of IF filters is therefore five and these provide a sharp roll off at the edge of the passband.

Switching is provided so that a ceramic filter can be inserted in circuit with CMOS analog gates. The ceramic filter provides a narrow bandwidth and a sharp cutoff for night time listening, as mentioned above.

Following the narrow band filter is a precision full wave rectifier. Conventional superhet tuners use a diode as a detector but, since diodes are very non-linear at low forward voltages, they are a considerable source of distortion. The precision rectifier overcomes the problems of non-linearity by placing the diode(s) in the feedback loop of an operational amplifier. This op amp must have a very wide bandwidth to be able to rectify a 455kHz signal.

Fig. 2 illustrates the detection process. Fig. 2(d) shows the final audio signal resultant after it is passed through a 9kHz filter to remove whistles due to adjacent stations, as mentioned before. The "notch" in the frequency response due to this filter is extremely narrow and so it has negligible effect on program content. For this reason it is permanently in circuit.

Returning now to the detector: this is

actually a dual detector which comprises two diodes, one to conduct in the positive direction and the other for the negative signals. The positive direction is used for audio signal detection, as already discussed, and the negative direction for the AGC and signal level display. A very low pass filter, below 1Hz, allows only the negative carrier signal level to be recovered without any impressed audio signal.

The voltage from this low pass filter is amplified and returned to the 2nd IF amplifier and 2nd RF amplifier to control the gain of these amplifiers. The gain is reduced when the carrier signal, representing the strength of the signal, increases. This AGC (automatic gain control) action therefore tends to stabilise the audio output level for a varying amount of signal strength.

The signal level display is also driven from the AGC amplifier and provides a rising level of LED indication for an increasing level of AGC. Consequently the signal level is an indication of signal strength over the operating region of the AGC.

### Circuit description

Although there are many components in the tuner circuit, some of it is repetitive and can be divided into separate basic circuit blocks. Three broad sections of the circuit are: the radio frequency section comprising the RF filters, mixer and oscillator; the low frequency areas including the low pass audio filter and notch filter, as well as the AGC; and the power supply.

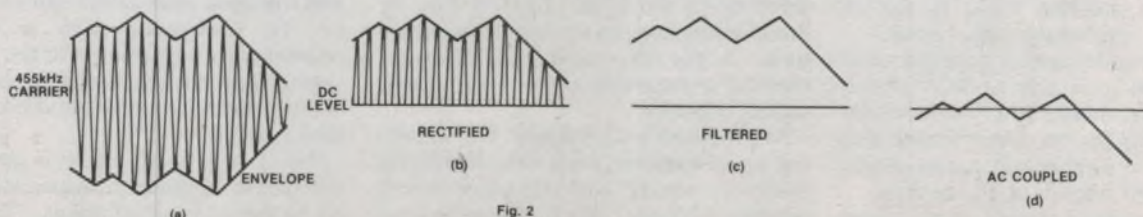
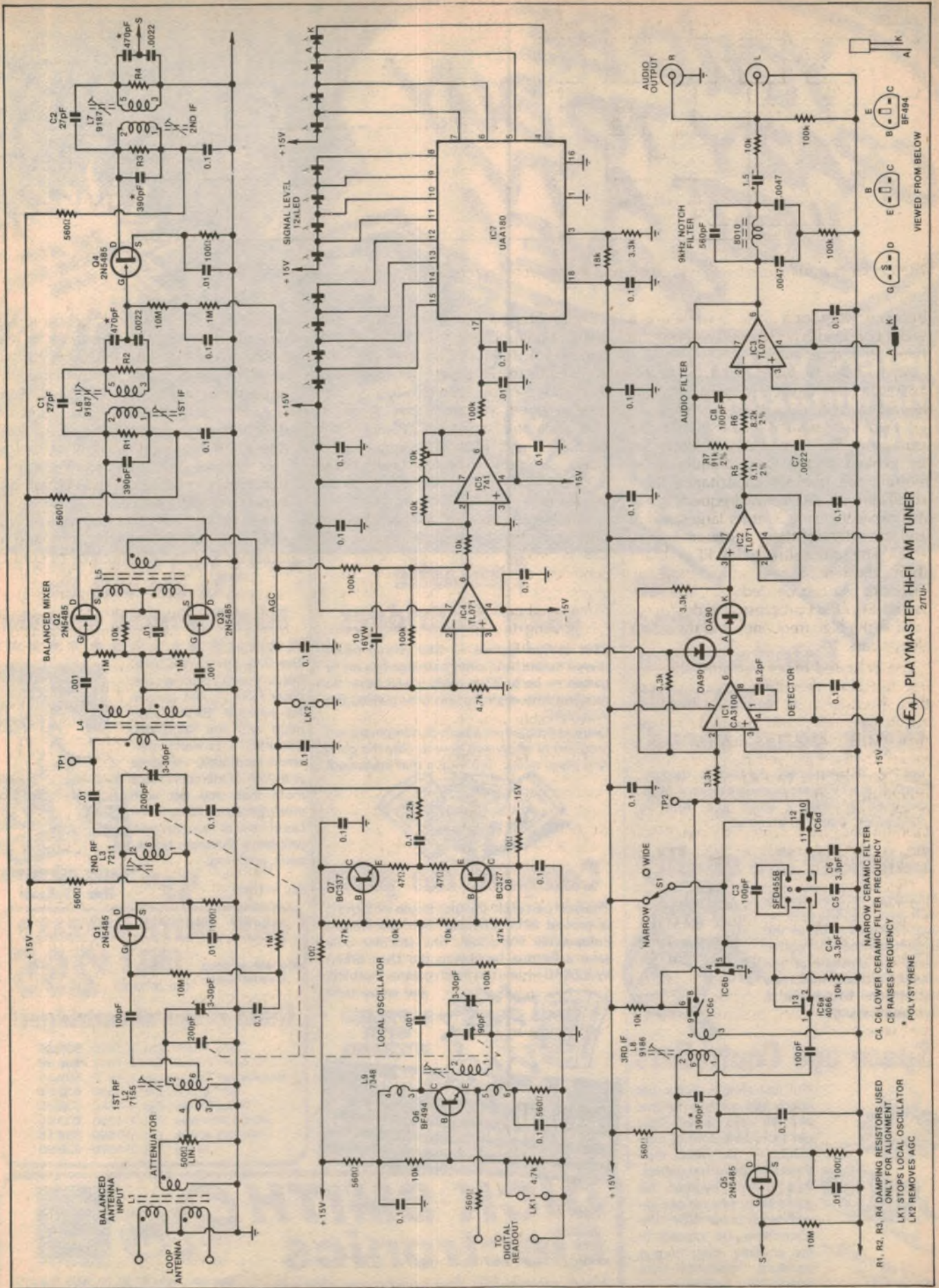

Fig. 2: The signal detection process in an AM tuner. Fig. 2(d) shows the final signal output.





**YOU'D BE CRAZY TO BUY JUST A TV GAME!**

**before you see the amazing DICK SMITH**

# WIZZARD

**the Home Entertainment Computer that's years ahead!**

Yes — an absolutely up-to-date design. Most of the TV game consoles around were designed at least 2 years ago. And in electronics, that's an eternity!

## Compare the quality

Amazing picture quality with over 49,000 dots — over twice as good as the largest selling TV game. You'll be amazed at the clarity, the detail — just like the screens NASA use in the space shuttle!



## Space age Controllers



**GREAT FEATURES — GREAT PRICE!**

Not just simple sticks: full space-age guiding devices with 48 keys as well. You get incredible control capability — far more than possible with other games. And slide-in overlays for controllers: you can see exactly what to do! When the controllers are placed in the console, they form a standard typewriter-style "QWERTY" keyboard — that's versatility!



**OUR MOST POPULAR VIDEO GAME**

## Fantastic game Cartridges

21st century games — like you've never played before. And every cartridge has many games — up to 32 in each! You'll never be satisfied with anything less after playing the WIZZARD.

Every cartridge has a built-in demonstration program to show you how to play the game. And plays music, too — it's that advanced!



## Compare the price

The best part of all: the Dick Smith WIZZARD is around \$200 cheaper than the closest comparable computer! Yes, you not only save a fortune by buying the Dick Smith WIZZARD — you get much greater flexibility and enjoyment!



**SUPPLIED WITH WIZZARD**

## 7 Day Trial Offer

**if you're not completely happy, you can return the WIZZARD within 7 days in original condition and packing for a full refund! You owe nothing — not even an explanation. So why not try the WIZZARD, today!**

## The one with the inbuilt personal computer



The Dick Smith WIZZARD has an inbuilt personal computer facility! Just plug in the optional 'BASIC' cartridge and the WIZZARD becomes a powerful personal computer, complete with 17K of memory (that's more than you get with many personal computers!) Learn how to run your own programs. Finance, home-work, anything!



**'69<sup>50</sup> 'BASIC' CARTRIDGE Now Available**

**DICK SMITH WIZZARD ONLY \$295**

\$6.85 weekly over 12 mths to approved customers

Cat. Y-1600

## Great range of cartridges!

Tank Attack	Cat. Y-1610	\$39.95
Astro Pinball	Cat. Y-1612	\$39.95
Wimbledon Tennis	Cat. Y-1620	\$39.95
Auto Chase	Cat. Y-1630	\$39.95
Crazy Chicky	Cat. Y-1640	\$39.95
Planet Defender	Cat. Y-1650	\$39.95
Air/Sea Attack	Cat. Y-1660	\$39.95
Skiing	Cat. Y-1670	\$39.95

**DICK SMITH Electronics**

See page 98 for address details



Mail Order Centre: PO Box 321, North Ryde 2113  
Phone: (02) 888 3200

The balanced antenna input comprises a toroidal transformer wound so that common mode signals are shunted to ground. Signal attenuation is provided by the preset potentiometer at the secondary of the transformer and the pot wiper connects to the antenna coil of L2, the 1st RF coil. The secondary winding of L2, in conjunction with the 200pF variable capacitor and trimmer, forms the RF tuned circuit. Q1, an N-channel FET, is capacitively coupled to the tap of L2.

Q1 is a self-biased common source amplifier with the tuned circuit formed by coil L3 and its associated 200pF variable capacitor and trimmer as the drain load. The 100Ω source resistor provides self bias while gate circuit current is allowed to flow through the 10MΩ and 1MΩ resistors to the AGC. A 0.1μF capacitor connected to the 10MΩ resistor shunts AC signals to ground. Circuit gain is increased for AC signals by placing a bypass .01μF capacitor across the 100Ω source resistor. Decoupling for the power supply comprises the 560Ω resistor to the supply and 0.1μF capacitor to ground.

The tap from L3 capacitively couples to the primary of L4, a toroid transformer.

Two opposite phase signals are obtained from the separate secondary windings of L4 and are fed to FETs Q2 and Q3. Q2 and Q3 comprise the balanced mixer. These RF signals then cancel at the commoned drain connections. The local oscillator signal is applied via the toroid transformer L5 and two out of phase signals are obtained at the secondaries of the L5 transformer. These are injected into the sources of Q2 and Q3 respectively.

The local oscillator Q6 is fairly conventional and uses a tuned circuit formed with the main winding of L9, a 90pF variable capacitor and the associated trimmer. The oscillator is decoupled from the power supply with a 560Ω resistor and 0.1μF capacitor. A complementary symmetry buffer amplifier comprising Q7 and Q8 follows the oscillator, and drives coil L5 and the reflected impedances in the source terminals of FETs Q2 and Q3 in the mixer.

To maintain the broad bandwidth developed in the RF stages, overcoupling is used between double-coupled IF transformers L6 and L7. As well as inductive coupling, these transformers have capacitive coupling between the two coils. Each coil is peaked at a different frequency so as to broaden the bandwidth. This method allows sharp skirt selectivity but with the disadvantage of a double hump in the frequency response.

This double humping is caused by the peaks of each coil resonance differing to

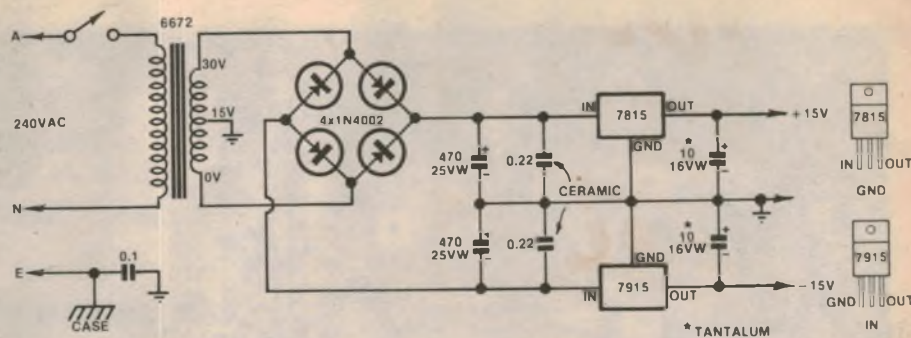

The power supply is conventional and consists of a centre-tapped transformer, a bridge rectifier and positive and negative three-terminal regulators.

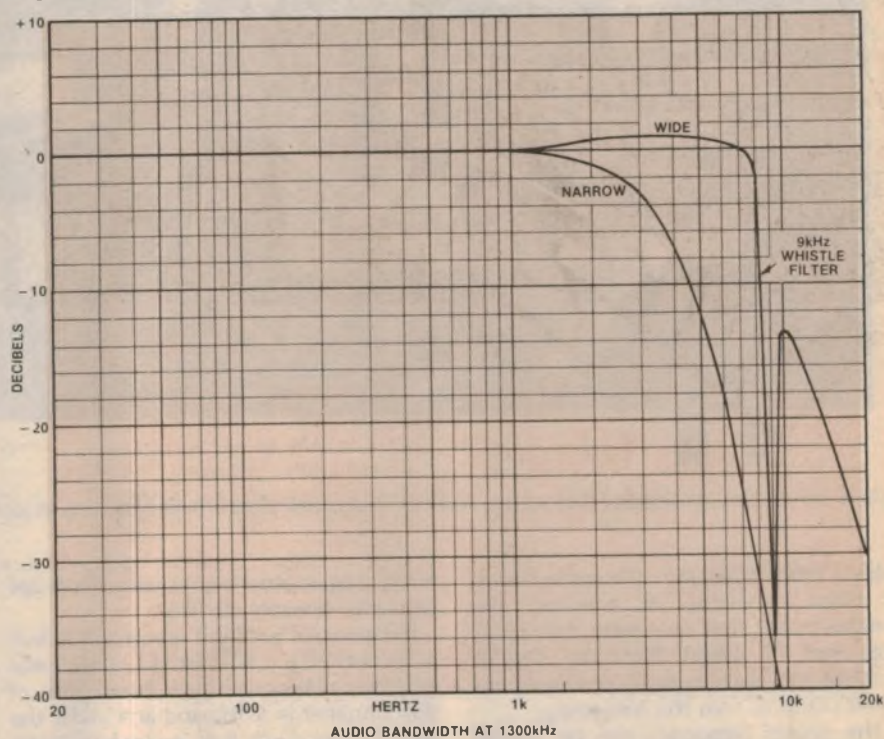

Although this graph plots the audio bandwidth when the tuner is set to 1300kHz, the response is virtually identical over the entire tuning range.

such an extent that a trough occurs in the centre of the passband. This causes peaking at the high end of the audio frequency response. To counter this, a further single IF stage is used to even out the trough at the centre of the passband and reduce the peak at the edges of the passband.

The common drain load for the mixer FETs is the coil winding of the 1st IF filter and a 390pF capacitor across the coil tunes the circuit. Power is derived from the associated 560Ω resistor decoupled by the 0.1μF capacitor. A 27pF capacitor top-couples the first coil to the second coil which is also tuned with 390pF, which in this case is a 470pF and .0022μF capacitor in series. The reason for using two capacitors is to provide a lower voltage tap from the winding to Q4.

Q4 provides impedance matching from L6 and amplification in the 2nd IF

stage, as well as AGC action. The second IF stage is virtually identical to the 1st IF stage and together they provide very sharp roll off at the edges of the passband.

Q5 buffers the capacitively coupled output from L7 and provides gain in the 3rd IF stage. Two outputs are taken from this IF transformer, one from the tap off the main winding and the other from the secondary winding. A CMOS gate package (IC6) is used here to switch the signal either directly to the input of IC1 or via the ceramic filter. These separate taps compensate for the fact that the ceramic filter has a signal loss of about 9dB.

The ceramic filter consists of two ceramic tuned circuits which are top coupled with C3. This capacitor can adjust the bandwidth of the filter from 2kHz with a 27pF capacitor up to 5.2kHz

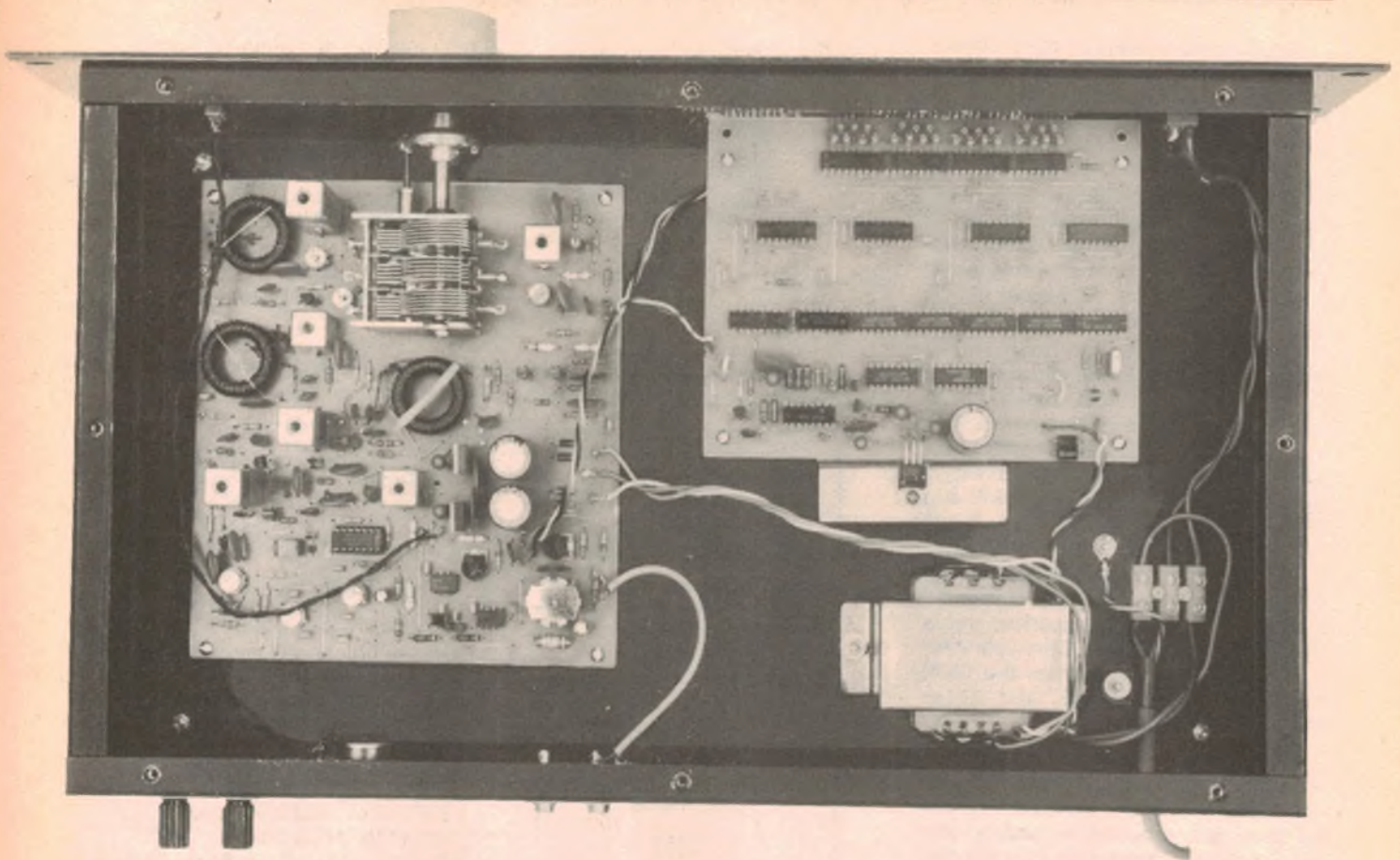

View inside the assembled AM tuner. Full constructional details will be given in next month's issue.

with a 150pF capacitor. We settled upon a 100pF capacitor. As supplied, the ceramic filter has a centre frequency tolerance of within 2kHz (ie, 455kHz  $\pm$ 1kHz) and consequently provision has been made to trim the frequency.

The centre frequency can be shifted low by adding C4 and C6 and making C5 a link. Alternatively, the centre frequency may be shifted high by adding C5 and omitting C4 and C6. The suggested values for these three capacitors will be noted later.

### Precision rectifier

IC1 is a CA3100 operational amplifier suitable for wideband applications and in fact has an uncompensated open loop gain of around 50dB at 455kHz. The amplifier is used here as a precision rectifier with unity gain. The amplifier is basically arranged in an inverting amplifier configuration, with feedback via two separate resistors each in series with a diode. Now there are two feedback paths, one for positive swings of the op amp and the other for negative swings. Tapping the signal at the anode of one diode and cathode of the other will result in detection of the negative and the positive rectified signals respec-

tively. Lag compensation with the 8.2pF capacitor ensures stability.

The positive rectified waveform is buffered with IC2, a TL071 BiFET operational amplifier. The unity gain bandwidth of this amplifier is 3MHz and at 455kHz the typical open-loop gain is close to 20dB. This amplifier is only satisfactory at these frequencies when used as a unity gain buffer. Buffering is required since any loading on the rectifier causes distortion of the rectified waveform.

A 40dB per decade Butterworth filter (IC3) is used to filter the rectified waveform and has a passband gain of 10. The following notch filter provides a very sharp null at 9kHz and is adjustable by rotating the ferrite cup to open or close the integral air gap.

At this stage the output of the filtered

audio signal has a DC component, and capacitive coupling with the 1.5 $\mu$ F capacitor provides a signal referenced about ground. The 100k $\Omega$  resistor to ground allows a path for the coupling capacitor to charge if there is no load on the output. The 10k $\Omega$  resistor in series with the output prevents any undue loading effects by the amplifier stage which could possibly reduce the depth of the notch.

### Automatic gain control

Meanwhile, the negative rectified signal output from IC1 is buffered and integrated by IC4. This heavily filtered signal has a negligible audio component since the integrator rolls off signals above one Hertz.

After further filtering with a 100k $\Omega$  resistor and two 0.1 $\mu$ F capacitors, the signal is virtually a DC level which varies according to the carrier level. This signal is then used to apply AGC to the two FETs in the RF amplifier and 2nd IF stage (Q2 and Q4). The more negative the AGC, representing a higher carrier signal, the less gain the FETs provide, thereby rendering the 455kHz signal level relatively constant for a wide range of input signal strengths.

We estimate that the current cost of components for this project is approximately

**\$250**

This includes the cost of a pre-punched case with silk-screened front panel, plus sales tax.

# Parts List for the Playmaster AM Tuner

## Chassis and Hardware

- 1 aluminium rack cabinet, 430 x 255 x 88mm, with pre-punched front panel and artwork
- 1 large knob to suit
- 1 power transformer, A&R 6672 or equivalent
- 2 SPDT mains switches
- 1 mains cord and plug
- 1 grommet to suit mains cord
- 1 mains cord cable clamp
- 4 rubber feet
- 5 19mm brass standoffs
- 4 25mm brass standoffs
- 1 dual RCA panel output socket
- 1 500Ω linear potentiometer
- 2 binding post terminals

## Main Tuner PCB

- 1 printed circuit board, code 82qr12a, 161 x 178mm
- 3 Neosid ferrite ring cores, 4328R/2 F14
- 18 metres 0.4mm (26 B&S) enamelled copper wire
- 1 label 7155 antenna coil
- 1 label 7211 2nd RF coil
- 2 label 9187 455kHz double-tuned IF transformers
- 1 label 9186 455kHz IF transformer
- 1 label 7348 oscillator coil
- 1 label 8010 whistle filter coil
- 1 Roblan SM3P padderless gang
- 1 reduction drive assembly
- 1 SFD455B Murata ceramic filter

## SEMICONDUCTORS

- 3 TL071, CA3140 or LF351 BiFET op amps
- 1 CA3100 wideband op amp
- 1 741 op amp (can be TL071)
- 1 μAA180 12-LED bar graph display driver IC
- 5 2N5485 N channel FETs
- 1 BF494 high frequency NPN transistor
- 1 BC337 NPN transistor
- 1 BC327 PNP transistor

- 2 OA90 germanium diodes
- 4 1N4002 1A rectifier diodes
- 1 7815 positive 15V 3-terminal regulator
- 1 7915 negative 15V 3-terminal regulator

## CAPACITORS

- 2 470μF/25VW electrolytic
- 1 10μF/16VW electrolytic
- 2 10μF/16VW tantalum
- 1 1.5μF/16VW electrolytic
- 2 0.22μF ceramic
- 13 0.1μF ceramic
- 12 0.1μF monolithic ceramic
- 1 0.1μF metallised polyester
- 6 .01μF ceramic
- 2 .0047μF metallised polyester
- 2 .0022μF ceramic
- 1 .0022μF metallised polyester (C7)
- 2 .001μF ceramic
- 1 560pF polystyrene
- 2 470pF polystyrene
- 3 390pF polystyrene
- 4 100pF ceramic
- 2 27pF ceramic
- 1 8.2pF ceramic
- 2 3.3pF ceramic (see text)

## RESISTORS

- (¼W, 5% unless specified)
- 3 x 10MΩ, 4 x 1MΩ, 6 x 100kΩ, 1 x 91kΩ 2%, 2 x 47kΩ, 9 x 10kΩ, 1 x 9.1kΩ 2%, 1 x 8.2kΩ 2%, 2 x 4.7kΩ, 3 x 3.3kΩ, 1 x 2.2kΩ, 6 x 560Ω, 3 x 100Ω, 2 x 47Ω, 2 x 10Ω, 1 x 10kΩ small horizontal mounting trimpot.

## Main Readout PCB

- 1 printed circuit board, code 82fc8a, 160 x 125mm
- 1 4MHz series mode crystal

## SEMICONDUCTORS

- 1 MC10116 triple differential line receiver

- 5 74LS90 decade counter/dividers
- 1 74LS93 divide-by-eight counter
- 1 74LS04 hex inverter
- 4 4029 presettable decade counters
- 4 4511 BCD to 7-segment decoders
- 1 4017 decade counter/divider
- 1 7805 3-terminal 5V regulator plus insulating hardware
- 4 1N4002 1A silicon diodes
- 1 2N5485 VHF FET
- 2 2N4258 PNP transistors

## CAPACITORS

- 1 1000μF/25VW PC electrolytic
- 1 10μF/25VW PC electrolytic
- 1 10μF/25VW tantalum
- 2 10μF/10VW tantalum
- 4 0.1μF monolithic
- 2 0.1μF ceramic
- 1 .01μF metallised polyester
- 1 47pF polystyrene
- 1 39pF NPO ceramic
- 2 27pF NPO ceramic

## RESISTORS

- (¼W, 5% unless specified)
- 1 x 1MΩ, 5 x 1kΩ, 2 x 1kΩ 1%, 8 x 470Ω, 29 x 270Ω, 1 x 220Ω, 1 x 100Ω, 1 x 22Ω.

## LED Readout PCB

- 1 printed circuit board, code 82qr12b, 146 x 33mm
- 4 FND500 common cathode displays
- 12 rectangular LEDs, 8 red, 4 green
- 2 0.1μF monolithic capacitors
- 1 18kΩ ¼W 5% resistor
- 1 3.3kΩ ¼W 5% resistor

## MISCELLANEOUS

Rainbow cable, hookup wire, machine screws and nuts, solder, etc.

NOTE: Components specified are those used in the prototype. Components with higher ratings may generally be used provided they are physically compatible.

Links LK1 and LK2 and resistors R1-R4 are used only during the alignment procedure. Note that only one 4.7kΩ resistor is required for R1-R4, since the same resistor is used at each position in turn.

## Signal strength indicator

The output of IC4 also drives IC5 which is an inverting amplifier with gain adjustable by means of a 10kΩ trimpot. In turn, IC5 drives IC7 which is the signal strength indicator. This has 12 LEDs to provide a logarithmic display. The range over which the LEDs operate is set by the 18kΩ and 3.3kΩ resistors connected to pin 3 of IC7.

In all cases, bypassing of the power

supply at each active device is affected with 0.1μF capacitors. This bypassing reduces the possibility of feedback being applied through the power supply and causing instability of the circuit. Ceramic capacitors are used for all bypassing involving RF, and small monolithic ceramic capacitors used for the audio stages.

The power supply is a conventional centre tapped full wave rectified circuit with positive and negative 15V three terminal regulators. The reservoir capacitors are 470μF/25VW electrolytics and, as these are not suitable for suppressing high frequency noise, 0.22μF ceramic capacitors are also used. The regulators are bypassed at the output with 10μF tantalum capacitors to im-

prove transient response and further bypass the supply lines.

Although the 1A capacity of the 6672 transformer is far more than is used by the circuit, the transformer was selected for the 30V secondary voltage necessary for the two 15V regulators.

A 0.1μF capacitor is used to shunt high frequency noise from the ground of the circuit to the chassis.

That completes the description of the circuit of our new AM tuner. Next month we shall continue with the assembly of the three printed circuit boards. These comprise the main tuner PCB, the main display PCB (which is similar to that described in the October issue), and a new companion LED readout board. ☺



**At last a graphic worthy of the 5000 NAMETAG  
SERIES 5000 1/3 OCTAVE GRAPHIC EQUALIZER**

Another brilliant DAVID TILBROOK no compromise design



Free  
Jetservice  
over-night  
delivery on  
this Kit —  
Nov. & Dec.

**SPECIFICATIONS:**

Noise — at zero gain and 20 KHZ Bandwidth — 102 db. Distortion 1 KHZ — typically .007%. Bandwidth — 12HZ — 105 KHZ + 0 — 1 db. Boost/Cut + and — 14 db.

**ALTRONICS EXCLUSIVES:**

\* All IC sockets provided \* Quality series Racking Case supplied \* Genuine Philips Synetics Low Noise 5534 IC op amps supplied \* Specially imported high accuracy linear slide potentiometers employed for precision control adjustment. (NOTE: Not compromise "Null Centre" types that some suppliers offer.)

K 5025 ..... See ETI Magazine November 1982 ..... **\$199.50**

**STUDIO FORMAT  
ETI 5000 STEREO CONTROL PREAMPLIFIER**

There have been countless accolades exclaiming this brilliant design by Australia's top audio design engineer David Tilbrook — and with good reason!

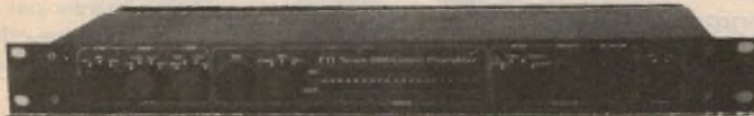

As a demonstration of our faith in this classic designed preamplifier we proudly release the **STUDIO FORMAT 5000 PREAMP** which includes some very worthwhile refinements as detailed here:—

\* Gold plated RCA Jacks on all phono inputs \* 1 x pair gold plated RCA Line Plugs, supplied \* Military spec. National Semiconductor LM 394's employed \* Low capacitance screened cable, supplied; IC sockets provided throughout; Multicoloured led display \* Metal film 1% resistors used throughout all audio circuitry \* Pretinned PCB's \* Satin Black brush finished, aluminium control knobs

**DELUXE STUDIO FORMAT 5000 PREAMP KIT**

Complete kit includes all ETI specified parts plus the Studio Format Package. Full instruction booklet included. SEE ETI MAG. JULY '81—OCT. '81 FOR FULL DETAILS.

K 5001 ..... **\$275.00**

**ETI 5000 STEREO MOSFET AMPLIFIER**

See ETI magazine Jan. '81—April '81. New generation mosfet power semis facilitate David Tilbrook's classic power amplifier. Listening tests prove it surpasses even the best in conventional amplifiers in low fatigue, high definition audio. Completely uncoloured crisp sound purity.



**EVEN BETTER:** This beautifully engineered amp design is based principally on two identical printed circuit boards with a minimum of other wiring, thus enabling even a relative "beginner" to accomplish by step instructions are followed.

The **ALTRONICS Kit** includes the **DELUXE FINISH FRONT PANEL HEATSINK**

\* Original specified chassis bar design case \* All metal work finished satin black \* Flux shorting strap transformers used to minimise hum \* Low leakage power supply electrolytics

**SPECIFICATIONS:** Power Output: 100 watts into 8 ohms x 2. Frequency Response: 8 HZ — 20 KHZ + 0 db — .4 db. Noise: 116 db below full output. Input sensitivity: 1V RMS for 100 W output. Distortion: Less than .001% at 1 KHZ and full output. Stability: Unconditional stable.

**COMPLETE MOSFET AMP KIT K 5005 ..... \$289.00**

**LOUDSPEAKER PROTECTION KIT**

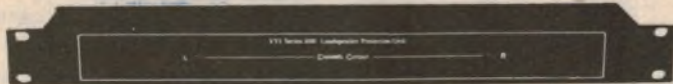

Protect your valuable loudspeaker system with this easy to build, professional appearance kit. This easy to construct kit, based on the latest ETI design (Oct. '82), provides both DC and overpower protection for your valuable HI-FI speakers. Self-powered unit disconnects the speakers within 1/10th of a second of a fault occurring yet in no way effects the sound quality.

The **ALTRONICS Kit** comes in a superb 1 unit rack box including quality silk screened front panel.

**EXCLUSIVES:** \* LED Monitoring of channel cutout \* Fujitsu 10 amp relays \* **ALTRONICS Kit** stereo unit complete to last nut bolt and washer \* Input/Output speaker cable terminals supplied.

Install it in minutes — no AC or DC connections required — simply connects into the left and right channel speaker lines.

K 5050 Stereo Rack Version ..... **\$79.50**

**SINGLE CHANNEL SPEAKER  
PROTECTOR KIT**

For the economy conscious the same electronics employed with the K 5050 are available in single channel format. Jiffy box, printed front panel and all terminals supplied.

K 5051 ..... **\$22.50**



**ETI'S BRILLIANT NEW  
DIRECT-CONNECT COMPUTER MODEM**



Employs unique 'Commutated Filter' design overcoming virtually all the problems involved with conventional modems.

Super flexible unit facilitates communications between computers over cables, the telephone network and radio links.

Unit connects to a standard RS 232 Interface and is capable of both 1200/75 Baud and 300/300 Baud transmission and reception \* Line switching; answer and dialing facilities on board.

**EXCLUSIVES:** \* Plated through, double sided PCB \* Complete set of IC sockets \* Kit requires 85 IN914 Diodes for programming these are included \* Ceralock resonator and matching balanced load capacitor used for long life and high accuracy \* Telecom approved Isolating transformer and Reed relays included.

K 9644 ..... (See ETI Oct 82) ..... **\$169.50**

**MODEM MONITOR AND CASE OPTION I**

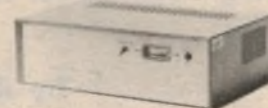

Having built the modems for our own computer use **ALTRONICS** strongly recommend (as do ETI) the Inclusion of Audio and Visual Monitoring (signal strength). Our K 9645 includes all the components listed on Page 23 October ETI, custom **ALTRONICS** PCB, speaker, panel meter, front panel and case to house these options plus the full modem.

K 9645 Modem Option I. .... **ONLY \$30.00**

**NEW UNIVERSAL DC-DC INVERTER**

SEE ETI MAG. SEPT. 1982

Rated at 200 watts this versatile inverter can be simply configured for virtually any desired input/output voltage required by the winding format of T2.

Typical input voltages: 12/24/32 V. Typical output voltages available: + 50, + 15, + 40, 1400 V.

Now you can use high power hi-fi and PA amps for your boat, caravan etc.

K 6509 includes metal case ..... **\$39.50**



**40W FLUORESCENT LIGHT INVERTER  
FOR 12V BATTERY OPERATION**

Self-oscillating, push-pull inverter operates above the audible frequency range and is capable of driving two 20 watt or one 40 watt fluorescent tube to 150% of normal (240 volt operation) efficiency.

Great for camping, working on the car, and of course, during power blackouts!

Complete boxed kit, including all winding wire.

K 6505 Includes Metal Case ..... **\$37.50**

**\$2 DELIVERY AUSTRALIA WIDE** We process your order the day received and despatch via Australia Post. Allow approx. 7 days from day you post order to when you receive goods. Weight limited 10kgs.

**\$4 DELIVERY AUSTRALIA WIDE** We process your order day received and despatch via Jetservice for delivery next day.

**BANKCARD HOLDERS CAN PHONE ORDER UP TO 8PM (EST) FOR NEXT DAY DELIVERY — SOUNDS INCREDIBLE DOESN'T IT?** Alright you cynics just try us! Weight limit 3.3kgs. Jetservice cannot deliver to P.O. box numbers (Australia Post would have a fit).

**\$10.00 HEAVY HEAVY SERVICE — AUSTRALIA WIDE** All orders over 10kgs must travel on the heavy service, that is — road express. Delivery time 7 days average.

**ALTRONICS**  
105 STIRLING ST., PERTH  
FOR INSTANT SERVICE  
**(09) 328 1599**

All Mail Orders: Box 8280 Stirling St, Perth, W.A. 6000

ALTRONICS ... ALTRONICS ... ALTRONICS ... ALTRONICS ...

ALTRONICS ... ALTRONICS ... ALTRONICS ... ALTRONICS ...

For use at home or in the laboratory

# An easy-to-build digital pH meter

From fish tanks to swimming pools to gardening, our new pH meter has many applications around the home. This unit features a large 3½-digit liquid crystal display and resolution to .01pH units, making it suitable for use in the laboratory as well.

by JEFF SKEEN

There are a number of uses for a pH meter outside the laboratory. Chief among these would be helping to keep algae at bay in the family swimming pool. Unfortunately for the pool owner, algae grows best in the warm summer months when the pool is in peak use. To prevent this growth and combat other "nasties", a chlorine-based chemical such as sodium hypochlorite is added to the pool water.

To allow the chlorine to function most effectively, and hence prevent waste, the pH of the swimming pool should be maintained between 7.2 and 7.6. If the pH is allowed to stray too far from these

limits algae will begin to stain the pool tiles despite the addition of chlorine. During periods of heavy use, the pool pH should be checked every second day and the appropriate chemicals added to keep it within bounds.

A pool with a pH below 7 (ie acidic) will consume large amounts of chlorine. In addition, excess acidity causes eye irritations, skin rashes, and corrosion of metal pipes and fittings.

Two hobbies in which the pH of the environment also plays an important role are gardening and pisciculture (got you there).

Plants will generally flourish in soils

with a pH somewhere in the range 6 to 8, although some familiar plants prefer soils outside this range. Camellias and azaleas cannot tolerate alkalinity and do best in soils of pH 4 to 5. On the other hand, tomatoes and potatoes like acidic soils of pH 6 to 7.

To analyse soil pH, "spear point" pH probes are available which measure the soil directly. In this project, however, analysis is carried out by mixing 10 grams of soil with 100 millilitres of water and measuring the pH of the resulting solution.

When keeping fish as a hobby (yes, pisciculture), the pH of the fish tank water has an obvious bearing on the health of the fish. A pH of around 6.5 to 7.5 is suitable for most freshwater fish but for best results (and the happiest fish!), the water should be maintained at the preferred pH for the fish species. For goldfish this is slightly alkaline, a pH of just over 7.5 being about optimum.

When raising either marine or rare tropical fish, where a lot of time, effort and money is involved, a pH meter is a logical accessory to have.

The pH meter to be described here is a general purpose instrument equivalent to commercial units costing hundreds of dollars more. It is simple to construct, easy to calibrate, and is built around a DPM-05 3½-digit liquid crystal display module to keep the parts count to a minimum.

Power is supplied by a single 9V battery, freeing the user from the requirement to have a power point handy. A "low battery" indicator is provided in the display to warn the user when the battery needs replacing. Sensing of solution pH is done with a standard glass pH probe which produces an output voltage proportional to the pH.

Other features of the meter include: compact size, direct readout of the solution pH, a measurement range from pH 0 to 14, and resolution to .01 pH units. To maintain the accuracy of the meter under varying conditions, three front panel calibration controls are provided:

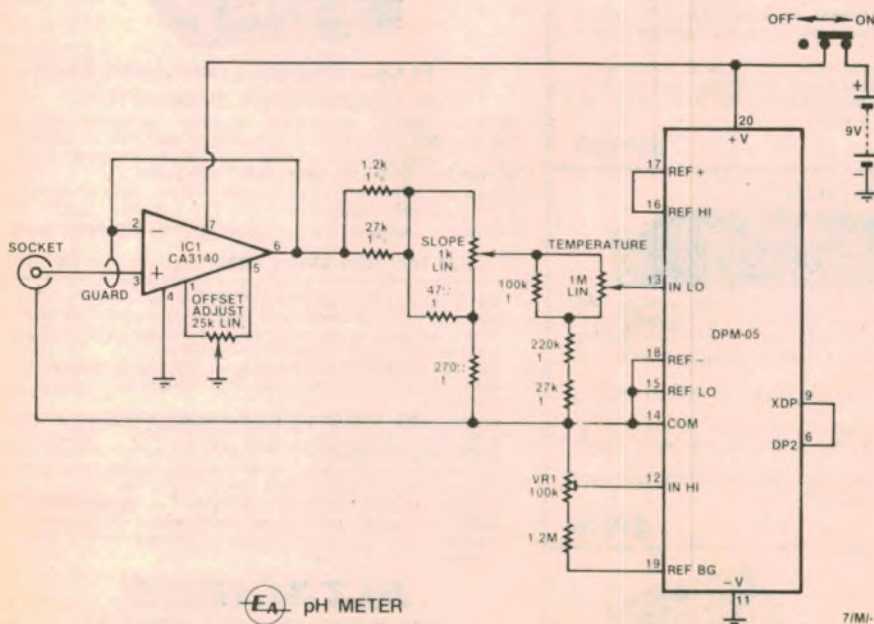

EA pH METER

A CA3140 op amp (IC1), a resistive divider network, and a 3½-digit LCD module make up the circuit. IC1 provides the required high input impedance.



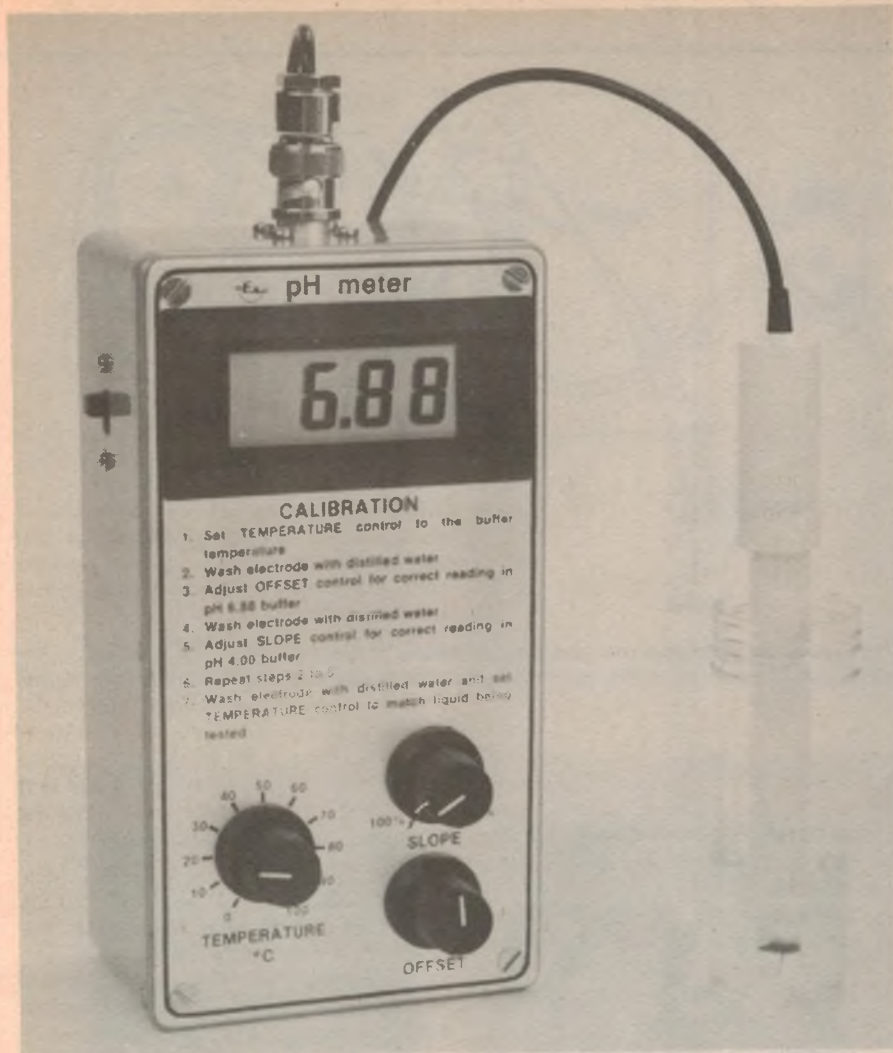

This view shows the completed unit measuring the pH 6.88 buffer solution provided with the probe. Note the front-panel calibration instructions.

Temperature, Slope, and Offset. More about these later.

### The pH probe

The device which makes this pH Meter possible is the pH probe. We are using an "lonode" probe, manufactured in Queensland and stocked by Sydney-based company Starcross Scientific Pty Ltd. At the time of writing the cost of the probe is \$45 plus sales tax.

In essence the probe is simply a wet cell, the output voltage of which is proportional to the pH of the solution. Cor-

rections need to be applied to this voltage to take into account the effects of age, temperature and a less than ideal probe characteristic.

The glass bulb on the end of the probe is porous to hydrogen ions but blocks the passage of larger ions which would contaminate the silver/silver chloride half-cell inside the bulb. Although porous, the glass bulb (or membrane) still presents a significant impedance to the free flow of the hydrogen ions. As the flow of these ions determines the probe output current, the glass bulb

## SPECIFICATIONS

MEASUREMENT RANGE	pH 0 to pH 14
RESOLUTION	0.01 pH units
ACCURACY	within 0.5% (dependent upon care taken in calibration)
TEMPERATURE RANGE	0°C to 100°C
POWER SUPPLY	Single 9V battery
CURRENT DRAIN	2.4mA

## PARTS LIST

- 1 printed circuit board, code 82ph12, 67 x 36mm
- 1 ABS plastic case, 152 x 80 x 47mm
- 1 Scotchcal label, 148 x 78mm
- 1 panel-mounting BNC socket
- 1 SPST slide switch
- 1 DPM-05 LCD module
- 3 knobs
- 1 14cm length of RG58 coaxial cable
- 1 9V battery (type 216)
- 1 9V battery clip
- 1 lonode pH probe (G101NFE) plus pH 4.00 and 6.88 calibration buffers (supplied with probe)
- 4 rubber feet
- 1 1M $\Omega$  linear potentiometer
- 1 100k $\Omega$  large vertical trimpot
- 1 25k $\Omega$  linear potentiometer
- 1 1k $\Omega$  linear potentiometer

### SEMICONDUCTORS

- 1 CA3140T operational amplifier (metal can version)

### RESISTORS (1/4W, 1% unless stated)

- 1 x 1.2M $\Omega$  5%, 1 x 220k $\Omega$ , 1 x 100k $\Omega$ , 2 x 27k $\Omega$ , 1 x 1.2k $\Omega$ , 1 x 270 $\Omega$ , 1 x 47 $\Omega$

### MISCELLANEOUS

- Rainbow cable, scrap aluminium, machine screws and nuts, solder etc.

determines the electrical impedance of the probe.

The major problem to overcome when designing a pH meter is the extremely high internal impedance of the probe. This impedance is of the order of 200 to 500M $\Omega$  depending upon the type of glass used for the membrane. To prevent the circuit from loading the probe (and reducing its output), the measuring circuit needs to have an input impedance at least 10 times greater than the internal impedance of the probe.

### How it works

To achieve the required input impedance, we used a CA3140 FET-input operational amplifier (op amp) which has an input impedance of one tera-ohm (1 x 10<sup>12</sup> $\Omega$ ). This is assured by connecting the CA3140 as a unity gain voltage follower. The limiting factor for the input impedance then becomes the resistance of the printed circuit board (PCB) material.

Leakage currents from other tracks can flow across the PCB, swamping the input current from the probe and causing incorrect readings. To prevent this a guard ring of copper track at the same potential as the input is placed around the input to the CA3140. Because the ring and the input are at the same potential, no leakage current will flow across the PCB.

As the CA3140 is connected as a

# Digital pH meter

voltage follower, a convenient place to connect the guard ring to the circuit is at the output of the CA3140.

The 25kΩ potentiometer connected between pins 1 and 5 initially cancels out any small DC offset voltage produced at the output of the CA3140. Later on, this potentiometer is also used to cancel out any offset in the probe output.

Following the CA3140 is a resistive divider network designed to reduce the probe output voltage to a level suitable for measurement by the DPM-05 LCD panel meter. Included in this network are two additional potentiometers – the Slope and Temperature controls.

These change the division ratio of the resistive network to compensate for variations in the probe output due to temperature and age.

In order to provide accurate front panel scales, the tolerance of these potentiometers must be greatly improved on their 20% values. This is achieved by connecting low-value close-tolerance resistors across the potentiometers, thus reducing their tolerance variation from 20% to around 2%.

The operation of the DPM-05 LCD module is virtually identical to the DPM-200 used previously, so we will not go into details of the module operation here. For a description of the DPM-200 module, see the February, 1982 issue. The module is connected as a 199.9mV full-scale reading voltmeter with one important difference to previous circuits – the input is fed to the IN LO rather than the IN HI input.

In this configuration, the module subtracts the voltage at the IN LO input from that at the IN HI input and displays the result. Another way of saying this is that the module inverts the polarity of the IN LO input and adds it to the IN HI input. Thus the display reading increases when the probe output is negative and decreases when the probe output is positive.

The reason for the inversion of the input signal polarity is evident from Fig. 1. This shows the probe output for solutions of varying pH. When pH is 7, the probe output is zero. For low pH (acid) the probe output is positive and for high pH, above 7, the probe output is negative. Therefore, the probe output signal needs to be inverted and offset (subtracted from a reference voltage) to enable it to be used in a conventional voltmeter circuit.

Trimpot VR1 in series with the 1.2MΩ resistor is adjusted during the calibration procedure to give exactly 70.0mV at the IN HI input. Because the module works in 10ths of a millivolt, this would normally be displayed as 700 but the perma-

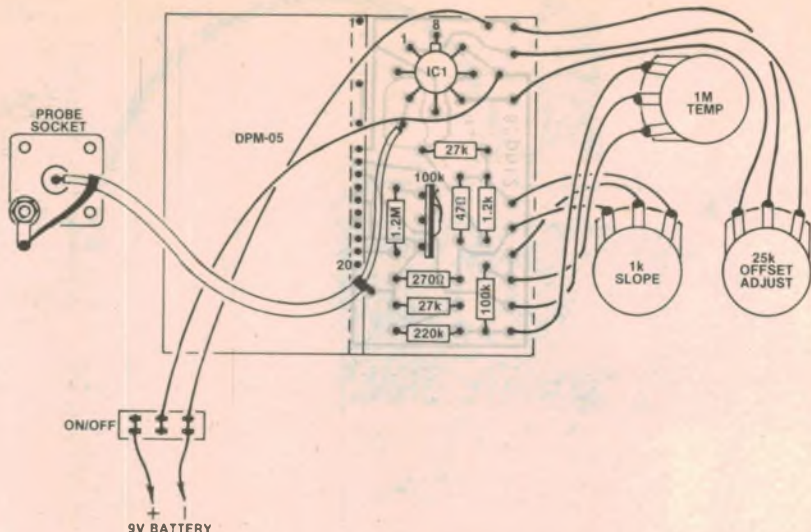

This wiring diagram and the photograph below show how the PCB is wired to the DPM-05 LCD module. Make sure that you mount the CA3140 the right way round.

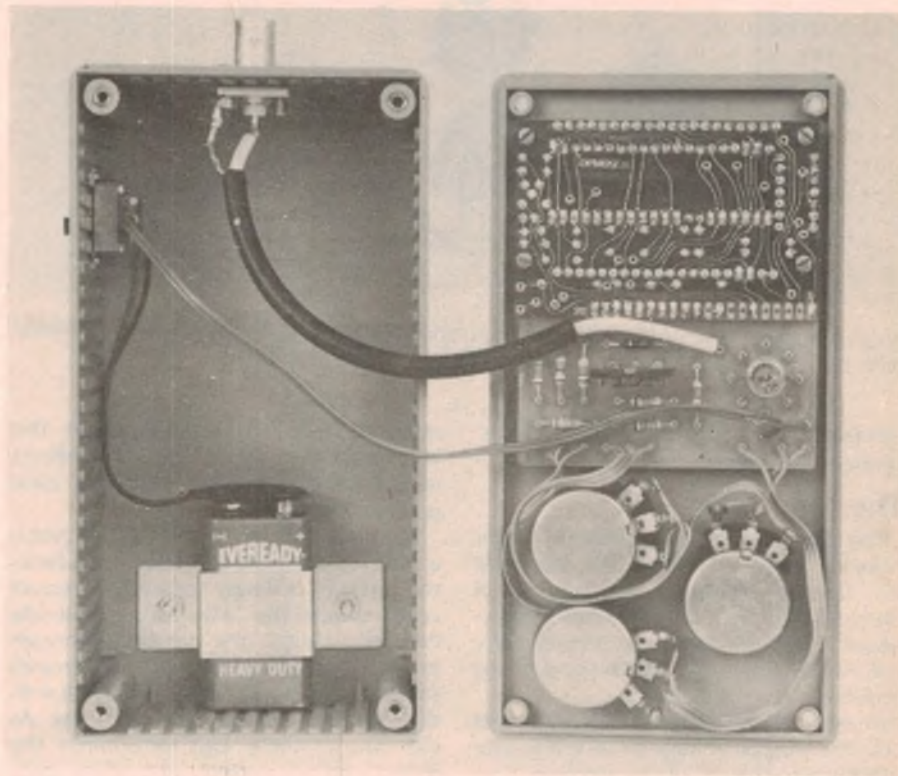

nent wiring in of DP2 changes this to read 7.00.

When the circuit is correctly calibrated, the input to the IN LO pin of the DPM-05 module will be 10.0mV for every pH unit that the solution differs from neutral (pH 7). As already noted, this voltage is positive for pH below 7 and negative for pH above 7; eg, for a pH 10 solution the input to the IN LO input will be  $(7 - 10) \times 10.0\text{mV} = -30.0\text{mV}$ .

The difference between the two inputs is measured and displayed by the

module as follows:  $70.0 - (-30.0) = 100.0\text{mV}$ . Since DP2 is wired in, this appears on the display as 10.00 which is the pH of the solution we are measuring.

## Construction

The circuit is built on a small printed circuit board (PCB) coded 82ph12 and measuring 67 x 36mm. Begin construction by mounting the components on the PCB according to the parts overlay diagram, taking care with the orientation of the CA3140 integrated circuit.

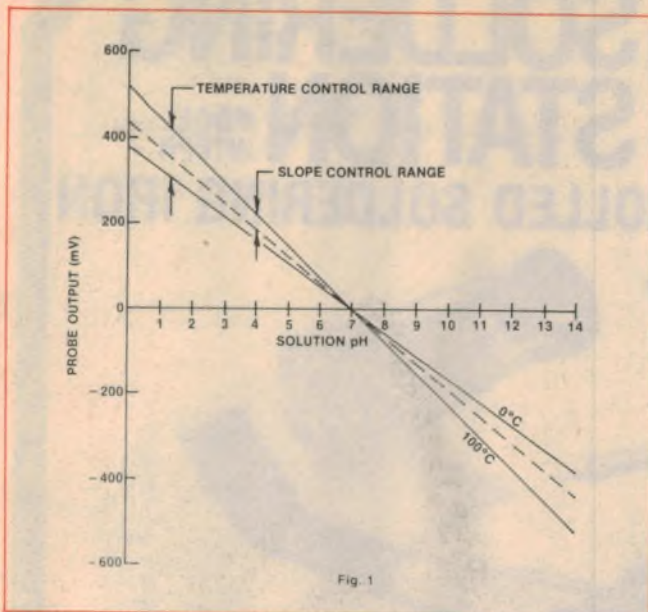
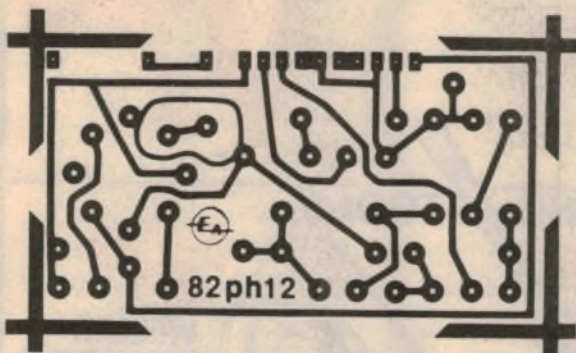

Fig. 1

Fig. 1 above shows how the probe output varies with changes in solution pH and temperature. The adjacent PCB and front panel artworks are shown actual size.



This done, the PCB and DPM-05 edge pads are aligned by overlapping the boards and wire links inserted through the corresponding holes (see wiring diagram). Clamp the two boards firmly together and then solder the links to their respective pads on both sides of the assembly. Note that the component side of the PCB faces in the opposite direction to the component side of the DPM-05.

An ABS plastic case measuring 80 x 47 x 152mm (W x D x H) is used to house the project, and is fitted with a Scotchcal label for a professional finish. Cut out and save the on/off switch markings inside the display rectangle, then trim the label to size and carefully affix it to the lid of the case. The label can now be used as a template to drill the necessary holes and make the display cutout.

The display cutout can be made by first drilling a series of holes around the inside perimeter and then filing the rec-

tangle to shape. Proceed carefully with this step and always file inwards, otherwise the file may tear the Scotchcal away from the plastic panel. Note the six clearance holes for the display bezel at the corners and sides of the display cutout.

Next, mount the BNC input socket and the on/off switch as shown in the photographs, and mount the three potentiometers on the front panel. The wiring can now be completed according to the wiring diagram. Note that a short length of RG58 coaxial cable is used to connect the BNC input socket to the

We estimate that the current cost of parts for this project is about

**\$115**

This includes sales tax.

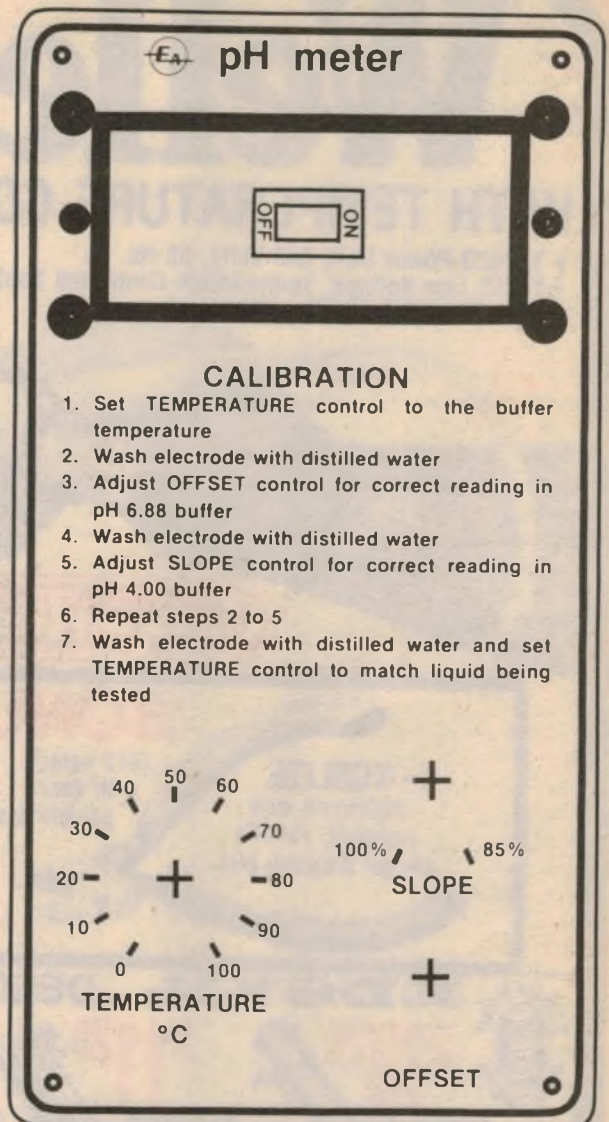

### CALIBRATION

1. Set TEMPERATURE control to the buffer temperature
2. Wash electrode with distilled water
3. Adjust OFFSET control for correct reading in pH 6.88 buffer
4. Wash electrode with distilled water
5. Adjust SLOPE control for correct reading in pH 4.00 buffer
6. Repeat steps 2 to 5
7. Wash electrode with distilled water and set TEMPERATURE control to match liquid being tested

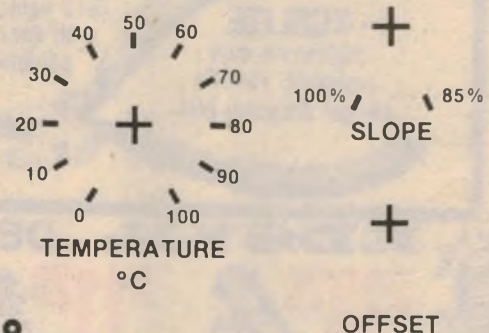

PCB. We do not recommend the use of shielded cable.

Power for the prototype is supplied from a small 9V battery, and this is held in position using a "U"-shaped clamp made from a piece of scrap aluminium. We mounted the clamp on the bottom of the case, beneath the three front panel pots, using machine screws and nuts.

With the wiring completed, glue the display bezel to the front panel using epoxy adhesive and mount the DPM-05 module using the self-tapping screws supplied. Finally, connect the battery clip to the battery, affix the four rubber feet, and you are ready for the calibration procedure.

### Calibration

To initially calibrate the pH Meter, we use the DPM-05 as a voltmeter to measure offset voltages within the circuit. To do this, place a short circuit



## What is pH?

Some readers may not be familiar with the pH scale although most will know that it measures the acidity or alkalinity of a solution. Let's take a look and see how the pH scale works.

The pH scale or notation was developed by a Danish chemist, S.P.L. Sorensen, in 1909. The notation was accepted for the same reason that scientific notation is: large numbers are reduced to an easily handled form. Whereas scientific notation refers to powers of 10, ie  $1,000,000 = 1 \times 10^6$ , the pH scale is based on logarithms to a base of 10; eg  $\log_{10}(1 \times 10^6) = 6$ .

When dealing with fractions, as we do in pH calculations, logarithms work out as negative numbers so we multiply the logarithm by  $-1$  to give a positive answer. This leads us to the equation for pH which is:

$$\text{pH} = -\log_{10}[\text{H}^+]$$

where  $[\text{H}^+]$  is the concentration of hydrogen ions in the solution.

Hydrogen ions are the active ingredient in acids and their concentration is a measure of the strength of the acid.

Concentrations are measured in a chemical unit called the mole (symbol M). This measure is simply a fixed number ( $6.023 \times 10^{23}$ ) of the fundamental units (atoms, molecules, ions, etc) that make up a substance. One mole of  $\text{H}^+$  ions is therefore  $6.023 \times 10^{23}$  ions.

In a container of pure water, the water molecules break down occasionally in the following manner:

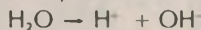

This breakdown happens, on average, to one molecule in 555 million and so the concentration of  $\text{H}^+$  ions in pure water is  $1 \times 10^{-7}\text{M}$ . The pH of pure water is therefore:

$$-\log_{10}[1 \times 10^{-7}] = 7$$

If an acid is added to the water, the concentration of  $\text{H}^+$  ions increases,

giving pH values below 7. As an example, assume an acid has increased the  $\text{H}^+$  concentration to  $1 \times 10^{-3}\text{M}$ .

The pH of this solution is:

$$\text{pH} = -\log_{10}[1 \times 10^{-3}] = 3$$

If an alkali is added to the water, the natural concentration of  $\text{H}^+$  ions in the water decreases as the alkali neutralises them. Thus, the strength of the alkali can be judged by how few  $\text{H}^+$  ions are left in solution.

If we put this  $\text{H}^+$  figure into the pH equation we get numbers greater than 7. For example, consider an alkali that has dropped the  $\text{H}^+$  ion concentration to  $1 \times 10^{-10}\text{M}$ .

The pH is:

$$\text{pH} = -\log_{10}[1 \times 10^{-10}] = 10$$

Contrary to what many people believe, it is possible to have acids with a pH below zero and alkalis with a pH above 14. These are very strong chemicals and are not normally found outside the laboratory.

across the probe input and set trimpot VR1 fully anticlockwise (as seen from the wiper side of the trimpot). Now turn the pH Meter on, adjust the offset control for a reading of 0.00 (the positions of the slope and temperature controls do not matter), then set trimpot VR1 for a display reading of 7.00.

The meter will now show a pH of 7.00 for zero probe output.

The rest of the calibration procedure adjusts the meter to match the probe with which it is to be used. This part of the procedure involves measuring standard buffer solutions (supplied with the probe) and is listed on the Scotchcal front panel. Buffer solutions are solutions of known pH which can absorb large amounts of contaminants with little change to their pH. This makes them suitable for use as standards to calibrate the meter.

Before carrying out the front panel calibration, remove any air bubbles from the glass bulb on the end of the probe. This can be done by flicking the probe gently. Now follow the calibration steps and be sure to wash the probe in distilled water when changing from one buffer to the next.

Note that the probe comes with a "wetting cap" on the end which serves the dual purpose of protecting the fragile glass bulb on the end and keeping the salt bridge wet. This cap must be carefully removed before the probe is used and replaced at the end of each measurement session.

A plastic protector cap is also supplied with the probe and this is fitted over the

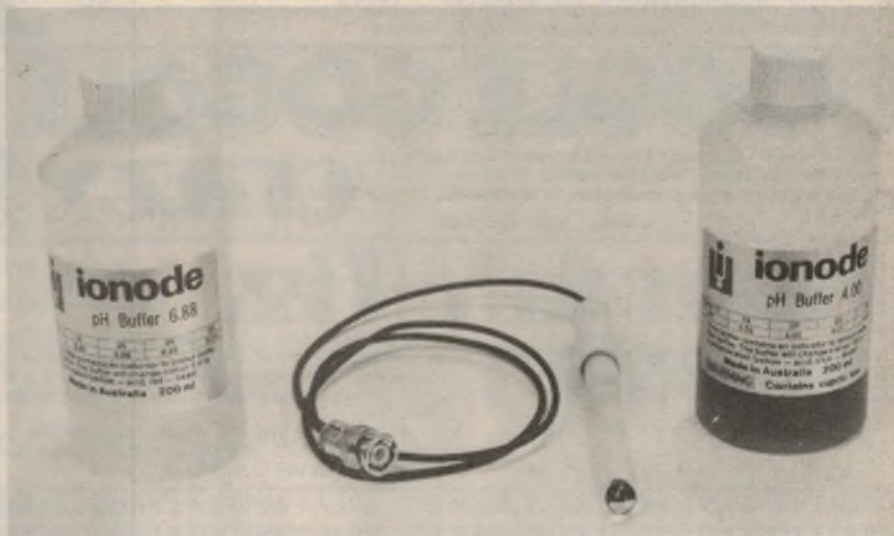

Two standard buffer solutions (pH 4 and pH 6.88) are supplied with the Ionode pH probe and are used to calibrate the meter before use.

end of the probe to protect it against knocks while taking readings.

If pH measurements are being taken regularly, eg every few days, then the meter will not need recalibrating before each use. If used infrequently, however, the calibration procedure on the front panel should be followed before you attempt a measurement.

### Using the pH Meter

After the pH Meter has been calibrated, simply place the probe into the solution to be measured. The meter will give a direct readout of the pH without further adjustment.

The main rules to follow when using the probe are:

- (1) Keep the glass membrane clean (do not allow fats or oils to dry on the surface);
- (2) Keep the salt bridge moist — ie replace the wetting cap after use;
- (3) Wash the probe in distilled water between measurements to prevent contamination of samples.

If the glass membrane becomes soiled, it may be chemically cleaned with solvents, detergents or acids as detailed in the instruction leaflet supplied with the probe. Never use an abrasive cleaner as this will damage the glass.



# CTS & KITS FOR '83!

A CHRISTMAS CHEER TO ALL OF OUR VALUED FRIENDS – HOPE TO SEE YOU IN 1983

## Video Enhancer

Unbelievable but true. This unit enables you to actually IMPROVE a copy of a recorded video tape. How? By amplifying the top end of the video signal by a small amount. This sharpens up the detail of the picture. Dubs can actually look better than the original. Works as a video distribution amplifier as well. Will drive up to 4 VCR's from one VCR input.

value for money

\$89

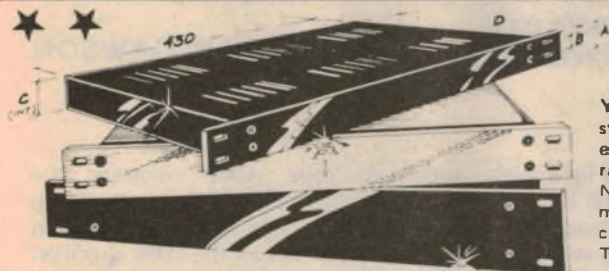
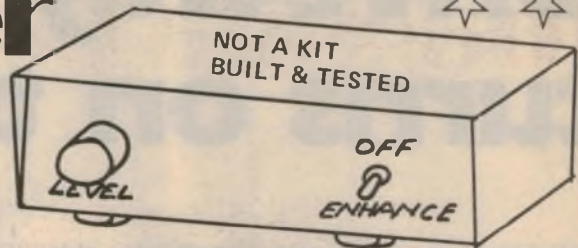

### GREAT RACK CABINETS IN STOCK!!

Your Budget probably will stretch to afford our professional series all aluminium rack cabinets. Now your Pre-amps, control modules, monitor panels etc can look every bit as good as Technics, Nakamichi etc.

Finish	A	B	C	Price	5 or more	Finish	A	B	C	Price	5 or more
Natural	44	34	38	\$39.50	\$38.00	Natural	88	57	82	\$45.00	\$42.50
Natural	132	89	126	\$49.50	\$45.00	Black	44	34	38	\$39.50	\$38.00
Black	88	57	82	\$45.00	\$42.50	Black	132	89	126	\$49.50	\$45.00

### PRO-GRADE SOLDER SUCKER

SEE REVIEW EA DECEMBER 1982  
Our claim. The best solder sucker for its price in Australia!

- Unique double diaphragm design
- O-ring seal
- Spare O-rings supplied
- Teflon tip
- Self-cleaning plunger
- One hand operation
- Non slip body
- Pro-grade for heavy usage.
- 225(l) x 28(d)mm
- Spare Teflon tip \$1.95



ONLY \$11.95

### QUALITY FM ANTENNA "JABBER GRABBER"

\$29<sup>50</sup>

Ground Plane Whips \$7.95ea



### JABBER-GRABBER

OK. So you have spent a fortune on your Hi Fi system. The FM is great. Almost. You are in a area where the FM fades badly or is affected by multipath distortion. Not all stations but only the ones that you want to listen to!! We may have the answer to your problem!! Jaycar has had a helical FM antenna SPECIALLY MADE for vertically polarised transmissions (i.e most FM stations). The unit is supplied with a vertical whip, heavy duty stainless steel bracket, pre-terminated coax lead (environmentally sealed), U-clamp. It will mount on top of your TV mast and give about 3dB of gain over isotropic. The bracket is designed to fit any flat surface & will even lock into a window sill! If you cannot mast mount you will need the two ground plane radials as shown in the illustration. The "Jabber-Grabber" may be the FM antenna to solve your problems!!

### low cost IC inserters extractors

Up until now these have cost a fortune!

Features:

- CMOS SAFE conductive plastic
- Exclusive bent pin alignment guides in handle . 8 to 40 pins.
- Ground strap can be connected.
- One hand operation.

INSERTERS

CIT820	8-20 pin	ONLY \$5.95
CIT2428	24-28 pin	ONLY \$6.95
CIT3640	36-40 pin	ONLY \$8.95
CIT22	22 pin	\$6.50

from \$2.95



### EXTRACTOR

Deceptively simple looking device. One piece metal construction. 8-40 pins ET-840 ONLY \$2.95 IMPORTANT!! Don't be conned into buying a non conductive inserter/extractor. The possible static damage to your MOS I.C.'s could cost you a fortune!!

### 'T-REX'

Our wirestripper, nicknamed 'Tyranosaurus-Rex' is far from extinct! It's a great way to strip all sorts of cable without damaging the conductors. It's also a price breakthrough!!

- Automatically adjusts to insulation diameter.
- One hand operation.
- New low price for an automatic wirestripper



top ONLY \$9<sup>95</sup>  
buy

### HIGH SPEED LOGIC PROBE



- DTL/TTL/HTL/CMOS/MOS compatible!!
- Pulse memory
- 10MHz input frequency (tested to 12MHz)
- ±50V input overload
- Complete with leads.

ONLY \$29<sup>95</sup>

## Jaycar NUMBER 1 FOR KITS

125 York Street, Sydney 2000  
Phone: 264 6688 Telex: 72293

"Nevilles Corner"  
Cnr. Carlingford & Pennant Hills Road,  
Carlingford  
Phone: 872 4422

Mail Orders To: Box 6-39 Haymarket  
Sydney 2000

POST AND PACKING CHARGES  
\$5-\$9.99 (\$1.20) \$10-\$24.99 (\$2.40)  
\$25-\$49.99 (\$3.50) \$50-\$99.99 (\$4.60)  
\$100 up (\$6.20)

NEW SHOP HOURS  
Mon-Fri: 8.30 to 5.30pm  
Sat: 8.30 to 12.00pm  
Thurs night to 8.30pm

MAIL ORDER BY  
BANKCARD VIA  
YOUR  
PHONE



There's no need to trip over the dog!

# Driveway Sentry turns on the lights

Activated by your car's headlights, this "Driveway Sentry" will turn on a driveway or garage light so that you can make a safe exit from your car on the darkest of nights. At the end of five minutes, it will automatically turn the light off again.

by COLIN DAWSON

For those people who normally garage their car at night, there is always a chance of tripping over an unexpected tool box, bicycle, or dog in an attempt to reach a light switch. Even if you don't normally garage your car – and in many cases when you do – there is still the garden path/verandah/front steps/moat (well, your home . . .) to be negotiated. These hazards can be avoided by turning on an exterior light before you leave home, but this is an inefficient solution. The light is on for hours but only required for a few minutes in most cases. Additionally, you must remember to turn it on before you leave.

This Driveway Sentry circuit solves these problems neatly. It was devised by Mr A. Lackey of Collaroy Plateau, NSW.

The Driveway Sentry can be left on permanently, as it senses ambient light and is automatically inhibited during daylight. The circuit is powered, via a transformer,

from the same supply as the light and consumes minimal power when it is untriggered. The printed circuit board has provision for a manual trigger switch – remotely located if desired – which will allow the Sentry to be triggered without using the car's headlights. This would, for example, give you five minutes of light to walk from your door to your car and allow you to drive away without worrying about the light.

A cancel switch may also be fitted – again remotely if desired – which can be used to turn off the light when it is no longer needed, but before its normal "on" time has expired. Both these switches are optional, and are shown dotted on the circuit.

## How it works

To monitor ambient light conditions and to detect the car headlights, two light dependent resistors (LDRs) are

used. As their name suggests, the resistance of these devices varies with the amount of light falling on them. In fact, the resistance of the LDRs specified varies from megohms with no light to a few hundred ohms with bright light. Each LDR faces in a different direction, so that only one of them can detect the relatively directional car headlights.

A 555 – set up as a monostable multivibrator – is used as both a detector and a timer. Provided that the ambient light level is low, any light falling on the headlight-sensing LDR will trigger the 555. Once triggered, it commences a timing cycle (in this case five minutes) during which the controlled light will be on.

To inhibit the headlight sensing function during high ambient light (daylight) conditions, the reset pin (4) of the 555 is used. When this is held low the trigger function (2) is inhibited, and we hold it low by connecting the ambient light LDR between it and the output pin (3), pin 3 being normally low unless the headlight LDR is illuminated.

Some readers may wonder why we use pin 3 rather than ground, as this would undoubtedly provide an equally effective inhibit. The problem with this is that if the controlled light is anywhere near the Sentry, the ambient sensing LDR will see a "daylight" condition as soon as the light comes on. In this situation the 555 would be "inhibited" and the light promptly extinguished – all within a fraction of a second. If the car headlights continued to trigger the Sentry a flashing effect would result. By connecting the ambient sensing LDR to pin 3, which is high during the 5 minute cycle, the Sentry cannot be "inhibited" once the headlight LDR has triggered pin 2.

The .01 $\mu$ F capacitor across the headlight LDR is a precaution against

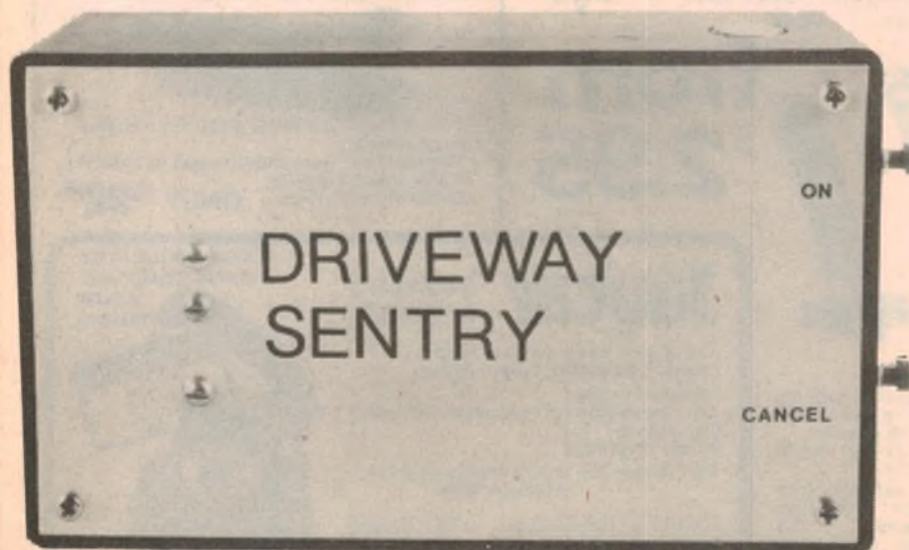

The Driveway Sentry is built into a plastic utility case.



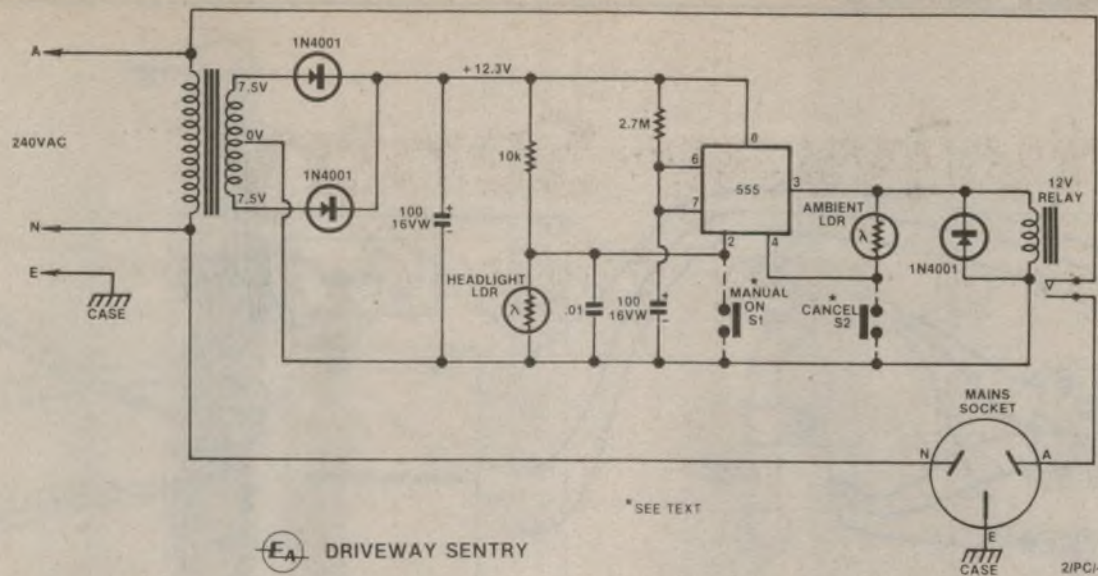

Two light dependent resistors and a 555 IC timer form the basis of the circuit.

false triggering due to a sudden increase in ambient light or, more specifically, lightning. Without it, the light from a lightning flash can turn on the controlled light and, while this will do no harm, some people tend to get upset when a lightning flash appears to be having some effect on the household electrical system.

To avoid such false triggering it is essential that the inhibit function take effect before the trigger has time to operate. The .01µF capacitor provides a short time delay in the trigger function. More specifically, it holds pin 2 high for a very brief period after the LDR has reached the trigger threshold, during which time the inhibit function can take effect.

The five minute delay is provided by the 100µF timing capacitor and the 2.7MΩ resistor. Pin 7 (discharge) of the 555 is normally clamped to ground via an internal transistor. This keeps the capacitor discharged and at the same time holds the threshold (pin 6) low. As soon as the trigger (pin 2) is taken low, the clamp is released and the capacitor begins to charge via the 2.7MΩ resistor, with the output (pin 3) going high. When the voltage across C1 exceeds 2/3 supply, pin 6 resets the clamp on pin 7. This causes C1 to discharge very rapidly and the 555 is reset. This cycle takes slightly less than 5 minutes with the components described. Increasing the value of the 2.7MΩ resistor will give a longer cycle and decreasing it a shorter cycle.

The 555 controls the load via a relay, with a 1N4001 diode across the coil to protect the IC from inductive kickback. Using the normally open contacts of the relay, the active line of the mains supply is switched. For this reason, the relay

contacts must be mains rated not only as regards voltage and current, but also as regards insulation. Make sure of this point before selecting a relay. Whilst we anticipate that most constructors would use the Sentry to control a light, you could use any device or appliance as the load – provided that it does not exceed the current rating of the relay contacts. The relay specified has a 5A rating on its contacts.

A 15V centre-tapped transformer supplies power for the circuit. This is a printed board mounting transformer, which minimises the chances of connecting it incorrectly. Its two output windings are connected in series to drive a full-wave rectifier. A 100µF capacitor filters this output and, with the AC voltage peaks and light load on the transformer, delivers about 12.3V.

## Construction

The printed circuit board used for this project is coded 82pc11 and measures 98 × 87mm. Before mounting any components on the board, check that the relay and transformer pins will fit into their intended mounting holes. If not, now is the time to enlarge them. The first components which should actually be mounted are the two resistors. Next come the three diodes and IC, each one being polarised. The two electrolytics are also polarised, but the greencap is not.

It will prove easier to connect the low voltage hook-up wire to the board now, rather than after the transformer and relay are mounted. You will need at least four lengths of wire, and an additional four if you are using both optional swit-

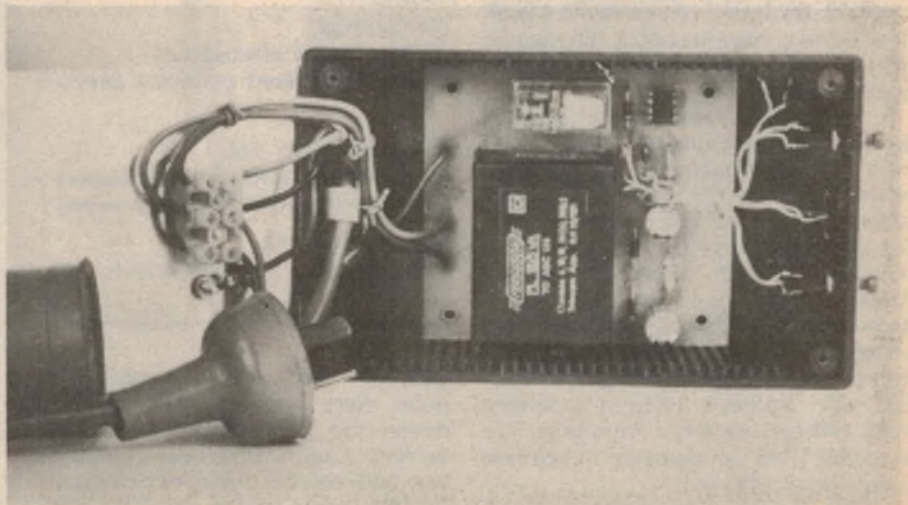

View inside the completed Driveway Sentry. Keep mains wiring neat and tidy, and make sure that you earth the lid of the case.

# Driveway Sentry

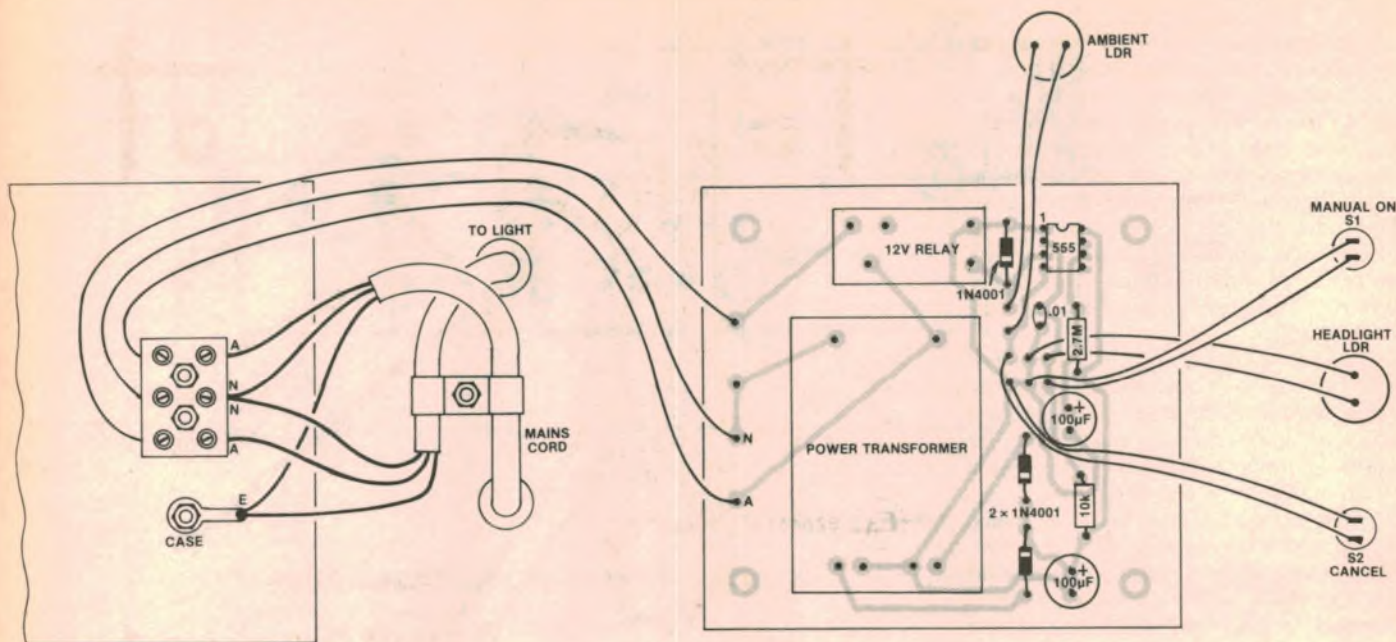

Parts overlay and wiring diagram. Note that the manual override switches (S1 and S2) are optional.

ches. Each piece should be cut to about 80mm in length – they can be trimmed later. The next stage of construction is to prepare the plastic box.

The box measures 158 × 95 × 50mm and the printed circuit board dimensions have been chosen to suit the variety which has three vertical slots on each long side, with notches about 12mm from the bottom, into which the board may be secured. It is available from most dealers and carries a catalog number, moulded into the inside surface, H 0101.

An alternative box is available from Dick Smith Electronics and has multiple vertical slots along each side. This is equally suitable, but the board is marginally too wide and will need to be filed a little to make it fit. If this is done carefully, the board can be made a push fit to make it more secure. It can then be held in place using four small spacers and suitable screws.

A reasonable idea of the physical layout of the components can be gained from the accompanying photographs. Notice that the mains wiring is kept quite separate from the low voltage wiring. For this reason, the two LDRs (and the switches, if used) should be located towards one end of the board. Remember also that the ambient light sensing LDR must face a different direction to the headlight sensing LDR. Each LDR will require a 14.5mm mounting hole, and each switch a 7mm hole. We fixed the LDRs permanently in position using epoxy adhesive.

At the opposite end of the box, two holes are required for the mains cords. The size will depend on the type of

## PARTS LIST

- 1 PC board, code 82pc11, 98 × 87mm
- 1 mains transformer, Ferguson PL15/5VA or A&R AL7VA/15
- 1 12V SPDT relay with 5A 240VAC contacts
- 1 plastic utility case, 158 × 95 × 50mm
- 1 3-pin mains plug
- 1 mains cord socket (in-line)
- 2 pushbutton switches (optional)
- 2 rubber grommets
- 1 length of mains cord to suit
- 2 cable clamps
- 1 3-way mains terminal block
- 3 1N4001 diodes
- 1 555 timer IC

### CAPACITORS

- 2 100µF/16VW electrolytics
- 1 .01µF metallised polyester (green-cap)

### RESISTORS (¼W, 5%)

- 1 × 2.7MΩ, 1 × 10kΩ, 2 × Light Dependent Resistors (ORP12 or equivalent)

### MISCELLANEOUS

- Hook-up wire, machine screws and nuts, solder etc.

grommet used – in our case, 13mm holes were required, and 40mm between the hole centres proved convenient. A single 3mm hole located midway between the two cord holes is used for the cable clamp retaining screw, which should be of the countersunk type.

The length of the mains cords will depend on your chosen location for the Sentry. It should, of course, be protected from the weather. The Sentry will also have to be located in such a position that it will normally fall within the car's headlight beam. If this should prove incompatible with the requirement to protect the device from the weather, it may be necessary to locate the headlight sensing LDR remotely from the rest of the circuit.

The mains terminal block is affixed to the metal lid of the box. Two 3mm holes are required for the machine screws which hold it in place. Locate the terminal block midway between the transformer and the end of the box to reduce the possibility of pinching the wires when fitting the lid. One other 3mm hole is required in the lid for the earth lug.

The earth wire (green or green with a yellow trace) from each cord is soldered to the earth lug. The neutral wires (black or blue) are connected to the same point on the terminal block. The two active (red or brown) wires have separate connections and you must make certain that they go to the correct points.

There are three connections from the terminal block to the printed circuit board – two actives and one neutral. Once again, make certain that the connections are correct. Use wire with mains rated insulation – three lengths cut from a mains cord would be an obvious choice. This completes the internal wiring for the project and the mains cords can now be run through their respective holes. Fit the two cable

clamps and make sure the wires will not be pinched between the lid and box.

A three pin mains plug can now be fitted to the power supply cord. Connect the earth wire (green or green/yellow) to the earth pin first, this pin always being clearly marked. Then connect the active and neutral wires to their respective pins, which are also usually marked. As an extra precaution we have included a wiring diagram showing these connections.

The output cord should be terminated with an in-line mains socket, and the same sequence should be adopted and the same care taken to ensure that the correct connections are made. A wiring diagram for this is also provided.

When you have checked the mains wiring and are sure that all is in order, the Sentry can be tested. Screw the lid on the plastic utility box and, without connecting any load, plug the power cord into a mains socket. At switch on, the 555 may trigger spontaneously (you

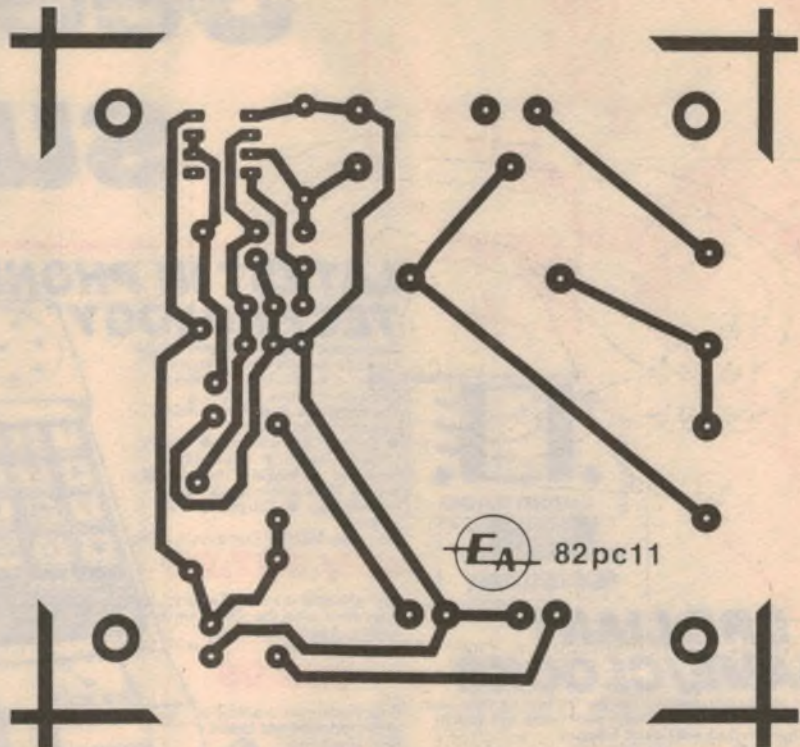

Here is an actual size reproduction of the PCB artwork.

We estimate that the current cost of components for this project is approximately

**\$32**

This includes sales tax.

will know it has triggered by the "click" of the relay pulling in). This is a limitation of the 555, but since the Sentry is intended to be powered continuously, it should not present a problem. If you have fitted a cancel switch, pressing it will cause another click from the relay as it releases. Otherwise, you will have to wait for the duration of the timing cycle.

Cover both LDRs with your fingers or a piece of black tape to simulate darkness. If you are working in a reasonably lit environment, briefly uncovering the headlight sensing LDR should cause the relay to pull in. If the ambient light level is not high enough, use a torch to trigger the circuit. Note that the Sentry will not cancel, even after the duration of its timing cycle, if the headlight sensing LDR is not covered again after triggering has occurred.

Using the manual trigger switch (where fitted) should cause the relay to pull in, even with the headlight sensing LDR still covered. Uncovering the ambient sensing LDR should prevent the Sentry from being triggered by any means.

Provided that your project operates as per the above description, you can now fit the light (or other load) and repeat the tests. When selecting the final location for the Sentry, some trial and error may be needed to find a position where it is

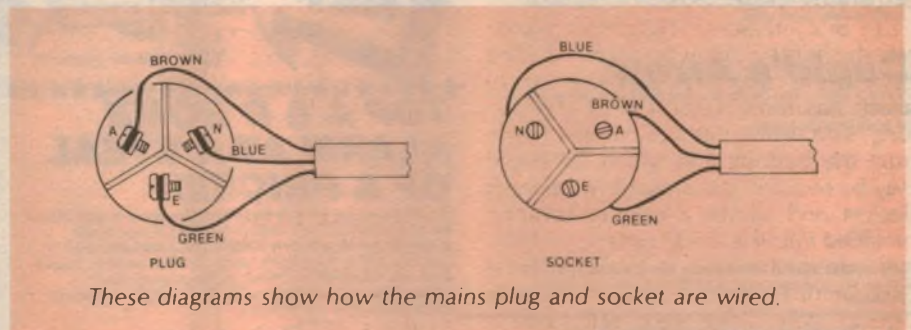

These diagrams show how the mains plug and socket are wired.

operated by your car's headlights but not by those of passing traffic or by street lamps.

Note that any electrical wiring, other than that which we have described here,

will probably transgress supply authority regulations unless performed by a licensed electrician. In any case, if there is any doubt, an electrician or the supply authority should be consulted.

## EA Magazine Holders

The magazine holders are available over the counter from Electronics Australia, .57 Regent Street, Chippendale, NSW — Price: \$4.50.

Mail orders should be sent to Electronics Australia, PO Box 163, Chippendale, NSW 2008.

Prices including postage are:  
\$5.50 NSW; \$5.60 other states; or six for \$29.00 NSW; \$31.50 other states, \$A33.00 NZ.



# See Santa super Ch

## LATEST IN PHONE TECHNOLOGY

The fantastic Fairphone telephone dialler has all the features of more expensive diallers at a price you can afford. Pushbutton phone technology. The Fairphone pushbutton phone includes the following:

- Dialing LED indicator
- Ringer ON/OFF Switch
- Pushbutton Keyboard
- Redial at the touch of a key
- Mute button for private conversation
- Telephone line powered.

Don't pay \$50.00!! Our price is a tiny **only \$27.95**

Also available is a model which plays tune while the other party is waiting. Again available at Christmas saving: **\$29.95**

Both models are available in white, red, blue and brown. Both telephones plug straight in

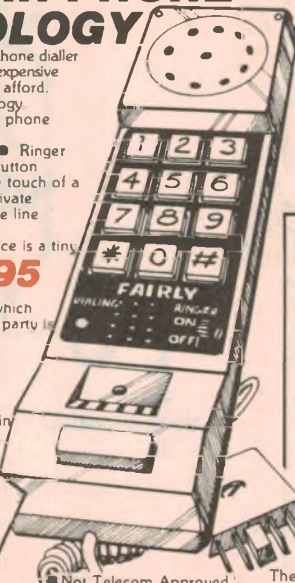

## PROFESSIONAL CAR ALARM. IT'S A STEAL!!

Now you can afford a professional quality, high technology car alarm. Built by A & R, the Model CA443 provides complete protection for your car. The alarm includes the following wanted features:

- 5 inch horn speaker with built in siren module
- Red LED warning light
- ON/OFF toggle switch
- Car window sticker
- Control module
- All screws, cables and instructions

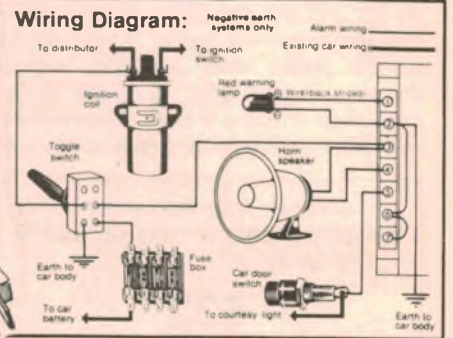

The alarm toggle switch activates the flashing red light and disables the ignition when the alarm is armed. An automatic delay provides 30 seconds exit and 10 seconds entry delay. The siren shuts off after 2 minutes. An optional 'instant' loop is included. This will trigger the alarm instantly if an attempt is made to remove roof racks, fog lights etc. Boot and bonnet switches can be connected into this loop.

With all these features you might expect to pay \$100.00. Recommended price is a low \$59.00. Our usual discount price is \$53.50. But for Christmas we have reduced the price still further to an all time low

**only \$49.95**

**SAVE \$10.00 ON RRP!!**

## BRILLIANT GAME/CLOCKS

These superb new game clocks are the best we have seen. A real challenge to play (harder than Game and Watch) they include clock with alarm function.

### Fighting Climber

Find a way to the top roof by avoiding many falling obstacles and get out by helicopter. But beware of King Kong!! Introductory price only

**\$19.95**

### Cupid's Arrow

Shoot a heart. The devils prevent the heart going up. Quality construction at a reasonable price!

**\$19.95**

## SUPER SANTA OFFER:- THE PAIR FOR ONLY \$36.00!!

Both games have 2 levels and a clock/alarm function. Others are charging over \$30.00 so save with Santa Sheridan!!

## A PUSHBUTTON PHONE COMPLETE!

Complete pushbutton phone with 10 memories. Includes plug and manual. We have sold hundreds of these superb phones from PYE/TMC UK. It's your chance to grab one of the last few. At a reduced Sheridan price, just for Christmas.

**\$49.00**  
**WAS \$59**



Not Telecom Approved.

### Battery Backup

Nicad battery backup. Keeps memories available when you move phone **\$20.00**



- Ultrasonic detection range of 26 feet
- Variable range control
- Mains electricity and/or battery operation. Battery backup in the case of mains failure or tampering.
- Automatic delay to permit owner exit and entry.
- Key Switch on/off control.
- Selectable instantaneous operation.
- Ear splitting siren.
- Supplied with additional horn speaker and cable
- Incorporates circuitry for optional external detectors and emergency alarm
- Automatic resetting.

Recommended price for this top quality system is \$129.00 but for Christmas Santa Shendans have brought the price right down!!

**only \$99.95**  
**Slashed from \$129.00.**

## RADIO CONTROLLED CARS FOR THE KIDS!

These beautiful radio controlled cars are perfect for the kids, especially dad!! You may have seen models like these for over \$100.00. Look at the features!!

- Digital proportional control
- 11 functions including forward and reverse, (variable speed), left and right turn, left and right indicators, headlights, and backup horn

Batteries not included

Two models: Mercedes Benz SLE and Ford Mustang

**\$69.00**



# Sheridan's for Christmas specials!

## PUT HI-FI SOUND IN YOUR CAR WITH ROADSTAR

We've slashed our prices on Roadstar car sound equipment for Christmas. Now you can afford the Rolls Royce of equalizer/boosters! Two models to choose from.

### RS-591 60W BOOSTER EQUALIZER

Get high power with precise equalization. The five band graphic dramatically improves tonal quality. Includes fader control (connects to 2 or 4 speakers), power level indicator and defeat switch. 20-40,000Hz response. Compact dimensions (120W x 40H x 150deep). Superb 70dB S/N ratio.



WAS \$89.00  
SAVE  
\$20.00!!!

**NOW \$69.00**

### POWER AMP WITH BASS & TREBLE.

This model trades graphic equalizer for bass and treble controls. Delivers the same 30 + 30Watts per channel. Has independent left and right power displays. Bypass switch included. Booster has same specs as the RS-591. Quality doesn't cost a fortune. Save with Santa Shendan!!

**\$45.00**

Was \$54.00  
save \$11.00



These Roadstar products are in limited quantities so it's first come first served!!

### NEON DISPLAY

Once in a lifetime offer. These 6 digit orange neon displays are used in pinball machines etc. Made by Cherry of Waukegan USA. Normally cost over \$30.00 but we are cleaning them out. 18mm high characters. Work on 160V DC.

Sorry no spec available

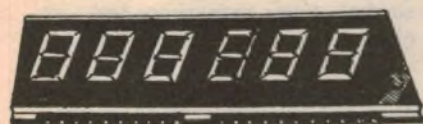

**\$10 each  
10up \$8.00**

### 60 WATT MICRO EQUALIZER. PRICE SLASHED OVER 30%

We have only 30 of these superb Phodis PH-5250 60 watt equalizer/boosters left. Tiny so they can fit into any car but boy do they pack a punch!! Size is 90mm x 29mm x 135mm deep. We're letting them go at this giveaway price for Christmas. Features include:



- 30 Watts per channel power output
- Direct coupled design for low distortion and 20-20,000Hz response
- 5 band Graphic Equalizer.
- Boost/Bypass switch
- 5 LED power meters
- Speaker Switching for 2 or 4 speakers
- Noise suppression circuit built in
- Installation instructions included.

Grab one of these fantastic boosters at a never to be repeated price!!  
**only \$39.95  
REDUCED FROM \$57.95!!!**

### PUSHBUTTON DIALER SAVING!!

Reduced just for Christmas. We were selling them for \$24.95. We have dropped the price even further. This dialer is top quality and connects in seconds. No soldering or technical knowledge needed. Has last memory recall.



**only \$22.95** Not Telecom Approved

### SCOOP ON CITIZEN CALCULATORS!!

We have just made a scoop purchase of brilliant **Solar Powered** calculators. These are famous Citizen brand. They require no batteries. These normally sell for \$24.95 each so make a big saving now!!

#### MODEL SOLAR 81

- 8 digit LCD display
- Basic calculation
- constant, power reciprocal, percentage, add on/discount, square root
- Memory
- complete with instruction book and wallet

#### SOLAR CARD

Has all the functions of the Solar 81.

**SAVE  
\$7.00!!**



**\$17.95 each**

### DISCO/STUDIO MIXER MODEL MM4

This superb mixer is part of Raimar's Studio Control range. It offers the qualities of a broadcast mixer with the features and flexibility needed by the disc jockey. Features:

- 5 band graphic equalizer using latest IC techniques
- Handles 4 stereo inputs plus two mic inputs
- Phono inputs may be switched to line inputs
- Defeat control on equalizer.
- Ultra low noise preamps for mic and phono inputs
- Professional stereo slide controls
- Headphone circuit to monitor each input
- Talk switch attenuates music by 14dB. No need to readjust music levels for voiceover.
- Professional VU meters

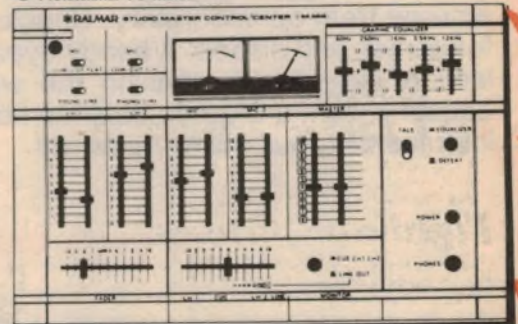

The MM4 is a solidly constructed professional quality unit, great for use at home or in road use.

The price is a steal. **only \$189.00**

### HY-10MX STEREO MIXER WITH CUE

The great mixer offers fantastic value for money. All the features you need at a price you can afford!!

- Stereo mic inputs
- Two stereo phono inputs for magnetic cartridges
- Two stereo phono inputs for ceramic cartridges
- Stereo line inputs for tape decks etc.
- Cue function for monitoring inputs via headphones
- Dual VU's
- Mono/Stereo
- DC Powered (9V) or AC with adaptor.
- Dimensions 265 x 195 x 70mm

Santa Shendan price!!

**\$99.00**

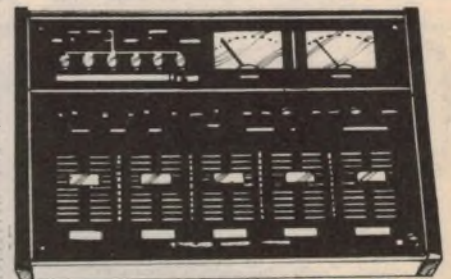

## SHERIDAN ELECTRONICS

164-166 Redfern St., Redfern NSW 2016. Phone (02)699 6912, (02)699 5922  
Mail Orders to Dept EA, PO Box 229 Redfern NSW 2016

**Trading Hours:-**  
Mon-Fri. 9am-5.30pm  
Thursday 9am-7pm  
Saturday 9am-12noon

**Mail Charges:**  
\$5.00-\$9.99 \$3.50  
\$10.00-\$24.99 \$4.00  
\$25.00-\$49.99 \$6.00  
\$50.00-\$99.99 \$7.00  
\$100.00 or over \$8.00



Be a real weirdo with these

# Mind-blowing Boggle Goggles

What sort of project uses two ICs, six LEDs and a pair of dark glasses? Boggle Goggles — what else! The latest creation to emerge from our laboratory, Boggle Goggles, is a great gimmick for parties and discos. A beady eyeball darts around behind each lens of the glasses making the wearer look like a shifty, evil escapee from a B-grade science fiction movie. So if you want to look just like our editor, read on!

By COLIN DAWSON

Boggle Goggles have no appeal to practicality or good taste; in fact, their only justification is that they are fun. We can almost guarantee that you will be the subject of much mirth if you wear these spectacles into a crowded room or on a busy street. In fact, your students/patients/passengers/jury may never take you seriously again! With a giant leap for mankind (who said backwards?) this project brings "Groucho Marx glasses" into the 1980s.

Depending on your leisure time activities, you may or may not have seen novelty dark glasses with a single LED

behind each lens. Whilst they are reasonably effective in attracting attention, the single LED can only blink on and off. By comparison, the Boggle Goggles have a much more animated display with the "eyeball" appearing to move randomly from side to side. If the single blinking LED causes people to do a double-take, this moving eye will surely stop them in their tracks!

The project came into being through our desire to present a novelty project for this Christmas issue. The primary objective was for something that would be fun to build and use, and preferably "dif-

ferent". Fortunately, it was not essential that the project serve any practical purpose. Last year, it was the LED Christmas tree decorations. Subsequently we presented the "Cudlipp Cricket" project (February '82) which, by all accounts, has proven very popular. For this month's project, various types of flashing LED jewellery were considered, but for sheer buffoonery, none could compete with electronic sunglasses.

Having decided on a project, the next problem was to find a suitably novel name. A certain staff member immediately suggested "Boggle Goggles", which was so bad that, inevitably, it stuck. Against this gem of pre-adolescent doggerel, titles like "Bright Eyes" or even "The Evil Eye" had no chance at all. It was even suggested that the name might be abbreviated to "BCs"!

For best effect, the glasses should be of the reflective type favoured by snow skiers. When these are used, the LEDs cannot be seen until they are actually illuminated. Being quite efficient for excluding ambient light, these glasses will unfortunately restrict one's vision somewhat — especially indoors or at night. In fact, with the LEDs flashing vigorously in front of your eyes, it is quite probable that you won't be able to see much at all. In fact, you'll be quite boggled. Hence the wearer should remain stationary whilst demonstrating the Boggle Goggles.

To simulate evil eyes, flitting from side to side, three LEDs are used in each lens of the glasses. The LEDs are wired in pairs so that at any given time, one LED from each eye will be on. A different pair of LEDs will be activated about every 0.5s, giving the impression that the "eyeballs" are alternating between left, right and straight ahead. Whilst we wired the prototype so that the LEDs were synchronised ie, the same LED position from each eye is activated at any given time, there is no compulsion to do this. For example, if the connections to one left and

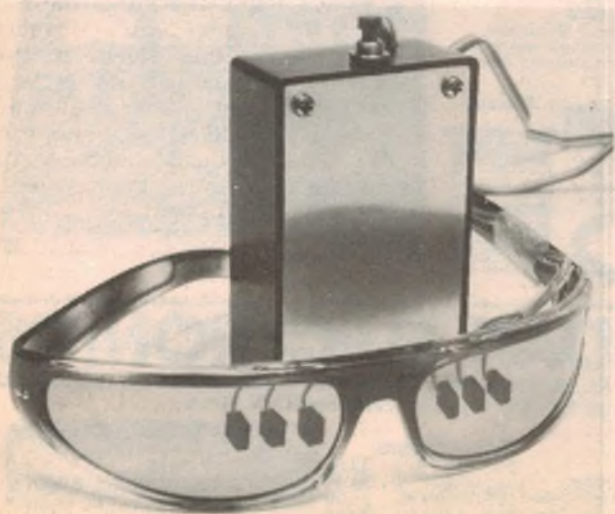

*These "moving" LEDs behind dark glasses should really create a stir. The circuitry is in a compact utility box.*



Magazine Promotions staff member Jenny Cardow models the new Boggle Goggles.

one right LED are transposed, the eyes will appear at one moment to be crossed and at another bug-eyed!

(It would be possible to wire the LEDs so that these two options were switchable. However, it would require several additional wires to the LEDs and rather more complex wiring.)

## The circuit

The circuit contains two ICs and very little else. IC1 is a 4011 CMOS quad NAND gate and IC2 is a 4017 CMOS decade counter. The sole function of IC1 is to oscillate and thereby provide a "clock" for the decade counter. For this purpose, only three of its gates are re-

quired, the fourth gate being tied permanently low. These three gates operate as a conventional three-inverter oscillator.

By connecting the inputs of a NAND gate together, the gate is caused to operate as an inverter ie, its output is in the opposite logic state to its input. Referring to the circuit diagram, it can be seen that three such inverters — IC1a, IC1b and IC1c — are connected in series. A  $1\mu\text{F}$  capacitor and series  $220\text{k}\Omega$  resistor (R1) are connected between the outputs of IC1b (pin 10) and IC1c (pin 3). Since these two outputs will always have the opposite polarity (let us say initially that pin 10 is low and pin 3 is high), the capacitor will be charged. The  $220\text{k}\Omega$

resistor provides a time constant of about 0.5s for this charging. After this time has elapsed, the input of IC1a (pins 12 and 13) will be taken past the upper threshold and the gate will toggle with its output going low.

This causes the other gates to simultaneously change states, with pin 10 going high and pin 3 going low. The  $1\mu\text{F}$  capacitor now begins charging in the reverse direction, the time constant of 0.5s again determined by the  $220\text{k}\Omega$  resistor. After this time period, the charge on the capacitor will fall below the lower threshold of IC1a and it will again toggle. The result of all this is a square wave output at pin 3, which then provides clock pulses for the decade counter.

The  $220\text{k}\Omega$  resistor (R2) feeding pins 12 and 13 is primarily a protective device, needed to avoid damaging the input diodes of IC1a. However, it will also have a small incidental effect on the time constant as determined mainly by the  $1\mu\text{F}$  capacitor and R1. If the time constant has to be changed, changing R1 will probably be sufficient, but R2 could also be changed if necessary.

IC2, being a decade counter, has 10 outputs. These are numbered 0-9 and each one, beginning with 0, goes high in turn. The counter triggers on the positive edge of each clock cycle so that each output goes high for one clock cycle, which in this case is 0.5s. The  $.0015\mu\text{F}$  capacitor connected to the clock input of IC2 prevents the counter from triggering on noise which may otherwise cause erratic counting.

Since there are only three pairs of LEDs to be driven and 10 outputs available from IC2, more than one output can be used to drive each LED pair. Actually, three outputs are connected to the LED pair representing eyeballs left, three to eyeballs right, and four to eyeballs centre. Because these outputs can not be connected directly to each other without causing IC2 to malfunction, each output drives through a diode.

By ensuring that none of these commoned outputs are consecutive numbers, the eyes appear to change position with each clock cycle. The sequence is left, middle, right, middle, right, left, middle, left, right, middle. Since it takes around 5s for the sequence to repeat, a casual observer sees the display as being random.

Each LED requires a current of 10mA, and since a pair of LEDs will be on at any given time, the most efficient means of driving them is as a series pair. The current is limited to 10mA by a  $68\Omega$  resistor which is common to each pair of LEDs. The total current drain of the circuit is around 11mA, which is quite severe for a type 216 9V battery. In consequence, this type of battery can be expected to give a useful life of no more than 1.5hrs

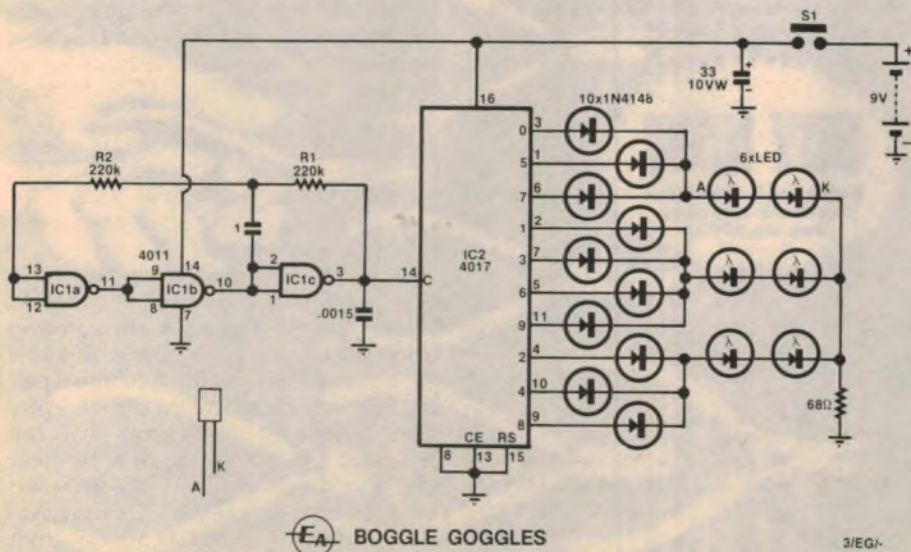

The circuit of the Boggle Goggles contains just two ICs and a handful of other components.

# Plug into 'Eveready' rechargeables.

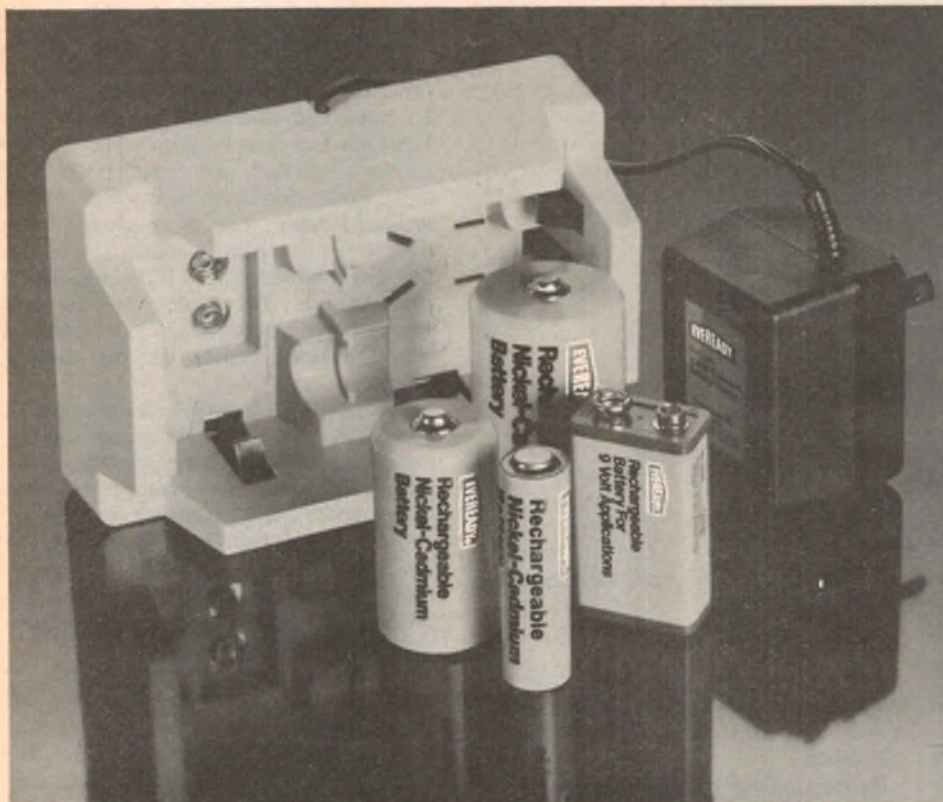

Our rechargeable range, in popular sizes, can be charged up to 1000 times on the new model ACC50E Charger, thus offering an extremely economical power source to the heavy-battery user. Especially ideal for photo-flash, movie cameras, tape recorders, transceivers and electronic games and toys.

Please don't hesitate to call for further information.

**EVEREADY**

## Rechargeable Nickel-Cadmium Batteries.

Union Carbide Australia Limited,  
Battery Products Division,  
157-167 Liverpool Street, Sydney  
Phone: 269 0656

### SALES OFFICES:

Brisbane: 47-49 Sherwood Road,  
Toowong. Phone: 371 6877  
Adelaide: 121 Greenhill Road,  
Unley. Phone: 272 0611  
Melbourne: 14 Queens Road.  
Phone: 26 1241, 26 2332  
Perth: 901 Hay Street  
Phone: 321 2926.



Eveready and Union Carbide are registered trade marks. 085 P8344

## For Fine Jobs That Need Firm Treatment

Channellock Little Champs are ideal for hundreds of fine jobs that need firm treatment. Precision made of highest grade forged steel. High lustre polished finish. Perfectly mated, hand honed cutters. Blue dipped plastic comfort grips. Specify Channellock Little Champ precision pliers. You'll really like them.

### Available from:

**Melbourne:** All Electronic Components 662 3506, Ritronica Wholesale 489 7099, Thos Warburton 62 1231, Stewart Electronics 543 3733. **Sydney:** Martin De Launay 29 5834. **Brisbane:** Fred Hoe & Sons 277 4311, St Lucia Electronics 52 3547, Audiotronics 44 7566. **Canberra:** Electronic Components 80 4654. **Perth:** Atkins Carlyle 321 0101.

**BUY NOW**

Extra 7½% Sales Tax becomes effective Jan. 1st, 1983.

**CHAN NEL LOCK**

Little Champ Precision Pliers

### For distributor enquiries call Australian agents:

Selectronic Components Pty. Ltd.  
25 Holloway Drive,  
Bayswater, 3153 Victoria.  
Telephone (03) 762 4822.



Manufacturers of a broad range of wound components, including transformers, pulse transformers and components for lighting and electrical requirements.





with continuous duty. This should be sufficient for several satisfying sessions of boggle goggling.

Its redeeming feature is, of course, its compact size. In this respect, it is the most practical power source. It can fit into the smallest size "zippy" box, or alternatively, it can be inconspicuously slipped into your pocket along with the printed circuit board. In any case, we anticipate that the circuit will usually be operated for only 5-10 seconds at a time, in which circumstances the battery life will probably be adequate. If longer battery life is essential, the circuit can be powered from a 6V battery pack such as four "AA" type cells. In this case, the 68Ω LED current limiting resistor would need to be reduced to 47Ω.

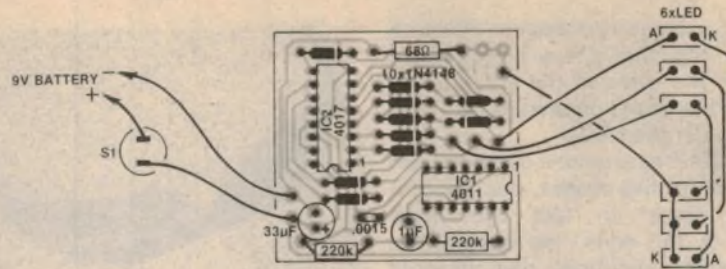

Parts overlay diagram for the Boggle Goggles. Make sure that all polarised components are inserted the right way round (ICs, diodes, LEDs, electrolytic capacitors).

We estimate that the current cost of components for this project is approximately

**\$9.60**

This includes the plastic utility box but not battery or glasses.

## Construction

Before embarking on the construction of your Boggle Goggles, you will have to decide whether to use a plastic utility box or not. The printed circuit board (PCB), code 82eg12, measures 47mm x 44mm and was designed to fit into the smallest of these boxes. This box has nominal dimensions of 83 x 23 x 54mm, but different manufacturers provide different PCB mounting slots. This means that the PCB may need to be filed down slightly to fit some boxes.

A momentary contact pushbutton switch is most suitable for this project. If using the "zippy" box, you will probably want to mount the switch on the box, in which case a 7mm mounting hole is required.

A second hole is needed in the box to run the wires to the LEDs. Its size will depend on the type of cable you use. A four-way rainbow cable will require a hole of about 3mm. Another approach would be to use three or four-cored shielded cable which would require a larger hole, but this would be practical only if small gauge, flexible cable can be obtained.

When mounting the 10 diodes on the PCB, take careful note of their polarity. Of the capacitors, only the 33μF electrolytic is polarised. Both of the ICs are CMOS, so it will be necessary to take the usual precautions. Use a clip lead to connect the barrel of the soldering iron to



View inside the prototype, showing how the PCB fits into a small plastic utility box. The battery sits on top of the PCB and should be wrapped in plastic foam to prevent shorts.

the earth track of the PCB. Solder the earth pins (7 for IC1 and 8 for IC2) first and then the positive pins (14 for IC1 and 16 for IC2). This will minimise the chances of the ICs being damaged by static charges.

A good idea of how the board and other components are fitted to, or in the box, can be gained from the photographs. The board sits on the bottom of the box, with the battery on top of it, to one side. A small piece of plastic foam is wrapped around the battery to insulate it from the board and the metal back of the box. This arrangement is a

snug fit so that no mounting screws are really necessary.

A number of considerations will determine the method of affixing the LEDs to the lenses. The most important of these is whether you will want to use the glasses for their normal purpose after Boggle Goggles have exhausted their novelty. If not, it is simply a matter of gluing the LEDs to the lenses. For a less permanent assembly, a strip of styrofoam or cardboard (about 5-8mm wide) can be stuck along the inside top of each lens using double sided tape. The legs of the LEDs can then be glued to this strip

without having any permanent effect on the lens. Note that it may be necessary to solder the wires to the LEDs before applying the glue, depending on how short you cut the leads.

If you intend to acquire a pair of glasses specifically for this project, our advice is anything goes. In fact the more outrageous the style, the better. We have already mentioned that mirrored lenses are quite suitable because they hide the LEDs and wiring, but any pair of glasses which is very dark should suffice. Wide framed glasses will make it easier to conceal the wiring, as will the "wrap around" type glasses popular with "new wave" music enthusiasts.

When positioning the LEDs, try to put them as nearly as possible where a normal eyeball would appear. In most cases, this will be towards the centre and upper part of the lens. Locating them elsewhere will tend to destroy the "eyeball" illusion. Although we used rectangular green LEDs, this aspect of construction is completely optional. Rectangular LEDs will usually prove easier to glue to the lens, but you may not find this type of eyeball as appealing. Red LEDs are usually more efficient than green and this can be an advantage with very dark glasses.

(You can, if you like, make one eye red and the other green. This arrangement, coupled with the cross-eyed to bug-eyed connection, should really slay 'em!)

In all cases, the LEDs should be butted up to the lens for mounting. This will keep them as far away as possible from the wearer's eyes. If you are not satisfied



As shown by the photograph above, the LEDs are glued inside of the lenses of the glasses and the wiring secured to the frame. The full-size printed circuit board pattern is shown at the right.

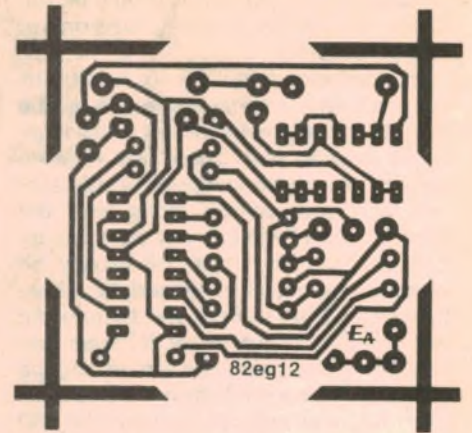

### PARTS LIST

- 1 4011 quad NAND gate
- 1 4017 decade counter
- 10 1N4148 diodes
- 6 light emitting diodes (LEDs)
- 1 33 $\mu$ F/10VW electrolytic capacitor
- 1 1 $\mu$ F/10VW non-polarised electrolytic capacitor
- 1 .0015 $\mu$ F metallised polyester capacitor (greencap)
- 2 220k $\Omega$  resistors (1/4W, 5%)
- 1 68 $\Omega$  resistor (1/4W, 5%)
- 1 printed circuit board, 47 x 44mm, code 82eg12

- 1 plastic utility (zippy) box, 83 x 53 x 24mm
- 1 pair of dark glasses (see text)
- 1 9V battery, Eveready 216 or equivalent (see text)
- 1 snap connector to suit type 216 battery
- 1 momentary contact pushbutton switch

#### MISCELLANEOUS

Rainbow cable (see text, styrofoam, epoxy adhesive, solder etc.

with this aspect of construction, it may be necessary to file the epoxy lens of the LEDs down to provide greater clearance. For the same reason the leads of each

LED should be bent towards the top of the glasses rather than left pointing back towards the eye. Having outlined these requirements, we can state that most glasses will have an ample amount of clearance for most wearers, but it is up to the constructor to make sure of this.

Four wires must be used to connect the PCB to the glasses. The length should be somewhere between 0.5 and 1m. One of the four wires is the common return – if three-way shielded cable is used, this should be the shield. It is connected to all the LED cathodes on one side (let us say the left side). Each of the other three wires connects to an LED anode on the right side. Each cathode of the right side LEDs connects to an anode of the LEDs on the left side (remember the LED pairs are connected in series).

Even if you decide against mounting the PCB in a "zippy" box, you would most likely still want to use the switch. The impact of the flashing eyeballs will be considerably reduced if you have to fiddle around with the battery connections. The switch – included in the positive supply line to the PCB – could be kept out of sight in your pocket or hand.

So go to it – and have fun!

## PROFESSIONAL SCOPE PROBES



### SP100

COLINE SP100 passive probe incorporates a 3-position slide switch in the head and has a cable length of 1.5 metres

**SPECIFICATION:** Position  $\times 1$  Bandwidth DC to 10MHz • Input R 1M $\Omega$  scope input • Input C 40pF • scope cap • Working Voltage 600Vdc (inc peak ac)

Position  $\times 10$  Bandwidth DC to 100MHz • Rise time 3.5ns • Input R 10M $\Omega$  when used with scopes having 1M $\Omega$  input probe 9M $\Omega$  • 1% • Input C 11.5pF when used with scopes having 30pF input capacitance • Compensation Range 10-60pF • Working Voltage 600Vdc (inc peak ac)

(As used by AWA, BHP, CSIRO, Universities, Techs etc.) Supplied complete in deluxe heavy duty plastic pouch

### LESS THAN HOBBYIST PRICES!!

**\$25.00**

plus sales tax  
P&P FREE  
Generous quantity discounts

## TLS2000 Test Lead Set

Silicone covered Test Leads with a working voltage of 2000V r.m.s. and a maximum current of 20 amps

These Leads are fitted with a 4mm shielded plug at each end and will accept a range of accessories

**\$25.00 ex tax**



See Coline probes at leading electronics stores or call

**ELMEASCO**

**Instruments Pty. Ltd.**

**Sydney** 736 2888  
**Melbourne** 233 4044  
**Adelaide** 271 1839  
**Brisbane** 369 8688  
**Perth** 398 3362

# ROD IRVING ELECTRONICS

## MINI CATALOGUE

Minimum P & P \$2.00

### NEW IC's & SPECIALS

DESCRIPTION	PRICE	DESCRIPTION	PRICE	DESCRIPTION	PRICE	DESCRIPTION	PRICE
XR2206	\$6.50	SC151D	\$2.00	6502A	\$11.00	10 4017 FOR	\$9.00
XR2207	\$5.50	TL074	\$2.90	6503	\$10.00	10 4026 FOR	\$15.00
XR2211	\$6.90	AY-3-8910	\$14.50	6504	\$10.00	10 4051 FOR	\$6.00
CA3059	\$4.90	MN3001	\$17.50	6505	\$10.00	10 4081 FOR	\$3.00
NE5534	\$1.95	82S123	\$3.90	6507	\$10.00	10 4040 FOR	\$11.00
NE5534A	\$2.50	BPW50	\$1.95	6520	\$5.50	6800	\$7.90
RC4136	\$1.25	MDC3011	\$2.95	6521	\$5.90	6802	\$8.00
BU126	\$1.95	MDC3020	\$2.50	6522	\$9.90	6809	\$15.00
BU326A	\$1.95	MDC3021	\$2.60	6522A	\$11.00	6821	\$3.50
TIP120	\$0.90	D3242	\$15.90	6532	\$12.50	6840	\$7.90
2N6122	\$0.50	D3245	\$10.90	6545	\$22.50	6850	\$5.00
2N6125	\$0.50	Z80CPU	\$8.00	6551	\$12.90	7805	\$0.80
BC108	\$0.30	Z80ACPU	\$10.00	2650	\$21.00	7812	\$0.80
BD139	\$0.45	Z80CTC	\$7.00	2651	\$23.00	7815	\$0.80
BD140	\$0.45	Z80ACTC	\$8.00	TR1602	\$7.50	7824	\$0.90
BUX80	\$3.90	Z80PIO	\$5.00	5303	\$5.25	7905	\$1.50
2114	\$1.95	Z80APIO	\$6.00	10 74LS00 FOR	\$2.00	7912	\$1.50
4116	\$1.95	Z80SIO	\$18.00	10 74LS02 FOR	\$2.00	7915	\$1.50
4164	\$9.50	Z80ASIO	\$20.00	10 74LS04 FOR	\$2.00	7924	\$1.50
6116	\$11.00	Z80BCPU	\$18.00	10 74LS10 FOR	\$2.00	8080	\$7.00
8725	\$10.00	Z80DMA	\$20.00	10 74LS30 FOR	\$2.00	8085	\$9.00
2708	\$4.90	1771	\$18.00	10 74LS32 FOR	\$2.00	8212	\$2.50
2716	\$4.90	1791	\$29.00	10 74LS367 FOR	\$4.00	8216	\$2.50
2732	\$8.00	1793	\$35.00	10 74LS368 FOR	\$4.00	8224	\$4.00
2764	\$25.00	1795	\$35.00	10 74LS240 FOR	\$7.50	8255	\$5.50
2N3773	\$5.90	1797	\$35.00	10 74LS241 FOR	\$7.50	8155	\$9.00
MJ802	\$3.50	ZN414	\$1.95	10 74LS242 FOR	\$7.50	78HO5KC	\$5.50
C106D	\$0.50	6502	\$10.00	10 74LS244 FOR	\$7.50	78PO5KC	\$11.50
SC141D	\$1.10	ZN5944	\$11.50	10 4000 FOR	\$2.00	LM323KC	\$5.90
XR205	\$9.50	ZN4945	\$13.50	ZN6084	\$18.50	10 BC212	\$2.50
XR210	\$6.90	ZN5946	\$16.50	10 74LS245	\$8.50	9368	\$1.90
XR215	\$6.90	NE570	\$4.50	10 4013	\$4.50	75107	\$1.90
XR2240	\$3.90	ZN6256	\$12.50	10 BC639	\$3.00	75108	\$1.90
XR2242	\$4.90	6845	\$29.00	10 BC640	\$3.00	75110	\$1.90
XR2243	\$4.90	95490	\$6.50	NE558	\$4.90	75150	\$1.90
CIZZE	\$1.50	11C90	\$14.50	BD233	\$0.60	75154	\$1.90
MJ4032	\$14.50	ZN3771	\$5.50	BD238	\$0.60	MJ11015	\$14.50
MJ4035	\$12.50	ZN3772	\$5.75	LM3915	\$4.00	MJ11016	\$14.50
MJ2501	\$5.90	MRF454	\$24.50	10 BD139	\$3.90	100 RED LEDS	\$8.00
ZN5589	\$16.50	MRF237	\$3.50	10BD140	\$3.90	100 GREEN LEDS	\$15.00
ZN5590	\$18.50	MRF245	\$32.50	100 BD139	\$35.00	100 YELLOW LEDS	\$15.00
ZN5591	\$22.50	ZN6083	\$16.50	100 BD140	\$35.00		

# ROD IRVING ELECTRONICS

425 HIGH STREET NORTHCOTE 3070 MELBOURNE (03) 489-8131



**DIGITAL ENG. ANALYSER**  
**\$48.50**



EA August 80

**DIGITAL CAPACITANCE METER**  
**\$45.00**



Here is an inexpensive Digital Capacitance Meter which measures from 1pF to 99.99uF in just three ranges. It's simple to use and features a big bright four-digit display with automatic updating and decimal points.  
EA March 80

**ELECTRONIC DUMMY LOAD**  
**\$99.00**



With this unit you can test power supplies at currents up to 15 Amps and Voltages up to 60 Volts. It can "sink" up to 200 Watts on a static test and you can modulate the load to perform dynamic tests.  
ETI 147 October 80

**SELECTALOTT**  
**\$22.00**



"Who wants to be a millionaire...?" I do "Selectalott" could help. It will select random numbers without superstition or bias. It could be you. EA December 80

**PHOTON TORPEDO GAME**



EA September 81

**\$24.50**

**7-SLOT S100 MOTHER BOARD**



ETI May 80

**\$85.00**

**FUZZBOX**  
**\$19.90**



Simple Fuzz Box for electric guitars. The no fuss, no nonsense Fuzz Box Confused — So are we. Seriously though if you want a sound with a difference, build this product and you can distort the waveform. It produces a sound which is buzzy (like politicians at election time). EA February 81

**150W MOSFET POWER AMP**  
**\$79.00**

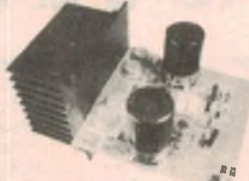

Plus Transformer \$43.50  
Plus Heatsink Drilled, Tapped and Black Anodised \$42.50

A general purpose 150W Mosfet Power Amp Module. Here's a high power, general purpose Power Amplifier Module for guitar and PA applications employing rugged, reliable Mosfets in the output. ETI 499 March 82

**CYLON VOICE** EA December 80  
**\$19.95**



Sound like Darth Vader

**ANALOGUE AND DIGITAL STORAGE CRO KIT**  
**\$189.00**



Store and record non-repetitive Analogue Signals. EA March 81

**TV CRO ADAPTOR**  
**\$38.50**

Includes Plug Pack. EA August 80



**VOICE CANCELLER**

**\$22.50**



Ever wondered how your voice substituted for your favourite vocalists would sound, well now its possible! You can cancel out the lead vocal on almost any stereo record and substitute your own voice or musical instrument. EA April 82

Oct 82 ETI



**ETI'S BRILLIANT NEW DIRECT-CONNECT COMPUTER MODEM**

Employs unique 'Commutated Filter' design overcoming virtually all the problems involved with conventional modems. Super flexible unit facilitates communications between computers over cables, the telephone network and radio links. Unit connects to a standard RS 232 interface and is capable of both 1200/75 Baud and 300/300 Baud transmission and reception. ★ Line switching, answer and dialing facilities on board.

**EXCLUSIVES:** ★ Plated through, double sided PCB ★ Complete set of IC sockets ★ Kit requires 85 IN914 Diodes for programming these are included ★ Ceralock resonator and matching balanced load capacitor used for long life and high accuracy ★ Telecom approved isolating transformer and Reed relays included

**Our Price**  
**\$169.00**

**LOUD SPEAKER PROTECTOR**

ETI 455 March 80

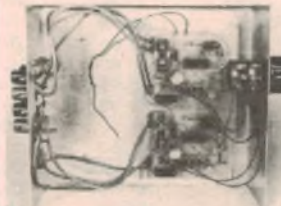

**\$32.50**

**CAR ALARM**  
**\$29.00**

This Car Alarm uses the battery earth strap as a sensor to detect when a "courtesy" light or other electrical load occurs when a thief enters a vehicle. The circuitry is simple and immune from false triggering problems. ETI July 81



**10-15V EXPANDED SCALE V-METER**

ETI 159 December 81

**\$26.50**



**CORE BALANCE RELAY** ETI 567

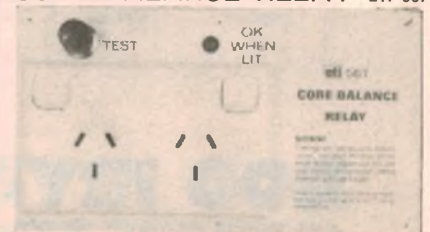

**\$44.50**

# \$\$\$ SAVE MONEY — USE OFF PEAK STD RATES \$\$\$

For your convenience we will accept phone bankcard orders until 6.30pm.  
**"PHONE THE HOT LINE AND TALK A DEAL WITH ROD THE COMPONENT DISCOUNTER . . . ONLY BETWEEN 6-6.30pm"**  
**I WANT YOUR BUSINESS!!"**

## ON SCREEN GRAPHIC ANALYSER \$109.00

The On Screen Graphic Analyser links your hi-fi to your TV set  
 Features:  
 Six colour bar graph display (Standard PAL receiver).  
 Ten vertical bars in the display corresponding to the 10 octave bands.  
 Gives you the best sound quality your system can deliver.



EA March 81

## CUDLIPP

\$12.00

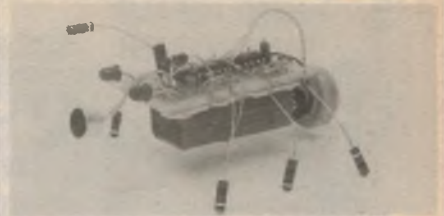

A fascinating Electronic Cricket with just two ICs. The Cudlipp can be used to bug your Home, Office or Board Room. Great fun. EA February 82

## FM WIRELESS MICROPHONE \$8.50

HOBBY ELECTRONICS May 81



## CAR BATTERY MONITOR

\$9.50

Fiat Battery! Don't get left out in the rain. Install a voltage monitor which monitors the state of your battery at a glance. EA. October 80.

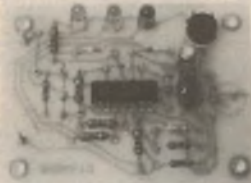

## UNIVERSAL RELAY BOARD \$13.50

Operating a relay to switch heavy current or mains voltages is a common requirement in electronic control applications. This project permits a relay to be switched in a variety of ways and from a variety of inputs. ETI May 81



## LOW FUEL INDICATOR EA March 81

\$16.50



## AM TUNER

\$99.00

ETI 475 September



Includes plug pack and punch metal work

\$9.50

## MINI DRILL SPEED CONTROLLER

Here's an easy to assemble project for a simple speed regulator for miniature DC electric drills. ETI July 81

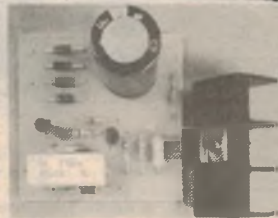

## ELECTROMYOGRAM \$89.00

ETI Top Projects Vol 6

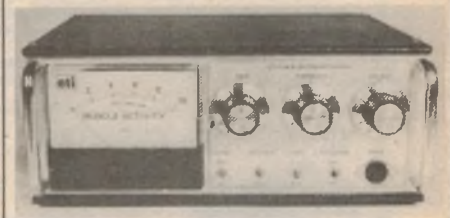

## SLOT CAR POWER SUPPLY \$19.50

ETI December 81

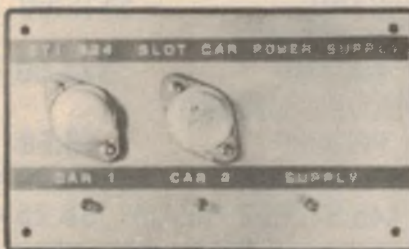

## SERIES 4000 SPEAKER KITS

Speakers and crossovers \$450  
 Speaker boxes \$249  
 Crossover kits \$189  
 Complete kit \$679



## EPROM PROGRAMMER EA July 80



Horwood Case Supplied \$77.50

## HUMIDITY METER. \$22.50

ETI 256



## BRIDGING ADAPTER

ETI March 82

\$10.95



## SLIDE CROSS FADER \$85.00

EA November 81



# ROD IRVING ELECTRONICS

425 HIGH STREET, NORTHCOTE 3070, MELBOURNE, VICTORIA. Ph (03) 489 8131. Telex No. 38897

**MIXER PREAMP TRANSFORMER** \$26.50



Easy construction and versatile operation, this Preamp was for coupling with the 300W "Brute" Power Amp. ETI 467 July 80

**AUDIO TEST UNIT FOR CASS DECKS** \$47.50



EA October 81

**CRYSTAL MARKER** \$34.50 (INC 1MHZ X) ETI 157 October 81



**TV PATTERN GENERATOR** \$57.50

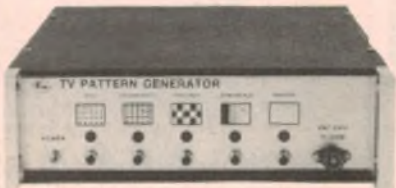

Adjust your TV for a first-class picture with EAs crystal controlled TV Pattern Generator. EA June 80

**BIPOLAR TRAIN CONTROLLER** \$28.50 EA December 80

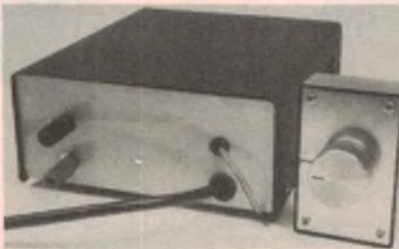

**SLOT CAR POWER CONTROLLER (WITHOUT CASE)** \$70.00

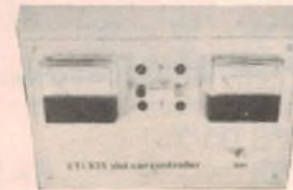

ETIs Slot Car Controllers will put more zip in your slot cars zap. Plus Power Supply as indicated. ETI December 81.

**ETI 477 MOSFET MODULE** \$58.50

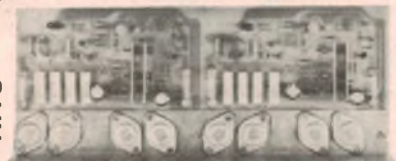

Remember the great ETI 5000 power amp. With this module as the hub of the ETI 5000 and a transformer you get an amazing power output of 150W RMS. Plus Power Supply (No Trans) \$49.00 Plus Transformer \$39.50

**PC BIRDIES** \$14.50



Granny's Birthday - PC Birdies

Granny's got a birthday coming up and you don't know what to give her! Her cat ran away, her dog starved and the fish turned upside down. Well here's the perfect gift. A nonsense, no maintenance companion. The PC Birdies - She'll whistle, sing and dance for hours to this amazing electronic canary. EA May 81

**DIGITAL COUNTER DISPLAY** HE 114 HOBBY ELECTRONICS \$13.50 October 81

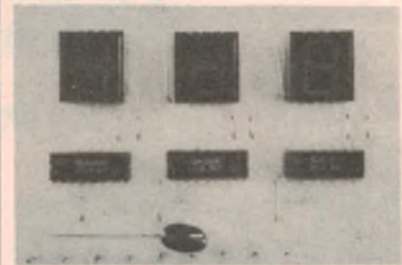

**TRANSISTOR ASSISTED IGNITION** EA November 79



\$32.50

**WIND SPEED INDICATOR** October 81 \$43.50



**MUSICOLOR IV** \$79.00



Add excitement to parties, card nights and discos with EAs new Musicolor IV light show. This is the latest in the famous line of Musicolors and it offers features such as four channel "Color Organ" plus four channel light chaser, front panel LED display internal microphone, single sensitivity control plus opto-coupled switching for increased safety. EA August 81

**ETI 50W MODULE** \$17.50  
**ETI 100W POWER AMP** \$22.00  
**VERSATILE EPROM CARD** \$115.00  
**MOVING COIL PREAMP** \$24.50  
**MOVING MAGNET PREAMP** 18.50  
**DREAM 6800** \$109.00  
**445 STEREO PREAMP** \$8.25

**ETI SERIES 5000**



Power Amp ..... \$299.00  
 Pre Amp ..... \$259.00



## EPROM PROGRAMMER

**\$43.00**

No need for a Micro with EA's great Eprom Programmer suitable for 2716/2758 Eproms.

With Textool Sockets **\$55.00**  
EA January 82

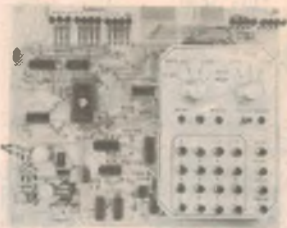

## DUAL TRACKING POWER SUPPLY

**\$83.50**

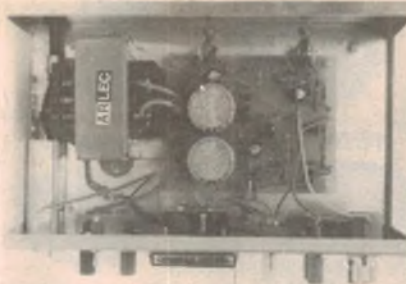

Built around positive and negative 3-Terminal Regulators, this versatile dual tracking Power Supply can provide voltages from  $\pm 1.3V$  to  $\pm 22V$  at currents up to 2A. In addition, the Supply features a fixed +5V 0.9A output and is completely protected against short circuits, overloads and thermal runaway. EA March 82

## SOUND TRIGGERED FLASH

**\$26.50**

This easy to build sound or light operated flash trigger has many features.

Catch those spectacular and humorous moments like that time your mother-in-law slipped on the moss covered patio and broke her neck. ETI 568 October 80



## ELECTRONIC METRONOME

**\$16.90**

Great new Metronome Circuit with low current drain (less than one milliamp) drives a Loudspeaker and a Led Indicator. EA January 82

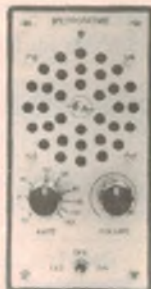

## VOICE OPERATED RELAY

**\$14.95**

EA's great new Voice Operated Relay can be used to control a tape recorder, as a VOX circuit for a transmitter, or to control a slide projector. EA April 82



## "LE GONG"

**\$14.95**

The "Le Gong" Doorbell with those unmistakable chimes generated by the LSI. A must for the man who has everything! EA February 81



## 3 1/2 DIGIT LCD CAPACITANCE METER

Handy pocket size Digital Capacitance Meter, runs off a 9V battery and measure 1pF to 1999uF in just three ranges. EA March 82



**\$69.00**

## LED LEVEL METER

**\$27.00**

Build a Led level Meter with simultaneous peak and average display plus 60dB dynamic range. This kit is ideal for any application requiring a wide dynamic range level display. ETI 458 June 81



## DIGITAL THERMOMETER: 3 1/2 DIGIT LCD

**\$69.00**

Measure temperatures from below freezing point to around boiling point. EA February 82



## FUNCTION GENERATOR \$79.50

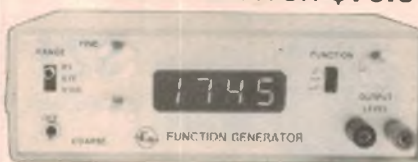

This Function Generator with digital readout produces Sine, Triangle and Square waves over a frequency range from below 20Hz to above 160kHz with low distortion and good envelope stability. It has an inbuilt four-digit frequency counter for ease and accuracy of frequency setting. EA April 82

## LOTTO/POOL'S SELECTOR

**\$22.50**

You have to be in it to win it. Take the chance out of winning the Pools as well as Lotto, and build the great new Pools/Lotto Number Selector. EA July 81

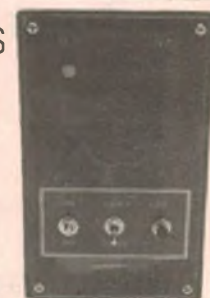

## LARGE SCREEN TV STORAGE CRO ADAPTER

**\$119.00**

For a low cost Storage CRO with Synchronised Display, Electronic Graticule, One-Shot Triggering and Optional Storage of up to four Screen Displays it can't be beaten. EA February 82



## LOW OHMS METER

**\$34.50**

How many times have you cursed your Multimeter when you had to measure a low value resistance. Well alas, with the "Low Ohms Meter" you can solve those old problems and in fact measure resistance from 100 Ohms down to 0.005 Ohms. ETI 158 November 81



## ELECTRONIC ORGAN

**\$59.00**

"Electrotune" no its not for your car. It's a 23-note Organ with Special Effects. Singalong with this fun to build Organ and amaze the family and neighbours like never before. EA July 81



## SOUNDBENDER

**\$29.00**

Have great fun creating your own recording effects with music and voice. The Sound Bender can receive from Electric Guitar, Microphones etc. ETI February 82



Mention the password "Rod The Discount Wizard" between 6-6.30pm and any item purchased by phone Bankcard orders during that time exceeding the value of \$50 will receive a 10% discount. (Does not include specials.)

## ETI 660 WITH OPTIONS

Kit inc PCB, ICs, Skts **\$99.00**  
Colour Option **\$13.50**  
Video Modulator In **\$14.50**  
Plugpack to Suit 8VAC/1A **\$11.95**  
Set of 4 (2114 Rams)  
3K Upgrade **\$17.00**  
18 Keys plus Scotchcal Labels **\$29.00**  
ETI October 81





# SERIES 5000

As designed by ETI



## SERIES 5000 PREAMPLIFIER — SPECIFICATIONS

Frequency response:	High-level input: 15Hz-130 kHz, +0, -1 db Low-level input — conforms to RIAA equalisation, $\pm 0.2$ dB
Distortion:	1kHz < 0.003% on all inputs (limit of resolution on measuring equipment due to noise limitation).
S/N noise:	High-level input, master full, with respect to 300 mV input signal at full output (1.2V): > 92 dB flat > 100 dB A-weighted. MM input, master full, with respect to full output (1.2V) at 5 mV input, 50 ohm source resistance connected: > 86 dB flat > 92 dB A-weighted. MC input, master full, with respect to full output (1.2V) and 200 $\mu$ V input signal: > 71 dB flat > 75 dB A-weighted



*N.B. Picture is only of original heatsink supplied with this project. Our one is tapped from the rear so that no screw heads are visible. New picture next month.*

Please note that the "Super Deluxe" Heatsink for the power amp was designed and developed by Rod Irving Electronics and is being supplied to other kit suppliers. This product costs \$1,200 to develop so that your amplifier kit would have a professional finish as well as sound. We also have a new range of rack mounting boxes which will be released soon.

## SERIES 5000 POWER AMPLIFIER — SPECIFICATIONS

Power output:	100W RMS into 8 ohms ( $\pm 55$ V supply).
Frequency response:	8 Hz to 20 kHz, +0 -0.4 dB 2.8 Hz to 65 kHz, +0 -3 dB NOTE: These figures are determined solely by passive filters.
Input sensitivity:	1V RMS for 100W output.
Hum:	- 100dB below full output (flat).
Noise:	- 116 dB below full output (flat, 20 kHz bandwidth).
2nd harmonic distortion:	< 0.001% at 1 kHz (0.0007% on prototypes) at 100 W output using a $\pm 56$ V supply rated at 4 A continuous. < 0.003% at 10 kHz and 100 W.
3rd harmonic distortion:	< 0.0003% for all frequencies less than 10 kHz and all powers below clipping.
Total harmonic distortion:	Determined by 2nd harmonic distortion (see above).
Intermodulation distortion:	< 0.003% at 100 W. (50 Hz and 7 kHz mixed 4:1).
Stability:	Unconditional

### EXTRA FEATURES OF OUR KITS POWER AMPLIFIER

- KIT PRICE \$289.00 P & P \$80.00
- 1% Metal Film Resistors are used where possible
  - Prewound Coils are supplied
  - Aluminium case as per the original article
  - All components are top quality
  - Over 200 Kits now sold
  - We have built this unit and so know what needs to go into every kit
  - SUPER FINISH Front panel supplied with every kit at no extra cost to you
  - We are so confident of this kit that we can now offer it assembled and tested so that people who do not have the time can appreciate the sound that this amplifier puts out. This is done on a per order basis delivery approx. two weeks after placement.

THE PRICE IS ONLY \$425.00

\*All parts available separately for both kits.

### PREAMPLIFIER

- KIT PRICE \$250.00 P & P \$80.00
- 1% Metal Film Resistors are supplied
  - 14 metres of Low Capacitance Shielded are supplied (a bit extra in case of mistakes)
  - English "Lorin" Switches are supplied no substitutes as others supply
  - We have built and tested this unit and so know what needs to go into every kit
  - Specially imported black anodised aluminium knobs
  - Again as with the power amp we are offering this kit A & T at a price which we do not believe there is a commercial unit available that sounds as good. Same delivery as the P.A.

All the above for only \$425.00



## SERIES 4000 SPEAKERS FROM ETI

### SERIES 4000/14-WAY SPEAKERS

A no compromise, top-line system designed by David Tilbrook and described in the February 1980 ETI. Those who own them or have heard them universally praise them for clarity of sound, superb stereo imaging and smoothness of response. Employing Philips' latest range of low distortion drivers and a specially-designed crossover network (another Tilbrook masterpiece) these speakers are the equal of other systems costing up to three times the price. The 4000/1 will handle 100 W continuous, up to 400 W peak. PLEASE CHECK PRICES AND AVAILABILITY

# ROD IRVING ELECTRONICS

425 HIGH STREET NORTHCOTE 3070 MELBOURNE (03) 489-8131

64K SS50 STATIC NOW AVAILABLE \$399 + TAX  
 64K S100 STATIC NOW AVAILABLE \$399 + TAX

DON'T FORGET TO CHECK WITH US BEFORE YOU BUY A COMPUTER OR OTHER PRODUCTS

# ROD IRVING ELECTRONICS

425 HIGH STREET, NORTHCOTE 3070, MELBOURNE, VICTORIA

MASSIVE PRICE CUTS ON BIG BOARD COMPUTER

64K SINGLE BOARD COMPUTER KIT NOW ONLY \$499 + TAX.

## \$100 COMPUTER PRODUCTS

### 16K EPROM CARD-S 100 BUSS



**\$89.50**  
KIT  
BLANK PC BOARD  
\$59  
USES 2708's!

Thousands of personal and business systems around the world use this board with complete satisfaction. Puts 16K of software on line at **ALL TIMES!** Kit features a top quality soldermasked and silk-screened PC board and first run parts and sockets. Any number of EPROM locations may be disabled to avoid any memory conflicts. Fully buffered and has WAIT STATE capabilities.

OUR 450 NS 2708'S ARE \$5.90EA. WITH PURCHASE OF KIT

ASSEMBLED AND FULLY TESTED ADD \$36

### 32K S-100 EPROM CARD



**\$99.95**  
KIT  
USES 2716's  
Blank PC Board - \$59  
ASSEMBLED & TESTED  
ADD \$30

SPECIAL: 2716 EPROM's (450 NS) Are \$5.90 EA. With Above Kit.

- KIT FEATURES:**
- 1. Uses +5V only 2716 (2Kx8) EPROM's
  - 2. Allows up to 32K of software on line!
  - 3. IEEE S-100 Compatible
  - 4. Addressable as two independent 16K blocks
  - 5. Cronimco extended or Noristar bank select
  - 6. On board wait state circuitry if needed
  - 7. Any of all EPROM locations can be disabled
  - 8. Double sided PC board solder-masked, silk screened
  - 9. Gold plated contact fingers
  - 10. Unsoldered EPROM's automatically powered down for low power
  - 11. Fully buffered and bypassed
  - 12. Easy and quick to assemble

### AVAILABLE AGAIN



- 16K Dynamic Ram Board
- Fully Expandable to 64K
- Assembled, tested and guaranteed
- \$100 Complete
- 16K Dynamic RAM Board assembled and tested:
- Special 5280 plus tax (40m Hz) 5290 plus tax (40mhz)
- This must be the best offer available on quality tested dynamic RAM boards.
- 32K Assembled and tested \$289 plus tax (40mhz)
- 48K Assembled and tested \$309 plus tax (40mhz)
- 64K Assembled and tested \$329 plus tax (40mhz)

### 16K STATIC RAM KIT-S 100 BUSS

KIT \$179  
A&T \$199



BLANK PC BOARD W DATA \$59

LOW PROFILE SOCKET SET \$22  
SUPPORT IC'S & CAPS \$29

ASSEMBLED & TESTED ADD \$30

OUR #1 SELLING RAM BOARD!

- KIT FEATURES:**
1. Addressable as four separate 4K blocks
  2. ON BOARD BANK SELECT circuitry (Cronimco Standard) Allows up to 512K on line
  3. Uses 2114 (6400) 4K Static Ram's
  4. ON BOARD SELECTABLE WAIT STATES
  5. Double sided PC Board with solder mask and silk screened layout. Gold plated contact fingers
  6. All address and data lines fully buffered
  7. Kit includes ALL parts and sockets
  8. PHANTOM is supported to PPI's E7
  9. LOW POWER under 1.5 amps TYPICAL from the +5 Volt Bus
  10. Blank PC Board can be populated in any multiple of 4K

### 16K STATIC RAM SS-50 BUSS

PRICE CUT!

\$199 KIT  
A&T \$219

FULLY STATIC AT DYNAMIC PRICES

FOR SWTPC 6800 BUSS!

BLANK PC BOARD \$59  
COMPLETE SOCKET SET - \$22  
SUPPORT IC'S AND CAPS - \$49



32K STATIC ALSO AVAILABLE

- KIT FEATURES:**
1. Addressable on 16K Boundaries
  2. Uses 2114 Static Ram
  3. Runs at Full Speed
  4. Double sided PC Board. Solder mask and silk screened layout. Gold fingers
  5. All Parts and Sockets included
  6. Low Power Under 1.5 Amps Typical

### ETI 660 THE \$99 COMPUTER!



**FEATURES INCLUDE:**  
 Colour capability operates from optional 9V plugpack, 16 memory expansion to 64K, on-board cassette construction, cassette interface, audio output, simple to program (uses Chip 6)  
 Expansion projects coming up include ASCII keyboard, light pen, games software, etc.  
 Starter Kit (1K RAM, 8KW Video) \$99.00  
 9V 1 amp plug pack to suit \$12.50  
 Colour video option \$13.50  
 RAM Expansion (add to PCB) \$16.00

ETI636 7 SLOT MOTHERBOARD WITH ACTIVE TERMINATION  
 Kit of Parts \$89.00. Assembled and tested \$115.00 inc tax.  
 RITRON COMPUTER GRADE POWER SUPPLY +5V Reg 10A  
 ± 16V Unreg. Kit of parts \$89.90 inc tax A&T \$109.00 inc tax  
 Write for list of other power supplies. Tax free prices also available.

## SINGLE BOARD COMPUTER KIT NOW ONLY \$475 Including tax (\$435 tax exempt)

Also available: Blank PCB's with Roms \$275 + Tax. Assembled & Tested \$599 inc. tax.

THE FERGUSON PROJECT: Three years in the works, and maybe too good to be true. A tribute to hard headed, no compromise, high performance American engineering! The Big Board gives you all the most needed computing features on one board at a very reasonable cost. The Big Board was designed from scratch to run the latest version of CP/M\*. Just imagine all the off-the-shelf software that can be run on the Big Board without any modifications needed! Take a Big Board, add a couple of 8 inch disc drives, power supply and an enclosure, and you have a total Business System for about 1/3 the cost you might expect to pay.

**FEATURES: (Remember, all this on one board!)**

### 64K RAM

Uses industry standard 4116 RAM'S. All 64K is available to the user, our VIDEO and EPROM sections do not make holes in system RAM. Also, very special care was taken in the RAM array PC layout to eliminate potential noise and glitches.

### Z-80 CPU

Running at 2.5 MHZ. Handles all 4116 RAM refresh and supports Mode 2 INTERRUPTS. Fully buffered and runs 8080 software.

### SERIAL I/C (OPTIONAL)

Full 2 channels using the Z80 SIO and the SMC 8116 Baud Rate Generator. FULL RS232! For synchronous or asynchronous communication in synchronous mode, the clocks can be transmitted or received by a modem. Both channels can be set up for either data communication or data-terminals. Supports mode 2 int. Price for all parts and connectors: \$49

### BASIC I/O

Consists of a separate parallel port (Z80 PIO) for use with an ASCII encoded keyboard for input. Output would be on the 80 x 24 Video Display.

### REAL TIME CLOCK (OPTIONAL)

Uses Z-80 CTC. Can be configured as a Counter on Real Time Clock. Set of all parts: \$15

### 24 x 80 CHARACTER VIDEO

With a crisp, flicker-free display that looks extremely sharp even on small monitors. Hardware scroll and full cursor control. Composite video or split video and sync. Character set is supplied on a 2716 style ROM, making customized fonts easy. Sync pulses can be any desired length or polarity. Video may be inverted or true.

### FLOPPY DISC CONTROLLER

Uses WD1771 controller chip with a TTL Data Separator for enhanced reliability. IBM 3740 compatible. Supports up to four 8 inch disc drives. Directly compatible with standard Shugart drives such as the SA800 or SA801. Drives can be configured for remote AC off-on. Runs CP/M\* 2.2

### FOUR PORT PARALLEL I/O (OPTIONAL)

Uses Z-80 PIO. Full 16 bits, fully buffered, bi-directional. User selectable hand shake polarity. Set of all parts and connectors for parallel I/O: \$21

### PFM 3.0 2K SYSTEM MONITOR

The real power of the Big Board lies in its PFM 3.0 on board monitor. PFM commands include: Dump Memory, Boot CP/M\*, Copy, Examine, Fill Memory, Test Memory, Go To, Read and Write I/O Ports, Disc Read (Drive, Track, Sector), and Search. PFM occupies one of the four 2716 EPROM locations provided. It does not occupy any of the 64K of system RAM!

SIZE: 8 1/2 x 13 1/2 IN.  
 SAME AS AN 8 IN. DRIVE.  
 REQUIRES: +5V @ 3 AMPS  
 + - 12V @ .5 AMPS

ETI 11/82/4

Please debit my Bankcard  
 Bankcard No. \_\_\_\_\_  
 Expiry Date \_\_\_\_\_  
 Name \_\_\_\_\_  
 Signature \_\_\_\_\_

General enquiries (03) 489-8131, Mail order enquiries (03) 481-1436. Ritronics Wholesale (03) 489-7099 (Tax Exempt Enquiries)

Price subject to change without notice. Send 60c and SAE for free Price lists. MAIL ORDERS PO BOX 235, NORTHCOTE, Vic. 3070. Minimum pack and post \$5.00. Telex AA38897.

PLEASE WRITE OR RING FOR THE BEST POSSIBLE PRICES ON DISC DRIVES, PRINTERS AND OTHER COMPUTER COMPONENTS.



# C. Itoh PRINTERS

FROM ROD IRVING ELECTRONICS

**SPECIAL OFFER NOVEMBER ONLY**

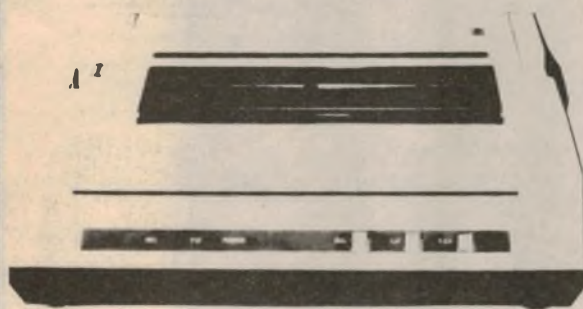

## Pro/Writer Printer 8510

**Print Features:** Number of columns—136 col. max. Print Speed—120 CPS. Print Direction—Single-directional and Bidirectional, Switch Selectable. Throughput Speed—From 44 to 152 lpm. Character spacing (max. number of columns per line)—Pica 10 CPI (80), Double Width 5 CPI (40), Compressed Font 17 CPI (136), Double Width 8.5 CPI (68), Elite 12 CPI (96), Double Width 6 CPI (48), Proportional Double Width Proportional. Line Spacing—Variable to 1/144". Print Width—203 mm (8") max.

**Forms Type: Fan Fold Roll or Cut Sheet:** Width—113 mm to 254 mm (4.5" to 10.0"). Total Thickness—0.05 to 0.28 mm (0.002" to 0.011"). Number of Copies—Original + 3 copies nominal.

**Form Feed:** Method—Tractor or Friction. Form Loading—Either rear or top. **Interface—Serial:** Method—EIA RS232-C and 20mA (40 & 60mA switchable option) Current Loop Serial Interface. Baud Rate (BPS)—110, 300, 600, 1200, 2400, 4800, 9600. Transmitting Method—Half Duplex. Synchronization—Asynchronous.

**Interface—Parallel:** Method—TTL compatible, 7-bit, parallel interface. Control Signals—ACK, BUSY, SELECT, DATA STB, INPUT PRIME FAULT, INPUT BUSY, PAPER EMPTY. Instruction Codes—(ASCII): CR, LF, VT, FF, CAN, SO, SI, DEL, DC1, DC2, DC3, DC4, GS, RS, US, FS, EM. GRAPHIC SYMBOLS: BIT GRAPHICS.

**Error Detection:** (1) Parity (VRC)—Odd, Even, No-parity. Switch selectable. (2) Framing Error—Stop bit check. (3) Overrun Error—Error is detected when data are received before the previous data have been processed.

**Physical dimensions:** 398 mm W x 120 mm H x 285 mm D (15.7" W x 4.7" H x 11.2" D). **Weight:** 8.5 kg (18 lbs., 12 oz.)

**P\* \$795 (\$725 ex)**

**S\*\* \$845 (\$775 ex)**

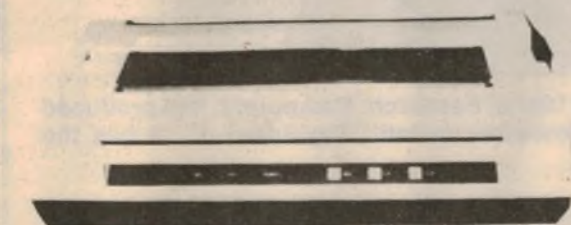

## Model 1550

The Model 1550 is a compact desk-top dot matrix serial impact printer used for data communication terminals, hardcopy of CRT displays, peripheral terminals for minicomputers and microcomputers, and small-sized business systems.

The character format is a dot matrix of 7(H) x 9(V) or 8(H) x 8(V). Print speed is 120 characters/second. Up to 136 characters can be printed per line at 10 CPI.

Its main features are: ● Compact desk-top dot matrix printer ● 136-column print ● Lightweight ● Low power-consumption ● High-quality print ● Bit image graphics ● Graphic Symbols ● Prints in six different languages ● High reliability ● Low cost.

**P\* \$1225 (\$1050 ex)**

**S\*\* \$1275 (\$1195 ex)**

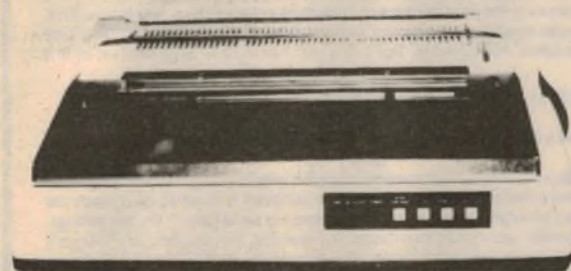

## F-10 Printmaster Daisy Wheel Printer

**Print Speed:** 40 CPS. **Print Method:** Static Print Impact. **Number of Printable Columns:** 136, 163, Variable. **Character Spacing:** 1/120 Inch (minimum). **Line Spacing:** 1/48.

**Return Time:** 900 msec. **Line Feed Time:** 40 msec. **Paper Width:** 406 mm (maximum).

**Print Characters:** 96. **Printwheel:** Industry Standard 96 Character Wheel. **Interface:** Industry Standard 8-bit Parallel, RS232-C Compatible, X-ON, X-OFF, 12-bit Qume and Diablo Compatible. **Dimensions:** 574 mm W x 405 mm d x 153.5 mm H (22.5" W x 15.9" D x 6" H). **Weight:** 14 kg (30.8 lbs.) with cover and power supply. **Noise:** Less than 65 Db (1M from Platen, A Scale).

**P\* \$1850 (\$1600 ex)**

**S\*\* \$1925 (1675 ex)**

\* Parallel Interface \*\* Serial Interface

**Extra Special Microline 80**  
\$499 incl. tax \$435 tax exempt

# RITRONICS WHOLESAL

425 HIGH STREET, NORTHCOTE 3070. MELBOURNE. (03) 489-8131.

TO ORDER: Heavy items sent Comet Freight on Mail Order Phone 481-1436. Wholesale Customers Phone: 489-7099. Mail Orders to RITRONICS WHOLESAL, P.O. Box 235, Northcote 3070. Minimum P&P \$2. Add extra for heavy items, registration and certified mail. Prices and specifications subject to change without notice.

**Turn to Page for our Big Board Specials**

Bankcard mail orders welcome  
**ORDER FORM**  
Please Debit my Bankcard ET110/82/6  
No. ....  
Expiry Date.....  
Name.....  
Signature.....

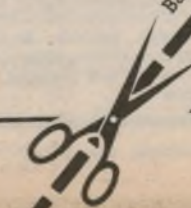

# RITRONICS WHOLESALE PTY LTD

425 HIGH ST, NORTHCOTE, VICTORIA 3070  
(03) 489 7099 (03) 481 1923

## “BIG BOARD II”

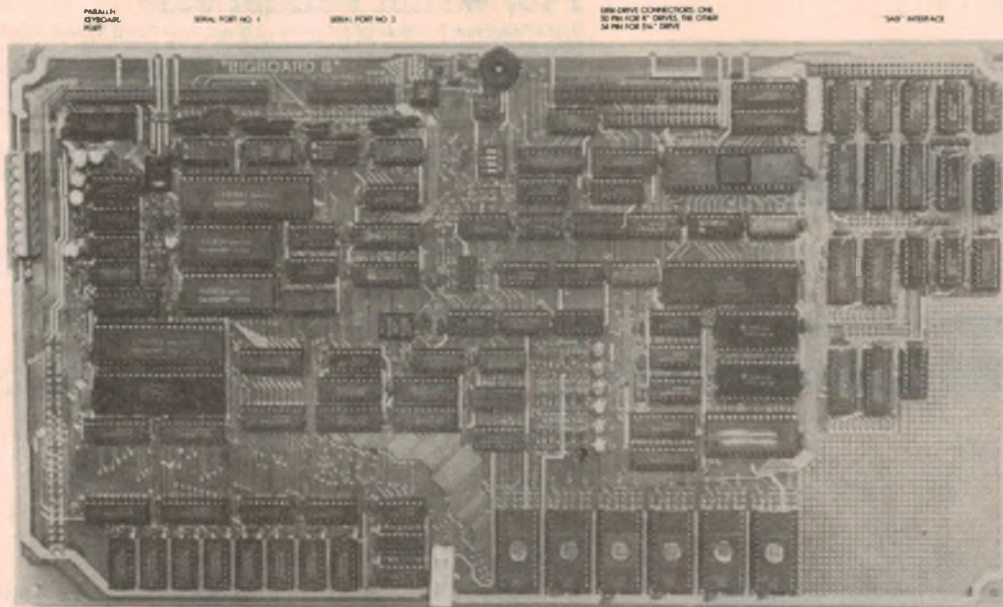

STD  
Bus  
Connector

Prototyping  
Area

Jim Ferguson, the designer of the “Big Board” distributed by Digital Research: Computers, has produced a stunning new computer that we will begin shipping in November called “Big Board II”, it has the following features:

#### 4 MHz Z80 — CPU AND PERIPHERAL CHIPS

The Ferguson computer runs at 4 MHz. Its monitor code is lean, uses Mode 2 interrupts, and makes good use of the Z80-A DMA chip.

#### 64K DYNAMIC RAM + 4K STATIC CRT RAM + 24K E(E)PROM OR STATIC RAM

“Big Board II” has the three memory banks. The first memory bank has eight 4164 RAMs that provide 60K of user space and 4K of monitor space. The second memory bank has two 2Kx8 SRAMs for the memory-mapped CRT display and space for six 2732 As, 2Kx8 staticRAMs, or pin-compatible E(E)PROMs. The third memory bank is for RAM or ROM added to the board via the STD bus. Whether bought as a bare board, a full kit, or assembled and tested, it comes with a 200 nS2732A EPROM containing the monitor

#### MULTIPLE-DENSITY CONTROLLER FOR SS/DS FLOPPY DISKS

The new Ferguson single-board computer has a multiple-density disk controller. It can use 1793, 1797, or 8877 controller chips since it generated the signal with TTL parts. The board has two connectors for disk signal with 34 pins for 5 25” drives, the other with 50 pins 8” drives.

#### VASTLY IMPROVED CRT DISPLAY

The new Ferguson SBC uses a 6845s CRT controller and 8002 Video Attributed controller to produce a display that will rival the display of quality terminals. Characters are formed by a 5x7 dot matrix on 15.75 KHz monitors and 7x9 dot matrix on 18.60 KHz monitors. The display is user programmable with the default display 24 lines of 80 characters.

#### STD BUS CONNECTOR

The Ferguson computer brings its bus signals to a convenient place on the PC board where users can solder an DSTD, bus cards can be plugged directly into it, and it can as well be connected by bus cable to industry standard card cages.

#### DMA

The new Ferguson computer has a Z80-A DMA chip that will allow byte-wise data transfers at 500K bytes per second and bit serial transfers via the Z80-A S10 at 880K bytes per second with serial processor overhead, though the monitor for the new computer uses the DMA chip mainly for transferring data to and from disk, the chip can readily be used for other things since its “wait/ready” pin can be connected under software control to some half a dozen signal lines. When a hard disk subsystem is connected to the “Big Board II” via its “SASI” interface, the DMA chip makes breathtaking disk performance possible.

#### “SASI” INTERFACE FOR WINCHESTER DISKS

The “Big Board II” implements the Host portion of the “Shugart Associates Systems Interface”. Adding a Winchester disk drive is no harder than attaching a floppy-disk drive. A user simply 1: Runs a 50-conductor ribbon cable from a header on the board to any of several inexpensive controller cards for Winchester drives that implement the controller portion of the SASI interface. 2: Cables the controller to an appropriate drive, and 3: Provides power for the controller-card and drive. Since our CBIOS contains code for communication with hard-disk, that’s all a user has to do to add a Winchester to a system!

#### A Z80-A S10/0 = TWO ASYNCHRONOUS/SYNCHRONOUS SERIAL PORTS

#### A PARALLEL KEYBOARD PORT = FOUR OTHER PARALLEL PORTS USER 1/0

The new Ferguson single-board computer has one parallel port for an ASCII keyboard and four others for user-defined I/O. When the computer is powered-up or reset, the monitor looks for a carriage-return at the keyboard and serial ports. If the first carriage-return the monitor gets comes from the parallel keyboard, the monitor uses the board’s video display circuitry to communicate with the user via a CRT. If the first carriage-return is typed at an ASCII terminal attached to a serial port, the monitor autabauds and makes the terminal the system console.

#### TWO Z80-A CTCs = EIGHT PROGRAMMABLE COUNTERS/TIMERS

The new Ferguson computer has two Z80-A CTCs. One is used to clock data into and out of the Z80-A S10/0, while the other is for systems and application use.

#### PROM PROGRAMMING CIRCUITRY AND SOFTWARE

The new Ferguson SBC has circuitry and drivers for programming 2716s, 2732(A)s, or pin-compatible (E)EPROMs.

#### CP/M

CP/M with Russell Smith’s CBIOS for the new Ferguson computer is available for \$190. The CBIOS is available separately for \$39.50. Actual board size: 39.6cm x 22.2cm

#### Pricing and Availability:

Availability: We should start shipping the second week in November. In single quantities, full kits cost \$750.00 + tax, and A&T’d computers cost \$895. There are attractive discounts that range to 35% for OEM’s and dealers. For details about them please call Rod Irving on (03) 489 7099. ie: 3 Ferguson II “Big Board” are less 20% off the one-off price, hard disks disk controllers, boxes and power supply to suit both 8” & 5 1/4” systems will be available.

# Circuit & Design Ideas

Interesting circuit ideas from readers and technical literature. While this material has been checked as far as possible for feasibility, the circuits have not been built and tested by us. As a consequence, we cannot accept responsibility, enter into correspondence or provide constructional details.

## Low-cost darkroom timer has audible output

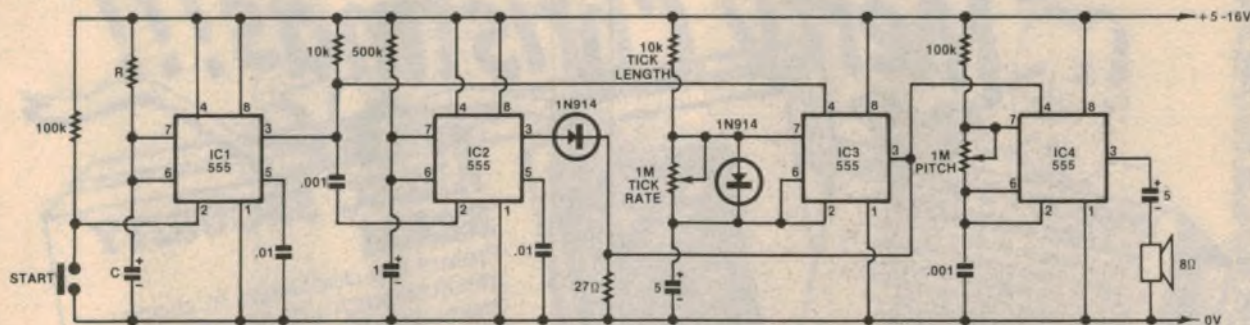

This is an audible process timer which can be used in a darkroom for timing development. The circuit is quite straightforward and used four 555 timer ICs.

The timer works as follows. IC1 is the "master timer" and the components R and C are chosen to give the desired timing interval. R may be a potentiometer to give a continuously variable timer or, for more accurate timing, you could use switched values to give a preset range of times.

IC2 gates the tone generator (IC4) to produce a beep at the end of the timing interval. The values given here should produce a beep of around 0.5 second, although with the large tolerance of some capacitors, you may have to experiment.

IC3 gates IC4 to produce a ticking sound which is set to 1Hz via the trimpot. Incidentally the diode from pin 7 to pin 6 allows a small duty cycle thus giving a "tick" rather than an annoying

"beep"; the 10kΩ resistor may be varied to alter the length of the tick if desired.

Finally, IC4 is a tone generator, the frequency of which is set by the 1MΩ trimpot. To produce the actual sound you can use a small 8Ω speaker or an ordinary 8Ω earpiece. In the darkroom situation this gives ample volume without being obtrusive.

B.A. Rees,  
Christchurch, NZ.

## Expanded scale voltmeter

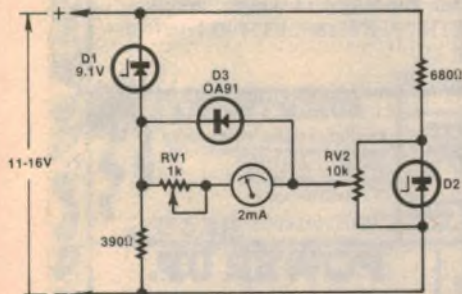

Sometimes an expanded scale voltmeter is desirable to monitor voltages over a restricted range. Such an application is a battery voltage monitor for a car or battery charger, with a range from 11 to 16 volts. A simple solution could use a zener diode in series with a moving coil meter but this results in a cramped, non-linear scale. The proposed bridge circuit allows a more linear expanded scale on a moving coil meter.

Zener diode D1 is selected to be about two volts less than the minimum voltage to be measured while zener diode D2 is chosen to be about two-thirds of the

## Simple headlight reminder

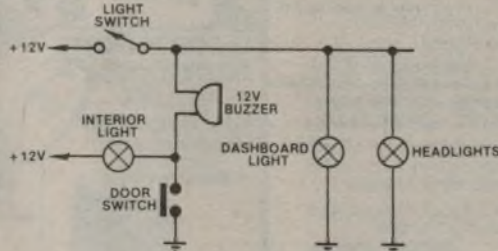

Instead of using a relay and buzzer as suggested in these pages in September 1982, a buzzer alone will function as a headlight reminder. This is wired between the dashboard/headlight circuit and the chassis side of the interior light globe, as shown in the circuit.

This allows the engine to be switched off without sounding the buzzer while the doors are closed. Only when a door is opened will the buzzer sound, if the headlights are still on.

H. Gravendyk,  
Jindalee, Qld.

value of D1. RV1 sets the precise voltage for zero scale deflection while RV2 sets full-scale deflection. D3 protects the meter against excessive downscale deflection when voltages less than the normal range are applied. The current through the zener diodes should be

limited to about five milliamps.

If the circuit is redesigned to suit a higher voltage range, care should be taken not to exceed the power ratings of the zener diodes.

K. Brooks,  
New Plymouth, NZ.

**BILL EDGE'S**

# ELECTRONIC AGENCIES

115-117 Parramatta Rd. Concord 2137  
(Corner Parramatta Rd & Lloyd George Ave)  
Telephone (02) 745 3077 (two lines)  
117 York St Sydney Phone 29 2098

**Mail Orders:**  
PO Box 185  
Concord  
2137

NSW & ACT ONLY	VIC. SA. QLD. TAS. WA. NT
\$10 — \$ 9.99	\$1 — \$ 9.99
\$10 — \$24.99	\$10 — \$24.99
\$25 — \$49.99	\$25 — \$49.99
\$50 — \$99.99	\$50 — \$99.99
\$100 or more	\$100 or more



**TRADING HOURS**  
BOTH STORES  
Mon-Fri ..... 9 am-5:30 pm  
Thursday ..... 9 am-8 pm  
Saturday ..... 9 am-12 pm

**What else do we carry? HI-FI ★ KITS ★ TEST EQUIPMENT ★ SEMICONDUCTORS ★ COMPONENTS ★**  
All prices correct and goods in stock at time of going to press. Please phone to check current availability.

## "Merry Christmas!!!"

### ET15000 1/3 OCTAVE GRAPHIC EQUALIZER KIT

Absolutely complete kit which includes pre punched chassis, all IC sockets, metal film resistors, and all the quality components you would expect from an Electronic Agencies kit.  
See ETI Nov 82.

KE5060 **\$199.00**  
or two for **\$389.00**



### NEW ARLEC SECURITY BEAM

Protect the doorways in shops, medical surgeries, reception areas and the home etc. The unit projects an infra red beam across a doorway to a reflector.

LE8655 **\$59.90**

### NEW BOGGLE GOGGLES KIT



See EA Dec. 82.  
KE0196 **\$9.50**

### NEW 0-30V POWER SUPPLY



See ETI Dec. 82.

KE1940 **\$48.50**



### FREEZER ALARM KIT

See EA Oct 82  
KE1627 **\$21.50**  
This beaut little kit will buzz you when your freezer fails. Complete with box and all parts

### SPEAKER PROTECTOR KIT

See ETI Oct 82  
The ultimate in speaker protectors. Needs no power supply, unit runs from amplifier output signal. Suits amplifiers from 20-10000 watts. Parts list only kit KE2077 **\$18.50 mono.**

### SUPER SIREN.

Ultra loud (over 100db) alarm beeper device built around a Motorola Piezo tweeter.

Complete kit including piezo tweeter KE1055

See EA Nov 82. **\$22.00.**

### 1/2 PRICE DOME MIDRANGE PHILIPS ADO210/SQB

BUY TWO FOR THE PRICE OF ONE  
KE2082 WAS \$32.00



Frequency Response 550-5Khz  
Resonant Frequency 350hz  
SPL 89db 1w/1mt  
50mm dome  
50 watt RMS handling  
Very low distortion

**NOW ONLY \$19.50**

### ELECTRIC FENCE KIT

See EA Sept 82  
KE1635 **\$15.00**  
Coil not included

### PLESSEY 12" WOOFER.

This price can never be repeated  
90 watt handling  
about 50w RMS  
Foam rubber surround  
beautiful white cone  
Freq response to 3500hz  
SPL 92db 1w/1mt  
CE2140 Res freq 25hz  
**ONLY \$25.00 each**

### SUPER TWEETER

Available again for a limited period. Plessey HO16N17 Horn  
Power 50 watts RMS  
Freq resp 5K-40KHZ  
SPL 96db 1w/1mt

CE2016 STILL ONLY **\$18.00 ea**

### POWER UP.

Switch all your HiFi equipment on with the flick of one switch. Just uplug your power leads from your Tuner, Amplifier, Equalizer, Cassette Deck, etc and plug them into the Power Up and Whammo, by switching off your Amplifier, you switch the power off on everything else

KE1940 Compleat Kit

See EA Nov 82 **\$39.50.**

### NEW DRIVEWAY SENTRY KIT

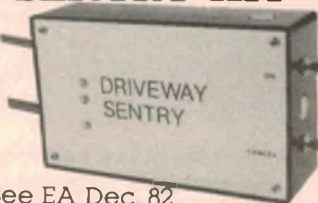

See EA Dec. 82.

KE1088 **\$32.00**

### 300 WATT INVERTER KIT

See June 82 EA  
Run your 12 volt appliances in your car. Great for power strikes. Kit includes everything even handles  
KE4085 **\$195.00**

### STEREO SYNTHESIZER KIT

Refer E/A Sept '82  
KE3020 **\$55.00**  
This kit gives you stereo sound from a mono source like your video



## Digital chess clock with time out alarm

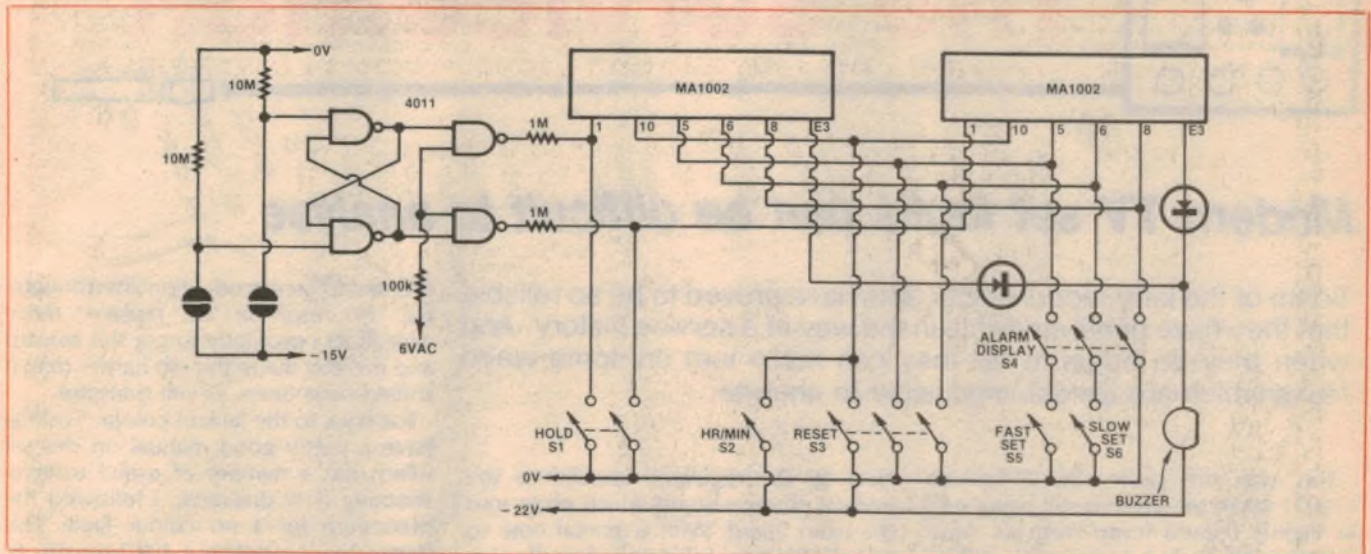

This circuit uses two National Semiconductor MA1002 clock modules (available from Sheridan Electronics) to function as a chess clock with time out buzzer. CMOS touch switchers are used to provide minimum effort switching and to avoid the need for interlocking.

A single 4011B provides gating for the clock signal. Two of the NAND gates are

wired as an RS flipflop which enables or disables one or other of the NAND gates to clock one module or the other. The 50Hz input is clipped by the internal protection diodes of the 4011B and these are protected, in turn, by the 100kΩ series resistor.

Switches S1 and S2 are toggle types while the others are momentary action.

The fast and slow set switches are interlocked with the alarm display switch so that devious chess players do not "fast forward" their opponent's clock while they are preoccupied with a move. S1 changes from seconds display (for games of lightning chess) to hours/minutes display for ordinary games.

P. Stoddard, South Coogee, NSW.

## Four-tone sound for the Super-80

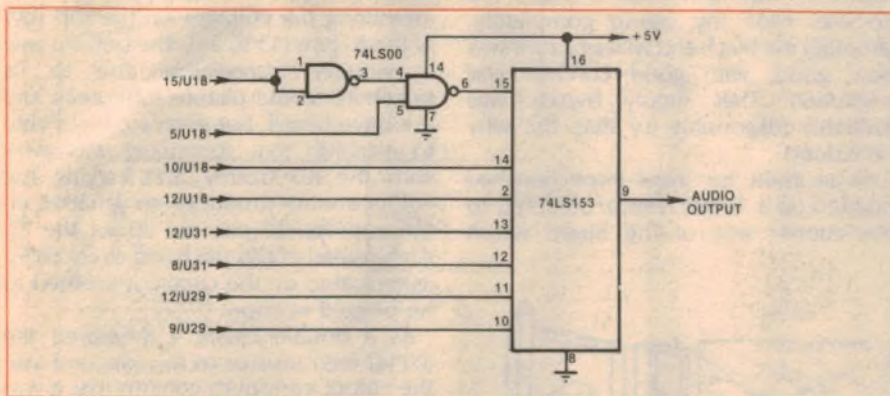

A simple four tone sound system can be constructed using one 74LS00 quad two-input NAND gate and one 74LS153 dual four-line to one-line data selector/multiplexer. The four tones are derived from the frequency divider chain consisting of U29, U31, U36, U40 and U45 of the Super-80. Suitable frequencies can be obtained from pins 9 and 12 of U29 and pins 8 and 12 of U31.

These frequencies are taken to pins 10, 11, 12 and 13 of the 74LS153 as shown in the diagram. The output of the multiplexer, pin 9, can be connected to a

suitable audio amplifier IC such as the LM380.

To select the desired tone the two output ports, pins 10 and 12 of U18, can be used to address the 74LS153. The strobe (chip enable) input of the 74LS153 is active low and can be driven from pins 5 and 15 of U18 after suitable gating. The LED driver, pin 15 of U18, is first inverted then NANDed with the cassette motor driver, pin 5 of U18. This gating is necessary so that the sound generator can be enabled by driving pin 15 low and pin 5 high and prevents unwanted

sounds when saving or loading programs.

The table below gives the codes necessary to select the desired tones.

	Basic	Monitor
210Hz	OUT240,06	0 FO 06
420Hz	OUT240,14	0 FO 0E
840Hz	OUT240,22	0 FO 16
1680Hz	OUT240,30	0 FO 1E
off	OUT240,38	0 FO 26

R. Dunncliff, Aranda, ACT.

## Personal portable modification

Some personal portable AM radios (earphones only) have a tuning indicator LED which draws quite a lot of current. An example of this is the Hanimex HR-1010 which has a 9V battery which is relatively short-lived. This is because the typical current drain is about 18mA which is far too high for this battery. By disconnecting the LED tuning indicator, the current is reduced by about 11mA.

Disconnecting the LED is very easy. Just clip off one of the wires soldered to LED pigtailed, and insulate it with plastic tape. This should give a three-to-one improvement in battery life.

J. Rowe, Arncliffe, NSW.

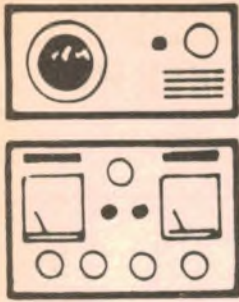

# The Serviceman

## Modern TV set faults can be difficult to analyse

Some of the later model colour sets have proved to be so reliable that they have generated little in the way of a service history. And when they do begin to fail they can really turn on some weird faults which are almost impossible to analyse.

This was the case with a Toshiba C-2021 48cm set which is still being sold in slightly revised form. From its initial introduction it has been sold with a three-year warranty which gives some idea of the confidence that the makers have in their product. The set in question was almost four years old and had given no trouble up to the occurrence of this fault. Apparently the fault had developed in the middle of winter and generally showed as no colour at first switch-on and when changing channels.

Since the fault was minor in the initial stages the owner had not worried much about it, but matters finally took a turn for the worse and I was called. And it was a weird fault. On the left hand side of the picture there was no true colour, although there was a slight greenish cast. Then towards the right hand side of the picture, at a change in contrast (for example, a face) the picture had colour but reds were shot through with green streaks while blues had red streaks. Greens seemed to be unaffected.

When the colour control was turned off, more or less normal black and white reception ensued although the contrast and picture resolution was not good.

### LEAKY ELECTROLYTICS

My first impressions were that something was wrong with the delay line circuitry or perhaps horizontal sync was getting into the ident circuitry. I did not really feel able to analyse the problem because the picture was such a mess. I fetched the service manual from the truck and studied it briefly before diving into the back of the set.

This set does not have a chassis as such but a large printed board measuring about  $25 \times 20$ cm with the power supply regulator heatsink on one corner and the line output transformer on the other.

Next to the regulator heatsink is the vertical chroma board which plugs into the main board. With a mental note to myself about the reliability of small value electrolytics, I resolved to first do a close visual check of the chroma board.

I seemed to hit paydirt straight away because two small electrolytics were clearly defective; they had leaked. One was a  $47\mu\text{F}/16\text{V}$  supply bypass capacitor (C424) while the other was a  $1\mu\text{F}/16\text{V}$  bypass (C506) for the colour control input to the single 24-pin chroma IC. Without going any further I replaced these, thinking that if this did cure the fault, then it would have been almost too easy. I was right. It didn't. What it did do was wipe the colour completely, although the black and white picture was now good, with good contrast and resolution. That supply bypass was probably responsible for that. But why no colour?

As an aside, my initial inspection had pointed up a  $100\text{k}\Omega$  resistor soldered to the copper side of the board which

seemed to be a production afterthought. But in resolving to replace those capacitors I promptly forgot this resistor and thereby made the job harder than it should have been, as will transpire.

But back to the lack of colour. Toshiba have a pretty good manual on this set which has a number of useful troubleshooting flow diagrams. I followed the procedure for a no colour fault. This begins by connecting a  $10\text{k}\Omega$  resistor to disable the colour killer and then voltages at each pin of the IC are checked. Unfortunately, you really need an adapter cable to allow the chroma board to be moved away from the main board, so that you can get at it. Otherwise it is almost impossible to measure the voltages on pins 1 to 12.

### A FAULTY IC

Since I did not have such a cable handy, I had to content myself with measuring the voltages on the top row of the IC pins (13 to 24). The bottom row is virtually inaccessible due to its proximity to the picture tube neck and the drive board. But even so, I was able to establish that something was awry with the IC, mainly that varying the colour control produced no variation on the appropriate pin, pin 20, of the IC. And instead of this pin being at about 6V as indicated on the circuit, it seemed to be pegged at about 0.7V.

As a double check, I measured the  $330\text{k}\Omega$  feed resistor to this pin, and also the colour control to confirm that it was indeed varying the voltage. With these points cleared I concluded that the IC was a dud. As bad luck would have it, I did not have a replacement IC on hand, and it would take me a day or so to get one. So, since the customer was happy to watch in monochrome in the meantime, I left him to it.

(Toshiba can supply a replacement chroma board for this set, but I was pretty confident that the IC was the source of the trouble.)

And so it was that a few days later I lobbed into the customer's lounge room and proceeded to change over the IC.



*"I thought that voice synthesiser would tell me my weight - not scream in pain". (Radio-Electronics).*



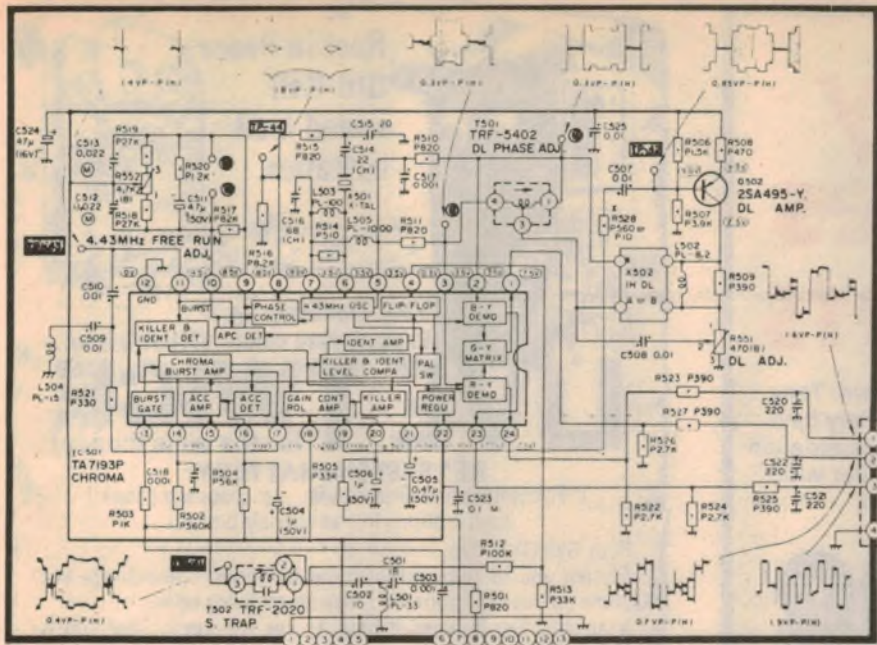

Chroma circuitry for the Toshiba C-2021 colour TV receiver. A faulty chroma IC and several leaky electrolytics were the cause of the problem.

When I am desoldering these large ICs I have sometimes thought that perhaps I should go to the extra trouble and put in a socket. This would make any subsequent repair easy and would not cost the customer very much. But each time I have mentally countered the idea with the thought that such a measure is almost certain to guarantee that the IC will never fail again!

(Well — what's wrong with that! Ed.)

Anyhow I soldered the IC in, replaced the chroma module and turned on. No colour. That set me back a little. In fact, it really rocked me. Because there is so much to potentially go wrong in one of these chips, I had fully expected that this was the problem.

However, I discovered that I had made some progress after the initial disappointment. Voltage checks now indicated that the colour control was varying the voltage at pin 20 and the other voltages were so close to being "spot-on" that it didn't matter. That is all except pin 13. This was supposed to be -2.3V but was in fact slightly positive. Why?

Pin 13 is in fact the burst gate input so I thought that there must be something lacking in the waveform to this pin. So I lugged in the CRO and started to look at the waveforms around the chroma chip. And this is where I really struck problems because most of the waveforms seemed to be completely absent. About the only thing I could confirm was that the 4.43MHz oscillator was running. I then proceeded on a wild goose chase to look for the absent waveforms.

At this stage I was about to give up in the customer's home. It was Friday and I

reckoned if I took the set back to the shop and studied the manual carefully over the weekend, I could come to the job fresh on Monday morning, perhaps with some inspiration. But the customer wasn't too keen on this idea. He wanted to watch the rugby league final that weekend, and was prepared to watch it in monochrome if necessary. He urged me to press on.

In fact, he bribed me with a much needed cup of coffee, and I weakened. But I was determined not to come back to his place after the weekend if I didn't fix it this time. When a set gets curly it is better to be back on home ground. (There you can swear at will if so moved, and I was, believe me.)

After I got back into it things were no better. I checked out the series sound trap which was the path for the burst waveform but was not convinced that anything was wrong there. I even went so far as to check the output of the video detector to see if the colour burst was present. It was. Still the set sat there and resolutely refused to produce colour no matter how much I twiddled the relevant control.

It was then that I decided to check the components around pin 13 more closely to see why the voltage there was positive instead of negative. And that's how I discovered that the 100kΩ resistor I had noticed before was part of a change not shown on the circuit. Instead of a 1kΩ from pin 13 there was now a diode which was biased by the 560kΩ connected to pin 14 and the 100kΩ to deck. Hence the voltage at pin 13 should have been slightly positive, as it was,

## COLOUR TV CHANGE OVER MODULES

<b>THORN 4KA</b>	
P/supply. Scan excluding tripler	\$57
Vertical	\$33
Chroma	\$39
Signals Complete	\$63
<b>THORN 3500</b>	
Convergence	\$53
Vert-Audio	\$33
Horizontal	\$57
Power Supply	\$42
Video	\$33
Chroma	\$45
<b>HMV — EMI C211</b>	
Power Supply	\$38
Horizontal	\$45
Vertical	\$22
<b>HMV — EMI C221</b>	
Power Supply	\$32
Horizontal	\$42
Vertical	\$24
<b>PYE T29-T30-34</b>	
Signals	\$53
Scan	\$53
Varicap Tuner ENV77405	\$48
<b>PHILIPS K9-K11-K12-K2</b>	
Power Supply	\$53
U190 Power supply	\$18
U240 Sound	\$15
U260 CHR-LUM	\$10
U270 Ref Comb	\$15
U280 Demod	\$12
U330 Line	\$18
U335 Frame	\$18
K12 Sync	\$24
k12 I.F.	\$20
K12 Matrix	\$27
<b>KREISLER 59-1-2-3</b>	
Power Supply	\$53
Power Supply control	\$18
Chroma Demod	\$27
Frame	\$30
Line	\$30
Ref Comb	\$27
CHR Lum	\$27
Remote	\$30
<b>RANK 2201-2601</b>	
Deflection Boards	\$48
PWC 296	\$21
PWC 411	\$22
PWC 367	\$15
<b>LUXOR</b>	
Power Supplies	\$30
<b>SHARP</b>	
Horizontal	\$24
Vertical	\$12
Chroma I	\$23
Chroma II	\$24
Blaupunkt tuners	\$28
<b>NATIONAL</b>	
CP 2000-TC86-TC20-2610	
Power Supply	\$30
Vert/pincushion	\$30
Horizontal	\$30
Video	\$48
Colour	\$48
<b>SONY KV 1830</b>	
Board A	\$48
Board D	\$36
Board E	\$48
Board F	\$48
<b>HANIMEX HCT26-700</b>	
Decoder Panel	\$48
R.G.B. Panel	\$22
Field Scan	\$48
Power Supply	\$35
Pincushion	\$22
Line Scan	\$53

Other modules available for most makes and models. Complete changeover chassis for Sharp, Luxor, Blaupunkt and others.

**LARGE RANGE OF TV SPARES IN STOCK — NEW AND SECOND-HAND**

Phone for availability:

**TRADE TELEVISION AND VIDEO SERVICES**

159 Queens Parade, Clifton Hill, Vic 3068.

Ph: (03) 489 1168

# Why pay high prices for cermet

The advantages of Cermet are well known. They are small, robust and totally enclosed. They have low thermal coefficients and high power-dissipation characteristics. They are very stable under wide variations in working conditions.

## SOANAR Cermet Trim Potentiometers

Offer you the same advantages but at real down-to-earth prices.

Soanar-Noble VTP/HTP Cermet are available in a range of values from 50Ω to 1 meg and are designed for PCB mounting with vertical or horizontal trim adjustment.

Terminations conform to the standard .1" grid spacing.

Ratings are .5 watts over the temperature Range — 30°C to +80°C

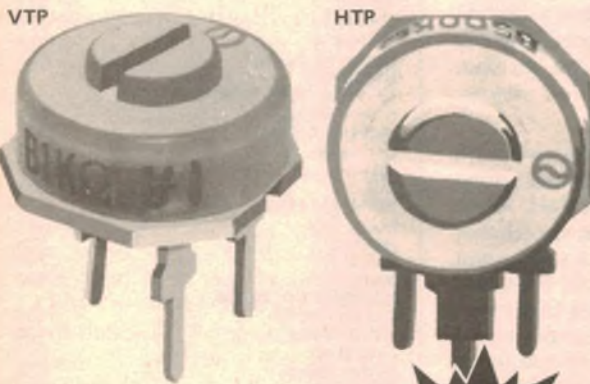

Enclosed, low cost cermet ideal for P.C.B. mounting.

TECHNICAL LITERATURE AVAILABLE ON REQUEST



**SOANAR** SOANAR ELECTRONICS PTY. LTD.

A MEMBER OF THE ARLEC-SOANAR GROUP 30-32 Lexton Road, Box Hill, Vic., 3128, Australia.

VICTORIA 840 1222  
N.S.W. 789 6733  
S.H. AUST. 42 8918

QUEENSLAND 52 1131  
WEST AUST. 381 9522  
TASMANIA 31 6533

Rest in Peace Old Gell sealed lead batteries.

Your number is up. Because here comes EXIDE's new... **LIVE TWICE** (for the same money)

**RE\* SYSTEMS BATTERY**  
(\*Recombination Electrolyte... a space-age breed built nothing like all you oldtimers.)

Poor Gell Oldtimers,  
Flatten you to zero volts and you stay dead. I take charge and come up near full potential. Now that's living twice. You only live 3 years at best. I live 5-6 years. That too is living twice.  
I fit anywhere you can (1-65 A.h). I standby on continuous charge. Or I take cycling duty. Living twice again.  
Folk who want to persevere with outmoded batteries, why that's their business. You OEMs and users who do your sums know a battery that LIVES TWICE for the SAME MONEY is twice the value.  
The RE Systems Battery... from Chloride. Call for details NOW:  
Sydney 646 2244, Melbourne 288 6244, Brisbane 44 1751, Adelaide 277 7255, Perth 271 7377, Hobart 34 4022

**commodore** COMPUTER **VIC SOFT**

**NEW!**  
SPECIAL OFFER  
SOFTWARE WORTH \$100  
WITH EVERY  
ARFON SOLD

**NEW VIC-20 BOOK with cassettes**  
— Introduction to Basic programming Part 2  
**NEW BOOK — 30 EXCELLENT GAMES**  
— Complete listings & program structure.

**VIC-20 PERSONAL COLOUR COMPUTER \$399**

Over 100 software cassettes available from \$14 inc

Vicrek (5 + 3K)	Word Processor (8.16K)	Amok	CARTRIDGES
Tank Wars	Home Inventory	City Bomber	Omega
Amazing	Home Finance 1 \$ 2	Dig & Bury	Jelly Monsters
Alien Blitz (Invaders)	Home Finance 3 & 4	Packman	Avengers
NEW EDUCATION!	Vic calc	Skier	Star Battle
Read spell	Typing Trainer/Tutor	Ski Run	Alien
Advanced maths	User Graphics	ICB Mission	Chess (Sargon)

3K, Super 3K, 8K, 16K RAM Cartridges, Joysticks and Joystick conversion kits.  
Books - VIC REVEALED LEARN PROGRAMMING PARTS 1 & 2, DR WATSONS ASSEMBLY LANGUAGE

**apple** personal computers **Apple II and Apple III 48K-256K**  
Latest **Apple Imagineering** Software  
Diskettes, Books and Reference Manuals

<b>BUSINESS APPLICATIONS</b>	<b>SOFTWARE &amp; HARDWARE</b>
Visischedule	<b>Word processing — 80 column</b>
Visicalc Electronic Worksheet	<b>Graphics</b>
Visicalc Business Planning Template	<b>Communications</b>
Personal Filing System	<b>Education — NEW SERIES</b>
Cash Book	<b>Books</b>
Accounting Modules	<b>Languages</b>
Communications	<b>Utilities</b>
Graph Plotting	<b>LATEST Games</b>
Mail List	
INSTALLATION AND STAFF TRAINING	

**Computer Focus**  
4/224 George Street, Liverpool. (02) 600 8222

ALSO OPEN THURS. P.M. SAT.

EXTENDED BUSINESS HOURS UP TO CHRISTMAS

instead of negative as shown on the circuit.

I cursed myself for being stupid and illogical. I decided that there was nothing wrong with the IC and that some external component must still be faulty. More or less at random, without any real hope of success, I decided to check another low voltage electrolytic capacitor on the board. It was C505, a 0.47 $\mu$ F/50V associated with pin 21, the colour indent detector input.

Without even bothering to get the RC bridge from the truck, I tested it by the old trick of setting the multimeter to the high ohms range and watching the needle flick as I touched the prods across the capacitor. (That's a trick you can't pull with those fancy digital VOMs.) Only the needle didn't flick — the capacitor was completely open circuit! Hot on the trail now, I checked the only other electrolytic capacitor on the board, but it is OK.

Having replaced the capacitor, it was almost an anti-climax when I plugged the chroma board back in, switched on, and had colour immediately. I made a remark about a naughty little capacitor ... or cogent words to that effect!

As I went home I reflected on how I could have saved so much time on that job. If only ... I had been close to the mark in thinking about an ident problem when I first saw the fault, and in thinking about low value electros I was also on the ball.

But in between those two insights I had been following my nose and getting nowhere. Naturally, the customer was very happy to have his colour restored so he could watch his rugby league final. And having seen all the trouble I had to go through he did not jibe too much at the bill.

After all that, any other story from my current list would seem tame by comparison, so I'll fall back on one of the recent reader contributions. The one selected is from Mr J. E., of Blue Creek, WA. This is how he tells it.

### THE MAGIC MULTIMETER

I have tentatively titled this story "The Magic Multimeter", for reasons which will become apparent as it unfolds. It concerns an early model HMV transistor radiogram which had been given to a resident of a local retirement village. The "gram" section worked but the radio did not, and the new owner was more interested in the latter.

When switched to "radio", with the volume control at maximum, the interference from the fluorescent light in

my workshop could be heard, but no stations were audible. I assumed that the local oscillator had failed and that what I was hearing was the 455kHz component of the interference finding its way through the aerial tuned circuit and into the IF stages. Significantly, the interference was most obvious when the receiver was tuned to the low end of the broadcast band, which is only about 100kHz from the IF.

To confirm this I tuned my own portable radio to a local station on 1206kHz and placed it next to the radiogram tuner. I then tuned the radiogram back and forth between 700 and 800kHz. At a dial setting of 751kHz the radiogram's local oscillator should have been on 751 plus 455kHz, or 1206kHz, and should have produced a heterodyne whistle in my own set, against the local station. No whistle was heard.

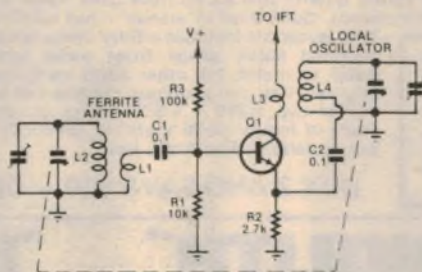

Tuned RF and local oscillator circuitry of the HMV radiogram.

I decided to check the voltages on the converter transistor. To my surprise, as soon as I touched the meter lead on the base of the transistor a local station came through loud and clear. Almost automatically I assumed that either the transistor or its base bias resistors were at fault and that the meter load had just made the difference between oscillating and not oscillating.

The easiest way to cure this, I thought, was to simply replace the transistor and its three associated resistors, which I did. But the fault remained. When the meter lead was placed on the base of the converter transistor the set sprang into life, but was dead without it.

But I did discover one other intriguing fact. With the meter negative lead clipped to the earthy side of the set, the set would work if the positive lead rested on the circuit board in a certain position, without making electrical contact. So it seemed that the fault was capacitive or, at least, could be cured by capacitive means.

At this juncture I decided to take another look at this commonly used circuit and refresh my memory as to its

operation. Referring to the simplified diagram of this set shows the tuned circuit, L4 and a variable capacitor, in which is generated the local oscillator frequency. Output from this tuned circuit is taken from the tapping on L4 and fed via C2 to the transistor input at the emitter. Note that the emitter resistor has no RF bypass.

Output from the transistor is then fed back into the tuned circuit via L3 which is inductively coupled to L4. Thus the tuned circuit continues to oscillate. It is important to note here that, although the transistor operates as a grounded emitter circuit as far as the received signal is concerned, it operates in a grounded base configuration as the local oscillator.

Having thus refreshed my memory I returned to the set. Bridging C2 with a similar capacitor produced no result, so I turned my attention to the base circuit of the transistor. How was it earthed in its role as a grounded base local oscillator? The capacitor, C1, which couples the ferrite antenna coil to the base of the converter, seemed the only possibility, so I bridged it, but again without result.

Then I saw something I should have seen much earlier. The earthy end of L1 had been snagged and broken. When this was repaired the set worked as it should have done. Apparently the impedance of L1 — which would have only a few turns anyway — was low enough to allow C1 to effectively earth the base of the transistor in so far as its role as a local oscillator was concerned.

With the earthy end of L1 open circuit, the effective capacitance to earth for the base of the transistor was just not sufficient to allow the circuit to oscillate. But the additional capacitance introduced by the multimeter leads was just enough to make the difference, and the circuit would oscillate.

But this explanation posed another question. When the circuit was made to oscillate in this way, how did the signals in the aerial coil reach the base of the transistor with L1 open circuit? Well, I imagine there must have been enough random coupling between L1 and L2 to enable the stronger local signals to brute force their way through.

Perhaps the moral of this story is that one of the first stages of servicing should be a good visual inspection; a check for broken leads, overheated resistors, tatty looking capacitors etc. Anyway, the set was returned to its owner in full voice, and everyone was happy.

Thank you J.E., for a most interesting story. Yes, I agree that a thorough visual inspection should be the first step in any service job and it is surprising how often this can save valuable time. On the other hand, even the best of us can sometimes overlook an important visual clue and waste much time as a result.

# MAGNIFICENT! NEW 5000

DAVID TILLBROOK HAS DONE IT AGAIN!! 5000 SERIES 1/3

## ★ ★ ★ ★ ★ ★ ★ ★ ★ ★ 5000 SERIES GRAPHIC EQUALISERS

★  
ALL IC  
SOCKETS  
PROVIDED



AUSTRALIAN (NOT HONG KONG)  
MADE - SPECIAL BUILT RACK  
CABINET - QUALITY!!!

**SPECIFICATIONS:**  
Signal-to-Noise: -102dB  
with respect to 1 Volt  
Frequency Response:  
12Hz - 105kHz to -1dB  
Boost/Cut: 14dB (28dB  
total)  
Distortion: 100Hz-0.007%  
1kHz-0.007%  
10kHz-0.008%  
(essentially irrespective of  
cut or boost)  
Current consumption (DC)  
Approx 100mA @ ±15V  
(Requires 30V AC CT)  
Output short-circuit proof.

Latest addition to the thoroughbred 5000 Series stable! David Tillbrook has once again produced a 'No Compromise' design. This new component, a 1/3 octave equaliser, gives you ABSOLUTE CONTROL over the acoustics of your particular listening environment. You get 3 SEPARATE CONTROLS for every octave of audio bandwidth to virtually eliminate the subtle nuances that are particular to your listening area.

1/3 octave equalisers have been used by professional engineers in Recording Studios and live concerts for over a decade now. It is no accident that the advent of the 1/3 octave equaliser and studio quality live sound have gone hand-in-hand. BUT THERE'S A CATCH. One of these equalisers is not enough. You will have to buy 2 (for stereo). Quite a lot of money - but worth it if you want the best.

For those whose budget does not extend to \$389, may we suggest the 2010MkIIA octave (10 band) equaliser. This unit is rack mounted and in the same format as the 5000 series equaliser. It is stereo (in one 3 1/2" cabinet) with one slider per octave. Basically an upgrade of the ETI 485 graphic, it represents outstanding value for money at only \$139.00.

The Jaycar kit includes a fully prepunched plated chassis, prepunched heavy gauge front panel with silkscreened front panel to match the other 5000 components. It is absolutely original. You can purchase the kits one at a time for \$199 ea. or, for two, \$389 - a \$10 saving. If you are one of the hundreds of happy 5000 users we are convinced that you will be just as delighted with this unit.

★ only ★  
\$199

BUY 2 AND SAVE \$10 - ONLY \$389

## "BLACK MONOLITH"

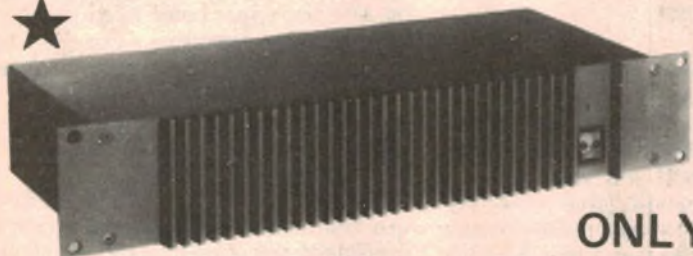

ONLY  
\$299

Once again, imitation is the sincerest form of flattery. The Black Monolith 5000 Mosfet Power Amp has the following EXCLUSIVE features:

- Beryllium Oxide (Space Age ceramic) TO 3 washers (Not flimsy mica! - jig drilled and extruded heavy gauge, anodised heatsink bracket)
- SUPERFINISH front panel STILL THE BEST now with blind tapped holes
- New heavy duty heatsinks for the driver transistors, 100% extra heatsink area and black anodised for greater efficiency. (Not in original design)
- Ventilation holes in metalwork at critical points. (Not in original design)
- Extra 3 pin DIN socket on rear panel (total 2) to power new 5000 components (1/3rd Octave 5000 series Equaliser coming soon!) Not in original design but now a must with the new additions in the family

IF YOU THINK THAT YOU CAN SAVE MONEY ON THESE KITS ASK YOUR SUPPLIER IF HE WILL GIVE YOU ALL OF THESE FEATURES AT THE PRICE. MAKE SURE THAT YOU GET IT IN WRITING!

A PRICE RISE ON BOTH KITS (i.e. SALES TAX AND METALWORK ETC) IS EXPECTED SOON! BUY THE BEST FOR NO MORE.

Write in (SAE) for a new glossy leaflet on both amps

### SPECIFICATIONS

#### POWER OUTPUT FREQUENCY RESPONSE

Around 100W RMS into 8 ohms  
8Hz to 20kHz, +0 - 0.4dB  
2.8Hz to 65kHz, +0 - 3dB  
Note: these figures are determined solely by passive filters

#### INPUT SENSITIVITY

#### HUM

#### NOISE

#### 2nd HARMONIC DISTORTION

#### 3rd HARMONIC DISTORTION

#### TOTAL HARMONIC DISTORTION

#### INTERMODULATION DISTORTION

#### STABILITY

1V RMS for 100W output  
-100dB below full output (flat)  
-116dB below full output (flat, 20kHz bandwidth)  
<0.001% at 1kHz (0.0007% on prototypes) at 100W output using a \*56V supply rated at 4A continuous  
<0.003% at 10kHz and 100W  
<0.0003% for all frequencies (less than 10kHz and all powers below clipping  
Determined by 2nd harmonic distortion (see above)  
<0.003% at 100W (50Hz and 7kHz mixed 4:1)  
Unconditional

## "BLUEPRINT"

5000 PREAMPLIFIER ★

"One Swallow does not make a spring"

- Neither does a few gold RCA sockets!

Several of our competitors are imitating our "Blueprint" preamp by adding a few bits and pieces, notably gold plated RCA sockets to their standard kits. Unfortunately they have missed the point. We supply gold plated sockets in our "Blueprint" preamp but only where it makes sense to do this, i.e. on the inputs - NOT the outputs. 16 gold sockets are provided by us. This, however, does not make a "Blueprint" THIS DOES:

- Low capacitance screened cable - 12 metres of it. NOT Taiwanese cable as supplied in other kits. Our cable costs us NEARLY 5 TIMES MORE than the Taiwanese stuff.
- Original ETI designed front panel. Not an "ADAPTION". Our front panel is by far the nicest
- Factory pre-tinned PCB's to reduce chances of dry or noisy solder joints
- Quality LEDs, polished finish, multicoloured display.
- IC sockets on line amp board
- Special rear panel
- Special low noise selection LM394H NOT CH device in M.C. preamp
- Thermalloy (U.S. made) heatsink on 7805 regulator
- English L orlin selector switches
- Apart from the 16 gold RCA's we throw in a pair of gold plated line RCA plugs - worth \$5
- Special Nylon rear panel grommets

So don't "Swallow" the facts before they are properly digested!!!

You can't make a silk purse out of a sow's ear. Send SAE for full specs



BLUEPRINT \$275

## ★ SPECIFICATIONS

#### Frequency Response

High level input: 10Hz-120kHz, 0 - 1dB  
Low level input: conforms to RIAA equalisation  
+0.2dB (see detail on Phono spec)

#### Distortion

1kHz: 0.003% on all inputs (limit of resolution on measuring equipment due to noise limitation)  
High level input: master full, with respect to 300mV input signal at full output (1.2V)  
92dB flat - 100dB A weighted

M.M. input: master full, with respect to full output (1.2V) at 5mV input, 500 ohm source resistance connected - 86dB flat  
92dB A weighted

M.C. input: master full, with respect to full output (1.2V) at 200mV input signal  
71dB flat - 75dB A weighted

#### ETI-478MM Moving Magnet input stage

Gain: 14dB  
Frequency Response: 5 Hz to 10kHz  
Total Harmonic Distortion: 0.001%, 1kHz, 10mV RMS input  
Headroom: 28dB with respect to 5mV RMS input signal, i.e. 130mV RMS  
Total equivalent input noise: 122mV A, input shorted, 28mV flat, input shorted  
S/N ratio: 10mV, 5mV, 10mV  
Flat: 73dB, 87dB, 93dB  
A weighted: 78dB, 92dB, 98dB

#### ETI-478MC Moving coil input stage

Gain: 24dB  
Frequency Response: 7Hz-135kHz, 0 - 1dB  
Total Harmonic Distortion: 0.002%, 1kHz, 30mV input  
Noise: Total equivalent input noise: 82mV flat, input shorted  
42mV A, input shorted  
140mV flat, after RIAA Eq. input shorted

# SERIES COMPONENT

OCTAVE GRAPHIC EQUALISER — BRILLIANT!!

FROM \$495

EX-STOCK  
CALL IN AND SEE WORKING



## 8 CHANNEL MIXER KIT

The Jaycar 8002 Mixer was originally conceived to be the successor to the very popular ET1414 Master Mixer. The 414 was basically configured as a 'stage' mixer and suffered from a number of severe technical limitations notably poor signal-to-noise figures. Enormous advances in Audio IC's have occurred since the 414 was designed. Jaycar engineers have taken advantage of this. The incredibly low noise and distortion figures of the 8002 are a testimony to the sound basic design of the mixer coupled with the performance capability of these IC's. Whilst the 8002 is the ideal 8 channel compact stage mixer, other applications have been kept in mind. AS A "STUDIO" MIXER. The prime requirement of a studio mixer is that it must be quiet - i.e. have good S/N. Due to the fact that the "miracle" 5534 IC's are used in the 8002 studio applications are entirely feasible. In addition to this, metal film resistors are used in critical signal areas. AS A DISCO MIXER. The balanced input feature of the 8002 is not really necessary for disco use. This section can easily be bypassed with either a moving magnet (Dynamic Cartridge) preamp, or a moving coil preamp. The sensible format of the 8002 and tremendous equalization facilities should make this mixer popular for disco use.

- Balanced (600 Ohm) Mic. Inputs/Line Inputs.
- Cannon Connectors included in the price.
- Bass, Mid & Treble Equalization on each Input.
- "Effects" (i.e. Echo etc.) capability.
- Foldback and Stereo Pan on ALL 8 Inputs.
- 60mm Slide Faders used throughout.
- 19" Rack Mount capability (or Console Mount).
- Professional Black Front Panel with Format borders & multi-coloured knobs to assist function identification.
- VU Metering.

Send SAE for full details + details on use as stage mixer

# MASSIVE BREAKTHROUGH! CAR COMPUTER BELOW \$200

COMPLETELY BUILT AND TESTED - NOT A KIT!!

MADE IN ENGLAND!  
- QUALITY!!



CONTAINS EQUIVALENT OF THOUSANDS OF TRANSISTORS  
- USES MASSIVE CUSTOM LSI CHIP TO ACHIEVE LOW PRICE

Never before has such a comprehensive car performance computer been offered at such a low price!! Once again miracle microprocessor technology has enabled us to pass enormous savings on to you!! But don't let the low cost fool you. The "Voyager" car computer IS THE MOST COMPREHENSIVE PRODUCT THAT WE HAVE SEEN. No other car computer matches this one AT EVEN TWICE THE PRICE! You could buy a \$20,000 Holden and not get a better car computer!! Just check the features. We are sure that you will calculate that the "Voyager" represents outstanding value!

IDEAL RALLY COMPUTER!

only \$199 complete

### FEATURES

- INSTANT FUEL CONSUMPTION IN LITRES/100KM AND MPG!! (MOST OTHERS HAVE ONLY ONE OF THE ABOVE) JUST SWITCH FROM ONE TO THE OTHER AS YOU DRIVE ALONG.
- INSTANT SPEED, TIME AND OTHER FUEL DATA
- VISUAL AND AUDIBLE EXCESS SPEED ALARM.

### INSTALLATION

The "Voyager" comes complete with an unbelievable array of mounting configurations, on dash, under dash or stalk mount. ALL installation hardware is supplied (even a roll of insulation tape!) as well of course, as the speed and fuel sensors. A lavishly illustrated installation manual is provided as well as a comprehensive operators manual.

A typically competent EA/ETI reader would be able to install this unit in 3-4 hours.

## "super siren"

Incredible CMOS circuit drives a Motorola piezo horn (KSN 1038A) to achieve extremely high sound pressure levels. Makes a great alarm and only draws - would you believe - 5mA average?

Runs for ages on a 9V battery. You can get the electronics including the PCB for only \$5.00. KSN1038A only \$17 extra.

Ref: EA 11/82 FROM \$5.00

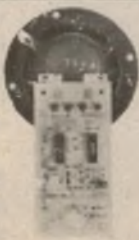

## Jaycar NUMBER 1 FOR KITS

125 York Street, Sydney 2000  
Phone: 264 6688 Telex: 72293

"Nevilles Corner"  
Cnr. Carlingford & Pennant Hills Road,  
Carlingford  
Phone: 872 4422

Mail Orders To: Box K-39 Haymarket  
Sydney 2000

POST AND PACKING CHARGES  
\$5 \$9.99 (\$1.20) \$10 \$24.99 (\$2.40)  
\$25 \$49.99 (\$3.00) \$50 \$99.99 (\$4.60)  
\$100 up (\$5.20)

NEW SHOP HOURS  
Mon Fri 8.30 to 5.30pm  
Sat 8.30 to 12.00pm  
Thurs night to 8.30pm

MAIL ORDER BY BANKCARD VIA YOUR PHONE



## DATUM: programming and monitor software

Last month we covered the design and construction of DATUM, a low-cost microcomputer designed to teach the basics of microprocessor systems. This article covers some of the software aspects, including the on-board Monitor routines and some sample programs.

First of all have a look at Fig. 1. This is a "programming model" of the MC6802 microprocessor, showing the internal registers of the chip which are available to the programmer. These registers are storage locations which are operated on by the various instructions of the microprocessor.

As shown in Fig. 1 the MC6802 has two 8-bit accumulators, A and B, shown at the top of the diagram. The accumulators (abbreviated ACC) have instructions associated with them which can perform basic arithmetic and logical operations. All instructions that operate on an accumulator can be used on either ACC A or ACC B, except for one, Decimal Adjust Accumulator, used in converting binary to BCD. This instruction operates only on ACC A.

Next is the index register (IX). This register is 16-bits long and is usually used

to store a 16-bit address which "points" to an item of interest, such as a memory location or an output port.

The Program Counter (PC) keeps track of the address of the current instruction, and is incremented automatically when the next instruction is required.

The Stack Pointer (SP) is also a 16-bit register, and stores the address of an area of memory defined by the user as a "stack". The stack is used by the processor as a temporary storage area to save the address to be returned to after executing a subroutine, or to save the contents of all registers (except the stack pointer) when an interrupt is encountered.

The stack pointer is set by the DATUM Monitor program to address 007F when the Reset key is pressed. The area of memory with addresses from 0000 to 007F is located on the MC6802 chip

itself, and is used by the Monitor for temporary storage.

Besides its use in automatically saving subroutine return addresses, and register contents at an interrupt, the stack can be accessed by the programmer with "Push" and "Pull" instruction. These instructions must be used carefully to ensure that the stack is not disorganised. A common cause of "crashing" programs is incorrect use of the stack. If, for example, a data byte is left on top of the stack when the processor is expecting to find a subroutine return address, the program will be off into the never-never.

The final register shown in Fig. 1 is the Condition Code Register (CCR). This register indicates the state of the machine after it has executed an instruction. The state of each bit or a logical combination of bits in this register are used to determine the operation of conditional instructions. There are six separate conditions which will be indicated after every instruction;

H: Half Carry (a carry bit from bit 3 to bit 4 of a binary number)

I: Interrupt mask. Determines whether the processor will respond to a maskable interrupt

N: Indicates a negative number in two's complement binary

Z: Indicates a zero byte.

V: Overflow. Result is too large to be represented in 8 bit two's complement binary

C: Carry (a carry bit from bit 7 of a binary number)

Although a standard 8 bit register is used for condition codes, bits 6 and 7 are permanently set to "1" and can be ignored.

For more detailed discussion of 6802

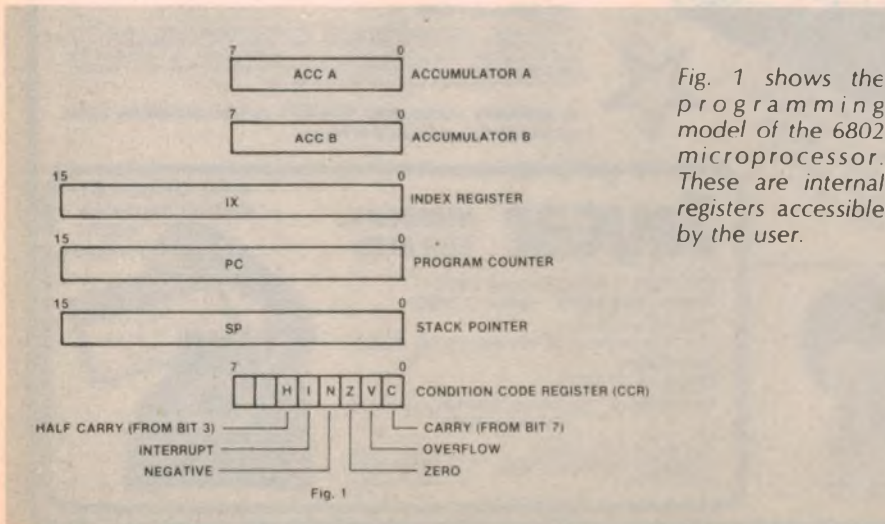

Fig. 1 shows the programming model of the 6802 microprocessor. These are internal registers accessible by the user.

registers and programming, refer to our series of four articles on "How to Program in Machine Language", which began in EA, March 1982. The "M6800 Microprocessor Applications Manual", published by Motorola Inc is also a useful reference source.

## What is a Monitor program?

A Monitor program is a collection of short programs that assist the user when communicating with the microprocessor system. The routines in the Monitor are directly related to the hardware of DATUM, and are called into action by the user's keypad input via a routine called the "command processor". This routine performs a number of tasks;

- Refreshing the display
- Scanning the keypad
- Checking the validity of the user's input
- Transferring to control to function routines when required.

Fig. 2 shows a simplified version of the command processor program. After the machine has been reset it outputs a prompt "—" in the leftmost display digit. The keypad is scanned, the display refreshed and if no key has been pressed the MC6802 will continue to refresh the display and check the keypad.

When a key is struck a test is carried out to determine whether or not the key was valid. If the key was not valid the program returns to the display refresh routine without changing the display or the contents of any memory locations in the user area of the system. If however, the key was valid and, for example, it was a hexadecimal digit, the display would then show that digit. This is a simple example of multi-tasking, where a number of jobs are being carried out in sequence by the processor. To the user however, it looks as though this happens instantaneously.

If the key pressed was one of the command keys and it is valid then the MC6802 will start to execute a program that corresponds to that command.

An important function of the Monitor and probably the one most frequently overlooked is that of base conversion. The microprocessor has only one language, that of binary numbers. Humans have difficulty when dealing with such numbers so the hexadecimal number system (base 16) is used instead. There are at least two reasons why base 16 is most frequently used in computing: (1) Conversion between base 2 and base 16 is mathematically a simple matter. (2) People can easily remember numbers written in hexadecimal.

Another important feature of a Monitor are functions that allow the user to examine and change the contents of given memory locations so that programs can be stored. Equally important

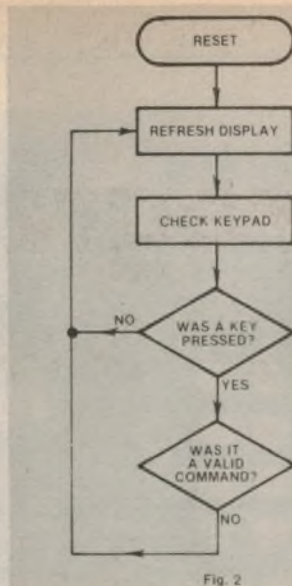
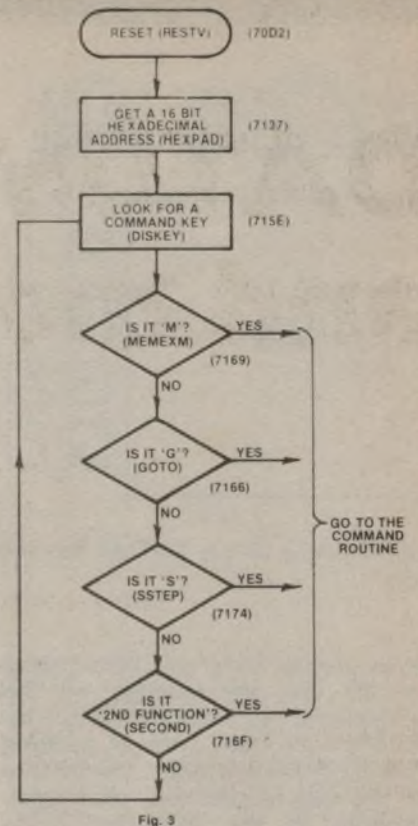

Fig. 2 is a flowchart of the command processor program, responsible for refreshing the LED display, scanning the keypad and verifying the user's input.

Fig. 3 is a more detailed flowchart of the command routine, showing the actual names and addresses of the individual command routines in the DATUM Monitor ROM.



is a "go" command, which allows the user's programs to be executed. Finally there should be some debugging aids that allow the programmer to trace through a program and so determine if the computation being performed is as intended.

Fig. 3 shows a flowchart similar to that of Fig. 2, with the difference that the actual names and addresses of the routines in the DATUM Monitor are also shown. Briefly, these routines operate as follows; shown with the name of "label", first, and the hexadecimal starting address shown in parentheses;

- DISKEY (7155): This subroutine refreshes the display and then scans the keypad.
- GOTO (7166): This routine causes a jump out of the Monitor to the user's program.
- HEXPAD (7137): This subroutine allows the user input a 4-digit hexadecimal number.
- MEMEXM (7169): This is the memory examine and change routine.
- SECOND (716F): This routine toggles the second function flag.
- SSTEP (7174): This is the single step or trace routine

## Monitor commands of DATUM

This section describes the operation of each Monitor command in detail. Fig. 4 shows the layout of the keypad and display of DATUM and should be referred to as an aid to understanding how to "drive" the machine.

First of all we should consider the operation of the memory display and change function. This is one of the most important functions of the Monitor as without it programs cannot be loaded into the memory of DATUM. To display the contents of a given memory location all the user need do is to enter the address of the required memory location using the keypad and press the M/R key. The data digits (the two right-hand digits) of the display will then show the contents of that location. If the user wants to change the contents of the displayed location two new hexadecimal digits can now be entered from the keypad.

When entering new data into memory or just inspecting the current contents of a number of locations the I/D key is used to increment the displayed address. Some of the less obvious features of the memory function are that the user can input any number of hexadecimal digits, however only the two digits on the display just prior to the user pressing either the I/O or RESET or the ESCAPE key will be stored. If the Second Function

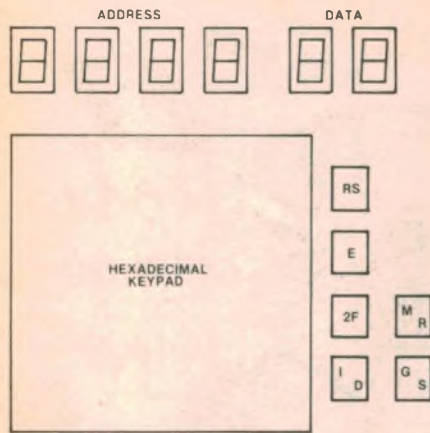
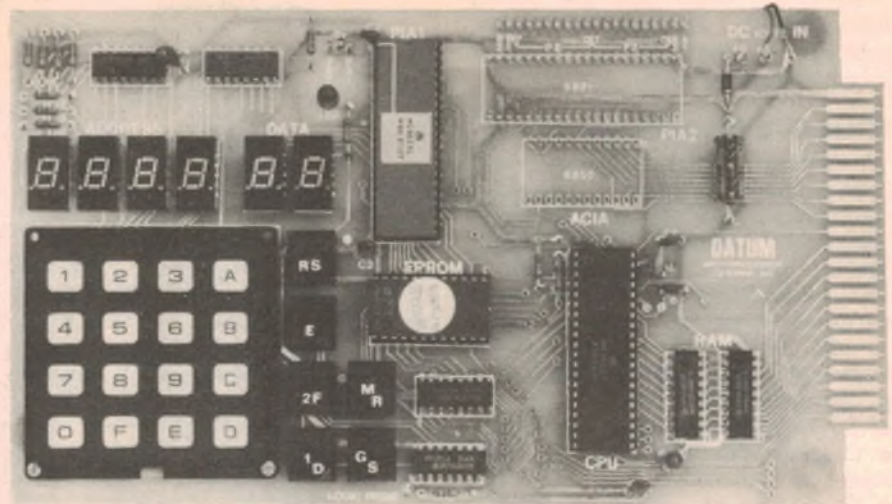

Fig. 4

Fig. 4: layout of the DATUM function keys.



key is pressed once only before using the I/D key, the address will be decremented each time the I/D key is used. There are three ways of escaping from this decrement mode. The first is to use the 2nd function key once again, returning to the increment mode without exiting from the memory function. The other two ways are by using the RESET or the ESCAPE keys, which do cause an exit from the memory function.

When the contents of a memory location are changed the data display changes with every key stroke (every half byte, or "nibble"). If only one nibble is changed the contents of the memory location will then be the new high order nibble and the old low order nibble.

Once a program has been stored in memory the next Monitor command required is one that tells the machine to set the program counter to the start address of the user's program and to begin to execute it. The G/S key provides this function. Pressing this key after entering the four digit start address will cause the program to begin to execute from that address. However, the user may find that the first few attempts at writing software may not always produce results that are expected. The type of unpredictable results can vary from a value not being calculated correctly to a "crash" where all of the memory in which the program had been stored is over-written. If the unit does "crash" as just described then the prompt may not return when the ESCAPE key is pressed. In this case a master RESET is needed.

Obviously some debugging functions are also required. A trace or single step mode is one such tool. The single stepping mode is entered by keying in the start address of the program, pressing the 2nd function key and then the G/S key. The display will now show the start

address and the opcode of the first instruction of the program. Now if the I/D key is pressed the address will be that of the next instruction and the data display will show the opcode of that instruction. In this mode none of the data bytes associated with these instructions are ever displayed. With this function programs can be checked one step at a time for correct operation.

When executing a program in this manner it is useful to inspect the contents of the registers, which can be done with the M/R key. In this case there is no need to press the 2nd function key before the M/R key because the 2nd function is already engaged in the single step mode.

For example, if the program shown in Fig. 5 is entered and run, examination of the registers will show the sum in Acc A, and the second addend in Acc B, where they were placed by the program. This illustrates an important point — the Store operation does not change the data in the source register, it merely copies it to the destination.

When the register display mode is entered the first register to be shown will be the condition code register. If the I/D key is then pressed a number of times the remainder of the registers will be displayed. Table 1 shows the order in which the registers are displayed, together with the actual display on DATUM. The two righthand displays are

(CC)	XX--CC
(ACC B)	XX--Ab
(ACC A)	XX--AA
(IX)	XXXX Id
(PC)	XXXX PC
(SP)	XXXX SP

Table 1: Order in which registers are displayed by the M/R function.

the register identification, 'X' is the contents of a register and "-" is a blank display.

When the user has incremented the register display through to the stack pointer, pressing the I/D key once again will cause the condition codes to be displayed again. If the user wants to exit from the register display mode but continue single stepping, then the G/S key should be used. On returning to the single step mode the step just before entering the register display will be shown.

Now that the operation of the single step function has been described, we should next look at how it works so that the user can gain the full benefit from this function. As a piece of software it is the most complex section of the monitor. The function is performed by software only, there being no special hardware added to DATUM to perform the interrupt. It operates in the following manner:

- (1) The opcode to be executed is checked to determine the number of bytes in the instruction. If it is a branch or a jump instruction the destination address is determined.
- (2) The single step program now knows where the target program will go to next, so the instruction in that location is stored away in the scratch pad memory and a software interrupt (SWI) is entered in its place. The opcode of this instruction is "3F".
- (3) The instruction is executed and then the processor will reach the software interrupt which will cause the processor to resume execution of the single step program.
- (4) Finally the software interrupt is replaced by the instruction opcode that was stored away. The above process is then repeated for the next instruction.



**SUPER LOW PRICES**

**AMPHENOL  
17 SERIES  
DB25 PLUGS  
& SOCKETS**

Plugs \$2.45 Sockets \$1.85



**SPEAK & SPELL  
IS HERE**

as featured in **E.T.**<sup>TM</sup>

**FRIEND**  
TEXAS INSTRUMENTS

**\$110.00**  
INCLUDES SALES TAX

**E.T. PACK INCLUDES**

- One Speak & Spell learning aid
- The new E.T. Fantasy Module
- New photo-filled activity book
- Colorful movie poster
- T-shirt decal with E.T. and Elliot

**MEMORY BARGAINS**

- HM6116P-3 (HITACHI) 2Kx8 CMOSRAM **\$7.50**
- MB2716 (FUJITSU) 2Kx8 EPROM **\$3.00**
- MB2764 (FUJITSU) 64K EPROM **\$12.00**
- MB8118 (FUJITSU) 16K DYNAMIC RAM (Intel 2118) 120ns **\$4.00**

**INDUSTRY STANDARD**

**BOURNS  
MODEL 3006P  
CERMET  
TRIMPOTS**

15 TURN 1.25 WATT  
ALL POPULAR VALUES

Standard Range  
100 OHM-1 MEG **\$1.10 ea.**

Was \$1.60

**MAGRATH'S —  
THE ONLY CITY SOURCE**  
Now you can make professional quality PC artwork and boards

**E-Z CIRCUIT**<sup>TM</sup>  
BY BISHOP GRAPHICS INC

**PRESSURE SENSITIVE  
DRAFTING AIDS**

Ideal for small volume OEM users, Consultants, Breadboarders, Experimenters, Designers, Hobbyists Bishop quality in small, economical packages.

**CHRISTMAS SPECIAL**

**Professional  
Video  
Monitor**

Was \$227

**\$199**

18MHZ Video Bandwidth  
BM-12E

- Input Signals: Composite Video Signal Negative SYNC 1.0 P-P 75 ohm
- CRT size: 31 cm diagonal
- Green Phosphor — P31 non glare
- Power input 230V 50Hz
- Display format: 1920 characters max. (80 characters X 24 lines)

**TI PERSONAL HOME  
COMPUTER**

See article in this issue of EA, Pages 100, 101, 102 and 103.

TI-99/4A

**\$499.00** INCLUDES SALES TAX

**You can buy just a video game — or you can get a full colour Home Computer**

- Typewriter Keyboard
- 16K bytes RAM
- Expandable to 52K bytes RAM
- Easy to follow instructions
- Extensive range of programmes
- Educational
- Add-on expandability

**AUDAX**

The Compact 200 as featured in EA, Sept 82

**HIGH QUALITY,  
LOW COST,  
DO-IT-YOURSELF  
BOOKSHELF  
SPEAKER SYSTEM**

Speakers, Electronics Kit **\$199**  
Cabinets (per pair) **\$99.50**

**MAGRATHS DECEMBER MONEY SAVERS  
SEMICONDUCTORS**

See 6 pack Specials for super prices, on asterisked products.

4011B 19c	*74LS04 20c	*LM340T 5 51c
*4016B 30c	*74LS14 40c	LM340T 15 60c
4023B 19c	74LS47 72c	LM386M 60c
4028B 55c	*74LS90 42c	LM555 25c
*4066B 44c	74LS161 53c	LM741N DIP 23c
*4511B 69c	81LS95 87c	LM741 DIP 36c
4520B 74c	81LS98 88c	*74C02 20c
7406 20c	LM301A DIP 35c	74C89 \$1.50
7414 33c	LM308 DIP 49c	*74C107 30c
74164 48c	*LM324 42c	*JA3170C REG \$1.20
74365 37c	LM339 DIP 42c	*KBPC602 6A 200V BR \$1.00
*74LS00 20c	*LM340KC 12 \$1.20	*S6006L 6A 600V SCR 80c

**TI CALCULATORS  
FROM MAGRATH'S**

- FINANCIAL
- SCIENTIFIC
- STUDENT

TI-35 Student math kit **\$27.00**  
TI-54 Engineers & Science **\$45.00**  
TI Business Analyst II **\$50.00**

PRICES INCLUDE SALES TAX

**Add Sales Tax if applicable**  
Prices valid until stock sold.  
Prices subject to alteration

Visit us at our new address  
**55 A'BECKETT STREET  
MELBOURNE, 3000.**  
Tel (03) 347 1122



**SUPER XMAS BARGAINS AT MAGRATH'S**

# CHERRY KEYBOARDS



**Actral** have been appointed sole Australian agents for the precision engineered range of quality keyboards from **CHERRY**.

We stock all popular models of:—

-  Gold crosspoint contact keyboards
-  Solid state capacitive keyboards
-  Hard contact and non-encoded keyboards

ALSO AVAILABLE:—

-  Custom made and touch panel keyboards

## CHERRY

*"The intelligent choice of replacement and O.E.M. users."*

**Actral Merchant Division**  
137-155 Adderley Street,  
West Melbourne, Vic., 3003.  
Phone: (03) 329 6911 Telex: 38221

PLEASE FORWARD LITERATURE ON THE **CHERRY** KEYBOARDS

Co NAME \_\_\_\_\_

ADDRESS \_\_\_\_\_

P/CODE \_\_\_\_\_

CONTACT \_\_\_\_\_

It should be noted that this type of single step will only work in a read/write memory. In fact if the operator tries to use this command to trace through the DATUM monitor EPROM the prompt will return to the display.

Some attention must be given to the subject of breakpoints. A breakpoint is another debugging tool, an instruction that is placed into the user's program to terminate the program when it is executed. By using this function programs that have long execution times such as those using delay loops can be executed at full speed till the breakpoint is reached. Due to the small number of function keys on DATUM it was decided that a breakpoint function could not be incorporated. However, the user can still have this if the following steps are taken.

Determine where in the program a breakpoint is needed (this at first may be only a guess) and change the opcode of the selected instruction to a "3F" for a software interrupt (SWI) (note down the original opcode for future reference). Run the program in the normal way and if it is correct and there are no very long delays in the program the displays should immediately light up with the address of the SWI and "3F" in the data display.

If the display does not return in reasonable time it can be assumed that the program has crashed and that the SWI should be placed closer to the start of the algorithm.

When SWI is being displayed the user can press the 2nd function and then the M/R key to display the register contents at this point of the program.

Having finished with this particular breakpoint the operator must replace the SWI opcode with the original code used in the program.

When attempting to use the register display function it should be noted that DATUM will only display registers after a SWI has been executed by the processor. This has been done deliberately so that only valid register contents are displayed.

Finally there is a base conversion package which is located in the monitor EPROM. There are three routines which allow the user to convert from hexadecimal to binary, octal, or decimal. In each case when these routines are running the prompt is moved to the second display from the right and every time a new hexadecimal value is keyed in on the right-hand side the result is displayed on the four left-hand side digits. To run these routines, key in relevant address and press the G/S key. The program address are hex 7500 for hexadecimal to binary, 7503 for hexadecimal to decimal, and 7506 for hexadecimal to octal.

1010 B6 10 00	START	LDA A	SUM1	LOAD ACC A WITH THE FIRST VALUE
1013 F6 10 01		LDA B	SUM2	LOAD ACC B WITH THE SECOND
1016 1B		ABA		ADD THE TWO ACCS. TOGETHER
1017 B7 10 02		STA A	SUM3	SAVE THE RESULT
101A 3F		SWI		STOP

Fig. 5: A short program to add two numbers together. The first four digits are address locations at which the corresponding op codes and data are entered.

1000 BD 71 07	START	JSR	PROMPT	CLEAR DISPLAY AND OUTPUT A PROMPT
1003 CE 00 10	LOOP1	LDX	##10	SET DELAY TIME
1006 BD 71 DD	LOOP2	JSR	DISPLY	GO TO THE DISPLAY ROUTINE
1009 09		DEX		DECREMENT THE X REG
100A 26 FA		BNE	LOOP2	IS X REG ZERO?
100C 96 10		LDA A	DISBUF	LOAD ACC A WITH DISBUF CONTENTS
100E 81 FF		CMP A	##FF	IS IT A BLANK?
1010 26 03		BNE	INCDIS	IF NOT BLANK GO TO INCDIS
1012 4A		DEC A		BLANK, DECREMENT FOR A PROMPT
1013 20 01		BRA	STORIT	SKIP INCREMENT
1015 4C	INCDIS	INC A		PROMPT, INCREMENT FOR A BLANK
1016 97 10	STORIT	STA A	DISBUF	STORE NEW DISPLAY VALUE
1018 20 E9		BRA	LOOP1	BRANCH TO DISPLAY/DELAY LOOP
	*			
	*			
	**			IF DISBUF = FE THEN A PROMPT IS DISPLAYED.
	**			IF DISBUF = FF THEN THE DISPLAY IS BLANK
	*			
	*			
	END			

Fig. 6: A program to flash the prompt on the LED display, showing the use of the Monitor routines SPROMPT and DISPLAY.

## Programs for DATUM

This subject will be covered in more detail in the next article, however, by way of introduction a few programs will be presented.

The first is a very simple program to add two hexadecimal numbers together and has been included to demonstrate the operation of the single step mode. The program listing in Fig. 5 should be placed in memory starting at location 1010 (hex) with the two numbers to be added placed in locations 1000 and 1001. Values that will be used for this example are 10 and 20 respectively. Once these values and the program have been placed in memory the user should begin the single step mode at location 1010. At this point the display will show the address 1010 and the contents of the location (data) equal to B6. If the I/D key is pressed four times the opcodes of the instructions and the corresponding addresses will be displayed as in Table 2.

Now that the program has been executed the user can check location 1002 to see if the correct value, 30, has been stored. If the user wants to display the registers while in the single step mode

HEX ADDRESS	DATA
1010	B6
1013	F6
1016	1B
1017	B7
101A	3F

Table 2: Addresses and data for the addition program shown in Fig. 5.

then the method described above should be used.

The next program, listed in Fig. 6, flashes the prompt segment on the display. This program uses two subroutines that reside in the Monitor. The first, "SPROMPT" is located at 7107 and it has the function of clearing the display then placing the prompt character in the display buffer. The second is called "DISPLAY" and is the display multiplex subroutine.

The flash rate may be varied by altering the value loaded into the index register at the beginning of LOOP1, that is, the 16-bit number in memory locations 1004 and 1005. Currently it is 0010, but if it is reduced the flash rate will increase. The final listing, Fig. 7, is that of a 12 hour clock. When running, this program prompts the user with a lower case "t" and waits till the time has been entered. If a non-decimal number is entered or an invalid digit is keyed in, then the incorrect digit will be set to zero. The program requires inputs of hours and minutes only, as the seconds are automatically set to zero. If the hours figure is less than 9 then a leading zero must be entered in the tens of hours digit.

The clock program is shown overleaf. The first four digits are addresses, followed by the op codes and data to be entered.

In the next article more programs and applications will be presented, including games and control applications for the hobbyist.

NOW YOU CAN ENJOY THE BENEFITS OF DICK SMITH SHOPPING AT 2 NEW STORES!



Terms available to approved applicants through... **HFC**



**Dear Customers,**  
Quite often, the products we advertise are so popular they run out within a few days. Or unforeseen circumstances might hold up shipments so that advertised lines are not in the stores by the time the advert appears. And very occasionally, an error might slip through our checks and appear in the advert (after all, we're human too!). Please don't blame the store manager or staff, they cannot solve a dock strike on the other side of the world, or fix an error that's appeared in print. If you're about to drive across town to pick up an advertised line, why not play it safe and give the store a call first... just in case. Thanks

**Dick Smith and Staff**



# DICK SMITH Electronics

**MAIL ORDER CENTRE**  
**PO BOX 321, NORTH RYDE NSW 2113**  
**Telephone orders: (02) 888 3200**

## POST & PACKING CHARGES

ORDER VALUE	CHARGE	ORDER VALUE	CHARGE
\$5.00-\$9.99	\$1.40	\$50.00-\$99.00	\$4.60
\$10.00-\$24.99	\$2.40	\$100.00 or more	\$6.20
\$25.00-\$49.99	\$3.50		

Charges are for goods sent by post in Australia only — not airmail, overseas or road freight.

## SPEEDY PHONE/BANKCARD ORDER SERVICE

Just phone through your order and Bankcard details — it's so simple!  
**(02) 888 3200**



## MAJOR RESELLERS

These are our major resellers. However, we cannot guarantee they will have advertised items in stock or at the prices advertised.

**Atherton QLD:** Joe Sue's Radio Service, 55 Main St. 91 1208 ● **Bendigo VIC:** Sumner Electronics, 7 Edward St. 43 1977 ● **Ballina NSW:** A. Cummings & Co. 91-93 River St. 86 2285 ● **Cairns QLD:** Thompson Instrument Services, 79-81 McLeod St. 51 2404 ● **Coffs Harbour NSW:** Coffs Harbour Electronics, 3 Coffs Plaza, Park Ave. 52 5684 ● **Darwin N.T.:** Kent Electronics, 42 Stuart Hwy. 81 4749 ● **Darwin N.T.:** Ventronics, 24-26 Kavanagh St. ● **Deniliquin NSW:** Dani Electronics, 220 Creasy St. 81 3672 ● **East Maitland NSW:** East Maitland Electronics, Cnr. Laws & High Sts. 33 7327 ● **Echuca VIC:** Webster Electronics, 220 Packanham St. ● **Geraldton WA:** KB Electronics & Marine, 361 Main Terrace 21 2176 ● **Gladstone QLD:** Purely Electronics, Shop 2, Cnr. Herbert & Auckland Sts. 72 4321 ● **Geelong NSW:** Tomorrow's Electronics & Hi-Fi, 68 William St. 24 7246 ● **Kingston TAS:** Kingston Electronics, Channel Court, 29 6802 ● **Launceston TAS:** Advanced Electronics, 5a The Quadrant, 31 7075 ● **Lismore NSW:** Decro Electric, 3A/6-18 Carrington St. **Mackay QLD:** Stevens Electronics, 42 Victoria St. 51 1723 ● **Maryborough QLD:** Keller Electronics, 218 Adelaide St. 21 4559 ● **Mt Gambier SA:** Hutchison's Comm. 5 Elizabeth St. 25 6404 ● **Mildura VIC:** McWilliam Electronics, 40 Lamont Ave. 23 6410 ● **Morwell VIC:** Maxwell Electronics, 128 George St. 34 6133 ● **Nambour QLD:** Nambour Electronics, Shop 4, Lowan House, Ann St. 41 1604 ● **Orange NSW:** MBW Electronics, 173 Sumner St. 62 6491 ● **Parrith NSW:** Acorn Electronics, Shop 12, 541 High St. 36 1466 ● **Port Macquarie NSW:** Hall Of Electronics, 113 Horton St. 837 440 ● **Rockhampton QLD:** Purely Electronics, 15 East St. 21 058 ● **Shepparton VIC:** G.V. Electronics Centre, 189b Corio St. 21 8866 ● **Southport QLD:** Amateurs Paradise, 121 Nerang St. 32 26 44 ● **Toowoomba QLD:** Hunt's Electronics, 18 Neil St. 32 9877 ● **Townsville QLD:** Tropical TV, 49 Fulham Rd. Vincent Village, 79 1421 ● **Wagga NSW:** Wagga Wholesale Electronics, 82 Forsyth St. ● **Wodonga VIC:** ABM Electronics, 78a High St. 24 4588 ● **Whyalla SA:** Mellor Enterprises, Shop 2, Forsyth St. 45 4764

- STORE LOCATIONS**
- |                              |             |           |
|------------------------------|-------------|-----------|
| NSW 145 Parramatta Rd        | AUBURN      | 648 0558  |
| T55 Terrace Level            | BANKST. SQ. | 707 4888  |
| 613 Princes Hwy              | BLAKEHURST  | 546 7744  |
| 552 Oxford St                | BONDI JCT.  | 387 1444  |
| 818 George St                | BROADWAY    | 211 3777  |
| 531 Pittwater Rd             | BROOKVALE   | 93 0441   |
| 147 Hume Hwy                 | CHULLORA    | 642 8922  |
| 162 Pacific Hwy              | GORE HILL   | 439 5311  |
| Elizabeth Dr & Bathurst St   | LIVERPOOL   | 600 9888  |
| 396 Lane Cove Rd             | NORTH RYDE  | 888 3200  |
| George & Smith Sts           | PARRAMATTA  | 689 2188  |
| 6 Bridge St                  | SYDNEY      | 27 5051   |
| 125 York St                  | SYDNEY      | 290 3377  |
| Tamworth Acde & Kable Ave    | TAMWORTH    | 61 1896   |
| 173 Maitland Rd              | TIGHES HILL | 28 3800   |
| 263 Keira St                 | WOLLONGONG  | 66 1961   |
| ACT 96 Gladstone St          | FYSHWICK    | 80 4944   |
| VIC 260 Sydney Rd            | COBURG      | 383 4455  |
| Ross Smith Av & Nepean Hwy   | FRANKSTON   | 783 9144  |
| 205 Melbourne Rd             | GEELONG     | 78 6766   |
| 399 Lonsdale St              | MELBOURNE   | 67 9834   |
| Bridge Rd & Coronation Blvd  | RICHMOND    | 428 1614  |
| QLD 293 Adelaide St          | BRISBANE    | 229 9377  |
| 166 Logan Rd                 | BURANDA     | 391 6233  |
| Gympie Rd & Hamilton St      | CHERMSIDE   | 59 6255   |
| SA 60 Wright St              | ADELAIDE    | 212 1962  |
| Main South & Flagstaff Rds   | DARLINGTON  | 298 8977  |
| WA 435 Main North Rd         | ENFIELD     | 260 6088  |
| Wharf St & Albany Hwy        | CANNINGTON  | 451 8666  |
| 414 William St               | PERTH       | 328 6944  |
| Hay St (The Center Way Acde) | PERTH       | Open soon |
| 25 Barrack St                | HOBART      | 31 0800   |

## STORE HOURS

All Dick Smith stores are open from 9am to 5.30pm (Saturday 9am to 12 noon) except Queensland stores which open and close half hour earlier. Many stores are open for late night trading. Phone your nearest store for details.



# Texas Instruments TI-99/4A computer

The new Texas Instruments TI-99/4A computer is the latest entrant in the home computer stakes. With 16 colour graphics, sound effects and a powerful Basic interpreter it should prove a hot competitor in the under \$500 market.

by PETER VERNON

When we reviewed the Texas Instruments TI-99/4 computer in September 1980 we called it "a total departure from previous small systems with their emphasis on programming". Plug-in program cartridges then were revolutionary, and so was the concept of a sound and colour graphics computer for the home user.

In those days of course there were no VIC-20s, Ataris or Tandy Colour Com-

puters, and many doubted the appeal of a "home computer".

The TI-99/4 didn't exactly set the world on fire. The chief problem, at least in Australia, was the price (\$931) and the fact that to use the machine an NTSC video monitor was required, an additional \$600 or so. Less importantly, the keyboard was a pushbutton model, although in an almost standard "qwerty" layout.

Since then a lot has happened in micro-computing terms. Colour systems with a respectable amount of memory, extensive sound effects and plug-in software are no longer out of the ordinary. In fact it is probably in this area of the micro-computer market that competition is fiercest, with Atari, Tandy and Commodore fighting it out to see who can produce the most impressive low cost computer for the home.

Not to be left behind in a field they pioneered, Texas Instruments has re-entered the fray with a revamped model, the TI-99/4A.

The new system has a lot going for it. First of all the price is right. With 16K of RAM and TI Basic the TI-99/4A sells for \$499. The user no longer needs a special video monitor — the price includes either a UHF or a VHF modulator so that the computer can be used with any PAL-D television set. Alternatively the user can purchase a Thorn UHF/VHF television set, converted by TI for direct video entry. The \$399 video monitor doubles as a standard TV. A cable for two cassette recorders, two instructional manuals and an external power supply are also included.

Two joysticks (or "wired remote controllers" in TI parlance) can be connected to a socket at the left of the keyboard console.

A major difference between the TI-99/4A and its predecessor is the new keyboard. The pushbuttons are gone, replaced by 48 full-size, full-travel typewriter style keys. The keyboard feel is certainly as good as any comparable machine, although a few non-standard aspects of the layout take some getting used to.

Three special function keys (Shift, Control and Function) allow many



The TI-99/4A has extensive sound and graphics capabilities, as shown by the "Music Maker" cartridge. Photo was taken using a television set modified for direct video.



Expanded system includes 32K memory module, disk controller and disk drive. The separate power supply is on the left.

of the ordinary keys to generate up to four different characters or commands. Template strips and a holder above the top row of keys help the user remember what the different key combinations are used for.

Other features include a 16-bit microprocessor (for those impressed with numbers), graphics with 16 colours and excellent sound effects and music capabilities. In many respects the colour and sound capabilities of the TI-99/4A are superior to anything else available.

Packaging of the TI-99/4A is identical to that of the earlier model. The keyboard console is small and light, measuring 260 x 390 x 70mm and weighing less than 2.3kg. A 2.4m cable connects the separate video modulator box and the separate power supply also had conveniently long connecting cables. The power switch, a small slider on the lower right hand front of the console, is a little difficult to use.

With the exception of the cassette recorders and joysticks all accessories connect to an expansion port at the right side of the keyboard console. Each item has a similar port, and multiple accessories slot into each other. This means that there is only one configuration possible for the system; the keyboard, memory expansion unit and disk controller, for example, all fixed in one line and plugged firmly together.

Due for release early next year is a "peripheral box" and connecting cables which will do away with the disadvantages of this approach. (At present a fully expanded system can occupy almost two metres of bench space).

### The keyboard and display

The keyboard occupies no more space than the keyboard of its predecessor so

some users may find it a little cramped. Certainly the keys seem just a fraction too close together for comfort, although this depends on the size of your hands. The ENTER key, too, is no larger than the normal keys.

While the keyboard conforms to the standard "qwerty" layout for alphanumeric characters, the placing of some punctuation symbols is unusual. The double quote sign, for example, is generated by pressing Function-P, while a backspace is Function-S and a question mark Function-I. The Function key is to the right of the spacebar, making it impossible to use these keys by touch. Even when the user has learned the locations of these symbols they are still time-consuming to use.

When the computer is first turned on an introductory screen comes up, displaying the TI logo and the notation "press any key to begin". Pressing "any key" displays a "menu" with only one option, unless a program cartridge is in place in the slot on the right side of the keyboard console.

With a program cartridge in place the title of the cartridge is added to the menu. Pressing 1 will enter TI Basic while

pressing 2 will give control to the program cartridge. Users can switch between Basic and a program cartridge at any time by typing "Function-Quit".

In the "programming mode" the screen is a light blue, with characters displayed in black. Text is displayed in 24 lines of 28 characters each with lowercase letters denoted by small capitals on the screen. An alphalock key is provided to shift the alphabetic characters to uppercase for programming.

When a program is running the screen is a light green, reverting to blue at the end of the program or when an error is encountered. Needless to say, other screen colours can be selected by the program.

### Texas Instruments Basic

TI Basic is provided with the standard machine. It is a comprehensive version of the language. Ten standard arithmetic functions are included, 14 commands and 24 statements, including IF . . . THEN . . . ELSE, automatic line numbering and renumbering commands and programming aids such as TRACE, BREAKPOINT and editing commands. See Table 1 for a full listing of the language.

### TI-99/4A home computer specifications

<b>Processor:</b>	TMS9900 16-bit
<b>RAM:</b>	16K standard, expandable to 48K
<b>ROM:</b>	26K, expandable with plug-in cartridges
<b>Display:</b>	16 colours, 24 lines x 28 characters, 32 x 24 dot resolution and higher using programmable characters, 32 "sprites"
<b>Keyboard:</b>	48 key, full-size typewriter style
<b>Sound effects:</b>	Three independent voices, each covering 5 octaves, and noise generator
<b>Languages:</b>	TI Basic, Extended Basic, Pascal and Logo

# TI-99/4A home computer

TI Basic has one general purpose string handling statement, SEQ\$, which takes a string expression and two parameters, returning a sub-string starting at the character specified by the first parameter, with a length specified by the second parameter. All of the standard string handling functions of Microsoft or any other Basic can be duplicated with SEQ\$, and this flexibility is an added attraction.

File handling statements are provided to control input and output to peripherals such as the thermal printer, disk drives, cassette and RS232C interface (an optional extra). Ten CALL statements are provided to manipulate screen and character colours, programmable characters and the built-in sound effects. CALL statements are also used to access the add-on joystick and to allow programs to accept keyboard input.

TI Basic allows variable names up to 15 characters long and scientific notation with a five-digit mantissa and exponents from -128 to +127. This is almost the only time that the use of a 16-bit micro-processor makes any difference at all to the computer user. Most 8-bit machines are limited to exponents in the range  $\pm 32$ . Whether the average user needs this extended mathematical capability is another matter.

The graphics are exceptional. The complement of 16 colours (including black and "transparent") is double that of most comparable systems. Combine this with the programmable graphics characters and quite good displays can be achieved. The 256 x 192 resolution though, is not complete, relying as it does on programmable characters.

Sound effects are also very good. The TI-99/4A uses a separate Texas Instruments sound generator chip which provides three voices, each with a five octave range, and a noise generator that can be used as a fourth tone source or for white or pink noise at various pitches.

TI Basic also provides the easiest sound commands that we have used. Using CALL SOUND the length of the sound can be specified directly in milliseconds and the frequency in Hertz, with volume between 1 and 16. A single CALL SOUND statement can activate one or all of the sound sources, setting different frequencies and volumes (but not different durations) for all voices. Quite complex effects can be produced by taking advantage of this feature.

## Extended Basic

Optionally available is a program cartridge containing "TI Extended Basic" that comes with a 220-page book and an addenda covering changes for the TI-99/4A. For an additional \$99 this package gives the "home computer" considerable power.

TI Extended Basic adds over 40 new commands and statements and allows multiple statements on each line. Blocks of graphics ("sprites") can be defined and moved for fast, flicker-free animation.

Sub-programs with local variables which are only affected by operations of the sub-program can be stored on disk and called up for insertion in any other program. Programs can also load and run other programs from disk, so that memory size is not a problem. Large programs can be subdivided and chained

together even though their total length exceeds the amount of memory available.

Extended Basic also allows comprehensive control of program errors, warnings and breakpoints, with ON ERROR, ON WARNING and ON BREAKPOINT. Note that there are two classes of error messages. Less serious errors cause a warning to be displayed, but do not interrupt program execution. Even attempted division by zero will not crash a program, but display a warning message, substituting the largest possible number for the affected variable. Table 2 shows the statements added by TI Extended Basic.

TI's approach to graphics is a little unusual. The properties of the TMS9918A Video Display Processor emphasise moving blocks of graphics rather than the more usual X, Y co-ordinate array of points. TI Extended Basic provides the capability to define and animate up to 32 separate graphics blocks, called "sprites", which can then be moved on the screen with single commands. Priority of images is built-in, so that Sprite 1, for example, is displayed on top of Sprite 2 if the images overlap.

One of the most difficult problems in computer graphics is the "hidden line" question. If two images are almost coincident, which parts should be displayed and which hidden? The "sprites" of the TMS9918A take care of this issue automatically. Sprites can be defined, moved on the screen and enlarged to up to four times their normal size with single CALL statements.

On the other hand, graphics resolution in the conventional sense is 32 horizontally by 24 points vertically, in 16 colours. The advertised 256 x 192 resolution is achieved by programming characters to represent line segments, and is not available for highly detailed or complex scenes, although sprites can be moved with this precision, making for very smooth animation.

In addition, since the graphics and sound effects are provided by dedicated circuits without tying up the processor, lack of speed is not a problem in these areas. Some of the TI demonstration programs, written in Extended Basic, provide better graphics and faster and smoother animation than most "video games machines". In fact, we were particularly impressed by this aspect of the TI-99/4A.

For those who really want to get involved in the nitty-gritty, TI Extended Basic supports the loading and running of TMS9900 assembly language programs if the optional 32K memory expansion unit is attached to the com-

## TI-99/4A BASIC AND EXTENDED BASIC

ABS ASC ATN BREAK BYT BYE CALL CHAR CALL CLEAR CALL COLOR  
CALL GCHAR CALL HCHAR CALL JOYST CALL KEY CALL SCREEN CALL  
SOUND CALL VCHAR CHAR CHR\$ CLEAR CLOSE COLOR CONTINUE  
COS DATA DEF DELETE DIM DISPLAY EDIT END EOF EXP FOR-TO-STEP  
GOSUB GOTO IF-THEN-ELSE INPUT INT LEN LET LIST LOG NEW NEXT  
NUMBER OLD ON GOSUB ON GOTO OPEN OPTION BASE POS PRINT  
RANDOMIZE READ MEM RESEQUENCE RESTORE RETURN RND RUN  
SAVE SEG\$ SGN SIN SOUND SQR STOP STR\$ TAB TAN TRACE UN-  
BREAK UNTRACE VAL

Table 1: TI Basic is a powerful and comprehensive language.

ACCEPT CALL CHARPAT CALL CHARSET CALL COINC CALL DELSPRITE  
CALL DISTANCE CALL ERR CALL INIT CALL LINK CALL LOAD CALL  
LOCATE CALL MAGNIFY CALL MOTION CALL PATTERN CALL PEEK  
CALL POSITION CALL SAY CALL SPGET CALL SPGET CALL VERSION  
DISPLAY USING IMAGE INPUT REC LINPUT MAX MERGE MIN ON BREAK  
ON ERROR ON WARNING PI PRINT USING SUB SUBEND SUBEXIT SIZE  
RPT\$

Table 2: Extended Basic adds more statements, providing exceptional power.



puter. An editor/assembler program cartridge is also available for developing machine language programs, although it requires a disk drive in addition to the memory expansion unit.

The accessories we used (32K memory expansion unit and disk controller) were 110V versions designed for the TI-99/4. Texas Instruments states that redesigned 240V versions are currently undergoing approval testing by the electricity authorities and will be available in the first quarter of next year.

## Speech synthesiser

A unique feature of the TI-99/4A Texas Instruments computer is the optional speech synthesiser. And although the speed synthesiser uses the same technology as the TI "Speak & Spell" the voice quality is far superior. Speech from the TI-99/4A is clear and easily understandable (although American). Programmed inflection and selectable pauses between words aid intelligibility.

The speech synthesiser is a compact (56 x 132 x 64mm) unit that plugs into the right side of the keyboard console. A "solid state software module" must be used in conjunction with the synthesiser. We used the "Speech Editor" which provides a vocabulary of 373 words and phrases. Words to be spoken are simply typed on the computer.

TI Basic can also produce speech using the statement CALL SAY "whatever". Command strings for the speech synthesiser can also be generated by CALL SPGET, which translates ASCII codes into speech codes, saving a little time when the resulting codes are sent to the synthesiser.

Note that these Basic statements are only available when a speech synthesiser software cartridge is plugged into the computer.

Other program cartridges, such as "Terminal Emulator II", provide software and instructions which further expand the capabilities of the speech synthesiser. A text-to-speech program, sound codes and inflection controls allow the user to program natural-sounding speech with an almost unlimited vocabulary.

## Software available

An extensive range of software is available for the TI-99/4A. The Texas Instruments "Home Computer Program Library" lists over 195 programs, available either as cartridge or on cassette or disk. The listing is divided into categories such as "home finance/management", educational applications, business and professional and entertainment, including music.

With all software modules an extensive manual guides the user through the features of each program, with examples of use and suggestions for further developments.



"Early Reader" program cartridge tells stories and asks the user to identify particular words and phrases. The speech synthesiser module is visible at right.

We reviewed the "Early Reader" program cartridge, which uses the speech synthesiser, graphics and sound to good effect in assisting children to recognise words. From a programmer's point of view this program is also interesting because it uses the TI computer's programmable characters to generate true lower case letters.

"Music Maker" lets the user compose music, either in traditional notation or as a "sound graph" for up to three voices and noise (which can be programmed as a fourth voice or used to add resonance). The graphics and music synthesis capabilities demonstrated by the cartridge are excellent.

Another software cartridge provides "TI Logo". The memory expansion unit is required to run Logo, and a disk controller and disk drive are an advantage.

Logo is a language designed for introducing children to computer concepts. Using Logo problems are divided into sections and a "procedure" written for each section. It is an interactive language with simple English commands. Books can and will be written on Logo as an educational language, so we won't go into details.

TI Logo makes full use of the graphics capabilities of the TI-99/4A including the sprites. The software is well-presented, coming with the Logo Command Module (tm), plus two easy-to-understand instruction manuals and a disk and cassette of sample programs.

Other software available includes the

language Pascal, and a terminal emulator cartridge which operates with the optional RS232C interface unit. In conjunction with the speech synthesiser "Terminal Emulator II" provides a full featured, talking computer terminal.

## Finally

Overall we found the TI-99/4A a difficult computer to review. The extensive range of features of the standard unit, combined with the program cartridges and other accessories mean that any short term use is not likely to fully explore the versatility of the system.

TI Basic is a very powerful language, but TI Extended Basic goes even further. Combined with the memory expansion and disk drive units, TI Extended Basic provides enormous scope for the programmer — a point which can only be touched on in a review such as this.

The TI-99/4A is a solid, well-conceived product, intended to stand or fall on its own merits. A little investigation reveals that these merits are considerable. The price is right, at \$499 for the basic configuration, and peripherals and expansion units are no more expensive than those of competing systems.

The TI-99/4A is not for business or word processing and it doesn't pretend to be. For families that want an all-round computer for the home, for children and teachers, and for hobbyists interested in graphics, voice and music synthesis the Texas Instruments TI-99/4A home computer has a great deal to offer.

I MUST CLEAR THIS STOCK BEFORE XMAS - NEW PRODUCTS COMING - YOU REAP THE BENEFIT!



## FT101Z FM



Cat D-2872

### SPECIFICATIONS

Frequency coverage: 160, 80, 40, 30, 20, 17, 15, 12 and 10m. Modes of operation: FM, LSB, USB, CW, AM. Input Power: 180W DC (SSB/CW), 50W DC (AM). Sensitivity: 0.25uV for 10dB S/N (SSB/CW), 0.4uV (AM). Selectivity: 2.4kHz (6dB), 4.0kHz (60dB). Carrier Suppression: better than 40dB. Spurious Radiation: better than 40dB below rated output. Operating Voltage: 100-240V AC (13.5V with optional conv.). Antenna output impedance: 50-75 ohms, unbalanced.

~~\$885~~

**\$825**

## 902 SERIES FT902D



Cat D-2853

### SPECIFICATIONS

Frequency coverage: 160, 80, 40, 30, 20, 17, 15, 12 & 10m. Modes of operation: LSB, USB, AM, CW, FSK, FM. Input power: 180W (SSB), 180W DC (CW), 80W DC (AM). Sensitivity: 0.25uV for 10dB S/N (SSB). Selectivity: 2.4kHz (6dB), 4kHz (60dB), SSB. Carrier suppression: better than 40dB. Spurious radiation: better than 40dB below rated output. Power requirements: 240V (13.5V with optional conv.). Antenna output impedance: 50-75 ohms unbal.

~~\$1195~~

**\$950**

## FT107 SERIES



## FT107M/DMS

### SPECIFICATIONS

Frequency coverage: 160, 80, 40, 30, 20, 17, 15, 12 & 10 Modes of operation: LSB, USB, CW, AM, FSK. Input power: 240W DC (SSB), 80W DC (AM, FSK\*). Sensitivity: 0.25uV for 10dB S/N (SSB, CW, FSK), 1uV (AM). Selectivity: 2.4kHz (6dB), 4kHz (60dB) SSB cont. variable from 300 to 2400 Hz. Carrier suppressor: Better than 40dB. Spurious radiation: better than 50dB below rated output. Power requirements: 240V & 13.5V supplies are built in. Antenna output impedance: 50 ohms unbal.

\*Can be modified for novice use

Cat. D-2871

NOTHING MORE TO BUY. Remember, the FT 107 comes ALREADY EQUIPPED with memory unit, AC & DC power supplies, etc. You don't have to spend another cent!

~~\$1328~~ **\$999**



## Antenna Coupler FC107

No problems with antenna mis-match on your FT 107, not with this superb couple. Designed to match the styling of the FT 107, but also just at home with any transceiver. Huge meters for power output & SWR. Cat D-2873

~~\$205~~ **\$185**



TH3JR offers top performance on 10, 15 and 20 metres. The TH3JR has an SWR of less than 1.5:1 at resonance. Cat. D-4304

**YOU WON'T BELIEVE THESE PRICES!!!**

## DC-DC INVERTER

Want to go mobile? Add this superb DC/DC inverter to your 101Z and run it from your car battery (13.5V nominal). Don't tie yourself to your shack and the 240 volts mains - get out to where the air is clean (and the DX is great)! Cat. D-2864

~~\$77~~ **\$55**

## DIGITAL DISPLAY (Optional)

Want a digital display but you can't afford it? Buy the FT-101Z then later on when you can afford it, buy the digital display and fit it yourself. It's so easy! Cat. D-2861

~~\$142.50~~ **\$99**

## DC POWER CABLE ONLY \$5.00! SD2231

with the purchase of the above inverter (Cat. D-2864)

(Usually \$22.00!)

## ABOVE DISPLAY ONLY \$10!!!

if purchased with FT101Z FM (Cat. D-2872) or FT101Z (Cat. D-2862)

## ANTENNA COUPLER



**500 WATTS**

## FC902

Cat D-2855

This coupler can feed anything from a random length of wire to a beam. Match the load perfectly so you can deliver more power up there where it's wanted! Suits all bands, has built-in SWR/power meter as well 50 or 75 ohm system, 500 watt rating

~~\$265~~ **\$195**

## MEMORY UNIT

You can get even more use and pleasure from your 902 with the optional memory unit. Instant recall of often used frequencies, repeaters, etc. Cat. D-2858

~~\$139.50~~ **\$99** ~~\$69~~ **\$49**

## DC/DC INVERTER

Go mobile with the FC902 12 volts inverter. Simple connection, gives base station performance from your car. Cat. D-2856

## FT901D

Cat. D-2854

### SPECIFICATIONS

Frequency coverage: 160, 80, 40, 20, 15, 10m. Input Power: 180W (SSB), 180W DC (CW), 80W DC (AM). Sensitivity: 0.25uV for 10dB S/N (SSB). Power requirements: 240V

## XTAL FILTER SPECIAL

901/902 - 107 - 707 - 101Z Series CWN (SD0418) CW (SD0417), AM (SD0416)

~~\$1075~~ **\$875**

~~\$33~~ **\$24 ea**

## YAESU FAN

If your 'rag chews' get a little long, give your FT 101Z a break by installing a cooling fan. Comes with all fittings. 110V operated (runs from a tap on the transformer). Now reduced in price too! Cat. D-2865



~~\$28.95~~ **ONLY \$19.95**

## FT101Z

HF - WARC - TX Cat. D-2862

~~\$849~~ **\$749**

## FT101ZD

HF - WARC - TX WITH DIGITAL READOUT. Cat. D-2859

~~\$910~~ **\$795**

# 2 METRE BARGAINS!

**FT-480R** Yaesu's top 2 metre rig: FM, CW & SSB!



~~\$589~~ **\$445**

Yaesu call this their total performance VHF-compensated transceiver. And total performance it is! As the top-of-the-line Yaesu 2 metre family, you'd expect a lot! You get it FM, SSB & CW over the full 2 metre band, with two VFO's which may be used for unusual repeater splits, four memory channels, scanning, 100kHz resolution on the digital frequency readout, a SAT switch to make satellite operation easy (with an external receiver), a receive clarifier, a hi/lo power switch (30W PEP max), an effective noise blanker, tone burst, priority channels, optical selector coupling... If you want the best you want Yaesu. If you want the best 2 metre Yaesu, you want the FT-480R! As they say Magnifique! Cat D-2887

**FT-227RB**



~~\$379~~ **\$299**

One of the most popular Yaesu transceivers we have ever had the pleasure to operate the incredible FT-227R. A PLL scanner will take you anywhere within the 2 metre band instantly - just press the scan button on the microphone. No need to worry about reaching for a selector switch in heavy traffic! And you have four memory channels to choose from, with a 600kHz repeater split for working standard repeaters, or up to a 4MHz split for unusual repeaters or requirements. Power output is ten watts, and the receiver has better than 0.3uV sensitivity (10dB S/N). It operates 13.5V DC with protection against reverse polarity and high antenna SWR. For value-for-money it's hard to go past the FT-227RB. Cat D-2891

**FT-207R**



with 10kHz steps  
**PRICE INCLUDES NICAD BATTERY PACK AND CHARGER (Cat. M-9517)**  
~~\$358~~ **\$235**

Imagine a hand-held 2 metre transceiver with all the punch of the big guns - with digital display, 800 channels, 4-bit CPU chip for frequency control, 4 memory channels, repeater splits, auto scan (up or down), weighing just 680g. You're imagining the unbelievable Yaesu FT-207R! How does it perform? How about 0.32uV sensitivity, or 7.5kHz selectivity (-60dB) - or a power output of 2.5W (min). If you've always wanted a 2 metre rig you can throw into a bag to take on holidays, this is it. But a word of warning, don't pick one of these up. You may never want to put it down again! Cat D-2888

**FT-720RVH**



~~\$450~~ **\$345**

Yaesu brings you the flexibility and performance you need in today's amateur world. The FT-720RVH not only gives you top performance, it's also the most flexible Yaesu. It comes apart - so you can locate the microprocessor-controlled works close by you, with the RF and out of the way. Or just as easily, snap the two sections back together again for a complete transceiver. That's versatility! But nothing is spared in performance. PLL circuitry for maximum stability, scanning, five memory channels, LED P.O/S meter, 25 W output, and full 144-148MHz operation. A superb transceiver designed specifically for today's small cars, which simply don't have much room to spare! Cat D-2890

## MMB8

Makes mobile mounting of the FT480 a breeze. Why put up with a jury rig when you can get the correct mount at this price? SD1335

~~\$21~~  
**\$10**  
**SAVE \$11**

**FREE! MMB5 MOUNTING BRACKET**

Yes - absolutely free with the purchase of the FT227RB SD1267



## FL2050 2 metre LINEAR AMP

Cat. D-2547



**SPECIFICATIONS**  
Frequency range 143.5 MHz - 148.5 MHz  
Mode: A1, A3J, A3, F3  
Input impedance: 50 ohms unbalanced  
Output impedance: 50 ohms unbalanced  
Power output: 70 W

~~\$239~~ **\$189**

## PA 2 MOBILE SUPPLY

Run your FT207 while mobile - includes 10.8V supply with in special holding cradle

~~\$15.95~~  
**\$15.95**  
Cat D-2894

**BELOW COST SPECIAL**

## SPECIAL OFFER! FT-207R & PA2 FOR AN AMAZING

**\$246.50**

**FREE EXTENDER CABLE E72L**

When you purchase an FT720RVH. The E72L allows you to split the 720 in two, great for compact installation! SD2120 **WORTH \$22.00!!!**

**WHILE THEY LAST!**

**MMB3**  
Mobile Mounting Bracket for FT720 RVH SD2119

**GREAT VALUE!**  
~~\$10.20~~ **\$10.20**

**IMPORTANT NOTE!**  
These prices will never be repeated and stock is limited. If you cannot obtain any item, ring Jim Powell in Sydney for help. (02) 888 3200

## FT707 SERIES



What a performer packed into such a tiny package! The FT707 is one of our fastest sellers, and no wonder. It's a full power all HF band (including WARC) multi-mode transceiver not much bigger than an average 2 metre mobile! And you get digital display as well LED S/power meter, push button operation... all the things the amateur needs for safe and yet reliable mobile operation. But it's more than that: team it up with a FP-707 supply below and it's a superb base station, too. We've waited a long time for a rig like this. Yaesu brought it to you, of course! Cat D-2869

**SPECIFICATIONS**  
Frequency coverage: 80, 40, 30, 20, 17, 15, 12 & 10m  
Modes of operation: AM, USB, LSB & CW  
Power input: 240W DC SSB, 80W AM\*  
Sensitivity: 0.25uV for 10dB S/N (SSB); 1uV for 10dB (AM)  
Selectivity: 2.4kHz (60dB) 4kHz (60dB) SSB 3.6kHz (6dB) 6.8kHz (-60dB) AM  
Image rejection: 60dB (80 - 12m); 50dB (10m)  
Carrier suppression: better than 40dB  
Spurious emissions: at least 50dB down  
Power requirements: 13.5V DC @ 20A (240V AC with FP-707)  
Antenna impedance: 50 ohms

~~\$795~~ **\$765**

## ANTENNA COUPLER



Get the most from your FT-707: use the Yaesu FC-707 antenna coupler and ensure your transceiver always delivers the power it should. Slim styling suits the FT-707 style, with all the features you need: large power/SWR meter, inbuilt dummy load, all band coverage (including WARC), less than 0.5dB insertion loss (you more than make up for that because of a better match!) Cat D-2875

~~\$157.50~~ **\$139**

**POWER SUPPLY (and external speaker)** Cat D-2895

The FT707 is a great mobile rig - but it's just as good as a base station. Just add the FP-707 mains power supply and you're away. You get a fully regulated 13.5V at 20A - just what your FT-707 needs. Plug in connections so you can't cause problems plus you get an extra large speaker - for greater clarity.

**GREAT VALUE**  
~~\$32~~ **\$175**

## MOBILE BRACKET MMB2

Don't let your valuable 707 jump around the car. Fit it in a mobile mounting bracket for safety and security. Also holds the digital VFO. A must for the serious mobile operator. Cat D-2897

~~\$36~~ **\$22.95**

## DIGITAL VFO FV707DM

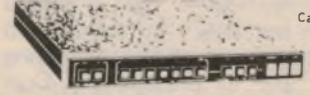

Cat. D-2899

Long 'n' Slim - intended to sit under the 707. 12 memories, up/down scanning in 10Hz steps and receiver offset tuning. Powered by FT-707.

~~\$299.50~~ **\$245**

**MR7 RACK FOR FT707**



SD1019  
~~\$32~~ **\$26**

**bankcard**  
welcome here

Prices correct and stock available at time of printing. Valid 1 NOV 82 to 1 JAN 83

Terms available to approved applicants through...



**SYDNEY:** 125 York St. 290 3377 • **Gore Hill:** 162 Pacific Hwy 439 5311 • **MELBOURNE:** 399 Lansdale St. 67 9834 • **Richmond:** 656 Bridge Rd 428 1614 • **Springvale:** cnr Springvale & Dandenong Rds 547 0522 • **BRISBANE:** Buranda: 166 Logan Rd 391 6233 • **Chormside:** 842 Gympie Rd 59 6255 • **ADELAIDE:** 60 Wnght St. 212 1962 • **PERTH:** 414 William St. 328 6944



The stores at right stock this complete list of Dick Smith Amateur Radio equipment. All other Dick Smith stores stock some amateur equipment, but may not be able to give you the service of 'Ham Shack' stores listed.



## Letters to the editor

### More on that Gordon River editorial

After reading the replies to Leo Simpson's editorial on the Franklin/Gordon river dam we felt we must write and voice our own support for his editorial.

Stephen Felmingham wrote his letter sitting in his comfortable all-electric home, using more power per capita than anyone in the world. It would seem that all that heat has gone to his head, as he seems to think Tasmania is not part of Australia and therefore "mainlanders" have no right to complain about a unique and valuable part of our country being pillaged and destroyed for all time. We wonder what he would say if Ayers Rock was to be broken up by the Terrorists for road fill?

As we read further through his letter we feel more and more that this must be the case, for he states: "The HEC is directly responsible to the Minister for Energy". Yet the official Tasmanian year book states, and I quote "...an autonomous semi-government authority, responsible almost entirely for the conduct of its own affairs".

We read on and at last a glimmer of hope. Maybe all that heat hasn't affected Stephen, as he writes: "We have enough generated power to cover ourselves without any restrictions". This is indeed true, as can be shown by the Pieman scheme. This power scheme is nearing completion and at present the Gray government has not been able to have one contract signed for the sale of

power generated by this hydro scheme — a hydro development far greater in generating capacity than the Gordon/Franklin scheme.

We then read in a letter from V. E. Roberts: "It is amazing to note what propaganda can do". It certainly is for he says "The HEC has an excellent record in estimating and providing power for all requirements in Tasmania". Just what propaganda does he read?

The HEC estimates (from their own report to Parliament) were based on past trends and were, for 1981, 20% greater than actual demand. Predictions were for a 35% growth in industrial demand between 1981 and the year 2000. However it dropped by 1% last year, and there would appear to be a 1.5% to 2.1% drop this year. Also, this year, all five major users of hydro power in Tasmania (a total usage of 46% of all generated power) have announced no new growth in the foreseeable future.

No new industry has come to Tasmania for cheap power in the last 10 years! As a result Tasmania has a staggering unemployment rate of 8%. Money that is desperately needed to alleviate this is constantly drained from the state treasury to continue to finance the HEC's bloody-minded, unrealistic power schemes. Yesterday's servant has become today's uncontrollable bureaucracy and tomorrow's monster.

John and Denise Addlem,  
Shelbourne, Victoria.

### Electric fence insulation standards

In your project "Electric Fence Controller." (Electronics Australia, September), there is a major design fault for mains operation.

A.S. 3129 states that under high voltages tests, insulation must withstand 10,000 volts between the fence circuit and the primary circuit and any exposed metal. You have wired these together!

If the controller is used as per your circuit, and a fault develops in the mains wiring of the homestead so the earth potential is raised to a

dangerous voltage, the entire electric fence network (maybe many km) could be energised with a deadly voltage.

It is for this same reason that an earth stake for even a battery electric fence controller is kept at least two metres away from mains earthing. Knowing the problems involved in complying to A.S. 3129, I would suggest only battery operation be used for your project.

Norm Deards,  
Gallagher R.S.M. Pty Ltd,  
West Heidelberg, Vic.

### Local manufacture of electronic power meter

Your September 1982 editorial was most interesting to this company.

Since April we have been investigating the possibility of producing an electronic energy meter of the type mentioned in your editorial.

Following an article in "The Sun" newspaper of July 6, page 2, we wrote to the Energy Authority. The paper mentioned that the Government was sending officers to America to examine electronic power metering. It appears that Australian manufacturers were not even being considered as possible suppliers of this type of equipment. This country has the expertise necessary to develop such a system, but as usual is not being given a fair go.

Features of our proposed system would include: recording power consumption over hourly intervals; ability to store 15,000 hours if extra memory fitted; basic unit can store 3000 hours of data (125 days); data can be printed on paper or stored on cassette or other storage device; back-up battery for storage of data during mains failure; crystal-controlled clock for accurate time-keeping; 6502 microprocessor; 4K RAM standard, 32K optional; non contact method of sensing power meter rotation; 3W power consumption; 14cm diameter size; Australian designed and manufactured.

Please find enclosed copies of correspondence to the Government. Up until now, no reply has been forthcoming.

D. Hughes, Technical Consultant,  
Paltronix Pty Ltd, Wollongong, NSW.  
PS. As this letter was written we received a telephone call from the Energy Authority. Some action now appears to be taking place.

### Electric fence: first find a blade of grass

I refer to your recent article and circuit for an electric fence. As one who has had years of user experience with home made and commercial electric fences, there is one handy hint that I think you should pass on to your readers.

The effectiveness of an electric fence system depends on the charging unit and the quality of the fence line. In practical farming situations many factors can, and do, reduce the insulation of a fence line, eg. grass touching the line, dew on dusty insulators, a wire from a conventional fence touching the line and partly earthing it, poor conductor contact at hand-tied joins etc.

If a fence line is partly earthed and only delivering a small "kick", cattle learn to test the fence and push through it. Thus

ALTRONICS ... ALTRONICS ... ALTRONICS ... ALTRONICS ... ALTRONICS ... ALTRONICS ... ALTRONICS ... ALTRONICS ... ALTRONICS ... ALTRONICS ...

ALTRONICS ... ALTRONICS ... ALTRONICS ... ALTRONICS ... ALTRONICS ... ALTRONICS ... ALTRONICS ... ALTRONICS ... ALTRONICS ... ALTRONICS ...

**WILL YOUR BUDGET PROBABLY WON'T STRETCH TO AFFORD OUR PROFESSIONAL SERIES ALL ALUMINIUM RACK CABINETS**

NOW YOUR PREAMPS, AMPS, CONTROL MODULES MONITOR PANELS ETC. CAN LOOK EVERY BIT AS GOOD AS TECHNICS, NAKAMICHI AND OTHER TOP MANUFACTURERS

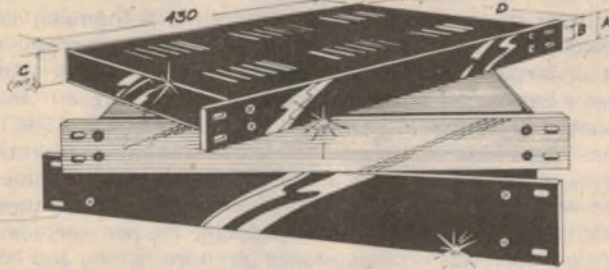

Cat No.	Finish	A	B	C	PRICE	5 or More
H 0401	Natural	44	34	38	\$39.50	\$38.00
H 0402	Natural	88	57	82	45.00	42.50
H 0403	Natural	132	89	126	49.50	45.00
H 0411	Black	44	34	38	39.50	38.00
H 0412	Black	88	57	82	45.00	42.50
H 0413	Black	132	89	126	49.50	45.00

Beware of other rack boxes that do not conform to international rack sizing.

**THE BRILLIANT MARC NR 82 FI**

FEATURING: Digital frequency Display, SSB/CW, FM/AM reception, B.F.O., Double Conversion, Double Super-het, crystal controlled (VHF) Local Oscillator, 4 inbuilt antennas and good looks, you will spend hours just learning how to drive it!

FREE DELIVERY ANYWHERE IN AUSTRALIA



See Review in Electronics Australia August 1982

- 3 Way Power
- Digital Tuning
- HI FI SOUND
- 4 Inbuilt Antennae

only \$349

**SPECIFICATIONS:**

Semi-conductors: 1-LSI, 4 - IC's, 7 - FET, 34 - Transistors, 42 - Diodes  
 Frequency range:  
 LW 145-360 KHz SW3 9-22 MHz VHF3 88-108 MHz  
 MW 525-1600 KHz SW4 22-30 MHz VHF4 108-136 MHz  
 SW1 1.6-3.8 MHz VHF1 30-50 MHz VHF5 144-176 MHz  
 SW2 3.8-9 MHz VHF2 68-86 MHz UHF 430-470 MHz  
 Power supply: AC 240V 50Hz, DC 12V (8 x "D" cells), Ext. DC 12V Car/Boat.  
 Speaker: 12.5cm Permanent Dynamic Speaker (3.2 ohm)  
 Antenna: Ferrite Bar Antenna for LW, MW and SW1  
 3 x Telescopic Antenna for SW, VHF and UHF  
 Controls: Power ON-OFF switch - Digital display ON-OFF switch - Tape-Radio switch, Wide-Narrow band selector switch, AM band selector (LW/MW/SW1/SW2/SW3/SW4), VHF band selector (VHF1/VHF2/VHF3/VHF4/VHF5/UHF), Ant. Selector (Telescopic ANT./EXT. ANT.), Tuning control (direct gear drive), volume control, Bass control, Treble control, Squelch control, BFO pitch control, RF gain control, Antenna adjustor control, Mode switch (USB-NOR-LSB/CW)  
 Terminals: Ext. Speaker/Headphone Jack, Tape IN-OUT jack, VHF/UHF ANT. connector (coaxial), SW EXT. ANT. terminal (Screw), Ext. battery jack  
 Meter: Tuning Meter  
 Digital Frequency Counter Section:  
 Display: LW/MW/SW-1 KHz SW2-4/VHF1-5 MHz  
 Control: SW Calibrator Dimensions: 452mm (W) x 288mm (H) x 130mm (D)

**ALTRONICS RESELLERS**

Please note that resellers may not have all the items advertised in stock, and as resellers have to bear the cost of freight, prices may be slightly higher than advertised. ALTRONICS reseller prices should however represent a considerable saving over our competitors' prices.

SOUTH AUSTRALIA		QUEENSLAND	
CITY	ADN Electronics 212 5505 Pratronics 212 3111	CITY	Delsound P/L 229 6155
SUBURBAN PROSPECT	Jensen Electronics 269 4744 ELIZABETH GROVE A.E. Cooling 255 2249 CHRISTIE'S BEACH Force Electronics 387 3366 KESWICK Freeway Electric Wholesalers 297 2033	SUBURBAN SALISBURY	Colbourne Wholesale 275 3188
		FORTITUDE VALLEY	St. Lucia Electronics 52 3547
		BIRKDALE	Wholesale Sound Accessories 207 2502
		COUNTRY CAIRNS	Thompson Instrument Services 51 2404
		TOWNSVILLE	Solis 72 2015
		ROCKHAMPTON	Purely Electronics 21058
		GLADSTONE	Purely Electronics 72 4321
		GYMPIE	T.V. Assistance Services 82 1671
		IPSWICH	P & P Electronics 281 8001
		TOOWOOMBA	Munis Electronics 32 9677 Down's Radio and TV 32 1044
		NAMBOUR	Nambour Electronics 41 1604
		NT DARWIN	Radio Paris Darwin 81 8508 Ken Electronics 81 4749 Ventronics 81 3491
		ALICE SPRINGS	Parsons Electronics 52 2967 Ascum Electronics 52 1713
		TASMANIA HOBART	Beta Electronics 34 8232
		KINGSTON	Kingston Electronics 29 6802
		AVOCA	Freemang TV 84 2166
		WEST AUSTRALIA ALBANY	BP Electronics 41 2681
		GERALDTON	Geraldton TV and Radio 21 2777
		WYALKATCHEM	S & J Music 81 1132
		MANDURAH	Kentronics 35 3227
		KALGOORLIE	Todays Electronics 215 212
		ACT SCIENTONICS	Scientonics 54 8334 Electronic Components 80 4654

**RESELLERS WANTED IN ALL AREAS (including WA)**

Phone: STEVE WROBLEWSKI (09) 381 7233 for details

**The Famous Microbee Comes to Altronics**

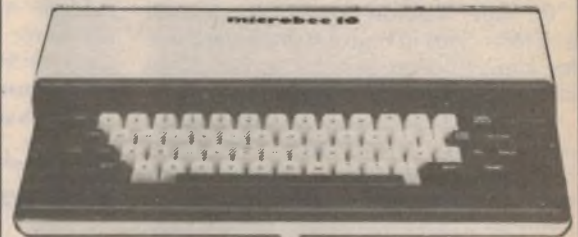

**16K Microbee**

Cat DI016..... just \$399.00  
 12v 1amp Plug Pack  
 Cat D2012..... \$24.95

**NEW COMPUTER CENTRE OPENS AT ALTRONICS 105 STIRLING ST., PERTH ON DECEMBER 1st.**

good farm management requires that you are down in the field, you check that the fence system is working. To do this, you can grab the fence — but that hurts!

The best method is to pick a piece of grass about 15cm long and hold the tip of it on the wire, and then slowly move your hand towards the wire. At about 10cm (depending on the moisture content of the grass) you will feel a weak tickle which will increase as your hand approaches the wire. If you get right up to the wire and it isn't "blasting" your hand off, then there is a point of low resistance on the line that you should find and repair.

The "grass method", simple as it is, is unknown to most farmers. It is a quick, cheap, painless way to check that the whole fence system is operational.

David Johns,  
Narrabri, NSW.

## 100W Subwoofer and mains wiring standards

During a recent lunch time browse through the August 1982 issue of your magazine, I came across the 100 Watt Subwoofer Speaker project. As my son is currently dabbling with a similar system, I decided to have a quick read.

My concern is directed to the recommended method of wiring to the active side of the mains supply to the amplifier. To quote: "the mains fuse is wired in series with the active lead, before the mains switch". This to me is a very dangerous practice.

The mains switch should be between the active lead and the device; be it fuse, transformer or whatever. Thus when the switch of the device is in the "off" position, everything apart from the wiring to the switch should be "dead". This way, the fuse is no longer alive and can be readily changed without the possibility of an electric shock.

The latter method of wiring is practised by electricians in house switchboard wiring and all power circuitry, as laid down in the SAA Wiring Rules AS3000.

An improvement would be the use of a double pole mains switch, switching both active and neutral, thus ensuring total disconnection is achieved just in case the active lead has been interchanged somewhere prior to the device.

Your magazine has been enjoyed for many years.

R. H. Simpson,  
Kalamunda, WA.

**COMMENT: While there is some merit in the points you raise, we have our method of wiring to be valid. By placing the fuse on the mains side of the switch, switch failures are protected against. We agree that double-pole switches are a good idea.**

## Tasmanian power — some facts and figures

In the past I have never written to a magazine or newspaper but, after reading the letter from John Coulson in the September issue, I was so angered that I must break a lifelong habit.

Firstly, John cannot understand what the Gordon River scheme has to do with electronics. This is an amazing statement for someone who reads an electronics magazine. Does he think power generation has nothing to do with electronics? Why didn't he complain about the October 1981 Forum article, which was on the problems of power generation in NSW? This topic was to continue in "Electronics Australia" for several issues.

The claim that Leo Simpson's editorial has damaged his credibility is utter rubbish. He was totally correct when he said "one must visit there to see how all powerful and ubiquitous the HEC is in Tasmania". Perhaps this is only obvious to a visitor who has not become conditioned to the Tasmanian situation. John writes: "the only time we come in contact with the HEC is at quarterly account time". This is future proof of his acceptance of the deplorable situation where the HEC dominates the state.

An example of this can be given if we look at the 1981-1982 state budget. A massive \$119.5 million of capital works expenditure was allocated to the HEC. This is a staggering 52% of total funds. Against this, a tiny 7% went to education and even less (5%) to health.

To meet its capital demand, the HEC is borrowing heavily from the private sector (offering high interest rates), draining money from banks, building societies and other lending institutions. It thus directly competes with housing loans, construction, business development and other sectors of the economy.

The depressive effect which the HEC monopoly on public expenditure has had on Tasmania would be much more evident if it had not been for the economic prop provided by the Federal Government (in fact federal taxpayers). Arrangements have been made for special financial assistance to projects in-

cluding expansion of the Launceston General Hospital, rebuilding the Tasman Bridge and construction of a second Hobart bridge, development of the Legana Industrial Estate, purchase of the Launceston Precision Tool Annexe, relocation of the Australian Antarctic Division, relocation of the CSIRO Division of Marine Research, and institution of a freight equalisation scheme. The Federal Government has returned to Tasmania double the per capita financial assistance given to Victoria and NSW.

Tasmania's decision to spend the majority of its funds on hydro development means that it has fewer resources to devote to projects such as housing, health, roads, sewerage, ports, water supply, assistance to manufacturing, forestry and agriculture.

As to if the dam was an election issue or not, the election was brought about by the direct fall of a government because they were going ahead with the building of the dam. You can't get much more of an election issue than that. Then pressure on both major parties, by the HEC and unions, to agree to build the dam caused it to fall from the election scene as an issue. It only occupied one sentence in Mr Gray's half hour policy speech. So much for the so called mandate from the people!

Now the Labor Party (both federal and in every state in Australia) has a strong policy of no dams in the south west of Tasmania. The Australian Democrats have an even stronger policy against the dam. Even the young Liberals are now against the dam, and public option polls right across Australia show a strong majority against the destruction of the Franklin/Gordon River area.

I congratulate your magazine on such an editorial, it shows you have your eyes, and mind, open to the full ramifications of all facets of electronic technology, and their far-reaching consequences. I for one will read your future editorials with new respect.

G. Nelkon,  
Eaglehawk, Vic.

---

## Thanks for the Gordon River editorial

I would like to take the opportunity to congratulate Leo Simpson for his timely editorial on the Gordon River power scheme in the June 1982 issue. Unfortunately, we local people who are interested in preserving national heritage for future generations have become voices crying in the wilderness rather than voices for the wilderness. Judging by recent statements, Premier Gray is so blind he cannot distinguish the breathtaking beauty of the Franklin River from an open drain!

Your assistance in providing a rational plea for environmental activity is welcome, although sadly, it seems, too late to help prevent this industrial vandalism. The wilderness will be destroyed just as Lake Pedder was some little time ago. Mankind seems intent on imposing his will on the environment at every opportunity and apparently will not be satisfied until the whole Earth is either fouled or destroyed.

Bob Palfreyman,  
Opossum Bay Rd, Tas.

# SORCERER DISPLAY STOCK

**SAVE OVER  
\$440!**  
WAS \$1395  
NOW ONLY \$950  
FULLY GUARANTEED!



\* Latest model, not superseded.

\* Full new computer warranty

\* Demo models, some with imperceptible case marks

\* Act quickly and you'll reap the benefit!

**OVER  
2000  
SOLD!**

HFC  
\$22.07  
per week

Cat X-3002

**FAMOUS  
EXIDY  
SYSTEMS**

**Word Processor Pac** Cat X-3085 \$4.62 per week  
This word processor pac features automatic text wrap-around, automatic checking of drastic commands, a powerful search function, automatic commands and macro programming. Includes a comprehensive instruction manual. **\$199**

**Word Processor Keytops** Cat X-3086 \$12.50  
A special set of red keytops to replace some of the keys on the Sorcerer numeric keypad, for use in word processing applications.



HFC  
\$23.11  
per week

**FDS DISK  
DRIVE SAVES  
YOU \$100's!**

The FDS Disk Drive plugs straight into the Sorcerer — you don't need an expansion unit so you save \$\$\$! And it will run up to two more drives. Comes with CP/M as standard, with a storage capacity of 308K. Add it to your Sorcerer and you have the lowest priced CP/M system in Australia! Cat. X-3220

and it's only  
**\$995**

was \$1290!

**UTILITIES**

**EDOS**  
Adds disk operating commands and many enhancements to ROMPAC™ BASIC Requires X-3205 Disk System. Cat. X-3602 **\$47.00**

**Tutorial Pack**  
Basic Tutorial takes you through all you need to know to start writing your first BASIC program. Teaches you the basic instructions of BASIC language. Cat. X-3607 **\$17.95**

**Machine**  
Teaches you the basics of machine language programming. It teaches you from the very first steps of Monitor Commands right through to the more complex Z-80 instruction set and coding of your own programs! Cat. X-3608 **\$22.95**

Why not give yourself the best Christmas present ever, a new SORCERER!



**HIGH RESOLUTION  
MONITOR**

With this monitor added to your computer system, you'll be able to use it for almost limitless applications: for accounts/statistics, education, medical, amusement and for any purpose data and video display. The anti-glare screen with its jitter and ghost free image makes viewing much easier and sharper and allows 80 characters with 24 lines. A must for the serious computer hobbyist or professional! Cat. X-1200 **\$349**  
HFC \$8.11 per week



**MICROSOFT EXTENDED  
BASIC FOR FDS**  
The most extensive version of BASIC available for Z80 computers. Features double precision variables, constants, maths, full line editing and all normal disk facilities and commands. Cat. X-3712 **\$399**

**COPYFILE**  
Allows you to transfer programs from one disk to another in CP/M, when using only one drive. It loads itself onto disk in both formats. Cat. X-3714 **\$24.50**

**DICK SMITH  
Electronics**

See page 98 for address details



Finance available on selected items to approved customers. All prices quoted are taken per week over a 12 month period.

**'Daisy Chain' cable  
for Exidy FDS \$49.95**

This cable enables you to connect up to 4 X-3208 add-on drives to your Floppy Disk Subsystem. Cat. X-3222

# Best bass yet from a kit!

As featured in Electronics Australia Projects June and July 1981.

Now Peerless introduces another major advance to kit-set loudspeaker technology. A bass speaker with a rigid polypropylene cone that clearly outperforms traditional paper composite cone speakers to provide:

- Cleaner, tighter bass sound reproduction
- Low colouration and distortion
- High efficiency, suiting 25W to 100W amplifiers
- Consistent rigid panel, low mass speaker cones

Other outstanding features of Danish-built Peerless speaker kit-sets are:

- Sealed back mid-range with excellent linearity and low distortion
- Latest Peerless 1" soft-dome tweeter
- State-of-the-art crossover networks
- Exceptionally flat response extending to 25,000 Hz

### Choose from these EA/Peerless speaker projects:

- PAS 100 12" 3-way 100W (100L)
- PAS 60 10" 3-way 90W (60L)
- PAS 25 8 1/4" 2-way 60W (25L)

includes drivers, crossover, wiring and instructions.

**Sole Australian Importer, G.R.D. GROUP PTY. LTD.**  
698 Burke Road, Camberwell, Vic. 3124. Trade enquiries welcome.



**Peerless**  
CONCORD/6480

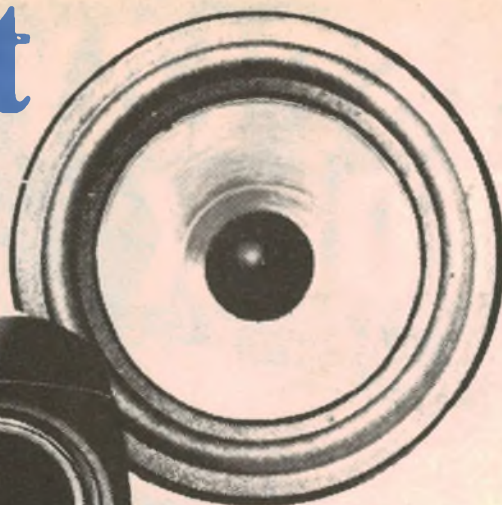

### N.S.W.

**Bondi Junction**  
Danish Hi-Fi Aust Pty Ltd Ph (02) 387 5878

**Concord**  
Electronic Agencies Ph (02) 745 3077

**Crows Nest**  
Deeva Hi-Fi Ph (02) 439 3999

**Dee Why**  
David Ryall Electronics Ph (02) 982 7500

**Wagga Wagga**  
Car Radio & Hi-Fi Centre Ph (069) 21 4618

### VIC.

**Ballarat**  
Turner Audio Ph (053) 32 2042

**Camberwell**  
Danish Hi-Fi (Aust) Pty Ltd Ph (03) 82 7348

**Cheltenham**  
Beland Electronics Ph (03) 550 2279

**Geelong**  
Steve Bennett Audio Ph (052) 21 6011

**Hawthorn**  
Tivoli Hi-Fi Ph (03) 818 8637

**Warrnambool**  
Bruce Henderson Audio World Ph (055) 62 5147

### S.A.

**Adelaide**  
Hi-Fi Acoustic Ph (08) 223 6774

**Adelaide**  
Danish Hi-Fi Aust Pty Ltd Ph (08) 51 2124

**Goodwood**  
The Acoustic Foundry Ph (08) 271 0276

**Hawthorn**  
Sound Craftsmen Ph (08) 272 0341

**St. Peters**  
Miltonix Ph (08) 42 3781

### W.A.

**Nedlands**  
Danish Hi-Fi Aust Pty Ltd Ph (09) 386 8564

**Kalamunda**  
Kalamunda Hi-Fi Ph (09) 293 4333

**QLD.**

**Brisbane**  
Brisbane Agencies Audio Centre Ph (07) 221 9944

**Barunda**  
G Mills Stereo Ph (07) 391 5606

**Redcliff**  
Hi-Fi Sales Ph (07) 284 2495

## ★ BRIGHT STAR CRYSTALS

Specifications, Dimensions and data sheets available on request

**BULK ORDERS:** In addition to our normal range we can supply quantity orders (100 up) at very competitive prices. All we ask is 50% of cost with order balance 30 days.

**DELIVERY:** 5-6 weeks from receipt of Order. Ring for quote: (03) 546 5076. Telex: AA 36004.

**NEW NSW AGENT: APP Master Communications, Sydney (02) 682 5044**

## BRIGHT STAR CRYSTALS

35 EILEEN RD, CLAYTON, VIC  
ALL MAIL TO: PO BOX 42, SPRINGVALE 3171



**CRYSTAL OVENS AND OVEN OSCILLATOR UNITS**

CRYSTALS

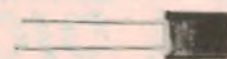

CRYSTAL UNITS FOR QUARTZ CRYSTAL CLOCK





# 50 & 25 YEARS AGO

"Electronics Australia" is one of the longest running technical publications in the world. We started as "Wireless Weekly" in August 1922 and became "Radio and Hobbies in Australia" in April 1939. The title was changed to "Radio, Television and Hobbies" in February 1955 and finally, to "Electronics Australia" in April 1965. Below we feature some items from past issues.



December 1932

**Tasma radio receiver:** This typical "Tasma" superheterodyne receiver gives you the station you want in an instant – even sooner than that – and that station alone. All Australia and New Zealand is within reach, and volume may be controlled from a whisper to dancing strength with reproduction just as natural as your own voice. Price £27/10 (prices slightly higher in Queensland, South Australia, and Tasmania).

☆ ☆ ☆

**What is modern music:** What of the music today, so-called Modern Music? "I can't understand it", say many of us, "it is just discord, and sometimes is obviously tommy-rot". We think that all the great composers are dead and gone. They always have been! A leader is one who leads. And he leads only because the crowd are behind him. When they catch him he is no longer a leader.

So when you hear really modern music do not frown and say it is awful, because in 50 years some of it might be accepted alongside the other good music that has been written and pronounced to be shocking at various times in the world's history.

☆ ☆ ☆

**Smithy's Tasman hop:** During recent weeks there has been much speculation as to what radio equipment would accompany Air-Commodore Sir Charles Kingsford-Smith on his flight to New Zealand, in the famous Southern Cross, which is scheduled to take off early in the morning of January 12, 1933, from the beach at Gerringong.

It has been revealed that Philips has arranged to supply for use on the trip the very latest type of aircraft transmitter developed at the works at Eindhoven, Holland.



December 1957

**Missile defence:** US scientists are experimenting with a sand cloud plan to counter the threat from intercontinental ballistic missiles. Scientists hope to counter the ICBM with a dense cloud of sand-like particles hurled into its path with such terrific speed that the missile's warhead would explode before it reached its target.

The nature of a ballistic missile – its adherence to a precommitted course – makes it possible to compute its course and effect an interception. This suggests the possibility of using a dense cloud of sand-like particles over the approach flight cone of the ICBM to explode the warhead.

☆ ☆ ☆

**Rocket mail in five years:** Transatlantic rocket mail delivery will be a fact by 1962, and "rocketliner" passenger travel may then be possible. These are the predictions of a group of German rocket experts. They base the rocket mail service prediction as much on the progress of their own work as on the implications of Sputnik, the Soviet earth satellite.

☆ ☆ ☆

**From the Serviceman who tells:** People who don't own a TV set are always on the lookout for a good excuse to conceal the fact that they can't afford one. When they run out of stock excuses, like the quality of programs, the difficulty of making Little Willie do his homework, the possible adverse effect on the eyesight, etc, the possible advent of colour TV is an excellent backstop!

The usual story is that these people have inside information (quite confidential, of course) to the effect that colour TV is to be introduced into Australia in the next 12 months.

For kitsets & projects  
and all general  
electronics

## SOLDERING

This professional quality soldering tool is designed for modern electrical/electronic circuitry.

Lightweight, slim barrel, with plated anti-seize tip.



Complete soldering instructions are printed on the back of each card.

Available from your  
electronic parts supplier

### DISTRIBUTORS

N.S.W.: (02) 709 5293    QLD: (07) 277 4311  
VIC.: (03) 543 5122    S.A.: (08) 42 6655  
TAS.: (002) 34 2233    W.A.: (09) 381 5500

R482

# GET INTO ELECTRONICS FOR \$4.95



## WITH DICK SMITH'S FUNWAY INTO ELECTRONICS

This is the top selling Fun Way Into Electronics Vol. 1 that has proven that electronics can be fun. For the raw beginner, this book introduces 20 exciting projects that can be built by using a unique 'breadboard' construction system - no soldering, so it's safe. Each project is fully illustrated so that mistakes are virtually impossible. This top-selling book is now into its fourth printing proving just how popular it has been. Don't miss out!

ONLY \$4.95

Cat B-2600

## Vol 1 KITS

Kit to build projects 1-10

You can build any of the first ten projects from 'Fun Way Into Electronics' with this kit. It even includes the base board on which you assemble the circuits! Cat K-2600

\$7.25

Kit to build projects 11-20

This kit contains the slightly more specialised components which, together with the components from kit 1, will enable you to make any of the projects in the book.

\$7.90

Cat K-2610



## PARENTS PLEASE NOTE

All Fun Way Into Electronics kits are battery powered so they are completely safe. Also, Fun Way Vol. 1 kits require no soldering.



## FUNWAY VOL. 2 20 MORE PROJECTS

After mastering Fun Way Vol. 1 what better way to go than Vol. 2. In Vol. 2 you are introduced to printed circuit boards and soldering. Both are fully explained and illustrated and they give you the choice of making your own boards or buying ready made. The basic laws of electronics, plus chapters on component codes, assembly hints etc. are fully explained. . . . . Cat. B-2605

\$6.95

## FUNWAY VOL 2 KITS FROM \$2.95

### MULTI-PURPOSE LED FLASHER . . . . \$2.95

A really simple kit that can be used as a warning device, electronic jewellery, etc. Cat K-2621

### DING DONG DOORBELL \$4.50

Welcome visitors to your home with this integrated circuit doorbell! Cat K-2622

### MORSE CODE TRAINER \$4.50

This simple oscillator circuit lets you learn Morse code the easy way! Cat K-2623

### UNIVERSAL TIMER \$5.50

Use it as an egg timer, a dark-room timer, etc. in fact, it's got a lot of applications! Cat K-2624

### ELECTRONIC DICE \$4.95

Throwing a dice is old hat: do it electronically! Simple circuit has other uses too. Cat K-2625

### MONOPHONIC ORGAN \$7.95

Easy to build, and easy to play! And it even has 'vibrato' - just like the big ones! Cat K-2626

### POCKET TRANSISTOR RADIO \$7.95

Simple to build, and it's nice and small. Listening is so much more fun! Cat K-2627

### TOUCH SWITCH \$5.50

One touch on, next touch off - or 'on while touched'! Dozens of uses in the home. Cat K-2628

### MOSQUITO REPELLER \$4.95

Don't get eaten by mozzies: scare them away electronically. Take it anywhere. Cat K-2629

### SIMPLE AMPLIFIER \$6.50

A useful little amplifier for all those projects needing audio amplification. Cat K-2630

### WIRELESS MIC. \$6.50

A tiny transmitter that can be received on any FM receiver. A great little kit! Cat K-2631

### LIGHT ACTIVATED SWITCH \$5.50

Highly useful for alarms, night light switches, etc etc. Sensitive and reliable. Cat K-2632

### METAL/PIPE LOCATOR \$8.50

A simple BFO circuit you can use to find metals, pipes, wiring, etc - maybe gold! Cat K-2633

### SOUND ACTIVATED SWITCH \$6.95

Picks up sound waves and trips a relay. Use as a telephone bell extender, too. Cat K-2634

### HOME/CAR BURGLAR ALARM \$6.50

Learn how burglar alarms work when you install your own! For home or car. Cat K-2635

### ELECTRONIC SIREN \$4.95

Great for alarm use - or where any warning is required. Good for kids toys, too! Cat K-2636

### LED LEVEL DISPLAY \$8.95

This fascinating project shows you the audio level of any amplifier. Cat K-2637

### INTERCOM UNIT \$8.95

Communicate! Build this intercom and talk between rooms, etc. Cat K-2638

### LED COUNTER MODULE \$7.95

Learn how digital circuits work by building a counter. Count slot car laps, etc. Cat K-2639

### SHORTWAVE RECEIVER \$8.95

Listen in to the exciting world of shortwave radio: amateurs, foreign countries! Cat K-2640

**SCHOOLS, RE-SELLERS, ETC.:**  
We'll negotiate a special price for bulk quantities on either books or kits, or both!

# DICK SMITH ELECTRONICS



SEE PAGE 98 FOR ADDRESS DETAILS

A383/CT



# Books & Literature

## ARRL Antenna Handbook

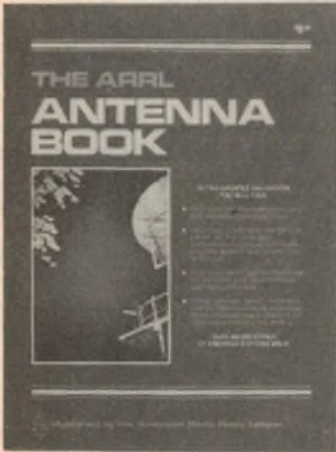

**THE ARRL ANTENNA BOOK**, edited by Gerald L. Hall, K1TD. Fourteenth Edition published 1982 by the American Radio Relay League, Newington, USA. Soft covers, 277 x 210mm, 328 pages, illustrated with many photos and diagrams. ISBN 0 87259 414 9 Price \$15.00.

This 14th edition of the ARRL Antenna Book is considerably revised over previous editions. It has a larger, more attractive format and quite an amount of new material which will make it of interest to those who already have a previous edition.

The book is divided into three sections with the first seven chapters devoted to the principles of antennas and transmission lines, wave propagation and the direction characteristics of different antenna systems. The following seven chapters give complete data on specific antenna designs for the various amateur frequency bands. The remaining two chapters are concerned with measurements, test equipment and antenna orientation.

The chapter on antenna orientation includes latitude and longitude bearings for 474 locations throughout the world for calculating beam (antenna) headings. Also featured is a BASIC program for simplifying these calculations. The program was written to run on a Tandy TRS-80 Level II computer.

Even if you are not an amateur radio operator there is much that is useful in this text. For example, shortwave

listeners would be interested in the chapters on principles and those on long-wire and fixed HF antennas.

Similarly, enthusiasts of long-distance television reception (TVDX) will be interested in the chapters on VHF and UHF antenna systems. We should add the proviso here that the wider bandwidth requirement for television (as opposed to amateur station use) would mean that some of the antenna designs would have to be modified.

A small drawback of the book is that most, if not all, dimensions are Imperial rather than metric. Some readers may regard this as an advantage.

In summary, in a field where useful references are few and far between, the new ARRL Antenna book is very welcome. Our copy came from McGills Authorised Newsagency, 187 Elizabeth Street, Melbourne, Vic, 3000.

## M68000 Manual



**MC68000 16-bit Microprocessor User's Manual**. Soft covers, 192 pages, 218mm x 278mm, illustrated with charts and diagrams. Published by Motorola Inc. 1980. Price \$12.95.

This book is a detailed description of the architecture and programming of the MC68000 microprocessor. Beginning with a general description of the chip and its place in the Motorola range, the book includes chapters on data organisation and addressing capabilities, descriptions of signals and bus

STOP PRESS

PRICES  
CRASH!

SAVE AN AMAZING \$100!  
the popular Commodore VIC 20 COLOUR COMPUTER  
WAS \$399  
NOW \$299  
CAT X2000  
ONLY \$6.85 PER WEEK OVER 12 MONTHS\*

SAVE \$56!  
HITACHI 15MHz DUAL TRACE CRO  
WAS \$655  
NOW \$599  
CAT Q1242  
ONLY \$13.84 PER WEEK OVER 12 MONTHS\*  
\*TERMS TO APPROVED PERSONAL APPLICANTS ONLY

DICK SMITH ELECTRONICS  
SEE PAGE 98 FOR ADDRESSES

operation, a summary of the instruction set, detailed instruction set formats and interfacing with standard Motorola peripheral chips.

Appendix B occupies at least half the volume, and is a detailed description of each machine language instruction. Other appendices provide details of execution times, bus connections and the Motorola Cross Assembler syntax.

The user's manual will be of interest to design engineers, hobbyists and anyone either using or planning to use the 68000.

Our review copy came from Paris Radio Electronics, Shop 1, 165 Bunnerong Rd, Kingsford, NSW. (PV)

(Continued on page 114)

# NEW BOOKS

NEW — NEW — NEW

Latest editions of some of the most popular books on the subject

The Radio Amateur's Handbook — 1983 Edition. A must for the Radio Amateur and Professional	\$19 95
RSGB Handbook Volume 1	\$21 85
RSGB Handbook Volume 2	\$18 90
Reference Data for Radio Engineers (New Edition) ITT	\$47 25
Radio Handbook — Orr New 22nd Ed	\$42 95

## Computer Books

Atari Sound and Graphics — Moore A self-teaching guide	\$13 95
Computer Reference Guide's Software Handbook — Australian buyers' guide to all types of software products for microcomputers	\$27 65
Fast Basic — Beyond TRS-80tm Basic — Gratzler	\$20 95
TRS-80 Programs and Applications for the Colour Computer — Baker	\$21 95
Basic Programming on the BBC Microcomputer — Cryer	\$15 95
Compute!'s first book of Atari	\$17 20
Compute!'s second book of Atari	\$17 20
Compute!'s first book of PET/CBM	\$17 20
IBM personal computer — An Introduction to Programming & Applications — Goldstein	\$24 95

## Adam Osborne Books

Z80 Programming for Logic Design	\$13 30
6800 Assembly Language Programming	\$22 40
Intro to Microcomputers — Volume 3: Some Real Support Devices	\$21 00
6502 Assembly Language Programming The 8086 Book	\$23 80
Intro to Microcomputers — Volume 1: Basic Concepts, 2/e	\$22 40
6809 Assembly Language Programming	\$23 80
Z8000 Assembly Language Programming	\$28 00
Interfacing To S 100/IEEE 696 Microcomputers	\$21 00
8089 I/O Processor Handbook	\$13 95
68000 Microprocessor Handbook	\$13 95
Osborne CP/M User Guide	\$22 35
CRT Controller Handbook	\$13 95
VISICALC Home and Office Companion	\$22 40
Assembly Language Programming for the Apple 11	\$18 15
Some Common Basic Programs — Atari Edition	\$21 00
Some Common Basic Programs — TRS-80/Edition	\$22 40
6502 Assembly Language Subroutines	\$22 35
Intro to Microcomputers — Volume 0: Beginners Your Atari Computer	\$17 50
Practical Basic Programs — Apple 11 Edition	\$23 75
Practical Basic Programs — TRS-80 Edition	\$22 40
Some Common Basic Programs — Apple 11 Edition	\$22 40
Wordstar Made Easy	\$21 00
Practical Pascal Programs	\$16 75
Discover Forth	\$22 40
6809 Microcomputer Design Guide	\$21 00
CP/M User Guide 2nd Ed	\$27 95
The HP-IL System. An Introductory Guide to the Hewlett-Packard Interface Loop	\$18 20
Practical Basic Programs — IBM PC Ed	\$23 80
Pet Personal Computer Guide	\$22 40
CBM tm Professional Computer Guide	\$21 00

## Other Titles

Practical Transformer Design Handbook	\$32 95
Piano Servicing & Tuning & Rebuilding — Arthur Reblitz	\$21 00
Hi-Fi Loudspeakers & Enclosures — Cohen	\$25 50
Motorola M6800 Microprocessor Applications Manual	\$16 70
Motorola Programming the 6800 Microprocessor	\$11 05
National CMOS Databook	\$7 50
National Linear Databook	\$11 25
National Logic Databook	\$10 00

Just a few of the thousands in stock. Call in or write. Prices subject to fluctuation. Correct at time of going to press.

If the book you require is not listed below, it can be ordered from us.

MAIL ORDERS BY RETURN  
PLEASE ADD \$1.50 per parcel postage (Vic)  
\$2.50 per parcel interstate

**TECHNICAL BOOK & MAGAZINE CO.**  
295-299 Swanston St,  
MELBOURNE 3000. Ph. 663 3951

# Books & Literature

## Microprocessor manual from Motorola



**MOTOROLA MICROPROCESSORS DATA MANUAL: Published by Motorola Inc. 1981. Soft Covers, 231 x 178mm, 1164 pages. Price \$19.95.**

This latest data manual from Motorola covers the full range of microprocessor and peripheral devices produced by that company. The book is divided into eight sections, including information on 8-bit and 16-bit processors, single chip microcomputer families and interface components.

The largest section of the book (1068 pages) consists of data sheets on all microprocessor products manufactured by Motorola. Other sections give details of memory devices, ready-built computer systems offered by Motorola,

and the company's training courses, although this will be of limited interest to Australian readers.

The book will be valuable to engineers and hobbyists using or planning to use any of the Motorola microprocessor range. Our review copy came from Paris Radio Electronics, 165 Bunnerong Rd, Kingsford, NSW.

## Microprocessor Books — in brief:

**BEGINNERS ASSEMBLY LANGUAGE PROGRAMMING VIC20, by P. Holmes from the Dr Watson Computer Learning Series. Published 1982 by Glentop Publishers Ltd, London. Soft covers, 210 pages, 151 x 209mm. ISBN 0 907192 05 7. Price \$29.95.**

This book contains an assembler for the Commodore VIC20 which is then used to produce machine code programs. The book was typeset using a word processor. Our copy came from Edible Electronics, 50 Park Street, Abbotsford, Victoria 3067.

**MICROPROCESSOR CIRCUITS VOL 1 by Edward M. Moll, Published 1982 by Howard W. Sams & Co, Indiana, USA. Soft covers, 110 pages, 215 x 280mm. Illustrated with circuit diagrams. ISBN 0 672 21877 1. Price \$14.75.**

This contains 30 demonstration circuits to illustrate logic concepts. 4000-series CMOS ICs are used throughout. No microprocessor circuitry is featured. Well written and useful. Sample copy supplied by Technical Book & Magazine Company Pty Ltd, Melbourne.

CHANNEL  
0/28



VIDEOTAPE MAINTENANCE

Applications are invited from suitably qualified persons for the following position at our Milsons Point studios

## TECHNICAL OFFICER

(\$17,117-\$20,791)

Applicants should have experience with broadcast or industrial/domestic videotape or videocassette recorders and should possess an appropriate certificate awarded by the NSW Department of Technical and Further Education or an equivalent.

Conditions of employment will be similar to those offered by other Commonwealth authorities.

Applications, including details of qualifications and experience and copies of appropriate certificates and references should be forwarded to

The Personnel Officer  
**Special Broadcasting Service**  
GPO Box 21 Sydney NSW 2001

by 31 December 1982.

Please quote reference number T222 on your application. Enquiries may be directed to **Mr Basil Byrne** on (02) 923 4811.

# GREAT NEW BOOKS

FROM JAYCAR THE ELECTRONIC BOOK SPECIALIST.....



## THE CHEAP VIDEO BOOK

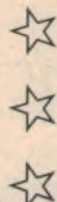

ONLY \$10.95

Complete discussion of a new, low-cost way to get words, pictures, and opcodes out of your computer and onto any ordinary TV set. Don Lancaster outlines an easy-to-build, seven IC circuit which you can build for less than \$20. This circuit can be software controlled to provide any alpha numeric or graphics format including high resolution (256x256) and four colour mode. By Don Lancaster. 256 pages. 5 1/2x8 1/2, soft. Ask for No. 21524.

## EXPERIMENTS IN ARTIFICIAL INTELLIGENCE FOR SMALL COMPUTERS

Conduct interesting and exciting experiments in artificial intelligence with this book, a small computer with extended BASIC, and some knowledge of the BASIC language. The author first introduces you to artificial intelligence — the capability of a device to perform functions normally associated with human intelligence, such as playing, problem solving, reasoning, creativity, and verbal communications. Then game-playing programs, with a checkers-playing game as the main topic, are explained. By John Krutch. 112 pages. 5 1/2x8 1/2, soft. Ask for No. 21785.

THE BEST FOR \$11.95



## ACTIVE FILTER COOKBOOK



GREAT READING — \$19.95

A practical, easy-to-read discussion of the many types and uses of active filters by popular author Don Lancaster. Learn how to construct filters of all types, including high pass, low pass, and band pass having Bessel, Chebyshev, or Butterworth response characteristics. Easy to understand — no advanced math or obscure theory is used. Active Filter Cookbook can be used as an introduction to active filter circuits or as a reference book for analysis and synthesis techniques for active filter specialists. By Don Lancaster. 240 pages. 5 1/2x8 1/2, soft. Ask for No. 21168.

## DESIGN OF ACTIVE FILTERS WITH EXPERIMENTS



An introduction to the implementation and design of active filter circuits that use the popular 741 op amp chip. The emphasis is on the use of active filters and their design, without complex maths. Twenty six detailed experiments and many practical examples. By Howard M. Berlin. 240 pages. 5 1/2x8 1/2, soft. Ask for No. 21539.

FOR THE SHELF — \$14.95

## CMOS COOKBOOK

One of the best selling technical books on the market, this cookbook gives you a solid understanding of CMOS technology and its application to real world circuitry. The author explains how CMOS differs from other MOS designs, how it is powered and what its advantages are over other constructions. A mini catalogue is included which lists over 100 devices, giving their pinouts and application notes. The final chapter shows you how to put all the previous information together to construct a number of large scale, working instruments. By Don Lancaster. 416 pages. 5 1/2x8 1/2, soft. Ask for No. 21398.

## GET COOKING FOR \$17.95

### IC OP-AMP COOKBOOK

An informal, easy-to-read guide covering basic op amp theory in detail, with 200 practical, illustrated circuit applications to reflect the latest technology. JFET and MOSFET units in both single and multiple formats are featured. Includes manufacturers' data sheets and lists addresses of the companies whose products are featured. By Walter G. Jung. 480 pages. 5 1/2x8 1/2, soft. Ask for No. 21695.

## GREAT BOOK ONLY \$21.95

### 555 TIMER APPLICATIONS SOURCEBOOK WITH EXPERIMENTS

Describes the construction and use of the 555 timer and gives you numerous, practical examples of its applications in all areas of electrical and computer engineering. Seventeen simple experiments are provided to give you working knowledge. By Howard M. Berlin. 160 pages. 5 1/2x8 1/2, soft. Ask for No. 21538.

## LATE NIGHT READING \$9.95

### DESIGN OF OP-AMP CIRCUITS WITH EXPERIMENTS

A series of 35 experiments illustrates the design and operation of linear amplifiers, differentiators and integrators, voltage and current converters, active filters and lots more. By Howard M. Berlin. 224 pages. 5 1/2x8 1/2, soft. Ask for No. 21537.

## EXPERIMENT FOR \$14.95



### REGULATED POWER SUPPLIES (3rd Edition)

'THE' BOOK ONLY \$25.95



The newest, most comprehensive discussion of internal architecture and operation of the latest solid state regulators. Thoroughly explains when regulated supplies are needed, and how to incorporate them into your design projects. Discusses markets, practical capacity, including open and switching circuits and state ICs. By Irving M. Gott. Soft. 424 pages. 5 1/2x8 1/2, soft. Ask for No. 21808.

## ELECTRONIC MUSIC CIRCUITS

Written for the computer and electronics hobbyist with an interest in music, as well as musicians and studio engineers. The author describes how to build a custom electronic music synthesizer, outlines numerous other circuit designs and then shows you how to modify them to achieve particular responses. Many of the circuits can be used as special effects boxes for guitars and other musical instruments. 288 pages. 5 1/2x8 1/2, soft. Ask for No. 21833.

FOR 'MUSO'S' — \$23.95

## RF CIRCUIT DESIGN

A user-oriented text with a practical approach to the design of RF amplifiers, impedance matching networks, and filters. Can be used in cookbook fashion as a catalogue of useful circuits with component values. Utilizes a minimum of complex math. A valuable bridge between the classroom and "real world" application, and an excellent reference manual. Approx. 352 pages. 5 1/2x8 1/2, soft. Ask for No. 21868.

## FOR DESIGNERS — \$25.95



### 'THE' PLL BOOK — \$14.95



### DESIGN OF PHASE-LOCKED LOOP CTS WITH EXPERIMENTS

An excellent introduction to the theory, design, and implementation of Phase-Locked Loop circuits using various TTL and CMOS devices. Useful self study course for the experimenter and for inclusion in college courses on control systems or linear ICs. Includes manufacturers' data sheets and describes the use of breadboarding aids in the wide range of laboratory type experiments. 256 pages. 5 1/2x8 1/2, soft. Ask for No. 21545.

### DESIGN OF VMOS CTS WITH EXPERIMENTS

VMOS technology easily surpasses the BJT, FET and CMOS circuitry in its mimicry of the ideal active circuit element. The authors provide an in-depth look at the technology which makes dramatic advancements possible, and show how these components can easily and effectively be integrated into common circuit designs to enhance their responses. 176 pages. 5 1/2x8 1/2, soft. Ask for No. 21686.

THE LATEST — \$16.95

### HOW TO READ SCHEMATIC DIAGRAMS (3rd Edition)

Learn to successfully read schematics — the road maps of electronic circuits. Defines many of the newer symbols including logic gates and provides up-to-date definitions of many electronic symbols. Author Herrington shows you how various components are combined to form circuits, and takes you step-by-step through a schematic for a radio receiver. 192 pages. 5 1/2x8 1/2, soft. Ask for No. 21127.

GREAT VALUE — \$9.95

## MODERN DICTIONARY OF ELECTRONICS

Join the millions who use this superb reference to the world of electronics. Contains over 20,000 terms, including the latest language used in the fields of communications, reliability, semiconductors, medical electronics, microelectronics, fibre optics, and computers. For quick and easy reference, separate coverage of schematic symbols, the International System of Units (metric) and a table of the Greek alphabet are provided. By Rudolf F. Graf. 832 pages. 5 1/2x8 1/2, hard. Ask for No. 21314.

THE GREAT TEST — \$29.95

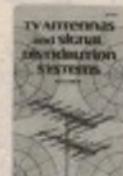

### TV ANTENNAS AND SIGNAL DISTRIBUTION SYSTEMS

As reviewed in Sept. E A page 107

WAS \$14.75 NOW \$12.50

An aid in selection and installation of TV antennas and signal distribution systems, and how to implement these systems for high quality TV reception. Includes valuable performance data based on actual measurements made by the author. 256 pages. 5 1/2x8 1/2, soft.

## LASER TECHNOLOGY (2nd Edition)

Update laser technology from a practical standpoint. Discover applied laser principles, laser holography, and beam capabilities and energies. Other chapters explain laser communications systems, laser systems for the military, and instrumentation in medical surgery and dentistry. 288 pages. 5 1/2x8 1/2, hard. Ask for No. 21588.

BE A LASER MAN — \$21.95



### MODERN RECORDING TECHNIQUES

FOR THE HI FI MAN \$17.95



Explains the equipment, controls and techniques found in the modern recording studio and how to use them creatively as well as properly to produce desired results. Numerous photographs, diagrams, and charts. 368 pages. 5 1/2x8 1/2, soft. Ask for No. 21037.

### 73 DIPOLE AND LONG-WIRE ANTENNAS

Experiment with one or more of 73 different wire antennas — from dipole to rhombic. By Edward M. Noll. W3FQJ. 160 pages. 5 1/2x8 1/2, soft. Ask for No. 24006.

### GOOD READING — \$9.95

## NATIONAL LINEAR DATA '82

Our thickest book — 170w x 230h x 65d. The book for linear data from the world leaders. Titles include: voltage regulators, op amps/buffers, instrumentation amps, comparators, analogue switches A/D, D/A, TV circuits, transistor and diode arrays. Digital/speech synthesiser and physical details of devices.

VALUE AT ONLY \$17.95

## Jaycar NUMBER 1 FOR KITS

125 York Street, Sydney 2000  
Phone: 264 6688 Telex: 72293

"Nevilles Corner"  
Cnr. Carlingford & Pennant Hills Road,  
Carlingford  
Phone: 872 4422

Mail Orders To: Box K-39 Haymarket  
Sydney 2000

POST AND PACKING CHARGES  
\$5.99 (S1.20) \$10.24 (S2.40)  
\$25.49 (S6.50) \$50.99 (S14.60)  
\$100 (S26.20)

NEW SHOP HOURS  
Mon-Fri 9:30 to 5:30pm  
Sat 9:30 to 12:30pm  
Thurs night to 8:30pm



# New Products...

Product reviews, releases & services

## Tools for the hobbyist and professional

A new range of construction tools for hobbyists and professionals alike is now available from Jaycar Pty Ltd. Included in the range are IC insertion and extraction tools, a solder sucker and a self-adjusting cable cutter/stripper.

Four sizes of IC insertion tools are available, at prices to suit the hobbyist's budget. Together they can safely handle 14 and 16-pin types, 20, 22 and 24-pin and 40-pin integrated circuits. All the tools are chrome plated for static dissipation and the moulded handles incorporate a lead straightener.

Other features of the solidly-constructed insertion tools include a clip neck for attachment of a grounding strap and easy, one-hand operation.

The IC extraction tool is a stainless steel tweezers-type gripper, said to be suitable for handling integrated circuits with from eight to 40 pins.

The desoldering tool in the range, the Model DT-600, is moulded of high impact plastic with a transparent body and steel plunger rod. It is a convenient, compact tool, capable of exerting a high suction force, and is easily disassembled for cleaning.

The cable stripper incorporates cutter blades and a wire stripper which can be used without adjustment on wires of all sizes encountered in construction work. The action is very firm and positive, removing insulation without damaging the conductors.

In use, the cable to be stripped is locked by external jaws while the insulation is cut and removed by a sliding pair of in-

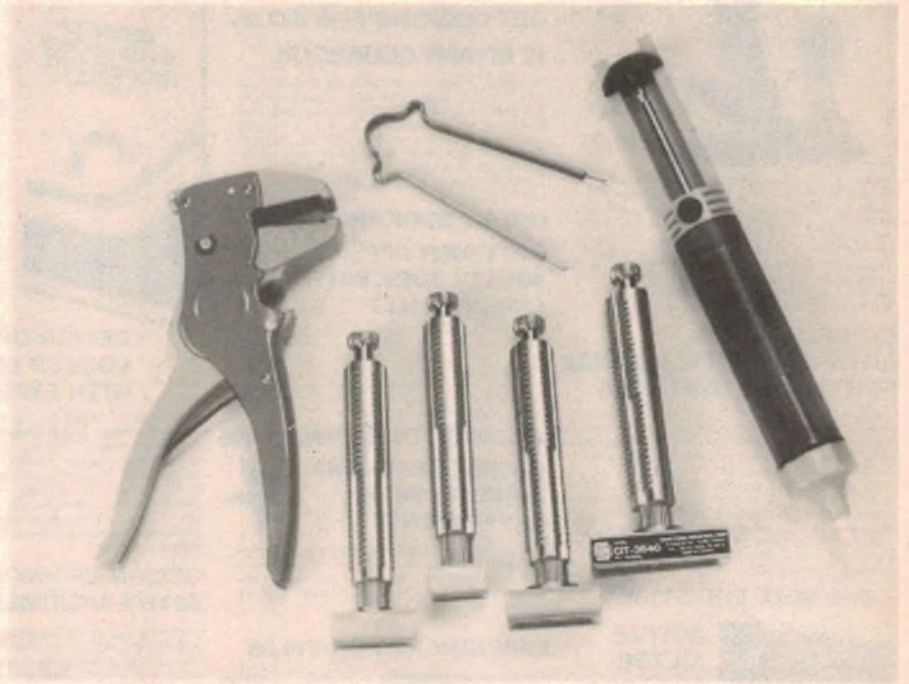

ner blades. If required the blade pressure can be adjusted by a set screw to deal with very hard or soft insulation.

Also available from Jaycar is a range of collet knobs with push fit coloured inserts for dressing up front panels. The

knobs fit standard potentiometer spindles.

For further information contact Jaycar, 125 York St, Sydney, NSW, 2000. Mail orders should be sent to Box K-39, Haymarket, NSW, 2000.

## Wide range of Sendata modems

There is an increasing demand for computer equipment with communications capabilities and there are a wide range of products to service the needs of this market.

One company alone, Electro Medical Engineering Pty Ltd, currently manufactures 57 different varieties of acoustically coupled data modems in its Sendata 700 Series.

The 700 Series is divided into two groups based on their speed of operation. Two 300bps models and six 1200bps models of the Sendata modem provide eight different units. Requests from various equipment manufacturers

available in the series.

There are currently 10 companies using a 700 Series modem which has been specifically tailored to suit their equipment. Most recent customers have included Atari, Osborne Computers and Commodore.

Feasibility studies and consultations are offered to help customers define their requirements and choose equipment to meet their needs. Modems can also be engineered to customers' requirements.

For more information contact Sales Manager Robert Powell, Electro Medical Engineering Pty Ltd, PO Box 263, Armadale, Vic 3143.

## Dual-in-line rectifier for PCB mounting

Soanar Electronics Pty Ltd has advised that they are now stocking the new Micro Electronics Ltd DIB 04 dual-in-line 1A bridge rectifier. Lead spacing of the rectifier package is 2.54mm, providing compatibility with integrated circuits and standard PCB layouts.

The DIB 04 is said to be capable of withstanding surge currents of 30A, with a peak inverse voltage specification of 280V RMS.

For further information contact Soanar Electronics branches in all states or write to Soanar Electronics Pty Ltd, 30 Lexton Rd, Box Hill, 3128.

# ELLISTRONICS

## SOLDERLESS BREADBOARD

Designed around two interlocking modular units, the WBDN is a distribution strip for power etc. and contains 100 contacts grouped in clusters of five. The WBTN is the terminal strip containing 640 contacts in two separate

rows of five interconnected contacts each separated by a .300" median. Contacts are made from non-corrosive nickel silver alloy and are reliable for more than 10,000 insertions. The boards accept all DIP size including RTL,

TTL, DTL, CMOS and most passive devices and interconnect with 20 to 29 awg solid wire. All boards are interlocking and elements are mounted on ground plane. Ideal for HF, High Speed, Low Noise application.

**THE EXPERIMENTER KIT COMPRISES OF A WB2N BREAD-BOARD TWO MATCHING DRILLED AND ETCHED CIRCUIT BOARDS AND ONE DESIGNER PAD**

### EXPERIMENTER KIT

KIT \$14.50  
+ 20% TAX

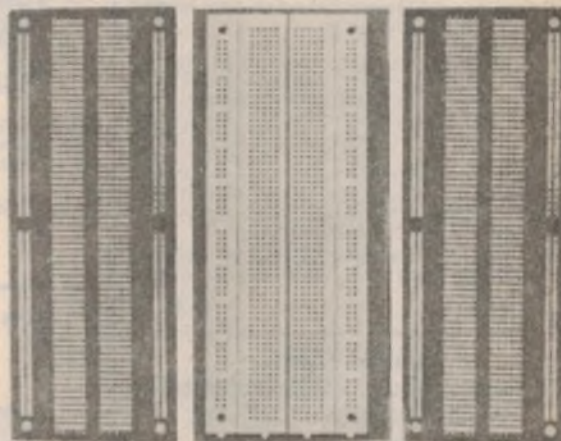

**THE MATCHING CIRCUIT BOARDS ARE AVAILABLE SEPERATELY FOR \$1.60 EA + TAX. MINIMUM PACK AND POST \$2 ALL PRICES PLUS 20% SALES TAX IF APPLICABLE**

### SPECIAL PRICE DECEMBER

**\$11.75**  
+ TAX

**WBDN \$1.80**  
+ TAX

1 Distribution Strip, Tie-point 100

**WBTN \$6.80**  
+ TAX

1 Terminal Strip, Tie-point 640

**WB2NI \$8.35**  
+ TAX

1 Terminal Strip, Tie-point 640  
1 Distribution Strip, Tie-point 100

**WB2N \$10.30**  
+ TAX

1 Terminal Strip, Tie-point 640  
2 Distribution Strips, Tie-point 200

**WB4N3 \$17.00**  
+ TAX

2 Terminal Strips, Tie-point 1280  
1 Distribution Strip, Tie-Point 100  
2 Binding posts.

**WB4NI \$20.50**  
+ TAX

2 Terminal Strips, Tie-point 1280  
3 Distribution Strips, Tie-point 300  
3 Binding Posts



**WB4N**  
\$23.00  
+ TAX

2 Terminal Strips, Tie-point 1280  
4 Distribution Strips, Tie-point 400  
3 Binding Posts



**WB6N**  
\$31.50  
+ TAX

3 Terminal Strips, Tie-point 1920  
5 Distribution Strips, Tie-point 500  
4 Binding Posts



**WB8N**  
\$44.50  
+ TAX

4 Terminal Strips, Tie-point 2560  
7 Distribution Strips, Tie-ppoint 700  
4 Binding Posts

### ELLISTRONICS LOGIC PROBES

**3800A**

**\$22<sup>00</sup>** + TAX

Max input 10MHz  
Memory/Pulse Sw.  
TTL/CMOS SW.  
Input impedance 300k



**DLP-1**

**\$14<sup>00</sup>**

+ TAX

Max input 1,5MHZ  
Strong Aluminium case  
LED: HI-LOW-PULSE  
80cm leads  
KEY to LEDs on back of probe  
Input impedance 300k

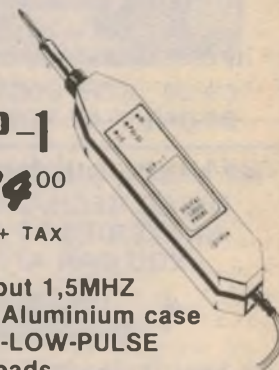

# ELLISTRONICS P/L

289 LATROBE ST, MELBOURNE 3000  
PHONE (03) 602 3499  
TELEX AA37758 LSTRON

**Available from:** VICTORIA: Rod Irving (03) 489 7099 Kalex (03) 458 2976 Truscott Electronics (03) 723 3860 Billco (Project Electronics) (03) 791 8655 Ballarat Electronic Services (053) 359 584 SOUTH AUSTRALIA: Electronic Equipment (08) 212 5999 WESTERN AUSTRALIA: Altrionics (09) 328 1599 Atkins Carlye (09) 277 0511 NEW SOUTH WALES: Electronic Developments (02) 438 2500 Jaycar (02) 264 6688 Bill Edge (02) 745 3077.

See EA November, 1982



# POWER UP

A MUST FOR YOUR COMPUTER SYSTEM

This great new Project from EA is the answer to a Maidens Prayer.

**What Does it Do?**

A single 240v mains plug and lead feeds one unswitched master 240v outlet plus 4 switched 240v outlets. With say a hi-fi system, plug your main equipment item (e.g. Amp) into the master outlet and whenever you "switch on" your amp — presto — mains power is applied to the other 4 outlets i.e. simply "turning on" your amp turns on your tape cassette, tuner, turntable, graphic equaliser without mains spikes, plops etc.

Just the shot for your Computer System. The Altronics Kit includes case and all outlets.

Cat K600 ..... \$39.50

**SAVE 30%  
MEMORY PRICE BREAKTHROUGH**  
Quality Hitachi 120 nsec

# 6116's



Z6116 Now only ..... \$9.50  
6 or more ..... \$8.50 ea.

## AM/FM CASSETTE

\* Quality AM/FM receiver \* Sensitivity 30V FM, 10 UV AM \* 6 watts per channel power output \* 33-10 KHZ frequency response \* Wow and flutter less than .2% \* Output impedance 4-16 OHMS \* Power source DC 13.2V neg. ground 350 MA No. sig. to 2.5 amps. Both channels fully driven.



C 9120 NOW JUST \$69.00  
30 ONLY AT THIS PRICE

**AT LAST — SINTERED PLATE  
NICAD RECHARGEABLE  
BATTERIES AT A PRICE  
YOU CAN AFFORD**

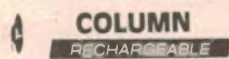

AA Size 1-2V Genuine Sintered Plate Nicad Construction by Furakawa — arguably the top Nicad designer/manufacture in the world today. Amazing low price.

Cat S3020 ..... ea \$1.95  
10-49 \$1.70, 50+ \$1.60

# ALTRONICS

For Address, Phone No. and Despatch details see our Double Page Advertisement pages 52/53

## BARGAIN OF 1982 240V / 7.5 AMP MOULDED POWER LEADS From 39c



Tough fully moulded 1 metre 3 pin power leads. We've bought a truckload of Manufacturers excess stock! Out they go! Fully approved.

CAT A2400 1's ..... 69c  
10-49 ..... 49c  
50 up ..... 39c

## 27 MHZ MARINE XSTALS



Below  
1/2 Price.

- \* Pairs of Transmit and Receive XSTALS
- \* Quality "Plug-in" Ferris brand
- \* Ideal for Hand helds etc.

D5880 — 27.880 MHZ ..... \$2.50  
D5900 — 27.900 MHZ ..... \$2.50  
D5910 — 27.910 MHZ ..... \$2.50

## PUSH BUTTON PHONE DIALLER



\$29<sup>95</sup>  
CAT A1110



- \* Memory Redial of last number called.
- \* Fitted with Australian standard colour coded leads and clips.
- \* Fits in minutes to any Telecom style phone.

## MINI HEADPHONES

3.5 mm Stereo Plug  
Amazing performance  
for the price!



**SUPER BARGAIN  
PRICE**  
C 9001 ..... \$8.50

## ABSOLUTELY BRILLIANT VOYAGER CAR COMPUTER

See review EA Oct. 1982

Made in  
England



Completely  
Built and Tested  
Not a Kit.

**FEATURES**

- INSTANT FUEL CONSUMPTION IN LITRES/100KM AND MPG!! (MOST OTHERS HAVE ONLY ONE OF THE ABOVE) JUST SWITCH FROM ONE TO THE OTHER AS YOU DRIVE ALONG.
- INSTANT SPEED, TIME AND OTHER FUEL DATA.
- VISUAL AND AUDIBLE EXCESS SPEED ALARM.

**INSTALLATION**

The "Voyager" comes complete with an unbelievable array of mounting configurations, on dash, under dash or stalk mount. ALL installation hard-ware is supplied (even a roll of insulation tape!) as well, of course, as the speed and fuel sensors. A lavishly illustrated installation manual is provided as well as a comprehensive operators manual.

This extremely compact Computer (20cm x 7.1cm x 9cm Deep) fits snugly on the dash of virtually any car. Read what Leo Simpson of Electronics Australia had to say!

CAT A4449 ..... \$199.50

## Smoke Detector \* CONSUMER FLOP — CONSUMER FLOP CLUB, HOTEL, HOSTEL & MOTEL MANAGERS PLEASE NOTE

One of the greatest consumer flops of the last decade was the Ionization Chamber Smoke Detector. Even though it is a brilliant product (reliable, compact, easy installation, fail-safe etc) it just did not sell. Human nature being what it is finds safety-oriented products just not worth the investment. We all know that accidents and fires never happen to US! As smoke is the greatest killer in a fire, the market research gurus thought that such a product would have wide appeal. When they were \$49.50 no one wanted them. The price fell to a very reasonable \$29.50 and still they stayed on the suppliers shelves. We have now been instructed to clear them for less than 1/3 of \$29.50

- Contains Americium 241 Ionization Chamber
- 9V Malfroy Duracell included
- Contains very loud solid state buzzer
- 12 month factory warranty



GENERAL ELECTRIC

Grab One NOW \$14.50

CAT A4441 ..... \$14.50

## \* FAMOUS \* GENERAL ELECTRIC BURGLAR ALARM SLASHED! HUGE SCOOP PURCHASE — ONCE SOLD FOR OVER \$100

\* Slashed to  
\$29.50



Amazing low price for a full feature ultrasonic proximity/burglar alarm. \* Completely self contained \* 12 month manufacturer guarantee \* Instant or delayed alarm \* Handsome imitation woodgrain \* Cabinet measures 180Wx85Hx100D \* Programmable multi code disable switch \* Single 9V Alkaline battery \* lasts one year \* Unit beeps when battery gets low \* Contains receiver element designed for greater sensitivity without false triggering \* Uses State of the art LSI circuitry \* Worth the money in parts alone \* Comprehensive 24 page manual included \* Comes complete with 4 window deterrent stickers \* Absolutely no installation needed. \* Battery extra  
SAVE A FORTUNE — COMPARES WITH UNITS OVER \$100  
Below cost distress stock — Factory orders to sell.

CAT A4430 ..... \$29.50



## New Products

### DC-DC converters from Scientific Electronics

Scientific Electronics, Australian designers and manufacturers of a wide range of power supplies, has released two new DC-DC converters.

The SM110D1 converter is said to be ideal for communications applications requiring 24V to 12V conversion. Features include low RF noise levels at both input and output and a fully floating output. Rating is 8A at 13.8V with a claimed load regulation better than 0.5%. The unit weighs 1kg and measures 150 x 75 x 175mm.



A second converter, the SM100D2, can provide up to 100W output and will operate over an input voltage range of 20-60VDC. The unit is fully protected from input and output voltage transients, reverse polarity inputs, short circuits and overloads and also includes thermal and output overvoltage protection.

Load and line regulation is claimed to be better than 0.1% with input and output noise less than 50mV peak to peak.

For further information on these and other Scientific Electronics, power supplies contact Mr Peter Lloyd, Scientific Electronics, 6 Holloway Drive, Bayswater, 3153. (03) 762 5777.

### STC-Cannon to handle HP components

In a move designed to broaden the distribution of its products, Hewlett-Packard Components Division has announced the appointment of STC Cannon Components Pty Ltd as a HP distributor.

Mr Bryen Tanner, HP's Australasian Components Division sales manager said that the appointment will mean greater availability of Hewlett-Packard components in major cities. "STC Cannon will be handling our full range of state-of-the-art components, including LEDs, displays, fibre optics, barcode readers and microwave semiconductors."

STC Cannon is at 248 Wickham Rd, Moorabbin, Vic, 3189.

# COMP-SOFT INTRODUCES THE MITSUBISHI RANGE OF DISK DRIVES



#### M2896-63

- SLIMLINE 8" Disk Drive
- Double Sided, Double Density
- No AC Power Required
- 3ms track to track
- 1.6 mbytes unformatted
- 77 track/side
- 10<sup>9</sup> bit soft error rate

**\$525 + TAX \***



#### M2894

- Standard size 8" drive
- Double sides, double density
- 3ms track to track access
- 1.6 mbytes unformatted
- 77 track/side
- 10<sup>8</sup> bit soft error rate

**\$485 + TAX \***



#### M4854

- Slimline 5 1/4" disk drive
- Double sides, double density
- 96 track/inch
- 9621 bits/inch
- 1.6 mbytes unformatted
- 3ms track to track access
- 77 track/side

**\$395 + TAX \***



#### M4853

- Slimline 5 1/4" disk drive
- Double sides, double density
- 1 mybte unformatted
- 3ms track to track
- 80 track/side
- 5922 bits/inch
- Steel band drive system

**\$375 + TAX \***

**\*INTRODUCTION PRICES ONLY FOR THE MONTH OF DECEMBER**

**COMP-SOFT** Microcomputer Services

233-235 Swan St, Richmond, Victoria, 3121.

Tel: (03) 428 5269

## New Products

### Thurlby 1504 multimeter from Parameters

A new Thurlby digital multimeter is now available from Parameters Pty Ltd. The new instrument is designed for bench or field use, and includes a true RMS measurement function. Thurlby call the multimeter a "4½-digit" instrument.



Measurements are displayed on a liquid crystal display with a full scale of  $\pm 32,000$  counts, said to provide 60% greater resolution than 4½ digit displays. The unit can measure DC voltages up to  $\pm 1200V$ , AC up to 750V, currents of up to 10A and resistances to 32M $\Omega$ .

The Thurlby 1504 multimeter also includes a frequency measurement function which allows pulse waveforms up to 3.9999MHz to be measured with a resolution of 100Hz.

Also available from Parameters is the 1982 Data Acquisition Handbook, a two volume, 1500 page manual on products from Analog Devices.

For more information contact Parameters Pty Ltd, 41 Herbert St, Artarmon, NSW, 2064. Phone (02) 439 3288.

## Selective calling codes for UHF band



Two versions of the Gaetjens Selective Calling unit are available for use on the 470MHz UHF band.

Because of the limited number of radio transmission channels available and the large number of people using radio transceivers, no person or organisation can expect to have exclusive use of a channel. Shared channels however can lead to frustrated operators turning their transceiver down to avoid distraction and then missing an important call.

In many cases, too, operators cannot be in constant attendance of the transceiver and may miss calls.

A South Australian manufacturer claims to have solved the problem with the introduction of "selective call" units for use on the UHF 470MHz band. The unit can be attached to any transceiver and in effect, converts the transceiver into a telephone, able to be called by a coded number.

The selective call unit is attached to the radio transceiver, which then reacts when it receives its own special code. Other units, of course, can

send these codes on command.

When other units receive the coded number they check for a match with their own number. If the match is successful the selective call unit will turn on the transceiver's speaker, sound a buzzer or other external device (such as a tape recorder) and flash an indicator light, then re-transmit the code to the caller to acknowledge reception.

Group calling is also possible. Organisations can call a pre-arranged group of codes, while members retain the use of their own individual codes.

Two versions of the selective call units are available, the MEG12A, which can transmit 10 codes, and the MEG13A which can send 100,000 different codes. Prices are \$130 and \$150 respectively.

For further information contact Malcolm Gaetjens, 59 Findon Ave, Seaton, SA, 5023.

# MASTER ELECTRONICS NOW!

## The PRACTICAL way!

This new style course will enable anyone to have a real understanding of electronics by a modern, practical and visual method. No previous knowledge is required, no maths, and an absolute minimum of theory.

You learn the practical way in easy steps mastering all the essentials of your hobby or to start or further a career in electronics or as a self-employed servicing engineer.

All the training can be carried out in the comfort of your own home and at your own pace. A tutor is available to whom you can write personally at any time, for advice or help during your work. A Certificate is given at the end of every course.

You will do the following:

- Build a modern oscilloscope
- Recognise and handle current electronic components
- Read, draw and understand circuit diagrams
- Carry out 40 experiments on basic electronic circuits used in modern equipment
- Build and use digital electronic circuits and current solid state 'chips'
- Learn how to test and service every type of electronic device used in industry and commerce today. Servicing of radio, T.V., Hi-Fi and microprocessor/computer equipment.

New Job? New Career? New Hobby? Get into **Electronics Now!**

Post coupon now:

**The Australian School of Electronics Pty. Ltd.,**  
(Inc. in Victoria)  
PO Box 108, Glen Iris, Victoria, 3146  
A Registered Correspondence College



**FREE**  
COLOUR BROCHURE

Please send your brochure without any obligation to:

Name \_\_\_\_\_

Address \_\_\_\_\_

Post Code \_\_\_\_\_

EA1282

PHONE  
(03)

288 3107

ENQUIRIES

# EASTERN

COMMUNICATION ELECTRONICS & COMPUTER CENTRE

168 Elgar Road, Box Hill Sth, Victoria, 3128

*Who? You might ask. For those of you who aren't into the amateur radio scene "Eastern" is probably a new name to you. In fact we have been in the communications business for the past 6 years and are one of Australia's largest suppliers having the full range of Kenwood, Icom and Yaesu communications equipment. We have now decided to expand our business to cater for the electronics hobbyist. We carry a full range of resistors, capacitors, semiconductors, plugs, sockets, tools, test equipment etc etc in other words everything for the person into electronics. So if you like or don't like shopping at Richards why not pay us a visit.*



### UNIVERSAL MULTIMETER IDEAL FOR THE BEGINNER

23 RANGES  
20,000Ω/VOLT DC  
10,000Ω/VOLT AC

OUR BEST SELLER  
135 x 91 x 39  
ONLY \$22.99

ALSO  
ECONOMY TESTER  
2000Ω/VOLT 90 x 60 x 30  
ONLY \$12.50

### MU 45 PANEL METERS

1mA 2000Ω \$8.50  
5A .02Ω \$8.50  
0-20V 2000Ω \$8.50

### COMPONENT PACKS

COMPUTER SELECTED VALUES  
.25W Resistor Pack  
Contains 300 Only \$5  
GreenCap Pack 100V  
Contains 50 Only \$5  
Ceramic Pack 50V  
Contains 100 Only \$5  
Electrolytic Pack PCB type  
Contains 40 Only \$5

### IC SOCKETS DIL LOW PROFILE

8 PIN 25c  
14 PIN 30c  
16 PIN 30c  
18 PIN 40c  
24 PIN 60c  
40 PIN 80c

### 12V SOLDERING IRON

Use a car battery or a 12V  
1AMP transformer  
Fantastic value only \$3.95



### REAL VALUE AT ONLY \$9.95

Replacement tips  
Flat tip 95c  
Conical tip 95c

### MINI TOGGLE SWITCHES

Dem quality 250V2A rated

SPDT \$1.20  
DPDT \$4.40

### METAL CABINETS

150 x 61 x 103mm \$4.75  
150 x 76 x 134mm \$4.95

### ZIPPY BOXES

UB1 \$1.50  
UB2 \$2.20  
UB3 \$3.75  
UB4 \$2.75

**SUPERPHONE**  
CORDLESS TELEPHONE  
SYSTEM  
TELECOM APPROVED

Both way call button for intercom operation.

Plug in Batt Cassette for remote power source.

Overcharge protection.  
300M range.

Ideal for the office, workshop, factory, poolside, restaurant, home, boat etc etc.

### AS ADVERTISED ON TV

Model CT505 only \$399.00  
Model C100 only \$349.00

### MICRON 30W IRON

240V  
Sec Approved  
Ideal for the hobbyist,  
electrician or handyman.

### ETI 160 POWER SUPPLY



13.8V  
@  
10A

Fantastic for powering high powered rigs or linears.  
Complete kit includes box.

ONLY \$79.50

## ALTRONICS & JAYCAR DISTRIBUTORS

### SCOTCHLOCK CONNECTORS

Cable Joiner  
No mess no fuss no solder  
PACK OF 3 ONLY 60c

### HEART RATE MONITOR



EA782

Measure your pulse instantly and accurately.  
A must for the fitness fanatic.

ONLY \$79.00

### FUNCTION GENERATOR



Pictured with EA Panel Companion to the 500MHZ DFM. 20HZ-160KHZ freq range. Inbuilt 4 digit freq counter. Uses 1% metal film resistors.

ONLY \$99.00

### 500MHZ DIGITAL FREQ COUNTER PERIOD COUNTER



EA DEC 81-FEB 82  
50MHZ VERSION ONLY \$125.00  
500MHZ UPGRADE KIT \$26.00

OUR SERVICE DEPT IS PROFESSIONALLY STAFFED TO HANDLE ALL REPAIRS AND WE SPECIALISE IN COMPUTER REPAIRS TRS-80, SYST 80, SORCERER, VIC 20, APPLE ETC ETC. WE CAN HANDLE THEM ALL.

**Mail Order Dept — Send to 168 Elgar Road, Box Hill Sth. 3128.**

## New Products

### New range of portable frequency counters



Vicom International Pty Ltd, Australian representatives of Global Specialities Corporation, now has available a new range of portable, solid-state frequency counters.

There are three models in the range; starting with the Max-100, a 100MHz frequency counter with an eight digit direct reading LED display. It can be powered from internal rechargeable batteries, from a car cigarette lighter socket or from any 7.2-12V DC source.

The Max-550 is a wide range, 550MHz frequency counter in a calculator size case. It provides a resolution of 1kHz,

and power supply requirements are the same as for the Max-100.

Third model in the range is the Max-50, a pocket-sized instrument able to measure from 100Hz to 50MHz.

A pre-scaler is available to suit both the Max-50 and Max-100, extending the range of these instruments to over 500MHz.

For further information contact Vicom International Pty Ltd, 57 City Rd, South Melbourne, Vic, 3205 or 339 Pacific Highway, Crows Nest, NSW, 2065. In New Zealand contact the branch office, 84 White Lines East, Lower Hutt.

### Pulse transformers for PCB-mounting

Selectronics has released a series of pulse transformers, intended for applications such as SCR and Triac triggering, inverters and oscillators. The transformers are wound on ferrite pot cores to ensure close coupling between and windings and low self capacitance so that fast rise times can be achieved. The transformers are designed for mounting on printed circuit boards with a 2.54mm lead spacing.

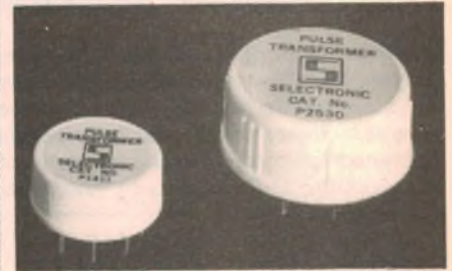

For further information contact Mr B. Scott, Selectronic Components Pty Ltd, 25 Holloway Drive, Bayswater, Vic 3153. Phone (03) 762 4822.

### Portable electronic thermometer

Digitron Instrumentation Ltd has introduced a new portable electronic thermometer, the 9000 Series Executive Kit.

The pocket size instrument weighs just 150 grams, and incorporates a LED display which shows temperature readings from  $-50^{\circ}\text{C}$  to  $999^{\circ}\text{C}$  using K type thermocouple probes. Four probes are included in the kit, together with a cold junction compensating coupling unit.

For further information contact Multisource International, Aust, 969 Burke Rd, Hawthorn, Vic, 3122.

## HOMELEC ELECTRONIC GLUE GUN

### It glues simply everything

The Homelec Gluefix 2000 outdates tube adhesives. Its hot melt glue replaces most tube adhesives and gives you a professional job in seconds. No need for clamps. Tiles, wood, leather, metals, plastics, rubbers and most other materials can be glued better. And the hot melt glue fills cracks and porous surfaces better than conventional glues. Gluefix's advanced solid state element means fast (5 minutes) warmup. And there is no conventional thermostat and heating element to burn out or go wrong. Gluefix can be left on all day without damage to glue or gun. Gluefix is fully approved by the electricity authorities. So throw away your messy tube adhesives. No more mixing or wastage. For just \$19.95 you can have the most advanced glueing technology at your fingertips!

To order your Gluefix 2000 send cheque or money order to: **Homelec Products, PO Box 185, West Ryde 2114 or phone order on your Bankcard on (02)85 2922**  
**Gluefix 2000 with 8 gluesticks \$19.95 plus \$2.00 P & P. Gluefix with 4 gluesticks \$19.25 plus \$2.00 P & P.**  
**Replacement gluesticks available.**

Available from: Homelec Products Pty Ltd 1073, Victoria Road, West Ryde and Natalean Pty Ltd 36, Lilydale Grove, Hawthorn Victoria 3123 Phone (03) 824-582



Repair indoor and outdoor furniture



Tiles can be glued very quickly



No clamps needed.



# NEW! NEW! JAYCAR★

## Walkie Talkies Sensational price for X'tal controlled units



Sensational price for CRYSTAL CONTROLLED UNITS!! Not your super-regen rubbish!! Don't be fooled! These units actually do work — well in fact. Will transmit voice or morse over fairly respectable distance (over a mile in ideal conditions). Fitted with proper transmit/receive crystal controlled superhet circuitry. DO NOT COMPARE with far inferior units that may only be a dollar or so cheaper anyway and almost always are a disappointment. At only \$12.50 each, how could you go wrong?

**only \$12.50**

## low cost balanced mic transformer

Sensational price for a completely MU-metal shielded unit!! Until now you had to pay a fortune for a shielded balanced tranny!  
 — 2-600 ohm (CT) input/output  
 — 50k output/input  
 — Can be used either way round  
 — Standard 9mm bushing mount  
 — Colour coded leads.  
 Don't pay over \$30!!!

**\$17.50**



## Cannon XL connectors ~ great new range

5 pin and right angle types now in stock.

DESCRIPTION	PRICE
3 pin male line	\$3.50
3 pin female line	\$3.95
3 pin male chassis	\$3.25
3 pin female chassis	\$3.95
5 pin male line	\$6.95
5 pin female line	\$7.95
5 pin male chassis	\$3.95
5 pin female chassis	\$6.95
240V Mains line	\$6.50
240V mains chassis	\$5.25
3 pin male right angle line (Neutrik)	\$4.95
3 pin female right angle line	\$5.95
3 pin female line (Neutrik)	\$4.95
3 pin male line (Neutrik)	\$3.95

## superbright LED

The average 15 cent LED has a light output of 0.8mCd (milli Candelas) at 20mA. Can you imagine a 200mCd LED? (at 20mA)? Well if you can't — buy one and find out. They are ideal for panel illumination or very low current work. (They will still give useful light at 1mA!).



Red with clear lens — 69c each  
 10 up only  
 62c each. . . .

## AT LAST!! INTERNATIONAL STANDARD (IEC 320) 240V APPLIANCE CONNECTOR

You asked for it and here it is. Fully approved 240V mains inlet to International Standard IEC 320.

- Front or rear panel mount
- 240V AC 6A rating
- Accepts IEC 320 International power cords
- Simplifies 240V wiring.
- Quick-connect/solder on terminals.

We also have the IEC 320 line plug assembly for ONLY \$4.95.

6.4 mm dia.

Beware of non-approved units!

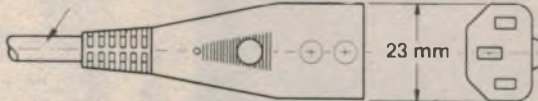

**\$2.95**

## NEW! INSULATION DISPLACEMENT CONNECTORS & RIBBON CABLE!!

I.D. Insulation displacement. The quick and reliable way of making multiple connections to computer peripheral connectors. Great for Disc Drives, Printers etc. Crimp them yourself and save a fortune!!

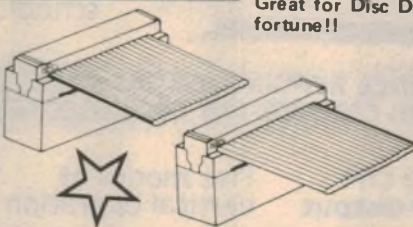

WE NOW CARRY

- CONNECTORS:
- 16 pin DIP HEADER \$1.99
  - 24 pin DIP HEADER \$2.50
  - P.C. Edge Connector 34 way (Suits 5 1/4" Disc Drives) \$8.50
  - 25 Pin Cannon 'D' Male \$8.95
  - 25 Pin Cannon 'D' Female \$8.95

- CABLE:
- 16 way \$1.50/metre
  - 25 way (suit DB25's & 24 way DIP) \$2.50/metre
  - 34 way for Disc Drives \$3.45/metre

## MAGAZINE BINDER

Keep your precious (and expensive) magazines in order for easy reference. Smart blue colour with gold lettering. Heavy gauge and richly chromed metal fittings. **LOW IMPORT PRICE ONLY \$4.95**  
 4 up \$4.50 each



## SCR AND TRIAC SELLOUT!!!!

We only have VERY SMALL quantities of some.

Part No.	Description	I.T.R.M.S.	VERMAX	PRICE
BT137/500	TRIAC	8 amp	500	\$1.50
BT139/600	TRIAC	16 amp	600	\$4.00
BT151/500R	SCR	12 amp	500	\$1.95
BT151/650R	SCR	12 amp	650	\$1.95
BTW24/600R	SCR	35 amp	600	\$2.95
BTW31/1000R	SCR (fast)	110 amp	1000	\$29.50
BTW38/1000R	SCR	16 amp	1000	\$4.95
BTW38/600R	SCR	16 amp	600	\$4.50
BTW41/500	TRIAC	40 amp	500	\$4.95
BTW43/800	TRIAC	15 amp	800	\$3.95
BTW92/1200R	SCR	31 amp	1200	\$9.95
BTY79/400R	SCR	16 amp	400	\$1.95

## LOW-COST COLLET-TYPE KNOBS

"Made in England" Quality. Economical slide-on fit to any 1/4" shaft pot with flat (i.e. Soanar or Jaycar pot.) Dull black finish on body with choice of SEVEN bright coloured snap-in tops.

- Knob body ONLY \$0.50 ea 1-9  
\$0.45 ea 10+
  - Caps ONLY \$0.10 ea any quantity
- Cap Colours: Red, Green, White, Yellow, Grey, Blue and Black



## Jaycar NUMBER 1 FOR KITS

125 York Street, Sydney 2000  
 Phone: 264 6688 Telex: 72293  
 "Nevilles Corner"  
 Cnr. Carlingford & Pennant Hills Road,  
 Carlingford  
 Phone: 872 4422  
 Mail Orders To: Box K-39 Haymarket  
 Sydney 2000

POST AND PACKING CHARGES  
 \$5-\$9.99 (\$1.20) \$10-\$24.99 (\$2.40)  
 \$25-\$49.99 (\$3.50) \$50-\$99.99 (\$4.60)  
 \$100 up \$5.20

NEW SHOP HOURS  
 Mon-Fri 8.30 to 5.30pm  
 Sat 8.30 to 12.00pm  
 Thurs night to 2.30pm



# NEW HITACHI F SERIES SQUARE SCREEN DUAL BEAM CRO

SUPERB NEW MODEL V152F DC TO 15 MHz 1mV/DIV DUAL TRACE



PRICE ONLY

**\$529<sup>50</sup>** TAX EXEMPT

**\$599<sup>50</sup>** TAX PAID

CAT Q0152

- ★ Newly developed square 140MM CRT with internal graticule.
- ★ Now with CH1 output.
- ★ High definition display — a must for every laboratory, workshop and school.

ALTRONICS ARE PROUD TO ANNOUNCE APPOINTMENT AS AGENTS FOR THE SUPERB RANGE OF HITACHI CATHODE RAY OSCILLOSCOPES

## FEATURES

### X-Y Operation

X-Y operation is an important function for assuring accurate measurement of phase differences. By inputting Ch1 signals into the X axis and CH2 signals into the Y axis, the phase for two frequencies can be accurately measured.

### Vertical sensitivity 1mV/div.

This 1mV/div. sensitivity is highly effective in checking microcomputer circuits that handle weak microsignals and measuring video signals.

### 10 x Sweeptime magnification with 1-touch operation

The sweep-time magnifier functions, incorporated in Hitachi Oscilloscopes, is essential for attaining fine measurement of waveforms. One-touch 10X magnification of sweep time assures precise measuring of complicated waveforms or noise.

### Convenient Ch1 signal DVM output

To eliminate messy T-connector cabling and time consuming cable switching a convenient Ch1 signal output connector has been provided for use with a DVM or DMM, thus increasing measurement speed and efficiency.

### Z-axis input provided — possible to use as CRT display

Provided in addition to the X-axis and Y-axis is a Z-axis input (intensity modulation terminal). Input to the Z-axis of external signals, plus X-Y display, enables a display in characters and/or figures.

### 0.2 us to 0.2s — wide sweep range setting

The sweep range can be set from 0.2 us to 0.2s in 19 calibrated steps. By setting the sweep time according to signal speeds, waveforms can be swept over the entire CRT tube surface.

### Five modes of vertical operation

Vertical display changes for five modes (CH1, CH2, DUAL, ADD, and DIFF) provides multipurpose applications for time difference measurements, calculation of waveform additions or reductions, and so on.

### Panel layout with colour coding of respective functions

The panel layout is designed to create maximum operating ease by considering the measuring processes and operation frequency. The layout is divided into three blocks according to respective functions identified by different colours. This convenience-oriented design for users improves daily controllability and drastically reduces operating errors.

## SPECIFICATIONS

Vertical deflection	5mV/div to 5V/div - 5%, 10 calibrated steps
Sensitivity	1mV/div to 1V/div - 6% (When using x5 amplifier) Uncalibrated continuous control between steps 1 - 2.5 (provided with click positioning function)
Bandwidth	DC to 15MHz -3dB (at 4div) DC to 7MHz -3dB (at 4div) (When using x5 amplifier) 24ns (for x5) 70ns typ
Rise time	
Signal delay time	
Max. input voltage	600Vp-p or 300V DC + AC peak, at 1kHz
Input Coupling	AC GND DC
Input impedance	Direct 1M ohm, approx 30pF
Operating modes	CH1 CH2 DUAL ADD DIFF
X-Y operation	CH1 X axis, CH2 Y axis
Sensitivity	5mV/div to 5V/div (When using x5 amplifier, 1mV/div)
Phase difference	DC to 10kHz within 3°
X bandwidth	DC to 500kHz -3dB
Dynamic range	4div or more
CH1 output	
Output voltage	20mV/div or more (terminated into 50Ω) 50Hz to 5MHz -3dB (Approx. 50Ω)
Bandwidth	
Output impedance	
Horizontal deflection	AUTO NORM TV (L) TV (L)
Trigger modes	CH1 CH2 LINE EXT
Trigger source	AC
Trigger coupling	TV sync-separation circuit
TV sync	1div or more (V sync signal)
Internal	1Vp-p or more (V sync signal)
External	
Trigger sensitivity	Frequency Internal External
	20Hz to 2MHz 0.5div 200mV
	2 to 15MHz 1.5div 800mV
	30Hz
AUTO low bandwidth	
Trigger slope	input impedance approx 1M ohm, 30pF or less
External trigger input	Max. input voltage 100V
	DC + AC peak at 1kHz
Sweep time	0.2us/div to 0.2s/div - 5%, 19 calibrated steps
	Uncalibrated continuous control between steps 1 - 2.5 (provided with click positioning function)
Sweep time magnifier	10 times (1-7%)
Max. sweep time	100ms/div (20ns/div and 50ns/div, not calibrated)
Amplitude calibrator	
Waveform	Approx. 1kHz - 10% (typ) square wave
Voltage	0.5V ±5%
Power requirements	100/120/220/240V -10% 50 to 60Hz, approx. 40W
Dimensions	Approx. 275(W) x 190(H) x 400(D)mm
Weight	Approx. 8.5kg

# ALTRONICS

105 STIRLING ST., PERTH, W.A.

PHONE (09) 328 1599

• OPEN FOR THURSDAY NIGHT SHOPPING •

ALL MAIL ORDERS: BOX 8280, STIRLING ST. PERTH, W.A. 6000.

# Shortwave Scene



by Arthur Cushen, MBE

## 50 years of BBC shortwave broadcasting

On December 19, 1982 the BBC External Service will celebrate 50 years of shortwave broadcasting and over the past few weeks special programs from London have highlighted the history of the External Service, which has an estimated daily audience of over one hundred million listeners.

On December 19, 1932 an experimental transmitter operated from Daventry with short messages read by the BBC Chairman, the Director General, the Chief Engineer and the Director of the new service, opening the Empire Service. The transmission was directed to Australasia at first, and at intervals throughout the day the messages were beamed to other parts of the world. On Christmas Day King George V started the traditional broadcast and the writer can recall listening at 3am NZT to this very first Christmas message broadcast. Although the BBC enjoyed a monopoly at home it had to face competition abroad, and during the 30's that competition intensified.

By the time the Empire Service began the Russians were already broadcasting in foreign languages, and the Germans and Italians had extended this practice with dramatic effect. The first foreign language on the BBC was introduced on January 3, 1938 when broadcasts in Arabic were transmitted. By the time of the outbreak of war seven languages were carried, quickly followed by Afrikaans, Spanish and Portuguese.

When the war ended the BBC was broadcasting in 45 languages. It had been a source of hope and inspiration to millions of people in Nazi-occupied Europe and had actively helped the resistance movements. Its prestige, like that of Britain herself, was at a peak. The BBC had acquired a reputation for honesty and truthfulness which it still retains, and was acknowledged as the foremost international broadcasting organisation in the world, both in quality and quantity.

Today there has been a slight decrease in the number of languages broadcast but for the English listener the Empire Service moved into the General Overseas Service, and now the World Service, which operates 24 hours a day from transmitters in the United Kingdom and other locations in the Caribbean, Ascension, Cyprus, Masirah, Singapore and through facilities of the Voice of America and Radio Canada International.

Over the past 40 years, the writer has represented the BBC as a technical monitor and has sent hundreds of international telgrams and thousands of reports to London. Broadcasts from London are in three phases, with morning reception in this areas at 1800-2230UTC on 9410, 11750 and 15070kHz; early evening at 0600-0915UTC on 7150, 9640, 11955kHz, and late evening at 0900-1315UTC on 11750, 15070 and 21550kHz.

### KVQM — AMERICAN SAMOA

A new broadcasting station is operating at Pago Pago, American Samoa, with the call KVQM, on 585kHz using 50kW. The station broadcasts gospel programs from 1600-1200UTC. Operated by Quality Media Corporation, KVQM is now proposing to operate a shortwave station from the same site. The mediumwave station should be

operating this month while an application to the US Federal Communications Commission has been made for shortwave transmissions which will cover the South Pacific, Australia and New Zealand. The programs will be nondenominational and the station will not carry commercial announcements.

The Quality Media Corporation has already established the Caribbean Beacon on Anguilla which has been heard on 1610kHz here in New Zealand. They plan to also include shortwave facilities in the Caribbean area. The Corporation plans five more stations for the Caribbean, three on the island of South Caicos which will include one shortwave transmitter and another shortwave transmitter to be established on Anguilla — the site of the Caribbean beacon. The new medium-wave stations in the Caribbean are expected to operate this month with English on 1570 and Spanish on 1030 but the date of opening the shortwave transmitters is not yet known.

### NEW STATIONS

**INDIA:** A new regional station at Aizawal on 5050kHz is being heard around 1430UTC when it relays All India Radio news in English. The station is also heard at weak strength around 1400UTC with some interference from Singapore. The schedule on this frequency is 1230-1630UTC, and a further frequency, 7295kHz is used for daytime operation.

**NORTH MARIANAS:** A new station, KYOI, is expected to commence operation this month with the following schedule: 1800-2100UTC on 9695kHz; 2100-0700UTC on 17795kHz and 0700-1800UTC on 11900kHz. According to WRH Newsletter, the programs will be in Japanese and English, and broadcasts are beamed to Japan. The power of the transmitter will be 100kW and the address is MARCOM, PO Box 795, Saipan, CM 96950.

**BOLIVIA:** Radio Stentor has returned to shortwave with 10kW and has been heard opening at 1000UTC on 6187kHz or as high as 6197kHz. The station opens with a program in a local dialect and according to DX Australia and reports from North America, is looking for reception reports.

### DO YOU WANT TO BE A RADIO AMATEUR?

The Wireless Institute of Australia, established in 1910 to further the interests of Amateur Radio, conducts a Correspondence Course for the A.O.C.P. and L.A.O.C.P. Examinations conducted by Telecom. Throughout the Course, your papers are checked and commented upon to lead you to a successful conclusion.

For further information, write to

**THE COURSE SUPERVISOR  
W.I.A. (N.S.W. DIVISION)**

P.O. BOX 1066  
PARRAMATTA, N.S.W. 2150.

# Software for the Super-80

Games

Education

Business

**Who said there's no Super-80 software?**

Improve your maths skills or go adventuring with "Caves & Monsters"; run a business or perhaps win a fortune on Tattslotto! Our Super-80 programs book has something for everyone. Compiled from entries in the Super-80 program competition, earlier this year, these program listings will interest every Super-80 enthusiast.

Why be content with a tacky photocopy, when for just \$5 you can have your own brand new copy, clearly printed and a pleasure to use? (And it's legal, too).

Use the coupon at right (and add \$1 for postage and packing), or call in at Electronics Australia, 57 Regent St, Chippendale, and save the postage. We're conveniently close to Central railway and open during normal business hours.

Available from "Electronics Australia", 57 Regent St, Chippendale. PRICE \$5.00 OR by mail order from "Electronics Australia", PO Box 163, Chippendale, 2008. PRICE \$5.00 plus \$1.00 for packaging and posting anywhere in Australia.



**Note: This book is exclusive to "Electronics Australia" and is available only from the address listed in this advertisement.**

**To: Electronics Australia, PO Box 163, Chippendale, 2008**

Please send me ..... copies of "Software for the Super-80 Computer" at \$6.00 each (includes post and packing)

**NAME** .....

**ADDRESS** .....

..... **POSTCODE** .....

I enclose cheque/postal order to the value of \$ .....

Please charge my Bankcard \$ .....

**Bankcard Number 496** .....

**Expiry Date** ..... **Cardholder Signature** .....

*If you are using Bankcard, be sure to include your full address (not a PO Box)*

# 'HEY'

Here's something all the Family can use by teaching yourself the working of the modern world of Computing.

## MICRO-PROFESSOR PRICE LIST

### 1. MPF-IB™ MICRO-PROFESSOR™ Microcomputer Set on Z-80 basis

**Standard Configuration:** 1 set of MPF-IB with built-in Basic Interpreter

1 unit of book-type package, 1 copy of User's Manual, 1 copy of Experiment Manual, 1 copy of Monitor Program

Source Listing, 1 copy of Basic-MPF Operation Manual

	EXCL.	SALES TAX INCL.
1. MPF-IB™ MICRO-PROFESSOR™ Microcomputer Set on Z-80 basis	\$115.00	138.00

### 2. OPTIONS:

AC/DC Adaptor, 9V DC/600mA (also for PRT-MPF Printer) 11.50 13.80

EPB-MPF - EPROM Programmer board for MPF-IB 145.00 174.40

SSB-MPF - TI TMS32005220 based Speech Synthesizer Board 145.00 174.40

PRT-MPF - Thermal printer (without AC/DC adaptor) 95.00 114.00

SGB-MPF - Sound Generation Board for MPF-1 95.00 114.00

SSB-MPF Vocabulary set, Total 400 English words stored in 8 TMS2532 EPROM for SSB-MPF usage 199.00 238.80

### 3. ACCESSORIES:

MPF-CPK - 280-CTC (citer & timer) & 280-P10 (para 1/0) Chip Kit 17.00 20.40

MPF-BBD - 31.50mm x 80mm Breadboard 6.50 7.80

MPF-UWB - Universal Wire-Wrapping Board 8.50 10.20

MPF-2KRAM - 2Kx8 RAM 6116, 5B/25 or equivalent 12.50 15.00

MPF-2KROM - Blank 2K Bytes EPROM TMS2516, 12716 or equiv 8.00 9.60

MPF-4KROM - Blank 4K Bytes EPROM tms2532, 12732 or equiv 12.50 15.00

MPF-FCC - 150mm flat cable with double end female & male connector 7.50 9.00

PRT-MPF Thermal Paper - Four rolls (30 feet each) per pack 7.50



**DAVID REID ELECTRONICS LIMITED**  
127 York Street, Sydney, 2000.  
or Telephone (02) 29.6601



## FREQUENCY CHANGES

**AUSTRALIA:** Radio Australia is using 11970kHz around 2045-2300UTC for a broadcast in Indonesian. This frequency replaces 11935kHz. The Radio Australia schedule is unchanged in other language broadcasts, with listeners in the South Pacific finding the service on 15240kHz 2100-0730, and 9570kHz at 0700-0900UTC giving the best reception of the many frequencies available.

**SWEDEN:** Radio Sweden is again using 21610kHz in English to Australia 1100-1130UTC. Additional English services are heard 2100-2130UTC on 11845 and 11955kHz and 0230-0300UTC on 9695 and 11705kHz.

**HUNGARY:** Radio Budapest recently celebrated 25 years of its DX Program which started on October 1, 1957. This program is heard on Wednesdays and the transmission to Australia has been retimed 1030-1100UTC and broadcast on 15160, 15220 and 17710kHz. Reception in our afternoons 0300-0330 is on 9585, 9835, 11910, 15220 and 17710kHz.

**USA:** The Voice of America transmission to Australia for morning reception 2200-2400UTC is now on 15290 and 2600kHz, the former frequency replacing 17740kHz. Broadcasts in our evening from 1100UTC onwards are carried on 9565, 15160 and 15425kHz. A new out of band frequency has been noted at 2130 when "VOA magazine" is carried on 15600kHz. At 2200 the station announcement indicates that the frequency is beamed to South Africa along with 621kHz medium-wave from Botswana. After 2200, 15600kHz carried news in English.

**UGANDA:** Radio Uganda at Kampala is again active on 15325kHz from 0300UTC. There is an hour-long program in English including a news comment at 0345 and from 0400-0430 the transmission continues in French. Our reports have indicated a poor quality signal, while Leigh Morris, reported in DX Post Adelaide, comments that the problem is between the studio and the feeder line to the transmitter at Soroti.

## NEW TRANSMITTERS

**INDONESIA:** The Indonesian Government is at present building two 250kW transmitters, one of which will operate from Padang Cermin, 30km from Medan, beaming transmissions to the west. The other will be located in Cimanggis near Jakarta, and will beam programs to eastern Indonesia and Australia. The Government has stated that these two transmitters will do much to introduce Indonesia to listeners aboard. ☺

Notes from readers should be sent to Arthur Cushen, 212 Earn Street, Invercargill NZ. All times are UTC (GMT). Add eight hours for WAST, 10 hours for EAST and 12 hours for NZT. In areas observing daylight time, add a further hour.

# 32K BYTES FOR THE ZX81

## SPECIAL RAM PACK FOR THE ZX81

This board uses dynamic RAM chips for lower cost and lower power consumption. Simply plugs into the ZX81 expansion port offering 32K BYTES for basic programmes and data handling. No extra PSU required.

Extra memory to help you build your ZX81 into a powerful microprocessor system at an affordable price. Compare the price with other RAM PACKS available on the market!

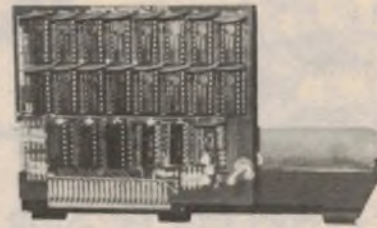

**Price for 32K Ram Pack (RP 32) only: \$165.00 incl. P & P (Aust.)**

**FREE CASES AVAILABLE SOON**

**JUST RELEASED!**

## ZX 80/81 PROGRAMMABLE CHARACTER GENERATOR

Using simple BASIC programs you can create your own unique character sets and graphic symbols for games, High Res graphs and charts and interesting patterns.

Program symbols normally available only on more expensive microprocessors and you are not limited to preprogrammed graphic sets.

**Fully assembled price \$95.00 incl. P & P (Australia).**

Uses the 8K ROM from Sinclair (not incl.)

## UPGRADE YOUR ZX80 GRAPHICS

Now you can upgrade your ZX80 to the full animated graphics of the ZX81. Your ZX80 will now run in SLOW mode.

**Fully assembled price only \$38.50 incl. P & P (Australia).**

Works only in conjunction with 8K ROM from Sinclair (not incl.)

Please send order or SAE for further information to: VENDA LE PTY. LTD., Dept A7, Box 456, Glen Waverley, Victoria 3150, 36 Plymouth St., Glen Waverley, (03) 232 0444.

# VENDALE

VEN 0261

# Engineering Manager

**\$A25-30,000 Low income tax benefit**

**Location: Hong Kong**

A major Hong Kong manufacturer of microprocessor based computers requires the services of an engineering manager to supervise a team of R & D and production engineers.

The suitable applicant must be a degree or diploma engineer with experience in microprocessor technology. A bachelor is preferred.

The position is based in Hong Kong for a minimum contract period of two years, which is renewable.

Accommodation and relocation expenses are provided. The salary package is envisaged at around \$A25-30,000 PA depending on experience and qualifications.

**Airmail applications to the general manager;**

**EACA INTERNATIONAL LTD,  
13, CHONG YIP ST,  
EACA INDUSTRIAL BUILDING,  
KWUN TONG, KOWLOON,  
HONG KONG.**

NB. The current income tax in Hong Kong is only 15%. Therefore take home salary is much higher than equivalent in Australia.



REVIEWS OF RECENT

# Records & Tapes

CLASSICAL • POPULAR • SPECIAL INTEREST

## SHOSTAKOVICH: Nos 1 & 9, "I liked the later work"

**SHOSTAKOVICH — Symphonies Nos. 1 and 9. London Philharmonic Orchestra conducted by Bernard Haitink. Decca Digital Cassette 7915.**

Shostakovich's No. 1 precocious symphony occupies side 2 of this digitally mastered cassette, No. 9 has the normal Side 1. This might on paper seem anomalous but a run through will do much to explain the maker's reasons. No. 1 gained immediate respectful acceptance from its first performance. No. 9 has never been enthusiastically received.

I was therefore very surprised to find how much I liked the later work and concluded that the reason was Haitink's eloquent performance. This is especially noticeable in the second movement where Haitink's eloquent phrases lighten the whole into an almost waltz-like rhythm. Other performances I have heard have left me with an impression of clumsiness.

It is well known that Ormandy's 1960 performance of the 9th was recorded with the composer standing almost at the conductor's elbow — or near enough to influence the entire interpretation. And it is also a well known fact that composers are not always the best judges of how their compositions can be played to reveal their best.

This new performance by Haitink seems to me not only different but much more attractive than Ormandy's. Thus, in the first movement Haitink uses grace instead of force, so changing the whole atmosphere. A great deal of the playing is beautifully delicate. Indeed, for the most part, it is made to dance even in the climaxes.

Everywhere, Haitink is aided by the sympathetic cooperation of the London Philharmonic at its best. Perhaps this is an expression of the members' pleasure at hearing the "new" version.

Haitink takes the second movement



much faster than the composer's marking "moderato", but I think with fine effect. Even the odd sounding Chorale of the second subject doesn't sound out of place but rather suggests the carnival-like religious spirit so often near the surface of most Russians.

After this almost hectic jollity, the slow movement follows with passion but never overdone lyricism. If you agree with Haitink's unorthodox treatment of the whole work this will be far and away the best account available. The dynamic range is beautifully judged, the softest pianissimos audible and the fortissimos bearable, all with Haitink at his most eloquent.

Importantly, the digital process makes much detail audible that I have never before heard in a recorded performance. Haitink also underlines some of the passages with just a little more than usual Shostakovich cheekiness. Some musicians call this, perhaps with justice, vulgarity. But what if it is? I find it none the less attractive for that reason. The kind of vulgarity I object to is when the aristocratic hero arrives in his rooms at the university in *Brideshead Revisited* and vomits solemnly through a window!

There is nothing outstanding in the way of originality in Haitink's interpretation of the First Symphony. It is a sound performance played with peerless skill.

It is perhaps his innate refinement that fails to reconcile him to the vagaries of the ill-constructed Finale. Nothing is seriously wrong but the spirit lacks recklessness. The violent contrasts are here but perhaps overemphasised.

By the way, to settle once and for all the correct pronunciation of the composer's name, his son, when he was in Australia lately told me it was ShosTAKovich. (J.R.)

## FALLA, CHOPIN: A problem of balance

**FALLA — Nights in the Gardens of Spain.**

**CHOPIN — Piano Concerto No. 2 in F Minor. Alicia de Larrocha (piano) with the Orchestra of the Swiss Romande conducted by Sergiu Comissiona. Decca Stereo Disc. SXL 6528.**

Alicia de Larrocha is a pianist with a formidable technique, and usually with a very sensitive ear for nuancing. On comparing this disc with others of her's I have heard, I am forced to speculate on the guilt of the recording engineer for the ill-judged balancing of piano and orchestra you find here. The Falla

is NOT a piano concerto. The composer made it everywhere clear that he was using the instrument solely as a member of the orchestra and this intention has been observed in most other recordings of note.

To further emphasise the piano's false importance, even on the attractive record sleeve, de Larrocha's name figures in the largest type — bigger than that used in the titles and for the composer and orchestra. And the pianist dominates the whole of the Falla work in similar manner. As a result, this most attractive romantic work is mercilessly distorted in far too many bars. Fragrance is lacking.

The orchestra struggles gamely to put

things right and restore the romantic atmosphere but alas in vain. In the record's favour is the piano which has a mellow tone and de Larrocha's excellent playing. The balance only is at fault but that is enough to spoil everything.

Not so in the Chopin. Here the balance is restored to normal although the Suisse Romande sounds a little thin after the fuller sounds produced by the New York Symphony, the London Symphony, the Vienna Philharmonic and many more versions abundantly obtainable.

Ms de Larrocha is again digitally (in the old meaning of the word) impressive but she has tendency to overdo the rubatos, pulling the tempo about like a rubber band sometimes drastically enough to destroy the logic of the work. A comparison with say Rubinstein's aristocratic treatment could be studied with profit by students anxious to know just how far to go in variation of tempo in rubatos. (J.R.)

## MOZART SONATA

**MOZART — Piano Sonata No. 5 (K.175). Piano Sonata No. 25 (K.503). Played by Murray Perahia with the English Chamber Orchestra. CBS Digital Disc D37267.**

These concertos are virtually the first and the last of any great importance that Mozart wrote. Although designated No. 5, K.175 follows four works that were only arrangements of other composers' pieces and had nothing in the way of greatness.

Perahia treats the whole recital



equally, some might think a bit too equally, because most other first class pianists inflate the Finale of No. 25 and blow it up into something approaching the feeling of early Beethoven. Perahia keeps his style consistent throughout both early and late works.

On my pressing there is faint pre-echo before the start of No. 5. This concerto is in "gallant" style and as its name suggests is brilliant, showy and imbued with a slight swagger. All this Perahia brings off to perfection. It all

## DVORAK-SCHWARZ

### A new role for a young American trumpet virtuoso

**DVORAK: Serenade Op 22. Waldesruhe (Silent Woods) for cello and orchestra Op 68. Notturmo Op 40. Los Angeles Chamber Orchestra conducted by Gerard Schwarz. Douglas Davis, cello. Digital stereo, Delos DMS 3011.**

Long-term classical music enthusiasts may well have some or all of these items in other albums by favoured orchestras and conductors.

For those, not in the position, this new release by Delos could be a very worthwhile acquisition. In typical Delos fashion, it comes in an elaborate double-fold jacket, with detailed notes on the composer and the music, the conductor and orchestra, the featured cellist and, of course, the digital technology used in the production of the disc.

Dvorak (1841-1904) composed the major work in this album — Serenade Op 22 — in the happy years around 1875, in a period of less than two weeks. Its five movements, averaging a little over five minutes each, take up the whole of side one and the beginning of side two: Moderato — Tempo di valse — scherzo — Larghetto — Finale.

Jacket notes by Jim Svejda discuss each movement, as well as the two remaining items: Waldesruhe (Silent Woods) Op 68 (with cellist Douglas Davis) and Notturmo.

sounds amazingly mature, but then so does all Mozart's music, even the very earliest.

Perahia has a beautiful Mozart touch and style without any suggestion of tick-tocking. Yet though his runs flow as smoothly as pouring oil, this doesn't obliterate the subtlest changes of dynamics and inflections during their progress. And, to back him up, the English Chamber Orchestra — conducted by the soloist while playing — lives up to its envied reputation.

The second movement is marked "andante ma un poco adagio." That the hint of adagio is small indeed is, in my opinion, a good thing. A slower tempo would rob it of much of its vitality. And the whole concerto has plenty of that.

After an allegretto start to the Finale, Perahia speeds up to a pace at which it is a miracle there is never a falter or one note scraping the heels of its predecessor. But, as I mentioned earlier, some eminent Mozartians might prefer a broader reading of the final movement.

The digital process is heard at its best here where no great changes in



Gerard Schwarz will need little introduction to readers of these columns. As a trumpet virtuoso, a member of American Brass and co-principal trumpet of the New York Philharmonic, he featured in two dazzling digital audiophile discs for Delos, before finally exchanging his trumpet for the baton.

Still only 34 years of age, he is the driving force behind two highly regarded chamber orchestras on opposite sides of the American continent — the Y Chamber Symphony of New York, and the Los Angeles Chamber Orchestra.

The music here is melodic through to exuberant (in classical terminology); the performance is good and the sound is well up to standard — a remark that could seem like a let-down to anyone expecting yet another Delos Soundstream hifi spectacular. It isn't a "spectacular" and it isn't intended to be.

It's a performance and an album that you will invest in if you're interested in its source, its contents and its presentation. (W.N.W.)

dynamics intrudes and clarity is all important. The balance between orchestra and soloist is faultless and their rapport perfect. Indeed I often found myself thinking "I don't believe it."

The orchestra has a chance to show their superb quality in the introductions to the second movement. At his entry Perahia, despite the change of mood, preserves his same limpid tone. His sudden change to staccato is as surprising as it is entrancing.

Mozart's music, even in these early days never suggests innocence — unless he deliberately wants it to, when it does so incomparably. And, as an example of supreme virtuosity, examine the workmanship of the contrapuntal Finale of No. 5. If you agree with Perahia's interpretation of it, the whole record is a triumph. (J.R.)

☆ ☆ ☆  
**BRAHMS — Piano Concerto No. 1 in D Minor. Claudio Arrau (piano) and the Concertgebouw Orchestra of Amsterdam conducted by Bernhard Haitink. Philips Stereo Universo disc. 6580 302.**

This is a big Brahms, both in conception and execution. The first movement finds Arrau in an unusual mood — dark, fearsome, angry, and at times violent enough to verge on ferocity. He is severe to the point of grimness. Could he be expressing, in magnified form, Brahms' outrage at the death of Clara Schumann? What else could explain these frowning brows, and hammering though never harsh fortissimos?

But when he moves on to the second movement, everything is different. Here is the Arrau we know better — expressive, lyrical, capable of exquisite delicacies while always respecting form. His shaping of the movement is superb. His overwhelming climax serves to make his whispered coda all the more worthy of rapturous reception. The Finale goes without a hitch. Arrau uses his effortless virtuosity to serve the general grandeur of the music.

Haitink and the Concertgebouw do their best to restrain his more explosive moments but Arrau, though a charming, gentle companion is no man to be dictated to. He goes his own way and Haitink perforce has to follow him with sufficient skill to avoid anomalies.

Arrau is reported to have once said: "I put the whole of my body into such passages." The result here is force without bashing and without vestige of ugliness of tone or form. The sound is good, the balance between piano and the mostly heavily scored orchestra perfect.

You may not like this strong, and let's admit it, sometimes highly personalised reading but, even if you don't I doubt if you will be able to restrain your admiration. (J.R.)

## A FINE LOCAL ALBUM

**THE SHIP MAHOGANY.** John and Mary Kopke. Stereo, Platypus Platters PPSLP-1002. [From APA Promotions, 43 Barter Crescent, Forest Hill, Vic 3131. Phone (01) 878 3953]

The voices on folk albums can often be somewhat raw, somewhat nasal, possibly because it is felt that the songs were traditionally sung that way. Authentic it may be but its appeal is certainly not universal.

No such complaint can be laid against John and Mary Kopke. Backed by several very capable musicians, the sound is, above all, pleasant and musical. But the backing is never overdone, never out of character with the songs.

They lead off with their own composition, the title track "The Ship Mahogany"



the story of a galleon that was reportedly wrecked on the coast near present-day Warrnambool. "Was her crew the first to land? Was she Spanish or Portuguese?"

Other tracks are a mix of traditional songs and others like "Bo The Banjo Man" acknowledged to Seona McDowell. The Leaving of Liverpool — Ballad of Cobb & Co — MTA — Flash Jack From Gundagai — Reedy Lagon — Mary's Choice — Blame It On The Kellys — Drover's Dream — Ballarat-O — Click Go The Shears.

Not only are the numbers presented very smoothly, but the recording itself is of excellent quality, adding up to an album that was a pleasure to review.

One other point: John and Mary are constant performers in the Free Entertainment in the Parks Program and they represented Australia in 1979 in Canada, for the Australian Tourist Commission. If you do buy a copy of the album, part of the proceeds goes to the Children's Welfare Association of Victoria. (W.N.W.)

## ANOTHER GOOD ONE

**SING OUT WITH JOY.** Cantus Choro, directed by Peter Chapman. Organ, Norman Kaye. Stereo, Move, MS-3032. From Move Records, 10 Glen Drive, Eaglemont 3084. Phone (03) 497 3105.



Rev W. D. Kennedy-Bell (Former Director, Religious Division of the BBC World Service) said of this album: "I have heard hymns recorded by the best cathedrals

and college chapels, but I can only say I have never heard better".

And I can only add that he was not exaggerating.

Cantus Coro is a Melbourne-based male vocal group, formed in 1979, but reinforced here with eight women sopranos.

The recording venue was the Trinity College Chapel within the University of Melbourne, a building which offers ideal atmosphere and acoustics.

Peter Chapman, who directs the choir, is a singer, conductor, and music teacher, with extensive experience both overseas and in Australia.

Norman Kay, actor, composer and organist produces magnificent organ support for the choir, plus solo stanzas that make one want to hear more.

The chosen hymns come from the Australian Hymnbook, published by the William Collins company. The track titles are:

All Creatures of our God and King — Let All Mortal Flesh Keep Silent — Praise My Soul, The King of Heaven — I To The Hills Will Lift My Eyes — Be Thou My Vision — For The Beauty of the Earth — Lord, Enthroned in Heavenly Splendour — Glorious Things of Thee Are Spoken — My Song Is Love Unknown — Immortal, Invisible — Love Divine — By Your Kingly Power — Be Known To Us Breaking Bread — The God of Abraham Praise.

In content, quality and spiritual atmosphere, this album will bear comparison with anything you will hear from overseas. As a rendition of great hymns, and as an adjunct to personal devotions, I strongly commend it. (W.N.W.)

## FAVOURITES, BUT . . .

**FAVOURITE HYMNS.** The Pendyrus Male Choir, conducted by Glynne Jones. Organist, Huw Tregelles Williams. Stereo, Word WST-9606. (From Word Records Aust, 18-26 Canterbury Rd, Heathmont, Vic 3135.)

Looking at the list of hymns, the jacket notes by Christopher Idle, the male choir, the organ and the recording locale (the Brangwyn Hall, Swansea, UK) one could logically expect a performance by people who love the old hymns. And that it obviously is.

What took me by surprise was the extremely slow tempo of many of Glynne Jones' arrangements. And I mean slow. Even the leisurely congregations in the tiny country churches of my youth would easily have outpaced them!

But there the comparison must end because none of those congregations could sound even remotely like the Pendyrus Male Choir. Nor did their pathetic reed harmoniums ever sound remotely like the real organ that supports the choir here, without ever seeming to compete for attention.

# DICK SMITH



# NEW ZEALAND

PRO. SIZED COMPUTER YOU BUILD YOURSELF & SAVE

## The DICK SMITH SUPER 80

A professional sized computer you build yourself - you are supplied with everything including power-on EPROM monitor, 16K of RAM, cassette interface (relay activated), power supply including transformer, TV modulator and direct video output PLUS full size professional keyboard - not a 'feel less' toy!

- RAM expansion up to 48 K on board
- S-100 expansion on board
- Room for further development on board
- Keyboard mounted on board - or fully detachable

OVER 2000 SOLD! Cat K-3600

AMAZING VALUE **\$445<sup>00</sup>** NZ

### SUPER 80 ACCESSORIES

BASIC Interpreter (tape) (K-3602)	NOW
WAS \$29.90	SAVE ALMOST 50% ... <b>\$14<sup>50</sup></b>
Basic in EPROM (K-3604)	
WAS \$120	SAVE \$40 NOW ... <b>\$79<sup>50</sup></b>
IC Socket Set (K-3603)	<b>\$18<sup>50</sup></b>
Lower Case Generator Option (K-3607)	<b>\$79<sup>50</sup></b>
S-100 Expansion Unit (K-3606)	<b>\$29<sup>75</sup></b>
Metal Case (H-3200)	<b>\$59<sup>50</sup></b>
Debug/Disassembler for Super 80 (X-3790)	<b>\$49<sup>95</sup></b>
Editor-Assembler for Super 80 (X-3791)	<b>\$49<sup>95</sup></b>

## SUPER 80 MANUALS

**NEW**  
NEW SUPER 80 PROGRAMS  
16 programs written especially for the Super 80 by enthusiasts like yourself. (B-3606) **\$7<sup>90</sup>** NZ

**SUPER 80 TECHNICAL**  
All the information of the 'works' available for all Super 80 builders. (B-3600) **\$13<sup>95</sup>** NZ

**SUPER 80 BASIC**  
Easy to understand - fully explains BASIC used in Super 80 - you can actually write your own programs! (B-3602) **\$13<sup>95</sup>** NZ



## LOOK AT THESE FEATURES

A home computer that goes far beyond anything you've seen before. The design is absolutely the very latest in technology. With a huge 12K BASIC interpreter - as much (or more than) most other microcomputers around!

## LOOK AT THESE FEATURES

- Outstanding picture quality: Resolution (49,128 pixels) is far greater than most other machines.
- Connects to your standard TV set (colour or b/w) - no need to buy an expensive monitor. You just plug it in!
- Sound effects with 4 different sound outlets.
- Hand controllers with 24 separate keys (as well as the NASA-type joystick controller). Splash-proof keyboard with slide-in overlays.

Who could ask for more? Collect your free brochure and be amazed!

**BE QUICK - FIRST SHIPMENT SELLING FAST!**

**4ch DIGITAL PROPORTIONAL REMOTE CONTROL**  
HERE AT LAST - life for your model boats, tanks, cars, planes - everything that will take a radio control!  
Beware of inferior units which are not true digital proportional. **\$279** NZ Cat Y-1240



## A WATCH IN A PEN

A superbly styled ball-point pen complete with an LCD digital clock right inside the pen - shows day, date & seconds also.  
Takes standard Parker refills. **\$19<sup>50</sup>** NZ Cat Y-1030

**NIBBLING TOOL** **\$15<sup>95</sup>**  
Can cut any shape in sheet steel up to 0.6 mm thick or light alloy to 1.5 mm. Great for plastics too!  
Cat T-1040



## MINI PCB DRILL

Small in size but powerful! Completely self contained and runs off 2 C cells. Easy to use. No trailing wires to annoy you.  
**AMAZING VALUE \$29<sup>95</sup>** NZ Cat T-4750

**LOGIC PROBE**  
A must for hobbyists, technicians, engineers etc. Tells at a glance what the logic level is by which of the three LEDs are glowing. 5V DC operated. **\$35<sup>00</sup>** NZ Cat D-1272

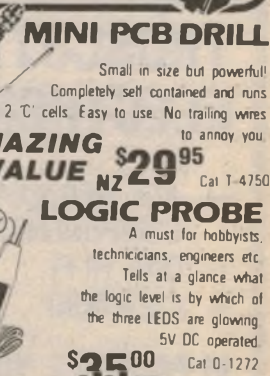

# DICK SMITH Electronics

98 Carlton Gore Rd.  
Newmarket,  
Auckland 1.  
Ph: 504 409

POST & PACKAGE CHARGES

ORDER VALUE CHARGES	
\$5 - \$9.99	\$1.00
\$10 - \$24.99	\$2.00
\$25 - \$49.99	\$3.00
\$50 - \$99.99	\$4.00
\$100 or more	\$5.00

Mail Orders: Private Bag, NEWMARKET



Shop by phone  
Use your Bankcard  
Or Visa card

Tempi aside, Glynn Jones also seeks a vivid contrast between the soft and loud passages and in so doing, I suspect, has pushed the recording system to its limits. Whatever the cause, that "papery" edge, which is sometimes heard in massed voice choirs, is a mite too evident, prompting the urge to cut back on the treble response.

The hymns are traditional, with traditional tunes: Praise My Soul, The King of Heaven — The Lord's My Shepherd — Now Thank We All Our God — Glorious Things Of Thee Are Spoken — Abide With Me — Holy, Holy, Holy — Jesus Shall Reign — When I Survey The Wondrous Cross — Onward Christian Soldiers — Mine Eyes Have Seen The Glory.

The album would obviously have the potential to please and delight some, but not everybody, for the reasons mentioned. (W.N.W.)

☆ ☆ ☆

**JAMAICA, With Lena Horne & Ricardo Montalban. RCA Victor LOC 1036 Original Cast Album.**

Twenty-five years ago, Harold Arlen's music hit the Broadway stage in a Caribbean extravaganza about a Jamaican girl who yearns for the bright lights of New York.

There are 18 titles from the show on the record, including: Savannah's Wedding — Push The Button — Little Biscuit — Pity The Sunset — Monkey In The Mango Tree — Napoleon — I Don't Think I'll End It All Today.

The record quality tends to show the vintage of the original and there is very little evidence of a stereo image, but Lena Horne's vocal skill makes the record worthwhile for the fans of the big stage musical. (N.J.M.)

**Festive Season**

**CHRISTMAS IN AUSTRALIA: Rose Marie. Stereo, Kyr Music Kyr 010. [From Kyr Music, P.O. Box 115, Killara, NSW 2071. Phone (02) 498 3929 or 406 5111]**

Sydney based singer, Rose Marie Longe, seems to get better every time I hear her perform, whether it be live, or on TV or on record. This album of Christmas songs and favourite carols is no exception.

Due for release through BP service stations and selected Christian bookshops, the record (or companion cassette) has a selection of old carols, arranged as two medleys: Away In A Manger — Silent Night — O Little Town of Bethlehem — O Come All Ye Faithful — Hark The Herald Angels Sing — Joy To The World — It Came Upon The Midnight Clear — The First Noel.



Rose Marie Longe

The remaining songs are mainly of more recent origin: Come On, Ring Those Bells — Christmas, Most Wonderful Time Of The Year — Have You Ever Wondered — Mary's Boy Child — Silver Bells — The World The Way I Want It — A Thousand Candles.

Rose Marie has excellent support from the backing musicians: Doug Gallagher on drums, Greg Lyon on bass, Jim Kelly and David Coulton on guitars, Ian Bloxoms on percussion, Tony Ansell on keyboards, and strings led by John Lyle.

The overall sound quality is excellent. (N.J.M.)

**SWINGLE SKYLINER: The Swingle Singers. Stereo, World Record Club R-10405.**

It's probably a matter of listening habits but most of my encounters with the Swingle Singers have been by courtesy of the ABC and involving items with a classical or novelty inspiration.

This record, originally released by EMI-Columbia in 1979, is inspired by tunes and arrangements of the big-band era. It involves the use of keyboards, bass guitar, guitar and drums but much of the orchestral arrangement is simulated by the skilful use of voices: two sopranos, two altos, two tenors and two basses.

The track titles are: Skyliner — Sunny

Side Of The Street — Mood Indigo — Chattanooga Choo Choo — Back Bay Shuffle — Opus No. 1 — L'il Darlin' — Fascinating Rhythm — Serenade in Blue — Us.

The mix of titles and arrangements is such as to provide variety but, despite this and despite the rare talents of the Swingle Singers, the record didn't exactly grab me. I couldn't help but feel that, for most people, the Swingle sound is novel and interesting a couple of tracks at a time, but not straight through a whole album.

Technically, the quality is excellent but, if you want to really hear how they put the sound together, listen to it through stereo headphones. (W.N.W.)

**TRUSCOTT ELECTRONICS**

- ALL SEMICONDUCTOR COMPONENTS
- CAR HI-FI
- CB RADIO

**IN FACT ALL YOUR ELECTRONIC NEEDS**

**SUPPLYING THE EASTERN SUBURBS WITH COMPETITIVE CITY PRICES AND SERVICE**

**TRUSCOTT ELECTRONICS**  
Cnr Eastfield and Bayswater Roads,  
South Croydon 3136, Vic.  
Phone (03) 723 3860.

# LOOPY VIDEO

MAIL ORDER DEPARTMENT: PO Box 254, Heidelberg, 3084.  
Phone: (03) 435 3004

## NEW PRICES:

### OHIO SOFTWARE & HARDWARE

#### OHIO SOFTWARE:

K1 Hardware Catalogue (incl new boards) \$1 98  
K2 Software Catalogue (over 200 pieces) \$2 98

#### OHIO HARDWARE:

C4P Video board (converts C1P Series 7) \$148.00

#### COLOUR BOARD — C1P — Series 2

H13 Short Kit, including documentation and tracks for 5v to 12v DC (only) \$39.00

H13 Assembled and Tested includes 5v to 12v tracks \$89.00

#### OPTIONS:

SOUND — Parts Kit \$2.50  
incl assembled and tested \$18.00

VIDEO — Parts Kit \$2.50  
incl assembled and tested \$15.00

5v to 12v DC — No kit available (Specialised) — incl assembled and tested \$24.00

#### COMBINATIONS:

Sound and 12v assembled and tested \$36.00

Video and 12v assembled and tested \$35.00

All 3 mods (H13B) assembled and tested \$45.00

"H13B — Deluxe" — All mods assembled and tested (\$89 and \$45) \$129.00

Note: All prices include sales tax.

#### COMPUTER EARS — SPEECH PROCESSOR

for PET, OHIO, UK101, TANDY, APPLE, NASCOM — Specify \$49.00

Write for **SALE** Price List — FREE.

# LIKE TO GET AN AMATEUR RADIO CERTIFICATE? IT'S MUCH EASIER WITH PROFESSIONAL HELP.



If something's worth doing, it's worth doing well. So don't waste your valuable spare time finding your own way through the Amateur Radio maze. Ask Stott's instead. We have top professional instructors, who'll make sure your time is well spent on your way to an operator's certificate. You'll have individual attention, working at your own speed, in the comfort of your own home. Any queries will be answered personally, and promptly.

So don't delay. Mail the coupon for full details.  
Over and out.

## Super 80 Users

WE ARE NOW OFFERING THE MOST COMPETITIVELY PRICED RANGE OF PROGRAMMES ON TAPE INCLUDING:

- Games
- Utilities
- Education
- Special user required support

FOR FULL INFORMATION CONTACT

# Bemak

PTY LTD  
PO BOX 218  
BELCONNEN ACT 2616  
Phone 586862 or 511558

## Stotts

TECHNICAL CORRESPONDENCE COLLEGE

The name to trust in correspondence education.

Please send me free, and without obligation, full details of the following courses:

\_\_\_\_\_  
(PLEASE PRINT)

MR MRS MISS \_\_\_\_\_ AGE \_\_\_\_\_

ADDRESS \_\_\_\_\_

POSTCODE \_\_\_\_\_

Stott's undertake that no sales counsellor will visit you.

Melbourne, 159 Flinders Lane 3000 Tel 63 6212  
Sydney, 383 George Street 2000 Tel 29 2445  
Brisbane, Suite 3 65 Mary Street 4000 Tel 221 3972  
Adelaide, 85 Pirie Street 5000 Tel 223 3700  
W Perth, 25 Richardson Street 6005 Tel 322 5481  
Hobart, 1st Fl 29 Argyle Street 7000 Tel 34 2399

The Stott's range of courses in Amateur Radio is:

- Novice Amateur Operator's Certificate of Proficiency.
- Amateur Operator's Certificate of Proficiency.
- Amateur Operator's Limited Certificate of Proficiency.
- Radio for Amateurs.

ALA/ST3595/EA1282

# AKG

ACOUSTICS



## Stage Quality - Studio Sound

The new D 300 mics for vocalists

AKG provide studio sound live on stage. The D 300 series—consisting of three microphones—offer the maximum sound quality. These microphones are designed especially for musicians, mainly for vocalists

**D 310 - D 320 B - D 330 BT**

- Extremely robust
  - Shock-mounted microphone cartridge
  - Excellent suppression of handling noise
  - Integral windscreen (total elimination of pop and breath sounds)
  - Uni-directional polar pattern to minimise acoustic feedback and ambient noises
  - Unequalled reproduction of both voice and music
  - Extra protection provided against all kinds of mechanical shock
  - Individual sound shaping by use of three-position contour switches (D 320 B, D 330 BT)
  - Abuse proof
- These microphones are designed for professional use. They'll be your best partner on stage.

## AKG AMALGAMATED WIRELESS (AUSTRALASIA) LIMITED

Incorporated in New South Wales

554 Parramatta Road, Ashtfield, NSW 2131 Phone 797 5757

Brisbane 44 1631	Canberra 80 5200	Adelaide 272 2366	Melbourne 560 4533	Perth 271 0888	Launceston 44 5155	Townsville 79 6155
---------------------	---------------------	----------------------	-----------------------	-------------------	-----------------------	-----------------------



AKG Akustische u. Kino-Geräte Ges. m. b. H. Brunhildengasse 1, A-1150 Wien, Austria.

Send this coupon for information about

AKG products

- HEADPHONES
- MICROPHONES
- PICK UPS
- REVERB UNITS
- TIME DELAY UNITS

Name \_\_\_\_\_

Street \_\_\_\_\_

Town \_\_\_\_\_

Postcode \_\_\_\_\_

adv 274/2/GB

## RADIO DESPATCH SERVICE

869 George St., Sydney,  
NSW 2000 (Near Harris Street)  
Phone 211 0816 • 211 0191

Open: Mon-Fri 8am to 5.30pm  
Thursday night late shopping  
till 8.30pm Sat 8am to 11.45am

# DUAL TRACE OSCILLOSCOPE 20MHz Model BS-601

# ARON

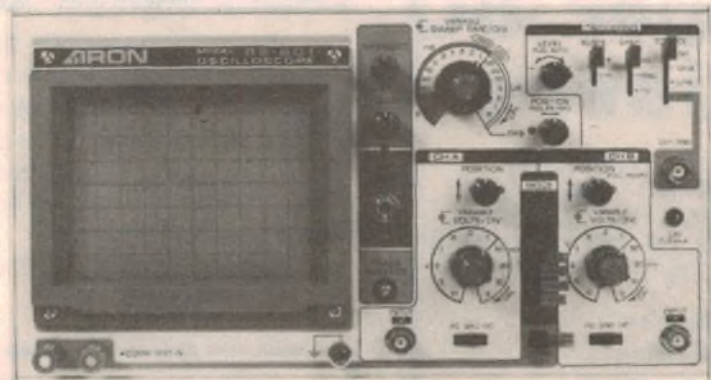

Was \$550.00 + sales tax

Now only  
**\$485.00**

+ sales tax =  
**\$582.00**  
tax paid



MAIL ORDERS TO: RADIO DESPATCH SERVICE

869 George St., Sydney 2000

Phones: (02) 211 0191 • 211 0816



# Microcomputer News



## M6801 controller board from Paris Radio

Paris Radio Electronics now has available an "applications prototype board" for the Motorola MC6801, 6803 and 68701 microprocessors.

The 157 x 100mm board provides 2K of RAM (expandable to 4K), space for a 2K EPROM, three 8-bit parallel I/O ports, an RS-232 serial port and a counter/timer. Depending on which processor is used an additional 2K of EPROM, 128 bytes of RAM and a second counter/timer are also available. Almost half of the board consists of a wire-wrap prototyping area.

The MC6801 is an enhanced MC6800 processor with 2K of internal mask-programmed ROM, 128 bytes of RAM, a 16-bit timer and a serial I/O section. The MC6801L1 is similar except that the internal ROM is programmed with a debug monitor called "LILbug". The 6803, without the internal ROM, can also be used with the board, with software contained in an external EPROM. The MC68701 is the same processor as the 6801, but the on-chip ROM is electrically programmable and can be erased by UV light.

The wirewrap area provided on the board allows the user to connect other peripheral devices to the microprocessor system. Data and ad-

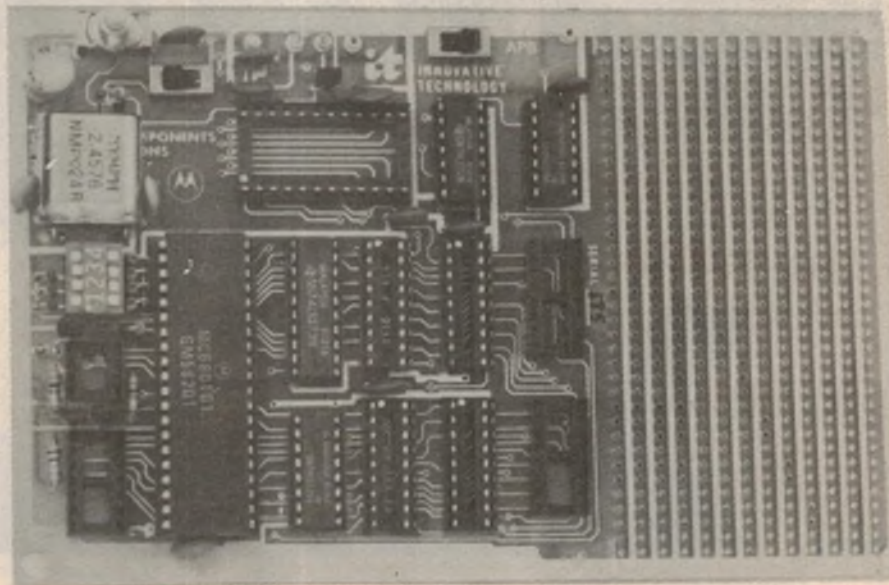

dress lines are available on two DIP sockets adjacent to the wirewrap area. The board can also be used with a serial terminal as a software development system.

Paris Radio Electronics are supplying the 6801 version of the board together with a listing of LILbug and extensive

documentation from Motorola. Cost is \$129.00.

For further information contact Paris Radio Electronics, Shop ., 165 Bunnerong Rd, Kingsford, NSW, 2032. The postal address is PO Box 380, Darlinghurst, NSW, 2010. Phone (02) 344 9111.

## Programmable characters for the ZX81

Vendale Pty Ltd has introduced a programmable character generator for the ZX80 and ZX81 microcomputers. The add-on unit allows users to define their own characters, creating graphics for games, graphs and other patterns.

Programmed characters are defined on an 8 x 8 matrix of dots using Basic commands. The Vendale programmable graphics character unit has its own on-board RAM and does not interfere with memory expansion units.

The character generator is constructed on a 6 x 8cm printed circuit board with a 24-pin DIP header which plugs into the ROM socket inside the computer. The Sinclair 8K ROM is then plugged into the add-on board. There is one other internal connection to the computer board to be made.

Price of the add-on board is \$95, including postage and packing.

Also available from Vendale is a video upgrade kit which allows Z80s fitted with the 8K ROM to run at two speeds - Slow and Fast. The upgrade board allows the ZX80 to compute and display information on the screen at the same time, as does the ZX81, and also allows animated displays without screen flicker.

The video unit is priced at \$38.50 including post and packing, or Vendale will install it in the customer's machine for an additional \$15.

For further information contact Vendale Pty Ltd, PO Box 456, Glen Waverley, Victoria, 3150.

## Competition for Sinclair

A new microcomputer competing directly with Clive Sinclair's ZX81 and colour micro has been launched in Britain.

Oric Products International Ltd will manufacture the machine, the "Oric 1".

## New look Osborne 1 portable computer

The Osborne 1 portable computer has been a great success with users, except for the appearance of the machine. It has been compared with the instrument panel of a DC-3, or "something removed from a tank after the Sinai battles".

The rugged, military look, it seems, has not been a great success, but a new Osborne 1 is on the way to dealers in Australia. Price and technical features are unchanged, but the front panel has been redesigned.

Managing Director of Osborne Computer Corporation in Australia, Richard Graham, says "The new look of the Osborne 1 has been extremely well received. . . It is likely that while the old look machine is being run out from the dealers there will be a few bargains around as dealers clear stocks of the older style cabinet".

## Listen. You need a 'Sendata' 700 Series Acoustic Coupler!

An easy solution to the complex problem of information gathering in the '80s...and there's one to suit your needs in bridging your communications gap.

# SENDATA



Manufactured by  
**ELECTRO-MED**  
Electro-Medical Engineering Pty. Ltd.  
Melbourne, Australia.  
(03) 509 5844 (02) 439 5488

## Choose **ROYEL** for high reliability soldering and desoldering.

*Sensitive components are easily damaged by uncontrolled soldering tip temperatures and electrical spikes. Royel soldering tools are helping to solve these problems, world wide.*

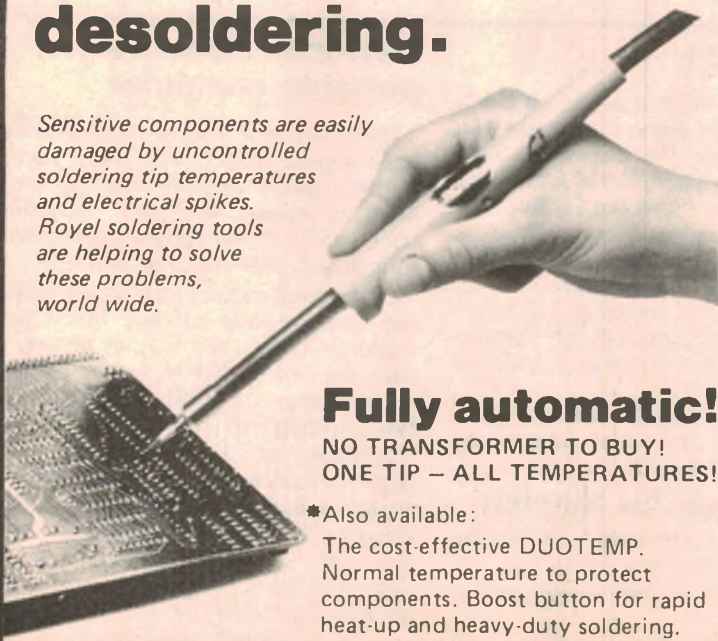

### Fully automatic!

**NO TRANSFORMER TO BUY!  
ONE TIP - ALL TEMPERATURES!**

\*Also available:

The cost-effective DUOTEMP. Normal temperature to protect components. Boost button for rapid heat-up and heavy-duty soldering.

### MAINS VOLTAGE **THERMATIC**

Slim. Lightweight. High power. 60 second heat up. Fully electronic AUTOMATIC feedback temperature control. In-handle temperature selector. For micro-miniature, medium and heavy duty soldering.

CHOICE OF 3 MODELS WITH TIP DIAMETERS OF 3, 5 OR 6.5 mm. EACH IN 6 PROFILES x 6 SIZES.

**BUY FROM YOUR ELECTRONIC PARTS SUPPLIER.**

# ROYEL

**Royston Electronics**

N.S.W. (02) 709 5293 QLD. (07) 277 4311  
VIC. (03) 543 5122 S.A. (08) 42 6655  
TAS. (002) 34 2233 W.A. (09) 381 5500

T 182 / A

## Microcomputer News

### New Sorcerer disk controller board

A new floppy disk controller designed specifically for the Exidy Sorcerer computer is now being manufactured by Digitrio of Melbourne. The controller plugs directly into the Sorcerer's expansion port, so no S-100 expansion unit is required.

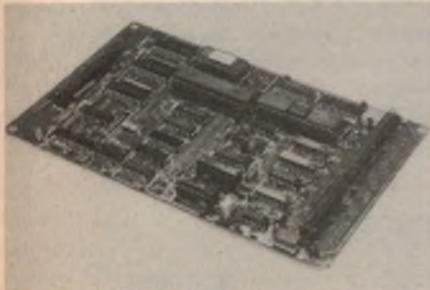

The controller can handle 14cm or 20cm disk drives in any combination. The 14cm disk drives may be 35, 40, 77 or 80 track units, either single or double density, single or double-sided. The type of disk in use is automatically determined by the controller and appropriate software routines called.

CP/M 2.2 is supplied with the controller, including all the standard Digital Research utilities and others written by Digitrio. Retail price of the unit is \$500, including CP/M and documentation. In addition to the controller, Digitrio can also supply complete disk drive systems. Dealer enquiries are invited.

For more information contact Digitrio, PO Box 4553, Melbourne, 3001. Phone (03) 578 4094.

### TRS-80 upgrades by DeForest Computers

DeForest Computers has announced a range of upgrades for the TRS-80 Model III which provide increased RAM, enhanced display capabilities, faster operation and access to CP/M software. There are three stages to the upgrade, called "Compactor" I, II and IV.

The Compactor I supports both TRSDOS and CP/M 2.2. A memory module plugs into the Z-80 socket of the TRS-80 Model III, and once it has been installed the user can insert either a TRSDOS disk or a CP/M disk. The Compactor I automatically determines which type of disk is inserted and boots up the appropriate operating system.

A further upgrade, the Compactor II, replaces the CPU of the Model III with a 4MHz Z80A processor and adds an additional 64K of RAM which can be addressed without bank switching. By using bank switching in 16K

banks, up to 112K of RAM can be added. The two CPU clock rates, either 2MHz for the standard Model III or 4MHz for the upgrade, can be selected under software control.

Compactor IV provides an enhanced 80 x 24 line video display capability and a serial interface. It is installed inside the cabinet of the Model III and allows either TRSDOS or CP/M to be used. A software controlled video switch allows the video signal from either the Model III or the Compactor IV to be sent to the display.

Both the Compactor I and IV systems add a resident Diagnostic/Debug monitor, auto-repeat on keys, support for audible output and automatic detection of disk types in use.

Additional information is available from DeForest Computers, 26 Station St, Nunawading, Vic. Phone (03) 877 6946.

### S-100 expander board for the Super-80



EL Graphix now has available an S-100 adapter board for the Super-80 computer. The small board plugs into the S-100 connector of the Super-80 and provides two standard 50-way edge connectors for the attachment of cables to an S-100 motherboard supplied by the user.

Solder pads are also provided for every signal connection for use in bread-

boarding and troubleshooting. Although designed for the Super-80, the adapter board can be used with any S-100 system.

Price of the board is \$8.50 plus \$1.00 post and packing per board. For further information contact EL Graphix, PO Box 278, Croydon, Vic 3136. Phone (03) 725 9842. Send a large, stamped, self-addressed envelope for details of other EL Graphix products.

### Microprocessor seminar

The Queensland Institute of Technology will be running an advanced microcomputer workshop in April, 1983, and is calling for papers to be presented.

The workshop will cover programming

# BILCO ELECTRONICS

SHOP 2, 31 PULTNEY ST, DANDENONG 3175

PHONE: (03) 791 8655

## INDUSTRIAL RADIO REMOTE CONTROL

BASIC UNITS OR CUSTOM MADE FROM \$90 + TAX

## Microcomputer News

and applications of the 6502 and 6809 microprocessors, and papers are required in the following areas; techniques for structured program design, development of operating systems, comparisons of high level languages for real-time operation, use of microprocessor development systems, techniques for hardware debugging, DMA techniques, multi-processor systems and practical applications and demonstrations of 6502 and 6809 systems.

All enquiries should be made to Dr C. J. Chesmond, Department of Electrical Engineering, Queensland Institute of Technology, GPO Box 2434, Brisbane, Qld, 4001. Phone (07) 223 2484.

## News from the clubs

● The Western Australian ZX Users Group commenced operations in September. For further information ring Phil Taylor (09) 328 4111 in business hours or (09) 328 8111 after hours.

● The Microcomputer Society will meet on December 10 at the Old Town Hall, corner of Vulture and Graham Streets, South Brisbane. Meetings commence at 7.30pm. For more information contact the secretary, PO Box 580, Fortitude Valley, Qld, 4006.

● The Adelaide Micro User Group publishes an excellent newsletter with advice and programming tips for users of the TRS-80, System-80 and other Z80 based systems. For more information contact the group at 36 Sturt St, Adelaide, 5000.

● The AT Microcomputer Club has

changed its name to the Microbee Users Group (uBUG) to reflect the growing number of users of this computer joining the club. The group meets on every second Wednesday of each month at Burwood Teachers College Building E. For further information ring Grant Forest, (03) 879 2257 or write to 10 Sunbeam Avenue, Ringwood East, 3135.

● The South Australian Microprocessor Group will meet at the Thebarton High School, Thebarton on December 10. Postal address of the group is PO Box 113, Plympton, SA, 5038.

● The Club for Peach Users (CPU) Perth meets "whenever there is enough to discuss about the Peach and other 6809 systems". Contact Brendon Butcher on (09) 367 5880 or write to the Secretary, 1 Charf Court, Riverton, WA, 6155. ☺

## Australian Beginning competition winners

Our "Australian Beginning" contest (May 1982) attracted a fair degree of interest, resulting in many useful suggestions for new "Australian Beginning" services and data bases. The 50 entrants who sent the best suggestions have won for themselves a free subscription to the "Australian Beginning".

Their names are listed below.

David Giddy,  
Hawthorn, Vic.  
R. R. Reber,  
Werribee, Vic.  
Peter Jennen,  
Dampier, WA.  
Gary Osborn,  
Blackburn South, Vic.  
Michael Mercuri,  
Forest Hill, Vic.  
James Barrett,  
French's Forest, NSW.  
Col Stewart,  
Broken Hill, NSW.  
A. Cameron,  
Vaucluse, NSW.

Robert Googe,  
Ipswich, Qld.  
Gregory See-Kee,  
Kensington, NSW.  
Paul Brodie,  
Graceville, Qld.  
C. Haynes,  
Faulconbridge, NSW.  
I. H. Agust,  
Everard Park, SA.  
Alex Reisner,  
North Ryde, NSW.  
Rodney Neilson,  
Mooroolbark, Vic.  
Sean Davidson,  
Mitcham, Vic.

W. J. Hughes,  
Gladstone, Qld.  
Bruce Carroll,  
Orange, NSW.  
R. K. Sommerville,  
Woodburn, NSW.  
J. W. Park,  
St Kilda, Vic.  
Peter Bennett,  
Buronga, NSW.  
Paul Wilkins,  
Peel, NSW.  
Warren Lee,  
Middle Brighton, Vic.  
Michael East,  
Goolmangar, NSW.

Alistair Fyfe,  
West Hobart, Tas.  
F. Tanner,  
South Hedland, WA.  
R. J. Maclean,  
Formartin, Qld.  
Colin Jenkins,  
Croydon, Vic.  
John Fawcett,  
Burnie, Tas.  
Mal Woods,  
Box Hill South, Vic.  
Mark Lipman,  
Burwood, NSW.  
Phil Dimond,  
North Lidcombe, NSW.  
Michael Saleeba,  
Croydon, Vic.  
Roy Stockman,  
Yarralumla, ACT.  
O. F. Kloester,  
Jabiru, NT.  
Mark Thompson,  
Rydalmere, NSW.  
Alan Hawkes,  
North Nowra, NSW.

B. J. Links,  
Howrah, Tas.  
Ian Davidson,  
Mitcham, Vic.  
Carmel Davidson,  
Mitcham, Vic.  
Wayne Irvine,  
Allambie, NSW.  
Mark Irwin,  
Condell Park, NSW.  
Paul Massa,  
Federal, NSW.  
Neil Brett,  
Red Hill, ACT.  
Clyde Swift,  
Fulham, WA.  
Mathew Swift,  
Fulham, WA.  
Andrew Lindner,  
Kingston Beach, Tas.  
David Maher,  
Kilor, Vic.  
Keith Halket,  
Traralgon, Vic.  
James McFarlane,  
Lesmurdie, WA.

## VIC 20s ★ ACCESSORIES ★ SOFTWARE ★ PERIPHERALS

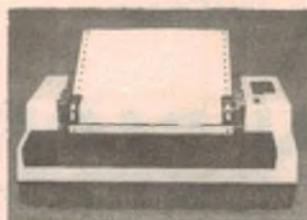

**Vic 20 \$399! Arfon module \$250! Printer \$479! Disk drive \$699! Cartridges from \$39.95!**

*We have a wide range of accessories, peripherals, and software for the Vic — including Commodore, Vicsoft, Acme, etc.*

**EDIBLE ELECTRONICS** 50 PARK ST, ABBOTSFORD 3067. (03) 41 5708





**LOWER GROUND FLOOR— MYER SYDNEY STORE**  
**436 GEORGE ST, SYDNEY**  
**PHONE 238 9984, 231 5791**

**MYER**

Computerwave at Myer Sydney store have limited stock of T199/4A personal home computer.

Computerwave have the largest stock of T199/4A software and hardware in Australia.

Computerwave were first with the T199/4A and know the T199/4A.

At Computerwave you can compare and get expert advice on home computers from our staff of experienced users and owners.

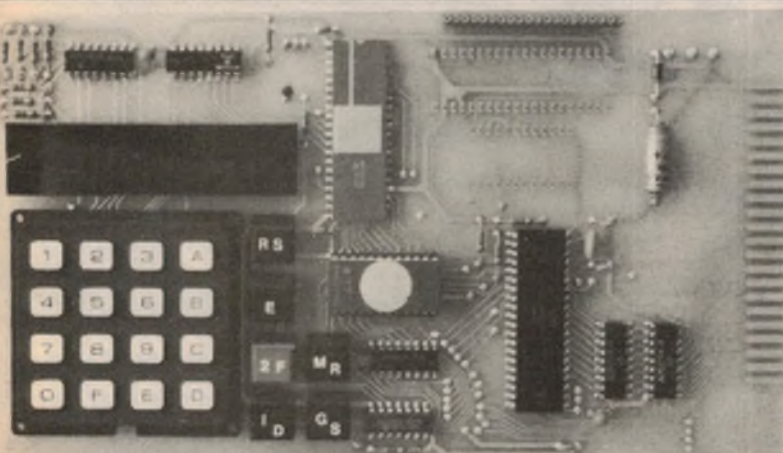
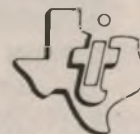

from  
**GAMMATRON**  
**“DATUM”**

*the true starting point*

**COMPUTER KIT**

for \$99.00 (inc S.T.)  
 Postage and handling \$3.00  
 when assembled kit.

**READY TO USE**

Developed by the S.A. Institute of Technology as a teaching aid for those who wish to learn about microprocessors at minimal cost. The kit uses a MC6802 microprocessor which is complete and ready to assemble with full instructions. Power source is either a reg. 5V Supply or 6V lantern battery provided by the user.

**Kit includes P.C. board, all IC's and components, pre-programmed 2716 ROM, key pad.**

*Send SAE for further information or  
 send money order, cheque, Bankcard and we will post haste a kit.*

*Available only from*

**GAMMATRON**

**ELECTRONIC SYSTEMS MANUFACTURERS**  
 UNIT 1, WEEN RD, POORAKA, SA 5095  
 PHONE: (08) 262 6555

*For Bankcard users:*

Bankcard No. ....  
 Expiry date. ....  
 Name. .... Signature .....

# THE DICK SMITH SYSTEM 80 GROWS WITH



**16K RAM  
expandable to 48K,  
CPU is the powerful  
Z80 microprocessor -  
that's the System 80...**

Looking for a computer that's suitable for the beginner... but ideal for the expert? You want the new Dick Smith System 80 Blue Label! If you know absolutely nothing about computers, the System 80 is the ideal way to learn. If you know a little about computers, it's a great way to improve your knowledge. And if you know a lot about computers, you'll find the System 80 will go as far as you want it to - and further. The System 80 is expandable (with the optional S-100 expansion unit - see opposite page) to accommodate a huge range of options and accessories. You could even run a small business if you wished! Have a look at the superb new Blue Label System 80 soon. Anything else could be wasting your money!

## Check these features:

- Flashing Cursor.
- Built-in speaker and Amplifier for programs with sound effects.
- Full upper and lower case video display capability.
- Screen print facility (obtain a printout of any 'page' appearing on the screen).
- Monitor program (suitable for the hobbyist to program in machine language).
- Access to enormous amounts of software that has been written for the TRS-80.
- Three month guarantee from date of purchase.
- Great expansion capability and flexibility.

Cat X-4005

Printer Interface and/or Expansion Unit Edge Connector. You can either connect your Printer here or another possible 32K bytes of RAM with the S-100 Expansion Unit (X-4020). The Expansion Unit has three connectors - the computer, the disk drive/s and the printer. Also an RS232 connector for High-speed serial printers, is available as an option.

Modulated RF output so you can use a normal TV set as the video display (you can also use a video monitor).

Connection for second cassette.

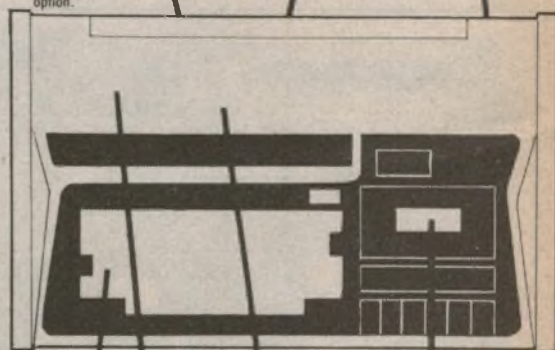

With System 80 there is no separate tape recorder to buy - it's inbuilt! Also there is provision for a second external recorder and the console has a level meter.

Powerful 12K Microsoft BASIC plus 16K of user memory (RAM), necessary for most serious programming and for using the huge range of software.

State-of-the-art microprocessor. At the heart of the System 80 is the modern Z80 chip, the industry standard because of its speed and powerful instruction set.

Full 52 key high tactile response keyboard. On System 80 you get a full typewriter-style keyboard with 52 normal keys and two additional function keys.

WAS  
\$750<sup>00</sup>

ONLY  
\$699

\$16.24 per week  
(to approved applicants)



# YOU!

"the best value around  
for a ready built Computer"  
- quotation from Electronics  
Australia, June 1982.

**OVER  
10,000  
SOLD**

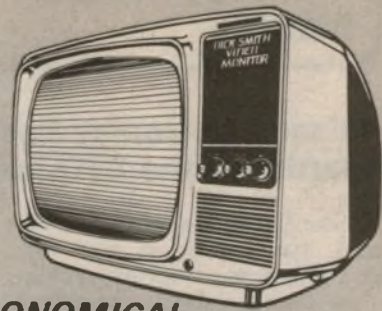

**ECONOMICAL  
MONITOR** **\$149<sup>50</sup>**

A video monitor gives a sharper clearer image - this black & white monitor is really economical and can be used with most computers on the market.  
Cat X-1196

**Why pay more?**

**& LOOK AT  
THIS TOP  
VALUE  
HI RES  
GREEN  
SCREEN  
MONITOR**

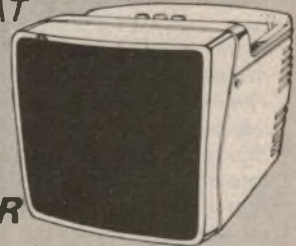

Anti-glare screen with its jitter and ghost free image makes viewing much easier and sharper (80 characters with 24 lines). A MUST for the serious computer hobbyist or professional.  
Cat X-1200

**ONLY**

**\$349**

**DIRECT COUPLED & 1/2 PRICE  
DATA PHONE MODEM**

A truly high performance direct coupled modem. Authorised by Telecom - and costs less than half the comparable acoustic modem! Simple plug-in connections, full duplex operation for speed & convenience. Ask for a brochure at your nearest Dick Smith Store!  
Cat X-3272



**ONLY**

**\$199**

**NEW AMATEUR  
RADIO LOG**

Disk based program enables you to store the necessary information for up to 500 calls on a single disk, save it, retrieve and display it by call or sequence no. A must for the amateur radio operator!  
Cat X-3774

**\$39<sup>50</sup>**

**NEW & INTERESTING  
SOFTWARE**

Starfighter (Cat X-3674)	\$36.50
Air Traffic Controller (Cat X-3681)	\$12.50
Asylum (Cat X-3687)	\$19.50
The Institute (Cat X-3661)	\$27.50
Z-80 Disassembler (Cat X-3690)	\$24.50
Penetrator (Cat X-3673)	\$34.50
Newdos 80 Vs 2.0 (Cat. X-3669)	\$225.00
Microsoft Fortran (Cat X-3669)	\$199.00
MMS Forth (Cat X-3668)	\$199.00

Unleash the full potential of your System 80 with this



**Expansion Unit**

To get the most from your computer, you need to be able to add on all sorts of peripherals; disk drives, printers etc. This unit gives interface ability and also a further 16K of memory with room for further 16K (giving a total of 48K).  
Cat X-4020

**FEATURES :**

- Optional S-100 interface with 2 vacant slots, provides further expansion.
- A floppy disk controller for controlling up to 4 disk drives giving up to 400K bytes.
- A Centronics-type parallel printer port.
- An optional RS-232C serial communications port for modems & acoustic couplers. May also drive a teleprinter.

**\$74 LESS  
THAN  
PREVIOUS  
MODEL!**

**Value  
Amazing**

**\$425**

**ON OUR  
TOP  
SELLING  
PRINTER  
Itoh DOT MATRIX**

We've sold more of these superb printers than any other type. Features high speed (up to 125 characters/sec) dot matrix type with bi-directional printing. Takes standard computer fan-form paper up to 240mm wide.  
Cat X-3255

**NOW \$699** **HURRY STOCK LIMITED**  
**WAS \$970**



**SUPERB  
LITTLE  
MATRIX  
PRINTER**

We've broken the \$400 barrier for a computer printer! A tractor-fed impact dot-matrix printer uses ordinary fan-fold sprocketed paper (up to 204mm wide). Great for high resolution graphics. At this price can you afford to miss out? Cat X-3252  
**STOCKS LIMITED**



**WAS \$495.00**  
**\$399**

**BRAND NEW DOT MATRIX  
PRINTER & WHAT A BEAUTY!**

Our very newest model - with built-in 2K buffer allowing storage of data to be printed - less down time on the computer. Numerous printing types. Superb (you've got to see to believe) high resolution graphics. You'll save hundreds of dollars on this printer! Accepts both standard stationery AND fan-form (tractor feed) paper.



**ONLY** Cat X-3260

**\$970**

**GIVE YOUR COMPUTER A VOICE!  
SEE THE VOTRAX TYPE-N-TALK  
ON PAGE 5**

Cat X-3290

**CHEAPEST PER BYTE!**

**DICK SMITH  
SYSTEM 80  
DISK DRIVE**

Fast reliable disk drive that not only gives your System 80 dramatically increased speed but also increases effective memory. Your computer can handle much more involved programs, and much faster! Drive includes inbuilt power supply.

Drive 0 - Cat X-4060  
Drive 1 - Cat X-4061



**ONLY**

**\$495**

**PRINTER CABLE**

This is a universal printer cable for connecting any standard centronics-type printer (eg. our X-3255 or X-3260 printers) to either the X-4020 expansion unit or X-4013 printer interface.



Cat X-3232 **\$57<sup>50</sup>**

**DAISY CHAIN  
DRIVE CABLE**



The 'daisy chain' cable allows you to connect up to 4 disk drives, quickly & easily.  
Cat X-4014 **\$42<sup>50</sup>**

**DICK SMITH  
ELECTRONICS**

**SEE PAGE 98 FOR ADDRESS DETAILS**



## Microcomputer News

### Pulsar Electronics has boards for the STD bus

Pulsar Electronics, of Pascoe Vale, Victoria, has introduced two new and powerful products for the STD bus.

The first release is the "Little Big Board" Series 6000 microcomputer, which packs a 4MHz Z80A processor, 64K of RAM, floppy disk controller, two RS232C serial ports, 2K of PROM, and a battery powered clock/calendar onto a board just 11.5cm by 20cm.

The board is provided with CP/M Version 2.2 with Pulsar's enhanced BIOS (Basic Input/Output System), bootstrap monitor in PROM, and a utility package. The BIOS provides automatic switching between single and double density disk drives, an enhanced double density disk format for larger disk capacity, an interrupt driven input buffer for keyboards etc, and support for the real clock/calendar feature.

Also from Pulsar Electronics is a new 256K byte RAM board with parity checking, designed, naturally enough, for use by Z80A processors on the STD bus. The board uses a 9-bit data format, with one bit allowing automatic generation and checking of parity, and includes a 16-bit error address register.

For further information contact Pulsar Electronics, 323 Bell Street, Pascoe Vale South, Vic 3044. Phone (03) 354 2125.

### Second-hand computers — see Micro Exchange

During the four or so years that present microcomputers have been available in Australia, many thousands have been sold so today there is a growing supply of used computer systems.

Buying a second-hand computer can save considerable amounts of money. Simple guidelines can be followed to avoid buying someone else's problems; establish that the equipment will suit your needs, talk with other users and, of course, see a demonstration of the working system. In other words the same care should be taken as when purchasing any other second-hand item.

A new service for buyers and sellers of second-hand computers is now being offered by the "Micro Exchange". Sellers can list their systems with the Exchange and prospective buyers can consult the listing and contact sellers directly.

For further information on the Micro Exchange contact Peter K. Smith, PO Box 62 Middle Brighton, Vic 3186.

### Multi-user computer system from SME

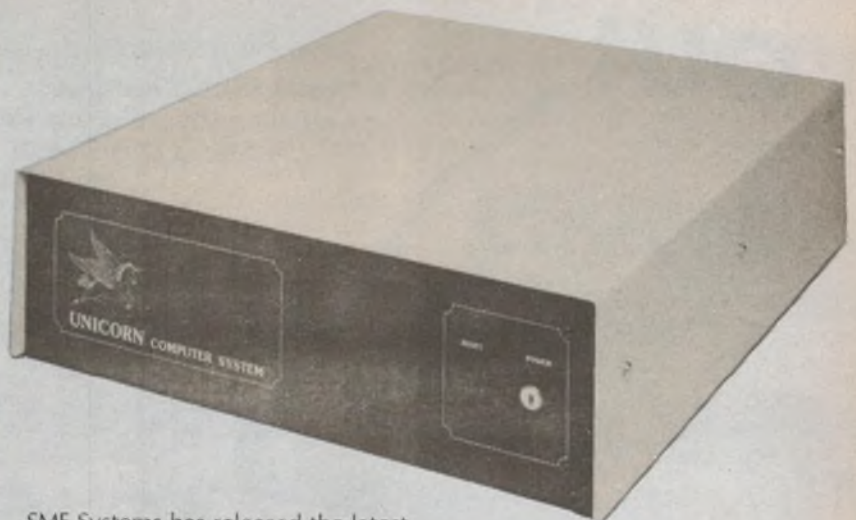

SME Systems has released the latest in its "Unicorn" microcomputer series, the low profile MPU-100 system, shown above.

Based on the Z80 processor, the S-100 system is entirely designed and assembled in Australia and is capable of multi-user operations with up to 15 terminals.

"The unit has been designed for use in commercial, industrial and engineering environments where speed and reliability are paramount," says SME Systems' Managing Director Mr Michael Pratt.

"The low profile cabinet is achieved by using a vertical motherboard with five S-100 slots per side. This allows rack mounting and minimises the likelihood of transmission line effects."

Basically the Unicorn MPU-100

provides an SBC 800 CPU board, a floppy disk controller capable of running up to four drives and a dynamic RAM board. Other boards can be added in the remaining seven slots.

Hard disk storage, colour graphics and 128K CMOS RAM boards are available from SME to expand the system for specific applications.

The MPU-100 can be rack mounted together with various combinations of disk drive modules. The rear panel makes provision for 12 25-way D connectors for additional terminals and four parallel connections. Two switched 240V outlets are provided for connection to other peripherals.

For further information contact SME Systems, 22 Queen St, Mitcham, Vic 3132. Phone (03) 874 3666.

### Sigma Data to market OKI if800 computer

Sigma Data Corporation of Sydney has established a new personal computer sales group to support the marketing of the OKI if800 computer system.

The OKI if800 is an integrated computer system, providing a 30cm colour monitor, dual 14cm floppy disk drives and an 80 character-per-second dot matrix printer built into the system keyboard console. The keyboard provides 98 keys including a numeric keypad and programmable functions. Single key commands control the built-in printer.

The if800 uses a Z80A microprocessor and comes fitted with 64K of RAM, expandable to 128K. A clock/calendar is standard, as is a cassette interface and a single RS-232C serial port. Three optional interface boards provide additional RS-232C ports, IEEE-488 interface, Centronics port and A/D and D/A con-

version for technical applications. A light pen is also available.

An audio output is standard, and a 20cm disk drive controller can be plugged into one of the three available expansion slots at the rear of the machine.

Two text display formats are available, either 80 or 40 characters a line, with 20 or 25 lines on the screen. Graphics resolution is 640 x 200 in eight colours, and according to Sigma Data some users of the if800 photograph the high resolution screen for direct production of illustrations and artwork.

The computer is supplied with OKI Basic, written by Microsoft, and a version of CP/M. Managing Director of Sigma Data, Michael Nathanson, says that there are already over 100 software packages available for the system, including WordStar, Supercalc, Spellstar, Mailmerge, Supersort and the FMS80 file manager.

For further information on the OKI if800 contact Sigma Data Corporation, 157 Walker St, North Sydney, NSW 2060, Phone (02) 436 3777.



# ELECTRONICS AUSTRALIA HANDBOOKS

## Fundamentals of SOLID STATE

An introduction to semiconductor theory and operation

JANUARY 1982



ELECTRONICS AUSTRALIA HANDBOOK

**FUNDAMENTALS OF SOLID STATE** provides a wealth of information on semiconductor theory and operation, delving much deeper than very elementary works, but without the maths and abstract theory which make many of the more specialised texts very heavy going. It's for anyone who wants to know just a little bit more about the operation of semiconductor devices.

## BASIC ELECTRONICS

Price \$3.50



**BASIC ELECTRONICS** is almost certainly the most widely used manual on electronic fundamentals in Australia. It is used by radio clubs, in secondary schools and colleges, and in WIA youth radio clubs. Begins with the electron, introduces and explains components and circuit concepts, and progresses through radio, audio techniques, servicing, test instruments, etc. If you've always wanted to become involved in electronics, but have been scared off by the mysteries involved, let Basic Electronics explain them to you.

Available from "Electronics Australia", 57 Regent St, Chippendale, NSW. **PRICE \$3.50 each** OR by mail order from "Electronics Australia", PO Box 163, Chippendale, 2008. **PRICE 4.40 each.**

## Software for the Super-80 Computer

\$5.00\*

An "Electronics Australia" publication

## EA Magazine Holders

The magazine holders are available over the counter from Electronics Australia, 57 Regent Street, Chippendale, NSW — Price: \$4.50.

Mail orders should be sent to Electronics Australia, PO Box 163, Chippendale, NSW 2008.

Prices including postage are:

\$5.50 NSW; \$5.60 other states; or six for \$29.00 NSW; \$31.50 other states. \$A33.00 NZ



# TOYO

## PRECISION EQUIPMENT FOR THE ELECTRONICS INDUSTRY

The TOYO mini drills and lathe offer a high level of accuracy comparable with larger machine tools.

The MINI LATHE (as illus) is fitted with a 240 volt motor, speed range from 250-3000 rpm. It has a swing of 100mm and is 250mm between centres. Weighs 15kg.

Basic Price \$435

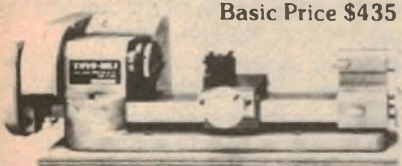

Accessories available  
\*Prices & Tax

The MINI DRILL comes in two models. MINI DRILL I, a standard speed drill offering 6 speeds from 850-3100 rpm, with a 6.5mm drilling capacity. Weight 5.4kg, ideal for model makers, instrument and repairers, etc. The high speed MINI DRILL IH has 2 speeds 8,000 + 12,000 rpm with a drilling capacity from No. 80 to 6.5mm and weighs 5.4kg, is suited for drilling printed circuit boards etc.

A machine vice is included with both models.

Mini Drill I \$165

Mini Drill IH \$165

For brochures, prices and information contact

MELBOURNE MACHINERY CO. (SALES) PTY LTD  
51 Queensbridge St, South Melbourne, Vic (03) 61 2911.



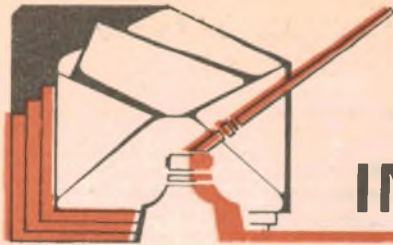

## INFORMATION CENTRE

**TAPING 78 RECORDS:** First I wish to compliment you on your magazine. Having read it since the war years I still have about 10 years magazines stacked away and spend many hours reading back numbers now and again.

The main reason I am writing came about when a friend asked me to tape a 78rpm record, a request I receive from time to time but put them off with a story about the scratch and distortion. I myself have 78 records some of which must be up to 50 years old, some in mint condition but definitely not hifi. But to get to the question, have you ever thought of designing a filter or filters to improve these records and perhaps split the frequency so that the higher frequency and lower frequency can be switched from left to right channels perhaps with a dual pot to give a slight stereo effect?

You may not think that there would be

much interest in a project such as this but with the number of enquiries I have received lately you may be surprised. (W. H., Narrabeen, NSW).

● As far as filter circuits are concerned, we have published two which could be adapted to your application. The first, in November 1975, was an adjustable sharp-cut low pass filter intended for reducing noise on old movie sound tracks. The second, in December 1975, was a dynamic noise filter intended for the same purpose. You could also use the Stereo Synthesiser described in the September issue this year.

**ENGINE ANALYSER:** I am thinking of building the engine analyser that was featured in October '80 and fitting it into my vehicle as a permanent fixture rather than using it as a portable device. My only problem is that I do not know how

to calibrate it as my car is a 3-cylinder 2-stroke Suzuki 4WD.

This tacho would suit my purposes better than the Dwell-Tacho in May '82 as it also shows voltage and I do not have a great deal of space under the dash to put extra gauges. (A. C., Croydon, Vic).

● No problem. A two-stroke motor has twice the number of firing strokes per revolution as a four stroke motor with the same number of cylinders. Therefore you need merely calibrate your engine analyser as for a four-stroke motor (as described in the article) and use it in the six cylinder mode for your Suzuki motor.

**ELECTRONIC STARTER:** I was delighted to see the circuit for the fluorescent lamp starter in your October 1982 magazine and am very pleased with its performance.

However, I had a problem, now solved, which I pass on to you in case others have a similar one. As you recollect, the PCB was unusual in that components were fitted to both sides and, as usual, I fitted all the components close to the board.

A test of the starter gave the correct resistance reading as on page 85 of your article, but in use, the fluoro came only to half brilliance. Eventually I discovered the 56Ω resistor body on the rear of the board touching a solder mound from the lead of the ST2. The voltages involved were apparently enough to cut through the resistor insulation and short the ST2 virtually to ground/neutral. Elevating the 56Ω resistor clear made the circuit operate correctly.

In 20 years of electronics I have not come across such a short before, but perhaps I have never made up a board with components on the back. We live and learn! (R. V., Greenwich, NSW).

● Thanks for the hint. It certainly is a beaut little circuit, isn't it?

**SPEECH SYNTHESISER:** Can the Compuvoice speech synthesiser described in October be used with the Apple II computer? (A. B., Redfern, NSW).

● As far as we are aware there are no problems with using the Compuvoice speech synthesiser connected by a Centronics type parallel interface to the Apple II. Monostable IC2 ensures that the required parameters of the Strobe signal are fulfilled, and the A/R output is compatible with standard Centronics interface requirements.

### Car Computer vs police radar?

**CAR COMPUTER:** In regard to your current project on the EA Car Computer, I would like to offer a suggested additional facility which could be implemented relatively easily, and that is a "hold" function. It occurred to me that since the EA Car Computer constitutes a highly accurate speed measuring device, and also that many car owners have installed speed radar detector units, it would be advantageous to interface the two so that an instantaneous speed reading at the moment the radar detector was triggered, would be displayed to the driver.

This reading could be compared with that on the police radar where an infringement was alleged, since it has been shown that some police radars and operating techniques can produce results which victims find hard, to refute in court. Obviously any defence would depend upon the court accepting the driver's evidence (not likely) or the vehicle for testing as to accuracy which one would assume would be known by the driver to be accurate before considering a legal challenge.

In the September '82 issue Information Centre, C. B. of Girrawheen WA asked about an automotive traffic indicator design to which the reply was that consideration to an electronic design would be made by EA.

Could I suggest that as a basis for this possible design, you look at "Elektor" July/August 1978, circuits 40 & 42 before embarking? These two separate circuits provide the majority of the design requirements specified as necessary, except for the desirable "blown globe" indication. Whilst I have constructed the two circuits and proven that they work, I have not carried out any investigation as to how this facility might be incorporated.

As was stated in the reply, despite the mechanical nature of the conventional device, it does its job very well. I entirely agree, and furthermore it would be rather difficult to produce an electronic equivalent of similar physical size and ease of installation using discrete components available to constructors. (R. H., Carine, WA).

● Unfortunately, while your idea for a "hold" facility for the Car Computer is attractive, it would not be easy to implement. First, there is the problem of interfacing between different radar detectors and the Peripheral Interface Adaptor. Second, the software would need to be changed to provide the additional function. After "getting it right" for publication in its present form, we are not at all keen to modify it.

Thank you for your comments on the traffic indicator circuit.

**INFRARED REMOTE CONTROL:** Recently I completed a project from "Electronics Australia", May '81 edition, a two channel infrared remote control. On completion of the project I found that it did not function as it should have.

After trouble shooting I found that the transmitter handset and the preamp in the receiver seemed to function correctly. Also, when applying a pulse to the input of the final latch, the relays did open and close correctly.

As can be seen from the above, the problem seems to be in the decoder section (ICs 1 & 2). My question: was there any change made to the circuit after publication or has there been an errata which I have missed? (J. E., Sth Caulfield, Vic).

● No, we did not publish any errata for this project and to our knowledge, there were no mistakes. You may have damaged IC1 or IC2 when soldering, as they are CMOS types. Most of the functions of these ICs could easily be checked with your multimeter while operating the transmitter module. For example, key the transmitter and the voltage at IC1e, pin 10, should briefly kick high.

**PLAYMASTER MOSFET STEREO AMP:** I have completed your Playmaster Mosfet Stereo Amp kit and it works satisfactorily for an hour or so then the relay switches off and so no output. When the on/off switch is returned off, the relay then switches back on and then off again as normal. Could you help me in deciphering what is wrong. (S. J., Sutherland, NSW).

● It is possible that your amplifier is oscillating supersonically which can cause the overload protection circuitry to operate. You can check this possibility by using a multimeter switched to a low AC voltage range, connected across the output of left or right channels. If either channel gives an AC reading when no signal is present, then it is likely that the amplifier is oscillating supersonically.

On the other hand, a temperature-sensitive DC fault may also cause the relay to operate. Again, you can confirm whether there is a DC offset voltage present at the output of either power amplifier by switching your multimeter to a low DC voltage range. If you have a digital voltmeter, so much the better. If neither of these faults is present then the fault lies in the relay driver circuit.

**500MHz FREQUENCY METER:** I have just completed construction of the 500MHz Frequency Meter published in the December issue of EA. The unit works quite well except for one small detail which I do not seem to be able to overcome, that is calibration. It is counting approximately 25 high per 1000.

I have changed the crystal and have

## Electronics Australia Reader Service

"Electronics Australia" provides the following services:

**PHOTOSTAT COPIES:** \$3 per project, or \$6 where a project spreads over multiple issues (price includes postage). Requests can be handled more speedily if projects are positively identified, and if not accompanied by technical queries. We reserve the right to supply complete back issues instead of photostats, where these are available.

**CHASSIS DIAGRAMS:** For the few projects which require a custom metal chassis (as distinct from standard cases) dyeline plans showing dimensions are normally available. \$3 including postage.

**PC BOARD PATTERNS:** High contrast, actual size transparencies: \$3, including postage. Please specify positive or negative.

**PROJECT QUERIES:** Members of our technical staff are not normally available to discuss individual projects, either in person at our office, or by telephone.

**REPLIES BY POST:** Limited to advice concerning projects published within the last three years.

Charge \$3. We cannot provide lengthy answers, undertake special research, or discuss design changes. Nor can we provide any information on commercial equipment.

**OTHER QUERIES:** Technical queries outside the scope of "Replies by Post" or submitted without fee may be answered in the "Information Centre" pages, at the discretion of the Editor.

**COMPONENTS:** We do not sell electronic components. Prices and specifications should be sought from advertisers or agents.

**BACK ISSUES:** Available only until our stocks are exhausted. Within six months of publication, face value plus 90c for post and packing for each issue. Seven months and older, \$3 (includes post and packing and storage fee).

**REMITTANCES:** Must be negotiable in Australia and made payable to "Electronics Australia". Where the exact charge may be in doubt, we recommend submitting an open cheque endorsed with a suitable limitation.

**ADDRESS:** All requests to the Assistant Editor, "Electronics Australia", Box 163, Chippendale, 2008.

also placed several different values of capacitors in parallel with the trimming capacitor, but it makes no difference. I cannot alter the reading in any way.

I have purposely waited for each month's "Notes & Errata" to be published in the hope that I was not the only person having this problem, but it appears that is not the case. Can you offer some assistance in this matter please? (B. P., Bicton, WA).

● The most likely reason for the reading error is timebase inaccuracy caused by using a series-resonant crystal. The circuit must use a parallel-resonant crystal, as specified. Unfortunately, up till the time of publication of this project, most parts stockists would have been supplying series resonant crystals in response to any request for a 4MHz crystal. It looks as though you may have been caught twice.

**AM CAR RADIO:** I am writing to seek technical advice on how to eliminate disturbance noise from my car radio. I have bought a Dick Smith AM Car Radio with its antenna and have installed it in my Toyota Scout car. The problem I'm facing is that although the reception is very clear and good without the engine running it produces a lot of disturbing noise with the engine running. The noise sort of follows the sound of the engine.

To eliminate the noise I have tried the following methods: "Inline Distributor Suppressor", "Spark Plug Noise Suppressor", and "Coaxial Alternator Noise Suppressor", but all without success. Could you please advise me further how to solve the problem? (J.N., Kainantu, PNG).

● Car radios can be very tricky to install and obtain noise-free reception. You do not state whether the noise is alternator whine or ignition noise. We assume that

it is the latter. A number of procedures may have to be tried, including electrically bonding the bonnet to the car body. We suggest you write to us for a copy of the article entitled, "Installing a Car Radio" which was published in February 1969. The cost, including surface mail, is \$3.00.

**760 ELECTRONIC ORGAN:** With interest I read (J.P., Merrylands) experiences with the 760 Electronic Organ and commiserate with him. I was running into problems such as his and ended up still not having completed the organ.

I refer you to technical information that I received from Master Instruments Pty Ltd, Sloane Street, Marrickville 2204 with respect to a SGS MOS IC M108 and M208 Single Chip Organ (solo and accompaniment).

This one chip eliminates all the hassles of organ building and would be the basis of a first class new organ design for Electronics Australia to, as J.P. put it, "Wire into my nice, mute console". (B.C., Cowra).

● You may be correct in saying that this SGS chip solves a lot of the problems of organ building. However the fact that it requires an external ROM (read only memory) plus a lot of other support circuitry may mean a completely fresh bunch of hard-to-solve problems. Thanks for the info, anyway.

**SUBWOOFER:** I have recently completed the EA subwoofer systems described in July and August of this year. On completion and setting up, I found that the volume was very low, almost inaudible. I have checked all the components but could find nothing wrong. I then replaced each 10k $\Omega$  mixing resistor with 5k $\Omega$  and bypassed the 47k $\Omega$  resistor from VR1. This now gives me ample volume.

# USE NO GREASE

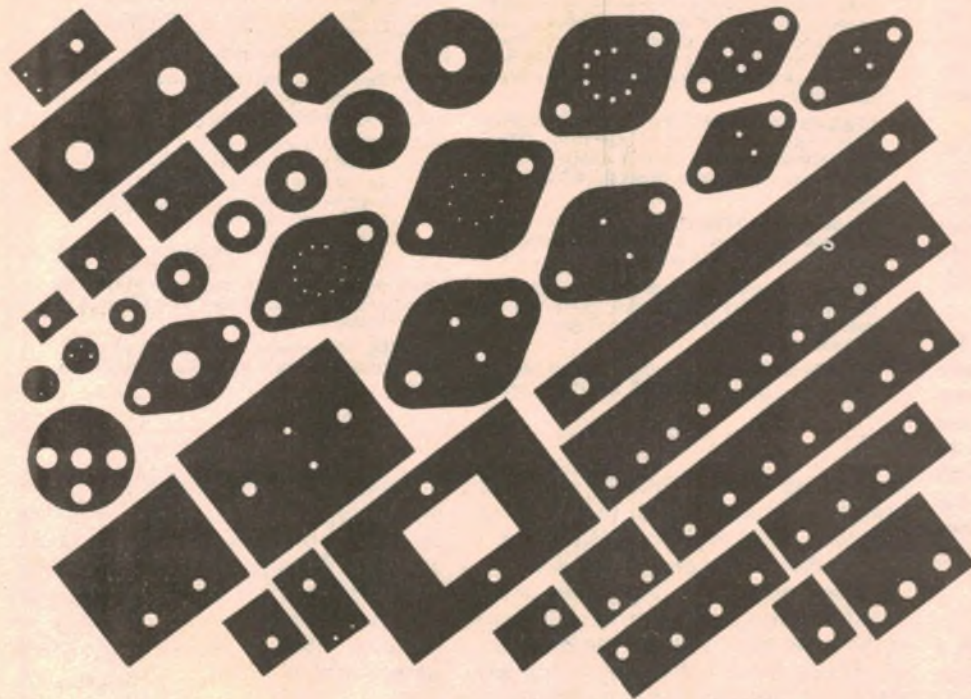

**SIL-PAD 400 is a greaseless heat sink insulator that provides electrical isolation and maximum heat transfer.**

- Available for a wide range of packages.
- No grease — no mess
- Low thermal resistance
- High electrical isolation
- Non toxic
- Fast, easy to use, neat
- Flame retardant
- Will not support fungal growth
- Can be sent through soldering and cleaning agents
- No deterioration with age
- Will not chip or break
- Maximum cut through resistance

Available only from

**Scientific Electronics**



6 Holloway Drive,  
Bayswater, Vic. 3153  
Tel. (03) 762 5777  
Telex AA36308

**The Power Supply Specialists**

Circle Enquiry Card No. 223

# THERE WILL BE 31,536,000 SECONDS IN 1983

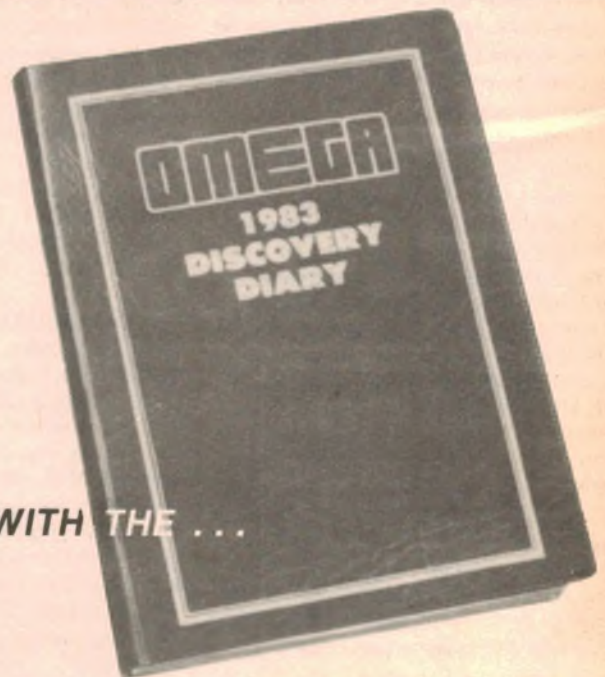

**KEEP TRACK OF THEM WITH THE ...**

**Perfect for next year's memoranda, appointments and personal notes. Packed with countless facts and stimulating predictions. Order now for Christmas.**

**Fill in this coupon and send it to: Omega Discovery Diary Offer, Magazine Promotions, PO Box 131, Chippendale, NSW 2008. Cheques should be crossed and made payable to Magazine Promotions.**

OMEGA DISCOVERY DIARY

Please send me ..... Omega Diaries @ \$8.60 each.  
Total amount enclosed \$ .....

NAME .....

ADDRESS .....

..... POSTCODE .....

## Super-80 expansion: Floppy disks and graphics

**SUPER-80:** I am considering constructing a Super-80 computer. However, some questions on this machine remain unanswered. Can a floppy disk be connected through the S100 interface? Is it possible to have both a floppy disk and a printer connected at the one time? Do you plan to publish designs for an expansion unit or can the System-80's expansion unit be used in conjunction with the S100 interface? Such an expansion unit would need to be able to run one or more floppy disks, both serial and parallel printers and include S100 expansion.

The S100 expansion is needed as the original S100 is occupied by the expansion unit. My last question refers to any possible usage of graphics. Using machine language, can graphics be obtained and if so what is the maximum number of pixels possible? I would be most grateful if you would answer these questions and so remove some confusion for myself and other readers. (P. W., Peel, NSW).

● Yes, a floppy disk controller can be connected to the S100 expansion interface of the Super-80, with two provisos. Firstly, the disk controller must

be of the type that uses "programmed I/O", interfacing to the computer as one or more parallel input/output ports, rather than using Direct Memory Access (DMA).

The second consideration is the software. The actual disk driver software would need to be altered to allow for the fact that the microprocessor of the Super-80 is switched off while the video display is generated.

In effect the disk controller would work in the same way as the present cassette interface, by first disabling the video scanning to prevent it interfacing with the timing of read/write operations. To use CP/M, for example, the Basic Input/Output system (BIOS) would need to be re-written to reflect this necessity.

Most floppy disk controller boards do not provide a printer interface, and some form of expansion bus is required to use more than one S100 board at a time with the Super-80. The System-80's expansion interface is not suitable as such, nor is it necessary, since it connects to the System-80 expansion port via the Z80 bus. Circuitry inside the expansion

box encodes the standard S100 signals, while the Super-80 has provision for this circuitry already on the board.

All that is required to expand the Super-80 with S100 boards is a suitable motherboard, connected by a cable to the existing S100 edge connector on the Super-80 board. An additional power supply would probably be an advantage if more than one or two S100 boards are used at the same time.

In the August, 1982 issue we published an article on a graphics add-on for the Super-80, produced by EL Graphix. Their character generator ROM kit number one, combined with a machine language routine, allows a graphics resolution of 64 x 32 blocks, with each block being one quarter the size of a standard character. A modification of this software, used with the EL Graphix kit two ROM, would allow graphics with 64 x 48 resolution.

In a future issue we will describe modifications to the Super-80 board which allows a graphics resolution of 64 x 32 and inverse characters without additional software.

My problem is that I do not know why this should be necessary. Certainly it works very well, as I now have a really good clean bass response.

Thanks for once again coming up with a great project. (W. R., Kambah, ACT.).

● It seems likely that the reason for the lack of gain is that the op amp is not working. If the op amp is mounted in a socket this can be easily verified. Just pull the op amp out and if no change occurs the op amp is defective.

An alternative diagnosis is that some of the resistor values in the op amplifier filter circuit are incorrect.

We are assuming here that you are connecting the output of your existing stereo amplifier to the subwoofer amplifier input.

**STEREO MULTIPLEX ADAPTER:** Would you please explain what a "Stereo Multiplex Adapter" is, and could you publish a circuit. I have a National 3-1 stereo, but its tuner is only AM. I also have a National Panasonic RF-2800 6 band portable with FM. This has a multiplex output jack (MPX). The handbook says it is "Used to connect an FM stereo multiplex adapter for enjoyment of FM stereo programs". With FM not far away, at long last, in New Zealand I would like to use the portable as the tuner for the 3-1 using a patch lead.

For many years I have enjoyed your

## Notes & Errata

**COMPUVOICE** (October 1982, File 2/CC/75): The circuit board pattern on page 78, and shown in the on the component overlay on page 75 contains an error. The track which runs from one end of the 150pF capacitor in the lower right hand corner of the overlay diagram to the adjacent 10kΩ resistor should actually run to the left side of VR2.

If you have a circuit board made to the wrong pattern, cut the track between the 150pF capacitor and the 10kΩ resistor and install a wire link from the capacitor pad to the left-hand pad of VR2.

**CAR COMPUTER:** (August 1982, File 3/AU/31) Due to low activity crystals being supplied with some kits, the computer powers up incorrectly when the ignition voltage is applied. This is due to the Reset occurring before the crystal starts to oscillate. A possible solution is to connect a 10MΩ resistor across each 27pF capacitor to ground. Alternatively a

10MΩ resistor across the crystal can aid the starting. The 0.1μF capacitor at pin 9 of IC5c can be increased to 0.47μF, giving a longer Reset time for very slow-to-start crystals. Specifications for the correct crystal are: 3.579545 MHz AT-cut parallel resonant, Co=7pF, CLoad=20pF, R1=500Ω.

Some computers are not registering the instant speed above 60km/h and in some cases only up to 45km/h. This is due to insufficient drive to the base of Q6. To solve this, try reverse connecting the distance sensor wiring. If this has no effect, then the 0.1μF capacitor at the base of Q6 can be reduced to .001μF, thereby decreasing the time constant. A metallised polyester (greencap) will be suitable.

The calibration number for the fuel flow sensors in some cases may be too low, giving a pessimistic fuel consumption figure. To correct the calibration number, check the fuel use (litres) against the amount of fuel registered on the service station fuel pump.

magazine, having built many of the more simple projects. The latest, "Cudlipp", has given many hours of fun to friends and family. The kids love it! Keep up the good work. (T. C., Hamilton, NZ).

● Stereo multiplex encoding and decoding was fully described in an arti-

cle which included an add-on decoder, in April, 1975 (File No. 1/MS/12). The decoder used a Motorola MC1310P decoder chip which should still be available. Photocopies of the article are available from our Information Service for \$3.

# INDEX TO VOLUME 44 — JANUARY 1982

## General Features

Australia's Radio Pioneers Pt 1	Jan	p12
Exide Torque Starter	Jan	p16
Magnetic Levitation	Jan	p24
Australian AM-FM Broadcasting Services	Jan	p26
Automatic Airliners	Feb	p12
Australia's Radio Pioneers Pt 2	Feb	p18
An Interview with Rodney Zaks	Feb	p32
Satellites Show a Warlike Face	Mar	p10
Video Terminals & Eyestrain	Mar	p17
Australia's Radio Pioneers Pt 3	Mar	p20
The Engineer's Dilemma	Apr	p8
The Story of Undersea Cables	Apr	p12
Australia's Radio Pioneers Pt 4	Apr	p18
The Perils of Simple Design	May	p10
Advances in Display Electronics	May	p16
The Story of Undersea Cables Pt 2	May	p18
Radio Moscow and the dB War	Jun	p12
Japan: Research Makes the Difference	Jun	p18

The Secrets of 3D Television	Jul	p12
Electromagnetic Mass Launchers	Jul	p18
Technology — Meeting Society's Needs?	Jul	p24
Health Hazards of VDUs	Aug	p12
Australia's Part in Starlab	Aug	p18
A Fresh Look at the Light Bulb	Sep	p12
Chicago Consumer Electronics Show	Sep	p26
Amplitude Modulation	Oct	p12
Sparkrite Voyager Car Computer	Oct	p26
All about Prototyping Boards	Oct	p108
Frequency Modulation	Nov	p12
How to Install Multiple TV Outlets	Nov	p24
Lasers get ready for War	Dec	p12
Expedition by sail to the Antarctic	Dec	p22
How the ABC covered the Games	Dec	p16

Fisher PH492K portable audio system	Mar	p35
Mitsubishi LT-5V turntable	Apr	p34
Technics RS-M280 3-head cassette recorder	May	p38
Technics RS-M07 stereo cassette recorder	Jun	p34
Teac X-1000R open-reel tape recorder	Jul	p38
Phonic SA-3000 stereo graphic equaliser	Aug	p36
Technics ST-Z45 AM/FM stereo tuner	Sep	p42
Sennheiser HD230 dynamic headphones	Sep	p46
Shure V-15 Type V phono cartridge	Oct	p44
Miller & Kreisel Volkswoofer & Satellite-1A loudspeakers	Nov	p40
Audiosound Linz 8066 studio monitor	Dec	p30

## Hifi Reviews

Sharp VZ-3000Z Combination System	Jan	p38
Sony ICF-2000 AM/FM synthesised receiver	Feb	p34

## Audio/Video Electronics

The blank tape levy: industry body calls for inquiry	Jan	p32
Morton Gould — a discussion on high technology recording	Feb	p26
There's more to dynamic range than loud music!	Mar	p28

## Constructional

Low-Cost Wind Direction Indicator	Jan	p54	2/MS/60
Build an Electronic Metronome	Jan	p64	3/MS/90
Simple Electronic Dice	Jan	p68	3/EG/23
Lyrebird Electronic Piano Pt 4	Jan	p72	1/EM/56
Digital Thermometer	Feb	p36	3/MS/91
500MHz 7-Digit Frequency Meter Pt 2	Feb	p46	7/F/29
Large Screen TV Storage CRO Adapter	Feb	p50	7/C/35
Cudlipp Electronic Cricket	Feb	p72	3/EG/24
Playmaster 3-70L Loudspeaker System	Mar	p38	1/SE/60
LCD Capacitance Meter	Mar	p48	7/CM/14
Dual Tracking ±22V Power Supply	Mar	p56	2/PS/52
Low Fuel Indicator for Cars	Mar	p74	3/AU/29
Function Generator with Digital Readout	Apr	p36	7/AO/35
Voice Operated Relay	Apr	p46	1/RA/36
Photographic Enlarger Timer	Apr	p52	2/PT/12
Vocal Canceller	Apr	p64	1/MS/23
Rediscover the Crystal Set	Apr	p68	4/CR/14
Tacho/Dwell Meter with Digital Display	May	p42	3/TM/17
High Performance Phono Preamplifier	May	p50	1/PRE/33
Low Power 12-240V Inverter	May	p61	3/IT/11
Low-Cost CMOS Touch Switch	May	p77	3/MS/92
High Power 300VA 12/230V Inverter	Jun	p38	3/IT/12
Playmaster 3-56L Loudspeaker System	Jun	p56	1/SE/61
Guitar Booster for Stereo Amplifiers	Jun	p76	1/GA/23
Better Bass for Electronic Organs	Jun	p80	1/SE/62
Theremin: A Weird Music Machine	Jun	p86	1/EM/57
100W Sub-Woofers Power Amplifier	Jul	p44	1/MA/58
Car Computer to Build Pt 1	Jul	p56	3/AU/30
Portable Heart Rate Monitor	Jul	p62	3/MS/93
A Decimal Point for the 500MHz DFM	Jul	p78	7/F/30
Simple Power Monitor	Jul	p84	7/MS/12
Car Computer Pt 2	Aug	p40	3/AU/31
100W Sub-Woofers Enclosure	Aug	p54	1/SE/63
Ultrasonic Rule	Aug	p76	3/MS/94
Stereo Synthesiser for Tuners & VCRs	Sep	p52	1/MS/24
Car Computer Pt 3	Sep	p60	3/AU/32

Audax Compact 200 Loudspeaker	Sep	p74	1/SE/64
Build an Electric Fence	Sep	p80	3/MS/95
Dynamic Noise Reduction Filter	Sep	p92	1/F/15
Easy-to-Build Bicycle Odometer	Sep	p99	3/MS/96
Digital Readout for SW Receivers	Oct	p48	7/F/31
Remote Display for the Car Computer	Oct	p66	3/AU/33
Electronic Starter for Fluorescent Lamps	Oct	p82	2/PC/33
Easy-to-Build Freezer Alarm	Oct	p90	3/MS/97
Digital Depth Sounder for Small Boats	Nov	p44	1/MS/25
Solar-Powered Fountain	Nov	p58	3/MS/98
Power Up Switch Controller	Nov	p66	2/PC/34
Build the Super Siren	Nov	p82	3/MS/99
A high performance AM tuner Pt 1	Dec	p24	2/TU/50
Easy to build digital pH meter	Dec	p54	7/MS/13
Driveway Sentry turns on the lights	Dec	p62	2/PC/34
Mind-blowing new Boggle Goggles	Dec	p68	3/MS/100

## Microprocessors — Constructional

An Easy-to-Use EPROM Programmer	Jan	p42	2/CC/66
Programming the Super-80 Computer	Jan	p82	8/M/53
Expansion for the DREAM 6800	Feb	p84	2/CC/67
How to Program in Machine Language Pt 1	Mar	p82	8/M/54
A Fullsize Keyboard for the ZK-81	Apr	p74	2/CC/68
How to Program in Machine Language Pt 2	Apr	p76	8/M/55
A Printer Interface for the Super-80	May	p80	2/CC/69
How to Program in Machine Language Pt 3	May	p116	8/M/56
Build an RS232C Cassette Interface	Jun	p94	2/CC/70
Extra Memory for the Sinclair ZX80	Jul	p121	2/CC/71
A Case for the Super-80	Jul	p122	2/CC/72
Shielding for the System-80	Aug	p86	2/CC/74
Adding Graphics to the Super-80	Aug	p88	2/CC/73
How to Program in Machine Language Pt 4	Aug	p94	8/M/57
Compuvoice Speech Synthesiser	Oct	p72	2/CC/75
Datum Microprocessor Trainer	Nov	p86	2/CC/77
A Votrax Vocabulary	Nov	p96	2/CC/76
Datum Microprocessor Trainer	Dec	p92	2/CC/78

# 2 to DECEMBER 1982

Las Vegas electronics show	Apr	p26
dbx Noise Reduction	May	p30
A look at the QUAD ESL-63 Loudspeaker	Jun	p28
Disco sound British style: equipment & manufacturers	Jun	p32
On being asked for advice on hifi — how do you react?	Jul	p30
Australian synthesiser for world market	Aug	p30
New audio at the Chicago CES	Sep	p34
A chicken or egg dilemma for Cherry Pie	Oct	p36
Stereo sound for television: on air tests in Australia	Nov	p32
Recording tape is getting better all the time	Dec	p35

## Official Line

New cable link across the Pacific	Jan	p9
Campaign against unlicensed operators	Feb	p9
Monitoring satellite transmissions	Apr	p96

## Forum

We cop a blast on power stations & digital recording	Jan	p28
VCRs present service problems in remote areas	Feb	p22
Equipment reliability: the key to commercial success	Mar	p24
A tangle in tape compensation	Apr	p25
Country serviceman may have good reason to be disgruntled	May	p24
Why don't journalists get things right?	Jun	p24
Electronic spare parts: there are two sides to the issue	Jul	p26
Service Manuals: The latest in banned books!	Aug	p24
TV receivers still catch fire — occasionally!	Sep	p30
What do you expect from a personal computer?	Oct	p32
Tracking, thorn needles & assorted topics	Nov	p28
Warranties are fine — provided they're effective	Dec	p26

## The Serviceman

Some sets have their own special faults	Jan	p76
A serviceman's life is not a happy one	Feb	p80
How many faults can there be in one set?	Mar	p64
It never pays to be over confident	Apr	p58
The customer's story — help or hindrance?	May	p71
A lot of good worry wasted for nothing!	Jun	p62
Power supplies, valves — and splattered aliens	Jul	p70
I thought I knew all the tricks	Aug	p69
Pride goes before a fall in income	Sep	p86
Fuses, focus and frustration	Oct	p86
Handyman repairs can prove expensive	Nov	p74
Modern TV set faults can be difficult to analyse	Dec	p86

## Personal Computers

Sphere microcomputer	Jan	p88
Are 8-bit processors on the way out?	Jan	p115
Tandy TRS-80C colour computer	Feb	p66
Useful information for System-80 owners	Mar	p120
Word processing & the System-80	Mar	p116
A simple RS232C testing box	Mar	p128
Attitudes to programs & programming	Apr	p113
The Australian Beginning	May	p90
Concord II bare-board computer	Jun	p120
System 80 blue label computer	Jun	p124
Vic-20 colour computer	Jul	p114
Choosing a printer — A buyer's guide	Sep	p18
Computer club listing	Sep	p129
Floppy disc drives	Oct	p14
Wizzard video game & personal computer	Oct	p128
Modems: computing by telephone	Nov	p14
Texas Instruments TI-99/4A computer	Dec	p100

## Circuit & Design Ideas

Musical tone generator peripheral	Jan	p80
Simple audio flasher	Jan	p80
"Patch" for Dream 6800 kaleidoscope program	Jan	p80
Modifications to the utility timer	Jan	p81
LED Indicator for remote AC loads	Jan	p81
Hum measurements	Jan	p81
Using the infrared relay as a door minder	Feb	p76
Simple crowbar protector	Feb	p76
Automatic reversing lamps	Feb	p76
Low power strobe	Feb	p79
Simple noise gate	Feb	p79
Suppressing audio switching transients	Mar	p71
Cure for fluctuating dwell & tach readings	Mar	p71
Switch-mode control of low voltage DC motors	Mar	p71
Battery tester for blind persons	Mar	p72
Simple relay latching circuit	Mar	p72
Up/down pushbutton-controlled power supply	Apr	p61
Register display routine for the "Sorcerer"	Apr	p61
Economy mains auto transformer	Apr	p61
Auto-repeat function for RCA VP601 keyboard	Apr	p63
Novel Wien bridge	Apr	p63
Alarm & fast shift for EA control timer	May	p69
Power inverter for motor-driven antenna	May	p69
Electronic thermostat	Jun	p83
Audible logic tester	Jun	p83
Cudlipp's brother	Jun	p84
Pseudo PC board	Jun	p84
Lights for model railways	Jun	p84
Programmed switch-on for IR remote control	Jul	p74
Low cost transistor checker	Jul	p74
Measuring top speed	Jul	p74

Resuscitation training aid	Jul	p74
Fast switching solid state relay	Jul	p76
Recycling etchant solution	Jul	p76
TRS-80 Cassette Control	Jul	p76
Customised keytops	Jul	p76
Regulated supply for flash meter	Aug	p67
Playmaster tone control bypass	Aug	p67
Computer as a pattern generator	Aug	p67
Four hour photographic timer	Aug	p68
Use your DVM as a capacitance meter	Aug	p68
Bugging a lizard on the FM broadcast band	Sep	p72
Fractional frequency multiplier	Sep	p72
Remember the lights!	Sep	p72
CRO trigger for the EA TV pattern generator	Sep	p73
Relay power saver	Sep	p73
Signal controller for model train layouts	Nov	p78
Cudlipp's sister a ladybug	Nov	p78
Digital chess clock with time out alarm	Dec	p83
Four-tone sound for the Super-80	Dec	p83
Personal portable modification	Dec	p83
Low-cost darkroom timer has audible output	Dec	p83
Expanded scale voltmeter	Dec	p83
Simple headlight reminder	Dec	p83

## Notes & Errata

Slide Cross-Fader (November 1981, 2/PC/32)	Jan	p125
Control Timer (April 1980, 7/CL/30)	Mar	p131
Lyrebird Piano (December 1981, 1/EM/35)	Mar	p131
Eprom Programmer (January 1982, 2/CC/66)	Mar	p131
Programming the Super-80 (January 1982, 8/M/53)	Mar	p131
Playmaster 3-70L Loudspeaker System (March 1982, 1/SE/60)	Apr	p117
Analog Storage CRO Adapter (March 1981, 7/C/34)	Apr	p117
TRS-80 Serial Printer Interface (November 1980, 2/CC/56)	May	p133
Voice-operated Relay (April 1982, 1/RA/36)	May	p133
Digital Thermometer (February 1982, 3/MS/91)	May	p133
Function Generator (April 1982, 7/AO/35)	Jun	p132
Large-Screen Storage CRO Adapter (February 1982, 7/C/35)	Jun	p132
Function Generator (April 1982, 7/AO/35)	Jul	p133
12/230V 300VA Inverter (June 1982, 3/IT/12)	Jul	p133
Sound Level Meter (May 1981, 7/M/59)	Aug	p133
500MHz DFM Decimal Point (July 1982, 7/F/30)	Aug	p133
12/230V Inverter (June 1982, 3/IT/12)	Sep	p141
Sound Level Meter (May 1981, 7/M/59)	Oct	p141
Information Centre (October 1982)	Nov	p141
Compuvoice (October 1982, 2/CC/75)	Dec	p147
Car Computer (August 1982, 3/AU/31)	Dec	p147

# MARKETPLACE

## FOR SALE

**SUPER 80 SOFTWARE:** For free list send SAE to: MEGASOFT, 151 Denton Ave, St Albans 3021. Ph (03) 367 1469.

**MEMORY COMPONENTS,** RAM 2114 \$1.35, 4116 \$1.45, 6116 \$6.88, EPROM 2716 \$3.49, 2532 \$4.99, 2764 \$14.19, and others. **COMPUTER FOCUS 4/224** George Street, Liverpool, (01) 600 8222.

**CB RADIOS** \$67, walkie-talkies, shortwave radios, military, outback, business, amateur marine, repairs, aerials, 40ch conversions, new rigs weekly. Gridge Disposals, 12 Old Town Plaza, Bankstown Rail Station. Ring Sam 7pm-9pm only (02) 407 1066.

**AMIDON FERROMAGNETIC CORES** — Large range for all receiver and transmitter applications. For data and price list send 105x220 SASE to: RJ & US Imports, PO Box 157, Mortdale, NSW 2223.

**US PRECISION RESISTORS.** 1% metal film, 2% cermet film and some 5% valves. Also high quality trimpots and diodes. Send stamped SAE for price list to: 106 Beverley St, E. Doncaster, Vic 3109. Ph: (03) 842 3239.

**PRINTED CIRCUIT BOARDS** from your own artwork. Prototypes, 100s or 1000s at Melbourne's lowest prices. Contact Peninsula Circuits, 7 Portrush Gr, Mornington 3931. (059) 75 5568.

**SUPER 80 JOYSTICKS & SOFTWARE.** Fully proportional dual joysticks with four pushbuttons for use in real time games. Comes complete with Assembly manual interface program, and a demonstration game. KIT \$39.95. Assembler/Editor. To run on a 16K (or more) Super 80 complete with 21 page instruction manual. \$35.45. Source listing of Monitor V1 .2. This is the original source listing of the Super 80 monitor program with comments. Great for learning machine code! \$11.95. Write to: Pelatronics, PO Box 807, Toowong, Qld 4066. Include \$1.50 P&P.

**RCS Radio Pty Ltd**

Tel. (02) 587 3491

IS THE ONLY COMPANY WHICH MANUFACTURES AND SELLS EVERY PCB & FRONT PANEL published in EA and ETI  
651 Forest Road Bexley 2207 AUSTRALIA

RING FOR INSTANT PRICES  
24 HOUR TURNAROUND SERVICE

*Palantir Data Systems*

announces some new products for the computer user and builder.

- Low cost RS 232 Box
- Serial interface for Video cards
- New CRT 1500 Video Card

Please send SASE to Box 27, Clifton Hill, Vic 3068 for further details.

**QUALITY NICAD BATTERIES.** Cheap. AA; subc; C & D. Size to 4 amp. Fast charge. Suit most gear inch. Flashguns, toys & Big Jim torches etc. Last for years. Info 557 Merrylands Rd, Merrylands 2160. (02) 636 1592 anytime.

**MOVIE POSTERS,** photos, books, records, video rental \$5 overnight, latest movie releases. Mon-Fri 10.30-5.30pm, Sat 10-5pm, Sun 12-5pm. Hollywood and Vine Cinema Shop, 4 Avoca St, South Yarra, Vic (off Toorak Road). Phone (03) 267 4541.

**S100 dynamic memory boards** 16k-64k, S100 disc controller boards, 2650 single board computer systems can be expended to S100. Ass or kit. Software available for tape or disc system. CAE Electronics 1/27 Forge St, Blacktown 2148 (02) 621 4242.

**ZX81 FUN GAMES:** Golf, Darts, Shove-half penny, Deadly Dungeons, Ancient Sumeria, Chess, Black jack and others. Send for catalogue. Adelaide Software Supplies, Box 153, St Marys 5042, SA.

## READER SERVICE

**HAVING TROUBLE** interfacing to your microcomputer? We will design and manufacture an interface to suit your individual requirement and supply the software to drive it. Also available EPROM programming services. CAE Electronics 1/27 Forge St, Blacktown 2148 (02) 621 4242.

**REPAIRS** to all home, hobby and small business microcomputer systems and peripherals, also all EA & ETI projects. CAE Electronics, 1/27 Forge St, Blacktown 2148. (02) 621 4242.

**COMPUTER REPAIRS** — WA all makes. Eproms programmed machine lang. routines written. Custom interfacing and Hardware Mods. Ph (09) 401 2733.

**COMPUTER CLINIC** repairs & services Sorcerer, Pet, Apple, Super 80, System 80, Tandy & others. Businesses & hobbyists catered for. (07) 269 8573, PO Box 68, Aspley, Qld.

**Texas Instruments Home Computer T1-3341**

Programming

You don't have to be a computer expert to use our Home Computer. T1 BASIC programming is designed for skilled computer users and beginners alike. The built-in T1 BASIC language makes the Home Computer a valuable desktop instruction tool at home or at the office. It's also a great way to introduce your children to programming computers.



TEXAS INSTRUMENTS  
INCORPORATED

16 Bit Colour Home Computer \$499. Plus Chess. Adventure T.I. Invaders Munchman.

COMPUTER SYSTEM SPECIALISTS  
**Computer Focus**  
4/224 George St - 1st Fl. Liverpool (02) 600 8222

## FOR SALE

Philips VHF 50 Watt base station including 2 x console/microphone assemblies and one remote telephone.

30 VHF 25 watt mobile transceivers complete with antenna and handset/microphones. All equipment tuned to 169.66 MHZ. Mobiles include models Philips/Pye overland 734, model F25 (type FM705).

For further information please telephone (02) 638 0122 — Ken Jarman or Bob Daisley.

**DISPLAY ADVERTS IN MARKETPLACE** are available in sizes from a minimum of 2cm x 1 col rated at \$15 for a col cm.

**CLASSIFIED RATES** \$3.60 for 40 letters or part thereof an insertion payable in advance. Minimum 80 letters.

Please use coupon below.

**CLOSING DATE** is six weeks prior to the on-sale date. Issues are on sale the first Wednesday of each month.

## FOR HIRE

**MICROCOMPUTERS FOR WEEKLY RENTAL** \$25 per week. Commodore PET systems, with manuals and software tapes. Cassettes include games and self-teaching tutorials in BASIC and 6502 Machine Language. David Bates & Associates. Ph (02) 630 8652.

**REMOTE ANTENNA SITE** 40 miles from Perth. Electrically quiet — ideal for large HF installations. We will erect and maintain to your specifications. Write to Antenna Science & Engineering, PO Box 238 Nedlands, WA 6009 or ring (09) 386 2010 for details.

## CLUBS

**AUSTRALIAN RADIO DX CLUB.** Founded 1965, now with 500 members. Monthly bulletin covers all aspects of overseas reception on shortwave, mediumwave, utility, amateur. Comprehensive new member kit. Full range of membership services, and publications. Beginners welcome. Send 40c in stamps for details to: ARDXC, Box 227, Box Hill, Victoria 3128. Mention EA!

## AN INTRODUCTION TO DIGITAL ELECTRONICS FOURTH EDITION

Electronic equipment now plays an important role in almost every field of human endeavour. And every day, more and more electronic equipment is "going digital". Even professional engineers and technicians find it hard to keep pace. In order to understand new developments, you need a good grounding in basic digital concepts, and An Introduction to Digital Electronics can give you that grounding. Tens of thousands of people — engineers, technicians, students and hobbyists — have used the previous editions of this book to find out what the digital revolutions is all about. The fourth edition has been updated and expanded,

to make it of even greater value.

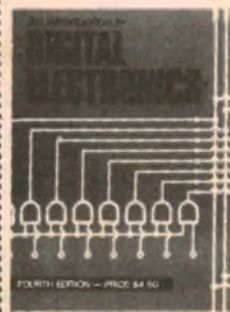

ONLY \$4.50 + 90c p&p

Available from "Electronics Australia", 57 Regent St, Chippendale. PRICE \$4.50 OR by mail order from "Electronics Australia", PO Box 163, Chippendale, 2008. PRICE \$5.40.



**A.C.E.**  
RADIO

136 VICTORIA RD. MARRICKVILLE, NSW 2204  
PHONE 51 3845

PROUD TO BE  
AUSTRALIAN 

**ELECTRONICS CENTRE**

BARGAIN PRICES • PERSONAL ATTENTION • SLICK MAIL ORDER SERVICE • SATISFACTION

\* SUPER SPECIAL \*  
VICTOR U.S.A. MODEL 5080  
DOT MATRIX PRINTER

Professional  
Quality

**\$675**

Plus freight.

• BRAND NEW •

(Ex U.S.A. price \$1100.)

Owners  
manual incl.

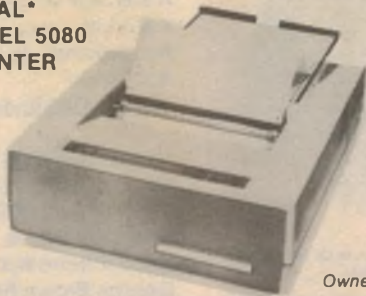

CAPABLE OF PRINTING ASCII OR GRAPHICS DATA FROM MINI/MICRO-COMPUTERS • DATA SETS • OTHER ELECTRONIC EQUIP UP TO 80 CHARACTERS OR 480 GRAPHIC COLUMNS MAY BE PRINTED ON ONE LINE — SPEED, 100 CHARACTERS OR 600 GRAPHIC COLUMNS PER SEC. SUPPORTS MOST SERIAL AND PARALLEL DATA FORMATS • SELECTOR SWITCH FOR THE FOLLOWING INTERFACES — RS-232C, ALL BAUD RATES THROUGH 9600, POS AND NEG • CURRENT LOOP, 20 — 60MA. AT ALL BAUD RATES TO 9600 • PARALLEL, FULLY TTL COMPATIBLE • IEEE-488, INDUSTRY STD • STANDARD FEATURES • SELF-TEST, AUTOMATIC LINE FEED, INTERFACE TYPE, BAUD RATE, ADDRESS CODE • STD PAPER UP TO FOUR COPIES, FONT — 5x7 AND 10x7, FORMAT — HORZ 80 COLS. AT 10 CH PER IN. VERT. 6 LINES PER INCH, GRAPHICS — RESOLUTION 3600 DOTS PER SQ. IN. DIMENSION — 465 DEEP 205H. 395W. MM. WEIGHT • 230VAC. 50Hz •

\* SUPER SPECIAL \*  
DIGITAL PROFESSIONAL COMPUTER KEYBOARD

**\$97.50**

P-P NSW \$4.50  
INTERSTATE \$7.50

Full size — 64 keys and spacer bar • separate, inbuilt 18 key numerical pal  
• Serial interface • ASC11 encoded •



**PYE** BELT-DRIVE STEREO PLAYER

PRO MODEL  
TA-10

**\$89.95**

P-P NSW \$5.50  
Q, V, T, SA \$6.50  
WA, NT \$7.50



Detachable Headshell  
Magnetic Cartridge  
Diamond Stylus

Features — Manual Start • Auto Return • Eject Lever • Cue Lever • Full Size, 30cm Heavyweight Aluminium Platter with Anti-static Mat • 2-speed 33-45 rpm • Fully Calibrated Adjustable Counterweight • Anti-Skate • 240 VAC 50Hz 4 Pole, Fully Shielded Motor • Switch Click Suppressor • 3 Core Power Cable, Audio Cable with RCA Plugs • Base Size 40 x 30.5cm •

HIGH GRADE  
POTTER AND  
BRUMFIELD  
RELAY



KU series • 240 VAC 50Hz operation • 3 sets of 240V 10 amp change over contacts • perspex cover and mounting base included • size 50mm x 37mm x 35mm • ex-computer • as new condition. At less than 1/2 of the normal price.

**\$3.50** P-P 95c



GENUINE FACTORY PRICES  
ETONE 30cm and 38cm SPEAKER SPECIALS

Rugged top quality Aust made brand new bargains — all with factory warranty.

Model	Size	Cone Type	Vicoil	Reson Hz	Freq Hz	Watts Rms	Price Ea	or	2 for
6110	30cm	Ribbed surround	8/15 Ohms	65	50-8000	30	\$28.50	or	\$49.95
6160	30cm	Twin cone	8 or 15 Ohms	65	50-15000	30	\$29.50	or	\$52.00
6180	30cm	Foam surround	8 Ohms	30	30-4000	60	\$34.95	or	\$64.00
4310	38cm	Straight surround	8-15 Ohms	45	40-6000	60	\$63.00	or	\$120.00
4510	38cm	Straight surround	8-15 Ohms	45	40-6000	100	\$84.00	or	\$156.00
4350	38cm	Hi-Fi	8 15 Ohms	30	30-4000	120	\$63.00	or	\$120.00

Pack — Postage add for one 30cm model. NSW \$3.50. Interstate \$5. For two 30cm models. NSW \$5. Interstate \$7. For one 38cm model. NSW \$4.00. Interstate \$6. For two 38cm models. NSW \$7. Interstate \$8.50.

PHILIPS  
• NEW TRANSMITTING  
VALVES

YL1370-6146B **\$13.95**  
QQE06/40 **\$45.00**  
QQE03/12 **\$12.50**  
QE03/10 **\$8.50**

N.B. VERY LIMITED STOCKS.  
ADD \$1.50 P-P

12VDC MINIATURE  
LATCHING RELAY

Coil 100 Ohms • Gold Plated 2 Amp Contacts • Spdt • Horizontal PCB Mounting • 30L x 15W x 10H MM • Perspex Cover included •

**\$2.95** P-P 75c

A FEW BULK BUYSPECIALS

Prices are for 10 pieces

- Audio D P D T Rocker Switches **\$3.50**
  - Motorola A1 2N3055 **\$5.90**
  - Metal 6.5m Stereo In-line Sockets **\$7.50**
  - 5 Pin Din Sockets **\$2.35**
  - 555 Timers **\$2.50**
  - Binding Posts 4 Colours. Socket for 4m Plug **\$2.95**
  - Modern 25mm Black Plastic Knobs. Silver Insert. Marker Shaft **\$4.75**
  - Mixed Green Caps. 1, 22, 39, 47 100v .047 630v. **\$1.70**
  - 4 Pin Mic. Plug, and Chassis Mt. Socket **\$17.50**
- P-P NSW \$2 Interstate \$3.50

**40W** RMS 4 WAY HI-FI SPEAKER SYSTEM KIT

30cm Etone Woofer with foam surround • Fully enclosed mid-range and two tweeters • Freq 40-18000Hz • 8 Ohms • Cross-over components and recommended enclosure dimensions included

**\$39.95** P-P NSW \$4.00 **OR \$72.95** P-P NSW \$5.50  
PER KIT INTERSTATE \$6.50 **FOR 2 KITS** INTERSTATE \$8.

**KRIESLER**

240 VAC  
50Hz

BRAND NEW  
GUARANTEED

**\$66**

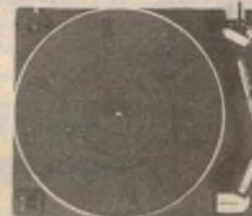

BELT DRIVE  
STEREO PLAYER

• MAGNETIC  
CARTRIDGE AND  
DIAMOND STYLUS •

P-P NSW \$4.50  
Q. V. T. SA \$5.50  
WA, NT \$6.50

Features — big aluminium turntable • 2 speeds 33-45rpm • Cue lever • Calibrated adjustable counterweight • Calibrated anti-skate • Auto return-stop • Switch click suppressor • Power cable, RCA connectors • **OUR BEST PRICE EVER. BE QUICK.**

**ATTENTION!! ELECTRONICS HOBBYISTS**

We have available a huge collection of ex-computer, and various other electronic apparatus — Printed Circuit Boards — crammed with goodies. Resistors, caps, tag tants, t'sistors, 1-Cs, trim pots, pot cores, etc. etc. 5 mixed for \$7. P-P NSW \$2.50. Interstate \$3.50. We guarantee — a bargain. Will throw in a few small P.C.B. for you to improve solder desolder technique.

**Eddystone**  
**Die-Cast Box**

Model 7134P. 110 x 60 x 30D. MM.  
**\$2.50 Ea** or **3 for \$6** P-P 90c.

**JUMBO PANEL METERS**

Easy to read • Clear plastic. 1 AMP and 10 AMP DC FSD. 118 x 112mm. Hole dia 85mm.

**\$11.50** p-p 95c

Also — Super Jumbo Panel Meters by Master Inst. Ex- PMG F.S.D 75MV. Flange mt dia. 185mm. Mixed scales — some volt, some Amp

**\$12.50** p-p \$1.50

# EA Magazine Holders



The binders and magazine holders are available over the counter from Electronics Australia, 57 Regent Street, Sydney, NSW — Price: \$5.10 binders, \$4.50 holders.

Mail orders should be sent to Electronics Australia, PO Box 163, Chippendale, NSW 2008

Prices including postage are:

Holders: \$5.50 NSW; \$5.60 other states; or six for \$29.00 NSW; \$31.50 other states. \$A33.00 NZ.

Binders: \$7.00 NSW; \$8.50 other states; or six for \$33.00 NSW; \$36.00 other states. \$A37.00 NZ.

## EA PC BOARDS AND FRONT PANELS

Some readers have problems obtaining PC boards and front panels for projects. Many of our advertisers sell these items and their advertisements should be checked in the first instance. Failing that, below is a list of firms which produce or sell PC boards and front panels.

### NSW

**Dick Smith Electronics,**  
125 York Street,  
Sydney, 2000.  
Telephone 290 3377.  
DSE also has branches  
and resellers throughout  
Australia.

**Electronic Agencies,**  
115-117 Parramatta Road,  
Concord, 2137.  
Telephone 745 3077.

117 York Street,  
Sydney 2000.  
Telephone 29 2098.

**Jaycar Pty Ltd,**  
125 York Street,  
Sydney 2000.  
Telephone 264 6688.

**Radio Despatch Service,**  
869 George Street,  
Sydney 2000.  
Telephone 211 0816.

**RCS Radio Pty Ltd,**  
651 Forest Road,  
Bexley, NSW 2207.  
Telephone: 587 3491

**VIC.**  
**Rod Irving Electronics,**  
425 High Street,  
Northcote, 3070.  
Telephone 489 8131.

**Kalextronics,**  
101 Burgundy Street,  
Heidelberg 3084.  
Telephone 743 1011.

Shop 11,  
Regional Shopping Centre,  
Melton 3338.  
Telephone 743 1011.

**Sunbury Printed Circuits,**  
Lot 14, Factory 3,  
MacDougal Road,  
Sunbury 3429.  
Telephone 744 2714

### WA

**Altrronics,**  
105 Stirling Street,  
Perth 6000.  
Telephone 328 1599.

**Jemal Products,**  
8/120 Briggs Street,  
Welshpool, 6106.

### N.Z.

**Marday Services,**  
PO Box 19 189,  
Avondale, Auckland.

**Mini Tech Manufacturing  
Co Ltd,**  
PO Box 9194,  
Newmarket.

**Printed Circuits Limited,**  
PO Box 4248,  
Christchurch.

## ADVERTISING INDEX

ADVERTISER	PAGE
Australian Govt (Special Broadcasting Services)	114
A & R Soanar	88
AWA Ltd	9, 25, 134
Actrol Parts	96
Ace Radio	151
Altronic Distributors Pty Ltd	20, 21, 52, 53, 107, 118, 124
A.M.S. Systems	27
Amtex Electronics	28
Aust. School of Electronics	120
Audio Engineers	39
Billco Electronics	137
George Brown Electronics	58
Bright Star Crystals	110
Bemak	133
L.E. Chapman	28
Chloride Batteries Aust Pty Ltd	88
Commodore	19
Comp Soft	119
Computer Focus	88, 150
Computer Wave	139
Danish Hi-fi	110
David Reid Electronics Ltd	126
Dick Smith Electronics Group	4, 5, 31, 32, 33, 34, 48, 98, 104, 105, 109, 112, 113, 131, 140, 141
Eastern Communications	121
Edible Electronics	138
Electronic Agencies	84
Electrocraft	40
Electro Medical Engineering	136
Ellistronics	117
Elmeasco Instruments Pty Ltd	2, 72
Gammatron	139
Homelec Products	122
Jaycar Pty Ltd	10, 11, 42, 43, 60, 61, 90, 91, 115, 123
Kalextronics	41
Looky Video	133
McGraths	95
Marantz (Aust) Pty Ltd	IBC
Melbourne Machinery Co.	143
Palantir Data Systems	150
Parameters	29
Radio Despatch Service	134
Radio Parts Group	36
Rheem	150
R.C.S. Radio	150
Rod Irving Electronics	73, 74, 75, 76, 77, 78, 79, 80, 81, 82, 111, 136
Royston Electronics	111, 136
Selectronic Components	70
Sheridan Electronics	66, 67
Scientific Electronics	146
Sony (Aust) Pty Ltd	IFC
Stotts Technical Correspondence College	133
TEAC	OBC
Technical Book and Magazine Co.	114
Trade Television & Video Service	87
Truscott Electronics	132
Union Carbide	70
Vendale Nominees Ltd	127
Wireless Institute of Australia	125

## SUBSCRIPTION SERVICE



**ELECTRONICS  
Australia**

### Subscription Rates

\$28.00 per year  
within Australia  
\$A29.50 per year  
elsewhere

Make sure you receive every copy of the magazine by ordering it from your newsagent or the publisher. For publisher subscriptions post this coupon, with your remittance to Electronics Australia Subscription Dept. John Fairfax & Sons Ltd, GPO Box 506, Sydney 2001. Subscription will start with first available issue.

Name .....

Address .....

Postcode ..... Enclosed is ..... for ..... years



# Marantz Gold. Life couldn't sound more beautiful. —

A day is made perfect by its ending.  
Sunset, anticipation for the evening  
to come.

Soothing, sounds of your favourite  
music. The day's problems disappear.

The moment is Marantz. Unmatched in  
its eloquence, unmatched for its purity of  
sound reproduction.

Elegant, indulgent.

The Marantz Gold Renaissance 1000.

Top-of-the-line in a range of superbly crafted  
hi-fi systems from Marantz.

Six separate components of unsurpassed  
technical excellence. Highly sophisticated  
Pre-amplifier and Power Amplifier, 14-station

preset AM/FM Stereo Tuner, Cassette Deck,  
Equalizer and fully automatic Turntable —  
subtly burnished gold tone.

And finally, the magnificent system  
speakers — matched in quality and luxury of  
design to rosewood finish furniture pieces.

Marantz Gold Renaissance Series.

Life couldn't  
sound better.

**Marantz Gold.**  
**The New Audio Standard.**

**marantz.**  
Now you're listening.

Distributed by: MARANTZ (Australia) Pty Limited, 19 Chard Road, Brookvale NSW 2100  
Telephone (02) 939 1900 Telex AA24121. Melbourne (03) 544 2011. Brisbane (07) 44 6477.  
Adelaide (08) 223 2699 Perth (09) 276 3706. Townsville (077) 72 2011

Design and specifications subject to change without notice.



**V-3RX** 3-motor, IC full logic transport control, newly developed CA (Cobalt Amorphous) head  
Recommended selling price \$449.\*

**Dynamic Range:  
110dB. It will  
astonish you.**

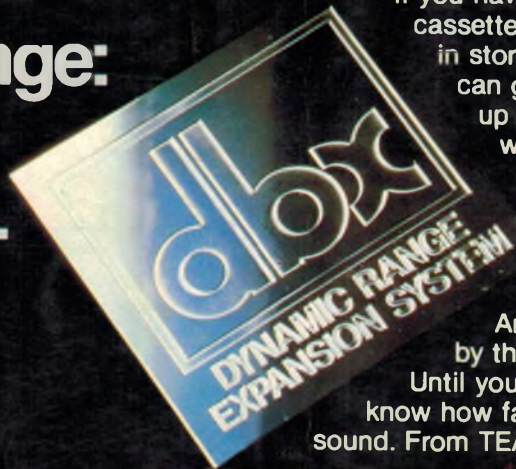

If you haven't heard a TEAC dbx\* cassette deck, you have a big surprise in store. The dbx system can give you dynamic ranges up as high as 110 dB—that's as wide as a live orchestra, big band or rock group. From the mighty blast of the full orchestra, to the tiniest sound of a pianissimo soloist, you get it all. And tape hiss? Gone. Banished by the incredible dbx system. Until you've heard it, you simply don't know how fantastic cassettes can sound. From TEAC, naturally.

**V-5RX**  
3-motor, IC full logic  
transport control  
Recommended selling  
price \$349.\*



\*"dbx" is a trademark of dbx incorporated.

\*Recommended selling prices are subject to change without notice.

**TEAC**  
Where Art and Technology Meet.

TEAC AUSTRALIA PTY. LTD.: 115 Whiteman Street, South Melbourne, Victoria 3205 Australia Phone: 699-6000  
TEAC CORPORATION: 3-7-3, Naka-cho, Musashino, Tokyo, Japan Phone: (0422) 53-1111

For further information and the name of your nearest retailer please write direct to TEAC Australia Pty. Ltd.

Use Reader Information Card for full details.